

# Service Manual

**CIRCUIT DESCRIPTIONS  
REPAIR & ADJUSTMENTS**



**ORDER NO.  
ARP-685-0**

**STEREO TURNTABLE**

# PL-L50

**MODEL PL-L50 COMES IN SEVEN VERSIONS DISTINGUISHED AS FOLLOWS:**

Type	Voltage	Remarks
KU	AC120V only	U.S.A. model
KUT	AC120V only	U.S.A. model without cartridge
KCT	AC120V only	Canada model without cartridge
HEM	AC220V, 240V (switchable)	European continent model
HB	AC220V, 240V (switchable)	United Kingdom model
S	AC110V, 120V, 220V, 240V (switchable)	General export model
S/G	AC110V, 120V, 220V, 240V (switchable)	U.S. Military model

- This service manual is applicable to the KU, KUT, KCT, HB, HEM, S and S/G types.
- As to the KUT, KCT, HEM, HB, S and S/G types please refer to pages 47 – 48.
- Ce manuel d'instruction se réfère au mode de réglage, en français.
- Este manual de servicio trata del método de ajuste escrito en español.

## CONTENTS

1. SAFETY INFORMATION . . . . .	2	10. P.C. BOARDS CONNECTION DIAGRAM . . . . .	26
2. SPECIFICATIONS . . . . .	3	11. SCHEMATIC DIAGRAM . . . . .	29
3. FRONT PANEL FACILITIES . . . . .	4	12. ELECTRICAL PARTS LIST . . . . .	32
4. BLOCK DIAGRAM . . . . .	5	13. ADJUSTMENTS . . . . .	34
5. CIRCUIT DESCRIPTIONS . . . . .	7	RÉGLAGE . . . . .	36
6. DISASSEMBLY . . . . .	17	AJUSTE . . . . .	38
7. PARTS LOCATIONS . . . . .	20	14. TROUBLESHOOTING . . . . .	40
8. EXPLODED VIEW AND PARTS LIST . . . . .	22	15. SUPPLEMENT FOR KUT, KCT, HEM, HB, S AND S/G TYPES . . . . .	47
9. PACKING . . . . .	25		

# 1. SAFETY INFORMATION

## 1. SAFETY PRECAUTIONS

The following check should be performed for the continued protection of the customer and service technician.

### LEAKAGE CURRENT CHECK

Measure leakage current to a known earth ground (water pipe, conduit, etc.) by connecting a leakage current tester such as Simpson Model 229-2 or equivalent between the earth ground and all exposed metal parts of the appliance (input/output terminals, screwheads, metal overlays, control shaft, etc.). Plug the AC line cord of the appliance directly into a 120V AC 60Hz outlet and turn the AC power switch on. Any current measured must not exceed 0.5mA.

**ANY MEASUREMENTS NOT WITHIN THE LIMITS OUTLINED ABOVE ARE INDICATIVE OF A POTENTIAL SHOCK HAZARD AND MUST BE CORRECTED BEFORE RETURNING THE APPLIANCE TO THE CUSTOMER.**

## 2. PRODUCT SAFETY NOTICE

Many electrical and mechanical parts in the appliance have special safety related characteristics. These are often not evident from visual inspection nor the protection afforded by them necessarily can be obtained by using replacement components rated for voltage, wattage, etc. Replacement parts which have these special safety characteristics are identified in this Service Manual.

Electrical components having such features are identified by marking with a ⚠ on the schematics and on the parts list in this Service Manual.

The use of a substitute replacement component which does not have the same safety characteristics as the PIONEER recommended replacement one, shown in the parts list in this Service Manual, may create shock, fire, or other hazards.

Product Safety is continuously under review and new instructions are issued from time to time. For the latest information, always consult the current PIONEER Service Manual. A subscription to, or additional copies of, PIONEER Service Manual may be obtained at a nominal charge from PIONEER.

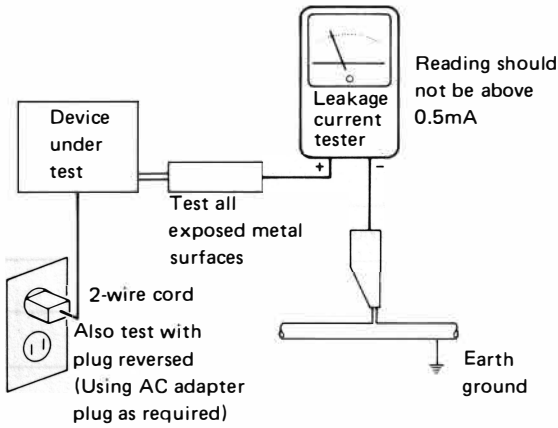

AC Leakage Test

## 2. SPECIFICATIONS

### Motor and Turntable

Drive System .....	Direct-drive
Motor .....	DC servo motor
Turntable Platter .....	304 mm diam. aluminum alloy die-cast
Speeds .....	33-1/3 and 45 rpm
Wow and Flutter .....	Less than *0.014% (WRMS) 0.025% (WRMS) ± 0.035% WTD Peak (DIN)

Values marked with an "\*" designate the wow and flutter for motor, and do not include the cartridge or tonearm load.

Signal-to-Noise-Ratio .....	More than 78 dB (DIN-B) (with Pioneer cartridge model PC-300T)
-----------------------------	---

### Tonearm

Type .....	Integrated straight tonearm
------------	-----------------------------

### PC-300T Specifications

Type .....	IM type
Stylus .....	0.3 x 0.7 mil diamond (PN-300T)
Output Voltage .....	2.5 mV (1 kHz, 5 cm/s LAT. Peak)
Tracking Force .....	1.0 g to 1.5 g (proper 1.25 g)
Frequency Response .....	10 to 33,000 Hz
Recommended Load .....	50 kΩ
Weight .....	5.9 g

### Subfunctions

Auto lead-in, auto return, auto cut, repeat  
 Arm elevation, manual play,  
 Auto disc size selector, record detection,  
 Auto speed selector

### Miscellaneous

#### Power Requirements

HEM, HB, HP models .....	AC 220 V/240 V~ (switchable), 50, 60 Hz
KUT, KCT, KU, KC models .....	AC 120 V, 60 Hz
S, S/G models .....	AC 110 V/120 V/220 V/240 V~ (switchable), 50, 60 Hz

#### Power Consumption

HEM, HB, HP models .....	13 W
KUT, KCT, KU, KC models .....	12 W
S, S/G models .....	9 W

Dimensions .....	420 (W) x 108 (H) x 365 (D) mm 16-1/2 (W) x 4-1/4 (H) x 14-3/8 (D) in.
------------------	---

Weight .....	4.8 kg/11 lb
--------------	--------------

### Accessories

EP Adapter .....	1
Operating Instructions .....	1

#### NOTE:

*Specifications and design subject to possible modification without notice, due to improvements.*

### INFORMATION TO USER [FOR U.S.A. MODEL]

This equipment generates and uses radio frequency energy and if not installed and used properly, that is, in strict accordance with the manufacturer's instructions, may cause interference to radio and television reception. It has been type tested and found to comply with the limits for a Class B computing device in accordance with the specifications in Subpart J of Part 15 of FCC Rules, which are designed to provide reasonable protection against such interference in a residential installation. However, there is no guarantee that interference will not occur in a particular installation.

If this equipment does cause interference to radio or television reception, which can be determined by turning the equipment off and on, the user is encouraged to try to correct the interference by one or more of the following measures:

- reorient the receiving antenna
- relocate this component with respect to the receiver
- move this component away from the receiver
- plug this component into a different outlet so that component and receiver are on different branch circuits.

If necessary, the user should consult the dealer or an experienced radio/television technician for additional suggestions. The user may find the following booklet prepared by the Federal Communications Commission helpful:

"How to Identify and Resolve Radio-TV Interference Problems".

This booklet is available from the US Government Printing Office, Washington, D.C., 20402, Stock No. 004-000-00345-4.

*The above instructions apply only to units which will be operated in the United States.*

### 3. FRONT PANEL FACILITIES

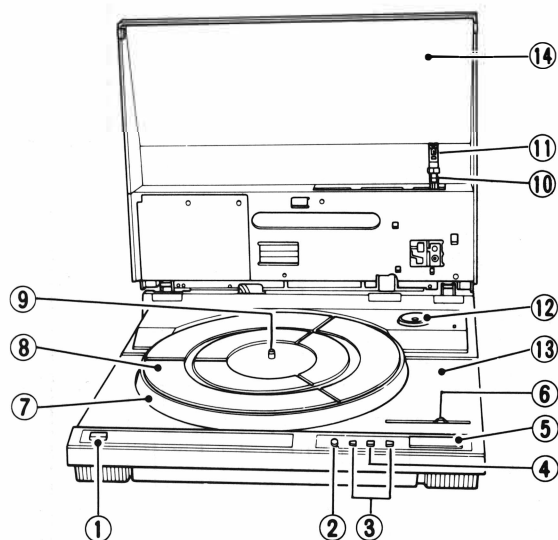

#### ① POWER switch

Press this switch to turn the power on and off.  
 [ON] (depressed position) : Power is switched ON.  
 [STAND-BY] (released position) : Power is switched OFF.

#### ② REPEAT switch/indicator

Press this switch so that the indicator lights for repeat play.

#### ③ LOCATE switches

Use these switches to start manual playback, or during playback to change the track being played. When the switches are pressed, the tonearm will move to the right or left.

[◀◀]: Tonearm moves to left.  
 [▶▶]: Tonearm moves to right.

#### ④ ARM ELEVATION switch(UP)/indicator

- Use the switch for manual play.
- Use the switch to suspend record play temporarily.
- Use the switch when changing the tracks during manual play.

[UP] indicator lights:

The tonearm rises (the stylus moves away from the record).

[UP] indicator goes out:

The tonearm descends (the stylus is lowered onto the record).

#### ⑤ START/STOP switch

Depress this switch when starting auto play or when stopping play.

#### ⑥ SPEED switch

Set this switch in accordance with the speed of the record which is to be played.

[AUTO]: Automatically sets rotation speed in accordance with the size of the record: Rotates at 33-1/3 rpm with 30 cm records. Rotates at 45 rpm with 17 cm records.

[33]: Rotates at 33-1/3 rpm

[45]: Rotates at 45 rpm

#### ⑦ Platter

#### ⑧ Rubber mat

#### ⑨ Platter shaft

#### ⑩ Tonearm

#### ⑪ CARTRIDGE (PC-300T)

**NOTE:**

*A cartridge is not provided with the KUT and KCT models and so your own cartridge should be mounted, following the instructions laid down in CARTRIDGE MOUNTING.*

#### ⑫ EP adapter

This is used when playing records with a "large center hole".

#### ⑬ Cabinet

#### ⑭ Dust cover

# 4. BLOCK DIAGRAM

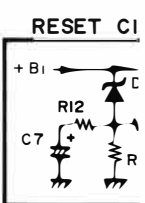

PHONO MOTOR CIRCUIT

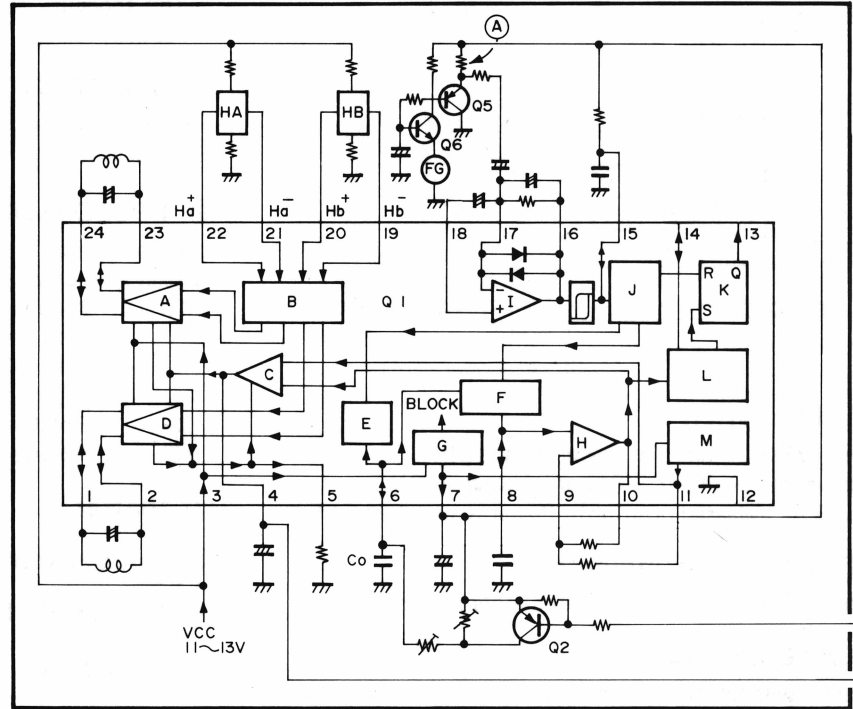

- A : DRIVING AMP
- B : HALL - AMP
- C : V - I CONVERTER
- D : DRIVING AMP
- E : RESET CIRCUIT
- F : SAMPLE & HOLD CIRCUIT
- G : VOLTAGE REGULATOR
- H : BUFFER AMP
- I : FG AMP
- J : TIMING CIRCUIT
- K : PHASE COMPARTOR
- L : LOCK INDICATOR
- M : 1/2 VCC2 CIRCUIT

POWER SUPPLY CIRCUIT

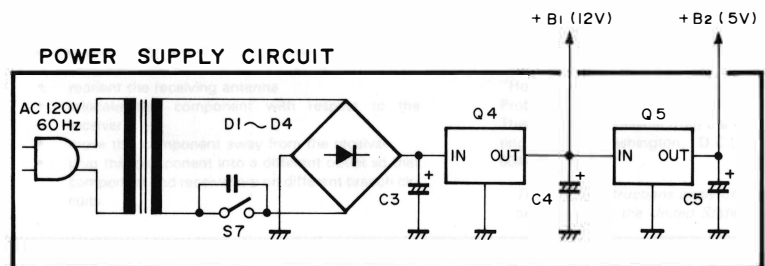

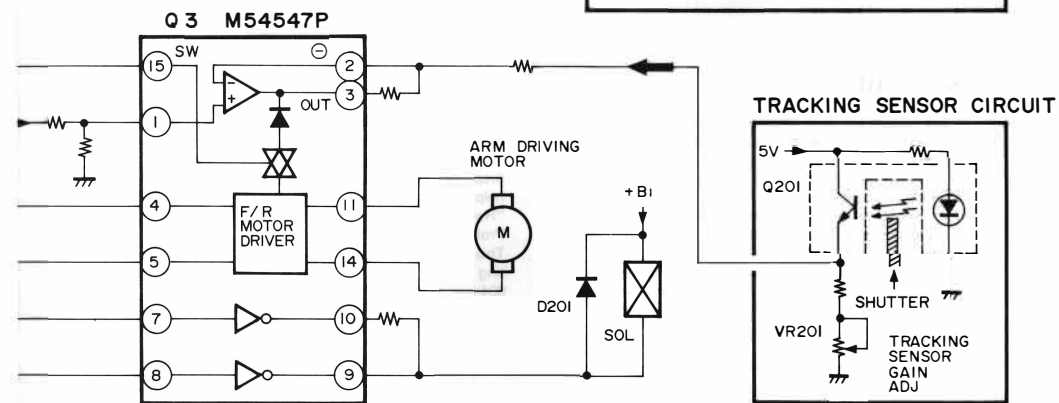
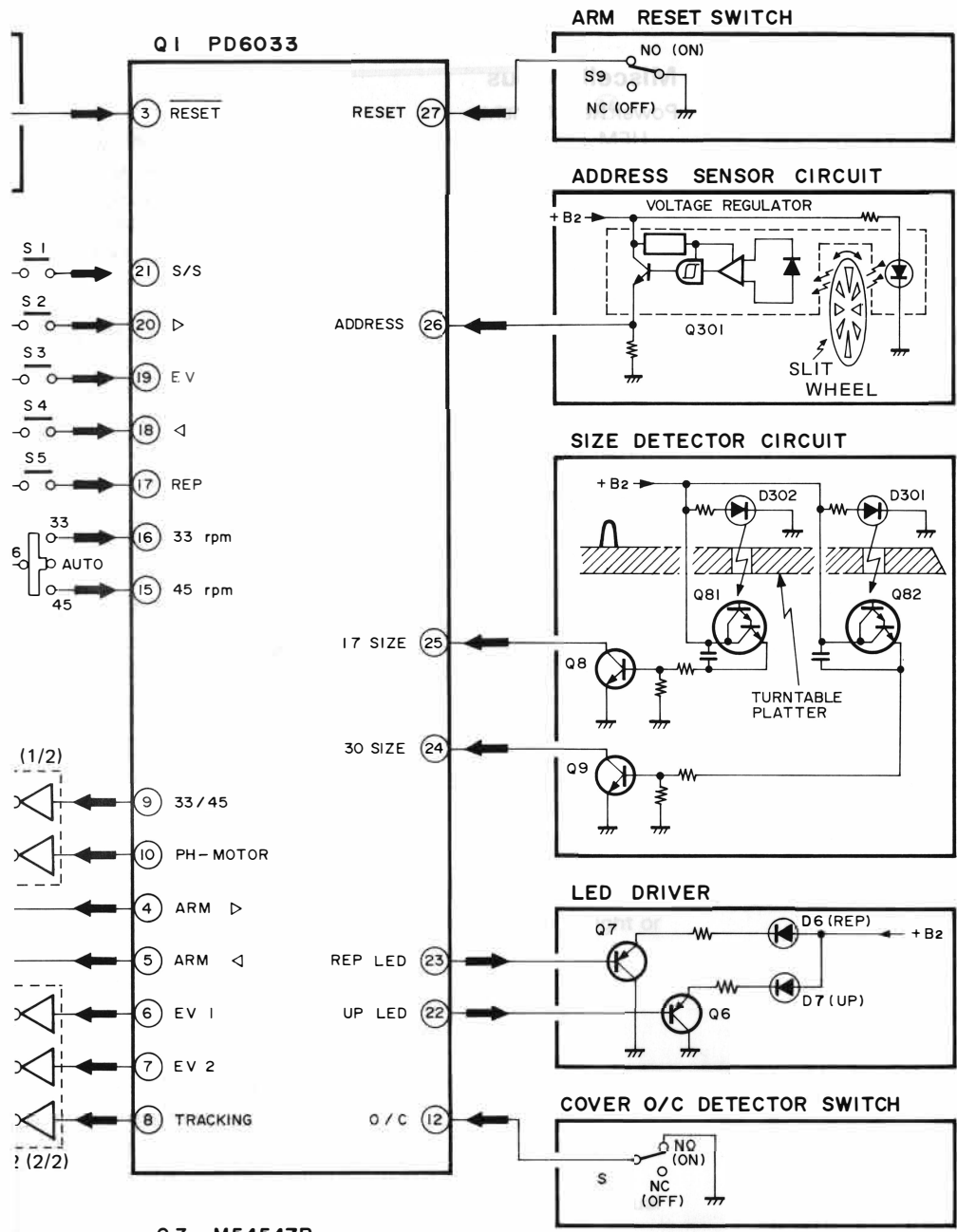

# 5. CIRCUIT DESCRIPTIONS

## 5.1 CIRCUIT DESCRIPTIONS

### 5.1.1 Address Sensor Circuit

The address sensor is located on the mechanism base unit. It detects the position of the tonearm and sends address pulses to the control IC as the tonearm moves. The address sensor is made up of an internal schmitt trigger circuit photo interrupter and a slit wheel which is synchronized with the carriage. The slit wheel spins when the carriage moves and intermittently cuts off light to the photo interrupter (Q301) in pulses which correspond to the carriage movement. These pulses are counted by the control IC, which detects the distance the carriage moves, the tonearm lowering position and the end of the record. It also registers band addresses.

The address pulses from the photo interrupter work as follows: When the light is cut off, the output is "L," and when the light is not cut off the output is "H." One address signal pulse is approximately equivalent to 0.114 mm of tonearm movement.

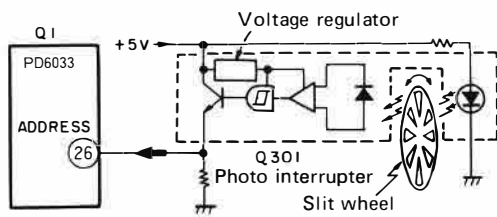

Fig. 5-1 Address Sensor Circuit

### 5.1.2 Tracking Sensor Circuit

This circuit detects tracking errors by means of a shutter which is synchronized with the tonearm and a photo interrupter.

The tracking sensor is made up of a shutter synchronized with the tonearm and a photo interrupter which is mounted onto the carriage base board. When the tonearm lowers and begins tracing the record surface the tonearm tracking errors increase as the number of rpms increases. When tracking errors increase, the shutter, which is synchronized with the tonearm, also moves and the light cut-off rate of the photo interrupter changes. Subsequently, the output of the photo interrupter changes and is sent to the tonearm drive unit in the form of tracking error signals.

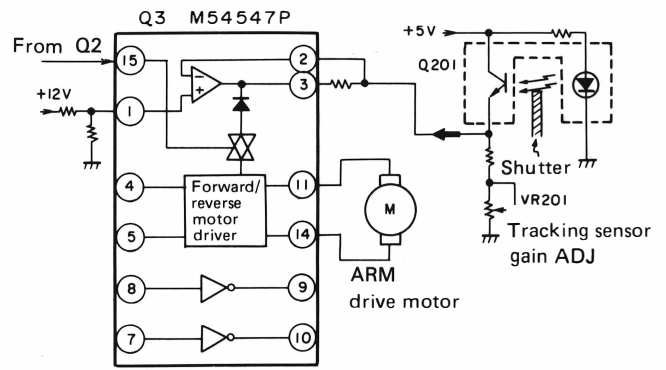

Fig. 5-2 Tracking sensor circuit

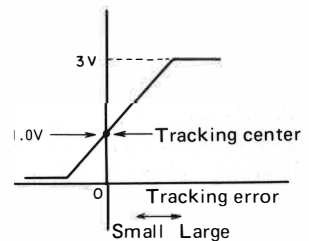
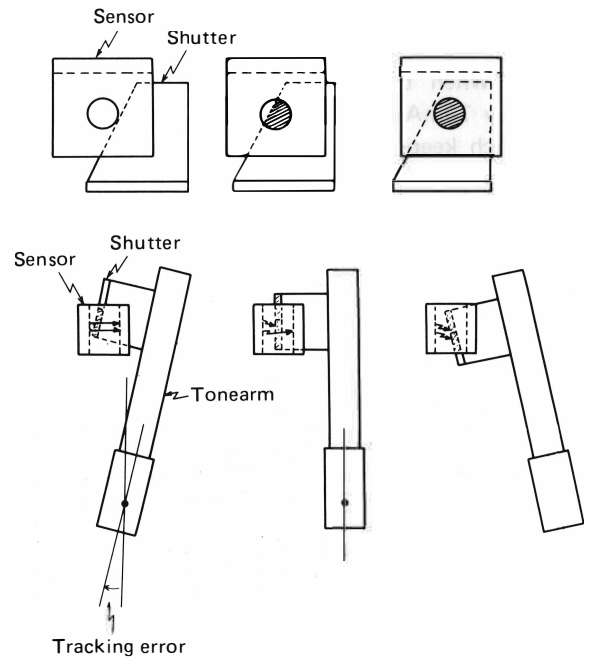

Fig. 5-3 Detection of tracking errors.

### 5.1.3 Elevation and Tonearm Circuits

The tonearm drive motor and EV solenoid are controlled by commands from the control IC (Q1), which also controls the horizontal and vertical movement of the tonearm. In addition to this, the IC controls tonearm tracking with the tracking sensor and tracking error signals.

- **EV solenoid drive**

The EV solenoid drive uses a large current at first to draw the plunger inside, and thereafter uses a lower current for holding the plunger in.

The signal to draw the plunger inside comes from the control IC (Q1), passes through the Q2 transistor array, and enters Q3 pin 8. This signal turns on the Q3 Darlington transistor, and approximately 170mA of current runs into the collector, turning on the EV solenoid which draws the plunger inside. Because of this, the tonearm will drop slightly. This "draw" signal from the control IC lasts about 1 second. Next, the hold signal, which was output at the same time as the draw signal, passes through the Q2 transistor array, enters Q3 pin 7 and turns on the Darlington transistor. When the draw signal ends, a current of approximately 70mA drawn from pin 10 holds the plunger inside, which keeps the tonearm elevation down until the hold signal ends.

- **Tonearm drive**

The tonearm drive is controlled by input to Q3 pin 4, pin 5, and pin 15. Their truth values are shown in Fig. 5-4

- **Lead-in (locate-in)**

Q3 receives locate-in signals from the control IC (Q1), and with an output of approximately 0V from Q3 pin 14 (O1) and approximately 11V from pin 11 (O2), the tonearm motor begins turning in the lead-in direction.

- **Lead-out (locate-out)**

Q3 receives locate-out signals from the control IC (Q1), and with an output of approximately 11V from pin 14 and approximately 0V from pin 11, the tonearm motor begins turning in the lead-out direction.

- **Stop**

Q3 receives stop signals from the control IC (Q1), and with an output of approximately 0V from both pin 14 and pin 11, stops the tonearm motor.

- **Tracking**

Q3 receives tracking signals from the control IC (Q1), and between pin 14 and pin 11, outputs an amplified tracking error signal (amplified by an internal OP amplifier) and begins turning the tonearm drive motor in such a way as to correct the error.

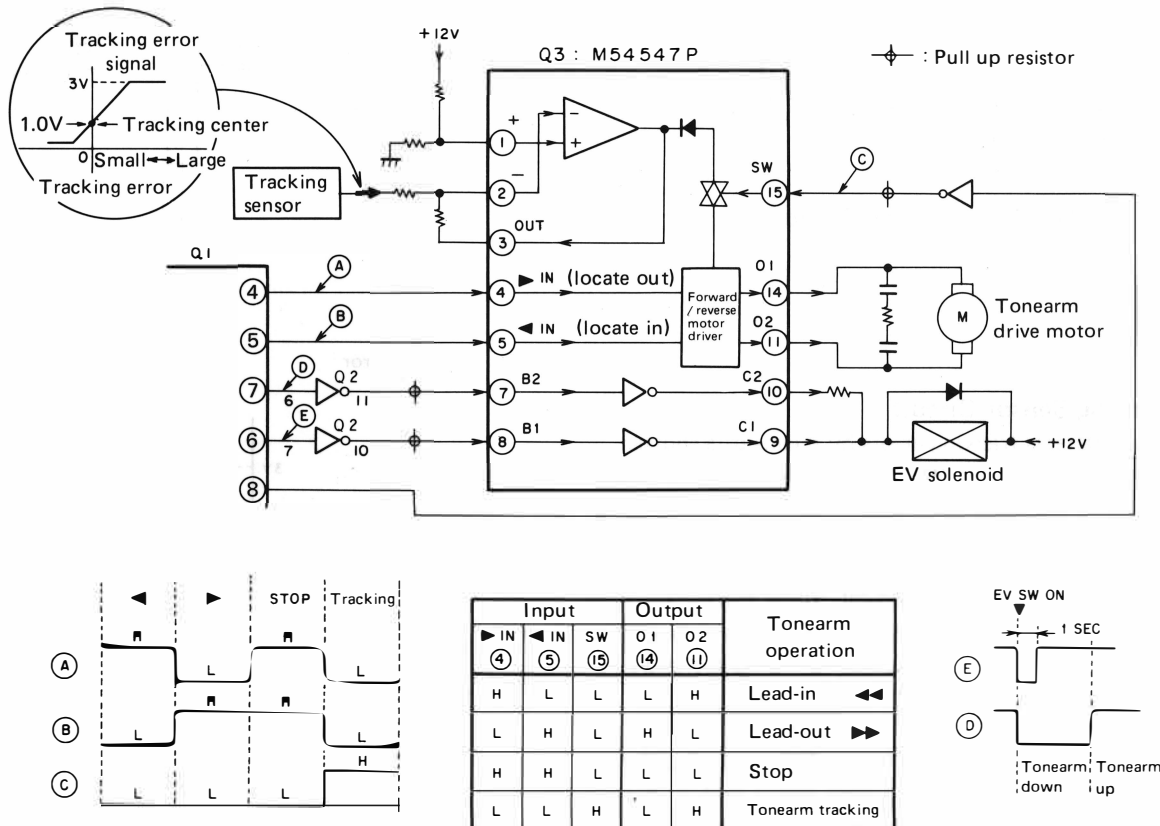

Fig. 5-4 Elevation and Tonearm Drive Circuit and I/O Truth Value Chart.



### 5.1.4 Seize Detector Circuit

The size detector is made up to three slits for detecting 30 cm records, three slits for detecting 17 cm records, and two LEDs and two photo transistors. It detects the record size by detecting the existence of LED light passing through the slits.

- **When there is no Record**

Light from LED D301 (for 30 cm) goes through the slits in the turntable and rubber sheet and strikes photo transistor Q82. Q82 goes ON and OFF according to the revolutions of the turntable. In the same way, the light from D302 (for 17 cm) strikes Q81, and Q81 ON and OFF.

When Q82 (Q81) turns on, Q9 (Q8) also turns on and that output goes to the Q1 pin 24 which is the 30 cm record size pin (pin 25 is the 17 cm record size pin). Q1 determines that there is no record.

- **When there is a 17 cm Record**

When the 17 cm record size slits are covered by a record, Q81 turns off, and Q80 remains off. Due to this, "H" is input into Q1 pin 25. When the 30 cm record size slits are not covered, it's the same as no record, and Q82 and Q9 go ON and OFF according to the revolutions of the turntable. The waveforms show in figure are then input into Q1 pin 24. Q1 then determines that there is a 17 cm record because of this.

- **When there is a 30 cm Record**

Since the 17 and 30 cm record size slits are both covered, Q81, Q8, Q82, and Q9 all turn off. Q1 pins 24 and 25 both receive "H" input, and because of this Q1 determines that there is a 30 cm record.

- **When there is no Record**

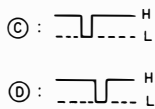

- **When there is a 70 cm Record**

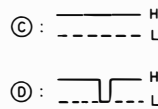

- **When there is a 30 cm Record**

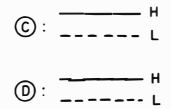

Fig. 5-5 (C), (D) point wave pattern

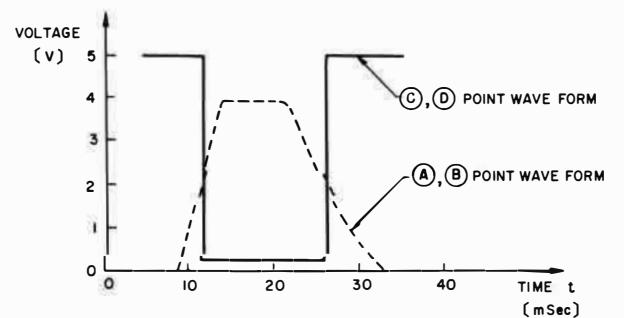
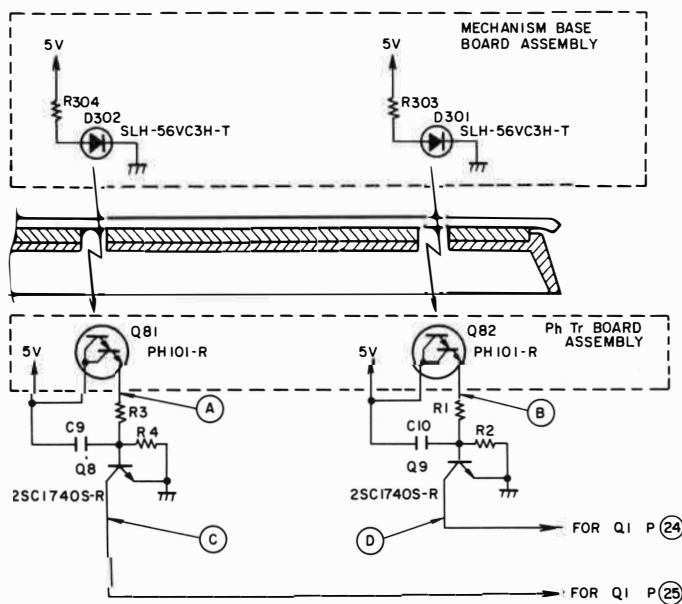

Fig. 5-6 Size Detector Circuit

### 5.1.5 Phono Motor Circuit

The phono motor of this player uses magnetism along the outside edge of the drive magnet to determine its rpm value. (Formerly, a separate magnet was needed in addition to the drive magnet.)

This motor uses a PA2017 as its control drive IC. Also, since this motor is brushless and coreless, the position of the rotor magnet is detected by two Hall elements HA and HB, which make the motor turn by switching the current to the drive coil electronically. When voltage is applied to the Hall elements HA and HB, a voltage differential is created in the output interval by the magnetic field of the approaching rotor. The Hall elements HA and HB are also attached 90° electrically out of phase so their output signals have a 90° phase difference. (See Fig. 5-13)

After the output voltage from the Hall elements have been amplified by the PA2017 Hall amplifier, it enters a position signal composite circuit (See Fig. 5-15). The output from the position signal composite circuit is then input into the respective drive amplifiers. The coil current at this time is as shown in figure 5-13 coils A and B. This

current produces a magnetic field in the drive coil, and the polarity of the coil and the polarity of the rotor attract and repel each other causing the motor to start turning.

When the motor starts turning, the signal (approximately 0.5mV p-p) produced by a frequency generator (FG) in the motor rotation unit, is amplified to about 0.3V p-p by an FG amplifier (Q5, Q6) and is input into the FG amplifier (input pin 17) inside PA2017. Possible frequencies at this point are 55.55 Hz for 33 rpm and 75 Hz for 45 rpm.

The signal then undergoes waveform shaping in the Schmitt transistor, and is then input into the reset circuit, the sample and hold circuit and finally the timing circuit for a timing pulse for the phase comparison circuit. In the

Signals are input into the reset circuit and the sample and hold circuit, and undergo F – V conversion (pin 8). The signals are then amplified by the buffer amplifier and then input into the V – I conversion circuit. The V – I conversion circuit controls the current that flows into the drive circuit based on the difference between the output of the buffer amplifier and the reference voltage (1/2VCC2).

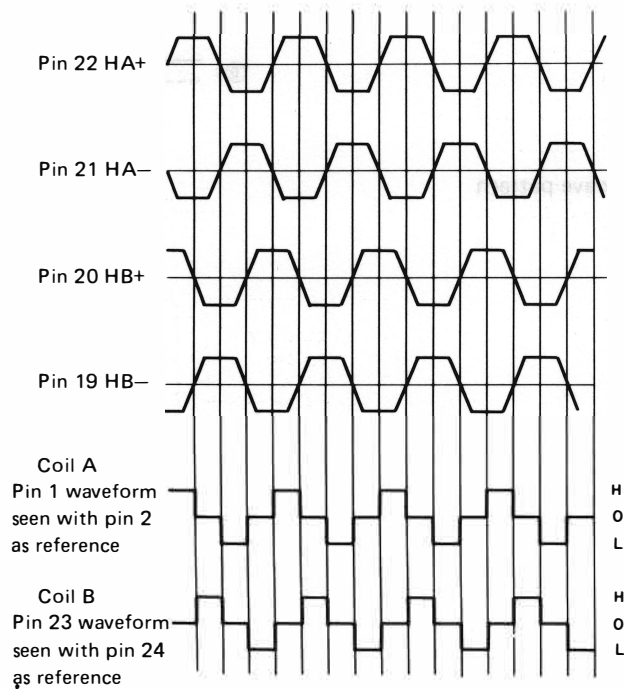

Fig. 5-7 Hall Elements and Coil Terminal Waveforms

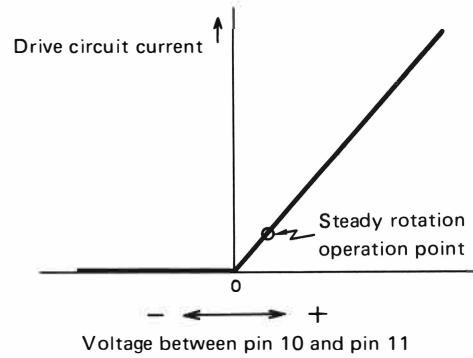

Fig. 5-8 V – I Conversion + Drive Circuit I/O Characteristics

When the motor has just begun turning, the F – V conversion voltage will be higher than the reference voltage, so current will flow into the drive coil, and the motor will speed up. Gradually, the motor will return to a constant rotation speed.

When the motor spins faster than regulation speed, both the P – V and F – V conversion voltage become lower than the reference voltage. This causes the current to stop flowing in the drive circuit and the rpms decrease because of a loss of torque.

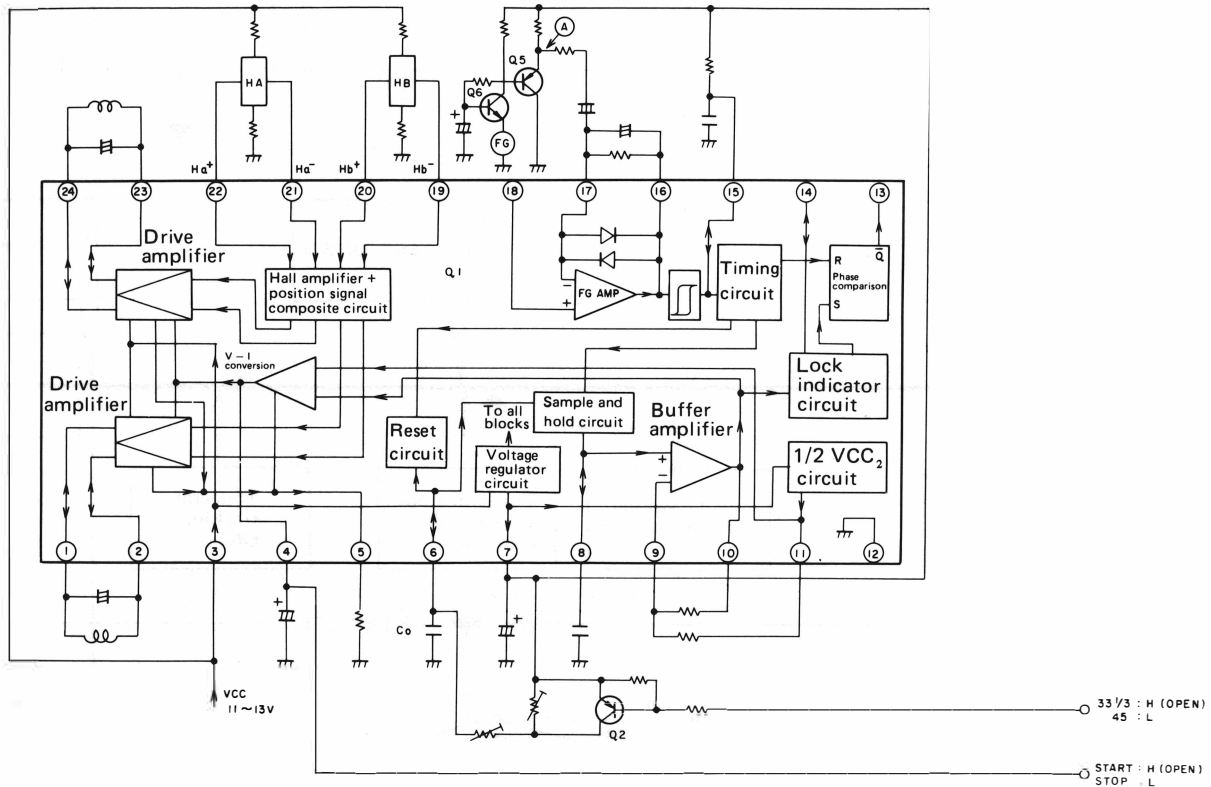

Fig. 5-9 Phono Motor Circuit

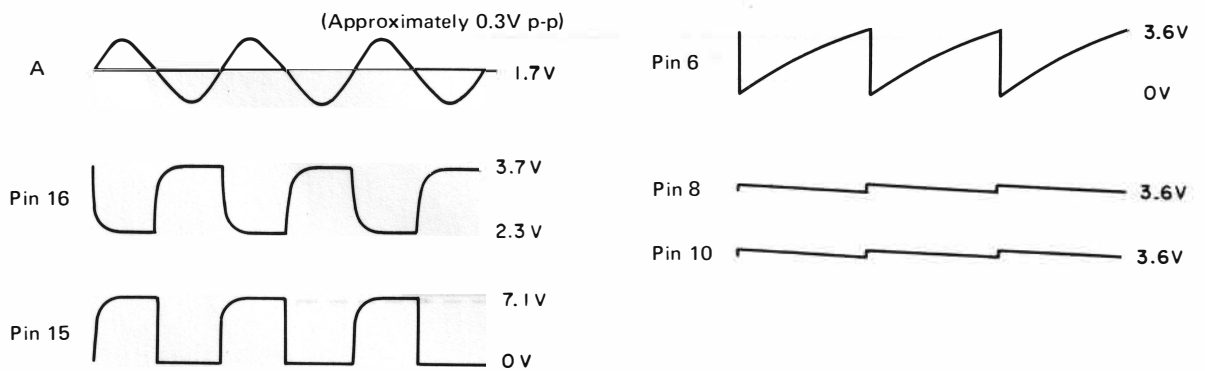



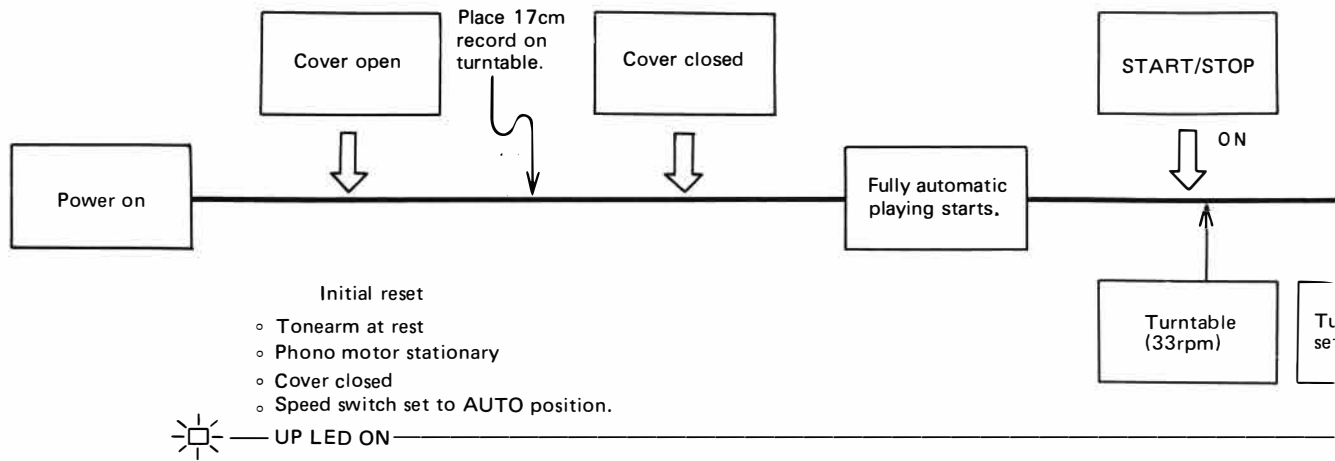

Fig. 5-10 Phono Motor Circuit Waveforms

## IC (PD6033) terminal descriptions

Pin No.	Symbol	I/O display	Terminal name	Description
1	EXtal	—	—	Internal clock oscillator external circuit terminal Ceramic oscillator "3MHz"
2	Xtal	—	—	
3	Reset	I	—	CPU initial reset input Reset <input type="checkbox"/> Normally "H"
4	Q0	O	ARM ▷	Tonearm motor drive output (toward outside edge) <input type="checkbox"/> OFF
5	Q1	O	ARM ◁	Tonearm motor drive output (toward center) <input type="checkbox"/> OFF
6	Q2	O	EV 1	Tonearm EV drive output (drawing plunger in) <input type="checkbox"/> OFF Drawing time 1 sec
7	Q3	O	EV 2	Tonearm EV drive output (holding plunger in) <input type="checkbox"/> OFF
8	Q4	O	TRACKING	Tonearm tracking output during tracing <input type="checkbox"/> OFF
9	Q5	O	33/45	Phono motor 33/45 switch output <input type="checkbox"/> 45 <input type="checkbox"/> 33
10	Q6	O	PHONO-MOTOR	Phono motor START/STOP output <input type="checkbox"/> Start <input type="checkbox"/> Stop
11	Q7			
12	R0	I	O/C	Cover O/C detection input <input type="checkbox"/> Open <input type="checkbox"/> Closed
13	R1			
14	Vss	—	—	GND
15	R2	I	45rpm	33/45 switch 45 input <input type="checkbox"/> Closed <input type="checkbox"/> AUTO
16	R3	I	33rpm	33/45 switch 33 input <input type="checkbox"/> Tonearm START/STOP switch input <input type="checkbox"/> AUTO
17	R4	I	REP	Repeat switch input <input type="checkbox"/> ON <input type="checkbox"/> OFF
18	R5	I	◁	Locate switch input (toward record center) <input type="checkbox"/> ON <input type="checkbox"/> OFF
19	R6	I	EV	Tonearm elevation switch input <input type="checkbox"/> ON <input type="checkbox"/> OFF
20	R7	I	▷	Locate switch input (Toward outside edge) <input type="checkbox"/> ON <input type="checkbox"/> OFF
21	R8	I	S/S	Tonearm START/STOP switch input <input type="checkbox"/> ON <input type="checkbox"/> OFF
22	R9	O	UP LED	Tonearm UP display LED output <input type="checkbox"/> UP <input type="checkbox"/> DOWN
23	R10	O	REP LED	Repeat display LED output <input type="checkbox"/> ON <input type="checkbox"/> OFF
24	K0	I	30 SIZE	30 cm record detector input <input type="checkbox"/> 17cm record 
25	K1	I	17 SIZE	17 cm record detector input <input type="checkbox"/> 30cm record 
26	K2	I	ADDRESS	Address sensor input 
27	K3	I	REST	Rest switch input <input type="checkbox"/> On rest <input type="checkbox"/> Off rest
28	Vcc	—	—	+5V

# 17cm EP Fully automatic playing



Q1 logic in initial reset complete status

1	—	8	H	15	H	When on AUTO or 33 rpm	22	L
2	—	9	H	16	H	When on AUTO or 45 rpm	23	H
3	H	10	H	17	H	When the switch is not pressed:	24	—
4	H	11	H	18	H	— " —	25	—
5	H	12	—	19	H	— " —	26	—
6	H	13	H	20	H	— " —	27	L
7	H	14	L (GND)	21	H	— " —	28	5V

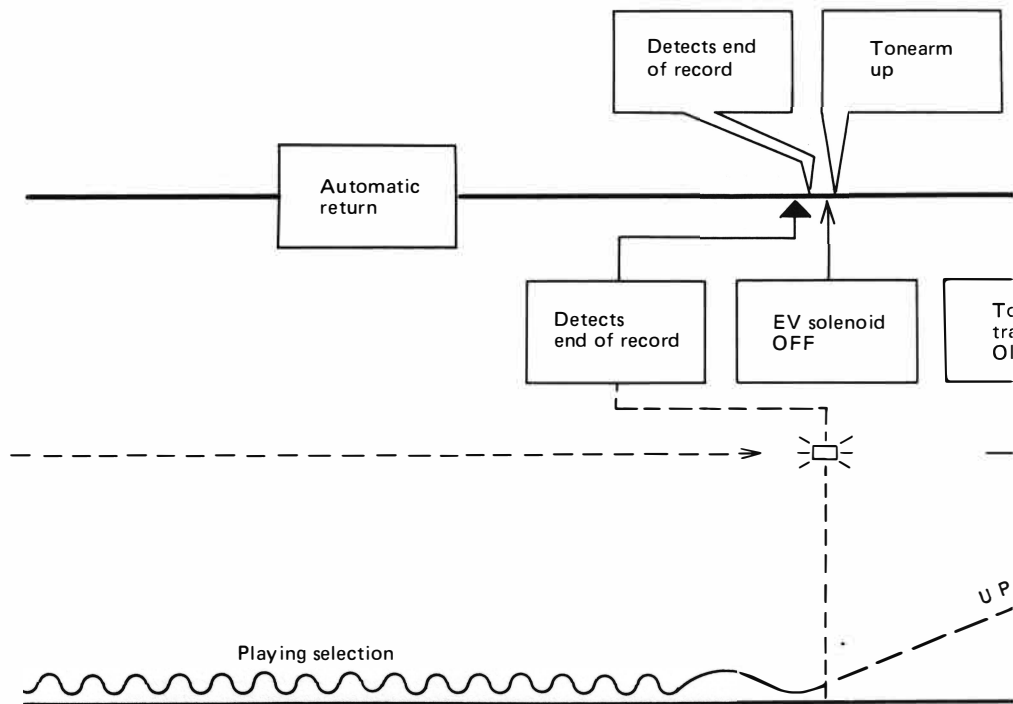

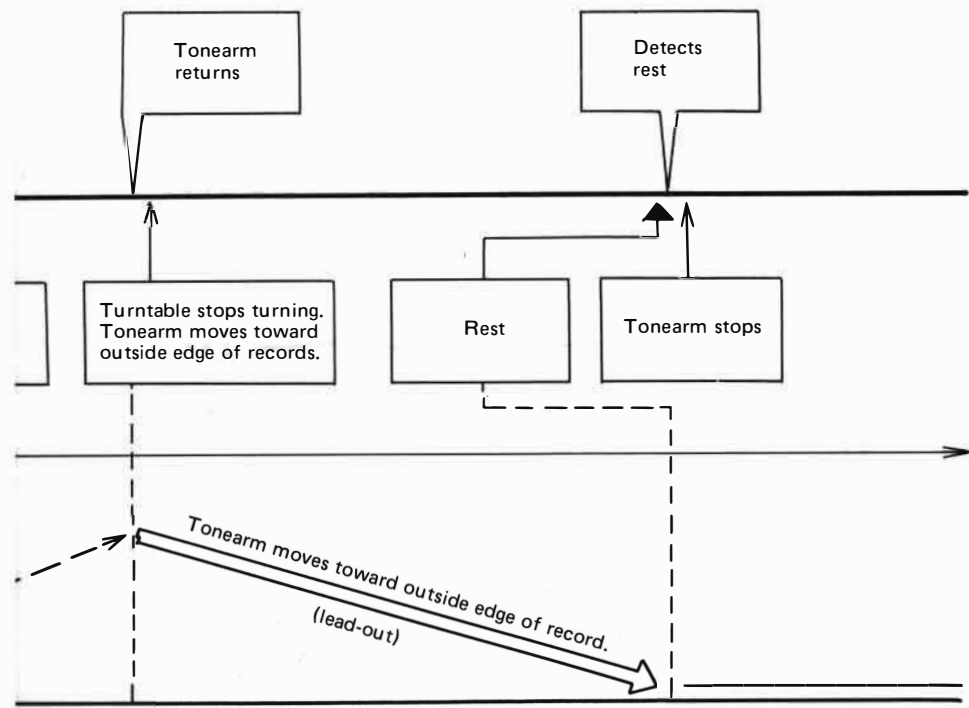
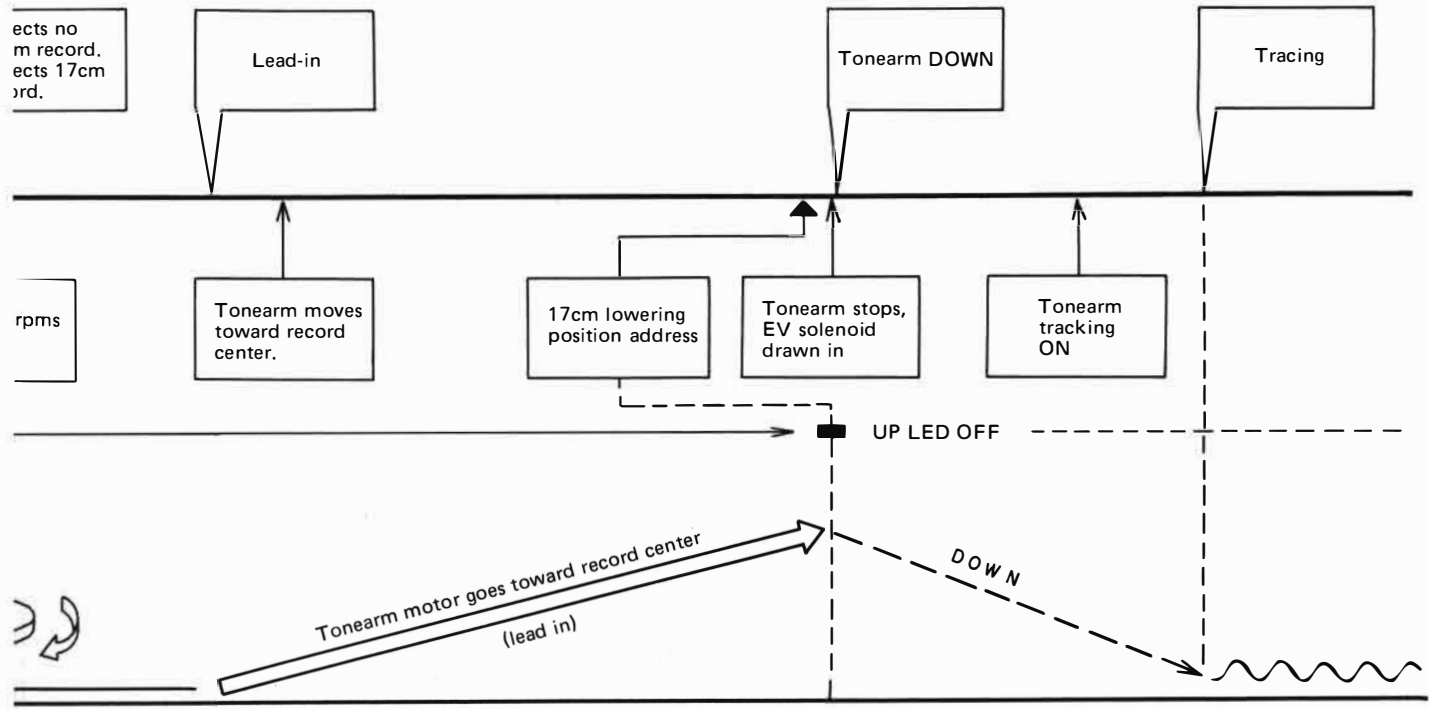
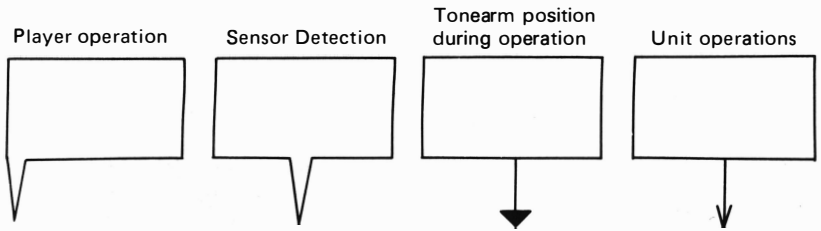

# Timing chart

17cm EP fully automatic operation 1 cycle

☆ Speed switch set to AUTO

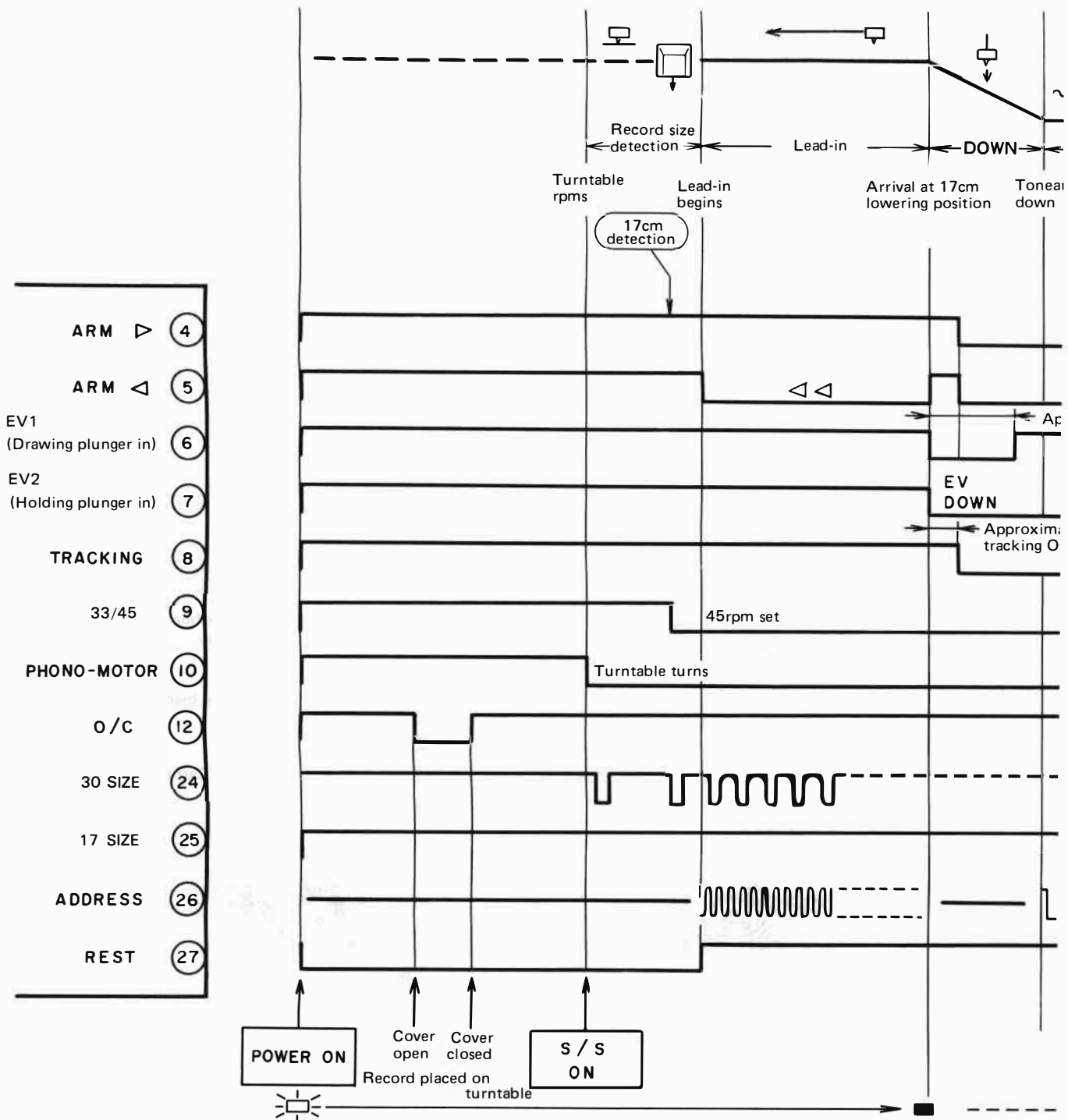

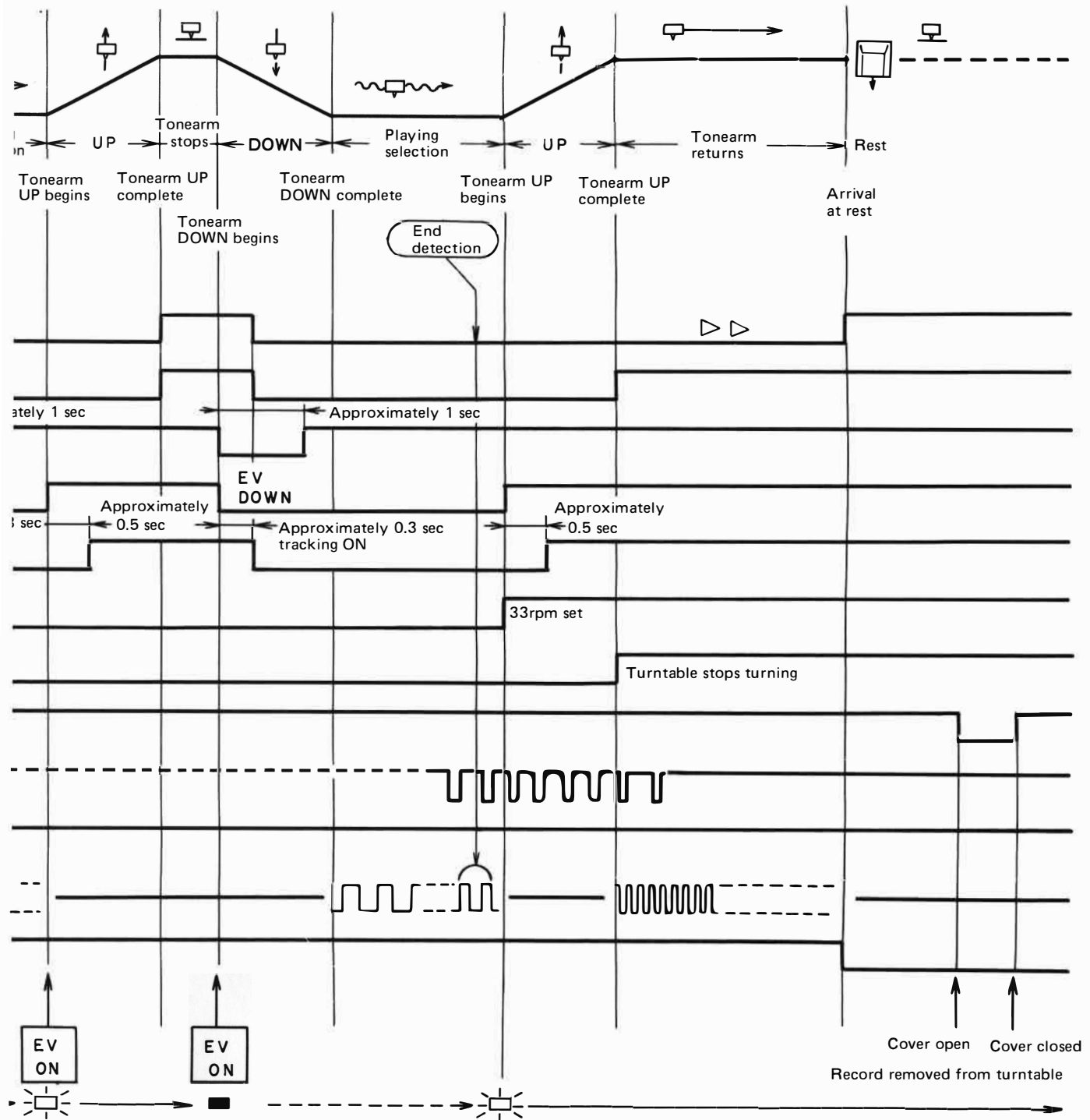



## 6. DISASSEMBLY

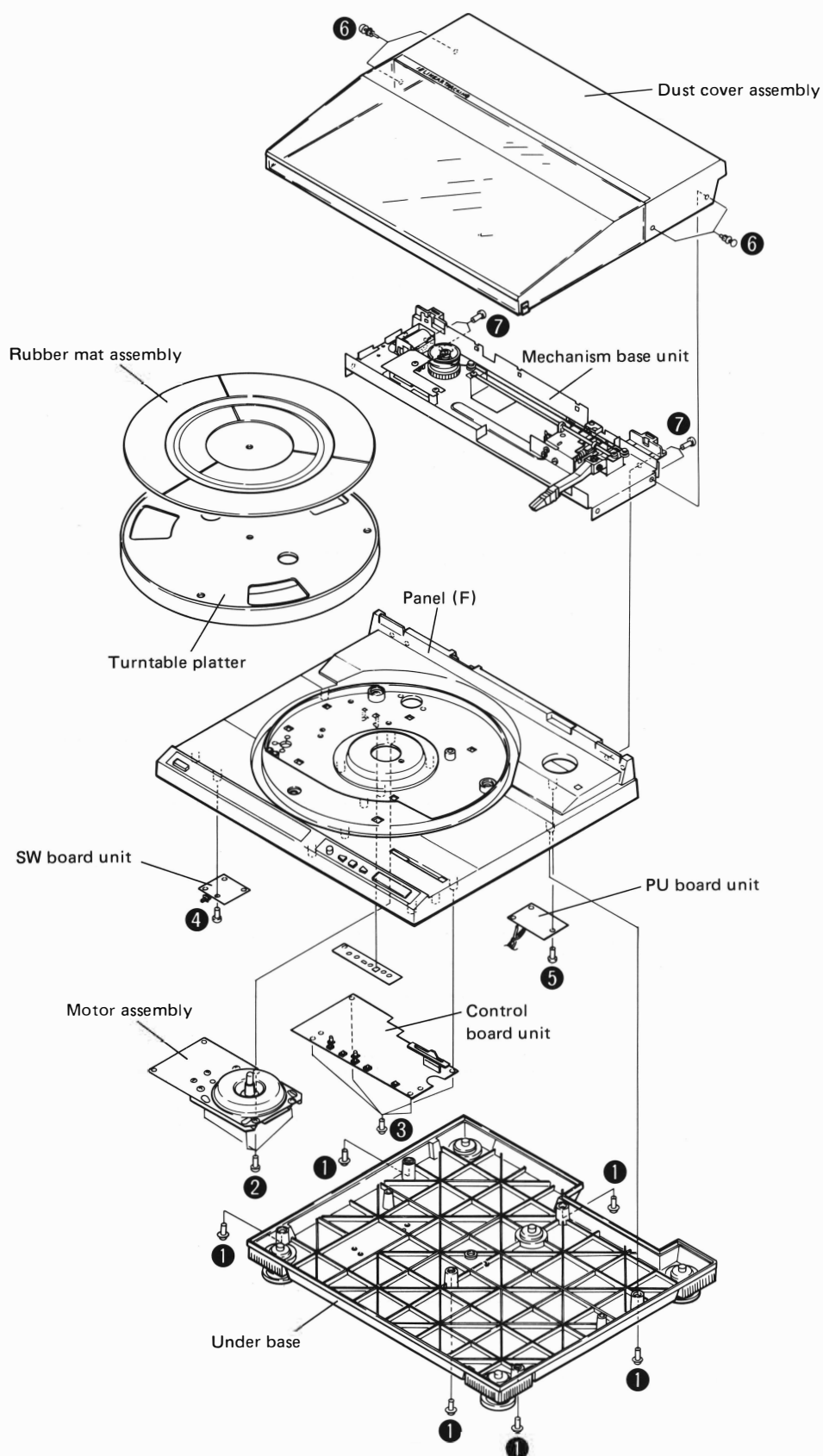

Fig. 6-1

## 6.1 UNIT DISASSEMBLY

1. Open the dust cover and remove the rubber sheet and turntable.
2. Close the dust cover and gently turn the unit over. Place the unit on something soft that won't scratch the dust cover.
3. Removing screw ① releases the under base.
4. Removing screw ② releases the motor assembly.
5. Removing screw ③ releases the control board unit.
6. Removing screw ④ releases the SW board unit, and removing screw ⑤ releases the PU board unit.
7. To remove the dust cover, open it up and remove the plastic rivets labeled ⑥. (The plastic rivets can be removed easily by pushing the pins from the inside of the dust cover.)
8. Removing screw ⑦ will release the mechanism base unit.

## 6.2 CARRIAGE REMOVAL

1. Remove the fixer from the carriage and the wire from the pulley. (See Figure 6.2)
2. Remove screw ⑧ and pull the guide bar away from the carriage in the direction indicated by the arrow. The carriage and tonearm assembly can now be removed.
3. Removing the spring will release the carriage board assembly, and removing screw ⑨ will release the mechanism base board assembly.

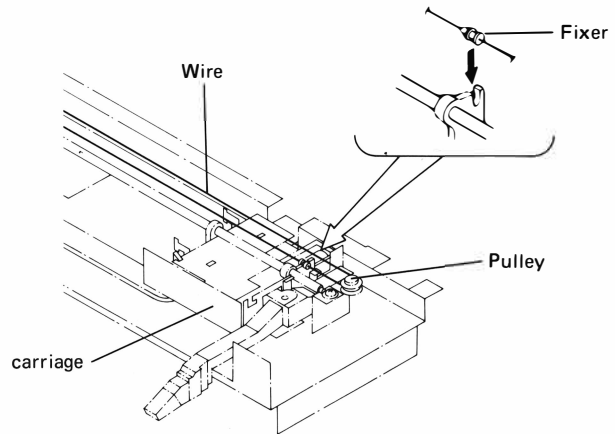

Fig. 6-2 Removing Carriage Wire

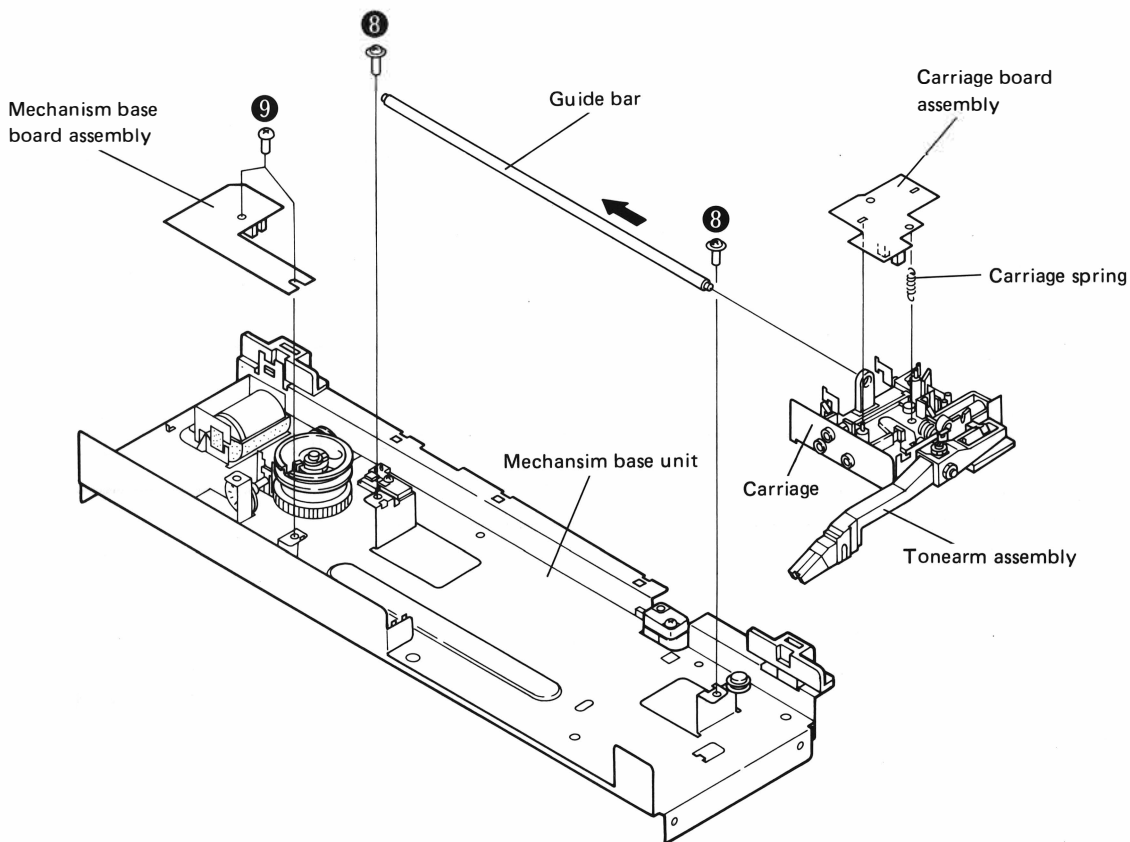

Fig. 6-3 Carriage Removal

### 6.3 REPLACING THE CARRIAGE WIRE

● After assembling the carriage and tonearm assemblies in the opposite order of the previous section, replace the carriage wire according to the following steps.

1. Adjust the length of the wire unit as shown in figure 6-4 (a).
2. Attach the wire unit grommet to the spring of the worm wheel as shown in figure 6-4 (b). Then wind the wire onto the worm wheel taking care not to let it get caught in the worm wheel groove. Also be careful not to let the wire overlap.

3. Holding both the wire and the worm wheel, connect the wire to the wire guard and attach the worm wheel to the mechanism base.
4. As shown in figure 6-4 (c), put the wire around the pulley, and push the fixer into the carriage until it locks with a click.

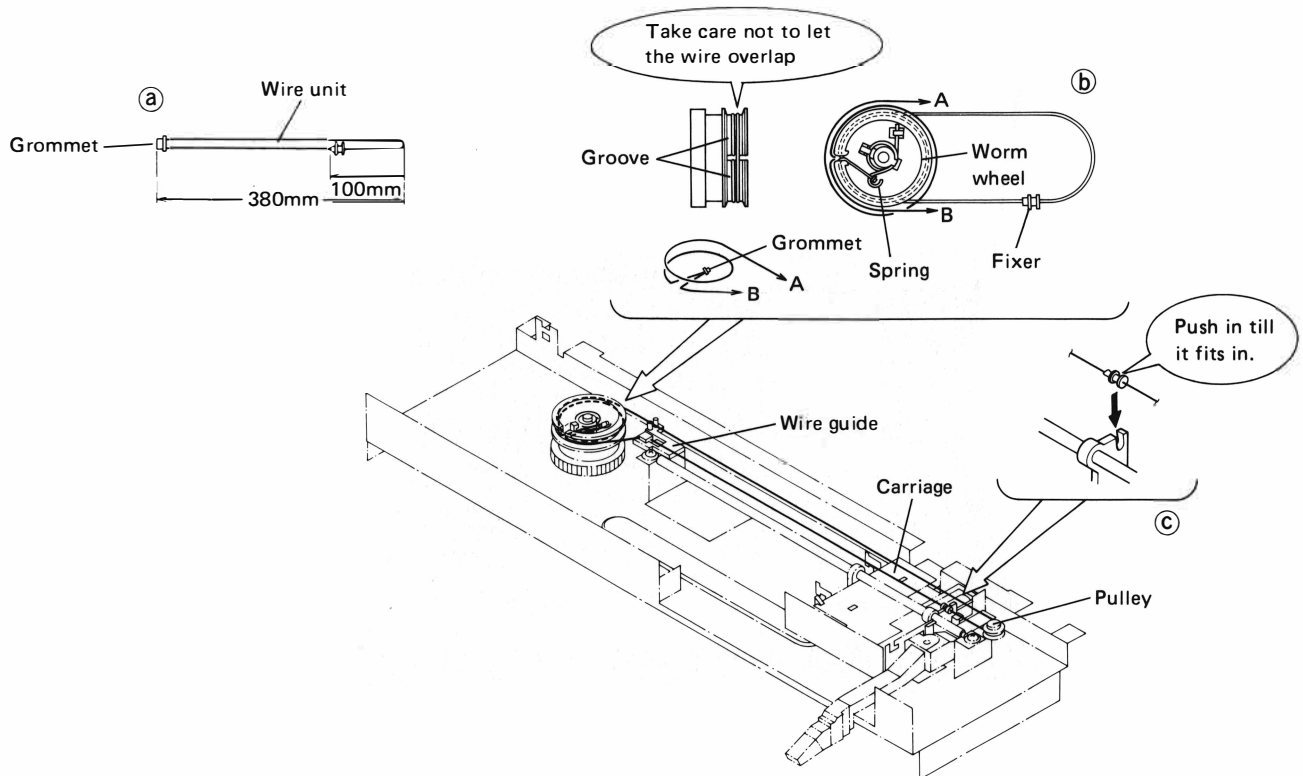

Fig. 6-4 Wire Replacement

### 6.4 LEAD LINE DISPOSAL

1. Slide carriage to the left as far as it will go.
2. Insert enough lead line to reach from the clamp to the motor holder. (Indicated by arrows) Insert the thickest line last.
3. Move the carriage to the left and right, and check to make sure that the lead lines don't hit the carriage.

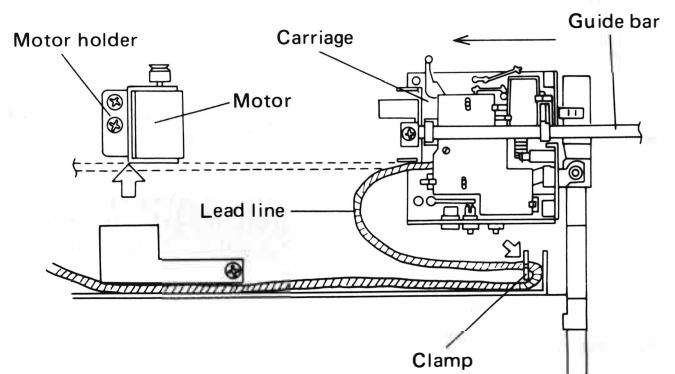



Fig. 6-5 Lead Line Disposal

# 7. PARTS LOCATIONS

**NOTES:**

- The  mark found on some component parts indicates the importance of the safety factor of the part. Therefore, when replacing, be sure to use parts of identical designation.
- For your Parts Stock Control, the fast moving items are indicated with the marks **★★** and **★**.  
**★★ GENERALLY MOVES FASTER THAN ★**  
This classification shall be adjusted by each distributor because it depends on model number, temperature, humidity, etc.

## Front Panel View



## Rear Panel View

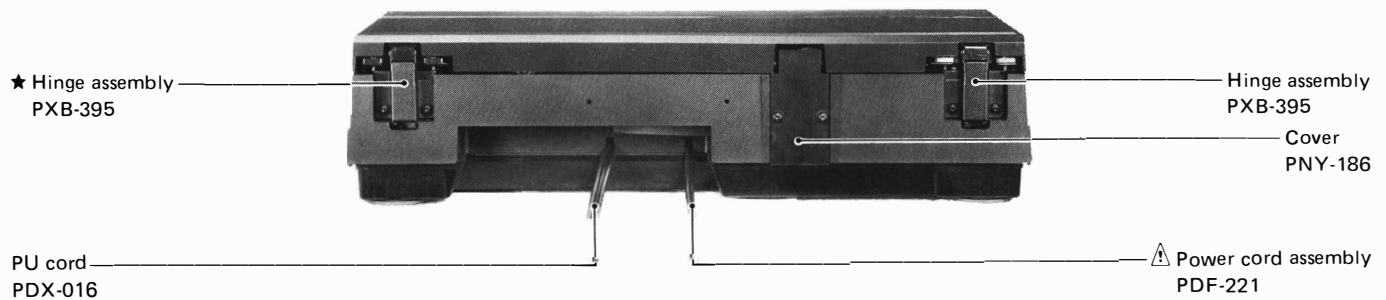

## Top View

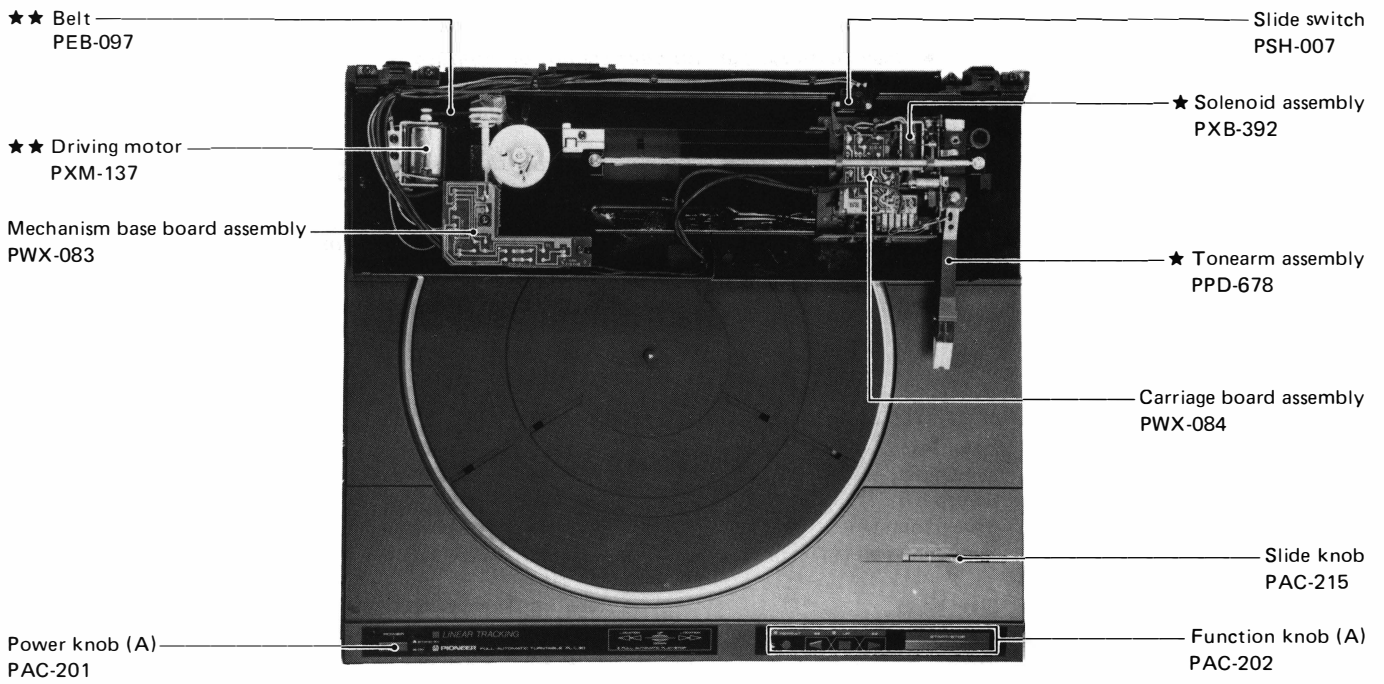



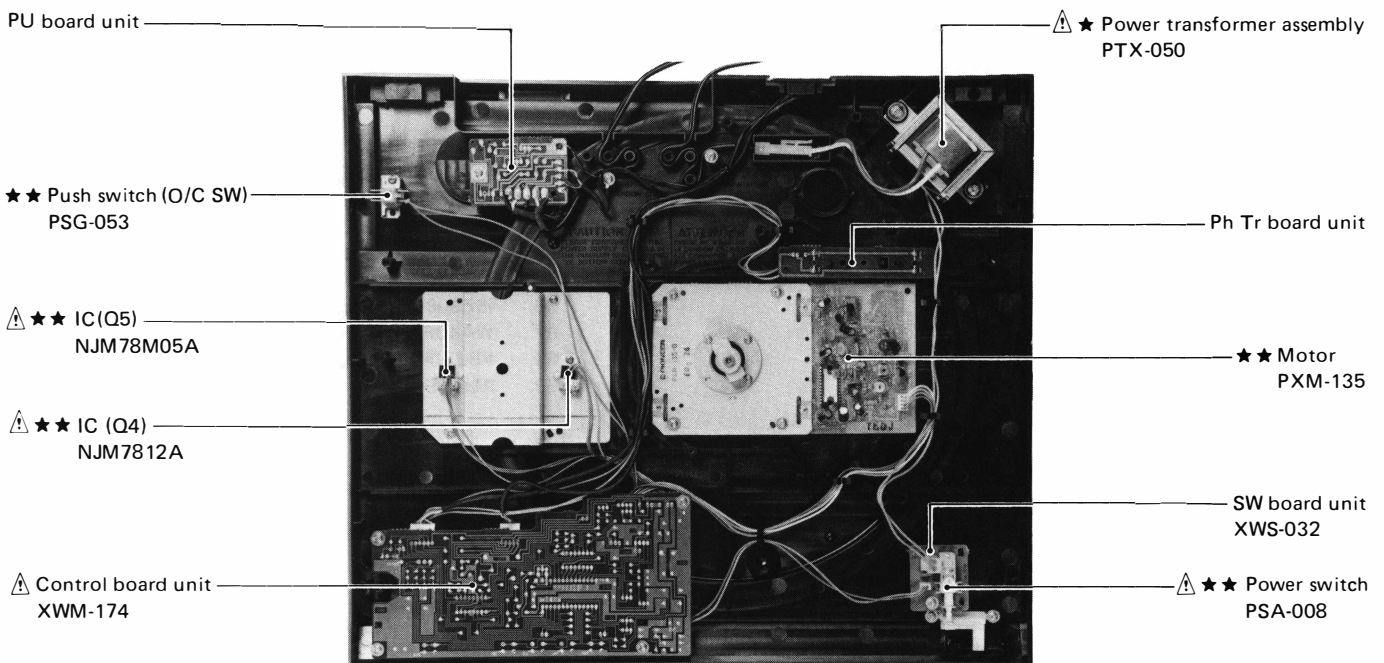

## Bottom View



## 8. EXPLODED VIEW AND PARTS LIST

### NOTES:

- Parts without part number cannot be supplied.
- The  mark found on some component parts indicates the importance of the safety factor of the part. Therefore, when replacing, be sure to use parts of identical designation.
- For your Parts Stock Control, the fast moving items are indicated with the marks **★★** and **★**.  
**★★ GENERALLY MOVES FASTER THAN ★**  
 This classification shall be adjusted by each distributor because it depends on model number, temperature, humidity, etc.

Mark	No.	Part No.	Description	Mark	No.	Part No.	Description
	1.	PNY-304	Panel (F)	★★	41.	PNX-498	Motor pulley
	2.	PAM-138	Screen (K)	★★	42.	PSH-007	Slide switch
	3.	PAM-136	Screen (G)		43.	PEB-267	Base rubber
	4.	PAC-201	Power knob (A)		44.	PBA-173	Screw
	5.	PAC-202	Function knob (A)		45.	PBA-170	Screw
	6.	PAC-215	Slide knob	★★	46.	PXB-394	Dust cover assembly
	7.	PNY-184	Switch cap		47.	PBM-012	Plastic rivet
	8.	PNY-186	Cover	★	48.	PXB-395	Hinge assembly
	9.	PNY-187	Switch lever		49.	PEB-269	Insulator (A)
	10.	PNR-200	Turntable platter		50.	PEB-270	Insulator (B)
	11.	PEA-074	Rubber mat assembly		51.	PBA-138	Screw
★★	12.	PXM-146	Motor		52.	N93-603	EP adaptor
	13.	PXV-104	Rotor unit		53.	WA21D040D025	Washer
	14.	PWM-179	Circuit board unit		54.	PNY-273	Carriage
	15.	PSZ30P050FMC	Screw		55.	ZMR30H150FZK	Screw
	16.	PPD-678	Tonearm assembly		56.	PSZ30P050FMC	Screw
★	17.	PXB-392	Solenoid assembly		57.	PSZ30P060FZK	Screw
★★	18.	PXM-137	Driving motor		58.	PBH-406	Spring
	19.	PEB-268	Damper rubber		59.	iSZ30P060FMC	Screw
	20.	PNC-325	Motor holder		60.	iPZ30P080FMC	Screw
★★	21.	PEB-097	Belt		61.	iPZ30P080FMC	Screw
	22.	PNY-190	Pulley		62.	PPZ30P080FMC	Screw
	23.	PNY-191	Slit plate		63.	PSZ30P060FMC	Screw
	24.	PNW-391	Collar		64.	iPZ30P080FZK	Screw
	25.	PNY-192	Worm wheel		65.	iPZ30P080FMC	Screw
	26.	PBH-391	Spring		66.	iSZ30P080FZK	Screw
	27.	PLB-237	Fixer		67.	WA40F160M080	Washer
	28.	PLB-256	Guide bar		68.	PBZ30P100FMC	Screw
	29.	PXB-393	Pulley assembly		69.	PSG-053	Push switch (O/C sw)
	30.	PEB-285	Rubber cap		101.		Mechanism base unit
	31.	PNY-196	Wire guide		102.		Under base
	32.	PNW-485	Worm unit		103.		Base sheet (F)
	33.	PBF-021	Washer		104.		Rubber foot
	34.	XWM-174	Control board unit		105.		Tr board (A) unit
	35.	XWS-032	SW board unit		106.		Tr board (B) unit
	36.	PWX-084	Carriage board assembly		107.		PU board unit
	37.	PWX-083	Mechanism base board assembly		108.		Ph Tr board unit
	★	PTX-050	Power transformer assembly		109.		Heat sink
	39.	PDF-221	Power cord assembly		110.		Cartridge
	40.	PDX-016	PU cord		111.		Stylus
					112.		Stylus cover

1

2

3

A

B

C

D

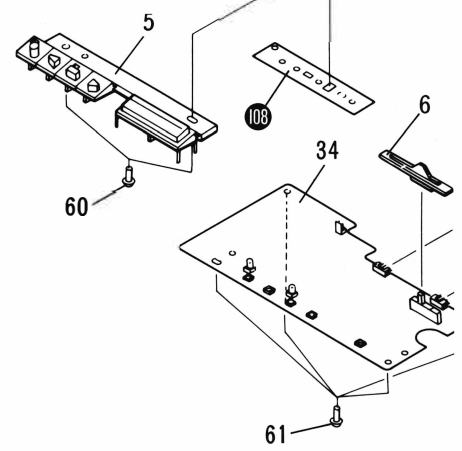
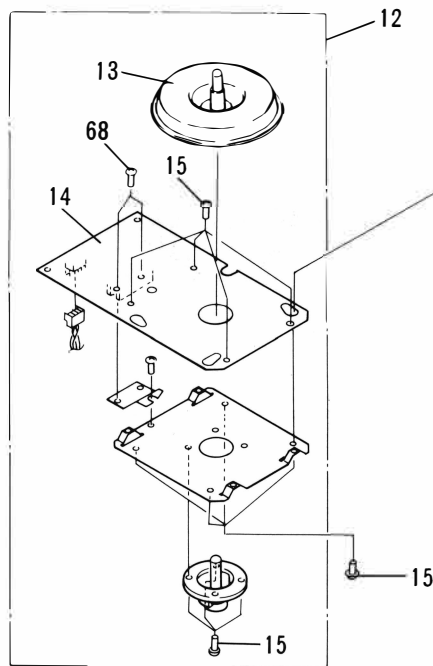
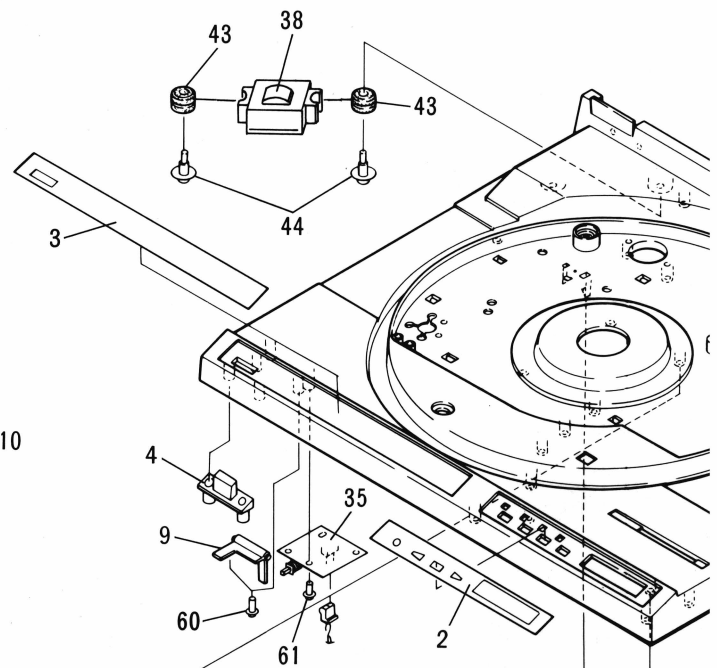
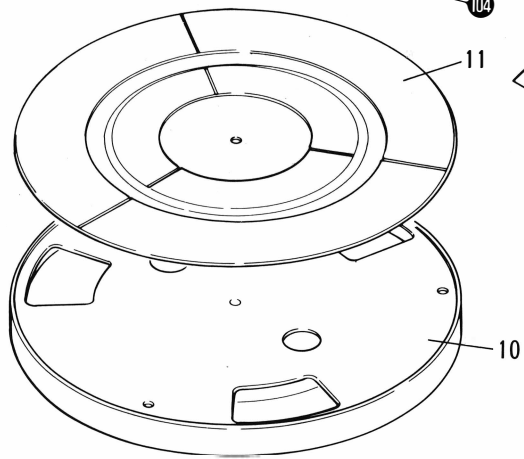
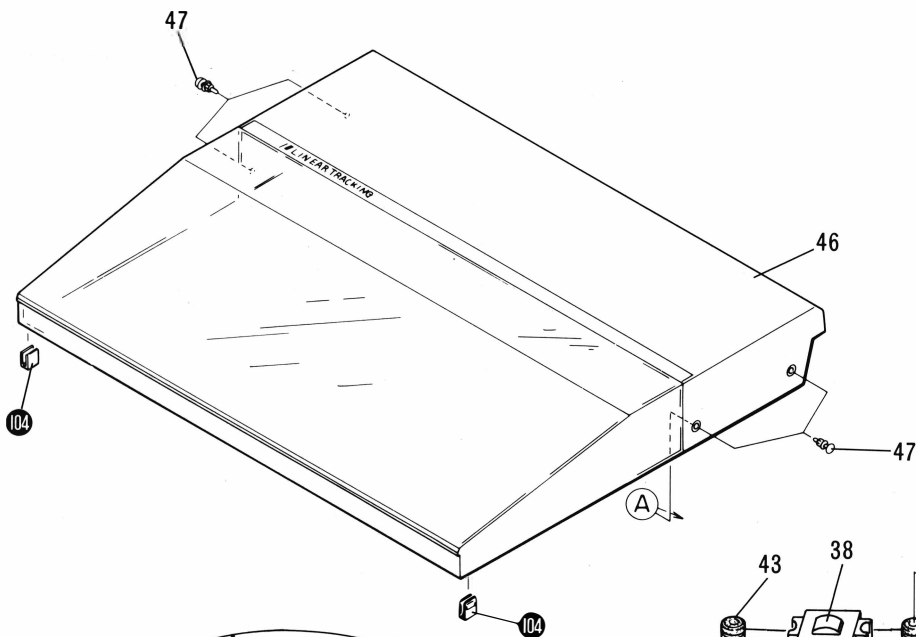

1

2

3

4

5

6

A

B

C

D

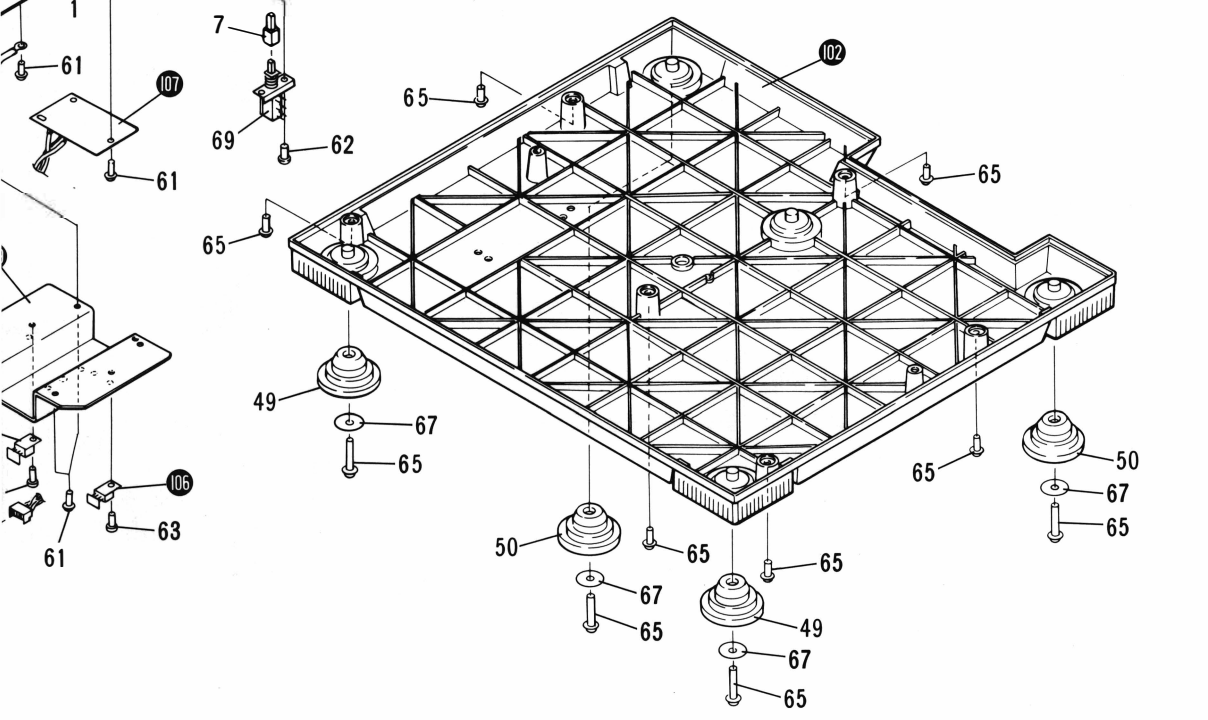
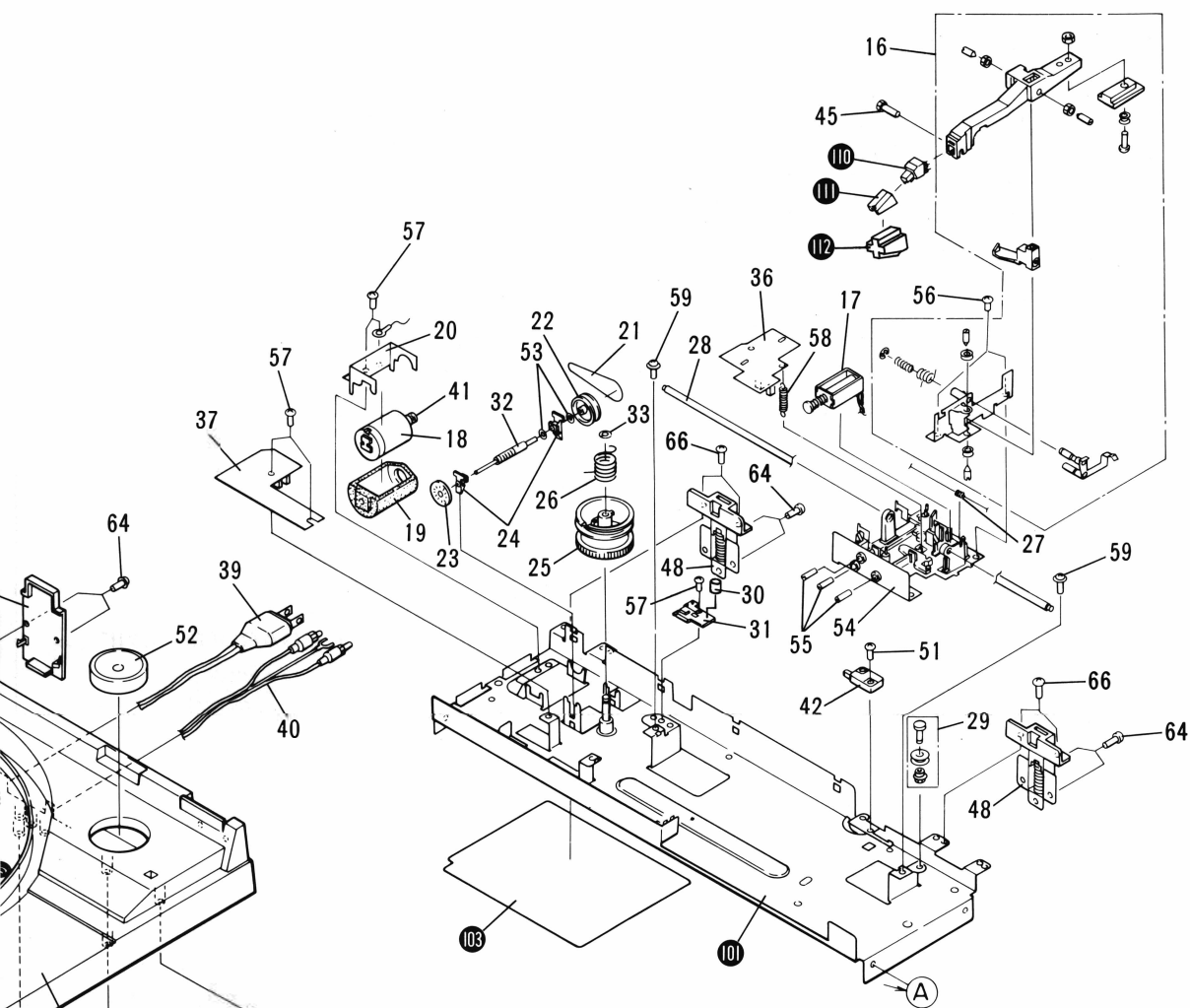

4

5

6

24



# 9. PACKING

A

B

C

D

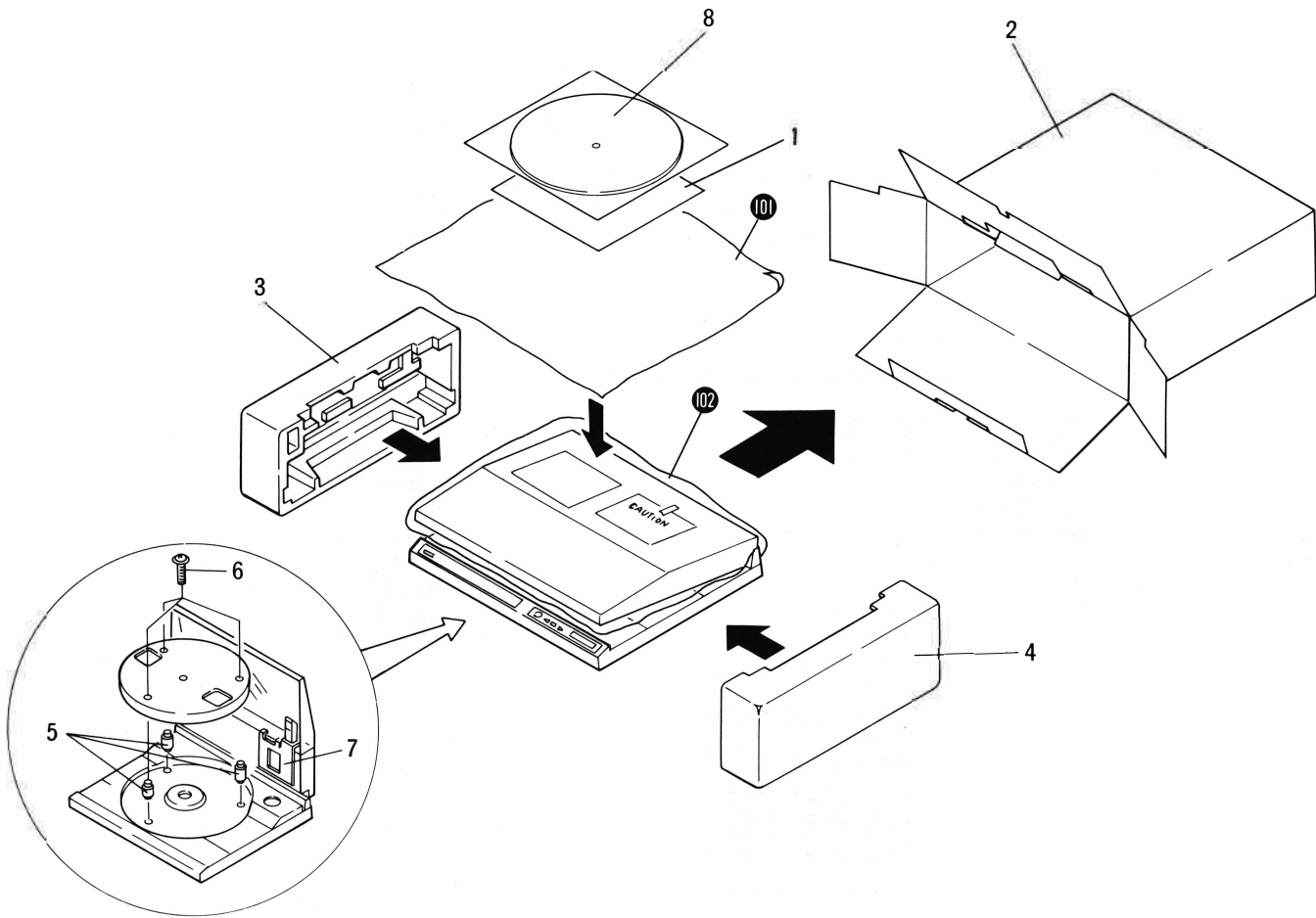

## Parts List of Packing

Mark	No.	Part No.	Description
	1.	PRB-275	Operating instructions
	2.	PHH-188	Packing case
	3.	PHA-178	Protector (L)
	4.	PHA-179	Protector (R)
	5.	PNY-198	Packing
	6.	PBA-178	Screw
	7.	PNY-194	Carriage clamber
	8.	PEA-074	Rubber mat assembly
	101.		Sheet
	102.		Sheet

# 10. P. C. BOARDS CONNECTION DIAGRAM

A  
B  
C  
D

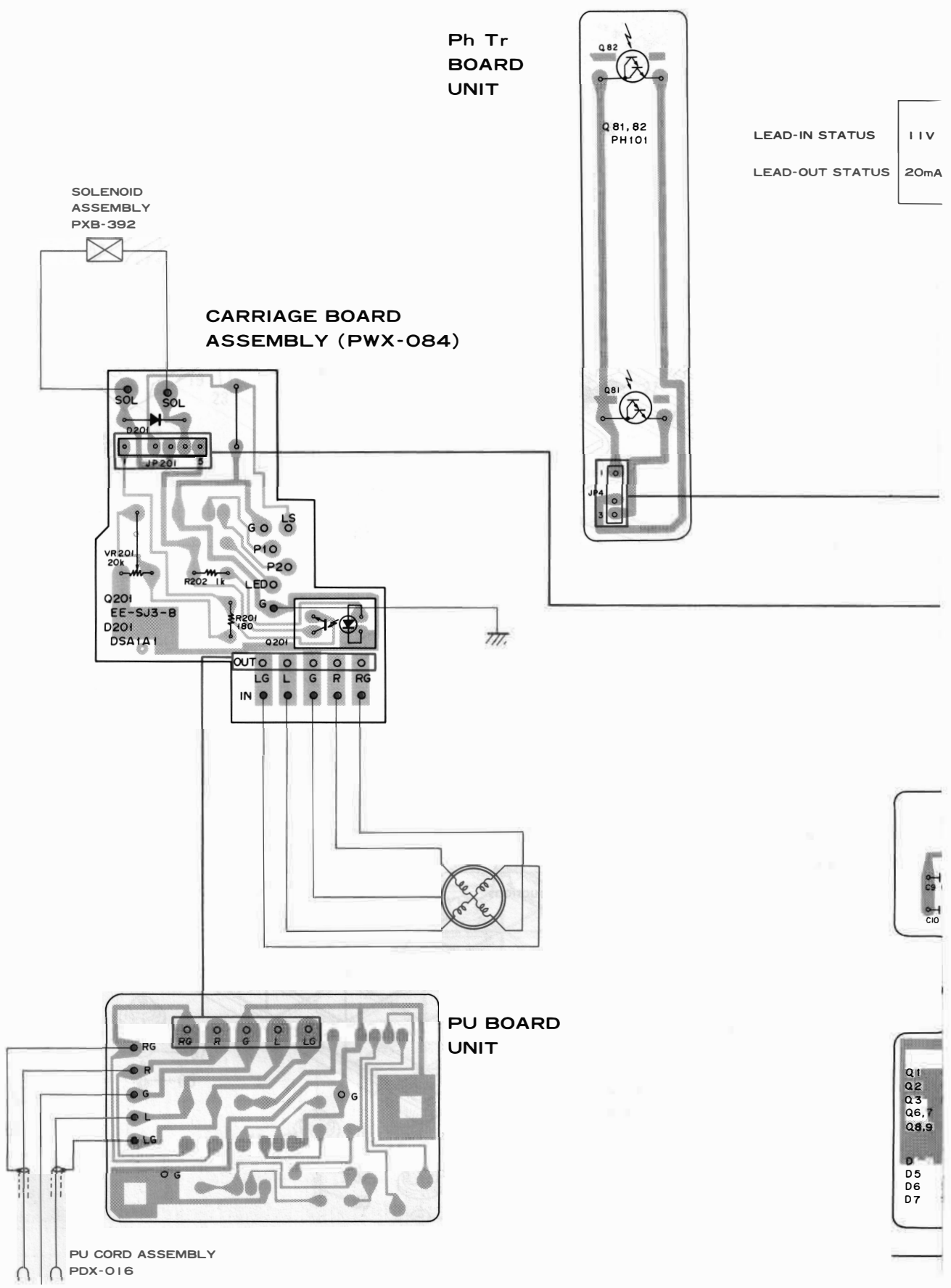

MECHANISM BASE BOARD ASSEMBLY (PWX-083)

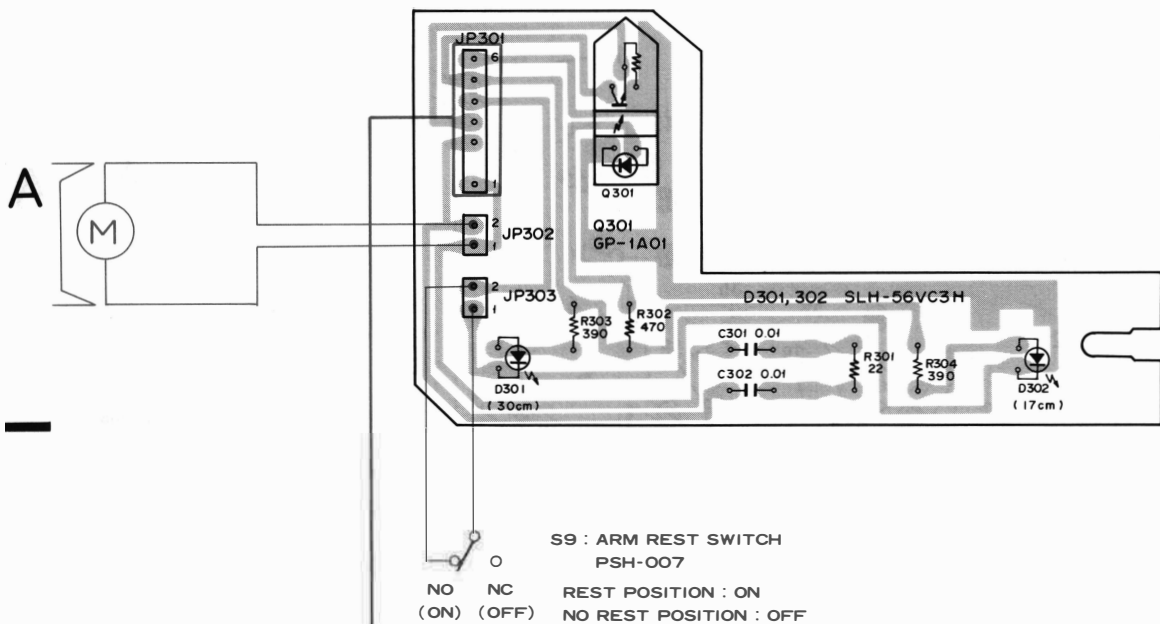

Tr BOARD(B) UNIT



C

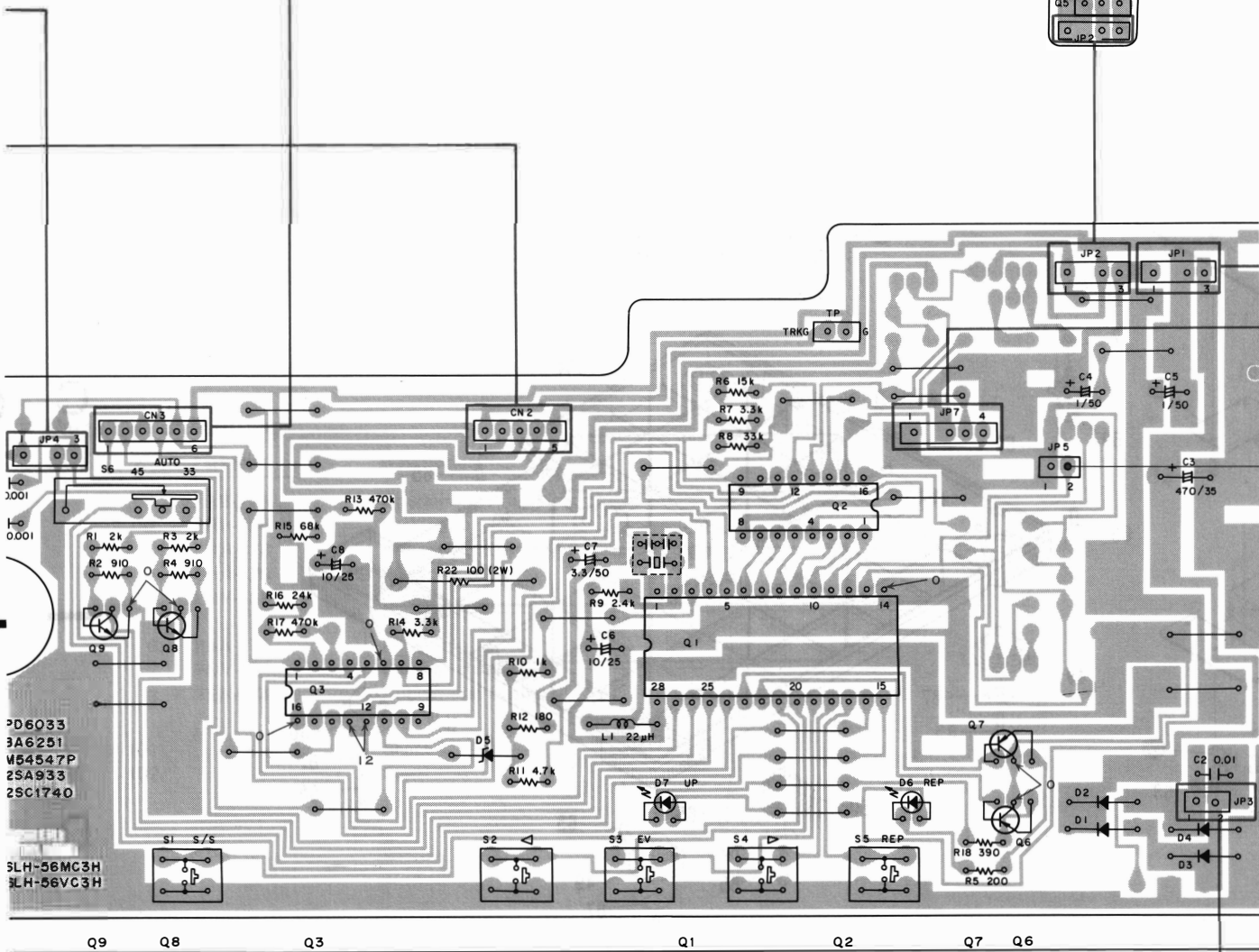

CONTROL BOARD UNIT(XWM-174)

7

8

9

### MOTOR BOARD UNIT (PXM-146)

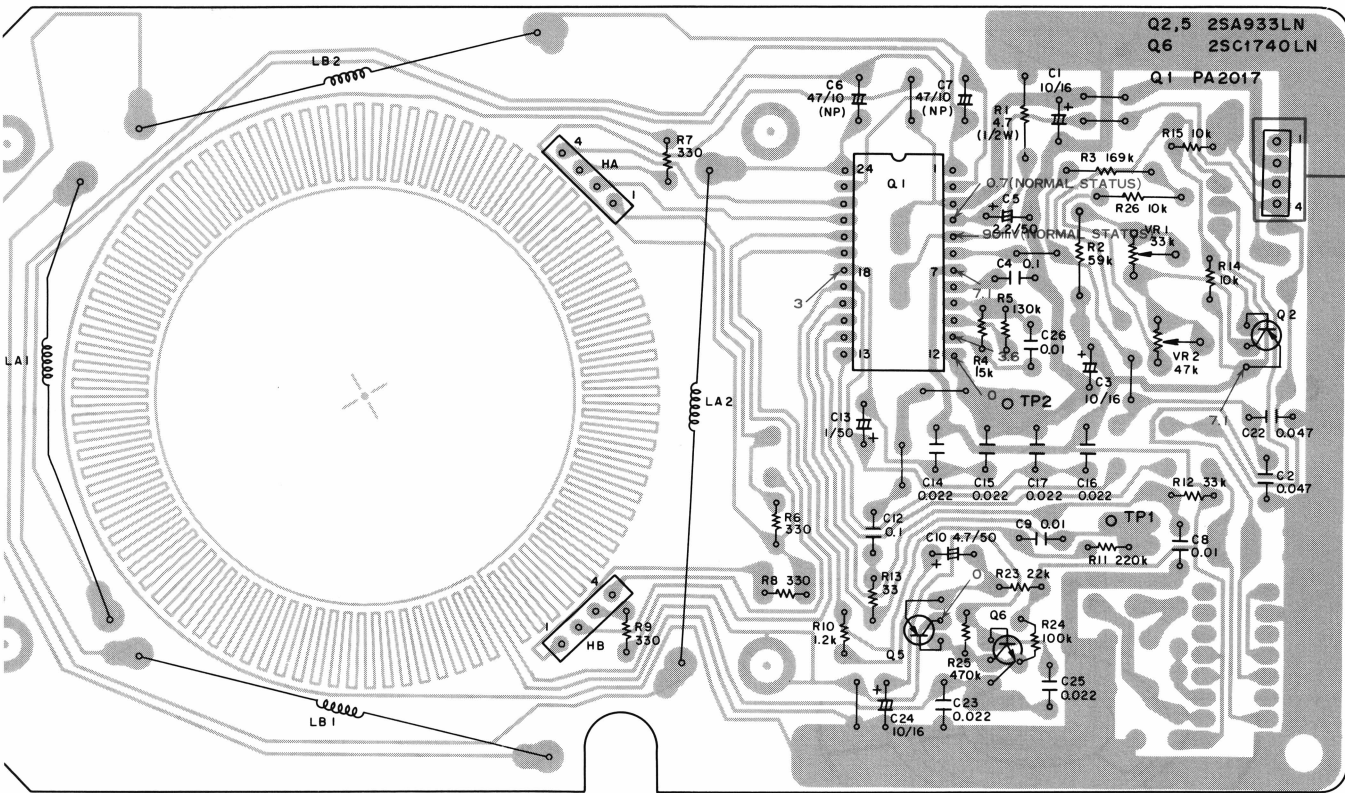

A

B

### Tr BOARD(A) UNIT

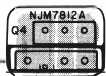

C

D

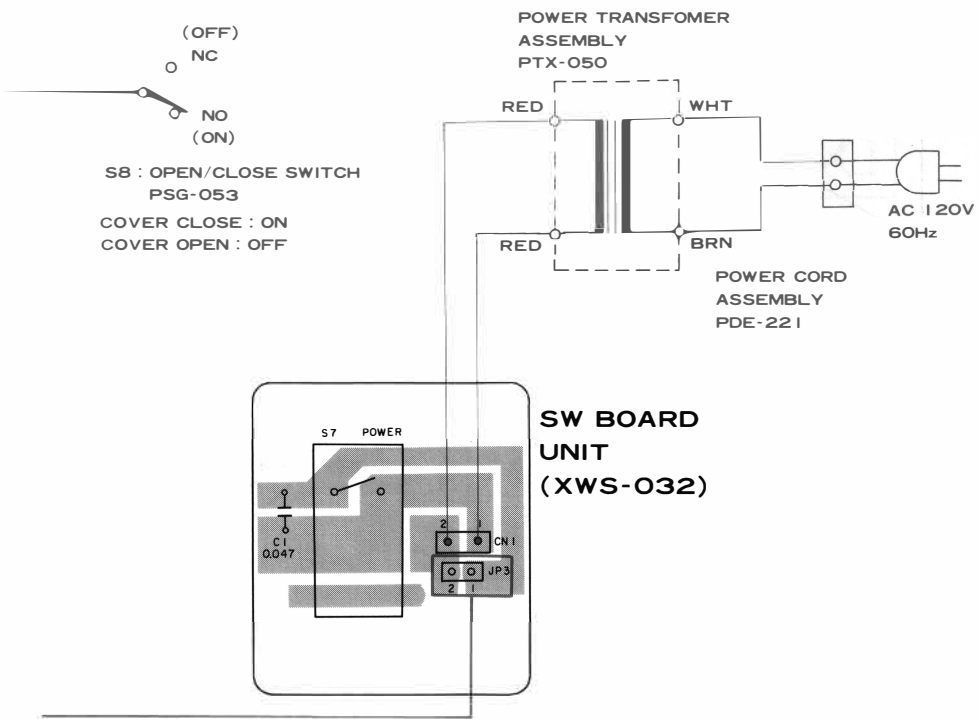

7

8

9

# 11. SCHEMATIC DIAGRAM

A

B

C

D

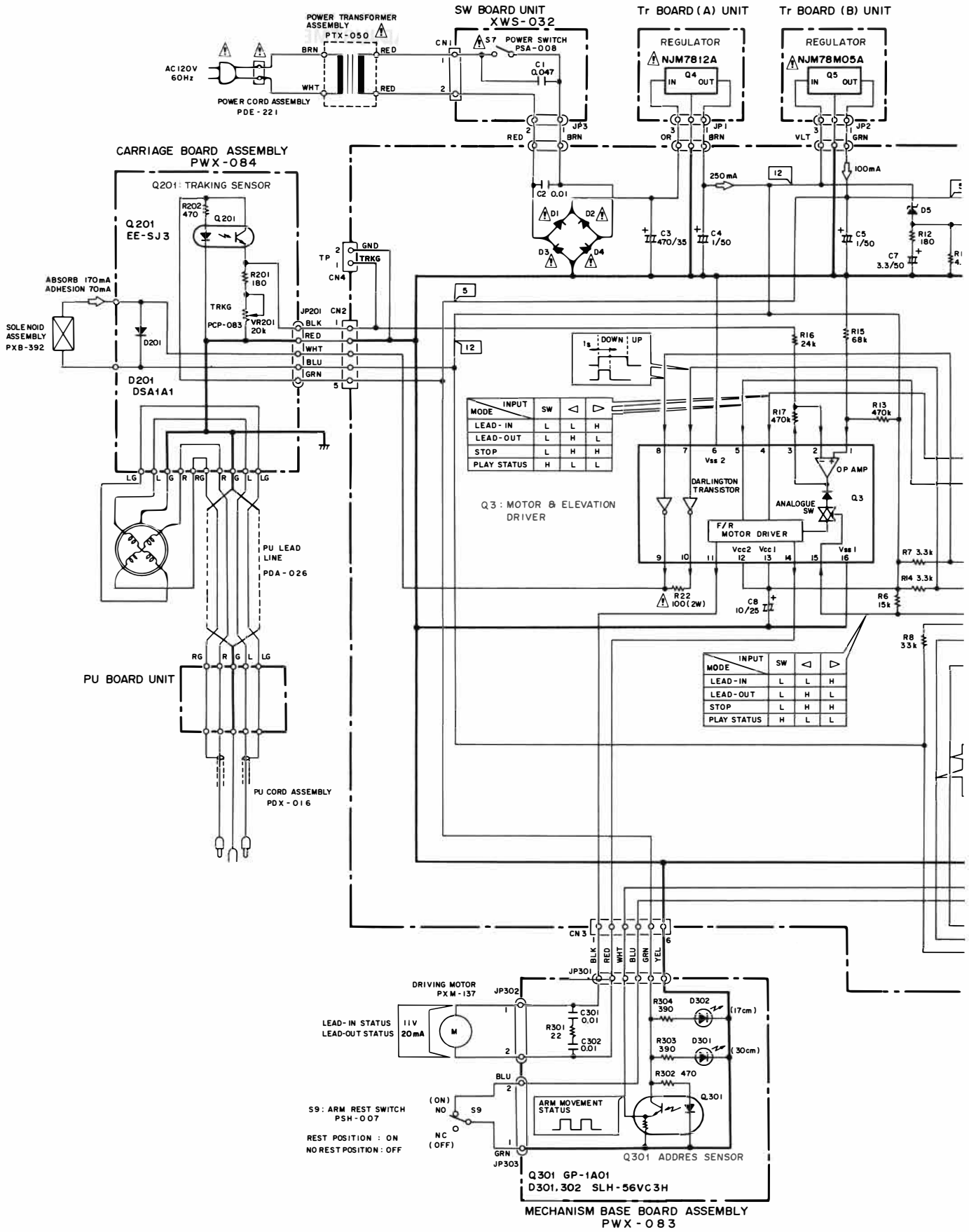

1

2

3

NOTE:

The indicated semiconductors are representative ones only. Other alternative semiconductors may be used and are listed in the parts list.

- 1. RESISTORS:  
Indicated in Ω, ¼W, ½W, +5% to M : MΩ, (F) : ±1%, (G) : ±2%, (K)
- 2. CAPACITORS:  
Indicated in capacity (μF)/voltage  
Indication without voltage is 5
- 3. VOLTAGE, CURRENT:  
□ : DC voltage (V) at no input  
◁ : mA : DC current at no input
- 4. OTHERS:  
→ : Signal route.  
⊙ : Adjusting point.  
The Δ mark found on some components indicates the importance of the safety factor of 1.5. Be sure to use parts of identical type.  
※ : marked capacitors and resistors

This is the basic schematic diagram due to improvements in design.

SWITCHES:

- CONTROL BOARD UNIT**
  - S 1 : START / STOP
  - S 2 : LOCATE
  - S 3 : ARM ELEVATION
  - S 4 : LOCATE
  - S 5 : REPEAT
  - S 6 : SPEED
- SW BOARD UNIT**
  - S 7 : POWER
- OTHER**
  - S 8 : OPEN / CLOSE
  - S 9 : ARM REST

The underlined

CONTROL BOARD UNIT XWM-174

- Q1 PD6033
- Q2 BA6251
- Q3 M54547P
- Q6,7 2SA933
- Q8,9 2SC1740
- D1~4 DSA1A1
- D5 RD7.5EB1
- D6 SLH-56MC3H
- D7 SLH-56VC3H

- S1~S5 PSG-052
- S6 PSH-010

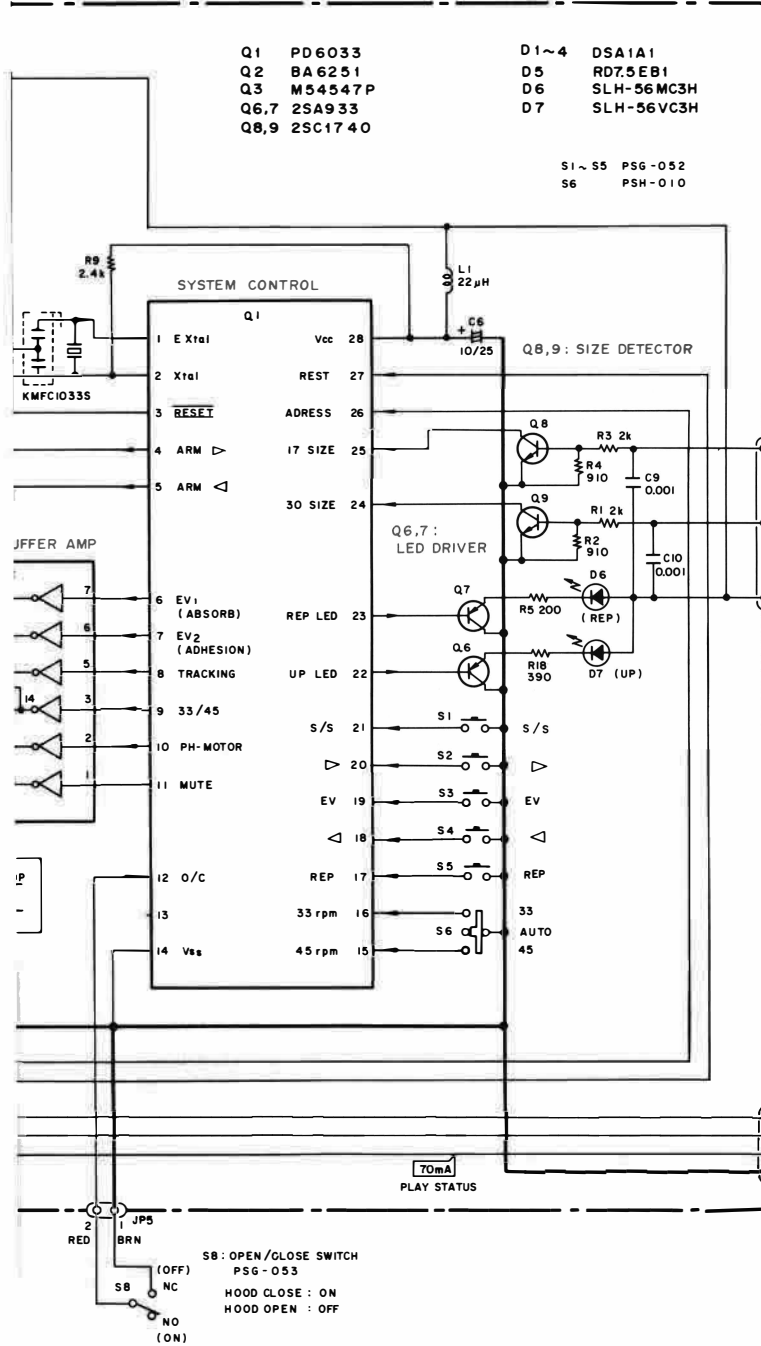

Ph Tr BOARD UNIT

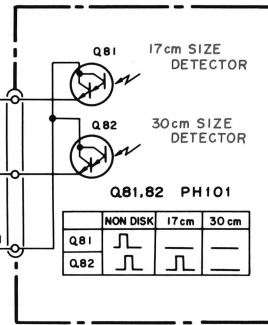

MOTOR BOARD UNIT PXM-146

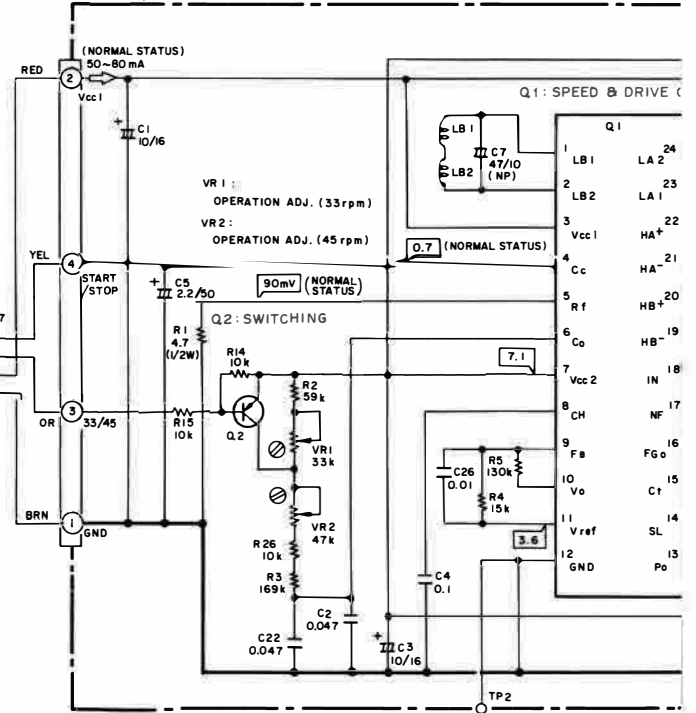

### External Appearance of Transistors and ICs

tolerance unless otherwise noted k: kΩ, M: ±10% (M); ±20% tolerance

**A**

Voltage (V) unless otherwise noted p: pF, Ω: Ω except electrolytic capacitor.

Input signal

Component parts indicates the impedance of the part. Therefore, when replacing,

parts have parts numbers.

Impedance, but the actual circuit may vary

- ON - OFF
- ON - OFF
- ON - OFF
- ON - OFF
- ON - OFF
- 3 - AUTO - 45

**B**

ON - OFF

ON - OFF

indicates the switch position.

2SA933LN  
2SC1740LN

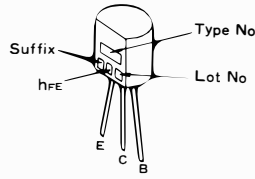

PD6033

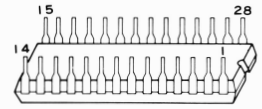

2SA933S  
2SC1740S

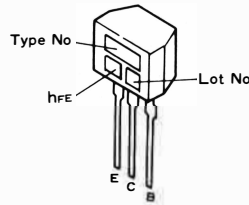

PH101-R



BA6251  
M54547P

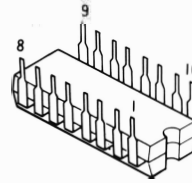

EE-SJ3-B

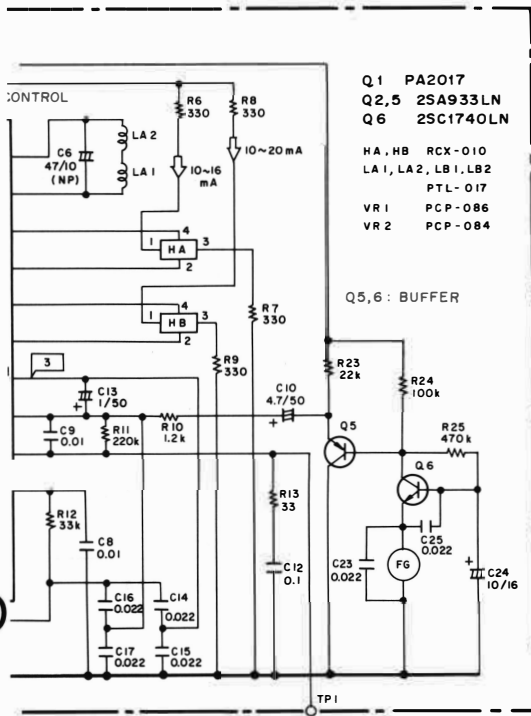
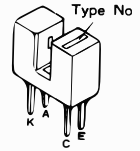

NJM7812A  
NJM78M05A

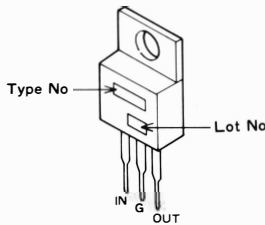

GP-1A01

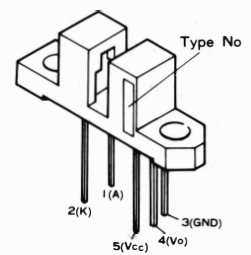

PA2017

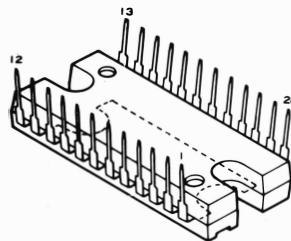

# 12. ELECTRICAL PARTS LIST

## NOTES:

- When ordering resistors, first convert resistance values into code form as shown in the following examples.

Ex. 1 When there are 2 effective digits (any digit apart from 0), such as 560 ohm and 47k ohm (tolerance is shown by J=5%, and K=10%).

560Ω    56 × 10<sup>1</sup>    561..... RD½PS 561 J  
 47kΩ    47 × 10<sup>3</sup>    473..... RD½PS 473 J  
 0.5Ω    0R5 ..... RN2H 0R5 K  
 1Ω    010 ..... RS1P 010 K

Ex. 2 When there are 3 effective digits (such as in high precision metal film resistors).

5.62kΩ    562 × 10<sup>1</sup>    5621 .... RN½SR 5621 F

- The  $\Delta$  mark found on some component parts indicates the importance of the safety factor of the part. Therefore, when replacing, be sure to use parts of identical designation.
- For your Parts Stock Control, the fast moving items are indicated with the marks **★★** and **★**.  
**★★ GENERALLY MOVES FASTER THAN ★**  
 This classification shall be adjusted by each distributor because it depends on model number, temperature, humidity, etc:

## Miscellaneous Parts

Mark	Symbol & Description	Part No.
$\Delta$	Control board unit	XWM-174
	Tr board (A) unit	
	Tr board (B) unit	
	SW board unit	XWS-032
	PU board unit	
	Ph Tr board unit	
	Carriage board assembly	PWX-084
	Mechanims base board assembly	PWX-083
$\Delta$ ★	Power transformer assembly	PTX-050
$\Delta$	Power cord assembly	PDF-221
	Motor assembly	PXM-146
	Circuit board unit	PWM-179

## Control Board Unit (XWM-174)

### SEMICONDUCTORS

Mark	Symbol & Description	Part No.
★★	Q1	PD6033
★★	Q2	BA6251
★★	Q3	M54547P
★★	Q6, Q7	2SA933S
★★	Q8, Q9	2SC1740S
$\Delta$ ★	D1 – D4	DSA1A1 (DSA1A2)
★	D5	RD7.5EB1 (RD7.5EB2)
★	D6	SLH-56MC3H-U
★	D7	SLH-56VC3H-T

### SWITCHES

Mark	Symbol & Description	Part No.
★★	S1 – S5 Tact switch	PSG-052
★★	S6 Slide switch (SPEED)	PSH-010
★★	Push switch (o/c sw)	PSG-053

## COIL

Mark	Symbol & Description	Part No.
	L1	LAL03T220K

## CAPACITORS

Mark	Symbol & Description	Part No.
	C3 Electrolytic (470/35)	PCL-051
	C6, C8	CEA100M25
	C4, C5	CEA1R0M50
	C7	CEA3R3M50
	C2	CKDYF103Z50

## RESISTORS

NOTE: When ordering resistors, convert the resistance value into code form, and then rewrite the part no. as before.

Mark	Symbol & Description	Part No.
$\Delta$	R22	RS2PF □□□J
	Other resistors	RD1/6PM □□□J

## OTHER

Mark	Symbol & Description	Part No.
		KMFC1033S

## Tr Board (A) Unit

Mark	Symbol & Description	Part No.
$\Delta$ ★★	Q4	NJM7812A

## Tr Board (B) Unit

Mark	Symbol & Description	Part No.
$\Delta$ ★★	Q5	NJM78M05A



### SW Board Unit (XWS-032)

Mark	Symbol & Description	Part No.
⚠ ★★ S7 C1	Power switch	PSA-008 CKDYF473Z50

### Ph Tr Board Unit

Mark	Symbol & Description	Part No.
★★ Q81, Q82		PH101-R

### Carriage Board Assembly (PWX-084)

*NOTE: When ordering resistors, convert the resistance value into code form, and then rewrite the part no. as before.*

Mark	Symbol & Description	Part No.
★★ Q201		EE-SJ3-B
★ D201		DSA1A1 (1SR35-100A)
★ VR201 R201 – R203	Semi-fixed (20k-B)	PCP-083 RD1/6PM□□□J

### Mechanism Base Board Assembly (PWX-083)

*NOTE: When ordering resistors, convert the resistance value into code form, and then rewrite the part no. as before.*

Mark	Symbol & Description	Part No.
★★ Q301 C301, C302 R301, R302		GP-1A01 CKDYF 103Z 50 RD1/6PM□□□J

### Motor Assembly (PXM-146)

Mark	Symbol & Description	Part No.
	Rotor unit	PXV-104
	Circuit board unit	PWM-179

- The motor assembly comprises the Rotor Unit and the Circuit Board Unit (PWM-179).

### Circuit Board Unit (PWM-179)

#### SEMICONDUCTORS

Mark	Symbol & Description	Part No.
	Q1	PA2017
	Q2	2SA933

#### CAPACITORS

Mark	Symbol & Description	Part No.
	C4, C12	PCL-046
	C2	CQPA104J50
	C8, C9	CQMA103K50
	C13 – C17	CKDYF223Z50
	C6, C7	CEANP470M10
	C1, C3	CEA100M16
	C11	CEA010M50
	C5	CEA2R2M50
	C10	CEA221M6R3

#### RESISTORS

*NOTE: When ordering resistors, convert the resistance value into code form, and then rewrite the part no. as before.*

Mark	Symbol & Description	Part No.
	VR1 Semi-fixed (33k-B)	RCP-224
	VR2 Semi-fixed (68k-B)	RCP-082
	R1	RD1/2PS4R7J
	R2, R3	RN1/4PQ □□□F
	Other resistors	RD1/6PM □□□.

#### OTHERS

Mark	Symbol & Description	Part No.
	HA, HB Hall element Screw	RCX-010 PSZ30P050FMC

# 13. ADJUSTMENTS

## 13.1 TONE ARM ADJUSTMENT

1. With the power ON place a test record (PLS-2001 or PLS-4001 side A up) on the turntable.
2. Press the START/STOP button and check the position of the tone arm as it comes to rest on the record.
3. Lift the dust cover and turn the adjustment screw ① until the tone arm comes into line with the record.
  - When the tone arm comes to rest to the right of the lead-in groove, (when the count is lower than the standard count tolerance) turn the adjustment screw ① counterclockwise.
  - When the tone arm comes to rest to the left of the lead-in groove, (when the count is higher than the standard count tolerance) turn the adjustment screw ① clockwise.
  - When using the test record the position will be set for 30cm records.

Test record	Adjustment position
PLS2001	$310 \pm 3$ counts
PLS4001	$13 \pm 6$ counts

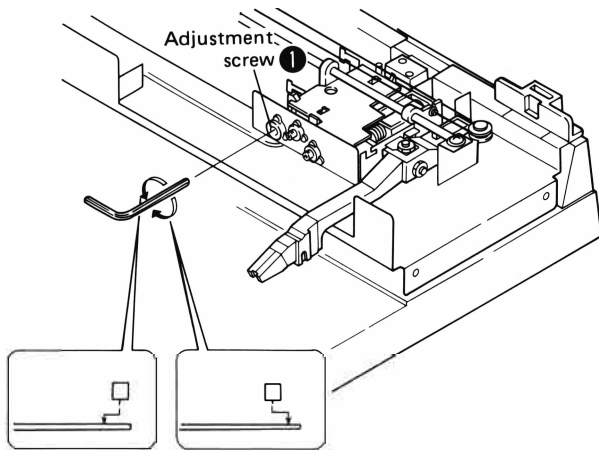

Fig. 13-1 Tone Arm Adjustment

## 13.2 TRACKING SENSOR GAIN AND OFFSET ADJUSTMENT

### • Gain Adjustment

1. Remove the dust cover and panel cover.
2. Connect a DC voltmeter to CN5 pin 4 (GND) and pin 5 (TRKG).
3. Turn screw ② counterclockwise and pull the carriage unit forward.
4. Turn on the power and while pushing the tone arm toward the center (as shown in the illustration) adjust VR201 (TRKG) until the DC voltmeter registers  $3V \pm 0.1V$ .

### • Offset Adjustment

5. Return the tone arm to the rest position. (It will return by itself when you release it.)
6. To adjust it, turn screw ② clockwise until the DC voltmeter registers  $1.0V \pm 0.1V$ .

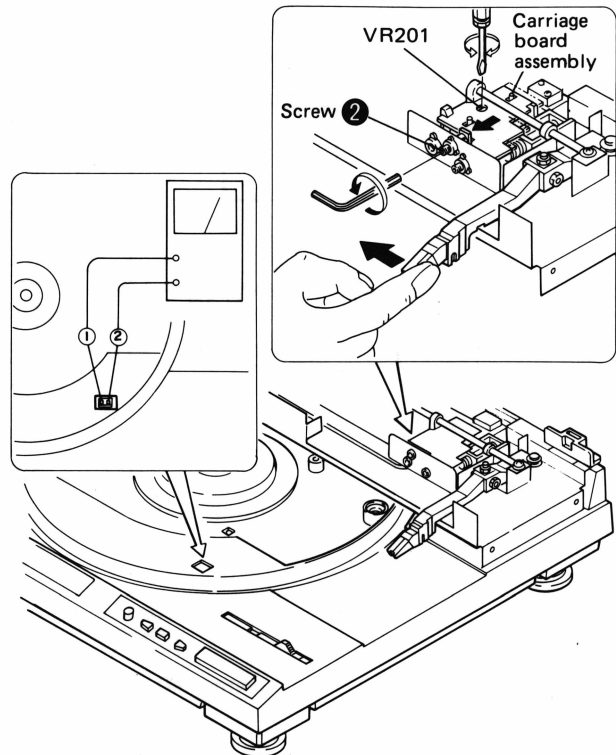
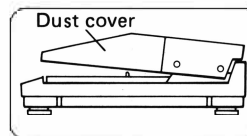

Fig. 13-2 Tracking Sensor Gain and Offset Adjustment

### 13.3 TONE ARM HEIGHT ADJUSTMENT

1. With the dust cover off, insert two 6mm spacers (one each on the right and left) to make it the same as when the dust cover and mechanism base are connected.
  2. Place a 30cm record on the turntable, turn on the power, and using the locate switch ( ◀◀ ) move the tone arm to within approximately 100mm of the center of the turntable.
  3. Turn screw ③ until the tip of the needle is 5 to 7 mm above the surface of the record.
- Turning the screw clockwise lowers the needle.
  - Turning the screw counterclockwise raises the needle.

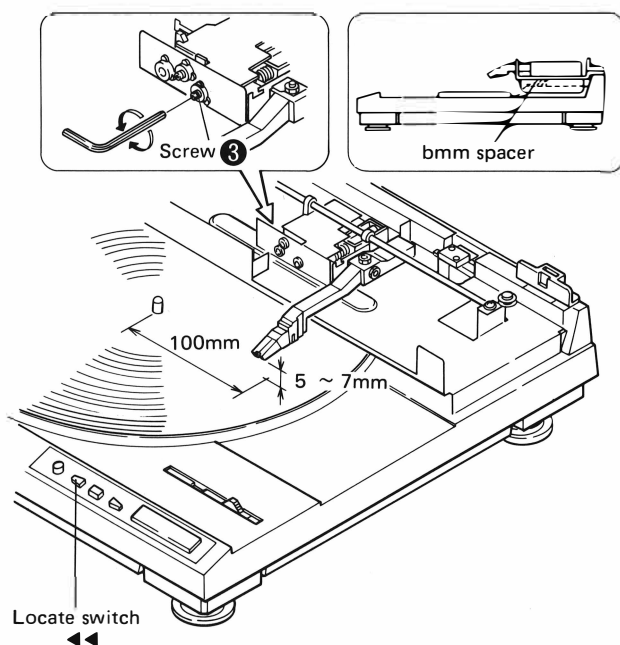

Fig. 13.3 Tone arm height adjustment

### 13.4 Phono-Motor Speed Adjustment

1. Place the strobe sheet on the platter. Turn on the power switch and the locate-switch ( ◀◀ ) to turn the phono-motor.
2. Insert a small screwdriver into the speed adjusting hole on the bottom panel and adjust VR1 and VR2 respectively.

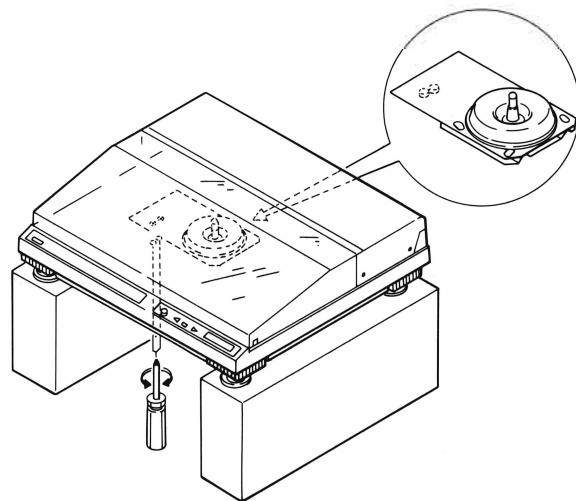

Fig. 13-4 Phono-motor speed adjustment

# 13. RÉGLAGE

## 13.1 RÉGLAGE DU BRAS DE PICK-UP

1. En mettant l'appareil sous tension, placer un disque d'essai (PLS-2001 ou PLS-4001, avec le côté A vers le haut) sur la platine de lecture de disques.
  2. Presser la touche de départ/arrêt (START/STOP) et vérifier la position du bras de pick-up lorsqu'il se pose sur le disque.
  3. Soulever le couvercle anti-poussière et tourner la vis ❶ de réglage jusqu'à ce que le bras de pick-up soit aligné avec le disque.
- Lorsque le bras de pick-up se pose sur la droite du sillon initial, (au cas où le compte est inférieur à la tolérance normale de compte) tourner la vis ❶ de réglage dans le sens contraire des aiguilles d'une montre.
  - Lorsque le bras de pick-up se pose sur la gauche du sillon initial, (au cas où le compte est supérieur à la tolérance normale de compte (tourner la vis ❶ de réglage dans le sens des aiguilles d'une montre.
  - Lorsque l'on utilise le disque d'essai, la position sera réglée pour les disques de 30 cm.

Disque d'essai	Position de réglage
PLS2001 PLS4001	310 ± 3 comptes 13 ± 6 comptes

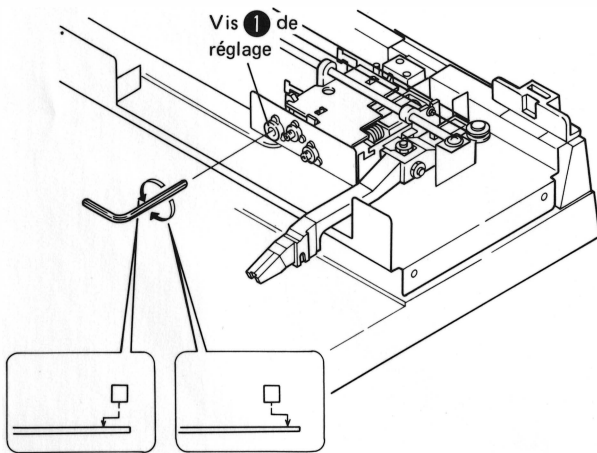

Fig. 13-1 Réglage du bras de pick-up

## 13.2 RÉGLAGE DU GAIN DU SENSEUR D'ALIGNEMENT ET DU DÉCENTRAGE

### ● Réglage du Gain

1. Déposer le couvercle anti-poussière et le couvercle du panneau.
2. Connecter un voltmètre CC à la broche No. 4 (GND) et à la broche No. 5 (TRKG) de CN5.
3. Tourner la vis ❷ dans le sens contraire des aiguilles d'une montre et tirer le bloc du chariot en avant.
4. Mettre l'appareil sous tension et tout en poussant le bras de pick-up vers le centre (comme indiqué sur la figure), régler VR201 (TRKG) jusqu'à ce que le voltmètre CC enregistre  $3V \pm 0,1V$ .

### ● Réglage de Décentrage

5. Remettre le bras de pick-up sur la position de repos. (Il retournera automatiquement lorsqu'on le relâche).
6. Pour le régler, tourner la vis ❷ dans le sens des aiguilles d'une montre jusqu'à ce que le voltmètre CC enregistre  $1,1V \pm 0,1V$ .

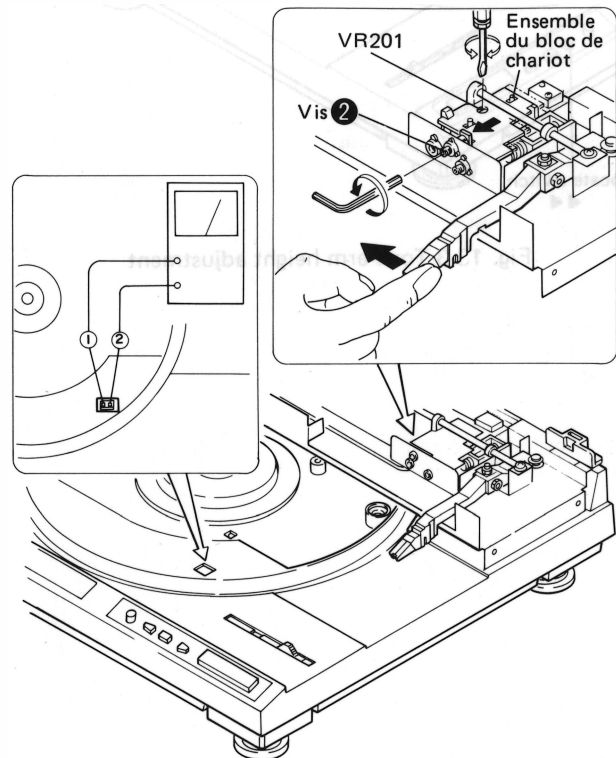
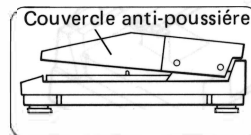

Fig. 13-2 Réglage du gain du senseur d'alignement et du décentrage

### 13.3 RÉGLAGE DE LA HAUTEUR DU BRAS DE PICK-UP

1. Avec le couvercle anti-poussière déposé, insérer deux pièces d'écartement de 6 mm (une sur la droite et l'autre sur la gauche) pour retourner à la situation à laquelle le couvercle anti-poussière et la base du mécanisme étaient connectés.
2. Placer un disque de 30 cm sur le plateau, mettre l'appareil sous tension, et en utilisant le commutateur de location (◀◀), déplacer le bras de pick-up à environ 100 mm du centre du plateau.
3. Tourner la vis ③ jusqu'à ce que le bout de l'aiguille soit à 5 à 7 mm au-dessus de la surface du disque.
  - En tournant la vis dans le sens des aiguilles d'une montre, abaisser l'aiguille.
  - En tournant la vis dans le sens contraire des aiguilles d'une montre, soulever l'aiguille.

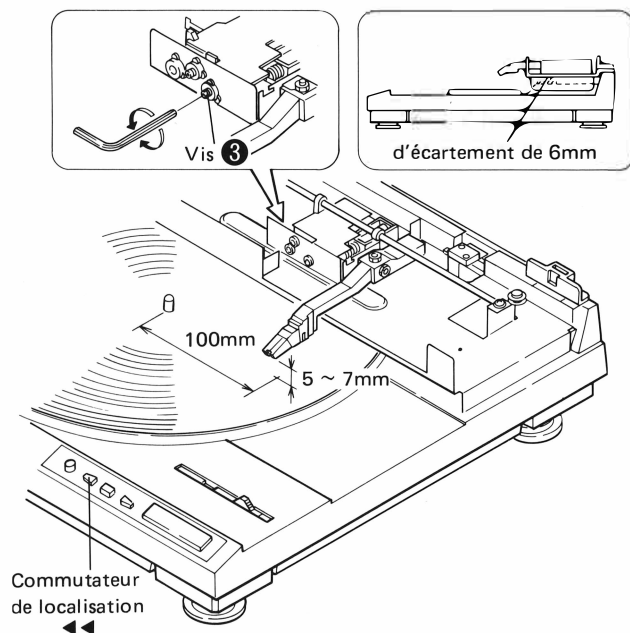

Fig. 13-3 Réglage de la hauteur du bras de pick-up

### 13.4 RÉGLAGE DE LA VITESSE DU MOTEUR DU LECTEUR DE DISQUE

1. Placer la feuille stroboscopique sur le plateau. Mettre en service le commutateur d'alimentation et le commutateur de positionnement (◀◀) pour mettre le moteur du lecteur de disque en fonctionnement.
2. Introduire un petit tournevis dans le trou de réglage de vitesse placé sur le panneau inférieur et régler respectivement VR1 et VR2.

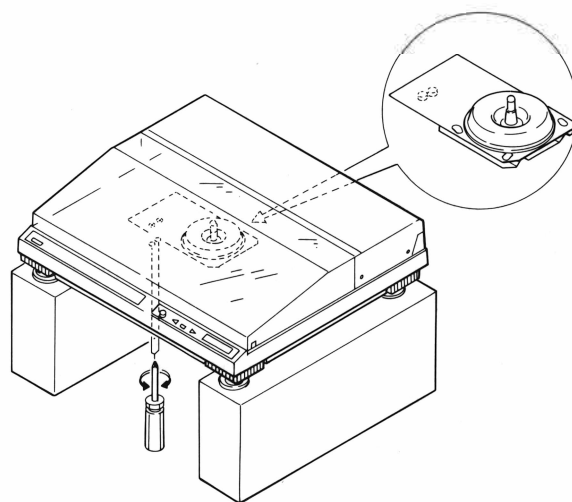

Fig. 13-4 Réglage de la vitesse du moteur du lecteur de disque

# 13. AJUSTE

## 13.1 AJUSTE DEL BRAZO DE FONOCAPTOR

1. Con el aparato encendido, ponga un disco de prueba (PLS-2001 o PLS-4001, lado A hacia arriba), sobre el plato giratorio.
  2. Presionar el botón de ARRANQUE-PARADA y verificar la posición del brazo de fonocaptor cuando se posa sobre el disco.
  3. Levantar la cubierta para el polvo y girar el tornillo ❶ de ajuste hasta que el brazo de fonocaptor quede alineado con el disco.
- Cuando el brazo de fonocaptor descansa a la derecha de la ranura inicial, (cuando la cuenta es menor que la tolerancia de cuenta estándar), girar el tornillo ❶ de ajuste en el sentido contrario a los punteros del reloj.
  - Cuando el brazo de fonocaptor descansa a la izquierda de la ranura de descanso, (cuando la cuenta es mayor que la tolerancia de cuenta estándar), girar el tornillo ❶ de ajuste en el sentido a los punteros del reloj.
  - Cuando se esté usando el disco de prueba, la posición quedará fijada para discos de 30 cm.

Disco de prueba	Posición de ajuste
PLS2001	$310 \pm 3$ cuentas
PLS4001	$13 \pm 6$ cuentas

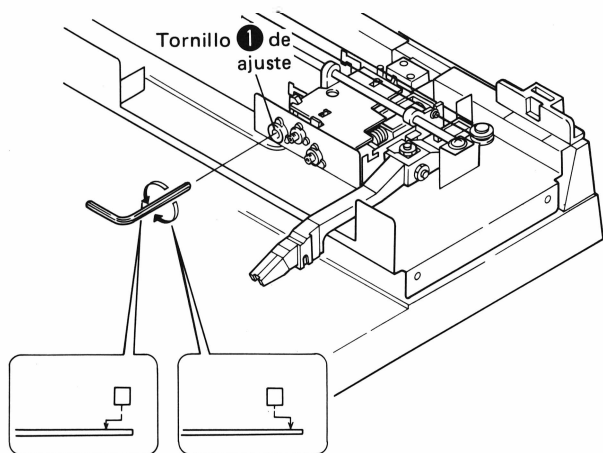

Fig. 13-1 Ajuste del brazo fonocaptor

## 13.2 AJUSTE DE GANANCIA DEL SENSOR DE SEGUIMIENTO Y DE DESCENTRADO

### • Ajuste de Ganancia

1. Sacar la cubierta para el polvo y la cubierta del panel.
2. Conectar un voltímetro de C.C. al pasador No. 4 (GND) y al pasador No. 5 (TRKG) del CN5.
3. Girar el tornillo ❷ en el sentido contrario a los punteros del reloj y tirar la unidad de carro adelante.
4. Encender el aparato y mientras se empuja el brazo de fonocaptor hacia el centro (como se muestra en la ilustración) ajustar el VR201 (TRKG) hasta que el voltímetro de C.C. registre  $3V \pm 0,1V$ .

### • Ajuste de Descentrado

5. Haga volver el brazo de fonocaptor a la posición de descanso. (Volverá por sí mismo cuando usted lo libere.)
6. Para ajustarlo, girar el tornillo ❷ en el sentido de los punteros del reloj hasta que el voltímetro de C.C. registre  $1,1V \pm 0,1V$ .

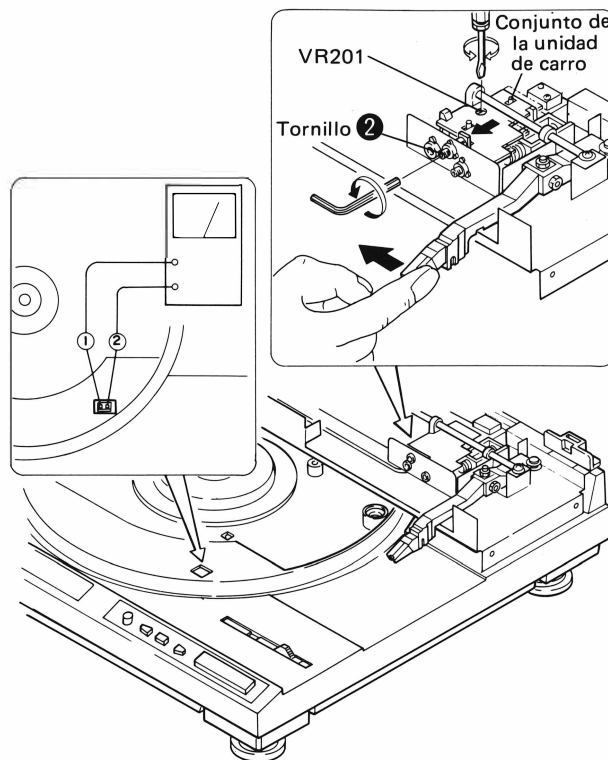
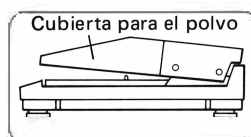

Fig. 13-2 Ganancia del sensor de seguimiento y ajuste de descentrado

### 13.3 AJUSTE DE LA ALTURA DEL BRAZO DE FONOCAPTOR

1. Con la cubierta para el polvo desmontada, insertar dos chavetas de 6mm (una derecha y una a la izquierda) para emular la situación en que la cubierta para el polvo y la base del mecanismo están conectadas.
2. Poner un disco de 30 cm sobre el plato giratorio, encender el aparato, y usando el conmutador de localización (◀◀) mover el brazo de fonocaptor a una distancia de aproximadamente 100 mm del centro del plato giratorio.
3. Girar el tornillo ③ hasta que la punta de la aguja esté de 5 a 7 mm sobre la superficie del disco.
  - Girando el tornillo en el sentido de los punteros del reloj, se baja la aguja.
  - Girando el tornillo en el sentido contrario a los punteros del reloj, se sube la aguja.

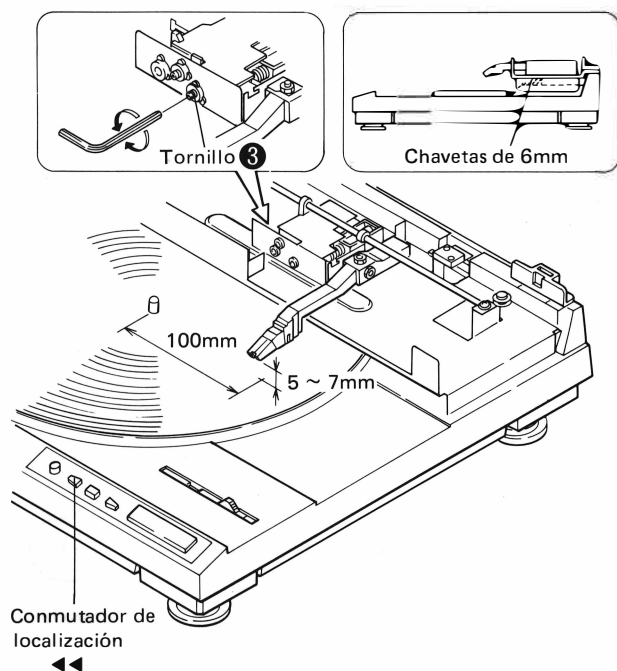

Fig. 13-3 Ajuste de la altura del brazo de fonocaptor

### 13.4 AJUSTE DE LA VELOCIDAD DEL MOTOR DEL TOCADISCOS

1. Colocar la hoja de estroboscopia sobre el platillo. Encender el conmutador de alimentación y el conmutador de colocación (◀◀) para girar el motor del tocadiscos.
2. Insertar un destornillador pequeño en el orificio de ajuste de velocidad situado en el panel inferior, y ajustar respectivamente VR1 y VR2.

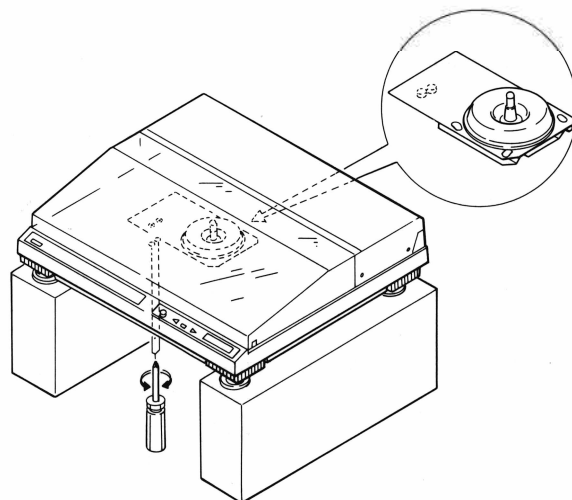
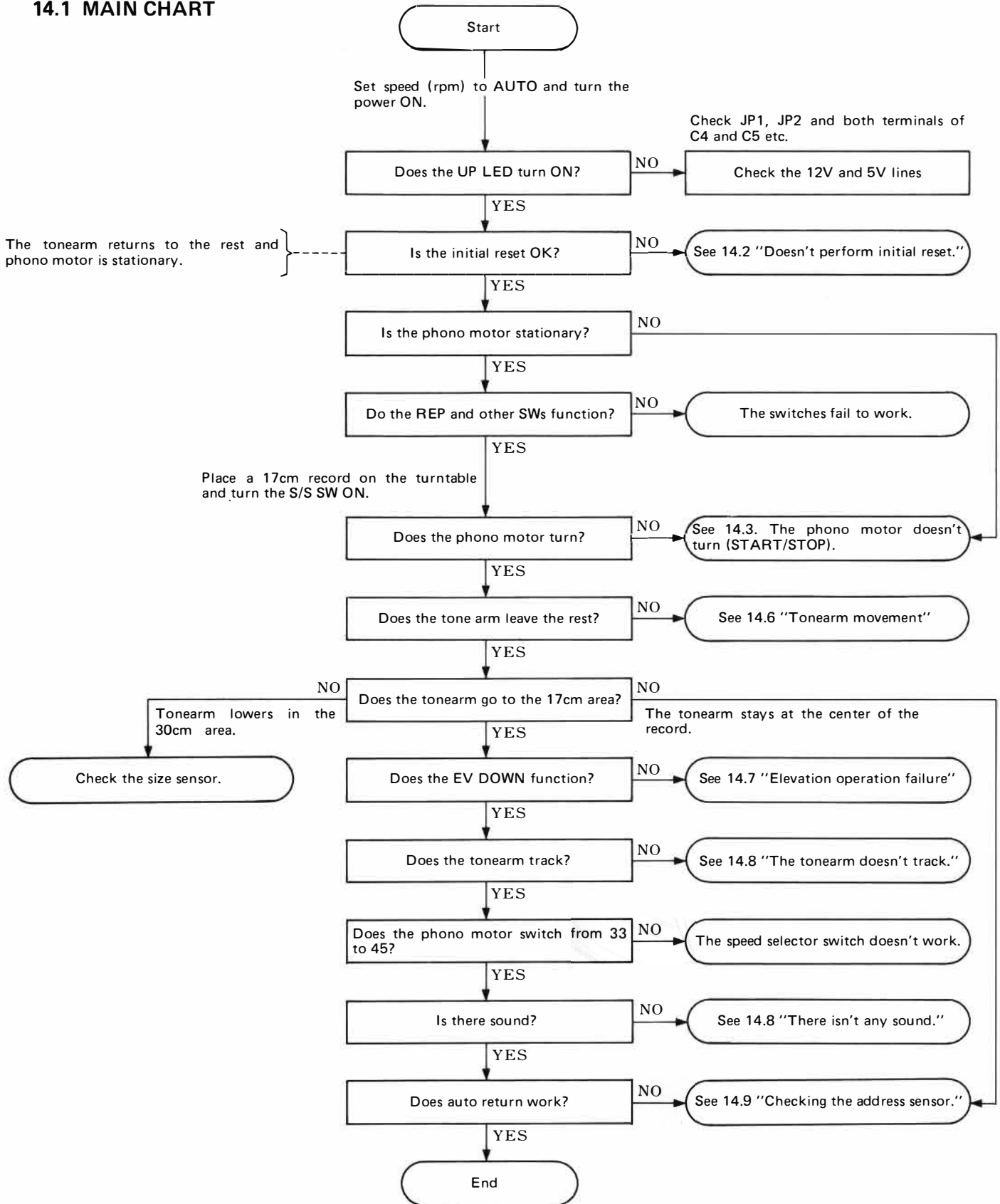

Fig. 13-4 Ajuste de la velocidad del motor del tocadiscos

# 14. TROUBLESHOOTING

## 14.1 MAIN CHART





## 14.2 THE UNIT DOESN'T PERFORM INITIAL RESET

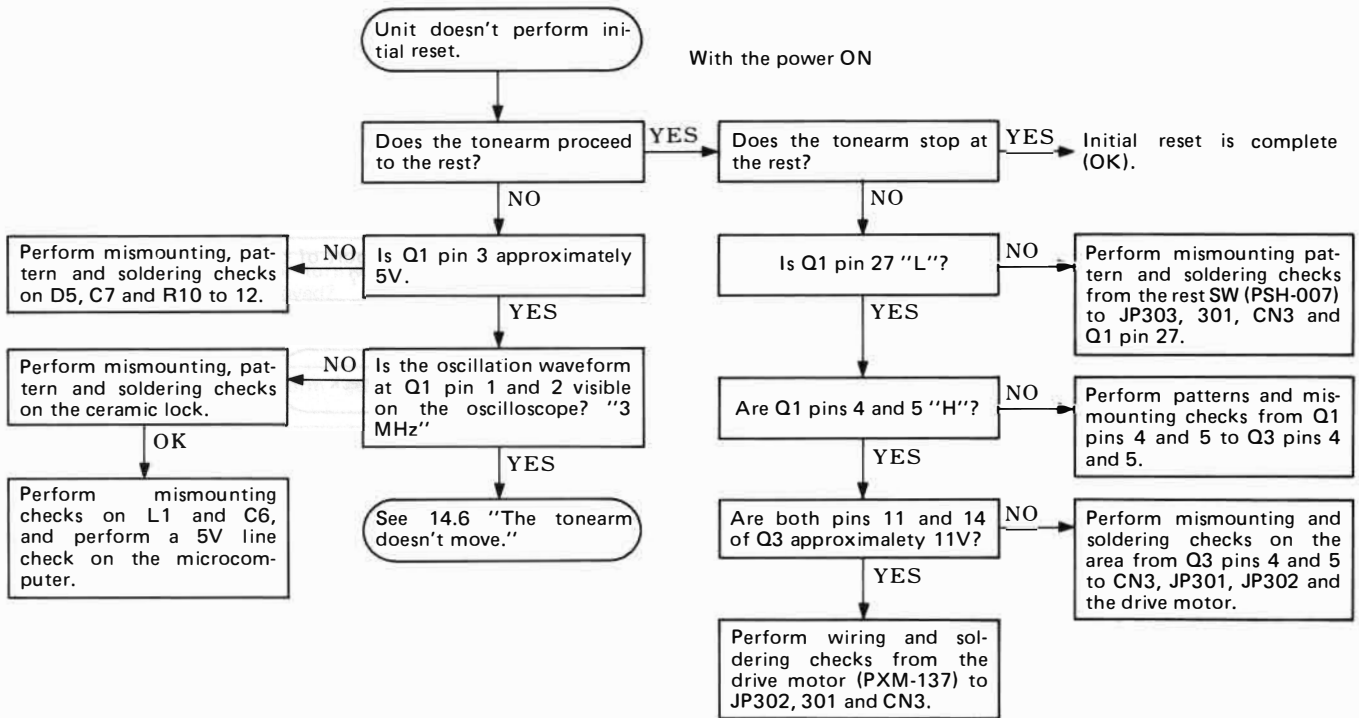

## 14.3 THE PHONO MOTOR DOESN'T TURN (START/STOP)

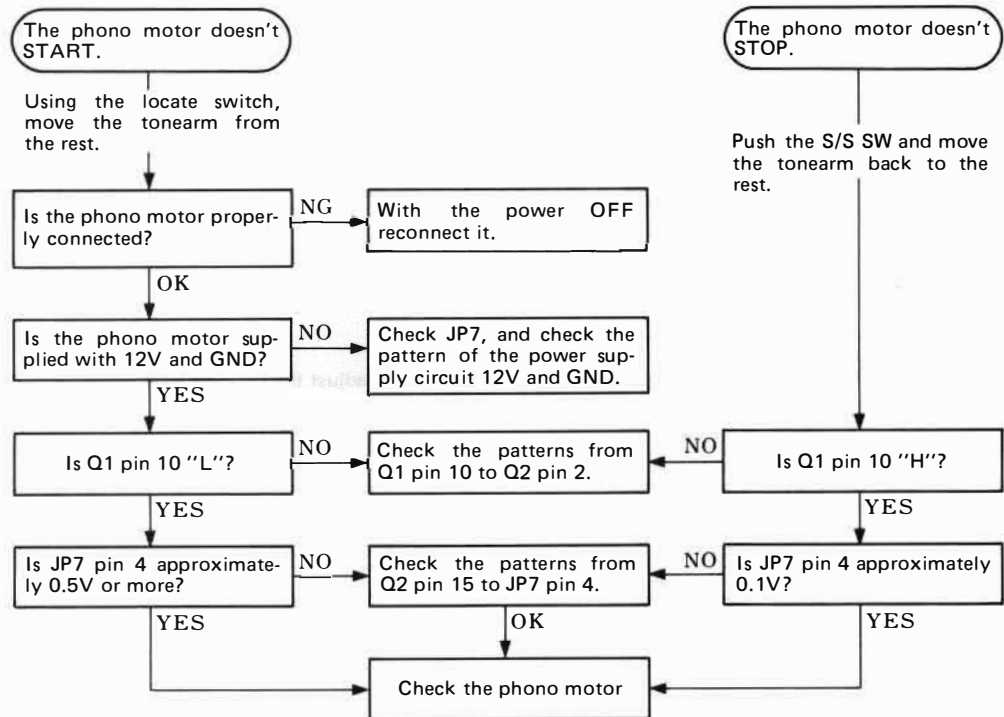

## 14.4 THE SWITCHES FAIL TO WORK

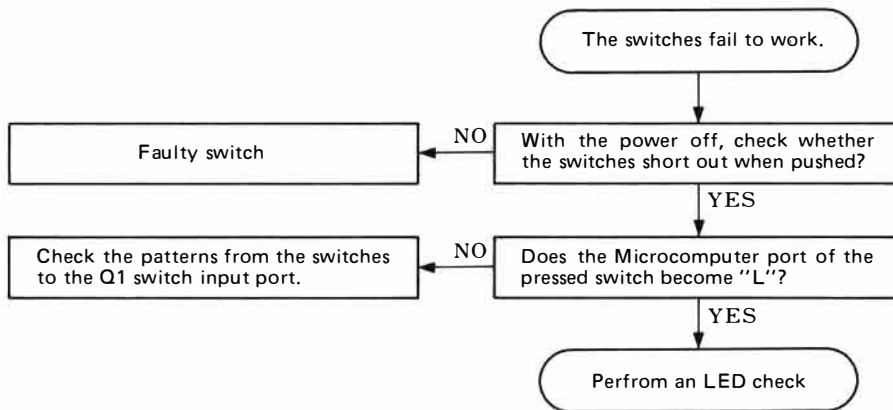

## 14.5 TRACKING FAILURE

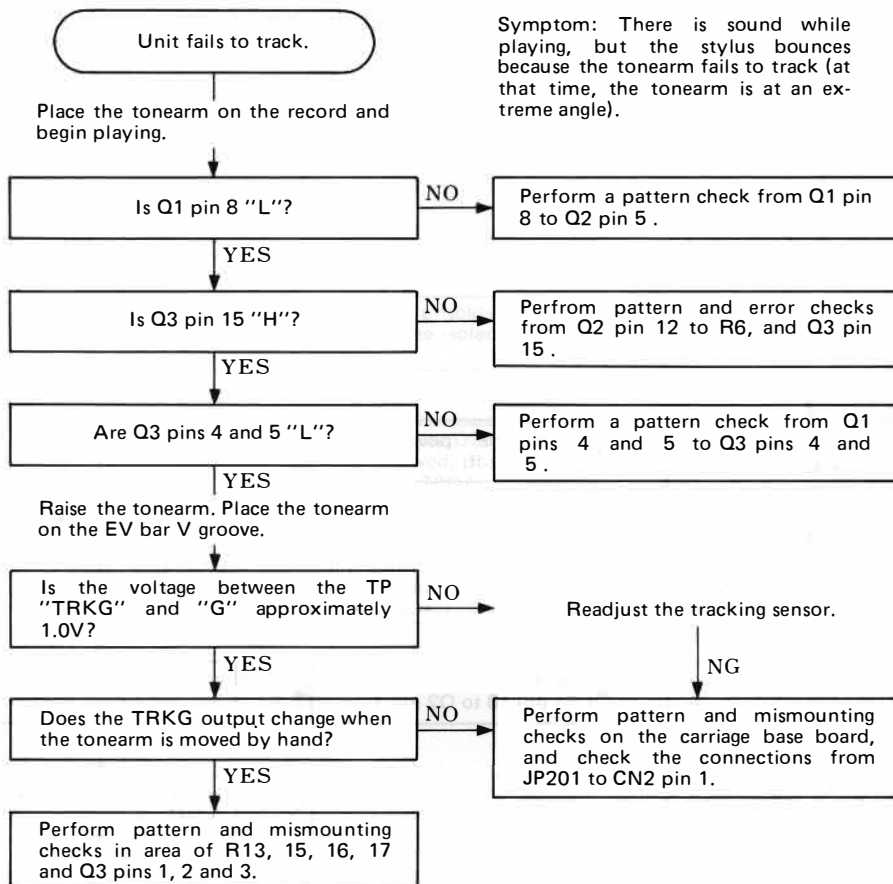

## 14.6 TONEARM MOVEMENT

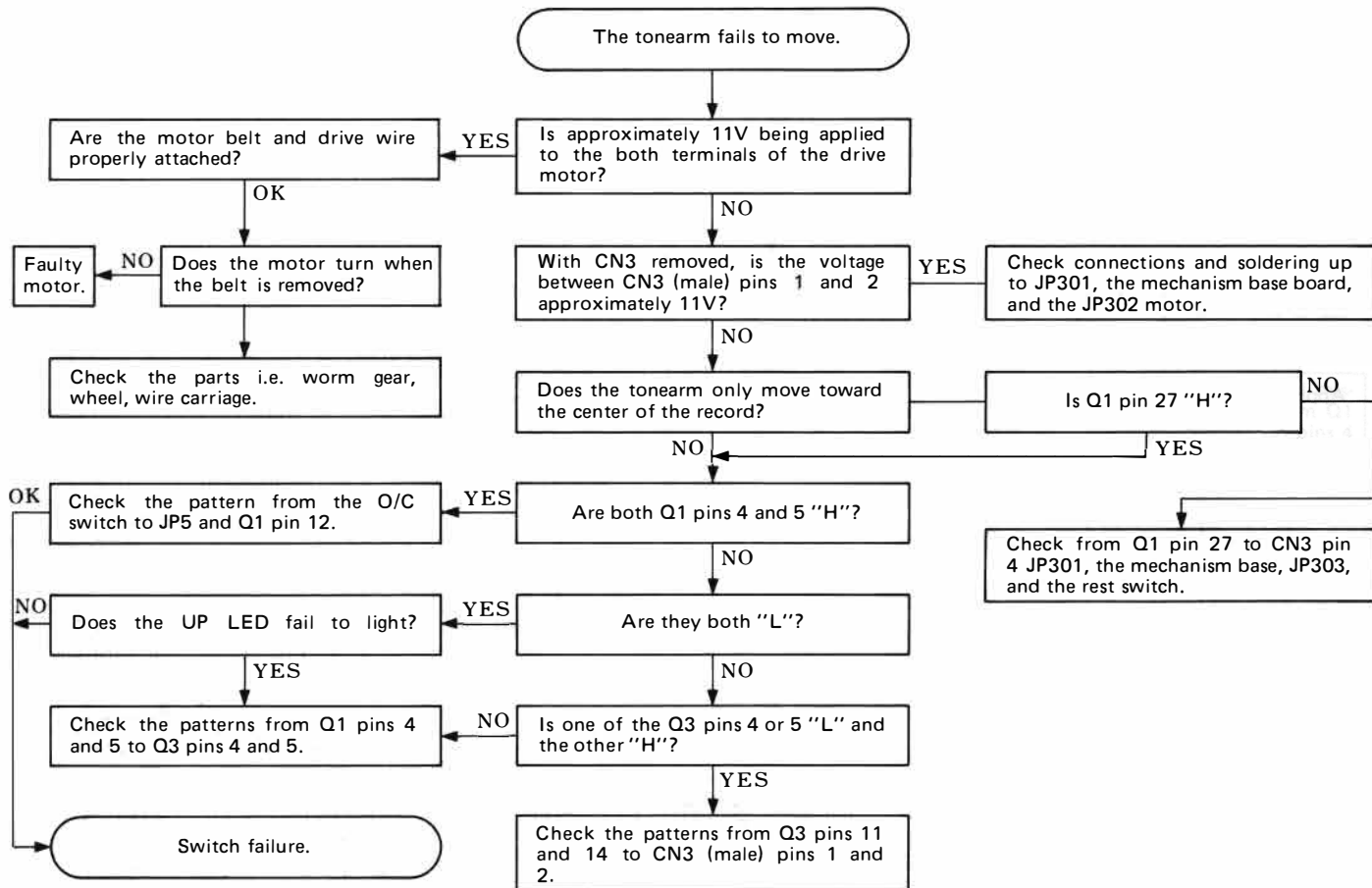

## 14.7 ELEVATION OPERATION FAILURE

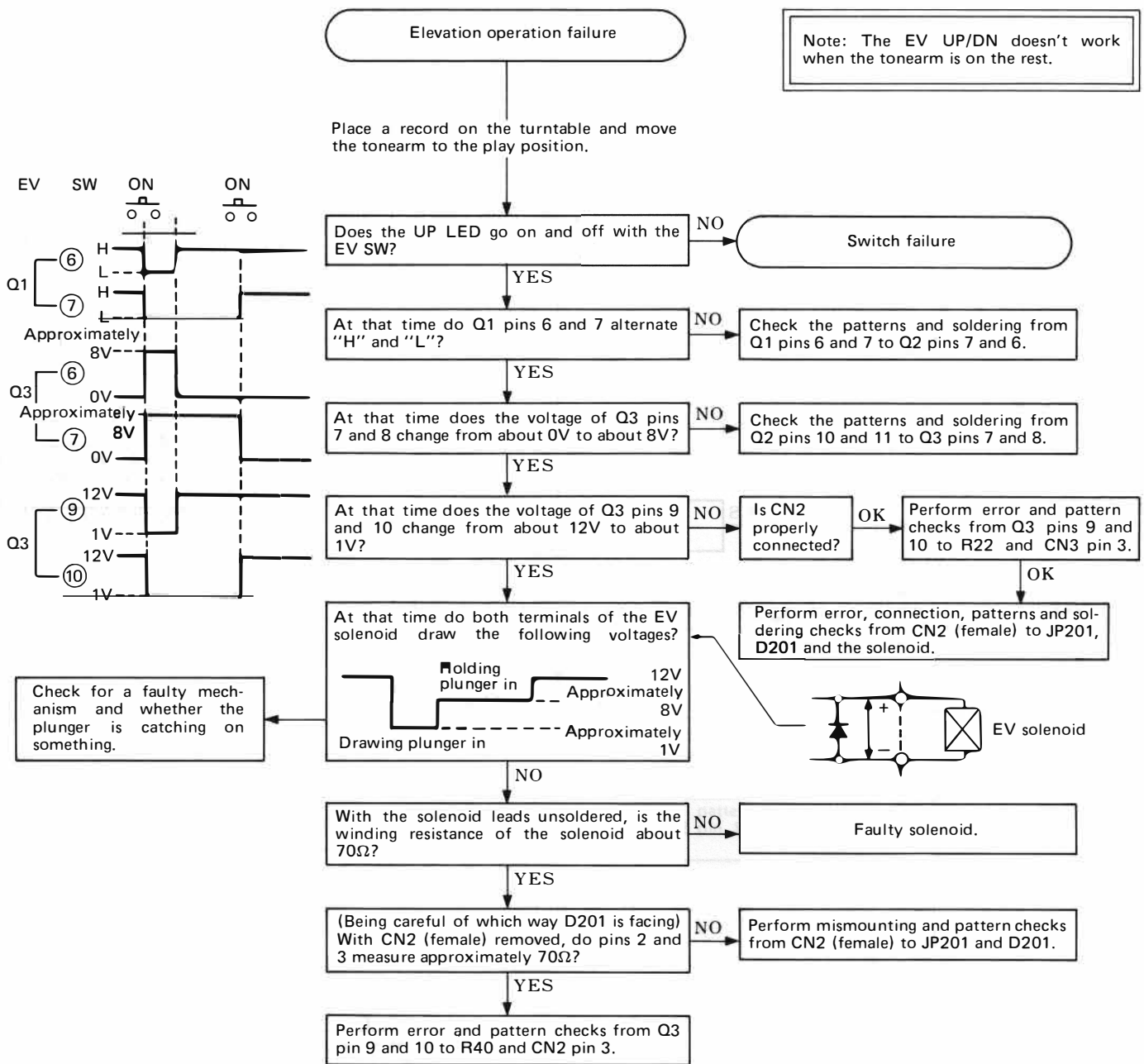

## 14.8 SOUND FAILURE

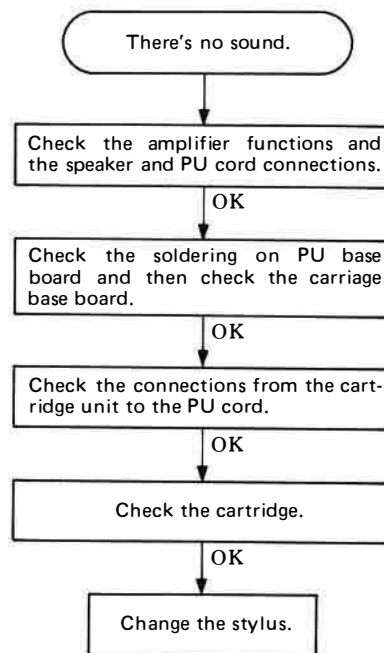

## 14.9 ADDRESS SENSOR CHECK

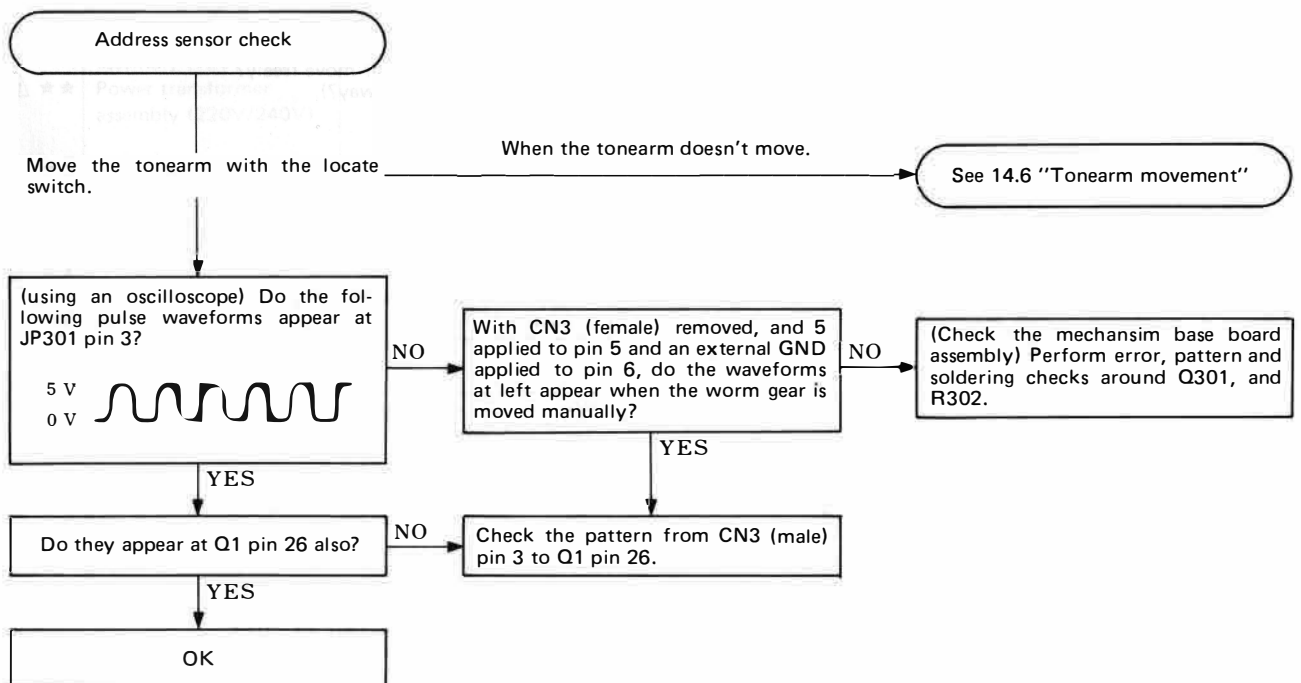

## 14.10 SIZE SENSOR CHECK

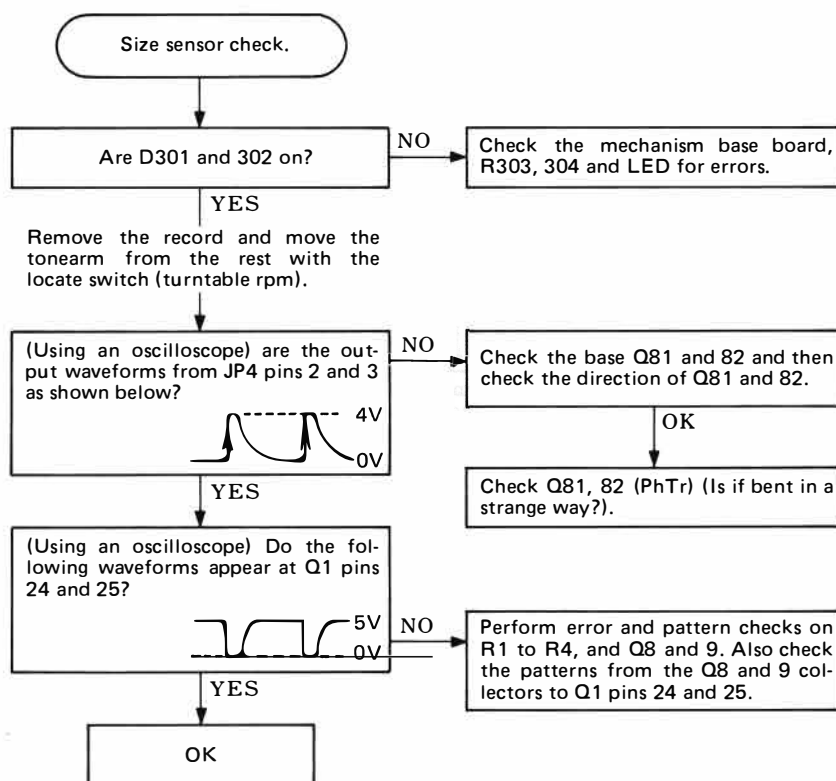

## 14.11 SPEED SELECTOR FAILURE

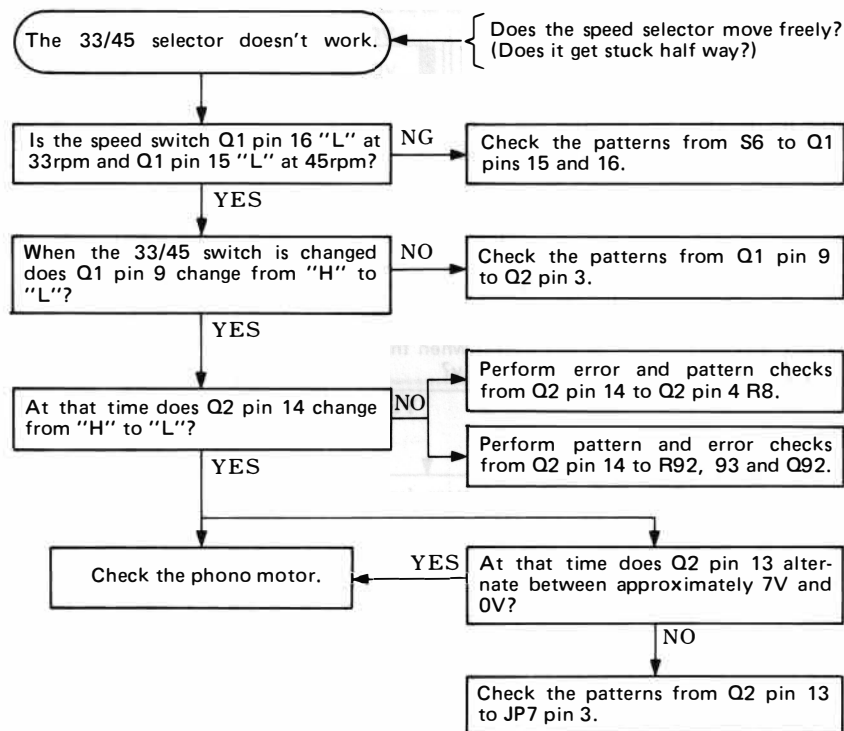

# 15. SUPPLEMENT FOR KUT, KCT, HEM, HB, S AND S/G TYPES

- Model PL-L50/KUT, KCT, HEM and HB are the PL-L50/KU with the exception of this supplement.

## Contrast of Miscellaneous Parts

### NOTES:

- When ordering resistors, first convert resistance values into code form as shown in the following examples.  
*Ex. 1 When there are 2 effective digits (any digit apart from 0), such as 560 ohm and 47k ohm (tolerance is shown by J=5%, and K=10%).*  
 $560\Omega$      $56 \times 10^1$      $561 \dots RD\frac{1}{4}PS$   $\begin{matrix} 5 & 6 & 1 \\ \hline \end{matrix}$  J  
 $47k\Omega$      $47 \times 10^3$      $473 \dots RD\frac{1}{4}PS$   $\begin{matrix} 4 & 7 & 3 \\ \hline \end{matrix}$  J  
 $0.5\Omega$      $0R5$  .....  $RN2H$   $\begin{matrix} 0 & 5 \\ \hline \end{matrix}$  K  
 $1\Omega$      $010$  .....  $RS1P$   $\begin{matrix} 0 & 1 & 0 \\ \hline \end{matrix}$  K  
*Ex. 2 When there are 3 effective digits (such as in high precision metal film resistors).*  
 $5.62k\Omega$      $562 \times 10^1$      $5621 \dots RN\frac{1}{4}SR$   $\begin{matrix} 5 & 6 & 2 & 1 \\ \hline \end{matrix}$  F
- The  $\Delta$  mark found on some component parts indicates the importance of the safety factor of the part. Therefore, when replacing, be sure to use parts of identical designation.
- For your Parts Stock Control, the fast moving items are indicated with the marks  $\star\star$  and  $\star$ .  
 $\star\star$  **GENERALLY MOVES FASTER THAN  $\star$**   
*This classification shall be adjusted by each distributor because it depends on model number, temperature, humidity, etc.:*

Mark	Symbol & Description	Part No.						
		KU type	KUT type	KCT type	HEM type	HB type	S type	S/G type
$\Delta$ $\star\star$	Panel (F)	PNY-304	PNY-304	PNY-304	PNY-305	PNY-305	PNY-305	PNY-305
$\Delta$ $\star\star$	Power transformer assembly (120V)	PTX-050	PTX-050	PTX-056	...	...	...	...
$\Delta$ $\star\star$	Power transformer assembly (220V/240V)	...	...	...	PTX-057	PTX-057	...	...
$\Delta$ $\star\star$	Power transformer assembly (110V/120V/220V/240)	...	...	...	...	...	PTX-058	PTX-058
$\Delta$ $\star\star$	Power cord assembly	PDF-221	PDF-221	PDF-221	PDF-224	PDF-225	PDF-220	PDF-220
$\Delta$ $\star\star$	Line voltage selector	...	...	...	PSB-013	PSB-013	PSB-014	PSB-014
	Operating instructions (English)	PRB-275	PRB-275	PRB-275	...	PRB-275	PRB-275	PRB-275
	Operating instructions (English/German/French/Italian)	...	...	...	PRE-034	...	...	...
	Packing case	PHH-188	PHH-187	PHH-189	PHH-190	PHH-190	PHH-190	PHH-191
		...	...	...	...	...	...	PHC-049

**Power Supply Circuit for HEM and HB types**

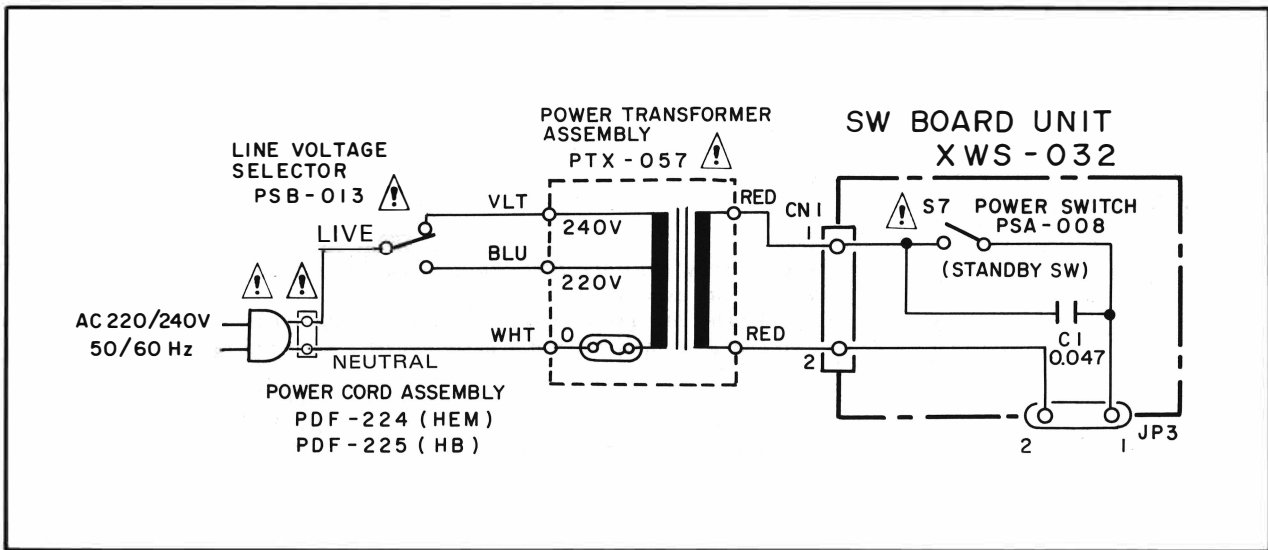

**Power Supply Circuit for S and S/G types**

