

4-CHANNEL STEREO RECEIVER
QX-949A
F, KCU

<ART-140-0>

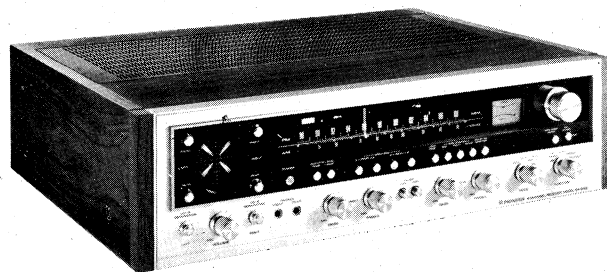

 **PIONEER®**

CONTENTS

| | | |
|------|--|----|
| 1. | SPECIFICATIONS | 3 |
| 2. | FRONT PANEL FACILITIES | 5 |
| 3. | CONNECTION DIAGRAM | 9 |
| 4. | BLOCK DIAGRAM | 11 |
| 5. | LEVEL DIAGRAM | 13 |
| 6. | CIRCUIT DESCRIPTIONS | |
| 6.1 | FM Tuner Section | 14 |
| 6.2 | AM Tuner Section | 14 |
| 6.3 | CD-4 Demodulator Section | 16 |
| 6.4 | SQ Full Logic/RM Decoder Section | 20 |
| 6.5 | Control Amplifier | 23 |
| 6.6 | Power Amplifier Section | 24 |
| 6.7 | Protection Circuit | 24 |
| 7. | DISASSEMBLY | |
| 7.1 | Wooden Cabinet | 26 |
| 7.2 | Bottom Plate | 26 |
| 7.3 | Front Panel | 27 |
| 8. | ADJUSTMENTS | |
| 8.1 | AM Section | 28 |
| 8.2 | FM Section | 29 |
| 8.3 | FM MPX Section | 30 |
| 8.4 | Power Amplifier Section | 31 |
| 9. | DIAL CORD STRINGING | 32 |
| 10. | PARTS LOCATIONS | |
| 10.1 | Front View 1 | 33 |
| 10.2 | Front View 2 | 35 |
| 10.3 | Top View | 37 |
| 10.4 | Bottom View | 39 |
| 10.5 | Rear View | 41 |
| 11. | EXPLODED VIEWS | 43 |
| 12. | PACKING | 52 |
| 13. | SCHMATIC DIAGRAMS, P.C. BOARD PATTERNS AND PARTS LISTS | |
| 13.1 | Schematic Diagrams and Miscellaneous Parts | 53 |
| 13.2 | Tuner Assembly (AWE-041) | 61 |

| | | |
|-------|---|-----|
| 13.3 | Headphone Jack Assembly (AWX-054) | 67 |
| 13.4 | Power Supply Circuit B Assembly (AWR-039) | 68 |
| 13.5 | CD-4 Assembly (AWM-076) | 69 |
| 13.6 | SQ/RM Decoder Assembly (AWM-077) | 77 |
| 13.7 | Protection Circuit Assembly (AWM-079) | 83 |
| 13.8 | Control Amplifier Assembly (AWG-023) | 86 |
| 13.9 | Power Supply Circuit A Assembly (AWR-080) | 91 |
| 13.10 | Switch Circuit Assembly (AWS-048) | 94 |
| 13.11 | Power Amplifier Assembly (AWH-027) | 98 |
| 14. | PARTS LIST OF EXPLODED VIEWS | 102 |

NOTE:

THE MODEL QX-949A COMES IN TWO VERSIONS DISTINGUISHED AS FOLLOWS:

| Round label on rear panel | Voltage | Type |
|---------------------------|---|---------------------------------------|
| F | 110V, 120V, 130V, 220V, and 240V (switchable) | General export model |
| KCU | 120V only | UL (U.S.A.) and CSA (Canada) approved |

1. SPECIFICATIONS

Semiconductors

| | | | |
|------|----|-------------|----|
| FETs | 12 | Transistors | 85 |
| ICs | 11 | Diodes | 63 |

Amplifier Section

| | |
|---|--|
| Continuous Power Output from 20 Hertz to 20,000 (4 channels driven) | 40 watts per channel (8ohms) 50 watts per channel (4ohms) |
|---|--|

| | |
|---|--|
| Continuous Power Output from 20 Hertz to 20,000 Hertz (2 CHANNEL POWER BOOSTING SWITCH set at "2 CH") (2 channels driven) | 60 watts per channel (8ohms) 75 watts per channel (4ohms) |
|---|--|

| | |
|--|--|
| Continuous Power Output at 1,000 Hertz (4-channels driven) | 44 watts per channel (8ohms) 58 watts per channel (4ohms) |
|--|--|

| | |
|--|--|
| Continuous Power Output at 1,000 Hertz (2 CHANNEL POWER BOOSTING SWITCH set at "2 CH") (2 channels driven) | 65 watts per channel (8ohms) 85 watts per channel (4ohms) |
|--|--|

Circuitry Direct Coupled Complementary OCL

| | |
|--|---|
| Total Harmonic Distortion (20 Hertz to 20,000 Hertz) (Continuous Rated Power Output) (1 watt per channel Power Output, 8 ohms) | No more than 0.3% No more than 0.05% |
|--|---|

| | |
|--|---|
| Intermodulation Distortion (Continuous Rated Power Output) (1 watt per channel Power Output, 8 ohms) | No more than 0.3% No more than 0.05% |
|--|---|

| | |
|-----------------|-------------------------------------|
| Output, Speaker | FRONT: A, B, A+B REAR: A, B, A+B |
|-----------------|-------------------------------------|

Headphones FRONT & REAR Low impedance

| | |
|-------------------------------------|----|
| Damping Factor (1,000 Hertz, 8ohms) | 35 |
|-------------------------------------|----|

| | |
|-----------------------------|----------------|
| Input Sensitivity/Impedance | |
| PHONO 1 | 2.5mV/50kohms |
| PHONO 2 | 2.5mV/50kohms |
| PHONO Overload Level (rms) | 100mV |
| AUX | 150mV/100kohms |
| TAPE MONITOR (2CH, 4CH) | 150mV/100kohms |

| | |
|---------------------|-------|
| Output Level | |
| TAPE REC (2CH, 4CH) | 150mV |

| | |
|---------------------------|-----------------------------------|
| Frequency Response | |
| PHONO (RIAA equalization) | 30 Hertz—15,000 Hertz ± 1 dB |
| AUX, TAPE PB | 7 Hertz—25,000 Hertz ± 1.5 dB |

| | |
|--|---|
| Tone Control | |
| BASS | ± 10 dB (100 Hertz) |
| TREBLE | ± 10 dB (10,000 Hertz) |
| Loudness Contour | |
| (Volume control set at -40dB position) | +6dB (100 Hertz) +3dB (10,000 Hertz) |

| | |
|---|------|
| Hum & Noise (IHF, Short-circuited, A Network) | |
| PHONO | 70dB |
| AUX, TAPE PB | 90dB |

| | |
|--------|-------------------------|
| Filter | |
| LOW | 50 Hertz (6dB/oct.) |
| HIGH | 10,000 Hertz (6dB/oct.) |

CD-4 Demodulator Section

| | |
|--|--------------------------|
| Input Sensitivity | 2.5mV (1—5mV adjustable) |
| Input Impedance | 100k Ω |
| Harmonic Distortion | 0.15% |
| Signal-to-Noise Ratio (IHF, A Network) | More than 70dB |
| Separation (STD Test Signal at 1kHz) | |
| Left ~ Right | 50dB |
| Front ~ Rear | 30dB |

FM Tuner Section

| | |
|--------------------------|--|
| Circuitry | 2 MOS FETs, 1-stage RF Amplifier, 4-ganged Tuning Capacitor, 6-stage Limiter |
| Usable Sensitivity (IHF) | 1.8 μ V |
| Capture Ratio (IHF) | 1dB |
| Selectivity (IHF) | 80dB |
| Signal-to-Noise Ratio | 70dB |
| Image Rejection (98MHz) | 85dB |
| IF Rejection (98MHz) | 100dB |
| Spurious Rejection | 100dB |
| AM Suppression | 55dB |
| Harmonic Distortion | |
| Mono | 0.2% |
| Stereo | 0.4% |
| Frequency Response | 20Hz—15kHz $^{+0.2}_{-2.0}$ dB 50Hz—10kHz $^{+0.2}_{-0.3}$ dB |

| | |
|-------------------------|---|
| Stereo Separation | |
| 1kHz | 40dB |
| 50Hz~10kHz | 30dB |
| Sub-carrier Suppression | 65dB |
| Antenna Input | 300 Ω Balanced, 75 Ω Unbalanced |
| Muting | ON-OFF |
| MPX Noise Filter | ON-OFF |

AM Section

| | |
|------------------------|---|
| Circuitry | 1 Stage RF Amplifier, 3-ganged Tuning Capacitor |
| Sensitivity | |
| (IHF, Ferrite Antenna) | 300 μ V/m |
| (IHF, Ext. Antenna) | 15 μ V |
| Selectivity | 40dB |
| Signal-to-Noise Ratio | 50dB |
| Image Rejection | 65dB |
| IF Rejection | 85dB |
| Antenna | Built-in Ferrite Loopstick Antenna |

Miscellaneous

| | |
|--|--|
| Built-in CD-4 Demodulator, Regular Matrix Decoder, SQ Full Logic Decoder | |
| Power Requirements | AC 120V 60 Hertz or 110V, 120V, 130V, 220V and 240V (Switchable) 50/60 Hertz |

| | |
|-------------------|--|
| Power Consumption | |
| KCU type | 400W (450VA) (UL, CSA approved model) |
| F type | 530W (General export model) |

| | |
|------------|--|
| AC Outlets | Unswitched 2, Switched 1 |
| Dimensions | 550(W) x 160(H) x 440(D)mm 22-1/16 x 6-5/16 x 17-5/16 in. |

| | |
|-------------------------|--------------------|
| Weight: Without Package | 22.4kg, 49 lb 5oz |
| With Package | 27.2kg, 59 lb 14oz |

Furnished Parts

| | |
|-----------------------------|--------------------------|
| FM T-type Dipole Antenna | 1 |
| CD-4 Test Record (PQX-1014) | 1 |
| FUSE 6A | 1 |
| FUSE 3A | 1 (5-line voltage model) |
| Operating Instructions | 1 |

NOTE:
Specifications and the design subject to possible modification without notice due to improvements.

2. FRONT PANEL FACILITIES

POWER SWITCH

Push button switch for turning on AC power. Also activates switched AC outlets on the rear panel. Depress once for power ON; press again for power OFF.

BALANCE CONTROLS

Individual balance controls for each of the four stereo channels.

4-CHANNEL LEVEL INDICATOR

All channels simultaneously displayed; relative intensity easily compared and adjusted.

VOLUME CONTROL

Control for adjusting sound volume. When rotated clockwise, 4-channel speaker sound increases.

CD-4 SEPARATION CONTROLS

Controls for adjusting front and rear separation when playing CD-4 records using a CD-4 cartridge.

Please refer to page 16 section on CD-4 channel separation adjustment procedures for detailed information. After adjustment, 2-channel records and matrix 4-channel records can also be played at the same setting.

When playing records employing a conventional 2-channel cartridge, set these controls (left & right) to center position.

LEFT Control: Front left (CH 1) and rear left (CH 2) separation adjustment.

RIGHT Control: Front right (CH 3) and rear right (CH 4) separation adjustment.

Be sure to readjust when replacing cartridge or stylus.

NOTE:

These SEPARATION CONTROLS are effective only when playing CD-4 record. When playing the other records, set MODE switch according to record type.

PHONES JACKS (FRONT & REAR)

Accept stereo headphone jacks

Front left and right (CH 1 & CH 3) can be heard when using FRONT jack.

Rear left and right (CH 2 & CH 4) can be heard when using REAR jack.

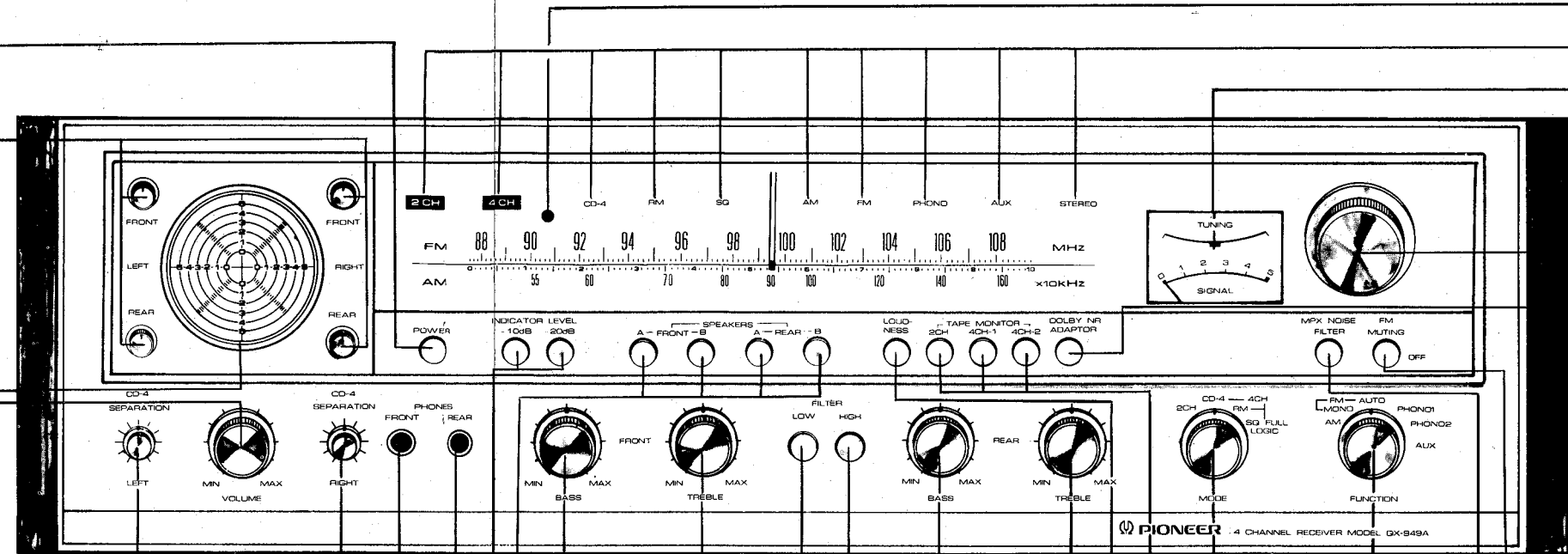

INDICATOR LEVEL BUTTONS

Step attenuator switches convenient for reading of the 4-Channel Level Indicator. If both buttons are depressed, their values are added.

| Both positions | Attenuation |
|----------------------|-------------|
| Both undepressed | 0dB |
| -10dB only depressed | -10dB |
| -20dB only depressed | -20dB |
| Both depressed | -30dB |

SPEAKER SWITCHES

Up to four pairs of speakers can be connected and switched on and off (in pairs) with the SPEAKERS SWITCH buttons.

Button depressed: respective pair of speakers in operation.

Button released: respective pair of speakers off.

By depressing all four buttons 2 sets of four-channel speaker systems can be used simultaneously (in different rooms, etc.).

BASS & TREBLE CONTROLS

Separate controls are provided for front and rear bass and treble.

FILTER BUTTON

LOW: Use this filter to cut out low-frequency noise (hum, rumble).

HIGH: Use this filter to cut out high-frequency noise (hiss).

LOUDNESS BUTTON

Depress when listening at low volume levels for proper sound balance relative to human ear sensitivity.

TAPE MONITOR BUTTONS (2CH, 4CH-1, 4CH-2)

These buttons are set to ON for checking the recording conditions or for playback with tape decks.

2CH: This button is set to ON for monitoring a recording in progress or for playback with a 2-channel tape deck connected to the 2CH TAPE PB and REC terminals.

4CH-1: This button is set to ON for monitoring a recording in progress or for playback with a 4-channel tape deck connected to the 4CH-1 TAPE PB and REC terminals.

4CH-2: This button is set to ON for monitoring a recording in progress or for playback with a 4-channel tape deck connected to the 4CH-2 TAPE PB and REC terminals.

NOTE:

For record/playback or listening to broadcasts, leave these buttons set to the OFF position. With the button set to ON no sound will be heard.

MODE SWITCH

Selector switch for 2-channel and each type of four channel reproduction method.

2CH: During 2-channel stereo reproduction (sound does not emerge from rear speakers.)

4CH: CD-4; For reproduction of discrete 4-channel tape, cartridge tape, or CD-4 records. 2-channel source can also be played in this position. At this time the same sounds are obtained from the rear left and right speakers as from the front left and right speakers (CH2 - CH1; CH4 - CH3).

RM; During 4-channel reproduction of Regular Matrix (RM) records and FM broadcasts. The matrix effect can also be obtained with a 2-channel program source.

SQ FULL LOGIC; For 4-channel reproduction of SQ system LOGIC; records and FM broadcasts. The matrix effect can also be obtained with a 2-channel program source.

NOTE:

Sound will not be heard from the rear speakers (CH 2 & CH 4) at any setting of the Mode switch when the 2 CH Power Boosting switch on the rear panel of the QX-949A has been set to 2 CH.

**CD-4 INDICATOR LAMP**

This lights to indicate that CD-4 record is being played (only when the MODE switch is set at 4CH CD-4).

MODE & FUNCTION INDICATORS

Separately lighted indicators provide one-glance recognition of the QX-949A operating mode and function. Left to right: 2CH, 4CH, CD-4, RM, SQ, AM, FM, PHONO, AUX, STEREO (FM stereo indicator)

**TUNING/SIGNAL METER**

When selecting an AM broadcast, tune so that the dial pointer of the lower meter deflects as far to the right as possible. For an FM broadcast, use the lower meter in the same way. Precise FM tuning is also possible by adjusting so that the dial pointer of the upper meter is centered.

**TUNING KNOB**

Rotate to tune in AM or FM broadcasts.

**DOLBY NR ADAPTOR BUTTON**

Used when employing separately sold Dolby NR Adaptor. Set to ON (depressed) for listening to FM Dolby broadcasts, playing Dolby encoded tape, or monitoring Dolby recording via the adaptor.

**FM MUTING BUTTON**

Circuit for eliminating inter-station noise and weak interfering stations when tuning FM broadcast. Up position is ON; depress button (OFF) when weak station reception is desired.

**MPX NOISE FILTER BUTTON**

Push this button to ON to eliminate high-frequency noise during FM stereo reception.

**FUNCTION SWITCH**

Switch for selecting program source for playing.

AM: When listening to AM broadcasts

FM MONO: When listening to FM monophonic broadcasts

FM AUTO: Select when listening to FM stereo broadcasts. During FM monophonic broadcasts, automatically receives monophonic signals. Stereo indicator lights during FM stereo broadcasts.

PHONO 1: When playing records on turntable connected to the PHONO 1 terminals.

PHONO 2: Same as above for PHONO 2 terminals.

AUX: When playing component connected to the AUX terminals.

ABOUT 2CH POWER BOOSTING SWITCH

To increase available power when using the QX-949A for 2-channel reproduction, a convenient power select feature is incorporated. The covered compartment on the rear panel houses a reversible connector panel. When added power is desired during 2-channel operation turn off set power. Open the cover, remove the connector panel and rotate it 180°, then re-insert it and close the cover. Be sure to reverse the connector again before returning to 4-channel operation.

These illustrations show how the boosting switch is employed.

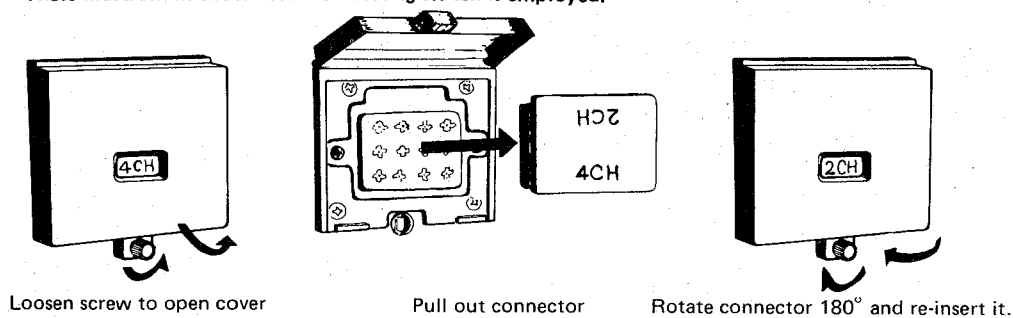

CHANGING LINE VOLTAGE SETTING AND FUSE (F MODEL)

To remove the fuse, unscrew the fuse cap located in the center of the line voltage selector and withdraw it, together with the fuse. Next, pull the line voltage selector plug out of its socket, rotate it until the cutaway aligns with the appropriate line voltage marked on the back of the unit, then push it back into its socket. It is important to check the rating of the fuse; a 3A fuse should be used with either 220V or 240V, while a 6A fuse should be used for 110V, 120V, or 130V operation. If the fuse rating is correct, reinsert it and screw in the fuse cap.

No selector plug is provided for "KCU" type (120V only model).

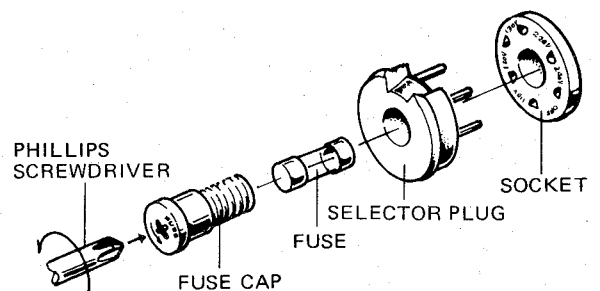

3. CONNECTION DIAGRAM

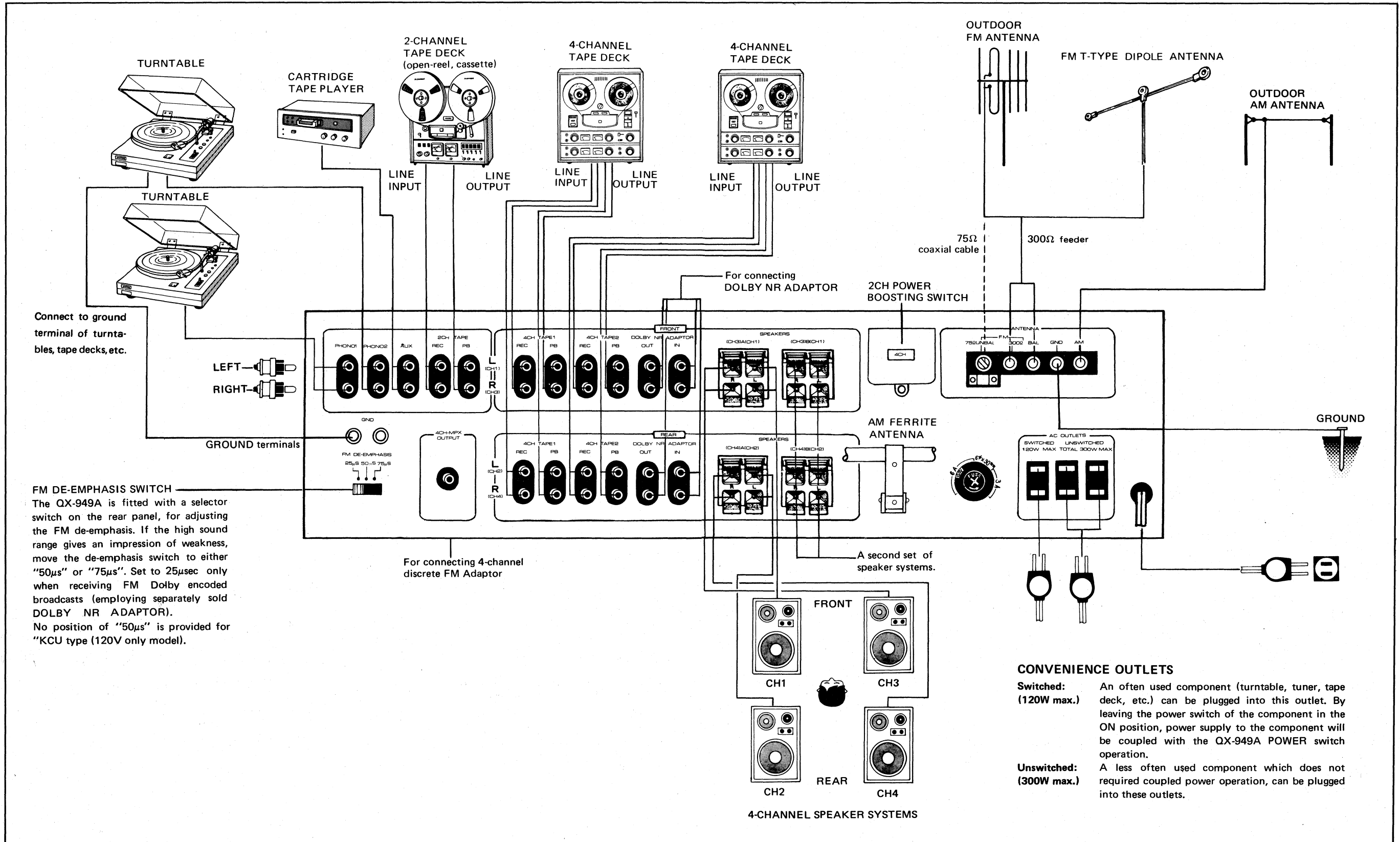

4. BLOCK DIAGRAM

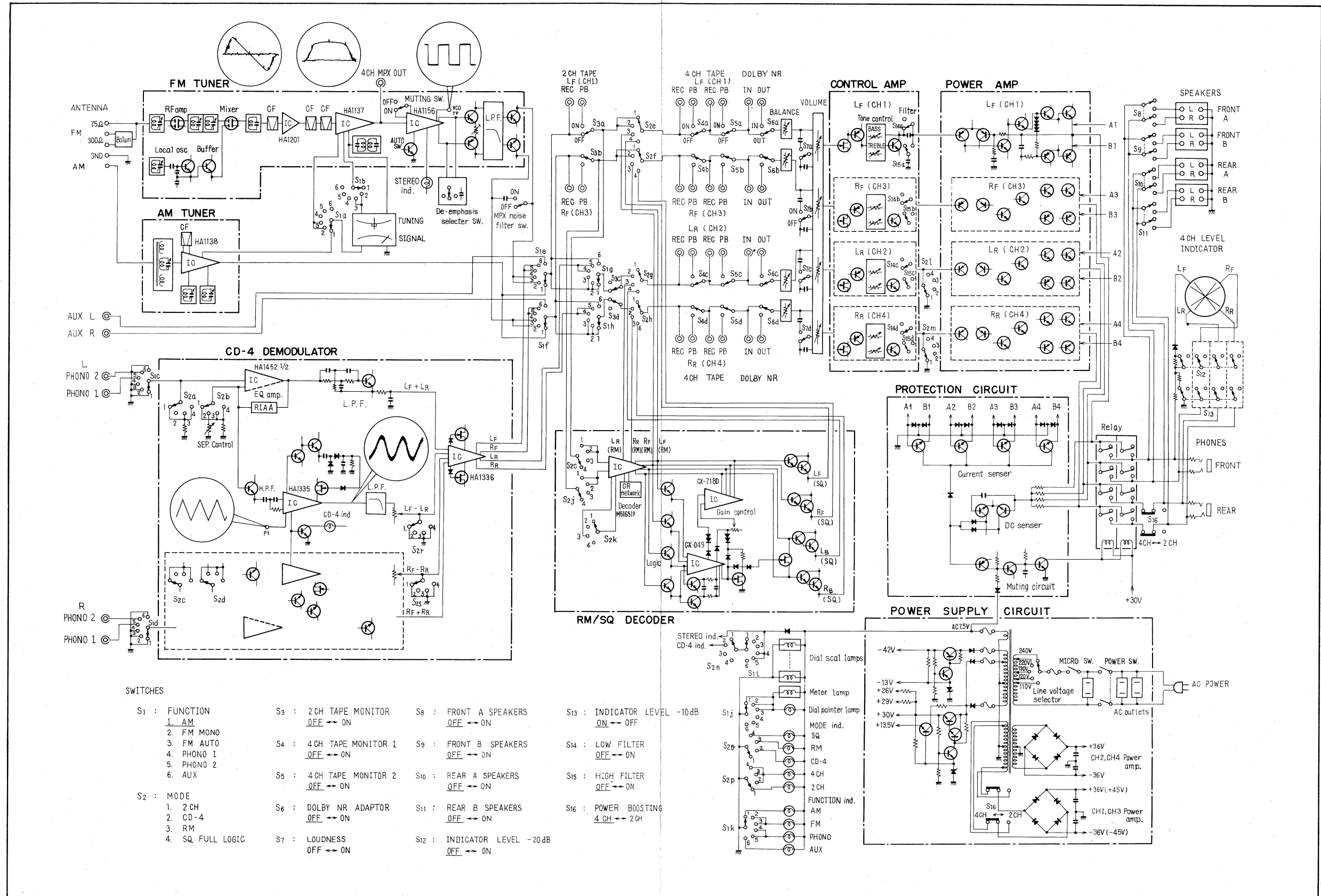

5. LEVEL DIAGRAM

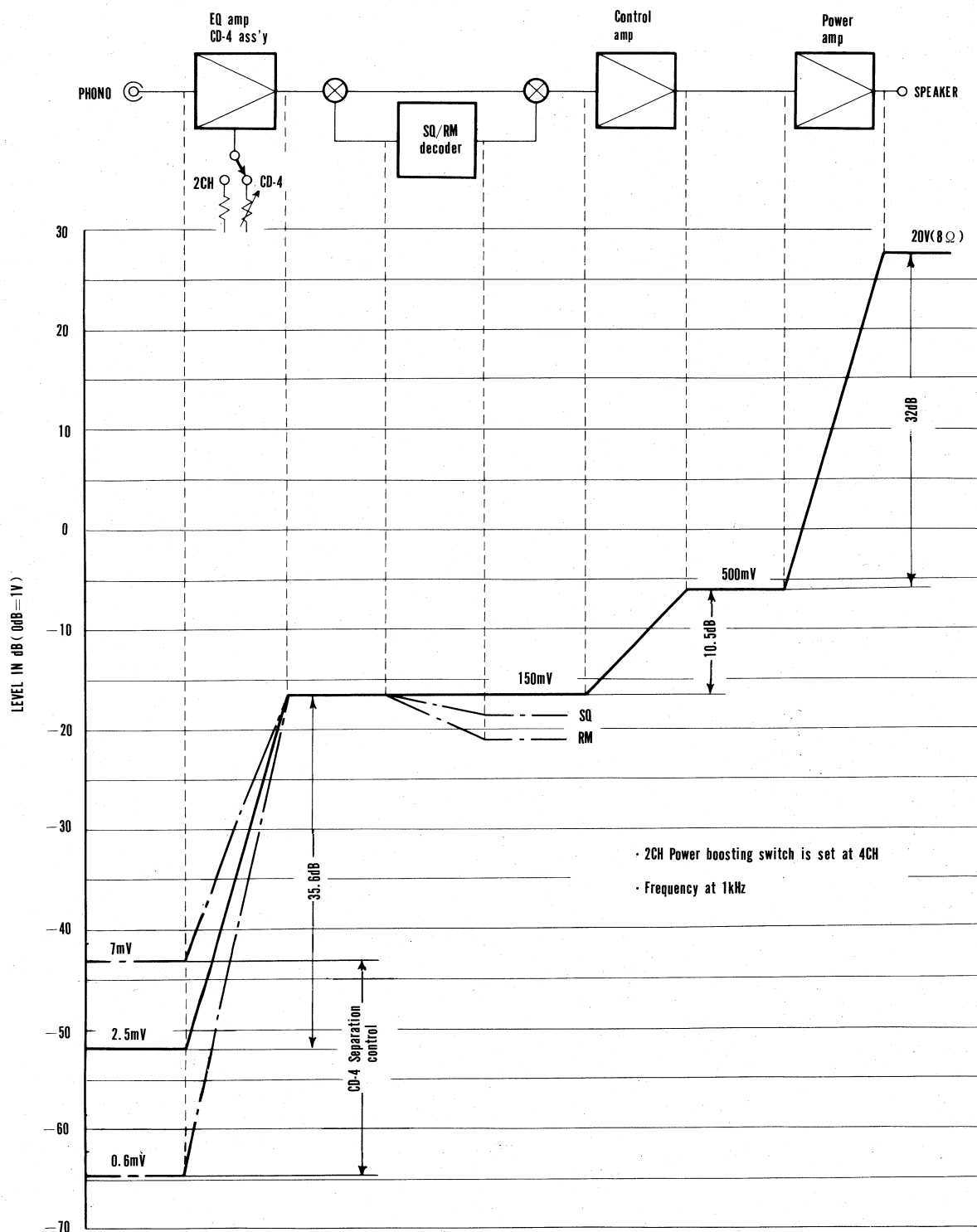

6. CIRCUIT DESCRIPTIONS

6.1 FM TUNER SECTION

Front End

This consists of a 4-gang variable capacitor tuning circuit, dual-gate MOS FET RF amplifier and mixer, and local oscillator with buffer. By employing a grounded gate-2 of the dual-gate MOS FET, the circuit becomes equivalent to a cascade amplifier, providing large gain with stable operation in the RF amplifier.

In the mixer stage, the signal is applied from the local oscillator to gate-2. This method allows input power from the local oscillator to be minimized and features low mutual interference. A variation of a Clapp circuit forms the local oscillator and by inserting a buffer amplifier between it and the mixer, the oscillator load is reduced and waveform distortion suppressed. The oscillation frequency drawing effect is also eliminated, to provide extremely stable operation even with strong inputs.

IF Amplifier and Detector

These are composed of three dual-element ceramic filters and two integrated circuits. The first stage IC (HA1201) incorporates a current limiter, while the second stage IC (HA1137) is shown in Fig. 2. When pin 12 of HA1137 is at more than $\pm 70\text{kHz}$ detuning and with an extremely low input level,

a DC voltage is produced. By setting the FM Muting switch to ON, pin 12 is connected to pin 5, and the analog switch in HA1137 is operated ON-OFF to perform muting.

Multiplex Decoder

Demodulation is performed by switching detection with the circuit contained in the IC (HA1156), depicted in Fig. 3. A phase locked loop (PLL) produces a 38kHz square wave synchronized to the pilot signal. The two gates are alternately switched ON-OFF by this signal to derive the L and R channels from the composite signal. By detecting the pilot signal level, the switching signal from PLL to demodulator is operated ON-OFF. The STEREO indicator lights at the same time.

6.2 AM TUNER SECTION

This consists of a 3-gang variable capacitor tuning circuit, a dual element ceramic filter and an IC (HA1138). The IC (Fig. 4) contains an RF stage and two IF amplifier stages.

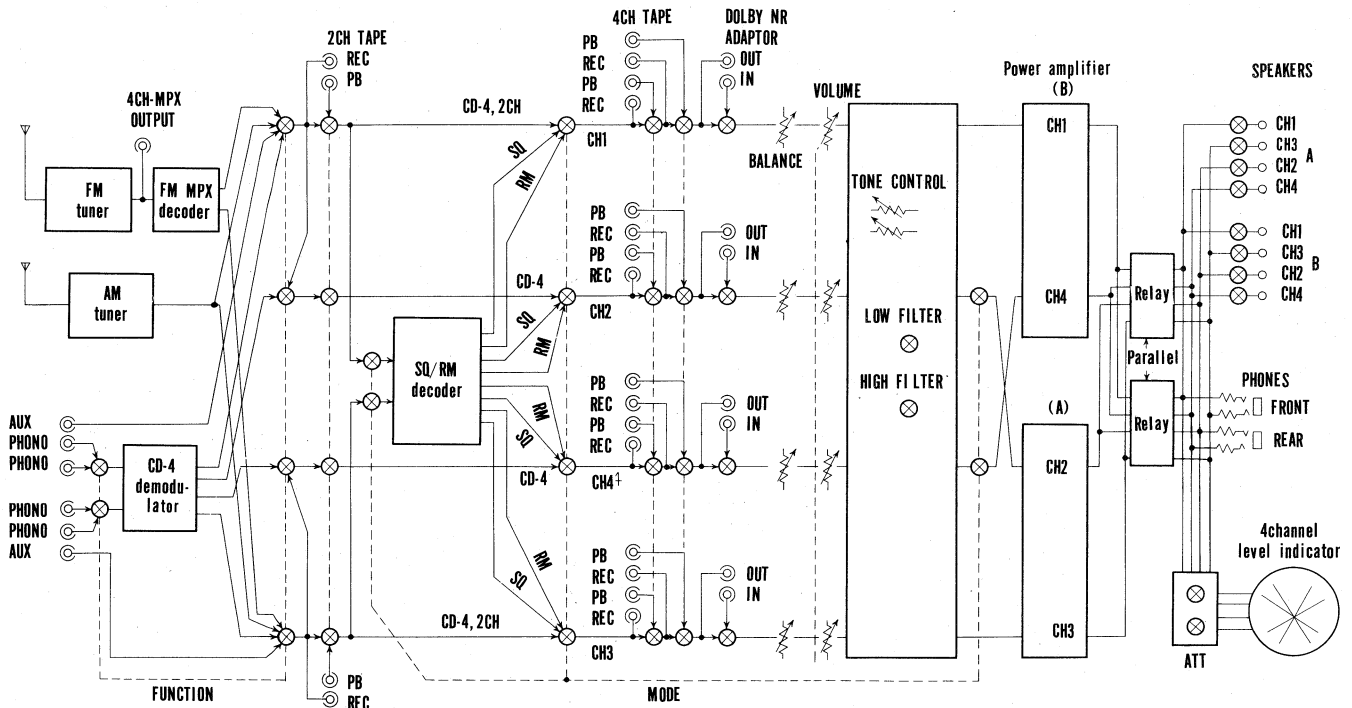
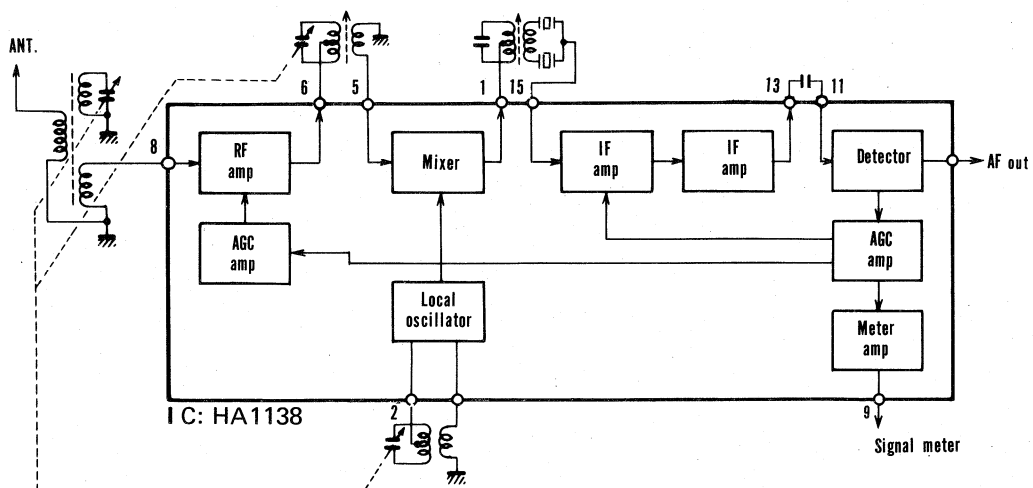
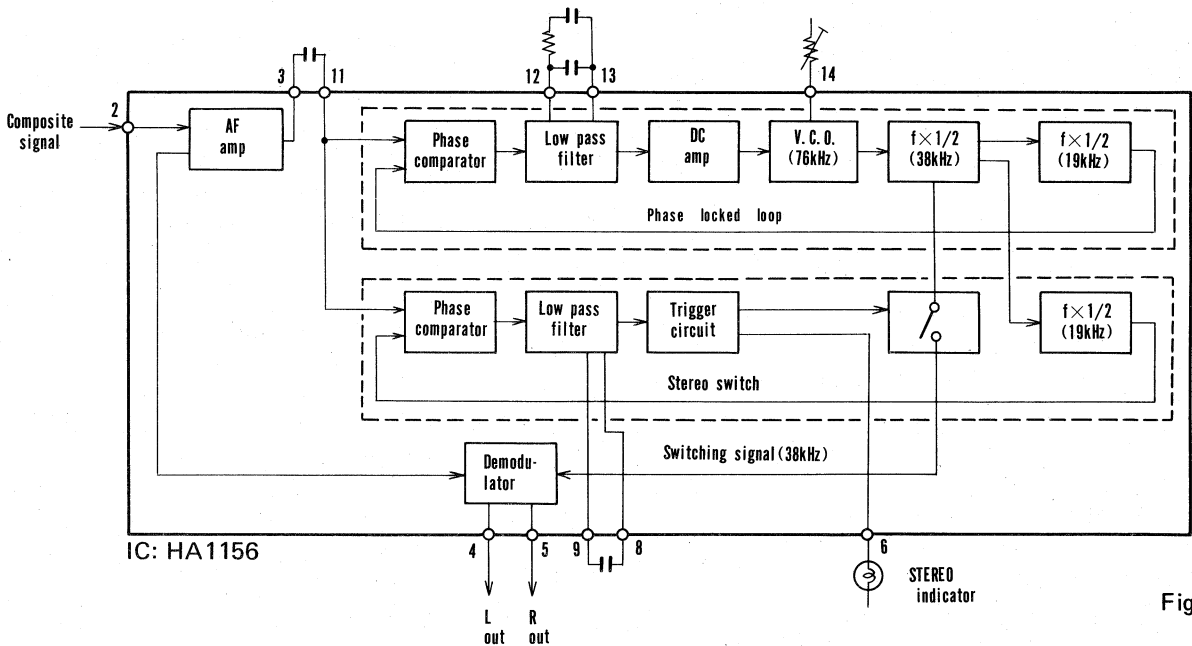
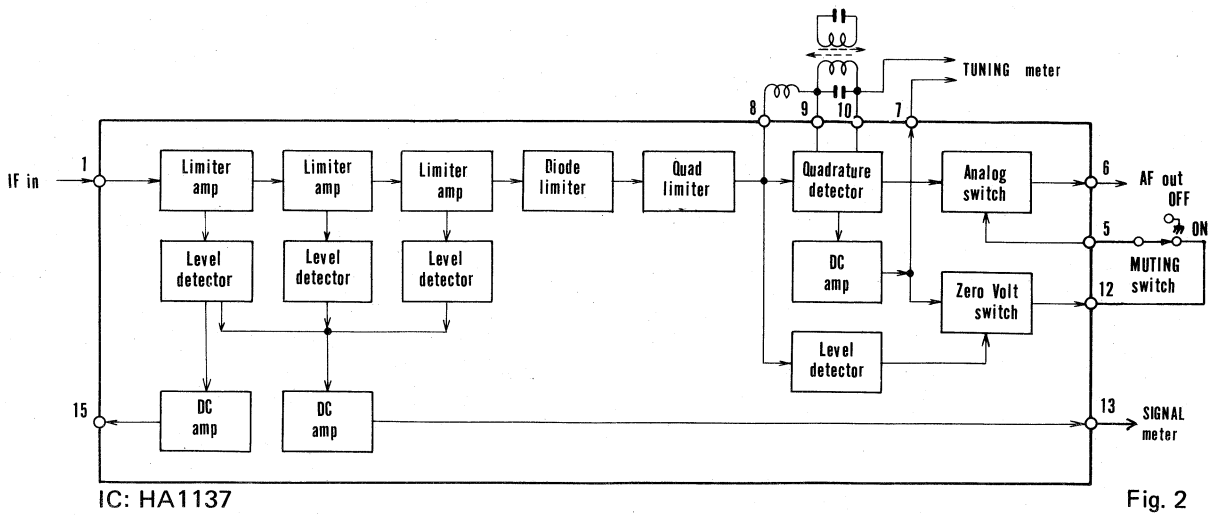

Fig. 1



6.3 CD-4 DEMODULATOR SECTION

Fig. 5 illustrates the composition of this section.

Sum Signal System

IC HA1452 is an orthodox 2-channel equalizer amplifier. In CD-4 operation, a variable resistor is inserted in the NFB circuit to provide separation control by varying the main signal (sum signal) gain. Although the final objective of the CD-4 demodulator is to matrix the sum and difference

signals, as the difference signal is demodulated from a frequency modulated 30kHz carrier (sub signal), and the sum signal varies according to the cartridge output level (though indirectly related), level matching becomes necessary.

In other than the CD-4 mode, a fixed resistor replaces of the variable resistor to provide a fixed gain (35.6dB at 1kHz) equalizer amplifier. The inclusion of a balanced power supply with this circuit maintains input and output point potentials at 0V, preventing click noises when switches are operated. The 100kΩ impedance of this circuit is changed to 50kΩ by inserting two 100kΩ resistors in parallel during other than CD-4 operation.

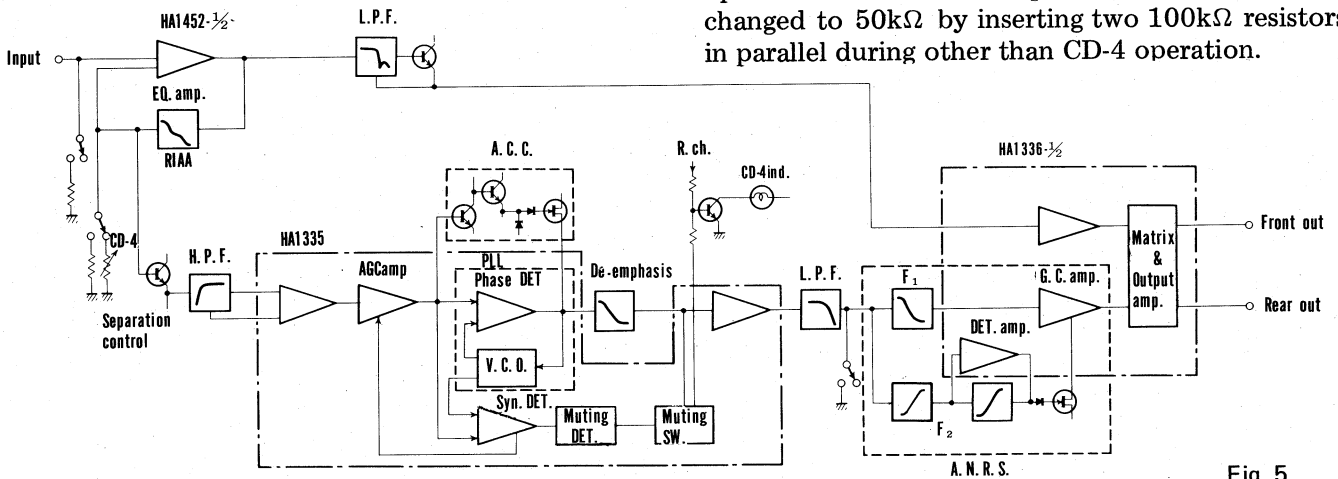

Fig. 5

RECORDING AND PLAYBACK OF CD-4 DISCS

The CD-4 disc is a recent development. Being a "Discrete" 4-channel medium, it features excellent channel separation when played over suitable 4-channel equipment, but can also be played as a conventional 2-channel stereo record.

Fig. 6 shows the configuration of signals present in a CD-4 record.

Each of the two sub-signals occupies a frequency modulated supersonic carrier with a center frequency of 30kHz.

The sub-signal conveys the "Front-Rear" difference information.

The main signals are recorded as a conventional

stereo record, occupying the 30Hz ~ 15kHz audio band and conveying the "Front+Rear" sum information.

From these sum and difference signals, the original 4 channel signals are retrieved in a series of algebraic operations performed in the demodulator:

$$\begin{aligned} (L_f + L_r) + (L_f - L_r) &= 2L_f \\ (L_f + L_r) - (L_f - L_r) &= 2L_r \\ (R_f + R_r) + (R_f - R_r) &= 2R_f \\ (R_f + R_r) - (R_f - R_r) &= 2R_r \end{aligned}$$

where "R" stands for Right, "L" for Left, "f" for front, "r" for rear.

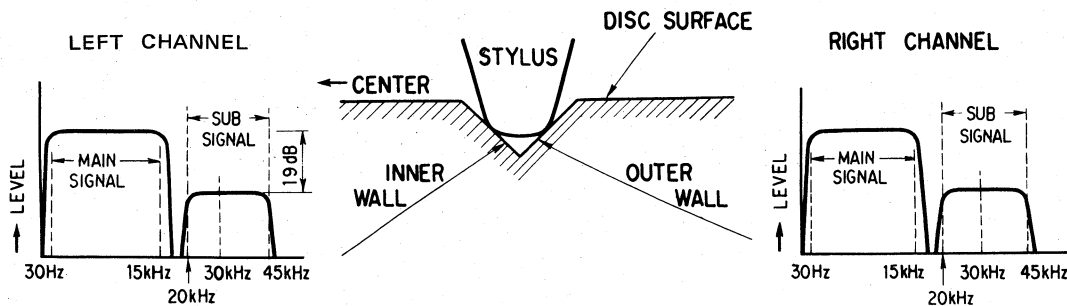

Fig. 6

The equalizer amplifier output goes through a low pass filter (LPF) to remove the sub signal (30kHz FM signal). This LPF is an active filter whose frequency response is shown in Fig. 7.

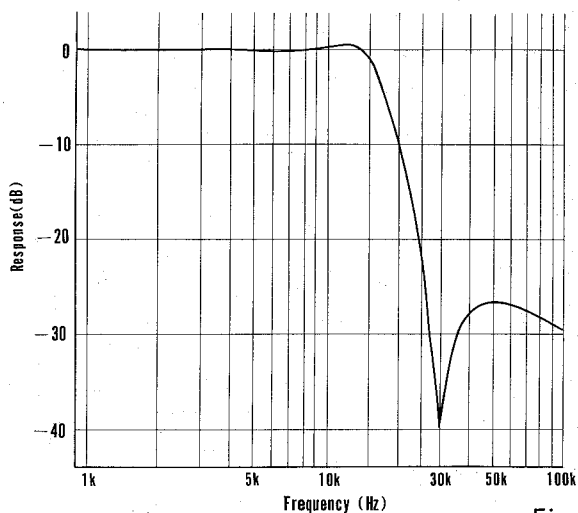

Fig. 7

Difference Signal System

The sub signal is taken from the equalizer amplifier NFB circuit. As it does not pass through the RIAA playback standard equalizer, it possesses a flat frequency response. After passing through a high pass filter ($f_c = 27\text{kHz}$, 12dB/oct.), the sub signal enters IC HA1335.

This IC contains a phase locked loop (PLL) FM demodulator circuit, an automatic gain control (AGC) circuit to stabilize the PLL input signal, a muting circuit to cut the demodulated output in the absence of an input signal, and a demodulated signal amplifier. In addition to the IC, a de-emphasis circuit, automatic capture range control (ACC) circuit, LPF, HPF, indicator lamp drive, and other circuits are used to demodulate the difference signal from the sub signal.

***AGC Amplifier**

Fig. 8 shows the AGC amplifier principle. In this circuit, e_1 is the input signal voltage, e_2 the output signal voltage, V_r the reference voltage, and V_b the control voltage.

If V_b is much greater than V_r , I_3 becomes approximately equal to I_2 and $e_2 \cong 0$. Conversely, if V_b is much less than V_r , I_3 becomes approximately equal to I_1 and e_2 reaches a maximum (determined by the maximum gain of the AGC amplifier). The amplifier gain can therefore be controlled by V_b in this manner, V_b being obtained from a synchronous detector.

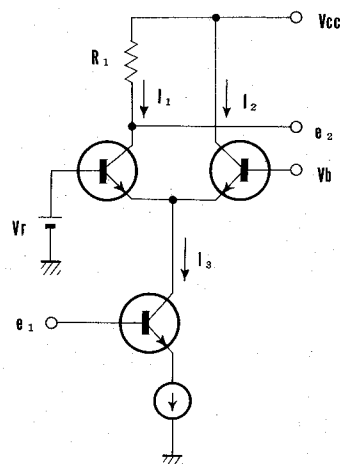

Fig. 8

***FM Demodulator**

The block diagram of the PLL FM demodulator circuit is depicted in Fig. 9. This circuit consists of a voltage control oscillator (VCO), phase comparator (PC), DC amplifier (A) and low pass filter (LPF), with a type of NFB loop following the input signal. The VCO oscillates at a controlled frequency according to the LPF output voltage. A voltage proportional to the phase difference between the input signal and VCO oscillation output is generated in the PC. By using this voltage to control the VCO oscillation, the oscillation becomes locked to the input signal phase.

If the input signal is frequency modulated, the control signal obtained from the LPF becomes the FM demodulated output. With an excessively large frequency deviation of the input signal, which the PLL circuit cannot follow, the lock becomes disengaged. The frequency range in which locking can be performed is termed the lock range.

Locking also becomes impossible when the VCO free running frequency (oscillating frequency without an input signal) and input signal frequency are excessively separated. The frequency range in which locking can be performed is termed the capture range. The locking and capture ranges are determined by the PLL loop gain and LPF constant.

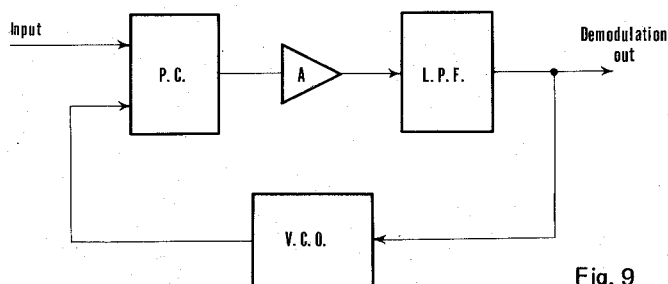

Fig. 9

*Synchronous Detector

The PLL produces a signal in phase with the input signal. By employing this to switch the input signal, full-wave rectification and a DC voltage proportional to the input signal oscillation are obtained. The same in-phase frequencies are required at this time. The frequencies become the same if the PLL is locked, they then become in-phase by shifting the VCO output phase by 90° .

A DC voltage rise proportional to the input level is obtained as AGC from this circuit, together with muting in the form of a DC voltage drop inversely proportional to the input level.

*Muting Circuit

The muting circuit is shown in Fig. 10. Q1 and Q2 form a Schmidt trigger. Q5 is inserted between the difference signal demodulator circuit signal line and ground. The collector of Q4 is connected to the CD-4 indicator circuit and its potential employed to determine whether or not the CD-4 demodulator circuit operates. The synchronous detector provides the input to this circuit.

DC voltage is supplied to the muting circuit from the synchronous detector when the sub signal is absent. Q1 then switches ON, Q2 OFF, and Q3, Q4 & Q5 ON. The difference signal demodulator circuit line is thus shorted to ground and Q4 collector potential reduced.

When a CD-4 record is played and the sub signal is applied to the synchronous detector, the input DC voltage of the muting circuit declines in inverse proportion to the sub signal level. If the sub signal is above a certain level, the Q1 & Q2 Schmidt trigger circuit reverses: Q1 switches OFF, Q2 ON, and Q3, Q4 and Q5 OFF. This removes the short to ground of the difference signal demodulator circuit output line and Q4 collector voltage increases.

*CD-4 Indicator Circuit

Q6 in Fig. 10 is the lamp drive transistor. With a high Q4 collector voltage (during CD-4 play), Q6 is switched ON and the CD-4 indicator lamp lights. This lighting operation is synchronized to the previously described muting circuit operation (in practice, it is slightly delayed). The lamp lights if either the right or left channel gate is open, and extinguishes when both gates are closed.

*ACC (Automatic Capture Range Control)

The PLL does not lock to frequencies out of the capture range and cannot follow frequency variations exceeding the lock range. Automatic control of the PLL capture range is provided by the ACC. It also functions to suppress noise and prevent misoperation with sources other than CD-4.

Peak values associated with amplitude variations in the PLL input sub signal, transients with which AGC is ineffective, noise, main signal interference with the sub signal (sub signal modulated by the main signal) and other causes are converted into a DC voltage. By using this voltage to regulate the equivalent internal resistance of the FET in the PLL load circuit, the PLL capture range (lock range) can be automatically controlled.

There is no PLL detector output with respect to sub signal AM components. However, if the sub signal is AM modulated by noise or the main signal, this can also be considered as phase modulation. This effect is minimized since amplification of the sub signal AM component narrows the PLL lock range (playback bandwidth becomes narrow).

AGC amplifier gain is maximum with no input signal. If some sort of input becomes available at this time, a large output can be temporarily obtained (until the AGC takes effect). For this reason,

the PLL capture range is narrowed by the ACC and remains completely unlocked with an input other than the sub signal. The PLL locks with a sub signal input and when the AGC takes effect, the PLL lock range becomes widened by the ACC.

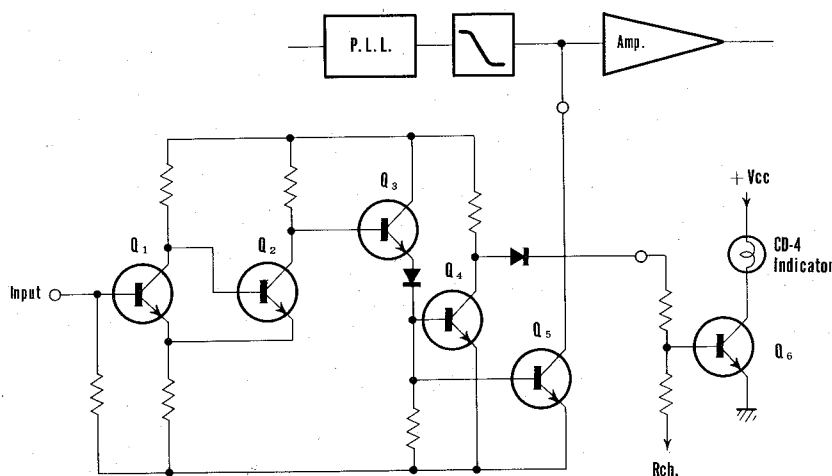

Fig. 10

***ANRS (Automatic Noise Reduction System)**

The ANRS is employed in the difference signal system for CD-4 records in order to improve SN ratio and reduce crosstalk distortion from the cartridge. It is not used in the sum signal system in order to preserve compatibility with 2-channel stereo records.

The ANRS consists of a mutually reciprocal compressor and expander compose the ANRS (Fig. 11). In CD-4 application, compression and expansion are performed in the area of 700Hz and above 2kHz. Fig. 12 shows the ANRS composition used in this set.

Although expansion is normally performed separately for middle and high frequencies, it is not divided in this set (in practice, this poses no difficulty). Filter F1 possesses ANRS expansion properties when compensation is maximum. F2 is a middle and high frequency bandpass filter (bands at which ANRS is employed). The output of this section is amplified and rectified, then used to control the equivalent internal resistance of the FET.

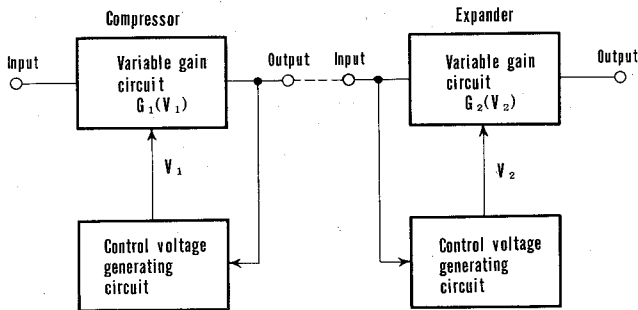

Fig. 11

This FET regulates the NFB in the gain control amplifier (GCA). Its equivalent internal resistance declines with a middle and high frequency input to the circuit, decreasing NFB to the GCA and increasing GCA gain. As these frequencies increase further, the resistance continues to decline and eventually saturates. At this point, the F1 frequency response is cancelled by GCA frequency response, resulting in a flat response in the ANRS expander circuit. In this manner, the GCA compensates F1 frequency response according to the input level.

Consequently, the ANRS frequency response becomes flat above a certain level and when middle and high frequency levels decline, it approaches the frequency response of F1. Below a certain level, the response of F1 is attained. Applying ANRS reduces noise level by an average of 8dB. Also, if 15dB separation is available in the cartridge, crosstalk distortion becomes negligible.

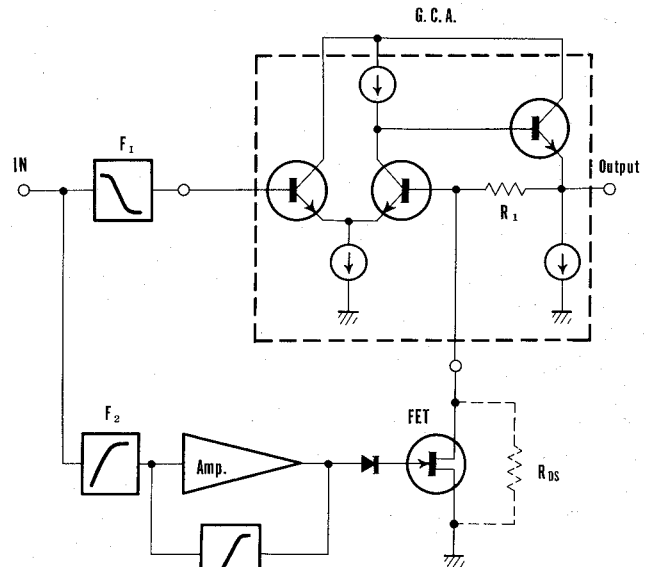

Fig. 12

***Matrix Section**

Matrixing (adding or subtracting) the front and rear sum signals of the main signal system, and the front and rear difference signals of the sub signal system, the front and rear signals are derived.

$$\begin{aligned}
 M &= F + R \\
 S &= F - R \\
 M + S &= (F + R) + (F - R) = 2F \\
 M - S &= (F + R) - (F - R) = 2R
 \end{aligned}$$

6.4 SQ FULL LOGIC/RM DECODER SECTION

SQ System

The Matrix four channel system utilizes 2-channel media (tape, records, broadcasts, etc.) to transmit 4 or more channel signals. Four channel playback systems employ matrixing 4-2-4 (n-2-4) to convert 2-channel into 4-channel. The main systems currently available for this purpose are RM (Regular Matrix) and SQ (Stereo Quad).

With the RM system, if the only sound source is LF (left front), -3dB crosstalk occurs in the RF (right front) and LB (left back). In the SQ system however, -3dB occurs in LB and RB (right back). RM and SQ are therefore not compatible.

Fig. 13 shows the basic SQ decoder construction and signal vectors. LT and RT are combined in LB and RB, while LF' and RF' are taken directly from LT and RT. LB' and RB' are obtained from LT and RT by phase shifting and blending. But LB' and RB' contain respective LF, RF other than necessary components. Left and right separation remains good since LF' does not combine with RF, and RF' does not combine with LF.

If the sound source is CF (center front) or CB (center back), front to rear separation cannot be obtained since LF', RF', LB' and RB' all become the same volume. The logic circuit is provided for improve this effect.

With CF crosstalk to LB and RB is at out of and since with CB crosstalk to LF and RF is also at out of, only these anti-phase components are cancelled. This is termed front-back logic. The objective of full logic is to deal not only with CF and CB sound sources, but also with various other directions.

Front-back logic performs CF and CB detection, while wave matching logic performs LF, RF, LB and RB detection. The combined detector signal passes through a time constant circuit and is applied to the gain control circuit, where gain is controlled in order to adequately reduce the crosstalk level.

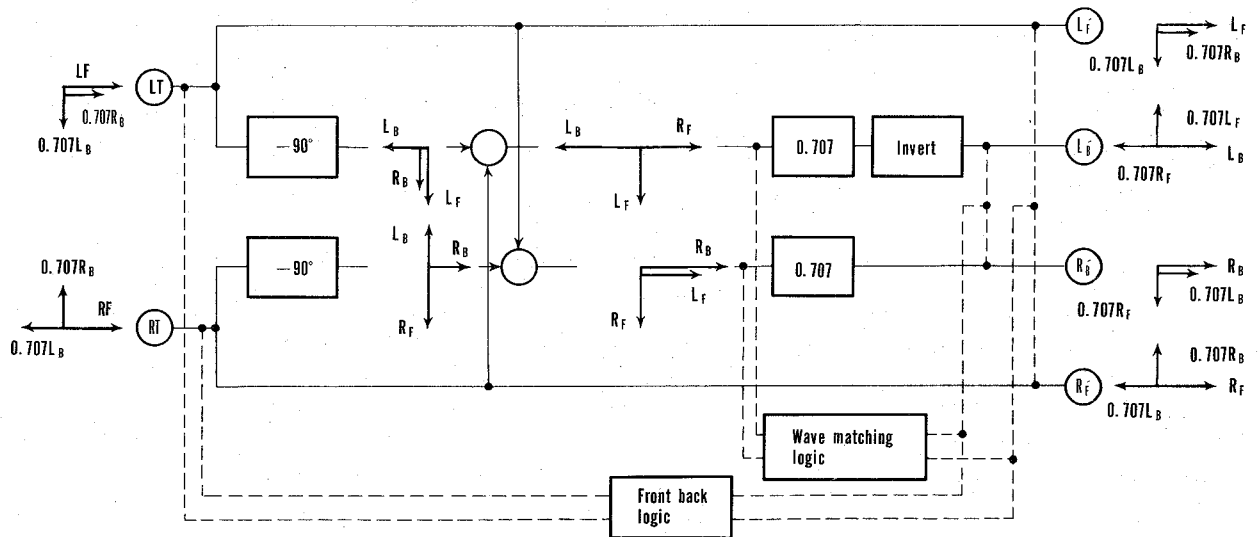

Fig. 13

Circuit Composition

Three ICs are employed, as shown in Fig. 15. M51651P is an SQ basic decoder and can function as an SQ decoder without independent logic. Although a phase shift network is not included, by a CR network, this IC perform to shift the phase 90° with cover wide range. A selector switch also permits the IC to be used as an RM decoder. During RM, a blend resistor is added at the front, while the rear is blended internally by the IC and taken from separate terminals.

CX-049 is a high density full logic IC incorporating both wave matching and front back logic. CX-718D is a gain control IC and contains four MOS FETs to form a variable resistance voltage control circuit. Since these MOS FETs are P channel enhancement types, equivalent internal resistance becomes infinite when gate voltage is zero. By applying a negative voltage to the gate (Fig. 14), the equivalent internal resistance can be varied from infinity to several hundred ohms.

2SK40V (FET) is employed for back blending. With a CF sound source, it functions to cancel the mutually opposite crosstalk phase to LB and RB. This is an N channel depletion type junction FET and when the gate voltage is zero, the channel is already established. LB and RB become normally blended for this reason, and the gate becomes open only in the case of a single signal from LB or RB.

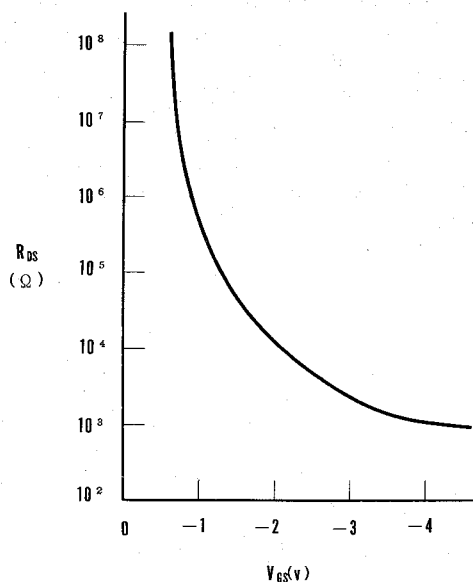

Fig. 14

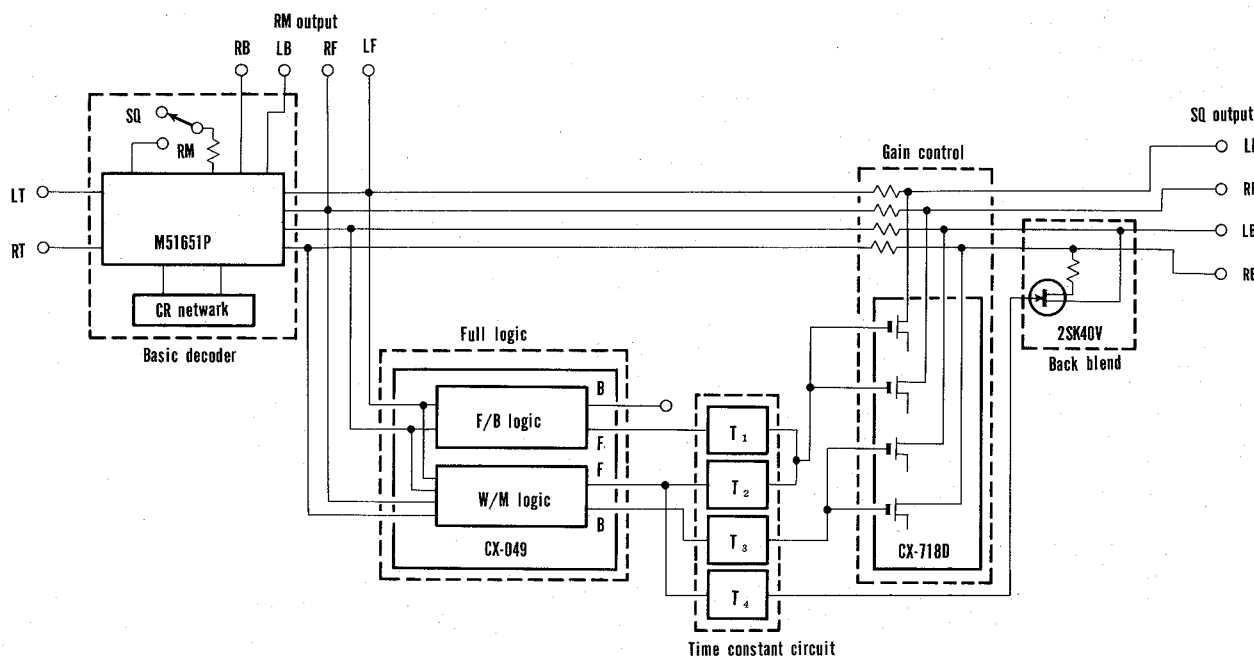

Fig. 15

Operating Description

The input signal (LT & RT) enters the SQ basic decoder (M51651P), where 4-channel signals LF, RF, LB and RB are obtained by the SQ decode matrix, then these signals enter the gain control, back blend and logic circuits. The front-back logic produces a positive voltage with a CF sound source, and a negative one with a CB source. This voltage passes through the time constant circuit and is applied to the gates of the MOS FETs for LF and RF gain control.

As these FETs are P channel enhancement types, their equivalent internal resistance decreases only when a negative voltage is applied. Front (LF & RF) output signal levels are attenuated with a CB sound source.

For rear control, wave matching logic produces a negative voltage with respect to a front single signal (LF or RF) and a positive voltage with respect to a rear single signal (LB or RB). Front control is also performed by producing the reverse polarity of these voltages.

The rear control voltage passes through the time constant circuit and is applied to the gates of MOS FETs for LB and RB gain control. The front control voltage passes through the time constant circuit and is applied to the gates of the junction FET for back blend and the MOS FETs for LF and LB gain control. As the junction FET is an N channel depletion type, LB and RB are normally blended, but the device becomes open when a negative voltage is applied.

The detector outputs of the full logic IC (CX-049) with respect to sound source are as shown in the following table.

| | | LF | RF | LB | RB | CF | CB | Gain control* |
|-----------|---|----|----|----|----|----|----|---------------|
| F/B logic | F | 0 | 0 | 0 | 0 | + | - | LF, RF |
| | B | 0 | 0 | 0 | 0 | - | + | ** |
| W/M logic | F | + | + | - | - | 0 | 0 | LF, RF*** |
| | B | - | - | + | + | 0 | 0 | LB, RB |

*Gain control operates (attenuates) with (-) detecting mode.

**Front back logic output B is not employed.

***Back blend is not performed only when wave matching logic output F mode is (-).

CAUTION

The gain control IC (CX-718D) is an MOS (metal oxide semiconductor) type and subject to dielectric breakdown from static electricity. Note the following precaution when handling.

*Do not remove the aluminum cap from the IC until it has been installed in the circuit. First solder the IC to the circuit board, then remove the aluminum cap.

6.5 CONTROL AMPLIFIER CIRCUIT

The control amplifier circuit of the QX-949A is the NFB type, using a FET (field effect transistor) in the first stage.

The FET amplifier being a controllable voltage type, which holds the input impedance constant, even if the level of the NFB changes, and has additional advantage as a coupled circuit, as the input impedance can be raised.

Low Frequency Control

The low frequency control circuit is shown in Fig. 16, and the equivalent circuit, when boosting low frequency, is shown in Fig. 17.

As the parallel impedance of VR1 and C29, in Fig. 17, is high at low frequency, the volume of the NFB decreases and the gain in the low frequency range increases.

The equivalent circuit, when cutting out low frequencies, is shown in Fig. 18. In this case, the input signal is applied to Q9, through the parallel impedance of VR1 and C33, which is high in the low frequency range and suppresses the lower frequency signals.

High Frequency Control

The high frequency control circuit is shown in Fig. 19, and the equivalent circuit, when boosting high frequencies, is shown in Fig. 20.

In this circuit, the input signal is applied to Q9 through the parallel impedance circuit. This impedance is small in the high frequency range and produces a signal with an enhanced high range. Fig. 21 shows the equivalent circuit when cutting out high frequencies. As the impedance of R53, R41 and C41 of the circuit becomes small, the level of the NFB increases and the gain of the circuit decreases.

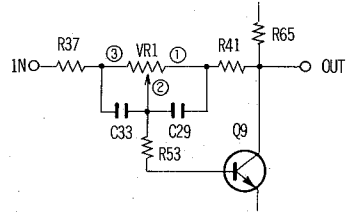

Fig. 16

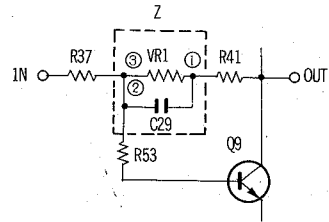

Fig. 17

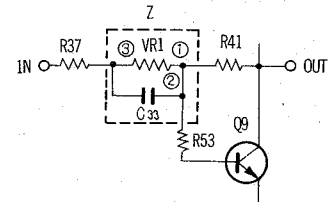

Fig. 18

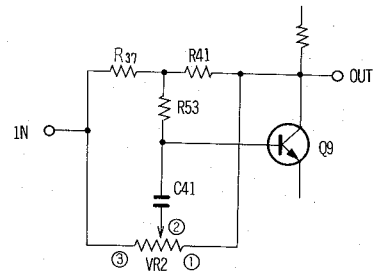

Fig. 19

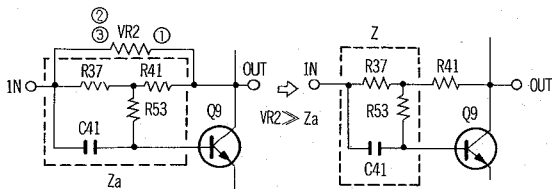

Fig. 20

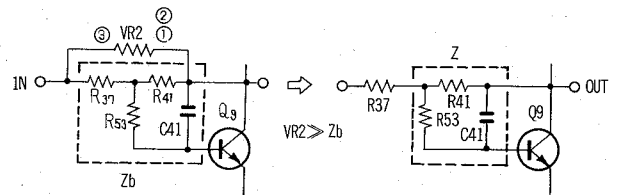

Fig. 21

6.6 POWER AMPLIFIER SECTION

This unit possesses four power amplifiers. The circuitry employs a balanced power supply and consists of direct-coupled Darlington connection pure complementary OCL amplifiers. By applying 100% DC NFB from the output stage center point to the first stage differential amplifier, circuit DC gain becomes 0dB. Since the center point potential is determined by the first stage base potential, temperature compensating and fine adjustment circuits are included in the first stage base bias circuit to maintain the center point potential at 0V.

2-channel Power Boosting Circuit

The power supply can be boosted when using this unit as a 2-channel stereo amplifier (using only ch1 and ch3, and with the MODE switch set to 2CH). Power transistors of channels 1 and 3 are of higher rating than those of channels 2 and 4. Their supply voltage can be raised during 2-channel operation to provide increased power to each channel.

Power boosting is available by turning over the rear panel plug. This raises the power transformer secondary winding taps and opens CH2 and CH4 power amplifier output circuits.

For safety reasons, a microswitch in the power transformer primary side cuts off the power supply when the selector plug cover is opened.

6.7 PROTECTION CIRCUIT

This protection circuit functions to protect the speakers from damage due to short-circuit of the load, etc., and performs a muting operation to cut noise and distortion which occur when switching the power on and off.

The circuit is shown in Fig. 22, and consists of a bridge type over-current and overload detector, a differential amplifier DC voltage detector, and a power switch on/off detector section.

Relay Driving Circuit

Q7 – Q9, in Fig. 22, comprise the relay driving circuit.

In the normal condition reverse bias is applied to the base of Q7, and Q7 is in a cutout condition. When one of the above mentioned detection circuits goes on, current flows through R28, the base potential falls and Q7 is turned on. Consequently Q8 comes on and Q9 goes off. When Q9 goes off, the current of the relay circuit is cut, to release the switch of the output circuit.

When the power switch is turned on, a delay operation occurs in this circuit. R33, R34 and C7, in the base circuit of Q9, are the time constant elements which determine the delay time. When the power switch is switched on, C7 charges to a potential of +30 volts through R33 and R34, and Q9 is kept in the OFF condition during this time. When the power source is switched off the muting operation of Q8 prevents shock noise. In the normal condition, the potentials of +30 volts and -5.1 volts are applied to Q8 through R31 and R32. The resultant potential at the base of Q8 is -1 volt in the cutout condition. When the power supply is turned off, the potential of -5.1 volts disappears immediately, due to the small time constant of the power circuit. Thus a positive base potential remains, switching Q8 on, which in turn switches off Q9 and hence the relay.

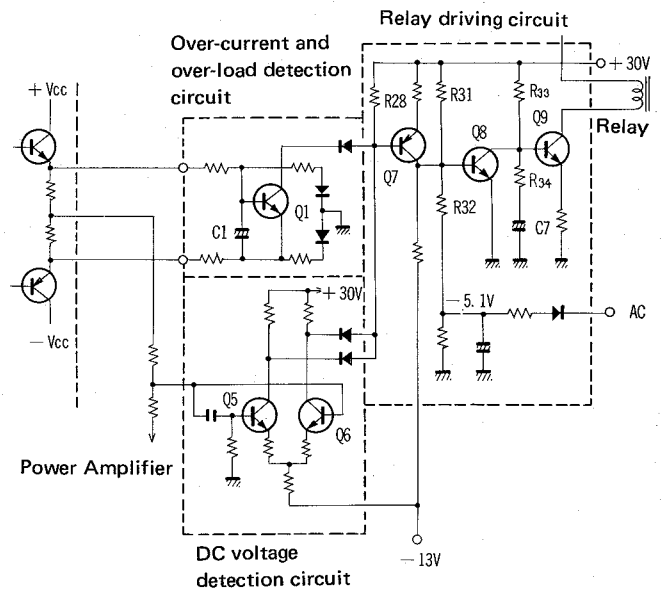

Fig. 22

Over-current and Overload Detection

The equivalent circuit of this detector section is shown in Fig. 23, and Fig. 24 shows the equivalent circuit at the time of a positive half cycle. When this equivalent circuit is overloaded, the balance of the bridge, formed by RE1, R1, R9 and RL, is disturbed, and a potential is produced between b and a in such a direction that Q1 is turned on. When Q1 is turned on, the collector current increases, the relay driving circuit functions and the relay switch of the output circuit is turned off. After the cause of the overload is removed, the bias of Q1 is reduced and the relay switch turns on to automatically restore normal operation, Fig. 25 shows the equivalent circuit at the time of a negative half cycle. In this circuit a potential is produced between b and e as above, and Q1 is turned on.

Detection of DC Voltage

This is a differential amplifier consisting of Q5 and Q6, as shown in Fig. 26. The bases of Q5 and Q6 are connected to the junction-points of the power amplifiers. When the DC balance of the power stage is lost for some reason, a potential difference is produced in the input signal to the differential amplifier, and the collector currents of Q5 and Q6 are put out of balance. Thus, the relay driving circuit functions, and the relay switch is turned off.

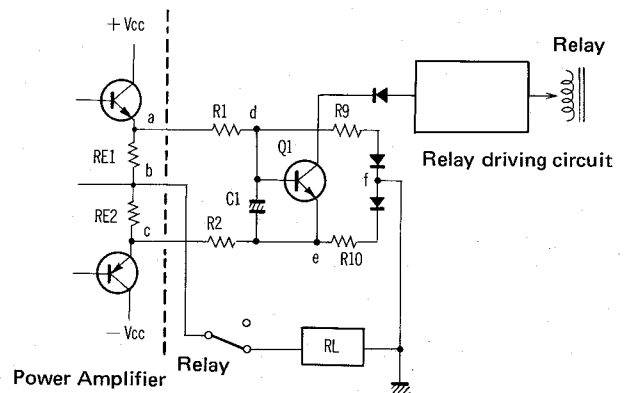

Fig. 23

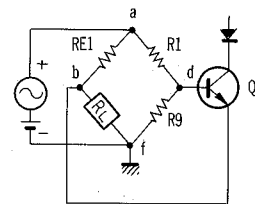

Fig. 24

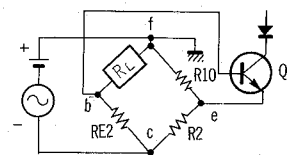

Fig. 25

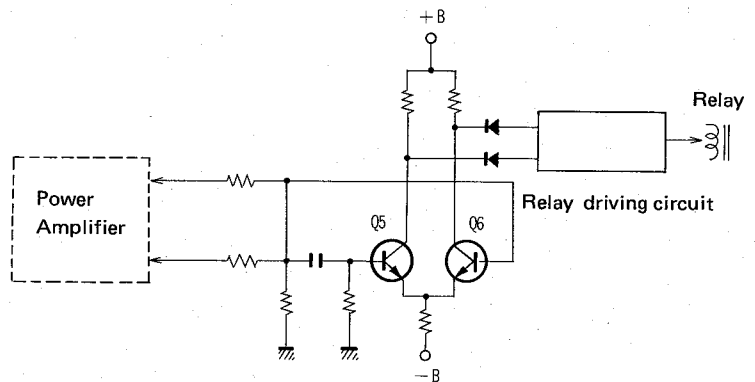
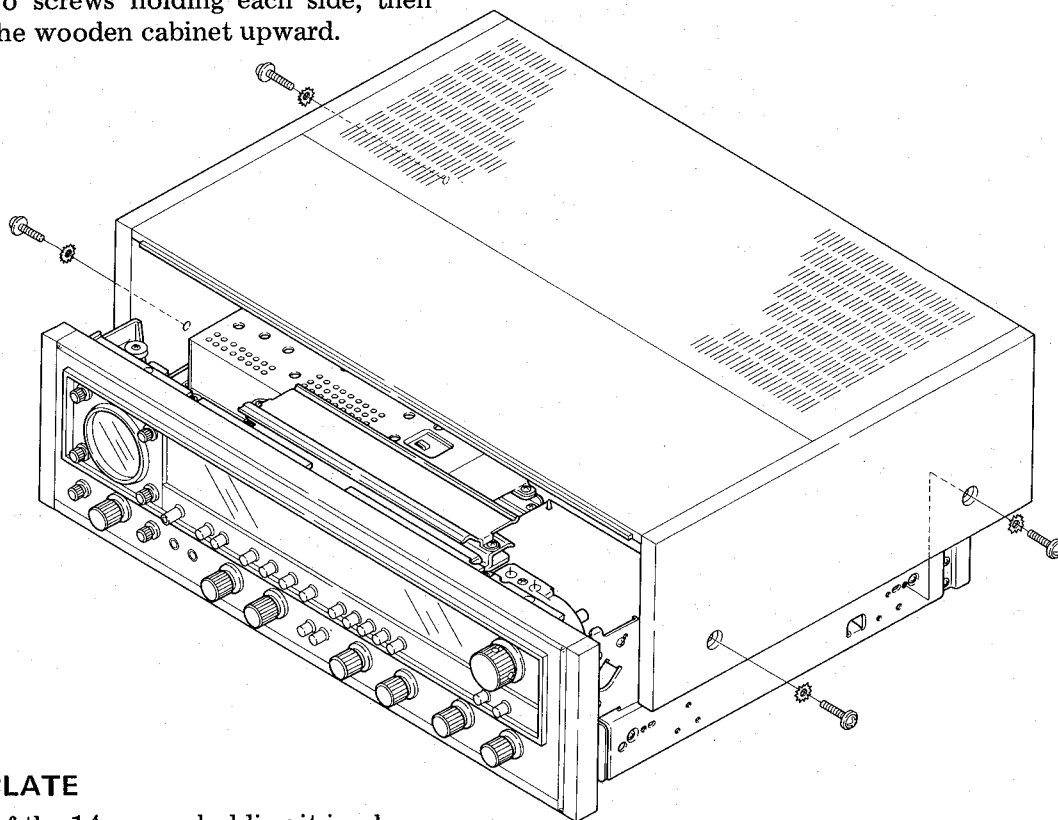

Fig. 26

7. DISASSEMBLY

7.1 WOODEN CABINET

Unscrew the two screws holding each side, then lift the back of the wooden cabinet upward.



7.2 BOTTOM PLATE

Unscrew a total of the 14 screws holding it in place.

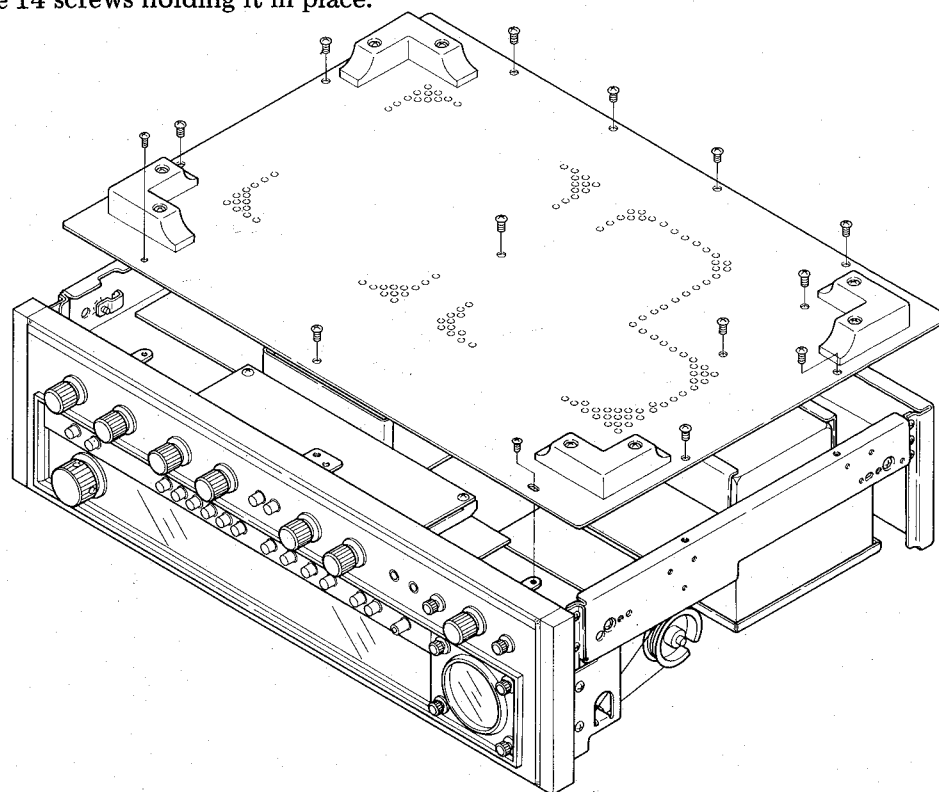

7.3 FRONT PANEL

Pull off knobs. For TUNING knob, loosen the setscrews with a hexagonal wrench before removing it. Unscrew the two screws in the upper edge of the front panel, and the three nuts from the shafts. Then pull the panel gently forward.

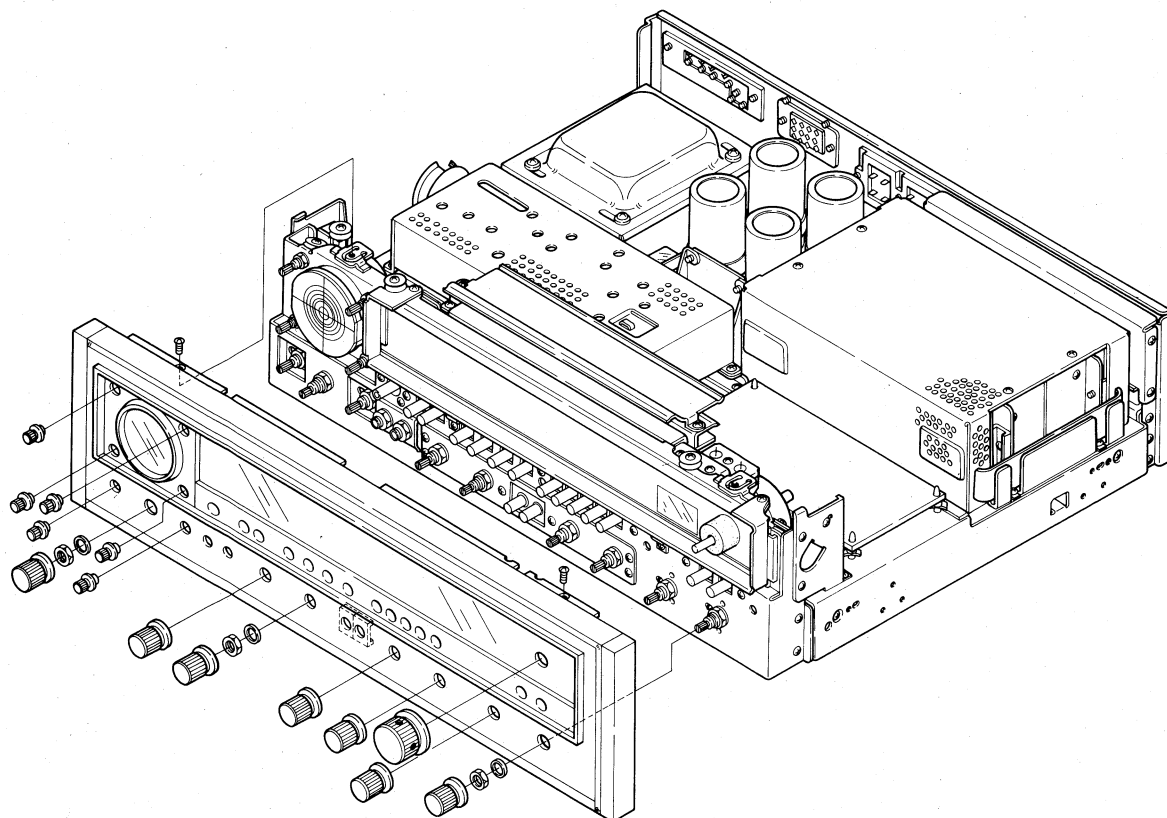

8. ADJUSTMENTS

*Do not attempt to adjust the CD-4 assembly or RM/SQ assembly. These adjustments require special test equipment, including a CD-4 signal generator, SQ encoder and other apparatus.

Required Measuring Instruments

- FM signal generator
- MPX signal generator
- AM signal generator
- Millivolt meter
- Distortion meter

8.1 AM SECTION

1. Set AM signal generator at 400Hz 30% modulation. Connect to AM antenna terminal via 1k-ohm resistor.
2. Connect oscilloscope and voltmeter in parallel to unit's TAPE REC terminals.
3. Tune signal generator and unit to 600kHz. Set signal generator output level at approx. 30dB.
4. Adjust T8 and T7 on tuner assembly and core of ferrite bar antenna for maximum output level reading.
5. Now tune unit and signal generator to 1,400kHz.
6. Adjust TC5, TC6 and TC7 on tuner assembly for maximum output level reading.
7. Repeat steps 3 thru 6 several times to obtain maximum readings at both frequencies.

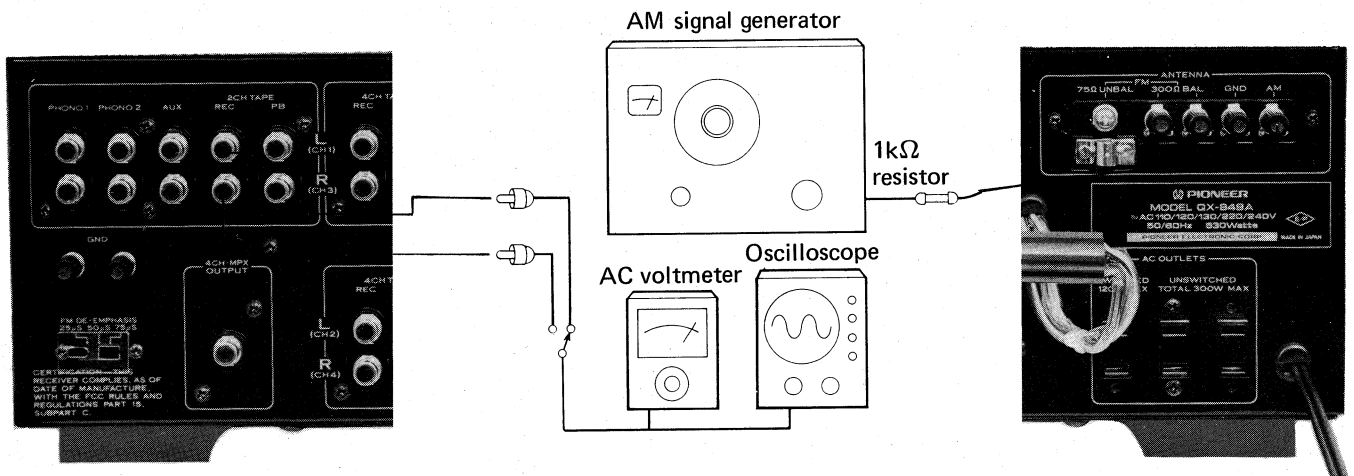
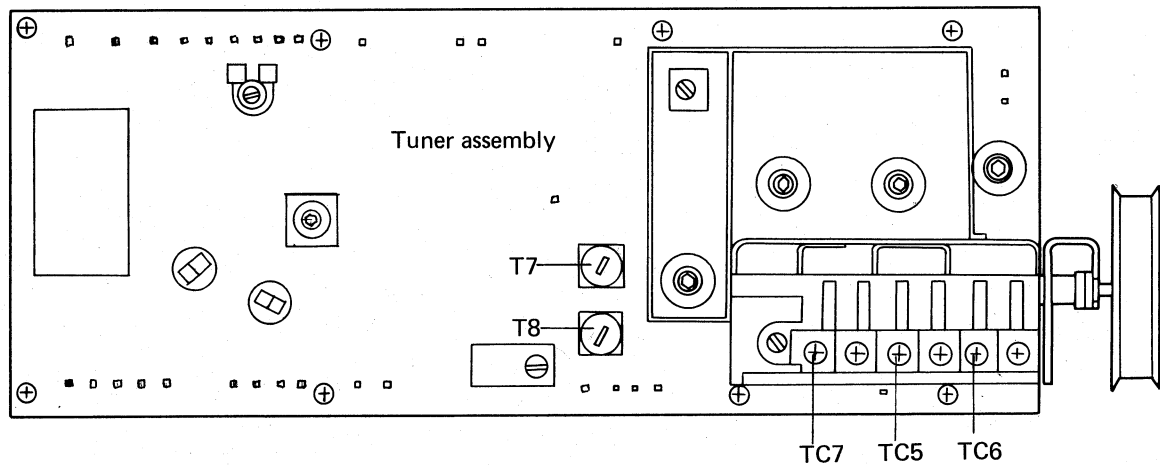

8.2 FM SECTION

1. Set the FM signal generator for 400Hz modulation at 100%.
Connect generator output to the FM antenna terminals through a 300Ω balanced dummy antenna.
2. Connect the oscilloscope, voltmeter, and distortion meter in parallel across TAPE REC jack.
3. Set the signal generator output level to 8~10dB.
Set the signal generator and set dials to 90MHz.
4. Adjust cores of T4 (tuner assembly) and T1, T2, and T3 to obtain peak output.
5. Set signal generator and set dials to 106MHz.
6. Adjust TC4 (tuner assembly) and TC1, TC2, and TC3 to obtain peak output.

7. Repeat steps (3) through (6) several times, to obtain optimum tracking.
8. Set the frequency to 90MHz and adjust the T5 core of the tuner assembly to obtain peak output.
9. Detune the set so that noise only is received. Adjust the primary (bottom) core of T6 so that the tuning meter pointer indicates the center position.
10. Set signal generator and set dials to 98MHz. Set signal generator output level to 60dB. Carefully tune the set to this frequency as indicated by the tuning meter.
11. Adjust the secondary (top) core of T6 (tuner assembly) for minimum distortion.

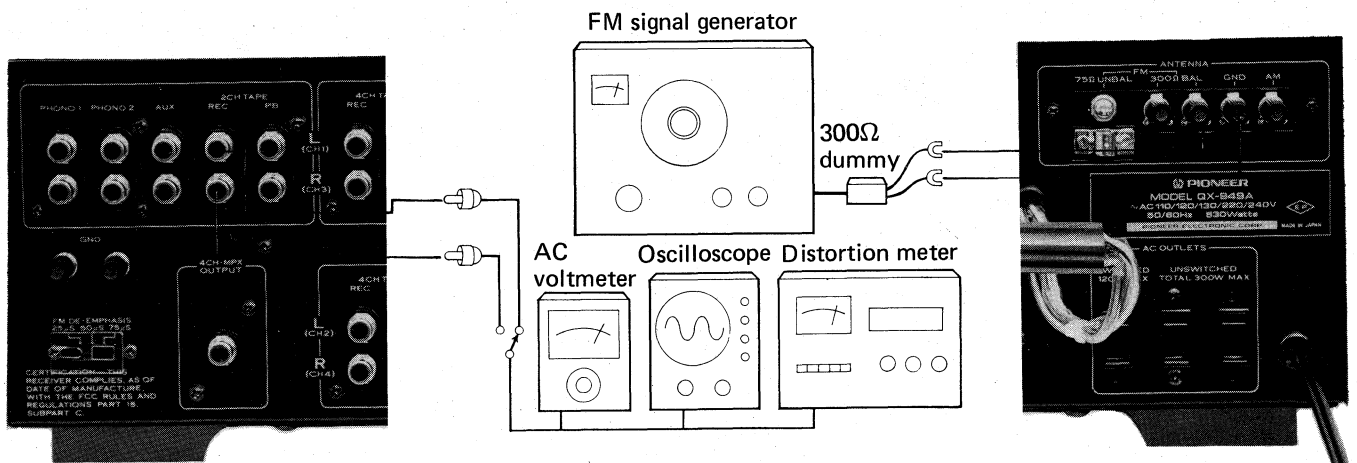
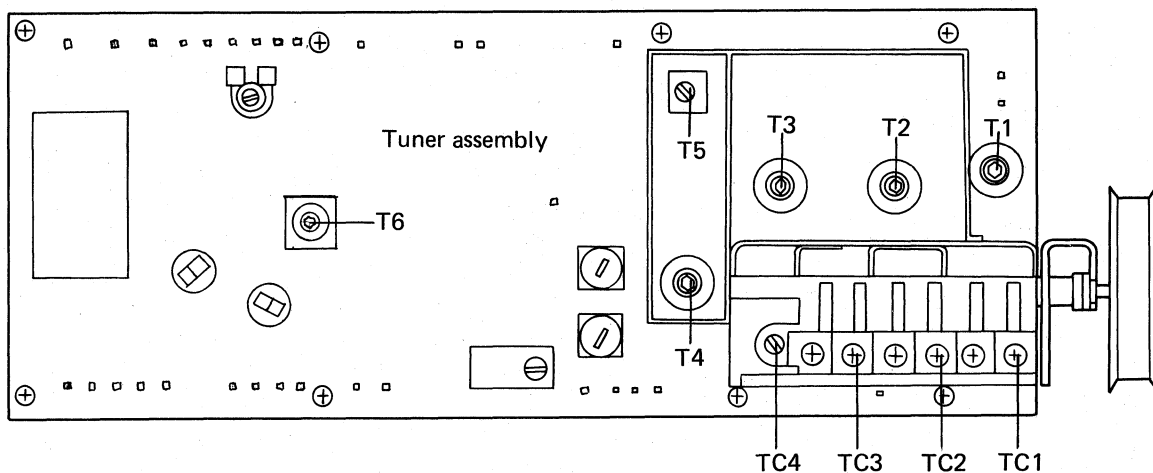

8.3 FM MPX SECTION

1. Set FM signal generator at external modulation. Connect to unit's FM antenna terminals via 300-ohm balanced dummy antenna. Set FM SG output to 60dB.
2. Adjust MPX signal generator to obtain main signal modulation of 1kHz, 67.5kHz frequency deviation. Connect to FM SG's external modulator terminals.

3. Connect the oscilloscope horizontal inputs to MPX SG's PILOT OUT terminals and Vertical inputs to No. 18 terminal of tuner assembly.
4. Tune unit and FM SG to 98MHz.
5. Produce a Lissajous pattern on oscilloscope and adjust VR1 to make the pattern still.
6. Then set signal generator for modulation of L (later R) and pilot. Adjust VR2 to obtain maximum channel separation.

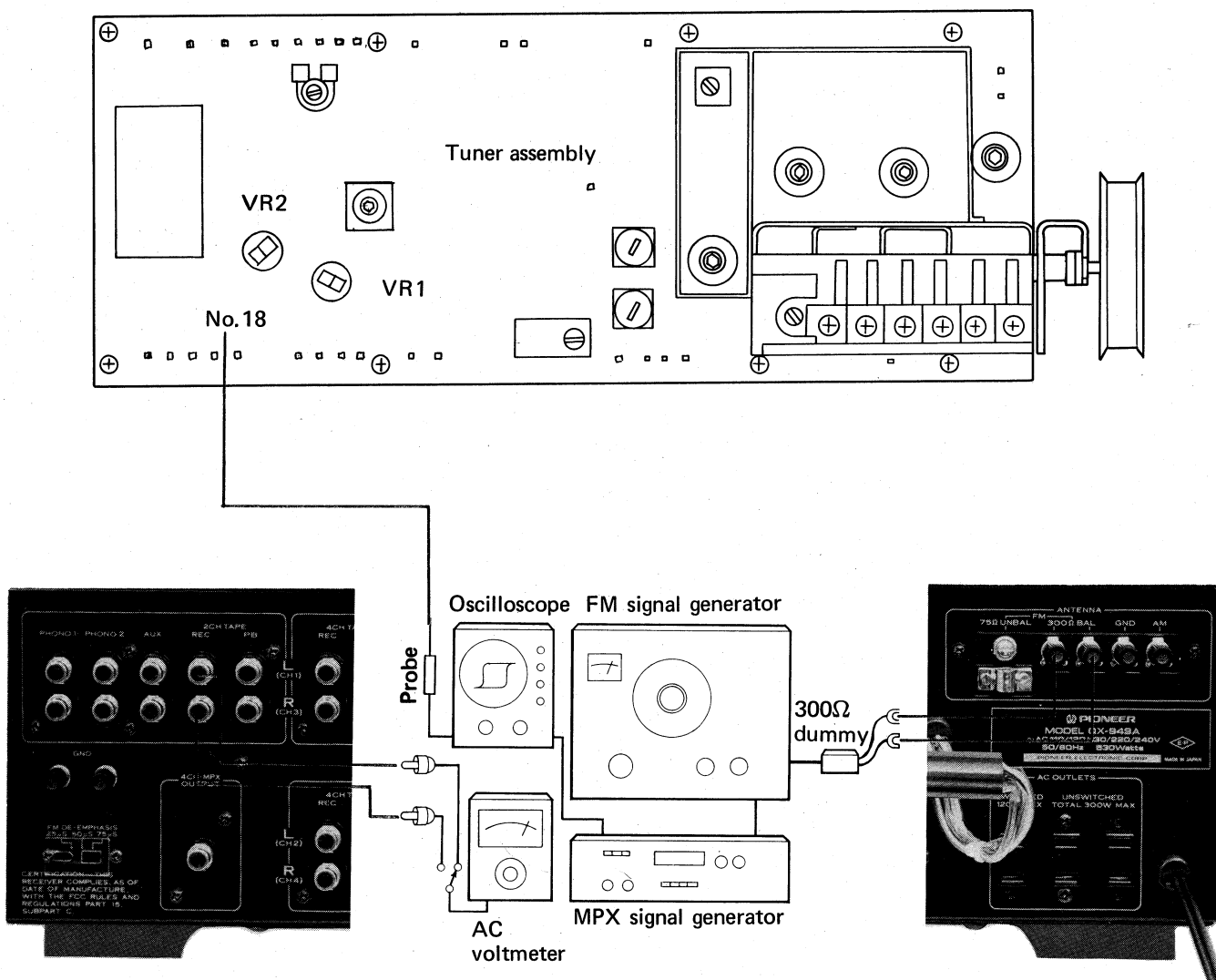

8.4 POWER AMPLIFIER SECTION

1. Do not connect load to speaker terminals. VOLUME Control set at minimum.
2. Set power boosting switch to 4CH position. Then energize unit.
3. For first approximately six seconds, the relay remains open, keeping the unit muted. Confirm that all voltages are as indicated in the circuit diagram on page 98.
4. If voltages are greatly different from rated values, shut off power immediately. Check suspicious areas, especially power supply unit.
5. If the relay opens immediately after the power

- amplifier has been come into operation, a defect in the output transistors can be suspected. Check the output stage.
6. After approx. 10~20 minutes of warming-up time, adjust VR3 so that the voltage across terminals 1 and 2 of the power amplifier assembly becomes 20mV.
7. In the same way, adjust VR4 to obtain 20mV voltage readings across the terminals 25 and 26.
8. Next, connect voltmeter between terminal 5 and ground. Adjust VR1 to obtain 0V reading.
9. In the same way, adjust VR2 to obtain zero readings between terminal 23 and ground.

Bottom View

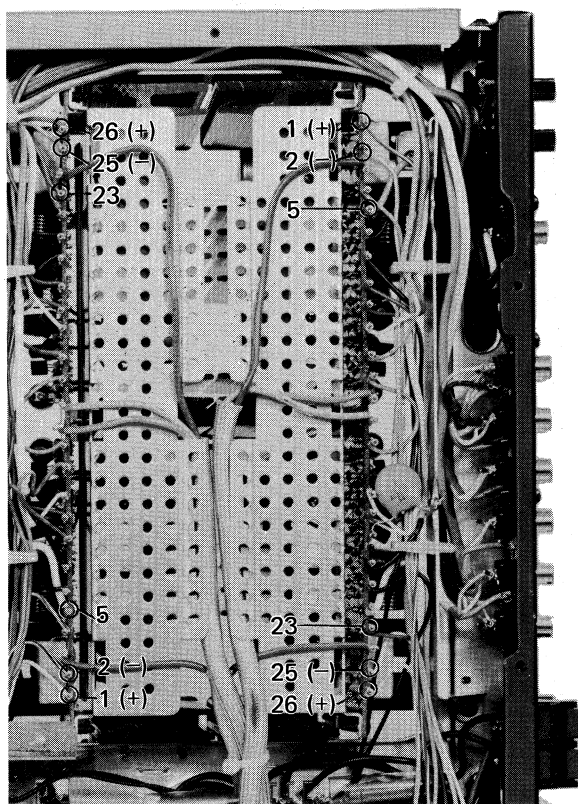

Top View

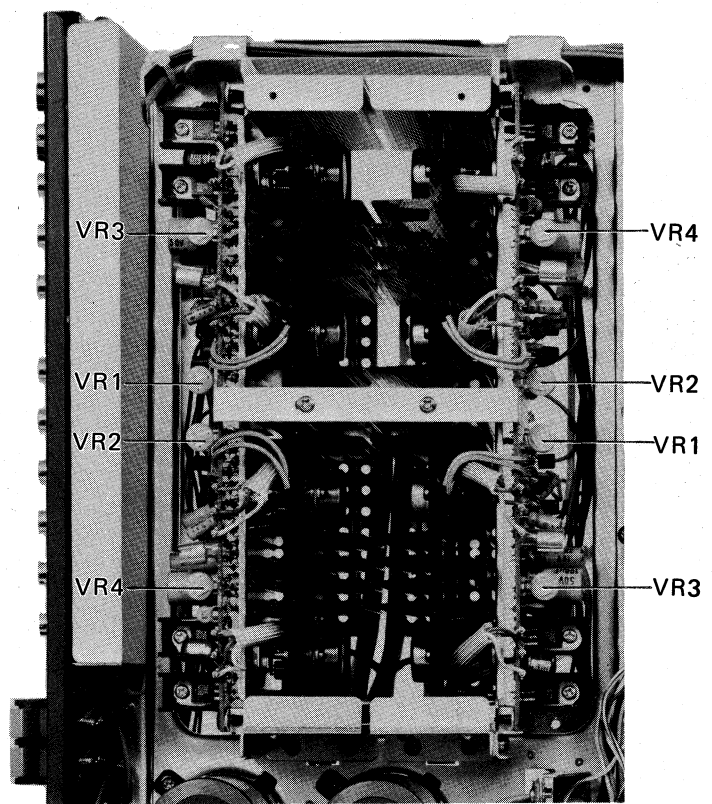

9. DIAL CORD STRINGING

1. Turn the tuning capacitor so that its plates protrude as much as possible.
2. Tie one end of the string to the spring on the Tuning drum (attached to the tuning capacitor).
3. Lead the string around pulleys A, B, C, D and E, then wind it 3 turns around the tuning shaft.
4. Lead the string around pulleys F and G, then wind it 2 turns around the Tuning drum.
5. Now tie the other end of the string to the spring on the Tuning drum. Turn the tuning shaft and check for proper function. Then trim the ends of the string.
6. Turn the tuning shaft until the plates of the variable are all the way in. Move the pointer to the left-end starting point on the dial and fasten it to the string in that position.

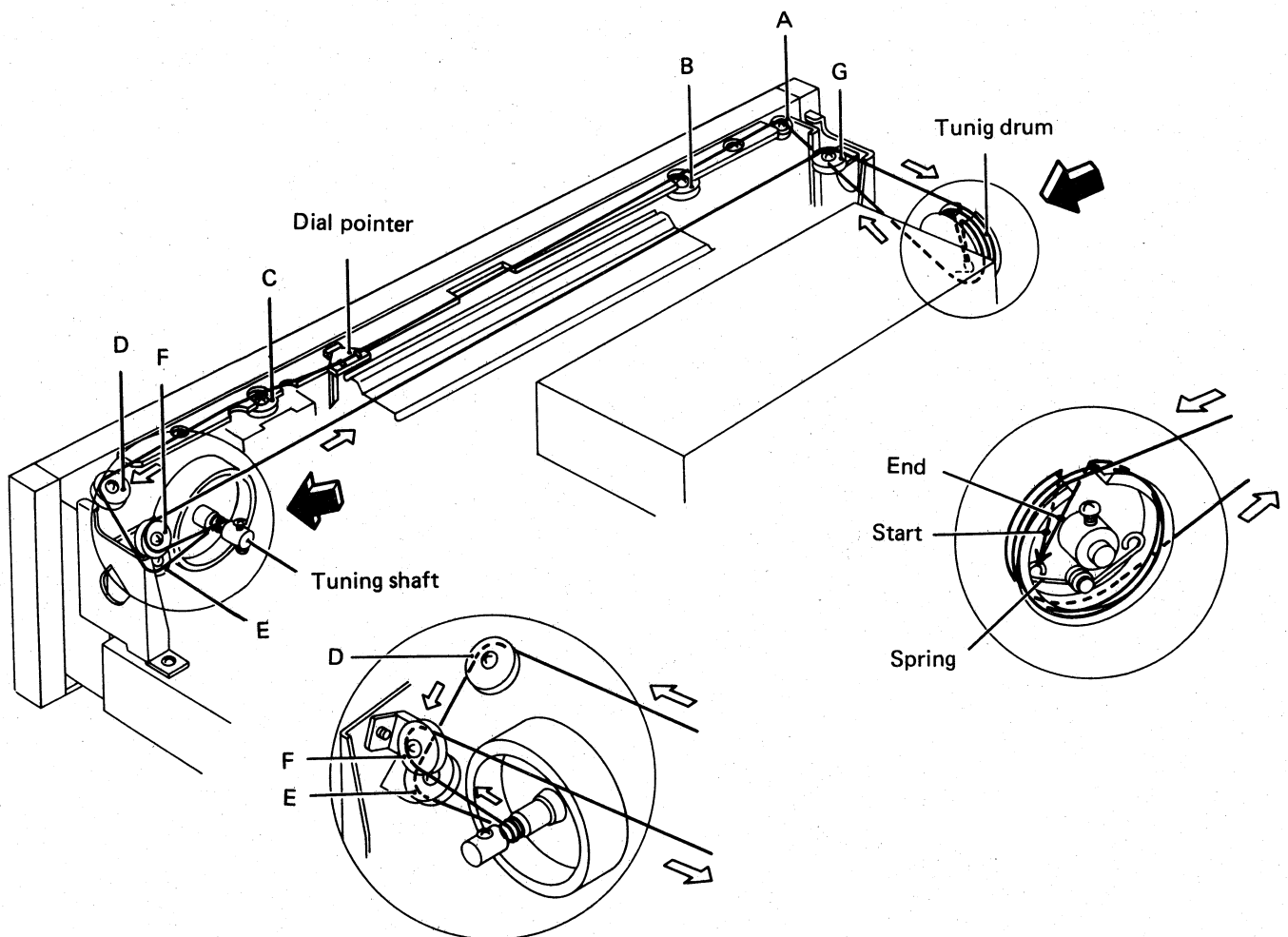

10. PARTS LOCATIONS

10.1 FRONT VIEW 1

Knob (INDICATOR LEVEL -20dB)
AAD-108

Knob (INDICATOR LEVEL -10dB)
AAD-108

Knob (POWER)
AAD-055

Knob (RIGHT REAR)
AAB-079

Knob (RIGHT FRONT)
AAB-079

Knob (LEFT FRONT)
AAB-079

Knob (LEFT REAR)
AAB-079

Knob (CD-4 SEPARATION LEFT)
AAB-080

Knob (VOLUME)
AAB-065

Knob (CD-4 SEPARATION RIGHT)
AAB-080

Phone jack (PHONES FRONT)
AKN-002

Phone jack (PHONES REAR)
AKN-002

Knob (SPEAKERS FRONT B)
AAD-108

Knob (SPEAKERS FRONT A)
AAD-108

Knob (FRONT BASS)
AAB-065

Knob (FRONT TREBLE)
AAB-065

Knob (SPEAKERS REAR A)
AAD-108

Knob (SPEAKERS REAR B)
AAD-108

Knob (LOUDNESS)
AAD-108

Knob (HIGH FILTER)
AAD-108

Knob (LOW FILTER)
AAD-108

Knob (TAPE MONITOR 2CH)
AAD-108

Knob (TAPE MONITOR 4CH-1)
AAD-108

Knob (TAPE MONITOR 4CH-2)
AAD-108

Knob (DOLBY NR ADAPTOR)
AAD-108

Front panel assembly
ANB-318

Knob (TUNING)
AAA-023

Knob (FM MUTING)
AAD-108

Knob (MPX NOISE FILTER)
AAD-108

Knob (FUNCTION)
AAB-065

Knob (MODE)
AAB-065

Knob (REAR TREBLE)
AAB-065

Knob (REAR BASS)
AAB-065

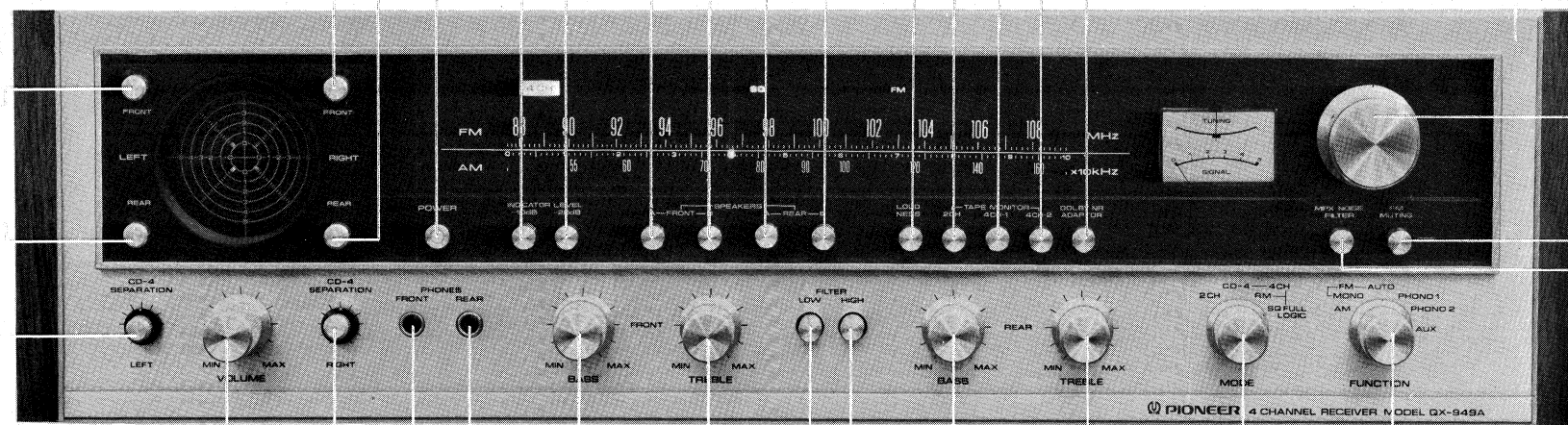

10.2 FRONT VIEW 2 (with Panel Removed)

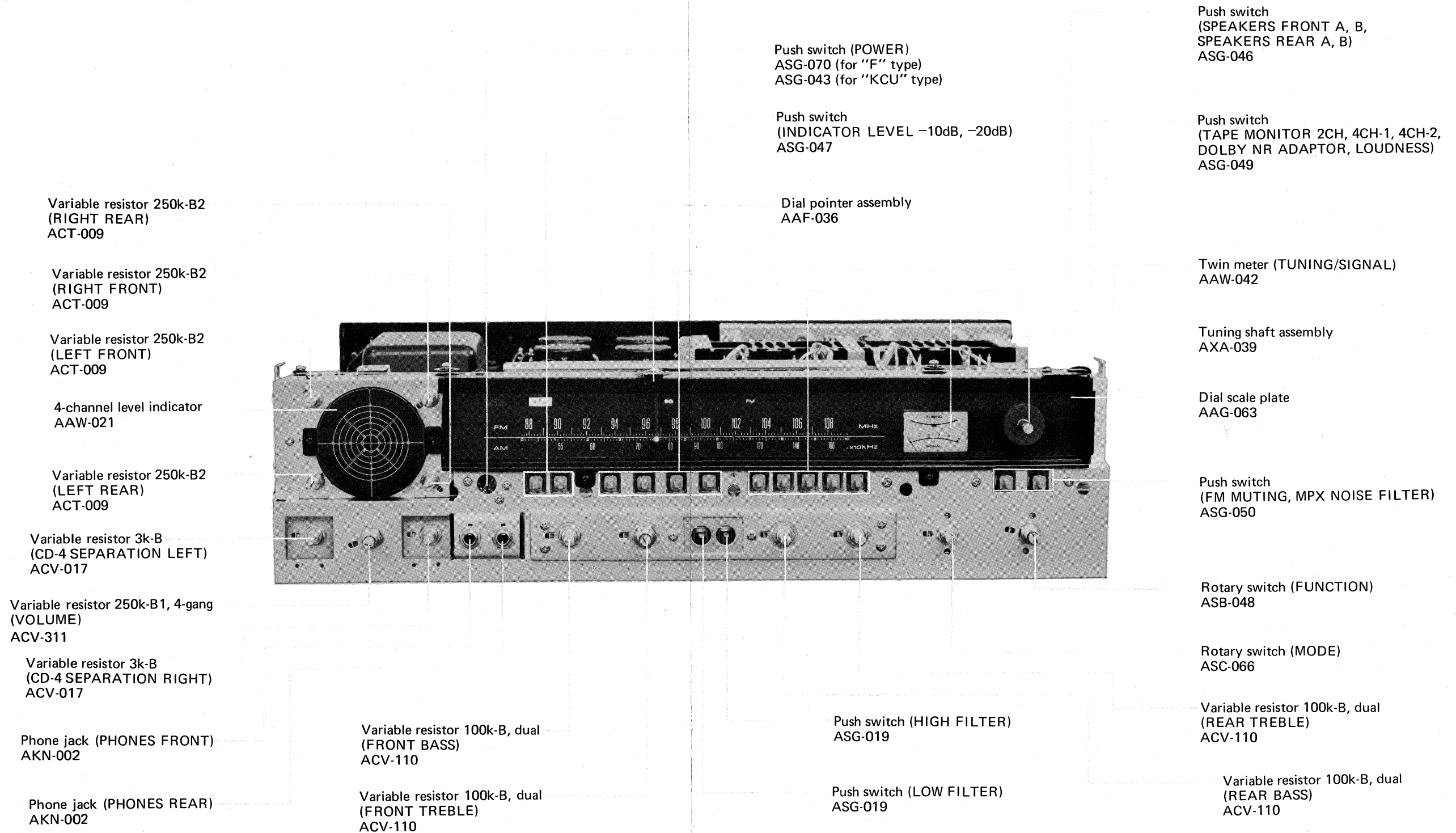

10.3 TOP VIEW

Electrolytic capacitor 10,000μF 50V (C8)
ACH-029

Electrolytic capacitor 10,000μF 50V (C6)
ACH-029

Electrolytic capacitor 10,000μF 50V (C7)
ACH-029

Electrolytic capacitor 10,000μF 50V (C9)
ACH-029

Ferrite balun
T22-025

Micro switch (S7)
ASF-001

Power transformer
ATT-222 (for "F" type)
ATT-221 (for "KCU" type)

Relay
ASR-007

Power supply circuit B assembly
AWR-039

Tuning drum assembly
AXA-015

Tuner assembly
AWE-041

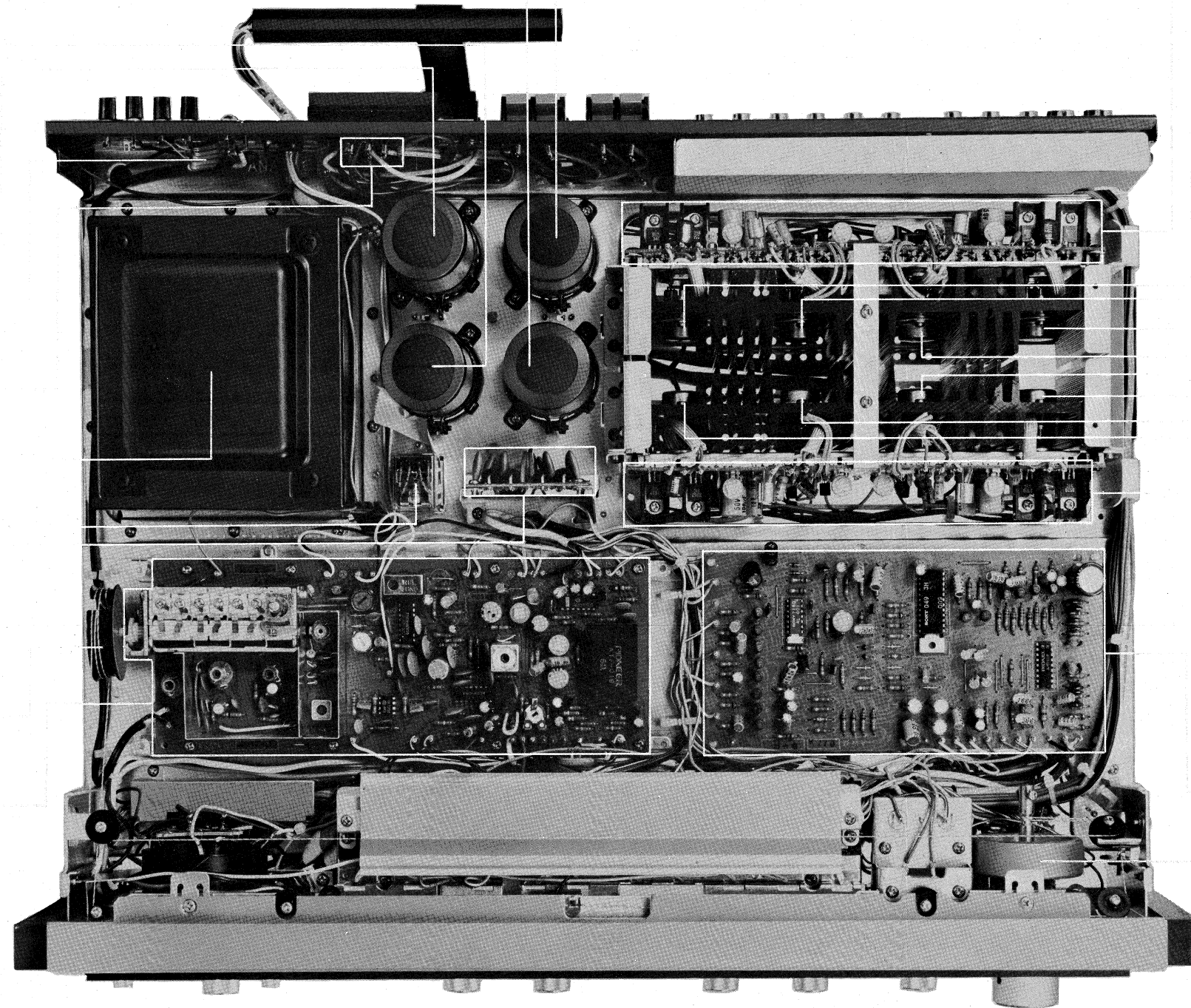

Power amplifier assembly (for CH1, CH4)
AWH-027

Transistor (Q16)
2SA679-R or Y (2SA747-R, O or Y)

Transistor (Q14)
2SC1079-R or Y (2SC1116-R, O or Y)

Transistor (Q15)
2SB530-R or O (2SA745-R, O or Y)

Transistor (Q13)
2SD370-R or O (2SC1403-R, O or Y)

Transistor (Q14)
2SC1079-R or Y (2SC1116-R, O or Y)

Transistor (Q16)
2SA679-R or Y (2SC1116-R, O or Y)

Transistor (Q13)
2SD370-R or O (2SA747-R, O or Y)

Transistor (Q15)
2SB530-R or O (2SA745-R, O or Y)

Power amplifier assembly (for CH2, CH3)
AWH-027

SQ/RM decoder assembly
AWM-077

Tuning shaft assembly
AXA-039

10.4 BOTTOM VIEW

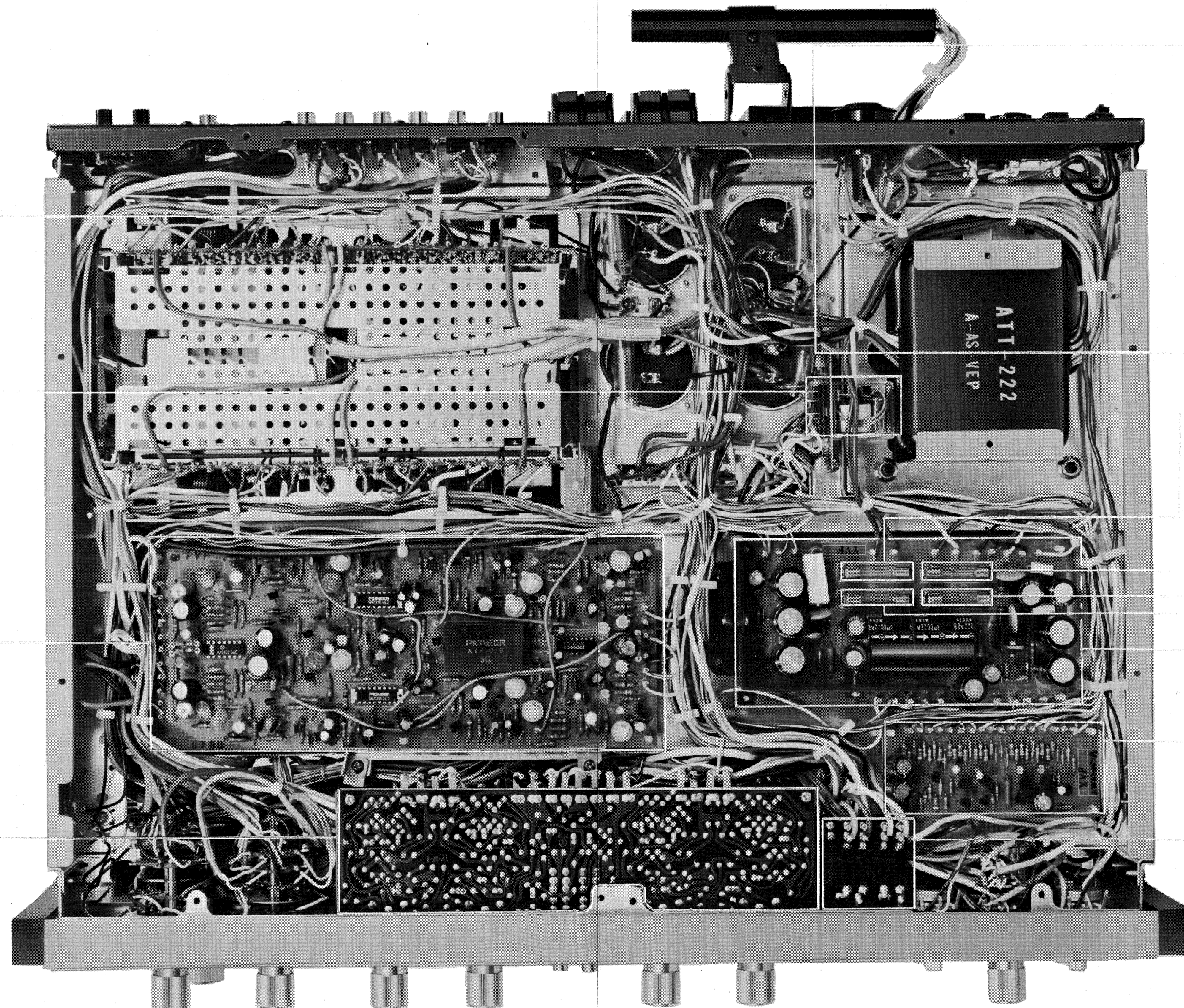

Ceramic capacitor 0.01 μ F 250V (C13)
ACG-001

Relay
ASR-007

CD-4 assembly
AWM-076

Control amplifier assembly
AWG-023

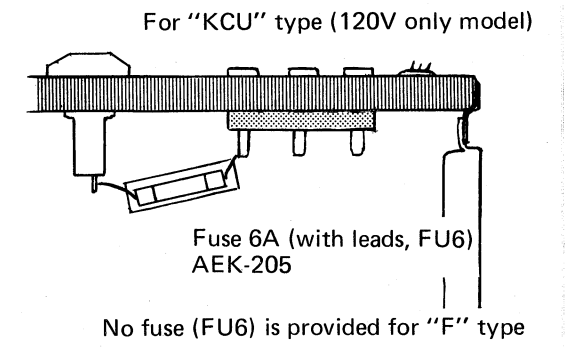

Fuse 1A (FU4)
AEK-106

Fuse 3A (FU1)
AEK-101

Fuse 1A (FU2)
AEK-106

Fuse 1A (FU3)
AEK-106

Power supply circuit A assembly
AWR-080

Protection circuit assembly
AWM-079

Headphone jack assembly
AWX-054

10.5 REAR VIEW

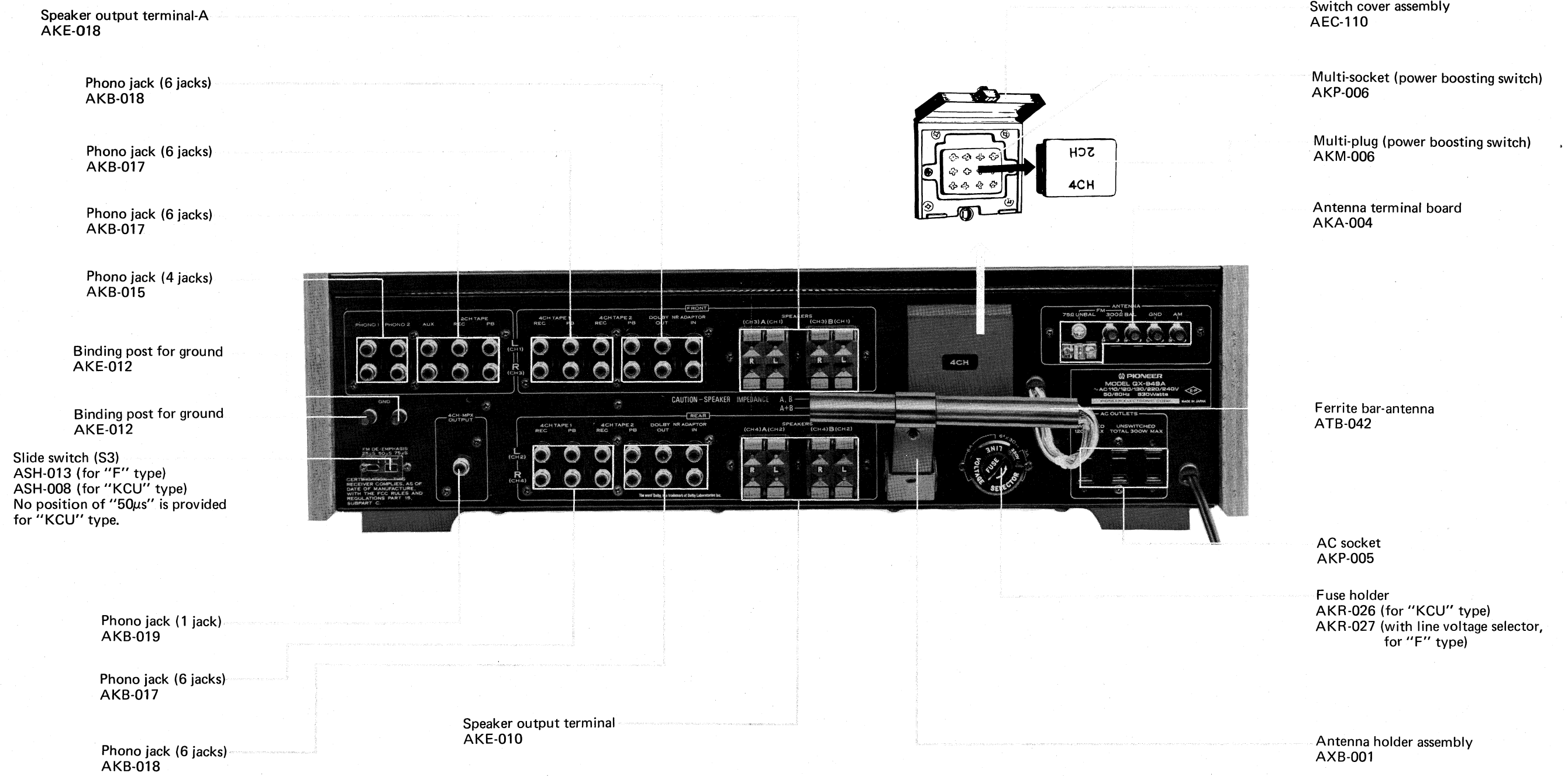

11. EXPLODED VIEWS

NOTE:
Parts indicated in green type cannot be supplied.

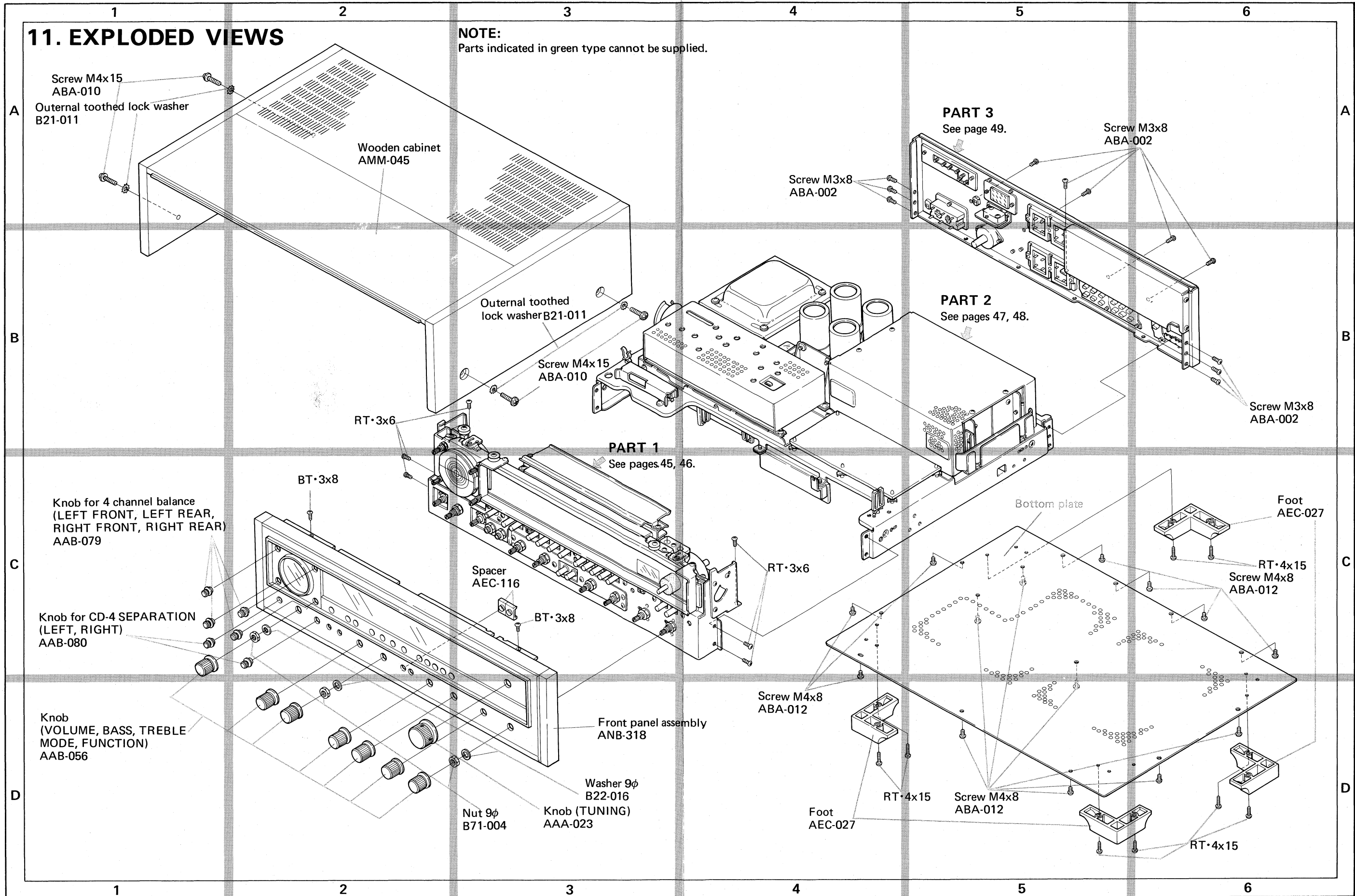

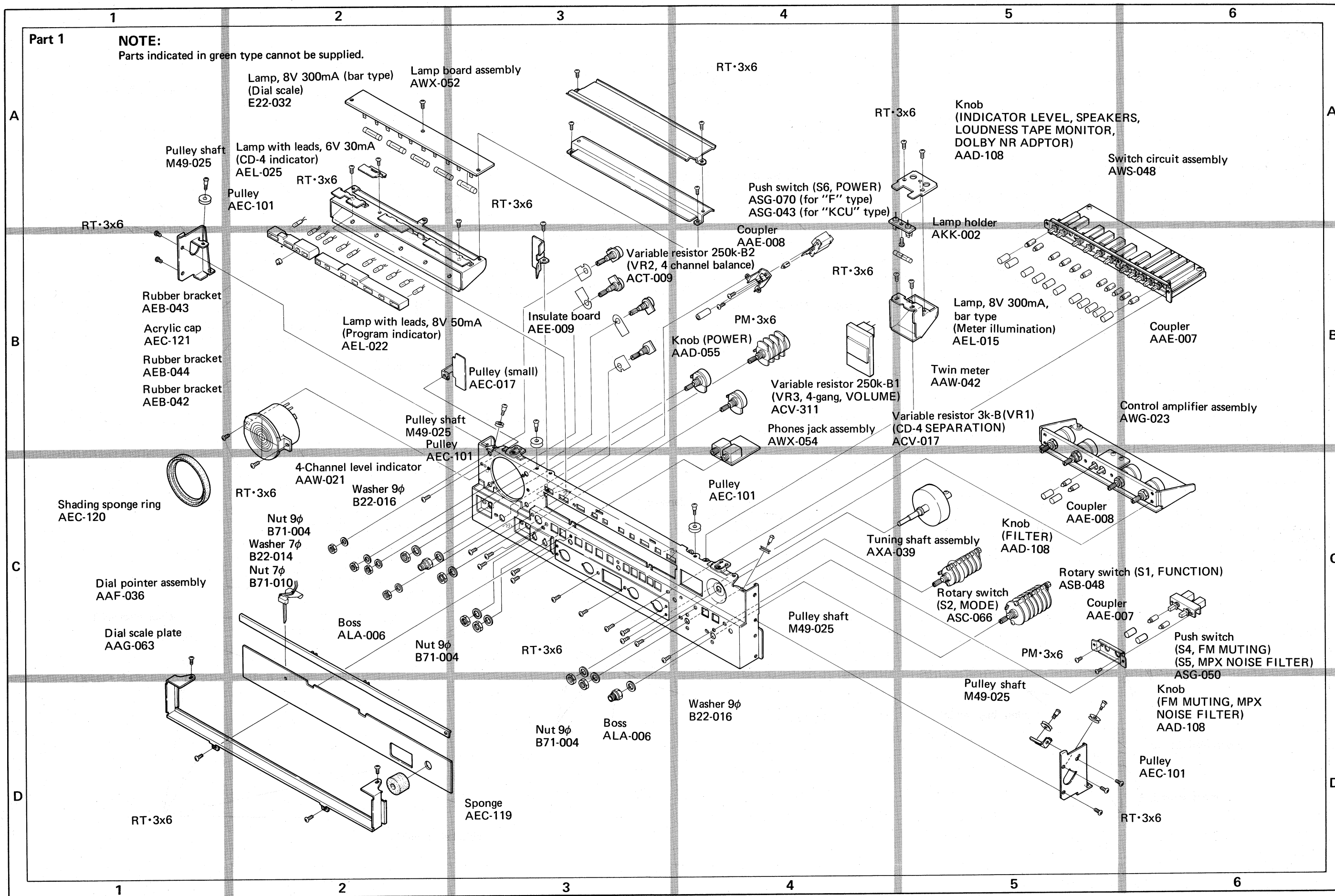

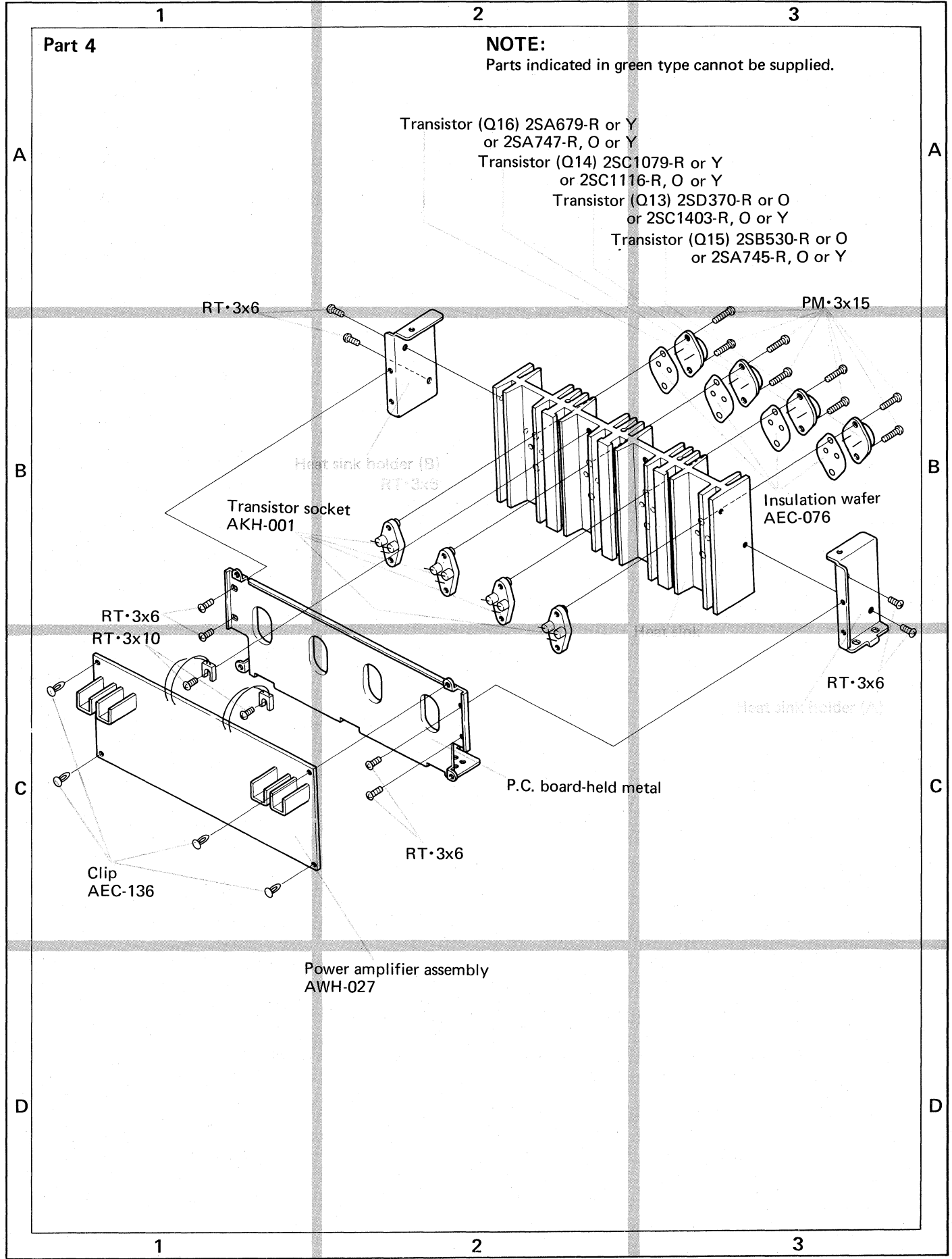
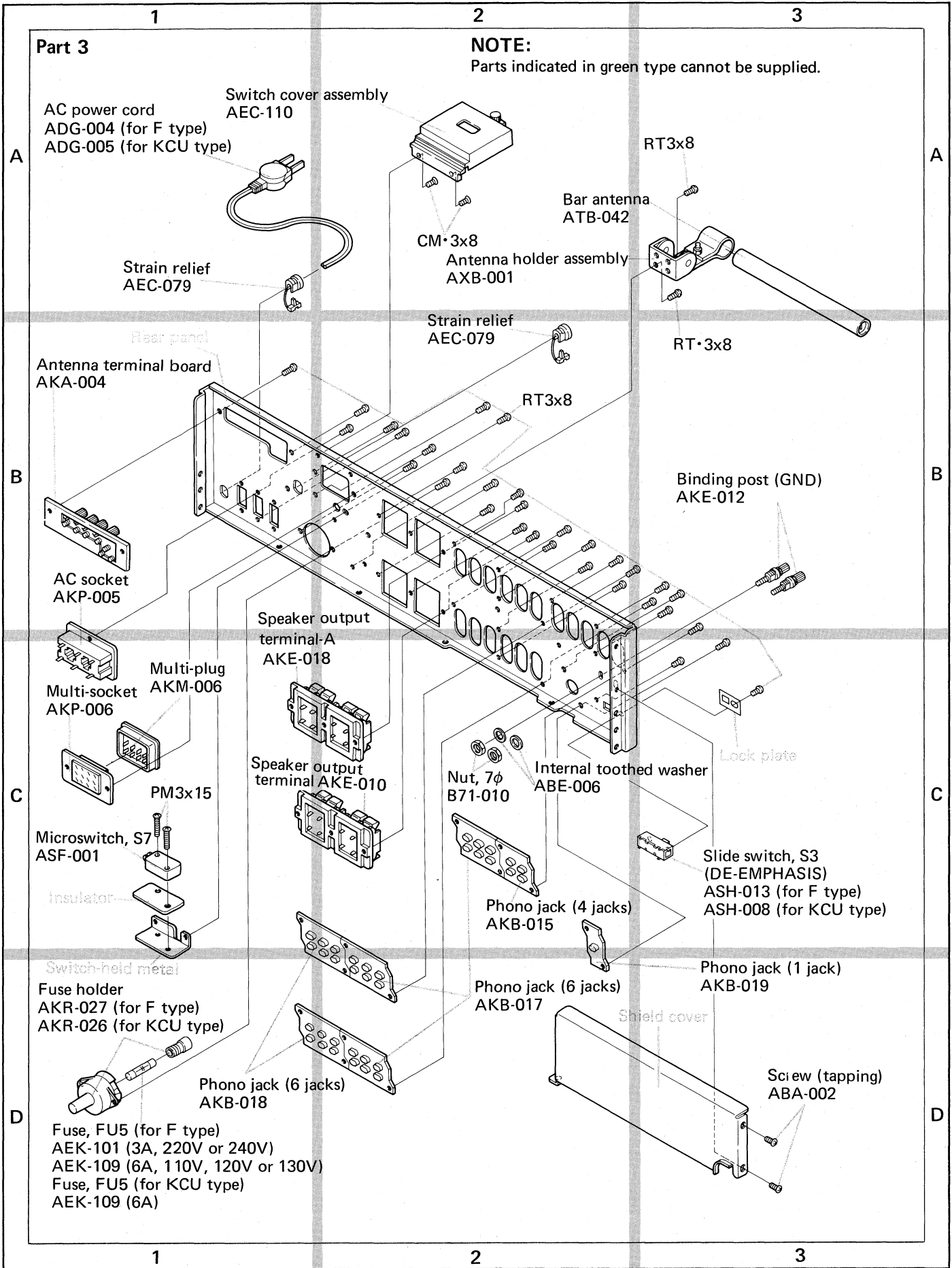



















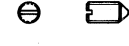







NOMENCLATURE OF SCREWS, WASHERS AND NUTS

The following symbols stand for screws, washers and nuts as shown in exploded view.

| Symbol | Description | Shape | Symbol | Description | Shape |
|--------|--|---|--------|-----------------------------------|---|
| RT | Brazier head tapping screw |  | EW | E type washer |  |
| PT | Pan head tapping screw |  | FW | Flat washer |  |
| BT | Binding head tapping screw |  | SW | Spring lock washer |  |
| CT | Countersunk head tapping screw |  | N | Nut |  |
| TT | Truss head tapping screw |  | WN | Washer faced nut |  |
| OCT | Oval countersunk head tapping screw |  | ITW | Internal toothed lock washer |  |
| PM | Pan head machine screw |  | OTW | Outernal toothed lock washer |  |
| CM | Countersunk head machine screw |  | SC | Slotted set screw (Cone point) |  |
| OCM | Oval countersunk head machine screw |  | SF | Slotted set screw (Flat point) |  |
| TM | Truss head machine screw |  | HS | Hexagon socket headless set screw |  |
| BM | Binding head machine screw |  | OCW | Oval countersunk head wood screw |  |
| PSA | Pan head screw with spring lock washer |  | CW | Countersunk head wood screw |  |
| PSB | Pan head screw with spring lock washer and flat washer |  | RW | Round head wood screw |  |
| PSF | Pan head screw with flat washer |  | | | |

EXAMPLE

PM • 3x8
 length in mm (*l*)
 diameter in mm (*d*)
 Symbol

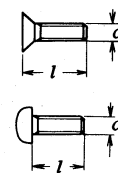

FW • 9φ x 1^t
 thickness in mm (*t*)
 diameter in mm (*d*)
 Symbol

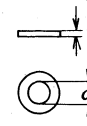

12. PACKING

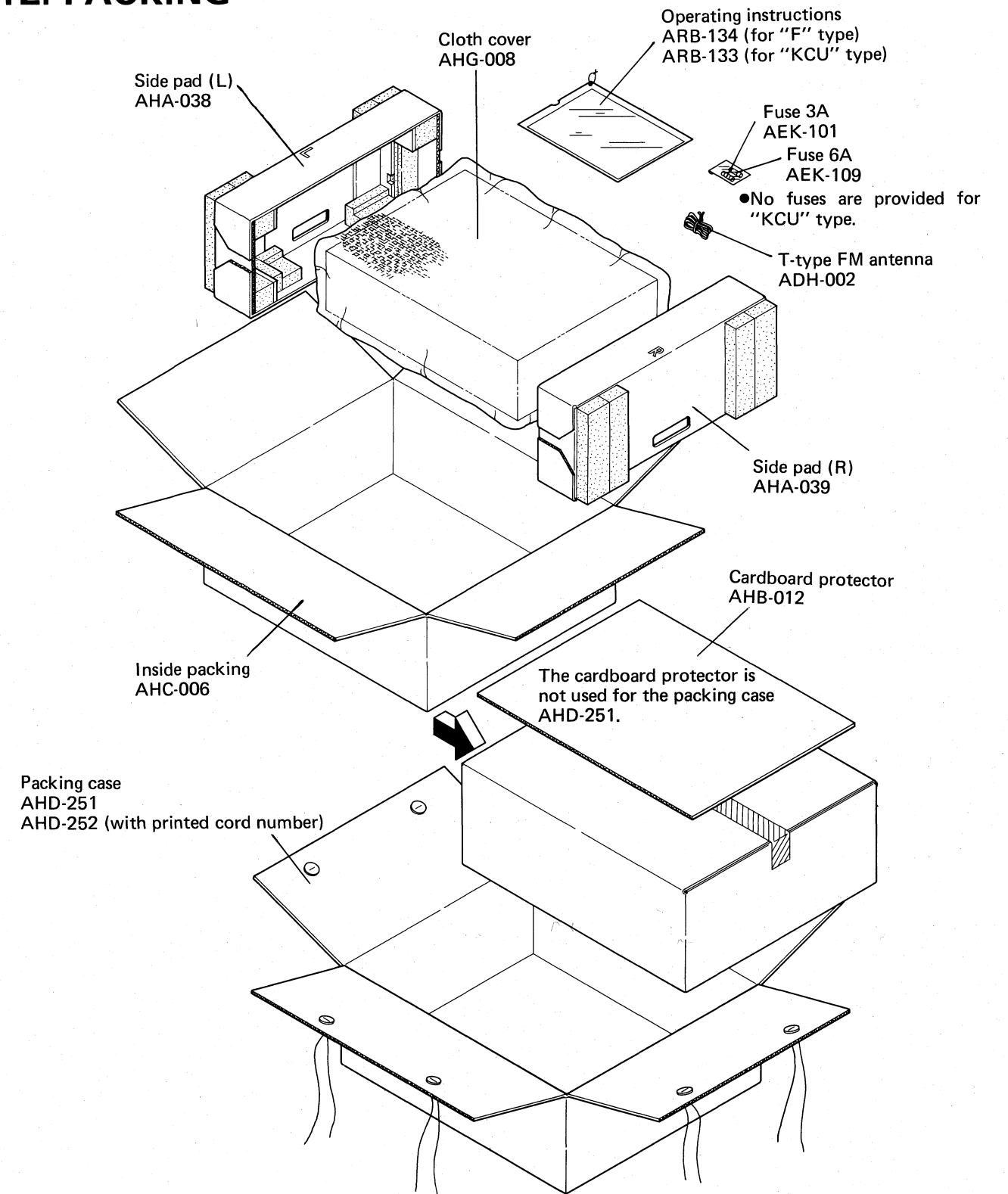

13. SCHEMATIC DIAGRAMS, P.C. BOARD PATTERNS AND PARTS LISTS

13.1 SCHEMATIC DIAGRAMS AND MISCELLANEOUS PARTS

For "F" type (5 line voltage model)

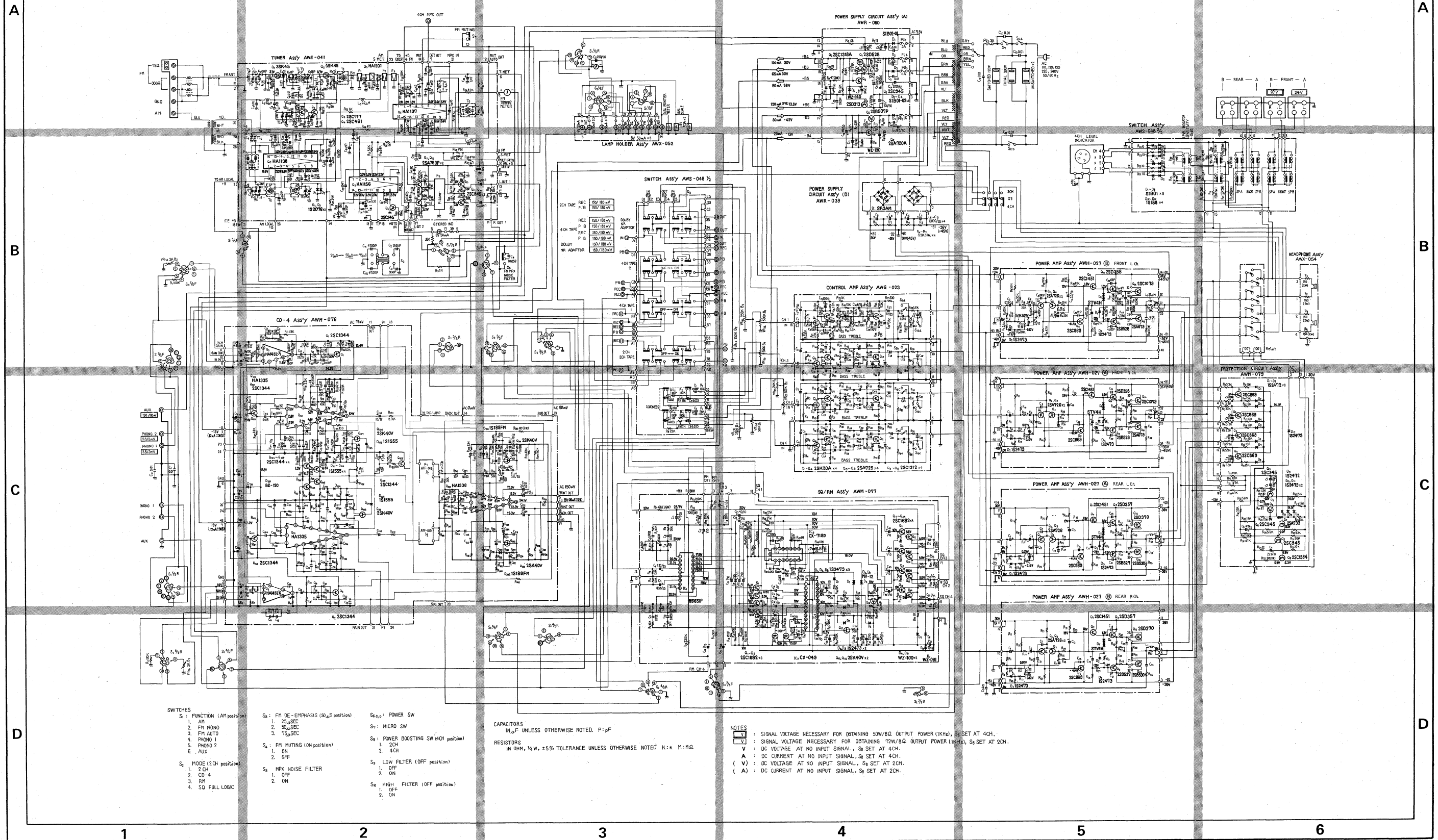

- SWITCHES**
- S₁: FUNCTION (AM position)
 - 1. AM
 - 2. FM MONO
 - 3. FM AUTO
 - 4. PHONO 1
 - 5. PHONO 2
 - 6. AUX
 - S₂: MODE (2CH position)
 - 1. 2CH
 - 2. CD-4
 - 3. RM
 - 4. SQ FULL LOGIC
 - S₃: FM DE-EMPHASIS (SQ₂ position)
 - 1. 25μSEC
 - 2. 50μSEC
 - 3. 75μSEC
 - S₄: FM MUTING (ON position)
 - 1. ON
 - 2. OFF
 - S₅: MPX NOISE FILTER
 - 1. OFF
 - 2. ON
 - S₆: POWER SW
 - 1. OFF
 - 2. ON
 - S₇: MICRO SW
 - 1. OFF
 - 2. ON
 - S₈: POWER BOOSTING SW (4CH position)
 - 1. 2CH
 - 2. 4CH
 - S₉: LOW FILTER (OFF position)
 - 1. OFF
 - 2. ON
 - S₁₀: HIGH FILTER (OFF position)
 - 1. OFF
 - 2. ON

CAPACITORS
IN μF UNLESS OTHERWISE NOTED. P: pF

RESISTORS
IN OHM, 1/4W, ±5% TOLERANCE UNLESS OTHERWISE NOTED. K: k M: MΩ

NOTES

- (V) : SIGNAL VOLTAGE NECESSARY FOR OBTAINING 50W/8Ω OUTPUT POWER (1KH_z), S₈ SET AT 4CH.
- (V) : SIGNAL VOLTAGE NECESSARY FOR OBTAINING 12W/8Ω OUTPUT POWER (1MH_z), S₈ SET AT 2CH.
- (A) : DC VOLTAGE AT NO INPUT SIGNAL, S₈ SET AT 4CH.
- (V) : DC CURRENT AT NO INPUT SIGNAL, S₈ SET AT 2CH.
- (A) : DC CURRENT AT NO INPUT SIGNAL, S₈ SET AT 4CH.

For "KCU" type (120V model)

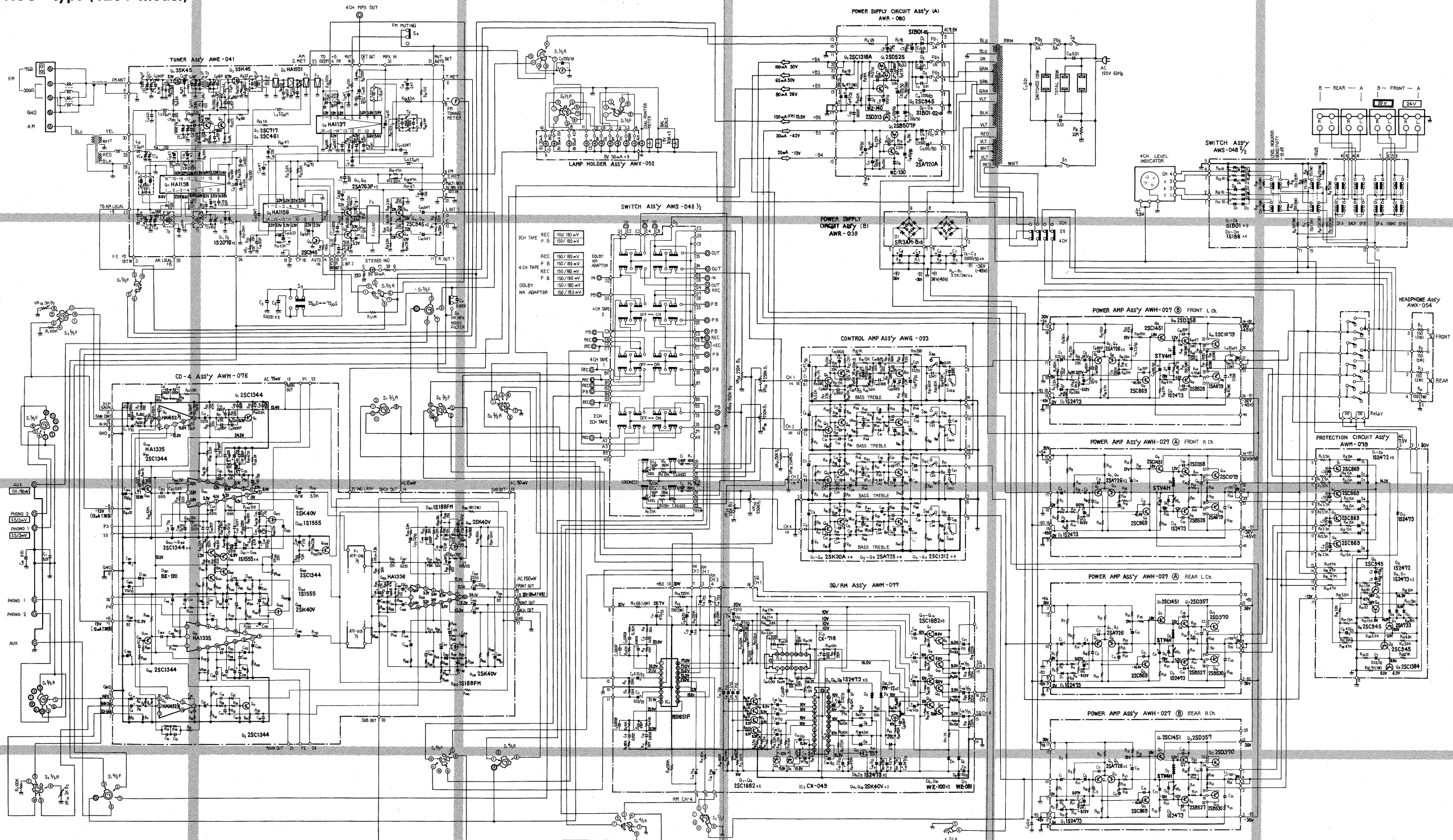

- SWITCHES**
- | | | |
|--|--|---|
| S ₁ : FUNCTION (A position) | S ₃ : FM DE-EMPHASIS (75 μS position) | S ₆ : POWER SW |
| 1. AM | 1. 75 μSEC | 1. OFF |
| 2. FM MONO | 2. 15 μSEC | 2. ON |
| 3. FM AUTO | | |
| 4. PHONO 1 | | |
| 5. PHONO 2 | S ₄ : FM MUTING (ON position) | S ₇ : POWER BOOSTING SW (4CH position) |
| 6. AUX | 1. ON | 1. 2CH |
| | 2. OFF | 2. 4CH |
| | | |
| S ₂ : MODE (2CH position) | S ₅ : MPX NOISE FILTER | S ₈ : LOW FILTER (OFF position) |
| 1. 2CH | 1. OFF | 1. OFF |
| 2. CD-4 | 2. ON | 2. ON |
| 3. RM | | |
| 4. SQ FULL LOGIC | | |

CAPACITORS
IN μF UNLESS OTHERWISE NOTED. P: pF

RESISTORS
IN OHM, 1/4W, ±5% TOLERANCE UNLESS OTHERWISE NOTED. K:k M:M Ω:Ω

NOTES

- (V) : SIGNAL VOLTAGE NECESSARY FOR OBTAINING 50W/8Ω OUTPUT POWER (1kHz), S₆ SET AT 4CH.
- (V) : SIGNAL VOLTAGE NECESSARY FOR OBTAINING 72W/8Ω OUTPUT POWER (1kHz), S₆ SET AT 2CH.
- (A) : DC VOLTAGE AT NO INPUT SIGNAL, S₆ SET AT 4CH.
- (V) : DC CURRENT AT NO INPUT SIGNAL, S₆ SET AT 4CH.
- (V) : DC VOLTAGE AT NO INPUT SIGNAL, S₆ SET AT 2CH.
- (A) : DC CURRENT AT NO INPUT SIGNAL, S₆ SET AT 2CH.

HA1137 (FM IF IC)

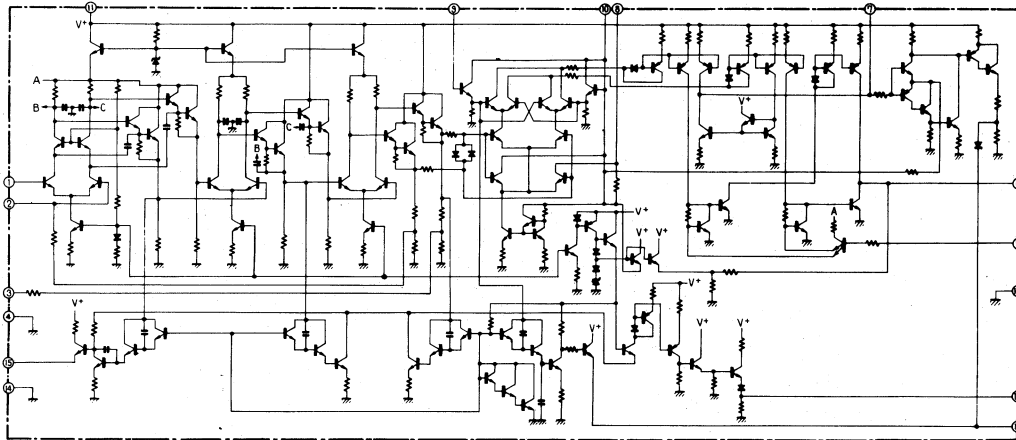

HA1138 (AM IC)

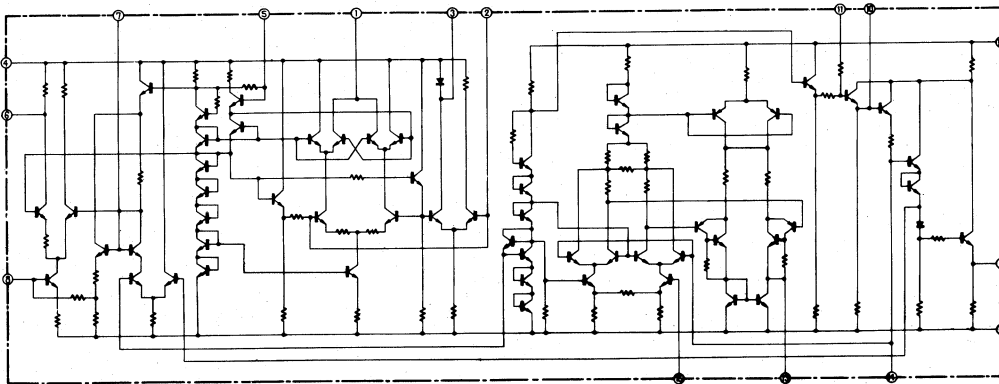

HA1156 (FM MPX IC)

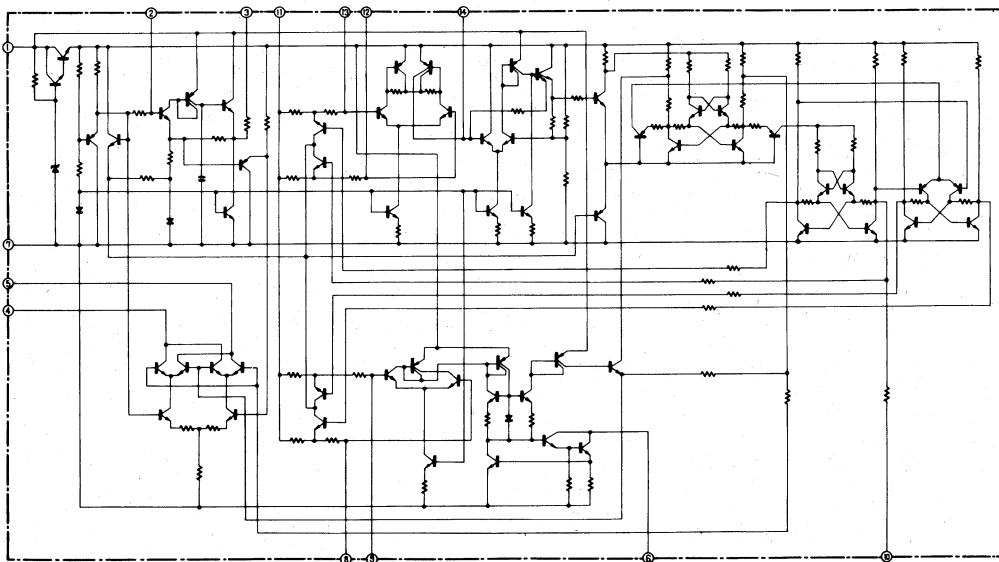

HA1452(EQ AMP IC)

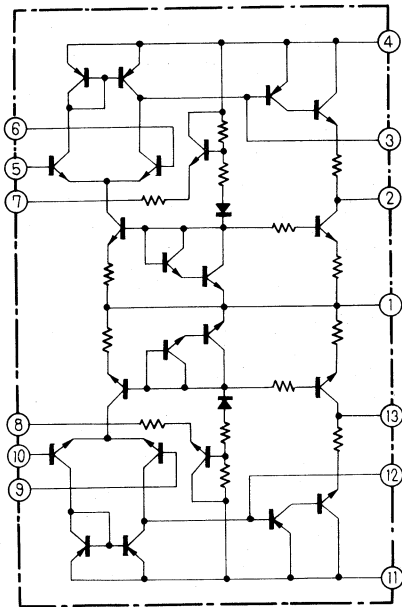

S1 (FUNCTION)

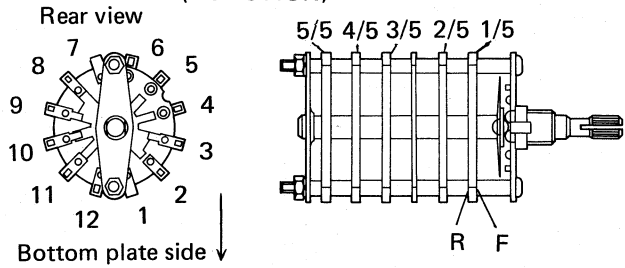

S2 (MODE)

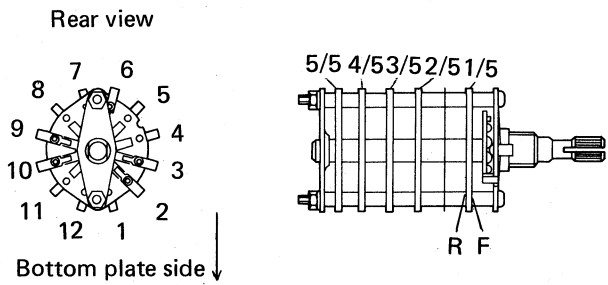

HA1335

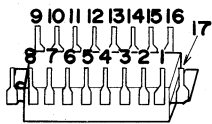

CX-718D

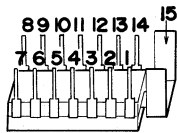

M51651P

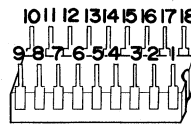

CX-049

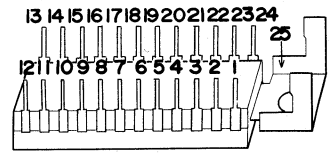

HA1137

HA1136

HA1336

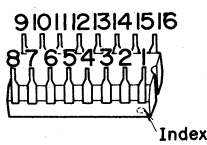

HA1156

HA1452

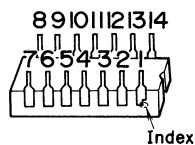

HA1201

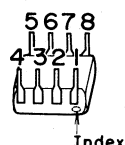

3SK45

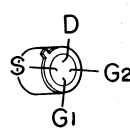

2SK40V

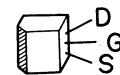

2SK30A

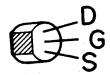

2SA725

2SA726

2SC869

2SC1312

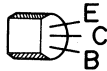

2SC461

2SC717

2SC1344

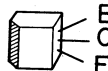

2SB507

2SD313

2SD525

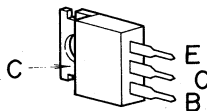

2SA720A

2SA733

2SA763P

2SC945

2SC1318A

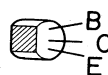

2SA679

2SB530

2SC1079

2SD370

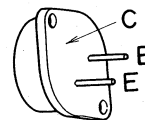

2SB527

2SB528

2SD357

2SD358

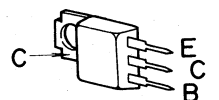

2SC1682

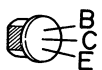

2SC1451

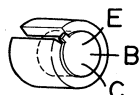

2SC1384

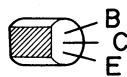

Miscellaneous Parts for "F" type

CAPACITORS

| Symbol | Description | Part No. |
|--------|-------------------------|---------------|
| C1 | Ceramic 0.01 50V | CKDYF 103Z 50 |
| C2 | Mylar 0.0091 50V | CQMA 912J 50 |
| C3 | Mylar 0.0091 50V | CQMA 912J 50 |
| C4 | Ceramic 0.0056 50V | CKDYB 562K 50 |
| C5 | Electrolytic 220 16V | CEA 221P 16 |
| C6 | Electrolytic 10,000 50V | ACH-029 |
| C7 | Electrolytic 10,000 50V | ACH-029 |
| C8 | Electrolytic 10,000 50V | ACH-029 |
| C9 | Electrolytic 10,000 50V | ACH-029 |
| C10 | Ceramic 0.01 250V | ACG-001 |
| C11 | Ceramic 0.01 250V | ACG-001 |
| C12 | Ceramic 0.01 250V | ACG-001 |
| C13 | Ceramic 0.01 250V | ACG-001 |
| C14 | Mylar 0.0047 50V | CQMA 472J 50 |
| C15 | Mylar 0.0047 50V | CQMA 472J 50 |
| C16 | Ceramic 0.01 50V | CKDYF 103Z 50 |
| C17 | Ceramic 0.01 250V | ACG-001 |

RESISTORS

| Symbol | Description | Part No. |
|--------|--|------------|
| R1 | Carbon film 100k | RD½PS 104J |
| R2 | Carbon film 100k | RD½PS 104J |
| R3 | Carbon film 1M | RD½PS 105J |
| R4 | Metal oxide 3.3k 3W | RS3P 332K |
| R5 | Metal oxide 3.3k 3W | RS3P 332K |
| R6 | Metal oxide 3.3k 3W | RS3P 332K |
| R7 | Metal oxide 3.3k 3W | RS3P 332K |
| VR1a | Variable resistor 3k-B (CD-4 SEPARATION LEFT) | ACV-017 |
| VR1b | Variable resistor 3k-B (CD-4 SEPARATION RIGHT) | ACV-017 |
| VR2a | Variable resistor 250k-B2 (FRONT L level) | ACT-009 |
| VR2b | Variable resistor 250k-B2 (REAR R level) | ACT-009 |
| VR2c | Variable resistor 250k-B2 (FRONT L level) | ACT-009 |
| VR2d | Variable resistor 250k-B2 (REAR R level) | ACT-009 |
| VR3 | Variable resistor 250k-B1, 4-gang (VOLUME) | ACV-311 |

NOTE:

- Capacitors: in μF unless otherwise noted p:pF
- Resistors: in Ω , $\frac{1}{4}W$ unless otherwise noted k:k Ω , M:M Ω

POWER TRANSISTORS (for Power amplifier)

| Symbol | Description | Part No. |
|--------|-------------|-------------|
| Q13 | | 2SD370-R |
| Q14 | | (2SC1403-R) |
| Q15 | | 2SC1079-R |
| Q16 | | (2SC1116-R) |
| | | 2SB530-R |
| | | (2SA745-R) |
| | | 2SA679-R |
| | | (2SA747-R) |

LAMPS

| Symbol | Description | Part No. |
|--------|---|----------|
| | Lamp 8V, 300mA, bar type (Dial illumination) | E22-032 |
| | Lamp 8V, 300mA, bar type (Meter illumination) | AEL-015 |
| | Lamp 6V, 30mA, with leads (CD-4 indicator) | AEL-025 |
| | Lamp 8V 50mA, with leads (Program indicator) | AEL-022 |

FUSES

| Symbol | Description | Part No. |
|--------|---|----------|
| FU1 | Fuse 3A (lamp circuit) | AEK-101 |
| FU2 | Fuse 1A (secondary) | AEK-106 |
| FU3 | Fuse 1A (secondary) | AEK-106 |
| FU4 | Fuse 1A (secondary) | AEK-106 |
| FU5 | Fuse 3A (220V, 240V, primary) or 6A (110V, 120V, 130V, primary) | AEK-101 |

SWITCHES

| Symbol | Description | Part No. |
|--------|---|----------|
| S1 | Rotary switch (FUNCTION) | ASB-048 |
| S2 | Rotary switch (MODE) | ASC-066 |
| S3 | Slide switch (DE-EMPHASIS) | ASH-013 |
| S4, S5 | Push switch (FM MUTING, MPX NOISE FILTER) | ASG-050 |
| S6 | Push switch (POWER) | ASG-070 |
| S7 | Micro switch (Switch cover) | ASF-001 |

Miscellaneous Parts for "KCU" type

CAPACITORS

| Symbol | Description | Part No. |
|--------|-------------------------|---------------|
| C1 | Ceramic 0.01 50V | CKDYF103Z 50 |
| C2 | Mylar 0.0091 50V | CQMA 912J 50 |
| C3 | Mylar 0.0091 50V | CQMA 912J 50 |
| C4 | Ceramic 0.0056 50V | CKDYB 562K 50 |
| C5 | Electrolytic 220 16V | CEA 221P 16 |
| C6 | Electrolytic 10,000 50V | ACH-029 |
| C7 | Electrolytic 10,000 50V | ACH-029 |
| C8 | Electrolytic 10,000 50V | ACH-029 |
| C9 | Electrolytic 10,000 50V | ACH-029 |
| C10 | Ceramic 0.01 150V | ACG-003 |
| C11 | Ceramic 0.01 150V | ACG-003 |
| C12 | Ceramic 0.01 150V | ACG-003 |
| C13 | Ceramic 0.01 250V | ACG-001 |
| C14 | Ceramic 0.01 50V | CKDYF 103Z 50 |

RESISTORS

| Symbol | Description | Part No. |
|--------|--|------------|
| R1 | Carbon film 100k | RD½PS 104J |
| R2 | Carbon film 100k | RD½PS 104J |
| R3 | Carbon film 1M | RD½PS 105J |
| R4 | Metal oxide 3.3k 3W | RS3P 332K |
| R5 | Metal oxide 3.3k 3W | RS3P 332K |
| R6 | Metal oxide 3.3k 3W | RS3P 332K |
| R7 | Metal oxide 3.3k 3W | RS3P 332K |
| R8 | Carbon film 2.2M ½W | RD½PS 225J |
| VR1a | Variable resistor 3k-B (CD-4 SEPARATION LEFT) | ACV-017 |
| VR1b | Variable resistor 3k-B (CD-4 SEPARATION RIGHT) | ACV-017 |
| VR2a | Variable resistor 250k-B2 (FRONT L level) | ACT-009 |
| VR2b | Variable resistor 250k-B2 (REAR R level) | ACT-009 |
| VR2c | Variable resistor 250k-B2 (FRONT L level) | ACT-009 |
| VR2d | Variable resistor 250k-B2 (REAR R level) | ACT-009 |
| VR3 | Variable resistor 250k-B1 4-gang (VOLUME) | ACV-311 |

POWER TRANSISTORS (for Power amplifier)

| Symbol | Description | Part No. |
|--------|-------------|-------------|
| Q13 | | 2SD370-R |
| Q14 | | (2SC1403-R) |
| Q15 | | 2SC1079-R |
| Q16 | | (2SC1116-R) |
| | | 2SB530-R |
| | | (2SA745-R) |
| | | 2SA679-R |
| | | (2SA747-R) |

LAMPS

| Symbol | Description | Part No. |
|--------|---|----------|
| | Lamp 8V, 300mA, bar type (Dial illumination) | E22-032 |
| | Lamp 8V, 300mA, bar type (Meter illumination) | AEL-015 |
| | Lamp 6V, 30mA, with leads (CD-4 indicator) | AEL-025 |
| | Lamp 8V, 50mA, with leads (Program indicator) | AEL-022 |

FUSES

| Symbol | Description | Part No. |
|--------|-------------------------------|----------|
| FU1 | Fuse 3A (lamp circuit) | AEK-101 |
| FU2 | Fuse 1A (secondary) | AEK-106 |
| FU3 | Fuse 1A (secondary) | AEK-106 |
| FU4 | Fuse 1A (secondary) | AEK-106 |
| FU5 | Fuse 6A (primary) | AEK-109 |
| FU6 | Fuse 6A (primary, with leads) | AEK-205 |

SWITCHES

| Symbol | Description | Part No. |
|--------|---|----------|
| S1 | Rotary switch (FUNCTION) | ASB-048 |
| S2 | Rotary switch (MODE) | ASC-066 |
| S3 | Slide switch (DE-EMPHASIS) | ASH-008 |
| S4, S5 | Push switch (FM MUTING, MPX NOISE FILTER) | ASG-050 |
| S6 | Push switch (POWER) | ASG-043 |
| S7 | Micro switch (Switch cover) | ASF-001 |

13.2 TUNER ASSEMBLY (AWE-041)

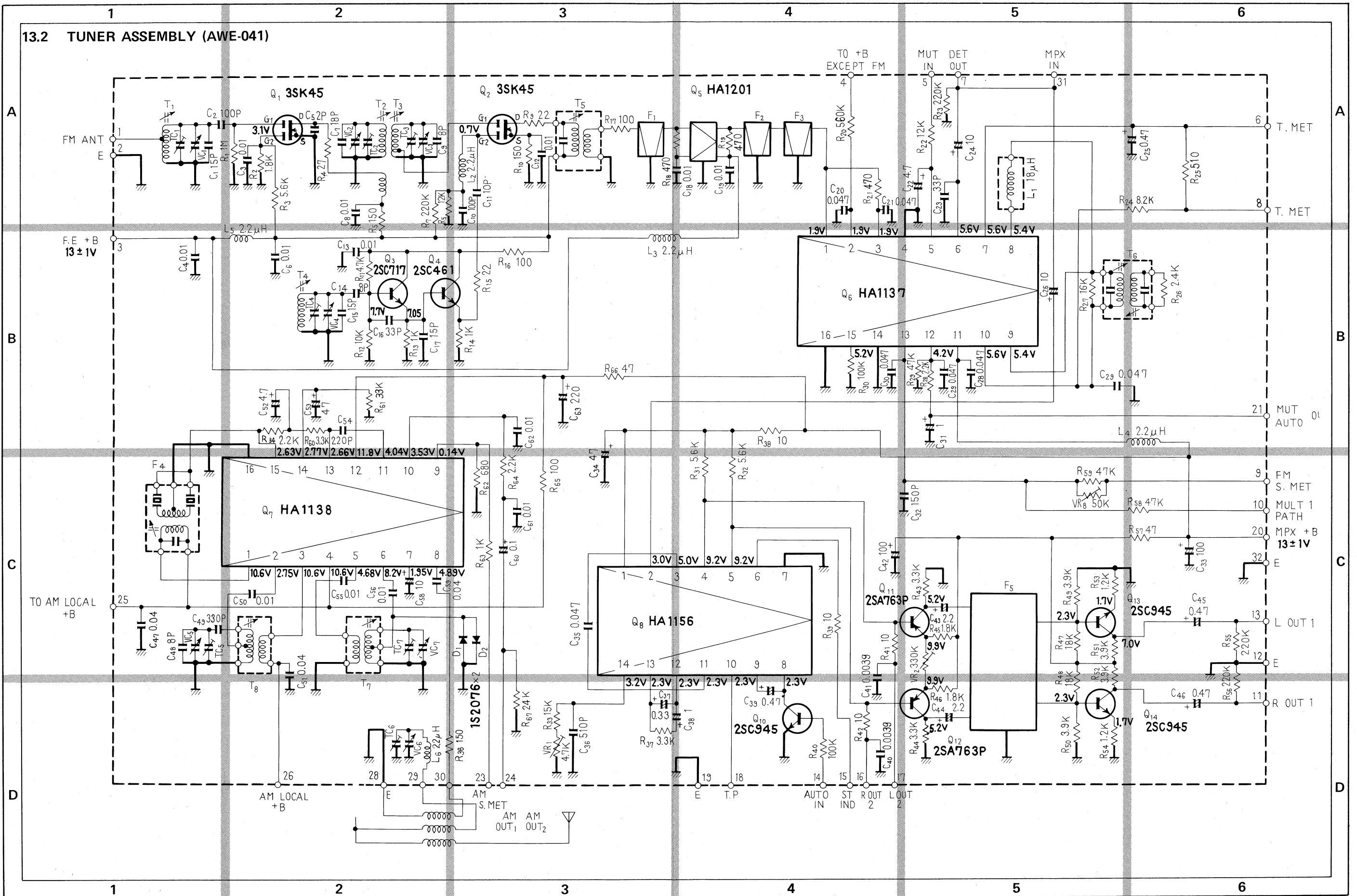

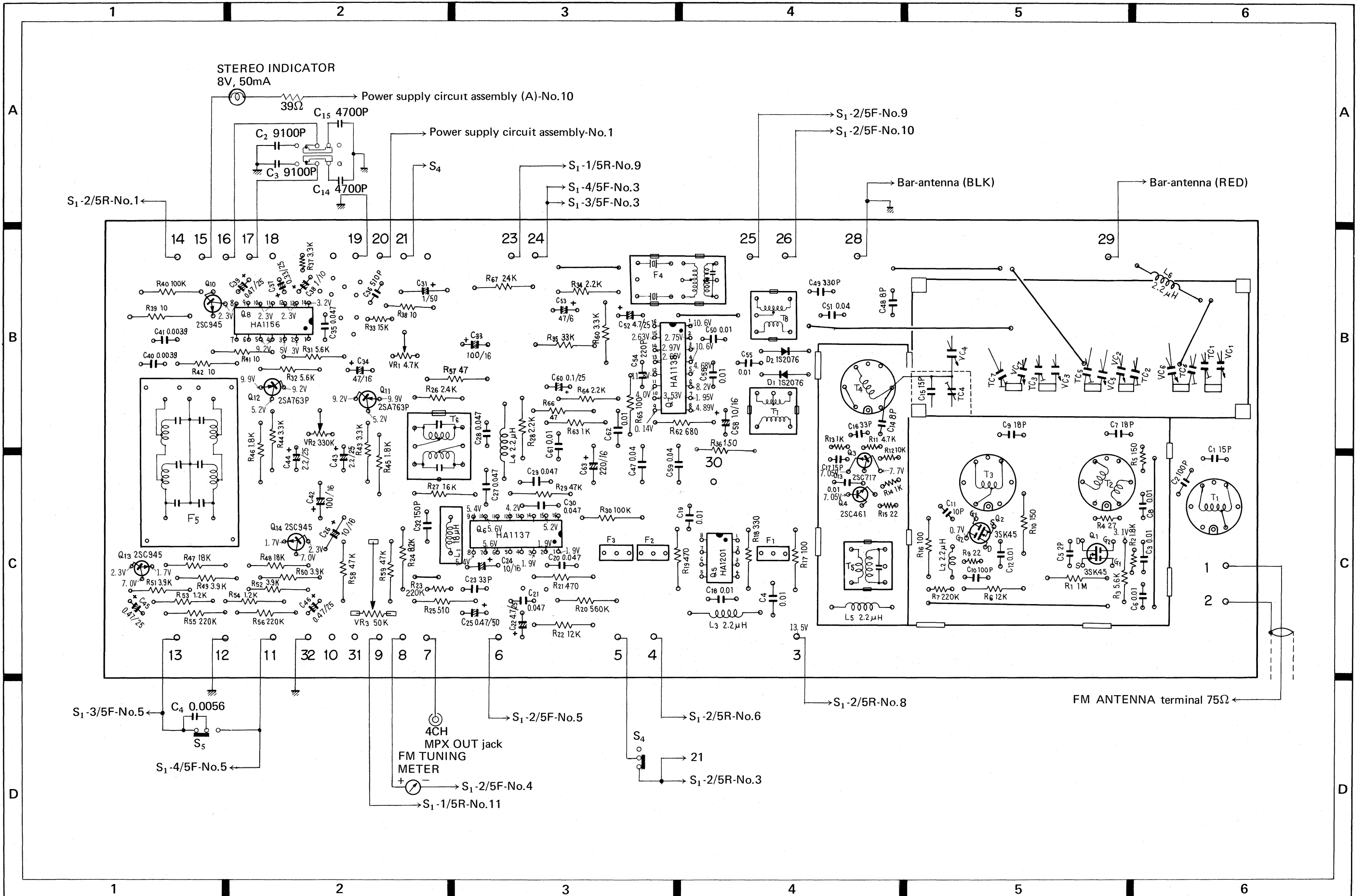

Parts List of Tuner Assembly (AWE-041)

CAPACITORS

| Symbol | Description | Part No. |
|--------|-----------------------|---------------|
| C1 | Ceramic 15p 50V | CCDSH 150K 50 |
| C2 | Ceramic 100p 50V | CCDSL 101K 50 |
| C3 | Ceramic 0.01 50V | CKDYF 103Z 50 |
| C4 | Ceramic 0.01 50V | CKDYF 103Z 50 |
| C5 | Ceramic 2p 50V | CCDSL 020C 50 |
| C6 | Ceramic 0.01 50V | CKDYF 103Z 50 |
| C7 | Ceramic 18p 50V | CCDSH 180K 50 |
| C8 | Ceramic 0.01 50V | CKDYF 103Z 50 |
| C9 | Ceramic 18p 50V | CCDSH 180K 50 |
| C10 | Ceramic 100p 50V | CCDSL 101K 50 |
| C11 | Ceramic 10p 50V | CCDSL 100F 50 |
| C12 | Ceramic 0.01 50V | CKDYF 103Z 50 |
| C13 | Ceramic 0.01 50V | CKDYB 103K 50 |
| C14 | Ceramic 8p 50V | CCDLH 080F 50 |
| C15 | Ceramic 15p 50V | CCDLH 150K 50 |
| C16 | Ceramic 33p 50V | CCDCH 330K 50 |
| C17 | Ceramic 15p 50V | CCDCH 150K 50 |
| C18 | Ceramic 0.01 50V | CKDYF 103Z 50 |
| C19 | Ceramic 0.01 50V | CKDYF 103Z 50 |
| C20 | Ceramic 0.047 25V | CKDBC 473Z 25 |
| C21 | Ceramic 0.047 25V | CKDBC 473Z 25 |
| C22 | Electrolytic 4.7 25V | CEA 4R7P 25 |
| C23 | Ceramic 33p 50V | CCDSL 330K 50 |
| C24 | Electrolytic 10 16V | CEA 100P 16 |
| C25 | Electrolytic 0.47 50V | CEA R47P 50 |
| C26 | Electrolytic 10 16V | CEA 100P 16 |
| C27 | Ceramic 0.047 25V | CKDBC 473Z 25 |
| C28 | Ceramic 0.047 25V | CKDBC 473Z 25 |
| C29 | Ceramic 0.047 25V | CKDBC 473Z 25 |
| C30 | Ceramic 0.047 25V | CKDBC 473Z 25 |
| C31 | Electrolytic 1 50V | CEA 010P 50 |
| C32 | Ceramic 150p 50V | CCDSL 151K 50 |
| C33 | Electrolytic 100 16V | CEA 101P 16 |
| C34 | Electrolytic 47 16V | CEA 470P 16 |
| C35 | Mylar 0.047 50V | CQMA 473K 50 |
| C36 | Styrol 510P 50V | CQSH 511J 50 |
| C37 | Electrolytic 0.33 25V | CSSA R33M 25 |
| C38 | Electrolytic 1 10V | CSSA 010M 10 |
| C39 | Electrolytic 0.47 25V | CSSA R47M 25 |
| C40 | Ceramic 0.0039 50V | CKDYA 392J 50 |
| C41 | Ceramic 0.0039 50V | CKDYA 392J 50 |
| C42 | Electrolytic 100 16V | CEA 101P 16 |
| C43 | Electrolytic 2.2 25V | CEA 2R2P 25 |
| C44 | Electrolytic 2.2 25V | CEA 2R2P 25 |
| C45 | Electrolytic 0.47 25V | CSSA R47M 25 |
| C46 | Electrolytic 0.47 25V | CSSA R47M 25 |
| C47 | Ceramic 0.04 50V | CKDYF 403Z 50 |
| C48 | Ceramic 8p 50V | CCDXL 080F 50 |

| Symbol | Description | Part No. |
|--------|-----------------------|---------------|
| C49 | Styrol 330p 50V | CQSA 331J 50 |
| C50 | Mylar 0.01 50V | CQMA 103K 50 |
| C51 | Ceramic 0.04 50V | CKDYF 403Z 50 |
| C52 | Electrolytic 4.7 25V | CEA 4R7P 25 |
| C53 | Electrolytic 47 6V | CEA 470P 6 |
| C54 | Ceramic 220p 50V | CCDSL 221K 50 |
| C55 | Ceramic 0.01 50V | CKDYF 103Z 50 |
| C56 | Ceramic 0.01 50V | CKDYF 103Z 50 |
| C57 | Vacancy | |
| C58 | Electrolytic 10 16V | CEA 100P 16 |
| C59 | Electrolytic 0.04 50V | CKDYF 403Z 50 |
| C60 | Electrolytic 0.1 25V | CSSA 0R1M 25 |
| C61 | Ceramic 0.01 50V | CKDYB 103K 50 |
| C62 | Ceramic 0.01 50V | CKDYB 103K 50 |
| C63 | Electrolytic 220 16V | CEA 221P 16 |
| VC | Tuning capacitor | ACK-006-A |
| TC4 | Ceramic trimmer | C43-007-A |

RESISTORS

| Symbol | Description | Part No. |
|--------|------------------|------------|
| R1 | Carbon film 1M | RD%PS 105J |
| R2 | Carbon film 1.8k | RD%VS 182J |
| R3 | Carbon film 5.6k | RD%PS 562J |
| R4 | Carbon film 27 | RD%VS 270J |
| R5 | Carbon film 150 | RD%VS 151J |
| R6 | Carbon film 12k | RD%PS 123J |
| R7 | Carbon film 220k | RD%VS 224J |
| R8 | Vacancy | |
| R9 | Carbon film 22 | RD%VS 220J |
| R10 | Carbon film 150 | RD%PS 151J |
| R11 | Carbon film 4.7k | RD%VS 472J |
| R12 | Carbon film 10k | RD%VS 103J |
| R13 | Carbon film 1k | RD%VS 102J |
| R14 | Carbon film 1k | RD%VS 102J |
| R15 | Carbon film 22 | RD%VS 220J |
| R16 | Carbon film 100 | RD%PS 101J |
| R17 | Carbon film 100 | RD%PS 101J |
| R18 | Carbon film 470 | RD%PS 471J |
| R19 | Carbon film 470 | RD%PS 471J |
| R20 | Carbon film 560k | RD%PS 564J |
| R21 | Carbon film 470 | RD%PS 471J |
| R22 | Carbon film 12k | RD%PS 123J |
| R23 | Carbon film 220k | RD%VS 224J |
| R24 | Carbon film 8.2k | RD%PS 822J |
| R25 | Carbon film 510 | RD%PS 511J |
| R26 | Carbon film 2.4k | RD%VS 242J |
| R27 | Carbon film 16k | RD%PS 163J |
| R28 | Carbon film 2.2k | RD%PS 222J |
| R29 | Carbon film 47k | RD%PS 473J |
| R30 | Carbon film 100k | RD%PS 104J |

| Symbol | Description | Part No. |
|--------|------------------------------|------------|
| R31 | Carbon film 5.6k | RD%PS 562J |
| R32 | Carbon film 5.6k | RD%PS 562J |
| R33 | Carbon film 15k | RD%VS 153J |
| R34 | Carbon film 2.2k | RD%PS 222J |
| R35 | Carbon film 33k | RD%PS 333J |
| R36 | Carbon film 150 | RD%PS 151J |
| R37 | Carbon film 3.3k | RD%VS 332J |
| R38 | Carbon film 10 | RD%VS 100J |
| R39 | Carbon film 10 | RD%PS 100J |
| R40 | Carbon film 100k | RD%PS 104J |
| R41 | Carbon film 10 | RD%PS 100J |
| R42 | Carbon film 10 | RD%PS 100J |
| R43 | Carbon film 3.3k | RD%PS 332J |
| R44 | Carbon film 3.3k | RD%PS 332J |
| R45 | Carbon film 1.8k | RD%PS 182J |
| R46 | Carbon film 1.8k | RD%PS 182J |
| R47 | Carbon film 18k | RD%PS 183J |
| R48 | Carbon film 18k | RD%PS 183J |
| R49 | Carbon film 3.9k | RD%PS 392J |
| R50 | Carbon film 3.9k | RD%PS 392J |
| R51 | Carbon film 3.9k | RD%PS 392J |
| R52 | Carbon film 3.9k | RD%PS 392J |
| R53 | Carbon film 1.2k | RD%PS 122J |
| R54 | Carbon film 1.2k | RD%PS 122J |
| R55 | Carbon film 220k | RD%PS 224J |
| R56 | Carbon film 220k | RD%PS 224J |
| R57 | Carbon film 47 | RD%PS 470J |
| R58 | Carbon film 47k | RD%PS 473J |
| R59 | Carbon film 47k | RD%PS 473J |
| R60 | Carbon film 3.3k | RD%PS 332J |
| R61 | Vacancy | |
| R62 | Carbon film 680 | RD%PS 681J |
| R63 | Carbon film 1k | RD%PS 102J |
| R64 | Carbon film 2.2k | RD%PS 222J |
| R65 | Carbon film 100 | RD%PS 101J |
| R66 | Carbon film 47 | RD%PS 470J |
| R67 | Carbon film 24k | RD%PS 243J |
| VR1 | Variable (semi-fixed) 4.7k-B | C92-051-0 |
| VR2 | Variable (semi-fixed) 330k-B | ACP-042-0 |
| VR3 | Variable (semi-fixed) 50k-B | ACP-043-0 |

SEMICONDUCTORS

| Symbol | Description | Part No. |
|--------|-------------|----------|
| Q1 | FET | 3SK45-B |
| Q2 | FET | 3SK45-B |
| Q3 | Transistor | 2SC717 |

| Symbol | Description | Part No. |
|--------|-------------|-----------------------------------|
| Q4 | Transistor | 2SC461-B |
| Q5 | IC | HA1201 |
| Q6 | IC | HA1137 |
| Q7 | IC | HA1138 |
| Q8 | IC | HA1156 |
| Q10 | Transistor | 2SC945-Q, R or S |
| Q11 | Transistor | 2SA763P-6 or 5 (2SA725-F or G) |
| Q12 | Transistor | 2SA763P-6 or 5 (2SA725-F or G) |
| Q13 | Transistor | 2SC945-Q, R or S |
| Q14 | Transistor | 2SC945-Q, R or S |
| D1 | Diode | 1S2076 |
| D2 | Diode | 1S2076 |

COILS, TRANSFORMERS, AND FILTERS.

| Symbol | Description | Part No. |
|--------|---------------------|----------|
| T1 | FM antenna coil | ATC-021 |
| T2 | FM RF coil | ATC-015 |
| T3 | FM RF coil | ATC-016 |
| T4 | FM osc coil | ATC-022 |
| T5 | FM IF transformer | ATE-008 |
| T6 | FM DET transformer | T73-035 |
| T7 | AM RF coil | ATB-014 |
| T8 | AM osc coil | ATB-013 |
| F1 | FM ceramic filter | ATF-013 |
| F2 | FM ceramic filter | ATF-013 |
| F3 | FM ceramic filter | ATF-013 |
| F4 | AM ceramic filter | ATF-009 |
| F5 | LOW Pass filter | ATF-019 |
| L1 | RF choke coil 18μH | ATH-007 |
| L2 | RF choke coil 2.2μH | T24-028 |
| L3 | RF choke coil 2.2μH | T24-028 |
| L4 | RF choke coil 2.2μH | T24-028 |
| L5 | RF choke coil 2.2μH | T24-028 |
| L6 | RF choke coil 2.2μH | T24-028 |

13.3 HEADPHONE JACK ASSEMBLY (AWX-054)

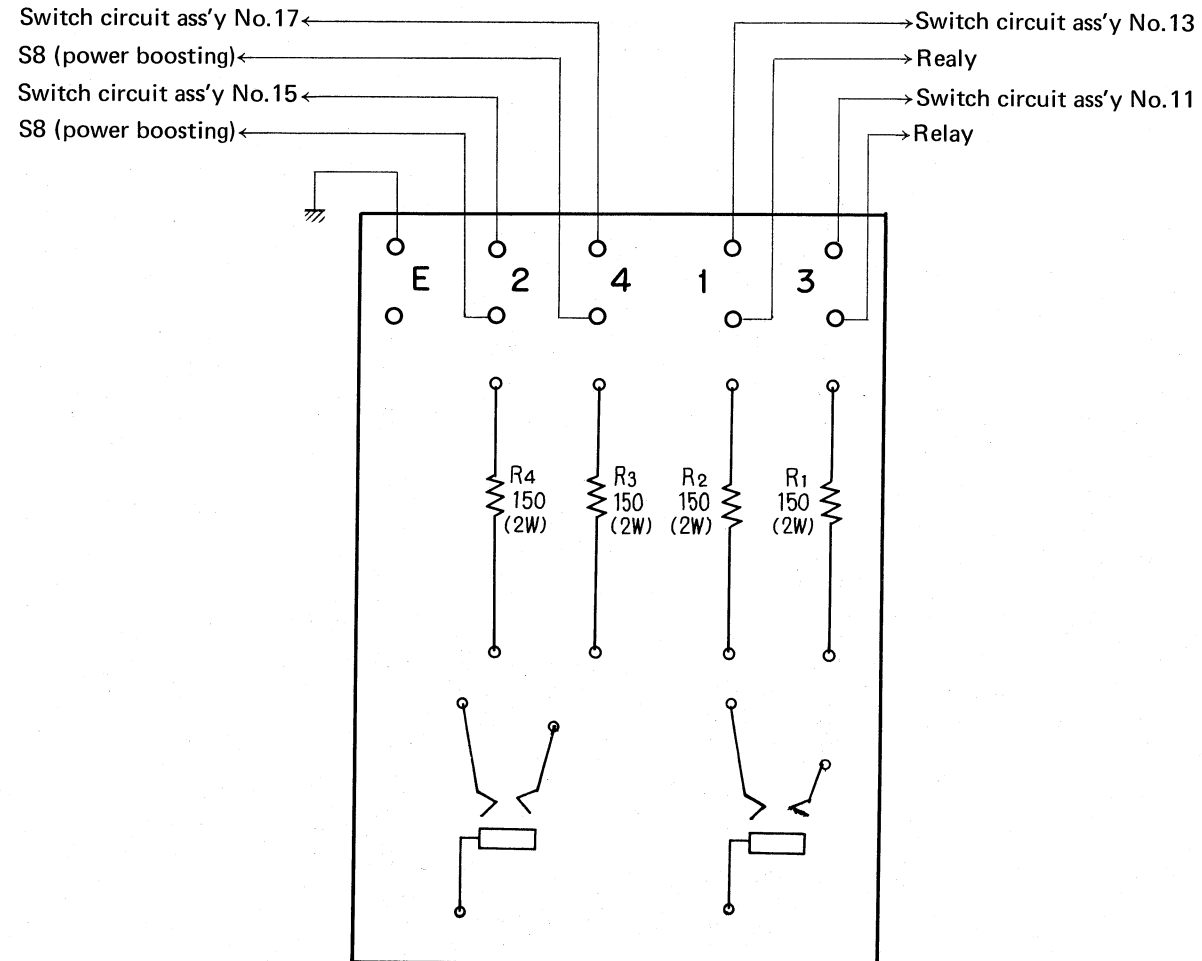

Parts List of Headphone Jack Assembly (AWX-054)

RESISTORS

| Symbol | Description | Part No. |
|--------|--------------------|-----------|
| R1 | Metal oxide 150 2W | RS2P 151K |
| R2 | Metal oxide 150 2W | RS2P 151K |
| R3 | Metal oxide 150 2W | RS2P 151K |
| R4 | Metal oxide 150 2W | RS2P 151K |

OTHERS

| Symbol | Description | Part No. |
|--------|--------------------|----------|
| | Phone jack (FRONT) | AKN-002 |
| | Phone jack (REAR) | AKN-002 |

13.4 POWER SUPPLY CIRCUIT B ASSEMBLY (AWR-039)

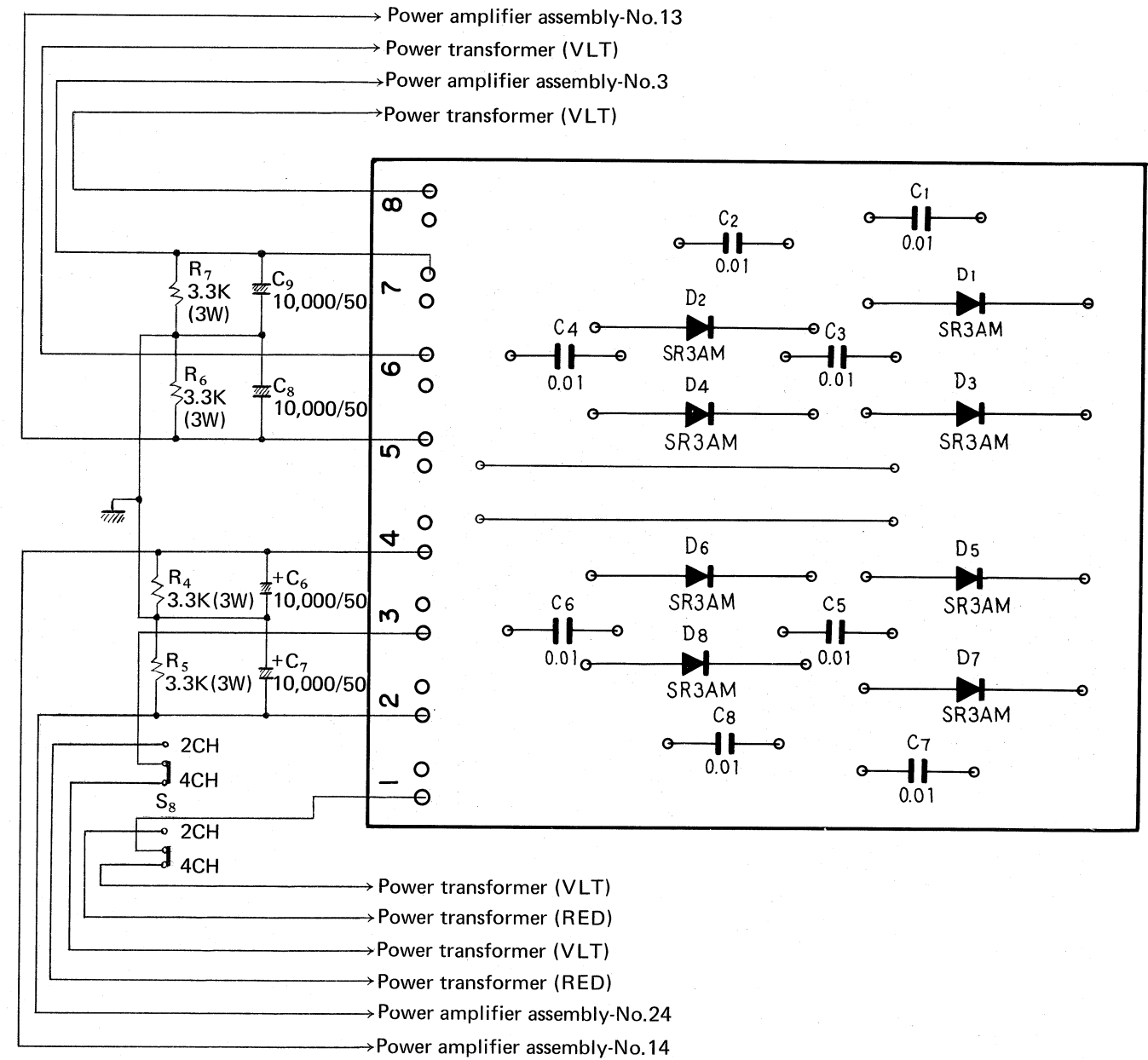

Parts List of Power Supply Circuit B Assembly (AWR-039)

CAPACITORS

| Symbol | Description | Part No. |
|--------|-------------------|----------|
| C1 | Ceramic 0.01 150V | ACG-004 |
| C2 | Ceramic 0.01 150V | ACG-004 |
| C3 | Ceramic 0.01 150V | ACG-004 |
| C4 | Ceramic 0.01 150V | ACG-004 |
| C5 | Ceramic 0.01 150V | ACG-004 |
| C6 | Ceramic 0.01 150V | ACG-004 |
| C7 | Ceramic 0.01 150V | ACG-004 |
| C8 | Ceramic 0.01 150V | ACG-004 |

SEMICONDUCTORS

| Symbol | Description | Part No. |
|--------|-------------|----------|
| D1 | Diode | SR3AM-4 |
| D2 | Diode | SR3AM-4 |
| D3 | Diode | SR3AM-4 |
| D4 | Diode | SR3AM-4 |
| D5 | Diode | SR3AM-4 |
| D6 | Diode | SR3AM-4 |
| D7 | Diode | SR3AM-4 |
| D8 | Diode | SR3AM-4 |

13.5 CD-4 ASSEMBLY (AWM-076)

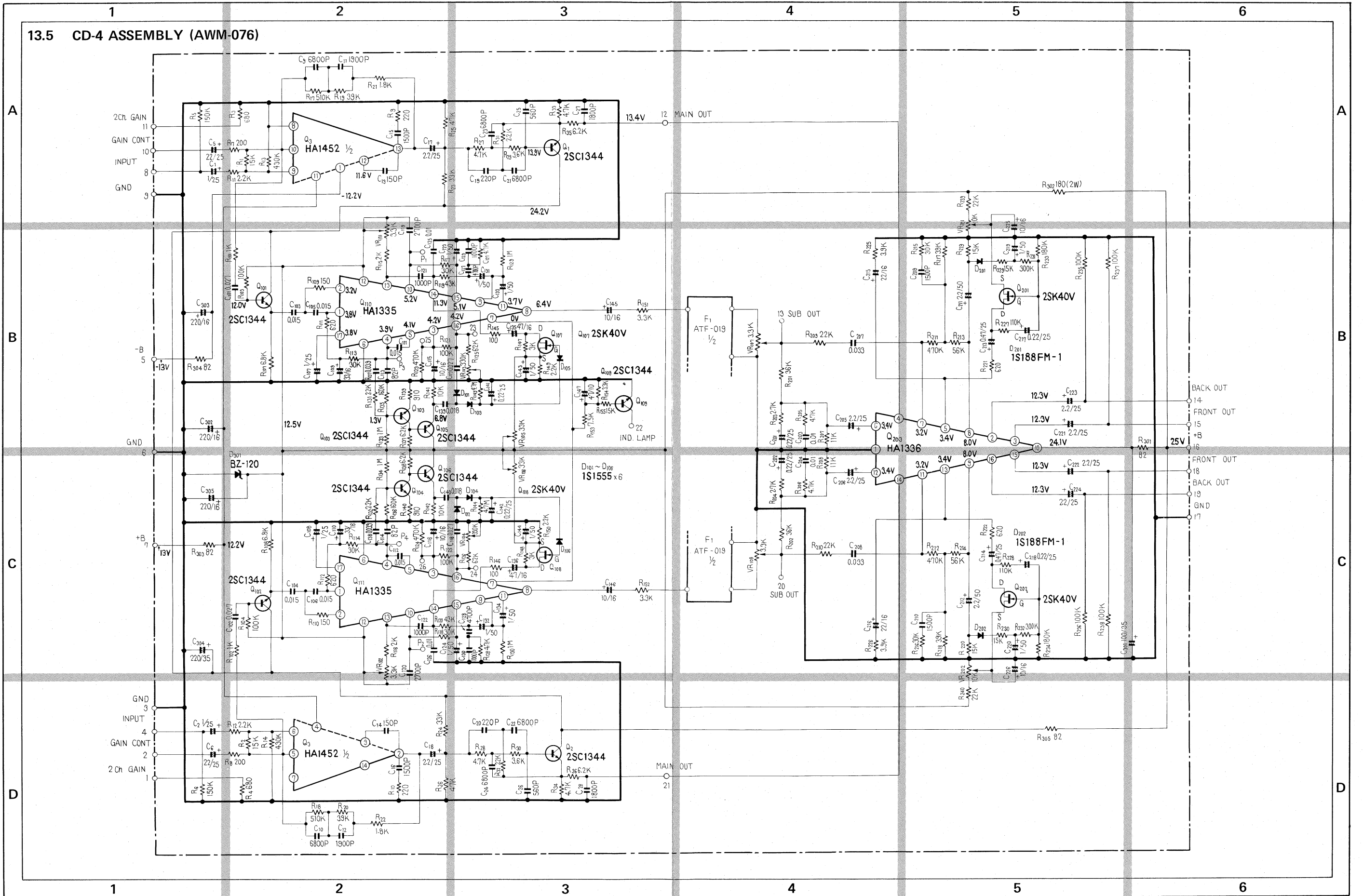

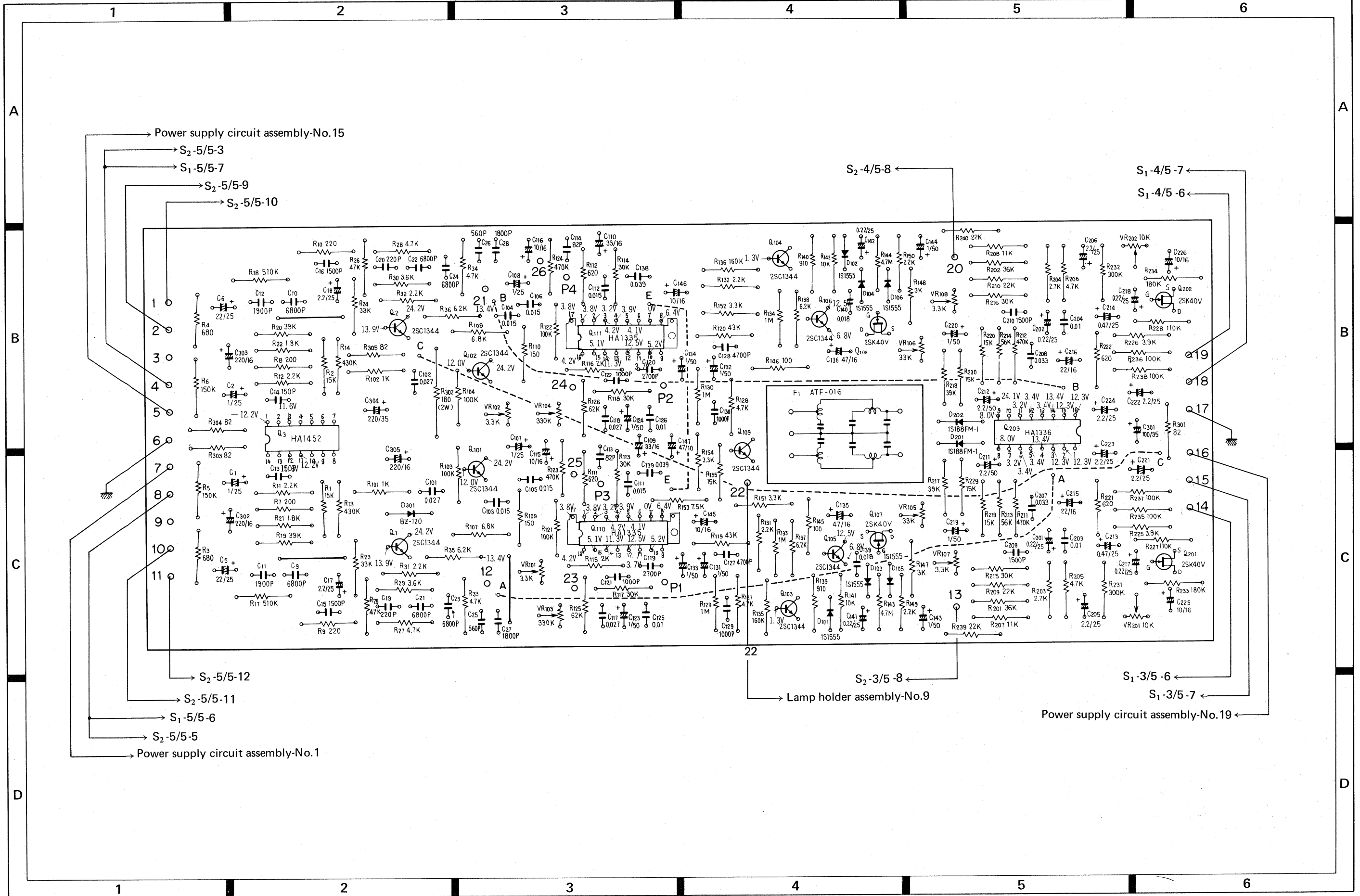

Parts List of CD-4 Assembly (AWM-076)

CAPACITORS

| Symbol | Description | Part No. |
|--------|----------------------|---------------|
| C1 | Electrolytic 1 25V | CSSA 010M 25 |
| C2 | Electrolytic 1 25V | CSSA 010M 25 |
| C3 | Vacancy | |
| C4 | Vacancy | |
| C5 | Electrolytic 22 25V | CEANL 220P 25 |
| C6 | Electrolytic 22 25V | CEANL 220P 25 |
| C7 | Vacancy | |
| C8 | Vacancy | |
| C9 | Styrol 6800p 50V | CQSA 682G 50 |
| C10 | Styrol 6800p 50V | CQSA 682G 50 |
| C11 | Styrol 1900p 50V | CQSA 192G 50 |
| C12 | Styrol 1900p 50V | CQSA 192G 50 |
| C13 | Ceramic 150p 50V | CCDSL 151K 50 |
| C14 | Ceramic 150p 50V | CCDSL 151K 50 |
| C15 | Mylar 0.0015 50V | CQMA 152K 50 |
| C16 | Mylar 0.0015 50V | CQMA 152K 50 |
| C17 | Electrolytic 2.2 25V | CSSA 2R2M 25 |
| C18 | Electrolytic 2.2 25V | CSSA 2R2M 25 |
| C19 | Styrol 220p 50V | CQSA 221J 50 |
| C20 | Styrol 220p 50V | CQSA 221J 50 |
| C21 | Mylar 0.0068 50V | CQMA 682J 50 |
| C22 | Mylar 0.0068 50V | CQMA 682J 50 |
| C23 | Mylar 0.0068 50V | CQMA 682J 50 |
| C24 | Mylar 0.0068 50V | CQMA 682J 50 |
| C25 | Ceramic 560p 50V | CKDYB 561K 50 |
| C26 | Ceramic 560p 50V | CKDYB 561K 50 |
| C27 | Mylar 0.0018 50V | CQMA 182K 50 |
| C28 | Mylar 0.0018 50V | CQMA 182K 50 |
| C101 | Mylar 0.027 50V | CQMA 273K 50 |
| C102 | Mylar 0.027 50V | CQMA 273K 50 |
| C103 | Mylar 0.015 50V | CQMA 153K 50 |
| C104 | Mylar 0.015 50V | CQMA 153K 50 |
| C105 | Mylar 0.015 50V | CQMA 153K 50 |
| C106 | Mylar 0.015 50V | CQMA 153K 50 |
| C107 | Electrolytic 1 25V | CSSA 010M 25 |
| C108 | Electrolytic 1 25V | CSSA 010M 25 |
| C109 | Electrolytic 33 16V | CEA 330P 16 |
| C110 | Electrolytic 33 16V | CEA 330P 16 |
| C111 | Mylar 0.015 50V | CQMA 153K 50 |
| C112 | Mylar 0.015 50V | CQMA 153K 50 |
| C113 | Ceramic 82p 50V | CCDSL 820K 50 |
| C114 | Ceramic 82p 50V | CCDSL 820K 50 |
| C115 | Electrolytic 10 16V | CEA 100P 16 |
| C116 | Electrolytic 10 16V | CEA 100P 16 |
| C117 | Mylar 0.027 50V | CQMA 273K 50 |
| C118 | Mylar 0.027 50V | CQMA 273K 50 |
| C119 | Mylar 0.0027 50V | CQMA 272K 50 |
| C120 | Mylar 0.0027 50V | CQMA 272K 50 |

| Symbol | Description | Part No. |
|--------|-----------------------|--------------|
| C121 | Mylar 0.001 50V | CQMA 102K 50 |
| C122 | Mylar 0.001 50V | CQMA 102K 50 |
| C123 | Electrolytic 1 50V | CEA 010P 50 |
| C124 | Electrolytic 1 50V | CEA 010P 50 |
| C125 | Mylar 0.01 50V | CQMA 103K 50 |
| C126 | Mylar 0.01 50V | CQMA 103K 50 |
| C127 | Mylar 0.0047 50V | CQMA 472K 50 |
| C128 | Mylar 0.0047 50V | CQMA 472K 50 |
| C129 | Mylar 0.001 50V | CQMA 102K 50 |
| C130 | Mylar 0.001 50V | CQMA 102K 50 |
| C131 | Electrolytic 1 50V | CEA 010P 50 |
| C132 | Electrolytic 1 50V | CEA 010P 50 |
| C133 | Electrolytic 1 50V | CEA 010P 50 |
| C134 | Electrolytic 1 50V | CEA 010P 50 |
| C135 | Electrolytic 47 16V | CEA 470P 16 |
| C136 | Electrolytic 47 16V | CEA 470P 16 |
| C137 | Mylar 0.039 50V | CQMA 393K 50 |
| C138 | Mylar 0.039 50V | CQMA 393K 50 |
| C139 | Mylar 0.018 50V | CQMA 183K 50 |
| C140 | Mylar 0.018 50V | CQMA 183K 50 |
| C141 | Electrolytic 0.22 25V | CSSA R22M 25 |
| C142 | Electrolytic 0.22 25V | CSSA R22M 25 |
| C143 | Electrolytic 1 50V | CEA 010 50 |
| C144 | Electrolytic 1 50V | CEA 010 50 |
| C145 | Electrolytic 10 16V | CEA 100P 16 |
| C146 | Electrolytic 10 16V | CEA 100P 16 |
| C147 | Electrolytic 47 10V | CEA 470P 10 |
| C201 | Electrolytic 0.22 25V | CSSA R22M 25 |
| C202 | Electrolytic 0.22 25V | CSSA R22M 25 |
| C203 | Mylar 0.01 50V | CQMA 103K 50 |
| C204 | Mylar 0.01 50V | CQMA 103K 50 |
| C205 | Electrolytic 2.2 25V | CSSA 2R2M 25 |
| C206 | Electrolytic 2.2 25V | CSSA 2R2M 25 |
| C207 | Mylar 0.033 50V | CQMA 333K 50 |
| C208 | Mylar 0.033 50V | CQMA 333K 50 |
| C209 | Mylar 0.0015 50V | CQMA 152K 50 |
| C210 | Mylar 0.0015 50V | CQMA 152K 50 |
| C211 | Electrolytic 2.2 50V | CEA 2R2P 50 |
| C212 | Electrolytic 2.2 50V | CEA 2R2P 50 |
| C213 | Electrolytic 0.47 25V | CSSA R47M 25 |
| C214 | Electrolytic 0.47 25V | CSSA R47M 25 |
| C215 | Electrolytic 22 16V | CEA 220P 16 |
| C216 | Electrolytic 22 16V | CEA 220P 16 |
| C217 | Electrolytic 0.22 25V | CSSA R22M 25 |
| C218 | Electrolytic 0.22 25V | CSSA R22M 25 |
| C219 | Electrolytic 1 50V | CSSA 010P 50 |
| C220 | Electrolytic 1 50V | CSSA 010P 50 |
| C221 | Electrolytic 2.2 25V | CSSA 2R2M 25 |
| C222 | Electrolytic 2.2 25V | CSSA 2R2M 25 |

| Symbol | Description | Part No. |
|--------|----------------------|--------------|
| C223 | Electrolytic 2.2 25V | CSSA 2R2M 25 |
| C224 | Electrolytic 2.2 25V | CSSA 2R2M 25 |
| C225 | Electrolytic 10 16V | CEA 100P 16 |
| C226 | Electrolytic 10 16V | CEA 100P 16 |
| C301 | Electrolytic 100 35V | CEA 101P 35 |
| C302 | Electrolytic 220 16V | CEA 221P 16 |
| C303 | Electrolytic 220 16V | CEA 221P 16 |
| C304 | Electrolytic 220 35V | CEA 221P 35 |
| C305 | Electrolytic 220 16V | CEA 221P 16 |

RESISTORS

| Symbol | Description | Part No. |
|--------|------------------|------------|
| R1 | Carbon film 15k | RD%PS 153J |
| R2 | Carbon film 15k | RD%PS 153J |
| R3 | Carbon film 680 | RD%PS 681J |
| R4 | Carbon film 680 | RD%PS 681J |
| R5 | Carbon film 150k | RD%PS 154J |
| R6 | Carbon film 150k | RD%PS 154J |
| R7 | Carbon film 200 | RD%PS 201J |
| R8 | Carbon film 200 | RD%PS 201J |
| R9 | Carbon film 220 | RD%PS 221J |
| R10 | Carbon film 220 | RD%PS 221J |
| R11 | Carbon film 2.2k | RD%PS 222J |
| R12 | Carbon film 2.2k | RD%PS 222J |
| R13 | Carbon film 430k | RD%PS 434J |
| R14 | Carbon film 430k | RD%PS 434J |
| R15 | Vacancy | |
| R16 | Vacancy | |
| R17 | Carbon film 510k | RD%PS 514J |
| R18 | Carbon film 510k | RD%PS 514J |
| R19 | Carbon film 39k | RD%PS 393J |
| R20 | Carbon film 39k | RD%PS 393J |
| R21 | Carbon film 1.8k | RD%PS 182J |
| R22 | Carbon film 1.8k | RD%PS 182J |
| R23 | Carbon film 33k | RD%PS 333J |
| R24 | Carbon film 33k | RD%PS 333J |
| R25 | Carbon film 47k | RD%PS 473J |
| R26 | Carbon film 47k | RD%PS 473J |
| R27 | Carbon film 4.7k | RD%PS 472J |
| R28 | Carbon film 4.7k | RD%PS 472J |
| R29 | Carbon film 3.6k | RD%PS 362J |
| R30 | Carbon film 3.6k | RD%PS 362J |
| R31 | Carbon film 2.2k | RD%PS 222J |
| R32 | Carbon film 2.2k | RD%PS 222J |
| R33 | Carbon film 4.7k | RD%PS 472J |
| R34 | Carbon film 4.7k | RD%PS 472J |
| R35 | Carbon film 6.2k | RD%PS 622J |
| R36 | Carbon film 6.2k | RD%PS 622J |
| R101 | Carbon film 1k | RD%PS 102J |
| R102 | Carbon film 1k | RD%PS 102J |

| Symbol | Description | Part No. |
|--------|------------------|------------|
| R103 | Carbon film 100k | RD%PS 104J |
| R104 | Carbon film 100k | RD%PS 104J |
| R105 | Vacancy | |
| R106 | Vacancy | |
| R107 | Carbon film 6.8k | RD%PS 682J |
| R108 | Carbon film 6.8k | RD%PS 682J |
| R109 | Carbon film 150 | RD%PS 151J |
| R110 | Carbon film 150 | RD%PS 151J |
| R111 | Carbon film 620 | RD%PS 621J |
| R112 | Carbon film 620 | RD%PS 621J |
| R113 | Carbon film 30k | RD%PS 303J |
| R114 | Carbon film 30k | RD%PS 303J |
| R115 | Carbon film 2k | RD%PS 202J |
| R116 | Carbon film 2k | RD%PS 202J |
| R117 | Carbon film 30k | RD%PS 303J |
| R118 | Carbon film 30k | RD%PS 303J |
| R119 | Carbon film 43k | RD%PS 433J |
| R120 | Carbon film 43k | RD%PS 433J |
| R121 | Carbon film 100k | RD%PS 104J |
| R122 | Carbon film 100k | RD%PS 104J |
| R123 | Carbon film 470k | RD%PS 474J |
| R124 | Carbon film 470k | RD%PS 474J |
| R125 | Carbon film 62k | RD%PS 623J |
| R126 | Carbon film 62k | RD%PS 623J |
| R127 | Carbon film 4.7k | RD%PS 472J |
| R128 | Carbon film 4.7k | RD%PS 472J |
| R129 | Carbon film 1M | RD%PS 105J |
| R130 | Carbon film 1M | RD%PS 105J |
| R131 | Carbon film 2.2k | RD%PS 222J |
| R132 | Carbon film 2.2k | RD%PS 222J |
| R133 | Carbon film 1M | RD%PS 105J |
| R134 | Carbon film 1M | RD%PS 105J |
| R135 | Carbon film 160k | RD%PS 164J |
| R136 | Carbon film 160k | RD%PS 164J |
| R137 | Carbon film 6.2k | RD%PS 622J |
| R138 | Carbon film 6.2k | RD%PS 622J |
| R139 | Carbon film 910 | RD%PS 911J |
| R140 | Carbon film 910 | RD%PS 911J |
| R141 | Carbon film 10k | RD%PS 103J |
| R142 | Carbon film 10k | RD%PS 103J |
| R143 | Carbon film 4.7M | RD%PS 475J |
| R144 | Carbon film 4.7M | RD%PS 475J |
| R145 | Carbon film 100 | RD%PS 101J |
| R146 | Carbon film 100 | RD%PS 101J |
| R147 | Carbon film 3k | RD%PS 302J |
| R148 | Carbon film 3k | RD%PS 302J |
| R149 | Carbon film 2.2k | RD%PS 222J |
| R150 | Carbon film 2.2k | RD%PS 222J |
| R151 | Carbon film 3.3k | RD%PS 332J |
| R152 | Carbon film 3.3k | RD%PS 332J |
| R153 | Carbon film 7.5k | RD%PS 752J |
| R154 | Carbon film 3.3k | RD%PS 332J |

| Symbol | Description | Part No. |
|--------|------------------------------|------------|
| R155 | Carbon film 15k | RD½PS 153J |
| R201 | Carbon film 36k | RD½PS 363J |
| R202 | Carbon film 36k | RD½PS 363J |
| R203 | Carbon film 2.7k | RD½PS 272J |
| R204 | Carbon film 2.7k | RD½PS 272J |
| R205 | Carbon film 4.7k | RD½PS 472J |
| R206 | Carbon film 4.7k | RD½PS 472J |
| R207 | Carbon film 11k | RD½PS 113J |
| R208 | Carbon film 11k | RD½PS 113J |
| R209 | Carbon film 22k | RD½PS 223J |
| R210 | Carbon film 22k | RD½PS 223J |
| R211 | Carbon film 470k | RD½PS 474J |
| R212 | Carbon film 470k | RD½PS 474J |
| R213 | Carbon film 56k | RD½PS 563J |
| R214 | Carbon film 56k | RD½PS 563J |
| R215 | Carbon film 30k | RD½PS 303J |
| R216 | Carbon film 30k | RD½PS 303J |
| R217 | Carbon film 39k | RD½PS 393J |
| R218 | Carbon film 39k | RD½PS 393J |
| R219 | Carbon film 15k | RD½PS 153J |
| R220 | Carbon film 15k | RD½PS 153J |
| R221 | Carbon film 620 | RD½PS 621J |
| R222 | Carbon film 620 | RD½PS 621J |
| R223 | Vacancy | |
| R224 | Vacancy | |
| R225 | Carbon film 3.9k | RD½PS 392J |
| R226 | Carbon film 3.9k | RD½PS 392J |
| R227 | Carbon film 110k | RD½PS 114J |
| R228 | Carbon film 110k | RD½PS 114J |
| R229 | Carbon film 15k | RD½PS 153J |
| R230 | Carbon film 15k | RD½PS 153J |
| R231 | Carbon film 300k | RD½PS 304J |
| R232 | Carbon film 300k | RD½PS 304J |
| R233 | Carbon film 180k | RD½PS 184J |
| R234 | Carbon film 180k | RD½PS 184J |
| R235 | Carbon film 100k | RD½PS 104J |
| R236 | Carbon film 100k | RD½PS 104J |
| R237 | Carbon film 100k | RD½PS 104J |
| R238 | Carbon film 100k | RD½PS 104J |
| R239 | Carbon film 22k | RD½PS 223J |
| R240 | Carbon film 22k | RD½PS 223J |
| R301 | Carbon film 82 | RD½PS 820J |
| R302 | Metal oxide 180 2W | RS2P 181J |
| R303 | Carbon film 82 | RD½PS 820J |
| R304 | Carbon film 82 | RD½PS 820J |
| R305 | Carbon film 82 | RD½PS 820J |
| VR101 | Variable (semi-fixed) 3.3k-B | ACP-047 |
| VR102 | Variable (semi-fixed) 3.3k-B | ACP-047 |
| VR103 | Variable (semi-fixed) 330k-B | ACP-042 |
| VR104 | Variable (semi-fixed) 330k-B | ACP-042 |
| VR105 | Variable (semi-fixed) 33k-B | ACP-025 |

| Symbol | Description | Part No. |
|--------|------------------------------|----------|
| VR106 | Variable (semi-fixed) 33k-B | ACP-025 |
| VR107 | Variable (semi-fixed) 3.3k-B | ACP-028 |
| VR108 | Variable (semi-fixed) 3.3k-B | ACP-028 |
| VR201 | Variable (semi-fixed) 10k-B | C92-049 |
| VR202 | Variable (semi-fixed) 10k-B | C92-049 |

SEMICONDUCTORS

| Symbol | Description | Part No. |
|--------|-------------|------------------------------------|
| Q1 | Transistor | 2SC1344-E or F (2SC1312-G or H) |
| Q2 | Transistor | 2SC1344-E or F (2SC1312-G or H) |
| Q3 | IC | HA1452 |
| Q101 | Transistor | 2SC1344-E or F (2SC1312-G or H) |
| Q102 | Transistor | 2SC1344-G or F (2SC1312-G or H) |
| Q103 | Transistor | 2SC1344-E or F (2SC1312-G or H) |
| Q104 | Transistor | 2SC1344-E or F (2SC1312-G or H) |
| Q105 | Transistor | 2SC1344-E or F (2SC1312-G or H) |
| Q106 | Transistor | 2SC1344-E or F (2SC1312-G or H) |
| Q107 | FET | 2SK40V-2 or 3 (2SK30AP-2 or 3) |
| Q108 | FET | 2SK40V-2 or 3 (2SK30AP-2 or 3) |
| Q109 | Transistor | 2SC1344-E or F (2SC1312-G or H) |
| Q110 | IC | HA1335 |
| Q111 | IC | HA1335 |
| Q201 | FET | 2SK40V-2 or 3 (2SK30AP-2 or 3) |
| Q202 | FET | 2SK40V-2 or 3 (2SK30AP-2 or 3) |
| Q203 | IC | HA1336 |
| D101 | Diode | 1S1555 (1S2473) |
| D102 | Diode | 1S1555 (1S2473) |
| D103 | Diode | 1S1555 (1S2473) |
| D104 | Diode | 1S1555 (1S2473) |
| D105 | Diode | 1S1555 (1S2473) |
| D106 | Diode | 1S1555 (1S2473) |

| Symbol | Description | Part No. |
|--------|-------------|-----------|
| D201 | Diode | 1S188FM-1 |
| D202 | Diode | 1S188FM-1 |
| D301 | Zener diode | BZ-120 |

13.6 SQ/RM DECODER ASSEMBLY (AWM-077)

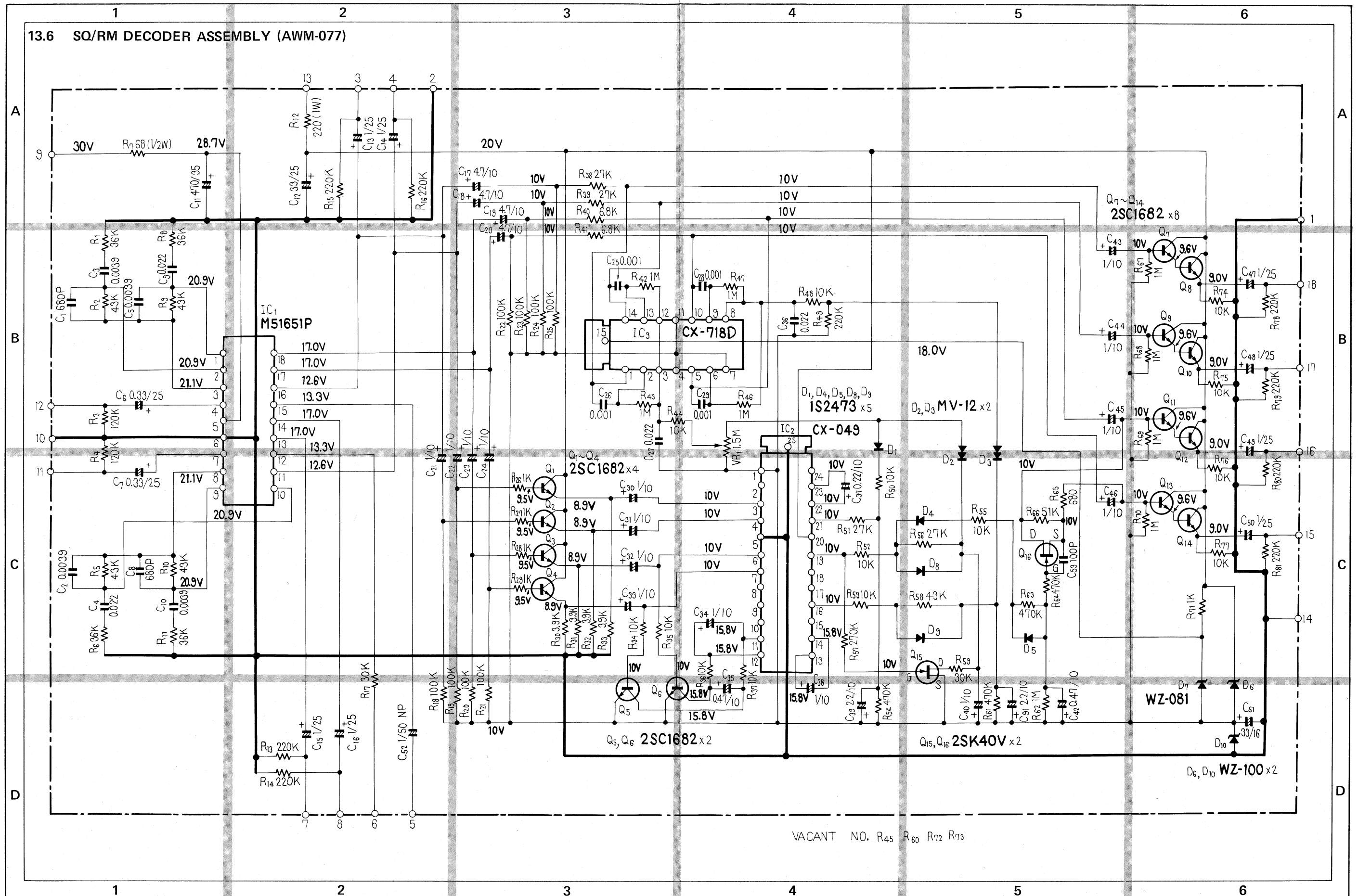

VACANT NO. R₄₅ R₆₀ R₇₂ R₇₃

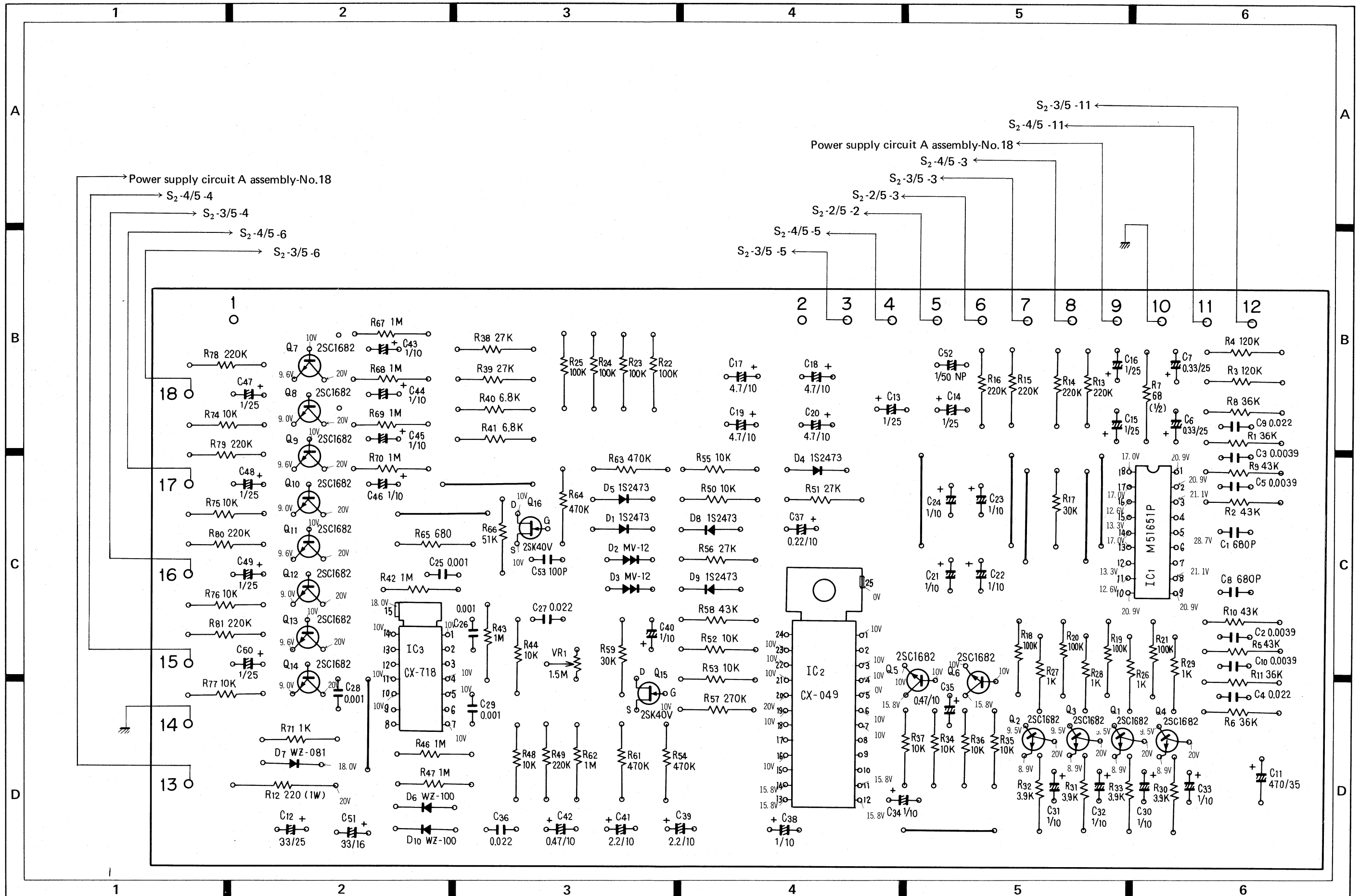

Parts List of SQ/RM Decoder Assembly (AWM-077)

CAPACITORS

| Symbol | Description | Part No. |
|--------|-----------------------|--------------|
| C1 | Styrol 680p 50V | CQSA 681J 50 |
| C2 | Mylar 0.0039 50V | CQMA 392J 50 |
| C3 | Mylar 0.0039 50V | CQMA 392J 50 |
| C4 | Mylar 0.022 50V | CQMA 223J 50 |
| C5 | Mylar 0.0039 50V | CQMA 392J 50 |
| C6 | Electrolytic 0.33 25V | CSSA R33M 25 |
| C7 | Electrolytic 0.33 25V | CSSA R33M 25 |
| C8 | Styrol 680p 50V | CQSA 681J 50 |
| C9 | Mylar 0.022 50V | CQMA 223J 50 |
| C10 | Mylar 0.0039 50V | CQMA 392J 50 |
| C11 | Electrolytic 470 35V | CEA 471P 35 |
| C12 | Electrolytic 33 25V | CEA 330P 25 |
| C13 | Electrolytic 1 25V | CSSA 010M 25 |
| C14 | Electrolytic 1 25V | CSSA 010M 25 |
| C15 | Electrolytic 1 25V | CSSA 010M 25 |
| C16 | Electrolytic 1 25V | CSSA 010M 25 |
| C17 | Electrolytic 4.7 10V | CSSA 4R7M 10 |
| C18 | Electrolytic 4.7 10V | CSSA 4R7M 10 |
| C19 | Electrolytic 4.7 10V | CSSA 4R7M 10 |
| C20 | Electrolytic 4.7 10V | CSSA 4R7M 10 |
| C21 | Electrolytic 1 10V | CSSA 010M 10 |
| C22 | Electrolytic 1 10V | CSSA 010M 10 |
| C23 | Electrolytic 1 10V | CSSA 010M 10 |
| C24 | Electrolytic 1 10V | CSSA 010M 10 |
| C25 | Mylar 0.001 50V | CQMA 102J 50 |
| C26 | Mylar 0.001 50V | CQMA 102J 50 |
| C27 | Mylar 0.022 50V | CQMA 223J 50 |
| C28 | Mylar 0.001 50V | CQMA 102J 50 |
| C29 | Mylar 0.001 50V | CQMA 102J 50 |
| C30 | Electrolytic 1 10V | CSSA 010M 10 |
| C31 | Electrolytic 1 10V | CSSA 010M 10 |
| C32 | Electrolytic 1 10V | CSSA 010M 10 |
| C33 | Electrolytic 1 10V | CSSA 010M 10 |
| C34 | Electrolytic 1 10V | CSSA 010M 10 |
| C35 | Electrolytic 0.47 10V | CSSA R47M 10 |
| C36 | Mylar 0.022 50V | CQMA 223J 50 |
| C37 | Electrolytic 0.22 10V | CSSA R22M 10 |
| C38 | Electrolytic 1 10V | CSSA 010M 10 |
| C39 | Electrolytic 2.2 10V | CSSA 2R2M 10 |
| C40 | Electrolytic 1 10V | CSSA 010M 10 |
| C41 | Electrolytic 2.2 10V | CSSA 2R2M 10 |
| C42 | Electrolytic 0.47 10V | CSSA R47M 10 |
| C43 | Electrolytic 1 10V | CSSA 010M 10 |
| C44 | Electrolytic 1 10V | CSSA 010M 10 |
| C45 | Electrolytic 1 10V | CSSA 010M 10 |
| C46 | Electrolytic 1 10V | CSSA 010M 10 |
| C47 | Electrolytic 1 25V | CSSA 010M 25 |
| C48 | Electrolytic 1 25V | CSSA 010M 25 |

| Symbol | Description | Part No. |
|--------|---------------------------|---------------|
| C49 | Electrolytic 1 25V | CSSA 010M 25 |
| C50 | Electrolytic 1 25V | CSSA 010M 25 |
| C51 | Electrolytic 33 16V | CEA 330P 16 |
| C52 | Electrolytic (N.P.) 1 50V | ACH-305 |
| C53 | Ceramic 100p 50V | CCDSL 101K 50 |

RESISTORS

| Symbol | Description | Part No. |
|--------|--------------------|------------|
| R1 | Carbon film 36k | RD½PS 363J |
| R2 | Carbon film 43k | RD½PS 433J |
| R3 | Carbon film 120k | RD½PS 124J |
| R4 | Carbon film 120k | RD½PS 124J |
| R5 | Carbon film 43k | RD½PS 433J |
| R6 | Carbon film 36k | RD½PS 363J |
| R7 | Carbon film 68 ½W | RD½PS 680J |
| R8 | Carbon film 36k | RD½PS 363J |
| R9 | Carbon film 43k | RD½PS 433J |
| R10 | Carbon film 43k | RD½PS 433J |
| R11 | Carbon film 36k | RD½PS 363J |
| R12 | Metal oxide 220 1W | RS1P 221J |
| R13 | Carbon film 220k | RD½PS 224J |
| R14 | Carbon film 220k | RD½PS 224J |
| R15 | Carbon film 220k | RD½PS 224J |
| R16 | Carbon film 220k | RD½PS 224J |
| R17 | Carbon film 30k | RD½PS 303J |
| R18 | Carbon film 100k | RD½PS 104J |
| R19 | Carbon film 100k | RD½PS 104J |
| R20 | Carbon film 100k | RD½PS 104J |
| R21 | Carbon film 100k | RD½PS 104J |
| R22 | Carbon film 100k | RD½PS 104J |
| R23 | Carbon film 100k | RD½PS 104J |
| R24 | Carbon film 100k | RD½PS 104J |
| R25 | Carbon film 100k | RD½PS 104J |
| R26 | Carbon film 1k | RD½PS 102J |
| R27 | Carbon film 1k | RD½PS 102J |
| R28 | Carbon film 1k | RD½PS 102J |
| R29 | Carbon film 1k | RD½PS 102J |
| R30 | Carbon film 3.9k | RD½PS 392J |
| R31 | Carbon film 3.9k | RD½PS 392J |
| R32 | Carbon film 3.9k | RD½PS 392J |
| R33 | Carbon film 3.9k | RD½PS 392J |
| R34 | Carbon film 10k | RD½PS 103J |
| R35 | Carbon film 10k | RD½PS 103J |
| R36 | Carbon film 10k | RD½PS 103J |
| R37 | Carbon film 10k | RD½PS 103J |
| R38 | Carbon film 27k | RD½PS 273J |
| R39 | Carbon film 27k | RD½PS 273J |
| R40 | Carbon film 6.8k | RD½PS 682J |

| Symbol | Description | Part No. |
|--------|------------------------------|------------|
| R41 | Carbon film 6.8k | RD½PS 682J |
| R42 | Carbon film 1M | RD½PS 105J |
| R43 | Carbon film 1M | RD½PS 105J |
| R44 | Carbon film 10k | RD½PS 103J |
| R45 | Vacancy | |
| R46 | Carbon film 1M | RD½PS 105J |
| R47 | Carbon film 1M | RD½PS 105J |
| R48 | Carbon film 10k | RD½PS 103J |
| R49 | Carbon film 220k | RD½PS 224J |
| R50 | Carbon film 10k | RD½PS 103J |
| R51 | Carbon film 27k | RD½PS 273J |
| R52 | Carbon film 10k | RD½PS 103J |
| R53 | Carbon film 10k | RD½PS 103J |
| R54 | Carbon film 470k | RD½PS 474J |
| R55 | Carbon film 10k | RD½PS 103J |
| R56 | Carbon film 27k | RD½PS 273J |
| R57 | Carbon film 270k | RD½PS 274J |
| R58 | Carbon film 43k | RD½PS 433J |
| R59 | Carbon film 30k | RD½PS 303J |
| R60 | Vacancy | |
| R61 | Carbon film 470k | RD½PS 474J |
| R62 | Carbon film 1M | RD½PS 105J |
| R63 | Carbon film 470k | RD½PS 474J |
| R64 | Carbon film 470k | RD½PS 474J |
| R65 | Carbon film 680 | RD½PS 681J |
| R66 | Carbon film 51k | RD½PS 513J |
| R67 | Carbon film 1M | RD½PS 105J |
| R68 | Carbon film 1M | RD½PS 105J |
| R69 | Carbon film 1M | RD½PS 105J |
| R70 | Carbon film 1M | RD½PS 105J |
| R71 | Carbon film 1k | RD½PS 102J |
| R74 | Carbon film 10k | RD½PS 103J |
| R75 | Carbon film 10k | RD½PS 103J |
| R76 | Carbon film 10k | RD½PS 103J |
| R77 | Carbon film 10k | RD½PS 103J |
| R78 | Carbon film 220k | RD½PS 224J |
| R79 | Carbon film 220k | RD½PS 224J |
| R80 | Carbon film 220k | RD½PS 224J |
| R81 | Carbon film 220k | RD½PS 224J |
| VR1 | Variable (semi-fixed) 1.5M-B | ACP-048 |

| Symbol | Description | Part No. |
|--------|-------------|----------------------------------|
| Q3 | Transistor | 2SC1682-V or BL (2SC1312-G or H) |
| Q4 | Transistor | 2SC1682-V or BL (2SC1312-G or H) |
| Q5 | Transistor | 2SC1682-V or BL (2SC1312-G or H) |
| Q6 | Transistor | 2SC1682-V or BL (2SC1312-G or H) |
| Q7 | Transistor | 2SC1682-V or BL (2SC1312-G or H) |
| Q8 | Transistor | 2SC1682-V or BL (2SC1312-G or H) |
| Q9 | Transistor | 2SC1682-V or BL (2SC1312-G or H) |
| Q10 | Transistor | 2SC1682-V or BL (2SC1312-G or H) |
| Q11 | Transistor | 2SC1682-V or BL (2SC1312-G or H) |
| Q12 | Transistor | 2SC1682-V or BL (2SC1312-G or H) |
| Q13 | Transistor | 2SC1682-V or BL (2SC1312-G or H) |
| Q14 | Transistor | 2SC1682-V or BL (2SC1312-G or H) |
| Q15 | FET | 2SK40V-2 or 3 (2SK30AP-2 or 3) |
| Q16 | FET | 2SK40V-2 or 3 (2SK30AP-2 or 3) |
| D1 | Diode | 1S2473 |
| D2 | Varistor | MV-12 |
| D3 | Varistor | MV-12 |
| D4 | Diode | 1S2473 |
| D5 | Diode | 1S2473 |
| D6 | Zener diode | WZ-100 |
| D7 | Zener diode | WZ-081 |
| D8 | Diode | 1S2473 |
| D9 | Diode | 1S2473 |
| D10 | Zener diode | WZ-100 |

SEMICONDUCTORS

| Symbol | Description | Part No. |
|--------|-------------|----------------------------------|
| IC1 | IC | M51651P |
| IC2 | IC | CX-049 |
| IC3 | IC | CX-718D |
| Q1 | Transistor | 2SC1682-V or BL (2SC1312-G or H) |
| Q2 | Transistor | 2SC1682-V or BL (2SC1312-G or H) |

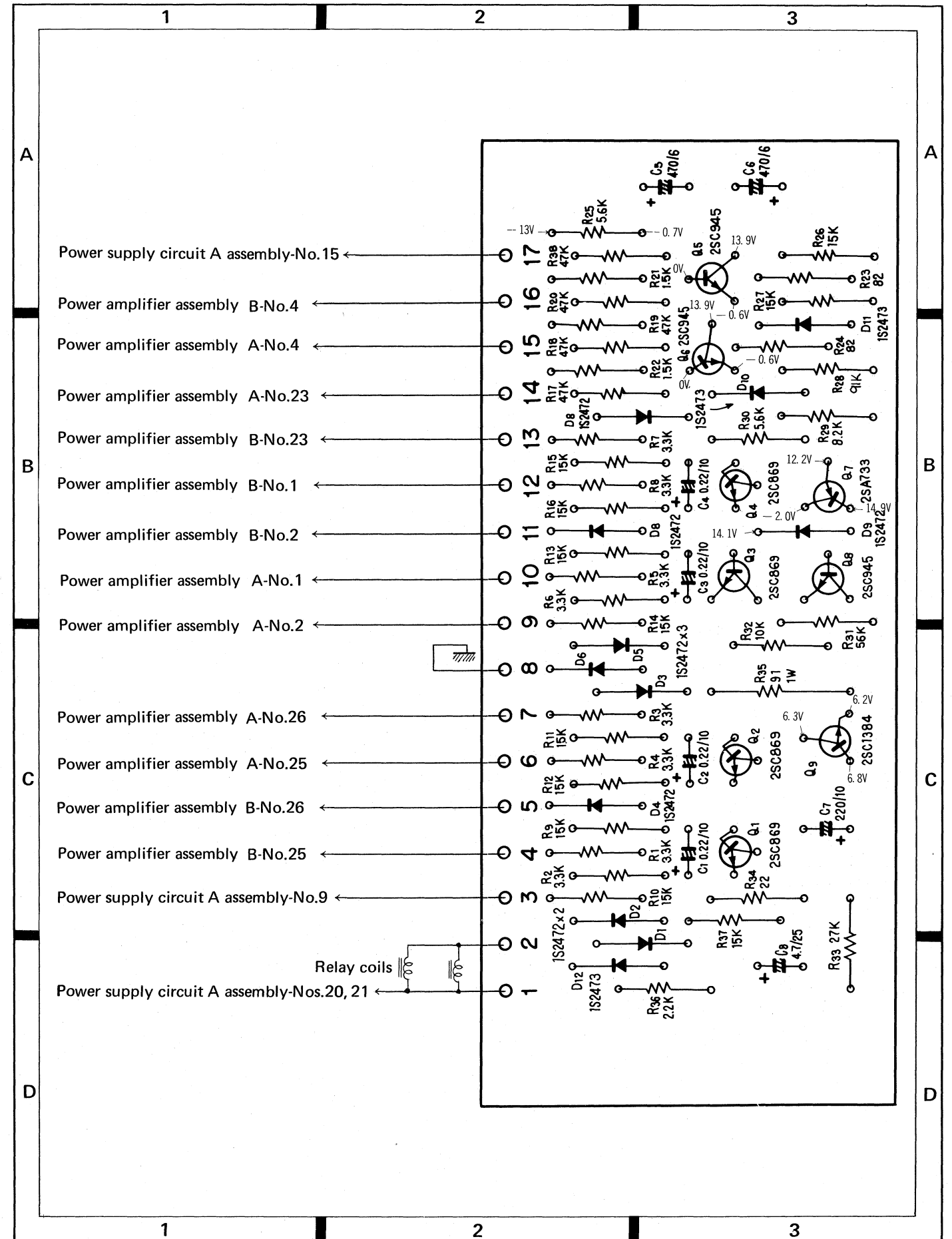
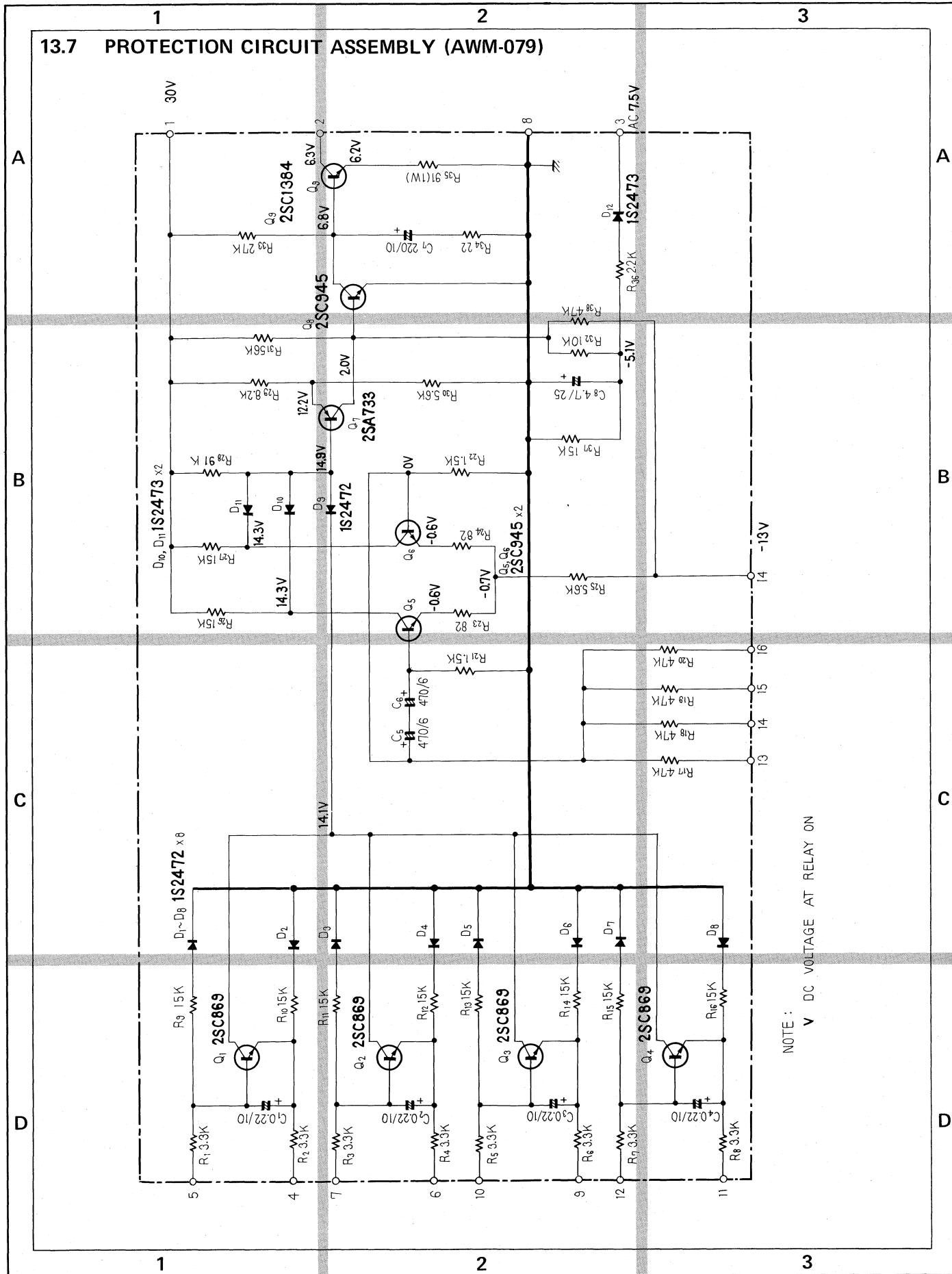

Parts List of Protection Circuit Assembly (AWM-079)

CAPACITORS

| Symbol | Description | Part No. |
|--------|-----------------------|--------------|
| C1 | Electrolytic 0.22 10V | CSSA R22M 10 |
| C2 | Electrolytic 0.22 10V | CSSA R22M 10 |
| C3 | Electrolytic 0.22 10V | CSSA R22M 10 |
| C4 | Electrolytic 0.22 10V | CSSA R22M 10 |
| C5 | Electrolytic 470 6V | CEA 471P 6 |
| C6 | Electrolytic 470 6V | CEA 471P 6 |
| C7 | Electrolytic 220 10V | CEA 221P 10 |
| C8 | Electrolytic 4.7 25V | CEA 4R7P 25 |

RESISTORS

| Symbol | Description | Part No. |
|--------|-------------------|------------|
| R1 | Carbon film 3.3k | RD¼PM 332J |
| R2 | Carbon film 3.3k | RD¼PM 332J |
| R3 | Carbon film 3.3k | RD¼PM 332J |
| R4 | Carbon film 3.3k | RD¼PM 332J |
| R5 | Carbon film 3.3k | RD¼PM 332J |
| R6 | Carbon film 3.3k | RD¼PM 332J |
| R7 | Carbon film 3.3k | RD¼PM 332J |
| R8 | Carbon film 3.3k | RD¼PM 332J |
| R9 | Carbon film 15k | RD¼PM 153J |
| R10 | Carbon film 15k | RD¼PM 153J |
| R11 | Carbon film 15k | RD¼PM 153J |
| R12 | Carbon film 15k | RD¼PM 153J |
| R13 | Carbon film 15k | RD¼PM 153J |
| R14 | Carbon film 15k | RD¼PM 153J |
| R15 | Carbon film 15k | RD¼PM 153J |
| R16 | Carbon film 15k | RD¼PM 153J |
| R17 | Carbon film 47k | RD¼PM 473J |
| R18 | Carbon film 47k | RD¼PM 473J |
| R19 | Carbon film 47k | RD¼PM 473J |
| R20 | Carbon film 47k | RD¼PM 473J |
| R21 | Carbon film 1.5k | RD¼PM 152J |
| R22 | Carbon film 1.5k | RD¼PM 152J |
| R23 | Carbon film 82 | RD¼PM 820J |
| R24 | Carbon film 82 | RD¼PM 820J |
| R25 | Carbon film 5.6k | RD¼PM 562J |
| R26 | Carbon film 15k | RD¼PM 153J |
| R27 | Carbon film 15k | RD¼PM 153J |
| R28 | Carbon film 91k | RD¼PM 913J |
| R29 | Carbon film 8.2k | RD¼PM 822J |
| R30 | Carbon film 5.6k | RD¼PM 562J |
| R31 | Carbon film 56k | RD¼PM 563J |
| R32 | Carbon film 10k | RD¼PM 103J |
| R33 | Carbon film 27k | RD¼PM 273J |
| R34 | Carbon film 22 | RD¼PM 220J |
| R35 | Metal oxide 91 1W | RS1P 910J |

| Symbol | Description | Part No. |
|--------|------------------|------------|
| R36 | Carbon film 2.2k | RD¼PM 222J |
| R37 | Carbon film 15k | RD¼PM 153J |
| R38 | Carbon film 47k | RD¼PM 473J |

SEMICONDUCTORS

| Symbol | Description | Part No. |
|--------|-------------|-----------------------------|
| Q1 | Transistor | 2SC869-C, B or D (2SC1515K) |
| Q2 | Transistor | 2SC869-C, B or D (2SC1515K) |
| Q3 | Transistor | 2SC869-C, B or D (2SC1515K) |
| Q4 | Transistor | 2SC869-C, B or D (2SC1515K) |
| Q5 | Transistor | 2SC945-R or Q |
| Q6 | Transistor | 2SC945-R or Q |
| Q7 | Transistor | 2SA733-R or Q |
| Q8 | Transistor | 2SC945-R or Q |
| Q9 | Transistor | 2SC1384-Q or R |
| D1 | Diode | 1S2472 |
| D2 | Diode | 1S2472 |
| D3 | Diode | 1S2472 |
| D4 | Diode | 1S2472 |
| D5 | Diode | 1S2472 |
| D6 | Diode | 1S2472 |
| D7 | Diode | 1S2472 |
| D8 | Diode | 1S2472 |
| D9 | Diode | 1S2472 |
| D10 | Diode | 1S2473 |
| D11 | Diode | 1S2473 |
| D12 | Diode | 1S2473 |

13.8 CONTROL AMPLIFIER ASSEMBLY (AWG-023)

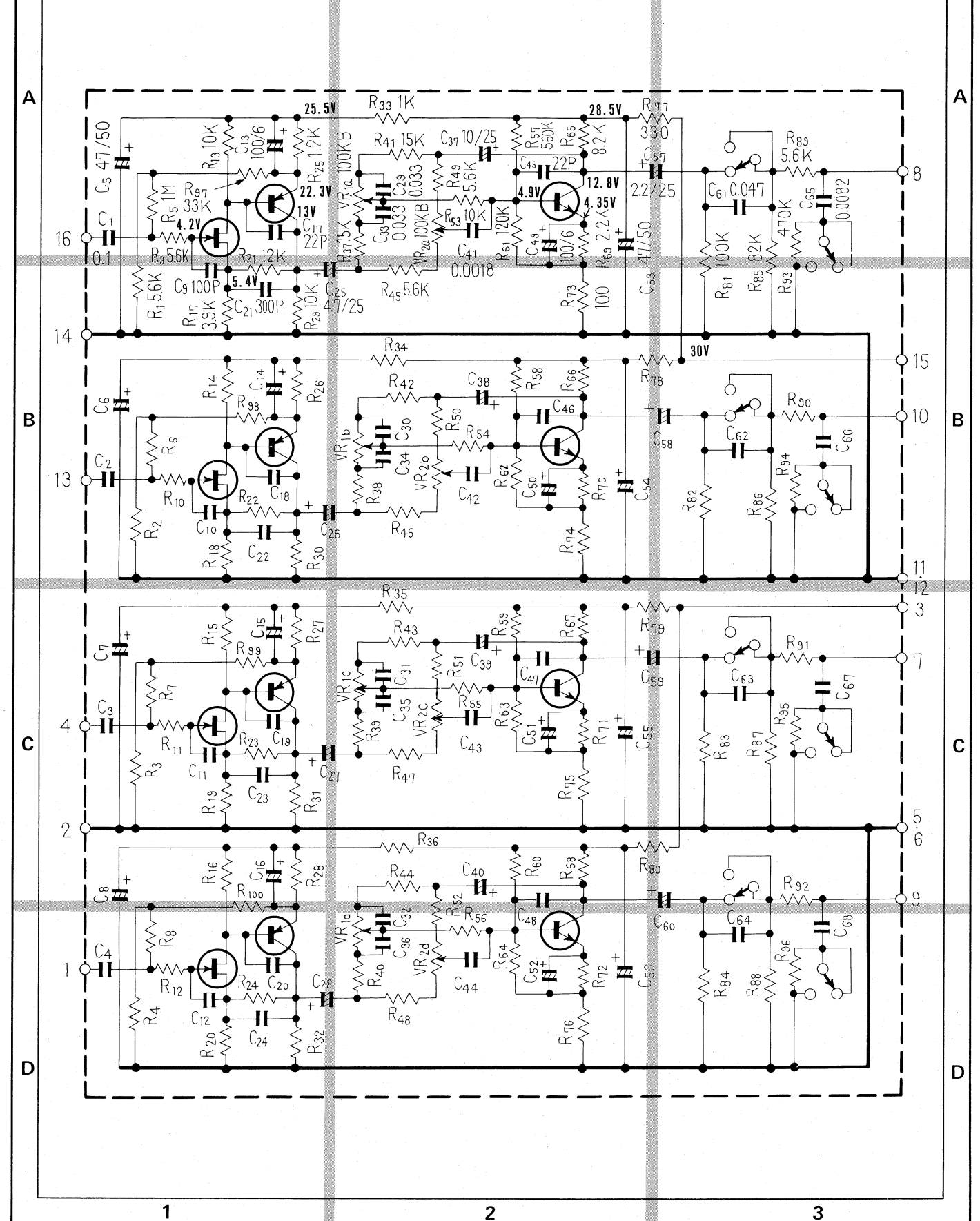

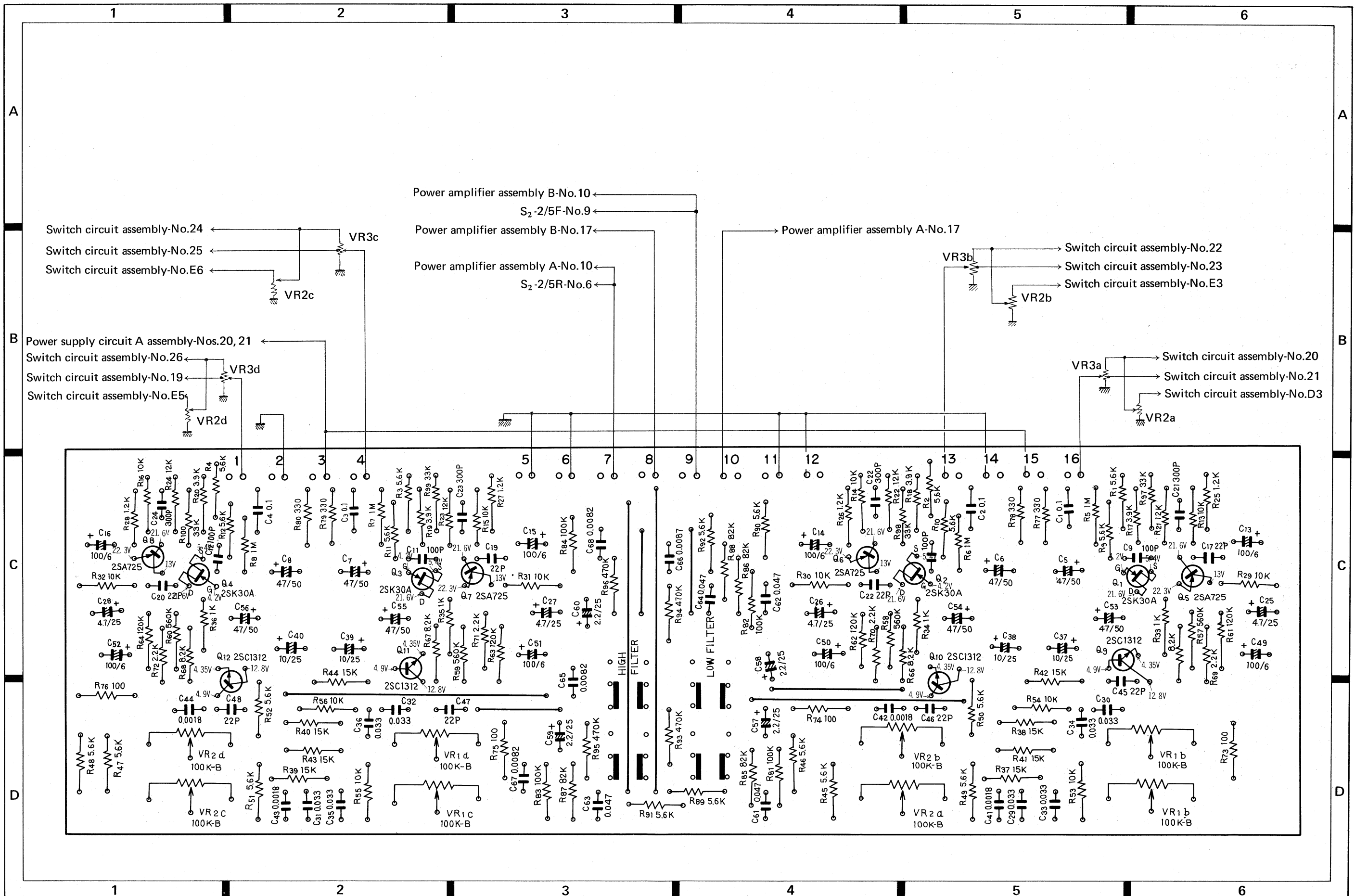

Parts List of Control Amplifier Assembly (AWG-023)

CAPACITORS

| Symbol | Description | | | Part No. |
|--------|--------------|--------|-----|---------------|
| C1 | Mylar | 0.1 | 50V | CQMA 104K 50 |
| C2 | Mylar | 0.1 | 50V | CQMA 104K 50 |
| C3 | Mylar | 0.1 | 50V | CQMA 104K 50 |
| C4 | Mylar | 0.1 | 50V | CQMA 104K 50 |
| C5 | Electrolytic | 47 | 50V | CEA 470P 50 |
| C6 | Electrolytic | 47 | 50V | CEA 470P 50 |
| C7 | Electrolytic | 47 | 50V | CEA 470P 50 |
| C8 | Electrolytic | 47 | 50V | CEA 470P 50 |
| C9 | Ceramic | 100p | 50V | CCDSL 101K 50 |
| C10 | Ceramic | 100p | 50V | CCDSL 101K 50 |
| C11 | Ceramic | 100p | 50V | CCDSL 101K 50 |
| C12 | Ceramic | 100p | 50V | CCDSL 101K 50 |
| C13 | Electrolytic | 100 | 6V | ACH-311-0 |
| C14 | Electrolytic | 100 | 6V | ACH-311-0 |
| C15 | Electrolytic | 100 | 6V | ACH-311-0 |
| C16 | Electrolytic | 100 | 6V | ACH-311-0 |
| C17 | Ceramic | 22p | 50V | CCDSL 220K 50 |
| C18 | Ceramic | 22p | 50V | CCDSL 220K 50 |
| C19 | Ceramic | 22p | 50V | CCDSL 220K 50 |
| C20 | Ceramic | 22p | 50V | CCDSL 220K 50 |
| C21 | Ceramic | 300p | 50V | CKDYB 301K 50 |
| C22 | Ceramic | 300p | 50V | CKDYB 301K 50 |
| C23 | Ceramic | 300p | 50V | CKDYB 301K 50 |
| C24 | Ceramic | 300p | 50V | CKDYB 301K 50 |
| C25 | Electrolytic | 4.7 | 25V | CSZA 4R7P 25 |
| C26 | Electrolytic | 4.7 | 25V | CSZA 4R7P 25 |
| C27 | Electrolytic | 4.7 | 25V | CSZA 4R7P 25 |
| C28 | Electrolytic | 4.7 | 25V | CSZA 4R7P 25 |
| C29 | Mylar | 0.033 | 50V | CQMA 333K 50 |
| C30 | Mylar | 0.033 | 50V | CQMA 333K 50 |
| C31 | Mylar | 0.033 | 50V | CQMA 333K 50 |
| C32 | Mylar | 0.033 | 50V | CQMA 333K 50 |
| C33 | Mylar | 0.033 | 50V | CQMA 333K 50 |
| C34 | Mylar | 0.033 | 50V | CQMA 333K 50 |
| C35 | Mylar | 0.033 | 50V | CQMA 333K 50 |
| C36 | Mylar | 0.033 | 50V | CQMA 333K 50 |
| C37 | Electrolytic | 10 | 25V | CEA 100P 25 |
| C38 | Electrolytic | 10 | 25V | CEA 100P 25 |
| C39 | Electrolytic | 10 | 25V | CEA 100P 25 |
| C40 | Electrolytic | 10 | 25V | CEA 100P 25 |
| C41 | Mylar | 0.0018 | 50V | CQMA 182K 50 |
| C42 | Mylar | 0.0018 | 50V | CQMA 182K 50 |
| C43 | Mylar | 0.0018 | 50V | CQMA 182K 50 |
| C44 | Mylar | 0.0018 | 50V | CQMA 182K 50 |
| C45 | Ceramic | 22p | 50V | CCDSL 220K 50 |

| Symbol | Description | | | Part No. |
|--------|--------------|--------|-----|---------------|
| C46 | Ceramic | 22p | 50V | CCDSL 220K 50 |
| C47 | Ceramic | 22p | 50V | CCDSL 220K 50 |
| C48 | Ceramic | 22p | 50V | CCDSL 220K 50 |
| C49 | Electrolytic | 100 | 6V | CEA 101P 6 |
| C50 | Electrolytic | 100 | 6V | CEA 101P 6 |
| C51 | Electrolytic | 100 | 6V | CEA 101P 6 |
| C52 | Electrolytic | 100 | 6V | CEA 101P 6 |
| C53 | Electrolytic | 47 | 50V | CEA 470P 50 |
| C54 | Electrolytic | 47 | 50V | CEA 470P 50 |
| C55 | Electrolytic | 47 | 50V | CEA 470P 50 |
| C56 | Electrolytic | 47 | 50V | CEA 470P 50 |
| C57 | Electrolytic | 2.2 | 25V | CSZA 2R2P 25 |
| C58 | Electrolytic | 2.2 | 25V | CSZA 2R2P 25 |
| C59 | Electrolytic | 2.2 | 25V | CSZA 2R2P 25 |
| C60 | Electrolytic | 2.2 | 25V | CSZA 2R2P 25 |
| C61 | Mylar | 0.047 | 50V | CQMA 473K 50 |
| C62 | Mylar | 0.047 | 50V | CQMA 473K 50 |
| C63 | Mylar | 0.047 | 50V | CQMA 473K 50 |
| C64 | Mylar | 0.047 | 50V | CQMA 473K 50 |
| C65 | Mylar | 0.0082 | 50V | CQMA 822K 50 |
| C66 | Mylar | 0.0082 | 50V | CQMA 822K 50 |
| C67 | Mylar | 0.0082 | 50V | CQMA 822K 50 |
| C68 | Mylar | 0.0082 | 50V | CQMA 822K 50 |

SWITCHES

| Symbol | Description | Part No. |
|--------|---------------------------|----------|
| S1 | Push switch (LOW FILTER) | ASG-019 |
| S2 | Push switch (HIGH FILTER) | ASG-019 |

RESISTORS

| Symbol | Description | | | Part No. |
|--------|-------------|------|--|------------|
| R1 | Carbon film | 5.6k | | RD%PM 562J |
| R2 | Carbon film | 5.6k | | RD%PM 562J |
| R3 | Carbon film | 5.6k | | RD%PM 562J |
| R4 | Carbon film | 5.6k | | RD%PM 562J |
| R5 | Carbon film | 1M | | RD%PM 105J |
| R6 | Carbon film | 1M | | RD%PM 105J |
| R7 | Carbon film | 1M | | RD%PM 105J |
| R8 | Carbon film | 1M | | RD%PM 105J |
| R9 | Carbon film | 5.6k | | RD%PM 562J |
| R10 | Carbon film | 5.6k | | RD%PM 562J |
| R11 | Carbon film | 5.6k | | RD%PM 562J |
| R12 | Carbon film | 5.6k | | RD%PM 562J |
| R13 | Carbon film | 10k | | RD%PS 103J |
| R14 | Carbon film | 10k | | RD%PS 103J |
| R15 | Carbon film | 10k | | RD%PS 103J |
| R16 | Carbon film | 10k | | RD%PS 103J |
| R17 | Carbon film | 3.9k | | RD%PM 392J |
| R18 | Carbon film | 3.9k | | RD%PM 392J |
| R19 | Carbon film | 3.9k | | RD%PM 392J |
| R20 | Carbon film | 3.9k | | RD%PM 392J |

| Symbol | Description | | | Part No. |
|--------|-------------|------|--|--------------|
| R21 | Carbon film | 12k | | RD%PS 123J |
| R22 | Carbon film | 12k | | RD%PS 123J |
| R23 | Carbon film | 12k | | RD%PS 123J |
| R24 | Carbon film | 12k | | RD%PS 123J |
| R25 | Carbon film | 1.2k | | RD%PM 122J |
| R26 | Carbon film | 1.2k | | RD%PM 122J |
| R27 | Carbon film | 1.2k | | RD%PM 122J |
| R28 | Carbon film | 1.2k | | RD%PM 122J |
| R29 | Carbon film | 10k | | RD%PM 103J |
| R30 | Carbon film | 10k | | RD%PM 103J |
| R31 | Carbon film | 10k | | RD%PM 103J |
| R32 | Carbon film | 10k | | RD%PM 103J |
| R33 | Carbon film | 1k | | RD%PM 102J |
| R34 | Carbon film | 1k | | RD%PM 102J |
| R35 | Carbon film | 1k | | RD%PM 102J |
| R36 | Carbon film | 1k | | RD%PM 102J |
| R37 | Carbon film | 15k | | RD%PM 153J |
| R38 | Carbon film | 15k | | RD%PM 153J |
| R39 | Carbon film | 15k | | RD%PM 153J |
| R40 | Carbon film | 15k | | RD%PM 153J |
| R41 | Carbon film | 15k | | RD%PM 153J |
| R42 | Carbon film | 15k | | RD%PM 153J |
| R43 | Carbon film | 15k | | RD%PM 153J |
| R44 | Carbon film | 15k | | RD%PM 153J |
| R45 | Carbon film | 5.6k | | RD%PM 562J |
| R46 | Carbon film | 5.6k | | RD%PM 562J |
| R47 | Carbon film | 5.6k | | RD%PM 562J |
| R48 | Carbon film | 5.6k | | RD%PM 562J |
| R49 | Carbon film | 5.6k | | RD%PM 562J |
| R50 | Carbon film | 5.6k | | RD%PM 562J |
| R51 | Carbon film | 5.6k | | RD%PM 562J |
| R52 | Carbon film | 5.6k | | RD%PM 562J |
| R53 | Carbon film | 10k | | RD%PM 103J |
| R54 | Carbon film | 10k | | RD%PM 103J |
| R55 | Carbon film | 10k | | RD%PM 103J |
| R56 | Carbon film | 10k | | RD%PM 103J |
| R57 | Carbon film | 560k | | RD%PS 564JNL |
| R58 | Carbon film | 560k | | RD%PS 564JNL |
| R59 | Carbon film | 560k | | RD%PS 564JNL |
| R60 | Carbon film | 560k | | RD%PS 564JNL |
| R61 | Carbon film | 120k | | RD%PS 124JNL |
| R62 | Carbon film | 120k | | RD%PS 124JNL |
| R63 | Carbon film | 120k | | RD%PS 124JNL |
| R64 | Carbon film | 120k | | RD%PS 124JNL |
| R65 | Carbon film | 8.2k | | RD%PM 822J |
| R66 | Carbon film | 8.2k | | RD%PM 822J |
| R67 | Carbon film | 8.2k | | RD%PM 822J |
| R68 | Carbon film | 8.2k | | RD%PM 822J |
| R69 | Carbon film | 2.2k | | RD%PM 222J |
| R70 | Carbon film | 2.2k | | RD%PM 222J |

| Symbol | Description | | | Part No. |
|--------|-------------------------------|------|--|------------|
| R71 | Carbon film | 2.2k | | RD%PM 222J |
| R72 | Carbon film | 2.2k | | RD%PM 222J |
| R73 | Carbon film | 100 | | RD%PM 101J |
| R74 | Carbon film | 100 | | RD%PM 101J |
| R75 | Carbon film | 100 | | RD%PM 101J |
| R76 | Carbon film | 100 | | RD%PM 101J |
| R77 | Carbon film | 330 | | RD%PM 331J |
| R78 | Carbon film | 330 | | RD%PM 331J |
| R79 | Carbon film | 330 | | RD%PM 331J |
| R80 | Carbon film | 330 | | RD%PM 331J |
| R81 | Carbon film | 100k | | RD%PM 104J |
| R82 | Carbon film | 100k | | RD%PM 104J |
| R83 | Carbon film | 100k | | RD%PM 104J |
| R84 | Carbon film | 100k | | RD%PM 104J |
| R85 | Carbon film | 82k | | RD%PM 823J |
| R86 | Carbon film | 82k | | RD%PM 823J |
| R87 | Carbon film | 82k | | RD%PM 823J |
| R88 | Carbon film | 82k | | RD%PM 823J |
| R89 | Carbon film | 5.6k | | RD%PM 562J |
| R90 | Carbon film | 5.6k | | RD%PM 562J |
| R91 | Carbon film | 5.6k | | RD%PM 562J |
| R92 | Carbon film | 5.6k | | RD%PM 562J |
| R93 | Carbon film | 470k | | RD%PM 474J |
| R94 | Carbon film | 470k | | RD%PM 474J |
| R95 | Carbon film | 470k | | RD%PM 474J |
| R96 | Carbon film | 470k | | RD%PM 474J |
| R97 | Carbon film | 33k | | RD%PM 333J |
| R98 | Carbon film | 33k | | RD%PM 333J |
| R99 | Carbon film | 33k | | RD%PM 333J |
| R100 | Carbon film | 33k | | RD%PM 333J |
| VR1 | Variable resistor dual 100k-B | | | ACV-110-0 |
| VR2 | Variable resistor dual 100k-B | | | ACV-110-0 |
| VR3 | Variable resistor dual 100k-B | | | ACV-110-0 |
| VR4 | Variable resistor dual 100k-B | | | ACV-110-0 |

SEMICONDUCTORS

| Symbol | Description | Part No. |
|--------|-------------|----------------|
| Q1 | FET | 2SK30A-Y or GR |
| Q2 | FET | 2SK30A-Y or GR |
| Q3 | FET | 2SK30A-Y or GR |
| Q4 | FET | 2SK30A-Y or GR |
| Q5 | Transistor | 2SA725-F or G |
| Q6 | Transistor | 2SA725-F or G |
| Q7 | Transistor | 2SA725-F or G |
| Q8 | Transistor | 2SA725-F or G |
| Q9 | Transistor | 2SC1312-F or G |
| Q10 | Transistor | 2SC1312-F or G |
| Q11 | Transistor | 2SC1312-F or G |
| Q12 | Transistor | 2SC1312-F or G |

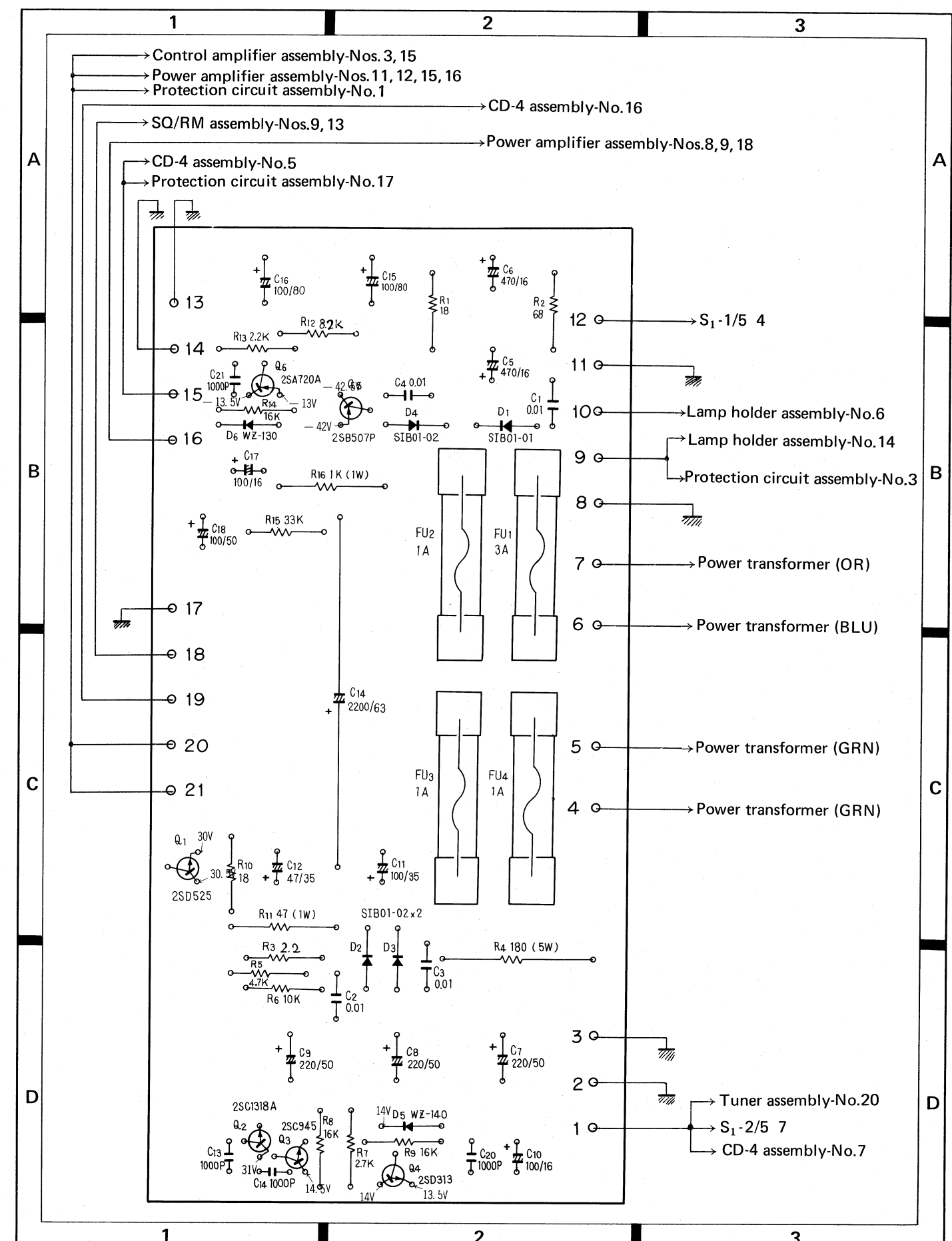
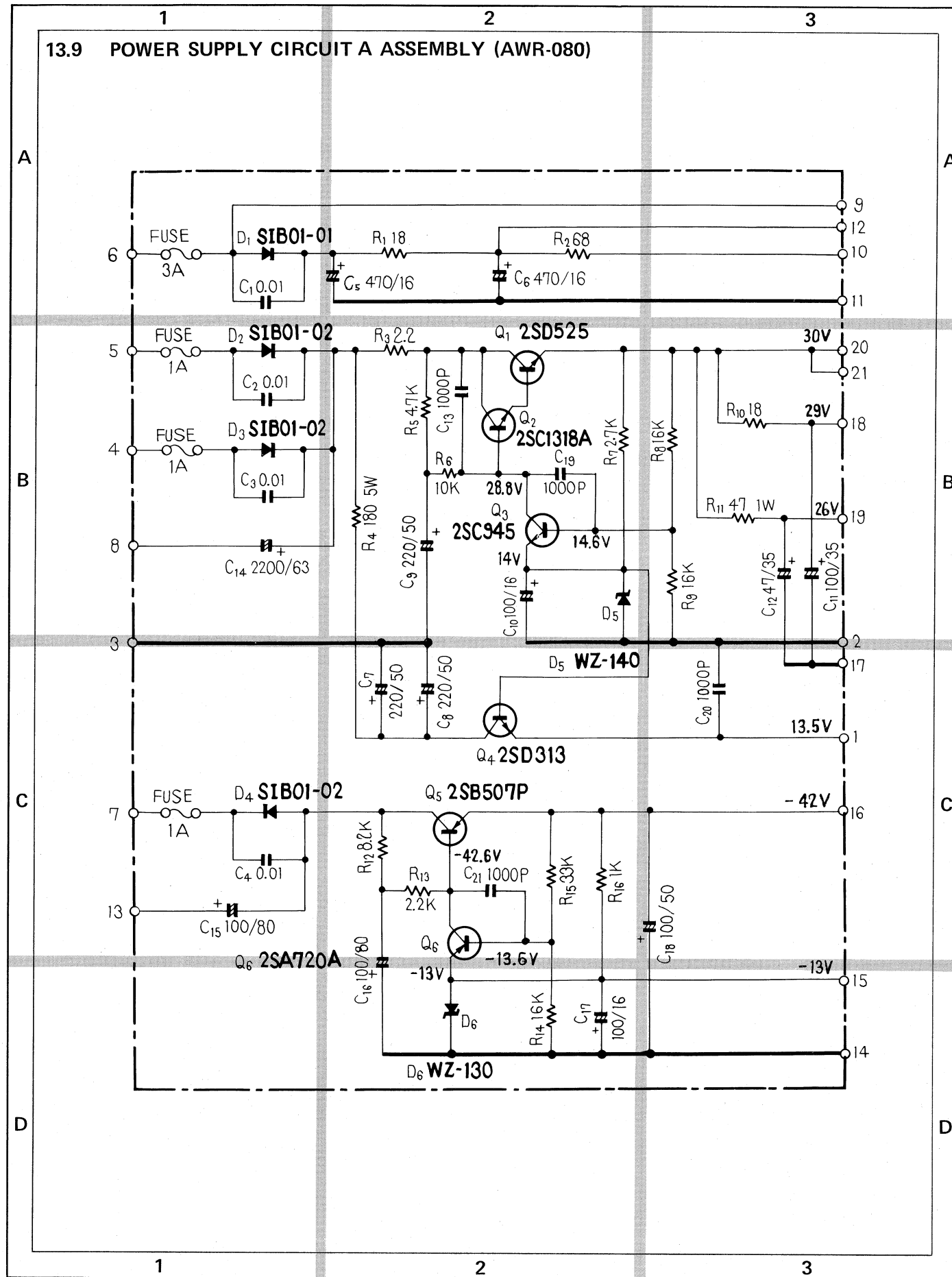

Parts List of Power Supply Circuit A Assembly (AWR-080)

CAPACITORS

| Symbol | Description | Part No. |
|--------|------------------------|---------------|
| C1 | Ceramic 0.01 150V | ACG-004 |
| C2 | Ceramic 0.01 150V | ACG-004 |
| C3 | Ceramic 0.01 150V | ACG-004 |
| C4 | Ceramic 0.01 150V | ACG-004 |
| C5 | Electrolytic 470 16V | CEA 471P 16 |
| C6 | Electrolytic 470 16V | CEA 471P 16 |
| C7 | Electrolytic 220 50V | CEA 221P 50 |
| C8 | Electrolytic 220 50V | CEA 221P 50 |
| C9 | Electrolytic 220 50V | CEA 221P 50 |
| C10 | Electrolytic 100 16V | CEA 101P 16 |
| C11 | Electrolytic 100 35V | CEA 101P 35 |
| C12 | Electrolytic 47 35V | CEA 470P 35 |
| C13 | Ceramic 0.01 50V | CKDYF 103Z 50 |
| C14 | Electrolytic 2,200 63V | CEB 222P 63 |
| C15 | Electrolytic 100 80V | CEA 101P 80 |
| C16 | Electrolytic 100 80V | CEA 101P 80 |
| C17 | Electrolytic 100 16V | CEA 101P 16 |
| C18 | Electrolytic 100 50V | CEA 101P 50 |
| C19 | Ceramic 0.01 50V | CKDYF 103Z 50 |
| C20 | Ceramic 0.01 50V | CKDYF 103Z 50 |
| C21 | Ceramic 0.01 50V | CKDYF 103Z 50 |

RESISTORS

| Symbol | Description | Part No. |
|--------|-------------------|------------|
| R1 | Carbon film 18 | RD¼PS 180J |
| R2 | Carbon film 68 | RD¼PS 680J |
| R3 | Carbon film 2.2 | RD¼PS 2R2J |
| R4 | Wire wound 180 5W | RT5B 181K |
| R5 | Carbon film 4.7k | RD¼PS 472J |
| R6 | Carbon film 10k | RD¼PS 103J |
| R7 | Carbon film 2.7k | RD¼PS 272J |
| R8 | Carbon film 16k | RD¼PS 163J |
| R9 | Carbon film 16k | RD¼PS 163J |
| R10 | Carbon film 18 | RD¼PS 180J |
| R11 | Metal oxide 47 1W | RS1P 470J |
| R12 | Carbon film 8.2k | RD¼PS 822J |
| R13 | Carbon film 2.2k | RD¼PS 222J |
| R14 | Carbon film 16k | RD¼PS 163J |
| R15 | Carbon film 33k | RD¼PS 333J |
| R16 | Metal oxide 1k 1W | RS1P 102J |

SEMICONDUCTORS

| Symbol | Description | Part No. |
|--------|-------------|-------------------|
| Q1 | Transistor | 2SD525-O or R |
| Q2 | Transistor | 2SC1318A-Q or R |
| Q3 | Transistor | 2SC945-R or Q |
| Q4 | Transistor | 2SD313-E or D |
| Q5 | Transistor | 2SB507P-E or D |
| Q6 | Transistor | 2SA720A-Q or R |
| D1 | Diode | SIB01-01 (1S1885) |
| D2 | Diode | SIB01-02 (1S1886) |
| D3 | Diode | SIB01-02 (1S1886) |
| D4 | Diode | SIB01-02 (1S1886) |
| D5 | Zener diode | WZ-140 |
| D6 | Zener diode | WZ-130 |

OTHERS

| Symbol | Description | Part No. |
|--------|-----------------|----------|
| | Tr socket | AKH-002 |
| | Insulator wafer | AEC-043 |
| | Fuse clip | AKR-013 |

13.10 SWITCH CIRCUIT ASSEMBLY (AWS-048)

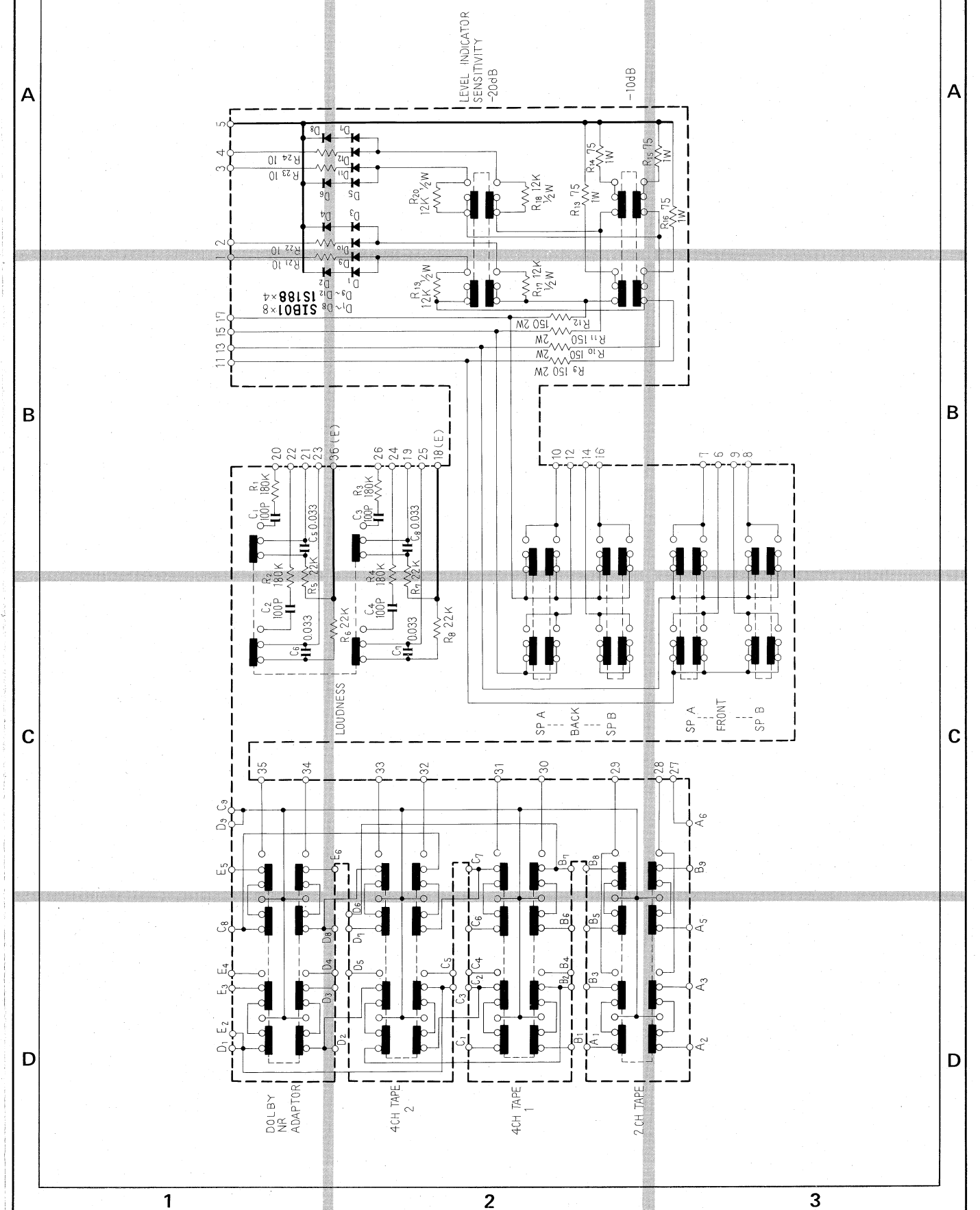

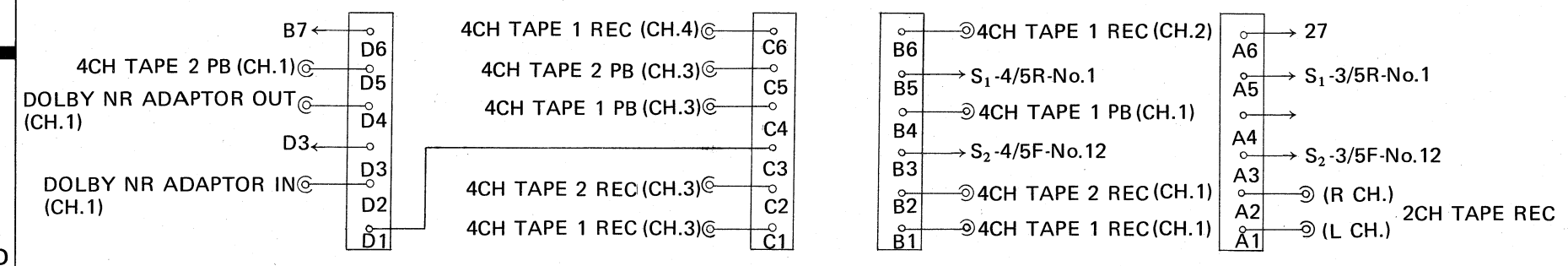
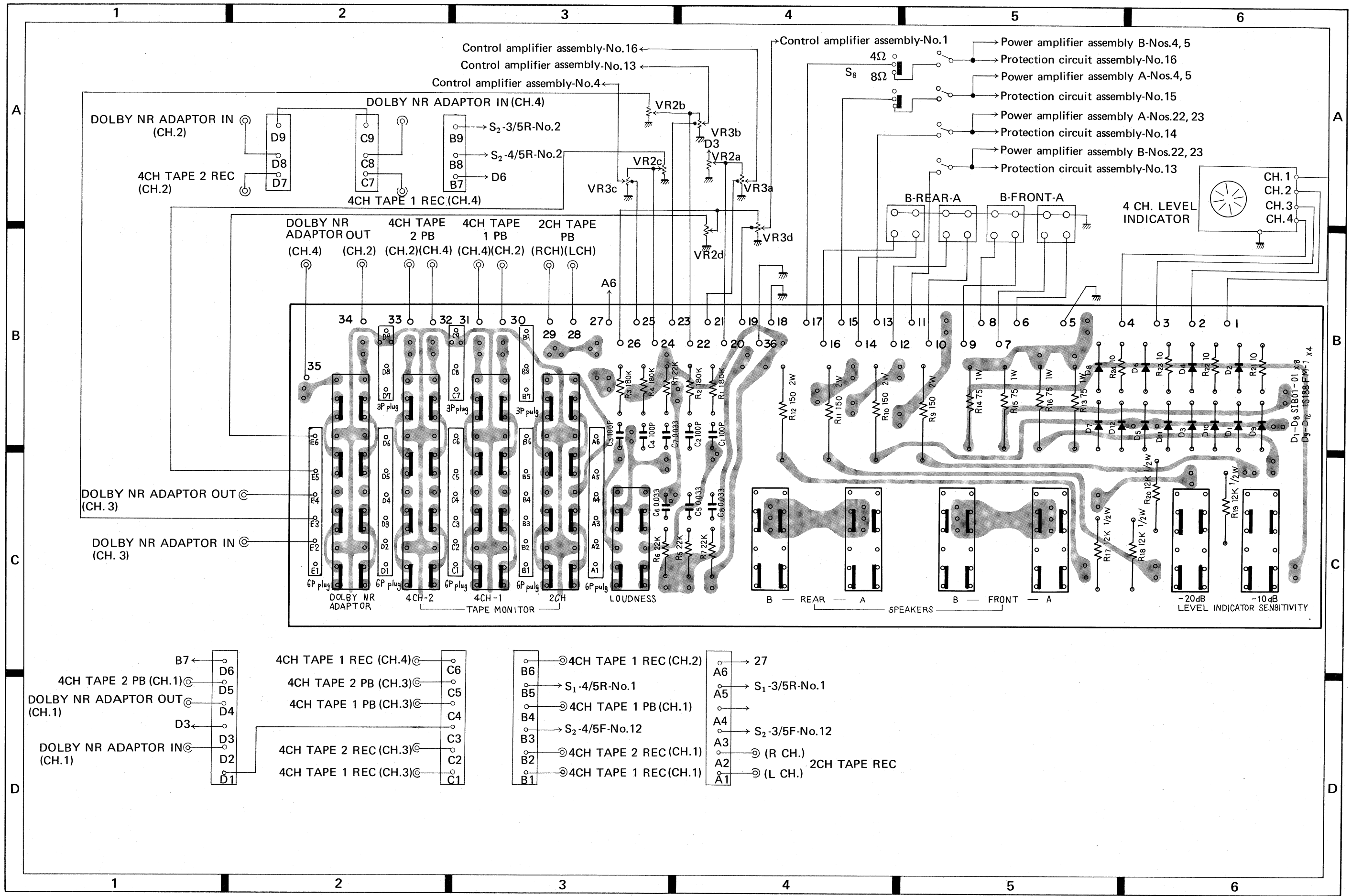

Parts List of Switch Circuit Assembly (AWS-048)

CAPACITORS

| Symbol | Description | Part No. |
|--------|------------------|---------------|
| C1 | Ceramic 100p 50V | CKDSL 101K 50 |
| C2 | Ceramic 100p 50V | CKDSL 101K 50 |
| C3 | Ceramic 100p 50V | CKDSL 101K 50 |
| C4 | Ceramic 100p 50V | CKDSL 101K 50 |
| C5 | Mylar 0.033 50V | CQMA 333K 50 |
| C6 | Mylar 0.033 50V | CQMA 333K 50 |
| C7 | Mylar 0.033 50V | CQMA 333K 50 |
| C8 | Mylar 0.033 50V | CQMA 333K 50 |

RESISTORS

| Symbol | Description | Part No. |
|--------|----------------------|------------|
| R1 | Carbon film 180k | RD4PM 184J |
| R2 | Carbon film 180k | RD4PM 184J |
| R3 | Carbon film 180k | RD4PM 184J |
| R4 | Carbon film 180k | RD4PM 184J |
| R5 | Carbon film 22k | RD4PM 223J |
| R6 | Carbon film 22k | RD4PM 223J |
| R7 | Carbon film 22k | RD4PM 223J |
| R8 | Carbon film 22k | RD4PM 223J |
| R9 | Metal oxide 150 2W | RS2P 151K |
| R10 | Metal oxide 150 2W | RS2P 151K |
| R11 | Metal oxide 150 2W | RS2P 151K |
| R12 | Metal oxide 150 2W | RS2P 151K |
| R13 | Metal oxide 75 1W | RS1P 750K |
| R14 | Metal oxide 75 1W | RS1P 750K |
| R15 | Metal oxide 75 1W | RS1P 750K |
| R16 | Metal oxide 75 1W | RS1P 750K |
| R17 | Carbon film 12k 1/2W | RD4PS 123J |
| R18 | Carbon film 12k 1/2W | RD4PS 123J |
| R19 | Carbon film 12k 1/2W | RD4PS 123J |
| R20 | Carbon film 12k 1/2W | RD4PS 123J |
| R21 | Carbon film 10 | RD4PM 100J |
| R22 | Carbon film 10 | RD4PM 100J |
| R23 | Carbon film 10 | RD4PM 100J |
| R24 | Carbon film 10 | RD4PM 100J |

SEMICONDUCTORS

| Symbol | Description | Part No. |
|--------|-------------|------------|
| D1 | Diode | SIB01-01 |
| D2 | Diode | SIB01-01 |
| D3 | Diode | SIB01-01 |
| D4 | Diode | SIB01-01 |
| D5 | Diode | SIB01-01 |
| D6 | Diode | SIB01-01 |
| D7 | Diode | SIB01-01 |
| D8 | Diode | SIB01-01 |
| D9 | Diode | 1S188 FM-1 |
| D10 | Diode | 1S188 FM-1 |
| D11 | Diode | 1S188 FM-1 |
| D12 | Diode | 1S188 FM-1 |

SWITCHES

| Symbol | Description | Part No. |
|--------|--|----------|
| | Push switch (TAPE MONITOR, DOLBY NR ADP, LOUDNESS) | ASG-049 |
| | Push switch (LEVEL INDICATOR SENSITIVITY) | ASG-047 |
| | Push switch (SPEAKERS) | ASG-046 |

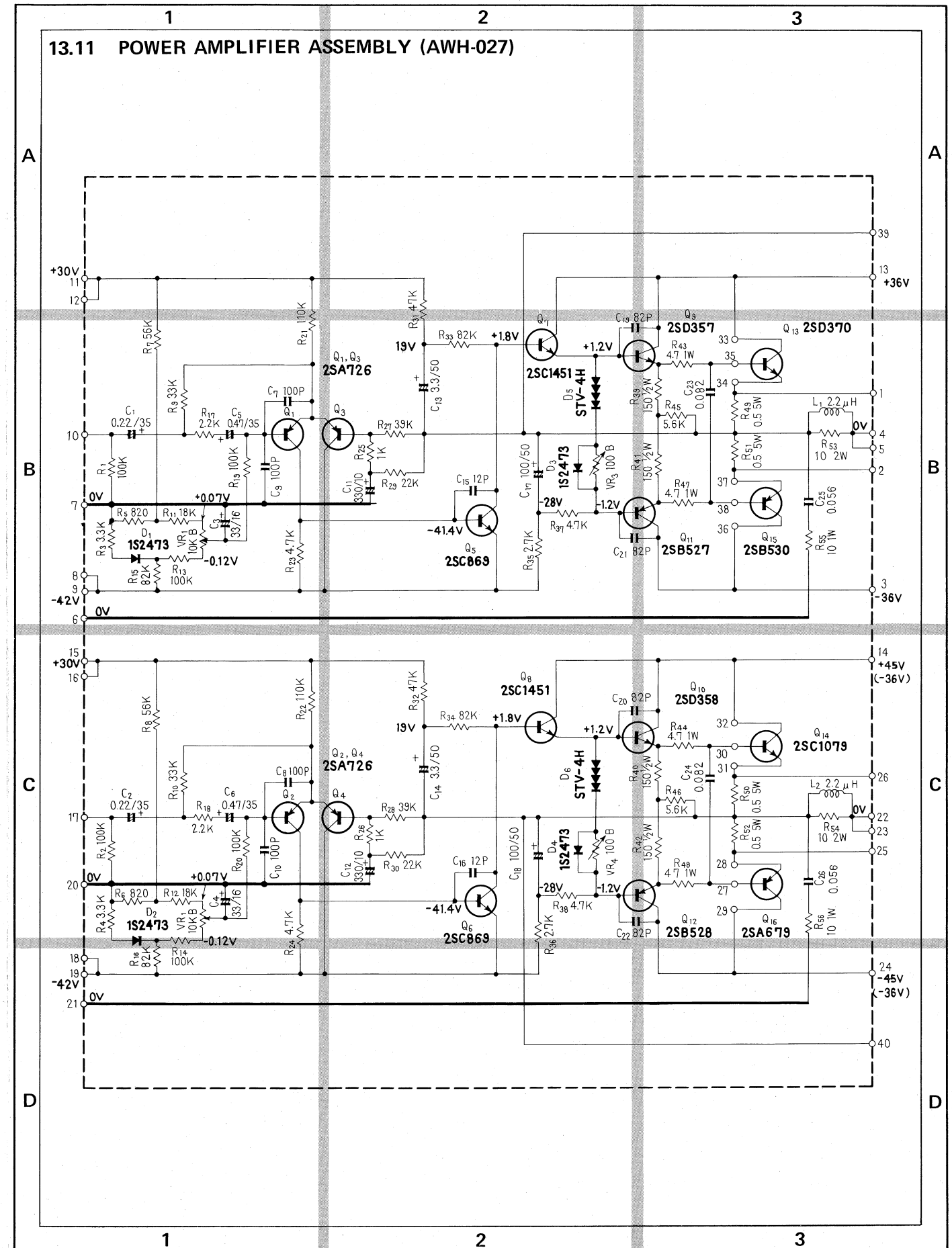

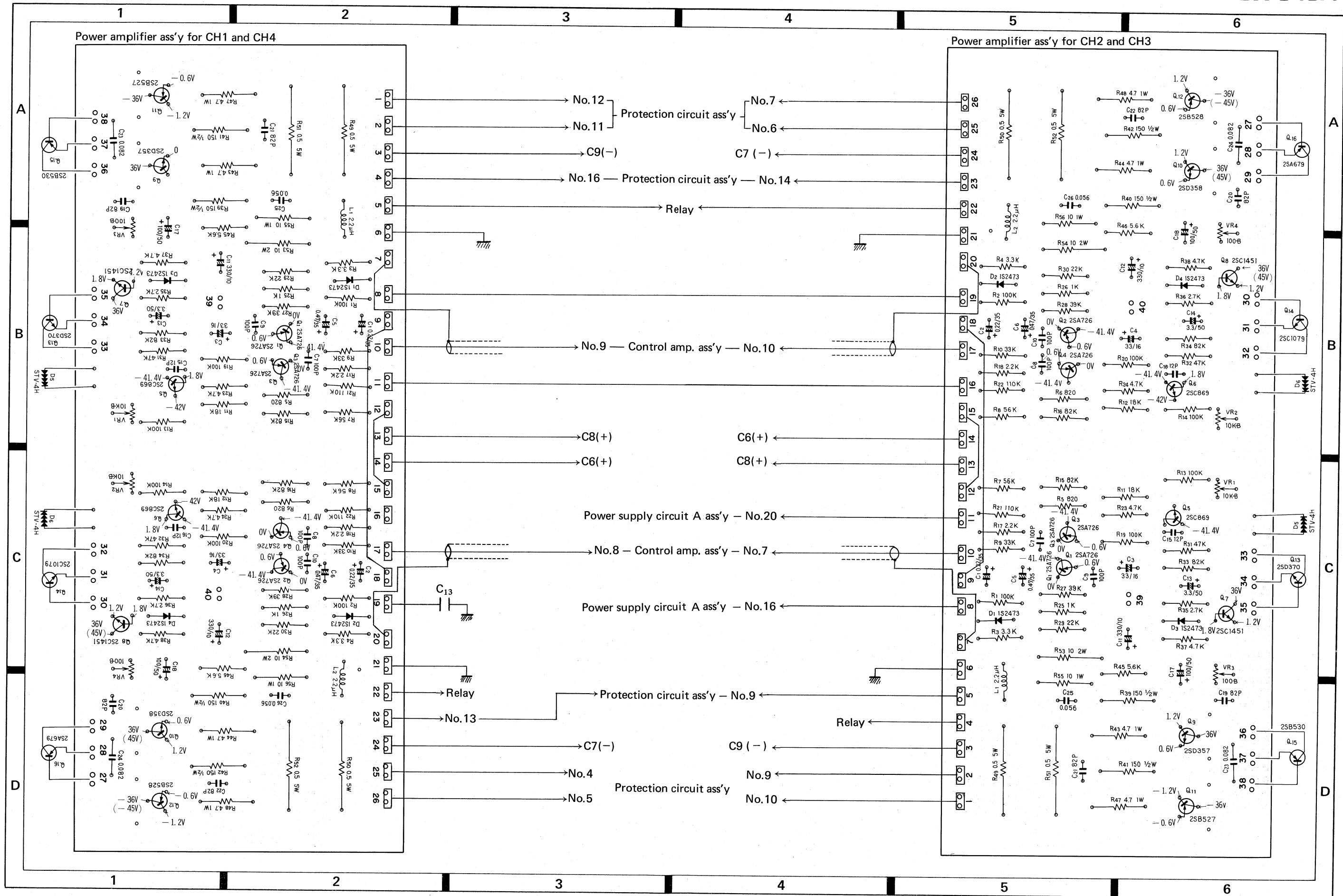

Parts List of Power Amplifier Assembly (AWH-027)

CAPACITORS

| Symbol | Description | | | Part No. |
|--------|--------------|-------|-----|---------------|
| C1 | Electrolytic | 0.22 | 35V | CSZA R22M 35 |
| C2 | Electrolytic | 0.22 | 35V | CSZA R22M 35 |
| C3 | Electrolytic | 33 | 16V | CEA 330P 16 |
| C4 | Electrolytic | 33 | 16V | CEA 330P 16 |
| C5 | Electrolytic | 0.47 | 35V | CSZA R47M 35 |
| C6 | Electrolytic | 0.47 | 35V | CSZA R47M 35 |
| C7 | Ceramic | 100p | 50V | CCDSL 101K 50 |
| C8 | Ceramic | 100p | 50V | CCDSL 101K 50 |
| C9 | Ceramic | 100p | 50V | CCDSL 101K 50 |
| C10 | Ceramic | 100p | 50V | CCDSL 101K 50 |
| C11 | Electrolytic | 330 | 10V | CEA 331P 10 |
| C12 | Electrolytic | 330 | 10V | CEA 331P 10 |
| C13 | Electrolytic | 3.3 | 50V | CEA 3R3P 50 |
| C14 | Electrolytic | 3.3 | 50V | CEA 3R3P 50 |
| C15 | Ceramic | 12p | 50V | CCDSL 120K 50 |
| C16 | Ceramic | 12p | 50V | CCDSL 120K 50 |
| C17 | Electrolytic | 100 | 50V | CEA 101P 50 |
| C18 | Electrolytic | 100 | 50V | CEA 101P 50 |
| C19 | Ceramic | 82p | 50V | CCDSL 820K 50 |
| C20 | Ceramic | 82p | 50V | CCDSL 820K 50 |
| C21 | Ceramic | 82p | 50V | CCDSL 820K 50 |
| C22 | Ceramic | 82p | 50V | CCDSL 820K 50 |
| C23 | Mylar | 0.082 | 50V | CQMA 823M 50 |
| C24 | Mylar | 0.082 | 50V | CQMA 823M 50 |
| C25 | Mylar | 0.056 | 50V | CQMA 563M 50 |
| C26 | Mylar | 0.056 | 50V | CQMA 563M 50 |

RESISTORS AND POTENTIOMETERS

| Symbol | Description | | | Part No. |
|--------|-------------|------|--|------------|
| R1 | Carbon film | 100k | | RD½PS 104J |
| R2 | Carbon film | 100k | | RD½PS 104J |
| R3 | Carbon film | 3.3k | | RD½PS 332J |
| R4 | Carbon film | 3.3k | | RD½PS 332J |
| R5 | Carbon film | 820 | | RD½PS 821J |
| R6 | Carbon film | 820 | | RD½PS 821J |
| R7 | Carbon film | 56k | | RD½PS 563J |
| R8 | Carbon film | 56k | | RD½PS 563J |
| R9 | Carbon film | 33k | | RD½PS 333J |
| R10 | Carbon film | 33k | | RD½PS 333J |
| R11 | Carbon film | 18k | | RD½PS 183J |
| R12 | Carbon film | 18k | | RD½PS 183J |
| R13 | Carbon film | 100k | | RD½PS 104J |
| R14 | Carbon film | 100k | | RD½PS 104J |
| R15 | Carbon film | 82k | | RD½PS 823J |

| Symbol | Description | | | Part No. |
|--------|--------------------------------|-------|----|------------|
| R16 | Carbon film | 82k | | RD½PS 823J |
| R17 | Carbon film | 2.2k | | RD½PS 222J |
| R18 | Carbon film | 2.2k | | RD½PS 222J |
| R19 | Carbon film | 100k | | RD½PS 104J |
| R20 | Carbon film | 100k | | RD½PS 104J |
| R21 | Carbon film | 110k | | RD½PS 114J |
| R22 | Carbon film | 110k | | RD½PS 114J |
| R23 | Carbon film | 4.7k | | RD½PS 472J |
| R24 | Carbon film | 4.7k | | RD½PS 472J |
| R25 | Carbon film | 1k | | RD½PS 102J |
| R26 | Carbon film | 1k | | RD½PS 102J |
| R27 | Carbon film | 39k | | RD½PS 393J |
| R28 | Carbon film | 39k | | RD½PS 393J |
| R29 | Carbon film | 22k | | RD½PS 223J |
| R30 | Carbon film | 22k | | RD½PS 223J |
| R31 | Carbon film | 47k | | RD½PS 473J |
| R32 | Carbon film | 47k | | RD½PS 473J |
| R33 | Carbon film | 82k | | RD½PS 823J |
| R34 | Carbon film | 82k | | RD½PS 823J |
| R35 | Carbon film | 2.7k | | RD½PS 272J |
| R36 | Carbon film | 2.7k | | RD½PS 272J |
| R37 | Carbon film | 4.7k | | RD½PS 472J |
| R38 | Carbon film | 4.7k | | RD½PS 472J |
| R39 | Carbon film | 150 | ½W | RD½PS 151J |
| R40 | Carbon film | 150 | ½W | RD½PS 151J |
| R41 | Carbon film | 150 | ½W | RD½PS 151J |
| R42 | Carbon film | 150 | ½W | RD½PS 151J |
| R43 | Metal film | 4.7 | 1W | RN1H 4R7K |
| R44 | Metal film | 4.7 | 1W | RN1H 4R7K |
| R45 | Carbon film | 5.6k | | RD½PS 562J |
| R46 | Carbon film | 5.6k | | RD½PS 562J |
| R47 | Metal film | 4.7 | 1W | RN1H 4R7K |
| R48 | Metal film | 4.7 | 1W | RN1H 4R7K |
| R49 | Wire wound | 0.5 | 5W | RT5B 0R5K |
| R50 | Wire wound | 0.5 | 5W | RT5B 0R5K |
| R51 | Wire wound | 0.5 | 5W | RT5B 0R5K |
| R52 | Wire wound | 0.5 | 5W | RT5B 0R5K |
| R53 | Metal oxide | 10 | 2W | RS2P 100J |
| R54 | Metal oxide | 10 | 2W | RS2P 100J |
| R55 | Metal oxide | 10 | 1W | RS1P 100J |
| R56 | Metal oxide | 10 | 1W | RS1P 100J |
| VR1 | Variable resistor (Semi-fixed) | 10k-B | | ACP-029 |
| VR2 | Variable resistor (Semi-fixed) | 10k-B | | ACP-029 |
| VR3 | Variable resistor (Semi-fixed) | 100-B | | ACP-019 |
| VR4 | Variable resistor (Semi-fixed) | 100-B | | ACP-019 |

SEMICONDUCTORS

| Symbol | Description | Part No. |
|--------|-------------|--------------------------------|
| Q1 | Transistor | 2SA726-G or F (2SA763F-6 or 5) |
| Q2 | Transistor | 2SA726-G or F (2SA763F-6 or 5) |
| Q3 | Transistor | 2SA726-G or F (2SA763F-6 or 5) |
| Q4 | Transistor | 2SA726-G or F (2SA763F-6 or 5) |
| Q5 | Transistor | 2SC869-C or D |
| Q6 | Transistor | 2SC869-C or D |
| Q7 | Transistor | 2SC1451-V or B |
| Q8 | Transistor | 2SC1451-V or B |
| Q9 | Transistor | 2SD357-C or D |
| Q10 | Transistor | 2SD358-C or D |
| Q11 | Transistor | 2SB527-C or D |
| Q12 | Transistor | 2SB528-C or D |
| D1 | Diode | 1S2473 |
| D2 | Diode | 1S2473 |
| D3 | Diode | 1S2473 |
| D4 | Diode | 1S2473 |
| D5 | Varistor | STV-4 |
| D6 | Varistor | STV-4 |

OTHER

| Symbol | Description | Part No. |
|--------|---------------|----------|
| L1 | AF Choke coil | T63-009 |
| L2 | AF Choke coil | T63-009 |

14. PARTS LIST OF EXPLODED VIEWS

| Parts No. | Parts Name |
|-----------|-----------------------------|
| AAA-023 | Knob |
| AAB-056 | Knob |
| AAB-065 | Knob |
| AAB-079 | Knob |
| AAB-080 | Knob |
| AAD-055 | Knob |
| AAD-108 | Knob |
| AAE-007 | Coupler |
| AAE-008 | Coupler |
| AAF-036 | Dial Pointer Ass. |
| AAG-063 | Dial Scale Plate |
| AAW-021 | 4-CH Level Indicator |
| AAW-042 | Twin Meter |
| ABA-002 | Screw M3x8 |
| ABA-010 | Screw M4x15 |
| ABA-012 | Screw M4x8 |
| ABE-006 | Washer |
| ABN-008 | Washer Faced Nut 5mm |
| ACG-001 | Ceramic Capacitor |
| ACH-029 | Ele. Capacitor |
| ACT-009 | Variable Resistor |
| ACV-017 | Variable Resistor |
| ACV-110 | Variable Resistor |
| ACV-311 | Variable Resistor |
| ADG-004 | AC Power Cord (QX-949A/F) |
| ADG-005 | AC Power Cord (QX-949A/KCU) |
| AEB-042 | Rubber Bracket |
| AEB-043 | Rubber Bracket |
| AEB-044 | Rubber Bracket |
| AEC-017 | Pulley |
| AEC-027 | Foot |
| AEC-076 | Insulation Wafer |
| AEC-079 | Strain Relief |
| AEC-101 | Pulley |
| AEC-110 | Switch Cover Ass. |
| AEC-116 | Spacer |
| AEC-119 | Sponge |
| AEC-120 | Shading Sponge Ring |
| AEC-121 | Acrylic Cap |
| AEC-136 | Clip |
| AEE-008 | Insulator |
| AEE-009 | Insulate Board |
| AEK-101 | Fuse 3A |
| AEK-106 | Fuse 1A |
| AEK-109 | Fuse 6A |
| AEK-205 | Fuse 6A (QX-949A/KCU) |
| AEL-015 | Lamp 8V 300mA |
| AEL-022 | Lamp 8V 50mA |
| AEL-025 | Lamp 6V 30mA |

| Parts No. | Parts Name |
|-----------|---------------------------------|
| AKA-004 | Ant. Terminal Board |
| AKB-015 | Phono Jack 4P |
| AKB-017 | Phono Jack 6P |
| AKB-018 | Phono Jack 6P |
| AKB-019 | Phono Jack 1P |
| AKE-010 | Sp. Output Terminal |
| AKE-012 | Binding Post (for Ground) |
| AKE-018 | Sp. Output Terminal-A |
| AKH-001 | Transistor Socket |
| AKK-002 | Lamp Holder |
| AKM-006 | Multi Plug |
| AKN-002 | Phone Jack |
| AKP-005 | AC Socket |
| AKP-006 | Multi Socket |
| AKR-026 | Fuse Holder (QX-949A/KCU) |
| AKR-027 | Fuse Holder (QX-949A/F) |
| ALA-006 | Boss |
| AMM-045 | Wooden Cabinet |
| ANB-318 | Front Panel Ass. |
| ASB-048 | Rotary Switch |
| ASC-066 | Rotary Switch |
| ASF-001 | Micro Switch |
| ASG-019 | Push Switch |
| ASG-043 | Push Switch (QX-949A/KCU) |
| ASG-046 | Push Switch |
| ASG-047 | Push Switch |
| ASG-049 | Push Switch |
| ASG-050 | Push Switch |
| ASG-070 | Push Switch (QX-949A/F) |
| ASH-008 | Slide Switch (QX-949A/KCU) |
| ASH-013 | Slide Switch (QX-949A/F) |
| ASR-007 | Relay |
| ATB-042 | Ferrite Bar-Antenna |
| ATT-221 | Power Transformer (QX-949A/KCU) |
| ATT-222 | Power Transformer (QX-949A/F) |
| AWE-041 | Tuner Ass. |
| AWG-023 | Control Amplifier Ass. |
| AWH-027 | Power Amplifier Ass. |
| AWM-076 | CD-4 Ass. |
| AWM-077 | SQ/RM Decoder Ass. |
| AWM-079 | Protection Ass. |
| AWR-039 | Power Supply (B) Ass. |
| AWR-080 | Power Supply (A) Ass. |
| AWS-048 | Switch Ass. |
| AWX-052 | Lamp Board Ass. |
| AWX-054 | Headphone Jack Ass. |
| AXA-015 | Tuning Drum Ass. |
| AXA-039 | Tuning Shaft Ass. |
| AXB-001 | Antenna Holder Ass. |
| B21-011 | Washer (Outernal Toothed Lock) |

| Parts No. | Parts Name |
|-----------|----------------|
| B22-016 | Washer 9mm |
| B71-004 | Nut 9mm |
| B71-010 | Nut 7mm |
| E22-032 | Lamp 8V 300mA |
| M45-105 | Wire Supporter |
| M49-025 | Pulley Shaft |
| T22-025 | Ferrite Balun |
| 2SA679 | Transistor |
| 2SB530 | Transistor |
| 2SC1079 | Transistor |
| 2SD370 | Transistor |

4-CHANNEL STEREO RECEIVER

QX-949A F

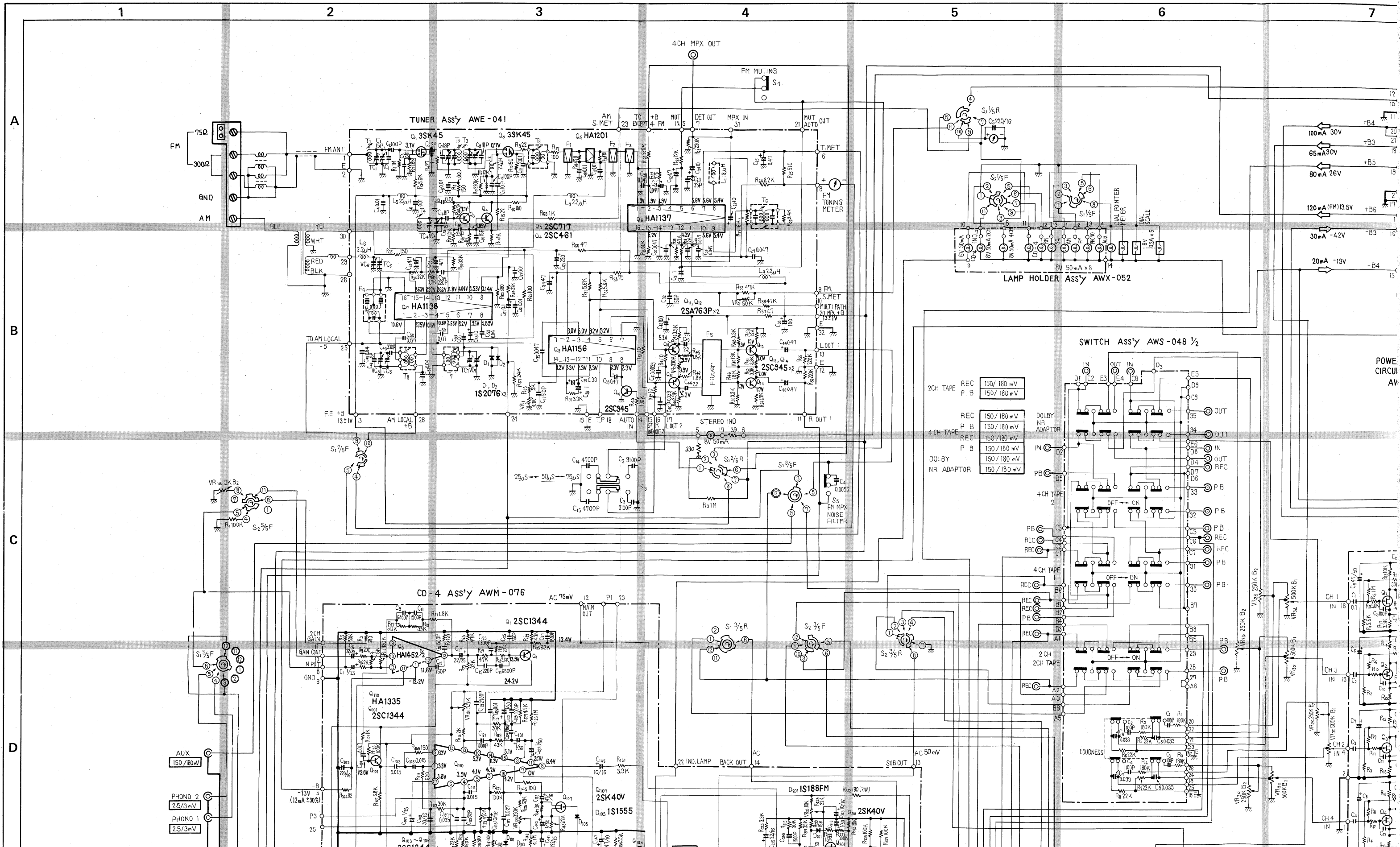

POWER SUPPLY CIRCUIT Ass'y (A)
AWR - 080

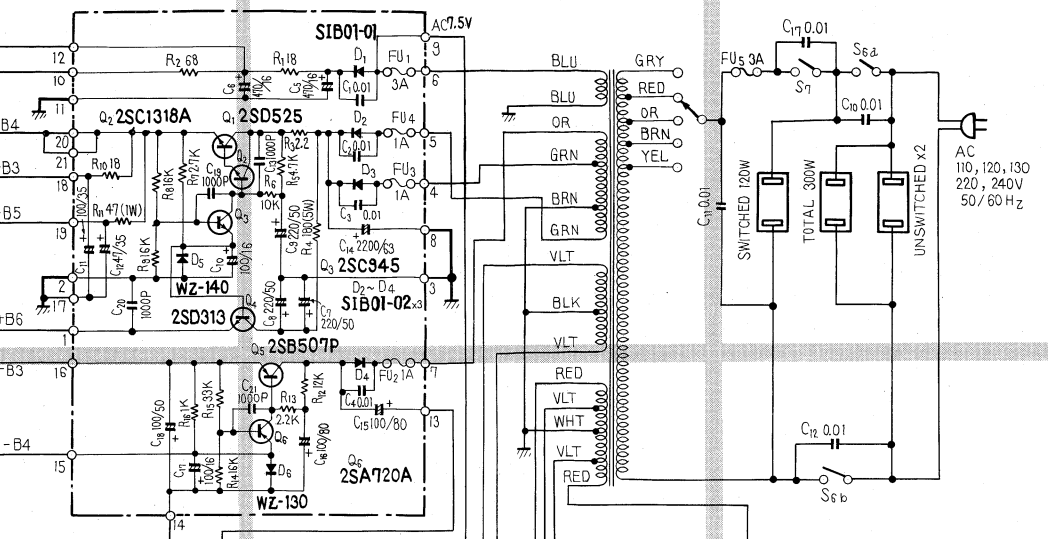

POWER SUPPLY CIRCUIT Ass'y (B)
AWR - 039

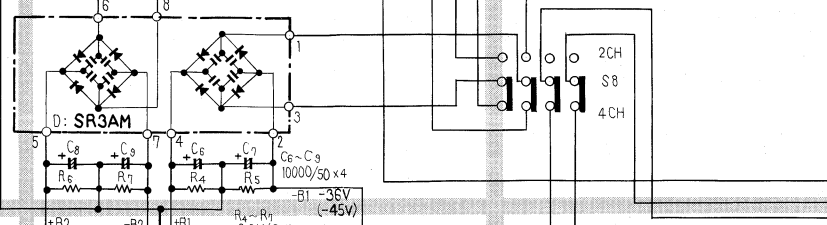

SWITCH ASS'y
AWS-048 1/2

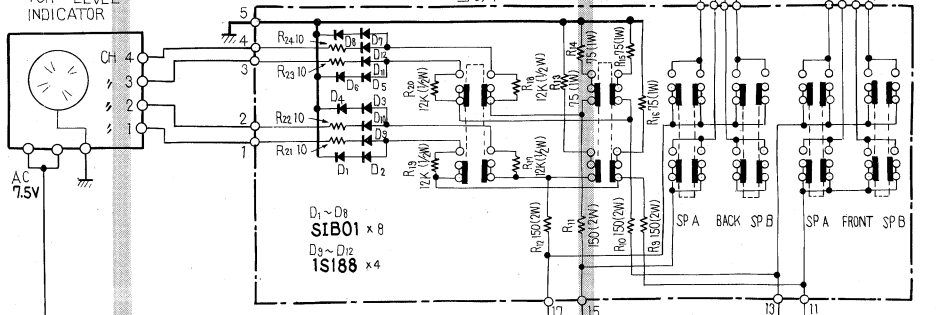

CONTROL AMP ASS'y AWG - 023

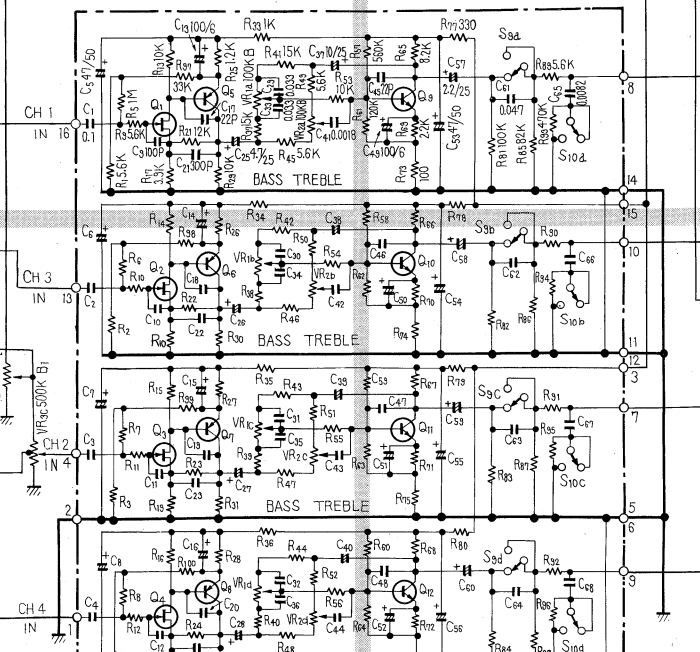

POWER AMP Ass'y AWH-027 (B) FRONT L ch.

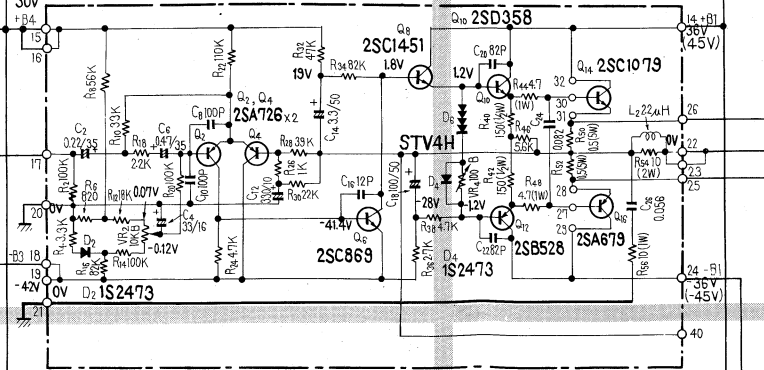

POWER AMP Ass'y AWH-027 (A) FRONT R ch.

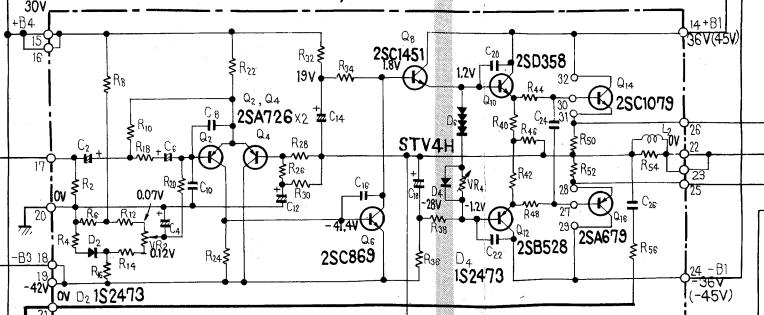

HEADPHONE Ass'y
AWX-054

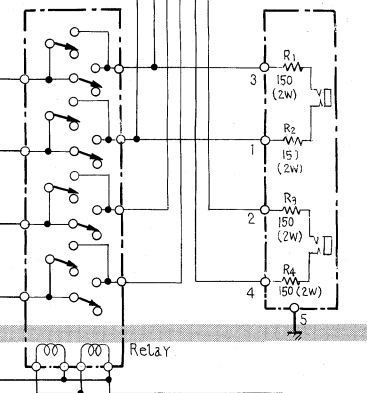

PROTECTION CIRCUIT Ass'y
AWM-079

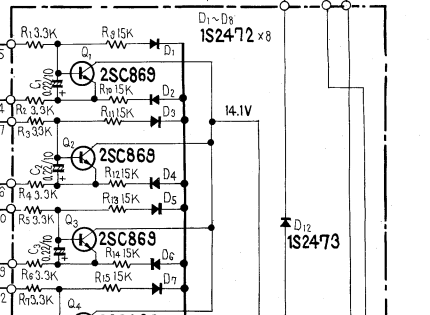

WS-048 1/2

A

B

C

D

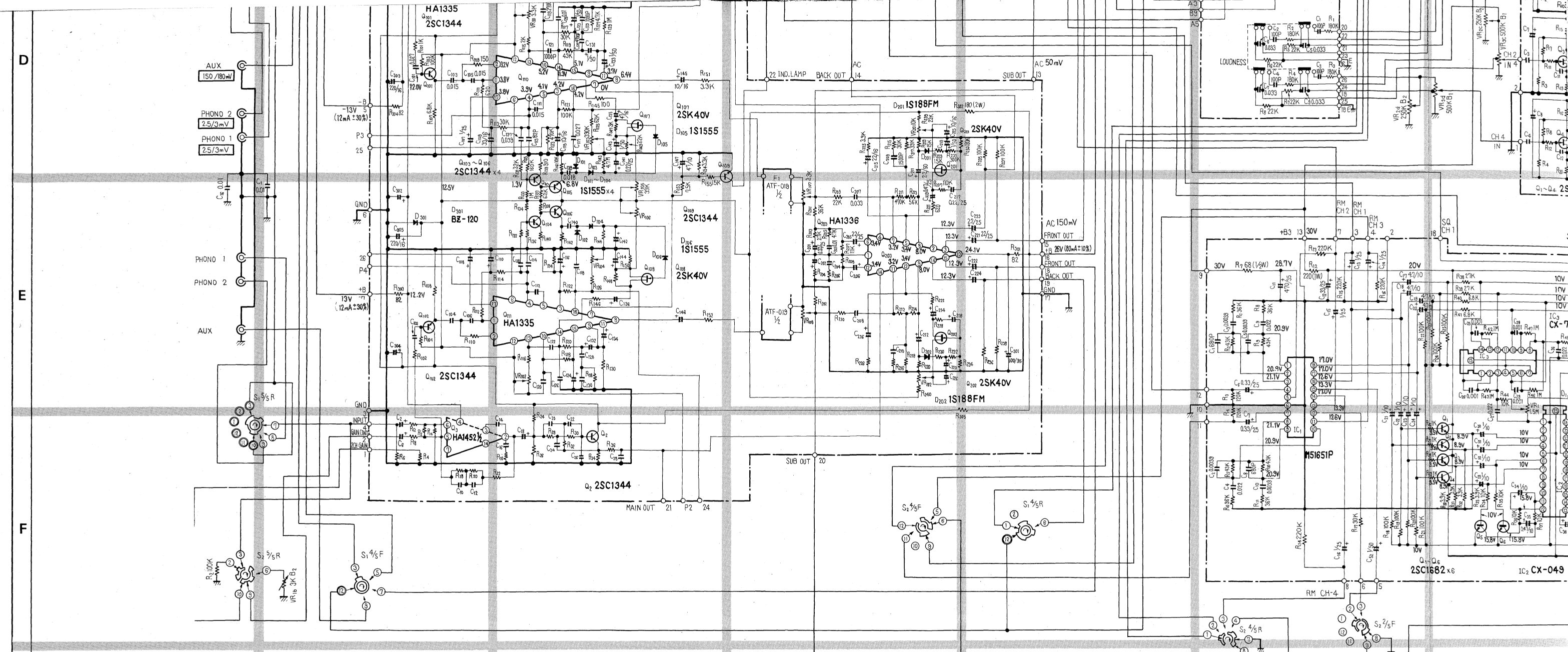

SWITCHES

- | | | |
|---|---|--|
| <p>S₁ : FUNCTION (AM position)</p> <ol style="list-style-type: none"> 1. AM 2. FM MONO 3. FM AUTO 4. PHONO 1 5. PHONO 2 6. AUX <p>S₂ MODE (2CH position)</p> <ol style="list-style-type: none"> 1. 2CH 2. CD-4 3. RM 4. SQ FULL LOGIC | <p>S₃ : FM DE-EMPHASIS (50μS position)</p> <ol style="list-style-type: none"> 1. 25μSEC 2. 50μSEC 3. 75μSEC <p>S₄ : FM MUTING (ON position)</p> <ol style="list-style-type: none"> 1. ON 2. OFF <p>S₅ MPX NOISE FILTER</p> <ol style="list-style-type: none"> 1. OFF 2. ON | <p>S_{6 a, b} : POWER SW</p> <p>S₇ : MICRO SW</p> <p>S₈ : POWER BOOSTING SW (4CH position)</p> <ol style="list-style-type: none"> 1. 2CH 2. 4CH <p>S₉ LOW FILTER (OFF position)</p> <ol style="list-style-type: none"> 1. OFF 2. ON <p>S₁₀ HIGH FILTER (OFF position)</p> <ol style="list-style-type: none"> 1. OFF 2. ON |
|---|---|--|

CAPACITORS

IN μ F UNLESS OTHERWISE NOTED. P: pF

RESISTORS

IN OHM, $\frac{1}{4}$ W, $\pm 5\%$ TOLERANCE UNLESS OTHERWISE NOTED K:K M:M Ω

NOTES

- \square V : SIGNAL VOLTAGE NECESSARY
- \square V : SIGNAL VOLTAGE NECESSARY
- V : DC VOLTAGE AT NO INPUT
- (V) : DC VOLTAGE AT NO INPUT
- (A) : DC CURRENT AT NO INPUT

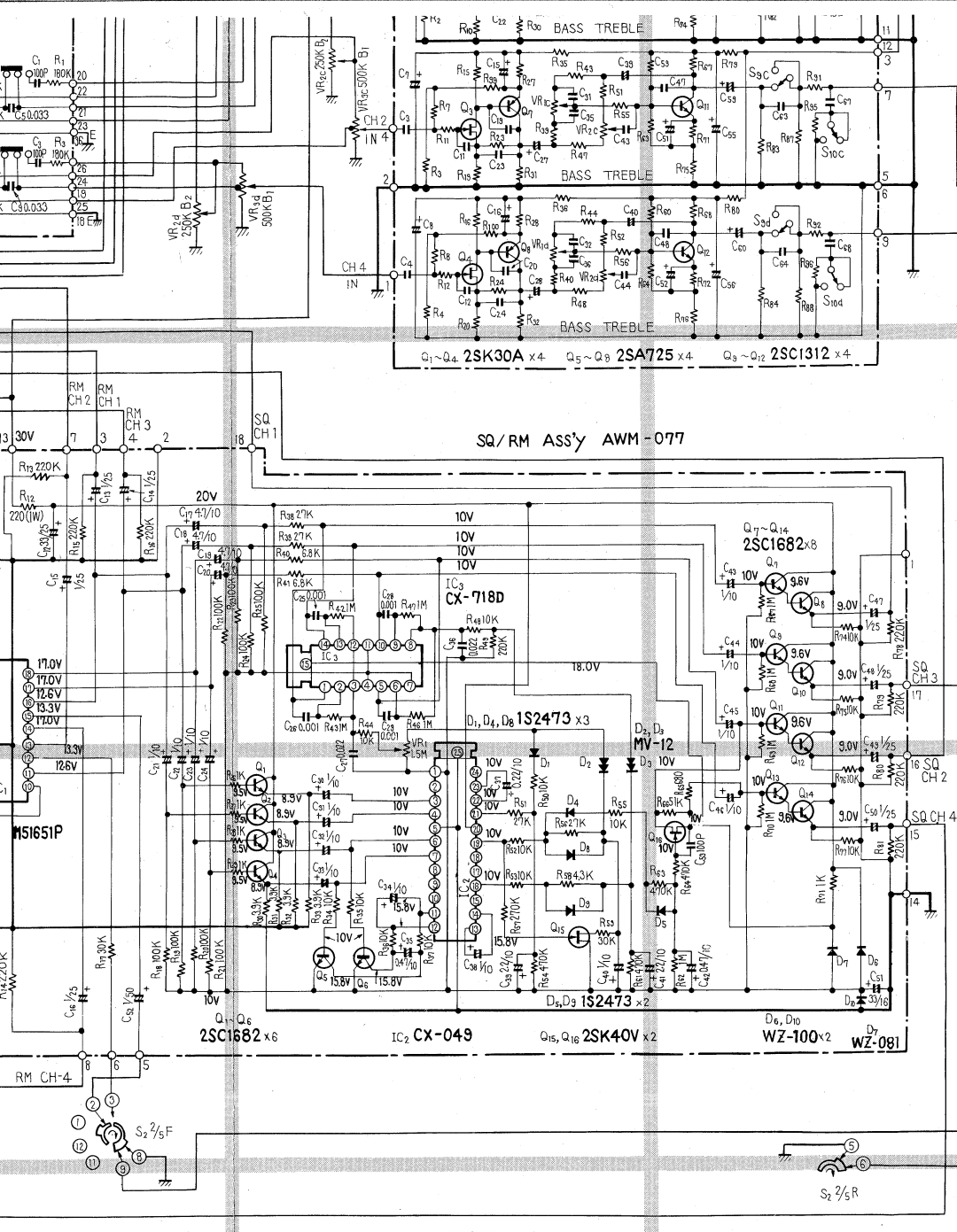

SQ/RM Ass'y AWM-077

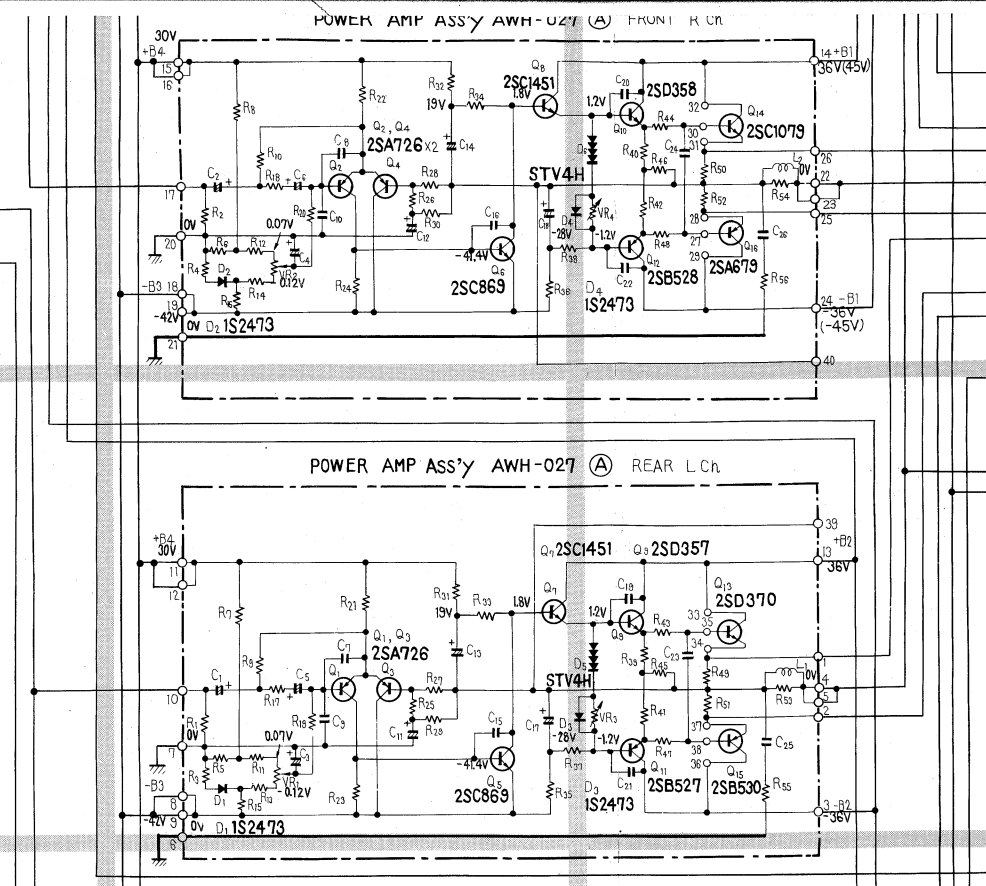

POWER AMP ASS'y AWH-027 (A) FRONT R CR

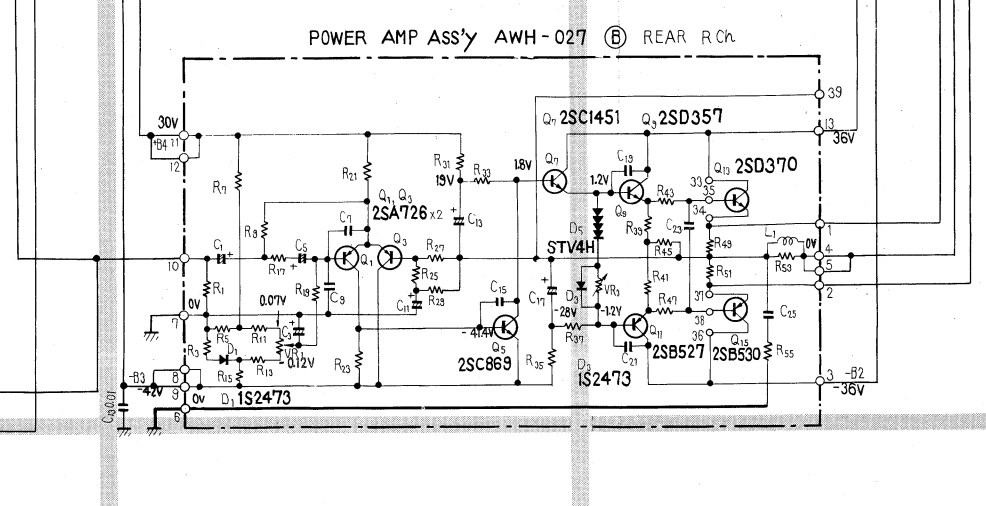

POWER AMP ASS'y AWH-027 (B) REAR R CR

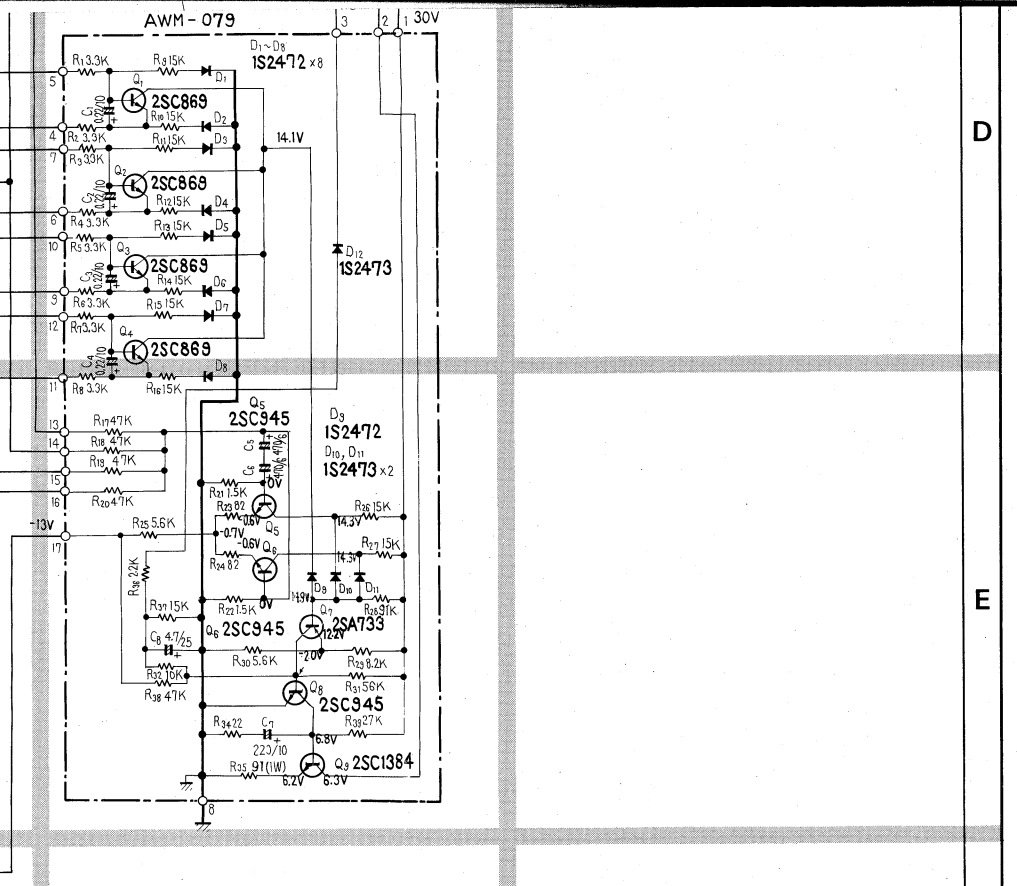

AWM-079

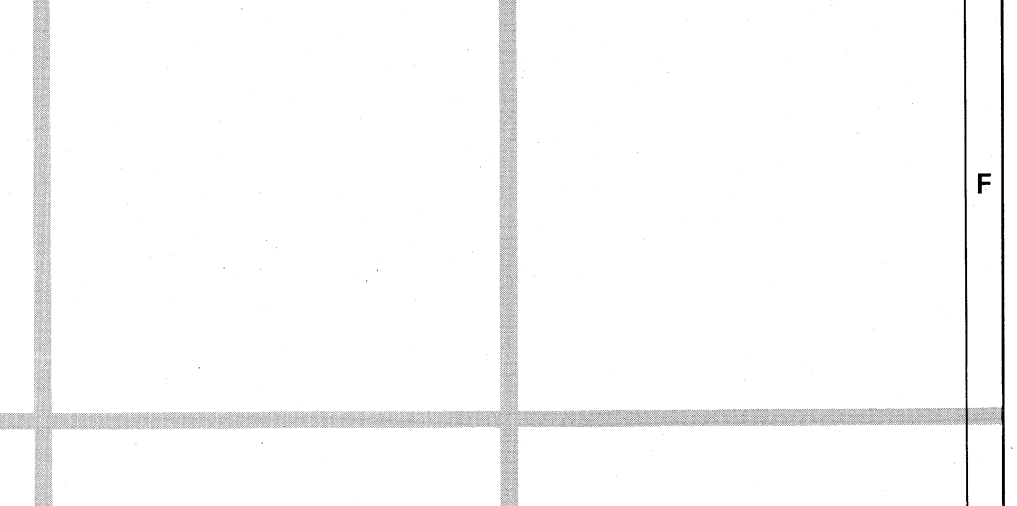

POWER AMP ASS'y AWH-027 (A) REAR L CR

- NOTES
- \bar{V} : SIGNAL VOLTAGE NECESSARY FOR OBTAINING 50W/8Ω OUTPUT POWER (1KHz), S₈ SET AT 4CH.
 - \bar{V} : SIGNAL VOLTAGE NECESSARY FOR OBTAINING 72W/8Ω OUTPUT POWER (1KHz), S₈ SET AT 2CH.
 - V : DC VOLTAGE AT NO INPUT SIGNAL, S₈ SET AT 4CH.
 - A : DC CURRENT AT NO INPUT SIGNAL, S₈ SET AT 4CH.
 - (V) : DC VOLTAGE AT NO INPUT SIGNAL, S₈ SET AT 2CH.
 - (A) : DC CURRENT AT NO INPUT SIGNAL, S₈ SET AT 2CH.

MΩ

D
E
F
G

6

7

8

9

10

11

12

4-CHANNEL STEREO RECEIVER

QX-949A KCU

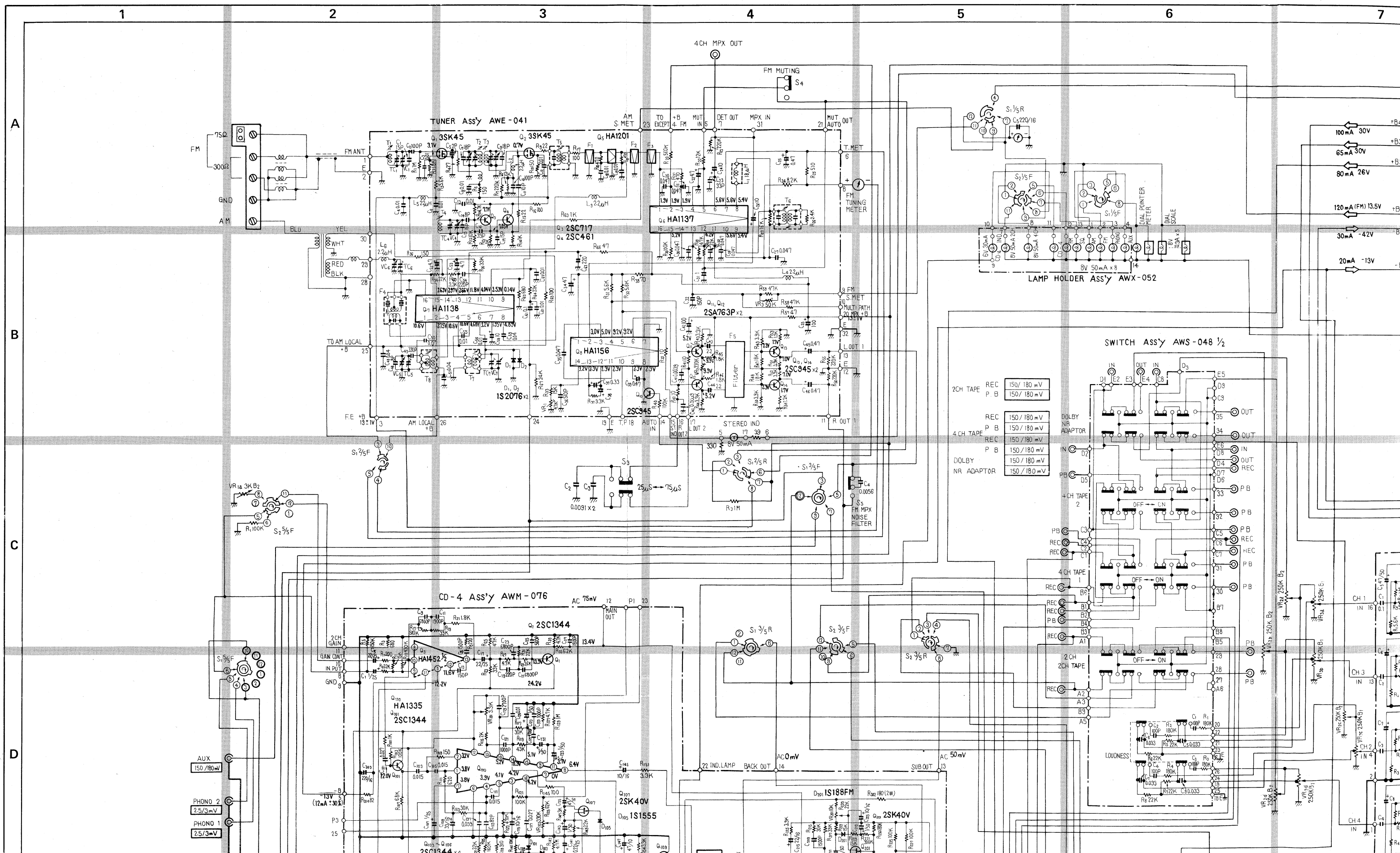

POWER SUPPLY CIRCUIT ASS'y (A)
AWR - 080

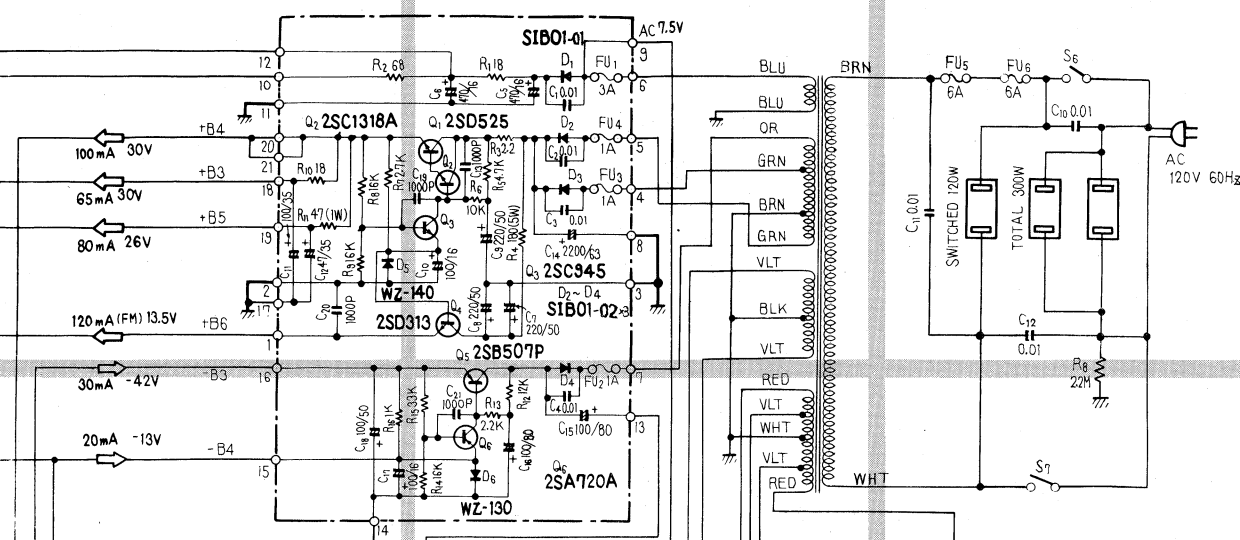

POWER SUPPLY CIRCUIT ASS'y (B)
AWR - 039

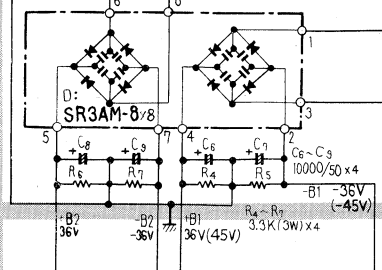

CONTROL AMP ASS'y AWG - 023

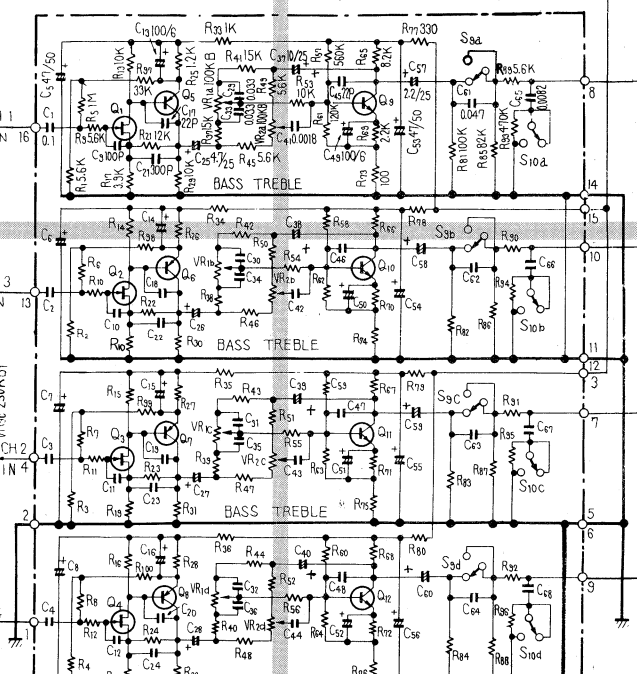

POWER AMP ASS'y AWH-027 (B) FRONT L Ch.

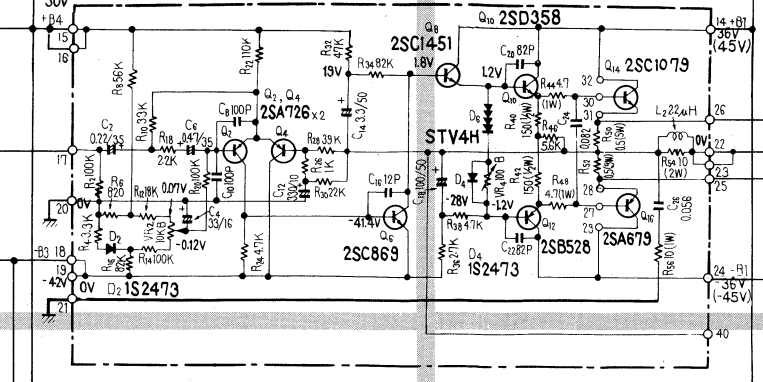

POWER AMP ASS'y AWH-027 (A) FRONT R Ch.

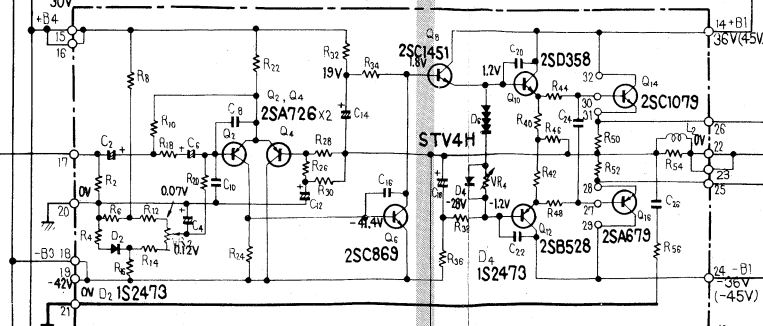

SWITCH ASS'y
AWS-048 1/2

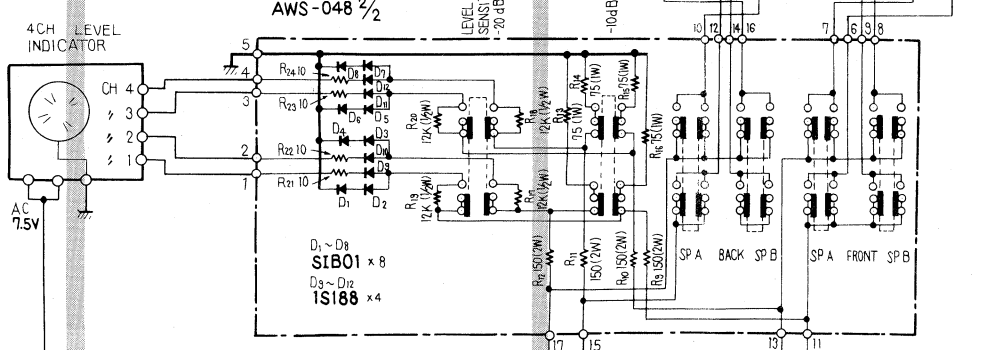

HEADPHONE ASS'y
AWX-054

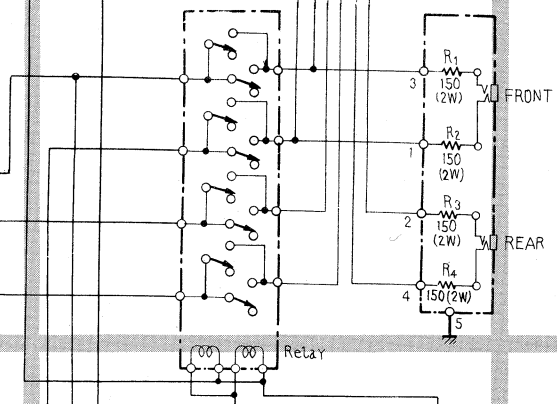

PROTECTION CIRCUIT ASS'y
AWM-079

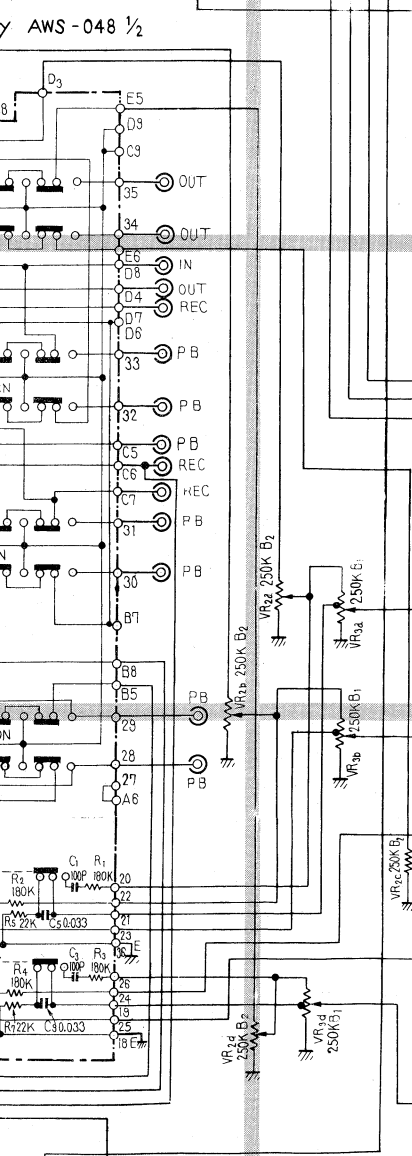
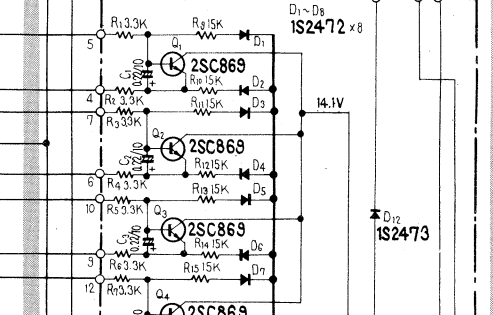

A
B
C
D

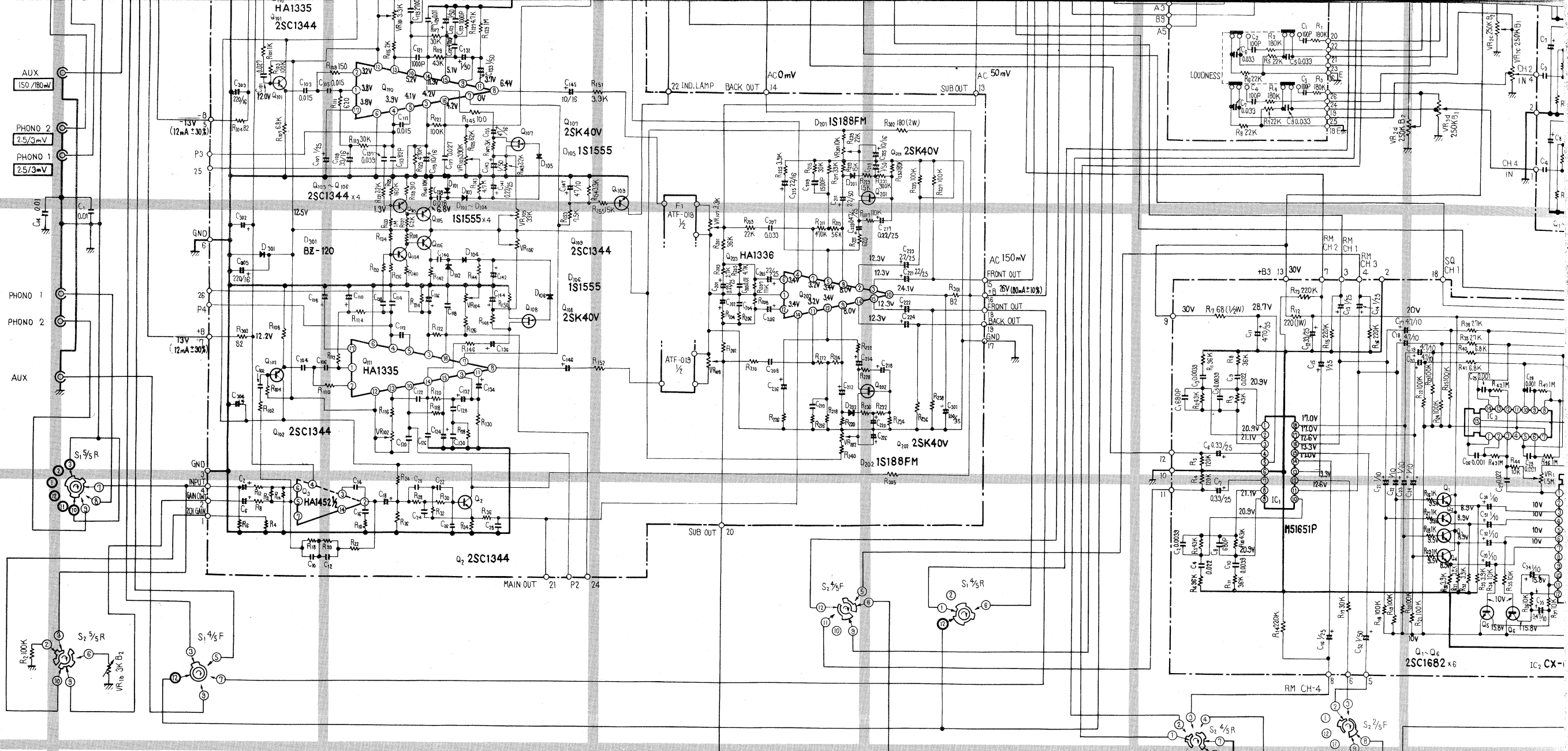

SWITCHES

- | | | |
|---|---|--|
| <p>S₁ : FUNCTION (AM position)</p> <ol style="list-style-type: none"> 1. AM 2. FM MONO 3. FM AUTO 4. PHONO 1 5. PHONO 2 6. AUX | <p>S₃ : FM DE-EMPHASIS (75 μS position)</p> <ol style="list-style-type: none"> 1. 75 μSEC 2. 25 μSEC | <p>S₆ : POWER SW</p> |
| <p>S₂ : MODE (2CH position)</p> <ol style="list-style-type: none"> 1. 2CH 2. CD-4 3. RM 4. SQ FULL LOGIC | <p>S₄ : FM MUTING (ON position)</p> <ol style="list-style-type: none"> 1. ON 2. OFF | <p>S₇ : MICRO SW</p> |
| | <p>S₅ : MPX NOISE FILTER</p> <ol style="list-style-type: none"> 1. OFF 2. ON | <p>S₈ : POWER BOOSTING SW (4CH position)</p> <ol style="list-style-type: none"> 1. 2CH 2. 4CH |
| | | <p>S₉ : LOW FILTER (OFF position)</p> <ol style="list-style-type: none"> 1. OFF 2. ON |
| | | <p>S₁₀ : HIGH FILTER (OFF position)</p> <ol style="list-style-type: none"> 1. OFF 2. ON |

CAPACITORS

IN μF UNLESS OTHERWISE NOTED. P: pF

RESISTORS

IN OHM, 1/4W, ±5% TOLERANCE UNLESS OTHERWISE NOTED K:k M:MΩ

NOTES

- V : SIGNAL VOLTAGE NE
- V : SIGNAL VOLTAGE N
- V : DC VOLTAGE AT N
- A : DC CURRENT AT N
- (V) : DC VOLTAGE AT N
- (A) : DC CURRENT AT N

1

2

3

4

5

6

7

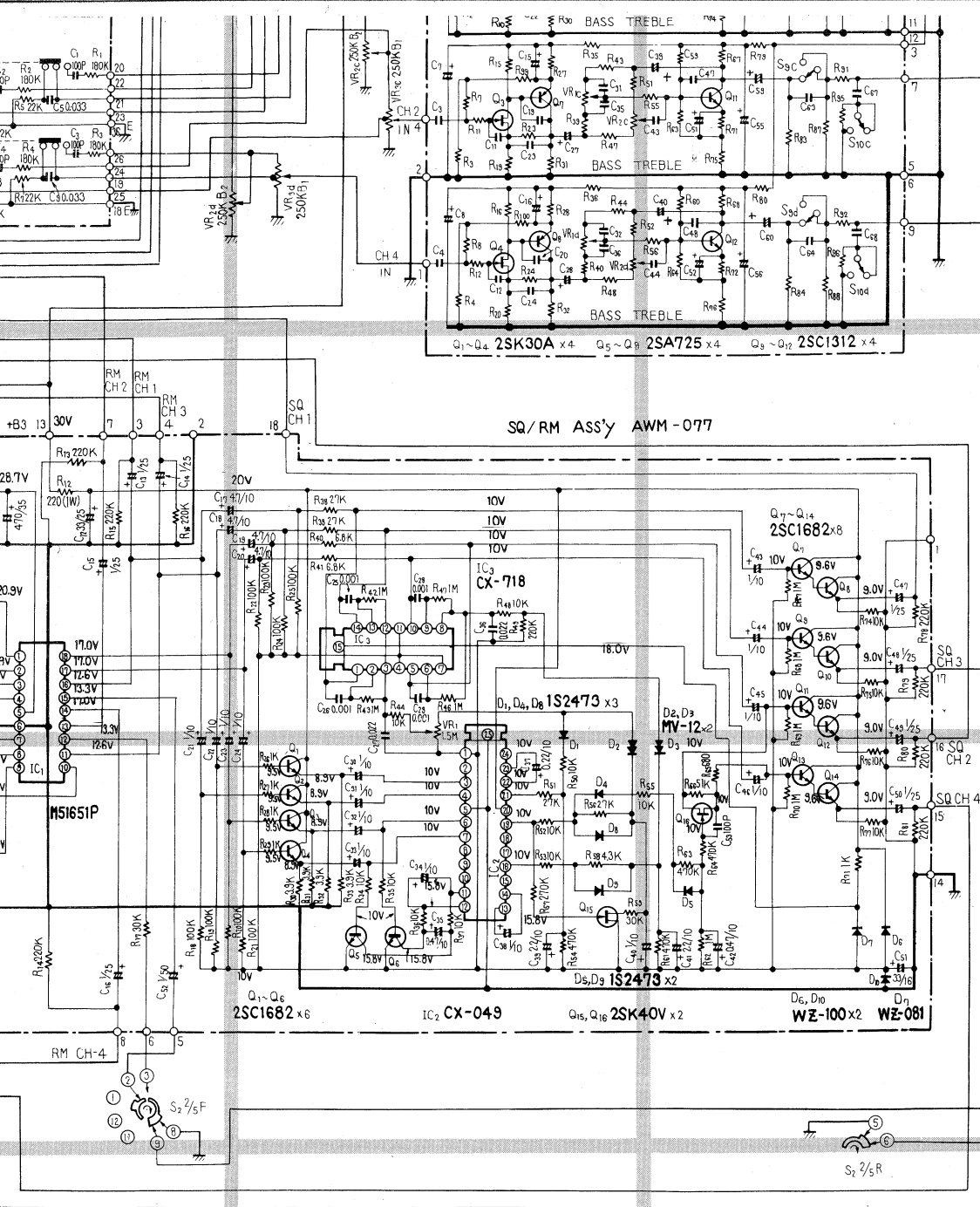

SQ/RM ASS'Y AWM-077

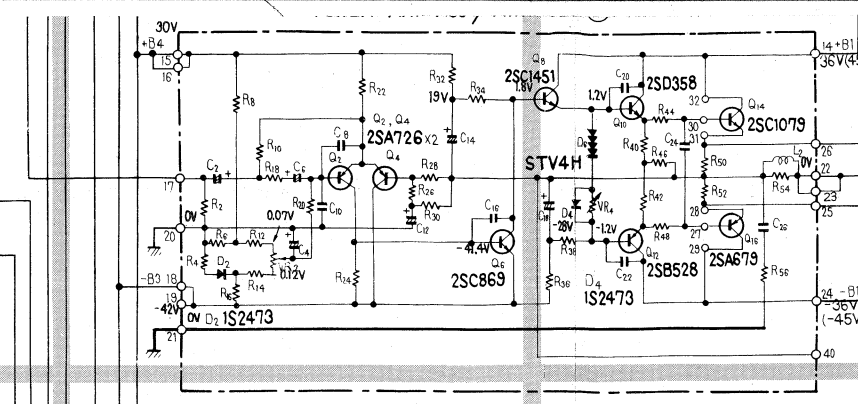

POWER AMP ASS'Y AWH-027 (A) REAR L Ch

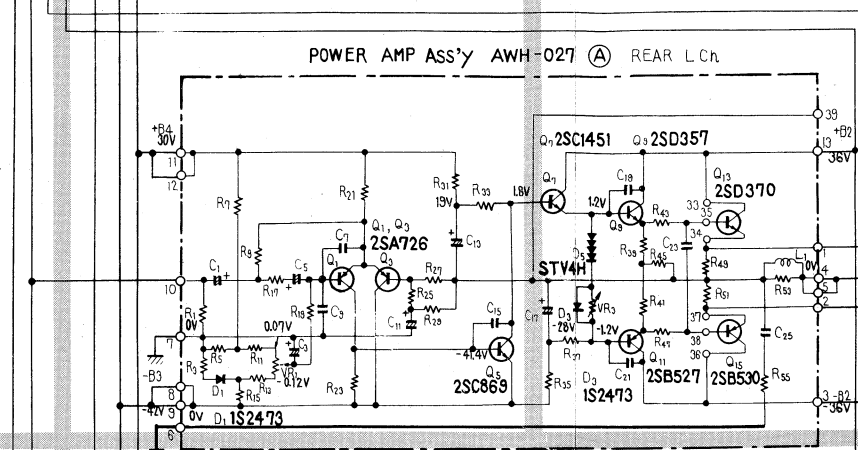

POWER AMP ASS'Y AWH-027 (B) REAR R Ch

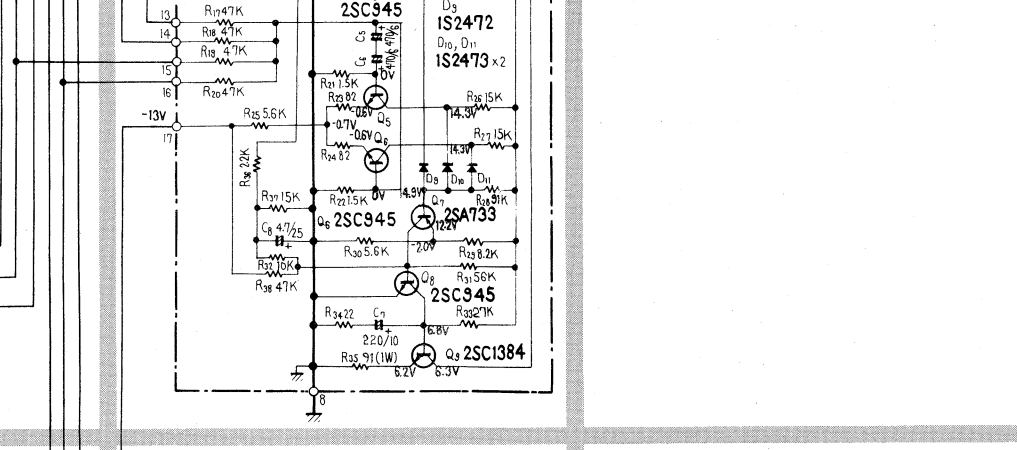
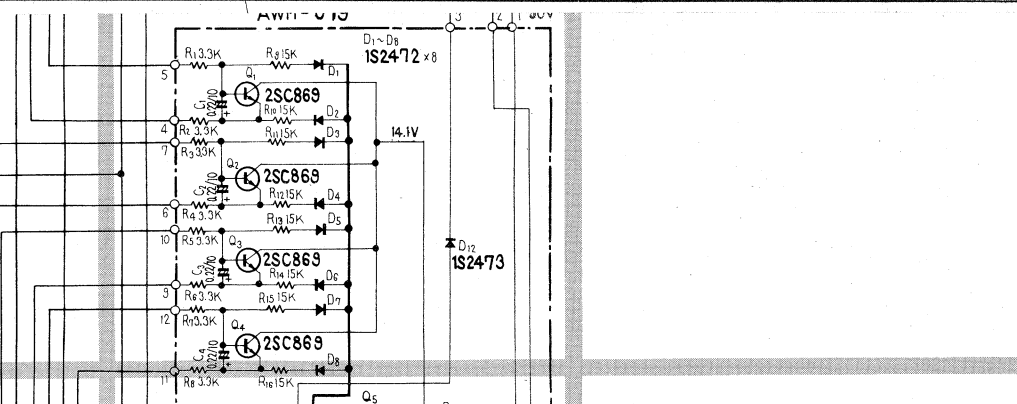

- NOTES
- V : SIGNAL VOLTAGE NECESSARY FOR OBTAINING 50W/8Ω OUTPUT POWER (1KHz), S₈ SET AT 4CH.
 - V : SIGNAL VOLTAGE NECESSARY FOR OBTAINING 72W/8Ω OUTPUT POWER (1KHz), S₈ SET AT 2CH.
 - V : DC VOLTAGE AT NO INPUT SIGNAL, S₈ SET AT 4CH.
 - A : DC CURRENT AT NO INPUT SIGNAL, S₈ SET AT 4CH.
 - (V) : DC VOLTAGE AT NO INPUT SIGNAL, S₈ SET AT 2CH.
 - (A) : DC CURRENT AT NO INPUT SIGNAL, S₈ SET AT 2CH.

M:MΩ

6

7

8

9

10

11

12

D

E

F

G