

Service Manual

**CIRCUIT DESCRIPTIONS
REPAIR & ADJUSTMENTS**

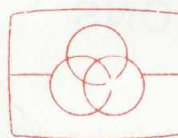

Free service manuals
Gratis schema's
Digitized by

www.freeservicemanuals.info



**ORDER NO.
ARP-106-0**

STEREO AMPLIFIER

SA-330

MODEL SA-330 COMES IN FOUR VERSIONS DISTINGUISHED AS FOLLOWS:

Type	Voltage	Remarks
HE	AC220V and 240V (Switchable)	Europe model
S	AC110V, 120V, 220V and 240V (Switchable)	General export model
YP	AC240V only	Australia model
HEZ	AC220V and 240V (Switchable)	West Germany model

- This service manual is applicable to the HE type. When repairing the S, YP and HEZ types, please see page 17-23.
- Ce manuel d'instruction se réfère au mode de réglage, en français.
- Este manual de servicio trata del método de ajuste escrito en español.

CONTENTS

1. SPECIFICATIONS	2	8. EXPLODED VIEW	8
2. FRONT PANEL FACILITIES	3	9. P.C. BOARDS CONNECTION DIAGRAM	10
3. PARTS LOCATION	4	10. SCHEMATIC DIAGRAM	13
4. BLOCK DIAGRAM	5	11. ADJUSTMENTS	15
5. CIRCUIT DESCRIPTIONS	5	RÉGLAGE	15
6. PARTS LIST	6	ADJUSTE	16
7. PACKING	7	12. FOR S, YP AND HEZ TYPES	17

1. SPECIFICATIONS

Amplifier Section

Continuous average power output is 30 watts per channel, min., at 8 ohms from 30 hertz to 20,000 hertz with no more than 0.08% total harmonic distortion.

28 watts (20Hz~20,000Hz, 0.05%)

Continuous Power Output at 1kHz (both channels driven)

T.H.D. 1%, 8ohms 40 watts per channel

Total Harmonic Distortion (20Hz to 20,000Hz, 8 ohms, from AUX/VIDEO)

14 watts per channel power output

. No more than 0.03%

Intermodulation Distortion (50Hz : 7,000Hz = 4 : 1, 8 ohms, from AUX/VIDEO)

Continuous rated power output . . No more than 0.08%

14 watts per channel power output

. No more than 0.05%

Damping Factor (1kHz, 8 ohms) 30

Input (Sensitivity/Impedance)

PHONO 2.5mV/50 kilohms

TUNER, AUX/VIDEO, TAPE 1,2/ADAPTOR

. 150mV/50 kilohms

Phono Overload Level (T.H.D. 0.01%, 1,000Hz)

PHONO 150mV

Output (Level)

TAPE REC 1,2/ADAPTOR 150mV

Speaker A, B, A+B, OFF

Frequency Response

PHONO (RIAA Equalization)

. 20Hz to 20,000Hz ±0.5dB

TUNER, AUX/VIDEO, TAPE PLAY 1,2/ADAPTOR	10Hz to 60,000Hz ±2dB
Tone Control	
BASS	±10dB (100Hz)
TREBLE	±10dB (10,000Hz)
Loudness Contour	
(Volume control set at -40dB position) . . .	+6dB (100Hz)
Hum and Noise (IHF, short-circuited, A network)	
PHONO	72dB
TUNER, AUX/VIDEO, TAPE PLAY 1,2/ADAPTOR	97 dB
Hum and Noise (DIN continuous Power/50mV)	
PHONO	71dB/62dB
TUNER, AUX/VIDEO, TAPE PLAY 1,2/ADAPTOR	88dB/62dB

Miscellaneous

Power Requirements a.c. 220 volts~50/60Hz

Power Consumption 200 watts

Dimensions 420(W) x 97(H) x 275(D) mm

16-9/16(W) x 3-13/16(H) x 10-13/16(D) in

Weight (without package) 5.0kg (11 lb)

Furnished Parts

Operating Instructions 1

NOTE:

Specifications and the design subject to possible modifications without notice due to improvements.

LINE VOLTAGE SELECTION

Line voltage can be changed as follows:

1. Disconnect the AC power cord.
2. Remove the bonnet case.
3. Take out the fuse from the P.C. board.
4. Re-install the fuse in the correct voltage indication.
5. Stick the line voltage lable on the rear panel.

Description	Part No.
220V label	AAX-193
240V label	AAX-192

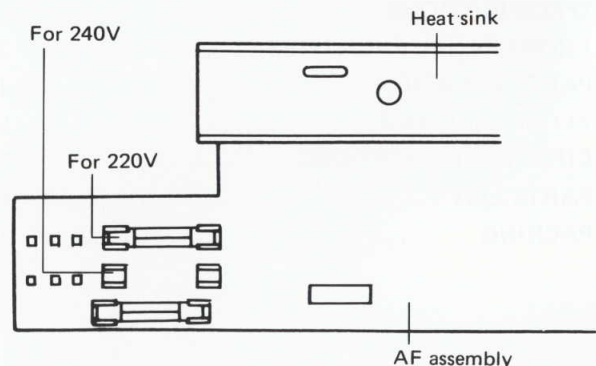

2. FRONT PANEL FACILITIES

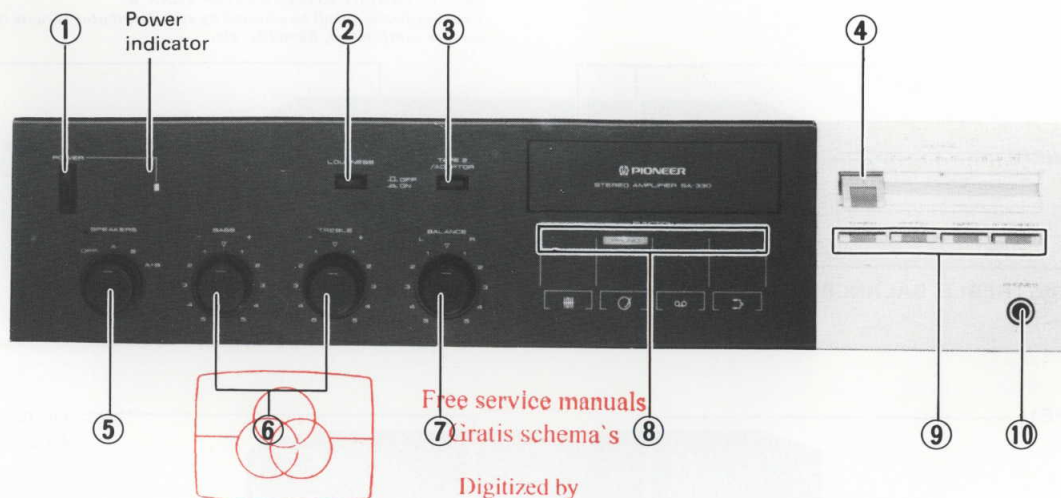

① POWER SWITCH

Push this switch to turn on or turn off power.

② LOUDNESS SWITCH

Set this switch to ON when listening at low volume, bass will be emphasized to compensate for human listening characteristics and provide natural listening curve.

③ TAPE 2/ADAPTOR SWITCH

Set this switch to ON when using a graphic equalizer or a second tape deck (or any equipment) connected to the TAPE 2/ADAPTOR terminals.

④ VOLUME CONTROL

Slide this control to adjust the output level of the speakers and the headphones. Output is minimum at 0 and increases as the control is slid rightward.

⑤ SPEAKERS SELECTOR

Use this selector to select the speaker system.

OFF: Use this setting when listening through headphones (no sound comes out of the speakers.)

A: Sound is heard from speakers connected to the A speaker terminals.

B: Sound is heard from speakers connected to the B speaker terminals.

A+B: Sound is heard from speakers connected to both A and B speaker terminals.

⑥ BASS AND TREBLE CONTROLS

Use these controls to adjust the tone. The right one controls treble and the left one controls bass. Turning knob clockwise accentuates the bass or treble, and turning counterclockwise attenuates the bass or treble.

⑦ BALANCE CONTROL

This control should normally be set to the center position, when the output from the left and right speakers or headphones is not the same, adjust by turning the control clockwise or counterclockwise.

⑧ FUNCTION INDICATORS

These indicate the function switch positions.

⑨ FUNCTION SWITCHES

Use these switches to select the program sources.

TUNER: Push when listening to a broadcast on the tuner which you have connected to the rear panel TUNER terminals.

PHONO: Push when playing records on the turntable which you have connected to the rear panel PHONO terminals.

TAPE 1: Push when playing back tapes on a tape deck which you connected to the rear panel TAPE 1 terminals.

AUX/VIDEO: Push when using a component which you have connected to the rear panel AUX/VIDEO terminals.

⑩ HEADPHONE JACK

Plug headphones into this jack for private listening through them. Set the SPEAKERS selector to OFF.

Free service manuals

Gratis schema's

Digitized by

www.freeservicemanuals.info

3. PARTS LOCATION

Front Panel

Push knob B
(LOUDNESS, TAPE2/ADAPTOR)
AAD-418

Push knob A (POWER)
AAD-417

Rotary knob
(SPEAKERS, BASS, TREBLE, BALANCE)
AAB-283

Bonnet case
ANE-353

Front panel assembly
ANM-145

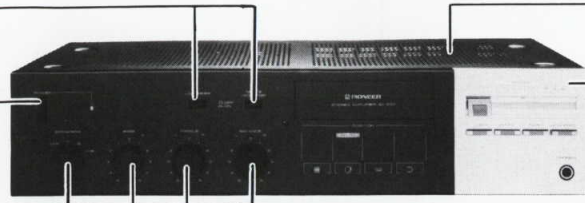

NOTES:

- Parts without part number cannot be supplied.
- The Δ mark found on some component parts indicates the importance of the safety factor of the part. Therefore, when replacing, be sure to use parts of identical designation.
- For your Parts Stock Control, the fast moving items are indicated with the marks **★★** and **★**.
★★ GENERALLY MOVES FASTER THAN ★.
This classification shall be adjusted by each distributor because it depends on model number, temperature, humidity, etc.

Rear Panel

Terminal 4P (TAPE1)
AKB-078

Terminal 4P (TAPE2/ADAPTOR)
AKB-078

Terminal 6P (INPUT)
AKB-079

Terminal (SPEAKERS)
AKE-102

Δ AC socket (AC OUTLETS)
AKP-502

Δ AC power cord
ADG-065

Terminal 2P (PHONES)
AKB-077

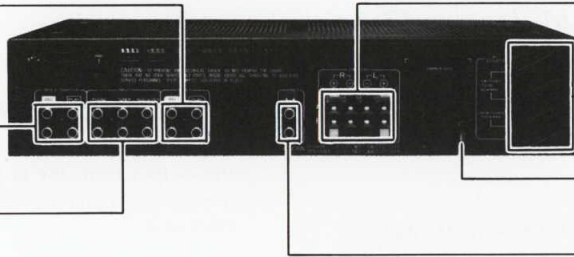

Top View with Bonnet Case Removed

★★ Fuse (FU2, FU3, T2.5A)
AEK-403

Δ **★** Power transformer
(220V, 240V)
ATT-899

★★ Rotary switch
(S3, SPEAKERS)
ASE-014

Δ **★★** Push switch (S1, POWER)
ASG-522

Δ **★★** Fuse (FU4, T2.5A)
AEK-403

AF assembly

Δ **★★** Fuse (FU1 T1A)
AEK-402

Control assembly
AWG-085

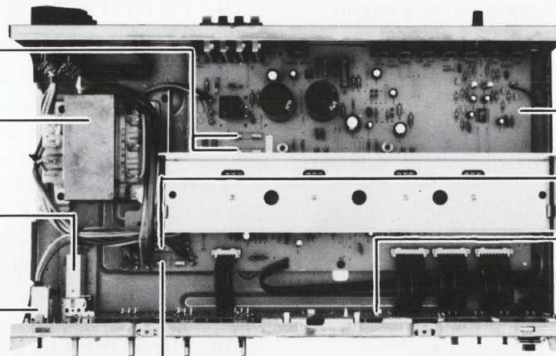

Front View with Front Panel Removed

★★ Push switch
(S2, LOUDNESS, TAPE2/ADAPTOR)
ASG-802

Δ **★★** Push switch (S1, POWER)
ASG-522

★★ Rotary switch
(S3, SPEAKERS)
ASE-014

★ Variable resistor
(VR3, BASS)
ACT-149

★ Variable resistor
(VR4, TREBLE)
ACT-149

★ Variable resistor
(VR1, VOLUME)
ACX-109

★ Push switch
(S1, FUNCTION)
ASG-801

Headphone jack
AKN-029

★★ Lamp assembly
(PL1-PL4)
AEL-157

★ Variable resistor
(VR2, BALANCE)
ACT-027

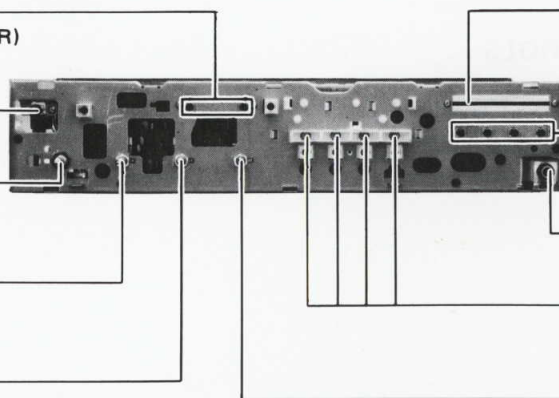

4. BLOCK DIAGRAM

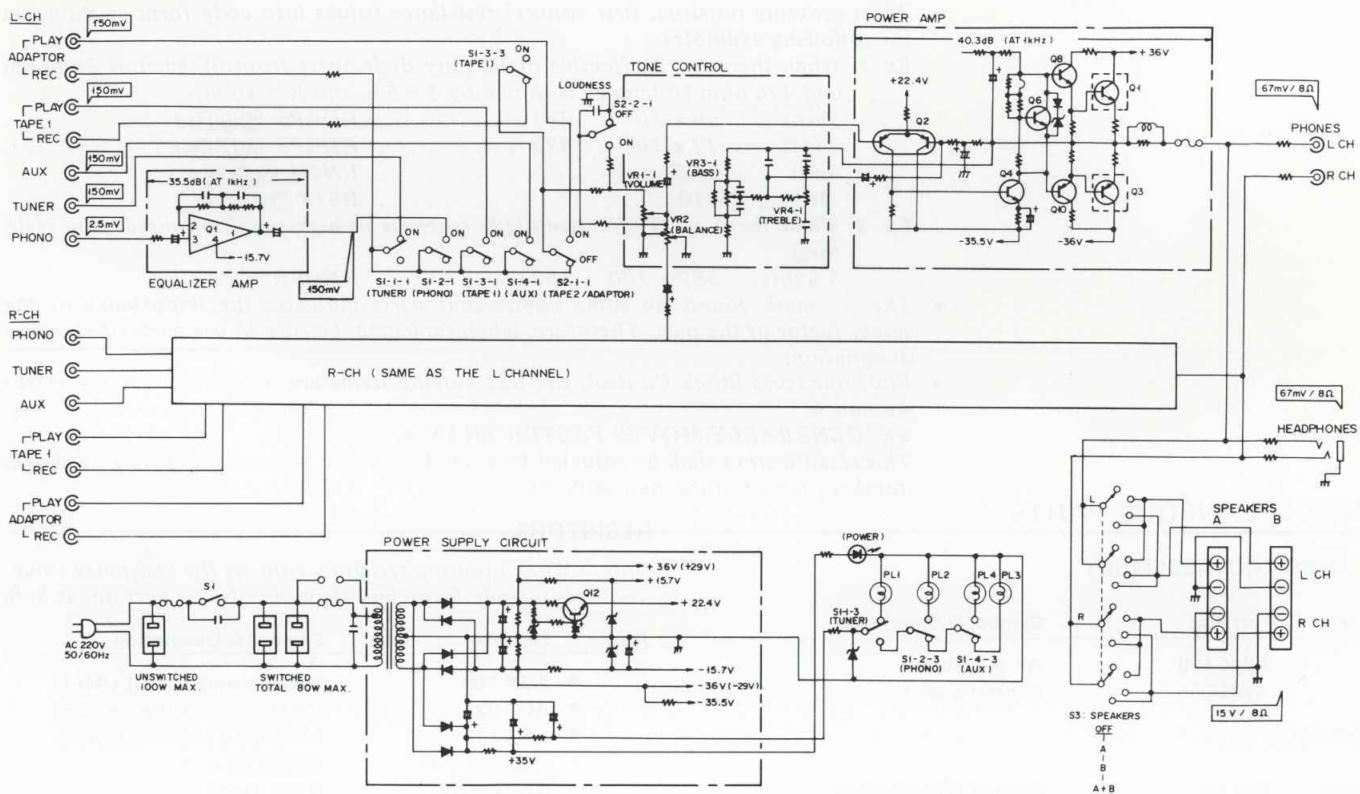

5. CIRCUIT DESCRIPTIONS

Equalizer Amplifier

The equalizer amp uses a low-noise IC (NJM 4558DX) that contains both the left and right channel circuits. This IC uses a balanced positive/negative power supply to permit the more than sufficient permissible input level of 150mV (at 1kHz, 0.01%THD).

Power Amplifier

This all-stage direct-coupled pure complementary SEPP circuit features a differential amplifier in the first stage, and incorporates the tone control circuits in the NFB loop.

The power stage is a complementary 2-stage Darlington connection, resulting in an output power rating of 30W+30W (8Ω, 30Hz~20kHz), harmonic distortion of less than 0.08%.

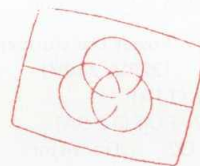

Free service manuals
Gratis schema's

Digitized by

www.freesevicemanuals.info

6. PARTS LIST

NOTES:

- When ordering resistors, first convert resistance values into code form as shown in the following examples.

Ex. 1 When there are 2 effective digits (any digit apart from 0), such as 560 ohm and 47k ohm (tolerance is shown by J = 5%, and K = 10%).

560Ω 56 x 10¹ 561 RD½PS 561J

47kΩ 47 x 10³ 473 RD½PS 473J

0.5Ω 0R5 RN2H 0R5K

1Ω 010 RS1P 010K

Ex. 2 When there are 3 effective digits (such as in high precision metal film resistors).

5.62kΩ 562 x 100 5621 RN¼SR 5621F

- The Δ mark found on some component parts indicates the importance of the safety factor of the part. Therefore, when replacing, be sure to use parts of identical designation.
- For your Parts Stock Control, the fast moving items are indicated with the marks **★★** and **★**.
★★ GENERALLY MOVES FASTER THAN ★.
This classification shall be adjusted by each distributor because it depends on model number, temperature, humidity, etc.

MISCELLANEOUS PARTS

P.C. BOARD ASSEMBLY

Mark	Part No.	Symbol & Description
	AWK-199	AF assembly
	AWG-085	Control assembly

OTHERS

Mark	Part No.	Symbol & Description
Δ ★	ATT-899	T1 Power transformer (220V, 240V)
Δ ★★	AEK-402	FU1 (T1A)
Δ ★★	AEK-403	FU2-FU4 (T2.5A)
★★	2SC2577/A/-O* (2SC2577/A/-P)* (2SC2577/A/-Y)*	Q1, Q2 Transistor
★★	2SA1102/A/-O* (2SA1102/A/-P)* (2SA1102/A/-Y)*	Q3, Q4 Transistor
	*hfe of Q1-Q4 should have the same value.	
Δ ★★	ASG-522	S1 Push switch (POWER)
Δ ★★	ACG-001	C1 Ceramic capacitor (0.01/AC250V)
Δ	AKP-502	AC socket (AC OUTLETS)
	AEC-818	Mica wafer
Δ	ADG-065	AC power cord

CONTROL ASSEMBLY (AWG-085)

CAPACITORS

Mark	Part No.	Symbol & Description
	CKDYF 473Z 50	C201, C202
	CQMA 273K 50	C203, C204
	CQMLA 124K 50	C205, C206
	CCDSL 270J 50	C207, C208
	CQMA 122K 50	C209, C210
	CQMA 562K 50	C211, C212

RESISTORS

Note: When ordering resistors, convert the resistance value into code form, and then rewrite the part no. as before.

Mark	Part No.	Symbol & Description
★	ACX-109	VR1 Variable (VOLUME)
★	ACT-027	VR2 Variable (BALANCE)
★	ACT-149	VR3, VR4 Variable (BASS, TREBLE)
	RD½PS102J	R223, R224
	RD¼PM □□□J	R201-R222, R225, R226

SEMICONDUCTORS

Mark	Part No.	Symbol & Description
★	WZ-081 (MZ-081)	D201
★	AEL-375	D202 LED

OTHERS

Mark	Part No.	Symbol & Description
★★	ASG-801	S1 Push switch (FUNCTION)
★★	ASG-802	S2 Push switch (ADAPTOR, LOUDNESS)
★	AEL-157	PL1-PL4 Lamp assembly

AF ASSEMBLY (AWK-199)

AF assembly

CAPACITORS

Mark	Part No.	Symbol & Description
	ACH-239	C42, C43 Electrolytic capacitor (5600/42V)
	ACG-019	C44 Ceramic capacitor (0.01/AC150V)
	CEANL 2R2M 50	C1, C2
	CEA 101M 50L	C46
	CEA 221M 25L	C25, C26, C37, C40
	CEA 331M 50L	C38

Mark	Part No.	Symbol & Description
	CEA R33M 50L	C15, C16
	CEANL 010M 50	C19, C20
	CEA 010M 50L	C13, C14
	CEA 220M 25L	C23, C24, C39
	CEA 470M 10L	C5, C6
	CEA 470M 25L	C41, C47
	CEA 470M 50L	C45
	CEA 221M 10L	C29, C30
	CQMA 222J 50	C7, C8
	CQMA 822J 50	C9, C10
	CCDSL 150K 500	C27, C28
	CCDSL 151K 500	C31-C34
	CCDSL 680J 50	C21, C22
	CCDSL 101J 50	C17, C18
	CCDSL 221J 50	C3, C4
	CKDYF 473Z 50	C11, C12, C35, C36, C48
	CCDSL 470J 50	C65-C68

RESISTORS

Note: When ordering resistors, convert the resistance value into code form, and then rewrite the part no. as before.

Mark	Part No.	Symbol & Description
	ACN-131	R55, R56 Wire wound
	RS3L271J	R80
	RS2L □□□J	R63, R64, R69, R81
	RS1L □□□J	R82-R84
	RD½PS □□□J	R61, R62, R65, R66, R73-R79
	RS¼PMFL □□□J	R47-R54, R57-R60, R70, R71
	RD¼PM □□□J	R1-R46, R72

SEMICONDUCTORS

Mark	Part No.	Symbol & Description
★★	NJM4558DX	Q1
★★	2SA798	Q2, Q3
★★	2SC2705	Q4, Q5
★★	2SC945A	Q6, Q7
★★	2SD438-E*	Q8, Q9
	(2SD438-F)*	
★★	2SB560-E*	Q10, Q11
	(2SB560-F)*	
*hfe of Q8-Q11 should have the same value.		
★★	2SD438	Q12
★	WZ-157	D1, D2
	(MZ-157)	
★	WZ-230	D3
	(MZ-230)	
★	10E2FD	D4, D5
★	S4VB20F	D6
★	WZ-032	D7, D8
★	US1035	D9, D10
	(1S1555)	
	(1S2076)	

OTHERS

Mark	Part No.	Symbol & Description
	AKB-077	Terminal 2P (PHONES)
	AKB-078	Terminal 4P (TAPE2/ADAPTOR, TAPE1)
	AKB-079	Terminal 6P (INPUT)
	AKE-102	Terminal (SPEAKERS)
	AKH-016	Transistor socket

Headphone assembly

Mark	Part No.	Symbol & Description
	AKN-029	Headphone jack

Switch assembly

Mark	Part No.	Symbol & Description
★★	ASE-014	S3 Rotary switch (SPEAKERS)

Resistor assembly

Mark	Part No.	Symbol & Description
	RD¼PM102J	R85

7. PACKING

Parts List

Mark	No.	Part No.	Description
	1.	AHA-298	Front rear pad
	2.	ARE-031	Operating instructions (English/German/French/Italian)
	3.	AHE-031	Packing case

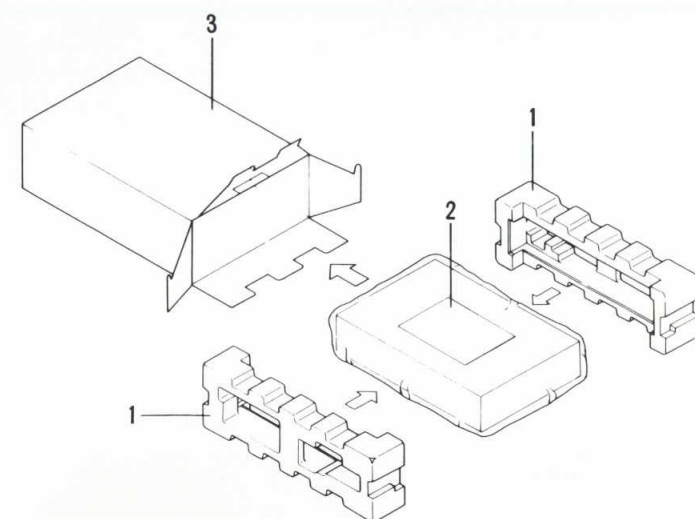

8. EXPLODED VIEW

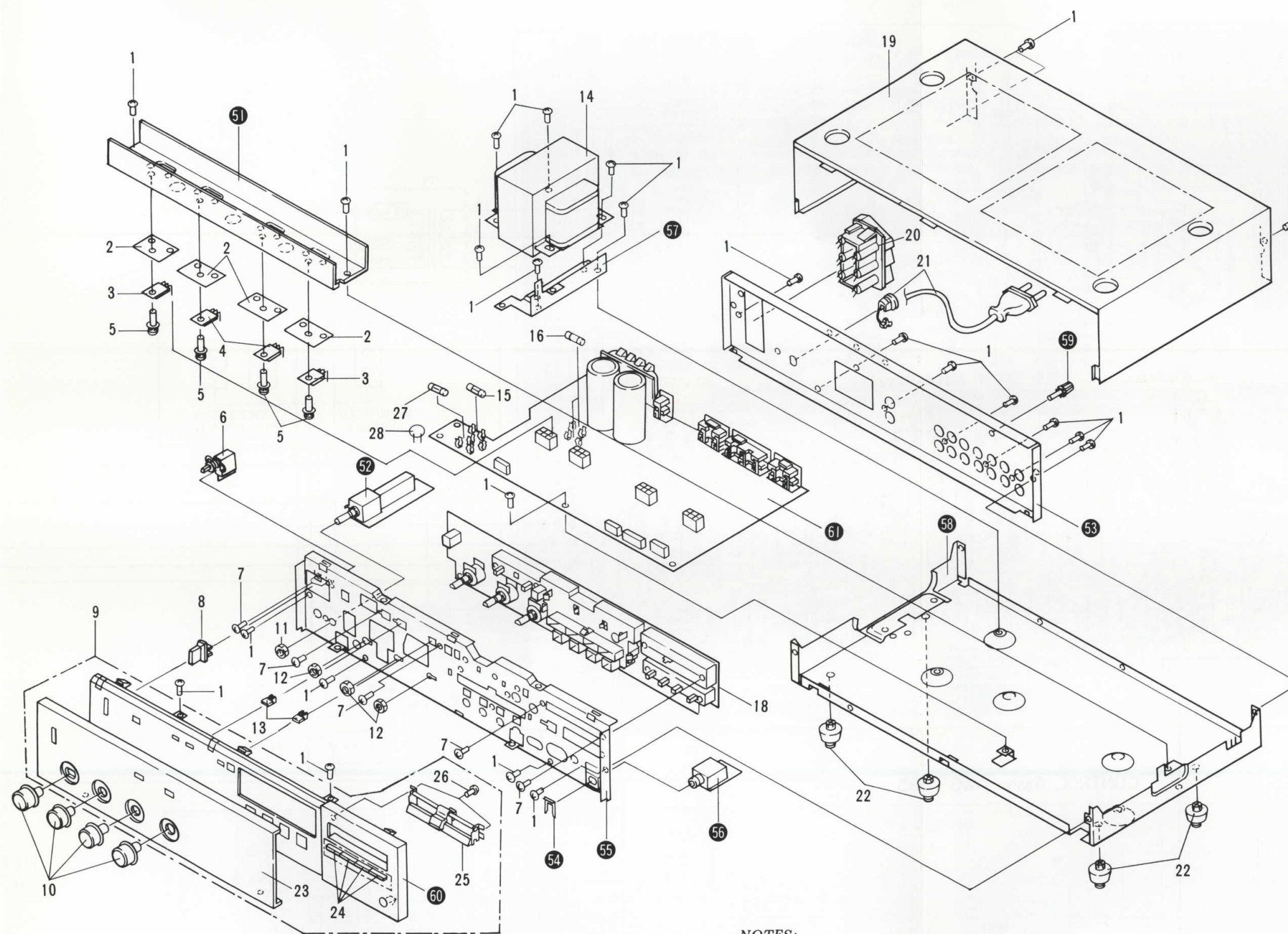

NOTES:

- Parts without part number cannot be supplied.
- The ⚠ mark found on some component parts indicates the importance of the safety factor of the part. Therefore, when replacing, be sure to use parts of identical designation.
- For your Parts Stock Control, the fast moving items are indicated with the marks ★★ and ★.
- ★★ **GENERALLY MOVES FASTER THAN ★.**
- This classification shall be adjusted by each distributor because it depends on model number, temperature, humidity, etc.

Parts List

Mark	No.	Part No.	Description
	1.	BBZ30P080FZK	Screw 3x8
	2.	AEC-818	Mica wafer
★★	3.	2SC2577/A/-O* (2SC2577/A/-P)* (2SC2577/A/-Y)*	Transistor (Q1, Q2)
★★	4.	2SA1102/A/-O* (2SA1102/A/-P)* (2SA1102/A/-Y)*	Transistor (Q3, Q4)
	5.	ABA-258	Screw φ3
⚠	★★	ASG-522	Push switch (S1, POWER)
	7.	PMZ30P060FMC	Screw 3x6
	8.	AAD-417	Push knob A (POWER)
	9.	ANM-145	Front panel assembly
	10.	AAB-283	Rotary knob (SPEAKERS, BASS, TREBLE, BALANCE)
	11.	NK90FUC	Nut
	12.	B71-010	Nut M7
	13.	AAD-418	Push knob B (LOUDNESS, TAPE2/ADAPTOR)
⚠	★	ATT-899	Power transformer (220V, 240V)
⚠	★★	AEK-402	Fuse (FU1, T1A)
⚠	★★	AEK-403	Fuse (FU2, FU3, T2.5A)
	17.	
	18.	AWG-085	Control assembly
	19.	ANE-353	Bonnet case
⚠	20.	AKP-502	AC socket (AC OUTLETS)
⚠	21.	ADG-065	AC power cord
	22.	AEC-784	Foot assembly
	23.	ANM-146	Front panel cover
	24.	AAD-419	Push knob C (TUNER, PHONO, TAPE1, AUX)
	25.	AXC-012	Slide knob assembly
	26.	PTZ26P060FMC	Screw 2.6x6
⚠	★★	AEK-403	Fuse (FU4, T2.5A)
⚠	28.	ACG-001	Ceramic capacitor (C1, 0.01/AC250V)
	51.		Heat sink
	52.		Switch assembly
	53.		Rear panel
	54.		Mounting plate
	55.		Panel stay
	56.		Headphone assembly
	57.		Transformer frame
	58.		Chassis
	59.		Terminal (GND)
	60.		Front panel base
	61.		AF assembly

9. P.C. BOARD CONNECTION DIAGRAM

AF Ass'y

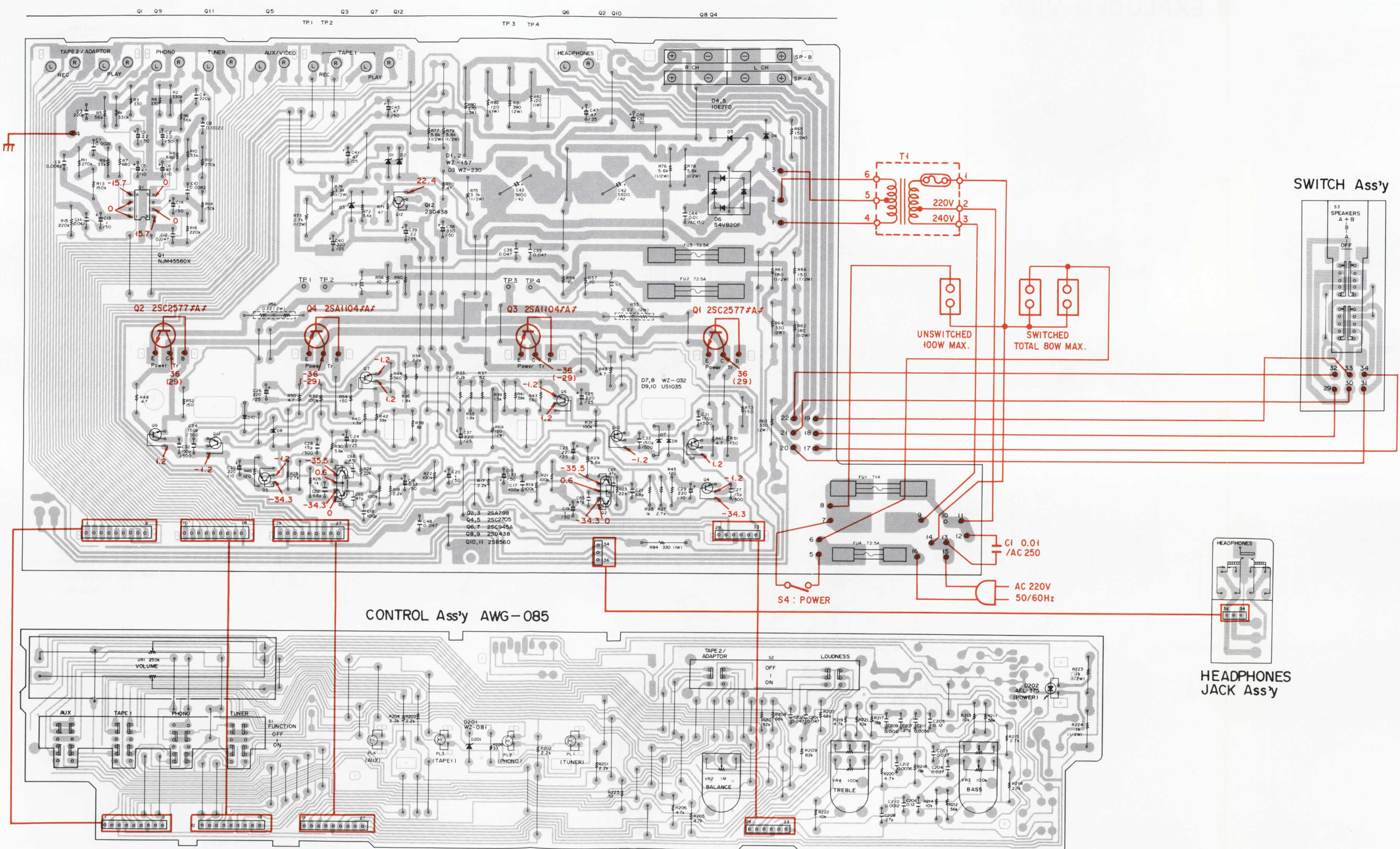

2SA1102/A/
2SC2577/A/

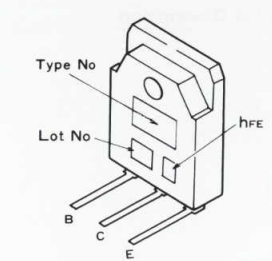

2SA798

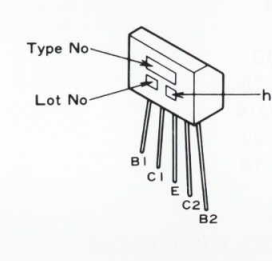

2SB560

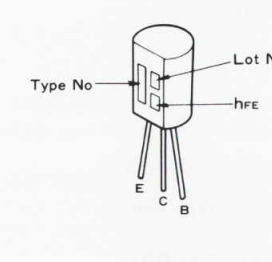

2SC945A

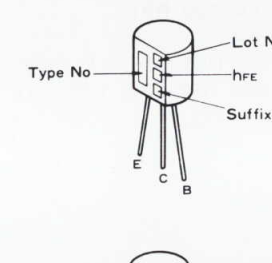

2SC2705

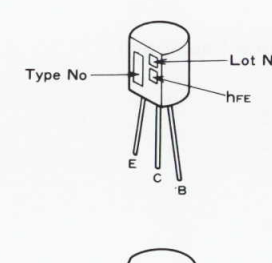

2SD438

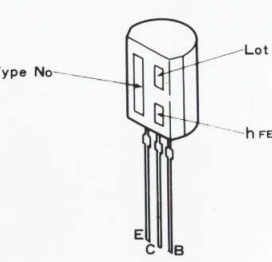

JIM4558-DX

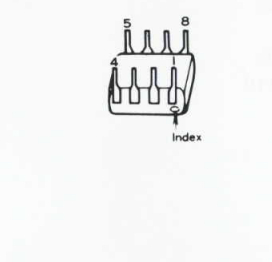

Digitized by WWW.FREERIV.COM/MANUALS.INFO

10. SCHEMATIC DIAGRAM

NOTE:
The indicated semiconductors are representative ones only. Other alternative semiconductors may be used and are listed in the parts list.

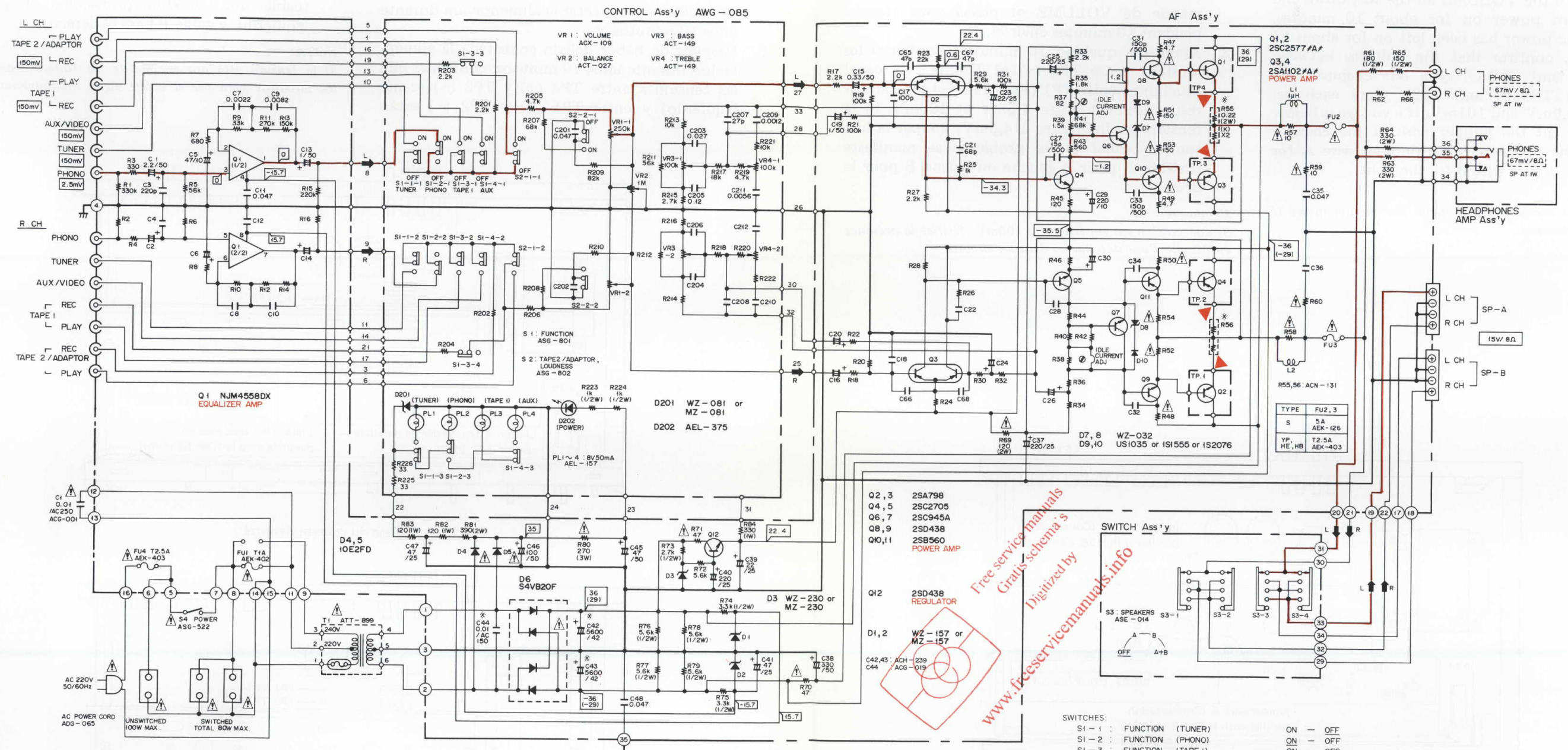

- 1. RESISTORS:**
Indicated in Ω , $\frac{1}{2}W$, $\pm 5\%$ tolerance unless otherwise noted k: k Ω , M: M Ω , (F): $\pm 1\%$, (G): $\pm 2\%$, (K): $\pm 10\%$ tolerance
- 2. CAPACITORS:**
Indicated in capacity (μF)/voltage (V) unless otherwise noted p: pF
Indication without voltage is 50V except electrolytic capacitor.
- 3. VOLTAGE, CURRENT:**
 : Signal voltage at 28 W + 28 W 8 Ω output (1kHz)
 : DC voltage (V) at no input signal
 Value in () is DC voltage at rated power.
 : mA: DC current at no input signal
 : mV: Signal voltage at FM 400Hz 75kHz DEV.

- 4. OTHERS:**
 : Signal route.
 : Adjusting point.
 The Δ mark found on some component parts indicates the importance of the safety factor of the part. Therefore, when replacing, be sure to use parts of identical designation.

- SWITCHES:**
- | | | | |
|------|-------------------------|---------------------------|-------|
| S1-1 | : FUNCTION (TUNER) | ON | - OFF |
| S1-2 | : FUNCTION (PHONO) | ON | - OFF |
| S1-3 | : FUNCTION (TAPE I) | ON | - OFF |
| S1-4 | : FUNCTION (AUX) | ON | - OFF |
| S2-1 | : TAPE 2 / ADAPTOR | ON | - OFF |
| S2-2 | : LOUDNESS | ON | - OFF |
| S3 | : SPEAKERS | OFF - A - B - A+B | |
| S4 | : POWER | ON | - OFF |
| S5 | : LINE VOLTAGE SELECTOR | 120V - 110V - 220V - 240V | |

The underlined indicates the switch position.

This is the basic schematic diagram, but the actual circuit may vary due to improvements in design.

Q2, 3 2SA798
 Q4, 5 2SC2705
 Q6, 7 2SC945A
 Q8, 9 2SD438
 Q10, 11 2SB560
 POWER AMP

Q12 2SD438
 REGULATOR

D1, 2 WZ-157 or MZ-157

C42, 43 ACH-239
 C44 ACG-019

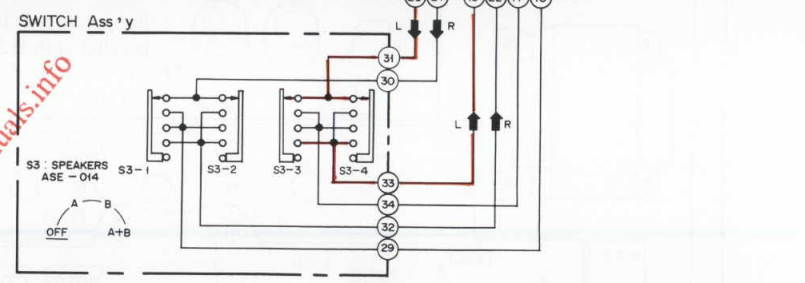

Digitized by WWW.FREESERVICE-MANUALS.INFO

11. ADJUSTMENTS

Idle Current

1. Set the SPEAKERS switch to the OFF position, turn the VOLUME all the way down and then turn power on for about 10 minutes.
2. After the power has been left on for about 10 minutes, confirm that the voltages between TP4 ⊕ and TP3 ⊖ (the left channel) and between TP1 ⊕ and TP2 ⊖ are each between 0.9mV and 101mV. If a voltage is below 0.9mV, cut the jumper wire of the channel where the problem exists (jumper wire A for the left, jumper wire B for the right).

NOTE:

If a voltage is above 101mV, check the circuits to see if there is a malfunction.

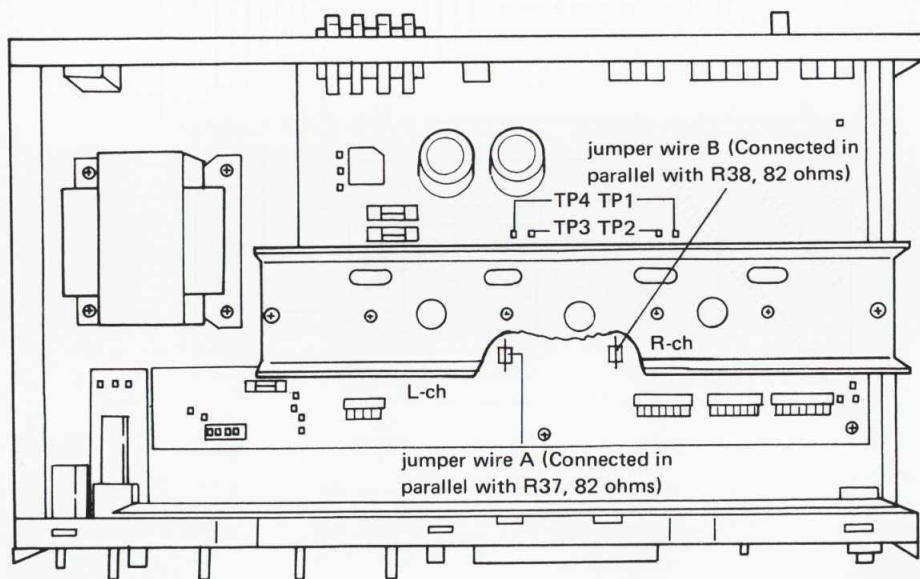

Fig. 11-1 Adjustment of idle current

11. RÉGLAGE

Courant déwatté

1. Régler sur OFF le sélecteur d'enceintes (SPEAKERS), réduire au maximum la commande de VOLUME et placer sous tension pendant 10 minutes environ.
2. Après ces quelque 10 minutes, vérifier si les tensions entre TP4 (+) et TP3 (-) (le canal gauche) et entre TP1 (+) et TP2 (-) se trouvent respectivement entre 4,5mV et 100mV. Si la tension est inférieure à 4,5mV, couper la liaison du canal où le problème se manifeste (liaison A pour le gauche ou liaison B pour le droit).

Remarque:

Si une tension est supérieure à 100mV, vérifier la présence éventuelle d'une défaillance dans les circuits.

11. ADJUSTE

Corriente reactiva

1. Poner el selector de altavoces (SPEAKERS) en la posición OFF, reducir completamente el VOLUMEN y conectar la alimentación durante unos 10 minutos.
2. Después de haber dejado conectada la alimentación durante unos 10 minutos, confirmar que las tensiones entre TP4 (+) y TP3 (-) (canal izquierdo) y entre TP1 (+) y TP2 (-) están

entre 4,5mV y 100mV. Si la tensión está por debajo de 4,5mV, cortar el cable de conexión provisional del canal donde exista el problema (cable de conexión provisional A para el izquierdo, y cable B para el derecho).

NOTA:

Si la tensión está por encima de los 100mV, comprobar los circuitos para ver si existe algún malfuncionamiento.

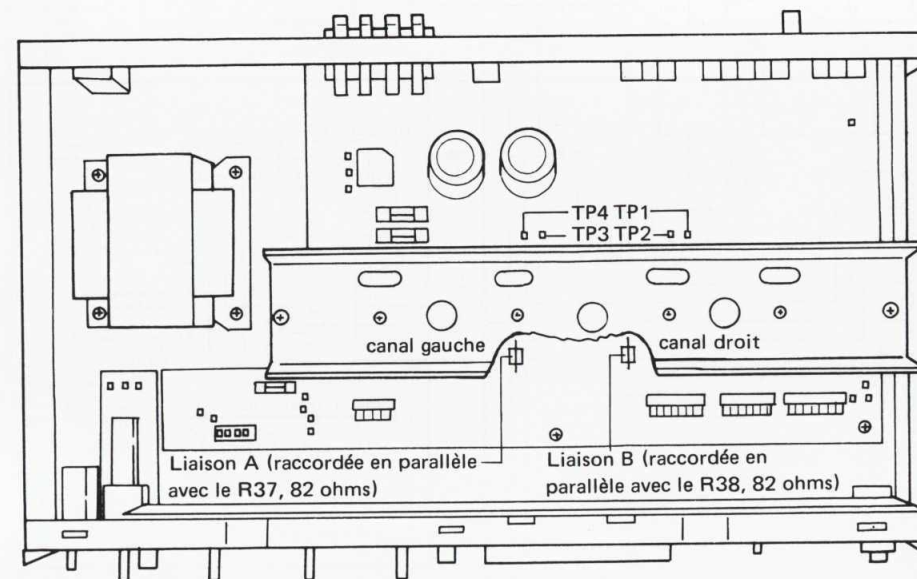

Fig. 11-1 Réglage du courant déwatté

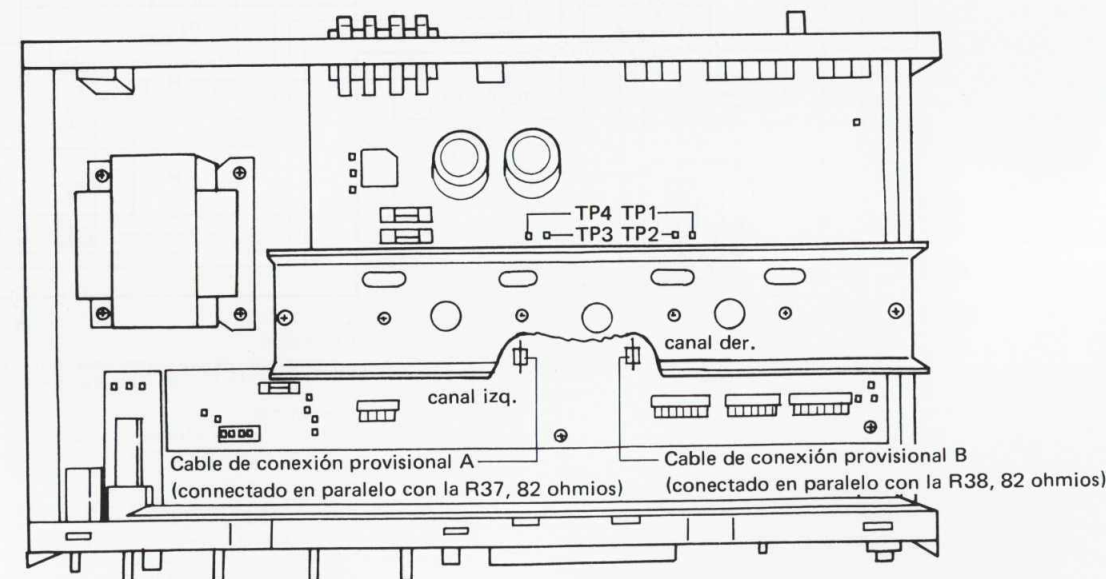

Fig. 11-1 Adjuste de corriente reactiva

12. FOR S, YP AND HEZ TYPES

12.1 CONTRAST PARTS

SA-330/S, YP and HEZ types are the same as the SA-330/HE type except for following sections.

MISCELLANEOUS PARTS

Mark	Symbol & Description	Part No.			
		HE type	S type	YP type	HEZ type
	AF assembly	AWK-199	AWK-199	AWK-199	AWK-202
⚠ ★	T1 Power transformer (220V, 240V)	ATT-899	ATT-899	ATT-899
⚠ ★	T1 Power transformer (110V, 120V, 220V, 240V)	ATT-900
⚠ ★★	FU1 Fuse (T1A)	AEK-402	AEK-402	AEK-402
⚠ ★★	FU2, FU3 Fuse (T2.5A)	AEK-403	AEK-403	AEK-403
⚠ ★★	FU4 Fuse (T2.5A)	AEK-403	AEK-403
⚠ ★★	FU1, FU4 Fuse (1.6A)	AEK-121
⚠ ★★	FU2, FU3 Fuse (5A)	AEK-126
⚠ ★★	S1 Push switch (POWER)	ASG-522	ASG-539	ASG-522	ASG-522
⚠ ★★	S2 Voltage selector switch	AKX-063
⚠	AC socket (AC OUTLETS)	AKP-502	AKP-501	AKP-502
⚠	AC power cord	ADG-065	ADG-060	ADG-067	ADG-065
	Screw 3 x 10 (For voltage selector switch)	MTZ30P100FZK
	Tapping screw (For SPEAKERS terminal)	ABA-115
	Operating instructions (English/German/French/Italian)	ARE-031
	Operating instructions (English)	ARB-482	ARB-482
	Operating instructions (Spanish)	ARC-021
	Operating instructions (German)	ARC-017

12.2 SPECIFICATIONS

The specifications for SA-330/S, YP and HEZ types are the same as the SA-330/HE type except for following sections.

Amplifier Section. . . S, YP, HEZ types

Continuous Power Output

30 to 20,000Hz . . 30W + 30W (T.H.D. 0.08%, 8 ohms)

1kHz (DIN) 40W + 40W (T.H.D. 1%, 8 ohms)

Total Harmonic Distortion (30Hz to 20,000Hz, 8 ohms, from AUX/VIDEO)

Continuous rated power output . . No more than 0.08%

NOTE:

The damping factor of HE type is not applied to HEZ type.

Miscellaneous

Power Requirements

S type AC110V, 120V, 220V, and 240V, 50/60Hz

YP type AC240V, 50/60Hz

Power Consumptions

S type 80W

Digitized by WWW.FREESERVICEMANUALS.INFO

12.3 SCHEMATIC DIAGRAM AND P.C. BOARD PATTERNS

SA-330/S, YP and HEZ types are the same as the SA-330/HE type except for following sections

For S type

POWER SUPPLY CIRCUIT

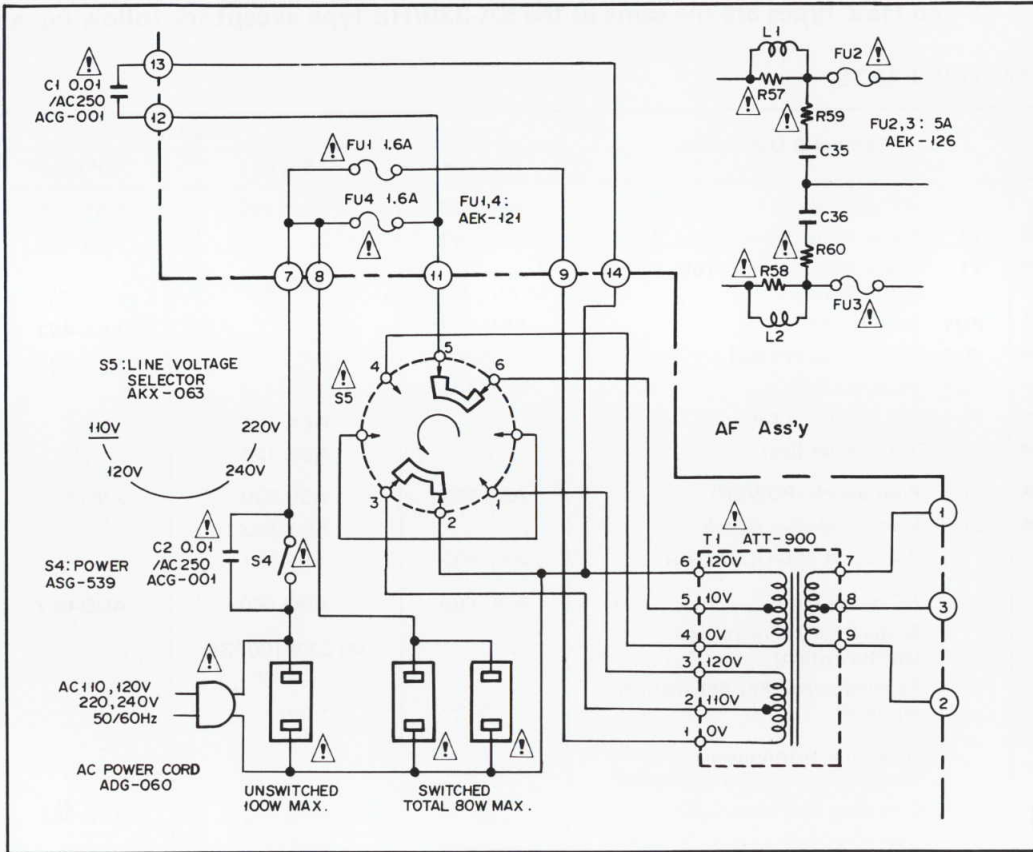

For YP type

POWER SUPPLY CIRCUIT

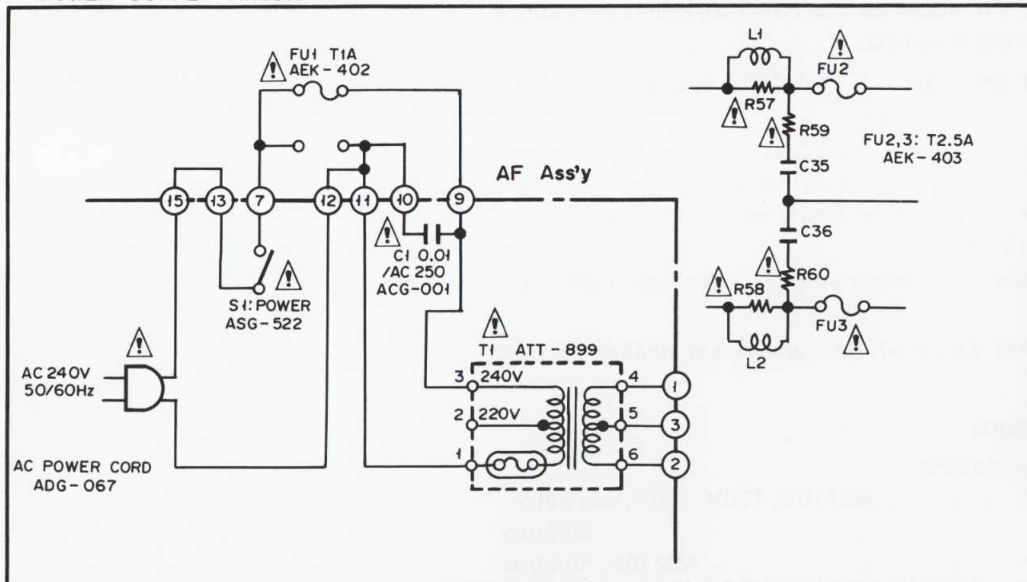

Digitized by WWW.FREESERVICEMANUALS.INFO

For HEZ type

NOTE: The indicated semiconductors are representative ones only. Other alternative semiconductors may be used and are listed in the parts list.

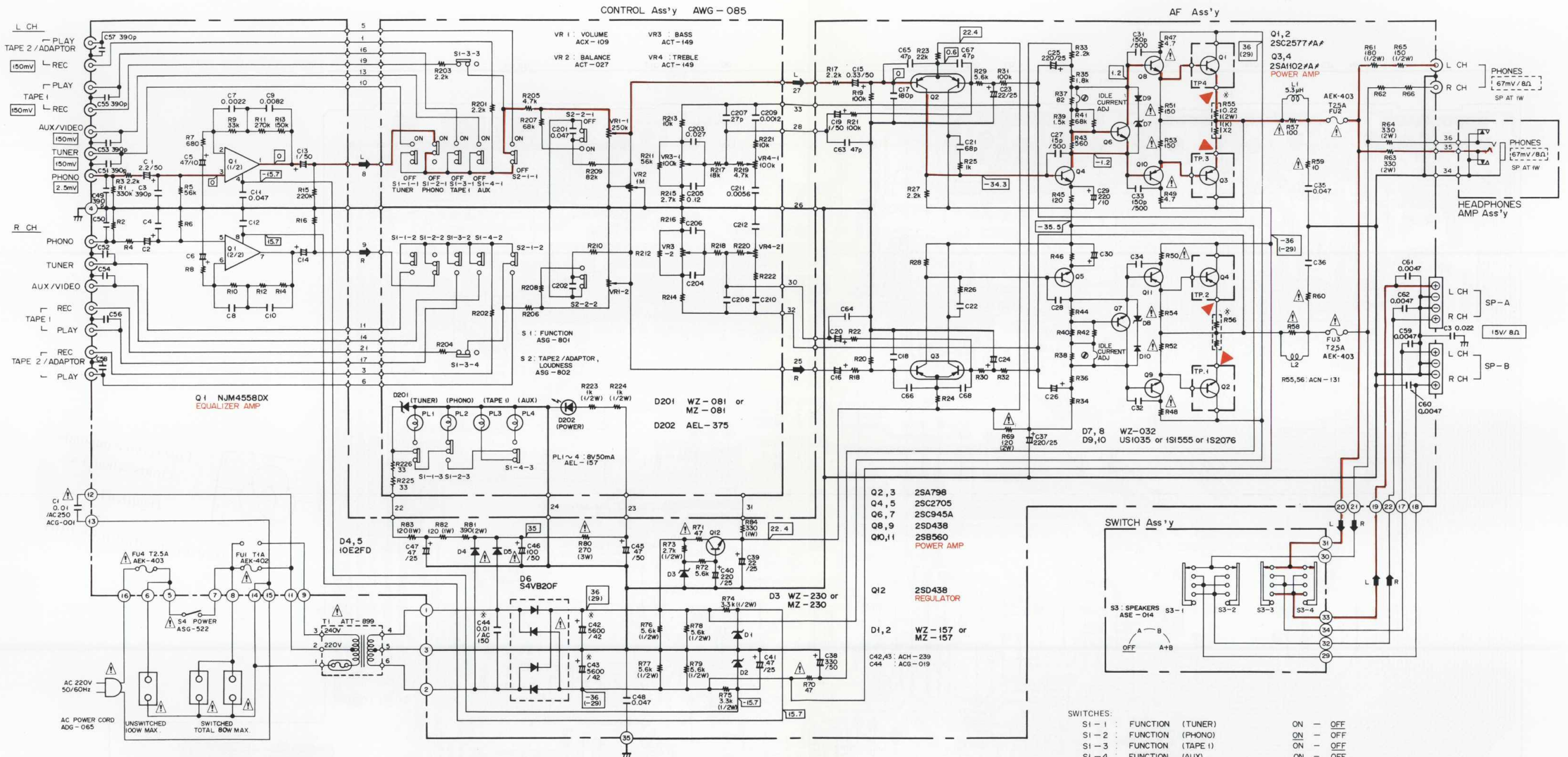

- RESISTORS:**
Indicated in Ω , $\frac{1}{2}W$, $\pm 5\%$ tolerance unless otherwise noted k : k Ω , M : M Ω , (F) : $\pm 1\%$, (G) : $\pm 2\%$, (K) : $\pm 10\%$ tolerance
- CAPACITORS:**
Indicated in capacity (μF)/voltage (V) unless otherwise noted p : pF
Indication without voltage is 50V except electrolytic capacitor.
- VOLTAGE, CURRENT:**
[Symbol] : Signal voltage at 20 W + 20 W 8 Ω output (1kHz)
[Symbol] : DC voltage (V) at no input signal
Value in () is DC voltage at rated power.
[Symbol] mA : DC current at no input signal
[Symbol] mV : Signal voltage at FM 400Hz 75kHz DEV.

- OTHERS:**
[Symbol] : Signal route.
[Symbol] : Adjusting point.
The Δ mark found on some component parts indicates the importance of the safety factor of the part. Therefore, when replacing, be sure to use parts of identical designation.

- SWITCHES:**
- | | | |
|------|-----------------------|---------------------------|
| S1-1 | FUNCTION (TUNER) | ON - OFF |
| S1-2 | FUNCTION (PHONO) | ON - OFF |
| S1-3 | FUNCTION (TAPE I) | ON - OFF |
| S1-4 | FUNCTION (AUX) | ON - OFF |
| S2-1 | TAPE 2 / ADAPTOR | ON - OFF |
| S2-2 | LOUDNESS | ON - OFF |
| S3 | SPEAKERS | OFF - A - B - A+B |
| S4 | POWER | ON - OFF |
| S5 | LINE VOLTAGE SELECTOR | 120V - 110V - 220V - 240V |

The underlined indicates the switch position.
This is the basic schematic diagram, but the actual circuit may vary due to improvements in design.

Digitized by WWW.FREESERVICE MANUALS.INFO

For HEZ type

AF Ass'y

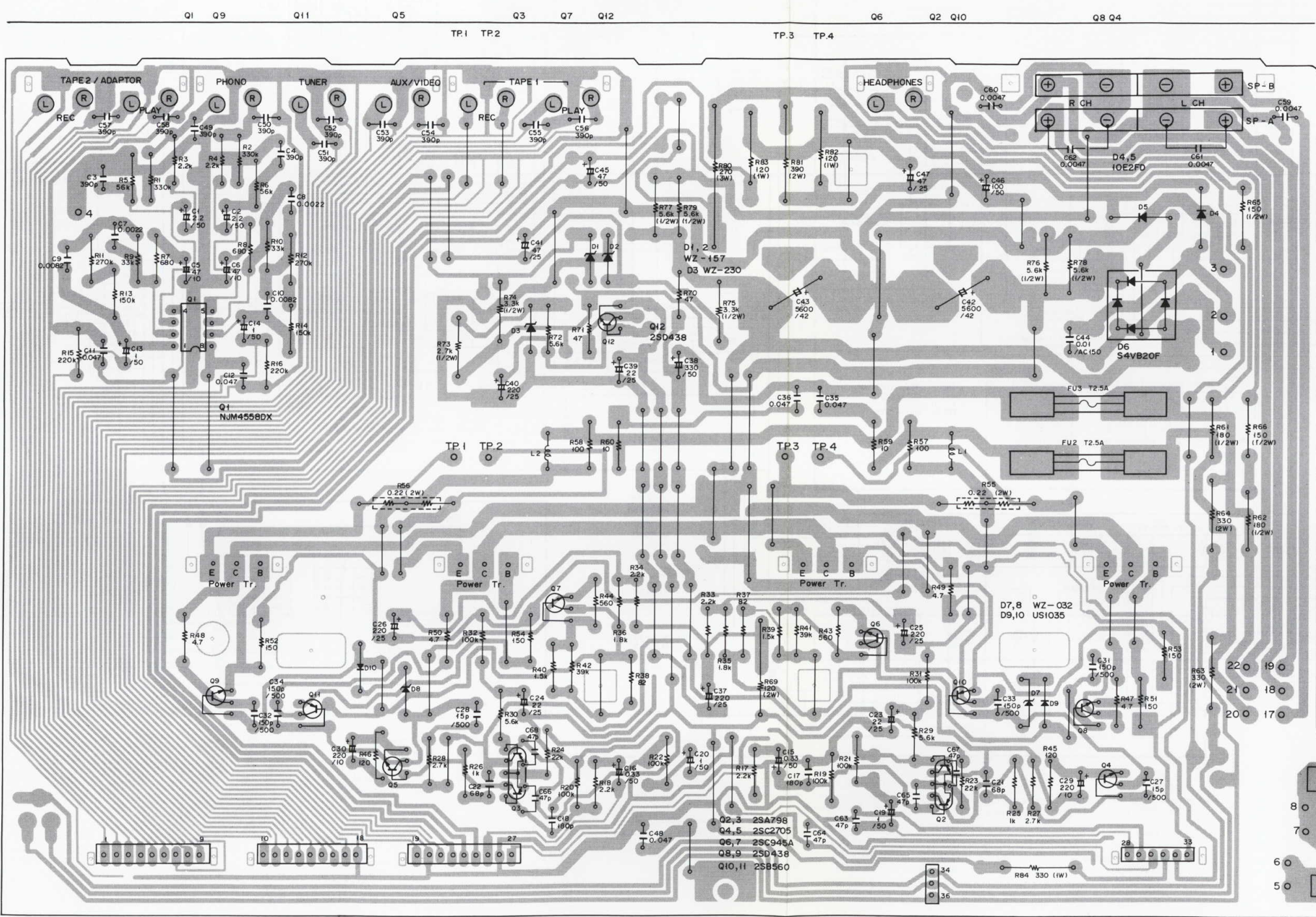

Free service manuals
 Gratis schema's
 Digitized by
www.freeservicemanuals.info

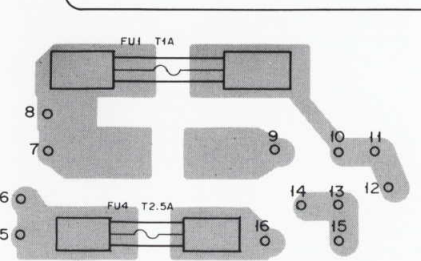

12.4 PARTS LIST (FOR HEZ TYPE)

AF Assembly (AWK-202)

AF assembly

CAPACITORS

Mark	Part No.	Symbol & Description
	ACH-239	C42, C43 Electrolytic capacitor (5600/42V)
	ACG-019	C44 Ceramic capacitor (0.01/AC150V)
	CEANL 2R2M 50	C1, C2
	CEA 101M 50L-SF	C46
	CEA 221M 25L-SF	C25, C26, C37, C40
	CEA331M 50L-SF	C38
	CEA R33M 50L	C15, C16
	CEANL 010M 50	C19, C20
	CEA 010M 50L	C13, C14
	CEA 220M 25L	C23, C24, C39
	CEA 470M 10L	C5, C6
	CEA 470M 25L	C41, C47
	CEA 470M 50L	C45
	CEA 221M 10L	C29, C30
	CQMA222J 50	C7, C8
	CQMA 822J 50	C9, C10
	CCDSL 150K 500	C27, C28
	CCDSL 151K 500	C31-C34
	CCDSL 680J 50	C21, C22
	CCDSL 181J 50	C17, C18
	CKDYF 473Z 50	C11, C12, C35, C36, C48
	CCDSL 470J 50	C63-C68
	CQMA 472K 50	C59-C62
	CKDYB 391K 50	C3, C4, C49-C58

RESISTORS

Note: When ordering resistors, convert the resistance value into code form, and then rewrite the part no. as before.

Mark	Part No.	Symbol & Description
	ACN-131	R55, R56 Cement resistor
	RS3L271J	R80
	RS2L □□□J	R63, R64, R69, R81
	RS1L □□□J	R82-R84
	RD½PS □□□J	R61, R62, R65, R66, R73-R79
⚠	RS¼PMFL □□□J	R47-R54, R57-R60, R70, R71
	RD¼PM □□□J	R1-R46, R72

SEMICONDUCTORS

Mark	Part No.	Symbol & Description
★★	NJM4558DX	Q1
★★	2SA798	Q2, Q3
★★	2SC2705	Q4, Q5
★★	2SC945A	Q6, Q7
★★	2SD438-E* (2SD438-F)*	Q8, Q9

Mark	Part No.	Symbol & Description
★★	2SB560-E* (2SB560-F)*	Q10, Q11
*hfe of Q8-Q11 should have the same value.		
★★	2SD438	Q12
★	WZ-157 (MZ-157)	D1, D2
★	WZ-230 (MZ-230)	D3
⚠	★ 10E2FD	D4, D5
⚠	★ S4VB20F	D6
★	WZ-032	D7, D8
★	US1035 (1S1555) (1S2076)	D9, D10

OTHERS

Mark	Part No.	Symbol & Description
	AKB-077	Terminal 2P (PHONES)
	AKB-078	Terminal 4P (TAPE2/ADAPTOR, TAPE1)
	AKB-079	Terminal 6P (INPUT)
	AKE-102	Terminal (SPEAKERS)
	AKH-016	Transistor socket

Headphone assembly

Mark	Part No.	Symbol & Description
	AKN-041	Headphone jack

Switch assembly

Mark	Part No.	Symbol & Description
★★	ASE-014	S3 Rotary switch (SPEAKERS)

Resistor Assembly

Mark	Part No.	Symbol & Description
	RD¼PM102J	R85