

STEREO AMPLIFIER

SA-7700

SA-706

SERVICE MANUAL

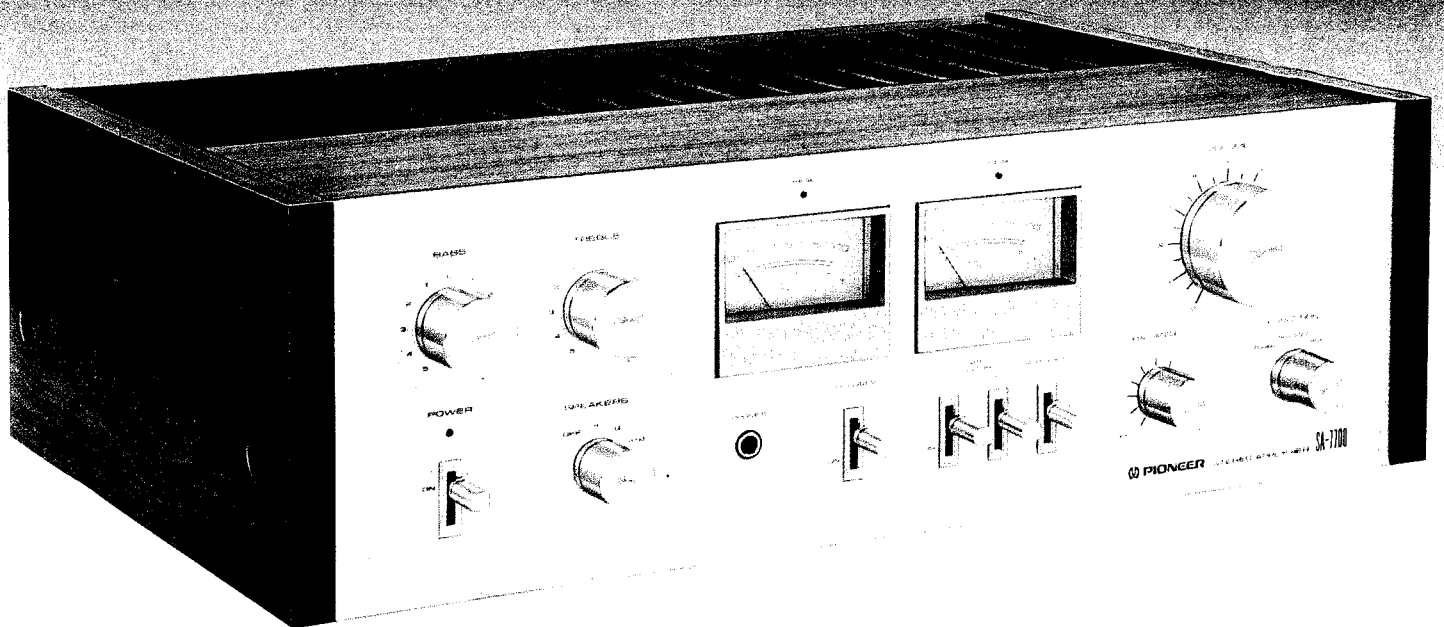

 **PIONEER**

SA-7700

Both Model SA-7700 and Model SA-706 have the same basic performance. The major difference is in appearance, Model SA-7700 being fitted with wooden side and top panels, while Model SA-706 employs metal. The following table is displayed on the SA-7700 and the SA-706.

MODEL SA-7700

Type	Voltage	Remarks
KU	120V only	U.S.A. model
KC	120V only	Canada model

MODEL SA-706

Type	Voltage	Remarks
HG	220V and 240V (Switchable)	Europe or Oceania model
S	110V, 120V, 220V and 240V (Switchable)	General export model
S/G	110V, 120V, 220V and 240V (Switchable)	U.S. Military model

This service manual is applicable to the SA-7700/KU. When repairing the SA-706, please see the additional service manual (pp. 35–49). When repairing the SA-7700/KC, please see page 34.

CONTENTS

1.	SPECIFICATIONS	3
2.	CONNECTION DIAGRAM	4
3.	FRONT PANEL FACILITIES	5
4.	BLOCK DIAGRAM	7
5.	LEVEL DIAGRAM	7
6.	CIRCUIT DESCRIPTIONS	
6.1	Phono Circuit	8
6.2	Power Amplifier	8
6.3	Output Meter Drive Circuit	9
6.4	Peak Indicator Circuit	9
6.5	Protection Circuit	9
6.6	Power Supply Circuit	10
7.	DISASSEMBLY	11
8.	PARTS LOCATION	13
9.	ADJUSTMENTS	15
10.	EXPLODED VIEW	16
11.	SCHMATIC DIAGRAMS, P.C. BOARD PATTERNS AND PARTS LIST	
11.1	Schematic Diagram	19
11.2	Miscellanea	21
11.3	Terminal Assembly (GWX-165)	22
11.4	AF Assembly (GWK-113)	23
11.5	Tone & Indicator Assembly (GWX-167)	30
11.6	RFI Switch Assembly (GWX-166)	32
11.7	VR Assembly (GWX-164)	32
12.	PACKING	33
13.	SUPPLEMENTS FOR MODEL SA-7700/KC	34
	Additional Service Manual (for SA-706/HG, S, S/G)	35

1. SPECIFICATIONS

Semiconductors

IC	1
Transistors	29
Diodes	26

Amplifier Section

Circuitry	1-st stage current mirror loaded differential amplifier, constant current loaded all-stage direct-coupled OCL.
-----------------	--

Continuous power output is 60watts* per channel, min., at 8ohms from 20Hertz to 20,000 Hertz with no more than 0.04% total harmonic distortion.

Total Harmonic Distortion (20Hertz to 20,000Hertz, from AUX)

continuous rated power output . . .	No more than 0.04%
30 watts per channel power output, 8 ohms	
.....	No more than 0.03%
1 watt per channel power output, 8 ohms	
.....	No more than 0.03%

Intermodulation Distortion (50Hertz : 7,000Hertz = 4 : 1)

continuous rated power output . . .	No more than 0.05%
30 watts per channel power output, 8 ohms	
.....	No more than 0.02%
1 watt per channel power output, 8 ohms	
.....	No more than 0.02%

Output

Speaker	A, B, A+B
---------------	-----------

Damping Factor

(20Hertz to 20,000Hertz, 8 ohms)	40
--	----

Input (Sensitivity/Impedance)

PHONO	2.5mV/50 kilohms
TUNER	150mV/50 kilohms
AUX	150mV/50 kilohms
TAPE PLAY 1	150mV/50 kilohms
TAPE PLAY 2	150mV/50 kilohms

Phono Overload Level (T.H.D. 0.01%, 1kHz)

PHONO	180mV
-------------	-------

Output (Level/Impedance)

TAPE REC 1	150mV
TAPE REC 2	150mV

Frequency Response

PHONO (RIAA Equalization)	
.....	20Hz to 20,000Hz±0.2dB
TUNER, AUX, TAPE PLAY	
.....	20Hz to 40,000Hz±2dB

Tone Control

BASS	+12dB, -10dB (100Hz)
TREBLE	+10dB, -10dB (10kHz)

Loudness Contour (Volume control set at -40dB position)	
.....	+6dB (100Hz), +3dB (10kHz)
Hum and Noise (IHF, short-circuited, A network)	
PHONO . . .	86dB (Phono interference filter switch off)
TUNER, AUX, TAPE PLAY	95dB

Miscellaneous

Power Requirements	120V 60Hz
Power Consumption	
.....	180W(UL), 380VA(CSA), 520W(max.)
Dimensions	450(W)x148(H)x329(D) mm
.....	17-3/4(W)x5-13/16(H)x12-15/16(D) in
Weight	Without package; 11.1kg(24 lb 7 oz)
.....	With package; 12.3kg(27 lb)

Furnished Parts

Operating instructions	1
------------------------------	---

**Measured pursuant to Federal Trade Commission's Trade Regulation rule on Power Claims for Amplifier.*

NOTE:
Specifications and the design subject to possible modification without notice due to improvements.

2. CONNECTION DIAGRAM

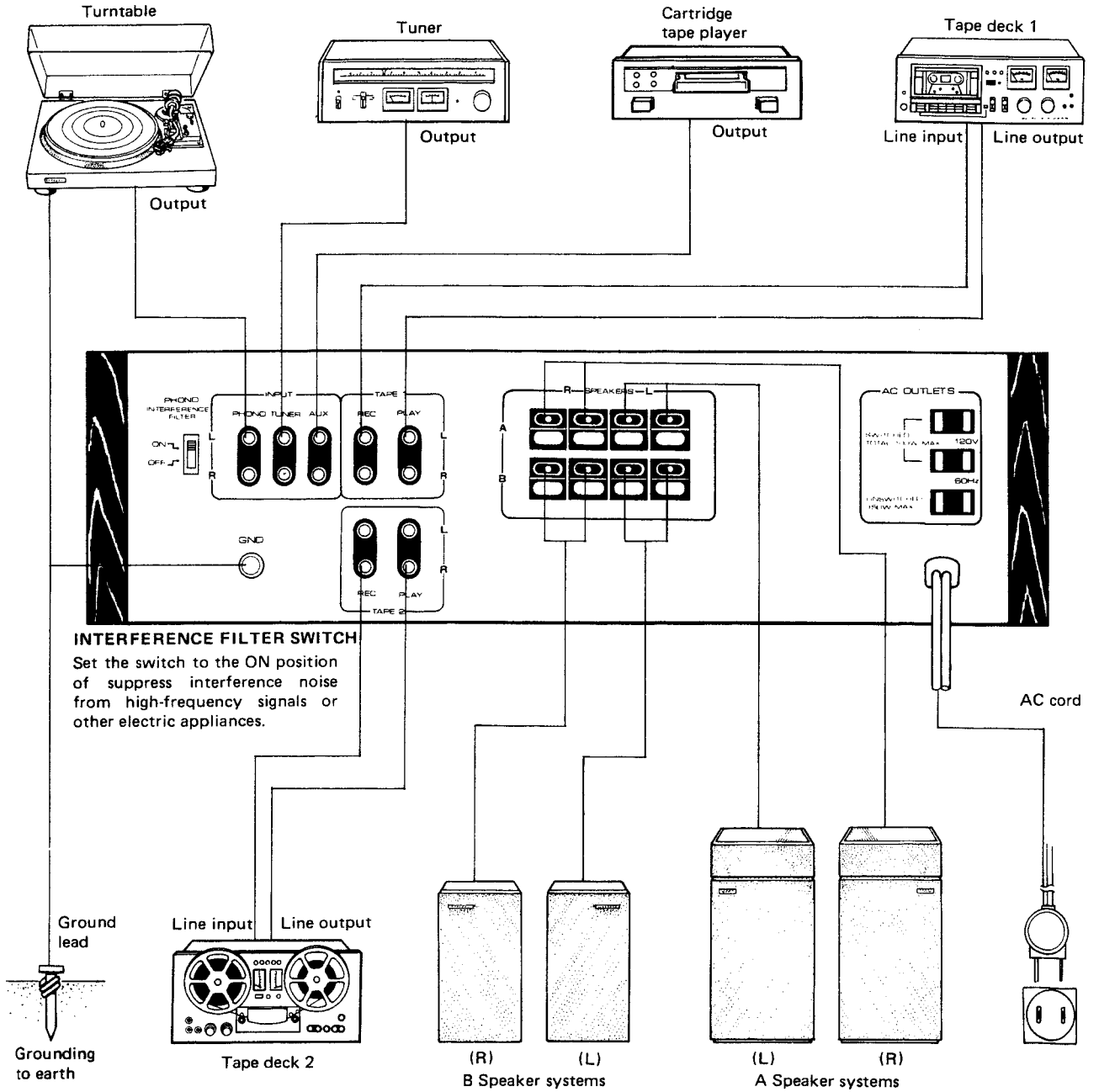

3. FRONT PANEL FACILITIES

POWER METERS

These power meters allow you to read out the rated power level when speakers with a nominal impedance of 8-ohms are connected to the amplifier's speaker terminals.

NOTE:
These values are related to the impedance of the speakers and they vary according to the frequency. In order to find out the exact output level, connect an 8-ohm dummy load instead of the speakers.

PEAK POWER INDICATORS

These lamps light up when the amplifier's output is at its peak level with 8 ohms load. Turn the VOLUME control to a lower position until the indicator does not light up continuously but only intermittently.

BASS, TREBLE CONTROLS

Adjust the bass with the BASS control and the treble with the TREBLE control. The bass and treble are strengthened when the controls are turned to the right and weakened when turned to the left. The sound quality of the music source depends on how the sound is absorbed and reflected in the listening room and also on the characteristics of the speakers. You can use these controls to compensate accordingly and adjust the sound to your preference.

POWER SWITCH

Flip this switch to the ON position to supply power to the stereo amplifier. There will be a short delay when it is set to ON, because the muting circuit has been actuated to suppress the unpleasant noise that is sometimes generated when the power is switched on and off.

SPEAKERS SWITCH

Selects speaker system operation.
OFF: Sound not obtained from speakers (when using headphones).
A: Sound obtained from speakers connected to A speaker terminals.
B: Sound obtained from speakers connected to B speaker terminals.
A + B: Sound obtained from speakers connected to both A and B speakers terminals.

NOTE:
When listening with headphones or to temporarily interrupt the speaker sound, set switch to OFF or to an unused speaker position.

PHONES JACK

When listening with stereo headphones, connect them to this jack.

NOTE:
Set the SPEAKERS switch to OFF when listening only with headphones.

LOUDNESS SWITCH

Set this switch to ON when listening at a low volume. The frequency response of the human ear varies according to the listening volume, and setting this switch to the ON position compensates for hearing response by emphasizing the bass and treble.

TAPE DUPLICATE SWITCH

Set this switch to ON when you want to duplicate or edit a pre-recorded tape using two tape decks.

TAPE MONITOR SWITCHES (1, 2)

Set switch 1 to ON with a tape deck which is connected to the TAPE 1 jacks (REC and PLAY) when you want to monitor the playback or recording of a tape. The tape on a deck which is connected to the TAPE 2 jacks (REC and PLAY) can be similarly monitored by setting switch 2 to ON.

NOTE:
Set these switches to the upper (off) position when listening to records or a radio broadcast.

VOLUME CONTROL

Use this control to adjust the output level to the speakers and headphones. Turn it clockwise to increase the output level.

FUNCTION SWITCH

Selects desired playback source.
TUNER: To listen to broadcasts with a tuner connected to the TUNER jacks.
PHONO: To play records on a turntable connected to the PHONO jacks.
AUX: To play a component connected to the AUX jacks.

NOTE:
Turn the VOLUME control down first before selecting a different function switch while the sound from one program source is being reproduced.

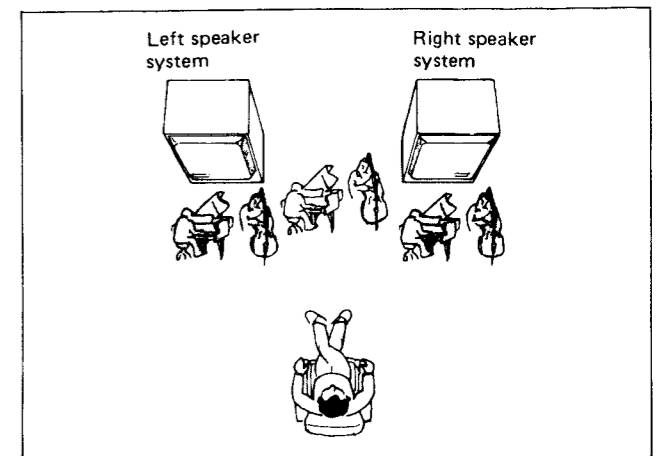
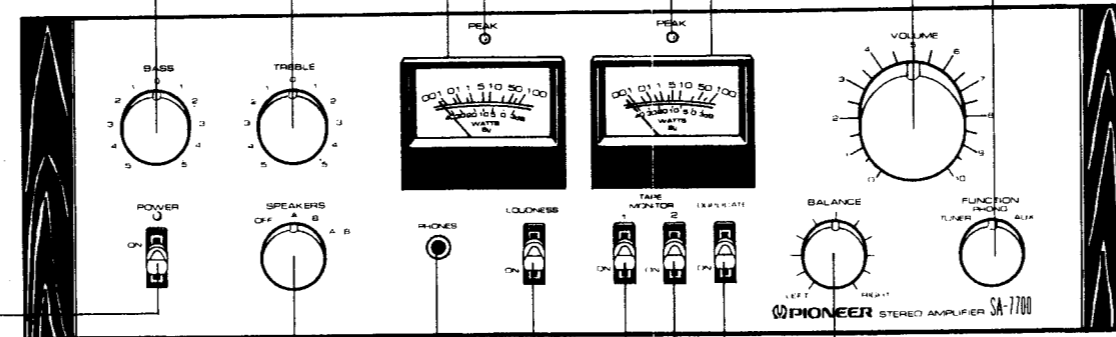

BALANCE CONTROL

Use this control to balance the volume of the left and right channels. First, however, tune the AM broadcast, and adjust so that the sound appears to come from somewhere exactly between the two speakers. If the sound appears to be louder on the right, it means that the volume of the right channel is higher. Turn the BALANCE control to the left and adjust. Conversely, if the sound appears to be louder on the left, it means that the volume of the left channel is higher. Therefore, turn the BALANCE control to the right and adjust.

4. BLOCK DIAGRAM

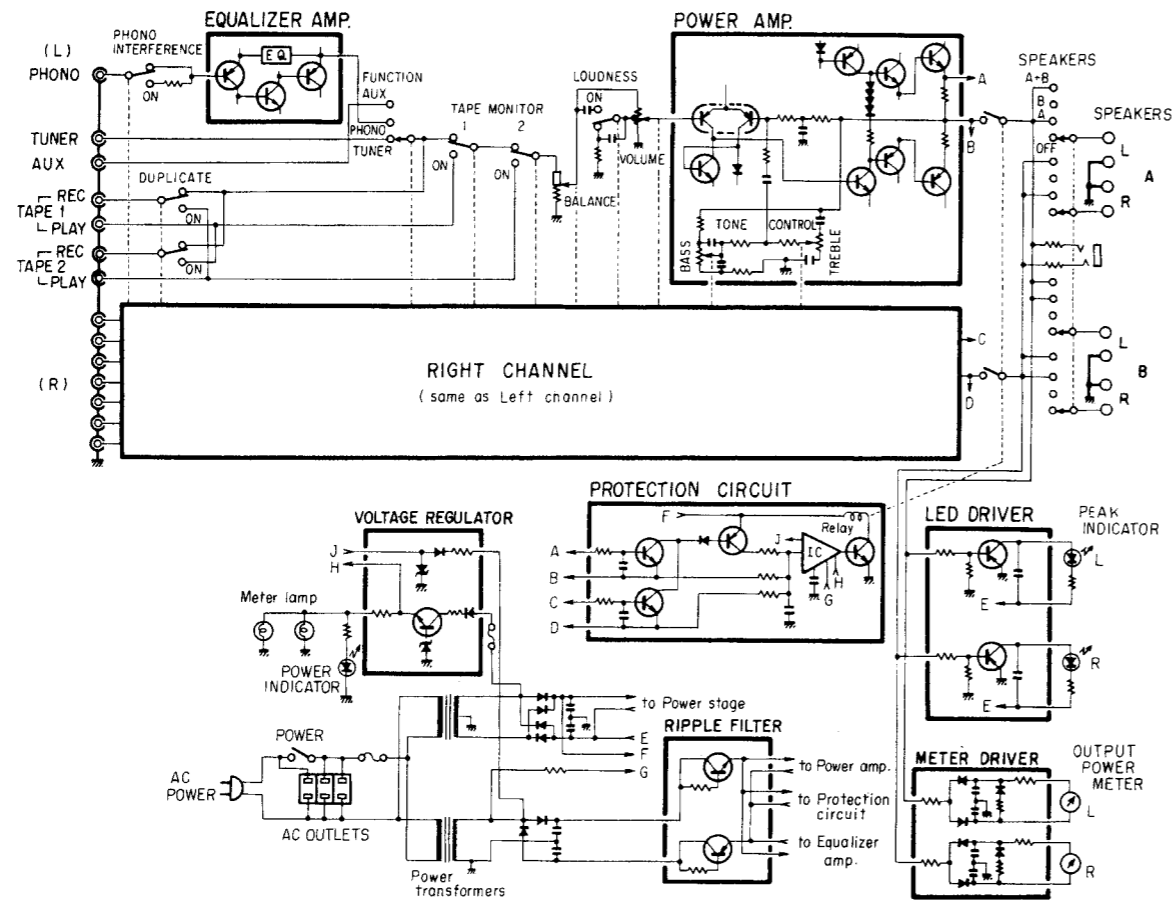

5. LEVEL DIAGRAM

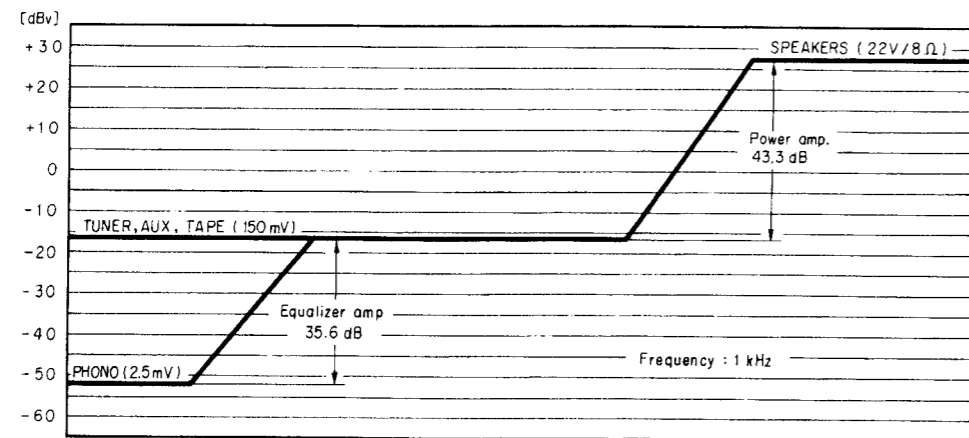

6. CIRCUIT DESCRIPTIONS

6.1 PHONO CIRCUIT

Phono Interference Filter

Since the phono input circuit is extremely sensitive, it is adversely affected by radio frequency interference. This interference is reduced by inserting a resistor in series with the phono input circuit by setting the PHONO INTERFERENCE FILTER switch on the rear panel to the ON position.

Equalizer Amplifier

The equalizer amplifier is a 3-stage direct-coupled amplifier with emitter-to-emitter feedback (Fig. 6-1). An S/N ratio of 85dB (at 2.5mV input, IHF-A, PHONO INTERFERENCE FILTER switch OFF) has been achieved by using a new ultra-low-noise PNP transistor (2SA978) at the first stage, and reducing the signal source resistance and equalizer element impedance.

The 2nd stage load has been reduced, a large output voltage obtained, and the output impedance lowered by using an emitter follower at the output stage.

Metal film resistors having a tolerance of $\pm 1\%$ and polypropylene film capacitors and polystyrene film capacitors having a tolerance of $\pm 2\%$ are used in the NFB circuit to obtain an equalizer deviation of within $\pm 0.2\text{dB}$ over the 20Hz ~ 20kHz range. The maximum allowable input of this circuit is 180mV (at 1kHz, THD 0.01%).

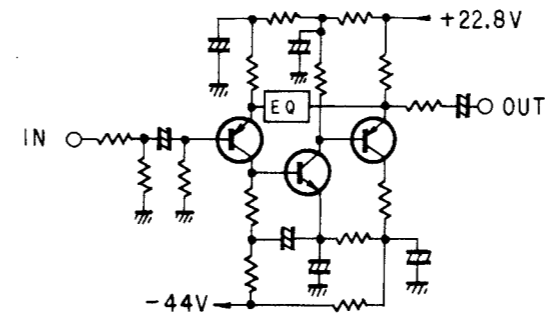

Fig. 6-1 Basic circuit of equalizer amplifier

6.2 POWER AMPLIFIER

The power amplifier is an 8-transistor (one of which is a dual transistor) all-stage direct-coupled pure complementary OCL circuit (Fig. 6-2).

Tone control (BASS, TREBLE) is accomplished by providing the power amplifier NFB circuit with a frequency selective characteristic. Since the number of elements through which the signal passes is small, this system is advantageous from the standpoints of distortion, noise, and cost. On the other hand, high gain and ample stability are demanded of the power amplifier.

The first stage of the power amplifier is a dual-transistor (Q_1) differential amplifier with a current mirror (Q_2, D_1) as its load circuit. The current mirror serves to make this stage operate in push-pull mode, thereby cancelling the even number harmonics, and doubling the gain.

A high voltage gain is obtained at the predriver stage (Q_3) by making its load circuit a constant-current source (Q_4, D_2).

The power stage ($Q_5 \sim Q_8$) is a 2-stage Darlington-connection SEPP circuit, and has an output of 60W (8Ω load, at both channels driven, THD 0.04%, 20Hz ~ 20kHz).

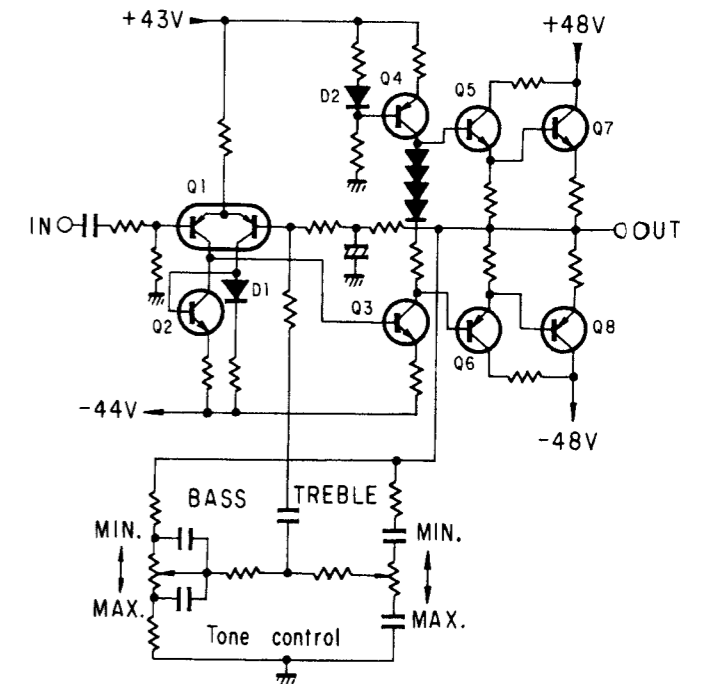

Fig. 6-2 Basic circuit of power amplifier

6.3 OUTPUT METER DRIVE CIRCUIT

This unit has an output meter that permits direct reading of an output from 0.01W to 100W at an 8Ω load without range switching.

The meter drive circuit is illustrated in Fig. 6-3. The output signal of the power amplifier is rectified by D_1 , D_2 , C_1 and C_2 through R_1 . The rectified signal is applied to the meter circuit (M, VR_1) and shunt circuit (R_2 , D_3). When the signal level is extremely low, D_3 is nonconductive, and all the signal current flows in M and VR_1 . D_3 begins to conduct as the signal level increases, and part of the signal current flows in R_2 and D_3 . The percentage of this shunt current increases as the signal level becomes higher. This keeps the increase in the signal current flowing in M and VR_1 smaller than the increase in the actual signal current. Therefore, 0.01W to 100W can be indicated on a single range.

There are two output meter indications, WATTS/ 8Ω and dB. The lower limit of the dB scale is -40dB. The conversion output at this time is $0.005W/8\Omega$.

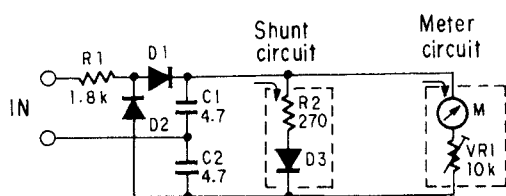

Fig. 6-3 Meter drive circuit

6.4 PEAK INDICATOR CIRCUIT

This circuit indicates clipping by saturation of the power amplifier. Basically, it lights an LED (light emitting diode) by sensing the output signal voltage of the power amplifier. (Fig. 6-4)

The output signal of the power amplifier is divided by R_1 and R_2 , and applied to the base of Q_1 , a PNP transistor. This transistor is turned ON by the minus peak of the signal, current flows in the LED and light is generated.

NOTE:

Since this circuit is untuned, its operating level varies, but it is operated by the following standards:

- Not lighted by a 50W output into an 8Ω load.
- Lighted by a 72W output into an 8Ω load.

6.5 PROTECTION CIRCUIT

The purpose of this circuit is to protect both the speakers and the power amplifiers. The relay in the output circuit is automatically opened in any of the following cases:

1. During the "transient operations" when the power supply is turned on and off.
2. Upon detection of an overload, caused by a short circuit in the load.
3. Upon detection of a DC voltage in the output circuit, caused by component failure or accident.

An outline of this circuit is shown in Fig. 6-5. The relay-activating transistor (Q_r) is controlled by the IC (PA3004).

Muting Operation When Power Supply is Tuned Off and On (Fig. 6-5)

When the power supply is first turned on, the voltages on pins 1, 7, and 6 of PA3004 will exceed a prescribed level. If there is no input (DC) on pin no.4, S_2 will be off, and a charging current will commence to flow to the timing capacitor (C_t) connected to pin no.8. Once C_t has been charged up to a level where the voltage on pin no.8 exceeds a prescribed level, S_1 will turn on, thereby applying a bias current (Q_r) from pin no.3 to the relay driving transistor (Q_r). Consequently, Q_r will turn on and current will flow through the relay coil to activate the relay, and close the connection in the output circuit. The time required for this connection to close after the power supply is first turned on is several seconds. During this period, any unwanted transient noises will be therefore muted.

When the power supply is turned off, the input (AC) applied to pin no.7 ceases immediately, resulting in S_2 turning on, C_t discharging rapidly, and S_1 and Q_r both turning off. The relay is thus opened, disconnecting the output circuit.

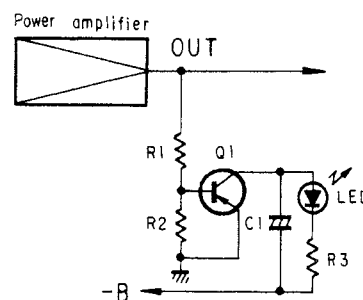

Fig. 6-4 Peak indicator circuit

DC Voltage Detector (Fig. 6-5)

The output circuit is connected to pin no.4 via a low-pass filter (R_8 and C_2). Any DC voltages appearing in the output circuit will also be applied to pin no.4, turning S_2 on. C_t will thus discharge rapidly, turning S_1 and Q_r off, thereby releasing the relay, and disconnecting the output circuit from the load.

Overload Detection

The overload detector circuit incorporates the load (R_L) in one side of a Wheatstone bridge (see Fig. 6-6). The base and emitter of a sensing transistor (Q_1) are connected to the opposite corners of the bridge, so if R_L decreases, Q_1 will become forward biased. If R_L falls below a prescribed value, will turn on, thereby passing a current through R_6 , R_5 and D_3 . Due to the voltage difference generated across R_6 , Q_2 will become forward biased, and consequently turn on. A DC voltage will then be applied to pin no.4, turning S_2 on, and resulting in the rapid discharge of C_t , and S_1 and Q_r both turning off. The relay will again be released to disconnect the output circuit.

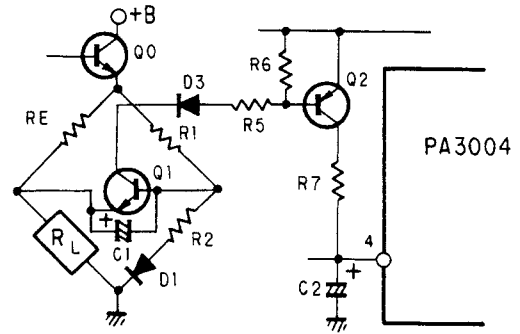

Fig. 6-6 Overload detector

6.6 POWER SUPPLY CIRCUIT

DC power is supplied by using two power transformers: one for the voltage amplifier stage and the other for the power stage. A bridge rectifier and a pair of $12,000\mu F$ capacitors supply $\pm 48V$ to the power stage. Power is supplied to the voltage amplifier stage through a full-wave voltage doubler rectifier and transistor ripple filter.

A transistor and Zener diode voltage regulator is used at the meter lamp power supply so that the meter illumination does not vary.

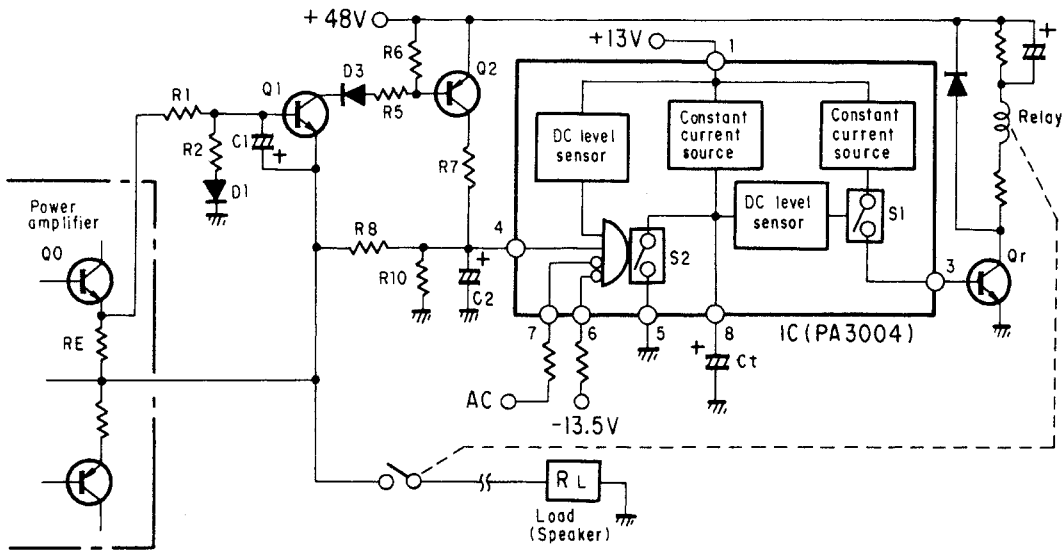

Fig. 6-5 Protection circuit

7. DISASSEMBLY

Top Cover (Side Panels, Top Plate)

Remove screws ① ~ ④, and remove the left and right-hand side panels.

Remove screws ⑤, ⑥, and remove the top plate.

Bottom Plate

Remove screws ⑦ ~ ⑩

Front Panel

1. Pull off all the knobs.
2. Remove the nuts ⑪ ~ ⑭
3. Pull the front panel forward and remove.

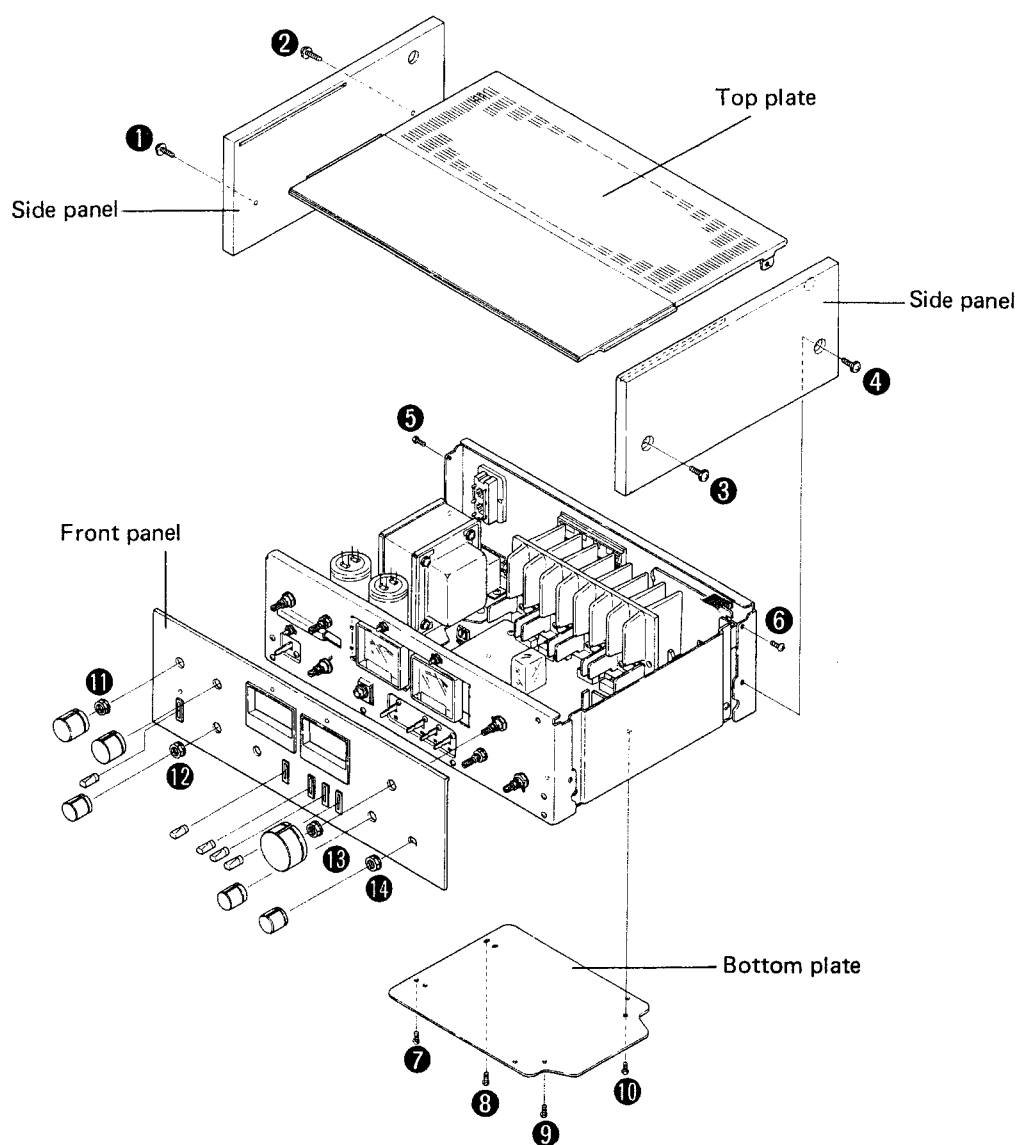

Heat Sink

Remove screws ⑮ ~ ⑱

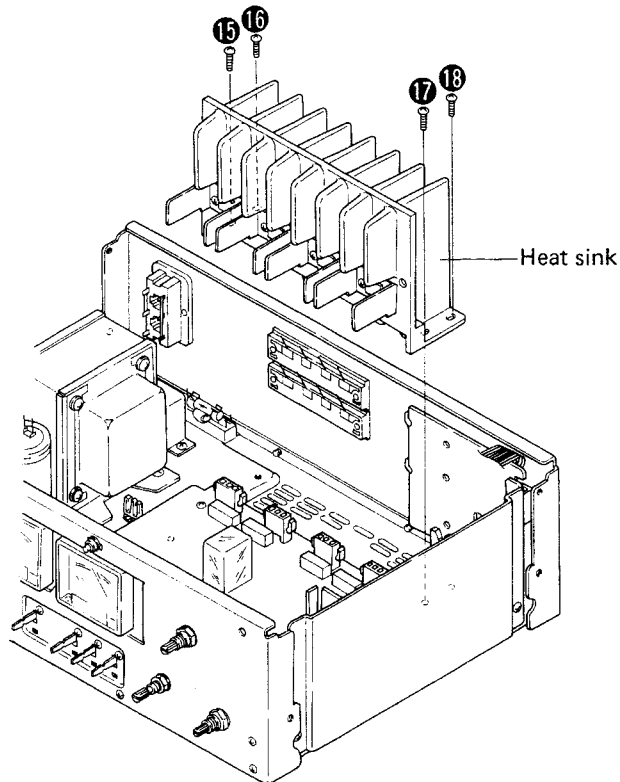

Meter Lamp Replacement

- (1) Remove the front panel.
- (2) Pull the meter from the body (the meter and panel stay are attached with double-sided adhesive tape through sponge).
- (3) Peel off the meter cover mounting tapes.
- (4) Peel off the reflective tape around the outside of the meter.
- (5) Remove the meter cover.
- (6) Remove the meter lamp, using a soldering iron.
- (7) Install the new lamp in the reverse order to removal.

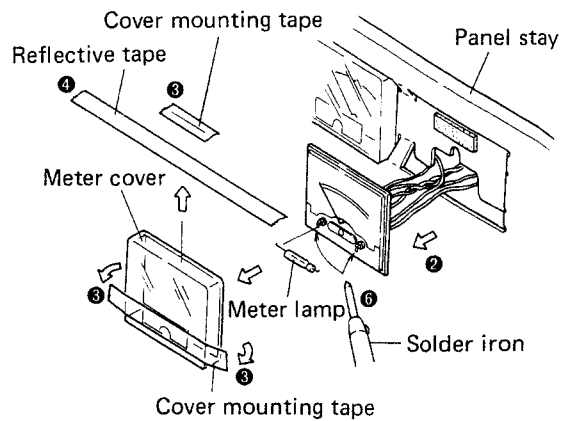

8. PARTS LOCATION

Front Panel View

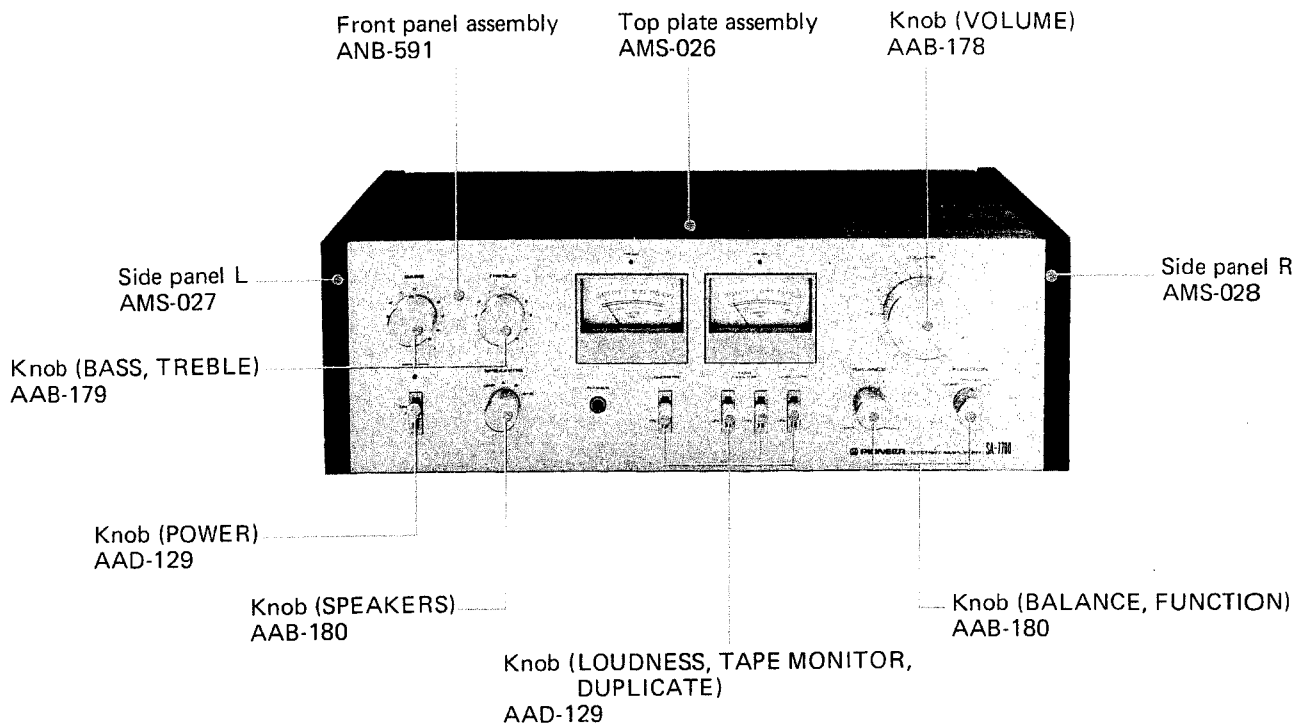

Front View with Panel Removed

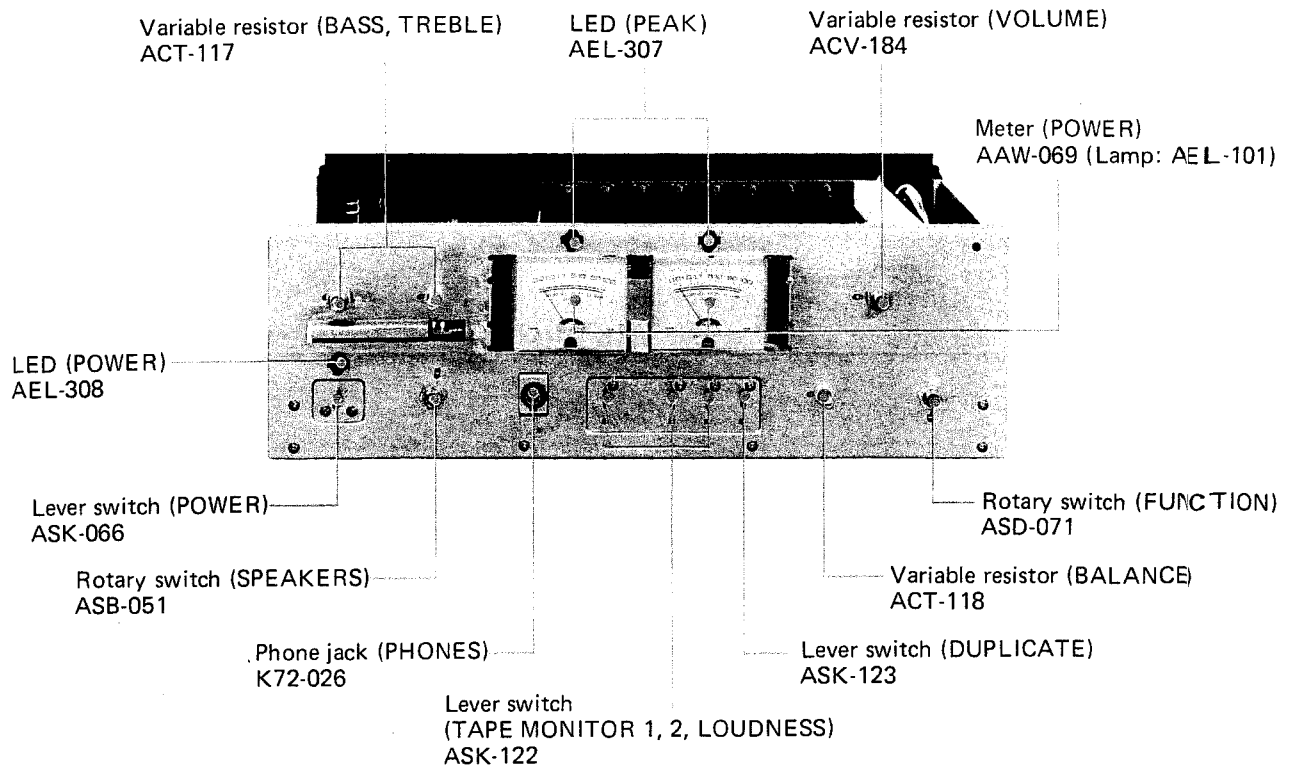

Top View

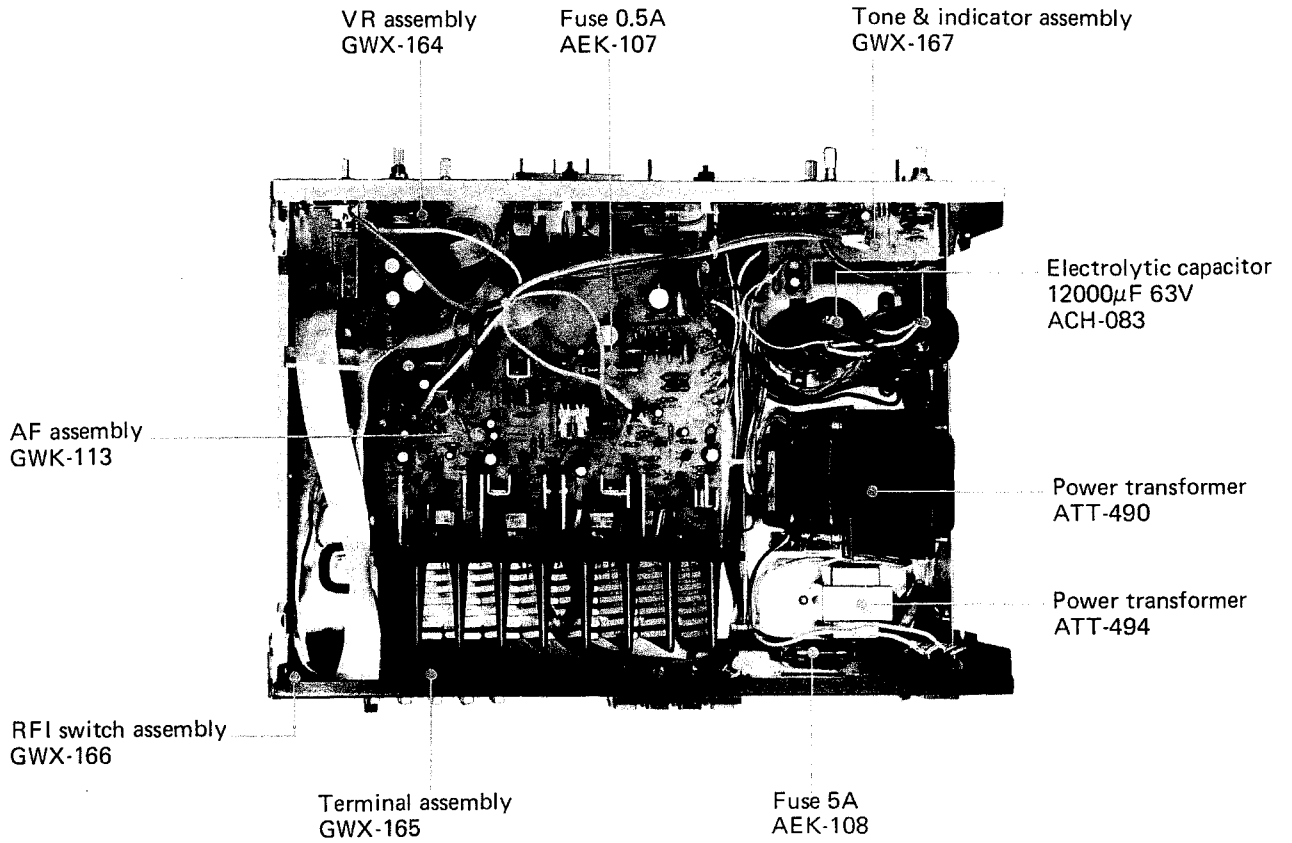

Rear Panel View

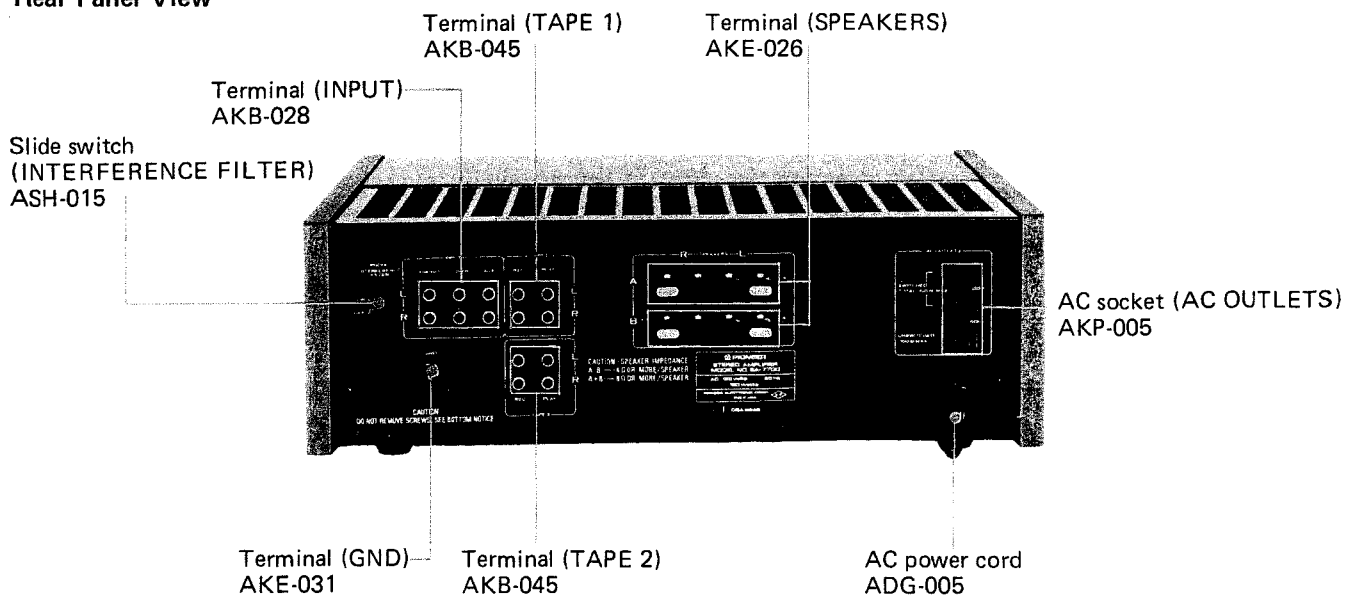

9. ADJUSTMENTS

Idle Current Adjustment

1. Set the VOLUME control to the minimum position (fully counterclockwise).
2. Set the BASS and TREBLE controls to the flat (center) position.
3. Set the SPEAKERS selector to the A position, and connect an 8Ω resistor to the output terminals.
4. Connect a DC voltmeter to the TP terminals (L ch: 25(+), 22(-), R ch: 26(+), 28(-)) of the AF ass'y.
5. Adjust the semifixed resistor (L ch: VR₃₀₁, R ch: VR₃₀₂) for a reading of 40mV at the DC voltmeter.
6. Power the set for more than 10 minutes under this state, and confirm that the DC voltmeter reading is within the 10mV ~ 70mV range.

Output Meter Adjustment

1. Set the BASS and TREBLE controls to the flat (center) position.
2. Set the SPEAKERS selector to the A position, and connect an 8Ω resistor and AC voltmeter to the output terminals.
3. Set the FUNCTION switch to the AUX position, and apply a 1kHz, 150mV signal to the input terminals.
4. Adjust the VOLUME control for an AC voltmeter reading of 6.32V (5W + 5W output by driving both channels).
5. Adjust the semifixed resistor (L ch: VR₄₀₁, R ch: VR₄₀₂) for a reading of -10dB at the output meter under this condition.
6. Change the input signal level in 10dB steps with an attenuator, and confirm that the output meter indication nearly coincides with the attenuator change at the 0dB, -20dB, -30dB, and -40dB points.

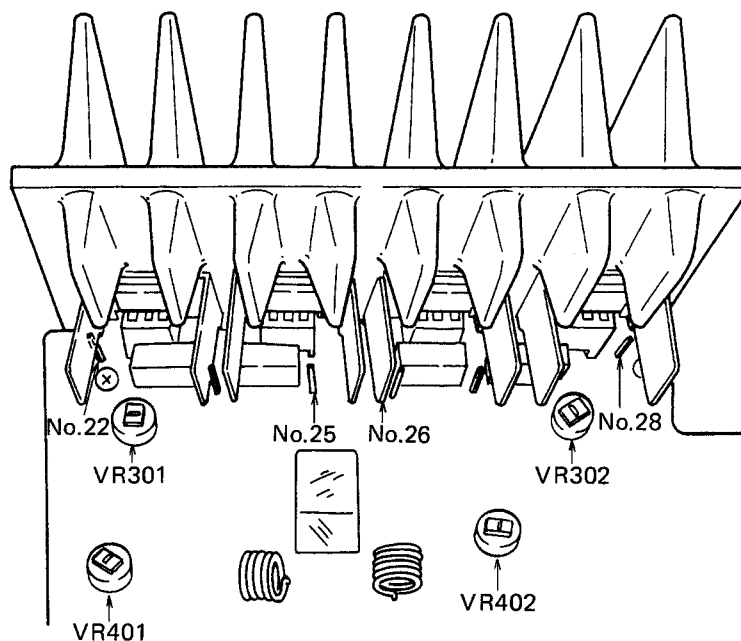

10. EXPLODED VIEW

NOTE:

Parts indicated in green type cannot be supplied.

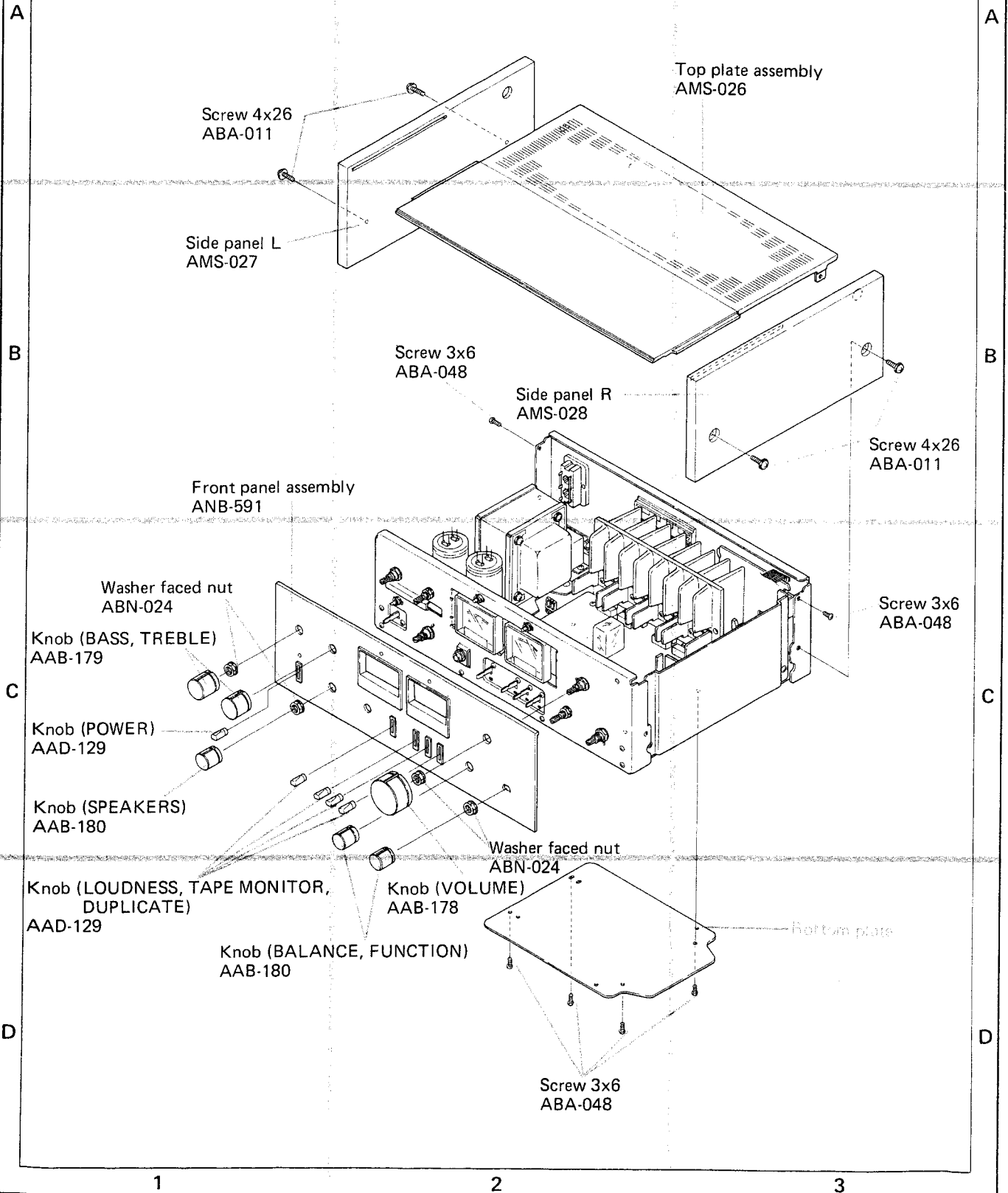

11.2 MISCELLANEA

External Appearance of Transistors and IC

2SC1313
2SC869
2SC1919
2SA978

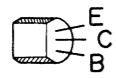

2SC1885
2SA912
2SC1384

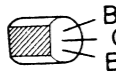

2SD712
2SD313
2SB682
2SB507

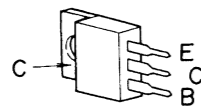

PA3004

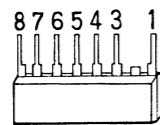

2SA798

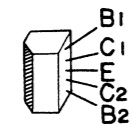

2SA720

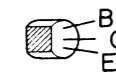

2SD737S
2SB701S

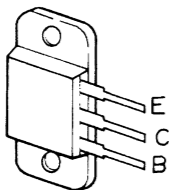

2SA913
2SC1913

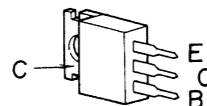

Miscellaneous Parts

SWITCHES

Symbol	Part No.	Description
S101	ASK-066	Lever switch (POWER)
S102	ASB-051	Rotary switch (SPEAKERS)

P.C. BOARD ASSEMBLIES

Symbol	Part No.	Description
	GWK-113	AF assembly
	GWX-167	Tone & Indicator assembly
	GWX-165	Terminal assembly
	GWX-164	VR assembly
	GWX-166	RFI switch assembly

FUSES

Symbol	Part No.	Description
FU1	AEK-107	Fuse (0.5A)
FU2	AEK-108	Fuse (5A)

CAPACITORS

Symbol	Part No.	Description		
C1	ACG-003	Ceramic	0.01	125V
C2	ACG-001	Ceramic	0.01	250V
C3	ACH-083	Electrolytic	12,000	63V
C4	ACH-083	Electrolytic	12,000	63V

SEMICONDUCTORS

Symbol	Part No.	Description
Q101	2SD737S-B or C	Transistor
Q102	2SB701S-B or C	Transistor
Q103	2SD737S-B or C	Transistor
Q104	2SB701S-B or C	Transistor
D1	AEL-308	LED (POWER indicator)
D2	AEL-307	LED (PEAK indicator)
D3	AEL-307	LED (PEAK indicator)

OTHERS

Symbol	Part No.	Description
T1	ATT-490	Power transformer
T2	ATT-494	Power transformer
	AAW-069	Meter (POWER)
	AKR-032	Fuse holder 1P
	AKP-005	AC socket (AC OUTLETS)
	ADG-005	AC power cord
	AKE-026	Terminal (SPEAKERS)
	K72-026	Phone jack (PHONES)
	AKE-031	Terminal (GND)
	AEL-101	Lamp 8V, 55mA (for meter)

11.3 TERMINAL ASSEMBLY (GWX-165)

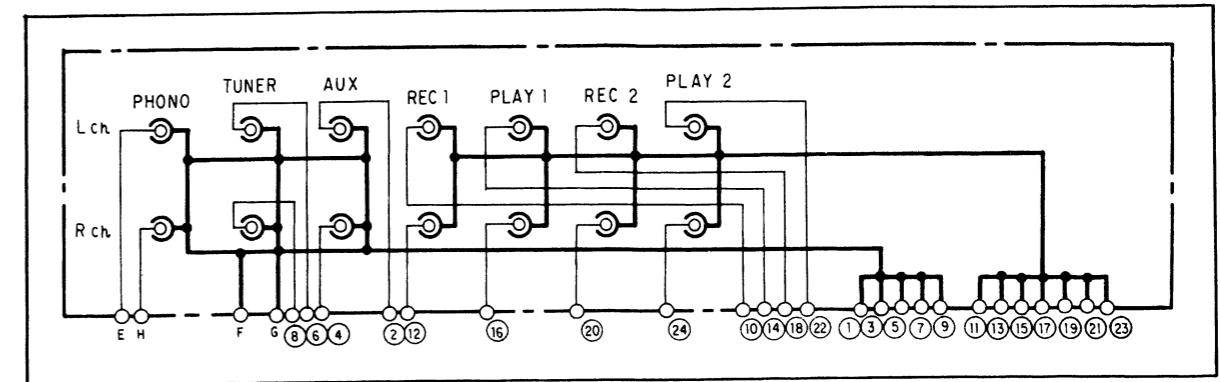

Foil side

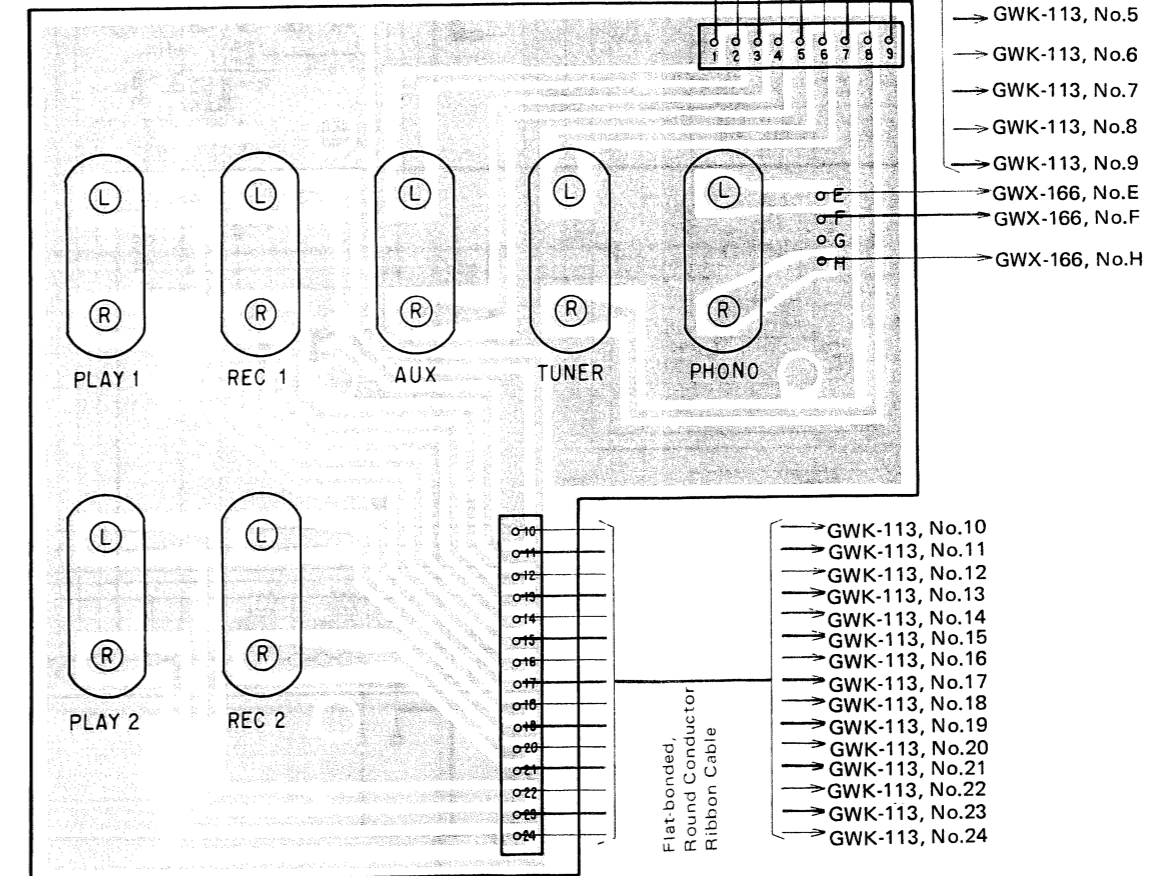

Parts List

Symbol	Part No.	Description
	AKB-045	Terminal (TAPE)
	AKB-028	Terminal (INPUT)

Parts List of AF Assembly (GWK-113)

SEMICONDUCTORS

Symbol	Part No.	Description
Q1	2SA978-G or F	Transistor
Q2	2SA978-G or F	Transistor
Q3	2SC1919-G or F	Transistor
Q4	2SC1919-G or F	Transistor
Q5	2SA912-R or Q	Transistor
Q6	2SA912-R or Q	Transistor
Q7	2SA798-G or F	Transistor
Q8	2SA798-G or F	Transistor
Q9	2SC1919-G or F	Transistor
	(2SC1313-G or F)	
Q10	2SC1919-G or F	Transistor
	(2SC1313-G or F)	
Q11	2SC1885-R or Q	Transistor
Q12	2SC1885-R or Q	Transistor
Q13	2SA912-R or Q	Transistor
Q14	2SA912-R or Q	Transistor
Q15	2SA913-Q or R	Transistor
Q16	2SA913-Q or R	Transistor
Q17	2SC1913-Q or R	Transistor
Q18	2SC1913-Q or R	Transistor
Q19	2SC869-C or D	Transistor
Q20	2SC869-C or D	Transistor
Q21	2SA720-R or Q	Transistor
Q22	2SC1384-Q or R	Transistor
Q23	PA3004	IC
Q24	2SD712-D or C	Transistor
	(2SD313-E or D)	
Q25	2SB682-D	Transistor
	(2SB507-E)	
Q26	2SD712-D or C	Transistor
	(2SD313-E or D)	
D1	SR3AM-8	Diode
D2	SR3AM-8	Diode
D3	SR3AM-8	Diode
D4	SR3AM-8	Diode
D5	10E2	Diode
D6	10E2	Diode
D7	10E2	Diode
D8	MZ-130	Zener diode
	(WZ-130)	
D9	1S2076	Diode
D10	2-1K261	Diode
D11	2-1K261	Diode
D12	1S2471	Diode
D14	1S2076	Diode
D15	2-1K261	Diode
D16	2-1K261	Diode
D17	1S2472	Diode

Symbol	Part No.	Description
D18	MZ-140	Zener diode
	(WZ-140)	
D19	1S2471	Diode
D20	1S2471	Diode
D21	1S2473	Diode
D22	1S2473	Diode
D23	1S2473	Diode
D24	1S2473	Diode
D25	1S2471	Diode
D26	STV-4H	Varistor
D27	STV-4H	Varistor

RESISTORS

Symbol	Part No.	Description
VR1	ACT-118	Variable resistor (BALANCE)
VR301	C92-063	Semi-fixed (100-B)
VR302	C92-063	Semi-fixed (100-B)
VR401	C92-049	Semi-fixed (10k-B)
VR402	C92-049	Semi-fixed (10k-B)
R101	RD½PS 820J	Carbon film 82
R102	RD½PS 820J	Carbon film 82
R103	RD½PS 104J NL	Carbon film 100k
R104	RD½PS 104J NL	Carbon film 100k
R105	RD½PS 104J NL	Carbon film 100k
R106	RD½PS 104J NL	Carbon film 100k
R107	RD½PS 473J	Carbon film 47k
R108	RD½PS 473J	Carbon film 47k
R109	RD½PS 513J	Carbon film 51k
R110	RD½PS 513J	Carbon film 51k
R111	RN½SQ 82R0F	Metal film 82 ½W
R112	RN½SQ 82R0F	Metal film 82 ½W
R113	RD½PS 273J	Carbon film 27k
R114	RD½PS 273J	Carbon film 27k
R115	RN½SQ 3901F	Metal film 3.9k ½W
R116	RN½SQ 3901F	Metal film 3.9k ½W
R117	RN½SQ 4702F	Metal film 47k ½W
R118	RN½SQ 4702F	Metal film 47k ½W
R119	RD½PS 181J	Carbon film 180
R120	RD½PS 181J	Carbon film 180
R121	RD½PS 182J	Carbon film 1.8k
R122	RD½PS 182J	Carbon film 1.8k
R123	RD½PS 471J	Carbon film 470
R124	RD½PS 471J	Carbon film 470
R125	RD½PS 104J	Carbon film 100k
R126	RD½PS 104J	Carbon film 100k
R127	RD½PS 682J	Carbon film 6.8k
R128	RD½PS 471J	Carbon film 470
R129	RD½PS 102J	Carbon film 1k

Symbol	Part No.	Description
R130	RD½PS 153J	Carbon film 15k
R201	RD½PS 222J	Carbon film 2.2k
R202	RD½PS 222J	Carbon film 2.2k
R203	RD½PS 222J	Carbon film 2.2k
R204	RD½PS 222J	Carbon film 2.2k
R205	RD½PS 332J	Carbon film 3.3k
R206	RD½PS 332J	Carbon film 3.3k
R207	RD½PS 333J	Carbon film 33k
R208	RD½PS 333J	Carbon film 33k
R301	RD½PS 222J	Carbon film 2.2k
R302	RD½PS 222J	Carbon film 2.2k
R303	RD½PS 104J	Carbon film 100k
R304	RD½PS 104J	Carbon film 100k
R305	RD½PS 102J	Carbon film 1k
R306	RD½PS 102J	Carbon film 1k
R307	RD½PS 102J	Carbon film 1k
R308	RD½PS 102J	Carbon film 1k
R309	RD½PS 433J	Carbon film 43k
R310	RD½PS 433J	Carbon film 43k
R311	RD½PS 114J	Carbon film 110k
R312	RD½PS 114J	Carbon film 110k
R313	RD½PS 221J	Carbon film 220
R314	RD½PS 221J	Carbon film 220
R315	RD½PS 392J	Carbon film 3.9k
R316	RD½PS 392J	Carbon film 3.9k
R317	RD½PS 511J	Carbon film 510
R318	RD½PS 511J	Carbon film 510
R319	RD½PS 270J	Carbon film 27
R320	RD½PS 270J	Carbon film 27
R321	RD½PS 753J	Carbon film 75k
R322	RD½PS 753J	Carbon film 75k
R323	RD½PS 362J	Carbon film 3.6k
R324	RD½PS 362J	Carbon film 3.6k
R325	RD½PS 221J	Carbon film 220
R326	RD½PS 221J	Carbon film 220
R327	RD½PS 104J	Carbon film 100k
R328	RD½PS 104J	Carbon film 100k
R329	RD½PSF 151J	Carbon film 150 ½W
R330	RD½PSF 151J	Carbon film 150 ½W
R331	RD½PSF 151J	Carbon film 150 ½W
R332	RD½PSF 151J	Carbon film 150 ½W
R333	RD½PSF 4R7J	Carbon film 4.7
R334	RD½PSF 4R7J	Carbon film 4.7
R335	RT5B 0R5K	Wire wound 0.5 5W
R336	RT5B 0R5K	Wire wound 0.5 5W
R337	RT5B 0R5K	Wire wound 0.5 5W
R338	RT5B 0R5K	Wire wound 0.5 5W
R339	RD½PS 272J	Carbon film 2.7k
R340	RD½PS 272J	Carbon film 2.7k
R341	RD½PS 153J	Carbon film 15k
R342	RD½PS 153J	Carbon film 15k

Symbol	Part No.	Description
R343	RD½PSF 100J	Carbon film 10 ½W
R344	RD½PSF 100J	Carbon film 10 ½W
R345	RS2P 151J	Metal oxide 150 2W
R346	RS2P 151J	Metal oxide 150 2W
R347	RD½PS 753J	Carbon film 75k
R348	RD½PS 753J	Carbon film 75k
R349	RD½PSF 100J	Carbon film 10 ½W
R350	RD½PSF 100J	Carbon film 10 ½W
R351	RD½PSF 4R7J	Carbon film 4.7
R352	RD½PSF 4R7J	Carbon film 4.7
R401	RD½PS 182J	Carbon film 1.8k
R402	RD½PS 182J	Carbon film 1.8k
R403	RD½PS 271J	Carbon film 270
R404	RD½PS 271J	Carbon film 270
R405	RD½PS 113J	Carbon film 11k
R406	RD½PS 105J	Carbon film 1M
R407	RD½PS 103J	Carbon film 10k
R408	RD½PS 512J	Carbon film 5.1k
R409	RD½PS 103J	Carbon film 10k
R410	RS1P 431J	Carbon film 430
R411	RD½PS 125J	Carbon film 1.2M
R412	RD½PS 751J	Carbon film 750
R413	RS1P 471J	Metal oxide 470 1W
R604	RD½PSF 112J	Carbon film 1.1k
R606	RD½PSF 220J	Carbon film 22
R607	RD½PS 912J	Carbon film 9.1k
R608	RD½PS 912J	Carbon film 9.1k
R609	RD½PS 183J	Carbon film 18k
R610	RD½PS 183J	Carbon film 18k
R611	RD½PSF 220J	Carbon film 22
R612	RS1P 821J	Metal oxide 820 1W
R613	RS1P 821J	Metal oxide 820 1W
R614	RD½PS 103J	Carbon film 10k
R615	RS2P 750J	Metal oxide 75 2W
R616	RS2P 750J	Metal oxide 75 2W
R617	RD½PS 153J	Carbon film 15k ½W
R618	RD½PS 153J	Carbon film 15k ½W
R619	RS1P 470J	Metal oxide 47 1W

CAPACITORS

Symbol	Part No.	Description
C101	CEANL 3R3P 25	Electrolytic 3.3 25V
C102	CEANL 3R3P 25	Electrolytic 3.3 25V
C103	CCDSL 221K 50	Ceramic 220p 50V
C104	CCDSL 221K 50	Ceramic 220p 50V
C105	CEA 102P 6	Electrolytic 1000 6V
C106	CEA 102P 6	Electrolytic 1000 6V
C107	CQPA 183G 50	Polypropylene 0.018 50V
C108	CQPA 183G 50	Polypropylene 0.018 50V
C109	CQPA 683G 50	Polypropylene 0.068 50V
C110	CQPA 683G 50	Polypropylene 0.068 50V

Symbol	Part No.	Description	Symbol	Part No.	Description
C111	CKDYB 561K 50	Ceramic 560p 50V	C601	ACG-004	Ceramic 0.01 150V
C112	CKDYB 561K 50	Ceramic 560p 50V	C602	CEA 331P 63	Electrolytic 330 63V
C113	ACH-323	Electrolytic 2.2 50V (NP)	C603	CEA 471P 63	Electrolytic 470 63V
C114	ACH-323	Electrolytic 2.2 50V (NP)	C604	CEA 220P 50	Electrolytic 22 50V
C115	CEA 221P 25	Electrolytic 220 25V	C605	CEA 220P 50	Electrolytic 22 50V
C116	CEA 101P 25	Electrolytic 100 25V	C606	CEA 220P 50	Electrolytic 22 50V
C117	CEA 102P 25	Electrolytic 1000 25V	C607	CEA 220P 50	Electrolytic 22 50V
C118	CCDSL 101K 50	Ceramic 100p 50V	C608	CEA 221P 25	Electrolytic 220 25V
C119	CCDSL 101K 50	Ceramic 100p 50V	C609	CEA 221P 25	Electrolytic 220 25V
C120	CQSA 122G 50	Polystyrene 1200p 50V	C610	CEA 221P 50	Electrolytic 220 50V
C121	CQSA 122G 50	Polystyrene 1200p 50V	C611	ACG-004	Ceramic 0.01 150V
C122	CEA 221P 25	Electrolytic 220 25V	C612	ACG-004	Ceramic 0.01 150V
C123	CKDYF 473Z 50	Ceramic 0.047 50V	C613	CEA 101P 16	Electrolytic 100 16V
C124	CKDYF 473Z 50	Ceramic 0.047 50V	C614	CEA 100P 16	Electrolytic 10 16V
C201	CCDSL 121K 50	Ceramic 120p 50V			
C202	CCDSL 121K 50	Ceramic 120p 50V			
C203	CQMA 183J 50	Mylar 0.018 50V			
C204	CQMA 183J 50	Mylar 0.018 50V			
C301	ACH-304	Electrolytic 0.22 35V (NP)			
C302	ACH-304	Electrolytic 0.22 35V (NP)			
C303	CEA 4R7P 50	Electrolytic 4.7 50V			
C304	CEA 4R7P 50	Electrolytic 4.7 50V			
C305	CEA 221P 6	Electrolytic 220 6V			
C306	CEA 221P 6	Electrolytic 220 6V			
C307	CCDSL 050D 50	Ceramic 5p 50V			
C308	CCDSL 050D 50	Ceramic 5p 50V			
C309	CKDYB 471K 50	Ceramic 470p 50V			
C310	CKDYB 471K 50	Ceramic 470p 50V			
C311	CEA 220P 10	Electrolytic 22 10V			
C312	CEA 220P 10	Electrolytic 22 10V			
C313	CKDYF 473Z 50	Ceramic 0.047 50V			
C314	CKDYF 473Z 50	Ceramic 0.047 50V			
C315	CCDSL 181K 50	Ceramic 180p 50V			
C316	CCDSL 181K 50	Ceramic 180p 50V			
C317	CCDSL 181K 50	Ceramic 180p 50V			
C318	CCDSL 181K 50	Ceramic 180p 50V			
C319	CSZA R22M 35	Electrolytic 0.22 35V			
C320	CSZA R22M 35	Electrolytic 0.22 35V			
C321	CKDYF 473Z 50	Ceramic 0.047 50V			
C322	CKDYF 473Z 50	Ceramic 0.047 50V			
C323	CKDYF 473Z 50	Ceramic 0.047 50V			
C324	CKDYF 473Z 50	Ceramic 0.047 50V			
C325	CEA 100P 50	Electrolytic 10 50V			
C401	CEA 4R7P 50	Electrolytic 4.7 50V			
C402	CEA 4R7P 50	Electrolytic 4.7 50V			
C403	CEA 4R7P 50	Electrolytic 4.7 50V			
C404	CEA 4R7P 50	Electrolytic 4.7 50V			
C405	CEA 470P 16	Electrolytic 47 16V			
C406	CEA 100P 16	Electrolytic 10 16V			
C407	CEA 330P 16	Electrolytic 33 16V			
C408	CEA 470P 50	Electrolytic 47 50V			

SWITCHES

Symbol	Part No.	Description
S1	ASD-071	Rotary switch (FUNCTION)
S2	ASK-123	Lever switch (DUPLICATE)
S3	ASK-122	Lever switch (TAPE MONITOR 1)
S4	ASK-122	Lever switch (TAPE MONITOR 2)
S5	ASK-122	Lever switch (LOUDNESS)

OTHERS

Symbol	Part No.	Description
L1	AKH-010	Transistor socket
L2	T63-009	AF choke coil
	T63-009	AF choke coil
	ASR-023	Relay
	ANH-309	Heat sink
	AKR-013	Fuse clip

11.5 TONE & INDICATOR ASSEMBLY (GWX-167)

Foil side

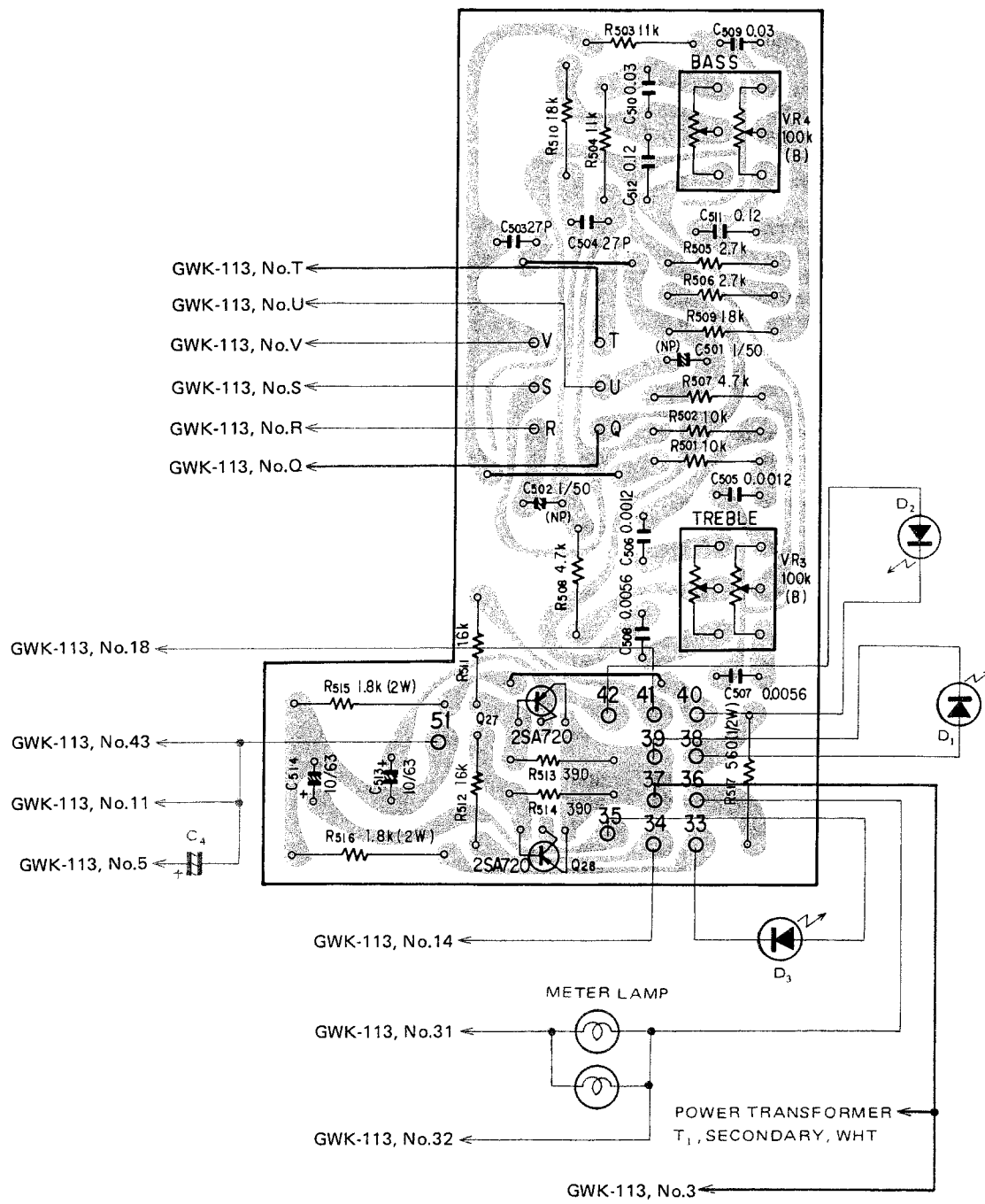

- GWK-113, No. T
- GWK-113, No. U
- GWK-113, No. V
- GWK-113, No. S
- GWK-113, No. R
- GWK-113, No. Q

- GWK-113, No. 18
- GWK-113, No. 43
- GWK-113, No. 11
- GWK-113, No. 5

GWK-113, No. 14

METER LAMP

GWK-113, No. 31

POWER TRANSFORMER
T₁, SECONDARY, WHT

GWK-113, No. 32

GWK-113, No. 3

Parts List of Tone & Indicator Assembly (GWX-167)

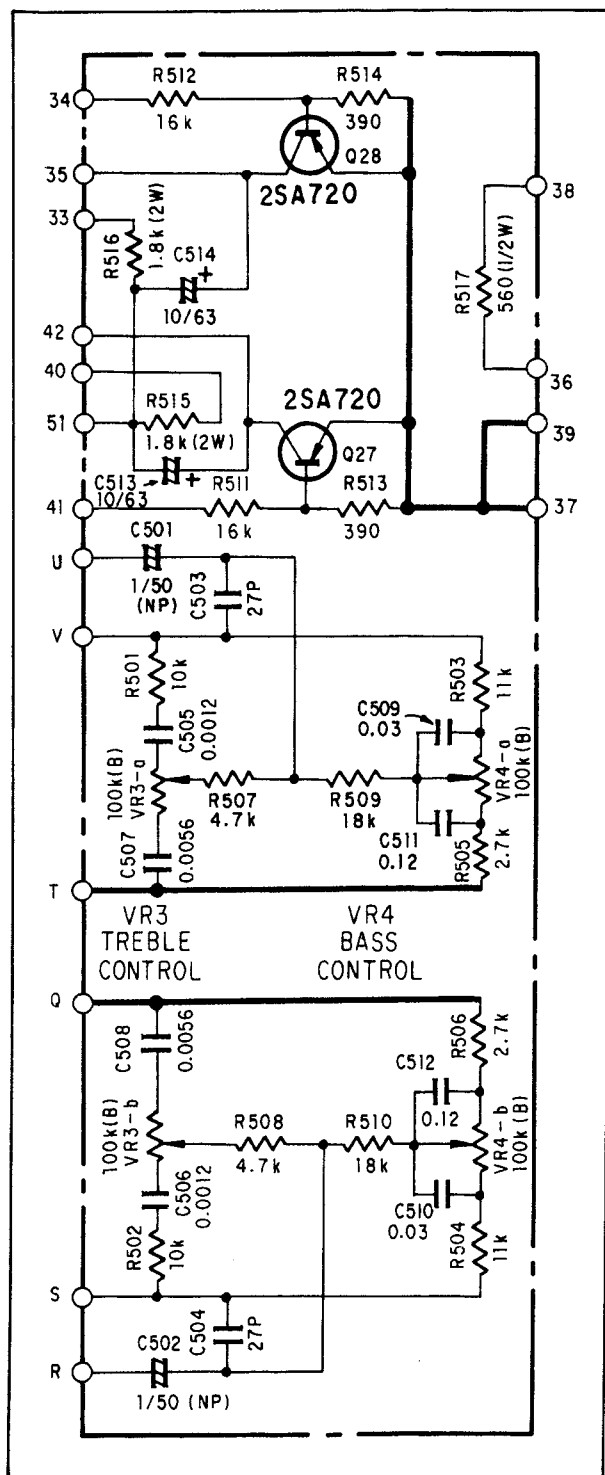

SEMICONDUCTORS

Symbol	Part No.	Description
Q27	2SA720-R or Q	Transistor
Q28	2SA720-R or Q	Transistor

CAPACITORS

Symbol	Part No.	Description
C501	ACH-326	Electrolytic 1 50V (NP)
C502	ACH-326	Electrolytic 1 50V (NP)
C503	CCDSL 270K 50	Ceramic 27p 50V
C504	CCDSL 270K 50	Ceramic 27p 50V
C505	CQMA 122J 50	Mylar 0.0012 50V
C506	CQMA 122J 50	Mylar 0.0012 50V
C507	CQMA 562J 50	Mylar 0.0056 50V
C508	CQMA 562J 50	Mylar 0.0056 50V
C509	CQMA 303J 50	Mylar 0.03 50V
C510	CQMA 303J 50	Mylar 0.03 50V
C511	CQMA 124J 50	Mylar 0.12 50V
C512	CQMA 124J 50	Mylar 0.12 50V
C513	CEA 100P 63	Electrolytic 10 63V
C514	CEA 100P 63	Electrolytic 10 63V

RESISTORS

Symbol	Part No.	Description
VR3	ACT-117	Variable resistor (TREBLE)
VR4	ACT-117	Variable resistor (BASS)
R501	RD¼PS 103J	Carbon film 10k
R502	RD¼PS 103J	Carbon film 10k
R503	RD¼PS 113J	Carbon film 11k
R504	RD¼PS 113J	Carbon film 11k
R505	RD¼PS 272J	Carbon film 2.7k
R506	RD¼PS 272J	Carbon film 2.7k
R507	RD¼PS 472J	Carbon film 4.7k
R508	RD¼PS 472J	Carbon film 4.7k
R509	RD¼PS 183J	Carbon film 18k
R510	RD¼PS 183J	Carbon film 18k
R511	RD¼PS 163J	Carbon film 16k
R512	RD¼PS 163J	Carbon film 16k
R513	RD¼PS 391J	Carbon film 390
R514	RD¼PS 391J	Carbon film 390
R515	RS2P 182J	Metal oxide 1.8k 2W
R516	RS2P 182J	Metal oxide 1.8k 2W
R517	RD¼PS 561J	Carbon film 560 ½W

11.6 RFI SWITCH ASSEMBLY (GWX-166)

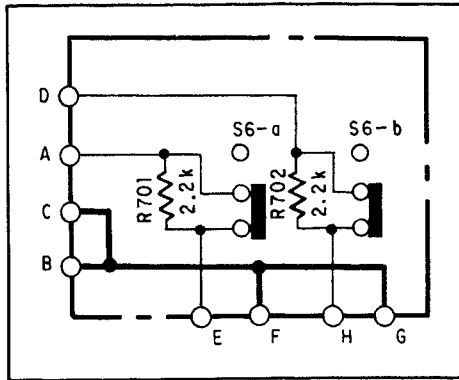

Parts List

Symbol	Part No.	Description
S6	ASH-015	Slide switch (PHONO INTERFERENCE)
R701	RD $\frac{1}{4}$ PS 222J	Carbon film resistor 2.2k
R702	RD $\frac{1}{4}$ PS 222J	Carbon film resistor 2.2k

Foil side

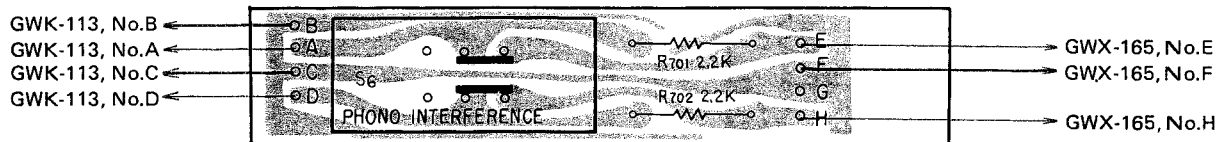

11.7 VR ASSEMBLY (GWX-164)

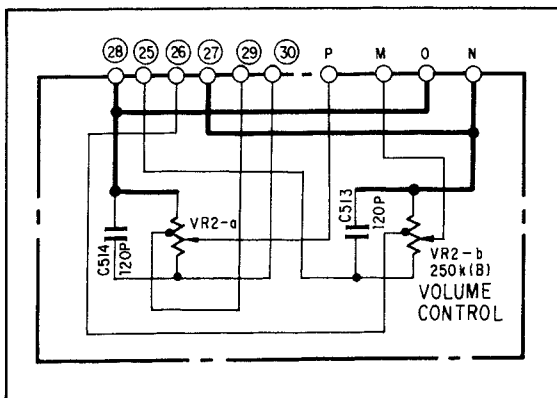

Parts List

Symbol	Part No.	Description
VR2	ACV-184	Variable resistor (VOLUME)
C513	CCDSL 121K 50	Ceramic capacitor 120p 50V
C514	CCDSL 121K 50	Ceramic capacitor 120p 50V

Foil side

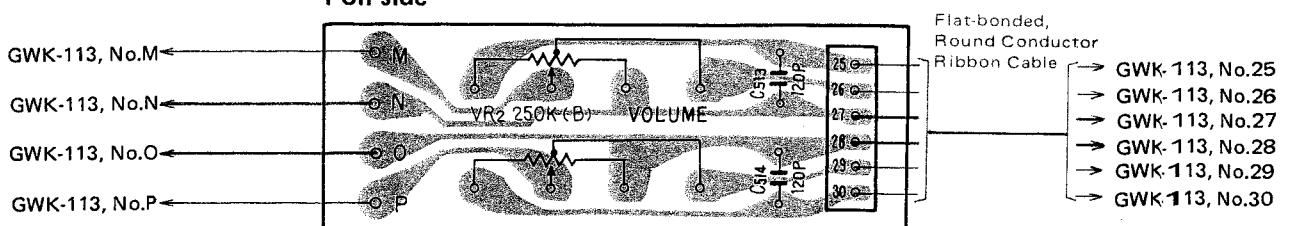

12. PACKING

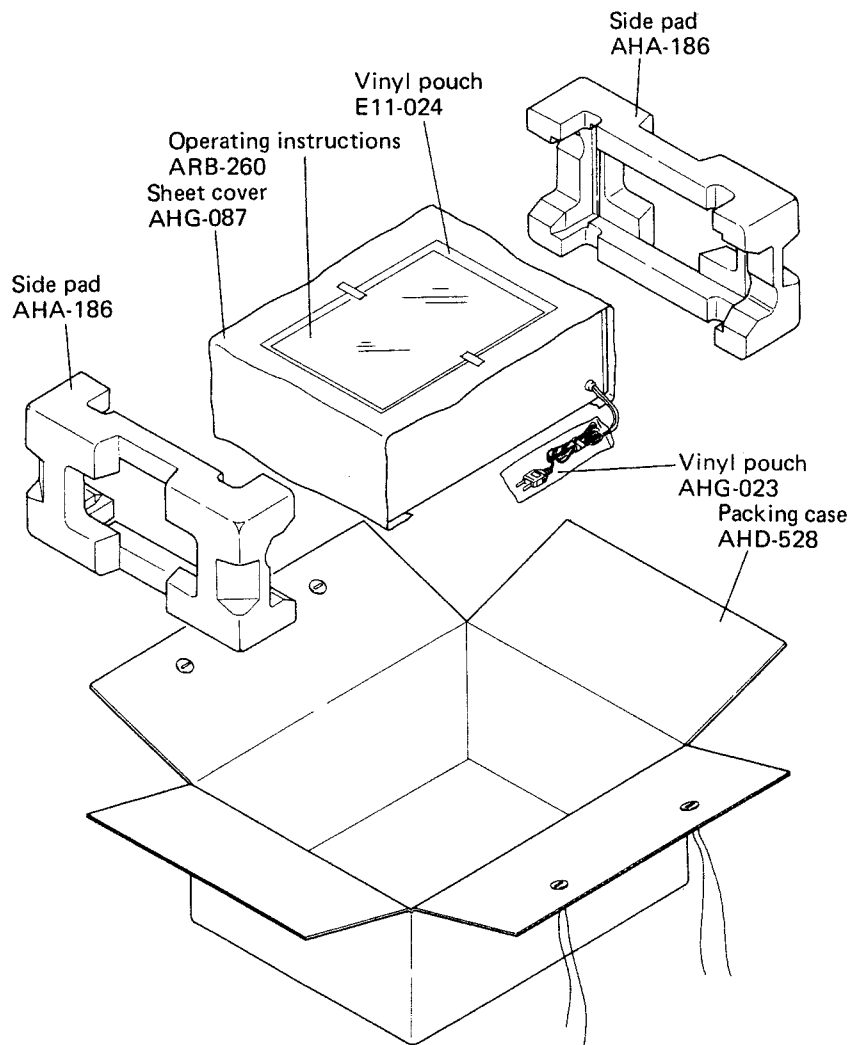

13. SUPPLEMENTS FOR MODEL SA-7700/KC

Model SA-7700/KU is the same as SA-7700/KC with exception of descriptions in this supplements.

Contrast of Miscellaneous Parts

Symbol	Description	Part No.		Remarks
		KU type	KC type	
T1	Power transformer	ATT-490	ATT-491	
FU3	Fuse 160mA	AEK-408	
C1	Ceramic 0.01 125V	ACG-003	ACG-014	
C2	Ceramic 0.01 250V	ACG-001	
	Ceramic 0.01 125V	ACG-014	
	Fuse holder	K91-008	for FU3 for C1 for C2
	Capacitor cover	AEC-279	AEC-365	
	Capacitor cover	AEC-294	AEC-365	
	Packing case	AHD-528	AHD-529	
	AF assembly	GWK-113	GWK-115	
	Tone & indicator assembly	GWX-167	GWX-173	
	Terminal assembly	GWX-165	GWX-171	
	VR assembly	GWX-164	GWX-170	
	RFI switch assembly	GWX-166	GWX-172	

AF ASSEMBLY (GWK-115)

The circuitry of the AF assembly GWK-115 is the same as the GWK-113 (for SA-7700/KU), with exception of the p.c. board material and the parts installation method.

TONE & INDICATOR ASSEMBLY (GWX-173)

The circuitry of the tone & indicator assembly GWX-173 is the same as the GWX-167 (for SA-7700/KU), with exception of the p.c. board material.

TERMINAL ASSEMBLY (GWX-171)

The circuitry of the terminal assembly GWX-171 is the same as the GWX-165 (for SA-7700/KU), with exception of the p.c. board material.

VR ASSEMBLY (GWX-170)

The circuitry of the VR assembly GWX-170 is the same as the GWX-164 (for SA-7700/KU), with exception of the p.c. board material.

RFI SWITCH ASSEMBLY (GWX-172)

The circuitry of the RFI switch assembly GWX-172 is the same as the GWX-166 (for SA-7700/KU), with exception of the p.c. board material.

STEREO AMPLIFIER

SA-7700

KU
KC

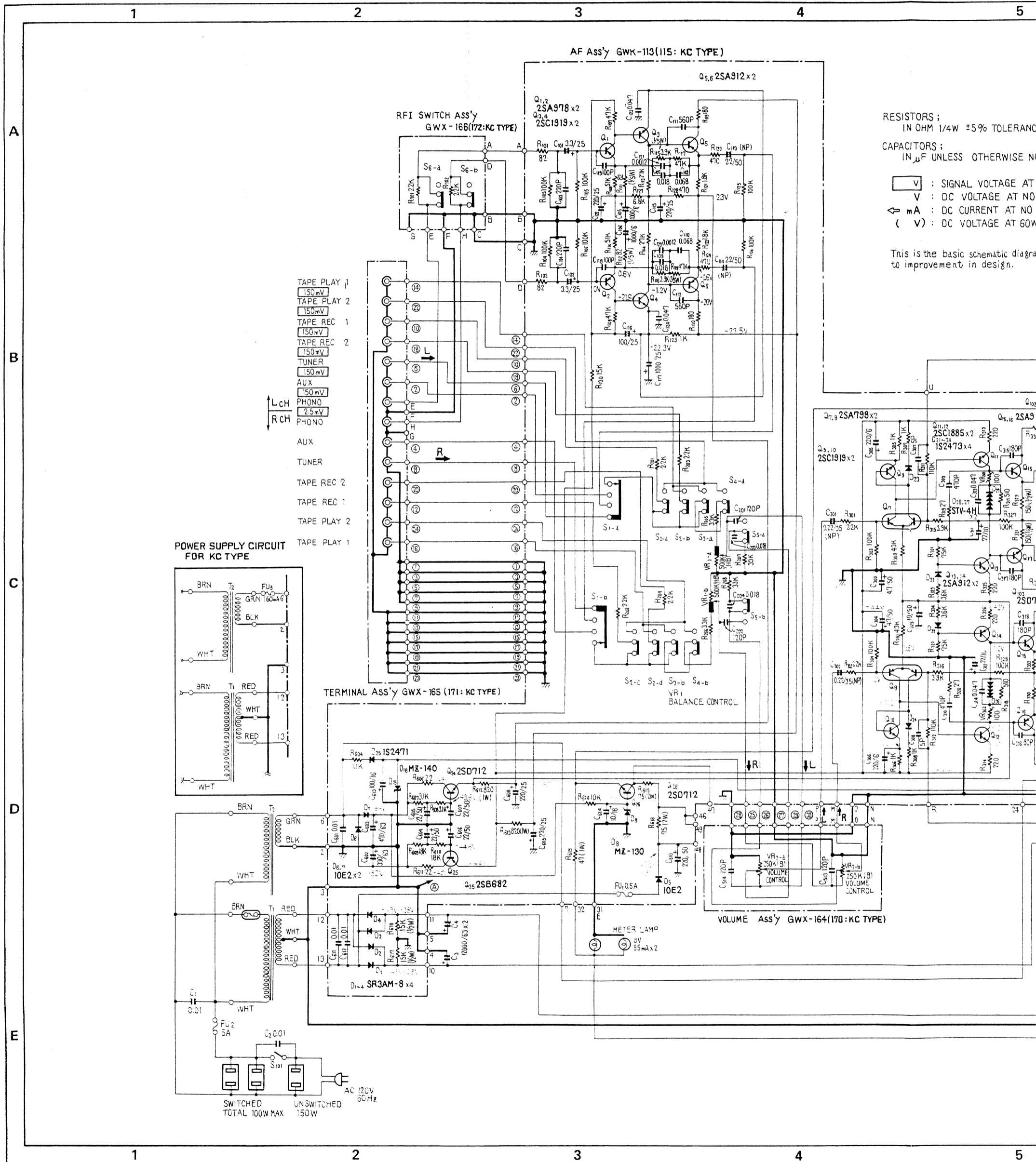

5 6 7 8

1/4W ±5% TOLERANCE UNLESS OTHERWISE NOTED K; kΩ M; MΩ
 UNLESS OTHERWISE NOTED P; pF
 SIGNAL VOLTAGE AT 60W +60W 8Ω OUTPUT (1KHz)
 DC VOLTAGE AT NO INPUT SIGNAL
 DC CURRENT AT NO INPUT SIGNAL
 DC VOLTAGE AT 60W OUTPUT

SWITCHES:

S ₁₀₁ POWER ON - OFF	S ₁ FUNCTION
S ₁₀₂ SPEAKER	1. TUNER
1. OFF	2. PHONO
2. A	3. AUX
3. B	S ₂ DUPLICATE ON - OFF
4. A + B	S ₃ TAPE MONITOR 1 ON - OFF
	S ₄ TAPE MONITOR 2 ON - OFF
	S ₅ LOUDNESS ON - OFF
	S ₆ PHONO INTERFERENCE ON - OFF

This is a basic schematic diagram, but the actual circuit may vary due to component tolerance and design.

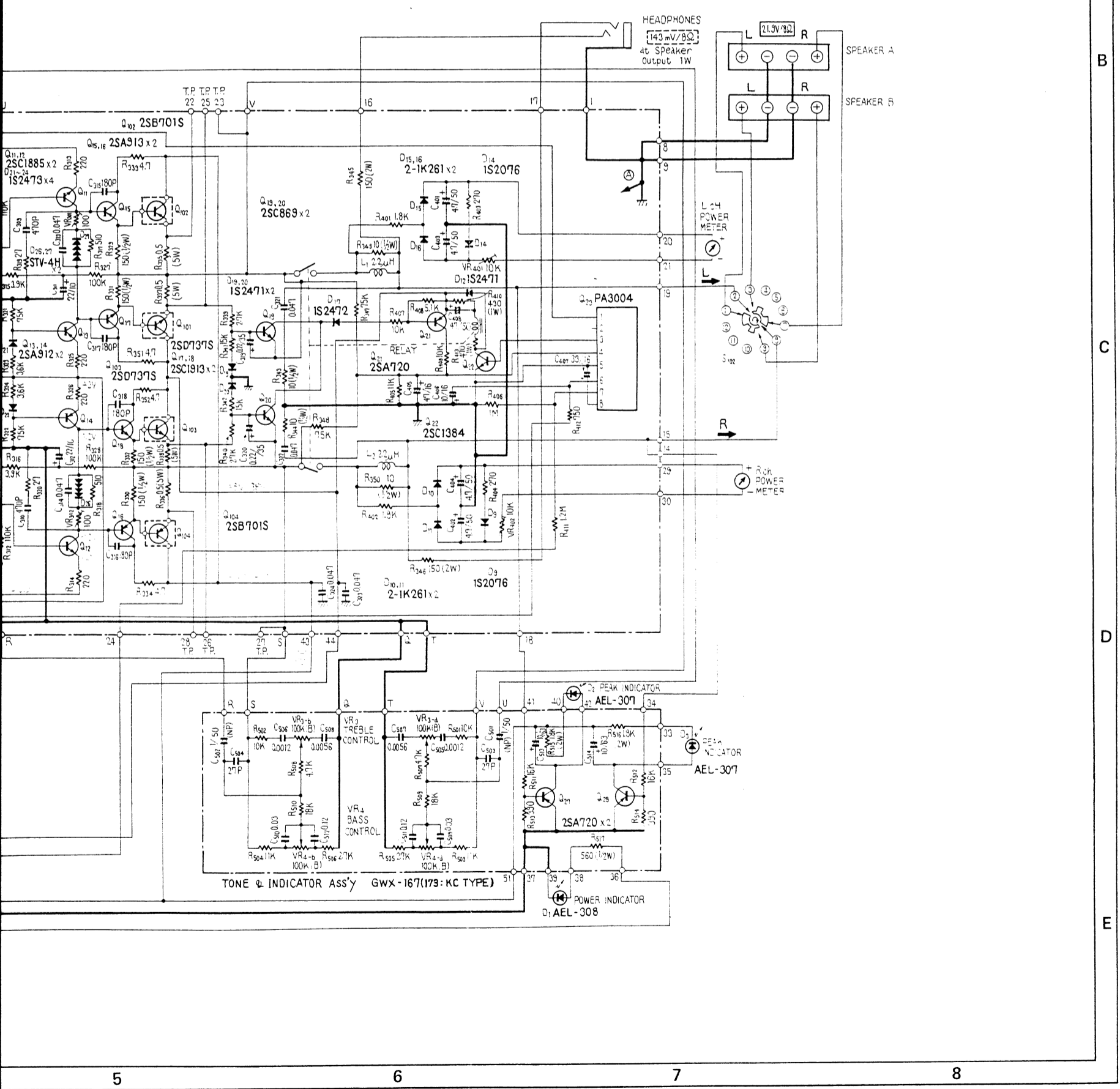

A
 B
 C
 D
 E

ADDITIONAL

PIONEER®

Service Manual

STEREO AMPLIFIER

SA-706 HG, S, S/G

The basic performance of the Model SA-706 is the same as the Model SA-7700. SA-7700 has wooden side and top panels, while SA-706 employs metal (Fig. A). This additional service manual is applicable to the SA-706, please refer to the SA-7700 service manual with the exception of this supplements.

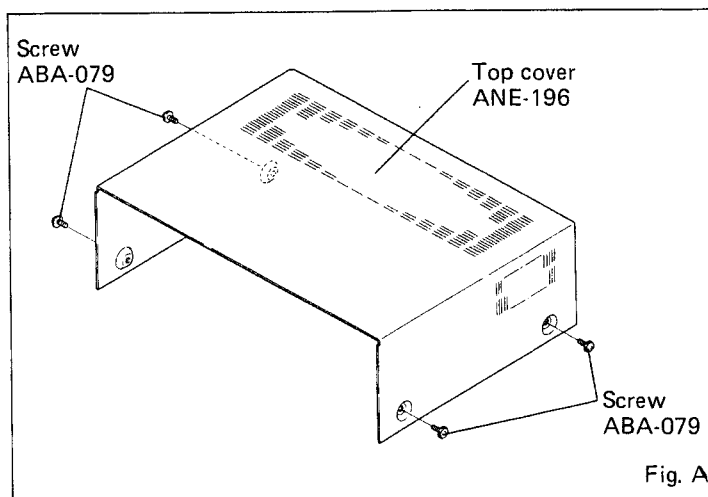

Fig. A

SPECIFICATIONS

The specifications for Model SA-706 is the same as Model SA-7700 except for following sections;

Amplifier Section

TAPE 2 (DIN connector, HG type only)

REC (Level/Impedance) 30mV/80 kilohms

PLAY (Sensitivity/Impedance) 150mV/50 kilohms

Hum and Noise (DIN, continuous power/50mW)

PHONO. 58dB/70dB

AUX. 60dB/85dB

Miscellaneous

Power Requirements

HG type AC 220/240V (switchable), 50/60Hz

S and S/G types AC 110/120/220/240V (switchable),
50/60Hz

Dimensions 420(W)x147(H)x327 (D)mm
16-9/16(W)x5-13/16(H)x12-7/8(D)in

Weight Without Package; 10.5kg (23 lb 2 oz)
With Package; 11.7kg (25 lb 13 oz)

Furnished Parts (S and S/G types)

Fuse 2.5A 1

Fuse 5A 1

CONTRAST OF MISCELLANEOUS PARTS

SWITCHES

Symbol	Description	Part No.			
		SA-7700/KU	S type	S/G type	HG type
S101	Lever switch (POWER)	ASK-066	ASK-097	ASK-097	ASA-505
S103	Plug in selector Plug in selector with fuse holder AKR-031 AKR-031	AKX-037

CAPACITORS

Symbol	Description	Part No.			
		SA-7700/KU	S type	S/G type	HG type
C1	Ceramic 0.01 125V	ACG-003
	Ceramic 0.01 250V	ACG-001	ACG-001	ACG-001
C2	Ceramic 0.01 250V	ACG-001	ACG-001	ACG-001

P.C. BOARD ASSEMBLIES

Symbol	Description	Part No.			
		SA-7700/KU	S type	S/G type	HG type
	AF assembly	GWK-113	GWK-115	GWK-115	GWK-112
	Tone & Indicator assembly	GWX-167	GWX-173	GWX-173	GWX-163
	Terminal assembly	GWX-165	GWX-171	GWX-171	GWX-161
	VR assembly	GWX-164	GWX-170	GWX-170	GWX-160
	RFI switch assembly	GWX-166	GWX-172	GWX-172	GWX-162
	DIN connector assembly	AWX-137

FUSES

Symbol	Description	Part No.			
		SA-7700/KU	S type	S/G type	HG type
FU1	Fuse (500mA)	AEK-107	AEK-107	AEK-107	AEK-401
FU2	Fuse (5A, for 110V/120V) Fuse (2.5A for 220V/240V)	AEK-108	AEK-108	AEK-108
		AEK-102	AEK-102	AEK-403
FU3	Fuse (160mA)	AEK-408

OTHERS

Symbol	Description	Part No.			
		SA-7700/KU	S type	S/G type	HG type
T1	Power transformer	ATT-490	ATT-492	ATT-492	ATT-493
T2	Power transformer	ATT-494	ATT-495	ATT-495	ATT-496
	Fuse holder 1P	AKR-032	K91-008
	AC socket (AC OUTLETS)	AKP-005	AKP-020	AKP-020
	Recessed plug (AC INLET)	AKP-008
	AC power cord	ADG-005	ADG-016	ADG-016
	Top plate assembly	AMS-026
	Side panel L	AMS-027
	Side panel R	AMS-028
	Top cover	ANE-196	ANE-196	ANE-196
	Screw (for Top cover)	ABA-079	ABA-079	ABA-079
	Meter (WATTS/8Ω)	AAW-069	AAW-087	AAW-087	AAW-087
	Front panel assembly	ANB-591	ANB-592	ANB-592	ANB-592
	Capacitor cover (for C1)	AEC-279	AEC-099	AEC-099	AEC-099
	Capacitor cover (for C2)	AEC-294	AEC-099	AEC-099

PACKING AND FURNISHED PARTS

Symbol	Description	Part No.			
		SA-7700/KU	S type	S/G type	HG type
	Packing case	AHD-528	AHD-530	AHD-531	AHD-532
	Flap stopper
	Side pad	AHA-186	AHA-187	AHA-187	AHA-187
	Sheet	AHG-087	AHG-079	AHG-079	AHG-079
	Vinyl pouch (for AC power cord)	AHG-023	AHG-023	AHG-023
	Cardboard spacer	AHB-093
	Fuse (5A)	AEK-108	AEK-108
	Fuse (2.5A)	AEK-102	AEK-102
	Vinyl pouch (for fuse)	E11-033	E11-033
	Operating instructions (English)	ARB-260	ARB-261	ARB-261	ARB-261
	Operating instructions (German/French)	ARD-120

SUPPLEMENTS FOR SA-706/HG

REAR PANEL COMPONENTS

NOTE:

Parts indicated in green type cannot be supplied.

A

A

B

B

C

C

D

D

1

2

3

1

2

3

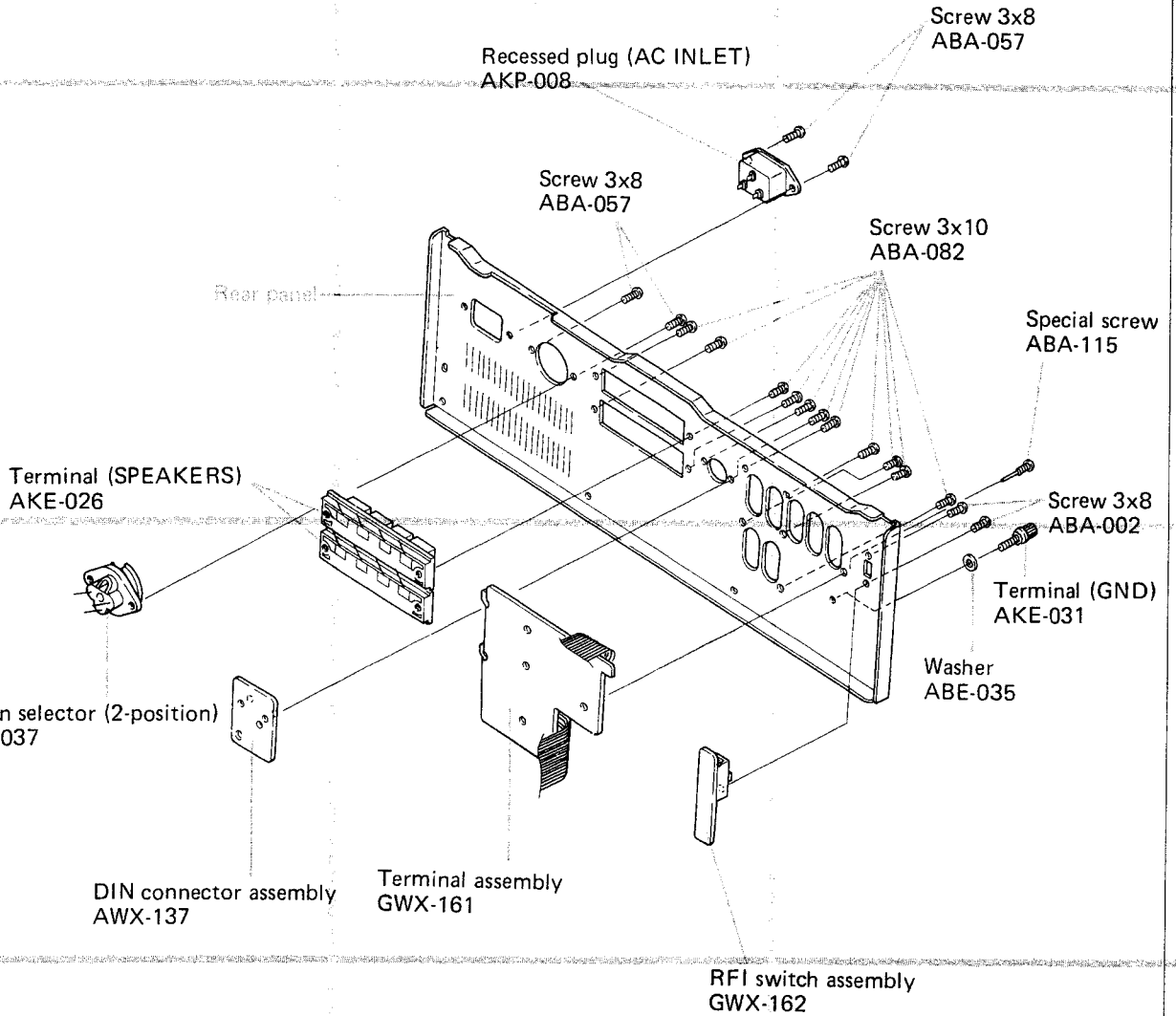

SCHEMATIC DIAGRAM

NOTE:

The indicated semiconductors are representative ones only. Other alternative semiconductors may be used and are listed in the parts list.

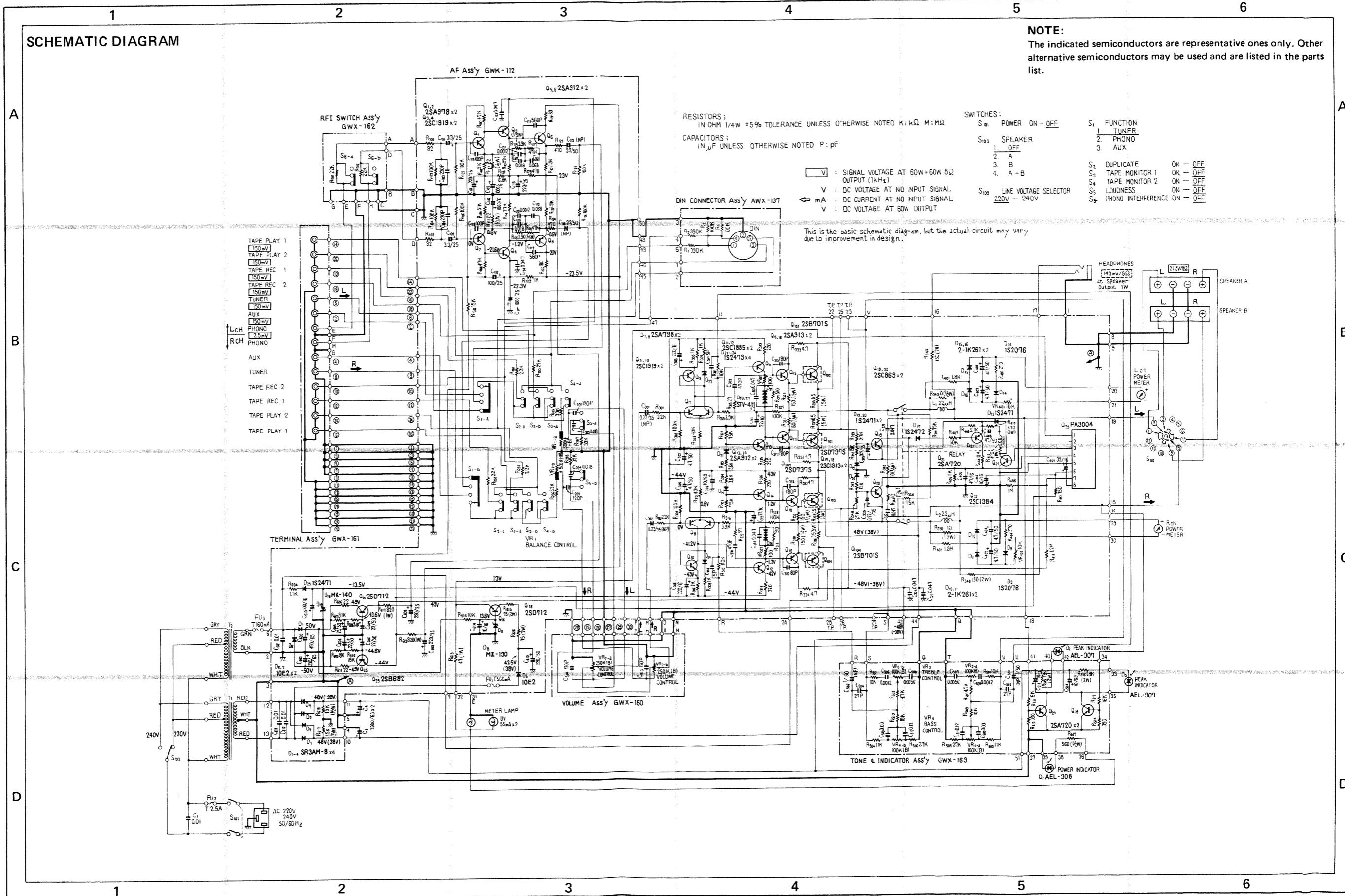

RESISTORS;
IN OHM 1/4W ±5% TOLERANCE UNLESS OTHERWISE NOTED K; kΩ M; MΩ
CAPACITORS;
IN μF UNLESS OTHERWISE NOTED P; pF

SWITCHES:
S₁₀₁ POWER ON - OFF
S₁₀₂ SPEAKER
1 OFF
2 A
3 B
4 A + B
S₁₀₃ LINE VOLTAGE SELECTOR
220V - 240V

S₁ FUNCTION
1 TUNER
2 PHONO
3 AUX
S₂ DUPLICATE ON - OFF
S₃ TAPE MONITOR 1 ON - OFF
S₄ TAPE MONITOR 2 ON - OFF
S₅ LOUDNESS ON - OFF
S₆ PHONO INTERFERENCE ON - OFF

⊖ : SIGNAL VOLTAGE AT 60W+60W Ω
OUTPUT (1KHz)
V : DC VOLTAGE AT NO INPUT SIGNAL
← mA : DC CURRENT AT NO INPUT SIGNAL
V : DC VOLTAGE AT 60W OUTPUT

This is the basic schematic diagram, but the actual circuit may vary due to improvement in design.

- TAPE PLAY 1 150mV
 - TAPE PLAY 2 150mV
 - TAPE REC 1 150mV
 - TAPE REC 2 150mV
 - TUNER 150mV
 - AUX 150mV
 - PHONO 2.5mV
 - PHONO
- LCH
RCH
- AUX
 - TUNER
 - TAPE REC 2
 - TAPE REC 1
 - TAPE PLAY 2
 - TAPE PLAY 1

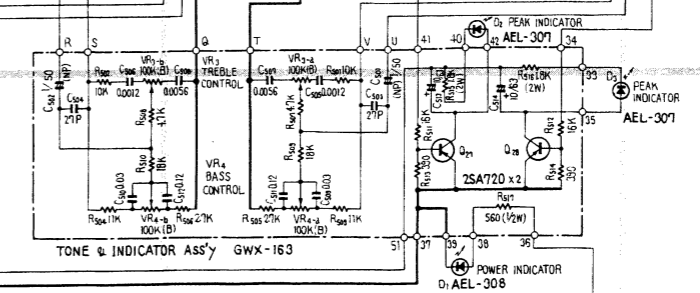
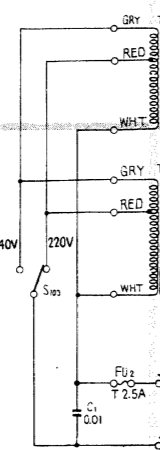
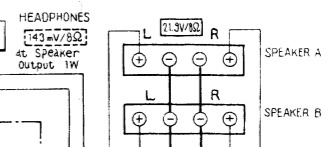

SA-706/HG

AF ASSEMBLY (GWK-112)

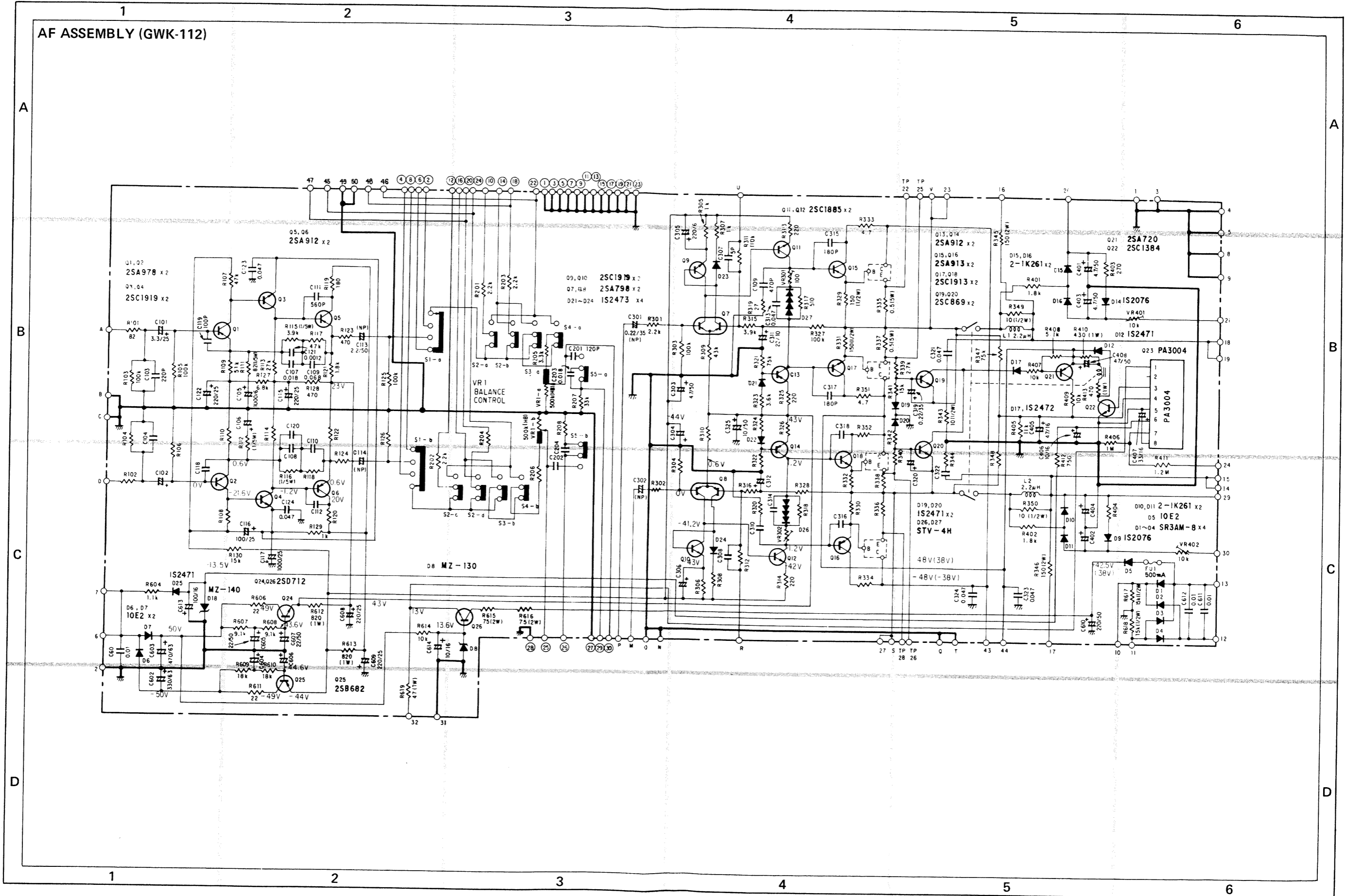

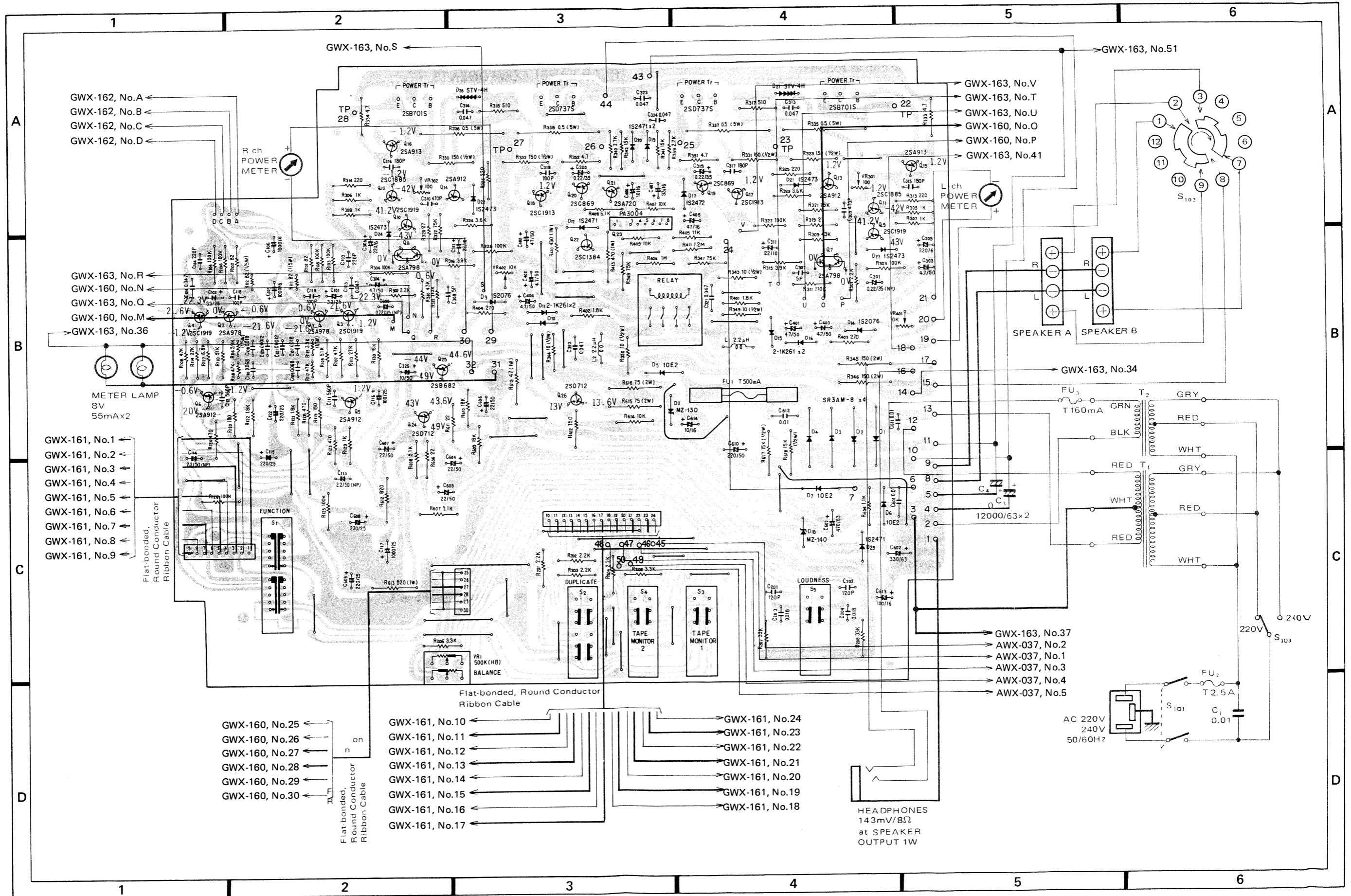

GWX-162, No.A
 GWX-162, No.B
 GWX-162, No.C
 GWX-162, No.D

GWX-163, No.R
 GWX-160, No.N
 GWX-163, No.Q
 GWX-160, No.M
 GWX-163, No.36

GWX-161, No.1
 GWX-161, No.2
 GWX-161, No.3
 GWX-161, No.4
 GWX-161, No.5
 GWX-161, No.6
 GWX-161, No.7
 GWX-161, No.8
 GWX-161, No.9

GWX-160, No.25
 GWX-160, No.26
 GWX-160, No.27
 GWX-160, No.28
 GWX-160, No.29
 GWX-160, No.30

GWX-161, No.10
 GWX-161, No.11
 GWX-161, No.12
 GWX-161, No.13
 GWX-161, No.14
 GWX-161, No.15
 GWX-161, No.16
 GWX-161, No.17

GWX-161, No.24
 GWX-161, No.23
 GWX-161, No.22
 GWX-161, No.21
 GWX-161, No.20
 GWX-161, No.19
 GWX-161, No.18

GWX-163, No.37
 AWX-037, No.2
 AWX-037, No.1
 AWX-037, No.3
 AWX-037, No.4
 AWX-037, No.5

HEADPHONES
 143mV/8Ω
 at SPEAKER
 OUTPUT 1W

AC 220V
 240V
 50/60HZ

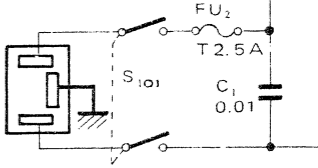
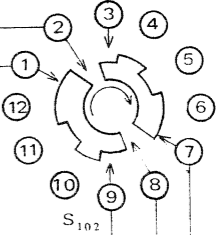

SA-706/HG

AF ASSEMBLY (GWK-112)

The circuitry of the AF assembly GWK-112 is the same as the GWK-113 (for SA-7700/KU), with exception of the p.c. board material, the parts installation method and the size of fuse clip as follows:

Part Name	Part No. (for GWK-112)	Part No. (for GWK-113)
Fuse clip	AKR-010	AKR-013

TONE & INDICATOR ASSEMBLY (GWX-163)

The circuitry of the tone & indicator assembly GWX-163 is the same as the GWX-167 (for SA-7700/KU), with exception of the p.c. board material.

TERMINAL ASSEMBLY (GWX-161)

The circuitry of the terminal assembly GWX-161 is the same as the GWX-165 (for SA-7700/KU), with exception of the p.c. board material.

VR ASSEMBLY (GWX-160)

The circuitry of the VR assembly GWX-160 is the same as the GWX-164 (for SA-7700/KU), with exception of the p.c. board material.

RFI SWITCH ASSEMBLY (GWX-162)

The circuitry of the RFI switch assembly GWX-162 is the same as the GWX-166 (for SA-7700/KU), with exception of the p.c. board material.

DIN CONNECTOR ASSEMBLY (AWX-137)

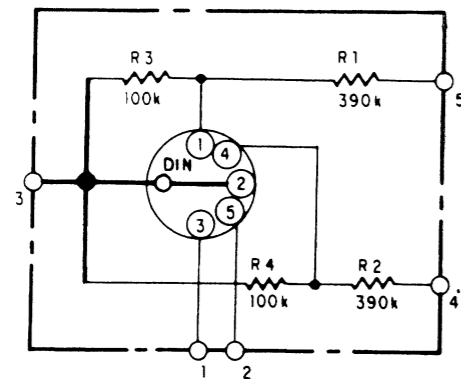

Parts List

Symbol	Part No.	Description
R1	RD¼PS 394J	Carbon film 390k
R2	RD¼PS 394J	Carbon film 390k
R3	RD¼PS 104J	Carbon film 100k
R4	RD¼PS 104J	Carbon film 100k
	AKP-011	5P connector socket (REC/PLAY)

Foil side

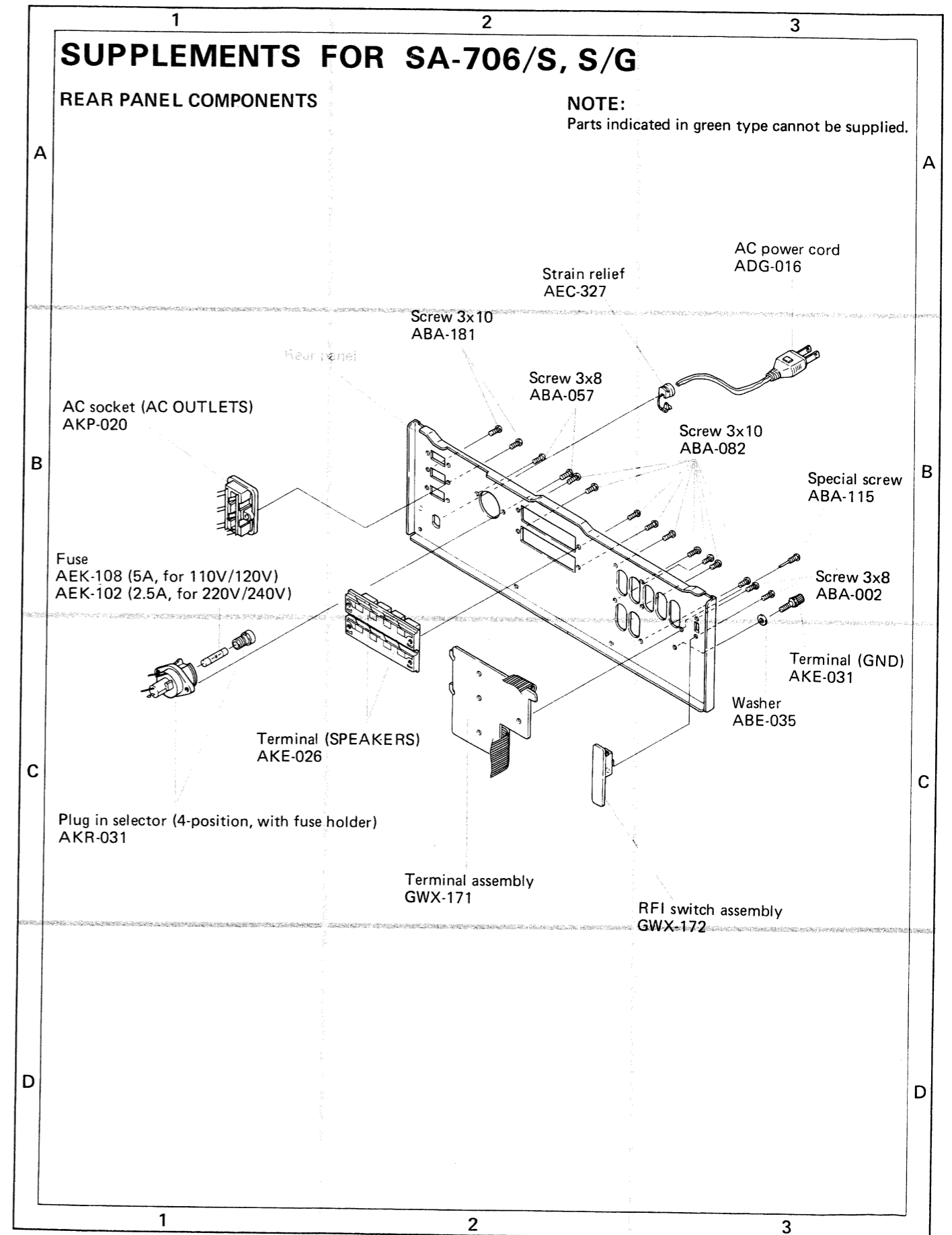
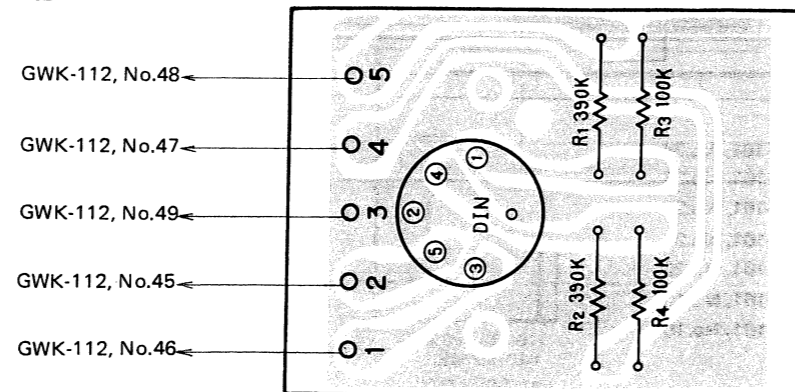

SCHEMATIC DIAGRAM

NOTE:

The indicated semiconductors are representative ones only. Other alternative semiconductors may be used and are listed in the parts list.

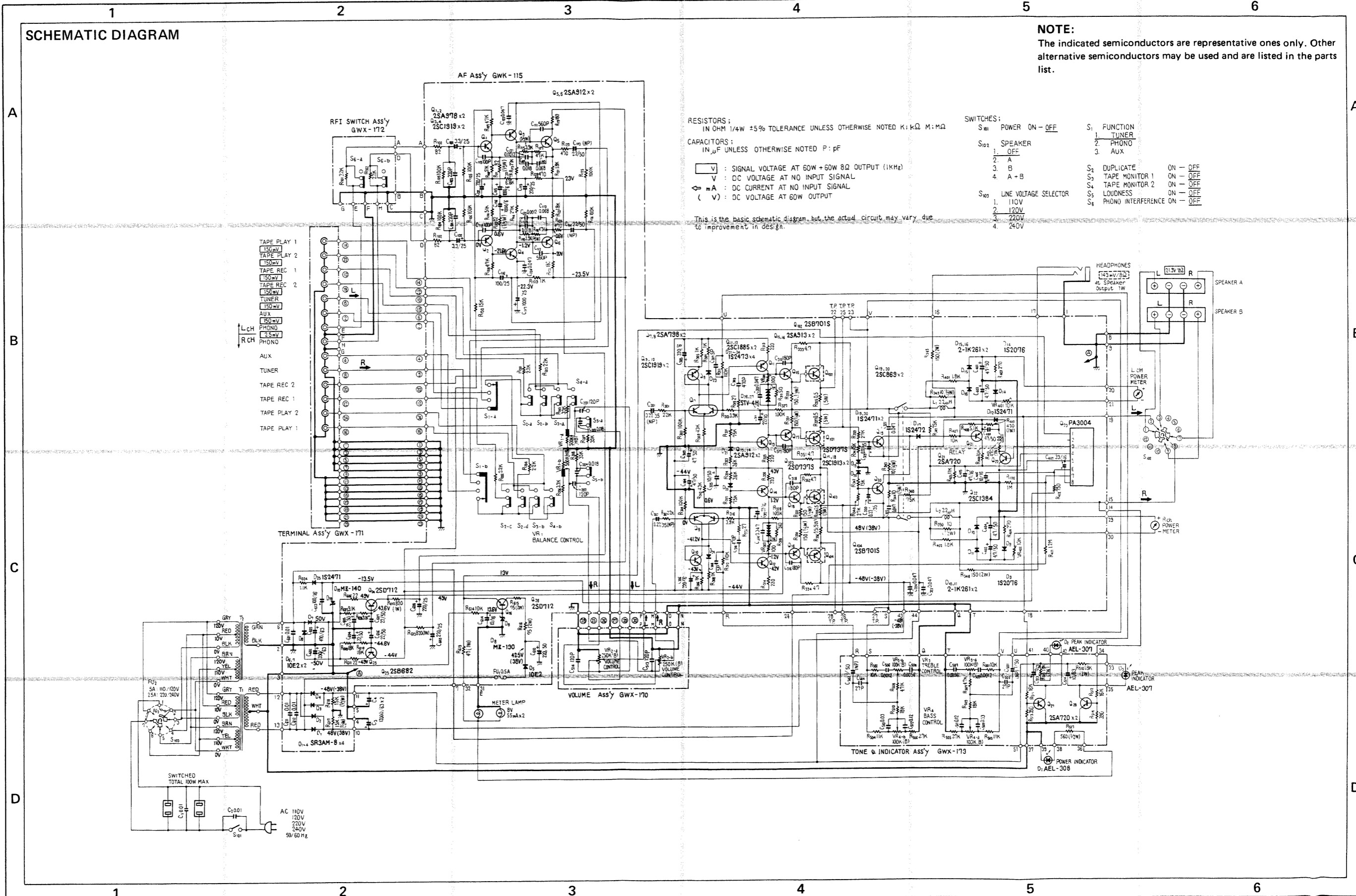

RESISTORS:
IN OHM 1/4W ±5% TOLERANCE UNLESS OTHERWISE NOTED K: KΩ M: MΩ

CAPACITORS:
IN μF UNLESS OTHERWISE NOTED P: pF

⊖ : SIGNAL VOLTAGE AT 60W +60W 8Ω OUTPUT (1KHz)
V : DC VOLTAGE AT NO INPUT SIGNAL
⊖ mA : DC CURRENT AT NO INPUT SIGNAL
(V) : DC VOLTAGE AT 60W OUTPUT

SWITCHES:
S101 POWER ON-OFF
S102 SPEAKER
S103 LINE VOLTAGE SELECTOR

S1 FUNCTION
1. TUNER
2. PHONO
3. AUX
S2 DUPLICATE ON-OFF
S3 TAPE MONITOR 1 ON-OFF
S4 TAPE MONITOR 2 ON-OFF
S5 LOUDNESS ON-OFF
S6 PHONO INTERFERENCE ON-OFF

1. 110V
2. 120V
3. 220V
4. 240V

This is the basic schematic diagram, but the actual circuit may vary due to improvement in design.

- TAPE PLAY 1 150mV
- TAPE PLAY 2 150mV
- TAPE REC 1 150mV
- TAPE REC 2 150mV
- TUNER 150mV
- AUX 150mV
- PHONO 3.5mV
- RCH
- LCH
- AUX
- TUNER
- TAPE REC 2
- TAPE REC 1
- TAPE PLAY 2
- TAPE PLAY 1

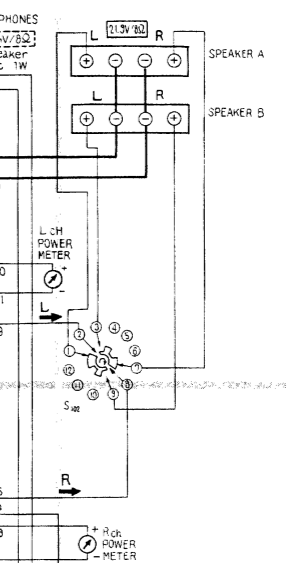
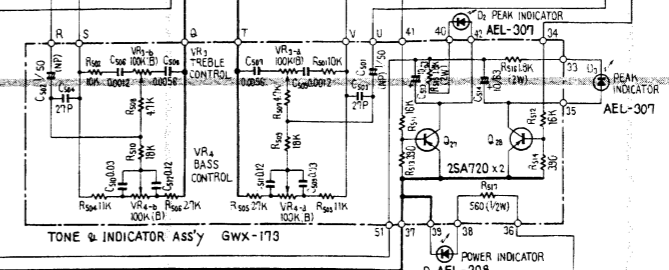
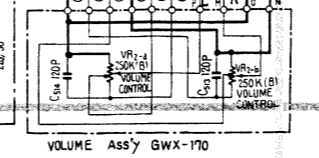
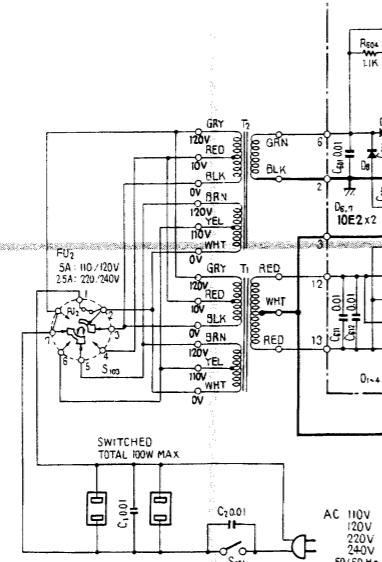

SA-706/S, S/G

AF ASSEMBLY (GWK-115)

The circuitry of the AF assembly GWK-115 is the same as the GWK-113 (for SA-7700/KU), with exception of the p.c. board material and the parts installation method.

TONE & INDICATOR ASSEMBLY (GWX-173)

The circuitry of the tone & indicator assembly GWX-173 is the same as the GWX-167 (for SA-7700/KU), with exception of the p.c. board material.

TERMINAL ASSEMBLY (GWX-171)

The circuitry of the terminal assembly GWX-171 is the same as the GWX-165 (for SA-7700/KU), with exception of the p.c. board material.

VR ASSEMBLY (GWX-170)

The circuitry of the VR assembly GWX-170 is the same as the GWX-164 (for SA-7700/KU), with exception of the p.c. board material.

RFI SWITCH ASSEMBLY (GWX-172)

The circuitry of the RFI switch assembly GWX-172 is the same as the GWX-166 (for SA-7700/KU), with exception of the p.c. board material.

STEREO AMPLIFIER

SA-706 HG

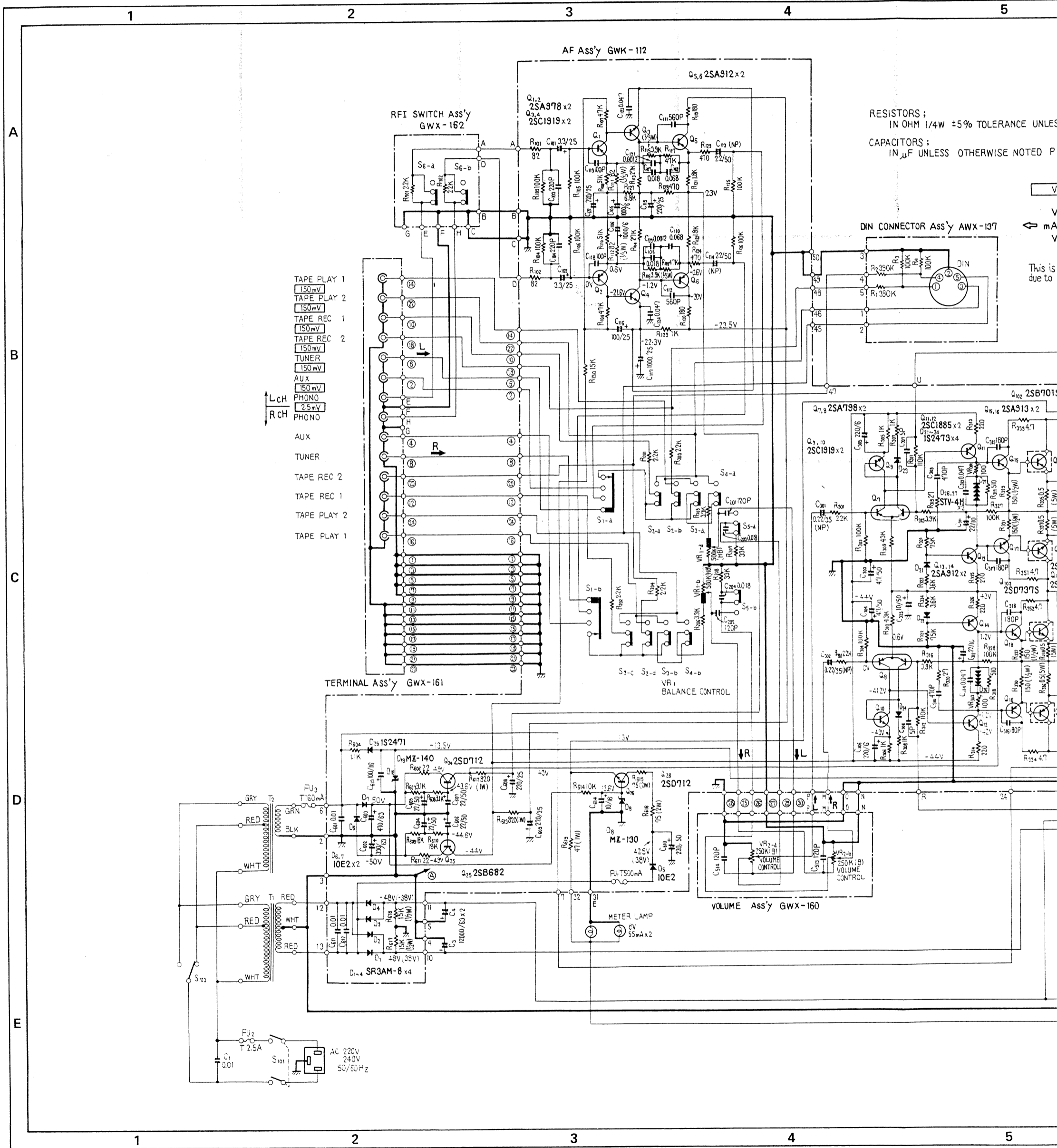

5 6 7 8

RES: 1/4W ±5% TOLERANCE UNLESS OTHERWISE NOTED K: kΩ M: MΩ

RES: UNLESS OTHERWISE NOTED P: pF

SWITCHES:

S₁₀₁ POWER ON - OFF

S₁₀₂ SPEAKER

- 1. OFF
- 2. A
- 3. B
- 4. A + B

S₁₀₃ LINE VOLTAGE SELECTOR
220V - 240V

S₁ FUNCTION

- 1. TUNER
- 2. PHONO
- 3. AUX

S₂ DUPLICATE ON - OFF

S₃ TAPE MONITOR 1 ON - OFF

S₄ TAPE MONITOR 2 ON - OFF

S₅ LOUDNESS ON - OFF

S₆ PHONO INTERFERENCE ON - OFF

V : SIGNAL VOLTAGE AT 60W+60W 8Ω
OUTPUT (1kHz)

V : DC VOLTAGE AT NO INPUT SIGNAL

mA : DC CURRENT AT NO INPUT SIGNAL

V : DC VOLTAGE AT 60W OUTPUT

TOR Ass'y AWX-137

This is the basic schematic diagram, but the actual circuit may vary due to improvement in design.

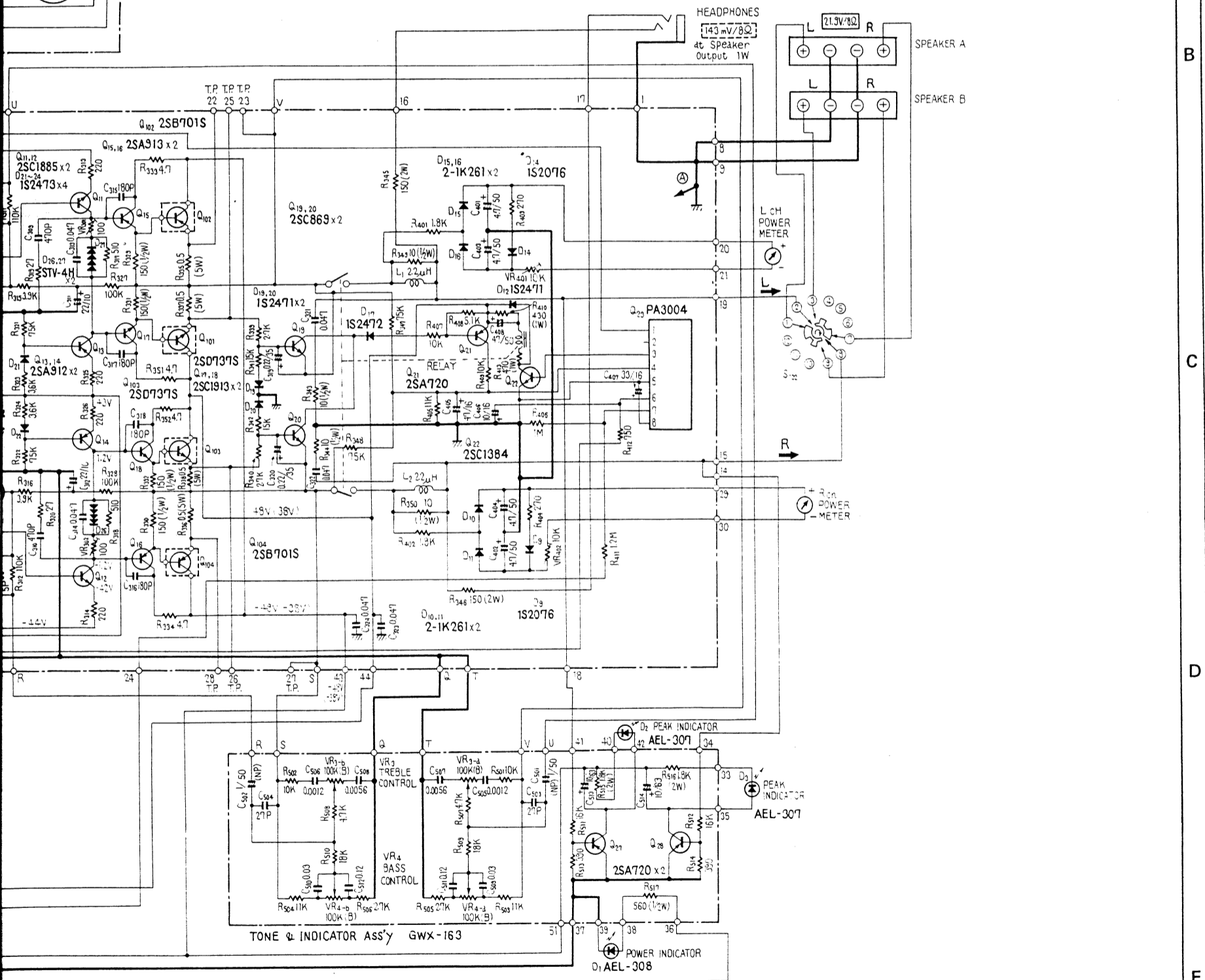
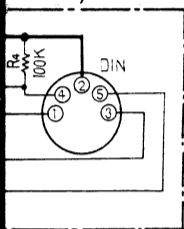

A
B
C
D
E

5 6 7 8

STEREO AMPLIFIER

SA-706 ^S_{S/G}

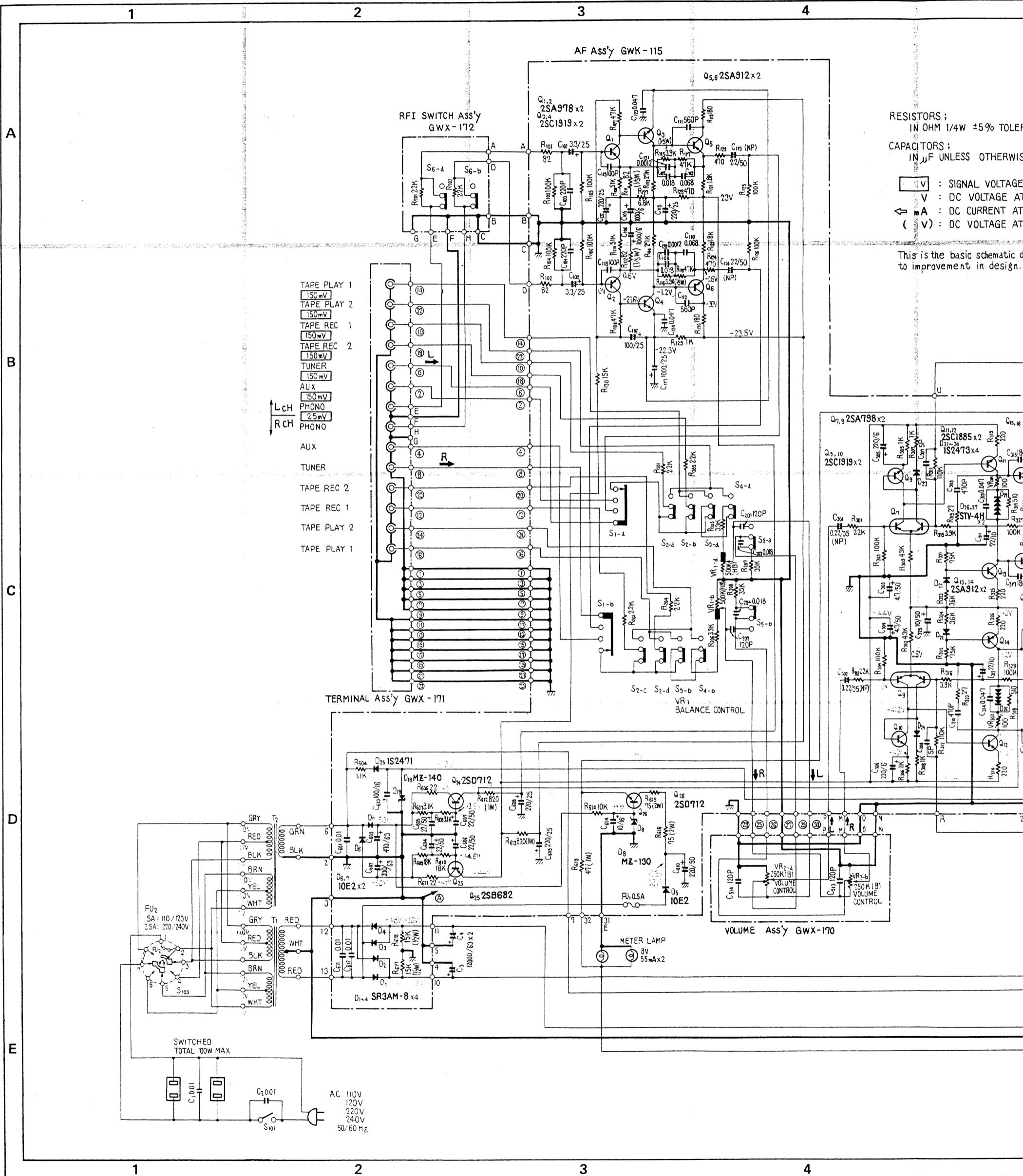

RES: 1/4W ±5% TOLERANCE UNLESS OTHERWISE NOTED K; kΩ M; MΩ
 CAPS: UNLESS OTHERWISE NOTED P: pF
 V: SIGNAL VOLTAGE AT 60W +60W 8Ω OUTPUT (1KHz)
 DC: DC VOLTAGE AT NO INPUT SIGNAL
 I: DC CURRENT AT NO INPUT SIGNAL
 V: DC VOLTAGE AT 60W OUTPUT

- SWITCHES:
- | | |
|--|--|
| S ₁₀₁ POWER ON-OFF | S ₁ FUNCTION |
| S ₁₀₂ SPEAKER | 1. TUNER |
| 1. OFF | 2. PHONO |
| 2. A | 3. AUX |
| 3. B | S ₂ DUPLICATE ON-OFF |
| 4. A+B | S ₃ TAPE MONITOR 1 ON-OFF |
| S ₁₀₃ LINE VOLTAGE SELECTOR | S ₄ TAPE MONITOR 2 ON-OFF |
| 1. 110V | S ₅ LOUDNESS ON-OFF |
| 2. 120V | S ₆ PHONO INTERFERENCE ON-OFF |
| 3. 220V | |
| 4. 240V | |

the basic schematic diagram, but the actual circuit may vary due to component movement in design.

