

STEREO AMPLIFIER

# SA-8500II

## SERVICE MANUAL



 PIONEER

MODEL SA-8500II COMES IN FOUR VERSIONS DISTINGUISHED AS FOLLOWS:

Type	Voltage	Remarks
KU	120V only	UL (U.S.A.) approved
KC	120V only	CSA (Canada) approved
HG	220V and 240V (Switchable)	SEMKO (Sweden), NEMKO (Norway), DEMKO (Denmark) and EI (Finland) approved
S	110V, 120V, 220V and 240V (Switchable)	General export model

This service manual is applicable to the KU-type. When repairing the KC-type, HG-type or S-type, please see the additional service manual.

## CONTENTS

1.	SPECIFICATIONS .....	5
2.	CONNECTION DIAGRAM .....	6
3.	FRONT PANEL FACILITIES .....	7
4.	BLOCK DIAGRAM .....	9
5.	CIRCUIT DESCRIPTIONS	
5.1	Equalizer Amplifier .....	11
5.2	Tone Controls .....	11
5.3	Power Amplifier .....	12
5.4	Protection Circuit .....	13
5.5	Power Supply Circuit .....	14
6.	LEVEL DIAGRAM .....	15
7.	DISASSEMBLY .....	16
8.	PARTS LOCATION	
8.1	Front Panel View .....	18
8.2	Front View with Panel Removed .....	19
8.3	Top View .....	20
8.4	Bottom View .....	21
8.5	Rear View .....	22
9.	ADJUSTMENT .....	23
10.	EXPLODED VIEWS .....	24

<b>11.</b>	<b>SCHEMATIC DIAGRAMS, P.C. BOARD PATTERNS AND PARTS LIST</b>	
11.1	Miscellanea .....	32
11.2	Schematic Diagram .....	33
11.3	Switch Assembly (AWS-108) .....	35
11.4	Phono Jack Assembly (AWX-107) .....	41
11.5	Equalizer Amplifier Assembly (AWF-023) .....	42
11.6	Control Amplifier Assembly (AWG-044) .....	46
11.7	Power Amplifier Assembly (AWH-051) .....	50
<b>12.</b>	<b>PACKING .....</b>	<b>53</b>

# 1. SPECIFICATIONS

## Semiconductor

Transistors . . . . .	47
Diodes . . . . .	29

## Power Amplifier Section

Circuitry . . . . . 2-stage differential amplifier Parallel  
PP direct-coupled OCL.

Continuous Power Output form 20 Hertz to 20,000 Hertz  
(Both channels driven) . . 60 watts per channel (8 ohms)  
75 watts per channel (4 ohms)

Total Harmonic Distortion at 20Hertz to 20,000Hertz  
Continuous rated power output . . . . . 0.05%  
30watts per channel power output, 8ohms . . . . 0.01%  
1 watt per channel power output, 8ohms . . . . . 0.01%

Intermodulation Distortion  
Continuous rated power output . . . . . 0.05%  
30watts per channel power output, 8ohms . . . . 0.01%  
1 watt per channel power output, 8ohms . . . . . 0.01%

Frequency Response . . . . . 5Hertz to 100,000Hertz  $\pm 0$  dB

Input (Sensitivity/Impedance)  
POWER AMP IN . . . . . 1V/50kohms  
Output . . . . . Speaker: A, B, A + B  
Headphone: Low impedance

Damping Factor (20Hertz to 20,000Hertz, 8ohms) . . . 30  
Hum and Noise (IHF, short-circuited, A network) . . 110dB

## Preamplifier Section

Circuitry  
Equalizer amplifier: 1st stage differential amplifier 3-  
stage direct-coupled A class SEPP.  
Control amplifier: 1st stage differential amplifier 2-  
stage direct-coupled, NFB type.

Input (Sensitivity/Impedance)  
PHONO 1 . . . . . 2.5mV/50kohms  
PHONO 2 . . . . . 2.5mV/50kohms  
CARTRIDGE LOAD . . . . . Both PHONO 1 and 2, 100,  
200, 300, 400pF  
TUNER . . . . . 150mV/50kohms  
AUX . . . . . 150mV/50kohms  
TAPE PLAY 1 . . . . . 150mV/50kohms  
TAPE PLAY 2 . . . . . 150mV/50kohms

PHONO Overload Level (T.H.D. : 0.05%)  
PHONO 1 . . . . . 250mV (1kHz)  
PHONO 2 . . . . . 250mV (1kHz)

Output (Level/Impedance)  
TAPE REC 1 . . . . . 150mV  
TAPE REC 2 . . . . . 150mV  
PRE OUT . . . . . 1V/2kohms, 6V/2kohms (Max.)

Total Harmonic Distortion  
(20Hz to 20,000Hz) . . . . . 0.02%

Frequency Response  
PHONO (RIAA Equalization) . . . . . 20Hz to 20,000Hz  
 $\pm 0.2$ dB  
TUNER, AUX, TAPE PLAY . . . . . 5Hz to 50,000Hz  
 $\pm 1$  dB

Tone Control  
BASS . . . . .  $\pm 10$ dB (25Hz/50Hz/100Hz)  
TURN OVER frequency 100Hz/200Hz/400Hz  
TREBLE . . . . .  $\pm 10$ dB (8kHz/16kHz/32kHz)  
TURN OVER frequency 2kHz/4kHz/8kHz

Filter  
LOW . . . . . 15Hz (6dB/oct.)  
HIGH . . . . . 8kHz (6dB/oct.)

Loudness Contour  
(Volume control set at -40dB position) : +6dB (100Hz)  
+3dB (10kHz)

Hum and Noise  
(IHF, short-circuited, A network)  
PHONO . . . . . 75dB  
TUNER, AUX, TAPE PLAY . . . . . 95dB  
Muting . . . . . 0, -20dB

## Miscellaneous

Power Requirements . . . . . 120V 60Hz only.  
Power Consumption . . . . . 180watts (UL)  
390VA (CSA), 490watts (Max.)  
Dimensions . . . . . 420(W) x 150 (H) x 376 (D) mm  
16-9/16 x 5-7/8 x 14-13/16 in  
Weight . . . . . Without Package: 13.9kg (30lb 10oz)  
With Package: 15.8kg (34lb 13oz)

## Furnished Parts

Operating Instructions . . . . . 1  
Connection Cord with Pin Plugs . . . . . 1  
Hex. Wrench (Used for fastening Volume Knob) . . . . . 1

*NOTE:*  
Specifications and the design subject to possible modifica-  
tion without notice due to improvements.

## 2. CONNECTION DIAGRAM

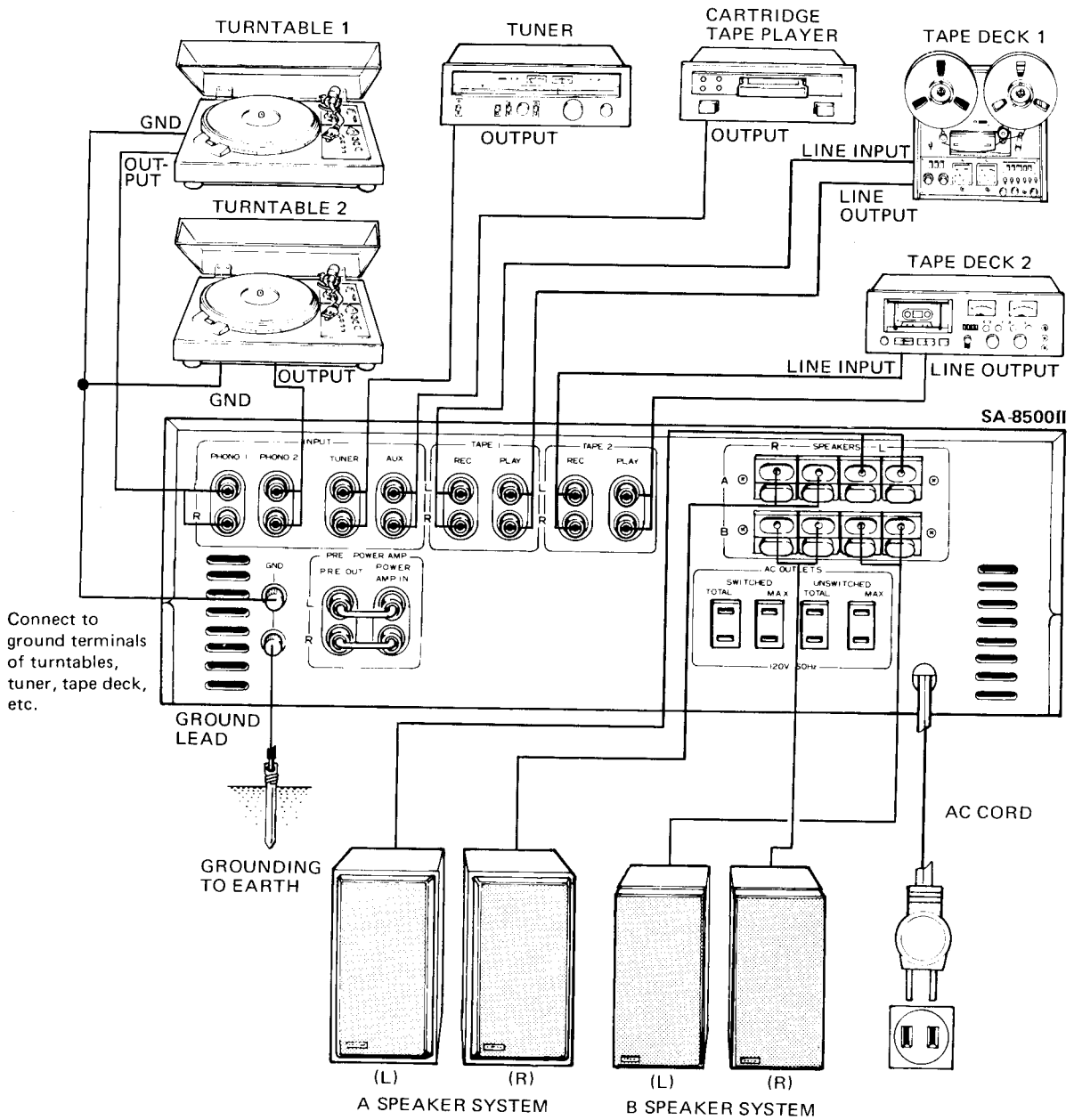

### 3. FRONT PANEL FACILITIES

#### BASS TURN OVER SWITCH

Selects the frequency below which the BASS control tone adjustments apply. Set switch to 100Hz, 200Hz or 400Hz according to listening room and speaker system characteristics or personal preference.

#### TONE SWITCH

In the ON position, tone adjustments can be performed with the BASS and TREBLE controls. When set to the upper (OFF) position, the tone control circuits are disengaged and frequency response is flat. This function is convenient for checking phono cartridge and speaker tone quality and listening room acoustics.

#### POWER SWITCH

Set to ON position to energize SA-8500II. After setting to ON, there is a brief delay before sound is obtained. This is due to the operation of the muting circuit which prevents noise when the POWER is switched. This function does not indicate difficulty and normal operating condition is attained in a few seconds. The POWER switch also controls the rear panel SWITCHED convenience outlets.

#### PHONES JACK

When listening with stereo headphones, connect them to this jack.

**NOTE:**

Set **SPEAKERS** switch to OFF when listening only with headphones.

#### SPEAKERS SWITCH

Selects speaker system operation.

- OFF: Sound not obtained from speakers (when using headphones).
- A: Sound obtained from speakers connected to A speaker terminals.
- B: Sound obtained from speakers connected to B speakers terminals.
- A + B: Sound obtained from speakers connected to both A and B speaker terminals.

**NOTE:**

When listening with headphones or to temporarily interrupt the speaker sound, set switch to OFF or to an unused speaker position.

#### BASS AND TREBLE CONTROLS

Controls for adjusting low and high frequency tones. With the TONE switch set to ON, turning the BASS control clockwise from center enhances the frequency band below the point selected by the BASS TURN OVER switch, while counter-clockwise rotation attenuates this band. In a similar manner, the TREBLE control adjusts the frequency range above the point selected by the TREBLE TURN OVER switch.

#### TREBLE TURN OVER SWITCH

Selects the frequency above which the TREBLE control tone adjustments apply. Set to 2kHz, 4kHz or 8kHz according to listening room and speaker system characteristics or personal preference.

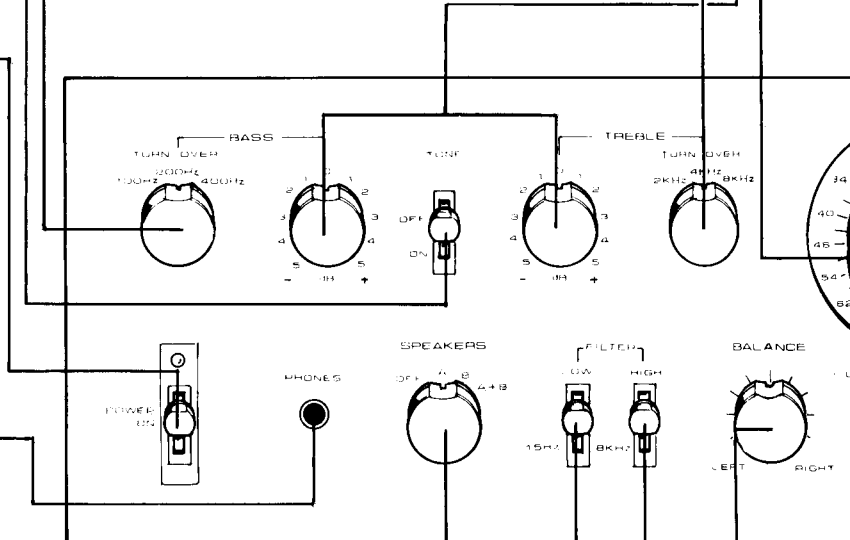

#### LOW FILTER SWITCH

Set to 15Hz position in the event that turntable rumble, recording cutting noise or other low frequency noise becomes objectionable. Attenuation in the frequency band below 15Hz is 6dB/octave.

#### HIGH FILTER SWITCH

Set to 8kHz position if record scratch noise or other high frequency noise becomes objectionable. Attenuation in the frequency band above 8kHz is 6dB/octave.

#### BALANCE CONTROL

Control for adjusting stereo balance between left and right speaker systems or headphones. Turn clockwise from center to increase right (R) channel volume and counter-clockwise from center to increase left (L) channel volume in order to obtain a balance.

#### VOLUME

Adjusts volume level. Turn clockwise to increase volume and counter-clockwise to decrease volume.

#### CART

Switches between different cartridge settings.

#### MUTE

Switches the audio signal on and off. Turn clockwise to unmute and counter-clockwise to mute.

#### LOW

When listening with headphones, turn clockwise to increase volume and counter-clockwise to decrease volume.

...y tones. With  
...BASS control  
...y band below  
...OVER switch,  
...es this band.  
...ol adjusts the  
...the TREBLE

...BLE control  
...kHz or 8kHz  
...tem character-

...TREBLE  
...TURN OVER  
...2KHZ 4KHZ 8KHZ  
...LOW HIGH  
...8KHZ  
...LEFT RIGHT  
...LEFT RIGHT

...turntable rumble,  
...frequency noise  
...the frequency

...se or other high  
...Attenuation in  
...ave.

...en left and right  
...clockwise from  
...ne and counter-  
...channel volume

**VOLUME CONTROL**

Adjusts speaker and headphone volume. Scale indicates attenuation in dB with maximum volume assigned an arbitrary value of 0dB. Control can also be used in combination with the MUTING switch to provide a finer and wider range of adjustment.

**CARTRIDGE LOAD SWITCH**

Switch for selecting phono circuit input capacitance to match the load capacitance of the employed cartridge.

**MUTING SWITCH**

Switch for reducing volume by 20dB from the VOLUME control setting. Convenient for temporarily reducing the volume when changing records of tapes, since it eliminates the need for continually readjusting the VOLUME control.

**LOUDNESS SWITCH**

When listening at low volume settings, set switch to ON to enhance low and high frequencies. The response of the human ear to sound differs according to loudness. This switch compensates for this effect at low volumes.

**FUNCTION SWITCH**

Selects desired playback program source.

PHONO 2: To play records on a turntable connected to the PHONO 2 jacks.

PHONO 1: To play records on a turntable connected to the PHONO 1 jacks.

TUNER: To listen to broadcasts with a tuner connected to the TUNER jacks.

AUX: To play a component connected to the AUX jacks.

**TAPE MONITOR SWITCH**

Employ for tape playback or to monitor a recording in progress.

1: Playback or monitoring of a tape deck connected to the TAPE 1 jacks.

SOURCE: Be sure to set to this position when not using the tape deck for playback.

2: Playback or monitoring of a tape deck connected to the TAPE 2 jacks.

**NOTE:**

When listening to records or broadcasts, be sure to set this switch to SOURCE. Sound will not be obtained from speakers if set to 1 or 2.

**TAPE DUPLICATE SWITCH**

Employ when using two tape decks for duplication or editing. Be sure to set to the OFF position at other times.

1 → 2: Duplication of tape from TAPE 1 (playback mode) to TAPE 2 (recording mode).

OFF: Set to this position when not using the duplication feature (this includes simultaneous recording with two tape decks and tape playback).

2 → 1: Duplication of tape from TAPE 2 (playback mode) to TAPE 1 (recording mode).

**MODE SWITCH**

REV: Reverses left and right channel stereo signals and reproduces them stereophonically.

STEREO: Set to this position for normal stereo reproduction.

L + R: Mixes left and right channel signals and reproduces them monophonically.

L: Left channel signal is reproduced monophonically from both speakers.

R: Right channel signal is reproduced monophonically from both speakers.

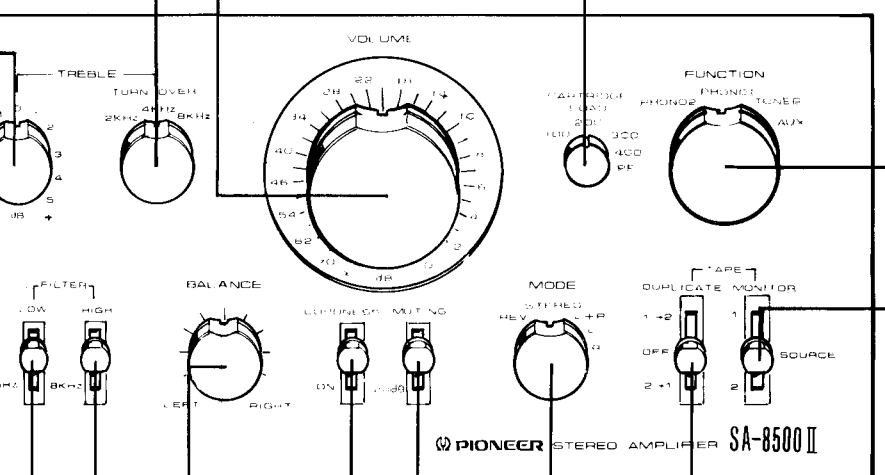

# 4. BLOCK DIAGRAM

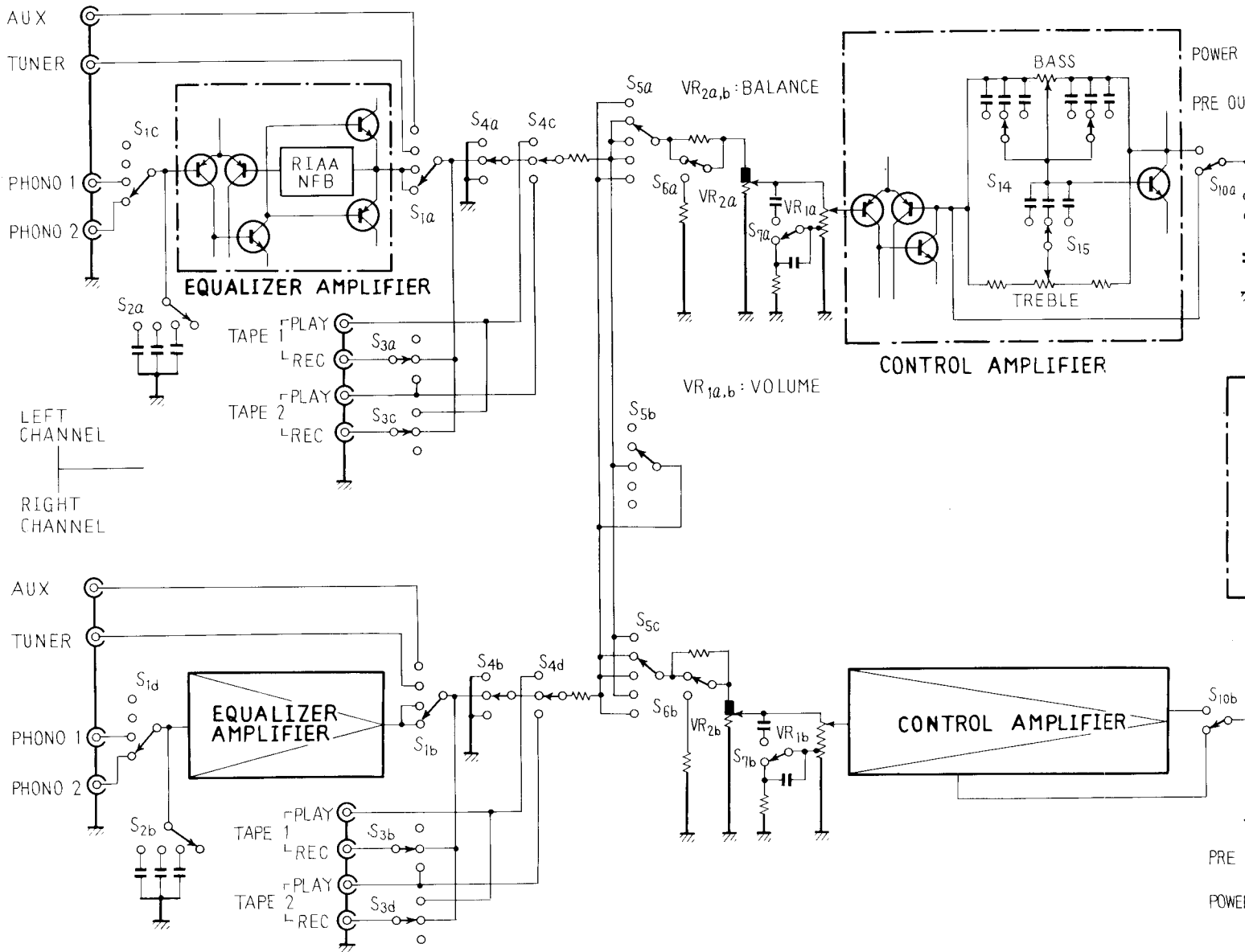

**SWITCHES:**

- S<sub>1a~d</sub> : FUNCTION**  
 1. PHONO 2    2. PHONO 1  
 3. TUNER      4. AUX
- S<sub>2a,b</sub> : C SELECTOR**  
 1. 100 pF    2. 200 pF  
 3. 300 pF    4. 400 pF
- S<sub>3a~d</sub> : DUPLICATE**  
 1. 1 → 2      2. OFF  
 3. 2 → 1

- S<sub>4a~d</sub> : TAPE MONITOR**  
 1. TAPE 1    2. OFF  
 3. TAPE 2
- S<sub>5a~c</sub> : MODE**  
 1. REV.      2. STEREO  
 3. L+R      4. L  
 5. R

- S<sub>6a,b</sub> : MUTING**      OFF - -20dB
- S<sub>7a,b</sub> : LOUDNESS**    OFF - ON
- S<sub>8a,b</sub> : HIGH FILTER** OFF - 8kHz
- S<sub>9a,b</sub> : LOW FILTER**  OFF - 15Hz
- S<sub>10a,b</sub> : TONE**        OFF - ON
- S<sub>11a~d</sub> : SPEAKER**  
 1. OFF      2. A  
 3. B        4. A+B

- S<sub>12</sub> : RELAY**
- S<sub>13</sub> : POWER**      OFF
- S<sub>14</sub> : BASS TURNOV**  
 1. 100Hz    2.  
 3. 400Hz
- S<sub>15</sub> : TREBLE TURN**  
 1. 2kHz     2.  
 3. 8kHz



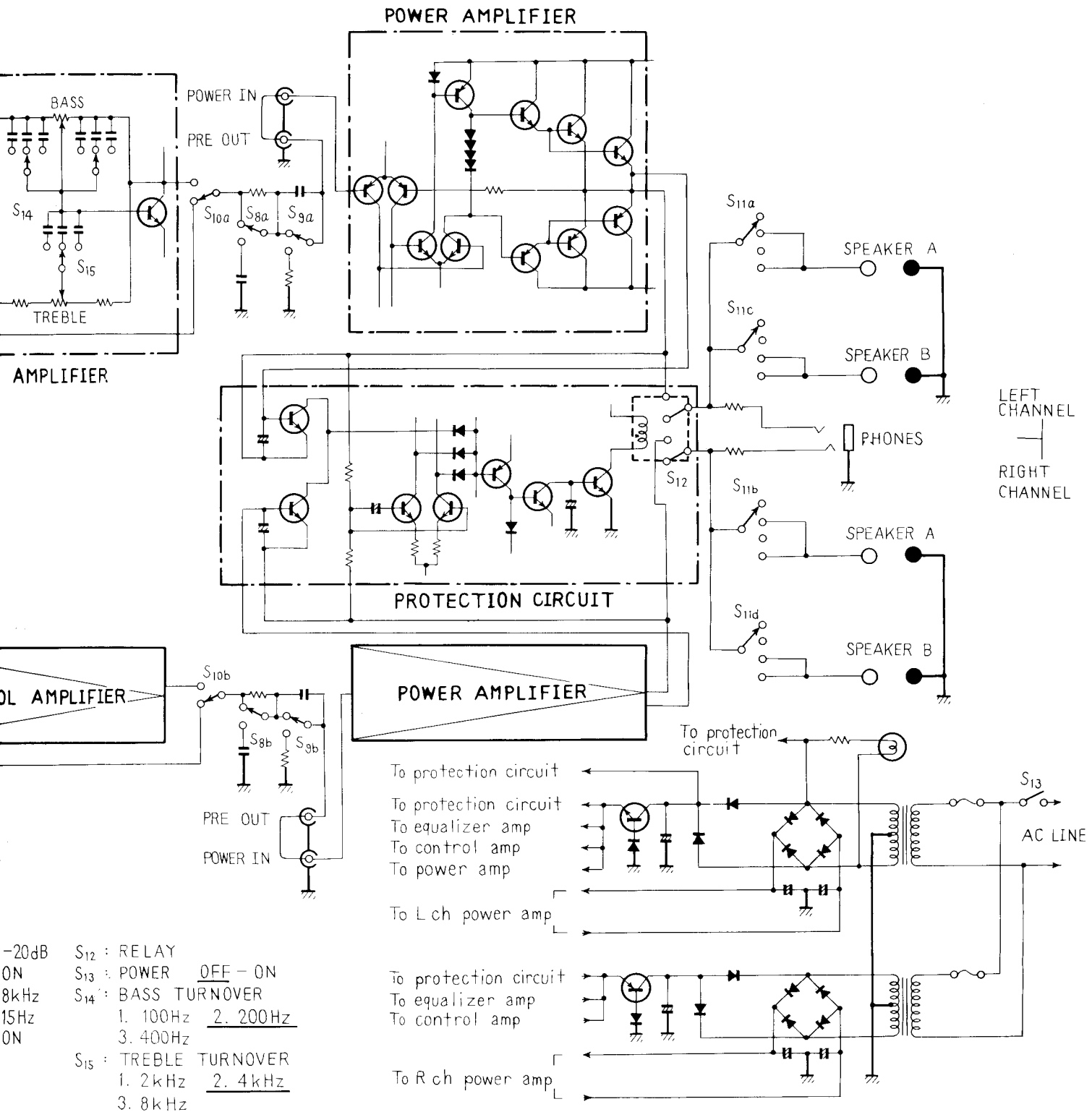

- 20dB
- ON
- 8kHz
- 15Hz
- ON
- S<sub>12</sub> : RELAY
- S<sub>13</sub> : POWER OFF - ON
- S<sub>14</sub> : BASS TURNOVER
  - 1. 100Hz
  - 2. 200Hz
  - 3. 400Hz
- S<sub>15</sub> : TREBLE TURNOVER
  - 1. 2kHz
  - 2. 4kHz
  - 3. 8kHz

## 5. CIRCUIT DESCRIPTIONS

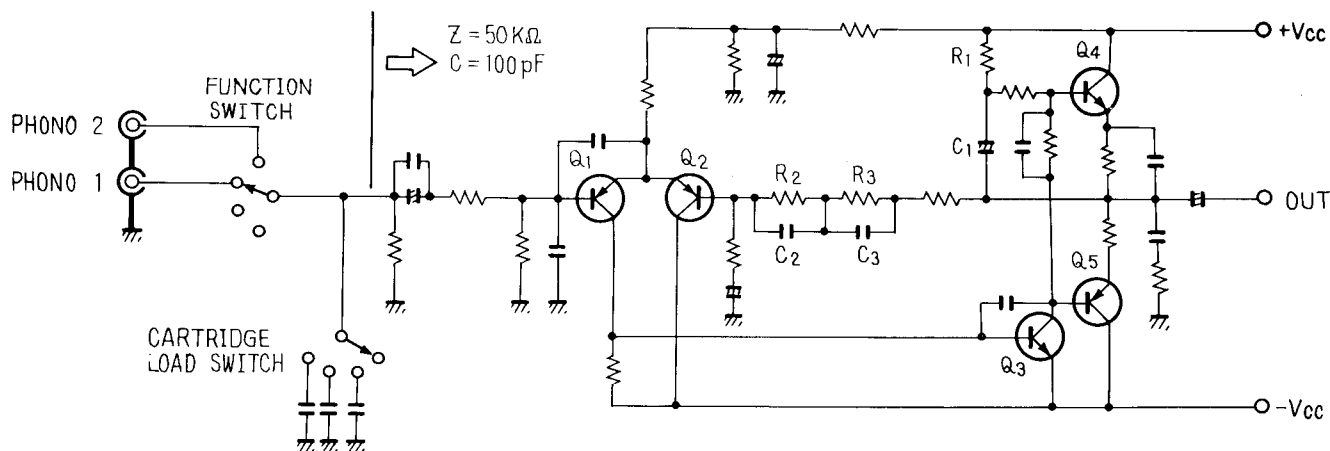

Fig. 1. Schematic diagram of equalizer amplifier

### 5.1 EQUALIZER AMPLIFIER

The circuit diagram for the equalizer amplifier is shown in Fig. 1. The two separate phono inputs are selected by the FUNCTION selector on the front panel. The input capacitance on the PHONO terminals can be adjusted to 4 different levels (100pF, 200pF, 300pF, and 400pF) by means of the CARTRIDGE LOAD control knob which switches in, or out, additional capacitors in parallel with the input terminal. Hence, the load capacitance of the phono cartridges can be changed, greatly effecting the cartridge's frequency response in the high frequency range, and thus providing considerable variation in its characteristics.

The first stage of the equalizer amplifier ( $Q_1$  &  $Q_2$ ) is a differential amplifier using PNP transistors. The next stage ( $Q_3$ ) is a bootstrap circuit employing  $C_1$ ,  $R_1$  to provide high voltage gain. The output stage ( $Q_4$  &  $Q_5$ ) is a complementary-symmetrical SEPP circuit, whose high voltage utility factor results in a high output voltage. This gives the equalizer amplifier a very wide dynamic range, and an overload input level of 250mV (RMS at 1kHz) with no more than 0.05% distortion.

The equalizer elements ( $C_2$ ,  $C_3$ ,  $R_2$  and  $R_3$ ) consist of polypropylene film capacitors (tolerance  $\pm 2\%$ ), and metal film resistors (tolerance  $\pm 1\%$ ). Phono equalizer RIAA deviation has been reduced to less than  $\pm 0.2\text{dB}$  (20Hz ~ 20kHz).

### 5.2 TONE CONTROLS

Incoming signals are amplified to the required level by the 2 stage amplifier which uses a differential amplifier at first stage. The tone control circuit is a collector-base negative feedback circuit (NFB) and features 3 turnover frequencies for both bass and treble.

The basic principles of the NFB type tone control circuit are outlined in Fig. 2.

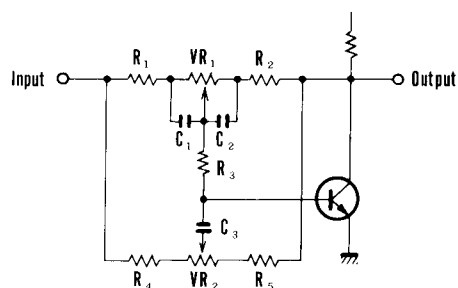

Fig. 2. Basic circuitry of NFB type tone control circuit

### Midrange Operation

The  $C_1$  and  $C_2$  reactances are considerably smaller than  $VR_1$  at frequencies above midrange, effectively shorting  $VR_1$ . At frequencies below midrange,  $C_3$  reactance becomes large and in effect, opens the circuit. Consequently, the circuit becomes equivalent to that shown in Fig. 3 with respect to the midrange. In this figure, the circuit parameters are not changed by any change in position of the  $VR_1$  and  $VR_2$  sliders. The NFB amount is therefore fixed and the circuit gain is also fixed without regard to  $VR_1$  and  $VR_2$  slider positions.

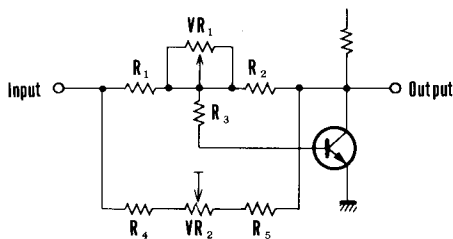

Fig. 3. Midrange operation of NFB type tone control circuit

### Low Frequency Operation

The reactance of  $C_1$  and  $C_2$  increases at low frequency to form a circuit as shown in Fig. 4. This reactance increases in proportion to the frequency declines. Also, the NFB amount varies greatly according to  $VR_1$  slider position. The circuit gain at low frequencies can therefore be varied by  $VR_1$ . Capacitance of  $C_1$  and  $C_2$  is changed by BASS TURNOVER switch (by adding a capacitor to each in parallel). This allows selection of the frequency at which  $VR_1$  begins to take effect.

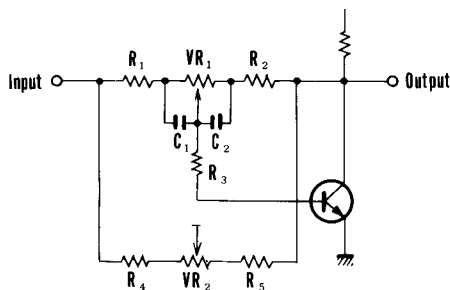

Fig. 4. Low frequency operation of NFB type tone control circuit

### High Frequency Operation

The considerably smaller reactance of  $C_1$  and  $C_2$  at high frequency in comparison with  $VR_1$  effectively shorts  $VR_1$  to form an equivalent circuit such as

that shown in Fig. 5.  $C_3$  reactance decreases in the same degree that the frequency increases and the NFB amount is now mainly controlled by the  $VR_2$  slider position. Consequently, the gain at high frequencies can be varied by  $VR_2$ .

$C_3$  capacitance is changed by TREBLE TURN-OVER switch (by adding another capacitor in series) to provide selection of the frequency at which  $VR_2$  begins to take effect.

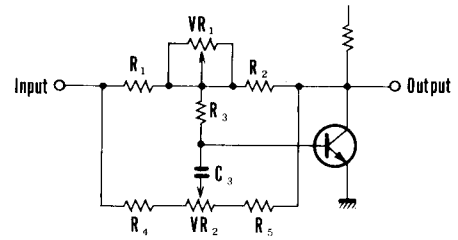

Fig. 5. High frequency operation of NFB type tone control circuit

## 5.3 POWER AMPLIFIER

The circuit diagram for the power amplifier section is shown in Fig. 6.

The input stage ( $Q_1$ ) constitutes a differential amplifier, employing a dual transistor (a 2-in-1 transistor "package" possessing the functions of 2 separate transistors). The second stage ( $Q_2, Q_3$ ) is also a differential amplifier, but with the inclusion of a current mirror ( $D_1, Q_4$ ). Since the  $Q_4$  base-emitter junction corresponds to a diode, the potential on the anode of  $D_1$  and the emitter of  $Q_4$  will be the same. Consequently, the potential drops across  $R_1$  and  $R_2$  will also be equal. So if the resistance of these 2 resistors is the same, the same current will flow through both sections. And if the  $h_{FE}$  of the transistor is sufficiently large, the base current can be neglected. That is, the  $Q_2$  collector current and the  $Q_4$  collector current will be the same. Since  $Q_2$  and  $Q_3$  operate out of phase with each other,  $Q_3$  and  $Q_4$  will operate as a push-pull amplifier. The bias voltage for the power stage is supplied by the potential difference produced across  $VR_1 - D_3 - D_2$ , where  $VR_1$  is the variable resistor used to set this potential difference.  $D_2$  is a varistor which compensates for thermal differences. The power stage ( $Q_5 - Q_{10}$ ) includes a 2-stage Darlington connection, with the final stage ( $Q_7 - Q_{10}$ ) forming two complementary symmetrical parallel circuits. The output mid-point is maintained at 0V by a balanced plus and minus power supply and a 100% DC NFB circuit.

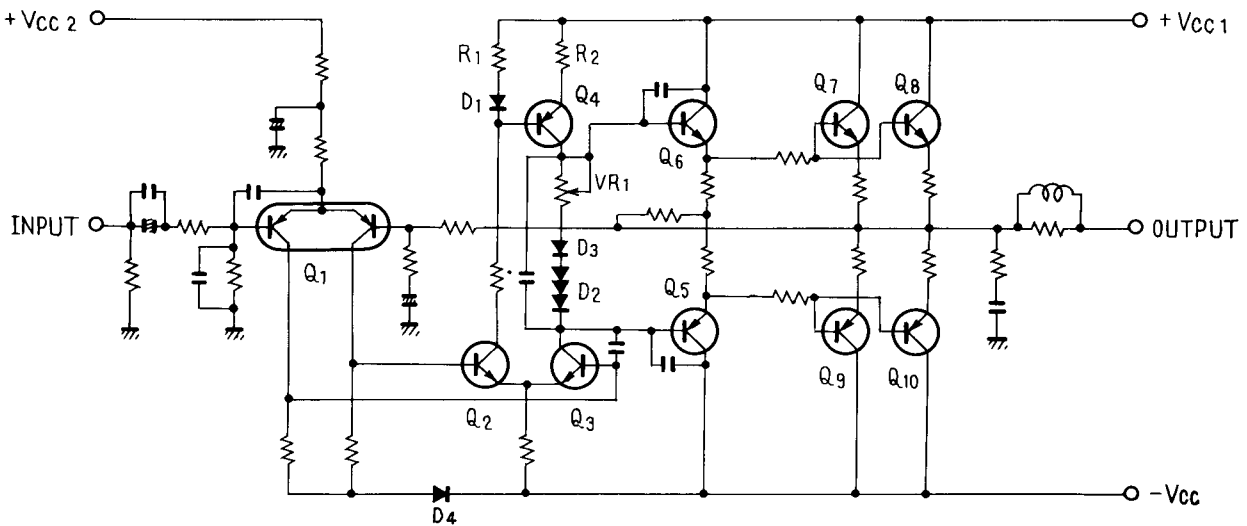

Fig. 6. Schematic diagram of power amplifier

### 5.4 PROTECTION CIRCUIT

This circuit protects the power transistors in case of overload, the speakers in case of power amplifier malfunction, and also performs a muting function when the power supply is turned ON or OFF. The protection circuit is composed of three sections (Fig. 7).

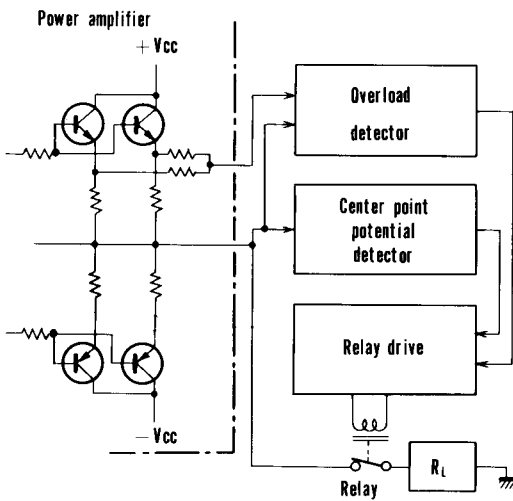

Fig. 7. Block diagram of protection circuit

#### 1. Relay Driver Circuit (Fig. 8)

The relay which connects the output circuits is driven by this circuit. It also performs a muting function to prevent unpleasant noise during ON-OFF operation of the power supply as well as opening the output circuit on command from the detector circuits.

#### Muting Operation

When the power supply is turned ON, Q<sub>6</sub> base is reverse biased, through D<sub>6</sub> and R<sub>20</sub>, turning Q<sub>6</sub> OFF. Q<sub>7</sub> base potential rises as C<sub>4</sub> charges through R<sub>22</sub> & R<sub>23</sub>, and Q<sub>7</sub> turns ON several seconds later. The collector current of Q<sub>7</sub> then flows through the relay coil, operating the relay to turn on the power amplifier output circuit. The reverse bias of Q<sub>6</sub> base from D<sub>6</sub> & R<sub>20</sub> disappears when the power supply is set from ON to OFF. Q<sub>6</sub> remains ON however, due to the residual power supply voltage. C<sub>4</sub> very rapidly discharges, Q<sub>7</sub> base potential drops and Q<sub>7</sub> turns OFF. The relay releases and the power amplifier output circuit turns OFF.

*Note:*

Q<sub>5</sub> is normally OFF due to base bias and does not participate in the muting operation.

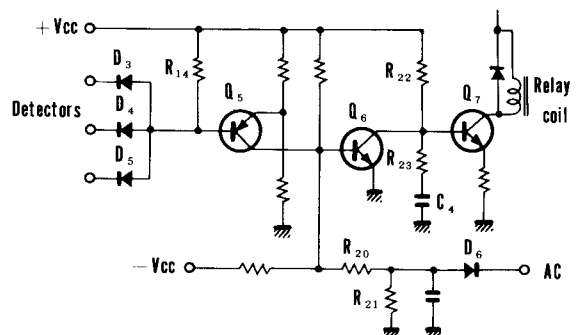

Fig. 8. Schematic diagram of relay driver circuit

### Operation by Detector Circuit Command

Command from the detector circuits pass through one of  $D_3$ ,  $D_4$  or  $D_5$  and are applied in the form of a current flow.  $Q_5$  is normally reverse biased through  $R_{14}$ , but when a large current flows through on of these diodes,  $Q_5$  base potential declines according to the voltage drop at  $R_{14}$ .  $Q_5$  then becomes ON,  $Q_6$  base potential rises and  $Q_6$  becomes ON.  $C_4$  rapidly discharges and  $Q_7$  base potential drops, turning  $Q_7$  OFF. The relay releases and the power amplifier output circuit becomes cut off.

### 2. Overload Detector Circuit

Shorting of the power amplifier load or a load impedance below the specified value causes a command to be sent to the relay drive circuit. This is illustrated in Fig. 9.

$Q_a$  emitter is connected to  $Q_1$  base through  $R_1$  and the junction point to  $Q_1$  emitter. When  $R_L$  is extremely small, large current flows in  $Q_a$ ,  $Q_1$  turns ON due to the  $RE_1$  voltage drop, and current flows in  $D_3$ .  $C_1$  prevents faulty operation due to external noise.

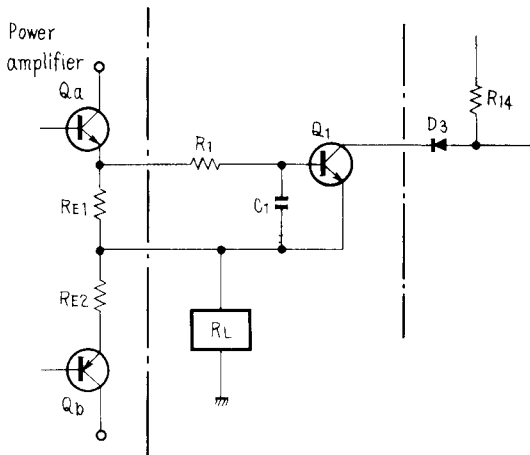

Fig. 9. Basic circuitry of overload detector

### 3. Center Point Potential Detector Circuit

If a DC potential is produced at the junction point of the power amplifier, a command is sent to the relay drive circuit. Fig. 10 shows this operating principle.

$Q_3$  and  $Q_4$  compose a differential amplifier. When the same input is applied to both input terminals ( $Q_3$  and  $Q_4$  bases), no output is present. However, if there is a difference between the terminal inputs, the difference is amplified and becomes the output between the two collectors. During normal operation, an AC signal only is present at the junction

point. As  $C_2$  reactance is sufficiently low, the signal is not applied to  $Q_3$ , resulting in an absence of output at the collector sides.

When a DC potential is produced at the junction point, it becomes the input of  $Q_3$  only. If the voltage is negative,  $Q_3$  collector current declines. And at  $Q_4$  the collector current increases and the potential drops, causing current to flow through  $D_4$ .

If the DC voltage is positive,  $Q_3$  collector current increases and the potential drops, while at  $Q_4$  the collector current decreases and the potential rises. Current therefore flows through  $D_5$ .

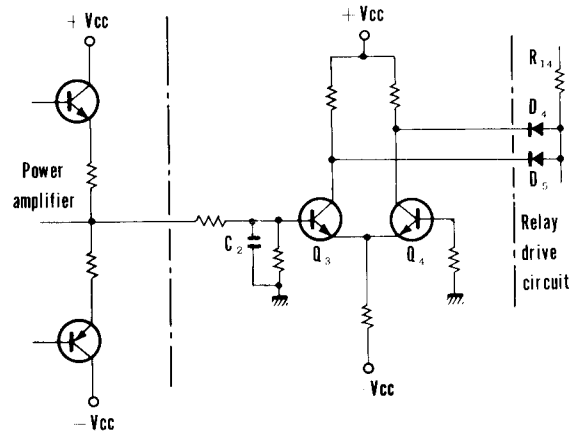

Fig. 10. Basic circuitry of center point potential detector

### 5.5 POWER SUPPLY CIRCUIT

The power stage provides voltage independently to both left and right channels, using 2 separate power transformers. Separate bridge rectifiers (one for each channel) and  $10,000\mu F$  ( $\times 2$ ) capacitors provide the plus and minus voltages. Positive voltage for other sections is provided by full-wave rectification from the same winding on the power transformer that is used for the left channel, and a negative voltage from the corresponding winding of the right channel transformer. Both are supplied via voltage regulator circuits.

*Note:*

*There is only one pair of secondary windings in each the left and right channel power transformers.*

# 6. LEVEL DIAGRAM

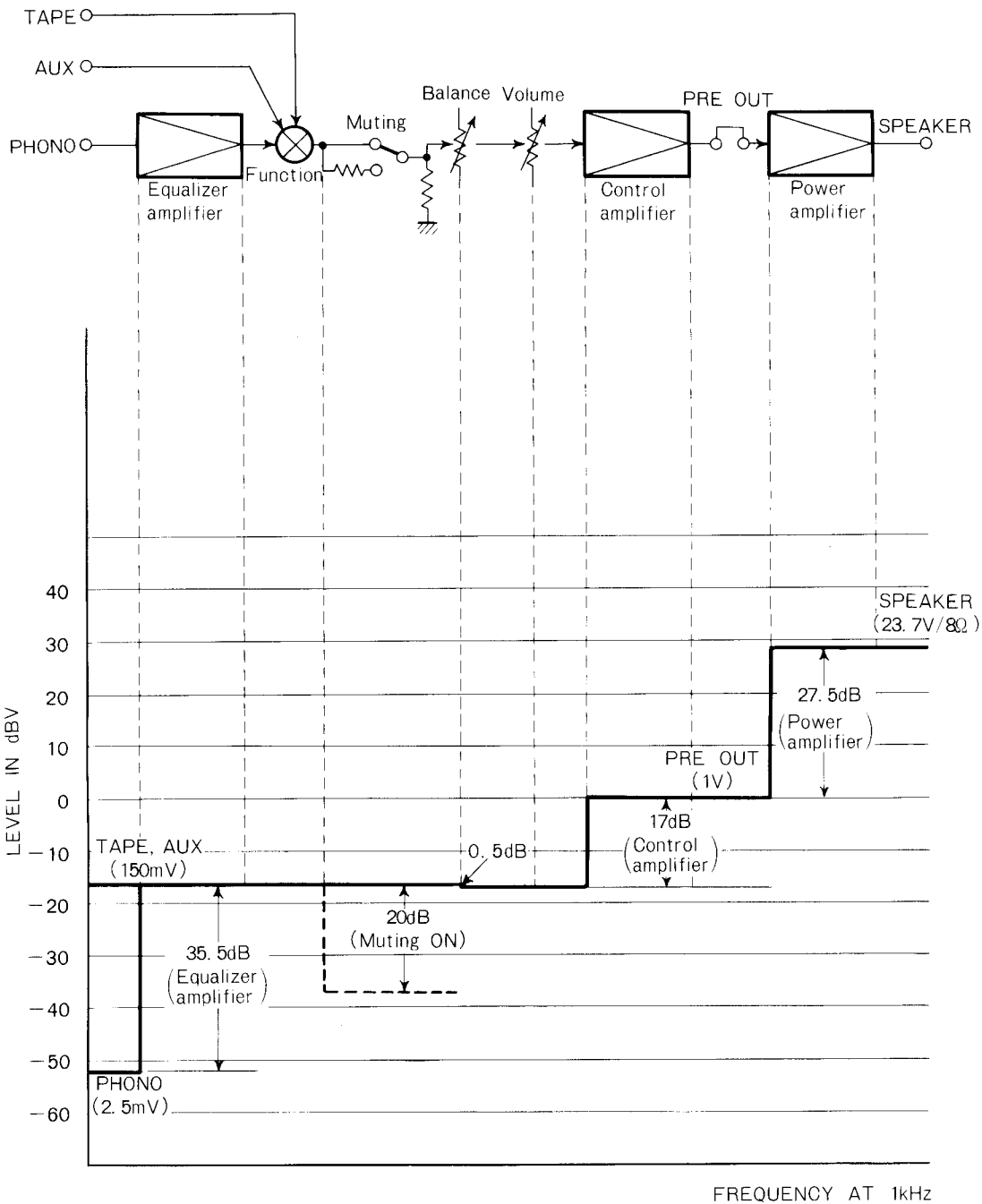

# 7. DISASSEMBLY

## Top Cover

Remove the four screws (A).

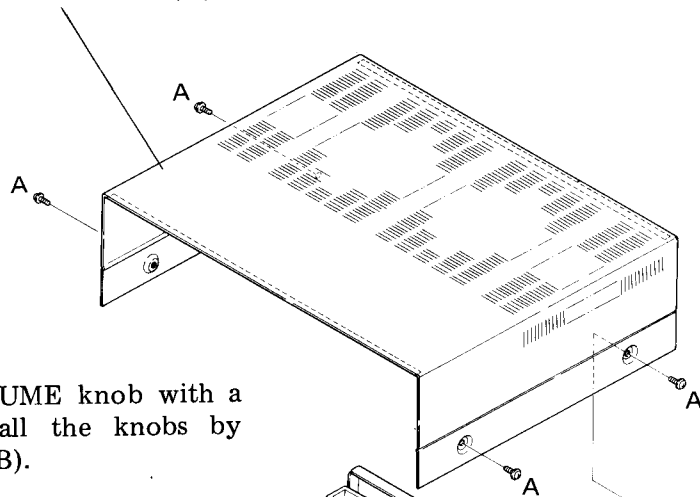

## Front Panel

Loosen the setscrews of VOLUME knob with a hexagonal wrench. Remove all the knobs by pulling. Remove the four nuts (B).

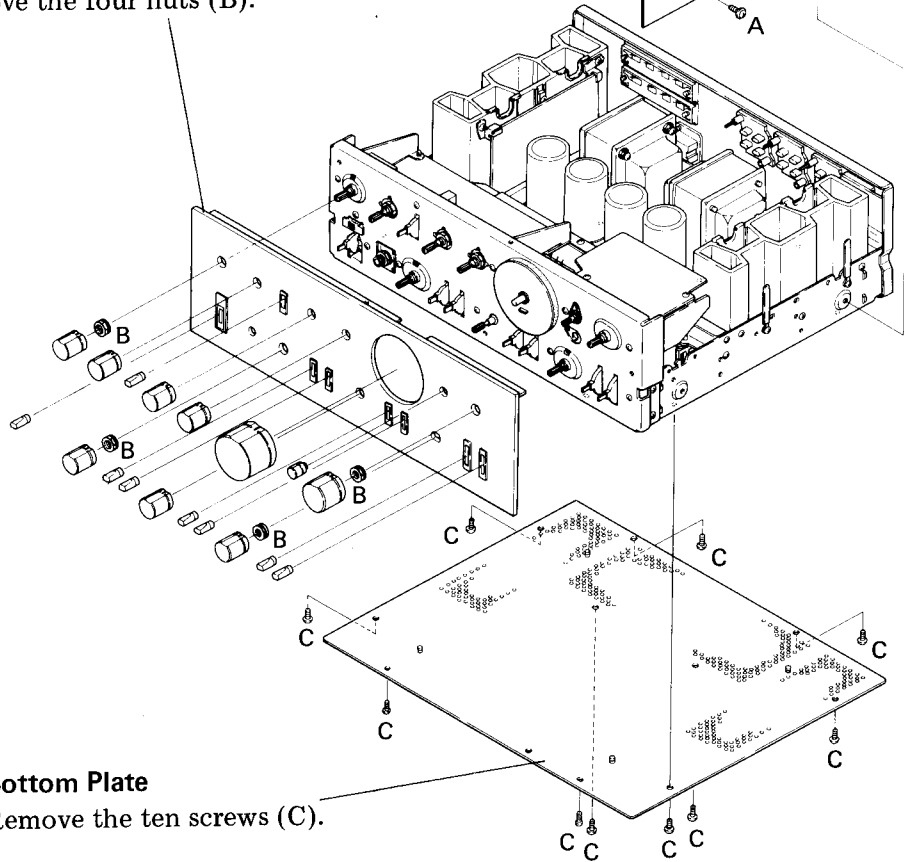

## Bottom Plate

Remove the ten screws (C).

**Power Amplifier Block (L)**  
Remove the three screws (E).

**Control Amplifier Assembly**  
Remove the three screws (D).

**Power Amplifier Block (R)**  
Remove the three screws (F).

**Equalizer Amplifier Assembly**  
Remove the two screws (G).

**Switch Assembly**  
Remove the seven screws (H).

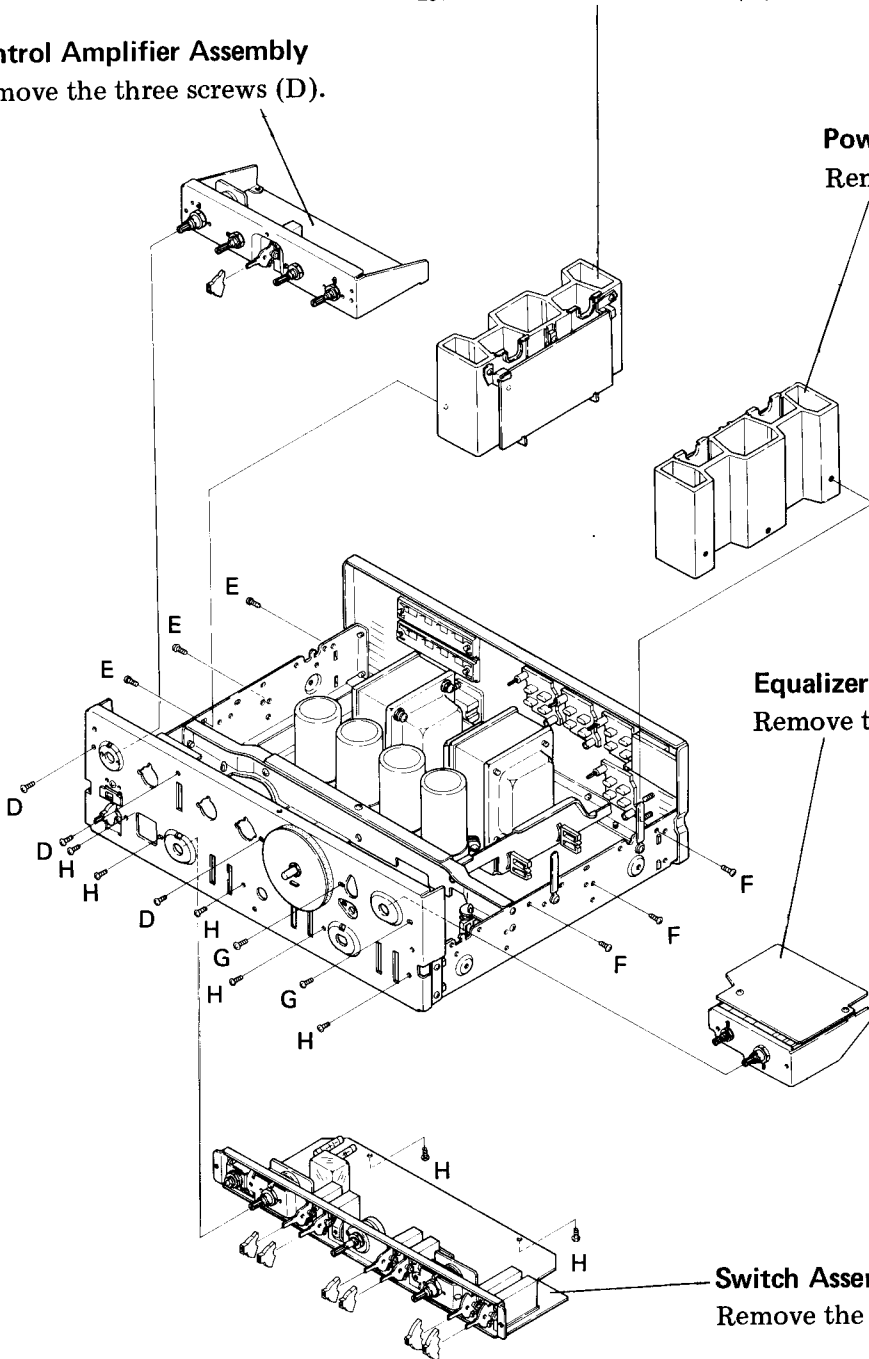



# 8. PARTS LOCATION

## 8.1 FRONT PANEL VIEW

Front panel  
ANB-481

Knob (TREBLE)  
AAB-116

Knob (VOLUME)  
AAB-114

Knob (TONE)  
AAD-117

Knob (CARTRIDGE LOAD)  
AAB-117

Knob (BASS)  
AAB-116

Knob (FUNCTION)  
AAB-115

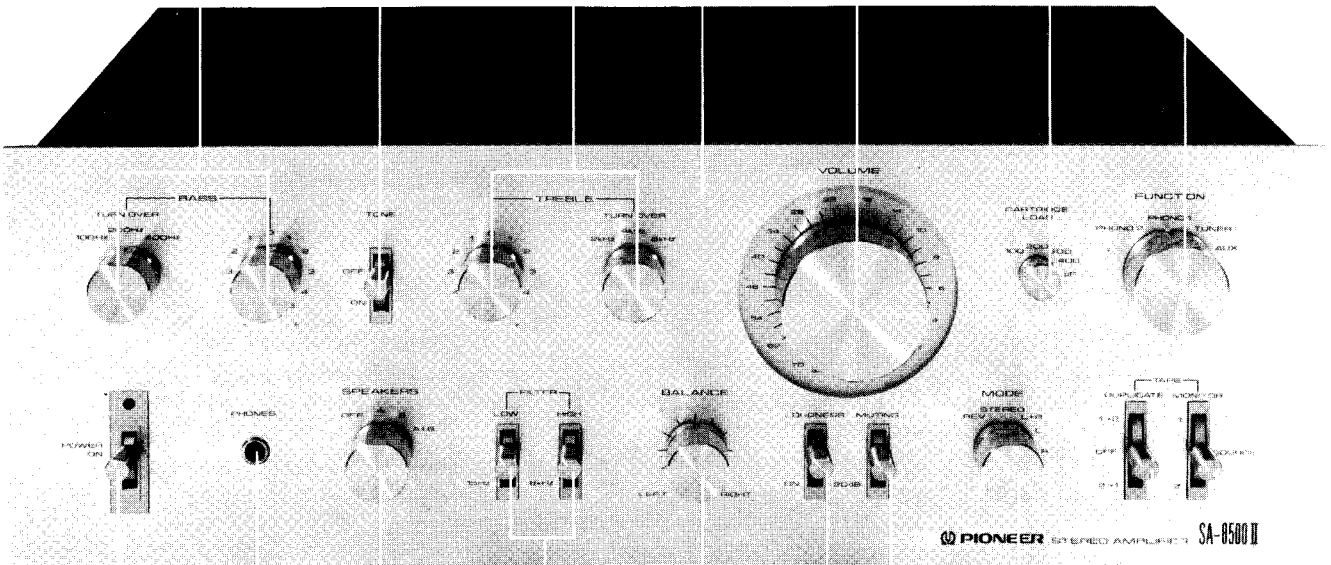

Knob (POWER)  
AAD-117

Knob (TAPE)  
AAD-117

Phone jack (PHONES)  
AKN-008

Knob (MODE)  
AAB-116

Knob (SPEAKERS)  
AAB-116

Knob (MUTING)  
AAD-117

Knob (FILTER)  
AAD-117

Knob (LOUDNESS)  
AAD-117

Knob (BALANCE)  
AAB-116

8.2 FRONT VIEW WITH PANEL REMOVED

Lever switch (TONE)  
ASK-109

Rotary switch  
(TREBLE TURNOVER)  
ASD-056

Variable resistor  
(BASS)  
ACV-136

Variable resistor  
(VOLUME)  
ACV-171

Rotary switch  
(BASS TURNOVER)  
ASD-057

Rotary switch  
(CARTRIDGE LOAD)  
ASD-065 (ASD-055)

Rubber bracket  
AEB-092

Variable resistor  
(TREBLE)  
ACV-136

Rotary switch  
(FUNCTION)  
ASD-052

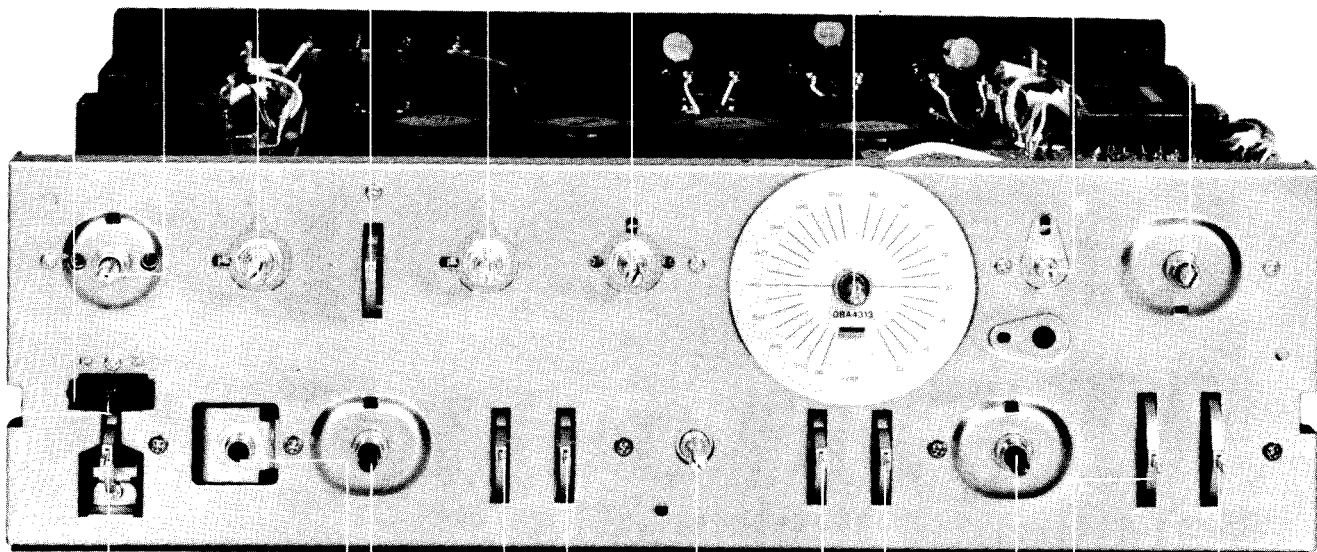

Lever switch  
(POWER)  
ASK-124

Lever switch  
(TAPE MONITOR)  
ASK-113

Lamp with leads 8V, 50mA  
AEL-081

Variable resistor  
(BALANCE)  
ACV-172

Lever switch  
(TAPE DUPLICATE)  
ASK-113

Phone jack (PHONES)  
AKN-008

Rotary switch (MODE)  
ASD-053

Rotary switch  
(SPEAKERS)  
ASD-054

Lever switch  
(MUTING)  
ASK-110

Lever switch  
(LOW FILTER)  
ASK-110

Lever switch  
(LOUDNESS)  
ASK-110

Lever switch  
(HIGH FILTER)  
ASK-110

### 8.3 TOP VIEW

Variable resistor  
(VOLUME)  
ACV-171

Control amplifier assembly  
AWG-044

Equalizer amplifier assembly  
AWF-023

Switch assembly  
AWS-108

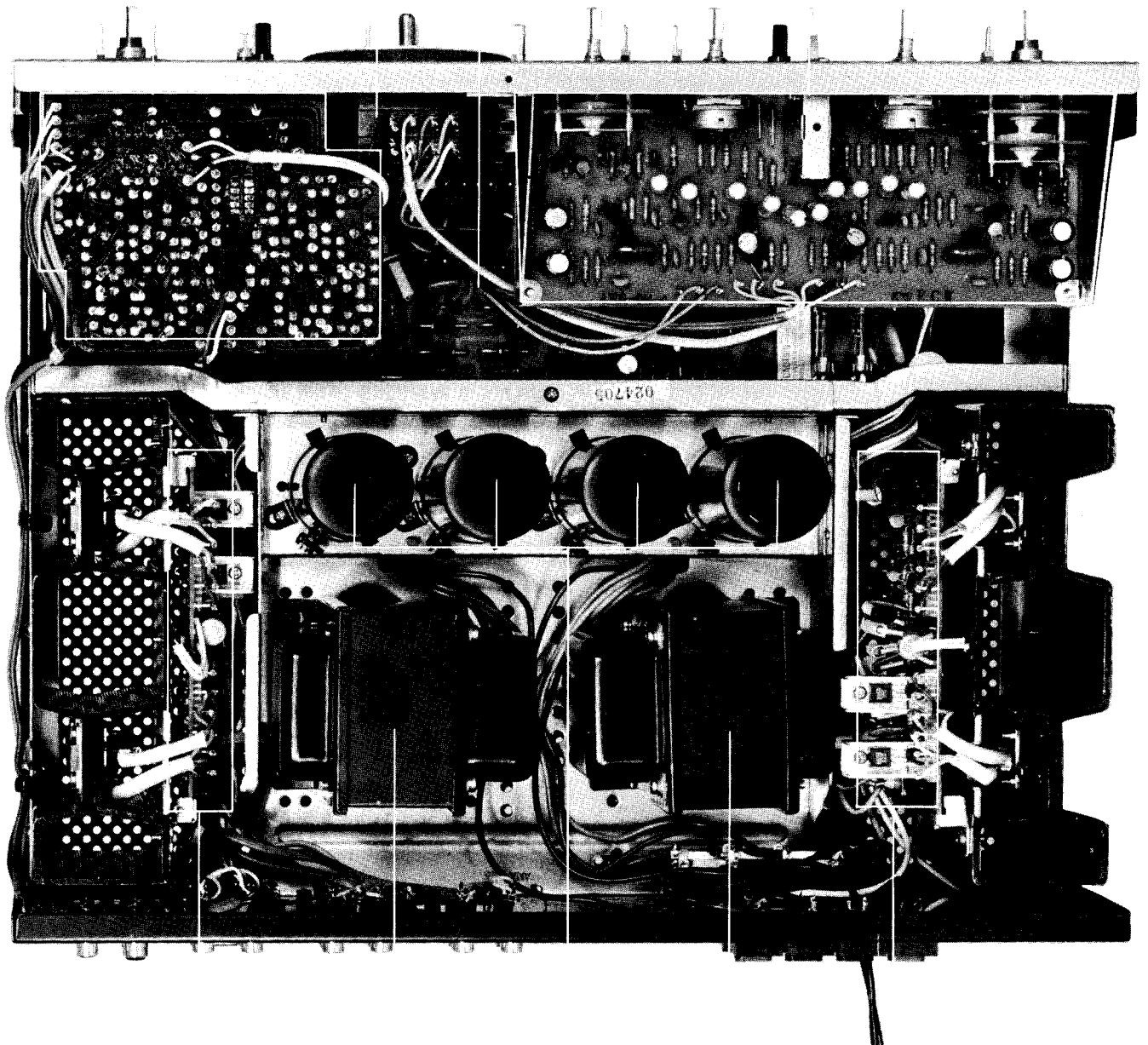

Power amplifier assembly  
AWH-051

Power amplifier assembly  
AWH-051

Power transformer (R)  
ATT-367

Power transformer (L)  
ATT-366

Electrolytic capacitor  
10,000 $\mu$ F 50V  
ACH-064

8.4 BOTTOM VIEW

Ceramic capacitor  
0.01 $\mu$ F 250V  
ACG-001

Switch assembly  
AWS-108

Lever switch (POWER)  
ASK-124

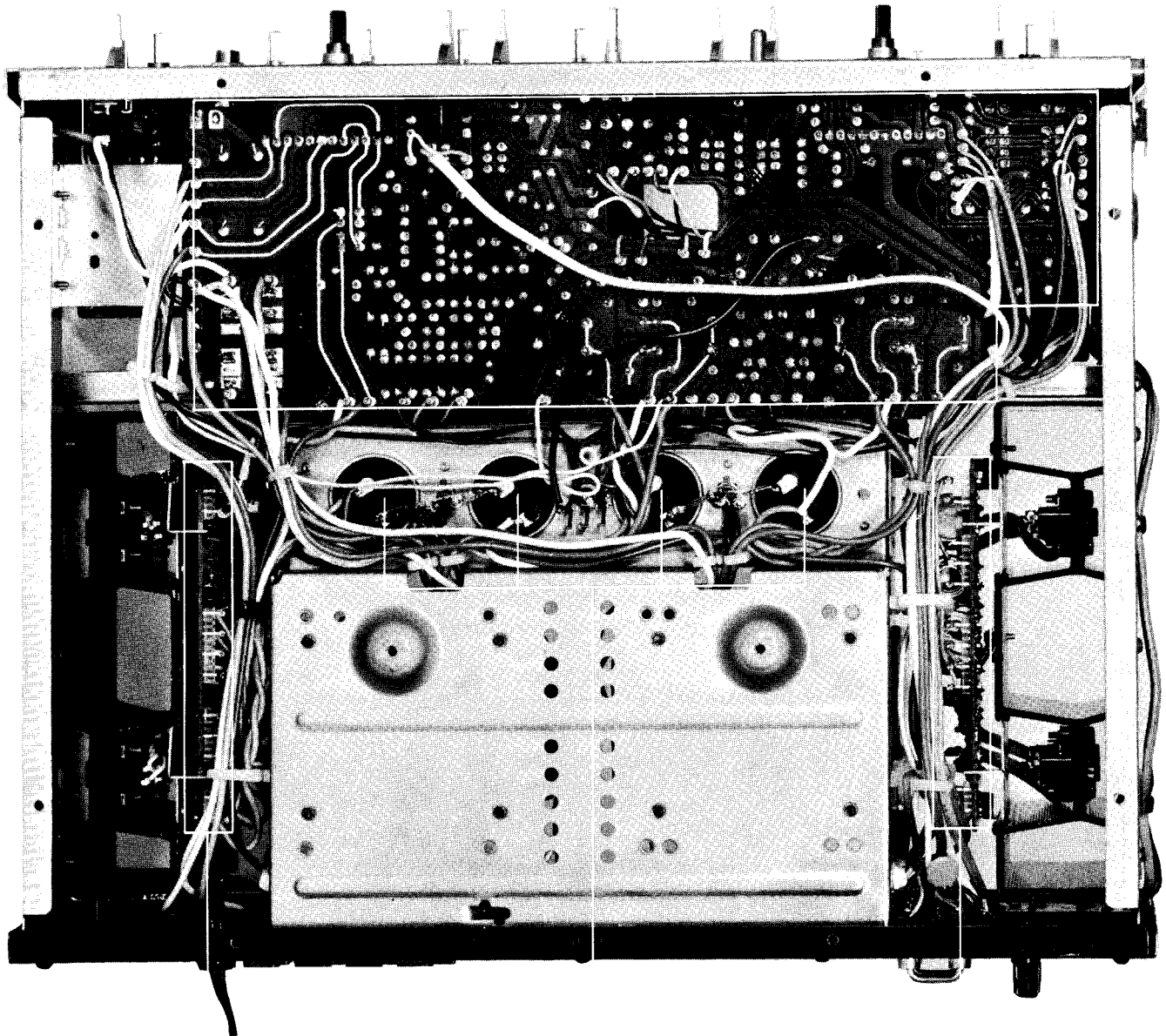

Power amplifier assembly  
AWH-051

Power amplifier assembly  
AWH-051

Electrolytic capacitor  
10,000 $\mu$ F 50V  
ACH-064

## 8.5 REAR VIEW

Terminal (PHONO)  
AKB-027

Terminal (TUNER/AUX)  
AKB-036

Terminal (SPEAKERS)  
AKE-026

Terminal (TAPE 1)  
AKB-035

Terminal (TAPE 2)  
AKB-035

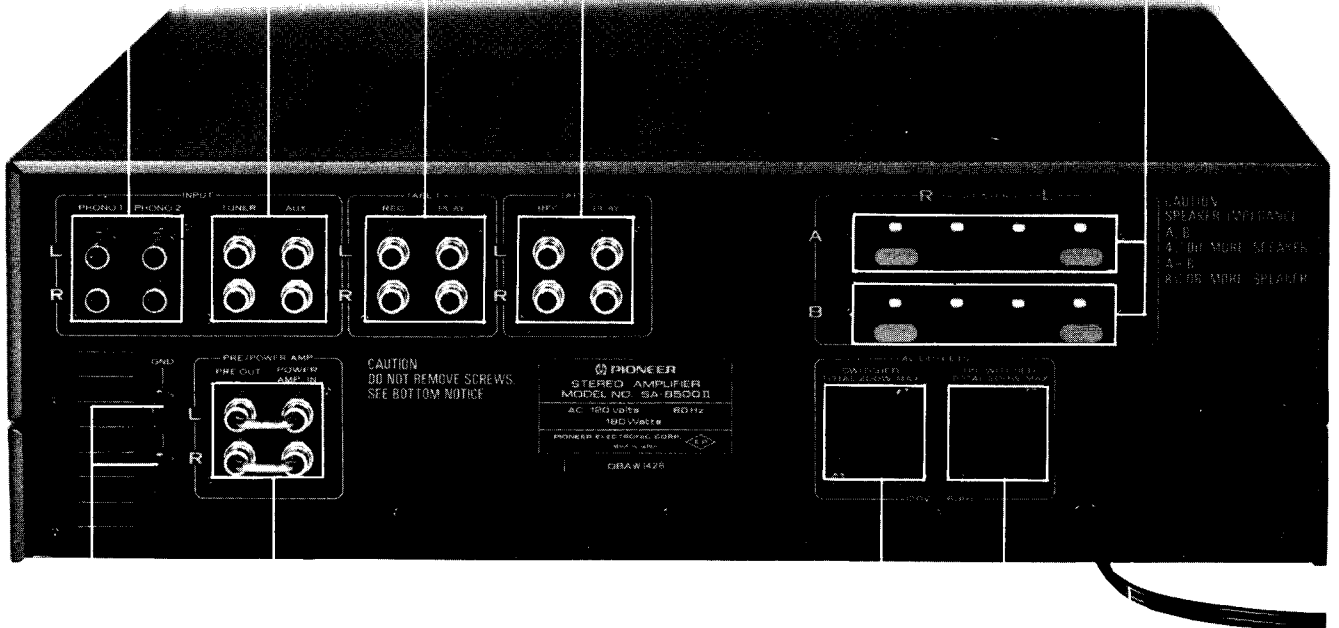

Terminal (PRE/POWER AMP)  
AKB-035

AC power cord  
ADG-005

Screw for ground (GND)  
AKE-030

AC socket (AC OUTLETS)  
AKP-004

## 9. ADJUSTMENT

The SA-8500 II amplifier employs the same type of power amplifier assembly in both left and right channels. Any adjustment will thus have to be identical in both channels, and is limited to adjustments of the idler current.



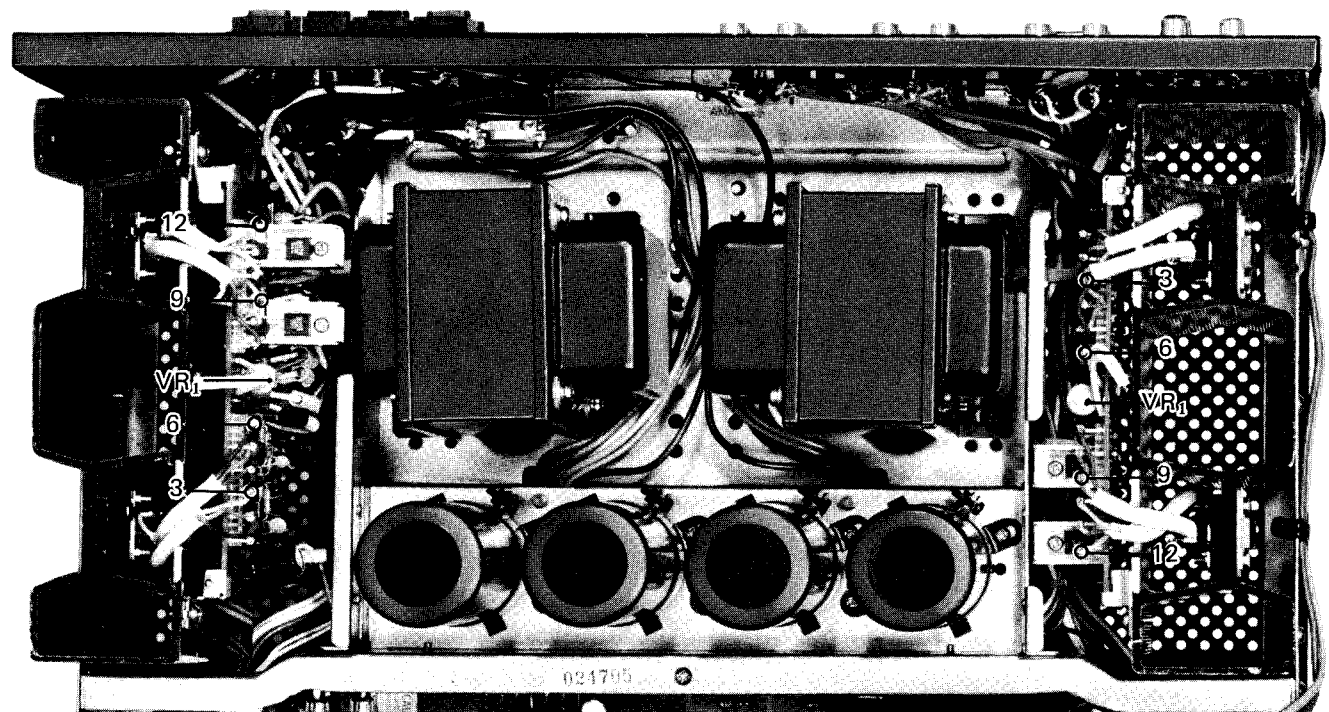
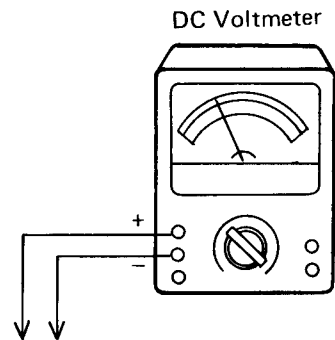
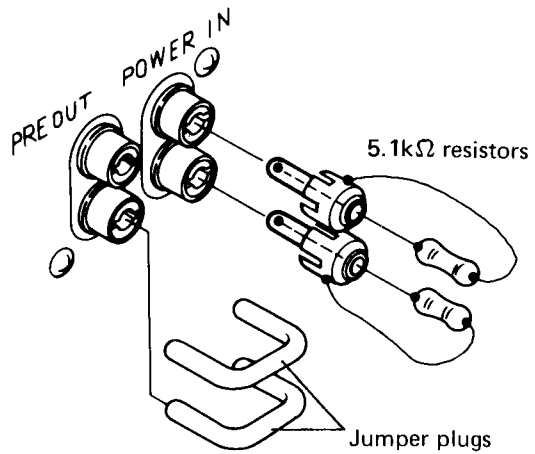











1. Disconnect the jumper plugs, and terminate the POWER IN terminals with  $5.1k\Omega$  resistors.
2. Connect  $8\Omega$  resistors to the SPEAKERS A terminals, and set the SPEAKERS switch to A.
3. Turn  $VR_1$  in a fully counter-clockwise.
4. Turn the POWER switch ON, and then readjust  $VR_1$  so that the voltage between terminals No. 3 (+) and No. 9 (-) reads 30mV.
5. Now check that the voltage between terminals No. 6 (+) and No. 12 (-) reads  $30mV \pm 10mV$  (in order to check the current distribution, since the final stages are in parallel).
6. Leave the amplifier ON for about 30 minutes, then repeat steps 4 and 5.
7. Finally, apply an actual signal, and check for no crossover distortion.











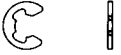

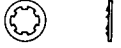

# 10. EXPLODED VIEWS

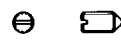
## NOMENCLATURE OF SCREWS, WASHERS AND NUTS

The following symbols stand for screws, washers and nuts as shown in exploded view.

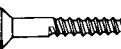
Symbol	Description	Shape
RT	Brazier head tapping screw	
PT	Pan head tapping screw	
BT	Binding head tapping screw	
CT	Countersunk head tapping screw	
TT	Truss head tapping screw	
OCT	Oval countersunk head tapping screw	
PM	Pan head machine screw	
CM	Countersunk head machine screw	
OCM	Oval countersunk head machine screw	
TM	Truss head machine screw	
BM	Binding head machine screw	
PSA	Pan head screw with spring lock washer	
PSB	Pan head screw with spring lock washer and flat washer	
PSF	Pan head screw with flat washer	

Symbol	Description	Shape
EW	E type washer	
FW	Flat washer	
SW	Spring lock washer	
N	Nut	
WN	Washer faced nut	
ITW	Internal toothed lock washer	
OTW	Outernal toothed lock washer	
SC	Slotted set screw (Cone point)	
SF	Slotted set screw (Flat point)	
HS	Hexagon socket headless set screw	
OCW	Oval countersunk head wood screw	
CW	Countersunk head wood screw	
RW	Round head wood screw	

### EXAMPLE

PM • 3x8  
 length in mm ( $l$ )  
 diameter in mm ( $d$ )  
 Symbol

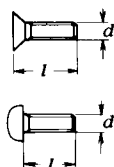

FW • 9φ x 1<sup>t</sup>  
 thickness in mm ( $t$ )  
 diameter in mm ( $d$ )  
 Symbol

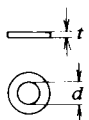

1

2

3

Screw 4x8  
ABA-079

Top cover  
ANE-117

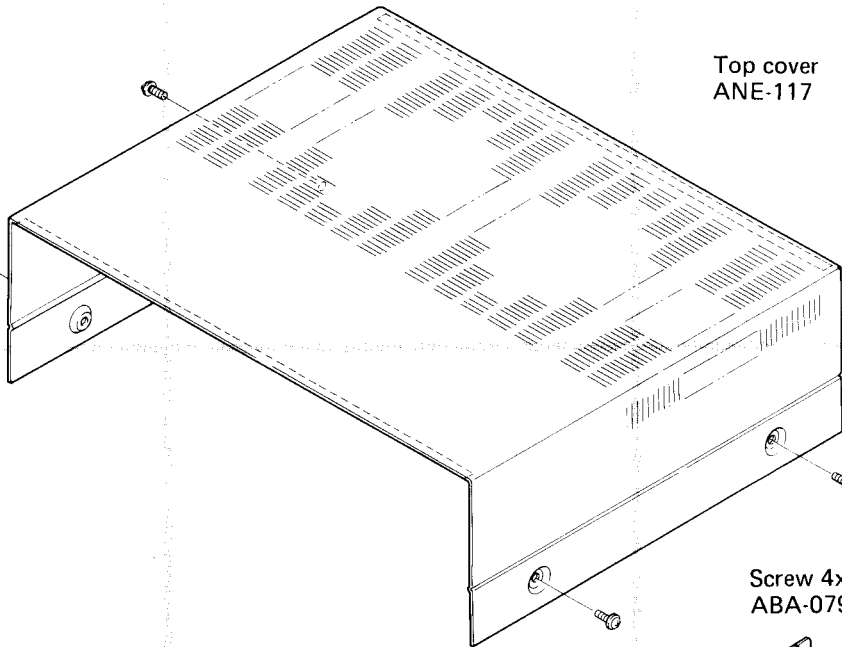

Screw 4x8  
ABA-079

RT3x6

Front panel  
ANB-481

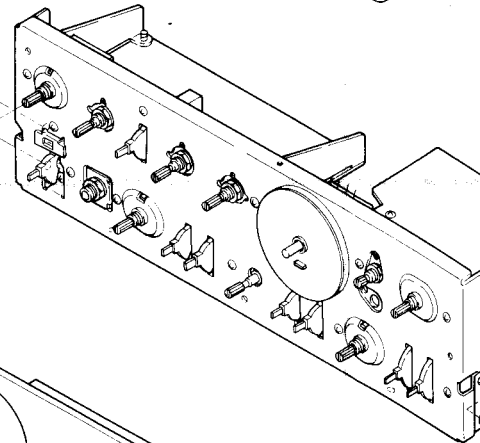

Knob (TONE)  
AAD-117  
Washer faced nut M9  
ABN-024

Knob (BASS)  
AAB-116

Knob (TREBLE)  
AAB-116

Washer faced nut M9  
ABN-024

Knob (POWER)  
AAD-117

Knob (SPEAKERS)  
AAB-116

Knob (FILTER)  
AAD-117

Knob (BALANCE)  
AAB-116

Knob (LOUDNESS, MUTING)  
AAD-117

Knob (MODE)  
AAB-116

Knob (TAPE)  
AAD-117

Washer faced nut M9  
ABN-024

Knob (FUNCTION)  
AAB-115

Knob (CARTRIDGE LOAD)  
AAB-117  
Knob (VOLUME)  
AAB-114

Washer faced nut M9  
ABN-024

Part 1  
See page 27.

1

2

3

A

B

C

D



4

5

6

**NOTE:**

Parts indicated in green type cannot be supplied.

**Part 3**  
See page 29.

**Part 2**  
See page 28.

Screw 3x8  
ABA-002

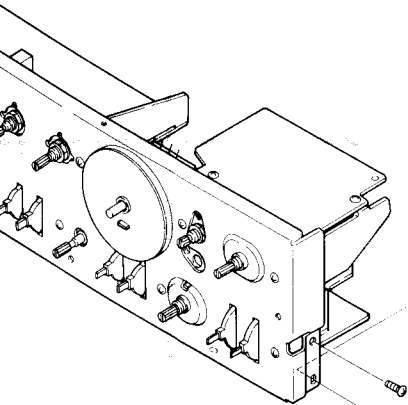
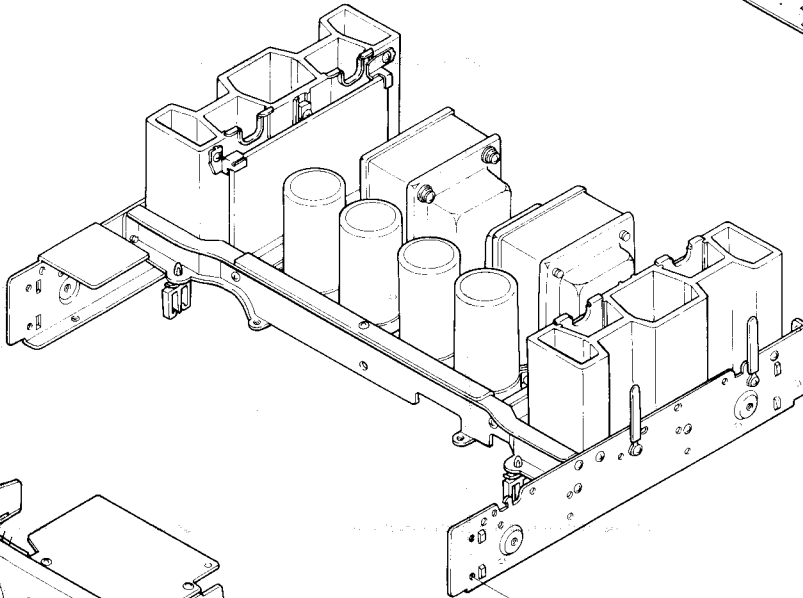
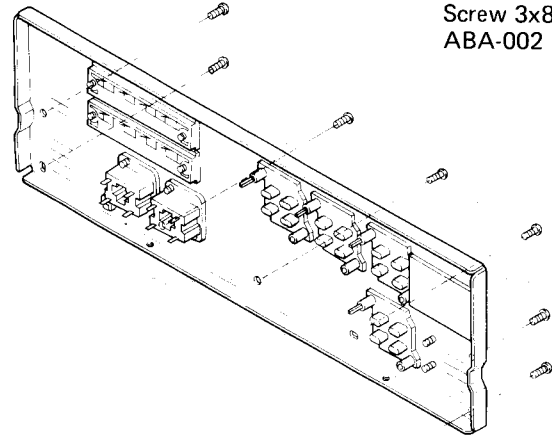

Screw 4x8  
ABA-012

RT3x6

**Part 1**  
See page 27.

Screw 4x8  
ABA-012

Screw 4x8  
ABA-012

Foot  
AEC-178

Foot  
AEC-178

RT4x15

RT4x15

Foot  
AEC-178  
RT4x15

Screw 4x8  
ABA-012

Foot  
AEC-178

RT4x15

er faced nut M9  
024  
NCTION)

GE LOAD)

4

5

6

A

B

C

D

1

2

3

**Part 1**

**NOTE:**  
Parts indicated in green type cannot be supplied.

A

A

B

B

C

C

D

D

1

2

3

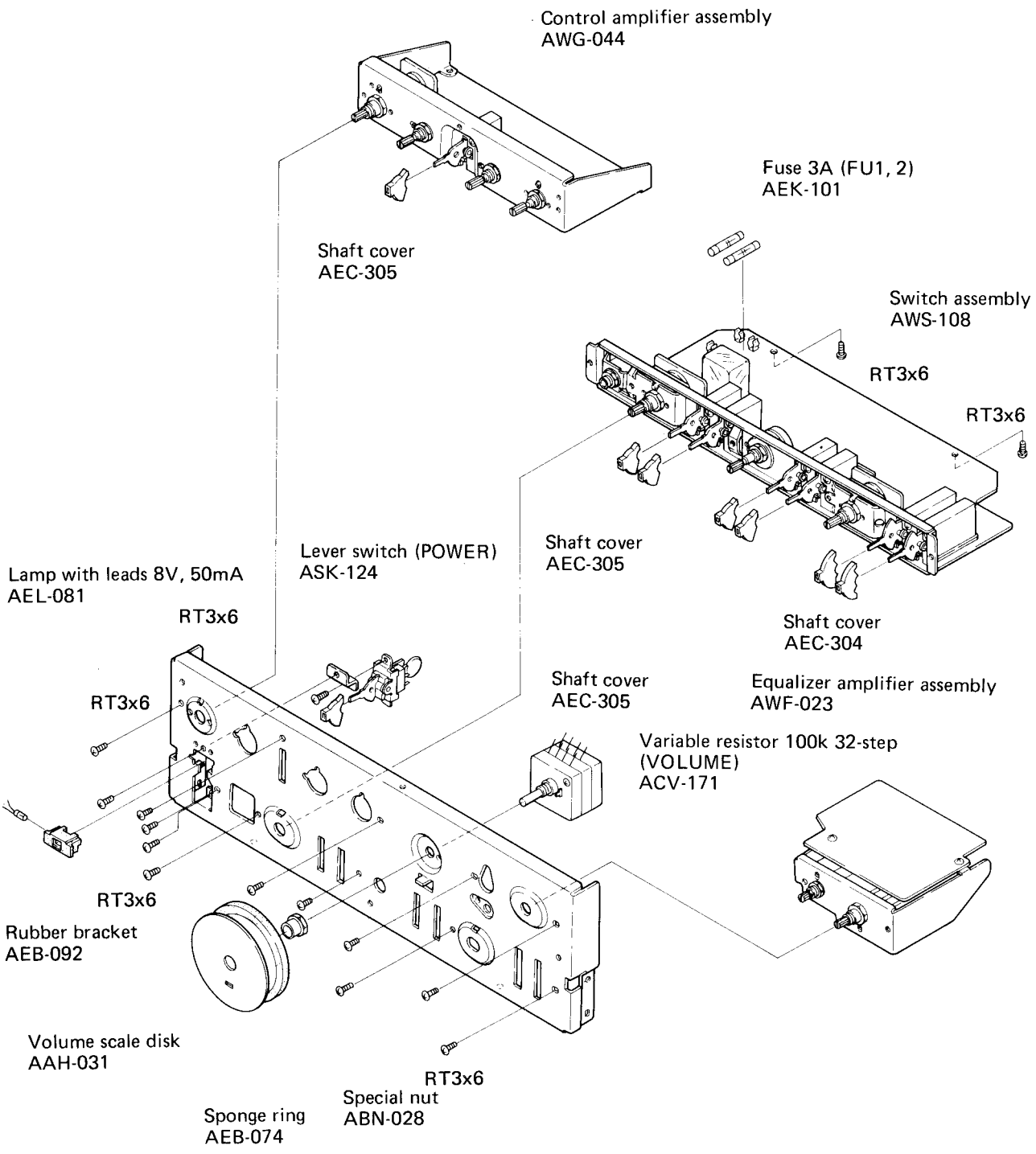

1

2

3

Part 2

**NOTE:**  
Parts indicated in green type cannot be supplied.

A

A

Power transformer (L)  
ATT-366

Screw 4x8  
ABA-012

Part 4  
See page 30.

Screw 4x8  
ABA-012

RT3x6

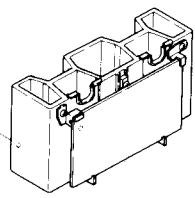
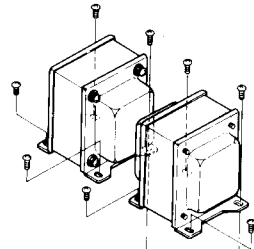

B

B

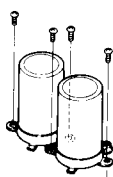

RT3x6

Power transformer (R)  
ATT-367

RT3x8



Electrolytic capacitor  
10,000μF 50V  
ACH-064

Part 4  
See page 30.

RT3x8

RT3x6

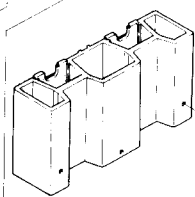

C

C

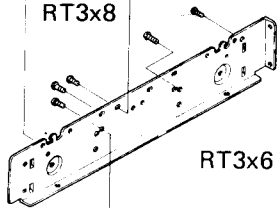

RT3x6

RT3x6

RT3x6

RT3x6

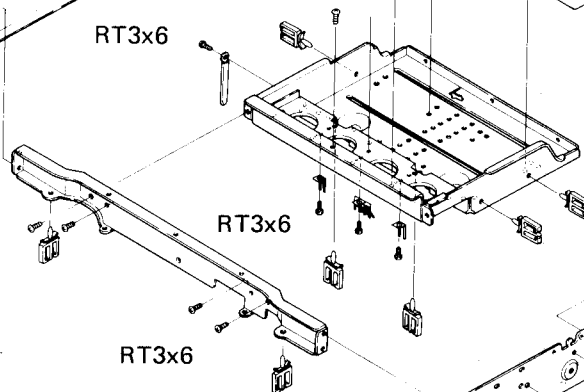

RT3x6

D

D

RT3x6

RT3x8

1

2

3

1

2

3

Part 3

NOTE:

Parts indicated in green type cannot be supplied.

A

A

B

B

C

C

D

D

Strain relief  
AEC-079

AC power cord  
ADG-005

Screw 3x10  
ABA-082

Screw 3x8  
ABA-093

Screw 3x10  
ABA-082

Screw 3x8  
ABA-093

Special screw  
ABA-115

Jumper plug  
AKM-004

Screw for ground (GND)  
AKE-030

Flat washer  
ABE-035

Screw 3x10  
ABA-082

Terminal (SPEAKERS)  
AKE-026

AC socket (AC OUTLET)  
AKP-004

Terminal (TAPE 2)  
AKB-035

Terminal (TAPE 1)  
AKB-035

Terminal (TUNER/AUX)  
AKB-036

Phono jack assembly  
AWX-107

Terminal (PRE/POWER AMP)  
AKB-035

1

2

3

Part 4

NOTE:

Parts indicated in green type cannot be supplied.

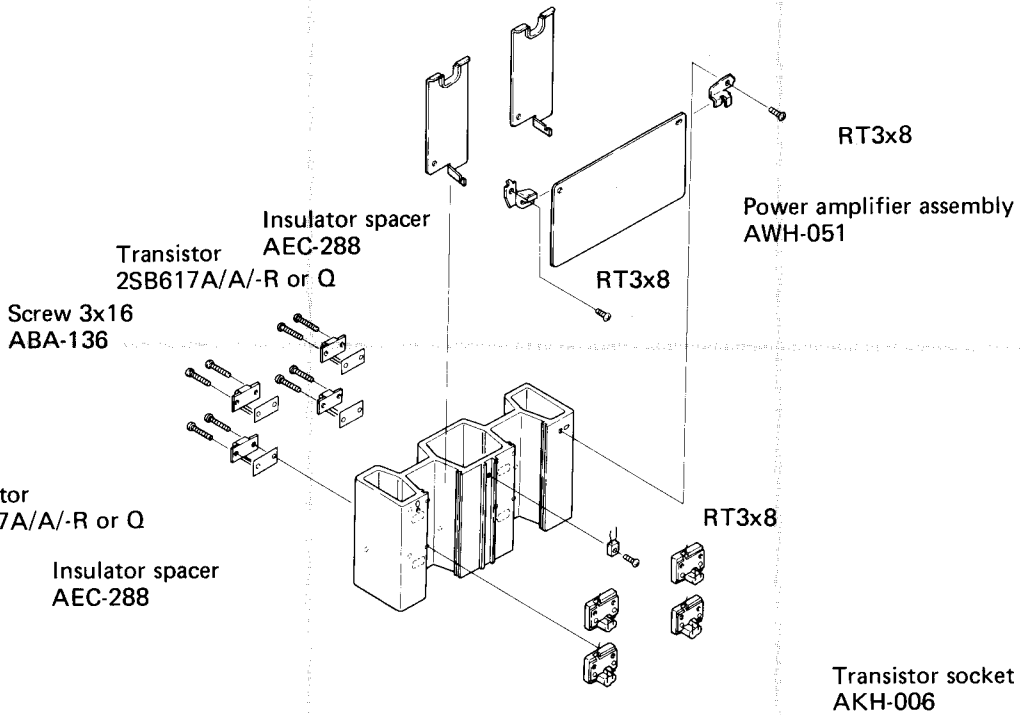

Switch Assembly (AWS-108)

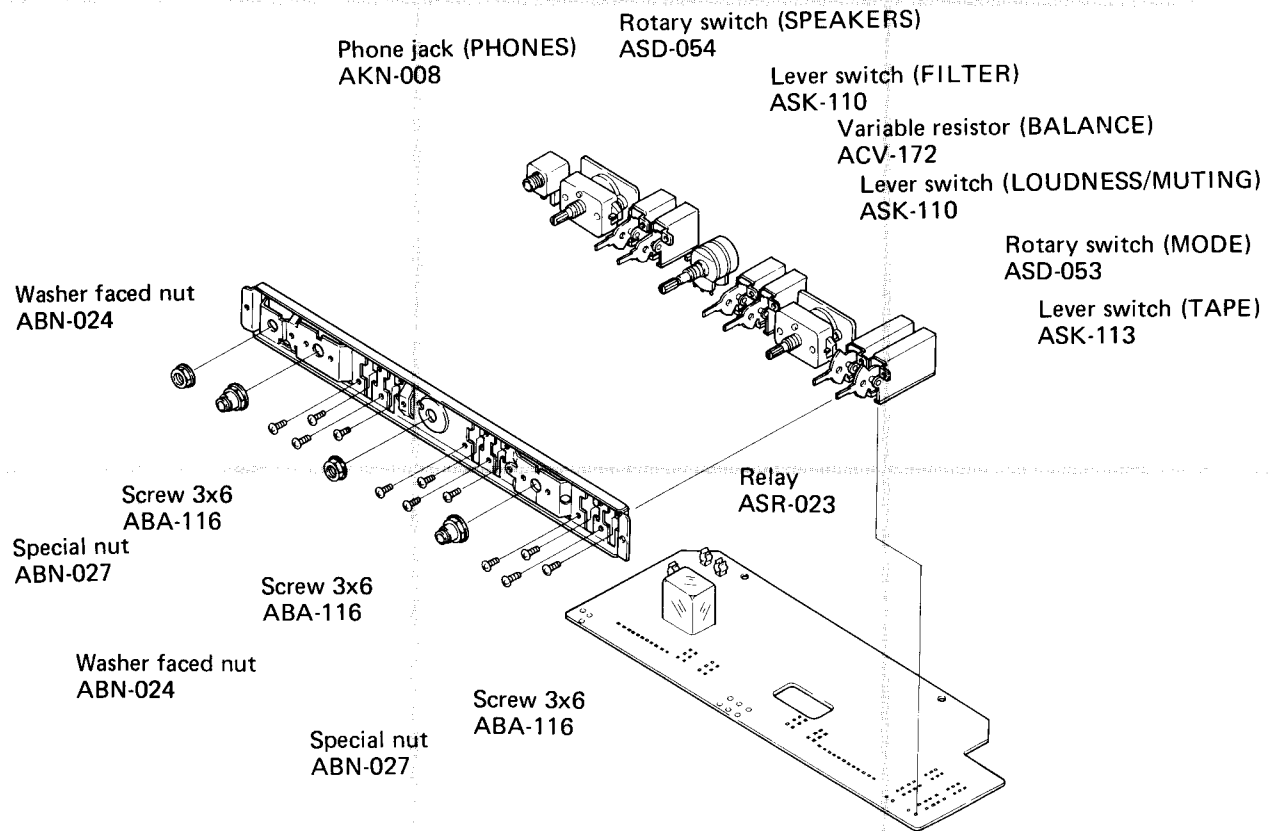

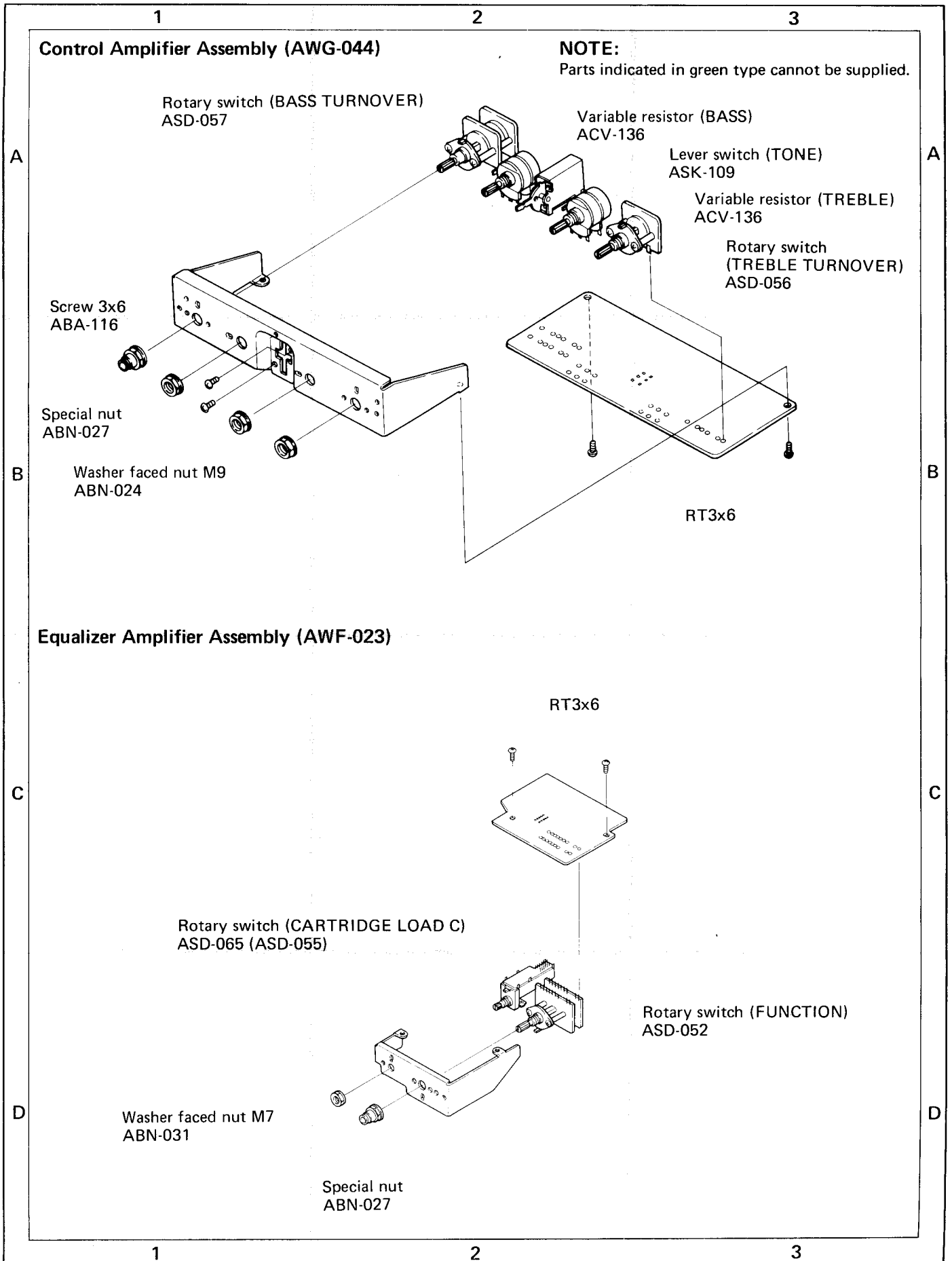

# 11. SCHEMATIC DIAGRAMS, P. C. BOARD PATTERNS AND PARTS LIST

## 11.1 MISCELLANEA

### Miscellaneous Parts

#### SEMICONDUCTORS

Symbol	Description	Part No.
Q1	Transistor	2SD587A/A/-R or Q
Q2	Transistor	2SD587A/A/-R or Q
Q3	Transistor	2SB617A/A/-R or Q
Q4	Transistor	2SB617A/A/-R or Q
Q5	Transistor	2SD587A/A/-R or Q
Q6	Transistor	2SD587A/A/-R or Q
Q7	Transistor	2SB617A/A/-R or Q
Q8	Transistor	2SB617A/A/-R or Q

#### LAMP, FUSES

Symbol	Description	Part No.
PL1	Lamp with leads 8V, 50mA	AEL-081
FU1	Fuse 3A	AEK-101
FU2	Fuse 3A	AEK-101

#### SWITCH

Symbol	Description	Part No.
S13	Lever switch (POWER)	ASK-124

#### TRANSFORMERS

Symbol	Description	Part No.
T1	Power transformer (L)	ATT-366
T2	Power transformer (R)	ATT-367

#### RESISTOR

Symbol	Description	Part No.
VR1	Variable resistor 100k 32-step (VOLUME)	ACV-171

#### NOTE:

- Capacitors: in  $\mu F$  unless otherwise noted p:pF
- Resistors: in  $\Omega$ ,  $\frac{1}{4}W$  unless otherwise noted k:k $\Omega$ , M:M $\Omega$

#### CAPACITORS

Symbol	Description	Part No.
C2	Ceramic 0.047 50V	CKDYF 473Z 50
C3	Ceramic 0.047 50V	CKDYF 473Z 50
C4	Ceramic 0.047 50V	CKDYF 473Z 50
C5	Ceramic 0.047 50V	CKDYF 473Z 50
C6	Ceramic 0.047 50V	CKDYF 473Z 50
C7	Electrolytic 10,000 50V	ACH-064
C8	Electrolytic 10,000 50V	ACH-064
C9	Electrolytic 10,000 50V	ACH-064
C10	Electrolytic 10,000 50V	ACH-064
C11	Ceramic 0.01 250V	ACG-001

#### External Appearances of Transistors

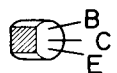
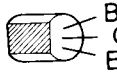
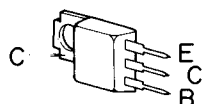
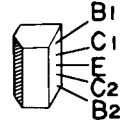
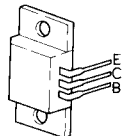
Type	Fig.
2SA725 2SA725P 2SA726 2SC869 2SC1919	
2SA733 2SC945A	
2SA912 2SC1384 2SC1885	
2SB526 2SD356	
2SA798	
2SB617A(A) 2SD587A(A)	

# 11.2 SCHEMATIC DIAGRAM

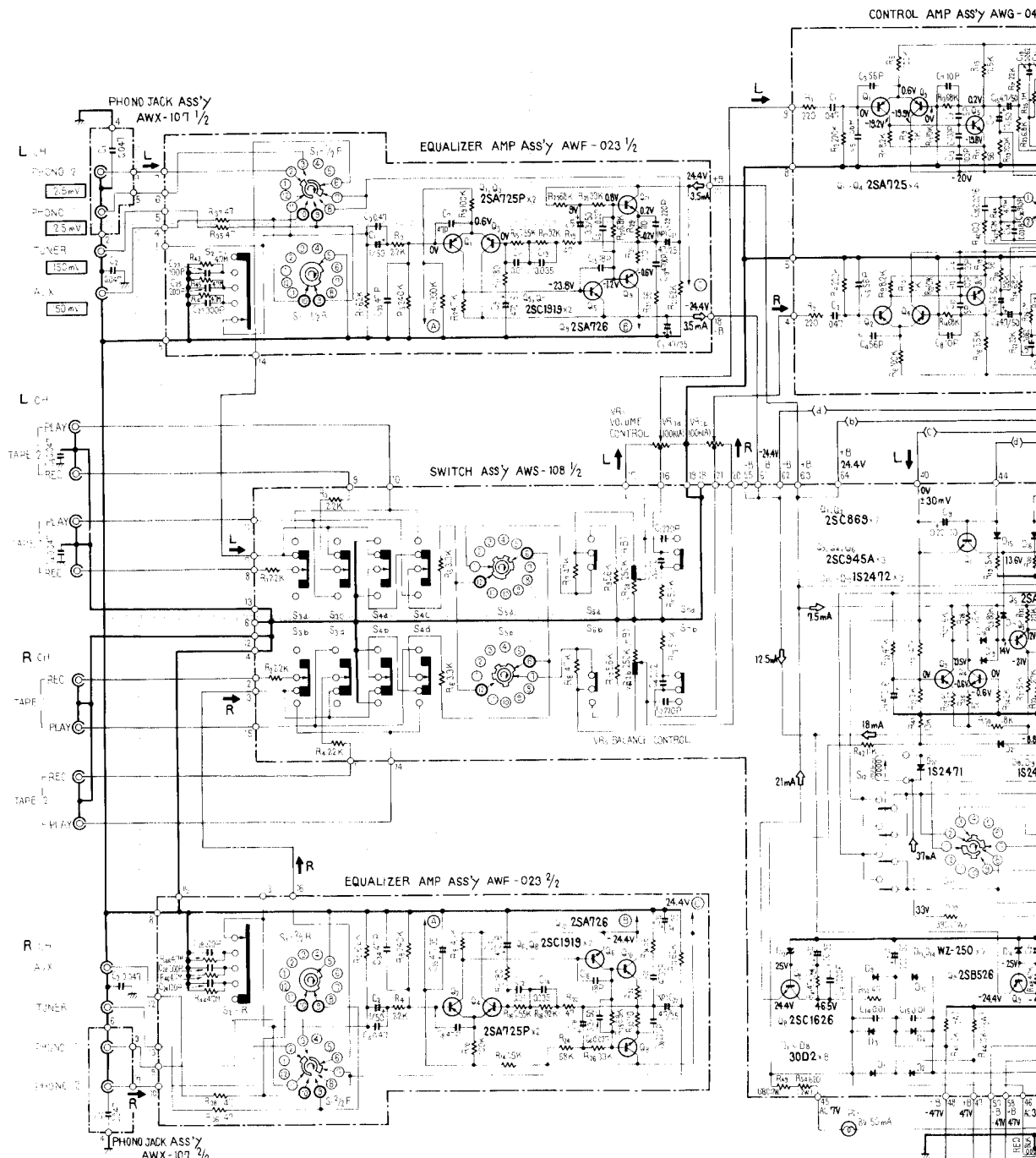

- SWITCHES:
- |  |   |   |   |   |   |  |  |   |  |   |   |
|--|---|---|---|---|---|--|--|---|--|---|---|
| S <sub>1</sub> - FUNCTION<br>(1) PHONO 2 (2) PHONO (3) TUNER (4) AUX | S <sub>2</sub> - INPUT CAPACITANCE SELECTOR (PH)<br>(1) 200 (2) 20 (3) 10 (4) 5 | S <sub>3</sub> - DUPLICATION<br>(1) OFF (2) 13.5 (3) 15 | S <sub>4</sub> - TAPE MONITOR<br>(1) OFF (2) ON | S <sub>5</sub> - MODE<br>(1) HV (2) STEREO (3) L+R (4) L+SR | S <sub>6</sub> - TONE MONITOR<br>(1) OFF (2) ON | S <sub>7</sub> - BASS/TREBLE<br>(1) OFF (2) ON | S <sub>8</sub> - HIGH FILTER<br>(1) OFF (2) ON | S <sub>9</sub> - LOW FILTER<br>(1) OFF (2) ON | S <sub>10</sub> - TONE<br>(1) OFF (2) ON | S <sub>11</sub> - SPLACEMENT<br>(1) 20 (2) 10 (3) 5 (4) 2.5 | S <sub>12</sub> - TRIPLE TUNE<br>(1) 100KHz (2) 40KHz (3) 15KHz |
|--|---|---|---|---|---|--|--|---|--|---|---|



4

5

6

**NOTE:**

The indicated semiconductors are representative ones only. Other alternative semiconductors may be used and are listed in the parts lists.

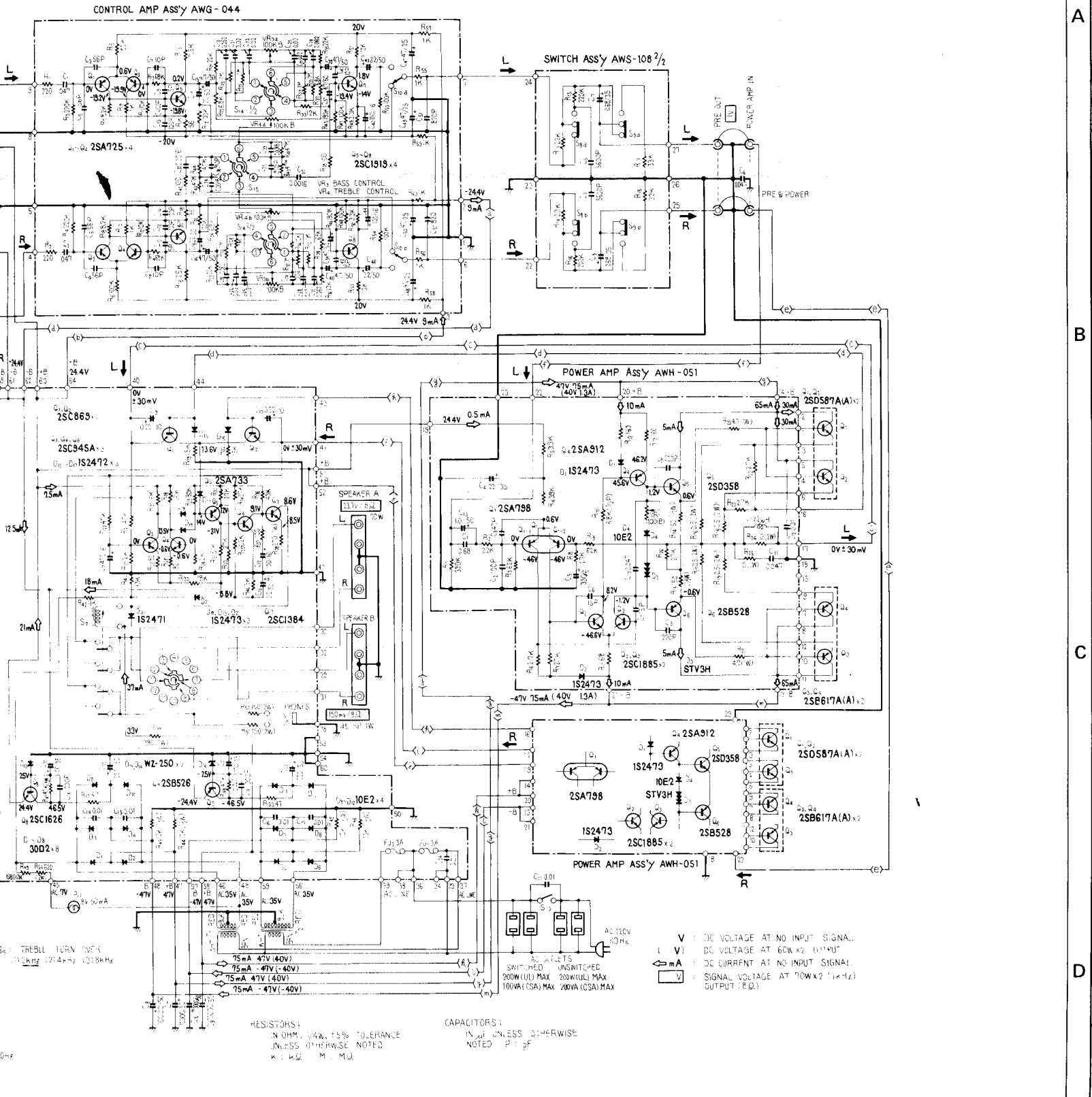

4

5

6

A  
B  
C  
D

### 11.3 SWITCH ASSEMBLY (AWS-108)

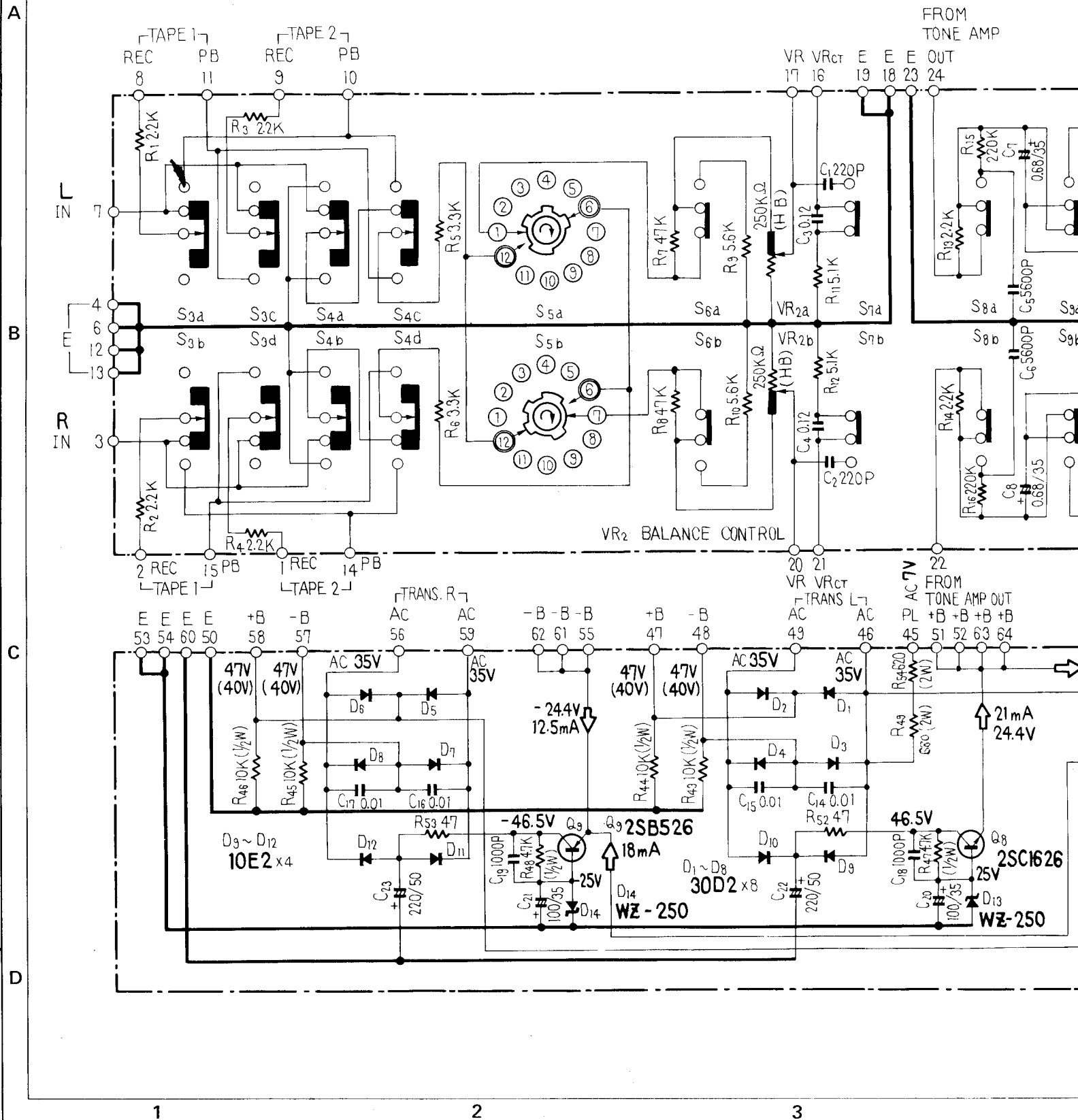

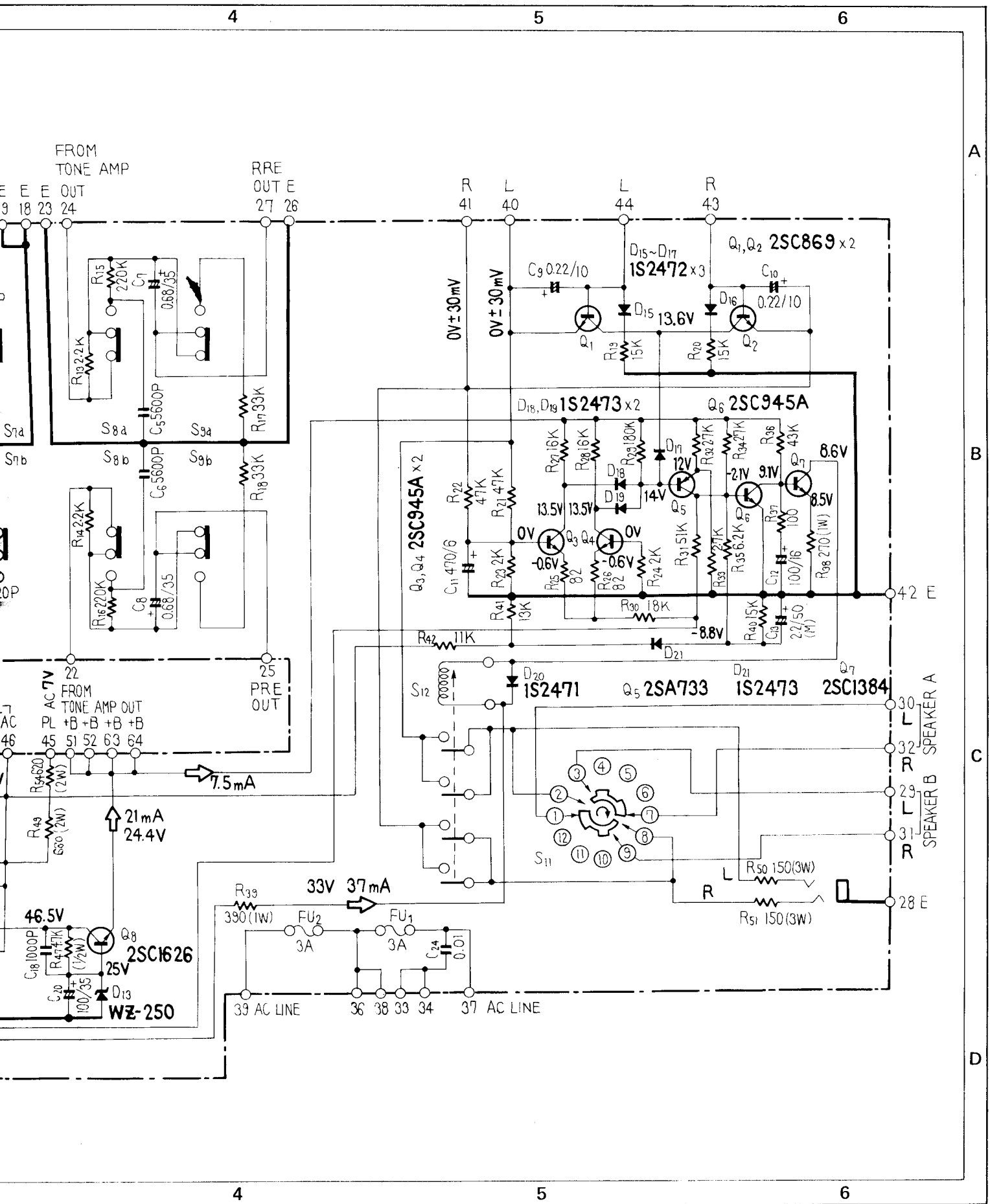

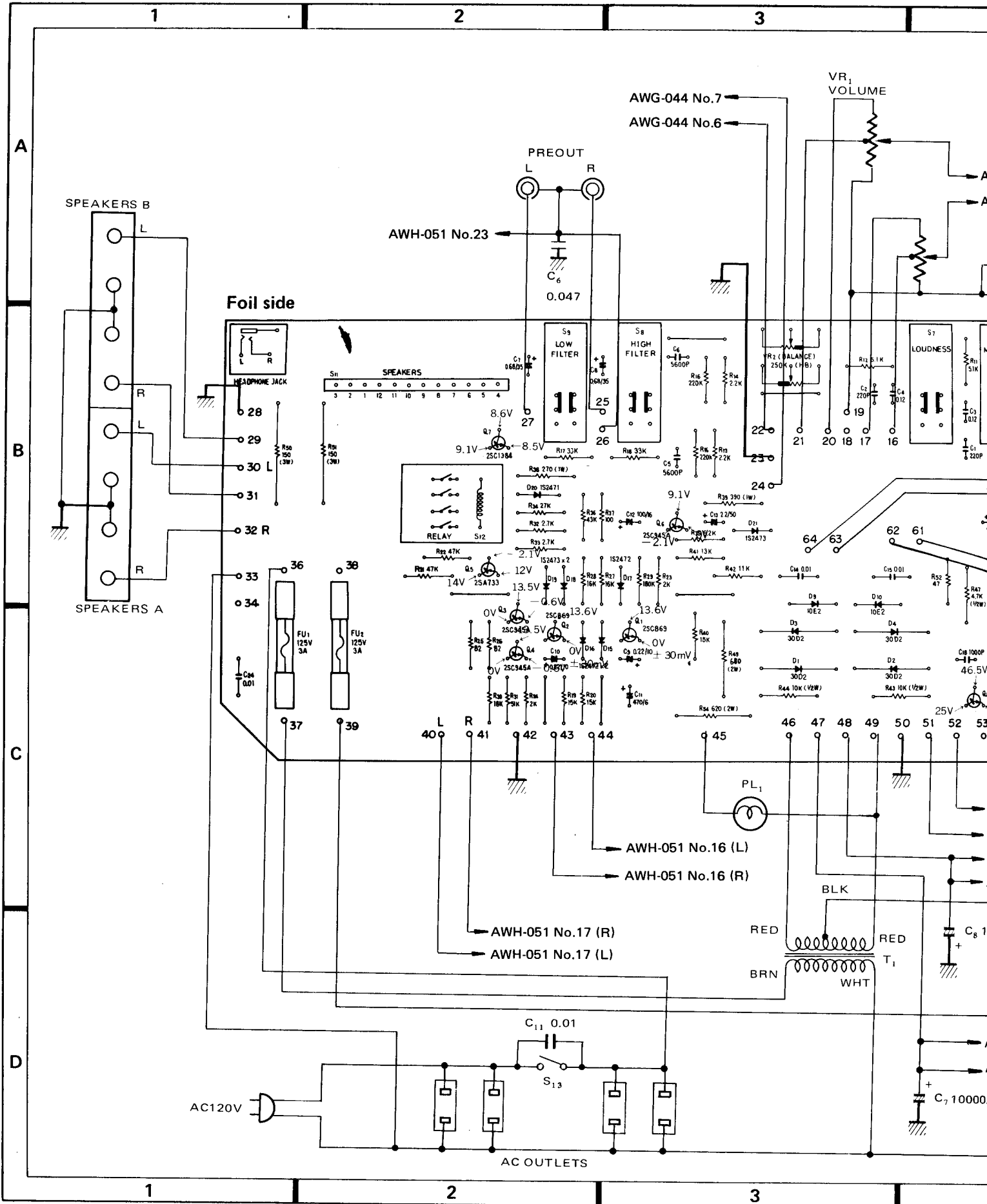

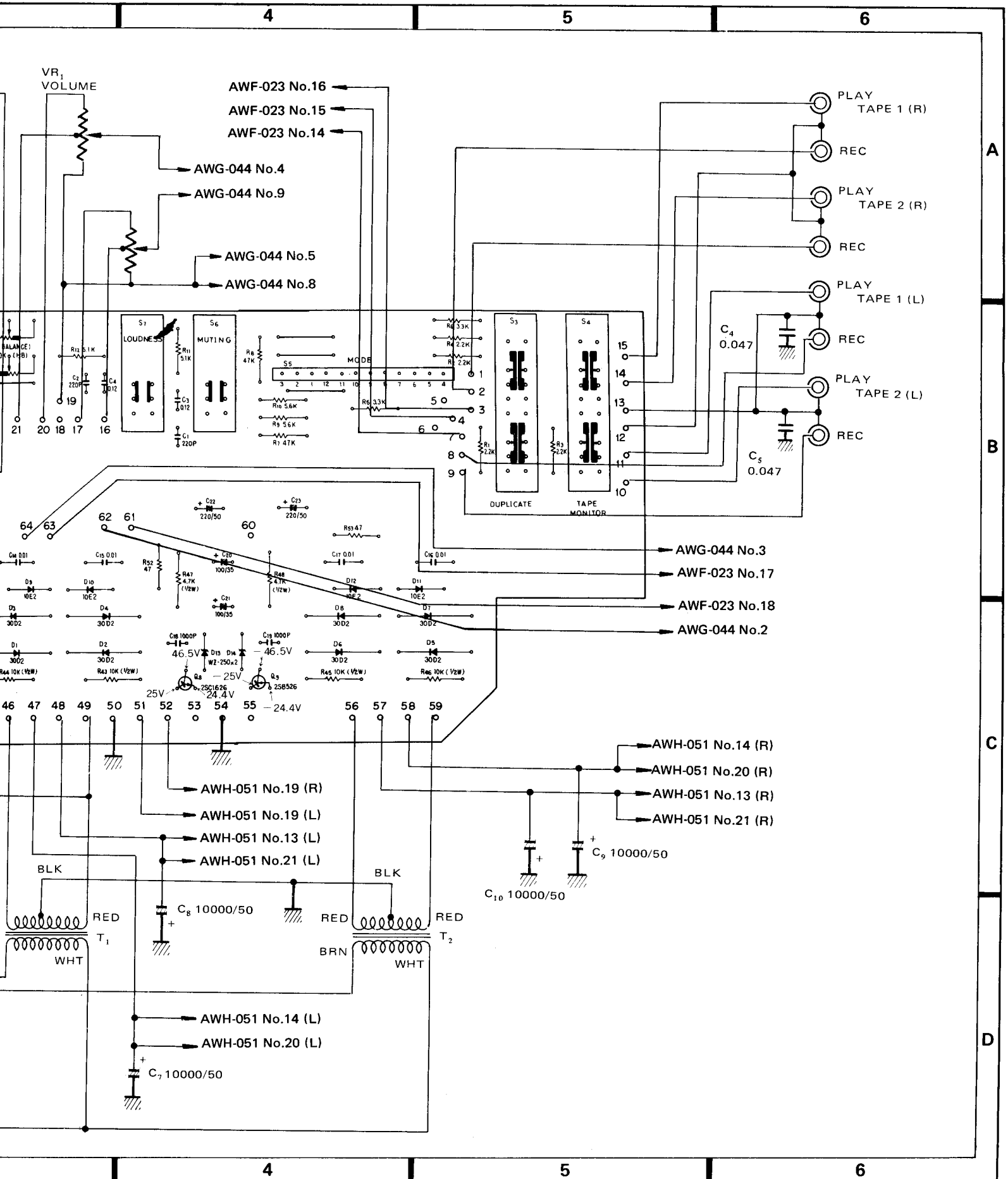

## Parts List of Switch Assembly (AWS-108)

### SEMICONDUCTORS

Symbol	Description	Part No.
Q1	Transistor	2SC869-D or C
Q2	Transistor	2SC869-D or C
Q3	Transistor	2SC945A-Q or R
Q4	Transistor	2SC945A-Q or R
Q5	Transistor	2SA733-Q or R (2SA823-Q or R)
Q6	Transistor	2SC945A-Q or R
Q7	Transistor	2SC1384-Q or R
Q8	Transistor	2SC1626-O or Y (2SD381-M or L)
Q9	Transistor	2SB526-C or D (2SA816-O or Y)
D1	Diode	30D2 (GP-25D) (ERC01-02)
D2	Diode	30D2 (GP-25D) (ERC01-02)
D3	Diode	30D2 (GP-25D) (ERC01-02)
D4	Diode	30D2 (GP-25D) (ERC01-02)
D5	Diode	30D2 (GP-25D) (ERC01-02)
D6	Diode	30D2 (GP-25D) (ERC01-02)
D7	Diode	30D2 (GP-25D) (ERC01-02)
D8	Diode	30D2 (GP-25D) (ERC01-02)
D9	Diode	10E2 (SIB01-02) (1S1886)
D10	Diode	10E2 (SIB01-02) (1S1886)
D11	Diode	10E2 (SIB01-02) (1S1886)

Symbol	Description	Part No.
D12	Diode	10E2 (SIB01-02) (1S1886)
D13	Zener diode	WZ-250
D14	Zener diode	WZ-250
D15	Diode	1S2472 (1S1554)
D16	Diode	1S2472 (1S1554)
D17	Diode	1S2472 (1S1554)
D18	Diode	1S2473 (1S1555)
D19	Diode	1S2473 (1S1555)
D20	Diode	1S2471
D21	Diode	1S2473 (1S1555)

### SWITCHES

Symbol	Description	Part No.
S3	Lever switch (DUPLICATE)	ASK-113
S4	Lever switch (MONITOR)	ASK-113
S5	Rotary switch (MODE)	ASD-053
S6	Lever switch (MUTING)	ASK-110
S7	Lever switch (LOUDNESS)	ASK-110
S8	Lever switch (HIGH FILTER)	ASK-110
S9	Lever switch (LOW FILTER)	ASK-110
S11	Rotary switch (SPEAKERS)	ASD-054
S12	Relay	ASR-023

### RESISTORS

Symbol	Description	Part No.
R1	Carbon film 2.2k	RD¼PS 222J
R2	Carbon film 2.2k	RD¼PS 222J
R3	Carbon film 2.2k	RD¼PS 222J
R4	Carbon film 2.2k	RD¼PS 222J
R5	Carbon film 3.3k	RD¼PS 332J
R6	Carbon film 3.3k	RD¼PS 332J
R7	Carbon film 47k	RD¼PS 473J
R8	Carbon film 47k	RD¼PS 473J
R9	Carbon film 5.6k	RD¼PS 562J
R10	Carbon film 5.6k	RD¼PS 562J
R11	Carbon film 5.1k	RD¼PS 512J
R12	Carbon film 5.1k	RD¼PS 512J
R13	Carbon film 2.2k	RD¼PS 222J

Symbol	Description	Part No.
R14	Carbon film 2.2k	RD¼PS 222J
R15	Carbon film 220k	RD¼PS 224J
R16	Carbon film 220k	RD¼PS 224J
R17	Carbon film 33k	RD¼PS 333J
R18	Carbon film 33k	RD¼PS 333J
R19	Carbon film 15k	RD¼PS 153J
R20	Carbon film 15k	RD¼PS 153J
R21	Carbon film 47k	RD¼PS 473J
R22	Carbon film 47k	RD¼PS 473J
R23	Carbon film 2k	RD¼PS 202J
R24	Carbon film 2k	RD¼PS 202J
R25	Carbon film 82	RD¼PS 820J
R26	Carbon film 82	RD¼PS 820J
R27	Carbon film 16k	RD¼PS 163J
R28	Carbon film 16k	RD¼PS 163J
R29	Carbon film 180k	RD¼PS 184J
R30	Carbon film 18k	RD¼PS 183J
R31	Carbon film 51k	RD¼PS 513J
R32	Carbon film 2.7k	RD¼PS 272J
R33	Carbon film 2.7k	RD¼PS 272J
R34	Carbon film 27k	RD¼PS 273J
R35	Carbon film 6.2k	RD¼PS 622J
R36	Carbon film 43k	RD¼PS 433J
R37	Carbon film 100	RD¼PS 101J
R38	Metal oxide 270 1W	RS1P 271J
R39	Metal oxide 390 1W	RS1P 391J
R40	Carbon film 15k	RD¼PS 153J
R41	Carbon film 13k	RD¼PS 133J
R42	Carbon film 11k	RD¼PS 113J
R43	Carbon film 10k ½W	RD½PS 103J
R44	Carbon film 10k ½W	RD½PS 103J
R45	Carbon film 10k ½W	RD½PS 103J
R46	Carbon film 10k ½W	RD½PS 103J
R47	Carbon film 4.7k ½W	RD½PS 472J
R48	Carbon film 4.7k ½W	RD½PS 472J
R49	Metal oxide 680 2W	RS2P 681J
R50	Metal oxide 150 3W	RS3P 151J
R51	Metal oxide 150 3W	RS3P 151J
R52	Carbon film 47	RD¼PSF 470J
R53	Carbon film 47	RD¼PSF 470J
R54	Metal oxide 620 2W	RS2P 621J
VR2	Variable resistor 250k-HB (BALANCE)	ACV-172

Symbol	Description	Part No.
C6	Mylar 0.0056 50V	CQMA 562J 50
C7	Electrolytic 0.68 35V	CSZA R68M 35
C8	Electrolytic 0.68 35V	CSZA R68M 35
C9	Electrolytic 0.22 10V	CSSA R22M 10
C10	Electrolytic 0.22 10V	CSSA R22M 10
C11	Electrolytic 470 6V	CEA 471P 6
C12	Electrolytic 100 16V	CEA 101P 16
C13	Electrolytic 2.2 50V	ACH-317
C14	Ceramic 0.01 150V	ACG-004
C15	Ceramic 0.01 150V	ACG-004
C16	Ceramic 0.01 150V	ACG-004
C17	Ceramic 0.01 150V	ACG-004
C18	Ceramic 0.001 50V	CKDYF 102Z 50
C19	Ceramic 0.001 50V	CKDYF 102Z 50
C20	Electrolytic 100 35V	CEA 101P 35
C21	Electrolytic 100 35V	CEA 101P 35
C22	Electrolytic 220 50V	CEA 221P 50
C23	Electrolytic 220 50V	CEA 221P 50
C24	Ceramic 0.01 125V	ACG-003

#### OTHERS

Symbol	Description	Part No.
	Phone jack (PHONES)	AKN-008
	Fuse clip	AKR-030
	Washer faced nut M9	ABN-024
	Special nut	ABN-027

#### CAPACITORS

Symbol	Description	Part No.
C1	Ceramic 220p 50V	CCDSL 221K 50
C2	Ceramic 220p 50V	CCDSL 221K 50
C3	Mylar 0.12 50V	CQMA 124K 50
C4	Mylar 0.12 50V	CQMA 124K 50
C5	Mylar 0.0056 50V	CQMA 562J 50

11.4 PHONO JACK ASSEMBLY (AWX-107)

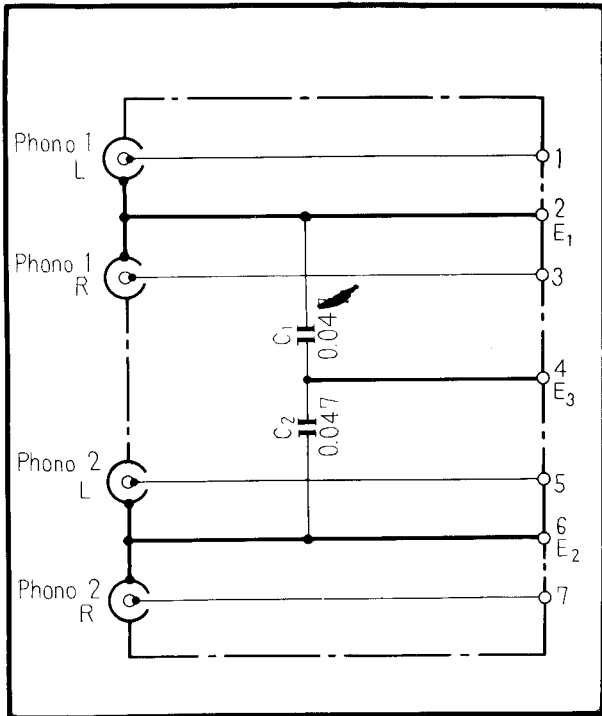

Parts List of Phono Jack Assembly (AWX-107)

Symbol	Description	Part No.
C1	Ceramic capacitor 0.047 50V	CKDYF 473Z 50
C2	Ceramic capacitor 0.047 50V	CKDYF 473Z 50
	Terminal (PHONO 1, 2)	AKB-027

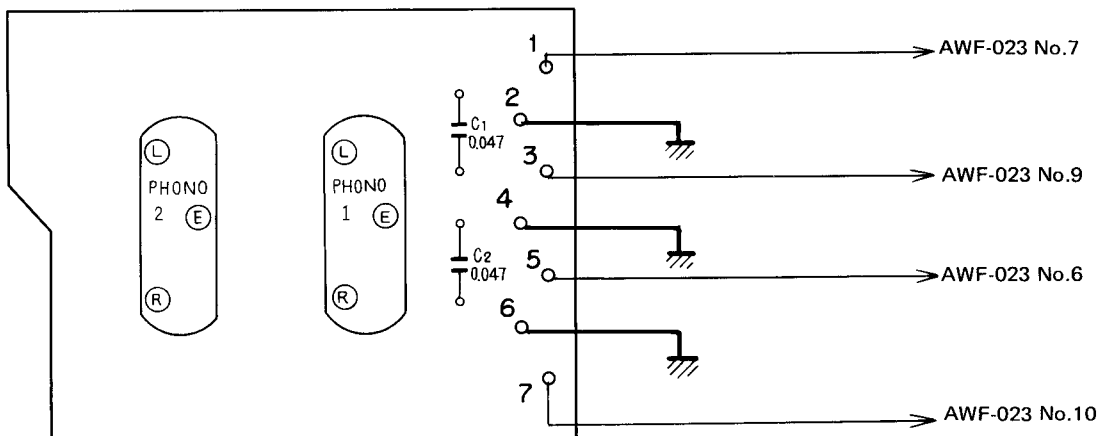



# 11.5 EQUALIZER AMPLIFIER ASSEMBLY (AWF-023)

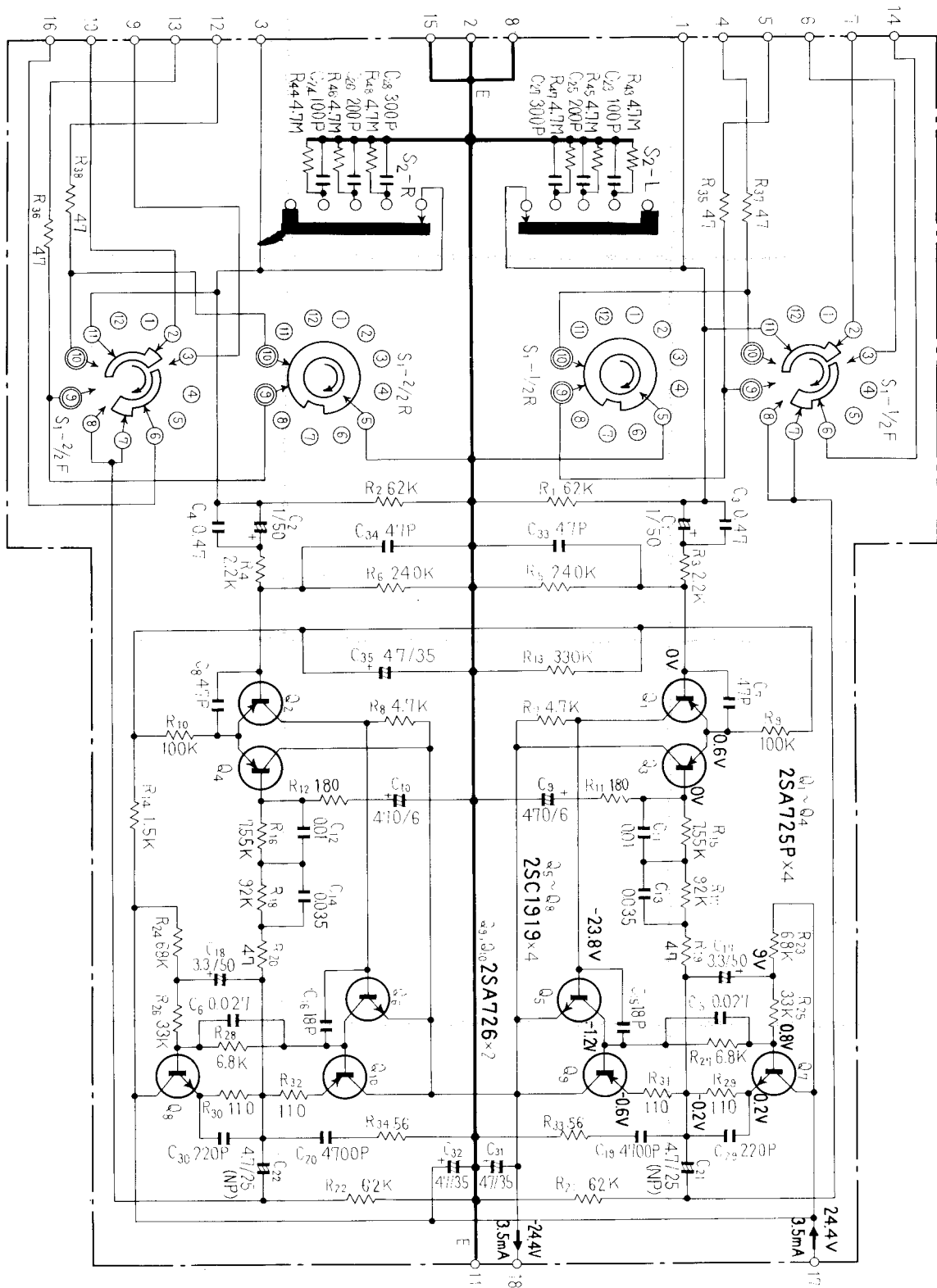

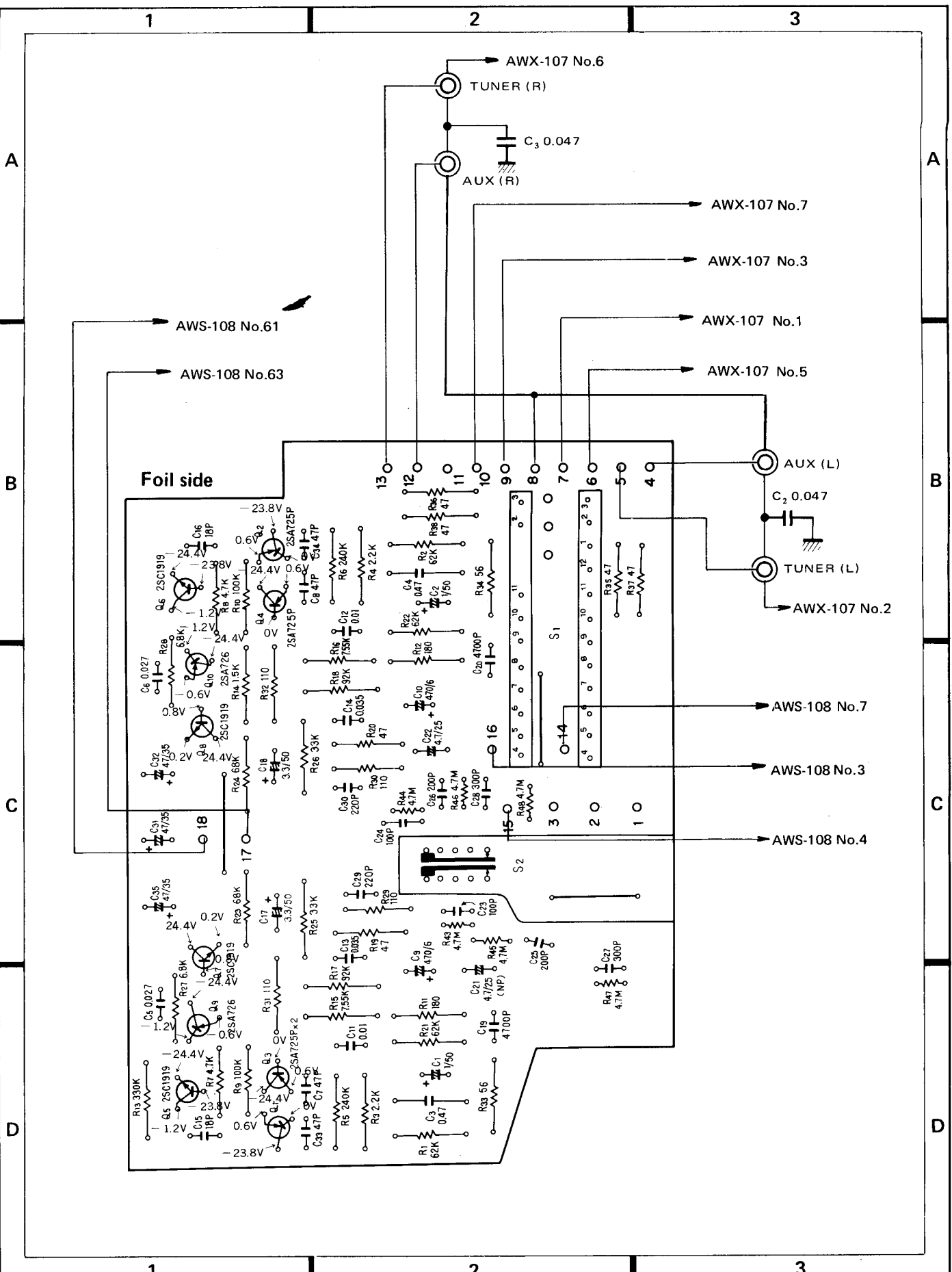

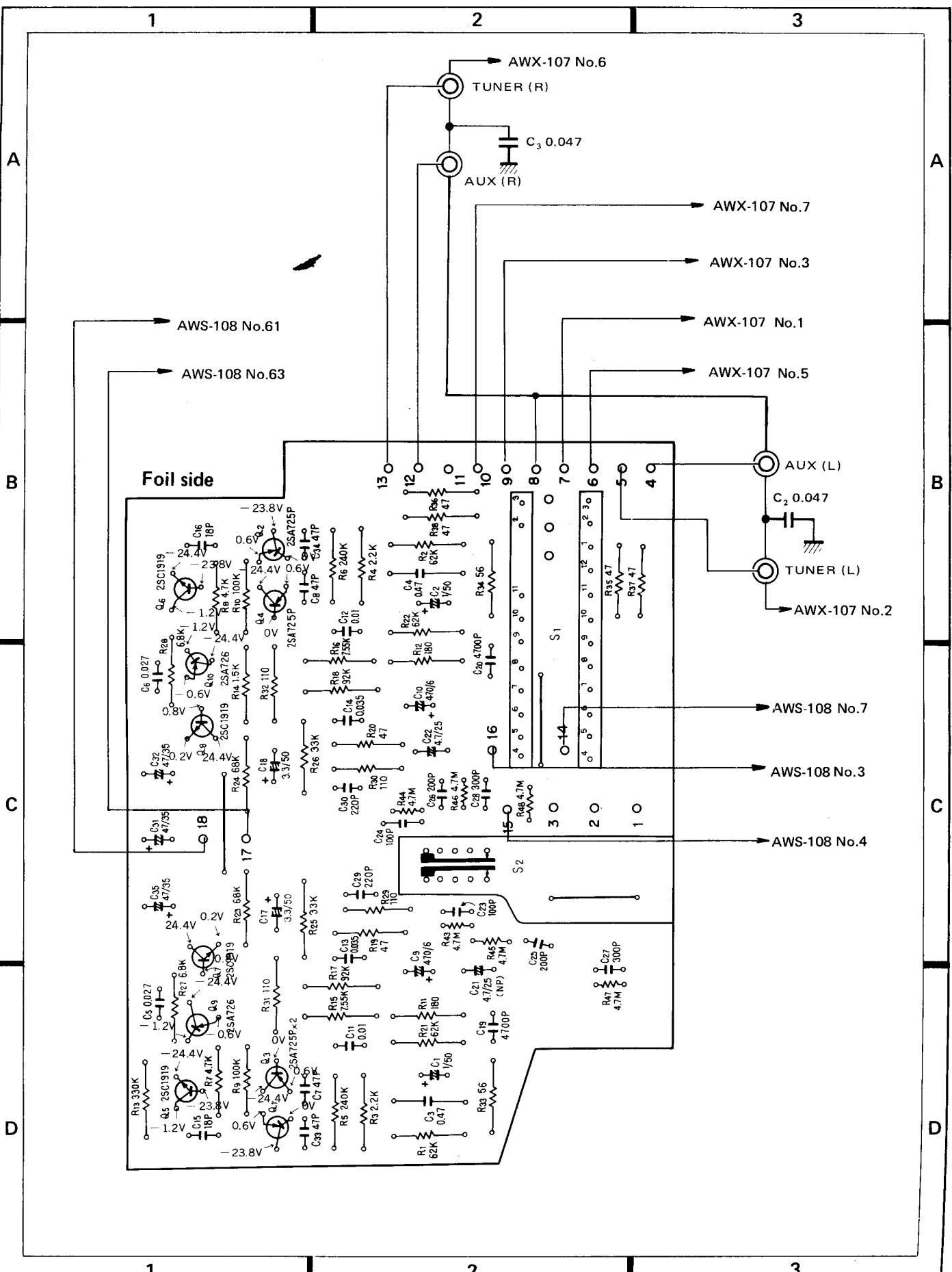

## Parts List of Equalizer Amplifier Assembly (AWF-023)

### SEMICONDUCTORS

Symbol	Description	Part No.
Q1	Transistor	2SA725P-G or F
Q2	Transistor	2SA725P-G or F
Q3	Transistor	2SA725P-G or F
Q4	Transistor	2SA725P-G or F
Q5	Transistor	2SC1919-G or F (2SC1222-G or F)
Q6	Transistor	2SC1919-G or F (2SC1222-G or F)
Q7	Transistor	2SC1919-G or F (2SC1222-G or F)
Q8	Transistor	2SC1919-G or F (2SC1222-G or F)
Q9	Transistor	2SA726-G or F (2SA640-E or F)
Q10	Transistor	2SA726-G or F (2SA640-E or F)

Symbol	Description	Part No.
R23	Carbon film 68k	RD¼PS 683J
R24	Carbon film 68k	RD¼PS 683J
R25	Carbon film 33k	RD¼PS 333J
R26	Carbon film 33k	RD¼PS 333J
R27	Carbon film 6.8k	RD¼PS 682J
R28	Carbon film 6.8k	RD¼PS 682J
R29	Carbon film 110	RD¼PS 111J
R30	Carbon film 110	RD¼PS 111J
R31	Carbon film 110	RD¼PS 111J
R32	Carbon film 110	RD¼PS 111J
R33	Carbon film 56	RD¼PS 560J
R34	Carbon film 56	RD¼PS 560J
R35	Carbon film 47	RD¼PS 470J
R36	Carbon film 47	RD¼PS 470J
R37	Carbon film 47	RD¼PS 470J
R38	Carbon film 47	RD¼PS 470J
R43	Carbon film 4.7M	RD¼VS 475J
R44	Carbon film 4.7M	RD¼VS 475J
R45	Carbon film 4.7M	RD¼VS 475J
R46	Carbon film 4.7M	RD¼VS 475J
R47	Carbon film 4.7M	RD¼VS 475J
R48	Carbon film 4.7M	RD¼VS 475J

### SWITCHES

Symbol	Description	Part No.
S1	Rotary switch (FUNCTION)	ASD-052
S2	Rotary switch (CARTRIDGE LOAD)	ASD-065 (ASD-055)

### RESISTORS

Symbol	Description	Part No.
R1	Carbon film 62k	RD¼PS 623J
R2	Carbon film 62k	RD¼PS 623J
R3	Carbon film 2.2k	RD¼PS 222J
R4	Carbon film 2.2k	RD¼PS 222J
R5	Carbon film 240k	RD¼PS 244J
R6	Carbon film 240k	RD¼PS 244J
R7	Carbon film 4.7k	RD¼PS 472J
R8	Carbon film 4.7k	RD¼PS 472J
R9	Carbon film 100k	RD¼PS 104J
R10	Carbon film 100k	RD¼PS 104J
R11	Metal film 180 ½W	RN¼SQ 1800F
R12	Metal film 180 ½W	RN¼SQ 1800F
R13	Carbon film 330k	RD¼PS 334J
R14	Carbon film 330k	RD¼PS 334J
R15	Metal film 7.55k	ACN-011
R16	Metal film 7.55k	ACN-011
R17	Metal film 92k	ACN-012
R18	Metal film 92k	ACN-012
R19	Carbon film 510	RD¼PS 511J
R20	Carbon film 510	RD¼PS 511J
R21	Carbon film 62k	RD¼PS 623J
R22	Carbon film 62k	RD¼PS 623J

### CAPACITORS

Symbol	Description	Part No.
C1	Electrolytic 1 50V	CEANL 010P 50
C2	Electrolytic 1 50V	CEANL 010P 50
C3	Metallized mylar 0.47 50V	ACE-006
C4	Metallized mylar 0.47 50V	ACE-006
C5	Mylar 0.027 50V	CQMA 273M 50
C6	Mylar 0.027 50V	CQMA 273M 50
C7	Ceramic 47p 50V	CCDSL 470K 50
C8	Ceramic 47p 50V	CCDSL 470K 50
C9	Electrolytic 470 6V	CEA 471P 6
C10	Electrolytic 470 6V	CEA 471P 6
C11	Polypropylene 0.01 50V	CQPA 103G 50
C12	Polypropylene 0.01 50V	CQPA 103G 50
C13	Polypropylene 0.035 50V	CQPA 353G 50
C14	Polypropylene 0.035 50V	CQPA 353G 50
C15	Ceramic 18p 50V	CCDSL 180K 50
C16	Ceramic 18p 50V	CCDSL 180K 50
C17	Electrolytic 3.3 50V	CEA 3R3P 50
C18	Electrolytic 3.3 50V	CEA 3R3P 50
C19	Ceramic 4700p 50V	CKDYB 472K 50
C20	Ceramic 4700p 50V	CKDYB 472K 50
C21	Electrolytic 4.7 25V	ACH-318

Symbol	Description			Part No.
C22	Electrolytic	4.7	25V	ACH-318
C23	Ceramic	100p	50V	CCDSL 101K 50
C24	Ceramic	100p	50V	CCDSL 101K 50
C25	Ceramic	200p	50V	CCDSL 201K 50
C26	Ceramic	200p	50V	CCDSL 201K 50
C27	Ceramic	300p	50V	CKDYB 301K 50
C28	Ceramic	300p	50V	CKDYB 301K 50
C29	Ceramic	220p	50V	CCDSL 221K 50
C30	Ceramic	220p	50V	CCDSL 221K 50
C31	Electrolytic	47	35V	CEA 470P 35
C32	Electrolytic	47	35V	CEA 470P 35
C33	Ceramic	47p	50V	CCDSL 470K 50
C34	Ceramic	47p	50V	CCDSL 470K 50
C35	Electrolytic	47	35V	CEA 470P 35

## OTHERS

Symbol	Description	Part No.
	Special nut	ABN-027
	Washer faced nut M7	ABN-031

# 11.6 CONTROL AMPLIFIER ASSEMBLY (AWG-044)

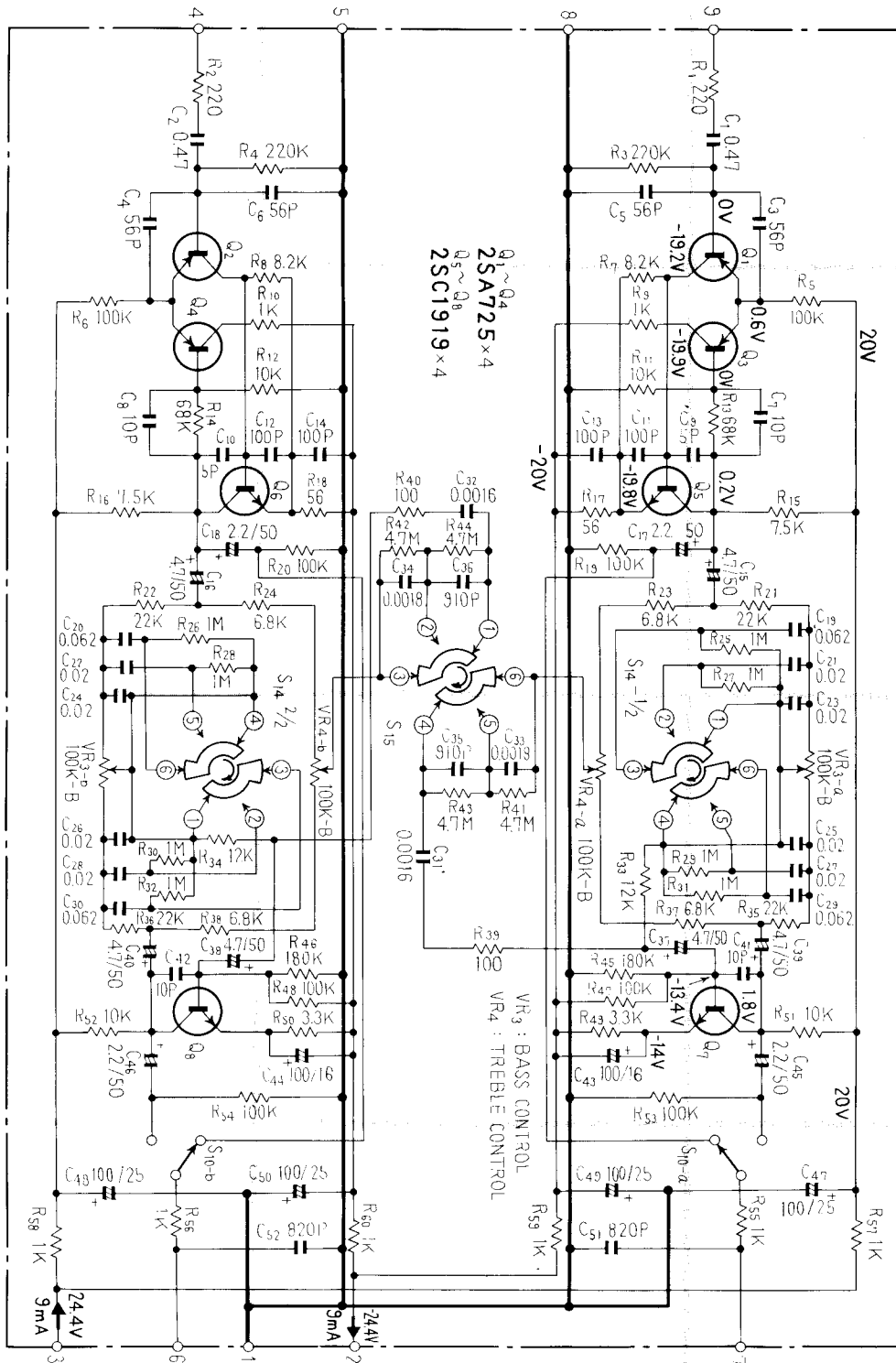

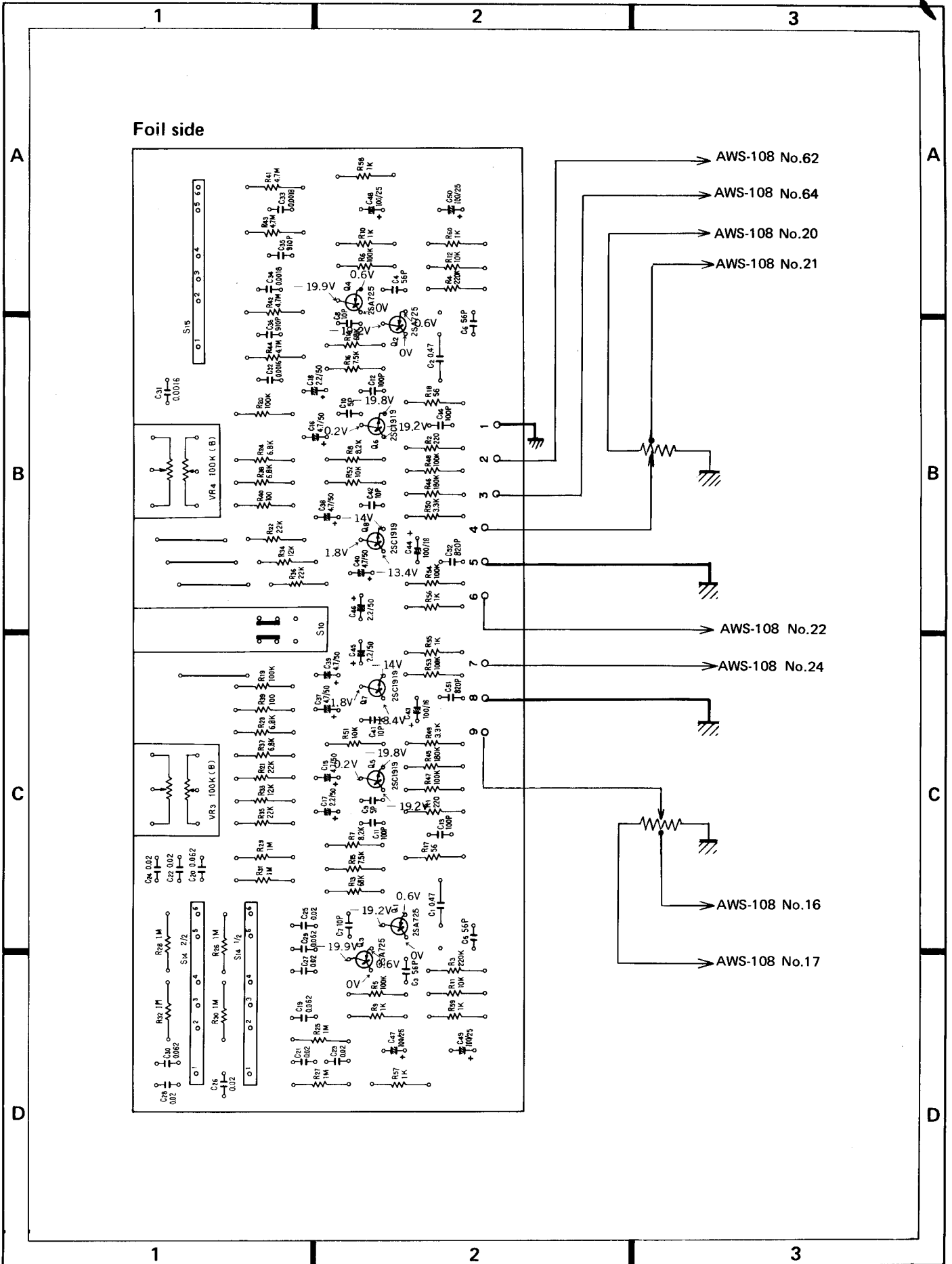

## Parts List of Control Amplifier Assembly (AWG-044)

### SEMICONDUCTORS

Symbol	Description	Part No.
Q1	Transistor	2SA725-G or F (2SA640-E or F)
Q2	Transistor	2SA725-G or F (2SA640-E or F)
Q3	Transistor	2SA725-G or F (2SA640-E or F)
Q4	Transistor	2SA725-G or F (2SA640-E or F)
Q5	Transistor	2SC1919-G or F (2SC1222-E or U)
Q6	Transistor	2SC1919-G or F (2SC1222-E or U)
Q7	Transistor	2SC1919-G or F (2SC1222-E or U)
Q8	Transistor	2SC1919-G or F (2SC1222-E or U)

### SWITCHES

Symbol	Description	Part No.
S10	Lever switch (TONE)	ASK-109
S14	Rotary switch (BASS TURNOVER)	ASD-057
S15	Rotary switch (TREBLE TURNOVER)	ASD-056

### RESISTORS

Symbol	Description	Part No.
R1	Carbon film 220	RD¼PS 221J
R2	Carbon film 220	RD¼PS 221J
R3	Carbon film 220k	RD¼PS 224J
R4	Carbon film 220k	RD¼PS 224J
R5	Carbon film 100k	RD¼PS 104J
R6	Carbon film 100k	RD¼PS 104J
R7	Carbon film 8.2k	RD¼PS 822J
R8	Carbon film 8.2k	RD¼PS 822J
R9	Carbon film 1k	RD¼PS 102J
R10	Carbon film 1k	RD¼PS 102J
R11	Carbon film 10k	RD¼PS 103J
R12	Carbon film 10k	RD¼PS 103J
R13	Carbon film 68k	RD¼PS 683J
R14	Carbon film 68k	RD¼PS 683J
R15	Carbon film 7.5k	RD¼PS 752J
R16	Carbon film 7.5k	RD¼PS 752J
R17	Carbon film 56	RD¼PS 560J
R18	Carbon film 56	RD¼PS 560J
R19	Carbon film 100k	RD¼PS 104J
R20	Carbon film 100k	RD¼PS 104J

Symbol	Description	Part No.
R21	Carbon film 22k	RD¼PS 223J
R22	Carbon film 22k	RD¼PS 223J
R23	Carbon film 6.8k	RD¼PS 682J
R24	Carbon film 6.8k	RD¼PS 682J
R25	Carbon film 1M	RD¼PS 105J
R26	Carbon film 1M	RD¼PS 105J
R27	Carbon film 1M	RD¼PS 105J
R28	Carbon film 1M	RD¼PS 105J
R29	Carbon film 1M	RD¼PS 105J
R30	Carbon film 1M	RD¼PS 105J
R31	Carbon film 1M	RD¼PS 105J
R32	Carbon film 1M	RD¼PS 105J
R33	Carbon film 12k	RD¼PS 123J
R34	Carbon film 12k	RD¼PS 123J
R35	Carbon film 22k	RD¼PS 223J
R36	Carbon film 22k	RD¼PS 223J
R37	Carbon film 6.8k	RD¼PS 682J
R38	Carbon film 6.8k	RD¼PS 682J
R39	Carbon film 100	RD¼PS 101J
R40	Carbon film 100	RD¼PS 101J
R41	Carbon film 4.7M	RD¼PS 475J
R42	Carbon film 4.7M	RD¼PS 475J
R43	Carbon film 4.7M	RD¼PS 475J
R44	Carbon film 4.7M	RD¼PS 475J
R45	Carbon film 180k	RD¼PS 184J NL
R46	Carbon film 180k	RD¼PS 184J NL
R47	Carbon film 100k	RD¼PS 104J NL
R48	Carbon film 100k	RD¼PS 104J NL
R49	Carbon film 3.3k	RD¼PS 332J
R50	Carbon film 3.3k	RD¼PS 332J
R51	Carbon film 10k	RD¼PS 103J
R52	Carbon film 10k	RD¼PS 103J
R53	Carbon film 100k	RD¼PS 104J
R54	Carbon film 100k	RD¼PS 104J
R55	Carbon film 1k	RD¼PS 102J
R56	Carbon film 1k	RD¼PS 102J
R57	Carbon film 1k	RD¼PS 102J
R58	Carbon film 1k	RD¼PS 102J
R59	Carbon film 1k	RD¼PS 102J
R60	Carbon film 1k	RD¼PS 102J
VR3	Variable resistor 100k-B (BASS)	ACV-136
VR4	Variable resistor 100k-B (TREBLE)	ACV-136



## CAPACITORS

Symbol	Description			Part No.
C1	Metallized mylar	0.47	50V	ACE-006
C2	Metallized mylar	0.47	50V	ACE-006
C3	Ceramic	56p	50V	CCDSL 560K 50
C4	Ceramic	56p	50V	CCDSL 560K 50
C5	Ceramic	56p	50V	CCDSL 560K 50
C6	Ceramic	56p	50V	CCDSL 560K 50
C7	Ceramic	10p	50V	CCDSL 100F 50
C8	Ceramic	10p	50V	CCDSL 100F 50
C9	Ceramic	5p	50V	CCDSL 050D 50
C10	Ceramic	5p	50V	CCDSL 050D 50
C11	Ceramic	100p	50V	CCDSL 101K 50
C12	Ceramic	100p	50V	CCDSL 101K 50
C13	Ceramic	100p	50V	CCDSL 101K 50
C14	Ceramic	100p	50V	CCDSL 101K 50
C15	Electrolytic	4.7	50V	CEANL 4R7P 50
C16	Electrolytic	4.7	50V	CEANL 4R7P 50
C17	Electrolytic	2.2	50V	ACH-309
C18	Electrolytic	2.2	50V	ACH-309
C19	Mylar	0.062	50V	CQMA 623J 50
C20	Mylar	0.062	50V	CQMA 623J 50
C21	Mylar	0.02	50V	CQMA 203J 50
C22	Mylar	0.02	50V	CQMA 203J 50
C23	Mylar	0.02	50V	CQMA 203J 50
C24	Mylar	0.02	50V	CQMA 203J 50
C25	Mylar	0.02	50V	CQMA 203J 50
C26	Mylar	0.02	50V	CQMA 203J 50
C27	Mylar	0.02	50V	CQMA 203J 50
C28	Mylar	0.02	50V	CQMA 203J 50
C29	Mylar	0.062	50V	CQMA 623J 50
C30	Mylar	0.062	50V	CQMA 623J 50
C31	Mylar	0.0016	50V	CQMA 162J 50
C32	Mylar	0.0016	50V	CQMA 162J 50
C33	Mylar	0.0018	50V	CQMA 182J 50
C34	Mylar	0.0018	50V	CQMA 182J 50
C35	Polystyrene	910p	50V	CQSA 911J 50
C36	Polystyrene	910p	50V	CQSA 911J 50
C37	Electrolytic	4.7	50V	CEANL 4R7P 50
C38	Electrolytic	4.7	50V	CEANL 4R7P 50
C39	Electrolytic	4.7	50V	CEANL 4R7P 50
C40	Electrolytic	4.7	50V	CEANL 4R7P 50
C41	Ceramic	10p	50V	CCDSL 100F 50
C42	Ceramic	10p	50V	CCDSL 100F 50
C43	Electrolytic	100	16V	CEANL 101P 16
C44	Electrolytic	100	16V	CEANL 101P 16
C45	Electrolytic	2.2	50V	ACH-309
C46	Electrolytic	2.2	50V	ACH-309
C47	Electrolytic	100	25V	CEA 101P 25V
C48	Electrolytic	100	25V	CEA 101P 25V
C49	Electrolytic	100	25V	CEA 101P 25V
C50	Electrolytic	100	25V	CEA 101P 25V

Symbol	Description			Part No.
C51	Ceramic	820p	50V	CKDYB 821K 50
C52	Ceramic	820p	50V	CKDYB 821K 50

## OTHERS

Symbol	Description	Part No.
	Special nut	ABN-027
	Washer faced nut M9	ABN-024

# 11.7 POWER AMPLIFIER ASSEMBLY (AWH-051)

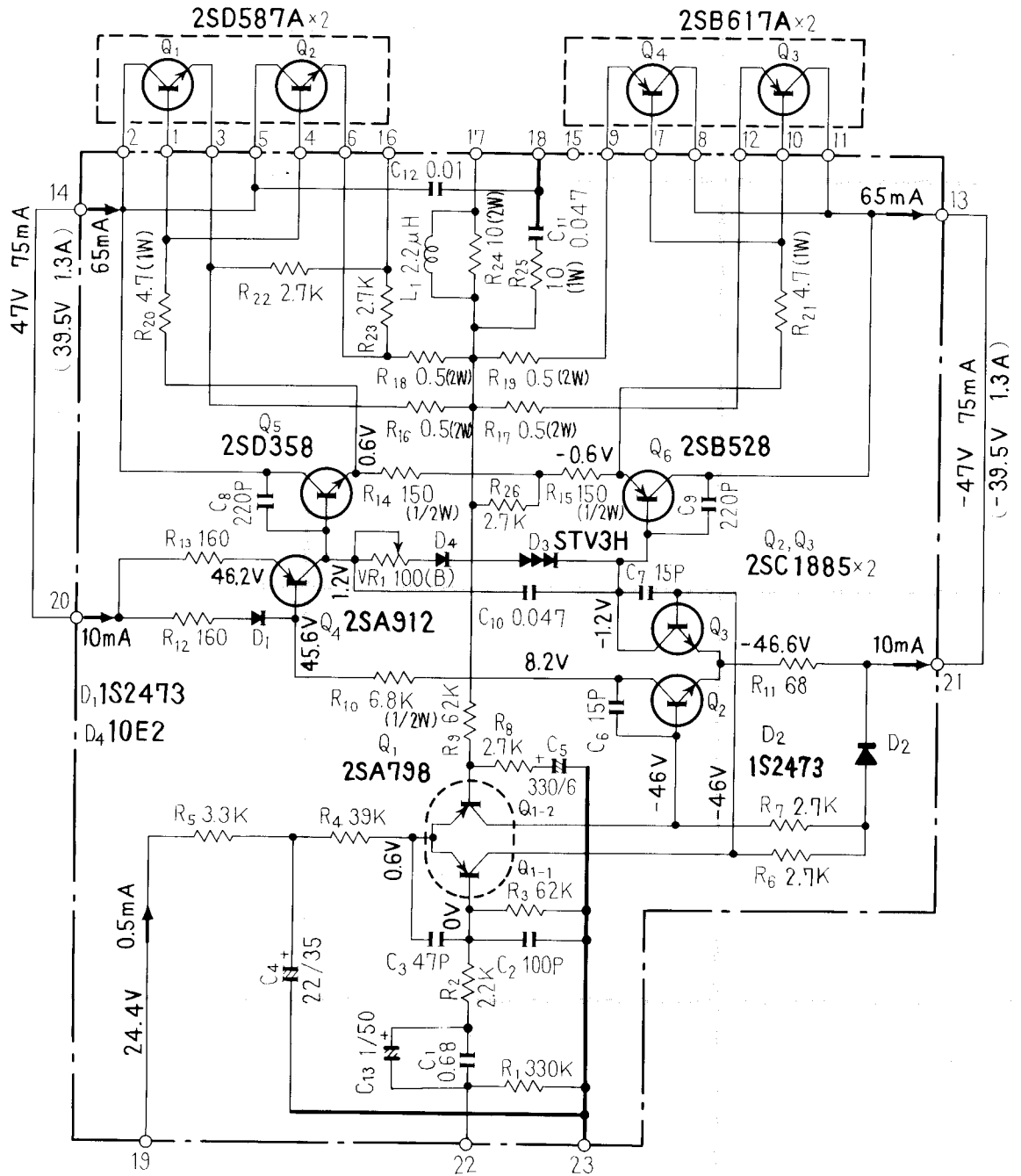

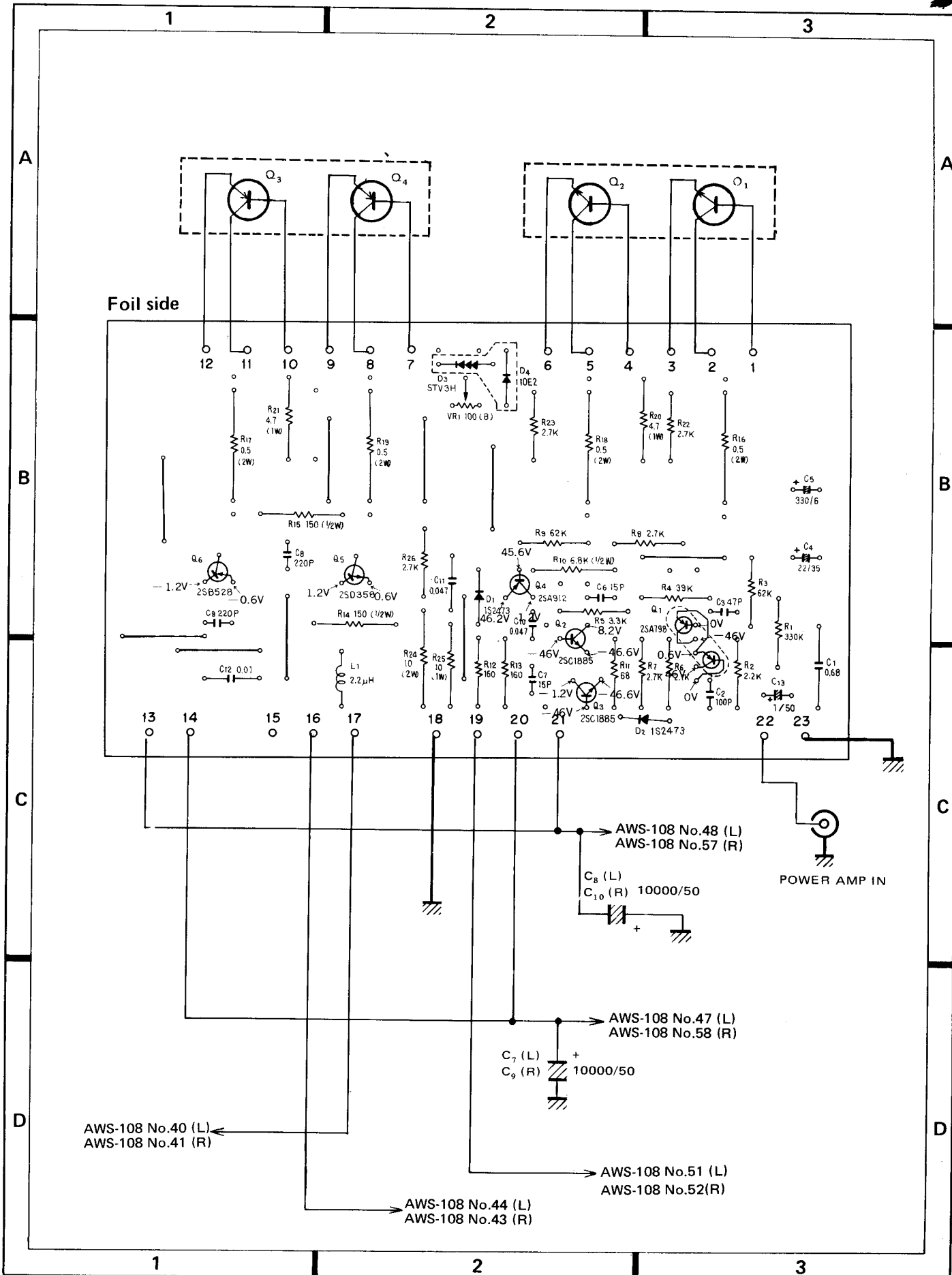

Foil side

AWS-108 No.40 (L)  
AWS-108 No.41 (R)

AWS-108 No.44 (L)  
AWS-108 No.43 (R)

AWS-108 No.47 (L)  
AWS-108 No.58 (R)

AWS-108 No.51 (L)  
AWS-108 No.52 (R)

AWS-108 No.48 (L)  
AWS-108 No.57 (R)

POWER AMP IN

C<sub>7</sub> (L)  
C<sub>9</sub> (R) 10000/50

C<sub>8</sub> (L)  
C<sub>10</sub> (R) 10000/50

## Parts List of Power Amplifier Assembly (AWH-051)

### SEMICONDUCTORS

Symbol	Description	Part No.
Q1	Transistor	2SA798-G or F
Q2	Transistor	2SC1885-S or R
Q3	Transistor	(2SC1903-V or B) 2SC1885-S or R (2SC1903-V or B)
Q4	Transistor	2SA912-R or S (2SA898-B or V)
Q5	Transistor	2SD358-D or C
Q6	Transistor	2SB528-D or C
D1	Diode	1S2473 (1S1555)
D2	Diode	1S2473 (1S1555)
D3	Varistor	STV-3H
D4	Diode	10E2 (SIB01-01) (1S1885)

### RESISTORS

Symbol	Description	Part No.
VR1	Semi-fixed 100-B	ACP-019
R1	Carbon film 330k	RD¼PS 334J
R2	Carbon film 2.2k	RD¼PS 222J
R3	Carbon film 62k	RD¼PS 623J
R4	Carbon film 39k	RD¼PS 393J
R5	Carbon film 3.3k	RD¼PS 332J
R6	Carbon film 2.7k	RD¼PS 272J
R7	Carbon film 2.7k	RD¼PS 272J
R8	Carbon film 2.7k	RD¼PS 272J
R9	Carbon film 62k	RD¼PS 623J
R10	Carbon film 6.8k ½W	RD½PS 682J
R11	Carbon film 68	RD¼PS 680J
R12	Carbon film 160	RD¼PSF 161J
R13	Carbon film 160	RD¼PSF 161J
R14	Carbon film 150 ½W	RD½PSF 151J
R15	Carbon film 150 ½W	RD½PSF 151J
R16	Metal film 0.5 2W	RN2H 0R5K
R17	Metal film 0.5 2W	RN2H 0R5K
R18	Metal film 0.5 2W	RN2H 0R5K
R19	Metal film 0.5 2W	RN2H 0R5K
R20	Metal film 4.7 1W	RN1H 4R7K
R21	Metal film 4.7 1W	RN1H 4R7K
R22	Carbon film 2.7k	RD¼PS 272J
R23	Carbon film 2.7k	RD¼PS 272J
R24	Metal oxide 10 2W	RS2P 100J
R25	Metal oxide 10 1W	RS1P 100J

### CAPACITORS

Symbol	Description	Part No.
C1	Metallized mylar 0.68 100V	ACE-010
C2	Ceramic 100p 50V	CCDSL 101K 50
C3	Ceramic 47p 50V	CCDSL 470K 50
C4	Electrolytic 22 35V	CEA 220P 35
C5	Electrolytic 330 6V	CEA 331P 6
C6	Ceramic 15p 500V	CCDSL 150K 500
C7	Ceramic 15p 50V	CCDSL 150K 50
C8	Ceramic 220p 500V	CCDSL 221K 500
C9	Ceramic 220p 500V	CCDSL 221K 500
C10	Ceramic 0.047 50V	CKDYF 473Z 50
C11	Ceramic 0.047 150V	ACG-009
C12	Ceramic 0.01 150V	ACG-001
C13	Electrolytic 1 50V	CEANL 010P 50

### OTHER

Symbol	Description	Part No.
L1	AF choke coil 2.2µH	T63-009

# 12. PACKING

