

Service Manual

STEREO AMPLIFIER

SA-9800

For Service Manuals Contact
MAURITRON TECHNICAL SERVICES
8 Cherry Tree Rd, Chinnor
Oxon OX9 4QY
Tel:- 01844-351694 Fax:- 01844-352554
Email:- enquiries@mauritron.co.uk

 PIONEER®

MODEL SA-9800 COMES IN FIVE VERSIONS DISTINGUISHED AS FOLLOWS:

Type	Voltage	Remarks
KU	120V only	U.S.A. model
KC	120V only	Canada model
HG	220V and 240V (Switchable)	Europe or Oceania model
S/G	110V, 120V, 220V and 240V (Switchable)	U.S. Military model
S	110V, 120V, 220V and 240V (Switchable)	General export model

The variations in safety standards in different countries has also necessitated variations in power supply and circuit component specifications.

This service manual is applicable to the KU type. For the servicing of the other types please refer to the additional service manuals.

CONTENTS

1. SPECIFICATIONS	3	11.11 PA-R Assembly (GWH-120)	45
2. FRONT PANEL FACILITIES	4	11.12 Tape Terminal Assembly (GWX-262)	48
3. REAR PANEL FACILITIES	7	11.13 Tape Switch Assembly (GWS-172)	48
4. BLOCK DIAGRAM	8	11.14 Indicator Assembly (AWV-002)	49
5. CIRCUIT DESCRIPTIONS		11.15 VR Assembly (GWX-256)	51
5.1 Pre-amplifier Section	8	11.16 Protection Assembly (AWM-163)	52
5.2 Power Amplifier Section	10	11.17 Rectifier Assembly (AWR-192)	53
5.3 Indicator Circuit	13	11.18 Power Supply Assembly (AWR-191)	54
5.4 Protection Circuit	14	Additional Service Manual for S, S/G Types	57
6. DISASSEMBLY	15		
7. PARTS LOCATION	16		
8. ADJUSTMENTS	18		
9. PACKING	20		
10. EXPLODED VIEW	21		
11. SCHEMATIC DIAGRAMS, P.C. BOARD PATTERNS AND PARTS LIST			
11.1 Miscellanea	25		
11.2 Schematic Diagram	27		
11.3 P.C. Boards Connection Diagram	31		
11.4 Input Terminal Assembly (GWX-261)	35		
11.5 CR Assembly (GWX-257)	35		
11.6 EQ Assembly (GWF-116)	36		
11.7 Switch Assembly (GWS-171)	39		
11.8 TC Assembly (GWS-176)	40		
11.9 Filter Assembly (GWS-176)	41		
11.10 PA-L Assembly (GWH-119)	42		

1. SPECIFICATIONS

Semiconductors

ICs	3
FETs	6
Transistors	73
Diodes	36
Others	3

Power Amplifier Section

Continuous Power Output is 100watts* per channel, min., at 8 ohms from 10 Hertz to 20,000 Hertz with no more than 0.005% total harmonic distortion, or 100 watts* per channel at 4 ohms from 10 Hertz to 20,000 Hertz with no more than 0.005% total harmonic distortion.

Continuous Power Output

10Hz to 50kHz	100W + 100W (T.H.D. 0.01%, 8 ohms)
	120W + 120W (T.H.D. 0.02%, 4 ohms)

Total Harmonic Distortion (10 Hertz to 20,000 Hertz)

continuous rated power output	No more than 0.005%
50 watts per channel power output, 8 ohms	No more than 0.004%
1 watt per channel power output, 8 ohms	No more than 0.004%

Intermodulation Distortion (50 Hertz : 7,000 Hertz = 4 : 1)

continuous rated power output	No more than 0.002%
50 watts per channel power output, 8 ohms	No more than 0.002%
1 watt per channel power output, 8 ohms	No more than 0.002%

Frequency Response

5 to 200,000 Hertz	± 0.2 dB (POWER AMP IN)
--------------------	-----------------------------

Input (Sensitivity/Impedance)

	1V/50 kilohms (POWER AMP IN)
--	------------------------------

Output

Speaker	A, B, A+B
Headphones	Low impedance

Damping Factor

(20 Hertz to 20,000 Hertz, 8 ohms)	55
------------------------------------	----

Hum and Noise

(IHF, short-circuited, A network)	118dB
-----------------------------------	-------

Preamplifier Section

Input (Sensitivity/Impedance)

PHONO 1 MM	2.5mV/50 kilohms
PHONO 2 MM	2.5mV/50 kilohms
PHONO 2 MC	100 μ V/100 ohms

CARTRIDGE LOAD	Both Phono 1 and 2
	100, 10k, 25k, 50k, 100k ohms
	100, 200, 300, 400, 500pF

TUNER	150mV/50 kilohms
-------	------------------

AUX	150mV/50 kilohms
-----	------------------

TAPE PLAY 1	150mV/50 kilohms
-------------	------------------

TAPE PLAY 2	150mV/50 kilohms
-------------	------------------

Phono Overload Level (T.H.D. 0.002%, 1kHz)

PHONO 1	250mV
---------	-------

PHONO 2	250mV (MM), 10mV (MC)
---------	-----------------------

Output (Level/Impedance)

TAPE REC 1	150mV
------------	-------

TAPE REC 2	150mV
------------	-------

PRE OUT	1V/600 ohms, 3V/600 ohms (max.)
---------	---------------------------------

Total Harmonic Distortion

10 to 50,000 Hertz, 1V output	No more than 0.006%
-------------------------------	---------------------

Frequency Response

PHONO (RIAA Equalization)	20Hz to 20,000Hz ± 0.2 dB
---------------------------	-------------------------------

TUNER, AUX, TAPE PLAY	5Hz to 100,000Hz ± 1 dB
-----------------------	-----------------------------

Tone Control

BASS 400Hz position	+10dB, -10dB (100Hz)
---------------------	----------------------

200Hz position	+10dB, -10dB (50Hz)
----------------	---------------------

Turnover Frequency	400Hz/200Hz
--------------------	-------------

TREBLE 2.5kHz position	+10dB, -10dB (10kHz)
------------------------	----------------------

5kHz position	+10dB, -10dB (20kHz)
---------------	----------------------

Turnover Frequency	2.5kHz/5kHz
--------------------	-------------

Filter SUBSONIC	15Hz (12dB/oct)
-----------------	-----------------

HIGH	8kHz (12dB/oct)
------	-----------------

Hum and Noise (IHF, short-circuited, A network)

PHONO MM/MC	90dB/72dB
-------------	-----------

TUNER, AUX, TAPE PLAY	110dB
-----------------------	-------

Muting

	-20dB
--	-------

Loudness Contour (Volume control set at -40dB position)

	+6dB (100Hz), +3dB (10kHz)
--	----------------------------

Miscellaneous

Power Requirements	120V, 60Hz
--------------------	------------

Power Consumption	280W (UL)
-------------------	-----------

Dimensions	453(W) x 155(H) x 425(D) mm
------------	-----------------------------

	17-11/16(W) x 6-1/8(H) x 16-3/4(D) in
--	---------------------------------------

Weight Without package	18.4kg (40 lb 9 oz)
------------------------	---------------------

Furnished Parts

Operating instructions	1
------------------------	---

* Measured pursuant to Federal Trade Commission's Trade Regulation rule on Power Output Claims for Amplifier.

NOTE:

Specifications and the design subject to possible modification without notice due to improvements.

2. FRONT PANEL FACILITIES

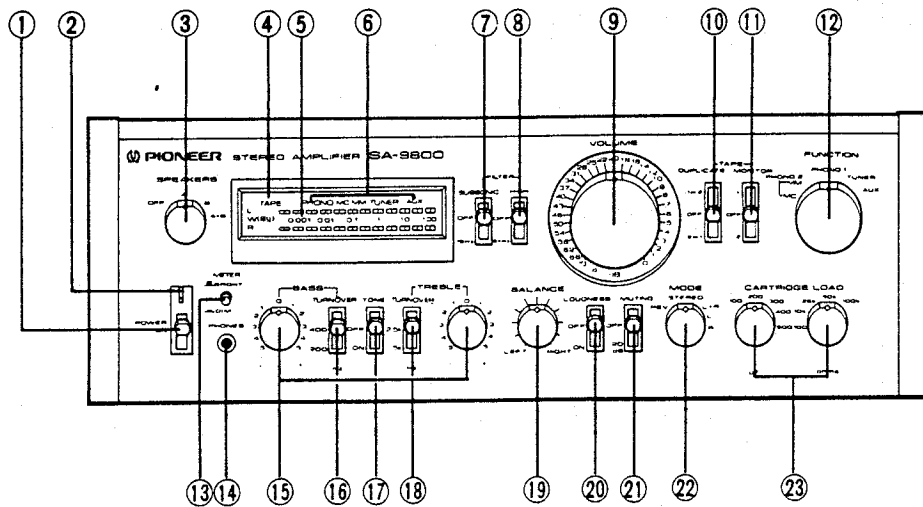

For Service Manuals Contact
 MAURITRON TECHNICAL SERVICES
 8 Cherry Tree Rd, Chinnor
 Oxon OX9 4QY
 Tel: 01844-351694 Fax: 01844-352554
 Email: enquiries@mauritron.co.uk

① POWER SWITCH

Set this switch to ON to supply power to the amplifier. There will be a short delay when it is set to ON, because the muting circuit has been actuated to suppress the unpleasant noise that is sometimes generated when the power is on and off.

② POWER INDICATOR

When the power switch is set to ON, this lamp lights up, indicating the amplifier is turned on.

③ SPEAKER SELECTOR

Use this selector to select the speaker systems.

OFF: Sound not obtained from speakers.

A: Sound obtained from speakers connected to the A speaker terminals.

B: Sound obtained from speakers connected to the B speaker terminals.

A+B: Sound obtained from speakers connected to both A and B speaker terminals.

④ TAPE MONITOR INDICATOR

The TAPE lamp lights up when the tape monitor switch is set to either position "1" or "2".

⑤ POWER METER

This meter allows you to read out the rated power level on the fluorescent display tube when speakers with a nominal impedance of 8 ohms are connected to the amplifier's speaker terminals.

⑥ FUNCTION INDICATORS

The PHONO, MC, MM, TUNER, AUX function indicators light up in accordance with the position of the function selector.

NOTE:

The function indicator will not go off when the tape monitor switch is set to position "1" or "2". This indicates a program at the recording source end during the monitoring of a recording.

⑦ SUBSONIC FILTER SWITCH

When this switch is set to the 15Hz position, the subsonic filter with a cut-off frequency of 15Hz is actuated. The subsonic filter serves to attenuate frequencies lower than 15Hz in a 12dB/oct slope. It is therefore effective in suppressing ultra-low frequency noise which is generated by record warp and other causes. You cannot actually hear this noise but it is a factor in the generation of intermodulation distortion and it may damage your speaker system. Set this switch to the 15Hz position during record play for the best effect.

⑧ HIGH FILTER SWITCH

The high filter with a cut-off frequency of 8kHz is actuated when this switch is set to the 8kHz position.

The high filter serves to attenuate frequencies higher than 8kHz in a 12dB/oct slope. This is why it is effective in suppressing high-frequency noise or noise from scratches on records being played.

⑨ VOLUME CONTROL

Use this control to adjust the output level to the speakers and headphones. Turn it clockwise to increase the output level. No sound will be heard if you set it to ∞. The scale is graduated in dB which indicate the attenuation when the maximum output level is 0dB.

⑩ TAPE DUPLICATE SWITCH

Use this switch when employing two tape decks to duplicate recorded tapes or edit tapes. This switch is otherwise kept at the OFF position.

1 ▶ 2: When playing back the tape on a deck connected to the TAPE 1 jacks and recording (duplicating) on a deck connected to the TAPE 2 jacks.

OFF: Set to this position when not duplicating.

2 ▶ 1: When playing back the tape on a deck connected to the TAPE 2 jacks and recording (duplicating) on a deck connected to the TAPE 1 jacks.

⑪ TAPE MONITOR SWITCH

Use this switch to select the program source which is being reproduced.

1: Set here to monitor a recording or a tape being played back on a tape deck which is connected to the TAPE 1 jacks.

OFF: Set here whenever you are not playing back a tape or monitoring a recording (i.e. when you have set the function selector to PHONO 1, PHONO 2 MM, MC, TUNER, or AUX for an alternative program source).

2: Set here to monitor a recording or a tape being played back on a tape deck which is connected to the TAPE 2 jacks.

⑫ FUNCTION SELECTOR

Use this selector to select the program source. When set, the function indicator above the meter panel corresponding to the position of the function selector will light up.

PHONO 2 MC: Set here when playing records on a turntable with a moving coil (MC) cartridge connected to the rear PHONO 2 jacks.

(The PHONO MC function indicator lights up.)

PHONO 2 MM: Set here when playing records on a turntable with a moving magnet (MM) cartridge connected to the rear PHONO 2 jacks.

(The PHONO MM function indicator lights up.)

PHONO 1: Set here when playing records on a turntable connected to the PHONO 1 jacks. (The PHONO MM function indicator lights up.)

If you intend to play a record on a turntable with a moving coil cartridge, connect the turntable to the rear PHONO 2 jacks and then set the function selector to the PHONO 2 MC position.

TUNER: Set here when listening to broadcasts on a tuner connected to the TUNER jacks. (The TUNER function indicator lights up.)

AUX: Set here when listening to a program source which is connected to the AUX jacks.

(The AUX function indicator lights up.)

NOTE:

When the function selector is set to the PHONO 2 MM or PHONO 1 position, you can select the input circuit resistance and the input capacitance in line with the load impedance of the cartridge being used with the CARTRIDGE LOAD selectors (ohms and pF).

⑬ METER SWITCH

This allows you to select the brightness of the meter panel.

BRIGHT (released position): This brightens the meter panel.

DIM (depressed position): This dims the meter panel. When your listening room is dark and the meter panel is too bright, set the switch to the DIM position.

⑭ HEADPHONE JACK

Plug the headphones into this jack when you want to listen through your stereo headphones.

NOTE:

Set the speaker selector to OFF when listening only with headphones.

⑮ BASS AND TREBLE CONTROLS

Use these controls to adjust the bass and the treble. If you set the tone switch to ON and turn the bass control to right from its center position, you will be able to emphasize the sound in a frequency range is lower than that selected by the bass turnover switch.

Conversely, turning this control from the center position to the left will attenuate the sound.

You can use the treble control to adjust the sound in a frequency higher than that selected by the treble turnover switch. For further details, refer to "TURNOVER SWITCHES" on page 6.

⑯ BASS TURNOVER SWITCH

Use this switch to change over the frequency in which the sound adjustment with the bass control is starting to take effect. Select 200Hz or 400Hz in accordance with the characteristics of your listening room and of your speakers, and with your general preference.

⑰ TONE SWITCH

Set this switch to ON when adjusting the bass and treble controls. When set to OFF, the tone control circuits are disengaged and frequency response is flat. This function is convenient for checking phono cartridge and speaker tone quality and listening room acoustics.

⑱ TREBLE TURNOVER SWITCH

Use this switch to change over the frequency in which the sound adjustment with the treble control is starting to take effect. Select 2.5kHz or 5kHz in accordance with the characteristics of your listening room and of your speakers, and with your general preference.

⑲ BALANCE CONTROL

Use this control to balance the volume of the left and right channels. First, however, set the mode selector to mono (L+R, L, or R), and adjust so that the sound appears to come from somewhere exactly between the two speakers. If the sound appears to be louder on the right, it means that the volume of the right channel is higher. Turn the balance control to the left and adjust.

Conversely, if the sound appears to be louder on the left, it means that the volume of the left channel is higher. Therefore, turn the balance control to the right and adjust. After adjusting, return the mode selector to STEREO.

⑳ LOUDNESS SWITCH

When listening to a performance with the volume control turned down, set this switch to ON and the bass and treble will be accentuated.

When the volume is low, the human ear finds it harder to hear the bass and treble than when the volume is high. The loudness switch is thus designed to compensate for this deficiency. By setting it to ON, the bass and treble come through much more strongly and the sound takes on a punch even when the volume control is turned down.

㉑ MUTING SWITCH

Set this switch to -20dB to attenuate the audio output indicated by the volume control by 20dB. There is no need to adjust the volume control if you use this switch when turning down the audio output temporarily and when changing over records or tapes.

㉒ MODE SELECTOR

Use this selector for selecting the performances.

REV: Reverses left and right channel stereo signals and reproduces them stereophonically.

STEREO: Set to this position for normal stereo reproduction.

L+R: Mixes left and right channel signals and reproduces them monophonically.

L: Left channels signal is reproduced monophonically from both speakers.

R: Right channel signal is reproduced monophonically from both speakers.

㉓ CARTRIDGE LOAD SELECTORS (ohms and pF)

These selectors allow you to select the input resistance and input capacitance in line with the rated load impedance and load capacitance of a moving magnet (MM) cartridge for record play.

Use these two switches to produce the sound quality of your preference or the ideal conditions for your cartridge.

TURNOVER SWITCHES

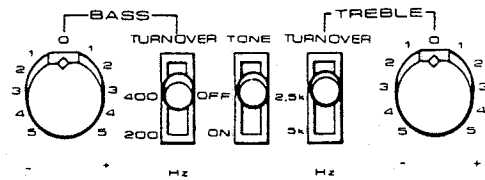

This amplifier adopts a tone control system that combined bass and treble controls with two turnover switches which are used to select the frequency. Select the frequency with the turnover switches and then enhance or attenuate the sound in the lower (or higher) frequencies with the bass (or treble) controls.

For instance, if the bass turnover switch is set to 400Hz (see Fig. A), the bass covers a wide with large gain per step of the bass control. For this reason, the reproduced sound sometimes seems unnatural depending on the program source, but this can be remedied by setting the switch to 200Hz.

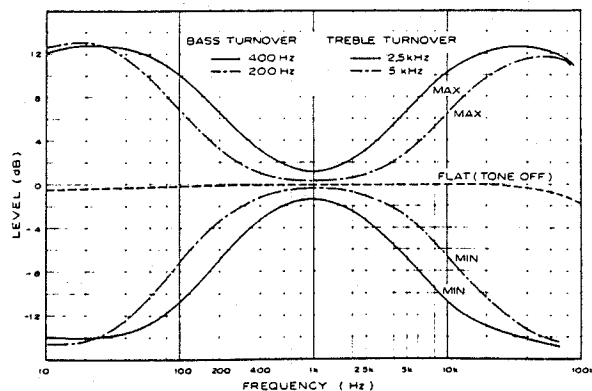
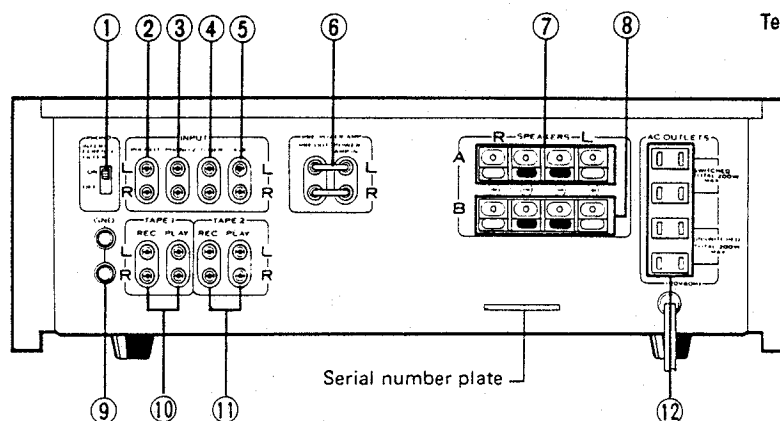

Fig. A

3. REAR PANEL FACILITIES

For Service Manuals Contact
 MAURITRON TECHNICAL SERVICES
 8 Cherry Tree Rd, Chinnor
 Oxon OX9 4QY
 Tel:- 01844-351694 Fax:- 01844-352554
 Email:- enquiries@mauritron.co.uk



① PHONO INTERFERENCE FILTER SWITCH

This is used to attenuate radio-frequency interference from external electronic or electrical appliances or products during record play.

NOTE:

When the function selector is at PHONO 2 MC, this function doesn't operate, since it is not necessary when playing with the moving coil cartridge.

② PHONO 1 JACKS

Connect the output cords of the turntable with the moving magnet (MM) cartridge to these jacks.

③ PHONO 2 JACKS

When using the moving coil (MC) cartridge, be sure to connect the output cords of the turntable to these jacks. However, these jacks can also be used for the moving magnet (MM) cartridge.

④ TUNER JACKS

Connect the tuner cords to these jacks.

⑤ AUX JACKS

These are auxiliary input jacks. Connect a TV tuner or cartridge tape player to them.

⑥ PREAMPLIFIER/POWER AMPLIFIER CONNECTOR BAR

When this connector bar is disconnected from the jacks, you can separate the SA-9800's pre-amplifier and power amplifier.

NOTE:

If this bar is not connected properly, you will not hear any sound from the speakers connected to the SPEAKERS terminals.

⑦ SPEAKERS TERMINALS A

Connect your first pair of speakers to these terminals.

⑧ SPEAKERS TERMINALS B

Connect your second pair of speakers to these terminals.

⑨ GND TERMINALS

These are the ground terminals. Connect the ground wire of the turntable, etc. to these terminals.

⑩ TAPE 1 JACKS

Connect the tape deck cords to these jacks. Connect the REC (recording) jacks to the INPUT jacks on the tape deck, and the PLAY (playback) jacks to the OUTPUT jacks.

⑪ TAPE 2 JACKS

Connect your second tape deck cords to these jacks.

⑫ AC OUTLETS

These are spare power outlets. Insert the power plug on the stereo components (turntable, tuner, tape deck, etc.) into these outlets.

SWITCHED: The power supplied through these outlets is coupled to the operation of the amplifier's power switch. The maximum power capacity which may be connected to the two SWITCHED outlets is 200W.

UNSWITCHED: The power is always supplied through these two outlets regardless of the position of the power switch. The maximum power capacity which may be connected to these two outlets is 200W.

NOTES:

- Never connect an iron or a toaster to these outlets.
- Do not get the power outlets and the power plugs wet or touch them with wet hands, since you may get an electric shock.

Phono Interference Filter

Because of the high sensitivity of the phono input circuits, a certain amount of radio frequency interference may occur. This may be reduced by simply turning the rear panel PHONO INTERFERENCE FILTER on (thereby connecting a resistor in series with the phono input circuits).

MC Amplifier

The MC amplifier is a flat-response voltage amplifier with a gain of 28dB, designed for use with low-output moving-coil-type cartridges. It is inserted in front of the equalizer amplifier when the FUNCTION switch is input in the PHONO 2 MC position.

Fig. 5-2 shows the basic configuration of the circuit. The MC amplifier is a completely symmetrical DC-coupled 3-stage amplifier, the first stage of which employs newly developed ultra-low-noise NPN and PNP transistors. The S-N ratio is 72dB (100 μ V input, IHF-A).

EQ Amplifier

Fig. 5-3 shows the basic circuit of the equalizer amplifier. The first stage is a differential amplifier consisting of a newly developed ultra-low-noise twin FET (Q_1) and NPN twin transistor (Q_2) connected in cascade, the load circuit of which is a current mirror circuit (Q_3, Q_4).

Because an FET is used in the first stage of the equalizer amplifier, the input coupling capacitor is rendered unnecessary, and thus noise and distortion are correspondingly reduced. The cascade connection serves to reduce the load impedance of the FET. This prevents deterioration in high-frequency response due to the Miller Effect, and also reduce gate leak current noise on account of the reduced drain-to-source voltage.

The next stage (Q_5) is a class A amplifier, the load circuit of which is a constant-current source (Q_6). This results in a high voltage gain.

The output stage (Q_7, Q_8) is a symmetrical complementary SEPP Class A configuration. The output current is of the same order of magnitude as that of a small power amplifier, and is sufficient to cope with low-impedance loads.

The resultant S-N ratio of the equalizer amplifier is 90dB, while the equalizer deviation is ± 0.2 dB (20Hz to 20,000Hz).

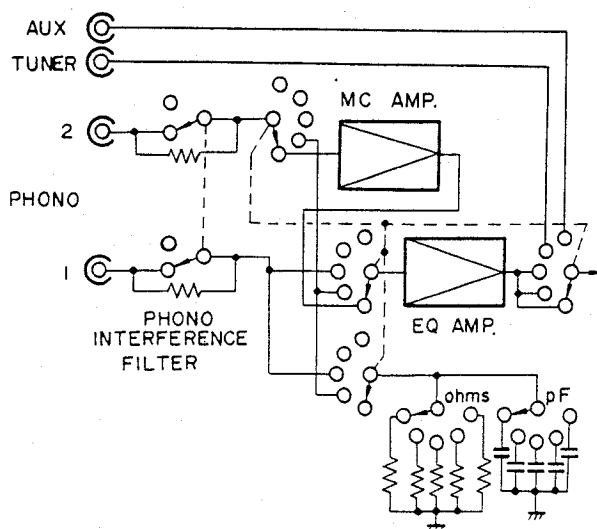

Fig. 5-1 Phono Circuit

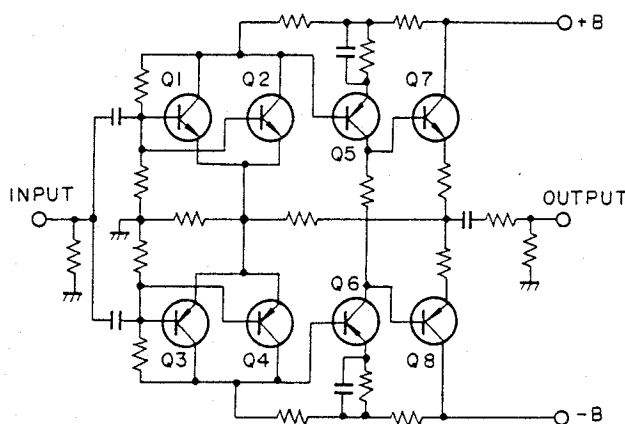

Fig. 5-2 MC Amplifier

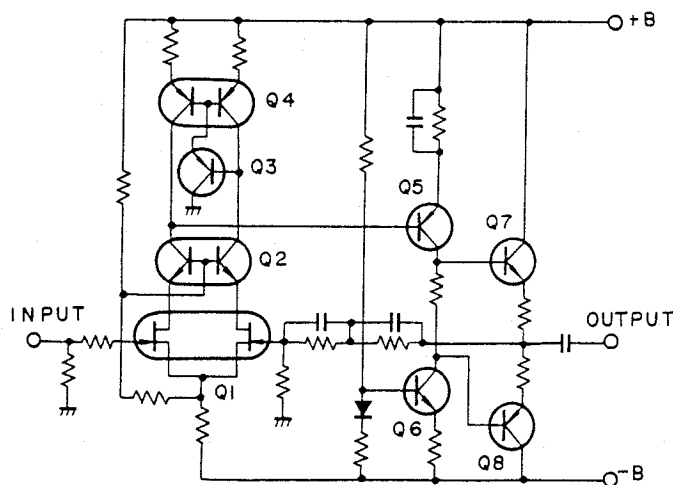

Fig. 5-3 EQ Amplifier

For Service Manuals Contact
MAURITRON TECHNICAL SERVICES
 8 Cherry Tree Rd, Chinnor
 Oxon OX9 4QY
 Tel: 01844-351694 Fax: 01844-352554
 Email: enquiries@mauritron.co.uk

Tone Controls

Fig. 5-4 shows the basic tone control circuit. The tone amplifier is a 3-stage DC-coupled amplifier, the first stage is a differential amplifier consisting of a ultra-low-noise twin FET. The second stage is a differential amplifier consisting of a PNP twin transistor, and the output impedance lowered by using an emitter follower at the output stage.

Tone control (BASS, TREBLE) is accomplished by providing the tone amplifier NFB circuit with a frequency selective characteristic. The capacitance of $C_1 - C_4$ are changed by the TURNOVER switches (by adding another capacitors in series) to provide selection of the frequency. The NFB circuit is changed to a flat frequency characteristic when the TONE switch is in the OFF position.

5.2 POWER AMPLIFIER SECTION

Amplifier Circuit

The basic circuit arrangement of the power amplifier is shown in Fig. 5-5. The first stage is a differential amplifier comprising PNP twin transistor (Q_2), the load circuit of which is a current mirror employing an NPN twin transistor (Q_3). The current mirror provides push-pull operation in this stage, which serves to cancel even harmonics and further increase gain.

Q_1 in the input circuit absorbs outflow of base current from Q_2 , and prevents the generation of a DC voltage. Because Q_1 follows any temperature drift in Q_2 , temperature drift of the center point voltage is prevented.

The pre-driver stage (Q_4, Q_5) is a Darlington arrangement, the load circuit of which employs a constant-current source (D_1, Q_6) resulting a high voltage gain.

The power stage bias voltage is supplied by the NSA circuit. The NSA circuit provides non-switching operation in the power stage (refer to "NSA Circuit").

The power stage ($Q_7 - Q_{12}$) is a 2-stage Darlington arrangement, the last stage is parallel SEPP circuit employing an SL RET (Super Linearity Ring Emitter Transistor). The RET is a kind of IC consisting of a number of small transistors on a single chip, with each transistor being connected in parallel via an emitter resistor. This provides excellent high frequency characteristics comparable to those of a small-signal transistor. Furthermore, because there is no time constant in the NFB circuit in the low-frequency region, amplification is possible down to DC (DC inputs will be cut off, however, by the input coupling capacitor).

The circuit features described above provide an extremely wide power frequency range (100W + 100W, 10Hz to 20kHz, THD 0.005%, 8Ω).

Power Limiter

The power limiter is a high-speed protection circuit which operates to protect the power transistors from overcurrent conditions caused by load shorts, etc.

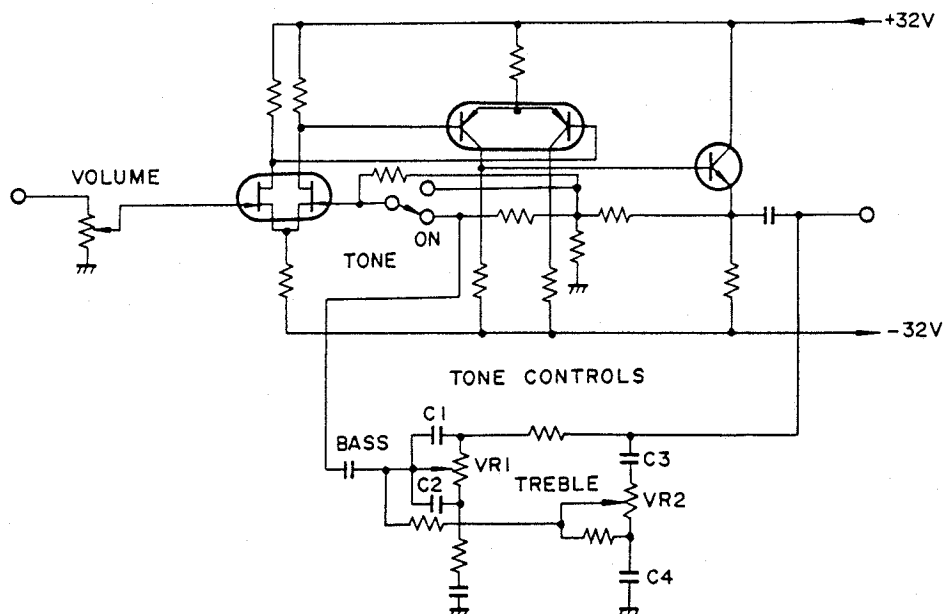

Fig. 5-4 Tone Control Circuit

The circuit (Fig. 5-6), constitutes a Wheatstone bridge (Fig. 5-7), one arm of which the load (R_L), which is arranged so that Q_1 (Q_2) is biased by the potential difference between the opposite corners of the bridge. As the value of R_L decreases, Q_1 (Q_2)

start to conduct, thus holding down the drive voltage and controlling the magnitude of the current flowing in to the power transistors. Q_3 (Q_4) is link connected to Q_1 (Q_2) which provides sharp clipping characteristics.

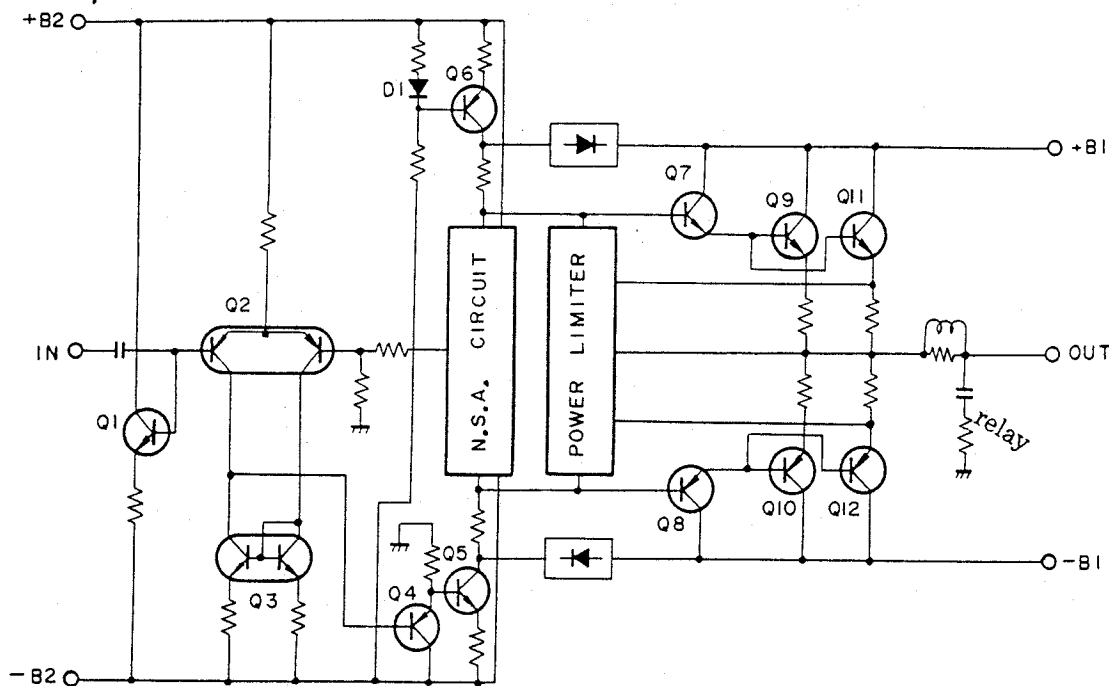

Fig. 5-5 Power Amplifier

For Service Manuals Contact
MAURITRON TECHNICAL SERVICES
 8 Cherry Tree Rd, Chinnor
 Oxon OX9 4QY
 Tel:- 01844-351694 Fax:- 01844-352554
 Email:- enquiries@mauritron.co.uk

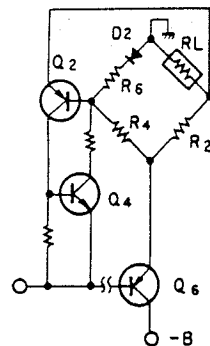
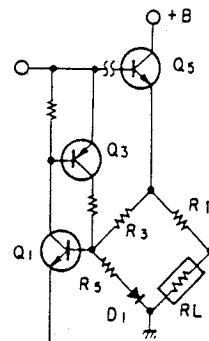

Fig. 5-7 Bridge Circuit

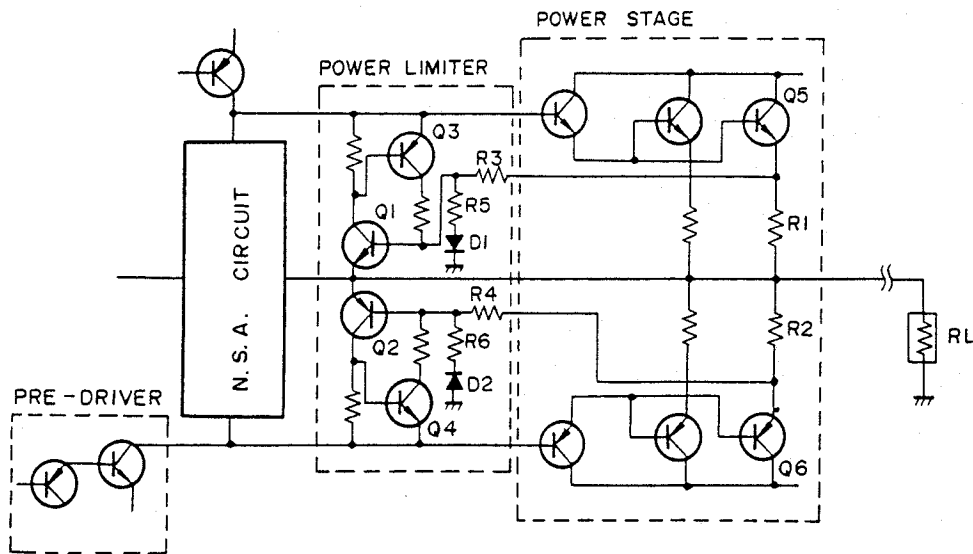

Fig. 5-6 Power Limiter

NSA (Non-Switching Amplifier) Circuit

By operating the power stage only within the active region (no possible cut-off) and with minimum idle current, the NSA circuit prevents the generation of switching distortion and reduces heat loss.

Operating Principle

Since idle current flows through normal class B SEPP power stages (see Fig. 5-8) when no signal a fixed amount (with the voltage across points P and R serving as a bias). The voltages across points P and Q, and Q and R at this time will be equal. When the positive portion of a signal is applied to this circuit, the power stage current on the NPN side is increased, resulting in the voltage across points P and Q also being increased. However, since the voltage across points P and R is practically constant (see note), the voltage across points P and R (PNP power stage bias) will be decreased, resulting in the PNP power stage being cut off.

The NSA circuit increases the voltage across points P and R by the same amount as the voltage increase across points P and Q, thereby cancelling the voltage decrease across points Q and R, and preventing the PNP power stage from being cut off.

This NSA circuit is outlined in Fig. 5-9. When there is no signal applied to the circuit, Q_1 and Q_2 are almost cut off, while Q_3 and Q_4 will be on. The voltage across the collector and base of both of these transistors (Q_3 and Q_4) at this time may be disregarded. Consequently, with the power stage bias circuit consisting of 4 PN junctions formed by Q_3 , D_3 , and Q_4 , and VR_1 , this circuit is equivalent to the previous circuit shown in Fig. 5-8.

With R_1 and D_1 ensuring a constant flow of current, the base of Q_1 and point Q may be brought to the same level (see Fig. 5-10) on an AC basis (level fluctuations due to the signal) by a simple shift in DC level. Furthermore, Q_1 may be considered emitter-follower with R_3 as the emitter resistance.

When the voltage across points P and Q is increased by the positive portion of the signal applied to this circuit, it becomes the input signal of this emitter-follower (Q_1). Since the emitter-follower voltage gain is practically 1, a voltage more or less equal to that of the input signal (that is, the voltage increase across points P and Q) is produced at R_3 . And the R_3 voltage is the voltage applied across the base and collector of Q_3 which forms part of the power stage bias circuit. So the bias voltage applied to Q_3 will be in excess by the same amount that the voltage across points P and Q is increased (by positive portion of the signal) above the voltage level when no signal is being

applied. Consequently, the increase in voltage across points P and Q cancels the decrease in voltage across points Q and R, thereby maintaining the idle current without cutting the PNP power

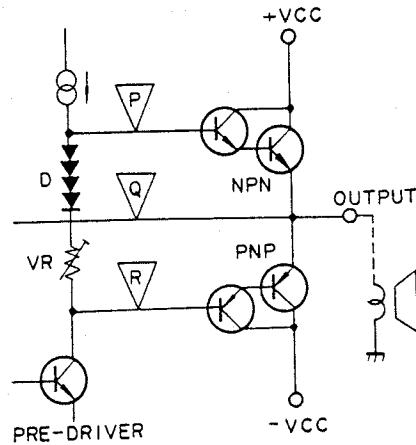

Fig. 5-8 Normal Power Stage

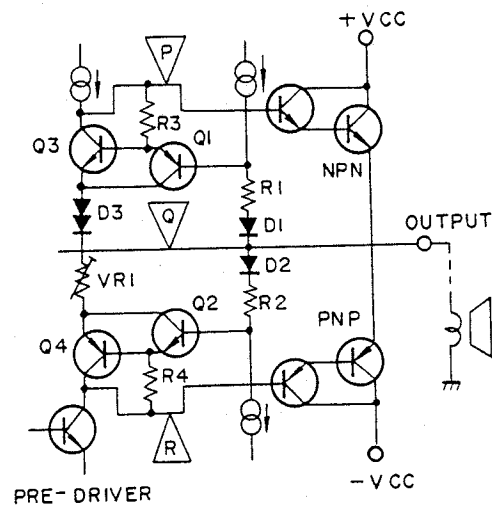

Fig. 5-9 NSA Circuit

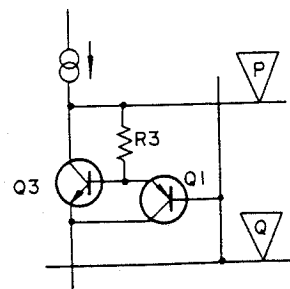

Fig. 5-10 NSA Circuit

stage off (noting that there actually is a slight decrease in current). For the negative portions of the signal, Q₃ and Q₄ are operated in the same manner, thereby preventing the NPN power stage from being cut off.

In other words, the NSA circuit acts to prevent any "power stage cut-off" signals from being applied to the power stage (see Fig. 5-11).

Note:
The pre-drive current actually decreases when the positive portion of the signal is applied, resulting in a decrease in the voltage across points P and R.

5.3 INDICATOR CIRCUIT

The SA-9800 output power and function indicators feature fluorescent indicator tube (FL tube). In this tube, thermionic emissions from the cathode are accelerated into the fluorescent substance of the segmental anodes, resulting in the emission of light. This tube is used to indicate numerals, letters, and other symbols.

An outline of the FL tube drive circuit is shown in Fig. 5-12. The output circuit signal is first passed through a low-pass filter and a compressor

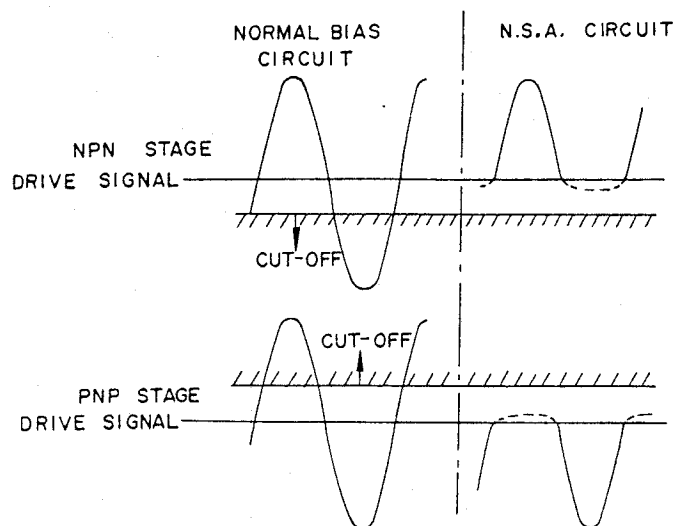

Fig. 5-11 Driving Signal of Power Stage

circuit before being applied to pin no.6 (4) of the IC (TA7318P-A). The compressor circuit makes use of the non-linearity of the rising portion of the diode's V_d - I_d characteristics to contract the signal dynamic range by 20dB. The IC contains a detector circuit, compressor (40dB), and peak

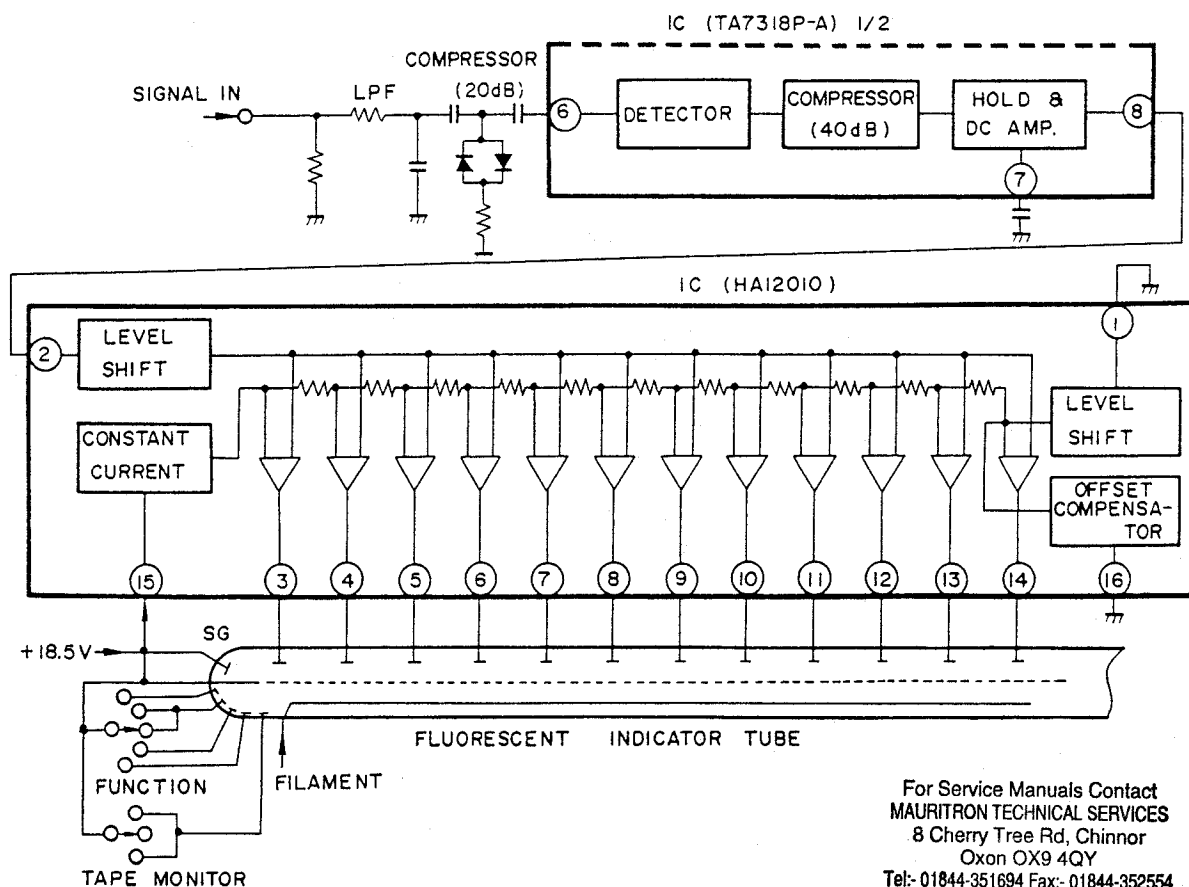

Fig. 5-12 Indicator Circuit

For Service Manuals Contact
MAURITRON TECHNICAL SERVICES
8 Cherry Tree Rd, Chinnor
Oxon OX9 4QY
Tel:- 01844-351694 Fax:- 01844-352554
Email:- enquiries@mauritron.co.uk

hold circuit for both left and right channels. The dynamic range of the signal is thus contracted by 60dB to obtain a "peak held" DC voltage.

The output power indicator segments of the FL tube are driven by the HA12010 ICs (one for each channel) equipped with 12 pairs of differential amplifiers. These amplifiers are biased at increasing levels, so each amplifier will commence to operate separately as the input level increases. And since these amplifiers apply the voltages to the output power indicator segments, each successive segment will light up in turn as the input level rises.

The function indicators are lit up as a result of a voltage being applied to the corresponding function indicator segment according to the selected positions of the FUNCTION and TAPE MONITOR switches.

5.4 PROTECTION CIRCUIT

The purpose of this circuit is to protect the speakers. The relay in the output circuit is automatically opened in any of the following cases:

1. During the "transient operations" when the power supply is turned on and off.
2. Upon detection of a DC voltage in the output circuit, caused by component failure or accident.

Muting Operation when Power Supply is Turned On and Off

With reference to Fig. 5-13 when the power supply is turned on, if there is no input (DC) on Q_1 and Q_2 , they will be off, and the timing capacitor C_2 charges up through R_5 and R_4 , and thus on. When Q_3 conducts, the relay operates, and the output muting on the power amplifier will be removed.

When the power supply is turned off, $+B_1$ will abruptly decay, C_2 will discharge through D_1 and D_2 . Q_3 will cease to conduct, whereupon the relay will become de-energized and restore muting.

DC Voltage Detector

The output circuit is connected to the Q_2 emitter and Q_1 base via a low-pass filter (R_1, C_1). Any DC voltages appearing the output circuit of the power amplifier, it will be applied to the Q_2 emitter and the Q_1 base. If the voltage is negative, Q_2 will rapidly discharge. As consequence, Q_3 will turn on and the relay will become de-energized, thus causing the output circuit to open.

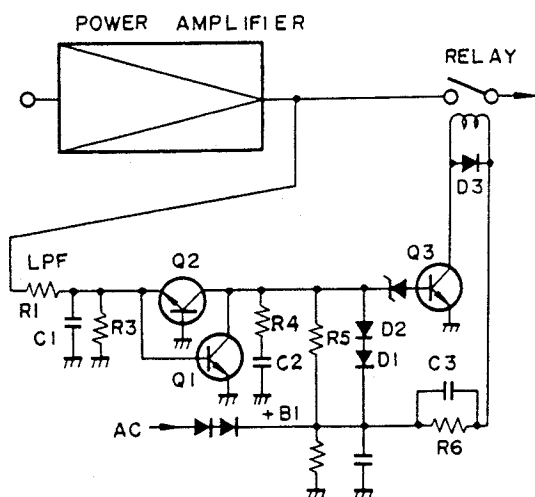

Fig. 5-13 Protection Circuit

6. DISASSEMBLY

Wooden Cover

Remove the two screws on each side of the wooden cover.

Bottom Plate

Remove the eleven screws to detach the bottom plate.

Front Panel

Loosen the setscrews of TUNING knob with a hexagonal wrench. Remove all the knobs by pulling. Remove the three screws from the top edge of the front panel. Remove the two nuts from the control shafts.

For Service Manuals Contact
MAURITRON TECHNICAL SERVICES
8 Cherry Tree Rd, Chinnor
Oxon OX9 4QY
Tel:- 01844-351694 Fax:- 01844-352554
Email:- enquiries@mauritron.co.uk

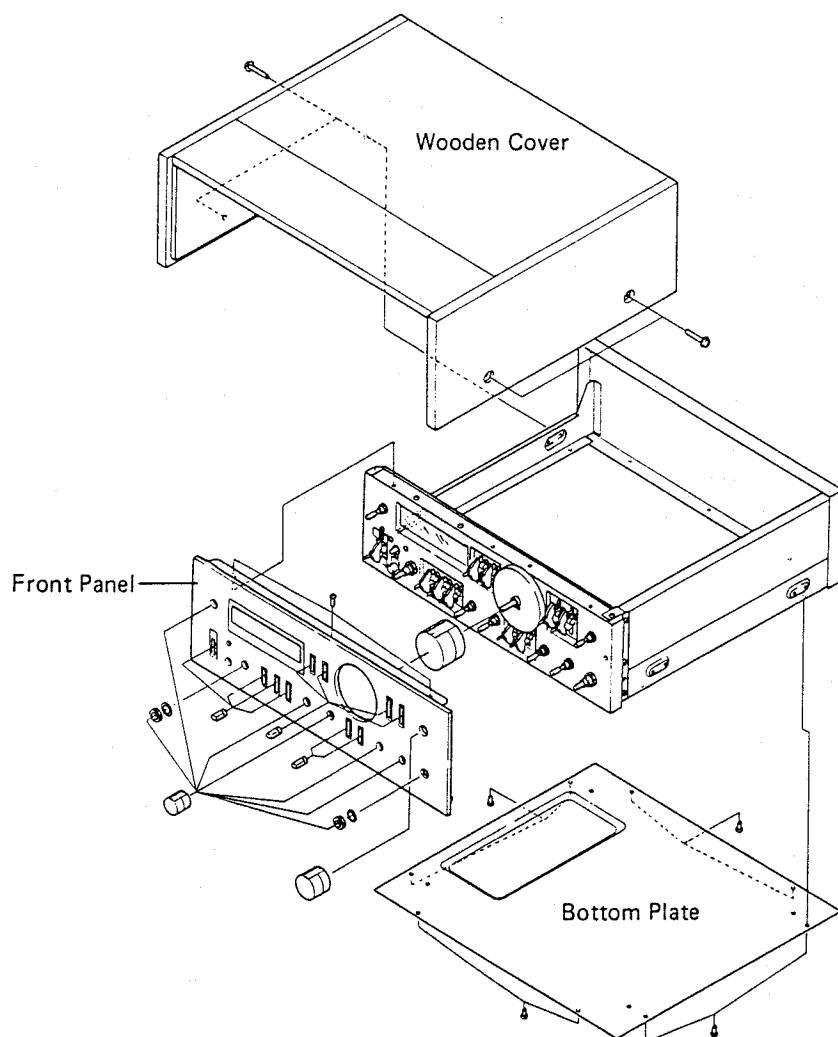

7. PARTS LOCATION

The \triangle mark found on some component parts indicates the importance of the safety factor of the part. Therefore, when replacing, be sure to use parts of identical designation.

Front Panel View

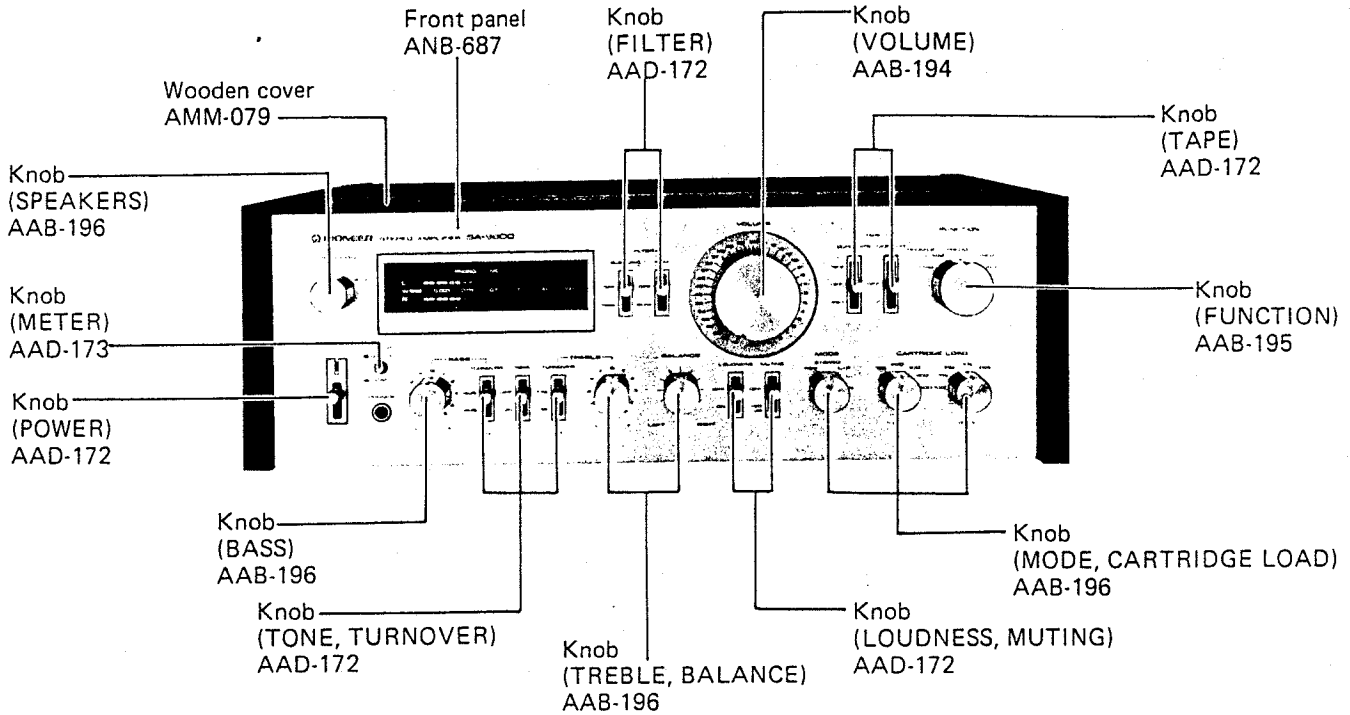

Front View with Panel Removed

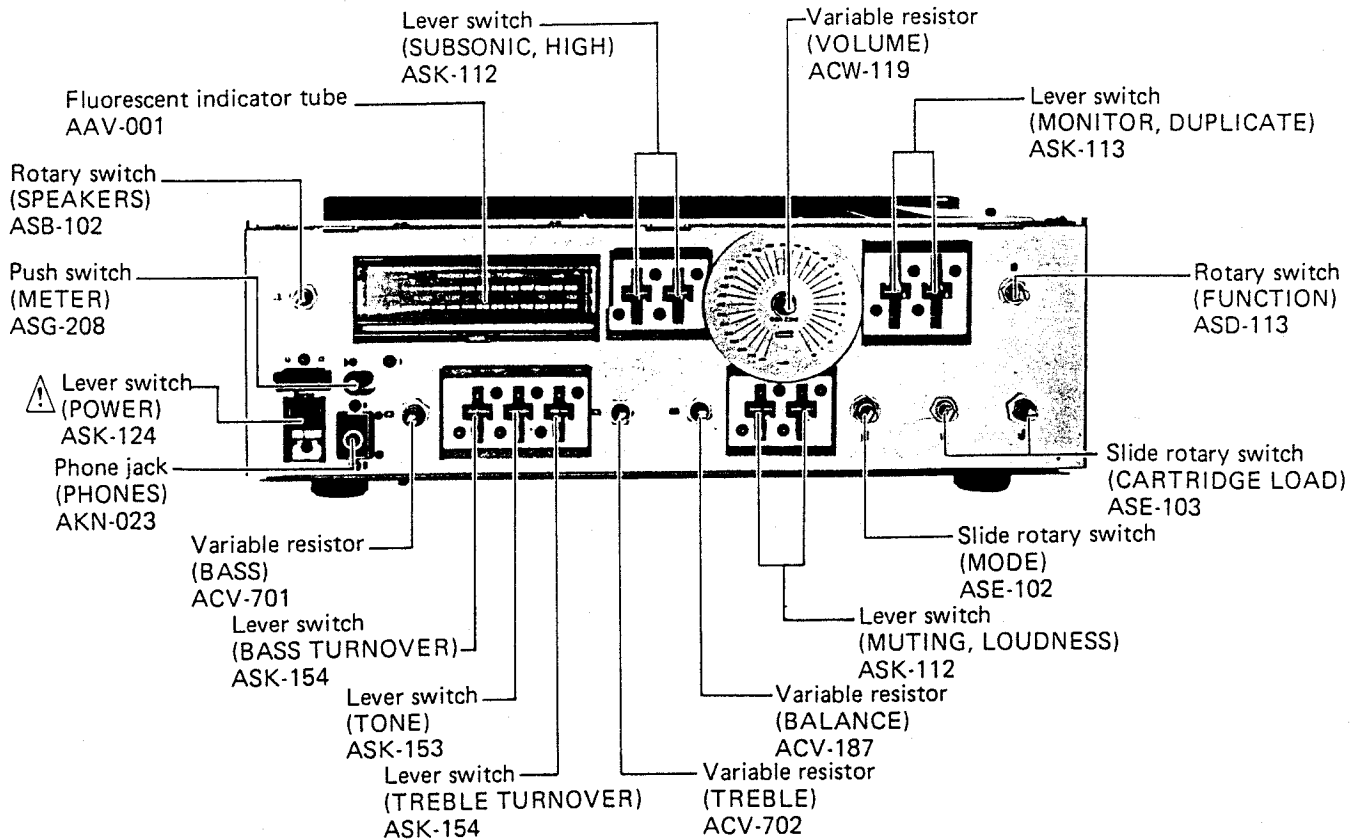

For Service Manuals Contact
 MAURITRON TECHNICAL SERVICES
 8 Cherry Tree Rd, Chinnor
 Oxon OX9 4QY
 Tel: 01844-351694 Fax: 01844-352554
 Email: enquiries@mauritron.co.uk

SA-9800

Top View

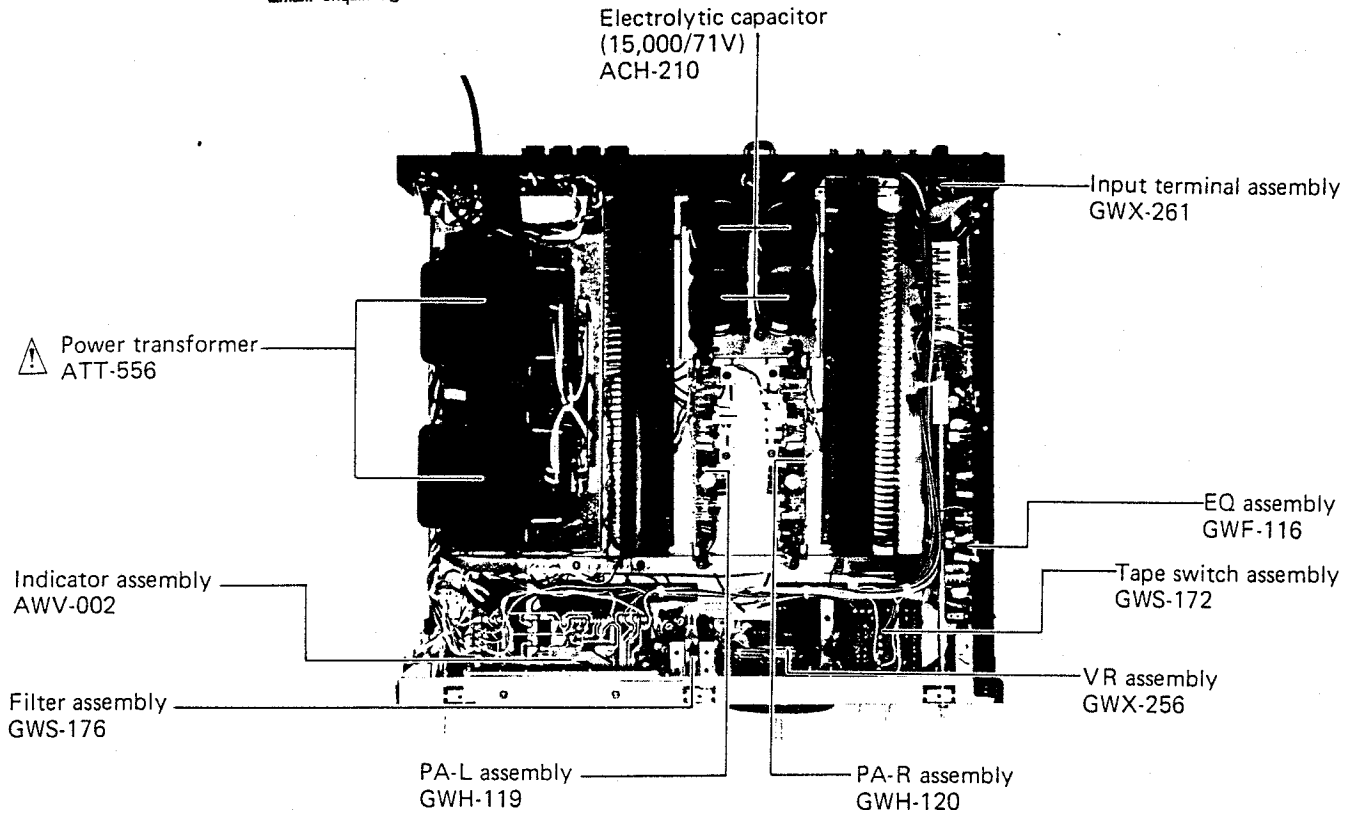

Bottom View

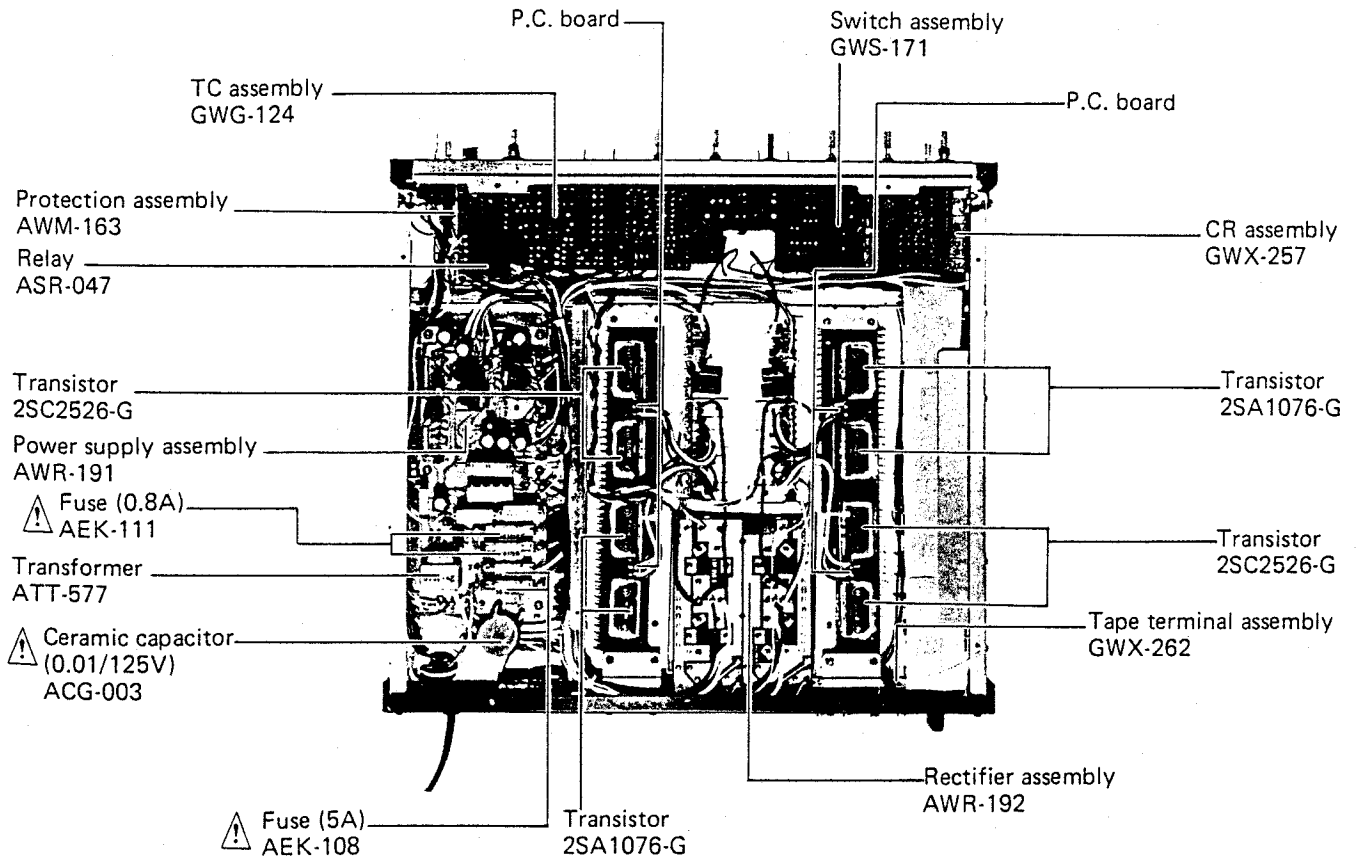

Rear Panel View

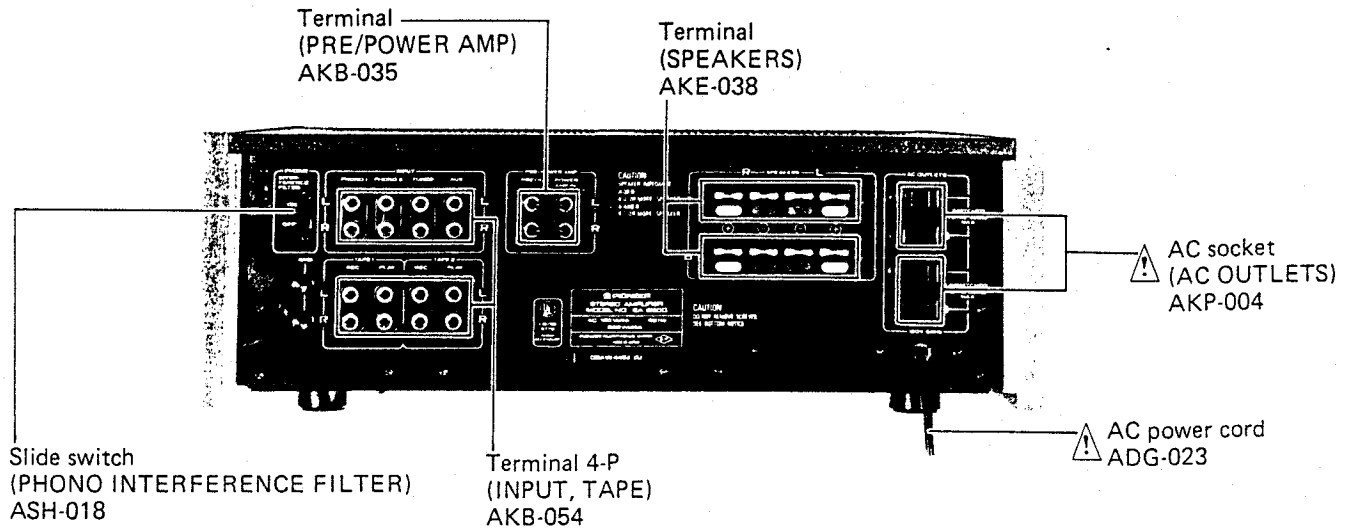

8. ADJUSTMENTS

Power Amplifier

Turn VR_3 , VR_5 (L) and VR_4 , VR_6 (R) fully around in the counter-clockwise direction, but set VR_1 (L) and VR_2 (R) to the center positions. Without any load or input signal, turn the POWER switch ON.

DC Balance

1. Adjust VR_1 (L) for 0V (to within ± 60 mV) between terminal No.26 and ground.
2. Adjust VR_2 (R) for 0V (to within ± 60 mV) between terminal No.11 and ground.

Idle Current

1. Adjust VR_3 (L) for 56mV between terminals No.39(+) and No.37(-). The potential difference between terminals No.40(+) and No.38(-) should register about 56mV at this time.
2. Adjust VR_4 (R) for 56mV between terminals No.18(+) and No.20(-). The potential difference between terminals No.17(+) and No.19(-) should register about 56mV at this time.
3. Adjust VR_5 (L) for 70mV between terminals No.39(+) and No.37(-). The potential difference between terminals No.40(+) and No.38(-) should register about 70mV at this time.
4. Adjust VR_6 (R) for 70mV between terminals No.18(+) and No.20(-). The potential difference between terminals No.17(+) and No.19(-) should register about 70mV at this time.

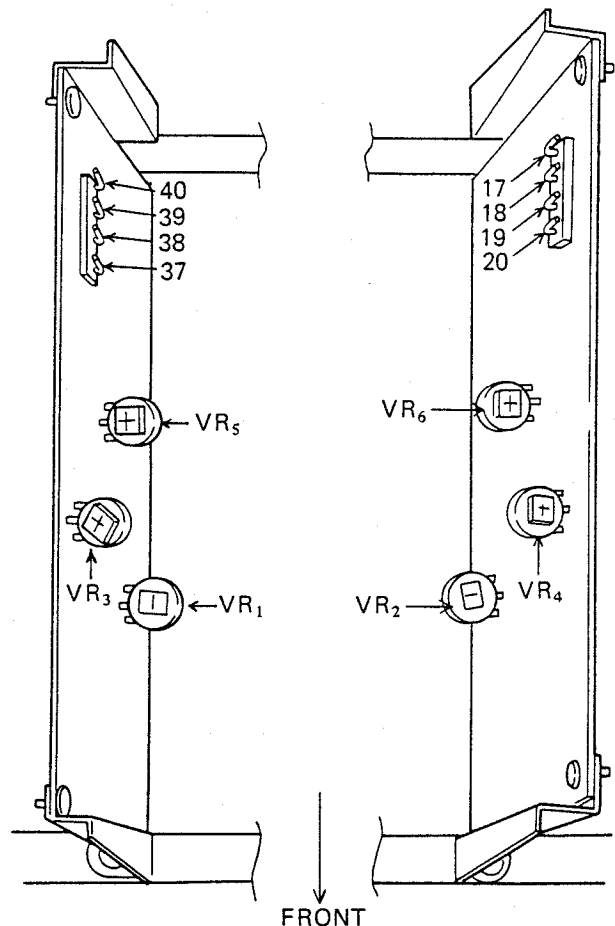

Fig. 8-1 Adjustments of Power Amplifier

Output Power Indicator Calibration

1. Apply a 1kHz signal to the POWER AMP IN terminals (or any other input power amplifier input terminals).
2. Adjust the level of this input signal so that the voltage on the output terminals (SPEAKERS) read 8.9V (AC).
3. Adjust VR₁ (L) and VR₂ (R) of the indicator assembly so that the output power indicator read 10 watts.

Preamplifier

Remove the shield covers.

MC Amplifier

Adjust VR₁ (L) for DC 0V (to within $\pm 0.2V$) between terminal No.15 and ground.

Adjust VR₂ (R) for DC 0V (to within $\pm 0.2V$) between terminal No.16 and ground.

EQ Amplifier

Adjust VR₃ (L) for DC 0V (to within $\pm 0.2V$) between terminal No.17 and ground.

Adjust VR₄ (R) for DC 0V (to within $\pm 0.2V$) between terminal No.18 and ground.

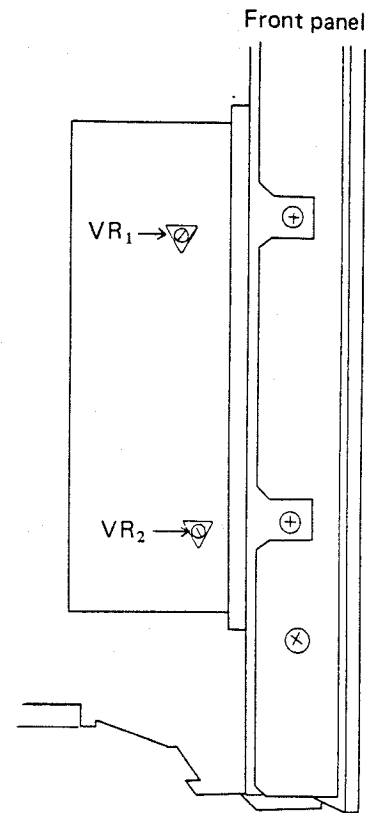

Fig. 8-2 Power Indicator Calibration

For Service Manuals Contact
MAURITRON TECHNICAL SERVICES
 8 Cherry Tree Rd, Chinnor
 Oxon OX9 4QY
 Tel:- 01844-351694 Fax:- 01844-352554
 Email:- enquiries@mauritron.co.uk

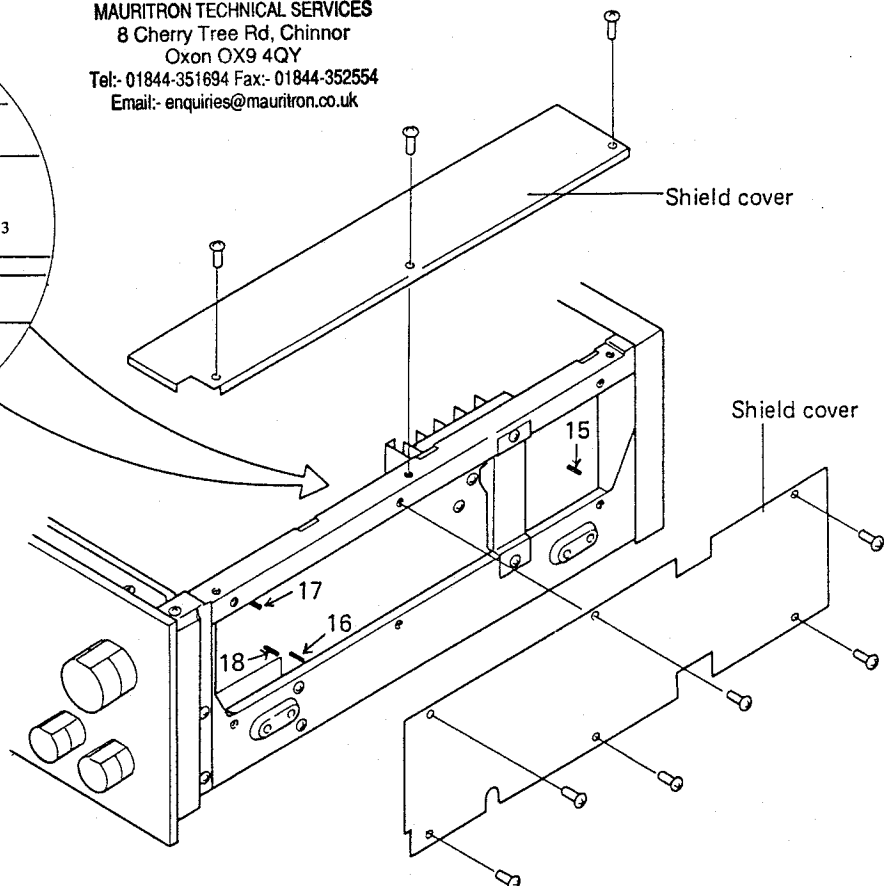
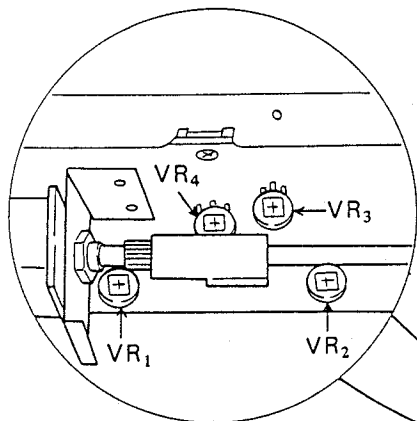
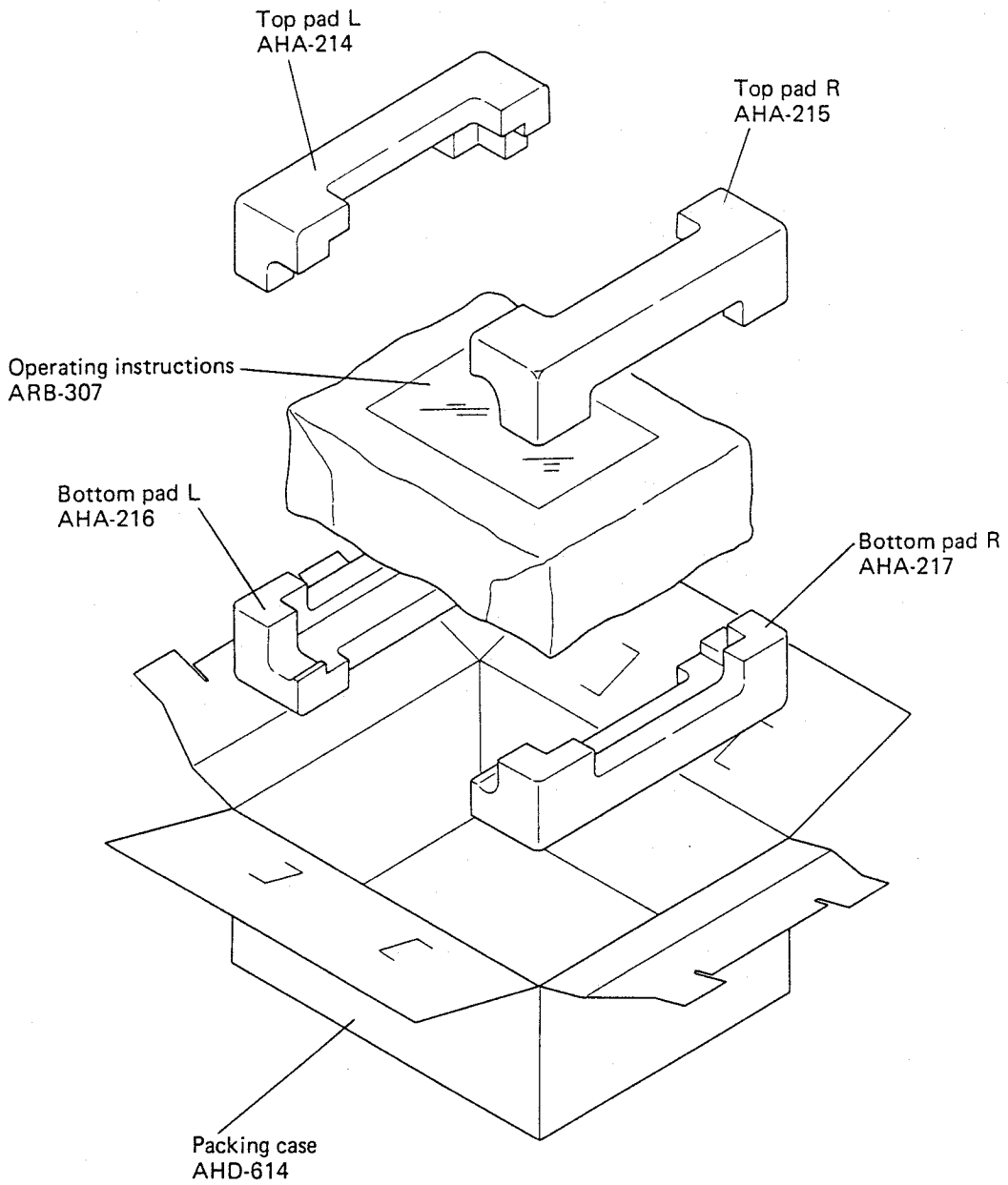

Fig. 8-3 Adjustments of Preamplifier

9. PACKING



10. EXPLODED VIEW

NOTES:

- marked parts cannot be supplied.
- The mark found on some component parts indicates the importance of the safety factor of the part. Therefore, when replacing, be sure to use parts of identical designation.

For Service Manuals Contact
MAURITRON TECHNICAL SERVICES
 8 Cherry Tree Rd, Chinnor
 Oxon OX9 4QY
 Tel: 01844-351694 Fax: 01844-352554
 Email: enquiries@mauritron.co.uk

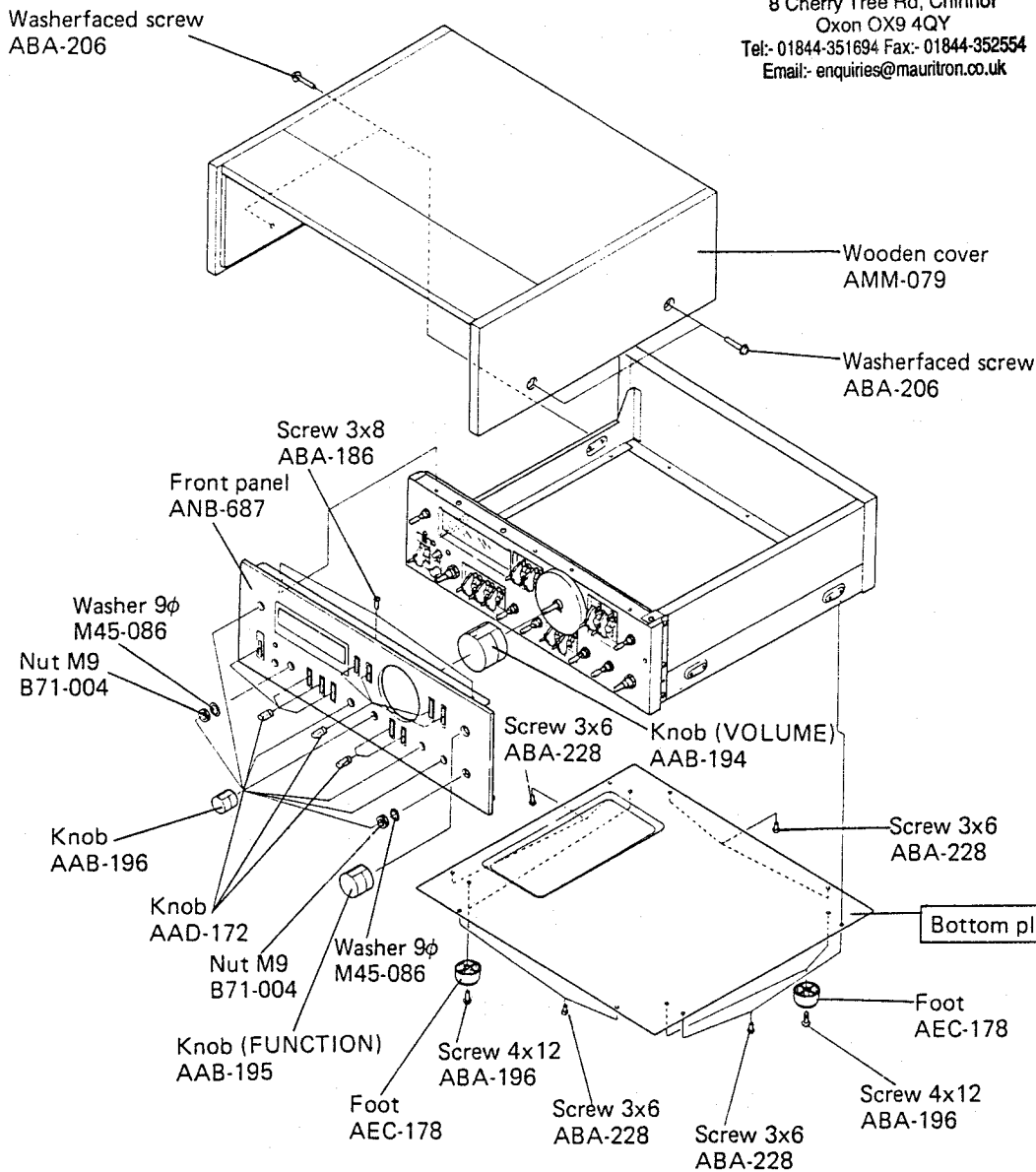

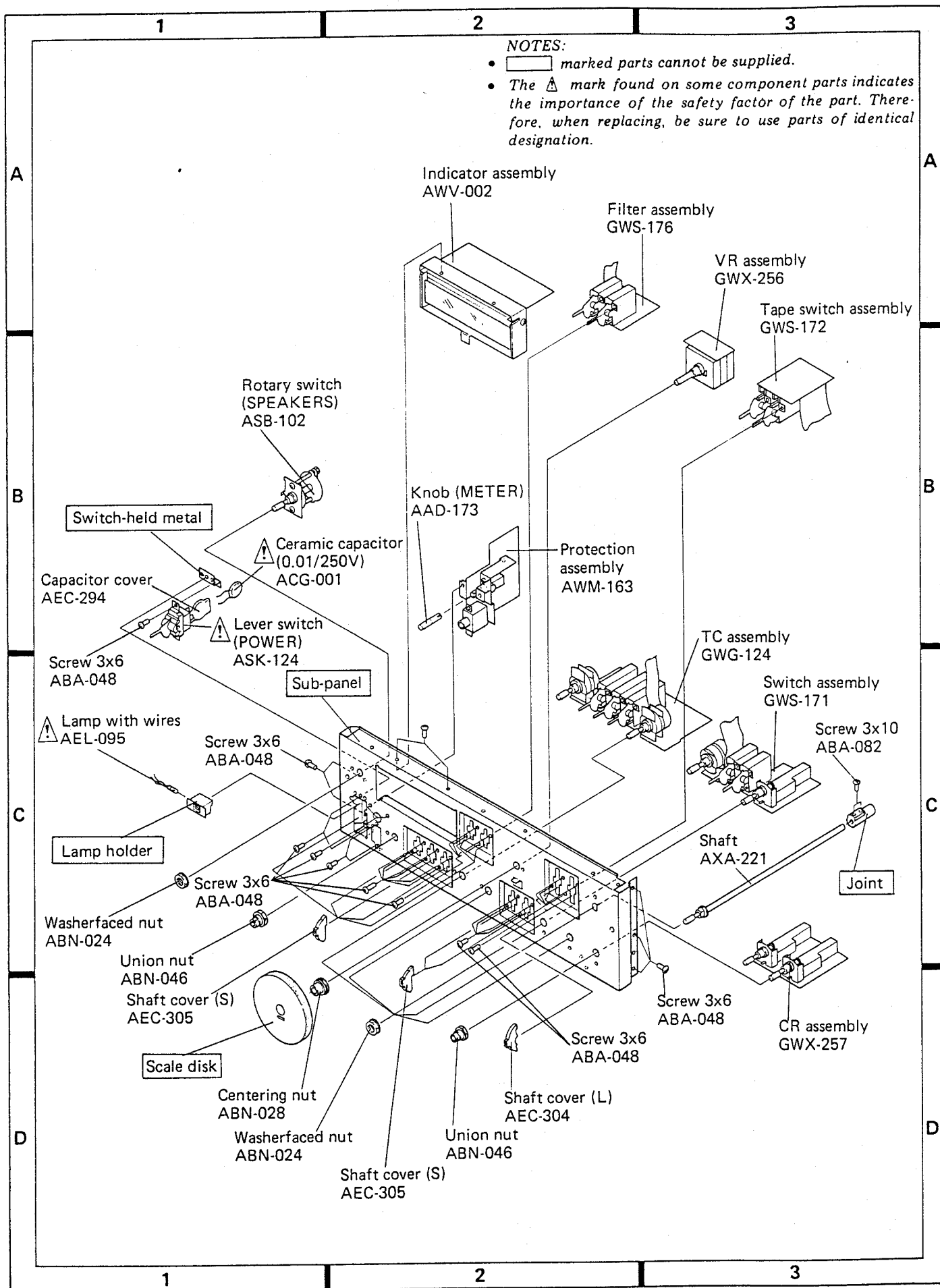

11. SCHEMATIC DIAGRAMS, P.C. BOARD PATTERNS AND PARTS LIST

NOTES:

• When ordering resistors, first convert resistance values into code form as shown in the following examples.

Ex. 1 When there are 2 effective digits (any digit apart from 0), such as 560 ohm and 47k ohm (tolerance is shown by J = 5%, and K = 10%).

560Ω 56 x 10¹ 561 RD4PS 560J
 47kΩ 47 x 10⁴ 473 RD4PS 473J
 0.5Ω 0R5 RN2H 055K
 1Ω 010 RSIP 010K

Ex. 2 When there are 3 effective digits (such as in high precision metal film resistors).

5.62kΩ 562 x 10¹ 5621 RN4SR 5621F

• The Δ mark found on some component parts indicates the importance of the safety factor of the part. Therefore, when replacing, be sure to use parts of identical designation.

For Service Manuals Contact
MAURITRON TECHNICAL SERVICES
 8 Cherry Tree Rd, Chinnor
 Oxon OX9 4QY

Tel: 01844-351694 Fax: 01844-352554

Email: enquiries@mauritron.co.uk

External Appearance of Transistors and ICs

2SA1114
 2SA904A
 2SA750
 2SA726S
 2SA726P
 2SC1914A
 2SC1919
 2SC2602



2SA850
 2SC1735



2SA733A
 2SA750
 2SC945A
 2SC1400
 2SC1775A
 2SC1890A



2SB662
 2SD712

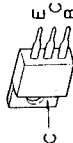

2SA912
 2SC1885



2SK129A
 2SK131S

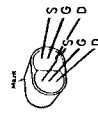

2SA798
 2SA979



TA7318P-A



HA12010

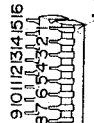

P.C. BOARD ASSEMBLIES

Part No.	Description
EQ assembly	EQ assembly
Input terminal assembly	Input terminal assembly
TC assembly	TC assembly
Filter assembly	Filter assembly
PAL assembly	PAL assembly
PA-R assembly	PA-R assembly
Power supply assembly	Power supply assembly
Rectifier assembly	Rectifier assembly
Protection assembly	Protection assembly
Switch assembly	Switch assembly
VR assembly	VR assembly
CR assembly	CR assembly
Indicator assembly	Indicator assembly
Tape terminal assembly	Tape terminal assembly
Tape switch assembly	Tape switch assembly
P.C. board	P.C. board

OTHERS

Part No.	Symbol & Description
ΔATT-556	T1, T2 Power transformer
ΔADG-023	AC power cord
ΔAKP-004	AC socket (AC OUTLETS)
AKE-038	Terminal (SPEAKERS)
AKB-035	Terminal (PRE/POWER AMP)

Note: When ordering resistors, convert the resistance value into code form, and then rewrite the part no. as before.

RESISTORS

Part No.	Symbol & Description
ΔACN-031	R1 Wire wound 220/5W
ΔACN-044	R2 Wire wound 150/5W

CAPACITORS

Part No.	Symbol & Description
ΔACG-001	C1 Ceramic 0.01/250V
CKDYF 473Z 50	C2-C6
CEA 010P 50	C7

SWITCHES

Part No.	Symbol & Description
ASB-102	S16 Rotary (SPEAKERS)
ASK-124	S18 Lever (POWER)

SEMICONDUCTORS

Part No.	Symbol & Description
2SC2526-G	O1-O4 Lamp with wires
2SA1076-G	FU1, FU2 Fuse (5A)
	FU3, FU4 Fuse (0.8A)

11.1 MISCELLANEA

Miscellaneous Parts

LAMP AND FUSES

Part No.	Symbol & Description
ΔAEL-095	PL1 Lamp with wires
ΔAEK-108	FU1, FU2 Fuse (5A)
ΔAEK-111	FU3, FU4 Fuse (0.8A)

11.2 SCHEMATIC DIAGRAM

For Service Manuals Contact
MAURITRON TECHNICAL SERVICES
 8 Cherry Tree Rd, Chinnor
 Oxon OX9 4QY
 Tel: 01844-351694 Fax: 01844-352554
 Email: enquiries@mauritron.co.uk

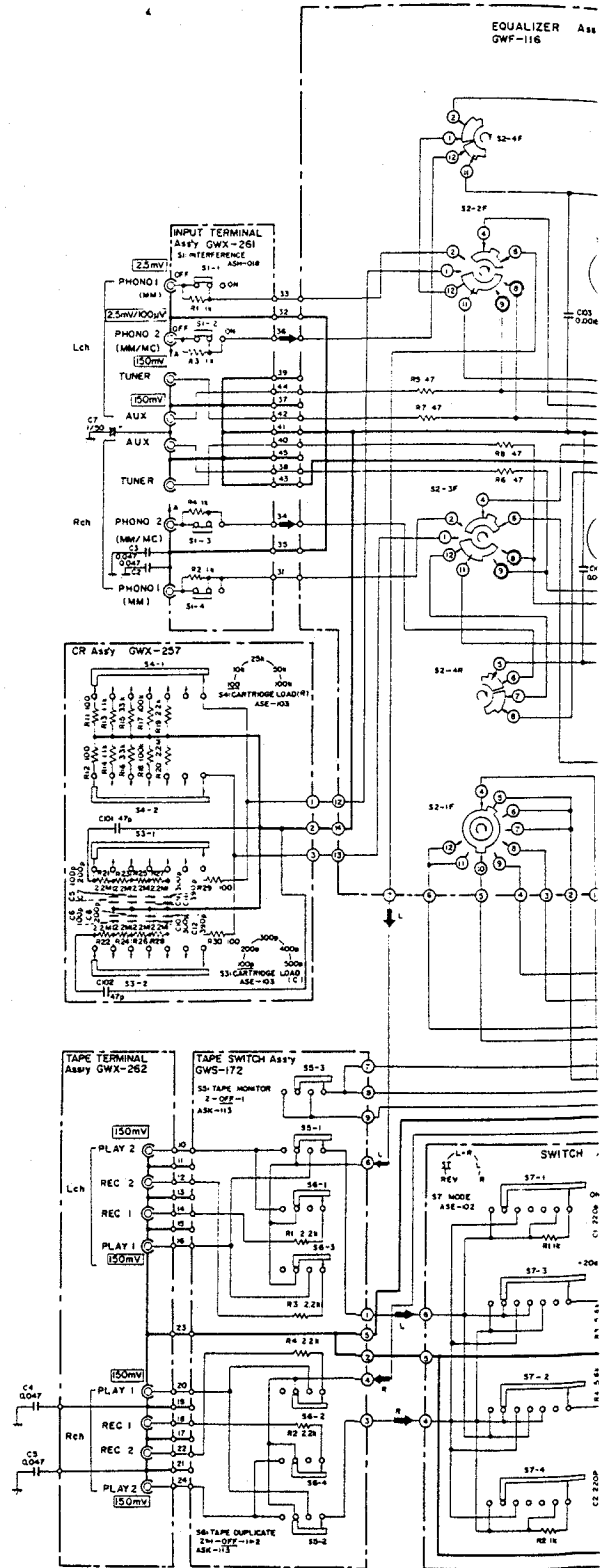

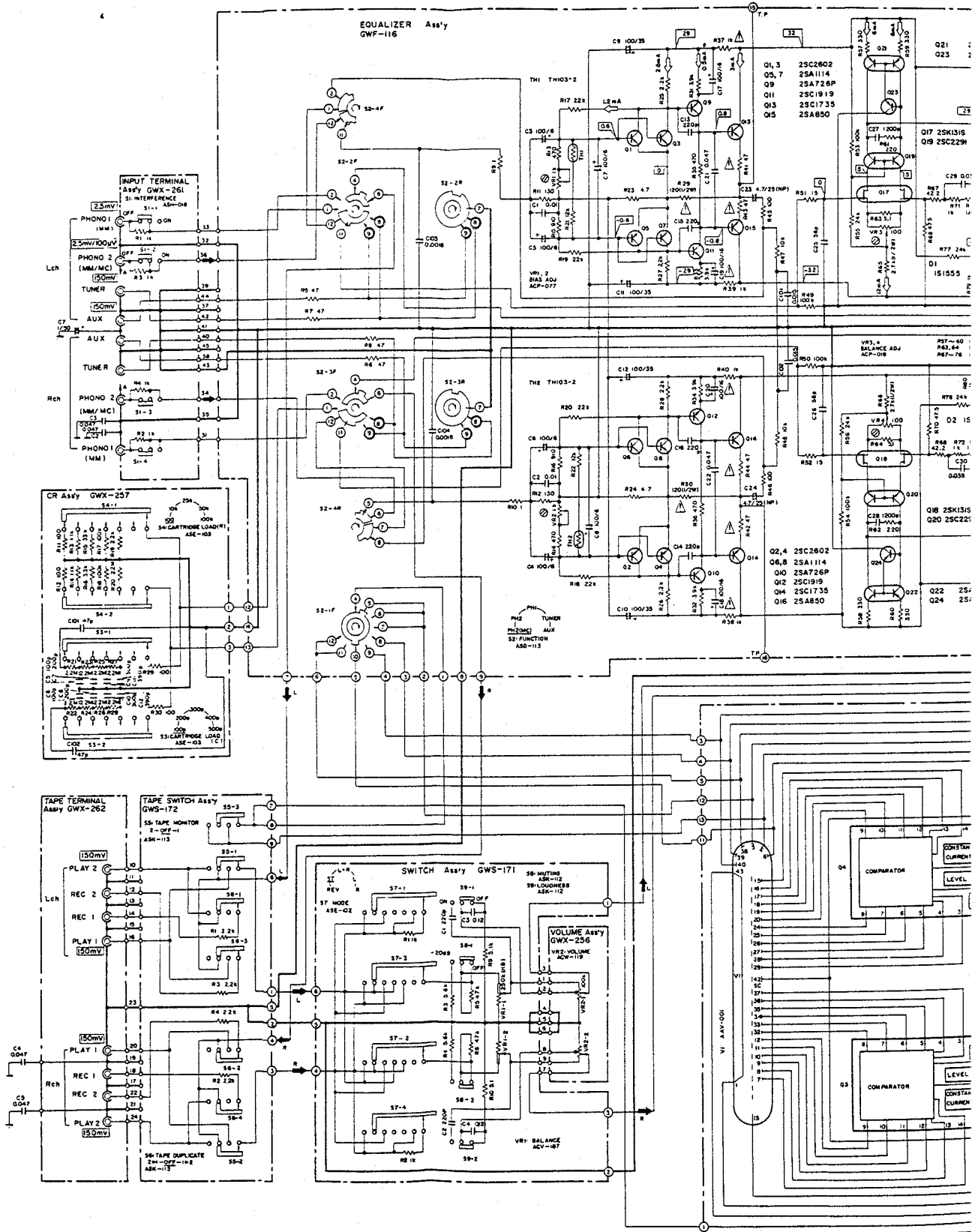

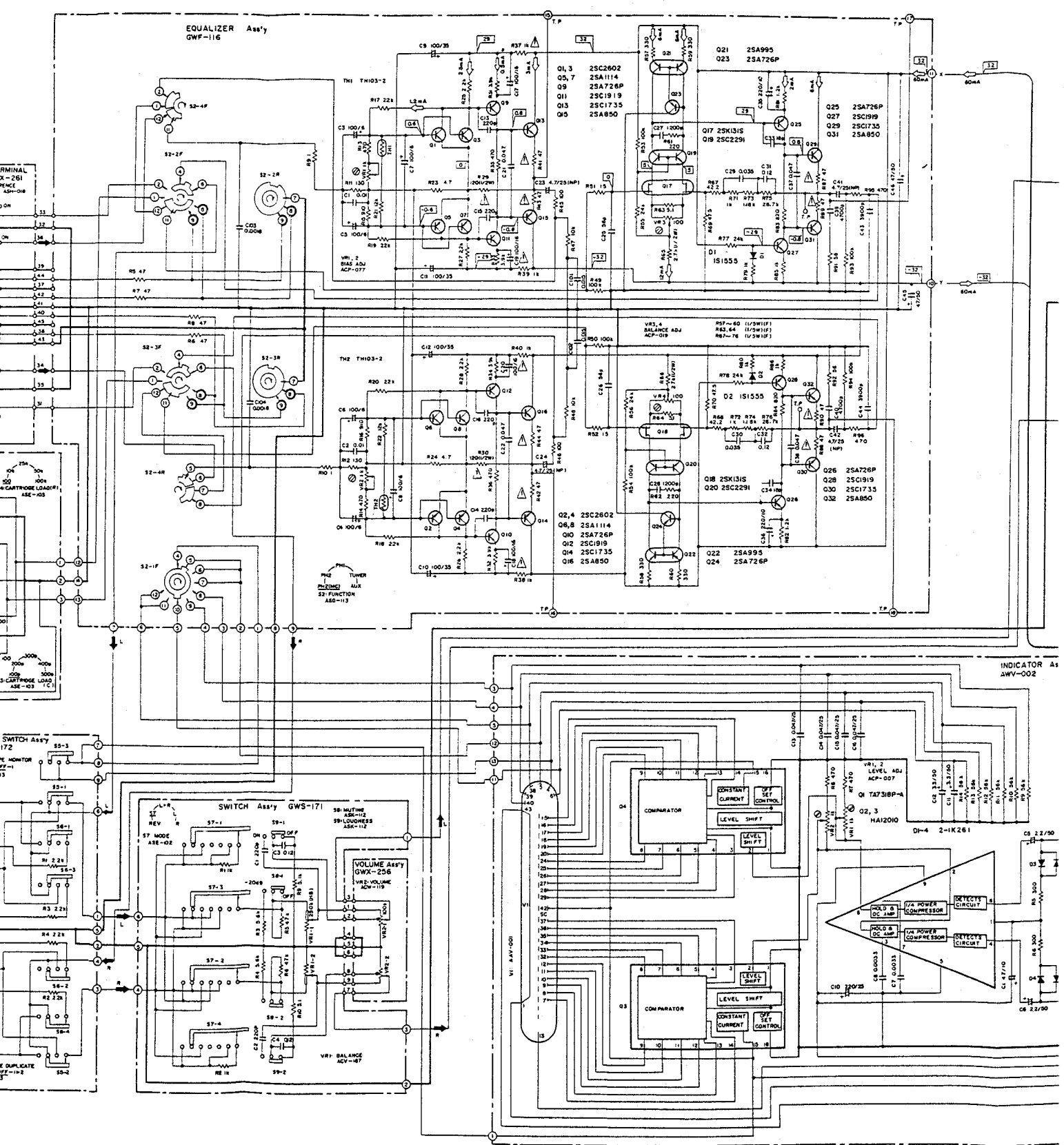

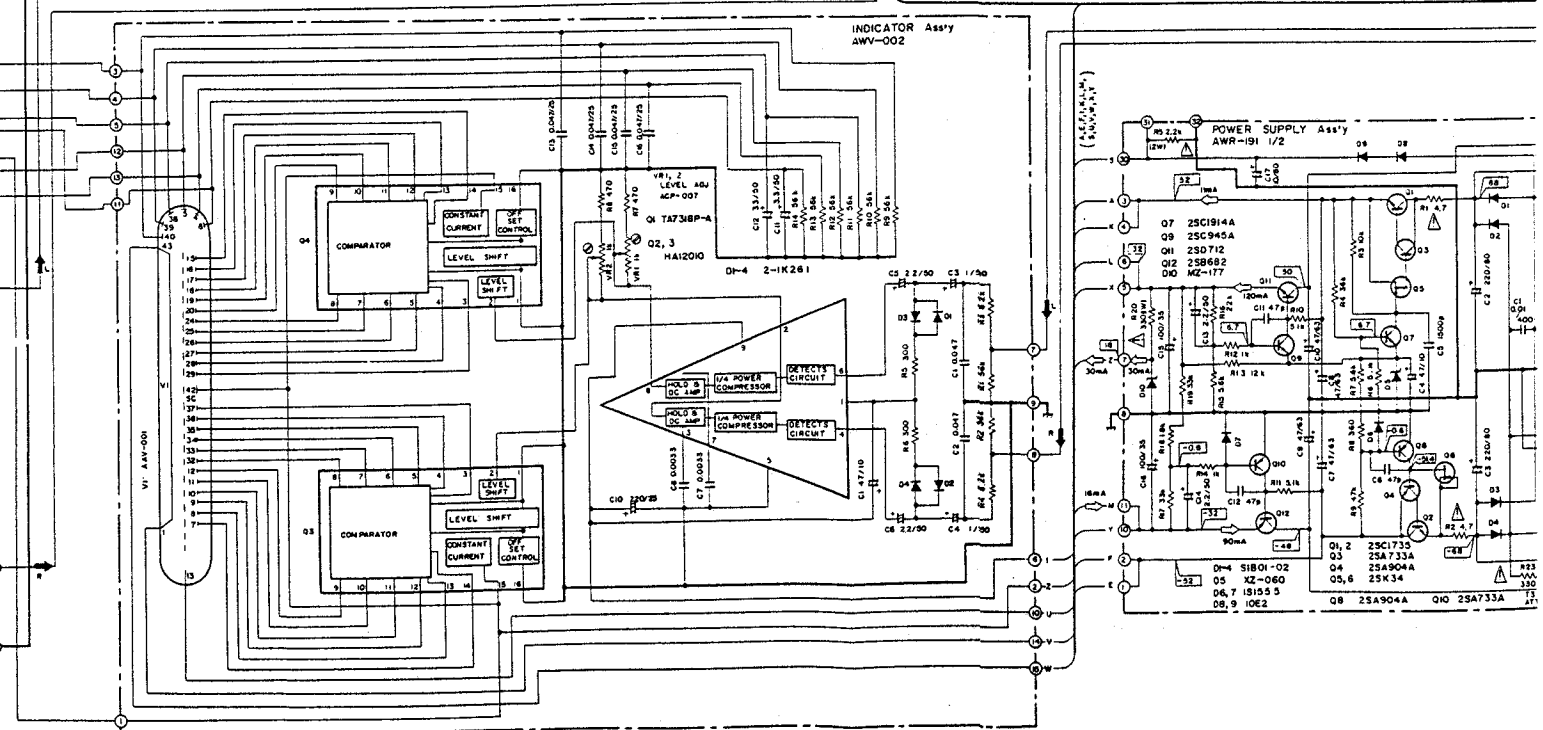
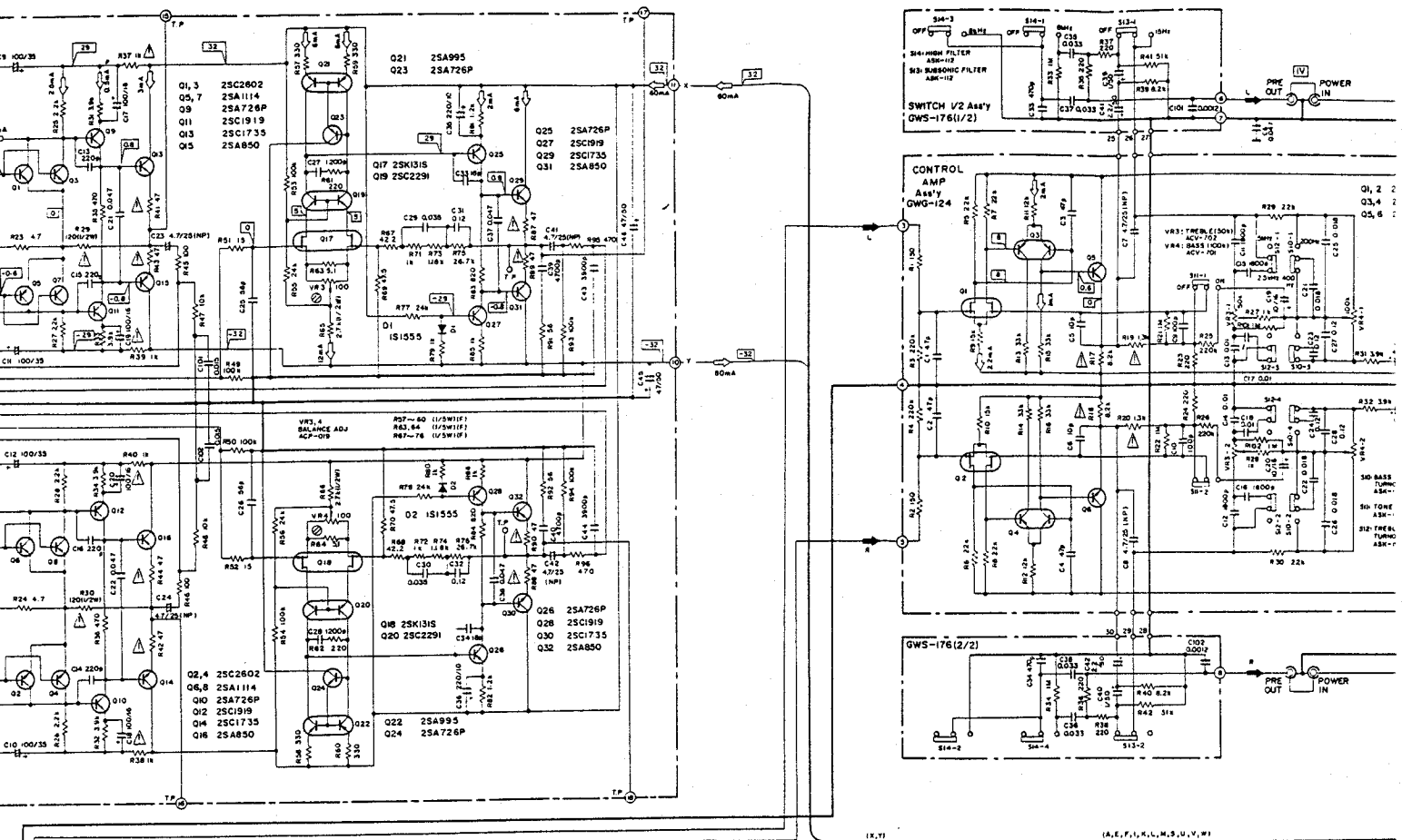

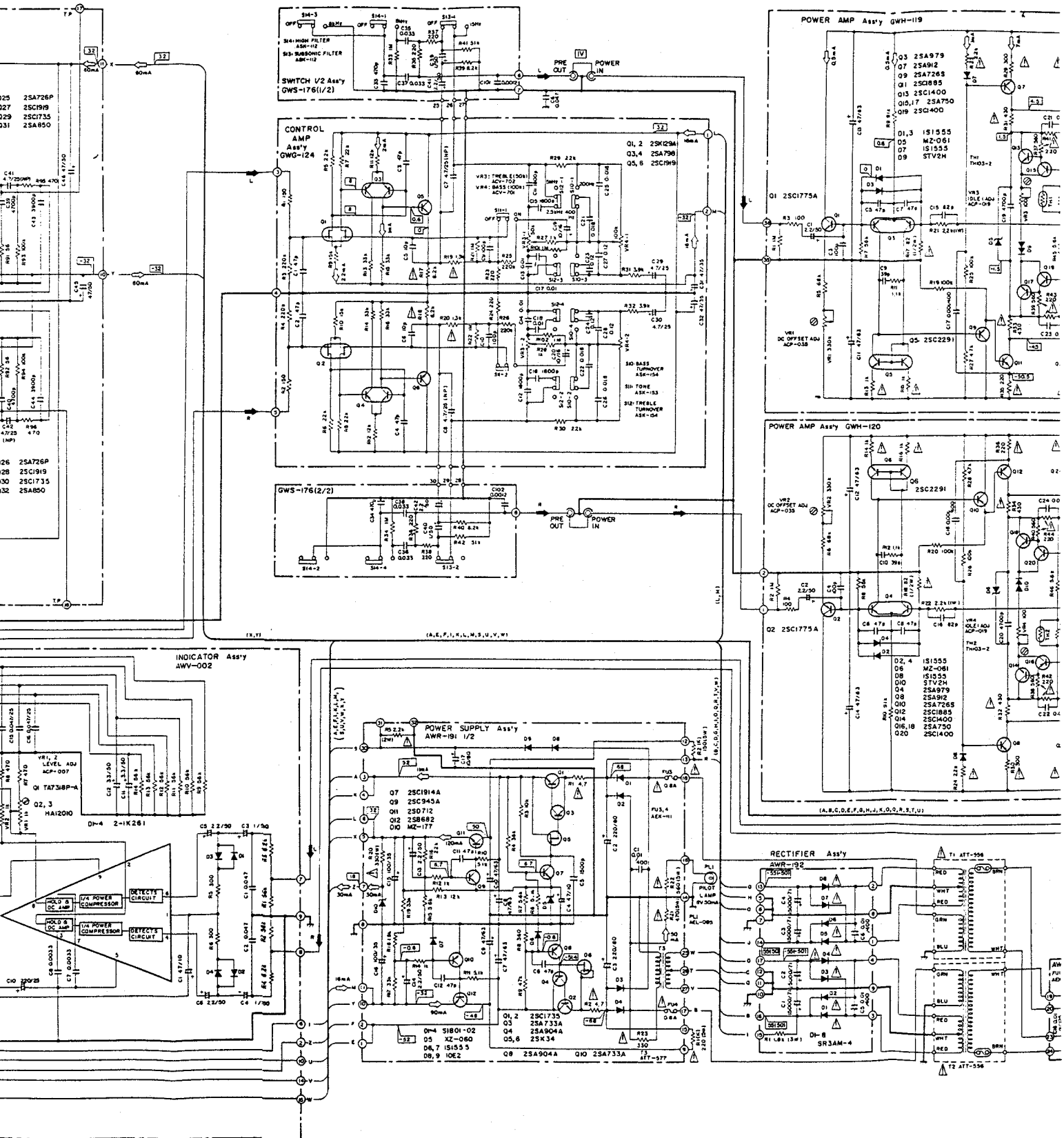

10

11

12

NOTE:
The indicated semiconductors are representative ones only. Other alternative semiconductors may be used and are listed in the parts list.

1. RESISTOR:
Indicated in Ω, 1/4W, .5% tolerance unless otherwise noted; K, M, M, M, (F), .1%, (G), 12%, (K), 10% tolerance.
2. CAPACITORS:
Indicated in capacity (μF/voltage V) unless otherwise noted; p, pF.
Indication without voltage is 50V except electrolytic capacitor.
3. VOLTAGE, CURRENT,
Signal voltage at 100W + 100W SET output
DC voltage (V) at no input signal
Value in () is DC voltage at rated power.
mA, DC current at no input signal
4. OTHERS:
Signal route.
Adjusting point.
The Δ mark found on some component parts indicates the importance of the safety factor of the part. Therefore, when replacing, be sure to use parts of identical designation.

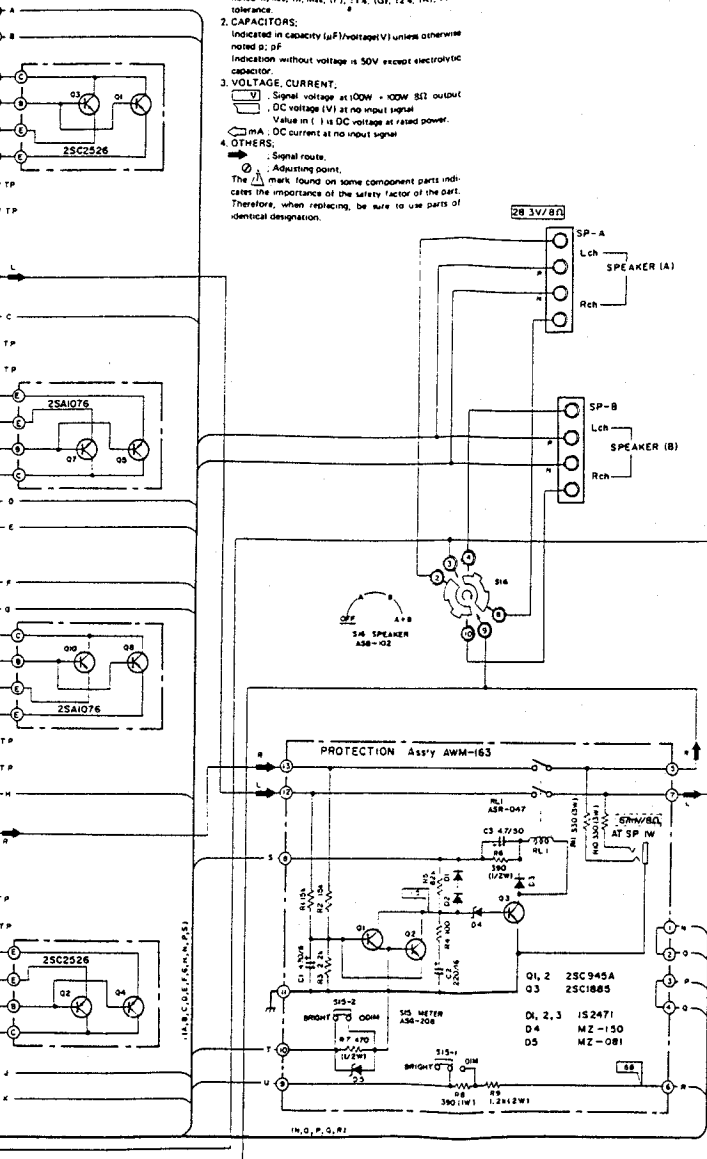

PHONO INTERFERENCE	QEE ON	S9: LOUDNESS	QEE ON
FUNCTION		S10: BASS TURNOVER	100Hz 200Hz
PHONO 2 (MC) PHONO 2 (MM) PHONO 1 (MM) TUNER AUX		S11: TONE	QEE ON
CARTRIDGE LOAD (C)		S12: TREBLE TURNOVER	2.5kHz 5kHz
100-200-300-400-500		S13: SUBSONIC FILTER	QEE 15Hz
CARTRIDGE LOAD (R)		S14: HIGH FILTER	QEE 8kHz
100-10k-25k-50k-100k		S15: METER	BRIGHT DIM
TAPE MONITOR	1-QEE 2	S16: SPEAKER	QEE ON
TAPE DUPLICATE	1=2 QEE 2=1	S18: POWER	OFF A-B-A-B
MODE			
REVERSE L-R-L-R			
MUTING	QEE -2008		

The underlined indicates the switch position.
This is the basic schematic diagram, but the actual circuit may vary due to improvements in design.

10

11

12

11.3 P.C. BOARDS CONNECTION DIAGRAM

EQ ASS'Y (GWF-116)

INPUT TERMINAL ASS'Y (GWX-261)

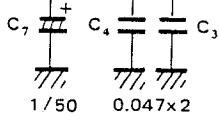
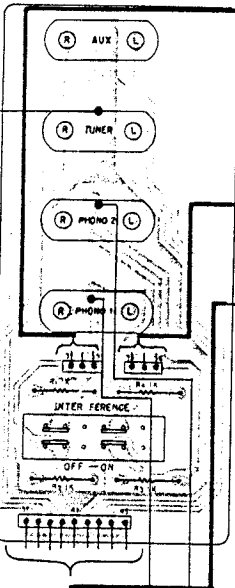

TAPE TERMINAL ASS'Y (GWX-262)

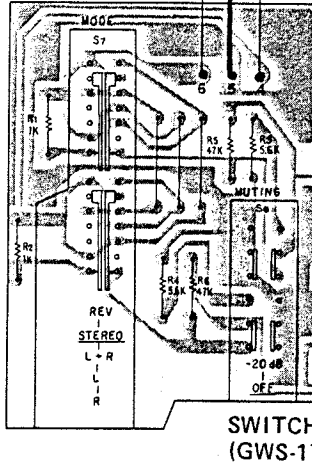
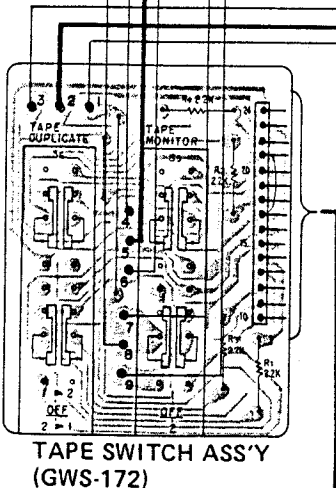
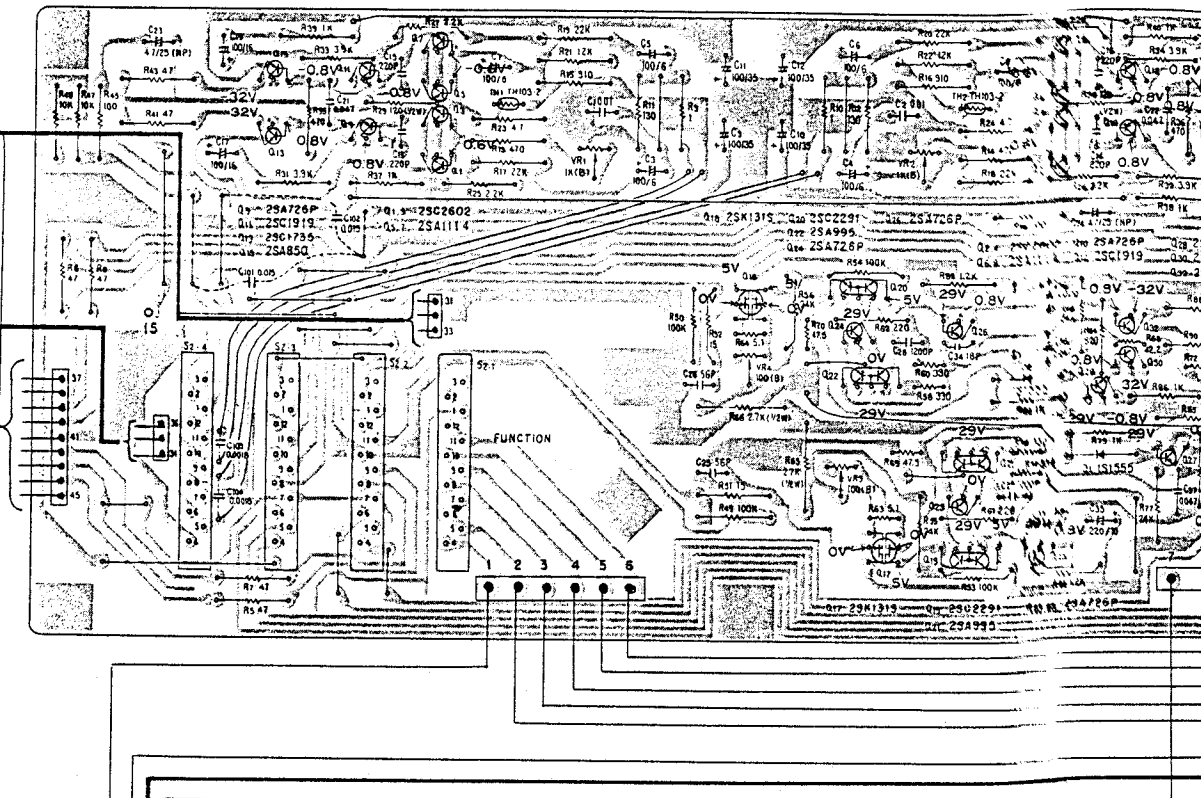
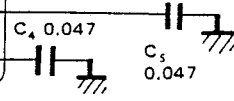
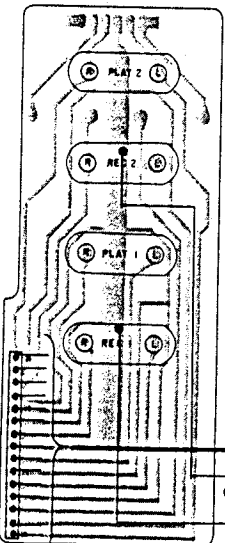

SWITCH ASS'Y (GWS-171)

TC ASS

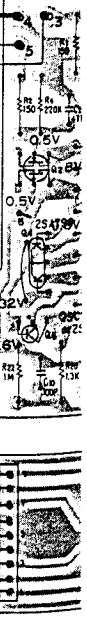

For Service Manuals Contact
MAURITRON TECHNICAL SERVICES
 8 Cherry Tree Rd, Chinnor
 Oxon OX9 4QY
 Tel:- 01844-351694 Fax:- 01844-352554
 Email:- enquires@mauritron.co.uk

CR ASS'Y (GWX-257)

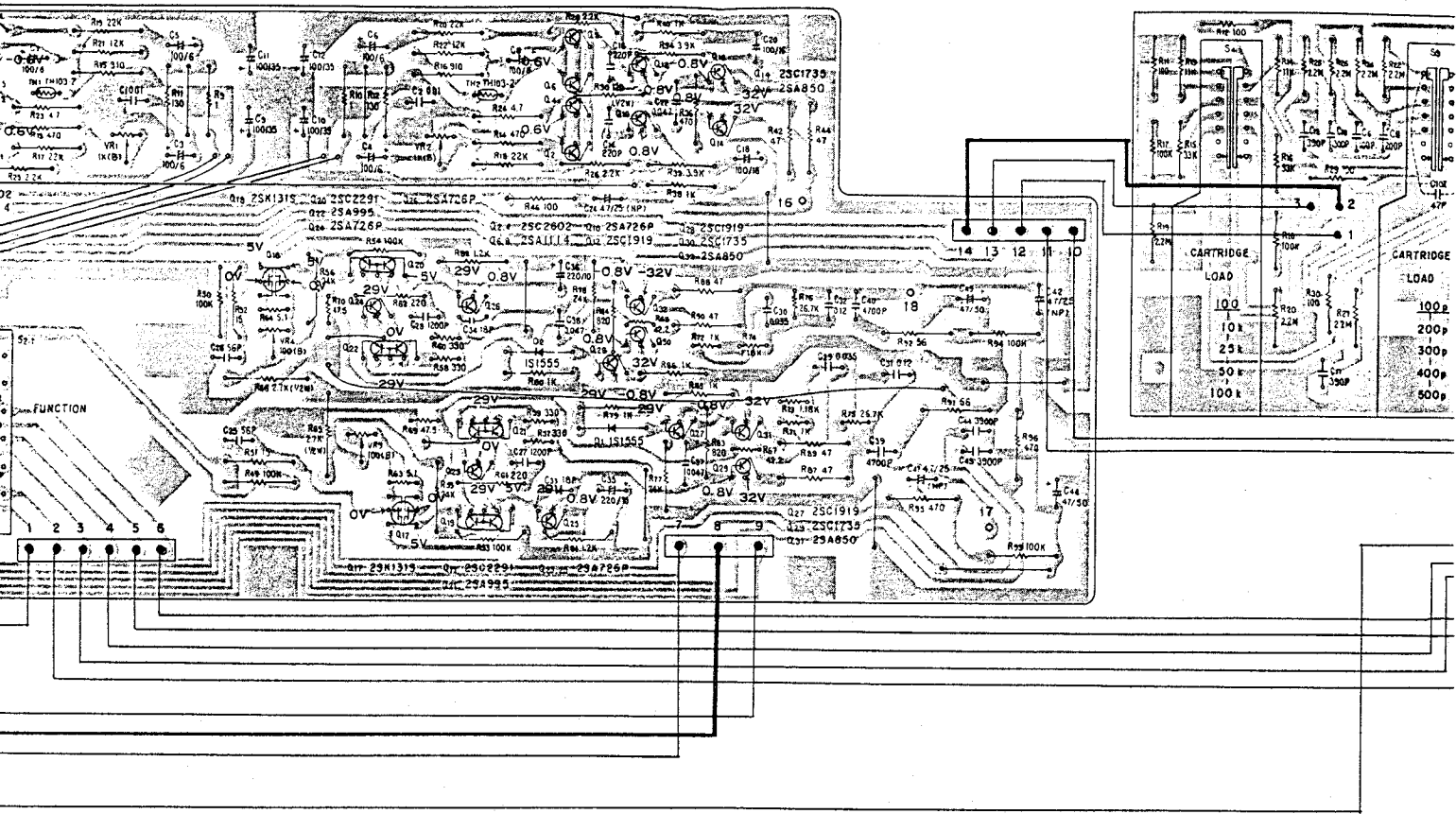

TC ASS'Y (GWG-124)

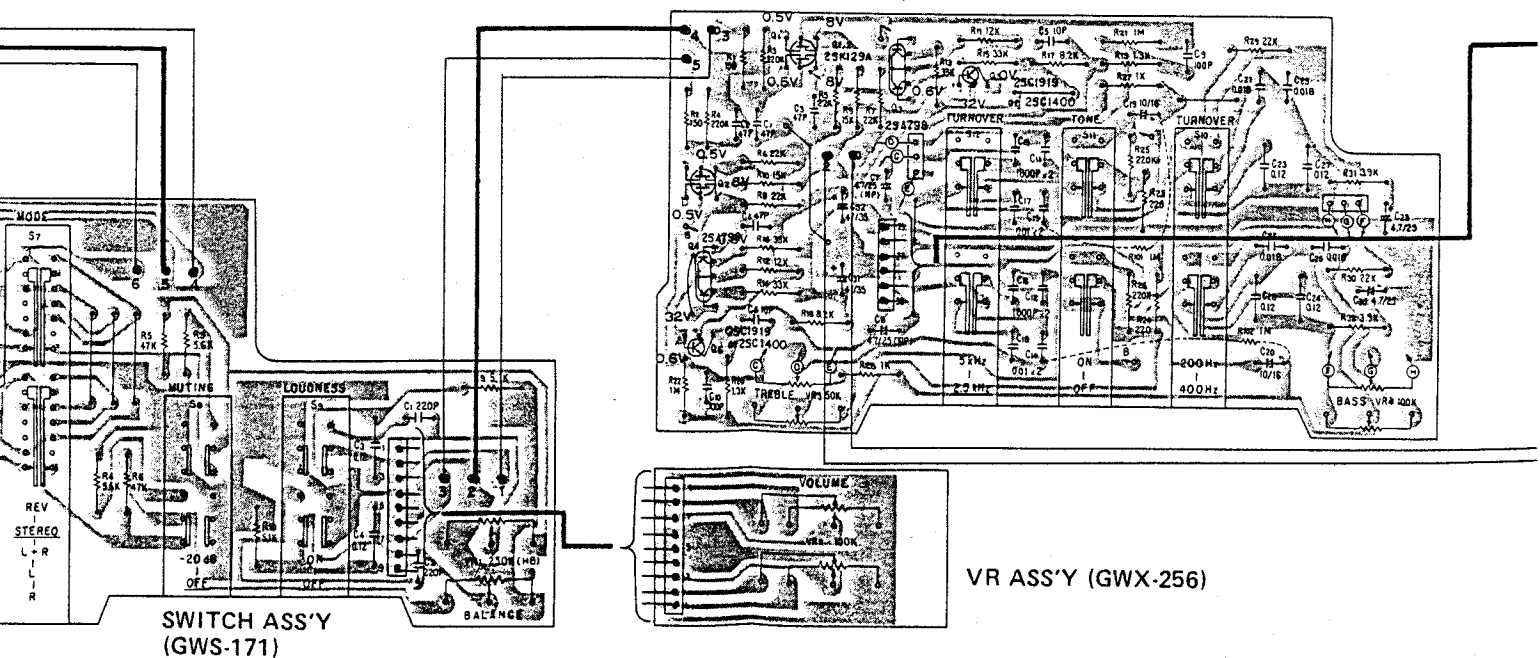

CR ASS'Y (GWX-257)

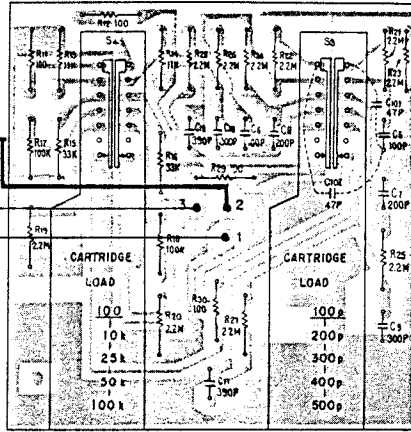

INDICATOR ASS'Y (AWV-)

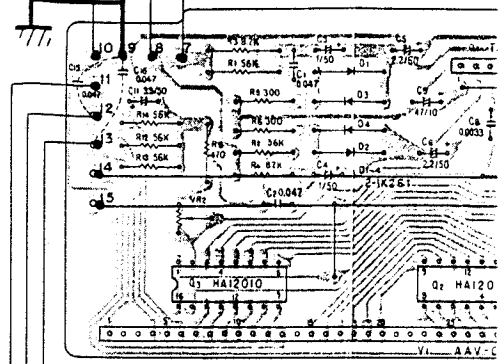

FILTER ASS'Y (GWS-1)

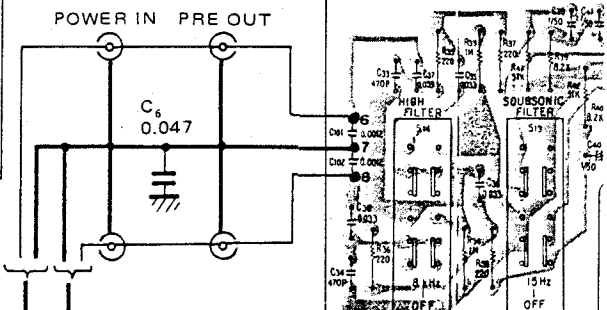

TC ASS'Y (GWG-124)

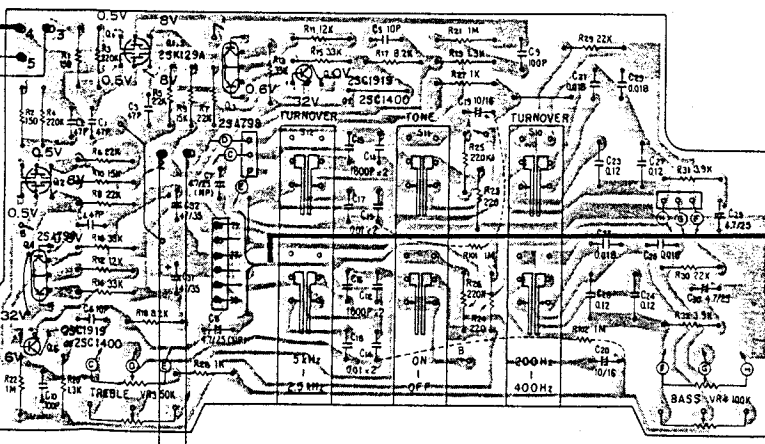

For Service Manuals Contact
MAURITRON TECHNICAL SERVICES
 8 Cherry Tree Rd, Chinnor
 Oxon OX9 4QY
 Tel: 01844-351694 Fax: 01844-352554
 Email: enquiries@mauritron.co.uk

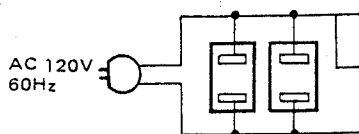

VR ASS'Y (GWX-256)

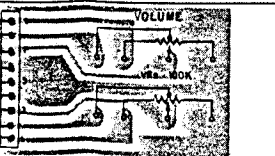

X-257)

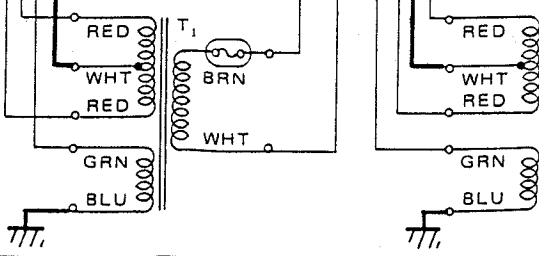
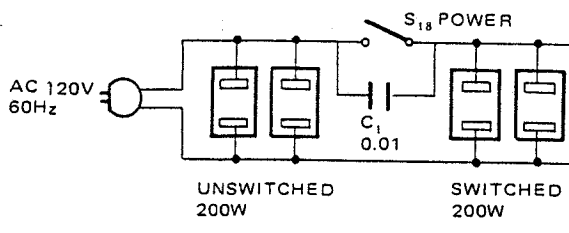
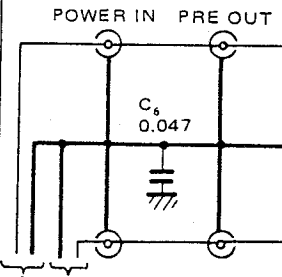
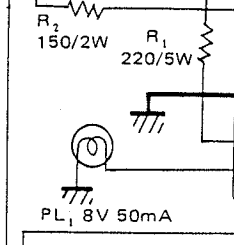
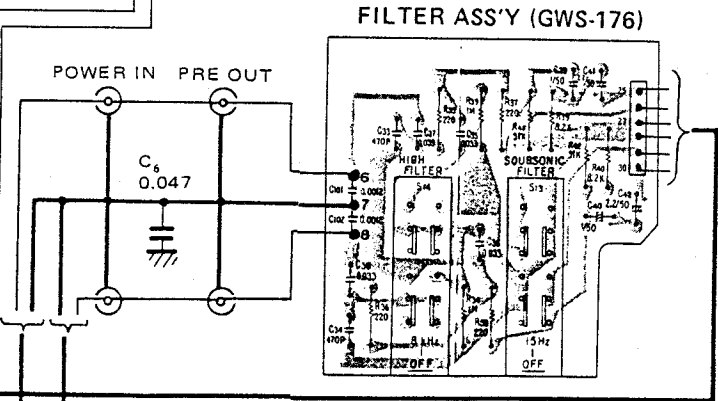
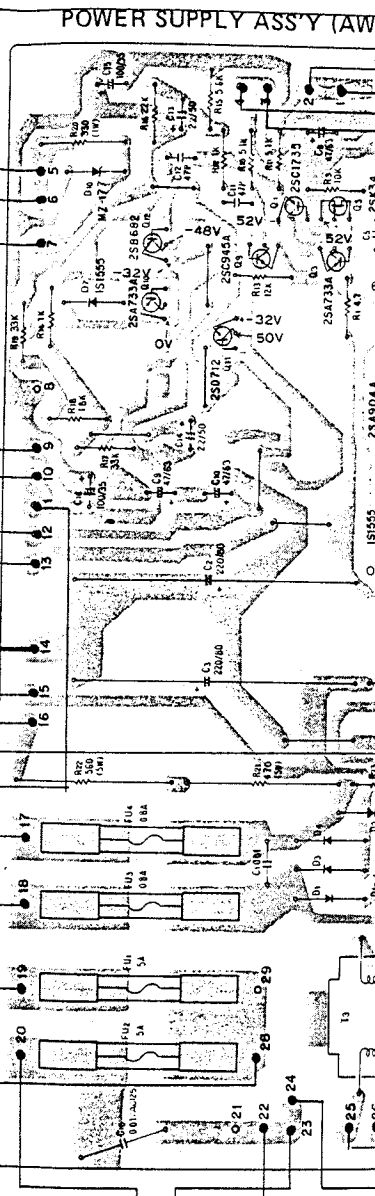
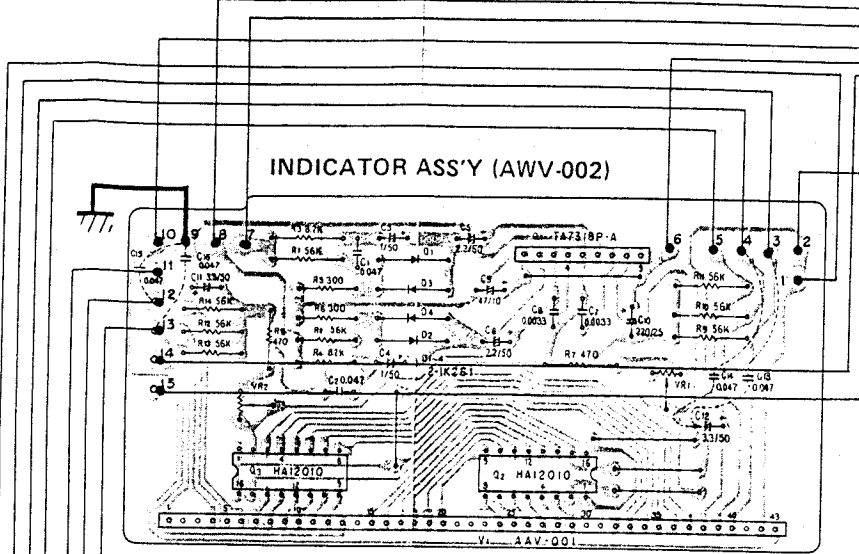
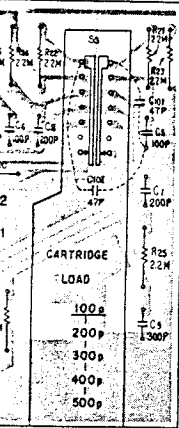

POWER SUPPLY ASS'Y (AWR-191)

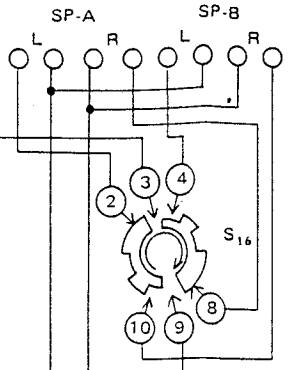
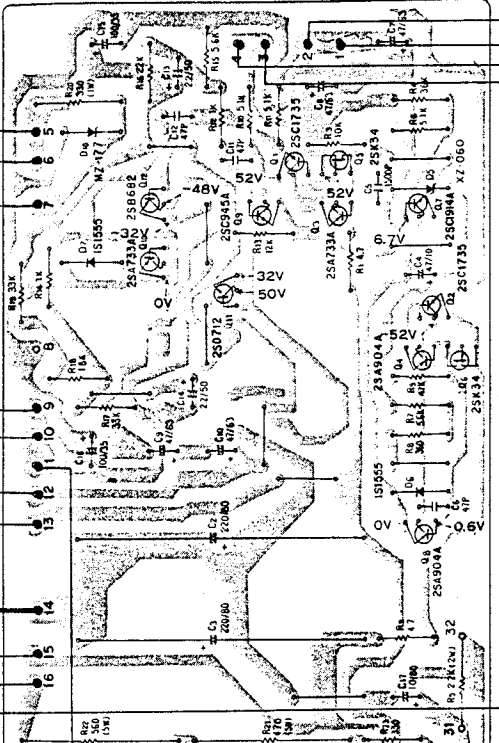

PA-R ASS'Y (GWH-120)

PROTECTION ASS'Y (AWM-163)

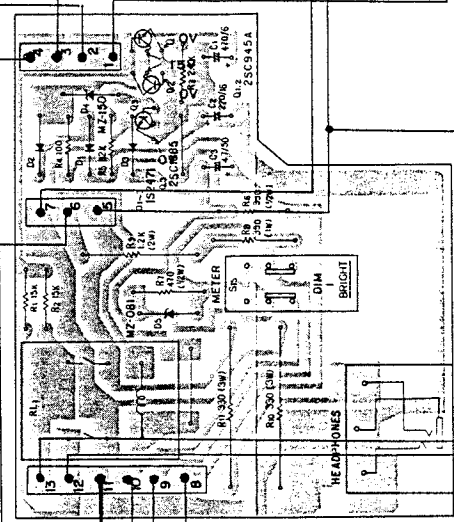

RECTIFIER ASS'Y (AWR-192)

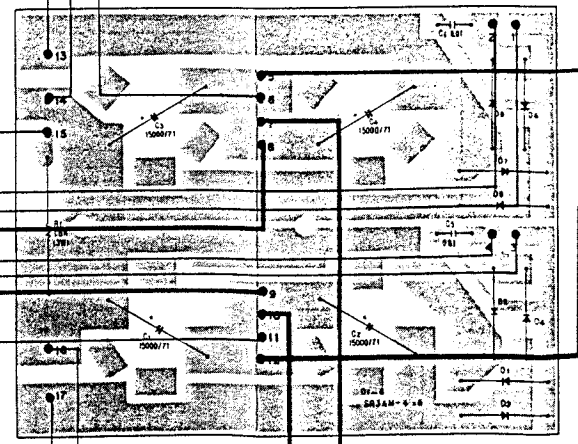

PA-L ASS'Y (GWH-119)

10

11

12

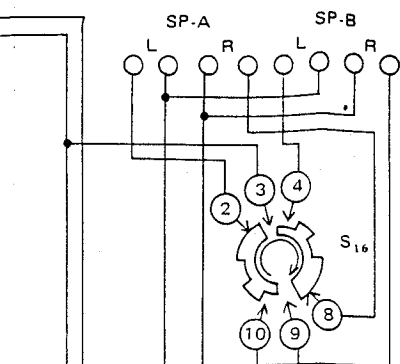

PA-R ASSY (GWH-120)

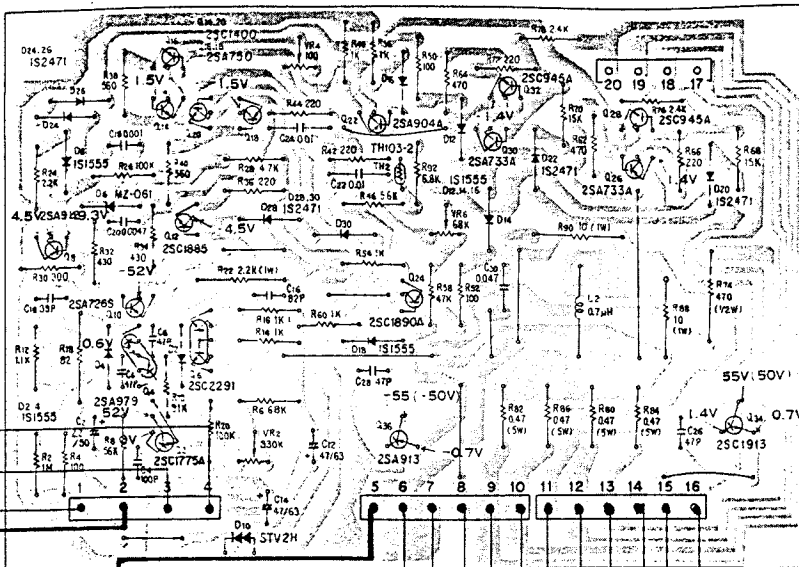

A

B

PROTECTION ASS'Y (AWM-163)

RECTIFIER ASS'Y (AWR-192)

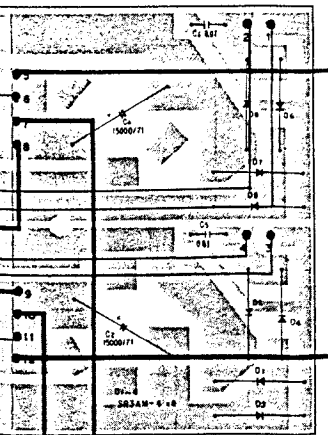

PA-L ASSY (GWH-119)

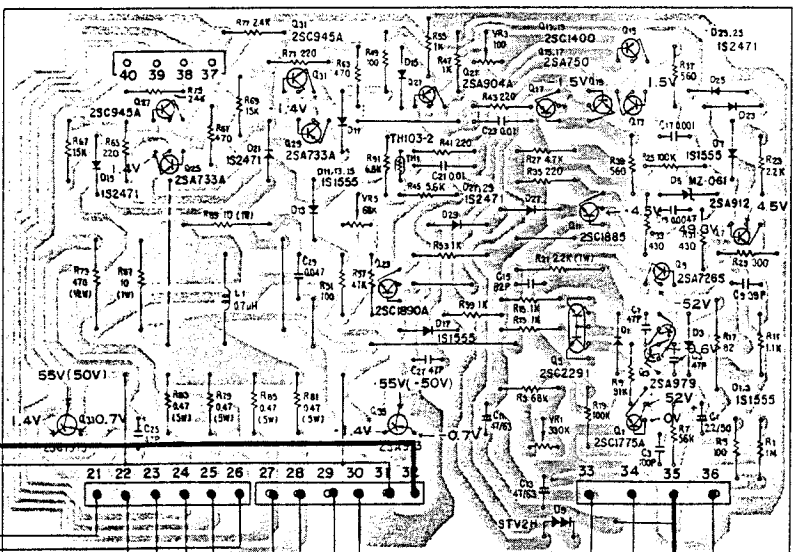

C

D

10

11

12

11.4 INPUT TERMINAL ASSEMBLY (GWX-261)

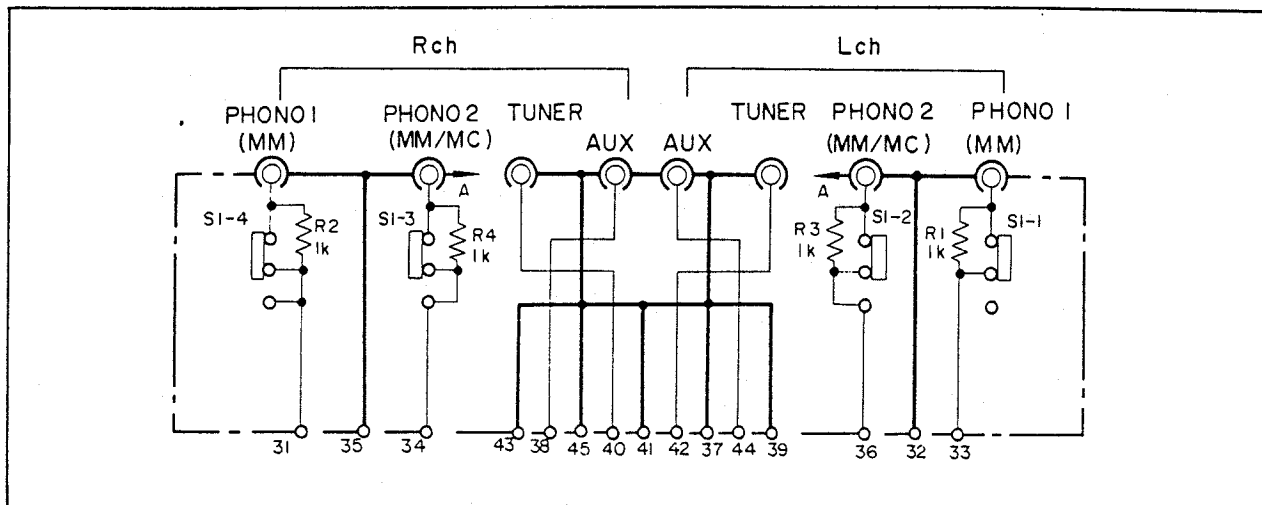

Parts List

Part No.	Symbol & Description
ASH-018	S1 Slide switch (PHONO INTERFERENCE)
RD¼PM 102J	R1-R4 Terminal (INPUT)
AKB-054	

11.5 CR ASSEMBLY (GWX-257)

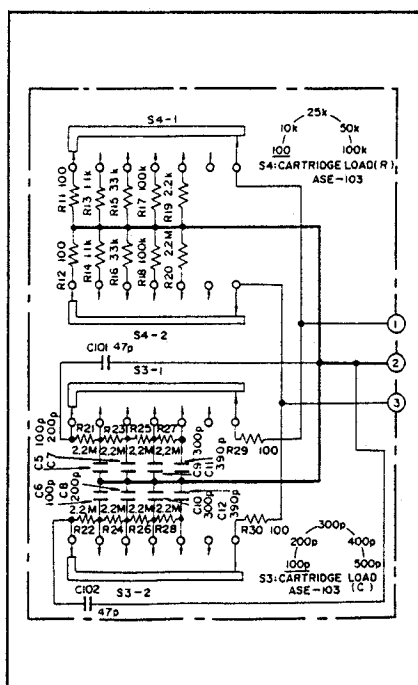

For Service Manuals Contact
MAURITRON TECHNICAL SERVICES
 8 Cherry Tree Rd, Chinnor
 Oxon OX9 4QY
 Tel: 01844-351694 Fax: 01844-352554
 Email: enquiries@mauritron.co.uk

Parts List

SWITCHES

Part No.	Symbol & Description
ASE-103	S3, S4 Slide rotary

Note: When ordering resistors, convert the resistance value into code form, and then rewrite the part no. as before.

RESISTORS

Part No.	Symbol & Description
RD¼PM □□□ J	R11-R30

CAPACITORS

Part No.	Symbol & Description
CQSH 101K 50	C5, C6
CQSH 201K 50	C7, C8
CQSH 301K 50	C9, C10
CQSH 391K 50	C11, C12
CCDSL 470K 50	C101, C102

11.6 EQ ASSEMBLY (GWF-116)

Parts List

CAPACITORS

Part No.	Symbol & Description
CQMA 103K 50	C1, C2
CEANL 101M 6	C3-C8
CEA 101P 35	C9-C12
CCDSL 221K 50	C13-C16
CEA 101P 16	C17-C20
CQMA 473K 50	C21, C22, C37, C38
ACH-318	C23, C24, C41, C42 Electrolytic 4.7/25 (NP)
CCDSL 560K 50	C25, C26
CKDYB 122K 50	C27, C28
CQPA 353G 50	C29, C30
CQPA 124G 50	C31, C32
CCDSL 180K 50	C33, C34
CEA 221P 10	C35, C36
CQMA 472K 50	C39, C40
CQMA 392K 50	C43, C44
CEA 470P 50	C45, C46
CQMA 153J 50	C101, C102
CQMA 182J 50	C103, C104

Note: When ordering resistors, convert the resistance value into code form, and then rewrite the part no. as before.

RESISTORS

Part No.	Symbol & Description
ACP-077	VR1, VR2 Semifixed 1k-B
ACP-019	VR3, VR4 Semifixed 100-B
RD $\frac{1}{2}$ PM $\square\square\square$ J	R5-R28, R31-R36, R45-R56, R61
RD $\frac{1}{2}$ PM $\square\square\square$ J	R62, R77-R86, R91-R96
Δ RD $\frac{1}{2}$ PSF $\square\square\square$ J	R29, R30
Δ RD $\frac{1}{2}$ PMF $\square\square\square$ J	R37-R44, R87-R90
RN $\frac{1}{5}$ SQ $\square\square\square$ F	R57-R60, R67-R76
RD $\frac{1}{2}$ PS $\square\square\square$ J	R65, R66
RN $\frac{1}{4}$ SR $\square\square\square\square$ F	R63, R64

SEMICONDUCTORS

Part No.	Symbol & Description
2SC2602	Q1-Q4
2SA1114	Q5-Q8
2SA726P (2SA750)	Q9, Q10, Q23-Q26
2SC1919 (2SC1400)	Q11, Q12, Q27, Q28
2SC1735	Q13, Q14, Q29, Q30
2SA850	Q15, Q16, Q31, Q32
2SK131S	Q17, Q18
2SC2291	Q19, Q20
2SA995	Q21, Q22
1S1555 (1S2473)	D1, D2
TH103-2	Th1, Th2

OTHERS

Part No.	Symbol & Description
ASD-113	S2 Rotary switch (FUNCTION)
ABA-048	Screw 3x6
ABN-024	Washerfaced nut

List of Changed Parts for Factory Modification

List of changed parts information will be furnished whenever necessary and you are requested to amend parts number in this parts list.

Symbol	Part No.	Description

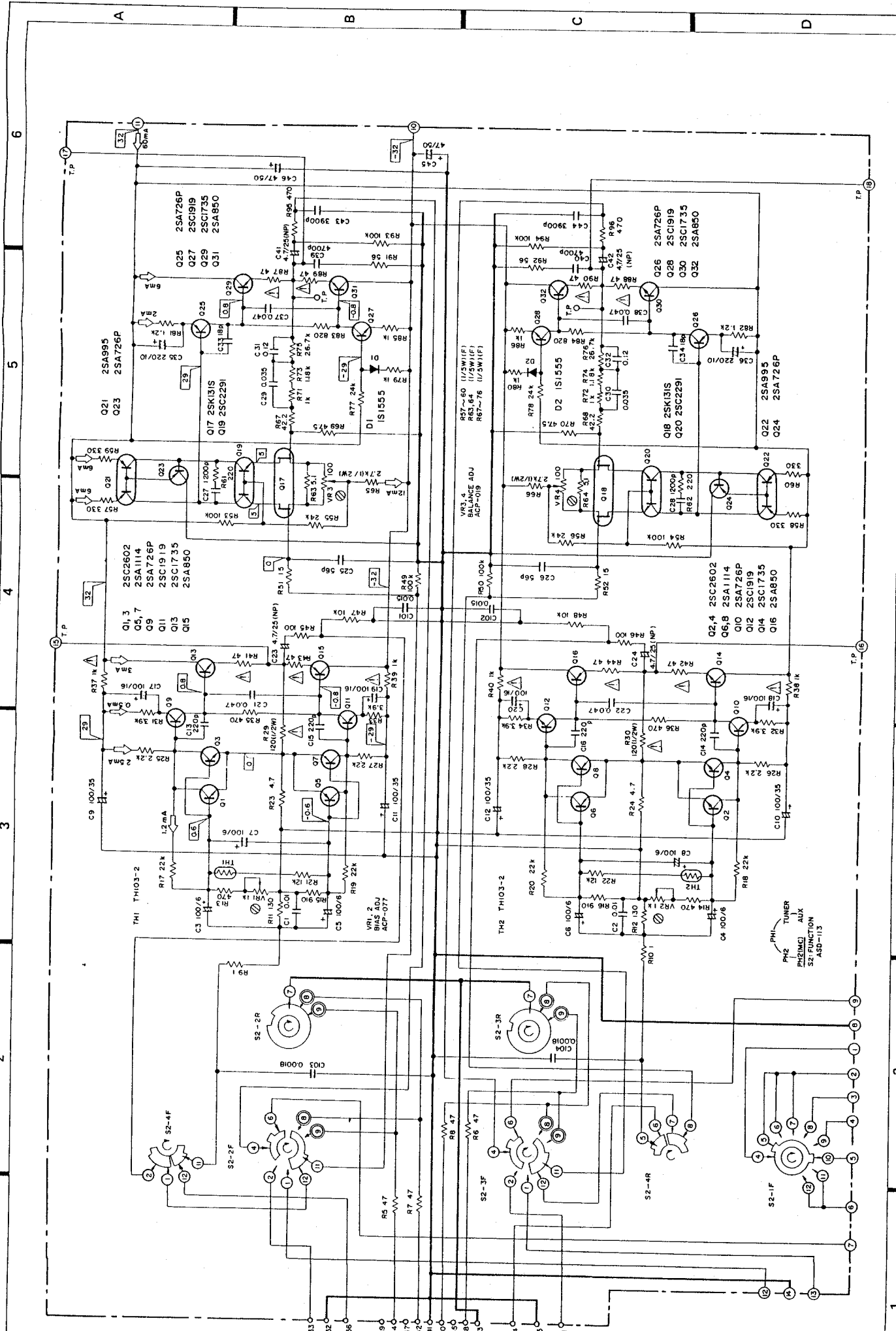

PH2
TUNER
PHEIMC) AUX
S2-FUNCTION
ASD-113

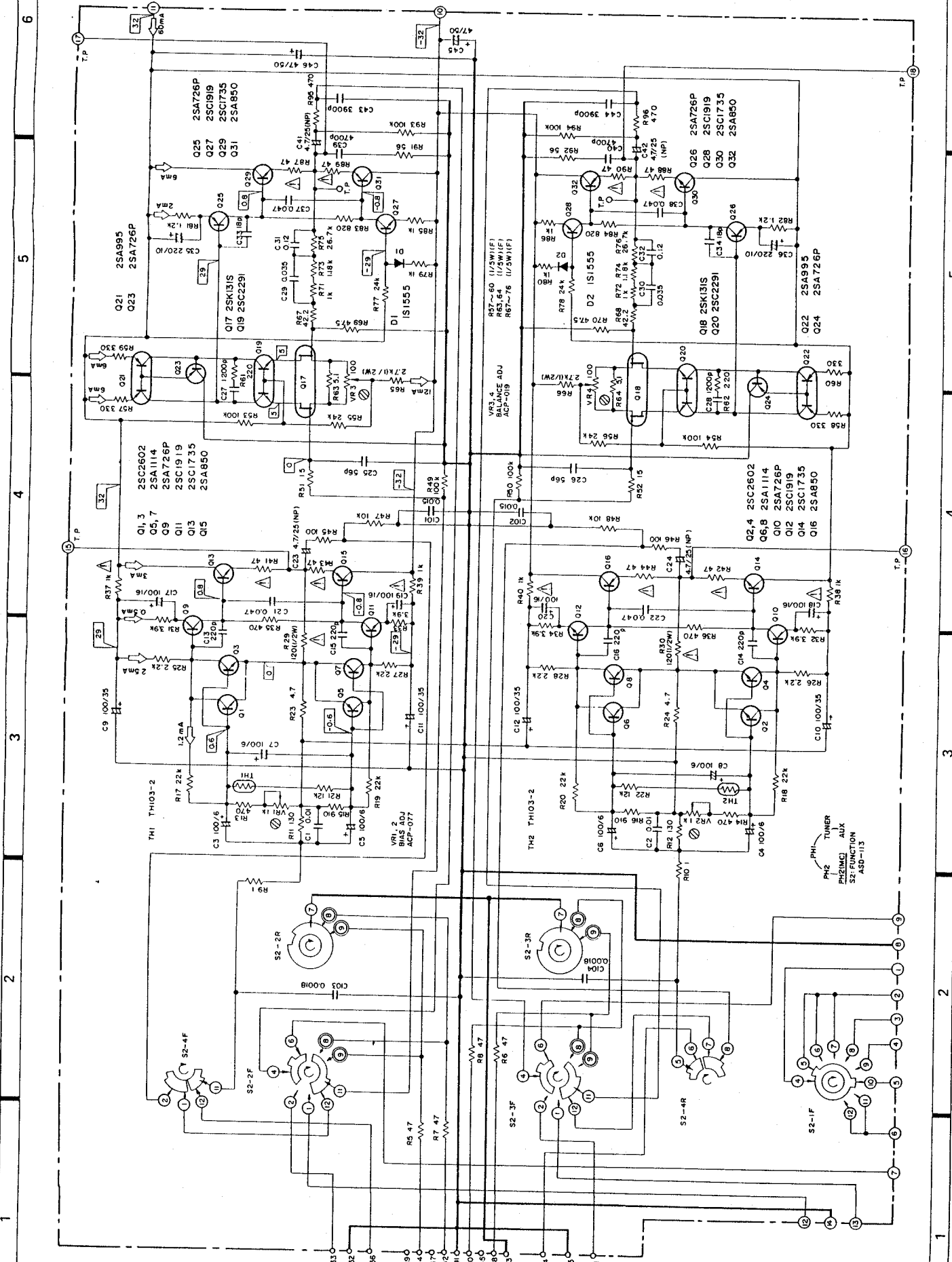

For Service Manuals Contact
MAURITRON TECHNICAL SERVICES
 8 Cherry Tree Rd, Chinnor
 Oxon OX9 4QY
 Tel: 01844-351694 Fax: 01844-352554
 Email: enquiries@maurtron.co.uk

ASSEMBLY (GWS-171)

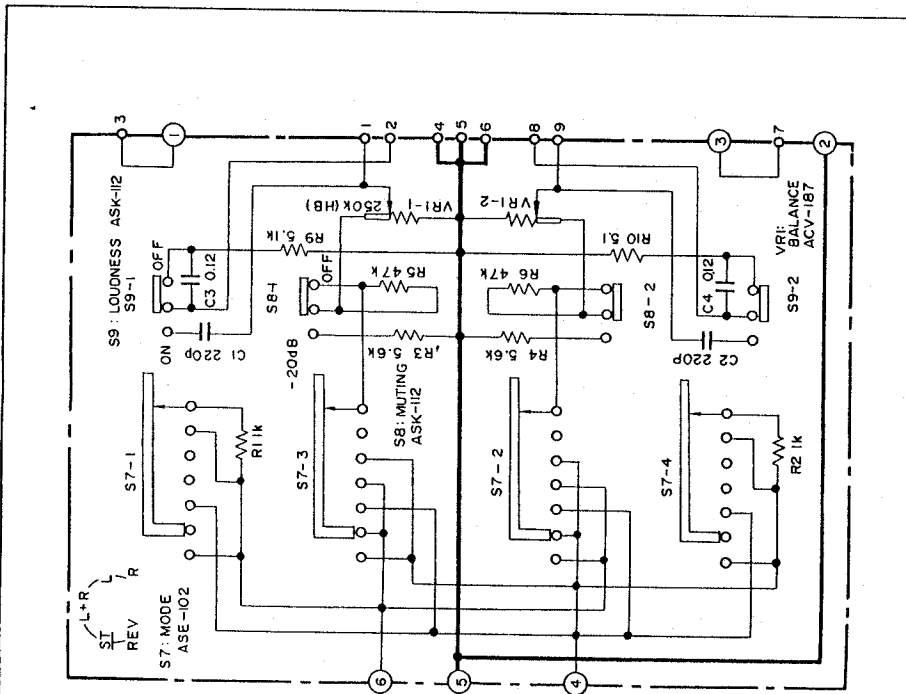

Note: When ordering resistors, convert the resistance value into code form, and then rewrite the part no. as before.

Symbol & Description	Part No.	Symbol & Description	
C1, C2	ACV-187	VR1	Variable (BALANCE)
C3, C4	RD4PM □□□J	R1-R6, R9, R10	

Symbol & Description	
S7	Slide-rotary (MODE)
S8, S9	Level (MUTING, LOUDNESS)

11.8 TC ASSEMBLY (GWG-124)

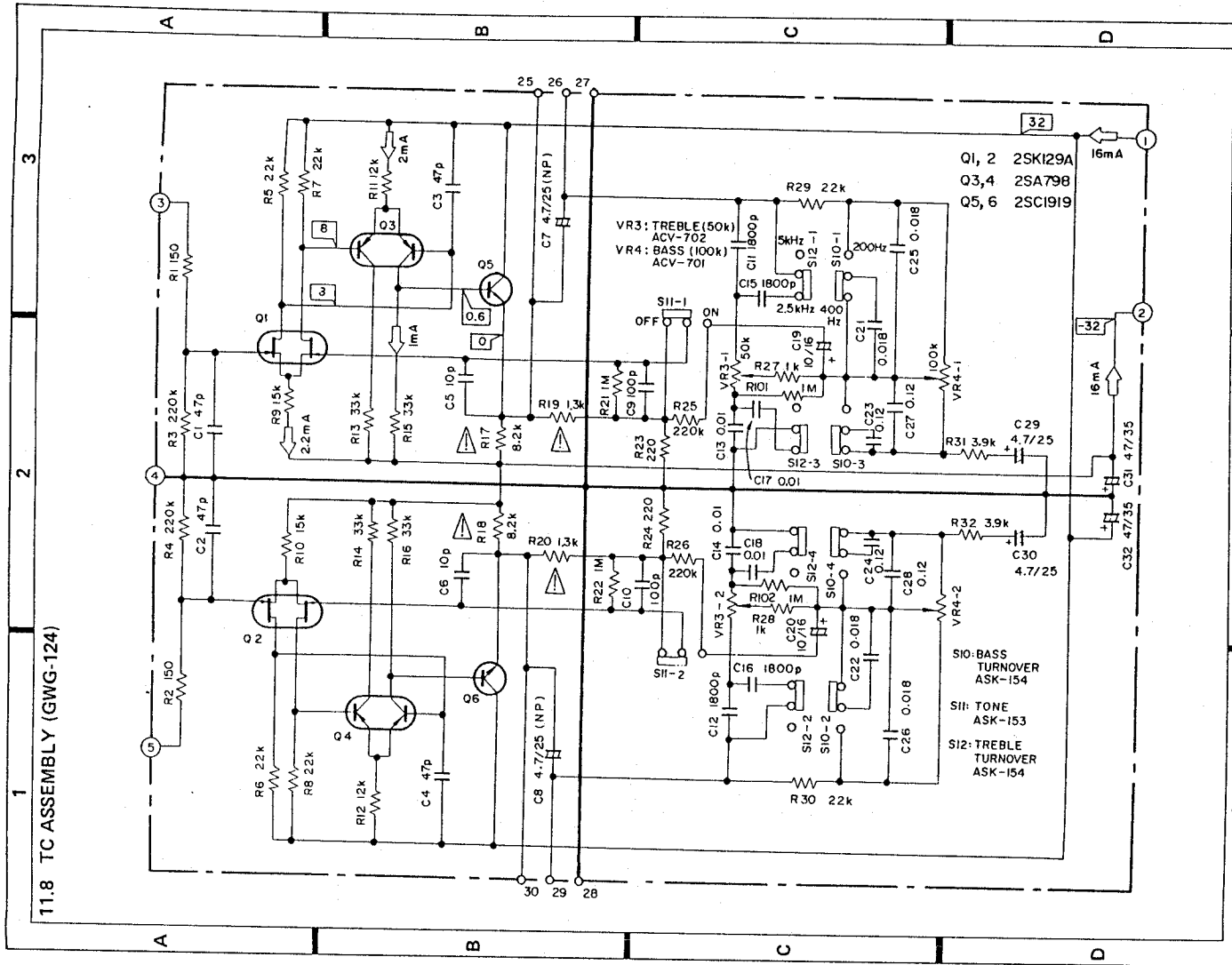

Q1, 2	2SK129A	16mA
Q3, 4	2SA798	
Q5, 6	2SC1919	

- S10: BASS TURNOVER ASK-154
- S11: TONE ASK-153
- S12: TREBLE TURNOVER ASK-154

Parts List of TC Assembly (GWG-124)

OTHER

Part No.	Description
ABA-026	Pan head screw

CAPACITORS

Part No.	Symbol & Description
CCDSL 470K 50	C1-C4
CCDSL 100K 50	C5, C6
ACH-318	C7, C8 Electrolytic 4.7/25V (NP)
CCDSL 101K 50	C9, C10
CKDYB 182K 50	C11, C12, C15, C16
CQMA 103J 50	C13, C14, C17, C18
CEANL 100M 16	C19, C20
CQMA 183J 50	C21, C22, C25, C26
CQMA 124J 50	C23, C24, C27, C28
CEANL 4R7M 25	C29, C30
CEA 470P 35	C31, C32

Note: When ordering resistors, convert the resistance value into code form, and then rewrite the part no. as before.

RESISTORS

Part No.	Symbol & Description
ACV-702	VR3 Variable (TREBLE)
ACV-701	VR4 Variable (BASS)
RD%PM □□□ J	R1-R16, R21-R32, R101, R102
RD%PMF □□□ J	R17-R20

SEMICONDUCTORS

Part No.	Symbol & Description
2SK129A	Q1, Q2
2SA798	Q3, Q4
2SC1919	Q5, Q6
(2SC1400)	

SWITCHES

Part No.	Symbol & Description
ASK-154	S10, S12 Lever (TURNOVER)
ASK-153	S11 Lever (TONE)

For Service Manuals Contact
MAURITRON TECHNICAL SERVICES
 8 Cherry Tree Rd, Chinnor
 Oxon OX9 4QY
 Tel: 01844-351894 Fax: 01844-352554
 Email: enquiries@mauritron.co.uk

11.9 FILTER ASSEMBLY (GWS-176)

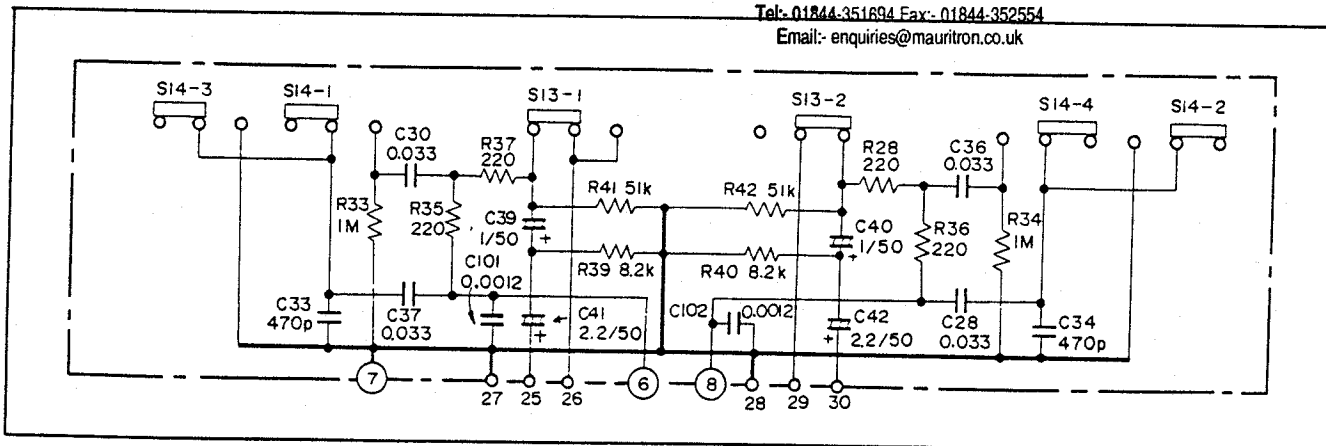

Parts List

CAPACITORS

Part No.	Symbol & Description
CCDSL 471K 50	C33, C34
CQMA 333J 50	C35-C38
CEANL 010M 50	C39, C40
CEANL 2R2M 50	C41, C42
CQMA 122J 50	C101, C102

SWITCHES

Part No.	Symbol & Description
ASK-112	S13, S14 Lever (FILTER)

Note: When ordering resistors, convert the resistance value into code form, and then rewrite the part no. as before.

RESISTORS

Part No.	Symbol & Description
RD%PM □□□ J	C33-C42

11.10 PA-L ASSEMBLY (GWH-119)

Parts List

CAPACITORS

Part No.	Symbol & Description
CEANL 2R2P 50	C1
CCDSL 101K 50	C3
CCDSL 470K 50	C5, C7
CCDSL 390K 50	C9
CEA 470P 63	C11, C13
CCDSL 820K 50	C15
CQMA 102K 400	C17
CQMA 472K 50	C19
CQMA 103K 50	C21, C23
CCDSL 470K 500	C25, C27
CQMA 473J 100	C29

Note: When ordering resistors, convert the resistance value into code form, and then rewrite the part no. as before.

RESISTORS

Part No.	Symbol & Description
ACP-035	VR1 Semifixed 330k-B
ACP-019	VR3 Semifixed 100-B
ACP-076	VR5 Semifixed 68k-B
RD¼PM □□□ J	R1, R3, R5, R7, R9, R11, R19, R25
RD¼PM □□□ J	R27, R45, R49, R51, R57, R67
RD¼PM □□□ J	R69, R91
△RD¼PM □□□ J	R13, R15, R23, R29, R31, R37, R39
△RD¼PM □□□ J	R41, R47, R53, R55, R59
△RD¼PM □□□ J	R75, R77
△RD¼PS □□□ J	R17, R73
RS1P □□□ J	R21
△RD¼PMF □□□ J	R33, R35, R43, R61, R63, R65, R71
△ACN-041	R79, R81, R83, R85 Wire wound 0.47/5W
△RS1P □□□ J	R87, R89

SEMICONDUCTORS

Part No.	Symbol & Description
2SC1775A-E	Q1
2SA979-F	Q3
2SC2291	Q5
2SA912	Q7
2SA726S	Q9
2SC1885	Q11
2SC1400	Q13, Q19
2SA750	Q15, Q17
2SA904A	Q21
2SC1890A	Q23

Part No.	Symbol & Description
2SA733A	Q25, Q29
2SC945A	Q27, Q31
2SC1913	Q33
2SA913	Q35
1S1555 (1S2473)	D1, D3, D7, D11, D13, D15, D17
MZ-061 (WZ-061)	D5
STV2H-O	D9
1S2471	D19, D21, D23, D25, D27, D29
TH103-2	Th1

OTHER

Part No.	Description
ABA-048	Screw 3x6
ABA-026	Screw 3x6 (Pan head)

List of Changed Parts for Factory Modification

List of changed parts information will be furnished whenever necessary and you are requested to amend parts number in this parts list.

Symbol	Part No.	Description

For Service Manuals Contact
MAURITRON TECHNICAL SERVICES
8 Cherry Tree Rd, Chinnor
Oxon OX9 4QY
Tel: 01844 351684 Fax: 01844 352354
Email: enquiries@mauritron.co.uk

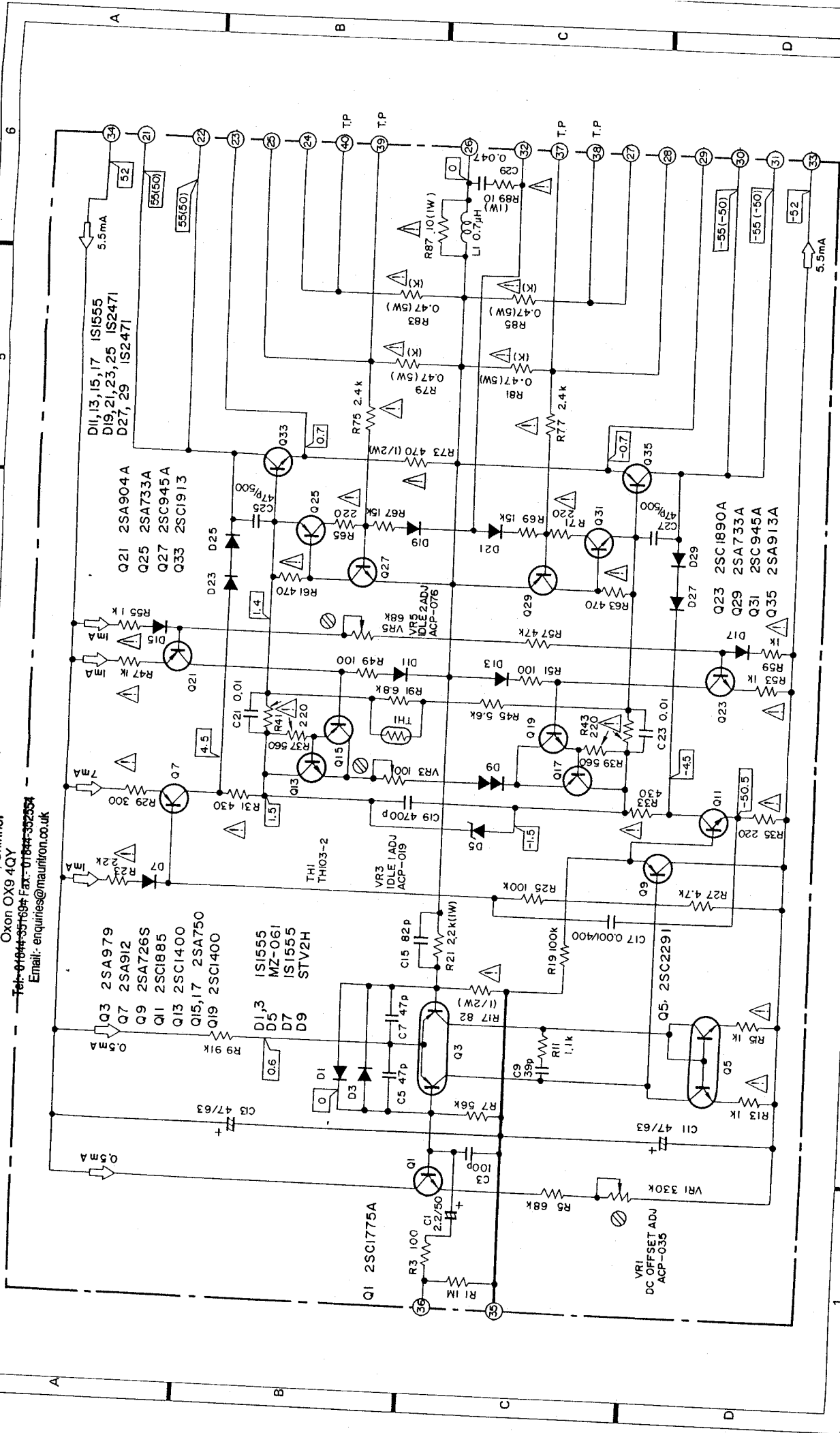

11.11 PA-R ASSEMBLY (GWH-120)

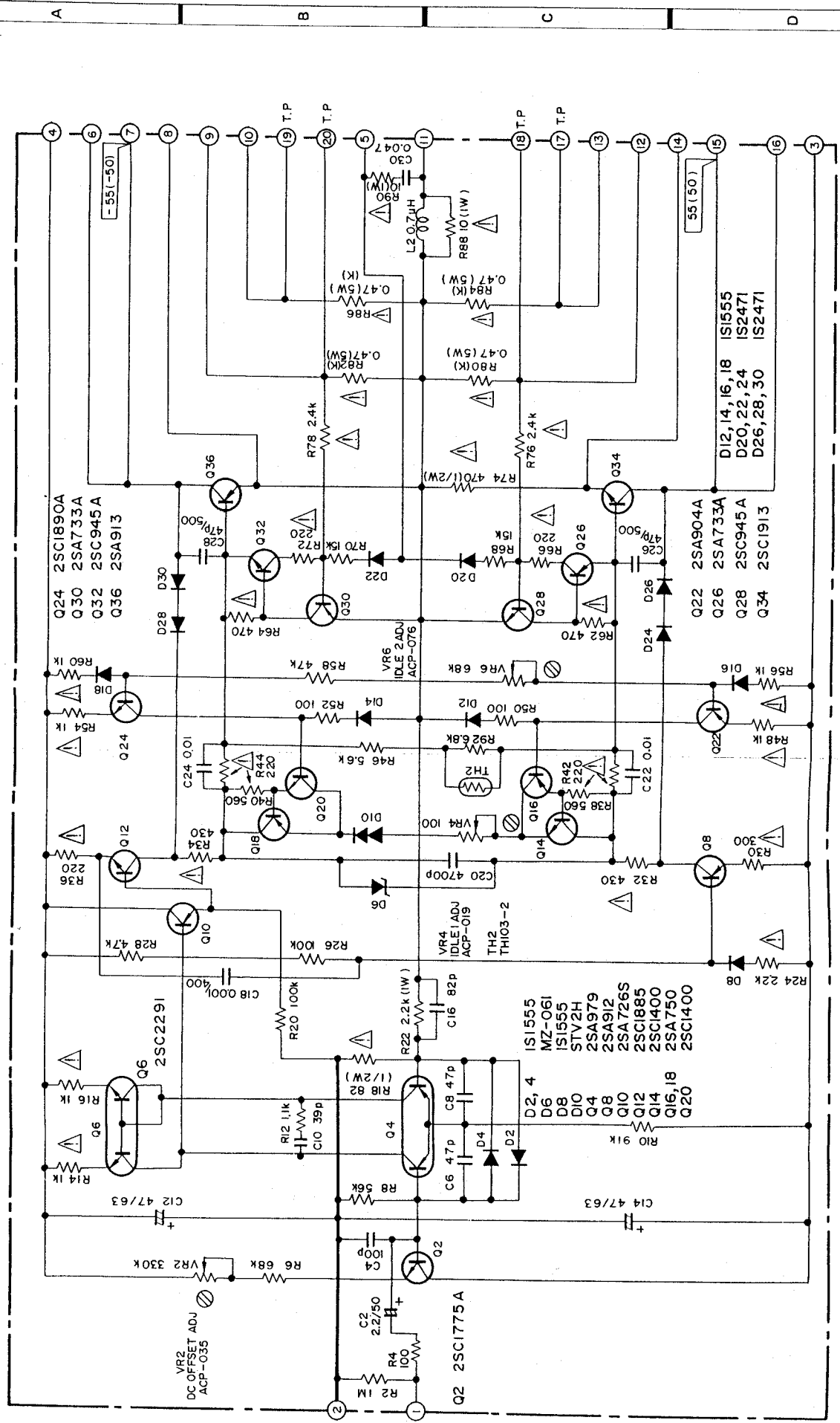

1 2 3 4 5 6

1 2 3 4 5 6

Q24 2SC1890A
Q30 2SA733A
Q32 2SC945A
Q36 2SA913

Q22 2SA904A
Q26 2SA733A
Q28 2SC945A
Q34 2SC1913

IS1555
MZ-061
IS1555
STV2H
2SA979
2SA912
2SA7265
2SC1885
2SC1400
2SA750
2SC1400

D12,14,16,18 IS1555
D20,22,24 IS2471
D26,28,30 IS2471

Q2 2SC1775A

VR2
DC OFFSET ADJ
ACP-035

VR4
IDLE ADJ
ACP-019

VR6
IDLE ADJ
ACP-076

Parts List of PA-R Assembly (GWH-120)

CAPACITORS

Part No.	Symbol & Description
CEANL 2R2P 50	C2
CCDSL 101K 50	C4
CCDSL 470K 50	C6, C8
CCDSL 390K 50	C10
CEA 470P 63	C12, C14
CCDSL 820K 50	C16
COMA 102K 400	C18
COMA 472K 50	C20
COMA 103K 50	C22, C24
CCDSL 470K 500	C26, C28
COMA 473J 100	C30

Note: When ordering resistors, convert the resistance value into code form, and then rewrite the part no. as before.

RESISTORS

Part No.	Symbol & Description
ACP-035	VR2 Semifixed 330k-B
ACP-019	VR4 Semifixed 100-B
ACP-076	VR6 Semifixed 68k-B
RD¼PM 000J	R2, R4, R6, R8, R10, R12, R20, R26
RD¼PM 000J	R28, R46, R50, R52, R58, R68
RD¼PM 000J	R70, R92
RD¼PM 000J	R14, R16, R24, R30, R32, R38, R40
RD¼PM 000J	R42, R48, R54, R56, R60
RD¼PM 000J	R76, R78
RD¼PS 000J	R18, R74
RS1P 000J	R22
RD¼PMF 000J	R34, R36, R44, R62, R64, R66, R72
ACN-041	R80, R82, R84, R86 Wire wound
RS1P 000J	R88, R90 0.47/5W

SEMICONDUCTORS

Part No.	Symbol & Description
ZSC1775A-E	Q2
2SA979-F	Q4
2SC2291	Q6
2SA912	Q8
2SA726S	Q10
ZSC1885	Q12
2SC1400	Q14, Q20
2SA750	Q16, Q18
2SA904A	Q22
2SC1890A	Q24
2SA733A	Q26, Q30
2SC945A	Q28, Q32
2SC1913	Q34
2SA913	Q36

11.12 TAPE TERMINAL ASSEMBLY (GWX-262)

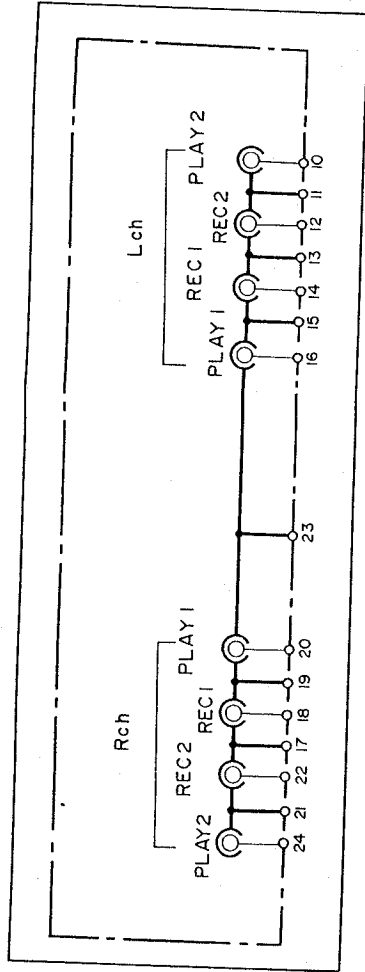

Parts List

Part No.	Description
AKB-054	Terminal (TAPE 1, 2)

11.13 TAPE SWITCH ASSEMBLY (GWS-172)

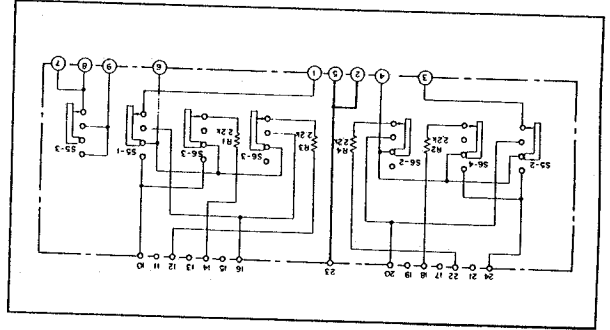

Parts List

Part No.	Symbol & Description
ASK-113	SS, S6 Lever switch (TAPE)
RD¼PM 000J	R1-R4

List of Changed Parts for Factory Modification

List of changed parts information will be furnished whenever necessary and you are requested to amend parts number in this parts list.

Symbol	Part No.	Description
<p>For Service Manuals Contact MAURITRON TECHNICAL SERVICES 8 Cherry Tree Rd, Chinnor Oxon OX9 4QY Tel: 01844-351634 Fax: 01844-352554 Email: enquiries@maurtron.co.uk</p>		

11.14 INDICATOR ASSEMBLY (AWV-002)

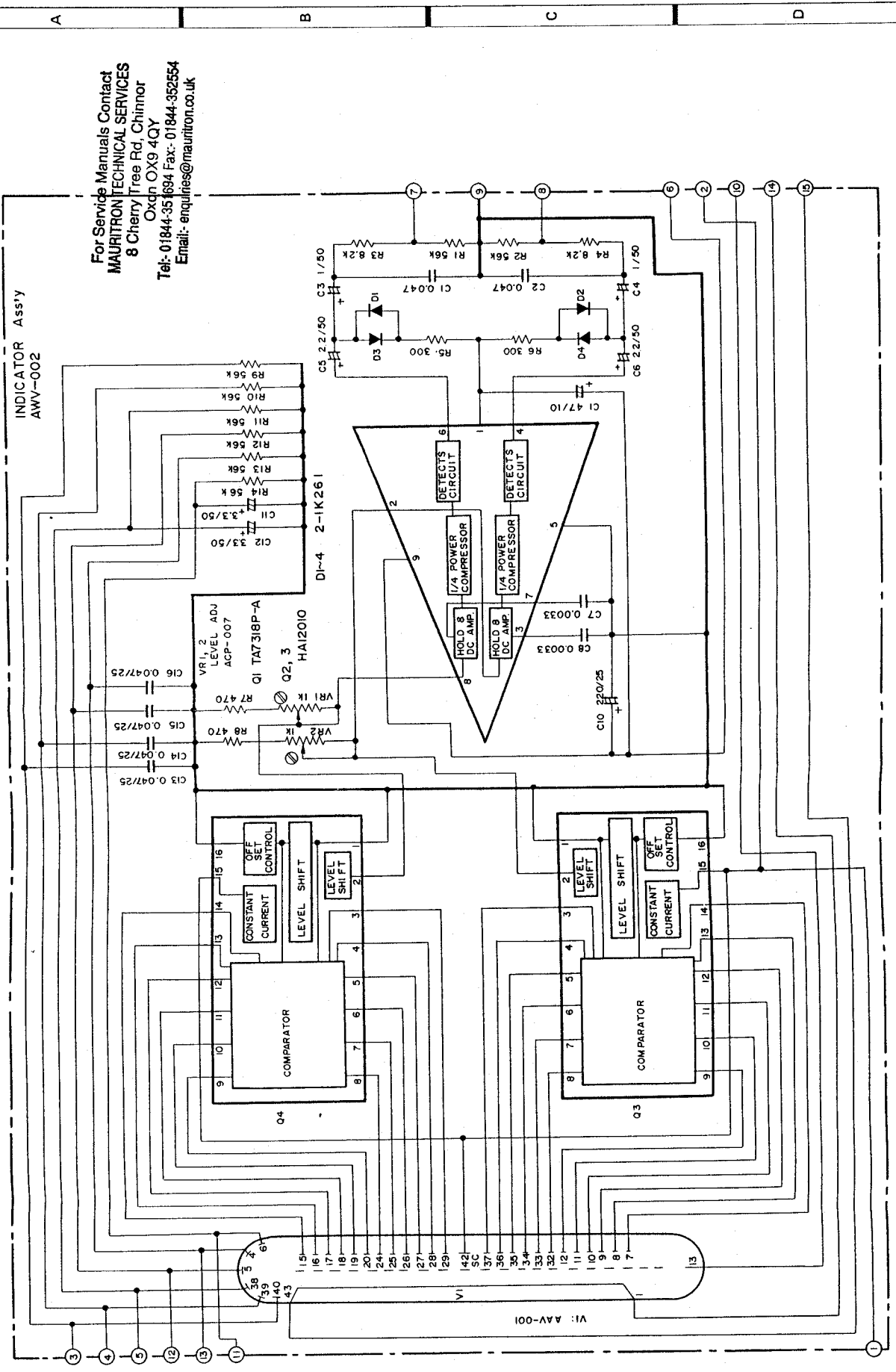

For Service Manuals Contact
MAURITRON TECHNICAL SERVICES
 8 Cherry Tree Rd, Chinnor
 Oxdn OX9 4QY
 Tel: 01844-351694 Fax: 01844-352554
 Email: enquiries@mauritron.co.uk

INDICATOR Assy
 AWV-002

DI-4 2-1K261

Q1 TA7318P-A
 HAI2010

Q2, 3

VI: AAV-001

1 2 3 4 5 6

1 2 3 4 5 6

A B C D

Parts List of Indicator Assembly (AWV-002)

CAPACITORS

Part No.	Symbol & Description
CQMA 473K 50	C1, C2
CEA 010P 50	C3, C4
CEA 2R2P 50	C5, C6
CQMA 332K 50	C7, C8
CEA 470P 10	C9
CEA 221P 25	C10
CEA 3R3P 50	C11, C12
CKDBC 473Z 25	C13-C16

Note: When ordering resistors, convert the resistance value into code form, and then rewrite the part no. as before.

RESISTORS

Part No.	Symbol & Description
ACP-007	VR1, VR2 Semifixed 1k-B
RD¼PM □□□J	R1-R14

SEMICONDUCTORS

Part No.	Symbol & Description
TA7318P-A	Q1
HA12010	Q2, Q3
2-1K261	D1-D4

OTHERS

Part No.	Symbol & Description
AAV-001	V1 Fluorescent indicator tube
ABA-048	Screw 3x6

11.15 VR ASSEMBLY (GWX-256)

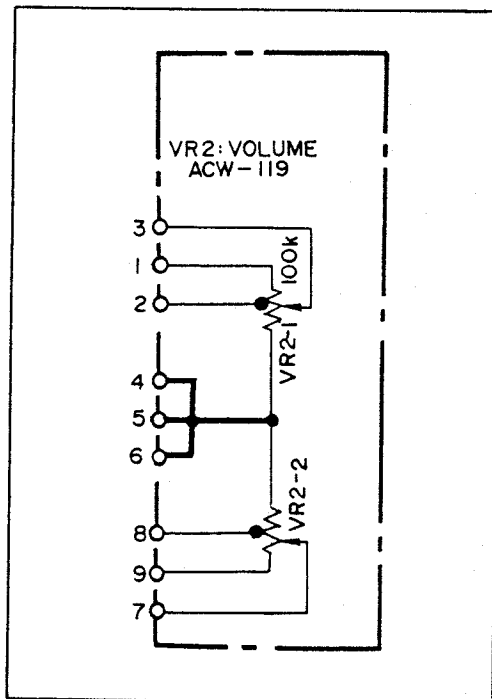

For Service Manuals Contact
 MAURITRON TECHNICAL SERVICES
 8 Cherry Tree Rd, Chinnor
 Oxon OX9 4QY
 Tel: 01844-351694 Fax: 01844-352554
 Email: enquiries@mauritron.co.uk

Parts List

Part No.	Symbol & Description
ACW-119	VR2 Variable resistor (VOLUME)

11.16 PROTECTION ASSEMBLY (AWM-163)

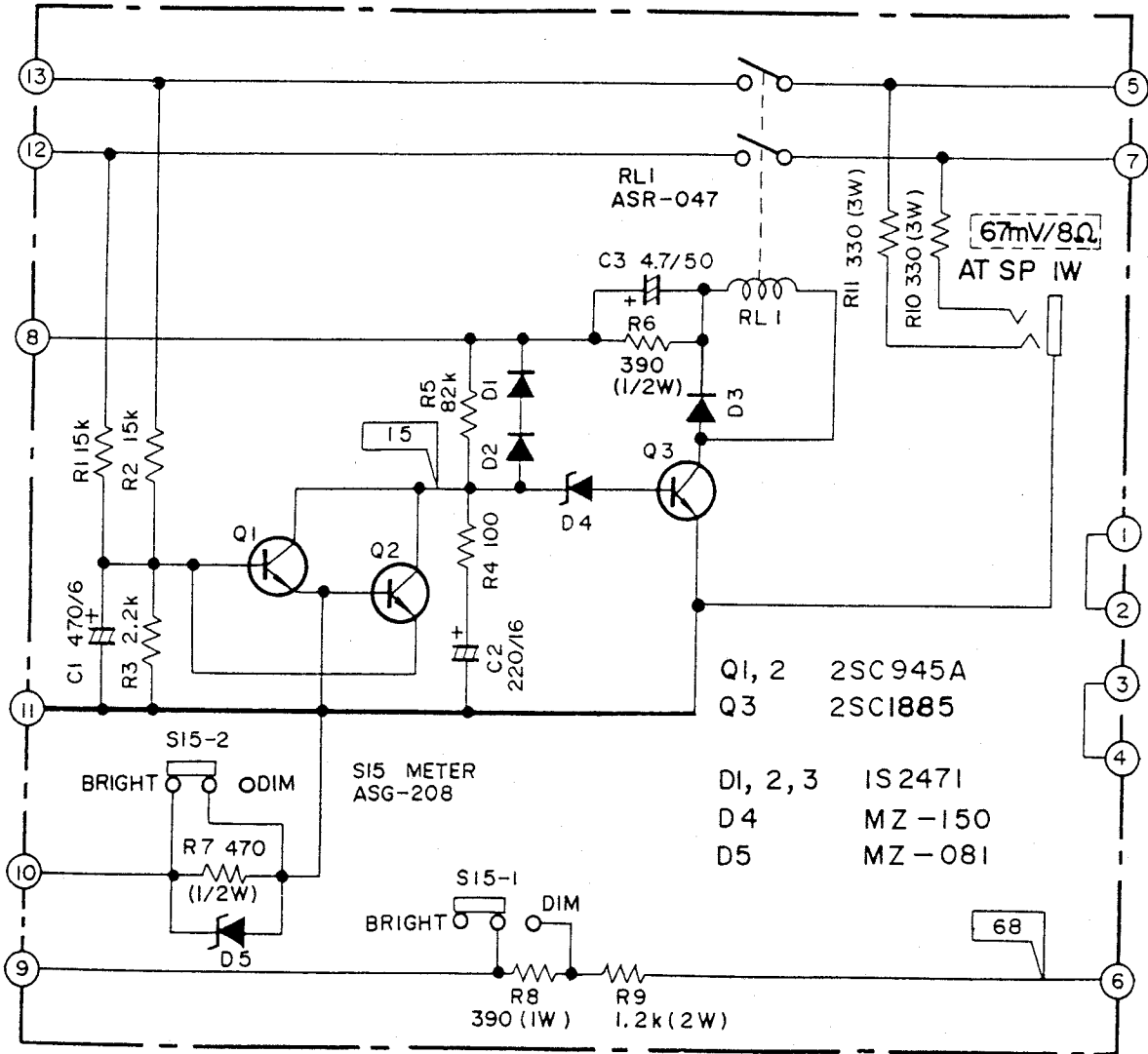

Parts List of Protection Assembly (AWM-163)

CAPACITORS

Part No.	Symbol & Description
CEA 471P 6	C1
CEA 221P 16	C2
CEA 4R7P 50	C3

Note: When ordering resistors, convert the resistance value into code form, and then rewrite the part no. as before.

RESISTORS

Part No.	Symbol & Description
RD½PM □□□ J	R1-R5
RD½PS □□□ J	R6, R7
RS1P □□□ J	R8
RS2P □□□ J	R9
RS3P □□□ J	R10, R11

SEMICONDUCTORS

Part No.	Symbol & Description
2SC945A	Q1, Q2
2SC1885	Q3
1S2471	D1-D3
MZ-150 (WZ-150)	D4
MZ-081 (WZ-081)	D5

OTHERS

Part No.	Symbol & Description
ASR-047	RL1 Relay
ASG-208	S15 Push switch (METER)
AKN-023	Phone jack(PHONES)
ABA-048	Screw 3x6

11.17 RECTIFIER ASSEMBLY (AWR-192)

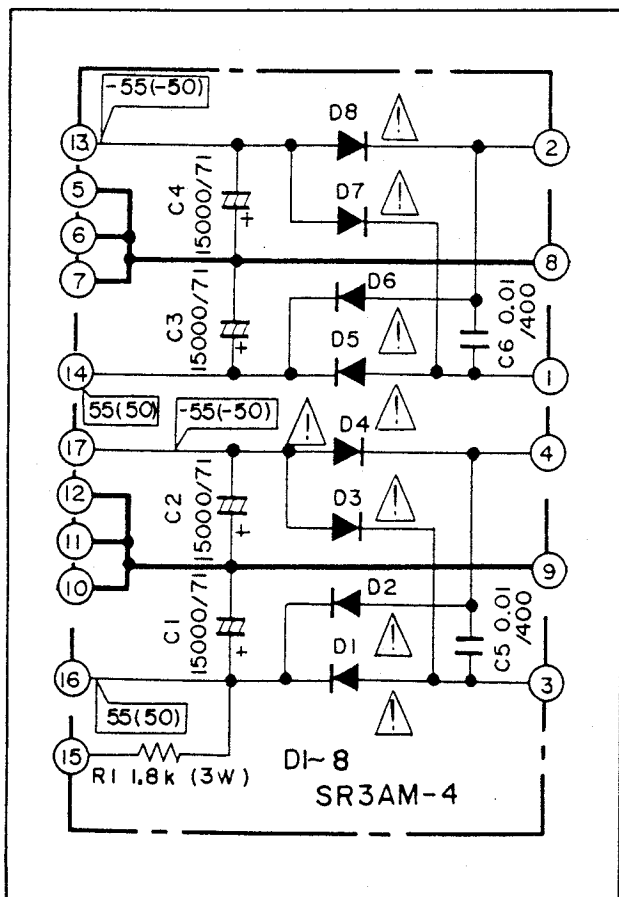

For Service Manuals Contact
MAURITRON TECHNICAL SERVICES
 8 Cherry Tree Rd, Chinnor
 Oxon OX9 4QY
 Tel:- 01844-351694 Fax:- 01844-352554
 Email:- enquiries@mauritron.co.uk

Parts List

CAPACITORS

Part No.	Symbol & Description
ACH-210	C1-C4 Electrolytic 15,000/71V
CQMA 103K 400	C5, C6

Note: When ordering resistors, convert the resistance value into code form, and then rewrite the part no. as before.

RESISTORS

Part No.	Symbol & Description
RS3P □□□ J	R1

SEMICONDUCTORS

Part No.	Symbol & Description
SR3AM-4	D1-D8

OTHERS

Part No.	Symbol & Description
ABA-048	Screw 3x6
ABA-051	Screw 3x12
ABE-020	Washer

11.18 POWER SUPPLY ASSEMBLY (AWR-191)

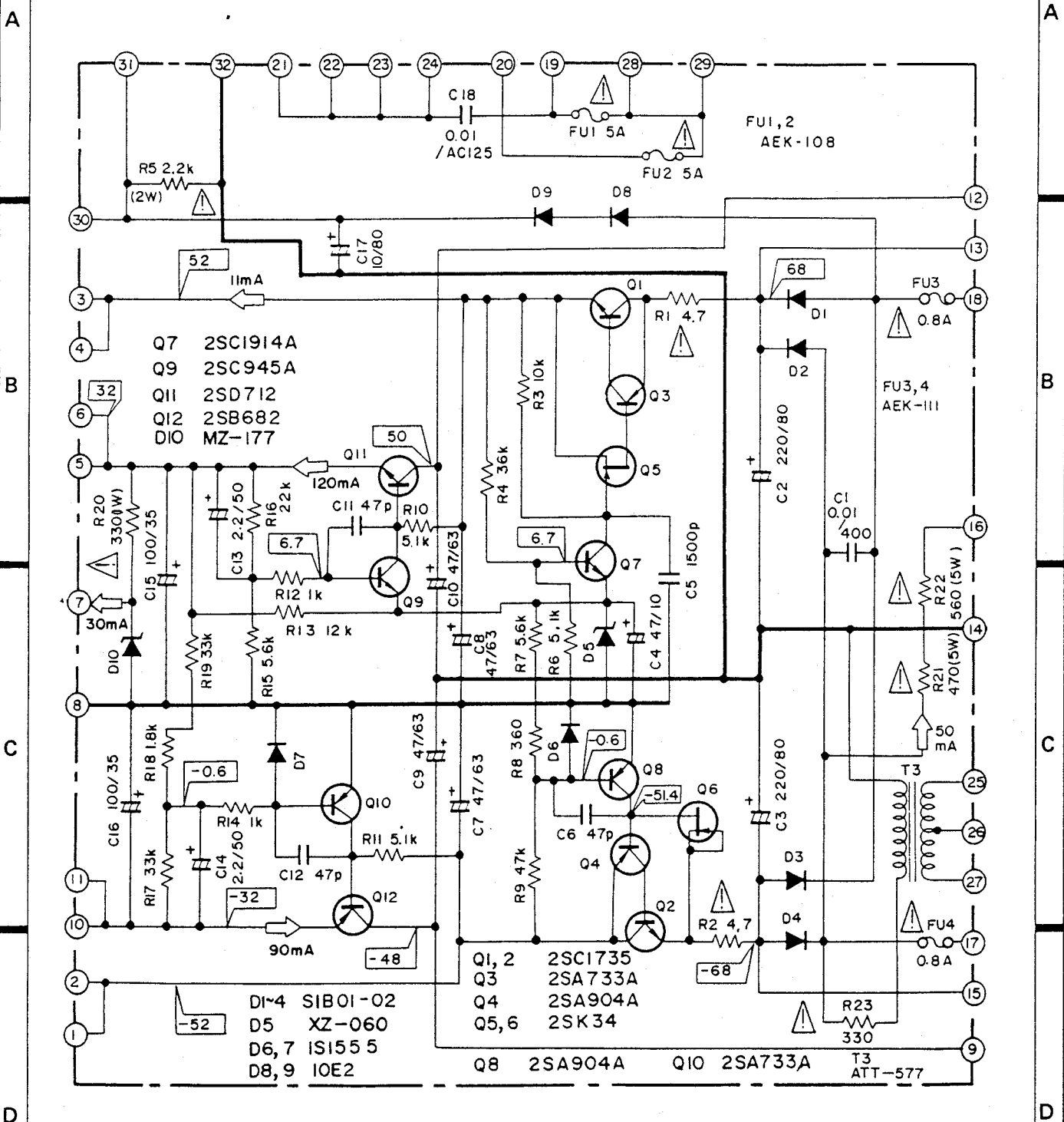

Parts List of Power Supply Assembly (AWR-191)

CAPACITORS

Part No.	Symbol & Description
CQMA 103K 400	C1
CEB 221P 80	C2, C3
CEA 470P 10	C4
CKDYB 152K 50	C5
CCDSL 470K 50	C6, C11, C12
CEA 470P 63	C7-C10
CEA 2R2P 50	C13, C14
CEA 101P 35	C15, C16
CEA 100P 80	C17
△ ACG-003	C18 Ceramic 0.01/125V

Note: When ordering resistors, convert the resistance value into code form, and then rewrite the part no. as before.

RESISTORS

Part No.	Symbol & Description
△ RD¼PMF □□□ J	R1, R2, R23
RD¼PM □□□ J	R3, R4, R6-R19.
△ RS2P □□□ J	R5
△ RS1P □□□ J	R20
△ RT5B □□□ K	R21, R22

SEMICONDUCTORS

Part No.	Symbol & Description
2SC1735	Q1, Q2
2SA733A	Q3, Q10
2SA904A (2SA893A)	Q4, Q8
2SK34	Q5, Q6
2SC1914A (2SC1890A)	Q7
2SC945A	Q9
2SD712 (2SD313P)	Q11
2SB682 (2SB507P)	Q12
S1B01-02	D1-D4
XZ-060	D5
1S1555 (1S2473)	D6, D7
10E2	D8, D9
MZ-177 (WZ-177)	D10

OTHERS

Part No.	Symbol & Description
ATT-577	T3 Transformer
ABA-026	Pan head screw
AEC-279	Capacitor cover

For Service Manuals Contact
MAURITRON TECHNICAL SERVICES
 8 Cherry Tree Rd, Chinnor
 Oxon OX9 4QY
 Tel:- 01844-351694 Fax:- 01844-352554
 Email:- enquiries@mauritron.co.uk

BLANK page.

ADDITIONAL

 PIONEER

Service Manual

STEREO AMPLIFIER

SA-9800 S S/G

The basic performance of the S and S/G types are the same as the KU type. The KU and S/G types have wooden covers, while S type employs metal. This additional service manual is applicable to the S and S/G types, please refer to the KU type service manual with the exception of this supplements.

SPECIFICATIONS

The specifications for S and S/G types are the same as the KU type except for following sections;

Micellaneous

Power Requirements . AC110/120/220/240V (switchable),
50/60Hz

Dimensions (S type) 420(W)x150(H)x425(D)mm
16-17/32(W)x5-29/32(H)x16-3/4(D)in

Weight

S type Without Package; 18kg (39 lb 11 oz)
With Package; 20kg (44 lb 1 oz)

S/G type Without Package; 19.1kg (42 lb 2 oz)

Furnished Parts

Fuse (5A) 1
Fuse (10A) 1

For Service Manuals Contact
MAURITRON TECHNICAL SERVICES
8 Cherry Tree Rd, Chinnor
Oxon OX9 4QY
Tel:- 01844-351694 Fax:- 01844-352554
Email:- enquiries@mauritron.co.uk

CONTRAST OF MISCELLANEOUS PARTS

- The Δ mark found on some component parts indicates the importance of the safety factor of the part. Therefore, when replacing, be sure to use parts of identical designation.

P.C. BOARD ASSEMBLIES

Symbol	Part Name	Part No.		
		KU type	S type	S/G type
	PA-L assembly	GWH-119	GWH-125	GWH-125
	PA-R assembly	GWH-120	GWH-126	GWH-126
	Power supply assembly	AWR-191	AWR-194	AWR-194

TRANSFORMERS

Symbol	Part Name	Part No.		
		KU type	S type	S/G type
△T1	Power transformer	ATT-556	ATT-578	ATT-559
△T2	Power transformer	ATT-556	ATT-579	ATT-560

FUSES

Symbol	Part Name	Part No.		
		KU type	S type	S/G type
△FU1	Fuse (5A)	AEK-108	AEK-108	(AEK-108)
△FU1	Fuse (10A)	(AEK-114)	AEK-114
△FU2	Fuse (5A)	AEK-108

CAPACITOR

Symbol	Part Name	Part No.		
		KU type	S type	S/G type
△C7	Ceramic 0.01/250V	ACG-001	ACG-001
C7	Electrolytic 1/50V	CEA 010P 50
C8	Electrolytic 1/50V	CEA 010P 50	CEA 010P 50

SWITCH

Symbol	Part Name	Part No.		
		KU type	S type	S/G type
△S18	Lever switch (POWER)	ASK-124	ASK-128	ASK-128

OTHERS

Symbol	Part Name	Part No.		
		KU type	S type	S/G type
△	AC power cord	ADG-023	ADG-017	ADG-017.
△	AC socket (AC OUTLETS)	AKP-004	AKP-021	AKP-021
△	Plug in selector	AKR-031	AKR-031
	Top cover (wooden)	AMM-079	AMM-079
	Top cover (metal)	ANE-222
	Screw (for top cover)	ABA-206	ABA-079	ABA-206

PACKING AND FURNISHED PARTS

Symbol	Part Name	Part No.		
		KU type	S type	S/G type
	Packing case	AHD-614	AHD-617	AHD-616
	Top pad L	AHA-214	AHA-214
	Top pad R	AHA-215	AHA-215
	Bottom pad L	AHA-216	AHA-216
	Bottom pad R	AHA-217	AHA-217
	Side pad	AHA-218
	Cardboard spacer	AHB-099
	Operating instructions	ARB-307	ARB-312	ARB-312
△	Fuse (5A)	AEK-108	AEK-108
△	Fuse (10A)	AEK-114	AEK-114

SCHEMATIC DIAGRAM FOR S, S/G TYPES

A
B
C
D

For Service Manuals Contact
MAURITRON TECHNICAL SERVICES
 8 Cherry Tree Rd, Chinnor
 Oxon OX9 4QY
 Tel:- 01844-351694 Fax:- 01844-352554
 Email:- enquiries@mauritron.co.uk

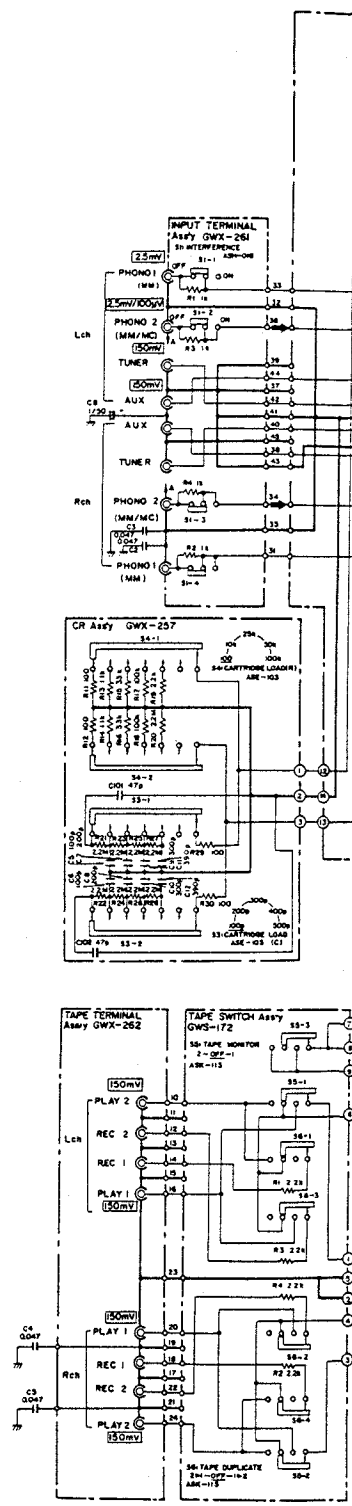

1 2 3
EMATIC DIAGRAM FOR S, S/G TYPES

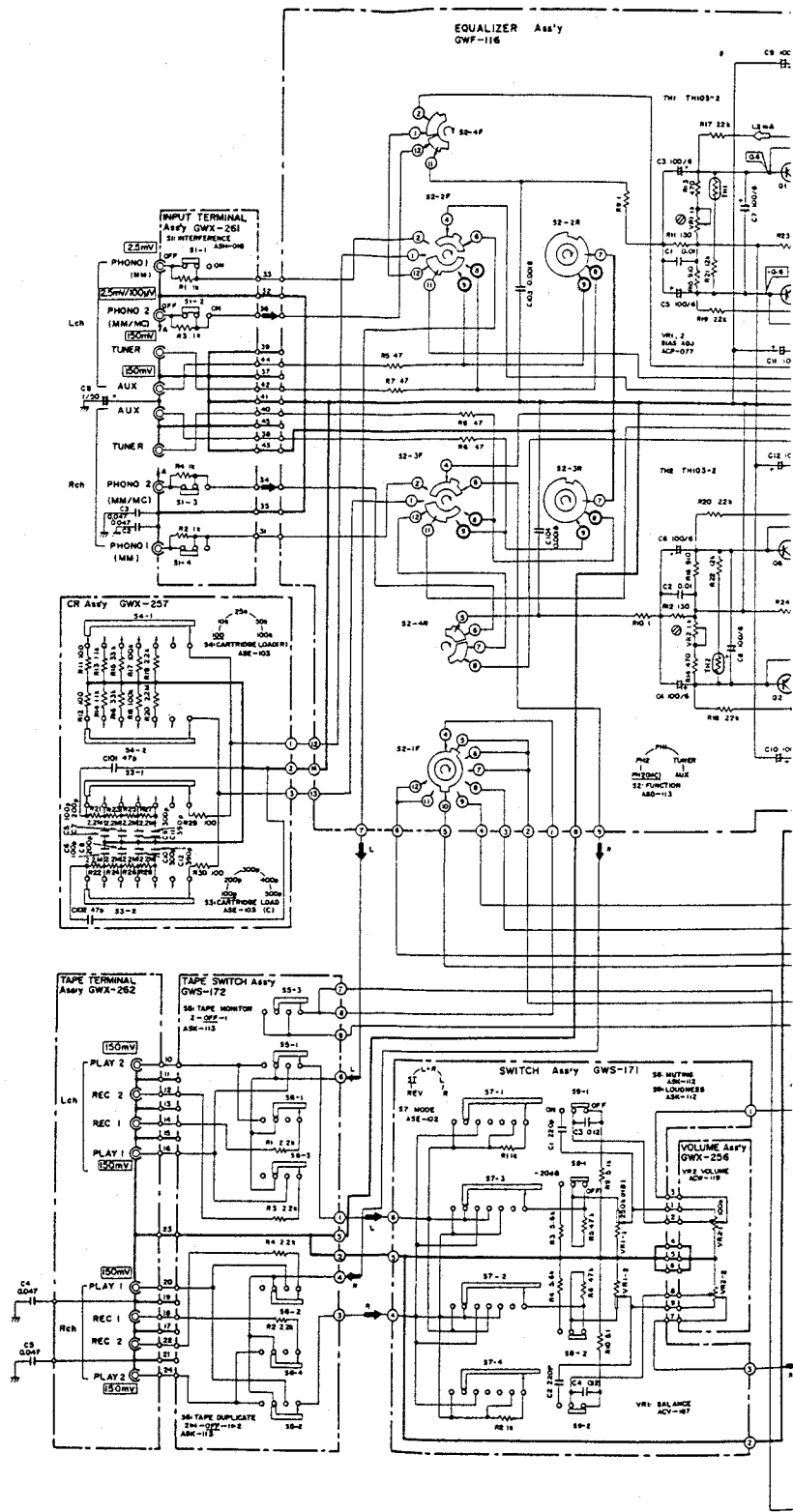

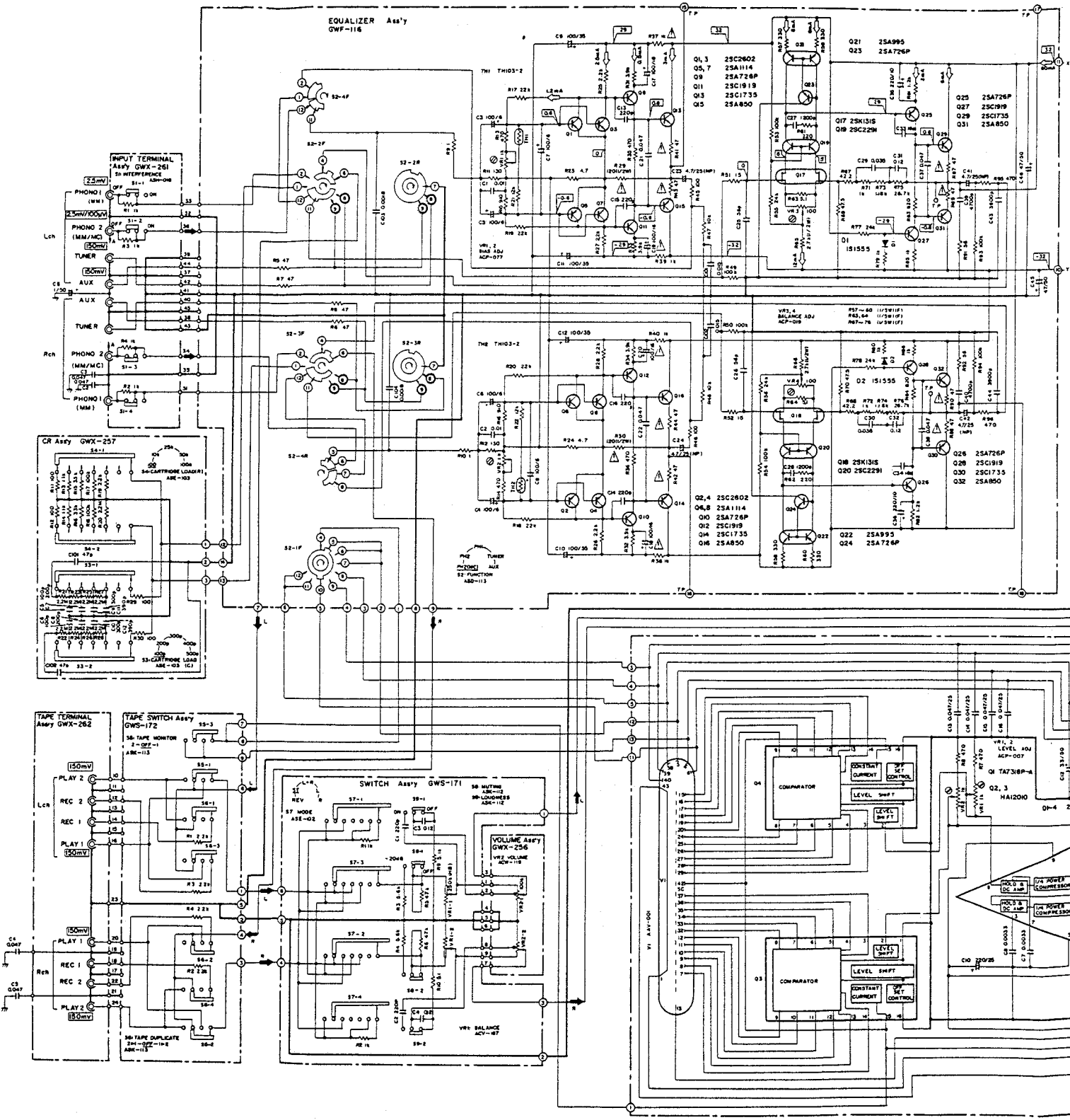

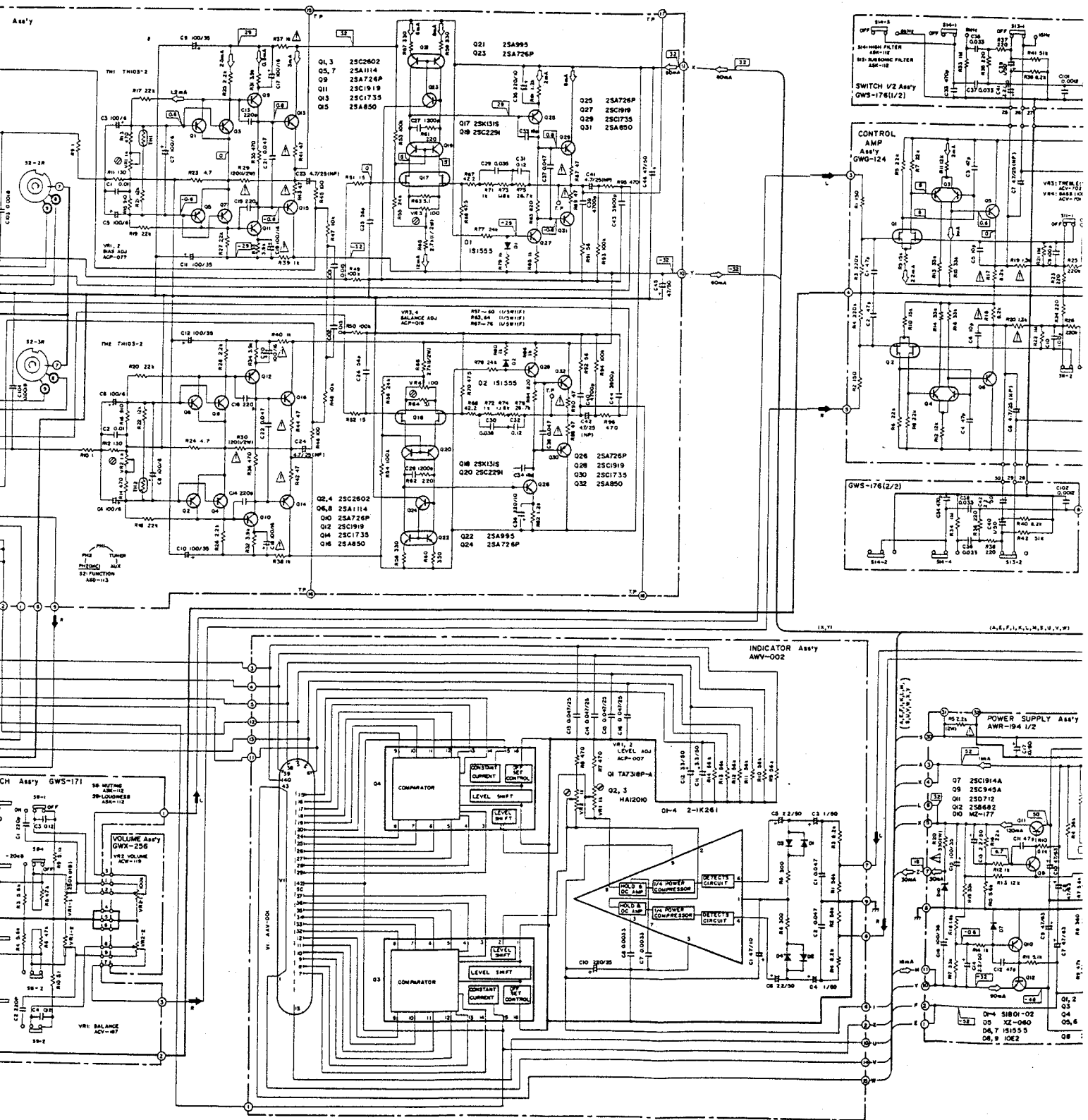

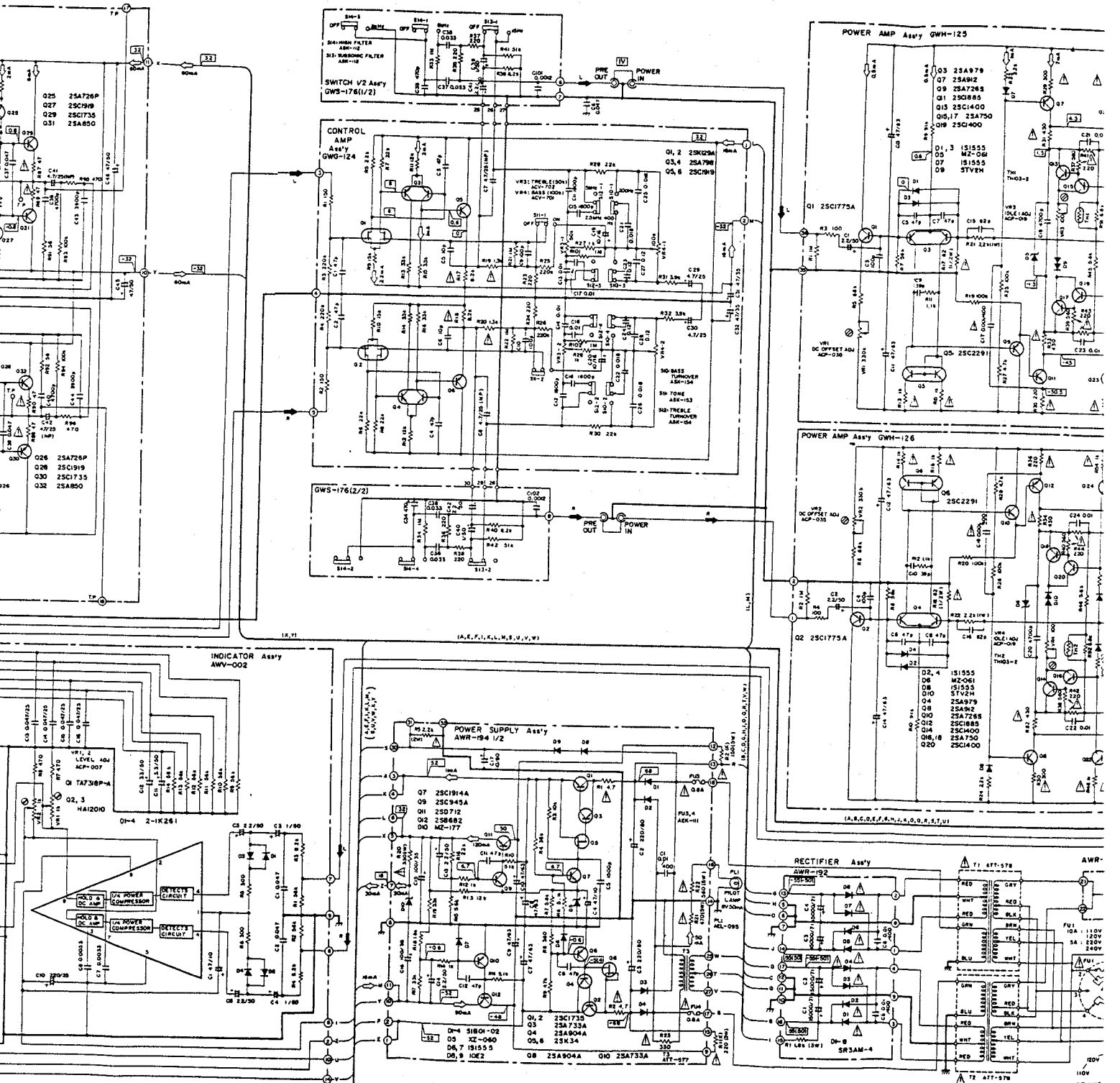

- 1. RESISTOR:**
Indicated in Ω , 1/4W, 15% tolerance unless otherwise noted: k, M, MR, (R); 1%, 1G; 2%, 1K; 10% tolerance
- 2. CAPACITORS:**
Indicated in capacity (μ F)/voltage (V) unless otherwise noted: p, pF
Indication without voltage is 50V except electrolytic capacitor
- 3. VOLTAGE CURRENT:**
V: Signal voltage at 100W - 100W SET output
DC voltage (V) at no input signal
Value in 1 is DC voltage at rated power
mA: DC current at no input signal
- 4. OTHERS:**
Signal route
Adjusting point
The Δ mark found on some component parts indicates the importance of the safety factor of the part. Therefore, when replacing, be sure to use parts of identical designation.

NOTE:

The indicated semiconductors are representative ones only. Other alternative semiconductors may be used and are listed in the parts list.

For Service Manuals Contact
MAURITRON TECHNICAL SERVICES
8 Cherry Tree Rd, Chinnor
Oxon OX9 4QY
Tel: 01844-351694 Fax: 01844-352554
Email: enquiries@mauritron.co.uk

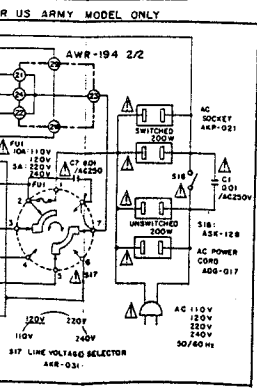
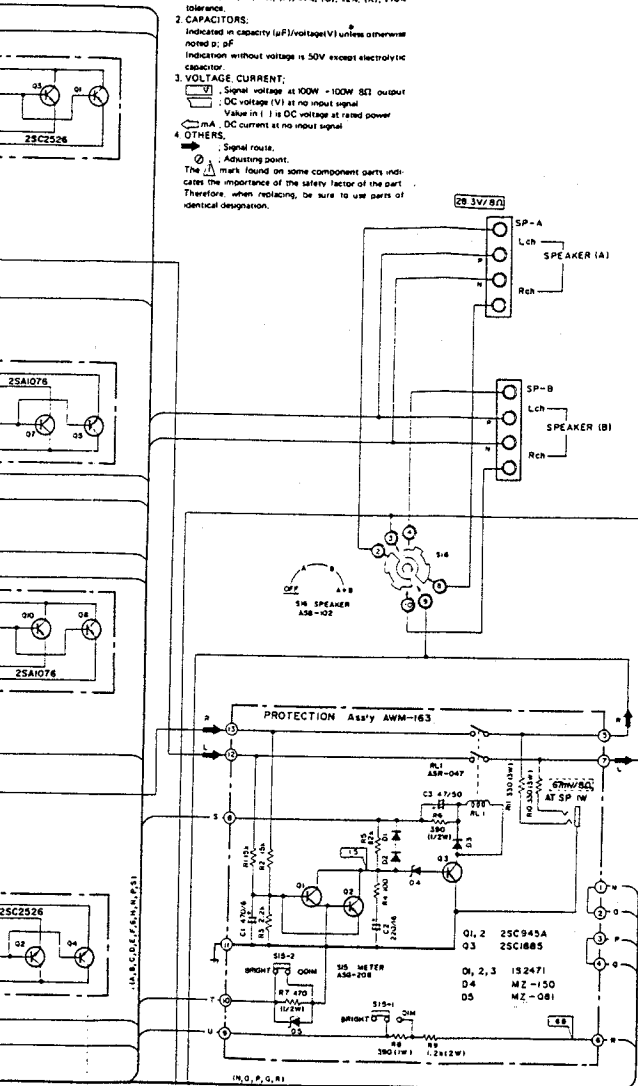

- SWITCHES:**
- S1: PHONO INTERFERENCE FILTER OFF ON
 - S2: FUNCTION
PHONO 2 (MC) PHONO 1 (MM) PHONO 1 (MM) TUNER AUX
 - S3: CARTRIDGE LOAD (C)
100 Ω -200 Ω -300 Ω -400 Ω -500 Ω
 - S4: CARTRIDGE LOAD (A)
100-10k-25k-50k-100k
 - S5: TAPE MONITOR 1 OFF 2
 - S6: TAPE DUPLICATE 1 \times 2 OFF 2 \times 1
 - S7: MODE
REVERSED-L-R-L-R
 - S8: MUTING OFF-70dB
 - S9: LOUDNESS OFF ON
 - S10: BASS TURNOVER 400Hz 2000Hz
 - S11: TONE OFF ON
 - S12: TREBLE TURNOVER 2.5kHz 5kHz
 - S13: SUBSONIC FILTER OFF 15Hz
 - S14: HIGH FILTER OFF 8kHz
 - S15: METER BRIGHT DIM
 - S16: SPEAKER OFF ON
 - S18: POWER OFF A-B-A-B

The underlined indicates the switch position.
This is the basic schematic diagram, but the actual circuit may vary due to improvements in design.

A

B

C

D

POWER SUPPLY ASSEMBLY (AWR-194)

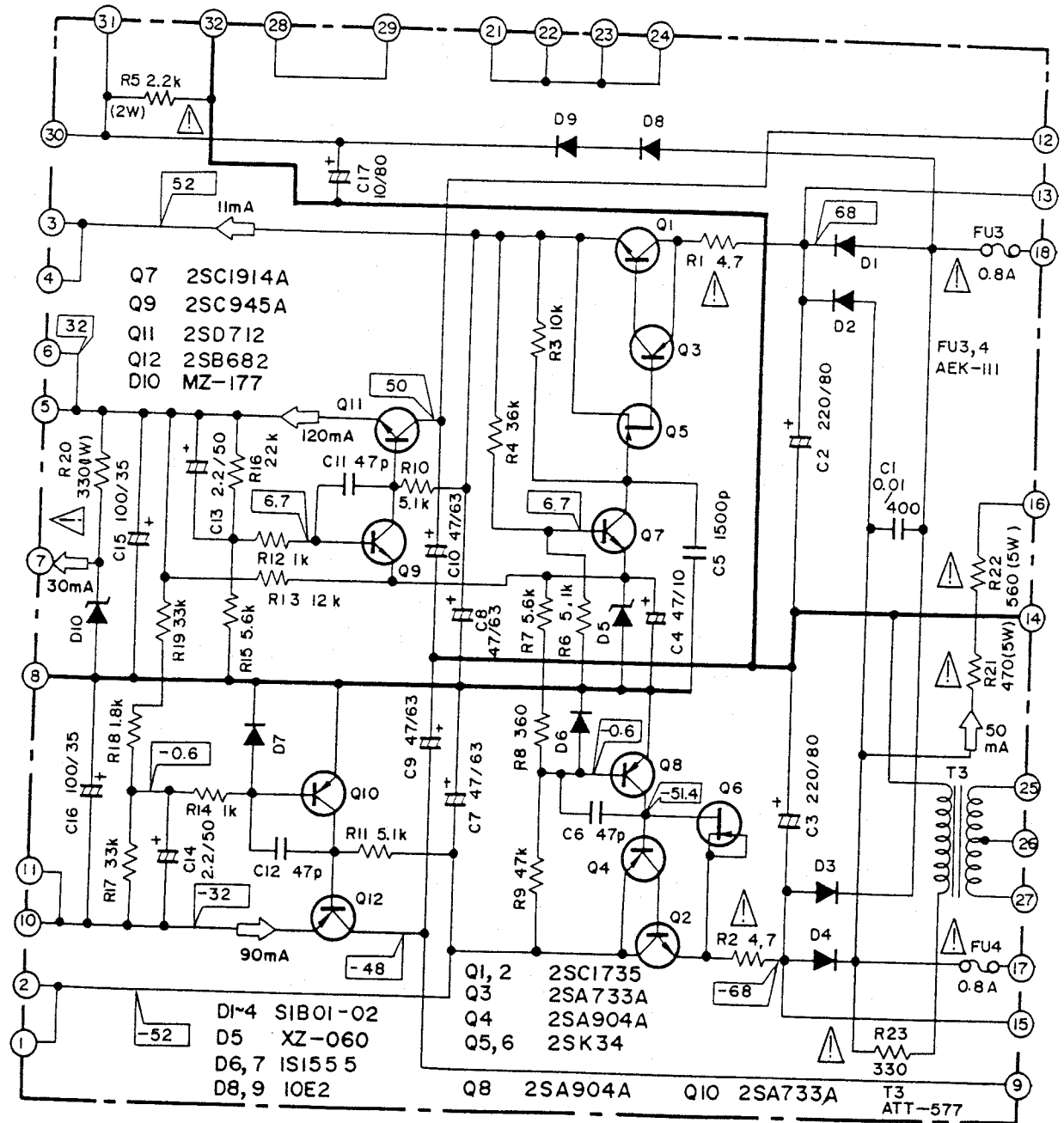

- DI-4 SIB01-02
- D5 XZ-060
- D6,7 IS155 5
- D8,9 IOE2

- Q1, 2 2SC1735
- Q3 2SA733A
- Q4 2SA904A
- Q5,6 2SK34
- Q8 2SA904A
- Q10 2SA733A

- T3 ATT-577

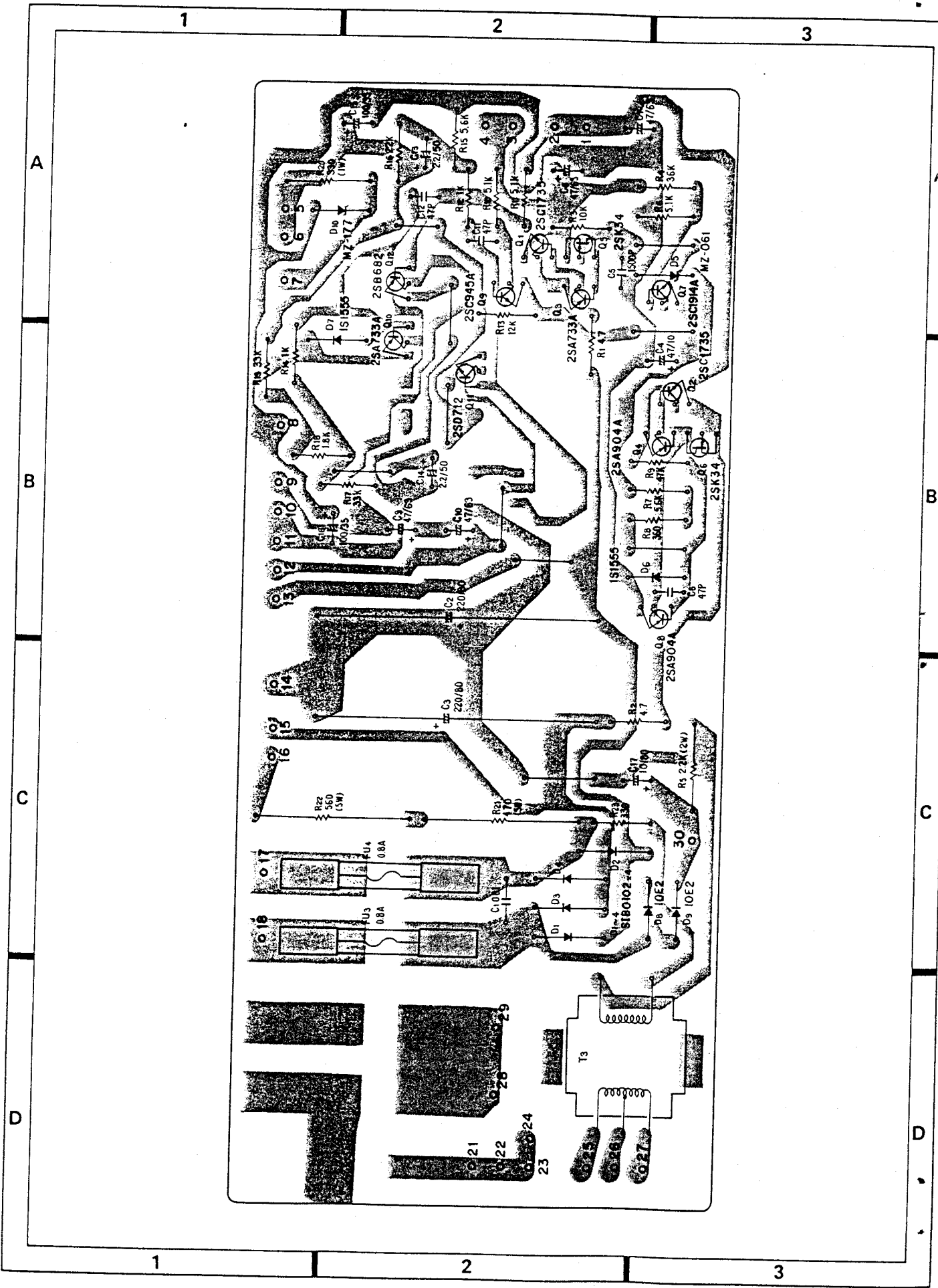

Parts List of Power Supply Assembly (AWR-194)

CAPACITORS

Part No.	Symbol & Description
CQMA 103K 400	C1
CEB 221P 80	C2, C3
CEA 470P 10	C4
CKDYB 152K 50	C5
CCDSL 470K 50	C6, C11, C12
CEA 470P 63	C7-C10
CEA 2R2P 50	C13, C14
CEA 101P 35	C15, C16
CEA 100P 80	C17

Note: When ordering resistors, convert the resistance value into code form, and then rewrite the part no. as before.

RESISTORS

Part No.	Symbol & Description
△RD%PMF □□□ J	R1, R2, R23
RD%PM □□□ J	R3, R4, R6-R19
RS2P □□□ J	R5
△RS1P □□□ J	R20
△RT5B □□□ K	R21, R22

For Service Manuals Contact
MAURITRON TECHNICAL SERVICES
 8 Cherry Tree Rd, Chinnor
 Oxon OX9 4QY
 Tel:- 01844-351694 Fax:- 01844-352554
 Email: enquiries@mauritron.co.uk

SEMICONDUCTORS

Part No.	Symbol & Description
2SC1735	Q1, Q2
2SA733A	Q3, Q10
2SA904A (2SA893A)	Q4, Q8
2SK34	Q5, Q6
2SC1914A (2SC1890A)	Q7
2SC945A	Q9
2SD712 (2SD313P)	Q11
2SB682 (2SB507P)	Q12
S1B01-02 XZ-060	D1-D4 D5
1S1555 (1S2473)	D6, D7
10E2 MZ-177 (WZ-177)	D8, D9 D10

OTHERS

Part No.	Symbol & Description
ATT-577	T3 Transformer
ABA-026	Pan head screw

POWER AMPLIFIERS FOR S, S/G TYPES
Schematic Diagram for PA-L Assembly (GWH-125)

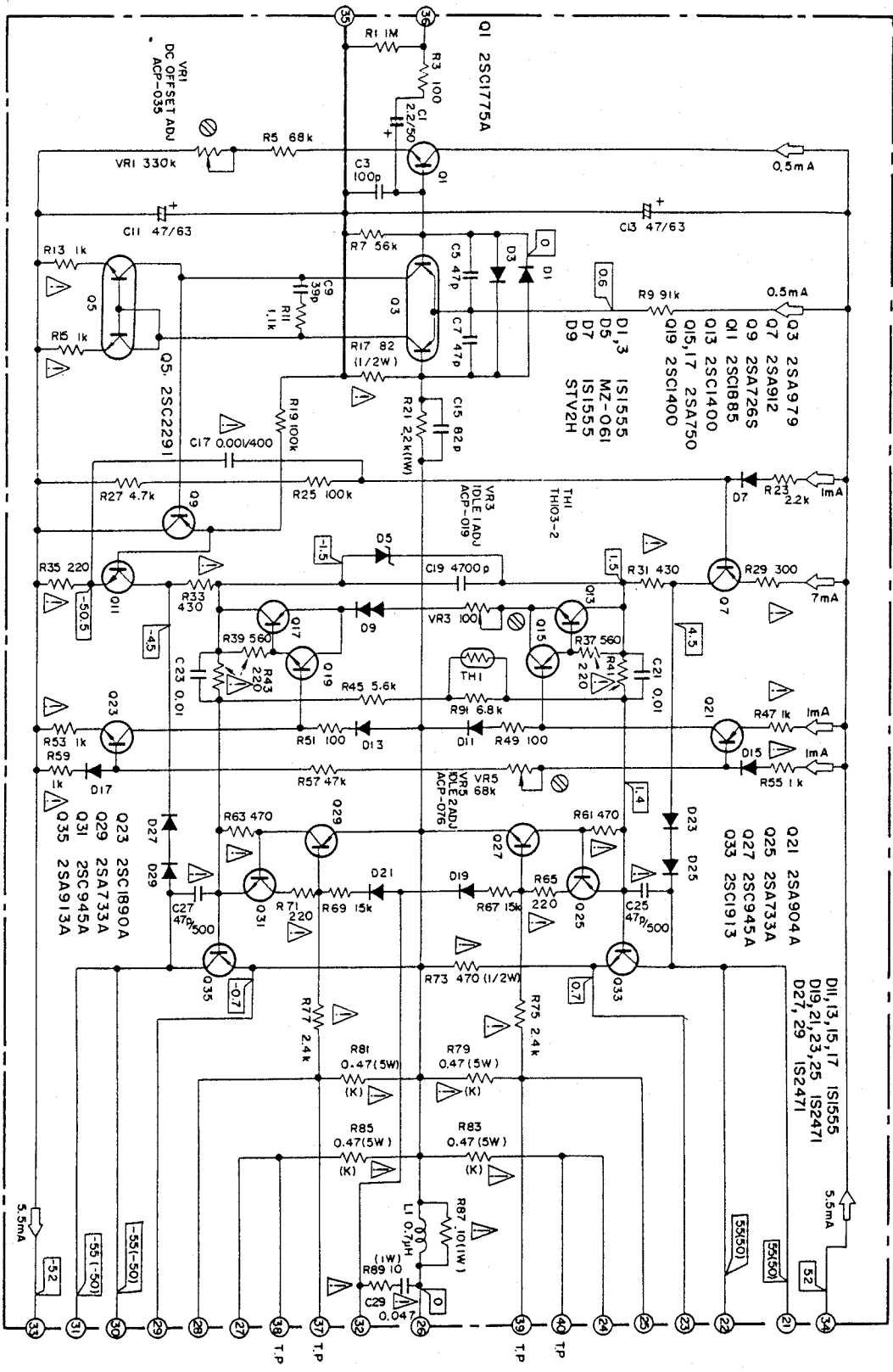

1

2

3

A

B

C

D

1

2

3

Schematic Diagram for PA-R Assembly (GWH-126)

For Service Manuals Contact
 MAURITRON TECHNICAL SERVICES
 8 Cherry Tree Rd, Chinnor
 Oxon OX9 4QY
 Tel:- 01844-351694 Fax:- 01844-352554
 Email:- enquiries@mauritron.co.uk

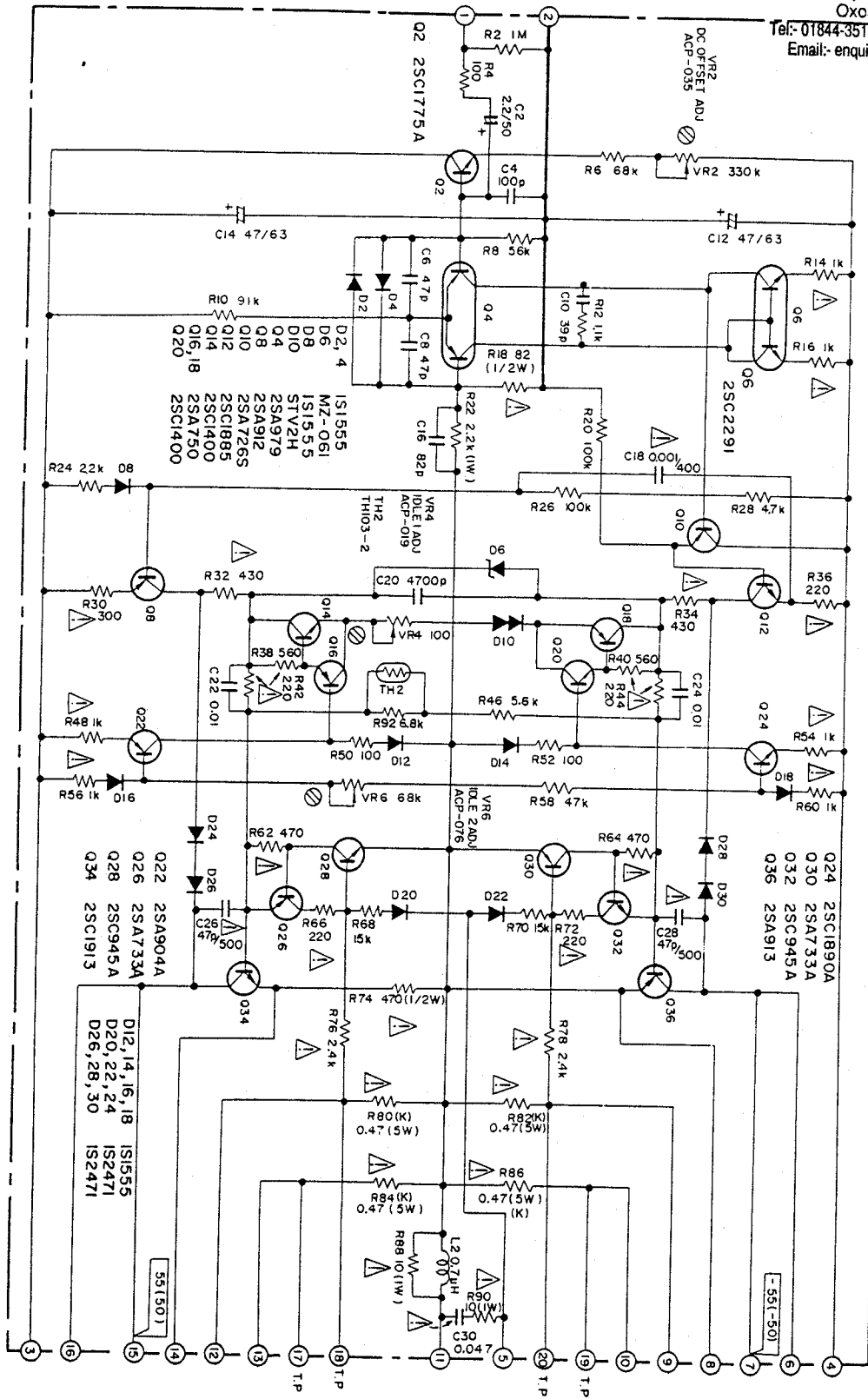

- The circuitry of the PA-L (GWH-125) and PA-R (GWH-126) assemblies are the same as the GWH-119 and GWH-120 (for KU type), with exception of the circuit component specifications and the parts installation method.

Parts List of PA-L Assembly (GWH-125)

CAPACITORS

Part No.	Symbol & Description
CEANL 2R2P 50	C1
CCDSL 101K 50	C3
CCDSL 470K 50	C5, C7
CCDSL 390K 50	C9
CEA 470P 63	C11, C13
CCDSL 820K 50	C15
△CQMA 102K 400	C17
CQMA 472K 50	C19
CQMA 103K 50	C21, C23
△CCDSL 470 K 500	C25, C27
△CQMA 473J 100	C29

Note: When ordering resistors, convert the resistance value into code form, and then rewrite the part no. as before.

RESISTORS

Part No.	Symbol & Description
ACP-035	VR1 Semifixed 330k-B
ACP-019	VR3 Semifixed 100-B
ACP-076	VR5 Semifixed 68k-B
RD½PM □□□ J	R1, R3, R5, R7, R9, R11, R19, R23, R25
RD½PM □□□ J	R27, R45, R49, R51, R57, R67, R69, R91
△RD½PM □□□ J	R37, R39, R75, R77
△RD½PMF □□□ J	R13, R15, R29, R31, R41, R47, R53
△RD½PMF □□□ J	R55, R59, R61, R63, R65, R71
△RD½PS □□□ J	R17, R73
RS1P □□□ J	R21
△RD½PMF □□□ J	R33, R35, R43
△ACN-041	R79, R81, R83, R85 Wire wound 0.47/5W
△RS1P □□□ J	R87, R89

SEMICONDUCTORS

Part No.	Symbol & Description
2SC1775A-E	Q1
2SA979-F	Q3
2SC2291	Q5
2SA912	Q7
2SA726S	Q9
2SC1885	Q11
2SC1400	Q13, Q19
2SA750	Q15, Q17
2SA904A	Q21
2SC1890A	Q23

Part No.	Symbol & Description
2SA733A	Q25, Q29
2SC945A	Q27, Q31
2SC1913	Q33
2SA913	Q35
1S1555 (1S2473)	D1, D3, D7, D11, D13, D15, D17
MZ-061 (WZ-061)	D5
STV2H-O	D9
1S2471	D19, D21, D23, D25, D27, D29
TH103-2	Th1

OTHERS

Part No.	Description
ABA-048	Screw 3x6
ABA-026	Screw 3x6 (Pan head)

Parts List of PA-R Assembly (GWH-126)

CAPACITORS

Part No.	Symbol & Description
CEANL 2R2P 50	C2
CCDSL 101K 50	C4
CCDSL 470K 50	C6, C8
CCDSL 390K 50	C10
CEA 470P 63	C12, C14
CCDSL 820K 50	C16
△CQMA 102K 400	C18
CQMA 472K 50	C20
CQMA 103K 50	C22, C24
△CCDSL 470K 500	C26, C28
△CQMA 473J 100	C30

Note: When ordering resistors, convert the resistance value into code form, and then rewrite the part no. as before.

RESISTORS

Part No.	Symbol & Description
ACP-035	VR2 Semifixed 330k-B
ACP-019	VR4 Semifixed 100-B
ACP-076	VR6 Semifixed 68k-B
RD½PM □□□ J	R2, R4, R6, R8, R10, R12, R20, R24, R26
RD½PM □□□ J	R28, R46, R50, R52, R58, R68, R70, R92
△RD½PM □□□ J	R38, R40, R76, R78
△RD½PMF □□□ J	R14, R16, R30, R32, R42, R48, R54
△RD½PMF □□□ J	R56, R60, R62, R64, R66, R72

Part No.	Symbol & Description
△ RD½PS □□□ J	R18, R14
RS1P □□□ J	R22
△ RD½PMF □□□ J	R34, R36, R44
△ ACN-041	R80, R82, R84, R86
△ RS1P □□□ J	R88, R90
	Wire wound 0.47/5W

SEMICONDUCTORS

Part No.	Symbol & Description
2SC1775A-E	Q2
2SA979-F	Q4
2SC2291	Q6
2SA912	Q8
2SA726S	Q10
2SC1885	Q12
2SC1400	Q14, Q20
2SA750	Q16, Q18
2SA904A	Q22
2SC1890A	Q24
2SA733A	Q26, Q30
2SC945A	Q28, Q32
2SC1913	Q34
2SA913	Q36
1S1555 (1S2473)	D2, D4, D8, D12, D14, D16, D18
MZ-061 (WZ-061)	D6
STV2H-O	D10
1S2471	D20, D22, D24, D26, D28, D30
TH103-2	Th2

OTHERS

Part No.	Description
ABA-048	Screw 3x6
ABA-026	Screw 3x6 (Pan head)

For Service Manuals Contact
MAURITRON TECHNICAL SERVICES
 8 Cherry Tree Rd, Chinnor
 Oxon OX9 4QY
 Tel: 01844-351694 Fax: 01844-352554
 Email: enquiries@mauritron.co.uk

ADDITIONAL



Service Manual

For Service Manuals Contact
MAURITRON TECHNICAL SERVICES
8 Cherry Tree Rd, Chinnor
Oxon OX9 4QY
Tel:- 01844-351694 Fax:- 01844-352554
Email:- enquiries@mauritron.co.uk

STEREO AMPLIFIER

SA-9800

HG

The basic performance of the HG type is the same as the KU type. The KU type has a wooden cover, while HG type employs metal. This additional service manual is applicable to the HG type, please refer to the KU type service manual with the exception of this supplements.

SPECIFICATIONS

The specifications for HG type is the same as the KU type except for following sections;

Semiconductors

Transistors 75

Preamplifier Section

TAPE 2 (DIN connector)

REC (Level/Impedance) 30mV/80 kilohms

PLAY (Sensitivity/Impedance) . . . 150mV/50 kilohms

Hum and Noise (DIN, Continuous Power/50mW)

PHONO 1 MM 72dB/62dB

PHONO 2 MM 72dB/62dB

TUNER, AUX, TAPE PLAY 1, 2 90dB/62dB

Power Amplifier Section

Continuous Power Output at 1kHz (both channel driven)

T.H.D. 0.002%, 8 ohms 100 watts per channel

Micellaneous

Power Requirements 220V/240V, 50/60Hz

Power Consumption 850W(max.)

Dimensions 420(W)x150(H)x425(D)mm

16-17/32(W)x5-29/32(H)x16-3/4(D)in

Weight (Without Package) 18.0kg (39 lb 11oz)

CONTRAST OF MISCELLANEOUS PARTS

P.C. BOARD ASSEMBLIES

Symbol	Description	Part No.		Remarks
		KU type	HG type	
	PA-L assembly	GWH-119	GWH-125	
	PA-R assembly	GWH-120	GWH-126	
	Power supply assembly	AWR-191	AWR-196	
	EQ assembly	GWF-116	GWF-118	
	Input terminal assembly	GWX-261	GWX-291	
	Tape terminal assembly	GWX-262	GWX-292	
	DIN connector assembly	GWX-293	
	Tape switch assembly	GWS-172	GWS-183	

PIONEER ELECTRONIC CORPORATION 4-1, Meguro 1-Chome, Meguro-ku, Tokyo 153, Japan

U.S. PIONEER ELECTRONICS CORPORATION 85 Oxford Drive, Moonachie, New Jersey 07074, U.S.A.

PIONEER ELECTRONIC (EUROPE) N.V. Luichagen-Haven 9, 2030 Antwerp, Belgium

PIONEER ELECTRONICS AUSTRALIA PTY. LTD. 178-184 Boundary Road, Braeside, Victoria 3195, Australia

<ART-341-0>

Y © FEB. 1979 Printed in Japan

FUSES

Symbol	Description	Part No.		Remarks
		KU type	HG type	
△ FU1	Fuse (5A)	AEK-108	
	Fuse (3.15A)	AEK-042	
△ FU2	Fuse (5A)	AEK-108	
	Fuse (3.15A)	AEK-042	
△ FU3	Fuse (800mA)	AEK-111	AEK-031	
△ FU4	Fuse (800mA)	AEK-111	AEK-031	

TRANSFORMERS

Symbol	Description	Part No.		Remarks
		KU type	HG type	
△ T1	Power transformer	ATT-556	ATT-561	
△ T2	Power transformer	ATT-556	ATT-562	

SWITCHES

Symbol	Description	Part No.		Remarks
		KU type	HG type	
△ S17	Plug in selector	AKX-057	2-position
△ S18	Lever switch (POWER)	ASK-124	ASK-127	

CAPACITORS AND RESISTOR

Symbol	Description	Part No.		Remarks
		KU type	HG type	
△ C1	Ceramic 0.01/250V	ACG-001	
△ R3		RS1P 331J	

OTHERS

Symbol	Description	Part No.		Remarks
		KU type	HG type	
△ △ △	AC power cord	ADG-023	Walnut grained finished Black
	AC socket (AC OUTLETS)	AKP-004	
	Recessed plug (AC INLET)	AKP-008	
	Top cover (wooden)	AMM-079	
	Top cover (metal)	ANE-222	
	Screw (for top cover)	ABA-243	ABA-079	
	Spring washer 4φ	ABE-056	
	Flat washer	B11-033	

PACKING AND FURNISHED PARTS

Symbol	Description	Part No.		Remarks	
		KU type	HG type		
	Packing case	AHD-614	AHD-618		
	Top pad L	AHA-214		
	Top pad R	AHA-215		
	Bottom pad L	AHA-216		
	Bottom pad R	AHA-217		
	Side pad	AHA-218		
	Operating instructions	ARB-307	ARB-312		
		ARD-130		
					English
					German/French

SCHEMATIC DIAGRAM

For Service Manuals Contact
MAURITRON TECHNICAL SERVICES
 8 Cherry Tree Rd, Chinnor
 Oxon OX9 4QY
 Tel: 01844-351694 Fax: 01844-352554
 Email: enquiries@mauritron.co.uk

A

B

C

D

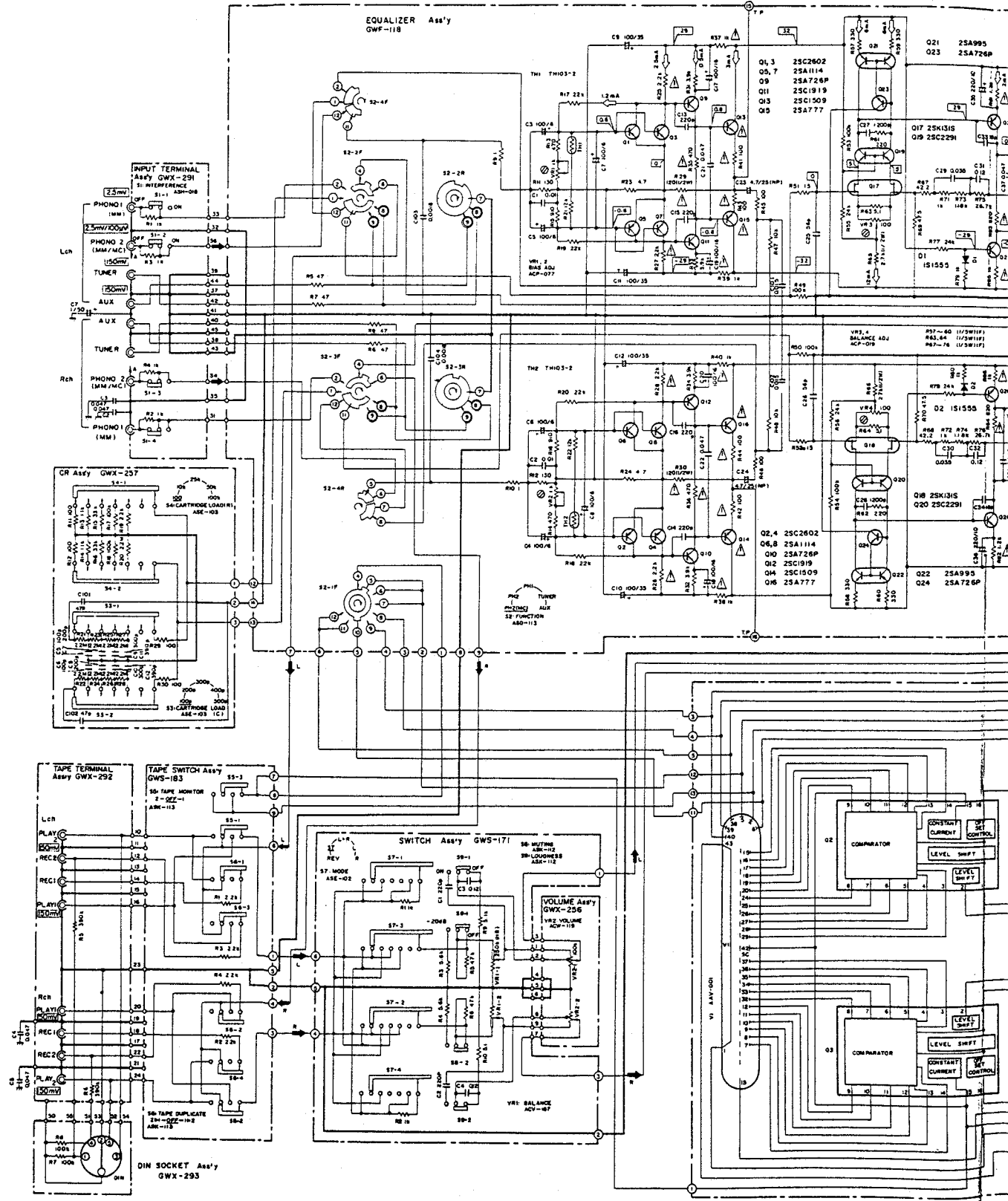

1

2

3

For Service Manuals Contact
MAURITRON TECHNICAL SERVICES
 8 Cherry Tree Rd, Chinnor
 Oxon OX9 4QY
 Tel: 01844-351694 Fax: 01844-352554
 Email: enquiries@mauritron.co.uk

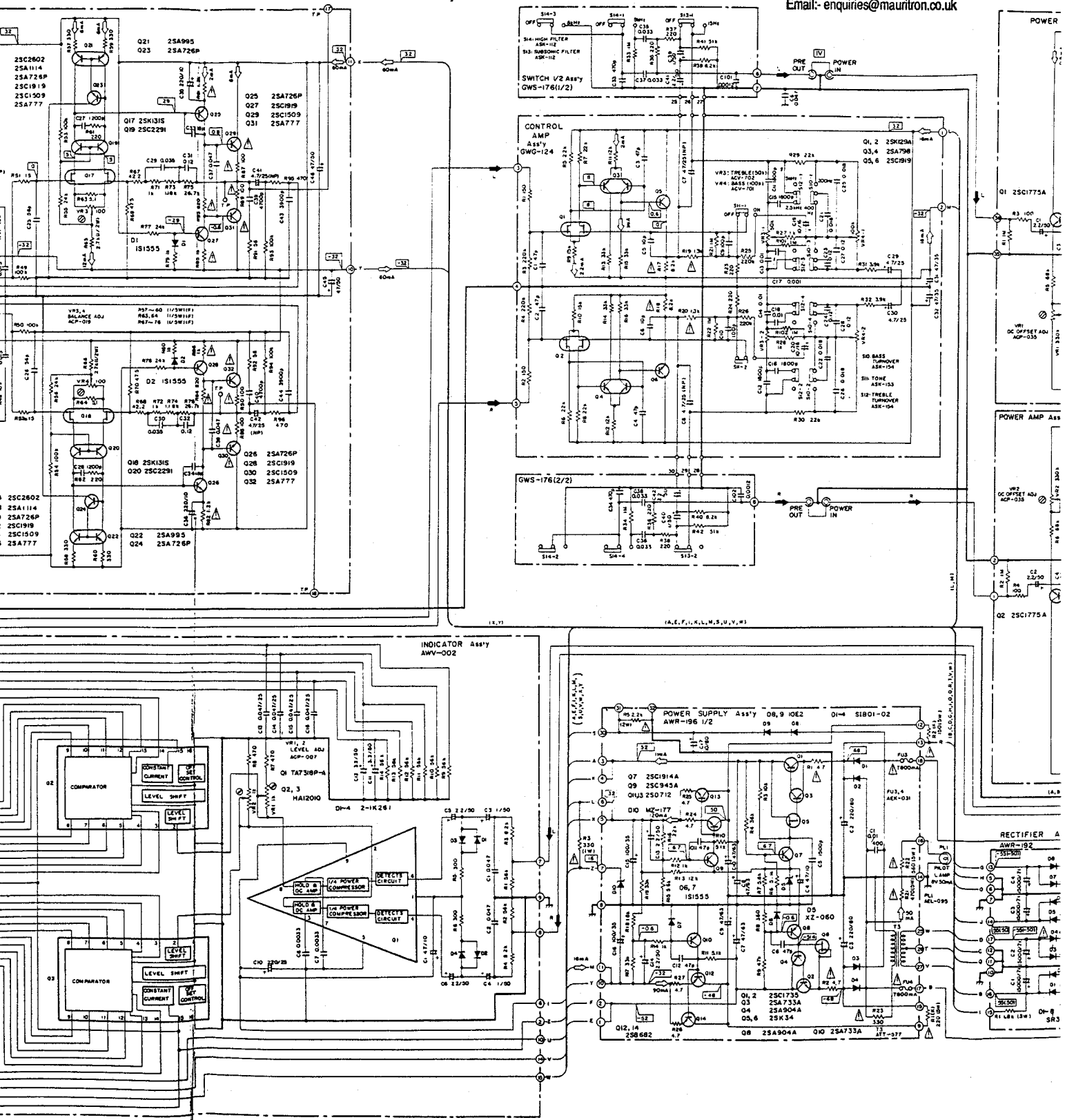

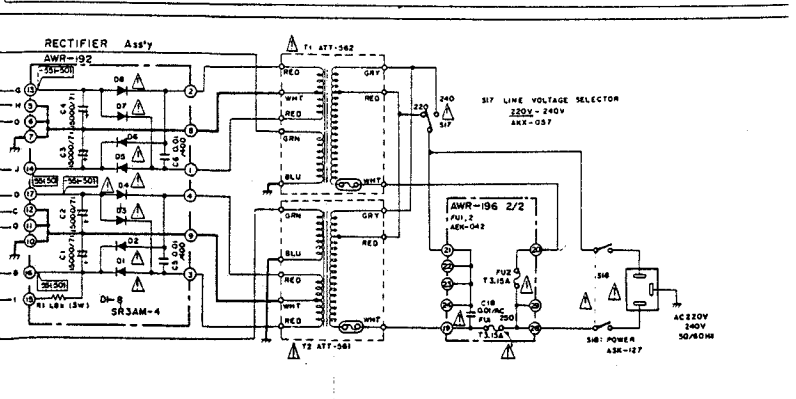
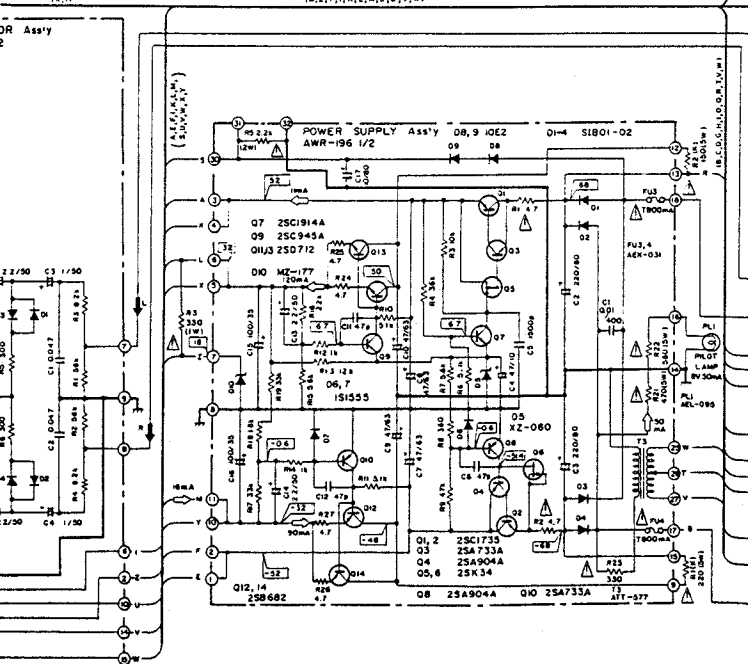
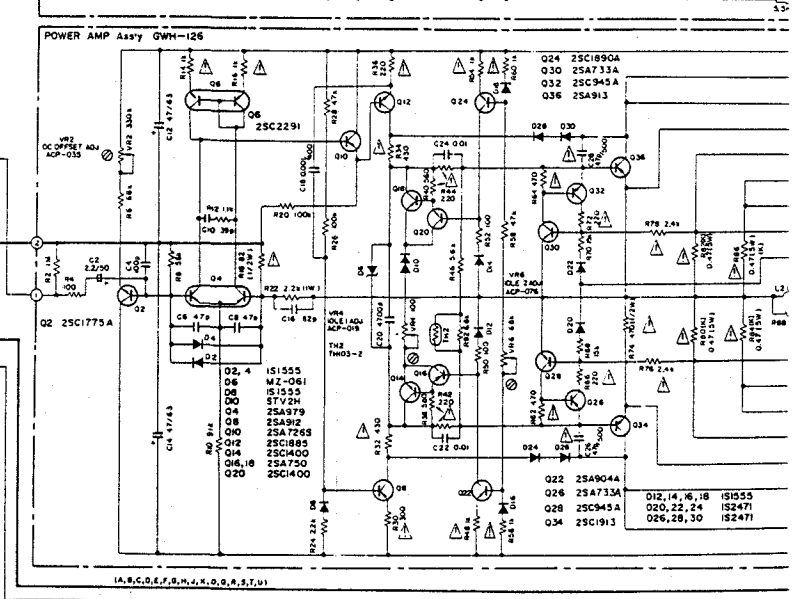
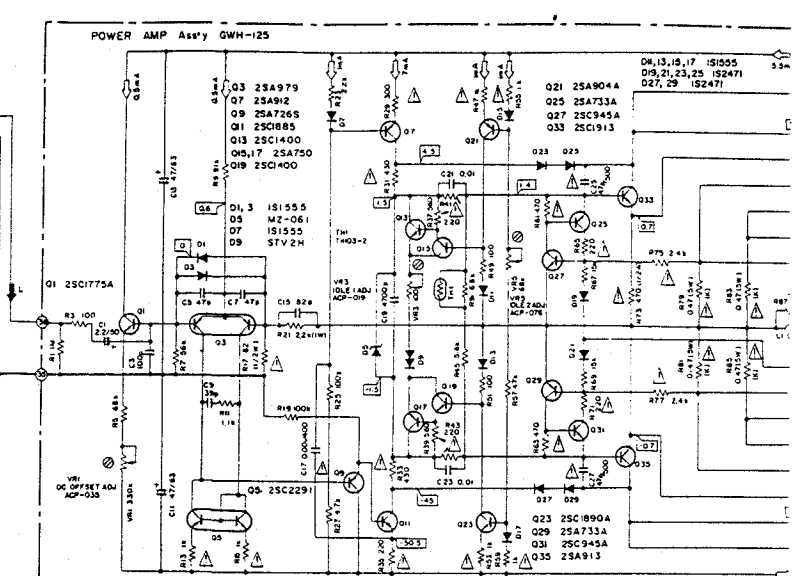
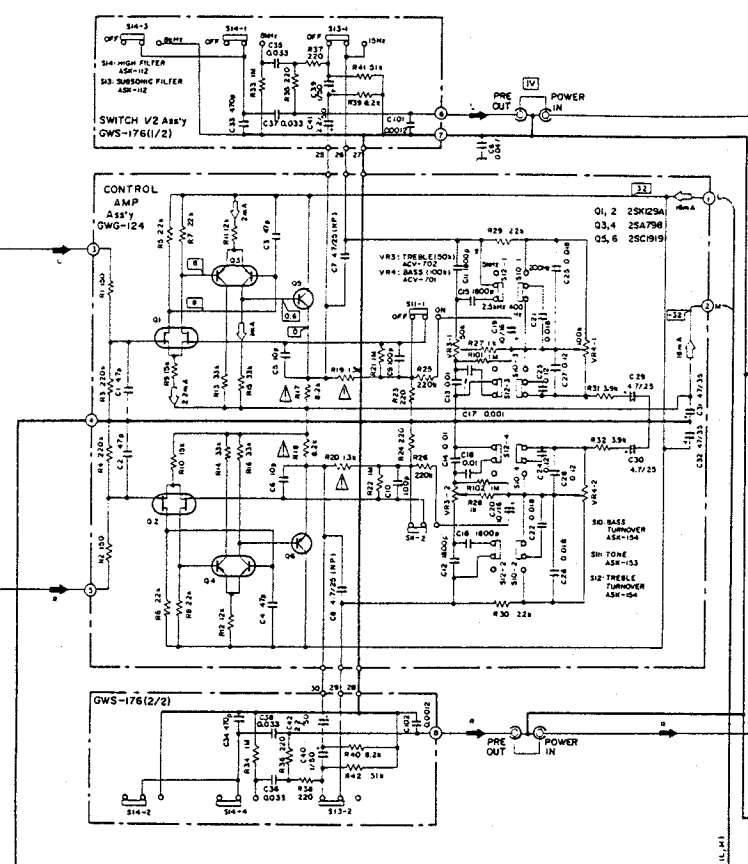

NOTE:

The indicated semiconductors are representative ones only. Other alternative semiconductors may be used and are listed in the parts list.

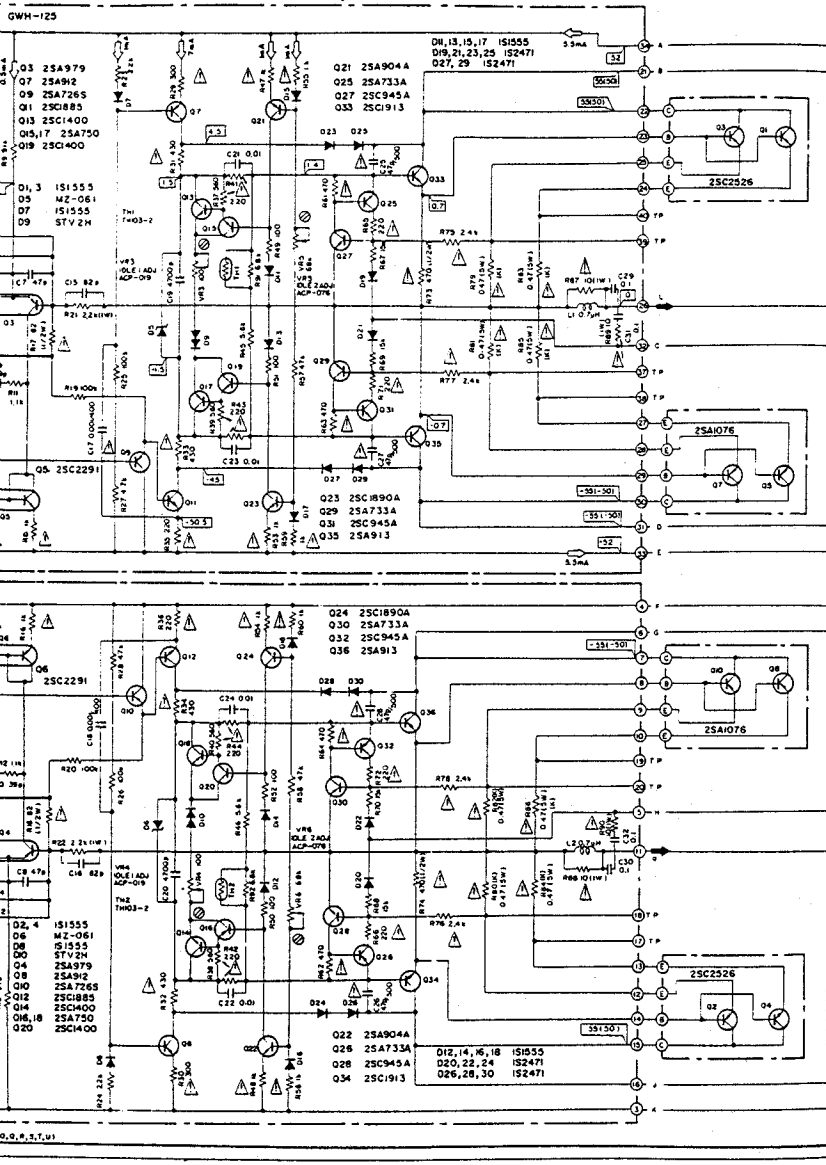

1. RESISTOR. Indicated in Ω, 1/kΩ, 1% tolerance unless otherwise noted. M, K, M, MΩ, F, 1N, 1G, 1T, 1K, 10% tolerance.
2. CAPACITORS. Indicated in capacity (μF/voltage V) unless otherwise noted. μ, pF. Indication without voltage is 50V except electrolytic capacitor.
3. VOLTAGE CURRENT. Signal voltage at 100W + 100W BEZ output. DC voltage (V) at no input signal. Value in () is DC voltage at rated power. OC current at no input signal.
4. OTHERS. Signal route. Adjusting point. The mark found on some component parts indicates the importance of the safety factor of the part. Therefore, when replacing, be sure to use parts of identical designation.

For Service Manuals Contact
MAURITRON TECHNICAL SERVICES
 8 Cherry Tree Rd, Chinnor
 Oxon OX9 4QY
 Tel: 01844-351694 Fax: 01844-352554
 Email: enquiries@mauritron.co.uk

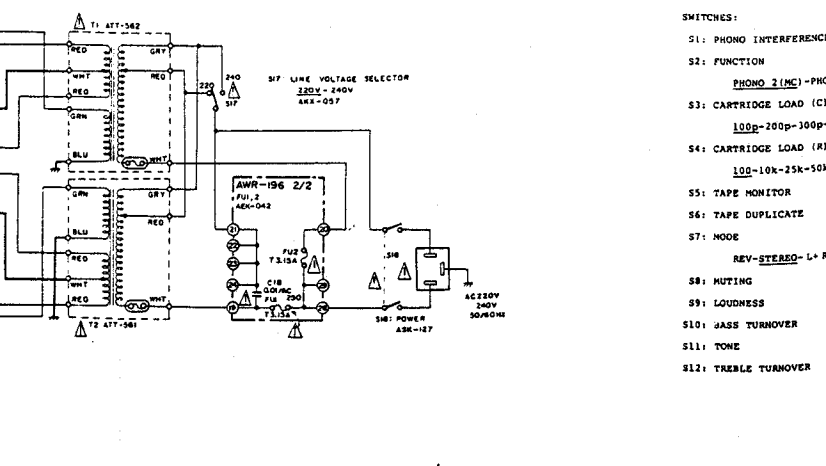
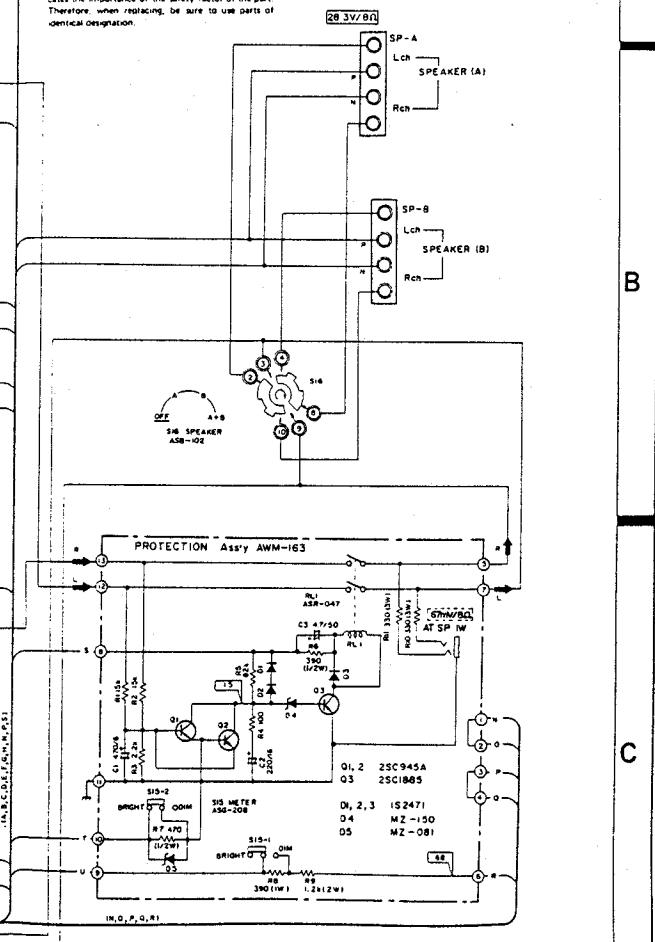

SWITCHES:

- S1: PHONO INTERFERENCE FILTER OFF-ON
- S2: FUNCTION PHONO 2(MC)-PHONO 2(MH)-PHONO 1(MM)-TUNER-AUX
- S3: CARTRIDGE LOAD (C) 100p-200p-300p-400p-500p
- S4: CARTRIDGE LOAD (R) 100-10k-25k-50k-100k
- S5: TAPE MONITOR 1-OFF-2
- S6: TAPE DUPLICATE 1-2-OFF-2-1
- S7: NOISE REV-STEREO-L-R-L-R
- S8: MUTING OFF-20dB
- S9: LOUDNESS OFF-ON
- S10: BASS TURNOVER 400Hz-200Hz
- S11: TONE OFF-ON
- S12: TREBLE TURNOVER 2.5kHz-5kHz

- S13: SUBSONIC FILTER OFF-15Hz
- S14: HIGH FILTER OFF-8kHz
- S15: METER BRIGHT-DIM
- S16: SPEAKER OFF-A-B-A+B
- S17: LINE VOLTAGE SELECTOR 220V-240V
- S18: POWER OFF-ON

The underlined indicates the switch position.

This is the basic schematic diagram, but the actual circuit may vary due to improvements in design.

P.C. BOARD ASSEMBLIES

Power Supply Assembly (AWR-196)

A

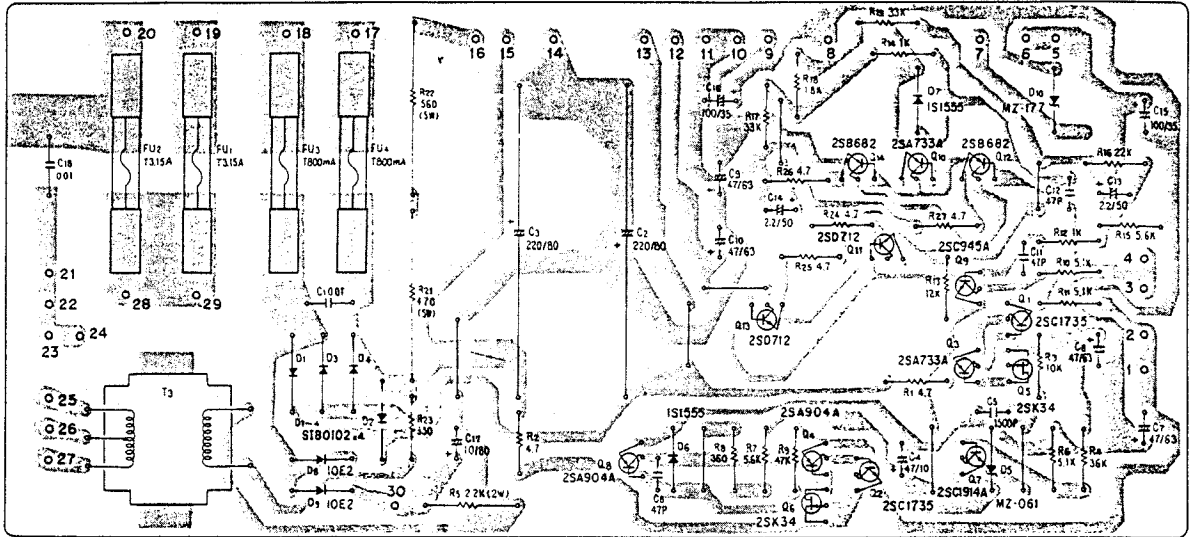

B

For Service Manuals Contact
MAURITRON TECHNICAL SERVICES
 8 Cherry Tree Rd, Chinnor
 Oxon OX9 4QY
 Tel: 01844-351694 Fax: 01844-352554
 Email: enquiries@mauritron.co.uk

EQ Assembly (GWF-118)

C

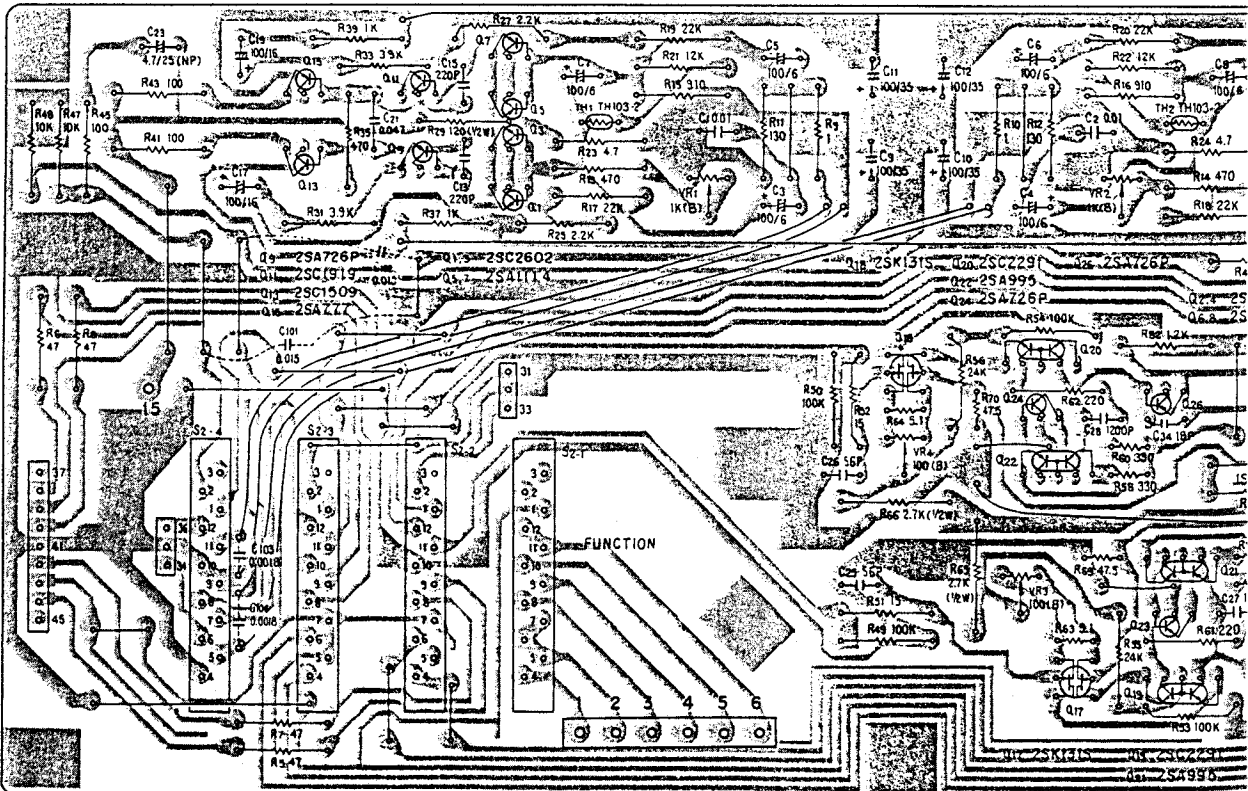

D

4

5

6

Input Terminal Assembly
(GWX-291)

Tape Terminal Assembly
(GWX-292)

DIN Connector Assembly
(GWX-293)

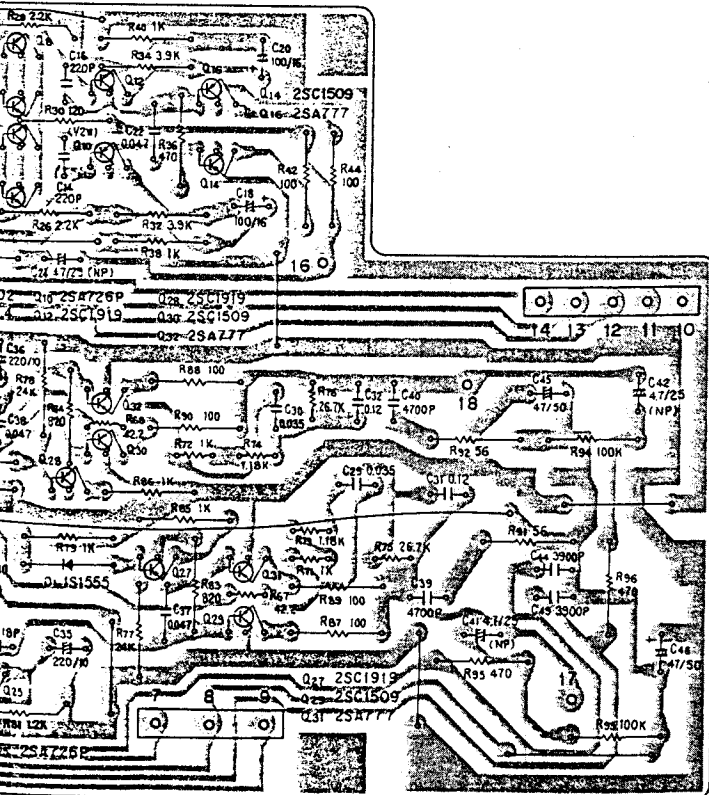
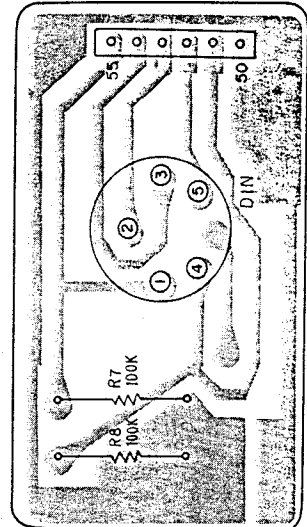
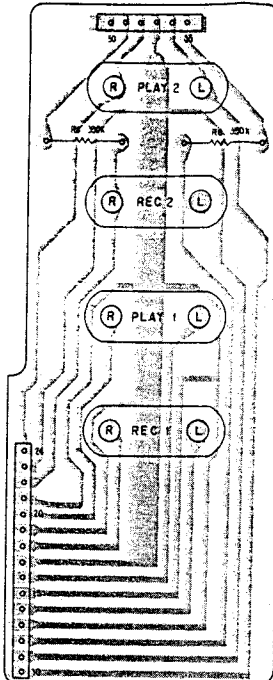
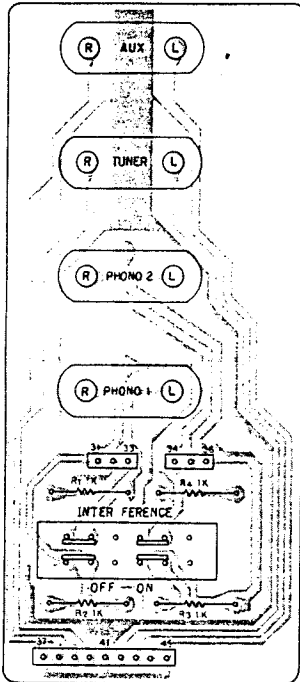

4

5

6

PA-L Assembly (GWH-125)

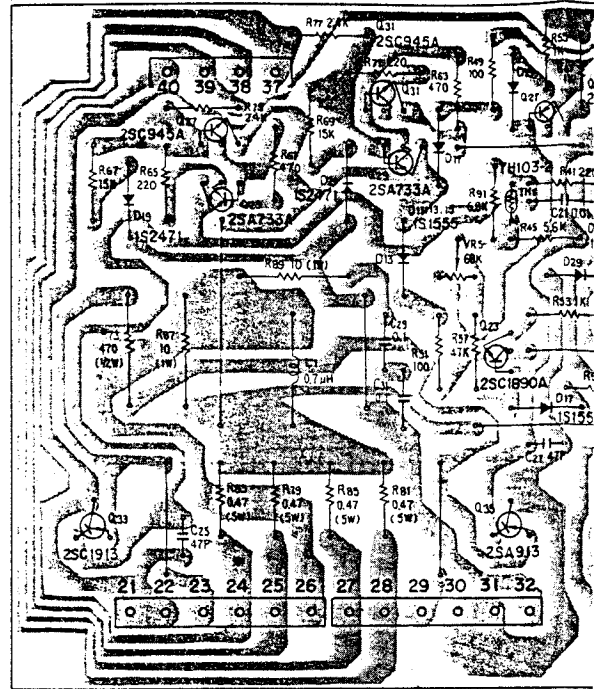

For Service Manuals Contact
MAURITRON TECHNICAL SERVICES
 8 Cherry Tree Rd, Chinnor
 Oxon OX9 4QY
 Tel:- 01844-351694 Fax:- 01844-352554
 Email:- enquiries@mauritron.co.uk

PA-R Assembly (GWH-126)

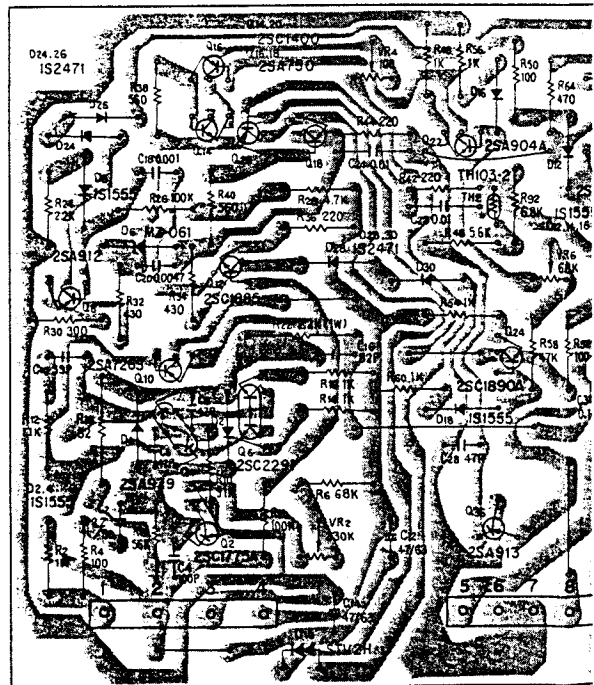

PA-L Assembly (GWH-125)

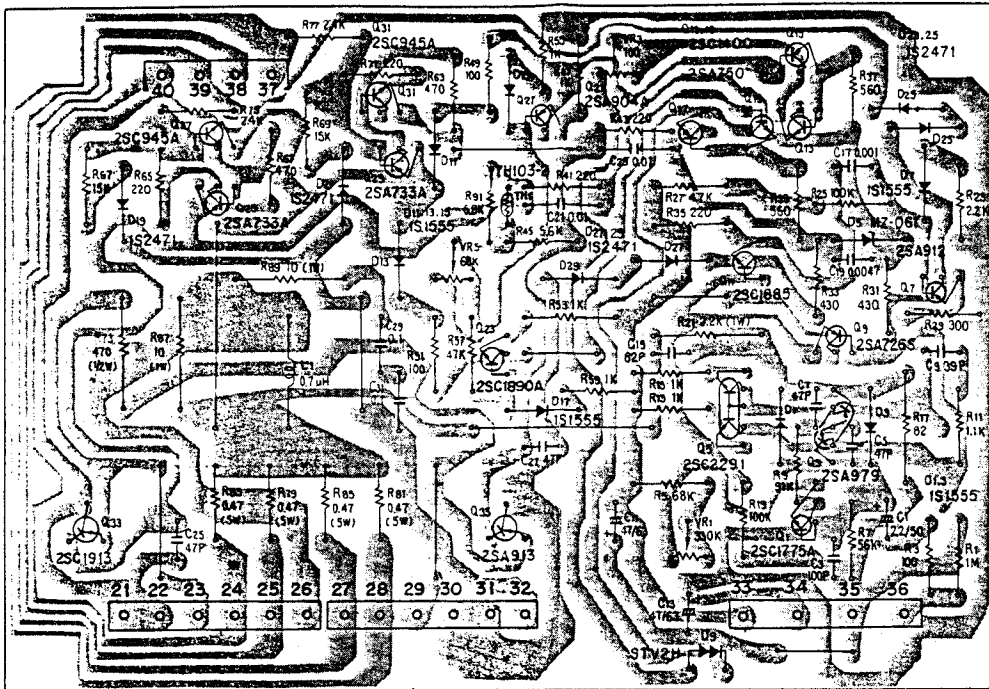

A

B

PA-R Assembly (GWH-126)

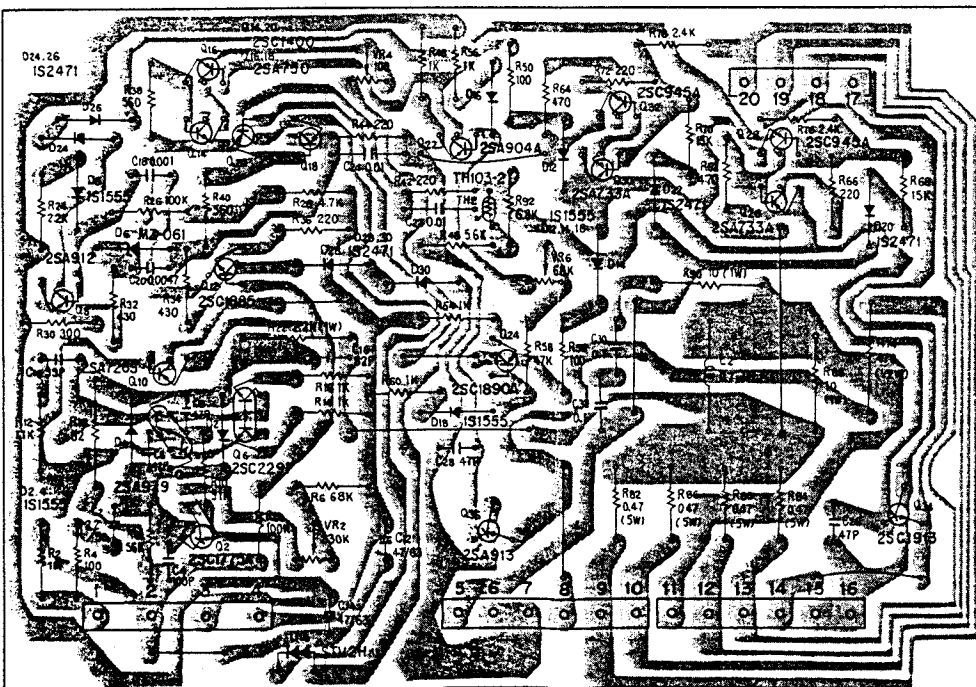

C

D

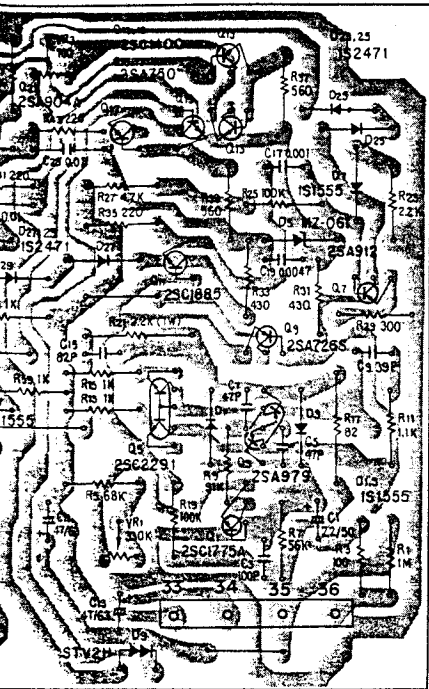

A

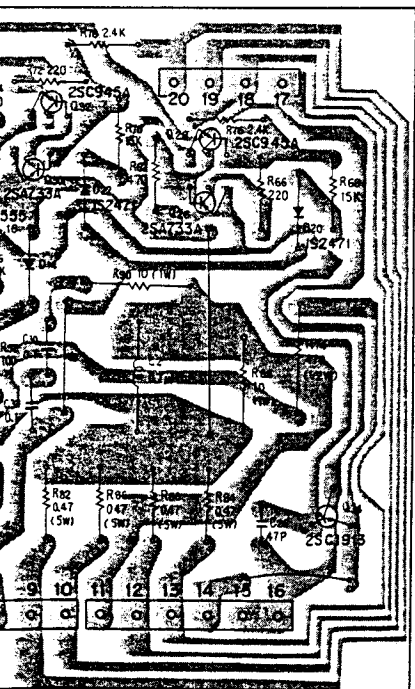

B

C

D

For Service Manuals Contact
 MAURITRON TECHNICAL SERVICES
 8 Cherry Tree Rd, Chinnor
 Oxon OX9 4QY
 Tel:- 01844-351694 Fax:- 01844-352554
 Email:- enquiries@mauritron.co.uk

- PA-L(GWH-125) and PA-R(GWH-126) assemblies for HG type are the same as the S, S/G types, please refer to the SA-9800/S, S/G additional service manual.
- The circuitry of the Tape switch assembly(GWS-183) is the same as the GWS-172(for KU type).

Parts List of Power Supply Assembly (AWR-196)

CAPACITORS

Part No.	Symbol & Description
CQMA 103K 400	C1
CEB 221P 80	C2, C3
CEA 470P 10	C4
CKDYB 152K 50	C5
CCDSL 470K 50	C6, C11, C12
CEA 470P 63	C7-C10
CEA 2R2P 50	C13, C14
CEA 101P 35	C15, C16
CEA 100P 80	C17
△ ACG-001	C18 Ceramic 0.01/250V

Note: When ordering resistors, convert the resistance value into code form, and then rewrite the part no. as before.

RESISTORS

Part No.	Symbol & Description
△ RD¼PMF □□□ J	R1, R2, R10, R11, R23
RD¼PM □□□ J	R3, R4, R6-R9, R12-R19, R24-R27
△ RS2P □□□ J	R5
△ RT5B □□□ K	R21, R22

SEMICONDUCTORS

Part No.	Symbol & Description
2SC1735	Q1, Q2
2SA733A	Q3, Q10
2SA904A (2SA893A)	Q4, Q8
2SK34	Q5, Q6
2SC1914A (2SC1890A)	Q7
2SC945A	Q9
2SD712 (2SD313P)	Q11, Q13
2SB682 (2SB507P)	Q12, Q14
S1B01-02	D1-D4
1S1555 (1S2473)	D6, D7
10E2	D8, D9
XZ-060	D5
MZ-177 (WZ-177)	D10

OTHERS

Part No.	Symbol & Description
△ ATT-577	T3 Transformer
△ AEC-294	Capacitor cover (for C18)
ABA-026	Pan head screw

Parts List of Input Terminal Assembly (GWX-291)

Part No.	Symbol & Description
ASH-018	S1 Slide switch (PHONO INTERFRERENCE)
RD¼PM 102J	R1-R4
AKB-054	Terminal (INPUT)

Parts List of Tape Terminal Assembly (GWX-292)

Part No.	Symbol & Description
RD¼PM 394J	R5, R6
AKB-054	Terminal (TAPE 1, 2)

Parts List of DIN Connector Assembly (GWX-293)

Part No.	Symbol & Description
AKP-011	Connector socket 5-P (REC/PLAY)
RD¼PM 104J	R7, R8

Parts List of EQ Assembly (GWF-118)

CAPACITORS

Part No.	Symbol & Description
CQMA 103K 50	C1, C2
CEANL 101M 6	C3-C8
CEA 101P 35	C9-C12
CCDSL 221K 50	C13-C16
CEA 101P 16	C17-C20
CQMA 473K 50	C21, C22, C37, C38
ACH-318	C23, C24, C41, C42 Electrolytic 4.7/25V(NP)
CCDSL 560K 50	C25, C26
CKDYB 122K 50	C27, C28
CQPA 353G 50	C29, C30
CQPA 124G 50	C31, C32
CCDSL 180K 50	C33, C34
CEA 221P 10	C35, C36
CQMA 472K 50	C39, C40
CQMA 392K 50	C43, C44
CEA 470P 50	C45, C46
CQMA 153K 50 (CQMA 153J 50)	C101, C102
CQMA 182K 50	C103, C104

Note: When ordering resistors, convert the resistance value into code form, and then rewrite the part no. as before.

RESISTORS

Part No.	Symbol & Description
ACP-077	VR1, VR2 Semifixed 1k-B
ACP-019	VR3, VR4 Semifixed 100-B
RD¼PM □□□ J	R5-R24, R31-R34, R45-R56, R61
RD¼PM □□□ J	R62, R77-R80, R91-R96
△ RD¼PMF □□□ J	R25-R28, R35-R44, R81-R90
△ RD¼PSF □□□ J	R29, R30
RN¼SQ □□□□ F	R57-R60, R67-R76
RN¼SR □□□□ F	R63, R64
RD¼PS □□□ J	R65, R66

SEMICONDUCTORS

Part No.	Symbol & Description
2SC2602	Q1-Q4
2SA1114	Q5-Q8
2SA726P (2SA750)	Q9, Q10, Q23-Q26
2SC1919 (2SC1400)	Q11, Q12, Q27, Q28
△ 2SC1509	Q13, Q14, Q29, Q30
△ 2SA777	Q15, Q16, Q31, Q32
2SK131S	Q17, Q18
2SC2291	Q19, Q20
2SA995	Q21, Q22
1S1555 (1S2473)	D1, D2
TH103-2	Th1, Th2

OTHERS

Part No.	Symbol & Description
ASD-113	S2 Rotary switch (FUNCTION)
AKH-009	Transistor socket
ABN-024	Washerfaced nut
ABA-048	Screw 3x6

For Service Manuals Contact
MAURITRON TECHNICAL SERVICES
 8 Cherry Tree Rd, Chinnor
 Oxon OX9 4QY
 Tel:- 01844-351694 Fax:- 01844-352554
 Email:- enquiries@mauritron.co.uk

Parts List of PA-L Assembly (GWH-125)

CAPACITORS

Part No.	Symbol & Description
CEANL 2R2P 50	C1
CCDSL 101K 50	C3
CCDSL 470K 50	C5, C7
CCDSL 390K 50	C9
CEA 470P 63	C11, C13
CCDSL 820K 50	C15
△ CQMA 102K 400	C17
CQMA 472K 50	C19
CQMA 103K 50	C21, C23
△ CCDSL 470 K 500	C25, C27
△ CQMA 104J 50	C29, C31

Note: When ordering resistors, convert the resistance value into code form, and then rewrite the part no. as before.

RESISTORS

Part No.	Symbol & Description
ACP-035	VR1 Semifixed 330k-B
ACP-019	VR3 Semifixed 100-B
ACP-076	VR5 Semifixed 68k-B
RD¼PM □□□ J	R1, R3, R5, R7, R9, R11, R19, R23, R25
RD¼PM □□□ J	R27, R45, R49, R51, R57, R67, R69, R91
△ RD¼PM □□□ J	R37, R39, R75, R77
△ RD¼PMF □□□ J	R13, R15, R29, R31, R41, R47, R53
△ RD¼PMF □□□ J	R55, R59, R61, R63, R65, R71
△ RD¼PS □□□ J	R17, R73
RS1P □□□ J	R21
△ RD¼PMF □□□ J	R33, R35, R43
△ ACN-041	R79, R81, R83, R85 Wire wound 0.47/5W
△ RS1P □□□ J	R87, R89

SEMICONDUCTORS

Part No.	Symbol & Description
2SC1775A-E	Q1
2SA979-F	Q3
2SC2291	Q5
2SA912	Q7
2SA726S	Q9
2SC1885	Q11
2SC1400	Q13, Q19
2SA750	Q15, Q17
2SA904A	Q21
2SC1890A	Q23

Part No.	Symbol & Description
2SA733A	Q25, Q29
2SC945A	Q27, Q31
2SC1913	Q33
2SA913	Q35
1S1555 (1S2473)	D1, D3, D7, D11, D13, D15, D17
MZ-061 (WZ-061)	D5
STV2H-O	D9
1S2471	D19, D21, D23, D25, D27, D29
TH103-2	Th1

OTHERS

Part No.	Description
ABA-048	Screw 3x6
ABA-026	Screw 3x6 (Pan head)

Parts List of PA-R Assembly (GWH-126)

CAPACITORS

Part No.	Symbol & Description
CEANL 2R2P 50	C2
CCDSL 101K 50	C4
CCDSL 470K 50	C6, C8
CCDSL 390K 50	C10
CEA 470P 63	C12, C14
CCDSL 820K 50	C16
△CQMA 102K 400	C18
CQMA 472K 50	C20
CQMA 103K 50	C22, C24
△CCDSL 470K 500	C26, C28
△CQMA 104J 50	C30, C32

Note: When ordering resistors, convert the resistance value into code form, and then rewrite the part no. as before.

RESISTORS

Part No.	Symbol & Description
ACP-035	VR2 Semifixed 330k-B
ACP-019	VR4 Semifixed 100-B
ACP-076	VR6 Semifixed 68k-B
RD¼PM □□□ J	R2, R4, R6, R8, R10, R12, R20, R24, R26
RD¼PM □□□ J	R28, R46, R50, R52, R58, R68, R70, R92
△RD¼PM □□□ J	R38, R40, R76, R78
△RD¼PMF □□□ J	R14, R16, R30, R32, R42, R48, R54
△RD¼PMF □□□ J	R56, R60, R62, R64, R66, R72

Part No.	Symbol & Description
△RD¼PS □□□ J	R18, R14
RS1P □□□ J	R22
△RD¼PMF □□□ J	R34, R36, R44
△ACN-041	R80, R82, R84, R86
△RS1P □□□ J	R88, R90

Wire wound 0.47/5W

SEMICONDUCTORS

Part No.	Symbol & Description
2SC1775A-E	Q2
2SA979-F	Q4
2SC2291	Q6
2SA912	Q8
2SA726S	Q10
2SC1885	Q12
2SC1400	Q14, Q20
2SA750	Q16, Q18
2SA904A	Q22
2SC1890A	Q24
2SA733A	Q26, Q30
2SC945A	Q28, Q32
2SC1913	Q34
2SA913	Q36
1S1555 (1S2473)	D2, D4, D8, D12, D14, D16, D18
MZ-061 (WZ-061)	D6
STV2H-O	D10
1S2471	D20, D22, D24, D26, D28, D30
TH103-2	Th2

OTHERS

Part No.	Description
ABA-048	Screw 3x6
ABA-026	Screw 3x6 (Pan head)