

SERVICE MANUAL

STEREO RECEIVER

SX-1010

KCU, F, GN

NOTE:

MODEL SX-1010 COMES IN THREE VERSIONS DISTINGUISHED AS FOLLOWS:

Round label on rear panel	Voltage	Type
KCU F	120V only 110V, 120V, 130V, 220V and 240V (Switchable)	UL (U.S.A.) and CSA (Canada) approved General export model.
GN	220V only	SEMCO (Sweden), NEMCO (Norway), DEMCO (Denmark) approved.

CONTENTS

About 220V only model labeled "GN"

This model whose rear panel is labeled "GN" circular mark operates only on 220V, substantially in its circuit design from two other models. When repairing this model, please see the manual on page 75 and the followings which include such items as Circuit connection diagram, Miscellaneous parts list, Schematic diagram of power supply circuit assembly, P.C. board pattern and its parts list.

Before servicing, also please do not fail to check to see if the "GN" mark is labeled on the rear panel.

1. SPECIFICATIONS	2
2. FRONT PANEL FACILITIES	5
3. CONNECTION DIAGRAM	7
4. BLOCK DIAGRAM	9
5. CIRCUIT DESCRIPTION	11
6. DIAL CORD STRINGING	12
7. DISASSEMBLY	13
8. PARTS AND P.C. BOARD LOCATIONS	14
9. LEVEL DIAGRAM	16
10. ALIGNMENT PROCEDURE	
10.1 English	17
10.2 Abgleichverfahren	72
11. EXPLODED VIEW AND PARTS LIST	20
12. SCHEMATIC DIAGRAMS, P.C. BOARD PATTERNS AND PARTS LIST	
12.1 Circuit Connection Diagram and Miscellaneous Parts	27
12.2 FM Front End (AWB-017)	32
12.3 Tuner Assembly (AWE-040)	33
12.4 Muting Circuit Assembly (AWM-039)	39
12.5 Equalizer Amplifier Assembly (AWF-013)	41
12.6 Control Amplifier Assembly (AWG-027)	44
12.7 Power Amplifier Assembly (AWH-032)	49
12.8 Protection Circuit Assembly (AWM-062)	52
12.9 Power Supply Circuit Assembly (AWR-053)	55
12.10 Power Supply Circuit Assembly (AWR-054)	57
12.11 Switch Circuit Assembly (AWS-064)	60
12.12 Switch Circuit Assembly (AWS-068)	61
12.13 Switch Circuit Assembly (AWS-069)	62
12.14 Switch Circuit Assembly (AWS-070)	64
12.15 Switch Circuit Assembly (AWS-071)	66
12.16 Switch Circuit Assembly (AWS-072)	68
12.17 5P Connector Assembly (AWX-062)	70
13. PACKING METHOD AND PART NUMBERS	71
14. SCHEMATIC DIAGRAMS, P.C. BOARD PATTERNS AND PARTS LIST FOR 220V ONLY MODEL	
14.1 Circuit Connection Diagram and Miscellaneous Parts	75
14.2 Power Supply Circuit Assembly (AWR-063)	80

1. SPECIFICATIONS

SEMICONDUCTORS

EETs	3
ICs	5
Transistors	73
Diodes	41

AMPLIFIER SECTION

Continuous Power Output

20Hz~20kHz

(Both channels driven) 100W + 100W (8Ω), 105W + 105W (4Ω)

1kHz (Both channels driven) 110W + 110W (8Ω), 110W + 110W (4Ω)

Harmonic Distortion

(20Hz~20kHz Continuous

Power Output) Less than 0.1%

(1W + 1W, Power Output) Less than 0.05%

Intermodulation Distortion

(Continuous Power Output) Less than 0.1%

(1W + 1W, Power Output) Less than 0.05%

Power Bandwidth

(IHF, Both channels driven) 5Hz~40kHz (T.H.D. 0.1%)

Frequency Response 7Hz~100kHz

Input Sensitivity/Impedance

POWER AMP IN 1V/50kΩ

Output

Speaker A, B, C, A + B, A + C, B + C (4Ω~16Ω)

Headphone 4Ω~16Ω

Damping Factor

(1kHz, 8Ω) More than 50

Hum & Noise

(IHF, short-circuited,

A Network) More than 100dB

Residual Hum & Noise

(8Ω, Pre & Power amplifier) Less than 1mV

PREAMPLIFIER SECTION

Input Sensitivity/Impedance

PHONO 1 2.5mV/50kΩ

PHONO 2 2.5mV/50kΩ

PHONO Overload Level

(rms/p-p) 250mV/700mV

MIC 2.0mV/50kΩ

AUX 150mV/70kΩ

TAPE PB 1, 2 150mV/70kΩ

TAPE PB 2 (DIN connector) 150mV/70kΩ

Output Level/Impedance

TAPE REC 1, 2 150mV

TAPE REC 2 (DIN connector) 30mV/80kΩ

PRE OUT 1V/1kΩ

Harmonic Distortion

(20Hz~20kHz) Less than 0.1%

Frequency Response

PHONO (RIAA equalization) 30Hz~15kHz ± 0.3 dB
 AUX, TAPE PB 10Hz~40kHz $^{+0}_{-1}$ dB

Tone Control**BASS:**

MAIN ± 10 dB (100Hz)
 SUB ± 5 dB (50Hz)

TREBLE:

MAIN ± 10 dB (10kHz)
 SUB ± 5 dB (20kHz)

Filter

LOW CUT -8 dB (50Hz) 6dB/oct.
 HIGH CUT -9 dB (10kHz) 6dB/oct.

Loudness Contour

(Volume control set at
 -40 dB position) $+8$ dB (100Hz), $+4$ dB (10kHz)

Hum & Noise

(IHF, short-circuited,
 A Network)

PHONO More than 70dB
 MIC More than 65dB
 AUX, TAPE PB More than 95dB

Muting -20 dB

FM SECTION

Usable Sensitivity (IHF) 1.7μ V
 Capture Ratio (IHF) 1.0dB
 Selectivity (IHF) 90dB
 Signal-to-Noise Ratio 72dB
 Image Rejection (98MHz) 110dB
 IF Rejection (98MHz) 110dB
 Spurious Rejection 110dB
 AM Suppression 55dB

Harmonic Distortion:

MONO Less than 0.2%
 STEREO Less than 0.3%

Frequency Response 20Hz~15kHz $^{+0.2}_{-2.0}$ dB
 50Hz~10kHz $^{+0.2}_{-0.5}$ dB

Stereo Separation

1kHz More than 40dB
 50Hz~10kHz More than 30dB

Sub Carrier Suppression 65dB

Antenna Input 300Ω Balanced, 75Ω Unbalanced

Muting ON-OFF

SX-1010

AM SECTION

Sensitivity	
(IHF, Ferrite antenna)	300 μ V/m
(IHF, Ext. antenna)	15 μ V
Selectivity	40dB
Signal-to-Noise Ratio	50dB
Image Rejection	65dB
IF Rejection	85dB

MISCELLANEOUS

Power Requirements	AC 120V 60Hz or 110, 120, 130, 220 and 240V (switchable) 50/60Hz
Power Consumption	400W (UL approved model only) 640W (5 line Voltage model only)
Dimensions	520 (W) x 175 (H) x 440 (D) mm 20-1/2 x 6-7/8 x 17-5/16 in.
Weight:	
Without Package	22.2 kg (48 lb 13 oz)
With Package	26.6 kg (58 lb 8 oz)

FURNISHED PARTS

FM T-type Antenna	1
Operating Instructions	1
Fuse 6A	1
Fuse 3A	1 (5-line voltage model only)

NOTE:

Specifications and the design subject to possible modification without notice due to improvements.

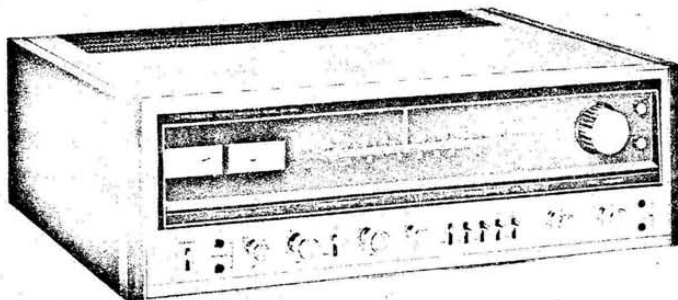

2. FRONT PANEL FACILITIES

FRONT PANEL FACILITIES

SPEAKER BUTTONS

Each of speaker systems A, B, and C is connected to each of output terminals A, B, and C.

By pushing the following:

- SPKR-A Speaker systems A into operation
- SPKR-B Speaker systems B into operation
- SPKR-C Speaker systems C into operation

NOTES:

1. When any two pairs of the buttons (A + B, B + C, C + A) are depressed, the corresponding pairs of speaker systems will come into operation. However, operating all three buttons even though depressed at the same time is not possible.
2. Only when listening through headphones, press again the SPKR button(s) in use to OFF (undepressed) from the ON position (pressed).

POWER SWITCH

Turn this switch ON but wait for some 3 to 6 seconds, during the silence of which the protection circuit eliminates the unpleasant noise not imputed to a receiver fault.

PHONES (1, 2) OUTPUT JACKS

Accept two pairs of headphones.

BASS CONTROLS

Adjust bass tone quality.

- 100Hz For the low frequencies below 400Hz. Possible up to 10dB of increasing or reducing at 100Hz in 2dB steps.
- 50Hz After adjustment by the 100Hz control, further adjust frequencies below 80Hz by this control, if necessary. Possible up to 5dB of increasing or reducing in bass response at 50Hz in 2.5dB steps.

LOW CUT, HIGH CUT BUTTONS

- LOW When the low-pitched rumble (turntable motor or other source) is obtrusive, depress the LOW CUT button to ON. In no interference, leave it undepressed (OFF).
- HIGH When the high frequency scratch noise (records or other source) is much, depress this button to ON. In no interference, leave it undepressed (OFF).

TONE SWITCH

When in the ON (up) position, this switch causes the amplifier section to operate with a flat frequency regardless of the tone control settings. Use this switch to check the audio characteristics of your listening room such as when it is necessary to check the tone quality of phono cartridges and speakers and also to particularly set the tone controls to be assessed.

SIGNAL METER

For AM and FM station tunings

- AM tuning: Tune the dial pointer so that the SIGNAL meter needle comes to the extreme right.
- FM tuning: Both the SIGNAL and FM TUNING meters work together. The optimum point of the SIGNAL meter needle is the same as in AM tuning. Then use the FM TUNING meter.

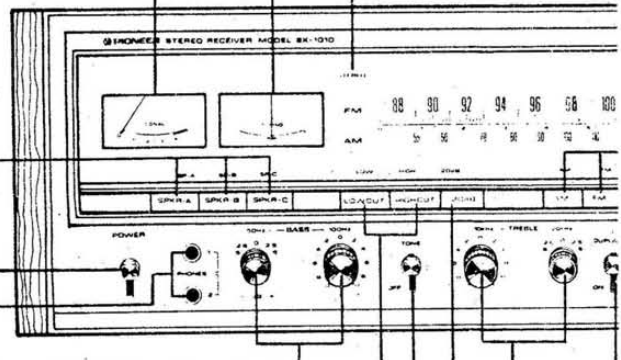

AUDIO MUTING BUTTON -20dB

Depress this button to mute the audio input to -20dB. No need to turn down the VOLUME control on each occasion for your convenience.

TREBLE CONTROLS

Adjust treble tone quality.

- 10KHz For the high frequencies above 2.5kHz. Possible up to 10dB of increasing or reducing in treble response at 10kHz in 2dB steps.
- 20KHz After adjustment by the 10KHz control, further adjust frequencies above 12KHz by this control, if necessary. Possible up to 5dB of increasing or reducing in treble response at 20kHz in 2.5dB steps.

TAPE DUPLICATE SWITCH

Leave this switch in the ON (down) position to duplicate or edit a recorded tape using two tape decks. For normal use, switch over to the OFF (up) position.

FM TUNING METER

While getting the SIGNAL meter needle going to the right, make fine adjustment with the FM TUNING meter whose needle comes to the center (indicating the optimum reception).

FM STEREO INDICATOR

TUNING KNOB

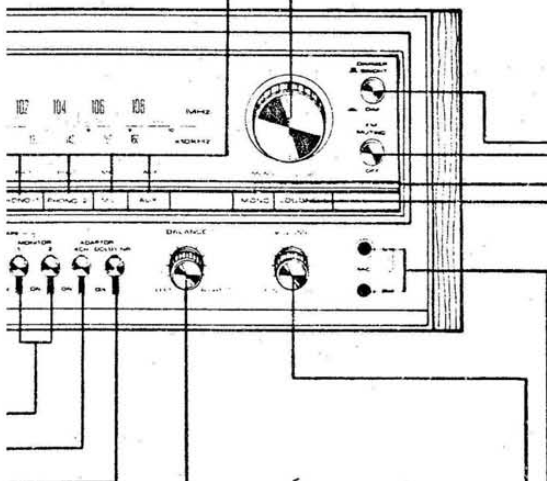

BALANCE CONTROL

Adjusts the balance between the sound volume from the left and right speaker systems.

DOLBY NR ADAPTOR SWITCH

When employing Dolby Noise Reduction Adaptor, depress this DOLBY NR ADAPTOR to ON.

4CH ADAPTOR SWITCH

When using the 4-channel rear amplifier connected to the 4CH jacks on the rear panel, depress this 4CH ADAPTOR to ON.

TAPE MONITOR (1, 2) SWITCHES

Monitor the recorded sound while recording with a tape deck. Also possible to play back tapes as follows:

- 1 With a tape deck connected to the TAPE 1 jacks (REC and PB), either monitoring of recording in progress or playing back is possible.
- 2 With a tape deck connected to the TAPE 2 jacks (REC and PB or REC/PB connector), the same as in 1 above is possible.

FUNCTION SELECTOR BUTTONS

For selecting the program source, push each button as follows:

- AM For AM broadcast reception.
- FM For FM broadcast reception. The STEREO indicator lights up when the broadcast is in stereo.
- PHONO 1 For operating a turntable connected to the PHONO 1 input jacks.
- PHONO 2 For operating a turntable connected to the PHONO 2 input jacks.
- MIC For using a microphone. Not possible to mix with other program source.
- AUX For listening to audio equipment (cartridge tape player, TV sound tuner, etc.) connected to the AUX input jacks.

DIMMER SWITCH

Dims the brightness of the indicator light. Press again to restore full brightness.

FM MUTING BUTTON

Leave this button undepressed (in the ON position) while tuning in FM stations. Inter-station noise may interfere with FM reception while tuning between stations. To suppress this noise, leave the MUTING button undepressed (in the ON position). If the low signal strength is due to distance from the transmitter or other influences, depress this button, at which the weak station will be heard with the MUTING "OFF."

MODE BUTTON

Leave this button undepressed (if necessary, depress this to release it when already depressed) for STEREO playback. For MONO playback, depress it. In this case stereo signals for left and right channels will be mixed into mono signal which will be heard from the center of both speaker systems.

LOUDNESS BUTTON

Depress this button to listen at low volume. The human ear's frequency response varies according to the listening volume. The depressed button compensates for hearing response with emphasis on the bass and treble.

MIC INPUT JACKS

L, R For connecting the left and right channel microphones.

NOTE:

Use the high impedance (above 20kΩ) with 6mm diam. phone plugs.

VOLUME CONTROL

Governs both the volume of sound outputs from the speaker systems and from the headphones.

3. CONNECTION DIAGRAM

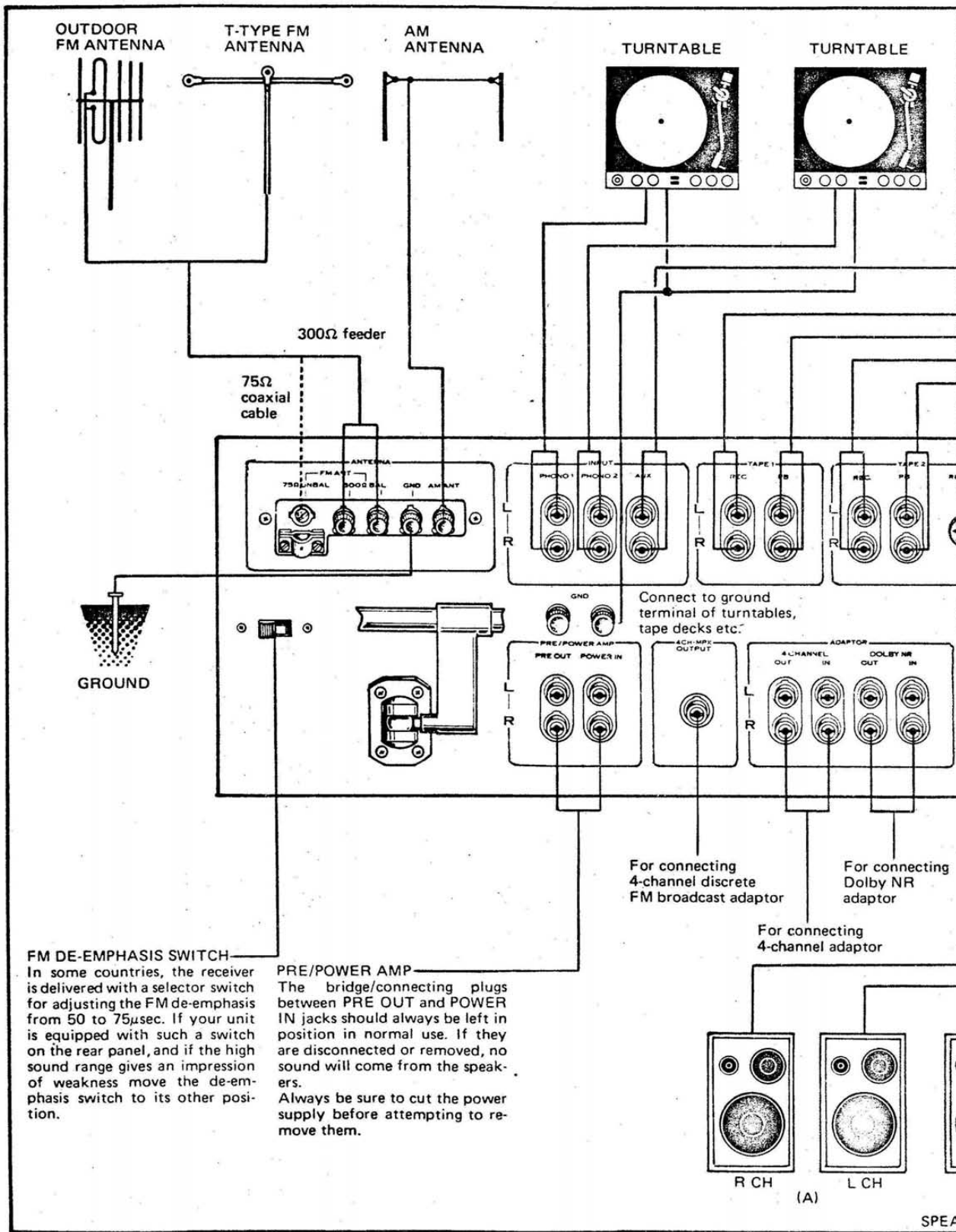

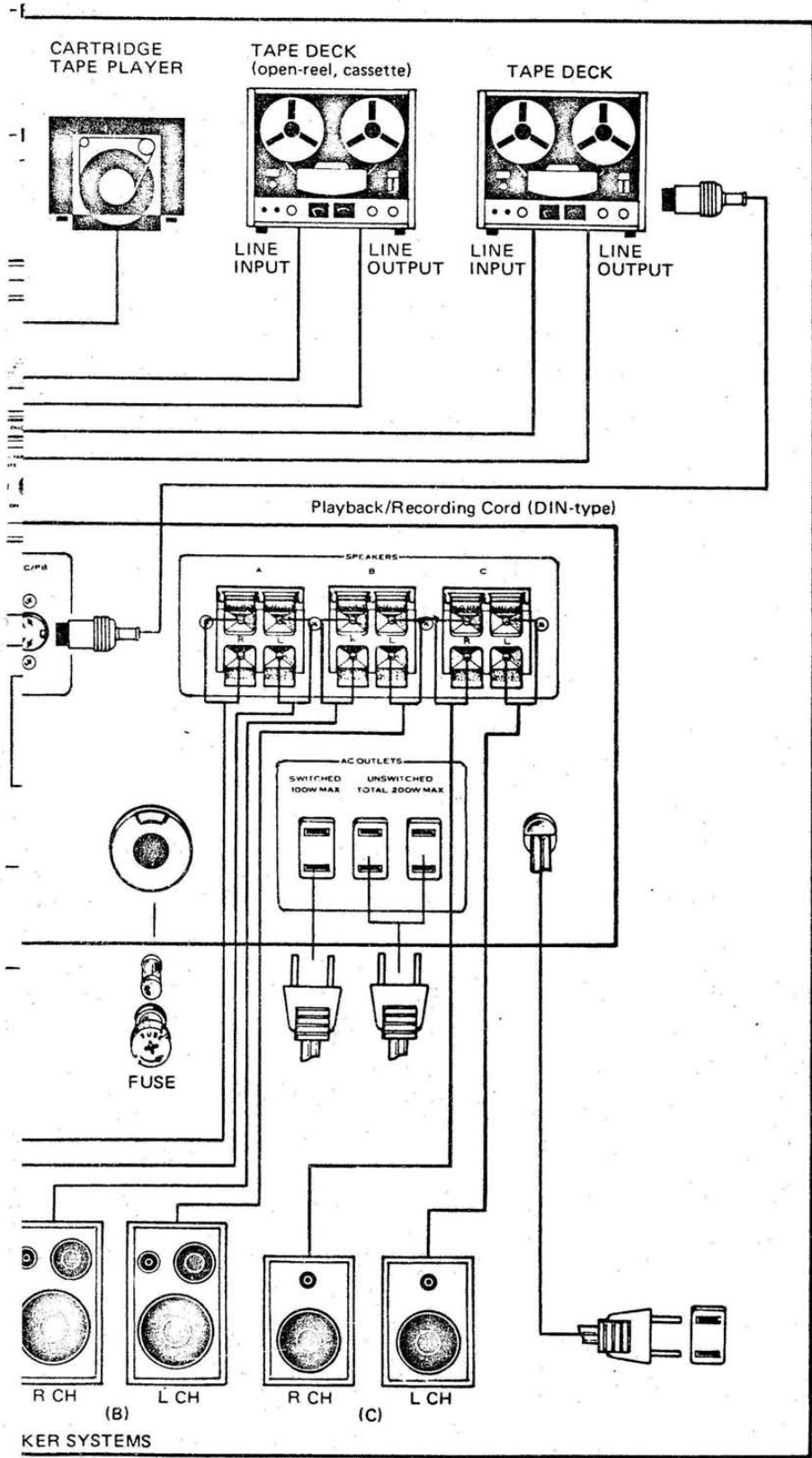

4. BLOCK DIAGRAM

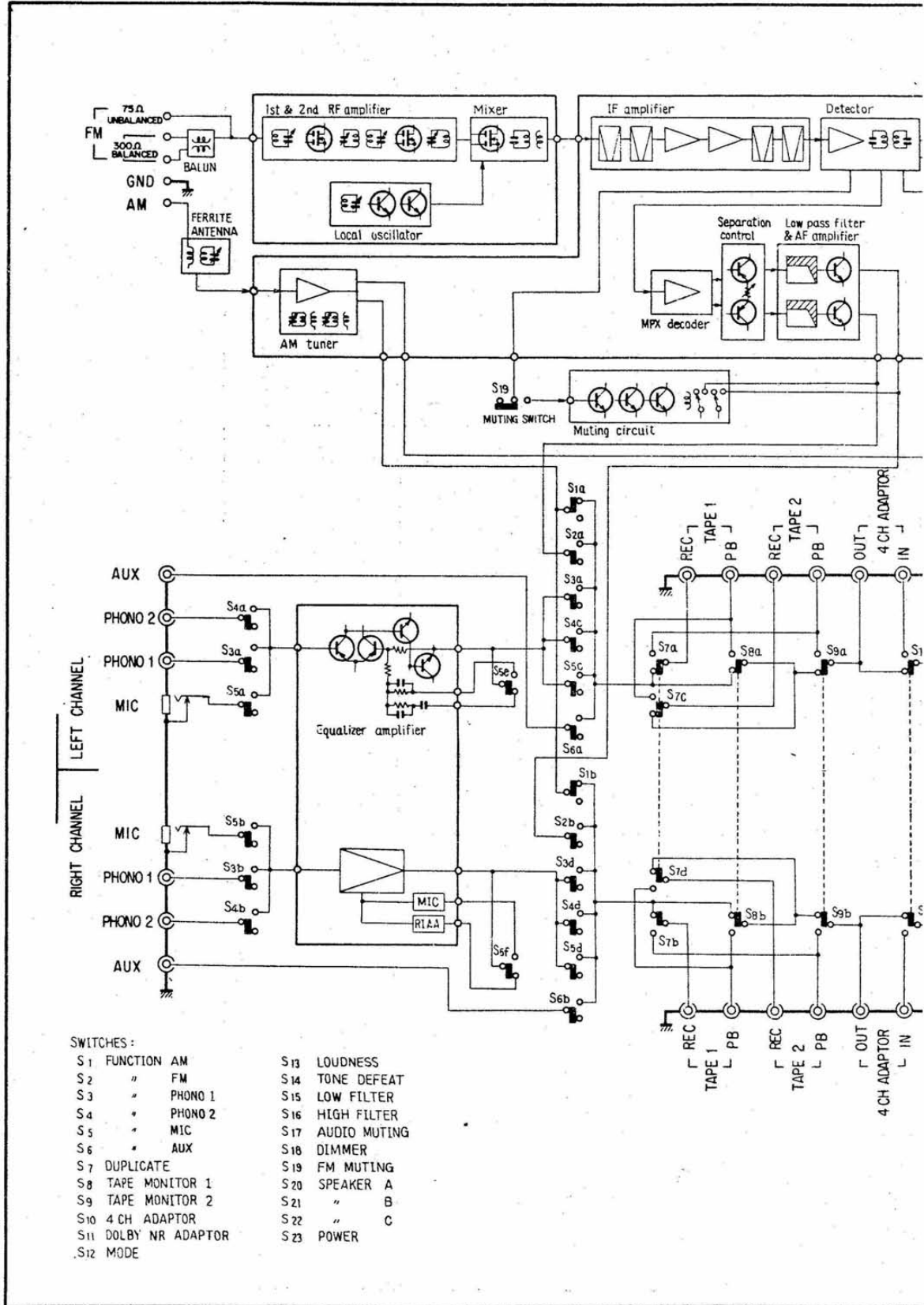

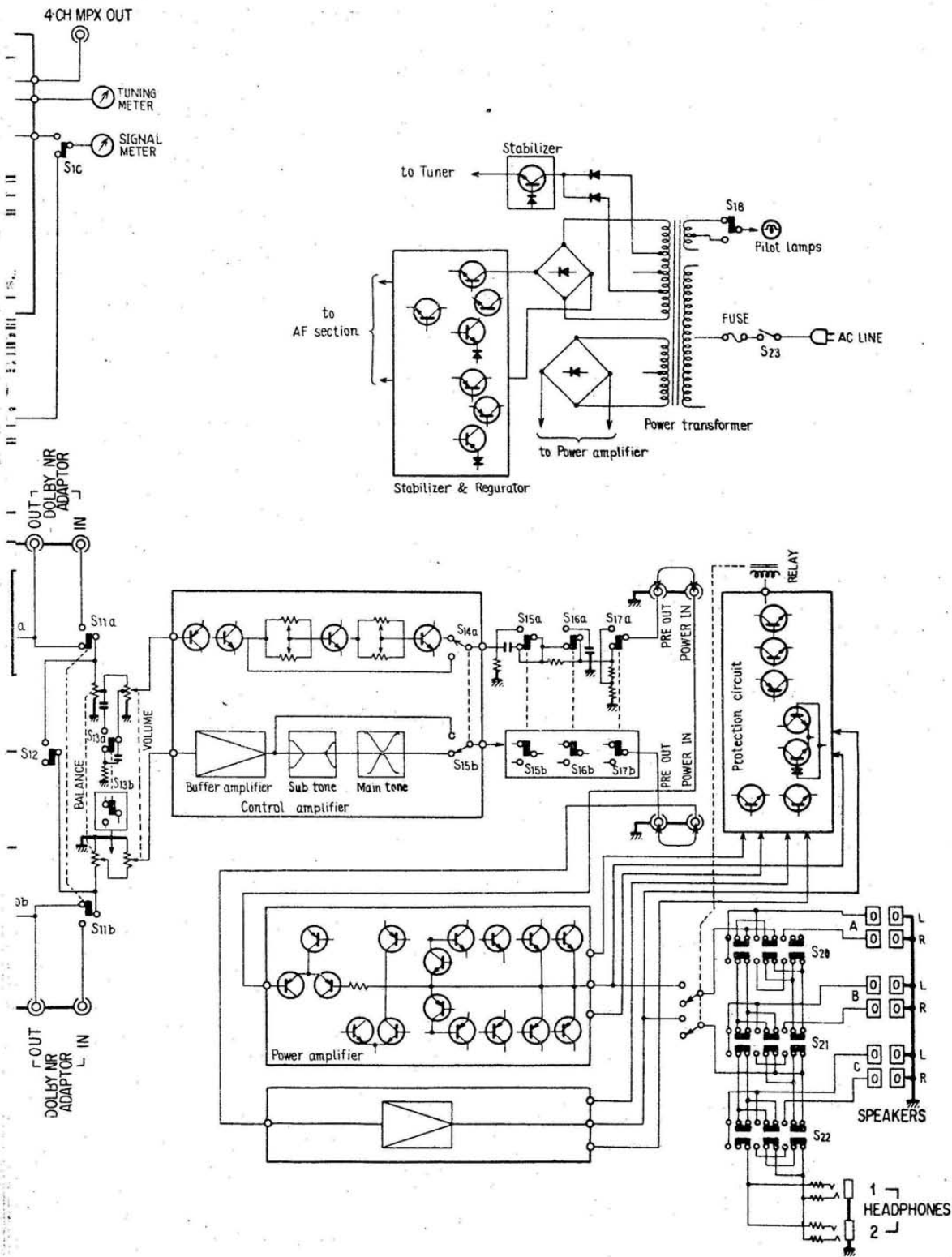

5. CIRCUIT DESCRIPTION

SIGNAL PATH

1. The FM broadcast signal waveform from the antenna is fed to the two dual-gate MOS field-effect transistors in the front end for radio frequency amplification. This signal is converted into an intermediate frequency by the dual-gate MOS FET mixer stage in combination with the signal from the local oscillator.
2. The intermediate frequency signal, converted within the front end, is fed to four ceramic filters and three ICs, where it is tuned, amplified, and detected, becoming a audio frequency (composite) signal. The composite signal following detection is fed to the 4 CH MPX terminal jack and the multiplex decoder stage.
3. The multiplex decoder stage uses one IC for three functions: to demodulate the composite signal into the left and right channel stereo signals, to operate the automatic mode switching between stereo/mono, and to switch the stereo indicator lamp appropriately. The decoding system uses a phase locked loop (PLL) circuit, which assures continuous stable operation and excellent stereo separation with low susceptibility to external noise (such as car ignition noise) and ambient temperature changes. After decoding, the signal is fed to four transistors and one LC filter, where the residual carrier component (38kHz, 19kHz, and SCA) is rejected, and then to the audio amplifier section.
4. The FM muting circuit consists effectively of two circuits, designed to reduce the pulse noise which can so easily arise when a muting circuit is operative. The one circuit is an electronic switch incorporated into the IC, so that the demodulated circuit is switched off and on in the IC, and the other short-circuits the audio signal by means of a reed relay.
5. The AM tuner section employs one monolithic IC which functions as radio frequency amplifier, frequency converter, local oscillator, intermediate frequency amplifier, and detector. The output is a pure audio signal.
6. The signals which are applied to the MIC and PHONO terminal jacks are selected by the FUNCTION switch before being fed to the first stage of the three-stage differential direct-coupled equalizer amplifier by which the signals are amplified. In order to reduce the switch noise, the circuit configuration employed enables the potential at the input and output terminals to be set at near zero volts.

It incorporates an independent differential circuit in the first stage of the equalizer amplifier whose DC supply uses twin plus and minus.

7. The output from the equalizer amplifier, together with that from the AUX terminal jacks, the audio signal from the AM tuner, and the audio signal from the FM tuner, are all selected by the FUNCTION switch, and pass through the switch circuits for TAPE DUPLICATE, TAPE MONITOR, 4 CH ADAPTOR, DOLBY NR ADAPTOR, and the circuits for BALANCE and VOLUME controls, before being fed to the control amplifier.
8. The control amplifier has an extremely high input impedance, using PNP and NPN transistors in a direct-coupled two-stage circuit. This greatly reduces the influence of the performance inherent in equipment connected externally. The output from this two-stage direct-coupled circuit is divided into two circuit systems. One goes to the TONE switch via the twin tone control circuit, and the other goes directly and unmodified in any way to the TONE switch. The TONE switch selects between them.
9. The amplifier section of the twin control has closed loop NFB amplifiers for both the main and sub circuits, each of which has its own transistor, eliminating mutual interference.
10. The control amplifier output is fed to the power amplifier after passing through the LOW FILTER, HIGH FILTER and AUDIO MUTING circuits. The first stage of the power amplifier is a differential amplifier element with constant current load, and the second stage, too, uses a differential amplifier element, so that DC potential drift is prevented. On the other hand, the final output stage uses two power transistors in parallel in both the upper and lower circuits, so that large collector dissipation is possible. Again, in order to reduce the distortion which occurs at low signal levels, the idle current has been set at a standard level of 100mA.
11. The power amplifier output is fed to the three push buttons which form the SPEAKER switch. This selects A, B, and C speaker system terminal connection. If all three speaker systems were to be connected simultaneously, the effective speaker impedance might be less than 4Ω. To guard against this possibility, when all three buttons are depressed together, all three systems are disconnected from the amplifier.
12. The power amplifier circuit board includes a

power limiter circuit which is independent of the signal circuit. If the power transistor current exceeds the maximum rated value, the power limiter circuit shorts the input signal to protect the power transistors.

The 'sensing' for this protective circuit is performed by detecting the voltage drop across the emitter resistors of the power transistors. There are also protective circuit which guard against DC potentials at the power amplifier output junctions, against

speaker complex load impedances less than 4Ω , and shorts across the speaker terminals. Their operation is such that, under the corresponding abnormal condition, a relay acts to separate the output junction and the output circuit. Further, these protective circuits also help to mute the unwanted signal which immediately follows switching the POWER switch ON, and to immediately disconnect the output after switched OFF.

7.

1. To
- the
- the
2. Pu
3. Re
- the
- wa
4. To
- the

6. DIAL CORD STRINGING

1. Turn the tuning capacitor so that its plates protrude as much as possible.
2. Tie one end of the string to the spring on the TUNING pulley (attached to the tuning capacitor).
3. Lead the string around pulley A, then wind it three turns around the TUNING shaft.
4. Lead the string around pulleys B, C and D, then wind it 1-1/2 turns around the TUNING pulley.
5. Now tie the other end of the string to the spring on the TUNING pulley. Turn the TUNING shaft and check for proper function. Then trim the ends of the string.
6. Turn the TUNING shaft until the plates of the variable are all the way in. Move the pointer to the left-end starting point on the dial and fasten it to the string in that position.

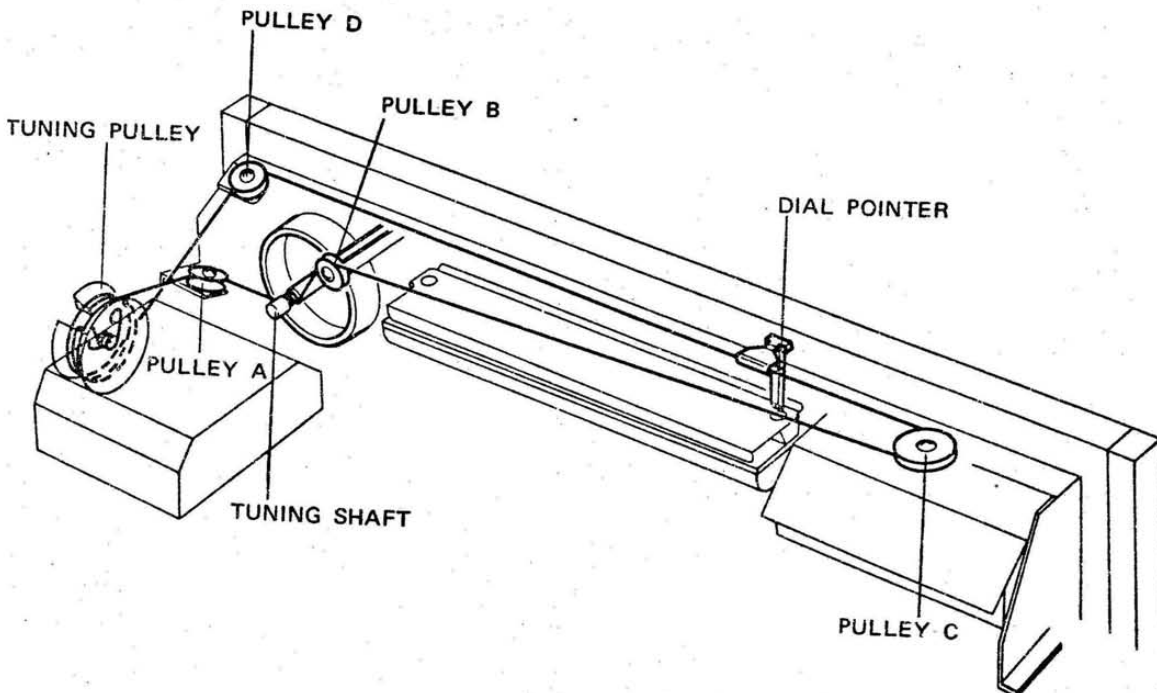

7. DISASSEMBLY

1. To remove the wooden cabinet, first remove the two screws holding each side, then lift the back of the wooden cabinet upward.
2. Pull off all knobs.
3. Remove the two screws in the upper edge of the front panel and remove two nuts and washers. Then pull the panel gently forward.
4. To remove the bottom plate, first remove the ten screws holding it in place.

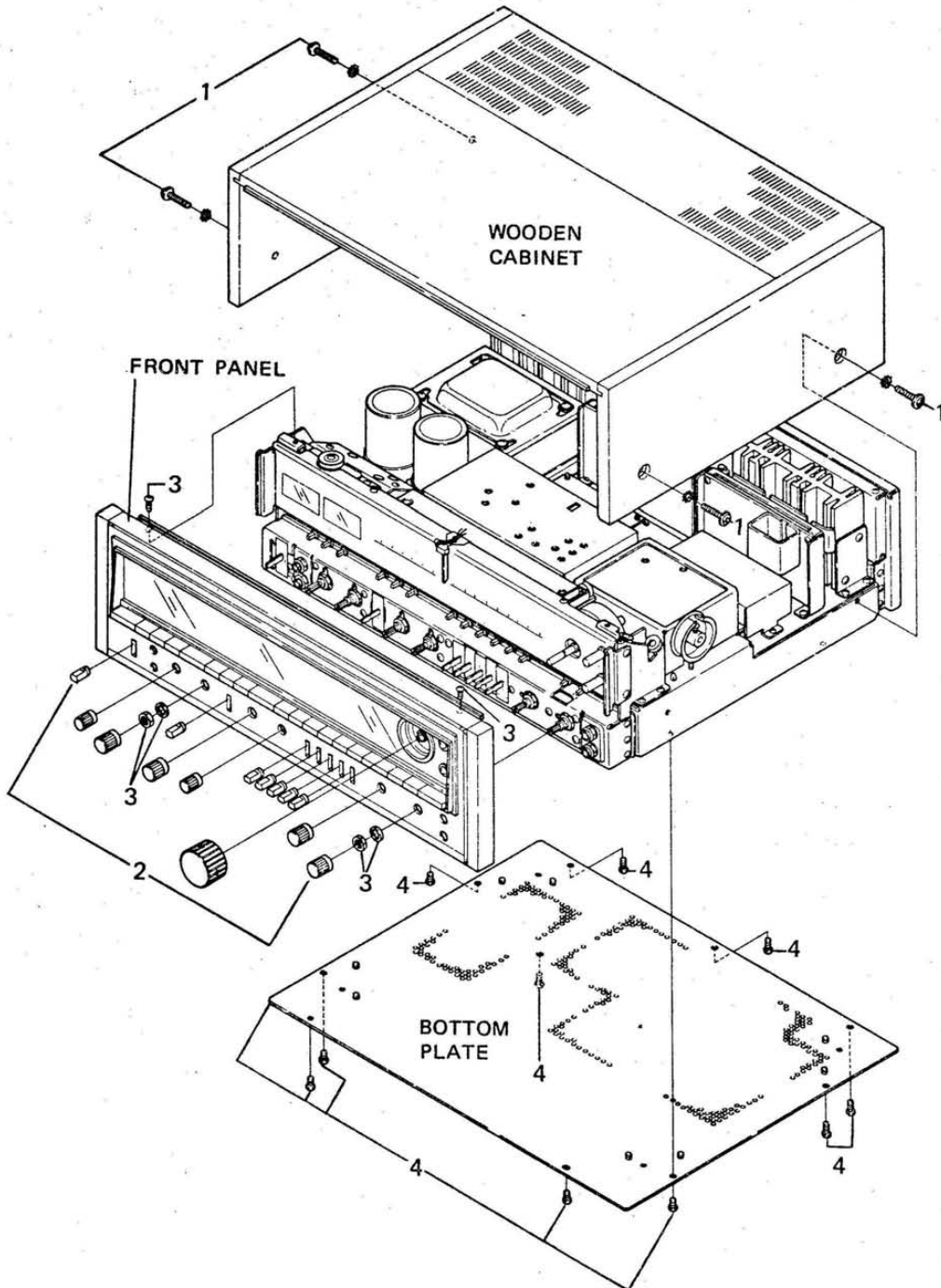

8. PARTS AND P.C. BOARD LOCATIONS

TOP VIEW

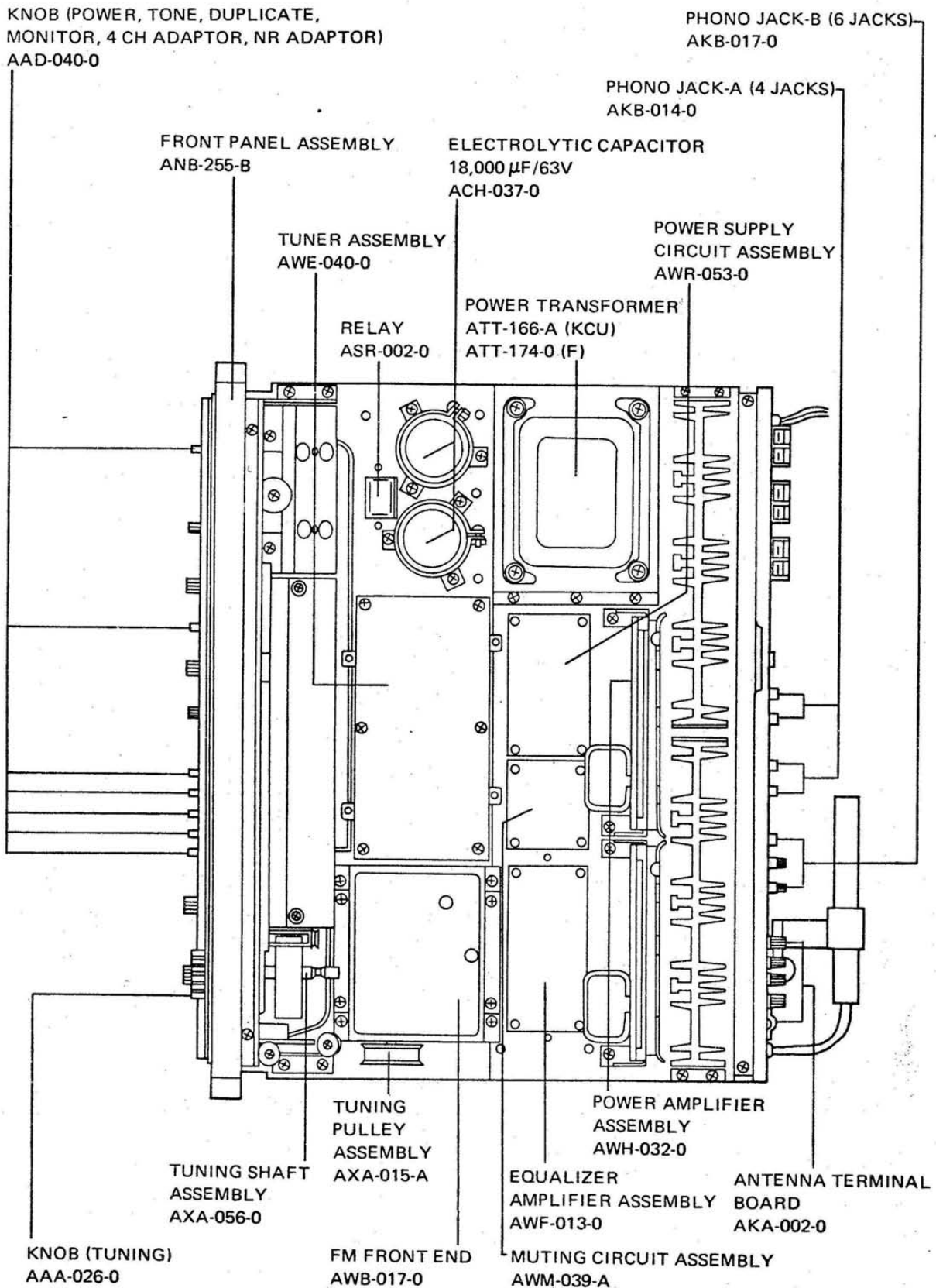

BOTTOM VIEW

KNOB (BASS-MAIN, TREBLE-MAIN,
VOLUME, BALANCE)
AAB-068-A

FERRITE LOOPSTICK ANTENNA
ATB-027-0

SWITCH CIRCUIT ASSEMBLY
AWS-072-0

FERRITE ANTENNA
HOLDER ASSEMBLY
W72-092-D

SWITCH CIRCUIT ASSEMBLY
AWS-069-A

PROTECTION CIRCUIT ASSEMBLY
AWM-062-0

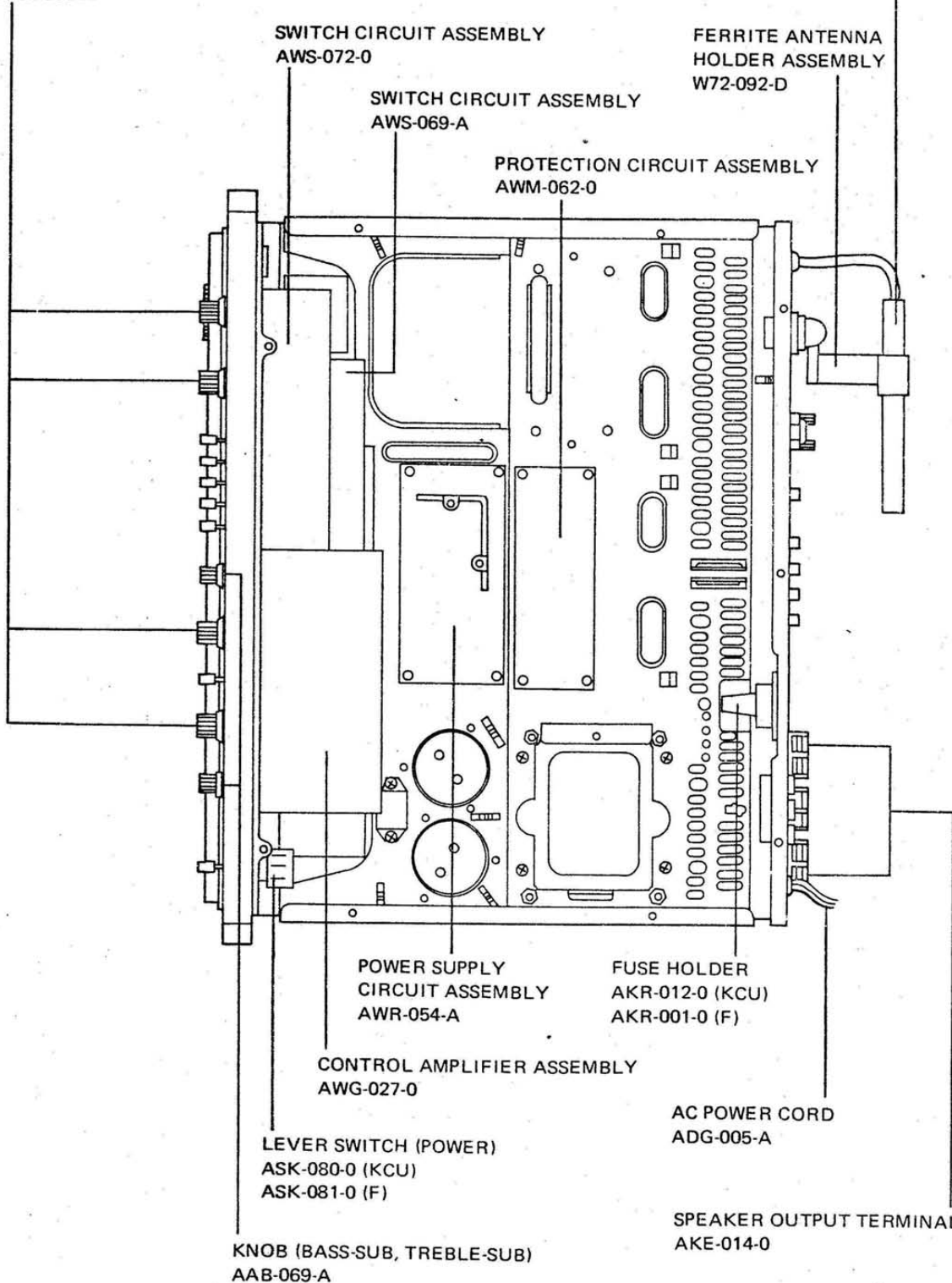

POWER SUPPLY
CIRCUIT ASSEMBLY
AWR-054-A

FUSE HOLDER
AKR-012-0 (KCU)
AKR-001-0 (F)

CONTROL AMPLIFIER ASSEMBLY
AWG-027-0

AC POWER CORD
ADG-005-A

LEVER SWITCH (POWER)
ASK-080-0 (KCU)
ASK-081-0 (F)

SPEAKER OUTPUT TERMINAL
AKE-014-0

KNOB (BASS-SUB, TREBLE-SUB)
AAB-069-A

9. LEVEL DIAGRAM

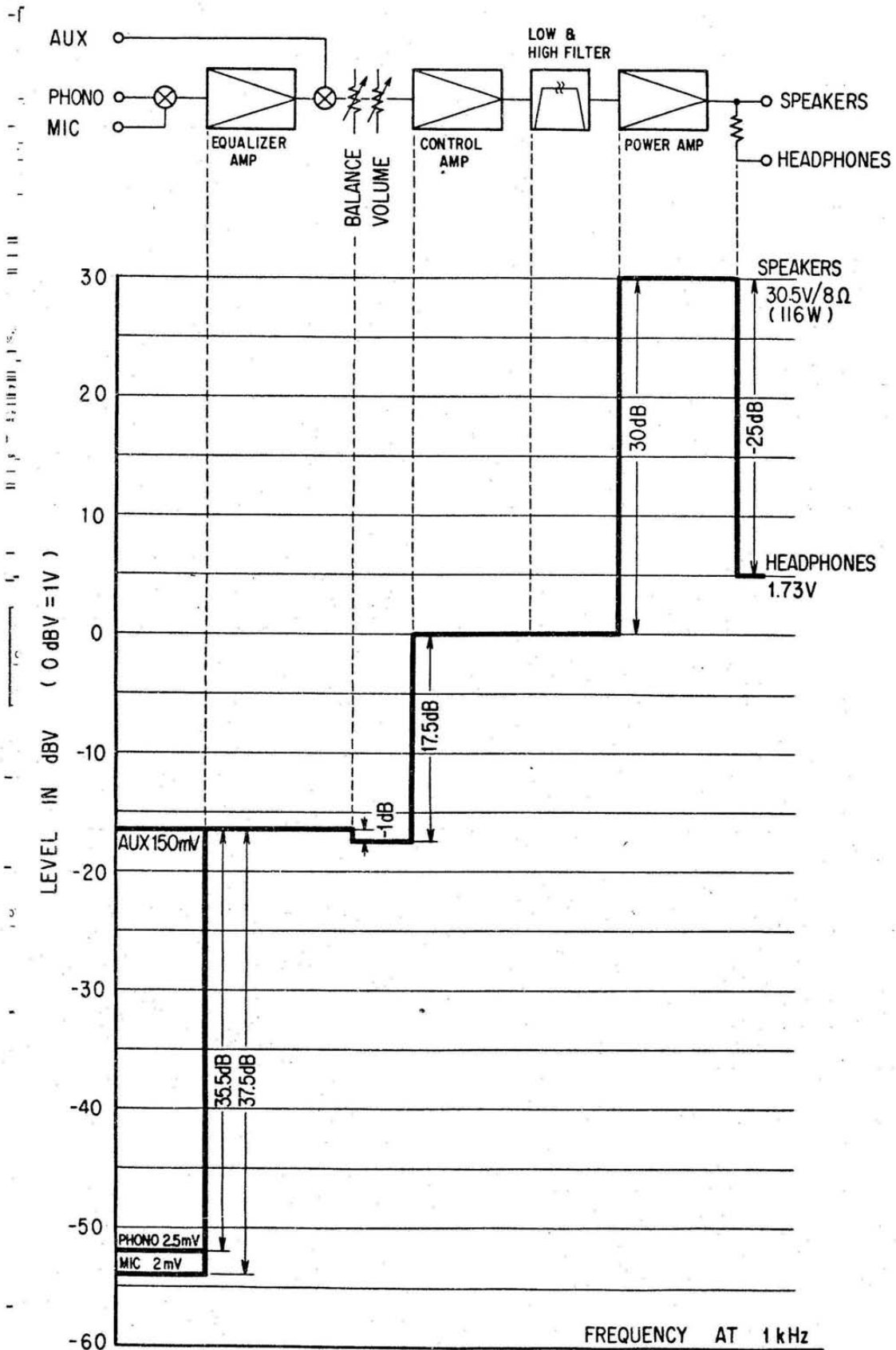

10. ALIGNMENT PROCEDURE

10.1 ENGLISH

ALIGNING THE FM SECTION

1. SX-1010 Control Settings

Set the controls (knob and switches) of the SX-1010 as follows:

POWER: ON
FUNCTION: FM
FM MUTING: OFF

2. Connections between Test Equipment and the SX-1010

- The output from an FM signal generator should be connected to the 300Ω antenna terminals of the SX-1010.
- A distortion meter should be connected to the TAPE REC terminal jacks on the SX-1010.
- An AC millivolt meter should be connected to the TAPE REC terminal jacks on the SX-1010 in parallel with the distortion meter.

3. Set both the FM signal generator and the SX-1010 to indicate 98MHz.

4. Turn the FM signal generator output level down to minimum.

5. Turn the lower core and adjust so that the TUNING meter needle is centered.

6. Increase the FM signal generator output to 60dB, modulated at 400Hz, with a deviation of ±75 kHz.

7. Turn the upper core and adjust so that the distortion is at a minimum.

Steps 4 ~ 7 above should be repeated several times in succession, until no significant improvement is obtained.

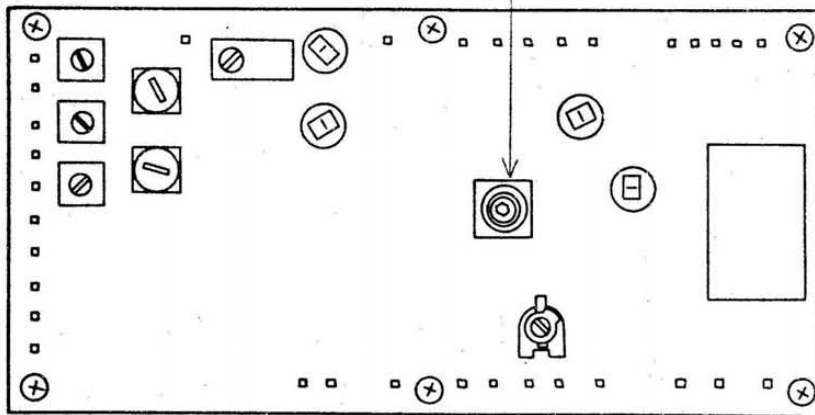

8. Set the FM signal generator output level to 10dB, modulated at 400Hz, with a frequency deviation of ±75 kHz.

9. Adjust for maximum output at 90MHz.

10. Adjust for maximum output at 106MHz.

11. Adjust for maximum output at 90MHz.

12. Adjust for maximum output at 106MHz.

Steps 11 ~ 12 above should be repeated several times in succession, until no further significant improvement is obtained.

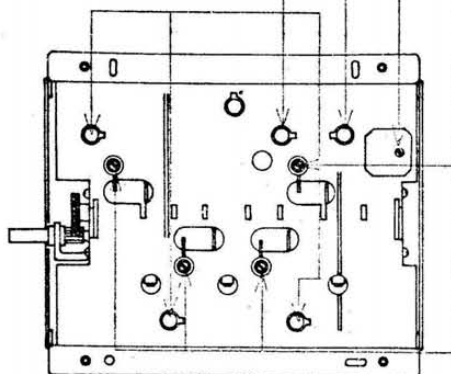

ALIGNING THE FM MPX SECTION

Note: This set of adjustments should not be carried out until the alignment of the FM section (1 ~ 12 above) has been completed.

The multiplex signal generator should be connected to the external modulator terminals of the FM signal generator.

1. SX-1010 Control Settings

Set the controls (knob and switches) of the SX-1010 as follows:

POWER: ON
FUNCTION: FM
FM MUTING: OFF

2. Connections between the Test Equipment and the SX-1010

- The output from the FM signal generator should be connected to the 300Ω antenna terminals of the SX-1010.
- The oscilloscope X plates (horizontal inputs) should be connected to the PILOT OUT terminals on the MPX signal generator, and the Y plates (vertical inputs) to terminal number 24.
- The AC millivolt meter should be connected to the TAPE REC terminals (with changeover possible from L to R channels).

3. Multiplex Signal Generator Modulation

L + R (1kHz): 67.5kHz deviation

PILOT (19kHz): 7.5kHz deviation

4. Set the FM signal generator output to minimum.

5. Adjust for a stationary Lissajous waveform on the oscilloscope.

6. Reset the FM signal generator to 60dB level output, and modulate either the L or R channel.

7. Adjust for the maximum separation.

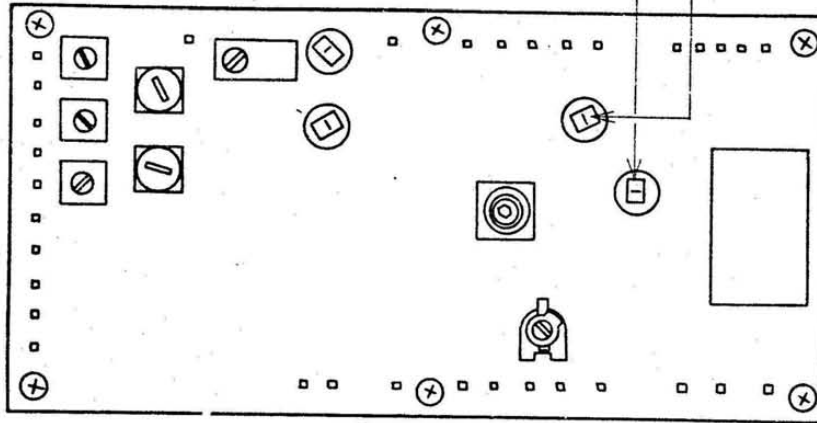

ALIGNING THE AM SECTION

1. SX-1010 Control Settings

Set the controls (knob and switch) of the SX-1010 as follows:

POWER: ON

FUNCTION: AM

2. Connections between Test Equipment and the SX-1010

- Connect the AM signal generator to the AM antenna terminals (in series with a 1k Ω dummy resistor).
- Connect the AC millivolt meter to the TAPE REC terminal jacks.

3. Set the AM signal generator to 30% modulation at 400Hz.

4. Set the AM signal generator output to 30dB at 600kHz.

Adjust for maximum output (Carry out the ferrite loopstick antenna core adjustment at the same time).

5. Adjust for maximum output with the frequency set at 1,400kHz.

Adjustments 4 ~ 5 above should be repeated several times until no further significant improvement is obtained.

6. Connect the AM signal generator directly to the AM ANT (antenna) terminals.

7. With a frequency of 1,400kHz and an AM signal generator output of 36dB, adjust for a low frequency output of 70mV.

8. With an AM signal generator output of 80dB, adjust for a low frequency output of 310mV.

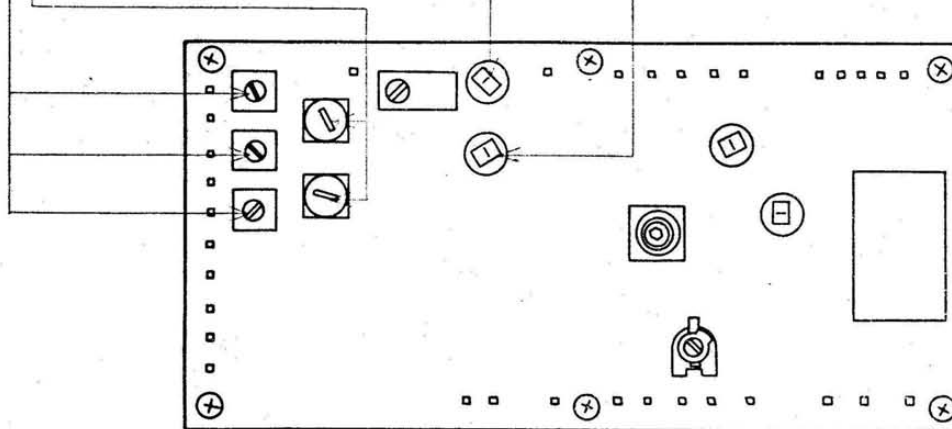

ALIGNING THE POWER AMPLIFIER SECTION

Note: There are individual circuit boards for the R and L channels. The following instructions apply to both channels (boards) and should be carried out for each in turn.

1. Nothing should be connected to the input jacks of the SX-1010, and an 8 Ω dummy resistor should be connected across the speaker terminals.
2. A DC millivolt meter should be connected across between terminal number 19 and earth.
3. Adjustment should be made to bring the voltage to zero.
4. The DC voltmeter should be connected between terminals number 14 and 16.
5. Adjustment should be made to bring the voltage to 50mV.

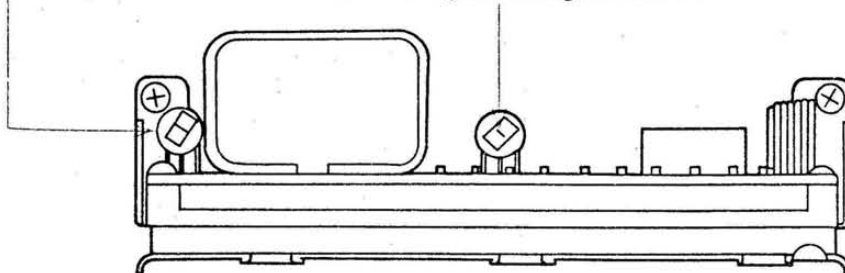

11. EXPLODED VIEW AND PARTS LIST

NOTE:

Parts number is subject to change for the purpose of improvement with notice of a service bulletin.

Service bulletin will be furnished whenever necessary and you are requested to amend parts number in this manual according to the instructions.

Parts List of Exploded View-1

NOTICE: Any parts asterisked(*) are subject to being not supplied.

Key No.	Description	Part No.	
1	Power transformer	ATT-166-A	KCU
	Power transformer	ATT-174-0	F
	Power transformer	ATT-179-0	GN
2*	Sub-chassis	ANF-242-A	
3*	Shield cover	ANH-213-A	
4	Tuner assembly	AWE-040-0	
5*	Tuner assembly-held metal	ANF-244-A	
6*	Tuner assembly-held metal	ANF-244-A	
7	Electrolytic capacitor 18,000 μ F 63V	ACH-037-0	
8	Power amplifier assembly	AWH-032-0	
9	Power supply circuit assembly	AWR-053-0	KCU, F
	Power supply circuit assembly	AWR-063-0	GN
10	Muting circuit assembly	AWM-039-A	
11	Screw M4X15	ABA-010-A	
12	Washer	B21-011-0	
13	Wooden cabinet assembly	AMM-034-A	
14*	Heat sink	ANH-205-0	
15*	Heat sink-held metal	ANF-231-0	
16*	Heat sink-held metal	ANF-232-0	
17*	Shield cover	ANH-212-0	
18	Equalizer amplifier assembly	AWF-013-0	
19*	P.C. board holder	AEB-019-0	
20	FM front end	AWB-017-0	
21	Tuning pulley assembly	AXA-015-A	
22	Ground terminal strip (2P)	K13-048-0	
23*	Wire clip	AEC-064-0	
24	Ground terminal strip (4P)	K13-047-0	
25*	Wire supporter	AEC-151-0	
26	Protection circuit assembly	AWM-062-0	
27	Power supply circuit assembly	AWR-054-A	
28	Ground terminal strip (4P)	K13-047-0	
29*	Wire clip	AEC-004-0	
30*	Chassis	ANA-067-C	
31	Relay	ASR-002-0	
32*	Bottom plate	ANE-056-0	
33	Foot	AEC-027-B	

Exploded View-1

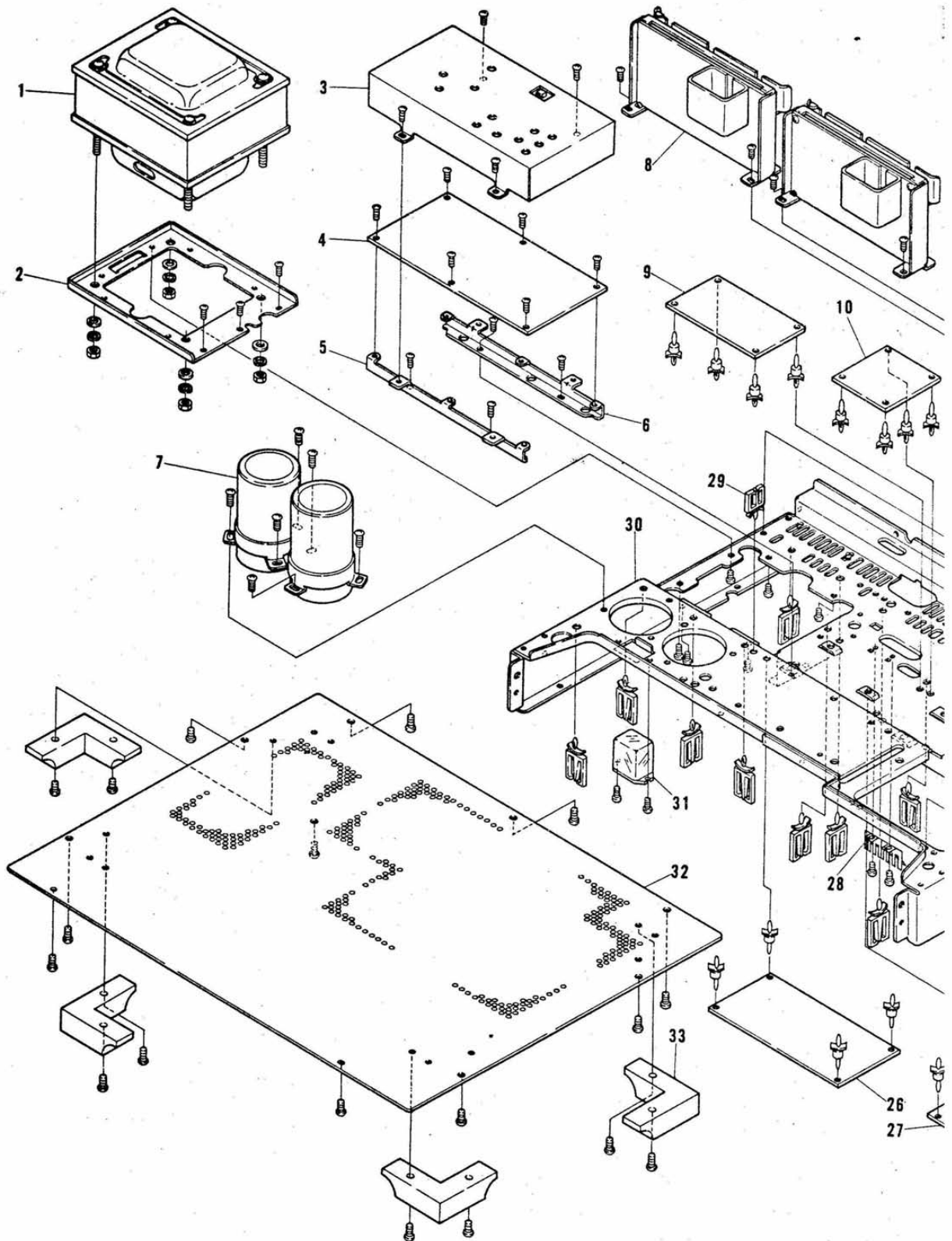

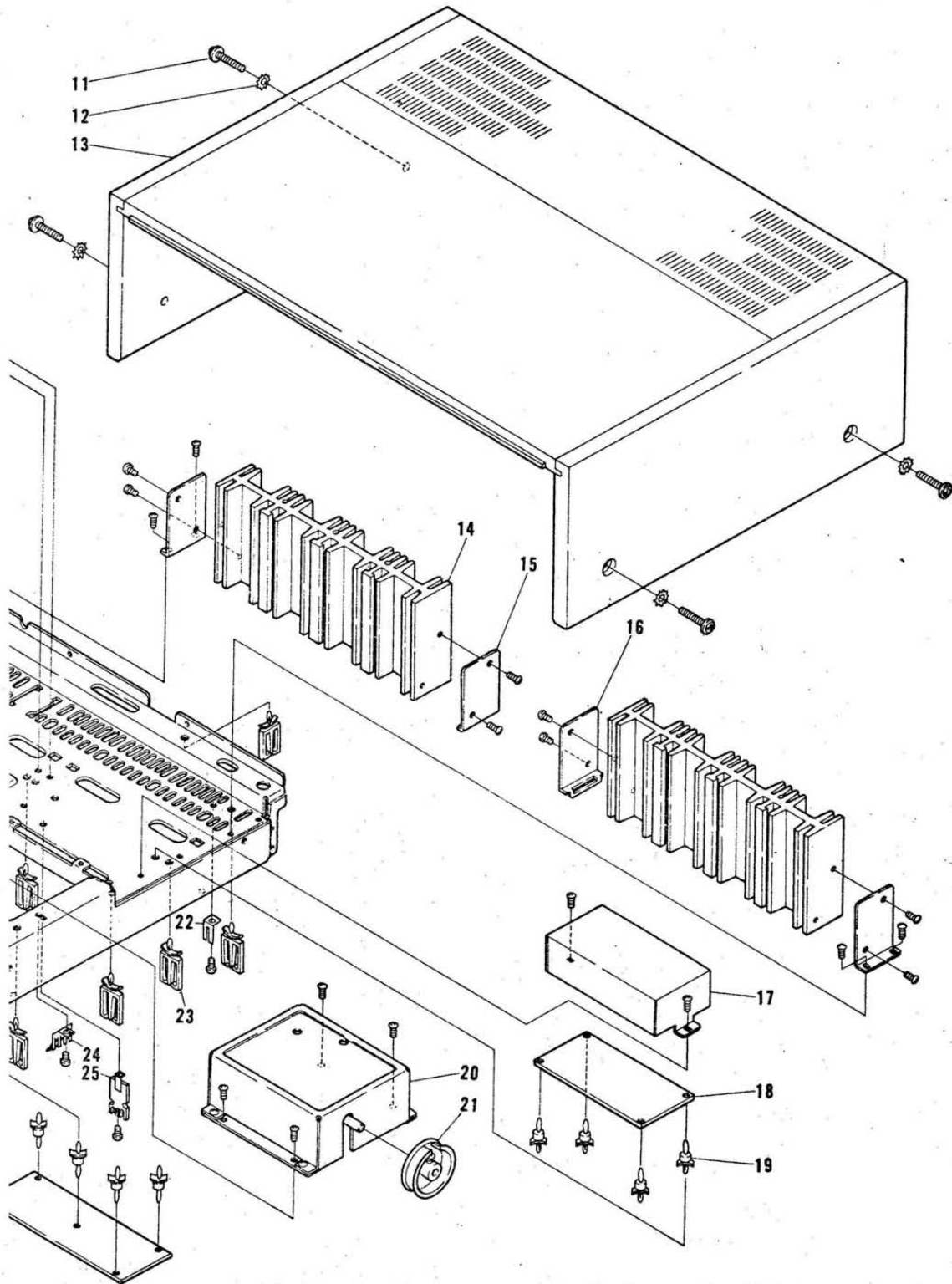

Parts List of Exploded View-2

NOTE:

Parts number is subject to change for the purpose of improvement with notice of a service bulletin.

Service bulletin will be furnished whenever necessary and you are requested to amend parts number in this manual according to the instructions.

NOTICE: Any parts asterisked(*) are subject to being not supplied.

Key No.	Description	Part No.	
1	Dial scale	AAG-072-A	
2*	Dial scale-held metal	ANF-243-A	
3	Dial pointer	AAF-031-A	
4	Meter (Signal & tuning)	AAW-029-0	
5*	Lamp Box	ANH-211-B	
6*	Lamp holder	ANG-097-0	
7	Pilot lamp socket	AKK-002-0	
8	Pilot lamp 8V, 0.3A (meter)	AEL-015-0	
9*	P.C. board cover	ANG-100-0	
10	Lamp board assembly	AWX-069-0	
11	Pilot lamp 8V, 0.3A (dial scale)	E22-032-0	
12*	Lamp box	ANH-210-A	
13	Pilot lamp 6V, 30mA (stereo indicator)	AEL-014-0	
14	Rubber bracket	AEB-031-0	
15	Front panel assembly	ANB-255-B	
16	Knob (Power, Tone, Duplicate, Monitor, 4 CH adaptor, NR adaptor)	AAD-040-0	
17	Knob (Bass-sub)	AAB-069-A	
18	Knob (Bass-main)	AAB-068-A	
19	Knob (Treble-main, Volume, Balance)	AAB-068-A	
20	Ornamental ring	AAC-034-A	
21	Knob (Tuning)	AAA-026-0	
22	Knob (Treble-sub)	AAB-069-A	
23	Knob (Dimmer, FM muting)	AAD-082-A	
24	Coupler (knob-to-switch)	AAE-007-0	
25	Spacer	AEC-152-A	
26	Bush	AEC-160-0	
27	Knob (SPKR A,B,C)	AAD-064-A	
28	Knob (Low cut, High cut, -20dB)	AAD-065-A	
29	Knob (Function)	AAD-066-A	
30	Knob (Mode, Loudness)	AAD-067-A	
31	Lever switch (Power)	ASK-080-0	KCU F, GN
	Lever switch (Power)	ASK-081-0	
32	Phone jack (Headphone)	K72-026-0	
33	Shading plate	AED-018-0	
34	Nut (insulator)	AEC-085-0	
35*	Sub-chassis	AND-072-A	
36	Phone jack (Microphone)	K72-024-0	
37	Switch circuit assembly	AWS-072-0	
38*	Shield cover	ANH-206-0	
39	Control amplifier assembly	AWG-027-0	
40*	Pulley shaft	M49-025-E	

Key No.	Description	Part No.	
41*	Pulley	AEC-153-0	
42	Rubber bracket	AEB-057-A	
43	Pilot lamp 8V, 50 mA (position)	AEL-023-0	
44*	Lamp holder	ANG-099-0	
45*	Pulley-held metal	ANG-102-A	
46*	Pulley	AEC-101-0	
47	Rubber bracket	AEB-057-A	
48	Rubber bracket	AEB-058-A	
49*	Sub-panel	AND-073-B	
50*	Shading metal	ANF-249-0	
51	Switch circuit assembly (dimmer)	AWS-068-0	
52	Tuning shaft assembly	AXA-056-0	
53	Switch circuit assembly (speaker)	AWS-064-0	
54	Switch circuit assembly (filter, -20dB)	AWS-071-0	
55	Switch circuit assembly (function)	AWS-069-A	
56	Switch circuit assembly (mode, loudness)	AWS-070-A	
57*	Shield cover	ANH-208-A	
58	Speaker output terminal	AKE-014-0	
59	AC socket	AKP-005-0	KCU, F
60	5P connector assembly	AWX-062-0	
61	Fuse holder (AC power)	AKR-012-0	KCU
	Fuse holder (AC power)	AKR-001-0	F
62	Phono jack-A (4 jacks)	AKB-014-0	
63	Phono jack (1 jack)	AKB-019-0	
64	Phono jack-B (6 jacks)	AKB-017-0	
65	Antenna terminal board	AKA-002-0	
66*	Rear panel	ANC-105-B	KCU
	Rear panel	ANC-111-0	F
	Rear panel	ANC-113-0	GN
67	AC cord grommet	AEC-079-0	
68	AC power cord	ADG-005-A	KCU, F
69	AC cord grommet	AEC-079-0	KCU, F
	Connector (AC power)	AKP-008-0	GN
70*	Model name plate	AAL-200-A	KCU
	Model name plate	AAL-204-0	F
	Model name plate	AAL-205-0	GN
71	Binding post for ground	AKE-012-A	
72	Ferrite loopstick antenna	ATB-027-0	
73	Ferrite antenna holder assembly	W72-092-D	

Exploded View-2

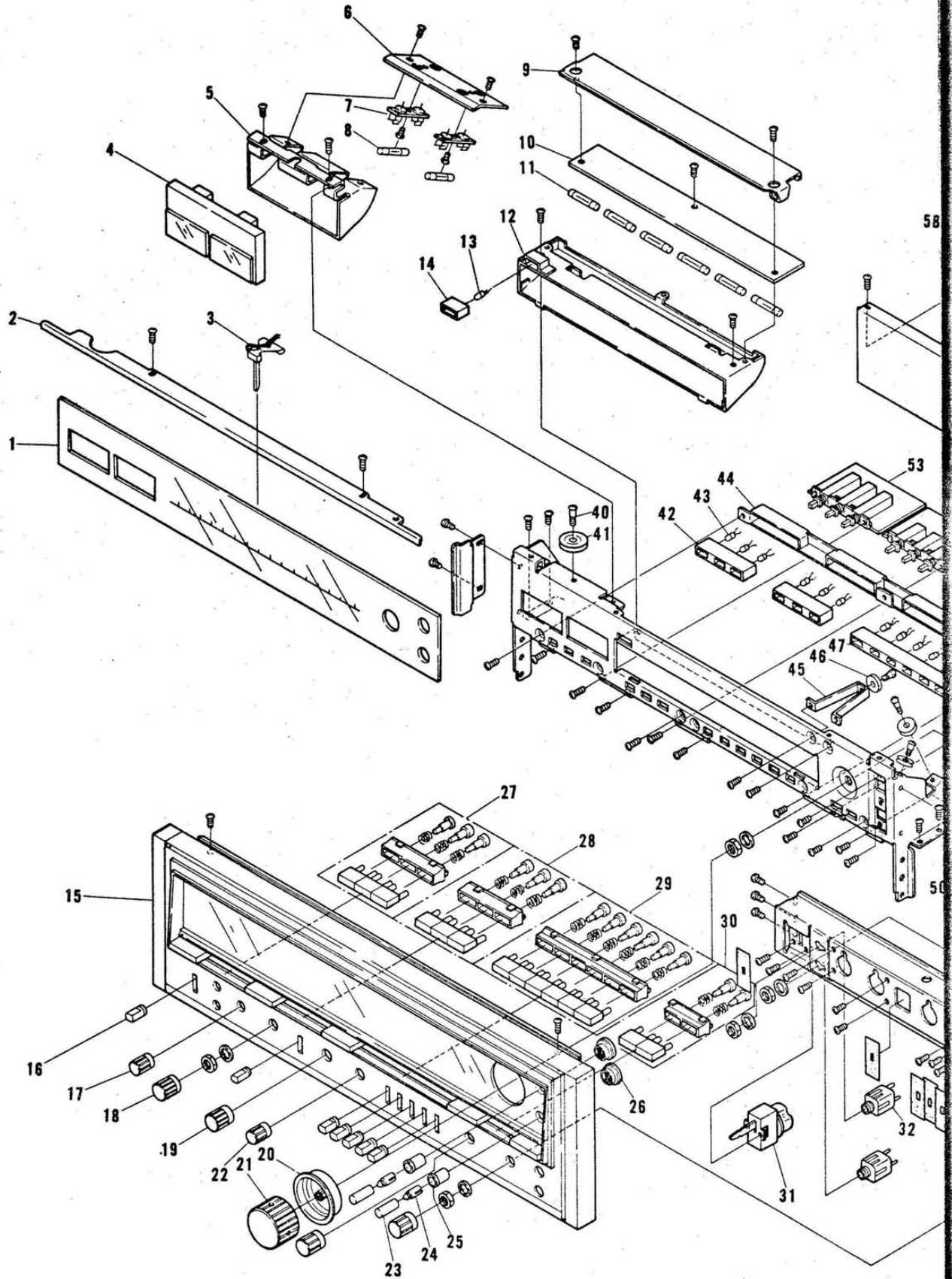

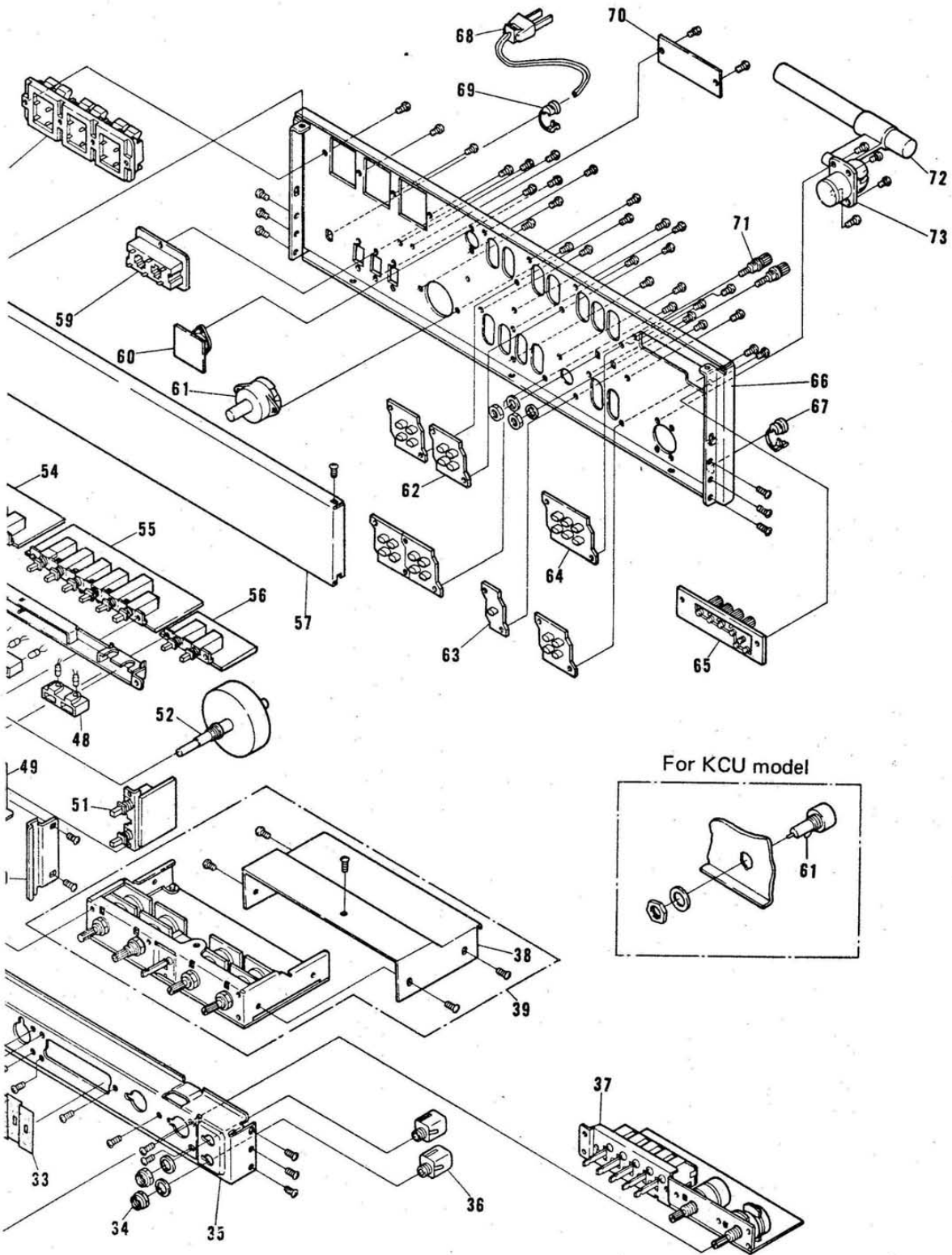

12. SCHEMATIC DIAGRAMS P.C. BOARD PATTERNS

12.1 CIRCUIT CONNECTION DIAGRAM AND MISCELLANEOUS PARTS

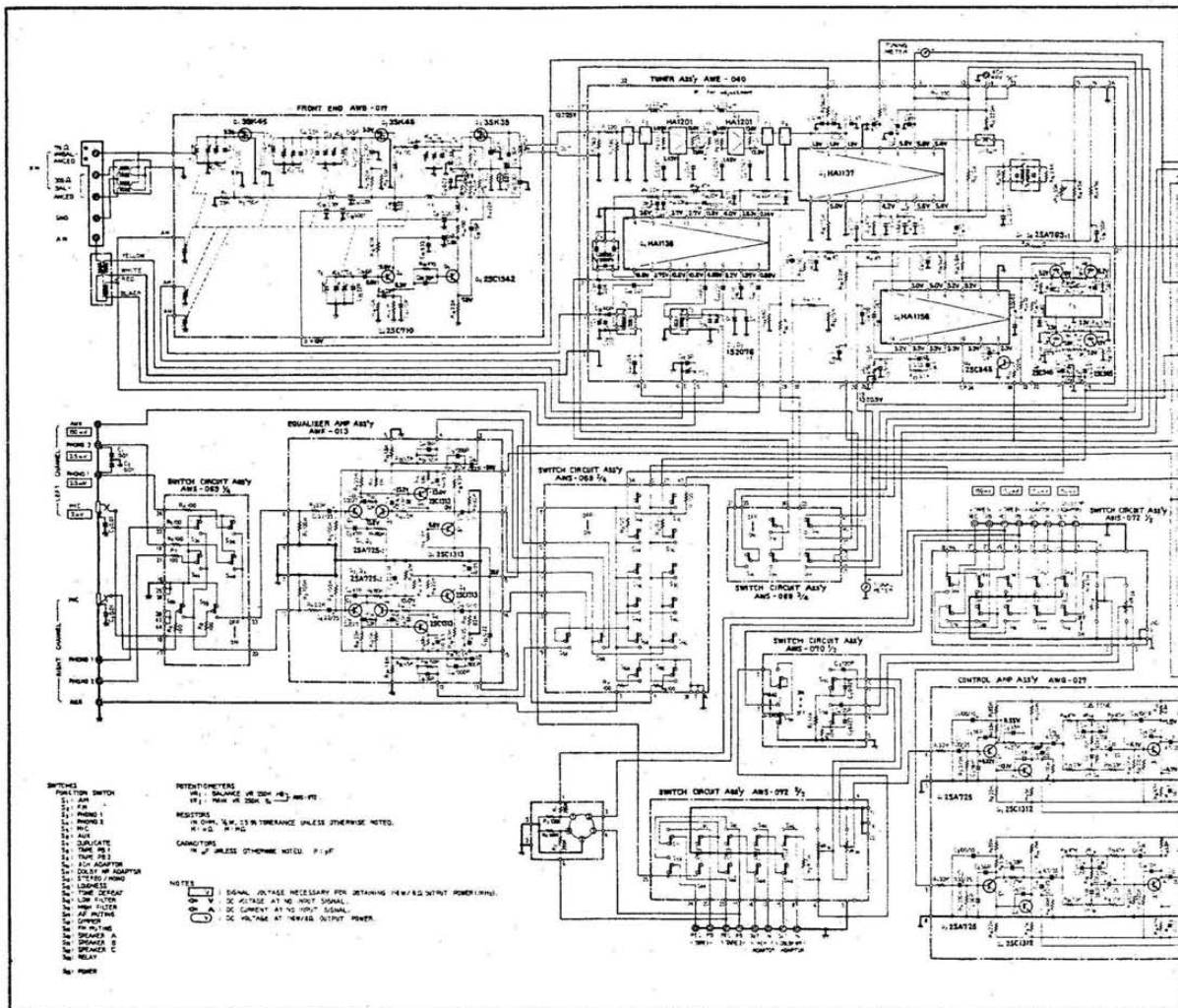

2SC11
2SA74

AND PARTS LIST

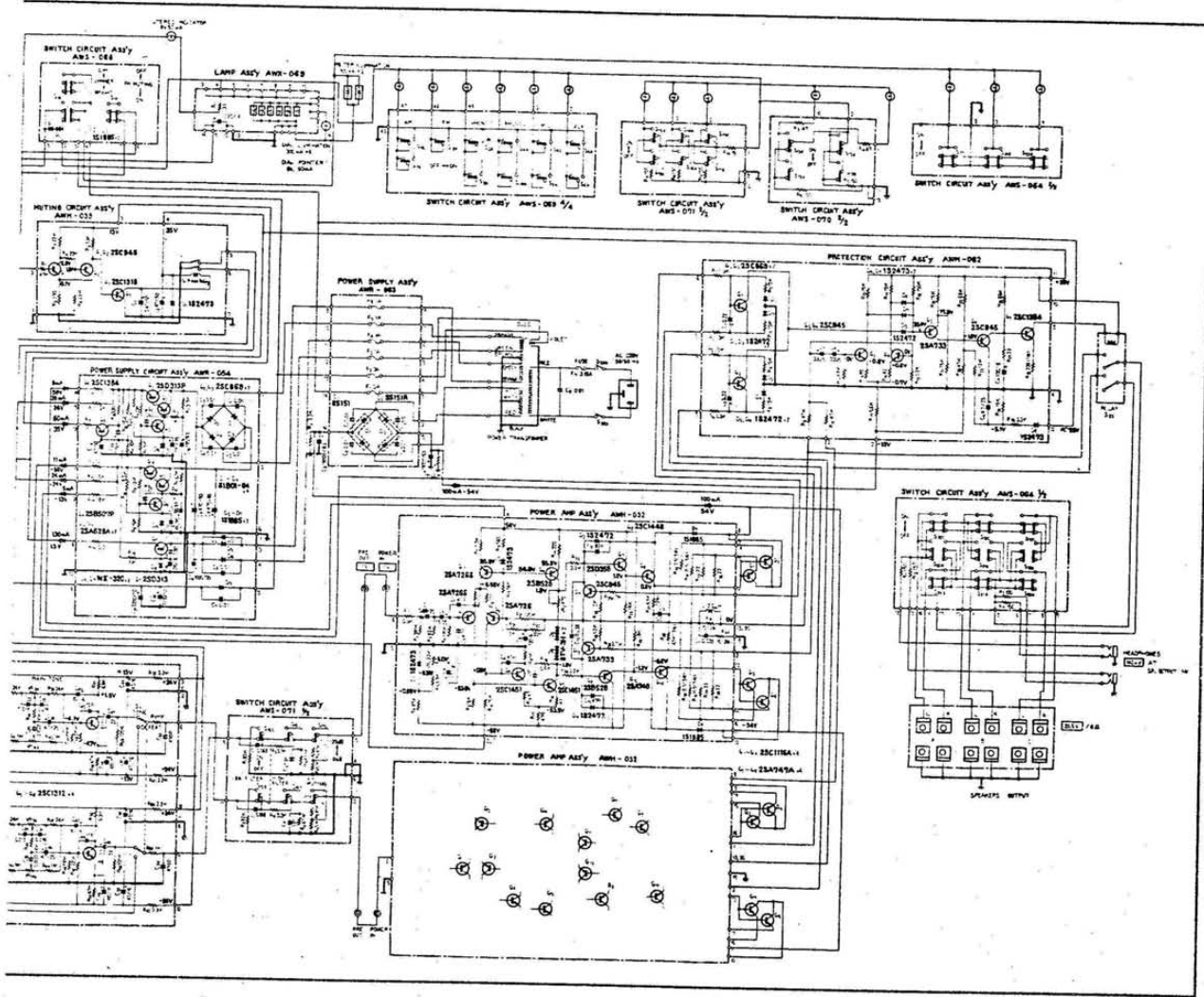

16A
7A

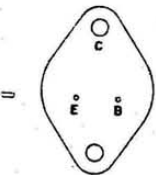

- CAPACITORS: IN μ F UNLESS OTHERWISE NOTED p:pF
- RESISTORS: IN Ω , $\frac{1}{2}$ W UNLESS OTHERWISE NOTED k:k Ω , M:M Ω .

Miscellaneous Parts

CAPACITORS

Symbol	Description			Part No.	
C1	Ceramic	0.01	50V	CKDYF 103Z 50	
C2	Ceramic	0.01	50V	CKDYF 103Z 50	
C3	Ceramic	0.01	50V	CKDYF 103Z 50	
C4	Ceramic	0.01	50V	CKDYF 103Z 50	
C5	Mylar	0.0047	50V	CQMA 472J 50	
C6	Mylar	0.0047	50V	CQMA 472J 50	
C7	Ceramic	0.01	250V	ACG-001-0	
C8	Ceramic	0.01	250V	ACG-003-0	KCU
	Ceramic	0.01	250V	ACG-001-0	F
C9	Electrolytic	18,000	63V	ACH-037-0	
C10	Electrolytic	18,000	63V	ACH-037-0	
C11	Ceramic	0.01	250V	ACH-001-0	F

RESISTORS

Symbol	Description			Part No.	
R1	Carbon film	2.2M	$\frac{1}{2}$ W	RD $\frac{1}{2}$ PS 225J	KCU
R2	Metal oxide	3.3k	2W	PS2P 332J	
R3	Metal oxide	3.3k	2W	RS2P 332J	

SEMICONDUCTORS

Symbol	Description			Part No.	
Q1	Transistor	2SC1116A-R, O or Y 2SC1079S-R or Y 2SD287P-K, L or M			
Q2	Transistor	2SC1116A-R, O or Y 2SC1079S-R or Y 2SD287P-K, L or M			
Q3	Transistor	2SC1116A-R, O or Y 2SC1079S-R or Y 2SD287P-K, L or M			
Q4	Transistor	2SC1116A-R, O or Y 2SC1079S-R or Y 2SD287P-K, L or M			
Q5	Transistor	2SA747A-R, O or Y 2SA679S-R or Y 2SB539P-K, L or M			
Q6	Transistor	2SA747A-R, O or Y 2SA679S-R or Y 2SB539P-K, L or M			
Q7	Transistor	2SA747A-R, O or Y 2SA679S-R or Y 2SB539P-K, L or M			
Q8	Transistor	2SA747A-R, O or Y 2SA679S-R or Y 2SB539P-K, L or M			

SWITCHES

Symbol	Description	Part No.	
S23	Relay	ASR-002-0	
S24	Fuse holder (AC power)	AKR-012-0	KCU
	Fuse holder (AC power)	AKR-001-0	F
S25	Lever switch (Power)	ASK-080-0	KCU
	Lever switch (Power)	ASK-081-0	F
S26	Slide switch (de-emphasis)	ASH-008-0	F

OTHERS

Symbol	Description	Part No.	
	FM front end	AWB-017-0	
	Tuner assembly	AWE-040-0	
	Equalizer amplifier assembly	AWF-013-0	
	Control amplifier assembly	AWG-027-0	
	Power amplifier assembly	AWH-032-0	
	Protection circuit assembly	AWM-062-0	
	Power supply circuit assembly	AWR-053-0	
	Power supply circuit assembly	AWR-054-A	
	Switch circuit assembly (function)	AWS-069-0	
	Switch circuit assembly (mode, loudness)	AWS-070-A	
	Switch circuit assembly (filter, -20dB)	AWS-071-0	
	Switch circuit assembly (speaker)	AWS-064-0	
	Switch circuit assembly (tape monitor)	AWS-072-0	
	Switch circuit assembly (dimmer)	AWS-068-0	
	Lamp board assembly	AWX-069-0	
	5P connector assembly	AWX-062-0	
	Muting circuit assembly	AWM-039-A	
	Wooden cabinet assembly	AMM-034-A	
	Foot	AEC-027-B	
	Tuning shaft assembly	AXA-056-0	
	Tuning pulley assembly	AXA-015-A	
	Ferrite antenna holder assembly	W72-092-D	
	Front panel assembly	ANB-255-B	
	Dial pointer assembly	AAF-031-A	
	Dial scale	AAG-072-A	
	Meter (Signal & tuning)	AAG-029-0	
	Knob (Bass-main, Treble-main, Volume, Balance)	AAB-068-A	
	Knob (Bass-sub, Treble-sub)	AAB-069-A	
	Knob (Tuning)	AAA-026-A	
	Knob (Power, Tone, Duplicate, Monitor, 4 CH adaptor, NR adaptor)	AAD-040-0	
	Knob (SPKR A,B,C)	AAD-064-A	
	Knob (Low cut, High cut, -20dB)	AAD-065-A	
	Knob (Function)	AAD-066-A	
	Knob (Mode, Loudness)	AAD-067-A	

Symbol	Description	Part No.	
	Coupler (knob-to-switch)	AAE-007-0	
	Knob (Dimmer, FM muting)	AAD-082-A	
	Ornamental ring	AAC-034-A	
	Phono jack-B(6 jacks)	AKB-017-0	
	Phono jack-A(4 jacks)	AKB-014-0	
	Phono jack (1 jack)	AKB-019-0	
	Antenna terminal board	AKA-002-0	
	Binding post for ground	AKE-012-A	
	Speaker output terminal	AKE-014-0	
	Power transformer	ATT-166-A	KCU
	Power transformer	ATT-174-0	F
	Ferrite loopstick antenna	ATB-027-0	
	Balun	T22-025-A	
	Pilot lamp 8V, 0.3A (dial scale)	E22-032-0	
	Pilot lamp 8V, 0.3A (meter)	AEL-015-0	
	Fuse 6A (AC power)	AEK-033-0	
	Fuse 3A (AC power)	E21-036-A	F
	Fuse 6A (protection)	AEK-041-0	KCU
	Fuse 3A (protection)	AEK-101-0	
	Fuse 1A (protection)	AEK-106-0	
	Pilot lamp 8V, 50mA (program indicator)	AEL-023-0	
	Pilot lamp 8V, 50mA (program indicator)	AEL-022-0	
	Pilot lamp 6V, 30mA (stereo indicator)	AEL-014-0	
	AC socket	AKP-005-0	
	Phone jack (Headphone)	K72-026-0	
	Phone jack (Microphone)	K72-024-0	
	Jumper plug	AKM-004-A	
	Transistor socket	AKH-001-0	
	Pilot lamp socket	AKK-002-0	
	AC cord grommet	AEC-079-0	
	Screw M4X15	ABA-010-A	
	Washer	B21-011-0	
	AC power cord	ADG-005-A	
	FM T-type antenna	ADH-002-0	
	Operating instructions (English)	ARB-100-0	
	Operating instructions (French/German)	ARD-068-0	
	Inside packing	AHC-013-A	
	Packing case	AHD-211-A	
	Side pad (L)	AHA-064-A	
	Side pad (R)	AHA-065-A	

12. 2 FM FRONT END (AWB-017-0)

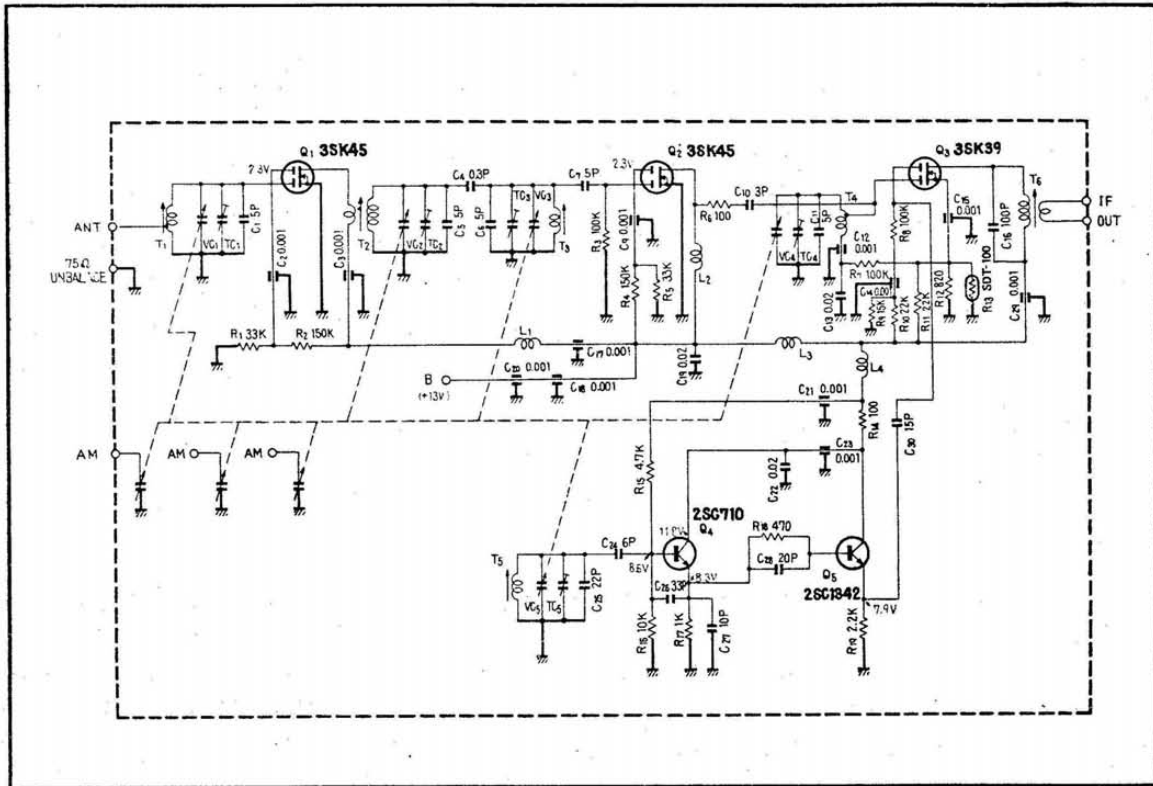

3SK39

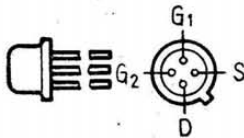

2SC710

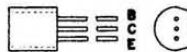

2SC1342

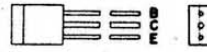

3SK45

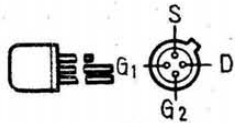

12. 3 TUNER ASSEMBLY (AWE-040-0)

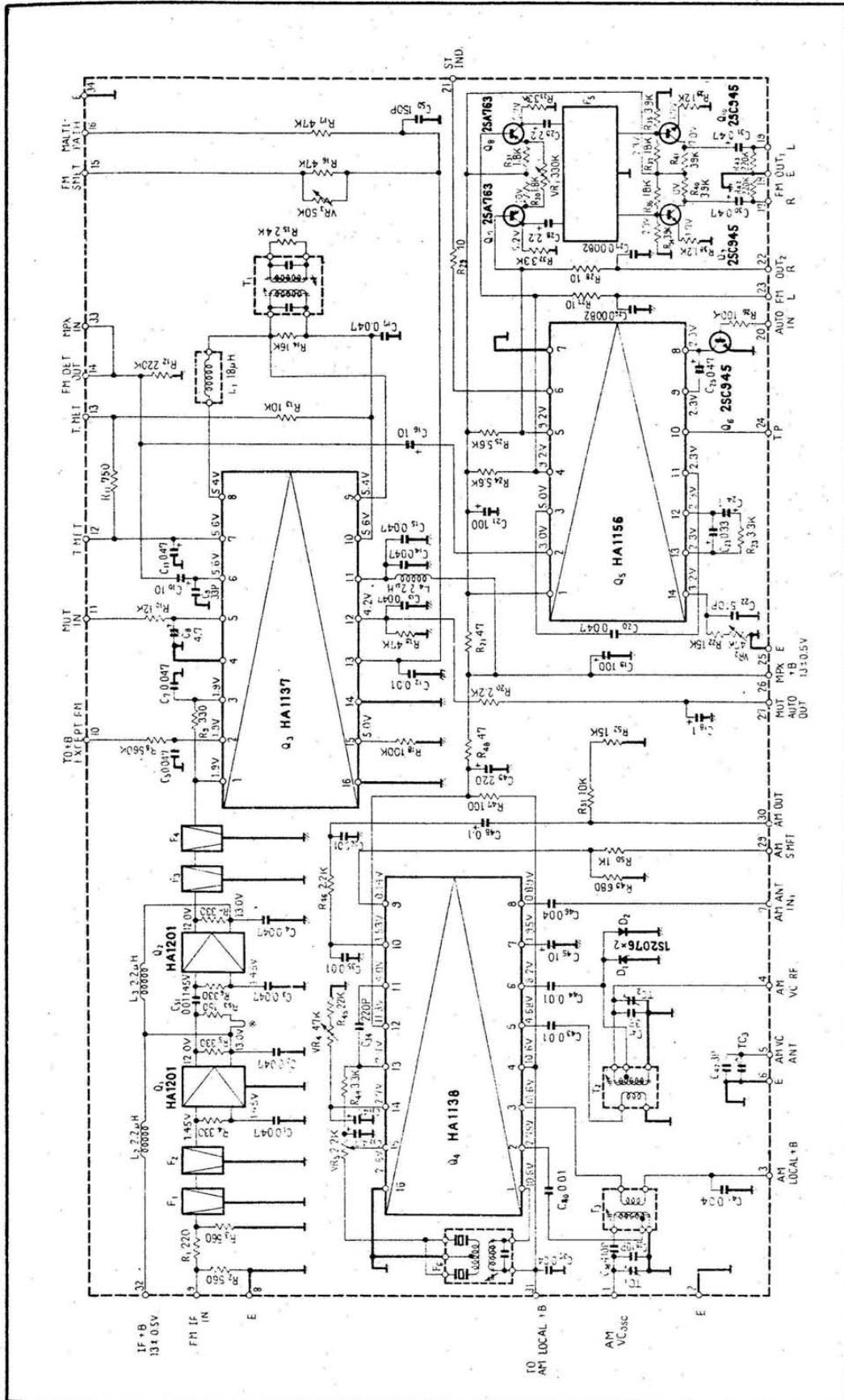

2SA763
2SC945

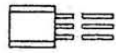

HA1137
HA1138

8 7 6 5 4 3

9 10 11 12 13 14

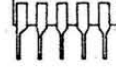

HA1156

432 1109

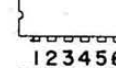

1 2 3 4 5 6

HA1201

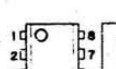

1 2 3 4 5 6

Foil Side

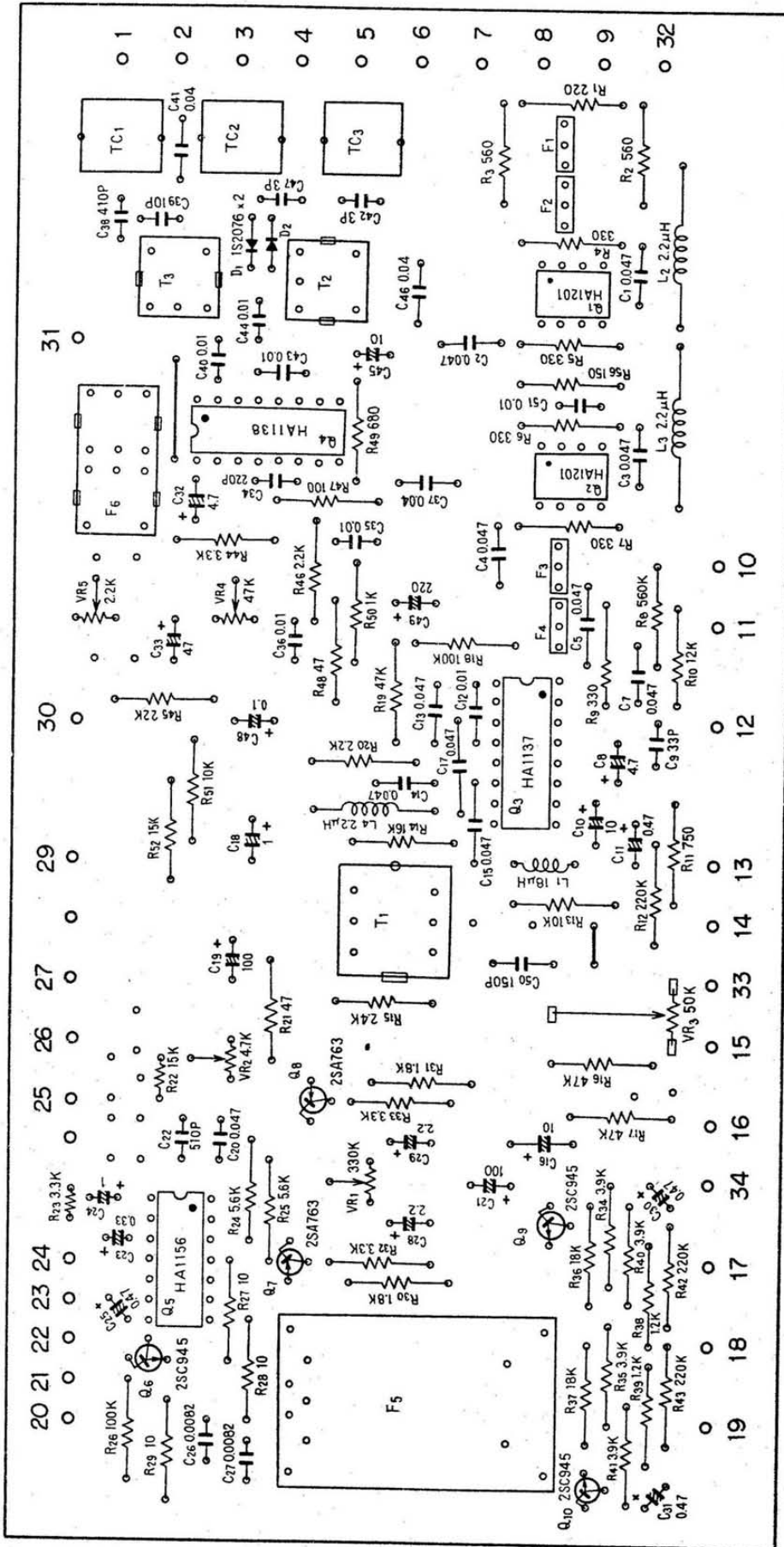

Parts List of Tuner Assembly (AWE-040-0)

CAPACITORS

Symbol	Description			Part No.
C1	Ceramic	0.047	25V	CKDBC 473Z 25
C2	Ceramic	0.047	25V	CKDBC 473Z 25
C3	Ceramic	0.047	25V	CKDBC 473Z 25
C4	Ceramic	0.047	25V	CKDBC 473Z 25
C5	Ceramic	0.047	25V	CKDBC 473Z 25
C6				
C7	Ceramic	0.047	25V	CKDBC 473Z 25
C8	Electrolytic	4.7	25V	CEA 4R7P 25
C9	Ceramic	33p	50V	CCDSL 330K 50
C10	Electrolytic	10	16V	CEA 100P 16
C11	Electrolytic	0.47	50V	CEA R47P 50
C12	Ceramic	0.01	50V	CKDYF 103Z 50
C13	Ceramic	0.047	25V	CKDBC 473Z 25
C14	Ceramic	0.047	25V	CKDBC 473Z 25
C15	Ceramic	0.047	25V	CKDBC 473Z 25
C16	Electrolytic	10	16V	CEA 100P 16
C17	Ceramic	0.047	25V	CKDBC 473Z 25
C18	Electrolytic	1	50V	CEA 010P 50
C19	Electrolytic	100	16V	CEA 101P 16
C20	Mylar	0.047	50V	CQMA 473K 50
C21	Electrolytic	100	16V	CEA 100P 16
C22	Styrol	510p	50V	CQSH 511J 50
C23	Electrolytic	0.33	10V	CSSA R33M 10
C24	Electrolytic	1	10V	CSSA 010M 10
C25	Electrolytic	0.47	10V	CSSA R47M 10
C26	Mylar	0.0082	50V	CQMA 822J 50
C27	Mylar	0.0082	50V	CQMA 822J 50
C28	Electrolytic	2.2	50V	CEA 2R2P 50
C29	Electrolytic	2.2	50V	CEA 2R2P 50
C30	Electrolytic	0.47	50V	CEA R47P 50
C31	Electrolytic	0.47	50V	CEA R47P 50
C32	Electrolytic	4.7	25V	CEA 4R7P 25
C33	Electrolytic	4.7	6V	CEA 470P 6
C34	Ceramic	220p	50V	CCDSL 221K 50
C35	Ceramic	0.01	50V	CKDYB 103K 50
C36	Ceramic	0.01	50V	CKDYB 103K 50
C37	Ceramic	0.04	50V	CKDYF 403Z 50
C38	Styrol	410p	50V	CQSA 411J 50
C39	Ceramic	10p	50V	CCDWK 100F 50
C40	Mylar	0.01	50V	CQMA 103K 50
C41	Ceramic	0.04	50V	CKDYF 403Z 50
C42	Ceramic	3p	50V	CCDSH 030D 50
C43	Ceramic	0.01	50V	CKDYF 103Z 50
C44	Ceramic	0.01	50V	CKDYF 103Z 50
C45	Electrolytic	10	16V	CEA 100P 16

Symbol	Description	Part No.
C46	Ceramic 0.04 50V	CKDYF 403Z 50
C47	Ceramic 3p 50V	CCDSH 030D 50
C48	Electrolytic 0.1 25V	CSSA 0R1M 25
C49	Electrolytic 220 16V	CEA 221P 16
C50	Ceramic 150p 50V	CCDSL 151K 50
C51	Ceramic 0.01 50V	CKDYF 103Z 50
TC1	Film trimmer	ACM-002-0
TC2	Film trimmer	ACM-002-0
TC3	Film trimmer	ACM-002-0

RESISTORS AND POTENTIOMETERS

Symbol	Description	Part No.
R1	Carbon film 220	RD¼PS 221J
R2	Carbon film 560	RD¼PS 561J
R3	Carbon film 560	RD¼PS 561J
R4	Carbon film 330	RD¼PS 331J
R5	Carbon film 330	RD¼PS 331J
R6	Carbon film 330	RD¼PS 331J
R7	Carbon film 330	RD¼PS 331J
R8	Carbon film 560k	RD¼PS 564J
R9	Carbon film 330	RD¼PS 331J
R10	Carbon film 12k	RD¼PS 123J
R11	Carbon film 750	RD¼PS 751J
R12	Carbon film 220k	RD¼PS 224J
R13	Carbon film 10k	RD¼PS 103J
R14	Carbon film 16k	RD¼PS 163J
R15	Carbon film 2.4k	RD¼PS 242J
R16	Carbon film 47k	RD¼PS 473J
R17	Carbon film 47k	RD¼PS 473J
R18	Carbon film 100k	RD¼PS 104J
R19	Carbon film 47k	RD¼PS 473J
R20	Carbon film 2.2k	RD¼PS 222J
R21	Carbon film 47	RD¼PS 470J
R22	Carbon film 15k	RD¼VS 153J
R23	Carbon film 3.3k	RD¼VS 332J
R24	Carbon film 5.6k	RD¼PS 562J
R25	Carbon film 5.6k	RD¼PS 562J
R26	Carbon film 100k	RD¼PS 104J
R27	Carbon film 10	RD¼PS 100J
R28	Carbon film 10	RD¼PS 100J
R29	Carbon film 10	RD¼PS 100J
R30	Carbon film 1.8k	RD¼PS 182J
R31	Carbon film 1.8k	RD¼PS 182J
R32	Carbon film 3.3k	RD¼PS 332J
R33	Carbon film 3.3k	RD¼PS 332J
R34	Carbon film 3.9k	RD¼PS 392J
R35	Carbon film 3.9k	RD¼PS 392J

Symbol	Description	Part No.
R36	Carbon film 18k	RD¼PS 183J
R37	Carbon film 18k	RD¼PS 183J
R38	Carbon film 1.2k	RD¼PS 122J
R39	Carbon film 1.2k	RD¼PS 122J
R40	Carbon film 3.9k	RD¼PS 392J
R41	Carbon film 3.9k	RD¼PS 392J
R42	Carbon film 220k	RD¼PS 224J
R43	Carbon film 220k	RD¼PS 224J
R44	Carbon film 3.3k	RD¼PS 332J
R45	Carbon film 22k	RD¼PS 223J
R46	Carbon film 2.2k	RD¼PS 222J
R47	Carbon film 100	RD¼PS 101J
R48	Carbon film 47	RD¼PS 470J
R49	Carbon film 680	RD¼PS 681J
R50	Carbon film 1k	RD¼PS 102J
R51	Carbon film 10k	RD¼PS 103J
R52	Carbon film 15k	RD¼PS 153J
R53	Carbon film 150	RD¼VS 151J
VR1	Variable resistor, semi-fixed 330k-B	ACP-042-0
VR2	Variable resistor, semi-fixed 4.7k-B	C92-051-0
VR3	Variable resistor, semi-fixed 50k-B	ACP-043-0
VR4	Variable resistor, semi-fixed 47k-B	C92-048-0
VR5	Variable resistor, semi-fixed 2.2k-B	ACP-001-0

SEMICONDUCTORS

Symbol	Description	Part No.
Q1	IC HA1201	
Q2	IC HA1201	
Q3	IC HA1137	
Q4	IC HA1138	
Q5	IC HA1156	
Q6	Transistor 2SC945-Q, R or S	
Q7	Transistor 2SA763P-5 or 6 (2SA725-F or G)	
Q8	Transistor 2SA763P-5 or 6 (2SA725-F or G)	
Q9	Transistor 2SC945-Q, R or S	
Q10	Transistor 2SC945-Q, R or S	
D1	Diode 1S2076	
D2	Diode 1S2076	

Continued on the Next Page

COILS, TRANSFORMERS AND FILTERS

Symbol	Description	Part No.	
T1	FM IF transformer	T73-035-A	
T2	AM RF coil	ATB-020-0	
T3	AM OSC coil	ATB-019-0	
F1	FM ceramic filter	ATF-018-0	
F2	FM ceramic filter	ATF-018-0	
F3	FM ceramic filter	ATF-018-0	
F4	FM ceramic filter	ATF-018-0	
F5	Low pass filter	ATF-019-0	
F6	AM ceramic filter	ATF-009-0	
L1	Choke coil	ATH-007-0	
L2	RF choke coil	T24-028-A	
L3	RF choke coil	T24-028-A	
L4	RF choke coil	T24-028-A	

12. 4 MUTING CIRCUIT ASSEMBLY (AWM-039-A)

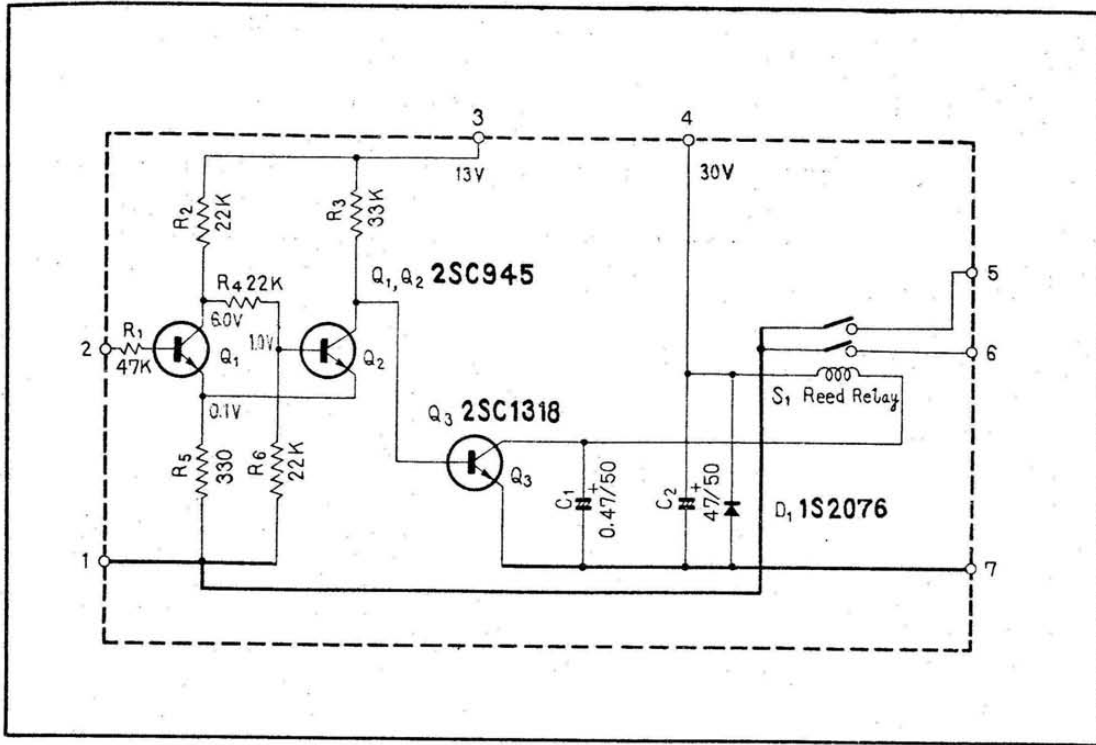

2SC945

2SC1318

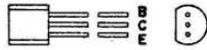

Foil Side

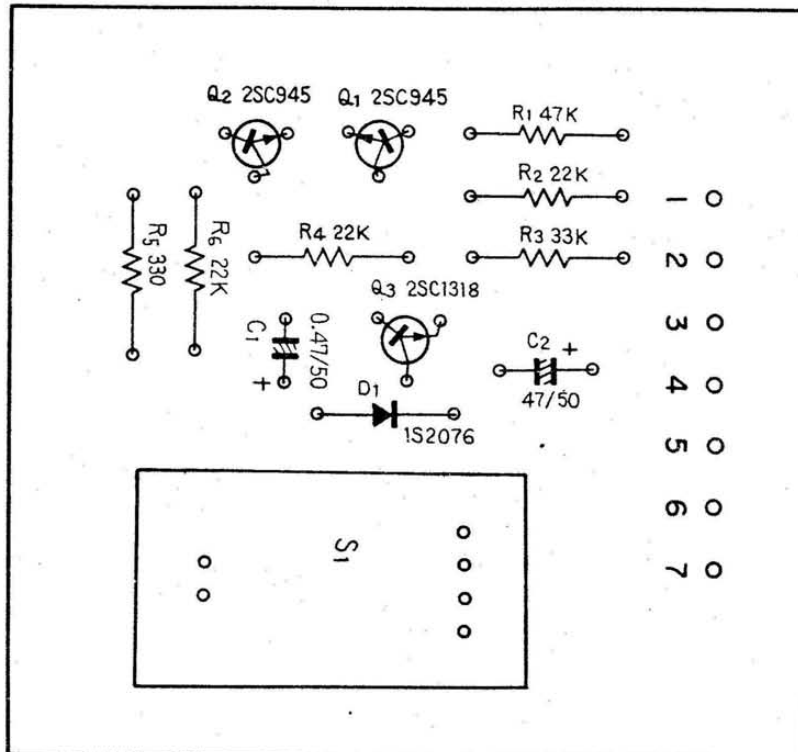

Parts List of Muting Circuit Assembly (AWM-039-A)

CAPACITORS

Symbol	Description	Part No.
C1	Electrolytic 0.47 50V	CEA R47P 50
C2	Electrolytic 47 50V	CEA 470P 50

RESISTORS

Symbol	Description	Part No.
R1	Carbon film 47k	RD½PS 473J
R2	Carbon film 22k	RD½PS 223J
R3	Carbon film 33k	RD½PS 333J
R4	Carbon film 22k	RD½PS 223J
R5	Carbon film 330	RD½PS 331J
R6	Carbon film 22k	RD½PS 223J

SEMICONDUCTORS

Symbol	Description	Part No.
Q1	Transistor 2SC945-Q or R	
Q2	Transistor 2SC945-Q or R	
Q3	Transistor 2SC1318-R or S	
D1	Diode 1S2473	

OTHER

Symbol	Description	Part No.
S1	Reed relay	ASR-004-B

12. 5 EQUALIZER AMPLIFIER ASSEMBLY (AWF-013-0)

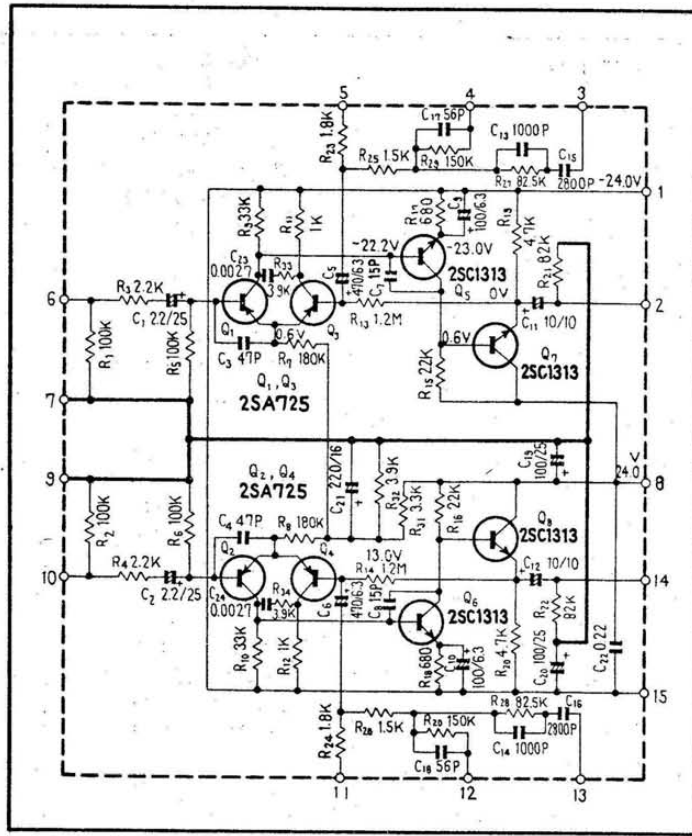

Foil Side

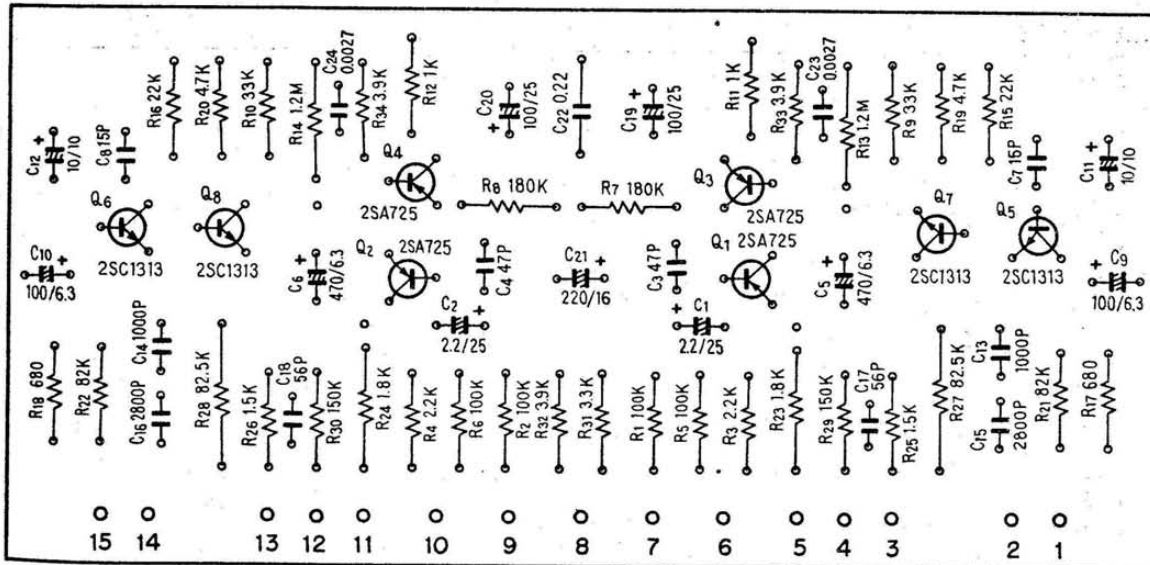

2SA725
2SC1313

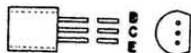

Parts List of Equalizer Amplifier Assembly (AWF-013-0)

CAPACITORS

Symbol	Description			Part No.
C1	Electrolytic	2.2	25V	CSSA 2R2M 25
C2	Electrolytic	2.2	25V	CSSA 2R2M 25
C3	Ceramic	47p	50V	CCDSL 470K 50
C4	Ceramic	47p	50V	CCDSL 470K 50
C5	Electrolytic	470	6V	CEANIL 471P 6
C6	Electrolytic	470	6V	CEANL 471P 6
C7	Ceramic	15p	50V	CCDSL 150K 50
C8	Ceramic	15p	50V	CCDSL 150K 50
C9	Electrolytic	100	6V	CEANL 101P 6
C10	Electrolytic	100	6V	CEANL 101P 6
C11	Electrolytic	10	10V	CEANL 100P 10
C12	Electrolytic	10	10V	CEANL 100P 10
C13	Styrol	0.001	50V	CQSA 102G 50
C14	Styrol	0.001	50V	CQSA 102G 50
C15	Styrol	0.0028	50V	CQSA 282G 50
C16	Styrol	0.0028	50V	CQSA 282G 50
C17	Ceramic	56p	50V	CCDSL 560K 50
C18	Ceramic	56p	50V	CCDSL 560K 50
C19	Electrolytic	100	25V	CEANL 101P 25
C20	Electrolytic	100	25V	CEANL 101P 25
C21	Electrolytic	220	16V	CEANL 221P 16
C22	Mylar	0.22	50V	CQMA 224K 50
C23	Mylar	0.0027	50V	CQMA 272K 50
C24	Mylar	0.0027	50V	CQMA 272K 50

RESISTORS

Symbol	Description			Part No.
R1	Carbon film	100k		RD $\frac{1}{2}$ PM 104J
R2	Carbon film	100k		RD $\frac{1}{2}$ PM 104J
R3	Carbon film	2.2k		RD $\frac{1}{2}$ PM 222J
R4	Carbon film	2.2k		RD $\frac{1}{2}$ PM 222J
R5	Carbon film	100k		RD $\frac{1}{2}$ PM 104J
R6	Carbon film	100k		RD $\frac{1}{2}$ PM 104J
R7	Carbon film	180k		RD $\frac{1}{2}$ PM 184J
R8	Carbon film	180k		RD $\frac{1}{2}$ PM 184J
R9	Carbon film	33k		RD $\frac{1}{2}$ PM 333J
R10	Carbon film	33k		RD $\frac{1}{2}$ PM 333J
R11	Carbon film	1k		RD $\frac{1}{2}$ PM 102J
R12	Carbon film	1k		RD $\frac{1}{2}$ PM 102J
R13	Carbon film	1.2M		RD $\frac{1}{2}$ PS 125J
R14	Carbon film	1.2M		RD $\frac{1}{2}$ PS 125J
R15	Carbon film	22k		RD $\frac{1}{2}$ PM 223J
R16	Carbon film	22k		RD $\frac{1}{2}$ PM 223J
R17	Carbon film	680		RD $\frac{1}{2}$ PM 681J
R18	Carbon film	680		RD $\frac{1}{2}$ PM 681J
R19	Carbon film	4.7k		RD $\frac{1}{2}$ PM 472J
R20	Carbon film	4.7k		RD $\frac{1}{2}$ PM 472J

Symbol	Description	Part No.
R21	Carbon film 82k	RD¼PM 823J
R22	Carbon film 82k	RD¼PM 823J
R23	Carbon film 1.8k	RD¼PS 182J
R24	Carbon film 1.8k	RD¼PS 182J
R25	Carbon film 1.5k	RD¼PM 152J
R26	Carbon film 1.5k	RD¼PM 152J
R27	Metal film 82.5k ¼W	RN¼SR 8252F
R28	Metal film 82.5k ¼W	RN¼SR 8252F
R29	Carbon film 150k	RD¼PM 154J
R30	Carbon film 150k	RD¼PM 154J
R31	Carbon film 3.3k	RD¼PM 332J
R32	Carbon film 3.9k	RD¼PM 392J
R33	Carbon film 3.9k	RD¼PM 392J
R34	Carbon film 3.9k	RD¼PM 392J

SEMICONDUCTORS

Symbol	Description	Part No.
Q1	Transistor 2SA725-G or F (2SA763P-5 or 6) (2SA640-K, L or M)	
Q2	Transistor 2SA725-G or F (2SA763P-5 or 6) (2SA640-K, L or M)	
Q3	Transistor 2SA725-G or F (2SA763P-5 or 6) (2SA640-K, L or M)	
Q4	Transistor 2SA725-G or F (2SA763P-5 or 6) (2SA640-K, L or M)	
Q5	Transistor 2SC1313-G or F (2SC1345-E or D) (2SC1222-F, E or U)	
Q6	Transistor 2SC1313-G or F (2SC1345-E or D) (2SC1222-F, E or U)	
Q7	Transistor 2SC1313-G or F (2SC1345-E or D) (2SC1222-F, E or U)	
Q8	Transistor 2SC1313-G or F (2SC1345-E or D) (2SC1222-F, E or U)	

12. 6 CONTROL AMPLIFIER ASSEMBLY (AWG-027-0)

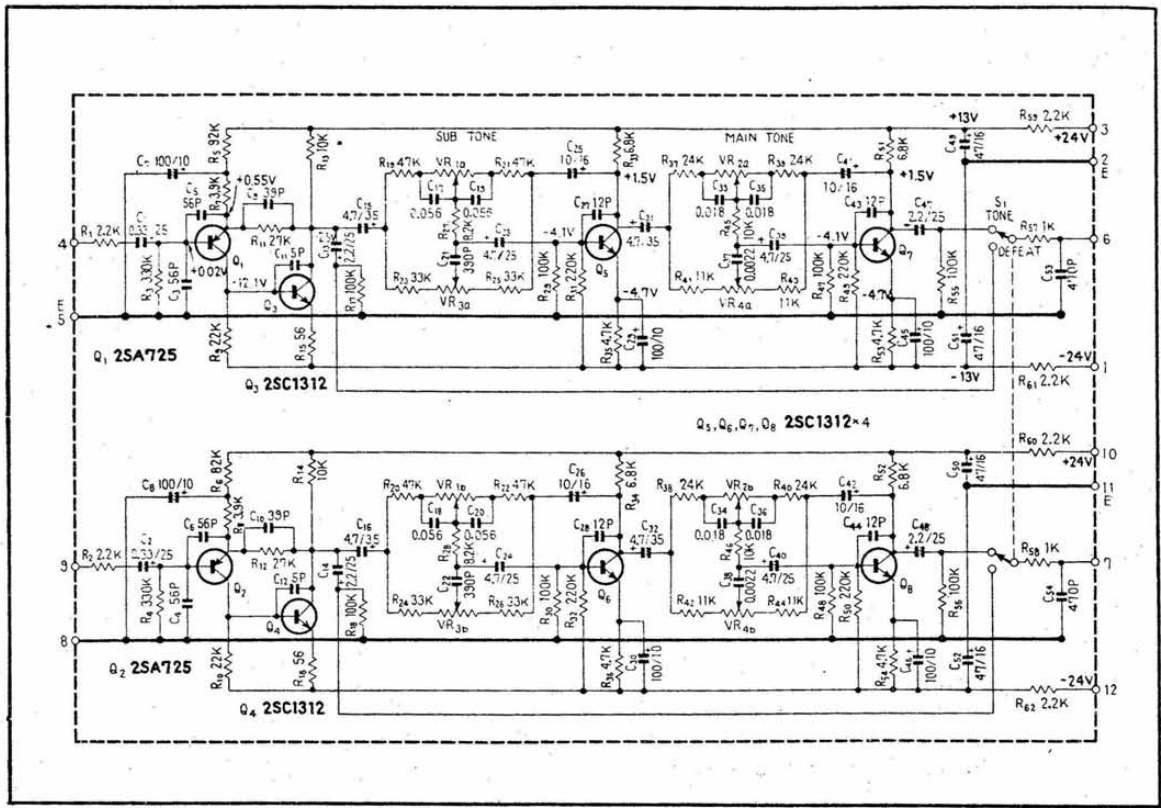

Foil Side

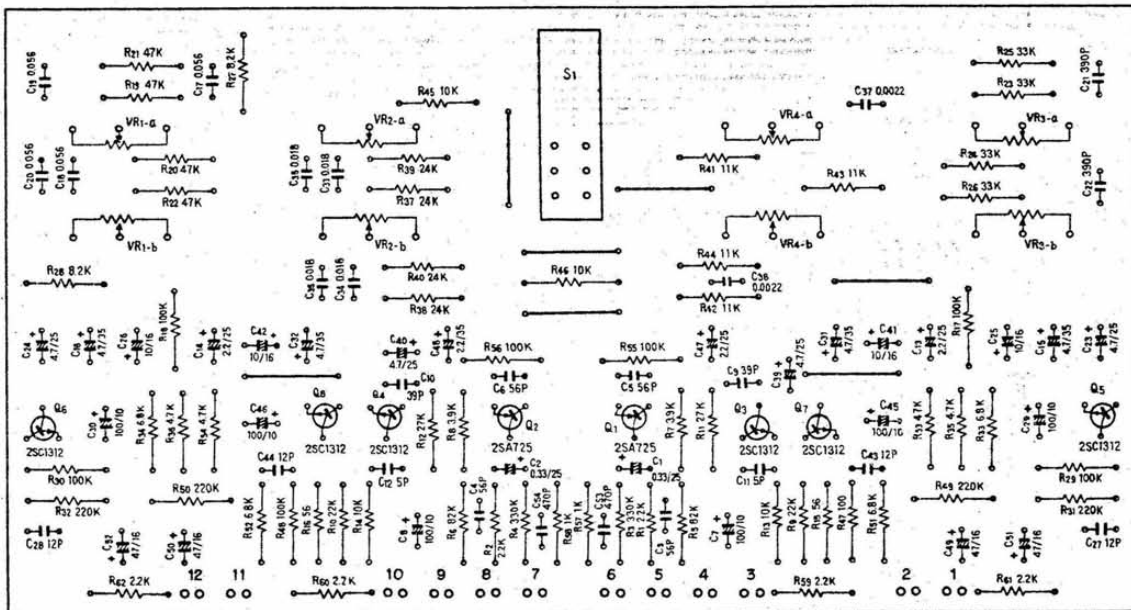

2SA725
2SC1312

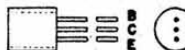

Parts List of Control Amplifier Assembly (AWG-027-0)

CAPACITORS

Symbol	Description			Part No.
C1	Electrolytic	0.33	25V	CSSA R33M 25
C2	Electrolytic	0.33	25V	CSSA R33M 25
C3	Ceramic	56p	50V	CCDSL 560K 50
C4	Ceramic	56p	50V	CCDSL 560K 50
C5	Ceramic	56p	50V	CCDSL 560K 50
C6	Ceramic	56p	50V	CCDSL 560K 50
C7	Electrolytic	100	10V	CEA 101P 10
C8	Electrolytic	100	10V	CEA 101P 10
C9	Ceramic	39p	50V	CCDSL 390K 50
C10	Ceramic	39p	50V	CCDSL 390K 50
C11	Ceramic	5p	50V	CCDSL 050D 50
C12	Ceramic	5p	50V	CCDSL 050D 50
C13	Electrolytic	2.2	25V	CSSA 2R2M 25
C14	Electrolytic	2.2	25V	CSSA 2R2M 25
C15	Electrolytic	4.7	35V	CEA 4R7P 35
C16	Electrolytic	4.7	35V	CEA 4R7P 35
C17	Mylar	0.056	50V	CQMA 563J 50
C18	Mylar	0.056	50V	CQMA 563J 50
C19	Mylar	0.056	50V	CQMA 563J 50
C20	Mylar	0.056	50V	CQMA 563J 50
C21	Styrol	390p	50V	CQSA 391J 50
C22	Styrol	390p	50V	CQSA 391J 50
C23	Electrolytic	4.7	25V	CEANL 4R7P 25
C24	Electrolytic	4.7	25V	CEANL 4R7P 25
C25	Electrolytic	10	16V	CEA 100P 16
C26	Electrolytic	10	16V	CEA 100P 16
C27	Ceramic	12p	50V	CCDSL 120K 50
C28	Ceramic	12p	50V	CCDSL 120K 50
C29	Electrolytic	100	10V	CEA 101P 10
C30	Electrolytic	100	10V	CEA 101P 10
C31	Electrolytic	4.7	35V	CEA 4R7P 35
C32	Electrolytic	4.7	35V	CEA 4R7P 35
C33	Mylar	0.018	50V	CQMA 183J 50
C34	Mylar	0.018	50V	CQMA 183J 50
C35	Mylar	0.018	50V	CQMA 183J 50
C36	Mylar	0.018	50V	CQMA 183J 50
C37	Mylar	0.0022	50V	CQMA 222J 50
C38	Mylar	0.0022	50V	CQMA 222J 50
C39	Electrolytic	4.7	25V	CEANL 4R7P 25
C40	Electrolytic	4.7	25V	CEANL 4R7P 25
C41	Electrolytic	10	16V	CEA 100P 16
C42	Electrolytic	10	16V	CEA 100P 16
C43	Ceramic	12p	50V	CCDSL 120K 50
C44	Ceramic	12p	50V	CCDSL 120K 50
C45	Electrolytic	100	10V	CEA 101P 10

Continued on the Next Page

Symbol	Description			Part No.
C46	Electrolytic	100	10V	CEA 101P 10
C47	Electrolytic	2.2	25V	CSSA 2R2M 25
C48	Electrolytic	2.2	25V	CSSA 2R2M 25
C49	Electrolytic	47	16V	CEA 470P 16
C50	Electrolytic	47	16V	CEA 470P 16
C51	Electrolytic	47	16V	CEA 470P 16
C52	Electrolytic	47	16V	CEA 470P 16
C53	Ceramic	470p	50V	CKDYB 471K 50
C54	Ceramic	470p	50V	CKDYB 471K 50

RESISTORS AND POTENTIOMETERS

Symbol	Description			Part No.
R1	Carbon film	2.2k		RD¼PS 222J
R2	Carbon film	2.2k		RD¼PS 222J
R3	Carbon film	330k		RD¼PS 334J
R4	Carbon film	330k		RD¼PS 334J
R5	Carbon film	82k		RD¼PS 823J
R6	Carbon film	82k		RD¼PS 823J
R7	Carbon film	3.9k		RD¼PS 392J
R8	Carbon film	3.9k		RD¼PS 392J
R9	Carbon film	22k		RD¼PS 223J
R10	Carbon film	22k		RD¼PS 223J
R11	Carbon film	27k		RD¼PS 273J
R12	Carbon film	27k		RD¼PS 273J
R13	Carbon film	10k		RD¼PS 103J
R14	Carbon film	10k		RD¼PS 103J
R15	Carbon film	56		RD¼PS 560J
R16	Carbon film	56		RD¼PS 560J
R17	Carbon film	100k		RD¼PS 104J
R18	Carbon film	100k		RD¼PS 104J
R19	Carbon film	47k		RD¼PS 473J
R20	Carbon film	47k		RD¼PS 473J
R21	Carbon film	47k		RD¼PS 473J
R22	Carbon film	47k		RD¼PS 473J
R23	Carbon film	33k		RD¼PS 333J
R24	Carbon film	33k		RD¼PS 333J
R25	Carbon film	33k		RD¼PS 333J
R26	Carbon film	33k		RD¼PS 333J
R27	Carbon film	8.2k		RD¼PS 822J
R28	Carbon film	8.2k		RD¼PS 822J
R29	Carbon film	100k		RD¼PS 104J
R30	Carbon film	100k		RD¼PS 104J
R31	Carbon film	220k		RD¼PS 224J
R32	Carbon film	220k		RD¼PS 224J
R33	Carbon film	6.8k		RD¼PS 682J
R34	Carbon film	6.8k		RD¼PS 682J
R35	Carbon film	4.7k		RD¼PS 472J

Symbol	Description	Part No.
R36	Carbon film 4.7k	RD½PS 472J
R37	Carbon film 24k	RD½PS 243J
R38	Carbon film 24k	RD½PS 243J
R39	Carbon film 24k	RD½PS 243J
R40	Carbon film 24k	RD½PS 243J
R41	Carbon film 11k	RD½PS 113J
R42	Carbon film 11k	RD½PS 113J
R43	Carbon film 11k	RD½PS 113J
R44	Carbon film 11k	RD½PS 113J
R45	Carbon film 10k	RD½PS 103J
R46	Carbon film 10k	RD½PS 103J
R47	Carbon film 100k	RD½PS 104J
R48	Carbon film 100k	RD½PS 104J
R49	Carbon film 220k	RD½PS 224J
R50	Carbon film 220k	RD½PS 224J
R51	Carbon film 6.8k	RD½PS 682J
R52	Carbon film 6.8k	RD½PS 682J
R53	Carbon film 4.7k	RD½PS 472J
R54	Carbon film 4.7k	RD½PS 472J
R55	Carbon film 100k	RD½PS 104J
R56	Carbon film 100k	RD½PS 104J
R57	Carbon film 1k	RD½PS 102J
R58	Carbon film 1k	RD½PS 102J
R59	Carbon film 2.2k	RD½PS 222J
R60	Carbon film 2.2k	RD½PS 222J
R61	Carbon film 2.2k	RD½PS 222J
R61	Carbon film 2.2k	RD½PS 222J
VR1	Variable resistor (Bass-sub)	ACV-132-0
VR2	Variable resistor (Bass-main)	ACV-130-0
VR3	Variable resistor (Treble-sub)	ACV-133-0
VR4	Variable resistor (Treble-main)	ACV-131-0

SEMICONDUCTORS

Symbol	Description	Part No.
Q1	Transistor 2SA725-F or G (2SA763P-5 or 6) (2SA640-K or L)	
Q2	Transistor 2SA725-F or G (2SA763P-5 or 6) (2SA640-K or L)	
Q3	Transistor 2SC1312-G or H (2SC1344-D or E) (2SC900-E or F)	
Q4	Transistor 2SC1312-G or H (2SC1344-D or E) (2SC900-E or F)	
Q5	Transistor 2SC1312-G or H (2SC1344-D or E) (2SC900-E or F)	

Continued on the Next Page

Symbol	Description	Part No.
Q6	Transistor 2SC1312-G or H (2SC1344-D or E) (2SC900-E or F)	
Q7	Transistor 2SC1312-G or H (2SC1344-D or E) (2SC900-E or F)	
Q8	Transistor 2SC1312-G or H (2SC1344-D or E) (2SC900-E or F)	

SWITCH

Symbol	Description	Part No.
S1	Lever switch (Tone)	ASK-070-0

12. 7 POWER AMPLIFIER ASSEMBLY (AWH-032-0)

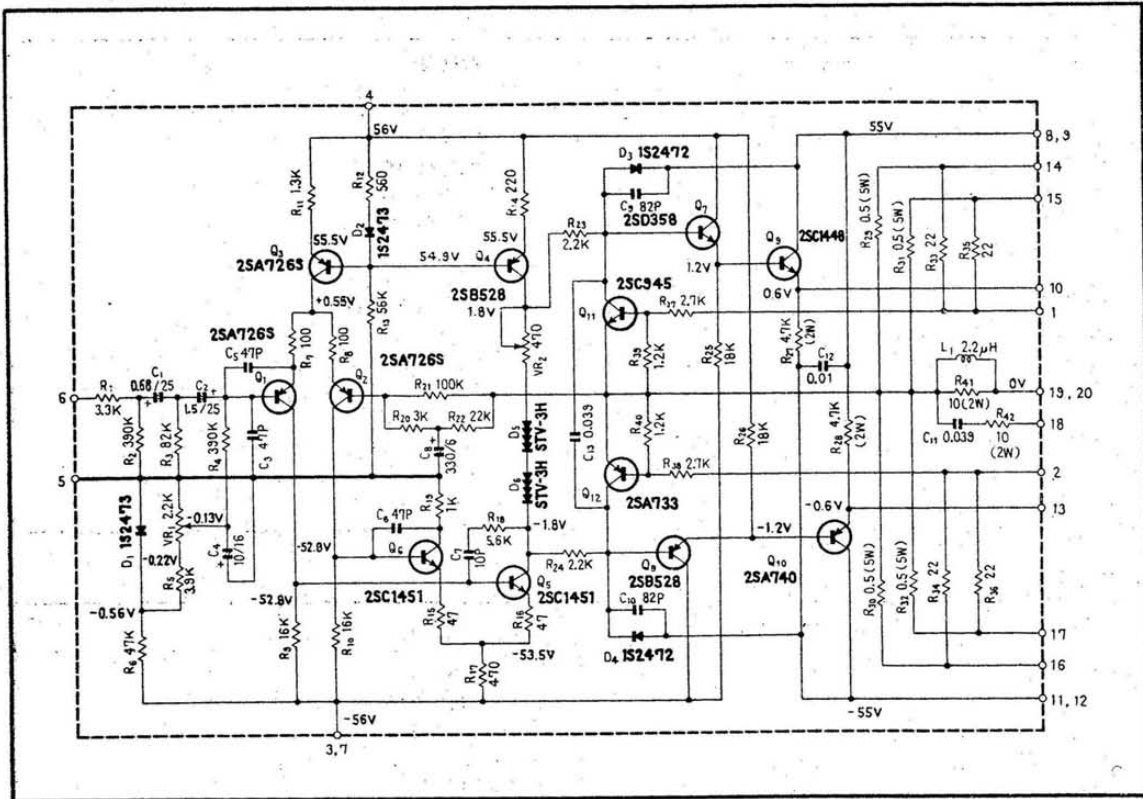

Foil Side

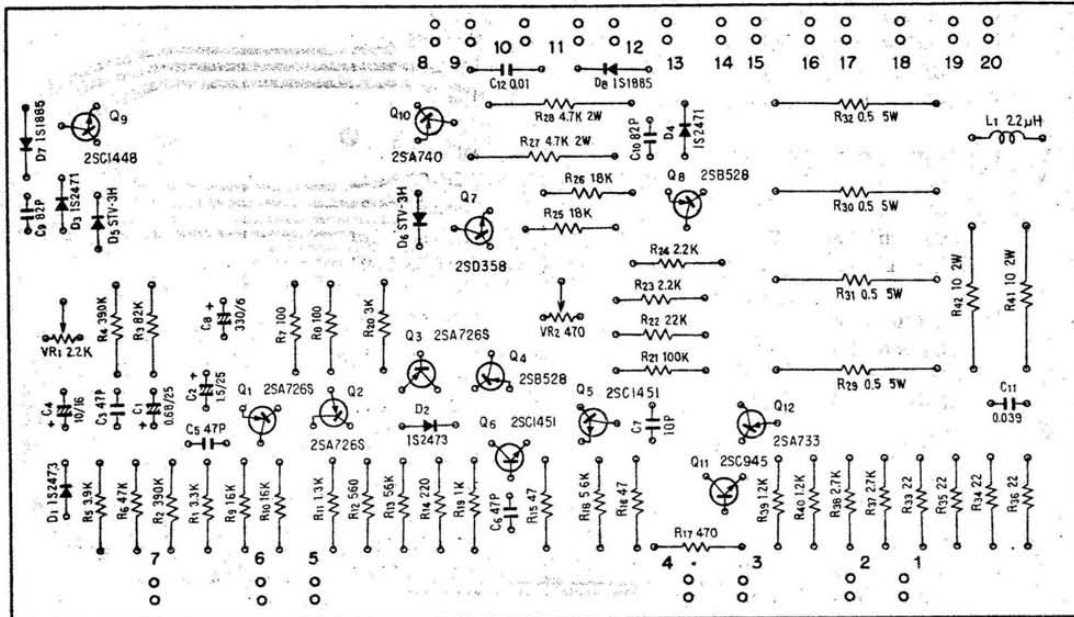

2SA726S



2SB528



2SA733

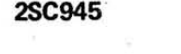

2SC1448

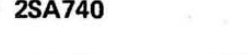

2SC1451

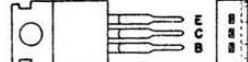
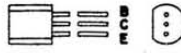
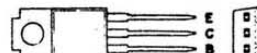
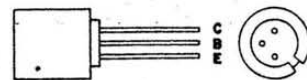

Parts List of Power Amplifier Assembly (AWH-032-0)

CAPACITORS

Symbol	Description			Part No.
C1	Electrolytic	0.68	25V	CSSA R68M 25
C2	Electrolytic	1.5	25V	CSSA 1R5M 25
C3	Ceramic	47p	50V	CCDSL 470K 50
C4	Electrolytic	10	16V	CEA 100P 16
C5	Ceramic	47p	50V	CCDSL 470K 50
C6	Ceramic	47p	50V	CCDSL 470K 50
C7	Ceramic	10p	500V	CCDSL 100K 500
C8	Electrolytic	330	6V	CEA 331P 6
C9	Ceramic	82p	500V	CCDSL 820K 500
C10	Ceramic	82p	500V	CCDSL 820K 500
C11	Mylar	0.039	50V	CQMA 393J 50
C12	Ceramic	0.01	150V	ACG-004-0
C13	Mylar	0.039	50V	CQMA 393J 50

RESISTORS AND POTENTIOMETERS

Symbol	Description			Part No.
R1	Carbon film	3.3k		RD½PS 332J
R2	Carbon film	390k		RD½PS 394J
R3	Carbon film	82k		RD½PS 823J
R4	Carbon film	390k		RD½PS 394J
R5	Carbon film	3.9k		RD½PS 392J
R6	Carbon film	47k		RD½PS 473J
R7	Carbon film	100		RD½PS 101J
R8	Carbon film	100		RD½PS 101J
R9	Carbon film	16k		RD½PS 163J
R10	Carbon film	16k		RD½PS 163J
R11	Carbon film	1.3k		RD½PS 132J
R12	Carbon film	560		RD½PS 561J
R13	Carbon film	56k		RD½PS 563J
R14	Carbon film	220		RD½PS 221J
R15	Carbon film	47		RD½PS 470J
R16	Carbon film	47		RD½PS 470J
R17	Carbon film	470		RD½PS 471J
R18	Carbon film	5.6k		RD½PS 562J
R19	Carbon film	1k		RD½PS 102J
R20	Carbon film	3k		RD½PS 302J
R21	Carbon film	100k		RD½PS 104J
R22	Carbon film	22k		RD½PS 223J
R23	Carbon film	2.2k		RD½PS 222J
R24	Carbon film	2.2k		RD½PS 222J
R25	Carbon film	18k		RD½PS 183J
R26	Carbon film	18k		RD½PS 183J
R27	Metal film	4.7k	2W	RS2P 472J
R28	Metal film	4.7k	2W	RS2P 472J
R29	Wire wound	0.5	5W	RT5B 0R5K
R30	Wire wound	0.5	5W	RT5B 0R5K

Symbol	Description	Part No.
R31	Wire wound 0.5 5W	RT5B 0R5K
R32	Wire wound 0.5 5W	RT5B 0R5K
R33	Carbon film 22	RD¼PS 220J
R34	Carbon film 22	RD¼PS 220J
R35	Carbon film 22	RD¼PS 220J
R36	Carbon film 22	RD¼PS 220J
R37	Carbon film 2.7k	RD¼PS 272J
R38	Carbon film 2.7k	RD¼PS 272J
R39	Carbon film 1.2k	RD¼PS 122J
R40	Carbon film 1.2k	RD¼PS 122J
R41	Metal film 10 2W	RS2P 100J
R42	Metal film 10 2W	RS2P 100J
VR1	Variable resistor 2.2k-B	ACP-041-0
VR2	Variable resistor 470-B	ACP-040-0

SEMICONDUCTORS

Symbol	Description	Part No.
Q1	Transistor 2SA726S-F or G (2SA763S-5 or 6)	
Q2	Transistor 2SA726S-F or G (2SA763S-5 or 6)	
Q3	Transistor 2SA726S-F or G (2SA763S-5 or 6)	
Q4	Transistor 2SB528-C or D (2SA809-G, B or V)	
Q5	Transistor 2SC1451-B, G or V	
Q6	Transistor 2SC1451-B, G or V	
Q7	Transistor 2SD358-C or D (2SC1451-G, B or V)	
Q8	Transistor 2SB528-C or D (2SA809-G, B or V)	
Q9	Transistor 2SC1448-O, Y or R	
Q10	Transistor 2SA740-O, Y or R	
Q11	Transistor 2SC945-R, Q or S	
Q12	Transistor 2SA733-R, Q or S	
D1	Diode 1S2473	
D2	Diode 1S2473	
D3	Diode 1S2471	
D4	Diode 1S2471	
D5	Varistor STV-3H	
D6	Varistor STV-3H	
D7	Diode 1S1885	
D8	Diode 1S1885	

OTHERS

Symbol	Description	Part No.
L1	AF choke coil Socket (transistor) Spacer (insulator)	T63-009-0 AKH-002-0 AEC-088-0

12. 8 PROTECTION CIRCUIT ASSEMBLY (AWM-062-0)

ts

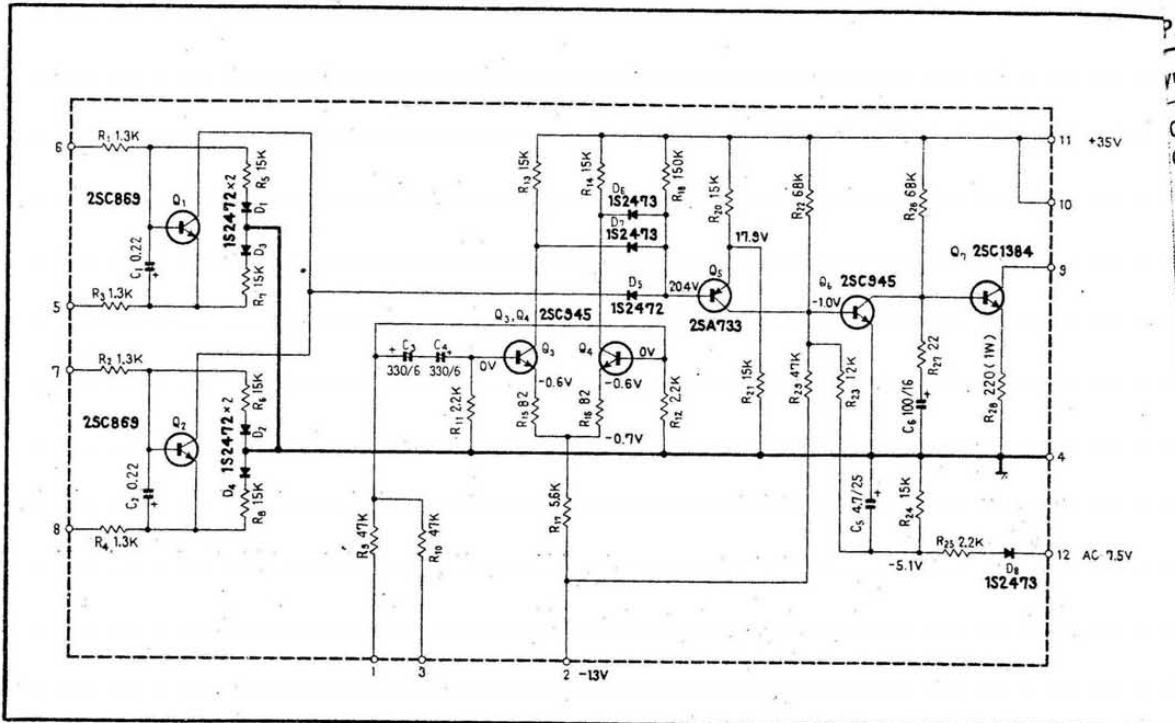

Foil Side

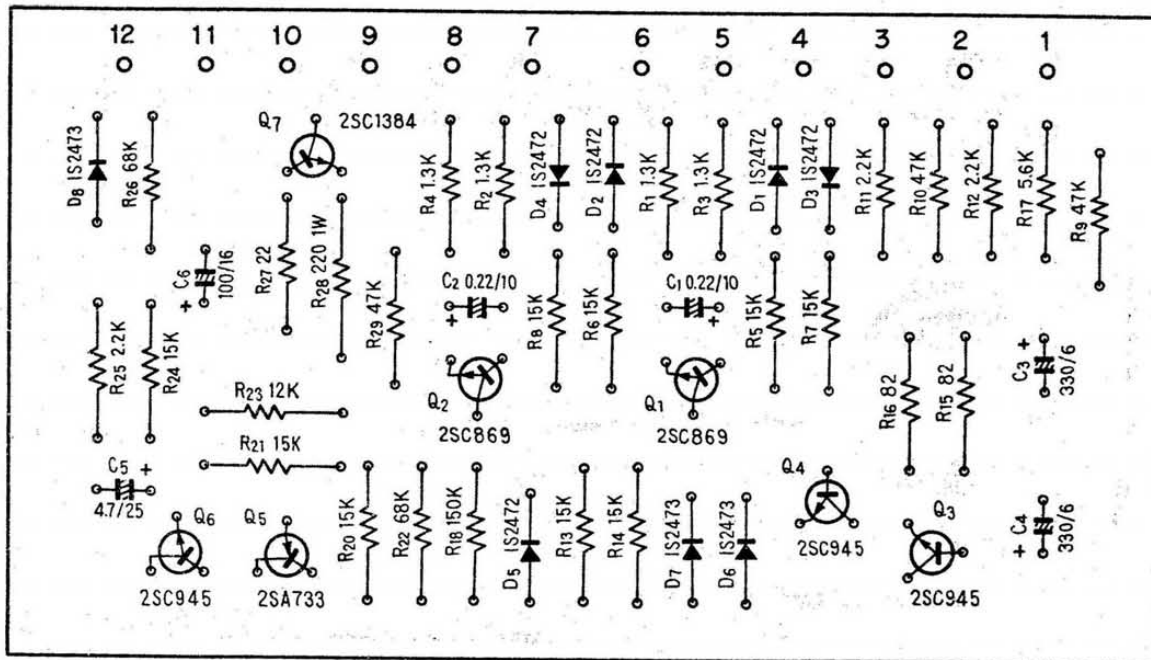

2SC869

2SA733
2SC945

2SC1384

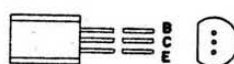

Parts List of Protection Circuit Assembly (AWM-062-0)

CAPACITORS

Symbol	Description			Part No.
C1	Electrolytic	0.22	10V	CSSA R22M 10
C2	Electrolytic	0.22	10V	CSSA R22M 10
C3	Electrolytic	330	6V	CEA 331P 6
C4	Electrolytic	330	6V	CEA 331P 6
C5	Electrolytic	4.7	25V	CEA 4R7P 25
C6	Electrolytic	100	16V	CEA 101P 16

RESISTORS

Symbol	Description			Part No.
R1	Carbon film	1.3k		RD¼PS 132J
R2	Carbon film	1.3k		RD¼PS 132J
R3	Carbon film	1.3k		RD¼PS 132J
R4	Carbon film	1.3k		RD¼PS 132J
R5	Carbon film	15k		RD¼PS 153J
R6	Carbon film	15k		RD¼PS 153J
R7	Carbon film	15k		RD¼PS 153J
R8	Carbon film	15k		RD¼PS 153J
R9	Carbon film	47k		RD¼PS 473J
R10	Carbon film	47k		RD¼PS 473J
R11	Carbon film	2.2k		RD¼PS 222J
R12	Carbon film	2.2k		RD¼PS 222J
R13	Carbon film	15k		RD¼PS 153J
R14	Carbon film	15k		RD¼PS 153J
R15	Carbon film	82		RD¼PS 820J
R16	Carbon film	82		RD¼PS 820J
R17	Carbon film	5.6k		RD¼PS 562J
R18	Carbon film	150k		RD¼PS 154J
R19				
R20	Carbon film	15k		RD¼PS 153J
R21	Carbon film	15k		RD¼PS 153J
R22	Carbon film	68k		RD¼PS 683J
R23	Carbon film	12k		RD¼PS 123J
R24	Carbon film	15k		RD¼PS 153J
R25	Carbon film	2.2k		RD¼PS 222J
R26	Carbon film	68k		RD¼PS 683J
R27	Carbon film	22		RD¼PS 220J
R28	Metal oxide	220	1W	RS1P 221J
R29	Carbon film	47k		RD¼PS 473J

Continued on the Next Page

SEMICONDUCTORS

Symbol	Description	Part No.
Q1	Transistor 2SC869-C, B or D (2SC857-K or A) (2SC1515-K)	
Q2	Transistor 2SC869-C, B or D (2SC857-K or A) (2SC1515-K)	
Q3	Transistor 2SC945-Q or R	
Q4	Transistor 2SC945-Q or R	
Q5	Transistor 2SA733-Q or R	
Q6	Transistor 2SC945-Q or R	
Q7	Transistor 2SC1384-R or Q	
D1	Diode 1S2472	
D2	Diode 1S2472	
D3	Diode 1S2472	
D4	Diode 1S2472	
D5	Diode 1S2472	
D6	Diode 1S2473	
D7	Diode 1S2473	
D8	Diode 1S2473	

12. 9 POWER SUPPLY CIRCUIT ASSEMBLY (AWR-053-0)

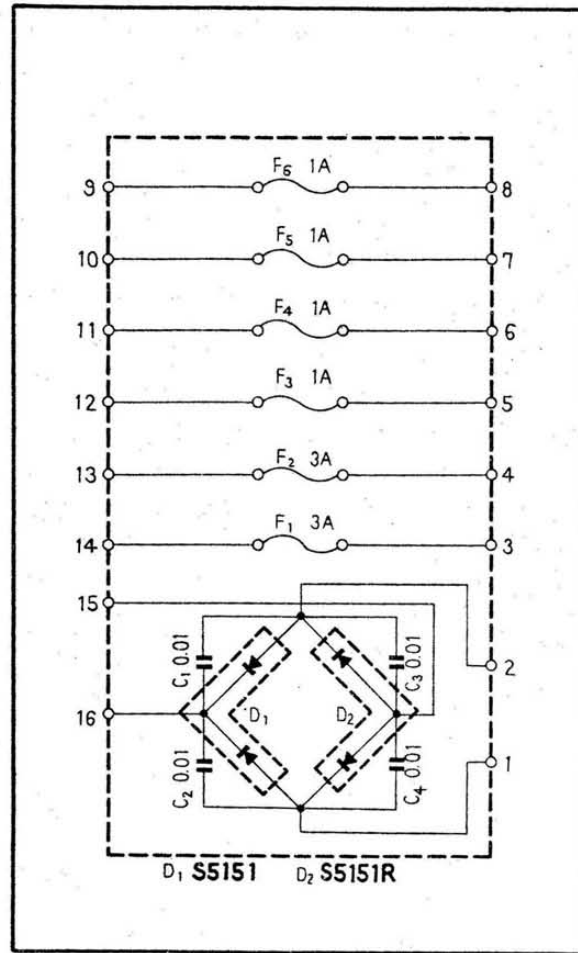

Foil Side

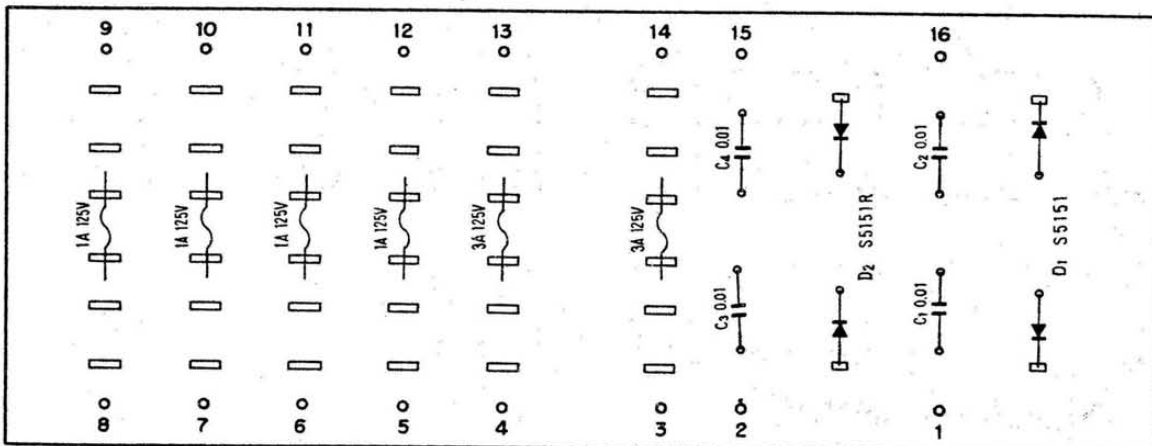

Parts List of Power Supply Circuit Assembly (AWR-053-0)

CAPACITORS

Symbol	Description	Part No.	
C1	Ceramic 0.01 150V	ACG-004-0	
C2	Ceramic 0.01 150V	ACG-004-0	
C3	Ceramic 0.01 150V	ACG-004-0	
C4	Ceramic 0.01 150V	ACG-004-0	

SEMICONDUCTORS

Symbol	Description	Part No.	
D1	Diode S5151		
D2	Diode S5151R		

OTHER

Symbol	Description	Part No.	
	Fuse holder	AKR-013-0	

12.10 POWER SUPPLY CIRCUIT ASSEMBY (AWR-054-A)

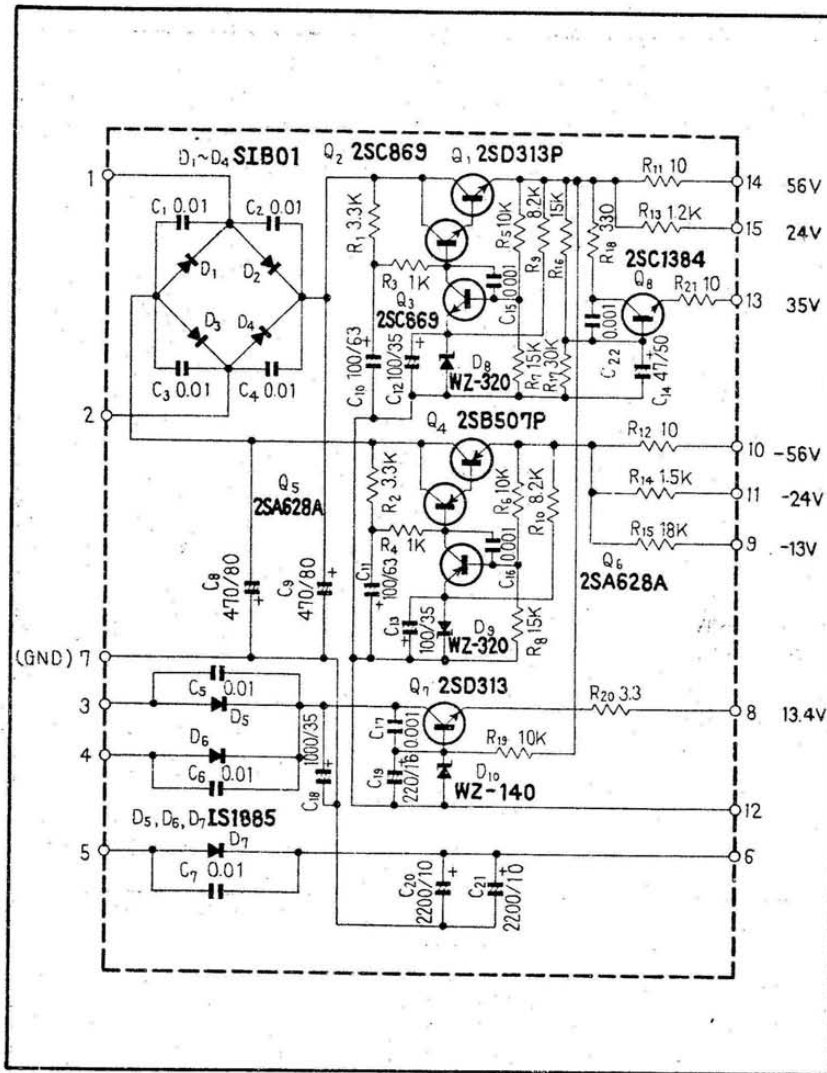

2SD313P
2SD313
2SB507P

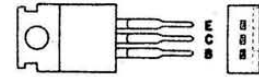

2SC869

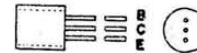

2SC1384

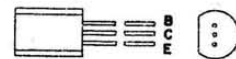

2SA628A

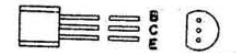

Foil Side

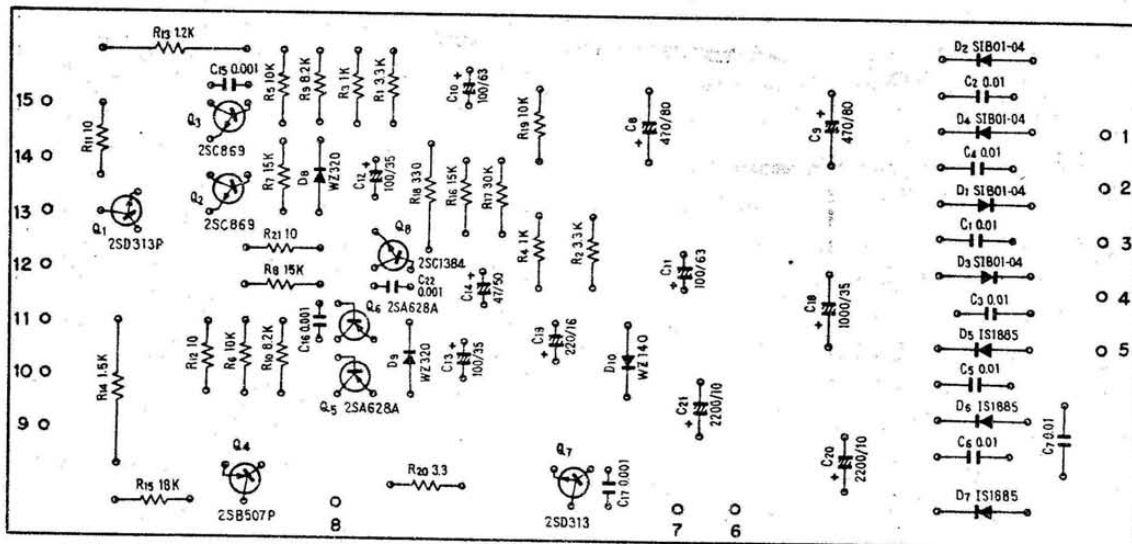

Parts List of Power Supply Circuit Assembly (AWR-054-A)

CAPACITORS

Symbol	Description			Part No.
C1	Ceramic	0.01	150V	ACG-004-0
C2	Ceramic	0.01	150V	ACG-004-0
C3	Ceramic	0.01	150V	ACG-004-0
C4	Ceramic	0.01	150V	ACG-004-0
C5	Ceramic	0.01	150V	ACG-004-0
C6	Ceramic	0.01	150V	ACG-004-0
C7	Ceramic	0.01	150V	ACG-004-0
C8	Electrolytic	470	80V	ACH-038-0
C9	Electrolytic	470	80V	ACH-038-0
C10	Electrolytic	100	63V	CEA 101P 63
C11	Electrolytic	100	63V	CEA 101P 63
C12	Electrolytic	100	35V	CEA 101P 35
C13	Electrolytic	100	35V	CEA 101P 35
C14	Electrolytic	47	50V	CEA 470P 50
C15	Ceramic	0.001	50V	CKDYF 102Z 50
C16	Ceramic	0.001	50V	CKDYF 102Z 50
C17	Ceramic	0.001	50V	CKDYF 102Z 50
C18	Electrolytic	1,000	35V	ACH-039-0
C19	Electrolytic	220	16V	CEA 221P 16
C20	Electrolytic	2,200	10V	CEA 222P 10
C21	Electrolytic	2,200	10V	CEA 222P 10
C22	Ceramic	0.001	50V	CKDYF 102Z 50

RESISTORS

Symbol	Description			Part No.
R1	Carbon film	3.3k		RD $\frac{1}{4}$ PM 332J
R2	Carbon film	3.3k		RD $\frac{1}{4}$ PM 332J
R3	Carbon film	1k		RD $\frac{1}{4}$ PM 102J
R4	Carbon film	1k		RD $\frac{1}{4}$ PM 102J
R5	Carbon film	10k		RD $\frac{1}{4}$ PM 103J
R6	Carbon film	10k		RD $\frac{1}{4}$ PM 103J
R7	Carbon film	15k		RD $\frac{1}{4}$ PM 153J
R8	Carbon film	15k		RD $\frac{1}{4}$ PM 153J
R9	Carbon film	8.2k		RD $\frac{1}{4}$ PM 822J
R10	Carbon film	8.2k		RD $\frac{1}{4}$ PM 822J
R11	Carbon film	10		RD $\frac{1}{4}$ PM 100J
R12	Carbon film	10		RD $\frac{1}{4}$ PM 100J
R13	Metal oxide	1.2k	2W	RS2P 122J
R14	Metal oxide	1.5k	2W	RS2P 152J
R15	Carbon film	18k		RD $\frac{1}{4}$ PM 183J
R16	Carbon film	15k		RD $\frac{1}{4}$ PM 153J
R17	Carbon film	30k		RD $\frac{1}{4}$ PM 303J
R18	Carbon film	330		RD $\frac{1}{4}$ PM 331J
R19	Carbon film	10k		RD $\frac{1}{4}$ PM 103J
R20	Carbon film	3.3		RD $\frac{1}{4}$ PM 3R3J
R21	Carbon film	10		RD $\frac{1}{4}$ PM 100J

SEMICONDUCTORS

Symbol	Description	Part No.
Q1	Transistor 2SD313P-E or D	
Q2	Transistor 2SC869	
Q3	Transistor 2SC869	
Q4	Transistor 2SB507P-E or D	
Q5	Transistor 2SA628A	
Q6	Transistor 2SA628A	
Q7	Transistor 2SD313-E or D	
Q8	Transistor 2SC1384	
D1	Diode SIB01-04	
D2	Diode SIB01-04	
D3	Diode SIB01-04	
D4	Diode SIB01-04	
D5	Diode 1S1885	
D6	Diode 1S1885	
D7	Diode 1S1885	
D8	Zener diode WZ-320	
D9	Zener diode WZ-320	
D10	Zener diode WZ-140	

OTHERS

Symbol	Description	Part No.
	Socket (transistor)	AKH-002-0
	Spacer (insulator)	AEC-043-0

12.11 SWITCH CIRCUIT ASSEMBLY (AWS-064-0)

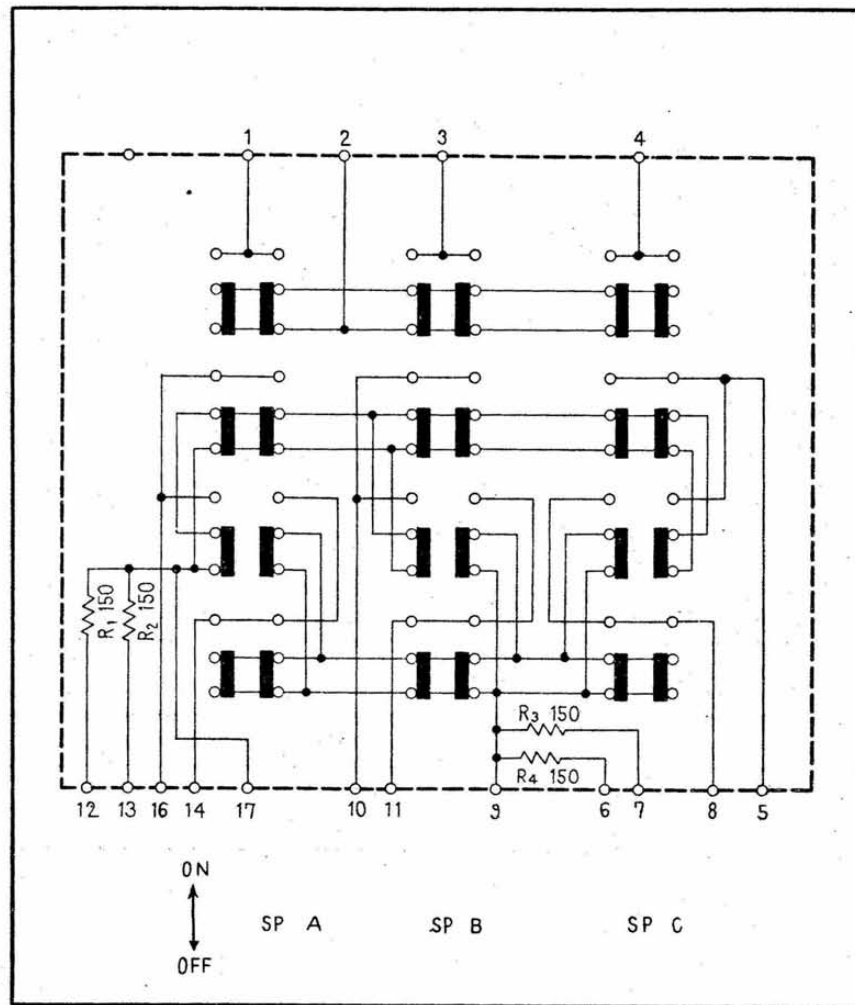

Foil Side

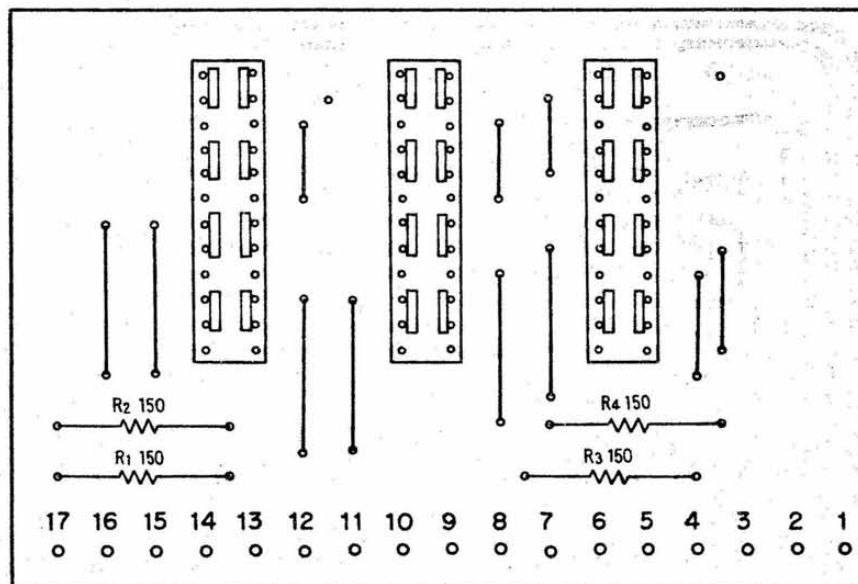

Parts List of Switch Circuit Assembly (AWS-064-0)

RESISTORS AND SWITCH

Symbol	Description	Part No.
R1	Metal oxide 150 2W	RS2PF 151J
R2	Metal oxide 150 2W	RS2PF 151J
R3	Metal oxide 150 2W	RS2PF 151J
R4	Metal oxide 150 2W	RS2PF 151J
	Push switch (Speakers)	ASG-061-0

12.12 SWITCH CIRCUIT ASSEMBLY (AWS-068-0)

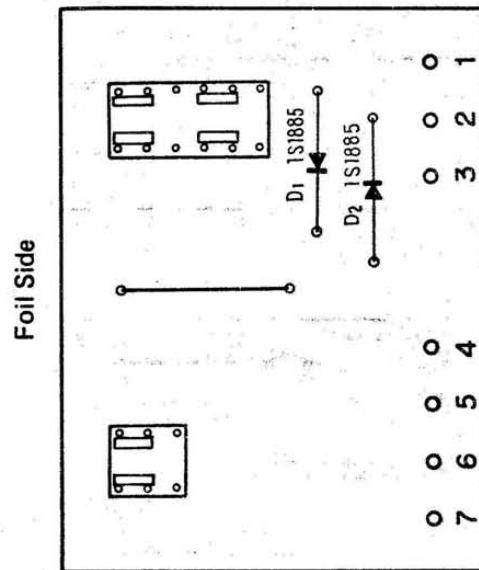
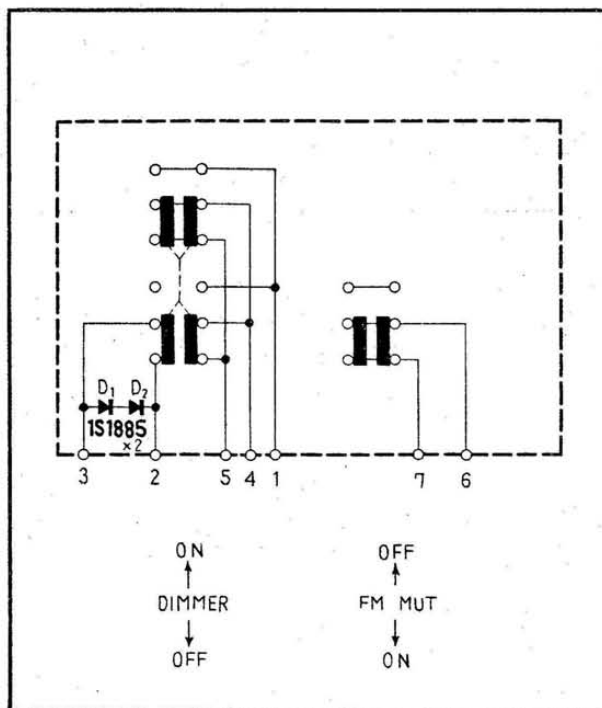

SEMICONDUCTORS AND SWITCH

Symbol	Description	Part No.
D1	Diodes 1S1885	
D2	Diode 1S1885	
	Push switch (Dimmer, FM muting)	ASG-064-0

12.13 SWITCH CIRCUIT ASSEMBLY (AWS-069-0)

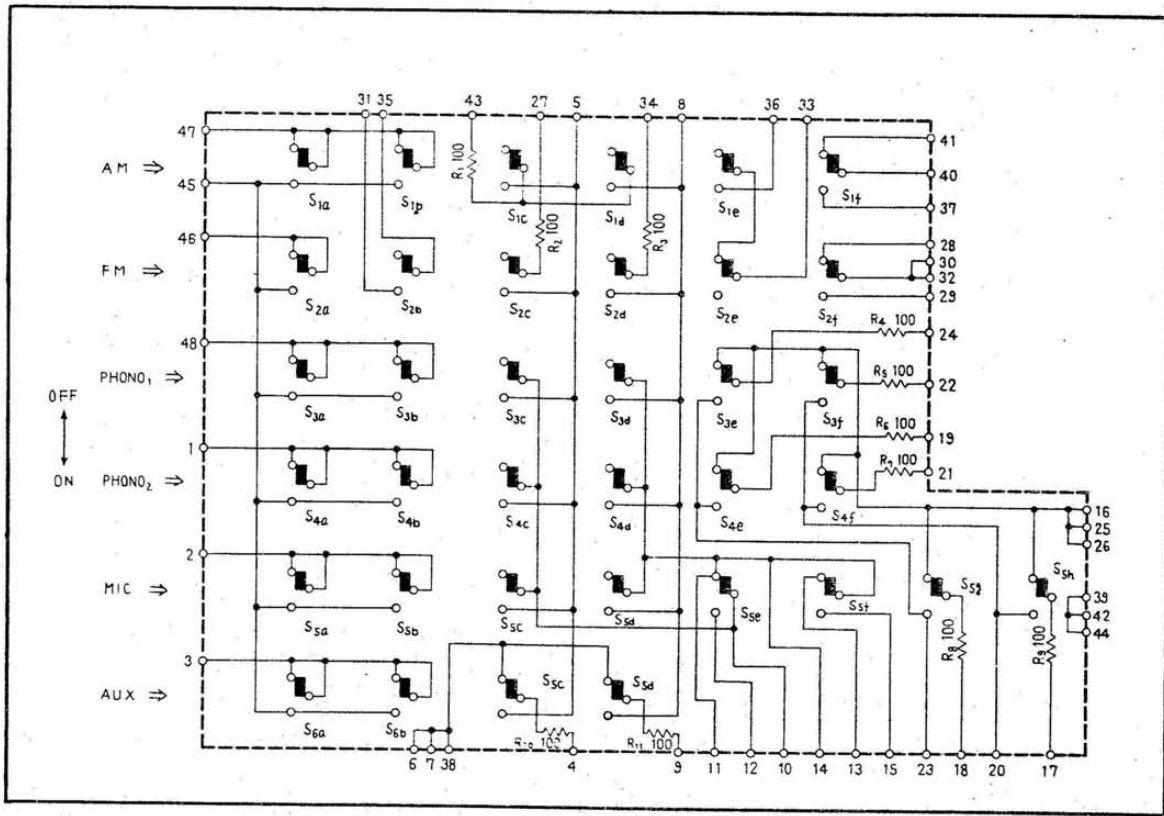

Foil Side

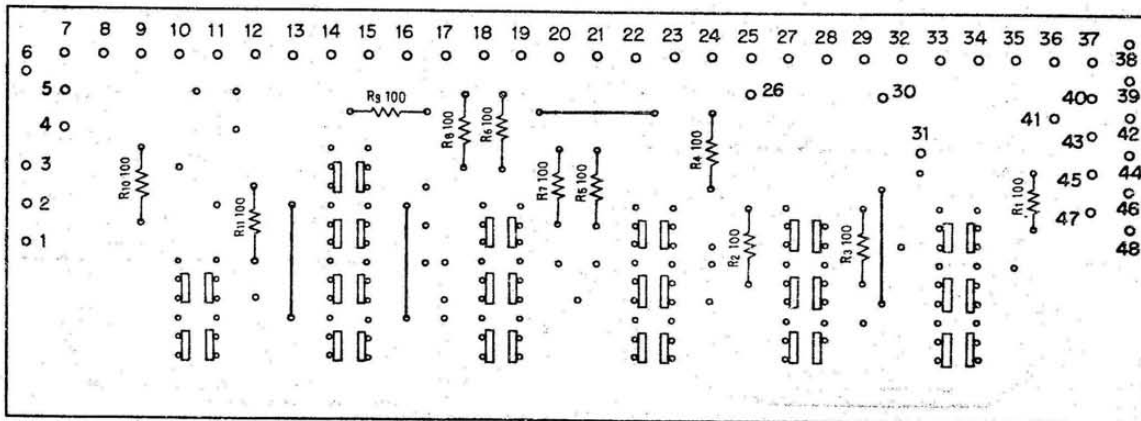

Parts List of Switch Circuit Assembly (AWS-069-0)

RESISTORS

Symbol	Description	Part No.
R1	Carbon film 100	RD¼PM 101J
R2	Carbon film 100	RD¼PM 101J
R3	Carbon film 100	RD¼PM 101J
R4	Carbon film 100	RD¼PM 101J
R5	Carbon film 100	RD¼PM 101J
R6	Carbon film 100	RD¼PM 101J
R7	Carbon film 100	RD¼PM 101J
R8	Carbon film 100	RD¼PM 101J
R9	Carbon film 100	RD¼PM 101J
R10	Carbon film 100	RD¼PM 101J
R11	Carbon film 100	RD¼PM 101J

SWITCH

Symbol	Description	Part No.
	Push switch (Function)	ASG-065-0

12.14 SWITCH CIRCUIT ASSEMBLY (AWS-070-A)

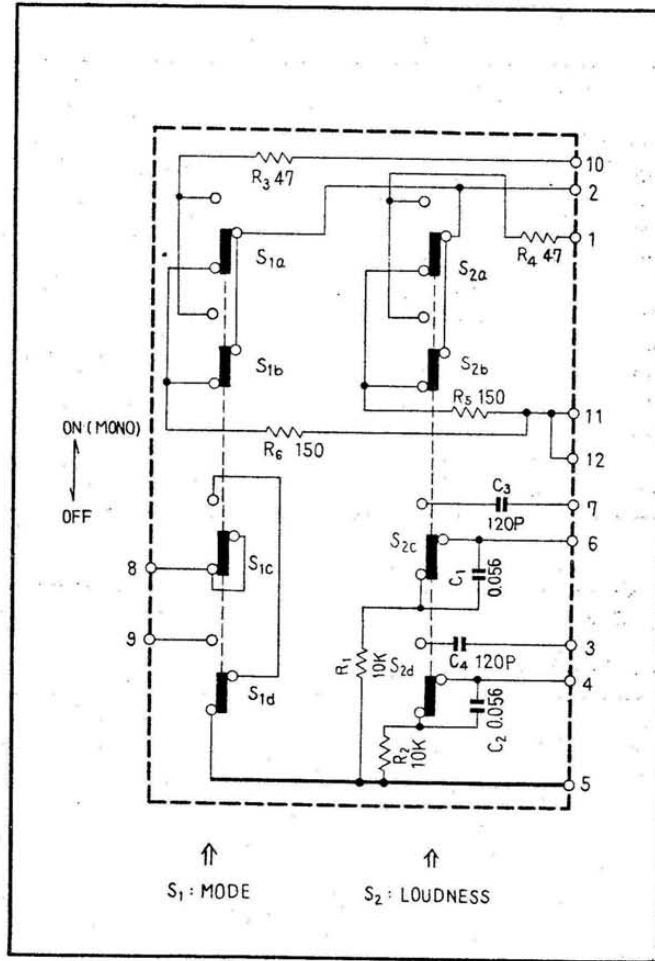

Foil Side

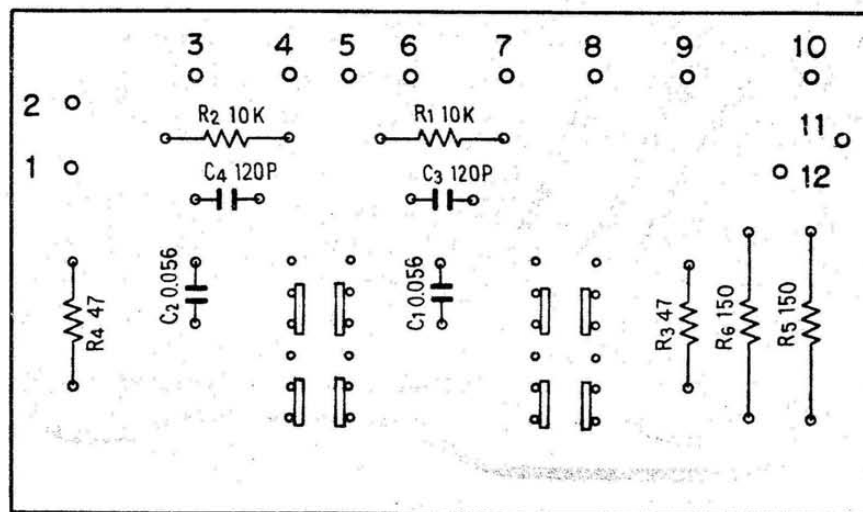

Parts List of Switch Circuit Assembly (AWS-070-A)

CAPACITORS

Symbol	Description	Part No.
C1	Mylar 0.027 50V	CQMA 273K 50
C2	Mylar 0.027 50V	CQMA 273K 50
C3	Ceramic 120p 50V	CCDSL 121J 50
C4	Ceramic 120p 50V	CCDSL 121J 50

RESISTORS

Symbol	Description	Part No.
R1	Carbon film 100k	RD¼PS 104J
R2	Carbon film 100k	RD¼PS 104J
R3	Carbon film 47	RD¼PS 470J
R4	Carbon film 47	RD¼PS 470J
R5	Metal axide 150 1W	RS1P 151K
R6	Metal oxide 150 1W	RS1P 151K

SWITCH

Symbol	Description	Part No.
	Push switch (Mode, Loudness)	ASG-067-0

12.15 SWITCH CIRCUIT ASSEMBLY (AWS-071-0)

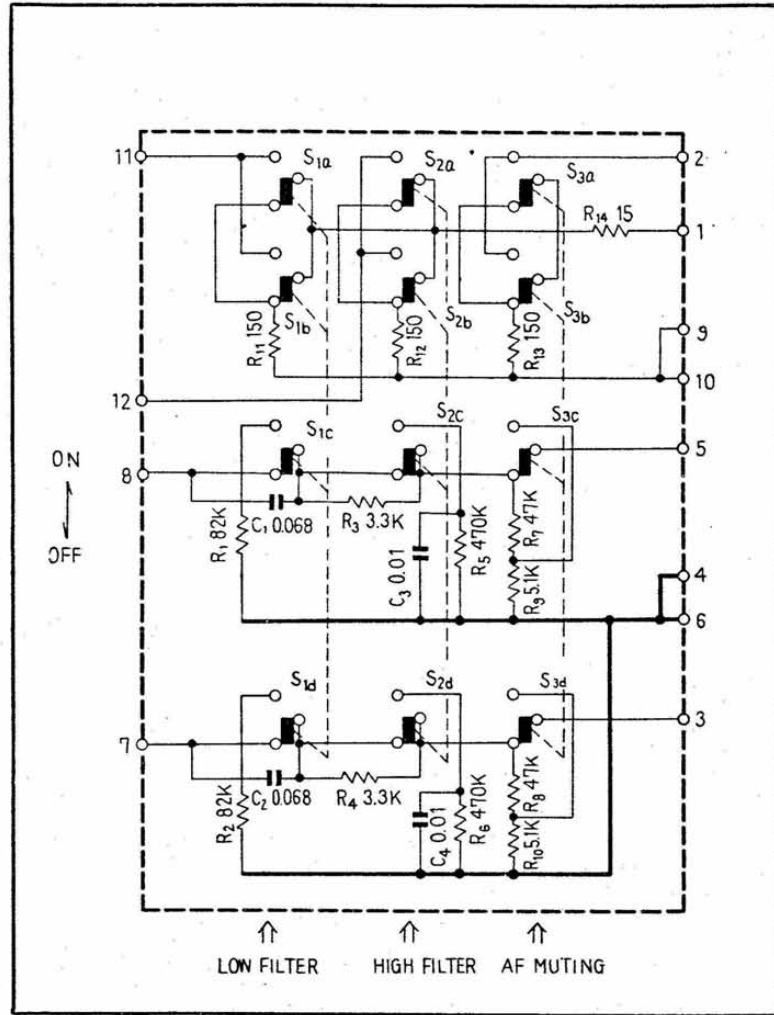

Foil Side

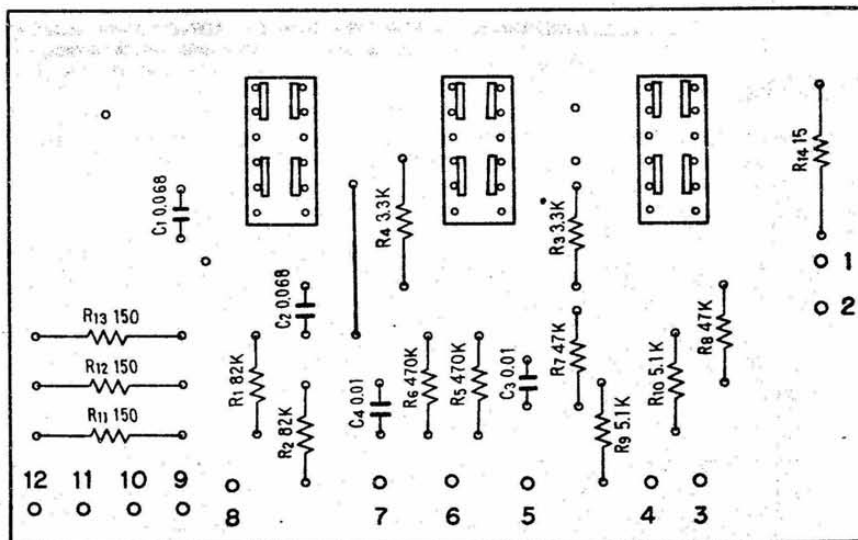

Parts List of Switch Circuit Assembly (AWS-071-0)

CAPACITORS

Symbol	Description			Part No.
C1	Mylar	0.068	50V	CQMA 683K 50
C2	Mylar	0.068	50V	CQMA 683K 50
C3	Mylar	0.01	50V	CQMA 103K 50
C4	Mylar	0.01	50V	CQMA 103K 50

RESISTORS

Symbol	Description			Part No.
R1	Carbon film	82k		RD $\frac{1}{2}$ PM 823J
R2	Carbon film	82k		RD $\frac{1}{2}$ PM 823J
R3	Carbon film	3.3k		RD $\frac{1}{2}$ PM 332J
R4	Carbon film	3.3k		RD $\frac{1}{2}$ PM 332J
R5	Carbon film	470k		RD $\frac{1}{2}$ PM 474J
R6	Carbon film	470k		RD $\frac{1}{2}$ PM 474J
R7	Carbon film	47k		RD $\frac{1}{2}$ PM 473J
R8	Carbon film	47k		RD $\frac{1}{2}$ PM 473J
R9	Carbon film	5.1k		RD $\frac{1}{2}$ PM 512J
R10	Carbon film	5.1k		RD $\frac{1}{2}$ PM 512J
R11	Metal oxide	150	1W	RS1P 151K
R12	Metal oxide	150	1W	RS1P 151K
R13	Metal oxide	150	1W	RS1P 151K
R14	Carbon film	15	$\frac{1}{2}$ W	RD $\frac{1}{2}$ PS 150J

SWITCH

Symbol	Description	Part No.
	Push switch (Filters, AF muting)	ASG-066-0

12.16 SWITCH CIRCUIT ASSEMBLY (AWS-072-0)

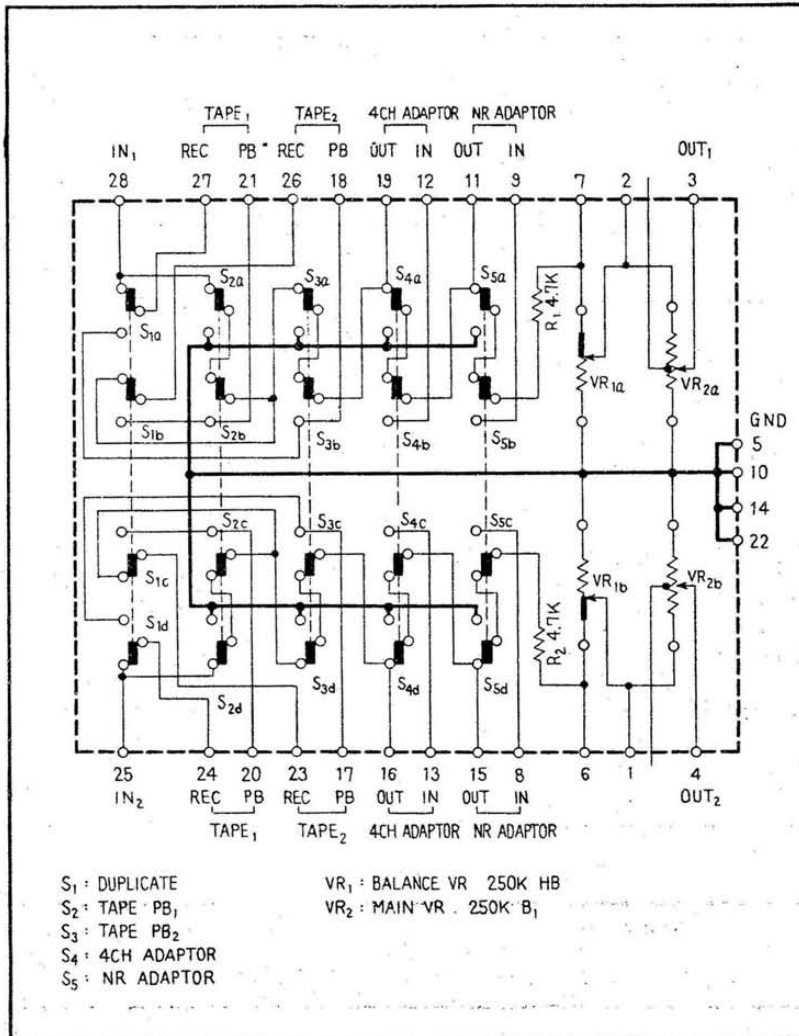

Foil Side

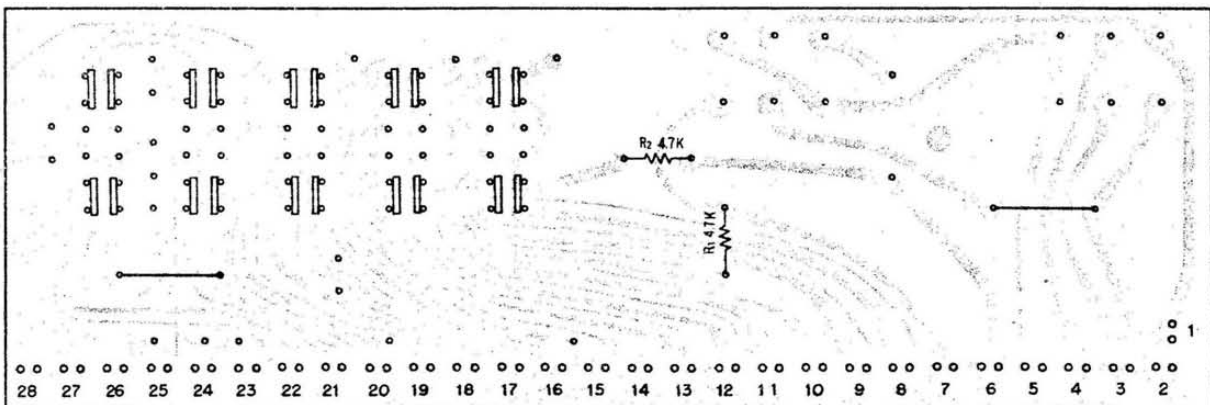

Parts List of Switch Circuit Assembly (AWS-072-0)

RESISTORS AND POTENTIOMETERS

Symbol	Description	Part No.
R1	Carbon film 4.7k	RD¼PS 472J
R2	Carbon film 4.7k	RD¼PS 472J
VR1	Variable resistor 250k-HB (Balance)	ACV-135-0
VR2	Variable resistor 250k-B1 (Volume)	ACV-134-0

SWITCHES

Symbol	Description	Part No.
S1	Lever switch (Duplicate)	ASK-072-0
S2	Lever switch (Tape 1)	ASK-072-0
S3	Lever switch (Tape 2)	ASK-072-0
S4	Lever switch (4 CH adaptor)	ASK-072-0
S5	Lever switch (NR adaptor)	ASK-072-0

12.17 5P CONNECTOR ASSEMBLY (AWX-062-0)

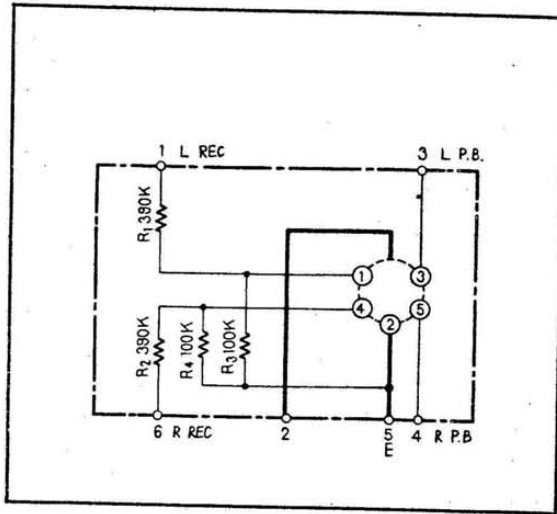

Foil Side

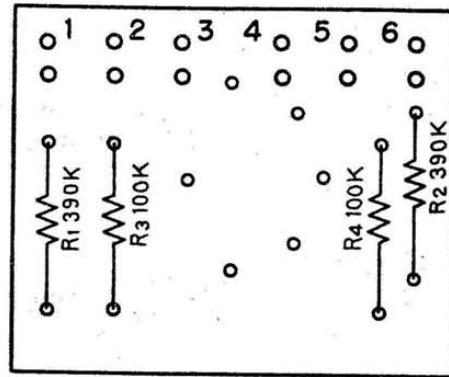

RESISTORS AND OTHERS

Symbol	Description	Part No.
R1	Carbon film 390k	RD¼PS394J
R2	Carbon film 390k	RD¼PS394J
R3	Carbon film 100k	RD¼PS104J
R4	Carbon film 100k	RD¼PS104J
	Connector (DIN type 5P)	AKP-007-0

13. PACKING METHOD AND PART NUMBERS

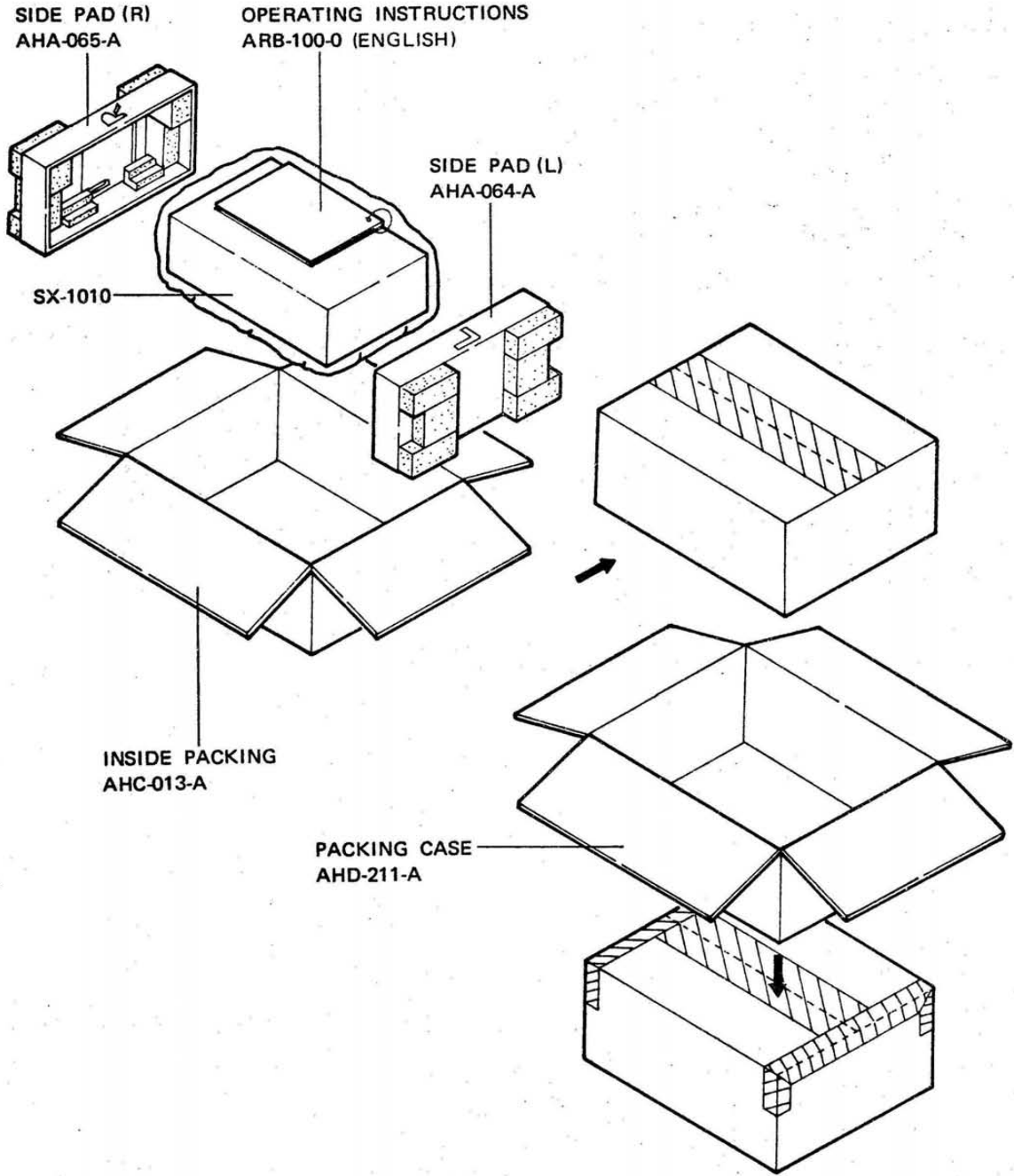

14. SCHEMATIC DIAGRAMS, P. C. BOARD PATTERN A

14.1 CIRCUIT CONNECTION DIAGRAM AND MISCELLANEOUS PARTS

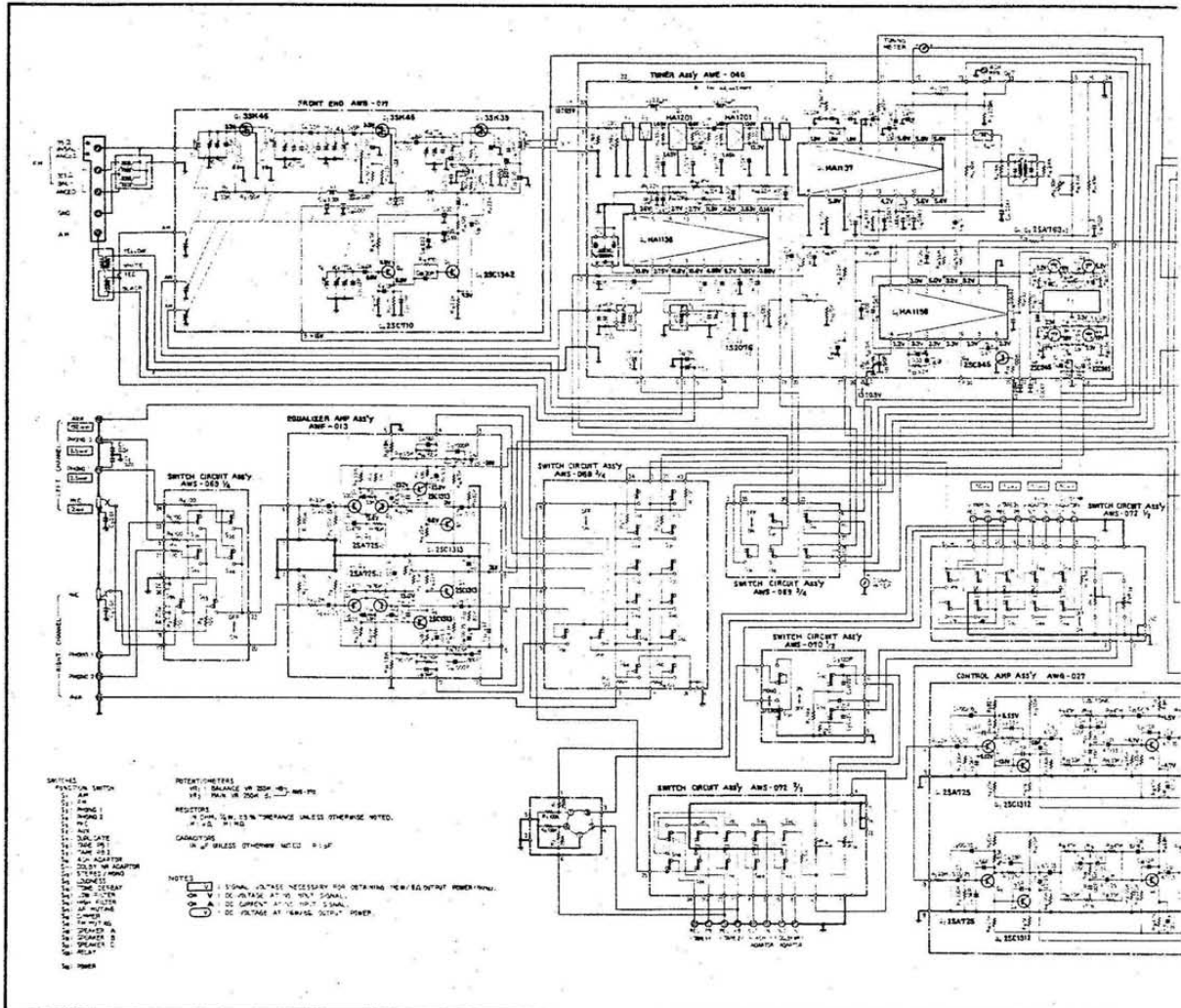

2SC111
2SA747

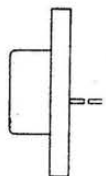

D PARTS LIST FOR 220V ONLY MODEL

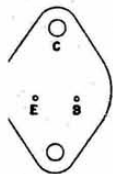
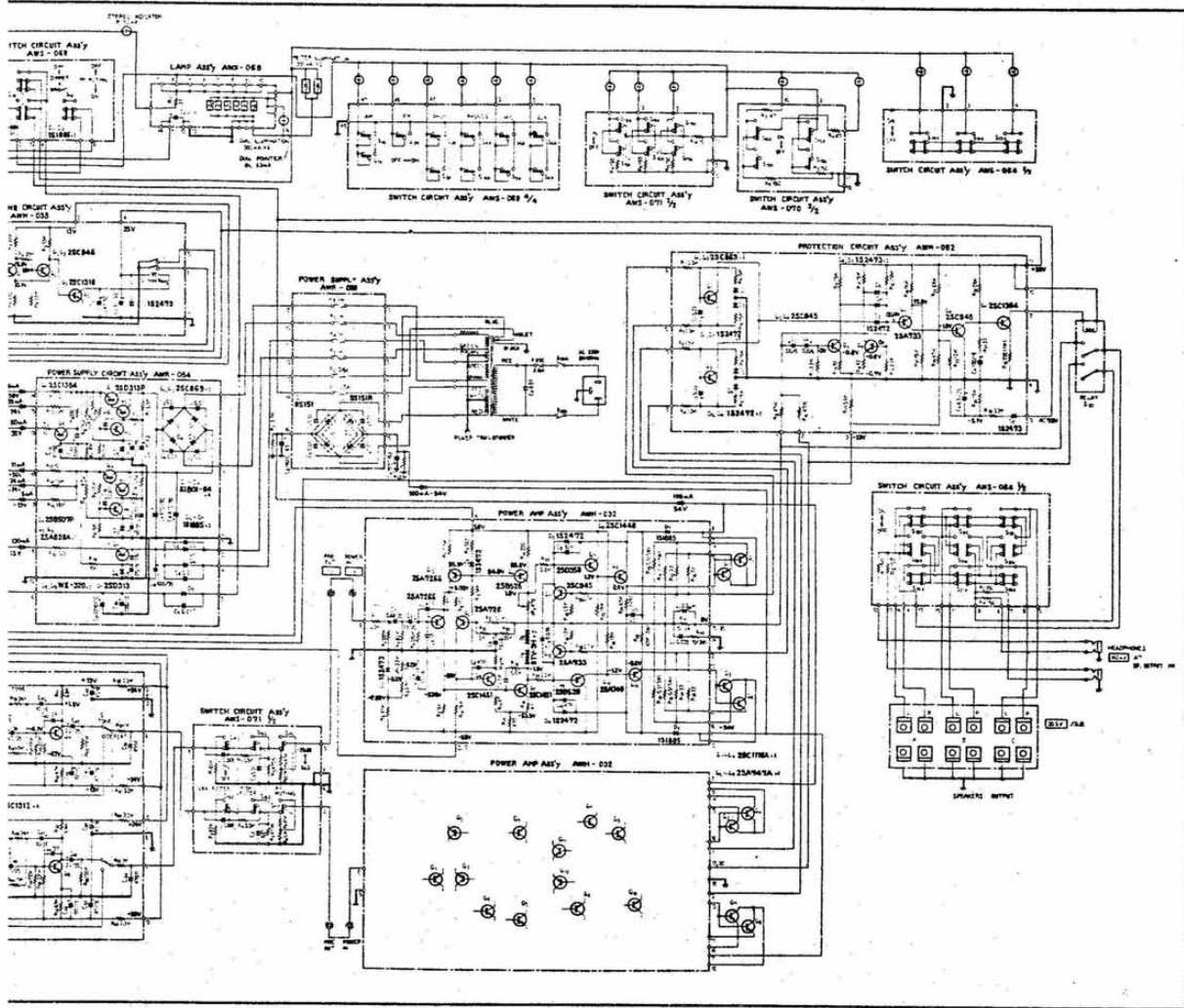

- CAPACITORS: IN μ F UNLESS OTHERWISE NOTED p:pF
- RESISTORS: IN Ω , $\frac{1}{4}$ W UNLESS OTHERWISE NOTED k:k Ω , M:M Ω .

Miscellaneous Parts

CAPACITORS

Symbol	Description			Part No.
C1	Ceramic	0.01	50V	CKDYF 103Z 50
C2	Ceramic	0.01	50V	CKDYF 103Z 50
C3	Ceramic	0.01	50V	CKDYF 103Z 50
C4	Ceramic	0.01	50V	CKDYF 103Z 50
C8	Ceramic	0.01	250V	ACG-001-0
C9	Electrolytic	18,000	63V	ACH-037-0
C10	Electrolytic	18,000	63V	ACH-037-0
C12	Ceramic	0.01	50V	CKDYF 103Z 50

RESISTORS

Symbol	Description			Part No.
R2	Metal oxide	3.3k	2W	PS2P 332J
R3	Metal oxide	3.3k	2W	RS2P 332J

SEMICONDUCTORS

Symbol	Description			Part No.
Q1	Transistor	2SC1116A-R, O or Y 2SC1079S-R or Y 2SD287P-K, L or M		
Q2	Transistor	2SC1116A-R, O or Y 2SC1079S-R or Y 2SD287P-K, L or M		
Q3	Transistor	2SC1116A-R, O or Y 2SC1079S-R or Y 2SD287P-K, L or M		
Q4	Transistor	2SC1116A-R, O or Y 2SC1079S-R or Y 2SD287P-K, L or M		
Q5	Transistor	2SA747A-R, O or Y 2SA679S-R or Y 2SB539P-K, L or M		
Q6	Transistor	2SA747A-R, O or Y 2SA679S-R or Y 2SB539P-K, L or M		
Q7	Transistor	2SA747A-R, O or Y 2SA679S-R or Y 2SB539P-K, L or M		
Q8	Transistor	2SA747A-R, O or Y 2SA679S-R or Y 2SB539P-K, L or M		

Continued on the Next Page

SWITCHES

Symbol	Description	Part No.	
S23	Relay	ASR-002-0	
S25	Lever switch (Power)	ASK-081-0	

OTHERS

Symbol	Description	Part No.	
	FM front end	AWB-017-0	
	Tuner assembly	AWE-040-0	
	Equalizer amplifier assembly	AWF-013-0	
	Control amplifier assembly	AWG-027-0	
	Power amplifier assembly	AWH-032-0	
	Protection circuit assembly	AWM-062-0	
	Power supply circuit assembly	AWR-063-0	
	Power supply circuit assembly	AWR-054-A	
	Switch circuit assembly (function)	AWS-069-0	
	Switch circuit assembly (mode, loudness)	AWS-070-A	
	Switch circuit assembly (filter, -20dB)	AWS-071-0	
	Switch circuit assembly (speaker)	AWS-064-0	
	Switch circuit assembly (tape monitor)	AWS-072-0	
	Switch circuit assembly (dimmer)	AWS-068-0	
	Lamp board assembly	AWX-069-0	
	5P connector assembly	AWX-062-0	
	Muting circuit assembly	AWM-039-A	
	Wooden cabinet assembly	AMM-034-A	
	Foot	AEC-027-B	
	Tuning shaft assembly	AXA-056-A	
	Tuning pulley assembly	AXA-015-A	
	Ferrite antenna holder assembly	W72-092-D	
	Front panel assembly	ANB-255-B	
	Dial pointer assembly	AAF-031-A	
	Dial scale	AAG-072-A	
	Meter (Signal & tuning)	AAW-029-0	
	Knob (Bass-main, Treble-main, Volume, Balance)	AAB-068-A	
	Knob (Bass-sub, Treble-sub)	AAB-069-A	
	Knob (Tuning)	AAA-026-A	
	Knob (Power, Tone, Duplicate, Monitor, 4 CH adaptor, NR adaptor)	AAD-040-0	
	Knob (SPKR A, B, C)	AAD-064-A	
	Knob (Low cut, High cut, -20dB)	AAD-065-A	
	Knob (Function)	AAD-066-A	
	Knob (Mode, Loudness)	AAD-067-A	
	Coupler (knob-to-switch)	AAE-007-0	

Symbol	Description	Part No.	
	Knob (Dimmer, FM muting)	AAD-082-A	
	Ornamental ring	AAC-034-A	
	Phono jack-B (6 jacks)	AKB-017-0	
	Phono jack-A (4 jacks)	AKB-014-0	
	Phono jack (1 jack)	AKB-019-0	
	Antenna terminal board	AKA-002-0	
	Binding post for ground	AKE-012-A	
	Speaker output terminal	AKE 014-0	
	Power transformer	ATT-179-0	
	Ferrite loopstick antenna	ATB-027-0	
	Balun	T22-025-A	
	Pilot lamp 8V, 0.3A (dial scale)	E22-032-0	
	Pilot lamp 8V, 0.3A (meter)	AEL-015-0	
	Fuse holder	K91-008-0	
	Fuse 3.15A (protection)	AEK-042-0	
	Fuse 1A (protection)	E21-031-0	
	Pilot lamp 8V, 50mA (program indicator)	AEL-023-0	
	Pilot lamp 8V, 50mA (program indicator)	AEL-022-0	
	Pilot lamp 6V, 30mA (stereo indicator)	AEL-014-0	
	Phone jack (Headphone)	K72-026-0	
	Phone jack (Microphone)	K72-024-0	
	Jumper plug	AKM-004-A	
	Transistor socket	AKH-001-0	
	Pilot lamp socket	AKK-002-0	
	AC cord grommet	AEC-079-0	
	Connector (AC power)	AKP-008-0	
	Screw M4 x 15	ABA-010-A	
	Washer	B21-011-0	
	FM T-type antenna	ADH-002-0	
	Operating instructions (English)	ARB-100-0	
	Operating instructions (French/German)	ARD-068-0	
	Inside packing	AHC-013-A	
	Packing case	AHD-211-A	
	Side pad (L)	AHA-064-A	
	Side pad (R)	AHA-065-A	

14.2 POWER SUPPLY CIRCUIT ASSEMBLY (AWR-063-0)

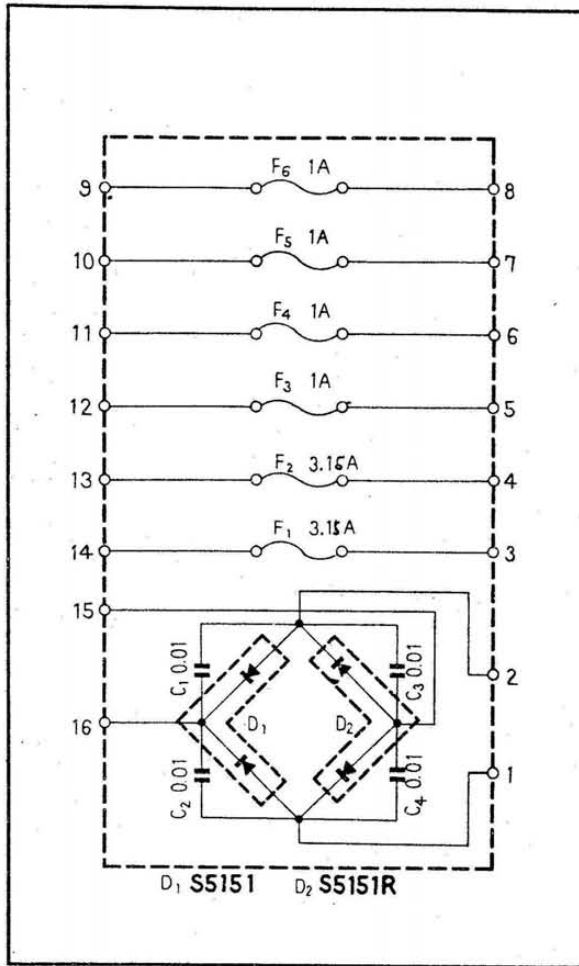

Foil Side

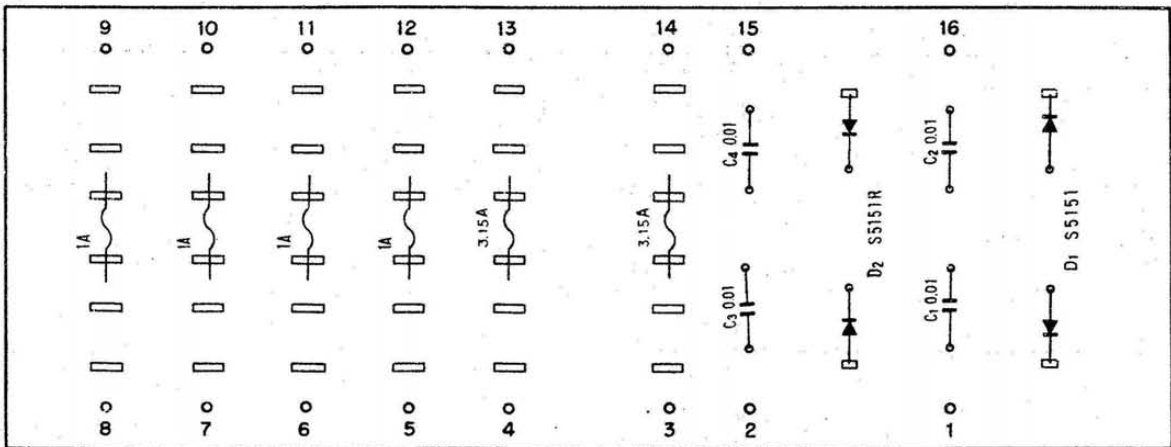

Parts List of Power Supply Circuit Assembly (AWR-063-0)

CAPACITORS

Symbol	Description			Part No.
C1	Ceramic	0.01	150V	ACG-004-0
C2	Ceramic	0.01	150V	ACG-004-0
C3	Ceramic	0.01	150V	ACG-004-0
C4	Ceramic	0.01	150V	ACG-004-0

SEMICONDUCTORS

Symbol	Description		Part No.
D1	Diode	S5151	
D2	Diode	S5151R	

OTHER

Symbol	Description	Part No.
	Fuse holder	AKR-010-0

PIONEER ELECTRONIC CORPORATION

4-1, 1-Chome, Meguro, Meguro-ku, Tokyo 153, Japan

U.S. PIONEER ELECTRONICS CORPORATION

178 Commerce Road, Carlstadt, New Jersey 07072, U.S.A.

PIONEER ELECTRONIC (EUROPE) N.V.

Meir-Center, Meir 21, 2000 Antwerp, Belgium

PIONEER ELECTRONICS AUSTRALIA PTY. LTD.

256-B City Road, South Melbourne, Victoria 3205, Australia

© FEB. 1974

Printed in Japan

SX-1010

FCU

PIONEER

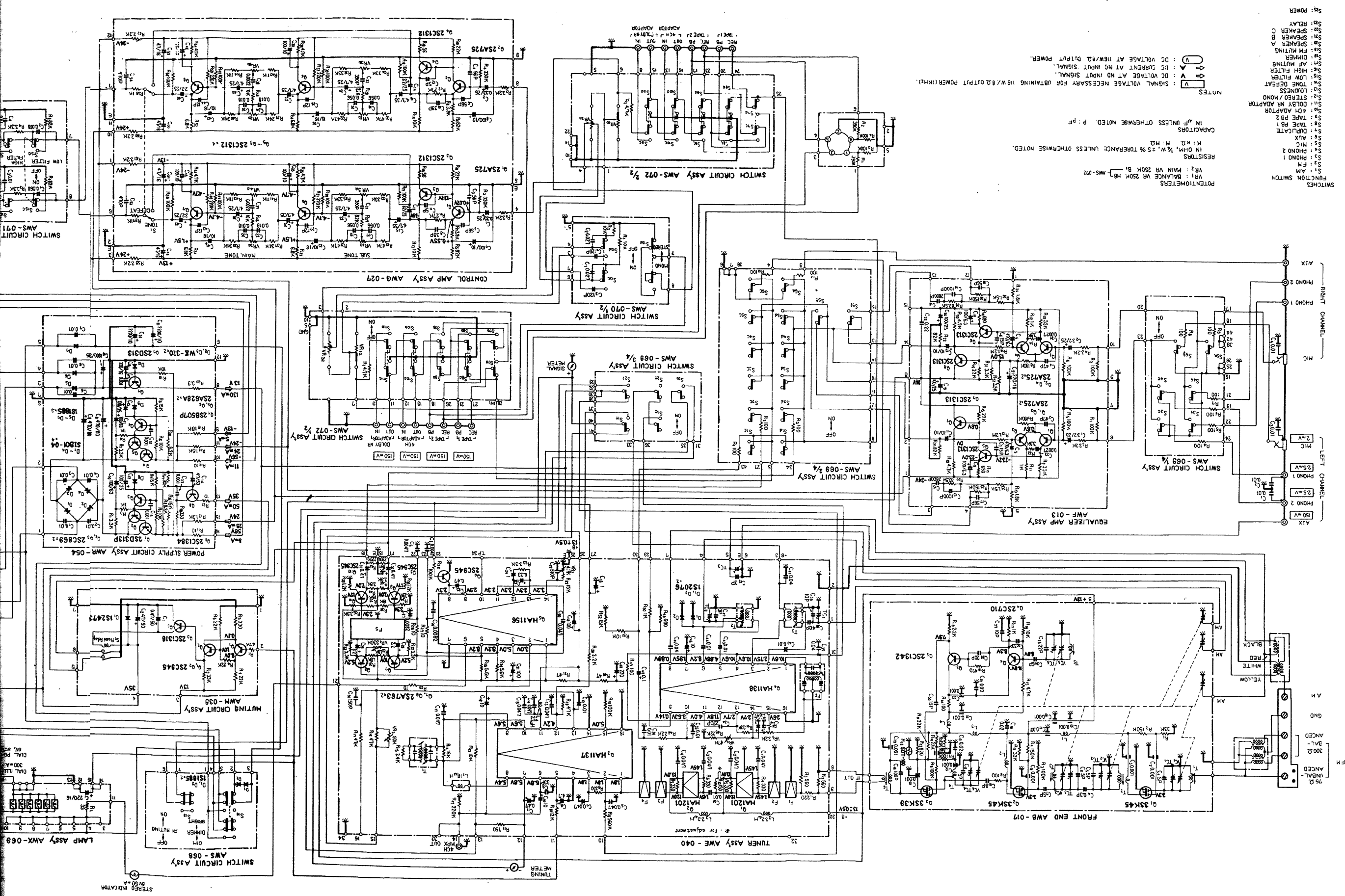

- FUNCTION SWITCHES**
- S1: AM
 - S2: FM
 - S3: PHONO 1
 - S4: PHONO 2
 - S5: MIC
 - S6: AUX
 - S7: DUAL/CATE
 - S8: TAPE PB2
 - S9: CH ADAPTOR
 - S10: DOLBY NR ADAPTOR
 - S11: STEREO/MONO
 - S12: DUNCESS
 - S13: TIME GREAT
 - S14: LOW FILTER
 - S15: HIGH FILTER
 - S16: AF MUTING
 - S17: FM MUTING
 - S18: DIMMER
 - S19: FM FILTERING
 - S20: SPEAKER A
 - S21: SPEAKER B
 - S22: RELAY
 - S23: POWER

POTENTIOMETERS

- VR1: BALANCE VR 250K B1, MS-072
- VR2: MAIN VR 250K B1, MS-072

RESISTORS

- K: K Ω, M: M Ω, % W, ±5% TOLERANCE UNLESS OTHERWISE NOTED.
- IN ΩF UNLESS OTHERWISE NOTED. P: P.F.

CAPACITORS

- IN ΩF UNLESS OTHERWISE NOTED. P: P.F.

NOTES

- V: SIGNAL VOLTAGE NECESSARY FOR OBTAINING 16W/8Ω OUTPUT POWER(LIKH2).
- V: DC VOLTAGE AT 16W/8Ω OUTPUT POWER.
- V: DC VOLTAGE AT NO INPUT SIGNAL.
- V: IC CURRENT AT NO INPUT SIGNAL.

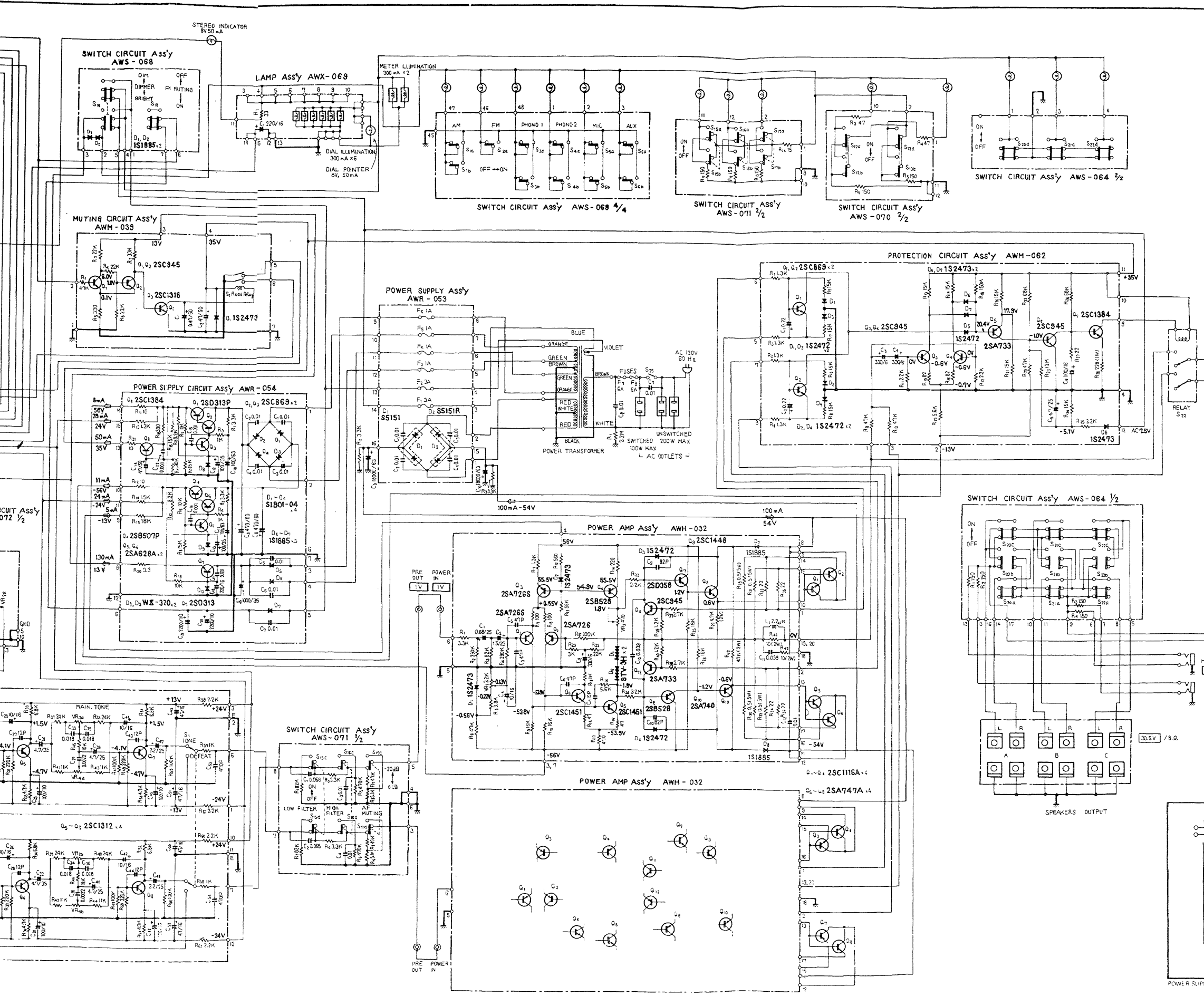

- 2SA725
- 2SA726S
- 2SC710
- 2SC869
- 2SC1312
- 2SC1313
- 2SA740
- 2SB507P
- 2SD313
- 2SC1448
- 2SA747A
- 2SC1116A
- 2SB528
- 2SD358
- 3SK39
- 3SK45
- 2SA733
- 2SC945
- 2SA763
- 2SA628A
- 2SC1318
- 2SC1342
- 2SC1384
- 2SC1451
- HA1156
- HA1201

