

Service Manual

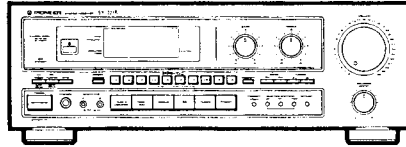

ORDER NO.
ARP2556

STEREO RECEIVER

SX-221R

SX-121

SX - 221R AND SX - 121 HAVE THE FOLLOWING :

Type	Model		Power Requirement	Remarks
	SX - 221R	SX - 121		
HEWZ	○	○	AC220V - 230V, 240V (Switchable) *	
HE	○	○	AC220V - 230V, 240V (Switchable) *	
HB	○	○	AC220V - 230V, 240V (Switchable) *	
YPW	○	—	AC240V only	

* Change the connection of the power transformer's primary wiring.

- This manual is applicable to the following : SX - 221R/HEWZ, HE, HB and YPW ; SX - 121/HEWZ, HE and HB.
- For the following : SX - 221R/HE, HB and YPW ; SX - 121/HE and HB, refer to page 38.
- Ce manuel pour le service comprend les explications de réglage en français.
- Este manual de servicio trata del método ajuste escrito en español.

CONTENTS

1. EXPLODED VIEWS, PACKING AND PARTS LIST	2	5. REGLAGES	34
2. SPECIFICATIONS	6	5. AJUSTES	36
3. SCHEMATIC AND PCB CONNECTIONS DIAGRAMS	7	6. FOR SX - 221R/HE, HB, YPW, SX - 121/HE AND HB TYPES	38
4. PCB PARTS LIST	25	7. PANEL FACILITIES	42
5. ADJUSTMENTS	32		

1. EXPLODED VIEWS, PACKING AND PARTS LIST

NOTES:

- Parts marked by "NSP" are generally unavailable because they are not in our Master Spare Parts List.
- The Δ mark found on some component parts indicates the importance of the safety factor of the part. Therefore, when replacing, be sure to use parts of identical designation.
- Parts marked by "●" are not always kept in stock. Their delivery time may be longer than usual or they may be unavailable.

Parts list of Exterior

Mark	No.	Description	Parts No.	Mark	No.	Description	Parts No.
	1	ROTARY KNOB S (BASS, TREBLE, BALANCE)	AAB1276	NSP	31	REAR PANEL (For SX-221R)	ANC1861
	2	ROTARY KNOB L (VOLUME)	AAB1277	NSP		REAR PANEL (For SX-121)	ANC1860
	3	POWER KNOB	AAD1984	●	32	CONTROL ASSEMBLY (For SX-221R)	AWZ4084
	4	BUTTON (SPEAKERS)	AAD2211	●		CONTROL ASSEMBLY (For SX-121) (For SX-121/HEWZ) 4093(SX-A4704)	AWZ4092
	5	BUTTON A (PLS)	AAD2212		33	BONNET CASE	ANE1334
	6	BUTTON B (PLS)	AAD2213	NSP	34	HEAT SINK	ANH1381
	7	DISPLAY PANEL (For SX-221R)	AAK2308		35	OPE. INSTRUCTIONS (German)	ARC1349
		DISPLAY PANEL (For SX-121)	AAK2310				
	8	FL FILTER (For SX-221R)	AAK2309	NSP	36	TRANS ASSEMBLY	AWZ4085
		FL FILTER (For SX-121)	AAK2311	NSP	37	SP SWITCH ASSEMBLY (For SX-221R/HEWZ)	AWZ4086
●	9	COMPLEX ASSEMBLY (For SX-221R/HEWZ)	AWZ4083	NSP		SP SWITCH ASSEMBLY (For SX-121/HEWZ)	AWZ4094
●		COMPLEX ASSEMBLY (For SX-121/HEWZ)	AWZ4091		38	REMOTE CONT'L UNIT (For SX-221R)	AXD1259
	10	SUB PANEL (PLS)	AAP1232		39	BATTERY COVER (For SX-221R)	AZA1297
	11	SCREW (STEEL)	ABA-297		40	SCREW	BCZ30P080FZK
	12	SCREW	ABA-298		41	SCREW	BPZ26P080FMC
	13	SCREW (STEEL)	ABA1009		42	NUT	NK90FUC
	14	SCREW (STEEL)	ABA1011	NSP	43	VR ASSEMBLY (For SX-221R/HEWZ)	AWZ4087
	15	SCREW	ABA1018	Δ	44	FUSE (T1A/250V, FU1)	AEK-508
	16	SCREW	ABA1054		45	LOOP ANTENNA (L)	ATB1005
Δ	17	AC POWER CORD	ADG1021	Δ	46	POWER TRANSISTOR (Q1)	2SC4688
	18	FM ANTENNA	ADH1002	Δ	47	POWER TRANSISTOR (Q2)	2SC4688
NSP	19	NYLON BINDER	AEC-093	Δ	48	POWER TRANSISTOR (Q3)	2SA1803
NSP	20	PURSE LOCK	AEC1325	Δ	49	POWER TRANSISTOR (Q4)	2SA1803
				Δ	50	POWER TRANSISTOR (Q5)	2SC4688
NSP	21	BINDER	AEP-215	Δ	51	POWER TRANSFORMER (T1)	ATS1412
NSP	22	BATTERY (R03, AAA) (For SX-221R)	AEX-021		52	NAME PLATE	PAM1407 (SC-447085)
	23	SIDE PAD (PS)	AHA1482				
	24	PACKING CASE (For SX-221R)	AHD2264				
		PACKING CASE (For SX-121)	AHD2265				
	25	PACKING SHEET	AHG1016				
	26	FRONT PANEL (For SX-221R)	AMB1998				
		FRONT PANEL (For SX-121)	AMB1999				
NSP	27	PCB MOULD	AMR1525				
	28	INSULATOR ASSY	AMR2140				
	29	VOLUME HOLDER	AMR2408				
NSP	30	CHASSIS	ANA1163				

● EXTERIOR

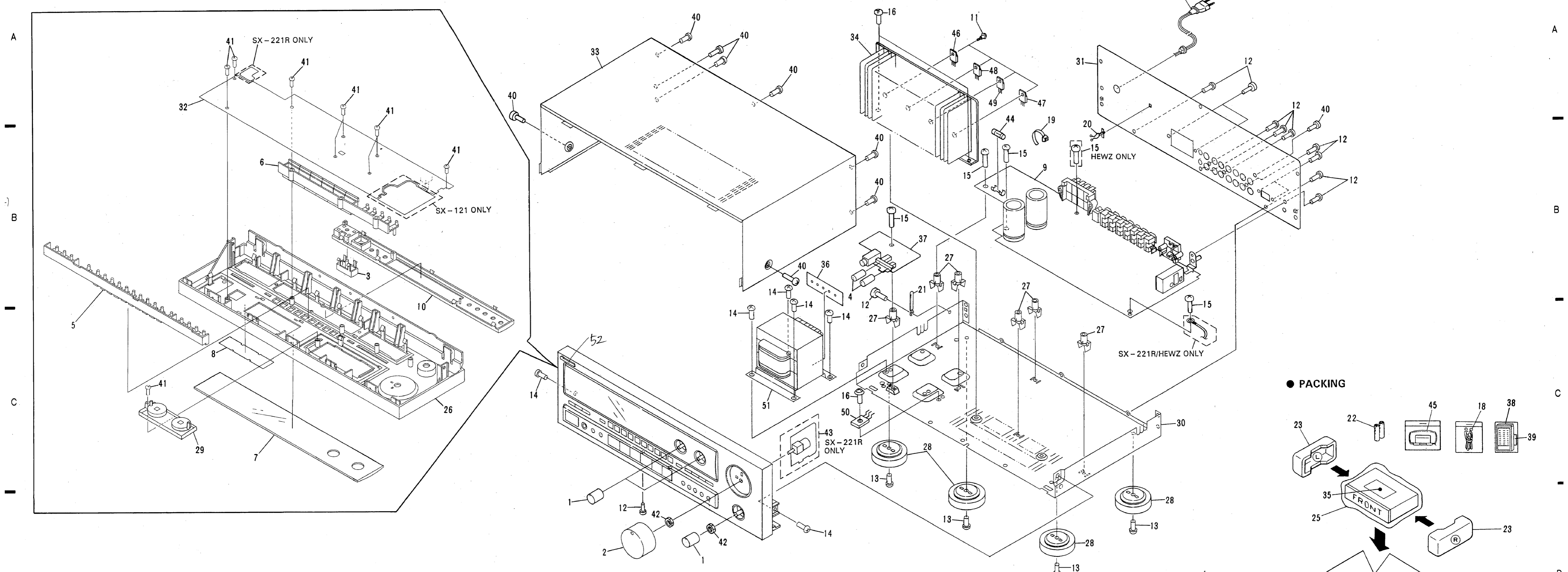

NOTE : Screws adjacent to ▼ mark on the product are used for disassembly.

● PACKING

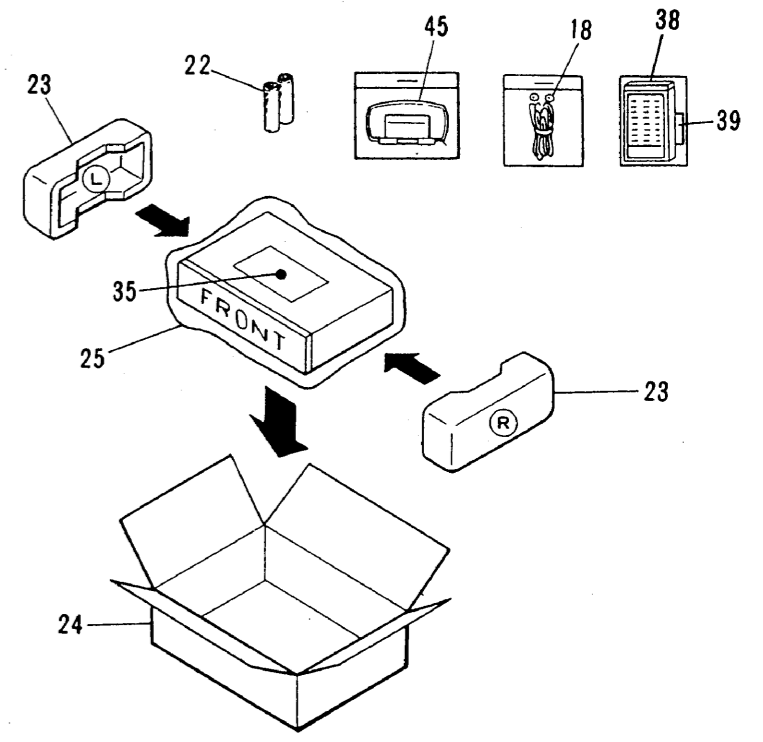

3. SCHEMATIC AND PCB CONNECTIONS DIAGRAMS

3.1 OVERALL SCHEMATIC DIAGRAM

2. SPECIFICATIONS

Verstärkerteil
 Fortlaufende Ausgangsleistung (Zweikanalbetrieb, DIN)*
 1 kHz, T.H.D. 1 %, 4 Ω 55 W + 55 W
 40 Hz - 20 kHz, T.H.D. 0,07 %, 8 Ω 45 W + 45 W
 Dynamischer Leistungsausgang (Mit EIA-Testsignal)
 4/8 Ω 85/65 W
 Klirrfaktor*
 40 Hz - 20 kHz, 45 W, 8 Ω 0,07 %
 * Die oben aufgeführten Daten gelten bei 230 V.

Eingang (Empfindlichkeit/Impedanz)
 PHONO 2,5 mV/47 kΩ
 CD, VCR/LD, TAPE 1/DAT, TAPE 2 MONITOR 150 mV/47 kΩ
 Plattenspieler-Überlastungspegel (T.H.D. 0,08 %, 1.000 Hz)
 PHONO 130 mV
Ausgang (Pegel/Impedanz)
 TAPE REC 150 mV/2,2 kΩ
Frequenzgang
 PHONO (RIAA-Entzerrung) 20 Hz bis 20.000 Hz ± 0,5 dB
 CD, VCR/LD, TAPE 1/DAT, TAPE 2 MONITOR 10 Hz bis 50.000 Hz ± 0,5 dB
Rauschabstand (IHF, kurzgeschlossen, A Netzwerk)
 PHONO 71 dB
 CD, VCR/LD, TAPE 1/DAT, TAPE 2 MONITOR 96 dB
Rauschabstand (DIN, Dauerleistung/50 mW)
 PHONO 67 dB/56 dB
 CD, VCR/LD, TAPE 1/DAT, TAPE 2 MONITOR 82 dB/56 dB
Ton-Regelung
 BASS ± 8 dB (100 Hz)
 TREBLE ± 8 dB (10 kHz)

UKW-Tunerteil
 Frequenzbereich 87,5 MHz bis 108 MHz
 Nutzeempfindlichkeit 14,2 dBf, IHF (1,4 μV/75 Ω)
 50 dB Empfindlichkeitsschwelle
 MONO 20,2 dBf (2,8 μV/75 Ω)
 STEREO 41,2 dBf (31,6 μV/75 Ω)
Empfindlichkeit (DIN)
 MONO 1,4 μV/75 Ω
 STEREO 32 μV/75 Ω
Rauschabstand
 MONO 75 dB (bei 85 dBf)
 STEREO 71 dB (bei 85 dBf)
Rauschabstand (DIN)
 MONO 68 dB
 STEREO 64 dB
Verzerrung
 STEREO 0,3 % (1 kHz)
 Trennungsvermögen von dem dritten Kanal 67 dB (400 kHz)
 Stereotrennung 35 dB (1 kHz)
 Frequenzgang 30 Hz bis 15 kHz (± 1 dB)
 Antennenausgang 75 Ω nicht balanciert

MW-Tunerteil
 Frequenzbereich 531 kHz bis 1.602 kHz
 Empfindlichkeit
 IHF, Rahmen-Antenne 300 μV/m
 Trennungsvermögen 25 dB
 Rauschabstand 53 dB
 Antenne MW-Rahmenantenne

Verschiedenes
 Stromversorgung Wechselstrom 220 - 230 Volt, 50/60 Hz
 Stromverbrauch
 Modell SX-121 290 W
 Modell SX-221R 290 W
 Abmessungen 420 (B) x 140 (H) x 289 (T) mm
 Gewicht (Ohne Verpackung)
 Modell SX-121 5,3 kg
 Modell SX-221R 5,5 kg

Zubehör
 T-förmige UKW-Antenne 1
 MW-Rahmenantenne 1
 Bedienungsanleitung 1
 [Nur bei SX-221R]
 Fernbedienungsgerät 1
 Trockenzelle-Batterie (Format "AAA" (IEC R03/UM-4)) 2

HINWEIS:
 Änderung der technischen Daten und des Design ohne vorherige Bekanntgabe vorbehalten.
 * Messungen durch Audio-Spektralanalysator.

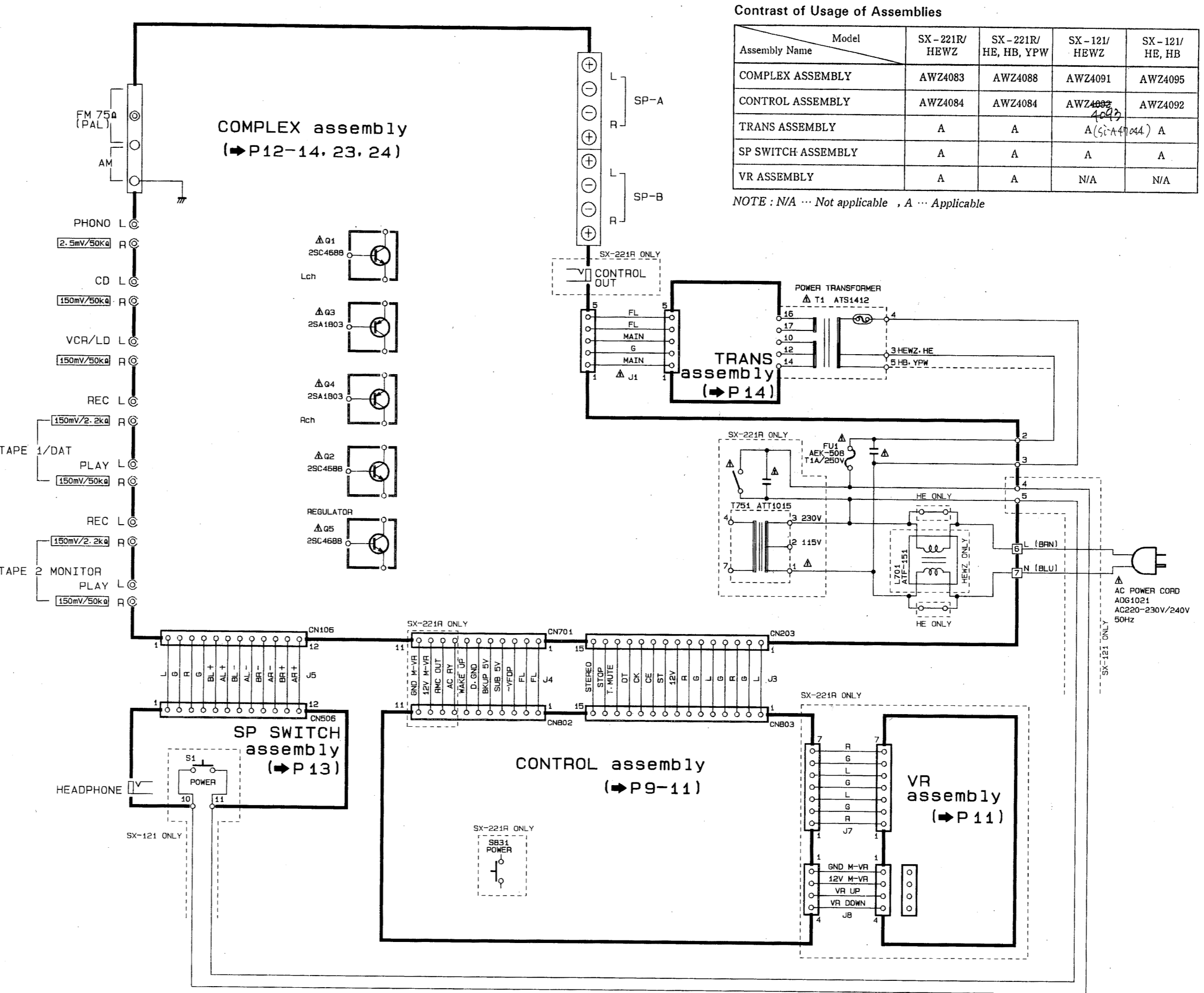

Contrast of Usage of Assemblies

Assembly Name	Model	SX-221R/HEWZ	SX-221R/HE, HB, YPW	SX-121/HEWZ	SX-121/HE, HB
COMPLEX ASSEMBLY		AWZ4083	AWZ4088	AWZ4091	AWZ4095
CONTROL ASSEMBLY		AWZ4084	AWZ4084	AWZ4092	AWZ4092
TRANS ASSEMBLY		A	A	A (S1-A4)	A
SP SWITCH ASSEMBLY		A	A	A	A
VR ASSEMBLY		A	A	N/A	N/A

NOTE: N/A ... Not applicable, A ... Applicable

Note: (Type 3)

- When ordering service parts, be sure to refer to "PARTS LIST of EXPLODED VIEWS" or "PCB PARTS LIST".
- Since these are basic circuits, some parts of them or the values of some components may be changed for improvement.
- RESISTORS:**
 Unit: k: kΩ, M: MΩ, or Ω unless otherwise noted.
 Rated power: 1/4W, 1/6W, 1/8W, 1/10W unless otherwise noted.
 Tolerance: (F): ±1%, (G): ±2%, (K): ±10%, (M): ±20% or ±5% unless otherwise noted.
- CAPACITORS:**
 Unit: p: pF or μF unless otherwise noted.
 Ratings: capacitor (μF)/ voltage (V) unless otherwise noted.
 Rated voltage: 50V except for electrolytic capacitors.
- COILS:**
 Unit: m: mH or μH unless otherwise noted.
- VOLTAGE AND CURRENT:**
 mV: Signal voltage at FM 1kHz, 100% MOD.
 V: DC voltage (V) at no input signal unless otherwise noted.
 Value in () is DC voltage at rated power.
 mA or -mA: DC current at no input signal unless otherwise noted.
- OTHERS:**
 ●: Signal route.
 ⊙: Adjusting point.
 ▼ (Red): Measurement point.
 The Δ mark found on some component parts indicates the importance of the safety factor of the parts. Therefore, when replacing, be sure to use parts of identical designation.

8. SWITCHES (Underline indicates switch position):

CONTROL assembly	SP SWITCH assembly	SP A/B
S801 TUNING +	S570	SP A/B
S802 TUNING -	S1	POWER
S803 2		(SX-121 ONLY)
S804 1		
S805 BAND FM		
S806 BAND AM		
S807 MEMORY		
S808 MEMORY SCAN		
S809 POP		
S810 ROCK		
S811 OTHER		
S812 HITS		
S813 CD		
S814 TUNER		
S815 PHONO		
S816 AUTO/MONO		
S817 AUTO/MANUAL		
S818 DIRECT ACCESS		
S819 VCR/LD		
S820 TAPE 1/DAT		
S821 TAPE 2/MONITOR		
S822 0		
S823 9		
S824 8		
S825 RETURN		
S826 7		
S827 6		
S828 5		
S829 4		
S830 3		
S831 POWER		(SX-221R ONLY)

3.3 COMPLEX ASSEMBLY (1/2) AND SP SWITCH ASSEMBLY

● Parts marked with * have the following variations :

Mark	Symbol & Description	(Note) HEWZ	(Note) HE • HB • YPW
	L561, L562	ATH1009	ATH1004
	L701	ATF-151	JUMPER
	L981-L984	ATH-133	VACANT
	C203-C222	390p	VACANT
	C223, C224	820p	470p
	C225, C226	680p	VACANT
	C527, C528	220p	VACANT
	C531, C532	3900p	VACANT
	C561, C562	0.047	0.1
	C563, C564	JUMPER	0.1
	C983, C984, C987, C988	0.01	VACANT
	C981, C982, C985, C986	680p	VACANT
△	R573, R574	680 (1W)	VACANT
△	R981, R982, R985, R986	100 (1/2W)	JUMPER
△	R987, R988	10 (1/4W)	VACANT

Note :
HEWZ indicates SX-221R/HEWZ and SX-121/HEWZ.
HE • HB • YPW indicates SX-221R/HE, HB, YPW, SX-121/HE and HB.

- SX-221R indicates models SX-221R/HEWZ, HE, HB and YPW.
- SX-121 indicates models SX-121/HEWZ, HE and HB.
- HEWZ indicates models SX-221R/HEWZ and SX-121/HEWZ.
- HE • HB • YPW indicates models SX-221R/HE, HB, YPW, SX-121/HE and HB.

COMPLEX assembly (1/2)(AWZ4083 : SX-221R/HEWZ)
(AWZ4088 : SX-221R/HE, HB, YPW)
(AWZ4091 : SX-121/HEWZ)
(AWZ4095 : SX-121/HE, HB)

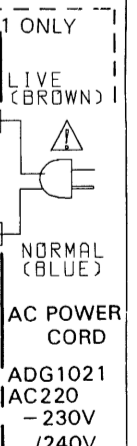
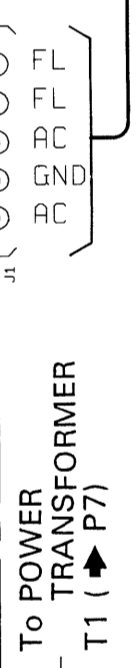
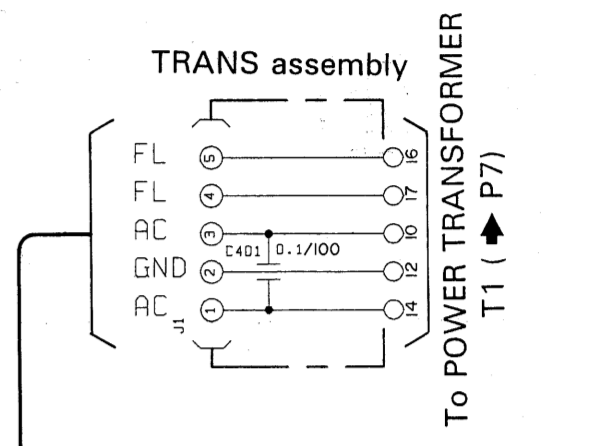
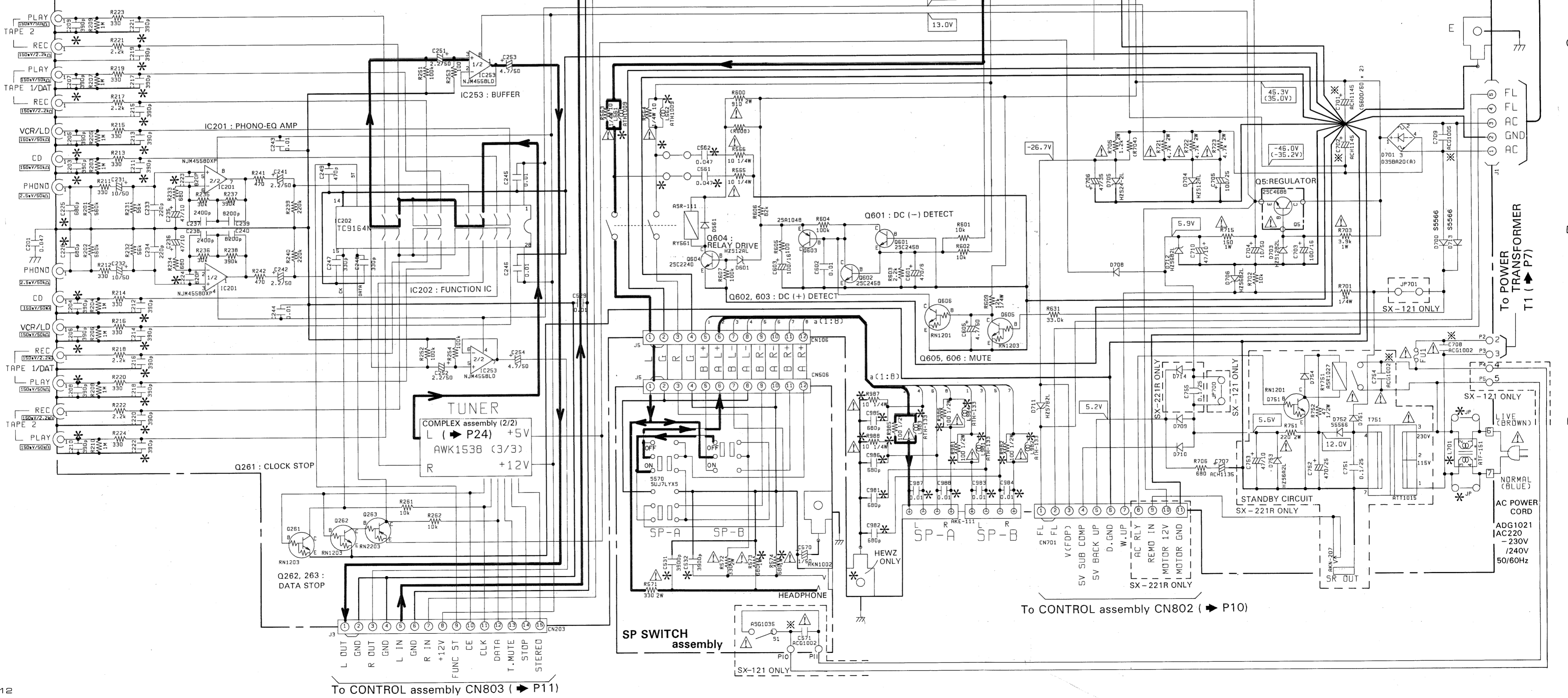

To CONTROL assembly CN802 (P10)

To CONTROL assembly CN803 (P11)

3.4 PCB CONNECTION DIAGRAM

- NOTE
- This P.C.B connection diagram is viewed from the parts mounted side.
 - The parts which have been mounted on the board can be replaced with those shown with the corresponding wiring symbols listed in the following Table.

P.C.B. pattern diagram indication	Corresponding part symbol	Part Name
		Transistor
		Radiator type transistor
		Diode
		Resistor
		Capacitor (Polarized)
		Capacitor (Non-polarized)

Others

P.C.B. pattern diagram indication	Part Name
	IC
	Switch
	Relay
	Coil
	Filter
	Variable resistor or Semi-fixed resistor

- The capacitor terminal marked with ⊕ (double circles) shows negative terminal.
- The diode terminal marked with ⊕ (double circles) shows cathode side.
- The transistor terminal to which E is affixed shows the emitter.

Line Voltage Selection

Line voltage can be changed with the following steps.

- Disconnect the AC Power cord.
- Remove the top cover.
- Change the connection with the power transformer (T) primary taps.
- Stick the line voltage label on the rear panel.

Part No.	Description
AAX-193	220V label
AAX-192	240V label

This P. C. B connection diagram is viewed from the parts mounted side.

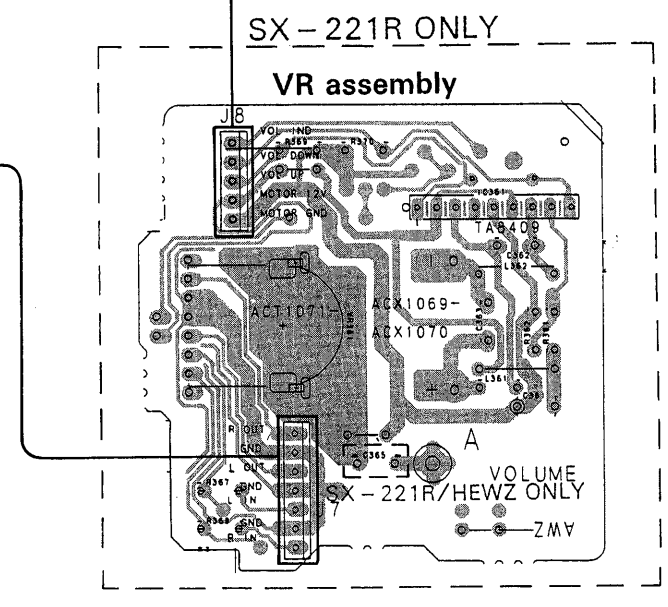
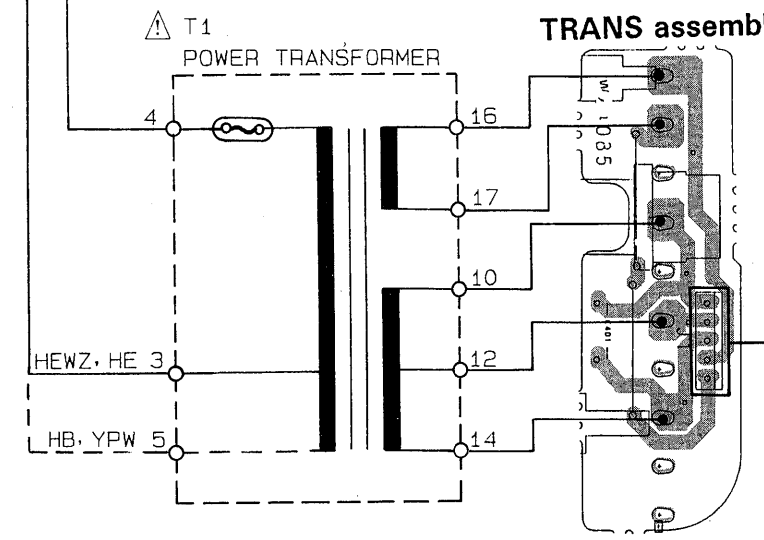
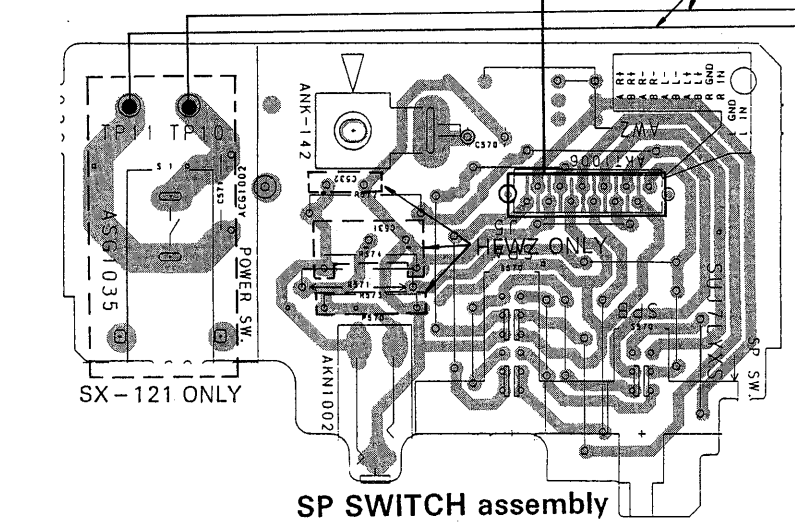
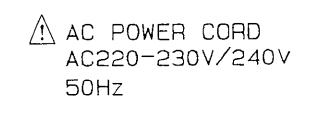

CONTROL assembly (AWZ4084 : SX-221R/HEWZ, HE, HB, YPW)
(AWZ4092 : SX-121/HEWZ, HE, HB)

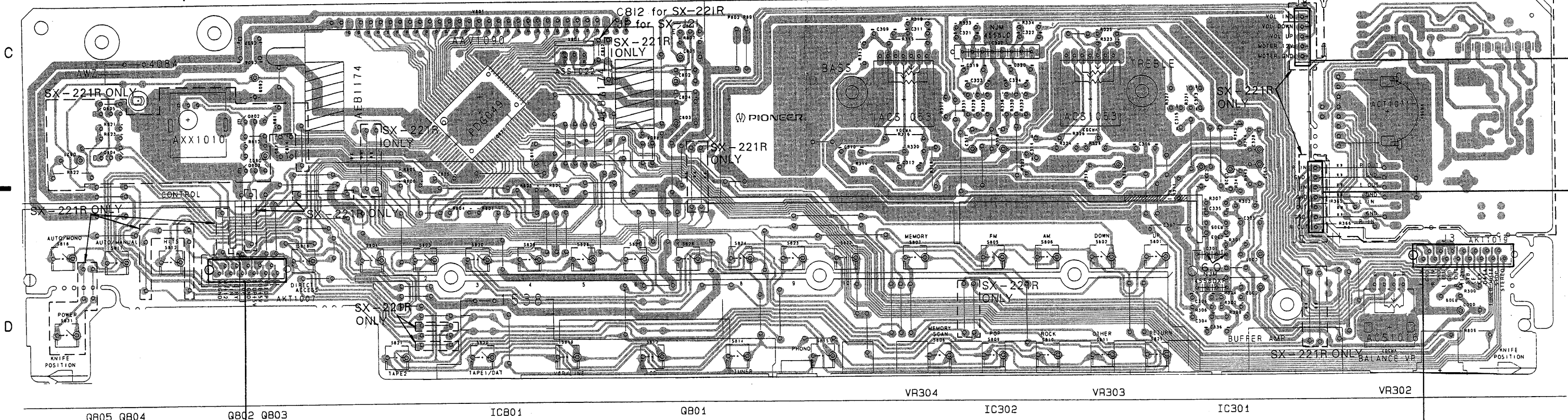

COMPLEX assembly
(AWZ4083 : SX-221R/HEWZ)
(AWZ4088 : SX-221R/HE, HB, YPW)
(AWZ4091 : SX-121/HEWZ)
(AWZ4095 : SX-121/HE, HB)

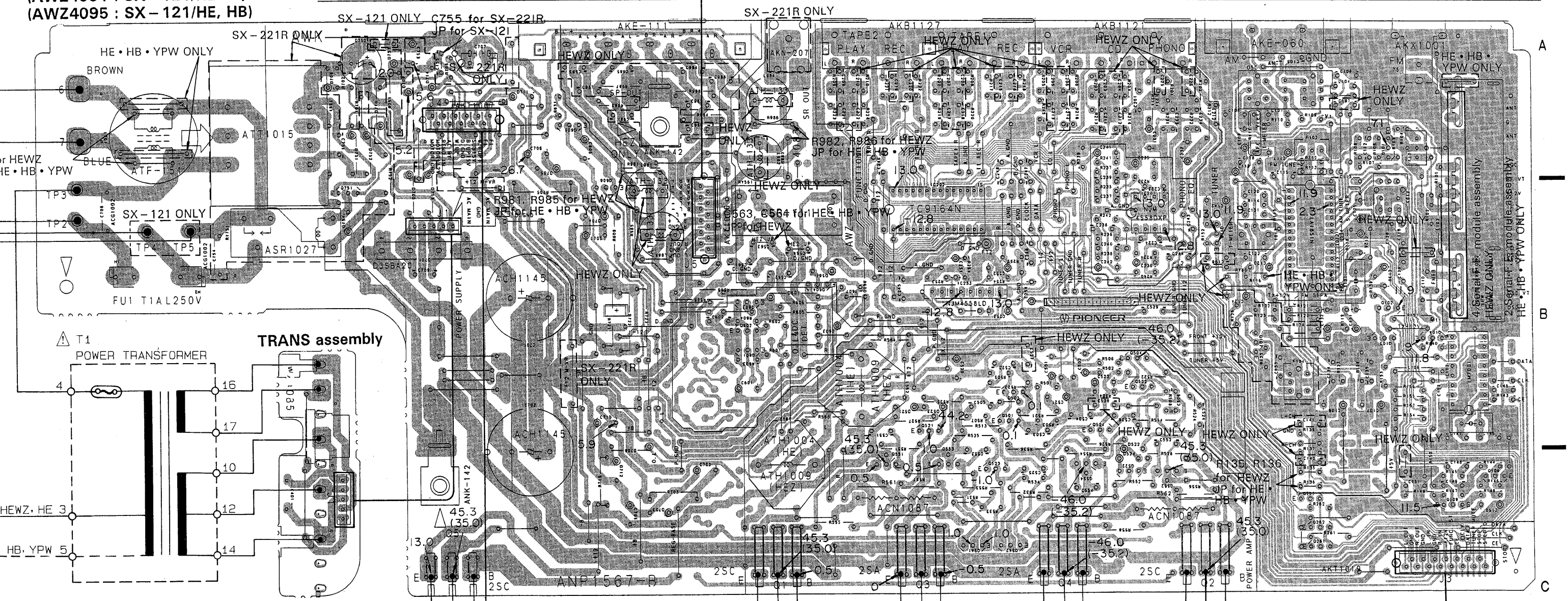

- SX-221R indicates models SX-221R/HEWZ, HE, HB and YPW.
- SX-121 indicates models SX-121/HEWZ, HE and HB.
- HEWZ indicates models SX-221R/HEWZ and SX-121/HEWZ.
- HE • HB • YPW indicates models SX-221R/HE, HB, YPW, SX-121/HE and HB.

This P. C. B. connection diagram is viewed from the foil side.

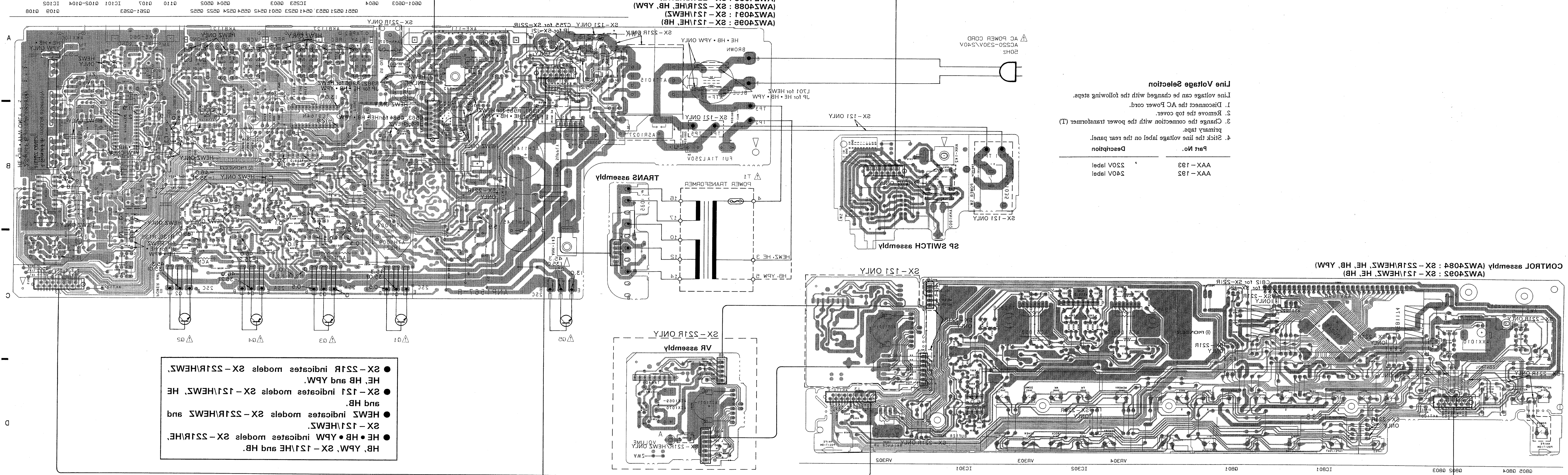

Line Voltage Selection

Line voltage can be changed with the following steps:

1. Disconnect the AC Power cord.
2. Remove the top cover.
3. Change the connection with the power transformer (T) primary taps.
4. Stick the line voltage label on the rear panel.

Part No.	Description
AAX-193	220V label
AAX-192	240V label

- HB, YPW, SX-121HE and HB.
- HE, HB, YPW indicates models SX-221R/HE, SX-121HEWZ, and HB.
- HEWZ indicates models SX-221R/HEWZ and SX-121HEWZ.
- SX-221R indicates models SX-221R/HEWZ, HE, HB and YPW.
- SX-121 indicates models SX-121/HEWZ, HE and HB.

COMPLEX assembly
 (AWZ4083 : SX-221R/HEWZ)
 (AWZ4088 : SX-221R/HE, HB, YPW)
 (AWZ4091 : SX-121/HEWZ)
 (AWZ4095 : SX-121/HE, HB)

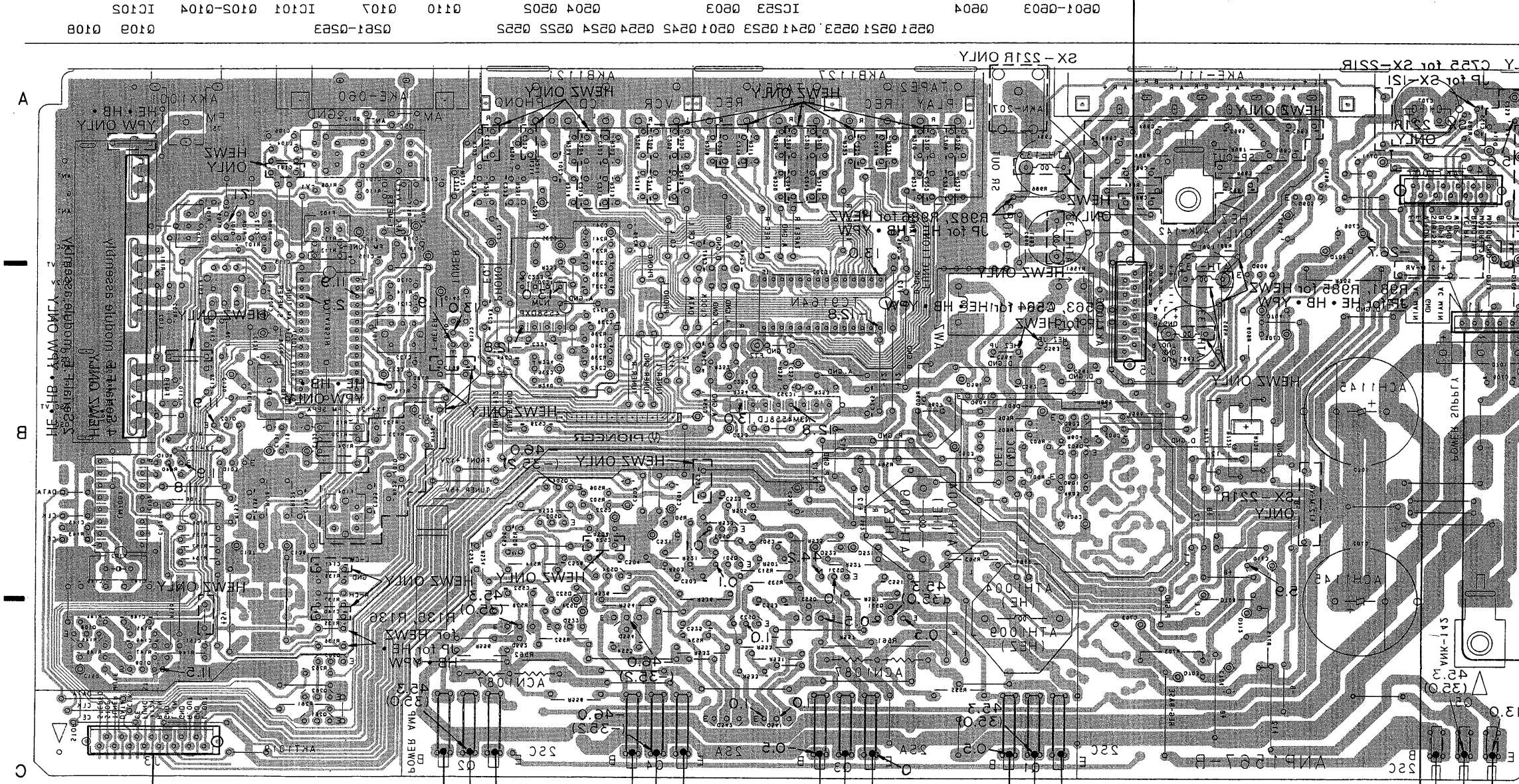
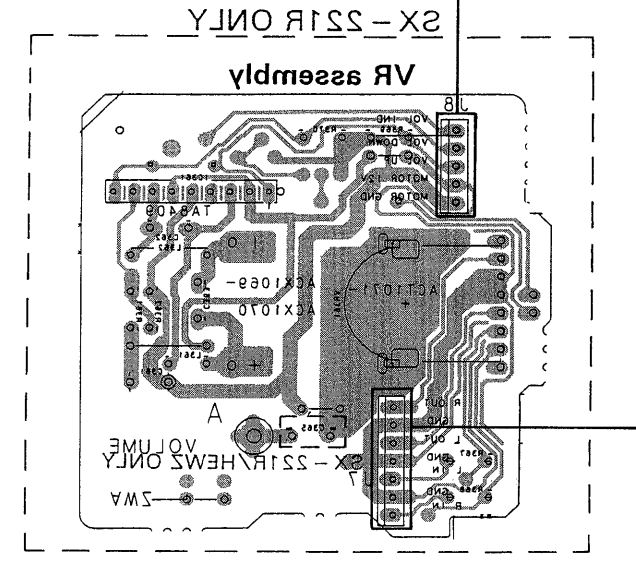
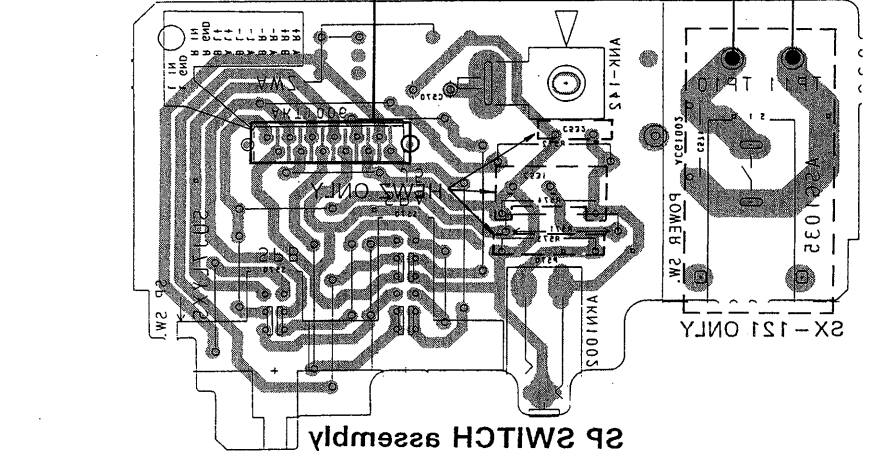
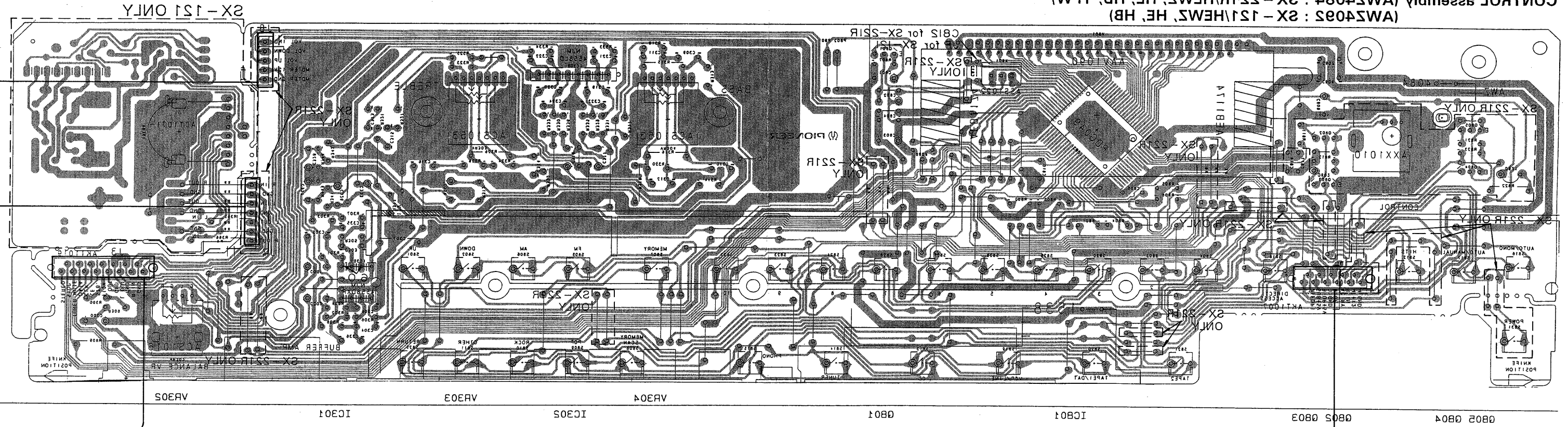
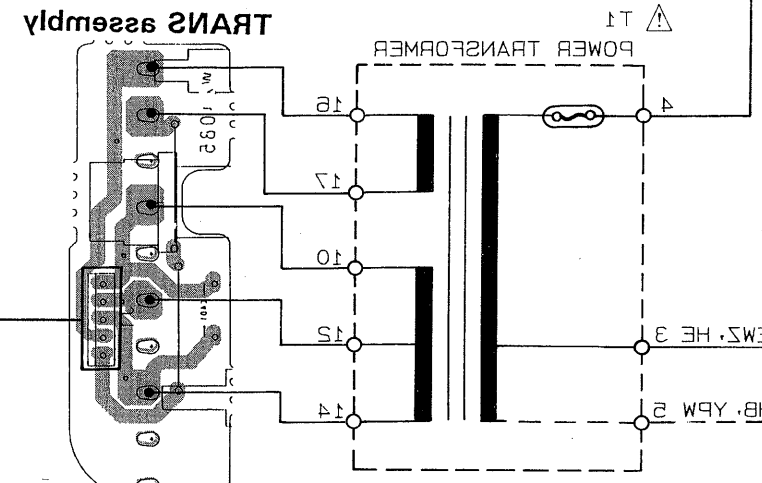

IC505
 IC504 0803
 IC503 0803
 IC502 0803
 IC501 0803
 IC500 0803
 IC401 0104
 IC400 0104
 IC301 0104
 IC300 0104
 IC201 0104
 IC200 0104
 IC101 0104
 IC100 0104
 IC001 0104
 IC000 0104

3.5 COMPLEX ASSEMBLY (2/2)(TUNER SECTION)

A
B
C
D

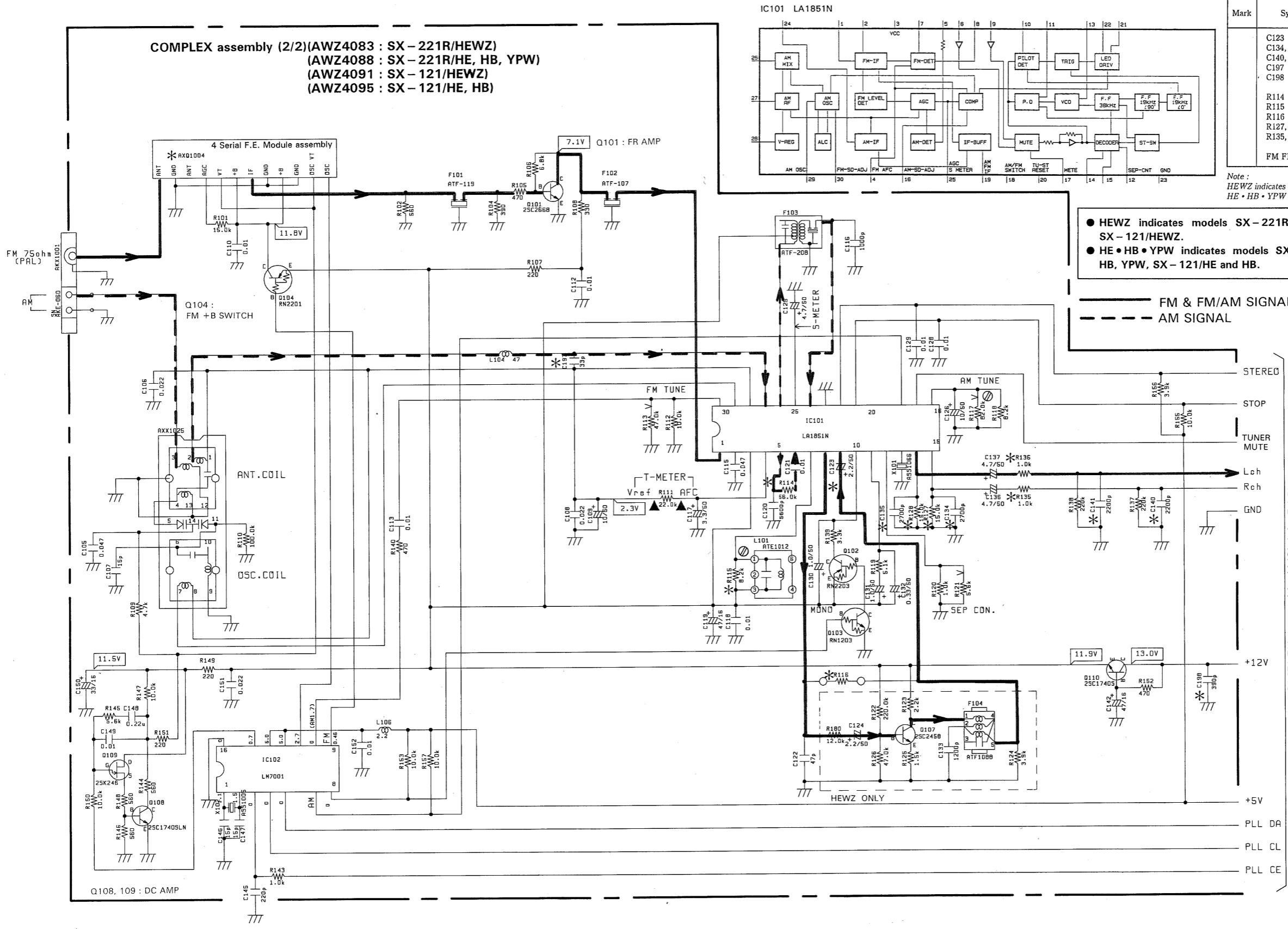

● Parts marked with * have the following variations :

Mark	Symbol & Description	(Note) HEWZ	(Note) HE • HB • YPW
C123		2.2/50	1.0/50
C134, C135		2700p	8200p
C140, C141		2200p	VACANT
C197		33p	VACANT
C198		390p	VACANT
R114		56k	43k
R115		8.2k	4.7k
R116		VACANT	15k
R127, R128		15k	10k
R135, R136		1k	JUMPER
FM FRONT END		AXQ1004	AXQ1002

Note :
HEWZ indicates SX-221R/HEWZ and SX-121/HEWZ.
HE • HB • YPW indicates SX-221R/HE, HB, YPW, SX-121/HE and HB.

- HEWZ indicates models SX - 221R/HEWZ and SX - 121/HEWZ.
- HE • HB • YPW indicates models SX - 221R/HE, HB, YPW, SX - 121/HE and HB.

— FM & FM/AM SIGNAL
- - - AM SIGNAL

To COMPLEX assembly (1/2) (▲ P12)

A
B
C
D

4. PCB PARTS LIST

NOTES:

- Parts marked by "NSP" are generally unavailable because they are not in our Master Spare Parts List.
- The Δ mark found on some component parts indicates the importance of the safety factor of the part. Therefore, when replacing, be sure to use parts of identical designation.
- Parts marked by "©" are not always kept in stock. Their delivery time may be longer than usual or they may be unavailable.
- When ordering resistors, first convert resistance values into code form as shown in the following examples.

Ex. 1 When there are 2 effective digits (any digit apart from 0), such as 560 ohm and 47k ohm (tolerance is shown by J = 5%, and K = 10%).

560 Ω \rightarrow 56 \times 10¹ \rightarrow 561 RD1/8PM \square \square \square J
 47k Ω \rightarrow 47 \times 10³ \rightarrow 473 RD1/4PS \square \square \square J
 0.5 Ω \rightarrow 0R5 RN2H \square \square \square K
 1 Ω \rightarrow 010 RS1P \square \square \square K

Ex. 2 When there are 3 effective digits (such as in high precision metal film resistors).

5.62k Ω \rightarrow 562 \times 10¹ \rightarrow 5621 RN1/4PC \square \square \square F

4.1 FOR SX - 221R/HEWZ

Mark No.	Description	Parts No.	Mark No.	Description	Parts No.
LIST OF ASSEMBLIES					
©	COMPLEX ASSEMBLY	AWZ4083			
©	CONTROL ASSEMBLY	AWZ4084			
NSP	TRANS ASSEMBLY	AWZ4085			
NSP	SP SWITCH ASSEMBLY	AWZ4086			
NSP	VR ASSEMBLY	AWZ4087			
COMPLEX ASSEMBLY					
SEMICONDUCTORS					
IC101	AM/FM IC	LA1851N	D521-524	DIODE	HSS104-02
IC102	PLL IC	LM7001	D561	DIODE	HSS104-02
IC201	OP-AMP IC	NJM4558DXP	D601	ZENER DIODE	HZS12AL
IC202	E-SW IC	TC9164N	D700, 713	DIODE	S5566
IC253	OP-AMP IC	NJM4558LD	D701	DIODE	D3SBA20 (A)
Q101	TRANSISTOR	2SC2668	D703	ZENER DIODE	HZS12B2L
Q102	TRANSISTOR	RN2203	D704	ZENER DIODE	HZS12AL
Q103	TRANSISTOR	RN1203	D705	ZENER DIODE	HZS24-2L
Q104	TRANSISTOR	RN2201	D706	ZENER DIODE	HZS6B2L
Q107	TRANSISTOR	2SC2458	D708-710	DIODE	HSS104-02
Q108	TRANSISTOR	2SC1740SLN	D711	ZENER DIODE	HZS7B2L
Q109	N-FET	2SK246	D712	ZENER DIODE	HZS6B2L
Q110	TRANSISTOR	2SC1740S	D714	DIODE	HSS104-02
Q261, 262	TRANSISTOR	RN1203	D751	DIODE	HSS104-02
Q263	TRANSISTOR	RN2203	D752	DIODE	S5566
Q501-504	TRANSISTOR	2SA992	D753	ZENER DIODE	HZS6A2L
Q521, 522	TRANSISTOR	2SA1145	D754	DIODE	HSS104-02
Q523, 524	TRANSISTOR	2SC2705	RELAIES		
Q541, 542	TRANSISTOR	2SC2458	RY561	RELAY	ASR-111
Q551, 552	TRANSISTOR	2SC2235	Δ RY751	RELAY	ASR1027
Q553, 554	TRANSISTOR	2SA965	COILS & TRANSFORMER		
Q601, 602	TRANSISTOR	2SC2458	F101	CERAMIC FILTER	ATF-119
Q603	TRANSISTOR	2SA1048	F102	CERAMIC FILTER	ATF-107
Q604	TRANSISTOR	2SC2240	F103	CERAMIC FILTER	ATF-208
Q605	TRANSISTOR	RN1203	F104	FILTER	ATF1088
Q606, 751	TRANSISTOR	RN1201	L101	COIL	ATE1012
			L104	AXIAL INDUCTOR	LAU470K
			L106	AXIAL INDUCTOR	LAU2R2M
			L561, 562	COIL	ATH1009
			L701	FILTER	ATF-151
			L981-984	COIL	ATH-133
			Δ T751	POWER TRANSFORMER	ATT1015

Mark No.	Description	Parts No.	Mark No.	Description	Parts No.
CAPACITORS					
C105	CERAMIC CAPACITOR	CKCYX473M16	C501, 502	ELECT. CAPACITOR	CEAS2R2M50
C106	AXIAL CERAMIC C.	CKPUYF223Z25	C503, 504	CERAMIC CAPACITOR	CKCYB102K50
C107	AXIAL CERAMIC C.	CCPUCH150J50	C505, 506	CERAMIC CAPACITOR	CKCYB681K50
C108	AXIAL CERAMIC C.	CKPUYF223Z25	C520	ELECT. CAPACITOR	CEAS101M16
C109	ELECT. CAPACITOR	CEAS100M50	C521, 522	ELECT. CAPACITOR	CEAS220M16
C110	CERAMIC CAPACITOR	CKPUYY103N16	C523, 524	CERAMIC CAPACITOR	CCCSL120K500
C112 113	CERAMIC CAPACITOR	CKPUYY103N16	C525, 526	CERAMIC CAPACITOR	CCCSL050C500
C115	CERAMIC CAPACITOR	CKDYX473M25	C527, 528	CERAMIC CAPACITOR	CKMYB221K50
C116	CERAMIC CAPACITOR	CKPUYB102K50	C529	CERAMIC CAPACITOR	CKCYF103Z50
C117	ELECT. CAPACITOR	CEAS3R3M50	C551-554	CERAMIC CAPACITOR	CCCSL101K500
C118	CERAMIC CAPACITOR	CKPUYY103N16	C561, 562	AUDIO FILM CAPACITOR	CFTXA473J50
C119	ELECT. CAPACITOR	CEAS470M16	C601	ELECT. CAPACITOR	CEAS471M6
C120	CERAMIC CAPACITOR	CKPUYX562M16	C602	AXIAL CERAMIC C.	CKPUYF103Z25
C121	CERAMIC CAPACITOR	CKPUYY103N16	C603	ELECT. CAPACITOR	CEAS101M16
C122	AXIAL CAPACITOR	CCPUSL470J50	C605	ELECT. CAPACITOR	CEAS4R7M50
C123, 124	ELECT. CAPACITOR	CEAS2R2M50	C701, 702	ELECT. CAPACITOR (5600/DC50V)	ACH1145
C125	ELECT. CAPACITOR	CEAS4R7M50	C703	ELECT. CAPACITOR	CEAS101M16
C126	ELECT. CAPACITOR	CEAS100M50	C704	ELECT. CAPACITOR	CEHAQ100M50
C128, 129	CERAMIC CAPACITOR	CKPUYY103N16	C705	ELECT. CAPACITOR	CEAS101M25
C130, 131	ELECT. CAPACITOR	CEAS010M50	C706	ELECT. CAPACITOR	CEHAQ470M35
C132	ELECT. CAPACITOR	CEASR33M50	C707	CAPACITOR (0.047/5.5)	ACH1135
C133	CERAMIC CAPACITOR	CKCYB122K50	Δ C708	CKA (0.01/AC400V)	ACG1002
C134, 135	CERAMIC CAPACITOR	CKCYB272K50	C709	CKA (0.01/AC250V)	ACG1005
C136, 137	ELECT. CAPACITOR	CEAS4R7M50	C710	ELECT. CAPACITOR	CEHAQ470M10
C140, 141	CERAMIC CAPACITOR	CKCYB222K50	C751	CERAMIC CAPACITOR	CKCYX104M25
C142	ELECT. CAPACITOR	CEAS470M16	C752	ELECT. CAPACITOR	CEAS471M25
C145	CERAMIC CAPACITOR	CKPUYB221K50	C753	ELECT. CAPACITOR	CEAS470M10
C146, 147	AXIAL CERAMIC C.	CCPUCH150J50	Δ C754	CKA (0.01/AC400V)	ACG1002
C148	AUDIO FILM CAPACITOR	CFTXA224J50	C755	CERAMIC CAPACITOR	CKCYX104M25
C149	AUDIO FILM CAPACITOR	CFTXA103J50	C981, 982	CERAMIC CAPACITOR	CKMYB681K50
C150	ELECT. CAPACITOR	CEAS330M16	C983, 984	CERAMIC CAPACITOR	CKCYF103Z50
C151	AXIAL CERAMIC C.	CKPUYF223Z25	C985, 986	CERAMIC CAPACITOR	CKMYB681K50
C152	CERAMIC CAPACITOR	CKPUYY103N16	C987, 988	CERAMIC CAPACITOR	CKCYF103Z50
C197	AXIAL CAPACITOR	CCPUSL330J50	RESISTORS		
C198	CERAMIC CAPACITOR	CKMYB391K50	R521, 522	CARBON FILM RESISTOR	RD1/4PM562J
C201	CERAMIC CAPACITOR	CKCYF473Z50	R523, 524	CARBON FILM RESISTOR	RD1/4PM104J
C203-222	CERAMIC CAPACITOR	CKMYB391K50	Δ R527, 528	CARBON FILM RESISTOR	RD1/4PMF680J
C223, 224	CERAMIC CAPACITOR	CKMYB821K50	Δ R535, 536	FUSLIBLE RESISTOR	RFA1/4PS101J
C225, 226	CERAMIC CAPACITOR	CKMYB681K50	Δ R551-554	FUSLIBLE RESISTOR	RFA1/4PS101J
C231, 232	ELECT. CAPACITOR	CEAS100M50	Δ R555-558	CARBON FILM RESISTOR	RD1/4PMF101J
C233, 234	CERAMIC CAPACITOR	CCCSL221J50	Δ R561, 562	RESISTOR (0.33, 5W)	ACN1087
C235, 236	ELECT. CAPACITOR	CEAS470M10	Δ R563-566	CARBON FILM RESISTOR	RD1/4PMF100J
C237, 238	MYLAR FILM CAPACITOR	CQMA242J50	Δ R600	METAL OXIDE RESISTOR	RS2LMF911J
C239, 240	MYLAR FILM CAPACITOR	CQMA822K50	R609	CARBON FILM RESISTOR	RD1/4PM123J
C241, 242	ELECT. CAPACITOR	CEAS2R2M50	R701	CARBON FILM RESISTOR	RD1/4PM302J
C243-246	AXIAL CERAMIC C.	CKPUYF103Z25			
C247, 248	CERAMIC CAPACITOR	CKCYB331K50			
C249	CERAMIC CAPACITOR	CKCYB471K50			
C251, 252	ELECT. CAPACITOR	CEAS2R2M50			
C253, 254	ELECT. CAPACITOR	CEAS4R7M50			

Mark No.	Description	Parts No.	Mark No.	Description	Parts No.
△ R703	METAL OXIDE RESISTOR	RS1LMF392J	SWITCHES		
△ R705	METAL OXIDE RESISTOR	RS2LMF122J	S801-831	SWITCH	ASG1034
△ R715	METAL OXIDE RESISTOR	RS1LMF151J	CAPACITORS		
△ R721-723	METAL OXIDE RESISTOR	RS2LMF472J	C300	ELECT. CAPACITOR	CEJA100M50
△ R751	METAL OXIDE RESISTOR	RS2LMF221J	C301, 302	ELECT. CAPACITOR	CEAS4R7M50
R752	CARBON FILM RESISTOR	RD1/2PM470J	C303, 304	CERAMIC CAPACITOR	CCCSL220J50
△ R981, 982	CARBON FILM RESISTOR	RD1/2PMF101J	C305, 306	CERAMIC CAPACITOR	CKCYB331K50
△ R985, 986	CARBON FILM RESISTOR	RD1/2PMF101J	C307	AXIAL CERAMIC C.	CKPUYF103Z25
△ R987, 988	CARBON FILM RESISTOR	RD1/4PMF100J	C309, 310	AUDIO FILM CAPACITOR	CFTXA153J50
	Other resistors	RD1/8PM□□□J	C311, 312	AUDIO FILM CAPACITOR	CFTXA823J50
OTHERS			C313, 314	MYLAR FILM CAPACITOR	CQMA332K50
	PIN JACK 6P (PHONO, CD, VCR/LD)	AKB1121	C315, 316	AUDIO FILM CAPACITOR	CFTXA183J50
	PIN JACK 8P (TAPE1/DAT, TAPE2 MONITOR)	AKB1127	C317	ELECT. CAPACITOR	CEJA2R2M50
	TERMINAL 2-P (ANTENNA)	AKE-060	C318	ELECT. CAPACITOR	CEAS2R2M50
	SPEAKER TERMINAL 8-P	AKE-111	C319, 320	CERAMIC CAPACITOR	CKCYB391K50
	JACK (CONTROL)	AKN-207	C321, 322	CERAMIC CAPACITOR	CCCSL220J50
X101	CRYSTAL RESONATOR (456kHz)	ASS1066	C323, 324	CERAMIC CAPACITOR	CKCYB331K50
X102	CRYSTAL RESONATOR (7.2MHz)	ASS1005	C326	ELECT. CAPACITOR	CEAS470M25
	CONNECTOR (PAL SOCKET)	AKX1001	C327, 328	ELECT. CAPACITOR	CEAS220M16
	AM RF TUNING BLOCK	AXX1025	C333	ELECT. CAPACITOR	CEJA2R2M50
	4 SERIAL F.E. MODULE ASSEMBLY	AXQ1004	C334	ELECT. CAPACITOR	CEAS2R2M50
	<i>h2-2" 7/16"</i>	<i>AKR1003 (50-A50001)</i>	C335, 336	CERAMIC CAPACITOR	CKCYB391K50
			C801	ELECT. CAPACITOR	CEJA4R7M50
			C802	ELECT. CAPACITOR	CEJA0R1M50
			C803	ELECT. CAPACITOR	CEJA221M6
			C804	AXIAL CERAMIC C.	CKPUYF103Z25
			C805	AXIAL CERAMIC C.	CKPUYF473Z16
			C807, 808	CERAMIC CAPACITOR	CKCYX473M25
			C809	ELECT. CAPACITOR	CEJA100M50
			C810	AXIAL CERAMIC C.	CKPUYF103Z25
			C811, 812	AXIAL CERAMIC C.	CKPUYF473Z16
			C814	AXIAL CERAMIC C.	CKPUYF473Z16
			C325	CERAMIC CAPACITOR	CKCYB473K50 (50-A49044)
NOTE :	4 Serial F.E. module assembly has no service parts.				
CONTROL ASSEMBLY			RESISTORS		
SEMICONDUCTORS			VR302	VR (500k- x1)	ACS1016
IC301	OP-AMP IC	NJM4558DXP	VR303, 304	VR (100k)	ACS1053
IC302	OP-AMP IC	NJM4558LD			
IC801	RECEIVER CONTROL	PDG049-B	R822	CARBON FILM RESISTOR	RD1/4PM221J
Q801	TRANSISTOR	RN1203		Other resistors	RD1/8PM□□□J
Q802	TRANSISTOR	RN2201	OTHERS		
Q803	TRANSISTOR	RN1201		FL SPACER	AEB1174
Q804	TRANSISTOR	RN1203		REMOTE RECEIVER UNIT	AXX1010
Q805	TRANSISTOR	2SC2458	V801	FL TUBE	AAV1090
D802	DIODE	HSS104-02	X801	CERAMIC OSCILLATOR (4.19MHz)	ASS1022
D821	LED (RED)	AEL1108			

Mark No.	Description	Parts No.
----------	-------------	-----------

TRANS ASSEMBLY

CAPACITORS

C401	CAPACITOR	CQMXA104J100
------	-----------	--------------

SP SWITCH ASSEMBLY

SWITCH

S570	PUSH SWITCH	SUJ7LYXS
------	-------------	----------

CAPACITORS

C531, 532	CERAMIC CAPACITOR	CKCYB392K50
C570	ELECT. CAPACITOR	CEAS010M50

RESISTORS

△ R571, 572	METAL OXIDE RESISTOR	RS2LMF331J
△ R573, 574	METAL OXIDE RESISTOR	RS1PMF681J

OTHERS

JACK (HEADPHONE)	AKN1002
------------------	---------

VR ASSEMBLY

SEMICONDUCTOR

IC361	MECHANISM DRIVER IC	TA8409S
-------	---------------------	---------

COILS

L361, 362	AXIAL INDUCTOR	LAU101K
-----------	----------------	---------

CAPACITORS

C361	ELECT. CAPACITOR	CEAS470M16
C362, 363	CERAMIC CAPACITOR	CKCYF473Z50
C365	CERAMIC CAPACITOR	CKCYF473Z50

RESISTORS

VR361	VARIABLE RESISTOR	ACX1069
Other resistors		RD1/8PM□□□J

4.2 FOR SX - 121/HEWZ

Mark No.	Description	Parts No.
----------	-------------	-----------

LIST OF ASSEMBLIES

NSP	TRANS ASSEMBLY	AWZ4085
●	COMPLEX ASSEMBLY	AWZ4091
●	CONTROL ASSEMBLY	AWZ4092
NSP	SP SWITCH ASSEMBLY	AWZ4094

TRANS ASSEMBLY

CAPACITOR

C401	CAPACITOR	CQMXA104J100
------	-----------	--------------

COMPLEX ASSEMBLY

SEMICONDUCTORS

IC101	AM/FM IC	LA1851N
IC102	PLL IC	LM7001
IC201	OP - AMP IC	NJM4558DXP
IC202	E - SW IC	TC9164N
IC253	OP - AMP IC	NJM4558LD

Q101	TRANSISTOR	2SC2668
Q102	TRANSISTOR	RN2203
Q103	TRANSISTOR	RN1203
Q104	TRANSISTOR	RN2201
Q107	TRANSISTOR	2SC2458

Q108	TRANSISTOR	2SC1740SLN
Q109	N - FET	2SK246
Q110	TRANSISTOR	2SC1740S
Q261, 262	TRANSISTOR	RN1203
Q263	TRANSISTOR	RN2203

Q501 - 504	TRANSISTOR	2SA992
Q521, 522	TRANSISTOR	2SA1145
Q523, 524	TRANSISTOR	2SC2705
Q541, 542	TRANSISTOR	2SC2458
Q551, 552	TRANSISTOR	2SC2235

Q553, 554	TRANSISTOR	2SA965
Q601, 602	TRANSISTOR	2SC2458
Q603	TRANSISTOR	2SA1048
Q604	TRANSISTOR	2SC2240
Q605	TRANSISTOR	RN1203

Q606	TRANSISTOR	RN1201
------	------------	--------

D521 - 524	DIODE	HSS104 - 02
D561	DIODE	HSS104 - 02
D601	ZENER DIODE	HZS12AL
D700	DIODE	S5566
D701	DIODE	D3SBA20 (A)

D703	ZENER DIODE	HZS12B2L
D704	ZENER DIODE	HZS12AL
D705	ZENER DIODE	HZS24 - 2L
D706	ZENER DIODE	HZS6B2L
D708 - 710	DIODE	HSS104 - 02

Mark No.	Description	Parts No.	Mark No.	Description	Parts No.
D711	ZENER DIODE	HZS7B2L	C197	AXIAL CAPACITOR	CCPUSL330J50
D712	ZENER DIODE	HZS6B2L	C198	CERAMIC CAPACITOR	CKMYB391K50
D713	DIODE	S5566			
RELAY					
RY561	RELAY	ASR-111	C201	CERAMIC CAPACITOR	CKCYF473Z50
COILS			C203-222	CERAMIC CAPACITOR	CKMYB391K50
F101	CERAMIC FILTER	ATF-119	C223, 224	CERAMIC CAPACITOR	CKMYB821K50
F102	CERAMIC FILTER	ATF-107	C225, 226	CERAMIC CAPACITOR	CKMYB681K50
F103	CERAMIC FILTER	ATF-208	C231, 232	ELECT. CAPACITOR	CEAS100M50
F104	FILTER	ATF1088			
L101	COIL	ATE1012	C233, 234	CERAMIC CAPACITOR	CCCSL221J50
L104	AXIAL INDUCTOR	LAU470K	C235, 236	ELECT. CAPACITOR	CEAS470M10
L106	AXIAL INDUCTOR	LAU2R2M	C237, 238	MYLAR FILM CAPACITOR	CQMA242J50
L561, 562	COIL	ATH1009	C239, 240	MYLAR FILM CAPACITOR	CQMA822K50
L701	FILTER	ATF-151	C241, 242	ELECT. CAPACITOR	CEAS2R2M50
L981-984	COIL	ATH-133			
CAPACITORS			C243-246	AXIAL CERAMIC C.	CKPUYF103Z25
C105	CERAMIC CAPACITOR	CKCYX473M16	C247, 248	CERAMIC CAPACITOR	CKCYB331K50
C106	AXIAL CERAMIC C.	CKPUYF223Z25	C249	CERAMIC CAPACITOR	CKCYB471K50
C107	AXIAL CERAMIC C.	CCPUCH150J50	C251, 252	ELECT. CAPACITOR	CEAS2R2M50
C108	AXIAL CERAMIC C.	CKPUYF223Z25	C253, 254	ELECT. CAPACITOR	CEAS4R7M50
C109	ELECT. CAPACITOR	CEAS100M50			
C110	CERAMIC CAPACITOR	CKPUYY103N16	C501, 502	ELECT. CAPACITOR	CEAS2R2M50
C112, 113	CERAMIC CAPACITOR	CKPUYY103N16	C503, 504	CERAMIC CAPACITOR	CKCYB102K50
C115	CERAMIC CAPACITOR	CKDYX473M25	C505, 506	CERAMIC CAPACITOR	CKCYB681K50
C116	CERAMIC CAPACITOR	CKPUYB102K50	C520	ELECT. CAPACITOR	CEAS101M16
C117	ELECT. CAPACITOR	CEAS3R3M50	C521, 522	ELECT. CAPACITOR	CEAS220M16
C118	CERAMIC CAPACITOR	CKPUYY103N16	C523, 524	CERAMIC CAPACITOR	CCCSL120K500
C119	ELECT. CAPACITOR	CEAS470M16	C525, 526	CERAMIC CAPACITOR	CCCSL050C500
C120	CERAMIC CAPACITOR	CKPUYX562M16	C527, 528	CERAMIC CAPACITOR	CKMYB221K50
C121	CERAMIC CAPACITOR	CKPUYY103N16	C529	CERAMIC CAPACITOR	CKCYF103Z50
C122	AXIAL CAPACITOR	CCPUSL470J50	C551-554	CERAMIC CAPACITOR	CCCSL101K500
C123, 124	ELECT. CAPACITOR	CEAS2R2M50			
C125	ELECT. CAPACITOR	CEAS4R7M50	C561, 562	AUDIO FILM CAPACITOR	CFTXA473J50
C126	ELECT. CAPACITOR	CEAS100M50			
C128, 129	CERAMIC CAPACITOR	CKPUYY103N16	C601	ELECT. CAPACITOR	CEAS471M6
C130, 131	ELECT. CAPACITOR	CEAS010M50	C602	AXIAL CERAMIC C.	CKPUYF103Z25
C132	ELECT. CAPACITOR	CEASR33M50	C603	ELECT. CAPACITOR	CEAS101M16
C133	CERAMIC CAPACITOR	CKCYB122K50	C605	ELECT. CAPACITOR	CEAS4R7M50
C134, 135	CERAMIC CAPACITOR	CKCYB272K50			
C136, 137	ELECT. CAPACITOR	CEAS4R7M50	C701, 702	ELECT. CAPACITOR (5600/DC50V)	ACH1145
C140, 141	CERAMIC CAPACITOR	CKCYB222K50			
C142	ELECT. CAPACITOR	CEAS470M16	C703	ELECT. CAPACITOR	CEAS101M16
C145	CERAMIC CAPACITOR	CKPUYB221K50	C704	ELECT. CAPACITOR	CEHAQ100M50
C146, 147	AXIAL CERAMIC C.	CCPUCH150J50	C705	ELECT. CAPACITOR	CEAS101M25
C148	AUDIO FILM CAPACITOR	CFTXA224J50	C706	ELECT. CAPACITOR	CEHAQ470M35
C149	AUDIO FILM CAPACITOR	CFTXA103J50			
C150	ELECT. CAPACITOR	CEAS330M16	C707	CAPACITOR (0.047/5.5)	ACH1135
C151	AXIAL CERAMIC C.	CKPUYF223Z25	△ C708	CKA (0.01/AC400V)	ACG1002
C152	CERAMIC CAPACITOR	CKPUYY103N16	C709	CKA (0.01/AC250V)	ACG1005
			C710	ELECT. CAPACITOR	CEHAQ470M10
			C981, 982	CERAMIC CAPACITOR	CKMYB681K50
			C983, 984	CERAMIC CAPACITOR	CKCYF103Z50
			C985, 986	CERAMIC CAPACITOR	CKMYB681K50
			C987, 988	CERAMIC CAPACITOR	CKCYF103Z50
			RESISTORS		
			R521, 522	CARBON FILM RESISTOR	RD1/4PM562J
			R523, 524	CARBON FILM RESISTOR	RD1/4PM104J

SX-221R, SX-121

Mark No.	Description	Parts No.
△ R527, 528	CARBON FILM RESISTOR	RD1/4PMF680J
△ R535, 536	FUSLIBLE RESISTOR	RFA1/4PS101J
△ R551-554	FUSLIBLE RESISTOR	RFA1/4PS101J
△ R555-558	CARBON FILM RESISTOR	RD1/4PMF101J
△ R561, 562	RESISTOR (0.33, 5W)	ACN1087
△ R563-566	CARBON FILM RESISTOR	RD1/4PMF100J
△ R600	METAL OXIDE RESISTOR	RS2LMF911J
R609	CARBON FILM RESISTOR	RD1/4PM123J
R701	CARBON FILM RESISTOR	RD1/4PM302J
△ R703	METAL OXIDE RESISTOR	RS1LMF392J
△ R705	METAL OXIDE RESISTOR	RS2LMF122J
△ R715	METAL OXIDE RESISTOR	RS1LMF151J
△ R721-723	METAL OXIDE RESISTOR	RS2LMF472J
△ R981, 982	CARBON FILM RESISTOR	RD1/2PMF101J
△ R985, 986	CARBON FILM RESISTOR	RD1/2PMF101J
△ R987, 988	CARBON FILM RESISTOR	RD1/4PMF100J
	Other resistors	RD1/8PM□□□J
OTHERS		
	PIN JACK 6P (PHONO, CD, VCR/LD)	AKB1121
	PIN JACK 8P (TAPE1/DAT, TAPE2 MONITOR)	AKB1127
	TERMINAL 2-P (ANTENNA)	AKE-060
	SPEAKER TERMINAL 8-P	AKE-111
	CONNECTOR (PAL SOCKET)	AKX1001
X101	CRYSTAL RESONATOR (456kHz)	ASS1066
X102	CRYSTAL RESONATOR (7.2MHz)	ASS1005
	AM RF TUNING BLOCK	AXX1025
	4 SERIAL F.E. MODULE ASSEMBLY	AXQ1004

NOTE :

4 Serial F.E. module assembly has no service parts.

Mark No.	Description	Parts No.
CONTROL ASSEMBLY		
SEMICONDUCTORS		
IC301	OP-AMP IC	NJM4558DXP
IC302	OP-AMP IC	NJM4558LD
IC801	RECEIVER CONTROL	PDG049-B
Q801	TRANSISTOR	RN1203
SWITCHES		
S801-830	SWITCH	ASG1034
CAPACITORS		
C300	ELECT. CAPACITOR	CEJA100M50
C301, 302	ELECT. CAPACITOR	CEAS4R7M50
C303, 304	CERAMIC CAPACITOR	CCCSL220J50
C305, 306	CERAMIC CAPACITOR	CKCYB331K50
C307	AXIAL CERAMIC C.	CKPUYF103Z25
C309, 310	AUDIO FILM CAPACITOR	CFTXA153J50
C311, 312	AUDIO FILM CAPACITOR	CFTXA823J50
C313, 314	MYLAR FILM CAPACITOR	CQMA332K50
C315, 316	AUDIO FILM CAPACITOR	CFTXA183J50
C317	ELECT. CAPACITOR	CEJA2R2M50
C318	ELECT. CAPACITOR	CEAS2R2M50
C319, 320	CERAMIC CAPACITOR	CKCYB391K50
C321, 322	CERAMIC CAPACITOR	CCCSL220J50
C323, 324	CERAMIC CAPACITOR	CKCYB331K50
C326	ELECT. CAPACITOR	CEAS470M25
C327, 328	ELECT. CAPACITOR	CEAS220M16
C333	ELECT. CAPACITOR	CEJA2R2M50
C334	ELECT. CAPACITOR	CEAS2R2M50
C335, 336	CERAMIC CAPACITOR	CKCYB391K50
C801	ELECT. CAPACITOR	CEJA4R7M50
C802	ELECT. CAPACITOR	CEJA0R1M50
C803	ELECT. CAPACITOR	CEJA221M6
C804	AXIAL CERAMIC C.	CKPUYF103Z25
C805	AXIAL CERAMIC C.	CKPUYF473Z16
C807, 808	CERAMIC CAPACITOR	CKCYX473M25
C809	ELECT. CAPACITOR	CEJA100M50
C810	AXIAL CERAMIC C.	CKPUYF103Z25
C811, 814	AXIAL CERAMIC C.	CKPUYF473Z16
RESISTORS		
VR302	VR (500k- ×1)	ACS1016
VR303, 304	VR (100k)	ACS1053
VR361	VR (100k-A5 ×2)	ACT1071
	Other resistors	RD1/8PM□□□J
OTHERS		
V801	FL SPACER	AEB1174
X801	FL TUBE	AAV1090
	CERAMIC OSCILLATOR (4.19MHz)	ASS1022

Mark No.	Description	Parts No.
SP SWITCH ASSEMBLY		
SWITCHES		
△ S1	PUSH SWITCH	ASG1035
S570	PUSH SWITCH	SUJ7LYXS
CAPACITORS		
C531, 532	CERAMIC CAPACITOR	CKCYB392K50
C570	ELECT. CAPACITOR	CEAS010M50
△ C571	CKA (0.01/AC400V)	ACG1002
RESISTORS		
△ R571, 572	METAL OXIDE RESISTOR	RS2LMF331J
△ R573, 574	METAL OXIDE RESISTOR	RS1PMF681J
OTHERS		
	JACK (HEADPHONE)	AKN1002

5. ADJUSTMENTS

- For connections and points to be adjusted, refer to Fig. 5-1, Fig. 5-2 and Fig. 5-3.

5.1 AM TUNER ADJUSTMENT

- Set the BAND selector "AM".

Step No.	Adjustment Title	AM SG (400Hz 30% Mod.)		Reception Frequency Display	Adjustment Location	Specifications
		Frequency (kHz)	Level (dB μ V)			
1	TUNED indicator sensitivity check	999	—	999kHz	R117	Check that the indicator lights up when the level is less than 64dB μ V/m. *1

*1. Remove R117 if the indicator does not light up.

Ensure that the adjustment is done in five minutes after power-on. 70 (Si-A47654)
(Si-A49054)

5.2 FM TUNER ADJUSTMENT

- Set the BAND selector to "FM".
- Perform VCO adjustment two minutes or more after turning the power ON.

Note:
Stereo modulation : Main 1kHz L+R \pm 68.25kHz dev.
Pilot 19kHz \pm 6.75kHz dev.

Step No.	Adjustment Title	FM SG (1kHz \pm 75kHz dev.)		Reception Frequency Display	Adjustment Location	Specifications
		Frequency (MHz)	Level (dB μ V)			
1	Detector coil T-meter adjustment	98.0	60	98.0MHz	L101	Adjust so that the DC voltage between both sides of R111 is 0 \pm 50mV.

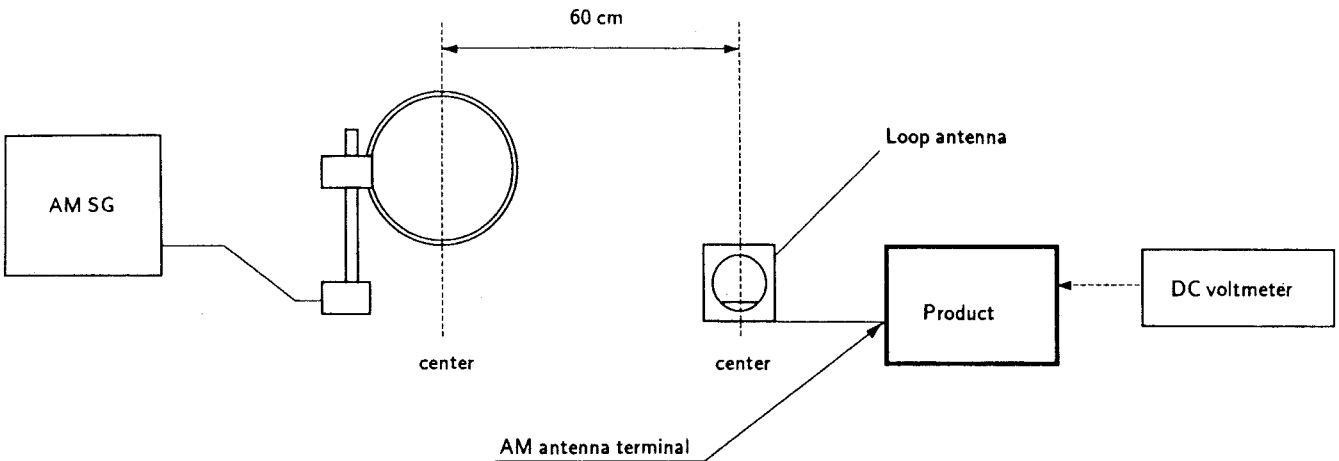

Fig. 5-1 AM Adjustment Connection Diagram

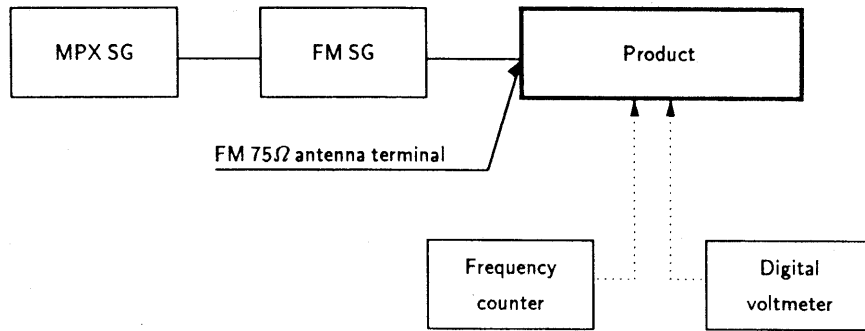

Fig. 5-2 FM Adjustment Connection Diagram

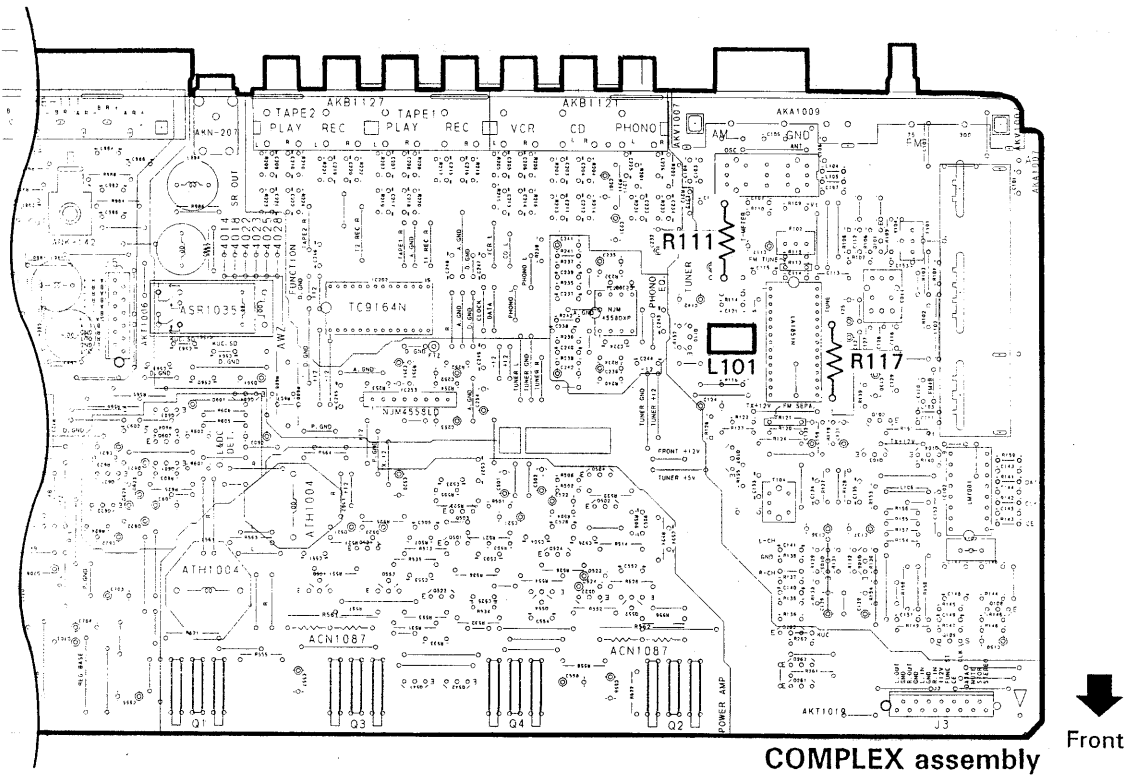

Fig. 5-3 Adjustment Points

5. REGLAGES

• Les raccordements et les points de réglages sont représentés à la Fig. 5-1, Fig. 5-2 et Fig. 5-3.

5.1 REGLAGE DU SYNTONISEUR AM

• Placer le sélecteur BAND sur la position "AM".

Etape No.	Items de réglage	AM SG (400Hz 30% Mod.)		Affichage de fréquence de réception	Lieu de réglage	Caractéristiques
		Fréquence (kHz)	Niveau (dB μ V)			
1	Contrôle de sensibilité de l'indicateur TUNED.	999	—	999kHz	R117	Vérifier que l'indicateur s'allume lorsque le niveau est inférieur à 64dB μ V/m. *1 70 (Si-A47054)

*1 Déposer R117 si l'indicateur ne s'allume pas.

Ensure that the adjustment is done in five minutes after power-on. (Si-A47054)

5.2 REGLAGE DU SYNTONISEUR FM

• Placer le sélecteur BAND sur la position "FM".

• Régler le VCO après deux minutes (ou plus) de mise sous tension.

Note :
Modulation stéréo : Principal 1kHz L+R \pm 68,25kHz dev.
Pilote 19kHz \pm 6,75kHz dev.

Etape No.	Items de réglage	FM SG (1kHz \pm 75kHz dev.)		Affichage de fréquence de réception	Lieu de réglage	Caractéristiques
		Fréquence (MHz)	Niveau (dB μ V)			
1	Régler de la bobine de détection	98,0	60	98,0MHz	L101	Régler de manière que la tension CC appliquée entre les deux côtés de R111 soit 0 \pm 50mV.

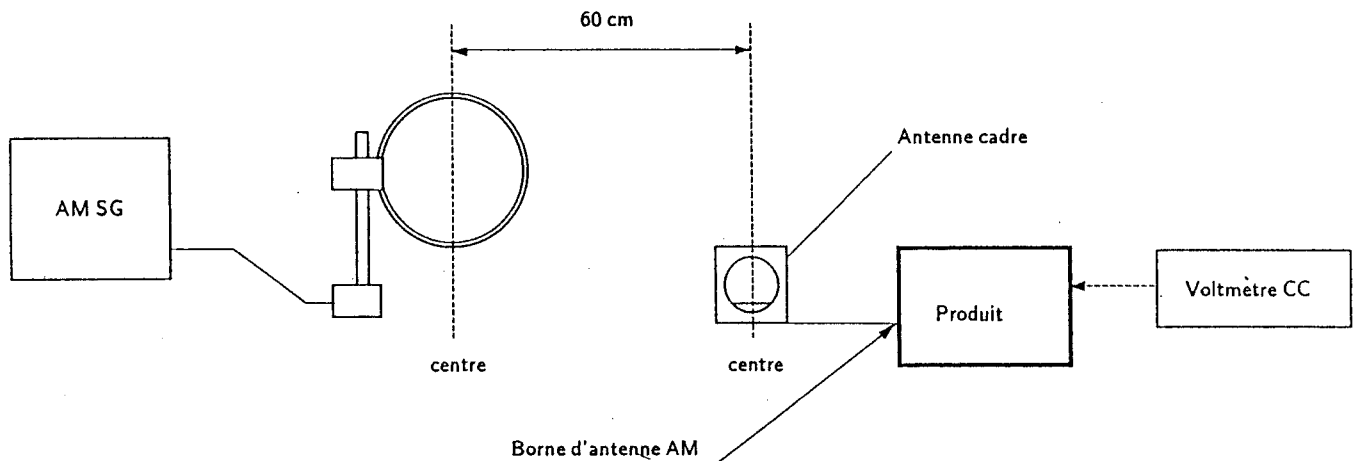

Fig. 5-1 Schéma de connexion de réglage AM

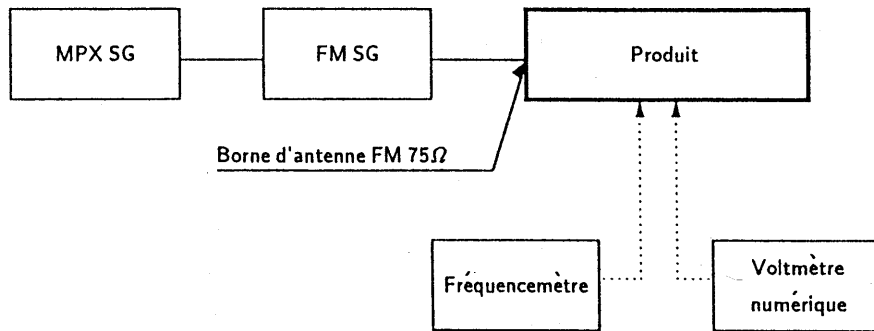

Fig. 5-2 Schéma de connexion de réglage FM

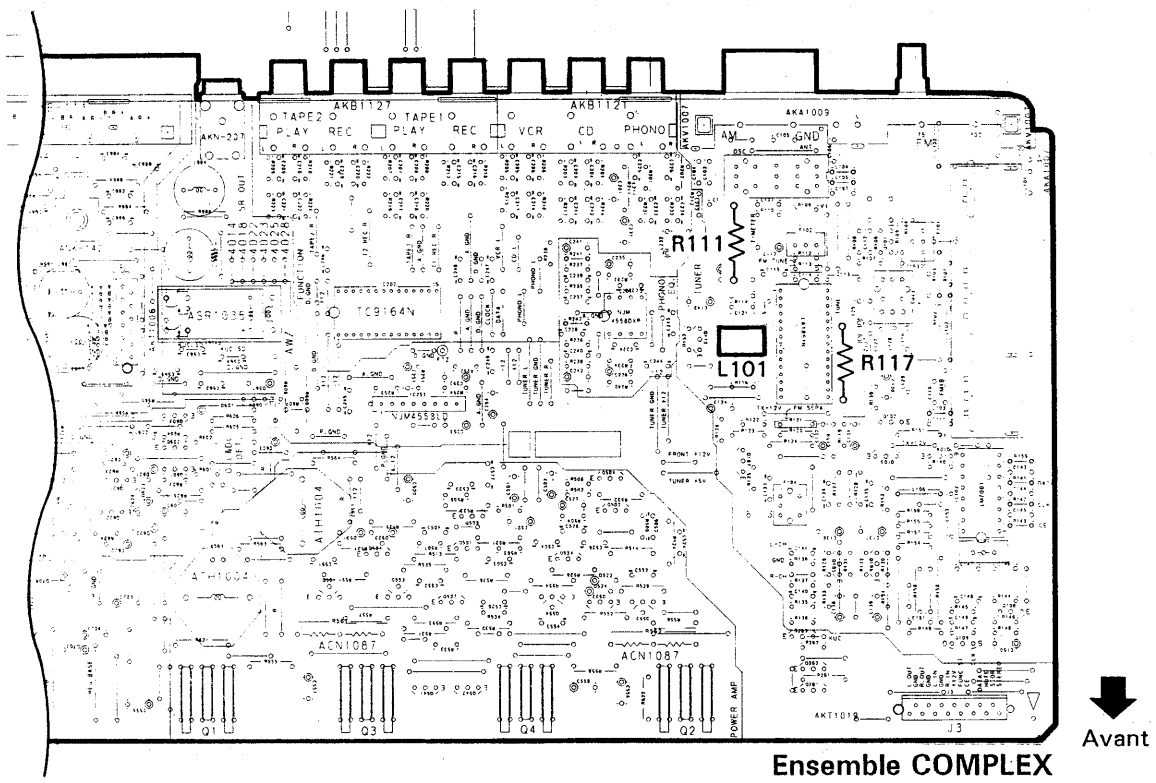

Fig. 5-3 Emplacements de réglage

5. AJUSTES

- Para las conexiones y puntos de ajuste, refiérase a la Fig. 5-1, Fig. 5-2 y Fig. 5-3.

5.1 AJUSTE DE LA SECCION DEL SINTONIZADOR DE AM

- Ajuste el selector BAND a la posición "AM".

N° de paso	Items de ajuste	AM SG (400Hz 30% Mod.)		Fresuencimetro de recepción	Lugar de Ajuste	Especificaciones
		Frecuencia (kHz)	Nivel (dB μ V/m)			
1	Comprobación de la sensibilidad del indicador TUNED.	999	—	999kHz	R117	Compruebe que se encienda el indicador cuando el nivel es de menos de 64dB μ V/m. *1 70 (S2-A47054)

*1 Extraiga el R117 si no se enciende el indicador.

Ensure that the adjustment is done in five minutes after power-on (S2-A47054)

5.2 AJUSTE DE LA SECCION DEL SINTONIZADOR DE FM

- Ajuste el selector BAND a la posición "FM".
- Realice el ajuste VCO dos minutos o más después de conectar la alimentación.

Nota :
Modulación estéreo : Principal 1kHz L+R \pm 68,25kHz dev.
Pilot 19kHz \pm 6,75kHz dev.

N° de paso	Items de ajuste	FM SG (1kHz \pm 75kHz dev.)		Fresuencimetro de recepción	Lugar de Ajuste	Especificaciones
		Frecuencia (MHz)	Nivel (dB μ V)			
1	Ajuste del medidor T de la bobina detectora	98,0	60	98,0MHz	L101	Ajuste de modo que la tensión de CC entre ambos lados de R111 sea de 0 \pm 50mV.

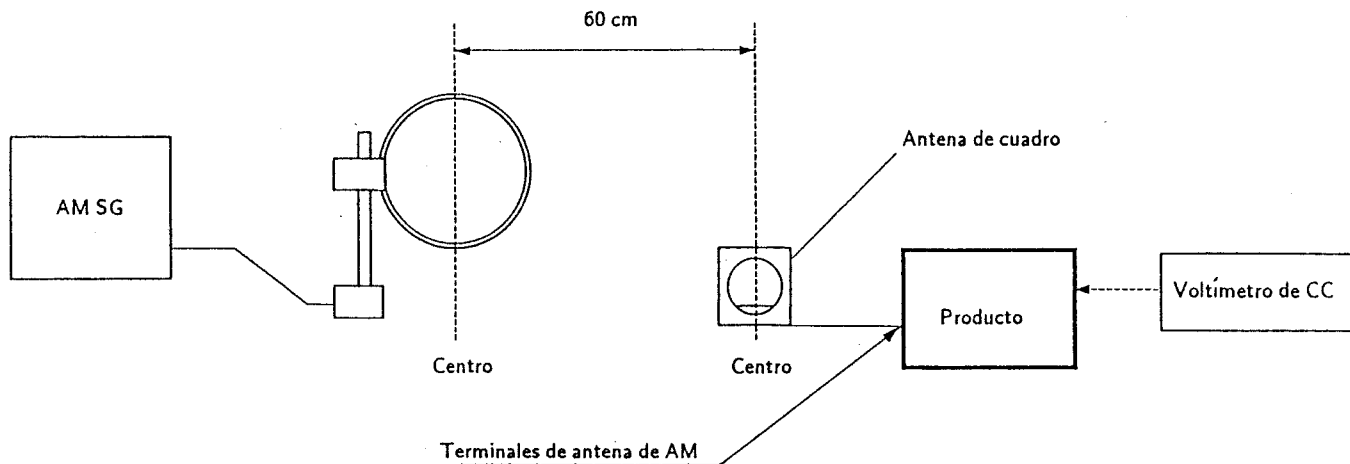

Fig. 5-1 Diagrama de conexiones para el ajuste de AM

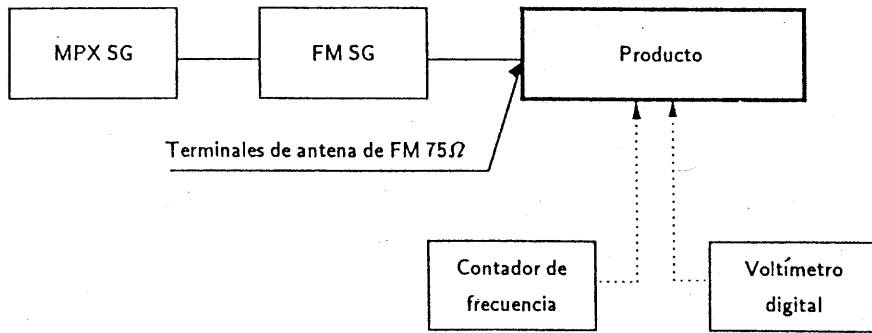

Fig. 5-2 Diagrama de conexiones para el ajuste de FM

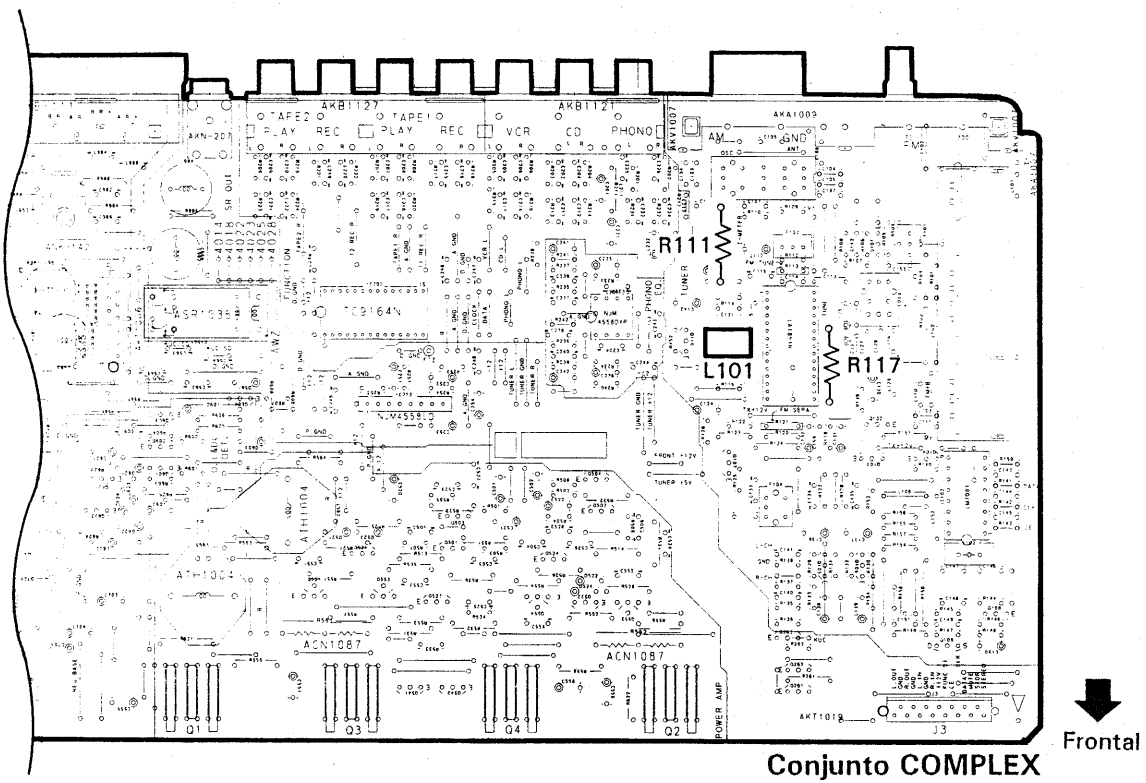

Fig. 5-3 Puntos de ajuste

6. FOR SX – 221R/HE, HB, YPW, SX – 121/HE AND HB TYPES

NOTES:

- Parts marked by “NSP” are generally unavailable because they are not in our Master Spare Parts List.
- The Δ mark found on some component parts indicates the importance of the safety factor of the part. Therefore, when replacing, be sure to use parts of identical designation.
- Parts marked by “ \odot ” are not always kept in stock. Their delivery time may be longer than usual or they may be unavailable.

6.1 FOR SX – 221R/HE, HB AND YPW

Contrast of Miscellaneous Parts

SX – 221R/HE, HB, YPW and SX – 221R/HEWZ have the same construction except for the following :

Mark	Symbol & Description	Part No.				Remarks
		SX – 221R/ HEWZ	SX – 221R/ HE	SX – 221R/ HB	SX – 221R/ YPW	
\odot NSP NSP	COMPLEX assembly	AWZ4083	AWZ4088	AWZ4088	AWZ4088	
	SP SWITCH assembly	AWZ4086	AWZ4089	AWZ4089	AWZ4089	
	VR assembly	AWZ4087	AWZ4090	AWZ4090	AWZ4090	
Δ	AC Power cord	ADG1021	ADG1021	ADG1085	ADG – 064	
	FL Filter	AAK2309	AAK2309	AAK2309	AAK2329	
	Operating instructions (German)	ARC1349	
	Operating instructions (English, French, German, Italian, Dutch, Swedish, Spanish, Portuguese)	ARE1239	
	Operating instructions (English)	ARB1369	ARB1369	

SP SWITCH ASSEMBLY

SP SWITCH assembly (AWZ4089) and SP SWITCH assembly (AWZ4086) have the same construction except for the following :

Mark	Symbol & Description	Part No.		Remarks
		AWZ4086	AWZ4089	
Δ	C531, C532	CKCYB392K50	
	R573, R574	RS1PMF681J	

VR ASSEMBLY

VR assembly (AWZ4090) and VR assembly (AWZ4087) have the same construction except for the following :

Mark	Symbol & Description	Part No.		Remarks
		AWZ4087	AWZ4090	
	C365	CKCYF473Z50	

COMPLEX ASSEMBLY

COMPLEX assembly (AWZ4088) and COMPLEX assembly (AWZ4083) have the same construction except for the following :

Mark	Symbol & Description	Part No.		Remarks
		AWZ4083	AWZ4088	
	Q107	2SC2458	
	F104	ATF1088	
	L561, L562	ATH1009	ATH1004	
	L701	ATF-151	
	L981-L984	ATH-133	
	C123	CEAS2R2M50	CEAS010M50	
	C124	CEAS2R2M50	
	C133	CKCYB122K50	
	C134, C135	CKCYB272K50	CKCYB822K50	
	C140, C141	CKCYB222K50	
	C197	CCPUSL330J50	
	C198, C203-C222	CKMYB391K50	
	C223, C224	CKMYB821K50	CKMYB471K50	
	C225, C226, C981, C982, C985	CKMYB681K50	
	C986	CKMYB681K50	
	C527, C528	CKMYB221K50	
	C561, C562	CFTXA473J50	CFTXA104J50	
	C563, C564	CFTXA104J50	
	C983, C984, C987, C988	CKCYF103Z50	
	R114	RD1/8PM563J	RD1/8PM433J	
	R115	RD1/8PM822J	RD1/8PM472J	
	R116	RD1/8PM153J	
	R122	RD1/8PM224J	
	R123	RD1/8PM222J	
	R124	RD1/8PM392J	
	R125	RD1/8PM152J	
	R126	RD1/8PM473J	
	R127, R128	RD1/8PM153J	RD1/8PM103J	
	R135, R136	RD1/8PM102J	
	R180	RD1/8PM123J	
△	R981, R982, R985, R986	RD1/2PMF101J	
△	R987, R988	RD1/4PMF100J	
	4 Serial F.E. module assembly	AXQ1004	*1
	2 Serial F.E. module assembly	AXQ1002	*1

*1 All of these assemblies has no service parts.

SX-221R, SX-121

6.2 FOR SX – 121/HE AND HB

Contrast of Miscellaneous Parts

SX – 121/HE, HB and SX – 121/HEWZ have the same construction except for the following :

Mark	Symbol & Description	Part No.			Remarks
		SX – 121/HEWZ	SX – 121/HE	SX – 121/HB	
● NSP	COMPLEX assembly	AWZ4091	AWZ4095	AWZ4095	(SC-A47044)
●	SP SWITCH assembly	AWZ4094	AWZ4096	AWZ4096	
●	CONTROL assembly	AWZ4093	AWZ4092	AWZ4092	
△	AC Power cord	ADG1021	ADG1021	ADG1085	
	Operating instructions (German)	ARC1349	
	Operating instructions (English, French, German, Italian, Dutch, Swedish, Spanish, Portuguese)	ARE1239	
	Operating instructions (English)	ARB1369	

SP SWITCH ASSEMBLY

SP SWITCH assembly (AWZ4096) and SP SWITCH assembly (AWZ4094) have the same construction except for the following :

Mark	Symbol & Description	Part No.		Remarks
		AWZ4094	AWZ4096	
△	C531, C532 R573, R574	CKCYB392K50 RS1PMF681J	

COMPLEX ASSEMBLY

COMPLEX assembly (AWZ4095) and COMPLEX assembly (AWZ4091) have the same construction except for the following :

Mark	Symbol & Description	Part No.		Remarks
		AWZ4091	AWZ4095	
	Q107	2SC2458	
	F104	ATF1088	
	L561, L562	ATH1009	ATH1004	
	L701	ATF – 151	
	L981 – L984	ATH – 133	
	C123	CEAS2R2M50	CEAS010M50	
	C124	CEAS2R2M50	
	C133	CKCYB122K50	
	C134, C135	CKCYB272K50	CKCYB822K50	
	C140, C141	CKCYB222K50	
	C197	CCPUSL330J50	
	C198, C203 – C222	CKMYB391K50	

Mark	Symbol & Description	Part No.		Remarks
		AWZ4091	AWZ4095	
	C223, C224	CKMYB821K50	CKMYB471K50	
	C225, C226, C981, C982, C985, C986	CKMYB681K50	
	C527, C528	CKMYB221K50	
	C561, C562	CFTXA473J50	CFTXA104J50	
	C563, C564	CFTXA104J50	
	C983, C984, C987, C988	CKCYF103Z50	
	R114	RD1/8PM563J	RD1/8PM433J	
	R115	RD1/8PM822J	RD1/8PM472J	
	R116	RD1/8PM153J	
	R122	RD1/8PM224J	
	R123	RD1/8PM222J	
	R124	RD1/8PM392J	
	R125	RD1/8PM152J	
	R126	RD1/8PM473J	
	R127, R128	RD1/8PM153J	RD1/8PM103J	
	R135, R136	RD1/8PM102J	
	R180	RD1/8PM123J	
△	R981, R982, R985, R986	RD1/2PMF101J	
△	R987, R988	RD1/4PMF100J	
	4 Serial F.E. module assembly	AXQ1004	*1
	2 Serial F.E. module assembly	AXQ1002	*1

*1 All of these assemblies has no service parts.

CONTROL ASSEMBLY

CONTROL assembly (AWZ4092) and CONTROL assembly (AWZ4093) have the same construction except for the following.

Mark.	Symbol & Description	Part. No.		Remarks.
		AWZ4093	AWZ4092	
	C325	CKMYB471K50	----	

(Si - A47044)

7. PANEL FACILITIES

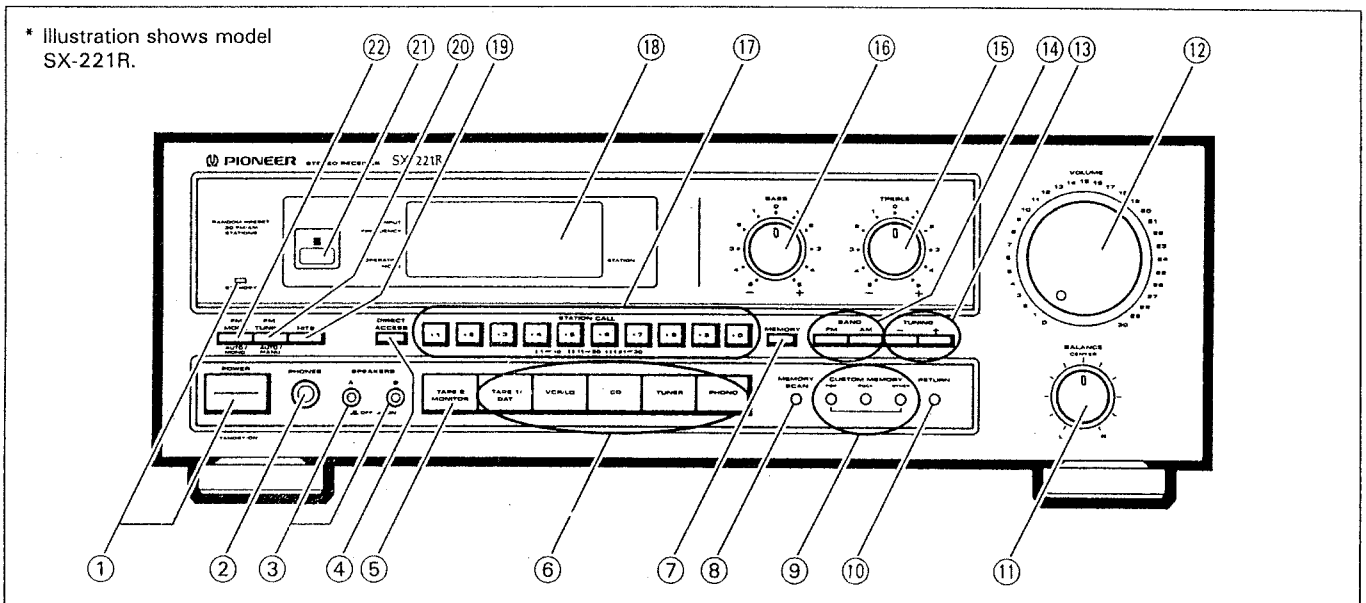

[SX-221R]

① POWER (STANDBY/ON) switch/STANDBY indicator

This is the switch for electric power.

ON: When set to the ON position, power is supplied and the unit becomes operational.

STANDBY: When set to the STANDBY position, the main power flow is cut and the unit is no longer fully operational. A minute flow of power feeds the unit to maintain operation readiness.

When the STANDBY indicator lights, the unit is in STANDBY and goes out during ON.

- When not using the unit for a long period, disconnect the power cord.

[SX-121]

① POWER switch

When this switch is pressed, power is supplied to the unit. Press the switch again to turn power OFF.

[Timer ON/OFF possible]

When the unit is switched ON, ON/OFF control can be performed by means of the optional timer.

NOTE (SX-121, SX-221R):

When the power is initially turned ON, muting will be applied to prevent sound from being output for about 5 seconds.

② PHONES jack

Connect the plug on your headphones to this jack. To listen to a program only through the headphones, set both SPEAKERS A and B buttons to the OFF position.

③ SPEAKERS buttons (**OFF**, **ON**)

These are used to select the speaker through which you wish to listen.

A: When the speakers connected to A terminals are in use.

B: When the speakers connected to B terminals are in use.

- Turn both A and B speakers to the OFF position when only headphones are in use.

NOTE:

No sound will be heard through the speakers when both A and B buttons are depressed if only one set of speakers has been connected to either A or B SPEAKERS terminals.

④ DIRECT ACCESS tuning button

When this button is pressed, the STATION CALL buttons function as 10-key number buttons for direct input of the desired reception frequency. Press again to cancel this mode.

If the input station falls outside of the receiver's tuning range, the display section will display a message: "UPPER" if the frequency is too high and "LOWER" if it is too low.

⑤ TAPE 2 MONITOR button

Switch on when using a cassette deck connected to the TAPE 2 MONITOR jacks.

⑥ Input selector buttons

Use to select playback source.

[TAPE 1/DAT] — Press when listening to tape playback with the cassette deck 1 or digital audio tape deck.

[VCR/LD] — Press when listening to programs from a component connected to the VCR/LD terminals.

[CD] — Press when listening to compact disc playback on a CD player.

[TUNER] — Press when listening to AM or FM broadcasts.

[PHONO] — Press when listening to record playback on a turntable.

⑦ MEMORY button

When the unit is in the frequency display mode, pressing this button will result in the memorization of the current broadcast band, reception frequency, and FM AUTO/MONO mode.

This button is also used to input custom memory names.

⑧ MEMORY SCAN button

This button is used for station memory scan and custom memory scan.

⑨ CUSTOM MEMORY buttons

Stations can be assigned to STATION CALL buttons according to the genre of material broadcast (POP, ROCK, OTHER). You can recall a particular genre, and scan all the stations of that genre with Memory Scan until you reach the desired one.

⑩ RETURN button

This is helpful during troubleshooting or when no sound is output. Pressing this button returns the receiver to the following settings, the sound level being controlled by VOLUME control.

- TAPE 2 MONITOR OFF
- FUNCTION TUNER
- BAND FM*

* The last FM broadcast you were listening to will be received. When reception is not possible, search begins for a frequency that can be received.

NOTE:

If no sound is output after the RETURN button is pressed make sure that SPEAKERS switches are turned ON.

⑪ BALANCE control

Should normally be left in the center position. Adjust balance if the sound is louder from one of the speakers. If the right side is louder, turn toward the L position and if the left side is louder, turn toward the R position.

⑫ VOLUME control

Use to adjust volume level.

⑬ TUNING buttons (+ -)

- +: The FM or AM band is scanned in the direction of increasing frequency.
- : The opposite operation to that of the + button takes place.

⑭ BAND buttons

These buttons are used to select either FM or AM reception.
FM: Push this button for FM reception.
AM: Push this button for AM reception.

⑮ TREBLE tone control

Use to adjust high-frequency tone. The center position is the flat (normal) position. When turned to the right, high-frequency tones are emphasized; when turned to the left, high-frequency tones are de-emphasized.

⑯ BASS tone control

Use to adjust the low-frequency tone. The center position is the flat (normal) position. When turned to the right, low-frequency tones are emphasized; when turned to the left, low-frequency tones are de-emphasized.

⑰ STATION CALL buttons

These buttons are used to preset and recall desired broadcasting stations.

⑱ OPERATION DISPLAY panel

- (a) Indicates the function or frequency by the function switches.
- (b) TUNED indicator
- (c) FM STEREO indicator
- (d) FM MONO indicator
- (e) TUNING AUTO/MANUAL indicator
- (f) DIRECT ACCESS tuning indicator
- (g) CUSTOM MEMORY indicator
- (h) Indicates channel, STATION CALL number or sleep time.
- (i) SEARCH indicator
- (j) SCAN indicator
- (k) MEMORY indicator
- (l) TAPE 2 monitor indicator.

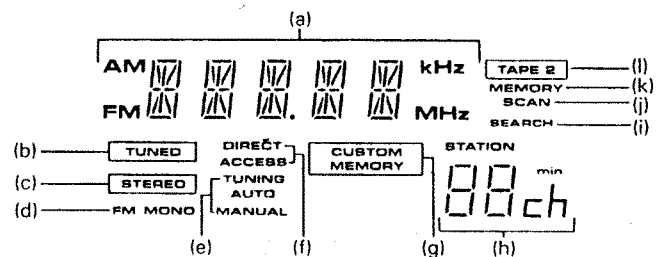

⑲ HITS (Hyper Intelligent Tuning System) button

Press this button to automatically search for and tune in broadcasts that can be received.

⑳ FM TUNING AUTO/MANU button

Works during FM reception.
 Use this button to select either the AUTO mode or the MANUAL mode. When the "AUTO" indicator is lit, the receiver is in the AUTO mode.

㉑ Remote sensor window (SX-221R only)

㉒ FM MODE AUTO/MONO selector button

Use to select the auto stereo mode or monaural mode when listening to FM broadcasts. The monaural mode has been selected when the FM MONO indicator is lit.

Auto stereo mode:

Normally leave in this mode for reception. When a stereo FM broadcast is received, it will be automatically reproduced in stereo sound.

Monaural mode:

When receiving distant stations or stations with weak broadcast signals, the input signal may be weak, thus resulting in increased noise during FM stereo broadcasts. In this event, setting the receiver to the monaural mode will reduce the noise, however, FM stereo broadcasts will be then reproduced in monaural sound.

NOTE:

This button has no effect on reception of AM broadcasts.

* Illustration shows model SX-221R.

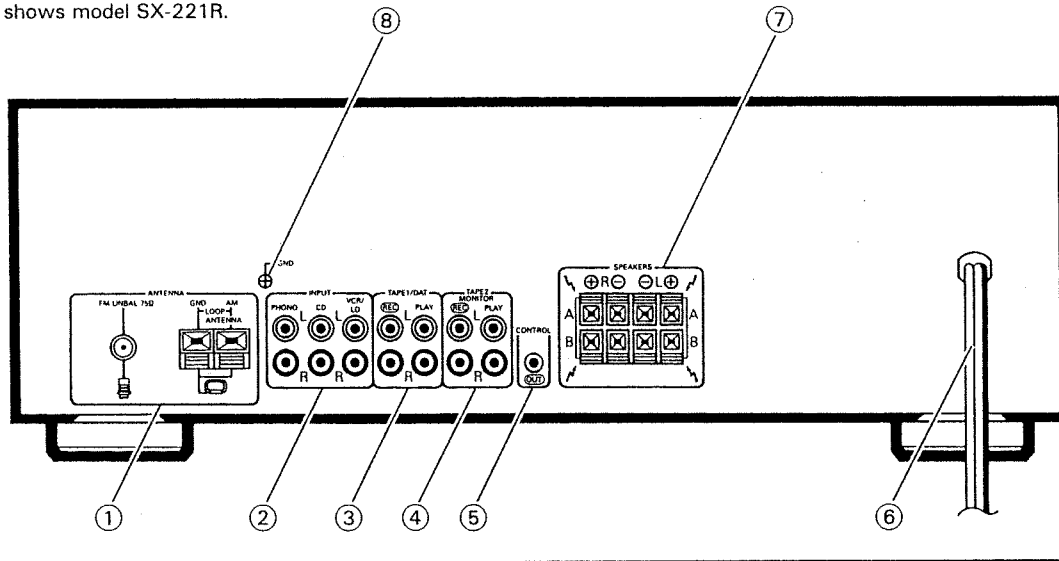

① FM/AM ANTENNA terminals

Use these antenna terminals for receiving FM and AM broadcasts.

② INPUT jacks

PHONO Connect to the output cables from a turntable.

CD Connect to the output jacks of a compact disc player.

VCR/LD Connect to the output jacks of a video cassette recorder or Laser Disc player.

③ TAPE 1/DAT jacks

Connect these jacks to the cassette deck or digital audio tape deck.

④ TAPE 2 MONITOR jacks

Connect these jacks to the cassette deck.

⑤ CONTROL OUT jack (SX-221R only)

Connect this jack to other Pioneer components bearing the  mark when using the remote control of this unit to control the other components.

⑥ Power cord

⑦ SPEAKERS terminals

A: Connect to a first set of speakers.

B: Connect to a second set of speakers.

NOTE:

No sound will be heard through the speakers when both A and B buttons are depressed if only one set of speakers has been connected to either A or B SPEAKERS terminals.

⑧ GND terminal

Connect to the ground lead of a turntable.

Use a screwdriver to connect with the ground terminal.

