

# Service Manual

**CIRCUIT DESCRIPTIONS  
REPAIR & ADJUSTMENTS**



**ORDER NO.  
ARP-230-0**

**AM/FM STEREO RECEIVER**

# SX-202

MODEL SX-202 (SX-202L) COMES IN SIX VERSIONS DISTINGUISHED AS FOLLOWS:

Model	Voltage	Remarks
SX-202/KU	AC120V only	U.S.A. model
SX-202/KC	AC120V only	Canada model
SX-202/S	AC110V, 120V, 220V and 240V (switchable)	General export model
SX-202/YP	AC240V only	Australia model
SX-202L/HE	AC220V only	European continent model with AM-LW band tuner
SX-202L/HEZ	AC220V only	West Germany model with AM-LW band tuner

- This service manual is applicable to the KU types. For servicing of the other types, please refer to the additional service manual.
- Ce manuel d'instruction se réfère au mode de réglage, en français.
- Este manual de servicio trata del método de ajuste escrito en español.

## CONTENTS

1. SPECIFICATIONS	2	8. P.C. BOARDS CONNECTION DIAGRAM	12
2. FRONT PANEL FACILITIES	3	9. SCHEMATIC DIAGRAM	15
3. PARTS LOCATION	4	10. ELECTRICAL PARTS LIST	17
4. BLOCK DIAGRAM	5	11. DIAL CORD STRINGING	19
5. CIRCUIT DESCRIPTIONS	6	12. ADJUSTMENTS	20
6. PACKING	8	RÉGLAGE	22
7. EXPLODED VIEW AND PARTS LIST	9	AJUSTE	24

# 1. SPECIFICATIONS

## Amplifier Section

Continuous Average Power Output is 25 watts\* per channel, min., at 8 ohms from 40Hertz to 20,000Hertz with no more than 0.3% total harmonic distortion.

Total Harmonic Distortion (40 Hertz to 20,000 Hertz, 8 ohms, from TAPE)

- continuous rated power output  
..... No more than 0.3%
- 12.5 watts per channel power output  
..... No more than 0.15%
- 1 watt per channel power output  
..... No more than 0.2%

Intermodulation Distortion (50 Hertz: 7,000 Hertz = 4 : 1, 8 ohms, from AUX)

- continuous rated power output  
..... No more than 0.3%

Damping Factor (1 kHz, 8 ohms) ..... 22  
Input (Sensitivity/Impedance)

- PHONO ..... 2.5 mV/50 kilohms
- TAPE PLAY ..... 150 mV/50 kilohms

Phono Overload Level (T.H.D.0.1%, 1,000Hz)

- PHONO ..... 150mV

Output Level

- TAPE REC ..... 150 mV
- SPEAKER ..... A, B, A series B, off

Frequency Response

- PHONO (RIAA Equalization)  
..... 30Hz to 20,000Hz±0.5dB
- TAPE PLAY ..... 15Hz to 50,000Hz <sup>+1</sup>/<sub>-3</sub>dB

Tone Control

- BASS ..... ±9dB (100Hz)
- TREBLE ..... ±9dB (10kHz)

Loudness Contour (Volum control set at -40dB position)  
..... +8dB (100Hz), +6dB (10,000Hz)

Hum and Noise (IHF, short circuited, A network)

- PHONO MM ..... 71dB
- TAPE PLAY ..... 97dB

## FM Tuner Section

\*Usable Sensitivity ..... 10.7dBf (0.9µV)  
50dB Quieting Sensitivity

\*\*MONO ..... 15.3dBf (1.6µV)  
STEREO ..... 37.6dBf (21µV)

Signal-to-Noise Ratio

- MONO ..... 75dB (at 85dBf)
- STEREO ..... 70dB (at 85dBf)

Distortion (at 65dBf)

- MONO 1kHz ..... 0.3%
- STEREO 1kHz ..... 0.6%

- Capture Ratio ..... 2.5dB
- Alternate Channel Selectivity (400kHz) ..... 50dB
- Stereo Separation (1kHz) ..... 35dB
- Frequency Response ..... 30Hz to 15kHz, <sup>+0.5</sup>/<sub>-1.0</sub> dB
- Spurious Response Ratio ..... 70dB
- Image Response Ratio ..... 45dB
- IF Response Ratio ..... 100dB
- AM Suppression Ratio ..... 45dB
- Subcarrier Product Ratio ..... 31dB
- Muting Threshold ..... 27dBf (6.3µV)
- Antenna Input  
..... 300 ohms balanced, 75 ohms unbalanced

## AM Tuner Section

Sensitivity

- IHF, Loop antenna ..... 320µV/m
- IHF, Ext, antenna ..... 30µV

Selectivity ..... 25dB

Signal-to-Noise Ratio ..... 43dB

Image Response Ratio ..... 40dB

IF Response Ratio ..... 45dB

Antenna ..... AM Loop Antenna

## Miscellaneous

Power Requirements ..... AC 120V, 60Hz

Power Consumption ... 125 Watts(UL), 150 VA(CSA)

Dimensions ..... 420(W) x 98(H) x 214(D) mm  
16-9/16(W) X 3-7/8(H) X 8-7/16(D) in

Weight (without package) ..... 4.3 kg (9lb 8 oz)

## Furnished Parts

- FM T-type Antenna ..... 1
- AM Loop Antenna ..... 1
- Operating Instructions ..... 1

*\*Measured pursuant to the Federal Trade Commission's Trade Regulation rule on Power Output Claims for Amplifier.*

*\*\*FM muting functions with this unit when the signals are weak. The unit's internal wires are therefore treated so that the signals are not muted when the sensitivity is measured.*

### NOTE:

*Specifications and design subject to possible modification without notice.*

## 2. FRONT PANEL FACILITIES

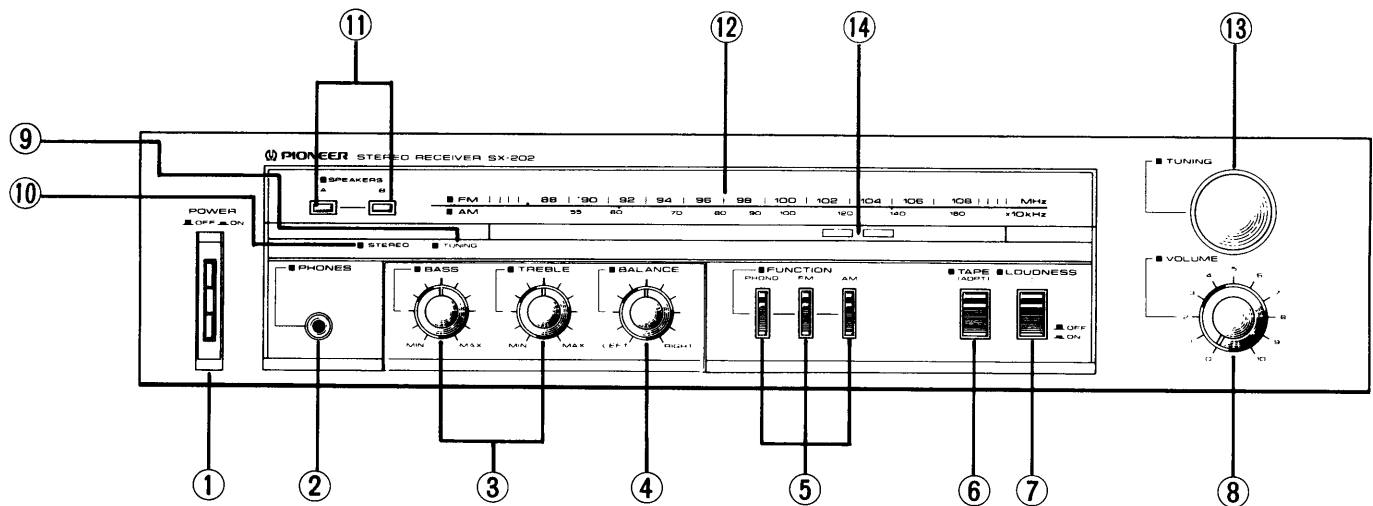

### ① POWER SWITCH

Push this to switch on and off the unit's power. Power is supplied at the depressed (▲) switch position (ON) and turned off at the released (■) position (OFF).

### ② HEADPHONE JACK

Connect the plug on the stereo headphones to this jack when listening to sound through headphones.

### ③ TONE CONTROLS

**BASS** : The bass is increased when this control is rotated clockwise from the center position and reduced when rotated counterclockwise.

**TREBLE** : The treble is increased when this control is rotated clockwise from the center position and reduced when rotated counterclockwise.

### ④ BALANCE CONTROL

This is normally kept at its center position. It is rotated when the volume of sound delivered through the left and right channels of the speakers or headphones differs.

The right channel volume is reduced when the control is rotated toward the LEFT from the center position while the left channel volume is reduced when it is rotated toward the RIGHT.

### ⑤ FUNCTION SWITCHES

**PHONO** : Press when listening to records.

**FM** : Press when listening to FM broadcasts.

**AM** : Press when listening to AM broadcasts.

### ⑥ TAPE (ADPT) SWITCH

This is depressed when using a tape deck or adaptor unit connected to the rear panel TAPE/ADAPTOR jacks.

### ⑦ LOUDNESS SWITCH

Depress this switch to the ON position when listening to sound at a low level of volume. This will enhance the bass and treble and give more life to the sound even at a low volume.

### ⑧ VOLUME CONTROL

Use this to adjust the volume of the sound delivered through the speakers or headphones.

The volume is increased when this control is rotated clockwise from the minimum "0" position.

### ⑨ TUNING INDICATOR (TUNING)

This lights up to indicate that an FM, AM station has been tuned in.

### ⑩ STEREO INDICATOR (STEREO)

This lights up automatically when an FM station broadcasting in stereo has been tuned in.

### ⑪ SPEAKERS SWITCHES

These are used to select the speakers through which you will listen to the sound.

The selected speakers are now working.

**A:** The sound is heard from the speakers connected to the speaker A terminals on the rear panel.

**B:** The sound is heard from the speakers connected to the speaker B terminals on the rear panel.

No sound will be heard when SPEAKERS A and B switches are both released. This is the position at which the sound can be heard through the headphones.

#### NOTE:

*No sound will be heard through the speakers when both the A and B switches are depressed if only one set of speakers has been connected to either the A or B SPEAKERS terminals.*

### ⑫ FREQUENCY SCALE

This indicates the frequency of the broadcasting station (FM, AM).

The top level figures (88 ~ 108) indicate the FM band.

The bottom level figures (55 ~ 160) indicate the AM band.

### ⑬ TUNING KNOB

Rotate this knob to pick up stations (FM, AM).

### ⑭ POWER INDICATOR/DIAL POINTER

### 3. PARTS LOCATION

**NOTES:**

- Parts without part number cannot be supplied.
- The **⚠** mark found on some component parts indicates the importance of the safety factor of the part. Therefore, when replacing, be sure to use parts of identical designation.
- For your Parts Stock Control, the fast moving items are indicated with the marks **★★** and **★**.  
**★★ GENERALLY MOVES FASTER THAN ★.**  
 This classification shall be adjusted by each distributor because it depends on model number, temperature, humidity, etc.

**Front Panel View**

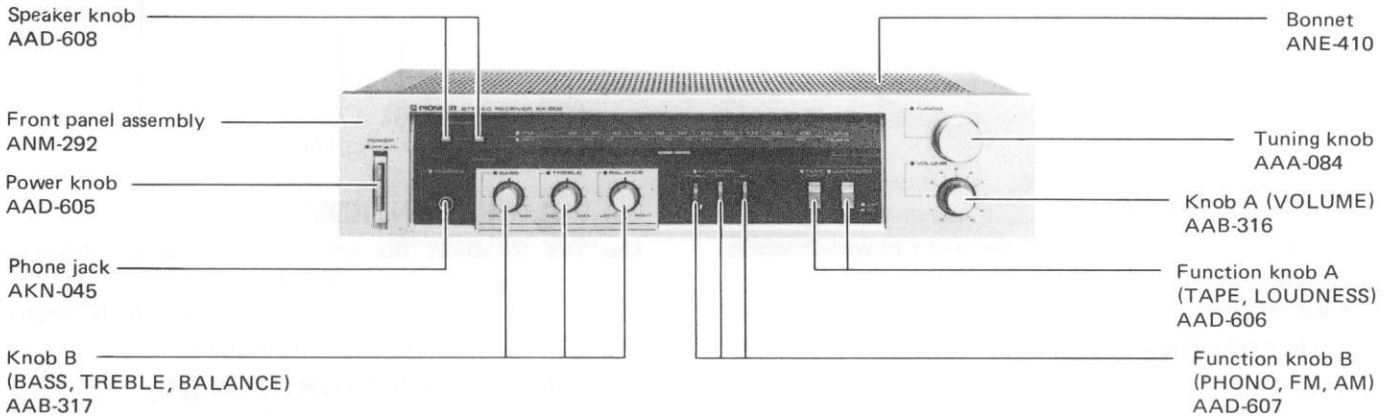

**Rear Panel View**

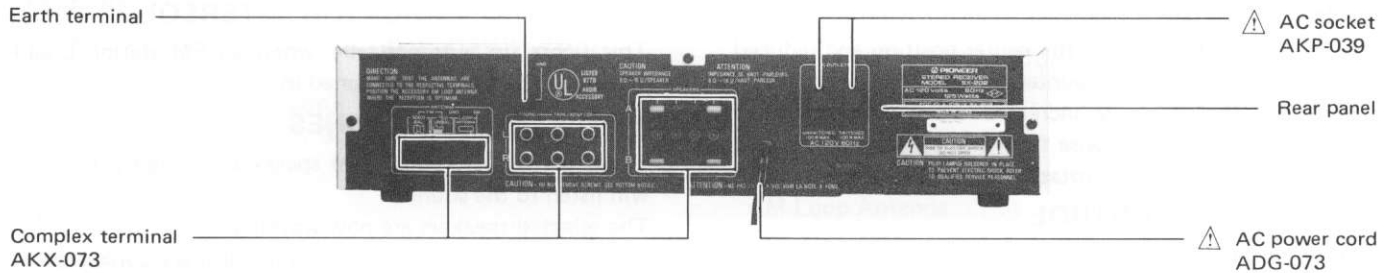

**Top View**

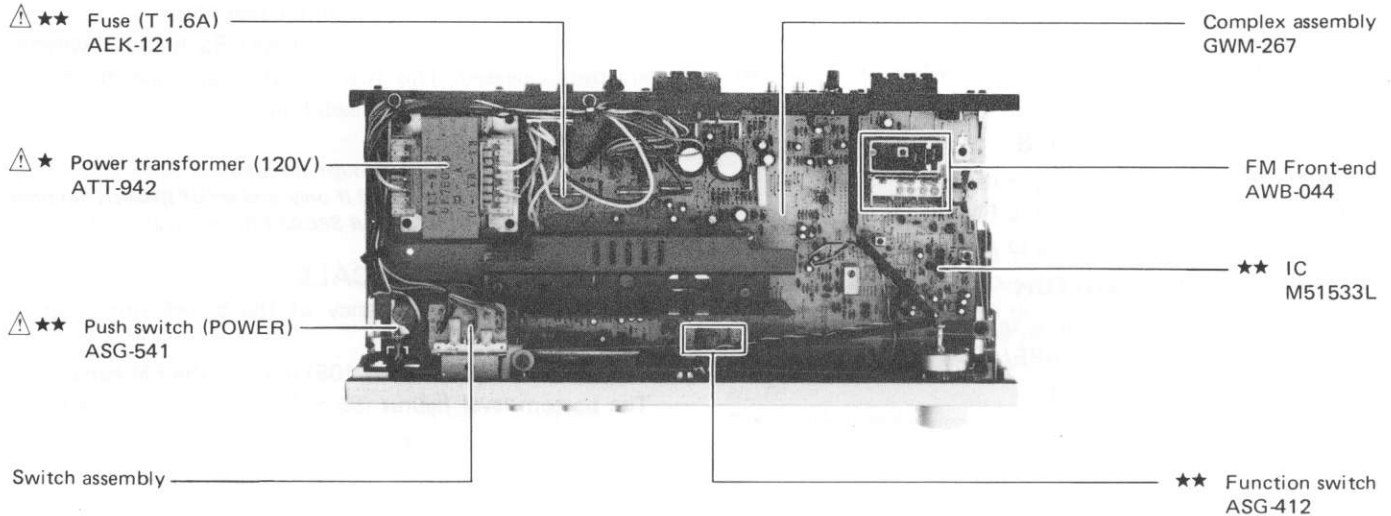

# 4. BLOCK DIAGRAM

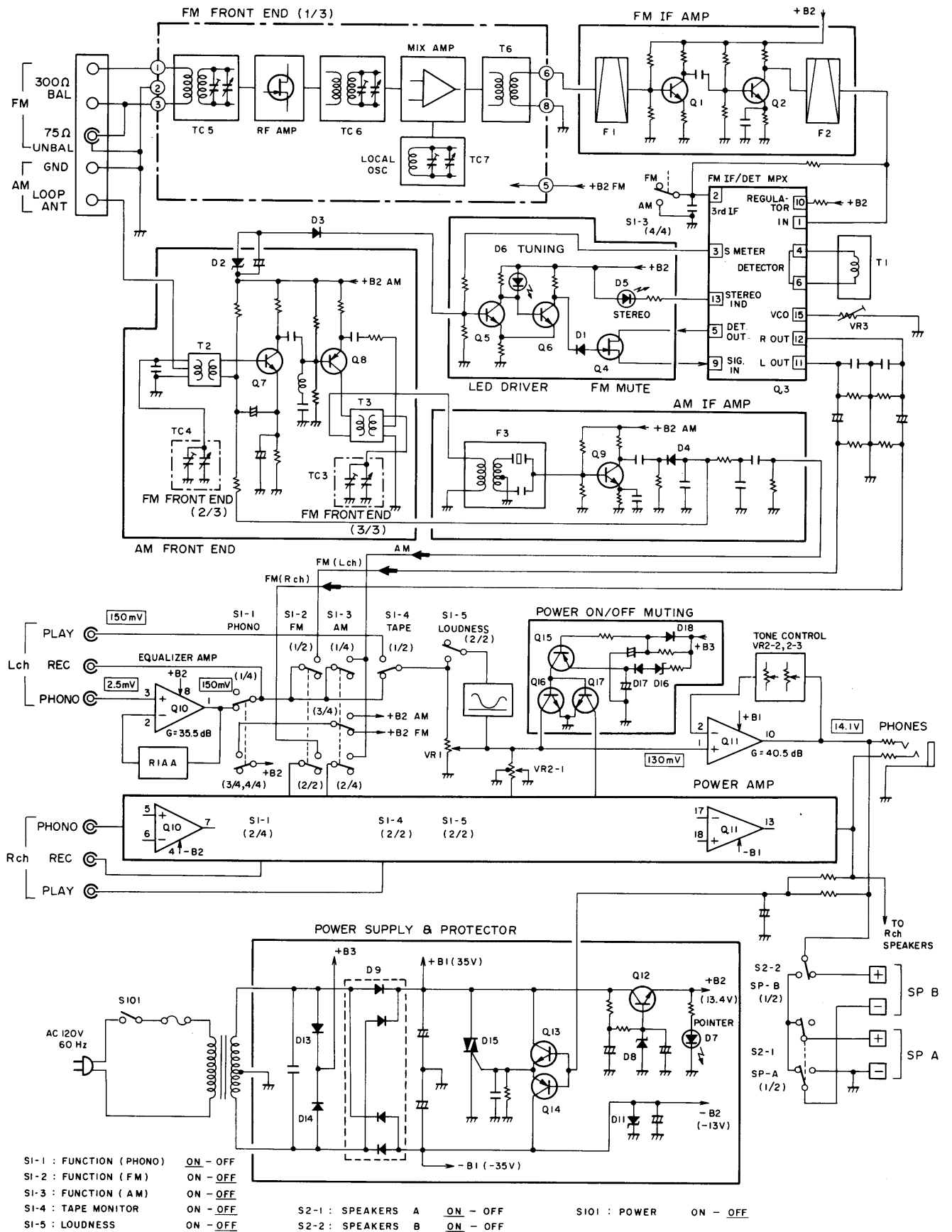

## 5. CIRCUIT DESCRIPTIONS

### FM Front End

A unitized variable capacitor type front end unit is used consisting of an FET RF single stage amp, local oscillator/mixer IC and an IF transformer.

### FM IF Amp, Detector and MPX Circuit

A 2-transistor IF amp with ceramic filter is used and the next stage has an IC (M51533L) containing the FM IF detector and MPX circuit. The block diagram of IC M51533L is shown in Fig. 5-1. This IC uses a peak detection method which can be adjusted with a single coil. The PLL method is employed to reconstitute the 38kHz sub-carrier for the MPX circuit.

The IF signal is input at pin 1 and the detection output is obtained from pin 5. The detection output passes through the muting Q4, goes to pin 9, passes through the MPX circuit and the stereo signals are obtained from pins 11 and 12. In addition, this unit detects the presence or absence

of a pilot signal to automatically switch between stereo and mono reception by R14 which is connected to pin 14. When a stereo signal is received, pin 13 drops to the low level to light the stereo indicator. When pin 2 is grounded, the PLL VCO and FM IF operation stop (for AM).

### FM Muting and LED Driver

With this unit, muting is automatically activated when the antenna input drops below  $10\mu V$ . As the antenna input decreases, the voltage at pin 3 drops, Q5 is turned off and Q6 is turned on. As a result, the gate voltage of Q4 drops, Q4 is turned off and the detector output circuit is blocked (Fig. 5-1). When an FM or AM station is tuned in, the base potential of Q5 is raised, Q5 is turned on and the tuning indicator lights.

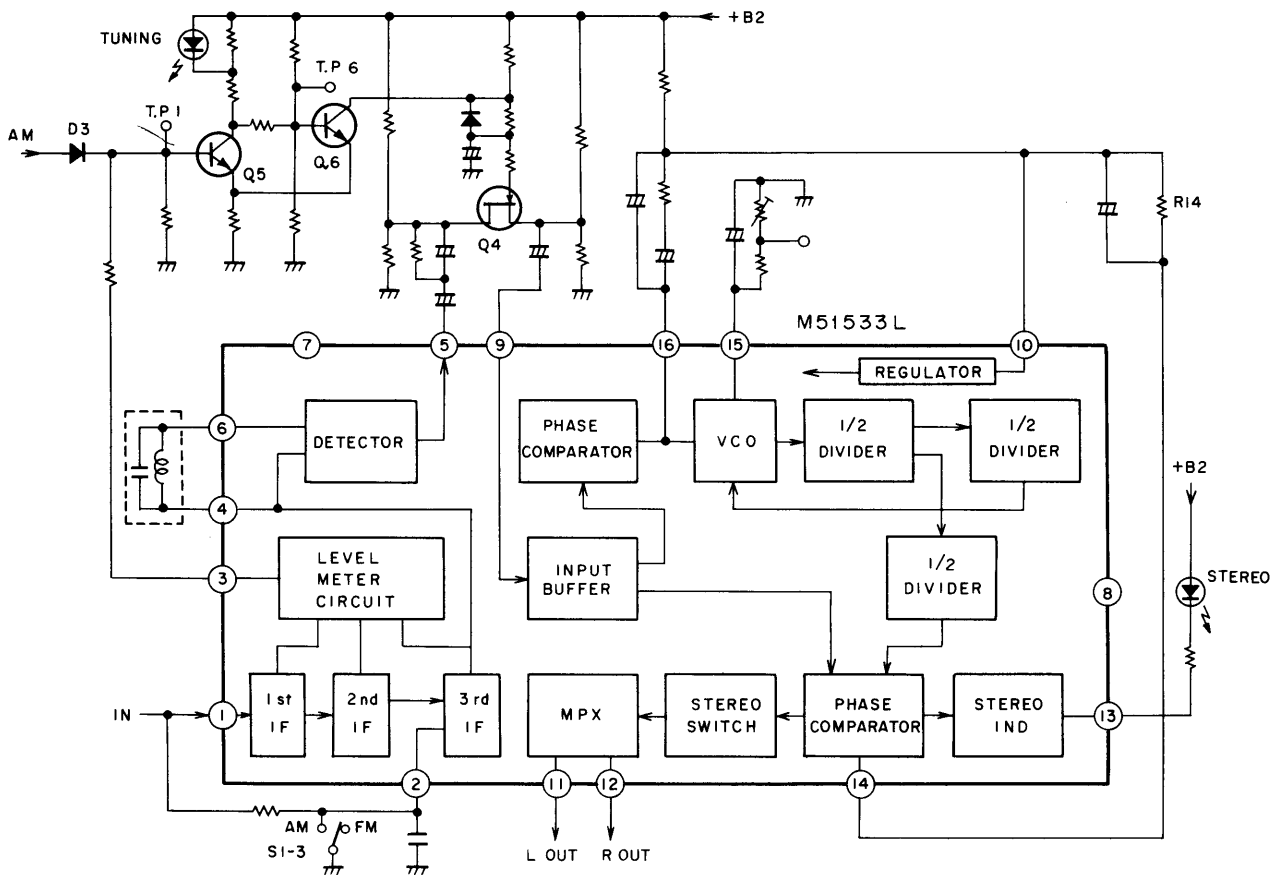

Fig. 5-1 FM IF, Detector and MPX circuit

**AM Tuner**

This uses a variable capacitor type tuning circuit composed of three transistors, a 2-transistor front end and a single transistor AM IF detector.

**AF Section**

The equalizer circuit has a low-noise operation amp (2 channel) M5218P.

The power amp has a 25 watt output power IC STK4141-2S (See Fig. 5-4).

The tone control circuit is placed in the negative feedback loop of the power amp.

**Protective Circuits**

This unit has a circuit to detect DC voltages at the power amp outputs and a muting circuit that operates when power is turned on and off.

Fig. 5-2 shows the construction of the DC voltage protection circuit. When a DC voltage

appears at the power amp output, either Q13 (plus) or Q14 (minus) is activated depending on the polarity of the DC voltage and a trigger is applied to D15. This turns on D15, +B1 is shorted, the fuse on the primary side is cut and the power supply circuit is shut off.

Fig. 5-3 shows the power on/off muting circuit. Time constant  $t_1$  is longer than  $t_2$  so that immediately after the power is turned on, the emitter potential of Q15 exceeds its base potential, Q15 is turned on to activate Q16 and Q17 and ground the signal. A few seconds later, the base potential of Q15 rises to turn off Q15 along with Q16 and Q17.

When the power is turned off, the charge of C161 passes through D18; it is almost completely discharged in an instant to make the base potential of Q15 zero. However, because the charge of C160 remains, Q15 is turned on and muting is activated in the same manner as when power is turned on.

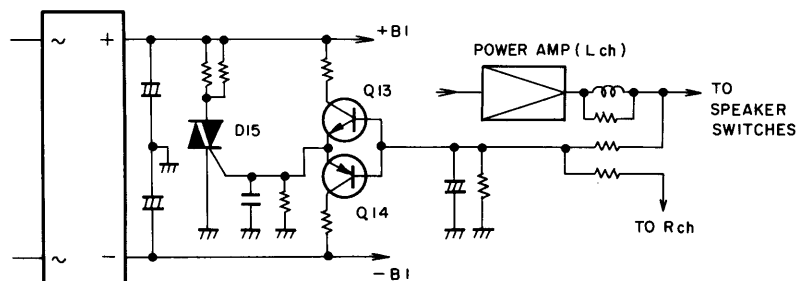

Fig. 5-2 DC Voltage protection circuit

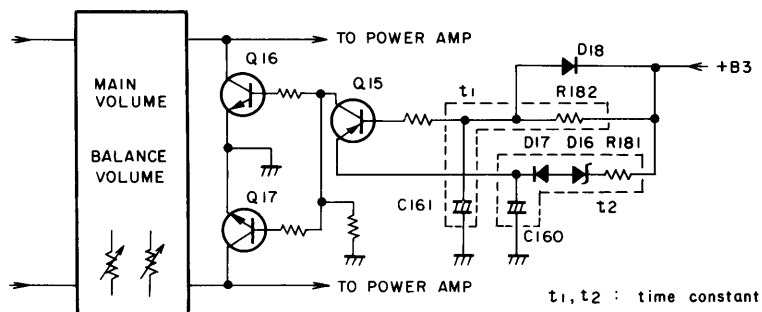

Fig. 5-3 Power ON/OFF muting circuit

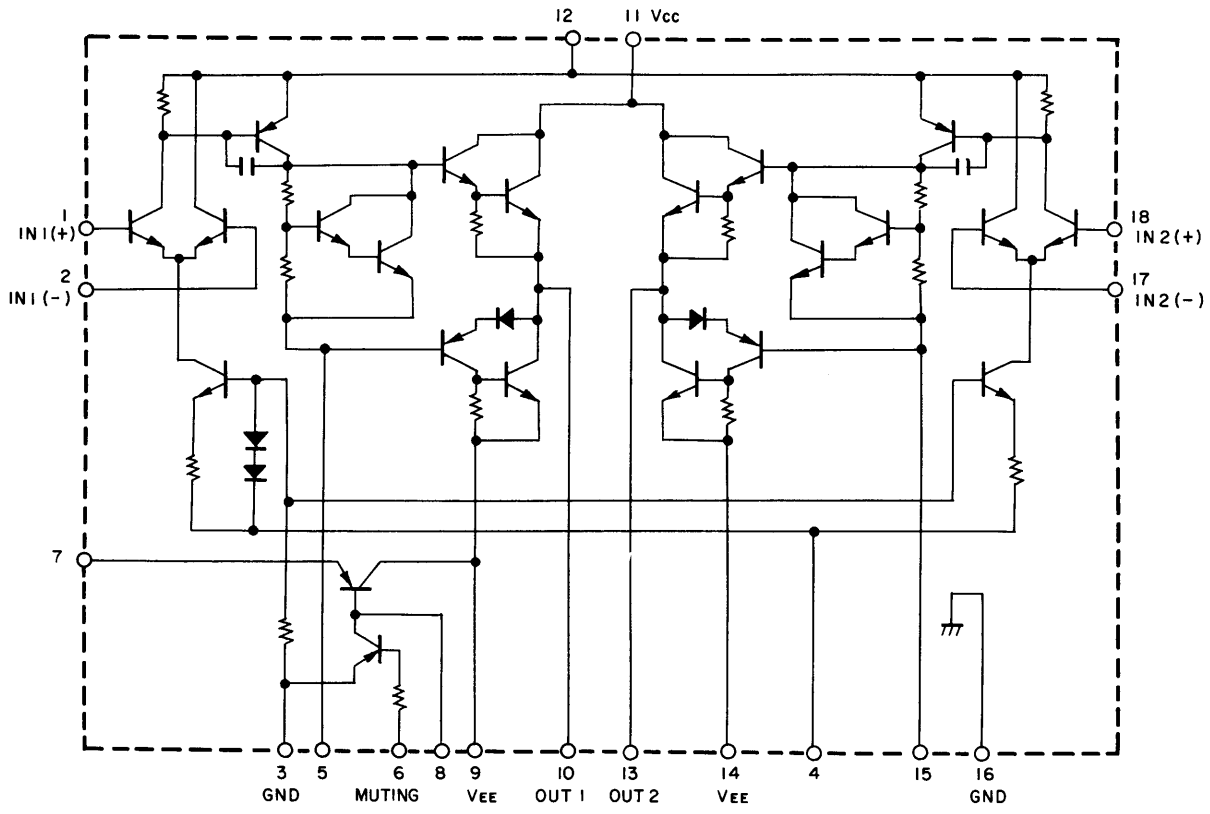
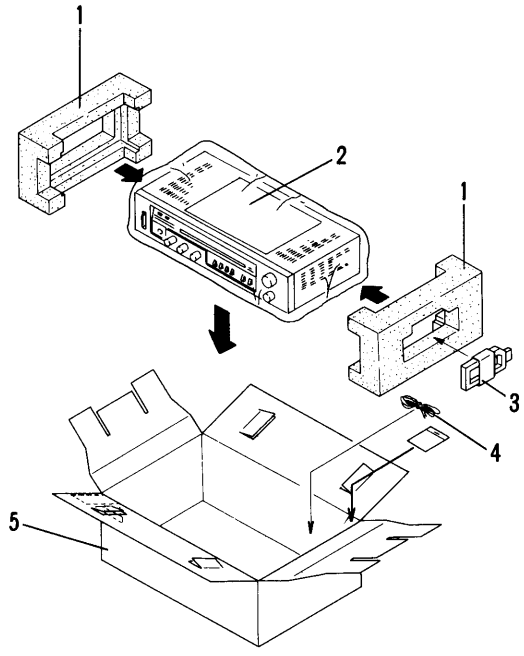

Fig. 5-4 Equivalent circuit of power IC

## 6. PACKING



Mark	No.	Part No.	Description
	1.	AHA-335	Side pad
	2.	ARB-525	Operating instructions (English)
	3.	ATB-076	Loop antenna assembly
	4.	ADH-005	T-type antenna
	5.	AHE-102	Packing case



# 7. EXPLODED VIEW AND PARTS LIST

**NOTES:**

- *Parts without part number cannot be supplied.*
- *The  $\triangle$  mark found on some component parts indicates the importance of the safety factor of the part. Therefore, when replacing, be sure to use parts of identical designation.*
- *For your Parts Stock Control, the fast moving items are indicated with the marks **★★** and **★**.*
- ★★ GENERALLY MOVES FASTER THAN ★.**
- This classification shall be adjusted by each distributor because it depends on model number, temperature, humidity, etc.*

A

B

C

D

Mark	No.	Part No.	Description	Mark	No.	Part No.	Descriptions
	1.	ANE-410	Bonnet		50.		Speaker switch assembly
	2.	BBZ30P080FZK	Screw (3 x 8)		51.		Switch holder
$\triangle$ ★	3.	ATT-942	Power transformer (120V)		52.		Pully assembly
	4.	PMZ30P060FMC	Screw (3 x 6)		53.		LED assembly
	5.	AAD-608	Speaker knob		54.		Earth
	6.	VMZ30P060FMC	Screw (3 x 6)		55.		Mounting plate
	7.	NK90FUC	Nut		56.		Pully assembly
	8.	AAB-317	Knob B (BASS, TREBLE, BALANCE)		57.		Pully assembly
	9.	NK70FUC	Nut		58.		Pully holder
	10.	AAA-084	Tuning knob		59.		Headphone jack assembly
	11.	AAB-316	Knob A (VOLUME)		60.		Chassis
	12.	ANM-292	Front panel assembly		61.		Bottom Plate
	13.	AAD-607	Function knob B (PHONO, FM, AM)		62.		Binder
	14.	AAD-606	Function knob A (TAPE, LOUDNESS)		63.		Earth terminal
$\triangle$ ★★	15.	ASG-541	Push switch (POWER)		64.		Rear panel
	16.	AAD-605	Power knob		65.		Tuning drum
	17.	AEC-784	Cabinet bumper		66.		Smoother
	18.	AXA-373	Tuning shaft		67.		Pointer holder
	19.	AEC-471	Nylon rivet		68.		Pointer assembly
	20.	MTZ30P100FZK	Screw (3 x 10)		69.		Heat sink
$\triangle$ ★★	21.	AEK-121	Fuse (T 1.6A)		70.		Wire holder
$\triangle$	22.	AKP-039	AC socket				
$\triangle$	23.	ADG-073	AC power cord				
	24.	GWM-267	Complex assembly				
	25.	AKN-045	Phone Jack (PHONES)				
★★	26.	SUJ8LYXSF	Speaker switch				
$\triangle$	27.	ACG-017	Ceramic (0.01)				
	28.	BBT30P080FZK	Screw (3 x 8)				

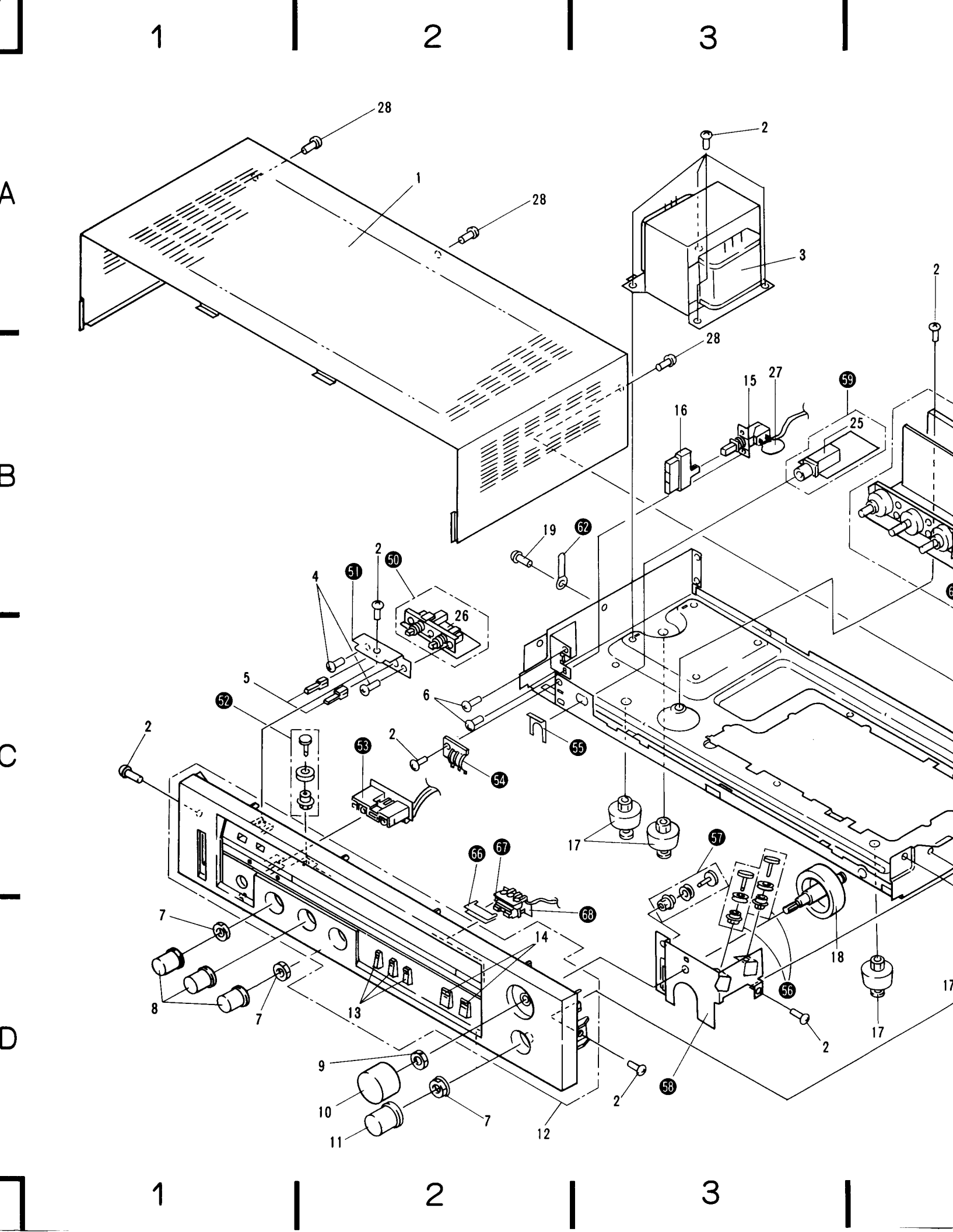

4

5

6

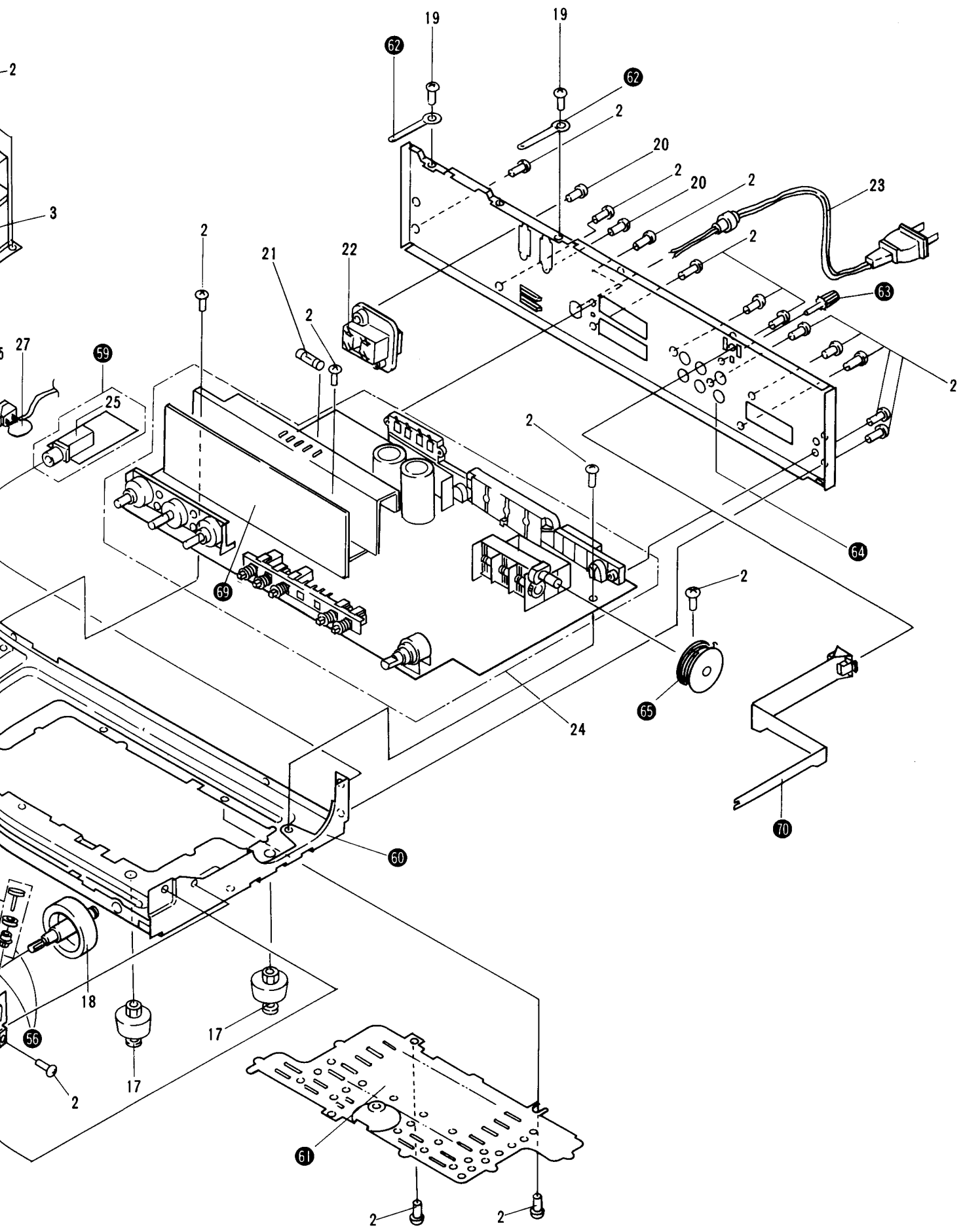

A

B

C

D

4

5

6

# 8. P.C. BOARDS CONNECTION DIAGRAM

## External Appearances of Transistors and IC's

A

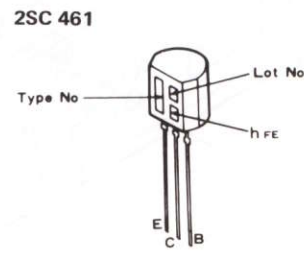
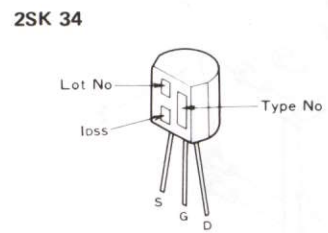
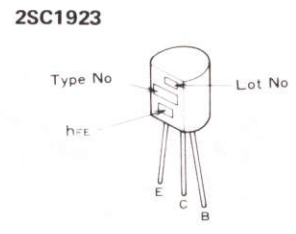
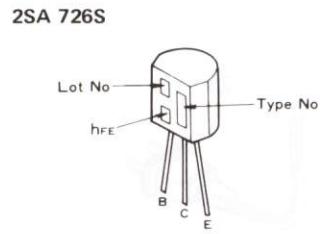

B

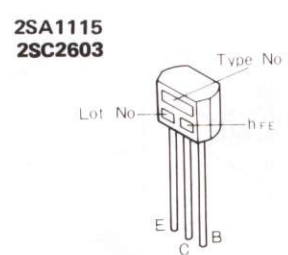
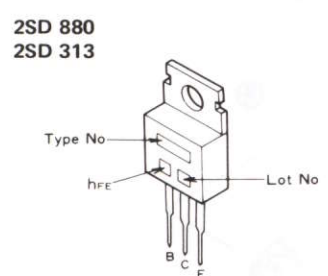

C

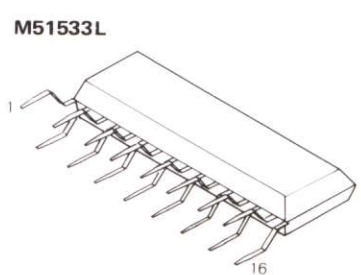
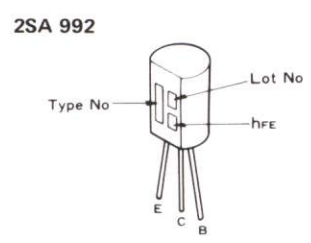
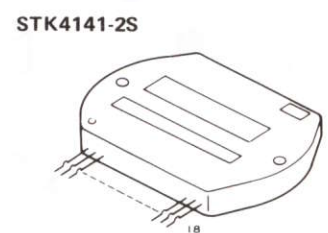
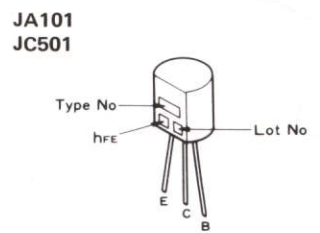

D

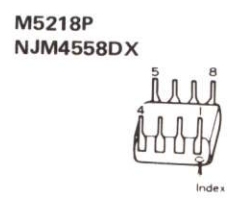
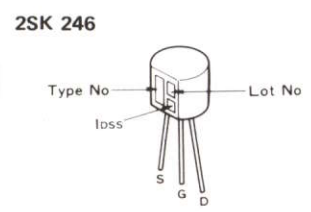

COMPLEX Ass'y GWM-267

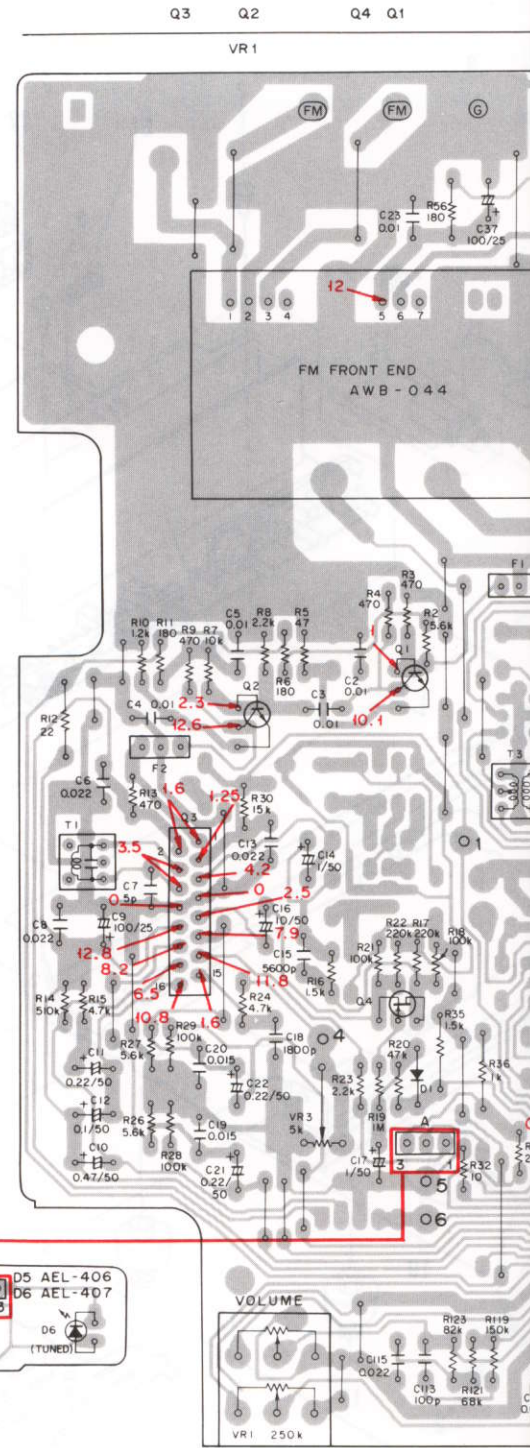



# Ass'y GWM-267

Q4 Q1                      Q6 Q5                      Q9 Q8                      Q7 Q10                      Q14                      Q13                      Q12 Q15                      Q16 Q11                      Q17

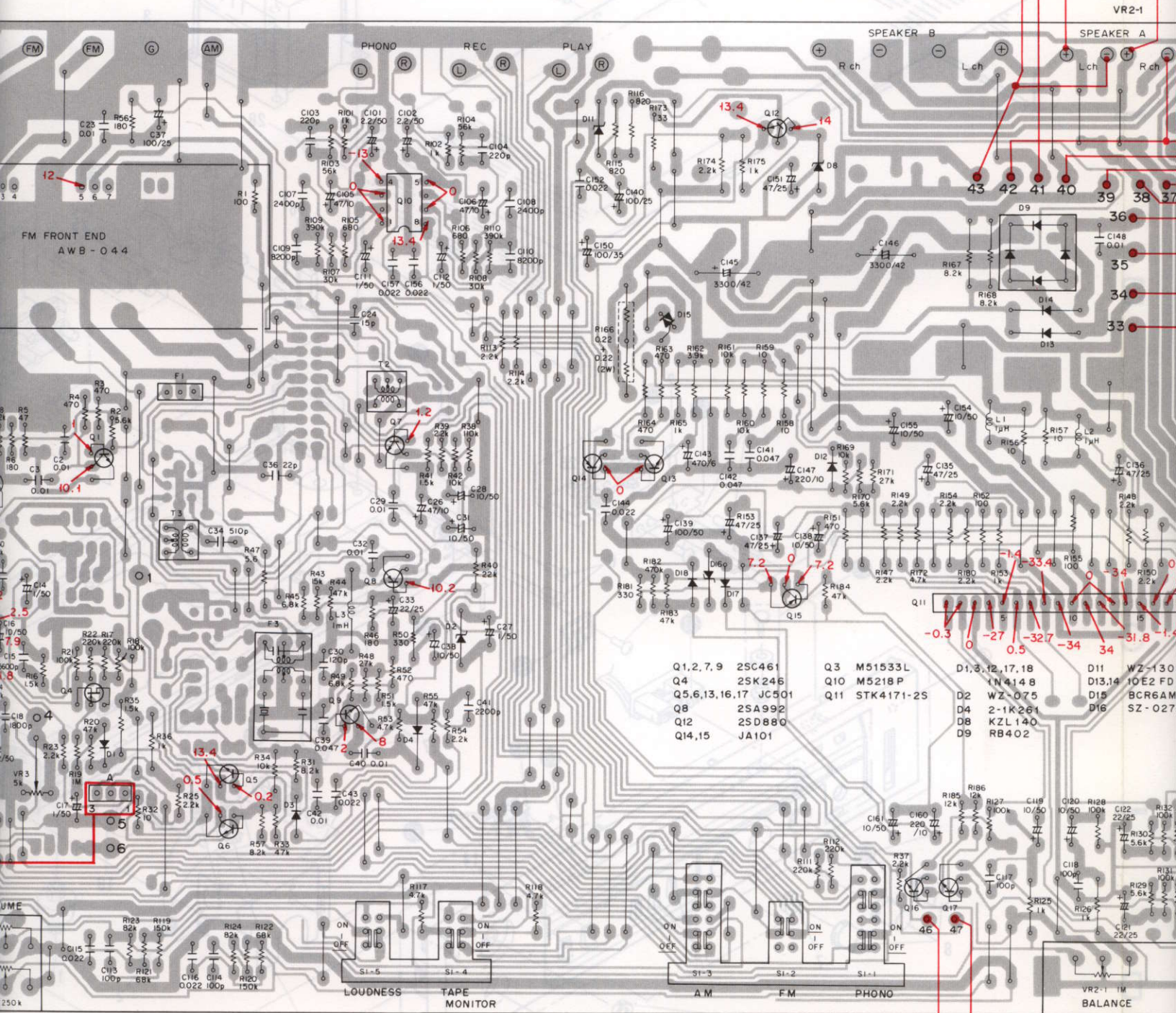

Q1,2,7,9	25C461	Q3	M51533L	D1,3,12,17,18	WZ-130
Q4	25K246	Q10	M5218P	D2	WZ-075
Q5,6,13,16,17	JC501	Q11	STK4171-25	D4	2-1K261
Q8	25A992	D8	KZL 140	D6	BCR6AM
Q12	25D880	D9	RB402		SZ-027
Q14,15	JA101				



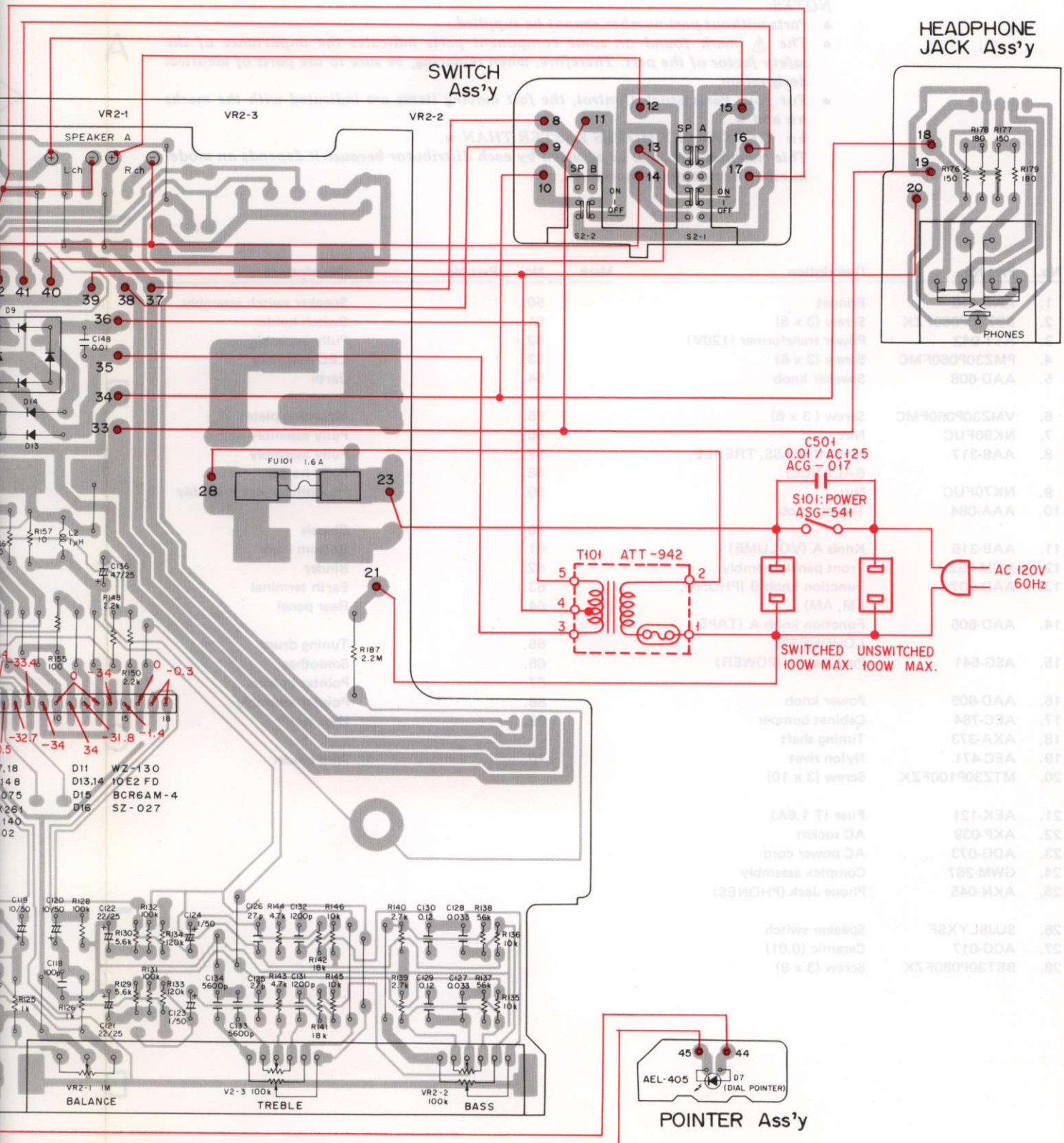

A

B

C

D

- D11 WZ-130
- D13,14 10E2 FD
- D15 BCR6AM-4
- D16 SZ-027

- 1. AEL-405 (DIAL POINTER)
- 2. BRT30P0805XK (Screw (3 x 8))
- 3. ACG-017 (Screw (3 x 8))
- 4. SUBLBXY5F (Speaker switch)
- 5. AKN-048 (Phone Jack (PHONE))
- 6. GWM-287 (Complex assembly)
- 7. ADD-073 (AC power cord)
- 8. AKP-029 (AC socket)
- 9. AEK-121 (Fuse (T 1BA))
- 10. MT30P100F2X (Screw (3 x 10))
- 11. AEC-471 (Nylon rivet)
- 12. AXA-373 (Tuning shaft)
- 13. AEC-184 (Cabinet bumper)
- 14. AAD-608 (Power knob)
- 15. AAG-541 (Switch)
- 16. AAD-608 (Screw (3 x 8))
- 17. AAB-317 (Screw (3 x 8))
- 18. NK80FUC (Switch)
- 19. VM30P080FMC (Screw (3 x 8))
- 20. VM30P080FMC (Screw (3 x 8))
- 21. AAD-608 (Screw (3 x 8))
- 22. AAB-317 (Screw (3 x 8))
- 23. NK80FUC (Switch)
- 24. AAG-541 (Switch)
- 25. AAB-317 (Screw (3 x 8))
- 26. NK80FUC (Switch)
- 27. VM30P080FMC (Screw (3 x 8))
- 28. VM30P080FMC (Screw (3 x 8))
- 29. AAD-608 (Screw (3 x 8))
- 30. AAB-317 (Screw (3 x 8))
- 31. NK80FUC (Switch)
- 32. AAG-541 (Switch)
- 33. AAB-317 (Screw (3 x 8))
- 34. NK80FUC (Switch)
- 35. VM30P080FMC (Screw (3 x 8))
- 36. VM30P080FMC (Screw (3 x 8))
- 37. AAD-608 (Screw (3 x 8))
- 38. AAB-317 (Screw (3 x 8))
- 39. NK80FUC (Switch)
- 40. AAG-541 (Switch)
- 41. AAB-317 (Screw (3 x 8))
- 42. NK80FUC (Switch)
- 43. VM30P080FMC (Screw (3 x 8))
- 44. VM30P080FMC (Screw (3 x 8))
- 45. AAD-608 (Screw (3 x 8))
- 46. AAB-317 (Screw (3 x 8))
- 47. NK80FUC (Switch)
- 48. AAG-541 (Switch)
- 49. AAB-317 (Screw (3 x 8))
- 50. NK80FUC (Switch)
- 51. VM30P080FMC (Screw (3 x 8))
- 52. VM30P080FMC (Screw (3 x 8))
- 53. AAD-608 (Screw (3 x 8))
- 54. AAB-317 (Screw (3 x 8))
- 55. NK80FUC (Switch)
- 56. AAG-541 (Switch)
- 57. AAB-317 (Screw (3 x 8))
- 58. NK80FUC (Switch)
- 59. VM30P080FMC (Screw (3 x 8))
- 60. VM30P080FMC (Screw (3 x 8))
- 61. AAD-608 (Screw (3 x 8))
- 62. AAB-317 (Screw (3 x 8))
- 63. NK80FUC (Switch)
- 64. AAG-541 (Switch)
- 65. AAB-317 (Screw (3 x 8))
- 66. NK80FUC (Switch)
- 67. VM30P080FMC (Screw (3 x 8))
- 68. VM30P080FMC (Screw (3 x 8))
- 69. AAD-608 (Screw (3 x 8))
- 70. AAB-317 (Screw (3 x 8))
- 71. NK80FUC (Switch)
- 72. AAG-541 (Switch)
- 73. AAB-317 (Screw (3 x 8))
- 74. NK80FUC (Switch)
- 75. VM30P080FMC (Screw (3 x 8))
- 76. VM30P080FMC (Screw (3 x 8))
- 77. AAD-608 (Screw (3 x 8))
- 78. AAB-317 (Screw (3 x 8))
- 79. NK80FUC (Switch)
- 80. AAG-541 (Switch)
- 81. AAB-317 (Screw (3 x 8))
- 82. NK80FUC (Switch)
- 83. VM30P080FMC (Screw (3 x 8))
- 84. VM30P080FMC (Screw (3 x 8))
- 85. AAD-608 (Screw (3 x 8))
- 86. AAB-317 (Screw (3 x 8))
- 87. NK80FUC (Switch)
- 88. AAG-541 (Switch)
- 89. AAB-317 (Screw (3 x 8))
- 90. NK80FUC (Switch)
- 91. VM30P080FMC (Screw (3 x 8))
- 92. VM30P080FMC (Screw (3 x 8))
- 93. AAD-608 (Screw (3 x 8))
- 94. AAB-317 (Screw (3 x 8))
- 95. NK80FUC (Switch)
- 96. AAG-541 (Switch)
- 97. AAB-317 (Screw (3 x 8))
- 98. NK80FUC (Switch)
- 99. VM30P080FMC (Screw (3 x 8))
- 100. VM30P080FMC (Screw (3 x 8))

# 9. SCHEMATIC DIAGRAM

COMPLEX Ass'y (1/3) GWM-267

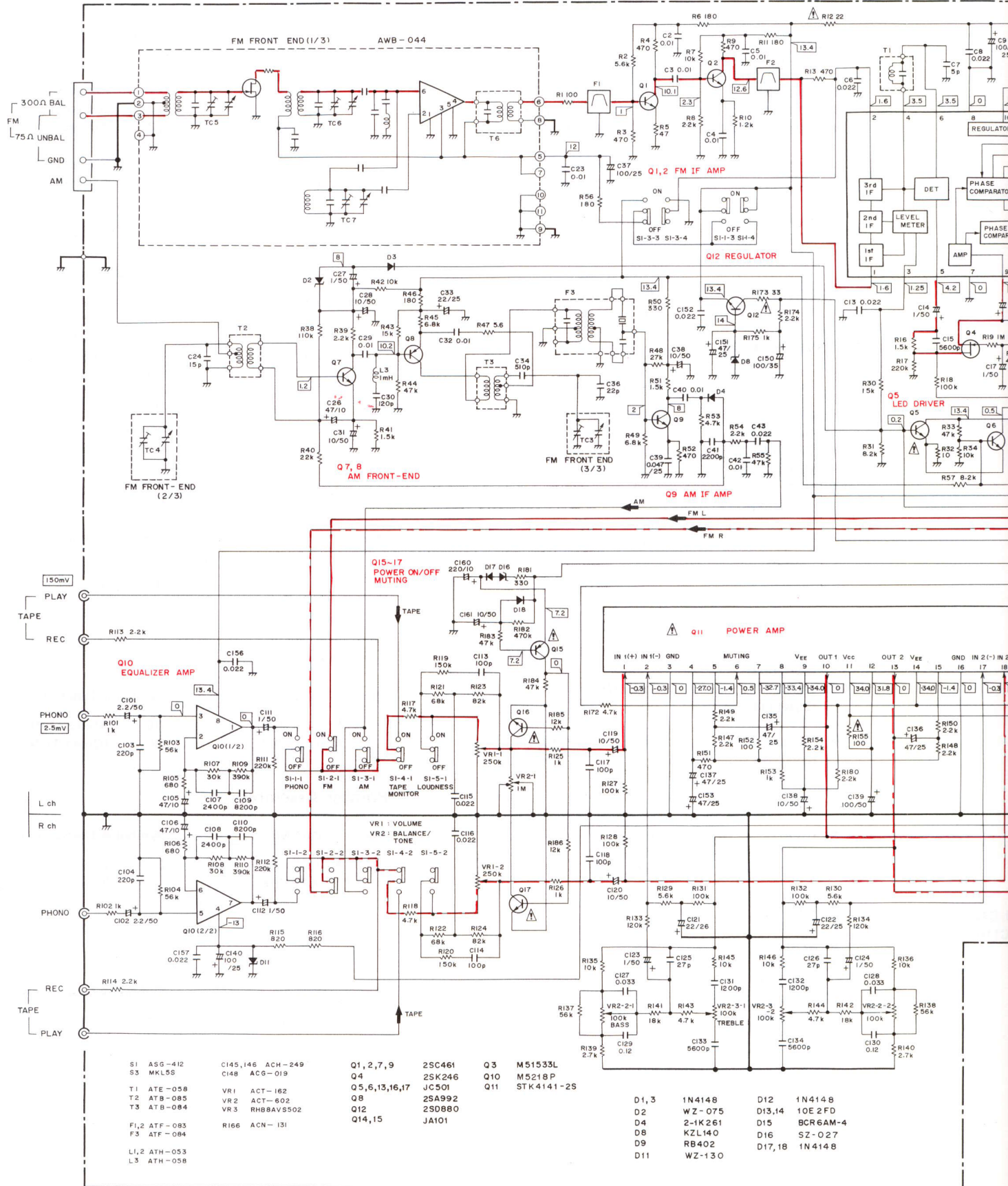



NOTE:

The indicated semiconductors are representative ones only. Other alternative semiconductors may be used and are listed in the parts list.

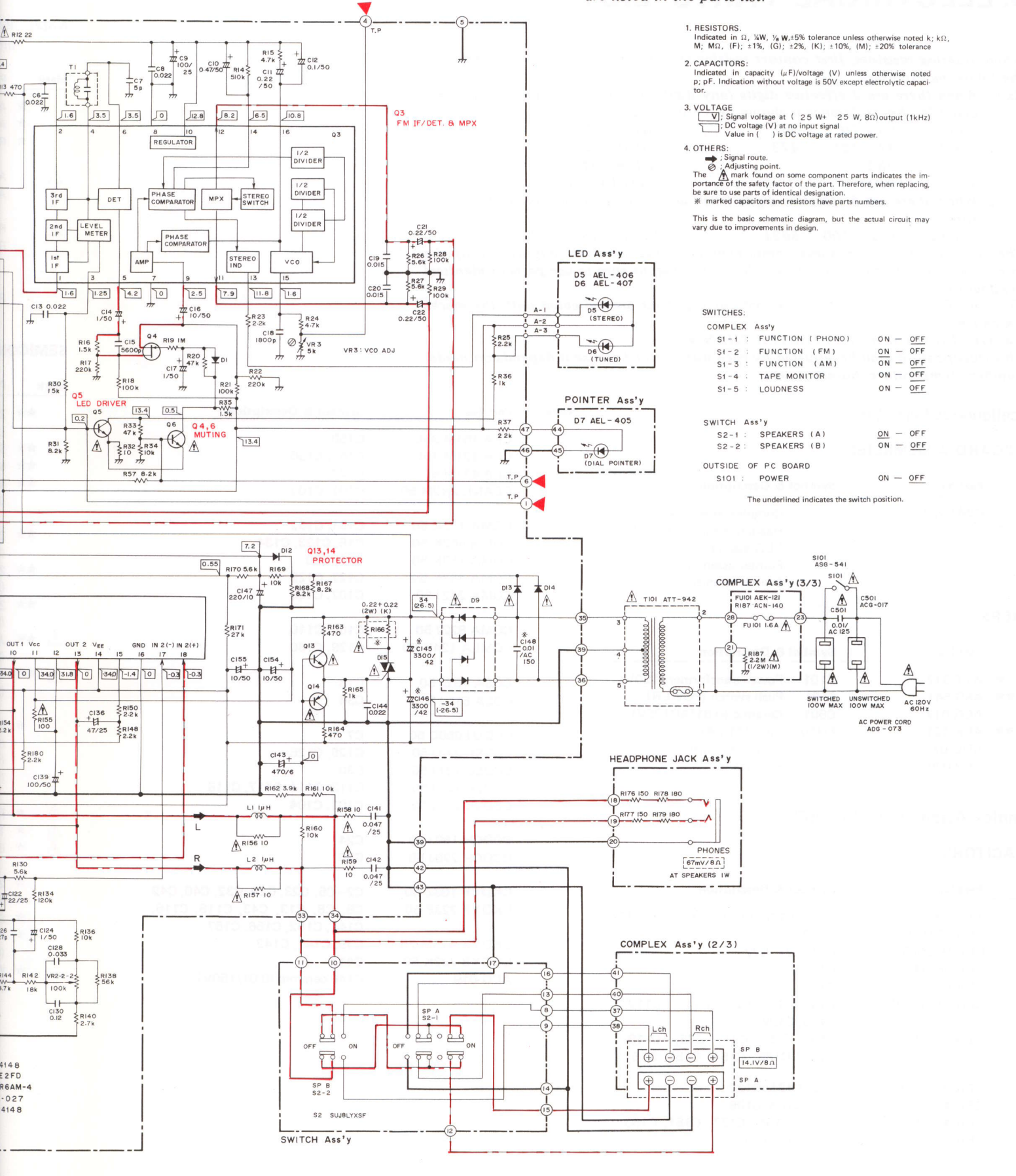

- 1. RESISTORS:  
Indicated in  $\Omega$ ,  $\frac{1}{4}W$ ,  $\frac{1}{2}W$ ,  $\pm 5\%$  tolerance unless otherwise noted; k,  $k\Omega$ , M; M $\Omega$ , (F);  $\pm 1\%$ , (G);  $\pm 2\%$ , (K);  $\pm 10\%$ , (M);  $\pm 20\%$  tolerance
- 2. CAPACITORS:  
Indicated in capacity ( $\mu F$ )/voltage (V) unless otherwise noted; p; pF. Indication without voltage is 50V except electrolytic capacitor.
- 3. VOLTAGE:  
[Symbol with V]: Signal voltage at ( $\geq 25W$  +  $25W$ , 8 $\Omega$ ) output (1kHz)  
[Symbol with V]: DC voltage (V) at no input signal  
Value in ( ) is DC voltage at rated power.
- 4. OTHERS:  
[Symbol with arrow]: Signal route.  
[Symbol with circle and arrow]: Adjusting point.  
The  $\Delta$  mark found on some component parts indicates the importance of the safety factor of the part. Therefore, when replacing, be sure to use parts of identical designation.  
\* marked capacitors and resistors have parts numbers.

This is the basic schematic diagram, but the actual circuit may vary due to improvements in design.

- SWITCHES:
- COMPLEX Ass'y
- |                         |          |
|-------------------------|----------|
| S1-1 : FUNCTION (PHONO) | ON - OFF |
| S1-2 : FUNCTION (FM)    | ON - OFF |
| S1-3 : FUNCTION (AM)    | ON - OFF |
| S1-4 : TAPE MONITOR     | ON - OFF |
| S1-5 : LOUDNESS         | ON - OFF |
- SWITCH Ass'y
- |                     |          |
|---------------------|----------|
| S2-1 : SPEAKERS (A) | ON - OFF |
| S2-2 : SPEAKERS (B) | ON - OFF |
- OUTSIDE OF PC BOARD
- |              |          |
|--------------|----------|
| S101 : POWER | ON - OFF |
|--------------|----------|
- The underlined indicates the switch position.

A

B

C

D



# 10. ELECTRICAL PARTS LIST

**NOTES:**

- When ordering resistors, first convert resistance values into code form as shown in the following examples.

Ex. 1 When there are 2 effective digits (any digit apart from 0), such as 560 ohm and 47k ohm (tolerance is shown by J = 5%, and K = 10%).

560Ω	56 x 10 <sup>1</sup>	561	RD4PS	561J
47kΩ	47 x 10 <sup>3</sup>	473	RD4PS	473J
0.5Ω	0R5		RN2H	0R5K
1Ω	010		RS1P	010K

Ex. 2 When there are 3 effective digits (such as in high precision metal film resistors).

5.62kΩ	562 x 100	5621	RN4SR	5621F
--------	-----------	------	-------	-------

- The  $\Delta$  mark found on some component parts indicates the importance of the safety factor of the part. Therefore, when replacing, be sure to use parts of identical designation.
- For your Parts Stock Control, the fast moving items are indicated with the marks **★★** and **★**.  
**★★ GENERALLY MOVES FASTER THAN ★.**  
 This classification shall be adjusted by each distributor because it depends on model number, temperature, humidity, etc.

**Miscellaneous Parts List**

Mark	Part No.	Symbol & Description
------	----------	----------------------

**P.C. BOARD ASSEMBLIES**

Mark	Part No.	Symbol & Description
	GWM-267	Complex assembly Headphone jack assembly LED assembly Pointer assembly Switch assembly

CEA 101M 35L	C150
CEA 221M 10L	C147, C160
CEA 471M 6L	C143
CEANL 2R2M 50	C101, C102
CQMA 122K 50	C131, C132
CQMA 562K 50	C15, C133, C134
CQMA 153K 50	C19, C20
CQMA 333K 50	C127, C128
CQMA 242J 50	C107, C108

**OTHERS**

Mark	Part No.	Symbol & Description
$\Delta$ ★	ATT-942	T101 Power transformer (120V)
$\Delta$ ★★	ASG-541	S101 Push switch (POWER)
$\Delta$	ACG-017	C501 Ceramic (0.01/AC125V)
$\Delta$ ★★	AEK-121	FU101 Fuse (T1.6A)
$\Delta$	ADG-073	AC power cord
$\Delta$	AKP-039	AC socket

CQMA 822J 50	C109, C110
CQMLA 124K 50	C129, C130
CQSA 182J 50	C18
CQSA 511J 50	C34
CCDUJ 050C 50	C7
CCDSL 270J 50	C125, C126
CCDSL 121J 50	C30
CCDSL 101J 50	C113, C114, C117, C118
CCDSL 221J 50	C103, C104

**Complex Assembly (GWM-267)**

**CAPACITORS**

Mark	Part No.	Symbol & Description
	ACH-249	C145, C146 Electrolytic (3300/42V)
	CEA 101M 50L	C139
	CEA R22M 50L	C11, C21, C22
	CEA 0R1M 50L	C12
	CEA R47M 50L	C10
	CEA 010M 50L	C14, C17, C27, C111, C112, C123, C124
	CEA 100M 50L	C16, C28, C31, C38, C119, C120, C138, C154, C155, C161
	CEA 220M 25L	C33, C121, C122
	CEA 470M 10L	C26, C105, C106
	CEA 470M 25L	C135, C136, C137, C151, C153
	CEA 101M 25L	C9, C37, C140

CCDCH 150J 50	C24
CCDCH 220J 50	C36
CKDYF 103Z 50	C2-C5, C23, C29, C32, C40, C42
CKDYF 223Z 50	C6, C8, C13, C43, C115, C116, C144, C152, C156, C157
CKDYX 473M 25	C39, C141, C142
CKDYB 222K 50	C41
ACG-019	C148 ceramic (0.01/150V)

## RESISTORS

Note: When ordering resistors, convert the resistance value into code form, and then rewrite the part no. as before.

Mark	Part No.	Symbol & Description
★	ACT-162	VR1 Volume (250k)
★	ACT-602	VR2 Volume assembly (100kx2, 1M)
★	RHB8AVS502	VR3 Semi-fixed (5k)
△	ACN-131	R166 Wire-wound (0.22x2,2W)
△	ACN-140	R187 Carbon composition (2.2M, 1/2W)
△	RD¼PMFL □□□ RD¼PM □□□	R12, R155-R159, R173 R35, R36, R115, R116, R147-R154, R160-R165, R167, R168, R172, R174, R175, R180
	RD1/8PM □□□J	Other resistors

## SEMICONDUCTORS

Mark	Part No.	Symbol & Description
★★	2SC461 (2SC1923)	Q1, Q2, Q7, Q9
★★	STK4141-2S	Q11
★★	M51533L-B	Q3
★★	M5218 P (NJM4558DX)	Q10
★★	2SK246 (2SK34)	Q4
★★	2SD880 (2SD313)	Q12
★★	2SA992 (2SA726S)	Q8
△	★★ JC501 (2SC2603)	Q5, Q6, Q13, Q16, Q17
△	★★ JA101 (2SA1115)	Q14, Q15
★	1N4148 (US1035) (1S2076) (1S1555)	D1, D3, D12, D17, D18
△	★ RB402	D9
△	★ 10E2FD	D13, D14
△	★ BCR6AM-4	D15
★	2-1K261	D4
★	KZL140	D8
★	SZ-027	D16
★	WZ-130 (MZ-130)	D11
★	WZ-075 (MZ-075)	D2

## COILS AND TRANSFORMERS

Mark	Part No.	Symbol & Description
	ATH-053	L1, L2 AF choke coil
	ATH-058	L3 Micro inductor
	ATE-058	T1 FM detector transformer
	ATB-085	T2 AM antenna coil
	ATB-084	T3 AM oscillator coil
	ATF-083	F1, F2 FM ceramic filter
	ATF-084	F3 AM ceramic filter

## OTHERS

Mark	Part No.	Symbol & Description
★★	ASG-412	S1 Push switch (FUNCTION, TAPE, LOUDNESS)
	AWB-044	FM Front-end
	AKX-073	Complex terminal
	AEC-940	Rivet
	PBZ30ZP060FMC	Screw (3 x 6)
	ABA-271	Screw

## Headphone Jack Assembly

Mark	Part No.	Symbol & Description
	AKN-045 RD¼PM □□□J	Phone jack (PHONES) R176-R179

## LED Assembly

Mark	Part No.	Symbol & Description
★	AEL-406	D5 (Red STEREO)
★	AEL-407	D6 (Green TUNING)

## Pointer Assembly

Mark	Part No.	Symbol & Description
★	AEL-405 AAF-118	D7 (Red) Pointer

## Switch Assembly

Mark	Part No.	Symbol & Description
★★	SUJ8LYXSF	S2 Push switch (SPEAKERS)

## 11. DIAL CORD STRINGING

1. Remove the bonnet.
2. Remove the tuning drum from the shaft of the tuning capacitor.
3. Tie one end of the cord to the stud A located inside the tuning drum.
4. Rotate the tuning capacitor right around until the rotor blades are fully intermeshed.
5. Secure the tuning drum back onto the tuning capacitor shaft, making sure that the securing screw B faces directly upward.
6. Pass the cord out through the small opening in the circumference of the tuning drum (see diagram), and then take it over pulleys C and D in that sequence.
7. Wind the cord around the tuning shaft 3 times.
8. Pass it over pulley E, wind it around the tuning drum 1 time, and finally tie it to the spring hook F so that it is tensioned.
9. Turn the tuning shaft, and check that the cord moves smoothly.
10. Cut off any excess cord.
11. Turn the tuning shaft counter-clockwise as far as it will go.
12. Align the dial pointer with the starting point of the dial scale, and then pass the cord over it.
13. Check that the dial pointer is in line with the starting point of the dial scale.
14. Finally apply the locking paint to the cord securing positions (stud A and spring hook F) and the dial pointer connection.

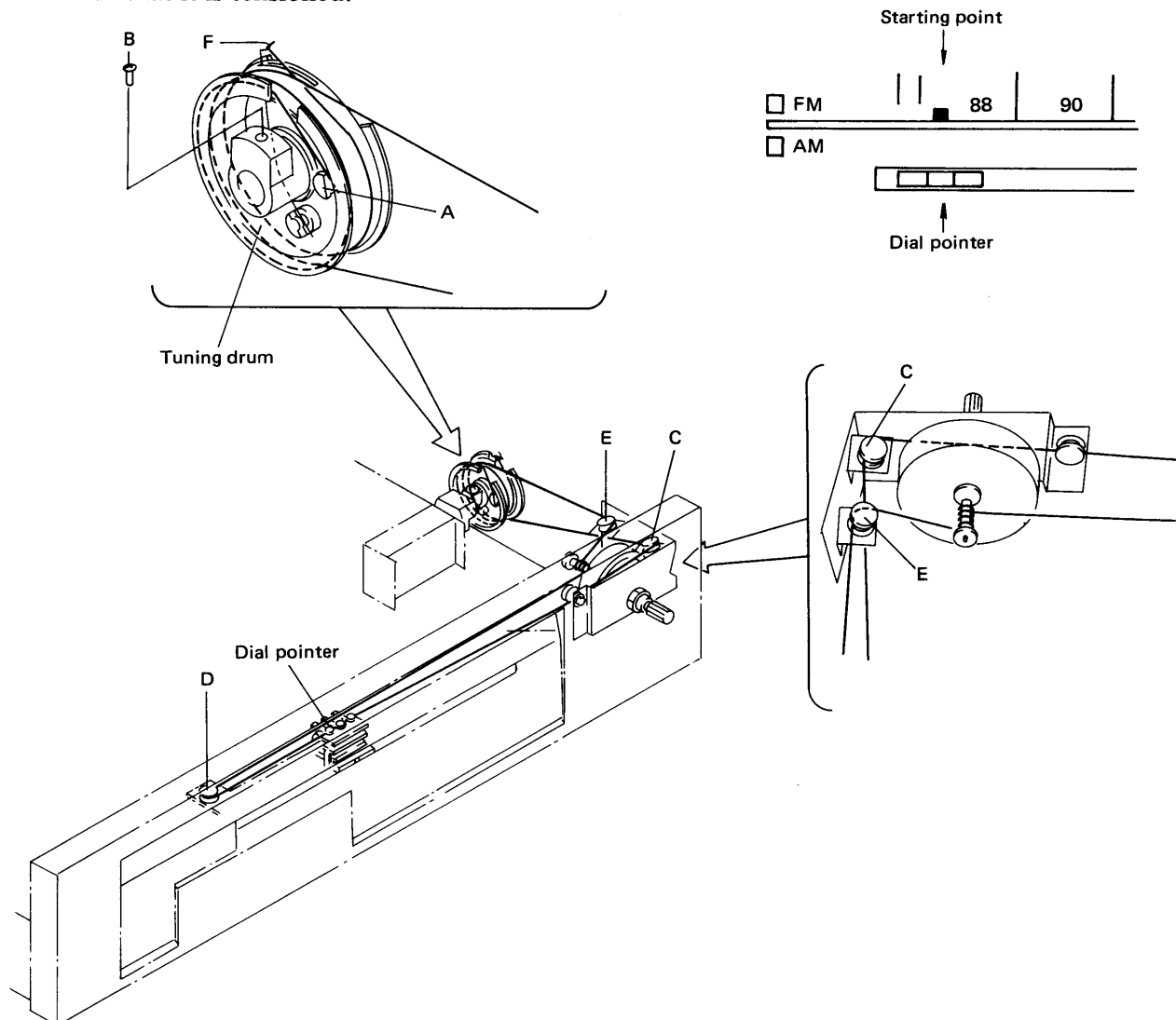

# 12. ADJUSTMENTS

## FM Tuner Section

- Check that the dial pointer indicates a starting point.
- Connect the SIGNAL meter between terminal no. 1 of complex assembly and the ground.
- In principle, no adjustment should be made on FM tracking. (See page 21, if necessary.)
- Set the FM switch to ON and connect terminal no. 6 to the ground.

Step	FM SG (400Hz, ±75kHz deviation)		Position of dial pointer	Adjustment point	Adjustment procedure
	Frequency	Level			
1.	98MHz	66dB	98MHz	T1	Set the output of the REC OUT terminal to the maximum value.
2.	98MHz	46dB	98MHz	T6	Set the SIGNAL meter to the maximum value.
3.	98MHz	66dB	98MHz	T1	Adjust the output of the REC OUT terminal distortion to the minimum level.
4.	Disconnect terminal no. 6 from the ground.				
5.	98MHz Not modulated	66dB	98MHz	VR3	Set the signal of the terminal no. 4 to 76kHz (±200Hz).
6.	98MHz * Stereo modulation	66dB	98MHz	T6 (within ±90°)	Minimize the distortion of the REC OUT terminal signal.

**NOTE:**

Connect the MPX SG to the FM SG external modulator terminal and set the modulation of Main (1kHz, L+R) ±67.5kHz deviation, Pilot (19kHz) ±7.5kHz deviation.

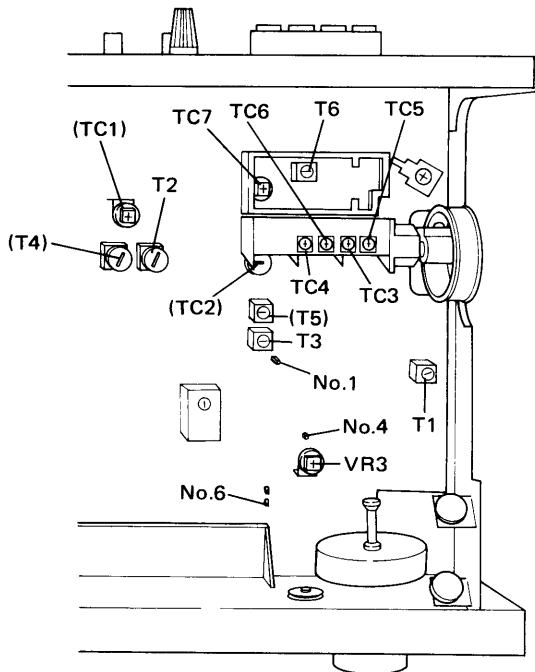

Adjustment points in brackets are for SX-202L (Low Wave) only.

Fig. 11-1 Adjustment points

## FM tracking

Step	FM SG (400Hz, $\pm 75$ kHz deviation)		Position of dial pointer	Adjustment point	Adjustment procedure
	Frequency	Level			
1.	106MHz	10dB	106MHz	TC7	Set the SIGNAL meter to the maximum value.
2.				TC5	
3.				TC6	
4.	Confirm that the dial pointer does not get out of position at 106MHz and 98MHz.				

### NOTE: (For SX-202L/HEZ)

- When 87.6MHz can not be received with this unit, adjust the oscillator (TC7) and then it can be received. It is prohibited to receive 87.2MHz or below and so after having adjusted the oscillator, make sure that it does not receive 87.2MHz or below.

## AM Tuner Section

- Check that the dial pointer indicates a starting point.
- Turn ON the MW switch.
- Connect the SIGNAL meter between the terminal no. 1 of complex assembly and the ground.

Step	AM SG (400Hz, 30% modulation)		Position of dial pointer	Adjustment point	Adjustment procedure
	Frequency	Level			
1.	1395kHz	100dB	1395kHz	TC3	Set the SIGNAL meter to the maximum value.
2.	603kHz	100dB	603kHz	T3	
3.	Set the AM SG to 30dB output level, repeat steps 1 to 2 above.				
4.	1395kHz	30dB	1395kHz	TC4	Set the SIGNAL meter to the maximum value.
5.	603kHz	30dB	603kHz	T2	
6.	Repeat steps 4 to 5 until maximum sensitivity is attained.				

## Long Wave Section (SX-202L/HE, HEZ only)

- Set the AM BAND switch to the LW position.

Setp	AM SG (400Hz, 30% modulation)		Position of dial pointer	Adjustment point	Adjustment procedure
	Frequency	Level			
1.	254kHz	100dB	254kHz	TC2	Set the SIGNAL meter to the maximum value.
2.	164kHz	100dB	164kHz	T5	
3.	Set the AM SG to 30dB output level, repeat steps 1 to 2 above.				
4.	254kHz	50dB	254kHz	TC1	Set the SIGNAL meter to the maximum value.
5.	164kHz	50dB	164kHz	T4	
6.	Repeat steps 4 to 5 until maximum sensitivity is attained.				