

SERVICE MANUAL

AM/FM STEREO RECEIVER

SX-300

FVW, NBW

SOUND PROJECT

BY PIONEER MODEL300

KUW, KCW

NOTE:

THE SX-300 AND THE MODEL 300 COME IN TWO VERSIONS EACH DISTINGUISHED AS FOLLOWS:

Round label on rear panel		Voltage	Type
SX-300	FVW	5-position selector 220V only	General export model SEMCO (Sweden), NEMCO (Norway) and DEMCO (Denmark) approved
	NBW		
Model 300	KUW	120V only	UL approved (U.S.A.) CSA approved (Canada)
	KCW	120V only	

CONTENTS

1. SPECIFICATIONS 3

2. FRONT PANEL FACILITIES 5

3. CONNECTION DIAGRAM 7

4. DISASSEMBLY 9

5. PARTS AND P.C BOARD LOCATION 10

6. DIAL CORD STRINGING 11

7. ALIGNMENT PROCEDURE

 7.1 FM/AM IF Alignment 12

 7.2 FM/AM Tracking Alignment 12

 7.3 MPX Decoder Alignment 13

 7.4 Other Alignments 13

8. LEVEL DIAGRAM 14

9. BLOCK DIAGRAM 15

10. EXPLODED VIEW AND PARTS LIST 17

11. SCHEMATIC DIAGRAMS, P.C. BOARD PATTERNS AND PARTS LISTS

 11.1 Circuit Connection Diagram and Miscellaneous Parts 21

 11.2 AF Amplifier Assembly (AWK-028) 27

 11.3 Power Switch Circuit Assembly (AWS-052) 34

 11.4 Power Switch Circuit Assembly (AWS-051) 36

 11.5 Power Switch Circuit Assembly (AWS-053) 38

 11.6 Tuner Assembly (AWE-004) 40

12. PACKING METHOD AND PARTS LIST 47



1. SPECIFICATIONS

SEMICONDUCTORS

FET	1
Transistors	31
Diodes	23

AMPLIFIER SECTION

Continuous Power Output	
1kHz (Both channels driven)	7W+7W (8Ω), 7W+7W (4Ω)
1kHz (Each channel driven)	10W/10W (8Ω), 12W/12W (4Ω)
Harmonic Distortion (Continuous Power Output)	
Output	Less than 1%
(1W+1W Power Output)	Less than 0.2%
Intermodulation Distortion (Continuous Power Output)	
Power Output	Less than 1%
(1W+1W Power Output)	Less than 0.5%
Power Bandwidth (IHF, Both channels driven)	
	25Hz~60kHz (T.H.D. 1%)
Output: Speaker	
	A, B, A+B (4~16Ω)
Headphones	
	4~16Ω
Damping Factor (1kHz, 8Ω)	
	More than 20
Residual Hum & Noise (8Ω Pre & Power amplifier)	
	Less than 0.6mV
Input Sensitivity/ Impedance	
PHONO	2.5mV/50kΩ
AUX	150mV/100kΩ
TAPE MONITOR	150mV/100kΩ
TAPE MONITOR (DIN connector)	150mV/100kΩ
Output Level/Impedance	
TAPE REC	150mV
TAPE REC (DIN connector)	30mV/80kΩ
Frequency Response	
PHONO (RIAA equalization)	30Hz~15kHz ±1dB
AUX, TAPE MON	30Hz~20kHz ±1dB
Tone Control	
BASS	+9dB, -9dB (100Hz)
TREBLE	+8dB, -11dB (10kHz)
Loudness Contour (Volume control set at -40dB Position)	
	+10dB (100Hz), +5dB (10kHz)
Hum & Noise (IHF, short circuited, A Network)	
PHONO	More than 70dB
AUX, TAPE MON	More than 80dB

FM TUNER SECTION

Usable Sensitivity (IHF)	2.3μV
Capture Ratio (IHF)	3.5dB
Signal-to-Noise Ratio	65dB
Image Rejection (98MHz)	More than 50dB
IF Rejection (98MHz)	More than 80dB
Spurious Rejection	More than 70dB
AM Suppression	45dB
Harmonic Distortion	
Mono	Less than 0.6%
Stereo	Less than 0.8%
Stereo Separation	
1kHz	More than 40dB
Sub carrier Suppression	35dB
Antenna Input	300Ω Balanced 75Ω Unbalanced

AM TUNER SECTION

Sensitivity	
(IHF, Ferrite antenna)	300μV/m
(IHF, Ext. antenna)	15μV
Signal-to-Noise Ratio	50dB
Image Rejection	More than 45dB
IF Rejection	More than 35dB
Antenna	Built-in Ferrite Loopstick Antenna

MISCELLANEOUS

Power Requirements	AC 120V, 60Hz or 110V, 120V, 130V, 220V and 240V (Switchable) 50Hz or 60Hz
Power Consumption	65W
AC Outlets	Switched 1, Unswitched 1
Dimensions	441(W) x 132(H) x 324(D)mm 17-3/8 x 5-3/16 x 12-3/4 in
Weight:	
Without package	6kg (13 lb)
With package	8kg (18 lb)

Furnished Parts

FM T-type Antenna	1
Operating Instructions	1

NOTE:

Specifications and the design subject to possible modification without notice due to improvements.

2. FRONT PANEL FACILITIES

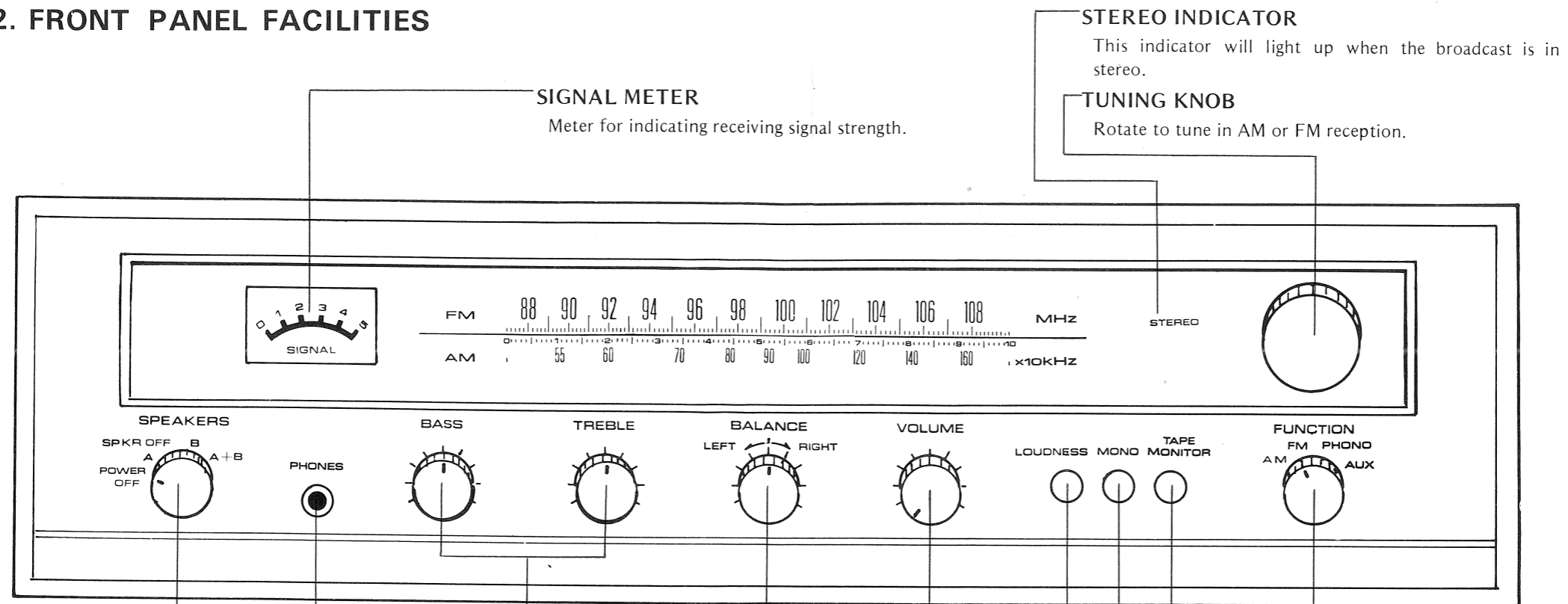

STEREO INDICATOR

This indicator will light up when the broadcast is in stereo.

TUNING KNOB

Rotate to tune in AM or FM reception.

SIGNAL METER

Meter for indicating receiving signal strength.

SPEAKERS SWITCH

A combination of the power ON/OFF switch and the speaker system selector switch.

POWER OFF: The equipment is off.

A: Speaker systems connected to speaker outputs A operate.

SPKR OFF: All speakers off. Use this position when listening through headphones.

B: Speaker systems connected to speaker outputs B operate.

A+B: Both speaker systems A and B operate.

HEADPHONE JACK

Stereo headphones can be plugged into this jack.

A wide variety of quality headphones is available from Pioneer.

BASS & TREBLE CONTROLS

Control bass and treble. Turning each control clockwise (counterclockwise) from the center position will boost (diminish) the tone.

BALANCE CONTROL

For balancing the relative sound volume of the left and right channel speakers. Clockwise rotation will reduce the volume from the left speaker, counterclockwise rotation will decrease the volume from the right speaker.

VOLUME CONTROL

Controls the listening volume. Clockwise rotation will increase the volume.

LOUDNESS SWITCH

Depress when listening at low volume levels for proper sound balance relative to human ear sensitivity.

MODE SWITCH

This switch is used for selecting stereo or mono sound.

STEREO: Remain unpushed.

MONO: Push the switch for monophonic sound into which the left and right channel signals blend.

TAPE MONITOR SWITCH

This switch is set to ON (depress) for monitoring a recording now in progress and for playback of recorded tapes, when the tape deck is connected to the TAPE MON jacks and TAPE REC jacks or TAPE REC/PB connector.

FUNCTION SWITCH

This selects the program source:

AM: AM reception.

FM: FM reception with automatic switching for either of stereo or mono programs.

PHONO: When playing records on turntable connected to the PHONO terminals.

AUX: When playing component connected to the AUX terminals.

3. CONNECTION DIAGRAM

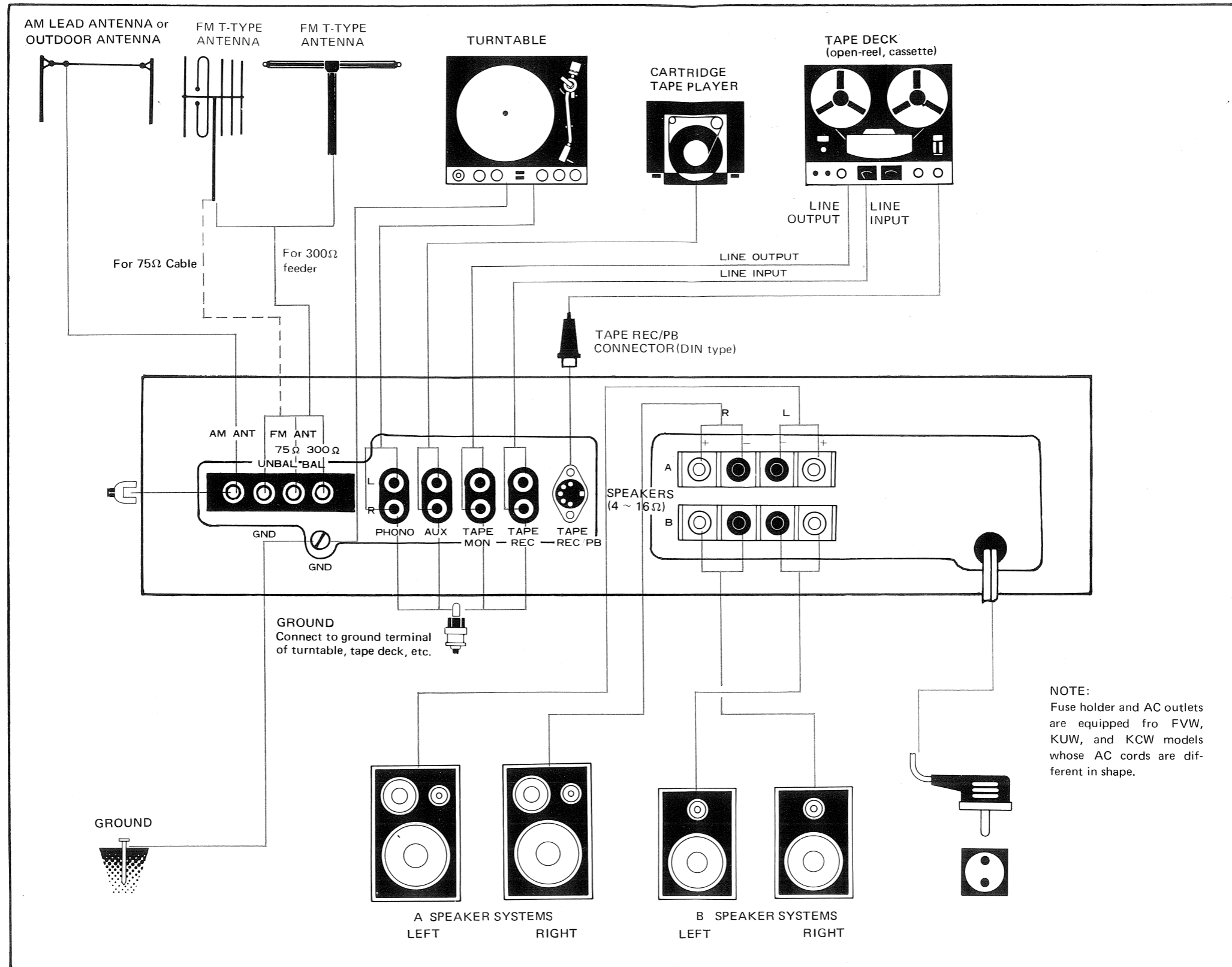

4. DISASSEMBLY

1. Remove the 3 screws from the rear panel.
2. Remove the 4 screws from the bottom of the wooden cabinet. Pull the receiver forward off from the wooden cabinet.
3. Pull off all knobs, then remove the nuts and washers from their shafts. The front panel can be now removed.

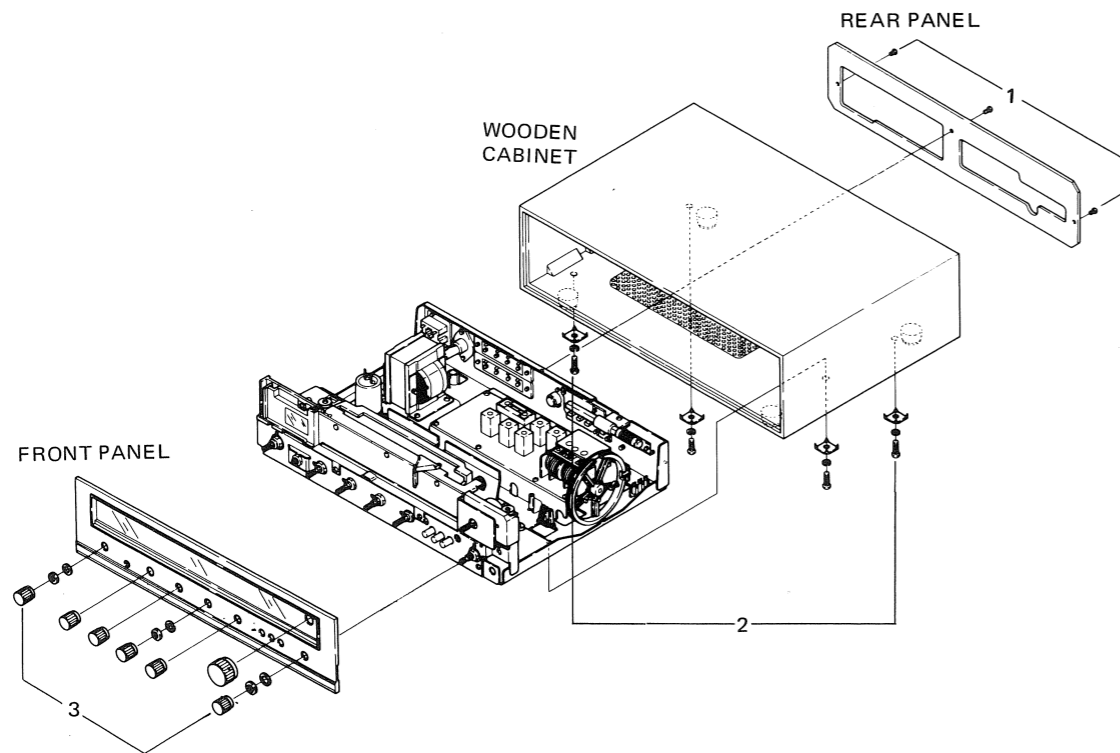

5. PARTS AND P.C. BOARD LOCATION

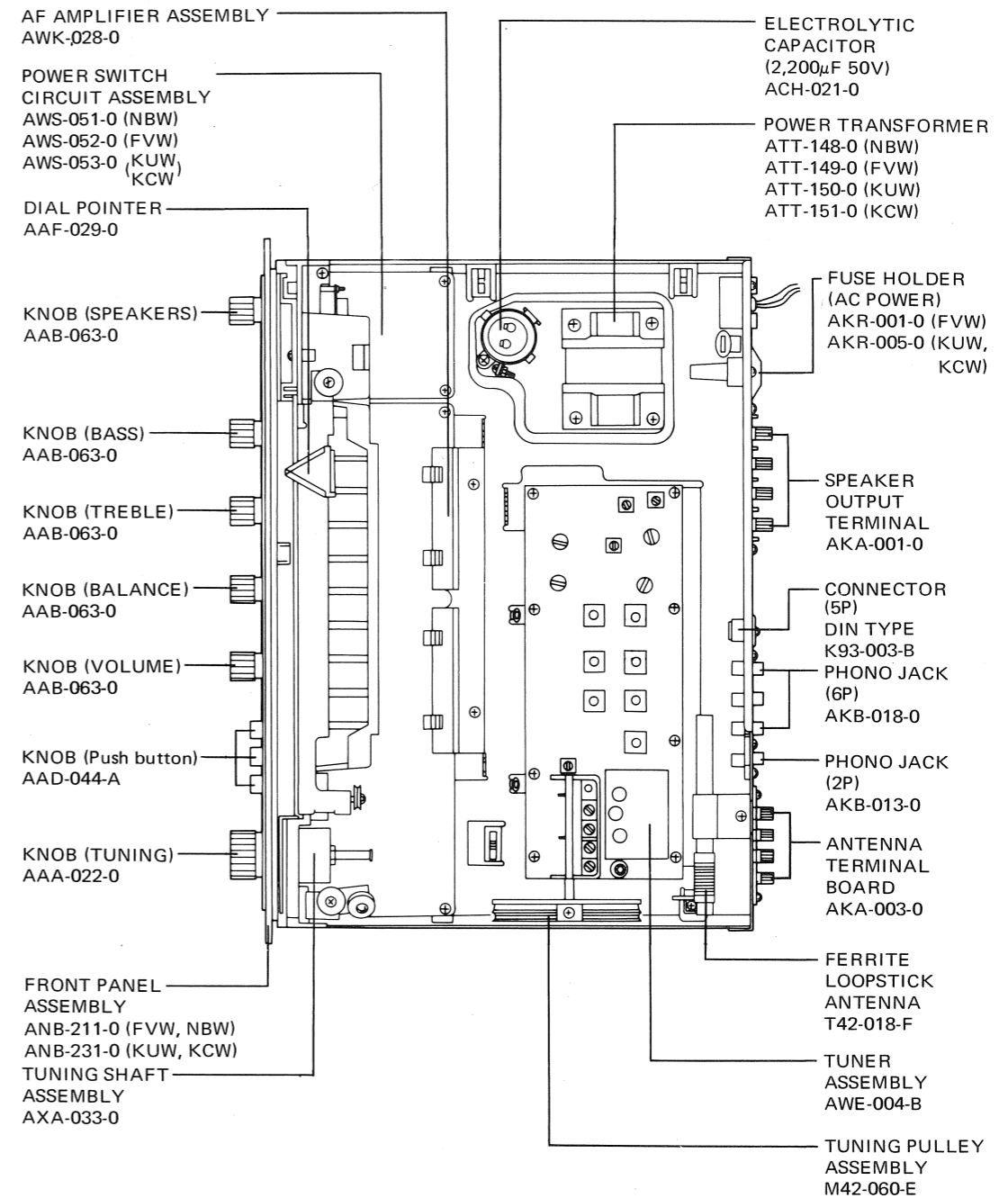

6. DIAL CORD STRINGING

1. Set the tuning capacitor to minimum capacitance.
2. Tie one end of the string to the spring on the tuning pulley.
3. Wind the string $\frac{1}{2}$ turn around the tuning pulley, then lead it to the small pulley A.
4. Wind the string 3 turns around the tuning shaft, then lead it to the small pulleys B and C.
5. Lead the string around the small pulley D, then wind it 1 turn around the tuning pulley.
6. Finally, tie end of the string to the remaining side of the spring on the tuning pulley.
7. Tune the receiver to low end. Fasten the dial pointer to the string so that it indicates the low end of the dial scale.

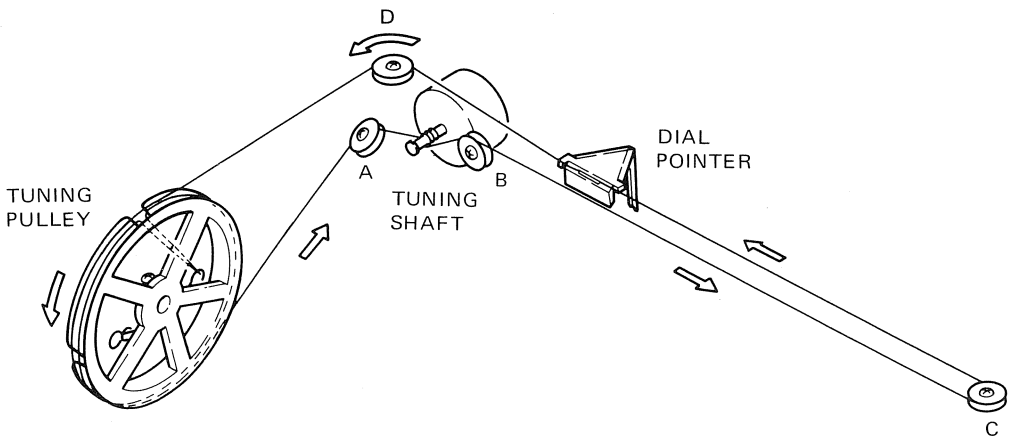

7. ALIGNMENT PROCEDURE

REQUIRED INSTRUMENTS

- FM/AM Signal generator
- FM/AM Sweep generator: Center frequency 10.7MHz, 455kHz
- Oscilloscope
- AC VTVM
- FM multiplex signal generator preferably with RF output

7.1 FM/AM IF ALIGNMENT

● FM SECTION

1. Connect a 0.01 μ F capacitor between TP 1 and ground before the alignment.
2. Connect a 220k Ω resistor in series with the vertical input terminal of the oscilloscope.
3. Remove the meter lead from terminal 18, then terminate a 4.7k Ω resistor between terminal 18 and ground.
4. Connect the vertical input to terminal 18.
5. Set the FUNCTION switch to FM.
6. Connect the output lead of the sweep generator to the FM antenna terminals.
7. Set the output level of the sweep generator to 90dB.
8. Adjust the primary and secondary cores of T6 to obtain a symmetrical pattern.
9. Set the output level of the sweep generator to 70dB.
10. Adjust the cores of T4 and T5 for maximum gain and symmetry of the pattern.
11. Vary the output level of the sweep generator from 60dB to 100dB, then keep the top of the pattern flat and make sure that the center frequency does not drift. If it drifts, repeat steps (7) to (10).
12. Remove the capacitor (4.7 μ F) from terminal 28.
13. Disconnect the vertical input from terminal 18, then reconnect it to TP1.
14. Set the output level of the sweep generator to 70dB.
15. Observe the S-curve pattern when adjusting the cores of T7. (Linearity is improved by the primary core; symmetry by the secondary core.)
16. Disconnect the 0.01 μ F capacitor from TP1 after the alignment has been completed.
17. Connect the capacitor (4.7 μ F) to terminal 28 after the alignment has been completed.

● AM SECTION

1. Turn the FUNCTION switch to AM.
2. Connect the output lead of the sweep generator to the AM antenna terminal.
3. Connect the vertical input of the oscilloscope to the TAPE REC jack.
4. Set the output level of the sweep generator to 75dB.
5. Adjust the IFT cores (T9, T10, T11) for maximum gain and symmetrical pattern.

7.2 FM/AM TRACKING ALIGNMENT

● FM SECTION

1. Turn the FUNCTION switch to FM.
2. Connect the output leads of the FM signal generator to the FM antenna terminals.
3. Set the FM signal generator to modulation 400Hz, 30% and output level 15dB frequency 90MHz; also set the receiver dial at 90MHz.
4. Connect the VTVM and oscilloscope (in parallel) to the TAPE REC jack.
5. Observing the output level on the VTVM, adjust the following cores for maximum reading on the meter.
 T3 Oscillator circuit
 T1 Antenna circuit
 T2 RF circuit
6. Set the frequency of the FM signal generator and the receiver dial to 106MHz.
7. Adjust as follows:
 Trimmer capacitor CT3: Oscillator circuit
 Trimmer capacitor CT1 . . . Antenna circuit
 Trimmer capacitor CT2 RF circuit
8. Repeat steps (5) to (7) several times.
9. Set the output level of the FM signal generator to maximum signal meter deflection.
10. Adjust the primary core of T7 for minimum sound distortion.

● AM SECTION

1. Turn the FUNCTION switch to AM.
2. Connect the AM signal generator to the AM antenna terminal.
3. Set the AM signal generator to modulation 400Hz, 30%, output level 30dB, frequency 600kHz. Set the receiver dial at 600kHz.
4. Connect the VTVM and oscilloscope (in parallel) to the TAPE REC jack.
5. Observing the output level on the VTVM, adjust the following cores for maximum reading.
 T8 Oscillator circuit
 Ferrite loopstick antenna: Antenna circuit
6. Set the AM signal generator and the receiver dial to 1,400kHz.
7. Observing the output level on the VTVM, adjust the following cores for maximum reading.
 CT5 Oscillator circuit
 CT4 Antenna circuit
8. Repeat steps (5) to (7) several times.
9. After these alignments, lock the trimmer capacitor with paint.

7.3 MPX DECODER ALIGNMENT

1. Modulate the FM signal generator output by FM MPX modulator.
2. Turn the FUNCTION switch to FM.
3. Connect the FM signal generator to the FM antenna terminals.
4. Set the FM MPX modulator to modulation; main 1kHz (L+R) 60%, pilot 8~10%.
5. Set the output level of the FM signal generator to 60dB.
6. Turn the tuning knob to maximum reading on the signal meter.
7. Set the modulation of the FM MPX modulator to pilot only.

8. Connect the oscilloscope to TP2.
9. Adjust the transformers (T13, T14, T15) until the output level of the 19kHz becomes maximum on the scope.
10. Set the FM MPX modulator to pilot with L or R signal.
11. Connect the dual-trace oscilloscope and VTVM to the TAPE REC jacks.
12. Adjust the semi-fixed potentiometer on the tuner assembly until the output level of the L or R signal becomes maximum on the scope.

7.4 OTHER ALIGNMENTS

● CHECKING THE SCA FILTER

1. Connect the FM signal generator to the FM antenna terminals.
2. Modulate the FM signal generator with the audio signal generator.
 Set the output level of the FM signal generator to 60dB.
 Measure the frequency response at the TAPE REC jack. Check that the frequency response shows troughs at around 67kHz and 72kHz.
3. Should the item (2) give the unsatisfactory result, adjust T18 and T12.

● CHECKING THE STEREO INDICATOR

1. Connect the FM MPX signal generator to the FM antenna terminals.
2. Set the FM MPX signal generator to pilot signal on and its output level to 25dB. Check that the stereo indicator lamp goes on. Then turn the pilot signal off, the stereo indicator lamp must go out.

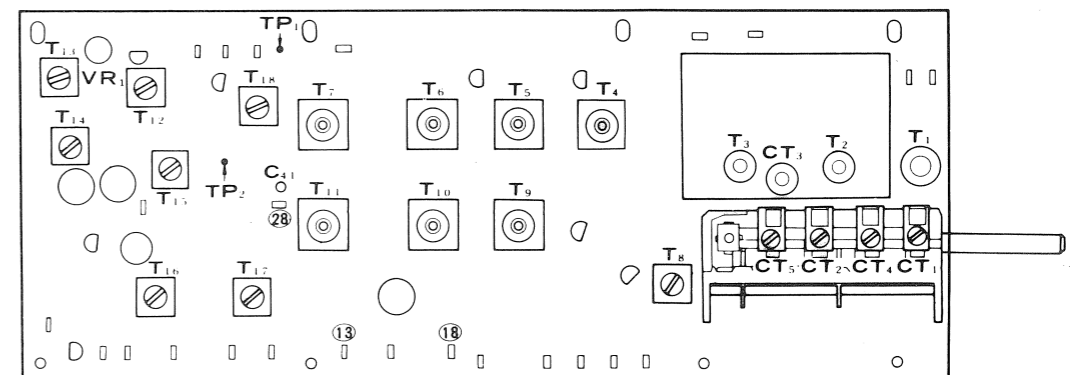

Tuner Assembly (AWE-004)

8. LEVEL DIAGRAM

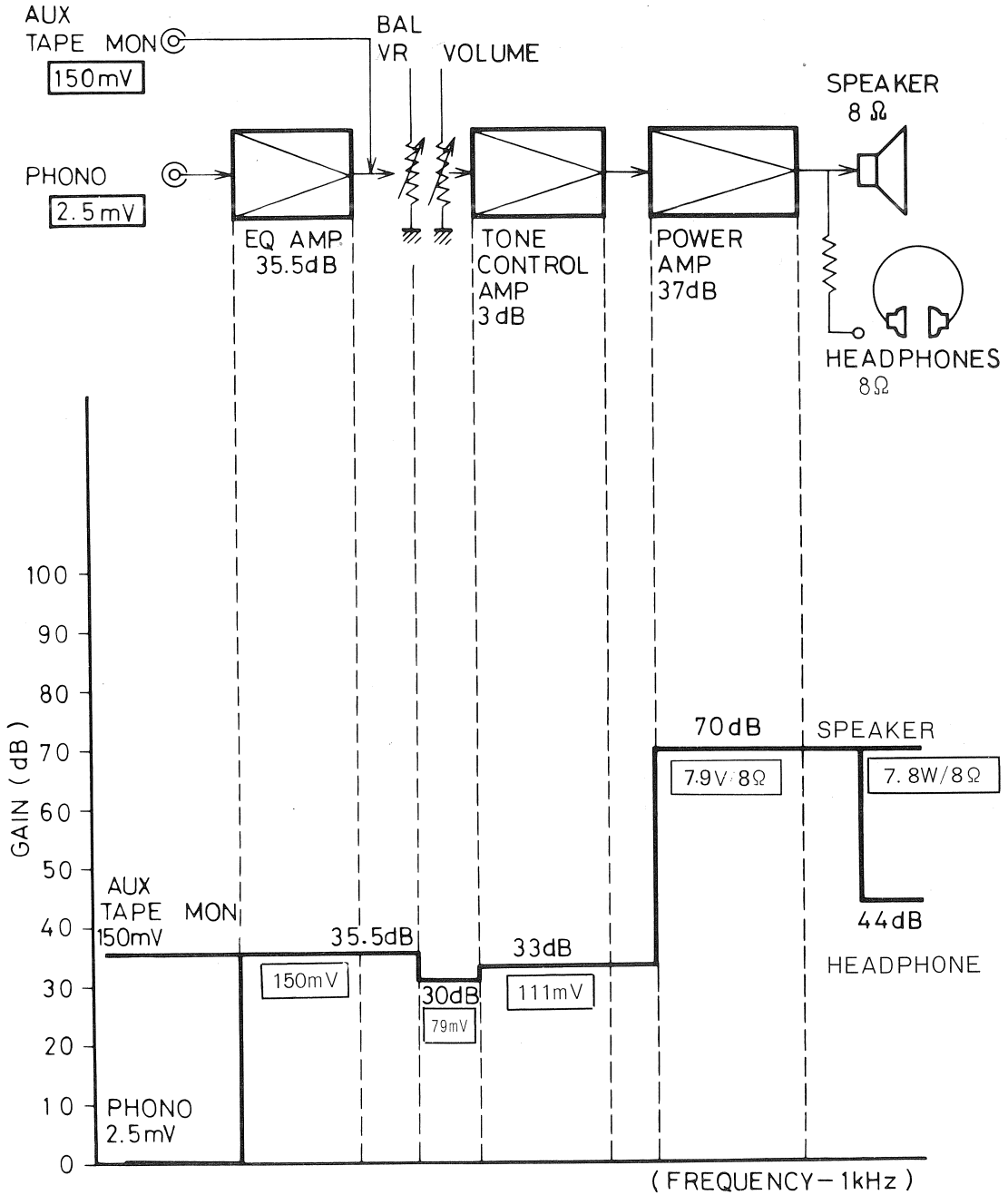

9. BLOCK DIAGRAM

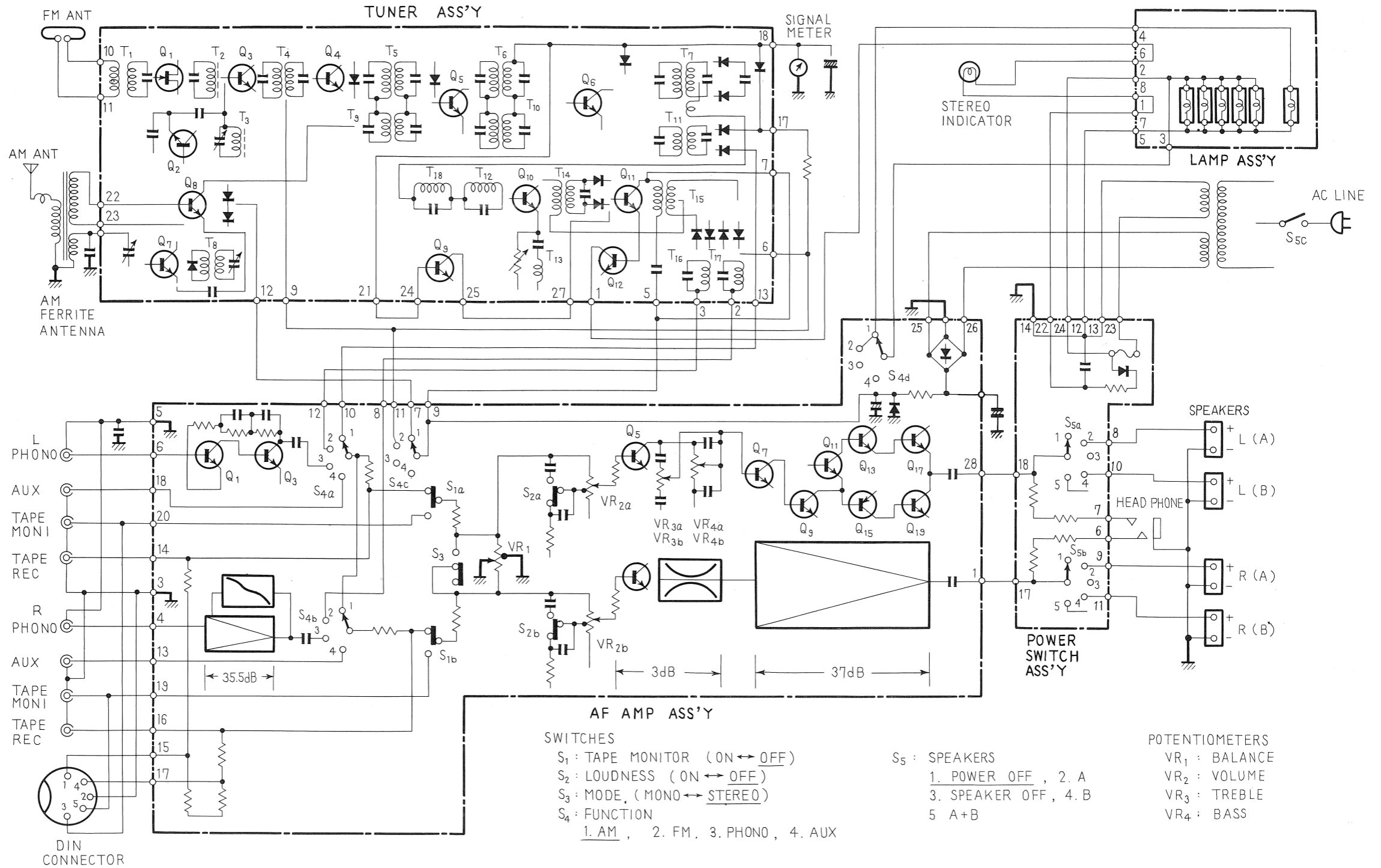

10. EXPLODED VIEW AND PARTS LIST

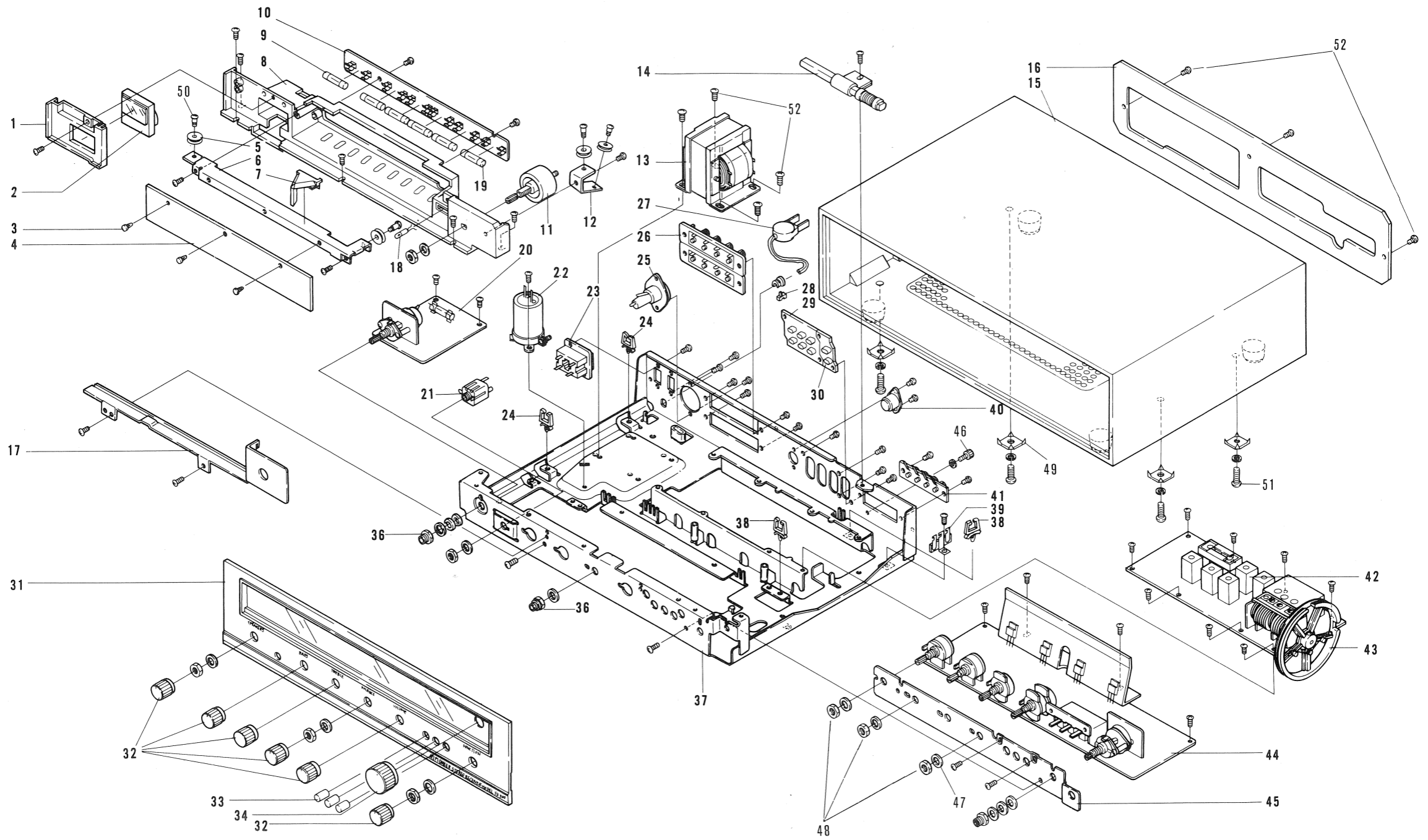

NOTE

Parts number is subject to change for the purpose of improvement with notice of a service bulletin.

Service bulletin will be furnished whenever necessary and you are requested to amend parts number in this manual according to the instructions.

Parts List of Exploded View

NOTICE:

Any parts asterisked* are subject to being not supplied.

Key No.	Description	Part No.	
1*	Meter-holder	AEC-107-0	
2	Signal meter	AAW-027-0	KUW, KCW models
	Signal meter	AAW-003-0	FVW, NBW models
3	Clip (Dial scale holder)	AEC-036-A	
4	Dial scale	AAG-068-0	
5	Pulley	AEC-006-0	
6	Dial scale holder	AND-062-0	
7	Dial pointer	AAF-029-0	
8*	Lamp box	AEC-106-0	FVW, NBW models
	Lamp box	AEC-129-0	KUW, KCW models
9	Pilot lamp 8V 0,3A (Dial scale)	E22-017-0	
10	Lamp assembly	AWX-055-0	
11	Tuning shaft assembly	AXA-033-0	
12	Pulley-held metal	ANG-085-0	
13	Power transformer	ATT-148-0	NBW model
	Power transformer	ATT-149-0	FVW model
	Power transformer	ATT-150-0	KUW model
	Power transformer	ATT-151-0	KCW model
14	Ferrite loopstick antenna	T42-018-F	
15	Wooden cabinet	AMM-027-0	
16*	Rear panel	AAK-011-0	FVW, model
	Rear panel	AAK-012-0	KUW, KCW models
	Rear panel	AAK-010-0	NBW model
17	Dial scale-held metal	ANF-139-0	
18	Pilot lamp 6V 0,03A (Indicator)	AEL-006-0	
19	Pilot lamp 8V 0,3A (Dial scale)	E22-017-0	
20	Power switch circuit assembly	AWS-051-0	NBW model
	Power switch circuit assembly	AWS-052-0	FVW model
	Power switch circuit assembly	AWS-053-0	KUW, KCW models
21	Phone jack (HEAD)	K72-026-0	
22	Electrolytic capacitor 2,200 μ F 50V	ACH-021-0	
23	AC socket	AKP-004-0	FVW model
			models
24*	Wire clip (D)	AEC-024-0	KUW, KCW models
	Wire clip (B)	ACE-005-0	FVW, NBW models
25	Fuse holder (AC power)	AKR-001-0	FVW model
	Fuse holder (AC power)	AKR-005-0	KUW, KCW models
26	Speaker output terminal	AKA-001-0	
27	AC power cord	ADG-004-0	FVW model
	AC power cord	ADG-005-0	KUW, KCW models
	AC power cord	D54-019-0	NBW model
28	AC cord grommet	AEC-079-0	

Key No.	Description	Part No.	
29	Phono jack (6P)	AKB-018-0	
30	Phono jack (2P)	AKB-013-0	
31	Front panel assembly	ANB-211-0	FVW, NBW models
	Front panel assembly	ANB-231-0	KUW, KCW models
32	Knob (SPEAKERS, BASS, TREBLE, BALANCE, VOLUME, FUNCTION)	AAB-063-0	
33	Knob (Push button)	AAD-044-A	
34	Knob (TUNING)	AAA-022-0	
36	Boss	ALA-008-0	
37*	Chassis	ANA-048-B	
38*	Wire clip (D)	AEC-024-0	
39	Terminal strip (1L2P)	K13-027-A	
40	Connector (DIN type 5P)	K93-003-B	
41	Antenna terminal board	AKA-003-0	
42	Tuner assembly	AWE-004-B	
43	Tuning pulley assembly	M42-060-E	
44	AF amplifier assembly	AWK-028-0	
45*	Sub panel	ANA-050-A	
46	Binding post (GROUND)	B11-012-A	
47	Washer	B22-016-0	
48	Nut 9φ	B71-004-0	
49	Lock washer	KBE-002-A	
50*	Pulley shaft	M49-025-E	
51	Screw M4 x 20		
52	Tapping screw M4 x 8		

11. SCHEMATIC DIAGRAMS, P.C. BOARD PATTERNS AND PARTS LISTS

11.1 CIRCUIT CONNECTION DIAGRAM AND MISCELLANEOUS PARTS

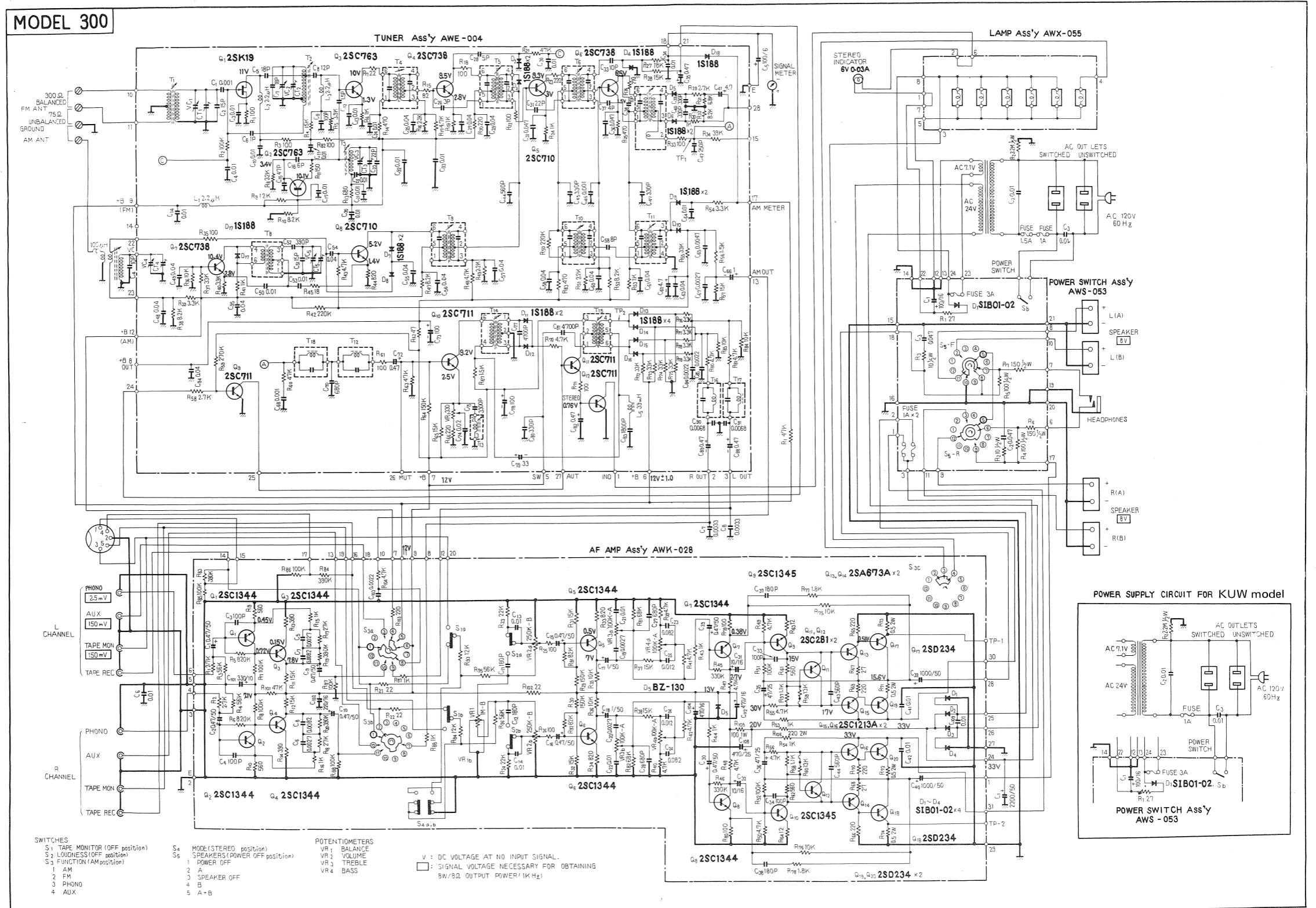

SX-300

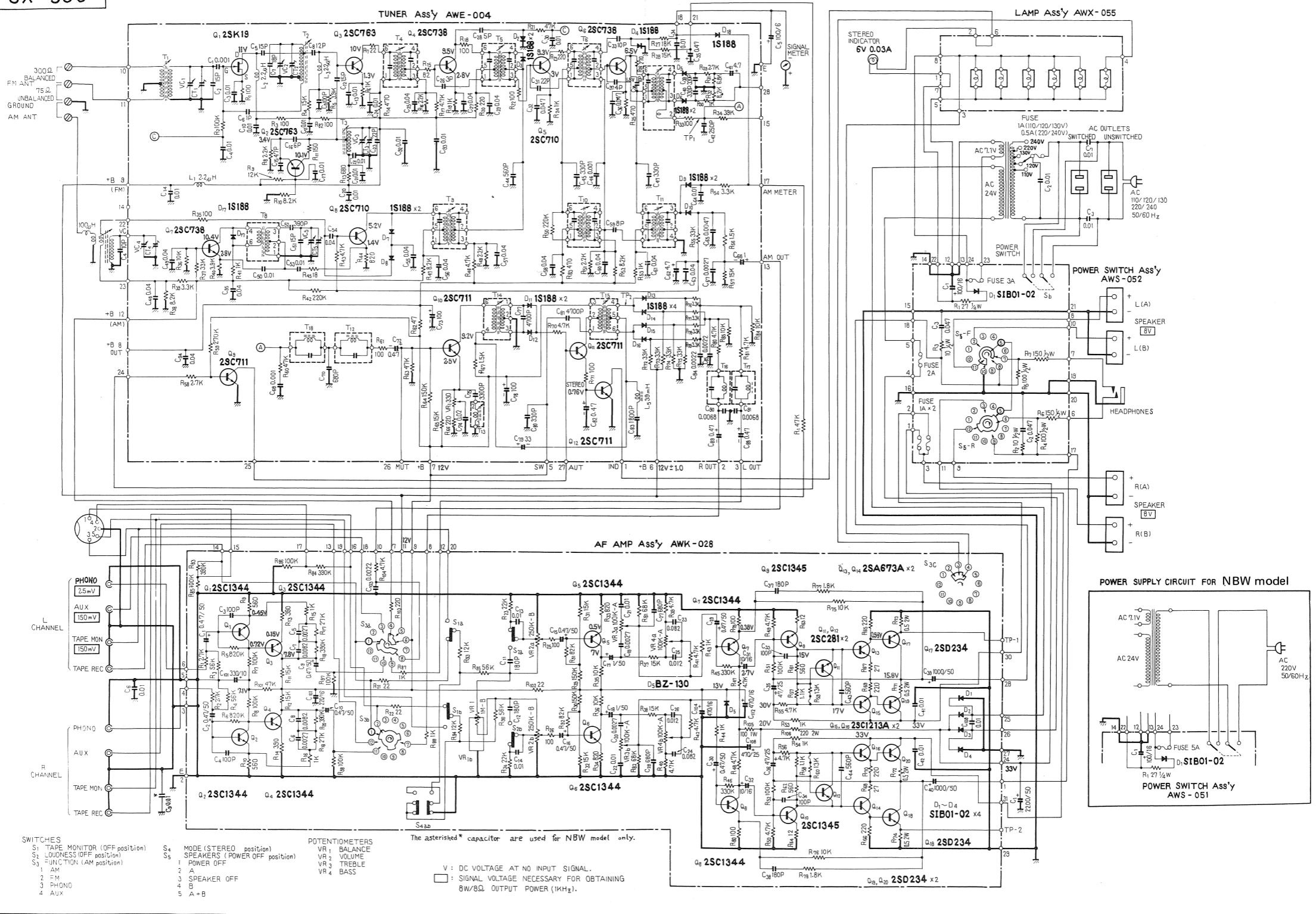

- SWITCHES
- S1 TAPE MONITOR (OFF position)
 - S2 LOUDNESS (OFF position)
 - S3 JUNCTION (AM position)
 - 1 AM
 - 2 FM
 - 3 PHONO
 - 4 AUX

- S4 MODE (STEREO position)
- S5 SPEAKERS (POWER OFF position)
- A
- B
- C
- D
- E

- POTENTIOMETERS
- VR1 BALANCE
 - VR2 VOLUME
 - VR3 TREBLE
 - VR4 BASS

The asterisked* capacitor are used for NBW model only.

V : DC VOLTAGE AT NO INPUT SIGNAL.

□ : SIGNAL VOLTAGE NECESSARY FOR OBTAINING 8W/8Ω OUTPUT POWER (1KH_z).

SX-300 / MODEL 300

- CAPACITORS: IN μ F UNLESS OTHERWISE NOTED p:pF
- RESISTORS: IN Ω , $\frac{1}{2}$ W UNLESS OTHERWISE NOTED k:k Ω , M: M Ω

Miscellaneous Parts List

CAPACITORS

Symbol	Description	Part No.	
C1	Electrolytic 2,200 50V	ACH-021-0	
C2	Ceramic 0.01 250V	ACG-001-0	FVW model only
	Metallized mylar 0.01 800V	ACE-002-0	KUW model only
	Ceramic 0.01 250V	ACG-003-0	KCW model only
C3	Ceramic 0.01 250V	ACG-001-0	FVW, KUW, KCW models
C4	Ceramic 10 50V	CCDSL 100K 50	
C5	Electrolytic 100 6V	CEA 101P 6	
C6	Ceramic 0.01 50V	CKDYF 103Z 50	
C7	Ceramic 0.01 250V	ACG-001-0	FVW model only
	Mylar 0.0033 50V	CQMA 332M 50	KUW, KCW models
C8	Mylar 0.0033 50V	CQMA 332M 50	KUW, KCW models
C9	Ceramic 0.01 50V	CKDYB 103Z 50	NBW model only

RESISTORS

Symbol	Description	Part No.	
R1	Carbon film 47k	RD $\frac{1}{4}$ PS 473J	
R2	Carbon film 2.2M $\frac{1}{2}$ W	RD $\frac{1}{2}$ PS 225J	KUW, KCW models

OTHERS

Symbol	Description	Part No.	
	Tuner assembly	AWE-004-B	
	AF amplifier assembly	AWK-028-0	
	Lamp assembly	AWX-055-0	
	Power switch circuit assembly	AWS-051-0	NBW model
	Power switch circuit assembly	AWS-052-0	FVW model
	Power switch circuit assembly	AWS-053-0	KUW, KCW models
	Power transformer	ATT-148-0	NBW model
	Power transformer	ATT-149-0	FVW model
	Power transformer	ATT-150-0	KUW model
	Power transformer	ATT-151-0	KCW model
	Ferrite loopstick antenna	T42-018-F	
	Choke coil 101k	T24-030-0	
	Speaker output terminal	AKA-001-0	
	Phono jack (2P)	AKB-013-0	
	Phono jack (6P)	AKB-018-0	
	Antenna terminal board	AKA-003-0	
	Fuse 1A (AC power)	E21-034-A	FVW model
	Fuse 1A (AC power)	E21-033-0	KUW, KCW models
	Fuse 1.5A (AC power)	AKE-029-0	KCW model
	Pilot lamp 6V, 0.03A (Indicator)	AEL-006-0	
	Pilot lamp 8V, 0.3A (Dial scale)	E22-017-0	
	AC socket	AKP-004-0	FVW, KUW, KCW models

Symbol	Description	Part No.	
	Connector (DIN type 5P) Fuse holder (AC power) Fuse holder (AC power) Phono jack (HEAD) AC power cord AC power cord AC power cord	K93-003-B AKR-001-0 AKR-005-0 K72-026-0 ADG-004-0 D54-019-0 ADG-005-0	 FVW model KUW, KCW models FVW model NBW model KUW, KCW models

11.2 AF AMPLIFIER ASSEMBLY (AWK-028-0)

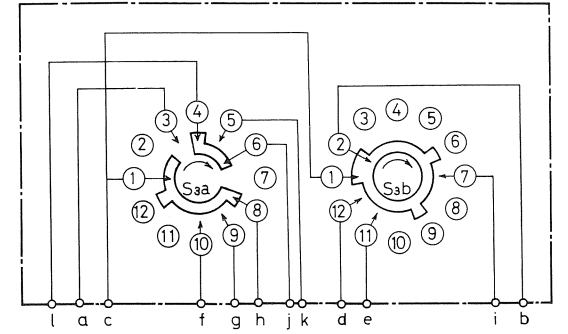
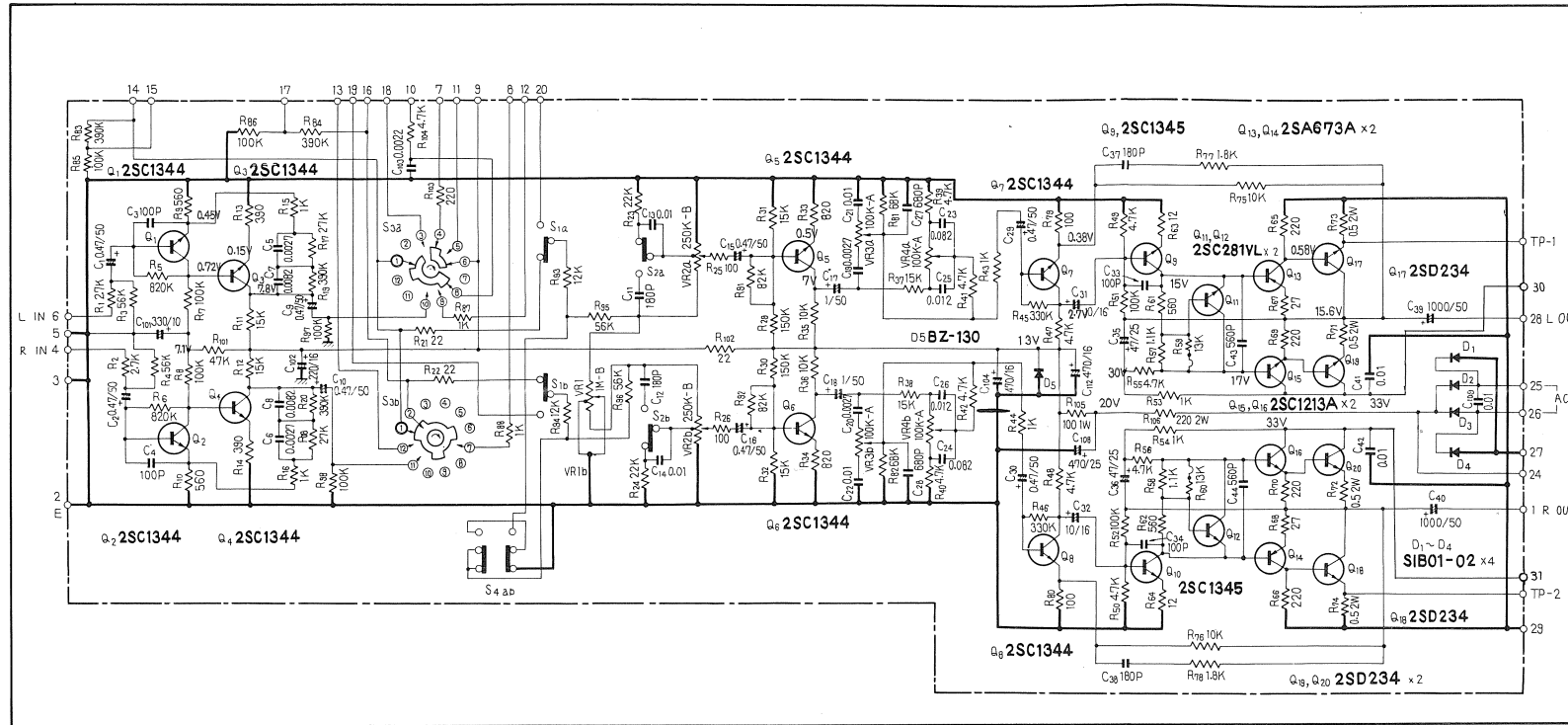

- 2SC1327
- 2SA720R
- 2SC1318R
- 2SC1344
- 2SC1345
- 2SC281VL
- 2SA673A
- 2SC1213A
- 2SD234

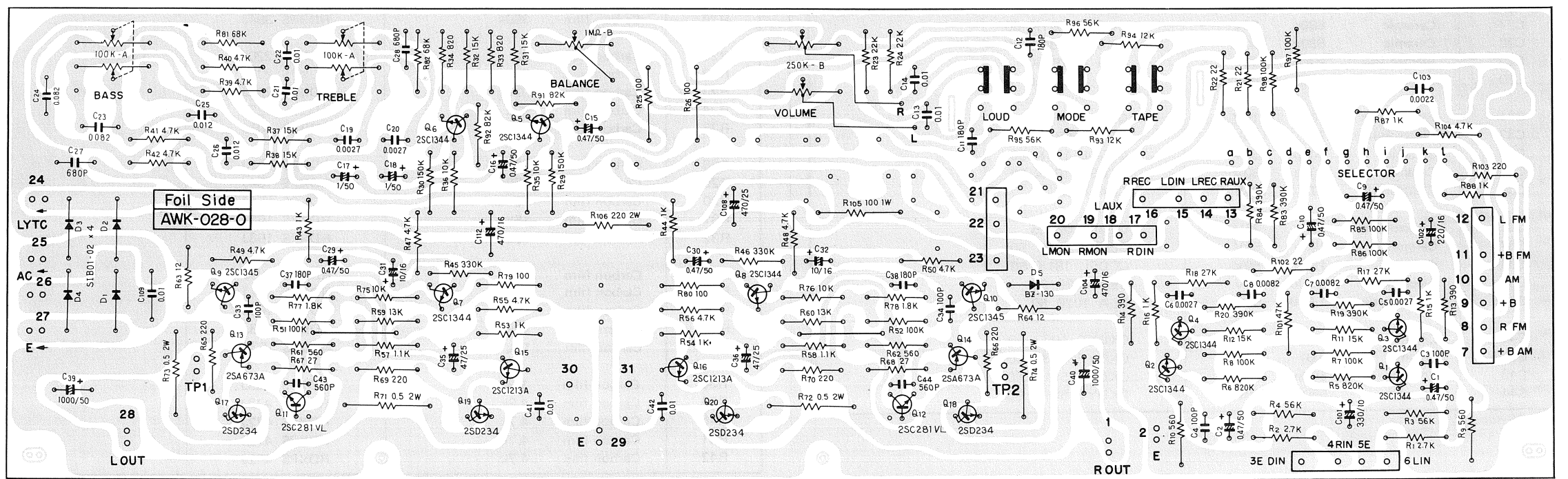

Parts List of AF Amplifier Assembly (AWK-028-0)

CAPACITORS

Symbol	Description	Part No.
C1	Electrolytic 0.47 50V	CEA R47P 50
C2	Electrolytic 0.47 50V	CEA R47P 50
C3	Ceramic 100p 50V	CCDSL 101K 50
C4	Ceramic 100p 50V	CCDSL 101K 50
C5	Ceramic 0.0027 50V	CKDYB 272K 50
C6	Ceramic 0.0027 50V	CKDYB 272K 50
C7	Ceramic 0.0082 50V	CKDYB 822K 50
C8	Ceramic 0.0082 50V	CKDYB 822K 50
C9	Electrolytic 0.47 50V	CEA R47P 50
C10	Electrolytic 0.47 50V	CEA R47P 50
C11	Ceramic 180p 50V	CCDSL 181K 50
C12	Ceramic 180p 50V	CCDSL 181K 50
C13	Mylar 0.01 50V	CQMA 103K 50
C14	Mylar 0.01 50V	CQMA 103K 50
C15	Electrolytic 0.47 50V	CEA R47P 50
C16	Electrolytic 0.47 50V	CEA R47P 50
C17	Electrolytic 1 50V	CEA 010P 50
C18	Electrolytic 1 50V	CEA 010P 50
C19	Ceramic 0.0027 50V	CKDYB 272K 50
C20	Ceramic 0.0027 50V	CKDYB 272K 50
C21	Mylar 0.01 50V	CQMA 103K 50
C22	Mylar 0.01 50V	CQMA 103K 50
C23	Mylar 0.082 50V	CQMA 823K 50
C24	Mylar 0.082 50V	CQMA 823K 50
C25	Mylar 0.012 50V	CQMA 123K 50
C26	Mylar 0.012 50V	CQMA 123K 50
C27	Ceramic 680p 50V	CKDYB 681K 50
C28	Ceramic 680p 50V	CKDYB 681K 50
C29	Electrolytic 0.47 50V	CEA R47P 50
C30	Electrolytic 0.47 50V	CEA R47P 50
C31	Electrolytic 10 16V	CEA 100P 16
C32	Electrolytic 10 16V	CEA 100P 16
C33	Ceramic 100p 50V	CCDSL 101K 50
C34	Ceramic 100p 50V	CCDSL 101K 50
C35	Electrolytic 47 25V	CEA 470P 25
C36	Electrolytic 47 25V	CEA 470P 25
C37	Ceramic 180p 50V	CCDSL 181K 50
C38	Ceramic 180p 50V	CCDSL 181K 50
C39	Electrolytic 1,000 50V	CEA 102P 50
C40	Electrolytic 1,000 50V	CEA 102P 50
C41	Ceramic 0.01 50V	CKDYF 103Z 50
C42	Ceramic 0.01 50V	CKDYF 103Z 50
C43	Ceramic 560p 50V	CKDYB 561K 50
C44	Ceramic 560p 50V	CKDYB 561K 50

Symbol	Description	Part No.
C101	Electrolytic 330 10V	CEA 331P 10
C102	Electrolytic 220 16V	CEA 221P 16
C103	Ceramic 0.0022 50V	CKDYB 222K 50
C104	Electrolytic 470 16V	CEA 471P 16
C108	Electrolytic 470 25V	CEA 471P 25
C109	Ceramic 0.01 150V	ACG-004-0
C112	Electrolytic 470 16V	CEA 471P 16

RESISTORS AND POTENTIOMETERS

Symbol	Description	Part No.
R1	Carbon film 2.7k	RD¼PS 272J
R2	Carbon film 2.7k	RD¼PS 272J
R3	Carbon film 56k	RD¼PS 563J
R4	Carbon film 56k	RD¼PS 563J
R5	Carbon film 820k	RD¼PS 824J
R6	Carbon film 820k	RD¼PS 824J
R7	Carbon film 100k	RD¼PS 104J
R8	Carbon film 100k	RD¼PS 104J
R9	Carbon film 560	RD¼PS 561J
R10	Carbon film 560	RD¼PS 561J
R11	Carbon film 15k	RD¼PS 153J
R12	Carbon film 15k	RD¼PS 153J
R13	Carbon film 390	RD¼PS 391J
R14	Carbon film 390	RD¼PS 391J
R15	Carbon film 1k	RD¼PS 102J
R16	Carbon film 1k	RD¼PS 102J
R17	Carbon film 27k	RD¼PS 273J
R18	Carbon film 27k	RD¼PS 273J
R19	Carbon film 390k	RD¼PS 394J
R20	Carbon film 390k	RD¼PS 394J
R21	Carbon film 22	RD¼PS 220J
R22	Carbon film 22	RD¼PS 220J
R23	Carbon film 22k	RD¼PS 223J
R24	Carbon film 22k	RD¼PS 223J
R25	Carbon film 100	RD¼PS 101J
R26	Carbon film 100	RD¼PS 101J
R29	Carbon film 150k	RD¼PS 154J
R30	Carbon film 150k	RD¼PS 154J
R31	Carbon film 15k	RD¼PS 153J
R32	Carbon film 15k	RD¼PS 153J
R33	Carbon film 820	RD¼PS 821J
R34	Carbon film 820	RD¼PS 821J
R35	Carbon film 10k	RD¼PS 103J
R36	Carbon film 10k	RD¼PS 103J
R37	Carbon film 15k	RD¼PS 153J
R38	Carbon film 15k	RD¼PS 153J
R39	Carbon film 4.7k	RD¼PS 472J
R40	Carbon film 4.7k	RD¼PS 472J
R41	Carbon film 4.7k	RD¼PS 472J
R42	Carbon film 4.7k	RD¼PS 472J

SX-300 / MODEL 300

Symbol	Description	Part No.
R43	Carbon film 1k	RD¼PS 102J
R44	Carbon film 1k	RD¼PS 102J
R45	Carbon film 330k	RD¼PS 334J
R46	Carbon film 330k	RD¼PS 334J
R47	Carbon film 4.7k	RD¼PS 472J
R48	Carbon film 4.7k	RD¼PS 472J
R49	Carbon film 4.7k	RD¼PS 472J
R50	Carbon film 4.7k	RD¼PS 472J
R51	Carbon film 100k	RD¼PS 104J
R52	Carbon film 100k	RD¼PS 104J
R53	Carbon film 1k	RD¼PS 102J
R54	Carbon film 1k	RD¼PS 102J
R55	Carbon film 4.7k	RD¼PS 472J
R56	Carbon film 4.7k	RD¼PS 472J
R57	Carbon film 1.1k	RD¼PS 112J
R58	Carbon film 1.1k	RD¼PS 112J
R59	Carbon film 13k	RD¼PS 133J
R60	Carbon film 13k	RD¼PS 133J
R61	Carbon film 560	RD¼PS 561J
R62	Carbon film 560	RD¼PS 561J
R63	Carbon film 12	RD¼PS 120J
R64	Carbon film 12	RD¼PS 120J
R65	Carbon film 220	RD¼PS 221J
R66	Carbon film 220	RD¼PS 221J
R67	Carbon film 27	RD¼PS 270J
R68	Carbon film 27	RD¼PS 270J
R69	Carbon film 220	RD¼PS 221J
R70	Carbon film 220	RD¼PS 221J
R71	Metal film 0.5 2W	RN2H 0R5K
R72	Metal film 0.5 2W	RN2H 0R5K
R73	Metal film 0.5 2W	RN2H 0R5K
R74	Metal film 0.5 2W	RN2H 0R5K
R75	Carbon film 10k	RD¼PS 103J
R76	Carbon film 10k	RD¼PS 103J
R77	Carbon film 1.8k	RD¼PS 182J
R78	Carbon film 1.8k	RD¼PS 182J
R79	Carbon film 100	RD¼PS 101J
R80	Carbon film 100	RD¼PS 101J
R81	Carbon film 68k	RD¼PS 683J
R82	Carbon film 68k	RD¼PS 683J
R83	Carbon film 390k	RD¼PS 394J
R84	Carbon film 390k	RD¼PS 394J
R85	Carbon film 100k	RD¼PS 104J
R86	Carbon film 100k	RD¼PS 104J
R87	Carbon film 1k	RD¼PS 102J
R88	Carbon film 1k	RD¼PS 102J
R91	Carbon film 82k	RD¼PS 823J
R92	Carbon film 82k	RD¼PS 823J
R93	Carbon film 12k	RD¼PS 123J
R94	Carbon film 12k	RD¼PS 123J
R95	Carbon film 56k	RD¼PS 563J

Symbol	Description	Part No.
R96	Carbon film 56k	RD½PS 563J
R97	Carbon film 100k	RD½PS 104J
R98	Carbon film 100k	RD½PS 104J
R101	Carbon film 47k	RD½PS 473J
R102	Carbon film 22	RD½PS 220J
R103	Carbon film 220	RD½PS 221J
R104	Carbon film 4.7k	RD½PS 472J
R105	Metal oxide 100 1W	RS1P 101K
R106	Metal oxide 220 2W	RS2P 221K
VR1	Variable resistor 1M-B (BALANCE)	ACV-015-0
VR2	Variable resistor 250k-B (VOLUME)	ACV-124-0
VR3	Variable resistor 100k-A (TREBLE)	ACV-123-0
VR4	Variable resistor 100k-A (BASS)	ACV-123-0

Symbol	Description	Part No.
D1	Diode SIB01-02	
D2	Diode SIB01-02	
D3	Diode SIB01-02	
D4	Diode SIB01-02	
D5	Zener diode BZ-130	

SWITCHES

Symbol	Description	Part No.
S1	Push switch (TAPE MON)	ASG-017-0
S2	Push switch (LOUDNESS)	ASG-017-0
S3	Rotary switch (FUNCTION)	ASD-005-0
S4	Push switch (MONO)	ASG-017-0

SEMICONDUCTORS

Symbol	Description	Part No.
Q1	Transistor 2SC1344-E 2SC1327-T	
Q2	Transistor 2SC1344-E 2SC1327-T	
Q3	Transistor 2SC1344-E 2SC1327-T	
Q4	Transistor 2SC1344-E 2SC1327-T	
Q5	Transistor 2SC1344-E 2SC1327-T	
Q6	Transistor 2SC1344-E 2SC1327-T	
Q7	Transistor 2SC1344-E 2SC1327-T	
Q8	Transistor 2SC1344-E 2SC1327-T	
Q9	Transistor 2SC1345-E or F	
Q10	Transistor 2SC1345-E or F	
Q11	Transistor 2SC281VL-C or B	
Q12	Transistor 2SC281VL-C or B	
Q13	Transistor 2SA673A-C or B 2SA720R	
Q14	Transistor 2SA673A-C or B 2SA720R	
Q15	Transistor 2SC1213A-C or B 2SC1318R	
Q16	Transistor 2SC1213A-C or B 2SC1318R	
Q17	Transistor 2SD234-O or Y	
Q18	Transistor 2SD234-O or Y	
Q19	Transistor 2SD234-O or Y	
Q20	Transistor 2SD234-O or Y	

11.3 POWER SWITCH CIRCUIT ASSEMBLY (AWS-052-0)

This is exclusively used for FVW model.

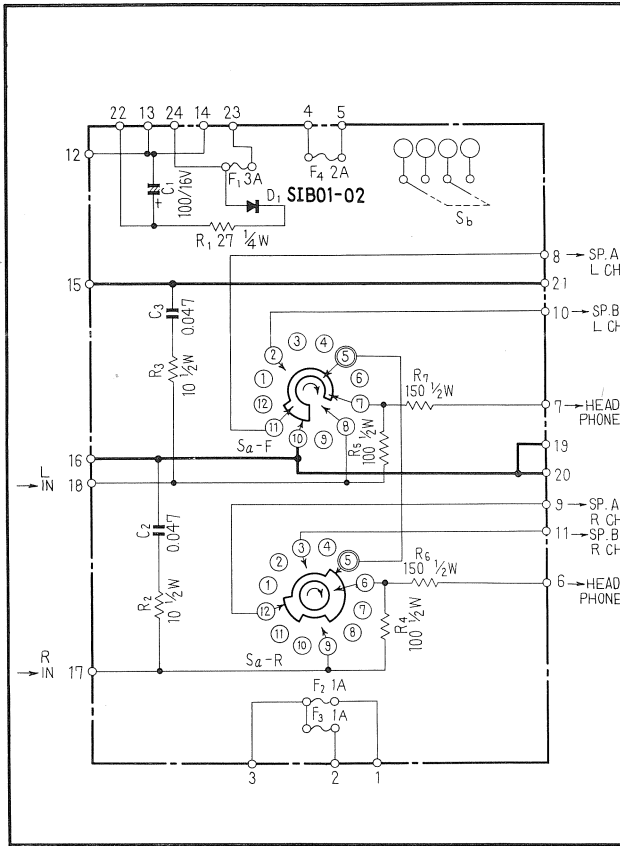

CAPACITORS

Symbol	Description	Part No.
C1	Electrolytic 100 16V	CEA 101P 16
C2	Mylar 0.047 50V	CQMA 473K 50
C3	Mylar 0.047 50V	CQMA 473K 50

RESISTORS

Symbol	Description	Part No.
R1	Carbon film 27	RD $\frac{1}{4}$ PS 270J
R2	Carbon film 10 $\frac{1}{2}$ W	RD $\frac{1}{2}$ PS 100K
R3	Carbon film 10 $\frac{1}{2}$ W	RD $\frac{1}{2}$ PS 100K
R4	Carbon film 100 $\frac{1}{2}$ W	RD $\frac{1}{2}$ PS 101K
R5	Carbon film 100 $\frac{1}{2}$ W	RD $\frac{1}{2}$ PS 101K
R6	Carbon film 150 $\frac{1}{2}$ W	RD $\frac{1}{2}$ PS 151K
R7	Carbon film 150 $\frac{1}{2}$ W	RD $\frac{1}{2}$ PS 151K

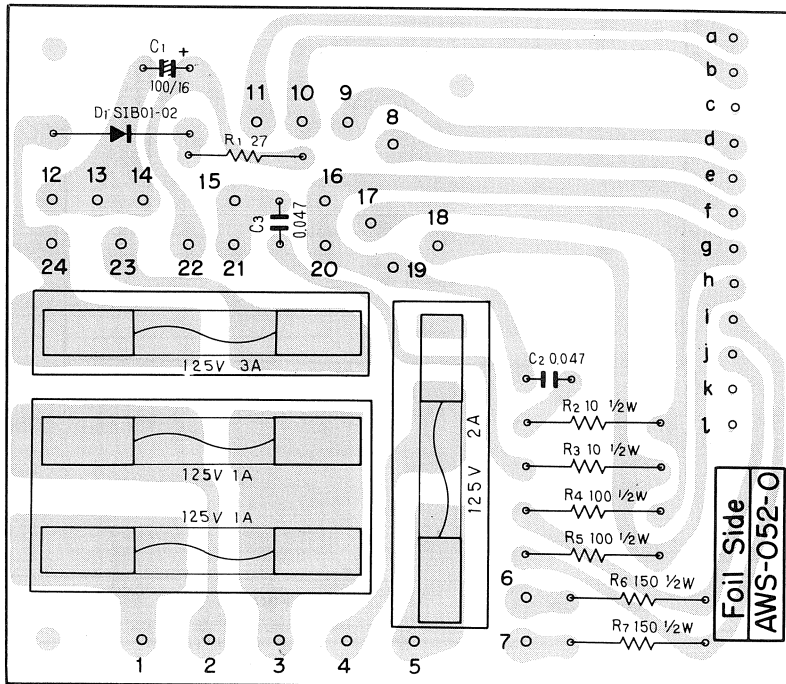
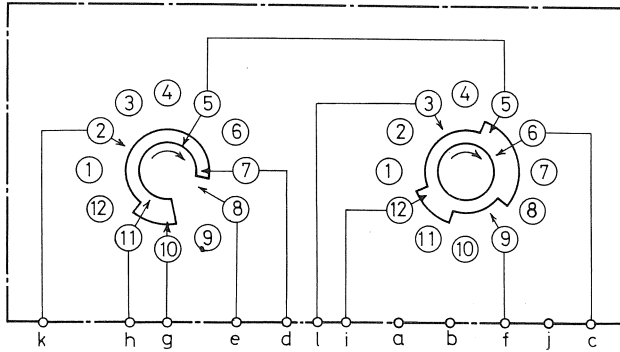

OTHERS

Symbol	Description	Part No.	
Sa	Rotary switch (SPEAKERS)	ASD-007-0	
D1	Diode SIB01-02		
F1	Protection fuse 3A (PROTECTION)	E21-036-A	
F2	Protection fuse 1A (PROTECTION)	E21-034-A	
F3	Protection fuse 1A (PROTECTION)	E21-034-A	
F4	Protection fuse 2A (PROTECTION)	E21-035-A	

11.4 POWER SWITCH CIRCUIT ASSEMBLY (AWS-051-0)

This is exclusively used for NBW model.

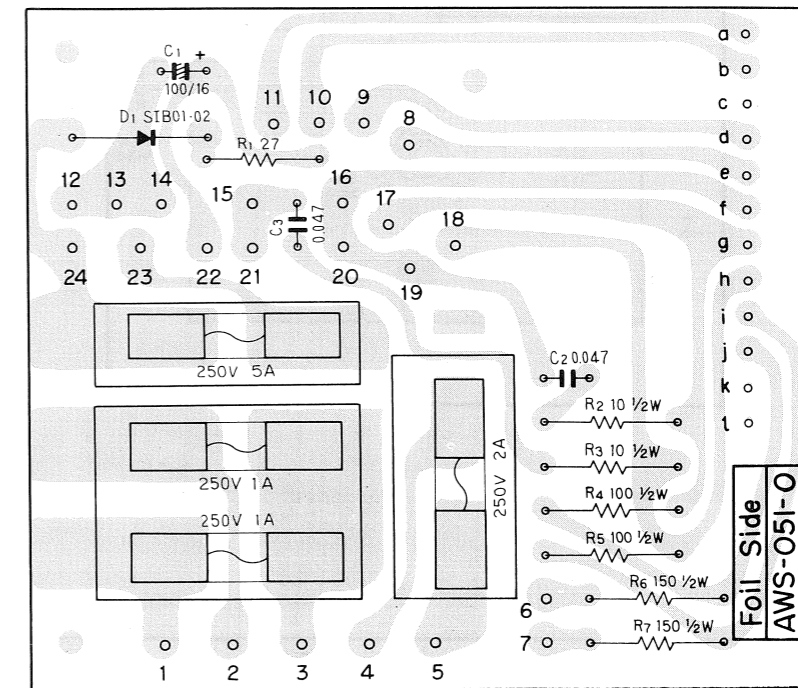
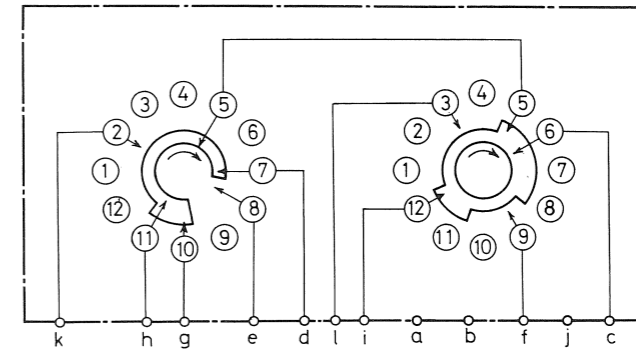
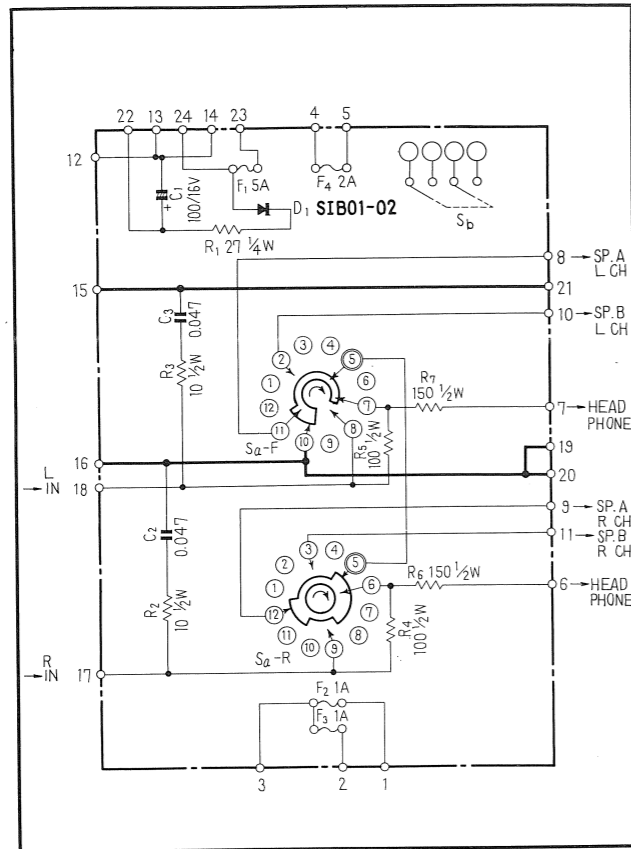

CAPACITORS

Symbol	Description	Part No.
C1	Electrolytic 100 16V	CEA 101P 16
C2	Mylar 0.047 50V	CQMA 473K 50
C3	Mylar 0.047 50V	CQMA 473K 50

RESISTORS

Symbol	Description	Part No.
R1	Carbon film 27	RD½PS 270J
R2	Carbon film 10 ½W	RD½PS 100K
R3	Carbon film 10 ½W	RD½PS 100K
R4	Carbon film 100 ½W	RD½PS 101K
R5	Carbon film 100 ½W	RD½PS 101K
R6	Carbon film 150 ½W	RD½PS 151K
R7	Carbon film 150 ½W	RD½PS 151K

OTHERS

Symbol	Description	Part No.
Sa	Rotary switch (SPEAKERS)	ASD-007-0
D1	Diode SIB01-02	
F1	Protection fuse 5A (PROTECTION)	AEK-015-0
F2	Protection fuse 1A (PROTECTION)	E21-031-0
F3	Protection fuse 1A (PROTECTION)	E21-031-0
F4	Protection fuse 2A (PROTECTION)	AEK-017-0

11.5 POWER SWITCH CIRCUIT ASSEMBLY (AWS-053-0)

This is exclusively used for KUW and KCW models.

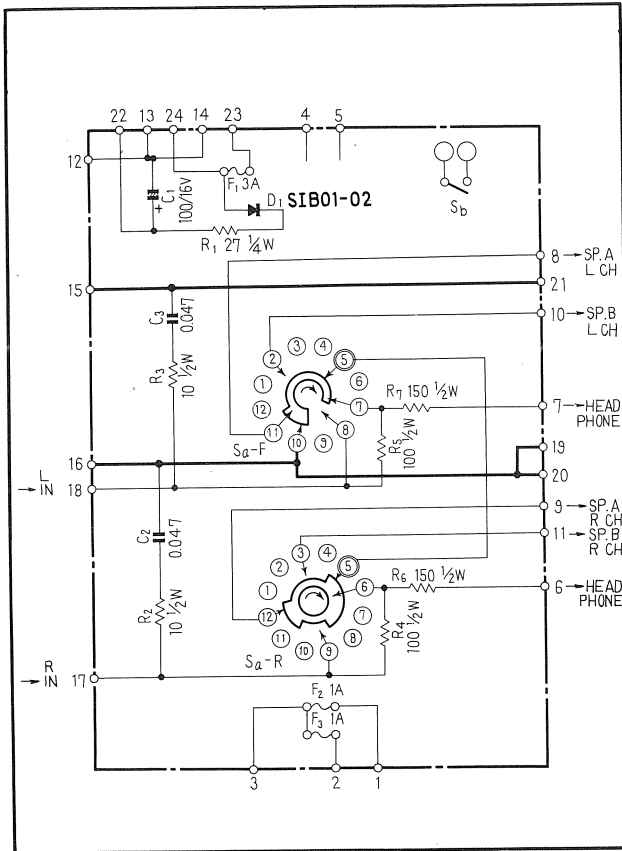

CAPACITORS

Symbol	Description	Part No.
C1	Electrolytic 100 16V	CEA 101P 16
C2	Mylar 0.047 50V	CQMA 473K 50
C3	Mylar 0.047 50V	CQMA 473K 50

RESISTORS

Symbol	Description	Part No.
R1	Carbon film 27 1/4W	RD1/4PS 270J
R2	Carbon film 10 1/2W	RD1/2PS 100K
R3	Carbon film 10 1/2W	RD1/2PS 100K
R4	Carbon film 100 1/2W	RD1/2PS 101K
R5	Carbon film 100 1/2W	RD1/2PS 101K
R6	Carbon film 150 1/2W	RD1/2PS 151K
R7	Carbon film 150 1/2W	RD1/2PS 151K

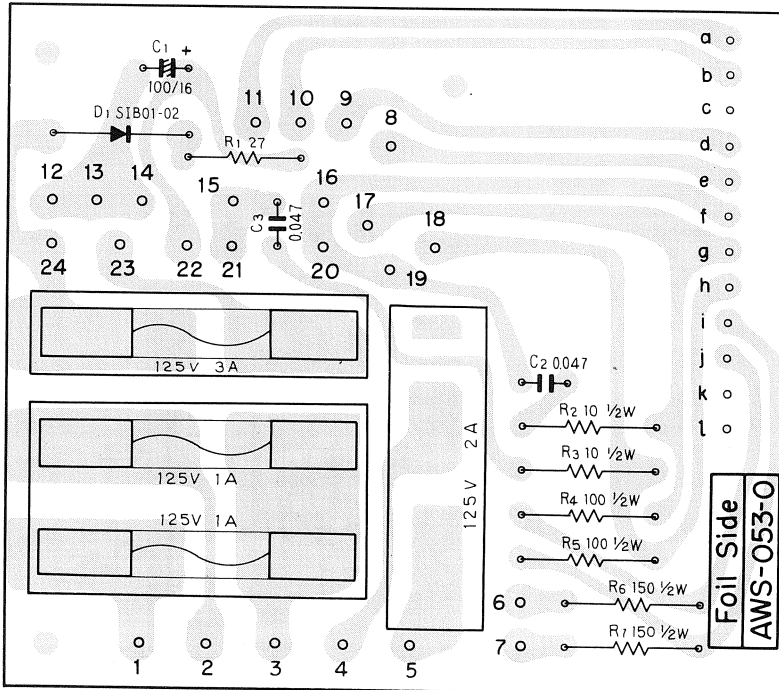
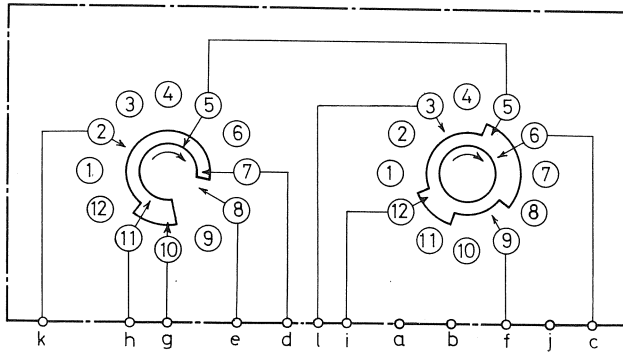

OTHERS

Symbol	Description	Part No.	
Sa	Rotary switch (SPEAKERS)	ASD-008-0	
D1	Diode SIB01-02		
F1	Protection fuse 3A (PROTECTION)	E21-036-A	
F2	Protection fuse 1A (PROTECTION)	E21-034-A	
F3	Protection fuse 1A (PROTECTION)	E21-034-A	

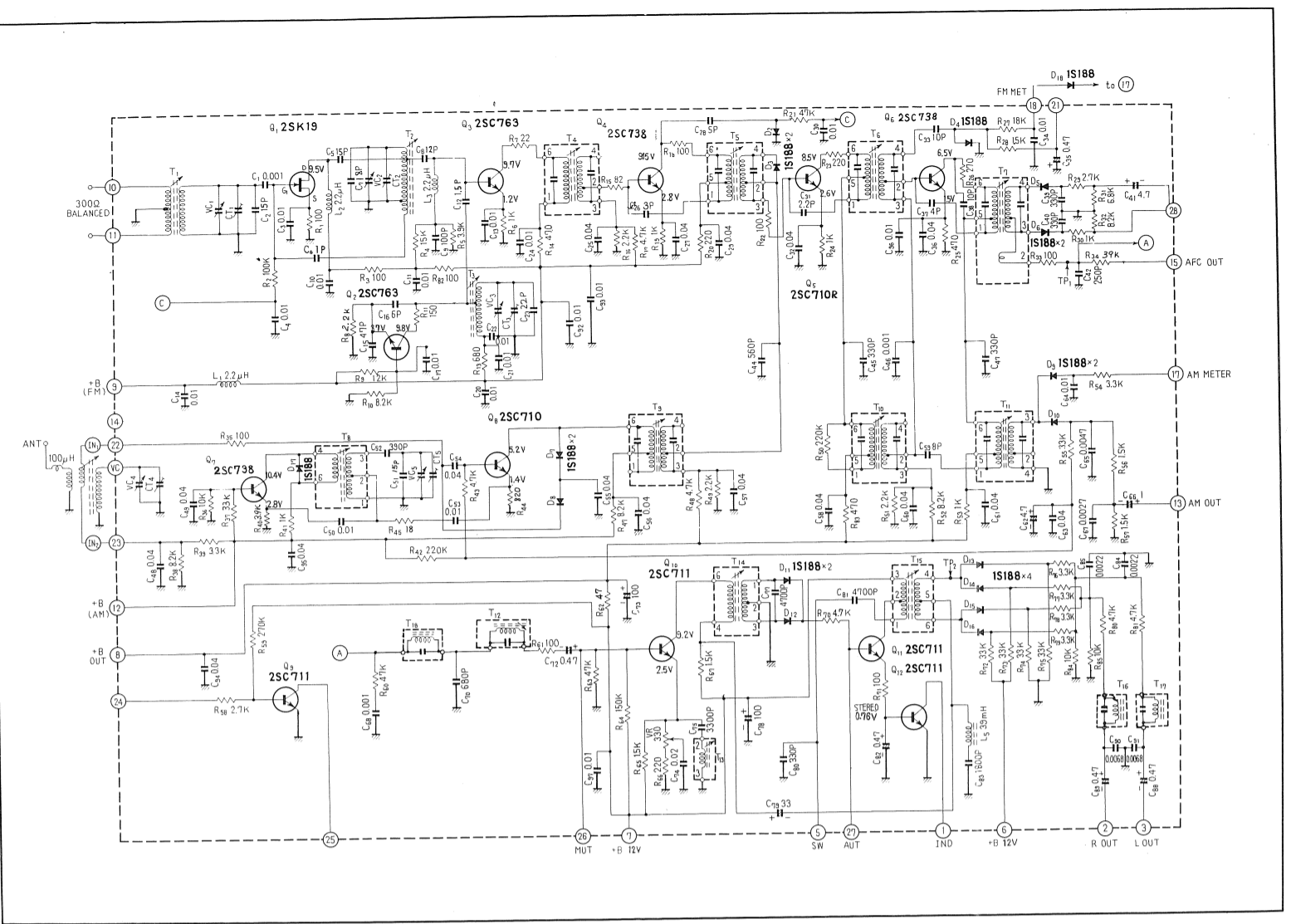

2SK19-Y



2SC763
2SC738
2SC710R
2SC710
2SC711



Foil side

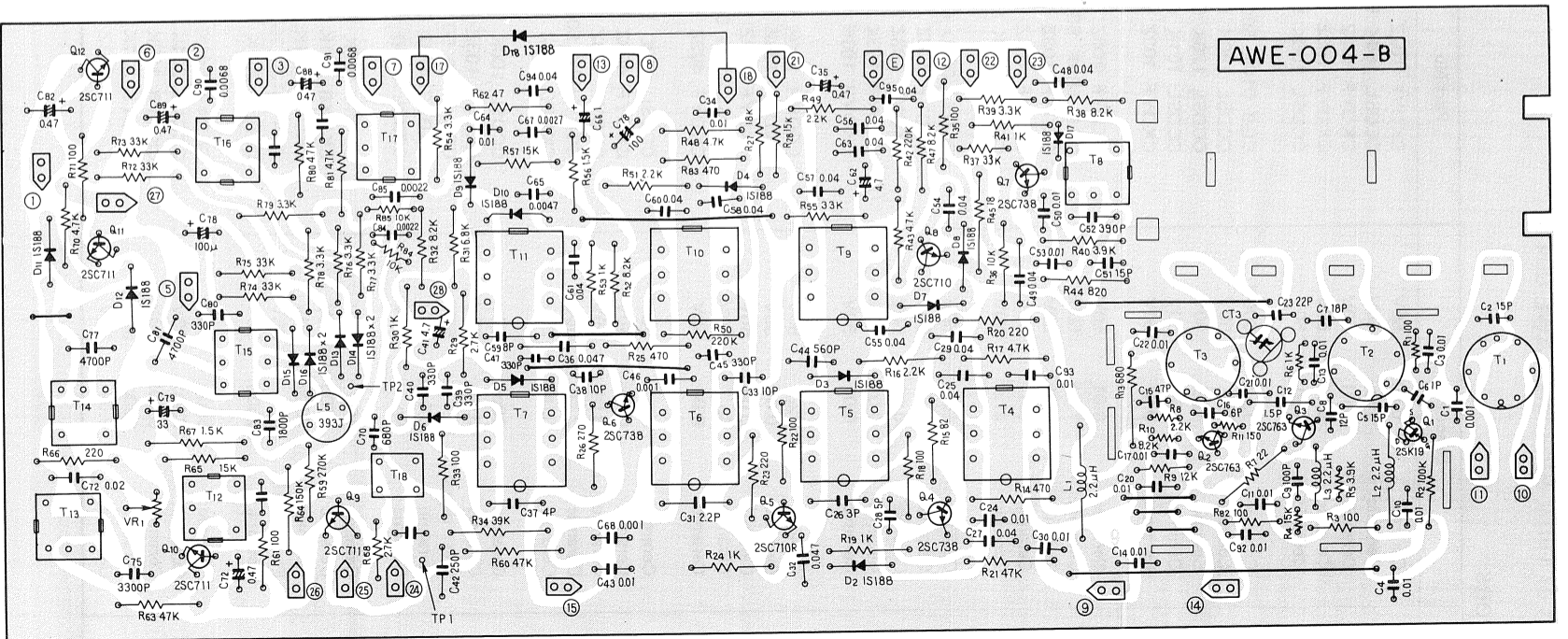

Parts List of Tuner Assembly (AWE-004-B)

CAPACITORS

Symbol	Description	Part No.
C1	Ceramic 0.001 50V	CKDYF 102Z 50
C2	Ceramic 15p 50V	CCDSL 150K 50
C3	Ceramic 0.01 50V	CKDYF 103Z 50
C4	Ceramic 0.01 50V	CKDYF 103Z 50
C5	Ceramic 15p 50V	CCDSL 150K 50
C6	Ceramic 1p 500V	CGB 010K 500
C7	Ceramic 18p 50V	CCDSL 180K 50
C8	Ceramic 12p 50V	CCDSL 120K 50
C9	Ceramic 100p 50V	CCDSL 101K 50
C10	Ceramic 0.01 50V	CKDYF 103Z 50
C11	Ceramic 0.01 50V	CKDYF 103Z 50
C12	Ceramic 1.5p 500V	CGB 1R5K 500
C13	Ceramic 0.01 50V	CKDYF 103Z 50
C14	Ceramic 0.01 50V	CKDYF 103Z 50
C15	Ceramic 47p 50V	CCDSL 470K 50
C16	Ceramic 6p 50V	CCDTJ 060D 50
C17	Ceramic 0.01 50V	CKDYF 103Z 50
C20	Ceramic 0.01 50V	CKDYF 103Z 50
C21	Ceramic 0.01 50V	CKDYB 103K 50
C22	Ceramic 0.01 50V	CKDYB 103K 50
C23	Ceramic 22p 50V	CCDRH 220K 50
C24	Ceramic 0.01 50V	CKDYF 103Z 50
C25	Ceramic 0.04 50V	CKDYF 403Z 50
C26	Ceramic 3p 50V	CCDSL 030D 50
C27	Ceramic 0.04 50V	CKDYF 403Z 50
C28	Ceramic 5p 50V	CCDSL 050D 50
C29	Ceramic 0.04 50V	CKDYF 403Z 50
C30	Ceramic 0.01 50V	CKDYF 103Z 50
C31	Ceramic 2.2p 500V	CGB 2R2K 500
C32	Ceramic 0.047 25V	CKDBC 473Z 25
C33	Ceramic 10p 50V	CCDSL 100K 50
C34	Ceramic 0.01 50V	CKDYF 103Z 50
C35	Electrolytic 0.47 50V	CEA R47P 50
C36	Ceramic 0.047 25V	CKDBC 473Z 25
C37	Ceramic 4p 50V	CCDSL 040D 50
C38	Ceramic 10p 50V	CCDSL 100K 50
C39	Ceramic 330p 50V	CKDYB 331K 50
C40	Ceramic 330p 50V	CKDYB 331K 50
C41	Electrolytic 4.7 25V	CEA 4R7P 25
C42	Ceramic 250p 50V	CCDSL 251K 50
C44	Ceramic 560p 50V	CKDYB 561K 50
C45	Ceramic 330p 50V	CKDYB 331K 50
C46	Ceramic 0.001 50V	CKDYB 102K 50
C47	Ceramic 330p 50V	CKDYB 331K 50
C48	Ceramic 0.04 50V	CKDYF 403Z 50

Symbol	Description			Part No.
C49	Ceramic	0.04	50V	CKDYF 403Z 50
C50	Mylar	0.01	50V	CQMA 103K 50
C51	Ceramic	15p	50V	CCDUJ 150K 50
C52	Styrol	390p	50V	CQSA 391K 50
C53	Mylar	0.01	50V	CQMA 103K 50
C54	Ceramic	0.04	50V	CKDYF 403Z 50
C55	Ceramic	0.04	50V	CKDYF 403Z 50
C56	Ceramic	0.04	50V	CKDYF 403Z 50
C57	Ceramic	0.04	50V	CKDYF 403Z 50
C58	Ceramic	0.04	50V	CKDYF 403Z 50
C59	Ceramic	8p	50V	CCDSL 080F 50
C60	Ceramic	0.04	50V	CKDYF 403Z 50
C61	Ceramic	0.04	50V	CKDYF 403Z 50
C62	Electrolytic	4.7	25V	CEA 4R7P 25
C63	Ceramic	0.04	50V	CKDYF 403Z 50
C64	Ceramic	0.01	50V	CKDYF 103Z 50
C65	Ceramic	0.0047	50V	CKDYB 472K 50
C66	Electrolytic	1	50V	CEA 010P 50
C67	Ceramic	0.0027	50V	CKDYB 272K 50
C68	Ceramic	0.001	50V	CKDYB 102K 50
C70	Styrol	680p	50V	CQSA 681J 50
C72	Electrolytic	0.47	50V	CEA R47P 50
C73	Electrolytic	100	16V	CEA 101P 16
C74	Mylar	0.02	50V	CQMA 203K 50
C75	Styrol	0.0033	50V	C15-011-A
C77	Styrol	0.0047	50V	C15-013-A
C78	Electrolytic	100	16V	CEA 101P 16
C79	Electrolytic	33	16V	CEA 330P 16
C80	Ceramic	330p	50V	CKDYB 331K 50
C81	Styrol	0.0047	50V	C15-013-A
C82	Electrolytic	0.47	50V	CEA R47P 50
C83	Styrol	0.0018	50V	CQSA 182J 50
C84	Mylar	0.0022	50V	CQMA 222K 50
C85	Mylar	0.0022	50V	CQMA 222K 50
C88	Electrolytic	0.47	50V	CEA R47P 50
C89	Electrolytic	0.47	50V	CEA R47P 50
C90	Mylar	0.0068	50V	CQMA 682K 50
C91	Mylar	0.0068	50V	CQMA 682K 50
C92	Ceramic	0.01	50V	CKDYF 103Z 50
C93	Ceramic	0.01	50V	CKDYF 103Z 50
C94	Ceramic	0.04	50V	CKDYF 403Z 50
C95	Ceramic	0.04	50V	CKDYF 403Z 50
VC	Tuning capacitor			C64-038-A
CT3	Ceramic trimmer			C43-007-A

RESISTORS

Symbol	Description	Part No.
R1	Carbon film 100	RD¼VS 101J
R2	Carbon film 100	RD¼PS 101J
R3	Carbon film 100	RD¼VS 101J
R4	Carbon film 15k	RD¼VS 153J
R5	Carbon film 3.9k	RD¼VS 392J
R6	Carbon film 1k	RD¼VS 102J
R7	Carbon film 22	RD¼PS 220J
R8	Carbon film 2.2k	RD¼VS 222J
R9	Carbon film 12k	RD¼VS 123J
R10	Carbon film 8.2k	RD¼VS 822J
R11	Carbon film 150	RD¼VS 151J
R13	Carbon film 680	RD¼PS 681J
R14	Carbon film 470	RD¼PS 471J
R15	Carbon film 82	RD¼PS 820J
R16	Carbon film 2.2k	RD¼PS 222J
R17	Carbon film 4.7k	RD¼PS 472J
R18	Carbon film 100	RD¼PS 101J
R19	Carbon film 1k	RD¼PS 102J
R20	Carbon film 220	RD¼PS 221J
R21	Carbon film 47k	RD¼PS 473J
R22	Carbon film 100	RD¼PS 101J
R23	Carbon film 220	RD¼PS 221J
R24	Carbon film 1k	RD¼PS 102J
R25	Carbon film 470	RD¼PS 471J
R26	Carbon film 270	RD¼PS 271J
R27	Carbon film 18k	RD¼PS 183J
R28	Carbon film 1.5k	RD¼PS 152J
R29	Carbon film 2.7k	RD¼PS 272J
R30	Carbon film 1k	RD¼PS 102J
R31	Carbon film 6.8k	RD¼PS 682J
R32	Carbon film 8.2k	RD¼PS 822J
R33	Carbon film 100	RD¼PS 101J
R34	Carbon film 39k	RD¼PS 393J
R35	Carbon film 100	RD¼PS 101J
R36	Carbon film 10k	RD¼PS 103J
R37	Carbon film 33k	RD¼VS 333J
R38	Carbon film 8.2k	RD¼PS 822J
R39	Carbon film 3.3k	RD¼PS 332J
R40	Carbon film 3.9k	RD¼PS 392J
R41	Carbon film 1k	RD¼PS 102J
R42	Carbon film 220k	RD¼PS 224J
R43	Carbon film 4.7k	RD¼PS 472J
R44	Carbon film 820	RD¼PS 821J
R45	Carbon film 18	RD¼PS 180J
R47	Carbon film 8.2k	RD¼PS 822J
R48	Carbon film 4.7k	RD¼PS 472J
R49	Carbon film 2.2k	RD¼PS 222J
R50	Carbon film 220k	RD¼PS 224J
R51	Carbon film 2.2k	RD¼PS 222J
R52	Carbon film 8.2k	RD¼PS 822J

Symbol	Description	Part No.
R53	Carbon film 1k	RD¼PS 102J
R54	Carbon film 3.3k	RD¼PS 332J
R55	Carbon film 33k	RD¼PS 333J
R56	Carbon film 1.5k	RD¼PS 152J
R57	Carbon film 1.5k	RD¼PS 152J
R58	Carbon film 2.7k	RD¼PS 272J
R59	Carbon film 270k	RD¼PS 274J
R60	Carbon film 47k	RD¼PS 473J
R61	Carbon film 100	RD¼PS 101J
R62	Carbon film 47	RD¼PS 470J
R63	Carbon film 47k	RD¼PS 473J
R64	Carbon film 150k	RD¼PS 154J
R65	Carbon film 1.5k	RD¼PS 152J
R66	Carbon film 220	RD¼PS 221J
R67	Carbon film 1.5k	RD¼PS 152J
R70	Carbon film 4.7k	RD¼PS 472J
R71	Carbon film 100	RD¼PS 101J
R72	Carbon film 33k	RD¼PS 333J
R73	Carbon film 33k	RD¼PS 333J
R74	Carbon film 33k	RD¼PS 333J
R75	Carbon film 33k	RD¼PS 333J
R76	Carbon film 3.3k	RD¼PS 332J
R77	Carbon film 3.3k	RD¼PS 332J
R78	Carbon film 3.3k	RD¼PS 332J
R79	Carbon film 3.3k	RD¼PS 332J
R80	Carbon film 4.7k	RD¼PS 472J
R81	Carbon film 4.7k	RD¼PS 472J
R82	Carbon film 100	RD¼VS 101J
R83	Carbon film 470	RD¼PS 471J
R84	Carbon film 10k	RD¼VS 103J
R85	Carbon film 10k	RD¼VS 103J
VR1	Semi-fixed 330-B	C92-065-A

SEMICONDUCTORS

Symbol	Description	Part No.
Q1	FET 2SK19-Y	
Q2	Transistor 2SC763-D or C	
Q3	Transistor 2SC763-D or C	
Q4	Transistor 2SC738-D	
Q5	Transistor 2SC710R-D or R, C	
Q6	Transistor 2SC738-D	
Q7	Transistor 2SC738-D or C	
Q8	Transistor 2SC710-D or R, D	
Q9	Transistor 2SC711-F	
Q10	Transistor 2SC711-E or F	
Q11	Transistor 2SC711-E or F	
Q12	Transistor 2SC711-F	

Symbol	Description	Part No.
D2	Diode 1S188FM-1	
D3	Diode 1S188FM-1	
D4	Diode 1S188FM-1	
D5	Diode 1S188FM-1	
D6	Diode 1S188FM-1	
D7	Diode 1S188FM-1	
D8	Diode 1S188FM-1	
D9	Diode 1S188FM-1	
D10	Diode 1S188FM-1	
D11	Diode 1S188FM-1	
D12	Diode 1S188FM-1	
D13	Diode 1S188FM-1	
D14	Diode 1S188FM-1	
D15	Diode 1S188FM-1	
D16	Diode 1S188FM-1	
D17	Diode 1S188FM-1	
D18	Diode 1S188FM-1	

COILS AND TRANSFORMERS

Symbol	Description	Part No.
T1	FM antenna coil	ATC-002-0
T2	FM RF coil	ATC-004-0
T3	FM OSC coil	ATC-003-0
T4	FM IF transformer	T73-034-0
T5	FM IF transformer	T73-035-A
T6	FM IF transformer	T73-036-0
T7	FM IF transformer	T74-011-0
T8	AM OSC coil	ATB-001-A
T9	AM IF transformer	T71-028-0
T10	AM IF transformer	T71-028-0
T11	AM IF transformer	T72-022-0
T12	SCA filter	ATM-006-0
T13	19kHz transformer	ATM-016-0
T14	19kHz transformer	ATM-017-0
T15	38kHz transformer	ATM-018-0
T16	38kHz leak filter	ATM-004-0
T17	38kHz leak filter	ATM-004-0
T18	SCA filter	ATM-007-0
L1	RF choke coil	T24-028-A
L2	RF choke coil	T24-028-A
L3	RF choke coil	T24-028-A
L5	Choke coil	T75-006-B

12. PACKING METHOD AND PARTS LIST

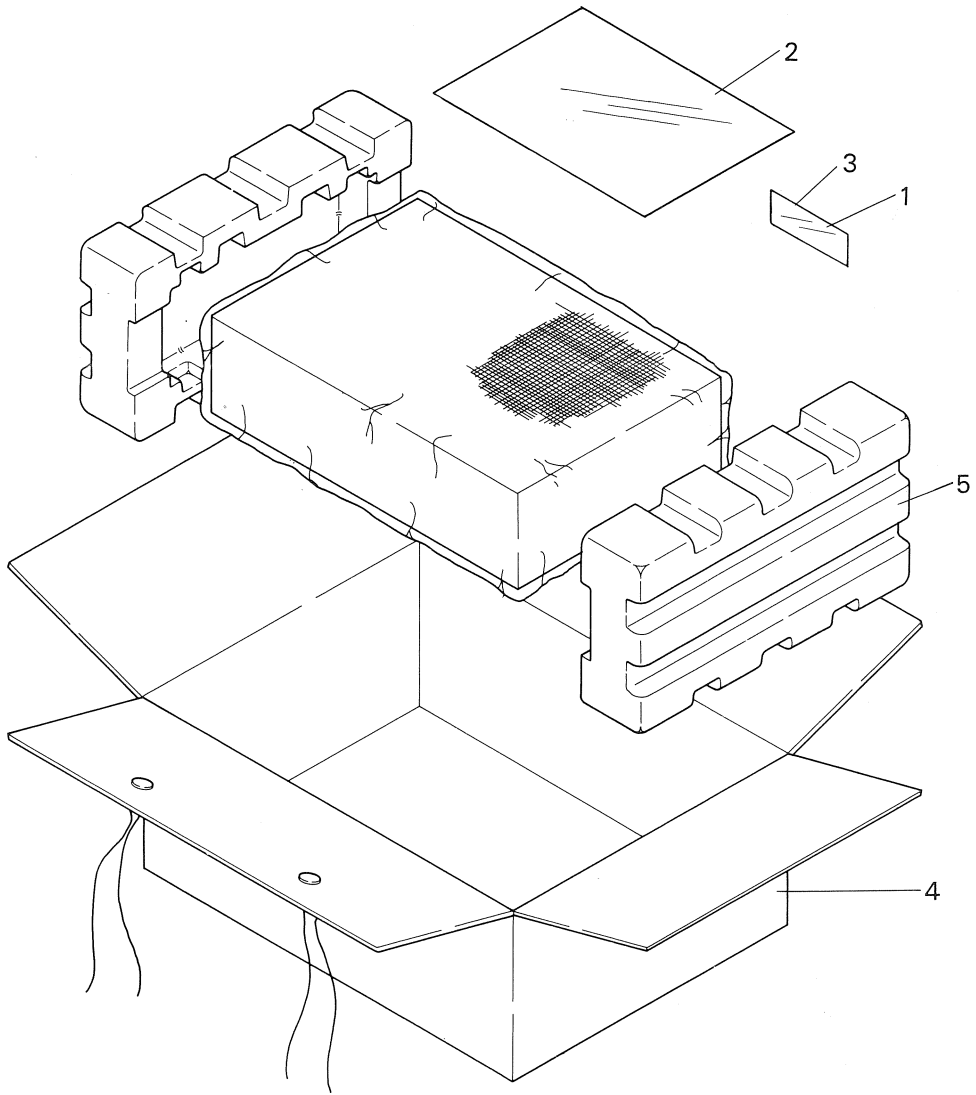

Key No.	Description	Part No.	
1	FM T-type antenna	D52-013-0	
2	Operating instructions	ARB-090-0	NBW model
	Operating instructions	ARB-091-0	FVW model
	Operating instructions	ARB-092-0	KUW, KCW models
3	Fuse 0,5A (AC power)	E21-007-0	FVW model
	Fuse 1A (Protection)	E21-034-A	FVW model
	Fuse 2A (Protection)	AEK-017-0	NBW model
4	Packing case	AHD-192-0	NBW model
	Packing case	AHD-193-0	FVW model
	Packing case	AHD-196-0	KUW model
	Packing case	AHD-197-0	KCW model
5	Side pad	AHA-037-0	

UKW-ABSTIMMUNG

Benötigte Geräte

- UKW-Meßoszillator
 - UKW-Ablenkungsoszillator: Ruheträgerfrequenz 10,7 MHz
 - Oszilloskop
 - Wechselstrom-Röhrenvoltmeter
1. Den Funktionshebel auf FM MONO drehen.
 2. Die Ausgangsleitungen des UKW-Meßoszillators mit den UKW-Antennenanschlüssen verbinden.
 3. Den UKW-Meßoszillator auf Modulation 400 Hz, 30% und Ausgangsniveau 15 dB bei Frequenz 87,4 MHz bringen; auch ist der Abstimmknopf in die untere Position (linke Seite) zu bringen.
 4. Röhrenvoltmeter und Oszilloskop (parallel) mit Anschluß TAPE REC verbinden.
 5. Ausgangsniveau am Röhrenvoltmeter beobachten und die folgenden Leiter auf maximale Ablesung am Meter einstellen:
 - T3 Oszillator-Schaltkreis
 - T1 Antennenschaltkreis
 - T2 HF-Abstimmkreis

6. Frequenz von UKW-Meßoszillator und Abstimmknopf auf 106 MHz einstellen.
7. Es ist wie folgt einzustellen:
 - Trimmer-Kondensator CT 3 Oszillator-Schaltkreis
 - Trimmer-Kondensator CT1 Antennenschaltkreis
 - Trimmer-Kondensator CT2 HF-Abstimmkreis
8. Stufen (5) bis (7) sind mehrmals zu wiederholen.
9. Das Ausgangsniveau des UKW-Meßoszillators ist auf maximale Meßgerät-Ablenkung einzustellen.

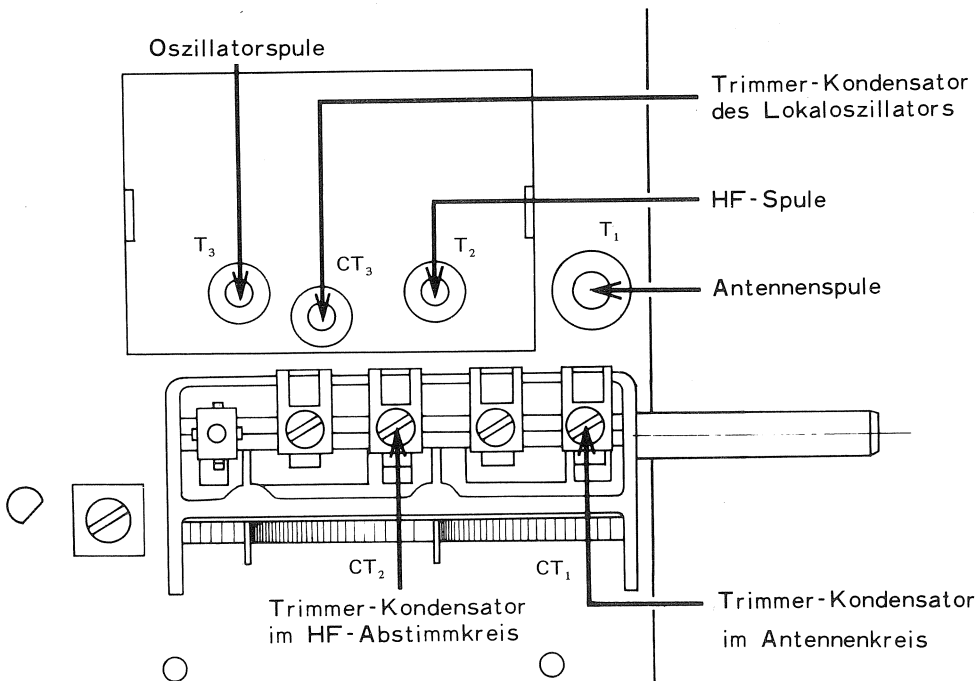

PIONEER ELECTRONIC CORPORATION

15-5, 4-Chome, Ohmori-nishi, Ohra-ku, Tokyo, Japan

U.S. PIONEER ELECTRONICS CORPORATION

178 Commerce Road, Carlstadt, New Jersey 07072 U.S.A.

PIONEER ELECTRONIC (EUROPE) N.V.

Meir-center, Meir 21, 2000 Antwerp, Belgium

© SEPT. 1973

Printed in Japan