

Service Manual

**CIRCUIT DESCRIPTIONS
REPAIR & ADJUSTMENTS**



**ORDER NO.
ARP-232-0**

AM/FM STEREO RECEIVER

SX-303

MODEL SX-303 (SX-303L) COMES IN FIVE VERSIONS DISTINGUISHED AS FOLLOWS:

Model	Voltage	Remarks
SX-303/KU	AC120V only	U.S.A. model
SX-303/KC	AC120V only	Canada model
SX-303/S	AC110V, 120V, 220V and 240V (switchable)	General export model
SX-303L/HE	AC220V only	European continent model with AM-LW band tuner
SX-303L/HEZ	AC220V only	West germany model with AM-LW band tuner

- This service manual is applicable to the KU types. For servicing of the other types, please refer to the additional service manual.
- Ce manuel d'instruction se réfère au mode de réglage, en français.
- Este manual de servicio trata del método de ajuste escrito en español.

CONTENTS

1. SPECIFICATIONS	2	8. P.C. BOARDS CONNECTION DIAGRAM	12
2. FRONT PANEL FACILITIES	3	9. SCHEMATIC DIAGRAM	15
3. PARTS LOCATION	4	10. ELECTRICAL PARTS LIST	17
4. BLOCK DIAGRAM	5	11. DIAL CORD STRINGING	19
5. CIRCUIT DESCRIPTIONS	6	12. ADJUSTMENTS	20
6. PACKING	8	RÉGLAGE	22
7. EXPLODED VIEW AND PARTS LIST	9	AJUSTE	24

1. SPECIFICATIONS

Amplifier Section

Continuous Average Power Output is 45 watts* per channel, min., at 8 ohms from 40Hertz to 20,000Hertz with no more than 0.3% total harmonic distortion.

- Total Harmonic Distortion (40 Hertz to 20,000 Hertz, 8 ohms, from TAPE)
 - continuous rated power output
 - No more than 0.3%
 - 22.5 watts per channel power output
 - No more than 0.15%
 - 1 watt per channel power output
 - No more than 0.2%
 - Intermodulation Distortion (50 Hertz: 7,000 Hertz = 4 : 1, 8 ohms, from AUX)
 - continuous rated power output
 - No more than 0.3%
 - Damping Factor (1 kHz, 8 ohms) 22
 - Input (Sensitivity/Impedance)
 - PHONO 2.5 mV/50 kilohms
 - TAPE PLAY 150 mV/50 kilohms
 - Phono Overload Level (T.H.D.0.1%, 1,000Hz)
 - PHONO 150 mV
 - Output Level
 - TAPE REC 150 mV
 - SPEAKER A, B, A series B, off
 - Frequency Response
 - PHONO (RIAA Equalization)
 - 30Hz to 20,000Hz±0.5dB
 - TAPE PLAY 15Hz to 50,000Hz ⁺¹/₋₃ dB
 - Tone Control
 - BASS ±9dB (100Hz)
 - TREBLE ±9dB (10kHz)
 - Loudness Contour (Volum control set at -40dB position)
 - +8dB (100Hz), +6dB (10,000Hz)
 - Hum and Noise (IHF, short circuited, A network)
 - PHONO MM 71dB
 - TAPE PLAY 97dB

FM Tuner Section**

- Usable Sensitivity 10.7dBf (0.9µV)
- 50dB Quieting Sensitivity
 - MONO 15.3dBf (1.6µV)
 - STEREO 37.6dBf (21µV)
- Signal-to-Noise Ratio
 - MONO 75dB (at 85dBf)
 - STEREO 70dB (at 85dBf)
- Distortion (at 65dBf)
 - MONO 1kHz 0.3%
 - STEREO 1kHz 0.6%

- Capture Ratio 2.5dB
- Alternate Channel Selectivity (400kHz) 50dB
- Stereo Separation (1kHz) 35dB
- Frequency Response 30Hz to 15kHz, ^{+0.5}/_{-1.0} dB
- Spurious Response Ratio 70dB
- Image Response Ratio 45dB
- IF Response Ratio 100dB
- AM Suppression Ratio 45dB
- Subcarrier Product Ratio 31dB
- Muting Threshold 27dBf (6.3µV)
- Antenna Input
 - 300 ohms balanced, 75 ohms unbalanced

AM Tuner Section

- Sensitivity
 - IHF, Loop antenna 320µV/m
 - IHF, Ext. antenna 30µV
- Selectivity 25dB
- Signal-to-Noise Ratio 43dB
- Image Response Ratio 40dB
- IF Response Ratio 45dB
- Antenna AM Loop Antenna

Miscellaneous

- Power Requirements AC 120 V, 60Hz
- Power Consumption ... 190 Watts(UL), 225 VA(CSA)
- Dimensions 420 (W) x 98 (H) x 214 (D) mm
16-9/16(W) X 3-7/8(H) X 8-7/16(D) in
- Weight (without package)5 kg (11 lb)

Furnished Parts

- FM T-type Antenna 1
- AM Loop Antenna 1
- Operating Instructions 1

*Measured pursuant to the Federal Trade Commission's Trade Regulation rule on Power Output Claims for Amplifier.



**FM muting functions with this unit when the signals are weak. The unit's internal wires are therefore treated so that the signals are not muted when the sensitivity is measured.

NOTE:
Specifications and design subject to possible modification without notice.

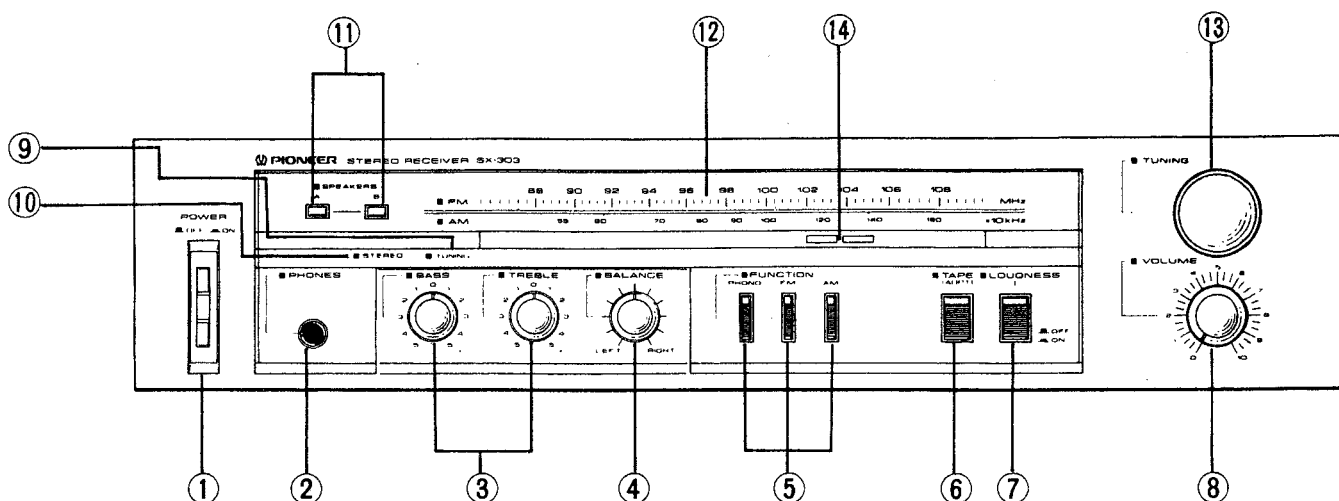
2. FRONT PANEL FACILITIES



① POWER SWITCH

Push this to switch on and off the unit's power. Power is supplied at the depressed () switch position (ON) and turned off at the released () position (OFF).

② HEADPHONE JACK

Connect the plug on the stereo headphones to this jack when listening to sound through headphones.

③ TONE CONTROLS

BASS : The bass is increased when this control is rotated clockwise from the center position and reduced when rotated counterclockwise.

TREBLE : The treble is increased when this control is rotated clockwise from the center position and reduced when rotated counterclockwise.

④ BALANCE CONTROL

This is normally kept at its center position. It is rotated when the volume of sound delivered through the left and right channels of the speakers or headphones differs.

The right channel volume is reduced when the control is rotated toward the LEFT from the center position while the left channel volume is reduced when it is rotated toward the RIGHT.

⑤ FUNCTION SWITCHES

PHONO : Press when listening to records.

FM : Press when listening to FM broadcasts.

AM : Press when listening to AM broadcasts.

⑥ TAPE (ADPT) SWITCH

This is depressed when using a tape deck or adaptor unit connected to the rear panel TAPE/ADAPTOR jacks.

⑦ LOUDNESS SWITCH

Depress this switch to the ON position when listening to sound at a low level of volume. This will enhance the bass and treble and give more life to the sound even at a low volume.

⑧ VOLUME CONTROL

Use this to adjust the volume of the sound delivered through the speakers or headphones.

The volume is increased when this control is rotated clockwise from the minimum "0" position.

⑨ TUNING INDICATOR (TUNING)

This lights up to indicate that an FM, AM station has been tuned in.

⑩ STEREO INDICATOR (STEREO)

This lights up automatically when an FM station broadcasting in stereo has been tuned in.

⑪ SPEAKERS SWITCHES

These are used to select the speakers through which you will listen to the sound.

The selected speakers are now working.

A: The sound is heard from the speakers connected to the speaker A terminals on the rear panel.

B: The sound is heard from the speakers connected to the speaker B terminals on the rear panel.

No sound will be heard when SPEAKERS A and B switches are both released. This is the position at which the sound can be heard through the headphones.

NOTE:

No sound will be heard through the speakers when both the A and B switches are depressed if only one set of speakers has been connected to either the A or B SPEAKERS terminals.

⑫ FREQUENCY SCALE

This indicates the frequency of the broadcasting station (FM, AM).

The top level figures (88 ~ 108) indicate the FM band.

The bottom level figures (55 ~ 160) indicate the AM band.

⑬ TUNING KNOB

Rotate this knob to pick up stations (FM, AM).

⑭ POWER INDICATOR

3. PARTS LOCATION

NOTES:

- Parts without part number cannot be supplied.
- The \triangle mark found on some component parts indicates the importance of the safety factor of the part. Therefore, when replacing, be sure to use parts of identical designation.
- For your Parts Stock Control, the fast moving items are indicated with the marks **★★** and **★**.
★★ GENERALLY MOVES FASTER THAN ★.
 This classification shall be adjusted by each distributor because it depends on model number, temperature, humidity, etc.

Front Panel View

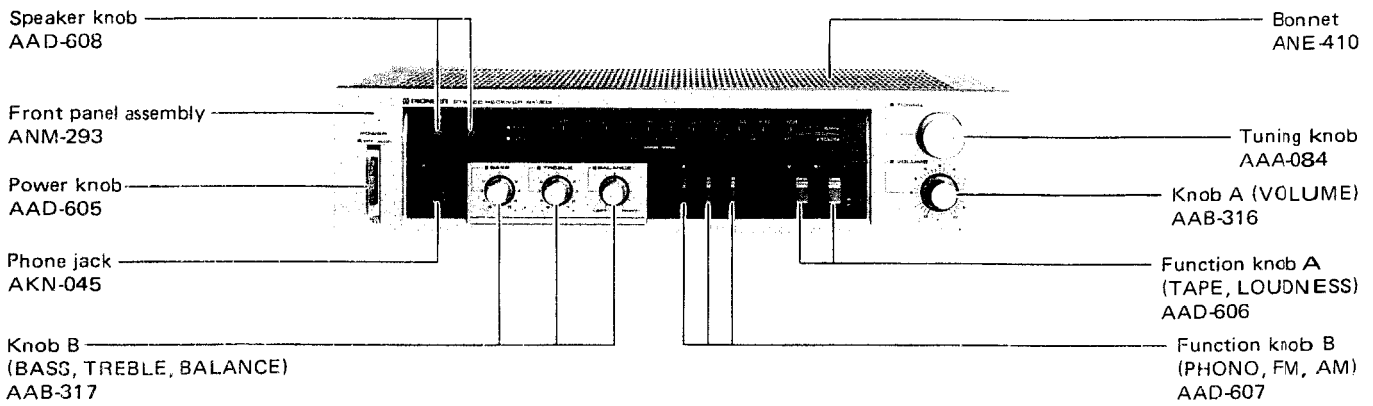

Rear Panel View

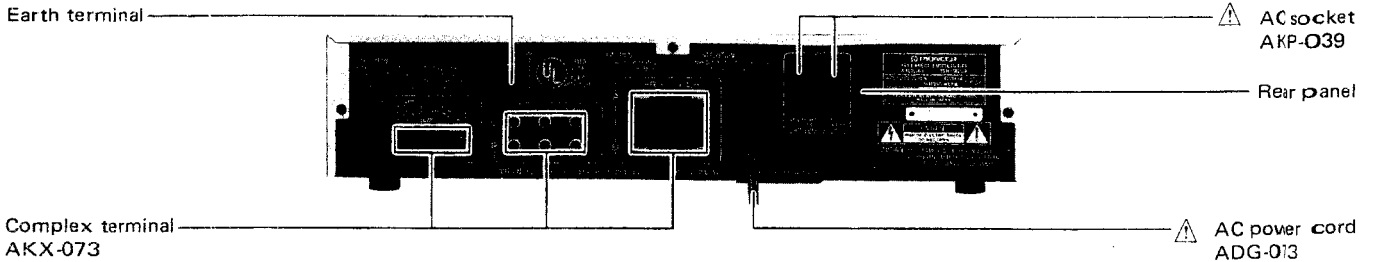

Top View

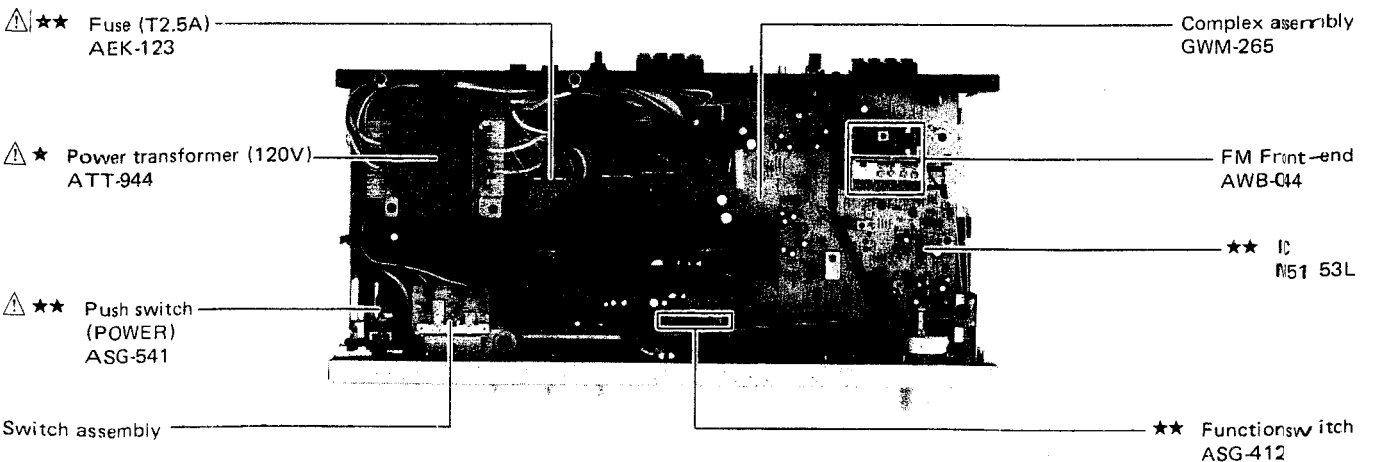

4. BLOCK DIAGRAM

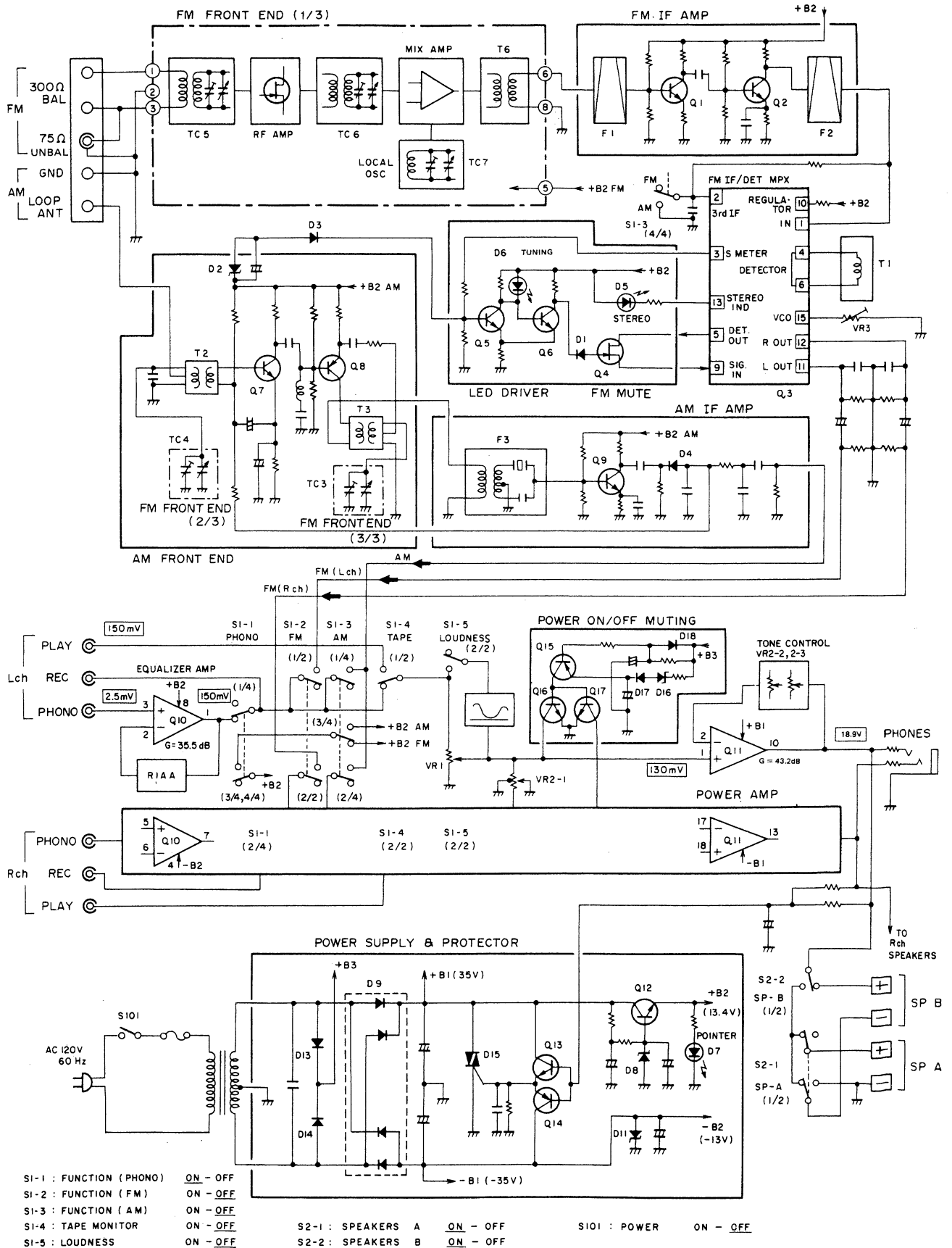

5. CIRCUIT DESCRIPTIONS

FM Front End

A unitized variable capacitor type front end unit is used consisting of an FET RF single stage amp, local oscillator/mixer IC and an IF transformer.

FM IF Amp, Detector and MPX Circuit

A 2-transistor IF amp with ceramic filter is used and the next stage has an IC (M51533L) containing the FM IF detector and MPX circuit. The block diagram of IC M51533L is shown in Fig. 5-1. This IC uses a peak detection method which can be adjusted with a single coil. The PLL method is employed to reconstitute the 38kHz sub-carrier for the MPX circuit.

The IF signal is input at pin 1 and the detection output is obtained from pin 5. The detection output passes through the muting Q4, goes to pin 9, passes through the MPX circuit and the stereo signals are obtained from pins 11 and 12. In addition, this unit detects the presence or absence

of a pilot signal to automatically switch between stereo and mono reception by R14 which is connected to pin 14. When a stereo signal is received, pin 13 drops to the low level to light the stereo indicator. When pin 2 is grounded, the PLL VCO and FM IF operation stop (for AM).

FM Muting and LED Driver

With this unit, muting is automatically activated when the antenna input drops below $10\mu\text{V}$. As the antenna input decreases, the voltage at pin 3 drops, Q5 is turned off and Q6 is turned on. As a result, the gate voltage of Q4 drops, Q4 is turned off and the detector output circuit is blocked (Fig. 5-1). When an FM or AM station is tuned in, the base potential of Q5 is raised, Q5 is turned on and the tuning indicator lights.

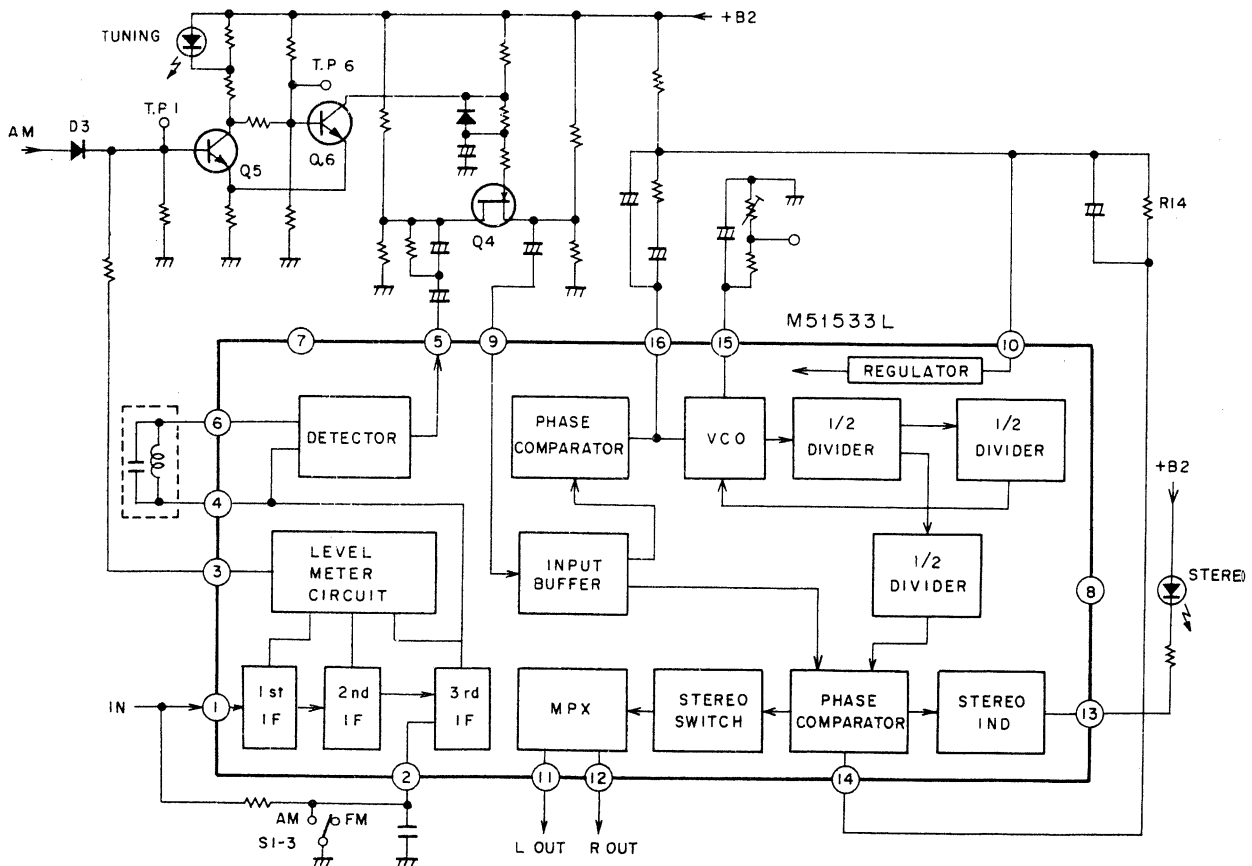

Fig. 5-1 FM IF, Detector and MPX circuit

AM Tuner

This uses a variable capacitor type tuning circuit composed of three transistors, a 2-transistor front end and a single transistor AM IF detector.

AF Section

The equalizer circuit has a low-noise operation amp (2 channel) M5218P.

The power amp has a 45 watt output power IC STK4141-2S (See Fig. 5-4).

The tone control circuit is placed in the negative feedback loop of the power amp.

Protective Circuits

This unit has a circuit to detect DC voltages at the power amp outputs and a muting circuit that operates when power is turned on and off.

Fig. 5-2 shows the construction of the DC voltage protection circuit. When a DC voltage

appears at the power amp output, either Q13 (plus) or Q14 (minus) is activated depending on the polarity of the DC voltage and a trigger is applied to D15. This turns on D15, +B1 is shorted, the fuse on the primary side is cut and the power supply circuit is shut off.

Fig. 5-3 shows the power on/off muting circuit. Time constant t_1 is longer than t_2 so that immediately after the power is turned on, the emitter potential of Q15 exceeds its base potential, Q15 is turned on to activate Q16 and Q17 and ground the signal. A few seconds later, the base potential of Q15 rises to turn off Q15 along with Q16 and Q17.

When the power is turned off, the charge of C161 passes through D18; it is almost completely discharged in an instant to make the base potential of Q15 zero. However, because the charge of C160 remains, Q15 is turned on and muting is activated in the same manner as when power is turned on.

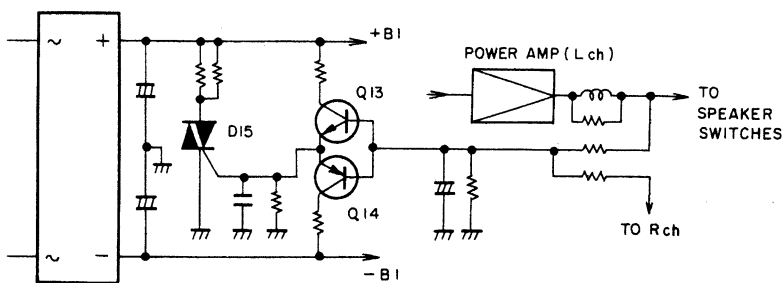

Fig. 5-2 DC Voltage protection circuit

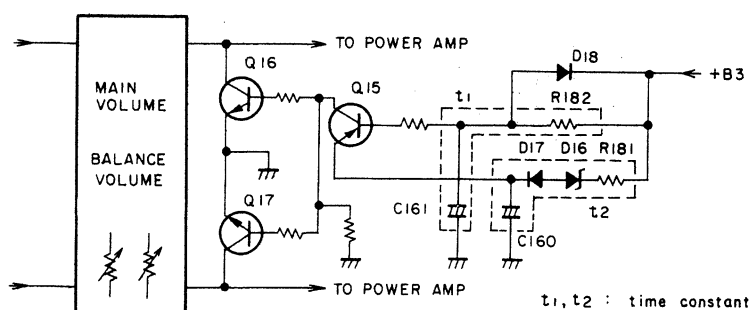

Fig. 5-3 Power ON/OFF muting circuit

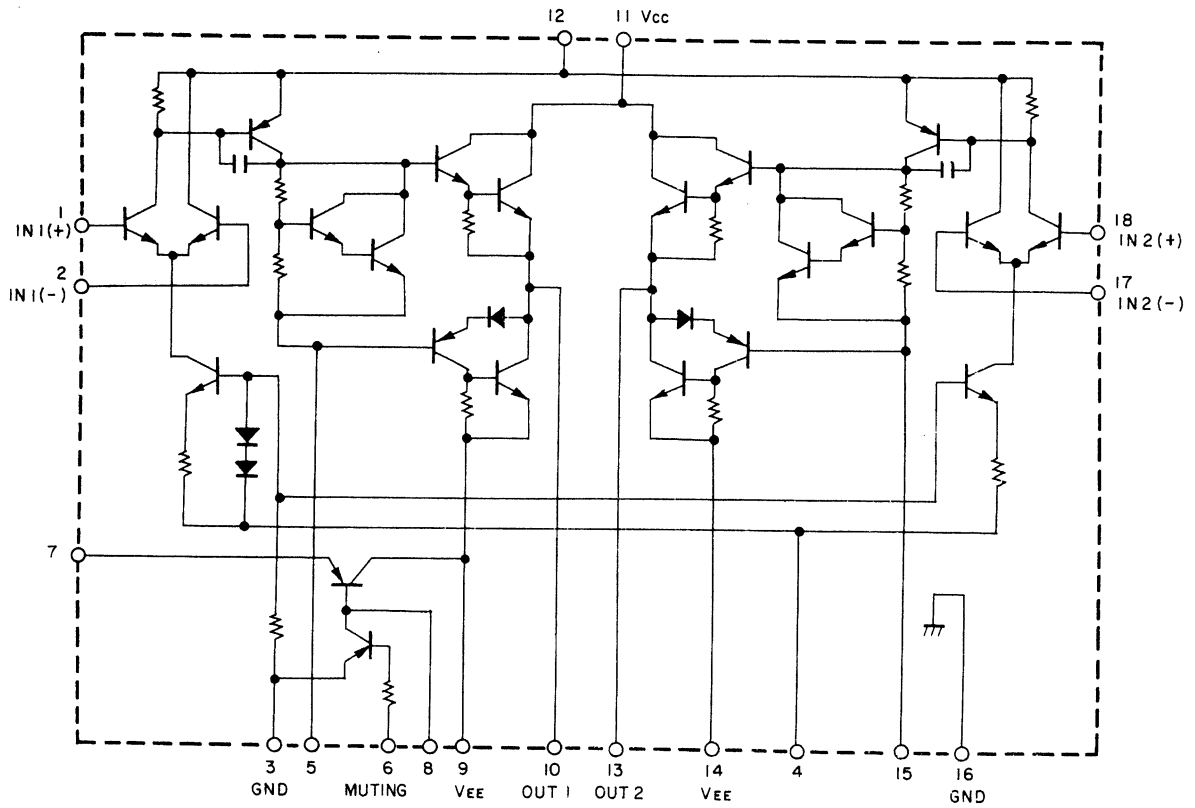
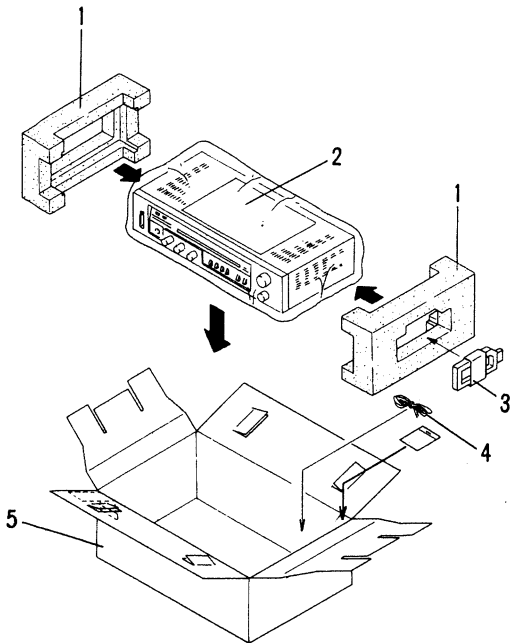

Fig. 5-4 Equivalent circuit of power IC

6. PACKING



Mark	No.	Part No.	Description
	1.	AHA-335	Side pad
	2.	ARB-526	Operating instructions (English)
	3.	ATB-076	Loop antenna assembly
	4.	ADH-005	T-type antenna
	5.	AHE-107	Packing case

7. EXPLODED VIEW AND PARTS LIST

NOTES:

- Parts without part number cannot be supplied.
- The Δ mark found on some component parts indicates the importance of the safety factor of the part. Therefore, when replacing, be sure to use parts of identical designation.
- For your Parts Stock Control, the fast moving items are indicated with the marks **★★** and **★**.
★★ GENERALLY MOVES FASTER THAN ★.
 This classification shall be adjusted by each distributor because it depends on model number, temperature, humidity, etc.

Mark	No.	Part No.	Description	Mark	No.	Part No.	Descriptions
	1.	ANE-410	Bonnet		50.		Speaker switch assembly
	2.	BBZ30P080FZK	Screw (3 x 8)		51.		Switch holder
Δ ★	3.	ATT-944	Power transformer (120V)		52.		Pully assembly
	4.	PMZ30P060FMC	Screw (3 x 6)		53.		LED assembly
	5.	AAD-608	Speaker knob		54.		Earth
	6.	VMZ30P060FMC	Screw (3 x 6)		55.		Mounting plate
	7.	NK90FUC	Nut		56.		Pully assembly
	8.	AAB-317	Knob B (BASS, TREBLE, BALANCE)		57.		Pully assembly
	9.	NK70FUC	Nut		58.		Pully holder
	10.	AAA-084	Tuning knob		59.		Headphone jack assembly
	11.	AAB-316	Knob A (VOLUME)		60.		Chassis
	12.	ANM-293	Front panel assembly		61.		Bottom Plate
	13.	AAD-607	Function knob B (PHONO, FM, AM)		62.		Binder
	14.	AAD-606	Function knob A (TAPE, LOUDNESS)		63.		Earth terminal
Δ ★★	15.	ASG-541	Push switch (POWER)		64.		Rear panel
	16.	AAD-605	Power knob		65.		Tuning drum
	17.	AEC-784	Cabinet bumper		66.		Smoother
	18.	AXA-373	Tuning shaft		67.		Pointer holder
	19.	AEC-471	Nylon rivet		68.		Pointer assembly
	20.	MTZ30P100FZK	Screw (3 x 10)		69.		Heat sink
Δ ★★	21.	AEK-123	Fuse (T2.5A)		70.		Wire holder
Δ	22.	AKP-039	AC socket				
Δ	23.	ADG-073	AC power cord				
Δ	24.	GWM-265	Complex assembly				
	25.	AKN-045	Phone Jack (PHONES)				
★★	26.	SUJ8LYXS	Speaker switch				
Δ	27.	ACG-017	Ceramic (0.01)				
	28.	BBT30P080FZK	Screw (3 x 8)				

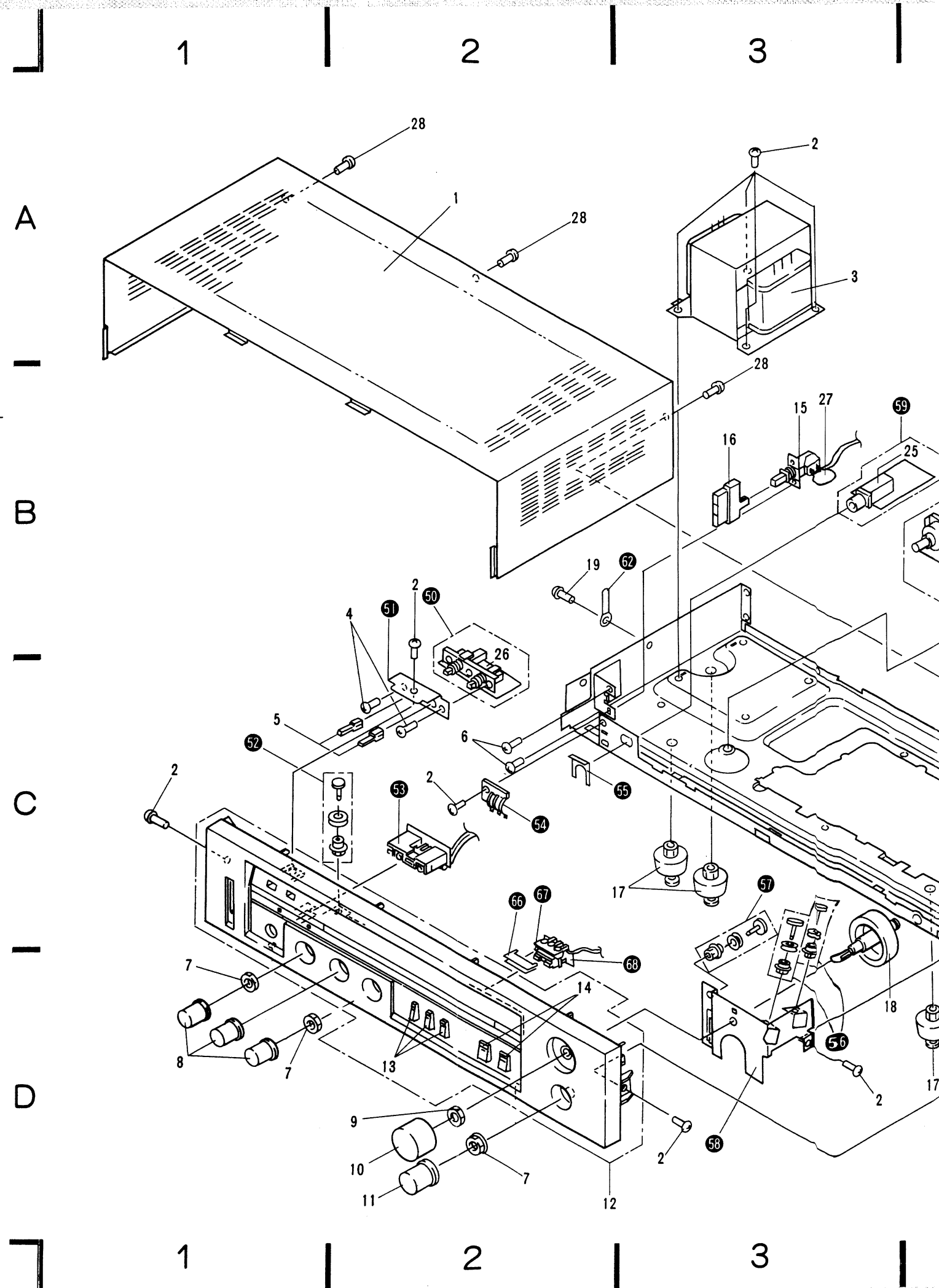

ence of the
of identical
the marks
is on model

n assembly

k assembly

ly

A

B

C

D

A

B

C

D

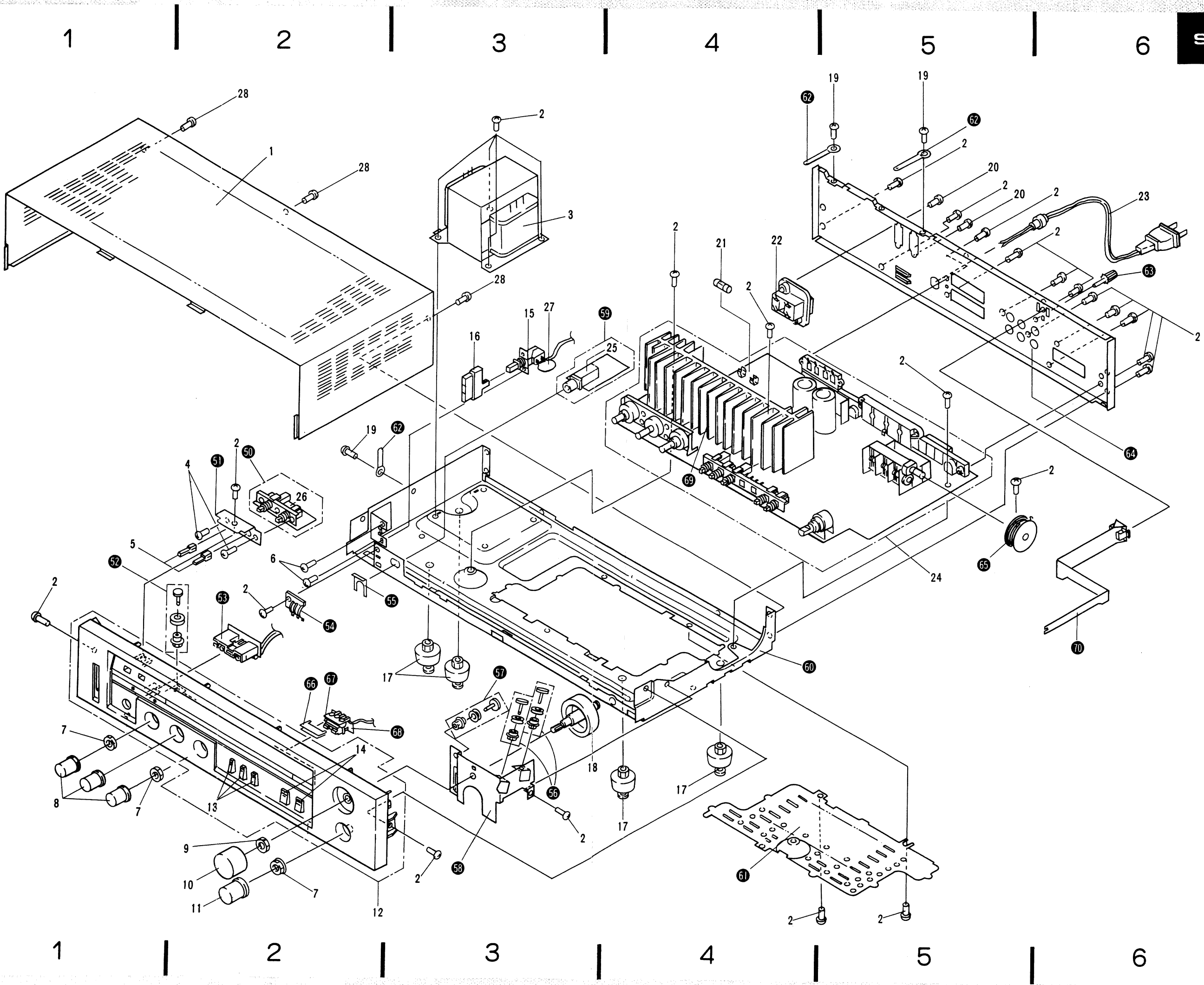

8. P.C. BOARDS CONNECTION DIAGRAM

External Appearances of Transistors and IC's

A

2SA 726S

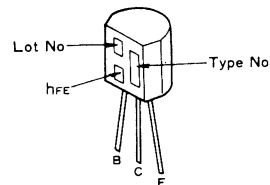

2SC1923

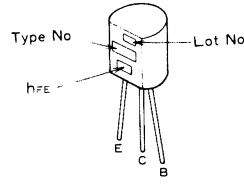

2SK 34

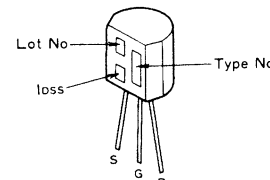

2SC 461

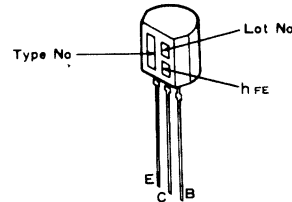

B

2SD 880
2SD 313

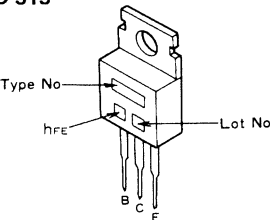

2SA1115
2SC2603

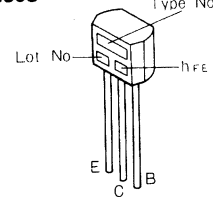

C

JA101
JC501

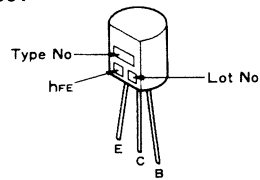

STK4171-2S

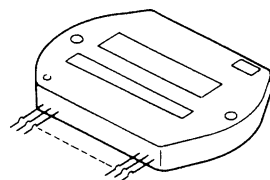

2SA 992

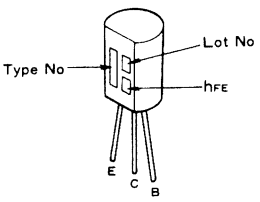

M51533L

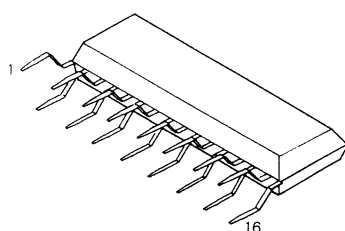

D

2SK 246

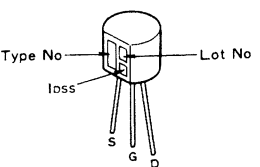

M5218P
NJM4558DX

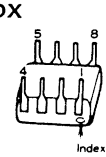

COMPLEX Ass'y GWM-265

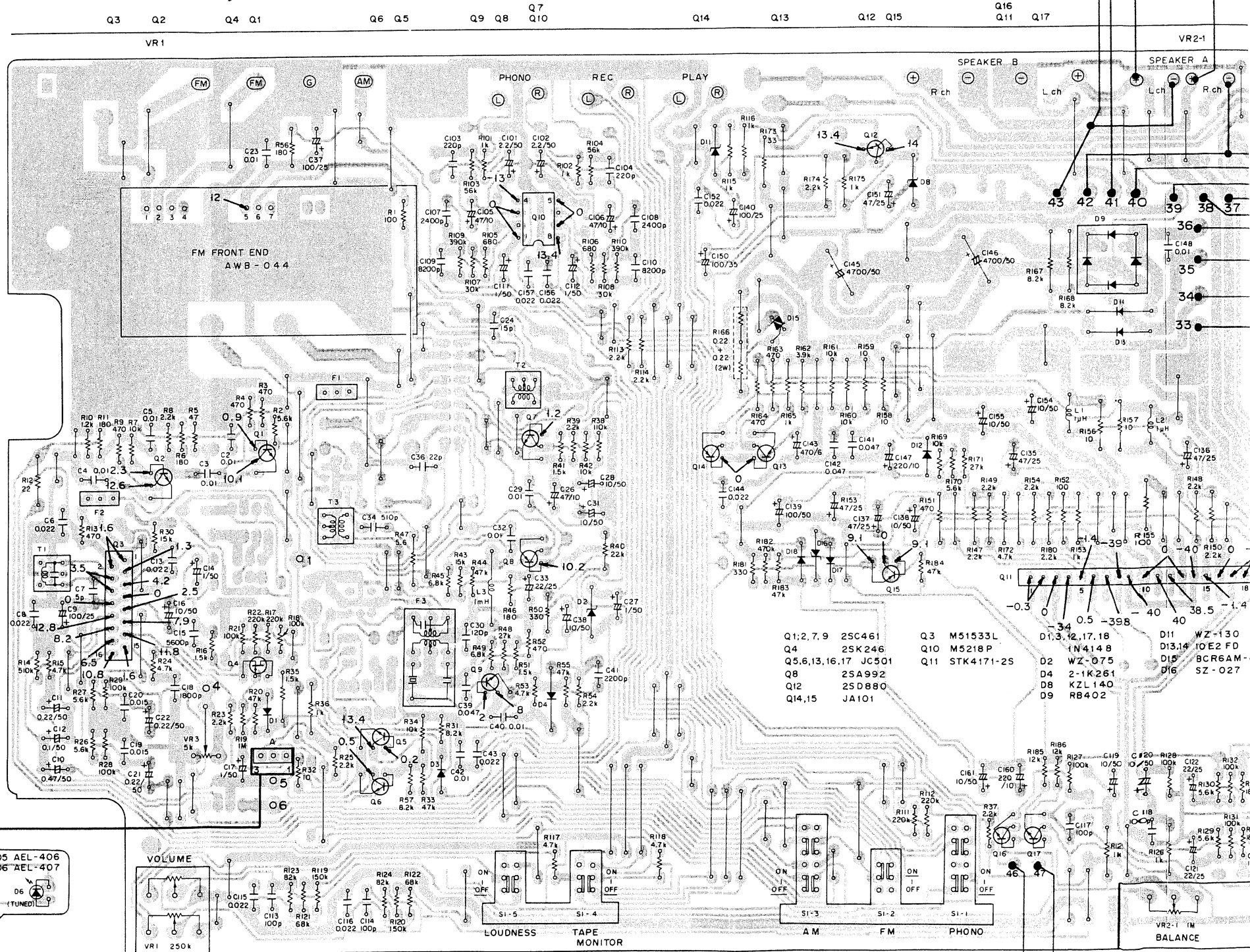

Q1, 2, 7, 9	2SC461	Q3	M51533L	D1, 3, 12, 17, 18	WZ-130
Q4	2SK 246	Q10	M5218P	D2	1N4148
Q5, 6, 13, 16, 17	JC501	Q11	STK4171-2S	D3, 14	10E2 FD
Q8	2SA992			D4	2-1K261
Q12	2SD880			D8	KZL 140
Q14, 15	JA101			D9	RB402

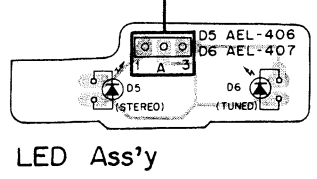

4

5

6

7

8

9

NOTE:
 The indicated semiconductors are representative ones only. Other alternative semiconductors may be used and are listed in the parts list.

X Ass'y GWM-265

2 Q4 Q1 Q6 Q5 Q9 Q8 Q7 Q10 Q14 Q13 Q12 Q15 Q16 Q11 Q17

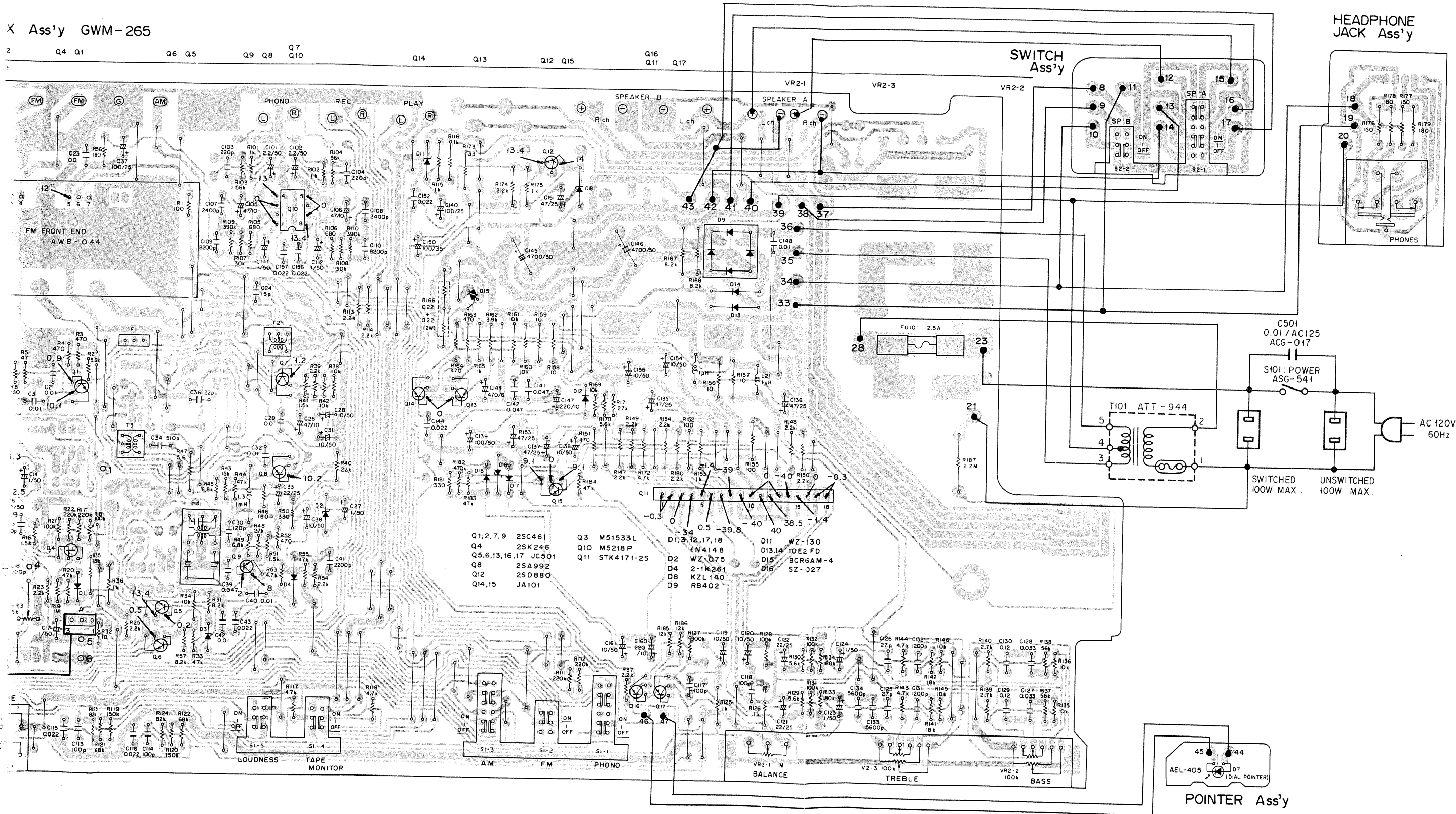

Q1, 2, 7, 9	25C461	Q3	M51533L	D1, 3, 12, 17, 18	WZ-130
Q4	25K246	Q10	M5218P	D13, 14	1N4148
Q5, 6, 13, 16, 17	JC501	Q11	STK4171-25	D2	WZ-075
Q8	25A992			D4	2-1K261
Q12	25D880			D8	KZL140
Q14, 15	JA101			D9	RB402

A

B

C

D

4

5

6

7

8

9

POINTER Ass'y

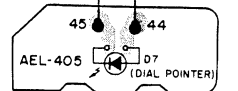

9. SCHEMATIC DIAGRAM

NOTE:
The indicated semiconductors are representative ones only. Other alternative semiconductors may be used and are listed in the parts list.

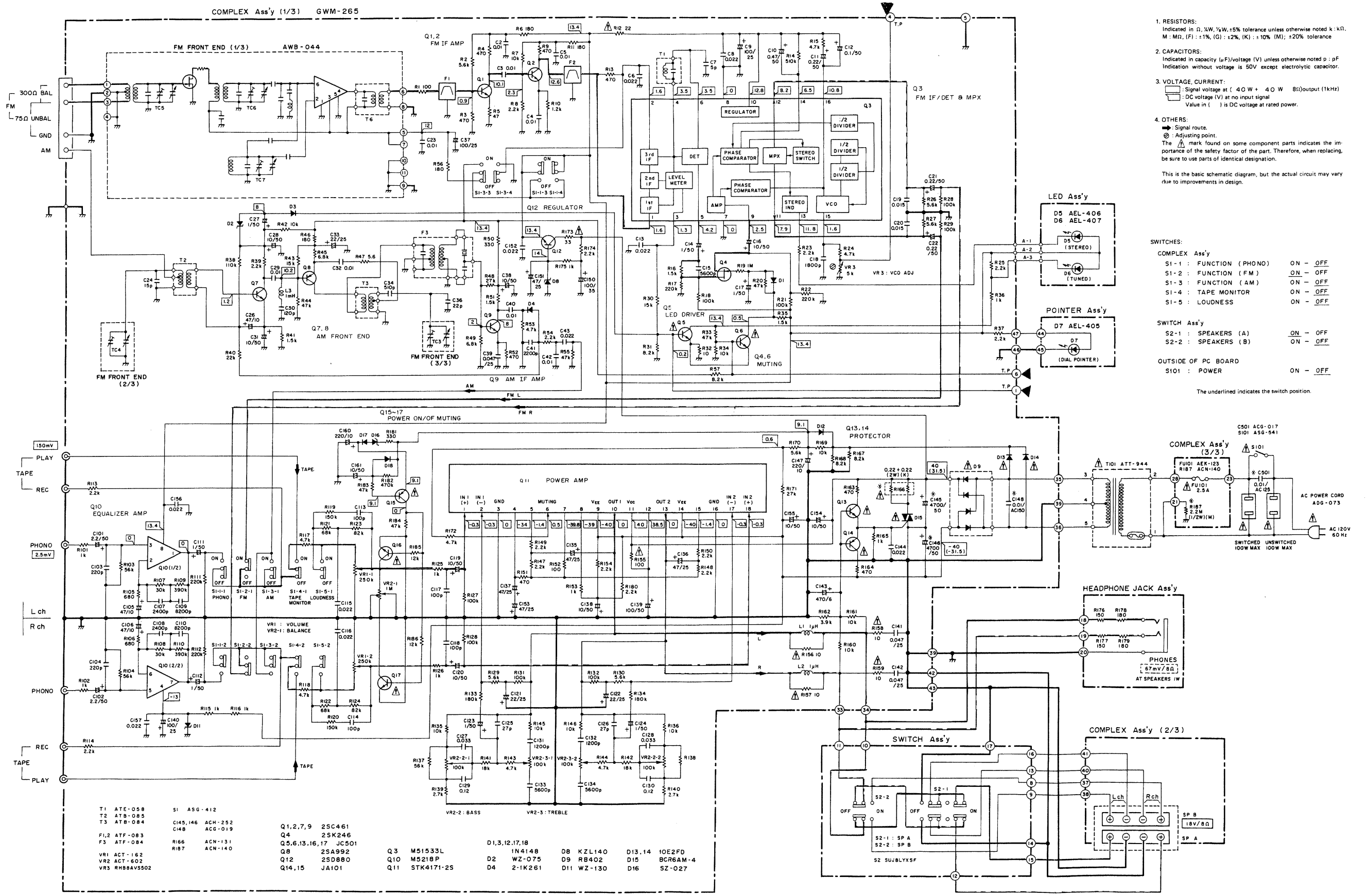

- 1. RESISTORS:**
Indicated in Ω, kΩ, MΩ, 1/2W, 1/4W, ±5% tolerance unless otherwise noted; k: kΩ.
M: MΩ, (F): ±1%, (G): ±2%, (K): ±10%, (M): ±20% tolerance
- 2. CAPACITORS:**
Indicated in capacity (μF)/voltage (V) unless otherwise noted; p: pF
Indication without voltage is 50V except electrolytic capacitor.
- 3. VOLTAGE, CURRENT:**
Signal voltage at (40W + 40W 8Ω) output (1kHz)
DC voltage (V) at no input signal
Value in () is DC voltage at rated power.
- 4. OTHERS:**
Signal route
Adjusting point
The mark found on some component parts indicates the importance of the safety factor of the part. Therefore, when replacing, be sure to use parts of identical designation.
- This is the basic schematic diagram, but the actual circuit may vary due to improvements in design.
- SWITCHES:**
COMPLEX Ass'y
S1-1: FUNCTION (PHONO) ON - OFF
S1-2: FUNCTION (FM) ON - OFF
S1-3: FUNCTION (AM) ON - OFF
S1-4: TAPE MONITOR ON - OFF
S1-5: LOUDNESS ON - OFF
- SWITCH Ass'y**
S2-1: SPEAKERS (A) ON - OFF
S2-2: SPEAKERS (B) ON - OFF
- OUTSIDE OF PC BOARD**
S101: POWER ON - OFF
- The underlined indicates the switch position.

- T1 ATE-058
T2 ATB-085
T3 ATB-084
- F1,2 ATF-083
F3 ATF-084
- VR1 ACT-162
VR2 ACT-602
VR3 RH8AV5502
- S1 ASG-412
C145,146 ACH-252
C148 ACG-019
- R166 ACN-131
R187 ACN-140
- Q1,2,7,9 25C461
Q4 25K246
Q5,6,13,16,17 JC501
Q8 25A992
Q12 25D880
Q14,15 JA101
- Q3 M51533L
Q10 M5218P
Q11 STK4171-25
- D1,3,12,17,18
D2 WZ-075
D4 2-1K261
- D8 KZL140
D9 RB402
D15 BC6AM-4
D16 SZ-027

10. ELECTRICAL PARTS LIST

NOTES:

• When ordering resistors, first convert resistance values into code form as shown in the following examples.

Ex. 1 When there are 2 effective digits (any digit apart from 0), such as 560 ohm and 47k ohm (tolerance is shown by J = 5%, and K = 10%).

560Ω 56 x 10¹ 561 RD4PS 561J

47kΩ 47 x 10³ 473 RD4PS 473J

0.5Ω 0R5 RN2H 0R5K

1Ω 010 RS1P 010K

Ex. 2 When there are 3 effective digits (such as in high precision metal film resistors).

5.62kΩ 562 x 100 5621 RN4SR 5621F

• The Δ mark found on some component parts indicates the importance of the safety factor of the part. Therefore, when replacing, be sure to use parts of identical designation.

• For your Parts Stock Control, the fast moving items are indicated with the marks **★★** and **★**.

★★ GENERALLY MOVES FASTER THAN ★.

This classification shall be adjusted by each distributor because it depends on model number, temperature, humidity, etc.

Miscellaneous Parts List

P.C. BOARD ASSEMBLIES

Mark	Part No.	Symbol & Description
	GWM-265	Complex assembly Headphone jack assembly LED assembly Pointer assembly Switch assembly

OTHERS

Mark	Part No.	Symbol & Description
Δ ★	ATT-944	T101 Power transformer (120V)
Δ ★★	ASG-541	S101 Push switch (POWER)
Δ	ACG-017	C501 Ceramic (0.01/AC125V)
Δ ★★	AEK-123	FU101 Fuse (T2.5A)
Δ	ADG-073	AC power cord
Δ	AKP-039	AC socket

Complex Assembly (GWM-265)

CAPACITORS

Mark	Part No.	Symbol & Description
	ACH-252	C145, C146 Electrolytic (4700/50V)
	CEA 101M 50L	C139
	CEA R22M 50L	C11, C21, C22
	CEA 0R1M 50L	C12
	CEA R47M 50L	C10
	CEA 010M 50L	C14, C17, C27, C111, C112, C123, C124
	CEA 100M 50L	C16, C28, C31, C38, C119, C120, C138, C154, C155, C161
	CEA 220M 25L	C33, C121, C122
	CEA 470M 10L	C26, C105, C106
	CEA 470M 25L	C135, C136, C137, C151, C153
	CEA 101M 25L	C9, C37, C140

Mark	Part No.	Symbol & Description
	CEA 101M 35L	C150
	CEA 221M 10L	C147, C160
	CEA 471M 6L	C143
	CEANL 2R2M 50	C101, C102
	CQMA 122K 50	C131, C132
	CQMA 562K 50	C15, C133, C134
	CQMA 153K 50	C19, C20
	CQMA 333K 50	C127, C128
	CQMA 242J 50	C107, C108
	CQMA 822J 50	C109, C110
	CQMLA 124K 50	C129, C130
	CQSA 182J 50	C18
	CQSA 511J50	C34
	CCDUJ 050C 50	C7
	CCDSL 270J 50	C125, C126
	CCDSL 121J 50	C30
	CCDSL 101J 50	C113, C114, C117, C118
	CCDSL 221J 50	C103, C104
	CCDCH 150J 50	C24
	CCDCH 220J 50	C36
	CKDYF 103Z 50	C2-C5, C23, C29, C32, C40, C42
	CKDYF 223Z 50	C6, C8, C13, C43, C115, C116, C144, C152, C156, C157
	CKDYX 473M 25	C39, C141, C142
	CKDYB 222K 50	C41
	ACG-019	C148 ceramic (0.01/150V)

RESISTORS

Note: When ordering resistors, convert the resistance value into code form, and then rewrite the part no. as before.

Mark	Part No.	Symbol & Description
★	ACT-162	VR1 Volume (250k)
★	ACT-602	VR2 Volume assembly (100kx2, 1M)
★	RHB8AVS502	VR3 Semi-fixed (5k)
Δ	ACN-131	R166 Wire-wound (0.22x2,2W)
Δ	ACN-140	R187 Carbon composition (2.2M, 1/2W)
Δ	RD4PMFL □□□	R12, R155-R159, R173
	RD4PM □□□	R35, R36, R115, R116, R147-R154, R160-R165, R167, R168, R172, R174, R175, R180
	RD1/8PM □□□ J	Other resistors

SEMICONDUCTORS

Mark	Part No.	Symbol & Description
★★	2SC461	Q1, Q2, Q7, Q9
	(2SC1923)	
★★	STK4171-2S	Q11
★★	M51533L-B	Q3
★★	M5218 P	Q10
	(NJM4558DX)	
★★	2SK246	Q4
	(2SK34)	
★★	2SD880	Q12
	(2SD313)	
★★	2SA992	Q8
	(2SA726S)	
Δ ★★	JC501	Q5, Q6, Q13, Q16, Q17
	(2SC2603)	
Δ ★★	JA101	Q14, Q15
	(2SA1115)	
★	1N4148	D1, D3, D12, D17, D18
	(US1035)	
	(1S2076)	
	(1S1555)	
Δ ★	RB402	D9
Δ ★	10E2FD	D13, D14
Δ ★	BCR6AM-4	D15
★	2-1K261	D4
★	KZL140	D8
★	SZ-027	D16
★	WZ-130	D11
	(MZ-130)	
★	WZ-075	D2
	(MZ-075)	

COILS AND TRANSFORMERS

Mark	Part No.	Symbol & Description
	ATH-053	L1, L2 AF choke coil
	ATH-058	L3 Micro inductor
	ATE-058	T1 FM detector transformer
	ATB-085	T2 AM antenna coil
	ATB-084	T3 AM oscillator coil
	ATF-083	F1, F2 FM ceramic filter
	ATF-084	F3 AM ceramic filter

OTHERS

Mark	Part No.	Symbol & Description
★★	ASG-412	S1 Push switch (FUNCTION, TAPE, LOUDNESS)
	AWB-044	FM Front-end
	AKX-073	Complex terminal
	AEC-940	Rivet
	PBZ30ZP060FMC	Screw (3 x 6)
	ABA-271	Screw

Headphone Jack Assembly

Mark	Part No.	Symbol & Description
	AKN-045	Phone jack (PHONES)
	RD4PM □□□ J	R176-R179

LED Assembly

Mark	Part No.	Symbol & Description
★	AEL-406	D5 (Red STEREO)
★	AEL-407	D6 (Green TUNING)

Pointer Assembly

Mark	Part No.	Symbol & Description
★	AEL-405	D7 (Red)
	AAF-118	Pointer

Switch Assembly

Mark	Part No.	Symbol & Description
★★	SUJ8LYXS F	S2 Push switch (SPEAKERS)

11. DIAL CORD STRINGING

1. Remove the bonnet.
2. Remove the tuning drum from the shaft of the tuning capacitor.
3. Tie one end of the cord to the stud A located inside the tuning drum.
4. Rotate the tuning capacitor right around until the rotor blades are fully intermeshed.
5. Secure the tuning drum back onto the tuning capacitor shaft, making sure that the securing screw B faces directly upward.
6. Pass the cord out through the small opening in the circumference of the tuning drum (see diagram), and then take it over pulleys C and D in that sequence.
7. Wind the cord around the tuning shaft 3 times.
8. Pass it over pulley E, wind it around the tuning drum 1 time, and finally tie it to the spring hook F so that it is tensioned.
9. Turn the tuning shaft, and check that the cord moves smoothly.
10. Cut off any excess cord.
11. Turn the tuning shaft counter-clockwise as far as it will go.
12. Align the dial pointer with the starting point of the dial scale, and then pass the cord over it.
13. Check that the dial pointer is in line with the starting point of the dial scale.
14. Finally apply the locking paint to the cord securing positions (stud A and spring hook F) and the dial pointer connection.

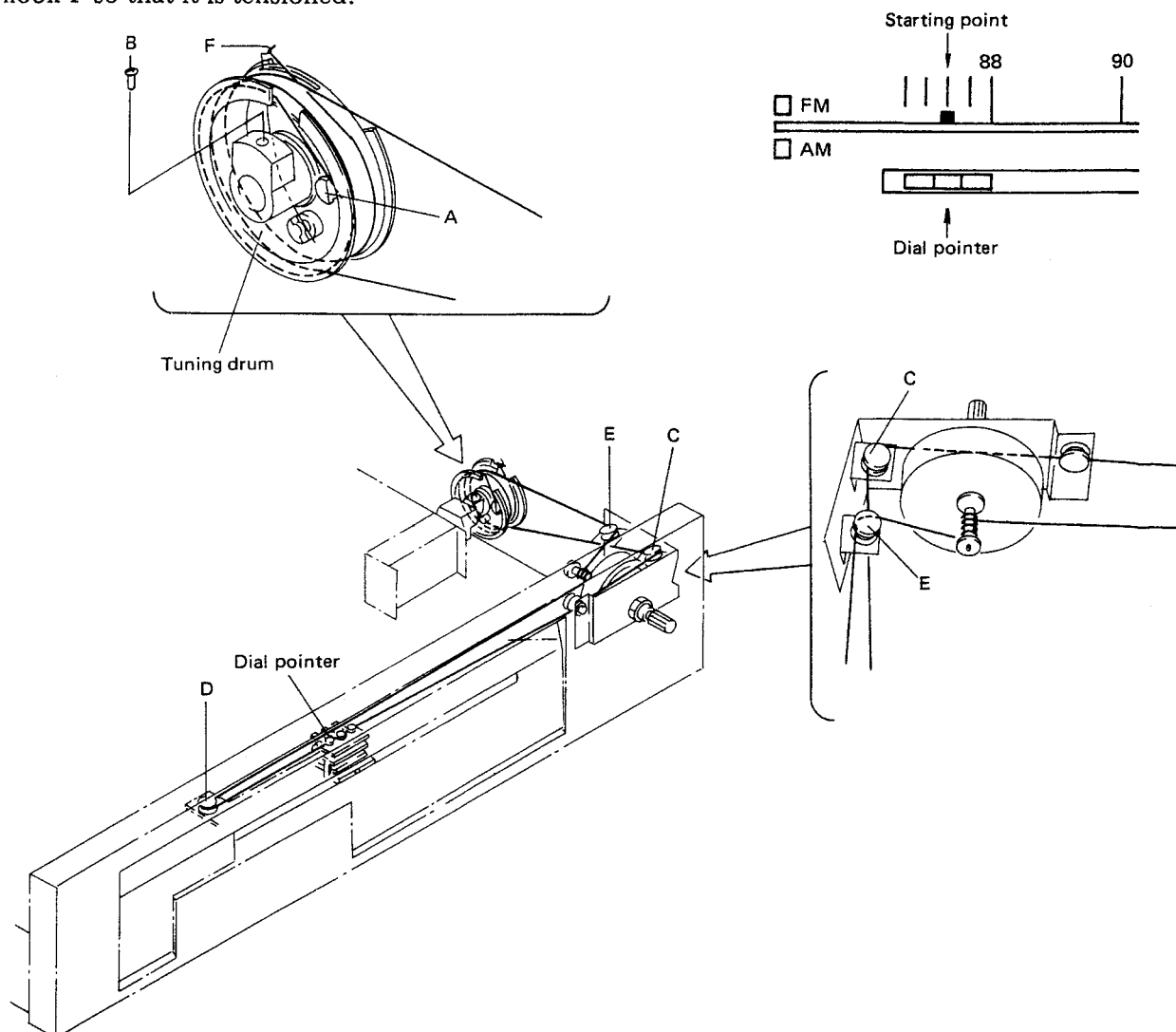

12. ADJUSTMENTS

FM Tuner Section

- Check that the dial pointer indicates a starting point.
- Connect the SIGNAL meter between terminal no. 1 of complex assembly and the ground.
- In principle, no adjustment should be made on FM tracking. (See page 21, if necessary.)
- Set the FM switch to ON and connect terminal no. 6 to the ground.

Step	FM SG (400Hz, ± 75 kHz deviation)		Position of dial pointer	Adjustment point	Adjustment procedure
	Frequency	Level			
1.	98MHz	66dB	98MHz	T1	Set the output of the REC OUT terminal to the maximum value.
2.	98MHz	46dB	98MHz	T6	Set the SIGNAL meter to the maximum value.
3.	98MHz	66dB	98MHz	T1	Adjust the output of the REC OUT terminal distortion to the minimum level.
4.	Disconnect terminal no. 6 from the ground.				
5.	98MHz Not modulated	66dB	98MHz	VR3	Set the signal of the terminal no. 4 to 76kHz (± 200 Hz).
6.	98MHz * Stereo modulation	66dB	98MHz	T6 (within $\pm 90^\circ$)	Minimize the distortion of the REC OUT terminal signal.

NOTE:

Connect the MPX SG to the FM SG external modulator terminal and set the modulation of Main (1kHz, L+R) ± 67.5 kHz deviation, Pilot (19kHz) ± 7.5 kHz deviation.

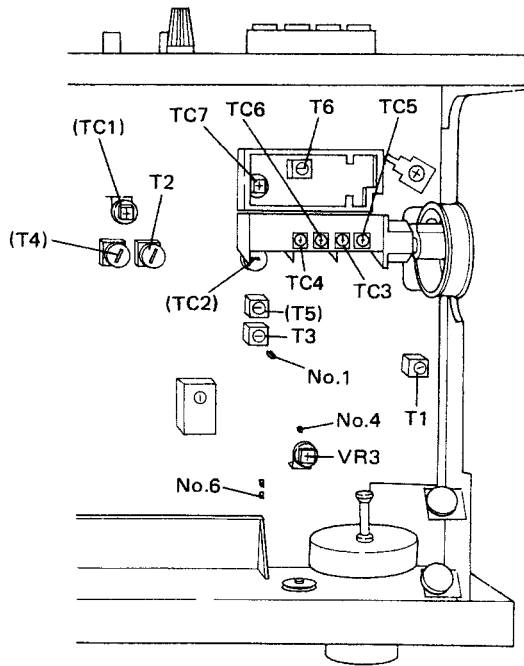

Adjustment points in brackets are for SX-303L (Low Wave) only.

Fig. 11-1 Adjustment points

FM tracking

Step	FM SG (400Hz, ±75kHz deviation)		Position of dial pointer	Adjustment point	Adjustment procedure
	Frequency	Level			
1.	106MHz	10dB	106MHz	TC7	Set the SIGNAL meter to the maximum value.
2.				TC5	
3.				TC6	
4.	Confirm that the dial pointer does not get out of position at 106MHz and 98MHz.				

NOTE: (For SX-303L/HEZ)

- When 87.6MHz can not be received with this unit, adjust the oscillator (TC7) and then it can be received. It is prohibited to receive 87.2MHz or below and so after having adjusted the oscillator, make sure that it does not receive 87.2MHz or below.

AM Tuner Section

- Check that the dial pointer indicates a starting point.
- Turn ON the MW switch.
- Connect the SIGNAL meter between the terminal no. 1 of complex assembly and the ground.

Step	AM SG (400Hz, 30% modulation)		Position of dial pointer	Adjustment point	Adjustment procedure
	Frequency	Level			
1.	1395kHz	100dB	1395kHz	TC3	Set the SIGNAL meter to the maximum value.
2.	603kHz	100dB	603kHz	T3	
3.	Set the AM SG to 30dB output level, repeat steps 1 to 2 above.				
4.	1395kHz	30dB	1395kHz	TC4	Set the SIGNAL meter to the maximum value.
5.	603kHz	30dB	603kHz	T2	
6.	Repeat steps 4 to 5 until maximum sensitivity is attained.				

Long Wave Section (SX-303L/HE, HEZ only)

- Set the AM BAND switch to the LW position.

Step	AM SG (400Hz, 30% modulation)		Position of dial pointer	Adjustment point	Adjustment procedure
	Frequency	Level			
1.	254kHz	100dB	254kHz	TC2	Set the SIGNAL meter to the maximum value.
2.	164kHz	100dB	164kHz	T5	
3.	Set the AM SG to 30dB output level, repeat steps 1 to 2 above.				
4.	254kHz	50dB	254kHz	TC1	Set the SIGNAL meter to the maximum value.
5.	164kHz	50dB	164kHz	T4	
6.	Repeat steps 4 to 5 until maximum sensitivity is attained.				

12. RÉGLAGE

Section Tuner MF

- Vérifier que l'aiguille du cadran indique un point de départ.
- Brancher le mesureur de signal sur la borne n° 1 et la masse du montage de l'ensemble.
- En principe, aucun réglage ne devrait être fait sur l'accord MF (Voir page 23 si nécessaire).
- Positionner le commutateur de MF sur ON et raccorder la borne n° 6 à la masse du montage.

Etape	FM SG (400Hz, déviation ±75kHz)		Position de l'aiguille	Point de réglage	Procédure de réglage
	Fréquence	Niveau			
1.	98MHz	66dB	98MHz	T1	Positionner la sortie sur la borne de REC OUT à la valeur maximum.
2.	98MHz	46dB	98MHz	T6	Positionner le mesureur de signal à la valeur maximum.
3.	98MHz	66dB	98MHz	T1	Régler la sortie de la borne REC OUT au niveau minimum de distorsion.
4.	Déconnecter la borne n° 6 de la masse du montage.				
5.	98MHz Non modulé	66dB	98MHz	VR3	Positionner le signal de la borne n° 4 à 76kHz (±20Hz).
6.	98MHz ★ Stéréo de modulation	66dB	98MHz	T6 (entre ±90°)	Abaisser la distorsion du signal sur la borne REC OUT.

★ REMARQUE:

Brancher le MPX SG sur la borne du modulateur extérieur du MF SG et régler la modulation sur le fil principal (1kHz, L+R) ±67,5kHz de déviation, sur le Pilote (19kHz) ±7,5kHz de déviation.

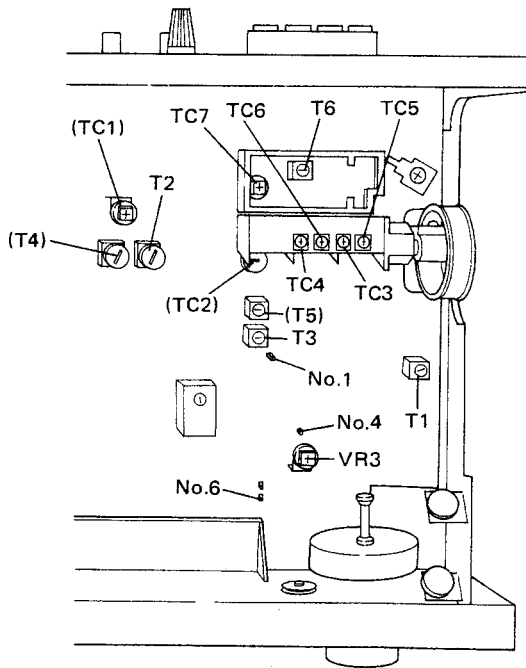

Les points de réglage entre parenthèses ne concernent que le SX-303L (onde inférieure).

Fig. 11-1 Points de réglage

ACCORD MF

Etape	FM SG (400Hz, déviation ±75kHz)		Position de l'aiguille	Point de réglage	Procédure de réglage
	Fréquence	Niveau			
1.	106MHz	10dB	106MHz	TC7	Positionner le mesureur de signal sur la valeur maximum.
2.				TC5	
3.				TC6	
4.	Vérifier que l'aiguille du cadran ne change pas de position à 106MHz ni à 98MHz.				

Section Tuner AM

- Vérifier que l'aiguille du cadran indique un point de départ.
- Branche le commutateur de MW (PO) sur ON.
- Brancher le mesureur de signal entre la borne n° 1 du récepteur et la masse.

Etape	AM SG (400Hz, modulation de 30%)		Position de l'aiguille	Point de réglage	Procédure de réglage
	Fréquence	Niveau			
1.	1395kHz	100dB	1395kHz	TC3	Positionner le mesureur de signal à la valeur maximum.
2.	603kHz	100dB	603kHz	T3	
3.	Positionner le AM SG à un niveau de sortie de 30dB, répéter les positions 1 et 2 ci-dessus.				
4.	1395kHz	30dB	1395kHz	TC4	Positionner le mesureur de signal à la valeur maximum.
5.	603kHz	30dB	603kHz	T2	
6.	Positionner le AM SG à un niveau de sortie de 30dB, répéter les positions 1 et 2 ci-dessus.				

Section Grandes Ondes (SX-303L/HE, HEZ uniquement)

- Mettre le commutateur de gamme d'ondes sur LW (GO).

Etape	AM SG (400Hz, modulation de 30%)		Position de l'aiguille	Point de réglage	Procédure de réglage
	Fréquence	Niveau			
1.	254kHz	100dB	254kHz	TC2	Positionner le mesureur de signal à la valeur maximum.
2.	164kHz	100dB	164kHz	T5	
3.	Positionner le AM SG à un niveau de sortie de 30dB, répéter les positions 1 et 2 ci-dessus.				
4.	254kHz	50dB	254kHz	TC1	Positionner le mesureur de signal à la valeur maximum.
5.	164kHz	50dB	164kHz	T4	
6.	Répéter les positions 4 et 5 jusqu'à avoir obtenu le maximum de sensibilité.				

12. AJUSTE

Sección del sintonizador de FM

- Comprobar que el indicador del cuadrante indica un punto de inicio.
- Conectar el medidor de señal (SIGNAL) entre el terminal no 1 del ensamble complejo y masa.
- En principio, no deberá efectuarse ningún ajuste en el seguimiento de FM. (Ver la página 25 si es necesario).
- Poner el selector de FM en ON y conectar el terminal no 6 a masa.

Paso	FM SG (400Hz, ± 75 kHz de desviación)		Posición del indicador del cuadrante	Punto de ajuste	Procedimientos de ajuste
	Frecuencia	Nivel			
1.	98MHz	66dB	98MHz	T1	Ajustar la salida del terminal REC PUT al valor máximo.
2.	98MHz	46dB	98MHz	T6	Ajustar el medidor SIGNAL al valor máximo.
3.	98MHz	66dB	98MHz	T1	Ajustar la salida del terminal REC OUT con distorsión al nivel mínimo.
4.	Desconectar el terminal no 6 de masa.				
5.	98MHz Sin modular	66dB	98MHz	VR3	Ajustar la señal del terminal no 4 a 76kHz (± 200 Hz).
6.	98MHz * Estéreo de modulación	66dB	98MHz	T6 (dentro de $\pm 90^\circ$)	Minimizar la distorsión de la señal del terminal REC OUT.

★ NOTA:

Conectar el generador de señales de multiplex (MPX SG) al terminal de modulador exterior del generador de señales de FM (FM SG) y ajustar la modulación a Principal (1kHz. L+R) $\pm 67,5$ kHz de desviación, Piloto (19kHz) $\pm 7,5$ kHz de desviación.

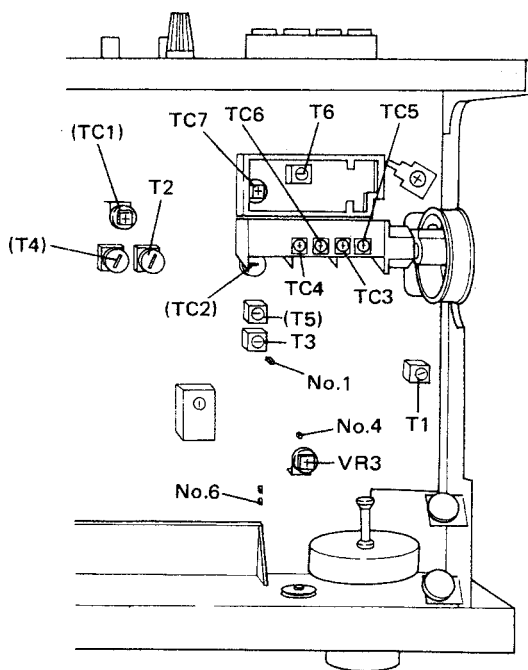

Los puntos de ajuste entre paréntesis son sólo para el modelo SX-303L (onda larga).

Fig. 11 Puntos de ajuste

Seguimiento de FM

Paso	FM SG (400Hz, ±75kHz de desviación)		Posición del indicador del cuadrante	Punto de ajuste	Procedimientos de ajuste
	Frecuencia	Nivel			
1.	106MHz	10dB	106MHz	TC7	Ajustar el medidor SIGNAL al valor máximo.
2.				TC5	
3.				TC6	
4.	Confirmar que el indicador del cuadrante no salga del margen de 106MHz y 98MHz.				

Sección del sintonizador de AM

- Comprobar que el indicador del cuadrante indique un punto de inicio.
- Poner en ON el selector de MW.
- Conectar el medidor SIGNAL entre el terminal no 1 del ensamble del sintonizador y masa.

Paso	AM SG (400Hz, 30% de modulación)		Posición del indicador del cuadrante	Punto de ajuste	Procedimientos de ajuste
	Frecuencia	Nivel			
1.	1395kHz	100dB	1395kHz	TC3	Ajustar el medidor SIGNAL al valor máximo.
2.	603kHz	100dB	603kHz	T3	
3.	Ajustar el generador de señales de AM (AM SG) al nivel de salida de 30dB, y repetir los pasos 1 y 2 de arriba.				
4.	1395kHz	30dB	1395kHz	TC4	Ajustar el medidor SIGNAL al valor máximo.
5.	603kHz	30dB	603kHz	T2	
6.	Ajustar el generador de señales de AM (AM SG) al nivel de salida de 30dB, y repetir los pasos 1 y 2 de arriba.				

Sección de onda larga (Sólo el SX-303L/HE, HEZ)

- Ajustar el selector AM BAND en la posición LW.

Paso	AM SG (400Hz, 30% de modulación)		Posición del indicador del cuadrante	Punto de ajuste	Procedimientos de ajuste
	Frecuencia	Nivel			
1.	254kHz	100dB	254kHz	TC2	Ajustar el medidor SIGNAL al valor máximo.
2.	164kHz	100dB	164kHz	T5	
3.	Ajustar el generador de señales de AM (AM SG) al nivel de salida de 30dB, y repetir los pasos 1 y 2 de arriba.				
4.	254kHz	50dB	254kHz	TC1	Ajustar el medidor SIGNAL al valor máximo.
5.	164kHz	50dB	164kHz	T4	
6.	Repetir los pasos 4 y 5 hasta lograrse la sensibilidad máxima.				