

Service Manual

PIONEER®
The Art of Entertainment

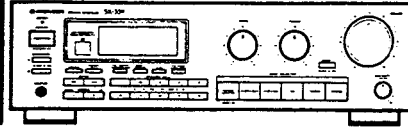

ORDER NO.
ARP2223

STEREO RECEIVER

SX-339

SX-229

SX-229 AND SX-339 HAVE THE FOLLOWING :

Type	Model		Power Requirement	Remarks
	SX-229	SX-339		
HE	○	○	AC220V-AC230V, 240V (Switchable) *	
HB	○	○	AC220V-AC230V, 240V (Switchable) *	
HEWZ	○	○	AC220V-AC230V, 240V (Switchable) *	
YPW	○	—	AC240V only	

* Change the connection of the power transformer primary taps.

- This manual is applicable to the SX-229/HE, HB, HEWZ, YPW, SX-339/HE, HB and HEWZ types.
- As to the SX-229/HB, HEWZ and YPW types, refer to pages 64, 65.
- As to the SX-339/HB and HEWZ types, refer to pages 66-68.
- Ce manuel pour le service comprend les explications de réglage en français.
- Este manual de servicio trata del método ajuste escrito en español.

CONTENTS

1. EXPLODED VIEWS, PACKING AND PARTS LIST	2	4. RÉGLAGE	60
2. SCHEMATIC DIAGRAMS AND PCB CONNECTION DIAGRAMS	6	4. AJUSTE	62
3. PCB's PARTS LIST	50	5. FOR SX-229/HB, YPW AND HEWZ TYPES	64
4. ADJUSTMENTS	58	6. FOR SX-339/HB AND HEWZ TYPES	66
		7. SPECIFICATIONS	69
		8. PANEL FACILITIES	70

PIONEER ELECTRONIC CORPORATION 4-1, Meguro 1-Chome, Meguro-ku, Tokyo 153, Japan

PIONEER ELECTRONICS SERVICE INC. P.O. Box 1760, Long Beach, California 90801 U.S.A.

PIONEER ELECTRONICS OF CANADA, INC. 505 Cochrane Drive, Markham, Ontario L3R 8E3 Canada

PIONEER ELECTRONIC [EUROPE] N.V. Keetberglaan 1, 2740 Beveren, Belgium

PIONEER ELECTRONICS AUSTRALIA PTY. LTD. 178-184 Boundary Road, Braeside, Victoria 3195, Australia TEL: [03] 580-9911

© PIONEER ELECTRONIC CORPORATION 1991

YX APR. 1991 Printed in

1. EXPLODED VIEWS, PACKING AND PARTS LIST

NOTES:

- Parts without part number cannot be supplied.
- The Δ mark found on some component parts indicates the importance of the safety factor of the part. Therefore, when replacing, be sure to use parts of identical designation.
- Parts marked by "©" are not always kept in stock. Their delivery time may be longer than usual or they may be unavailable.

Parts list of Exterior and Packing

Mark	No.	Description	Parts No.	Mark	No.	Description	Parts No.
	1	VOL KNOB (VOLUME) (SX-339)	AAB1152	31	PCB SPACER (SX-339 only)		
	1	VOL KNOB (VOLUME) (SX-229)	AAB1153	32	PCB SPACER (SX-339 only)		
	2	ROTARY KNOB (BALANCE)	AAB1154	33	COMPLEX ASSEMBLY (SX-339)	AWZ3312	
	3	KNOB (TREBLE, BASS)	AAB1221	33	COMPLEX ASSEMBLY (SX-229)	AWZ3315	
	4	KNOB (POWER)	AAD1661	34	SHEET	AEE1014	
	5	SPEAKER KNOB	AAD1662	35	CLAMPER		
	6	PUSH KNOB (DIRECT)	AAD1811	36	DRY CELL BATTERIES (R03, AAA) (SX-339 only)		
	7	FUNCTION KNOB	AAD1812	37	FRONT PAD	AHA1336	
	8	STATION KNOB (SX-339)	AAD1982	38	REAR PAD	AHA1337	
	8	STATION KNOB (SX-229)	AAD1810	39	PACKING CASE (SX-339)	AHD2019	
	9	PLATE	AAK1979	39	PACKING CASE (SX-229)	AHD2020	
	10	PANEL (SX-339)	AAK2124	40	SP SWITCH ASSEMBLY		
	10	PANEL (SX-229)	AAK2125				
	11	NAME PLATE (METAL)	AAM1029	41	PACKING SHEET	AHG1016	
	12	CONTROL ASSEMBLY (SX-339)	AWZ3299	42	TERMINAL SCREW		
	12	CONTROL ASSEMBLY (SX-229)	AWZ3307	43	PANEL BASE (SX-339)	AMB1792	
	13	SCREW	ABA-298	43	PANEL BASE (SX-229)	AMB1791	
	14	SCREW (STEEL)	ABA1007	44	INDICATING LENS (SX-339 only)	AMR1160	
	15	SCREW (STEEL)	ABA1009	45	INSULATOR ASSEMBLY	AMR2140	
	16	SCREW (STEEL)	ABA1011	46	CHASSIS		
	17	SCREW (STEEL)	ABA1026	47	FRONT PANEL (SX-339)	ANB1444	
	18	SCREW (STEEL)	ABA1048	47	FRONT PANEL (SX-229)	ANB1445	
	19	SCREW	ABA1052	48	REAR PANEL		
	20	SCREW	ABA1054	49	SCREW (SX-229 only)	BPZ26P080FMC	
	21	SCREW	ABA1082	50	HEAT SINK		
	22	COIL SPRING	ABH1064	51	OPERATING INSTRUCTIONS (English, French, German, Italian, Dutch, Swedish, Spanish, Portuguese)	ARE1182	
	23	NUT	ABN-065	52	SP TERMINAL ASSEMBLY		
Δ	24	AC POWER CORD	ADG1021	53	MOTOR VOL ASSEMBLY (SX-339 only)		
	25	FM ANTENNA	ADH1004	54	TRANSISTOR ASSEMBLY (SX-339 only)		
	26	SPACER		55	REMOTE CONTROL UNIT (CU-SX022),(SX-339 only)	AXD1198	
	27	NYLON BINDER					
	28	PCB SUPPORT					
	29	PCB SUPPORT (SX-339 only)					
	30	BARRIER					

Mark	No.	Description	Parts No.
	56	METAL BONNET	AZN1783
	57	SCREW	BBZ26P080FMC
	58	SCREW	BBZ30P060FZK
	59	SCREW (SX-339 only)	BBZ30P120FZK
	60	SCREW	BDZ30P060FMC
	61	NUT	NK90FUC
	62	BATTERY LID (SX-339 only)	PZN1001
	63	SCREW (SX-339 only)	VMZ30P060FMC
⚠	64	CKA (0.022/AC400V, C1)	ACG1030
⚠	65	FUSE (T2A, FU1) (SX-339)	AEK-511
⚠	65	FUSE (T1A, FU1) (SX-229)	AEK-508
	66	LOOP ANTENNA	ATB1005
⚠	67	TRANSISTOR (Q1) (SX-339)	2SC3181N
⚠	67	TRANSISTOR (Q1) (SX-229)	2SC3180N
⚠	68	TRANSISTOR (Q2) (SX-339)	2SC3181N
⚠	68	TRANSISTOR (Q2) (SX-229)	2SC3180N
⚠	69	TRANSISTOR (Q3) (SX-339)	2SA1264N
⚠	69	TRANSISTOR (Q3) (SX-229)	2SA1263N
⚠	70	TRANSISTOR (Q4) (SX-339)	2SA1264N
⚠	70	TRANSISTOR (Q4) (SX-229)	2SA1263N
⚠	71	POWER TRANSFORMER (T1) (SX-339)	ATS1336
⚠	71	POWER TRANSFORMER (T1) (SX-229)	ATS1337
	72	PCB SUPPORT (SX-229 only)	
	73	PCB SUPPORT (SX-229 only)	
	74	NUT (SX-229 only)	NK70FUC
	75	TRANS ASSEMBLY	
	76	SCREW	ABA1047
	77	PCB HOLDER	
	78	LINE FILTER ASSEMBLY	

PACKING

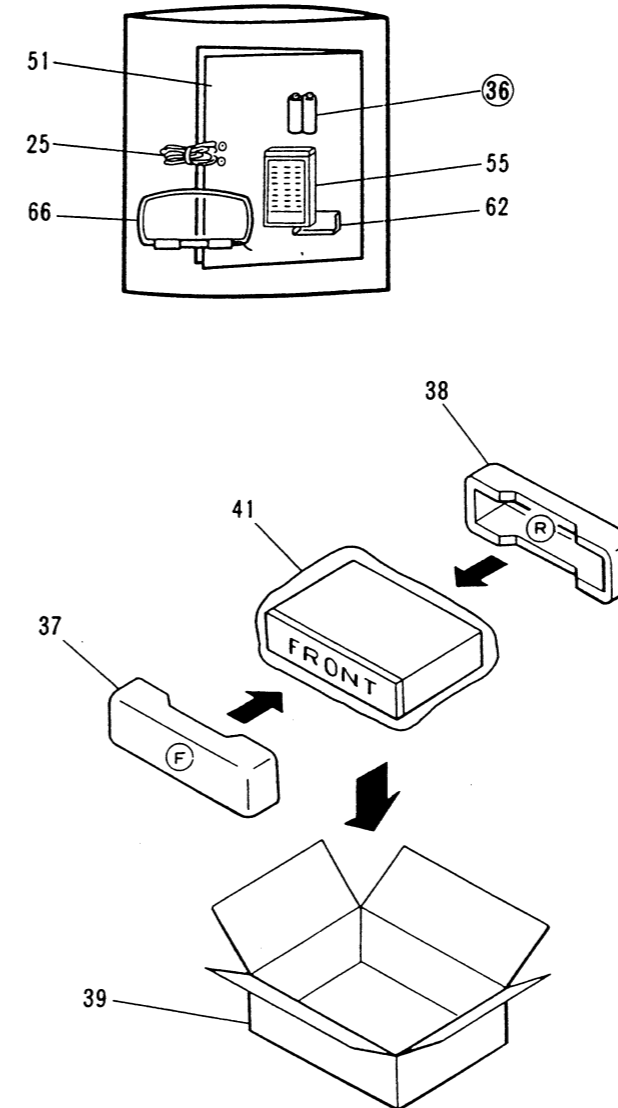

2. SCHEMATIC DIAGRAMS AND PCB CONNECTION DIAGRAMS

2.1 FOR SX-229/HE, HB, YPW AND HEWZ TYPES

COMPLEX assembly (AWZ3315: SX-229/HE, HB, YPW)
(AWZ3313: SX-229/HEWZ)

PARTS NO.	SX-229/HE, HB, YPW	SX-229/HEWZ
C167	1000	2200
R152	91k	79k
R158, R160	8.2k	3.9k
R161, R162	12k	18k

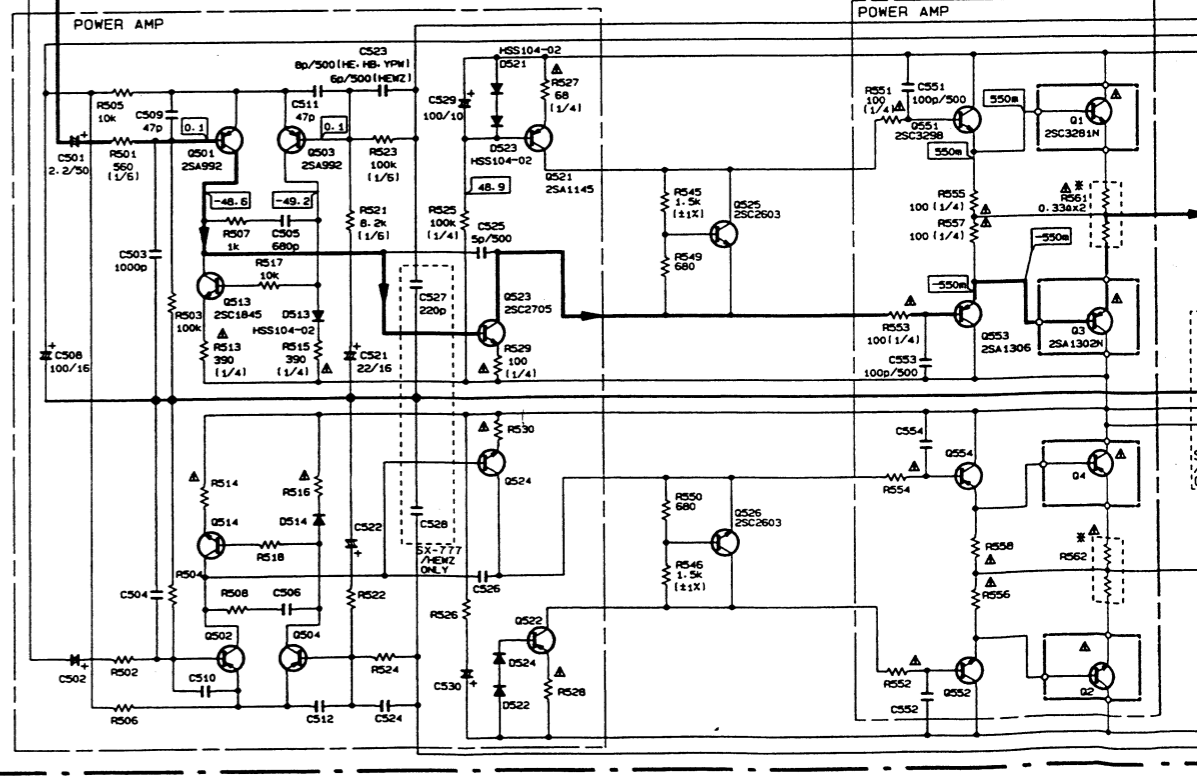
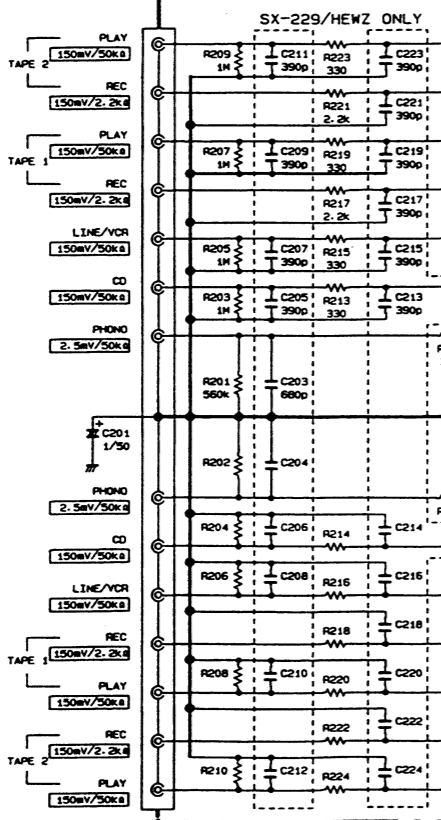
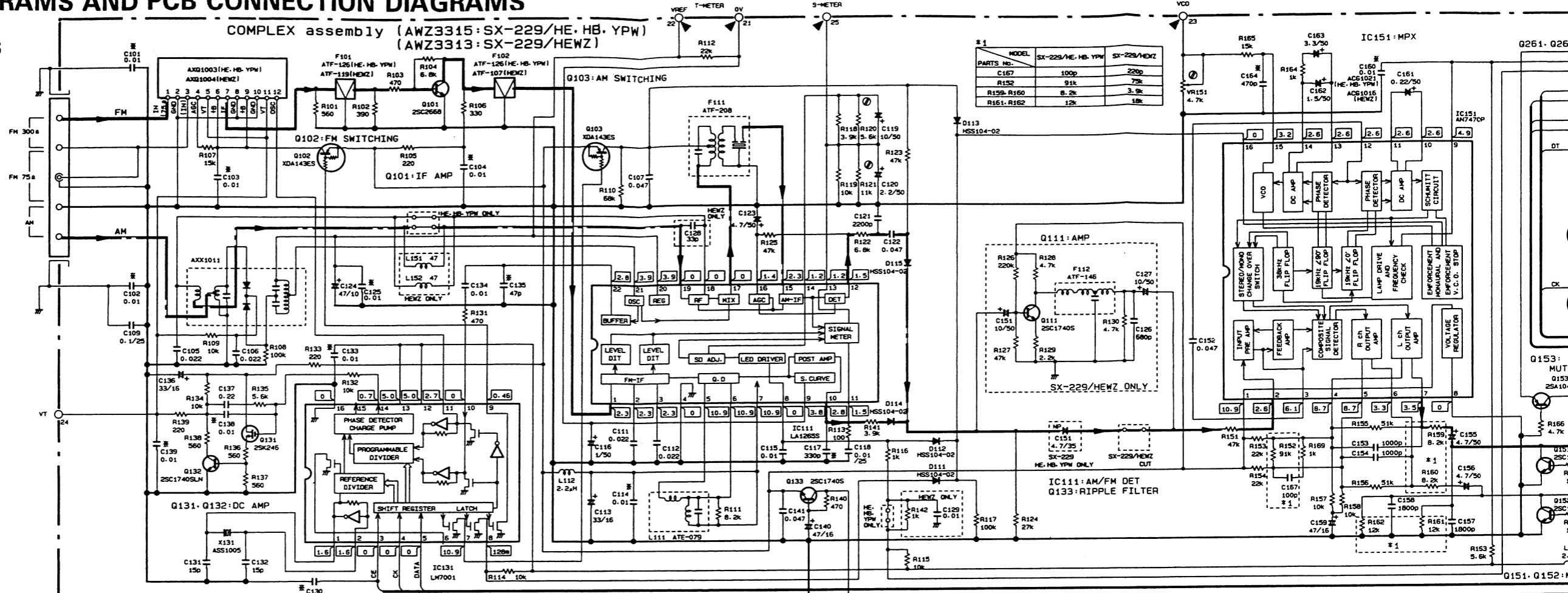

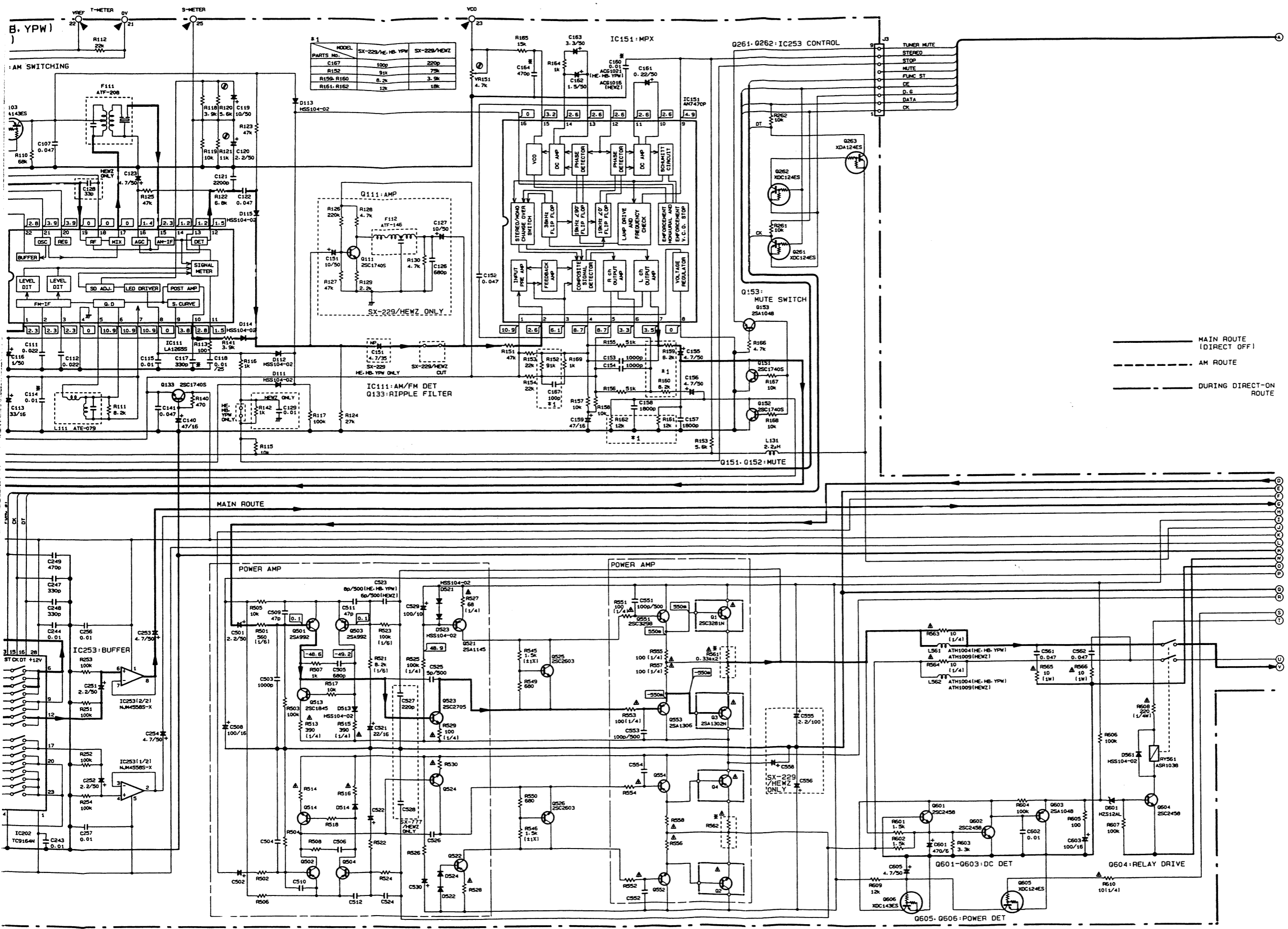

MODEL	SX-229/HE, HB, YPW	SX-229/HEWZ
C167	100p	220p
R152	91k	75k
R159, R160	8.2k	3.3k
R161, R162	12k	18k

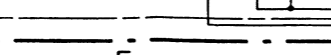
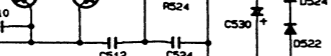
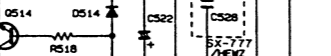
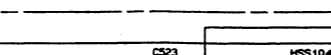
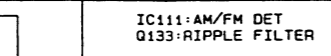
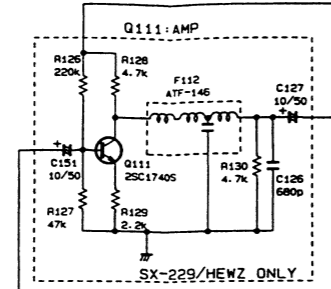

• FOR HE, HB AND YPW TYPES

To SP
(To page 16)

A

COMPLEX assembly (AWZ3315)

To CONTROL assembly J3
(To page 16)

B

NOTE

1. This P.C.B. connection diagram is viewed from the parts mounted side.
2. The parts which have been mounted on the board can be replaced with those shown with the corresponding wiring symbols listed in the following Table.

P.C.B. pattern diagram indication	Corresponding part symbol	Part Name
		Transistor
		Radiator type transistor
		Diode
		Resistor
		Capacitor (Polarity)
		Capacitor (Non-polarity)

C

Others

P.C.B. pattern diagram indication	Part Name
IC	IC
S	Switch
RY	Relay
L	Coil
F	Filter
VR	Variable resistor or Semi-fixed resistor

3. The capacitor terminal marked with ⊖ (double circles) shows negative terminal.
4. The diode terminal marked with ⊕ (double circles) shows cathode side.
5. The transistor terminal to which E is affixed shows the emitter.

D

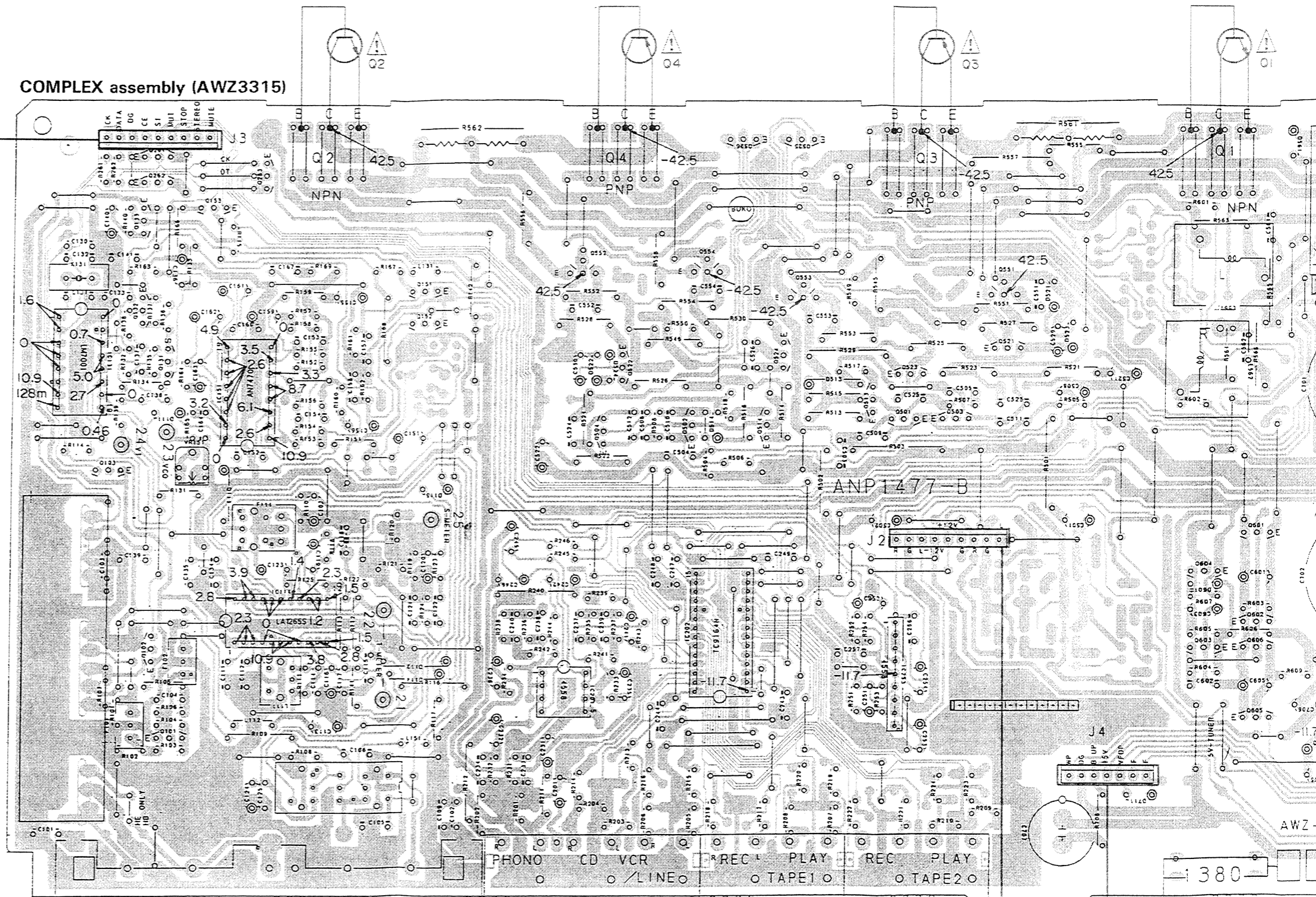

Q133 Q261 Q262 Q153 Q263 Q2 Q151 Q552 Q4 Q554 Q526 Q525 Q553 Q3 Q551
 Q103 IC131 Q132 Q131 IC151 Q152 Q504 Q522 Q502 Q514 Q524 Q513 Q501 Q523 Q503 Q521 Q1
 Q102 IC111 Q101 IC201 IC202 IC253 Q601-Q606 IC70

To CONTROL assembly J2
(To page 15)

To CONTROL assembly J3
(To page 16)

1

2

3

4

5

6

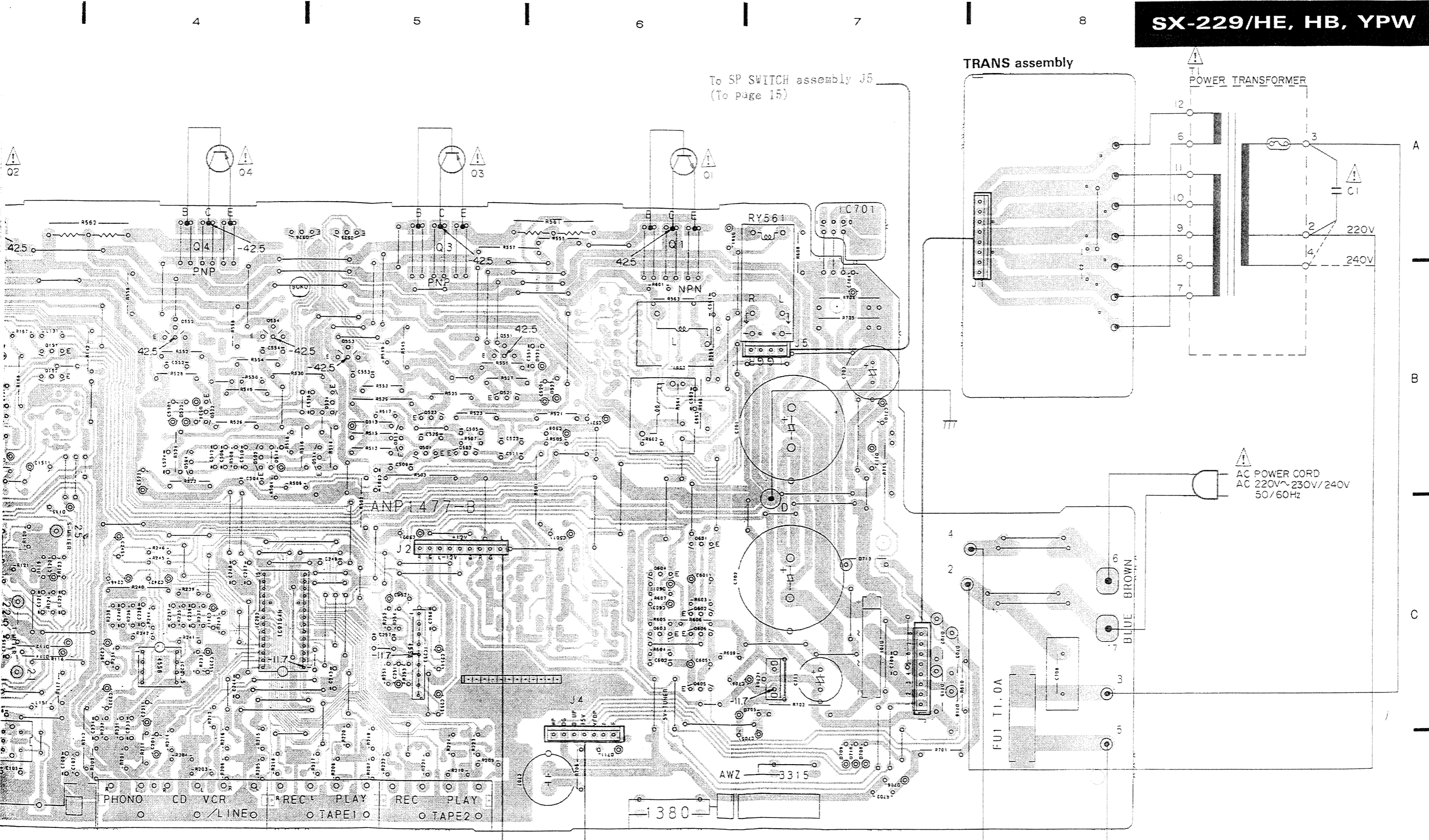

TRANS assembly

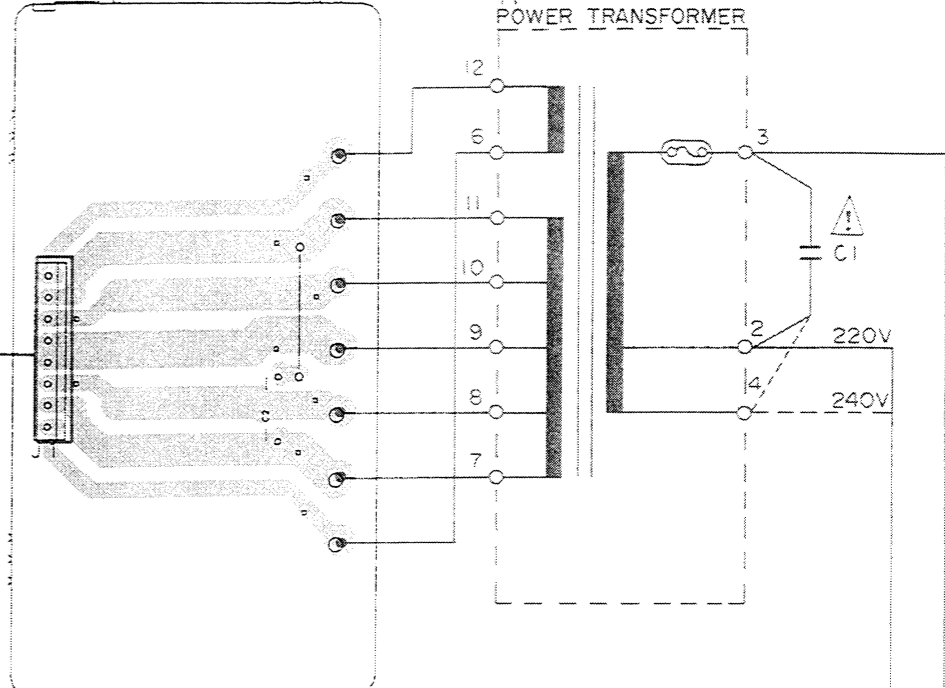

POWER TRANSFORMER

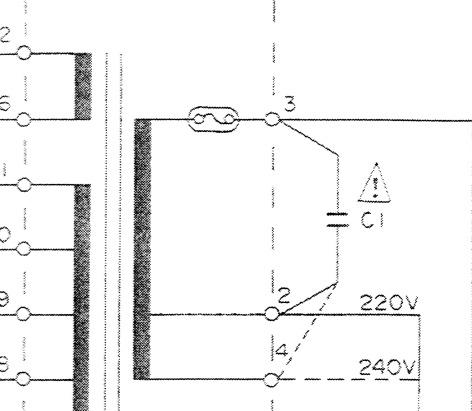

AC POWER CORD
AC 220V~230V/240V
50/60Hz

Q151 Q152 Q552 Q554 Q552 Q502 IC201 IC202 Q4 Q526 Q524 Q514 Q524 Q513 Q501 Q523 Q503 Q521 Q553 Q551 Q513 Q501 Q523 Q503 Q521 IC253 Q3

To CONTROL assembly J2
(To page 15)

Q601-Q606 IC702

To CONTROL assembly J4
(To page 16)

To SP SWITCH assembly 9
(To page 16)

To SP SWITCH assembly 8
(To page 16)

A

B

C

D

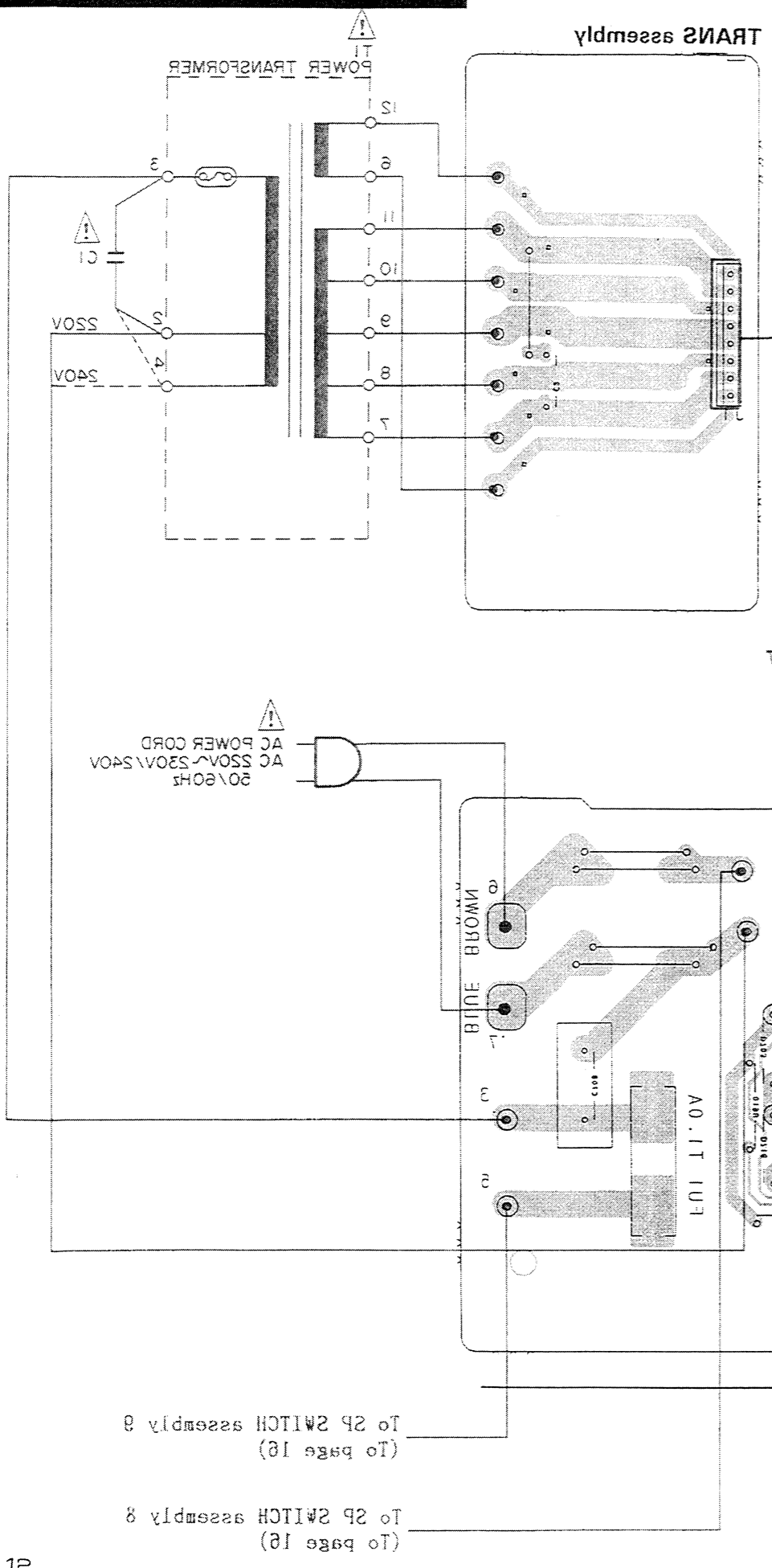

To 2P SWITCH assembly 15 (To page 15)

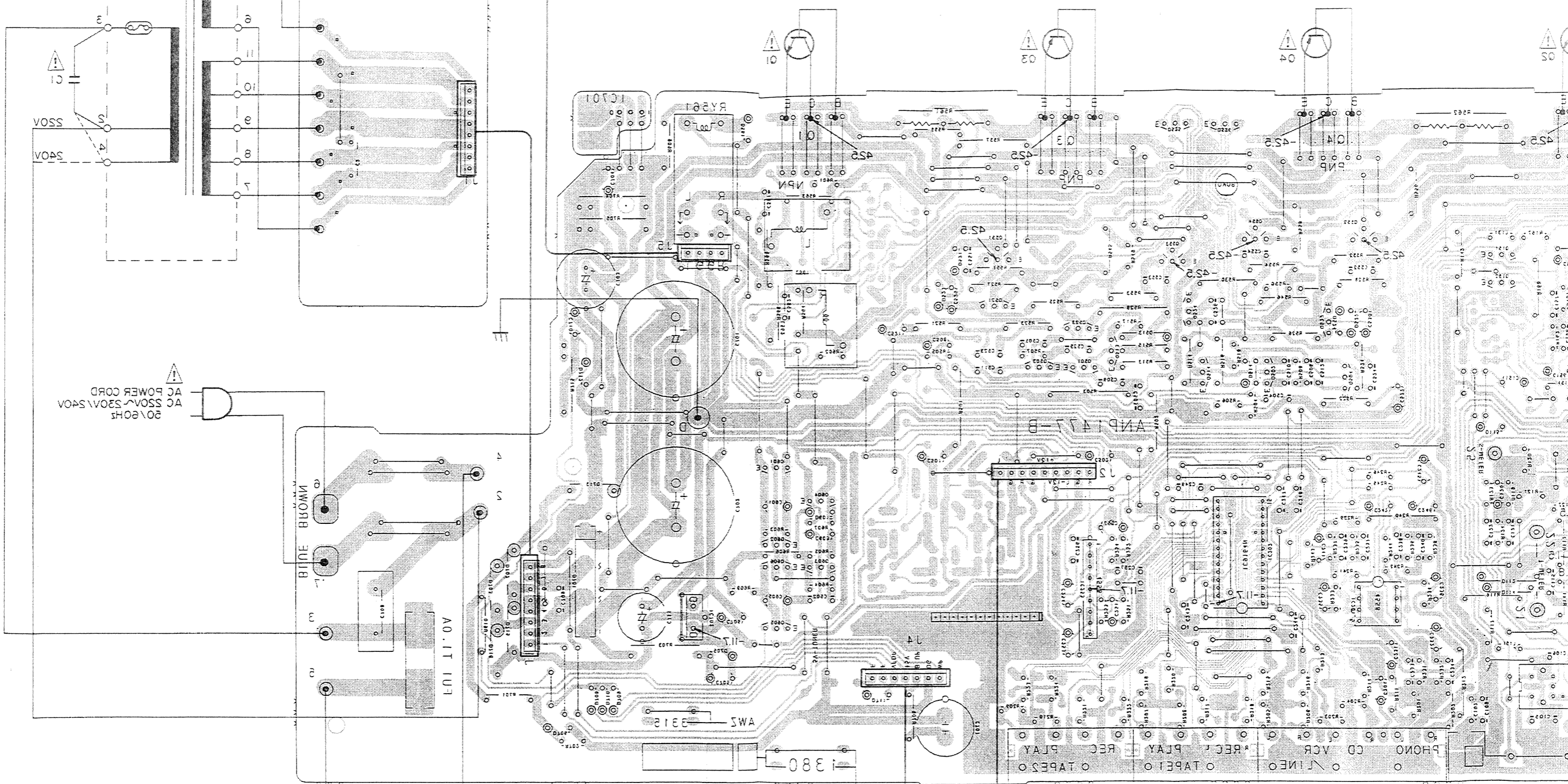

To CONTROL assembly 14 (To page 16)

To CONTROL assembly 15 (To page 15)

To 2P SWITCH assembly 8 (To page 16)

To 2P SWITCH assembly 9 (To page 16)

This P.C.B. connection diagram is viewed from the foil side.

(To page 11)
To SW1T

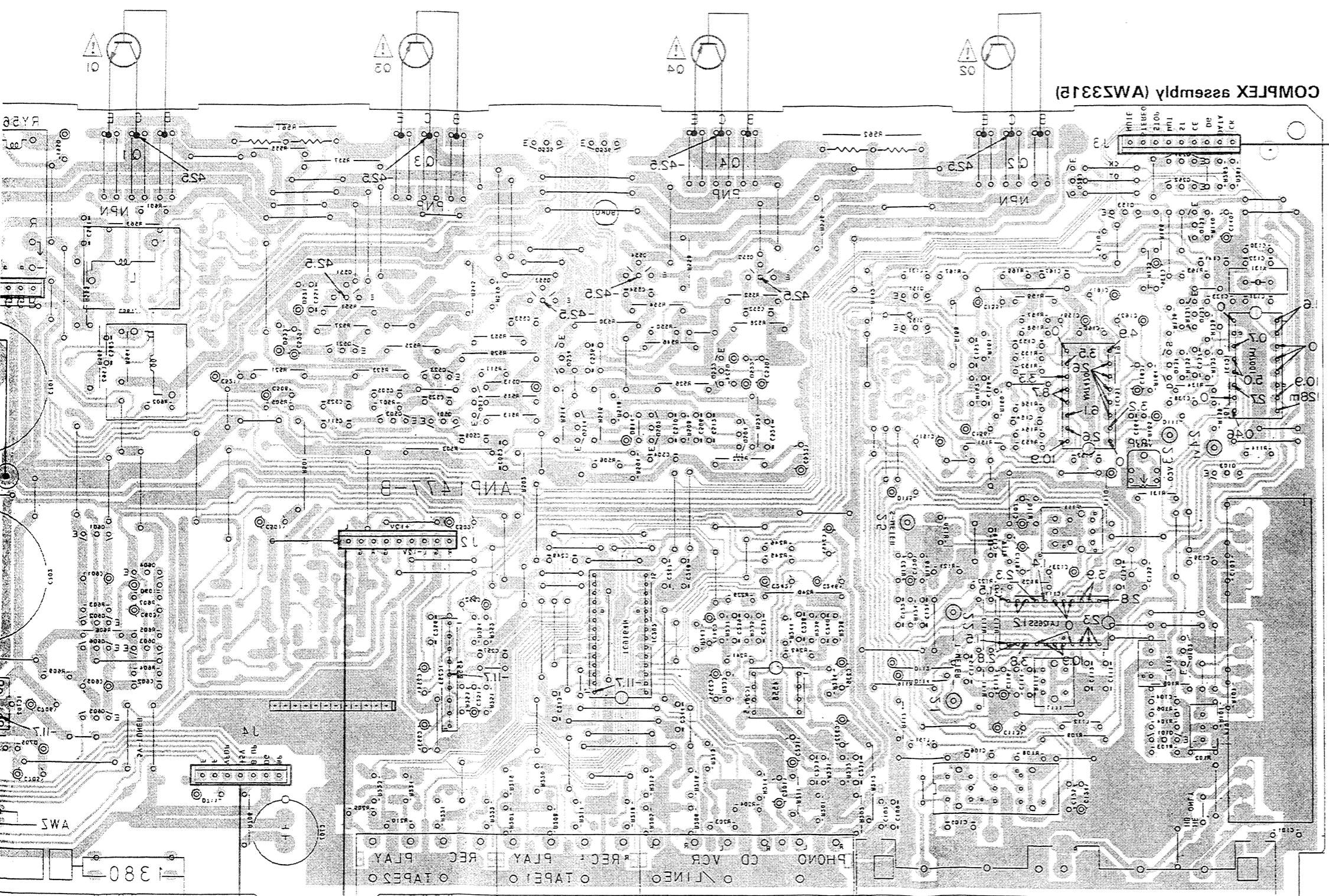

To CONTROL assembly 13
(To page 10)

To CONTROL assembly 14
(To page 10)
IC205
0601-0606
01

To CONTROL assembly 15
(To page 12)

IC203
0201 0202 0203 0204 0205 0206 0207 0208 0209 0210 0211 0212 0213 0214 0215 0216 0217 0218 0219 0220 0221 0222 0223 0224 0225 0226 0227 0228 0229 0230 0231 0232 0233 0234 0235 0236 0237 0238 0239 0240 0241 0242 0243 0244 0245 0246 0247 0248 0249 0250 0251 0252 0253 0254 0255 0256 0257 0258 0259 0260 0261 0262 0263 0264 0265 0266 0267 0268 0269 0270 0271 0272 0273 0274 0275 0276 0277 0278 0279 0280 0281 0282 0283 0284 0285 0286 0287 0288 0289 0290 0291 0292 0293 0294 0295 0296 0297 0298 0299 0300 0301 0302 0303 0304 0305 0306 0307 0308 0309 0310 0311 0312 0313 0314 0315 0316 0317 0318 0319 0320 0321 0322 0323 0324 0325 0326 0327 0328 0329 0330 0331 0332 0333 0334 0335 0336 0337 0338 0339 0340 0341 0342 0343 0344 0345 0346 0347 0348 0349 0350 0351 0352 0353 0354 0355 0356 0357 0358 0359 0360 0361 0362 0363 0364 0365 0366 0367 0368 0369 0370 0371 0372 0373 0374 0375 0376 0377 0378 0379 0380 0381 0382 0383 0384 0385 0386 0387 0388 0389 0390 0391 0392 0393 0394 0395 0396 0397 0398 0399 0400 0401 0402 0403 0404 0405 0406 0407 0408 0409 0410 0411 0412 0413 0414 0415 0416 0417 0418 0419 0420 0421 0422 0423 0424 0425 0426 0427 0428 0429 0430 0431 0432 0433 0434 0435 0436 0437 0438 0439 0440 0441 0442 0443 0444 0445 0446 0447 0448 0449 0450 0451 0452 0453 0454 0455 0456 0457 0458 0459 0460 0461 0462 0463 0464 0465 0466 0467 0468 0469 0470 0471 0472 0473 0474 0475 0476 0477 0478 0479 0480 0481 0482 0483 0484 0485 0486 0487 0488 0489 0490 0491 0492 0493 0494 0495 0496 0497 0498 0499 0500 0501 0502 0503 0504 0505 0506 0507 0508 0509 0510 0511 0512 0513 0514 0515 0516 0517 0518 0519 0520 0521 0522 0523 0524 0525 0526 0527 0528 0529 0530 0531 0532 0533 0534 0535 0536 0537 0538 0539 0540 0541 0542 0543 0544 0545 0546 0547 0548 0549 0550 0551 0552 0553 0554 0555 0556 0557 0558 0559 0560 0561 0562 0563 0564 0565 0566 0567 0568 0569 0570 0571 0572 0573 0574 0575 0576 0577 0578 0579 0580 0581 0582 0583 0584 0585 0586 0587 0588 0589 0590 0591 0592 0593 0594 0595 0596 0597 0598 0599 0600 0601 0602 0603 0604 0605 0606 0607 0608 0609 0610 0611 0612 0613 0614 0615 0616 0617 0618 0619 0620 0621 0622 0623 0624 0625 0626 0627 0628 0629 0630 0631 0632 0633 0634 0635 0636 0637 0638 0639 0640 0641 0642 0643 0644 0645 0646 0647 0648 0649 0650 0651 0652 0653 0654 0655 0656 0657 0658 0659 0660 0661 0662 0663 0664 0665 0666 0667 0668 0669 0670 0671 0672 0673 0674 0675 0676 0677 0678 0679 0680 0681 0682 0683 0684 0685 0686 0687 0688 0689 0690 0691 0692 0693 0694 0695 0696 0697 0698 0699 0700 0701 0702 0703 0704 0705 0706 0707 0708 0709 0710 0711 0712 0713 0714 0715 0716 0717 0718 0719 0720 0721 0722 0723 0724 0725 0726 0727 0728 0729 0730 0731 0732 0733 0734 0735 0736 0737 0738 0739 0740 0741 0742 0743 0744 0745 0746 0747 0748 0749 0750 0751 0752 0753 0754 0755 0756 0757 0758 0759 0760 0761 0762 0763 0764 0765 0766 0767 0768 0769 0770 0771 0772 0773 0774 0775 0776 0777 0778 0779 0780 0781 0782 0783 0784 0785 0786 0787 0788 0789 0790 0791 0792 0793 0794 0795 0796 0797 0798 0799 0800 0801 0802 0803 0804 0805 0806 0807 0808 0809 0810 0811 0812 0813 0814 0815 0816 0817 0818 0819 0820 0821 0822 0823 0824 0825 0826 0827 0828 0829 0830 0831 0832 0833 0834 0835 0836 0837 0838 0839 0840 0841 0842 0843 0844 0845 0846 0847 0848 0849 0850 0851 0852 0853 0854 0855 0856 0857 0858 0859 0860 0861 0862 0863 0864 0865 0866 0867 0868 0869 0870 0871 0872 0873 0874 0875 0876 0877 0878 0879 0880 0881 0882 0883 0884 0885 0886 0887 0888 0889 0890 0891 0892 0893 0894 0895 0896 0897 0898 0899 0900 0901 0902 0903 0904 0905 0906 0907 0908 0909 0910 0911 0912 0913 0914 0915 0916 0917 0918 0919 0920 0921 0922 0923 0924 0925 0926 0927 0928 0929 0930 0931 0932 0933 0934 0935 0936 0937 0938 0939 0940 0941 0942 0943 0944 0945 0946 0947 0948 0949 0950 0951 0952 0953 0954 0955 0956 0957 0958 0959 0960 0961 0962 0963 0964 0965 0966 0967 0968 0969 0970 0971 0972 0973 0974 0975 0976 0977 0978 0979 0980 0981 0982 0983 0984 0985 0986 0987 0988 0989 0990 0991 0992 0993 0994 0995 0996 0997 0998 0999 1000

IC205
0601-0606
01

1 | 2 | 3 | 4 | 5

To COMPLEX assembly J5
(To page 11)

To COMPLEX assembly 5
(To page 11)

To COMPLEX assembly 4
(To page 11)

A

NOTE

1. This P.C.B. connection diagram is viewed from the parts mounted side.
2. The parts which have been mounted on the board can be replaced with those shown with the corresponding wiring symbols listed in the following Table.

P.C.B. pattern diagram indication	Corresponding part symbol	Part Name
		Transistor
		Radiator type transistor
		Diode
		Resistor
		Capacitor (Polarity)
		Capacitor (Non-polarity)

Others	
P.C.B. pattern diagram indication	Part Name
	IC
	Switch
	Relay
	Coil
	Filter
	Variable resistor or Semi-fixed resistor

3. The capacitor terminal marked with ⊕ (double circles) shows negative terminal.
4. The diode terminal marked with ⊙ (double circles) shows cathode side.
5. The transistor terminal to which E is affixed shows the emitter.

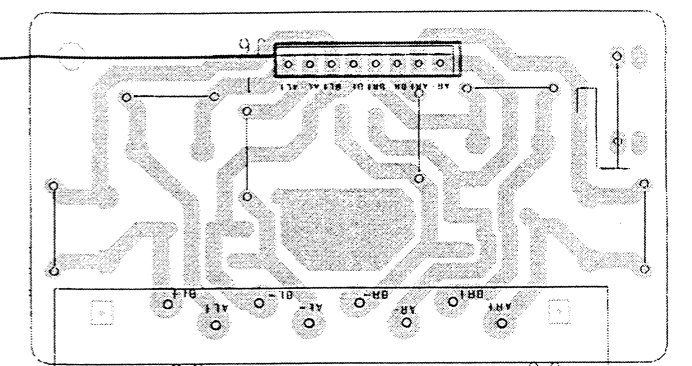
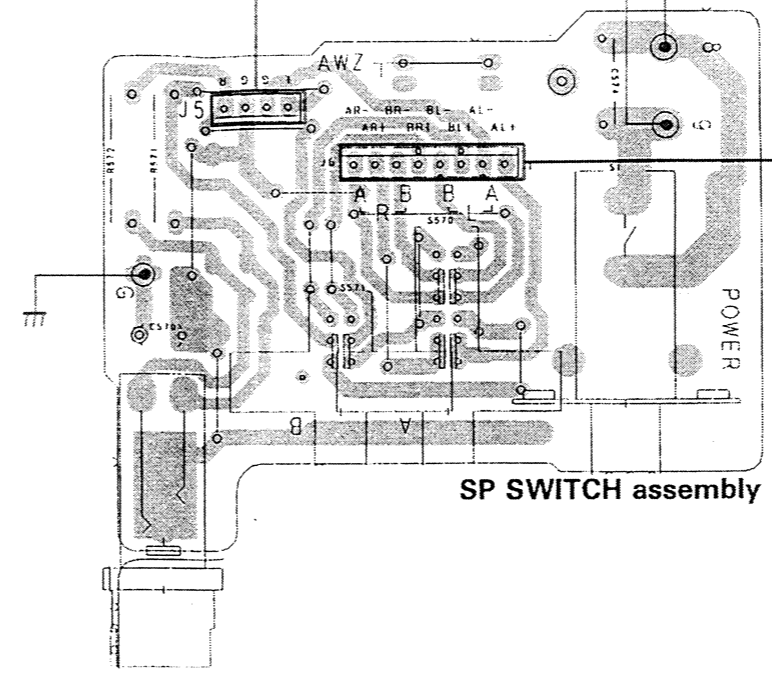

B

IC301

IC971

IC302

Q801

IC801

VR301

VR907

VR303

VR302

CONTROL assembly (AWZ3307)

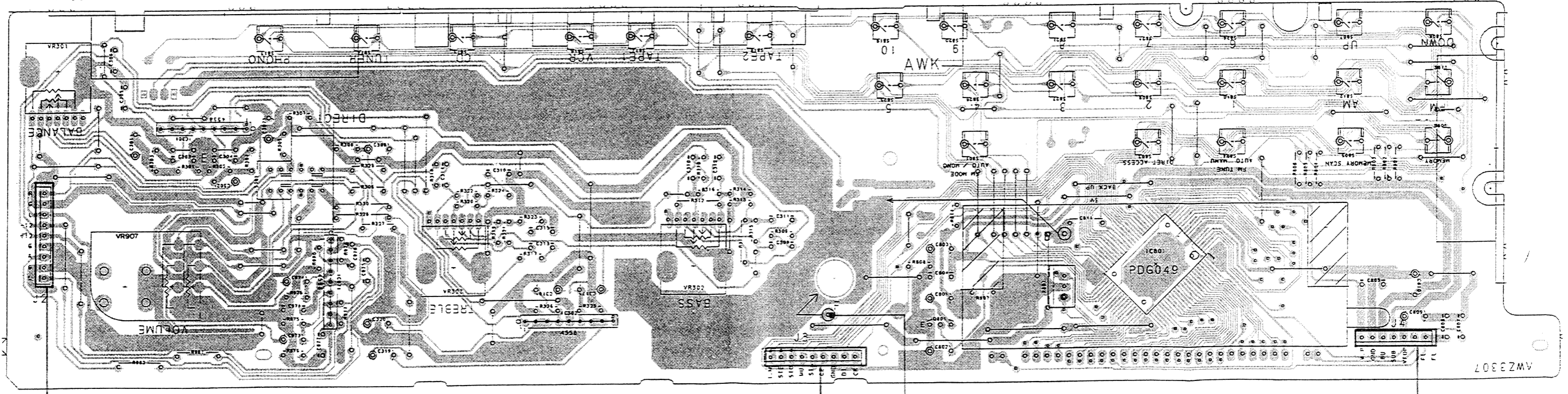

To COMPLEX assembly J2
(To page 10)

To COMPLEX assembly J3
(To page 9)

To COMPLEX assembly J4
(To page 10)

1 | 2 | 3 | 4 | 5 | 6

A

B

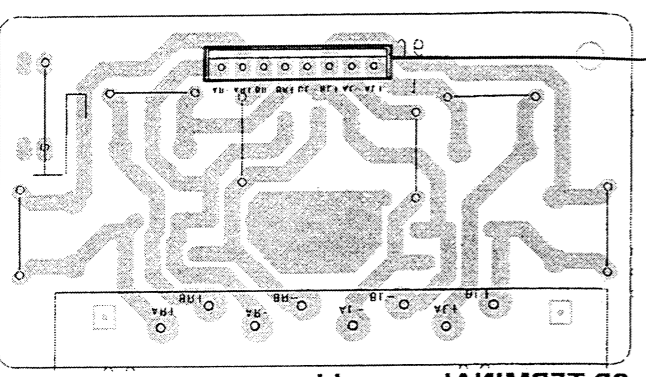

To COMPLEX assembly 2
(To page 11)

To COMPLEX assembly 4
(To page 11)

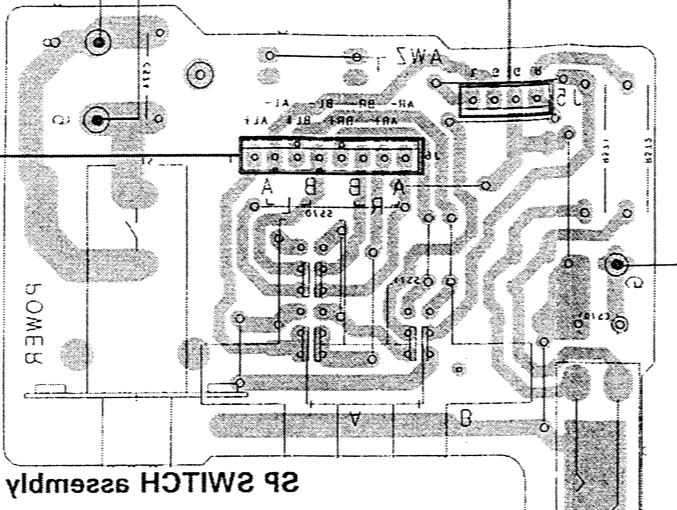

To COMPLEX assembly 15
(To page 11)

A

B

CONTROL assembly (W43307)

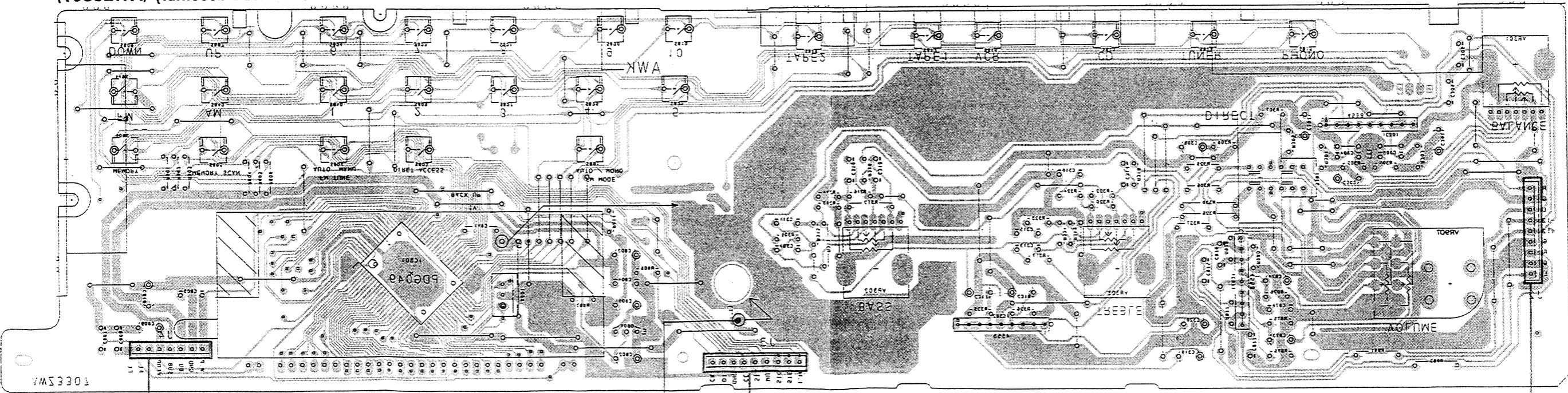

To COMPLEX assembly 14
(To page 10)

To COMPLEX assembly 13
(To page 9)

To COMPLEX assembly 12
(To page 10)

D

D

e

e

e

e

e

e

• FOR HEWZ TYPE

- As to the other assemblies, refer to "FOR HE, HB AND YPW TYPES"

A

Q133 Q261 Q262 Q153 Q263 Q2 Q151 Q552 Q4 Q554 Q526 Q525 Q553 Q3 Q551 Q1 IC701
 Q103 IC131 Q132 Q131 IC151 Q152 Q111 Q504 Q522 Q502 Q514 Q524 Q513 Q501 Q523 Q503 Q521 Q601-Q606
 Q102 IC111 IC201 IC202 IC253 IC702

B

C

D

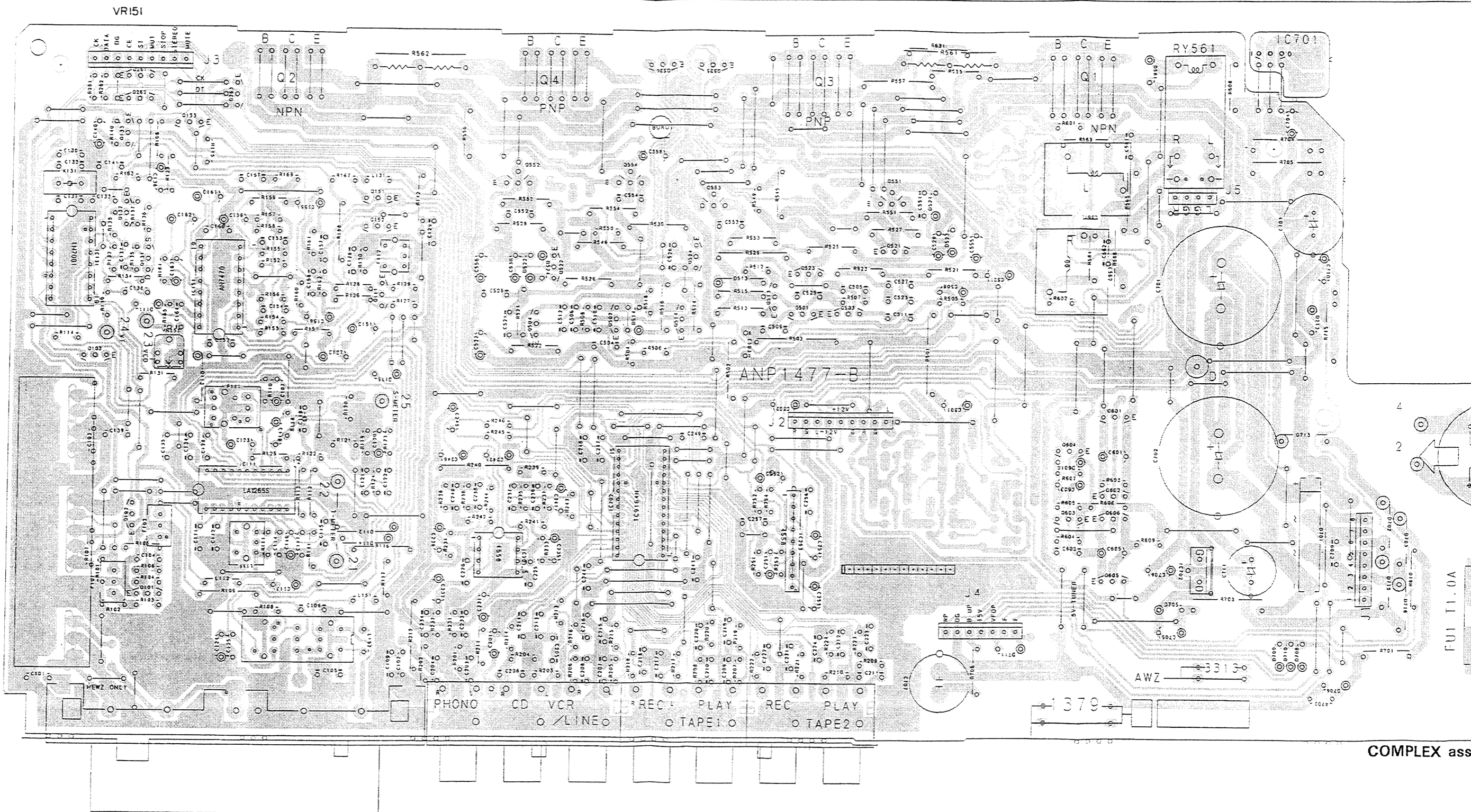

COMPLEX assm

1

2

3

4

5

6

4

5

6

7

8

Q554 Q526 Q525 Q553 Q3 Q551 Q1 IC701
 Q514 Q524 Q513 Q501 Q523 Q503 Q521 Q601-Q606 IC702
 Q2 IC253

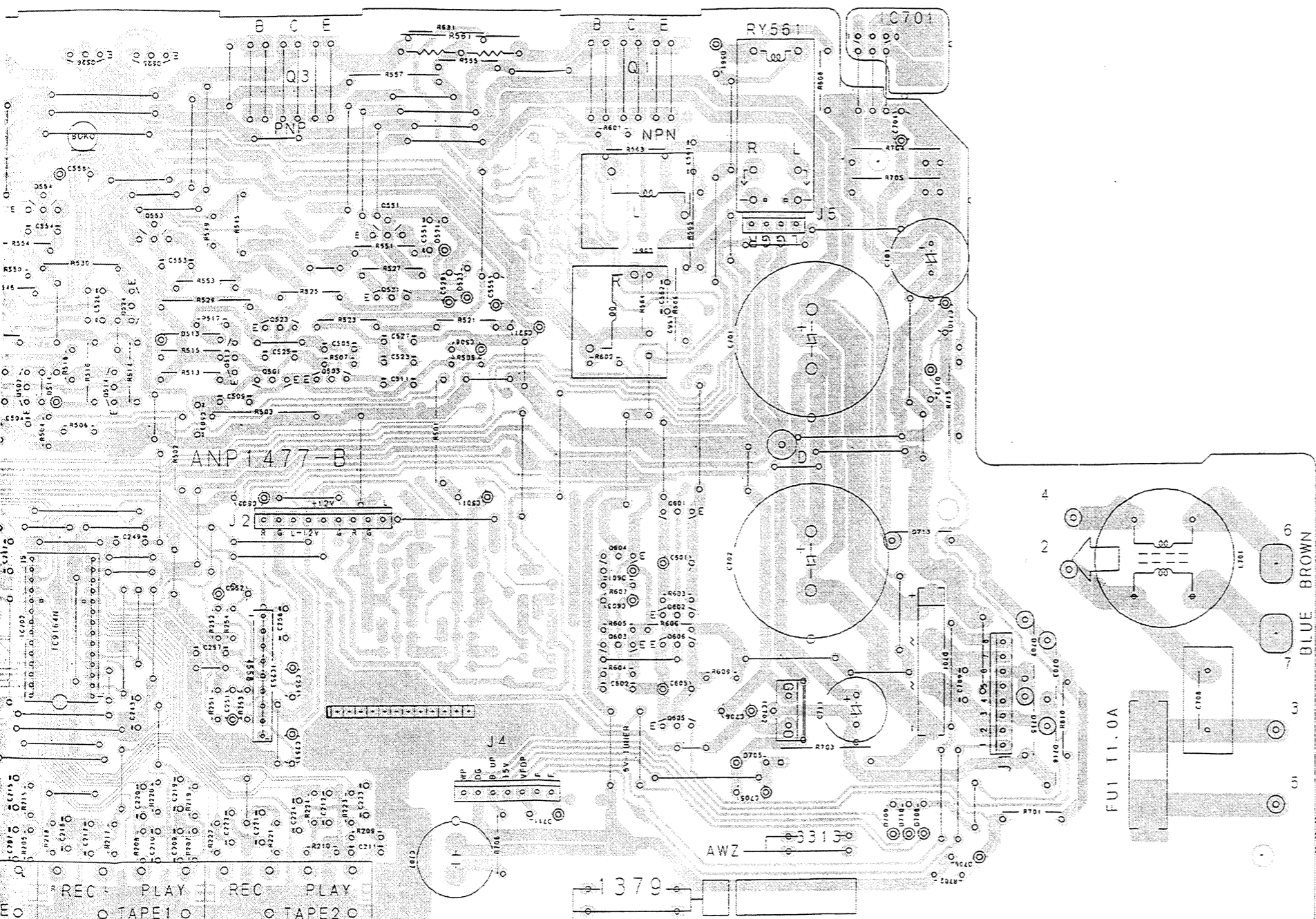

COMPLEX assembly (AWZ3313)

NOTE

1. This P.C.B. connection diagram is viewed from the parts mounted side.
2. The parts which have been mounted on the board can be replaced with those shown with the corresponding wiring symbols listed in the following Table.

P.C.B. pattern diagram indication	Corresponding part symbol	Part Name
		Transistor
		Radiator type transistor
		Diode
		Resistor
		Capacitor (Polarity)
		Capacitor (Non-polarity)

Others

P.C.B. pattern diagram indication	Part Name
IC	IC
S	Switch
RY	Relay
L	Coil
F	Filter
VR	Variable resistor or Semi-fixed resistor

3. The capacitor terminal marked with ⊕ (double circles) shows negative terminal.
4. The diode terminal marked with ⊕ (double circles) shows cathode side.
5. The transistor terminal to which E is affixed shows the emitter.

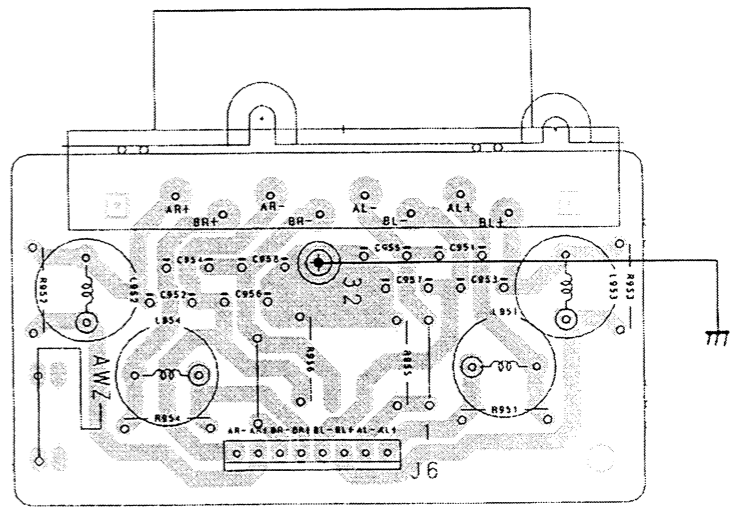

SP TERMINAL assembly

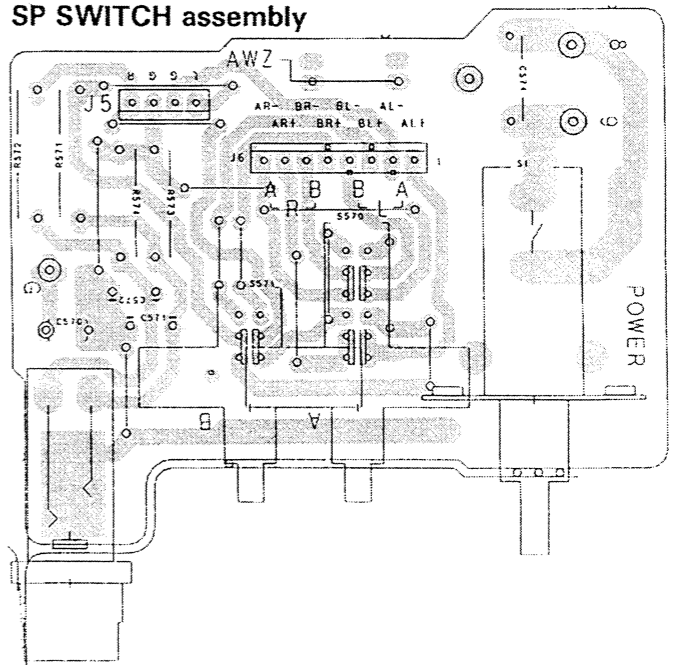

SP SWITCH assembly

4

5

6

7

8

9

A

B

C

D

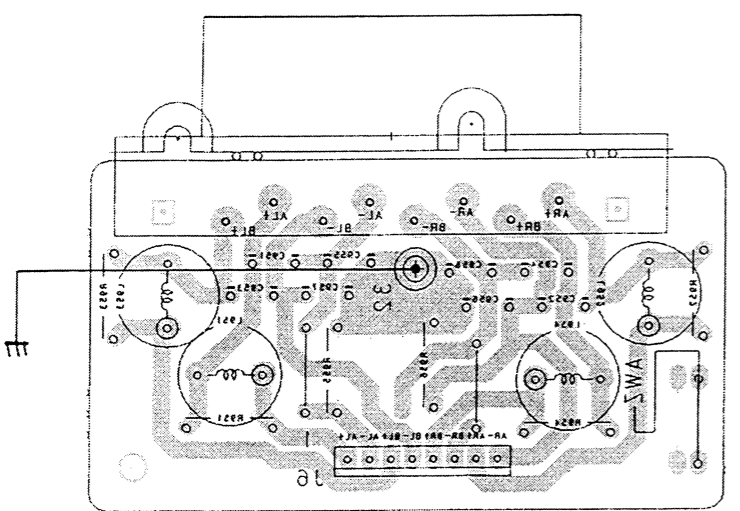

SP SWITCH assembly

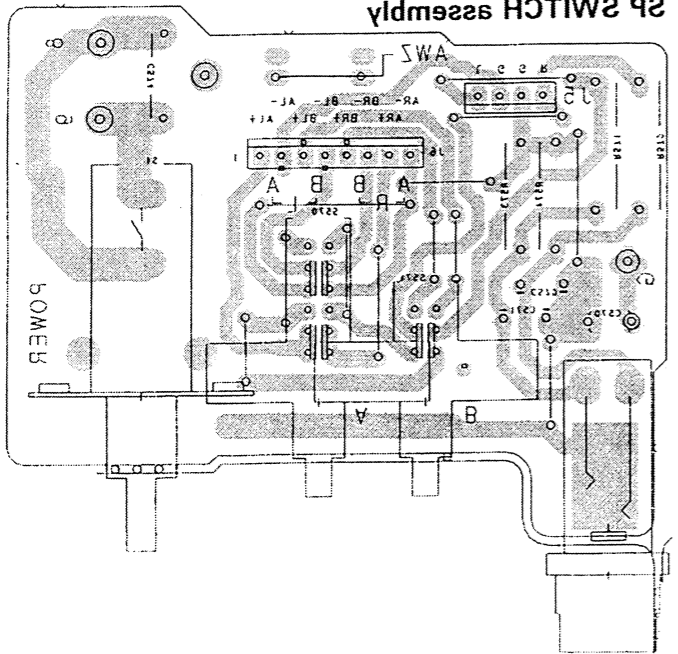

COMPLEX assembly (AW3313)

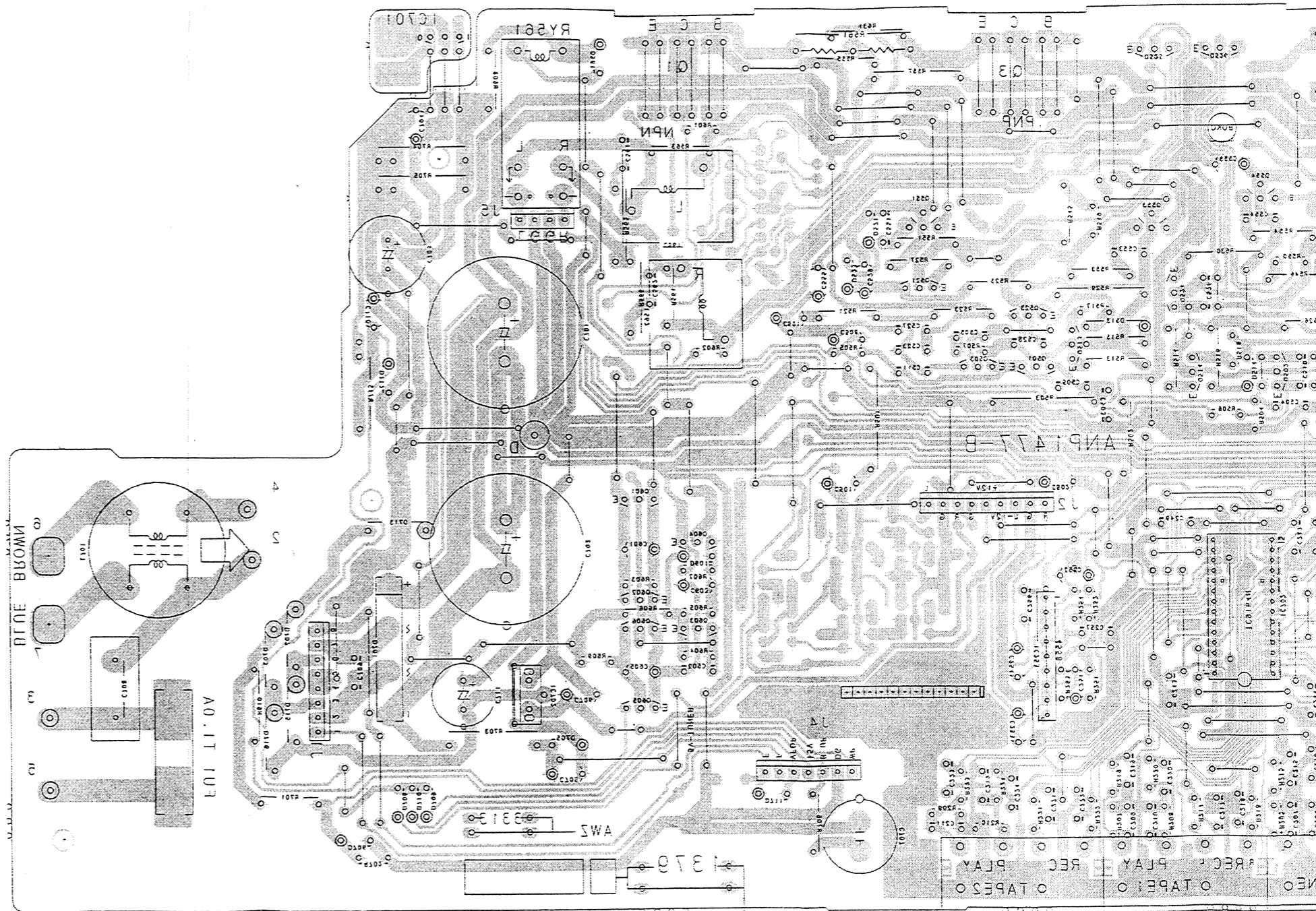

IC205 0901-0908
 IC201 0224 0258 0252 0223
 IC201 0213 0201 0253 0203 0251
 IC201 0214 0254 0213 0201 0253 0203 0251
 IC201 0224 0258 0252 0223

• FOR HEWZ TYPE

• As to the other assemblies, refer to "FOR HE, HB AND 7PW TYPES"

0101 0105 0103 0101 0135 0131 0131 0103 0103 0111 0125 0111 01504 0255 0205 0214 0254 0213 0201 0253 0203 0251 01CS23 01CS01 01CS05 0255 04 0254 0256 0252 0223 0251 03 0251 01 01 01C201 01C205 01C201-0202

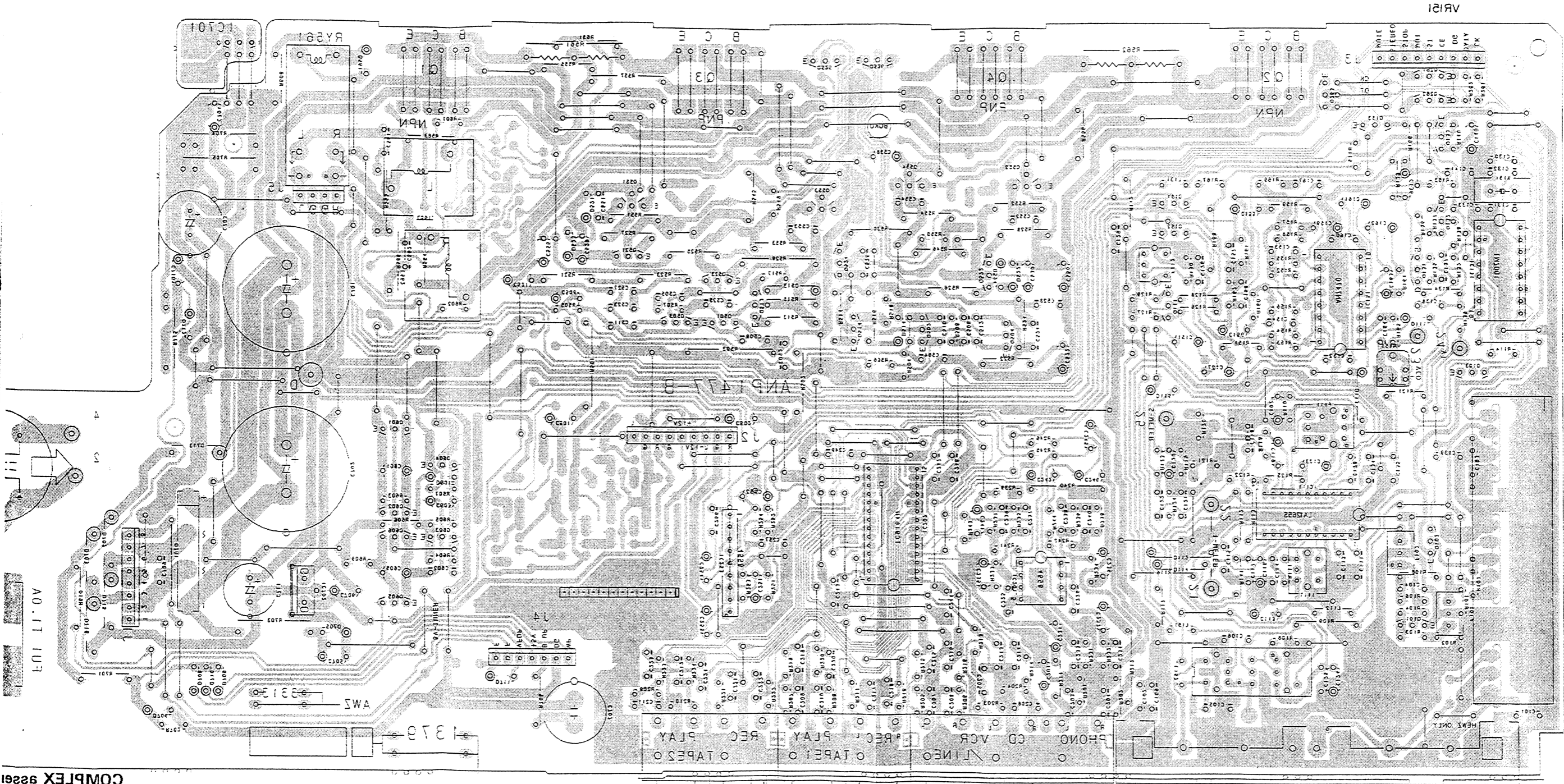

COMPLEX assen

A0.11 107

1 2 3 4 5

A B C D

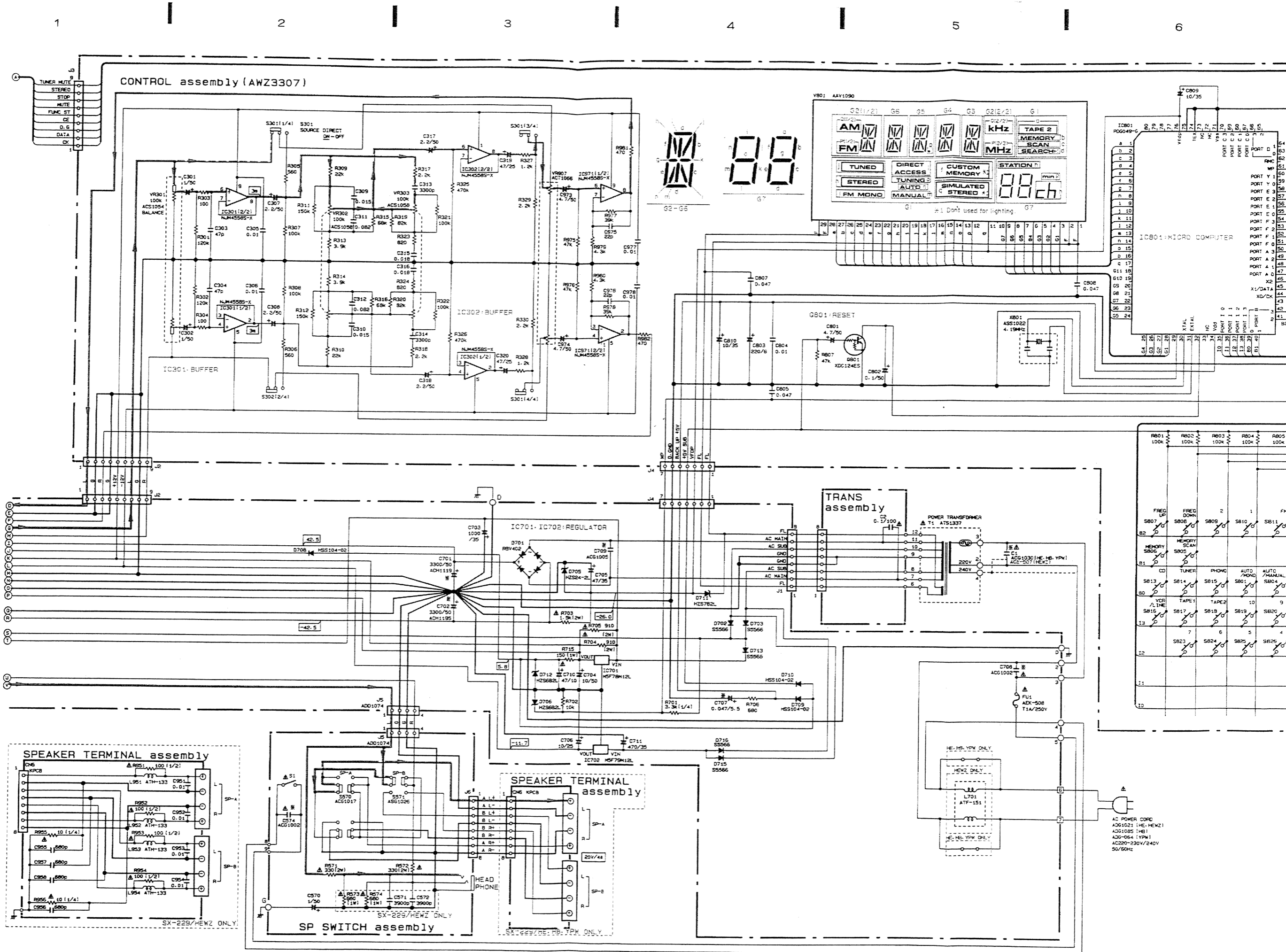

1

2

3

4

5

6

A

B

C

D

1

2

3

4

5

6

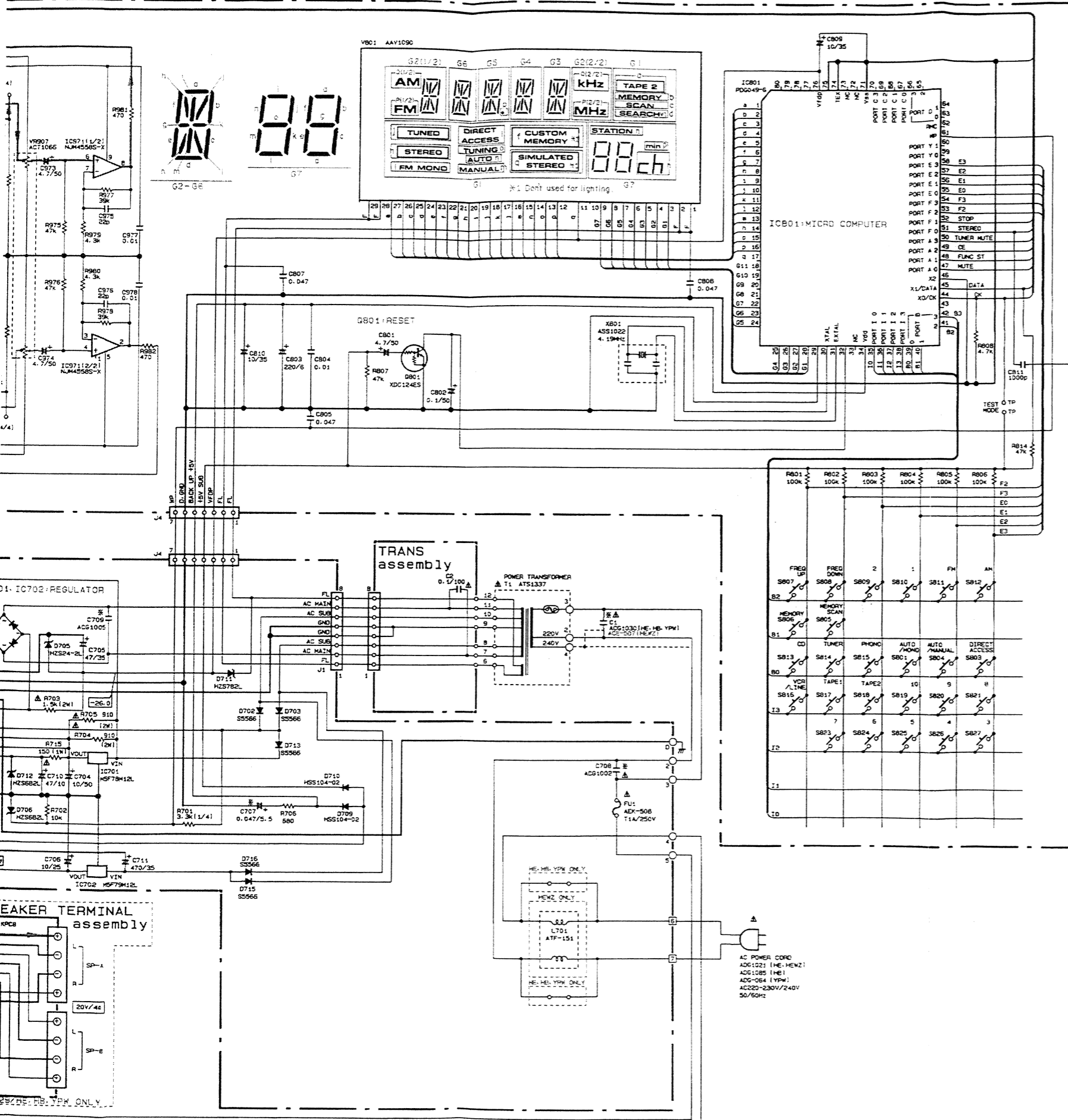

- RESISTORS:**
Indicated in Ω , $\frac{1}{4}W$, $\frac{1}{8}W$, $\pm 5\%$ tolerance unless otherwise noted k: k Ω , M: M Ω , (F): $\pm 1\%$, (G): $\pm 2\%$, (K): $\pm 10\%$ (M): $\pm 20\%$ tolerance
- CAPACITORS:**
Indicated in capacity (μF)/voltage (V) unless otherwise noted p: pF
Indication without voltage is 50V except electrolytic capacitor.
- VOLTAGE, CURRENT:**
 - Signal voltage at (55 W + 55 W 8 Ω) output (1kHz)
 - DC voltage (V) at no input signal
 - Value in () is DC voltage at rated power.
 - mA: DC current at no input signal
- OTHERS:**
 - Signal route.
 - Adjusting point.

The Δ mark found on some component parts indicates the importance of the safety factor of the part. Therefore, when replacing, be sure to use parts of identical designation.
* marked capacitors and resistors have parts numbers.

This is the basic schematic diagram, but the actual circuit may vary due to improvements in design.

- SWITCHES:**
- SP SWITCH assembly**
- S1 POWER
 - S570 SP A ON-OFF
 - S571 SP B ON-OFF
- CONTROL assembly**
- S801 FM MODE AUTO/MONO
 - S803 DIRECT ACCESS
 - S804 FM TUNING AUTO/MANUAL
 - S805 MEMORY SCANS
 - S806 MEMORY
 - S807 FREQ UP
 - S808 FREQ DOWN
 - S809 2
 - S810 1
 - S811 FM
 - S812 AM
 - S813 CD
 - S814 TUNER
 - S815 PHONO
 - S816 VCR/LINE
 - S817 TAPE 1/DAT
 - S818 TAPE 2/ADAPTOR
 - S819 10
 - S820 9
 - S821 8
 - S823 7
 - S824 6
 - S825 5
 - S826 4
 - S827 3
- S301 DIRECT ON/OFF

Line voltage selection (For HE, HB and HEWZ types)

- Line voltage can be changed with the following steps.
1. Disconnect the AC Power cord.
 2. Remove the top cover.
 3. Change the connection of the power transformer primary taps.
 4. Change the connection to the capacitor (C1) on the primary side of the power transformer.
 5. Stick the line voltage label on the rear panel.

Part No.	Description
AAX-193	220V label
AAX-192	240V label

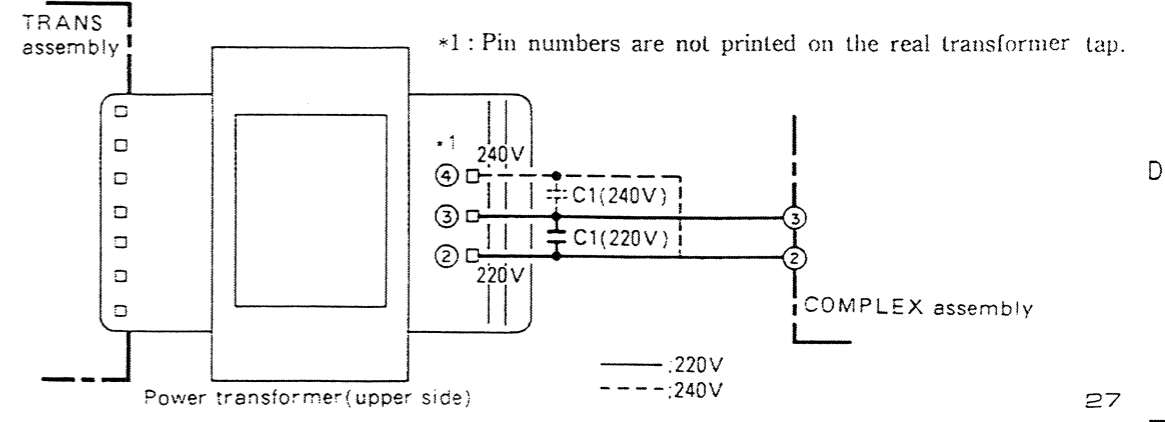

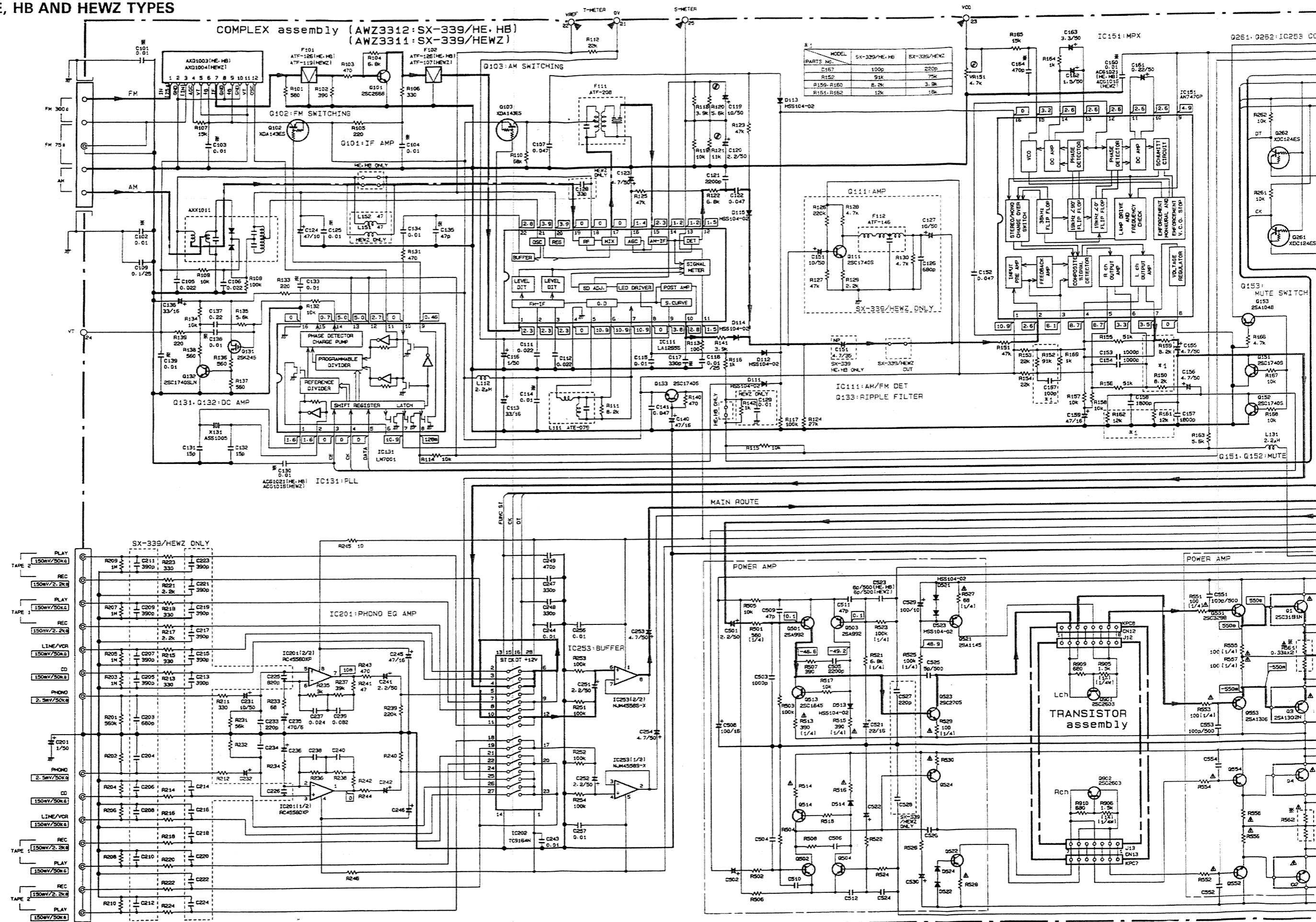

PARTS NO.	SX-339/HE, HB	SX-339/HEWZ
C167	100p	220p
R150	91k	75k
R159-R160	5.2k	3.3k
R161-R162	12k	10k

A

B

C

D

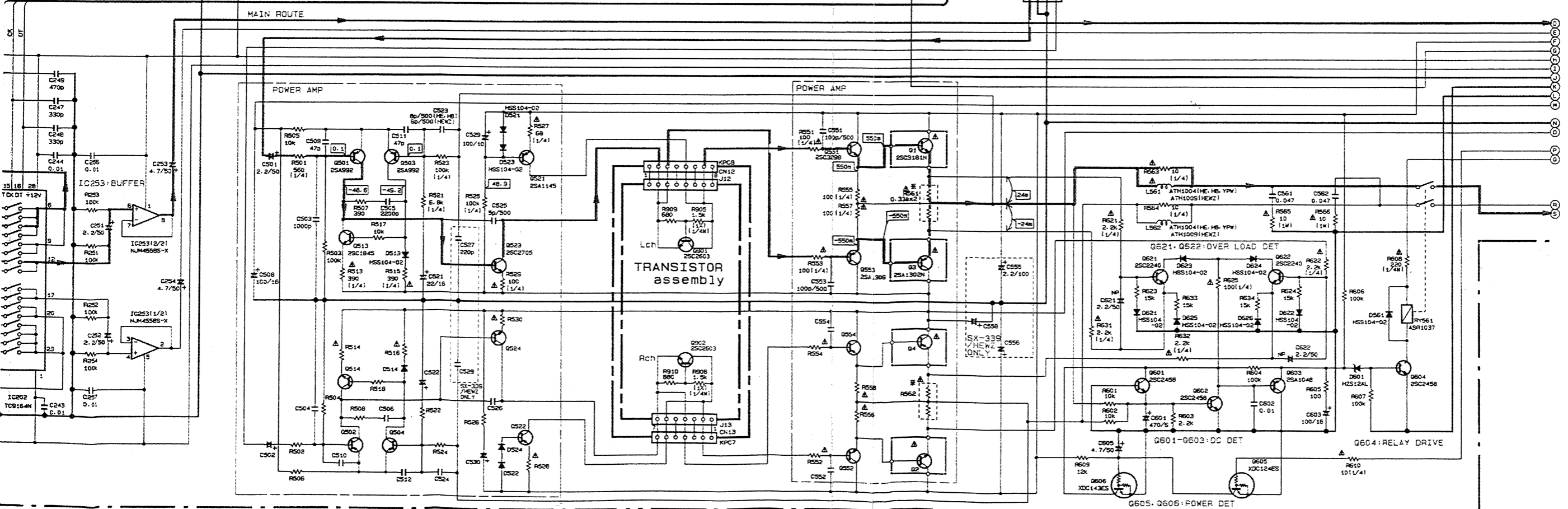
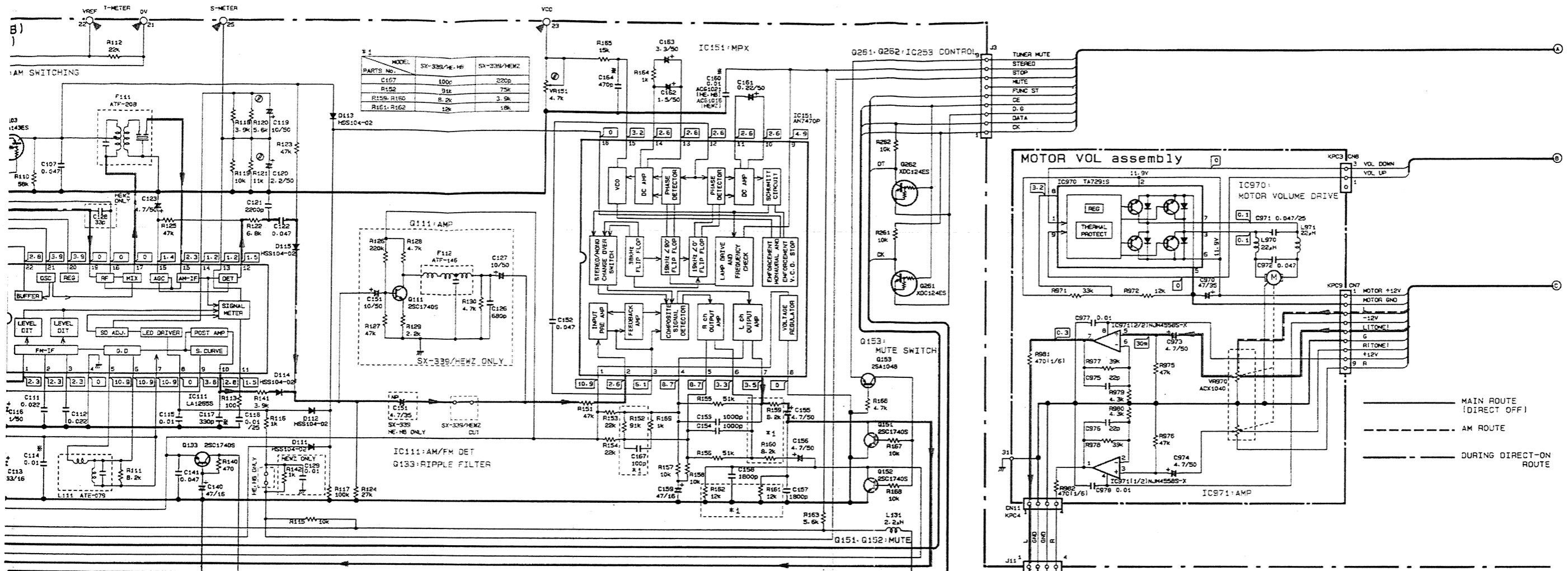

A

B

C

D

PCB Pattern

The differences in PCB patterns between AWZ4877 and AWZ3299 are as follows.

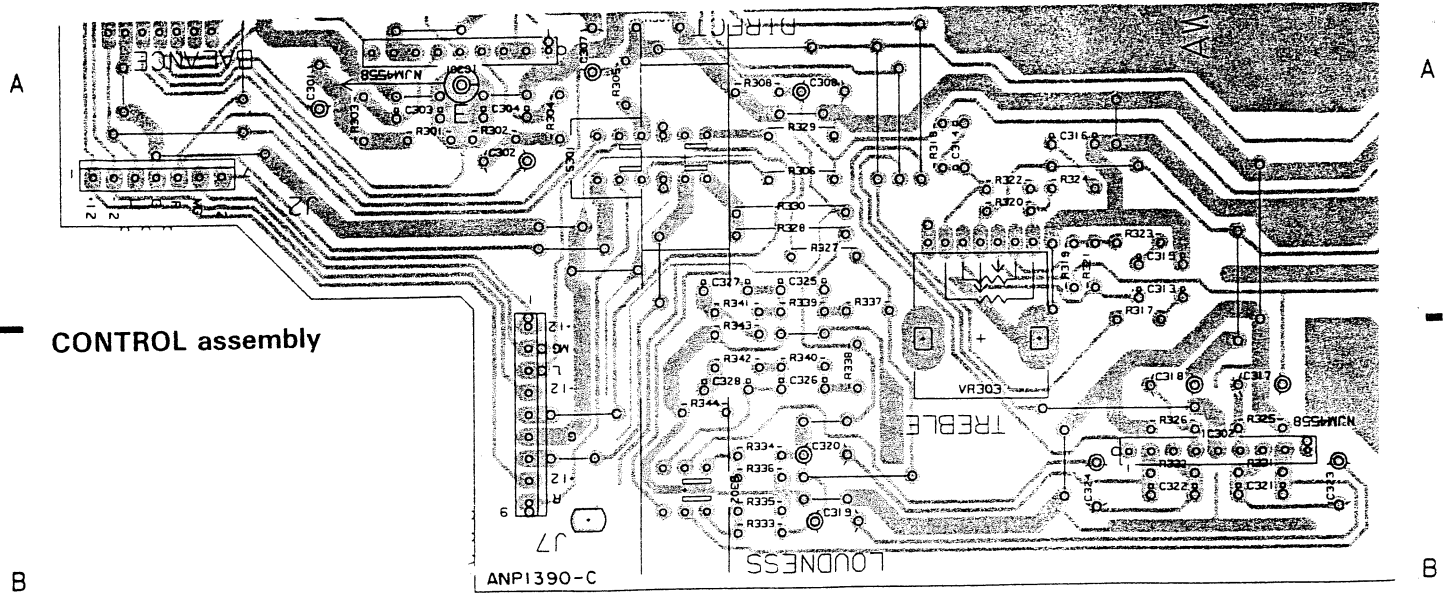

This PCB connection diagram is viewed from the parts mounted side.

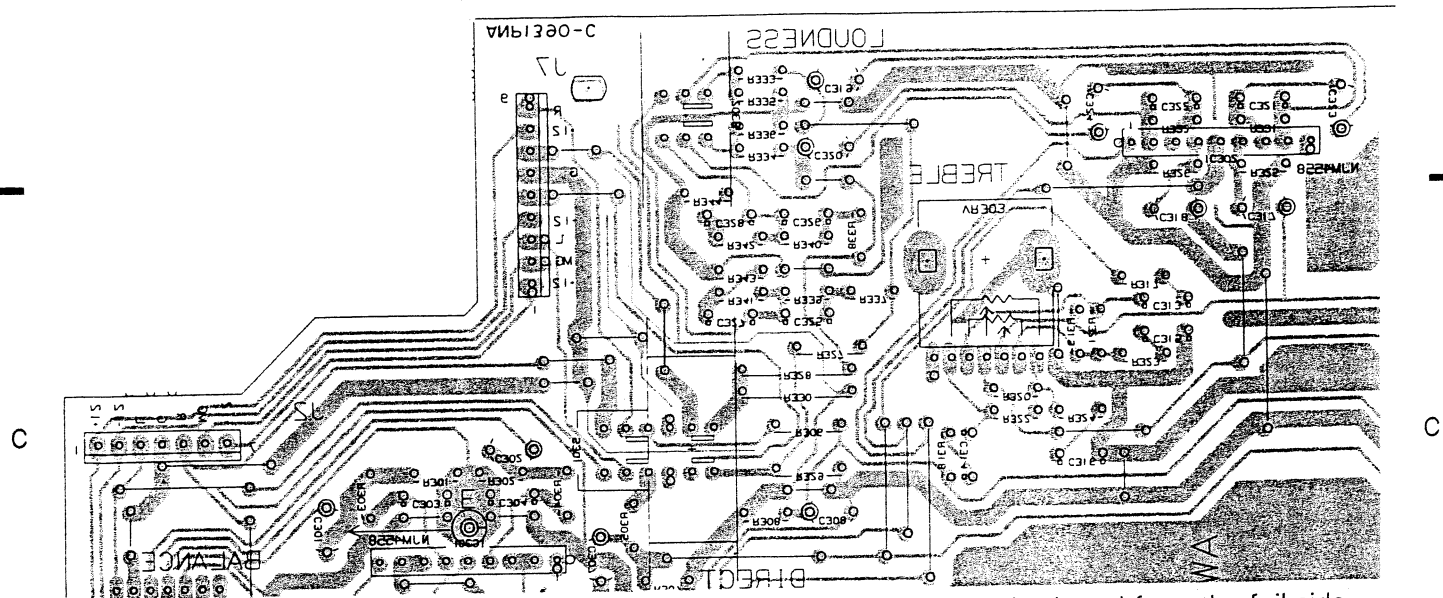

This PCB connection diagram is viewed from the foil side.

NOTE

1. This P.C.B connection diagram is viewed from the parts mounted side.
2. The parts which have been mounted on the board can be replaced with those shown with the corresponding wiring symbols listed in the following Table.
3. The capacitor terminal marked with ⊕ (double circles) shows negative terminal.
4. The diode terminal marked with ⊕ (double circles) shows cathode side.
5. The transistor terminal to which E is affixed shows the emitter.

P.C.B. pattern diagram indication	Corresponding part symbol	Part Name	P.C.B. pattern diagram indication	Corresponding part symbol	Part Name
		Transistor			Resistor
		Radiator type transistor			Capacitor (Polarized)
		Diode			Capacitor (Non-polarized)

Others

P.C.B. pattern diagram indication	Part Name	P.C.B. pattern diagram indication	Part Name
IC	IC	L	Coil
S	Switch	F	Filter
RY	Relay	VR	Variable resistor or Semi-fixed resistor

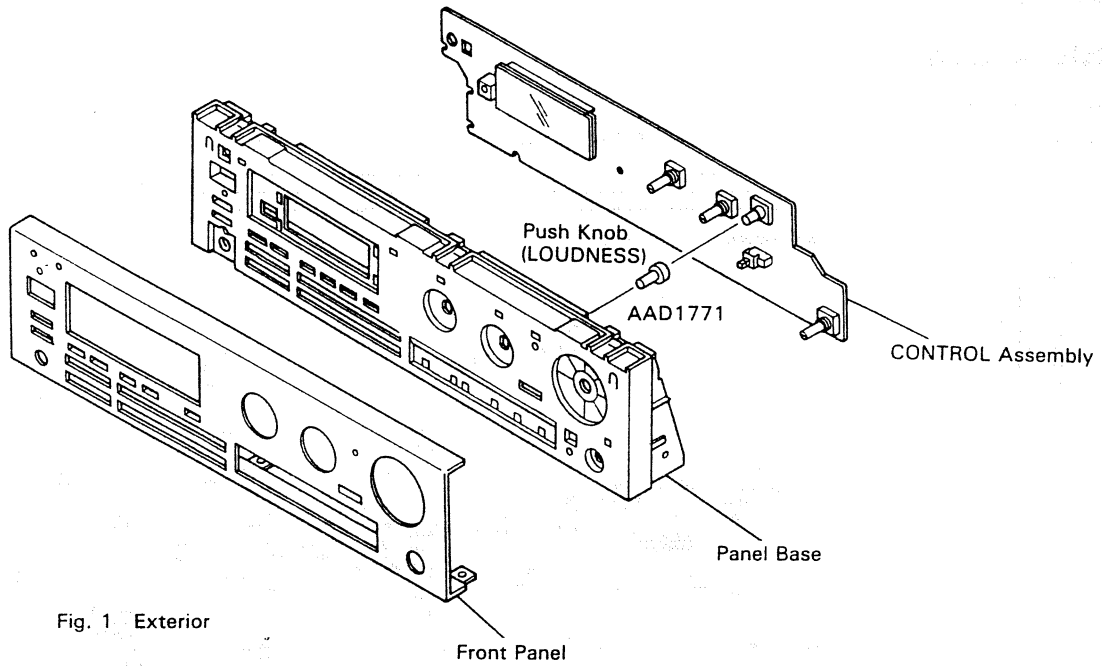

Fig. 1 Exterior

CONTROL ASSEMBLY

AWZ4877 and AWZ3299 have the same construction except for the following :

Mark	Symbol & Description	Part No.		Remarks
		AWZ3299	AWZ4877	
	S302 (LOUDNESS)	ASG1041	
	C321, C322	CCCSL390J50	
	C323, C324	CEAS100M50	
	C325, C326	CFTXA104J50	
	C327, C328	CFTXA823J50	
	R327, R328	RD1/8PM122J	RD1/8PM332J	
	R329, R330	RD1/8PM222J	RD1/8PM821J	
	R331, R332	RD1/8PM154J	
	R333, R334	RD1/8PM332J	
	R335, R336	RD1/8PM182J	
	R337, R338	RD1/8PM392J	
	R339, R340	RD1/8PM223J	
	R341, R342	RD1/8PM152J	
	R343, R344	RD1/8PM122J	

SCHEMATIC DIAGRAM AND PCB PATTERN

• For assemblies which are different in SX-302/HE, HB, HEWZ and SX-339/HE, the schematic diagram and PCB pattern are shown below.

CONTROL ASSEMBLY

Schematic Diagram

• The differences in schematic diagram between AWZ4877 and AWZ3299 are as follows.

CONTROL assembly (AWZ4877)

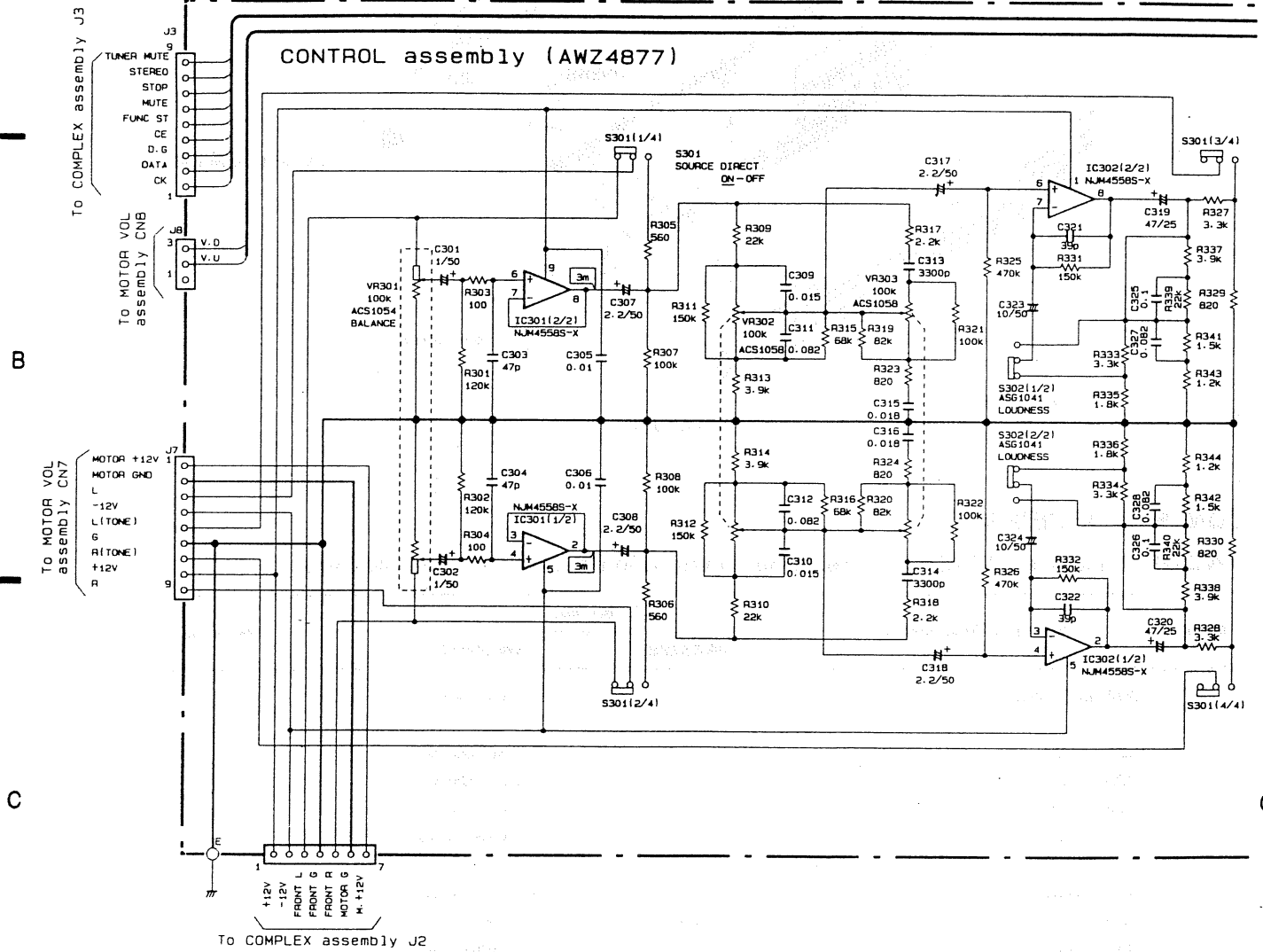

Note:

Type 1

1. When ordering service parts, be sure to refer to "PARTS LIST of EXPLODED VIEWS" or "PCB PARTS LIST".
2. Since these are basic circuits, some parts of them or the values of some components may be changed for improvement.
3. RESISTORS:
Unit: k:kΩ, M:MΩ, or Ω unless otherwise noted.
Rated power: 1/4W, 1/6W, 1/8W, 1/10W unless otherwise noted.
Tolerance: (F): ±1%, (G): ±2%, (K): ±10%, (M): ±20% or ±5% unless otherwise noted.
4. CAPACITORS:
Unit: p:pF or μF unless otherwise noted.
Ratings: capacitor (μF)/ voltage (V) unless otherwise noted.
Rated voltage: 50V except for electrolytic capacitors.

5. COILS:
Unit: m:mH or μH unless otherwise noted.
6. VOLTAGE AND CURRENT:
V : Signal voltage at rated output.
V : DC voltage (V) at no input signal unless otherwise noted.
Value in () is DC voltage at rated power.
mV : Signal voltage at FM 1kHz, 100% MOD.
mA or - mA : DC current at no input signal unless otherwise noted.
7. OTHERS:
• → : Signal route.
• ⊙ : Adjusting point.
• ▼ (Red) : Measurement point.
• The Δ mark found on some component parts indicates the importance of the safety factor of the parts. Therefore, when replacing, be sure to use parts of identical designation.
8. SWITCHES (Underline indicates switch position):

SCH - 1F

CONTROL assembly
S302 LOUDNESS

CONTROL assembly

CONTRAST OF MISCELLANEOUS PARTS

NOTES :

- Parts marked by "NSP" are generally unavailable because they are not in our Master Spare Parts List.
- The Δ mark found on some component parts indicates the importance of the safety factor of the part. Therefore, when replacing, be sure to use parts of identical designation.
- Parts marked by "⊙" are not always kept in stock. Their delivery time may be longer than usual or they may be unavailable.

SX-302/HE, HB, HEWZ and SX-339/HE have the same construction except for the following :

Mark	Symbol & Description	Part No.				Remarks	
		SX-339/HE	SX-302/HE	SX-302/HB	SX-302/HEWZ		
NSP	CONTROL assembly	AWZ3299	AWZ4877	AWZ4877	AWZ4877		
	COMPLEX assembly	AWZ3312	AWZ3312	AWZ3312	AWZ3311 *		
	SP SWITCH assembly	AWZ3007	AWZ3307	AWZ3307	AWZ3000 *		
NSP	SP TERMINAL assembly	AWZ3306	AWZ3306	AWZ3306	AWZ3302 *		
NSP	LINE FILTER assembly	AWZ3002 *		
Δ	C1 capacitor (0.1)	ACE-507 *		
Δ	C1 capacitor (0.022)	ACG1030	ACG1030	ACG1030		
Δ	AC power cord	ADG1021	ADG1049	ADG1118	ADG1049		For AC power cord
Δ	Strain relief	AEC-882	AEC-882	AEC-882		
NSP	Front panel	ANB1444	ANB1565	ANB1565	ANB1565		Refer to Fig. 1
	Rear panel	ANC1679	ANC2086	ANC2086	ANC2085		
	Panel	AAK2124	AAK2477	AAK2477	AAK2477		
	Name plate	AAM1029	VAM1032	VAM1032	VAM1032		
	Push knob (LOUDNESS)	AAD1771	AAD1771	AAD1771		
	Function knob	AAD1812	AAD2454	AAD2454	AAD2454		
	Screw (EARTH)	ABA1047 *		
	PCB holder	ANG1062 *		
	Packing case	AHD2019	AHD2647	AHD2603	AHD2647		
	Remote control unit (CU-SX022)	AXD1198		
Remote control unit (CU-SX070)	AXD1364	AXD1364	AXD1364			
FM antenna assembly	ADH1002 *			
FM antenna	ADH1004	ADH1004	ADH1004			
Operating instructions (English, French, German, Italian, Dutch, Swedish, Spanish, Portuguese)	ARE1182	ARE1286			
Operating instructions (English)	ARB1445			
Operating instructions (German)	ARC1435			

Note : All the assemblies and the parts with * are the same as those of SX-339/HEWZ type in the service manual ARP2223 for SX-339. Therefore, refer to SX-339/HEWZ type.

-R352

4107

 **PIONEER**
The Art of Entertainment

Service Manual

ORDER NO.
ARP2772

STEREO RECEIVER

SX-302

HE, HB, HEWZ

- Refer to the service manual ARP2223 for SX-339/HE.
- This manual is applicable to SX-302/HE, HB and HEWZ.

PIONEER ELECTRONIC CORPORATION 4-1, Meguro 1-Chome, Meguro-ku, Tokyo 153, Japan
PIONEER ELECTRONICS SERVICE INC. P.O. Box 1760, Long Beach, California 90801 U.S.A.
PIONEER ELECTRONICS OF CANADA, INC. 300 Allstate Parkway Markham, Ontario L3R 0P2 Canada
PIONEER ELECTRONIC [EUROPE] N.V. Haven 1087 Keetberglaan 1, 9120 Melsele, Belgium
PIONEER ELECTRONICS AUSTRALIA PTY. LTD. 178-184 Boundary Road, Braeside, Victoria 3195, Australia TEL: [03] 580-9911

4109

• FOR HE AND HB TYPES

NOTE

1. This P.C.B. connection diagram is viewed from the parts mounted side.
2. The parts which have been mounted on the board can be replaced with those shown with the corresponding wiring symbols listed in the following Table.

P.C.B. pattern diagram indication	Corresponding part symbol	Part Name
		Transistor
		Radiator type transistor
		Diode
		Resistor
		Capacitor (Polarity)
		Capacitor (Non-polarity)

Others

P.C.B. pattern diagram indication	Part Name
IC	IC
S	Switch
RY	Relay
L	Coil
F	Filter
VR	Variable resistor or Semi-fixed resistor

3. The capacitor terminal marked with ⊕ (double circles) shows negative terminal.
4. The diode terminal marked with ⊕ (double circles) shows cathode side.
5. The transistor terminal to which E is affixed shows the emitter.

TRANSISTOR assembly

To SP SWITCH assembly J5
(To page 37)

To CONTROL assembly J3
(To page 38)

To CONTROL assembly E
(To page 37)

To CONTROL assembly J8
(To page 38)

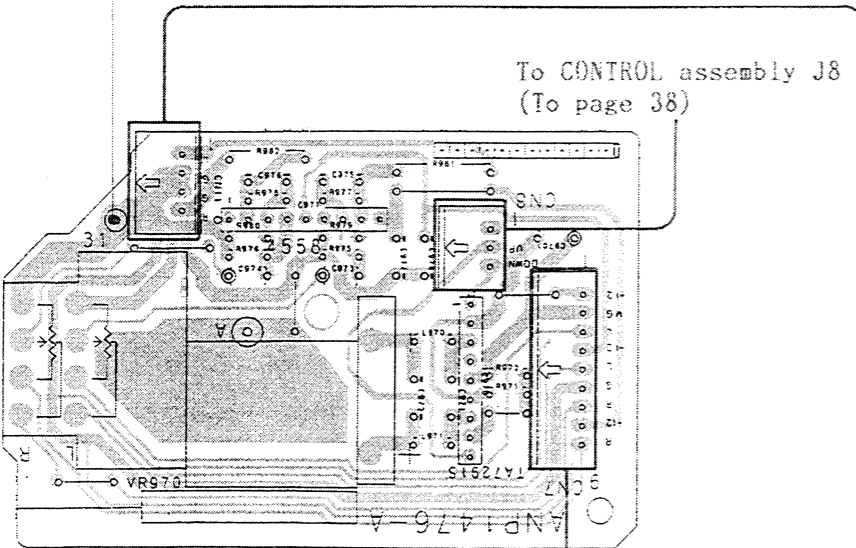

MOTOR VOL assembly

To CONTROL assembly J7
(To page 37)

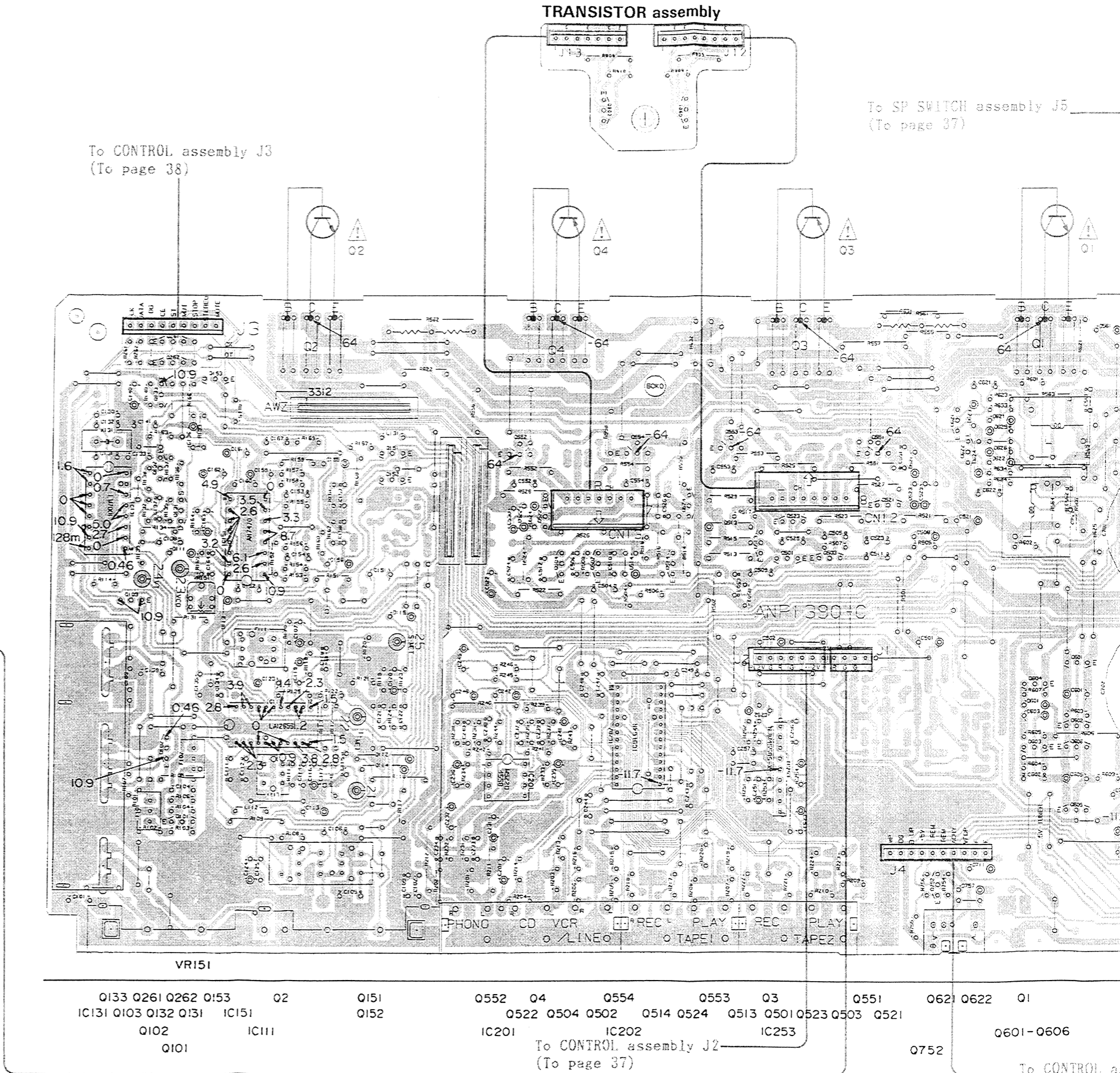

Q133 Q261 Q262 Q153 Q2 Q151 Q152 Q552 Q4 Q554 Q553 Q3 Q551 Q621 Q622 Q1 Q601-Q606 Q752

IC131 Q103 Q132 Q131 IC151 Q102 IC111 Q101

Q522 Q504 Q502 Q514 Q524 Q513 Q501 Q523 Q503 Q521 IC201 IC202 IC253

To CONTROL assembly J2
(To page 37)

To CONTROL assembly J3
(To page 38)

4

5

6

7

8

TRANSISTOR assembly

To SP SWITCH assembly J5
(To page 37)

assembly J3

TRANS assembly

POWER TRANSFORMER

AC POWER CORD
AC 220V~230V/240V
50/60Hz

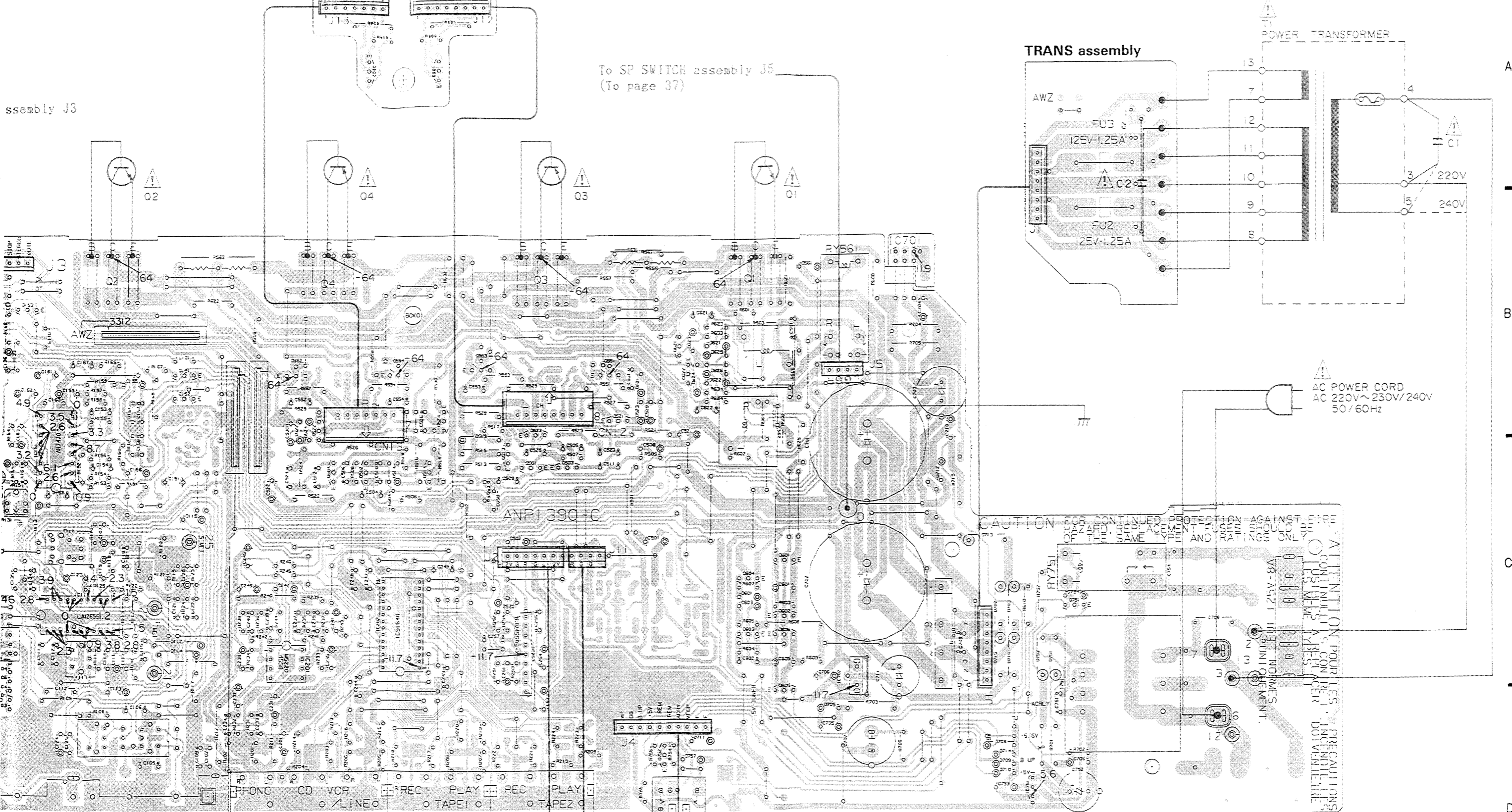

COMPLEX assembly (AWZ3312)

CAUTION

ATTENTION POUR LES PRECAUTIONS CONTINUES, CONTRE LES DANGERS D'INCENDIE

ATTENTION FOR CONTINUOUS PRECAUTIONS AGAINST THE DANGERS OF FIRE

15V 15V 15V

RY75

15V 15V 15V

15V 15V 15V

15V 15V 15V

IC151

IC201

To CONTROL assembly J2
(To page 37)

IC253

IC701

IC702

To CONTROL assembly J4
(To page 38)

IC751

IC111

IC151

IC151

IC201

IC202

IC253

IC701

IC702

IC751

4

5

6

7

8

9

A
B
C
D

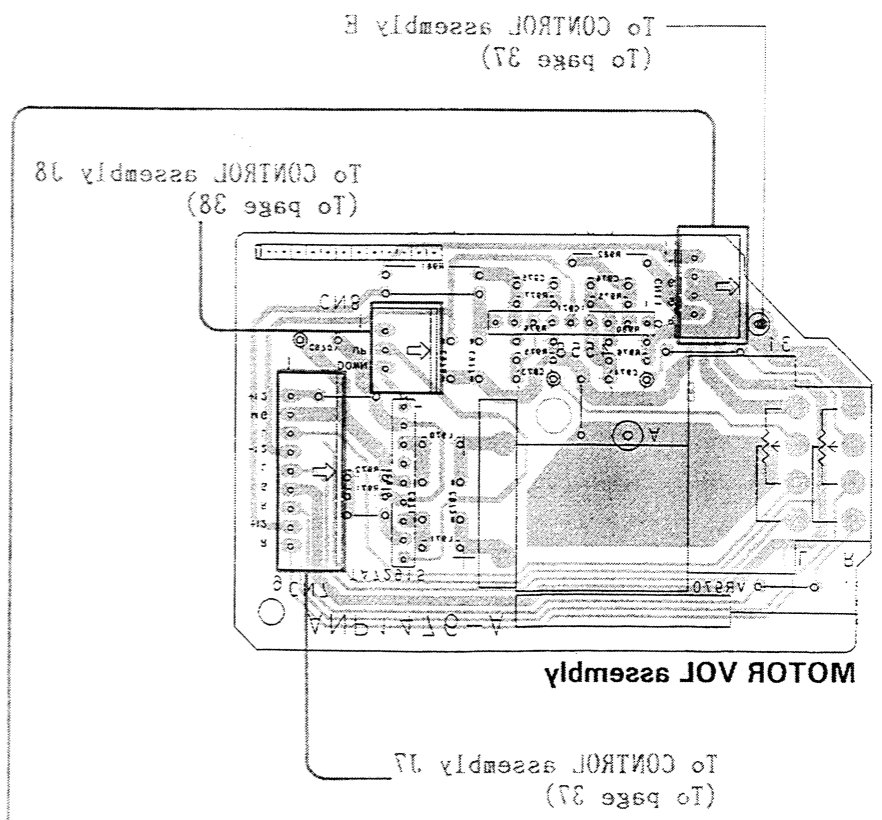
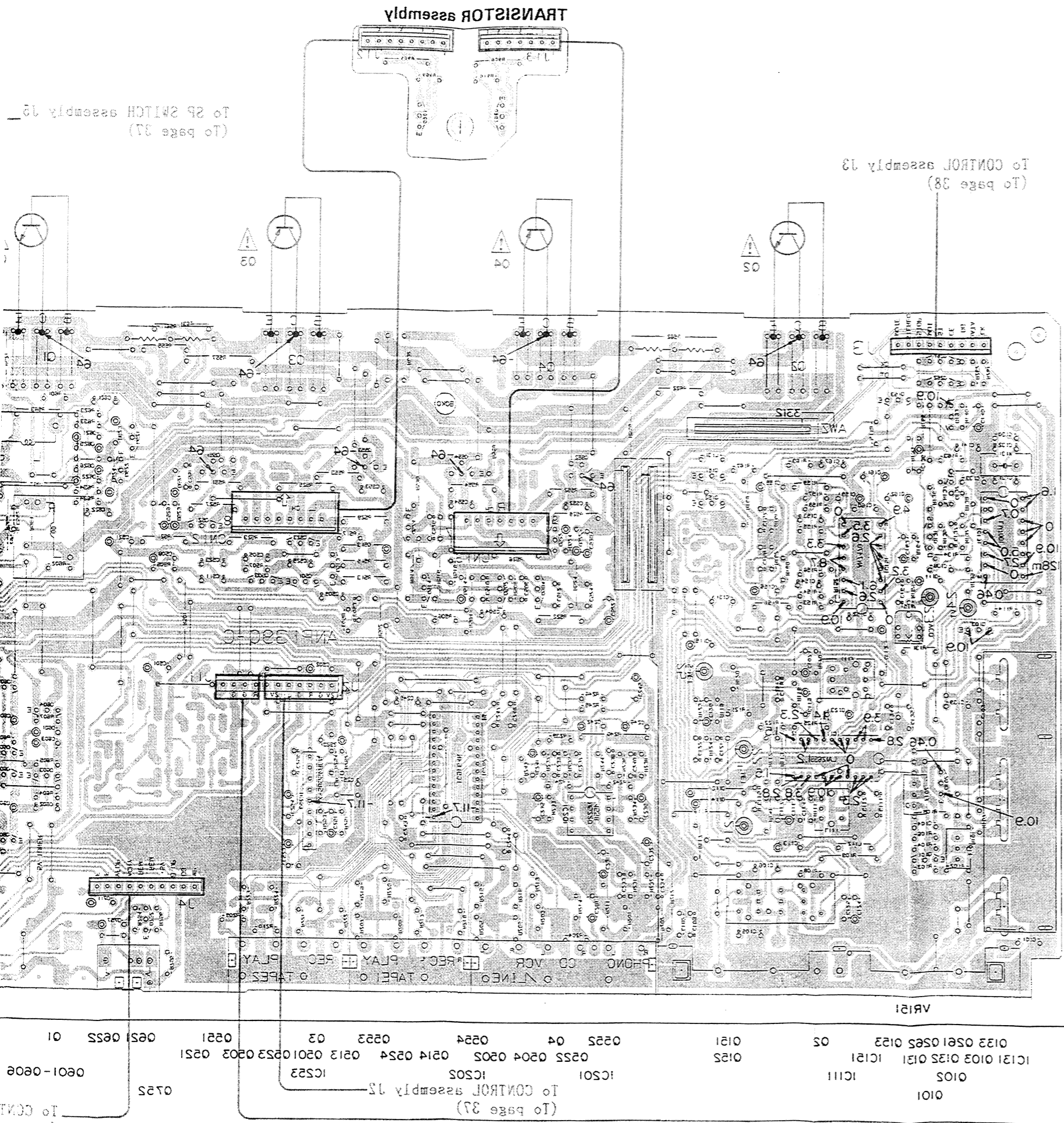

0 1 2 3 4 5 6 7 8 9

0 1 2 3 4 5 6 7 8 9

1 | 2 | 3 | 4 | 5

To COMPLEX assembly J5
(To page 33)

NOTE

1. This P.C.B. connection diagram is viewed from the parts mounted side.
2. The parts which have been mounted on the board can be replaced with those shown with the corresponding wiring symbols listed in the following Table.

P.C.B. pattern diagram indication	Corresponding part symbol	Part Name
		Transistor
		Radiator type transistor
		Diode
		Resistor
		Capacitor (Polarity)
		Capacitor (Non-polarity)

Others	
P.C.B. pattern diagram indication	Part Name
	IC
	Switch
	Relay
	Coil
	Filter
	Variable resistor or Semi-fixed resistor

3. The capacitor terminal marked with ⊕ (double circles) shows negative terminal.
4. The diode terminal marked with ⊕ (double circles) shows cathode side.
5. The transistor terminal to which E is affixed shows the emitter.

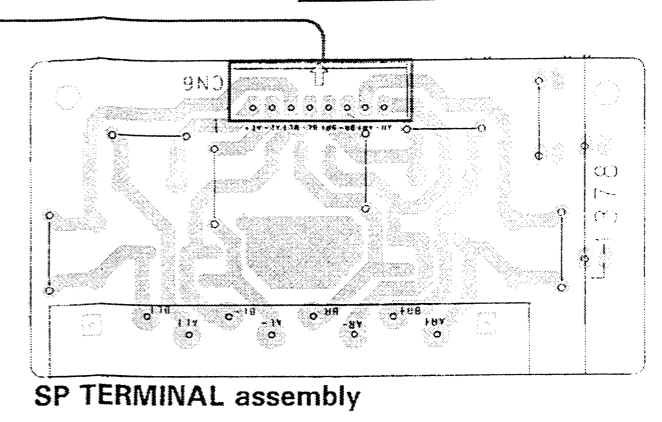
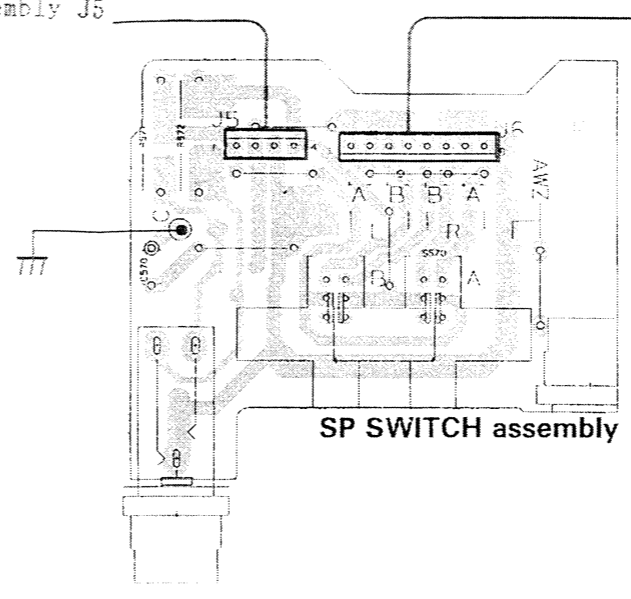

To MOTOR VOL. assembly CN8
(To page 31)

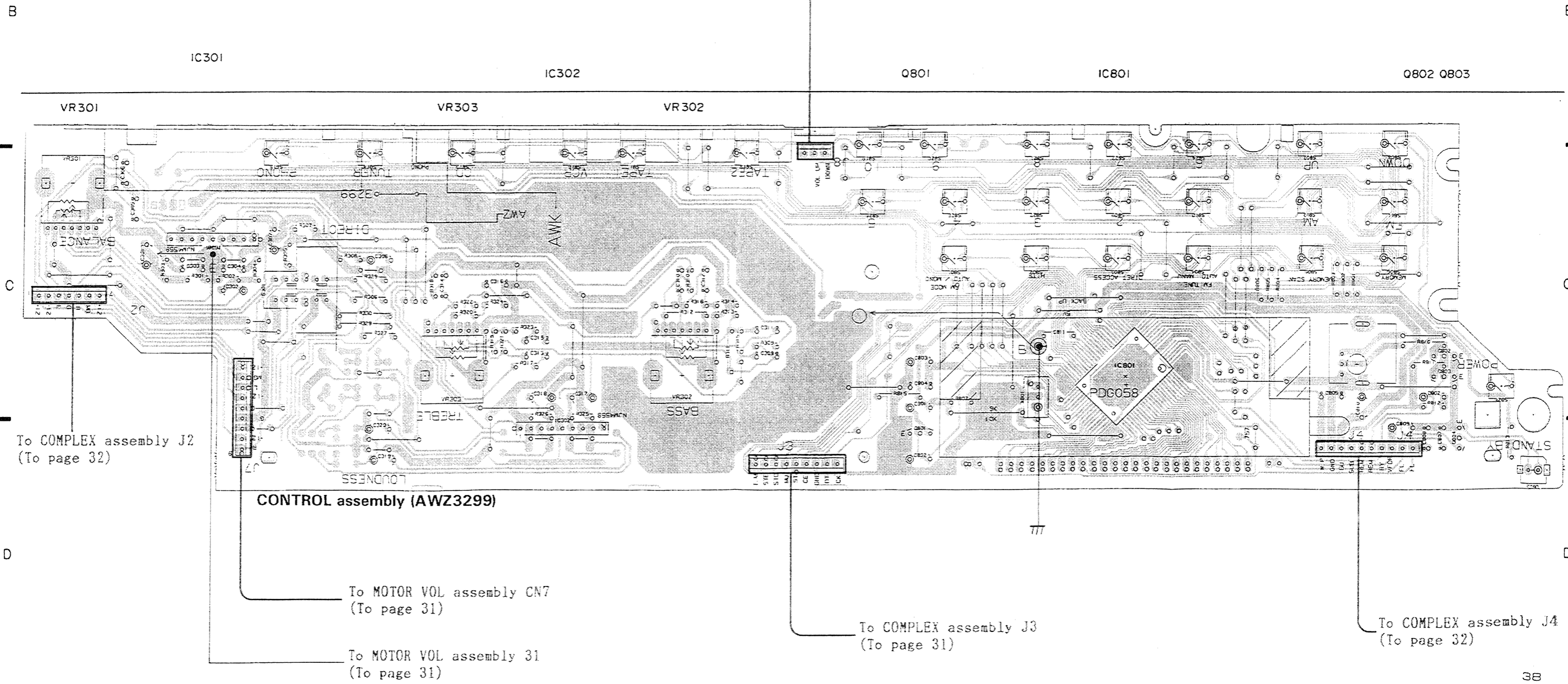

1 | 2 | 3 | 4 | 5 | 6

A

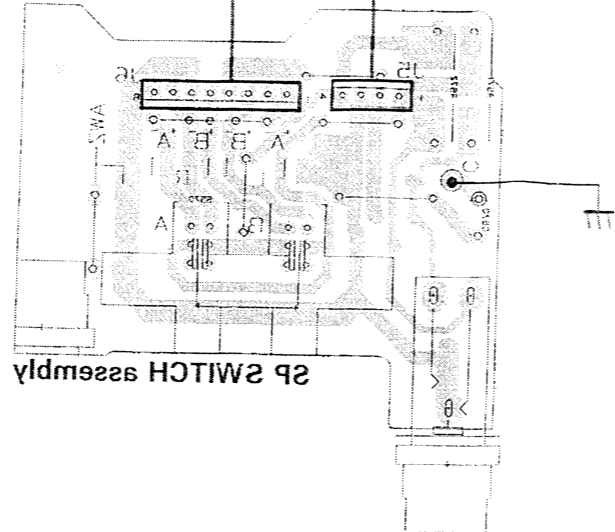
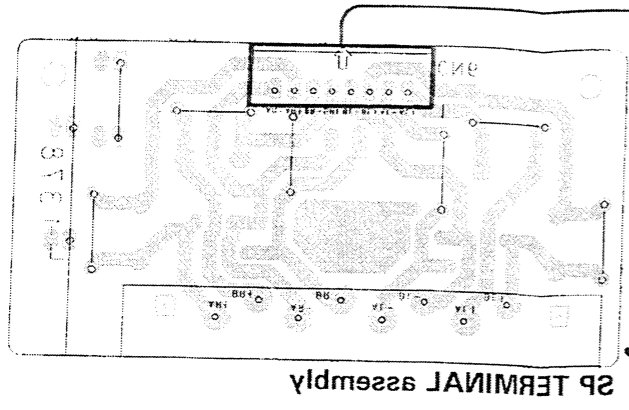

To COMPLEX assembly 12
(To page 33)

B

To MOTOR VOL assembly CM8
(To page 31)

0805 0803

IC801

0801

IC305

IC301

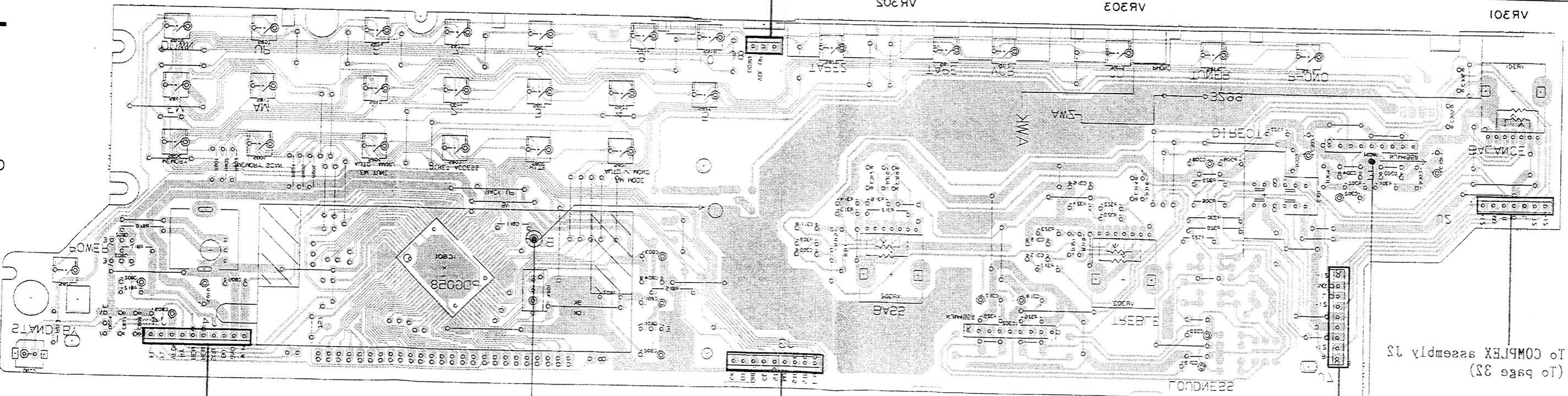

To COMPLEX assembly 12
(To page 32)

D

To COMPLEX assembly 14
(To page 32)

To COMPLEX assembly 13
(To page 31)

To MOTOR VOL assembly CM7
(To page 31)

To MOTOR VOL assembly 31
(To page 31)

e

2

4

3

2

1

A

B

C

D

- FOR HEWZ TYPE
- As to the other assemblies, refer to "FOR HE AND HB TYPES".

A

NOTE

1. This P.C.B. connection diagram is viewed from the parts mounted side.
2. The parts which have been mounted on the board can be replaced with those shown with the corresponding wiring symbols listed in the following Table.

P.C.B. pattern diagram indication	Corresponding part symbol	Part Name
		Transistor
		Radiator type transistor
		Diode
		Resistor
		Capacitor (Polarity)
		Capacitor (Non-polarity)

Others

P.C.B. pattern diagram indication	Part Name
IC	IC
S	Switch
RY	Relay
L	Coil
F	Filter
VR	Variable resistor or Semi-fixed resistor

3. The capacitor terminal marked with ⊕ (double circles) shows negative terminal.
4. The diode terminal marked with ⊕ (double circles) shows cathode side.
5. The transistor terminal to which E is affixed shows the emitter.

B

COMPLEX assembly (AWZ3311)

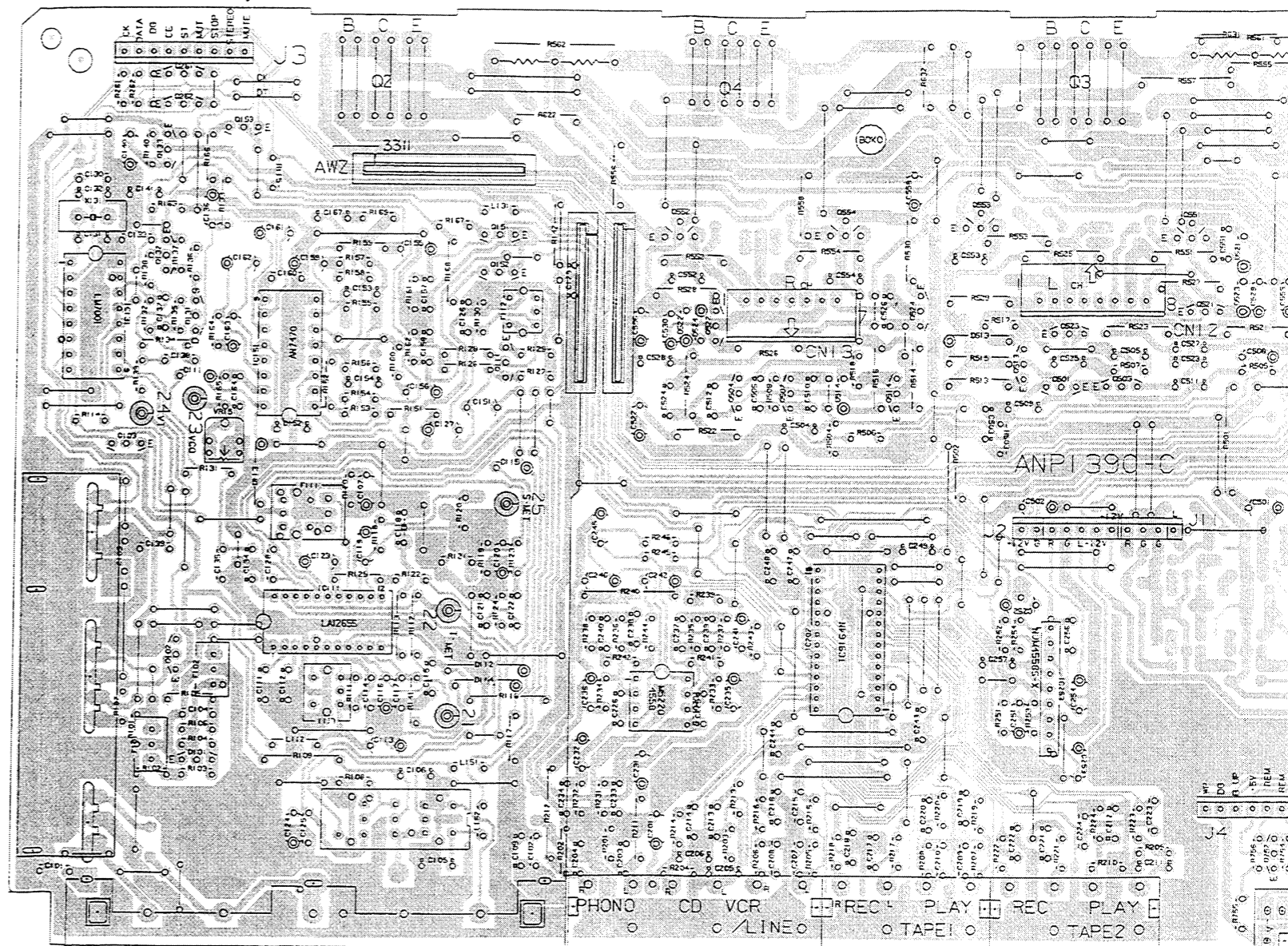

C

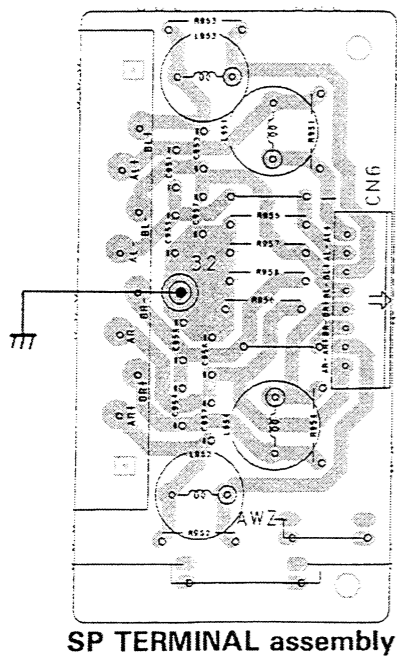

SP TERMINAL assembly

D

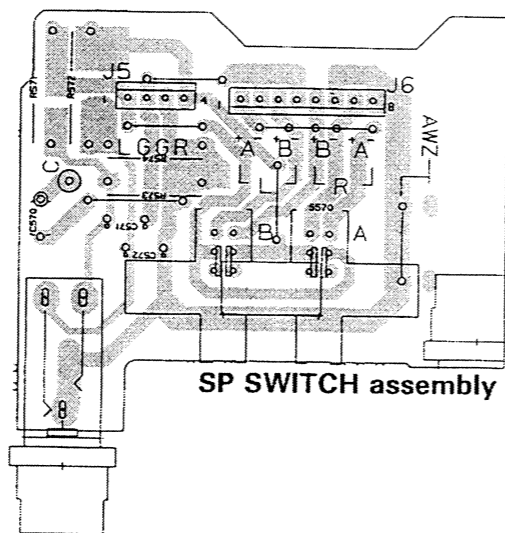

SP SWITCH assembly

VR151

Q133 Q261 Q262 Q153 Q2 Q151 Q552 Q4 Q554 Q553 Q3 Q551 Q62
 IC131 Q103 Q132 Q131 IC151 Q152 Q111 Q522 Q504 Q502 Q514 Q524 Q513 Q501 Q523 Q503 Q521
 Q102 IC111 IC201 IC202 IC253
 Q101

Q752

COMPLEX assembly (AWZ3311)

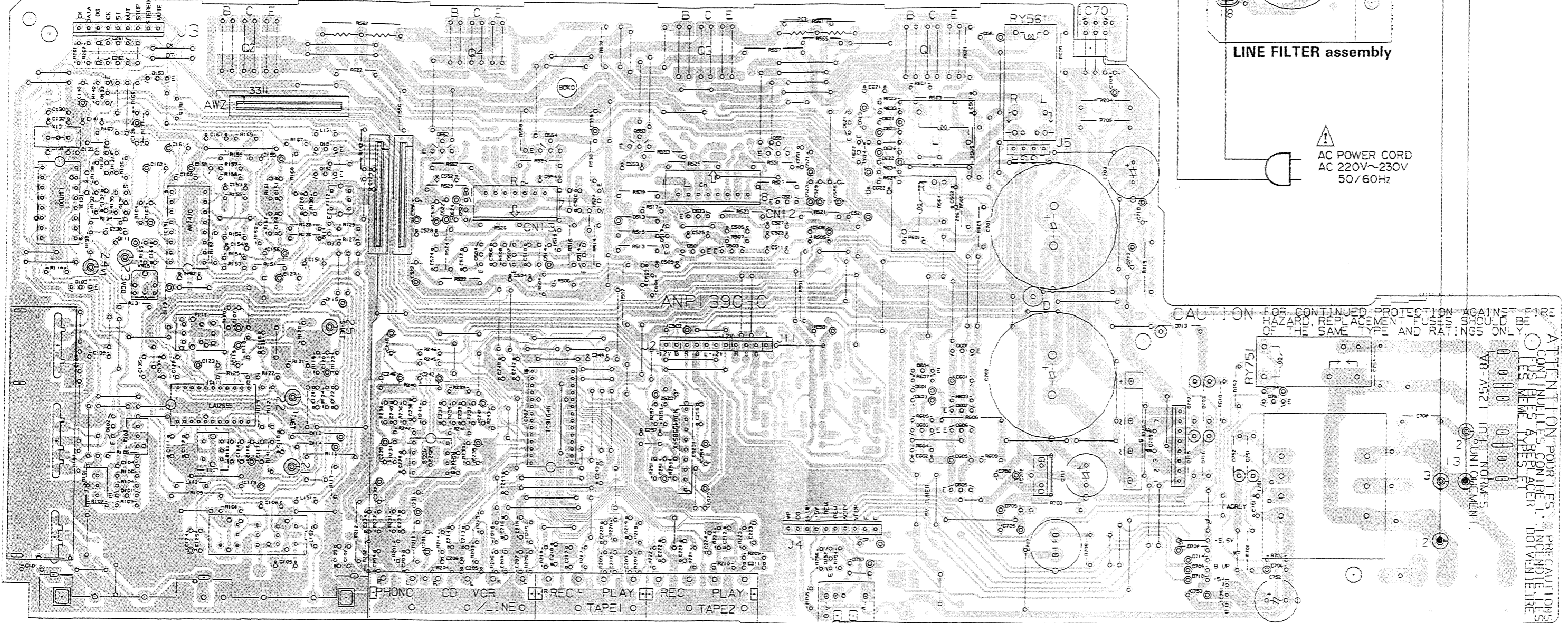

VR151

- | | | | | | | | | | | | | | | | | |
|-------|-------|-------|-------|-------|------|-----------|-------|------|-------|------|------|------|------|------|-------|------|
| Q133 | Q261 | Q262 | Q153 | Q2 | Q151 | Q552 | Q4 | Q554 | Q553 | Q3 | Q551 | Q621 | Q622 | Q1 | IC701 | |
| IC131 | Q103 | Q132 | Q131 | IC151 | Q152 | Q111 | Q522 | Q504 | Q502 | Q514 | Q524 | Q513 | Q501 | Q523 | Q503 | Q521 |
| Q102 | IC111 | IC201 | IC202 | IC253 | Q752 | Q601-Q606 | IC702 | Q751 | IC751 | | | | | | | |
| Q101 | | | | | | | | | | | | | | | | |

A 8 7 e 2 4

COMPLEX assembly (W3311)

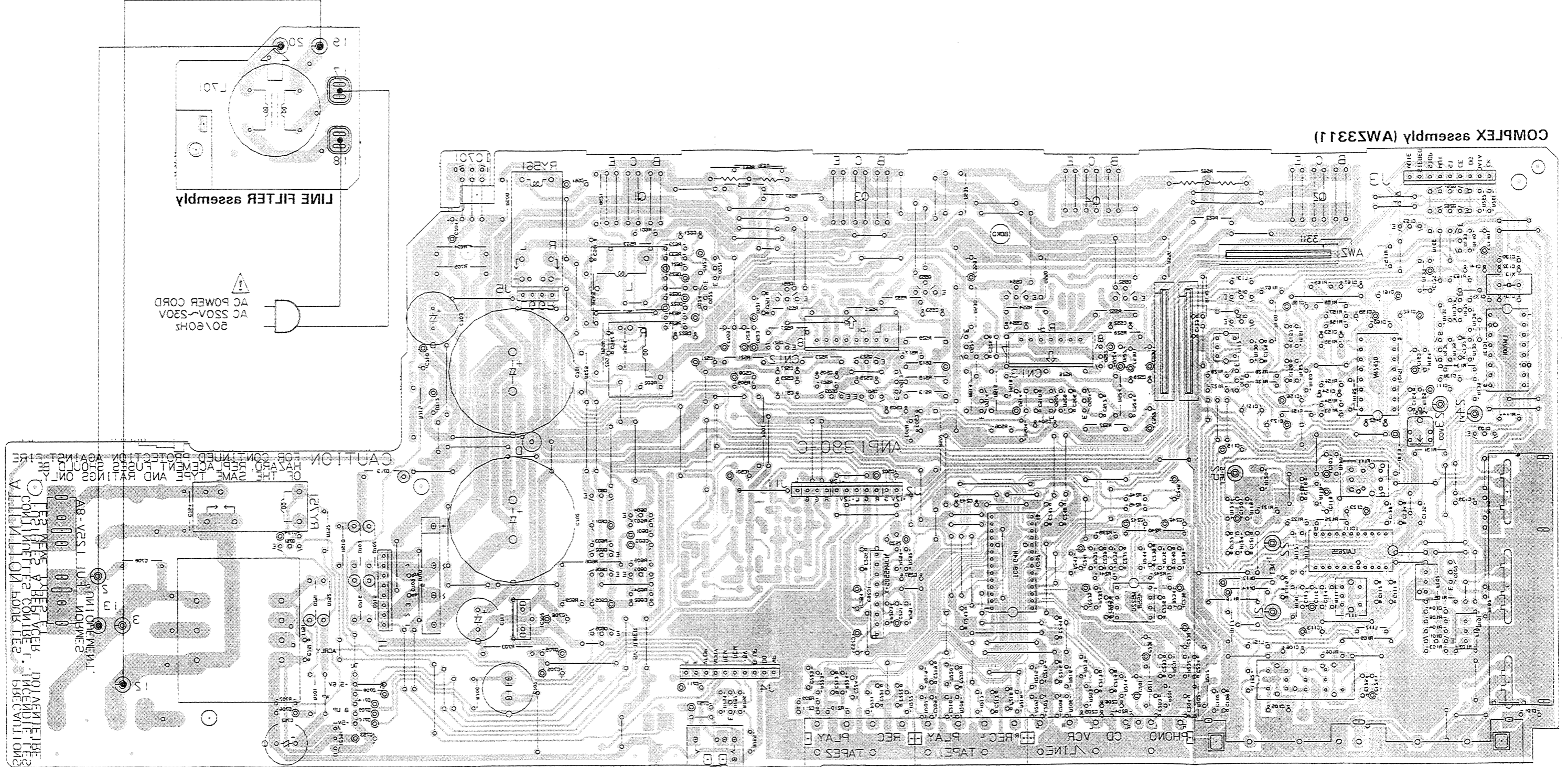

AC POWER CORD
50V 60Hz

LINE FILTER assembly

CAUTION: THE SAME TYPE AND RATINGS OF THE SAME TYPE AND RATINGS SHOULD BE USED FOR CONTINUED PROTECTION AGAINST FIRE

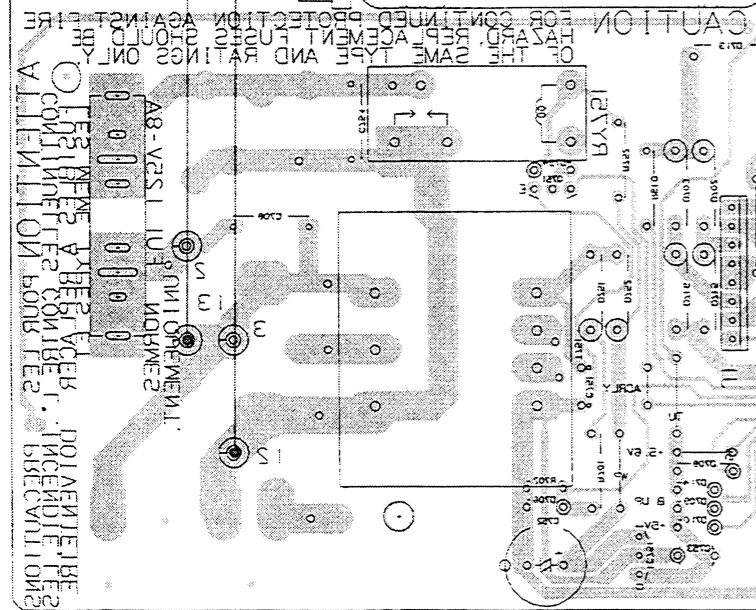

AR121

0101	0105	0121	0125	0131	0103	0121	0121	0130	0501	0523
0251	0255	0255	0255	0255	0204	0205	0214	0254	0212	0201
0252	0253	0253	0253	0253	0254	0254	0254	0254	0253	0253
0251	0251	0251	0251	0251	0251	0251	0251	0251	0251	0251

A

B

C

D

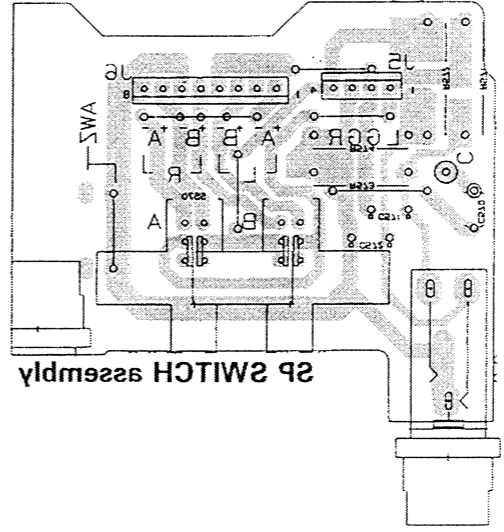
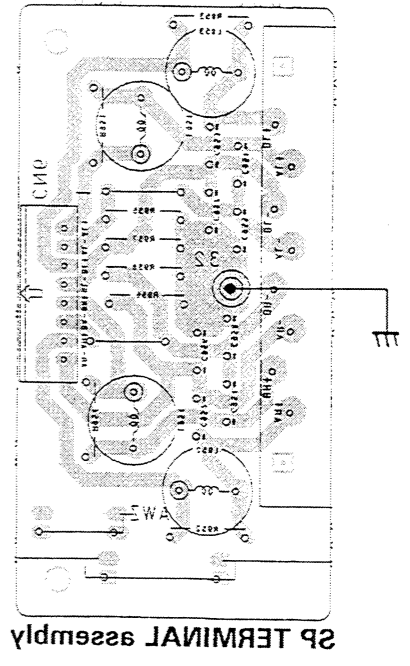

COMPLEX assembly (AWZ3311)

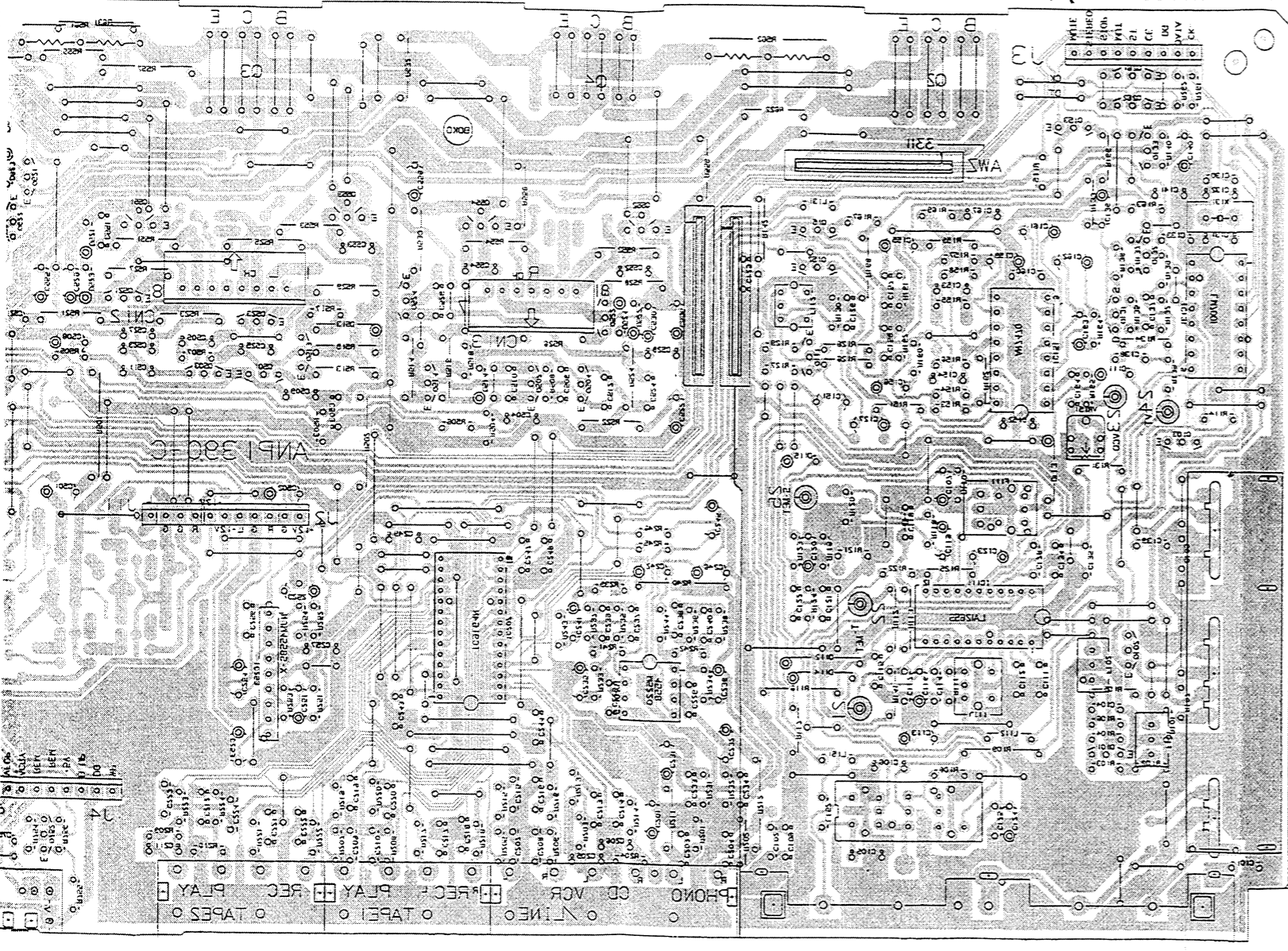

- 0101 IC101 0103 0135 0121 IC121 0133 0521 0525 0123 05 0111 IC111
- 0125 0111 IC125 0111
- 0125 0204 0205 0214 0254 0213 0201 0253 0203 0251 IC223 04 0224 0223 03 0221 0251 0
- 0125 IC223

1
2
3
4
5

1
2
3
4
5

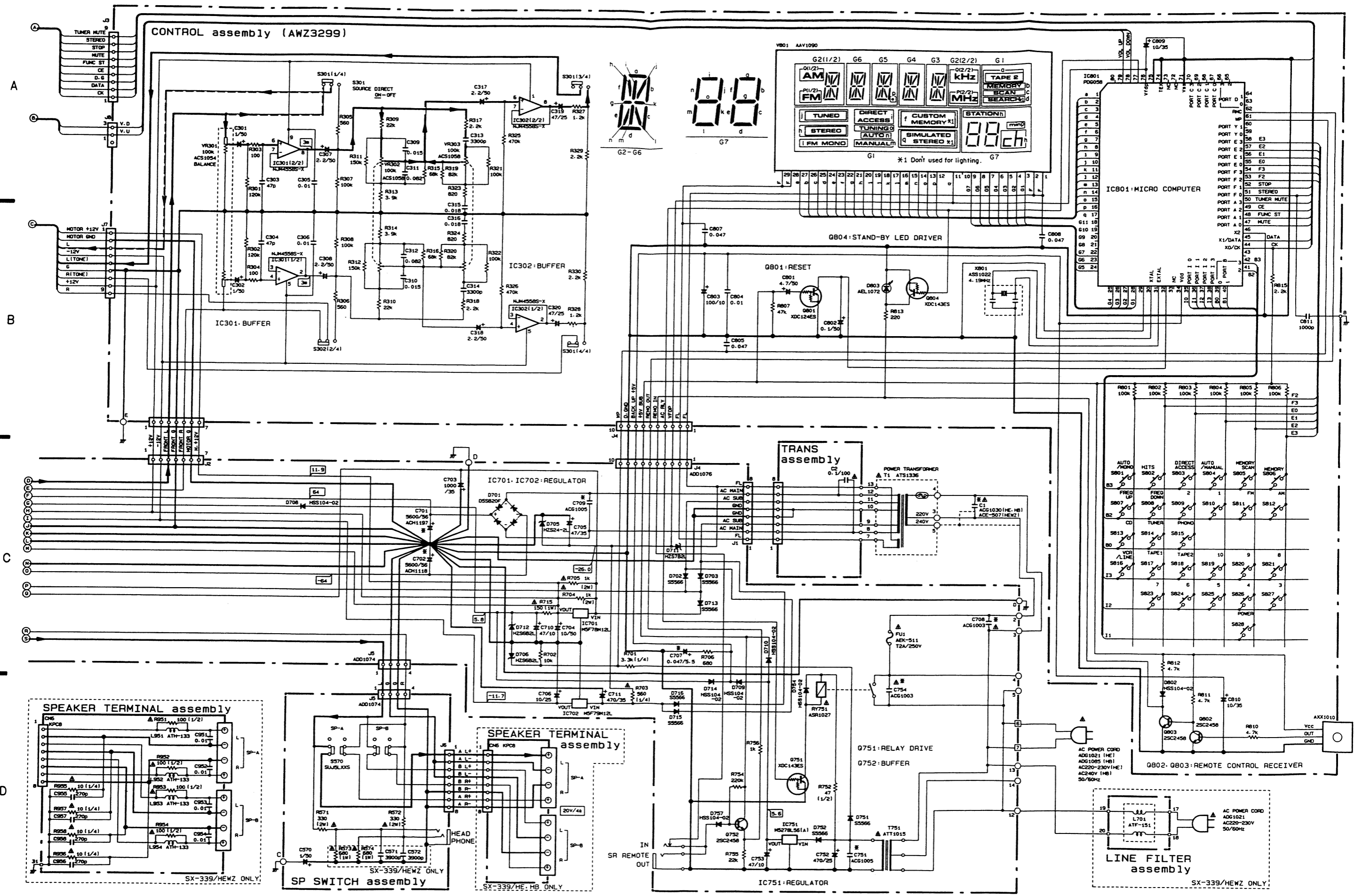

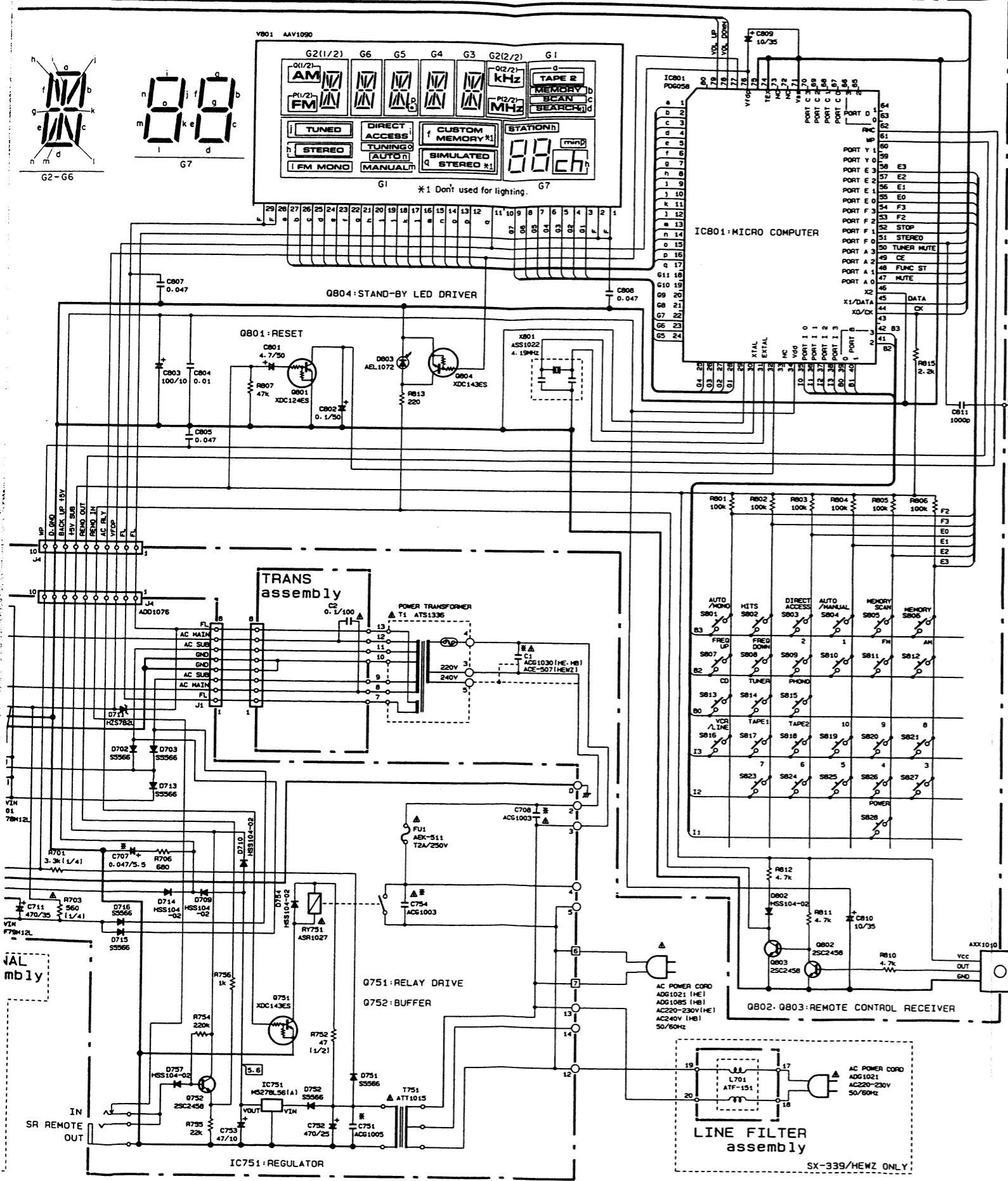

1. RESISTORS:
Indicated in Ω , $\frac{1}{4}W$, $\frac{1}{8}W$, $\pm 5\%$ tolerance unless otherwise noted k: k Ω , M: M Ω , (F): $\pm 1\%$, (G): $\pm 2\%$, (K): $\pm 10\%$ (M): $\pm 20\%$ tolerance
2. CAPACITORS:
Indicated in capacity (μF)/voltage (V) unless otherwise noted p: pF Indication without voltage is 50V except electrolytic capacitor.
3. VOLTAGE, CURRENT:
 : Signal voltage at (85 W + 85 W 8 Ω)output (1kHz)
 : DC voltage (V) at no input signal
 Value in () is DC voltage at rated power.
 mA: DC current at no input signal
4. OTHERS:
 : Signal route.
 : Adjusting point.
 The Δ mark found on some component parts indicates the importance of the safety factor of the part. Therefore, when replacing, be sure to use parts of identical designation.
 * marked capacitors and resistors have parts numbers.

This is the basic schematic diagram, but the actual circuit may vary due to improvements in design.

- SWITCHES:
 SP SWITCH assembly
 S570 SP A ON-OFF / SP B ON-OFF
- CONTROL assembly
- | | |
|----------------------------|-------------------------|
| S801 FM MODE AUTO/MONO | S816 VCR/LINE |
| S802 HITS | S817 TAPE 1/DAT |
| S803 DIRECT ACCESS | S818 TAPE 2/ADAPTOR |
| S804 FM TUNING AUTO/MANUAL | S819 10 |
| S805 MEMOLY SCANS | S820 9 |
| S806 MEMOLY | S821 8 |
| S807 FREQ UP | S823 7 |
| S808 FREQ DOWN | S824 6 |
| S809 2 | S825 5 |
| S810 1 | S826 4 |
| S811 FM | S827 3 |
| S812 AM | S828 POWER STANDBY / ON |
| S813 CD | S301 DIRECT ON/OFF |
| S814 TUNER | |
| S815 PHONO | |

Line voltage selection (For HE, HB and HEWZ types)

- Line voltage can be changed with the following steps.
1. Disconnect the AC Power cord.
 2. Remove the top cover.
 3. Change the connection of the power transformer primary taps.
 4. Change the connection to the capacitor (C1) on the primary side of the power transformer.
 5. Stick the line voltage label on the rear panel.

Part No.	Description
AAX-193	220V label
AAX-192	240V label

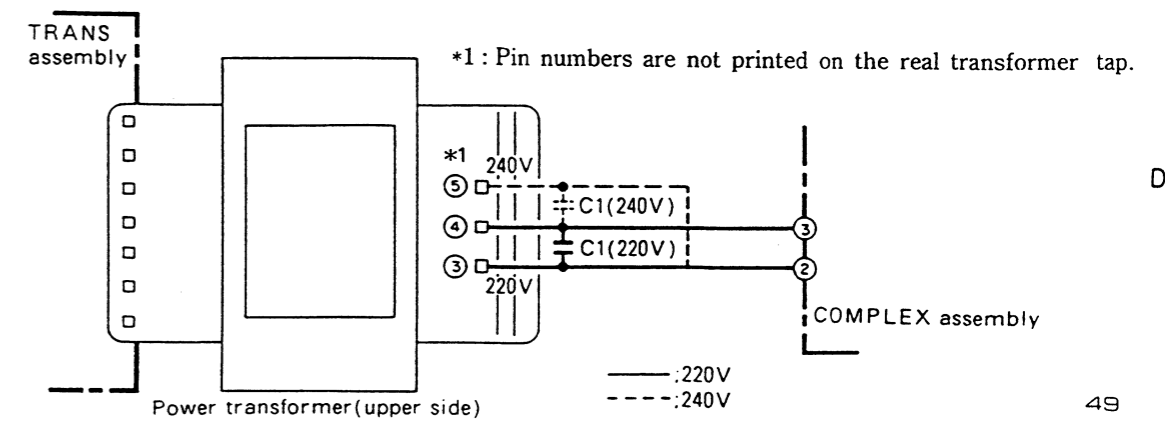

3. PCB's PARTS LIST

NOTES:

- Parts without part number cannot be supplied.
- Parts marked by "⊙" are not always kept in stock. Their delivery time may be longer than usual or they may be unavailable.
- The Δ mark found on some component parts indicates the importance of the safety factor of the part. Therefore, when replacing, be sure to use parts of identical designation.
- When ordering resistors, first convert resistance values into code form as shown in the following examples.

Ex. 1 When there are 2 effective digits (any digit apart from 0), such as 560 ohm and 47k ohm (tolerance is shown by J = 5%, and K = 10%).

560 Ω	56 × 10 ¹	561.....	RD1/4PS	Δ	Δ	Δ	J
47k Ω	47 × 10 ³	473.....	RD1/4PS	Δ	Δ	Δ	J
0.5 Ω	0R5.....		RN2H	Δ	Δ	Δ	K
1 Ω	010.....		RS1P	Δ	Δ	Δ	K

Ex. 2 When there are 3 effective digits (such as in high precision metal film resistors).

5.62k Ω	562 × 10 ¹	5621.....	RN1/4SR	Δ	Δ	Δ	F
----------------	-----------------------	-----------	---------	----------	----------	----------	---

3.1 FOR SX – 229

Mark No.	Description	Parts No.	Mark No.	Description	Parts No.
CONTROL ASSEMBLY (AWZ3307)			C804	CERAMIC CAPACITOR	CKDYF103Z50
SEMICONDUCTORS			C805, 807	CERAMIC CAPACITOR	CKDYF473Z50
IC301, 302	OP – AMP IC	NJM4558S – X	C808	CERAMIC CAPACITOR	CKDYF473Z50
IC801	RECEIVER CONTROL	PDG049 – B	C809, 810	ELECTROLYTIC CAPACIT	CEJA100M35
IC971	OP – AMP IC	NJM4558S – X	C811	CERAMIC CAPACITOR	CKPUYB102K50
Q801	TRANSISTOR	XDC124ES	C973	ELECTROLYTIC CAPACIT	CEJA4R7M50
SWITCHES			C974	ELECTR.CAPACITOR	CEAS4R7M50
S301	PUSH SWITCH	ASG1036	C975, 976	CERAMIC CAPACITOR	CCCSL220J50
S801, 803	SWITCH	ASG1034	C977, 978	CERAMIC CAPACITOR	CKDYF103Z50
S804 – 821	SWITCH	ASG1034	RESISTORS		
S823 – 827	SWITCH	ASG1034	VR301	VARIABLE RESISTOR	ACS1054
CAPACITORS			VR302, 303	VARIABLE RESISTOR	ACS1058
C301, 302	ELECTR.CAPACITOR	CEAS010M50	VR907	VARIABLE(50k – A5X2)	ACT1066
C303, 304	CERAMIC CAPACITOR	CCCSL470J50	R981, 982	CARBON FILM RESISTOR	RDR1/4PM471J
C305, 306	CERAMIC CAPACITOR	CKDYF103Z50	Others resistors RD1/8PM□□□□		
C307, 308	ELECTR.CAPACITOR	CEAS2R2M50	OTHERS		
C309, 310	AUDIO FILM CAPACITOR	CFTXA153J50	V801	FL SPACER	AEB1120
C311, 312	AUDIO FILM CAPACITOR	CFTXA823J50	X801	FL TUBE	AAV1090
C313, 314	MYLOR FILM CAPACITOR	CQMA332K50		CERAMIC OSCILLATOR	ASS1022
C315, 316	AUDIO FILM CAPACITOR	CFTXA183J50			
C317, 318	ELECTR.CAPACITOR	CEAS2R2M50			
C319, 320	ELECTR.CAPACITOR	CEAS470M25			
C801	ELECTROLYTIC CAPACIT	CEJA4R7M50			
C802	ELECTROLYTIC CAPACIT	CEJA0R1M50			
C803	ELECTR.CAPACITOR	CEJA221M6			

Mark No.	Description	Parts No.
TRANS ASSEMBLY		
CAPACITORS		
C2	POLYESTER CAPACITOR	CQMXA104J100

SP TERMINAL ASSEMBLY

OTHERS

SPEAKER TERMINAL AKE-111
8-P

COMPLEX ASSEMBLY (AWZ3315)

SEMICONDUCTORS

IC111	AM/FM IC	LA1265S
IC131	PLL IC	LM7001
IC151	MPX IC	AN7470P
IC201	OP-AMP IC	RC4558DXP
IC202	E-SW IC	TC9164N
IC253	OP-AMP IC	NJM4558S-X
IC701	REGULATOR IC	M5F78M12L
IC702	REGULATOR IC	M5F79M12L
Q101	TRANSISTOR	2SC2668
Q102, 103	TRANSISTOR	XDA143ES
Q131	N-FET	2SK246
Q132	TRANSISTOR	2SC1740SLN
Q133, 151	TRANSISTOR	2SC1740S
Q152	TRANSISTOR	2SC1740S
Q153	TRANSISTOR	2SA1048
Q261, 262	TRANSISTOR	XDC124ES
Q263	TRANSISTOR	XDA124ES
Q501-504	TRANSISTOR	2SA992
Q513, 514	TRANSISTOR	2SC1845
Q521, 522	TRANSISTOR	2SA1145
Q523, 524	TRANSISTOR	2SC2705
Q525, 526	TRANSISTOR	2SC2603
Q551, 552	TRANSISTOR	2SC3298
Q553, 554	TRANSISTOR	2SA1306
Q601, 602	TRANSISTOR	2SC2458
Q603	TRANSISTOR	2SA1048
Q604	TRANSISTOR	2SC2458
Q605	TRANSISTOR	XDC124ES
Q606	TRANSISTOR	XDC143ES

Mark No.	Description	Parts No.
D111-115	DIODE	HSS104-02
D513, 514	DIODE	HSS104-02
D521-524	DIODE	HSS104-02
D561	DIODE	HSS104-02
D601	ZENER DIODE	HZS12AL
D701	DIODE	RBV402
D702, 703	DIODE	S5566
D705	ZENER DIODE	HZS24-2L
D706	ZENER DIODE	HZS6B2L
D708-710	DIODE	HSS104-02
D711	ZENER DIODE	HZS7B2L
D712	ZENER DIODE	HZS6B2L
D713, 715	DIODE	S5566
D716	DIODE	S5566

RELAY

RY561 RELAY ASR1038

COILS

F101, 102 CERAMIC FILTER ATF-126
F111 CERAMIC FILTER ATF-208
L111 COIL ATE-079
L112, 131 AXIAL INDUCTOR LAU2R2M
L561, 562 COIL ATH1004

CAPACITORS

C101-104 CERAMIC CAPACITOR ACG1021
C105, 106 CERAMIC CAPACITOR CKDYF223Z50
C107 CERAMIC CAPACITOR CKDYF473Z50
C109 CERAMIC CAPACITOR CKDYX104M25
C111, 112 CERAMIC CAPACITOR CKDYF223Z50
C113 ELECTR.CAPACITOR CEAS330M16
C114 CERAMIC CAPACITOR ACG1021
C115 CERAMIC CAPACITOR CKDYF103Z50
C116 ELECTR.CAPACITOR CEAS010M50
C117 CERAMIC CAPACITOR ACG1018
C118 CERAMIC CAPACITOR CKDYX103M25
C119 ELECTR.CAPACITOR CEAS100M50
C120 ELECTR.CAPACITOR CEAS2R2M50
C121 CERAMIC CAPACITOR CKDYF222Z50
C122 CERAMIC CAPACITOR CKDYF473Z50
C123 ELECTR.CAPACITOR CEAS4R7M50
C124 ELECTR.CAPACITOR CEAS470M10
C125, 130 CERAMIC CAPACITOR ACG1021
C131, 132 CERAMIC CAPACITOR CCDCH150J50
C133 CERAMIC CAPACITOR ACG1021

Mark No.	Description	Parts No.
C134	CERAMIC CAPACITOR	CKDYF103Z50
C135	CERAMIC CAPACITOR	ACG1016
C136	ELECTR.CAPACITOR	CEAS330M16
C137	AUDIO FILM CAPACITOR	CFTXA224J50
C138, 139	CERAMIC CAPACITOR	ACG1021
C140	ELECTR.CAPACITOR	CEAS470M16
C141	CERAMIC CAPACITOR	CKDYF473Z50
C151	ELECTR.CAPACITOR	CEANP4R7M35
C152	CERAMIC CAPACITOR	CKDYF473Z50
C153, 154	MYLOR FILM CAPACITOR	CQMA102J50
C155, 156	ELECTR.CAPACITOR	CEAS4R7M50
C157, 158	CERAMIC CAPACITOR	CKDYB182K50
C159	ELECTR.CAPACITOR	CEAS470M16
C160	CERAMIC CAPACITOR	ACG1021
C161	ELECTR.CAPACITOR	CEASR22M50
C162	ELECTROLYTIC CAPACIT	CEAS1R5M50
C163	ELECTR.CAPACITOR	CEAS3R3M50
C164	CAPACITOR	ACE1039
C167	CERAMIC CAPACITOR	CCCSL101J50
C201	ELECTR.CAPACITOR	CEAS010M50
C231, 232	ELECTR.CAPACITOR	CEAS100M50
C233, 234	CERAMIC CAPACITOR	CCCSL221J50
C235, 236	ELECTROLYTIC CAPACIT	CEAS471M6
C237, 238	AUDIO FILM CAPACITOR	CFTXA243J50
C239, 240	AUDIO FILM CAPACITOR	CFTXA823J50
C241, 242	ELECTR.CAPACITOR	CEAS2R2M50
C243, 244	CERAMIC CAPACITOR	CKDYF103Z50
C245, 246	ELECTR.CAPACITOR	CEAS470M16
C247, 248	CERAMIC CAPACITOR	CKCYB331K50
C249	CERAMIC CAPACITOR	CKCYB471K50
C251, 252	ELECTR.CAPACITOR	CEAS2R2M50
C253, 254	ELECTR.CAPACITOR	CEAS4R7M50
C256, 257	CERAMIC CAPACITOR	CKDYF103Z50
C501, 502	ELECTR.CAPACITOR	CEAS2R2M50
C503, 504	MYLOR FILM CAPACITOR	CQMA102J50
C505, 506	CERAMIC CAPACITOR	CKMYB681K50
C508	ELECTR.CAPACITOR	CEAS101M16
C509-512	CERAMIC CAPACITOR	CCMSL470J50
C521, 522	ELECTR.CAPACITOR	CEAS220M16
C523, 524	CERAMIC CAPACITOR	CCCSL080D500

Mark No.	Description	Parts No.
C525, 526	CERAMIC CAPACITOR	CCCSL050C500
C529, 530	ELECTR.CAPACITOR	CEAS101M10
C551-554	CERAMIC CAPACITOR	CCCSL101K500
C561, 562	AUDIO FILM CAPACITOR	CFTXA473J50
C601	ELECTROLYTIC CAPACIT	CEAS471M6
C602	CERAMIC CAPACITOR	CKDYF103Z50
C603	ELECTR.CAPACITOR	CEAS101M16
C605	ELECTR.CAPACITOR	CEAS4R7M50
C701	ELECTROLYTIC CAPACIT	ACH1119
C702	ELECTROLYTIC CAPACIT	ACH1195
C703	ELECTROLYTIC CAPACIT	CEAS102M35
C704	ELECTR.CAPACITOR	CEAS100M50
C705	ELECTROLYTIC CAPACIT	CEAS470M35
C706	ELECTR.CAPACITOR	CEAS100M25
C707	CEA (47000/5.5V)	ACH1037
C708	CKA (0.01/AC400V)	ACG1002
C709	CKA (0.01/AC250V)	ACG1005
C710	ELECTR.CAPACITOR	CEAS470M10
C711	ELECTROLYTIC CAPACIT	CEAS471M35

RESISTORS

Mark No.	Description	Parts No.
VR151	VR	ACP1042
R501, 502	CARBON FILM RESISTOR	RDR1/6PU561J
△ R513-516	FUSIBLE RESISTOR	RFA1/4PS391J
R521, 522	CARBON FILM RESISTOR	RDR1/6PU822J
R523, 524	CARBON FILM RESISTOR	RDR1/6PU104J
R525, 526	CARBON FILM RESISTOR	RD1/4PM104J
△ R527, 528	CARBON FILM RESISTOR	RD1/4PMF680J
△ R529, 530	FUSIBLE RESISTOR	RFA1/4PS101J
R545, 546	METALFILM RESISTER	RN1/4PQ1501F
△ R551-554	FUSIBLE RESISTOR	RFA1/4PS101J
△ R555-558	CARBON FILM RESISTOR	RD1/4PMF101J

Mark No.	Description	Parts No.
△ R561, 562	RESISTOR (0.33, 5W)	ACN1063
△ R563, 564	CARBON FILM RESISTOR	RD1/4PMF100J
△ R565, 566	METAL OXIDE RESISTOR	RS1LMF100J
△ R608	CARBON FILM RESISTOR	RD1/4PMF221J
△ R610	FUSIBLE RESISTOR	RFA1/4PS100J
R701	CARBON FILM RESISTOR	RD1/4PM332J
△ R703	METAL OXIDE RESISTOR	RS2LMF152J
△ R704, 705	METAL OXIDE RESISTOR	RS2LMF911J
△ R715	METAL OXIDE RESISTOR	RS1LMF151J
	Others resistor	RD1/8PM□□□J

OTHERS

	ANTENNA TERMINAL	AKA1010
	4-P	
	PIN JACK (4P)	AKB1101
	PIN JACK (6P)	AKB1121
	2 SERIAL F.E. MODULE ASSEMBLY	AXQ1002
	AM RF TUNING BLOCK	AXX1011
X131	CRYSTAL RESONATOR	ASS1005

SP SWITCH ASSEMBLY

SWITCHES

△ S1	POWER SWITCH	ASG1027
S570	PUSH SWITCH	ASG1017
S571	PUSH SWITCH	ASG1026

CAPACITORS

C570	ELECTR.CAPACITOR	CEAS010M50
△ C574	CKA (0.01/AC400V)	ACG1002

RESISTORS

△ R571, 572	METAL OXIDE RESISTOR	RS2LMF331J
-------------	-------------------------	------------

OTHERS

	JACK	AKN1002
--	------	---------

3.2 FOR SX-339

Mark No.	Description	Parts No.
SP SWITCH ASSEMBLY		
SWITCH		
S570	PUSH SWITCH	SUJ5LXXS
CAPACITOR		
C570	ELECTR.CAPACITOR	CEAS010M50
RESISTORS		
△ R571, 572	METAL OXIDE RESISTOR	RS2LMF331J
OTHERS		
	JACK	AKN1002

CONTROL ASSEMBLY (AWZ3299)

SEMICONDUCTORS

IC301, 302	OP-AMP IC	NJM4558S-X
IC801	AMP CONTROL UCOM	PDG058
Q801	TRANSISTOR	XDC124ES
Q802, 803	TRANSISTOR	2SC2458
Q804	TRANSISTOR	XDC143ES
D802	DIODE	HSS104-02
D803	LED	AEL1072

SWITCHES

S301	PUSH SWITCH	ASG1036
S801-821	SWITCH	ASG1034
S823-828	SWITCH	ASG1034

CAPACITORS

C301, 302	ELECTR.CAPACITOR	CEAS010M50
C303, 304	CERAMIC CAPACITOR	CCCSL470J50
C305, 306	CERAMIC CAPACITOR	CKDYF103Z50
C307, 308	ELECTR.CAPACITOR	CEAS2R2M50
C309, 310	AUDIO FILM CAPACITOR	CFTXA153J50
C311, 312	AUDIO FILM CAPACITOR	CFTXA823J50
C313, 314	MYLOR FILM CAPACITOR	CQMA332K50
C315, 316	AUDIO FILM CAPACITOR	CFTXA183J50
C317, 318	ELECTR.CAPACITOR	CEAS2R2M50
C319, 320	ELECTR.CAPACITOR	CEAS470M25
C801	ELECTROLYTIC CAPACIT	CEJA4R7M50
C802	ELECTROLYTIC CAPACIT	CEJA0R1M50
C803	ELECTROLYTIC CAPACIT	CEJA101M10
C804	CERAMIC CAPACITOR	CKDYF103Z50
C805, 807	CERAMIC CAPACITOR	CKDYF473Z50

Mark No.	Description	Parts No.
C808	CERAMIC CAPACITOR	CKDYF473Z50
C809, 810	ELECTROLYTIC CAPACIT	CEJA100M35
C811	CERAMIC CAPACITOR	CKPUYB102K50
RESISTORS		
VR301	VARIABLE RESISTOR	ACS1054
VR302, 303	VARIABLE RESISTOR	ACS1058
	Other resistors	RD1/8PM□□□□
OTHERS		
V801	FL TUBE	AAV1090
X801	CERAMIC OSCILLATOR	ASS1022
	FL SPACER	AEB1120
	REMOTE RECEIVER UNIT	AXX1010

TRANS ASSEMBLY

CAPACITORS

C2	POLYESTER CAPACITOR	CQMXA104J100
----	---------------------	--------------

COMPLEX ASSEMBLY (AWZ3312)

SEMICONDUCTORS

IC111	AM/FM IC	LA1265S
IC131	PLL IC	LM7001
IC151	MPX IC	AN7470P
IC201	OP-AMP IC	RC4558DXP
IC202	E-SW IC	TC9164N
IC253	OP-AMP IC	NJM4558S-X
IC701	REGULATOR IC	M5F78M12L
IC702	REGULATOR IC	M5F79M12L
IC751	REGULATOR IC	M5278L56 (A)
Q101	TRANSISTOR	2SC2668
Q102, 103	TRANSISTOR	XDA143ES
Q131	N-FET	2SK246
Q132	TRANSISTOR	2SC1740SLN
Q133, 151	TRANSISTOR	2SC1740S
Q152	TRANSISTOR	2SC1740S
Q153	TRANSISTOR	2SA1048
Q261, 262	TRANSISTOR	XDC124ES
Q501-504	TRANSISTOR	2SA992
Q513, 514	TRANSISTOR	2SC1845
Q521, 522	TRANSISTOR	2SA1145
Q523, 524	TRANSISTOR	2SC2705
Q551, 552	TRANSISTOR	2SC3298
Q553, 554	TRANSISTOR	2SA1306
Q601, 602	TRANSISTOR	2SC2458

Mark No.	Description	Parts No.	Mark No.	Description	Parts No.
Q603	TRANSISTOR	2SA1048	C115	CERAMIC CAPACITOR	CKDYF103Z50
Q604	TRANSISTOR	2SC2458	C116	ELECTR.CAPACITOR	CEAS010M50
Q605	TRANSISTOR	XDC124ES	C117	CERAMIC CAPACITOR	ACG1018
Q606	TRANSISTOR	XDC143ES	C118	CERAMIC CAPACITOR	CKDYX103M25
Q621, 622	TRANSISTOR	2SC2240	C119	ELECTR.CAPACITOR	CEAS100M50
Q751	TRANSISTOR	XDC143ES	C120	ELECTR.CAPACITOR	CEAS2R2M50
Q752	TRANSISTOR	2SC2458	C121	CERAMIC CAPACITOR	CKDYF222Z50
D111-115	DIODE	HSS104-02	C122	CERAMIC CAPACITOR	CKDYF473Z50
D513, 514	DIODE	HSS104-02	C123	ELECTR.CAPACITOR	CEAS4R7M50
D521-524	DIODE	HSS104-02	C124	ELECTR.CAPACITOR	CEAS470M10
D561	DIODE	HSS104-02	C125, 130	CERAMIC CAPACITOR	ACG1021
D601	ZENER DIODE	HZS12AL	C131, 132	CERAMIC CAPACITOR	CCDCH150J50
D621-626	DIODE	HSS104-02	C133	CERAMIC CAPACITOR	ACG1021
D701	DIODE	D5SB20F	C134	CERAMIC CAPACITOR	CKDYF103Z50
D702, 703	DIODE	S5566	C135	CERAMIC CAPACITOR	ACG1016
D705	ZENER DIODE	HZS24-2L	C136	ELECTR.CAPACITOR	CEAS330M16
D706	ZENER DIODE	HZS6B2L	C137	AUDIO FILM CAPACITOR	CFTXA224J50
D708-710	DIODE	HSS104-02	C138, 139	CERAMIC CAPACITOR	ACG1021
D711	ZENER DIODE	HZS7B2L	C140	ELECTR.CAPACITOR	CEAS470M16
D712	ZENER DIODE	HZS6B2L	C141	CERAMIC CAPACITOR	CKDYF473Z50
D713	DIODE	S5566	C151	ELECTR.CAPACITOR	CEANP4R7M35
D714	DIODE	HSS104-02	C152	CERAMIC CAPACITOR	CKDYF473Z50
D715, 716	DIODE	S5566	C153, 154	MYLOR FILM CAPACITOR	CQMA102J50
D751, 752	DIODE	S5566	C155, 156	ELECTR.CAPACITOR	CEAS4R7M50
D754, 757	DIODE	HSS104-02	C157, 158	CERAMIC CAPACITOR	CKDYB182K50
RELAY			C159	ELECTR.CAPACITOR	CEAS470M16
RY561	RELAY	ASR1037	C160	CERAMIC CAPACITOR	ACG1021
△ RY751	RELAY	ASR1027	C161	ELECTR.CAPACITOR	CEASR22M50
COILS & TRANSFORMER			C162	ELECTROLYTIC CAPACIT	CEAS1R5M50
L111	COIL	ATE-079	C163	ELECTR.CAPACITOR	CEAS3R3M50
L112, 131	AXIAL INDUCTOR	LAU2R2M	C164	CAPACITOR	ACE1039
L561, 562	COIL	ATH1004	C167	CERAMIC CAPACITOR	CCCSL101J50
F101, 102	CERAMIC FILTER	ATF-126	C201	ELECTR.CAPACITOR	CEAS010M50
F111	CERAMIC FILTER	ATF-208	C231, 232	ELECTR.CAPACITOR	CEAS100M50
△ T751	POWER TRANSFORMER	ATT1015	C233, 234	CERAMIC CAPACITOR	CCCSL221J50
CAPACITORS			C235, 236	ELECTROLYTIC CAPACIT	CEAS471M6
C101-104	CERAMIC CAPACITOR	ACG1021	C237, 238	AUDIO FILM CAPACITOR	CFTXA243J50
C105, 106	CERAMIC CAPACITOR	CKDYF223Z50	C239, 240	AUDIO FILM CAPACITOR	CFTXA823J50
C107	CERAMIC CAPACITOR	CKDYF473Z50			
C109	CERAMIC CAPACITOR	CKDYX104M25			
C111, 112	CERAMIC CAPACITOR	CKDYF223Z50			
C113	ELECTR.CAPACITOR	CEAS330M16			
C114	CERAMIC CAPACITOR	ACG1021			

Mark No.	Description	Parts No.
C241, 242	ELECTR.CAPACITOR	CEAS2R2M50
C243, 244	CERAMIC CAPACITOR	CKDYF103Z50
C245, 246	ELECTR.CAPACITOR	CEAS470M16
C247, 248	CERAMIC CAPACITOR	CKCYB331K50
C249	CERAMIC CAPACITOR	CKCYB471K50
C251, 252	ELECTR.CAPACITOR	CEAS2R2M50
C253, 254	ELECTR.CAPACITOR	CEAS4R7M50
C256, 257	CERAMIC CAPACITOR	CKDYF103Z50
C501, 502	ELECTR.CAPACITOR	CEAS2R2M50
C503, 504	MYLOR FILM CAPACITOR	CQMA102J50
C505, 506	CERAMIC CAPACITOR	CKDYF222Z50
C508	ELECTR.CAPACITOR	CEAS101M16
C509-512	CERAMIC CAPACITOR	CCMSL470J50
C521, 522	ELECTR.CAPACITOR	CEAS220M16
C523, 524	CERAMIC CAPACITOR	CCCSL080D500
C525, 526	CERAMIC CAPACITOR	CCCSL050C500
C529, 530	ELECTR.CAPACITOR	CEAS101M10
C551-554	CERAMIC CAPACITOR	CCCSL101K500
C561, 562	AUDIO FILM CAPACITOR	CFTXA473J50
C601	ELECTROLYTIC CAPACIT	CEAS471M6
C602	CERAMIC CAPACITOR	CKDYF103Z50
C603	ELECTR.CAPACITOR	CEAS101M16
C605	ELECTR.CAPACITOR	CEAS4R7M50
C621, 622	ELECTR.CAPACITOR	CEANP2R2M50
C701	ELECTROLYTIC CAPACIT	ACH1197
C702	ELECTROLYTIC CAPACIT	ACH1118
C703	ELECTROLYTIC CAPACIT	CEAS102M35
C704	ELECTR.CAPACITOR	CEAS100M50
C705	ELECTROLYTIC CAPACIT	CEAS470M35
C706	ELECTR.CAPACITOR	CEAS100M25
△ C707	CEA (47000/5.5V)	ACH1037 - A - S
C708	CKA (0.01/AC400V)	ACG1003
C709	CKA (0.01/AC250V)	ACG1005
C710	ELECTR.CAPACITOR	CEAS470M10
C711	ELECTROLYTIC CAPACIT	CEAS471M35
C751	CKA (0.01/AC250V)	ACG1005
C752	ELECTROLYTIC CAPACIT	CEAS471M25
△ C753	ELECTR.CAPACITOR	CEAS470M10
C754	CKA (0.01/AC400V)	ACG1003

Mark No.	Description	Parts No.
RESISTORS		
VR151	VR	ACP1042
R501, 502	CARBON FILM RESISTOR	RDR1/4PM561J
△ R513-516	FUSIBLE RESISTOR	RFA1/4PS391J
R521, 522	CARBON FILM RESISTOR	RDR1/4PM682J
R523, 524	CARBON FILM RESISTOR	RDR1/4PM104J
R525, 526	CARBON FILM RESISTOR	RD1/4PM104J
△ R527, 528	CARBON FILM RESISTOR	RD1/4PMF680J
△ R529, 530	FUSIBLE RESISTOR	RFA1/4PS101J
△ R551-554	FUSIBLE RESISTOR	RFA1/4PS101J
△ R555-558	CARBON FILM RESISTOR	RD1/4PMF101J
△ R561, 562	RESISTOR (0.33, 5W)	ACN1063
△ R563, 564	CARBON FILM RESISTOR	RD1/4PMF100J
△ R565, 566	METAL OXIDE RESISTOR	RS1LMF100J
△ R608	CARBON FILM RESISTOR	RD1/4PMF221J
△ R610	FUSIBLE RESISTOR	RFA1/4PS100J
△ R621, 622	CARBON FILM RESISTOR	RD1/4PMF222J
△ R625	CARBON FILM RESISTOR	RD1/4PMF101J
△ R631, 632	CARBON FILM RESISTOR	RD1/4PMF222J
R701	CARBON FILM RESISTOR	RD1/4PM332J
△ R703	CARBON FILM RESISTOR	RD1/4PMF561J
△ R704, 705	METAL OXIDE RESISTOR	RS2LMF102J
△ R715	METAL OXIDE RESISTOR	RS1LMF151J
R752	CARBON FILM RESISTOR	RD1/2PM470J
Other resistors		RD1/8PM□□□J

OTHERS

ANTENNA TERMINAL 4-P	AKA1010
PIN JACK (4P)	AKB1101
PIN JACK (6P)	AKB1121
JACK	AKN1006
3 Serial F.E. MODULE ASSEMBLY	AXQ1003

AM RF TUNING BLOCK	AXX1011
JUMPER CONNECTOR	KPC8
CONNECTOR (7P)	KPC7
CRYSTAL RESONATOR	ASS1005
CN12	
CN13	
X131	

Mark No.	Description	Parts No.
----------	-------------	-----------

MOTOR VOL ASSEMBLY

SEMICONDUCTOR

IC970	MECHANISM DRIVER IC	TA7291S
IC971	OP-AMP IC	NJM4558S-X

COILS

L970, 971	AXIAL INDUCTOR	LAU220K
-----------	----------------	---------

CAPACITORS

C970	ELECTROLYTIC CAPACIT	CEAS470M35
C971	CERAMIC CAPACITOR	CKDYX473M25
C972	CERAMIC CAPACITOR	CKDYF473Z50
C973, 974	ELECTR.CAPACITOR	CEAS4R7M50
C975, 976	CERAMIC CAPACITOR	CCDSL220J50
C977, 978	CERAMIC CAPACITOR	CKDYF103Z50

RESISTORS

R981, 982	CARBON FILM RESISTOR	RDR1/6PU471J
VR970	VARIABLE RESISTOR	ACX1040
	Other resistors	RD1/8PM□□□J

OTHERS

CN11	CONNECTOR (4P)	KPC4
CN7	CONNECTOR (9P)	KPC9

TRANSISTOR ASSEMBLY

SEMICONDUCTOR

Q901, 902	TRANSISTOR	2SC2603
-----------	------------	---------

RESISTORS

R905, 906	METALFILM RESISTER	RN1/4PQ1501F
	Other resistors	RD1/8PM□□□J

SP TERMINAL ASSEMBLY

OTHERS

CN6	JUMPER CONNECTOR SPEAKER TERMINAL (8P)	KPC8 AKE-111
-----	---	-----------------

4. ADJUSTMENTS

4.1 ADJUSTMENT OF THE FM TUNER SECTION

- Set the mode selector to FM BAND.
- Connect the wiring as shown in the Fig. 4-2.

Step No.	Adjustment title	FM SG (1kHz ±75kHz dev.)		Reception frequency display	Adjustment location	Specifications						
		Frequency (MHz)	Level (dBμV)									
1	Center adjustment	98.0	60	98.0MHz	L111	Adjust so that the DC voltage between the TP-21 and TP-22 becomes 0V ±50mV.						
2	VCO adjustment	98.0 (Non modulation)	60	98.0MHz	VR151	Adjust so that the output of the TP-23 becomes 76kHz ±0.5kHz.						
3	TUNED IND. Lighting level	98.0*1 (Stereo modulation)	—	98.0MHz	R121	<p>The R121 of the COMPLEX assembly has been mounted or removed at the time of adjustment in the production. Mount or remove R121 referring to the table below, and adjust it so that the indicators of TUNED start to light up at 24dBμV (±15dB).</p> <table border="1"> <thead> <tr> <th>Input level</th> <th>R121</th> </tr> </thead> <tbody> <tr> <td>The indicators of TUNED start lighting up at a larger input than 39dBμV.</td> <td>Remove</td> </tr> <tr> <td>The indicators of TUNED start lighting up at a less input than 9dBμV.</td> <td>Mount</td> </tr> </tbody> </table>	Input level	R121	The indicators of TUNED start lighting up at a larger input than 39dBμV.	Remove	The indicators of TUNED start lighting up at a less input than 9dBμV.	Mount
						Input level	R121					
						The indicators of TUNED start lighting up at a larger input than 39dBμV.	Remove					
The indicators of TUNED start lighting up at a less input than 9dBμV.	Mount											

*1 Stereo modulation : Main 1kHz L+R ±68.25kHz dev.
Pilot 19kHz ±6.75kHz dev.

4.2 ADJUSTMENT OF THE AM TUNER SECTION

- Set the mode selector to AM BAND.
- Connect the wiring as shown in the Fig. 4-3.

Step No.	Adjustment title	AM SG (400Hz 30% MOD.)		Reception frequency display	Adjustment location	Specifications				
		Frequency (kHz)	Level (dBμV)							
1	TUNED IND. Lighting level	999	—	999kHz	R120	<p>The R120 of the COMPLEX assembly has been mounted or removed at the time of adjustment in the production. Mount or remove R120 referring to the table below, and adjust it so that the indicators of TUNED start to light up at less input than 65dBμV.</p> <table border="1"> <thead> <tr> <th>Input level</th> <th>R120</th> </tr> </thead> <tbody> <tr> <td>The indicators of TUNED start lighting up at a larger input than 65dBμV/m.</td> <td>Remove</td> </tr> </tbody> </table>	Input level	R120	The indicators of TUNED start lighting up at a larger input than 65dBμV/m.	Remove
Input level	R120									
The indicators of TUNED start lighting up at a larger input than 65dBμV/m.	Remove									

COMPLEX assembly

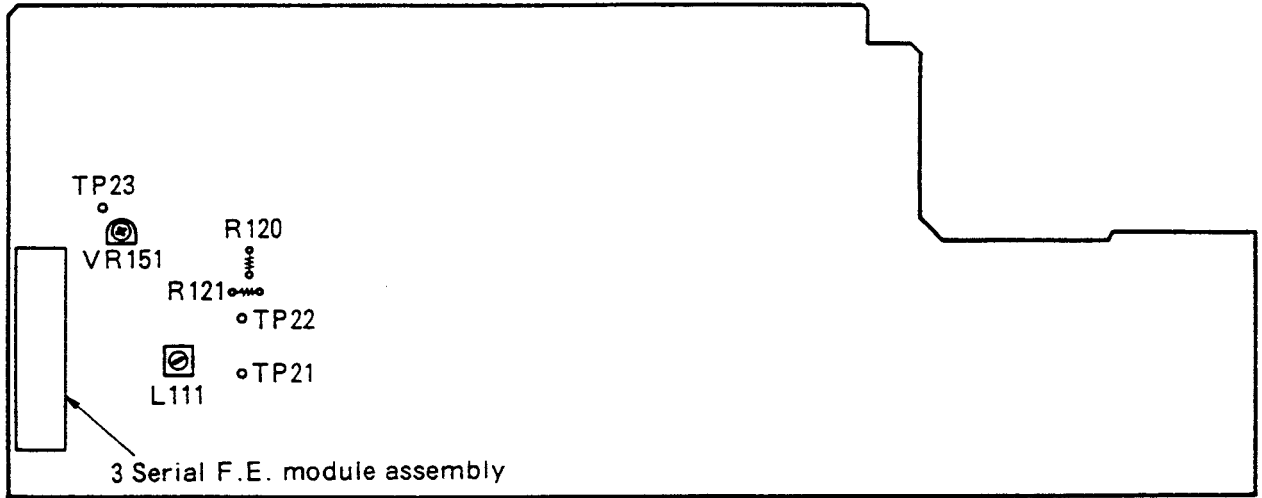

Fig. 4-1 Adjustment point

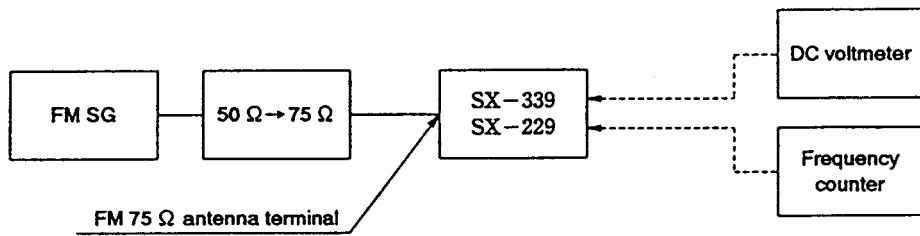

Fig. 4-2 FM Adjustment Connection Diagram

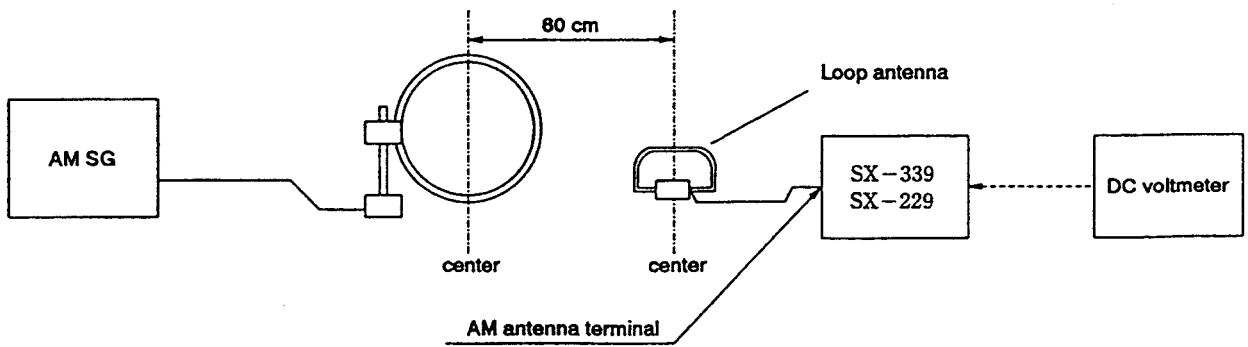

Fig. 4-3 AM Adjustment Connection Diagram

5. FOR SX – 229/HB, YPW AND HEWZ TYPES

NOTES:

- Parts without part number cannot be supplied.
- The Δ mark found on some component parts indicates the importance of the safety factor of the part. Therefore, when replacing, be sure to use parts of identical designation.
- Parts marked by “ \odot ” are not always kept in stock. Their delivery time may be longer than usual or they may be unavailable.

CONTRAST OF MISCELLANEOUS PARTS

The SX – 229/HB, YPW and HEWZ types are the same as the SX – 229/HE type with the exception of the following sections.

Mark	Symbol & Description	Part No.				Remarks
		SX – 229/ HE type	SX – 229/ HB type	SX – 229/ YPW type	SX – 229/ HEWZ type	
	COMPLEX assembly SP SWITCH assembly SP TERMINAL assembly	AWZ3315 Non supply Non supply	AWZ3315 Non supply Non supply	AWZ3315 Non supply Non supply	AWZ3313 Non supply Non supply	
Δ	C1 Power capacitor (0.022/AC400V)	ACG1030	ACG1030	ACG1030	
Δ	C1 Power capacitor (0.1/AC250V)	ACE – 507	
Δ	AC Power cord	ADG1021	ADG1085	ADG – 064	ADG1021	
	Plate	AAK1979	AAK1979	AAK1980	AAK1979	
	Screw (EARTH)	ABA1047	
	FM antenna	ADH1004	ADH1004	ADH1004	
	FM antenna assembly	ADH1002	
	Operating instructions (English, French, German, Italian, Dutch, Swedish, Spanish, Portuguese)	ARE1182	
	Operating instructions (English)	ARB1292	ARB1292	
	Operating instructions (German)	ARC1250	

SP TERMINAL assembly (HEWZ type)

The SP TERMINAL assembly (HEWZ type) is the same as the SP TERMINAL assembly (HE type) with the exception of the following sections.

Mark	Symbol & Description	Part No.		Remarks
		HE type	HEWZ type	
	C951 – C954 C955 – C958	CKDYF103Z50 CKDYB681K50	
	L951 – L954	ATH – 133	
Δ	R951 – R954	RD1/2PMF101J	
Δ	R955, R956	RD1/4PMF100J	

COMPLEX assembly (AWZ3313)

The COMPLEX assembly (AWZ3313) is the same as the COMPLEX assembly (AWZ3315) with the exception of the following sections.

Mark	Symbol & Description	Part No.		Remarks
		AWZ3315	AWZ3313	
	Q111	2SC1740S	
	F101, F102	ATF-126	
	F101	ATF-119	
	F102	ATF-107	
	F112	ATF-146	
	L151, L152	LAU470K	
	L561, L562	ATH1004	ATH1009	
	L701	ATF-151	
	C126, C203, C204	CKMYB681K50	
	C127	CEAS100M50	
	C128	CCDSL330J50	
	C129	CKDYF103Z50	
	C130, C160	ACG1021	ACG1016	
	C151	CEANP4R7M35	CEAS100M50	
	C167	CCCSL101J50	CCCSL221J50	
	C203, 204	CKMYB681K50	
	C205-C224	CKMYB391K50	
	C225, C226	CKDYB821K50	
	C523, C524	CCCSL080D500	CCCSL060D500	
	C527, C528	CKMYB221K50	
	C555, C556, C558	CEAS2R2M100	
	R126	RD1/8PM224J	
	R127	RD1/8PM473J	
	R128, R130	RD1/8PM472J	
	R129	RD1/8PM222J	
	R142	RD1/8PM102J	
	R152	RD1/8PM913J	RD1/8PM753J	
	R159, R160	RD1/8PM822J	RD1/8PM392J	
	R161, R162	RD1/8PM123J	RD1/8PM183J	
	2 Serial F.E. module assembly	AXQ1002	
	4 Serial F.E. module assembly	AXQ1004	
	Antenna terminal (4P)	AKA1010	
	Antenna terminal (2P)	AKA1012	

SP SWITCH assembly (HEWZ type)

The SP SWITCH assembly (HEWZ type) is the same as the SP SWITCH assembly (HE type) with the exception of the following sections.

Mark	Symbol & Description	Part No.		Remarks
		HE type	HEWZ type	
	C571, C572	CKDYB392K50	
⚠	R573, R574	RS1PMF681J	

6. FOR SX – 339/HB AND HEWZ TYPES

NOTES:

- Parts without part number cannot be supplied.
- Parts marked by "⊙" are not always kept in stock. Their delivery time may be longer than usual or they may be unavailable.
- The Δ mark found on some component parts indicates the importance of the safety factor of the part. Therefore, when replacing, be sure to use parts of identical designation.
- When ordering resistors, first convert resistance values into code form as shown in the following examples.

Ex. 1 When there are 2 effective digits (any digit apart from 0), such as 560 ohm and 47k ohm (tolerance is shown by J = 5%, and K = 10%).

560Ω	56 × 10 ¹	561.....	RD1/4PS	⊙	⊙	⊙	J
47kΩ	47 × 10 ³	473.....	RD1/4PS	⊙	⊙	⊙	J
0.5Ω	0R5.....	RN2H	⊙	⊙	⊙	K
1Ω	010.....	RSIP	⊙	⊙	⊙	K

Ex. 2 When there are 3 effective digits (such as in high precision metal film resistors).

5.62kΩ	562 × 10 ¹	5621.....	RN1/4SR	⊙	⊙	⊙	F
--------	-----------------------	-----------	---------	---	---	---	---

CONTRAST OF MISCELLANEOUS PARTS

The SX – 339/HB and HEWZ types are the same as the SX – 339/HE type with the exception of the following sections

Mark	Symbol & Description	Part No.			Remarks
		SX – 339/ HE type	SX – 339/ HB type	SX – 339/ HEWZ type	
	COMPLEX assembly	AWZ3312	AWZ3312	AWZ3311	
	SP SWITCH assembly	Non supply	Non supply	Non supply	
	LINE FILTER assembly	Non supply	
	SP TERMINAL assembly	Non supply	Non supply	Non supply	
Δ	C1 Power capacitor (0.022/AC400V)	ACG1030	ACG1030	
Δ	C1 Power capacitor (0.1/AC250V)	ACE – 507	
Δ	AC Power cord	ADG1021	ADG1085	ADG1021	
	Screw (EARTH)	ABA1047	
	FM antenna	ADH1004	ADH1004	
	FM antenna assembly	ADH1002	
	Operating instructions (English, French, German, Italian, Dutch, Swedish, Spanish, Portuguese)	ARE1182	
	Operating instructions (English)	ARB1292	
	Operating instructions (German)	ARC1250	

COMPLEX assembly (AWZ3311)

The COMPLEX assembly (AWZ3311) is the same as the COMPLEX assembly (AWZ3312) with the exception of the following sections.

Mark	Symbol & Description	Part No.		Remarks
		AWZ3312	AWZ3311	
	Q111	2SC1740S	
	F101, F102	ATF-126	
	F101	ATF-119	
	F102	ATF-107	
	F112	ATF-146	
	L151, L152	LAU470K	
	L561, L562	ATH1004	ATH1009	
	C126, C203, C204	CKMYB681K50	
	C127	CEAS100M50	
	C128	CCDSL330J50	
	C129	CKDYF103Z50	
	C130, C160	ACG1021	ACG1016	
	C151	CEANP4R7M35	CEAS100M50	
	C167	CCCSL101J50	CCCSL221J50	
	C203, C204	CKMYB681K50	
	C205-C224	CKMYB391K50	
	C225, C226	CKDYB821K50	
	C523, C524	CCCSL080D500	CCCSL060D500	
	C527, C528	CCCSL221J50	
	C555, C556, C558	CEAS2R2M100	
	R126	RD1/8PM224J	
	R127	RD1/8PM473J	
	R128, R130	RD1/8PM472J	
	R129	RD1/8PM222J	
	R142	RD1/8PM102J	
	R152	RD1/8PM913J	RD1/8PM753J	
	R159, R160	RD1/8PM822J	RD1/8PM392J	
	R161, R162	RD1/8PM123J	RD1/8PM183J	
	3 Serial F.E. module assembly	AXQ1003	
	4 Serial F.E. module assembly	AXQ1004	
	Antenna terminal (4P)	AKA1010	
	Antenna terminal (2P)	AKA1012	

SP SWITCH assembly (HEWZ type)

The SP SWITCH assembly (HEWZ type) is the same as the SP SWITCH assembly (HE type) with the exception of the following sections.

Mark	Symbol & Description	Part No.		Remarks
		HE type	HEWZ type	
⚠	C571, C572	CKDYB392K50	
	R573, R574	RS1PMF681J	

SP TERMINAL assembly (HEWZ type)

The SP TERMINAL assembly (HEWZ type) is the same as the SP TERMINAL assembly (HE type) with the exception of the following sections.

Mark	Symbol & Description	Part No.		Remarks
		HE type	HEWZ type	
⚠	C951 - C954	CKDYF103Z50	
	C955 - C958	CCDSL271J50	
	L951 - L954	ATH - 133	
	R951 - R954	RD1/2PMF101J	
	R955 - R958	RD1/4PMF100J	

Mark No. Description Parts No.

LINE FILTER ASSEMBLY (HEWZ type)

COIL

L701 LINE FILTER ATF - 151

7. SPECIFICATIONS

Amplifier Section

[SX-339]

Continuous Power Output (both channels driven, DIN)*	
1 kHz, T.H.D. 1 %, 4 Ω	85 W + 85 W
20 Hz - 20 kHz, T.H.D. 0.07 %, 8 Ω	55 W + 55 W
Dynamic power output (with EIA test signal)	
2/4/8 Ω	120/110/80 W
Total Harmonic Distortion*	
1 kHz, 55 W, 8 Ω	0.01 %
20 Hz - 20 kHz, 55 W, 8 Ω	0.07 %
Damping factor 1 kHz, 8 Ω	
	27
Input (Sensitivity/Impedance)	
PHONO	2.5 mV/47 kΩ
CD, VCR/LINE, TAPE 1/DAT, TAPE 2	150 mV/47 kΩ
Phono Overload Level (T.H.D. 0.08 %, 1,000 Hz)	
PHONO	130 mV
Output (Level/Impedance)	
TAPE REC	150 mV/2.2 kΩ
Frequency Response	
PHONO (RIAA Equalization)	20 Hz to 20,000 Hz ± 0.5 dB
CD, VCR/LINE, TAPE 1/DAT, TAPE 2	10 Hz to 70,000 Hz ± _{3.0} ^{0.5} dB
Signal-to-Noise Ratio (IHF, short circuited, A network)	
PHONO	72 dB
CD, VCR/LINE, TAPE 1/DAT, TAPE 2	97 dB
Signal-to-Noise Ratio (DIN, continuous power/50 mW)	
PHONO	67 dB/60 dB
CD, VCR/LINE, TAPE 1/DAT, TAPE 2	88 dB/63 dB
Tone control	
BASS	± 8 dB (100 Hz)
TREBLE	± 8 dB (10 kHz)

[SX-229]

Continuous Power Output (both channels driven, DIN)*	
1 kHz, T.H.D. 1 %, 4 Ω	55 W + 55 W
40 Hz - 20 kHz, T.H.D. 0.07 %, 8 Ω	39 W + 39 W
Dynamic power output (with EIA test signal)	
4/8 Ω	65/55 W
Total Harmonic Distortion*	
1 kHz, 39 W, 8 Ω	0.01 %
40 Hz - 20 kHz, 39 W, 8 Ω	0.07 %
Damping factor 1 kHz, 8 Ω	
	27
Input (Sensitivity/Impedance)	
PHONO	2.5 mV/47 kΩ
CD, VCR/LINE, TAPE 1/DAT, TAPE 2	150 mV/47 kΩ
Phono Overload Level (T.H.D. 0.08 %, 1,000 Hz)	
PHONO	130 mV
Output (Level/Impedance)	
TAPE REC	150 mV/2.2 kΩ
Frequency Response	
PHONO (RIAA Equalization)	20 Hz to 20,000 Hz ± 0.5 dB
CD, VCR/LINE, TAPE 1/DAT, TAPE 2	10 Hz to 70,000 Hz ± _{3.0} ^{0.5} dB
Signal-to-Noise Ratio (IHF, short circuited, A network)	
PHONO	72 dB
CD, VCR/LINE, TAPE 1/DAT, TAPE 2	97 dB
Signal-to-Noise Ratio (DIN, continuous power/50 mW)	
PHONO	67 dB/60 dB
CD, VCR/LINE, TAPE 1/DAT, TAPE 2	88 dB/63 dB
Tone control	
BASS	± 8 dB (100 Hz)
TREBLE	± 8 dB (10 kHz)

FM Tuner Section

Frequency range	87.5 MHz to 108 MHz
Usable Sensitivity	
Model SX-229	12.1 dBf, IHF (1.1 μV/75 Ω)
Model SX-339	11.3 dBf, IHF (1.0 μV/75 Ω)
50 dB Quieting Sensitivity	
Model SX-229	
MONO	17.3 dBf (2.0 μV/75 Ω)
STEREO	40.2 dBf (28 μV/75 Ω)
Model SX-339	
MONO	16.4 dBf (1.8 μV/75 Ω)
STEREO	38.1 dBf (22 μV/75 Ω)
Sensitivity (DIN)	
MONO	0.9 μV/75 Ω
STEREO	29 μV/75 Ω
Signal-to-Noise Ratio	
MONO	78 dB (at 85 dBf)
STEREO	73 dB (at 85 dBf)
Signal-to-Noise Ratio (DIN)	
MONO	70 dB
STEREO	66 dB
Distortion	
STEREO	0.3 % (1 kHz)
Alternate Channel Selectivity	55 dB (400 kHz)
Stereo Separation	40 dB (1 kHz)
Frequency Response	30 Hz to 15 kHz (± 1 dB)
Antenna Input	300 Ω balanced, 75 Ω unbalanced

AM Tuner Section

Frequency range	531 kHz to 1,602 kHz
Sensitivity	
IHF, Loop antenna	300 μV/m
Selectivity	25 dB
Signal-to-Noise Ratio	53 dB
Antenna	AM Loop Antenna

Miscellaneous

Power Requirements	a.c. 240 Volts ~, 50/60 Hz
Power Consumption	
Model SX-229	250 W
Model SX-339	500 W
Dimensions	420 (W) X 125 (H) X 336 (D) mm
Weight (without package)	
Model SX-229	5.9 kg
Model SX-339	7.0 kg

Furnished Parts

FM T-type Antenna	1
AM Loop Antenna	1
Operating Instructions	1

[SX-339 only]

Remote control unit	1
Dry cell battery (size "AAA" (IEC R03/UM-4))	2

NOTE:

Specifications and design subject to possible modification without notice due to improvements.

* Measured by audio spectrum analyzer.

8. PANEL FACILITIES

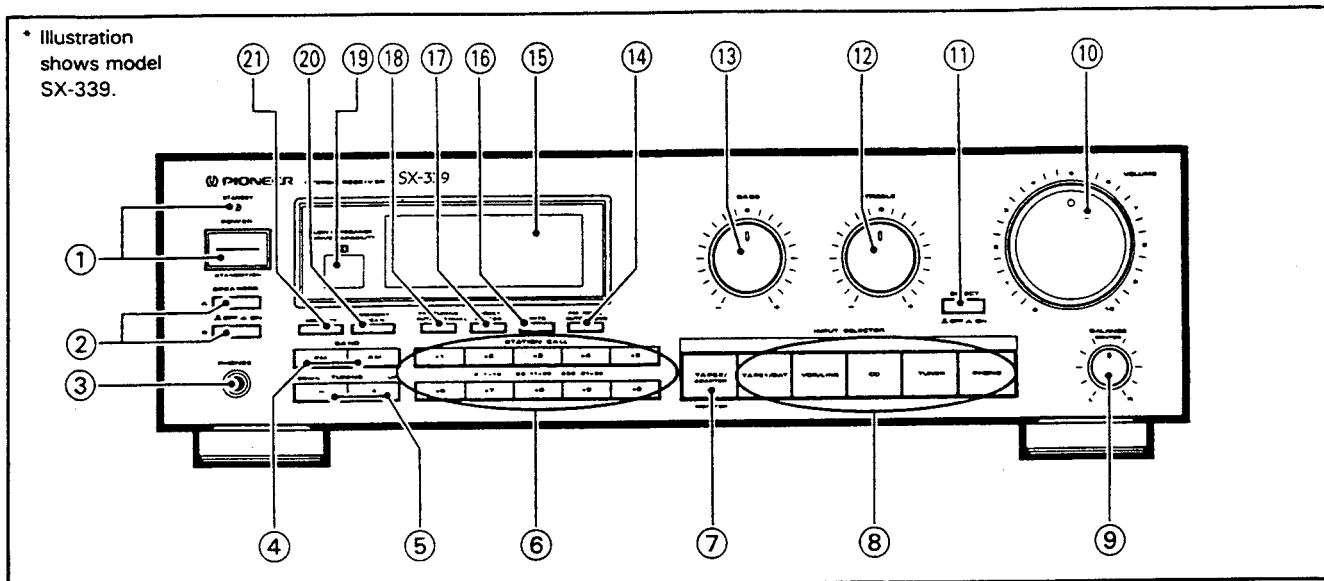

[SX-339]

① POWER (STANDBY/ON) switch/indicator

This is the switch for electric power.

ON: When set to the ON position, power is supplied and the unit becomes operational.

STANDBY: When set to the STANDBY position, the main power flow is cut and the unit is no longer fully operational. A minute flow of power feeds the unit to maintain operation readiness.

When the STANDBY indicator lights, the unit is in STANDBY.

- The accessory remote control unit can also be used to operate the STANDBY/ON and SLEEP functions of this switch.
- When not using the unit for a long period, disconnected the power cord.

[SX-229]

① POWER switch

When this switch is pressed, power is supplied to the unit. Press the switch again to turn power OFF.

[Timer ON/OFF possible]

When the unit is switched ON, ON/OFF control can be performed by means of the optional timer.

NOTE (SX-229, SX-339):

When the power is initially turned ON, muting will be applied to prevent sound from being output for about 5 seconds.

② SPEAKERS buttons (■ OFF, ▲ ON)

These are used to select the speaker through which you wish to listen.

A: When the speakers connected to A terminals are in use.

B: When the speakers connected to B terminals are in use.

- Turn both A and B speakers to the OFF position when only headphones are in use.

NOTE FOR SX-229:

No sound will be heard through the speakers when both A and B buttons are depressed if only one set of speakers has been connected to either A or B SPEAKERS terminals.

③ PHONES jack

Connect the plug on your headphones to this jack. To listen to a program through the headphones, set both SPEAKERS A and B buttons to the OFF position.

④ BAND Selector buttons

These buttons are used to select either AM or FM reception.

AM: Push this button for AM reception.

FM: Push this button for FM reception.

⑤ TUNING buttons (DOWN, UP)

UP: The FM or AM band is scanned in the direction of increasing frequency.

DOWN: The opposite operation to that of the UP button takes place.

⑥ STATION CALL buttons

These buttons are used to preset and recall desired broadcasting stations.

⑦ TAPE 2/ADAPTOR MONITOR button

Switch on when using a cassette deck or audio adaptor component connected to the TAPE 2/ADAPTOR jacks.

⑧ INPUT SELECTOR buttons

Use to select playback source.

[TAPE 1 /DAT] — Press when listening to tape playback with the cassette deck 1 or digital audio tape deck.

[VCR/LINE] — Press when listening to programs from a component connected to the VCR/LINE terminals.

[CD] — Press when listening to compact disc playback on a CD player.

[TUNER] — Press when listening to AM or FM broadcasts.

[PHONO] — Press when listening to record playback on a turntable.

⑨ BALANCE control

Should normally be left in the center position. Adjust balance if the sound is louder from one of the speakers. If the right side is louder, turn toward the L position and if the left side is louder, turn toward the R position.

NOTE:

This control does not operate when the DIRECT button is in the ON position.

⑩ VOLUME control

Use to adjust volume level.

⑪ DIRECT button (■ OFF, ▲ ON)

Use this button when you do not wish to pass the output from input terminal through the various frequency adjusting circuits (TREBLE, BASS). When this button is on, the BALANCE control does not operate.

⑫ TREBLE tone control

Use to adjust high-frequency tone. The center position is the flat (normal) position. When turned to the right, high-frequency tones are emphasized; when turned to the left, high-frequency tones are de-emphasized.

NOTE:

- At volume levels lower than "4" the set tone control effect is obtained.
- At volume levels higher than "4" the effect becomes increasingly weaker.
- Near maximum volume, there is no effect.
- This control does not operate when the DIRECT button is in the ON position.

⑬ BASS tone control

Use to adjust the low-frequency tone. The center position is the flat (normal) position. When turned to the right, low-frequency tones are emphasized; when turned to the left, low-frequency tones are de-emphasized.

NOTE:

- At volume levels lower than "4" the set tone control effect is obtained.
- At volume levels higher than "4" the effect becomes increasingly weaker.
- Near maximum volume, there is no effect.
- This control does not operate when the DIRECT button is in the ON position.

⑭ FM MODE AUTO/MONO selector button

Use to select the auto stereo mode or monaural mode when listening to FM broadcasts. The monaural mode has been selected when the FM MONO indicator is lit.

Auto stereo mode:

Normally leave in this mode for reception. When a stereo FM broadcast is received, it will be automatically reproduced in stereo sound.

Monaural mode:

When receiving distant stations or stations with weak broadcast signals, the input signal may be weak, thus resulting in increased noise during FM stereo broadcasts. In this event, setting the receiver to the monaural mode will reduce the noise. In this case, however, FM stereo broadcasts will be reproduced in monaural sound.

NOTE:

This button has no effect on reception of AM broadcasts.

⑮ OPERATION DISPLAY panel

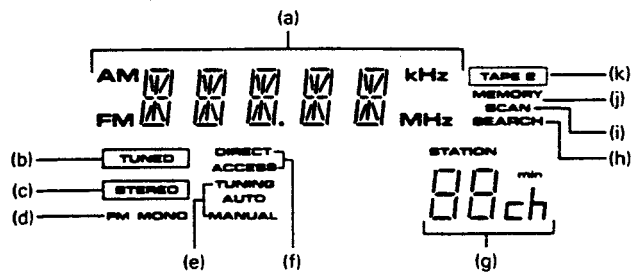

- (a) Indicates the function or frequency (SX-229, SX-339) or SLEEP (SX-339 only).
- (b) TUNED indicator
- (c) FM STEREO indicator
- (d) FM MONO indicator
- (e) TUNING AUTO/MANUAL indicator
- (f) DIRECT ACCESS tuning indicator
- (g) Indicates channel, STATION CALL number (SX-229, SX-339) or sleep time (SX-339 only).
- (h) SEARCH indicator (SX-339 only)
- (i) SCAN indicator
- (j) MEMORY indicator
- (k) TAPE 2 monitor indicator.

⑯ HITS (Hyper Intelligent Tuning System) button (SX-339 only)

Press this button to automatically search for and tune in broadcasts that can be received.

⑰ DIRECT ACCESS tuning button

When this button is pressed, the STATION CALL buttons function as ten-key number buttons for direct input of the desired reception frequency. Press again to cancel this mode.

If the input station falls outside of the receiver's tuning range, the display section will display a message: "UPPER" if the frequency is too high and "LOWER" if it is too low.

⑱ FM TUNING AUTO/MANUAL button

Works during FM reception.

Use this button to select either the AUTO mode or the MANUAL mode.

When the "AUTO" indicator is lit, the receiver is in the AUTO mode

⑲ Remote sensor window (SX-339 only)

⑳ MEMORY SCAN button

This button is used for station memory scan.

㉑ MEMORY button

When the unit is in the frequency display mode, pressing this button will result in the memorization of the current broadcast band, reception frequency, and FM AUTO/MONO mode.