

Service Manual

 **PIONEER**[®]
The Art of Entertainment

ORDER NO.
ARP2887

STEREO RECEIVER

SX-404RDS

SX-304RDS

SX-254R

- Refer to the service manual ARP2859 for SX-403RDS /HEWZ XK and SX-303RDS/HEWZ XK.

THIS MANUAL IS APPLICABLE TO THE FOLLOWING MODEL(S) AND TYPE(S).

Type	Model			Power Requirement	The voltage can be converted by the following method.
	SX-404RDS	SX-304RDS	SX-254R		
HEXK	○	○	○	AC 220-230V	AC240V, *
HBWXK	—	○	—	AC230V	AC220-230V, *
HEWZ XK	○	○	○	AC220-230V	AC240V, *

* : Alter the wiring of the Power-supply block at the primary winding of Power-transformer referring to the "Line Voltage Selection" described in Service Manual.

CONTENTS

1. CONTRAST OF MISCELLANEOUS PARTS	2
● PACKING	7
● SCHEMATIC AND PCB DIAGRAMS	8

PIONEER ELECTRONIC CORPORATION 4-1, Meguro 1-Chome, Meguro-ku, Tokyo 153, Japan
PIONEER ELECTRONICS SERVICE INC. PO Box 1760, Long Beach, California 90801 U.S.A.
PIONEER ELECTRONICS OF CANADA, INC. 300 Allstate Parkway Markham, Ontario L3R 0P2 Canada
PIONEER ELECTRONIC [EUROPE] N.V. Haven 1087 Keetberglaan 1, 9120 Melsele, Belgium
PIONEER ELECTRONICS AUSTRALIA PTY. LTD. 178-184 Boundary Road, Braeaeide, Victoria 3195, Australia TEL [03] 580-9911
© PIONEER ELECTRONIC CORPORATION 1995

Q-SSO APR 1995 printed in Japan

SX-404RDS, SX-304RDS, SX-254R

1. CONTRAST OF MISCELLANEOUS PARTS

NOTES:

- Parts marked by "NSP" are generally unavailable because they are not in our Master Spare Parts List.
- The Δ mark found on some component parts indicates the importance of the safety factor of the part. Therefore, when replacing, be sure to use parts of identical designation.
- Parts marked by "⊙" are not always kept in stock. Their delivery time may be longer than usual or they may be unavailable.

● SX-404RDS/HEXK, HEWZ XK, SX-304RDS/HEXK, HBW XK AND HEWZ XK

SX-404RDS/HEXK, HEWZ XK, SX-304RDS/HEXK, HBW XK, HEWZ XK and SX-403RDS/HEWZ XK have the same construction except for the following :

Mark	Symbol & Description	Part No.						Remarks
		SX-403RDS /HEWZ XK	SX-404RDS		SX-304RDS			
			HEXK	HEWZ XK	HEXK	HBW XK	HEWZ XK	
NSP	AF Complex Assy	AWK1820	AWK7163	AWK7163	AWK7160	AWK7159	AWK7160	
	AF Assy	AWK5491	AWZ7677	AWZ7677	AWZ7674	AWZ7673	AWZ7674	
	FRONT Assy	AWZ5489	AWZ7668	AWZ7668	AWZ7668	AWZ7668	AWZ7668	
	VR Assy	AWZ5502	AWZ7728	AWZ7728	AWZ7728	AWZ7728	AWZ7728	
	RDS Assy	AWZ5479	AWZ7679	AWZ7679	AWZ7679	AWZ7679	AWZ7679	
	Hinge Button	AAD2534	AAD2534	AAD2534	AAD2533	AAD2533	AAD2533	
Δ	Fuse (T2A/250V, FU1)	AEK - 511	AEK - 511	AEK - 511	Not Used	Not Used	Not Used	
	Fuse (T1.6A/250V, FU1)	Not Used	Not Used	Not Used	AEK - 510	AEK - 510	AEK - 510	
	Front Panel	AMB2222	AMB7196	AMB7196	AMB7197	AMB7197	AMB7197	
	Rear Panel	ANC2213	ANC7192	ANC7192	ANC7191	ANC7191	ANC7191	
NSP	Radiator	ANH1475	ANH1475	ANH1475	ANH1476	ANH1476	ANH1476	
Δ	Power Transformer	ATS1544	ATS1544	ATS1544	ATS1543	ATS1543	ATS1543	
Δ	Transistor (Q3, Q4)	2SA1302	2SA1302	2SA1302	2SA1264N	2SA1264N	2SA1264N	
Δ	Transistor (Q1, Q2)	2SC3281	2SC3281	2SC3281	2SC3181N	2SC3181N	2SC3181N	
Δ	AC Power Cord	ADG1135	ADG1135	ADG1135	ADG1135	ADG1162	ADG1135	* 1
	Fuse (5A/250V)	Not Used	Not Used	Not Used	Not Used	AEK1046	Not Used	
	Serial Sheet	AAX1523	Not Used	AAX1523	Not Used	Not Used	AAX1523	
	Shield Plate	ANK1494	Not Used	Not Used	Not Used	Not Used	Not Used	
	FM Antenna Assy	ADH1019	ADH7001	ADH7001	ADH7001	ADH7001	ADH7001	
NSP	Battery (R6P, AA)	AEX - 101	AEX7001	AEX7001	AEX7001	AEX7001	AEX7001	
	Pad Side A	AHA2009	AHA7046	AHA7046	AHA7046	AHA7046	AHA7046	
	Pad Side B (L)	AHA2010	AHA7047	AHA7047	AHA7047	AHA7047	AHA7047	
	Pad Side B (R)	AHA2011	AHA7066	AHA7066	AHA7066	AHA7066	AHA7066	
	Sub Pad	Not Used	AHA7067	AHA7067	AHA7067	AHA7067	AHA7067	
	Packing Case	AHD2719	AHD7123	AHD7123	AHD7124	AHD7124	AHD7124	
	Loop Antenna Assy	ATB1011	ATB7001	ATB7001	ATB7001	ATB7001	ATB7001	
	Remote Control Unit (CU-SX087)	AXD1397	Not Used	Not Used	Not Used	Not Used	Not Used	
	Remote Control Unit (CU-SX092)	Not Used	AXD7051	AXD7051	AXD7051	AXD7051	AXD7051	
	Operating Instructions (German)	ARC1480	Not Used	Not Used	Not Used	Not Used	Not Used	
	Operating Instructions (English/ French/German/Italian/Dutch/ Swedish/Spanish/Portuguese)	Not Used	ARE7029	Not Used	ARE7029	Not Used	Not Used	
	Operating Instructions (English)	Not Used	Not Used	Not Used	Not Used	ARB7030	Not Used	
	Operating Instructions (German)	Not Used	Not Used	ARC7046	Not Used	Not Used	ARC7046	
	Speaker Terminal 8-P	Not Used	AKE1011	AKE1011	AKE1011	AKE1011	AKE1011	

* 1: For AC power cord (ADG1162)

SX-404RDS, SX-304RDS, SX-254R

● FRONT ASSY

AWZ7668 and AWZ5489 have the same construction except for the following:

Mark	Symbol & Description	Part No.		Remarks
		AWZ5489	AWZ7668	
	D821 IC300 R317, R318 R321, R322 R327, R328 R341, R342 R823 R825 Cable Holder	AEL1148 NJM4558D RD1/8PM331J RD1/8PM821J RD1/8PM823J RD1/8PM332J RD1/8PM562J RD1/4PM221J Not Used	AEL1099 Not Used RD1/8PM391J RD1/8PM102J RD1/8PM104J RD1/8PM272J RD1/8PM472J RD1/8PM221J AKT1007	

● VR ASSY

AWZ7728 and AWZ5502 have the same construction except for the following:

Mark	Symbol & Description	Part No.		Remarks
		AWZ5502	AWZ7728	
	C361 R361 R362	CEAS470M16 RD1/8PM303J RD1/8PM183J	CEAS470M25 RD1/8PM333J RD1/8PM223J	

SX-404RDS, SX-304RDS, SX-254R

● AF ASSY

AWZ7677, AWZ7674, AWZ7673 and AWZ5491 have the same construction except for the following:

Mark	Symbol & Description	Part No.				Remarks
		AWZ5491	AWZ7677	AWZ7674	AWZ7673	
	C253, C256, C603, C711 C501, C502, C520 C521, C522 C543, C544	CEAS101M16 CEEA2R2M50 CEXA101M25 CEEA101M16 CEAS2R2M50	CEAS101M25 CEEA2R2M50 CEXA101M25 CEEA101M16 CEAS2R2M50	CEAS101M25 CEAS2R2M50 CEAS101M25 CEAS101M25 Not Used	CEAS101M25 CEAS2R2M50 CEAS101M25 CEAS101M25 Not Used	
	C701, C702 C708, C754 C714 C753 CN302	ACH1265 ACG1002 CFTXA104J50 CEAS470M10 KM200IA12	ACH1265 ACG1054 CKCYF473250 CEAS470M25 KM200IA9	ACH1105 ACG1054 CKCYF473250 CEAS470M25 KM200IA9	ACH1105 ACG1054 CKCYF473250 CEAS470M25 KM200IA9	
	CN700 CN8108 D701 IC201, IC253 L701, L702	AKP1132 AKB1127 D5SB20F UPC4570C LAU070J	AKP1132 AKB7022 D5SB20F UPC4570C SAU070J	AKP1132 AKB7022 D3SBA20 (B) NJM4558D Not Used	AKP1132 AKB7022 D3SBA20 (B) NJM4558D Not Used	
	R213 – R216, R219, R220, R223, R224 R231, R232 R239, R240 R501, R502 R521, R522	RD1/8PM331J RD1/8PM563J RD1/8PM224J RD1/8PM561J RD1/4PM911J	RD1/8PM391J RD1/8PM683J RD1/8PM104J RD1/8PM681J RD1/2PM911J	RD1/8PM391J RD1/8PM683J RD1/8PM104J RD1/8PM681J RD1/2PM102J	RD1/8PM391J RD1/8PM683J RD1/8PM104J RD1/8PM681J RD1/2PM102J	
	R523, R524 R543, R544 R606 R609 R701	RD1/4PM104J RD1/8PM911J RD1/8PM154J RD1/4PM123J RD1/4PM302J	RD1/2PM104J RD1/8PM911J RD1/8PM104J RD1/2PM123J RD1/8PM272J	RD1/2PM104J RD1/8PM102J RD1/8PM104J RD1/2PM123J RD1/8PM272J	RD1/2PM104J RD1/8PM102J RD1/8PM104J RD1/2PM123J RD1/8PM272J	
	R955, R956 R958 RY561 RY751 Pin Jack 6P	RD1/8PM332J RD1/8PM122J ASR – 112 ASR1044 AKB1121	RD1/8PM472J RD1/8PM152J ASR – 112 ASR1027 AKB7012	RD1/8PM472J RD1/8PM152J ASR1035 ASR1027 AKB7012	RD1/8PM472J RD1/8PM152J ASR1035 ASR1027 AKB7012	
	Speaker Terminal 8-P	AKE111	Not Used	Not Used	Not Used	

● AF ASSY

AWZ7671 and AWZ5487 have the same construction except for the following:

Mark	Symbol & Description	Part No.		Remarks
		AWZ5487	AWZ7671	
	C235, C236, C520, C603, C711 C521, C522 C541 C542 C701, C702	CEAS101M16 CEAS101M16 CCPUSL470J50 CCCSL100D50 ACH1105	CEAS101M25 CEAS470M25 Not Used Not Used ACH1266	
	C708, C754 C714 C753 C951 CN302	ACG1002 CFTXA104J50 CEAS470M10 CKDYF103Z50 KM200IA12	ACG1054 CKCYF473Z50 CEAS470M25 Not Used Not Used	
	CN8108 D701 Q951 R213 - R216, R219, R220, R223, R224 R231, R232	AKB1127 D3SBA20 2SC2668 RD1/8PM331J RD1/8PM563J	AKB7022 D3SBA20 Not Used RD1/8PM391J RD1/8PM683J	
	R239, R240 R501, R502 R521, R522 R523, R524 R541, R542	RD1/8PM224J RD1/8PM561J RD1/4PM102J RD1/4PM104J RD1/8PM104J	RD1/8PM104J RD1/8PM681J RD1/2PM122J RD1/2PM104J Not Used	
	R543, R544 R606 R701 R706, R707 R951	RD1/8PM102J RD1/8PM154J RD1/4PM302J RS2LMF272J RD1/8PM221J	Not Used RD1/8PM104J RD1/8PM272J RS2LMF222J Not Used	
	R952 R953 R955, R956 R958 RY751	RD1/8PM221J RD1/8PM472J RD1/8PM332J RD1/8PM122J ASR1044	Not Used Not Used RD1/8PM472J RD1/8PM152J ASR1027	
	Pin Jack 6P	AKB1121	AKB7012	

● RDS ASSY

AWZ7679 and AWZ5479 have the same construction except for the following:

Mark	Symbol & Description	Part No.		Remarks
		AWZ5479	AWZ7679	
	CN901 Q901 Q903	KP200IA12L 2SA933S 2SC1740S	KP200IA9L 2SC1048 2SC2458	

● SX-254R/HEXK AND HEWZXX

SX-254R/HEXK, HEWZXX and SX-303RDS/HEWZXX have the same construction except for the following :

Mark	Symbol & Description	Part No.			Remarks
		SX-303RDS /HEWZXX	SX-254RDS		
			HEXK	HEWZXX	
NSP	AF Complex Assy AF Assy FRONT Assy VR Assy RDS Assy	AWK1818 AWZ5487 AWZ5485 AWZ5486 AWZ5479	AWK7157 AWZ7671 AWZ7667 AWZ7727 Not Used	AWK7157 AWZ7671 AWZ7667 AWZ7727 Not Used	
Δ	FL Panel Fuse (T1.6A/250V, FU1) Fuse (1.25A/250V, FU1) Front Panel Rear Panel	AAK2556 AEK - 510 Not Used AMB2226 ANC2164	AAK7149 Not Used AEK - 509 AMB7195 ANC7193	AAK7149 Not Used AEK - 509 AMB7195 ANC7193	
NSP Δ	Radiator Power Transformer Nut Serial Sheet FM Antenna Assy	ANH1476 ATS1543 Not Used AAX1523 ADH1019	ANH1477 ATS1542 NK90FUC Not Used ADH7001	ANH1477 ATS1542 NK90FUC AAX1523 ADH7001	For VR Assy
NSP	Battery (R6P, AA) Pad Side A Pad Side B (L) Pad Side B (R) Sub Pad Packing Case Loop Antenna Assy Remote Control Unit (CU-SX087) Remote Control Unit (CU-SX091) Battery Cover Operating Instructions (German) Operating Instructions (English/ French/German/Italian/Dutch/ Swedish/Spanish/Portuguese) Operating Instructions (German)	AEX - 010 AHA2009 AHA2010 AHA2011 Not Used AHD2720 ATB1011 AXD1397 Not Used AZA7031 ARC1480 Not Used Not Used	AEX7001 AHA7046 AHA7047 AHA7066 AHA7067 AHD7125 ATB7001 Not Used AXD7050 AZN2249 Not Used ARE7030 Not Used	AEX7001 AHA7046 AHA7047 AHA7066 AHA7067 AHD7125 ATB7001 Not Used AXD7050 AZN2249 Not Used Not Used ARC7047	
Δ	Transistor (Q3, Q4)	2SA1264N	2SA1263N	2SA1263N	
Δ	Transistor (Q1, Q2)	2SC3181N	2SC3180N	2SC3180N	

● FRONT ASSY

AWZ7667 and AWZ5485 have the same construction except for the following:

Mark	Symbol & Description	Part No.		Remarks
		AWZ5485	AWZ7667	
	D821 R317, R318 R321, R322 R327, R328 R341, R342	AEL1148 RD1/8PM331J RD1/8PM821J RD1/8PM823J RD1/8PM332J	AEL1099 RD1/8PM391J RD1/8PM102J RD1/8PM104J RD1/8PM272J	
	R823 R825	RD1/8PM562J RD1/4PM221J	RD1/8PM472J RD1/8PM221J	

● VR ASSY

AWZ7727 and AWZ5486 have the same construction except for the following:

Mark	Symbol & Description	Part No.		Remarks
		AWZ5486	AWZ7727	
	C361 R361 R362	CEAS470M16 RD1/8PM303J RD1/8PM183J	CEAS470M25 RD1/8PM333J RD1/8PM223J	

● PACKING

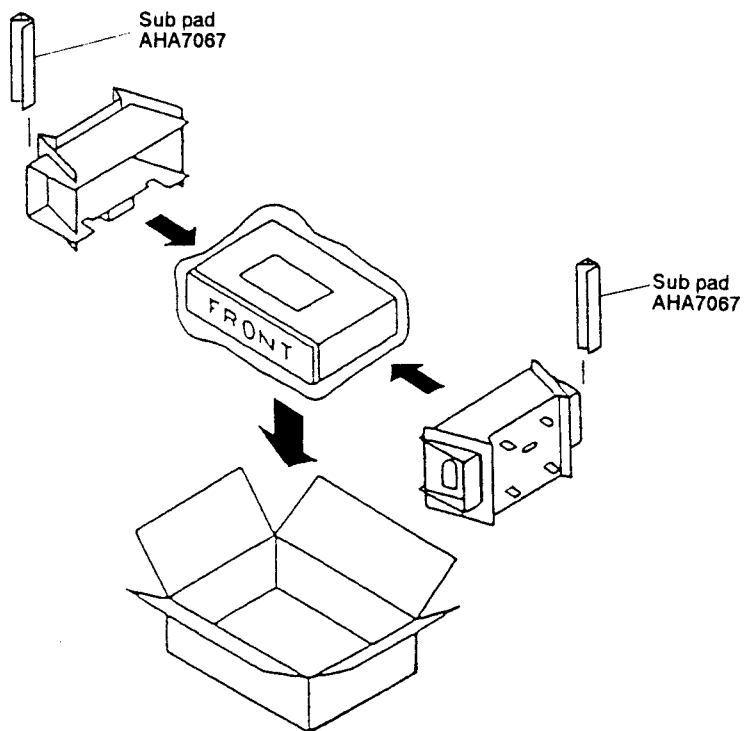

2. SCHEMATIC AND PCB DIAGRAMS

2-1. FRONT ASSY, VR ASSY AND RDS ASSY

- This diagram is viewed from the mounted parts side.

Note :
PCB diagrams of FRONT ASSY and VR ASSY for SX-254R, refer to the SX-303RDS service manual.

FRONT ASSY (For SX-404RDS and SX-304RDS)

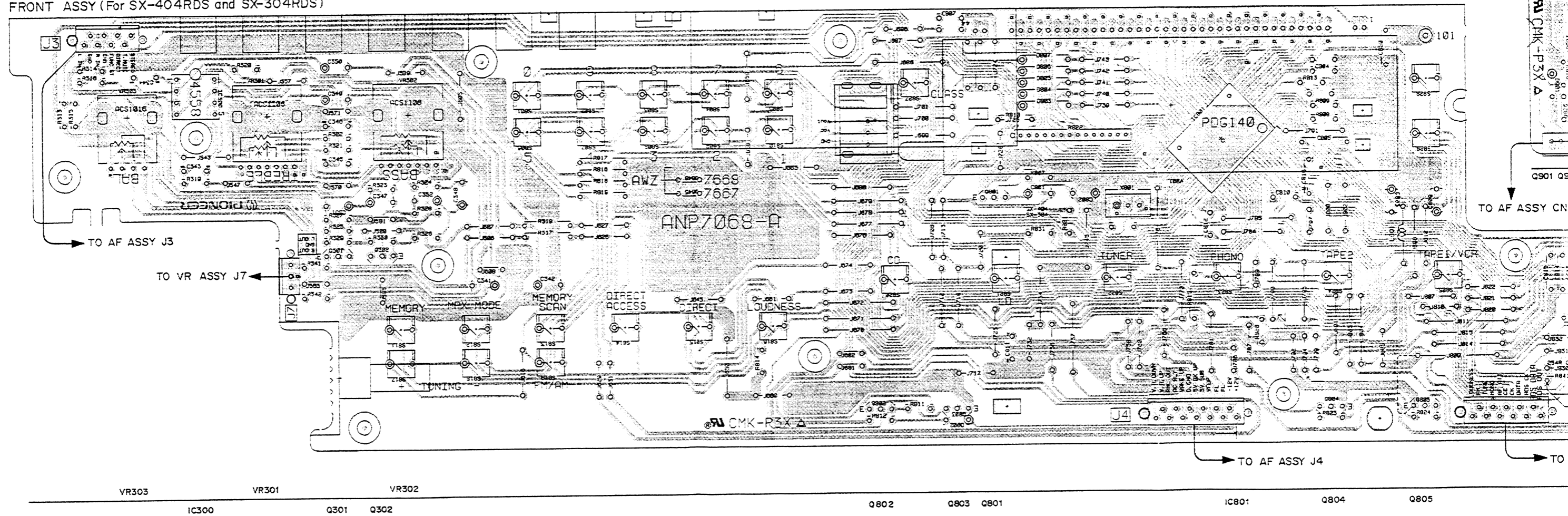

PCB-1

RDS A



TO AF ASSY CN

TO

TO

Note:
PCB diagrams of FRONT ASSY and VR ASSY for SX-254R, refer to the SX-303RDS service manual.

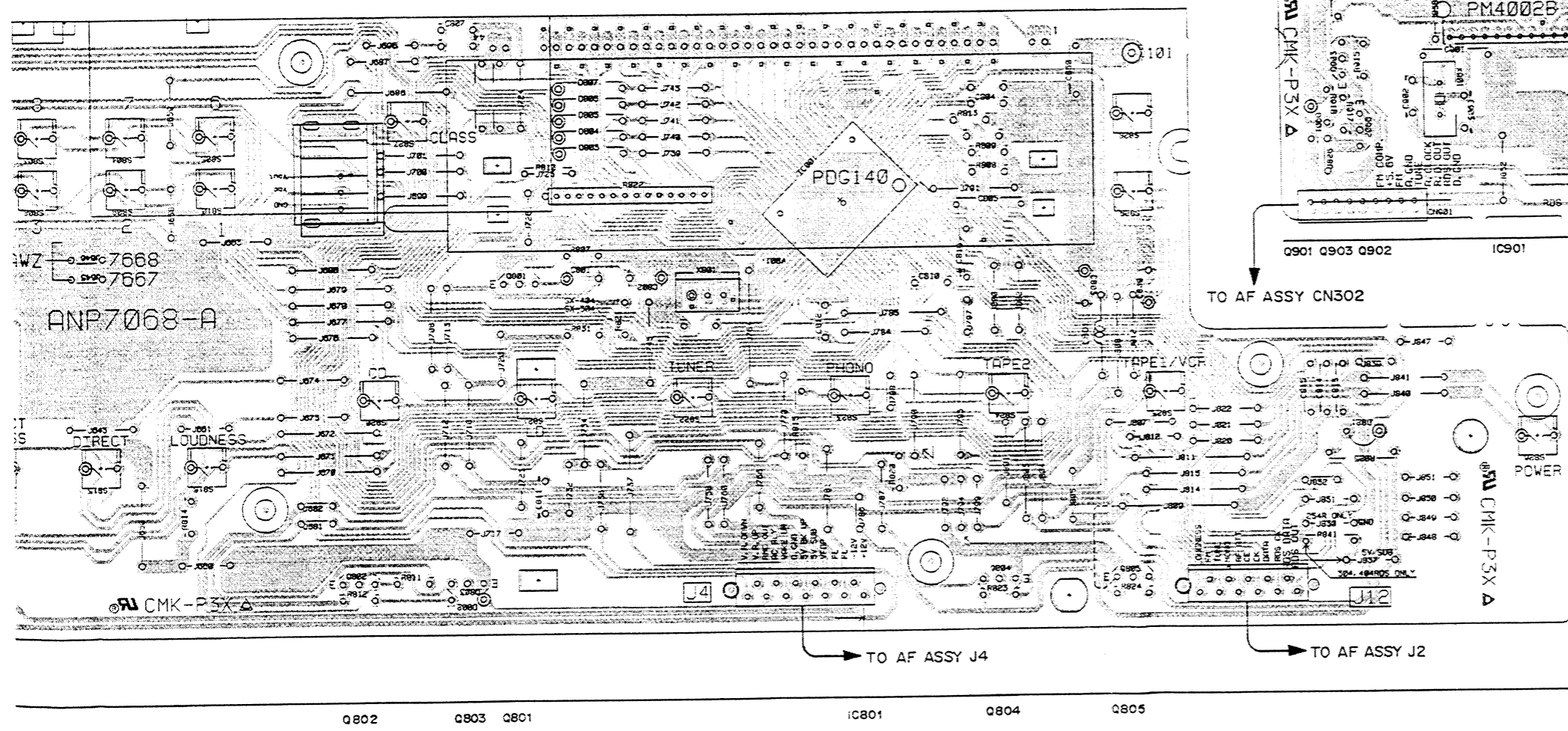

PCB-1F

RDS ASSY(SX-404RDS and SX-304RDS only)

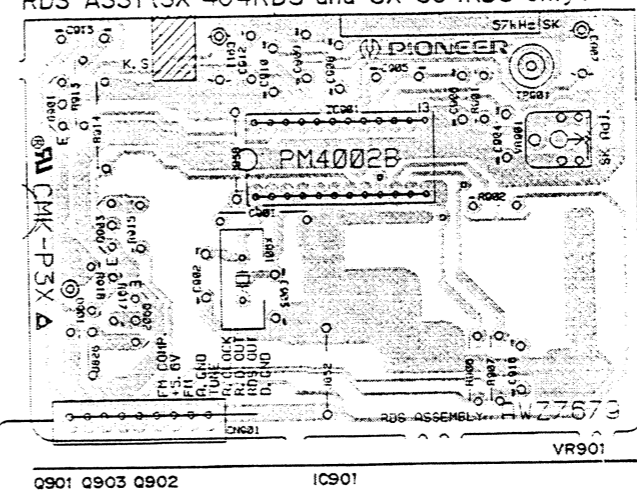

NOTE FOR PCB DIAGRAMS.
1. Part numbers in PCB diagrams match those in the schematic diagrams.
2. A comparison between the main parts of PCB and schematic diagrams is shown below.

Symbol in PCB Diagrams	Symbol in Schematic Diagrams	Part Name
		Transistor
		Diode
		Capacitor (Polarized)

3. The transistor terminal marked with E or C shows the emitter.
4. The diode terminal marked with @ or C shows cathode side.
5. The capacitor terminal marked with @ or C shows negative terminal.
6. The parts mounted on each PCB include all necessary parts for several destinations. For further information for respective destinations, be sure to check with the schematic diagram.

VR ASSY(For SX-404RDS and SX-304RDS)

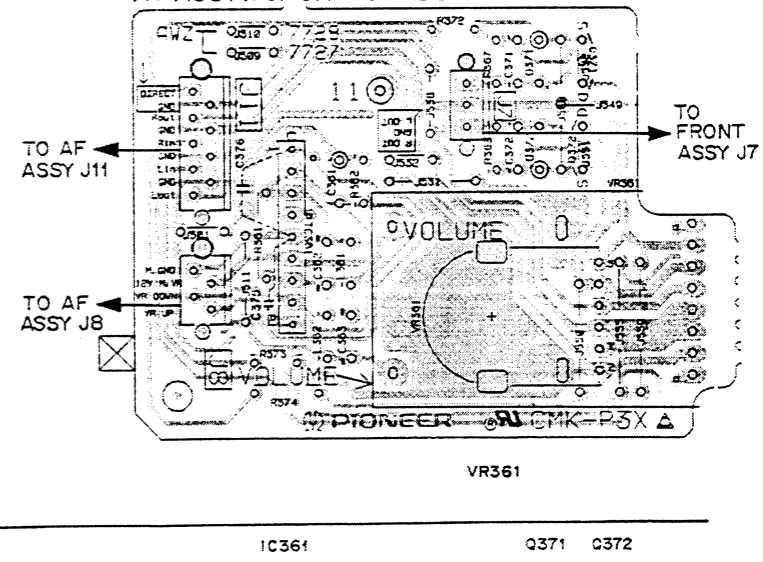

FRONT ASSY (AWZ7668 : SX-404RDS, SX-304RDS)
 (AWZ7667 : SX-254R)

VOL DOWN
 VOL UP
 RMC OUT
 AC RLY
 WAKE UP
 D.CMD
 5V BK UP
 5V SUB
 VFDP
 FL
 FL
 -12V
 +12V

TO AF ASSY J4 (→SCH-2F)
 J4
 AKT1011

SX-404RDS, SX-304RDS
 015411-550-2651 AKT1007
 015408-550-2651 AKT1021

TO AF ASSY J12 (→SCH-2F)
 FM
 RDS OUT
 RDS DATA
 RDS CLOCK
 DATA
 CLOCK
 PLL CE
 RF ATT
 MOND
 TUNE
 (SX-404RDS, SX-304RDS only)
 LOUDNESS

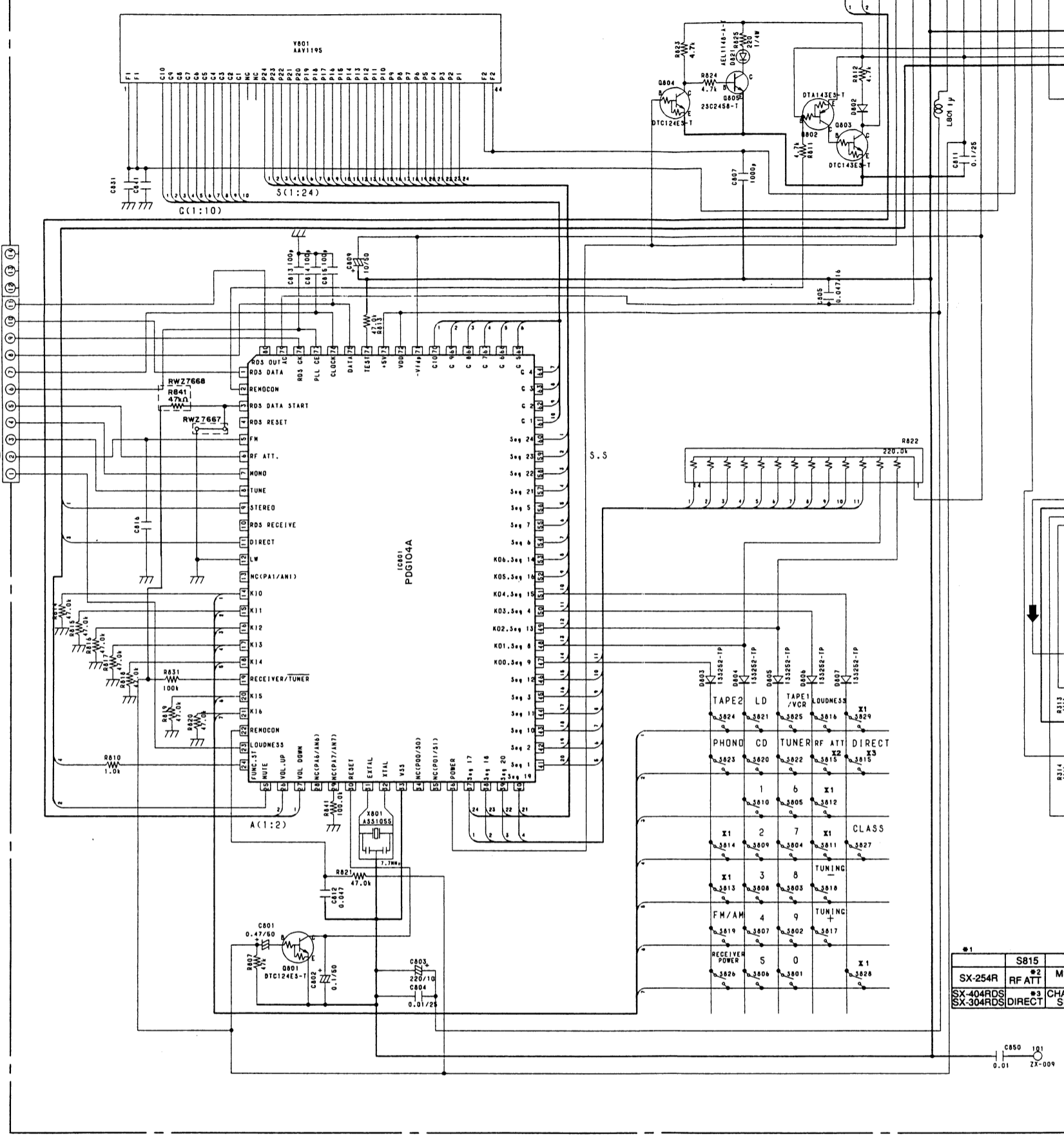

*1

SX-254R	S815	S
SX-404RDS	RF ATT	ME
SX-304RDS	DIRECT	SE

C850 101
 0.01 2X-009

SCH-1F

FRONT ASSY, RDS ASSY

NOTE FOR SCHEMATIC DIAGRAMS (Type 1A)

- When ordering service parts, be sure to refer to "PARTS LIST of EXPLODED VIEWS" or "PCB PARTS LIST".
- Since these are basic circuits, some parts of them or the values of some components may be changed for improvement.
- RESISTORS:**
Unit: k:kΩ, M:MΩ, or Ω unless otherwise noted.
Rated power: 1/4W, 1/6W, 1/8W, 1/10W unless otherwise noted.
Tolerance: (F): ±1%, (G): ±2%, (K): ±10%, (M): ±20% or ±5% unless otherwise noted.
- CAPACITORS:**
Unit: p:pF or μF unless otherwise noted.
Ratings: capacitor (μF)/ voltage (V) unless otherwise noted.
Rated voltage: 50V except for electrolytic capacitors.
- COILS:**
Unit: m:mH or μH unless otherwise noted.
- VOLTAGE AND CURRENT:**
V : Signal voltage at rated output.
or - V :
DC voltage (V) at no input signal unless otherwise noted.
Value in () is DC voltage at rated power.
mA or - mA :
DC current at no input signal unless otherwise noted.
- OTHERS:**
⊗ or ⊙ : Adjusting point.
• : Measurement point.
The Δ mark found on some component parts indicates the importance of the safety factor of the parts. Therefore, when replacing, be sure to use parts of identical designation.
- SCH-□ ON THE SCHEMATIC DIAGRAM:**
• SCH-□ indicates the drawing number of the schematic diagram. (SCH stands for schematic diagram.)
- SWITCHES (Underline indicates switch position):**

FRONT assy			
S801	0	S815	DIRECT (SX-404RDS and SX-304RDS)
S802	9	S815	RF ATT (SX-254R)
S803	8	S816	LOUDNESS
S804	7	S817	TUNING +
S805	6	S818	TUNING -
S806	5	S819	FM/AM
S807	4	S820	CD
S808	3	S821	LD
S809	2	S822	TUNER
S810	1	S823	PHONO
S811	MEMORY (SX-404RDS and SX-304RDS)	S824	TAPE2
S811	STATION + (SX-254R)	S825	TAPE1/VC
S812	MPX MODE (SX-404RDS and SX-304RDS)	S826	RECEIVER
S812	STATION - (SX-254R)	S827	CLASS
S813	MEMORY SCAN (SX-404RDS and SX-304RDS)	S828	CHARACTER/SEARCH (SX-404RDS and SX-304RDS)
S813	MEMORY (SX-254R)	S828	MEMORY SCAN (SX-254R)
S814	DIRECT ACCESS (SX-404RDS and SX-304RDS)	S829	DISPLAY MODE (SX-404RDS and SX-304RDS)
S814	MPX MODE (SX-254R)	S829	DIRECT ACCESS (SX-254R)

SCH-1F

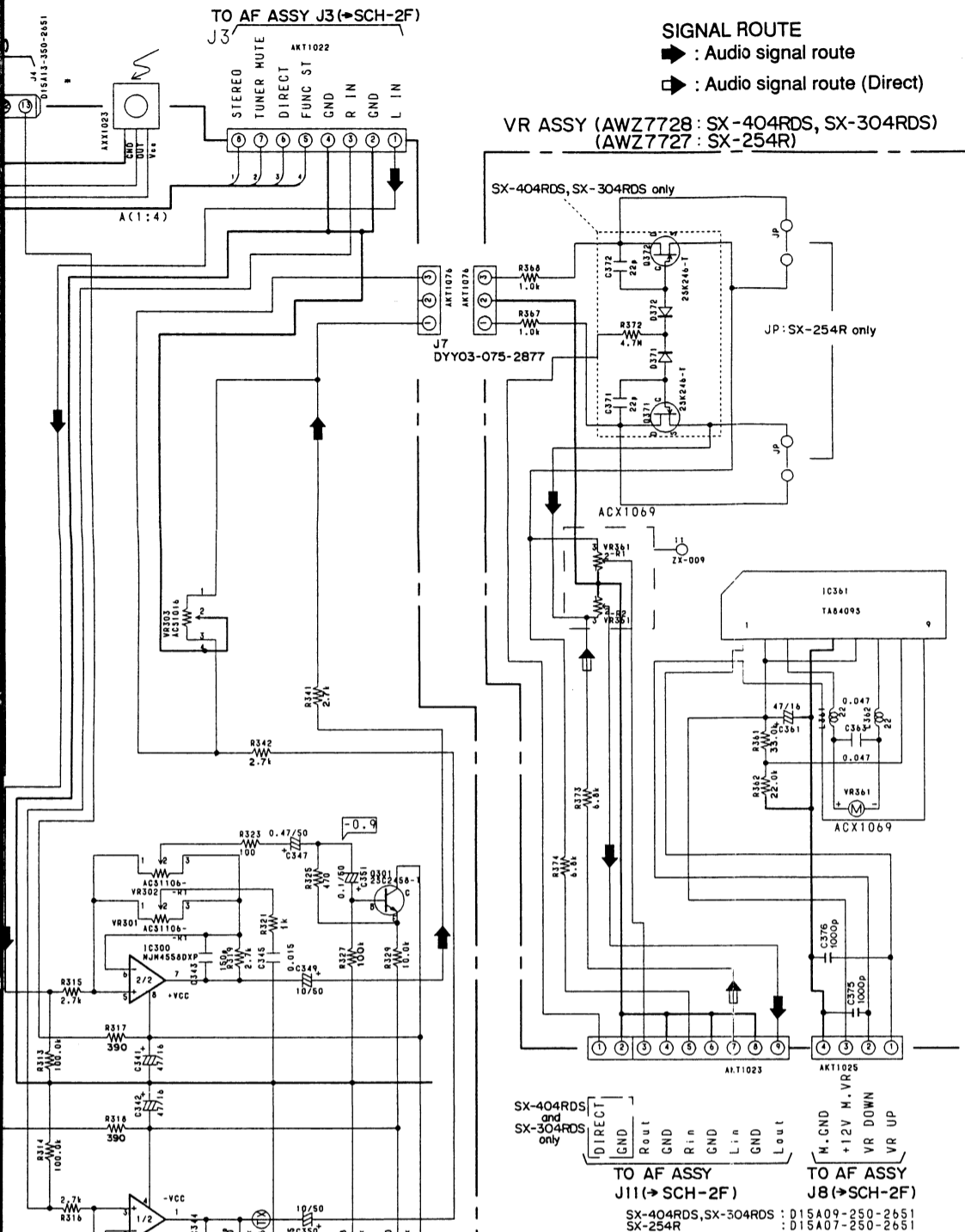

SCH-1F

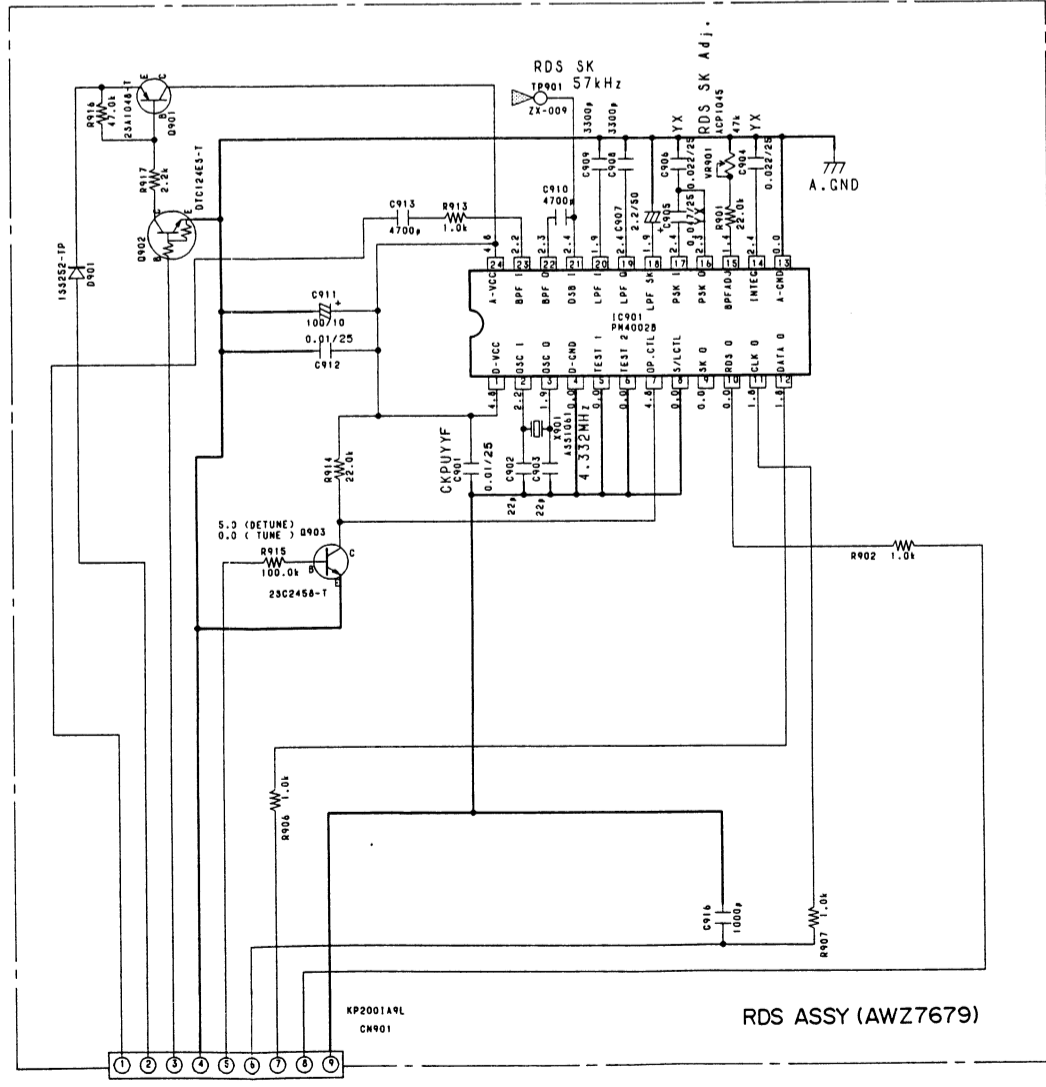

FM COMPOSITE
 +5.6V(DIGITAL)
 FM(POWER CONTROL)
 TUNE
 RDS CLOCK OUT
 RDS DATA OUT
 RDS OUT
 D.CND

TO AF ASSY (SCH-2F)

FRONT ASSY, RDS ASSY

SCH-1F

2-2. AF ASSY, SP SWITCH ASSY AND TRANS ASSY

* TABLE 1

MODEL	SX-254R	SX-304RDS	SX-404RDS
R521, R522	1.2k/1/2W	1.0k/1/2W	910/1/2W
R543, R544		1.0k	910
R706, R707	2.2k/2W	2.7k/2W	2.7k/2W
C701, C702	ACH1266	ACH1105	ACH1265
C521, C522	47/25	100/25	100/16 (EA)
C543, C544			2.2/50
L701, L702			1.0u
D701	D3SBA20	D3SBA 20	D5SB20F
RY561	ASR1035	ASR1035	ASR112
IC201, 253	NJM4558DXP	NJM4558DXP	UPC4570C

AF ASSY (AWZ7677 : S
(AWZ7674 : S
(AWZ7673 : S
(AWZ7671 : S

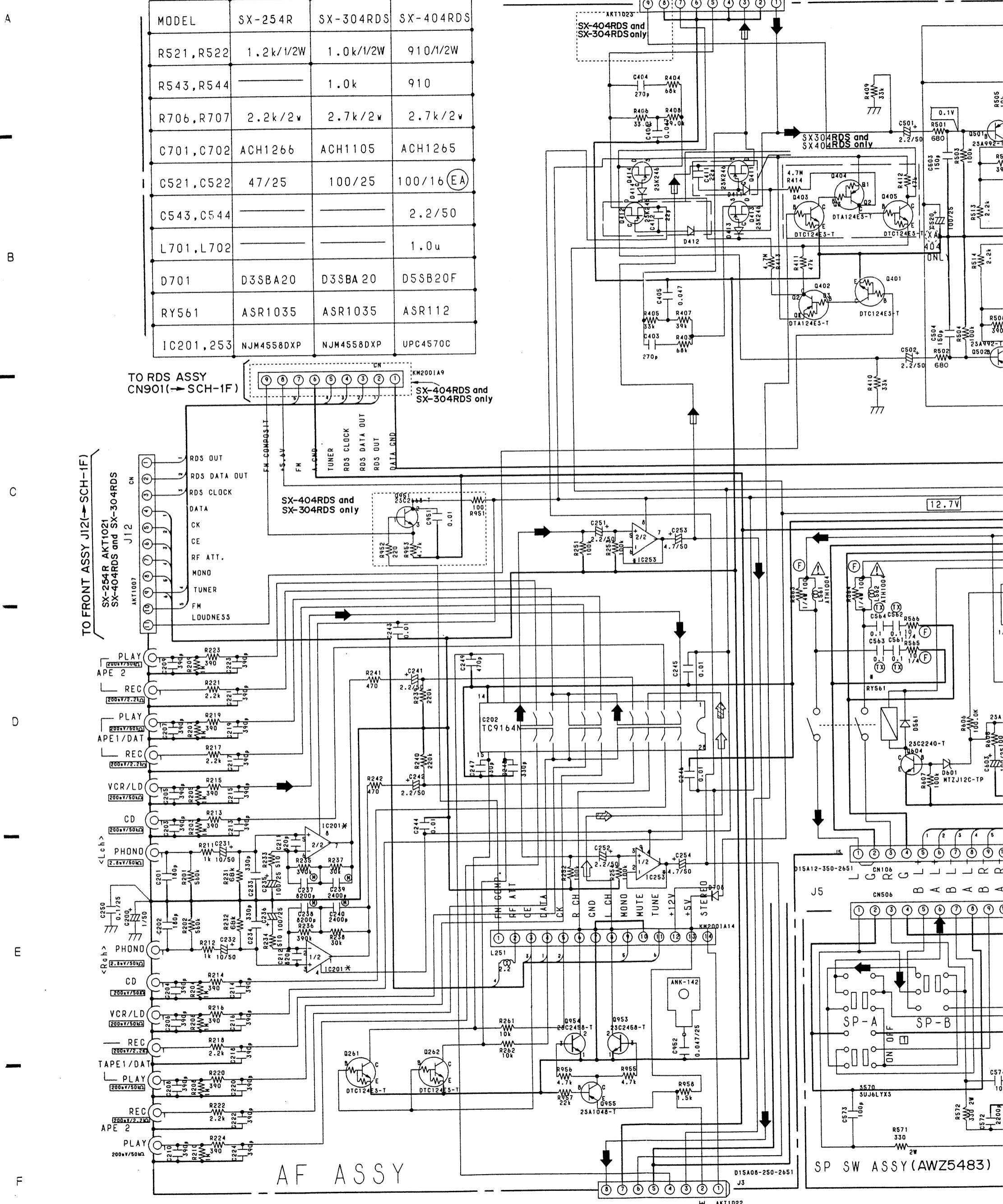

SCH-2F

AF ASSY

677: SX-404RDS)
 674: SX-304RDS/HEXK and SX-304RDS/HEWZK)
 673: SX-304RDS/HBWXK)
 671: SX-254R)

SCH-2F

*Refer to Table 1

- SIGNAL ROUTE**
- : Audio signal route
 - ➡ : Audio signal route (Direct)
 - ⚡ : FM signal route
 - ⇨ : AM signal route

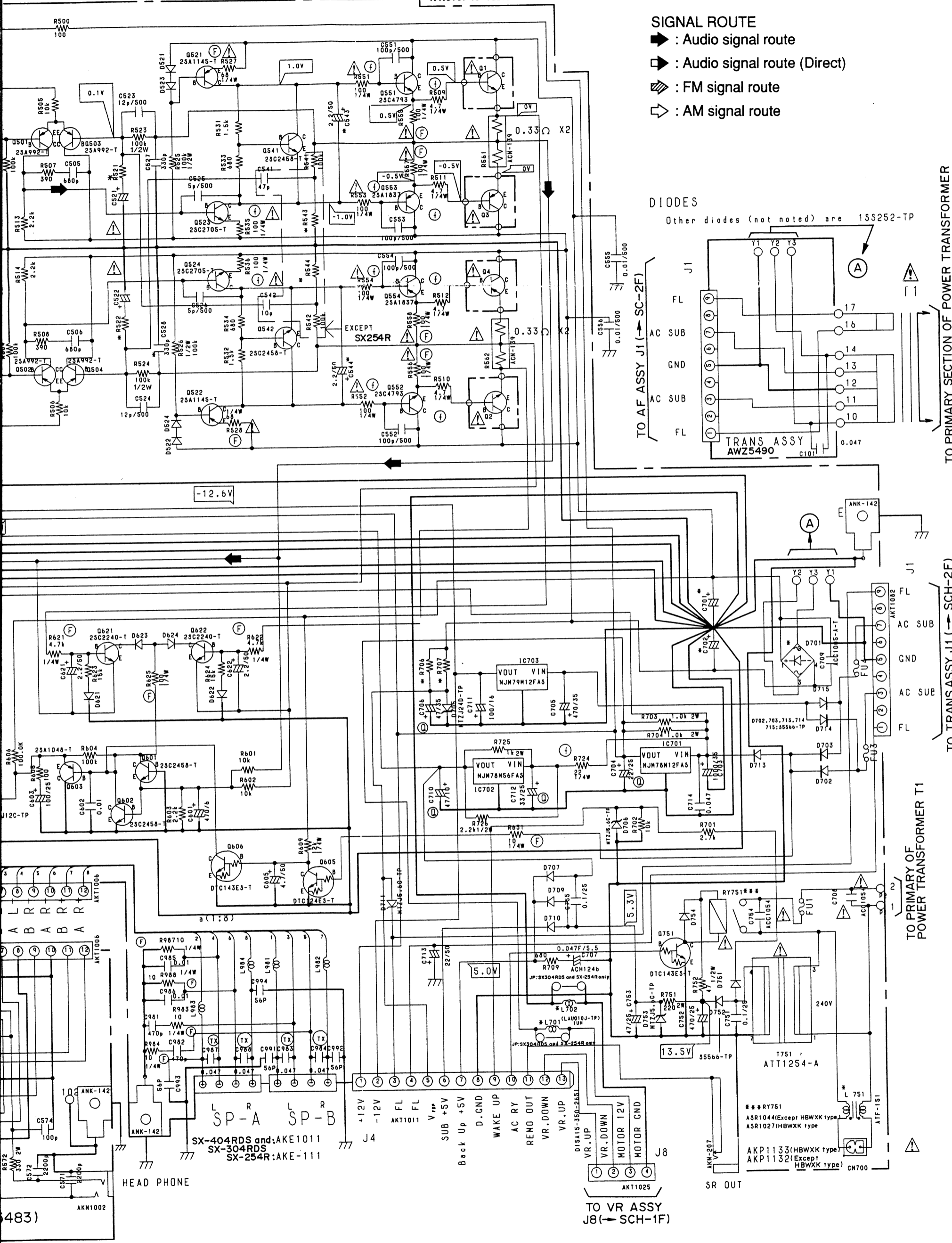

DIODES
 Other diodes (not noted) are 1S5252-TP

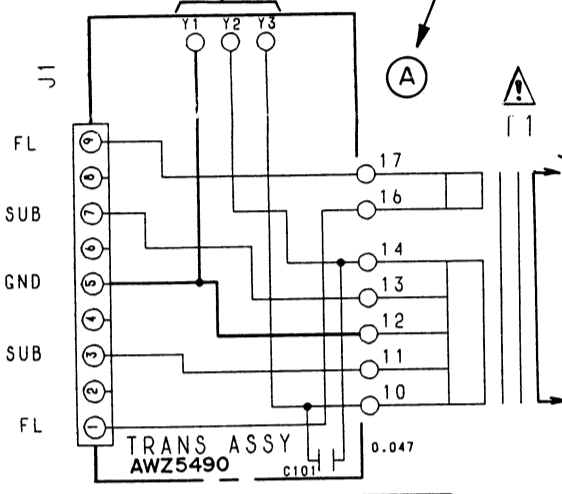

TO PRIMARY SECTION OF POWER TRANSFORMER

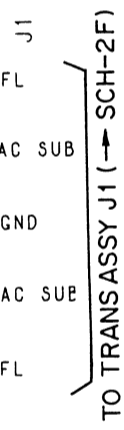

TO TRANS ASSY J1 (SCH-2F)

TO PRIMARY OF POWER TRANSFORMER T1

TO VR ASSY J8 (SCH-1F)

SCH-2F

AF ASSY

• This diagram is viewed from the mounted parts side.

Note :
PCB diagram of AF ASSY for SX-254R, refer to AF ASSY for SX-303RDS.

PCB-2F

