

SERVICE MANUAL

STEREO TUNER **TX-7100** FW, KUW, KCW, FVZW

NOTE:
MODEL TX-7100 COMES IN FOUR VERSIONS DISTINGUISHED AS FOLLOWS:

Round label on rear panel	Voltage	Type
KUW KCW FVZW FW	120V only 120V only 5-position selector 5-position selector	UL approved (U.S.A.) CSA approved (Canada) FTZ approved (West Germany) General export model

CONTENTS

1.	SPECIFICATIONS	3
2.	FRONT PANEL FACILITIES	5
3.	CONNECTION DIAGRAM	7
4.	DISASSEMBLY	8
5.	PARTS LOCATION	
5.1	Top View	9
5.2	Bottom View	10
6.	BLOCK DIAGRAM	11
7.	CIRCUIT ANALYSIS	
7.1	FM Front End	13
7.2	FM IF Amplifier	13
7.3	FM MPX Section	13
7.4	AM Section	14
7.5	AF Section	14
7.6	Power Supply	14
8.	ADJUSTMENT	
8.1	Required Measuring Instruments	15
8.2	AM Adjustment	15
8.3	FM Adjustment	15
9.	DIAL STRINGING PROCEDURE	16
10.	EXPLODED VIEW AND PARTS LIST	17
11.	SCHEMATIC DIAGRAMS, P.C. BOARD PATTERNS AND PARTS LISTS	
11.1	Circuit Connection Diagram and Miscellaneous Parts List	21
11.2	Tuner Assembly (AWE-024)	25
11.3	AF Amplifier Assembly (AWK-019)	30
11.4	Power Supply Circuit Assembly (AWR-027)	34
11.5	Switch Circuit Assembly (AWS-031)	36
12.	PACKING METHOD AND PART NUMBERS	37
13.	TUNER CHARACTERISTICS	38

MISCELLANEOUS

Power Requirements	AC 120V 60Hz or AC 110V, 120V, 130V, 220V and 240V (switchable) 50/60Hz
Power Consumption	25W
AC Outlet	Unswitched 1
Dimensions	430(W) x 138(H) x 345(D)mm 16-15/16 x 5-7/16 x 13-9/16 in.
Weight Without Package	7.7 kg, 16 lb 15oz
With Package	9.7 kg, 21 lb 5oz

FURNISHED PARTS

FM T-type Antenna	1
Connection Cord with Pin Plugs	1
Polishing Cloth	1
Operating Instructions	1
Fuse 0.5A (5-line voltage)	1
Fuses 1.0A (model only)	2

NOTE:

Specifications and the design subject to possible modification without notice due to improvements.

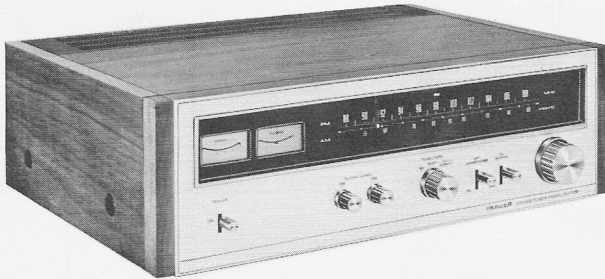

2. FRONT PANEL FACILITIES

POWER SWITCH

Move up to ON to power the set, down to turn it OFF.

SIGNAL METER

Optimum AM or FM reception is indicated when the needle swings to the extreme right.

TUNING METER

Works together with the SIGNAL METER to indicate the correct tuning position (indicated by the broadcast tuning to indicate precise tuning position).

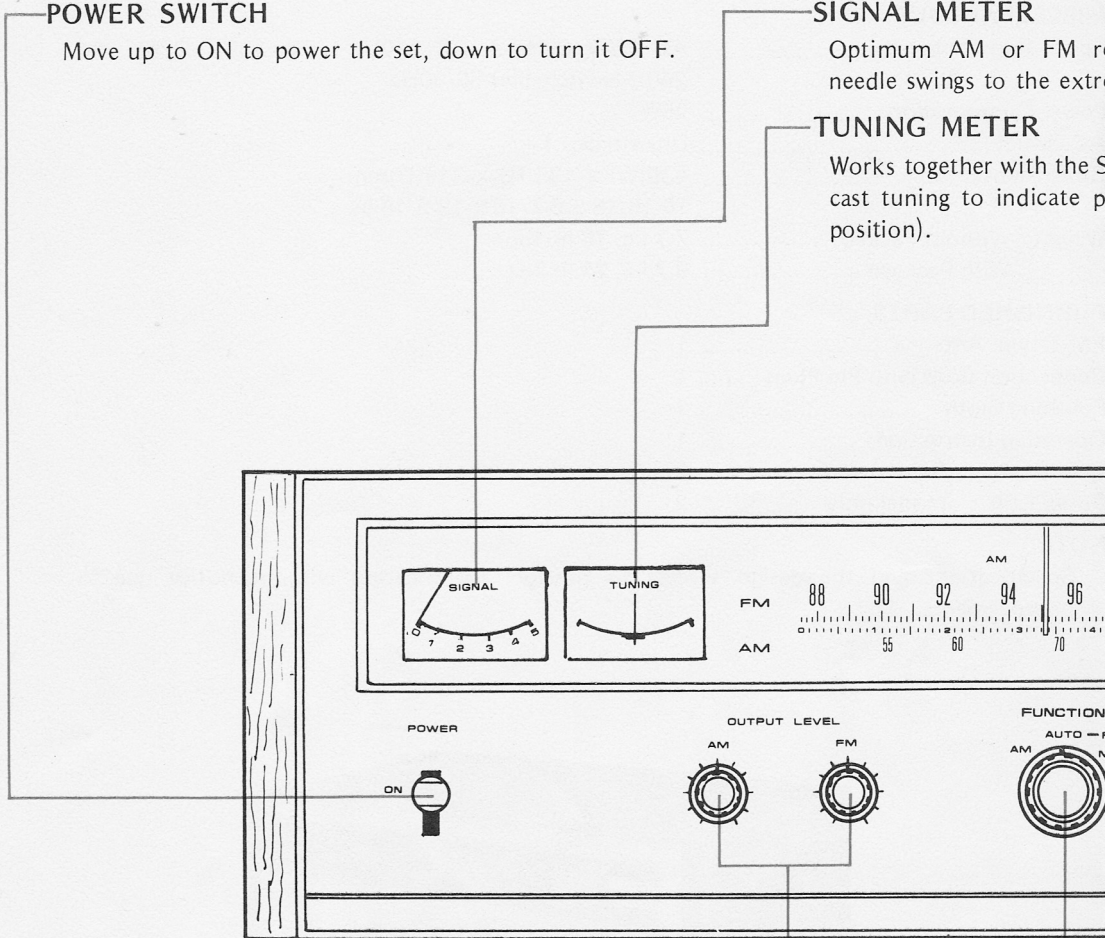

AM and FM OUTPUT LEVEL KNOBS

Control the volume of the signal from the OUTPUT (VARIABLE) terminals on the rear panel.

Separate controls for AM and FM signals. Turn to the right to increase the volume.

FUNCTION SWITCH

Used to select the type of broadcast reception.

AM For AM broadcast reception.

FM AUTO . . . For normal FM reception. Provides automatic switchover to stereo when a stereo signal is received.

FM MONO. . . For monophonic reception of both mono and stereo FM signals.

ception is obtained when the
me right.

IGNAL meter during FM broad-
recise station alignment (center

FM STEREO INDICATOR

When the FUNCTION switch is set to FM AUTO, this lamp lights whenever an FM stereo broadcast is being received.

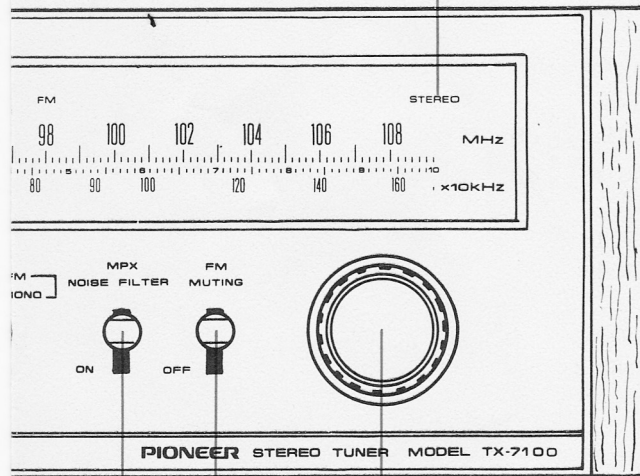

TUNING KNOB

Used to tune in both AM and FM stations.

FM MUTING LEVER SWITCH

In keeping the lever upper (not moved down to OFF), the FM muting circuit cancels out noise on unused FM bands (inter-station noise), but it also rejects very weak, faint FM stations. To receive such a station, move the lever to OFF to turn off the FM muting circuit.

MPX NOISE FILTER SWITCH

Switch on to cut high-frequency noise during FM stereo broadcast reception.

3. CONNECTION DIAGRAM

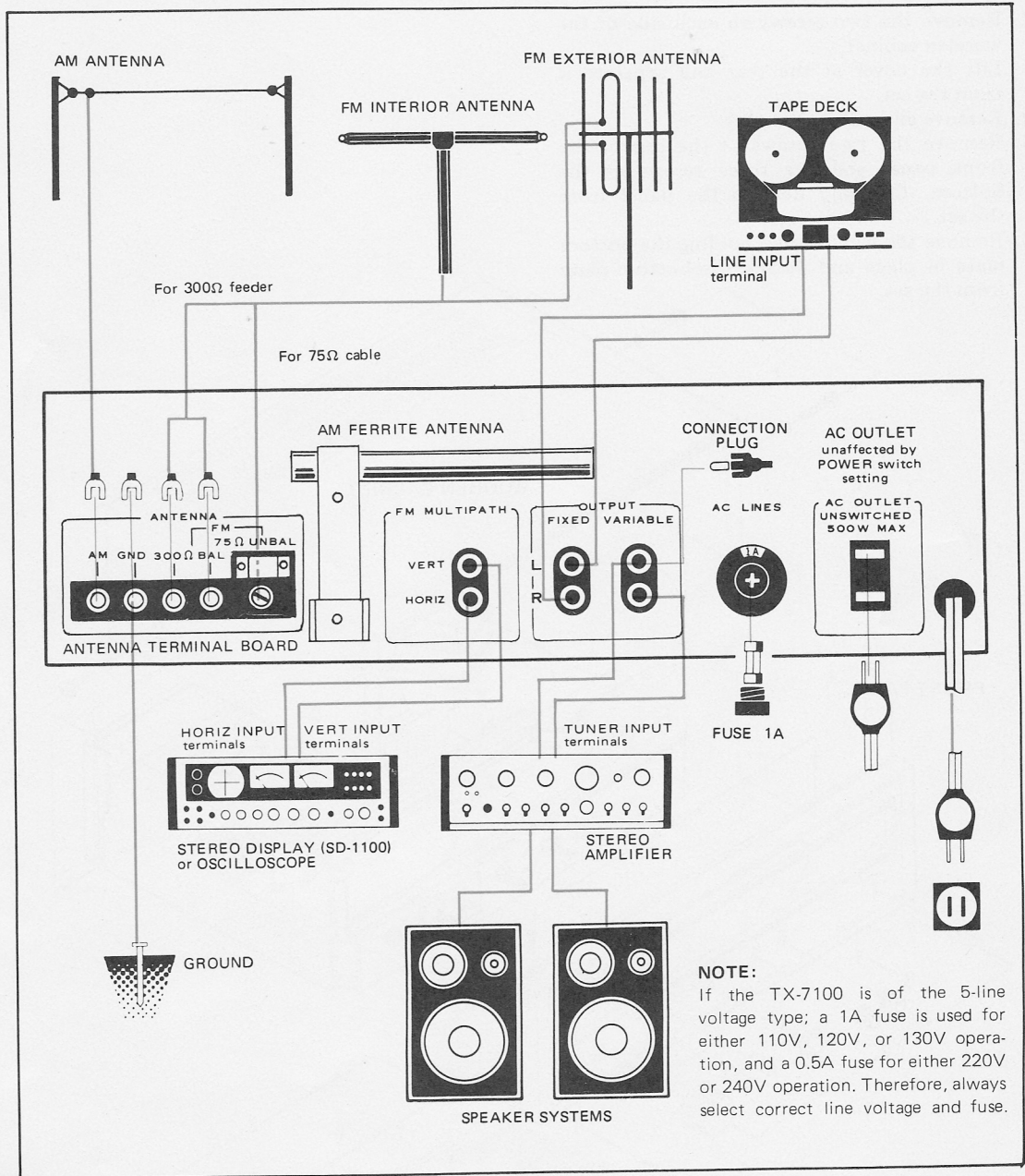

4. DISASSEMBLY

1. Remove the two screws on each side of the wooden cabinet.
Lift the cover at the rear and separate it from the set.
2. Remove all knobs.
3. Remove the two screws at the top of the front panel and the three screws at the bottom. Carefully detach the panel from the set.
4. Remove the eight screws holding the bottom plate in place and detach the bottom plate from the set.

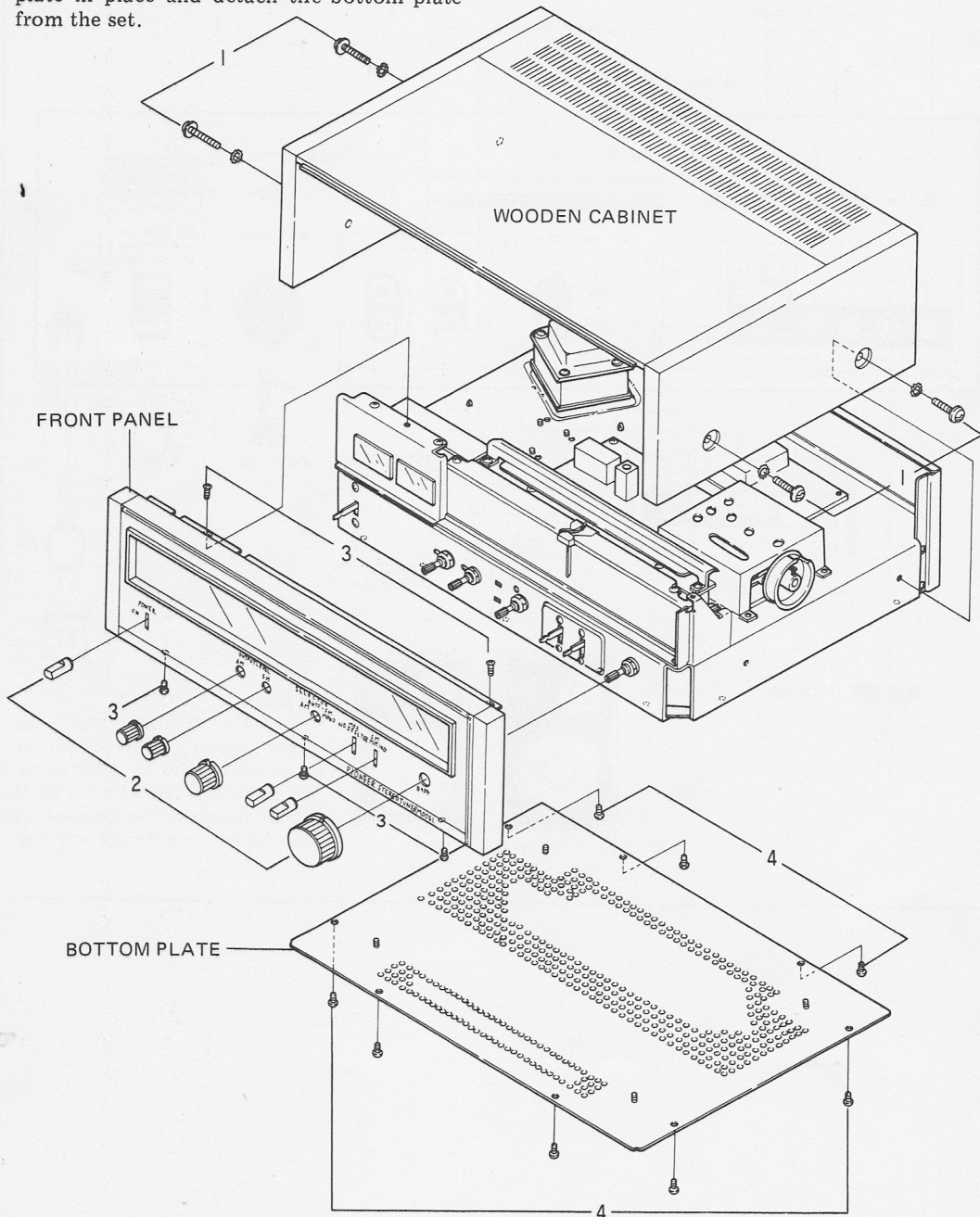

5. PARTS LOCATION

5.1 TOP VIEW

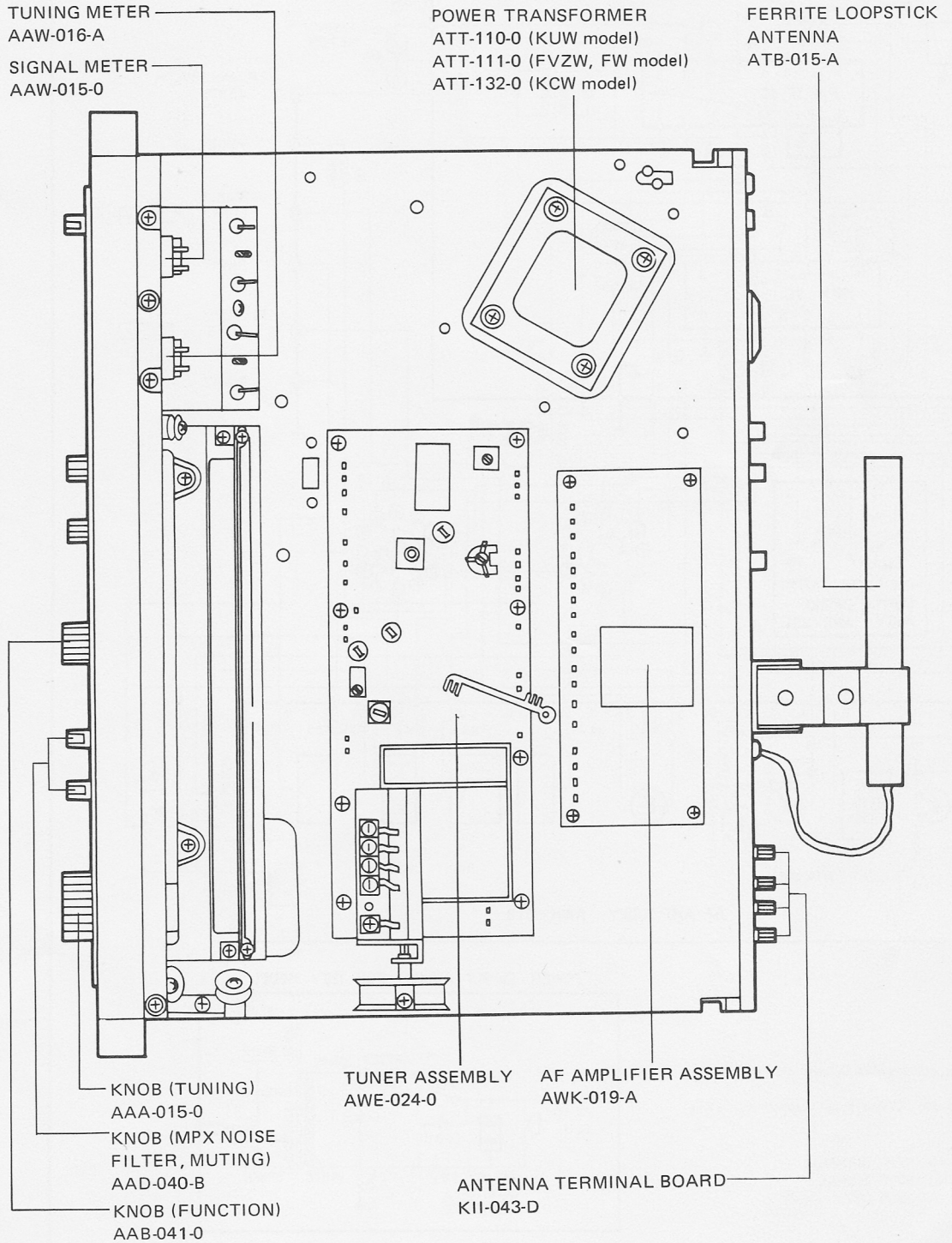

5.2 BOTTOM VIEW

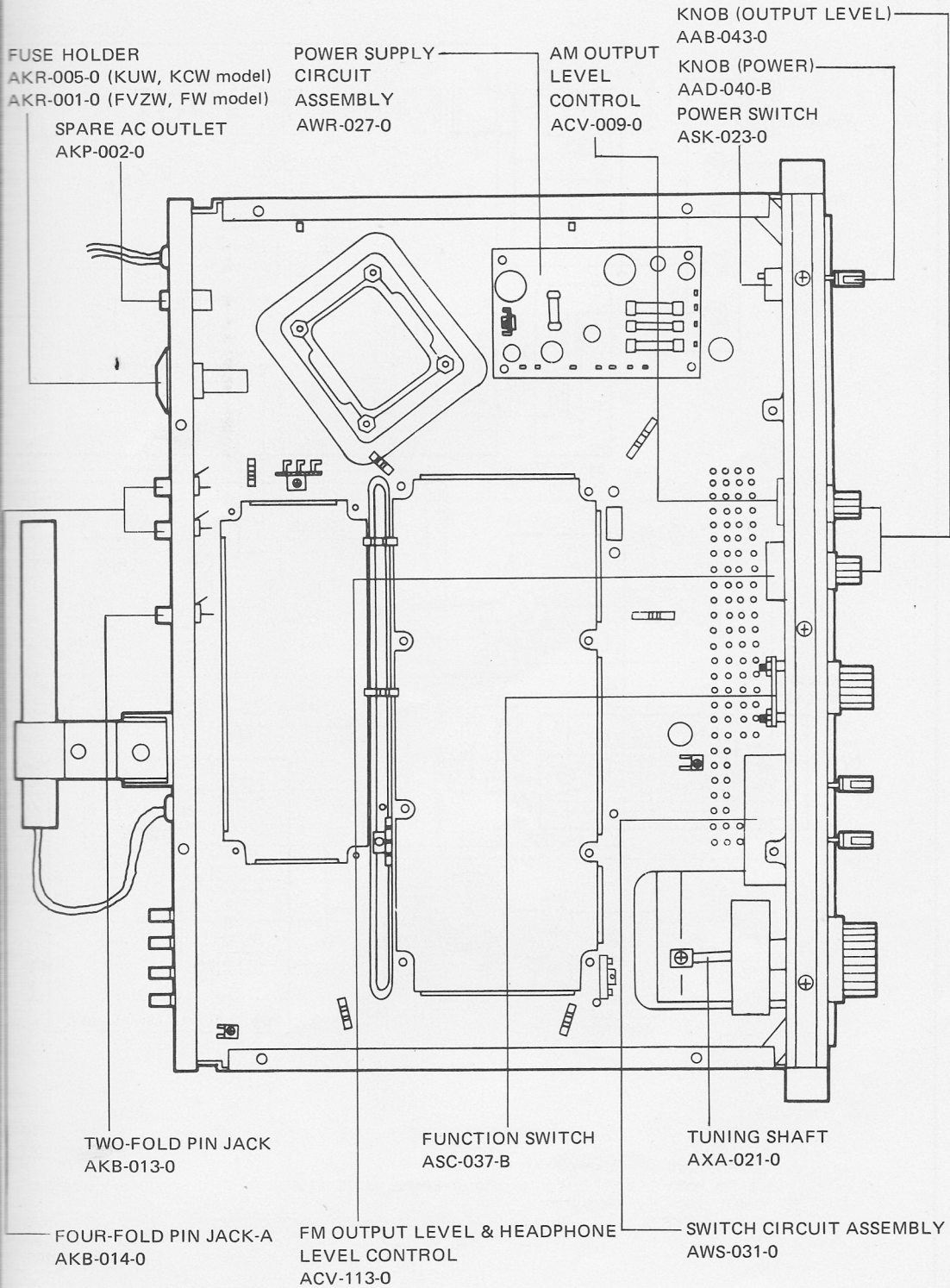

6. BLOCK DIAGRAM

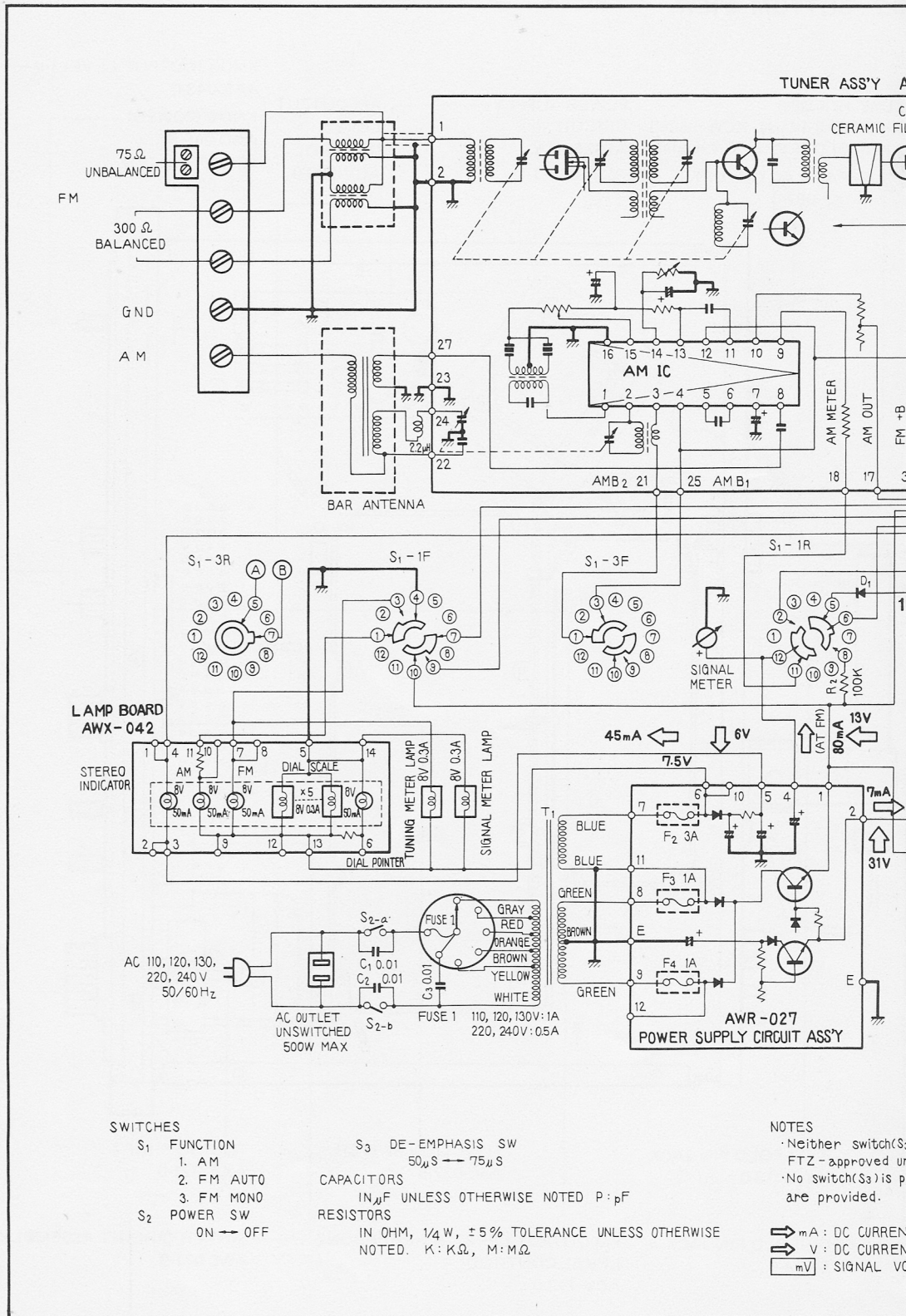

7. CIRCUIT ANALYSIS

7.1 FM FRONT END

The front end consists of a single RF amplifier with a four-section ganged tuning capacitor. The RF amplifier is constructed from a dual gate MOS FET which gives a low noise figure (1.5dB at 100MHz) and high gain (power gain of 21.5dB). Design provides for high sensitivity, but eliminates intermodulation distortion. The four-section tuning capacitor provides double tuning of the RF tuning coils, thereby improving rejection to spurious and image signals. The signal appearing at the antenna terminals is applied to first tuning coil T1.

The secondary of T1 is a tuned circuit.

The signal is applied to one of the gates of Q1 and is amplified. The drain load consists of an RF transformer in a double tuned configuration. The amplified signal is applied to the base of transistor Q2, for frequency conversion. In parallel with this input, the local oscillator (Q3) signal is applied. The difference signal is extracted from the collector of Q2. (The difference signal is the IF signal.) The collector load of Q2 is IF transformer T5 tuned to the intermediate frequency (10.7MHz). Output of T5 goes to the IF amplifier.

7.2 FM IF AMPLIFIER

The IF amplifier consists of an integrated circuit and ceramic filter. The filter provides high selectivity without introducing delay distortion. A quadrature detection system consisting of a balanced bridge circuit in the differential amplifier of the IC is employed. This arrangement gives excellent linearity over a wide band and limits distortion to a low level.

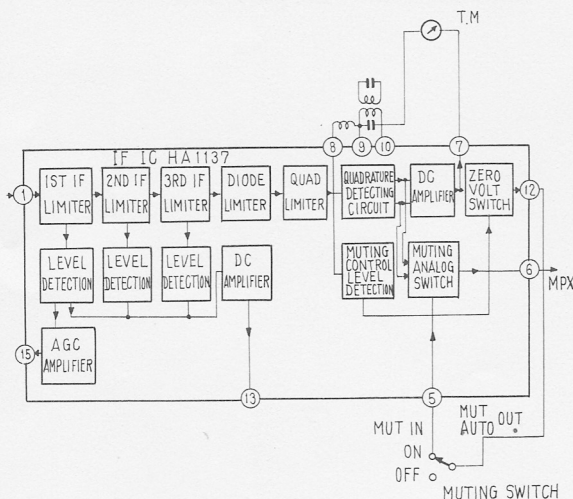

Fig. 1

Fig. 1 shows internal construction of the IC. The first, second, and third limiters are differential amplifiers. Hence, AM suppression and the capture ratio are excellent.

The signal from the front end passes through the 10.7MHz ceramic filter, transistor Q4, and another ceramic filter to pin (1) of the IC (Q5). Inside the IC, the signal passes through the three differential type limiters, diode limiter, and quad limiter. Detection is effected with the quadrature detector.

Output from the detector passes to the muting circuit within the IC and is extracted in the form of a composite signal from pin (5). Muting provides a means of controlling the muting analog switch with DC voltage from the IF section and DC voltage from the detector section. This circuit produces no "plop" noise (regardless of whether a station is being tuned or not) providing stable operation. Output is also fed to the MPX IC for stereo auto switching.

7.3 FM MPX SECTION

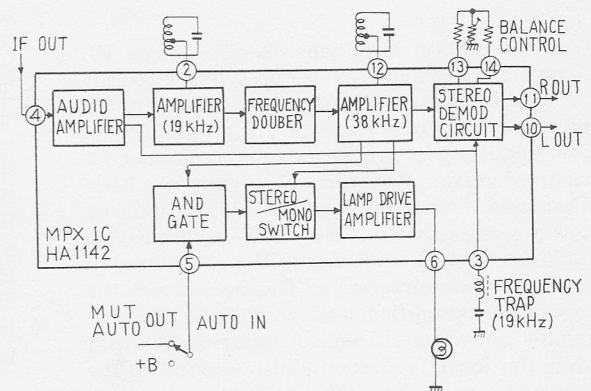

Fig. 2

The FM MPX section consists of a single IC. Construction of this IC is shown in Fig. 2. Demodulation of the signal is effected with two differential amplifiers in a "double balanced differential amplifier circuit." This arrangement provides excellent channel separation over a wide band, rejects SCA beat interference, and results in low carrier leakage and distortion. The composite signal from the IF section is applied to pin (4) of the IC and is subjected to single stage amplification. Output is split to a pilot signal path, main path (L+R), and sub path (L-R). Main and sub signals pass through a 19kHz trap circuit to the demodulator. The pilot signal is subjected to selective amplification in a 19kHz tuned amplifier and is converted to 38kHz with next multiplier circuit. The 38kHz switching signal is applied to

the demodulator. Main and sub signals are switched to provide L and R stereo signals. A part of the switching signal is also fed to the auto switching section. Auto switching involves an AND gate with input of DC voltage from the IF section and of the 38kHz signal. Control of the stereo indicator lamp is also taken from inside the IC. Switched stereo signals pass through the function switch, Q1 of the AF amplifier assembly, and a low-pass filter, providing added protection against carrier leakage and SCA beat interference.

7.4 AM SECTION

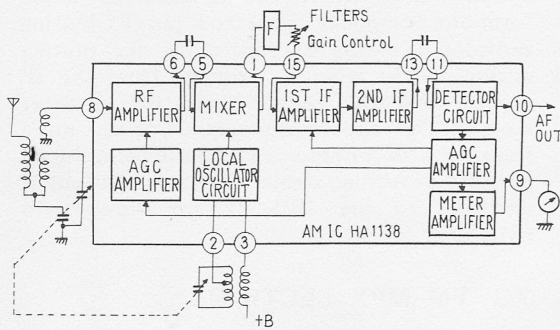

Fig. 3

The AM section also consists of a single IC. Construction is depicted in Fig. 3. The circuit is untuned but image rejection and sensitivity are improved with one stage of RF amplification. The frequency converting circuit consists of a balanced mixer. Waveform distortion has been eliminated from the local oscillator, limiting spurious response to a very low level. AGC is applied to the RF and IF amplifiers, resulting in good input characteristics. The signal from the antenna is amplified and applied to the frequency converter through a capacitor. Output from the local oscillator is also applied to the frequency converter. The difference between these inputs is taken as the IF signal. The IF signal passes through a lumped filter which removes all unwanted components. Filter output passes to the next IF amplifier stage. The IF amplifier section consists of two amplifiers. AGC is applied to the first amplifier. Detection of the IF signal follows. The resultant audio signal passes through the function switch to the AF amplifier assembly. A part of the detected signal is used as the AGC and meter drive sources.

7.5 AF SECTION

The audio section consists of four transistors for each channel (total of eight). Q1 of the AF amplifier ass'y is buffer amplifier for driving the FM low-pass filter. An emitter follower connection is used. Q3 and Q5 form a direct coupled amplifier with high input impedance. This arrangement limits any effect on the low-pass filter to a negligible level. Output from Q5 is divided into two paths, one through the output level control, function switch, and Q7 emitter follower to the OUTPUT (VARIABLE) terminal and the other directly to the OUTPUT (FIXED) terminal (level established by the voltage divider connected to the collector circuit of Q5). The low-cut filter (12dB/octave) inserted in the base circuit of Q3 functions to reject the very low range, so that the low-band component generated during muting operation does not appear at the output terminal.

7.6 POWER SUPPLY

The power supply consists of two transistors and five diodes. The set requires three DC supplies, for the AF amplifier ass'y, tuner ass'y, and the stereo indicator lamp. The AF amplifier ass'y requires 31V and 13V, the tuner ass'y 13V. The 13V supply for the AF amplifier ass'y is also applied to a part of the tuner ass'y.

The 31V DC supply is obtained through full wave rectification of the AC appearing at the secondary of the power transformer. Smoothing is effected with a single transistor ripple filter. The 13V DC supply is also obtained through full wave rectification but is applied to a voltage stabilizing circuit consisting of a transistor and zener diode.

The 6V DC supply for the stereo indicator lamp is taken from the pilot lamp supply through a half wave rectifier and RC π filter.

8. ADJUSTMENT

8.1 REQUIRED MEASURING INSTRUMENTS

- FM signal generator
- MPX signal generator
- AM signal generator
- Voltmeter (VTVM)
- Oscilloscope
- Distortion meter

8.2 AM ADJUSTMENT

● Tracking

1. Set the AM signal generator for 400Hz modulation at 30%. Connect the generator output to the AM antenna terminal through a 1k Ω dummy.
2. Connect the oscilloscope and voltmeter (VTVM) is parallel to VARIABLE OUTPUT.
3. Set the signal generator output to approximately 30dB. Set signal generator and set dials to 600kHz.
4. Adjust cores of T9 (tuner ass'y) and the bar antenna for peak output.
5. Set signal generator and set dials to 1,400kHz.
6. Adjust CT5 and CT6 (tuner ass'y) for peak output.
7. Repeat steps (3) through (6) several times, to obtain optimum tracking.

8.3 FM ADJUSTMENT

● Tracking

1. Set the FM signal generator for 400Hz modulation at 100%. Connect generator output to the FM antenna terminals through a 300 Ω balanced dummy antenna.
2. Connect the oscilloscope, voltmeter (VTVM), and distortion meter in parallel across VARIABLE OUTPUT.

3. Set the signal generator output level to 8 ~ 10dB.

● KCW and KUW model:

Set the signal generator and set dials to 90MHz.

● FW and FVZW model:

Set the signal generator dial to 87.4MHz, and set dial to lower end (● left side).

4. Adjust cores of T4 (tuner ass'y) and T1, T2, and T3 to obtain peak output.
5. Set signal generator and set dials to 106MHz.
6. Adjust CT4 (tuner ass'y) and CT1, CT2, and CT3 to obtain peak output.
7. Repeat steps (3) through (6) several times, to obtain optimum tracking.
8. Set the frequency to 90MHz and adjust the T5 core of the tuner ass'y to obtain peak output.
9. Detune the set so that noise only is received. Adjust the primary (bottom) core of T6 so that the tuning meter pointer indicates the center position.
10. Set signal generator and set dials to 82MHz. Set signal generator output level to 60dB. Carefully tune the set to this frequency as indicated by the tuning meter.
11. Adjust the secondary (top) core of T6 (tuner ass'y) for minimum distortion.

● FM MPX adjustment

1. Set MPX signal generator modulation for the main signal (L+R) to 1kHz at 67.5kHz deviation and for the pilot (19kHz) at 7.5kHz deviation. Set the output level to 60dB.
2. Apply signal generator modulation to the left channel only. Adjust T8 (tuner ass'y) for peak output.
3. Under this condition, adjust the core of T5 (tuner ass'y) for minimum distortion.
4. Set signal generator modulation to the pilot and L(R). Adjust VR1 (tuner ass'y) to obtain maximum channel separation.

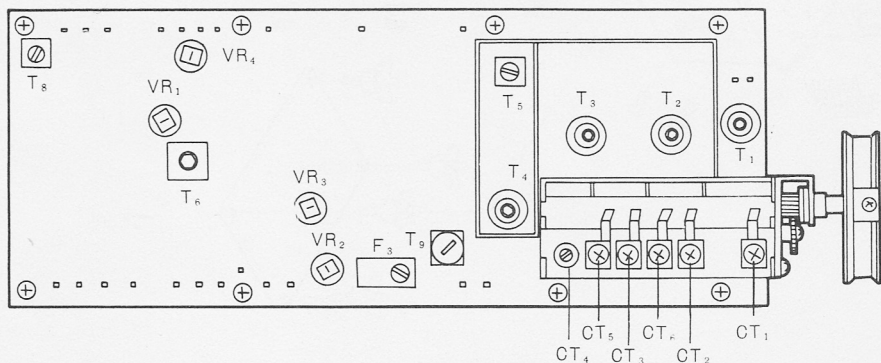

9. DIAL STRINGING PROCEDURE

1. Set the tuning capacitor to minimum capacitance (rotor swung fully out).
2. Tie one end of the dial cord to the spring attached to the tuning pulley.
3. Pass the dial cord over pulley A and wind it around the tuning shaft (three turns).
4. String the dial cord over pulleys B, C, D, and E. Wind it around the tuning pulley (one turn).
5. Tie the end of the dial cord to the tuning pulley spring.
Turn the tuning shaft through the full range and insure that dial cord operation is smooth. Cut off any excess dial cord at the spring.
6. Set the tuning capacitor to maximum capacitance. Shift the dial pointer to the left end of the scale (starting point) and secure it there. ↓

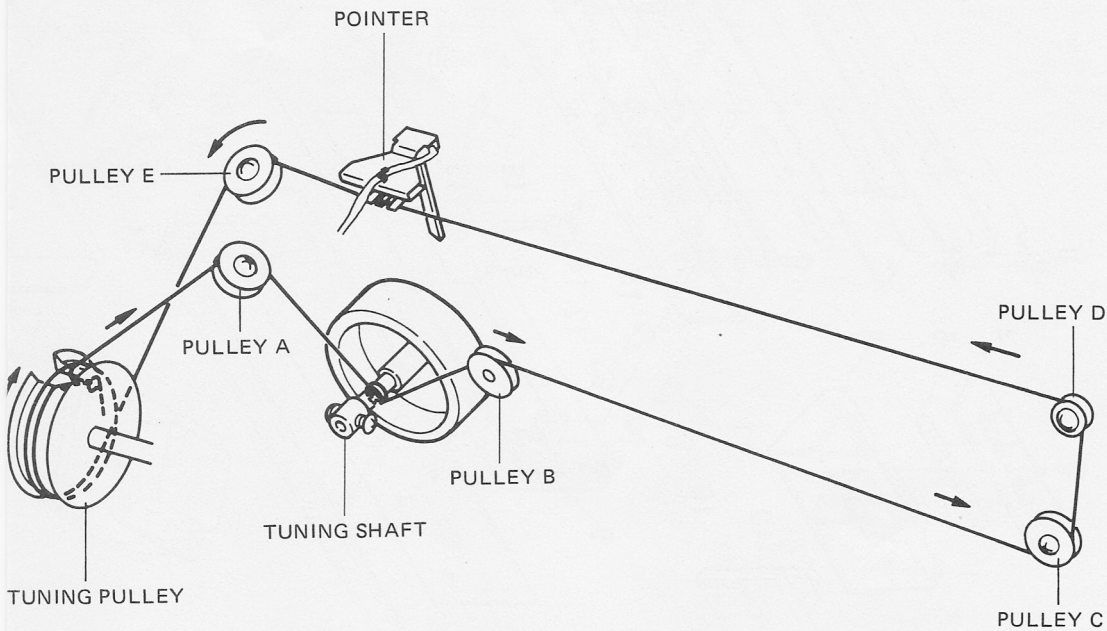

10. EXPLODED VIEW AND PARTS LIST

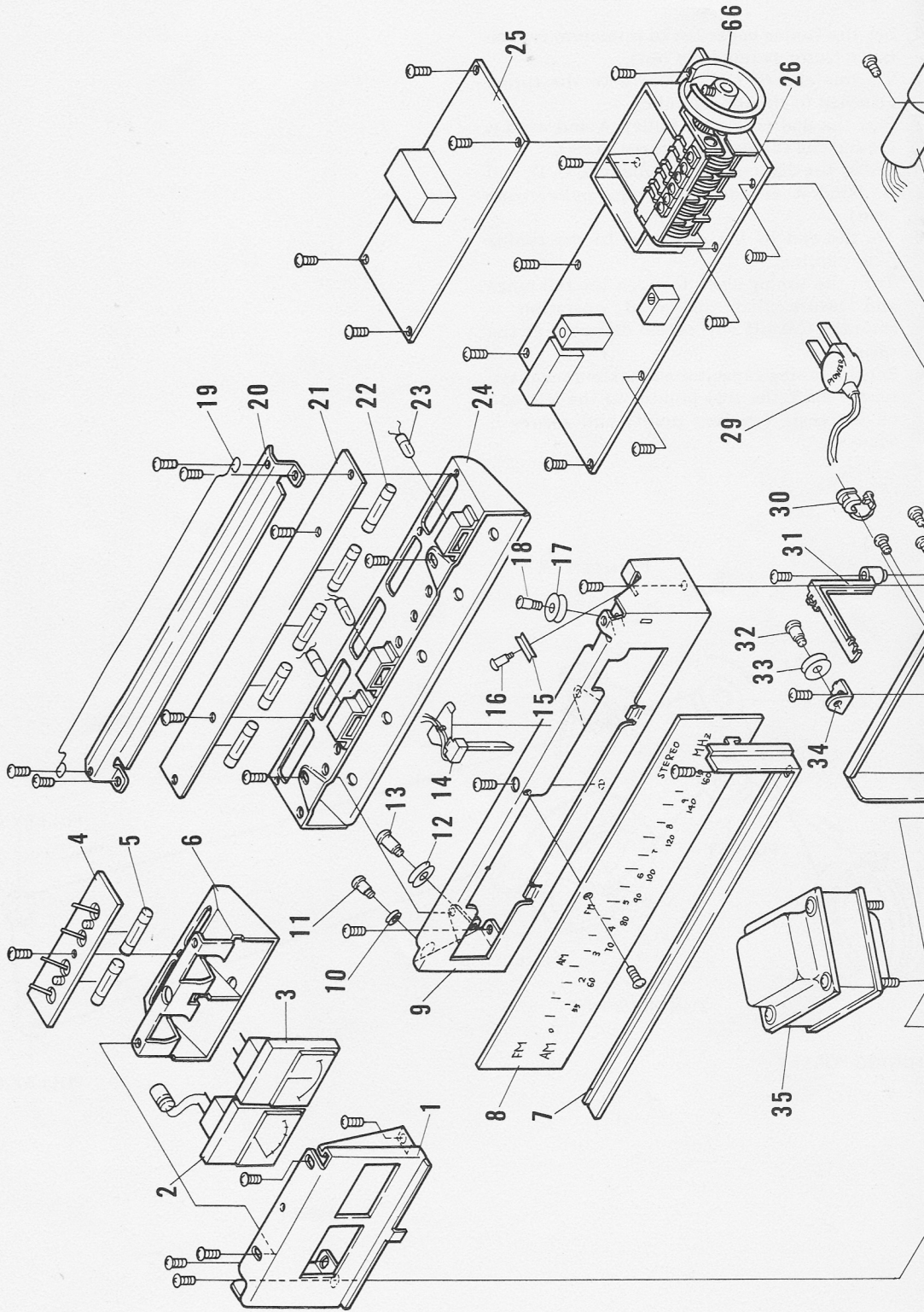

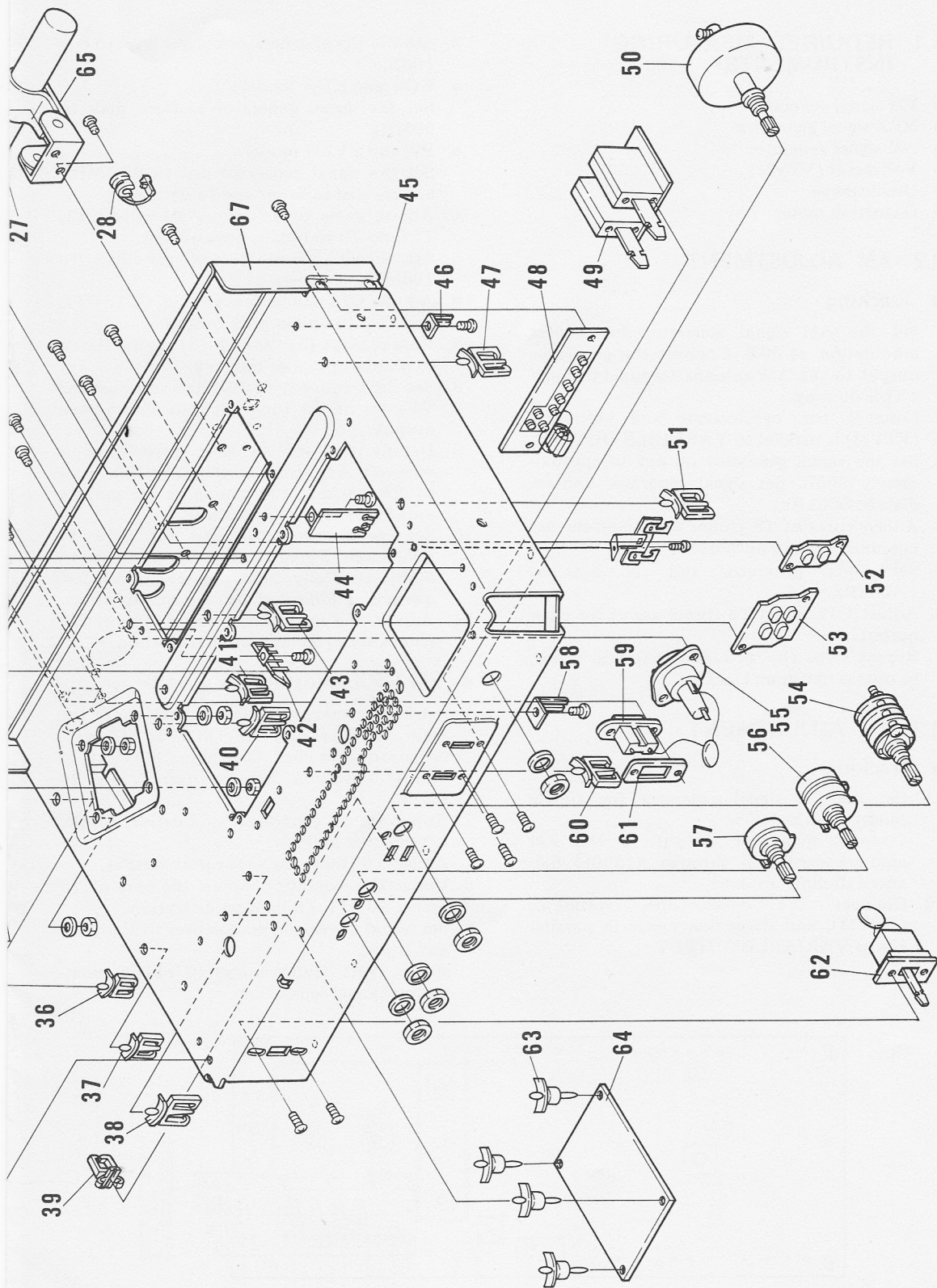

NOTICE:

Any parts asterisked(*) are subject to being not supplied.

PARTS LIST

Key No.	Description	Part No.	
1*	Meter-held metal	ANF-106-C	
2	Signal meter	AAW-015-0	
3	Tuning meter	AAW-016-A	
4	Pilot lamp socket holder	ANF-107-0	
5	Pilot lamp (tuning and signal meters)	AEL-015-0	
6*	Lamp box-B	ANH-127-C	
7*	Dial scale holder	ANG-075-0	
8	Dial scale	AAG-045-0	
9*	Sub panel	AND-051-C	
10*	Pulley	AEC-006-0	
11*	Pulley's shaft	M49-025-E	
12*	Pulley	AEC-006-0	
13*	Pulley's shaft	M49-025-E	
14	Dial pointer	AAF-025-0	
15*	Pulley	AEC-006-0	
16*	Pulley's shaft	M49-025-E	
17*	Pulley	AEC-006-0	
18*	Pulley's shaft	M49-025-E	
19*	Wire holder	ANK-035-0	
20*	P.C. board cover	ANK-034-0	
21	Lamp board assembly	AWX-042-0	
22	Pilot lamp (dial scale)	E22-032-0	
23	Pilot lamp (program indicator)	AEL-007-0	
24*	Lamp box-A	ANH-126-0	
25	AF amplifier assembly	AWK-019-A	
26	Tuner assembly	AWE-024-0	
27	Ferrite loopstick antenna	ATB-015-A	
28	AC cord stopper	AEC-079-0	
29	AC power cord	ADG-003-0	KUW, KCW model FVZW, FW model
	AC power cord	ADG-004-0	
30	AC cord stopper	AEC-079-0	
31*	Wire supporter	AEC-084-C	
32*	Pulley's shaft	M49-025-E	
33*	Pulley	AEC-006-0	
34*	Pulley-held metal	ANG-076-A	
35	Power transformer	ATT-110-0	KUW model FVZW, FW model KCW model
	Power transformer	ATT-111-0	
	Power transformer	ATT-132-0	
36*	Wire clip (B)	AEC-005-0	
37*	Wire clip (B)	AEC-005-0	
38*	Wire clip (A)	AEC-004-0	
39*	Wire clip S	AEC-037-0	
40*	Wire clip (A)	AEC-004-0	
41*	Wire clip (B)	AEC-005-0	
42	4P terminal strip	K13-047-0	
43*	Wire clip (A)	AEC-004-0	
44*	Wire supporter	M46-139-0	
45*	Chassis	ANA-034-C	

Key No.	Description	Part No.	
46	2P terminal strip	K13-048-0	
47*	Wire clip (B)	AEC-005-0	
48	Antenna terminal board	K11-043-D	
49	Switch circuit assembly	AWS-031-0	
50	Tuning shaft assembly	AXA-021-0	
51*	Wire clip (B)	AEC-005-0	
52	Two-fold pin jack board	AKB-013-0	
53	Four-fold pin jack board A	AKB-014-0	
54	Function switch (rotary type)	ASC-037-B	
55	Fuse holder	AKR-005-0	KUW, KCW model FVZW, FW model
	Fuse holder (with line voltage switch)	AKR-001-0	
56	FM output level control (dual)	ACV-113-0	
57	AM output level control	ACV-009-0	
58	2P terminal strip	K13-048-0	
59	Spare AC outlet	AKP-002-0	
60*	Wire clip (B)	AEC-005-0	
61	AC outlet-held metal	M49-127-A	KUW, KCW model FVZW, FW model
62	Power switch (lever type)	ASK-025-0	
	Power switch (lever type)	ASK-024-0	
63*	P.C. board holder	AEB-019-0	
64	Power supply circuit assembly	AWR-027-0	
65	Bar antenna holder assembly	AXB-001-0	
66	Tuning pulley assembly	AXA-015-A	
67*	Rear panel	ANC-067-A	
	Smoothing nylon	AEC-031-0	

S AND PARTS LISTS

ST

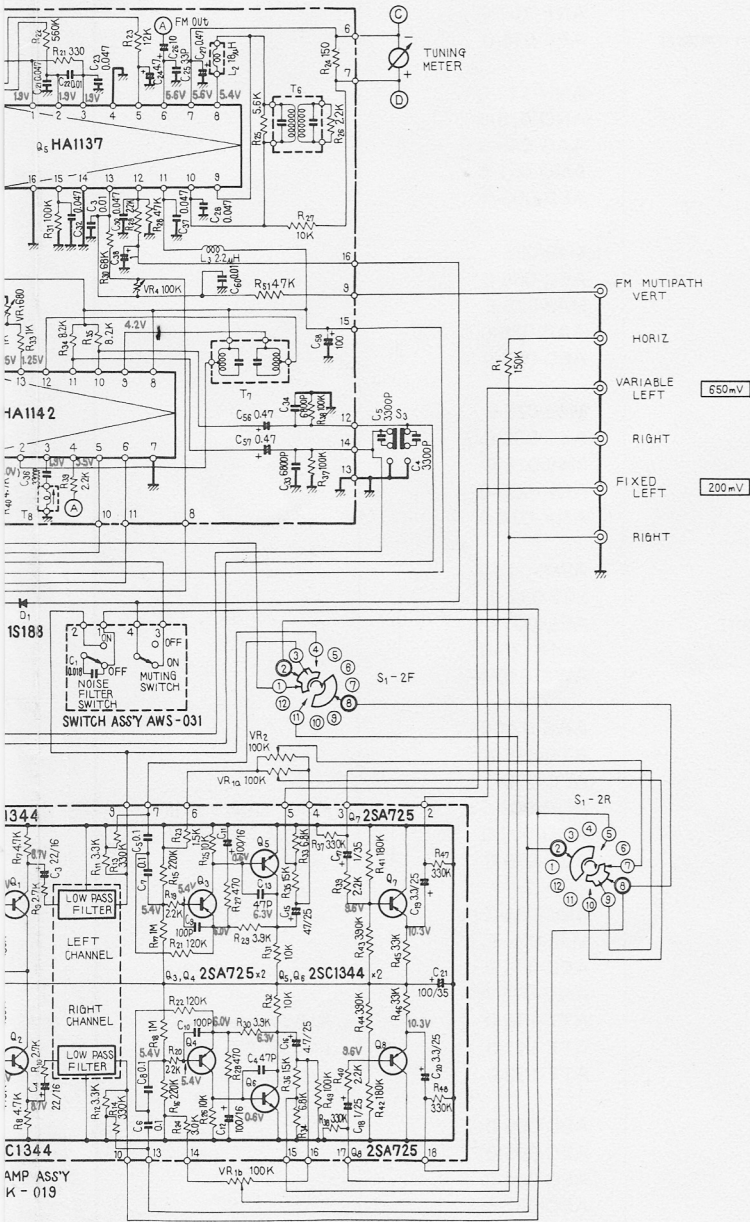

- CHES
- 1 FUNCTION (AM position)
 1. AM
 2. FM AUTO
 3. FM MONO
 - 2 POWER SW (OFF position)

ON → OFF
 - 3 DE - EMPHASIS SW (50μS position)

50μS → 75μS
- CAPACITORS
 IN μF UNLESS OTHERWISE NOTED. P: pF.
- RESISTORS
 IN OHM, 1/4W, ±5% TOLERANCE UNLESS OTHERWISE NOTED. K: KΩ, M: MΩ.

Miscellaneous Parts

- CAPACITORS: IN μ F UNLESS OTHERWISE NOTED p: pF.
- RESISTORS: IN Ω , $\frac{1}{4}$ W UNLESS OTHERWISE NOTED k: k Ω , M: M Ω .

CAPACITORS

Symbol	Description	Part No.	
C1	Ceramic 0.01 150V	ACG-002-0	KUW, KCW model
	Ceramic 0.01 DC1.4kV	C43-003-0	
C2	Metallized mylar 0.01 800V	ACE-002-0	FVZW, FW model KUW model
	Ceramic 0.01 150V	ACG-003-0	
	Ceramic 0.01 DC1.4kV	C43-003-0	
C3	Ceramic 0.01 DC1.4kV	C43-003-0	FVZW, FW model
C4	Mylar 0.0033 50V	CQMA 332J 50	KUW, FW model
C5	Mylar 0.0033 50V	CQMA 332J 50	KUW, FW model

RESISTORS AND POTENTIOMETERS

Symbol	Description	Part No.	
R1	Carbon film 150k	RD $\frac{1}{4}$ PS 154J	KUW, KCW model
R2	Carbon film 100k	RD $\frac{1}{4}$ PS 104J	
R3	Carbon film 2.2M $\frac{1}{4}$ W	RD $\frac{1}{4}$ PS 225J	
VR1	Potentiometer (dual) 100k-B2	ACV-113-0	
VR2	Potentiometer 100k-B2	ACV-009-0	

SWITCHES

Symbol	Description	Part No.	
S1	Function (rotary type)	ASC-037-B	KUW, KCW model FVZW, FW model FW model
S2	Power (lever type)	ASK-025-0	
S3	De-emphasis (slide type)	S41-022-A	

COILS AND TRANSFORMERS

Symbol	Description	Part No.	
	Balune	T22-025-A	KUW model FVZW, FW model KCW model
	Ferrite loopstick antenna	ATB-015-A	
	RF choke coil	T24-028-A	
	Power transformer	ATT-110-0	
	Power transformer	ATT-111-0	
	Power transformer	ATT-132-0	

SEMICONDUCTOR

Symbol	Description	Part No.	
D1	Diode 1S188 FM-1		

OTHERS

Symbol	Description	Part No.	
	Front panel assembly	ANB-187-A	
	Foot assembly	AEC-083-A	
	Wooden cabinet	AMM-022-A	
	Knob (TUNING)	AAA-015-0	
	Knob (FUNCTION)	AAB-041-0	
	Knob (OUTPUT LEVEL)	AAB-043-0	
	Knob (MPX NOISE FILTER, MUTING, POWER)	AAD-040-B	
F1	Fuse 1A (AC power)	E21-033-0	KUW model
	Fuse 1A (AC power)	E21-034-A	KCW model
	Fuse 0.5A (AC power)	AEK-016-0	FVZW, FW model
F2	Fuse 3A (protection)	E21-021-0	KUW model
	Fuse 3A (protection)	AEK-008-0	KCW model
	Fuse 3A (protection)	E21-036-0	FVZW, FW model
F3	Fuse 1A (protection)	E21-033-0	KUW model
	Fuse 1A (protection)	AEK-022-0	KCW model
	Fuse 1A (protection)	E21-034-A	FVZW, FW model
F4	Fuse 1A (protection)	E21-033-0	KUW model
	Fuse 1A (protection)	AEK-022-0	KCW model
	Fuse 1A (protection)	E21-034-A	FVZW, FW model
F5	Fuse 1.2A (protection)	AEK-019-0	KCW model
	Screw to fix wooden cabinet	ABA-010-A	
	Polishing cloth	E33-009-B	
	Connection cord	ADE-005-0	
	Vinyl bag	E32-034-0	
	Fuse 1A (AC power)	E21-034-A	FVZW, FW model
	FM T-type antenna	D52-013-0	
	Pilot lamp socket	AKK-002-0	

11.2 TUNER ASSEMBLY (AWE-024-0)

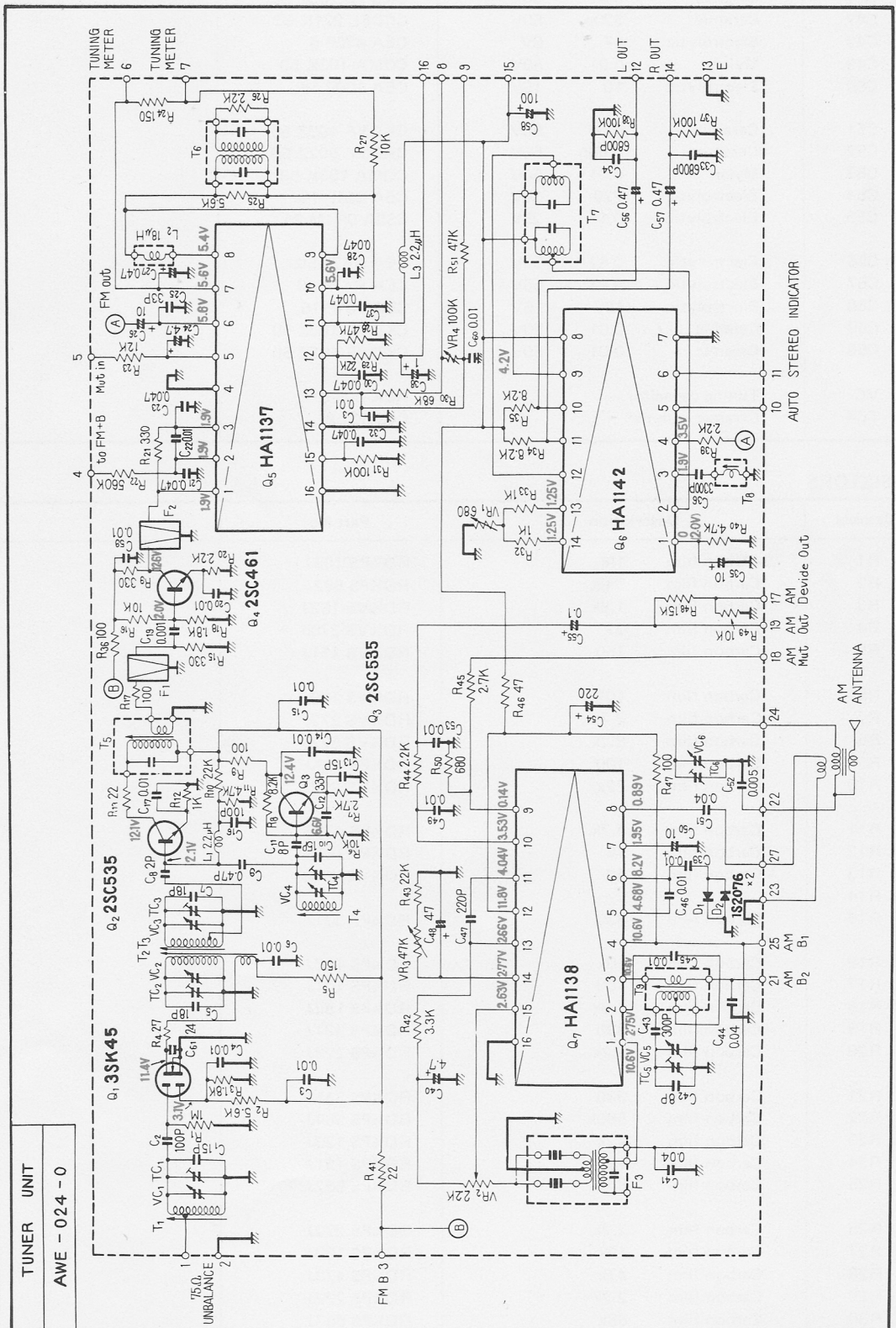

Foil Side

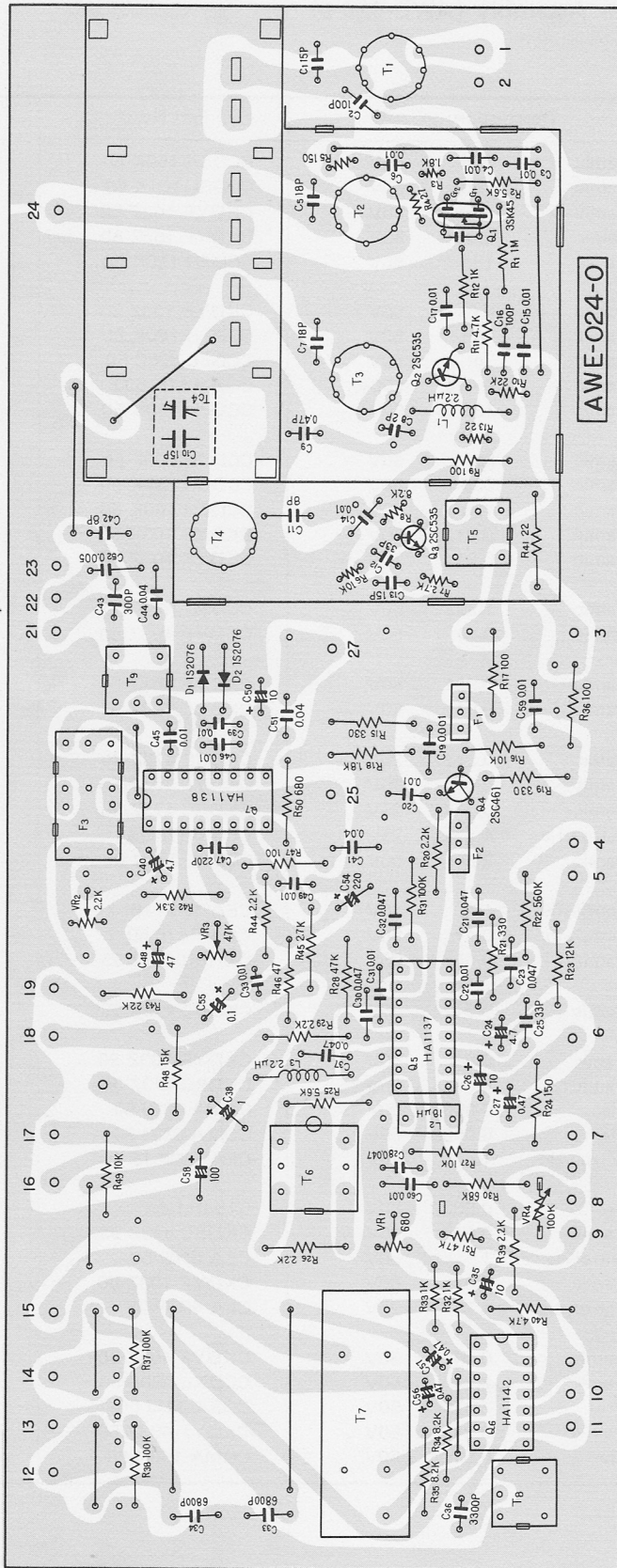

Parts List of Tuner Assembly (AWE-024-0)

CAPACITORS

Symbol	Description			Part No.
C1	Ceramic	15p	50V	CCDSH 150K 50
C2	Ceramic	100p	50V	CCDSL 101K 50
C3	Ceramic	0.01	50V	CKDYF 103Z 50
C4	Ceramic	0.01	50V	CKDYF 103Z 50
C5	Ceramic	18p	50V	CCDSH 180K 50
C6	Ceramic	0.01	50V	CKDYF 103Z 50
C7	Ceramic	18p	50V	CCDSH 180K 50
C8	Ceramic	2p	50V	CCDSL 020C 50
C9	Ceramic	0.47p	500V	CGB R47K 500
C10	Ceramic	15p	50V	CCDPH 150K 50
C11	Ceramic	8p	50V	CCDCH 080F 50
C12	Ceramic	33p	50V	CCDCH 330K 50
C13	Ceramic	15p	50V	CCDCH 150K 50
C14	Ceramic	0.01	50V	CKDYB 103K 50
C15	Ceramic	0.01	50V	CKDYF 103Z 50
C16	Ceramic	100p	50V	CCDSL 101K 50
C17	Ceramic	0.01	50V	CKDYF 103Z 50
C18				
C19	Ceramic	0.001	50V	CKDYF 102Z 50
C20	Ceramic	0.01	50V	CKDYF 103Z 50
C21	Ceramic	0.047	25V	CKDBC 473Z 25
C22	Ceramic	0.01	50V	CKDYF 103Z 50
C23	Ceramic	0.047	25V	CKDBC 473Z 25
C24	Electrolytic	4.7	25V	CEA 4R7P 25
C25	Ceramic	33	50V	CCDSL 330K 50
C26	Electrolytic	10	16V	CEA 100P 16
C27	Electrolytic	0.47	50V	CEA R47P 50
C28	Ceramic	0.047	25V	CKDBC 473Z 25
C29				
C30	Ceramic	0.047	25V	CKDBC 473Z 25
C31	Ceramic	0.01	50V	CKDYF 103Z 50
C32	Ceramic	0.047	25V	CKDBC 473Z 25
C33	Mylar	0.0068	50V	CQMA 682J 50
C34	Mylar	0.0068	50V	CQMA 682J 50
C35	Electrolytic	10	16V	CEA 100P 16
C36	Styrol	0.0033	50V	C15-011-A
C37	Ceramic	0.047	25V	CKDBC 473Z 25
C38	Electrolytic	1	50V	CEA 010P 50
C39	Ceramic	0.01	50V	CKDYF 103Z 50
C40	Electrolytic	4.7	25V	CEA 4R7P 25
C41	Ceramic	0.04	50V	CKDYF 403Z 50
C42	Ceramic	8p	50V	CCDXL 080F 50
C43	Styrol	300p	50V	CQSA 301J 50
C44	Ceramic	0.04	50V	CKDYF 403Z 50
C45	Mylar	0.01	50V	CQMA 103K 50

Symbol	Description	Part No.
C46	Ceramic 0.01 50V	CKDYF 103Z 50
C47	Ceramic 220p 50V	CCDSL 221K 50
C48	Electrolytic 47 6V	CEA 470P 6
C49	Mylar 0.01 50V	CQMA 103K 50
C50	Electrolytic 10 16V	CEA 100P 16
C51	Ceramic 0.04 50V	CKDYF 403Z 50
C52	Ceramic 0.005 50V	CKDYF 502Z 50
C53	Mylar 0.01 50V	CQMA 103K 50
C54	Electrolytic 220 16V	CEA 221P 16
C55	Electrolytic 0.1 25V	CSSA 0R1M 25
C56	Electrolytic 0.47 50V	CEA R47P 50
C57	Electrolytic 0.47 50V	CEA R47P 50
C58	Electrolytic 100 16V	CEA 101P 16
C59	Ceramic 0.01 50V	CKDYF 103Z 50
C60	Ceramic 0.01 50V	CKDYF 103Z 50
VC	Tuning capacitor	ACK-005-0
TC4	Ceramic trimmer	C43-007-A

RESISTORS

Symbol	Description	Part No.
R1	Carbon film 1M	RD¼PS 105J
R2	Carbon film 5.6k	RD¼PS 562J
R3	Carbon film 1.8k	RD¼VS 182J
R4	Carbon film 27	RD¼VS 270J
R5	Carbon film 150	RD¼VS 151J
R6	Carbon film 10k	RD¼VS 103J
R7	Carbon film 2.7k	RD¼VS 272J
R8	Carbon film 8.2k	RD¼VS 822J
R9	Carbon film 100	RD¼PS 101J
R10	Carbon film 22k	RD¼VS 223J
R11	Carbon film 4.7k	RD¼PS 472J
R12	Carbon film 1k	RD¼PS 102J
R13	Carbon film 22	RD¼VS 220J
R14		
R15	Carbon film 330	RD¼PS 331J
R16	Carbon film 10k	RD¼PS 103J
R17	Carbon film 100	RD¼PS 101J
R18	Carbon film 1.8k	RD¼PS 182J
R19	Carbon film 330	RD¼PS 331J
R20	Carbon film 2.2k	RD¼PS 222J
R21	Carbon film 330	RD¼PS 331J
R22	Carbon film 560k	RD¼PS 564J
R23	Carbon film 12k	RD¼PS 123J
R24	Carbon film 150	RD¼PS 151J
R25	Carbon film 5.6k	RD¼PS 562J
R26	Carbon film 2.2k	RD¼PS 222J
R27	Carbon film 10k	RD¼PS 103J
R28	Carbon film 47k	RD¼PS 473J
R29	Carbon film 2.2k	RD¼PS 222J
R30	Carbon film 68k	RD¼PS 683J

Symbol	Description	Part No.
R31	Carbon film 100k	RD¼PS 104J
R32	Carbon film 1k	RD¼VS 102J
R33	Carbon film 1k	RD¼VS 102J
R34	Carbon film 8.2k	RD¼PS 822J
R35	Carbon film 8.2k	RD¼PS 822J
R36	Carbon film 100	RD¼PS 101J
R37	Carbon film 100k	RD¼PS 104J
R38	Carbon film 100k	RD¼PS 104J
R39	Carbon film 2.2k	RD¼PS 222J
R40	Carbon film 4.7k	RD¼PS 472J
R41	Carbon film 22	RD¼PS 220J
R42	Carbon film 3.3k	RD¼PS 332J
R43	Carbon film 22k	RD¼PS 223J
R44	Carbon film 2.2k	RD¼PS 222J
R45	Carbon film 2.7k	RD¼PS 272J
R46	Carbon film 47	RD¼PS 470J
R47	Carbon film 100	RD¼PS 101J
R48	Carbon film 15k	RD¼PS 153J
R49	Carbon film 10k	RD¼PS 103J
R50	Carbon film 680	RD¼PS 681J
R51	Carbon film 47k	RD¼VS 473J
VR1	Semi-fixed 680-B	ACP-013-0
VR2	Semi-fixed 2.2k-B	ACP-001-0
VR3	Semi-fixed 47k-B	C92-048-0
VR4	Semi-fixed 100k-B	ACP-021-0

COILS, TRANSFORMERS AND FILTERS

Symbol	Description	Part No.
L1	RF choke coil	T24-028-A
L2	Choke coil	ATH-007-0
L3	RF choke coil	T24-028-A
T1	FM antenna coil	ATC-021-0
T2	FM RF coil	ATC-015-0
T3	FM RF coil	ATC-016-0
T4	FM oscillator coil	ATC-022-0
T5	FM matching transformer	ATE-008-0
T6	FM IF transformer	T73-035-A
T7	MPX transformer	ATM-011-0
T8	19kHz transformer	T75-023-B
T9	AM oscillator coil	ATB-013-0
F1	AM ceramic filter	ATF-013-B
F2	AM ceramic filter	ATF-013-B
F3	AM ceramic filter	ATF-009-0

SEMICONDUCTORS

Symbol	Description	Part No.
Q1	FET	3SK45-B
Q2	Transistor	2SC535-B or A
Q3	Transistor	2SC535-B
Q4	Transistor	2SC461-B
Q5	IC	HA1137
Q6	IC	HA1142
Q7	IC	HA1138
D1	Diode	1S2076
D2	Diode	1S2076

11.3 AF AMPLIFIER ASSEMBLY (AWK-019-A)

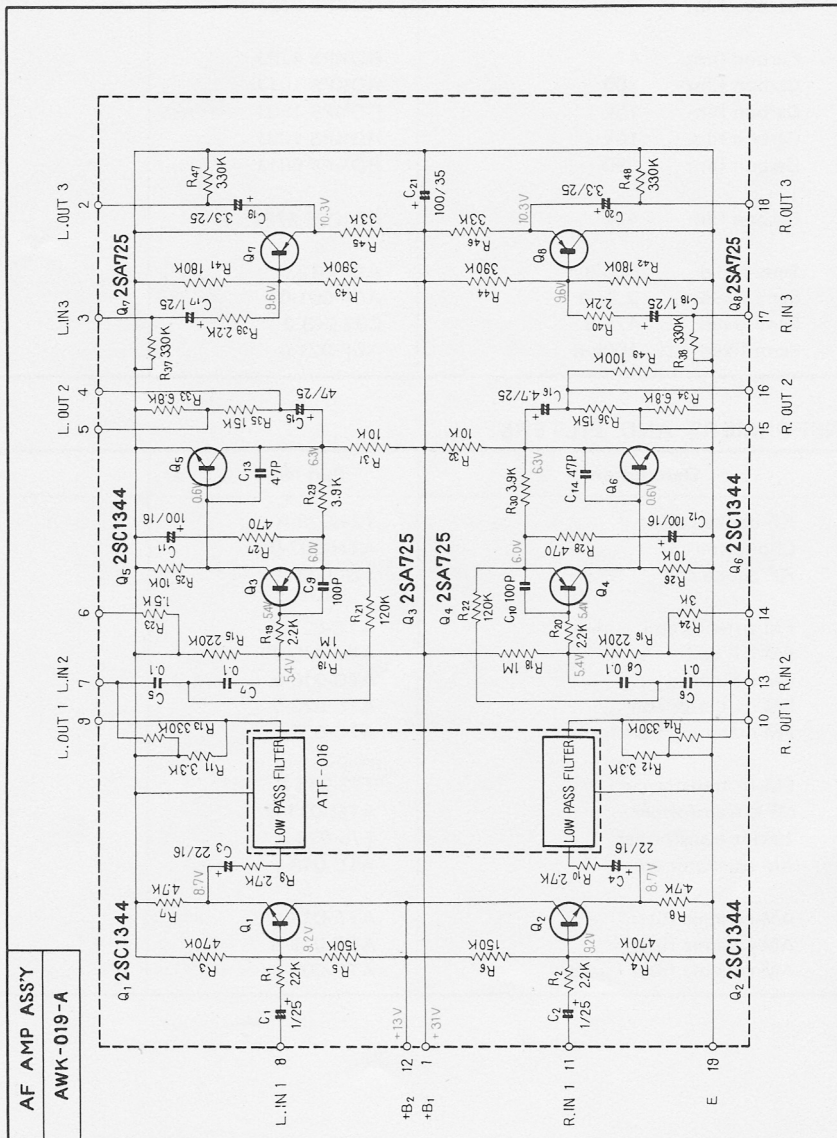

Foil Side

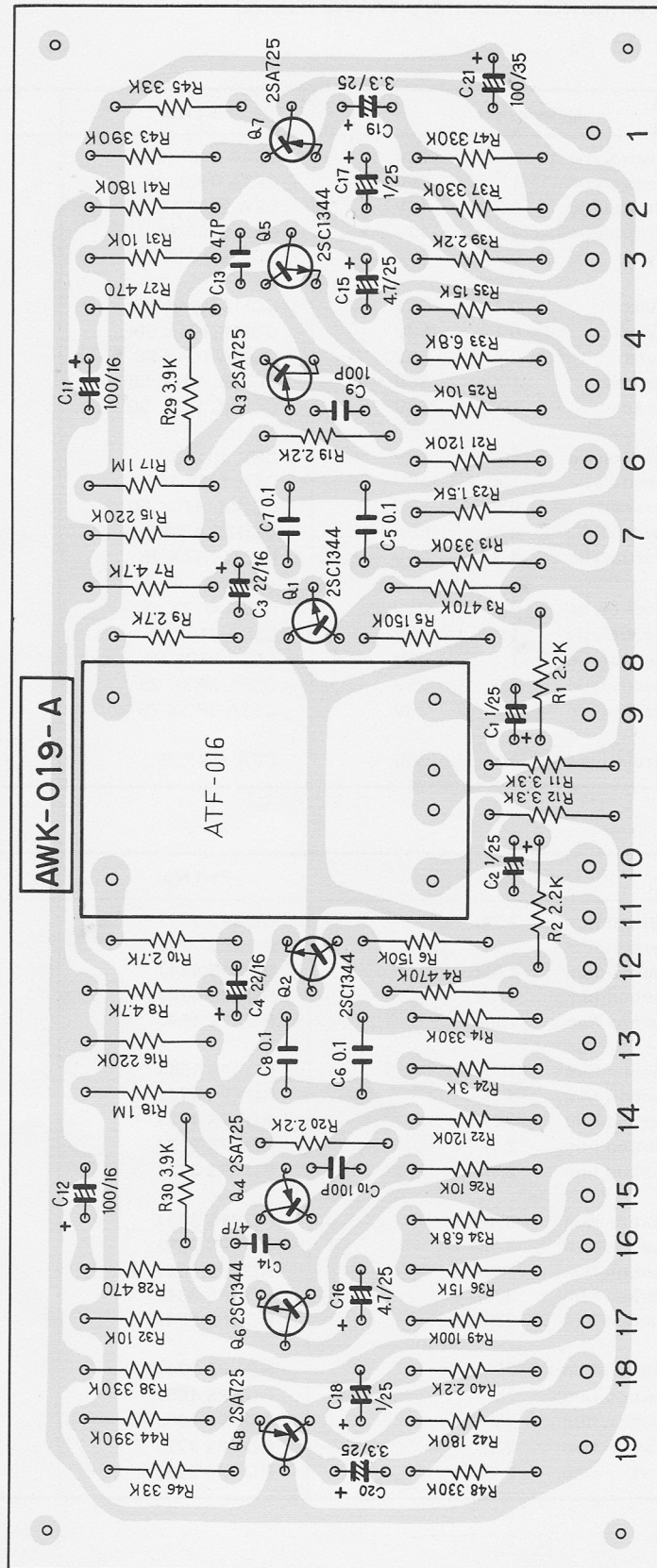

Parts List of AF Amplifier Assembly (AWK-019-A)

CAPACITORS

Symbol	Description	Part No.
C1	Electrolytic 1 25V	CSSA 010X 25
C2	Electrolytic 1 25V	CSSA 010X 25
C3	Electrolytic 22 16V	CEA 220P 16
C4	Electrolytic 22 16V	CEA 220P 16
C5	Mylar 0.1 50V	CQMA 104K 50
C6	Mylar 0.1 50V	CQMA 104K 50
C7	Mylar 0.1 50V	CQMA 104K 50
C8	Mylar 0.1 50V	CQMA 104K 50
C9	Ceramic 100p 50V	CCDSL 101K 50
C10	Ceramic 100p 50V	CCDSL 101K 50
C11	Electrolytic 100 16V	CEA 101P 16
C12	Electrolytic 100 16V	CEA 101P 16
C13	Ceramic 47p 50V	CCDSL 470K 50
C14	Ceramic 47p 50V	CCDSL 470K 50
C15	Electrolytic 4.7 25V	CSSA 4R7X 25
C16	Electrolytic 4.7 25V	CSSA 4R7X 25
C17	Electrolytic 1 25V	CSSA 010X 25
C18	Electrolytic 1 25V	CSSA 010X 25
C19	Electrolytic 3.3 25V	CSSA 3R3X 25
C20	Electrolytic 3.3 25V	CSSA 3R3X 25
C21	Electrolytic 100 35V	CEA 101P 35

RESISTORS

Symbol	Description	Part No.
R1	Carbon film 2.2k	RD¼PS 222J
R2	Carbon film 2.2k	RD¼PS 222J
R3	Carbon film 470k	RD¼PS 474J
R4	Carbon film 470k	RD¼PS 474J
R5	Carbon film 150k	RD¼PS 154J
R6	Carbon film 150k	RD¼PS 154J
R7	Carbon film 4.7k	RD¼PS 472J
R8	Carbon film 4.7k	RD¼PS 472J
R9	Carbon film 2.7k	RD¼PS 272J
R10	Carbon film 2.7k	RD¼PS 272J
R11	Carbon film 3.3k	RD¼PS 332J
R12	Carbon film 3.3k	RD¼PS 332J
R13	Carbon film 330k	RD¼PS 334J
R14	Carbon film 330k	RD¼PS 334J
R15	Carbon film 220k	RD¼PS 224J
R16	Carbon film 220k	RD¼PS 224J
R17	Carbon film 1M	RD¼PS 105J
R18	Carbon film 1M	RD¼PS 105J
R19	Carbon film 2.2k	RD¼PS 222J
R20	Carbon film 2.2k	RD¼PS 222J

Symbol	Description	Part No.
R21	Carbon film 120k	RD¼PS 124J
R22	Carbon film 120k	RD¼PS 124J
R23	Carbon film 1.5k	RD¼PS 152J
R24	Carbon film 3k	RD¼PS 302J
R25	Carbon film 10k	RD¼PS 103J
R26	Carbon film 10k	RD¼PS 103J
R27	Carbon film 470	RD¼PS 471J
R28	Carbon film 470	RD¼PS 471J
R29	Carbon film 3.9k	RD¼PS 392J
R30	Carbon film 3.9k	RD¼PS 392J
R31	Carbon film 10k	RD¼PS 103J
R32	Carbon film 10k	RD¼PS 103J
R33	Carbon film 6.8k	RD¼PS 682J
R34	Carbon film 6.8k	RD¼PS 682J
R35	Carbon film 15k	RD¼PS 153J
R36	Carbon film 15k	RD¼PS 153J
R37	Carbon film 330k	RD¼PS 334J
R38	Carbon film 330k	RD¼PS 334J
R39	Carbon film 2.2k	RD¼PS 222J
R40	Carbon film 2.2k	RD¼PS 222J
R41	Carbon film 180k	RD¼PS 184J
R42	Carbon film 180k	RD¼PS 184J
R43	Carbon film 390k	RD¼PS 394J
R44	Carbon film 390k	RD¼PS 394J
R45	Carbon film 33k	RD¼PS 333J
R46	Carbon film 33k	RD¼PS 333J
R47	Carbon film 330k	RD¼PS 334J
R48	Carbon film 330k	RD¼PS 334J
R49	Carbon film 100k	RD¼PS 104J

SEMICONDUCTORS

Symbol	Description	Part No.
Q1	Transistor 2SC1344-E or D	
Q2	Transistor 2SC1344-E or D	
Q3	Transistor 2SA725-G or F	
Q4	Transistor 2SA725-G or F	
Q5	Transistor 2SC1344-E or D	
Q6	Transistor 2SC1344-E or D	
Q7	Transistor 2SA725-G or F	
Q8	Transistor 2SA725-G or F	

OTHER

Symbol	Description	Part No.
	Low-pass filter	ATF-016-0

11.4 POWER SUPPLY CIRCUIT ASSEMBLY (AWR-027-0)

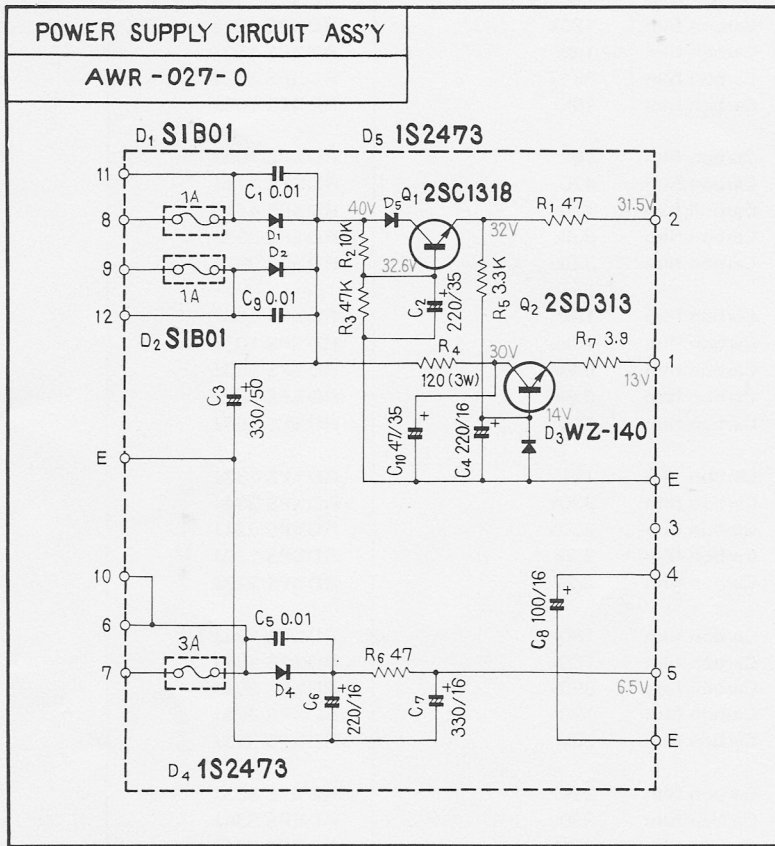

Foil Side

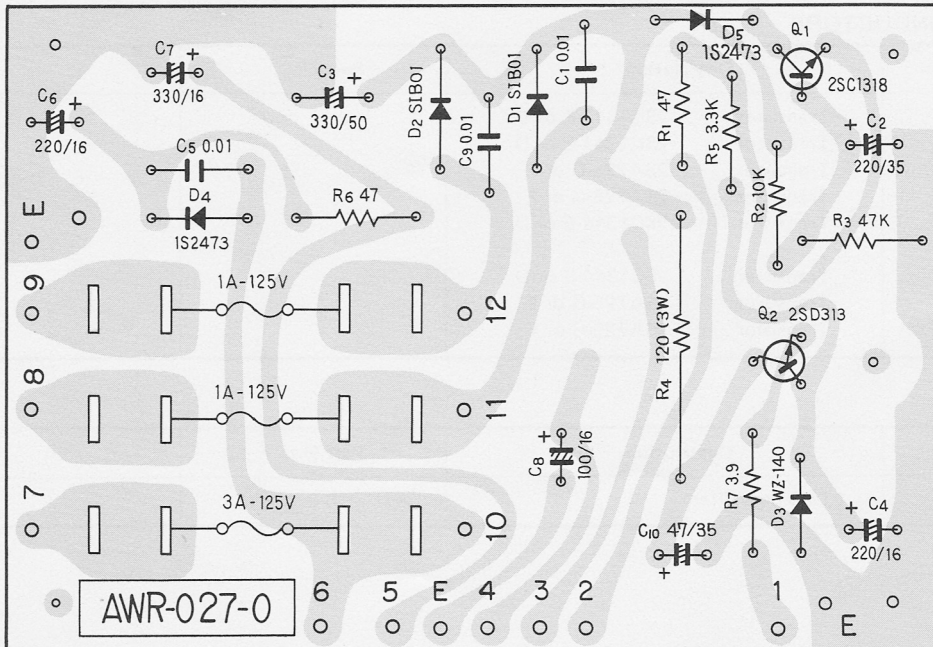

Parts List of Power Supply Circuit Assembly (AWR-027-0)

CAPACITORS

Symbol	Description			Part No.
C1	Ceramic	0.01	150V	ACG-002-0
C2	Electrolytic	220	35V	CEA 221P 35
C3	Electrolytic	330	50V	CEA 331P 50
C4	Electrolytic	220	16V	CEA 221P 16
C5	Ceramic	0.01	150V	ACG-002-0
C6	Electrolytic	220	16V	CEA 221P 16
C7	Electrolytic	330	16V	CEA 331P 16
C8	Electrolytic	100	16V	CEA 101P 16
C9	Ceramic	0.01	150V	ACG-002-0
C10	Electrolytic	47	35V	CEA 470P 35

RESISTORS

Symbol	Description			Part No.
R1	Carbon film	47		RD¼PS 470J
R2	Carbon film	10k		RD¼PS 103J
R3	Carbon film	47k		RD¼PS 473J
R4	Metal oxide	120	3W	RS3P 121K
R5	Carbon film	3.3k		RD¼PS 332J
R6	Carbon film	47		RD¼PS 470J
R7	Carbon film	3.9		RD¼PS 3R9J

SEMICONDUCTORS

Symbol	Description			Part No.
Q1	Transistor	2SC1318-Q or R		
Q2	Transistor	2SD313-D or E		
D1	Diode	SIB01-02		
D2	Diode	SIB01-02		
D3	Zener diode	WZ-140		
D4	Diode	1S2473		
D5	Diode	1S2473		

11.5 SWITCH CIRCUIT ASSEMBLY (AWS-031-0)

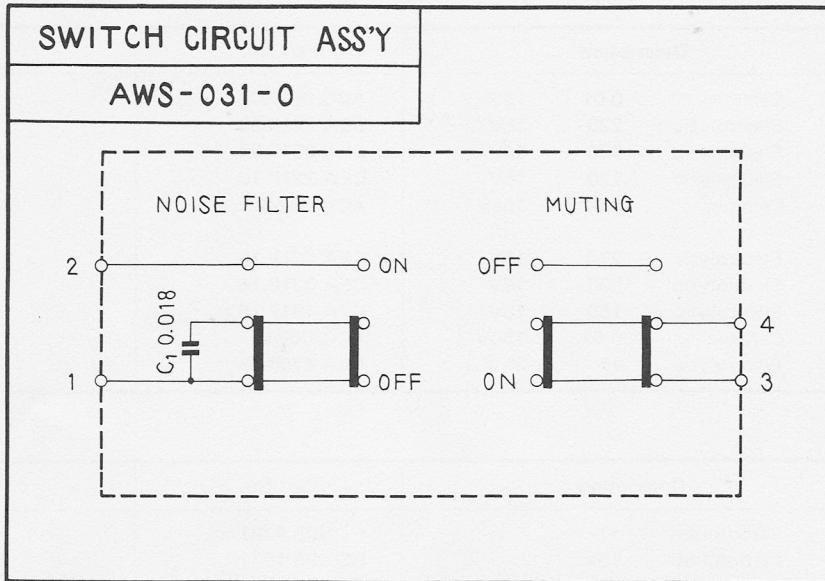

Foil Side

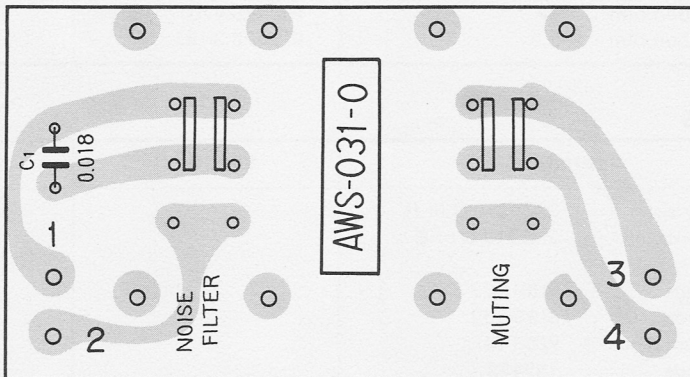

Parts List

CAPACITORS

Symbol	Description	Part No.
C1	Mylar 0.018 50V	CQMA 183K 50

SWITCH

Symbol	Description	Part No.
	Lever switch	ASK-027-0

12. PACKING METHOD AND PART NUMBERS

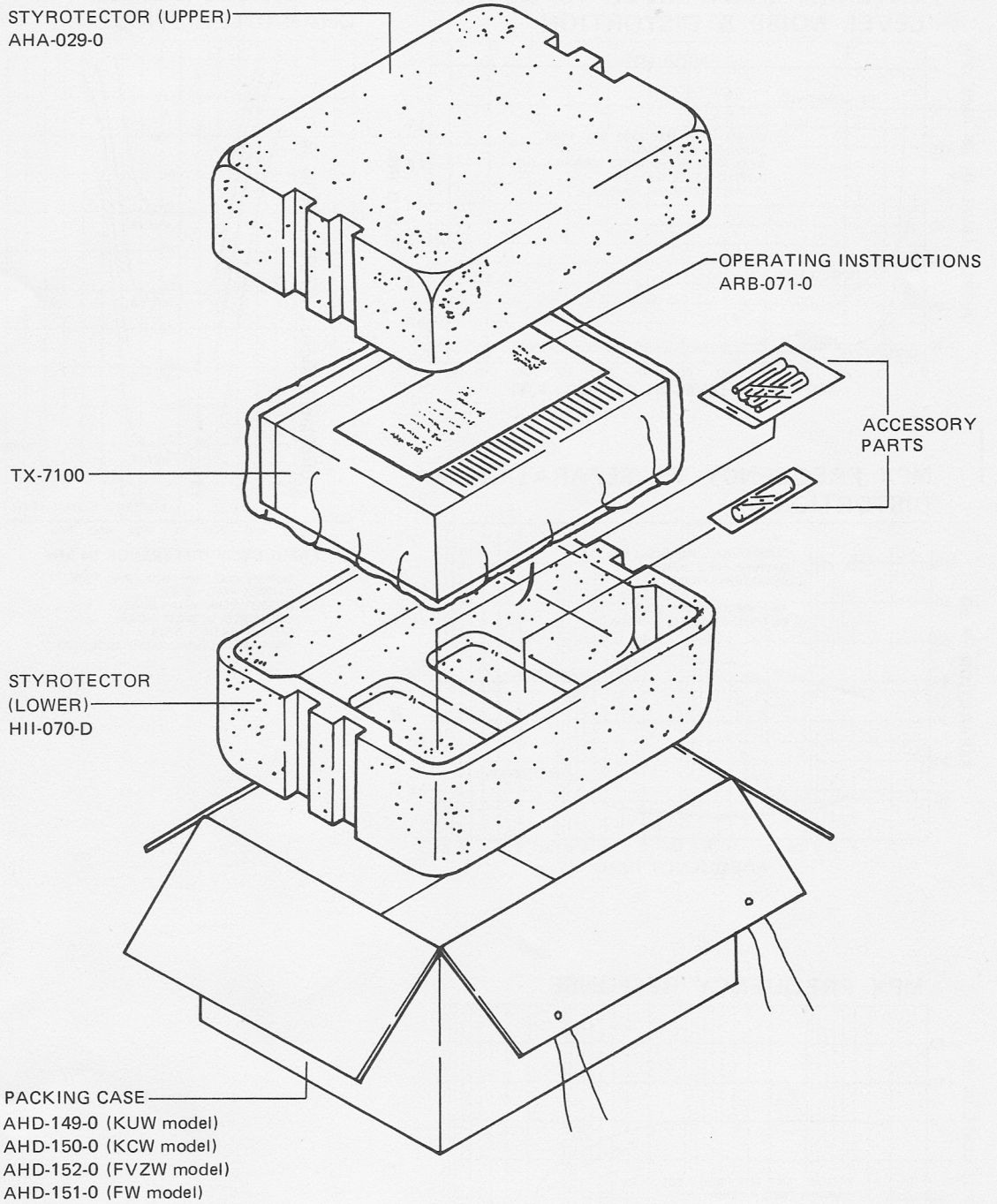

13. TUNER CHARACTERISTICS

ANTENNA INPUT LEVEL VS. OUTPUT LEVEL NOISE & DISTORTION

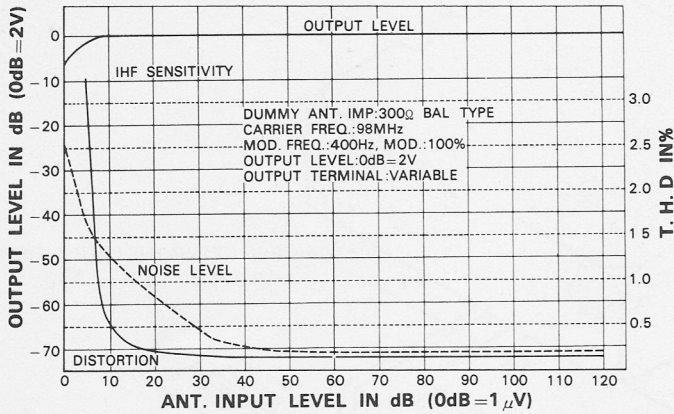

FM USABLE SELECTIVITY CHARACTERISTICS

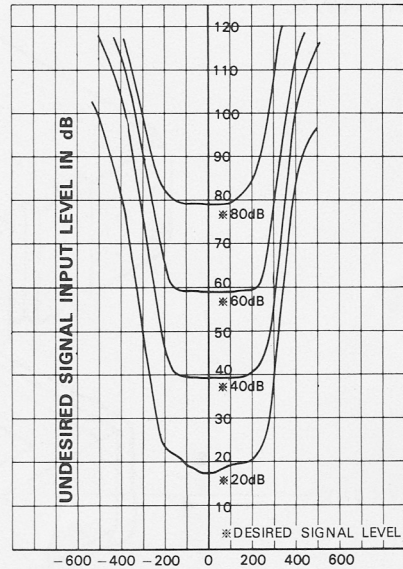

MPX FREQUENCY VS. SEPARATION & DISTORTION

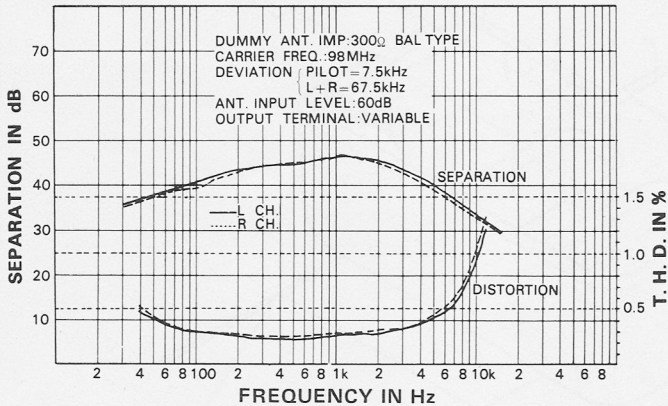

FREQUENCY DIFFERENCE IN kHz

DUMMY ANT. IMP: 300Ω BAL TYPE
 CARRIER FREQ: 98MHz
 OUTPUT TERMINAL: VARIABLE
 UNDESIRE/DESIRED SIGNAL
 OUTPUT RATIO: -30dB
 UNDESIRE SIGNAL: 400Hz 100% MOD

MPX FREQUENCY RESPONSE

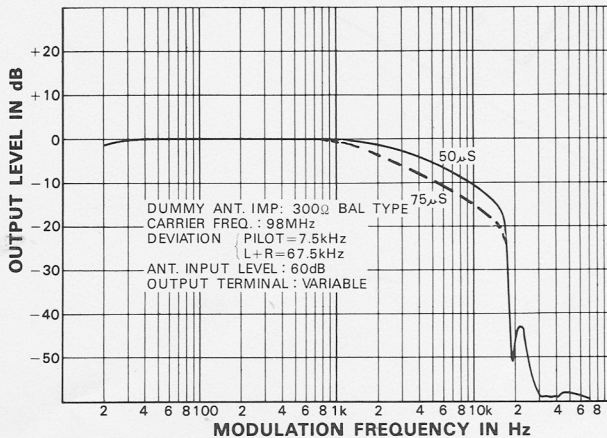

PIONEER ELECTRONIC CORPORATION
15-5, 4-Chome, Ohmori-nishi, Ohta-ku, Tokyo, Japan
U.S. PIONEER ELECTRONICS CORPORATION
178 Commerce Road, Carlstadt New Jersey 07072 U.S.A.
PIONEER ELECTRONIC (EUROPE) N.V.
Meir-center, Meir 21, 2000 Antwerp, Belgium

© MAR. 1973

PRINTED IN JAPAN