

AM/FM STEREO RECEIVER

SX-750

SERVICE MANUAL



 PIONEER®

CONTENTS

1. SPECIFICATIONS	5
2. FRONT PANEL FACILITIES	7
3. CONNECTION DIAGRAM	9
4. BLOCK DIAGRAM	11
5. CIRCUIT DISCRIPTIONS	
5.1 AM Tuner	13
5.2 FM Tuner	13
5.3 FM Muting Circuit	15
5.4 Phono Equalizer Amplifier	15
5.5 Microphone Circuit	15
5.6 Tone Control	15
5.7 Protection Circuit	16
5.8 Power Amplifier Circuit	17
5.9 Power Supply	17
6. ADJUSTMENTS	
6.1 AM Section	18
6.2 FM Section	19
6.3 MPX Adjustment	20
6.4 Power Amplifier Section	21
7. DIAL CORD STRINGING	22
8. LEVEL DIAGRAM	23
9. DISASSEMBLY	24
10. PARTS LOCATION	
10.1 Front Panel View	25
10.2 Front Panel View (with removed front panel)	27
10.3 Top View	29
10.4 Bottom View	31
10.5 Rear View	33
11. EXPLODED VIEW	35
11.1 Part I	37
11.2 Part II	38
11.3 Part III	39
11.4 Part IV	40
11.5 Part V	41
11.6 Part VI	42
11.7 Part VII	43

11.8	Packing	44
12.	SCHEMATIC DIAGRAMS P.C. BOARD PATTERNS AND PARTS LIST	
12.1	Schematic Diagrams	45
12.2	Miscellaneous Parts	47
12.3	Internal Circuitry of Integrated Circuits	48
12.4	Filter & Muting Assembly (AWM-094)	50
12.5	Tone Control Assembly (AWG-046)	52
12.6	Power Amplifier Assembly (AWH-046)	54
12.7	Power Supply & Protection Assembly (AWR-099)	58
12.8	Power Supply Assembly (AWR-100)	62
12.9	Headphone Jack Assembly (AWX-106)	64
12.10	Tuner, AF & Control Assembly (AWE-073)	65
12.11	Amplifier Assembly (AWK-065)	73
12.12	De-emphasis Switch assembly (AWX-095)	74

1. SPECIFICATIONS

Semiconductors

FET	1
ICs	7
Transistors	42
Diodes	40

Amplifier Section

Continuous Power Output from 20 Hertz to 20,000 Hertz
(Both channels driven) . . . 50 watts per channel (8 ohms)
60 watts per channel (4 ohms)

Total Harmonic Distortion

(20 Hertz to 20,000 Hertz, from AUX)

Continuous Rated Power Output . . . No more than 0.1%
25 watts per channel power
output, 8 ohms No more than 0.05%
1 watt per channel power
output, 8 ohms No more than 0.05%

Intermodulation Distortion

(50 Hertz: 7,000 Hertz=4:1, from AUX)

Continuous Rated Power Output . . . No more than 0.1%
25 watts per channel power
output, 8 ohms No more than 0.05%
1 watt per channel power
output, 8 ohms. No more than 0.05%

Damping Factor

(20 Hertz to 20,000 Hertz) 30

Input (Sensitivity/Impedance)

PHONO 2.5mV/50k ohms
MIC 5mV/50k ohms
AUX 150mV/50k ohms
TAPE PLAY 1 150mV/50k ohms
TAPE PLAY 2 150mV/50k ohms
TAPE PLAY 2 (DIN connector) . . . 150mV/50k ohms

PHONO Overload Level (T.H.D. 0.1%)

. 200mV (1kHz)

Output (Level/Impedance)

TAPE REC 1 150mV
TAPE REC 2 150mV
TAPE REC 2 (DIN connector) 30mV/80k ohms
SPEAKER A, B, A+B
HEADPHONES Low Impedance

Frequency Response

PHONO (RIAA equalization)
. 30 Hertz to 15,000 Hertz ± 0.2 dB
AUX, TAPE PLAY
. 10 Hertz to 50,000 Hertz $\begin{matrix} +0 \\ -1 \end{matrix}$ dB

Tone Control

BASS +8dB, -7dB (100 Hz)
TREBLE +9dB, -7dB (10 kHz)

Filter

HIGH 6 kHz (6dB/oct.)

Loudness Contour (Volume control set

at -40dB position) +6dB (100 Hz), +3dB (10 kHz)

Hum and Noise

(IHF, short-circuited, A Network, rated power)

PHONO 70dB
AUX, TAPE PLAY 90dB

FM Section

Usable Sensitivity MONO 10.7dBf (1.9 μ V)
STEREO 19.0dBf (9.8 μ V)

50dB Quieting Sensitivity

MONO 17.2dBf (4.0 μ V)
STEREO 39.2dBf (50 μ V)

Signal to Noise Ratio at 65dBf

MONO 72dB
STEREO 67dB

Distortion at 65dBf 100Hz . . . MONO 0.15%

STEREO 0.3%

1kHz MONO 0.15%

STEREO 0.3%

6kHz MONO 0.4%

STEREO 0.4%

Frequency Response 30Hz to 15,000Hz $\begin{matrix} +0.2 \\ -2.0 \end{matrix}$ dB

Capture Ratio 1.0dB

Alternate Channel Selectivity 80dB

Spurious Response Ratio 90dB

Image Response Ratio 80dB

IF Response Ratio 100dB

AM Suppression Ratio 55dB

Muting Threshold 14dBf (2.8 μ V)

Stereo Separation 40dB (1kHz), 30dB (30Hz
~15kHz)

Subcarrier Product Ratio 62dB

SCA Rejection Ratio 62dB

Antenna Input 300 ohms balanced
75 ohms unbalanced

AM Section

Sensitivity (IHF, Ferrite antenna)	300 μ V/m
(IHF, Ext. antenna).	15 μ V
Selectivity	35dB
Signal to Noise Ratio	50dB
Image Rejection	40dB
IF Rejection	65dB
Antenna	Built-in Ferrite Loopstick Antenna

Miscellaneous

Power Requirements	120V, 60Hz
Power Consumption	160W (UL), 350W (max.)
Dimensions	480(W) x 149(H) x 371(D)mm
	18-7/8 (W) x 5-7/8(H) x 14-5/8(D)in.
Weight without package	13.7kg(30 lb 2 oz)
with package	15.3kg (33 lb 11 oz)

Furnished Parts

FM T-type Antenna	1
Operating Instructions	1

NOTE:

Specifications and design subject to possible modification without notice, due to improvements.

2. FRONT PANEL FACILITIES

POWER INDICATOR LAMP

Lights when **SPEAKERS** switch is moved to any position from **POWER OFF**, and AC power is supplied to the receiver.

SPEAKERS SWITCH

Functions both as power switch and speaker selection switch.

POWER OFF: AC power is off.

A: Sound will be heard from speakers connected to A speaker terminals.

OFF: No sound will be heard from speaker systems. This position should be used when listening with headphones.

B: Sound will be heard from speakers connected to B speaker terminals.

A + B: Sound will be heard from speakers connected to A terminals and from speakers connected to B terminals.

PHONES OUTPUT

Insert headphone plug into this jack when headphone listening is desired. In this case, **SPEAKERS** switch should be in **OFF** position.

BASS, TREBLE CONTROLS

For tone adjustment when **TONE** switch is in **ON** position. When knobs are turned clockwise from "0" position, response in bass or treble range, respectively, is boosted. Turning counterclockwise attenuates response.

TONE SWITCH

Controls **ON-OFF** operation of tone control circuit. In the **ON** position, tone control by means of **BASS** and **TREBLE** knobs may be accomplished. In the **OFF** position, the tone control circuit is bypassed and frequency response in high and low ranges is flat.

HIGH FILTER SWITCH

For high frequency noise due to scratches on the record, place switch in **6kHz** position. This will provide **6dB/octave** attenuation at frequencies above **6kHz**. For normal operation switch should be in **OFF** (upper) position.

SIGNAL METER

For FM and AM reception, turn **TUNING** knob until needle of the **SIGNAL** meter is deflected a maximum to the right.

STEREO INDICATOR LAMP

Lights when FM stereo broadcast is being received.

FM TUNING

With the right, fine tuning

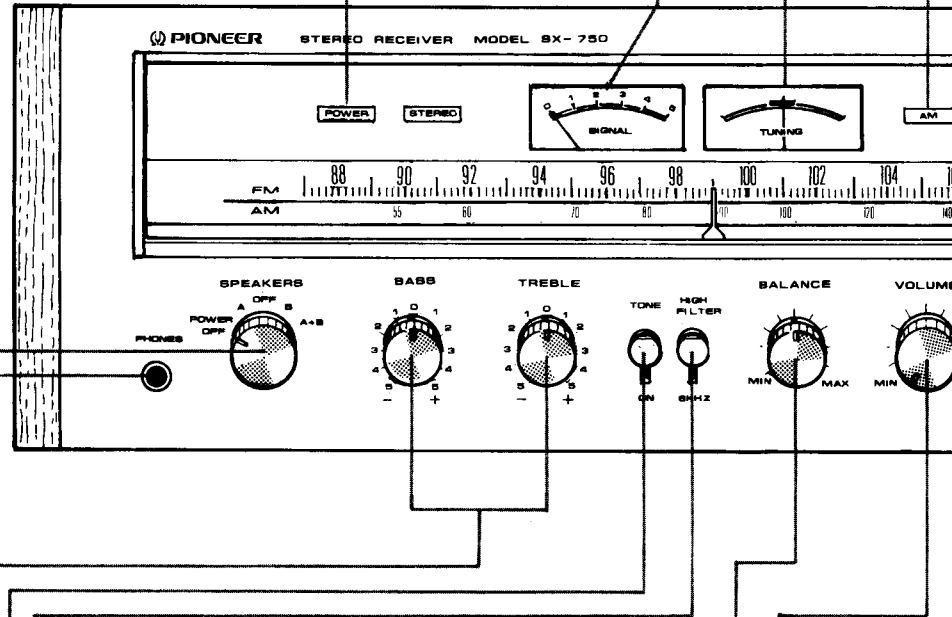

BALANCE CONTROL

For adjustment of relative output levels of L and R channels of speaker systems or headphones. Clockwise rotation from center position increases volume of R over L channel. Counterclockwise rotation increases volume of L channel over R.

VOLUME CONTROL

For adjustment of speaker or headphone output level. Level increases with clockwise rotation of knob.

LOUDNESS SWITCH

For listening at low volume level, placing this switch in the **ON** position will boost response in low and high frequency ranges.

The response of the human ear to low and high sound volumes is different. At low volume levels, the ear is relatively insensitive to sounds at either extreme of the frequency scale. By means of the **LOUDNESS** switch, these sounds are given additional amplification.

MODE

For selection of playback mode: **STEREO** (two channel speakers) or **MONO** (one channel speaker).

NOTE: Recording rate.

DUPLICATION

With switch in two tap position, operation

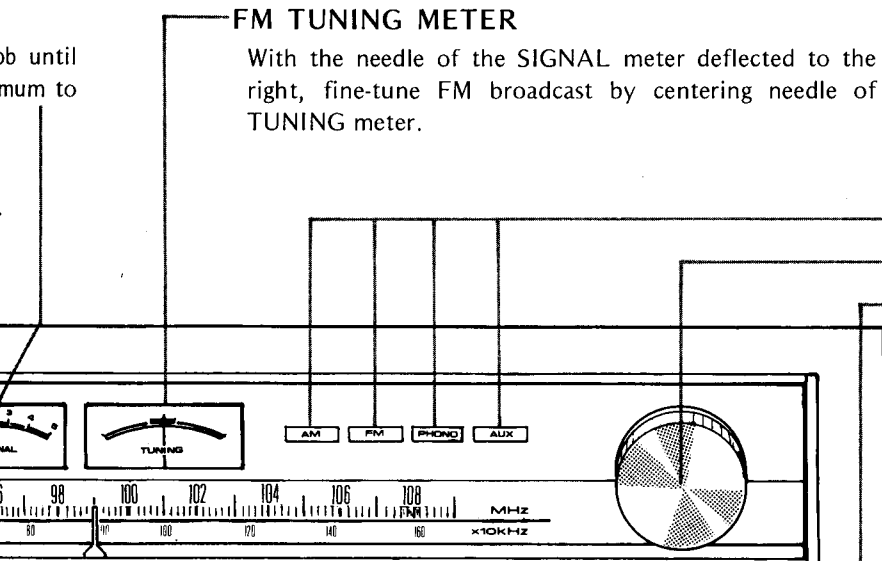

FM TUNING METER

With the needle of the SIGNAL meter deflected to the right, fine-tune FM broadcast by centering needle of TUNING meter.

PROGRAM SOURCE INDICATORS

Indicate program source selected by means of FUNCTION switch.

TUNING KNOB

For selection of FM or AM stations.

FM MUTING BUTTON

For selection of FM broadcasts, button should be in ON (released) position. When button is in ON position, unpleasant interstation noise is suppressed. When signal strength is poor, it may not be possible to bring in the desired station if MUTING is ON. In this case, press button to place it in the OFF position.

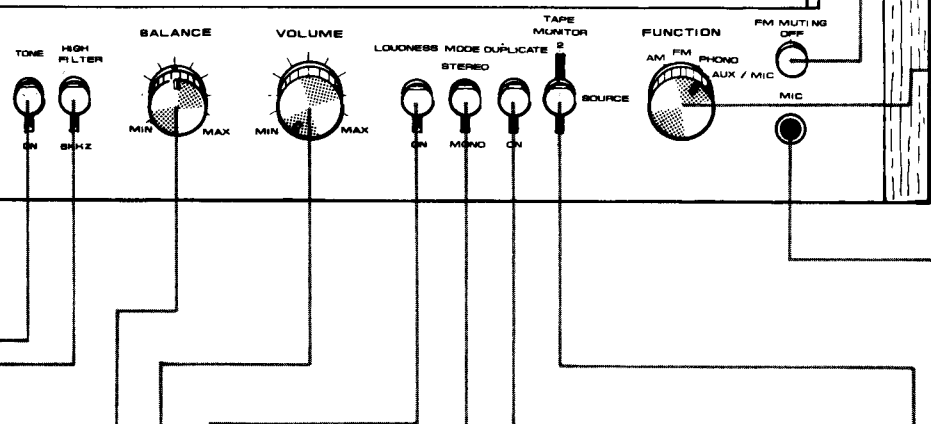

FUNCTION SELECTOR

For selection of program source.

- AM: AM broadcasts
- FM: FM broadcasts
- PHONO: Playing records
- AUX/MIC: For use of component connected at AUX terminals of receiver, or microphones which may be plugged into MIC jack.

NOTE:
AUX and MIC program sources cannot be used simultaneously. When using AUX hi-fi component, microphone should be disconnected.

MODE SWITCH

For selection of stereophonic or monophonic mode of playback. In normal operation, switch should be in STEREO position. In the MONO position, R and L channel signals will be mixed, and sounds coming from speakers of both channels will be the same.

NOTE:
Recording stereophonically with the MODE switch in the MONO position may cause channel separation to deteriorate.

DUPLICATE SWITCH

With switch in ON position, signals recorded on one of two tape decks connected to the receiver may be recorded onto the other, with or without editing. For normal operation, this switch must be in OFF (upper) position.

MIC JACK

Accepts standard 6mmϕ plug. Microphone input signal enters both R and L channels.

TAPE MONITOR SWITCH

- 1: For program sources other than tape deck (playback). (REC or PLAY).
- SOURCE: For program sources other than tape deck (playback).
- 2: For monitoring of playback or record mode of tape deck connected to TAPE 2 terminals (REC or PLAY).

NOTE:
When not monitoring record or playback mode of a tape deck, switch should be in SOURCE position. In position 1 or 2, the program source indicated by the FUNCTION selector will not be heard through speaker systems or headphones.

3. CONNECTION DIAGRAM

REAR VIEW

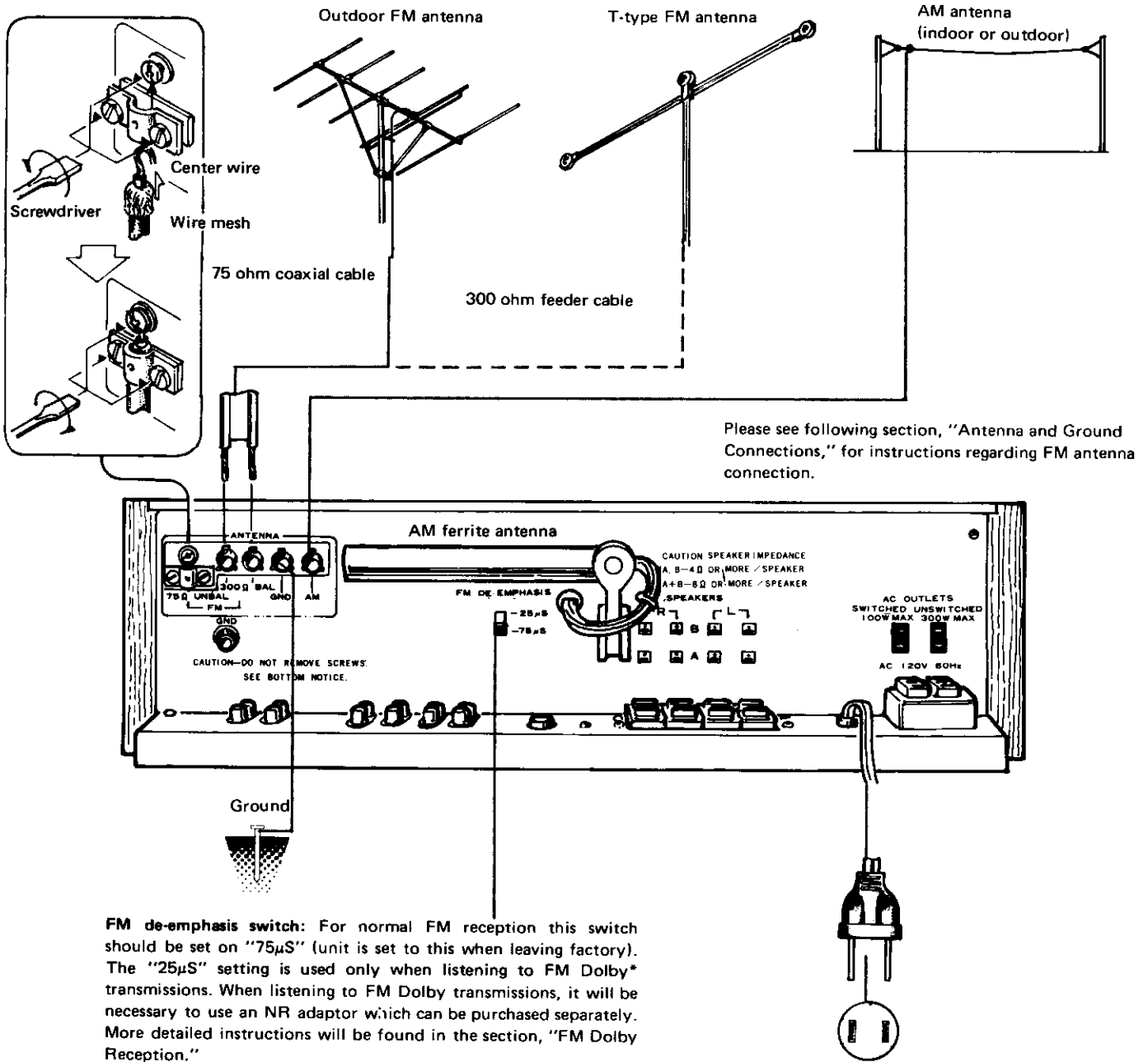

ANTENNA PLACEMENT

Make note of the following points when choosing a location for the FM antenna.



Direction of signals →

1.5 meter (5 ft.) above

More than 4 meters (15 ft.) above ground

- Feeder wire and cable should be insulated at mounting points.
- Length should be as short as possible.
- Feeder wire should not be coiled.

Antenna should not be placed where it will be subject to electrical interference from motor vehicles.

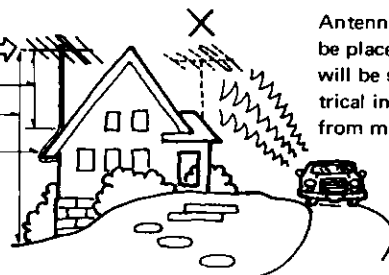

Fig. 1

TOP VIEW

Accessory AC outlets:

Switched Power to this outlet is controlled by the SX-750 power switch. When power to the receiver is "On," this outlet will provide AC current (100 watts maximum).

Unswitched Power to this outlet is not controlled by the SX-750 power switch. As long as the power cord is plugged into a live outlet, this outlet will supply AC current (maximum 300 watts).

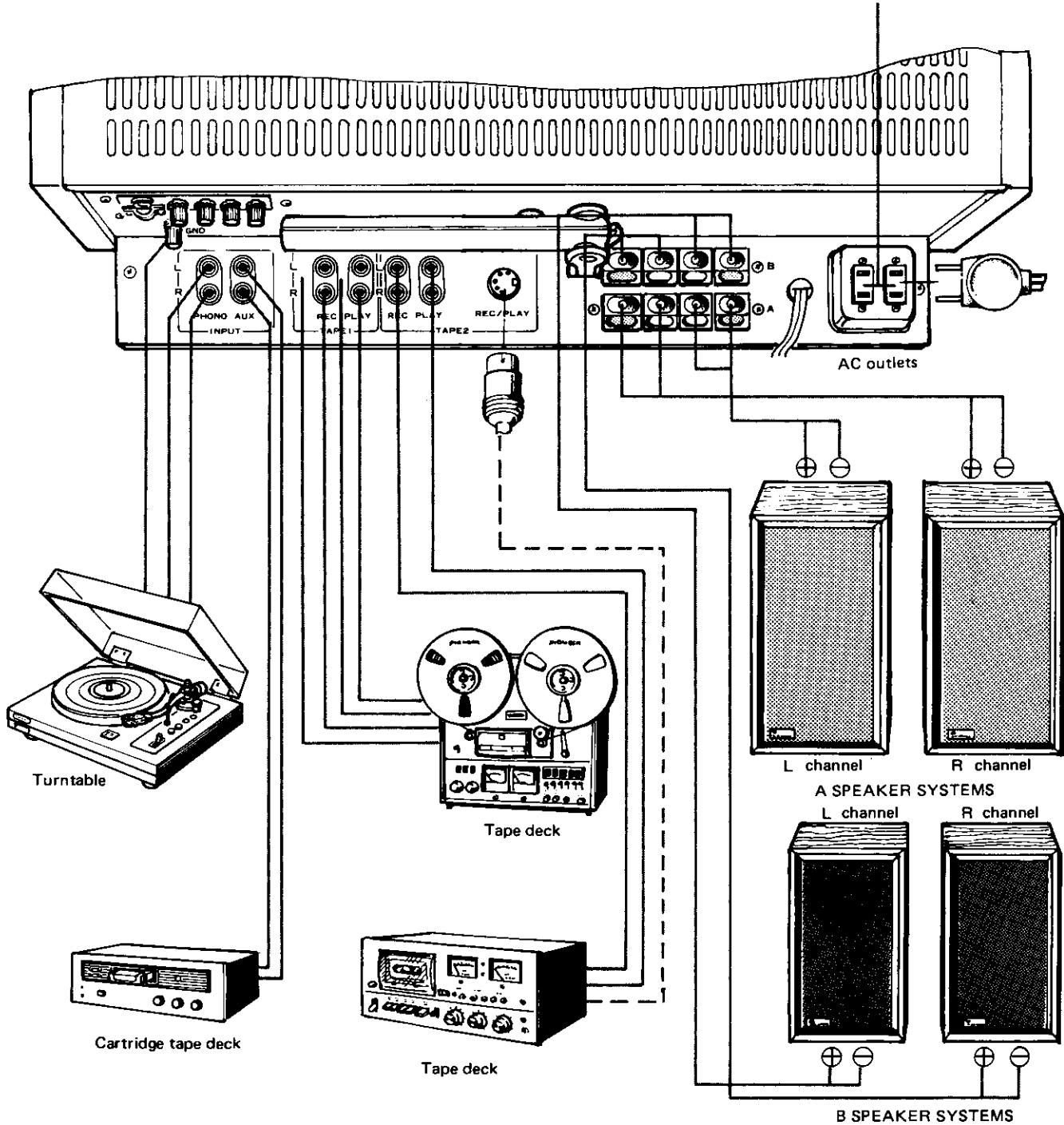
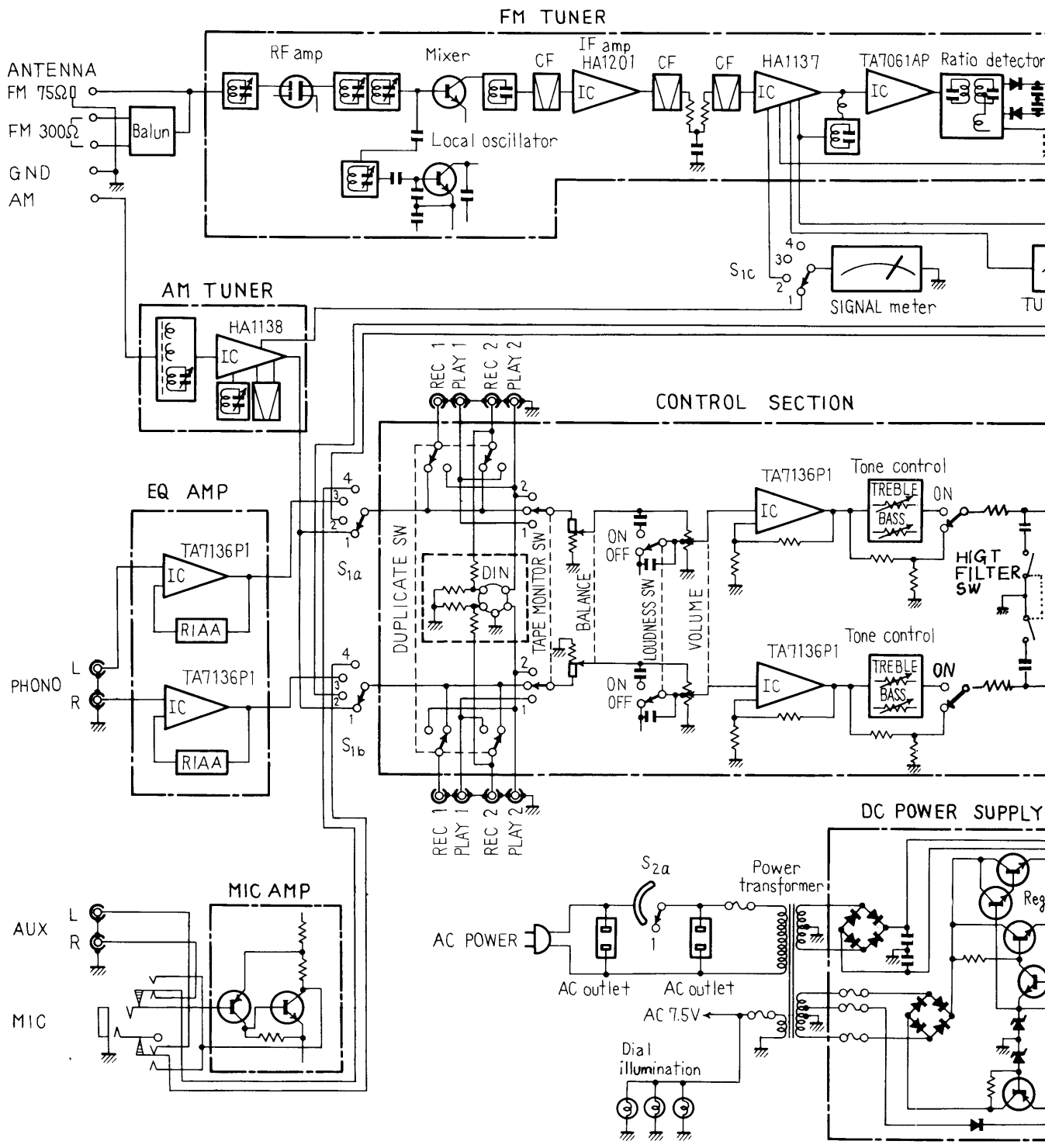
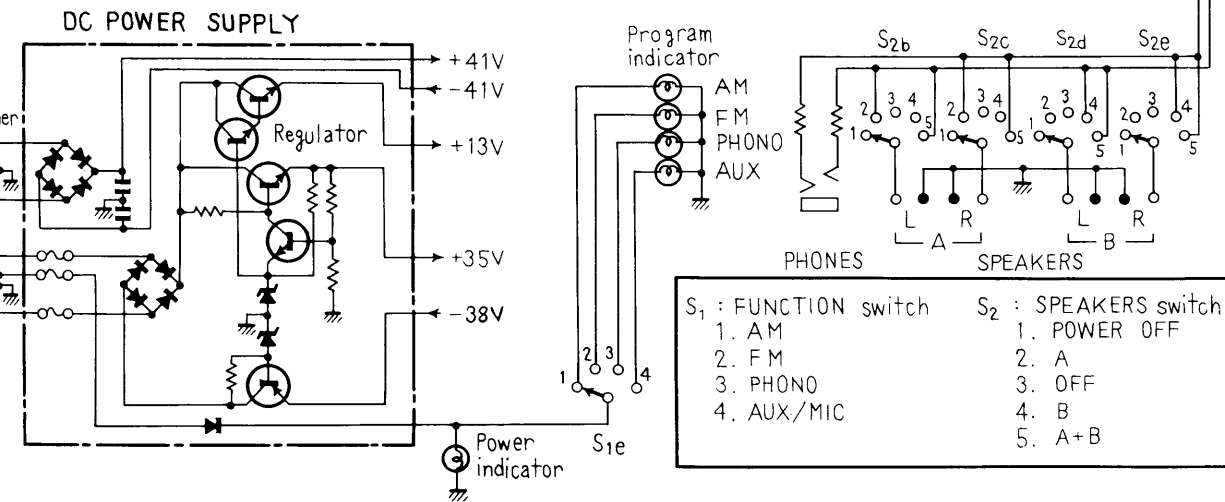
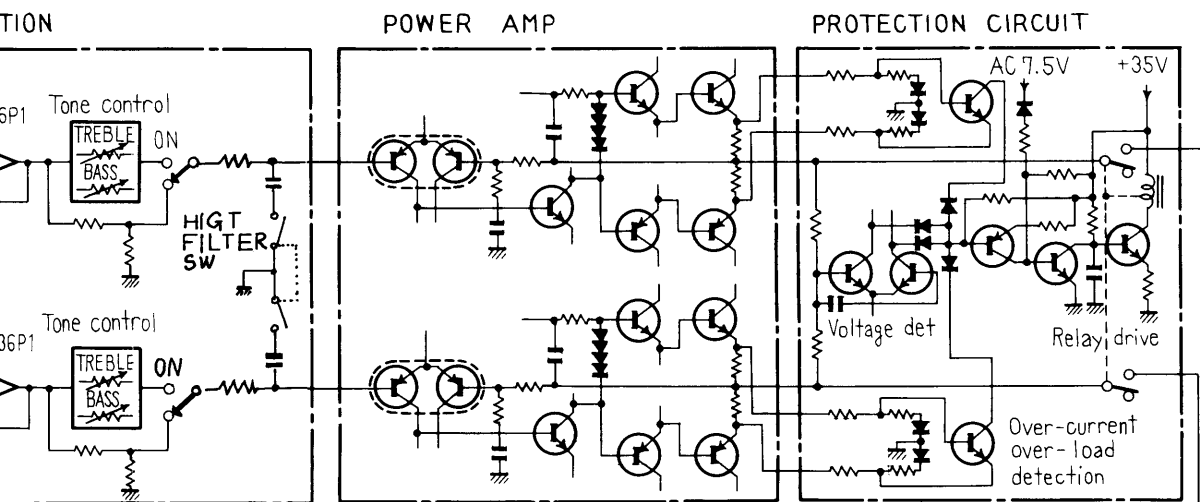
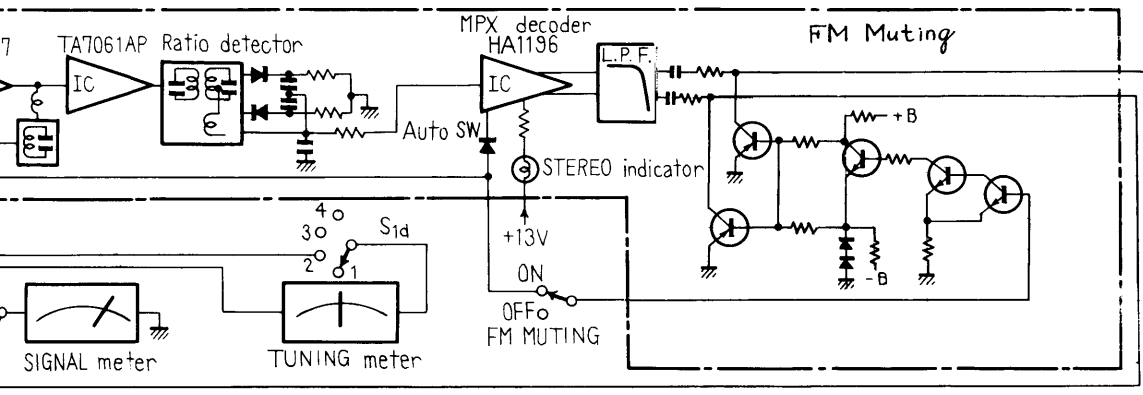

Fig. 2

4. BLOCK DIAGRAM





5. CIRCUIT DESCRIPTIONS

5.1 AM TUNER

Composed of single IC (HA1138) combining a 1 stage RF amplifier and a 2 stage IF amplifier (Fig. 1).

5.2 FM TUNER

Front End

The outstanding performance, exemplified by the remarkable 80dB imaging and 90dB spurious rejection, originates in the dual-gate MOS FET RF amplifier and 4-gang variable capacitor tuning circuit. A modified Clapp circuit is employed in the local oscillator, leading to high frequency stability. Since the output is taken from the oscillator tuning circuit, higher harmonics in the oscillator signal and spurious response become reduced.

IF Amplifier and Detector

Comprise 2 dual element ceramic filters, 1 transistor, and 1 IC (integrated circuit). The IC (HA1137) circuit is illustrated in Fig. 2.

FM IF Amplifier and Detector Circuit

Three dual element ceramic filters, an IC (HA1201) containing a differential amplifier, and an IC (HA1137) containing a 3-stage limiter amplifier compose the FM IF amplifier. Fig. 2 shows the HA1137 block diagram (see circuit diagram on page 65).

In addition to limiter amplifier, the HA1137 IC includes detector, meter drive circuits. The detector circuit in the HA1137 is not employed in this set however a separate ratio detector circuit is employed instead, resulting in improved S.N ratio.

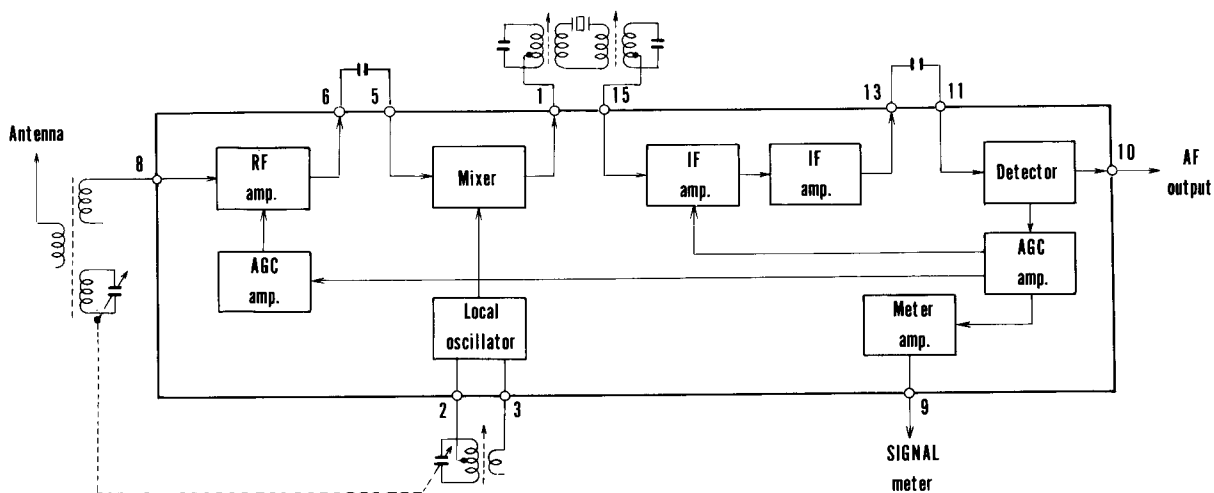

Fig. 1 Block Diagram of HA1138

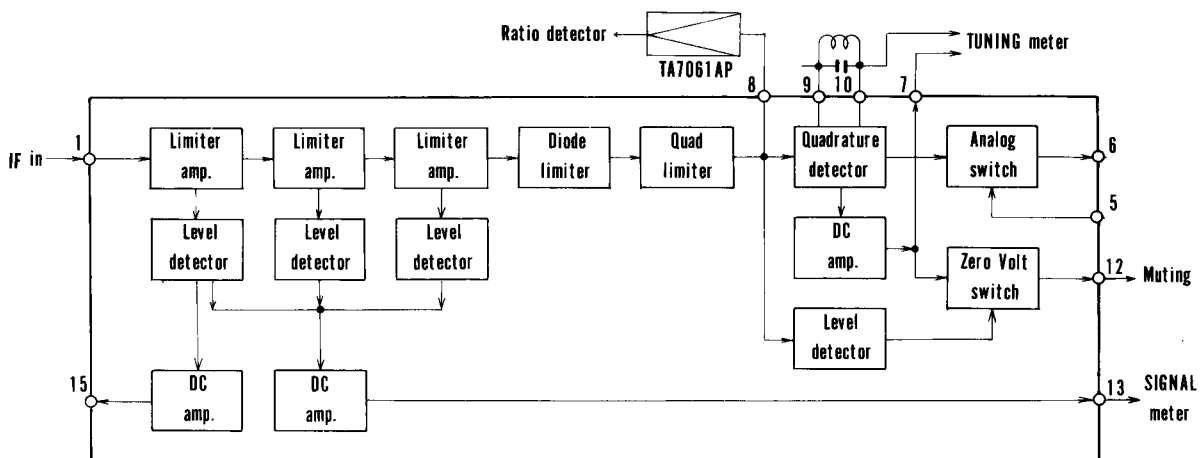

Fig. 2 Block Diagram of HA1137

Multiplex Decoder

Demodulation is performed by switching detection. A single IC (HA1196) composes the circuit, which is divided into 3 sections. Fig. 3 shows the HA1196 block diagram (see circuit diagram on page 65).

1. Switching signal generator

A PLL (phase locked loop) system is employed. 76kHz is generated by a VCO (voltage controlled oscillator: oscillator in which the frequency is varied by a control voltage) and converted into 19kHz by a frequency divider. This signal and the pilot (19kHz) of the received signal are applied to a phase comparator, which converts the phase differences of the two signals into a voltage. The voltage is then fed back to the VCO. The oscillator signal phase becomes locked to the pilot signal by this loop (PLL) and a 38kHz signal synchronised to the pilot signal is obtained and employed as the switching signal.

2. Automatic stereo detector

With the PLL locked to the pilot signal, the pilot signal and a 19kHz signal of the same phase are produced. A voltage is then obtained at the phase comparator that is proportional to the pilot signal amplitude. As it increases, the lamp lights and the switch becomes on. The switching signal is applied to the demodulator.

3. Demodulator

This is a switching circuit employing two differential amplifiers (Fig. 4). Q1 and Q2 are alternately switched on and off by the switch-

ing signal. The composite signal is amplified at Q3, switched and demodulated. Q6 and Q3 are loosely coupled at their emitters by R1 - R3. Q6 is driven in reverse phase to Q3. This is switched at Q4 and Q5, and by composing with Q1 and Q2 at the collector, crosstalk becomes cancelled.

Adequate current flow is required to Q3 and Q6 to improve distortion figures at this point. However, if the base bias voltage is raised, the voltage component at the collector becomes reduced and clipping occurs (power supply voltage is limited by IC voltage endurance). For this reason, current from an external source is inserted at Q3 and Q6 collectors to become I_1 and I_2 . The same current amounts are obtained as I_3 and I_4 from the emitters. Q3 and Q6 therefore operate with adequate current, and distortion at this stage becomes remarkably improved. A feedback amplifier amplifies the demodulated output.

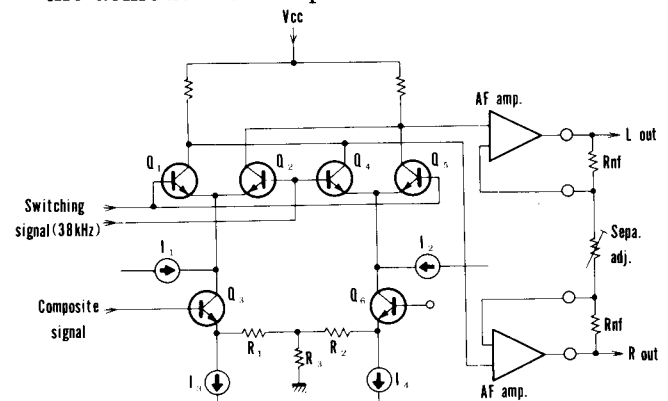

Fig. 4 Equivalent Circuit of Demodulator

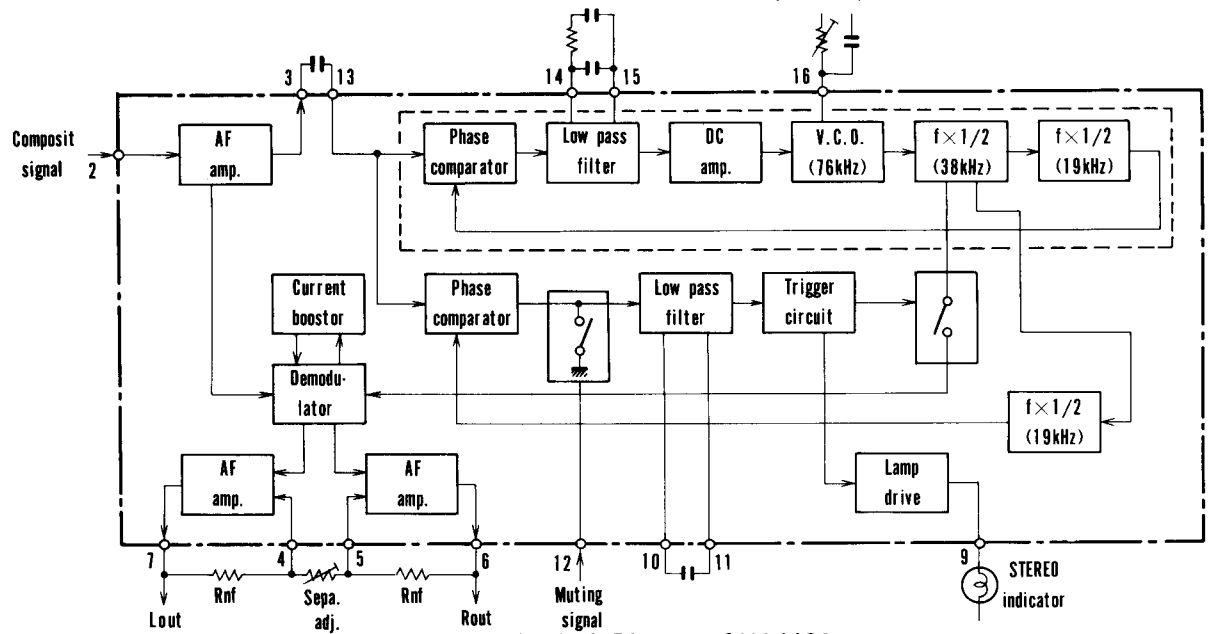

Fig. 3 Block Diagram of HA1196

5.3 FM MUTING CIRCUIT

At time of detuning (more than $\pm 70\text{kHz}$) and with an antenna input of less than 10dB ($0\text{dB} = 1\mu\text{V}$), a DC voltage is produced at pin 12 of IC₁ (HA1137). This voltage is employed as the muting trigger. With the MUTING switch ON, Q1 becomes ON and Q2 OFF in the Q1-Q2 Schmitt circuit as the muting trigger is produced. Q3 becomes ON when Q2 is OFF, and Q4, Q5 and Q6 also become ON. With Q4 & Q5 ON, the FM output becomes grounded, while IC₁ output is grounded by Q6 to apply muting.

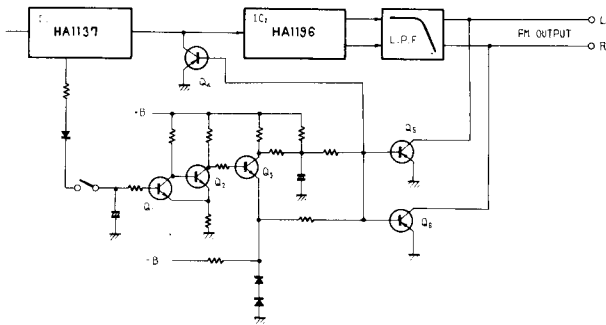

Fig. 5 FM Muting Circuit

5.4 PHONO EQUALIZER AMPLIFIER

IC (TA7136P1) is used with independent left and right channels. Grade G styrole capacitors and grade F metal film resistors comprise the equalizer elements, leading to an RIAA deviation within 0.2dB from 30Hz to 15kHz .

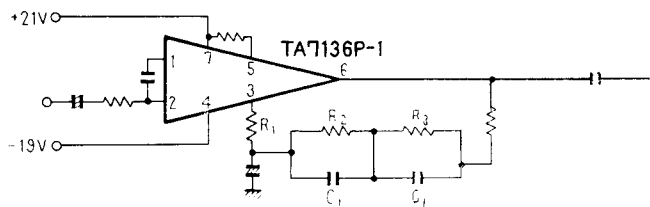

Fig. 6

5.5 MICROPHONE CIRCUIT

A 2 stage transistor amplifier (monophonic) is provided in addition to the phono equalizer amplifier. A selector switch cuts the AUX jack input when a plug is inserted into the MIC jack. The amplified microphone signal is then supplied to both the left and right channels. The FUNCTION switch is set to the AUX position when using a microphone.

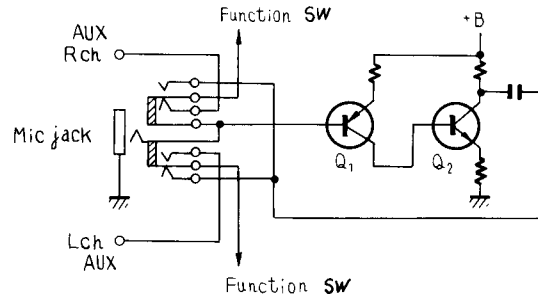

Fig. 7

5.6 TONE CONTROL

CR type tone controls are connected to an extremely low output impedance flat amplifier (IC = TA7136, 31dB gain). Bass can be varied in the range of $+8\text{dB} \sim -7\text{dB}$ (100Hz) and treble in the range of $+9\text{dB} \sim -7\text{dB}$ (10kHz). A TONE switch also allows the tone controls to be switch ON/OFF.

R1 and R2 are designed to provide the same loss when the TONE switch is OFF as obtained with the TONE switch ON and the BASS and TREBLE controls at center positions (flat). Frequency response thus becomes flat when the TONE switch is set to OFF.

R3, and C1 form a 6kHz 6dB/octave HIGH CUT filter which is connected following the TONE switch.

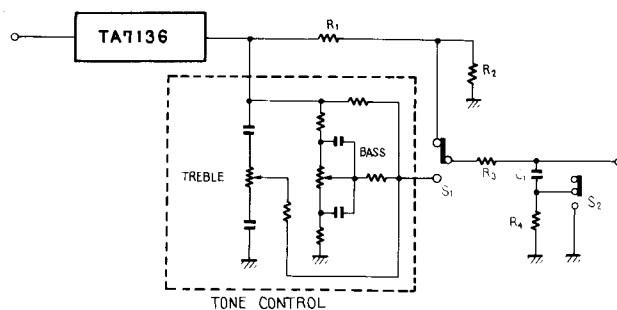

Fig. 8

5.7 PROTECTION CIRCUIT

This protection circuit functions to protect the speakers and the power amplifiers from damage due to short-circuit of the load, etc., and performs a muting operation to cut noise and distortion which occur when switching the power on and off. The circuit is shown in Fig. 15, and consists of a bridge type over-current and overload detector, a differential amplifier DC voltage detector, and a power switch ON/OFF detector section.

Relay Driving Circuit

Q4—Q6, in Fig. 9, comprise the relay driving circuit.

In the normal condition reverse bias is applied to the base of Q4, and Q4 is in a off state. When one of the above mentioned detection circuits goes on, current flows through R11, the base potential falls and Q4 is turned on. Consequently Q5 comes on and Q6 goes off. When Q6 goes off, the current of the relay circuit is cut, to release the switch of the output circuit.

When the power switch is turned on, a delay operation occurs in this circuit. R17 and C3, in the base circuit of Q6, are the time constant elements which determine the delay time. When the power switch is turned on, C3 charges to a potential of +60 volts through R17 and R18, and Q6 is kept in the off state during this time. When the power source is switched off, the muting operation of Q5 prevents shock noise. In the normal condition, the potentials of +33 volts and -5.1 volts are applied to Q5 through R14 and R15. The resultant potential at the base of Q5 is -1 volt in the cutout condition. When the power supply is turned off,

of -5.1 volts disappears immediately due to the small time constant of the power circuit. Thus a positive base potential remains, switching Q5 on, which in turn switches off Q6 and hence the relay.

Detection of DC Voltage

This is a differential amplifier consisting of Q2 and Q3, as shown in Fig. 10. The bases of Q2 and Q3 are connected to the center points of the right and the left power amplifiers. When the DC balance of the power stage is lost for some reason, a potential difference is produced in the input signal to the differential amplifier, and the collector currents of Q2 and Q3 are put out of balance. Thus, the relay driving circuit functions, and the relay switch is turned off.

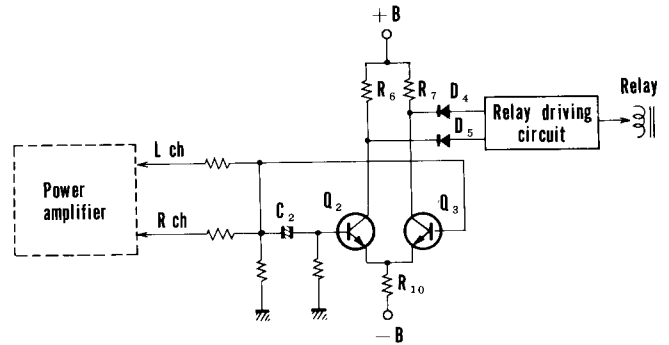

Fig. 10 DC Voltage Detection Circuit

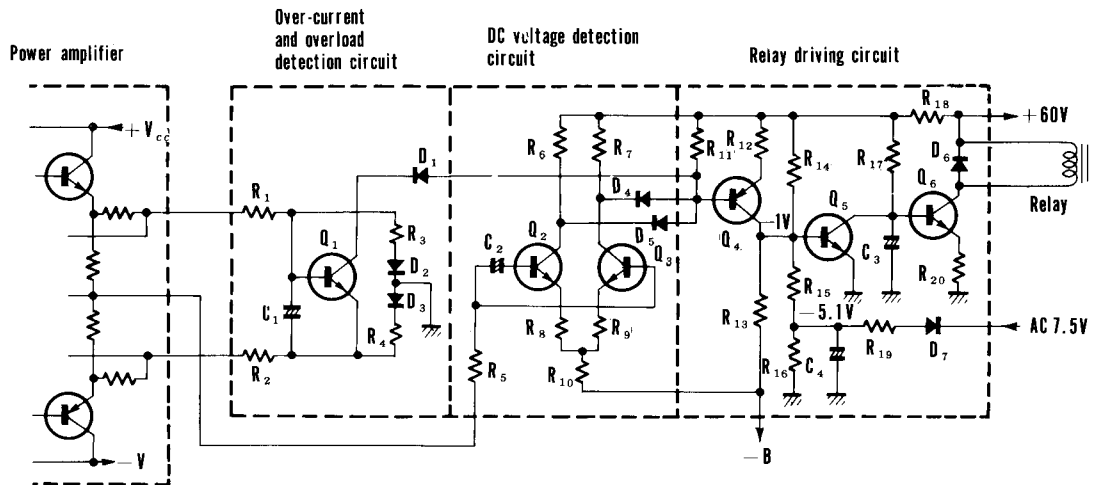

Fig. 9 Protection Circuit

Over-current and Overload Detection

The equivalent circuit of this detector section is shown in Fig. 11, and Fig. 12-a shows the equivalent circuit at the time of a positive half cycle. When this equivalent circuit is overloaded, the balance of the bridge, formed by RE1, R1, R3 and RL, is disturbed, and a potential is produced between b and a in such a direction that Q1 is turned on. When Q1 is turned on, the collector current increases, the relay driving circuit functions and the relay switch of the output circuit is turned off.

After the cause of the overload is removed, the bias of Q1 is reduced and the relay switch turns on to automatically restore normal operation, Fig. 18-b shows the equivalent circuit at the time of a negative half cycle. In this circuit, a potential is produced between b and e as above, and Q1 is turned on.

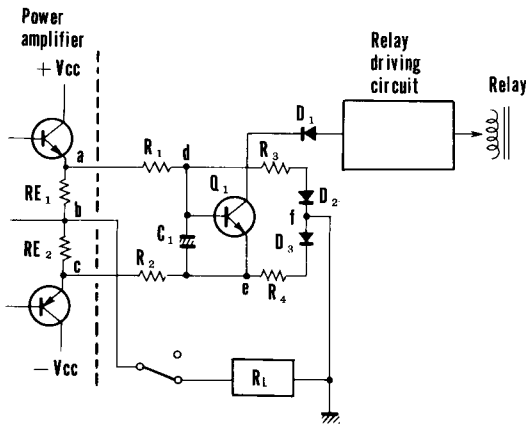

Fig. 11 Over-current and Overload Detection Circuit

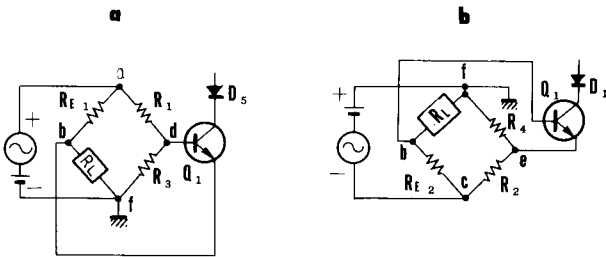

Fig. 12 Equivalent Circuit of

5.8 POWER AMPLIFIER CIRCUIT

Composed of differential first stage, all stages direct coupled pure complementary OCL circuit. Open gain at 1kHz is approximately 80dB and NFB amount is approximately 50dB. R3 and R4 are provided with this circuit in order to obtain adequate stability even with the NFB disconnected. Q1 form a differential amplifier: 100% d.c. feedback is applied from the junction point of the power stage to the base of Q1 so the potential of the junction point is always maintained at the same level.

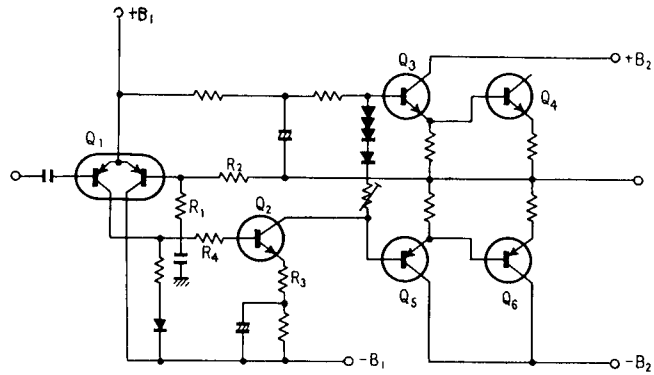

Fig. 13

5.9 POWER SUPPLY

Two windings are provided in the power transformer secondary and each is separately bridge rectified. One of these is sent as ± 48 VDC to the voltage stabilizer circuit to become 13V, 33V and -37V regulated voltages for supply to each assembly.

The other secondary voltage is bridge rectified and becomes ± 4 IV or supply to the power amplifier predriver stage. Extremely low power supply impedance is maintained by a 15,000 μ F electrolytic capacitor.

6. ADJUSTMENTS

6.1. AM SECTION

1. Set function switch to AM.
2. Connect AM signal generator through 1k-ohm resistor to AM antenna terminal.
3. Set DUPLICATE switch to OFF and connect an AC voltmeter to TAPE 1 REC jacks.
4. Set AM SG for 400Hz 30% modulation 74dB output.
5. Set SX-750 dial indication and AM SG frequency for 600kHz.
6. Adjust T8 core for maximum reading on AC voltmeter.
7. Set SX-750 dial indication and AM SG frequency for 1,400kHz.
8. Adjust TC2 for maximum reading on AC voltmeter.
9. Set AM SG for 30dB output.
10. Set SX-750 dial indication and AM SG frequency for 600kHz.
11. Adjust T8 and bar antenna core for maximum reading on AC voltmeter.
12. Set SX-750 dial indication and AM SG frequency for 1,400kHz.
13. Adjust TC2, TC4 for maximum reading on AC voltmeter.
14. Repeat steps 10~13 to eliminate variations in AC voltmeter readings.

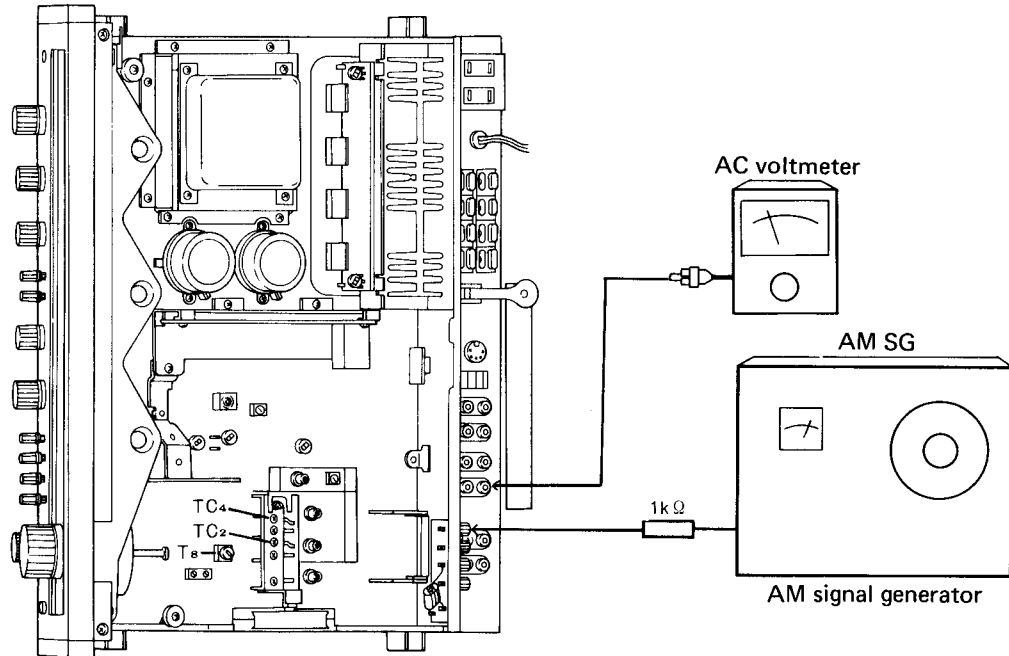

Fig. 14

6.2 FM SECTION

FM Tracking

1. Connect measuring equipment as shown in Fig. 15.
2. Set FM SG to 100% modulation ($\pm 75\text{kHz}$ deviation) at 400Hz and 100dB output.
3. On SX-750 front panel, set FM switch to ON, FM muting to OFF and VOLUME control to minimum position.
4. Set TC6 to center of turning range.
5. Tune FM SG and SX-750 to dial readings of 90MHz.
6. Adjust T4 core for maximum indication on Signal meter.
7. Adjust T6 core for center of scale indication on Tuning meter.
8. Set FM SG output to 8~10dB and adjust cores of T1, T2, and T3 for maximum indication on Signal meter.
9. Tune FM SG and SX-750 to dial readings of 106MHz.
10. Set FM SG output to 100dB and adjust TC6 for maximum indication on Signal meter.
11. Set FM SG output to 8~10dB and adjust TC1, TC3, TC5 and TC6 for maximum indication on Signal meter.
12. Repeat above adjustment steps 5~11 and adjust for optimum conditions.
13. Tune FM SG and SX-750 to dial readings of 90MHz.
14. Adjust T5 core for maximum indication on Signal meter.
15. Detune SX-750 (to noise only).
16. Adjust T6 for center of scale indication on Tuning meter.
17. Tune FM SG and SX-750 to dial readings of 98MHz.
18. Set FM SG output to 60dB and adjust upper core of T7 for maximum reading on AC voltmeter.
19. Adjust lower core of T7 for minimum audio frequency output distortion.
20. Set FM SG for 100dB output and adjust VR1 so that Signal meter indicates 5 of the scale.

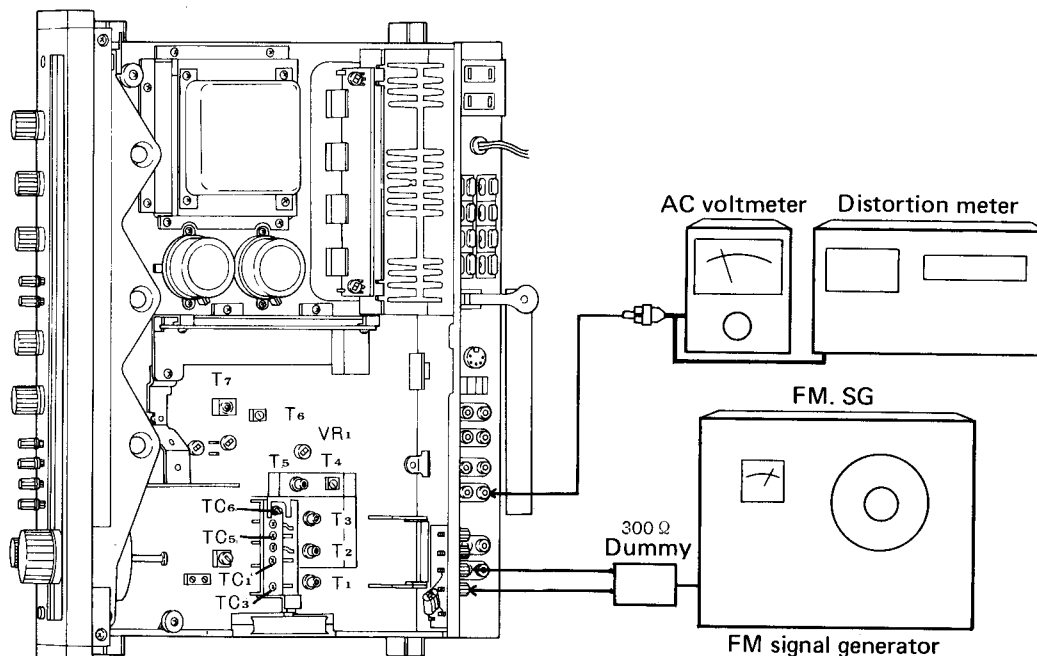

Fig. 15

6.3 MPX Adjustment

1. Connect measuring equipment as shown in Fig. 16.
2. Tune FM SG and SX-750 to dial readings of 98MHz.
3. Set FM SG for 60dB unmodulated output.
4. Connect the output signal (19kHz) of MPX SG PILOT OUT terminal to the horizontal input of an oscilloscope, and pin 20 of the tuner assembly (AWE-073) via a probe to the oscilloscope vertical input.
5. Adjust VR2 so that lissajous pattern displayed on oscilloscope becomes stationary (Fig. 16).
6. Set MPX SG to 67.5kHz deviation at 1kHz for left and right channels, and to 7.5kHz deviation for 19kHz pilot signal.
7. Adjust T5 core for minimum audio frequency distortion. Take care to turn core only within $\pm 180^\circ$.
8. Adjust VR3 for minimum signal leakage from R channel to L channel, and from L channel to R channel.

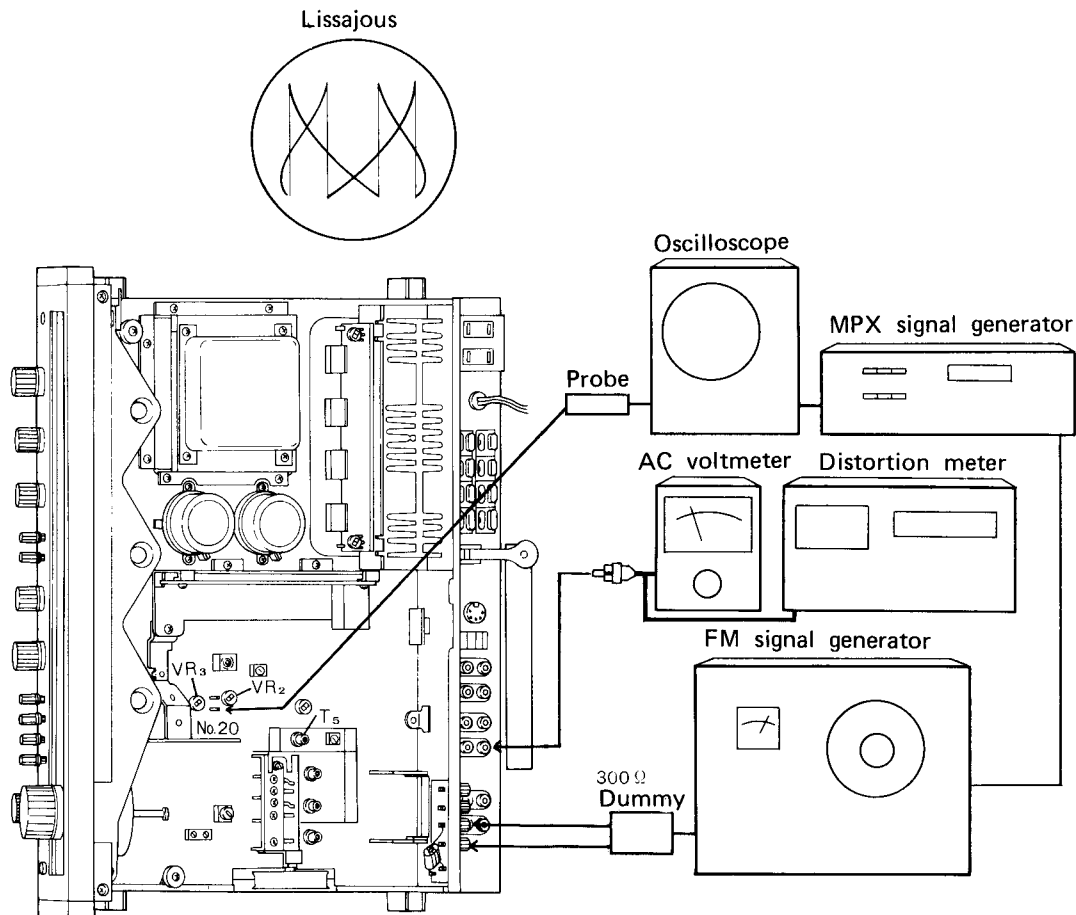

Fig. 16

6.4 POWER AMPLIFIER SECTION

Idle Current Adjustment

1. Connect DC voltmeter as shown in Fig. 17.
2. Do not connect load to speaker terminals. Set VOLUME control to minimum (fully counter-clockwise).
3. Turn VR1 and VR2 (shown in Fig. 17) fully counter-clockwise, then set POWER switch to ON.
4. 1~2 minutes after turning on the power, adjust VR3 (L channel) and VR4 (R channel) for 50mV indication on DC voltmeter.
5. 20 minutes after turning on the power, again adjust VR1 and VR2 for 30mV indication on DC voltmeter.

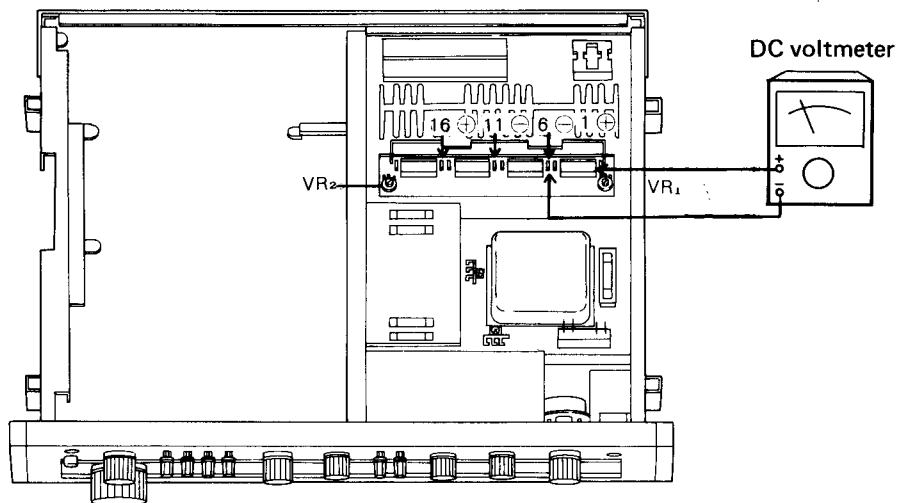

Fig. 17

7. DIAL CORD STRINGING

1. Remove the wooden cover and the front panel.
2. Turn tuning drum fully clockwise (as viewed from X direction in Fig. 18).
3. Tie one end of cord to stud on inner section of tuning drum (more easily performed by loosening setscrew and temporarily removing tuning drum from shaft).
4. Route cord through tuning drum cutout, make a half turn around the drum, then route in sequence to pulley A—dial pointer—pulley B—pulley C.
5. Wind cord 3 turns clockwise (as viewed from rear panel) around tuning shaft, then route to pulley D.
6. Wind cord two turns around tuning drum and tie to spring hook so that tension is applied to the cord.
7. Turn TUNING knob and confirm normal cord motion, then trim off excess cord.
8. With tuning drum at step 1 setting, restrain cord from moving and slip dial pointer on cord. Align it with the starting point (extreme left end of frequency scale).

Dial Pointer Installation Caution

Metal portion of dial pointer is plated. If this section is touched directly by hand or fingerprints and other impurities, it is difficult to remove dirt from aventurine finish. As this is not desirable in terms of both appearance and anticorrosion, take extreme care not to touch the metal section when handling the dial pointer.

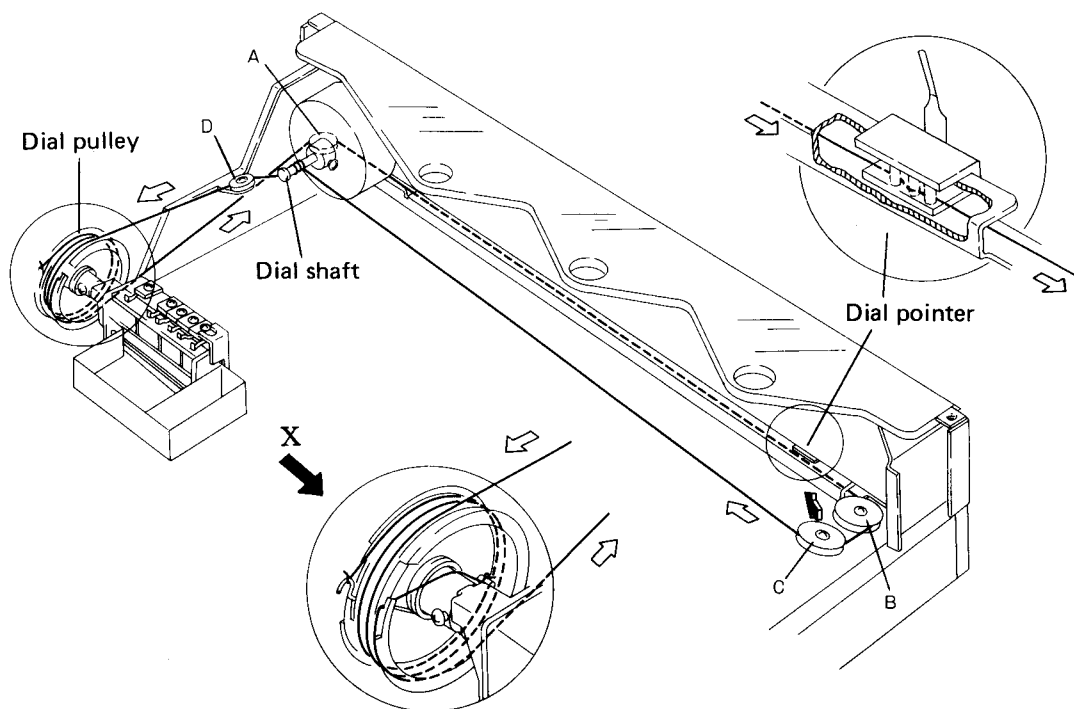
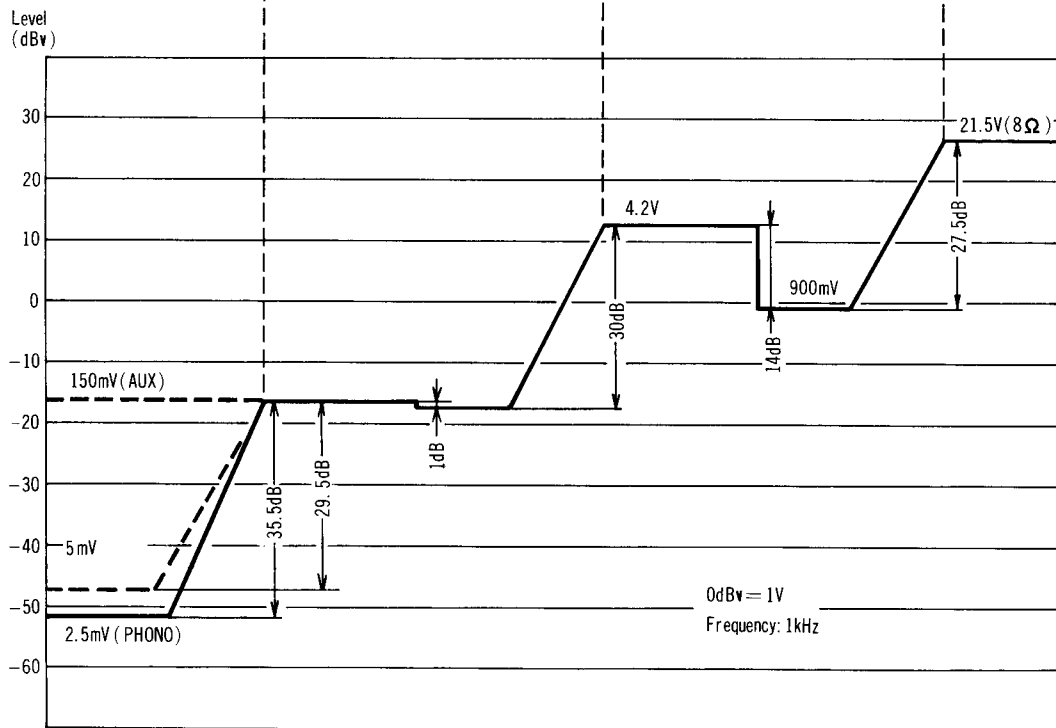
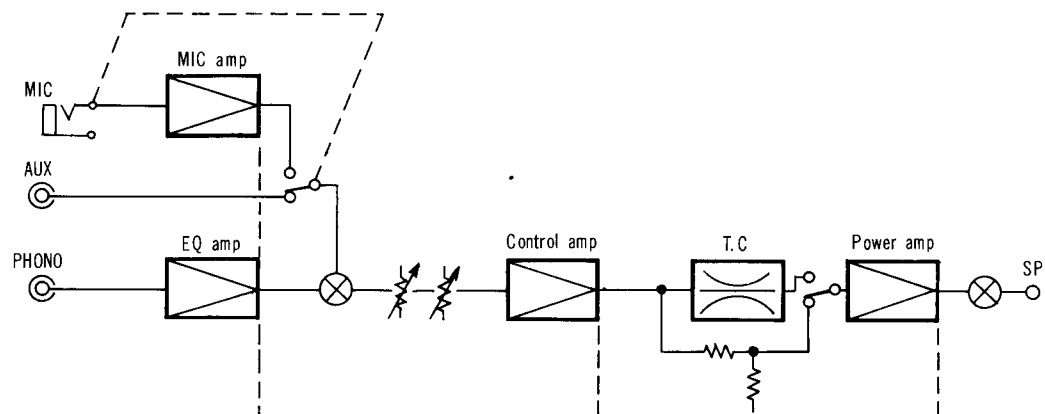

Fig. 18

8. LEVEL DIAGRAM



9. DISASSEMBLY

Top Cover (Fig. 19)

Take out 2 screws each at left and right (total 4 screws) to remove.

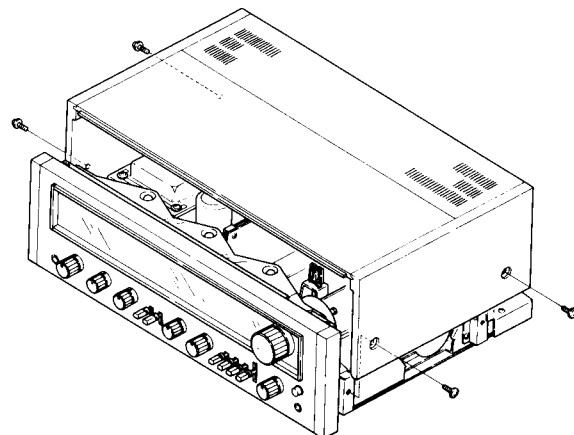

Fig. 19

Bottom Plate (Fig. 20)

Take out screws ①~⑪ to remove.

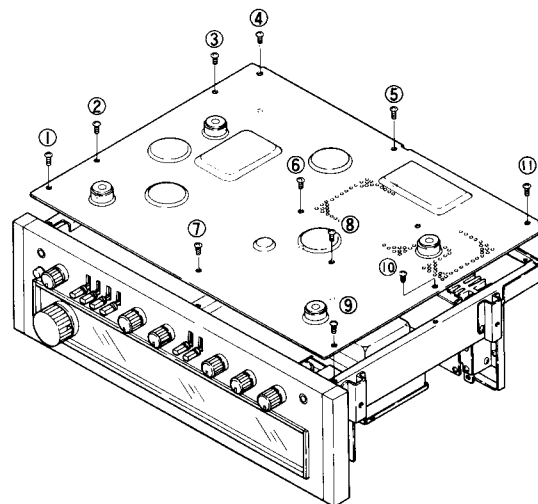

Fig. 20

Front Panel (Fig. 21)

Pull off all knobs and remove shaft nuts of SPEAKERS and FUNCTION switches. Front panel can then be removed by taking out screws ⑫ & ⑬.

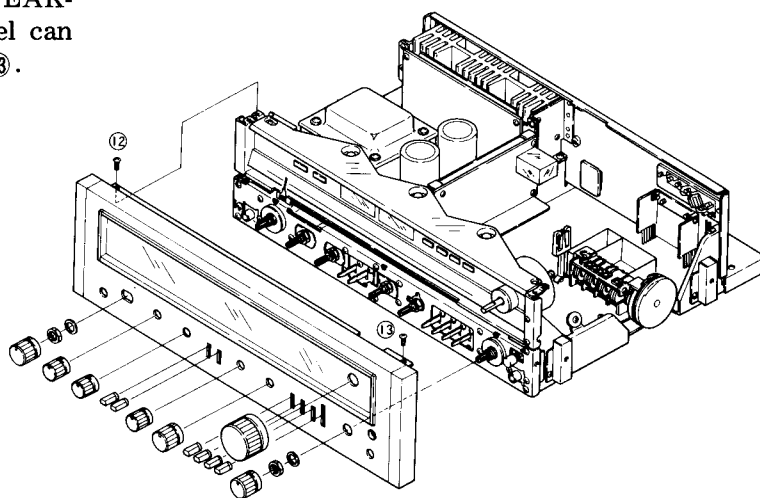
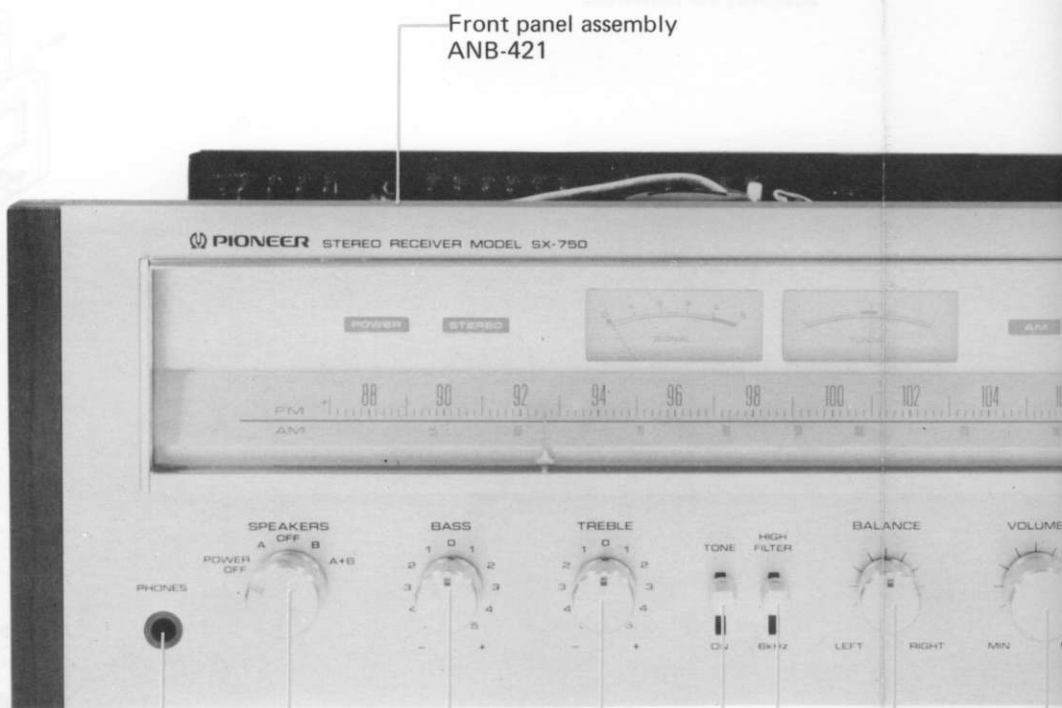

Fig. 21

10. PARTS LOCATION

10.1 FRONT PANEL VIEW



Front panel assembly
ANB-421

Phone jack (Head phone)
AKN-010

Knob (SPEAKERS)
AAB-100

Knob (BASS)
AAB-099

Knob (TREBLE)
AAB-099

Knob (TONE)
AAD-013

Knob (HIGH FILTER)
AAD-013

Knob (BALANCE)
AAB-099

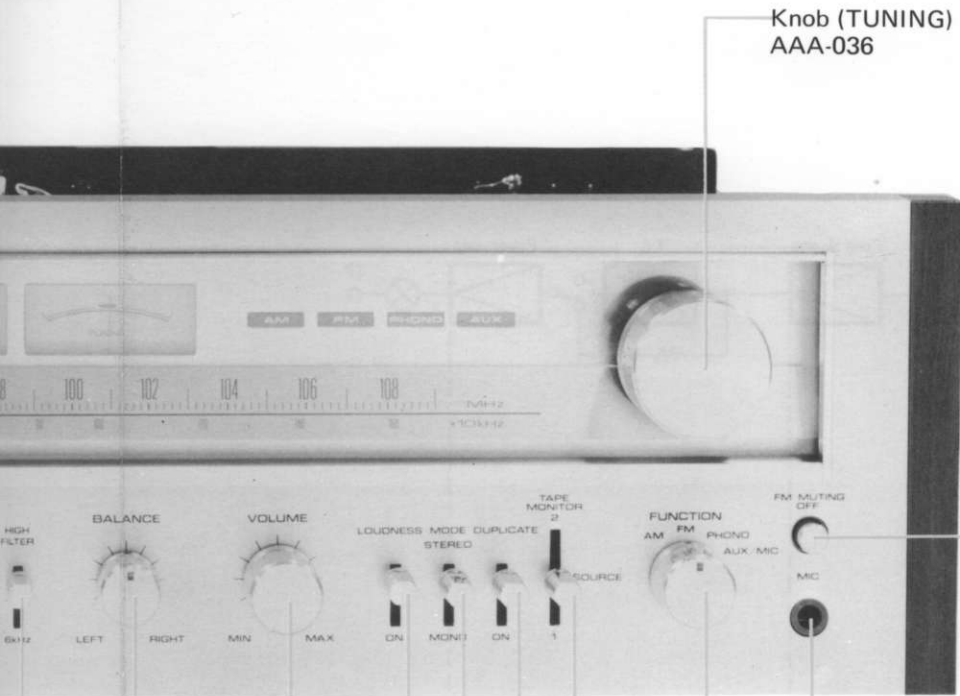

Knob (TUNING)
AAA-036

Knob (FM MUTING)
AAD-112

Phone jack (MIC)
AKN-013

Knob (FUNCTION)
AAB-100

Knob (TAPE MONITOR)
AAD-013

Knob (DUPLICATE)
AAD-013

Knob (MODE)
AAD-013

Knob (LOUDNESS)
AAD-013

Knob (VOLUME)
AAB-100

NCE)

10.2 FRONT PANEL VIEW (with removed Front panel)

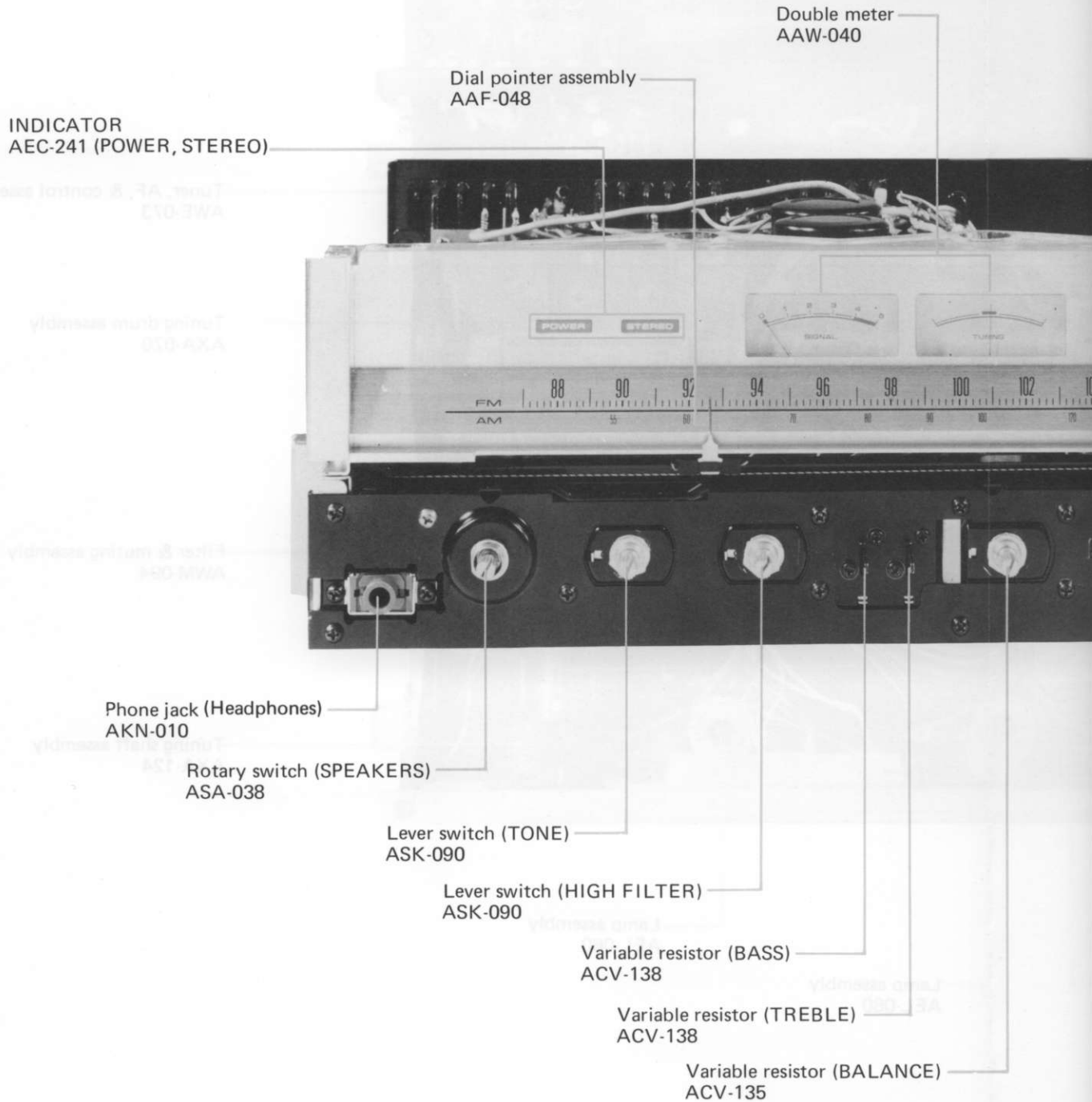

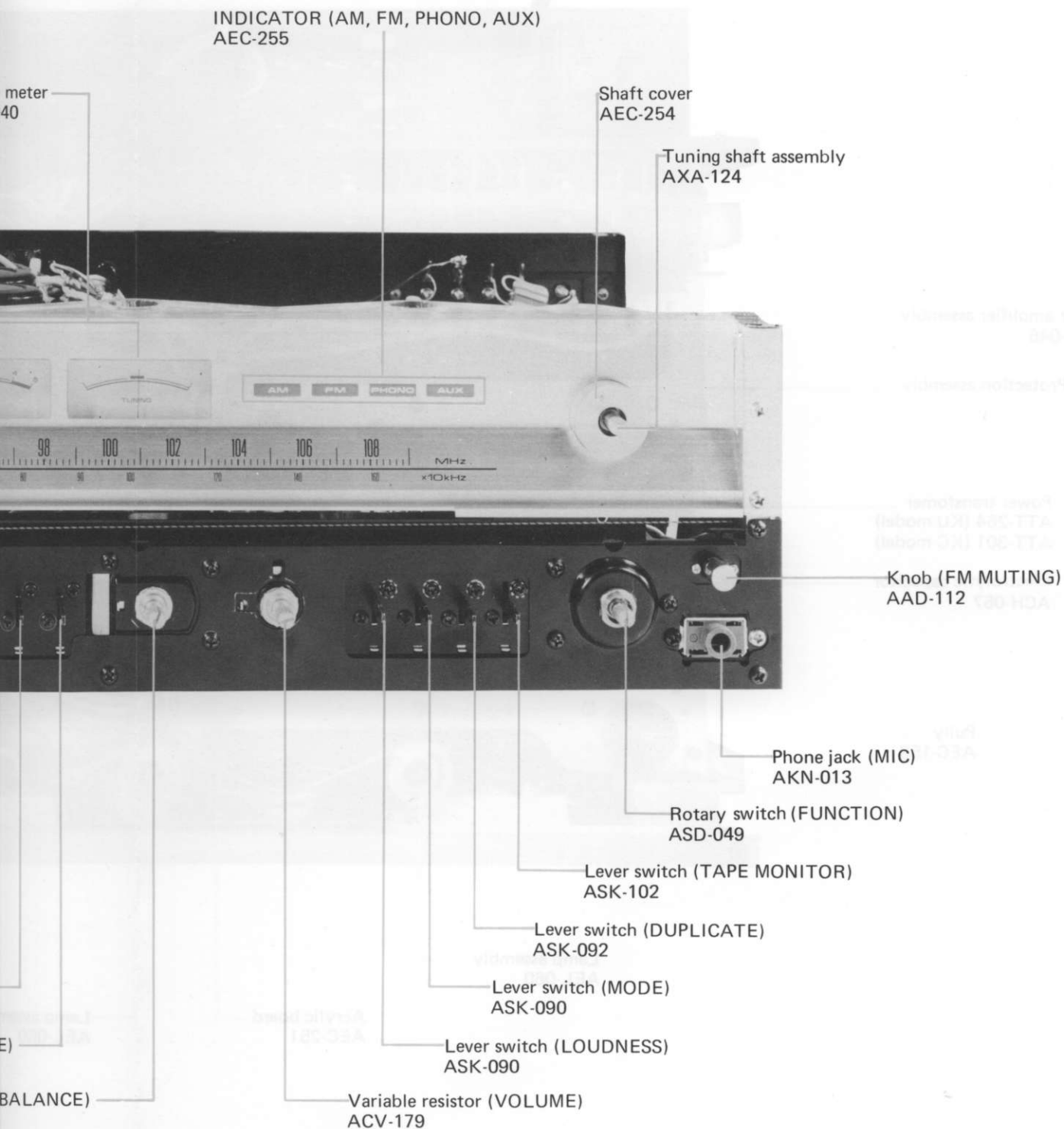

10.3 TOP VIEW

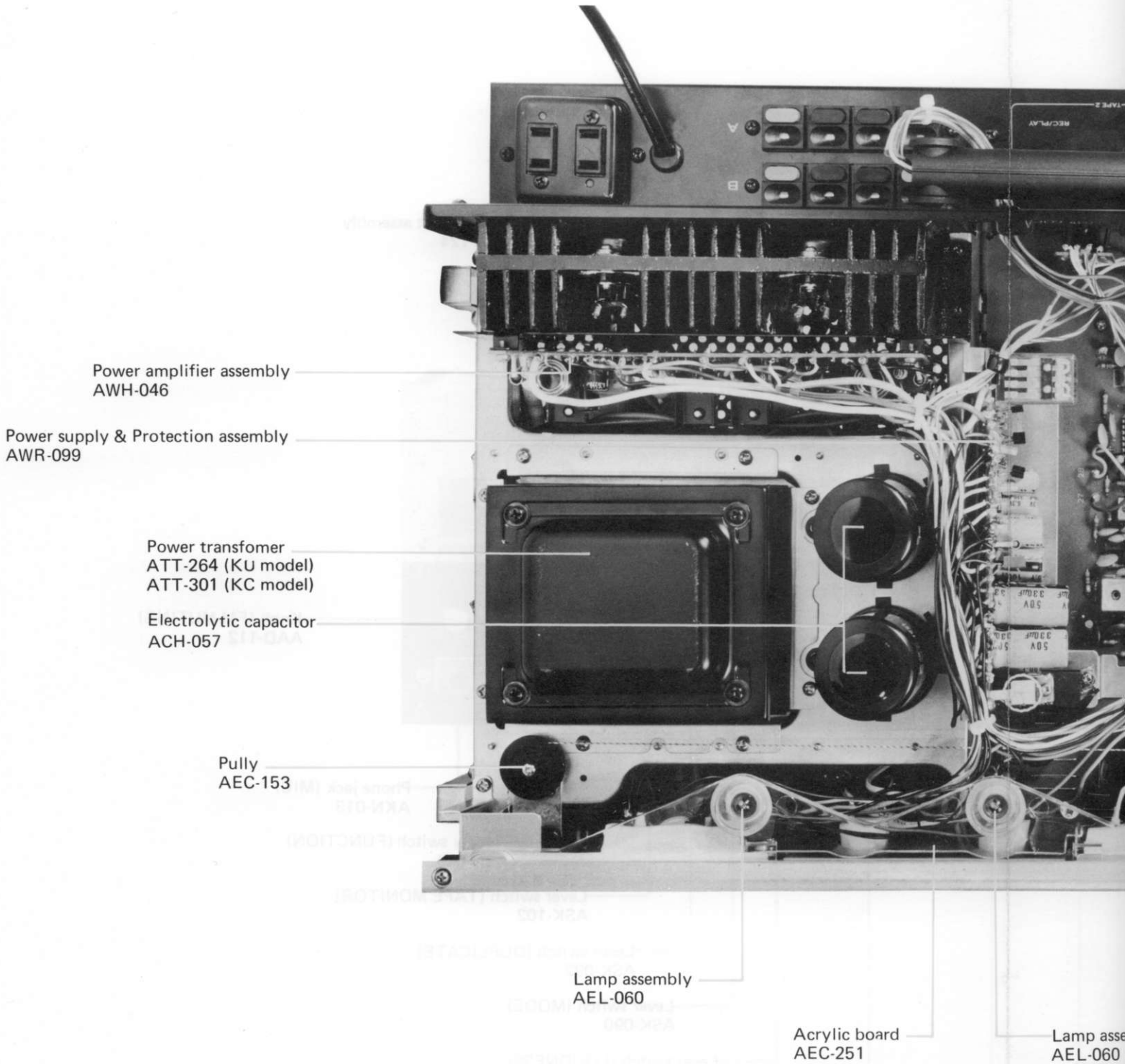

Power amplifier assembly
AWH-046

Power supply & Protection assembly
AWR-099

Power transformer
ATT-264 (KU model)
ATT-301 (KC model)

Electrolytic capacitor
ACH-057

Pully
AEC-153

Lamp assembly
AEL-060

Acrylic board
AEC-251

Lamp asse
AEL-060

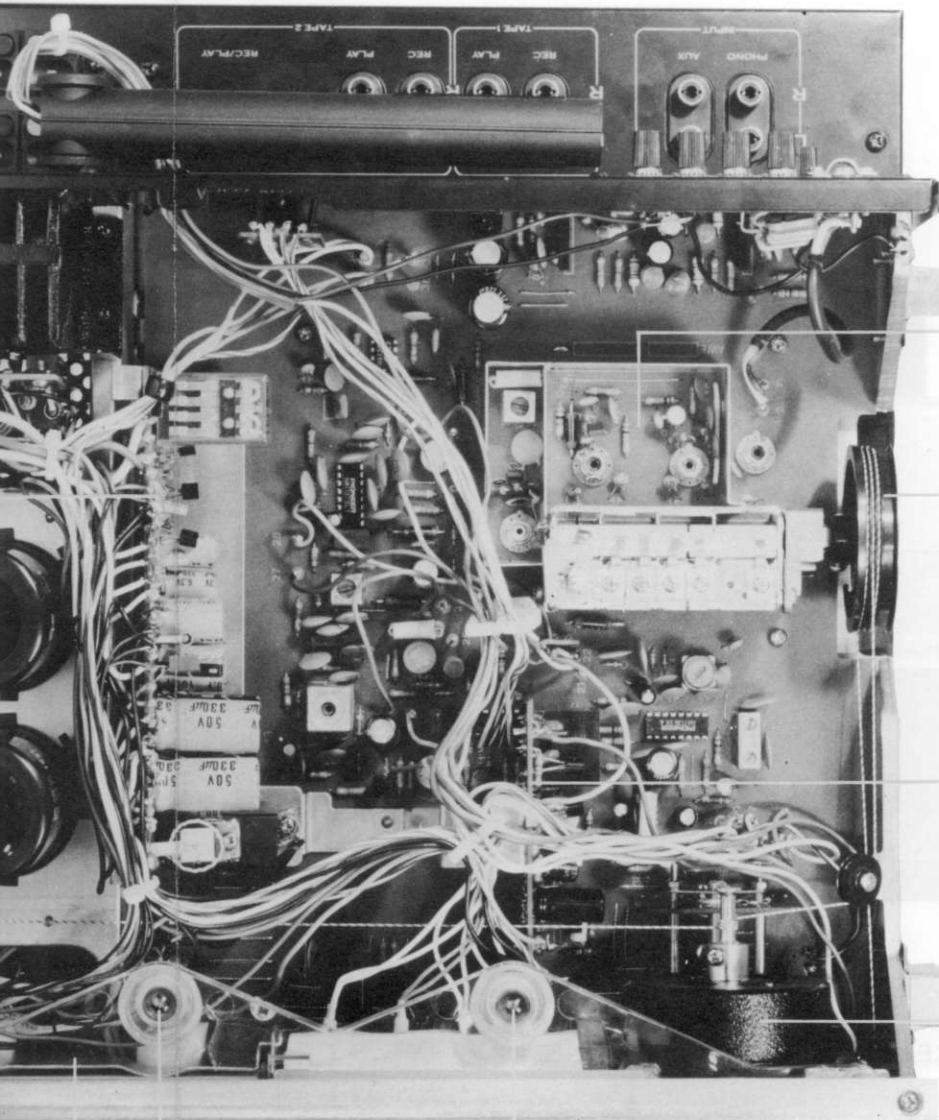

Tuner, AF, & control assembly
AWE-073

Tuning drum assembly
AXA-070

Filter & muting assembly
AWM-094

Tuning shaft assembly
AXA-124

Lamp assembly
AEL-060

Lamp assembly
AEL-060

10.4 BOTTOM

Tone control assembly
AWG-046

Rotary switch (SPEAKER)
ASA-038

Cover

Capacitor

Power transformer
ATT-264

Power supply assembly
AWR-100

Power amplifier assembly
AWH-046

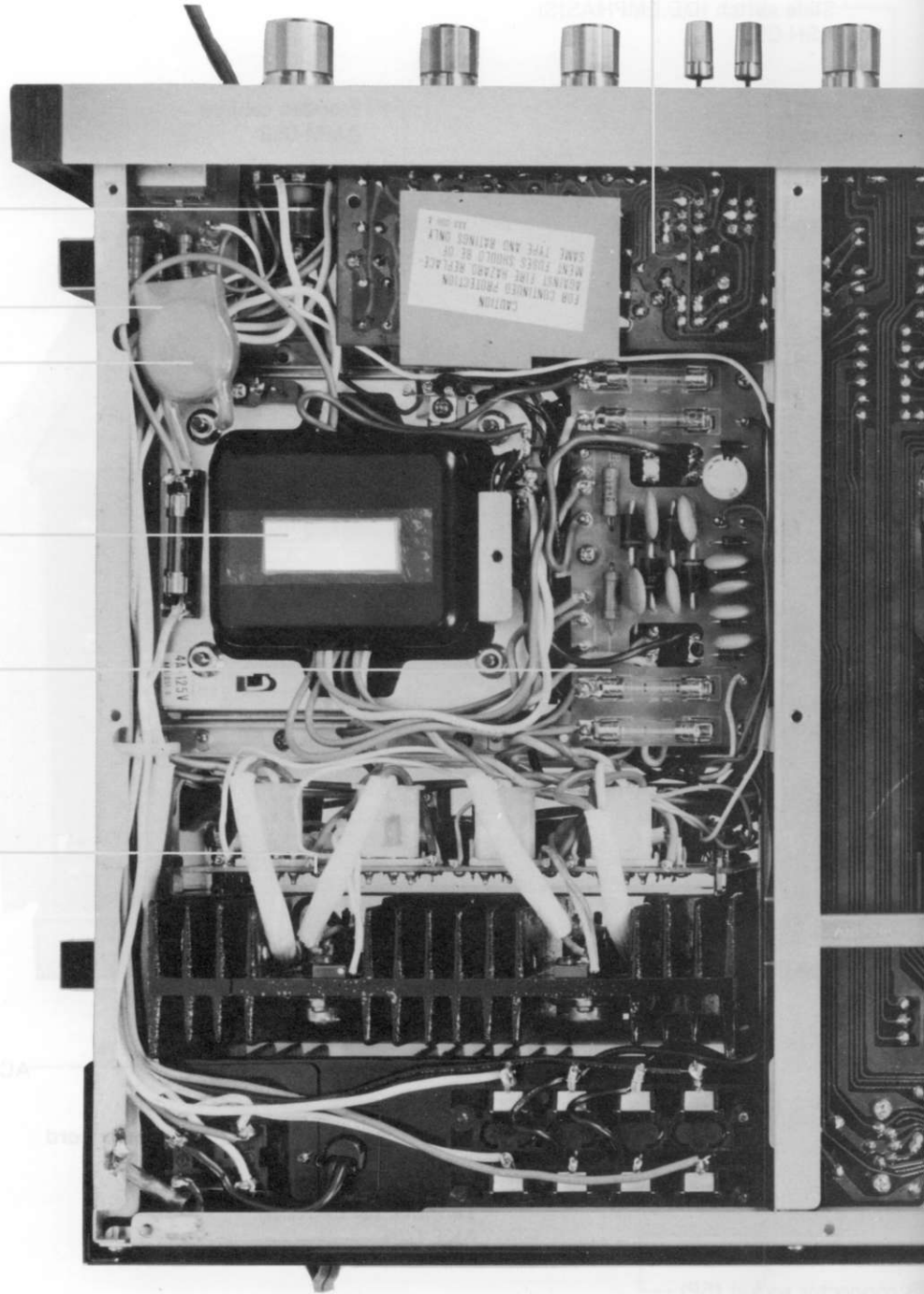

Tone control assembly
AWG-046

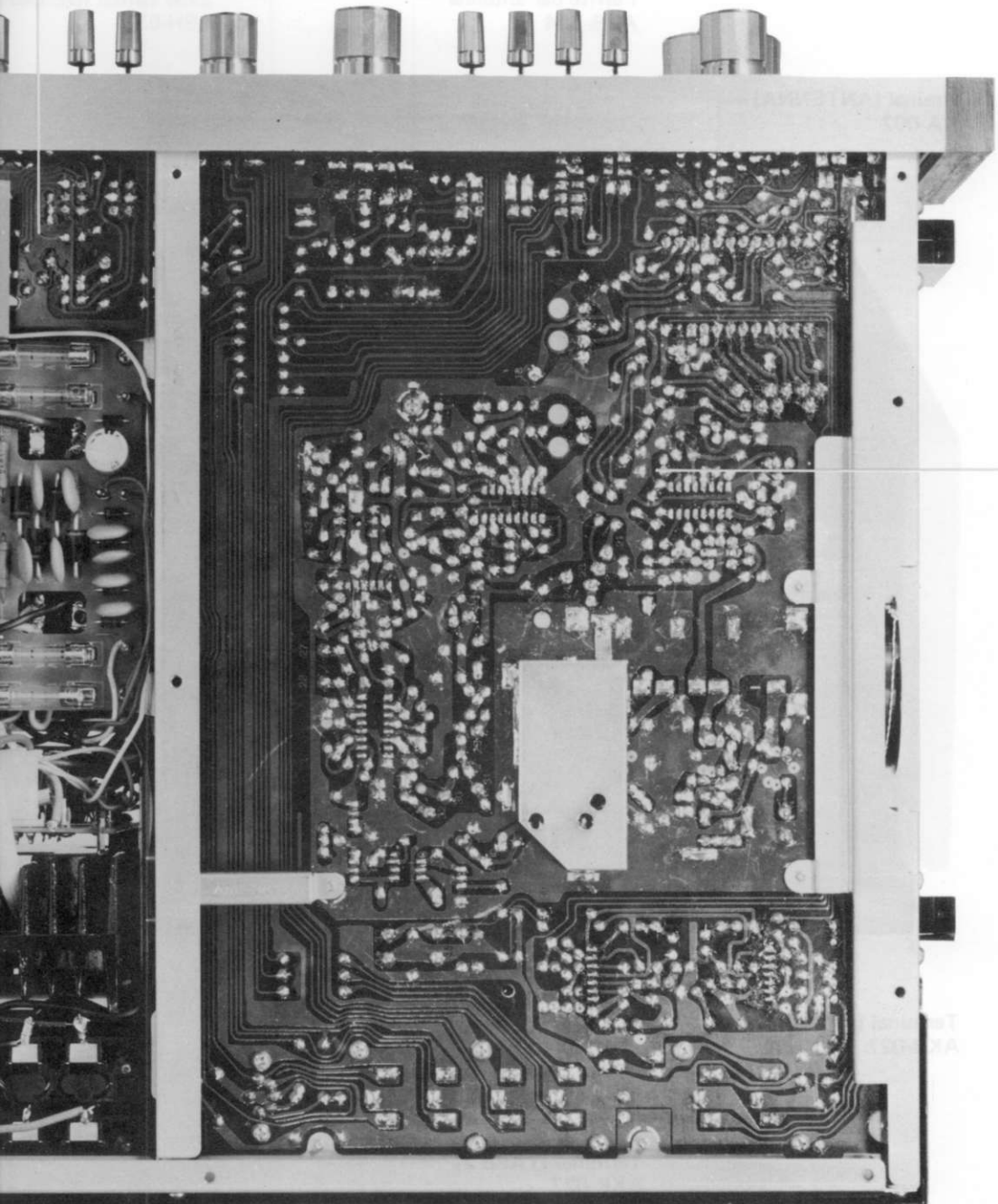

Tuner, AF & control assembly
AWE-073

10.5 REAR VIEW

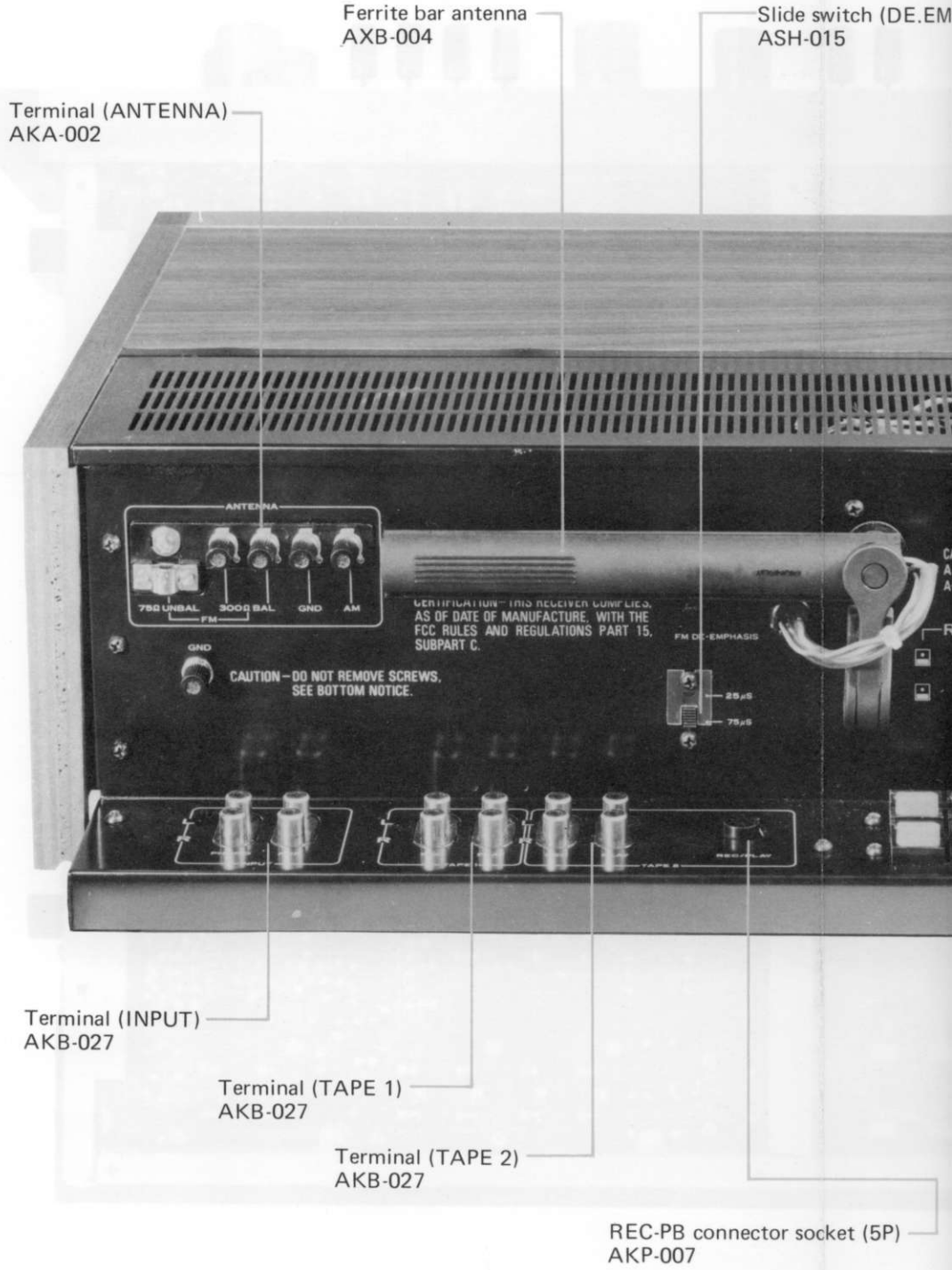

Slide switch (DE.EMPHASIS)
ASH-015

Wooden cabinet
AMM-053

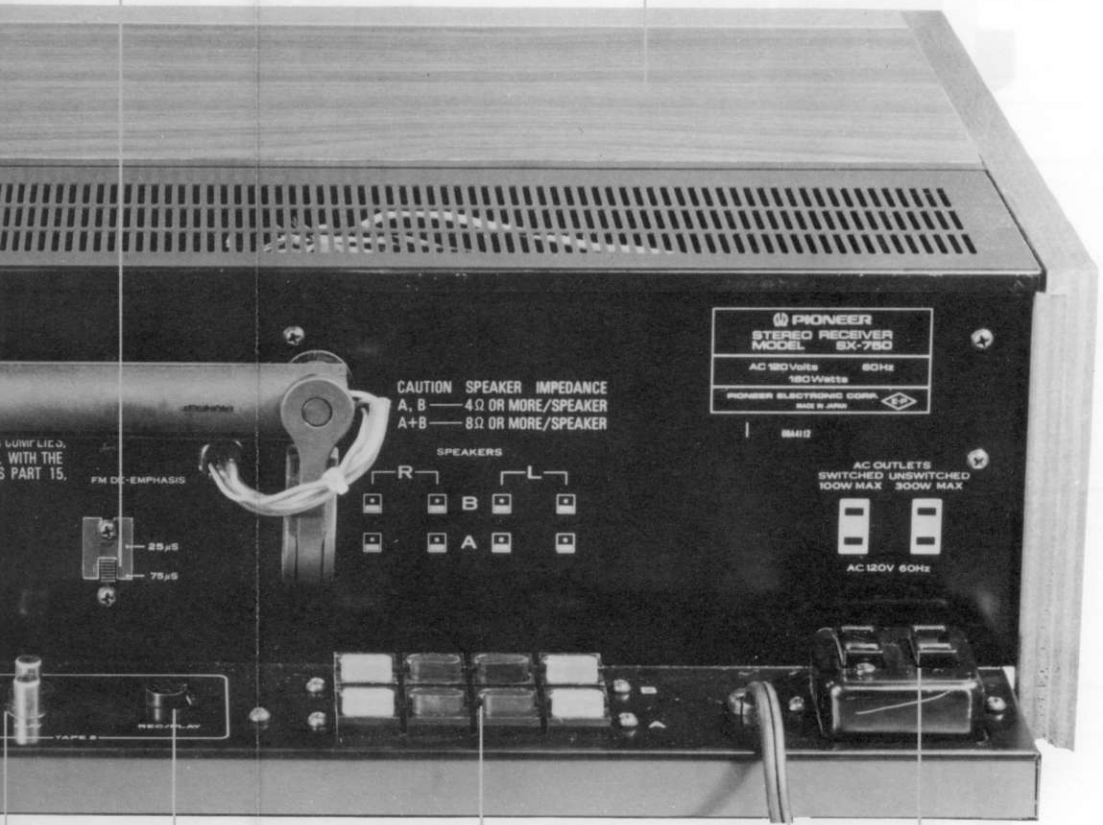

AC socket cover

AC power cord
ADG-005

Terminal (SPEAKER)
AKE-029

REC-PB connector socket (5P)
AKP-007

11. EXPLODED VIEW

A
B
C
D

1 2 3

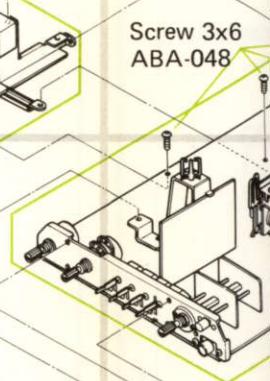
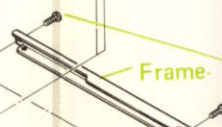
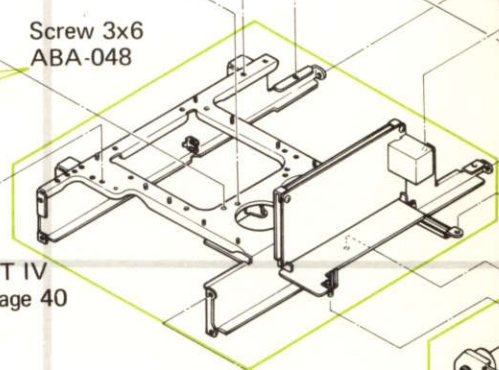
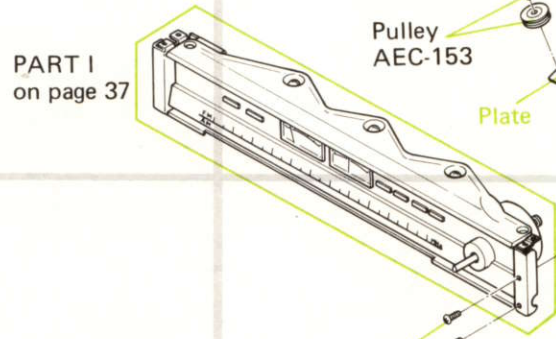
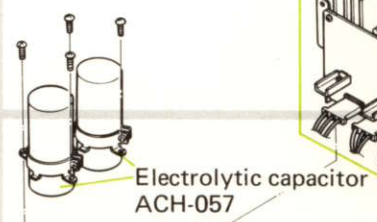
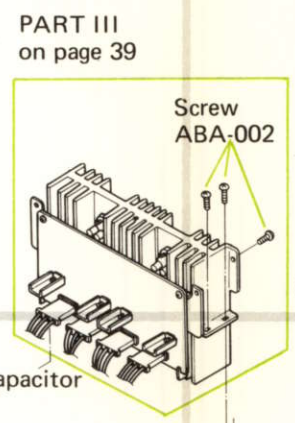
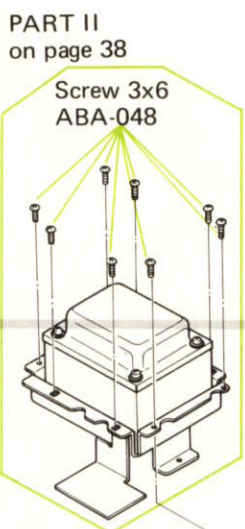

PART IV
on page 40

PART VI
on page 42

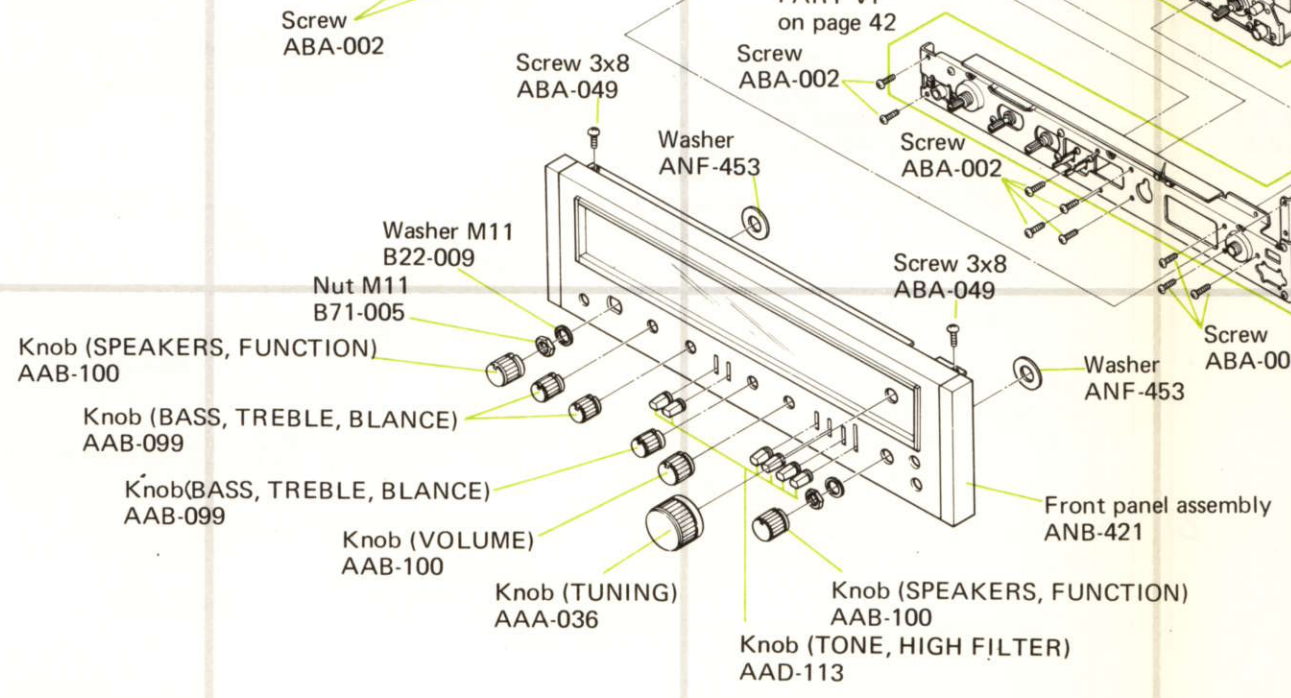

1 2 3

4

5

6

NOTE:

Parts indicated in green type cannot be supplied.

A

B

C

D

PART III
on page 39

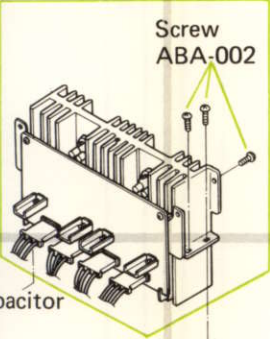

Screw 4x15
ABA-113

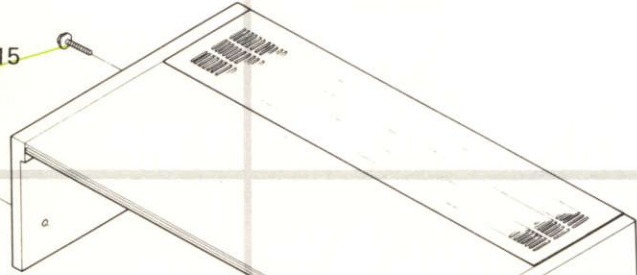

Frame

Screw 3x6
ABA-048

Wooden cabinet
AMM-053

Screw 4x15
ABA-113

Screw 3x6
ABA-048

Screw 3x6
ABA-048

Screw
ABA-002

PART V
on page 41

Screw
ABA-002
PART VII
on page 43

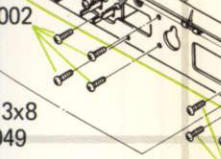

Screw
ABA-002

Screw
ABA-012

Bottom cover

Screw
ABA-012

Screw
ABA-012

Foot
AEC-083

Foot
AEC-083

(KERS, FUNCTION)
FILTER)

Screw
ABA-012

Foot
AEC-083

Screw
ABA-012

Screw
ABA-012

4

5

6

11.1 PART I

NOTE:

Parts indicated in green type cannot be supplied.

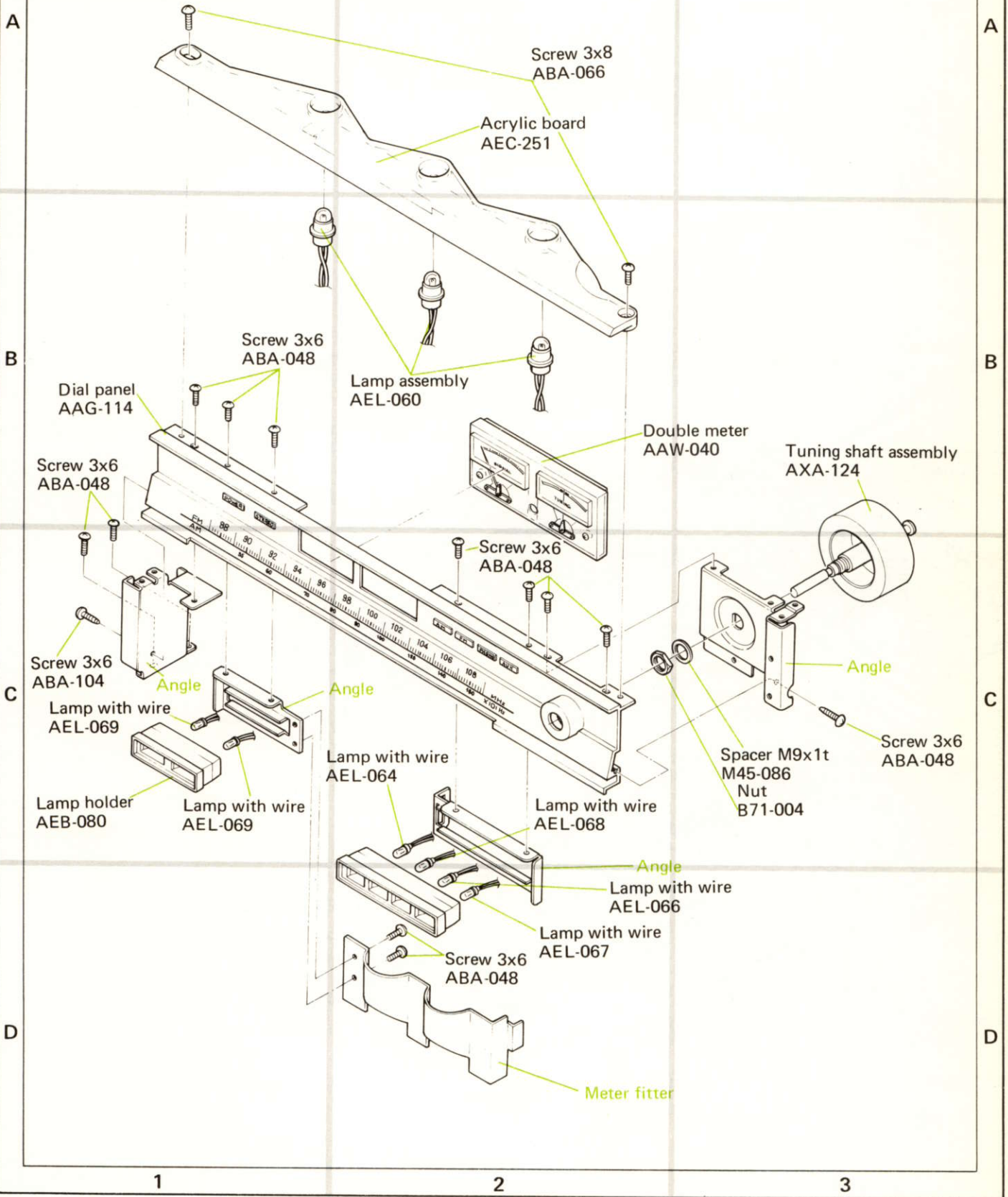

11.2 PART II

NOTE:

Parts indicated in green type cannot be supplied.

A

A

B

B

C

C

D

D

1

2

3

1

2

3

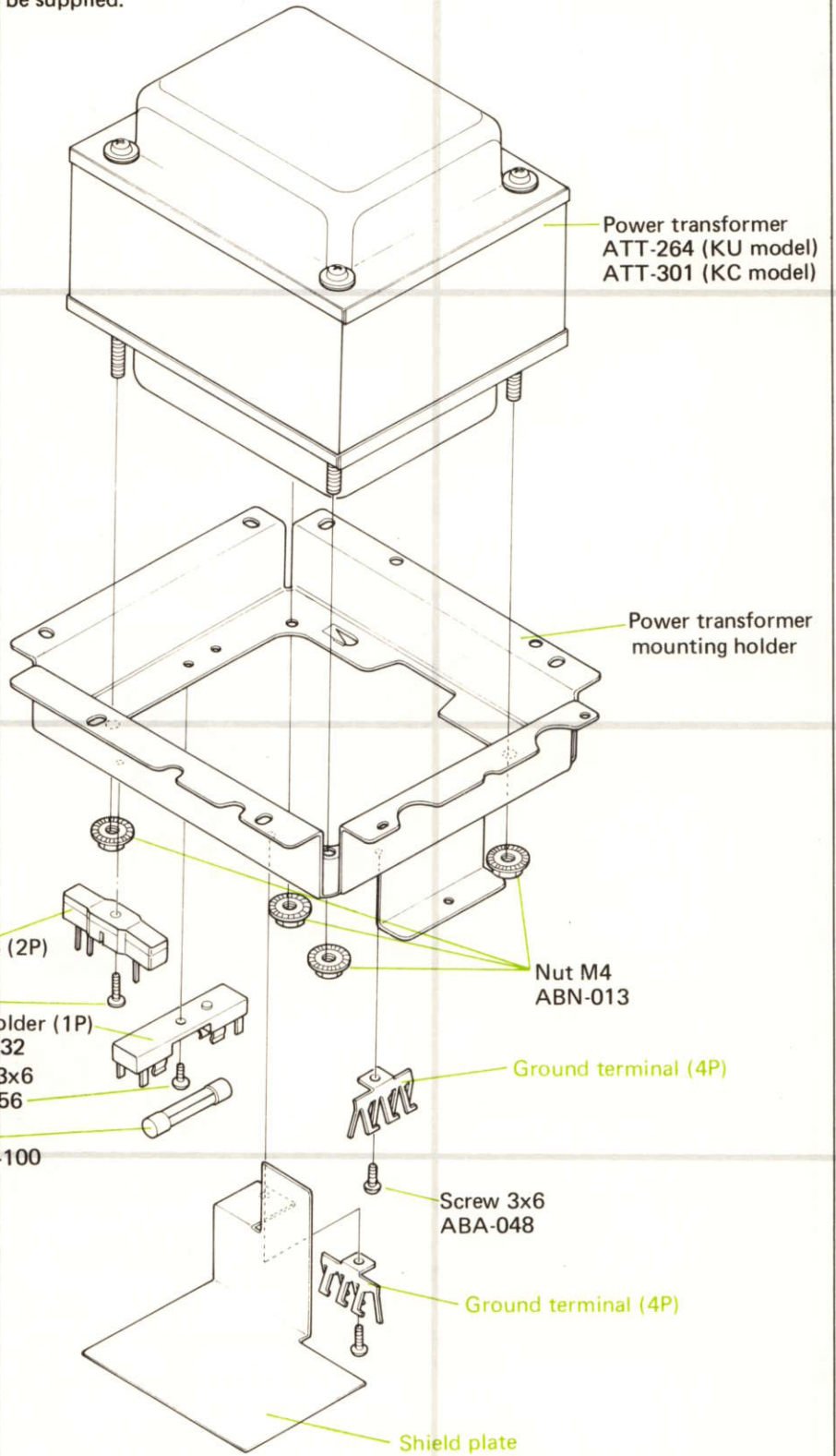

Power transformer
ATT-264 (KU model)
ATT-301 (KC model)

Power transformer
mounting holder

Terminal strip (2P)
AKC-030
Screw 3x6
ABA-048

Fuse holder (1P)
AKR-032
Screw 3x6
ABA-056

Fuse
AEK-100

Nut M4
ABN-013

Ground terminal (4P)

Screw 3x6
ABA-048

Ground terminal (4P)

Shield plate

11.3 PART III

NOTE:
Parts indicated in green type cannot be supplied.

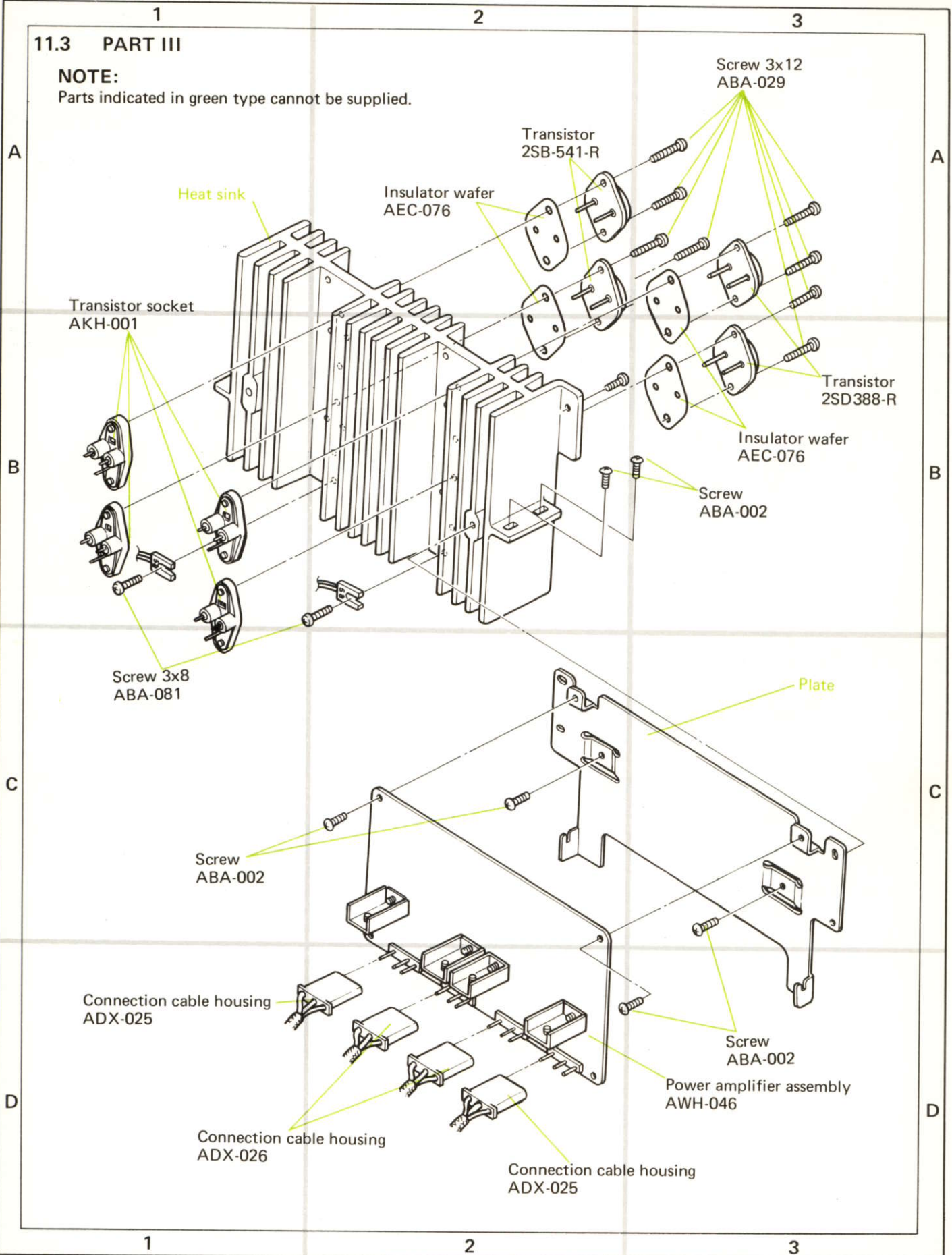

11.4 PART IV

NOTE:

Parts indicated in green type cannot be supplied.

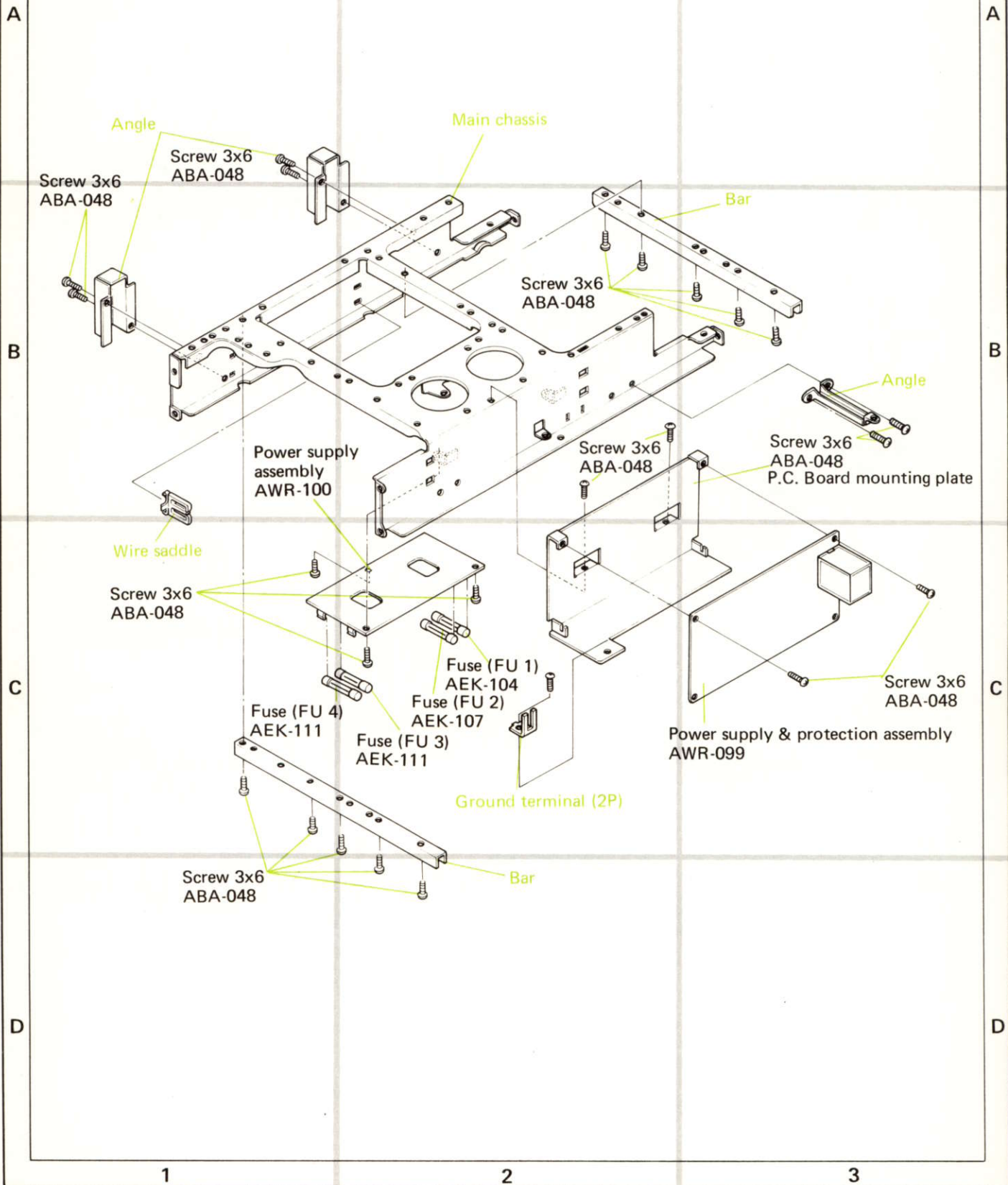

11.5 PART V

NOTE:

Parts indicated in green type cannot be supplied.

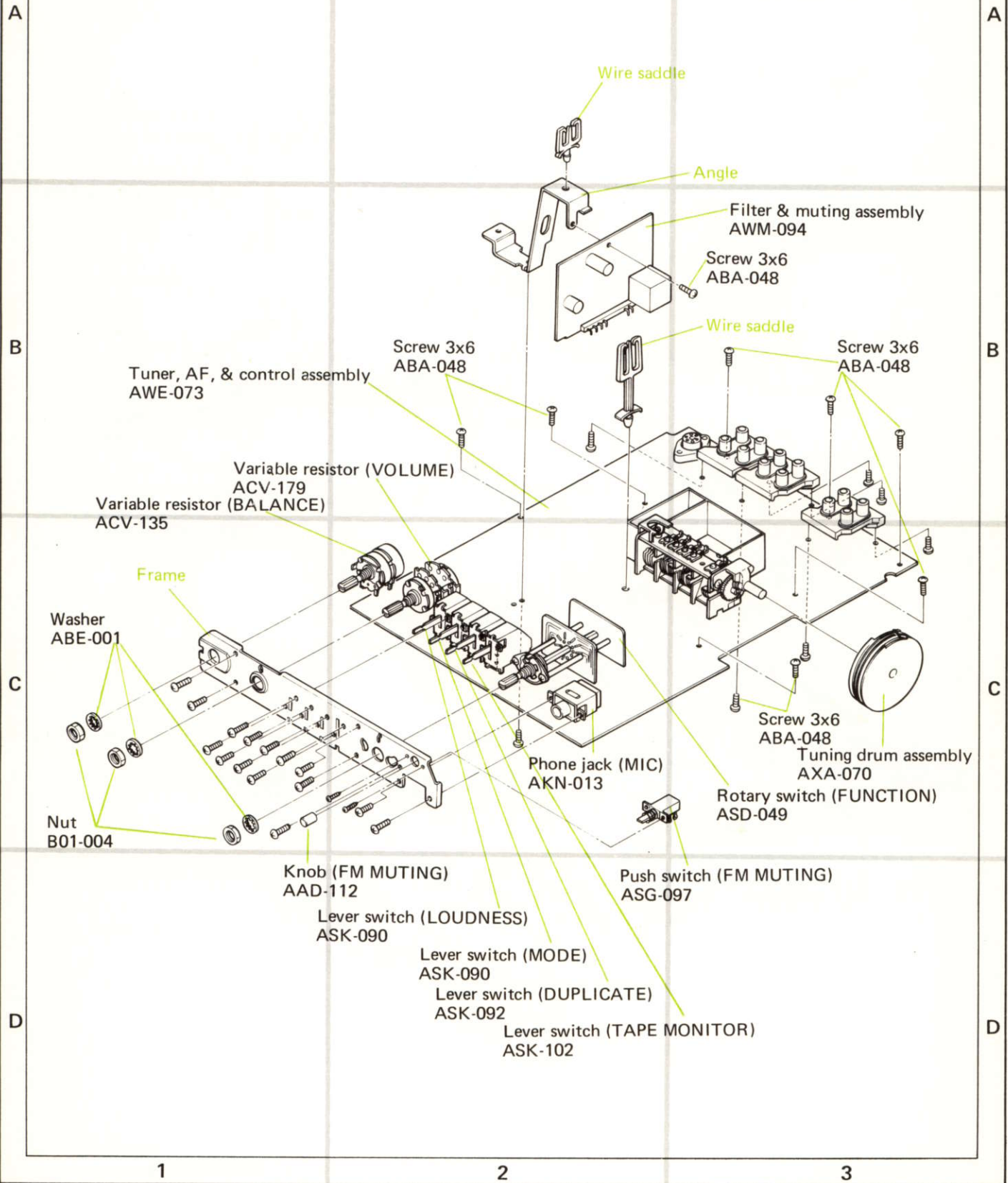

11.6 PART VI

NOTE:

Parts indicated in green type cannot be supplied.

A

B

C

D

1

2

3

A

B

C

D

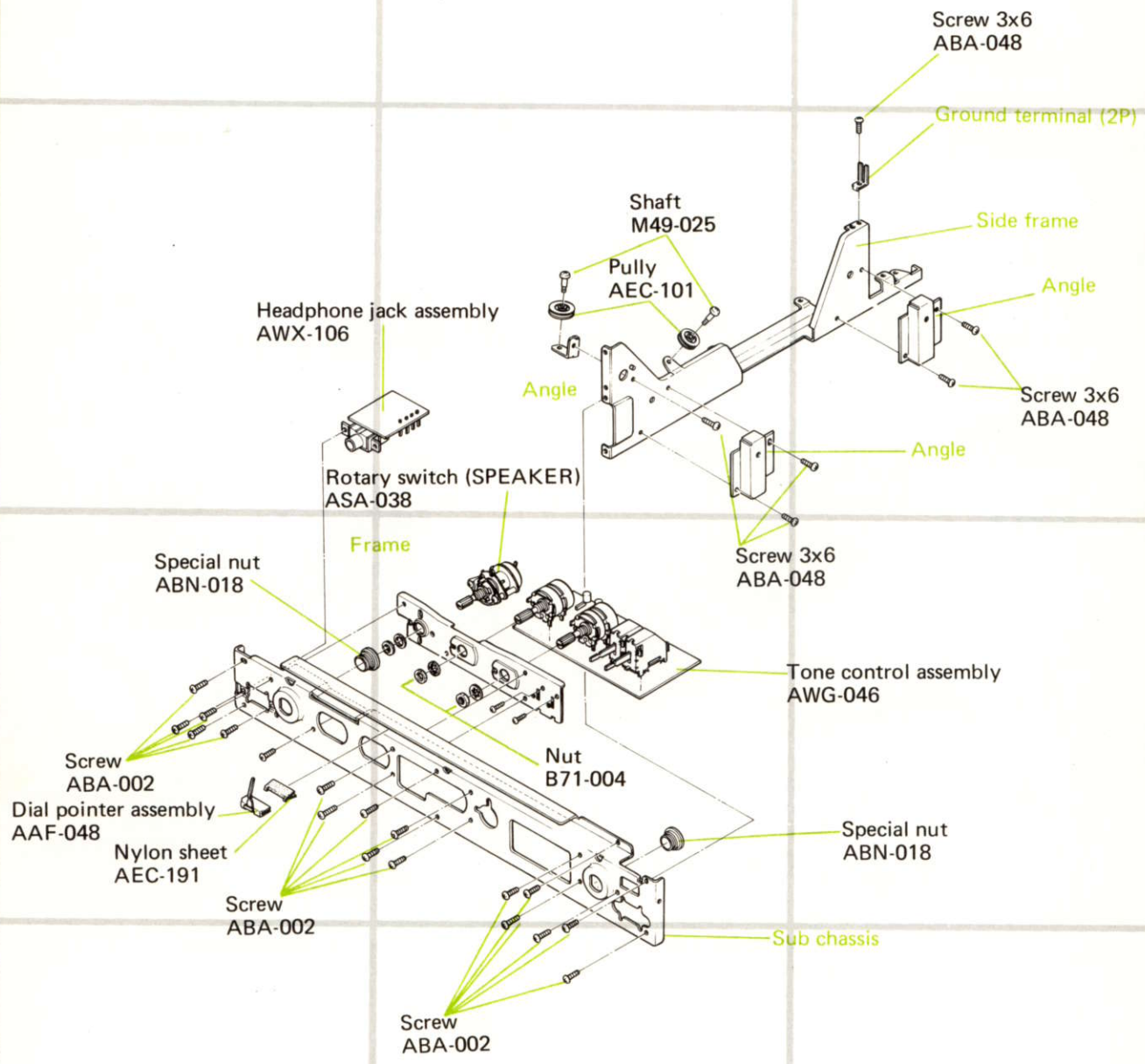

11.7 PART VII

NOTE:

Parts indicated in green type cannot be supplied.

Although there are some units in the SX-750 series which do not contain green line encircled components, this is not an error.

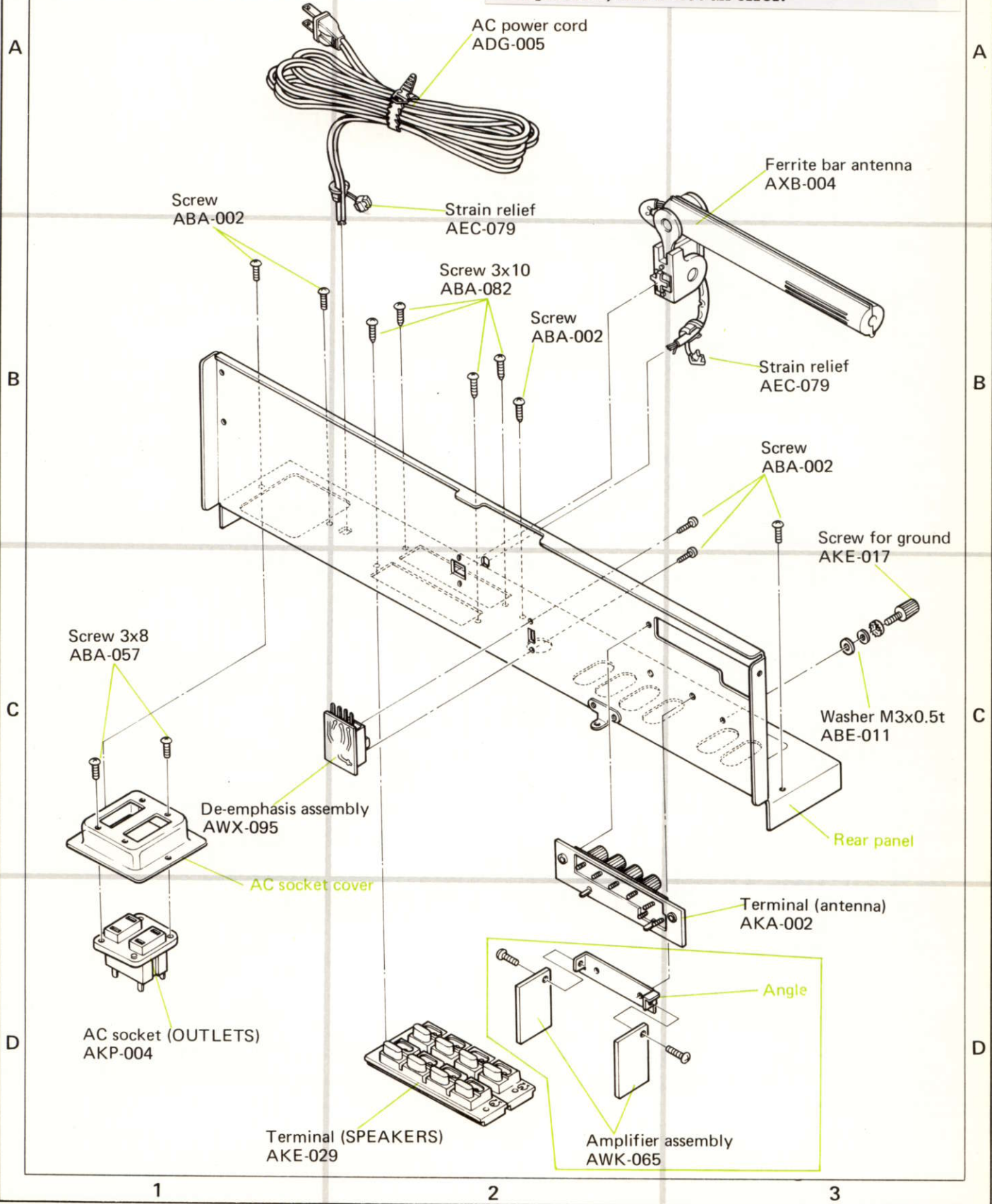

11.8 PACKING

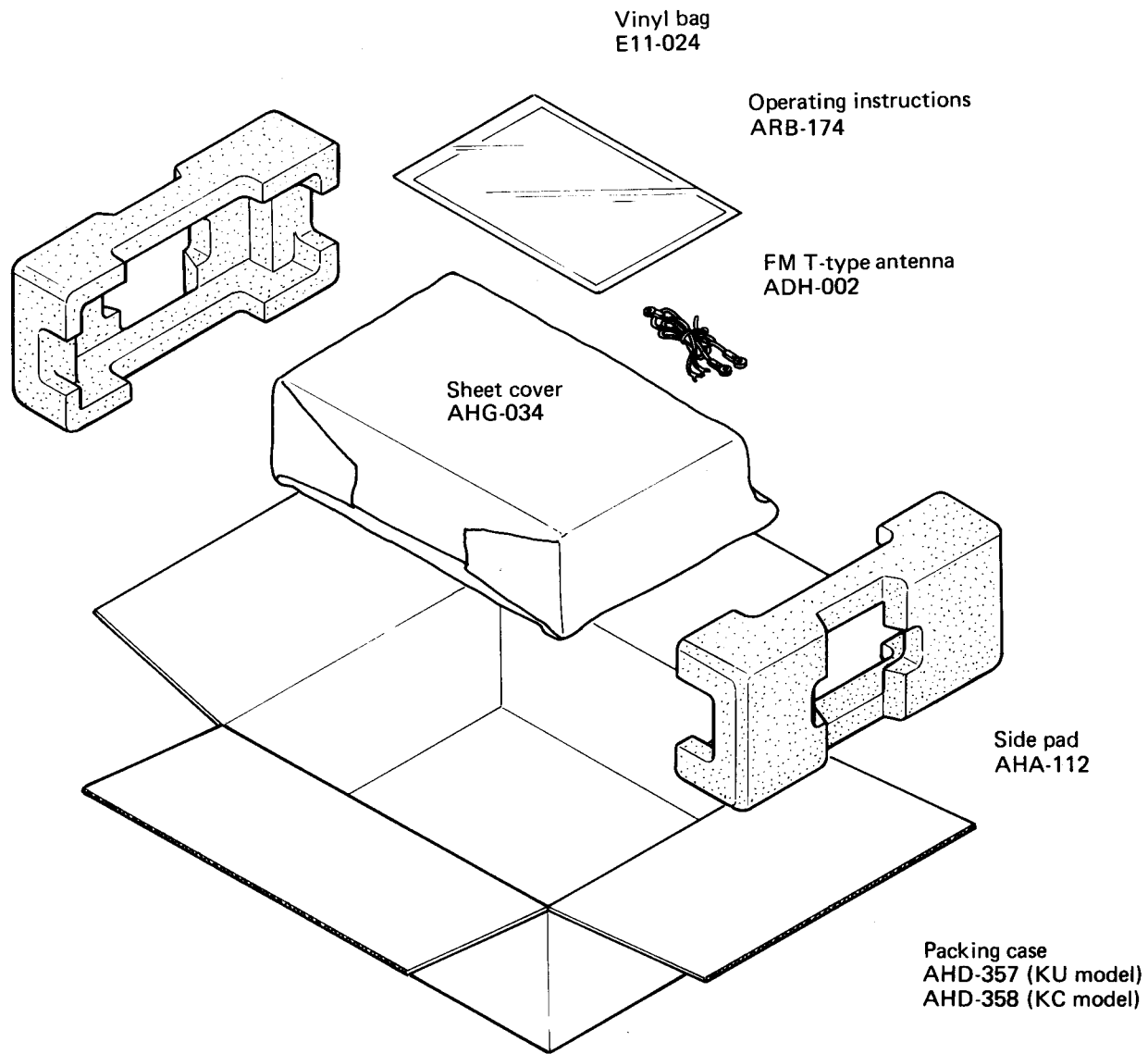

12. SCHEMATIC DIAGRAMS. P.C. BOARD PATTERNS AND PARTS

12.1 SCHEMATIC DIAGRAMS

A

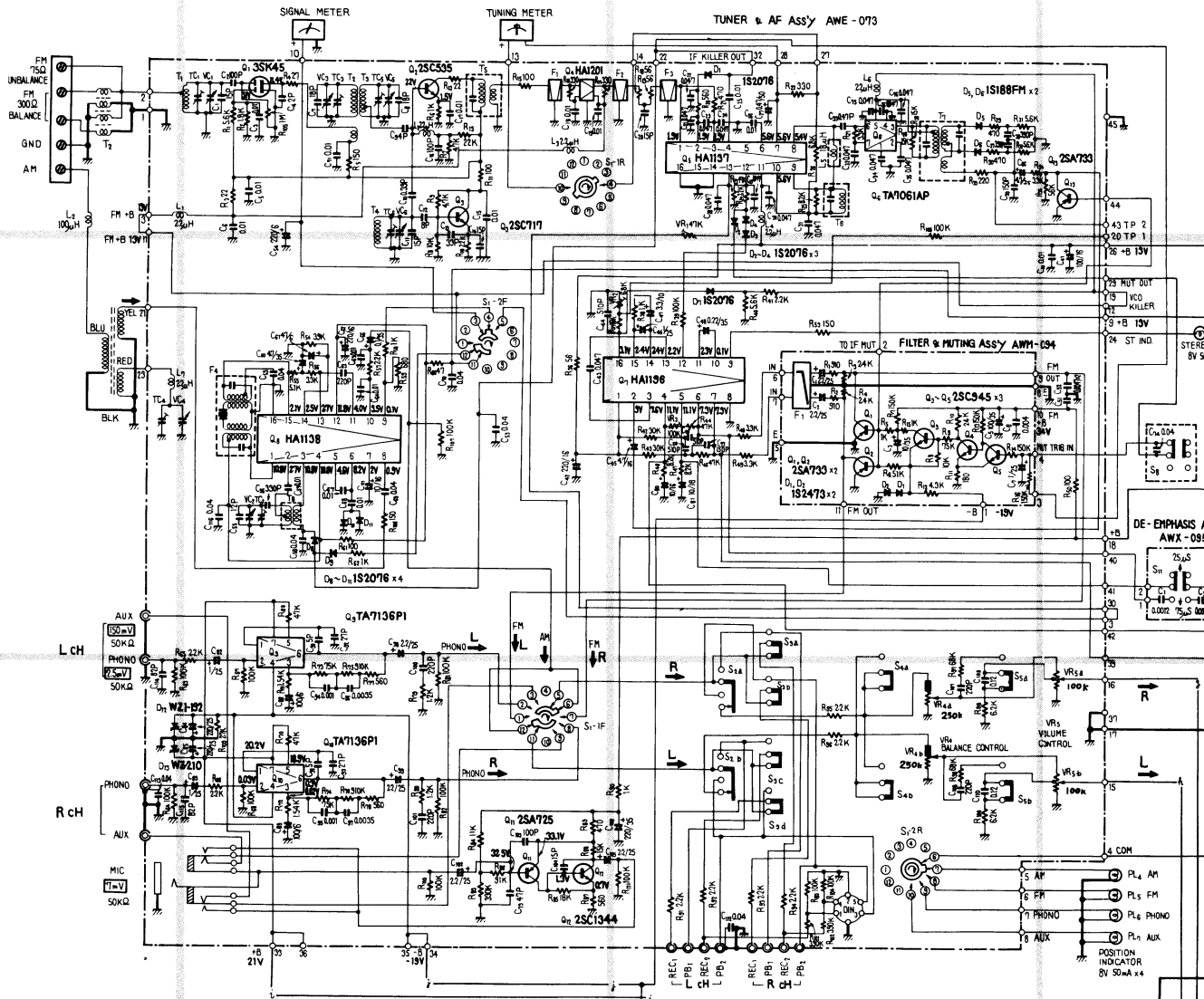

B

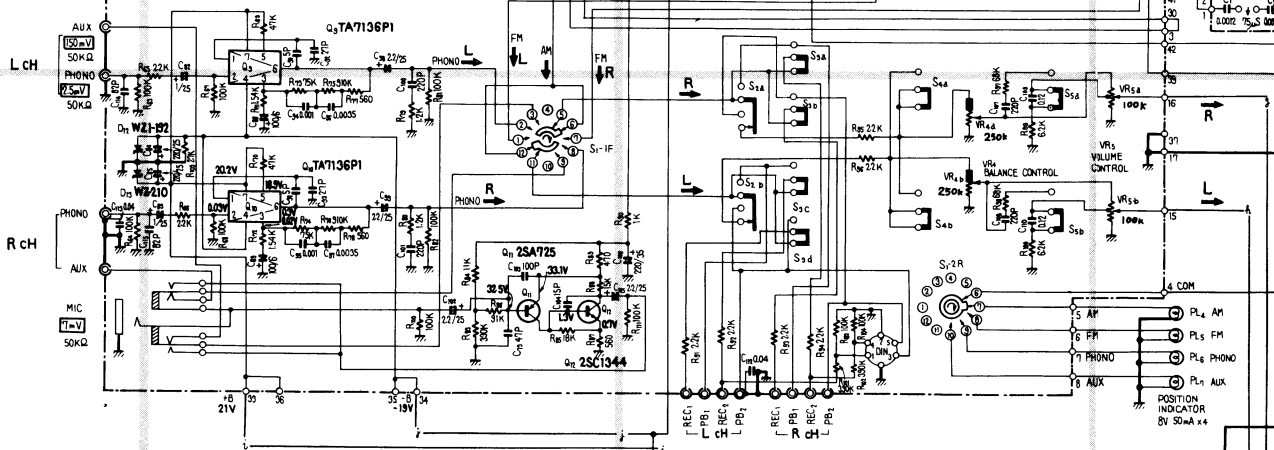

C

- SWITCHES:**
- | | | |
|--|--|---|
| S ₁ FUNCTION:
1 AM
2 FM
3 PHONO
4 AUX/MIC | S ₄ MODE
STEREO → MONO | S ₉ RELAY
1 POWER OFF
2 SP A
3 SP OFF
4 SP B
5 SP A+B |
| S ₂ TAPE MONITOR
1 OFF → 2 | S ₅ LOUDNESS
OFF → ON | S ₁₁ DE-EMPHASIS
25µS → 13µS F |
| S ₃ DUPLICATE
OFF → ON | S ₆ TONE
OFF → ON | |
| | S ₇ HIGH FILTER
OFF → ON | |
| | S ₈ FM MUTING
ON → OFF | |

RESISTORS:
IN OHM, 1/4W, ±5% TOLERANCE UNLESS OTHERWISE NOTED K: KΩ M: MΩ

CAPACITORS:
IN µF UNLESS OTHERWISE NOTED P: pF

NOTES:
 [V] : SIGNAL VOLTAGE NECESSARY FOR OBTAINING 50W/Ω OUTPUT POWER (1KHz)
 [V] : DC VOLTAGE AT NO INPUT SIGNAL
 [mA] : DC CURRENT AT NO INPUT SIGNAL

D

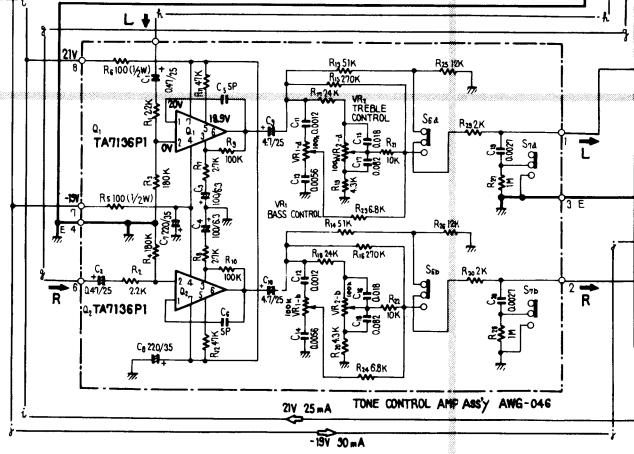

1

2

3

PARTS AND PARTS LIST

0793

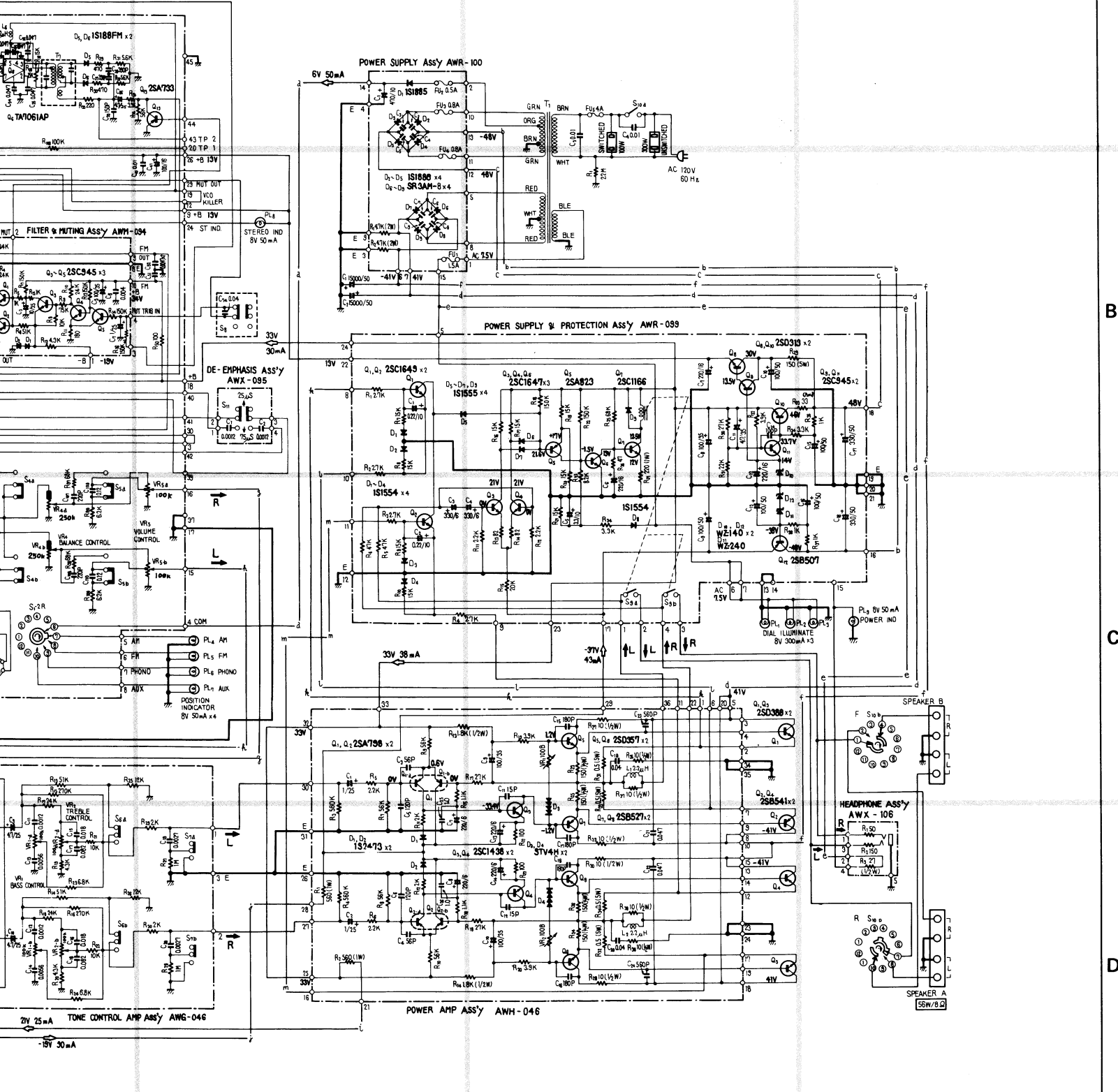

A

B

C

D

4

5

6

12.2 MISCELLANEOUS PARTS

SEMICONDUCTORS

Symbol	Description	Part No.
Q1	Transistor	2SD 388-R
Q2	Transistor	2SB 541-R
Q3	Transistor	2SD 388-R
Q4	Transistor	2SB 541-R

CAPACITORS

Symbol	Description	Part No.
C1	Electrolytic 15,000 50V	ACH-057
C2	Electrolytic 15,000 50V	ACH-057
C3	Ceramic 0.01 150V (DC1.4kV)	ACG-003
C4	Ceramic 0.01 150V (DC1.4kV)	ACG-001

SWITCHES

Symbol	Description	Part No.
S1	Rotary switch	ASA-039

LAMPS

Symbol	Description	Part No.
PL1	Lamp assembly (8V, 0.3A)	AEL-060
PL2	Lamp assembly (8V, 0.3A)	AEL-060
PL3	Lamp assembly (8V, 0.3A)	AEL-060
PL4	Lamp with leads (8V, 50mA)	AEL-064
PL5	Lamp with leads (8V, 50mA)	AEL-068
PL6	Lamp with leads (8V, 50mA)	AEL-066
PL7	Lamp with leads (8V, 50mA)	AEL-067
PL8	Lamp with leads (8V, 50mA)	AEL-069
PL9	Lamp with leads (8V, 50mA)	AEL-069

FUSES

Symbol	Description	Part No.
FU1	Fuse 1.5A	AEK-104
FU2	Fuse 0.5A	AEK-107
FU3	Fuse 0.8A	AEK-111
FU4	Fuse 0.8A	AEK-111
FU5	Fuse 4A	AEK-100

COILS, TRANSFORMER

Symbol	Description	Part No.
T1	Power transformer (KU model) Power transformer (KC model)	ATT-264 ATT-301
T2	Ferrite balun	T22-025
L1	Ferrite bar antenna	AXB-004
L2	Chock coil	T24-030

RESISTOR

Symbol	Description	Part No.
R1	Carbon film 2.2M 1/4W	RD1/4PS 225J

12.3 INTERNAL CIRCUITRY OF INTEGRATED CIRCUITS

HA1137 (FM IF IC)

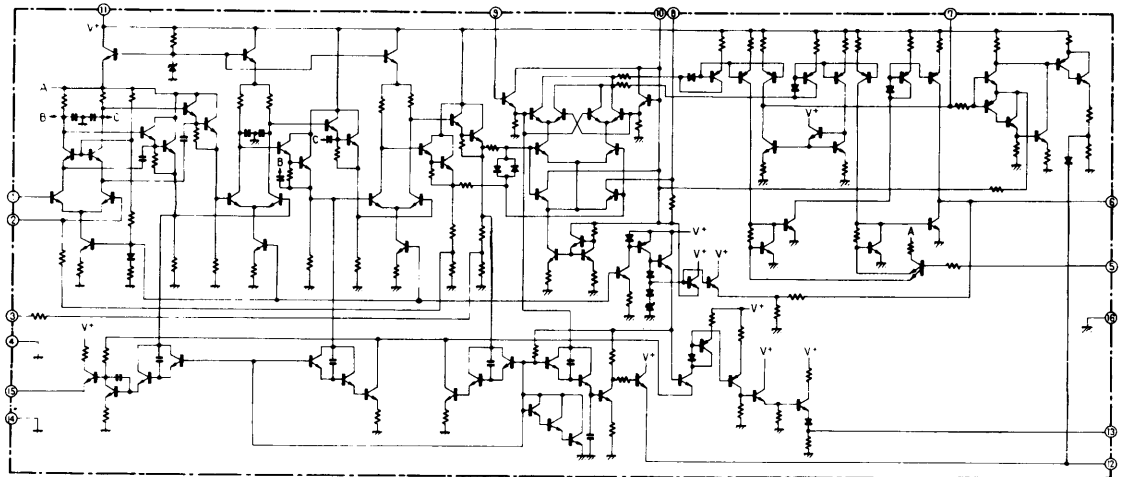

HA1138 (AM IC)

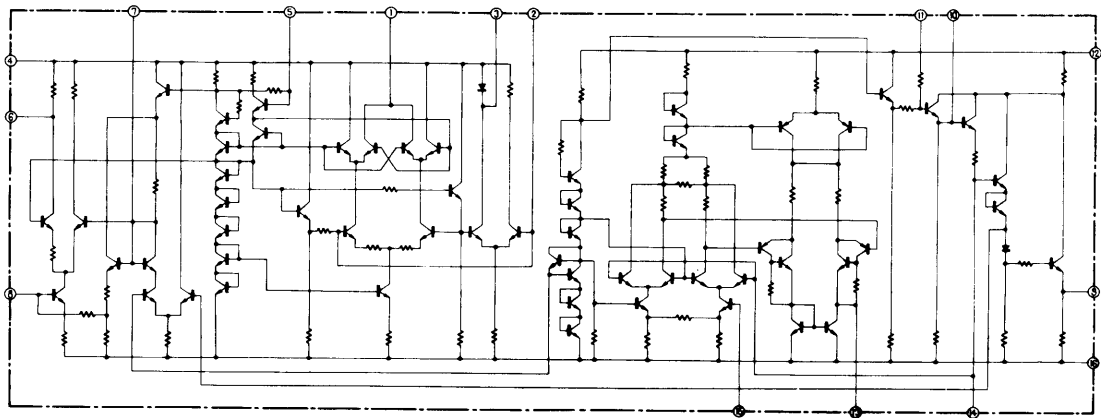

HA1196

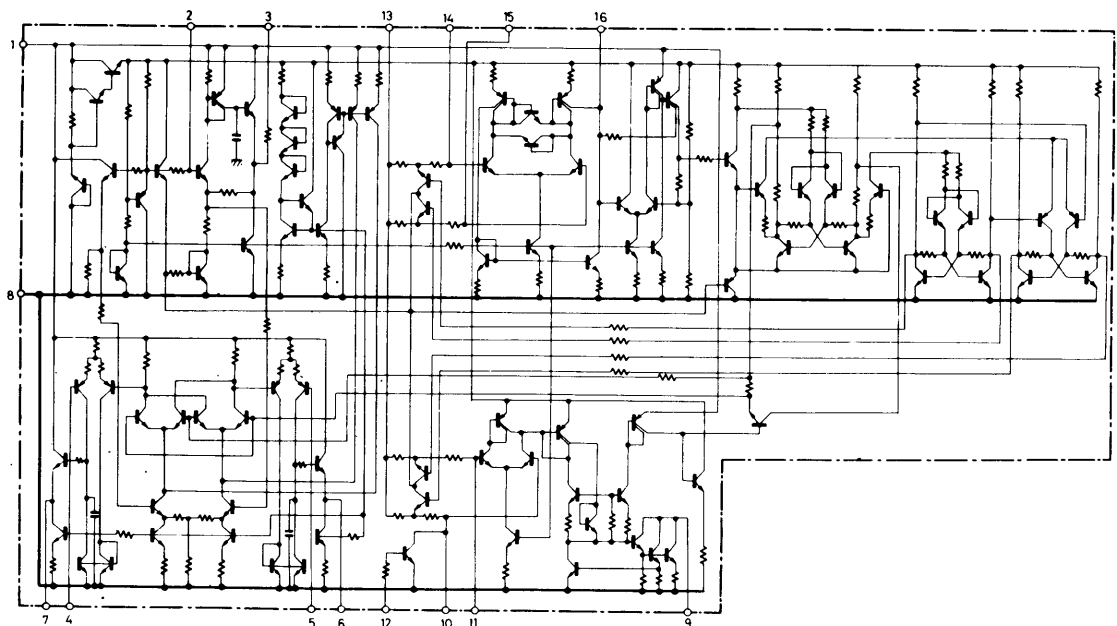

HA1201

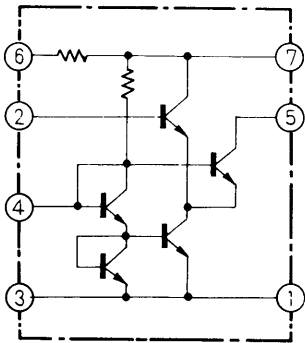

TA7061AP

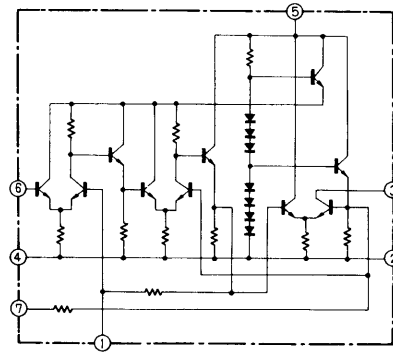

TA7136P1

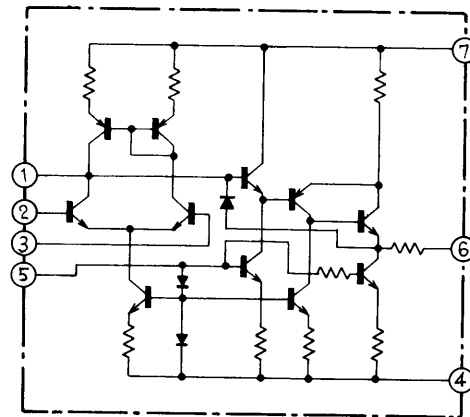

External Appearance of Transistors and ICs

- 2SA823
- 2SC945A
- 2SC1438
- 2SC1647
- 2SC1649

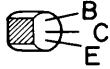

- 2SB507
- 2SD313

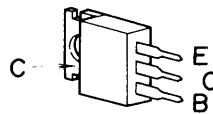

- HA1137
- HA1138
- HA1196

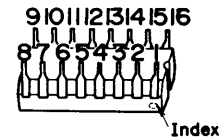

- TA7061AP
- TA7136P1

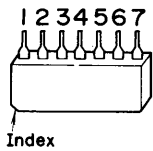

- 2SB527
- 2SD357

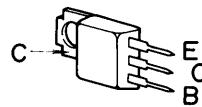

- 2SC461
- 2SC535
- 2SC1344

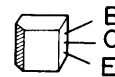

- 2SB541
- 2SD388

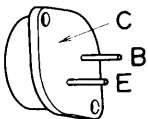

- 3SK45

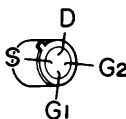

- HA1201

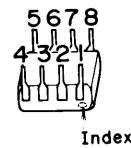

- 2SA798

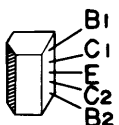

- 2SC1166

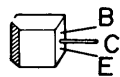

- 2SK30A



- 2SA725

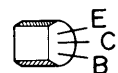

12.4 FILTER & MUTING ASSEMBLY (AWM-094)

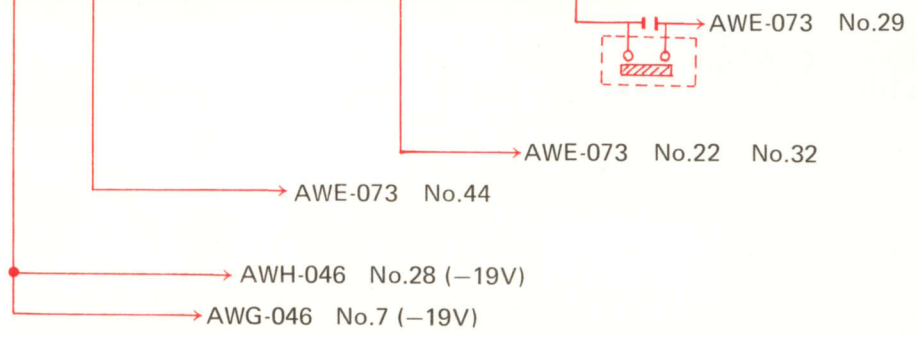
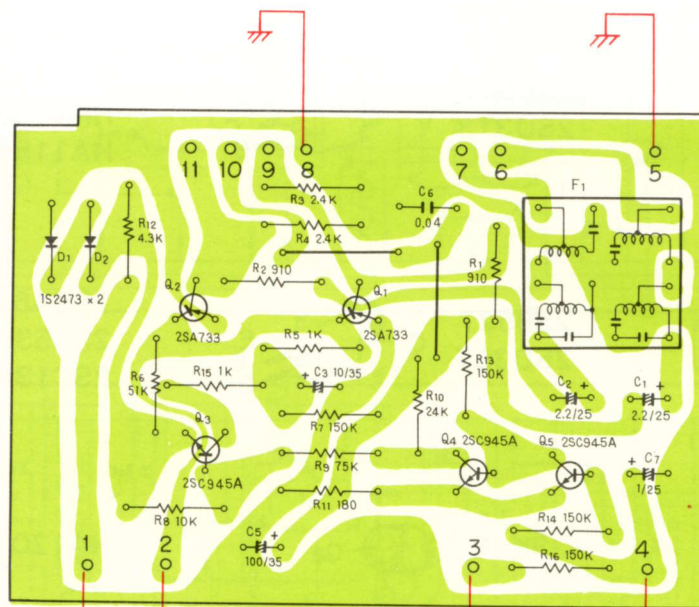
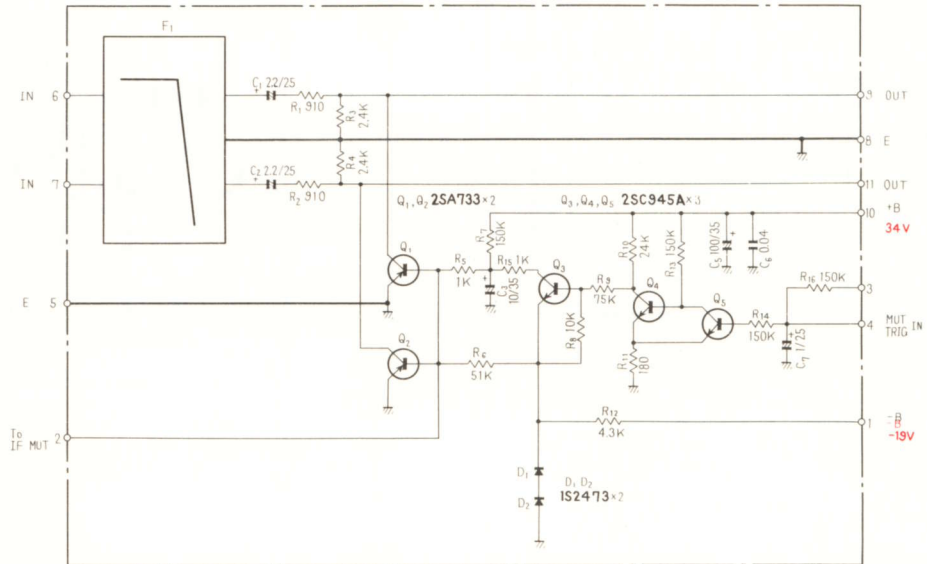

Parts List of Filters & Muting Assembly (AWM-094)

SEMICONDUCTORS

Symbol	Description	Part No.
D1	Diode	1S2473
D2	Diode	1S2473
Q1	Transistor	2SA733-Q
Q2	Transistor	2SA733-Q
Q3	Transistor	2SC945-R
Q4	Transistor	2SC945-R
Q5	Transistor	2SC945-R

RESISTORS

Symbol	Description	Part No.
R1	Carbon film 910	RD½PS 911J
R2	Carbon film 910	RD½PS 911J
R3	Carbon film 2.4k	RD½PS 242J
R4	Carbon film 2.4k	RD½PS 242J
R5	Carbon film 1k	RD½PS 102J
R6	Carbon film 51k	RD½PS 513J
R7	Carbon film 150k	RD½PS 154J
R8	Carbon film 10k	RD½PS 103J
R9	Carbon film 75k	RD½PS 753J
R10	Carbon film 24k	RD½PS 243J
R11	Carbon film 180	RD½PS 181J
R12	Carbon film 4.3k	RD½PS 432J
R13	Carbon film 150k	RD½PS 154J
R14	Carbon film 150k	RD½PS 154J
R15	Carbon film 1k	RD½PS 102J
R16	Carbon film 150k	RD½PS 154J

CAPACITORS

Symbol	Description	Part No.
C1	Electrolytic 2.2 25V	CSZA 2R2M 25
C2	Electrolytic 2.2 25V	CSZA 2R2M 25
C3	Electrolytic 10 35V	CEA 100P 35
C4
C5	Electrolytic 100 35V	CEA 101P 35
C6	Ceramic 0.04 50V	CKDYF 403Z 50
C7	Electrolytic 1 25V	CSZA 010M 25

OTHERS

Symbol	Description	Part No.
	Low pass filter	ATF-033
	L-type terminal	AKC-035

12.5 TONE CONTROL ASSEMBLY (AWG-046)

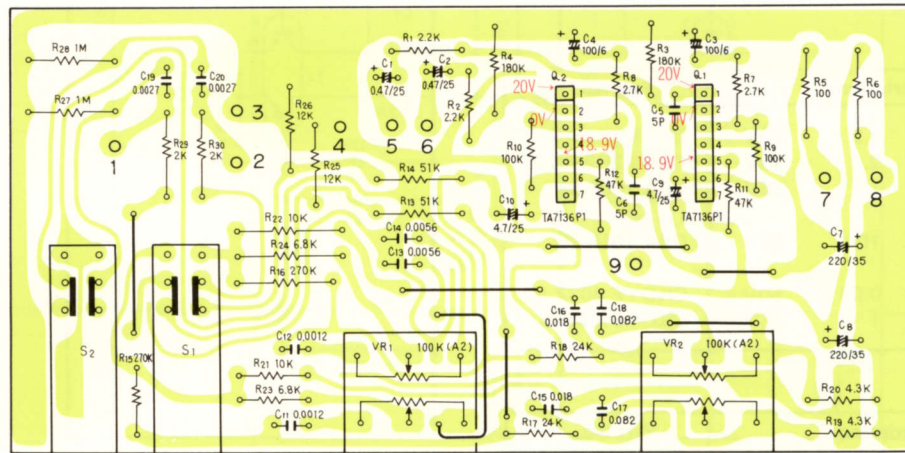
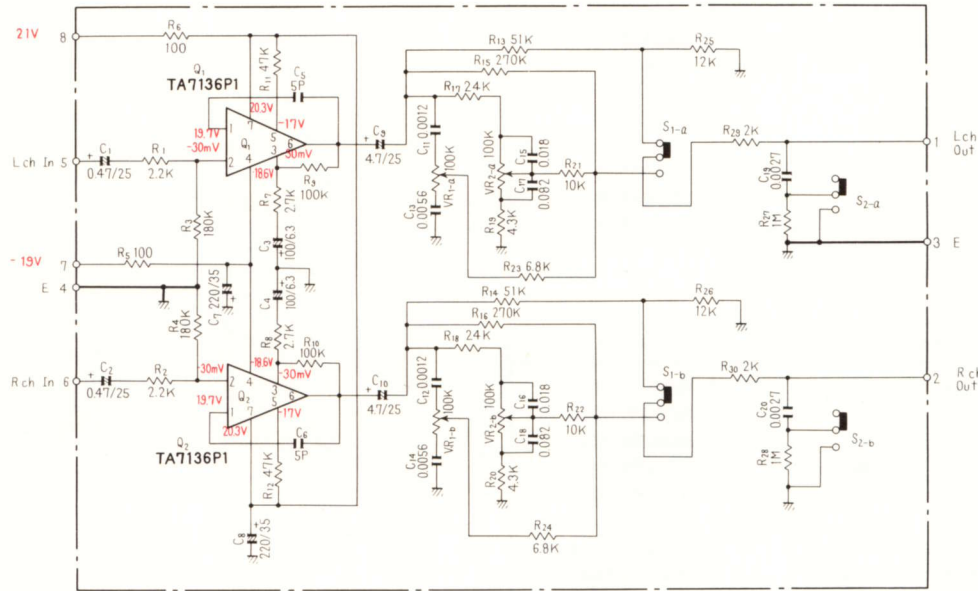

- AWE-073 No.34 (-19V)
- AWM-094 No.1 (-19V)
- AWH-046 No.28 (-19V)
- AWE-073 No.33 (+21V)
- AWH-046 No.21 (+21V)

Parts List of Tone Control Assembly (AWG-046)

SEMICONDUCTORS

Symbol	Description	Part No.
Q1	IC	TA7136P1
Q2	IC	TA7136P1
VR1	Volume switch	
VR2	Variable resistor (BASS) 100k-A2	ACV-138
VR2	Variable resistor (TREBLE)100k-A2	ACV-138
SW1	Lever switch (S1-TONE)	ASK-090
SW2	Lever switch (S2-HIGH FILTER)	ASK-090

RESISTORS

Symbol	Description	Part No.
R1	Carbon film 2.2k	RD¼PM 222J
R2	Carbon film 2.2k	RD¼PM 222J
R3	Carbon film 180k	RD¼PM 184J
R4	Carbon film 180k	RD¼PS 184J
R5	Carbon film 100	RD¼PS 101J
R6	Carbon film 100	RD¼PS 101J
R7	Carbon film 2.7k	RD¼PM 272J
R8	Carbon film 2.7k	RD¼PM 272J
R9	Carbon film 100k	RD¼PM 104J
R10	Carbon film 100k	RD¼PM 104J
R11	Carbon film 47k	RD¼PM 473J
R12	Carbon film 47k	RD¼PM 473J
R13	Carbon film 51k	RD¼PS 513J
R14	Carbon film 51k	RD¼PS 513J
R15	Carbon film 270k	RD¼PM 274J
R16	Carbon film 270k	RD¼PS 274J
R17	Carbon film 24k	RD¼PM 243J
R18	Carbon film 24k	RD¼PM 243J
R19	Carbon film 4.3k	RD¼PM 432J
R20	Carbon film 4.3k	RD¼PM 432J
R21	Carbon film 10k	RD¼PM 103J
R22	Carbon film 10k	RD¼PS 103J
R23	Carbon film 6.8k	RD¼PM 682J
R24	Carbon film 6.8k	RD¼PS 682J
R25	Carbon film 12k	RD¼PS 123J
R26	Carbon film 12k	RD¼PS 123J
R27	Carbon film 1M	RD¼PS 105J
R28	Carbon film 1M	RD¼PS 105J
R29	Carbon film 2k	RD¼PS 202J
R30	Carbon film 2k	RD¼PS 202J

CAPACITORS

Symbol	Description	Part No.
C1	Electrolytic 0.47 25V	CSSA R47M 25
C2	Electrolytic 0.47 25V	CSSA R47M 25
C3	Electrolytic 100 6V	CEA 101P 6

Symbol	Description	Part No.
C4	Electrolytic 100 6V	CEA 101P 6
C5	Ceramic 5p 50V	CCDSL 050D 50
C6	Ceramic 5p 50V	CCDSL 050D 50
C7	Electrolytic 220 35V	CEA 221P 35
C8	Electrolytic 220 35V	CEA 221P 35
C9	Electrolytic 4.7 25V	CEANL 4R7P 25
C10	Electrolytic 4.7 25V	CEANL 4R7P 25
C11	Mylar 0.0012 50V	CQMA 122J 50
C12	Mylar 0.0012 50V	CQMA 122J 50
C13	Mylar 0.0056 50V	CQMA 562J 50
C14	Mylar 0.0056 50V	CQMA 562J 50
C15	Mylar 0.018 50V	CQMA 183J 50
C16	Mylar 0.018 50V	CQMA 183J 50
C17	Mylar 0.082 50V	CQMA 823J 50
C18	Mylar 0.082 50V	CQMA 823J 50
C19	Mylar 0.0027 50V	CQMA 272J 50
C20	Mylar 0.0027 50V	CQMA 272J 50

OTHERS

Symbol	Description	Part No.
	Nut	B71-004
	Washer	ABE-001

12.6 POWER AMPLIFIER ASSEMBLY (AWH-046)

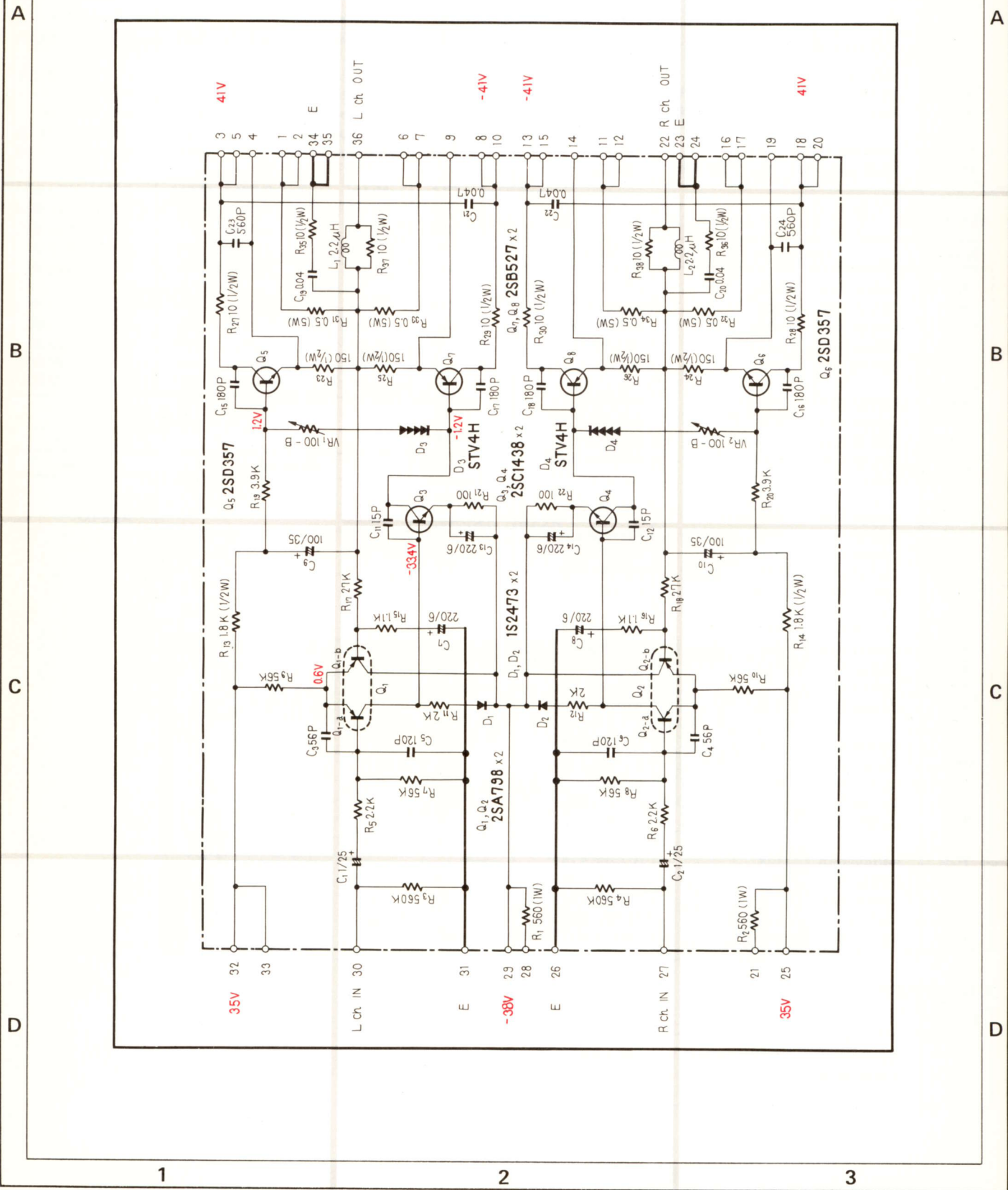

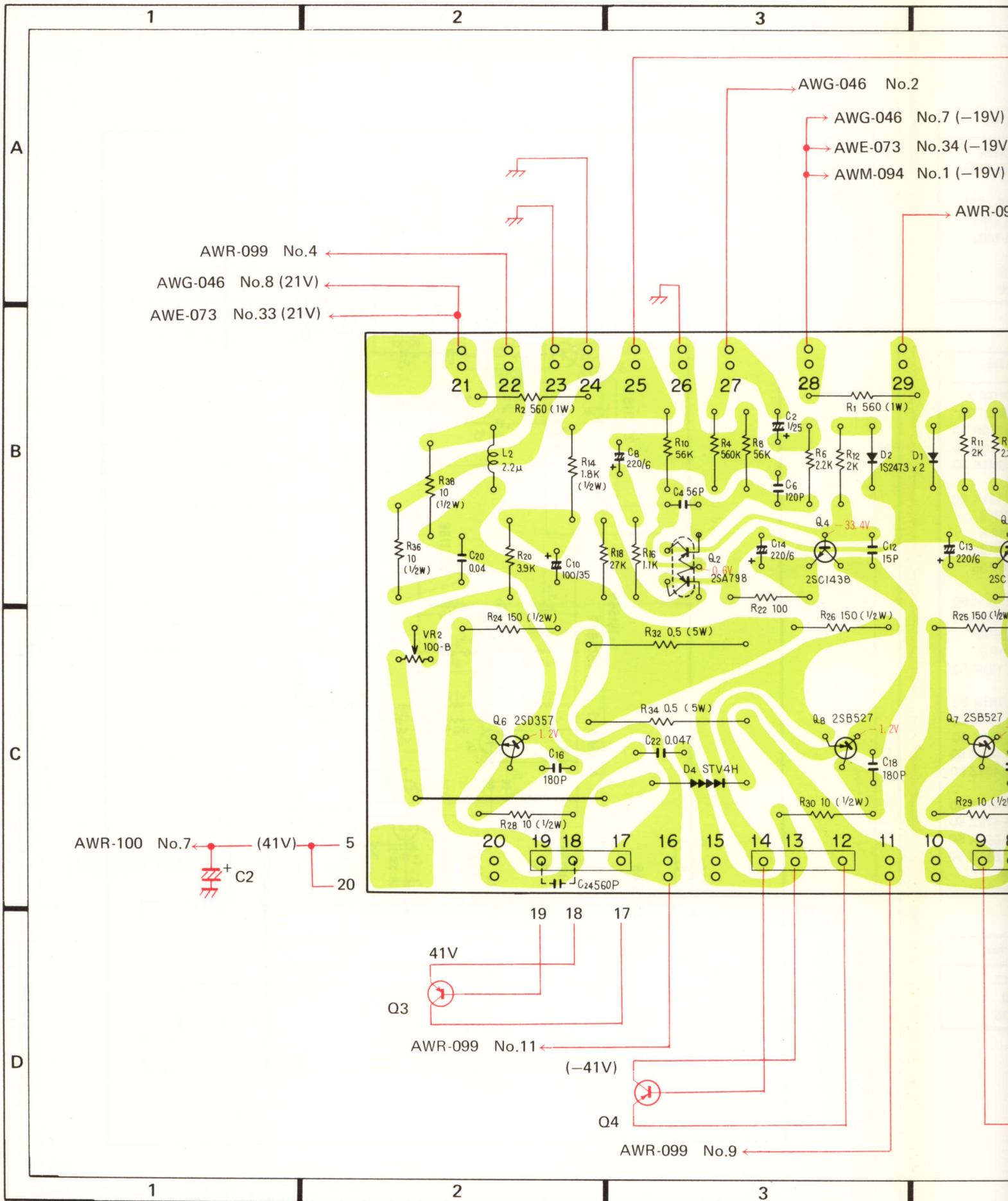

AWR-099 No.4
 AWR-046 No.8 (21V)
 AWE-073 No.33 (21V)

AWG-046 No.2
 AWR-046 No.7 (-19V)
 AWE-073 No.34 (-19V)
 AWM-094 No.1 (-19V)
 AWR-05

AWR-100 No.7 (41V)
 AWR-100 No.7 (-41V)

AWR-099 No.11
 AWR-099 No.9

4

5

6

A

B

C

D

AWG-046 No.2

AWG-046 No.7 (-19V)

AWE-073 No.34 (-19V)

AWM-094 No.1 (-19V)

AWR-099 No.17

AWR-099 No.23

AWR-099 No.1

30 → AWG-046 No.1

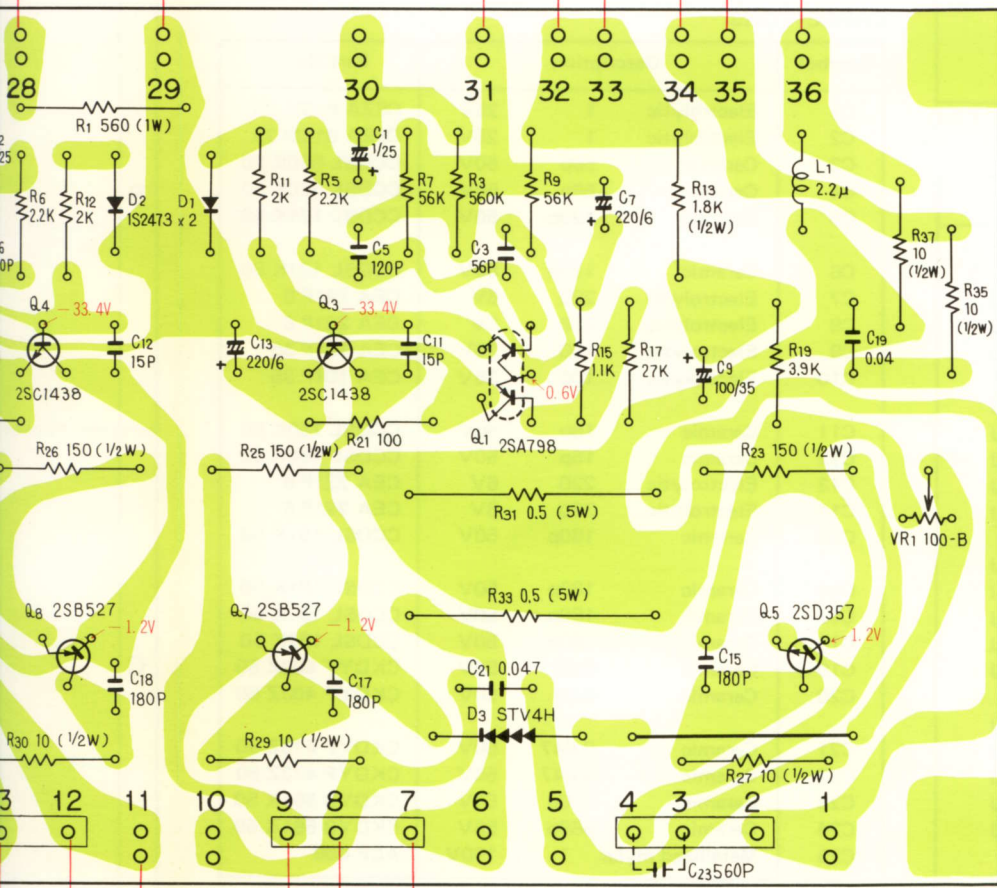

10 (-41V) → AWE-100 No.6
15 → C1

AWR-099 No.8

Q1

AWR-099 No.8

Q2

(-41V)

4

5

6

Parts List of Power Amplifier Assembly (AWH-046)

SEMICONDUCTORS

Symbol	Description	Part No.
Q1	Transistor	2SA798-F
Q2	Transistor	2SA798-F
Q3	Transistor	2SC1438-V
Q4	Transistor	2SC1438-V
Q5	Transistor	2SD357-C
Q6	Transistor	2SD357-C
Q7	Transistor	2SB527-C
Q8	Transistor	2SB527-C
D1	Diode	1S2473
D2	Diode	1S2473
D3	Diode	STV4H
D4	Diode	STV4H

RESISTORS

Symbol	Description	Part No.
R1	Metal oxide 560 1W	RS1P 561K
R2	Metal oxide 560 1W	RS1P 561K
R3	Carbon film 560k	RD½PS 564J
R4	Carbon film 560k	RD½PS 564J
R5	Carbon film 2.2k	RD½PS 222J
R6	Carbon film 2.2k	RD½PS 222J
R7	Carbon film 56k	RD½PS 563J
R8	Carbon film 56k	RD½PS 563J
R9	Carbon film 56k	RD½PS 563J
R10	Carbon film 56k	RD½PS 563J
R11	Carbon film 2.0k	RD½PS 202J
R12	Carbon film 2.0k	RD½PS 202J
R13	Carbon film 1.8k ½W	RD½PS 182J
R14	Carbon film 1.8k ½W	RD½PS 182J
R15	Carbon film 1.1k	RD½PS 112J
R16	Carbon film 1.1k	RD½PS 112J
R17	Carbon film 27k	RD½PS 273J
R18	Carbon film 27k	RD½PS 273J
R19	Carbon film 3.9k	RD½PS 392J
R20	Carbon film 3.9k	RD½PS 392J
R21	Carbon film 100	RD½PS 101J
R22	Carbon film 100	RD½PS 101J
R23	Carbon film 150 ½W	RD½PSF 151J
R24	Carbon film 150 ½W	RD½PSF 151J
R25	Carbon film 150 ½W	RD½PSF 151J
R26	Carbon film 150 ½W	RD½PSF 151J
R27	Carbon film 10 ½W	RD½PSF 100J
R28	Carbon film 10 ½W	RD½PSF 100J
R29	Carbon film 10 ½W	RD½PSF 100J
R30	Carbon film 10 ½W	RD½PSF 100J
R31	Wire wound 0.5 5W	RT5B 0R5K
R32	Wire wound 0.5 5W	RT5B 0R5K
R33	Wire wound 0.5 5W	RT5B 0R5K

Symbol	Description	Part No.
R34	Wire wound 0.5 5W	RT5B 0R5K
R35	Carbon film 10 ½W	RD½PSF 100J
R36	Carbon film 10 ½W	RD½PSF 100J
R37	Carbon film 10 ½W	RD½PS 100J
R38	Carbon film 10 ½W	RD½PS 100J
VR1	Semi-fixed 100-B	ACP-019
VR2	Semi-fixed 100-B	ACP-019

CAPACITORS

Symbol	Description	Part No.
C1	Electrolytic 1 25V	CSZA 010M 25
C2	Electrolytic 1 25V	CSZA 010M 25
C3	Ceramic 56p 50V	CCDSL 560K 50
C4	Ceramic 56p 50V	CCDSL 560K 50
C5	Ceramic 120p 50V	CCDSL 121K 50
C6	Ceramic 120p 50V	CCDSL 121K 50
C7	Electrolytic 220 6V	CEA 221P 6
C8	Electrolytic 220 6V	CEA 221P 6
C9	Electrolytic 100 35V	CEA 101P 35
C10	Electrolytic 100 35V	CEA 101P 35
C11	Ceramic 15p 50V	CCDSL 150K 50
C12	Ceramic 15p 50V	CCDSL 150K 50
C13	Electrolytic 220 6V	CEA 221P 6
C14	Electrolytic 220 6V	CEA 221P 6
C15	Ceramic 180p 50V	CCDSL 181K 50
C16	Ceramic 180p 50V	CCDSL 181K 50
C17	Ceramic 180p 50V	CCDSL 181K 50
C18	Ceramic 180p 50V	CCDSL 181K 50
C19	Ceramic 0.04 50V	CKDYF 403Z 50
C20	Ceramic 0.04 50V	CKDYF 403Z 50
C21	Ceramic 0.047 50V	CKDYF 473Z 50
C22	Ceramic 0.047 50V	CKDYF 473Z 50
C23	Ceramic 560p 50V	CKDYB 561K 50
C24	Ceramic 560p 50V	CKDYB 561K 50
C25	Metallized mylar 1 100V	ACE-008

OTHERS

Symbol	Description	Part No.
	Heat sink	ANH-117
	AF chock coil 2.2μH	T63-009
	Contact strip (3PL-type)	AKM-018

12.7 POWER SUPPLY & PROTECTION ASSEMBLY (AWR-099)

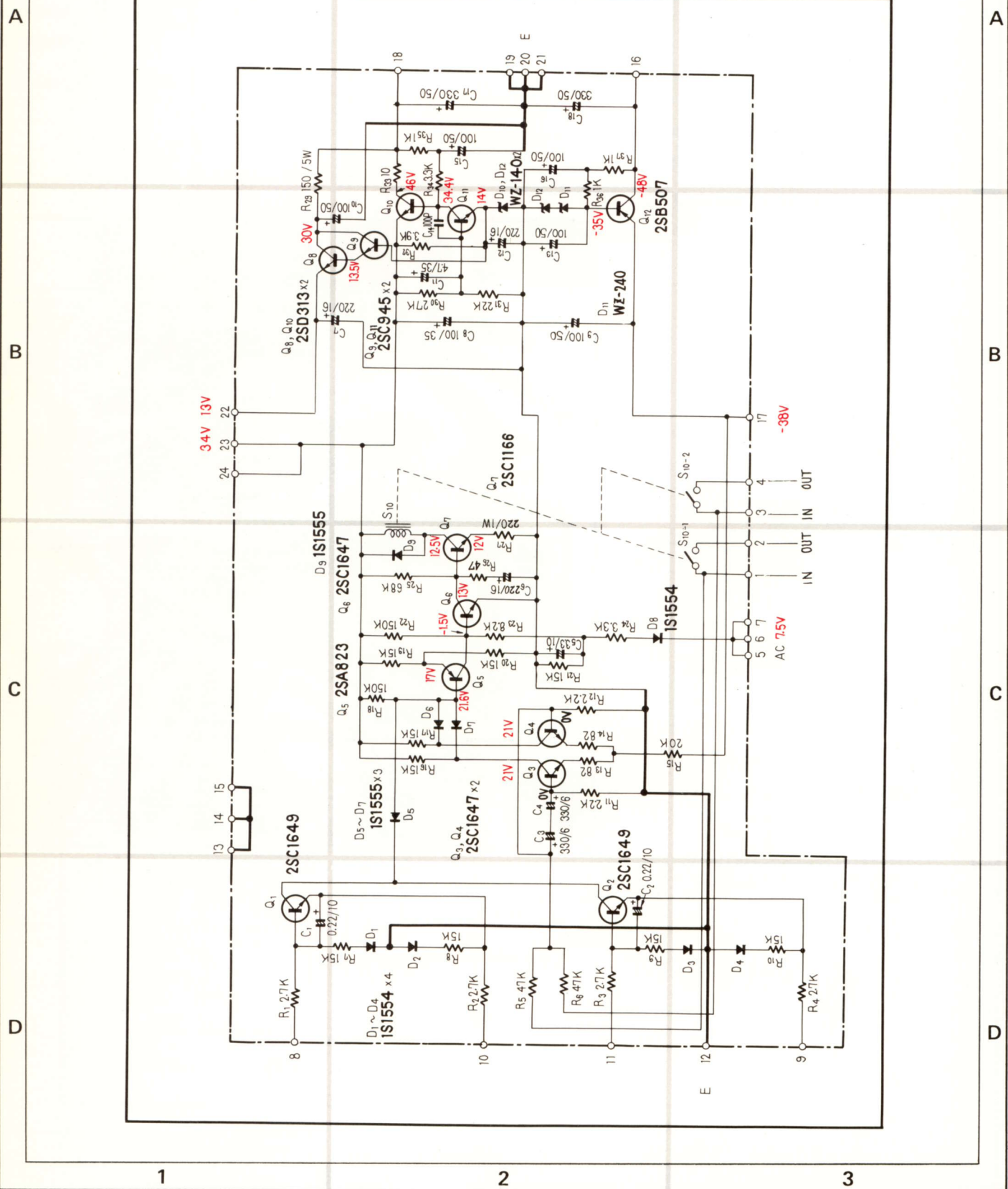

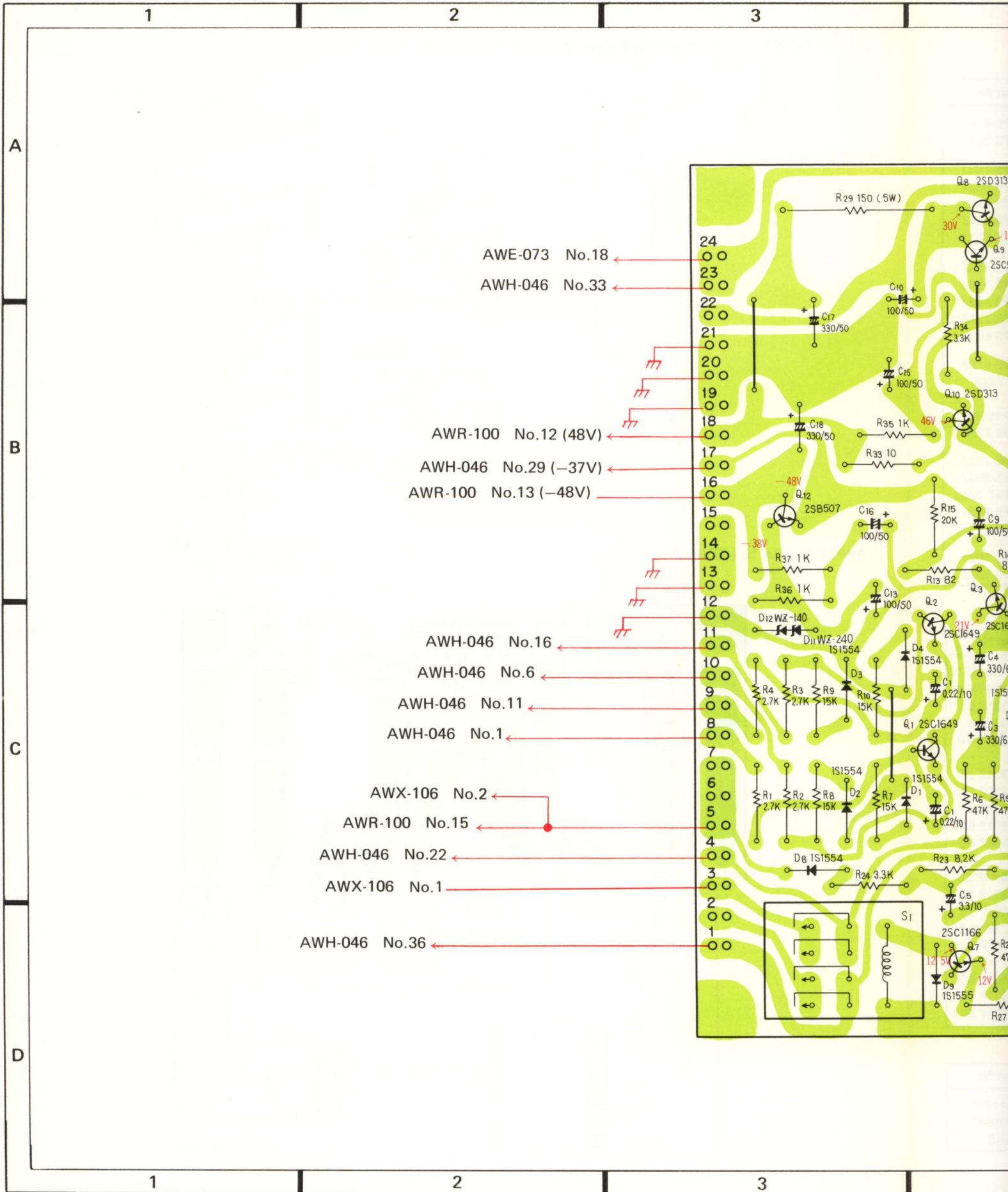

4

5

6

A

B

C

D

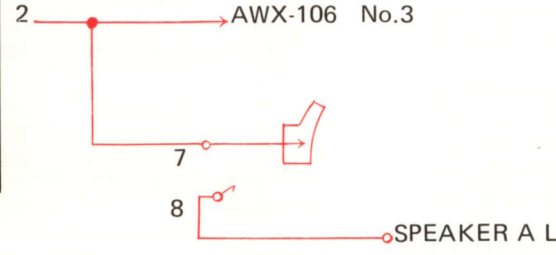
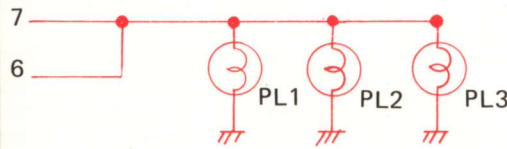
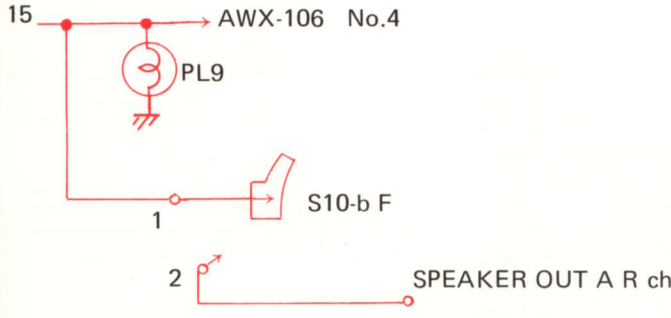
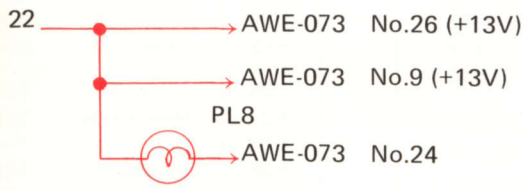
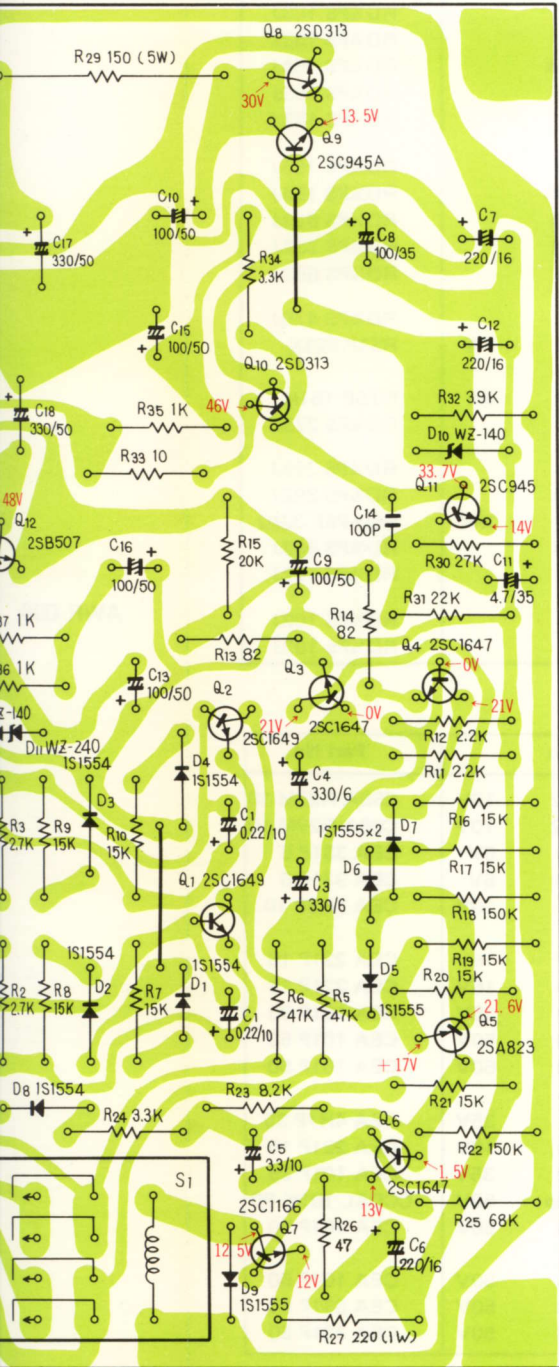

4

5

6

Parts List of Power Supply & Protection Assembly (AWR-099)

SEMICONDUCTORS

Symbol	Description	Part No.
Q1	Transistor	2SC1649-N or 2SC869-C
Q2	Transistor	2SC1649-N or 2SC869-C
Q3	Transistor	2SC1647-P or 2SC945-A
Q4	Transistor	2SC1647-P or 2SC945-A
Q5	Transistor	2SA823-P or 2SA733-Q
Q6	Transistor	2SC1647-P or 2SC945-A
Q7	Transistor	2SC1167-Y or 2SC1384-R
Q8	Transistor	2SD313-D
Q9	Transistor	2SC945-Q
Q10	Transistor	2SD313-D
Q11	Transistor	2SC945-Q
Q12	Transistor	2SB507-D
D1	Diode	1S1554
D2	Diode	1S1554
D3	Diode	1S1554
D4	Diode	1S1554
D5	Diode	1S1555
D6	Diode	1S1555
D7	Diode	1S1555
D8	Diode	1S1554
D9	Diode	1S1555
D10	Zener diode	WZ-140
D11	Zener diode	WZ-240
D12	Zener diode	WZ-140

RESISTORS

Symbol	Description	Part No.
R1	Carbon film 2.7k	RD¼PS 272J
R2	Carbon film 2.7k	RD¼PS 272J
R3	Carbon film 2.7k	RD¼PS 272J
R4	Carbon film 2.7k	RD¼PS 272J
R5	Carbon film 47k	RD¼PS 473J
R6	Carbon film 47k	RD¼PS 473J
R7	Carbon film 15k	RD¼PS 153J
R8	Carbon film 15k	RD¼PS 153J
R9	Carbon film 15k	RD¼PS 153J
R10	Carbon film 15k	RD¼PS 153J
R11	Carbon film 2.2k	RD¼PS 222J
R12	Carbon film 2.2k	RD¼PS 222J
R13	Carbon film 82	RD¼PS 820J

Symbol	Description	Part No.
R14	Carbon film 82	RD¼PS 820J
R15	Carbon film 20k	RD¼PS 203J
R16	Carbon film 15k	RD¼PS 153J
R17	Carbon film 15k	RD¼PS 153J
R18	Carbon film 150k	RD¼PS 154J
R19	Carbon film 15k	RD¼PS 153J
R20	Carbon film 15k	RD¼PS 153J
R21	Carbon film 15k	RD¼PS 153J
R22	Carbon film 150k	RD¼PS 154J
R23	Carbon film 8.2k	RD¼PS 822J
R24	Carbon film 3.3k	RD¼PS 332J
R25	Carbon film 68k	RD¼PS 683J
R26	Carbon film 47	RD¼PS 470J
R27	Metal oxide 220 1W	RS1P 221K
R28		
R29	Wire wound 150 5W	RT5B 151K
R30	Carbon film 27k	RD¼PS 273J
R31	Carbon film 22k	RD¼PS 223J
R32	Carbon film 3.9k	RD¼PS 392J
R33	Carbon film 33 ½W	RD½PSF 330J
R34	Carbon film 3.3k	RD¼PS 332J
R35	Carbon film 1k	RD¼PS 102J
R36	Carbon film 1k	RD¼PS 102J
R37	Carbon film 1k	RD¼PS 102J

CAPACITORS

Symbol	Description	Part No.
C1	Electrolytic 0.22 10V	CSSA R22M 10
C2	Electrolytic 0.22 10V	CSSA R22M 10
C3	Electrolytic 330 6V	CEA 331P 6
C4	Electrolytic 330 6V	CEA 331P 6
C5	Electrolytic 3.3 10V	CEA 3R3P 10
C6	Electrolytic 220 16V	CEA 221P 16
C7	Electrolytic 220 16V	CEA 221P 16
C8	Electrolytic 100 35V	CEA 101P 35
C9	Electrolytic 100 50V	CEA 101P 50
C10	Electrolytic 100 50V	CEA 101P 50
C11	Electrolytic 4.7 35V	CEA 4R7P 35
C12	Electrolytic 220 16V	CEA 221P 16
C13	Electrolytic 110 35V	CEA 101P 35
C14	Ceramic 100p 50V	CCDSL 101K 50
C15	Electrolytic 100 50V	CEA 101P 50
C16	Electrolytic 100 50V	CEA 101P 50
C17	Electrolytic 330 50V	CEA 331P 50
C18	Electrolytic 330 50V	CEA 331P 50

OTHERS

Symbol	Description	Part No.
	Heat sink	ANH-117-0
	Heat sink	ANH-259-0
	Relay	ASR-018

12.8 POWER SUPPLY ASSEMBLY (AWR-100)

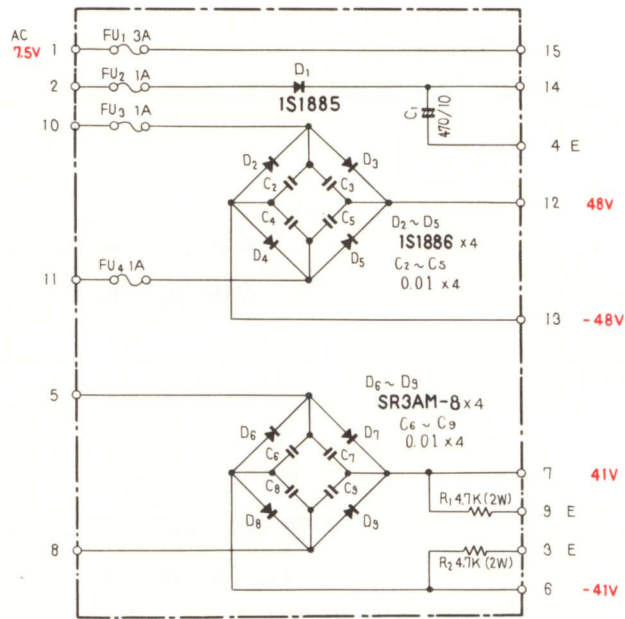

AWR-099 No.18 (48V) →

→ AWR-099 No.16 (-48V)

→ AWE-073 No.4 (6V)

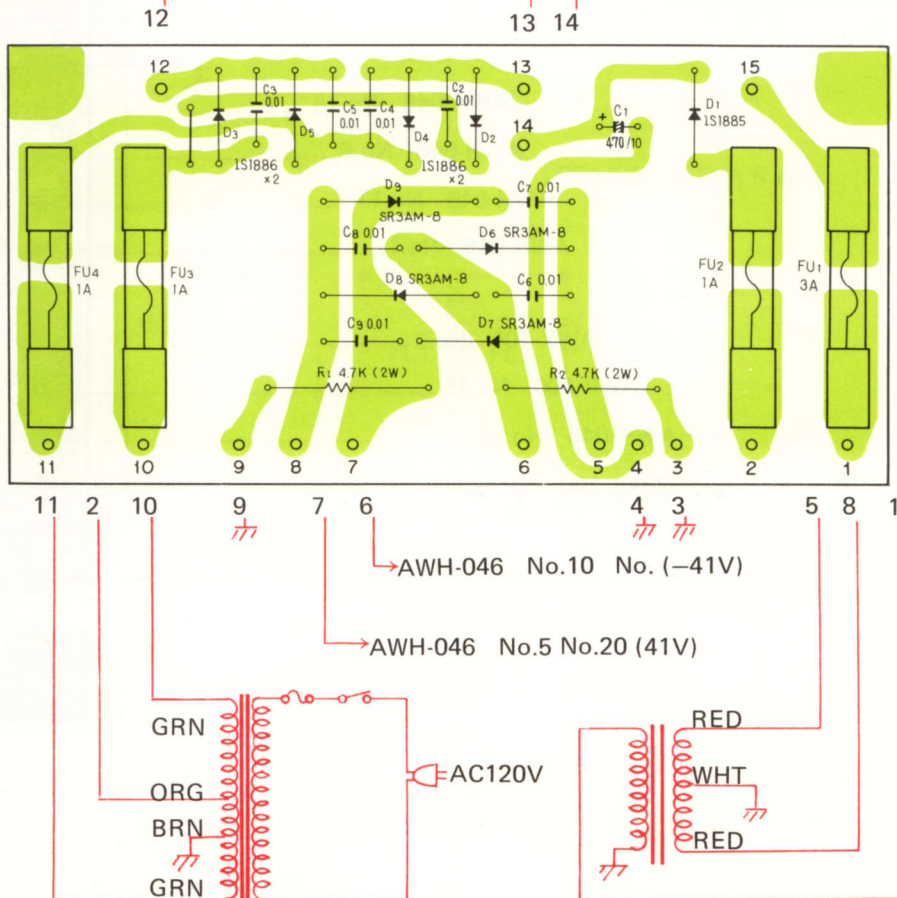

Parts List of Power Supply Assembly (AWR-100)

SEMICONDUCTORS

Symbol	Description	Part No.
D1	Diode	1S1885
D2	Diode	1S1886
D3	Diode	1S1886
D4	Diode	1S1886
D5	Diode	1S1886
D6	Diode	SR3AM-8
D7	Diode	SR3AM-8
D8	Diode	SR3AM-8
D9	Diode	SR3AM-8

RESISTORS

Symbol	Description	Part No.
R1	Metal oxide 4.7k 2W	RS2P 472K
R2	Metal oxide 4.7k 2W	RS2P 472K

CAPACITORS

Symbol	Description	Part No.
C1	Electrolytic 470 10V	CEA 471P 10
C2	Electrolytic 0.01 250V	ACG-001
C3	Electrolytic 0.01 250V	ACG-001
C4	Electrolytic 0.01 250V	ACG-001
C5	Electrolytic 0.01 250V	ACG-001
C6	Electrolytic 0.01 250V	ACG-001
C7	Electrolytic 0.01 250V	ACG-001

OTHERS

Symbol	Description	Part No.
	Fuse clip	AKR-013
	Fuse clip	AKR-030

12.9 HEADPHONE JACK ASSEMBLY (AWX-106)

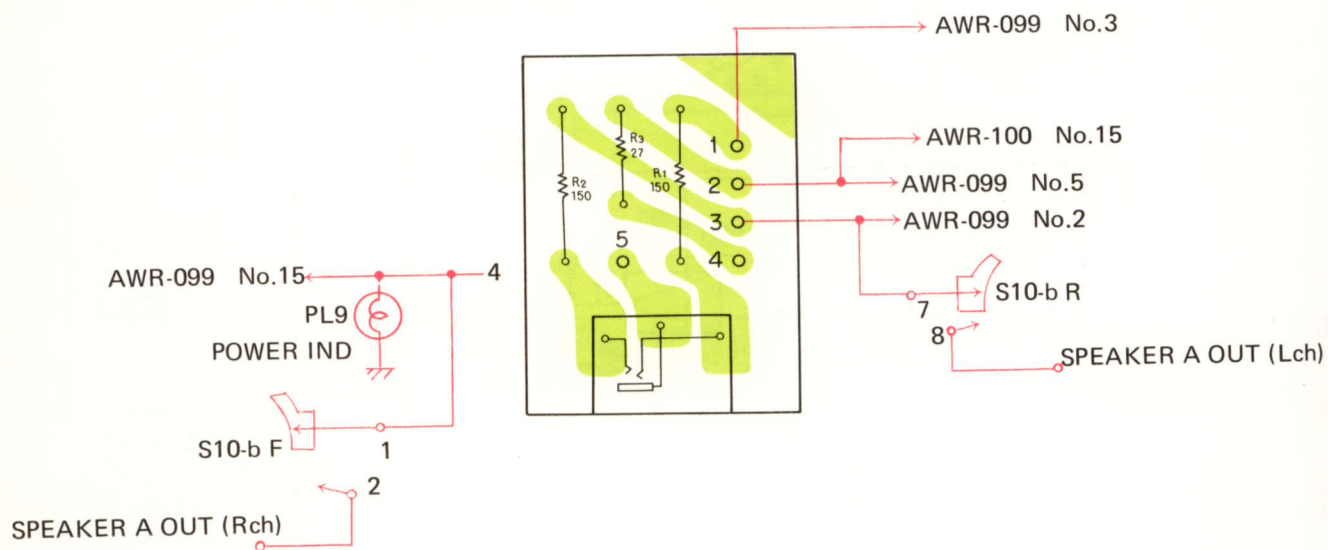
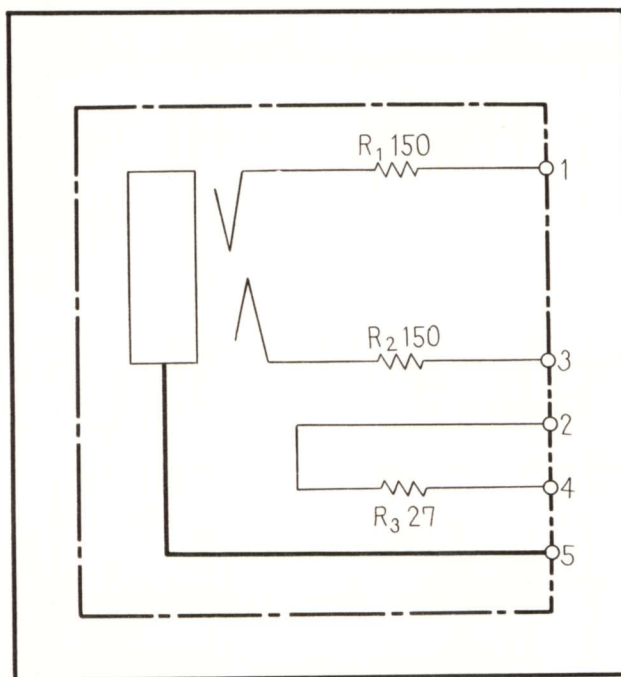

Parts List of Headphones Jack Assembly (AWX-106)

RESISTORS

Symbol	Description	Part No.
R1	Metal oxide 150 2W	RS 2P 151J
R2	Metal oxide 150 2W	RS 2P 151J
R3	Carbon film 27	RD¼PS 270J

12.10 TUNER, AF, & CONTROL ASSEMBLY (AWE-073)

A

B

C

D

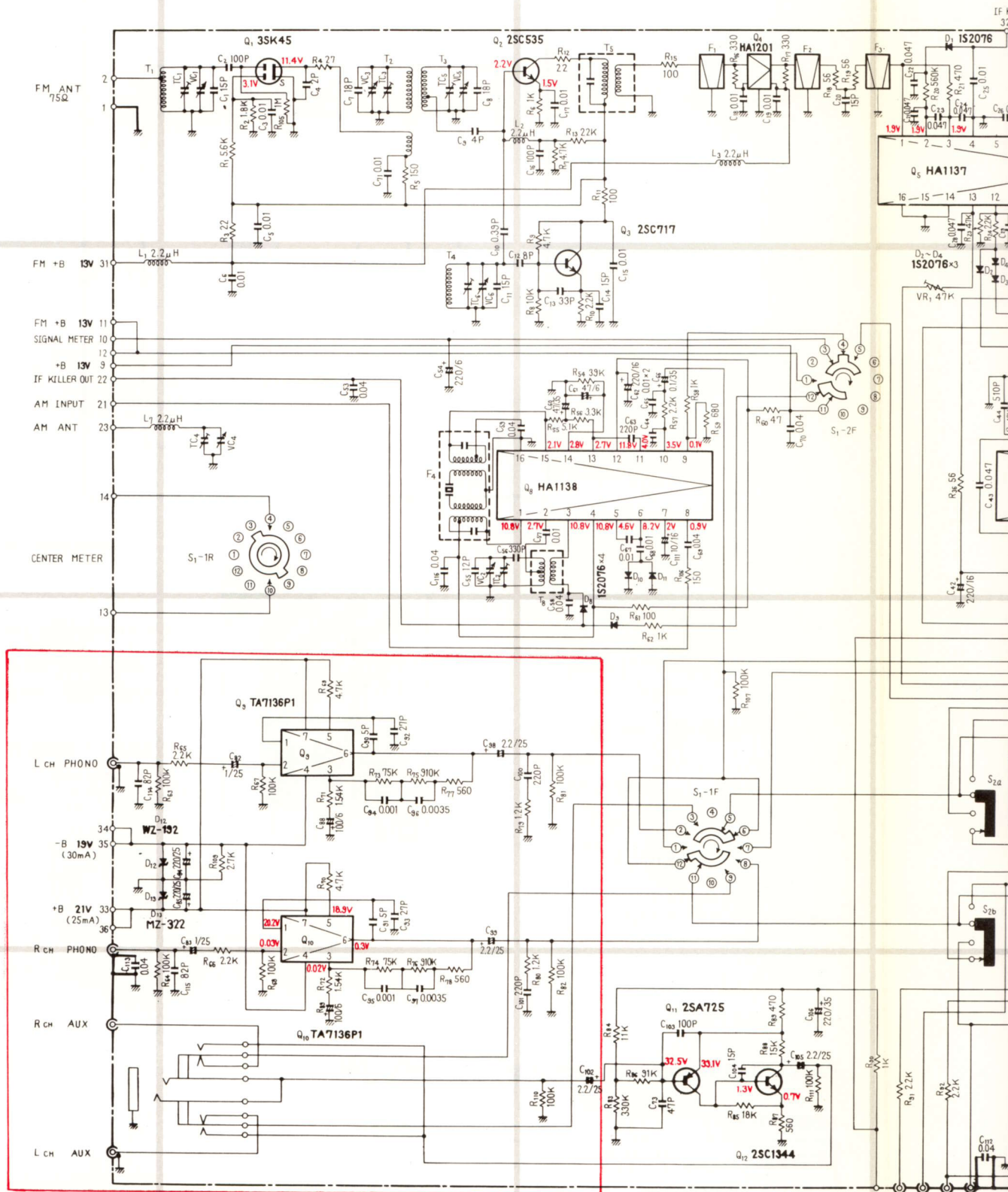

For units in which amplifier assembly (AWK-065) is used in place of IC (Q9, Q10 = TA7136P) indicated by red line, see Page 73.

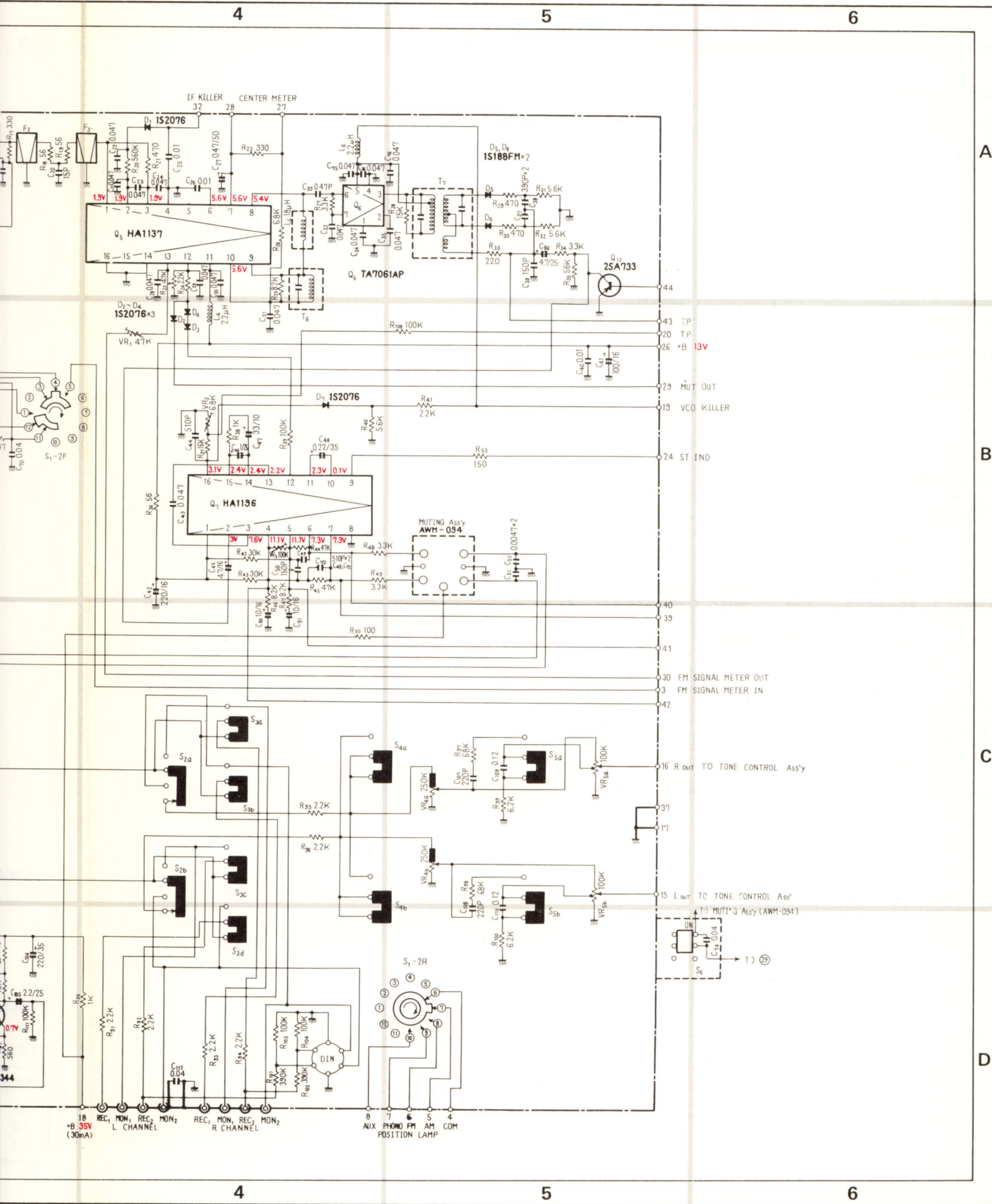

1 2 3

AWG-046 No.8 ←
AWH-046 No.21 ←
AWM-094 No.1 (-19V) ←
AWG-046 No.7 (-19V) ←
AWH-046 No.28 (-19V) ←
34 33

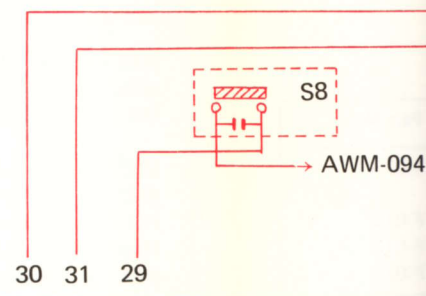

A

B

C

D

AWX-095 No.3 ← 39
AWX-095 No.1 ← 40
AWX-095 No.2 ← 41
AWX-095 No.4 ← 42
TP2 ← 43
AWM-094 No.2 ← 44

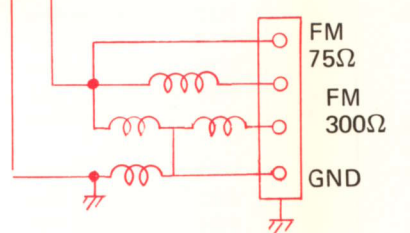
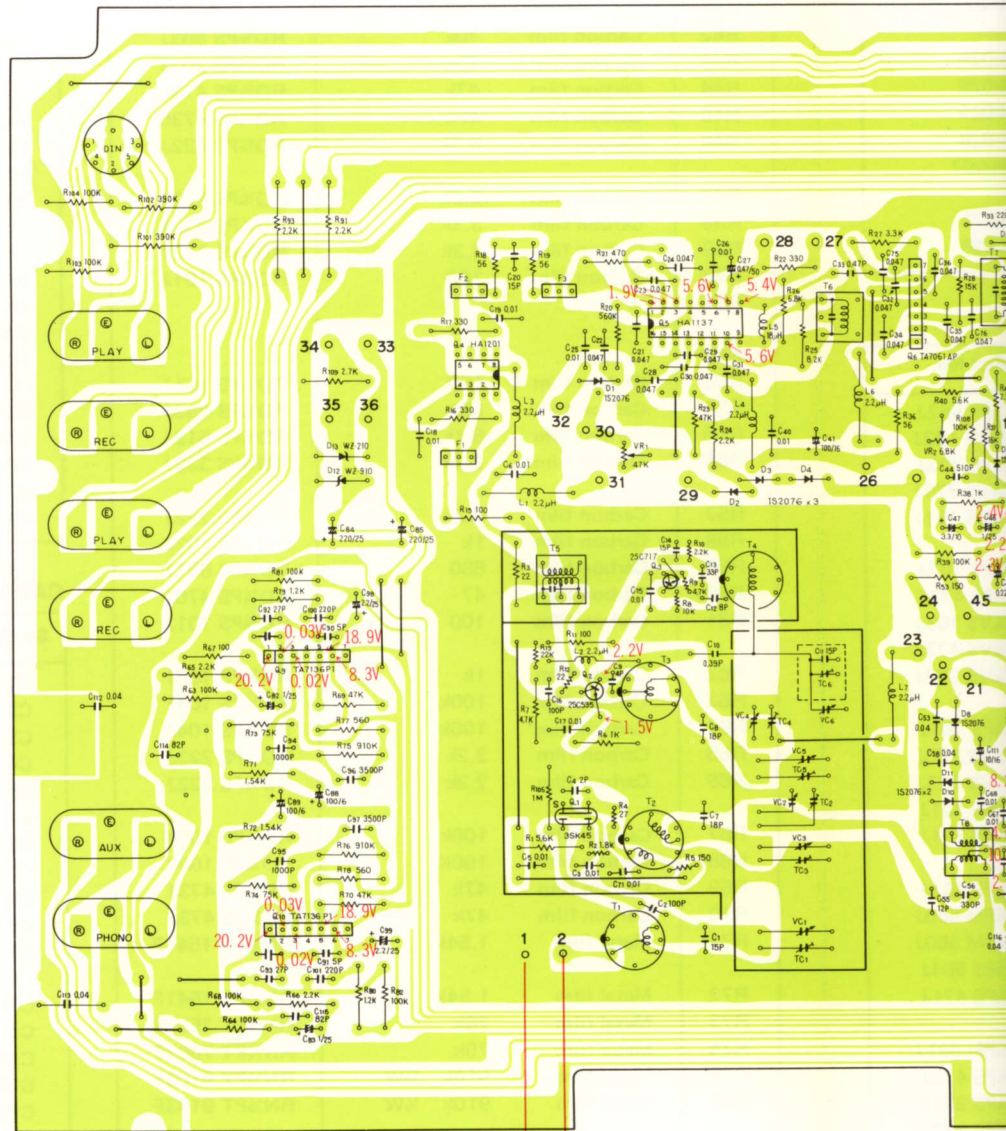

1 2 3

10

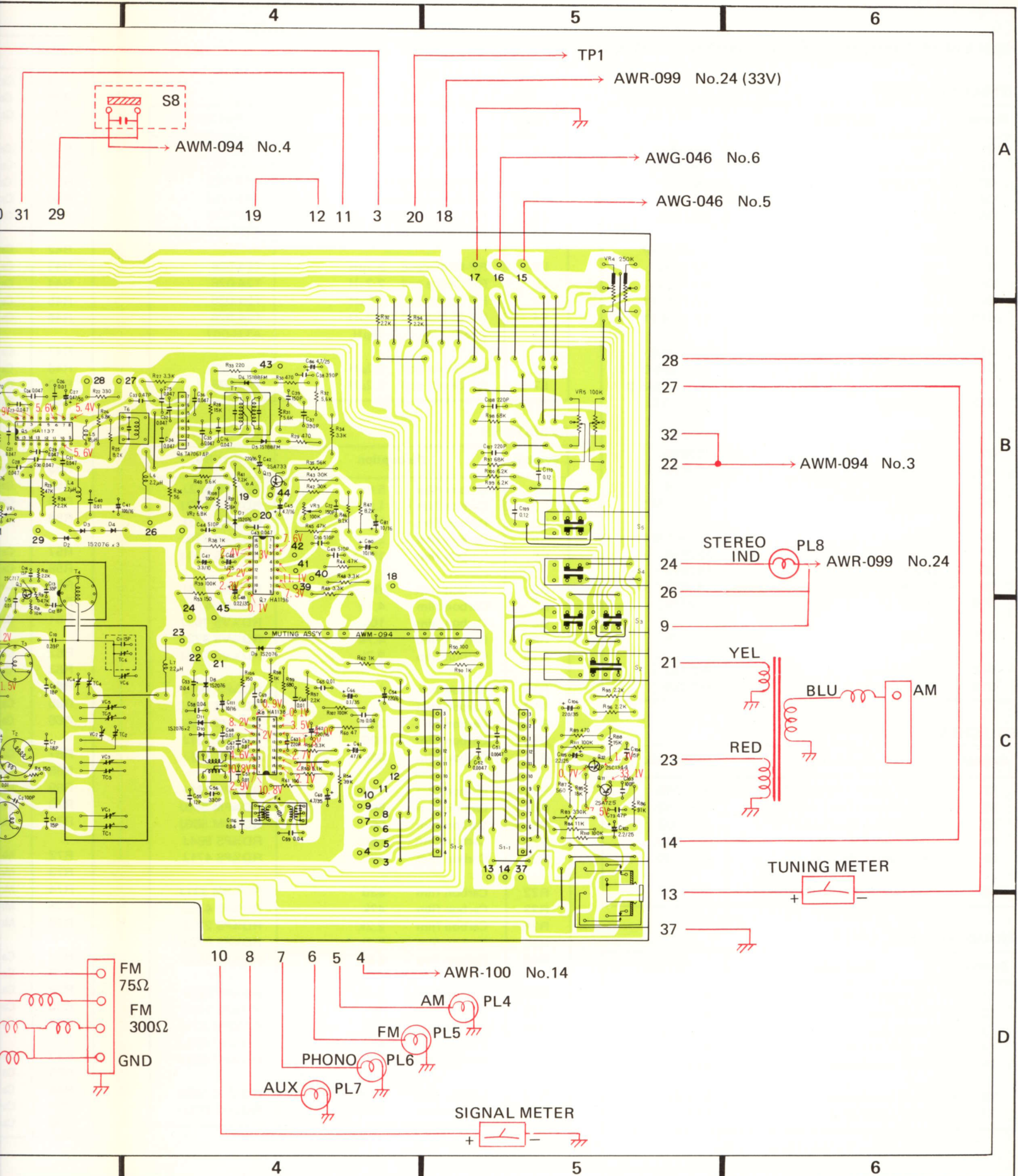

A

B

C

D

Parts List of Tuner, AF & Control Assembly (AWE-073)

SEMICONDUCTORS

Symbol	Description	Part No.
Q1	FET	3SK45-B
Q2	Transistor	2SC535-B
Q3	Transistor	2SC717
Q4	IC	HA1201
Q5	IC	HA1137
Q6	IC	TA7061AP
Q7	IC	HA1196
Q8	IC	HA1138
Q9	IC	TA7136 P1
Q10	IC	TA7136 P1
Q11	Transistor	2SA725-G
Q12	Transistor	2SC1344-D or 2SC1345-D
Q13	Transistor	2SA733-Q
D1	Diode	1S2076
D2	Diode	1S2076
D3	Diode	1S2076
D4	Diode	1S2076
D5	Diode	1S188FM-1
D6	Diode	1S188FM-1
D7	Diode	1S2076
D8	Diode	1S2076
D9	Diode	1S2076
D10	Diode	1S2076
D11	Diode	1S2076
D12	Zener Diode	WZ-192
D13	Zener Diode	WZ-210

SWITCHES

Symbol	Description	Part No.
S1	Rotary switch (FUNCTION)	ASD-049
S2	Lever switch (TAPE MONITOR)	ASK-102
S3	Lever switch (DUPLICATE)	ASK-092
S4	Lever switch (MODE)	ASK-090
S5	Lever switch (MODE)	ASK-090
S6	Push switch (FM MUTING)	ASG-097

TRANSFORMERS, COILS

Symbol	Description	Part No.
T1	FM antenna coil	ATC-021
T2	FM RF coil	ATC-015
T3	FM RF coil	ATC-016
T4	FM O, S, C coil	ATC-022
T5	FM IF transformer	ATE-026
T6	FM IF transformer	ATE-027
T7	FM IF transformer	ATE-013

Symbol	Description	Part No.
T8	AM O, S, C coil	ATB-013
F1	FM ceramic filter	ATF-013
F2	FM Ceramic filter	ATF-013
F3	FM Ceramic filter	ATF-013
F4	AM Ceramic filter	ATF-027
L1	RF Choke coil 2.2 μ H	T24-028
L2	RF Choke coil 2.2 μ H	T24-028
L3	RF Choke coil 2.2 μ H	T24-028
L4	RF Choke coil 2.2 μ H	T24-028
L5	Choke coil 18 μ H	ATH-007
L6	RF Choke coil 2.2 μ H	T24-028
L7	RF Choke coil 2.2 μ H	T24-028

RESISTORS

Symbol	Description	Part No.
R1	Carbon film 5.6k	RD $\frac{1}{2}$ PS 562J
R2	Carbon film 1.8k	RD $\frac{1}{2}$ VS 182J
R3	Carbon film 22	RD $\frac{1}{2}$ PS 220J
R4	Carbon film 27	RD $\frac{1}{2}$ VS 270J
R5	Carbon film 150	RD $\frac{1}{2}$ VS 151J
R6	Carbon film 1k	RD $\frac{1}{2}$ PS 102J
R7	Carbon film 4.7k	RD $\frac{1}{2}$ PS 472J
R8	Carbon film 10k	RD $\frac{1}{2}$ VS 103J
R9	Carbon film 4.7k	RD $\frac{1}{2}$ VS 472J
R10	Carbon film 2.2k	RD $\frac{1}{2}$ VS 222J
R11	Carbon film 100	RD $\frac{1}{2}$ PS 101J
R12	Carbon film 22	RD $\frac{1}{2}$ VS 220J
R13	Carbon film 22k	RD $\frac{1}{2}$ VS 223J
R15	Carbon film 100	RD $\frac{1}{2}$ PS 101J
R16	Carbon film 330	RD $\frac{1}{2}$ PS 331J
R17	Carbon film 330	RD $\frac{1}{2}$ PS 331J
R18	Carbon film 56	RD $\frac{1}{2}$ PM 560J
R19	Carbon film 56	RD $\frac{1}{2}$ PM 560J
R20	Carbon film 560k	RD $\frac{1}{2}$ PS 564J
R21	Carbon film 470	RD $\frac{1}{2}$ PS 471J
R22	Carbon film 330	RD $\frac{1}{2}$ PM 331J
R23	Carbon film 47k	RD $\frac{1}{2}$ PS 473J
R24	Carbon film 2.2k	RD $\frac{1}{2}$ PS 222J
R25	Carbon film 8.2k	RD $\frac{1}{2}$ PS 822J
R26	Carbon film 6.8k	RD $\frac{1}{2}$ PS 682J
R27	Carbon film 3.3k	RD $\frac{1}{2}$ PS 332J
R28	Carbon film 15k	RD $\frac{1}{2}$ PS 153J
R29	Carbon film 470	RD $\frac{1}{2}$ PM 471J
R30	Carbon film 470	RD $\frac{1}{2}$ PM 471J
R31	Carbon film 5.6k	RD $\frac{1}{2}$ PM 562J
R32	Carbon film 5.6k	RD $\frac{1}{2}$ PM 562J
R33	Carbon film 220	RD $\frac{1}{2}$ PS 221J

Symbol	Description	Part No.
R34	Carbon film 3.3k	RD½PS 332J
R35	Carbon film 56k	RD½PS 563J
R36	Carbon film 56	RD½PS 560J
R37	Carbon film 16k	RD½PS 163J
R38	Carbon film 1k	RD½PS 102J
R39	Carbon film 100k	RD½PS 104J
R40	Carbon film 5.6k	RD½PS 562J
R41	Carbon film 2.2k	RD½PS 222J
R42	Carbon film 30k	RD½PS 303J
R43	Carbon film 30k	RD½PS 303J
R44	Carbon film 47k	RD½PS 473G
R45	Carbon film 47k	RD½PS 473G
R46	Carbon film 8.2k	RD½PS 822J
R47	Carbon film 8.2k	RD½PS 822J
R48	Carbon film 3.3k	RD½PS 332J
R49	Carbon film 3.3k	RD½PS 332J
R50	Carbon film 100	RD½PS 101J
R51
R52
R53	Carbon film 150	RD½PS 151J
R54	Carbon film 39k	RD½PS 393J
R55	Carbon film 5.1k	RD½PS 512J
R56	Carbon film 3.3k	RD½PS 332J
R57	Carbon film 2.2k	RD½PS 222J
R58	Carbon film 1k	RD½PS 102J
R59	Carbon film 680	RD½PS 681J
R60	Carbon film 47	RD½PS 470J
R61	Carbon film 100	RD½PS 101J
R62	Carbon film 1k	RD½PS 102J
R63	Carbon film 100k	RD½PS 104J
R64	Carbon film 100k	RD½PS 104J
R65	Carbon film 2.2k	RD½PS 222J
R66	Carbon film 2.2k	RD½PS 222J
R67	Carbon film 100k	RD½PS 100K
R68	Carbon film 100K	RD½PS 100K
R69	Carbon film 47k	RD½PS 473J
R70	Carbon film 47k	RD½PS 473J
R71	Metal film 1.54k	RN½PT 1541F
R72	Metal film 1.54k	RN½PT 1541F
R73	Metal film 75k	RN½PT 7502F
R74	Metal film 75k	RN½PT 7502F
R75	Metal film 910k ½W	RN½PT 9103F
R76	Metal film 910k ½W	RN½PT 9103F
R77	Carbon film 560	RD½PS 561J
R78	Carbon film 560	RD½PS 561J
R79	Carbon film 1.2k	RD½PS 122J
R80	Carbon film 1.2k	RD½PS 122J
R81	Carbon film 100k	RD½PS 104J
R82	Carbon film 100k	RD½PS 104J
R83	Carbon film 330k	RD½PS 334J
R84	Carbon film 11k	RD½PS 113J
R85	Carbon film 18k	RD½PM 183J
R86	Carbon film 91k	RD½PS 913J

Symbol	Description	Part No.
R87	Carbon film 560	RD½PS 561J
R88	Carbon film 15k	RD½PM 153J
R89	Carbon film 470	RD½PS 471J
R90	Carbon film 1k	RD½PS 102J
R91	Carbon film 2.2k	RD½PS 222J
R92	Carbon film 2.2k	RD½PS 222J
R93	Carbon film 2.2k	RD½PS 222J
R94	Carbon film 2.2k	RD½PS 222J
R95	Carbon film 2.2k	RD½PS 222J
R96	Carbon film 2.2k	RD½PS 222J
R97	Carbon film 68k	RD½PS 683J
R98	Carbon film 68k	RD½PS 683J
R99	Carbon film 6.2k	RD½PS 622J
R100	Carbon film 6.2k	RD½PS 622J
R101	Carbon film 390k	RD½PS 394J
R102	Carbon film 390k	RD½PS 394J
R103	Carbon film 100k	RD½PS 104J
R104	Carbon film 100k	RD½PS 104J
R105	Carbon film 1M	RD½PS 105J
R106	Carbon film 150	RD½PS 151J
R107	Carbon film 100k	RD½PS 104J
R108	Carbon film 100k	RD½PM 104J
R109	Carbon film 2.7k	RD½PS 272J
R110	Carbon film 100k	RD½PS 104J
R111

CAPACITORS

Symbol	Description	Part No.
C1	Ceramic 15p 50V	CCDSH 150K 50
C2	Ceramic 100p 50V	CCDSL 101K 50
C3	Ceramic 0.01 50V	CKDYF 103Z 50
C4	Ceramic 2p 50V	CCDSL 020C 50
C5	Ceramic 0.01 50V	CKDYF 103Z 50
C6	Ceramic 0.01 50V	CKDYF 103Z 50
C7	Ceramic 18p 50V	CCDSH 180K 50
C8	Ceramic 18p 50V	CCDSH 180K 50
C9	Ceramic 4p 50V	CCDSL 040D 50
C10	Ceramic 0.39p 500V	CGB R39K 500
C11	Ceramic 15p 50V	CCDRH 150K 50
C12	Ceramic 8p 50V	CCDCH 080F 50
C13	Ceramic 33p 50V	CCDCH 330K 50
C14	Ceramic 15p 50V	CCDSL 150K 50
C15	Ceramic 0.01 50V	CKDYB 103K 50
C16	Ceramic 100p 50V	CCDSL 101K 50
C17	Ceramic 0.01 50V	CKDYF 103Z 50
C18	Ceramic 0.01 50V	CKDYF 103Z 50
C19	Ceramic 0.01 50V	CKDYF 103Z 50
C20	Ceramic 15p 50V	CCDSL 150K 50
C21	Ceramic 0.047 25V	CKDBC 473Z 25
C22	Ceramic 0.047 25V	CKDBC 473Z 25
C23	Ceramic 0.047 25V	CKDBC 473Z 25
C24	Ceramic 0.047 25V	CKDBC 473Z 25
C25	Ceramic 0.01 50V	CKDYF 103Z 50

Symbol	Description			Part No.
C26	Ceramic	0.01	50V	CKDYF 103Z 50
C27	Electrolytic	0.47	50V	CEA R47P 50
C28	Ceramic	0.047	25V	CKDBC 473Z 25
C29	Ceramic	0.047	25V	CKDBC 473Z 25
C30	Ceramic	0.047	25V	CKDBC 473Z 25
C31	Ceramic	0.047	25V	CKDBC 473Z 25
C32	Ceramic	0.047	25V	CKDBC 473Z 25
C33	Ceramic	0.47p	500V	CGB R47K 500
C34	Ceramic	0.047	25V	CKDBC 473Z 25
C35	Ceramic	0.047	25V	CKDBC 473Z 25
C36	Ceramic	0.047	25V	CKDBC 473Z 25
C37	Ceramic	390p	50V	CKDYB 391K 50
C38	Ceramic	390p	50V	CKDYB 391K 50
C39	Ceramic	150p	50V	CCDSL 151K 50
C40	Ceramic	0.01	50V	CKDYF 103Z 50
C41	Electrolytic	100	16V	CEA 101P 16
C42	Electrolytic	220	16V	CEA 221P 16
C43	Mylar	0.047	50V	CQMA 473K 50
C44	Polystyrene	510p	50V	CQSH 511J 50
C45	Electrolytic	4.7	16V	CSZA 4R7M 16
C46	Electrolytic	1	25V	CSZA 010M 25
C47	Electrolytic	3.3	10V	CSZA 3R3M 10
C48	Electrolytic	0.22	35V	CSZA R22M 35
C49	Polystyrene	510p	50V	CQSA 511J 50
C50	Polystyrene	510p	50V	CQSA 511J 50
C51	Mylar	0.0047	50V	CQMA 472J 50
C52	Mylar	0.0047	50V	CQMA 472J 50
C53	Ceramic	0.04	50V	CKDYF 403Z 50
C54	Electrolytic	220	6V	CEA 221P 6
C55	Ceramic	12p	50V	CCDXL 120K 50
C56	Polystyrene	330p	50V	CQSA 331J 50
C57	Ceramic	0.01	50V	CKDYF 103Z 50
C58	Ceramic	0.04	50V	CKDYF 403Z 50
C59	Ceramic	0.04	50V	CKDYF 403Z 50
C60	Electrolytic	4.7	35V	CEA 4R7P 35
C61	Electrolytic	47	6V	CEA 470P 6
C62	Electrolytic	220	16V	CEA 221P 16
C63	Ceramic	220p	50V	CCDSL 221K 50
C64	Ceramic	0.01	50V	CKDYF 103Z 50
C65	Ceramic	0.01	50V	CKDYF 103Z 50
C66	Electrolytic	0.1	35V	CSZA 0R1M 35
C67	Ceramic	0.01	50V	CKDYF 103Z 50
C68	Ceramic	0.01	50V	CKDYF 103Z 50
C69	Ceramic	0.04	50V	CKDYF 403Z 50
C70	Ceramic	0.04	50V	CKDYF 403Z 50
C71	Ceramic	0.01	50V	CKDYF 103Z 50
C72	Ceramic	150p	50V	CCDSL 151K 50
C73	Ceramic	47p	50V	CCDSL 470K 50
C74	Ceramic	0.04	50V	CKDYF 403Z 50
C75	Ceramic	0.047	25V	CKDBC 473Z 25
C76	Ceramic	0.047	25V	CKDBC 473Z 25
C80	Electrolytic	10	16V	CEA 100P 16

Symbol	Description			Part No.
C81	Electrolytic	10	16V	CEA 100P 16
C82	Electrolytic	1	25V	CSZA 010M 25
C83	Electrolytic	1	25V	CSZA 010M 25
C84	Electrolytic	220	25V	CEA 221P 25
C85	Electrolytic	220	25V	CEA 221P 25
C86	Electrolytic	4.7	16V	CEANL 4R7M16NP
C88	Electrolytic	100	6V	CEA 101P 6
C89	Electrolytic	100	6V	CEA 101P 6
C90	Ceramic	5p	50V	CCDSL 050D 50
C91	Ceramic	5p	50V	CCDSL 050D 50
C92	Ceramic	27p	50V	CCDSL 270K 50
C93	Ceramic	27p	50V	CCDSL 270K 50
C94	Polystyrene	1000p	50V	CQSA 102G 50
C95	Polystyrene	1000P	50V	CQSA 102G 50
C96	Polystyrene	3500p	50V	CQSA 352G 50
C97	Polystyrene	3500p	50V	CQSA 352G 50
C98	Electrolytic	2.2	25V	CSZA 2R2M 25
C99	Electrolytic	2.2	25V	CSZA 2R2M 25
C100	Ceramic	220p	50V	CCDSL 221K 50
C101	Ceramic	220p	50V	CCDSL 221K 50
C102	Electrolytic	2.2	25V	CSZA 2R2M 25
C103	Ceramic	100p	50V	CCDSL 101K 50
C104	Ceramic	15p	50V	CCDSL 150K 50
C105	Electrolytic	2.2	25V	CSZA 2R2M 25
C106	Electrolytic	220	35V	CEA 221P 35
C107	Ceramic	220p	50V	CCDSL 221K 50
C108	Ceramic	220p	50V	CCDSL 221K 50
C109	Mylar	0.12	50V	CQMA 124K 50
C110	Mylar	0.12	50V	CQMA 124K 50
C111	Electrolytic	10	16V	CEA 100P 16
C112	Ceramic	0.04	50V	CKDYF 403Z 50
C113	Ceramic	0.04	50V	CKDYF 403Z 50
C114	Ceramic	82p	50V	CCDSL 820K 50
C115	Ceramic	82p	50V	CCDSL 820K 50
C116	Ceramic	0.04	50V	CKDYF 403Z 50
VC1	Tuning capacitor			ACK-015
TC6	Ceramic trimmer			ACM-006

VARIABLE RESISTORS, OTHERS

Symbol	Description	Part No.
VR1	Semi-fixed 47k-B	C92-048
VR2	Semi-fixed 4.7k-B	ACP-055
VR3	Semi-fixed 100k-B	C92-047
VR4	Variable resistor (BALANCE)	ACV-135
VR5	Variable resistor (VOLUME)	ACV-179

OTHERS

	Terminal (TAPE 1)	AKB-027
	(TAPE 2)	AKB-027
	(INPUT)	AKB-027
	Connector socket (REC/PLAY)	AKP-011
	Phone jack (MIC)	AKN-011

Symbol	Description	Part No.
	Nut Washer Screw	B71-004 ABE-001 ABA-121

12.11 AMPLIFIER ASSEMBLY (AWK-065)

Tuner, AF & Control assembly (AWE-073)

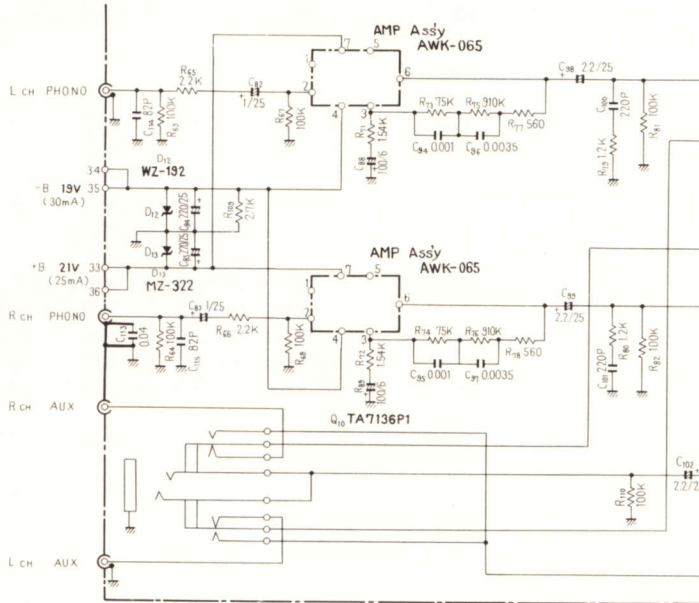

AWK-065 circuit diagram

AWK-065 PCB

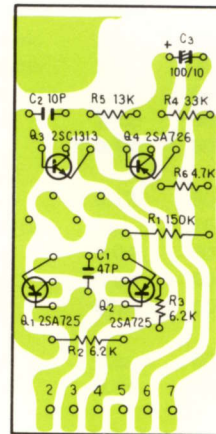
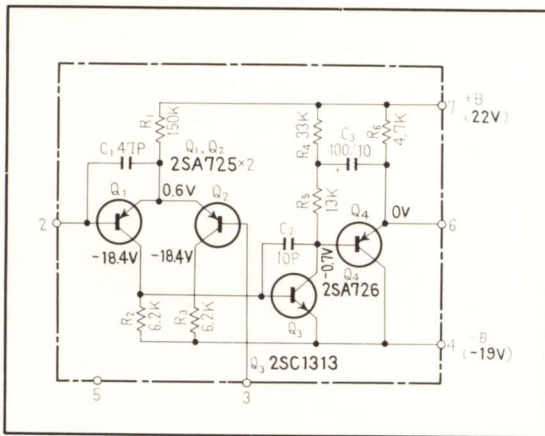

Parts List of Amplifier Assembly (AWK-065)

SEMICONDUCTORS

Symbol	Description	Part No.
Q1	Transistor	2SA725-G (2SA640-E)
Q2	Transistor	2SA725-G (2SA640-E)
Q3	Transistor	2SC1313-G
Q4	Transistor	2SA726-G ₂ (2SA640-E)

RESISTORS

Symbol	Description	Part No.
R1	Carbon film 150k	RD¼VS 154J NL
R2	Carbon film 6.2k	RD¼VS 622J
R3	Carbon film 6.2k	RD¼VS 622J
R4	Carbon film 33k	RD¼VS 333J
R5	Carbon film 13k	RD¼VS 133J
R6	Carbon film 4.7k	RD¼VS 472J

CAPACITORS

Symbol	Description	Part No.
C1	Ceramic 47p 50V	CCDSL 470K 50
C2	Ceramic 10p 50V	CCDSL 100K 50
C3	Electrolytic 100 10V	CEA 101P 10

12.12 DE-EMPHASIS SWITCH ASSEMBLY (AWX-095)

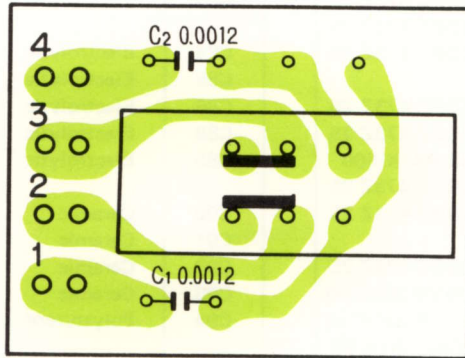

Parts List of De-emphasis Switch Assembly (AWX-095)

Symbol	Description	Part No.
	Slide switch (DE-EMPHASIS)	ASH-015
C1	Mylar capacitor 0.0012 50V	CQMA 122J 50
C2	Mylar capacitor 0.0012 50V	CQMA 122J 50

AM/FM STEREO RECEIVER

SX-750

HG , S

<ART-185-0>

Additional

Service Manual

This leaflet provides the description of the parts applies only to the HG, S model.

For detailed please refer to the Service Manual of SX-750/KC, KU.

 **PIONEER®**

MODEL SX-750 COMES IN FOUR VERSIONS DISTINGUISHED AS FOLLOWS:

Type	Voltage	Remarks
KC KU	120V only	CSA (Canada) and UL (U.S.A) approved with de-emphasis selector switch (25 μ s/75 μ s)
HG	220V and 240V (Switchable)	SEMKO (Sweden), NEMKO (Norway), DEMKO (Denmark) and EI (Finland) approved
S	110V, 120V, 220V and 240V (Switchable)	General export model with de-emphasis selector switch (25 μ s/50 μ s/75 μ s)

CONTENTS

1.	SX-750 HG model		
1.1	Schematic Diagram		5
1.2	Power Supply Assembly (AWR-116)		7
1.3	Exploded View		9
2.	SX-750 S model		
2.1	Schematic Diagram		11
2.1	De-emphasis Switch Assembly (AWX-100)		13
2.3	Exploded View		14

MODEL DIFFERENCE TABLE

Except for the items listed in the following table the parts and circuitry are as described in SX-750/KU, KC service manual. The locations of parts as used in the SX-750/KU, KC are shown in the brackets.

Description	Model		
	HG	S	KU·KC
Power Supply Assembly (page 62)	AWR-116	AWR-100	AWR-100
De-emphasis Switch Assembly (page 74)	—	AWX-100	AWX-095
Wooden Cabinet (page 36 5-B block)	AMM-054	AMM-053	AMM-053
Terminal (antenna) (page 43 2-D block)	AKA-007	AKA-002	AKA-002
Power Transformer (page 38 2-A block)	ATT-325	ATT-324	ATT-264 (KU) ATT-301 (KC)
Fuse FU1 (page 46 4-B block)	AEK-405 (1.6A)	AEK-104 (1.5A)	AEK-104 (1.5A)
Fuse FU2 (page 46 4-A block)	AEK-401 (500mA)	AEK-107 (500mA)	AEK-107 (500mA)
Fuse FU3, FU4 (page 46 4-A, block)	AEK-031 (800mA)	AEK-111 (800mA)	AEK-111 (800mA)
Fuse FU5 (page 46 5-A block)	AEK-403 (2.5A)	110V, 120V AEK-100 (4A) 220V, 240V AEK-103 (2A)	AEK-100 (4A)
Line Voltage Selector	AKX-037	AKR-033	—
Rotary Switch (SPEAKER) (page 42 2-C block)	ASA-040	ASA-038	ASA-039
Fuse holder (1P) (page 38 2-C block)	K91-008	—	AKP-032

Description	Model		
	HG	S	KU·KC
AC Inlet	AKP-008	—	—
Capacitor C3 (page 46 5-A block)	ACG-001	ACG-001	ACG-003
Capacitor C4 (page 46 5-A block)	—	ACG-001	ACG-001 (KU) ACG-003 (KC)
AC Power Cord (page 43 2-A block)	—	ADG-002	ADG-005
Operating Instructions (page 44)	ARB-184 (English) ARD-094 (German/ French)	ARB-181	ARB-174

Specifications	HG	S	KU·KC
Power Requirements	220V 240V 50Hz	110V 120V 220V 240V 50/60Hz	120V 60Hz
Power Consumption	430W	350W (Max)	350W

1. SX-750/HG model

1.1 SCHEMATIC DIAGRAM

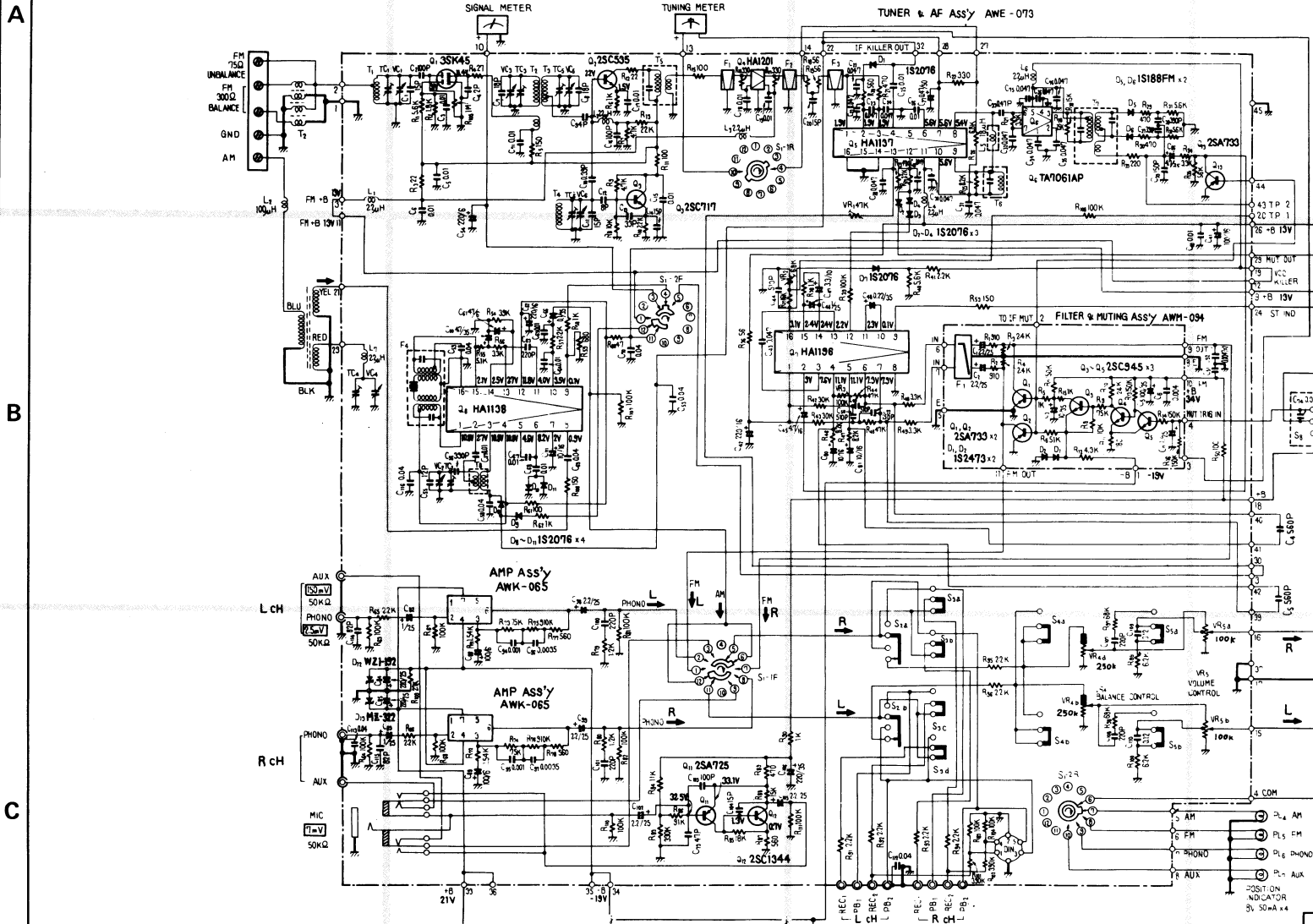

- SWITCHES:**
- | | | |
|---|--|--|
| S ₁ FUNCTION
1 AM
2 FM
3 PHONO
4 AUX/MIC | S ₅ LOUDNESS
OFF → ON | S ₁₀ SPEAKER
1 POWER OFF
2 SP A
3 SP OFF
4 SP B
5 SP A + B |
| S ₂ TAPE MONITOR
1 OFF → 2 | S ₆ TONE
OFF → ON | S ₁₁ AC VOLTAGE SELECTOR
240V → 220V |
| S ₃ DUPLICATE
OFF → ON | S ₇ HIGH FILTER
OFF → ON | S ₈ FM MUTING
ON → OFF |
| S ₄ MODE
STEREO → MONO | S ₉ RELAY | |

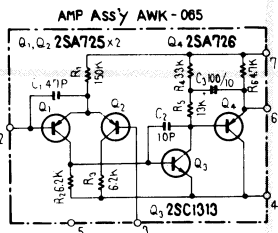

RESISTORS:
IN OHM, 1/4W, ±5% TOLERANCE UNLESS OTHERWISE NOTED K: kΩ M: MΩ

CAPACITORS:
IN μF UNLESS OTHERWISE NOTED P: pF

NOTES:
 [V] : SIGNAL VOLTAGE NECESSARY FOR OBTAINING 56W/8Ω OUTPUT POWER (1kHz)
 [V] : DC VOLTAGE AT NO INPUT SIGNAL
 [mA] : DC CURRENT AT NO INPUT SIGNAL

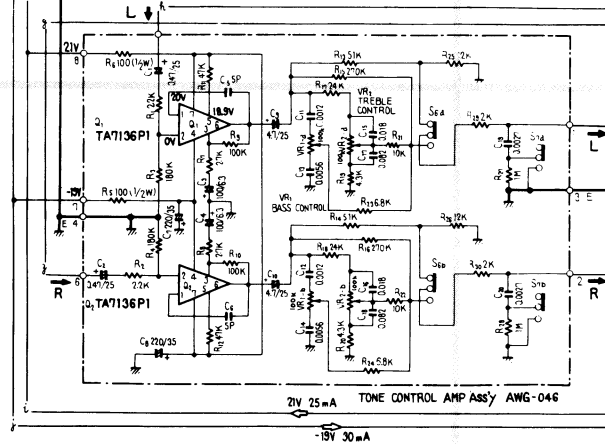

-073

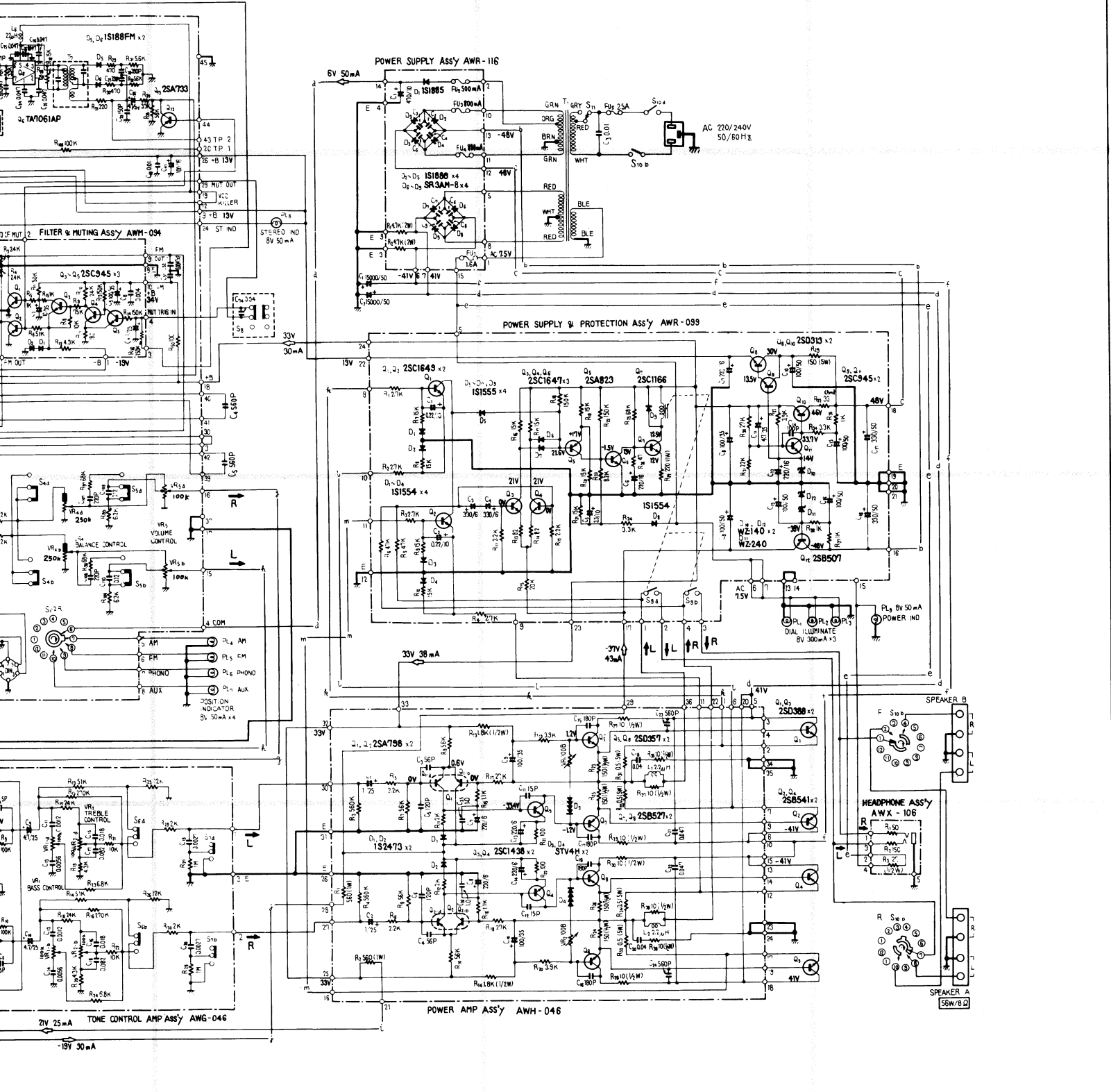

A

B

C

D

1.2 POWER SUPPLY ASSEMBLY (AWR-116)

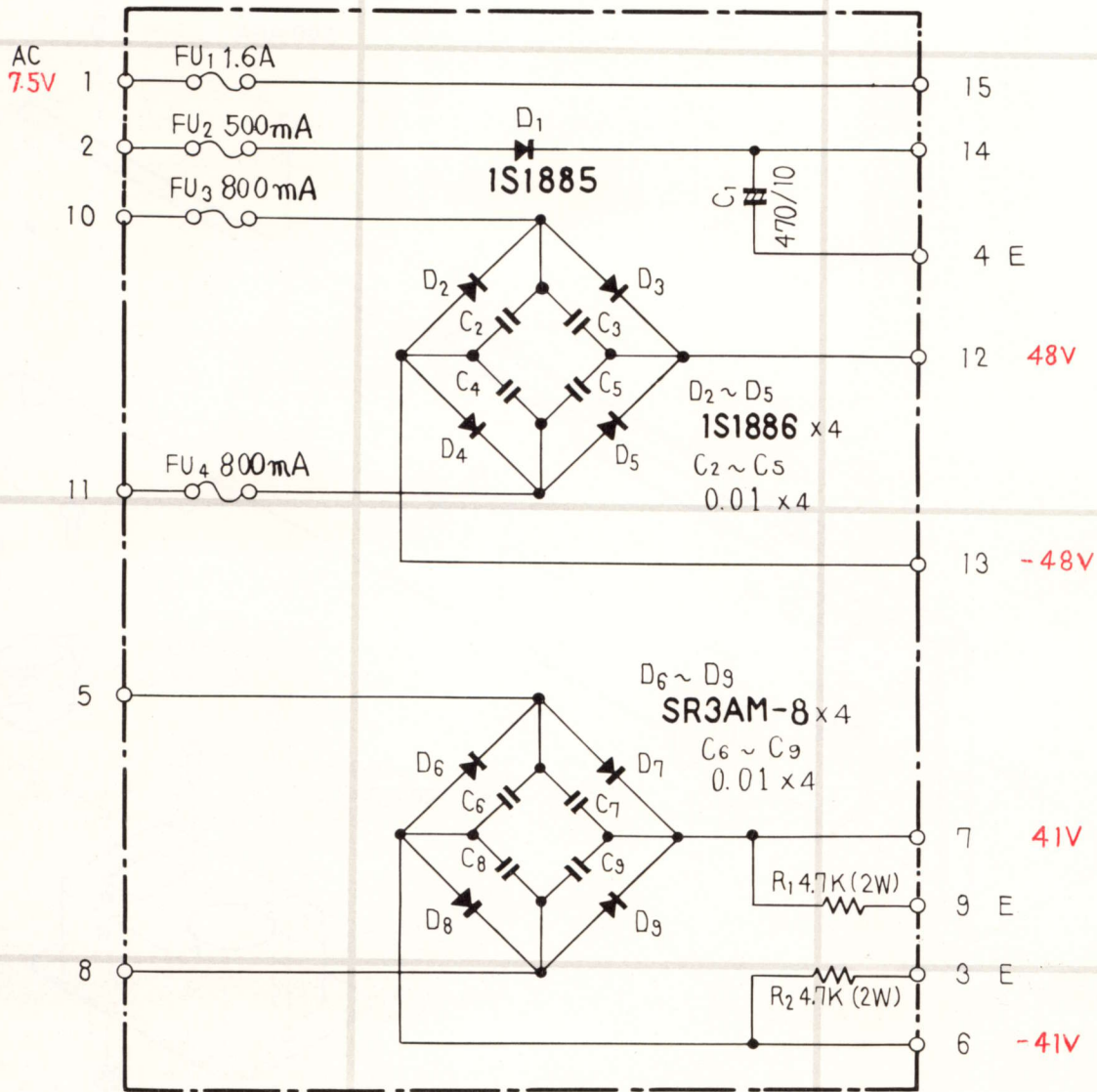

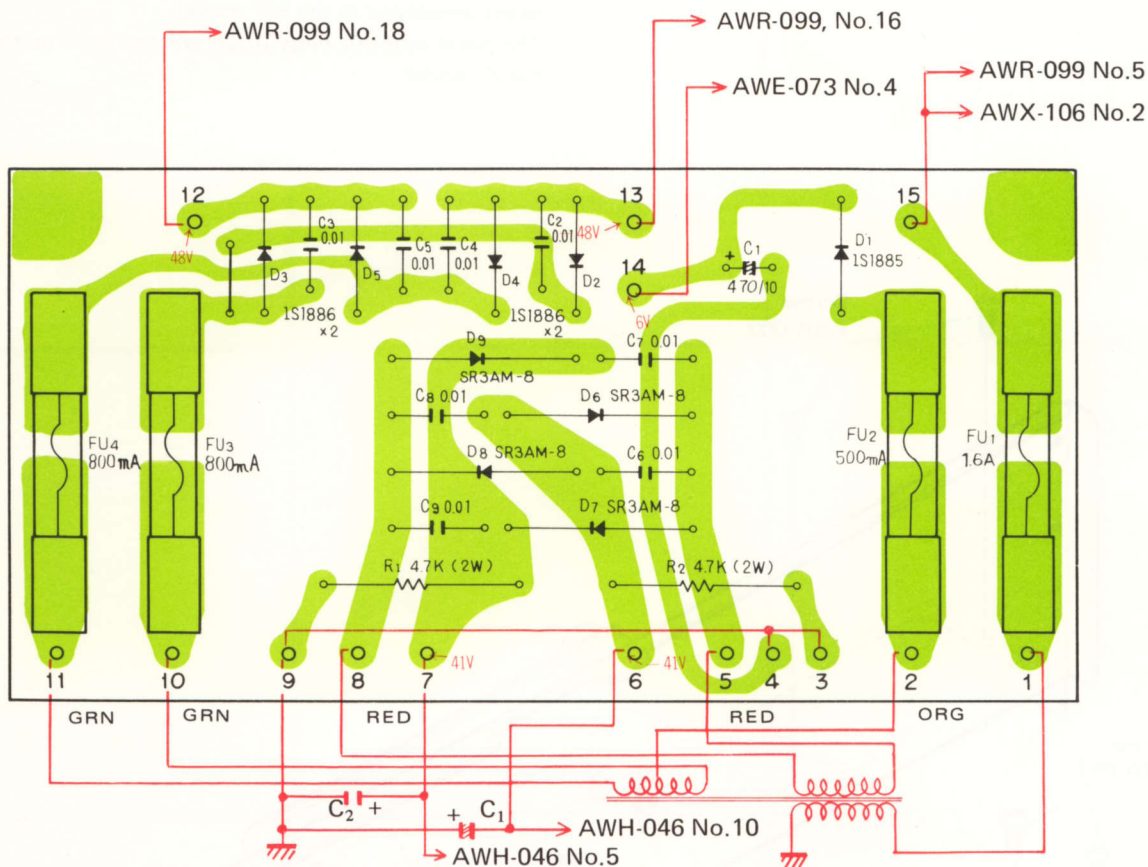

Parts List of Power Supply Assembly (AWR-116)

SEMICONDUCTORS

Symbol	Description	Part No.
D1	Diode	1S1885
D2	Diode	1S1886
D3	Diode	1S1886 or SIB-01-02
D4	Diode	1S1886 or SIB-01-02
D5	Diode	1S1886 or SIB-01-02
D6	Diode	SR3AM-8
D7	Diode	SR3AM-8
D8	Diode	SR3AM-8
D9	Diode	SR3AM-8

CAPACITORS

Symbol	Description	Part No.
C1	Electrolytic 470 10V	CEA 471P 10
C2	Ceramic 0.01 250V	ACG-001-0
C3	Ceramic 0.01 250V	ACG-001-0
C4	Ceramic 0.01 250V	ACG-001-0
C5	Ceramic 0.01 250V	ACG-001-0
C6	Ceramic 0.01 250V	ACG-001-0
C7	Ceramic 0.01 250V	ACG-001-0
C8	Ceramic 0.01 250V	ACG-001-0
C9	Ceramic 0.01 250V	ACG-001-0

OTHERS

Symbol	Description	Part No.
	Fuse clip	AKR-010-0

RESISTORS

Symbol	Description	Part No.
R1	Metal oxide 4.7k 2W	RS2P 472K
R2	Metal oxide 4.7k 2W	RS2P 472K

1.3 EXPLODED VIEW

*The parts indicated by designation and part numbers are newly-employed in the HG model.
The parts without description are the same as the parts in the K model.*

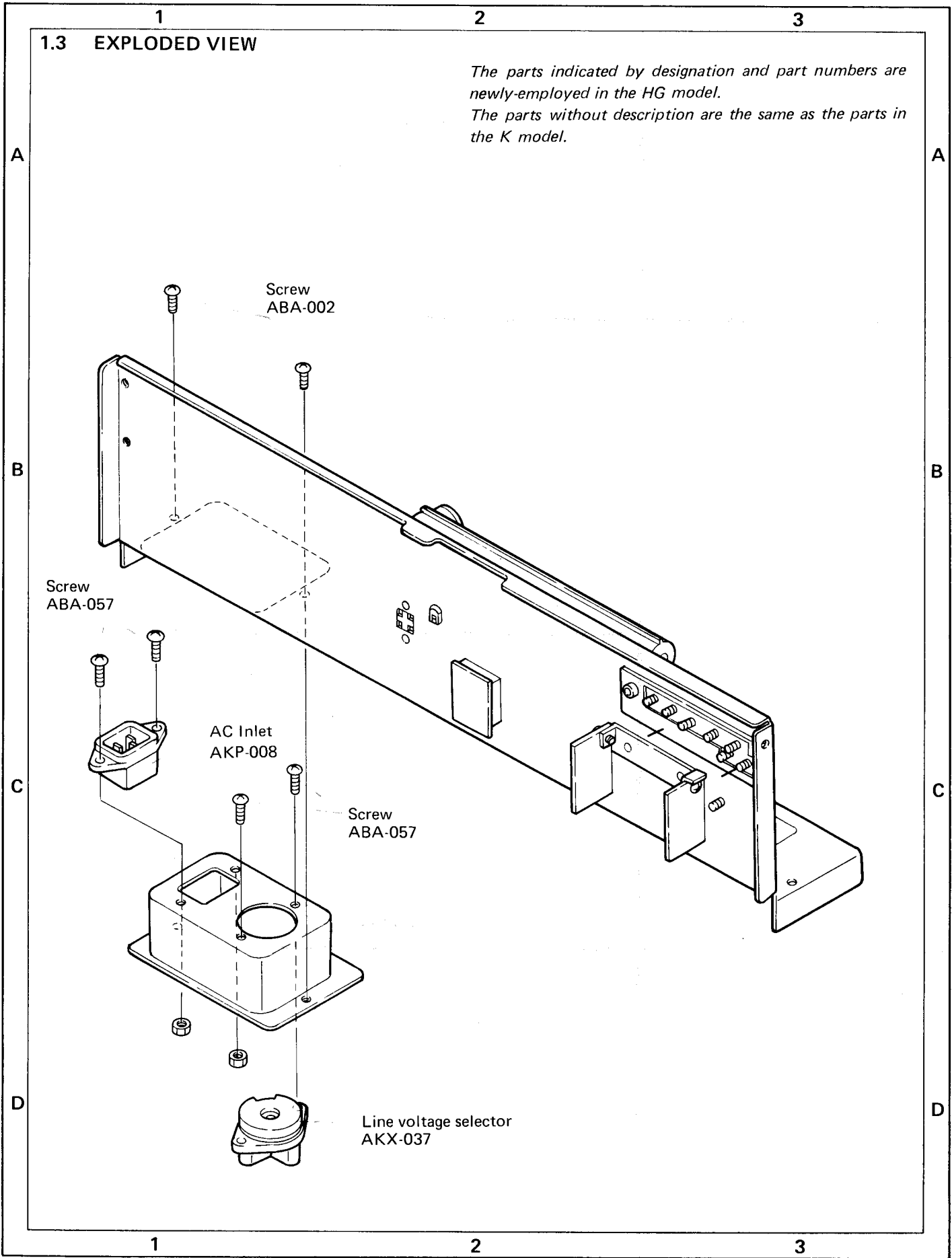

2. SX-750/S model

2.1 SCHEMATIC DIAGRAM

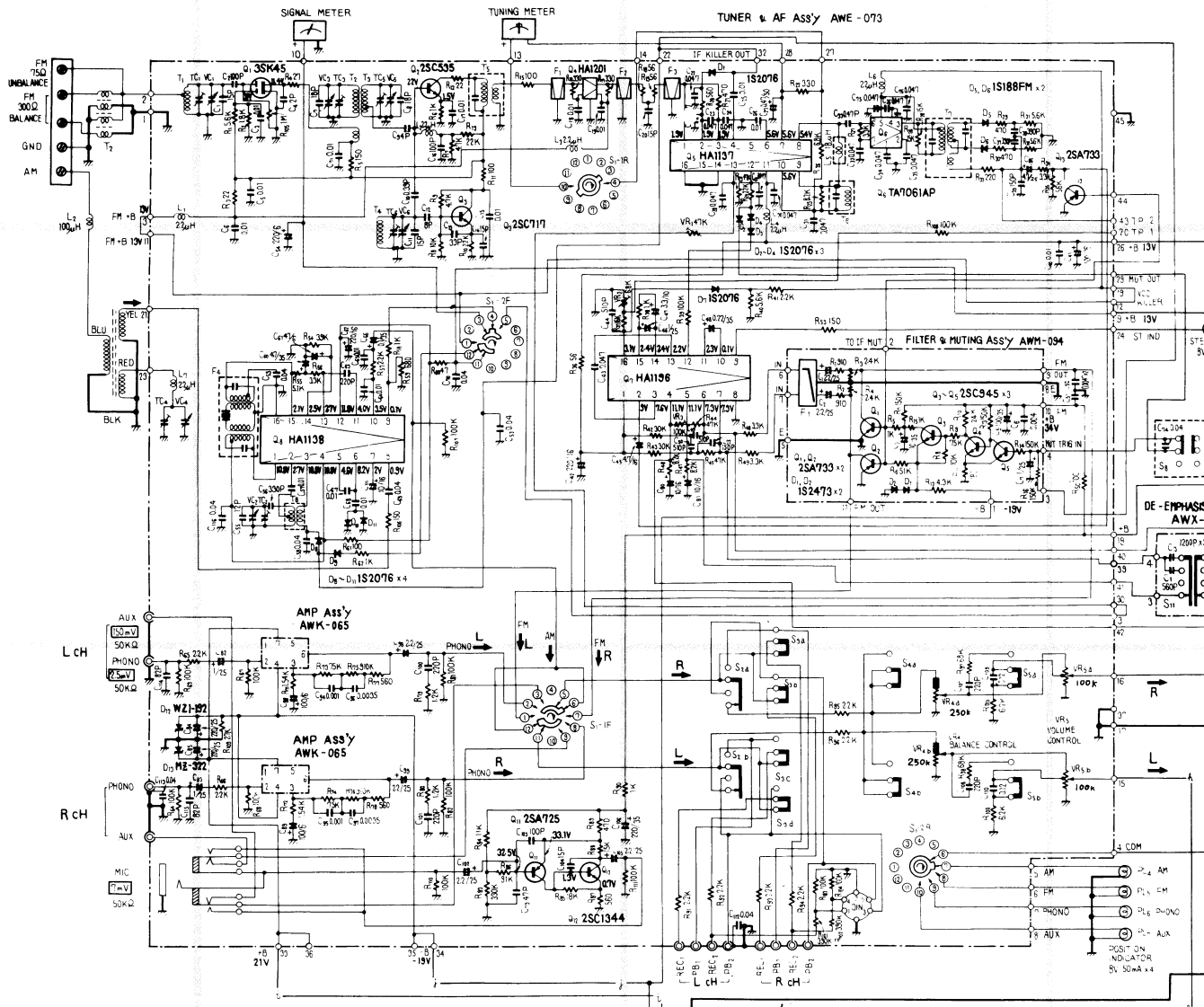

- SWITCHES:**
- | | | |
|-----------------------------|----------------------------|-----------------------------|
| S ₁ FUNCTION | S ₅ LOUDNESS | S ₁₀ SPEAKER |
| 1 AM | OFF → ON | POWER OFF |
| 2 FM | | 1 SP A |
| 3 PHONO | S ₆ TONE | 2 SP B |
| 4 AUX/MIC | OFF → ON | 3 SP A + B |
| S ₂ TAPE MONITOR | S ₇ HIGH FILTER | S ₁₁ DE-EMPHASIS |
| 1 → OFF → 2 | OFF → ON | 25μS - 50μS - 75μS |
| S ₃ DUPLICATE | S ₈ FM MUTING | S ₁₂ FUSE HOLDER |
| OFF → ON | ON → OFF | 1 110V |
| S ₄ MODE | S ₉ RELAY | 2 120V |
| STEREO → MONO | | 3 230V |
| | | 4 240V |

RESISTORS:
IN OHM, 1/4W, ±5% TOLERANCE UNLESS OTHERWISE NOTED K: KΩ M: MΩ

CAPACITORS:
IN μF UNLESS OTHERWISE NOTED P: pF

NOTES:
 [V] : SIGNAL VOLTAGE NECESSARY FOR OBTAINING 5W/8Ω OUTPUT POWER (1KHz)
 [V] : DC VOLTAGE AT NO INPUT SIGNAL
 [mA] : DC CURRENT AT NO INPUT SIGNAL

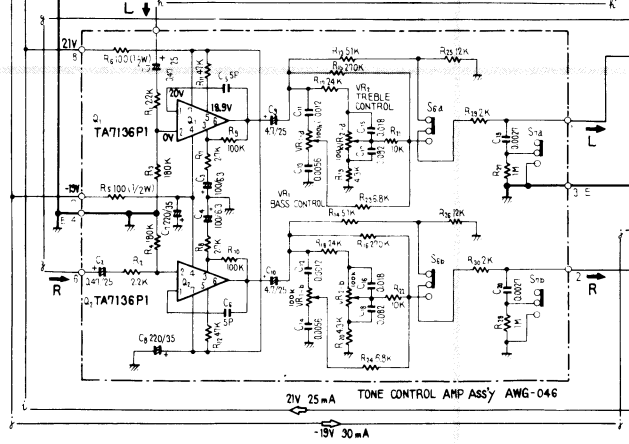

4

5

6

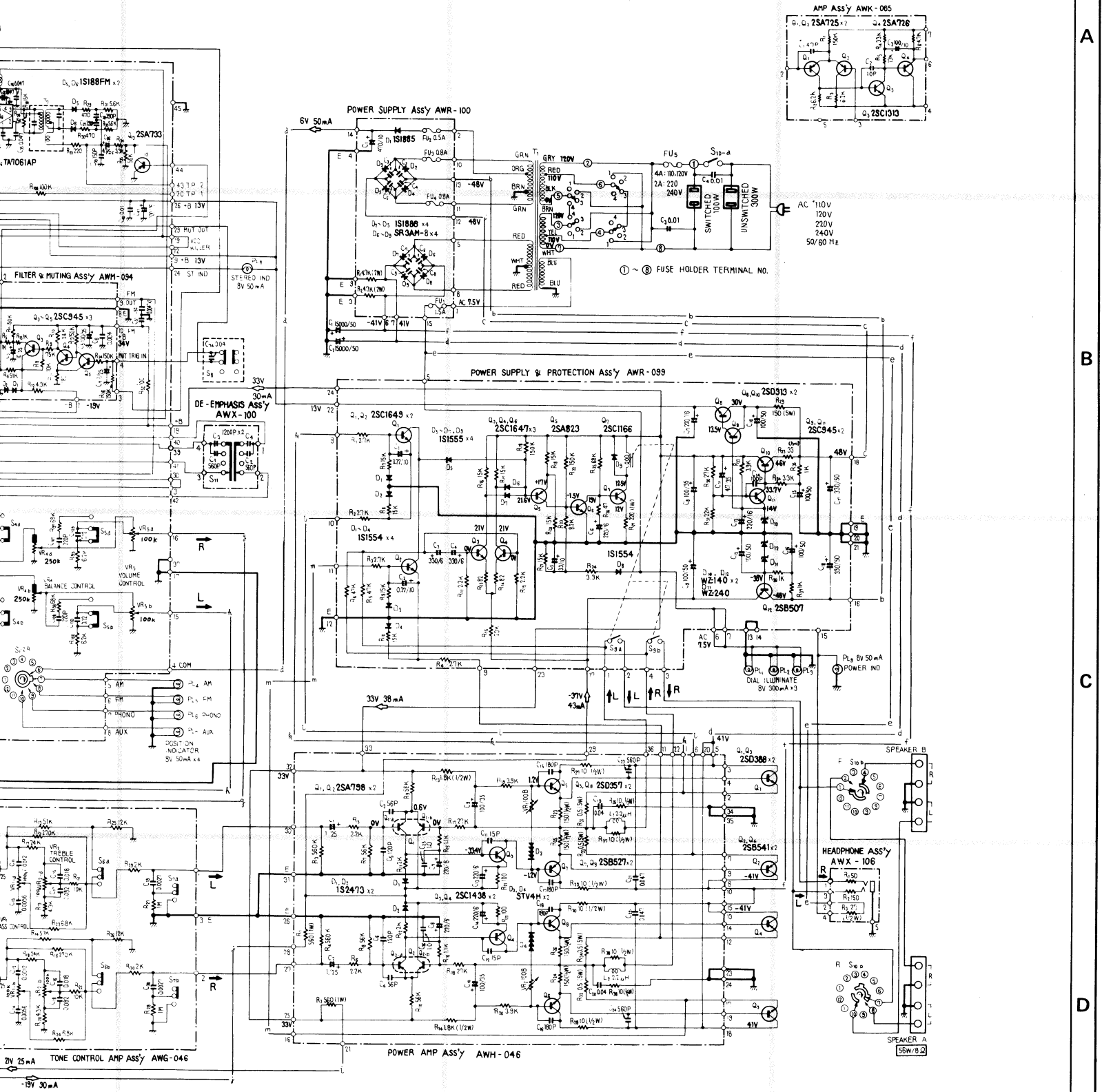

4

5

6

2.2 DE-EMPHASIS SWITCH ASSEMBLY (AWX-100)

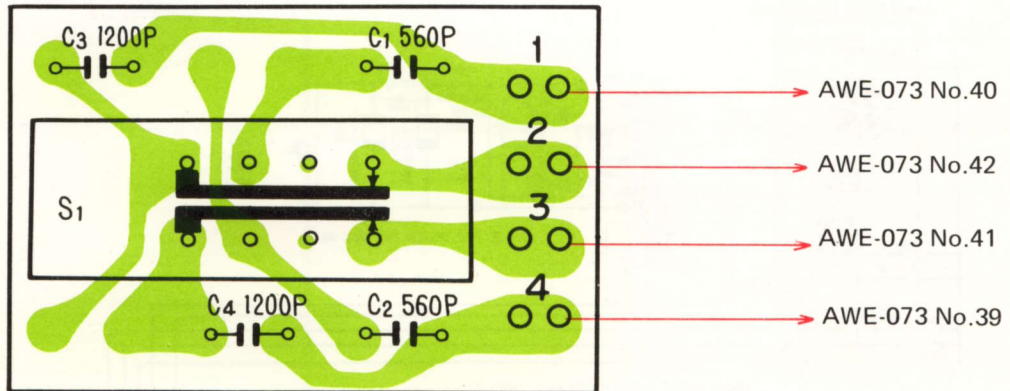

Part List

Symbol	Description	Part No.
S1	Slide switch (DE-EMPHASIS)	ASH-017
C1	Polystyrene capacitor 560p 50V	CQSA 561J 50
C2	Polystyrene capacitor 560p 50V	CQSA 561J 50
C3	Mylar capacitor 0.0012 50V	CQMA 122J 50
C4	Mylar capacitor 0.0012 50V	CQMA 122J 50

2.3 EXPLODED VIEW

The parts indicated by designation and part numbers are newly-employed in the S model.
The parts without description are the same as the parts in the K model.

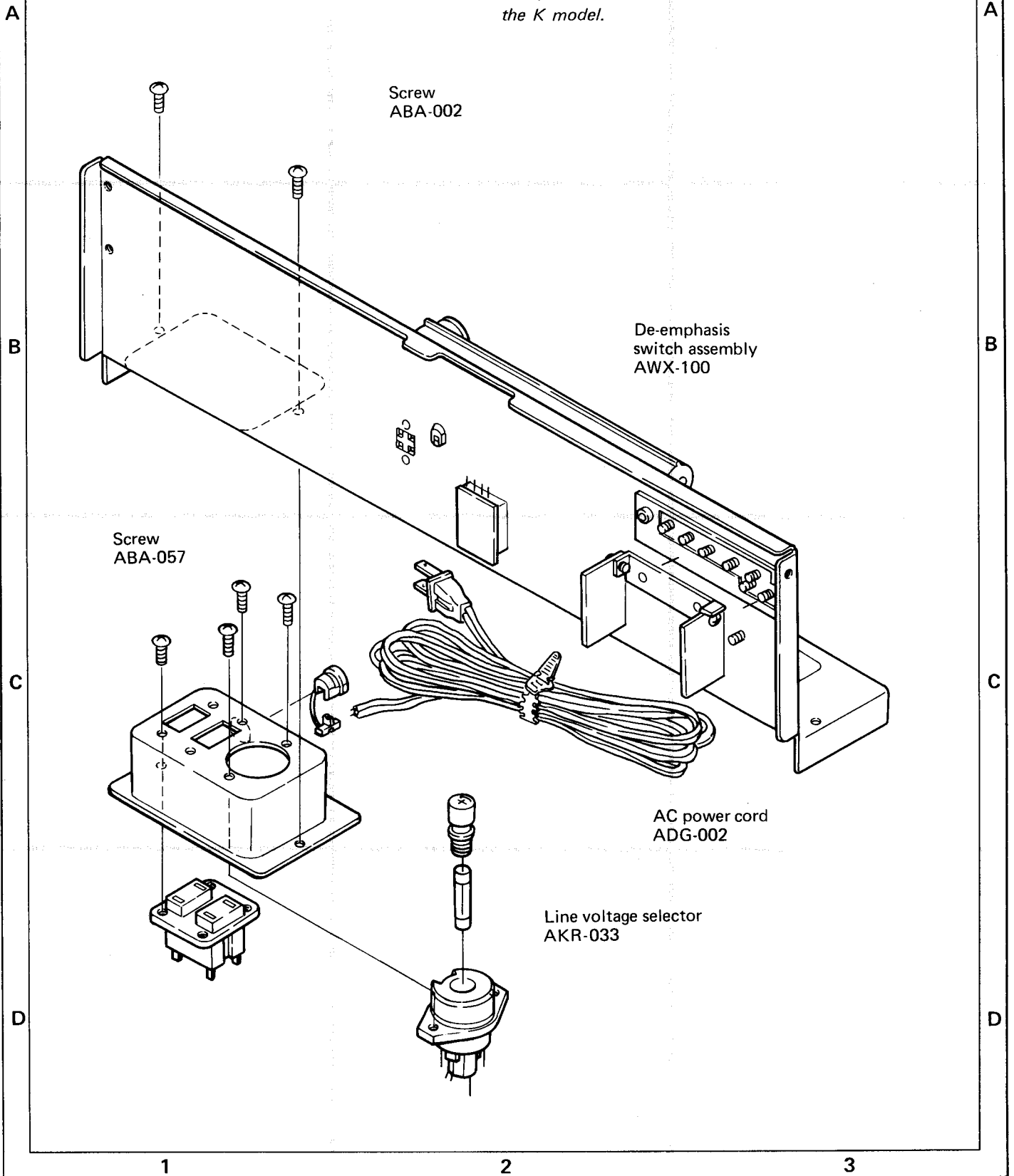

PIONEER ELECTRONIC CORPORATION

4-1, Meguro 1-Chome, Meguro-ku, Tokyo 153, Japan

U.S. PIONEER ELECTRONICS CORPORATION

75 Oxford Drive, Moonachie, New Jersey 07074, U.S.A.

PIONEER ELECTRONIC (EUROPE) N.V.

Luithagen-Haven 9, 2030 Antwerp, Belgium

PIONEER ELECTRONICS AUSTRALIA PTY. LTD.

178-184 Boundary Road, Braeside, Victoria 3195, Australia

© JULY 1976

Printed in Japan

AMENDMENT TO SX-750/KU·KC Service Manual

A misprint appears on page 52 "12.5 TONE CONTROL ASSEMBLY (AWG-046)" in point of voltage value.

Please replace the original P.C. Board by the ones provided below.

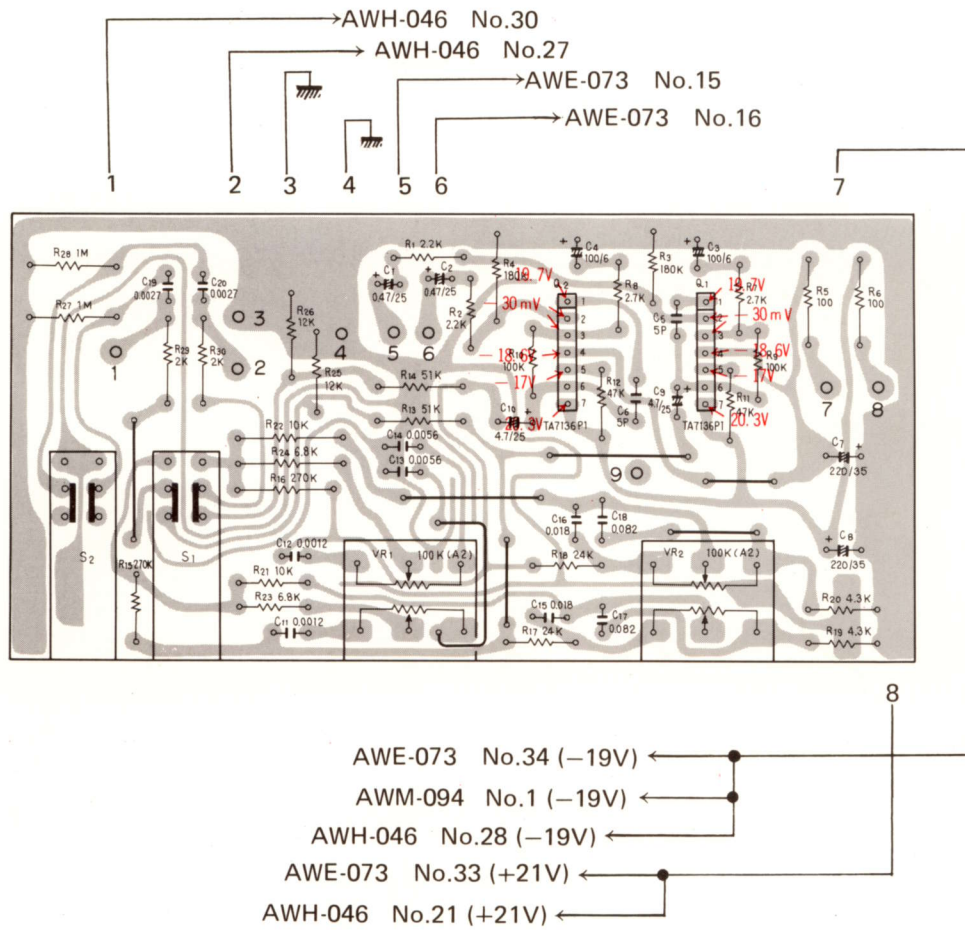

PIONEER ELECTRONIC CORPORATION

4-1, Meguro 1-Chome, Meguro-ku, Tokyo 153, Japan

U.S. PIONEER ELECTRONICS CORPORATION

75 Oxford Drive, Moonachie, New Jersey 07074, U.S.A.

PIONEER ELECTRONIC (EUROPE) N.V.

Luiithagen-Haven 9, 2030 Antwerp, Belgium

PIONEER ELECTRONICS AUSTRALIA PTY. LTD.

178-184 Boundary Road, Braeside, Victoria 3195, Australia