



# *Service Manual*

STEREO RECEIVER

# **SX-3700**

# **SX-820**

 **PIONEER**

**MODEL SX-3700 COMES IN FOUR VERSIONS DISTINGUISHED AS FOLLOWS.**

Type	Voltage	Remarks
KU	120V only	U.S.A. model
KC	120V only	Canada model
S	110V, 120V, 220V, and 240V (Switchable)	General export model
S/G	110V, 120V, 220V, and 240V (Switchable)	U.S. Military model

- This service manual is applicable to the SX-3700/KU. For servicing of the other types, please refer to the additional service manual.

## CONTENTS

1. SPECIFICATIONS .....	3	7. DIAL CORD STRINGING .....	16
2. FRONT PANEL FACILITIES .....	4	8. ADJUSTMENTS	
3. BLOCK DIAGRAM .....	6	8.1 FM Tuner .....	17
4. CIRCUIT DESCRIPTIONS		8.2 AM Tuner .....	18
4.1 FM Tuner .....	7	8.3 Idle Current Adjustment .....	19
4.2 AM Tuner .....	8	8.4 FL Indicator Circuit .....	19
4.3 Display Circuit .....	8	9. SCHEMATIC DIAGRAMS, P.C. BOARD	
4.4 Equalizer Amplifier .....	11	CONNECTION DIAGRAM AND PARTS	
4.5 Tone Control Amplifier .....	11	LIST	
4.6 Power Amplifier .....	11	9.1 Schematic Diagram .....	21
4.7 Power Indicator Circuit .....	11	9.2 P.C. Board Connection Diagram .....	25
4.8 Protection Circuit .....	11	9.3 Parts List .....	30
5. DISASSEMBLY .....	13	10. PACKING .....	34
6. PARTS LOCATION .....	14	11. EXPLODED VIEW .....	35
		12. ADDITIONAL SERVICE MANUAL SX-820 ...	41

# 1. SPECIFICATIONS

## Amplifier Section

Continuous power output of 45 watts\* per channel, min., at 8 ohms from 20 Hertz to 20,000 Hertz with no more than 0.02% total harmonic distortion.

Total Harmonic Distortion (20 Hertz to 20,000 Hertz, 8 ohms, from AUX)

continuous rated power output . . . No more than 0.02%  
22.5 watts per channel power output

..... No more than 0.02%

Intermodulation Distortion (50 Hertz to 7,000 Hertz = 4 : 1, 8 ohms, from AUX)

continuous rated power output . . . No more than 0.02%  
22.5 watts per channel power output

..... No more than 0.02%

Damping Factor (20 Hertz to 20,000 Hertz, 8 ohms)

..... 40

Input (Sensitivity/Impedance)

PHONO ..... 2.5mV/50 kilohms

AUX, TAPE PLAY 1, 2 ..... 150mV/50 kilohms

Phono Overload Level (T.H.D. 0.02%, 1,000Hz)

PHONO ..... 250mV

Output

TAPE REC 1, 2 ..... 150mV

Speaker ..... A, B, A+B

Frequency Response

PHONO (RIAA Equalization)  
..... 20Hz to 20,000Hz  $\pm 0.2$ dB

AUX, TAPE PLAY 1, 2  
..... 10Hz to 100,000Hz  $\pm 1$ dB

Tone Control

BASS .....  $\pm 8$ dB (100Hz)

TREBLE .....  $\pm 8$ dB (10,000Hz)

Subsonic Filter ..... 15Hz (-6dB/oct)

Loudness Contour (Volume control set at -40dB position)

..... +6dB (100Hz)

Hum and Noise (IHF, short-circuited, A network)

PHONO ..... 79dB

AUX, TAPE PLAY 1, 2 ..... 95dB

## FM Tuner Section

Usable Sensitivity (IHF) ..... 10.3dBf (1.8 $\mu$ V)

50dB Quieting Sensitivity

MONO ..... 15dBf (3.1 $\mu$ V)

STEREO ..... 37dBf (39 $\mu$ V)

Signal-to-Noise Ratio

MONO ..... 80dB (at 65dBf)

STEREO ..... 75dB (at 85dBf)

Distortion (at 65dBf)

MONO 100Hz ..... 0.1%

1kHz ..... 0.07%

6kHz ..... 0.15%

STEREO 100Hz ..... 0.2%

1kHz ..... 0.15%

6kHz ..... 0.25%

Capture Ratio ..... 1.0dB

Alternate Channel Selectivity

400kHz ..... 75dB

Stereo Separation

1kHz ..... 45dB

30Hz to 15kHz ..... 35dB

Frequency Response ..... 20Hz to 15kHz  $\pm 0.2$ dB

Spurious Response Ratio ..... 65dB

Image Response Ratio ..... 65dB

IF Response Ratio ..... 90dB

AM Suppression Ratio ..... 55dB

Subcarrier Product Ratio ..... 50dB

SCA Rejection Ratio ..... 65dB

Muting Threshold ..... 19.2dBf (5 $\mu$ V)

Antenna Input ..... 300 ohms balanced,  
75 ohms unbalanced.

## AM Tuner Section

Sensitivity (IHF, Ferrite Antenna) . . . 300 $\mu$ V/m

(IHF, Ext. antenna) . . . 15 $\mu$ V

Selectivity ..... 27dB

Signal-to-Noise Ratio ..... 52dB

Image Response Ratio ..... 32dB

IF Response Ratio ..... 40dB

Antenna ..... Ferrite loopstick antenna

## Miscellaneous

Power Requirements ..... AC 120V, 60Hz

Power Consumption ..... 290W (UL)

Dimensions ..... 480(W) x 145(H) x 364(D)mm  
18-14/16(W) x 5-11/16(H) x 14-5/16(D)in

Weight (without package) ..... 11.6kg (25 lb 9oz)

## Furnished Parts

Operating instructions ..... 1

FM T-type antenna ..... 1

*\*Measured pursuant to the Federal Trade Commission's Trade Regulation rule on Power Output Claims for Amplifiers.*

### NOTE:

*Specifications and the design subject to possible modifications without notice due to improvements.*

## 2. FRONT PANEL FACILITIES

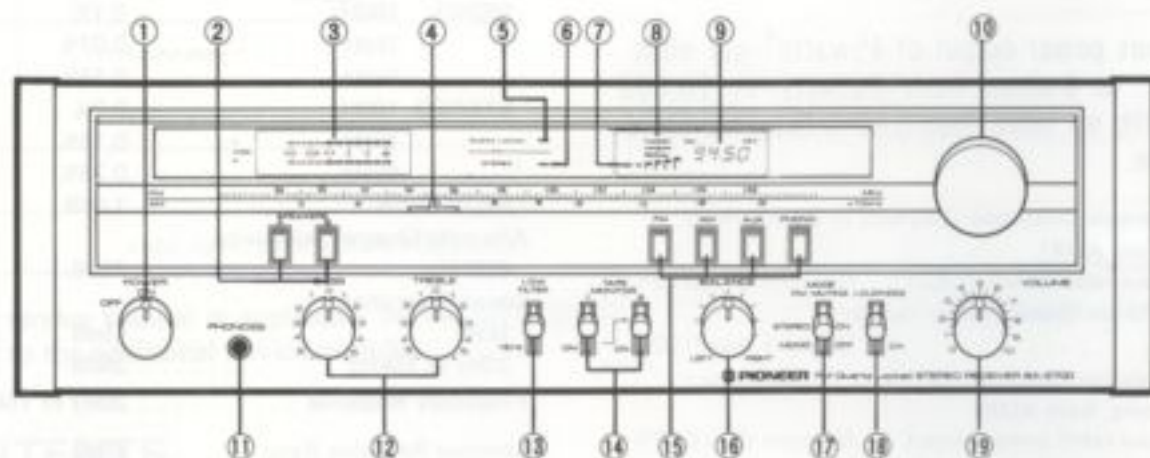

### ① POWER SWITCH

Set this switch to ON to supply power to the receiver. There will be a short delay when it is set to ON, because the muting circuit has been actuated to suppress the unpleasant noise that is sometimes generated when the power is switched on and off.

### ② SPEAKER SWITCHES

Depress the switch corresponding to the speakers connected to the SPEAKERS terminals (A or B) on the rear panel.

You can depress both of these buttons to listen to the sound from two pairs of speaker systems at the same time.

### ③ POWER METER

This meter allows you to read out the rated power level on the fluorescent display tube when speakers with a nominal impedance of 8 ohms are connected to the speaker terminals.

### ④ DIAL POINTER

This pointer indicates the broadcasting stations.

### ⑤ QUARTZ LOCKED INDICATOR

This indicator lights up after the optimum tuning point has been obtained and displays that the receiving state is stabilized by the built-in quartz lock circuit.

### ⑥ FM STEREO INDICATOR

This indicator lights up when receiving an FM stereo program.

### ⑦ SIGNAL INDICATOR

This indicator lights in sequence from left through right during the tuning of an AM or FM broadcast in accordance with the strength of the signals being received. The optimum tuning point is where the maximum number of indicators light.

### ⑧ TUNING INDICATOR

When tuning in an FM station, the optimum reception point is indicated when the center indicator lights up. When the left indicator has come on, rotate the tuning knob slightly clockwise. When the right indicator comes on, rotate the knob slightly counterclockwise.

### ⑨ FREQUENCY DISPLAY

This indicates the frequency which is tuned. With FM reception, the letters "FM" appear on the left of the display and "MHz" on the right. With AM reception, "AM" appears on the left and "kHz" on the right. These change when the function selector position is changed.

### ⑩ TUNING KNOB

Use this knob to tune in to broadcasting stations.

### ⑪ HEADPHONES JACK

Plug the headphones into this jack when you want to listen through your stereo headphones. Release both speaker switches if you want to listen to the sound through your headphones only.

**12 BASS AND TREBLE CONTROLS**

Use these controls to adjust the bass and the treble. If you turn the bass control to the right from its center (0) position, you will be able to emphasize the sound in the low-frequency range. Conversely, turning this control to the left from the center (0) position will attenuate the sound. You can use the treble control to adjust the sound in the high-frequency range.

**13 LOW FILTER SWITCH**

When this switch is set to 15Hz, a 6dB/oct attenuation can be provided for frequencies below 15Hz. This means that you can cancel out noise in the ultra-low frequencies which is generated by low-pitched rumble from a turntable and other forms of distortion. Although this noise cannot be heard, it can generate intermodulation distortion and damage the speakers.

**14 TAPE MONITOR SWITCHES**

Employ for tape playback or to monitor a recording in progress.

- 1: Playback or monitoring of a tape deck connected to the TAPE 1 jacks.
- 2: Playback or monitoring of a tape deck connected to the TAPE 2 jacks.

**NOTE:**

1. Be sure to set the switches to the upper (OFF) position when playing records or listening to broadcasts.
2. When recording with two tape decks simultaneously, do not operate the tape monitor 1 switch as this will interrupt the signal to the TAPE 2 deck.

**15 FUNCTION SELECTOR**

Depress the function switch which corresponds to the program source. Turn the volume control down first before selecting a different function switch while the sound from one program source is being reproduced.

- FM:** Depress this switch for FM broadcasts.  
**AM:** Depress this switch for AM broadcasts.  
**AUX:** Depress this switch when listening to an audio component connected to the AUX jacks.  
**PHONO:** Depress this switch when playing a record on the turntable connected to the PHONO jacks.

**NOTE:**

Only one function switch should be depressed at a time.

**16 BALANCE CONTROL**

Use this control to balance the volume of the left and right channels. First, however, set the mode/FM muting switch to MONO/OFF. If the sound appears to be louder on the right, it means that the volume of the right channel is higher. Turn the balance control to the left and adjust. Conversely, if the sound appears to be louder on the left, it means that the volume of the left channel is higher. Therefore, turn the balance control to the right and adjust. After adjusting, return the mode/FM muting switch to STEREO/ON.

**17 MODE/FM MUTING SWITCH**

This switch is a combination of the FM muting switch and the mode select switch. When setting this switch at STEREO/ON position the reproduction is in stereo mode, while the FM muting function acts to suppress unpleasant interstation noise while tuning between FM stations when listening to FM broadcasting. When setting this switch at MONO/OFF position, however, reproduction is in mono mode, while the FM muting function does not act, thus enabling suitable reception of weak radio stations when tuning in to the FM broadcasting station.

**NOTE:**

Recording stereophonically with the mode/FM muting switch in the MONO/OFF position may cause deterioration in channel separation.

**18 LOUDNESS SWITCH**

When listening to a performance with the volume control turned down, depress this switch and the bass will be accentuated.

When the volume is low, the human ear finds it harder to hear the bass than when the volume is high. The loudness switch is thus designed to compensate for this deficiency. By depressing this switch, the bass come through much more strongly and the sound takes on a punch even when the volume control is turned down.

**19 VOLUME CONTROL**

Use this control to adjust the output level to the speakers and headphones. Turn it clockwise to increase the output level. No sound will be heard if you set it to "0."

### 3. BLOCK DIAGRAM

#### RF Block

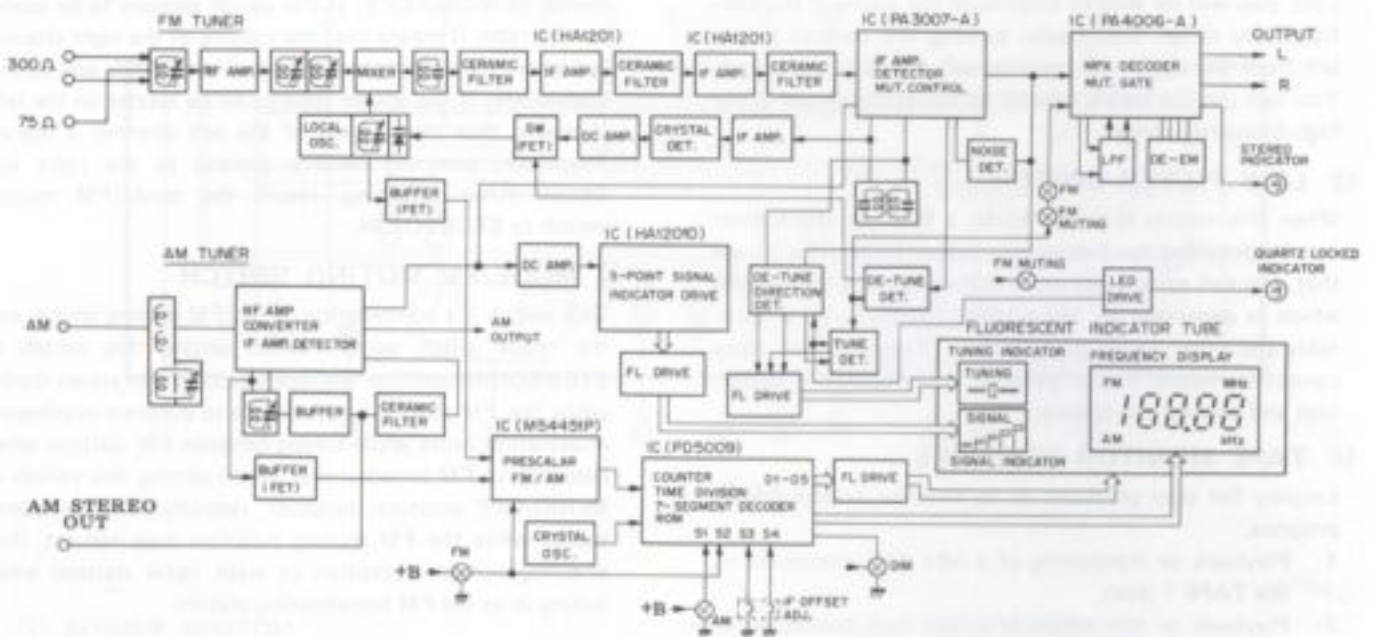

#### AF Block

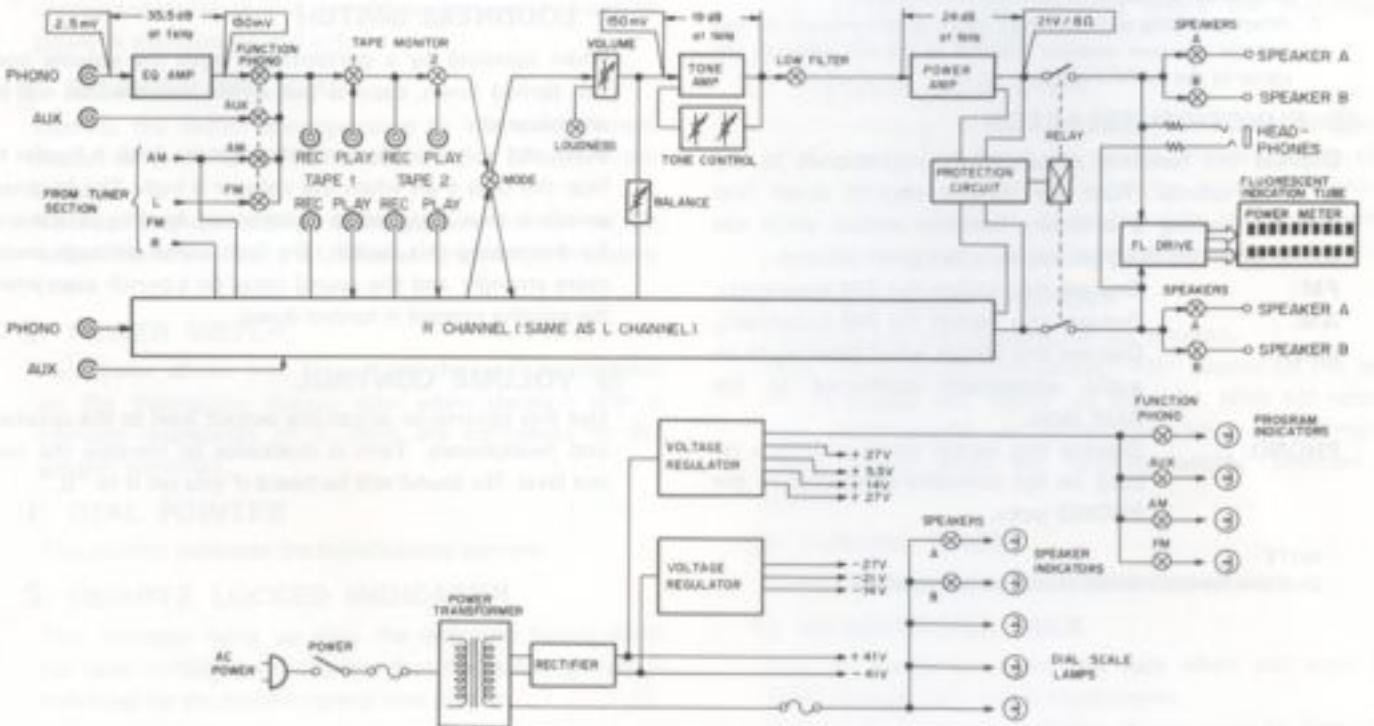

## 4. CIRCUIT DESCRIPTIONS

### 4.1 FM TUNER

#### Front End

The FM front end of SX-3700 includes a 3 ganged tuning capacitor, a dual-gate MOS EFT-equipped 1-stage RF amplifier, and a modified Clapp circuit local oscillator. This oscillator is a voltage controlled oscillator employing a vari-cap (variable capacitance diode). When the quartz-lock system (refer to "Quartz-lock system") is not in operation, a constant voltage is applied to the diode.

#### IF Amplifier and Detector

These employ 3 ICs and 3 dual-element ceramic filters. The IC (HA1201) of the first 2 stage constitutes a single-stage differential amplifier current-limiting limiter. The IC (PA3007-A) in the third stage, an improvement on the former IF system IC (PA3001-A), includes an IF limiter amplifier, quadrature detector, meter drive, and other circuits. Performance in terms of distortion, S/N ratio, delay characteristics, and other parameters, shows a marked improvement in comparison to the PA3001-A.

#### Multiplex Decoder

The recently developed multiplex decoder IC (PA4006-A) combines MPX decoding with muting functions in a single IC, thereby handling the functions of the more conventional MPX IC (PA1001-A) and AF MUTING IC (PA1002-A).

Distortion ratings and S/N ratio have been further improved by incorporating a chopper type MPX decoder. The chopper type switching circuit (see Fig. 4-1) operates by switching the signal either to ground or to the through circuit, thereby eliminating the generation of unwanted noise or distortion. Furthermore, since the PA4006-A features DC direct-coupled switching with the detec-

tor, there is no deterioration in separation at the low frequency end.

Besides the decoder and muting circuits, the PA4006-A also incorporates the pilot signal canceler, stereo auto selector, VCO killer circuit, MUT amplifier, and MUT control circuit.

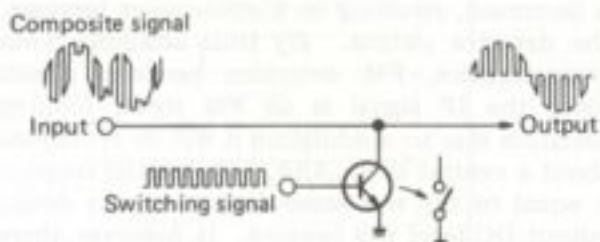

Fig. 4-1 Chopper type switching circuit

#### Quartz-Lock System

The quartz-lock system featured in the SX-3700 stereo receiver is a frequency servocontrol system employing a crystal resonator. Any displacement in the intermediate frequency (IF) is detected as a DC voltage by the discriminator (equipped with a crystal resonator), resulting in the local oscillator frequency being corrected and subsequently locked. This extremely stable frequency servo-control system thus ensures that tuned frequencies remain tuned securely for as long as required.

When the IF signal appears at pin no.17 of the IF system IC (PA3007-A), it is amplified and applied to crystal detector (see Fig. 4-2) which consists of diodes connected in parallel in a series resonance circuit equipped with a crystal resonator. The resonance frequency is the same as the IF frequency (10.7MHz), which means the impedance at this time will be minimal, resulting in the output being reduced to a minimum level. If the input frequency increases, the reactance of the capacitance

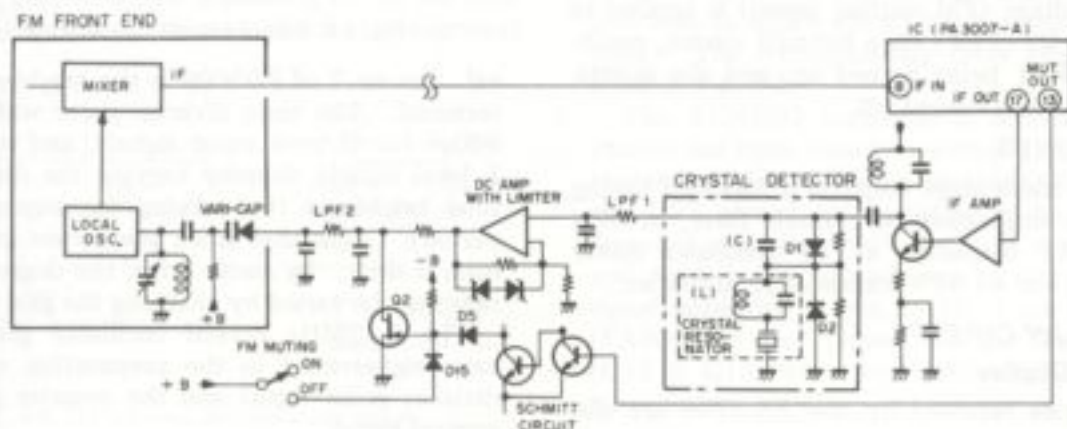

Fig. 4-2 FM quartz-lock system

stage (C) is reduced, and the reactance of the inductance stage (L) increased, resulting in AM detection by D2 which leaves the positive portion of the IF signal. If the input frequency decreases, L stage reactance is decreased and C stage reactance increased, resulting in AM detection by D1 which leaves the negative portion of the IF signal. The L stage and C stage reactances increase as the degree of detuning in the respective directions is increased, resulting in a subsequent increase in the detector output. By thus attaining S-curve characteristics, FM detection becomes possible. Since the IF signal is an FM signal frequency deviation due to modulation it will be symmetrical about a central axis. And if the central frequency is equal to the resonance frequency, the detector output DC level will be zero. If, however, there is any displacement in the central frequency, frequency deviation in respect to the detector will become asymmetrical, resulting in the generation of a DC voltage. This DC voltage is passed through LPF1 (IF filter) and LPF2 (AC filter) to form a correction voltage which is applied to the variable capacitance diode in the local oscillator, thereby correcting the oscillator frequency to obtain a constant IF (i.e. a constant tuned frequency).

Since the central frequency of the crystal detector is regulated by the crystal resonator, tuned frequencies of extremely high stability are obtained.

#### • Limiting the Locking Range

If the quartz-lock range is too wide, it will overlap with strong adjacent broadcasting frequencies and result in considerable tuning difficulties. A DC amplifier is therefore used as a limiter (limiter action by NFB circuit zener diodes) which restricts the voltage applied to the variable capacitance diode, thereby limiting the quartz-lock range.

A DC voltage appears at pin no.13 of the IF system IC (PA3007-A) when the antenna input level drops below  $5\mu\text{V}$ , or when the tuned frequency has been detuned by more than  $\pm 100\text{kHz}$ . This DC voltage (FM muting signal) is applied to the gate of Q2 (FET) via a Schmitt circuit, resulting in the FET being turned on, and the quartz-lock circuit being turned off.

## 4.2 AM TUNER

The AM tuner stage employs a 2-ganged tuning capacitor, a single-element ceramic filter, an NPN transistor RF amplifier, a PNP transistor mixer (converter), and an NPN transistor IF amplifier.

## 4.3 DISPLAY CIRCUIT

### Frequency Display

Frequencies received by the SX-3700 are dis-

played in digital form by fluorescent indicator tube (FL tube). Each digit employs up to 7 segments (a ~ g) (see Fig. 4-3) to display all numerals from 0 to 9 (with the exception of the left hand digit which employs only 2 segments b and c).

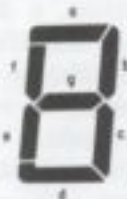

Fig. 4-3 7-segment display

The signal source during both AM and FM reception is the local oscillator. The signal is passed via a buffer amplifier (FET) to the prescaler IC (M54451P) where it is subjected to frequency division ( $1/8$  for AM and  $1/80$  for FM) before being applied to the frequency counter IC (PD5009). This IC is responsible for the dynamic drive of the 7-segment 5-digit display (each digit being turned on according to time-shared sequential scanning).

An outline of the composition of PD5009 is given in block diagram form in Fig. 4-5. With the FL tube a ~ g segments (anode) for each digit connected in parallel, the D1 ~ D5 time division pulse signals (see Fig. 4-6) applied to each grid (independent grid for each digit) result in the digits being lit up in succession from the left hand side. Each digit is lit up for 1ms during each 5ms inter-

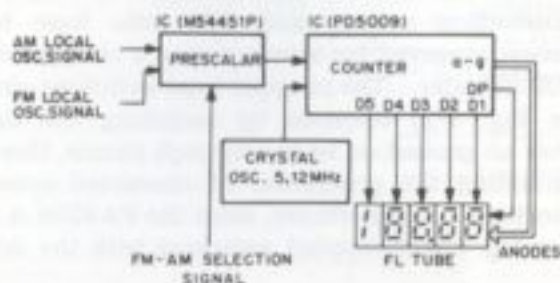

Fig. 4-4 Frequency display block diagram

val. Pin no.7 of PD5009 is the brightness selector terminal. The time division pulse width is set to  $800\mu\text{s}$  for H level input signals, and to  $200\mu\text{s}$  for L level signals, thereby varying the degree of FL tube brightness (by varying the segment lighting period). Note that since the power indicator FL tube is driven by static drive, the degree of brightness may be varied by changing the grid voltage.

The 5.12MHz crystal oscillator generates the basic signal used in the preparation of the time division pulse signal and the counter gate circuit control signal.



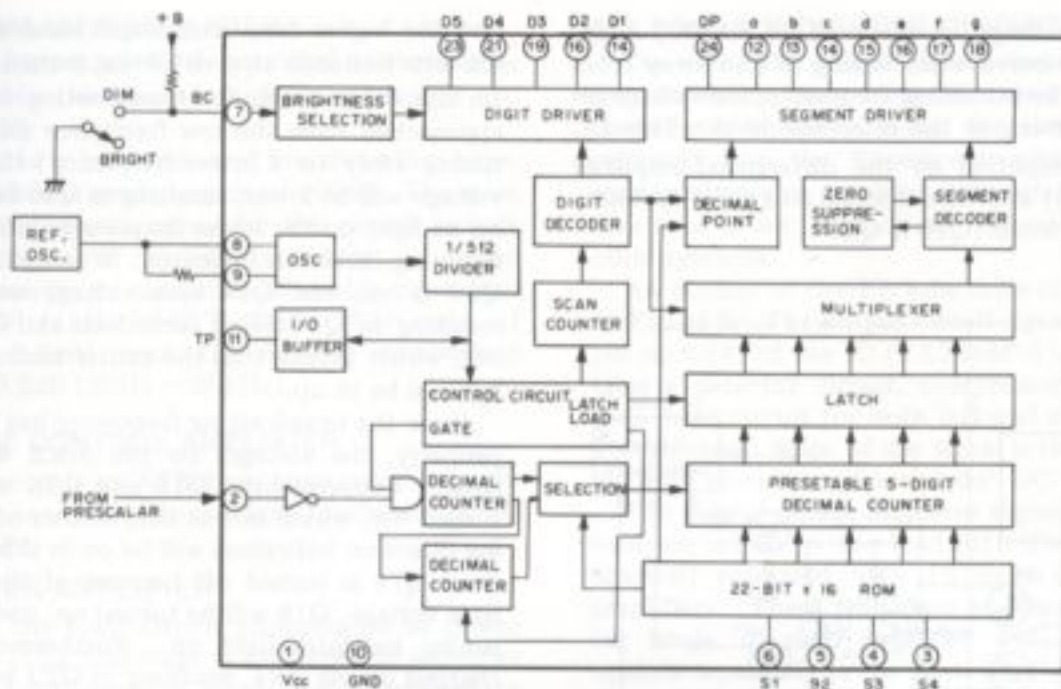

Fig. 4-5 Block diagram of PD5009

Terminals S1 ~ S4 (pin nos. 3 ~6) are used in designating reception mode. The 2 reception modes employed in the SX-3700 (see Table 1) are designated by varying the combination of input levels (H and L). The 3 different IFs during FM mode are required in coping with IF offset in the IF ceramic filter stage, S3 and S4 being preset during FM mode according to the ceramic filter characteristics.

Although the SX-3700 FM stage quartz-lock system is capable of locking any frequency within the FM band, the 10kHz digit (digit in the second decimal place) in the FM frequency display will appear only as 5 or 0.

The frequency display FL tube also incorporates the TUNING and SIGNAL indicators. And although the segments (anode) for these indicators are static driven by the corresponding drive circuits, the grid is driven according to the D3 time division pulse timing, thereby placing the segments

under dynamic drive. In addition, the AM and FM indicators in the frequency display section are lit according to the D5 timing, while the kHz and MHz indicators are lit according to the D1 timing.

MODE	S1	S2	S3	S4	IF (MHz)
FM	H	L	L	H	10.73
	H	L	H	L	10.70
	H	L	H	H	10.67
AM	L	H	H	L	450kHz

Table 1

**TUNING Indicator Circuit**

The TUNING indicator consists of a center tuning indicator (which lights up when a broadcasting station frequency is properly tuned) and 2 detuning direction indicators which indicate the direction in which the station has been tuned away from. The corresponding drive circuits are outlined in Fig. 4-7.

The TUNING indicator is activated once the station has been tuned to within ± 100kHz of the center frequency. This is because Q22 is turned on and Q21 turned off (resulting in the detector differential amplifier [Q19 & Q20] being turned off and Q14 being turned on) by the FM muting signal appearing at pin no.13 of the IF system IC (PA3007-A) and passed via the Schmitt circuit (Q15 & Q16) when the station is tuned away by more than ± 100kHz.

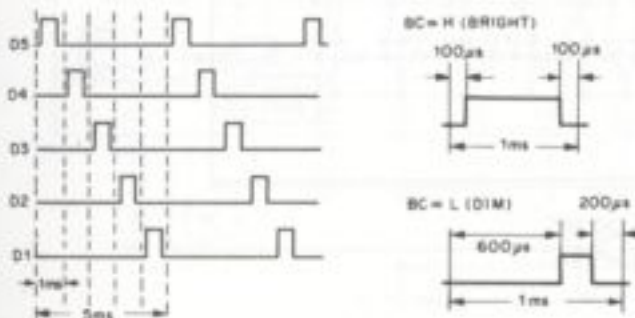

Fig. 4-6 D1-D5 time division pulse signals

The DC voltage on pin no.4 of PA3007-A describes an S curve when tuning to and away from a particular broadcasting frequency, the voltage on pin no.2 serving as the reference level. This DC voltage is amplified by the differential amplifier (Q19 & Q20) and then applied to a polarity detectors switch circuit (Q16 & Q26).

and the higher frequency (right hand side) detuning direction indicator also being turned on. When, on the other hand, the broadcasting frequency is approached from the low frequency side (or when tuning away to a lower frequency) the pin no.4 voltage will be lower, resulting in Q16 being turned on to light up the lower frequency (left hand side) detuning direction indicator. When either Q16 or Q26 is on, the Q14 base voltage will be high, resulting in Q14 being turned on and Q18 turned off, which means that the center tuning indicator will not be lit up.

Once the broadcasting frequency has been tuned properly, the voltages on pin nos.2 & 4 will be equal. Consequently, Q16 and Q26 will both be turned off, which means that neither of the detuning direction indicators will be on in this case. And since Q14 is turned off because of the decreased base voltage, Q18 will be turned on, and the center tuning indicator light up. Furthermore, C16 is charged via R84, resulting in Q23 being turned on, thereby lighting up the Quartz Locked indicator LED.

**SIGNAL Indicator Circuit**

The SX-3700 SIGNAL indicator consists of an FL tube 5-point indicator display. The signal meter drive signal obtained from the FM IF system IC (PA3007-A) and AM tuner is first amplified and then applied to the indicator drive IC (HA12010). This IC contains 12 pairs of voltage comparators similar to those employed in the power indicator circuit, 5 of these pairs being used to drive the SIGNAL indicator.

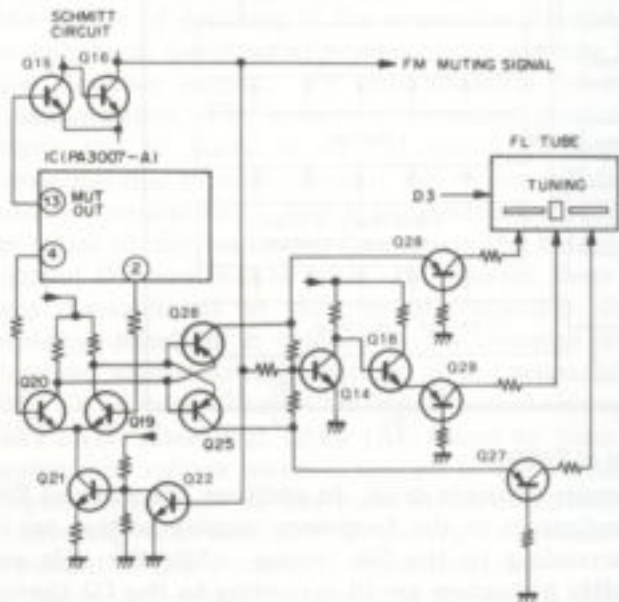

Fig. 4-7 TUNING indicator driver circuit

When tuning to a frequency from the high frequency side (or tuning away from the frequency to a higher frequency), the voltage on pin no.4 will be higher than that on pin no.2. The Q20 collector voltage will thus be lowered and the Q19 collector voltage raised, resulting in Q26 being turned on,

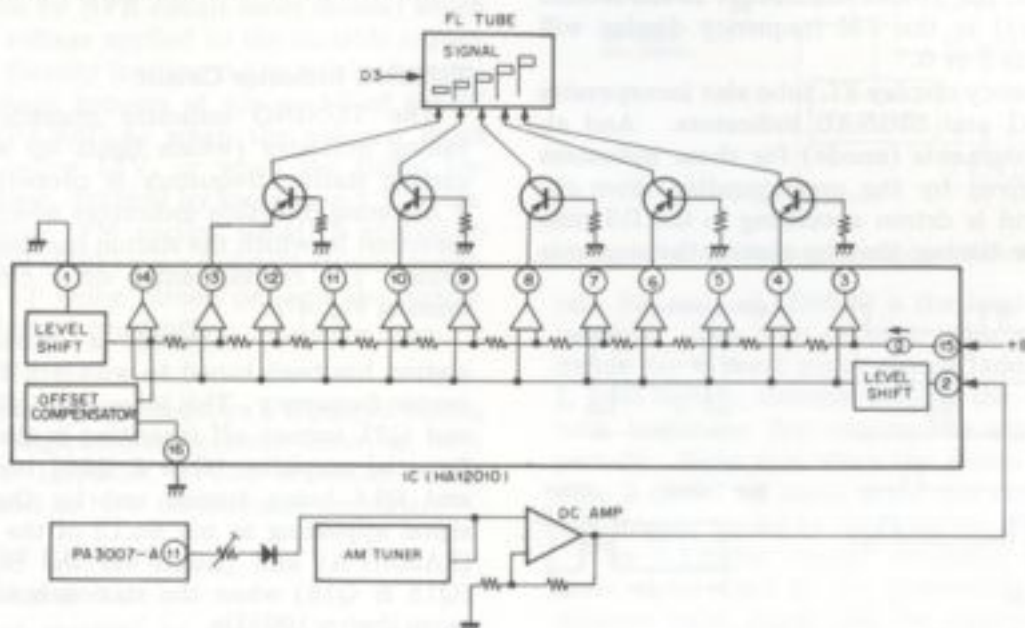

Fig. 4-8 SIGNAL indicator driver circuit

**4.4 EQUALIZER AMPLIFIER**

This circuit is an NFB type equalizer amplifier with newly developed high performance IC (M5214L-P).

This IC is a low-noise and low distortion type, and provide an openloop gain of 105dB. The main performance specifications for this circuit include a voltage gain of 35.5dB (at 1kHz), a phono dynamic margin or maximum allowable input level of 250mV (1kHz, 0.02% THD), S/N ratio of 79dB (at 2.5mV input, IHF-A), and equalization within  $\pm 0.2$ dB (20Hz - 20kHz).

**4.5 TONE CONTROL AMPLIFIER**

This circuit is an NFB type tone control amplifier with newly developed high performance IC (M5214L-P).

**4.6 POWER AMPLIFIER**

This is the basic circuit arrangement of power amplifier. The first stage is a differential amplifier (Q3), the load circuit of which is a current mirror employing an NPN twin transistor (Q5). The current mirror provides push-pull operation in this stage, which serves to cancel even numbered harmonics and further increase gain.

The pre-driver stage (Q7) with a current mirror circuit (D5, Q11), enables stable operation and provides high voltage gain.

The power stage is a Darlington connection pure complementary SEPP circuit, and has an output of 45W (8 $\Omega$  load, at both channels driven, THD 0.02%, 20Hz-20kHz).

**4.7 POWER INDICATOR CIRCUIT**

The SX-3700 output power indicators feature fluorescent indicator tube (FL tube). In this tube, thermionic emissions from the cathode are accelerated into the fluorescent substance of the segmental anodes, resulting in the emission of light. This tube is used to indicate numerals, letters, and other symbols.

An outline of the FL tube drive circuit is shown in Fig. 4-9. The output circuit signal is applied to pin no.6 (4) of the IC (TA7318P-A). The IC contains a detector circuit, compressor (40dB), and peak hold circuit for both left and right channels. The dynamic range of the signal is thus contracted by 40dB to obtain a "peak held" DC voltage.

The output power indicator segments of the FL tube are driven by the HA12010 ICs (one for each channel) equipped with 12 pairs of differential amplifiers. These amplifiers are biased at increasing levels, so each amplifier will commence to operate separately as the input level increases. And since these amplifiers apply the voltage to the output power indicator segments, each successive segment will light up in turn as the input level rises.

**4.8 PROTECTION CIRCUIT**

In order to protect both the amplifier and the speakers, the SX-3700 has been equipped with a protection circuit which is opened and closed automatically by a relay in the output circuit. As can be seen from Fig. 4-11, this circuit consists of 3 main component parts.

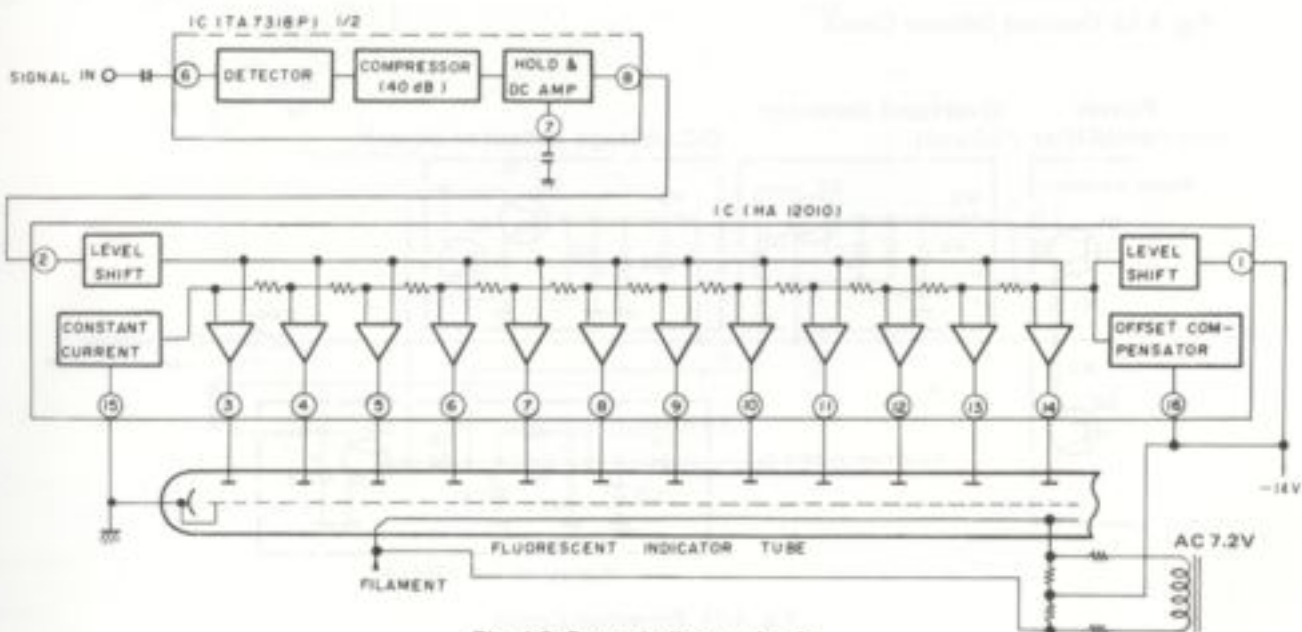

Fig. 4-9 Power indicator circuit

The relay drive circuit controls relay operation, delaying relay closure when the power is switched on, opening the relay quickly when the power is turned off, and also opening the relay in response to instructions from each detector circuit. When the power is first switched on, C4 is charged up via R8, thereby increasing the potential difference across the capacitor terminals. Once this potential difference exceeds the zener diode, Q6 is turned on due to the forward biasing, thereby closing the relay contacts. When the power is switched off, C4 is discharged rapidly via D5 and R7, resulting in Q6 being turned off and the relay contacts being opened.

The overload detector circuit outlined in Fig. 4-10 below consists of a Wheatstone bridge with the load RL forming one of the arms. Q3 is biased by the potential difference between diametrically opposite corners of the bridge circuit. If the RL value drops below a certain fixed level, Q3 will be turned on due to forward biasing. The charge on C4 in the relay drive circuit will thus be discharged via D3 and Q3, resulting in Q6 being turned off and the relay contacts being opened.

If for any reason a DC voltage is generated at the output, it will be detected by the DC voltage detector circuit, resulting in the relay contacts being opened to thereby protect the speakers. R5 and C2 form a low-pass filter designed to block normal signal components, thereby preventing the application of signal voltages to the bases of Q4 and Q5. If a positive DC voltage appears at the output, it is divided by R5 and R6, and applied to Q4 and Q5. Since the base of Q5 is connected to ground, this transistor will remain off due to the reverse bias applied. And since the emitter of Q4 is connected to ground, this transistor will be turned on due to a forward bias. Consequently, the base of Q6 is grounded by Q4, resulting in Q6 being turned off and the relay contacts being opened. If a negative DC voltage appears at the output, Q4 is turned off due to a reverse bias, while Q5 is turned on due to a forward bias. And since a negative voltage is applied to the emitter of Q5 in this situation, Q6 is turned off and the relay contacts opened.

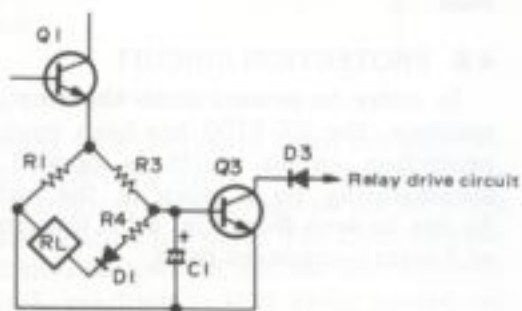

Fig. 4-10 Overload Detector Circuit

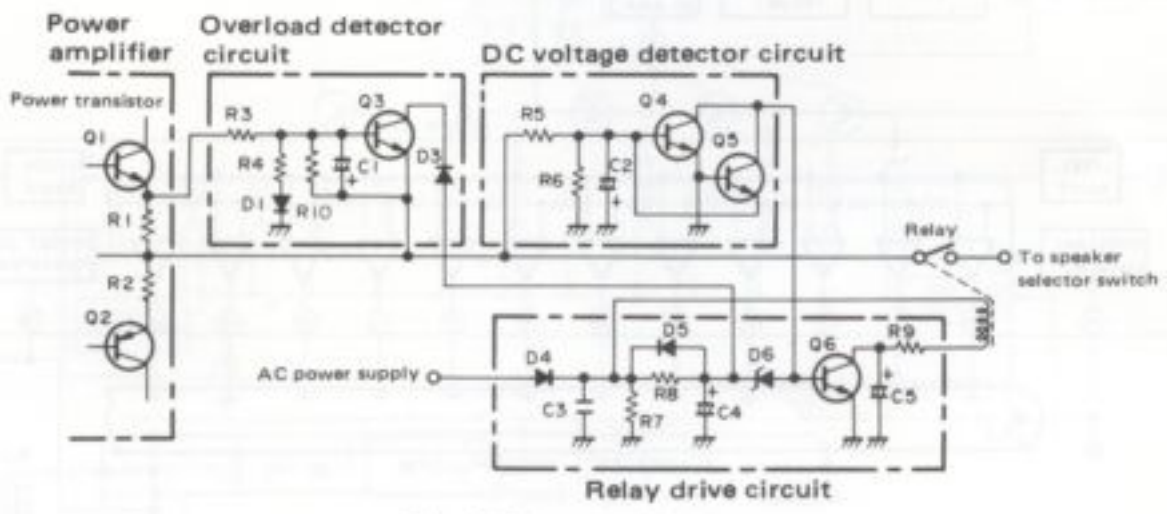

Fig. 4-11 Protection Circuit

## 5. DISASSEMBLY

### Bonnet Case

Remove the four screws ❶ on each side of the bonnet case.

### Bottom Plate

Remove the eleven screws ❷ to detach the bottom plate.

### Front Panel

Remove the all control knobs except push knobs. Remove the two screws ❸ and two nuts ❹ from the front panel.

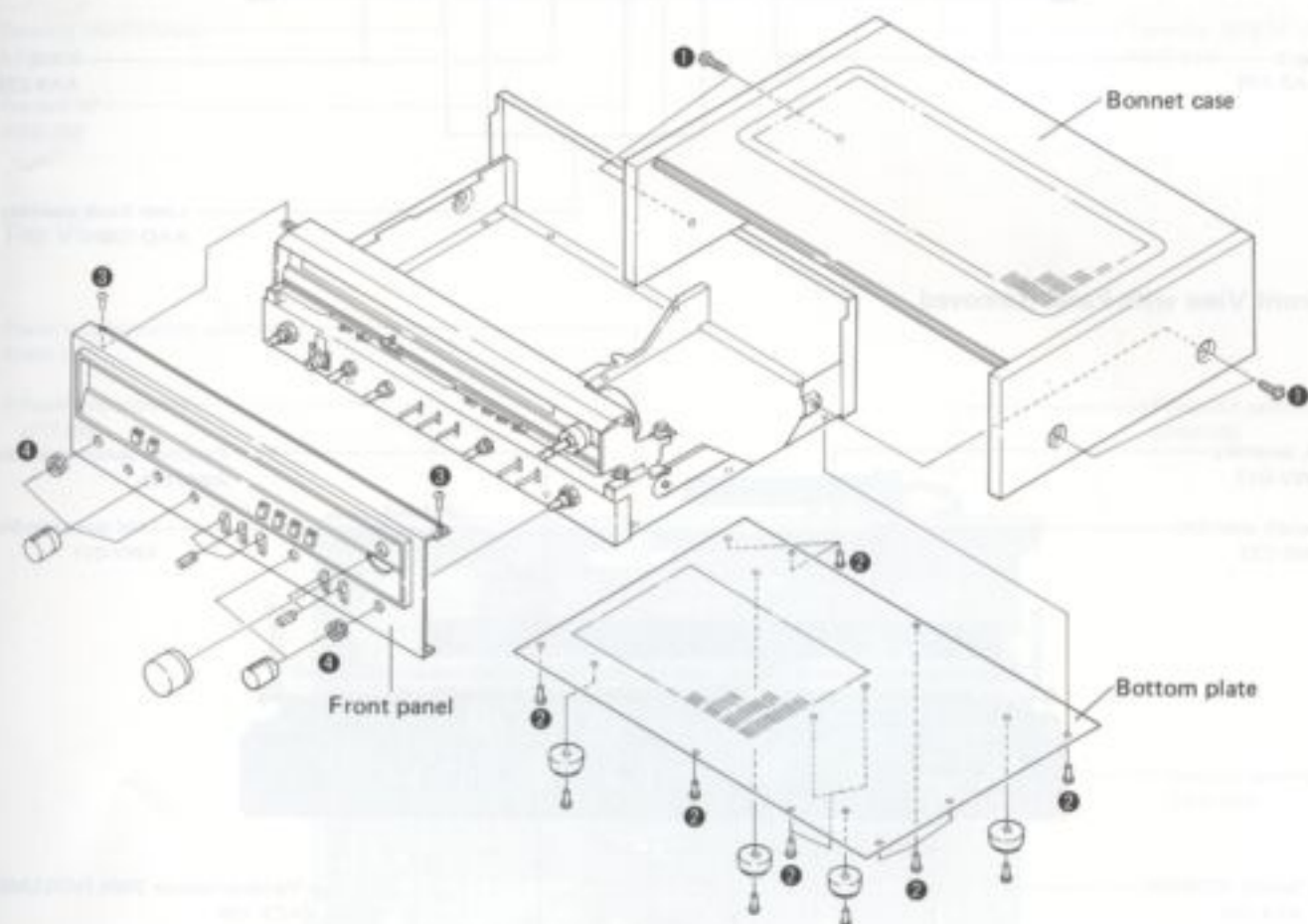
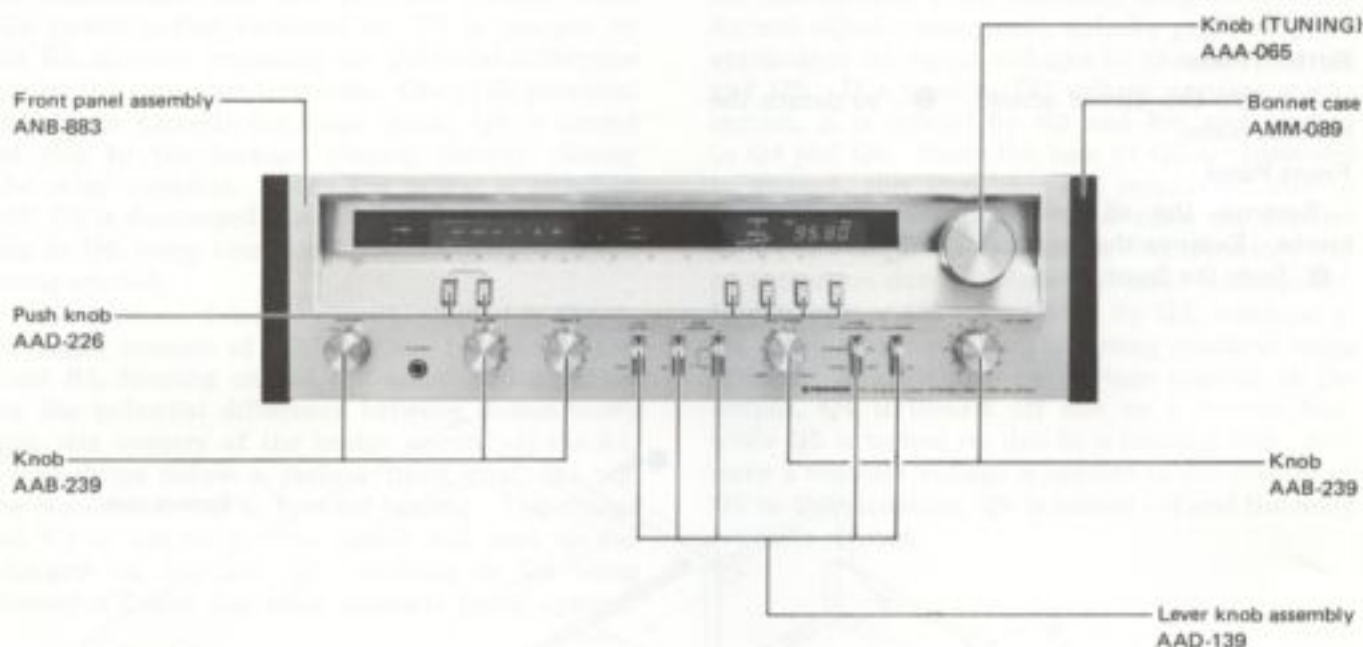

Fig. 5-1 Disassembly

## 6. PARTS LOCATIONS

### Front Panel



- The  $\Delta$  mark found on some component parts indicates the importance of the safety factor of the part. Therefore, when replacing, be sure to use parts of identical designation.

### Front View with Panel Removed

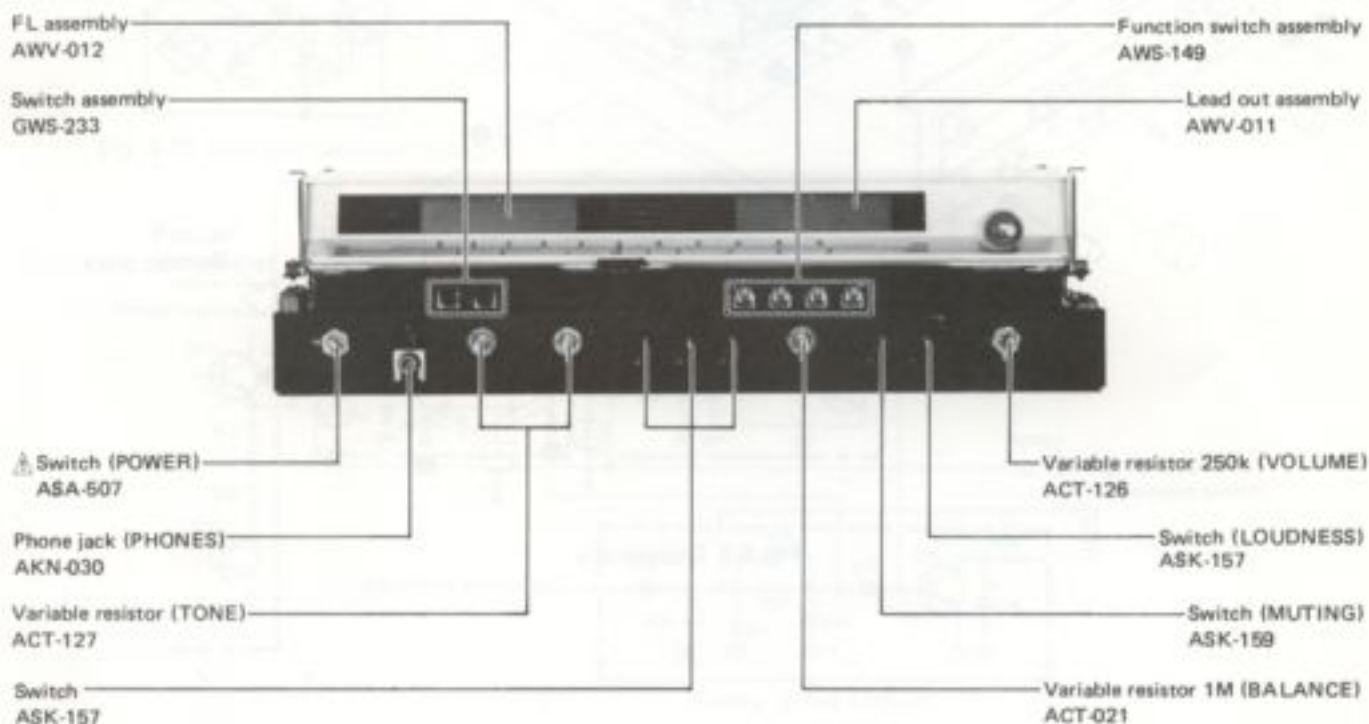

Rear Panel

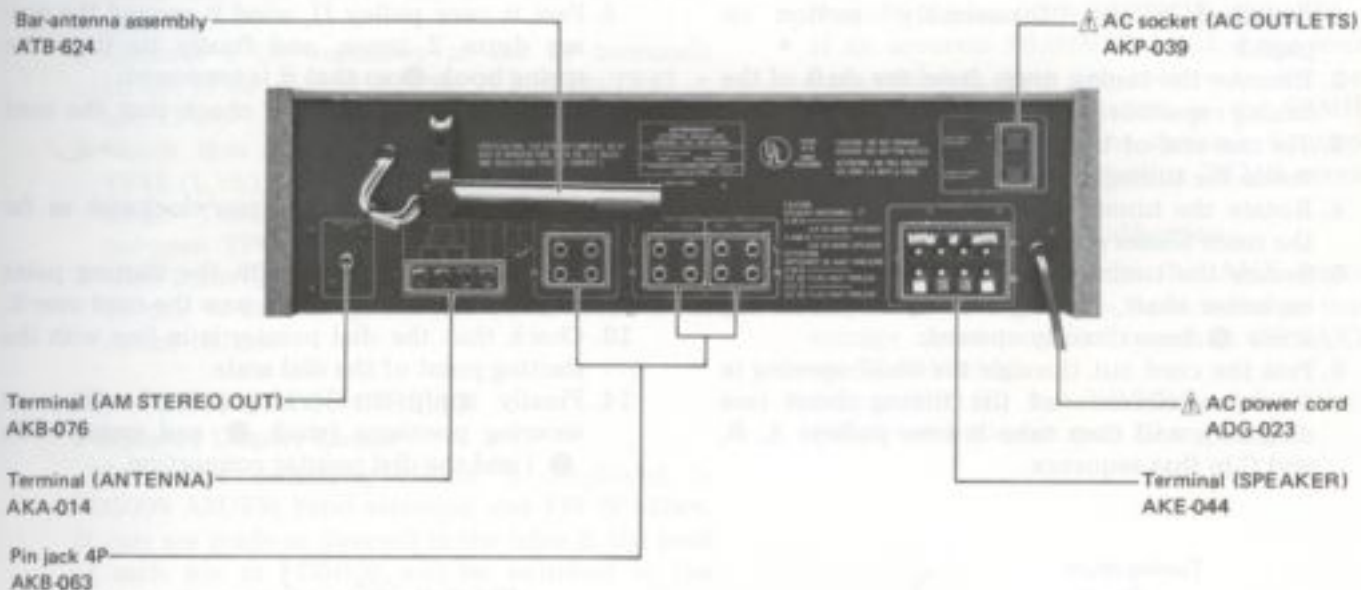

Top View

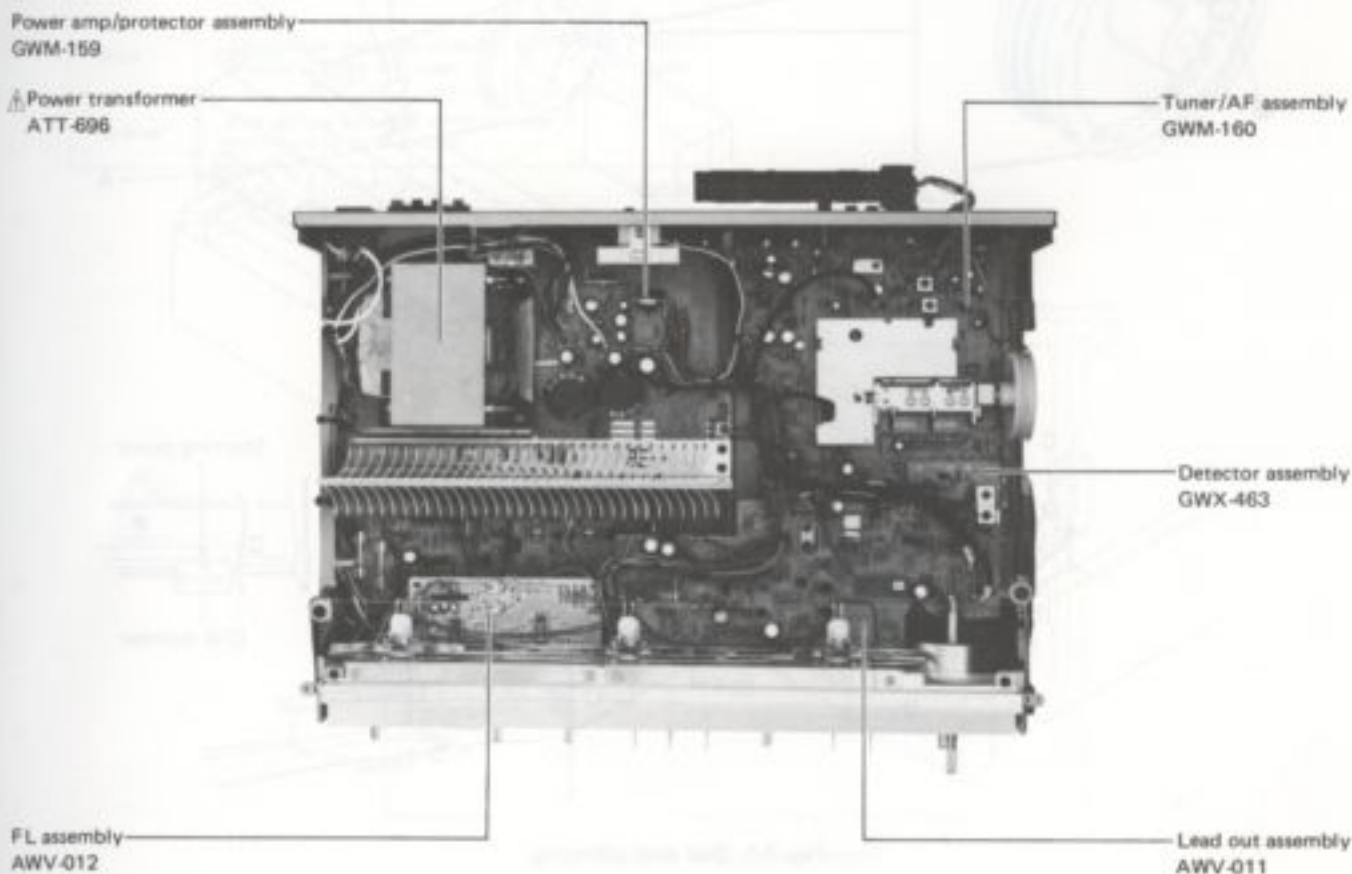

## 7. DIAL CORD STRINGING

1. Remove the bonnet case and front panel as described in the "Disassembly" section on page 1
2. Remove the tuning drum from the shaft of the tuning capacitor.
3. Tie one end of the cord to the stud ❶ located inside the tuning drum.
4. Rotate the tuning capacitor right around until the rotor blades are fully intermeshed.
5. Secure the tuning drum back onto the tuning capacitor shaft, making sure that the securing screw ❷ faces directly upward.
6. Pass the cord out through the small opening in the circumference of the tuning drum (see diagram), and then take it over pulleys A, B, and C in that sequence.
7. Wind the cord around the dial shaft 3 times.
8. Pass it over pulley D, wind it around the tuning drum 2 times, and finally tie it to the spring hook ❸ so that it is tensioned.
9. Turn the dial shaft, and check that the cord moves smoothly.
10. Cut off any excess cord.
11. Turn the dial shaft counter-clockwise as far as it will go.
12. Align the dial pointer with the starting point of the dial scale, and then pass the cord over it.
13. Check that the dial pointer is in line with the starting point of the dial scale.
14. Finally apply the locking point to the cord securing positions (stud ❶ and spring hook ❸) and the dial pointer connection.

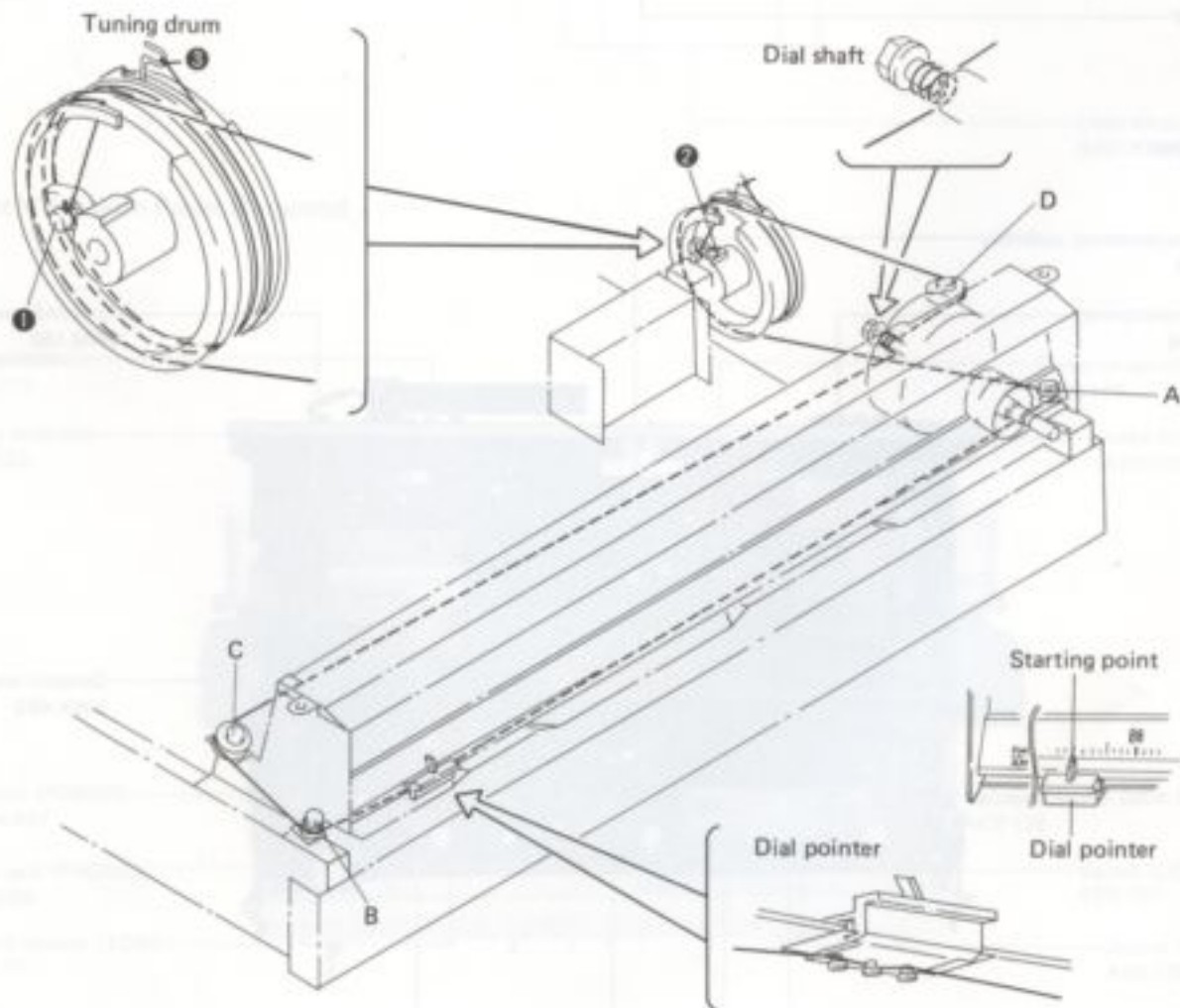

Fig. 7-1 Dial cord stringing



## 8. ADJUSTMENTS

### 8.1 FM TUNER

- Connect the FM SG (FM signal generator) to the FM antenna 300Ω terminal.
- Set the FUNCTION switch to FM. Set the FM MUTING switch to MONO.
- The tuning coils in the FM front end does not have an adjusting core. Consequently, tracking adjustments at 90MHz are performed by regulating the gap between rotor and stator of the tuning capacitors (VC-1, VC-2, and VC-3). The expression "adjust VC (VC-1, VC-2, and VC-3) found in the text means that the two outer rotor blades of each of these tuning capacitors are to be extended outwards with spatula (Part No. G GK-066) as shown in Fig. 8-1.

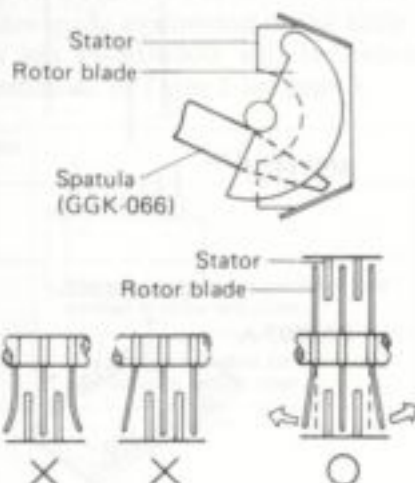

Fig. 8-1 Adjustment of tuning capacitor

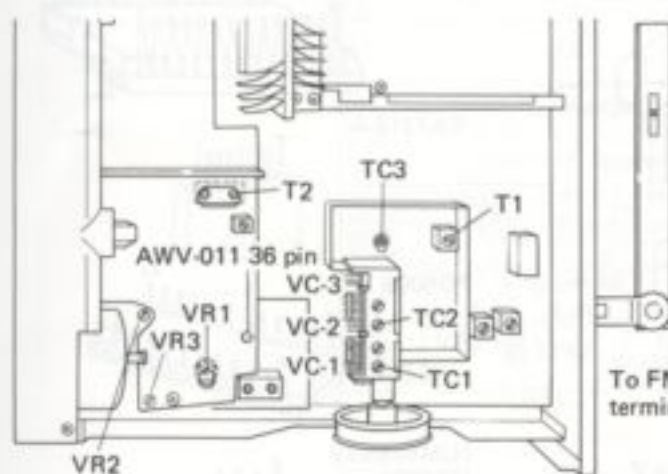
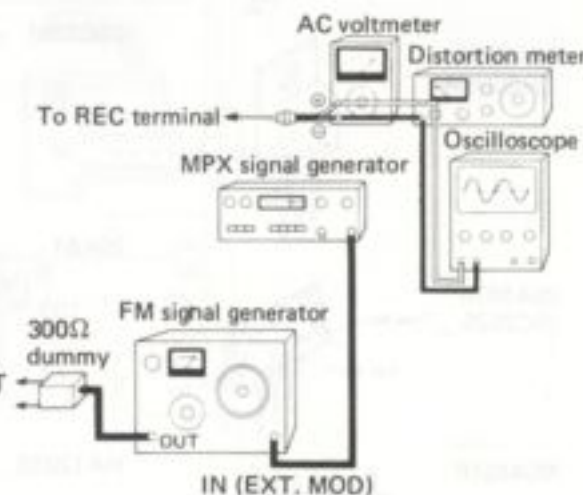

Fig. 8-2 Adjustment point

1. Set the SX-3700's dial pointer to 106MHz, and the FM SG output to 106MHz, 106dB (modulation  $-400\text{Hz}$ ,  $\pm 75\text{kHz}$  deviation).
2. Adjust the TC3 to obtain a maximum output level (REC terminal).
3. Then tune the dial pointer to 90MHz, and set the FM SG output frequency to 90MHz.
4. Adjust the VC-3 to obtain a maximum output level (REC terminal).
5. Repeat steps 1 to 4 above.
6. Reset the FM SG output level to 20 - 30dB, and adjust TC1, TC2, and T3 at 106MHz, and VC-1 and VC-2 at 90MHz in the same manner as described above in steps 1 to 5. These adjustments will ensure optimum sensitivity in the 90MHz to 106MHz range, and minimum difference in sensitivity between the two extreme frequencies.
7. Set the FM SG output to 98MHz, 66dB, and tune the SX-3700 to this frequency.
8. Adjust the core of T2 to reduce distortion in the output (REC terminal) to a minimum.
9. Adjust the VR3 so that the 5-point SIGNAL indicator reads 5 at 55dB of FM SG output.



### Multiplex Decoder

- \* Connect the MPX SG (FM multiplex generator) to the external modulator terminals of FM SG, thereby using FM SG as external modulation.
1. Set the FM SG output frequency to 98MHz, output level to 60dB (unmodulated), and tune the SX-3700 to this frequency.
  2. Adjust the VR1 to obtain a 76kHz signal at No. 7 terminal (AWV-011, 36 Pin) on the tuner assembly.
  3. Set the MPX SG modulation output to pilot signal (19kHz) only, and set the FM deviation of 7.5kHz (10% modulation).
  4. Adjust the VR2 to obtain minimum leakage of the 19kHz pilot signal at the REC terminal.
  5. Raise the FM SG output level to 80dB, and set the MPX SG to Main 1kHz (L+R), 67.5kHz deviation (90% modulation), and pilot signal to 7.5kHz deviation (10% modulation).
  6. Adjust the T1 core to within  $\pm 90^\circ$  to obtain minimum distortion in the demodulated output (REC terminal).

### 8.2 AM TUNER

- Connect the AM SG (AM signal generator) to the AM antenna terminal via a  $1k\Omega$  resistor.
  - Set the FUNCTION switch to AM.
1. Tune the SX-3700's dial pointer to 600kHz, and the AM SG output to 600kHz, 100dB (modulation -400Hz, 30%).
  2. Adjust the core of T101 to obtain maximum output level (REC terminal).
  3. Then tune to 1400kHz, and set the AM SG output frequency to 1400kHz also.
  4. This time adjust TC5 to obtain maximum output level (REC terminal).
  5. Repeat steps 1 to 4 above.
  6. Set the AM SG output level to 30dB, adjust the antenna coil along the bar-antenna and TC4 and TC5 at 1400kHz in the same manner as described in the above steps. This is the adjustment for optimum sensitivity across the frequency band, and minimum difference in sensitivity at different frequencies.

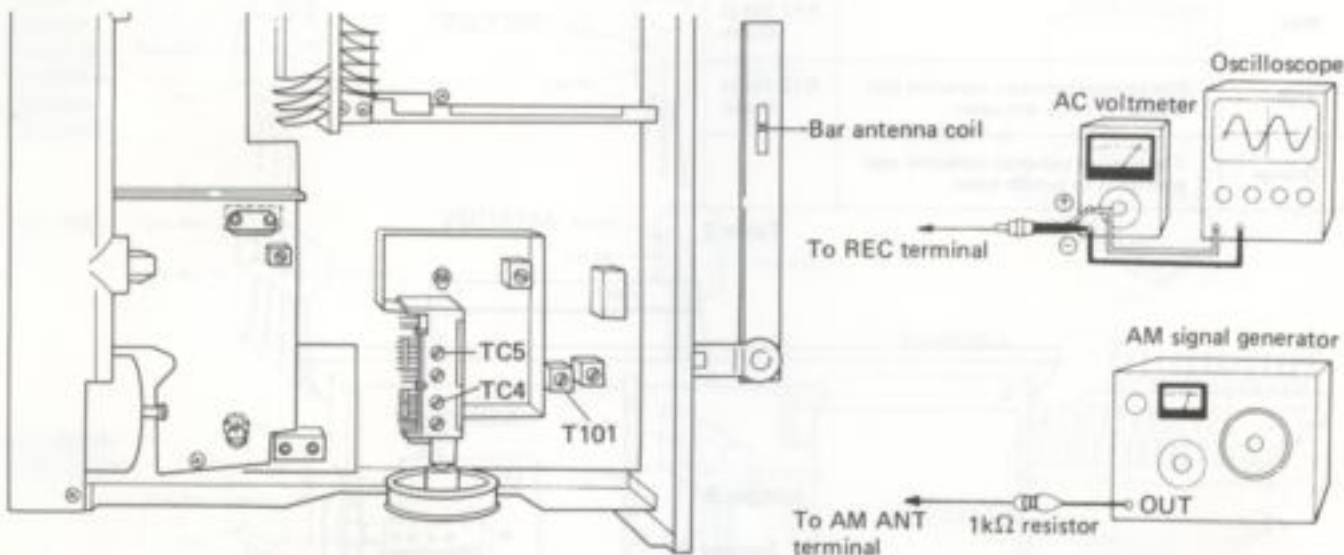

Fig. 8-3 Adjustment point

### 8.3 IDLE CURRENT ADJUSTMENT

1. Turn the VOLUME control down to minimum level, turn the power on, and wait about 10 minutes.
2. Connect a DC voltmeter to the TP terminals (L ch; TP48 + and 49 Pin - ; R ch; TP47 + and TP46 - ) of the GWM-159.
3. Check that the voltage between 49 Pin and TP48 (L ch) lies within the DC 2.2mV–100mV range. Then make a similar check for the R ch between TP47 and TP46. If the voltage is less than 2.2mV, cut jumper A (L ch), and jumper B (R ch). If the voltage exceeds 100mV, check for circuit failure.

### 8.4 FL INDICATOR CIRCUIT

#### Frequency Display Circuit

The offset switching circuit is employed in PD5009 AM/FM band selection and FM IF offset. If cuts are made as directed in the table 2, the level of each pin in PD5009 will be switched to the mode indicated in Table 1 on page 9.

FM ceramic filter	Q11	Q12
Red		R12 10k $\Omega$ Open
Blue	The jumper between collector and emitter is to be left open.	R12 10k $\Omega$ Open
Orange	The jumper between collector and emitter is to be left open.	

Table 2

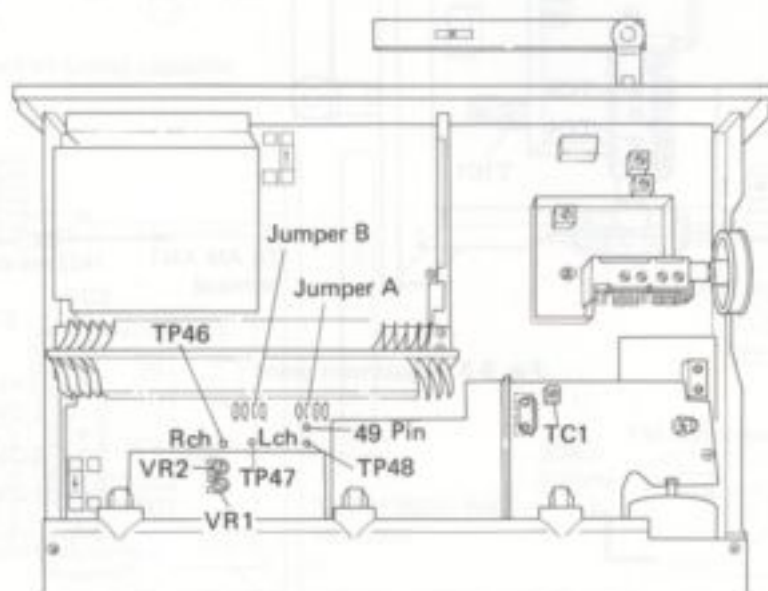

Fig. 8-4 Adjustment point

- If the SX-3700 frequency display reads 97.95MHz or 98.05MHz when a 98.00MHz signal is applied to the receiver, adjust TC1 so that the display reads 98.00MHz correctly.
- If an accurate 98.00MHz input signal source is not available, tune the receive to the nearest known broadcasting station in the 98MHz region, and check that the station's frequency is correctly displayed, adjusting TC1 if necessary.

#### Output Power Indicator Calibration

1. Apply a 1kHz signal to the AUX terminals.
2. Adjust the level of this input signal so that the voltage on the output terminals (SPEAKERS) read 8.95V (AC).
3. Adjust VR1(L) and VR2(R) so that the output power indicator read 10 watts.

# 9. SCHEMATIC DIAGRAMS, P.C.BOARD CONNECTION DIAGRAM AND PARTS LIST

## External Appearance of Transistors and ICs

2SA733A  
2SC945A

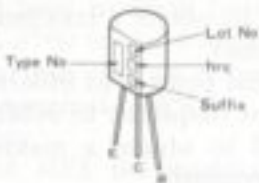

2SA1100  
2SC2575

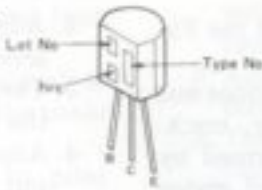

2SK34

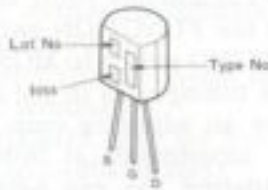

2SA726S

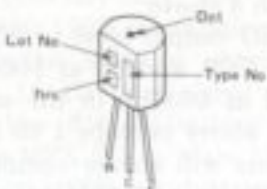

2S8507

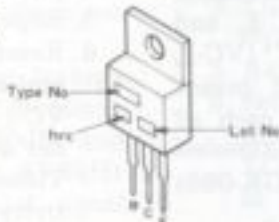

2SK168

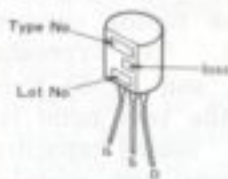

2SA912  
2SA949  
2SC1885  
2SC2229

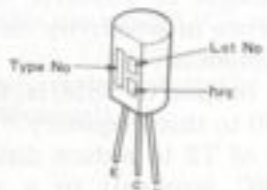

2SC461  
2SC535

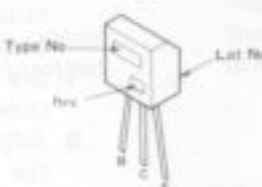

3SK73

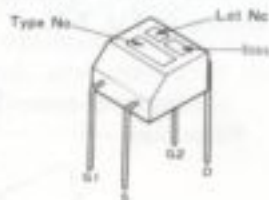

2SA913  
2SB834  
2SD313  
2SD836A  
2SD880  
2SC1913

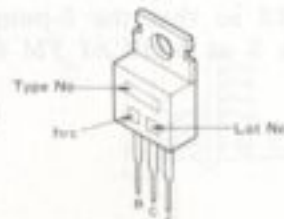

2SC1384

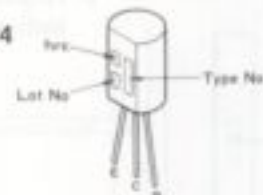

M5214L-P



PA3007-A

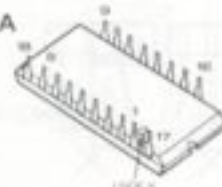

2SA798

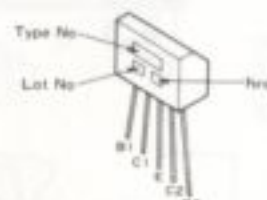

2SC1914A

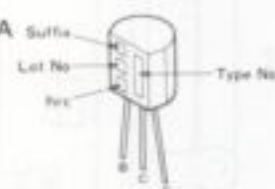

PA4006-A

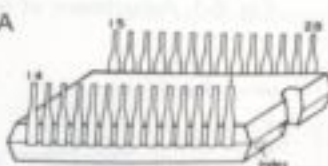

2SA985A  
2SC2275A

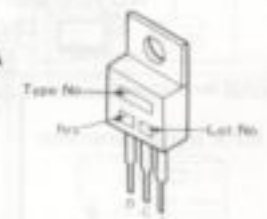

2SC2291

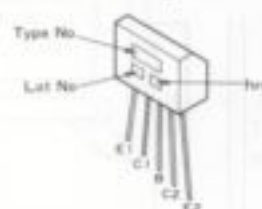

TA7318-A



2SA1075  
2SC2525



2SK61

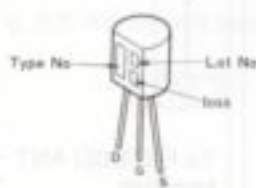

PD5009

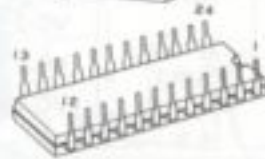

M54451P

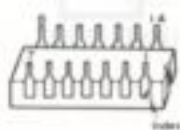

HA12010

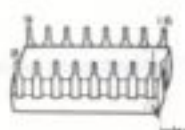

NJM4558DV  
HA1201  
μPC4558C



1

2

3

## 9.1 SCHEMATIC DIAGRAM

A

B

C

D

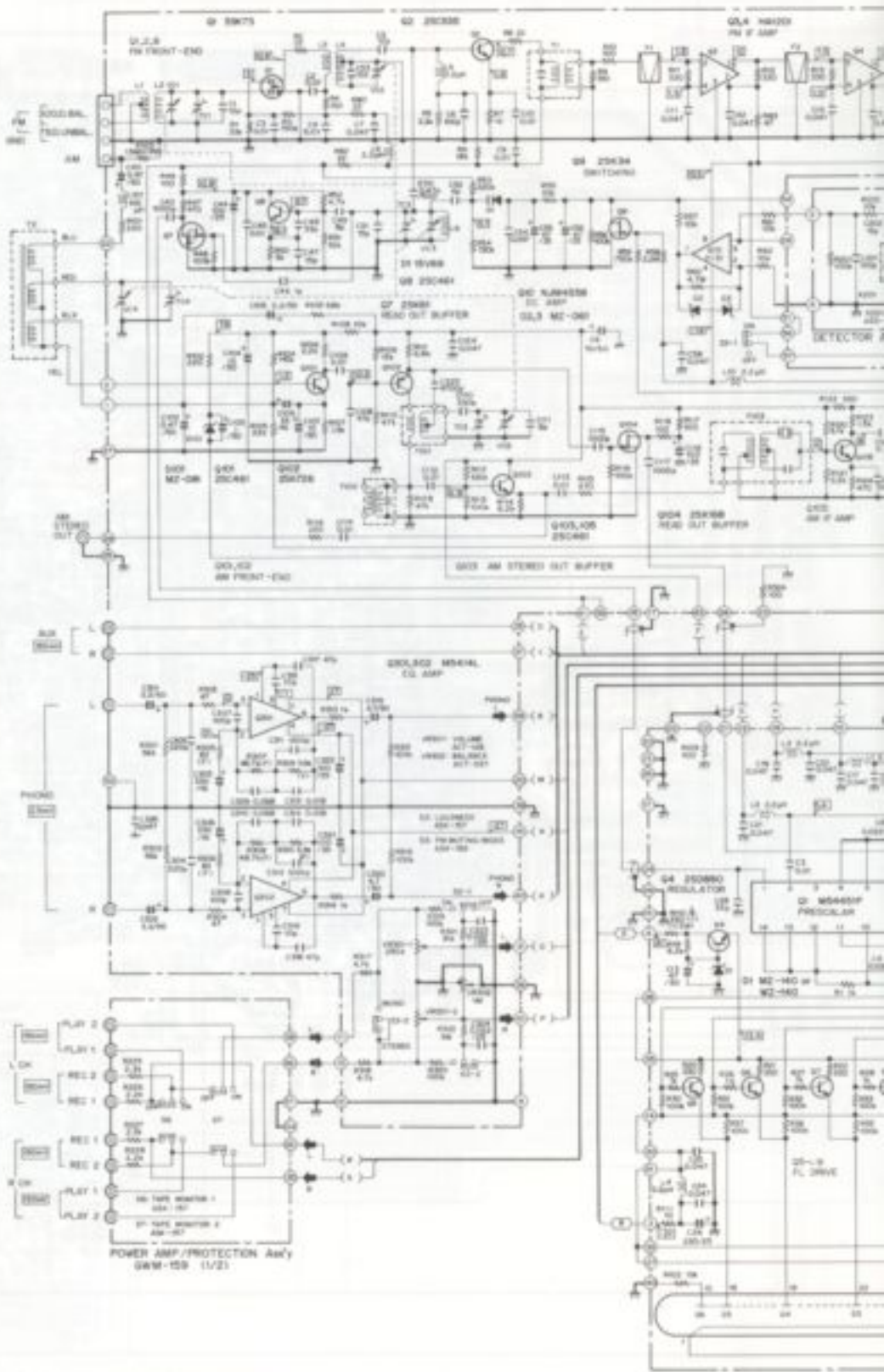

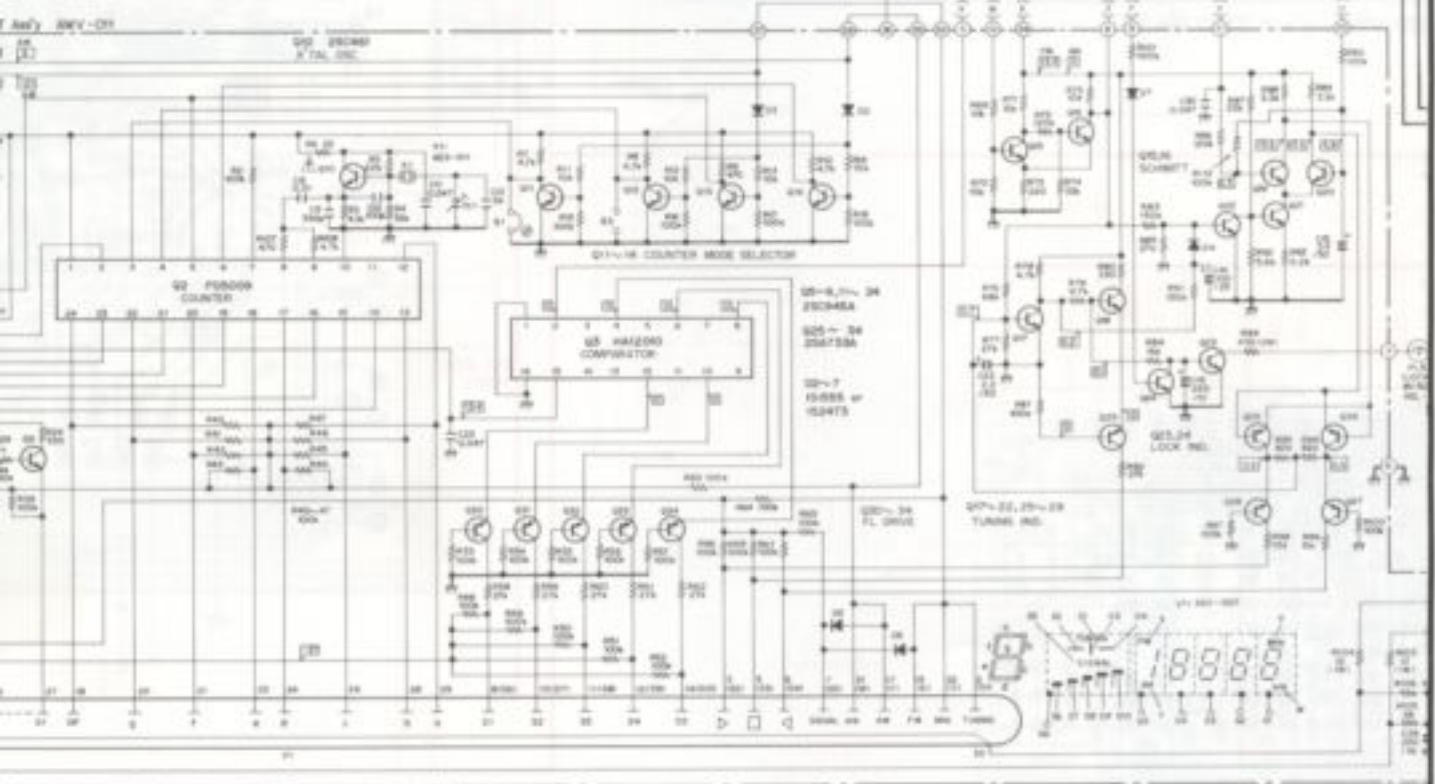
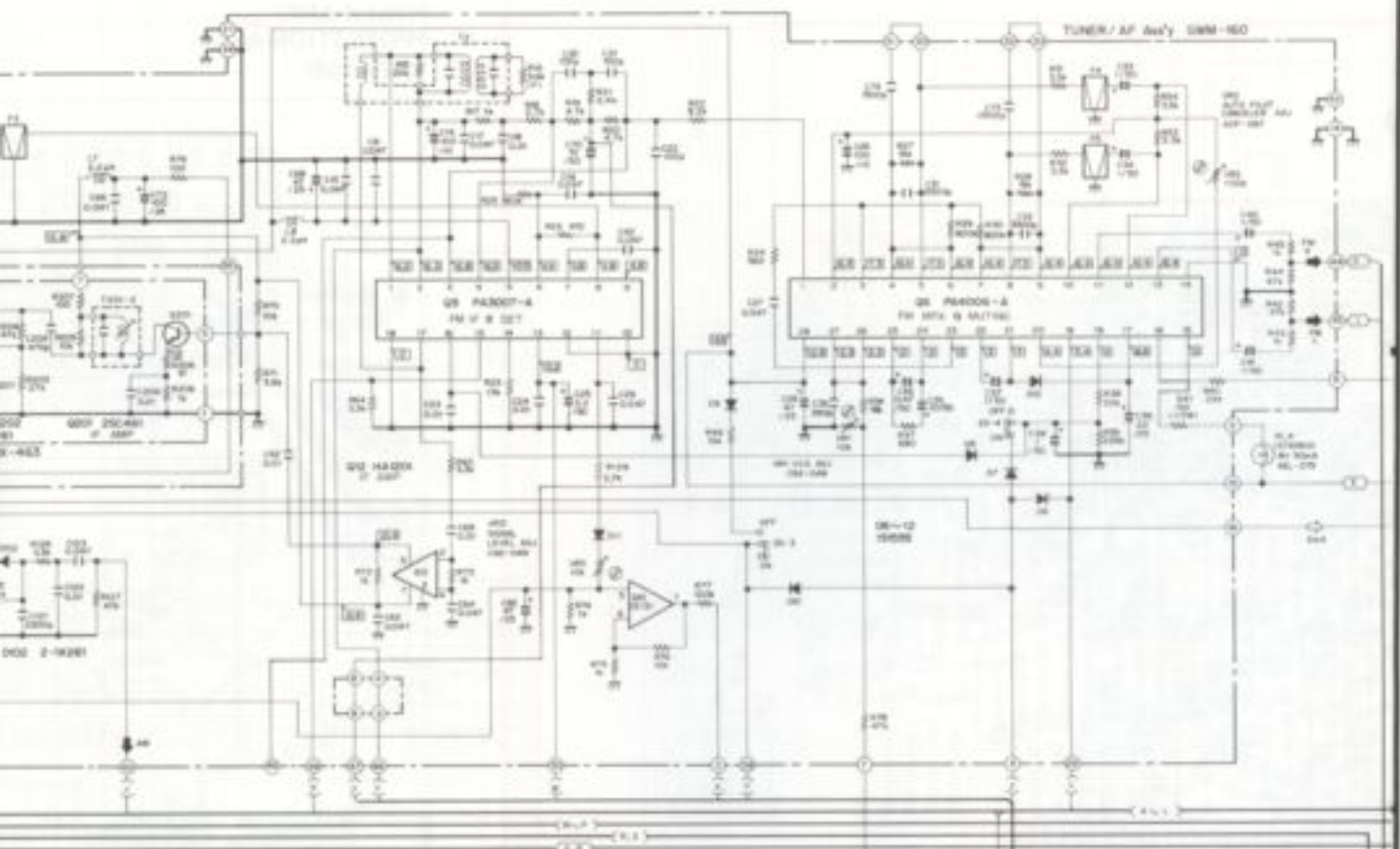

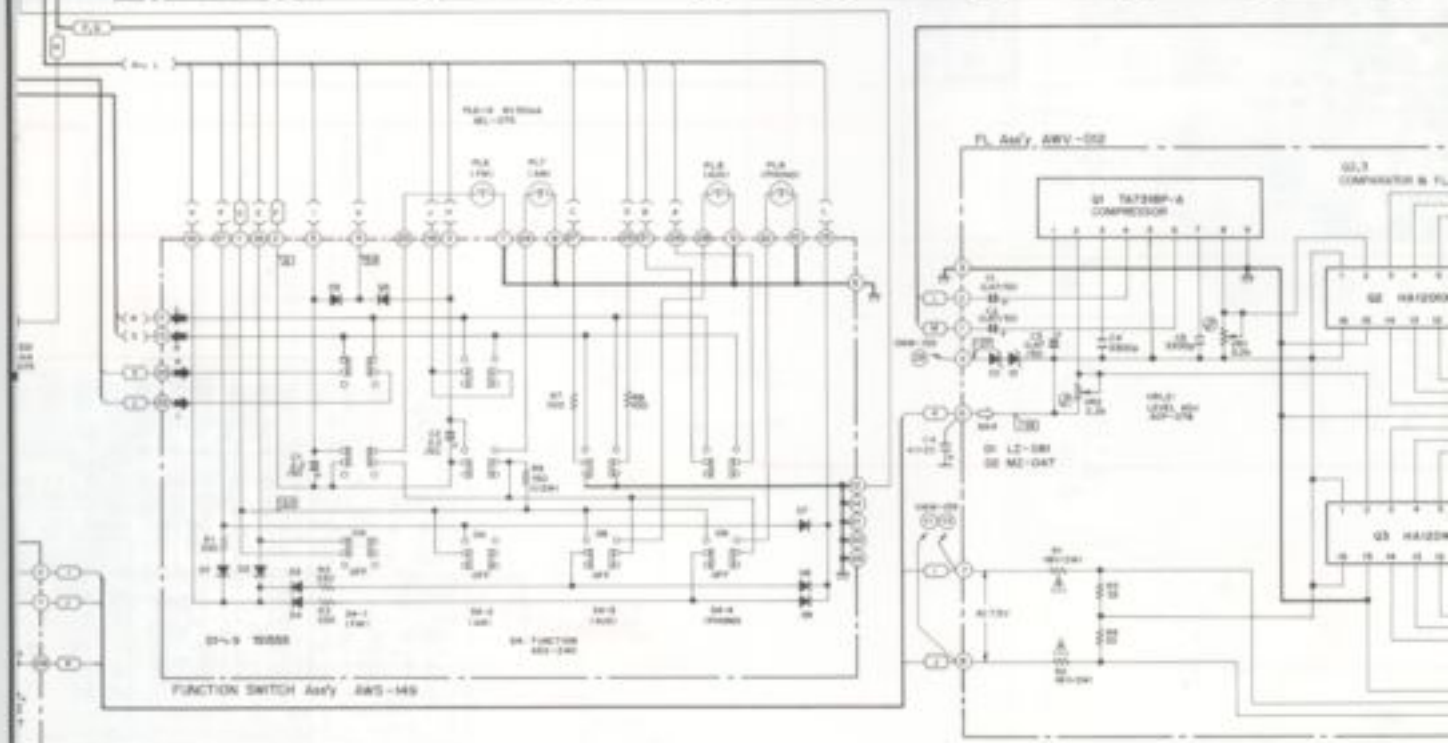
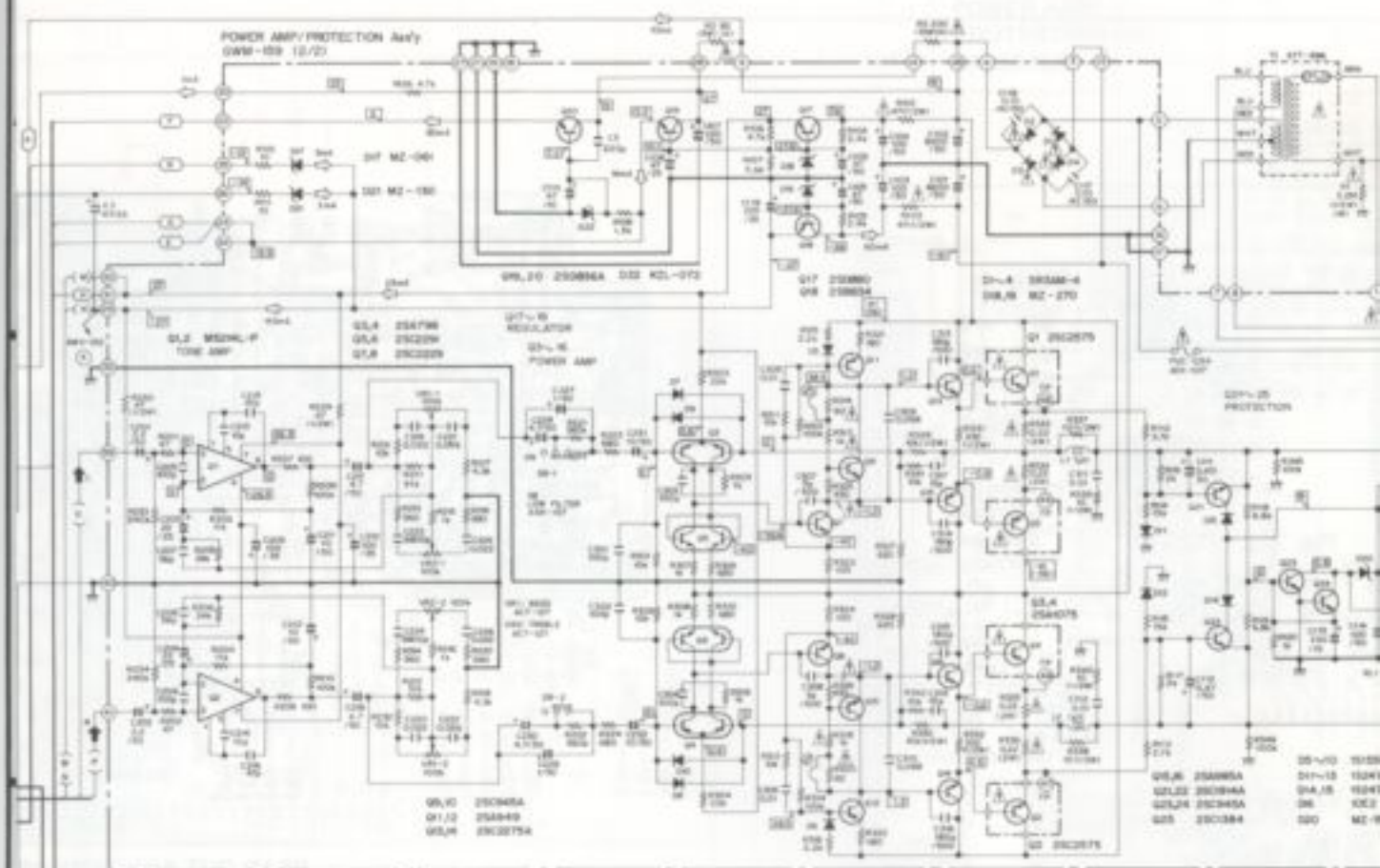

10

11

12

## NOTE:

The indicated semiconductors are representative ones only. Other alternative semiconductors may be used and are listed in the parts list.

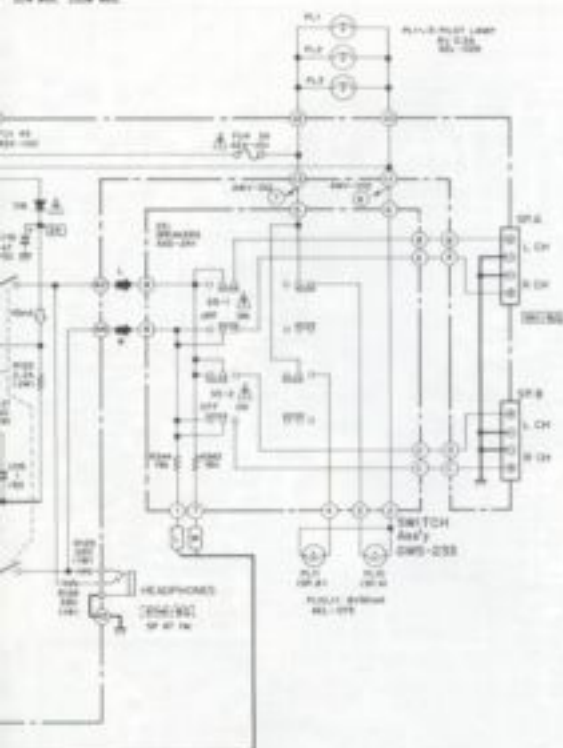
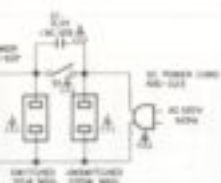

## 1. RESISTORS

Indicated in Ω, kΩ, MΩ unless otherwise noted. ± - tolerance.

## 2. CAPACITORS

Indicated in capacity (μF) or voltage (V) unless otherwise noted. μF - tolerance.

## 3. VOLTAGE, CURRENT

Signal voltage at 40 Ω ± 40 Ω load (MARK)  
DC voltage (V) or no input signal  
Value in ( ) is DC voltage at rated power  
① - mA, DC current at no input signal

## 4. OTHERS

● - Signal trace

⊙ - Adjusting point

The mark found on some component parts indicates the importance of the safety factor of the part. Therefore, when replacing, be sure to use parts of identical designation.

## 5. SWITCHES

S1 - POWER	ON - OFF
S2 - LOUDNESS	ON - OFF
S3 - FM MULTIWIDE	SYSTEMS - OFF/MONO
S4-1 FUNCTION (FM)	ON - OFF
S4-2 FUNCTION (LAW)	ON - OFF
S4-3 FUNCTION (AUX)	ON - OFF
S4-4 FUNCTION (PANEL)	ON - OFF
S5-1 SPEAKERS (A)	ON - OFF
S5-2 SPEAKERS (B)	ON - OFF
S6 - TAPE MONITOR 1	ON - OFF
S7 - TAPE MONITOR 2	ON - OFF
S8 - LOW FILTER (Bypass)	ON - OFF

The underline indicates the switch position.

This is the basic schematic diagram, but the actual circuit may vary due to improvements in design.

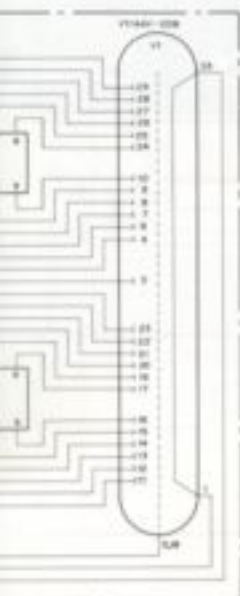

10

11

12



9.2 P.C. BOARD CONNECTION DIAGRAM

A

TUNER/AF Ass'y  
(GWM-160)

B

T2  
AM STEREO OUT

C

D

DETECTOR Ass'y (GWX-463)

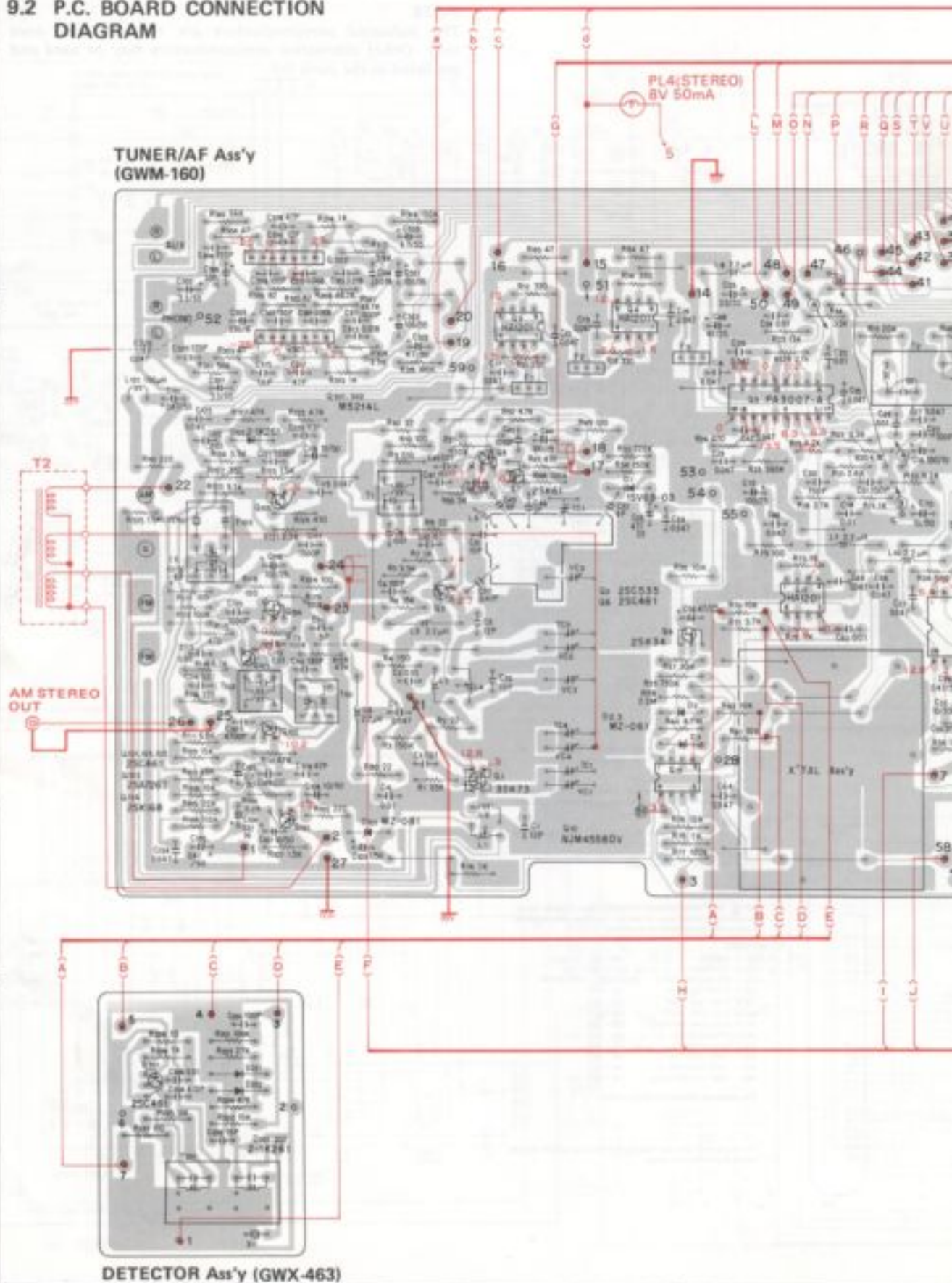

4

5

6

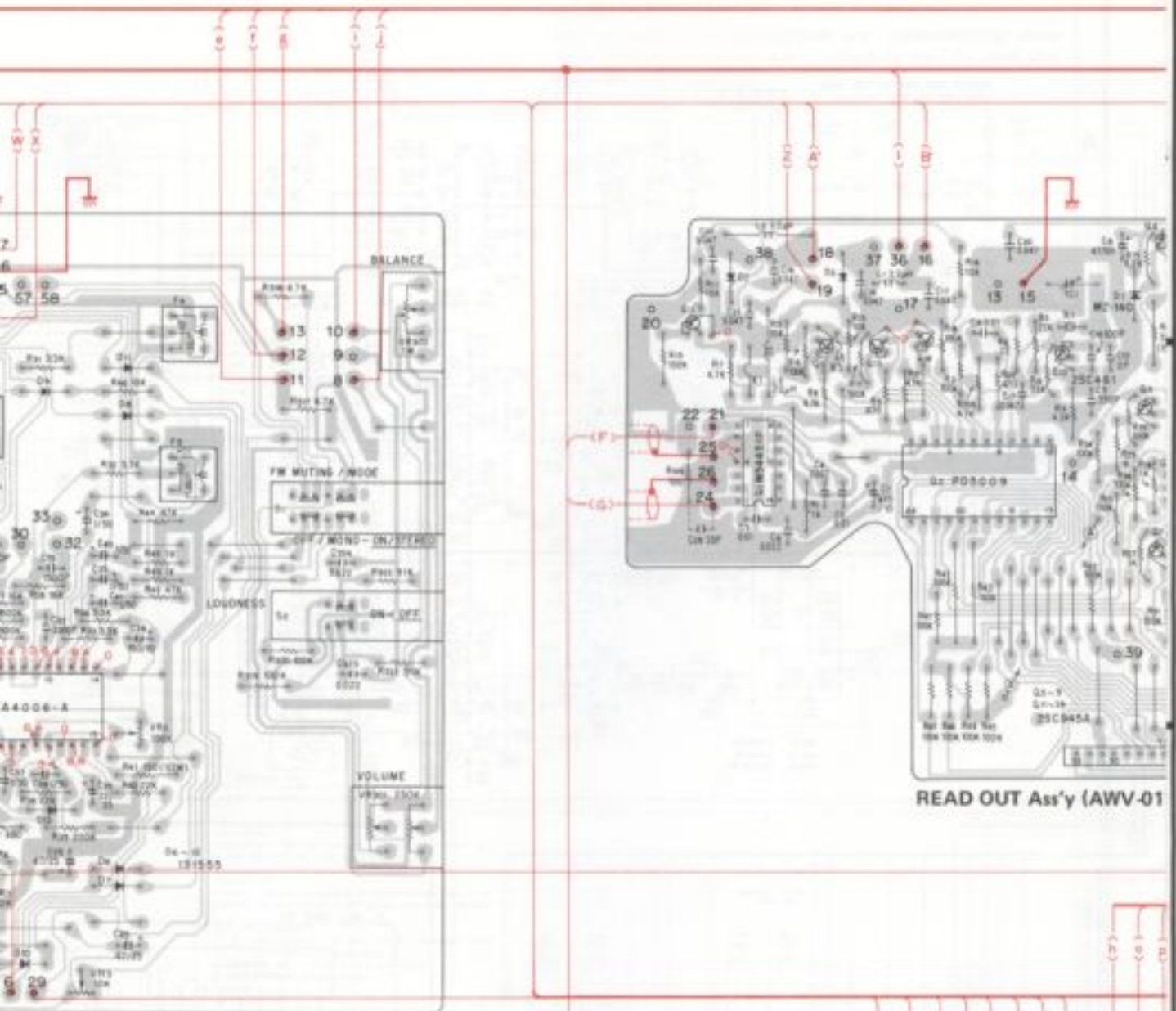

READ OUT Ass'y (AWV-01)

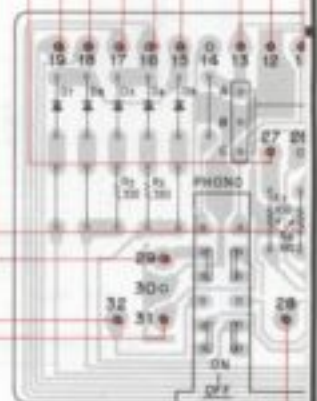
PLS  
(PHONO)

FUNCTION SWITCH Ass'y (AWS-149)

4

5

6

7

8

9

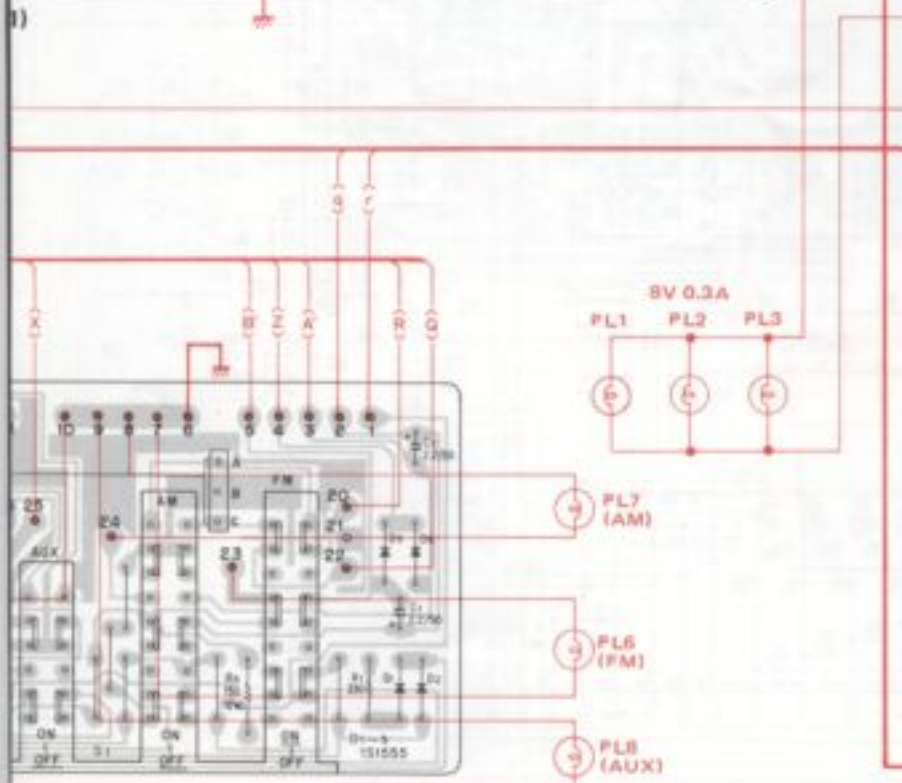
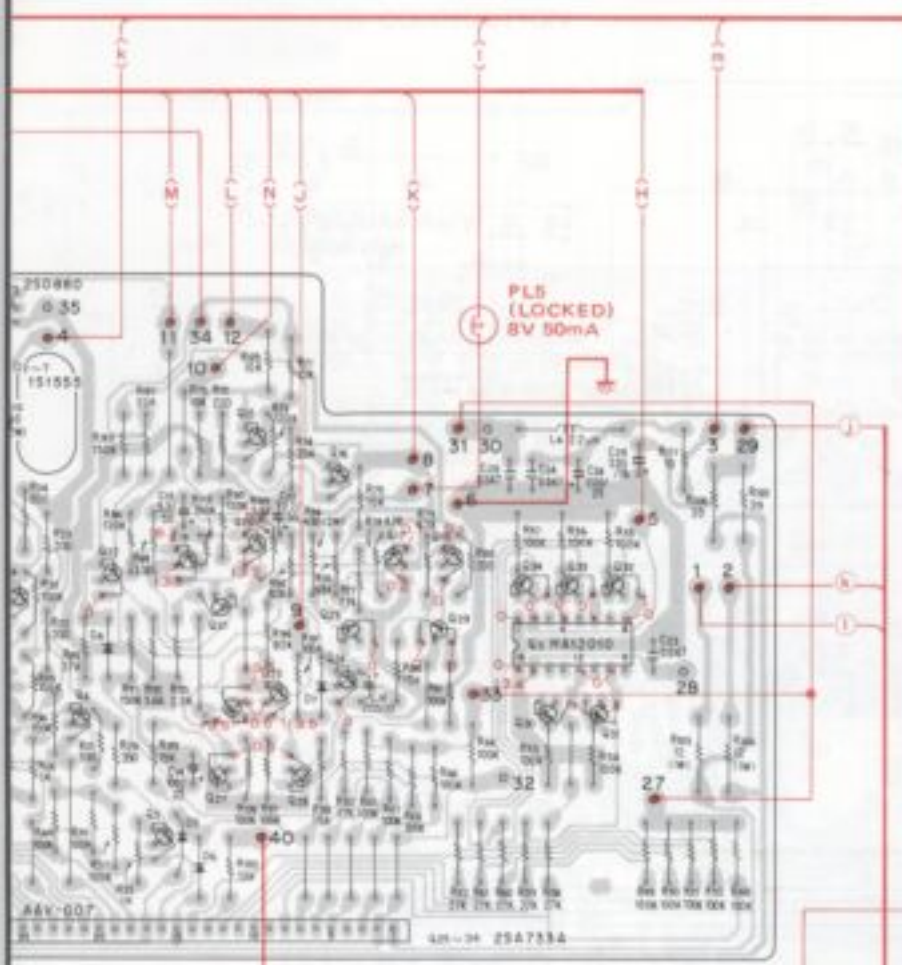

**POWER AMP/  
PROTECTION Ass'y  
(GWM-159)**

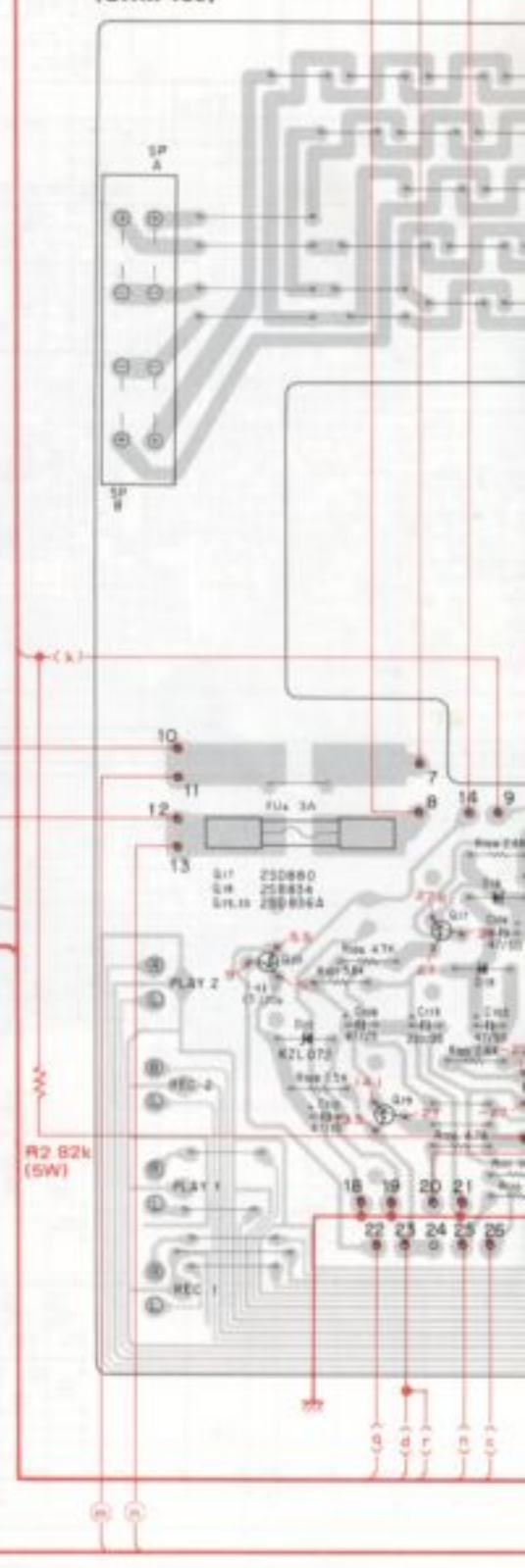

7

8

9

10

11

12

10W)

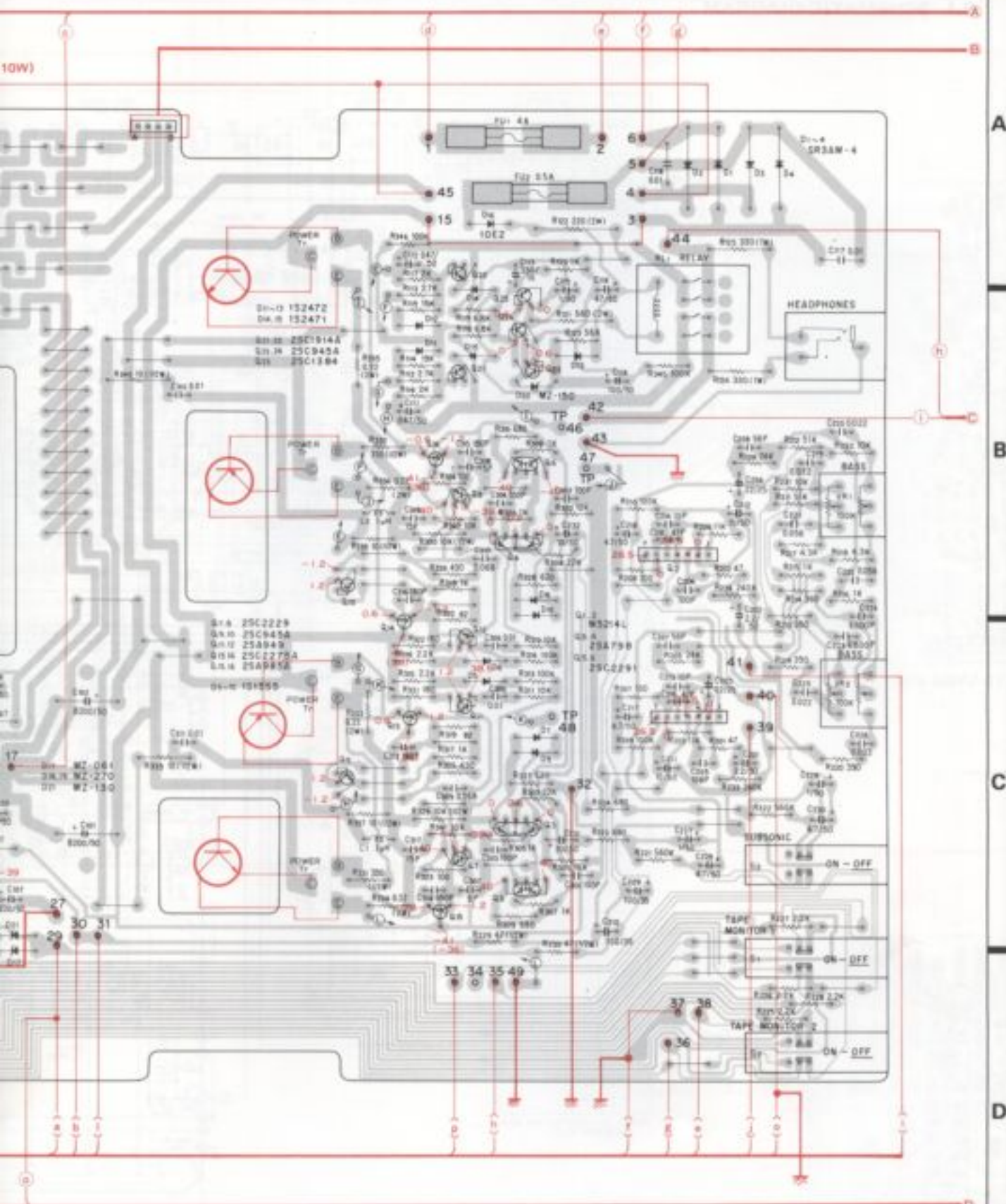

A

B

C

D

10

11

12

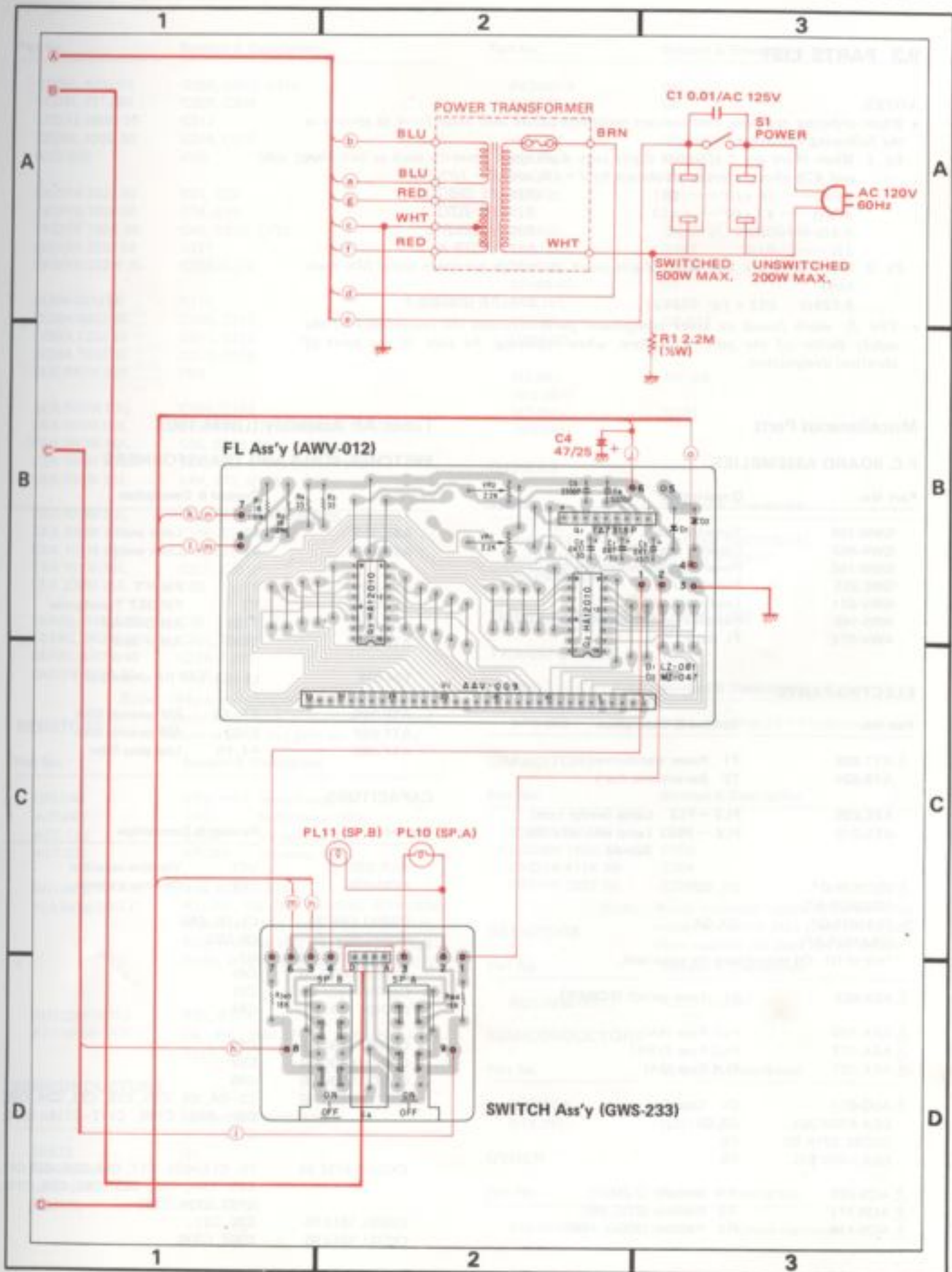

## 9.3 PARTS LIST

### NOTES:

- When ordering resistors, first convert resistance values into code form as shown in the following examples.

Ex. 1 When there are 2 effective digits (any digit apart from 0), such as 560 ohm and 47k ohm (tolerance is shown by J = 5%, and K = 10%).

560Ω — 56 × 10<sup>1</sup> — 561 ..... RD4PS (3)(3)(3) J

47kΩ — 47 × 10<sup>3</sup> — 473 ..... RD4PS (3)(3)(3) J

0.5Ω — 0R5 ..... RN2H (3)(3)(3) K

1Ω — 010 ..... RS1P (3)(3)(3) K

Ex. 2 When there are 3 effective digits (such as in high precision metal film resistors).

5.62kΩ 562 × 10<sup>1</sup> 5621 ..... RN4SR (3)(3)(3) F

- The  $\Delta$  mark found on some component parts indicates the importance of the safety factor of the part. Therefore, when replacing, be sure to use parts of identical designation.

### Miscellaneous Parts

#### P.C. BOARD ASSEMBLIES

Part No.	Description
GWM-160	Tuner/AF Ass'y
GWX-463	Detector Ass'y
GWM-156	Power amp/Protection Ass'y
GWS-233	Switch Ass'y
AWV-011	Lead out Ass'y
AWS-149	Function Switch Ass'y
AWV-012	FL Ass'y

#### ELECTRO-PARTS

Part No.	Symbol & Description
$\Delta$ ATT-896	T1 Power transformer
ATB-624	T2 Bar-antenna Ass'y
AEL-029	PL1 ~ PL3 Lamp (wedge type)
AEL-075	PL4 ~ PL11 Lamp with wire (8V, 50mA)
$\Delta$ 25C2525-G* (25C2525-B*)	Q1, Q2
$\Delta$ 25A1075-G* (25A1075-B*)	Q3, Q4
*Hfe of Q1-Q4 should have the same rank.	
$\Delta$ ASA-507	S1 Lever switch (POWER)
$\Delta$ AEK-100	FU1 Fuse (4A)
$\Delta$ AEK-107	FU2 Fuse (0.5A)
$\Delta$ AEK-101	FU4 Fuse (3A)
$\Delta$ ACG-017	C1 Capacitor
CEA 470M 25L	C3, C4
CCDSL 221K 50	C5
CEA 100M 50L	C6
$\Delta$ ACN-029	R1 Resistor (2.2MΩ)
$\Delta$ ACN-117	R2 Resistor (82Ω, 5W)
$\Delta$ ACN-116	R3 Resistor (200Ω, 10W)

### Tuner/AF Assembly (GWM-160)

#### SWITCHES, COILS AND TRANSFORMERS

Part No.	Symbol & Description
ASK-159	S1 Lever switch
ASK-157	S2 Lever switch
ATE-039	T1 FM IFT
ATE-045	T2 FM DET Transformer
ATB-066	T101 AM OSC coil
ATB-069	T102 AM IF coil
T24-028	L5-L8, L10 RF choke coil
ATF-106	F1-F3 FM ceramic filter
ATF-084	F103 AM ceramic filter
ATF-089	F4, F5 Low-pass filter

#### CAPACITORS

Part No.	Symbol & Description
ACK-035	VC1 Variable capacitor
ACM-006	TC1 Ceramic trimmer
CCDUJ 120J 50	C1, C5, C69
CCDSL 101J 50	C6, C22
CKDYX 473M 25	C7
CCDLH 080D 50	C49
CCDRH 150J 50	C51
CCDCH 150J 50	C47
CCDCH 330J 50	C48
CCDCH 040C 50	C52
CCDCH 010C 50	C46
CKDYF 103Z 50	C2-C4, C9, C10, C18, C23, C24, C45, C62, C69, C109, C112-C114, C120, C122
CKDYF 473Z 50	C8, C11-C15, C17, C19, C26, C27, C42, C53, C54, C58, C63, C64, C66, C119, C123, C124, C326
CCDSL 151J 50	C20, C21
CCDSL 101J 50	C307, C308

Part No.	Symbol & Description
CCDSL 470J 50	C108, C317, C318
CCDSL 221J 50	C303, C304
CCDXL 080D 50	C111
CCDSL 100D 50	C315, C316
ACG-018	C30 390p 50V
CKDYA 332J 50	C31, C32
CKDYA 152J 50	C74, C75
CKDYB 102K 50	C43, C115, C117
CKDYA 222J 50	C121
CKDYX 223M 25	C323, C324
CQSH 331J 50	C110
CQMA 683J 50	C309, C310
CQMA 122J 50	C311, C312
CQMA 183J 50	C313, C314
CGB R47K 500	C50
CEA R47M 50L	C101, C102
CEA 010M 50L	C33, C34, C37, C38, C40, C41, C103
CEA 2R2M 50L	C25, C105
CEA 100M 50L	C35, C70, C104, C107, C118
CEA 101M 25L	C44, C72, C116
CEA 470M 25L	C29, C55, C56, C65, C68
CEA 330M 16L	C106, C305, C306
CEA 101M 10L	C16, C28
CEA 101M 35L	C321, C322
CEA 220M 25L	C39
CEANL R47M 50	C36
CEANL 3R3M 50	C301, C302
CEANL 4R7M 50	C319, C320
CKDYB 472K 50	C325

Note: When ordering resistors, convert the resistance value into code form, and then rewrite the part no. as before.

**RESISTORS**

Part No.	Symbol & Description
C92-049	VR1, VR3 Semi-fixed, 10k
ACP-067	VR2 Semi-fixed, 100k
ACT-126	VR301 Variable, 250k
ACT-021	VR302 Variable, 1M
RN1/4PQ 0000 F	R16, R305-R310
RD1/4PM 000 J	R1-R3, R5-R7, R9-R15, R17-R34, R36-R40, R42-R48, R50-R64, R70-R78, R101-R116, R118-R121, R123-R129, R301-R304, R313-R322, R324
RD1/2PS 000 J	R41, R325
RD1/4PMF 000 J	R4, R8, R49, R79, R80, R82-R84, R117, R122

**SEMICONDUCTORS**

Part No.	Symbol & Description
35K73	Q1
NJM4558DV (μPC4558C)	Q10
M5214L	Q301, Q302

Part No.	Symbol & Description
PA3007-A	Q5
PA4006-A	Q6
HA1201	Q3, Q4, Q12
2SK61	Q7
2SK34	Q8
2SC535	Q2,
2SC461	Q8, Q101, Q103, Q105
2SA726S	Q102
2SK168	Q104
1SV69-03	D1
2-1K261	D102
1S1555 (1S2473)	D6-D12
MZ-061 (WZ-061)	D2, D3
MZ-081 (WZ-081)	D101

**OTHERS**

Part No.	Symbol & Description
AKA-014	Terminal (ANTENNA)
AKB-063	Pinjack (PHONE)
PMZ30P040FMC	Screw

**Detector Assembly (GWX-463)**

**TRANSFORMER**

Part No.	Symbol & Description
ATE-050	T201 FM DET Transformer

**CAPACITORS**

Part No.	Symbol & Description
CCDSL 101J 50	C201
CCDWK 150K 50	C202
CKDYB 471K 50	C204
CKDYF 103Z 50	C206

Note: When ordering resistors, convert the resistance value into code form, and then rewrite the part no. as before.

**RESISTORS**

Part No.	Symbol & Description
RD1/4PM 000 J	R201-R208

**SEMICONDUCTORS**

Part No.	Symbol & Description
2SC461-B	Q201
2-1K261	D201, D202

**OTHER**

Part No.	Symbol & Description
ASS-012	X201 Cristal resonator

## Switch Assembly (GWS-233)

Part No.	Symbol & Description
ASG-241	S4 Push switch
RD1/4PM000J	R343, R344

## Lead Out Assembly (AWV-011)

### COILS

Part No.	Symbol & Description
T24-028	L1-L4 RF choke coil

### CAPACITORS

Part No.	Symbol & Description
ACM-010	TC1 Trimmer
CKDYB 103K 50	C3, C5, C8
CKDYF 473Z 50	C11, C17-C21, C23-C25, C30
QOMA 223K 50	C4, C6
CCDCH 101J 50	C10
CKDYF 391K 50	C9
CCDCH 020C 50	C12
CEA 3R3M 50L	C15
CEA 471M 10L	C7
CEA 101M 25L	C14
CEA 221M 16L	C29
CEA 470M 50L	C13
CEA 221M 25L	C26
CEA 2R2M 50L	C22
CEA 221M 10L	C16

*Note: When ordering resistors, convert the resistance value into code form, and then rewrite the part no. as before.*

### RESISTORS

Part No.	Symbol & Description
RD1/4PMF 000J	R111
RD1/4PMF 000J	R6
RR1/4PMF 000J	R105, R106
RD1/4PM000J	R1-R5, R7-R93, R95-R102, R107-R109, R112
RS1P000J	R103, R104
RD1/2PSF 000J	R110
RS2P000J	R94

### SEMICONDUCTORS

Part No.	Symbol & Description
M54451P	Q1
PD5009	Q2
HA12010	Q3
2SC945A (2SC2575)	Q5-Q9, Q11-Q24
2SA733A (2SA1100)	Q25-Q29

Part No.	Symbol & Description
2SA733A (2SA1100)	Q30-Q34
2SC461	Q10
2SD880 (2SD313)	Q4
MZ-140 (WZ-140)	D1
1S1555 (1S2076)	D2-D7

### OTHERS

Part No.	Symbol & Description
ASS-011	X1 Crystal resonator (5.12 MHz)
AAV-007	V1 Fluorescent indicator tube (FREQUENCY)
VBZ30P060FMC	Screw

## Function switch Assembly (AWS-149)

### SWITCH

Part No.	Symbol & Description
ASG-240	S1 Push switch

### CAPACITORS

Part No.	Symbol & Description
CEA 2R2M 50L	C1, C2

### RESISTORS

Part No.	Symbol & Description
RD1/4PM000J	R1-R3, R7, R8
RD1/2PS000J	R9

### SEMICONDUCTORS

Part No.	Symbol & Description
1S1555 (1S2473)	D1-D9

## FL Assembly (AWV-012)

### CAPACITORS

Part No.	Symbol & Description
CEA R47M 50L	C1-C3
CKDYF 332Z 50	C4, C5

*Note: When ordering resistors, convert the resistance value into code form, and then rewrite the part no. as before.*

### RESISTORS

Part No.	Symbol & Description
ACP-078	VR1, VR2 Semi-fixed
RD1/2PSF 000J	R1, R2
RD1/4PM000J	R3, R4



SEMICONDUCTORS

Part No.	Symbol & Description
TA7318P-A	Q1
HA12010	Q2, Q3
LZ-081	D1
MZ-047	D2

OTHERS

Part No.	Symbol & Description
AAV-009	V1 Fluorescent indicator tube (POWER)
VBZ30P060FMC	

Power Amp/Protection Assembly (GWM-159)

SWITCHES

Part No.	Symbol & Description
ASK-157	S1-S3 Lever switch
ASR-033	RL1 Relay

CAPACITORS

Part No.	Symbol & Description
ACH-215	C101, C102 Electrolytic
ACG-004	C117, C118 Ceramic
CEA R47M 50L	C111, C112
CEA 010M 50L	C115, C227, C228
CEA 470M 10L	C110
CEA 470M 25L	C108
CEA 470M 50L	C105, C106, C116
CEA 101M 50L	C103, C104, C114
CEA 221M 35L	C119
CEA 221M 50L	C107
CEA 331M 10L	C113
CEANL 100M 50	C231, C232
CEANL 2R2M 50	C201, C202
CEANL 4R7M 50	C217, C218
CEA 4R7M 50L	C229, C230
CEA 100M 50L	C211, C212
CEA 220M 25L	C203, C204
CEA 101M 35L	C209, C210
CCDSL 150J 50	C317, C318
CCDSL 050D 500	C307, C308
CCDSL 100D 50	C213, C214
CCDSL 470J 50	C215, C216
CCDSL 560J 50	C207, C208
CCDSL 101J 50	C205, C206, C301-C304
CCDSL 181K 500	C313-C316
CQMA 682J 50	C223, C224

Part No.	Symbol & Description
CQMA 223J 50	C219, C220, C225, C226
CQMA 563J 50	C221, C222
CQMA 683J 50	C309, C310
CKDYB 103K 50	C305, C306, C311, C312

Note: When ordering resistors, convert the resistance value into code form, and then rewrite the part no. as before.

RESISTORS

Part No.	Symbol & Description
ACT-127	VR1, VR2 Variable (TONE)
RD1/4PM000J	R104-R108, R110-R120, R123, R126, R201-R228, R231-R234, R301-R306, R311-R316, R327, R328, R341, R342, R345, R346
RD1/4PM000J	R319, R320
RD1/2PSF000J	R102, R103, R229, R230
RD1/4PMF000J	R307-R310, R317-R324
RD1/4PMF000J	R325, R326
RS1P000J	R124, R125
RS2P000J	R121, R122
RD1/2PS000J	R329-R330, R337-R340
RD1/2PSF000J	R331, R332
ACN-039	R333-R336 0.22/2W

SEMICONDUCTORS

Part No.	Symbol & Description
M5214L-P	Q1, Q2
2SA798	Q3, Q4
2SC2291	Q5, Q6
2SC2229	Q7, Q8
(2SC1885)	
2SC945A	Q9, Q10
(2SC2575)	
2SA949	Q11, Q12
(2SA912)	
2SC2275A	Q13, Q14
(2SC1913)	
2SA985A	Q15, Q16
(2SA913)	
2SC1914A	Q21, Q22
2SC945A	Q23, Q24
(2SC2575)	
2SC1384	Q25
2SD880	Q17
(2SD313)	
2SB834	Q18
(2SB507)	
2SD836A	Q19, Q20
SR3AM-4	D1-D4
10E2	D16
(S1B01-02)	
1S2472	D11-D13
(1S1554)	

Part No.	Symbol & Description
1S2471	D14, D15
MZ-061 (WZ-061)	D17
MZ-150 (WZ-150)	D20
MZ-270	D18, D19
MZ-130 (WZ-130)	D21
1S1555 (1S2473)	D5-D10
KZL-072	D22

**OTHERS**

Part No.	Symbol & Description
AKN-030	Headphone jack
AKB-063	Pinjack 4P
AKE-044	Terminal (SPEAKERS)
VBZ30P060FMC	Screw

**10. PACKING**

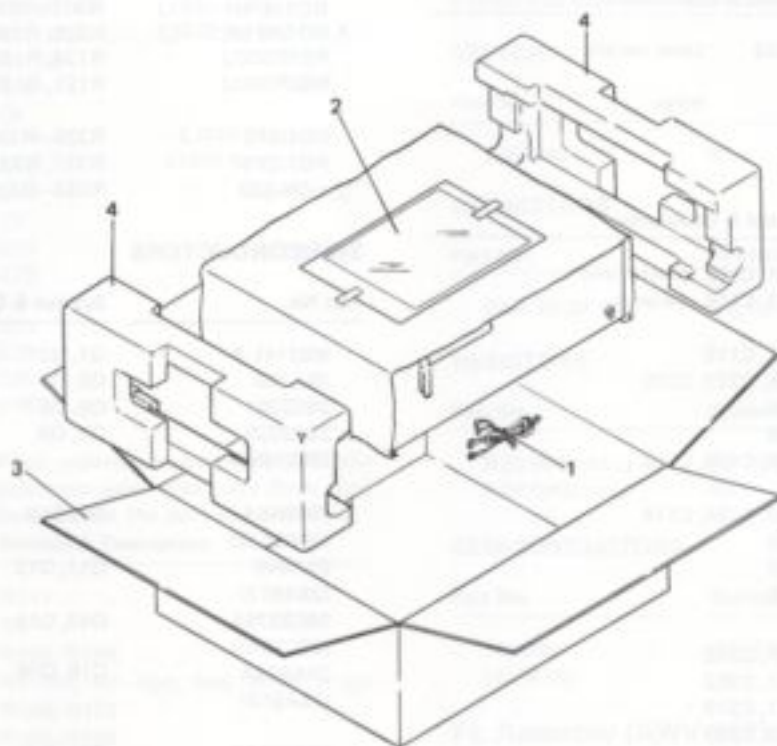

Key No.	Part No.	Description
1.	ADH-002	T-type FM antenna
2.	ARB-360	Operating instructions
3.	AHD-765	Packing case
4.	AHA-252	Side pad

## 11. EXPLODED VIEW

## Exterior Components

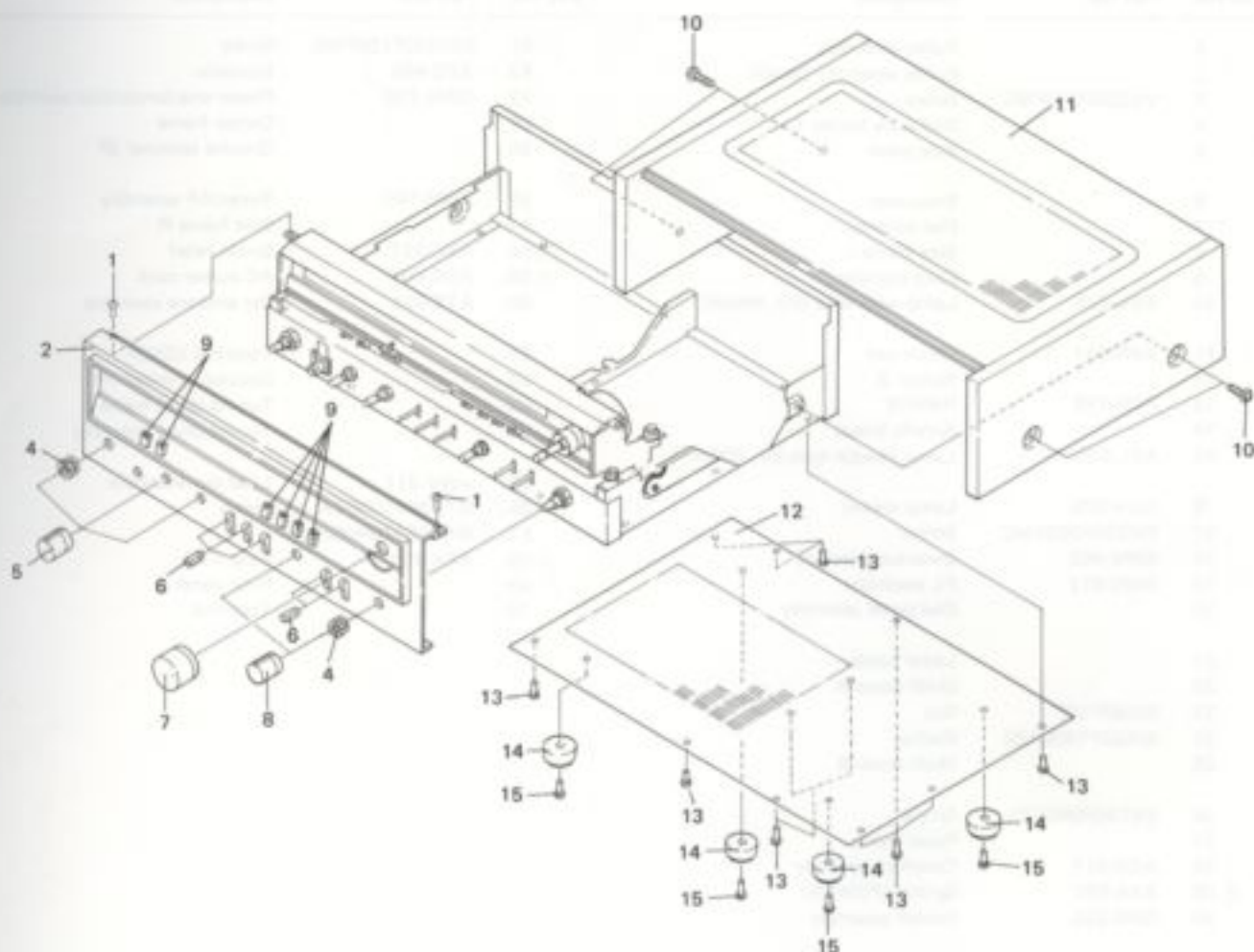

## NOTES:

- Parts without part number cannot be supplied.
- The  $\Delta$  mark found on some component parts indicates the importance of the safety factor of the part. Therefore, when replacing, be sure to use parts of identical designation.

## Parts list

Key No.	Part No.	Description	Key No.	Part No.	Description
1.	VBZ30P060FMC	Screw	11.	AMM-089	Bonnet case
2.	ANB-883	Front panel assembly	12.		Bottom plate
3.	.....		13.	VBZ30P060FMC	Screw
4.	ABN-024	Nut	14.	AEC-178	Foot assembly
5.	AAB-239	Knob	15.	VTZ40P120FMC	Screw
6.	AAD-139	Lever knob assembly			
7.	AAA-065	Knob			
8.	AAB-239	Knob			
9.	AAD-226	Push knob			
10.	DCZ40P150FZK	Screw			

## Interior Components

### Parts list

Key No.	Part No.	Description	Key No.	Part No.	Description
1.		Pulley assembly	51.	VMH30P120FMC	Screw
2.		Pulley assembly (small)	52.	AEC-488	Insulator
3.	VBZ30P060FMC	Screw	53.	GWM-159	Power amp/protection assembly
4.		Dial scale holder L	54.		Center frame
5.		Side plate	55.		Ground terminal 2P
6.		Smoothing	56.	GWM-160	Tuner/AF assembly
7.		Dial pointer	57.		Side frame R
8.		Side frame L	58.	AEC-327	Strain relief
9.		Cord clasper	59.	ADG-023	AC power cord
10.	AEL-075	Lamp with wire (8V, 50mA)	60.	ATB-624	Bar-antenna assembly
11.	ABN-047	Union nut	61.		Terminal (GND)
12.		Spacer B	62.		Ground terminal 7P
13.	ACN-116	Resistor	63.		Tuning drum frame
14.		Acrylic board	64.		Tuning drum assembly
15.	AEL-029	Lamp (wedge type 8V, 300mA)	65.	AWV-011	Lead out assembly
16.	AKK-005	Lamp socket	66.	MTZ30P100FZK	Screw
17.	PMZ30P060FMC	Screw	67.	WA35F100N080	
18.	GWX-463	Detector assembly	68.	AEK-107	Fuse 0.5A
19.	AWV-012	FL assembly	69.		Rear panel
20.		Dial panel assembly	70.		Terminal
21.		Lamp holder			
22.		Shaft cover A			
23.	NK90FUC	Nut			
24.	WA92F140U100	Washer			
25.		Shaft cover B			
26.	BBT30P080FZK	Screw			
27.		Panel frame			
28.	ACG-017	Ceramic capacitor			
29.	ASA-507	Switch (POWER)			
30.	GWS-233	Switch assembly			
31.	PMT30P060FZB	Screw			
32.		Mounting plate			
33.	NK90FUC	Nut			
34.	ABE-001	Internal toothed lock washer			
35.	AEK-100	Fuse 4A			
36.	AEK-101	Fuse 3A			
37.	AWS-149	Function switch assembly			
38.	VTZ40P080FMC	Screw			
39.	ATT-696	Power transformer			
40.		Transformer holder			
41.	AXA-271	Dial shaft assembly			
42.		Dial scale holder R			
43.	ABA-176	Screw			
44.	AKP-039	AC socket (AC OUTLETS)			
45.	AKB-076	Terminal 1P			
46.	ACN-117	Resistor			
47.		Resistor holder			
48.		Heat sink			
49.	2SC2625-G	Transistor			
50.	2SA1075-G	Transistor			

1 2 3  
**Interior Components**

A

B

C

D

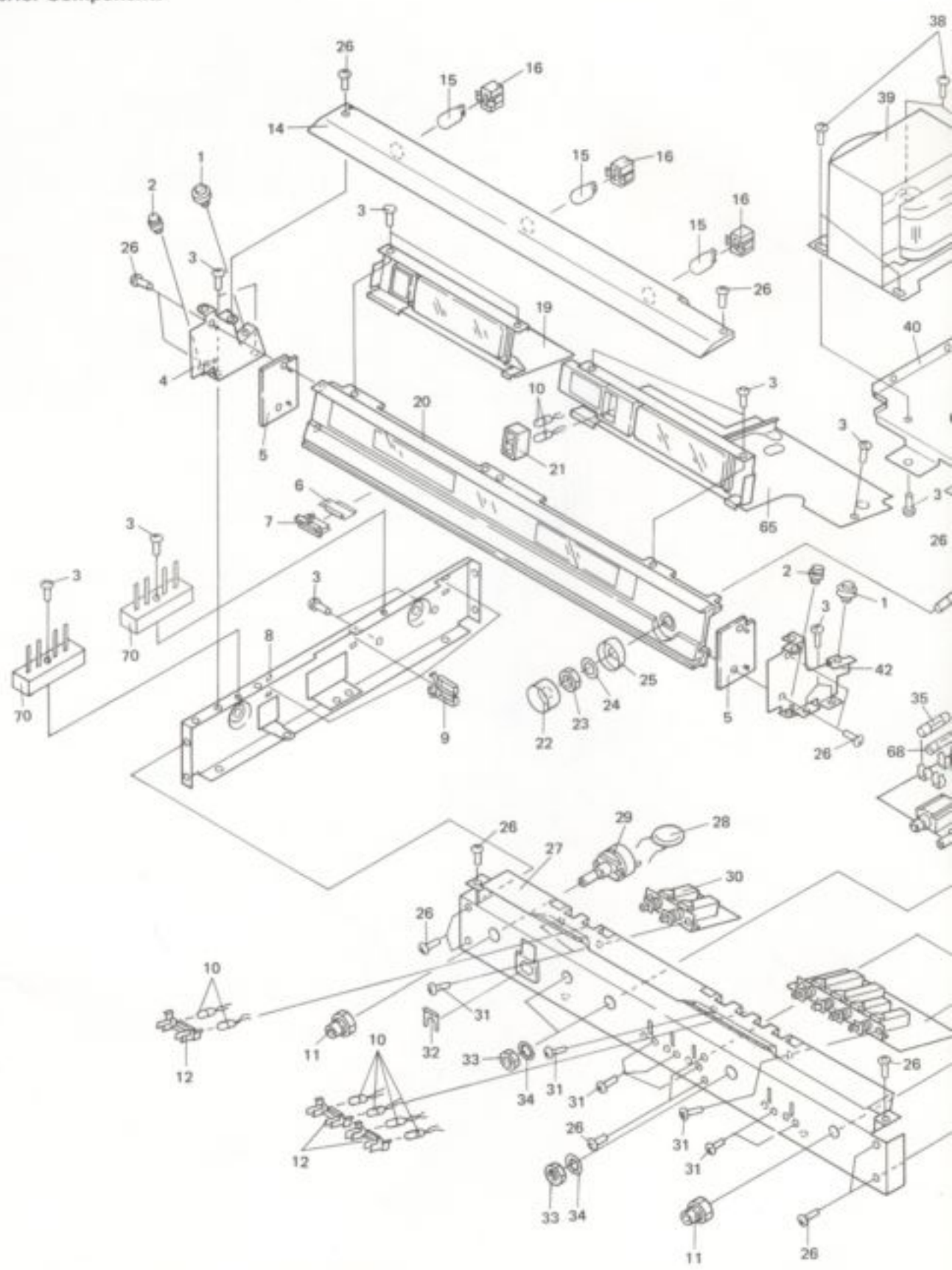

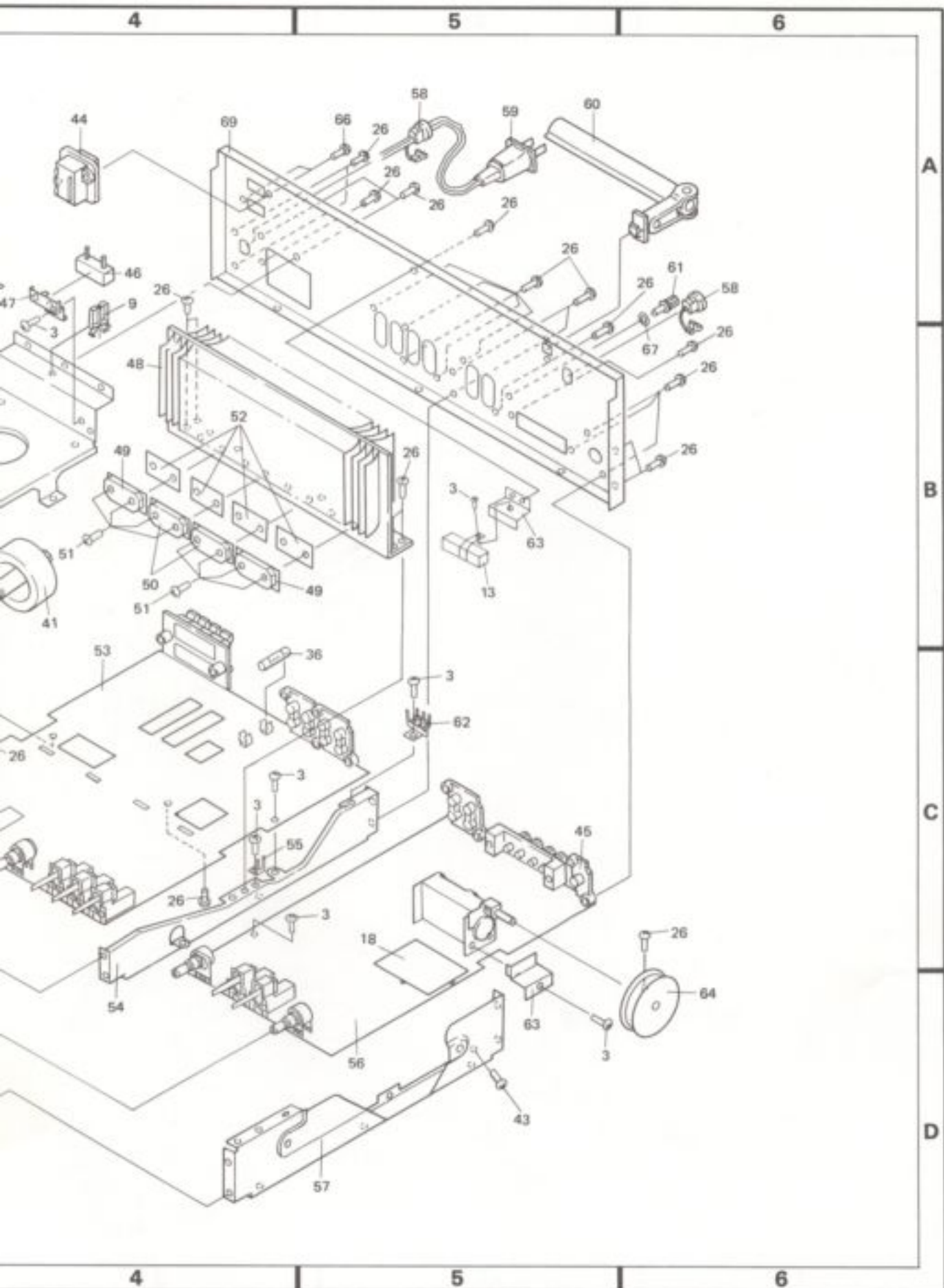

A  
B  
C  
D

ADDITIONAL

 PIONEER

# Service Manual

STEREO RECEIVER

# SX-820 KU

**Note**

- This additional service manual is applicable to the SX-820/KU types, please refer to the SX-3700/KU type service manual with the exception of this supplements.

## CONTRAST OF MISCELLANEOUS PARTS

Symbol	Part Name	Part No.	
		SX-3700	SX-820
	FL assembly	AWV-012	AWV-013
	Front panel assembly	ANB-883	ANB-916
	Operating instructions	ARB-360	ARB-375
	Packing case	AHD-765	AHD-782

### FL assembly

Symbol	Part Name	Part No.	
		SX-3700	SX-820
		AWV-012	AWX-013
D2	Diode	MZ-047	SZ-027

**PIONEER ELECTRONIC CORPORATION** 4-1, Meguro 1-Chome, Meguro-ku, Tokyo 153, Japan  
**U.S. PIONEER ELECTRONICS CORPORATION** 85 Oxford Drive, Moonachie, New Jersey 07074, U.S.A.  
**PIONEER ELECTRONIC (EUROPE) N.V.** Luthegen-Heaven 9, 2030 Antwerp, Belgium  
**PIONEER ELECTRONICS AUSTRALIA PTY. LTD.** 178-184 Boundary Road, Braeside, Victoria 3195, Australia



Interior Components

1

2

3

A

B

C

D

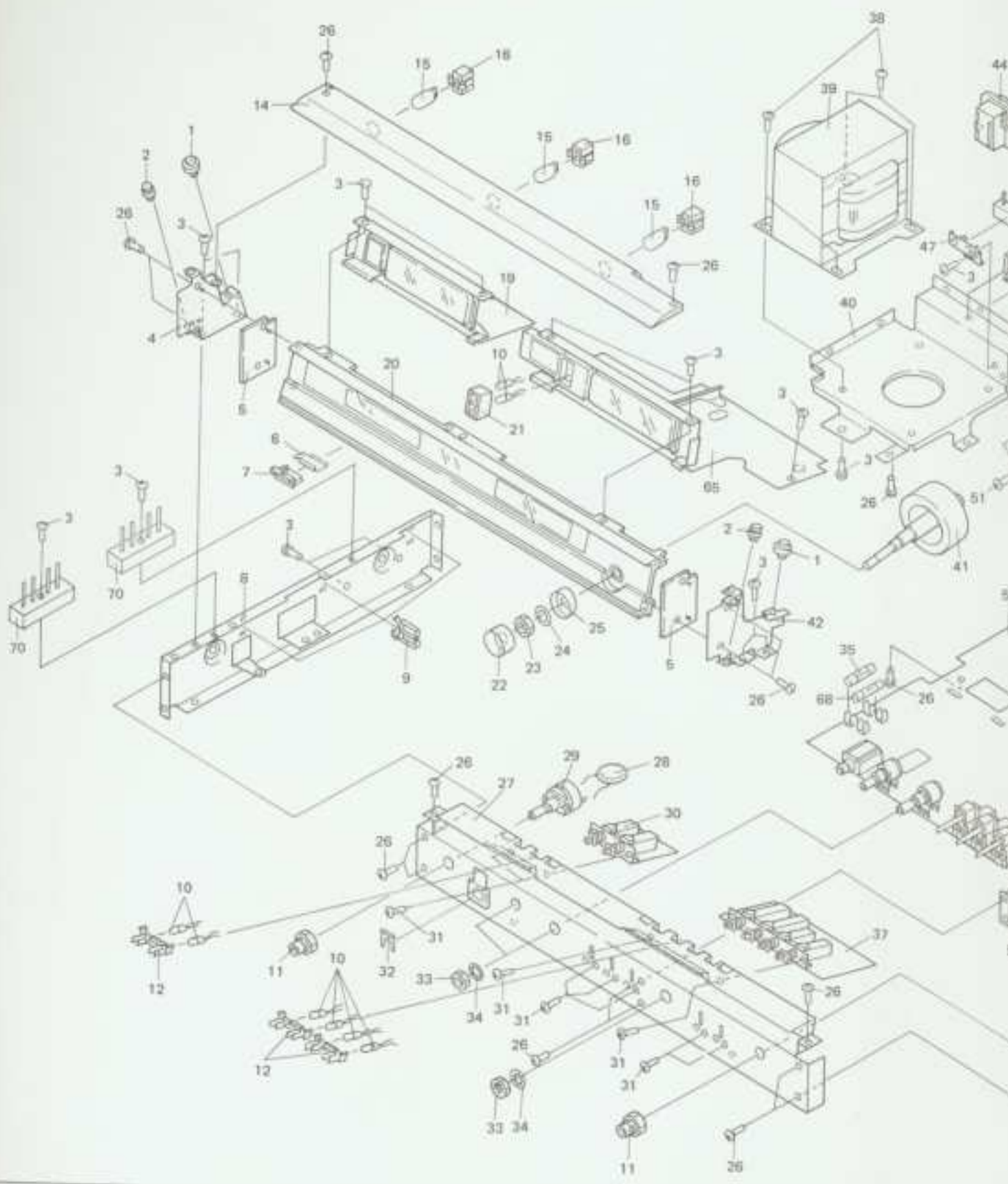

9.2 P.C. BOARD CONNECTION DIAGRAM

A

TUNER/AF Ass'y  
(GWM-160)

B

T2  
AM STEREO OUT

C

D

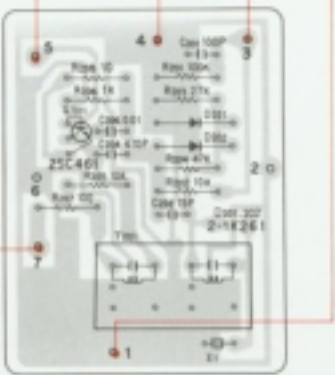

DETECTOR Ass'y (GWX-463)

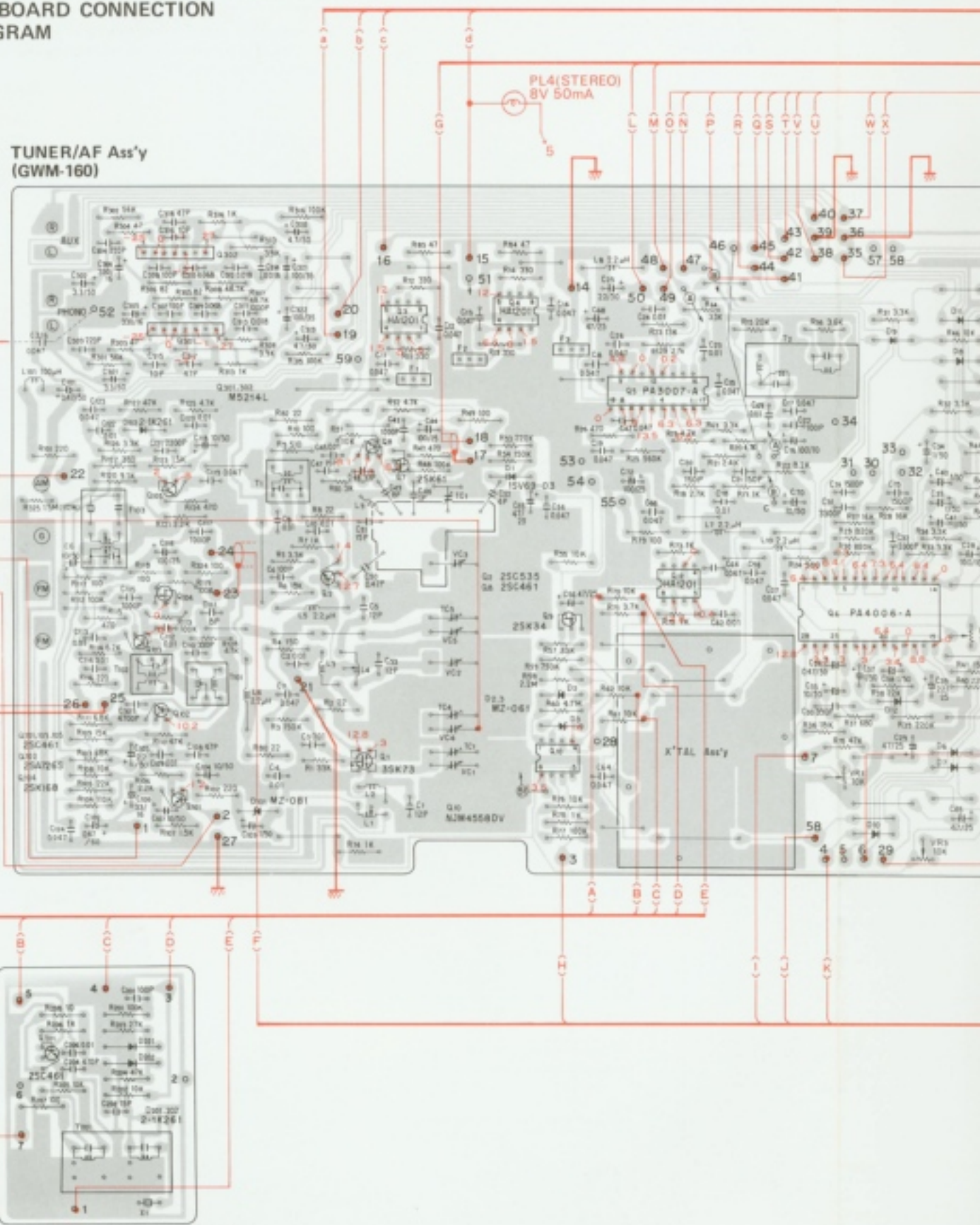

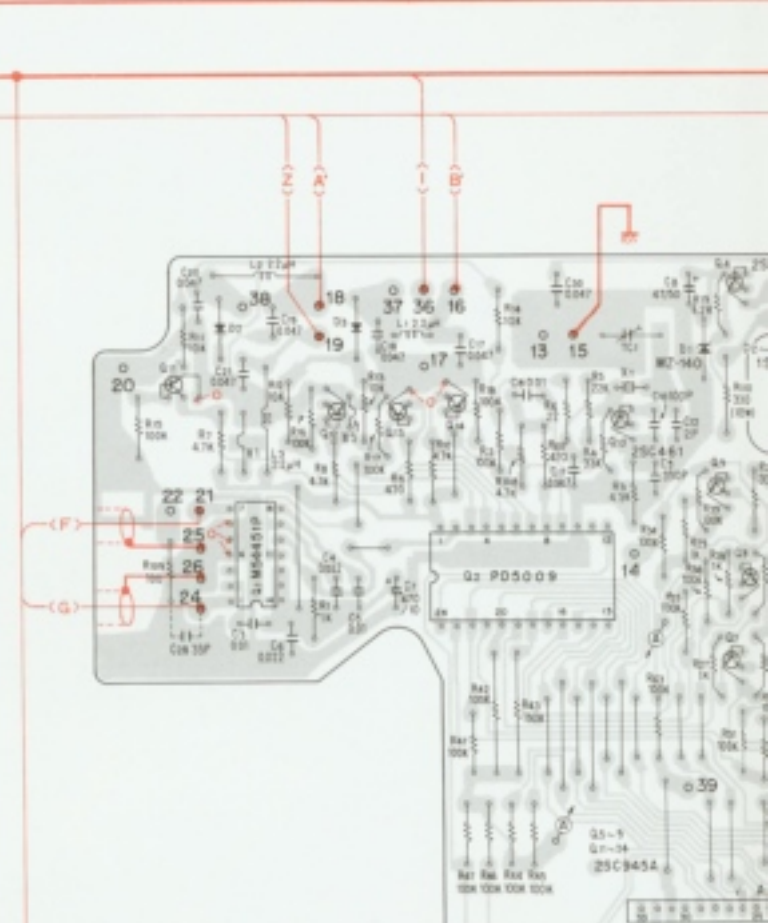
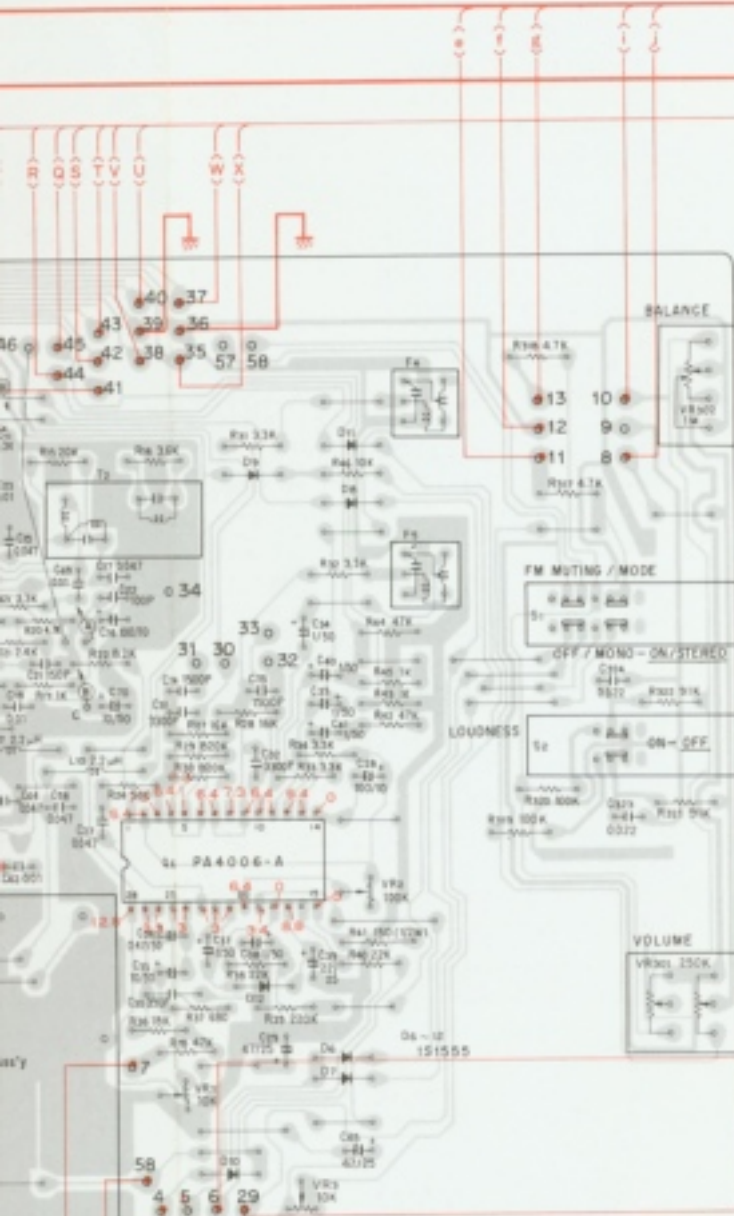

READ OUT Ass'y (AWV-011)

PL9 (PHONO)

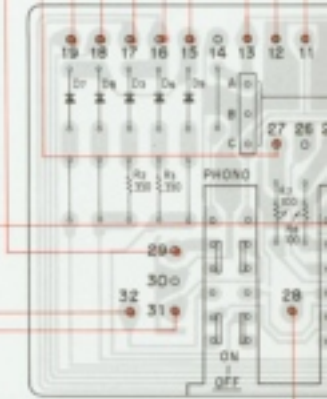

FUNCTION SWITCH Ass'y (AWS-149)

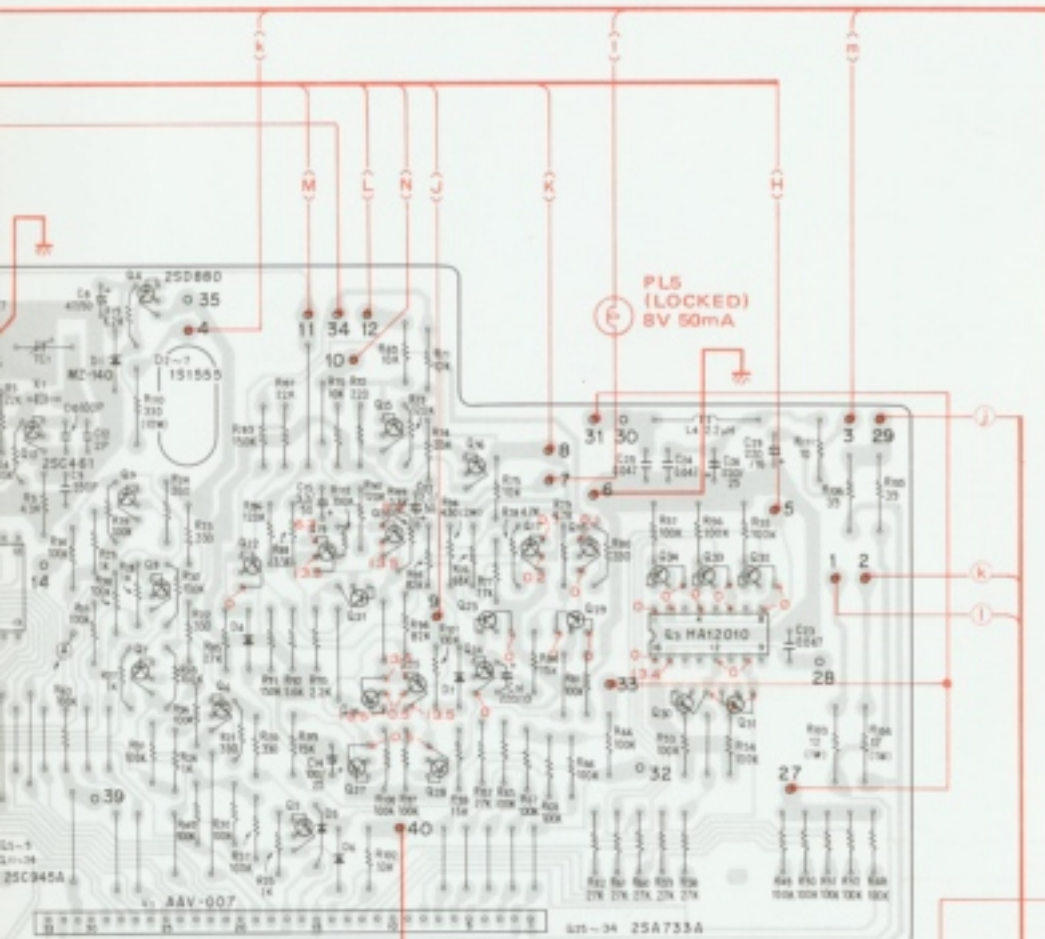

Ass'y (AWV-011)

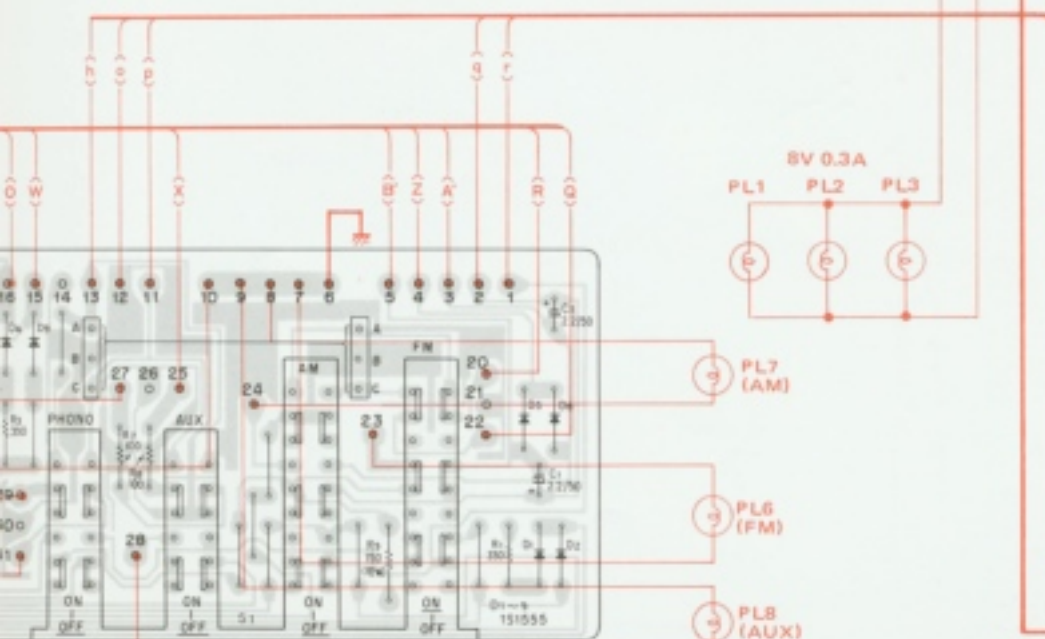

Ass'y (AWS-149)

POWER AMP/ PROTECTION Ass'y (GWM-159)

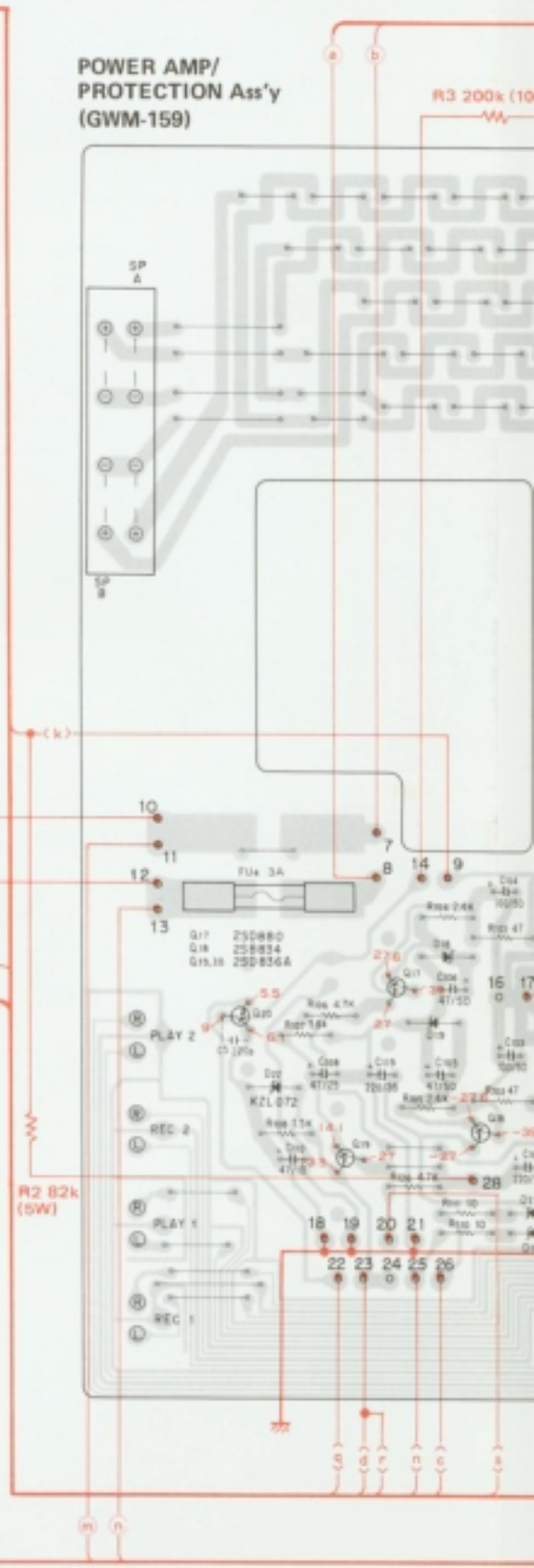

R3 200k (10)

R2 82k (5W)

10

11

12

3 200k (10W)

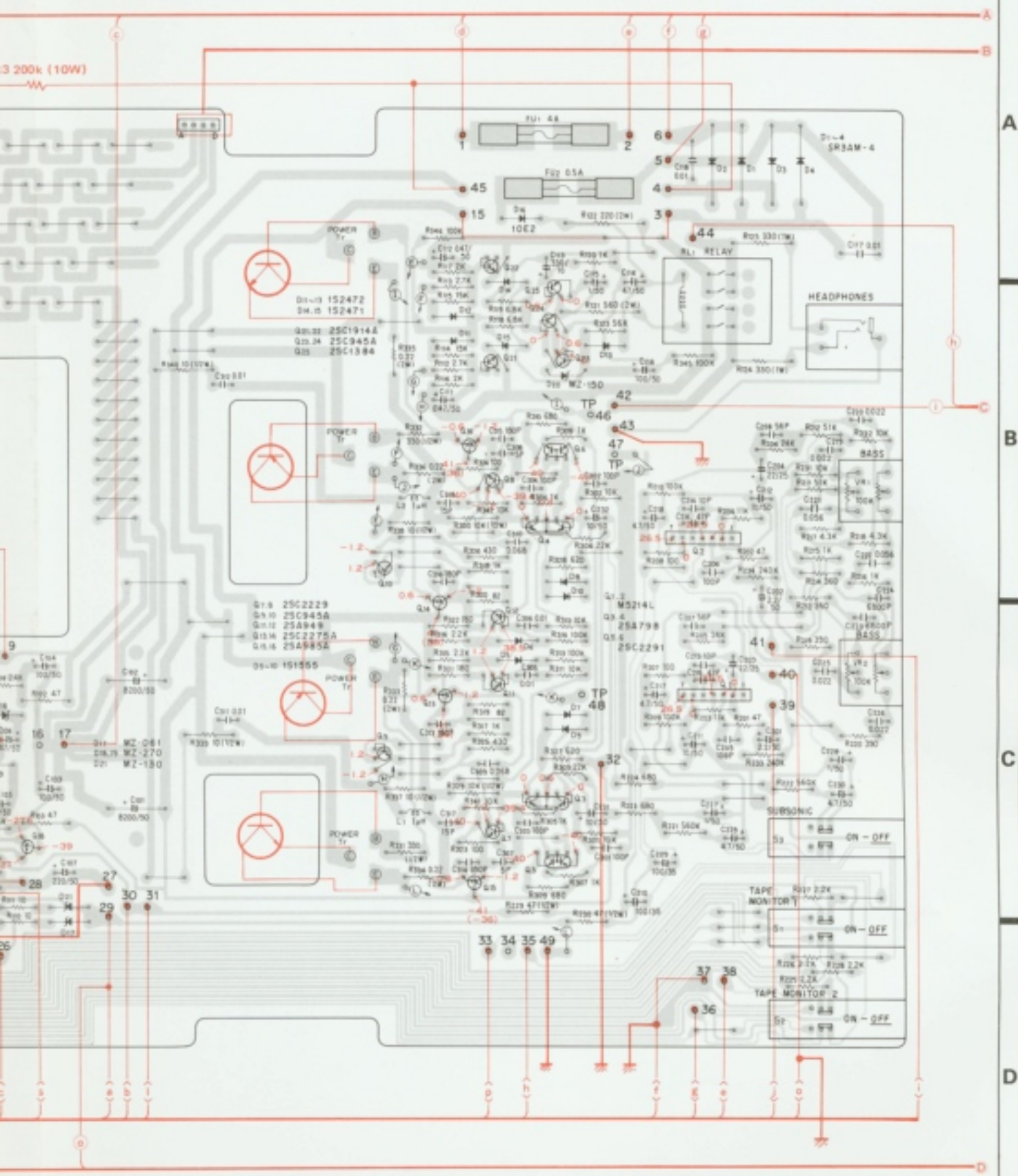

A  
B  
C  
D

10

11

12

10

11

12

**NOTE:**  
The indicated semiconductors are representative ones only. Other alternative semiconductors may be used and are listed in the parts list.

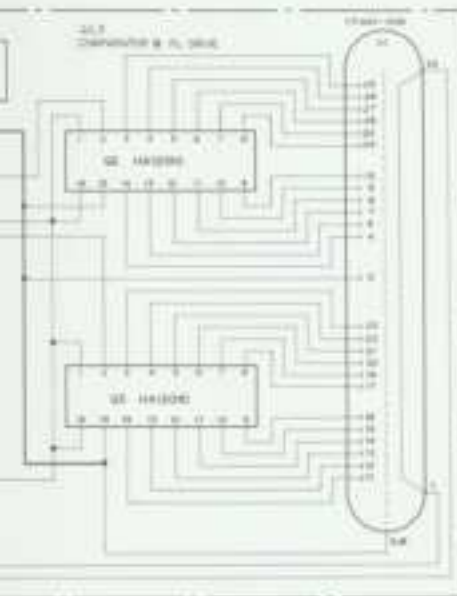
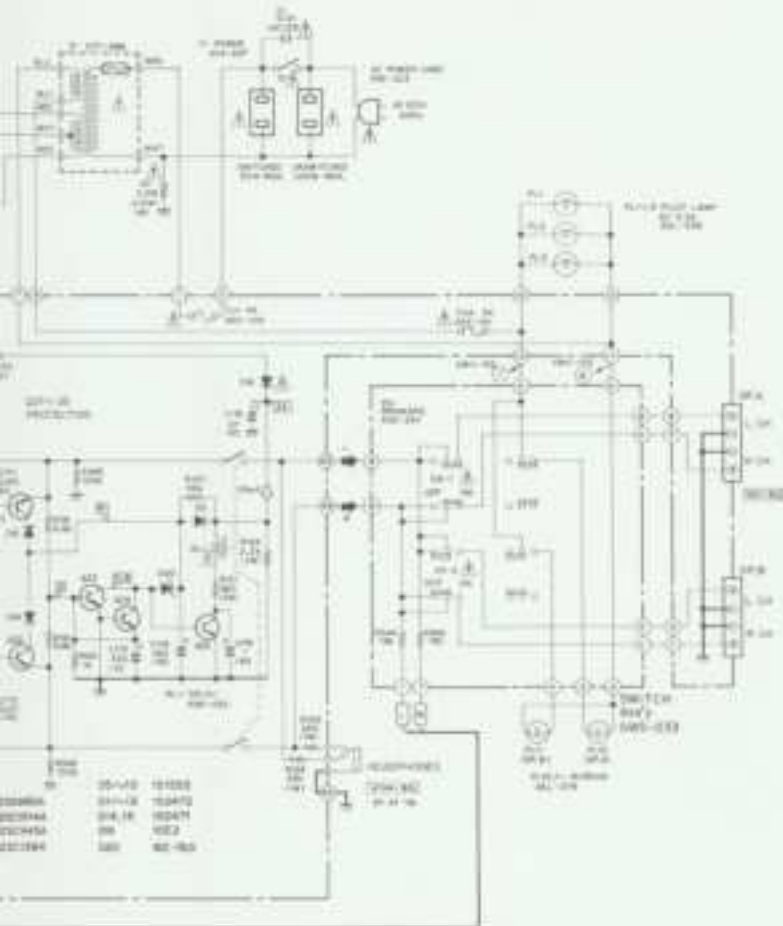

- 1 RESISTORS:**  
Indicated in  $\square$ ,  $\square$ ,  $\square$ ,  $\square$  (tolerance unless otherwise noted) A = 1%, M = 5%, 20% = 20%, 50% = 50%, 10% = 10%
- 2 CAPACITORS:**  
Indicated in  $\square$ ,  $\square$ ,  $\square$  (tolerance unless otherwise noted)  $\square$  = 5%,  $\square$  = 10%,  $\square$  = 20% unless otherwise specified
- 3 VOLTAGE COEFFICIENT:**  
 $\square$  = 50V,  $\square$  = 100V,  $\square$  = 250V,  $\square$  = 500V,  $\square$  = 1000V  
 $\square$  = 50V,  $\square$  = 100V,  $\square$  = 250V,  $\square$  = 500V,  $\square$  = 1000V  
Data in  $\square$  = 100V,  $\square$  = 250V,  $\square$  = 500V,  $\square$  = 1000V  
 $\square$  = 50V,  $\square$  = 100V,  $\square$  = 250V,  $\square$  = 500V,  $\square$  = 1000V
- 4 OTHERS:**  
 $\square$  = Regulator  
 $\square$  = Resistor  
The  $\square$  symbol found on some component parts indicates the availability of the alpha factor of the part. Therefore, when replacing, be sure to use parts of identical designation.
- 5 SETTINGS:**
- |    |            |          |
|----|------------|----------|
| 10 | FUNCTION 1 | ON - OFF |
| 11 | FUNCTION 2 | ON - OFF |
| 12 | FUNCTION 3 | ON - OFF |
| 13 | FUNCTION 4 | ON - OFF |
| 14 | FUNCTION 5 | ON - OFF |
| 15 | FUNCTION 6 | ON - OFF |
| 16 | FUNCTION 7 | ON - OFF |
| 17 | FUNCTION 8 | ON - OFF |
| 18 | FUNCTION 9 | ON - OFF |
- The customer indicates the correct setting.
- This is a no-load schematic diagram, but the actual circuit may vary due to manufacturing tolerances.

A

B

C

D

10

11

12

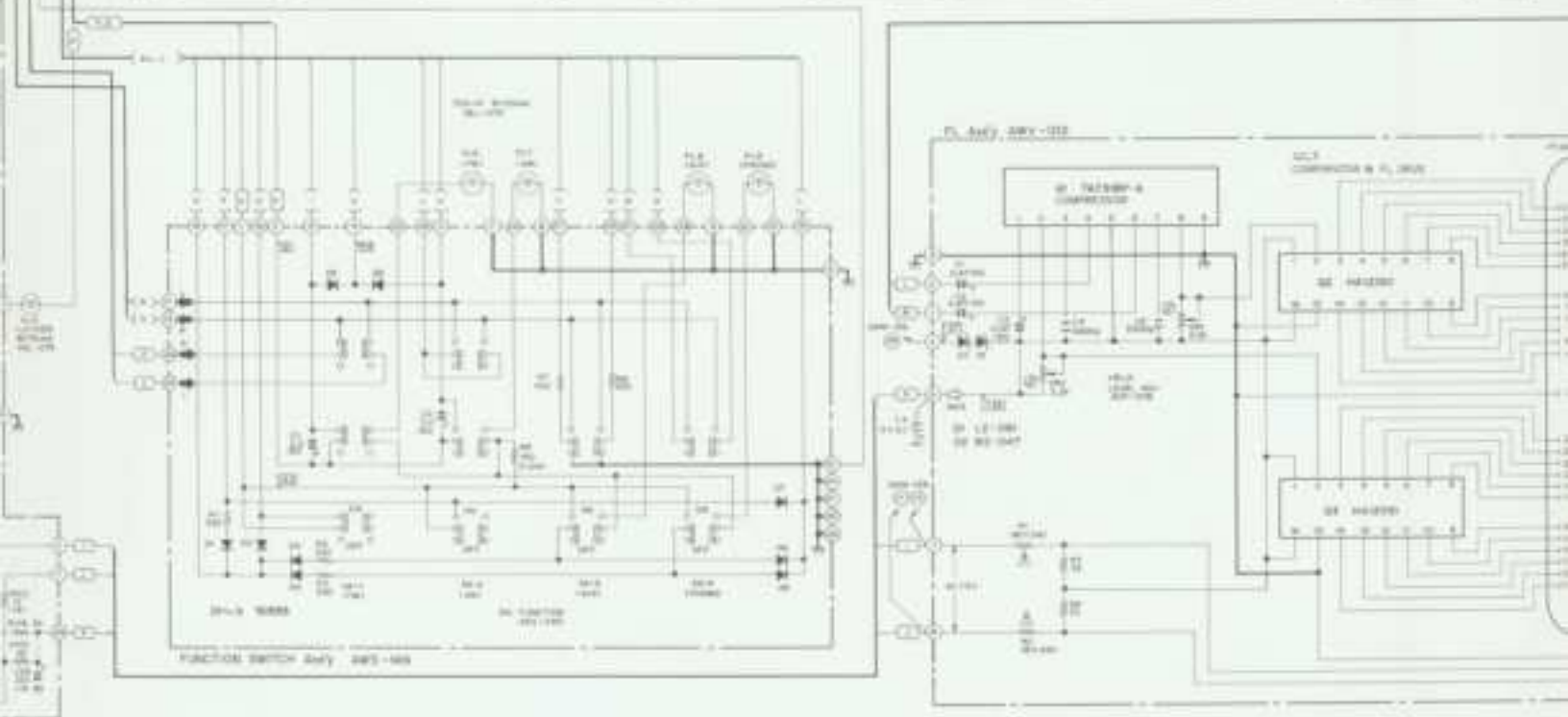
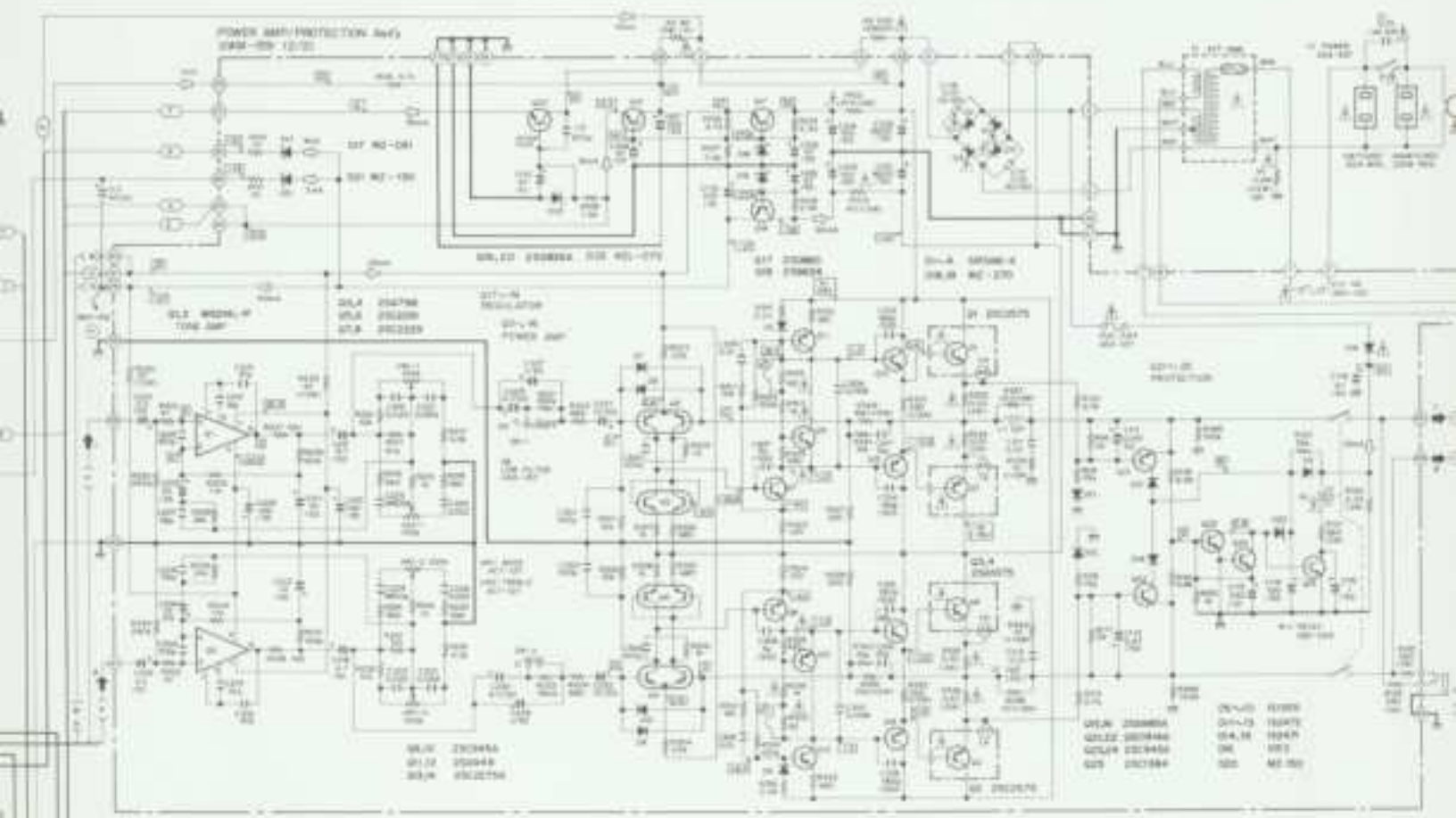

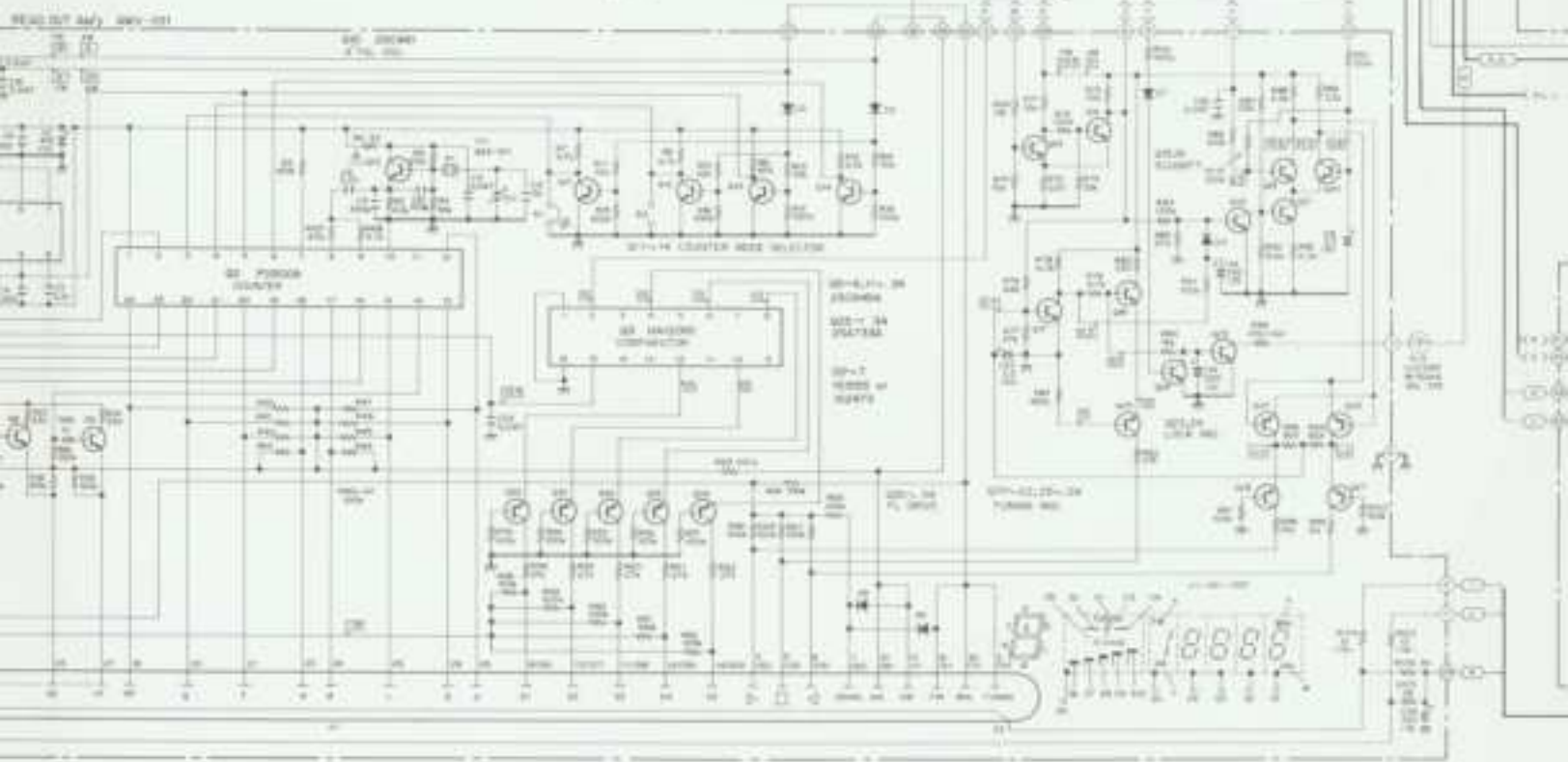
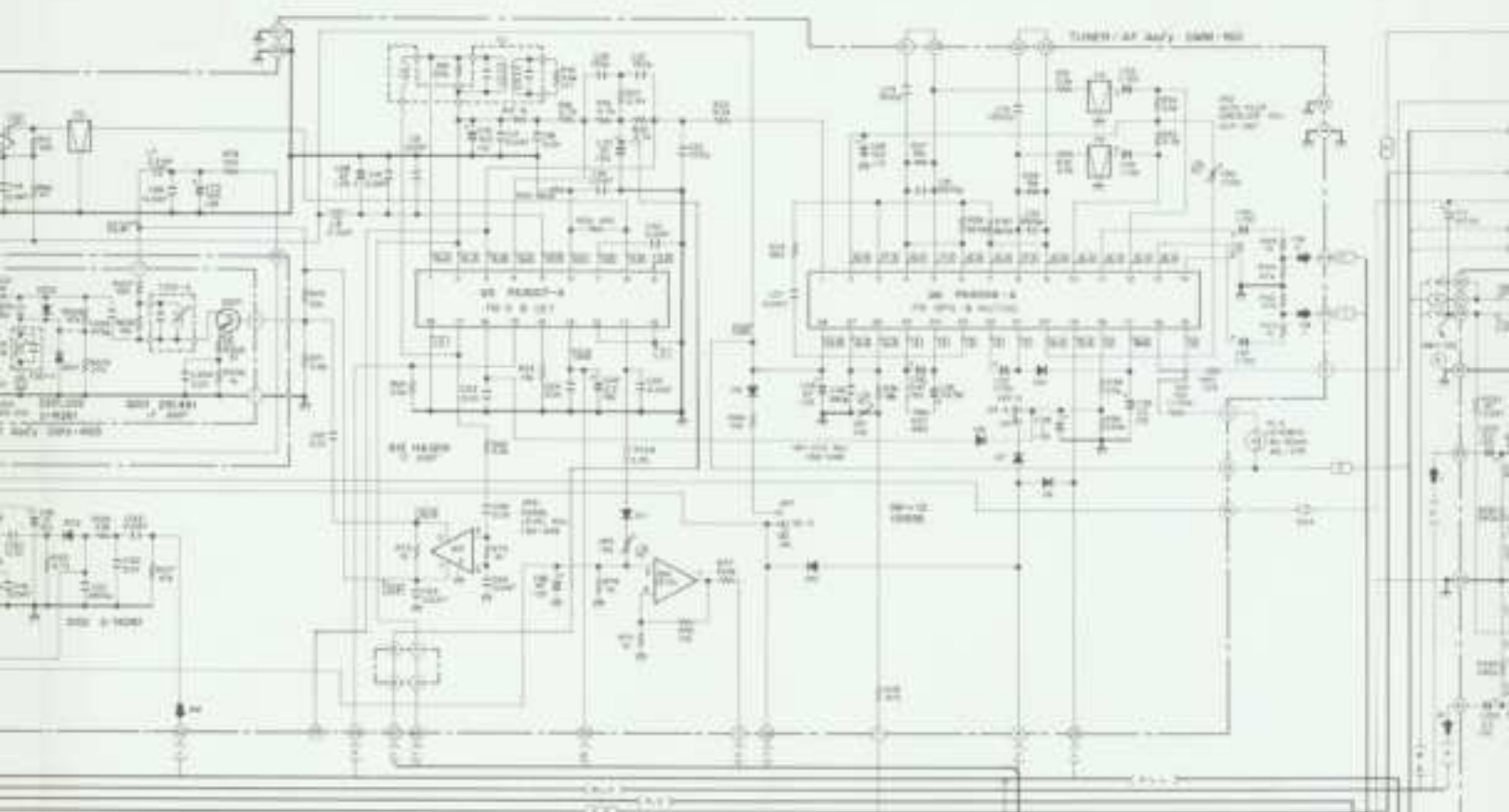



1

2

3

9.1 SCHEMATIC DIAGRAM

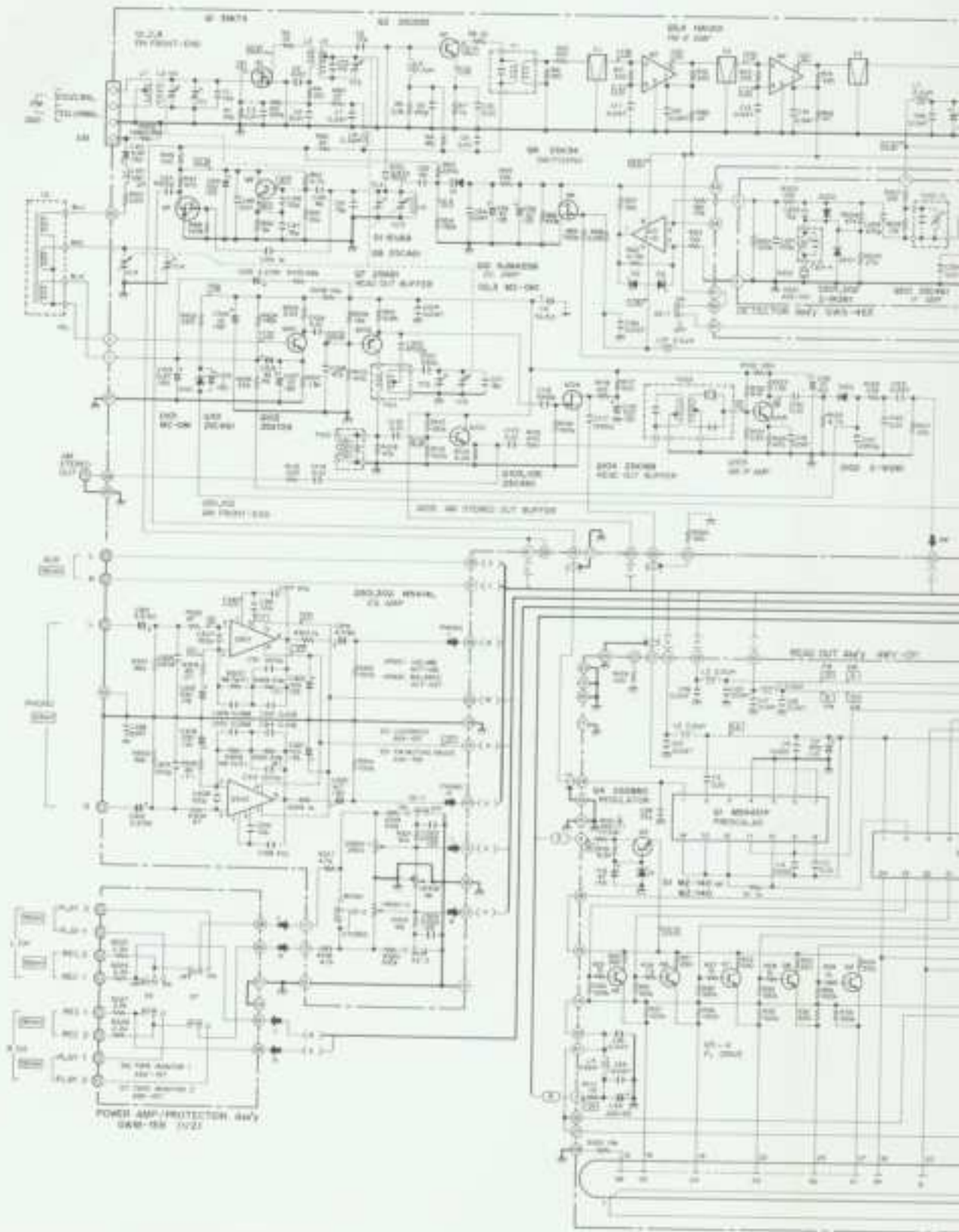

1

2

3

