

Service Manual

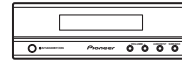
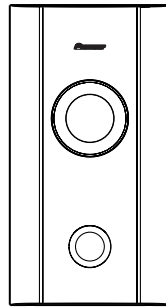

SX-SW77

ORDER NO.
RRV3158

AUDIO MULTI-CHANNEL RECEIVER SUBWOOFER

SX-SW77

SX-SW55

SX-SW950

THIS MANUAL IS APPLICABLE TO THE FOLLOWING MODEL(S) AND TYPE(S).

Model	Type	Power Requirement	Remarks
SX-SW77	WYXCN	AC220-240V	
SX-SW77	WVXCN	AC220-240V	
SX-SW55	WYXCN	AC220-240V	
SX-SW55	WVXCN	AC220-240V	
SX-SW950	KUXCN	AC120V	



For details, refer to "Important Check Points for Good Servicing".

SAFETY INFORMATION



This service manual is intended for qualified service technicians; it is not meant for the casual do-it-yourselfer. Qualified technicians have the necessary test equipment and tools, and have been trained to properly and safely repair complex products such as those covered by this manual.

Improperly performed repairs can adversely affect the safety and reliability of the product and may void the warranty. If you are not qualified to perform the repair of this product properly and safely, you should not risk trying to do so and refer the repair to a qualified service technician.

WARNING

This product contains lead in solder and certain electrical parts contain chemicals which are known to the state of California to cause cancer, birth defects or other reproductive harm.

Health & Safety Code Section 25249.6 – Proposition 65



NOTICE

(FOR CANADIAN MODEL ONLY)

Fuse symbols  (fast operating fuse) and/or  (slow operating fuse) on PCB indicate that replacement parts must be of identical designation.

REMARQUE

(POUR MODÈLE CANADIEN SEULEMENT)

Les symboles de fusible  (fusible de type rapide) et/ou  (fusible de type lent) sur CCI indiquent que les pièces de remplacement doivent avoir la même désignation.

(FOR USA MODEL ONLY)

1. SAFETY PRECAUTIONS

The following check should be performed for the continued protection of the customer and service technician.

LEAKAGE CURRENT CHECK

Measure leakage current to a known earth ground (water pipe, conduit, etc.) by connecting a leakage current tester such as Simpson Model 229-2 or equivalent between the earth ground and all exposed metal parts of the appliance (input/output terminals, screwheads, metal overlays, control shaft, etc.). Plug the AC line cord of the appliance directly into a 120V AC 60 Hz outlet and turn the AC power switch on. Any current measured must not exceed 0.5 mA.

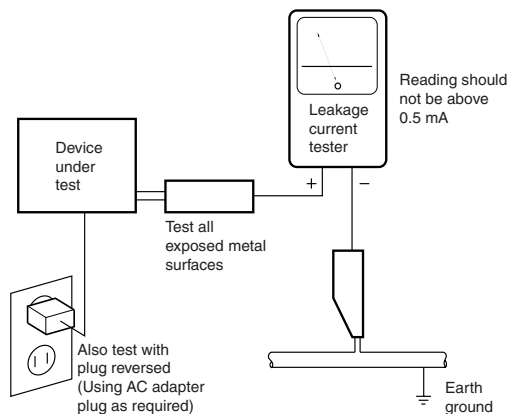

AC Leakage Test

ANY MEASUREMENTS NOT WITHIN THE LIMITS OUTLINED ABOVE ARE INDICATIVE OF A POTENTIAL SHOCK HAZARD AND MUST BE CORRECTED BEFORE RETURNING THE APPLIANCE TO THE CUSTOMER.

2. PRODUCT SAFETY NOTICE

Many electrical and mechanical parts in the appliance have special safety related characteristics. These are often not evident from visual inspection nor the protection afforded by them necessarily can be obtained by using replacement components rated for voltage, wattage, etc. Replacement parts which have these special safety characteristics are identified in this Service Manual.

Electrical components having such features are identified by marking with a Δ on the schematics and on the parts list in this Service Manual.

The use of a substitute replacement component which does not have the same safety characteristics as the PIONEER recommended replacement one, shown in the parts list in this Service Manual, may create shock, fire, or other hazards.

Product Safety is continuously under review and new instructions are issued from time to time. For the latest information, always consult the current PIONEER Service Manual. A subscription to, or additional copies of, PIONEER Service Manual may be obtained at a nominal charge from PIONEER.

[Important Check Points for Good Servicing]

In this manual, procedures that must be performed during repairs are marked with the below symbol. Please be sure to confirm and follow these procedures.

1. Product safety



Please conform to product regulations (such as safety and radiation regulations), and maintain a safe servicing environment by following the safety instructions described in this manual.

- ① Use specified parts for repair.

Use genuine parts. Be sure to use important parts for safety.

- ② Do not perform modifications without proper instructions.

Please follow the specified safety methods when modification (addition/change of parts) is required due to interferences such as radio/TV interference and foreign noise.

- ③ Make sure the soldering of repaired locations is properly performed.

When you solder while repairing, please be sure that there are no cold solder and other debris. Soldering should be finished with the proper quantity. (Refer to the example)

- ④ Make sure the screws are tightly fastened.

Please be sure that all screws are fastened, and that there are no loose screws.

- ⑤ Make sure each connectors are correctly inserted.

Please be sure that all connectors are inserted, and that there are no imperfect insertion.

- ⑥ Make sure the wiring cables are set to their original state.

Please replace the wiring and cables to the original state after repairs. In addition, be sure that there are no pinched wires, etc.

- ⑦ Make sure screws and soldering scraps do not remain inside the product.

Please check that neither solder debris nor screws remain inside the product.

- ⑧ There should be no semi-broken wires, scratches, melting, etc. on the coating of the power cord.

Damaged power cords may lead to fire accidents, so please be sure that there are no damages. If you find a damaged power cord, please exchange it with a suitable one.

- ⑨ There should be no spark traces or similar marks on the power plug.

When spark traces or similar marks are found on the power supply plug, please check the connection and advise on secure connections and suitable usage. Please exchange the power cord if necessary.

- ⑩ Safe environment should be secured during servicing.

When you perform repairs, please pay attention to static electricity, furniture, household articles, etc. in order to prevent injuries. Please pay attention to your surroundings and repair safely.

2. Adjustments



To keep the original performance of the products, optimum adjustments and confirmation of characteristics within specification. Adjustments should be performed in accordance with the procedures/instructions described in this manual.

3. Lubricants, Glues, and Replacement parts



Use grease and adhesives that are equal to the specified substance. Make sure the proper amount is applied.

4. Cleaning



For parts that require cleaning, such as optical pickups, tape deck heads, lenses and mirrors used in projection monitors, proper cleaning should be performed to restore their performances.

5. Shipping mode and Shipping screws



To protect products from damages or failures during transit, the shipping mode should be set or the shipping screws should be installed before shipment. Please be sure to follow this method especially if it is specified in this manual.

CONTENTS

	SAFETY INFORMATION	2
	1. SPECIFICATIONS	4
A	2. EXPLODED VIEWS AND PARTS LIST	6
	2.1 PACKING	6
	2.2 EXTERIOR.....	8
	2.3 DISPLAY UNIT	10
	3. BLOCK DIAGRAM AND SCHEMATIC DIAGRAM	12
	3.1 OVERALL WIRING CONNECTION DIAGRAM AND BLOCK DIAGRAM	12
	3.2 MAIN ASSY (1/5)	14
	3.3 MAIN ASSY (2/5)	16
	3.4 MAIN ASSY (3/5)	18
	3.5 MAIN ASSY (4/5)	20
	3.6 MAIN ASSY (5/5)	22
	3.7 AC INLET, CONNECT and FL ASSYS	24
B	3.8 POWER SUPPLY UNIT.....	26
	3.9 WAVEFORMS	28
	4. PCB CONNECTION DIAGRAM	29
	4.1 MAIN ASSY	30
	4.2 AC INLET and CONNECT ASSYS	34
	4.3 FL ASSY	35
	4.4 POWER SUPPLY UNIT.....	36
	5. PCB PARTS LIST	38
	6. ADJUSTMENT	40
	7. GENERAL INFORMATION	41
	7.1 DIAGNOSIS	41
	7.1.1 TEST MODE.....	41
C	7.1.2 SPECIFICATIONS OF SPEAKER SETUP	43
	7.1.3 PROPOSAL OF DSP ERROR DISPLAY	44
	7.1.4 CIRCUIT DESCRIPTION OF DIGITAL AMP. SECTION	45
	7.1.5 SPECIFICATIONS FOR THE PROTECTION CIRCUITS FOR THE DIGITAL AMPLIFIER	46
	7.1.6 CONDITIONS FOR SWITCHING THE ROTATION SPEED OF THE FAN	47
	7.1.7 DISASSEMBLY.....	48
	7.2 IC	51
	8. PANEL FACILITIES	67

1. SPECIFICATIONS

SX-SW950

• Amplifier section

RMS Power Output :

Front, Center, Surround 60 W per channel
(1 kHz, 10 % THD, 6 Ω)

Subwoofer 60 W (200 Hz, 10 % THD, 6 Ω)

FTC Power Output :

Front, Center, Surround 50 W per channel
(200 Hz, - 20 kHz 1 % THD, 6 Ω)

Subwoofer 50 W (45 Hz - 200 Hz, 1 % THD, 6 Ω)

• FM tuner section

Frequency range 87.5 MHz to 108 MHz

Antenna 75 Ω, unbalanced

• AM tuner section

Frequency range 530 kHz to 1,700 kHz

Antenna Loop antenna

• Subwoofer section

Enclosure..... Bass-reflex floor type
(magnetically shielded)

System 16 cm 1-way system

Speaker 16 cm cone type

Nominal impedance 6 Ω

Frequency range 25 Hz to 1.0 kHz

Maximum Input Power 60 W

• Miscellaneous

Power requirements AC 120 V, 50/60 Hz

Power consumption..... 47 W

Power consumption in standby 0.2 W

Dimensions 7 7 / 8 (W) x 14 3 / 4(H) x 17 3 / 16 (D) in.
200 (W) x 375 (H) x 437 (D) mm

Weight 19 lb. 13 oz.
9.0 kg

• Accessories

Remote control 1

Display unit 1

AA/R6 dry cell batteries 2

Coaxial cable 1

Display cable 1

AM loop antenna 1

FM wire antenna 1

Power cord 1

Warranty card 1

Operating instructions

SX-SW77

• **Amplifier section**

RMS Power Output :

Front, Center, Surround110 W per channel
 (1 kHz, 10 % T.H.D., 3Ω)
 Subwoofer 70 W (200 Hz, 10 % T.H.D., 3Ω)

Front, Center, Surround60 W per channel
 (1 kHz, 10 % T.H.D., 6Ω)
 Subwoofer..... 60 W (200 Hz, 10 % T.H.D., 6Ω)

• **FM tuner section**

Frequency range 87.5 MHz to 108 MHz
 Antenna..... 75Ω, unbalanced

• **AM tuner section**

Frequency range..... 531 kHz to 1,602 kHz
 Antenna..... Loop antenna

• **Subwoofer section**

Enclosure Bass-reflex floor type
 (magnetically shielded)
 System.....16 cm 1-way system
 Speaker16 cm cone type
 Nominal impedance..... 6Ω
 Frequency range 25 Hz to 1.0 kHz
 Maximum Input Power 60 W

• **Miscellaneous**

Power requirements..... AC 220-240 V, 50/60 Hz
 Power consumption......51 W
 Power consumption in standby 0.4 W
 Dimensions..... 200 (W) x 375 (H) x 437 (D) mm
 Weight..... 9.0 kg

• **Accessories**

Remote control......1
 Display unit......1
 AA/R6 dry cell batteries......2
 Audio cable (red/white)......1
 Optical cable......1
 Control cable......1
 Display cable......1
 AM loop antenna......1
 FM wire antenna......1
 Power cord......1
 Warranty card......1
 Operating instructions......1

Note

- Specifications and design subject to possible modification without notice, due to improvements.

Manufactured under license from Dolby Laboratories."Dolby", "Pro Logic" and the double-D symbol are trademarks of Dolby Laboratories.

"DTS" and "DTS Digital Surround" are registered trademarks of Digital Theater Systems, Inc.

Receiver subwoofer (SX-SW77)

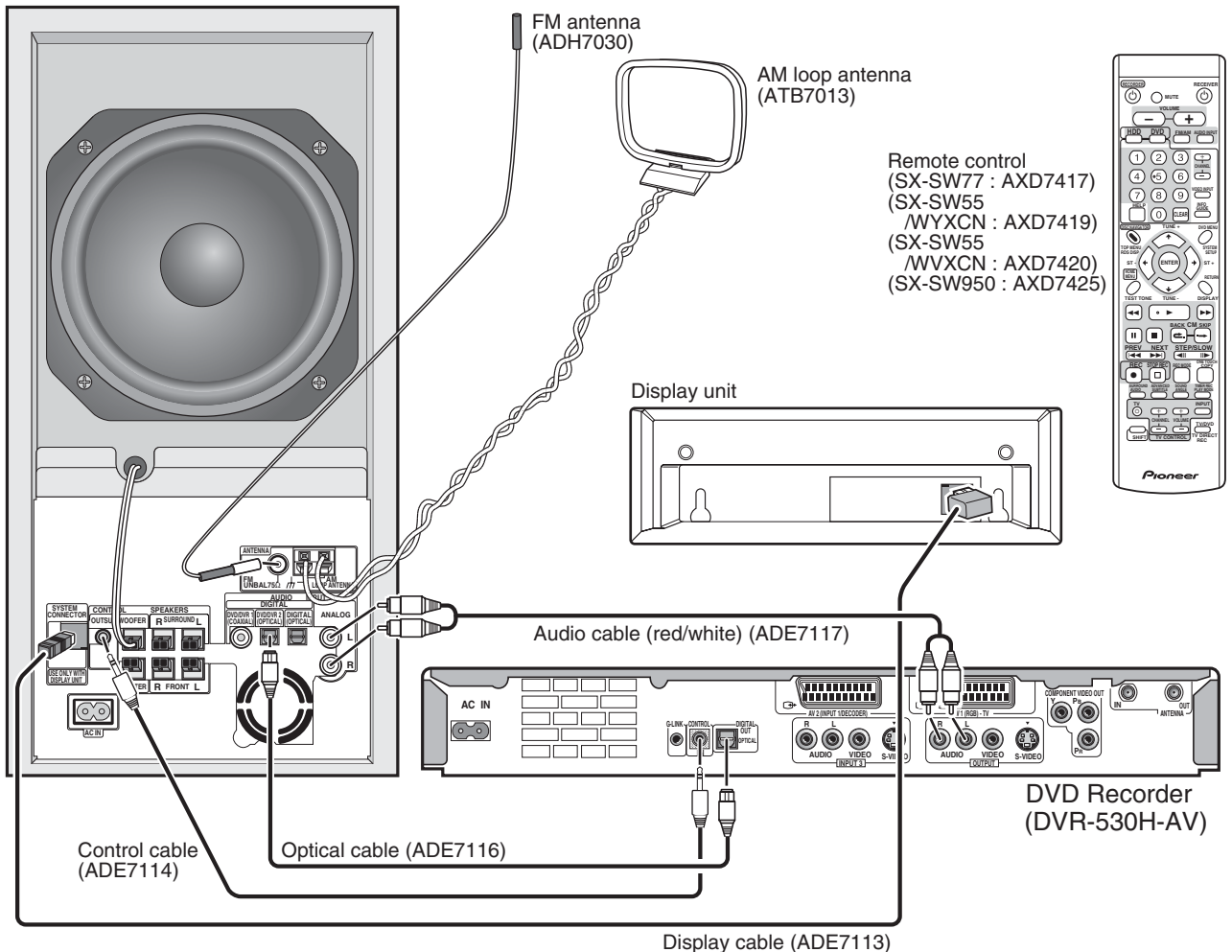

2. EXPLODED VIEWS AND PARTS LIST

- NOTES:**
- Parts marked by "NSP" are generally unavailable because they are not in our Master Spare Parts List.
 - The \triangle mark found on some component parts indicates the importance of the safety factor of the part. Therefore, when replacing, be sure to use parts of identical designation.
 - Screws adjacent to \blacktriangledown mark on product are used for disassembly.
 - For the applying amount of lubricants or glue, follow the instructions in this manual. (In the case of no amount instructions, apply as you think it appropriate.)

2.1 PACKING

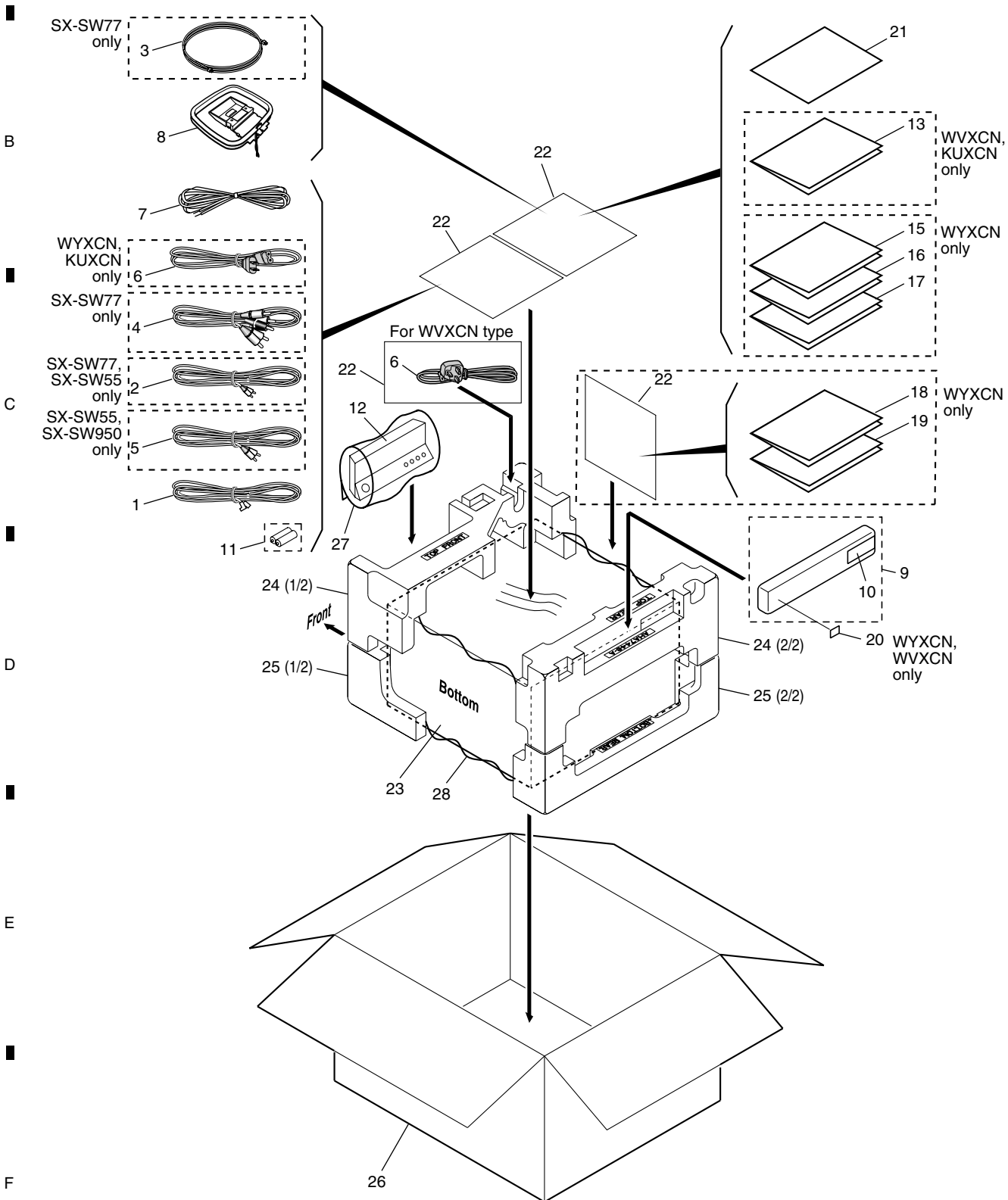

(1) PACKING SECTION PARTS LIST

Mark No.	Description	Part No.	Mark No.	Description	Part No.
1	Display Cable	ADE7113	16	Operating Instructions (Spanish)	See Contrast table (2)
2	Control Cable	See Contrast table (2)	17	Operating Instructions (French)	See Contrast table (2)
3	Optical Cable	See Contrast table (2)	18	Operating Instructions (Italian)	See Contrast table (2)
4	Audio Cable (red/white)	See Contrast table (2)	19	Operating Instructions (Dutch)	See Contrast table (2)
5	Coaxial Cord	See Contrast table (2)	20	Label (WEEE)	See Contrast table (2)
⚠ 6	AC Power Cord	See Contrast table (2)	NSP 21	Warranty Card	See Contrast table (2)
7	FM Wire Antenna	ADH7030	NSP 22	Polyethylene Bag	Z21-038
8	AM Loop Antenna	ATB7013	NSP 23	Polyethylene Bag	AHG7126
9	Remote Control Unit	See Contrast table (2)	24	Pad T	AHA7448
10	Battery Cover	AZA7424	25	Pad B	AHA7449
NSP 11	Dry Cell Battery (R6P, AA)	VEM1010	26	Packing Case SW	See Contrast table (2)
12	DISPLAY Unit	See Contrast table (2)	27	Packing Sheet	AHG7125
13	Operating Instructions (English)	See Contrast table (2)	28	Packing Sheet L	AHG7128
14	•••••				
15	Operating Instructions (German)	See Contrast table (2)			

(2) CONTRAST TABLE

SX-SW77/WYXCN, WVXCN, SX-SW55/WYXCN, WVXCN and SX-SW950/KUXCN are constructed the same except for the following:

Mark	No.	Symbol and Description	SX-SW77/ WYXCN	SX-SW77/ WVXCN	SX-SW55/ WYXCN	SX-SW55/ WVXCN	SX-SW950/ KUXCN
⚠	2	Cord with Mini Plug	ADE7114	ADE7114	ADE7114	ADE7114	Not used
	3	Optical Fiber Cable	ADE7116	ADE7116	Not used	Not used	Not used
	4	Cord with Plug	ADE7117	ADE7117	Not used	Not used	Not used
	5	Coaxial Cord	Not used	Not used	ADE7115	ADE7115	ADE7115
	6	AC Power Cord	ADG1154	ADG1156	ADG1154	ADG1156	ADG7022
	NSP	9	Remote Control Unit	AXD7417	AXD7417	AXD7419	AXD7420
12		DISPLAY Unit	AXX7204	AXX7204	AXX7204	AXX7204	Not used
12		DISPLAY Unit	Not used	Not used	Not used	Not used	AXX7205
13		Operating Instructions (English)	Not used	ARB7342	Not used	ARB7343	ARE7385
15		Operating Instructions (German)	ARC7636	Not used	ARC7638	Not used	Not used
16		Operating Instructions (Spanish)	ARC7637	Not used	ARC7639	Not used	Not used
17		Operating Instructions (French)	ARC7646	Not used	ARC7649	Not used	Not used
18		Operating Instructions (Italian)	ARC7647	Not used	ARC7650	Not used	Not used
19		Operating Instructions (Dutch)	ARC7648	Not used	ARC7651	Not used	Not used
20		Label (WEEE)	ARW7322	ARW7322	ARW7322	ARW7322	Not used
NSP	21	Warranty Card	ARY7065	ARY7065	ARY7065	ARY7065	ARY7045
	26	Packing Case SW	AHD8375	AHD8375	AHD8381	AHD8381	AHD8392

2.2 EXTERIOR

A
B
C
D
E
F

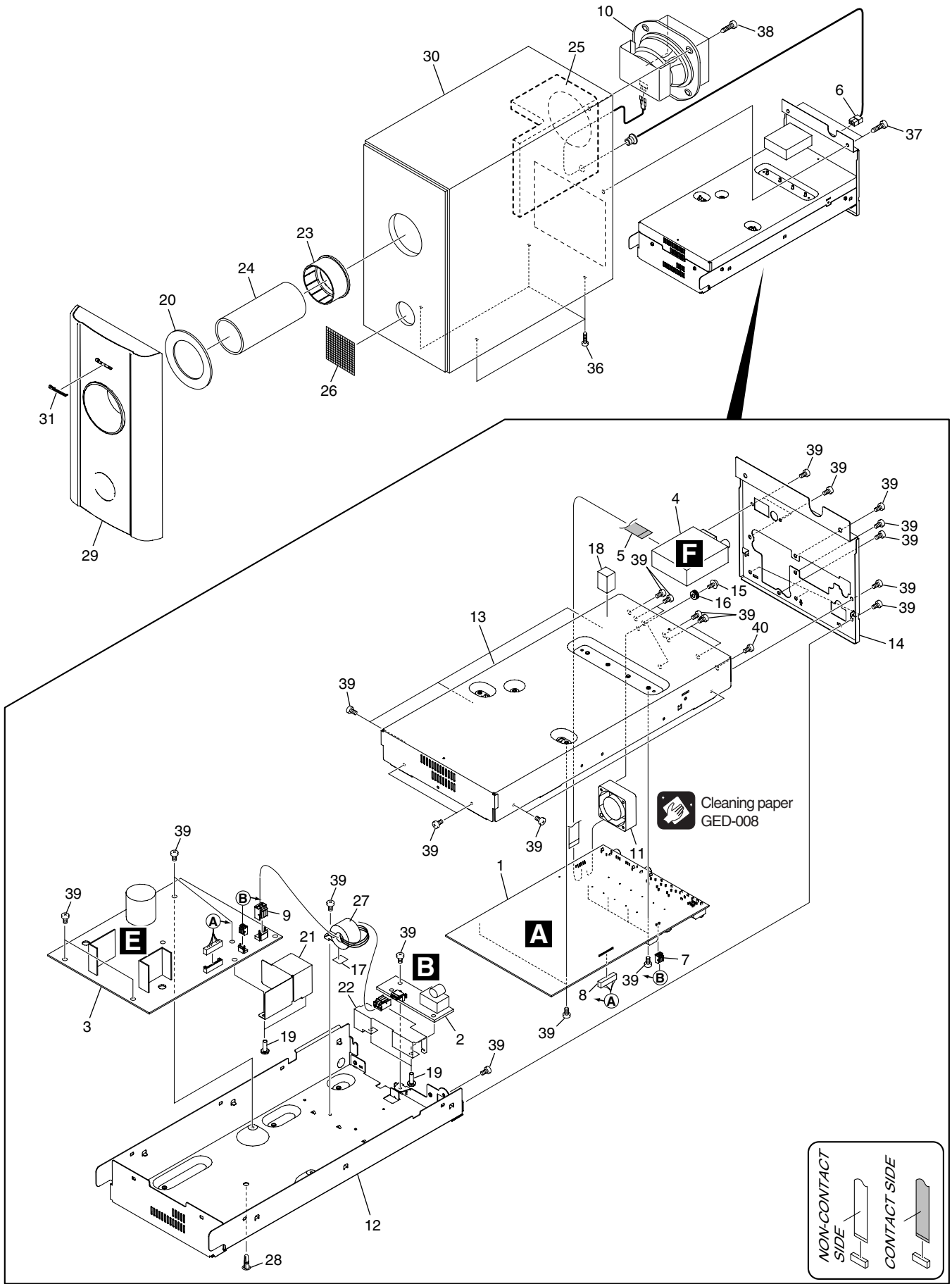

(1) EXTERIOR SECTION PARTS LIST

<u>Mark No.</u>	<u>Description</u>	<u>Part No.</u>	<u>Mark No.</u>	<u>Description</u>	<u>Part No.</u>
1	MAIN Assy	See Contrast table (2)	NSP 21	Barrier SW	AEC7552
2	AC INLET Assy	See Contrast table (2)	NSP 22	Barrier AC	AEC7553
△ 3	POWER SUPPLY Unit	AWR7037	NSP 23	Duct Ring	AMR7511
4	FM/AM TUNER Unit	See Contrast table (2)	NSP 24	Paper Tube 60	AMR7512
5	11P Flexible Cable	ADD7506	NSP 25	Acoustic Absorbent	AMV7001
6	Connecting Cord	ADX7484	NSP 26	Mesh	ANC8354
7	2P Lead with Housing	ADX7485	NSP 27	Ferrite Clamp	DTH1158
8	11P Lead with Housing	ADX7486	NSP 28	PCB Holder	PNW2029
9	2P Lead with Housing	ADX7487	NSP 29	Cosmetic Baffle	See Contrast table (2)
10	Speaker	A14LR75-51D	NSP 30	Cabinet	AMM7009
11	DC Fan Motor	VXM1121	31	Pioneer Name Plate	VAM1152
NSP 12	Chassis B	ANA7179	32	Baffle Assy	See Contrast table (2)
NSP 13	Chassis T	ANA7180	33	•••••	
14	Rear Panel SW	See Contrast table (2)	34	•••••	
15	Screw (3 x 11.5)	ABA7129	35	•••••	
16	Rubber Bushing	AEB7369	36	Screw	BBZ40P120FNI
17	Cushion F	AEB7370	37	Screw	BYC40P160FNI
18	Cushion TX	AEB7371	38	Screw	BYC40P200FNI
19	Rivet	AEC7514	39	Screw	PBZ30P080FTC
20	Packing	AEC7548	40	Screw	PSZ30P060FNI

(2) CONTRAST TABLE

SX-SW77/WYXCN, WVXCN, SX-SW55/WYXCN, WVXCN and SX-SW950/KUXCN are constructed the same except for the following:

<u>Mark</u>	<u>No.</u>	<u>Symbol and Description</u>	<u>SX-SW77/ WYXCN</u>	<u>SX-SW77/ WVXCN</u>	<u>SX-SW55/ WYXCN</u>	<u>SX-SW55/ WVXCN</u>	<u>SX-SW950/ KUXCN</u>
NSP	1	MAIN Assy	AWK7883	AWK7883	AWK7883	AWK7883	AWK7884
	2	AC INLET Assy	AWU8273	AWU8273	AWU8273	AWU8273	AWU8274
	4	FM/AM TUNER Unit	AXX7170	AXX7170	AXX7170	AXX7170	AXX7172
	14	Rear Panel SW	ANC8323	ANC8323	ANC8356	ANC8356	ANC8362
	29	Cosmetic Baffle	AMB7903	AMB7903	AMB7903	AMB7903	AMB7905
	32	Baffle Assy	AXG7278	AXG7278	AXG7278	AXG7278	AXG7279

2.3 DISPLAY UNIT

1

2

3

4

A

B

C

D

E

F

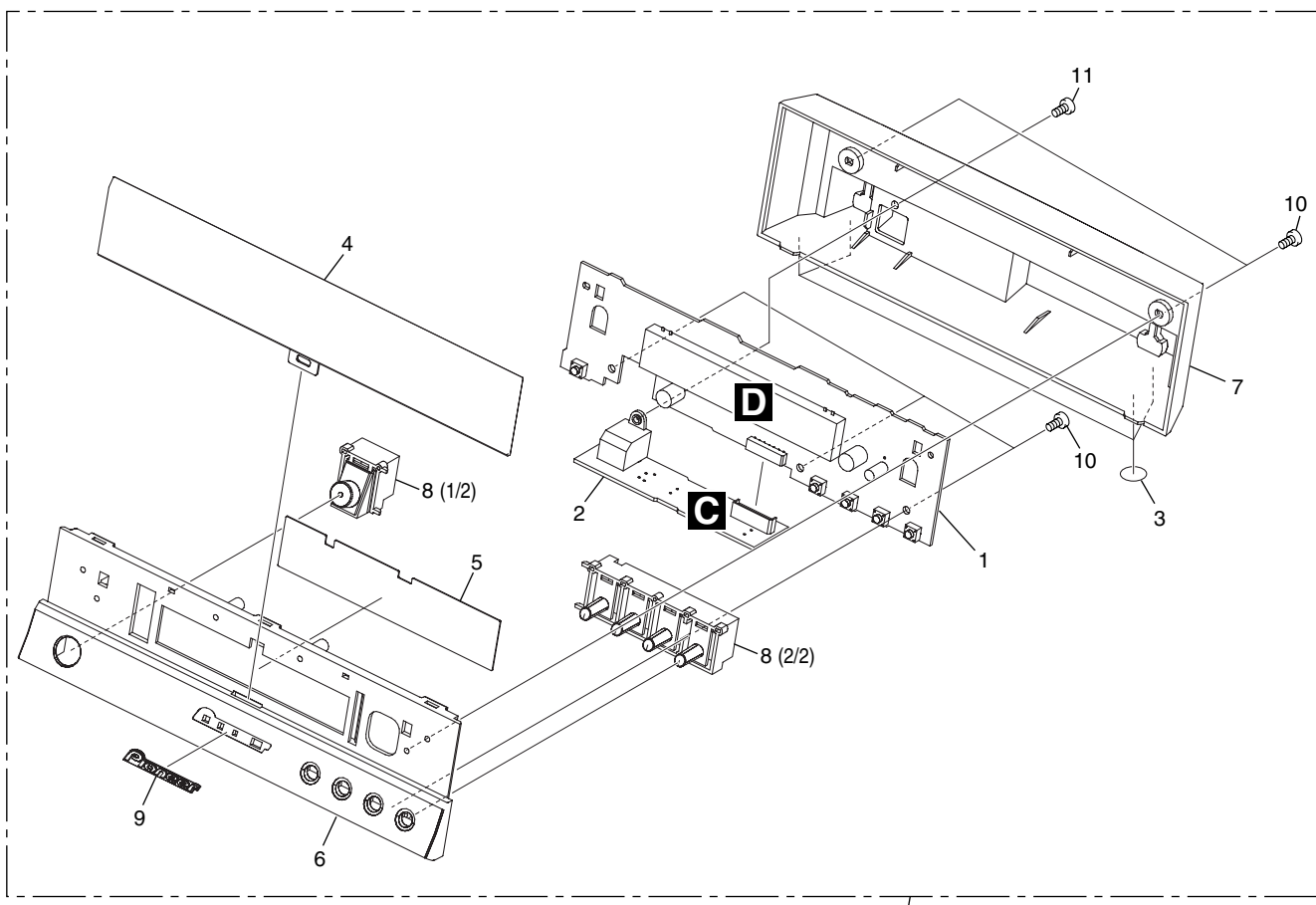

12

1

2

3

4

5 6 7 8

(1) DISPLAY UNIT PARTS LIST

<u>Mark No.</u>	<u>Description</u>	<u>Part No.</u>
1	FL Assy	AWU8271
2	CONNECT Assy	AWU8272
3	Leg	AEB7368
4	Window	AAK8285
5	FL Filter	AEC7535
6	Display Panel	AMB7899
7	Display Cover	AMC7059
8	PWR Button Assy	AXG7260
9	Pioneer Name Plate	VAM1152
10	Screw	BPZ30P080FNI
11	Screw	PSZ30P060FNI
12	DISPLAY Unit	See Contrast table (2)

(2) CONTRAST TABLE

SX-SW77/WYXCN, WVXCN, SX-SW55/WYXCN, WVXCN and SX-SW950/KUXCN are constructed the same except for the following:

Mark	No.	Symbol and Description	SX-SW77/ WYXCN	SX-SW77/ WVXCN	SX-SW55/ WYXCN	SX-SW55/ WVXCN	SX-SW950/ KUXCN
	12	DISPLAY Unit	AXX7204	AXX7204	AXX7204	AXX7204	Not used
NSP	12	DISPLAY Unit	Not used	Not used	Not used	Not used	AXX7205

3. BLOCK DIAGRAM AND SCHEMATIC DIAGRAM

3.1 OVERALL WIRING CONNECTION DIAGRAM AND BLOCK DIAGRAM

A
B
C
D
E
F

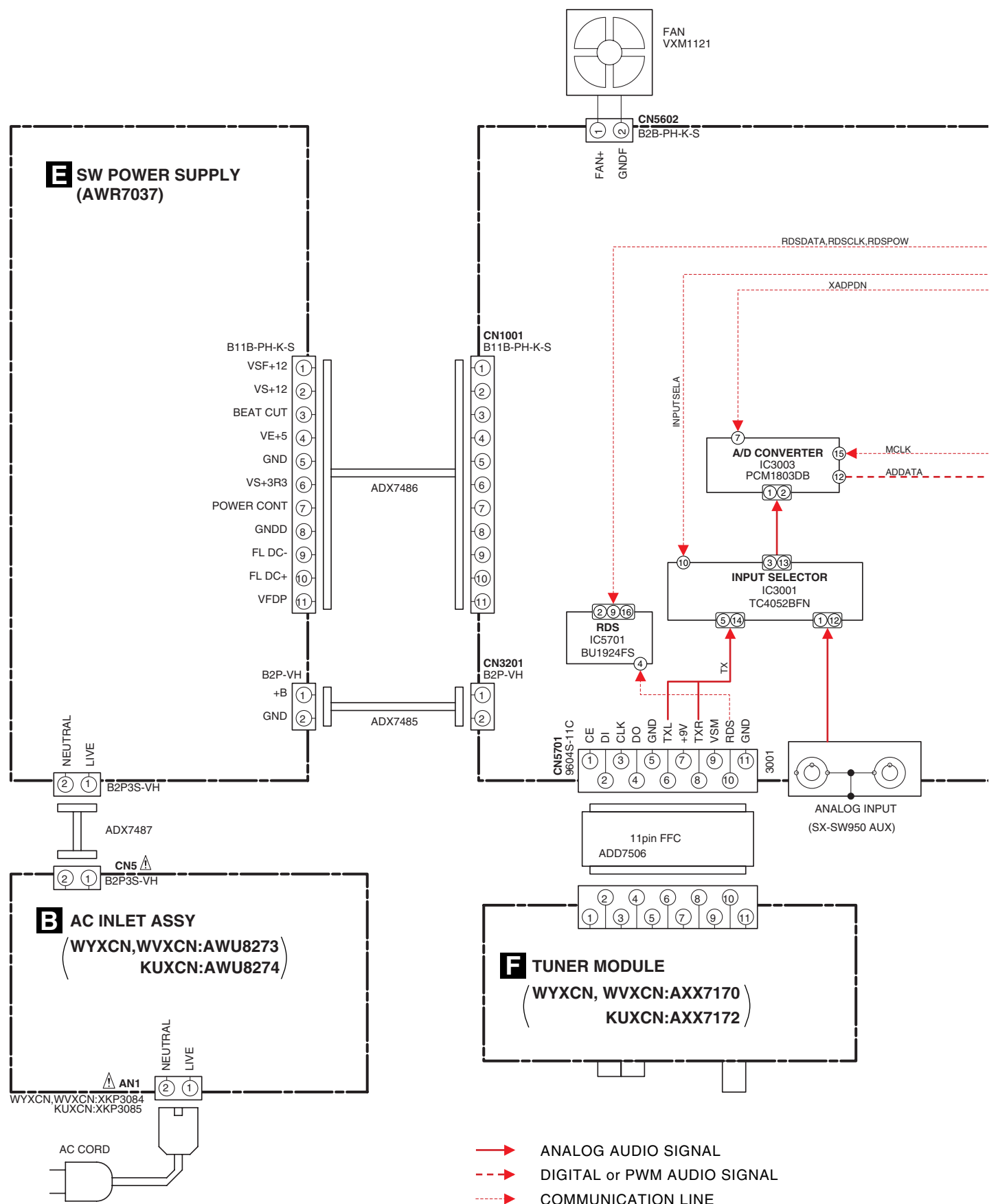

- When ordering service parts, be sure to refer to "EXPLODED VIEWS and PARTS LIST" or "PCB PARTS LIST".
- The ⚠ mark found on some component parts indicates the importance of the safety factor of the part. Therefore, when replacing, be sure to use parts of identical designation.
-  : The power supply is shown with the marked box.

A MAIN ASSY
 (WYXCN,WVXCN:AWK7883)
 KUXCN:AWK7884)

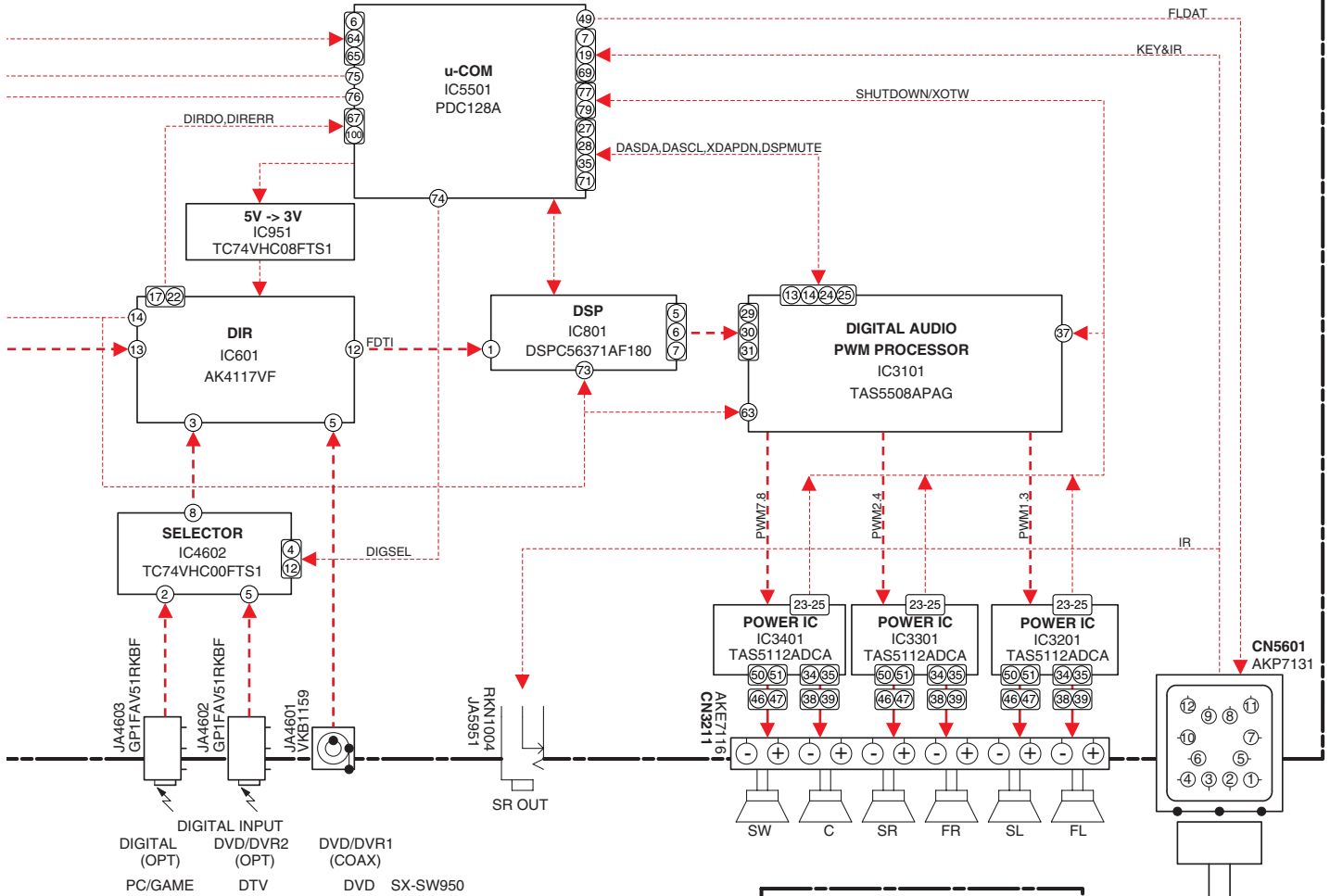

D FL ASSY
 (AWU8271)

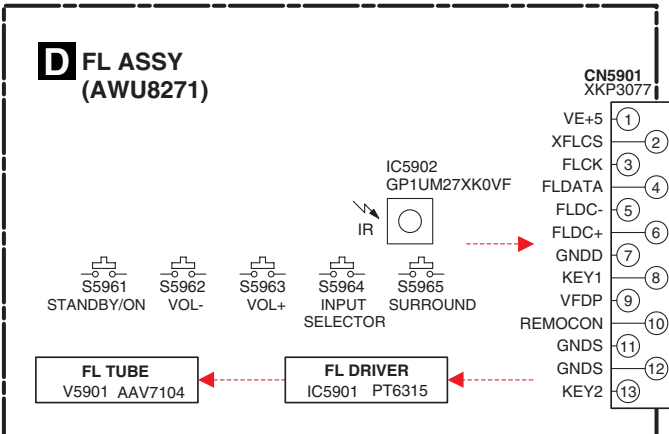

C CONNECT ASSY
 (AWU8272)

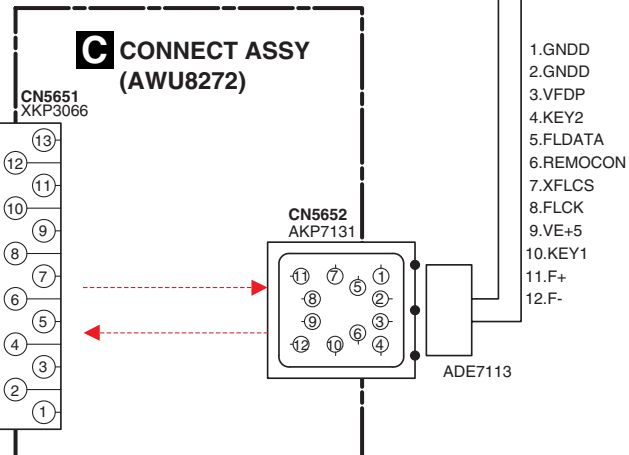

3.2 MAIN ASSY (1/5)

1

2

3

4

A

B

C

D

E

F

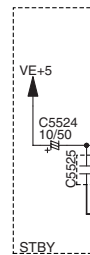
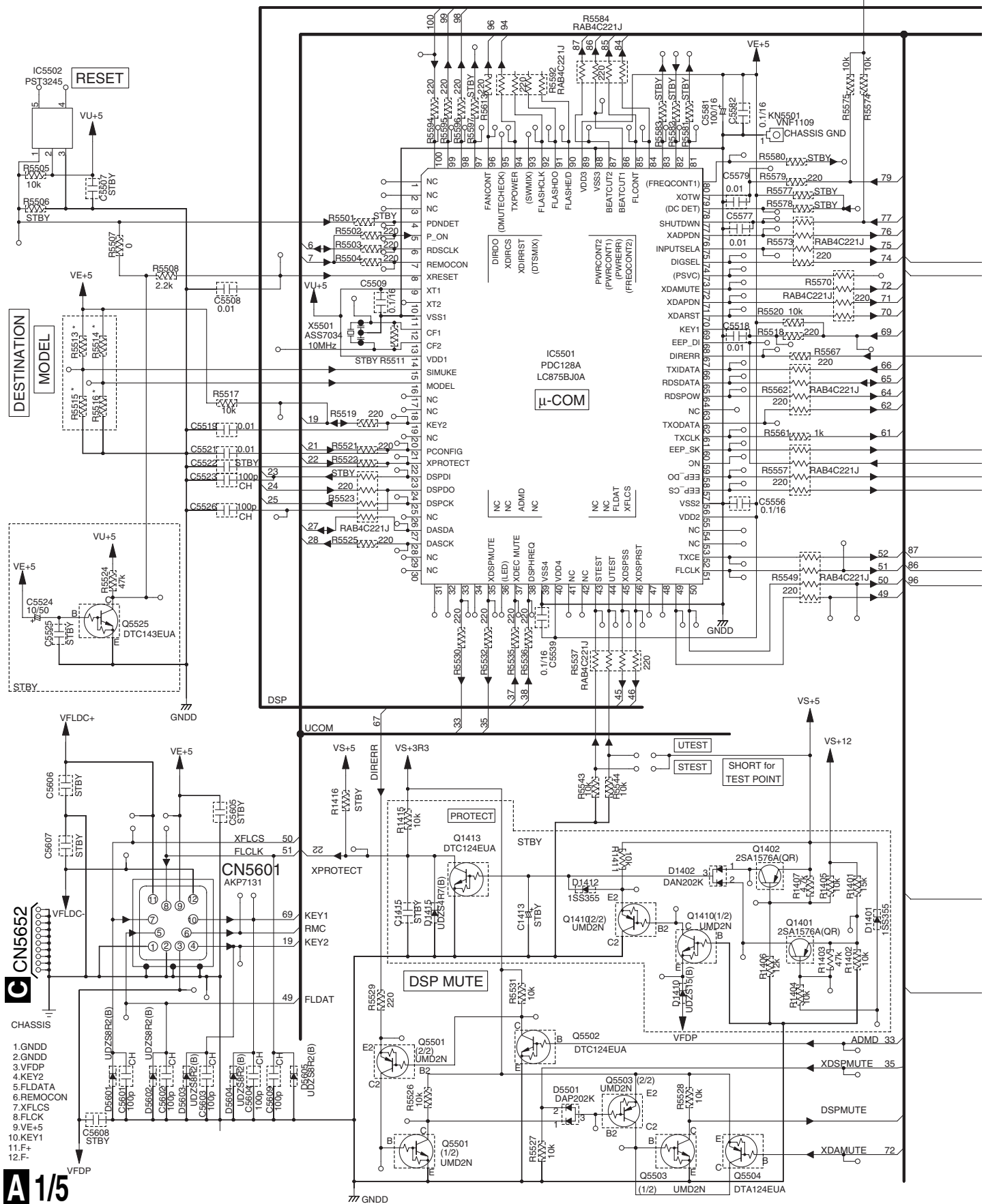

A 1/5

1

2

3

4

3.3 MAIN ASSY (2/5)

A

B

C

D

E

F

ANALOG INPUT SELECTOR

A	FUNCTION
L	ANALOG IN
H	TUNER

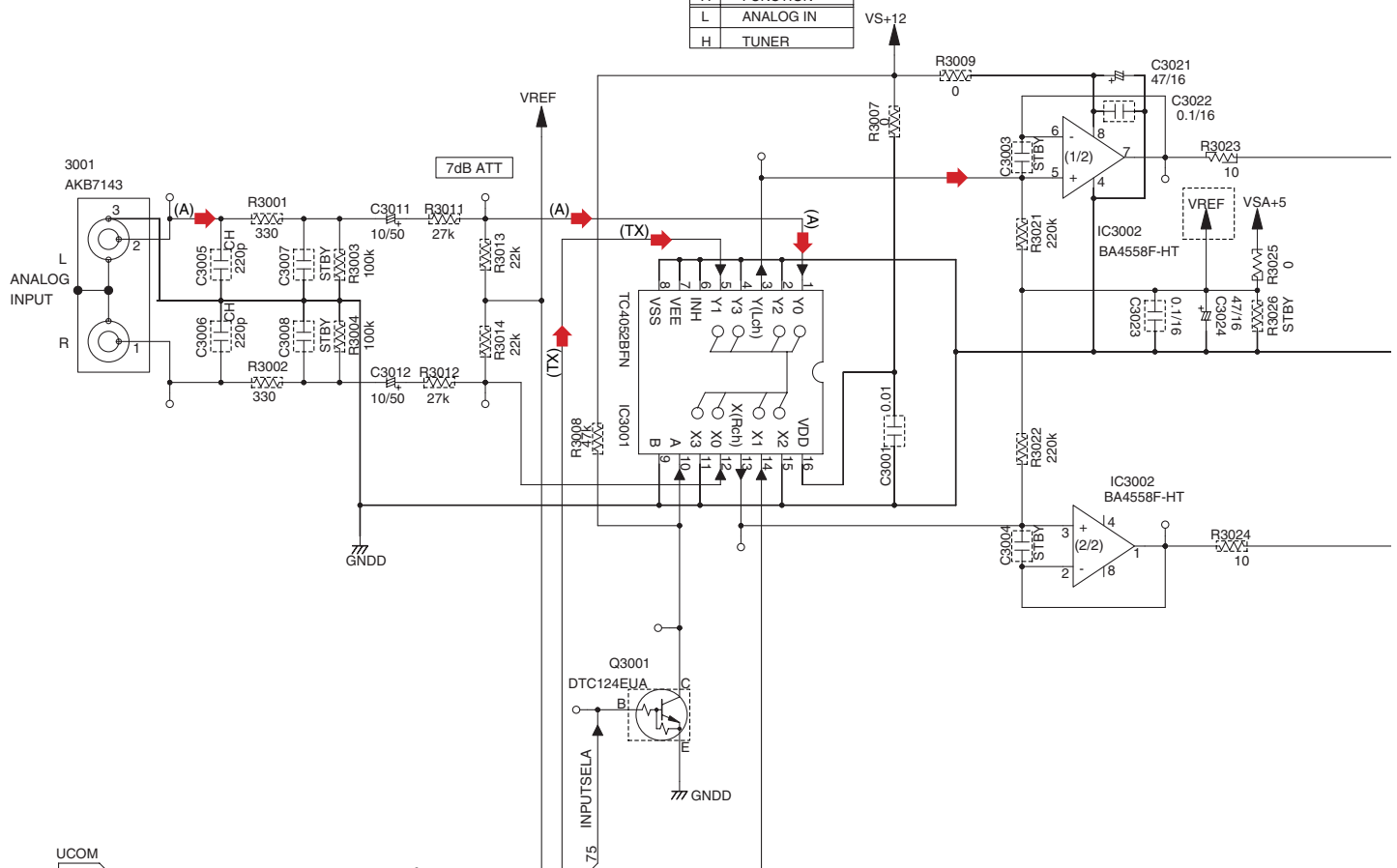

A 1/5

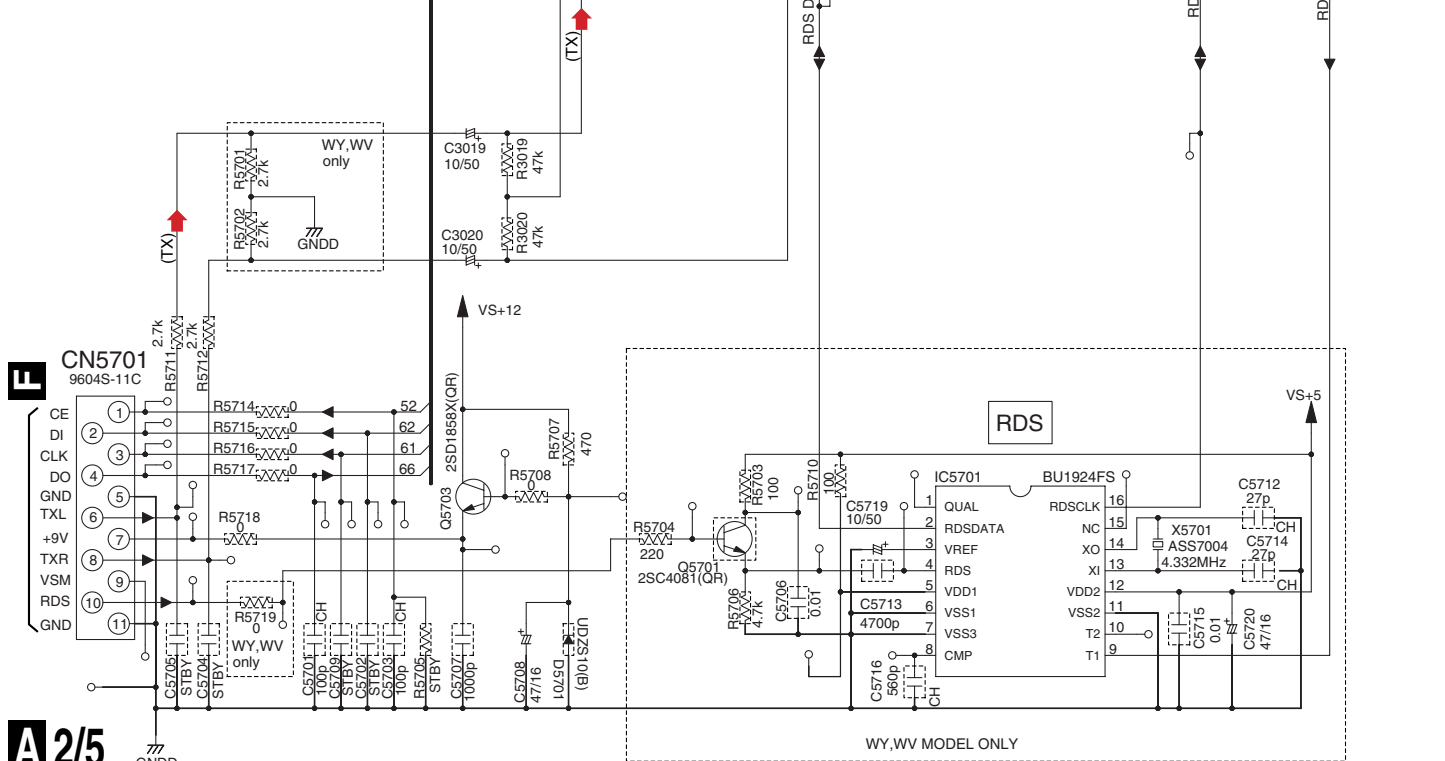

A 2/5

A 2/5 MAIN ASSY
 (WYXCN,WVXCN:AWK7883)
 (KUXCN:AWK7884)

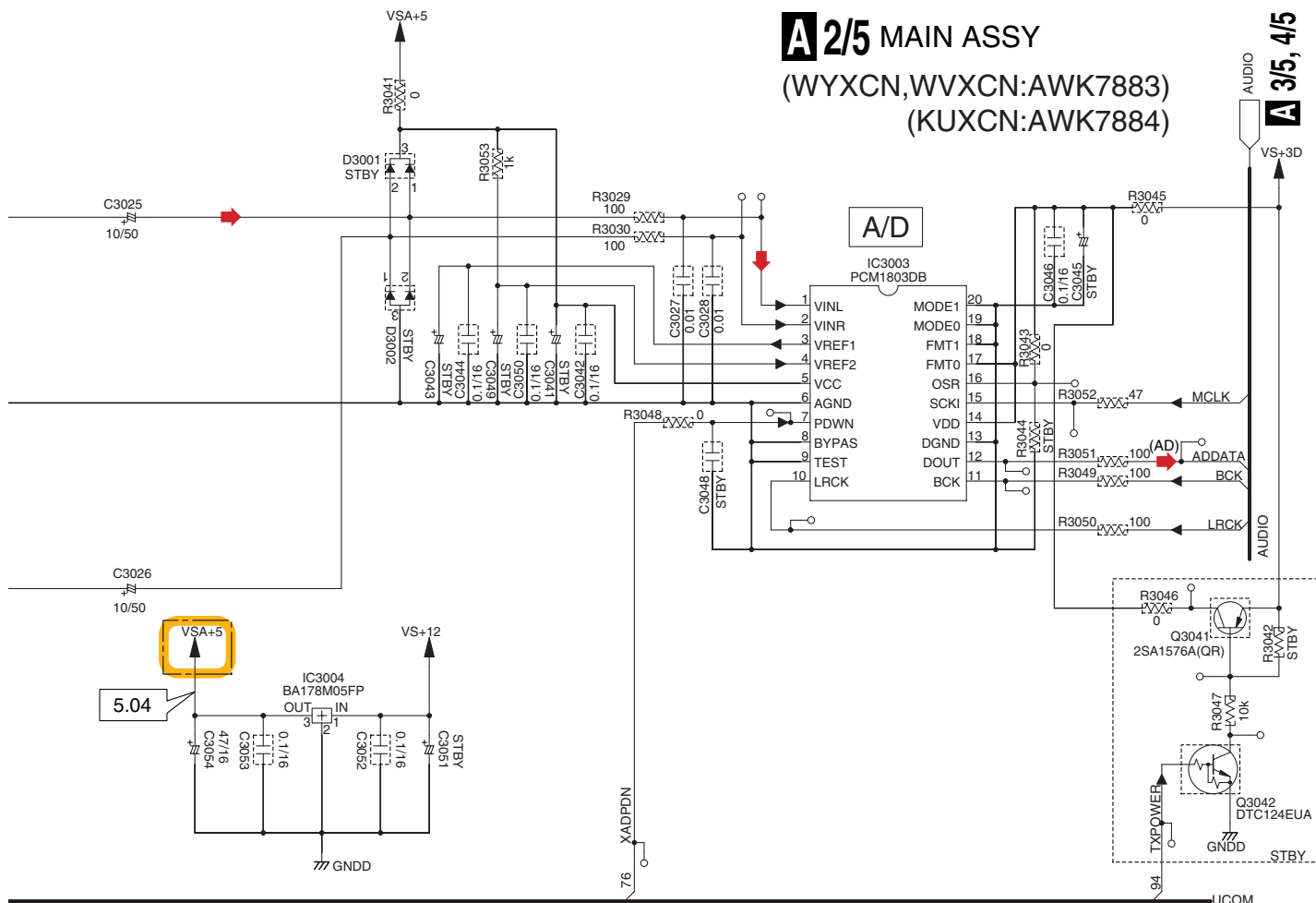

- (A) → : AUDIO SIGNAL ROUTE (ANALOG IN)
- (TX) → : AUDIO SIGNAL ROUTE (FM/AM)
- : AUDIO SIGNAL ROUTE
- (AD) → : AUDIO DATA SIGNAL ROUTE

NOTES

All Capacitors are in p-pF or uF unless otherwise specified
 Ratings : Capacity(uF)/Voltage(V)
 Rated Voltage : 50V unless otherwise specified

SQ : CKSQ**(2125size)
 CH : CCSRCH(1608size)
 (others : CKSRYB(1608size))

JQ : CEJQ
 (others : CEAT)

All Resistors are in k-k Ω, M-M Ω or Ω

1/8W : RS1/8S***J(3216size)
 1/10W : RS1/10S***J(2125size)
 (others : RS1/16S***J(1608size))

3.4 MAIN ASSY (3/5)

A
B
C
D
E
F

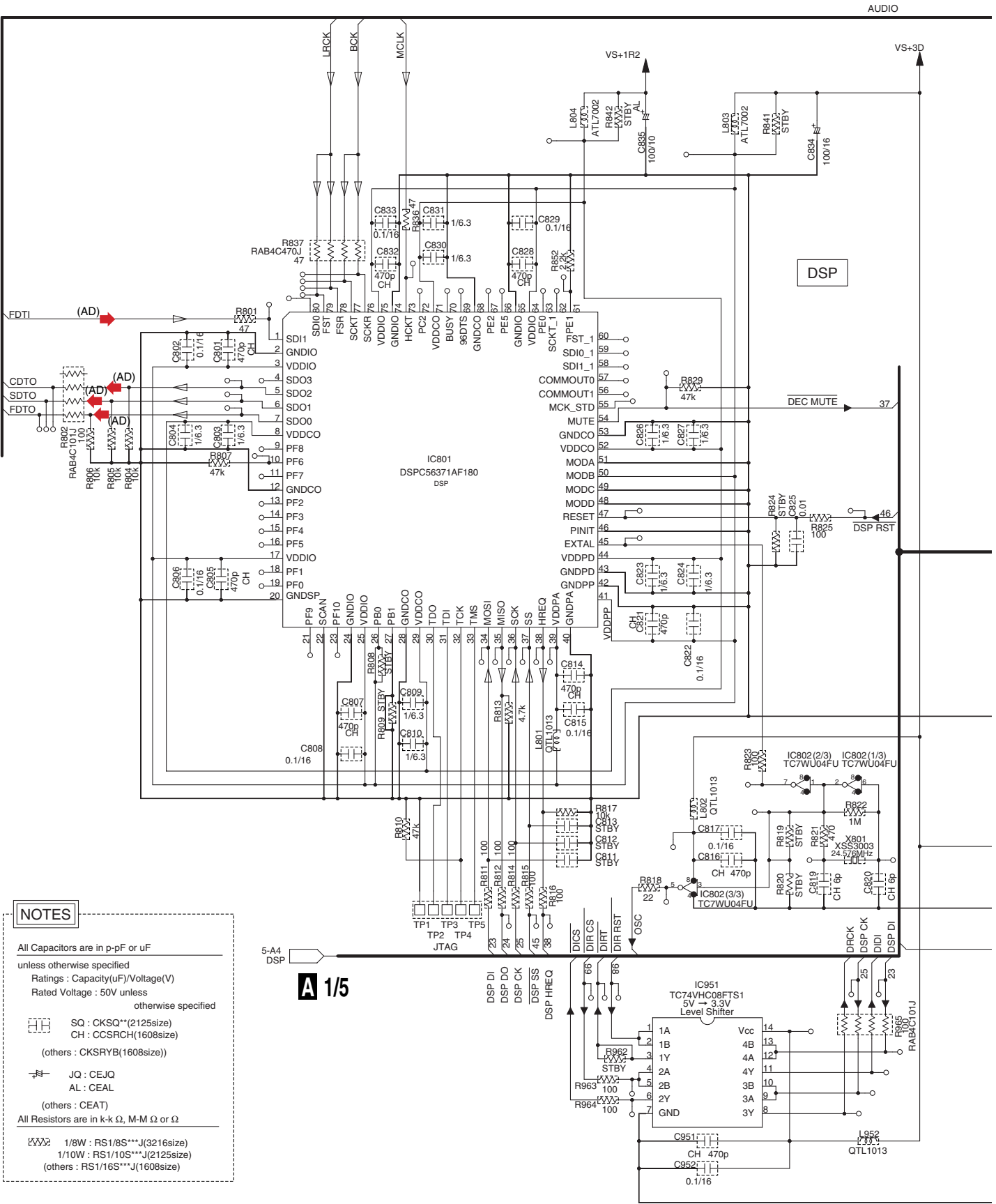

NOTES

All Capacitors are in p-pF or uF unless otherwise specified
 Ratings : Capacity(uF)/Voltage(V)
 Rated Voltage : 50V unless otherwise specified

SQ : CKSQ**(2125size)
 CH : CCSRCH(1608size)
 (others : CKSRYB(1608size))

JQ : CEJQ
 AL : CEAL
 (others : CEAT)

All Resistors are in k-k Ω, M-M Ω or Ω

1/8W : RS1/8S***J(3216size)
 1/10W : RS1/10S***J(2125size)
 (others : RS1/16S***J(1608size))

A 1/5

A 3/5

A 3/5 MAIN ASSY
 (WYXCN,WVXCN:AWK7883)
 (KUXCN:AWK7884)

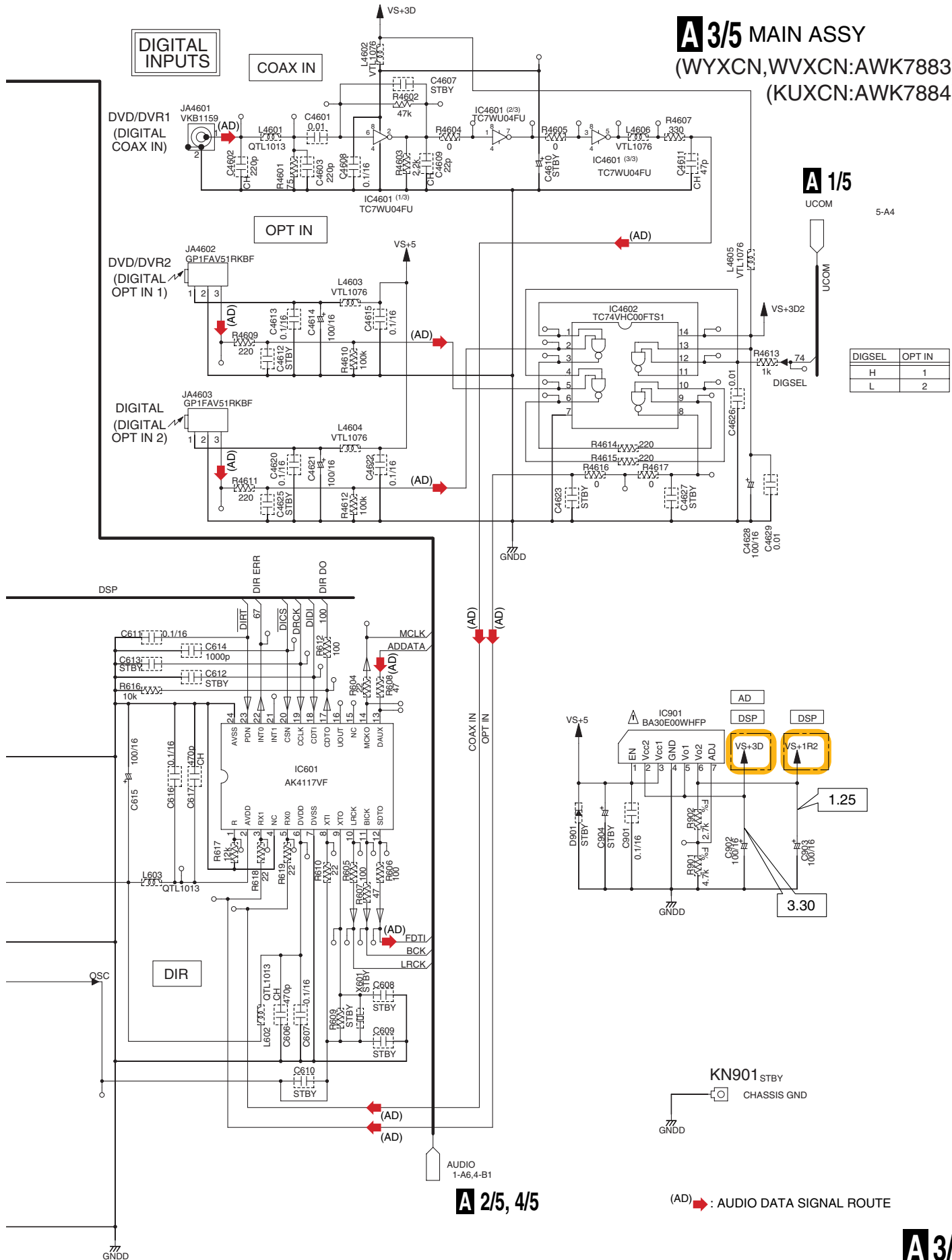

A 1/5

DIGSEL	OPT IN
H	1
L	2

A 2/5, 4/5

(AD) → : AUDIO DATA SIGNAL ROUTE

A 3/5

3.5 MAIN ASSY (4/5)

1

2

3

4

A

B

C

D

E

F

A 2/5, 3/5

A 1/5

for control by PC

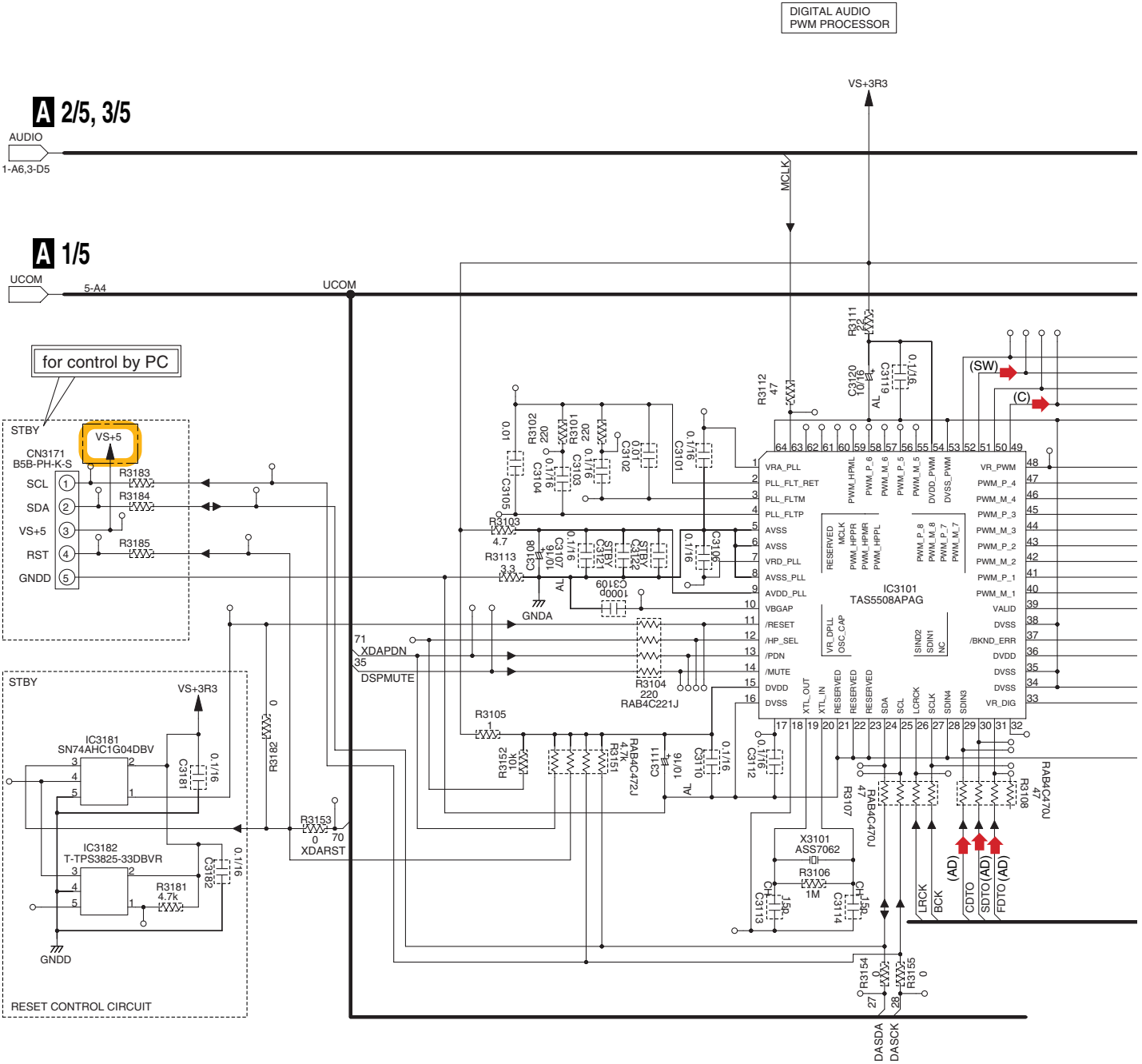

A 4/5

1

2

3

4

A 4/5 MAIN ASSY

(WYXCN, WVXCN:AWK7883)
(KUXCN:AWK7884)

NOTES

All Capacitors are in p-pF or uF unless otherwise specified
 Ratings : Capacity(uF)/Voltage(V)
 Rated Voltage : 50V unless otherwise specified

SQ : CKSQ**(2125size)
 CH : CCSRCH(1608size)
 (others : CKSRYB(1608size))

JQ : CEJQ
 AL : CEAL
 (others : CEAT)

All Resistors are in k-k Ω, M-M Ω or Ω

1/8W : RS1/8S***J(3216size)
 1/10W : RS1/10S***J(2125size)
 (others : RS1/16S***J(1608size))

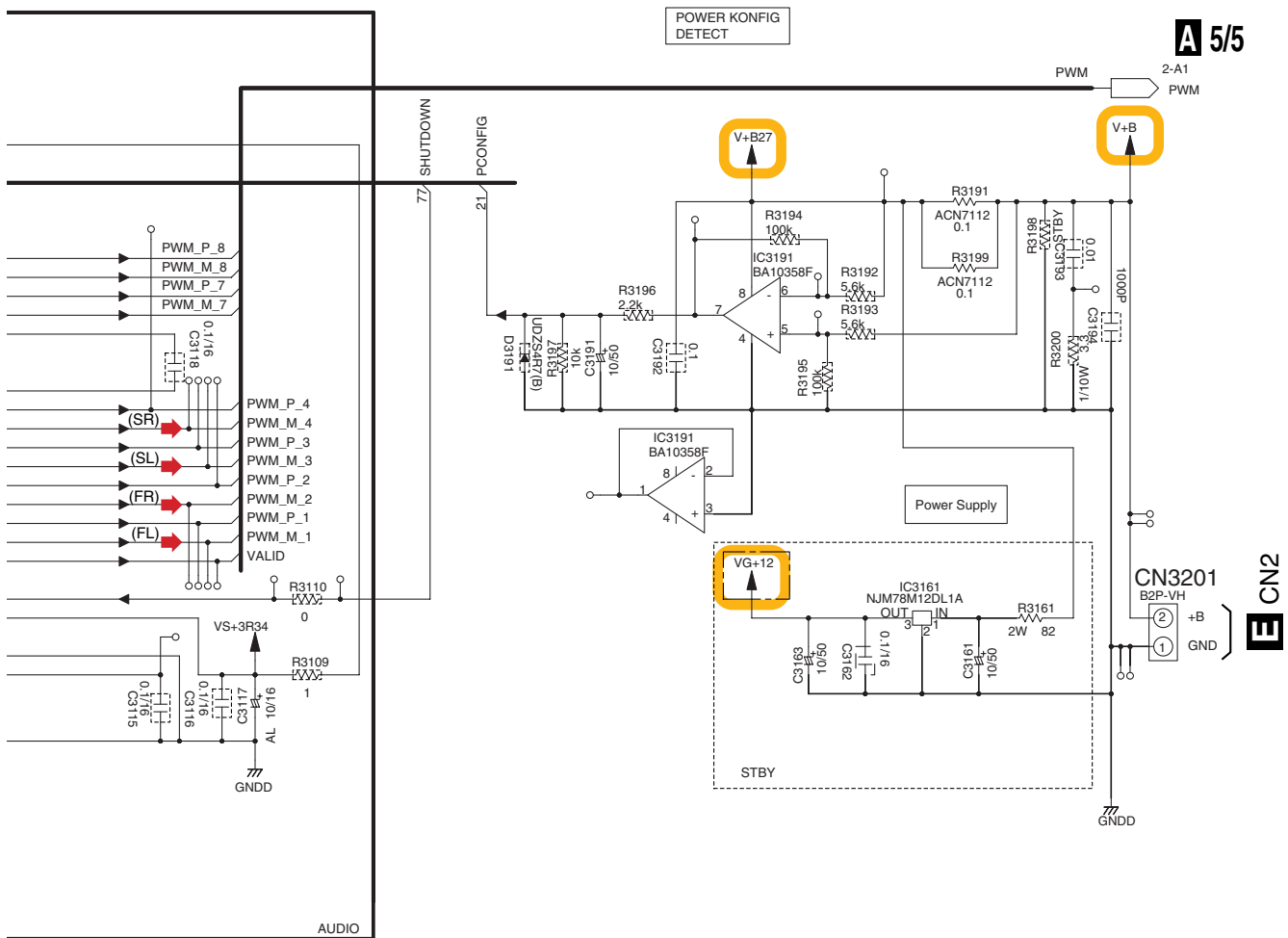

- (FL) ➡ : AUDIO SIGNAL ROUTE (PWM)(Front Lch)
- (FR) ➡ : AUDIO SIGNAL ROUTE (PWM)(Front Rch)
- (SL) ➡ : AUDIO SIGNAL ROUTE(PWM)(Surround Lch)
- (SR) ➡ : AUDIO SIGNAL ROUTE(PWM)(Surround Rch)
- (C) ➡ : AUDIO SIGNAL ROUTE(PWM)(Center ch)
- (SW) ➡ : AUDIO SIGNAL ROUTE(PWM)(Sub Woofer ch)
- (AD) ➡ : AUDIO DATA SIGNAL ROUTE

3.6 MAIN ASSY (5/5)

1

2

3

4

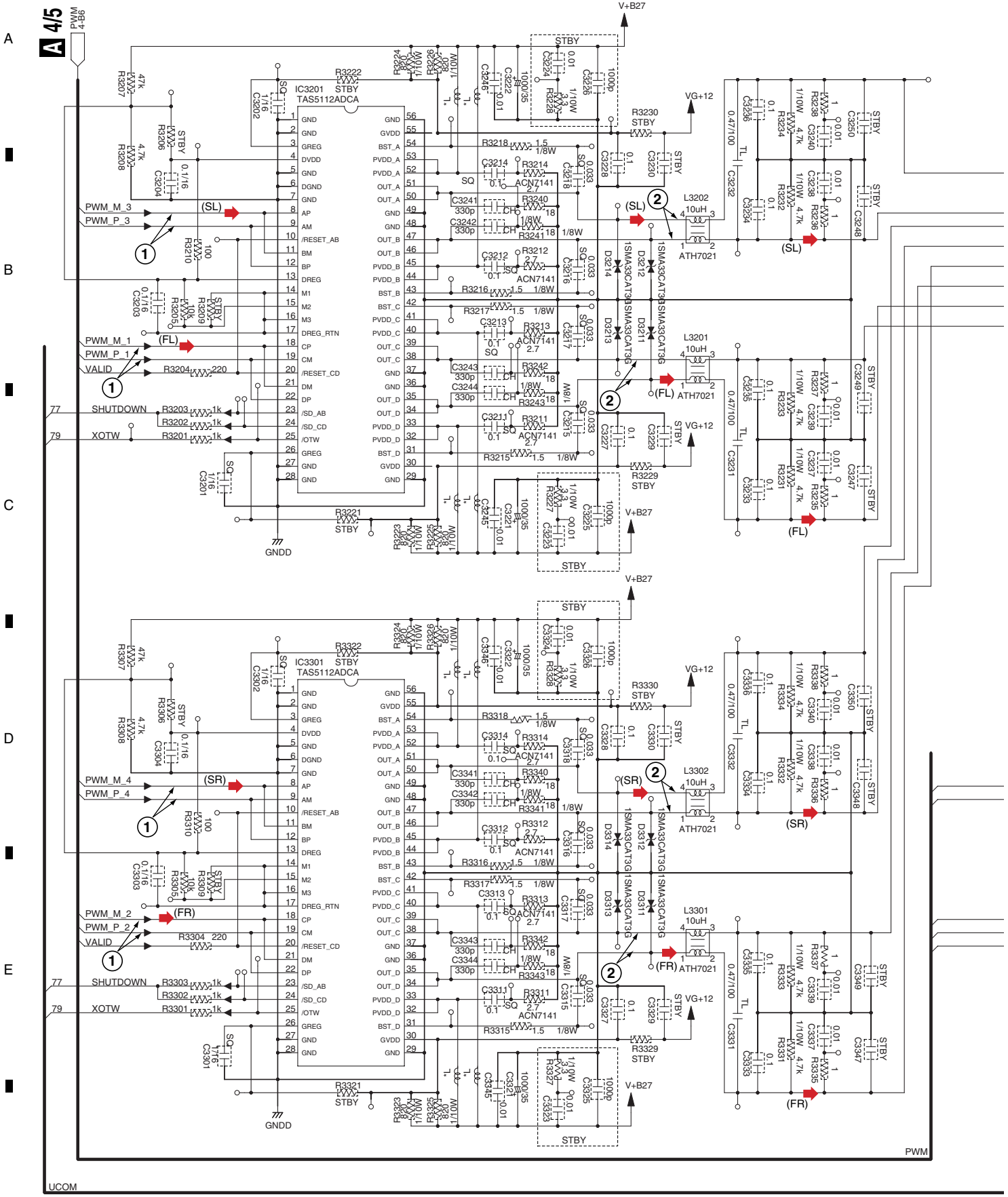

LAYOUT NOTE :
 *L are PCB track inductors approx. 50mm long and 1mm wide

A 5/5

SX-SW77

1

2

3

4

NOTES

All Capacitors are in p-pF or uF unless otherwise specified
 Ratings : Capacity(uF)/Voltage(V)
 Rated Voltage : 50V unless otherwise specified

SQ : CKSQ**(2125size)
 CH : CCSRCH(1608size)
 (others : CKSRVB(1608size))

TL : CFTLA
 JQ : CEJQ
 (others : CEAT)

All Resistors are in k-k Ω, M-M Ω or Ω

1/8W : RS1/8S***J(3216size)
 1/10W : RS1/10S***J(2125size)
 (others : RS1/16S***J(1608size))

A 5/5 MAIN ASSY
 (WYXCN,WVXCN:AWK7883)
 (KUXCN:AWK7884)

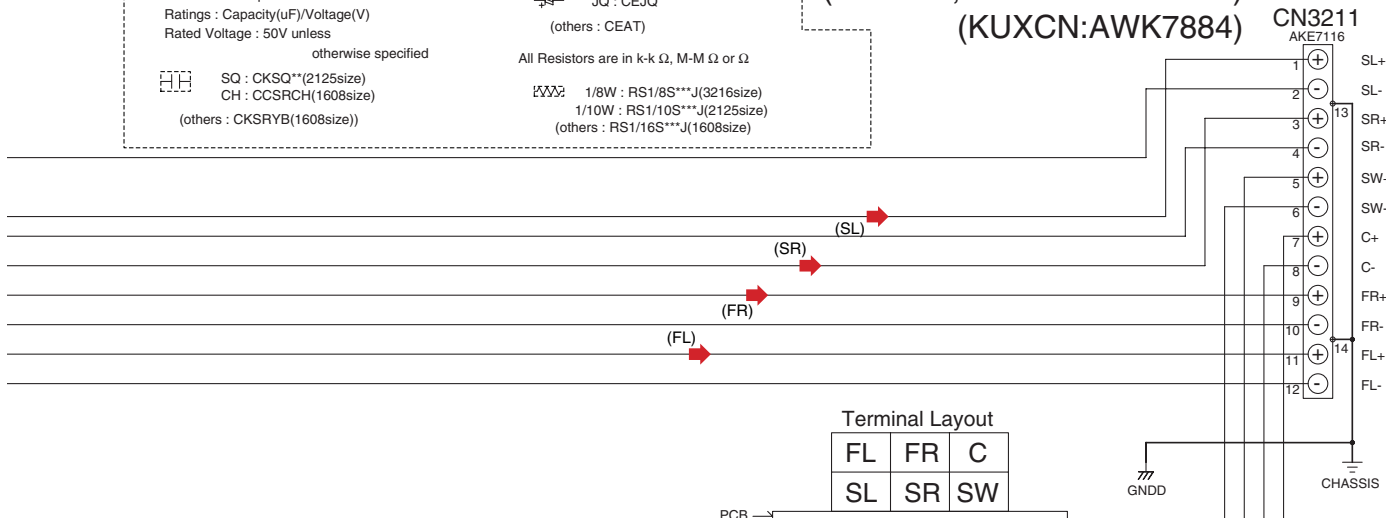

AMP POWER STAGE

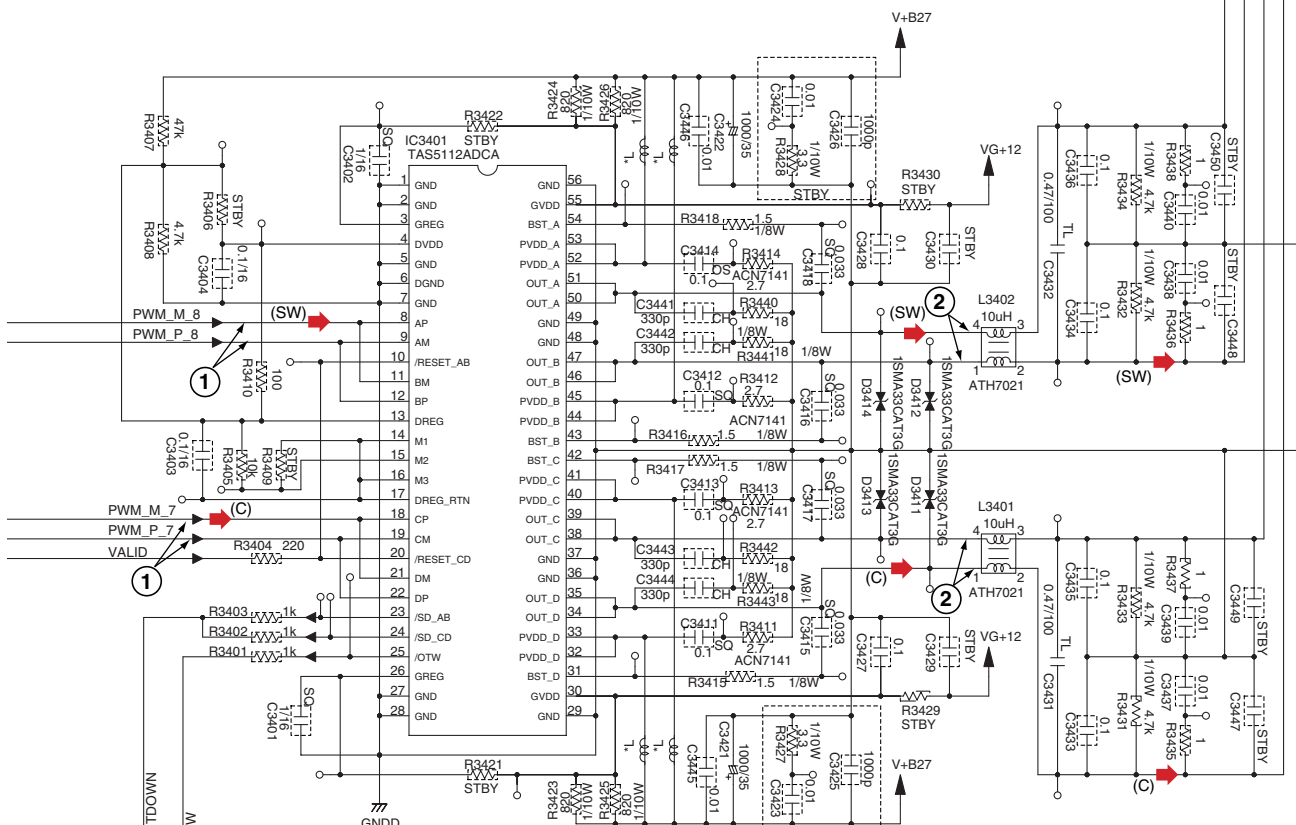

- (FL) : AUDIO SIGNAL ROUTE (PWM)(Front Lch)
- (FR) : AUDIO SIGNAL ROUTE (PWM)(Front Rch)
- (SL) : AUDIO SIGNAL ROUTE (PWM)(Surround Lch)
- (SR) : AUDIO SIGNAL ROUTE (PWM)(Surround Rch)
- (C) : AUDIO SIGNAL ROUTE (PWM)(Center ch)
- (SW) : AUDIO SIGNAL ROUTE (PWM)(Sub Woofer ch)

5-A4 **A 1/5**

SX-SW77

A 5/5

3.7 AC INLET, CONNECT and FL ASSYS

A

NOTES

All Capacitors are in p-pF or uF
 unless otherwise specified
 Ratings : Capacity(uF)/Voltage(V)
 Rated Voltage : 50V unless otherwise specified

CH : CCSRCH(1608size)
 (others : CKSRYB(1608size))

AL : CEAL

All Resistors are in k-k Ω, M-M Ω or Ω
 RS1/16S***J(1608size)

All Inductors are in uH
 LFEA***J

B

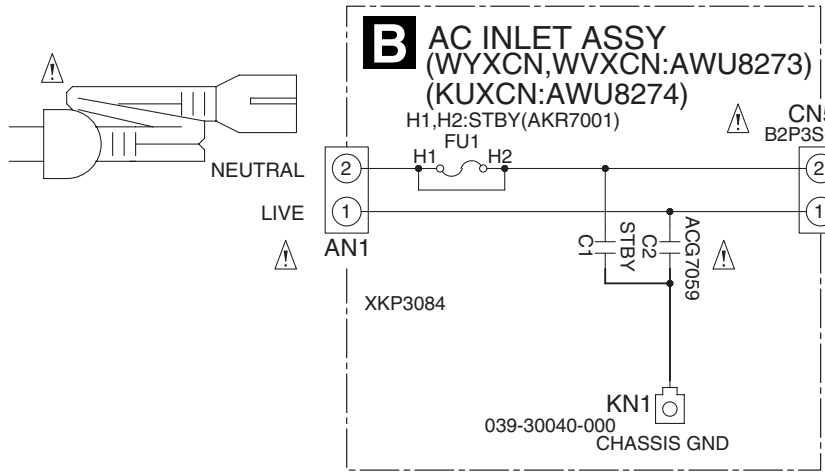

C

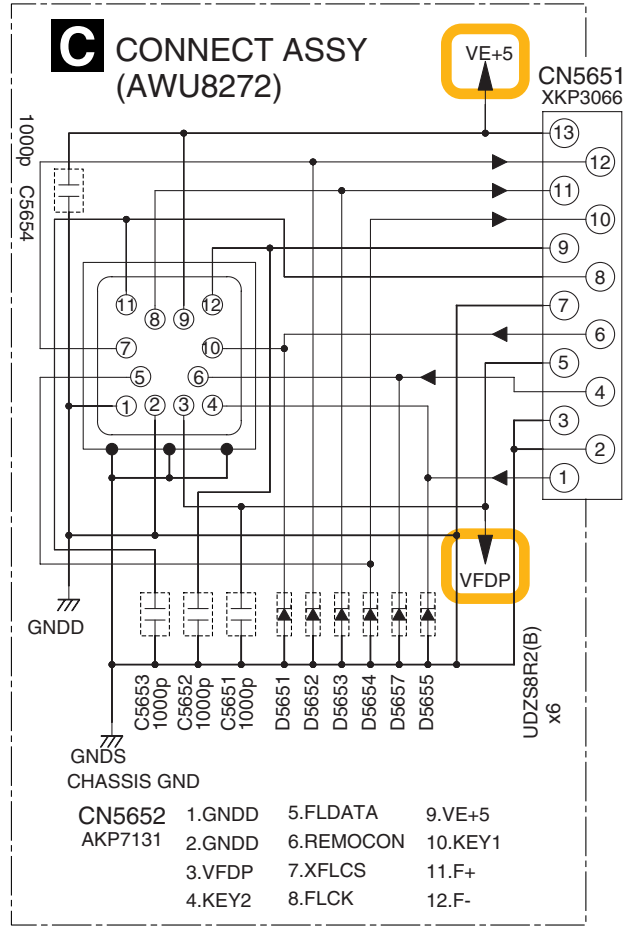

D

E

F

BC

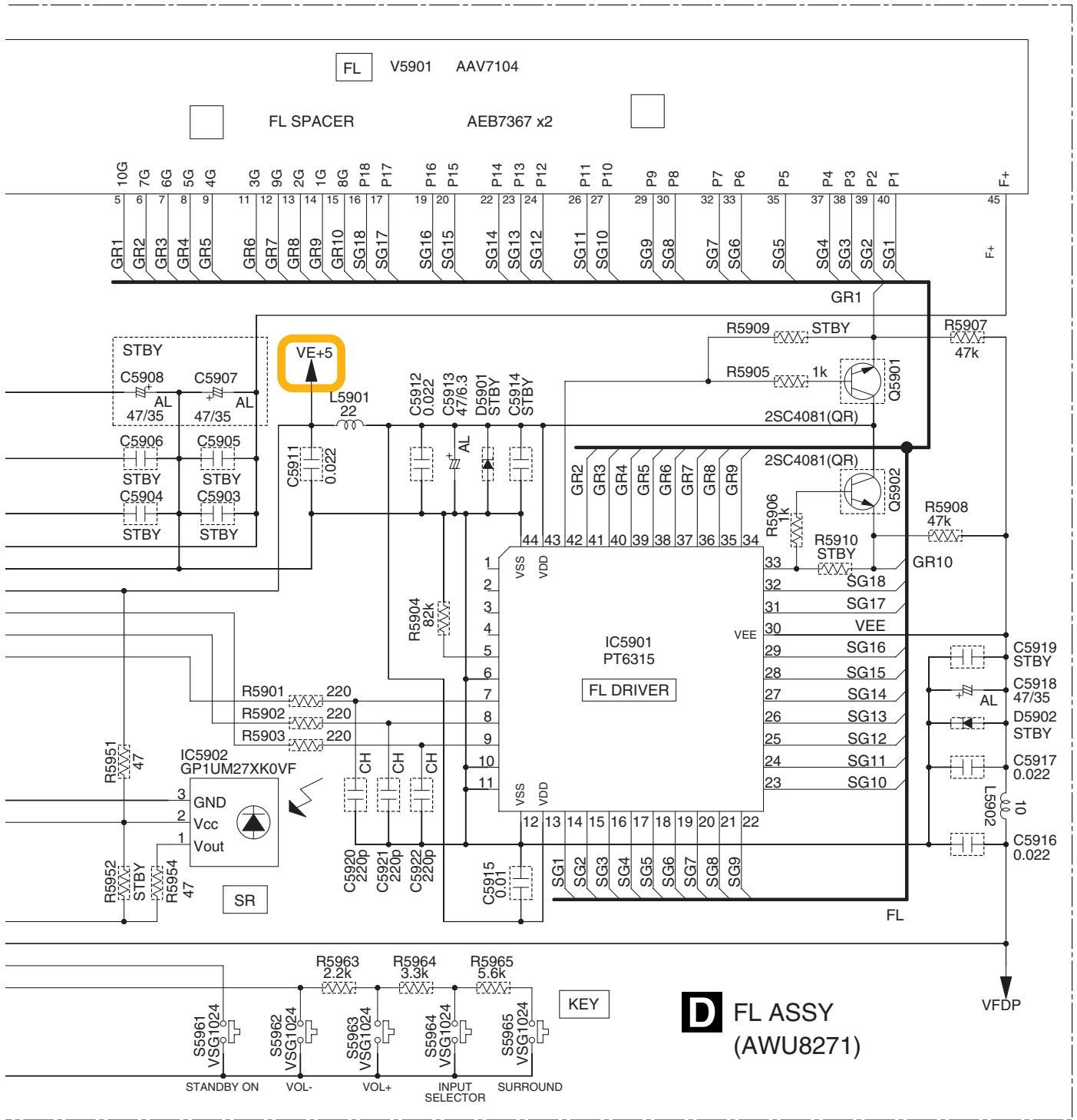

Switches

FL ASSY

- S5961 : \updownarrow STANDBY/ON
- S5962 : \up +
- S5963 : \down -] VOLUME
- S5964 : AUDIO INPUT
- S5965 : SURROUND



3.8 POWER SUPPLY UNIT

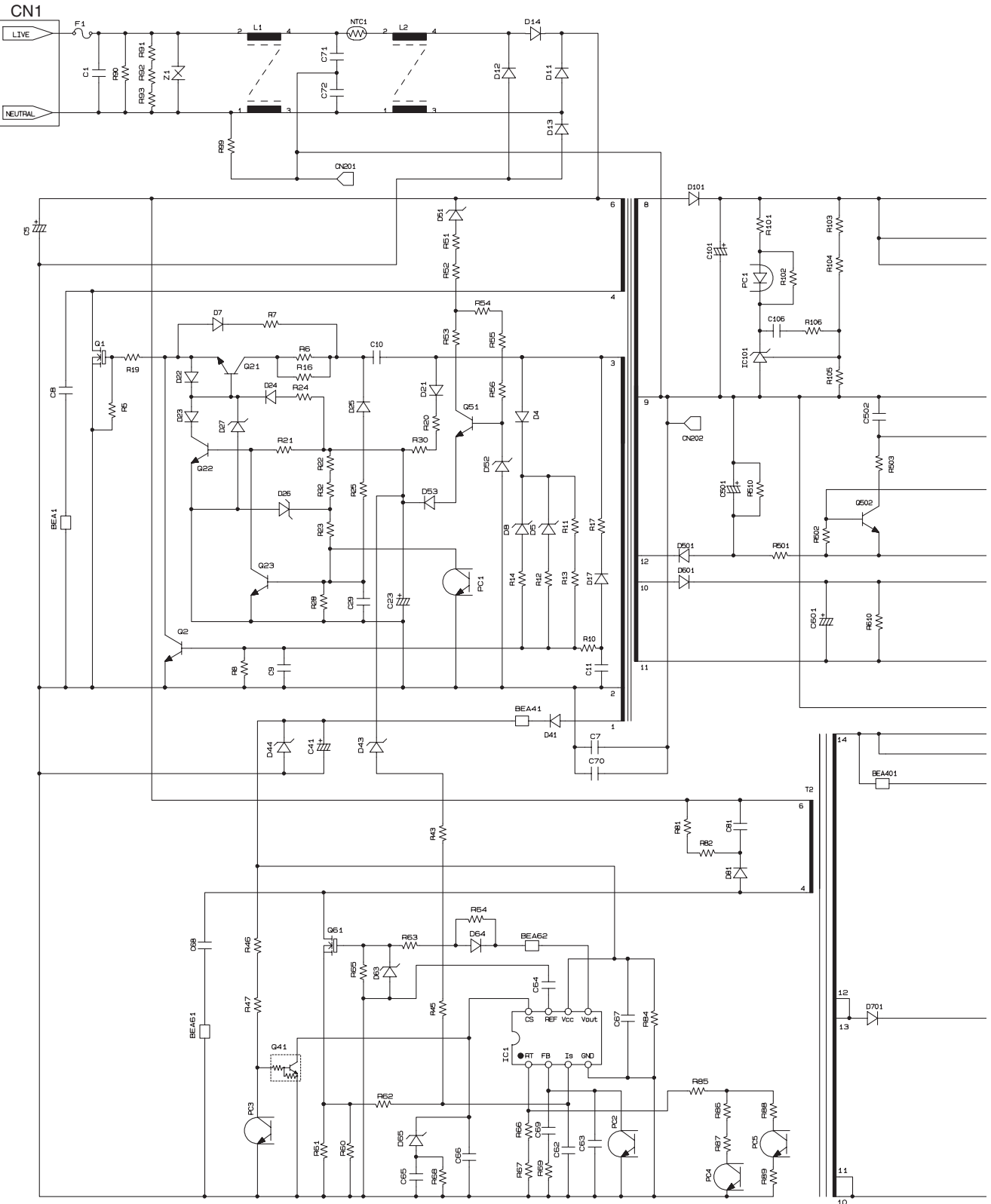

POWER SUPPLY UNIT (AWR7037)

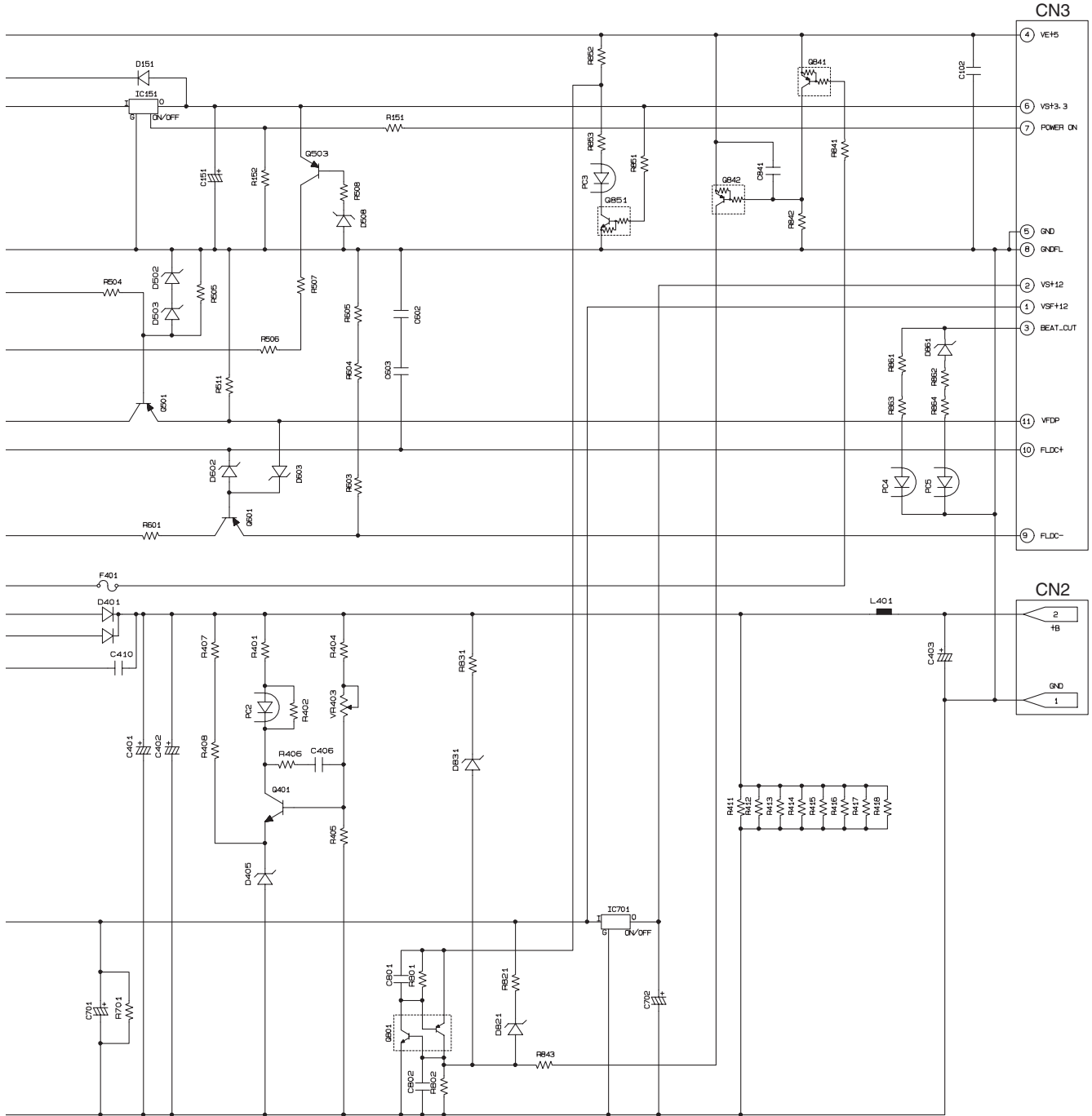

A 1/5 CN1001

A 4/5 CN3201



3.9 WAVEFORMS



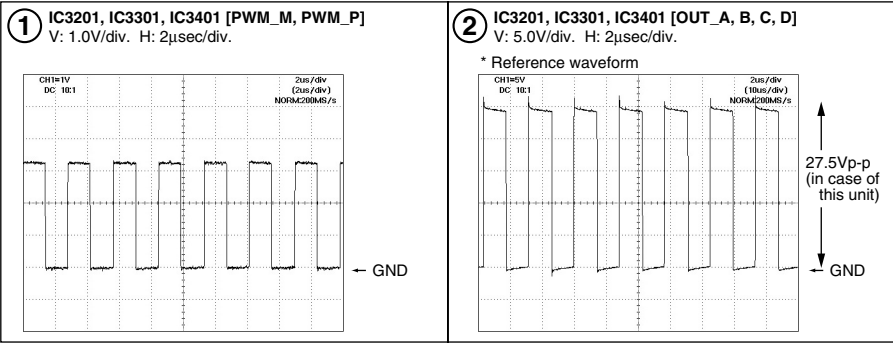





A MAIN ASSY

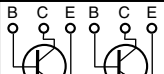

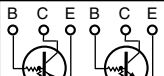
4. PCB CONNECTION DIAGRAM

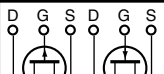
NOTE FOR PCB DIAGRAMS :

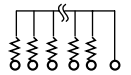
1. Part numbers in PCB diagrams match those in the schematic diagrams.
2. A comparison between the main parts of PCB and schematic diagrams is shown below.

Symbol In PCB Diagrams	Symbol In Schematic Diagrams	Part Name
		Transistor
		Transistor with resistor
		Field effect transistor
		Resistor array
		3-terminal regulator

3. The parts mounted on this PCB include all necessary parts for several destinations.
For further information for respective destinations, be sure to check with the schematic diagram.
4. View point of PCB diagrams.

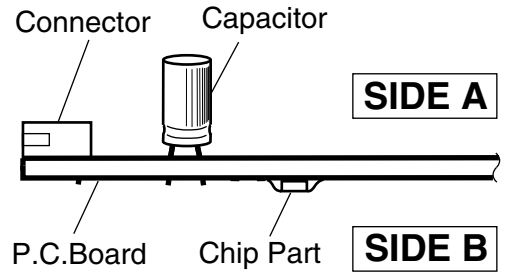

1 2 3 4
4.1 MAIN ASSY

SIDE A

A MAIN ASSY

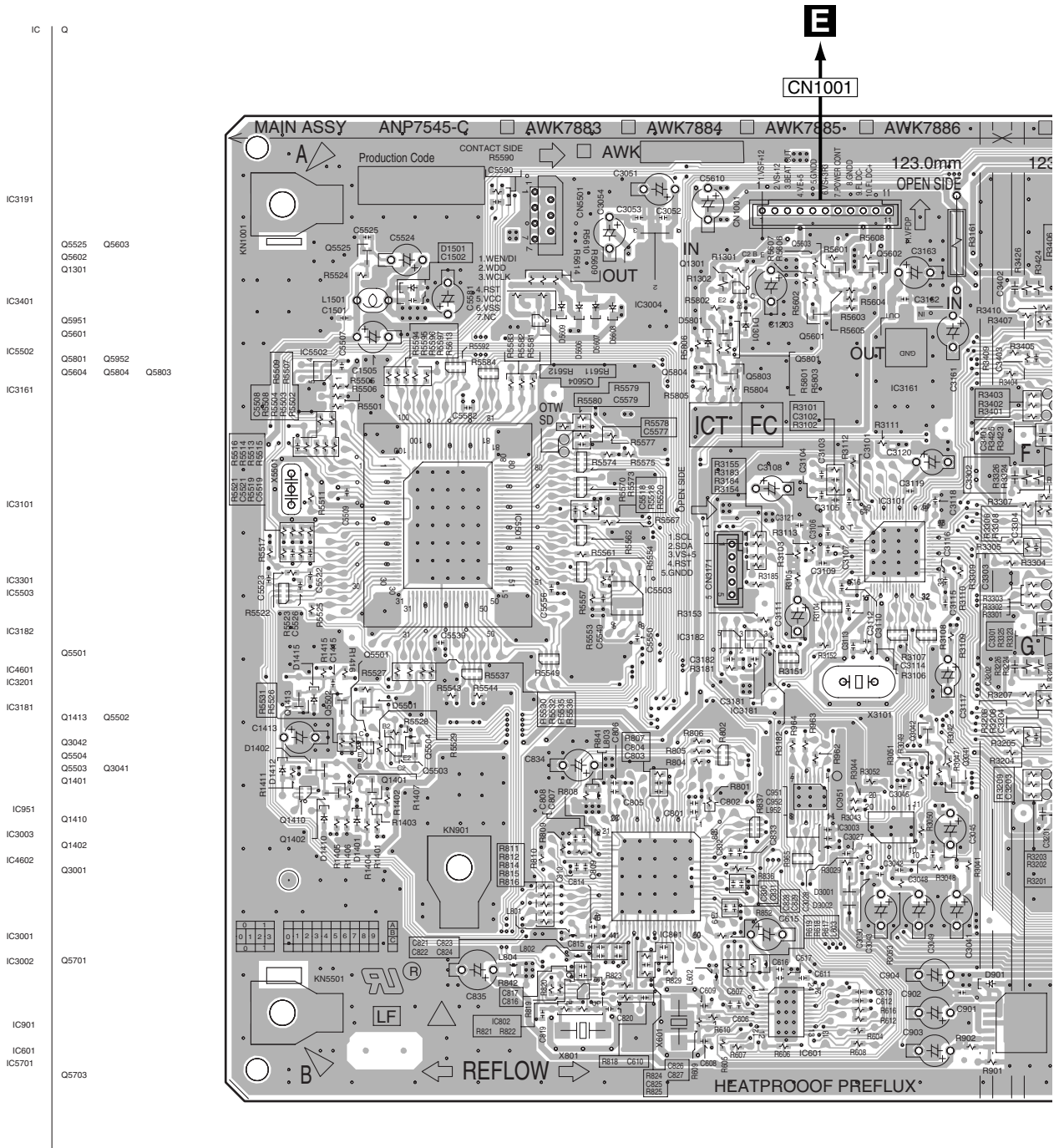

E
CN1001

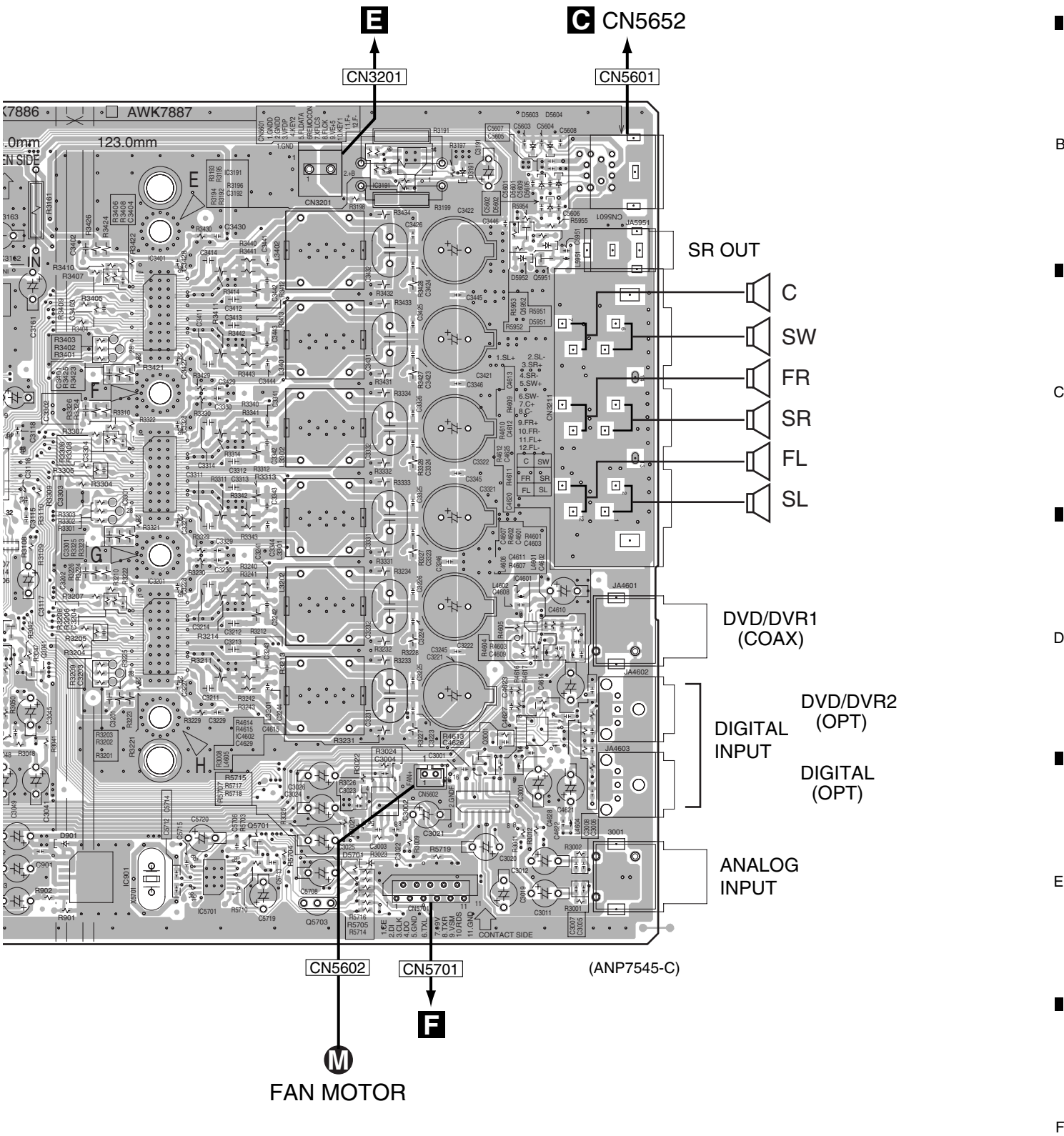

SIDE B

A

A MAIN ASSY

B

C

D

E

F

CN5601

CN3201

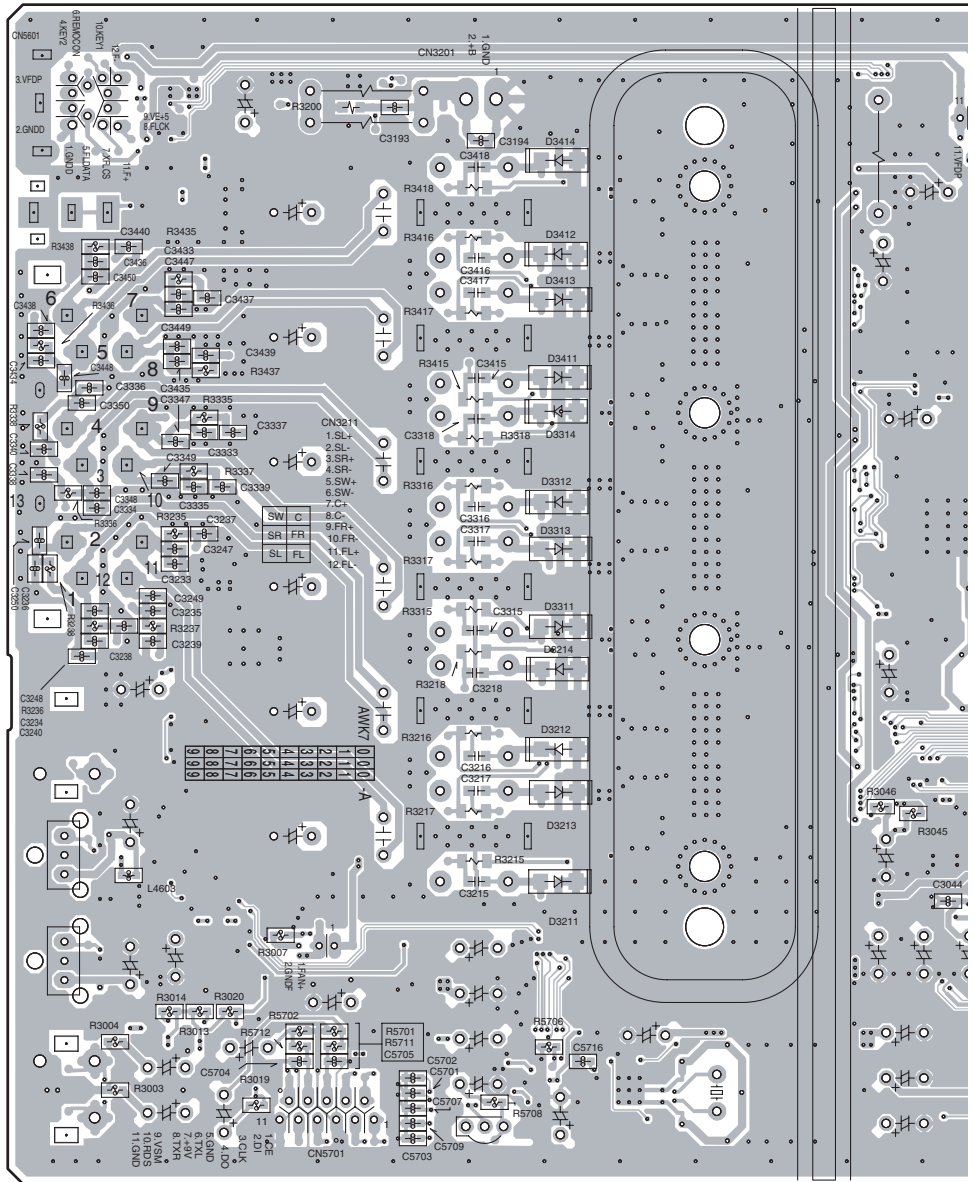

CN5701

CN5602

A

A
B
C
D
E
F

CN1001

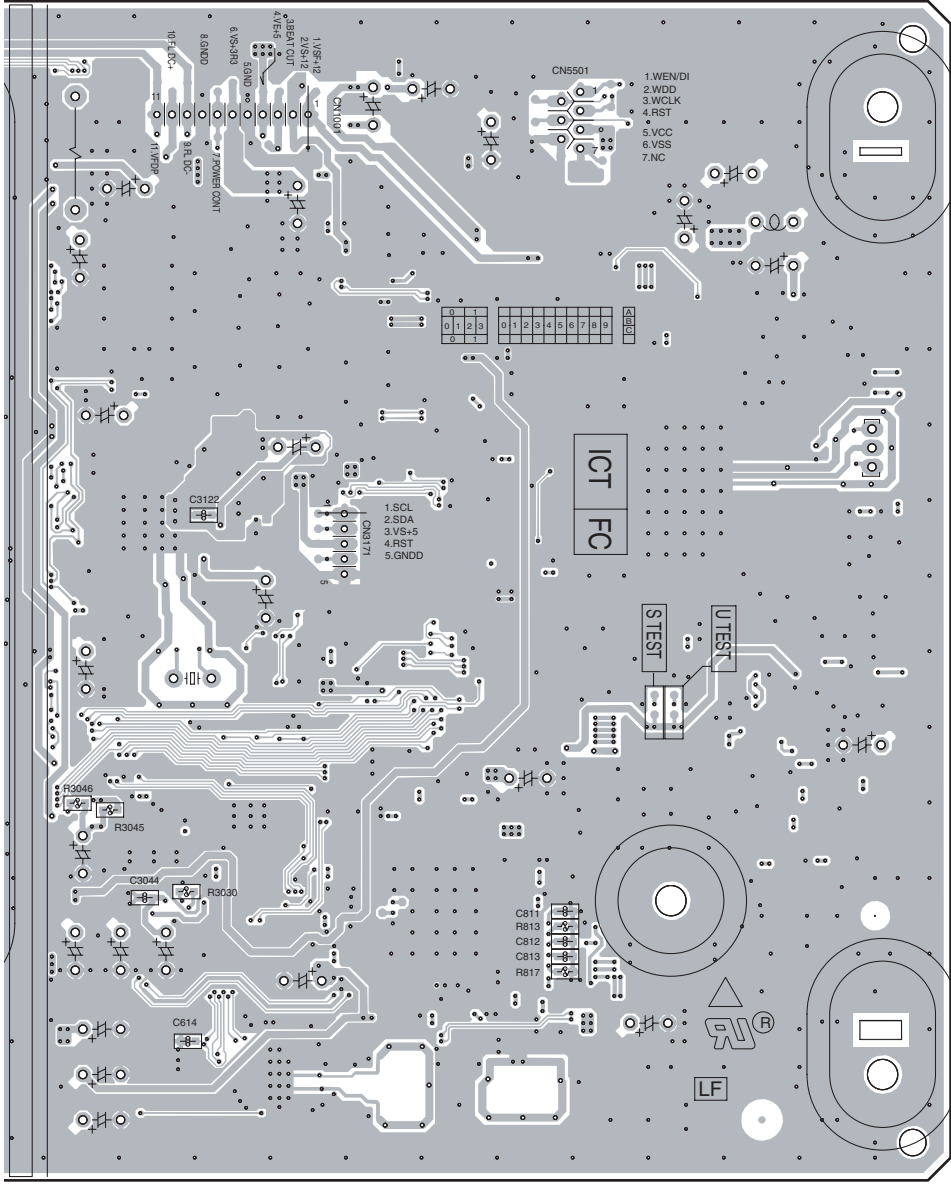

(ANP7545-C)

4.2 AC INLET and CONNECT ASSYS

SIDE A

SIDE B

C CONNECT ASSY

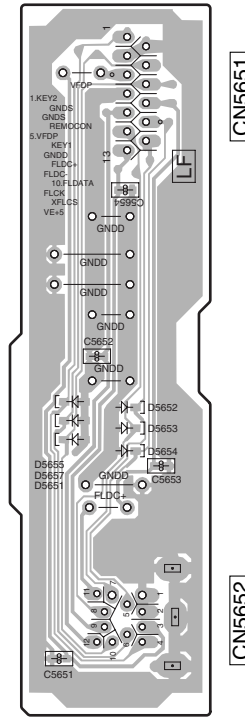
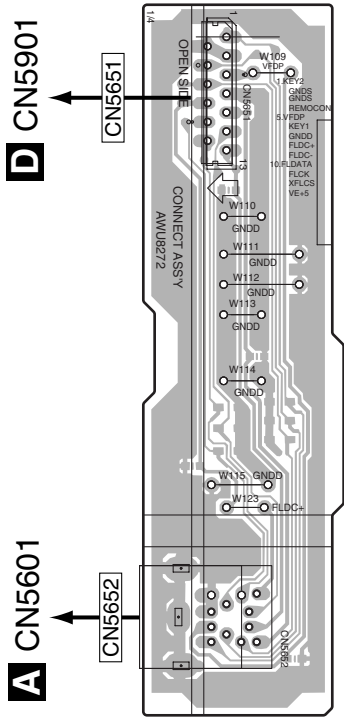

(ANP7546-C)

(ANP7546-C)

SIDE A

SIDE B

B AC INLET ASSY

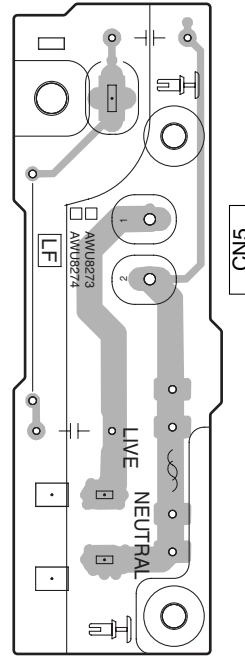
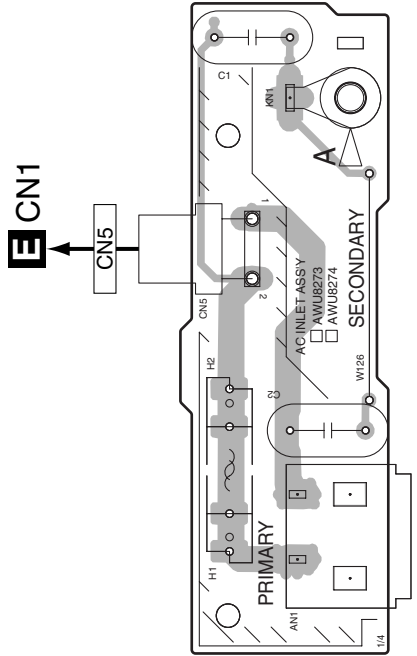

(ANP7546-C)

(ANP7546-C)

SIDE A

SIDE B

BC

BC

4.3 FL ASSY

SIDE A

SIDE B

D FL ASSY

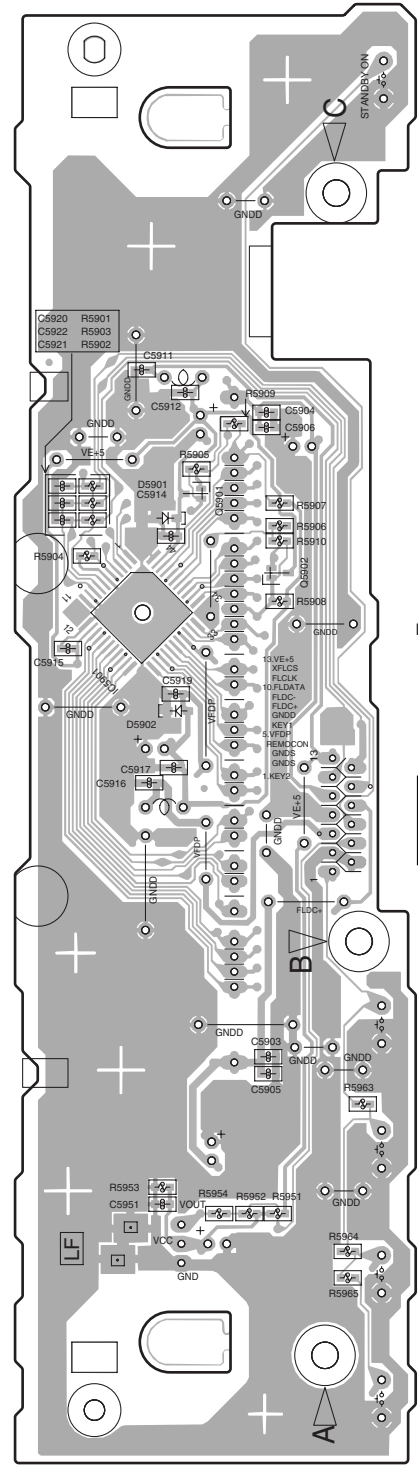
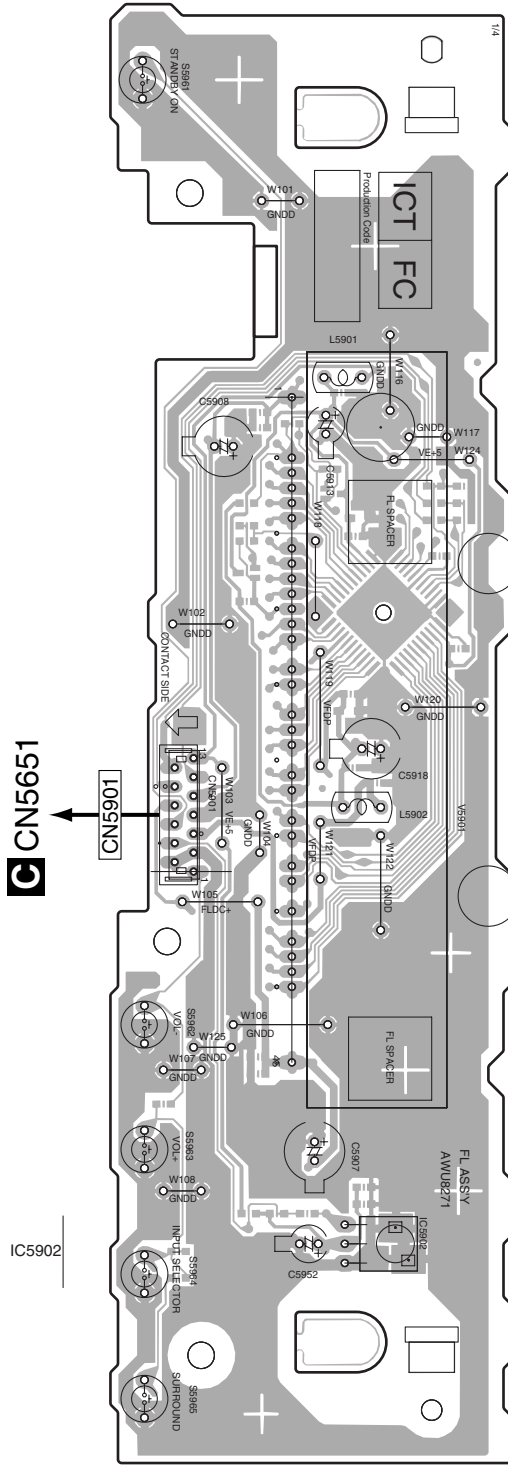

(ANP7546-C)

(ANP7546-C)

SIDE A

SIDE B

D

D

4.4 POWER SUPPLY UNIT

SIDE A

SIDE A

POWER SUPPLY UNIT

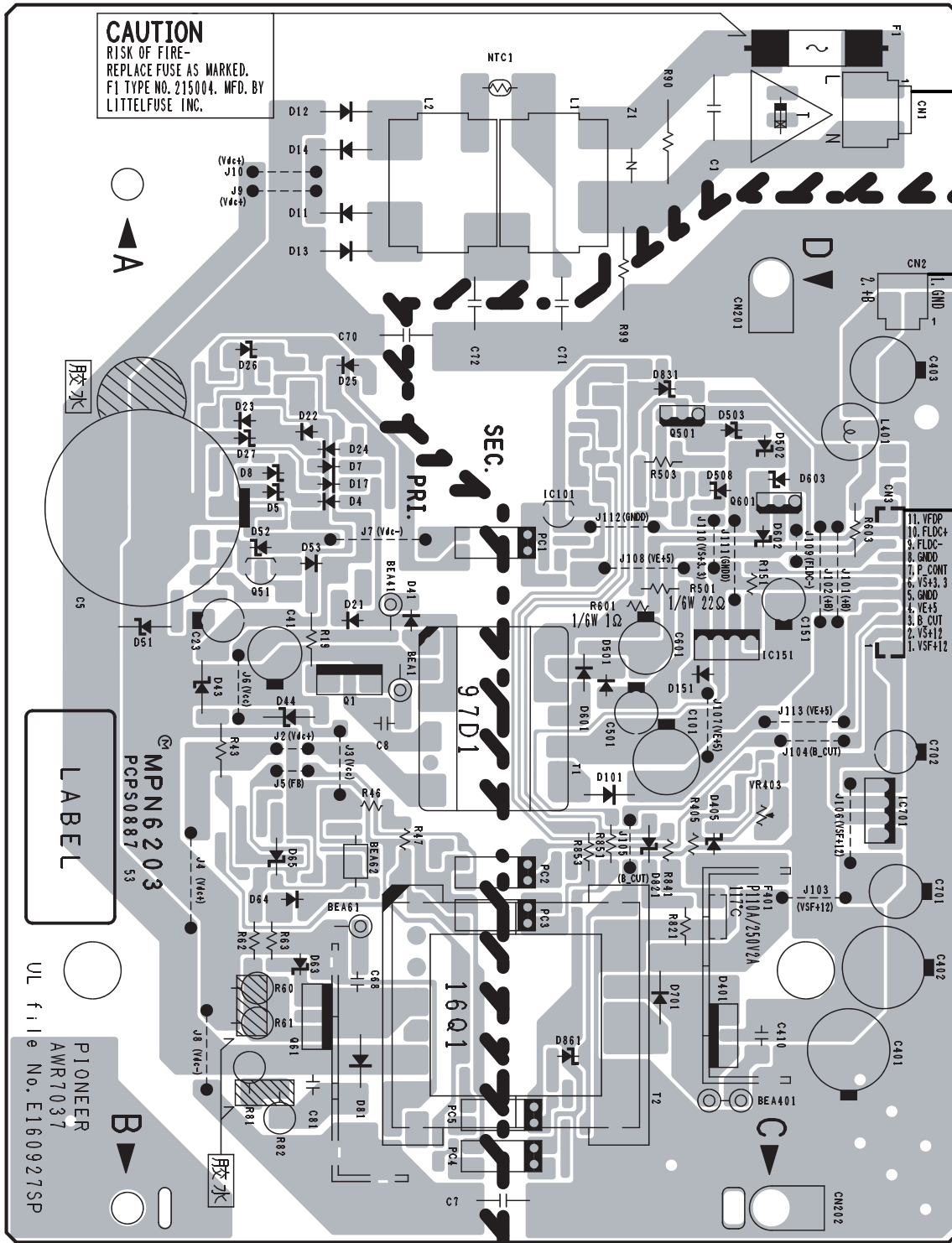

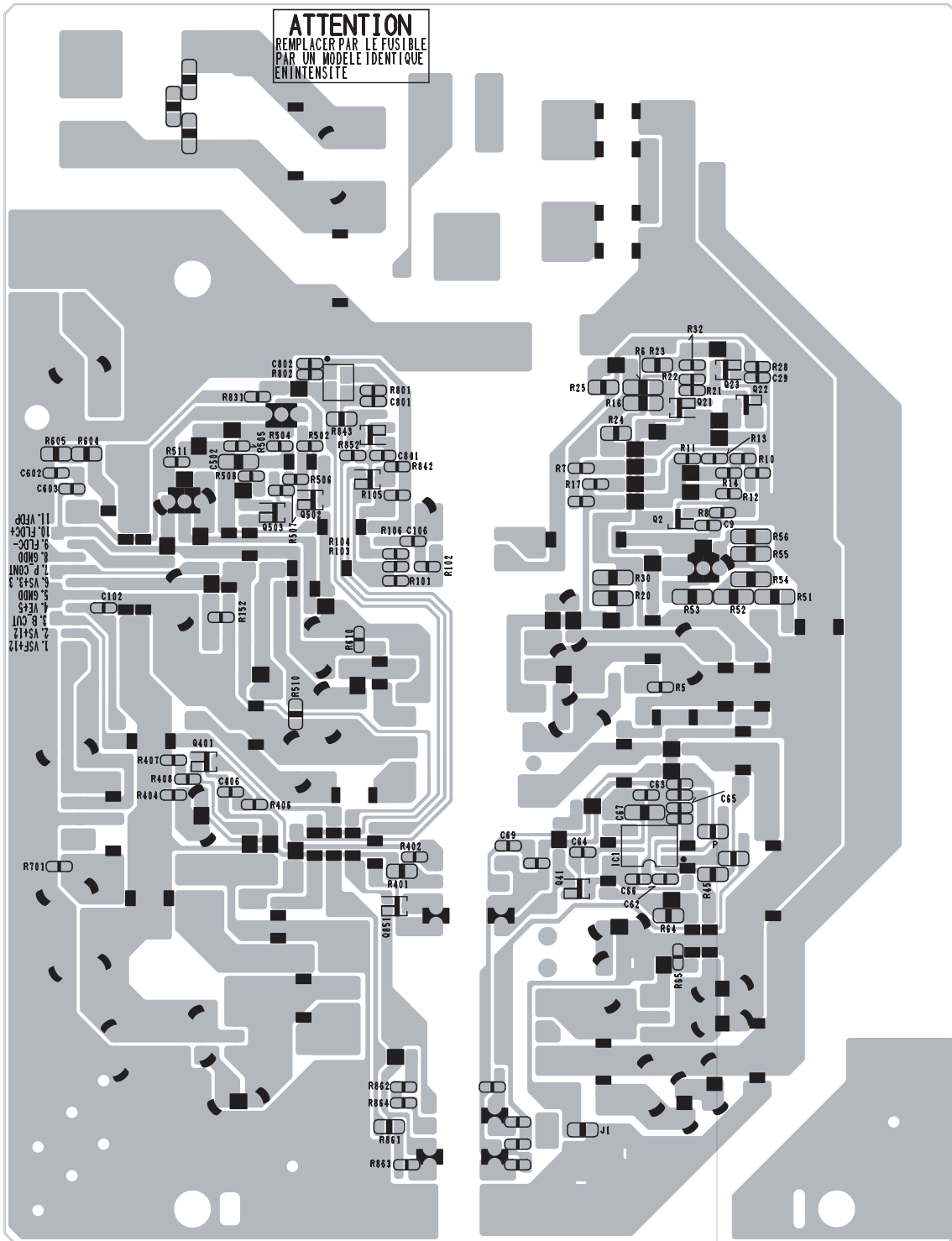

ATTENTION
 REMPLACER PAR LE FUSIBLE
 PAR UN MODELE IDENTIQUE
 EN INTENSITE

- 1. VFCP
- 10. FLDC
- 9. FLDC
- 8. GND
- 7. P. GND
- 6. VSF+3
- 5. GND
- 4. VES
- 3. B. CUT
- 2. VSF+12Z
- 1. VSF+12

5. PCB PARTS LIST

NOTES: ● Parts marked by "NSP" are generally unavailable because they are not in our Master Spare Parts List.

● The Δ mark found on some component parts indicates the importance of the safety factor of the part. Therefore, when replacing, be sure to use parts of identical designation.

● When ordering resistors, first convert resistance values into code form as shown in the following examples.

Ex.1 When there are 2 effective digits (any digit apart from 0), such as 560 ohm and 47k ohm (tolerance is shown by J=5%, and K=10%).

560 Ω \rightarrow 56×10^1 \rightarrow 561 RD1/4PU $\overline{5}$ $\overline{6}$ $\overline{7}$ J
 47k Ω \rightarrow 47×10^3 \rightarrow 473 RD1/4PU $\overline{4}$ $\overline{7}$ $\overline{3}$ J
 0.5 Ω \rightarrow R50 RN2H \overline{R} $\overline{5}$ $\overline{0}$ K
 1 Ω \rightarrow 1R0 RS1P $\overline{7}$ \overline{R} $\overline{0}$ K

Ex.2 When there are 3 effective digits (such as in high precision metal film resistors).

5.62k Ω \rightarrow 562×10^1 \rightarrow 5621 RN1/4PC $\overline{5}$ $\overline{6}$ $\overline{2}$ $\overline{1}$ F

LIST OF HOLE PCB ASSEMBLIES

Mark	Symbol and Description	SX-SW77/ WYXCN	SX-SW77/ WVXCN	SX-SW55/ WYXCN	SX-SW55/ WVXCN	SX-SW950/ KUXCN
	1..MAIN ASSY	AWK7883	AWK7883	AWK7883	AWK7883	AWK7884
	1..DISPLAY ASSY	AWM8010	AWM8010	AWM8010	AWM8010	AWM8011
	2..FL ASSY	AWU8271	AWU8271	AWU8271	AWU8271	AWU8271
	2..CONNECT ASSY	AWU8272	AWU8272	AWU8272	AWU8272	AWU8272
	2..AC INLET ASSY	AWU8273	AWU8273	AWU8273	AWU8273	AWU8274
Δ	1..POWER SUPPLY UNIT	AWR7037	AWR7037	AWR7037	AWR7037	AWR7037
	1..FM/AM TUNER UNIT	AXX7170	AXX7170	AXX7170	AXX7170	AXX7172

CONTRAST OF PCB ASSEMBLIES

A MAIN ASSY

AWK7883 and AWK7884 are constructed the same except for the following :

Mark	Symbol and Description	AWK7883	AWK7884
	IC5701	BU1924FS	Not used
	Q5701	2SC4081(QR)	Not used
	C5706, C5715	CKSRYB103K50	Not used
	C5712, C5714	CCSRCH270J50	Not used
	C5713	CKSRYB472K50	Not used
	C5716	CCSRCH561J50	Not used
	C5719	CEAT100M50	Not used
	C5720	CEAT470M16	Not used
	R5513	Not used	RS1/16S473J
	R5515	RS1/16S473J	Not used
	R5701, R5702	RS1/16S272J	Not used
	R5703, R5710	RS1/16S101J	Not used
	R5704	RS1/16S221J	Not used
	R5706	RS1/16S472J	Not used
	R5719	RS1/16S0R0J	Not used
	X5701 Crystal resonator	ASS7004	Not used

B AC INLET ASSY

AWU8273 and AWU8274 are constructed the same except for the following :

Mark	Symbol and Description	AWU8273	AWU8274
Δ	AN1 1P AC inlet	XKP3084	XKP3085

Mark No. Description**Part No.**

R3231-R3234,R3331-R3334
R3431-R3434
R1302
R3223-R3226,R3323-R3326
R3423-R3426

RS1/10S472J
RS1/10S472J
RS1/10S561J
RS1/10S821J
RS1/10S821J

R902
R901
R3240-R3243,R3340-R3343
R3440-R3443
R3215-R3218,R3315-R3318

RS1/16S2701F
RS1/16S4701F
RS1/8S180J
RS1/8S180J
RS1/8S1R5J

R3415-R3418
Other Resistors

RS1/8S1R5J
RS1/16S###J

OTHERS

X801 CRYSTAL RESONATOR
(24.576MHz)
CN5501 7P FFC CONNECTOR
CN5701 11P FFC CONNECTOR
3001 2P PIN JACK

XSS3003

CN3211 6CH SPEAKER JACK
CN5601 12P CONNECTOR
X5701 CRYSTAL RESONATOR
X5501 CERAMIC RESONATOR
X3101 CRYSTAL RESONATOR
(13.5MHz)

AKE7116
AKP7131
ASS7004
ASS7034
ASS7062

CN1001 KR CONNECTOR
CN5602 KR CONNECTOR
CN3201 2P VH CONNECTOR
JA4602,JA4603 OPT. LINK IN
JA5951 REMOTE CONTROL JACK

B11B-PH-K
B2B-PH-K
B2P-VH
GP1FAV51RKBF
RKN1004

JA4601 1P PIN JACK
KN1001,KN5501
EARTH METAL FITTING

VKB1159
VNF1109

B AC INLET ASSY
CAPACITORS

C2

ACG7059

OTHERS

1 C4 SOLDERING LUG
⚠ CN5 2P VH CONNECTOR
⚠ AN1 1P AC INLET

039-30040-000
B2P3S-VH
XKP3084

C CONNECT ASSY
SEMICONDUCTORS

D5651-D5655,D5657

UDZS8R2(B)

CAPACITORS

C5651-C5654

CKSRYB102K50

OTHERS

CN5652 12P CONNECTOR
CN5651 13P PLUG

AKP7131
XKP3066

Mark No. Description**Part No.****D FL ASSY**
SEMICONDUCTORS

IC5901
Q5901,Q5902

PT6315
2SC4081

COILS AND FILTERS

L5902
L5901

LFEA100J
LFEA220J

SWITCHES AND RELAYS

S5961-S5965

VSG1024

CAPACITORS

C5920-C5922
C5918
C5913,C5952
C5915
C5911,C5912,C5916,C5917,C5951

CCSRCH221J50
CEAL470M35
CEAL470M6R3
CKSRYB103K50
CKSRYB223K50

RESISTORS

All Resistors

RS1/16S###J

OTHERS

V5901 FL TUBE
2, 3 FL SPACER
IC5902 REMOTE RECEIVER UNIT
CN5901 13P SOCKET

AAV7104
AEB7367
GP1UM27XK0VF
XKP3077

E POWER SUPPLY UNIT

This unit has no service part.

**F FM/AM TUNER UNIT**

This unit has no service part.

6. ADJUSTMENT

There is no information to be shown in this chapter.

7. GENERAL INFORMATION

7.1 DIAGNOSIS

7.1.1 TEST MODE

1. Conditions During Test Mode

- During Test mode, the unit will not be shut down for an emergency even if one of the failures mentioned below occurs.
- After the unit has been shut down in Normal mode for an emergency upon detection of one of the failures mentioned below, you can turn it on immediately, without waiting for one minute, in Test mode.

2. How to enter Test mode

- During Standby mode, hold the AUDIO INPUT and STANDBY/ON keys on the Display unit pressed for 3 seconds.
- Test mode can also be entered in either of the following ways:

1. Turn on the power with the STEST port (microcomputer terminal IC5501: 43-pin) at High (5 V).
(See "Test mode connecting point".)

2. Turn on the power while holding both the AUDIO INPUT and STANDBY/ON keys on the Display unit pressed.

Note: If the power cord was disconnected immediately before, be sure to wait at least one minute before turning on the power in the manner mentioned above. Otherwise, the unit may not operate properly.

3. How to quit Test mode, and conditions for quitting

- To quit Test mode, turn the power off to turn the power off.
- When Test mode is quit, only data on failure in RAM will be initialized, and data on user settings in RAM will not be initialized.

4. Indications on the FL display when Test mode is entered

- The function setting will be DVD/DVR1.
- The indication on the FL display when Test mode is entered will differ depending on whether the unit was shut down normally or with an abnormality detected, as shown below:
- ADV mode will become 5-channel STEREO so that multichannel output can be obtained.

[After a normal power-off]

FL display P:O:W:ER O:N
↓
FL display :V:O:L 0:
↓
FL display D:V:1 S:ER:V

[After a shutdown caused by over current detection]

FL display O:C E:R:R:O:R
↓
FL display :V:O:L 0:
↓
FL display D:V:1 S:ER:V

[After a shutdown caused by an EEPROM failure]

FL display E:E:P E:R:R:
↓
FL display :V:O:L 0:
↓
FL display D:V:1 S:ER:V

[After a shutdown caused by high-temperature detection]

FL display O:V:E:R:T:E:M:P
↓
FL display :V:O:L 0:
↓
FL display D:V:1 S:ER:V

5. Operations during Test Mode

- Basically, operations in Test mode are the same as in Normal mode. However, to indicate that the unit is in Test mode, the following are displayed when the functions are changed:

• Excepting North America

[Functions]	[FL display]
DVD/DVR1	D:V:1 S:ER:V
DVD/DVR2	D:V:2 S:ER:V
DIGITAL	D:I:G S:ER:V
ANALOG	A:N:A S:ER:V
FM/AM	T:X S:ER:V

• North America

[Functions]	[FL display]
DVD	D:V:D S:ER:V
DTV	D:T:V S:ER:V
PC/GAME	P:C S:ER:V
AUX	A:U:X S:ER:V
TUNER	T:X S:ER:V

6. Failures

- Depending on the types of errors, one of the following error messages will be displayed when the unit is turned on:

E E P R O M E R R O R

- Breakage or short-circuiting of the communication line to the EEPROM can be suspected.
- A failure in the EEPROM can be suspected.

O C E R R O R

- If "OC ERROR" is not displayed when the unit is turned on in Normal mode, short-circuiting of the speaker terminals can be suspected.
- If "OC ERROR" is displayed again when the unit is turned on in Normal mode, the following causes can be suspected:
 - One or more of the ICs among the three digital amplifier ICs (IC3201, IC3301, and IC3401: TAS5122DCA) on the MAIN Assy is in failure.
 - The line between one of the above digital amplifier ICs and the speaker terminals is short-circuited.
 - The XSD line from one of the above digital amplifier ICs to the system-control IC (PDC128A) is short-circuited by grounding or is broken.

O V E R T E M P

- If "OVERTEMP" is not displayed when the unit is turned on in Normal mode, the unit is normal. (It is likely that this was a temporary temperature rise, lower the volume of the speakers.)
- If "OVERTEMP" is displayed again when the unit is turned on in Normal mode, the following causes can be suspected:
 - One or more of the ICs among the three digital amplifier ICs (IC3201, IC3301, and IC3401: TAS5122DCA) on the MAIN Assy is in failure.
 - The OTW line from one of the above digital amplifier ICs to the system-control IC (PDC128A) is short-circuited by grounding or is broken.

7. DSP error display

- Each time the SOUND key on the remote control unit is pressed while the power is on, the DSP error display and the normal display are alternately switched.

8. Accumulated power-on time display and speaker setting display

- If the AUDIO INPUT key on the main unit is held pressed for 8 seconds while the power is on, the accumulated power-on time display and the speaker-setting display will be alternately switched at intervals of 3 seconds.

Speaker-setting display

T A L L S P

↑ ↓ At intervals of 3 seconds

Accumulated power-on time display

1 0 H 3 0 M

- Power-on time is always counted while the power is on, regardless of unit's functions and operations. However, it is not counted during Standby mode.
- The maximum countable power-on time is 255H59M (255 hours 59 minutes.) The indication will not advance beyond that.
- The accumulated power-on time basically cannot be cleared.

Test Mode connecting point

A MAIN ASSY **SIDE B**

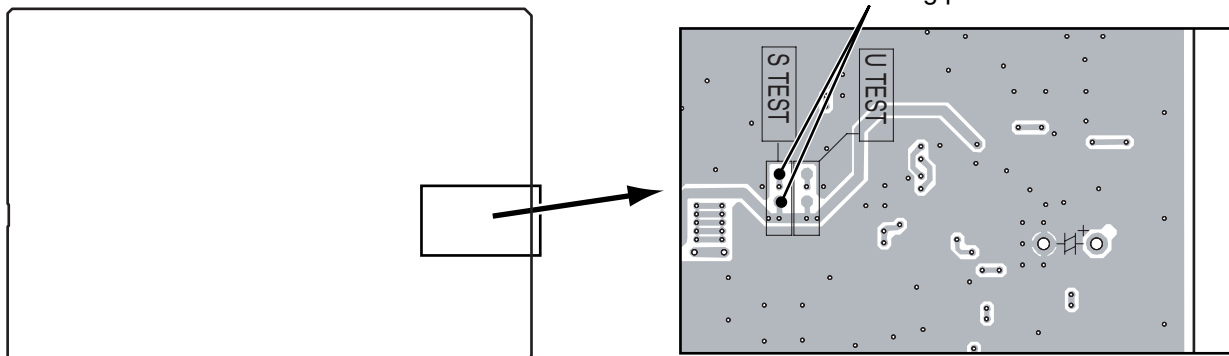

7.1.2 SPECIFICATIONS OF SPEAKER SETUP

1. Overview

Several types of speakers are planned to be used with this product, and according to speaker type, the sound-quality parameters to be sent to the Digital Amplifier section are different. Since the parameters for the planned speaker types have been written in the EEPROM, by simply selecting the speaker type, as shown below, speaker setting is completed.

2. How to select the settings

1. While holding the VOL+ and STANDBY/ON keys on the Display unit pressed, connect the power cord to the wall outlet.

Note: If the power cord was disconnected immediately before, be sure to wait at least one minute before turning on the power in this way. Otherwise, the unit may not operate properly.

Or, during Standby mode, hold the VOL+ and STANDBY/ON keys pressed for 3 seconds.

2. The power comes on; then the following indication appears.

S P . T Y P E

3. Press the key corresponding to the speaker to be used to determine the setting. The power will automatically be turned off.

VOL- key R E G U L A R 1
 VOL+ key T A L L S P
 AUDIO INPUT key N X T S P
 SURROUND key R E G U L A R 2
 STANDBY/ON key A V G A T E

□ : Flashing

Note: Be sure to select the setting corresponding to the model number of the speaker. (See the table below.)

Destination	Model Number	Speaker	Remarks	Speaker setting
Europe	SX-SW55/WYXCN, /MVXCN SX-SW77/WYXCN, /MVXCN	SMALL1 TALL		REGULAR1 TALL
North America	SX-SW950/KUXCN	NXT		NXT
Japan	SX-06SW/JJXCN SX-E230SW/JJXCN	AV GATE TALL	AV rack with SP	AV GATE TALL
General	SX-SW100/TDLPWXCN	SMALL2 TALL		REGULAR2 REGULAR2
China	SX-SW100/NAXCN	TALL		TALL

3. How to confirm the speaker setting

1. While holding the AUDIO INPUT and STANDBY/ON keys on the Display unit pressed, connect the power cord to the wall outlet.

Note: If the power cord was disconnected immediately before, be sure to wait at least one minute before turning on the power in this way. Otherwise, the unit may not operate properly.

Or, during Standby mode, hold the AUDIO INPUT and STANDBY/ON keys pressed for 3 seconds.

2. Enter Service/Test mode.
3. Hold the AUDIO INPUT key pressed for 8 seconds.
4. The setting is displayed.

T A L L S P
 U N K N O W N

5. If no setting has been written in the EEPROM, "UNKNOWN" is displayed. In this case, the unit will operate in the same way as if "REGULAR 1" (satellite) were set.

4. Error indication

When the unit is turned on without any speaker setting, a warning "NO SPTYP" will be displayed. Even with this warning displayed, all key operation is possible. After a key operation, the display will return to this warning indication.

N O S P T Y P

7.1.3 PROPOSAL OF DSP ERROR DISPLAY

• Specification of DSP error display

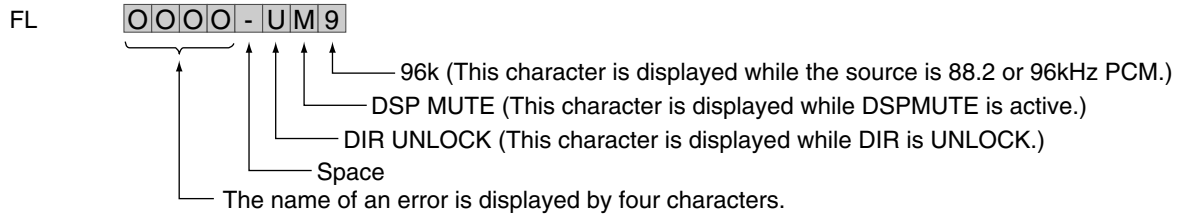

Example)

ERR. 0	D I E R - U M	Data cannot be received from DIR. → DIR is assumed to be in failure.
ERR. 1	D S E R - U M	Data cannot be received from DSP. → Communication between DIR and DSP is in failure. → DSP is assumed to be in failure.
ERR. 2	H R E Q - U M	No value is returned from HREQ. → DSP is assumed to be in failure.
ERR. 3	D S N G - U M	There are DSP error data. → Communication between DIR and DSP is in failure. → DSP is assumed to be in failure.
ERR. 4	D M U T - M	DECMUTE is always activated. → Communication between DIR and DSP is in failure. → DSP is assumed to be in failure.
NO ERR (The source is 88.2/96kHz.)	D S O K - 9	96-kHz source data are being played back.
NO ERR (The source is 88.2/96kHz.)	D S O K -	No abnormality

• DSP error message mode

Press the "SOUND" key in test mode, to select the mode that DSP error messages are displayed.
 Press the "SOUND" key again to select the normal test mode.
 For this reason, make the usual function of "SOUND" not effective in the test mode.

7.1.4 CIRCUIT DESCRIPTION OF DIGITAL AMP. SECTION

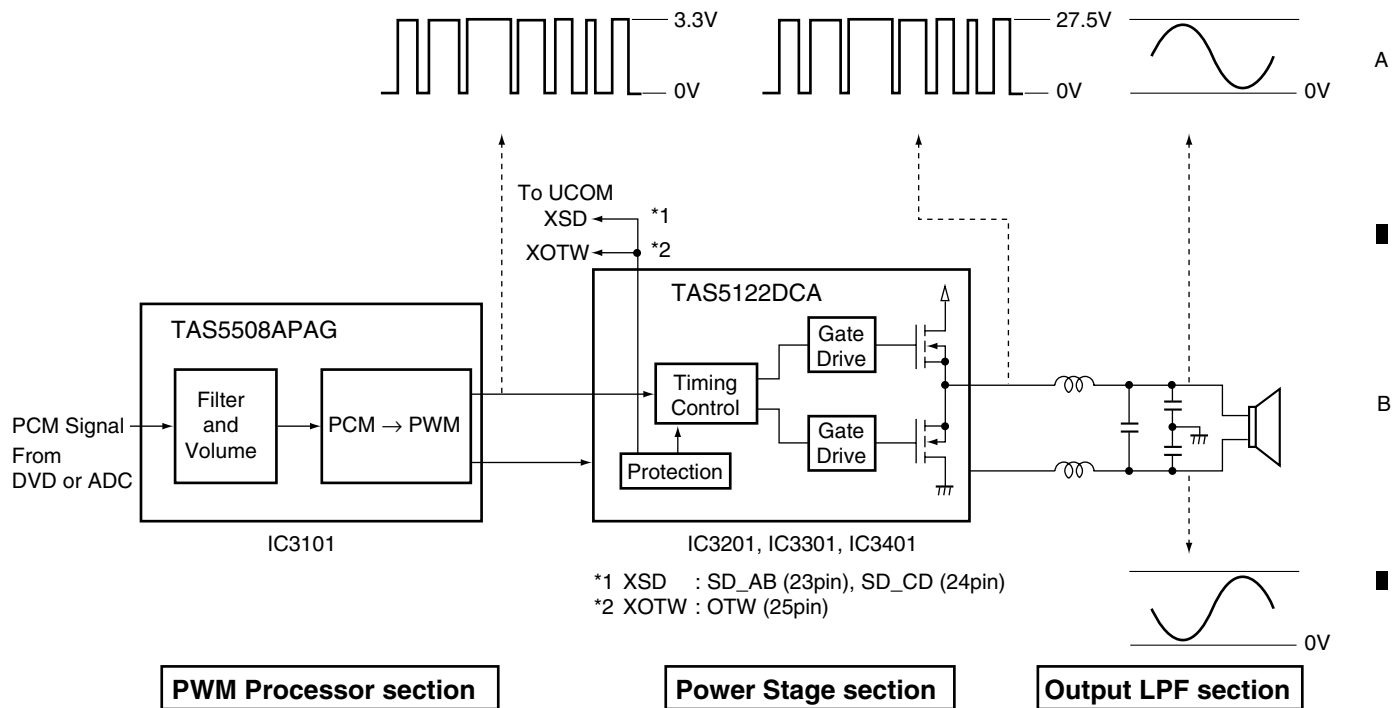

PWM Processor section

The PCM signals output from the DVD decoder or AD converter are input to this section, and their volume and sound quality are digitally adjusted. At the output stage, after conversion from PCM to PWM, the signals are output to the Power stage.

Power Stage section

In this section, timing is controlled so that the MOSFETs on the high and low sides will not be turned on simultaneously. The voltage of the PWM signals are raised to drive the gates of the MOSFET, and the PWM signals to drive the speakers are output from the MOSFET at the output stage. Detection and protection functions against short-circuiting of the output signals and temperature exceeding the standard value are also provided.

If the detection and protection work, the ports of the power stage ICs become the following state.

Power Stage ICs No.	Protection Enable State
IC3201	SD_AB (23pin) ⇒ L
IC3301	SD_CD (24pin) ⇒ L
IC3401	OTW (25pin) ⇒ L

Output LPF section

The carrier elements, high-frequency signals that are unnecessary for these speakers, are eliminated. The signals passed through the LPF will become sine-wave signals, as shown in the figure above.

Attention :

As a signal to drive the BTL is output from the negative speaker terminal, DO NOT short-circuit between the negative speaker terminal and ground, such as the chassis.

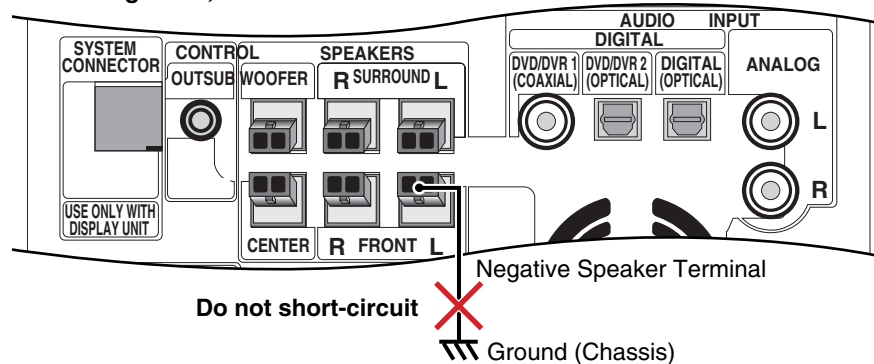

7.1.5 SPECIFICATIONS FOR THE PROTECTION CIRCUITS FOR THE DIGITAL AMPLIFIER

The protection circuits for the Digital Amplifier are activated, following the specifications shown below. The error indication on the FL display shows the reason a protection circuit was activated.

Upon diagnosis of the Digital Amplifier, refer to the specifications for the protection circuits here and the overview of the Digital Amplifier circuitry.

1. Overview

The system microcomputer monitors the ports for shutdown requests (Pin 23:SD_AB and Pin 24: SD_CD) and the ports for abnormal-temperature detection (Pin 25: /OTW) of the Power Stage ICs (IC3201, IC3301, and IC3401). As soon as any abnormality is detected, it shuts the unit down.

To notify the user of the possibility of a too high a volume, when the unit is turned on the next time, the volume level will be set to 0, and an error message will be displayed on the FL display.

2. Ports on the system microcomputer to be used for detection

Pin 77: SHUTDOWN

Low voltage at this pin means overcurrent or voltage too low (= V+B27) at a Power Stage IC.

Pin 79: XOTW

Low voltage at this pin means the temperature at the Power Stage ICs exceeded 125°C.

Note: As one Power Stage IC is provided with two channels, three Power Stage ICs (in total 6 channels) are mounted in this unit. For abnormality detection, the unit implements a logical OR operation regarding these three ICs. Therefore, which IC is abnormal cannot be known directly. To find which IC is abnormal, it is required to check whether abnormality detection is activated or not with the abnormality detection port of each IC open (by temporarily removing a series resistor (IC3201:R3201-R3203, IC3301:R3301-R3303, IC3401:R3401-R3403)).

3. Detection timing

Start : Detection starts 500 ms after the PWRCONT 2 port (Pin 84) of the system microcomputer becomes active by your pressing the STANDBY/ON key.

Finish : When the STANDBY/ON key is pressed again (when the power-off process starts).

4. Operation of the protection circuits

The following three protection circuits are activated when the conditions shown below are met:

Overcurrent detection: Indication on the FL display: OC ERROR

Conditions: If the SHUTDOWN ports, which are monitored every 10 ms, become low 7 out of 10 times. (If they become low 7 times in succession, the conditions are met at that point.)

Abnormal temperature detection 1: Indication on the FL display: OVERTEMP

Conditions: If the XOTW ports, which are monitored every 10 ms, become low in succession for one minute.

Abnormal temperature detection 2: Indication on the FL display: OVERTEMP

(Prerequisite: The XOTW ports, which are monitored every 10 ms, become low three times in succession.)

Conditions: The above prerequisite is upheld, and the conditions for an overcurrent detection are met.

5. Process when the protection circuits are activated

The unit is shut down within 30 ms after abnormality detection then the volume level is set to 0. The unit can be turned on immediately after the shutdown.

7.1.6 CONDITIONS FOR SWITCHING THE ROTATION SPEED OF THE FAN

A fan is provided with this unit. Its rotation speed can be switched between low and high under the following conditions.

1. Conditions for switching the rotation speed from low to high

In a case where an audio signal is input and the main volume becomes VOL 20 or more

- The rotation speed is not switched to high immediately after the main volume becomes VOL 20 but with a delay of 30 seconds.
- If a digital stream signal is not input, the rotation speed is not switched to high even if the main volume becomes VOL 20 or more.
- If the function is ANALOG IN, even if there is no audio signal input, 30 seconds after the main volume becomes VOL 20 or more, the rotation speed is switched to high.

2. Conditions for switching the rotation speed from high to low

- If the main volume becomes less than VOL 20
- During muting
- If a digital stream signal is not input

Note: The rotation speed is immediately switched to low when one of the above conditions is met.

3. Fan drive circuit and drive voltage

The fan drive circuit and the drive voltages at low/high rotation speed are shown below:

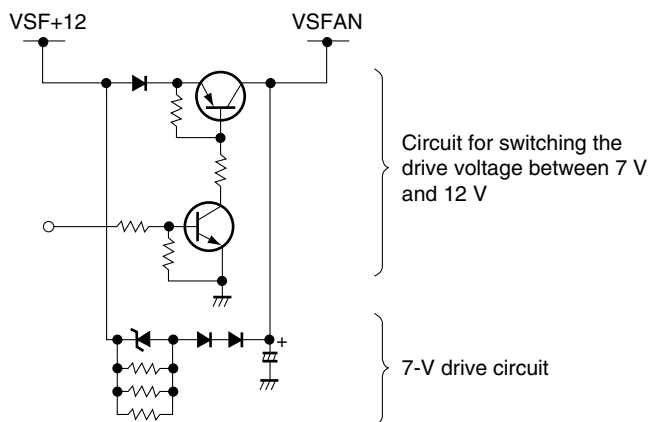

	Power	Voltage (V)
Low speed, no digital stream signal (except when the function setting is ANALOG IN)	VSF+12	12.3
	VSFAN	6.7
Low speed, with audio input, with VOL 19 or less	VSF+12	13.1
	VSFAN	7.4
High speed, with VOL 20 or more	VSF+12	13.0
	VSFAN	12.2

Note: The above voltage values are references. They differ from product to product.

7.1.7 DISASSEMBLY

Note 1: Even if the unit shown in the photos and illustrations in this manual may differ from your product, the procedures described here are common.

1 DISPLAY Unit

- 1 Remove the two screws.
- 2 Remove the one screw.
- 3 Remove the display cover.

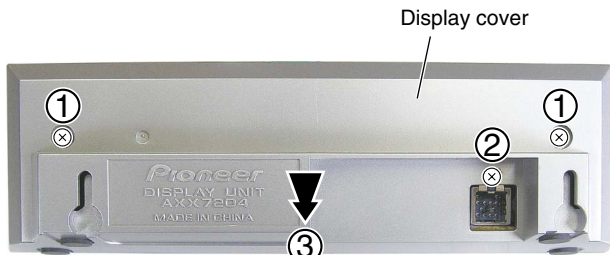

● Rear view



- 4 Remove the three screws.
- 5 Unhook the two hooks.
- 6 Remove the FL and CONNECT Assys.

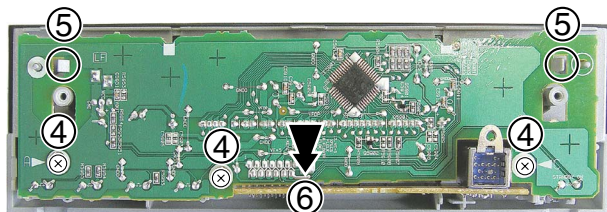

● Rear view

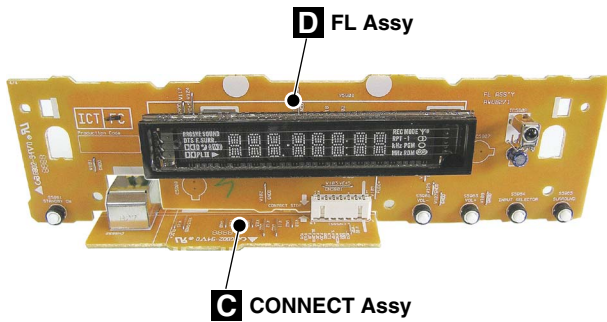

2 Cosmetic Baffle

- 1 Insert a thin slot screwdriver into the gap between the cosmetic baffle and main housing and gently pry the baffle away.

Note: To avoid damage, alternately pry at two points, as shown in the photo below, little by little, not in a single motion.

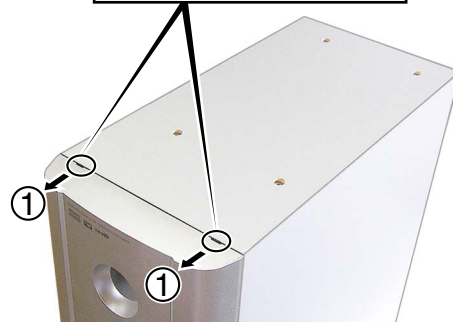
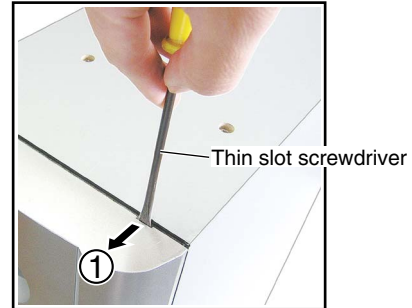

● Bottom view



- 2 Remove the cosmetic baffle.



3 Speaker

- ① Remove the four screws.
- ② Remove the speaker.



- ③ Disconnect the connection cord.

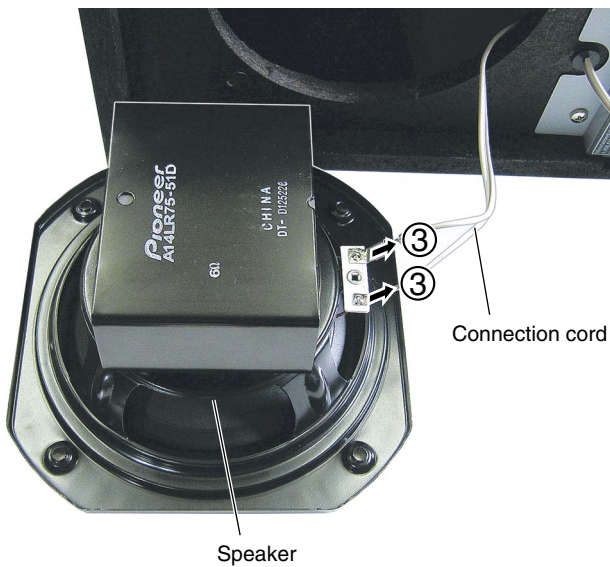

4 Main Section

- ① Remove the four screws.



- ② Disconnect the connection cord.
- ③ Remove the two screws.
- ④ Pull out the Main Section.

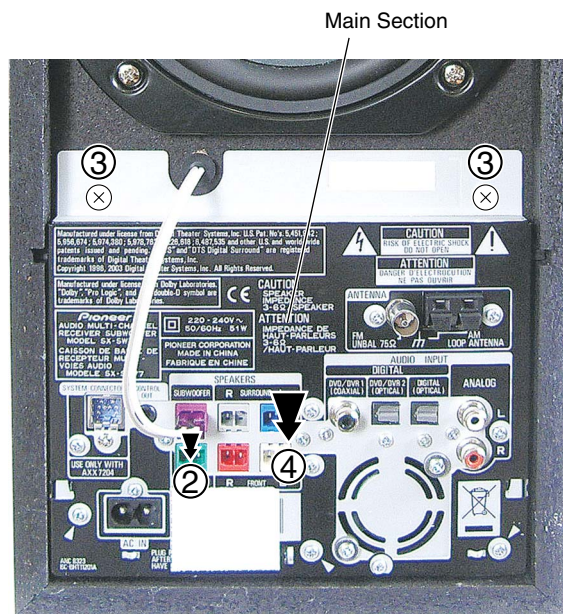

A

B

C

D

E

F

A

⑤ Remove the three screws.

⑥ Remove the seven screws.

⑦ Remove the chassis T with rear panel SW by unhooking the two hooks.

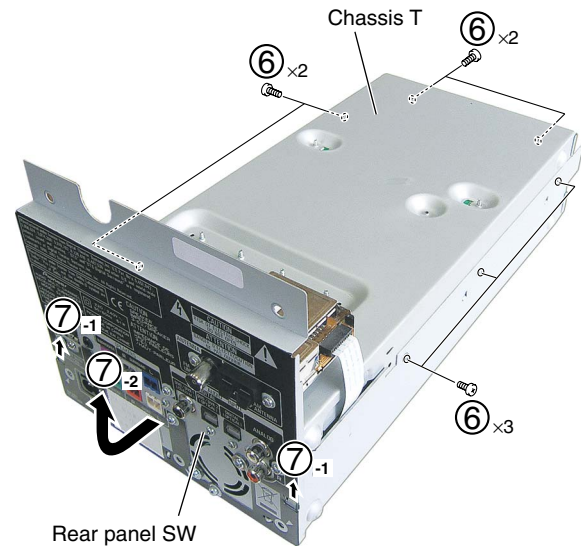

B

C

⑧ Connect the DISPLAY Unit.

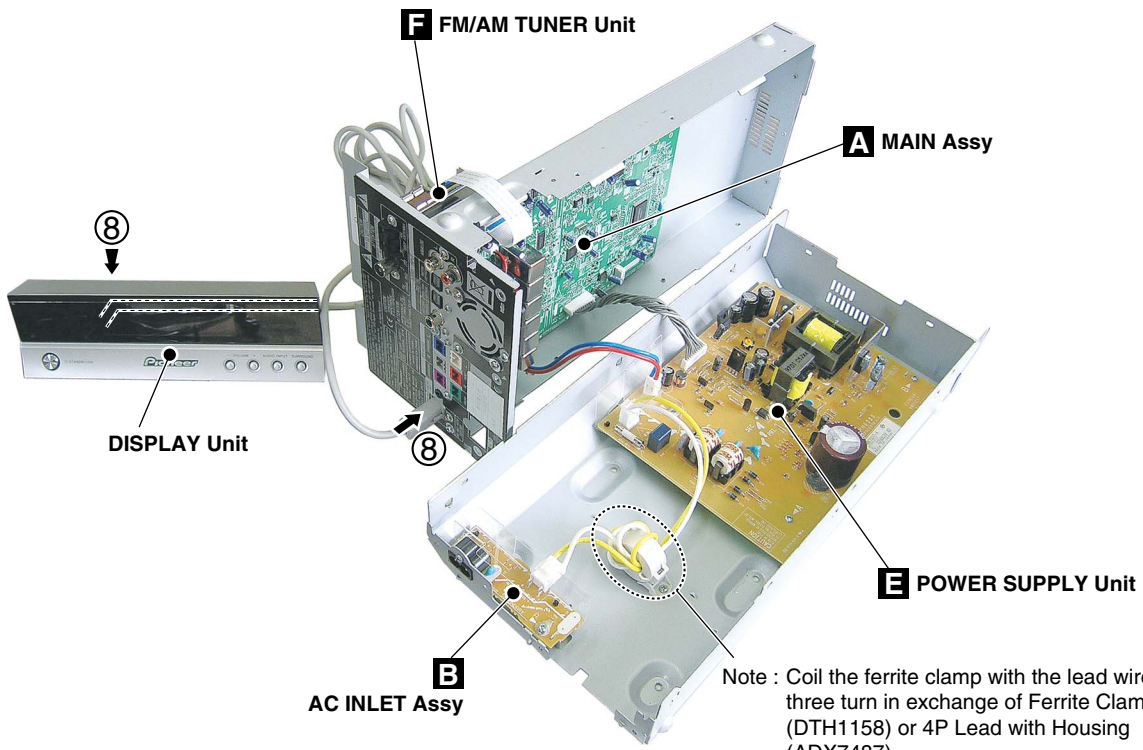

Diagnosis

7.2 IC

• The information shown in the list is basic information and may not correspond exactly to that shown in the schematic diagrams.

• List of IC

AK4117VF, DSPC56371AF180, PCM1803DB, TAS5508APAG, TAS5112ADCA, PDC128A, BR93L46RFJ-W, BU1924FS, PT6315

■ AK4117VF (MAIN ASSY : IC601)

• Low Power 192 kHz Digital Audio Receiver

• Pin Arrangement (Top view) • Block Diagram

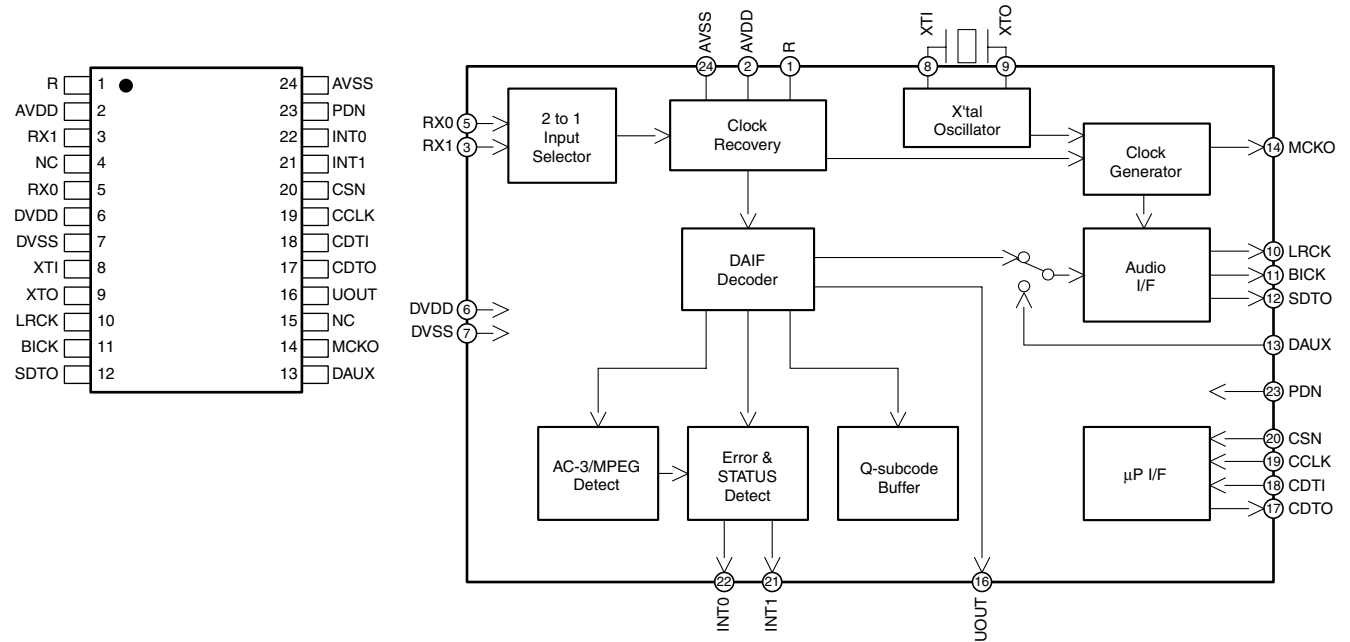

• Pin Function

No.	Pin Name	I/O	Pin Function
1	R	-	External Resistor Pin 12Ω-5% ~ 13Ω+5% resistor to AVSS externally.
2	AVDD	-	Analog Power Supply Pin
3	RX1	I	Receiver Channel 1 (Internal Biased Pin)
4	NC	-	No Connect
5	RX0	I	Receiver Channel 0 (Internal Biased Pin)
6	DVDD	-	Digital Power Supply Pin
7	DVSS	-	Digital Ground Pin
8	XTI	I	X'tal Input Pin
9	XTO	O	X'tal Output Pin
10	LRCK	O	Output Channel Clock Pin
11	BICK	O	Audio Serial Data Clock Pin
12	SDTO	O	Audio Serial Data Output Pin
13	DAUX	I	Auxiliary Audio Data Input Pin
14	MCKO	O	Master Clock Output Pin
15	NC	-	No Connect
16	UOUT	O	U-bit Output Pin When UOUTE bit = "0", UOUT pin = "L".
17	CDTO	O	Control Data Output Pin
18	CDTI	I	Control Data Input Pin
19	CCLK	I	Control Data Clock Pin
20	CSN	I	Chip Select Pin
21	INT1	O	Interrupt 1 Pin
22	INT0	O	Interrupt 0 Pin
23	PDN	I	Power-Down & Reset Pin When "L", the AK4117 is powered-down and reset, and all output pins go to "L" and the control registers are reset to default state.
24	AVSS	-	Analog Ground Pin

■ DSPC56371AF180 (MAIN ASSY : IC801)

• DSP IC

● Pin Arrangement (Top view)

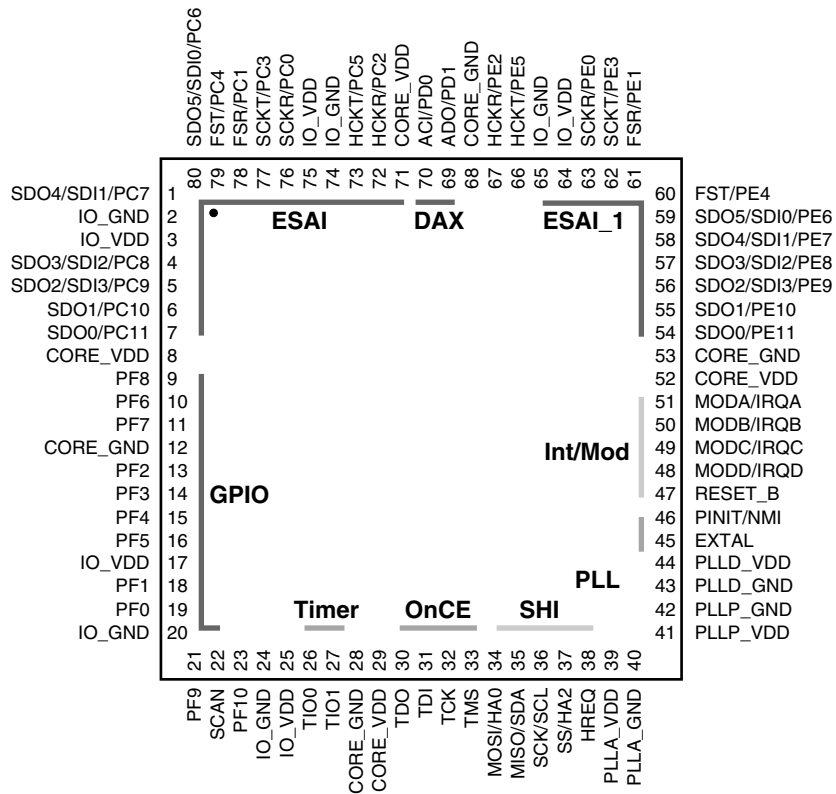

● Pin Functions

No.	Pin Name	I/O	Pin Function
1	SDO4/SDI1/PC7	I/O	Serial Data Output 4/Serial Data Input 1/Port C7
2	IO_GND	-	I/O ground
3	IO_VDD	-	I/O power supply (3.3V)
4	SDO3/SDI2/PC8	I/O	Serial Data Output 3/Serial Data Input 2/Port C8
5	SDO2/SDI3/PC9	I/O	Serial Data Output 2/Serial Data Input 3/Port C9
6	SDO1/PC10	I/O	Serial Data Output 1/Port C10
7	SDO0/PC11	I/O	Serial Data Output 0/Port C11
8	CORE_VDD	-	Core power supply (1.25V)
9	PF8	I/O	Port F8
10	PF6	I/O	Port F6
11	PF7	I/O	Port F7
12	CORE_GND	-	Core ground
13	PF2	I/O	Port F2
14	PF3	I/O	Port F3
15	PF4	I/O	Port F4
16	PF5	I/O	Port F5
17	IO_VDD	-	I/O power supply (3.3V)
18	PF1	I/O	Port F1
19	PF0	I/O	Port F0
20	IO_GND	-	GPIO I/O Ground
21	PF9	I/O	Port F9
22	SCAN	I	SCAN-Manufacturing test pin. This pin should be pulled low.
23	PF10	I/O	Port F10
24	IO_GND	-	I/O ground

No.	Pin Name	I/O	Pin Function
25	IO_VDD	–	I/O power supply (3.3V)
26	TIO0	I/O	Timer 0 Schmitt-Trigger Input/Output
27	TIO1	I/O	Timer 1 Schmitt-Trigger Input/Output
28	CORE_GND	–	Core ground
29	CORE_VDD	–	Core power supply (1.25V)
30	TDO	O	Test Data Output
31	TDI	I	Test Data Input
32	TCK	I	Test Clock
33	TMS	I	Test Mode Select
34	MOSI/HA0	I/O	SPI Master-Out-Slave-In/I2C Slave Address 0 input
35	MISO/SDA	I/O	SPI Master-In-Slave-Out/I2C Data and Acknowledge
36	SCK/SCL	I/O	SPI Serial Clock/I2C Serial Clock
37	SS/HA2	I	SPI Slave Select/I2C Slave Address 2
38	HREQ	I/O	Host Request
39	PLLA_VDD	–	PLL power supply (3.3V)
40	PLLA_GND	–	PLL ground
41	PLL_P_VDD	–	PLL power supply (3.3V)
42	PLL_P_GND	–	PLL ground
43	PLLD_GND	–	PLL ground
44	PLLD_VDD	–	PLL power supply (1.25V)
45	EXTAL	I	External Clock Input
46	PINIT/NMI	I	PLL Initial/Nonmaskable Interrupt
47	RESET_B	I	Reset
48	MODD/IRQD	I	Mode Select D/External Interrupt Request D
49	MODC/IRQC	I	Mode Select C/External Interrupt Request C
50	MODB/IRQB	I	Mode Select B/External Interrupt Request B
51	MODA/IRQA	I	Mode Select A/External Interrupt Request A
52	CORE_VDD	–	Core power supply (1.25V)
53	CORE_GND	–	Core ground
54	SDO0/PE11	I/O	Serial Data Output 0/Port E11
55	SDO1/PE10	I/O	Serial Data Output 1/Port E10
56	SDO2/SDI3/PE9	I/O	Serial Data Output 2/Serial Data Input 3/Port E9
57	SDO3/SDI2/PE8	I/O	Serial Data Output 3/Serial Data Input 2/Port E8
58	SDO4/SDI1/PE7	I/O	Serial Data Output 4/Serial Data Input 1/Port E7
59	SDO5/SDI0/PE6	I/O	Serial Data Output 5/Serial Data Input 0/Port E6
60	FST/PE4	I/O	Frame Sync for Transmitter/Port E4
61	FSR/PE1	I/O	Frame Sync for Receiver/Port E1
62	SCKT/PE3	I/O	Transmitter Serial Clock/Port E3
63	SCKR/PE0	I/O	Receiver Serial Clock/Port E0
64	IO_VDD	–	I/O power supply (3.3V)
65	IO_GND	–	I/O ground
66	HCKT/PE5	I/O	High Frequency Clock for Transmitter/Port E5
67	HCKR/PE2	I/O	High Frequency Clock for Receiver/Port E2
68	CORE_GND	–	Core ground
69	ADO/PD1	I/O	Digital Audio Data Output/Port D1
70	ACI/PD0	I/O	Audio Clock Input/Port D0
71	CORE_VDD	–	Core power supply (1.25V)
72	HCKR/PC2	I/O	High Frequency Clock for Receiver/Port C2
73	HCKT/PC5	I/O	High Frequency Clock for Transmitter/Port C5
74	IO_GND	–	I/O ground
75	IO_VDD	–	I/O power supply (3.3V)
76	SCKR/PC0	I/O	Receiver Serial Clock/Port C0
77	SCKT/PC3	I/O	Transmitter Serial Clock/Port C3
78	FSR/PC1	I/O	Frame Sync for Receiver/Port C1
79	FST/PC4	I/O	Frame Sync for Transmitter/Port C4
80	SDO5/SDI0/PC6	I/O	Serial Data Output 5/Serial Data Input 0/Port C6

PCM1803DB (MAIN ASSY : IC3003)

A • Single-ended, Analog-input 24-bit, 96-kHz Stereo A/D Converter

● Pin Arrangement (Top view) ● Block Diagram

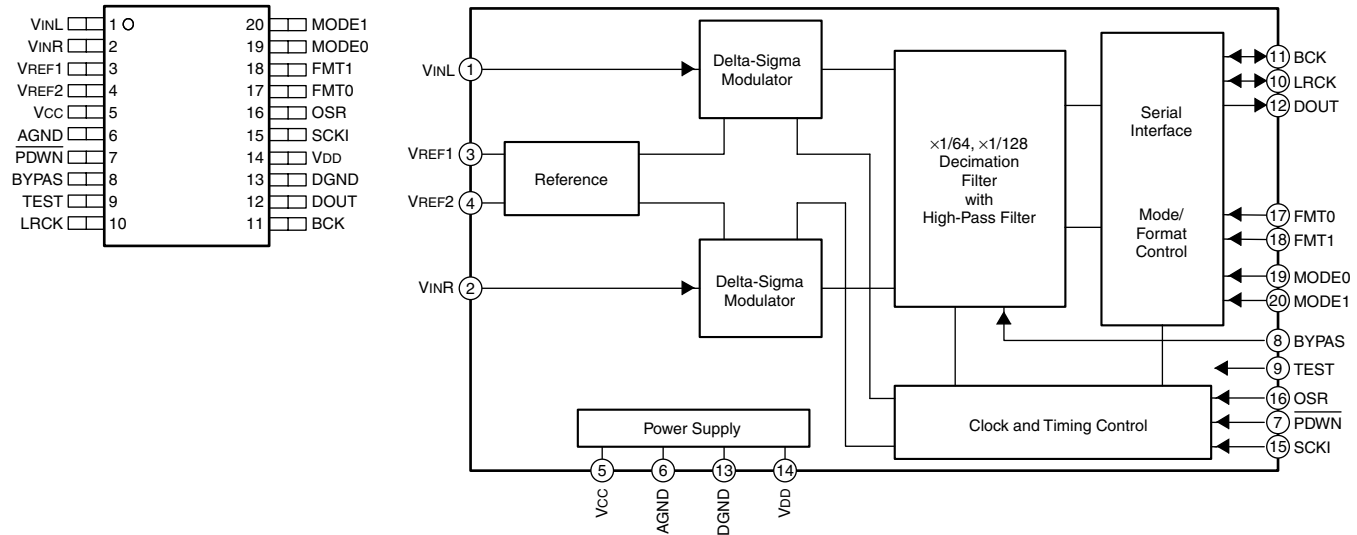

● Pin Function

No.	Pin Name	I/O	Pin Function
1	VINL	I	Analog input, L-channel
2	VINR	I	Analog input, R-channel
3	VREF1	-	Reference-voltage-1 decoupling capacitor
4	VREF2	-	Reference-voltage-2 decoupling capacitor
5	VCC	-	Analog power supply, 5-V
6	AGND	-	Analog GND
7	PDWN	I	Power-down control, active-low (2)
8	BYPAS	I	HPF bypass control. LOW: Normal mode (dc reject); HIGH: Bypass mode (through)(2)
9	TEST	I	Test, must be connected to DGND (2)
10	LRCK	I/O	Audio data latch enable input/output (1)
11	BCK	I/O	Audio data bit clock input/output (1)
12	DOUT	O	Audio data digital output
13	DGND	-	Digital GND
14	VDD	-	Digital power supply, 3.3-V
15	SCKI	I	System clock input: 256 fs, 384 fs, 512 fs or 768 fs (3)
16	OSR	I	Oversampling ratio select input. LOW: $\times 64$ fs, HIGH: $\times 128$ fs (2)
17	FMT0	I	Audio data format select input 0 (2)
18	FMT1	I	Audio data format select input 1 (2)
19	MODE0	I	Mode select input 0 (2)
20	MODE1	I	Mode select input 1 (2)

(1) Schmitt-trigger input

(2) Schmitt-trigger input with internal pulldown (50 kohm typically), 5-V tolerant

(3) Schmitt-trigger input, 5-V tolerant

TAS5508APAG (MAIN ASSY : IC3101)

• 8 Channel Digital Audio PWM Processor

• Pin Arrangement (Top view)

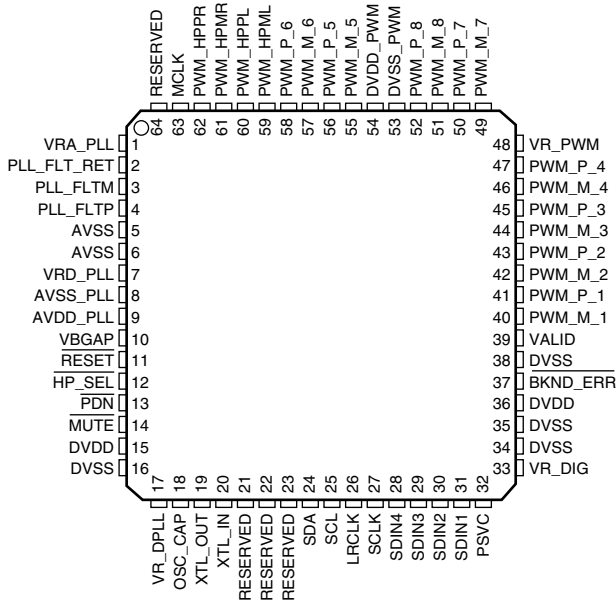

• Block Diagram

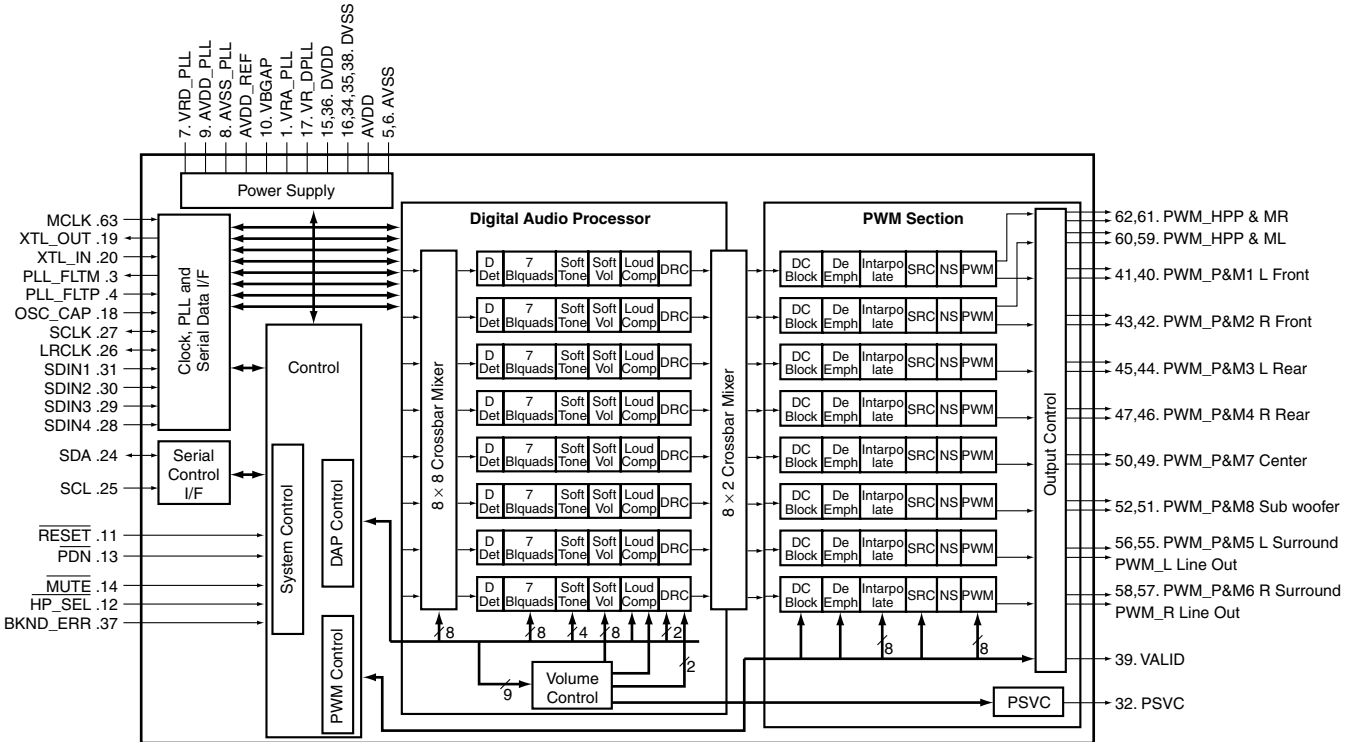

● Pin Function

A

No.	Pin Name	I/O	Pin Function	
1	VRA_PLL	–	Voltage reference for PLL analog supply 1.8V	
2	PLL_FLT_RET	AO	PLL external filter return	
3	PLL_FLTM	AO	PLL negative input	
4	PLL_FLTP	AI	PLL positive input	
5	AVSS	P	Analog ground	
6	AVSS	P	Analog ground	
7	VRD_PLL	P	Voltage reference for PLL digital supply 1.8V	
8	AVSS_PLL	P	Analog ground for PLL	
9	AVDD_PLL	P	3.3V analog power supply for PLL	
B	10	VBGAP	P	Band gap voltage reference
11	$\overline{\text{RESET}}$	DI	System reset input, active low	
12	$\overline{\text{HP_SEL}}$	DI	Headphone input/output selector	
13	PDN	DI	Power down, active low	
14	$\overline{\text{MUTE}}$	DI	Soft mute of outputs, active low	
15	DVDD	P	Digital power supply 3.3V supply for digital core and most of I/O buffers	
16	DVSS	P	Digital ground for digital core and most of I/O buffers	
17	VR_DPLL	P	Voltage reference for digital PLL supply 1.8V	
18	OSC_CAP	AO	Oscillator capacitor	
19	XTL_OUT	AO	XTL_OUT and XTL_IN are the only LVCMOS terminals on the device	
C	20	XTL_IN	AI	XTL_OUT and XTL_IN are the only LVCMOS terminals on the device
21	RESERVED	–	Connect to digital ground	
22	RESERVED	–	Connect to digital ground	
23	RESERVED	–	Connect to digital ground	
24	SDA	DIO	I ² C serial control data interface input/output	
25	SCL	DI	I ² C serial control clock input/output	
26	LRCLK	DI	Serial audio data left/right clock (sampling rate clock)	
27	SCLK	DI	Serial audio data clock (shift clock)	
28	SDIN4	DI	Serial audio data 4 input is one of the serial data input ports	
29	SDIN3	DI	Serial audio data 3 input is one of the serial data input ports	
30	SDIN2	DI	Serial audio data 2 input is one of the serial data input ports	
D	31	SDIN1	DI	Serial audio data 1 input is one of the serial data input ports
32	PSVC	O	Power supply volume control PWM output	
33	VR_DIG	P	Voltage reference for digital core supply 1.8V	
34	DVSS	P	Digital ground	
35	DVSS	P	Digital ground	
36	DVDD	P	3.3V digital power supply	
37	$\overline{\text{BKND_ERR}}$	DI	Active low. A backend error sequence is generated by applying logic low to this terminal	
38	DVSS	P	Digital ground	
39	VALID	DO	Output indicating validity of PWM outputs active high	
E	40	PWM_M_1	DO	PWM 1 output (differential –)
41	PWM_P_1	DO	PWM 1 output (differential +)	
42	PWM_M_2	DO	PWM 2 output (differential –)	
43	PWM_P_2	DO	PWM 2 output (differential +)	
44	PWM_M_3	DO	PWM 3 output (differential –)	
45	PWM_P_3	DO	PWM 3 output (differential +)	
46	PWM_M_4	DO	PWM 4 output (differential –)	
47	PWM_P_4	DO	PWM 4 output (differential +)	
48	VR_PWM	P	Voltage reference for digital PWM core supply 1.8V	
49	PWM_M_7	DO	PWM 7 (Line out L) output (differential –)	
F	50	PWM_P_7	DO	PWM 7 (Line out L) output (differential +)

No.	Pin Name	I/O	Pin Function
51	PWM_M_8	DO	PWM 8 (Line out R) output (differential -)
52	PWM_P_8	DO	PWM 8 (Line out R) output (differential +)
53	DVSS_PWM	P	Digital ground for PWM
54	DVDD_PWM	P	3.3V digital power supply for PWM
55	PWM_M_5	DO	PWM 5 output (differential -)
56	PWM_P_5	DO	PWM 5 output (differential +)
57	PWM_M_6	DO	PWM 6 output (differential -)
58	PWM_P_6	DO	PWM 6 output (differential +)
59	PWM_HPML	DO	PWM left channel headphone (differential -)
60	PWM_HPPL	DO	PWM left channel headphone (differential +)
61	PWM_HPMR	DO	PWM right channel headphone (differential -)
62	PWM_HPPR	DO	PWM right channel headphone (differential +)
63	MCLK	DI	MCLK is a 3.3V clock master clock input
64	RESERVED	-	Connect to digital ground

Note of types : A = analog, D = 3.3V digital, P = power/ground/decoupling, I = input, O = output

TAS5122ADCA (MAIN ASSY : IC3201, IC3301, IC3401)

• 50W Stereo Digital Amplifier

• Pin Arrangement (Top view)

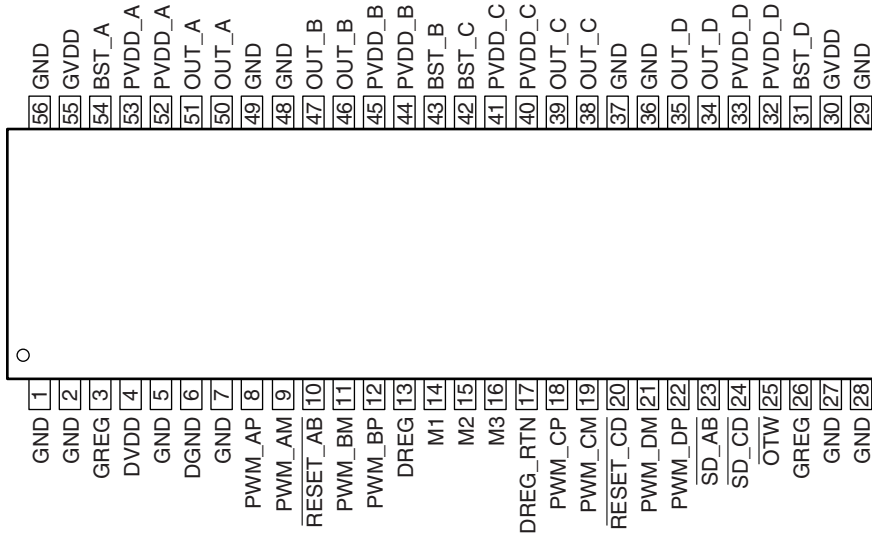

• Block Diagram

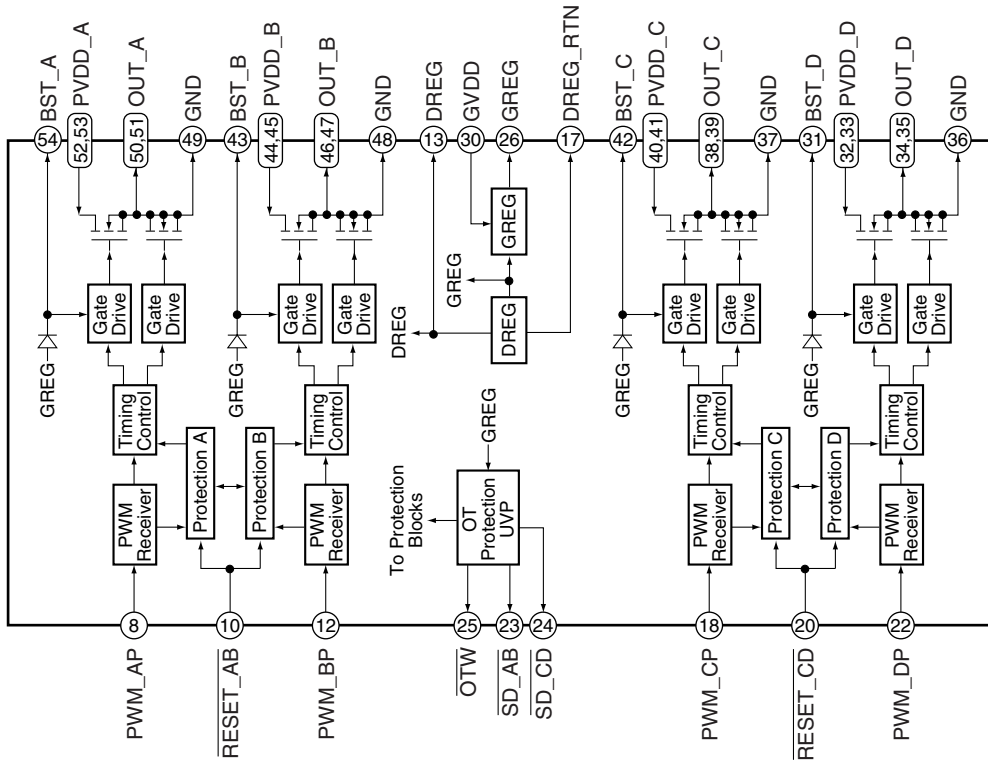

● Pin Function

No.	Pin Name	I/O	Pin Function	No.	Pin Name	I/O	Pin Function
1	GND	–	Power ground	29	GND	–	Power ground
2	GND	–	Power ground	30	GVDD	–	Voltage supply to on-chip gate drive and digital supply voltage regulators
3	GREG	–	Gate drive voltage regulator decoupling pin, capacitor connected to REG_GND	31	BST_D	–	HS bootstrap supply (BST), external capacitor to OUT_D required
4	DVDD	–	I/O reference supply input (3.3V)	32	PVDD_D	–	Power supply input for half-bridge D
5	GND	–	Power ground	33	PVDD_D	–	Power supply input for half-bridge D
6	DGND	–	Digital I/O reference ground	34	OUT_D	O	Output, half-bridge D
7	GND	–	Power ground	35	OUT_D	O	Output, half-bridge D
8	PWM_AP	I	Input signal (positive), half-bridge A	36	GND	–	Power ground
9	PWM_AM	I	Input signal (negative), half-bridge A	37	GND	–	Power ground
10	RESET_AB	I	Reset signal, active low	38	OUT_C	O	Output, half-bridge C
11	PWM_BM	I	Input signal (negative), half-bridge B	39	OUT_C	O	Output, half-bridge C
12	PWM_BP	I	Input signal (positive), half-bridge B	40	PVDD_C	–	Power supply input for half-bridge C
13	DREG	–	Digital supply voltage regulator decoupling pin, capacitor connected to GND	41	PVDD_C	–	Power supply input for half-bridge C
14	M1	I	Mode selection pin	42	BST_C	–	HS bootstrap supply (BST), external capacitor to OUT_C required
15	M2	I	Mode selection pin	43	BST_B	–	HS bootstrap supply (BST), external capacitor to OUT_B required
16	M3	I	Mode selection pin	44	PVDD_B	–	Power supply input for half-bridge B
17	DREG_RTN	–	Digital supply voltage regulator decoupling return pin	45	PVDD_B	–	Power supply input for half-bridge B
18	PWM_CP	I	Input signal (positive), half-bridge C	46	OUT_B	O	Output, half-bridge B
19	PWM_CM	I	Input signal (negative), half-bridge C	47	OUT_B	O	Output, half-bridge B
20	RESET_CD	I	Reset signal, active low	48	GND	–	Power ground
21	PWM_DM	I	Input signal (negative), half-bridge D	49	GND	–	Power ground
22	PWM_DP	I	Input signal (positive), half-bridge D	50	OUT_A	O	Output, half-bridge A
23	SD_AB	O	Shutdown signal for half-bridges A and B, active-low	51	OUT_A	O	Output, half-bridge A
24	SD_CD	O	Shutdown signal for half-bridges C and D, active-low	52	PVDD_A	–	Power supply input for half-bridge A
25	OTW	O	Overtemperature warning output, open drain with internal pullup resistor	53	PVDD_A	–	Power supply input for half-bridge A
26	GREG	O	Gate drive voltage regulator decoupling pin, capacitor connected to REG_GND	54	BST_A	–	HS bootstrap supply (BST), external capacitor to OUT_A required
27	GND	–	Power ground	55	GVDD	I	Voltage supply to on-chip gate drive and digital supply voltage regulators
28	GND	–	Power ground	56	GND	–	Power ground

■ PDC128A (MAIN ASSY : IC5501)

- System Control Microcomputer

● Pin Function

No.	Mark	Pin Name	I/O	Pin Function
1	PA3/WR#		O	
2	PA4/RD#		O	
3	PA5/RS		O	
4	P70 / INT0 / T0LCP / AN8	PDNDET	I	Powerdown Detection
5	P71 / INT1 / T0HCP / AN9	P_ON	I	REMOCON 2 (Power On)
6	P72 / INT2 / T0IN	RDSCLK	I (O)	Clock input from RDS decoder (Interruption 2, without RDS : Low output)
7	P73 / INT3 / T0IN	REMOCON	I	REMOCON signal input (Interruption 3)
8	RES#	XRESET	I	Microcomputer reset input
9	XT1 / AN10	XT1	-	Subclock (connect to VDD when no use)
10	XT2 / AN11	XT2	-	Subclock (leave open when no use, and set the bit 6 of OCR SFR)
11	VSS1	VSS1	-	Ground
12	CF1	CF1	-	Main Clock (connect to VDD when no use)
13	CF2	CF2	-	Main Clock (leave open when no use)
14	VDD1	VDD1	-	Power supply
15	P80 / AN0	SIMUKE	I	Destination distinction input
16	P81 / AN1	MODEL	I	Model distinction input
17	P82 / AN2		O	
18	P83 / AN3		O	
19	P84 / AN4	KEY2	I	Key2 input
20	P85 / AN5		O	
21	P86 / AN6	PCONFIG	I	POWER CONFIG INPUT
22	P87 / AN7	XPROTECT	I	Protection and Fan Error detection input
23	P10/SO0	DSPDI	O	Data output to DSP (MOTOROLA) and DIR
24	P11 / SI0 / SB0	DSPDO	I	Data input from DSP (MOTOROLA)
25	P12 / SCK0	DSPCK	O	Clock output to DSP (MOTOROLA) and DIR
26	P13 / SO1		O	
27	P14 / SI1 / SB1	DASDA	I (O)	I2C data for D-AMP
28	P15 / SCK1	DASCK	O	I2C clock for D-AMP
29	P16/T1PWML		O	
30	P17/T1PVMH/BUZ		O	
31	PE0		O	
32	PE1		O	
33	PE2	ADMD	O	Control of DSPMUTE combining DIRERR., "H" at digital mode, "L" at analog mode.
34	PE3		O	
35	PE4	XDSPMUTE	O	MUTE request to DSP MODULE
36	PE5	(LED)	O	Control for subwoofer mix
37	PE6	XDEC MUTE	I	Detection of 1stDSP boot success from DSP MODULE
38	PE7	DSPHREQ	I	Error detection from DSP(MOTOROLA)
39	VSS4	VSS4	-	Ground
40	VDD4	VDD4	-	Power supply

No.	Mark	Pin Name	I/O	Pin Function
41	PF0		O	
42	PF1		O	
43	PF2	STEST	I	Set TESTMODE for Service
44	PF3	UTEST	I	Set UNITCHECK for checker
45	PF4	XDSPSS	O	Slave selection to DSP(MOTOROLA)
46	PF5	XDSPRST	O	RESET to DSP(MOTOROLA) MODULE
47	PF6		O	
48	PF7		O	
49	SI2P0/SO2	FLDAT	O	Data for FL driver (serial data input)
50	SI2P1/SI2/SB2	XFLCS	O	Chip enable for FL driver
51	SI2P2/SCK2	FLCLK	O	Clock for FL driver
52	SI2P3/SCK20	TXCE	O	Chip enable for tuner LSI
53	PWM1		O	
54	PWM0		O	
55	VDD2	VDD2	-	Power supply
56	VSS2	VSS2	-	Ground
57	P00	EEP_CS	O	EEPROM CHIP SELECT
58	P01	EEP_DO	O	EEPROM DATA OUT
59	P02		O	
60	P03	EEP_SK	O	EEPROM CLOCK
61	P04	TXCLK	O	Clock for tuner LSI
62	P05	TXODATA	O	Data for tuner LSI
63	P06		O	
64	P07	RDSP0W	O	Control power supply of RDS (L: POWER ON)
65	P20/INT4/T1IN	RDSDATA	I (O)	Input RDS data
66	P21/INT4/T1IN	TXIDATA	I	Input data from tuner LSI
67	P22/INT4/T1IN	DIRERR	I	LOCK/UNLOCK from DIR
68	P23/INT4/T1IN	EEP_DI	I	EEPROM DATA IN
69	P24/INT5/T1IN	KEY1	I	Key1 input (PowerOn/Standby key only)
70	P25/INT5/T1IN	XDARST	O	RESET for D-AMP
71	P26/INT5/T1IN	XDAPDN	O	POWER DOWN for D-AMP
72	P27/INT5/T1IN	XDAMUTE	O	D-AMP MUTE
73	P30	(PSVC)	O	Power Supply Voltage Control
74	P31	DIGSEL	O	DIGITAL INPUT SELECT
75	P32	INPUTSELA	O	AUDIO INPUT SELECT
76	P33	XADPDN	O	POWER DOWN for A/D
77	P34	SHUTDWN	I	D-AMP SHUTDOWN detection
78	P35	(DCDET)	I	D-AMP DC detection
79	P36	XOTW	I	D-AMP Over Temperature Warning
80	PB7/D7	(FREQCONT1)	O	Frequency control1 for SMPS

A

No.	Mark	Pin Name	I/O	Pin Function	
81	PB6/D6	(FREQCONT2)	O	Frequency control2 for SMPS	
82	PB5/D5	(PWRERR)	I	POWER Error input from SMPS	
83	PB4/D4	(PWRCONT1)	O	Power control for SMPS	
84	PB3/D3	PWRCONT2	O	Power control for Sub SMPS	
85	PB2/D2	FLCONT	O	FL Power	
86	PB1/D1	BEATCUT1	O	BEATCUT Control 1	
87	PB0/D0	BEATCUT2	O	BEATCUT Control 2	
88	VSS3	VSS3	-	Ground	
89	VDD3	VDD3	-	Power supply	
B	90	PC7/A7	FLASHE/D	I	for FLASH writing / On board debugger
91	PC6/A6	FLASHDO	O	for FLASH writing / On board debugger	
92	PC5/A5	FLASHCLK	O	for FLASH writing / On board debugger	
93	PC4/A4	(SWMIX)	O	Control for subwoofer mix	
94	PC3/A3	TXPOWER	O	Control power supply of Tuner etc.	
95	PC2/A2	(DMUTECHECK)	O	D-AMP SOFT MUTE MONITOR	
96	PC1/A1	FANCONT	O	Control fan speed	
97	PC0/A0	(DTSMIX)	O	Control for dts mix	
98	PA0/CS2#	XDIRRST	O	Reset to DIR /CODEC	
99	PA1/CS1#	XDIRCS	O	Chip select to DIR/CODEC	
C	100	PA2/CS0#	DIRDO	I	Data input from DIR/CODEC

- Port0 (P00-P07) can be selected for input or output by each 4 bits (P00-P03,P04-P07). Set for input when reset. And it can be set C-MOS or Nch-OD by each 1 bit in option.
- Port1 (P10-P17) can be selected for input or output by each 1 bit. Set for input when reset. And it can be set C-MOS or Nch-OD by each 1bit in option.
- Port2 (P20-P27) can be selected for input or output by each 1 bit. Set for input when reset. And it can be set C-MOS or Nch-OD by each 1 bit in option.
- Port3 (P30-P36) can be selected for input or output by each 1 bit. Set for input when reset. And it can be set C-MOS or Nch-OD by each 1 bit in option.
- Port7 (P70-P73) can be selected for input or output by each 1 bit. Set for input when reset.
- Port8 (P80-P87) can be selected for input or output by each 1 bit. Set for input when reset.
- PortA (PA0-PA5) can be selected for input or output by each 1 bit. Set for input when reset. And it can be set C-MOS or Nch-OD by each 1 bit in option.
- PortB (PB0-PB7) can be selected for input or output by each 1 bit. Set for input when reset. And it can be set C-MOS or Nch-OD by each 1 bit in option.
- PortC (PC0-PC7) can be selected for input or output by each 1 bit. Set for input when reset. And it can be set C-MOS or Nch-OD by each 1 bit in option.
- PortE and PortF can be selected for input or output by each 2 bits.
- In case of without RDS, it is best that RDSDATA and RDSCLK are assigned as I/O port which can be set output and output low level.

E

F

■ BR93L46RFJ-W (MAIN ASSY : IC5503)

- 64 × 16 bit EEPROM

● Pin Arrangement (Top view)

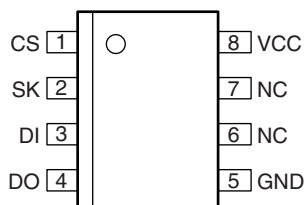

● Block Diagram

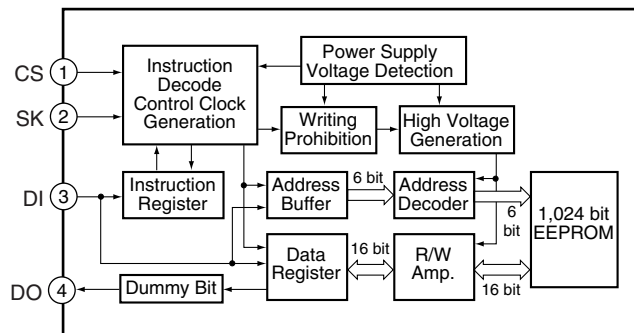

● Pin Function

No.	Pin Name	I/O	Pin Function
1	CS	I	Chip select input
2	SK	I	Serial clock input
3	DI	I	Start bit, OP code, address and serial data inputs
4	DO	O	Serial data output and READY/BUSY internal state display output
5	GND	-	Ground
6	NC	-	Non connection
7	NC	-	Non connection
8	VCC	-	Power supply

BU1924FS (MAIN ASSY : IC5701)(SX-SW77 and SX-SW55 only)

A • RDS Demodulator

● Pin Arrangement

● Block Diagram

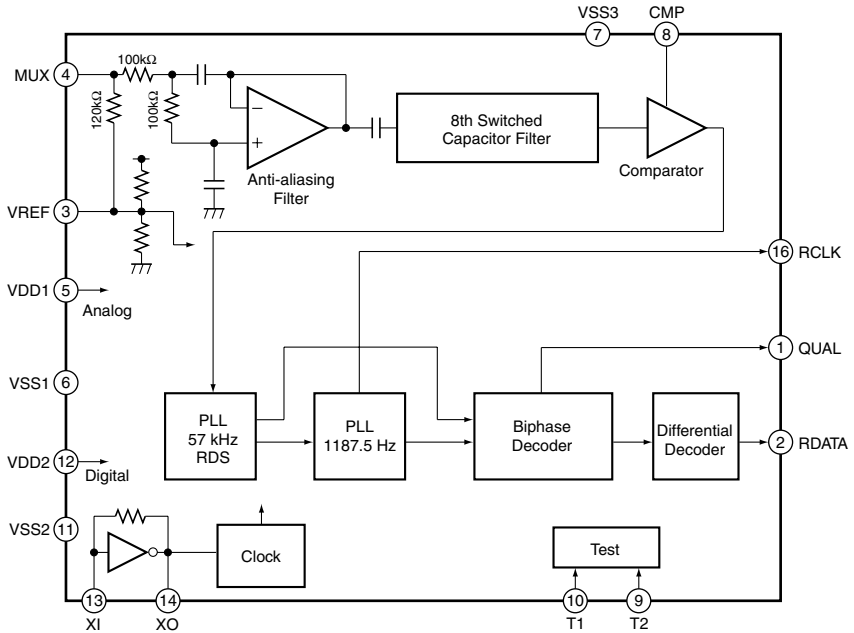
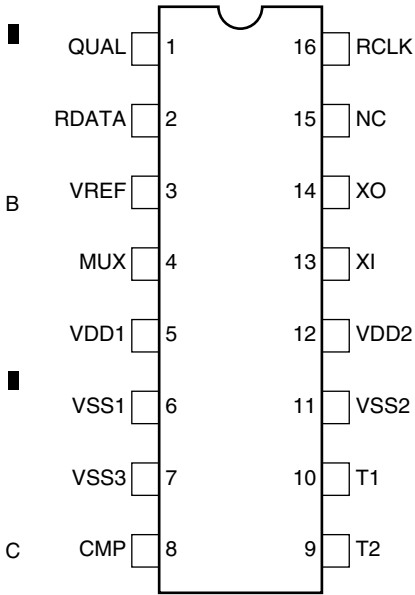

● Pin Function

No.	Pin Name	Pin Function
1	QUAL	Output signal quality
2	RDATA	Data
3	VREF	Reference
4	MUX	Composite signal input
5	VDD1	Analog power supply
6	VSS1	
7	VSS3	
8	CMP	Comparator
9	T2	Test input
10	T1	
11	VSS2	Digital power supply
12	VDD2	
13	XI	Crystal OSC
14	XO	
15	NC	Non connection
16	RCLK	Clock

PT6315 (FL ASSY : IC5901)

• FL Driver IC

• Pin Arrangement

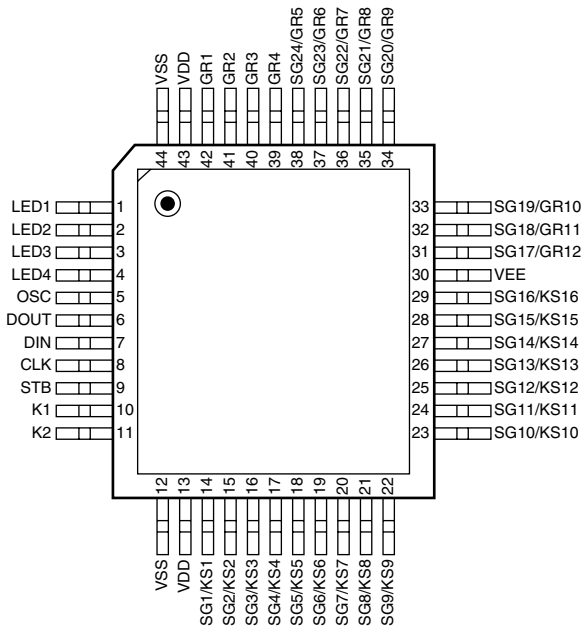

• Block Diagram

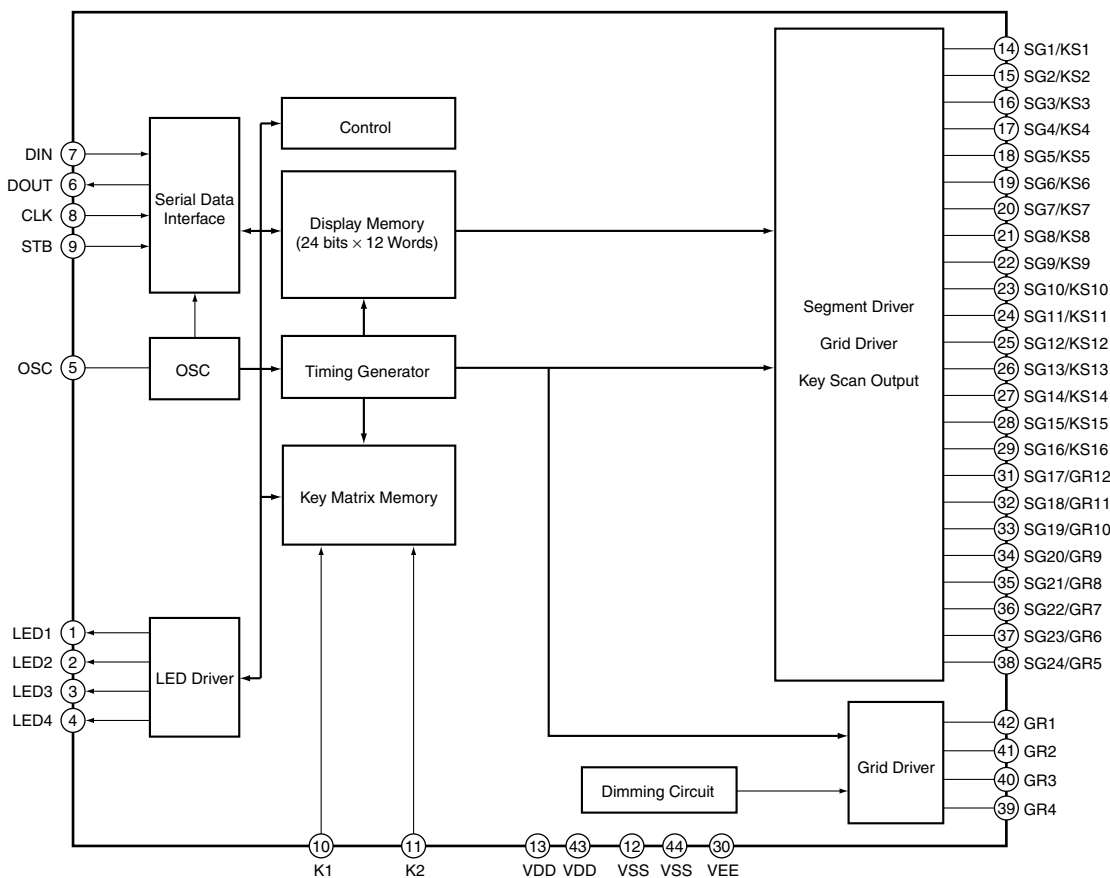

● Pin Function

A

No.	Pin Name	I/O	Pin Function	
1	LED1	O	LED output pin	
2	LED2			
3	LED3			
4	LED4			
5	OSC	I	Oscillator input pin	
6	DOUT	O	Data output pin	
7	DIN	I	Data input pin	
8	CLK	I	Clock input pin	
9	STB	I	Serial interface strobe pin	
B	10	I	Key data input pin	
	11			K2
	12	-	Logic ground pin	
	13	-	Logic power supply	
	14	O	High-voltage segment output pin	
	15			SG2/KS2
	16			SG3/KS3
	17			SG4/KS4
	18			SG5/KS5
	19			SG6/KS6
C	20			SG7/KS7
	21			SG8/KS8
	22			SG9/KS9
	23			SG10/KS10
	24			SG11/KS11
	25			SG12/KS12
	26			SG13/KS13
	27			SG14/KS14
	28	SG15/KS15		
	29	SG16/KS16		
D	30	-	Pull-down level	
	31	O	High-voltage segment / Grid output pin	
	32			SG17/GR12
	33			SG18/GR11
	34			SG19/GR10
	35			SG20/GR9
	36			SG21/GR8
	37			SG22/GR7
	38			SG23/GR6
	39	O	High-voltage grid output pin	
E	40			GR4
	41			GR3
	42			GR2
	43	-	Logic power supply	
	44	-	Logic ground pin	

F

8. PANEL FACILITIES

Display unit

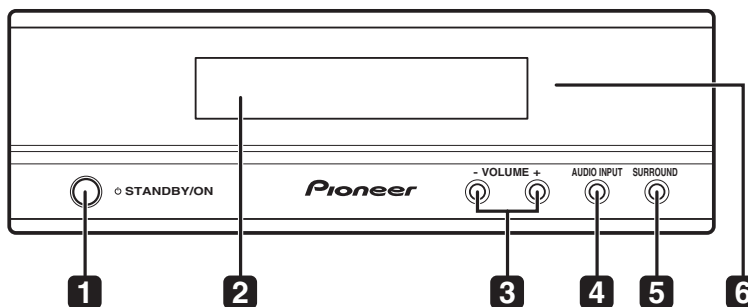

1 **STANDBY/ON**
Press to switch the system on/into standby.

2 **Front panel display**
See below for details.

3 **VOLUME buttons**
Use to adjust the volume.

4 **AUDIO INPUT**
Press repeatedly to select one of the external audio inputs.
(DVD/DVR1, DVD/DVR2, DIGITAL or ANALOG)
Except North America
(DVD,DTV, PC/GAME or AUX)
North America only

5 **SURROUND**
Use to select a Surround mode

6 **IR remote sensor**

Display

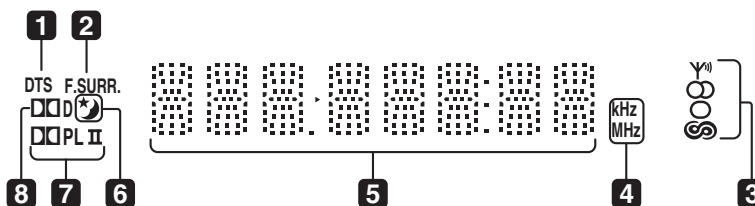

1 **DTS**
Lights during playback of a DTS source

2 **F.SURR.**
Lights when the Front Surround listening mode is selected.

3 **Tuner indicators**
 Y^{FM} – Lights when a broadcast is being received.
 ∞ – Lights when a stereo FM broadcast is being received in auto stereo mode.
 ○ – Lights when FM mono reception is selected.
 Ⓢ – Lights when in one of the RDS display or search modes.

4 **kHz / MHz**
Indicates the frequency unit shown in the character display (kHz for AM, MHz for FM).

5 **Character display**

6 **Sleep timer indicator**
Lights when sleep timer is active

7 **PL II**
Lights during Dolby Pro Logic II decoding

8 **D**
Lights during playback of a Dolby Digital source

Rear Panel (Receiver subwoofer)

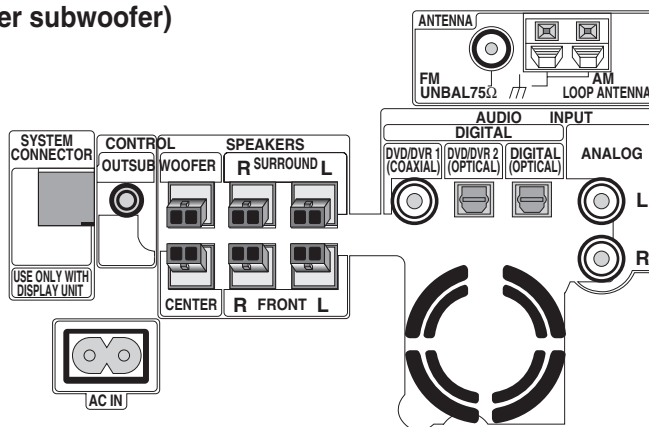

Remote control (SX-SW77)

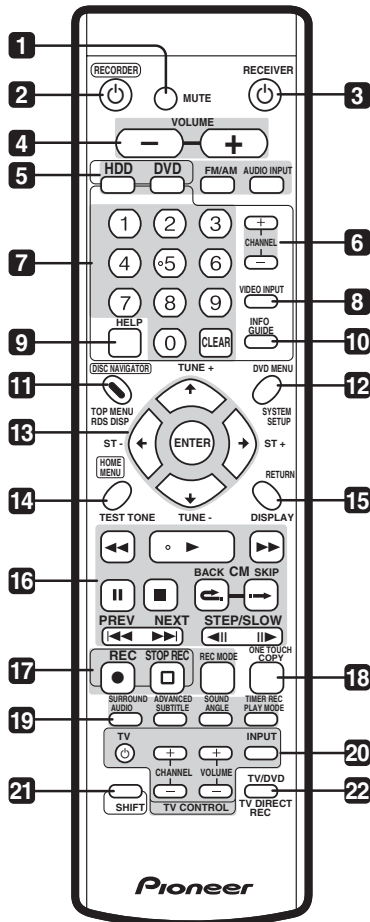

Important

- Functions printed in green on the remote control are accessed by pressing the button indicated while holding down the **SHIFT** button.

1 MUTE

Press to mute all audio from the speakers. Press again to cancel and restore the sound.

2 RECORDER

Press to switch the recorder on or into standby.

3 RECEIVER

Press to switch the receiver on or into standby.

4 VOLUME +/-

Use to adjust the volume.

5 Function select buttons

HDD

Press to select the hard disk (HDD) for recording or playback. The receiver subwoofer's audio input is also switched to **DVD/DVR2.1**

DVD

Press to select the DVD for recording or playback. The receiver subwoofer's audio input is also switched to **DVD/DVR2.1**

FM/AM

Press to select the built-in radio tuner.

AUDIO INPUT

Press repeatedly to select one of the receiver subwoofer's audio inputs (**DVD/DVR1**, **DVD/DVR2**, **DIGITAL** or **ANALOG**).

6 CHANNEL +/-

Press to change the channel of the built-in TV tuner.

7 Numeric buttons and CLEAR

Use the number buttons for track/chapter/title selection; channel selection, and so on.

Use **CLEAR** to clear an entry and start again.

8 VIDEO INPUT

Press to change the DVD recorder input for recording and playback.

9 HELP

Press for help on how to use the current GUI screen

10 GUIDE Plus+™ system controls

GUIDE

Press to display the GUIDE Plus+™ screen; press again to exit.

+ SHIFT: INFO

Press to see additional information for the highlighted item in GUIDE Plus+™.

11 DISC NAVIGATOR / TOP MENU

Press to display the Disc Navigator screen, or the top menu if a DVD-Video disc is loaded.

+ SHIFT: RDS DISP

Changes RDS displays

12 DVD MENU

Press to display the disc menu if a DVD-Video disc is loaded.

When in the GUIDE Plus+™ system, use to jump directly to the Menu bar.

+ SHIFT: SYSTEM SETUP

Use to access the menu system for surround sound setup, tuner settings and so on.

13 ↑/↓/←/→ (cursor buttons) and ENTER

Use to navigate all DVD recorder on-screen displays. Press **ENTER** to select the currently highlighted option.

Use together with the **SHIFT** button to navigate the receiver subwoofer menus.

14 HOME MENU

Press to display the Home Menu, from which you can navigate many the functions of the system.

+ SHIFT: TEST TONE

Use to output the test tone (for speaker setup)

15 RETURN

Press to go back one level in the on-screen menu or display.

+ SHIFT: DISPLAY

Displays/changes the on-screen information displays.

16 Playback controls



Press to start reverse or forward scanning. Press again to change the speed.



Press to start playback.



Press to pause playback or recording.



Press to stop playback.

CM BACK (commercial back)

Press repeatedly to skip progressively backward through the audio or video playing.

CM SKIP (commercial skip)

Press repeatedly to skip progressively forward through the audio or video playing.



Press to skip to the previous or next title/chapter/track/folder; or to display the previous or next menu page.

When GUIDE Plus+™ is displayed, use to display the previous/next page.



During playback, press to start slow-motion playback; while paused, press to show the previous or next video frame.

When GUIDE Plus+™ is displayed, use to display the previous/next day.

17 Recording controls

● REC

Press to start recording. Press repeatedly to set the recording time in blocks of 30 mins.

□ STOP REC

Press to stop recording.

REC MODE

Press repeatedly to change the recording mode (picture quality).

18 ONE TOUCH COPY

Press to start One Touch Copy of the currently playing title to DVD or the HDD.

19 GUIDE Plus+™ Action buttons, DVD playback functions and surround sound mode/sound enhancement buttons

When in the GUIDE Plus+™ system, these buttons act as the Red, Green, Yellow and Blue Action buttons (the functions of these buttons change according to the GUIDE Plus+™ Area).

AUDIO

Changes the audio language or channel. (When no disc is playing or recording, press to change the tuner audio.)

+ SHIFT: SURROUND

Use to select a Surround mode

SUBTITLE

Displays/changes the subtitles included in multilingual DVD-Video discs.

+ SHIFT: ADVANCED

Use to select an Advanced Surround mode.

ANGLE

Switches camera angles on discs with multi-angle scenes.

+ SHIFT: SOUND

Press to access the sound menu, from which you can adjust bass and treble, etc.

PLAY MODE

Press to display the Play Mode menu (for features such as search, repeat and program play).

+ SHIFT: TIMER REC

Press to set a timer recording from the GUIDE Plus+™ system.

20 TV CONTROL

After setting up, use these controls to control your TV.

21 SHIFT

Press to access functions on the remote printed in green.

22 TV DIRECT REC

Press to start recording whatever channel your TV is set to.

+ SHIFT: TV/DVD

Press to switch between 'TV mode', in which you get the picture and sound from the TV's tuner, and 'DVD mode', in which you get picture and sound from the system's tuner (or an external input).

Remote control (SX-SW950)

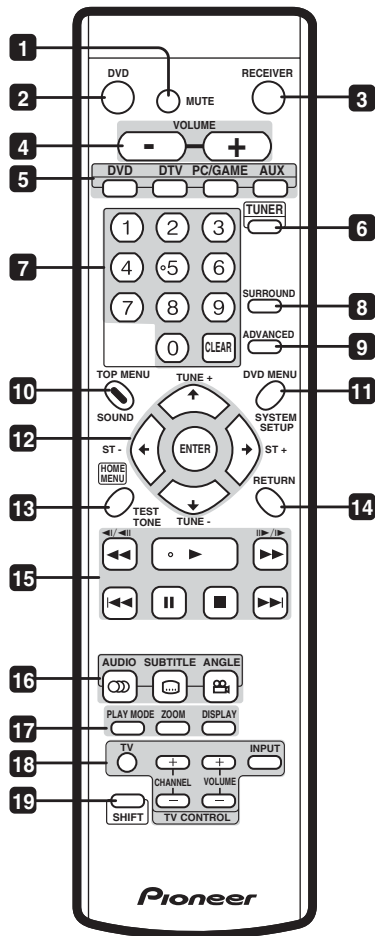

Important

- Functions printed in green on the remote control are accessed by pressing the button indicated while holding down the **SHIFT** button.

1 MUTE

Press to mute all audio from the speakers. Press again to cancel and restore the sound.

2 DVD

Press to switch the DVD player on or into standby.

3 RECEIVER

Press to switch the receiver on or into standby.

4 VOLUME +/-

Use to adjust the volume.

5 Function select buttons

DVD

Press to select the DVD input.

DTV

Press to select the DTV input.

PC/GAME

Press to select the PC/game console (**PC/GAME**) input.

AUX

Press to select the auxiliary (**AUX**) input.

6 TUNER

Press to select the built-in radio tuner.

7 Numeric buttons and CLEAR

Use the number buttons for track/chapter/title selection, and so on.

Use **CLEAR** to clear an entry and start again.

8 SURROUND

Use to select a Surround mode

9 ADVANCED

Use to select an Advanced Surround mode

10 TOP MENU

Press to display the top menu if a DVD-Video disc is loaded.

+ SHIFT: SOUND

Press to access the sound menu, from which you can adjust bass and treble, etc.

11 DVD MENU

Press to display the disc menu if a DVD-Video disc is loaded.

+ SHIFT: SYSTEM SETUP

Use to access the menu system for surround sound setup, tuner settings and so on.

12 ↑/↓/←/→ (cursor buttons) and ENTER

Use to navigate all DVD player on-screen displays. Press **ENTER** to select the currently highlighted option.

Use together with the **SHIFT** button to navigate the receiver subwoofer menus.

13 HOME MENU

Press to display the Home Menu, from which you can navigate many the functions of the system.

+ SHIFT: TEST TONE

Use to output the test tone (for speaker setup)

14 RETURN

Press to go back one level in the on-screen menu or display.

15 Playback controls



Press to start reverse or forward scanning. Press again to change the speed.



Press to skip to the previous or next title/chapter/track/folder; or to display the previous or next menu page.



Press to start playback.



Press to pause playback.



Press to stop playback.

16 AUDIO

Changes the audio language or channel.

SUBTITLE

Displays/changes the subtitles included in multilingual DVD-Video discs.

ANGLE

Switches camera angles on discs with multi-angle scenes.

17 PLAY MODE

Press to display the Play Mode menu (for features such as search, repeat and program play).

ZOOM

Press to change the zoom level.

DISPLAY

Press to display/change the current disc information.

18 TV CONTROL

After setting up, use these controls to control your TV.

19 SHIFT

Press to access functions on the remote printed in green.

A

B

C

D

E

F

■ Jigs list

A

Name	Jig No.	Remarks
Speaker Cable with terminal	SDS1174 (FL/WHITE) SDS1175 (FR/RED), SDS1176 (SL/BLUE) SDS1177 (SR/GRAY), SDS1178 (C/GREEN)	For checking audio at the SP terminal

B

■ CLEANING



Before shipping out the product, be sure to clean the following positions by using the prescribed cleaning tools:

■

Position to be cleaned	Cleaning tools
Fans	Cleaning paper : GED-008

C

D

E

F