

---

# NEW REEL BASE KIT REPLACEMENT MANUAL

---

## OPEN REELTAPE DECK

---

<b>T-6600</b>	<b>QT-6600</b>	<b>T-500</b>
<b>T-6100</b>	<b>QT-6100</b>	<b>T-600</b>

---

## Replacement Manual for New Reel Base Kit RXX-081-0

Erratic reel and brake mechanisms of tape decks are usually indicated by one or more of the following symptoms:

- Mechanical noises induced around the reel base area
- Faulty FAST FORWARD mode – causing tape to stop or slow down
- Tape slackening during FAST FORWARD-STOP switching or during PLAY-STOP switching

These defect symptoms are eliminated following a replacement of your old reel and brake mechanisms with the new Reel Base Kit RXX-081-0.

Designed for full compatibility with tape deck Models T-500, T-600, T-6600, QT-6100 and QT-6600, the New Reel Base Kit RXX-081-0 is factory-aged for five hours and thoroughly tested for utmost precision prior to delivery.

As applied to the different tape deck models, the New Reel Base Kit RXX-081-0 has a sequence which is as follows:

Model	Serial No.	Reference No.
T-6100	15001 and after	V → Q
T-6600	21101 and after	V → Q
QT-6100	13251 and after	V → Q
QT-6600	14651 and after	V → Q

For the correct procedures of replacement and adjustment using the Reel Base Kit RXX-081-0, carefully follow the steps given in this manual.

# DISMANTLING OLD REEL BASE AND BRAKE MECHANISMS

## Preparatory Steps

Observe the following steps corresponding to the different models prior to dismantling the old reel base and brake mechanisms.

**Caution:** Do not unsolder the wire leads of both the printed circuit board unit and power transformer.

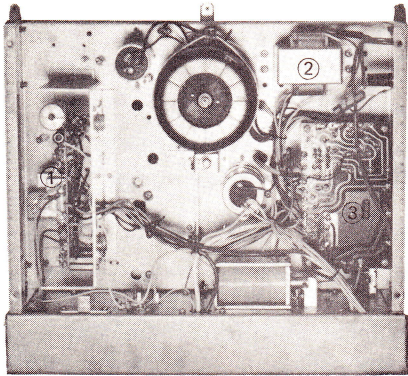

Photo (1)

### For T-500

As shown in the opposite photo (1), remove the following:

- ① Oscillator unit
- ② Power transformer
- ③ Power supply unit

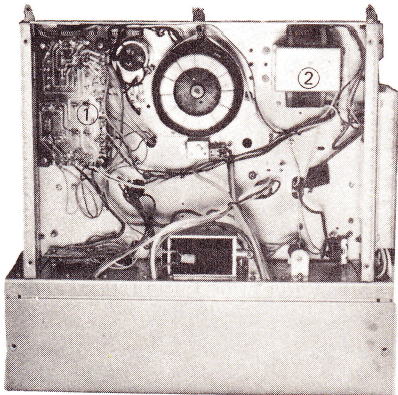

Photo (2)

### For T-600

As shown in the opposite photo (2), remove the following:

- ① Power supply unit
- ② Power transformer

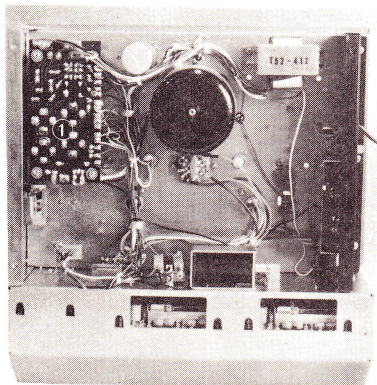

Photo (3)

### For T-6100 and T-6600

As shown in the opposite photo (3), remove the power supply unit:

- ① Power supply unit  
(Photo: T-6600)

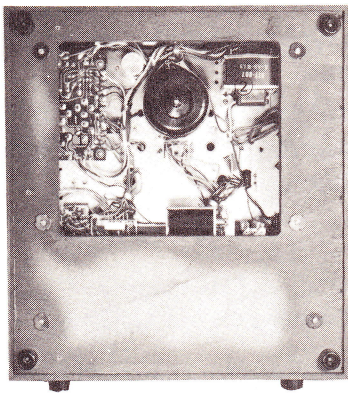

Photo (4)

## For QT-6100 and QT-6600

As shown in the opposite photo (4), remove the following:

- ① Power supply unit
- ② Power transformer

(Photo: QT-6600)

## Dismantling Procedure

The following steps for dismantling must be observed. Each step corresponds to a number in the illustration (Fig. 1).

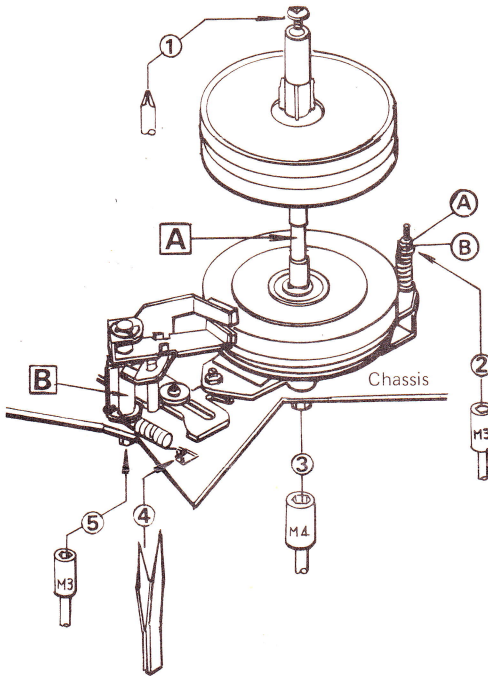

(Fig. 1)

- ① Release the top screw using a plus type screwdriver (Phillips type).
- ② Remove M3 nut (A) and M3 spring washer (B).  
Note: Keep the M3 nut and M3 spring washer which will be needed in assembling the new reel base.
- ③ Holding the shaft (section A) with long nose pliers, remove M4 nut and spring washer in order to release the reel base shaft from the chassis.
- ④ Unhook and remove the coil spring.
- ⑤ Holding the brake pole (section B) with long nose pliers, remove M3 nut and M3 spring washer from the brake arm shaft.

The steps above are employed in removing both right and left reel bases and likewise in removing the brake assembly from chassis.

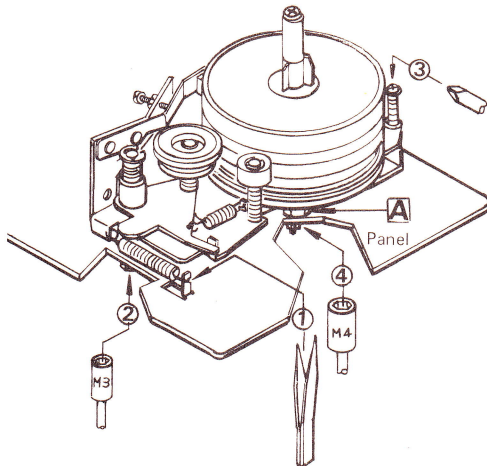

(Fig. 2)

## DISMANTLING NEW REEL BASE

Prior to mounting, the following operations must be done on the new reel base. Each step corresponds to a number in the illustration below (Fig. 2).

- ① Unhook and remove the coil spring.
- ② Remove M3 nut and M3 spring washer securing the brake arm shaft. Remove grease from nylon washer on the reel base mounting panel.

- ③ Using a plus type screwdriver, remove the mounting screw.
- ④ Holding part **A** (see illustration) with long nose pliers, remove M4 nut and M4 spring washer from the panel rear.

**Note:** Keep the M4 nut and M4 spring washer which will be needed in mounting the new reel base.

Repeat the steps above for removing both right and left reel bases of the kit.

### MOUNTING NEW REEL BASE AND BRAKE MECHANISM

For mounting the new reel base, follow the procedure below. Each step corresponds to a number in the illustration (Fig. 3).

- ① Using the M4 nut and M4 spring washer (previously removed from the panel in step ④ of Fig. 2), mount the new reel base onto the chassis.
- ② Replace the M3 nut and M3 spring washer (previously removed in step ② of Fig. 1), carefully holding section **A** at 14 mm (35/64 in) as shown in Fig. 3.
- ③ Using the M3 nut and M3 spring washer (previously removed in step ② of Fig. 2), mount the brake arm shaft.
- ④ Hook the coil spring.

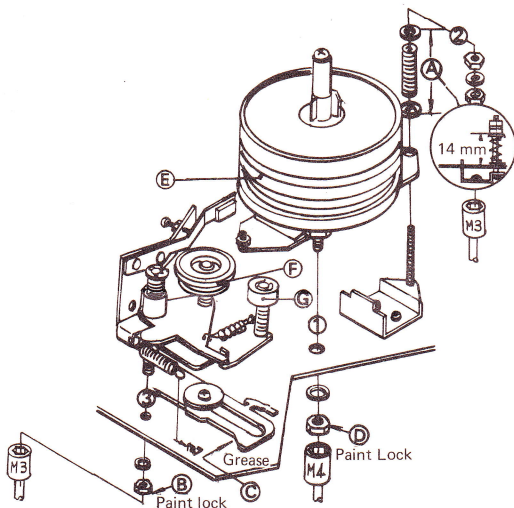

(Fig. 3)

Repeat the steps mentioned above for mounting both right and left reel bases. After mounting of both reels and brakes is completed, proceed with the following steps. The capitalized letters correspond to sections in the illustration (Fig. 3).

- Paint lock nuts **B** and **D**.
- Sparingly apply grease to slide **C**.
- Using a piece of cotton dipped in alcohol, clean outer surfaces of the new reel base assembly **E**, the back tension pulley **F** and the brake roller **G**.
- Replace removed parts in position as shown in the previous photos (1 to 4).

## ADDITIONAL OPERATIONS

These additional steps are required for models T-500 and T-600 only.

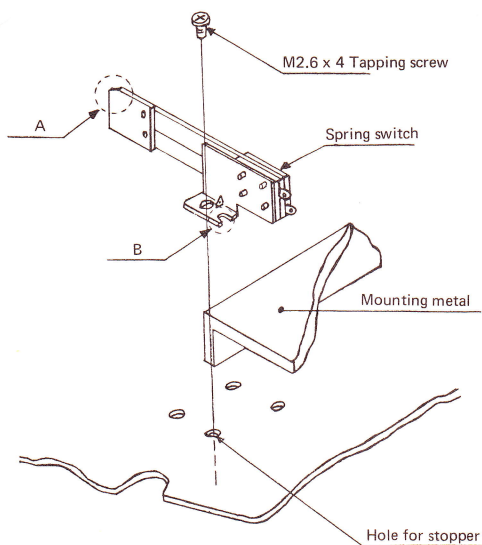

(Fig. 4)

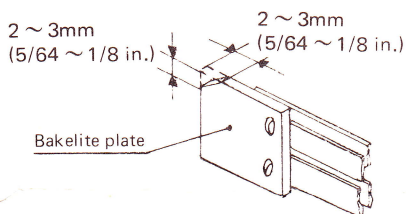

(Fig. 4A)

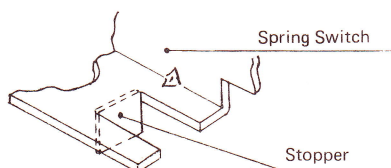

(Fig. 4B)

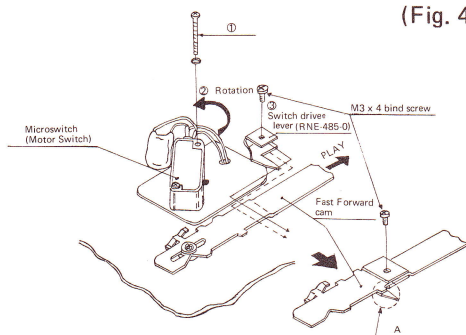

(Fig. 5)

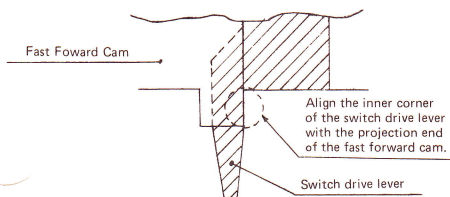

(Fig. 5A)

### Model T-500

There are two spring switches located near the left reel base as seen from the front. Remove the leftmost one from the chassis as shown in Fig. 4.

### Model T-600

One spring switch is provided close to the left reel base as seen from the front. Remove this switch as shown in Fig. 4.

### Models T-500 and T-600

Cut section A of bakelite plate as shown in the illustration (Fig. 4A); otherwise it will rub with the brake arm thereby causing faulty operation.

Cut section B of switch stopper as shown in the illustration (Fig. 4B).

Now replace spring switches in position.

### Model T-500 and T-600

- ① Remove mounting screw from terminal side of microswitch.
- ② Shift the microswitch towards the direction indicated by the arrow.
- ③ Set the control lever to PLAY position then mount the switch drive lever (provided) on the fast forward cam as illustrated in Fig. 5.

As shown in Fig. 5A at left, position the switch drive cam before securing it with mounting screws.

Slide back and secure the lever the microswitch to its initial position.

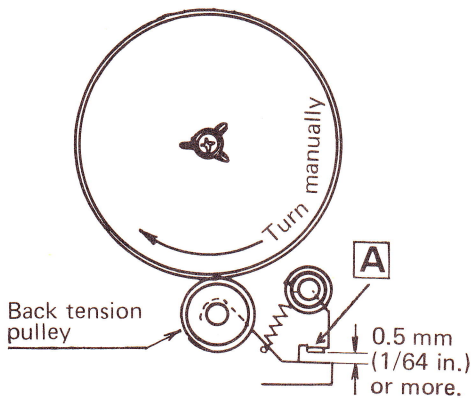
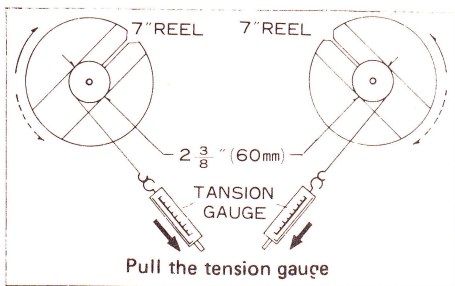

(Fig. 6)

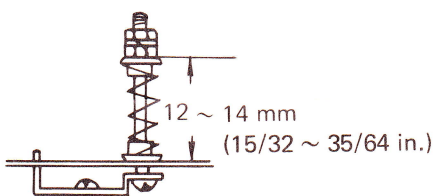

(Fig. 7)

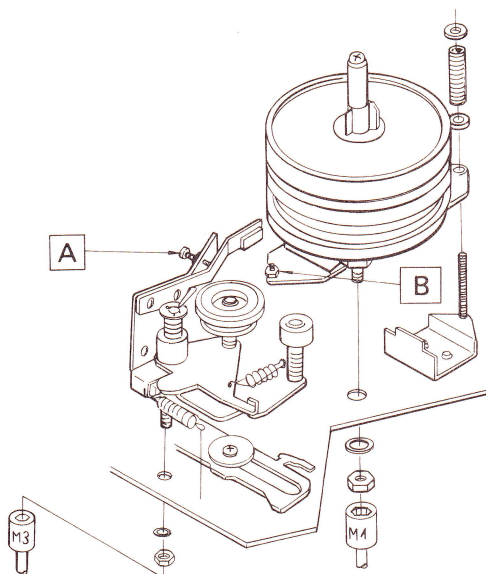

(Fig. 8)

## ADJUSTMENT OF NEW REEL BASE

For details of back tension measurement, please refer to the applicable Service Manual, "Adjustment of Mechanism" section. The adjustment procedure of the new reel base differs from that employed with the old reel. The correct steps should be as follows:

1) With the POWER switch ON, set the deck to PLAY mode — the back tension pulley should engage the reel base. Check section **A** (Fig. 6). This gap must be at least 0.5 mm (1/64 in.) or more. If smaller, the gap must be widened by bending section **A**. Once the required dimension of 0.5 mm (1/64 in.) or more is obtained, set the deck to FAST FORWARD mode to confirm that the back tension pulley is completely separated from the reel base.

2) Adjustment of take-up tension at 19.5 cm/sec. (7-1/2 ips) — PLAY mode

Use a tension gauge to measure take-up tension. If there is a deviation from the rating of 35–100g (0.07–0.2 lb), repeat adjustment of the coil spring until you obtain a rated tension within the rated coil length of 12–14 mm (15/32–35/64 in.).

Setting the deck to FAST FORWARD mode, measure back tension of the supply reel. This must register within 8–16g (0.016–0.032 lb). If otherwise, readjust the adjustment screw for tension brake (refer to section **A** of Fig. 8).

3) Adjustment of take-up tension — FAST FORWARD mode

Load a tension test reel on the base and set the deck to FAST FORWARD mode. Adjust the tension adjusting screw (section **B** of Fig. 8) in order to obtain a starting tension of approximately 220g (0.4 lb) at FAST FORWARD. Once this value is obtained, continue sliding the reel for 30 seconds (no more) and make final readjustment of the screw to obtain the correct FAST FORWARD take-up tension rating which should be within 180–200g (0.36–0.4 lb).

**Caution:** Do not allow rotation of the reel beyond 30 seconds as this will wear out the felt of the sliding surface thereby causing interference w take-up tension at FAST FORWARD.

## TEST ITEMS AFTER ADJUSTMENT

1) Confirm proper PLAY operation following these test steps:

- Using a test reel, set the deck to PLAY. Allow the tape to run a while before changing the direction. This process must be repeated two or three times.
- Do this test once more after reversing right and left reels.

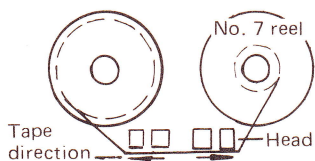

(Fig. 9)

If any erratic operation is observed with the reel base, the PLAY take-up tension might be incorrect and must be further adjusted (see Fig. 7 on take-up tension).

2) Confirm normal take-up tension at FAST FORWARD and that there is no tape slackening during STOP-FAST FORWARD switching.

- Repeat STOP-FAST FORWARD switching several times.
- Do this test once more after reversing right and left reels.

If the reel base shows any erratic operation, the FAST FORWARD take-up tension and FAST FORWARD back tension require further readjustment (see Fig. 8).

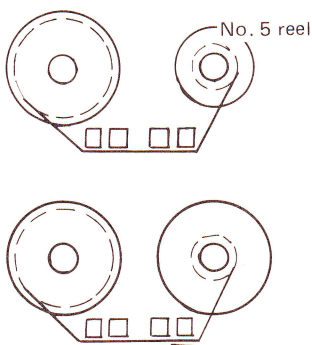

(Fig. 10)

3) Confirm normal tape functioning (no slackening) during FAST FORWARD-STOP switching.

- Repeat FAST FORWARD-STOP switching several times.
- Repeat the test after reversing the right and left reels. Erratic operation, if any, can be corrected following a readjustment of the 0.5 mm (1/64 in.) gap (see Fig. 4) and/or cleaning the contact surfaces of both reel base and brake roller with alcohol.

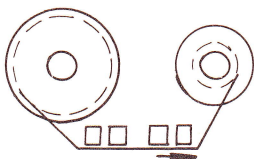

(Fig. 11)



