

PION-05909

AM/FM STEREO TUNER

TX-8500II

SERVICE MANUAL



 PIONEER

MODEL TX-8500II COMES IN FOUR VERSIONS DISTINGUISHED AS FOLLOWS:

Type	Voltage	Remarks
KC	120V only	CSA (Canada) approved with de-emphasis selector switch (25μs/75μs)
KU	120V only	UL (U.S.A.) approved with de-emphasis selector switch (25μs/75μs)
HG	220V and 240V (Switchable)	SEMKO (Sweden), NEMKO (Norway), DEMKO (Denmark) and EI (Finland) approved
S	110V, 120V, 220V and 240V (Switchable)	General export model with de-emphasis selector switch (25μs/50μs/75μs)

- Service informations for TX-8500II/KU is described on page 5 through 44 in this manual.
- For servicing of KC, S and HG types please refer to TX-8500II/KU manual with the exception of descriptions in the "Additional Service Manual" (p.45–p.82).

CONTENTS

1.	SPECIFICATIONS	5
2.	CONNECTION DIAGRAM	6
3.	FRONT PANEL FACILITIES	7
4.	BLOCK DIAGRAM	9
5.	CIRCUIT DESCRIPTIONS	
5.1	FM Tuner	10
5.2	AM Tuner	13
5.3	REC LEVEL CHECK Signal Generator Circuit	13
5.4	Power Supply Circuit	13
6.	DISASSEMBLY	14
7.	PARTS LOCATION	
7.1	Front Panel View	15
7.2	Front View with Panel Removed	16
7.3	Top View	17
7.4	Rear Panel View	18
8.	DIAL CORD STRINGING	19
9.	ADJUSTMENTS	
9.1	FM Section	20
9.2	AM Section	24
10.	PACKING	25

11. EXPLODED VIEWS	
11.1 Nomenclature of Screws, Washers and Nuts	26
11.2 Top Side	27
11.3 Bottom Side	29
12. SCHEMATIC DIAGRAMS, P.C. BOARD PATTERNS AND PARTS LIST	
12.1 Schematic Diagram and Miscellaneous Parts List	31
12.2 FM Front End (AWB-028)	34
12.3 Tuner Assembly (AWE-084)	35
12.4 Power Supply Assembly (AWR-119)	43
Additional Service Manual	
1. CONTRAST OF MISCELLANEOUS PARTS	46
2. KC TYPE	
2.1 Schematic Diagram and Miscellaneous Parts List	48
2.2 Power Supply Assembly (AWR-135)	51
2.3 Packing	53
3. HG TYPE	
3.1 Schematic Diagram and Miscellaneous Parts List	54
3.2 Tuner Assembly (AWE-069)	57
3.3 Power Supply Assembly (AWR-133)	65
3.4 Packing	67
4. S TYPE	
4.1 Schematic Diagram and Miscellaneous Parts List	68
4.2 Tuner Assembly (AWE-085)	71
4.3 Switch Assembly (AWX-113)	74
4.4 Power Supply Assembly (AWR-132)	80
4.5 Packing	82

1. SPECIFICATIONS

Semiconductors

FETs	3
ICs	6
Transistors	11
Diodes	16

FM Section

Circuitry MOS FET 1-stage RF amplifier 4-gang variable capacitor, IF Band Selector, double balanced NFB type PLL MPX built-in pilot signal auto canceller.

Usable Sensitivity MONO: 10.3dBf (1.8 μ V)
 50dB Quieting Sensitivity . . MONO: 16.1dBf (3.5 μ V)
 STEREO: 37.2dBf (40 μ V)

Signal-to-Noise Ratio
 at 65dBf MONO: 79dB
 STEREO: 75dB

Distortion at 65dBf	MONO:	WIDE		NARROW
		100Hz	0.1%	
		1kHz	0.08%	0.15%
		10kHz	0.1%	0.15%
		15kHz	0.15%	—
	STEREO:			
		100Hz	0.15%	0.4%
		1kHz	0.1%	0.4%
		10kHz	0.5%	0.9%
		15kHz	0.8%	—

Capture Ratio 0.8dB 2.0dB
 Alternate Channel Selectivity 35dB 80dB
 Stereo Separation 1kHz: 45dB 45dB
 50Hz to 15kHz: 35dB 30dB

Frequency Response 20Hz to 10kHz \pm 0.2dB
 20Hz to 15kHz $^{+0.2}_{-0.5}$ dB

Spurious Response Ratio . . . 90dB
 Image Response Ratio 85dB
 IF Response Ratio 100dB
 AM Suppression Ratio 55dB
 Muting Threshold 19.2dBf (5 μ V)
 Subcarrier Product Ratio . . 72dB
 SCA Rejection Ratio 62dB
 Antenna Input 300ohms balanced
 75ohms unbalanced

AM Section

Circuitry 1 stage RF amplifier 2-gang variable capacitor

Sensitivity
 IHF, ferrite antenna . . . 300 μ V
 IHF, external antenna . . 15 μ V
 Selectivity 30dB
 Signal-to-Noise Ratio 50dB
 Image Response Ratio 45dB
 IF Response Ratio 50dB
 Antenna Built-in ferrite loopstick antenna

Audio Section

Output (Level/Impedance)
 FM (100% MOD.) FIXED: 650mV/4.2k Ω
 VARIABLE: 50mV to 1.3V/3.6k Ω
 AM (30% MOD.) FIXED: 200mV/4.2k Ω
 VARIABLE: 15mV to 400mV/3.6k Ω

Miscellaneous

Power Requirements 120V 60Hz only.
 Power Consumption 20W
 Dimensions 420(W)x150(H)x395(D) mm
 16-9/16x5-7/8x15-9/16 in
 Weight Without Package:
 8.1kg (17lb 14oz)
 With Package:
 9.6kg (21lb 3oz)

Furnished Parts

FM T-type antenna	1
Operating Instructions	1
Connection Cord with Pin Plugs	1
Hex. Wrench (used for fastening Tuning knob)	1

NOTE:
 Specifications and the design subject to possible modification without notice.

2. CONNECTION DIAGRAM

FM DE-EMPHASIS SWITCH

Normally, set this switch to "75 μ s." Be sure to set it to "25 μ s," only when listening to an FM broadcast (pre-emphasis: 25 μ s) with a Dolby* system.

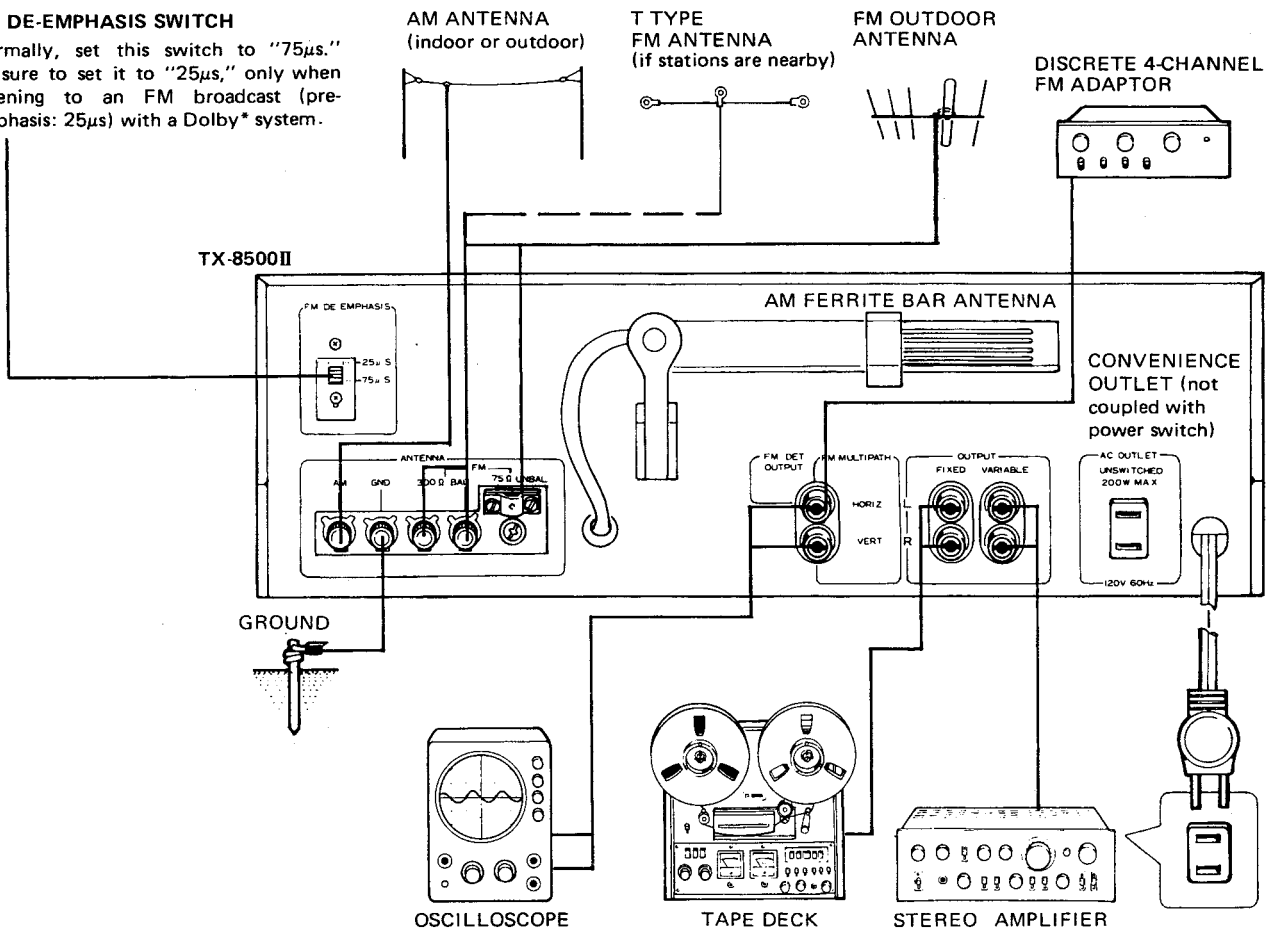

* The word "Dolby" is a trademark of Dolby Laboratories Inc.

3. FRONT PANEL FACILITIES

POWER SWITCH

Set to ON position to turn on power. Pilot lamp will light.

IF BAND SWITCH

FM IF (intermediate frequency) passband can be set to for wide or narrow.

WIDE: Normally set switch to this position.
NARROW: If adjacent station interference is a problem at the WIDE setting, set switch to this position.

REC LEVEL CHECK SWITCH

When set to ON, a 440Hz signal (level corresponding to 50% FM modulation) is produced at approximately 1.7 second intervals. Employ for setting tape deck recording levels. This feature does not operate if the FUNCTION switch is set to AM.

MEMORY MARKERS

Convenient for designating most often tuned in stations. Slide markers with fingertip to desired positions.

OUTPUT LEVEL CONTROL

Adjust level at OUTPUT (VARIABLE) jacks. Clockwise rotation increases output level.

SIGNAL METER

Employ when tuning AM and FM stations. Optimum tuning point occurs when maximum meter deflection toward the right is obtained.

TUNING METER

Use when tuning FM stations. First tune for maximum deflection of the SIGNAL meter (toward the right), then tune carefully so that the meter indicates center of scale (optimum tuning point).

FM STEREO INDICATOR

With the FUNCTION switch set to FM AUTO (or FM NOISE FILTER), the indicator will light during stereo signal reception.

FUNCTION SWITCH

Switch for selecting type of reception.
AM: AM broadcast reception.
FM AUTO: FM stereo reception. If broadcast is FM mono, the mono mode is automatically selected.
FM NOISE FILTER: Set to this position if comparatively high frequency noise becomes objectionable during FM stereo reception. Note that some loss of stereo separation occurs at this position.
FM MONO: FM monophonic reception. Set to this position if reception at FM AUTO position is noisy or signals weak.

FM MUTING SWITCH

Set to upper (ON) position to eliminate interstation noise on the FM band and provide comfortable station tuning. Since this can also prevent reception of a desired weak signal station, set the switch to OFF in such situations.

TUNING KNOB

Knob for selecting stations. Refer to the SIGNAL meter when tuning AM stations and to both SIGNAL and TUNING meters when tuning FM stations.

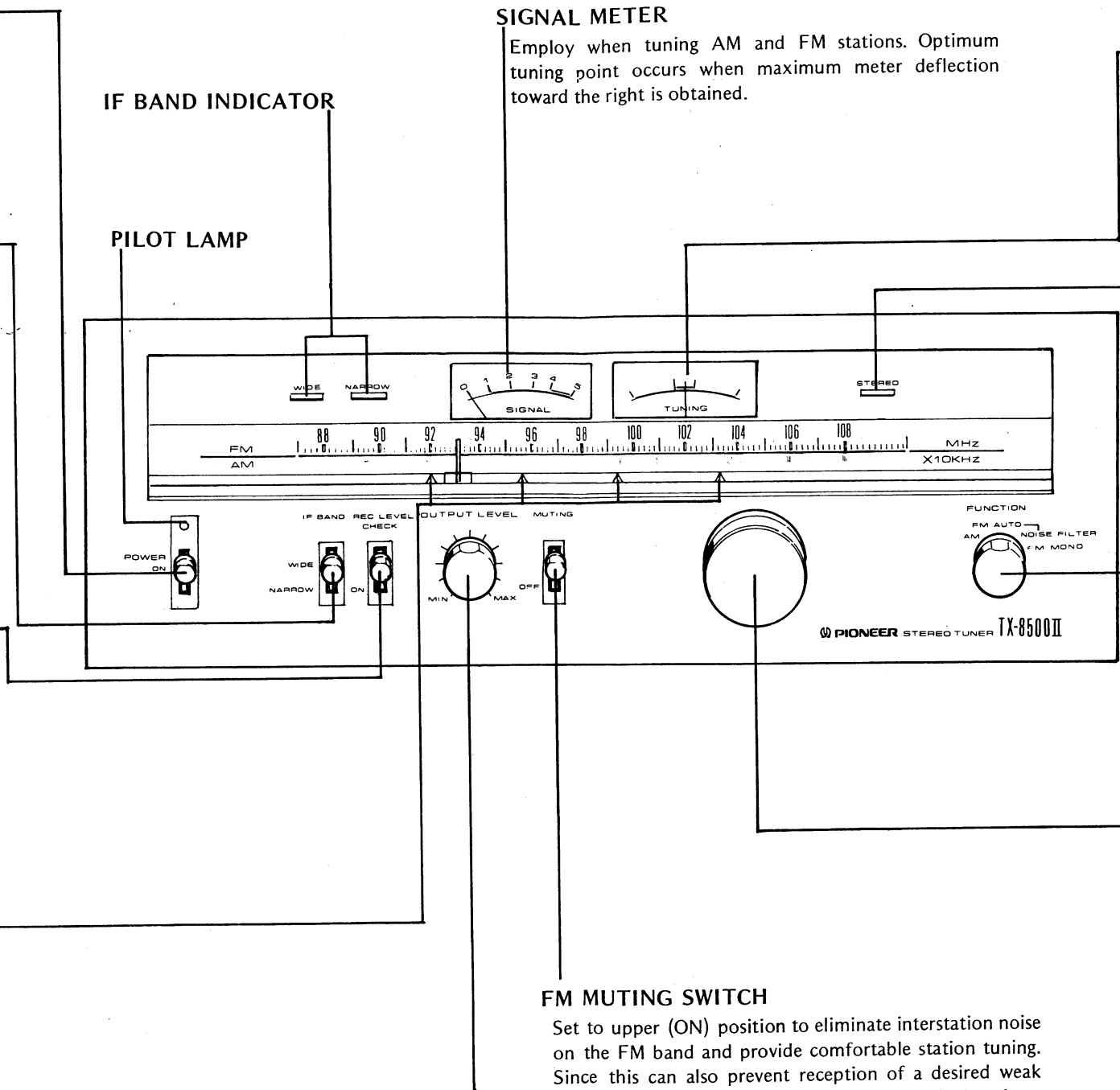

4. BLOCK DIAGRAM

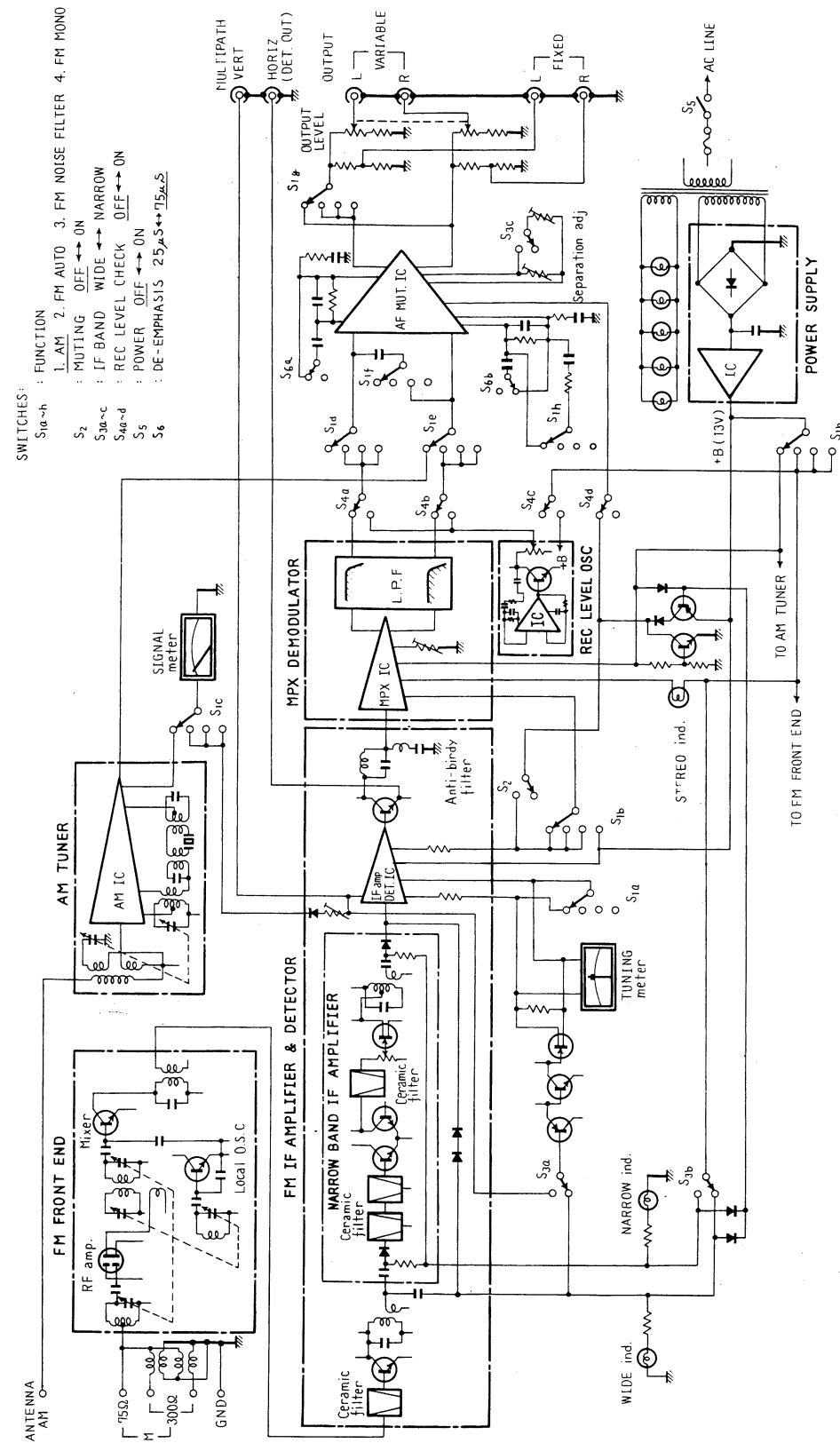

5. CIRCUIT DESCRIPTIONS

5.1 FM TUNER

FM Front-End

The major component parts of the front-end are a dual gate MOS FET equipped RF amplifier, a 4-ganged variable capacitor, and a modified Clapp oscillator. Since the transmission characteristics of this FET describe a square relation, there is considerable reduction in the generation of odd harmonics, the main factor which determines the level of spurious response in the linearity of the input/output characteristics. And since input impedance is high, effective connections are possible without decreasing the Q of the tuning circuit, providing a great improvement in selectivity. The dual gate MOS FET also means a higher gain with a higher stability.

In the modified Clapp oscillator, there is very little drift in frequency due to variations in power supply voltage and temperature etc. This type of circuit also improves spurious response since it generates a very clean waveform.

As a result of the incorporation of the above mentioned elements, a usable sensitivity of 1.8μV, an image rejection of 85dB, and a spurious response of 90dB, and other outstanding figures are obtained.

FM IF Amplifier

In this FM IF amplifier, there are two selectable IF frequency pass band widths, viz. a WIDE band and a NARROW band, selected by the IF BAND switch (S₃).

This circuit is shown in Fig. 1.

When the S₃ switch is put in the WIDE position, D₂ and D₃ are biased in the forward direction by +B, and thus turned ON. Consequently, the incoming signal passes from the front-end → ceramic filter (F₁) → Q₁ → T₁ → D₂ and D₃, to FM IF IC (PA3001). That is, the signal passes only one (2-element) ceramic filter (which influences the group delay time flatness characteristics), resulting in a reduction in the generation of phase distortion. This circuit then, has excellent low distortion characteristics.

When S₃ is put in the NARROW position, +B is applied to the NARROW IF AMP. including D₁ and D₄, which are turned ON by the forward direction biasing. So the incoming signal passes from the front-end → ceramic filter (F₁) → Q₁ → T₁ → D₁ → ceramic filters (F₂ and F₃) → Q₂ → Q₃ → ceramic filter (F₄) → VR₁ → Q₄ → T₂ → D₄, and on to FM IF IC (PA3001).

This circuit includes four 2-element ceramic filters, thus the distortion characteristics are not as good as in the WIDE position, but the selectivity is outstanding. So this circuit is particularly suitable for locations where adjacent radio stations are very close together on the FM band.

The FM IF IC (PA3001) is a new IC developed by Pioneer. In comparison to its predecessor, the IC (HA1137), noise in all sections has been reduced, while improvements have been made in the detector circuit (greater efficiency and reduced distortion).

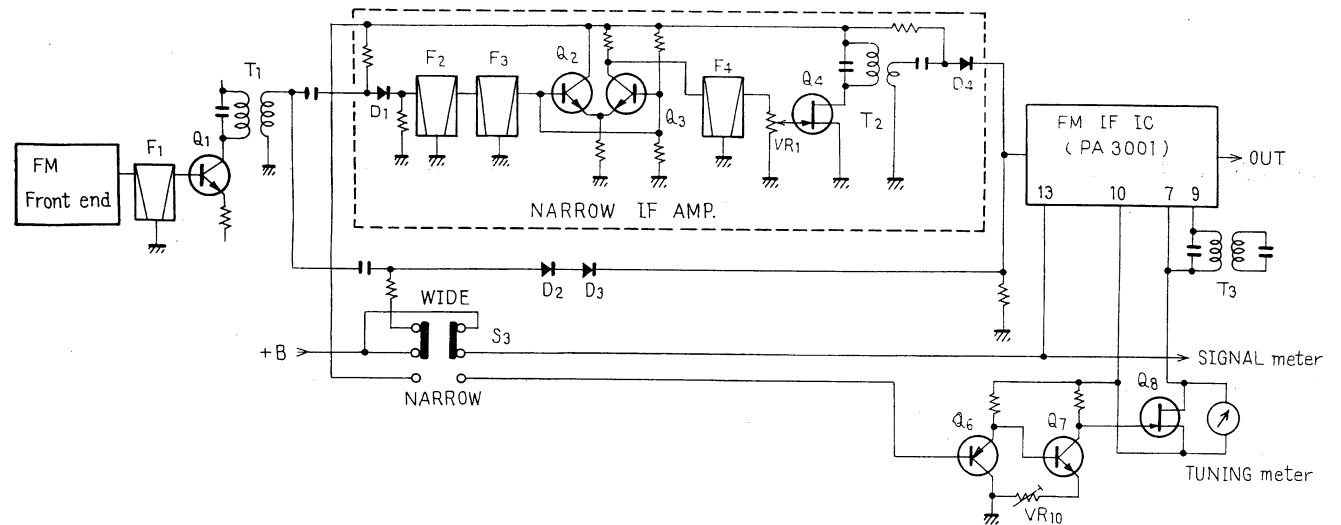

Fig. 1 FM IF Amplifier circuit

Furthermore, differences in the center position of the TUNING meter between WIDE band and NARROW band (due to change in band width), have been eliminated by the use of the $Q_6 - Q_8$ circuitry.

The TUNING meter needle is adjusted to the center position when no station is tuned with the WIDE band, by means of T_3 . When operating in the NARROW band, the base of Q_6 is connected to terminal no. 13 of PA3001. This terminal is designed for the SIGNAL meter, and is set to 0V when no station is tuned. Since its base voltage is 0V, Q_6 will be ON, Q_7 will turn OFF, and Q_8 turn ON. With Q_8 ON, the voltage between the terminals of the TUNING meter is also 0V, thus keeping the meter needle in the central position. When a station is tuned in, the voltage in the SIGNAL meter circuit (terminal no.13 of PA3001) increases, turning Q_6 OFF, Q_7 ON, and Q_8 OFF. When Q_8 is turned OFF, the TUNING meter needle will deflect in the same manner as in the WIDE band position.

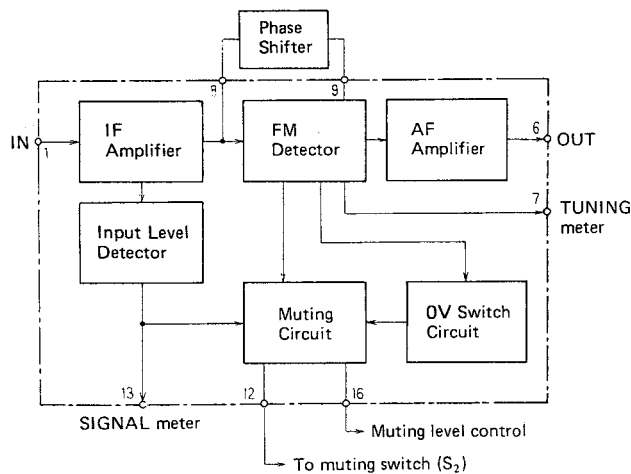

Fig. 2 Block diagram of PA3001

FM Multiplex Decoder

This section includes another IC recently developed by Pioneer, the PA1001. See Fig. 3 for the block diagram.

This IC, an improvement over a previous IC (HA1196), incorporates a pilot auto-canceller circuit. This circuit filters out the leak carrier (19kHz) contained in the demodulated signal without any loss in the frequency characteristics of the audio signal. This filtering action is a considerable improvement over the previous low pass filter method. Other features include a wider input dynamic range, and the ability to perform

well even when a 300% modulated input signal is applied to the IC. S/N ratio and distortion factor have also been improved by the incorporation of an NFB circuit in the decoder amplifier. Distortion has also been improved in the case of MONO signals by connecting together the output circuits of the L and R channels. Thus the out-of-phase distortion components contained in the L and R channel audio signals will be cancelled.

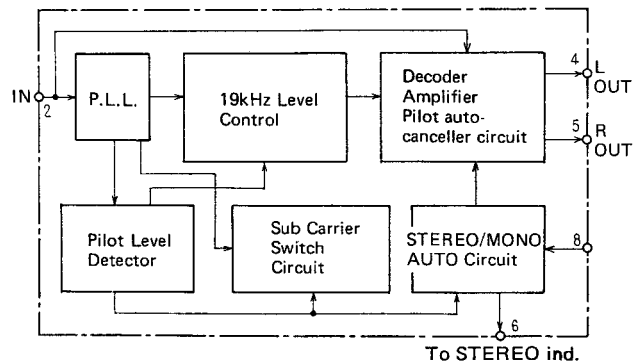

Fig. 3 Block diagram of PA1001

AF Amplifier and Muting

This circuit employs the Pioneer developed IC (PA1002). The block diagram is shown in Fig. 4.

This AF amplifier is a direct coupled amplifier used as a differential NFB amplifier providing outstanding dynamic range, S/N ratio, and distortion factor. De-emphasis has been provided by inserting a time constant circuit in the NFB loop of the AF amplifier. The elements in this time constant circuit include a metal film resistor (1% tolerance) and a polystyrene film capacitor (2% tolerance)

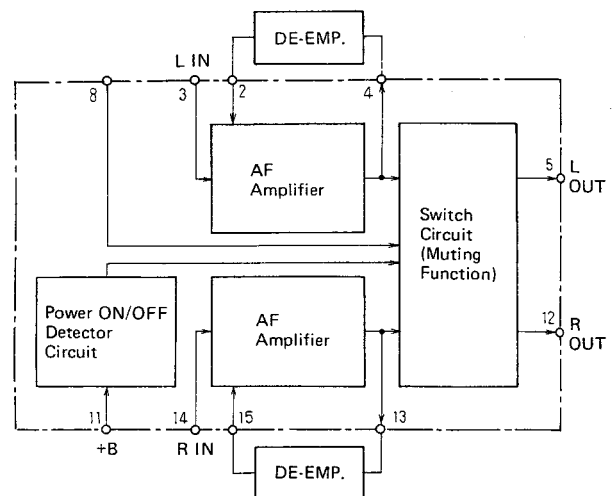

Fig. 4 Block diagram of PA1002

which have made it possible to reduce de-emphasis deviation to within +0.2dB to -0.5dB in the 20Hz to 15kHz range.

The switching circuit for the muting function is activated when a DC voltage from the power ON/OFF detector section, or from terminal no.8 is received. The signal circuit is then connected to ground, thus preventing the output of any signals. This power ON/OFF detector circuit detects the instantaneous change when the POWER switch is turned ON or OFF, sending a trigger signal to the switching circuit, and thus usually activating the muting function. As a result, the popping noise generated when the POWER switch is turned ON or OFF, plus the residual noise, is eliminated.

Muting Circuit

See Fig. 5 for the Muting Control Circuit.

Terminal no.12 of PA3001 is designed to generate a DC voltage of 1.3 to 5V when the tuning frequency is at least approx. 70kHz distant from the nearest radio station, or when the antenna input drops below 14dB (5 μ V).

When the MUTING switch is turned ON, terminal no.8 of PA1002 is connected to terminal no.12 of PA3001. The DC voltage from terminal no.12 activates a switch circuit in PA1002 to operate the muting function.

Muting is also brought into operation when the FUNCTION switch is turned from AM to FM, or when the IF BAND switch is changed over between NARROW and WIDE.

That is, the moment the FUNCTION switch is turned from AM to FM, the +B switching section of the FUNCTION switch is opened and +B₁ and +B₂ will both drop momentarily to 0V. Q₁₃ will turn ON the instant its base voltage becomes 0V, allowing +B₃ to pass through and charge C₈₉.

Q₁₃ is turned OFF again almost immediately, but the electrical charge on C₈₉ passes through D₈, and is applied to terminal no.8 of PA1002, activating the switch circuit, and the system passes into muting status. This muting status is released when the charge on C₈₉ finally discharges via R₆₈.

When the IF BAND switch setting is changed, the Q₁₃ base voltage is designed to drop to 0V instantaneously by means of an open contact in the +B switching section of the IF BAND switch. Q₁₃ will thus be turned ON as before, with all subsequent steps being the same as when the FUNCTION switch was operated.

When the FUNCTION switch is in the AM position, or when the REC LEVEL CHECK is ON, the muting circuit is not activated. That is, in the AM position, +B₁ is applied to the bases of Q₁₃ and Q₁₁, turning Q₁₃ OFF and Q₁₁ ON. Hence, terminal no.8 of PA1002 is connected to ground.

When the REC LEVEL CHECK is ON, the circuitry connected to terminal no.8 of PA1002 is disconnected, thus preventing the muting circuit from operating.

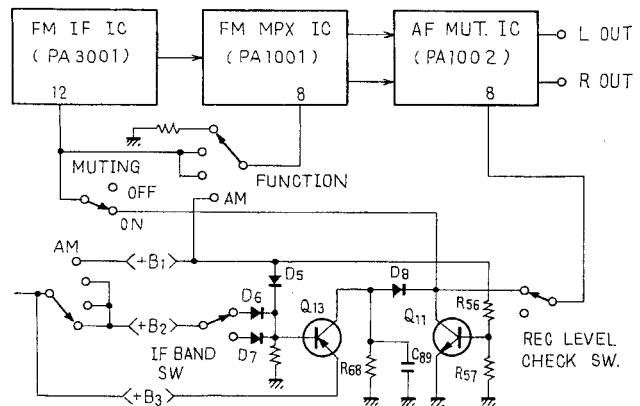

Fig. 5 Muting control circuit

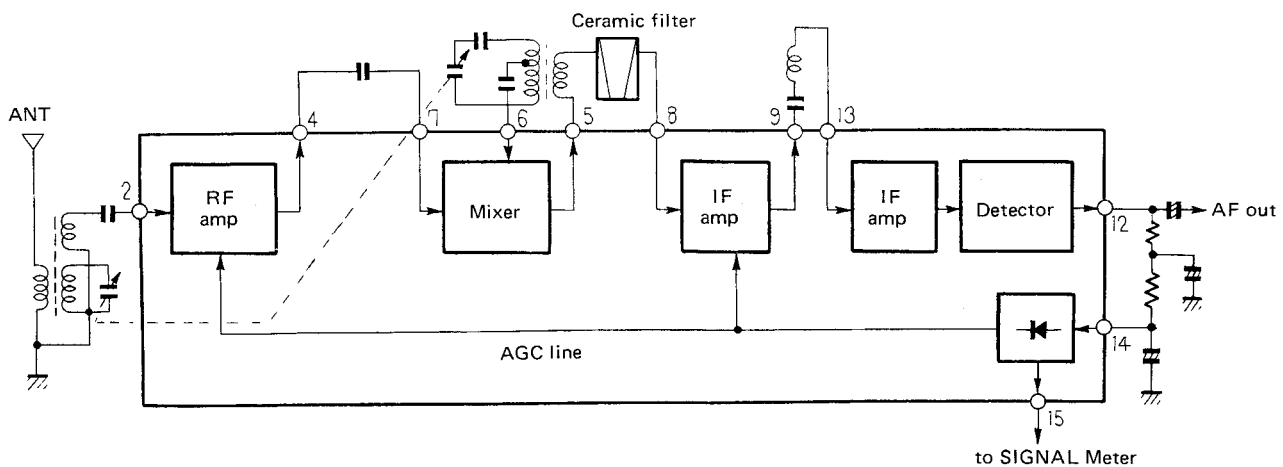

Fig. 6 Block diagram of HA1197

5.2 AM TUNER

The major components of the AM tuner are the 2-ganged variable capacitor, a newly developed IC (HA1197), and an AM ceramic filter. A block diagram of the HA1197 is shown in Fig. 6.

This IC consists of an RF amplifier in the first stage, followed by a mixer stage which also includes a self-oscillating local oscillator, the IF amplifier 3rd and 4th stages, and a detector circuit final stage. The AGC (Automatic Gain Control) receives an AGC voltage from the output of the detector circuit, and applies it to the RF amplifier and IF amplifier stages. The advantage of the HA1197 is a large reduction in distortion at low frequencies. Whereas the distortion at 100Hz was 1.5% in the previous HA1138, this figure has been reduced to 0.4% (100Hz) in the HA1197.

5.3 REC LEVEL CHECK SIGNAL GENERATOR CIRCUIT

This circuit, consisting of one transistor and an IC (HA1452W), produces tone bursts every 3.4 sec. for 1.7 sec. intervals by means of a 440Hz signal. The output level corresponds to a value equivalent to an FM broadcast with 50% modulation. The circuit is outlined in Fig. 7.

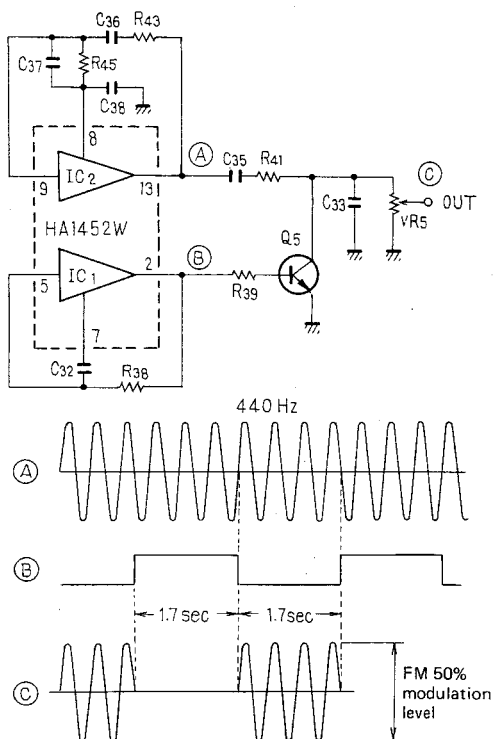

Fig. 7

The IC HA1452W incorporates two pairs of operational amplifiers, one being used as a 440Hz sine wave oscillator, and the other as a square wave oscillator, which cycles on or off every 3.4 sec. for 1.7 sec. The switching action of Q₅ converts this square wave into tone bursts. When the square wave is applied to the base of Q₅, Q₅ is turned ON and OFF, thus converting into a 440Hz tone bursts by shorting the sine wave oscillator to ground when Q₅ is turned ON.

5.4 POWER SUPPLY CIRCUIT

This circuit, too, employs one of Pioneer's recently developed IC (PA2002), resulting in better S/N ratio, stability, and a greater degree of reliability. PA2002 is an IC used to provide constant voltages, and it incorporates a protection circuit. A block diagram is outlined in Fig. 8.

The protection circuit is composed of control circuits activated by overcurrents, and control circuits activated by overvoltages. The protection circuit is activated when either a current in excess of 760mA (resulting from an overload) flows through the IC output (terminal no.10), or a voltage in excess of 27V is applied to the IC input (terminal no.1). Once this protector circuit is activated, no output voltage will appear at terminal no.10.

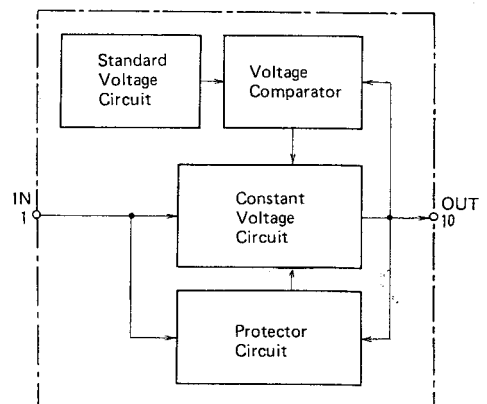

Fig. 8 Block diagram of PA2002

6. DISASSEMBLY

1. Remove the 4 screws (A) securing both sides of the bonnet case.
2. Remove the 9 screws (B) securing the bottom plate.
3. Remove all the knobs from the front panel. In the case of the TUNING knob, a securing screw must first be loosened. Now remove the 3 nuts (C) and the 2 screws (D) securing the top of the front panel, which may now be taken off.

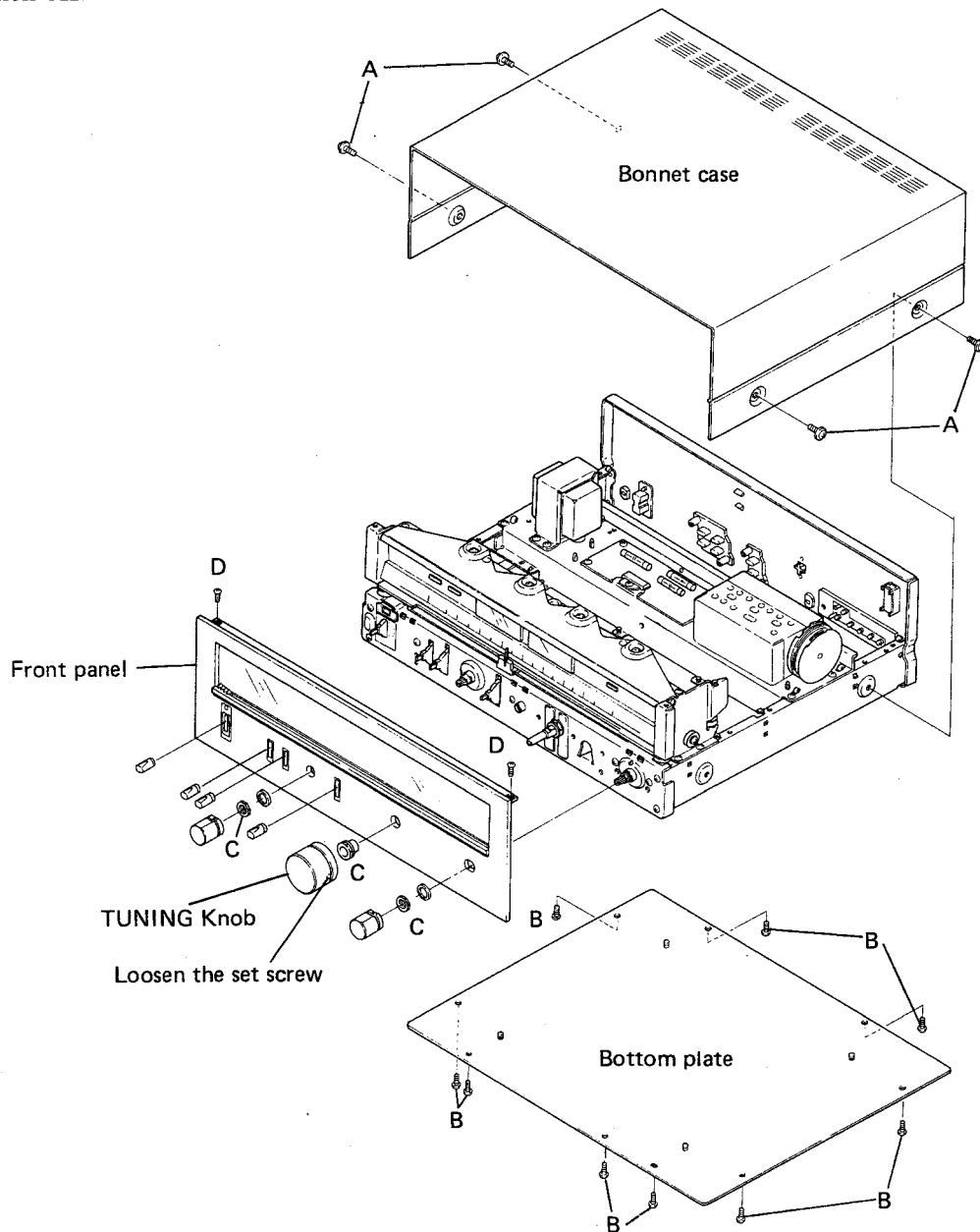
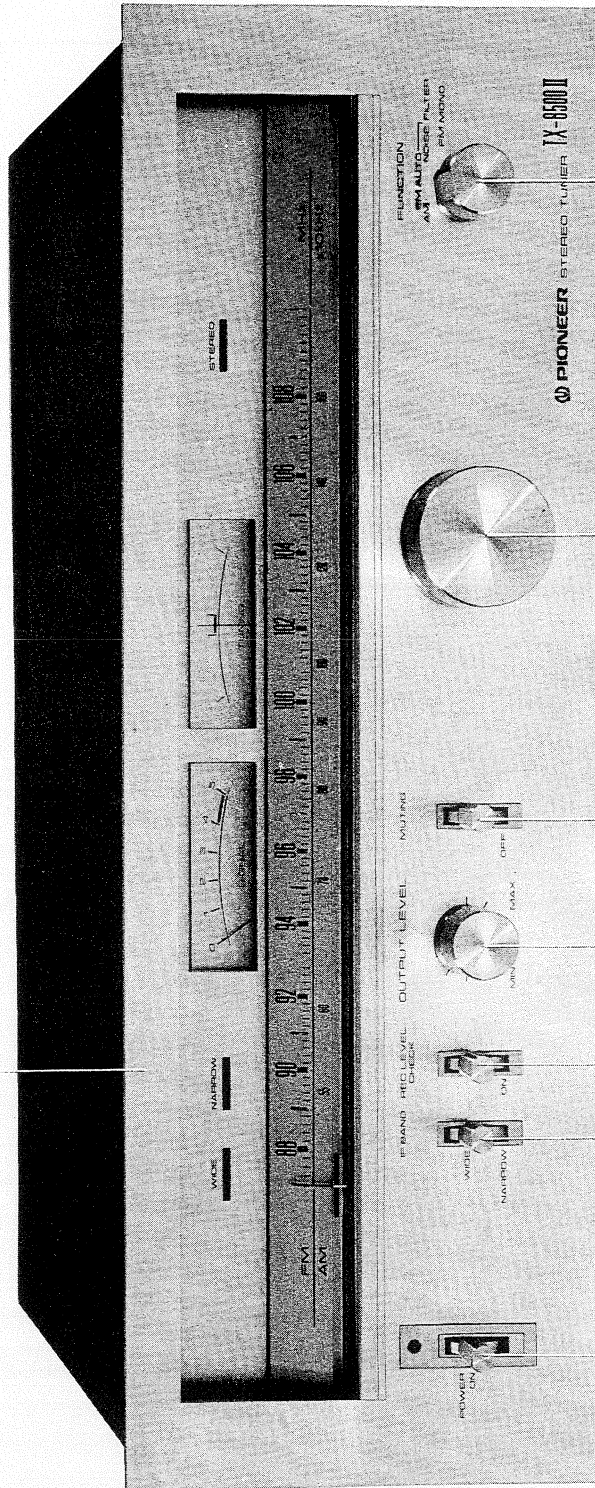

Fig. 9

7. PARTS LOCATION

7.1 FRONT PANEL VIEW

Front panel assembly
ANB-484 ✓



Knob (POWER)
AAD-117 ✓

Knob (IF BAND)
AAD-117 ✓

Knob (REC LEVEL CHECK)
AAD-117 ✓
Knob (OUTPUT LEVEL)
AAB-116 ✓

Knob (FUNCTION)
AAB-116 ✓

Knob (TUNING)
AAA-038 ✓

Knob (MUTING)
AAD-117 ✓

7.2 FRONT VIEW WITH PANEL REMOVED

Dial panel assembly
AAG-130 ✓

Tuning meter
AAW-055 ✓

Signal meter
AAW-054 ✓

Dial pointer
AAF-054 ✓

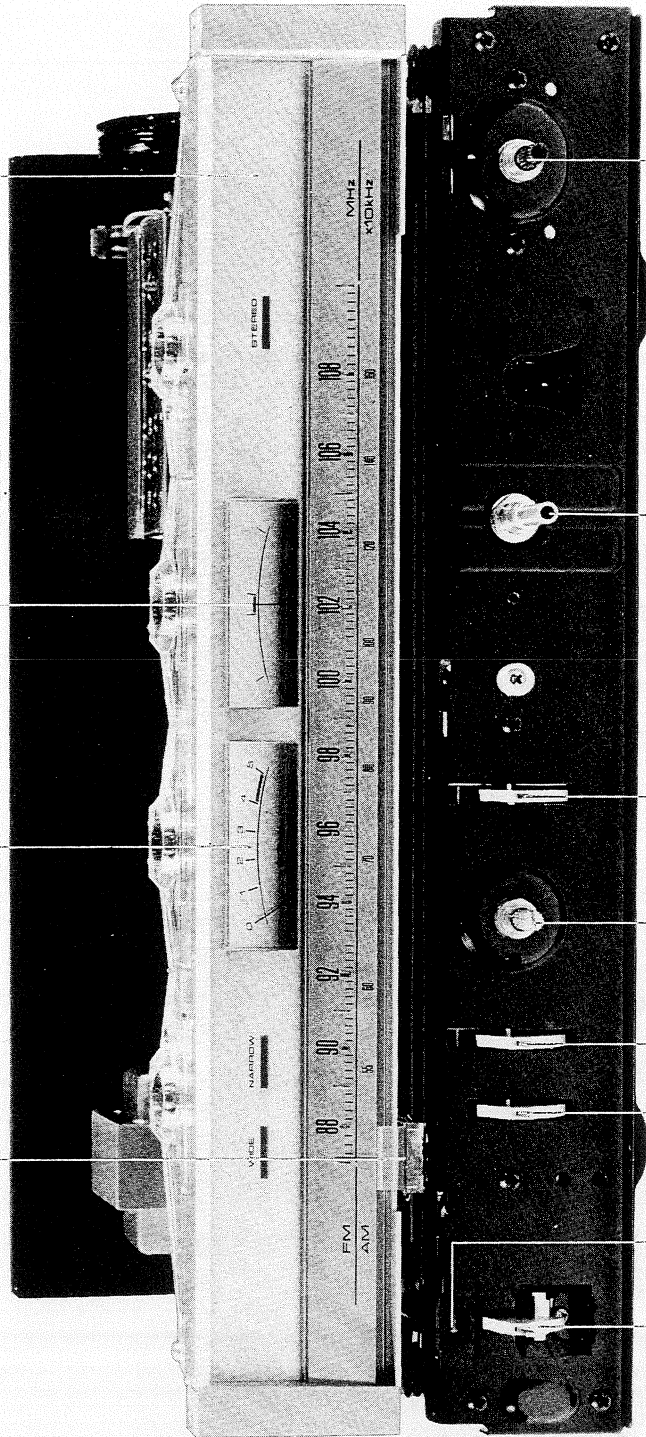

Lever switch (S₁ POWER)
ASK-124 ✓

Lamp with wire 8V 50mA
AEL-072 ✓

Lever switch
(IF BAND)
ASK-112 ✓

Lever switch
(REC LEVEL CHECK)
ASK-112 ✓

Lever switch
(MUTING)
ASK-109 ✓

Variable resistor
(OUTPUT LEVEL)
ACV-178 ✓

Dial shaft assembly
AXA-114 ✓

Rotary switch
(FUNCTION)
ASD-063 ✓

7.3 TOP VIEW

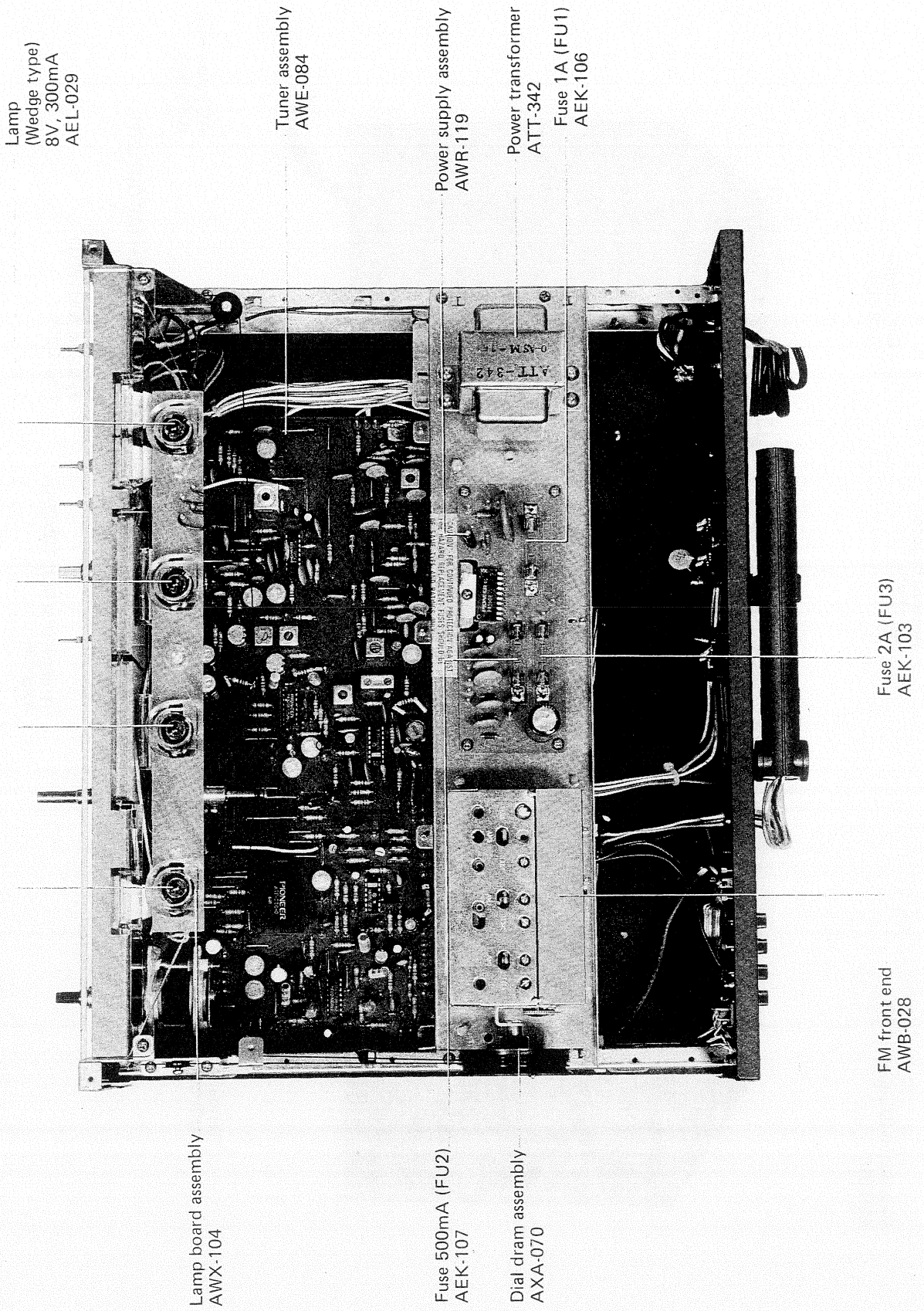

7.4 REAR PANEL VIEW

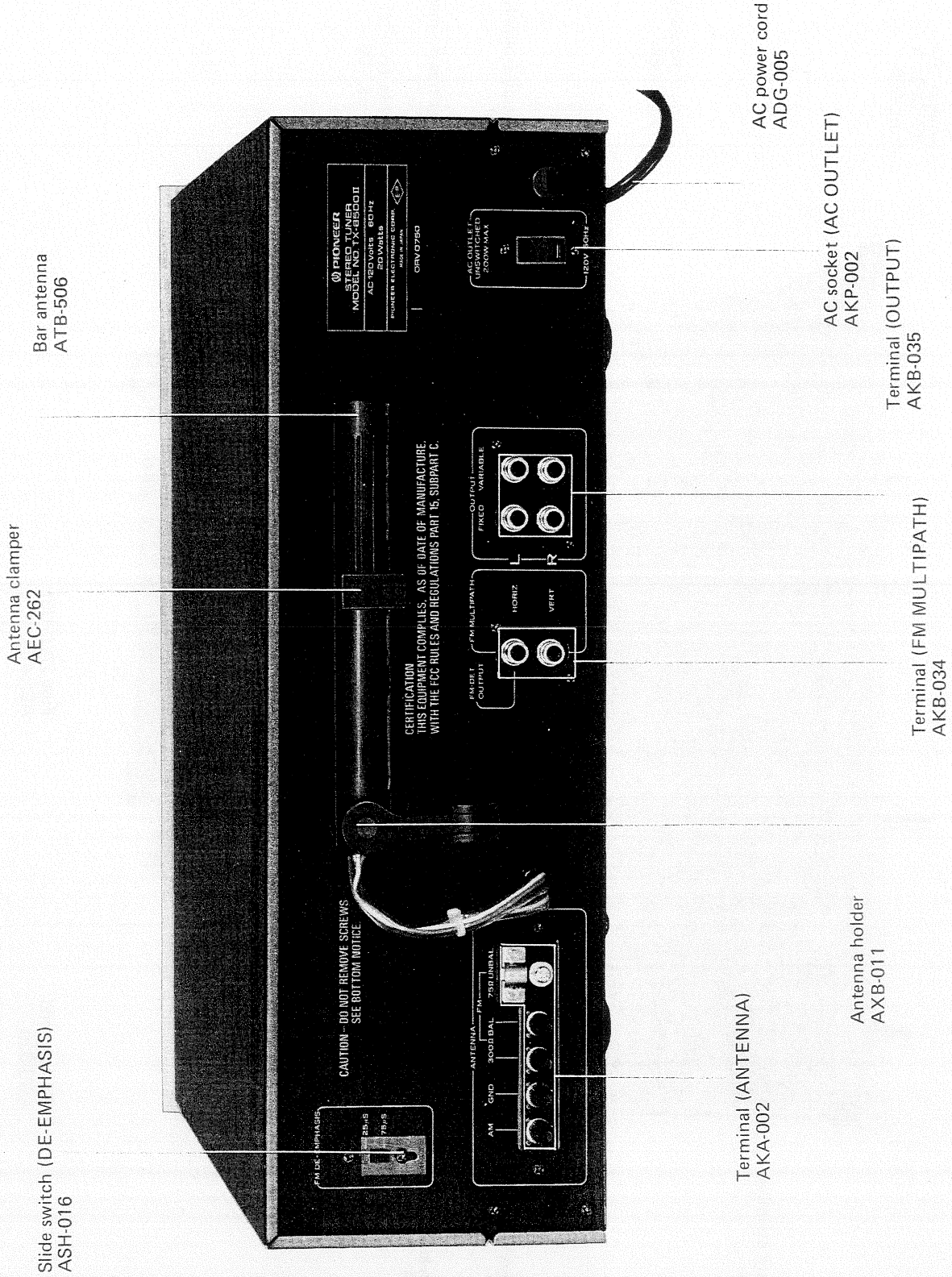

8. DIAL CORD STRINGING

1. Remove the top cover and the front panel (p.14).
2. Rotate the front-end variable capacitor shaft right around in the maximum clockwise direction.
3. Tie one end of the cord around the protruding pin on the inside of the dial drum assembly.
4. Fix the dial drum assembly to the variable capacitor shaft so that the set screw is pointing upwards.
5. Pass the cord tied to the dial drum assembly, through the cut out part of the assembly.
6. Now pass the cord over pulley A, wind 3 times around the dial tuning shaft, and continue over pulleys B, C, D, and E.
7. From pulley E, wind the cord twice around the dial drum assembly along the grooves, and then tie to the spring.
8. Rotate the dial tuning shaft to check for any abnormal behavior in the movement of the cord and the dial drum assembly. If everything is in order, cut off the remaining cord.
9. Rotate the dial tuning shaft around in the counterclockwise direction until it stops. Adjust the dial indicator to the starting point at the left hand side of the dial scale, and then secure the cord reasonably firm.

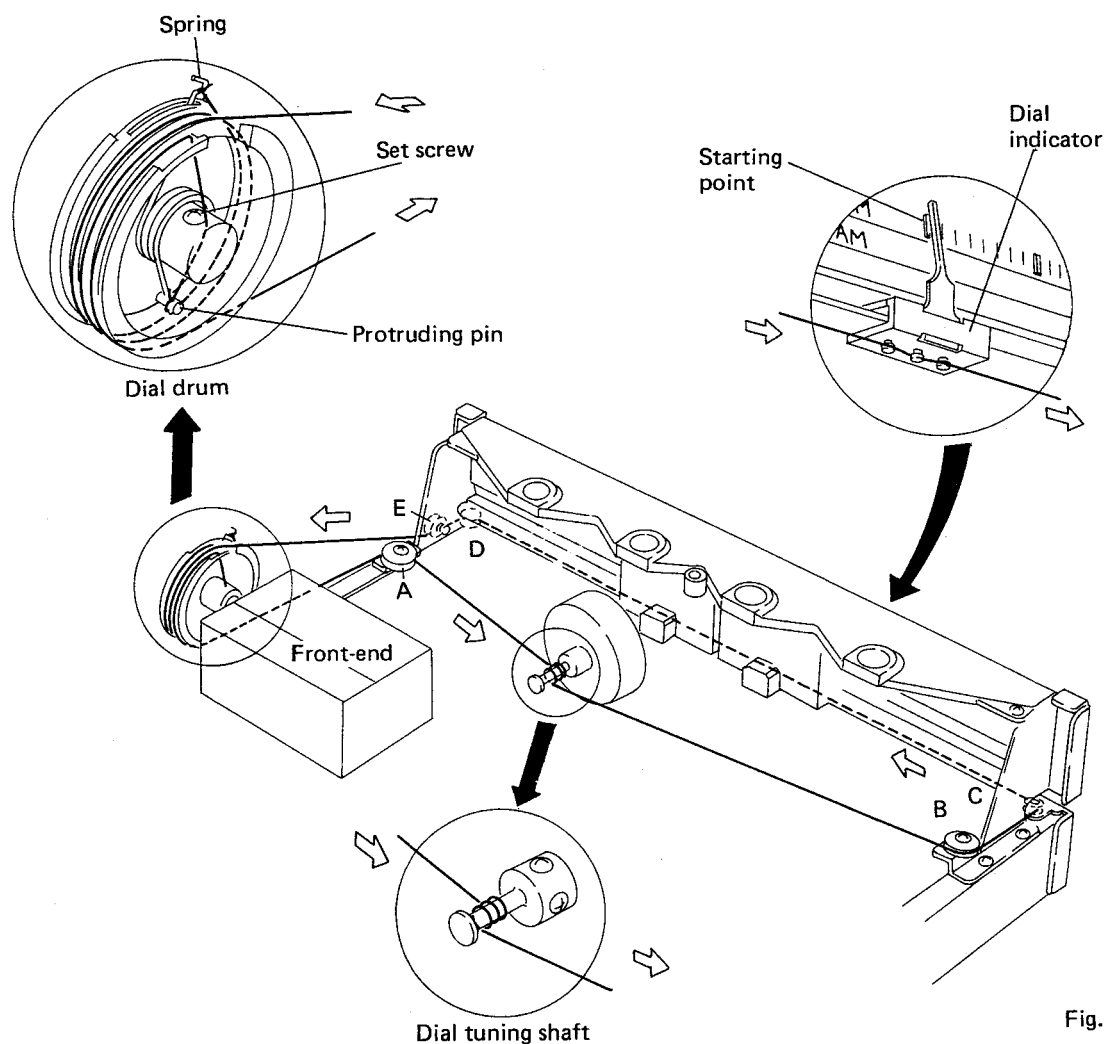

Fig. 10

9. ADJUSTMENTS

9.1 FM SECTION

FM Front-end

When the TUNING knob is turned completely in the counterclockwise direction, the dial indicator should be aligned with the starting point on the far left of the dial scale.

1. Turn the MUTING, and REC LEVEL CHECK switches on the front panel to the OFF positions, turn the IF BAND switch to the NARROW position, and the FUNCTION switch to the FM MONO position.
2. Connect up the test instruments as shown in Fig. 11, and adjust FM Signal Generator (FM SG) to 90MHz, modulation frequency of 400Hz, 100% modulation, and output of 10dB.
3. Set the dial indicator of the TX-8500II to 90MHz, and adjust each of the cores of L_0 , L_A , L_{R1} , and L_{R2} in the front-end for maximum deflection in the AC voltmeter.
4. Now set the dial indicator of TX-8500II and FM SG to 106MHz, and adjust each of the trimmers of TC_0 , TC_A , TC_{R1} , and TC_{R2} in the FM front-end to give maximum deflection on the AC voltmeter.
5. Repeat steps 2 to 4 so that the AC voltmeter deflections are more or less the same at both 90MHz and 106MHz.
6. Once these adjustments have been completed, check for the occurrence of oscillations etc.

FM Muting Circuit

1. Connect the test instruments as shown in Fig. 12.
2. Turn the MUTING and REC LEVEL CHECK switches on the front panel OFF, turn the IF BAND switch to the NARROW position, and the FUNCTION switch to FM AUTO.
3. Turn VR_{10} of the tuner assembly completely in the clockwise direction, and VR_1 in the maximum counterclockwise direction.
4. Adjust the FM Signal Generator (FM SG) to 100% modulation, 40dB output, and 400Hz modulation frequency.
5. Set the FM SG and TX-8500II dial indicator to 98MHz, and then adjust the core of T_2 in the tuner assembly, and the IF TRANS in the FM front-end to give maximum deflection on the SIGNAL meter.

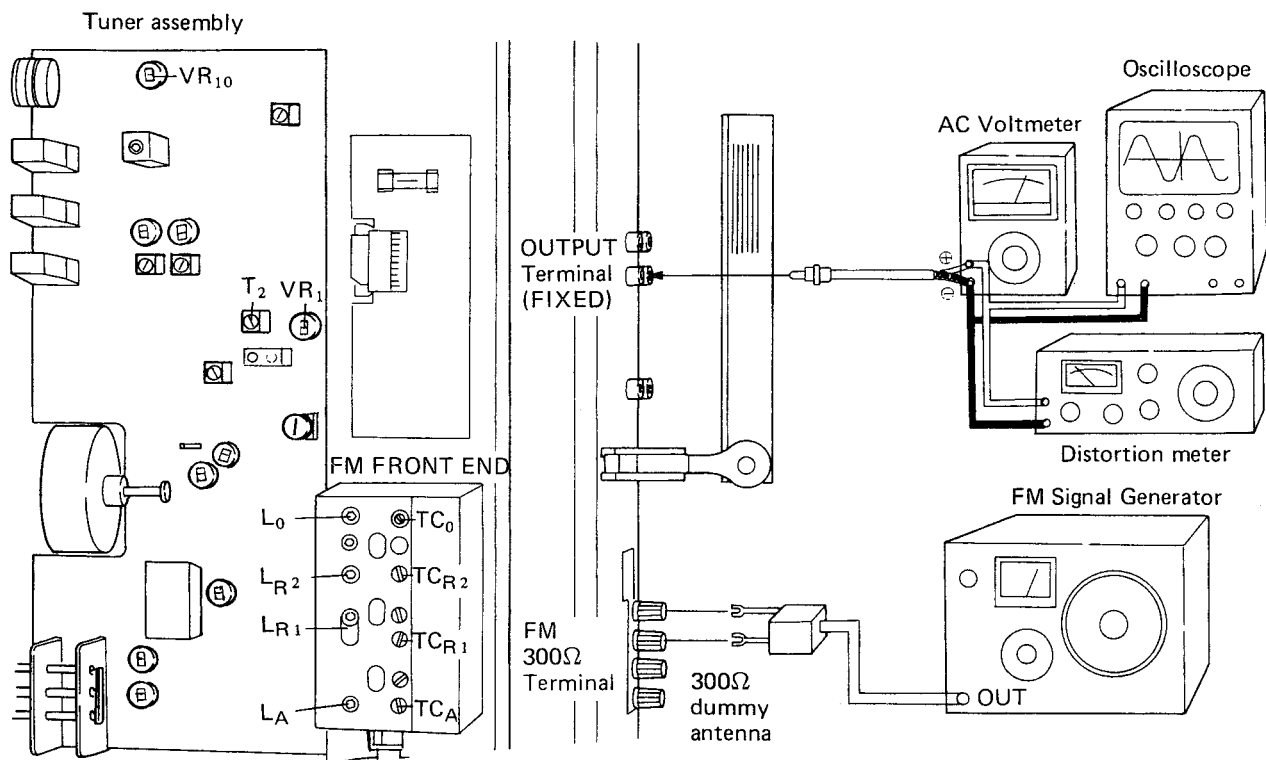

Fig. 11

6. Change the IF BAND switch to the WIDE position.
7. Set the dial indicator to a station-free position near 98MHz, and then adjust the primary coil (lower side) of T₃ so that the TUNING meter needle is right at the center of the marker.
8. Retune TX-8500II to 98MHz, but change the FM SG output to 60dB. Now adjust the secondary coil (upper side) of T₃ to reduce distortion to a minimum.
9. Recheck that the TUNING meter needle indicates dead center when no station is tuned. If it is not exactly in the center as before, readjust by repeating steps 7 and 8 above.
10. Change the FM SG output to 100dB. Adjust VR₂ so that the SIGNAL meter needle reads 4.8 on the scale. Set the FM SG to 30% modulation. And then readjust the FM SG output so that the needle now reads 2.5.
11. Change the FM BAND switch to the NARROW position, and adjust VR₁ so that the SIGNAL meter needle again reads 2.5.
12. Change the IF BAND switch back to the WIDE position, and turn the MUTING switch ON.
13. Set the FM SG to 100% modulation, 20dB output, and adjust VR₉ to a position just below that necessary to activate the muting function.
14. Change the IF BAND back to the NARROW position and check that the muting is activated as a result of the change over at 22dB ±3dB.
15. Turn the MUTING switch OFF, and set the IF BAND switch to the NARROW position. Adjust the FM SG output to 15dB.
16. Tune the TUNING knob a bit so that TUNING meter needle is near the marker end (Fig. 13). Adjust VR₁₀ so that the needle indicates dead center of the marker.
17. Now turn the FM SG output down, and change the IF BAND switch when there is only noise present. The TUNING meter needle discrepancy should be less than 1/2 of the needle's width.

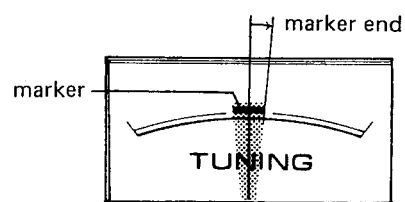

Fig. 13 TUNING meter

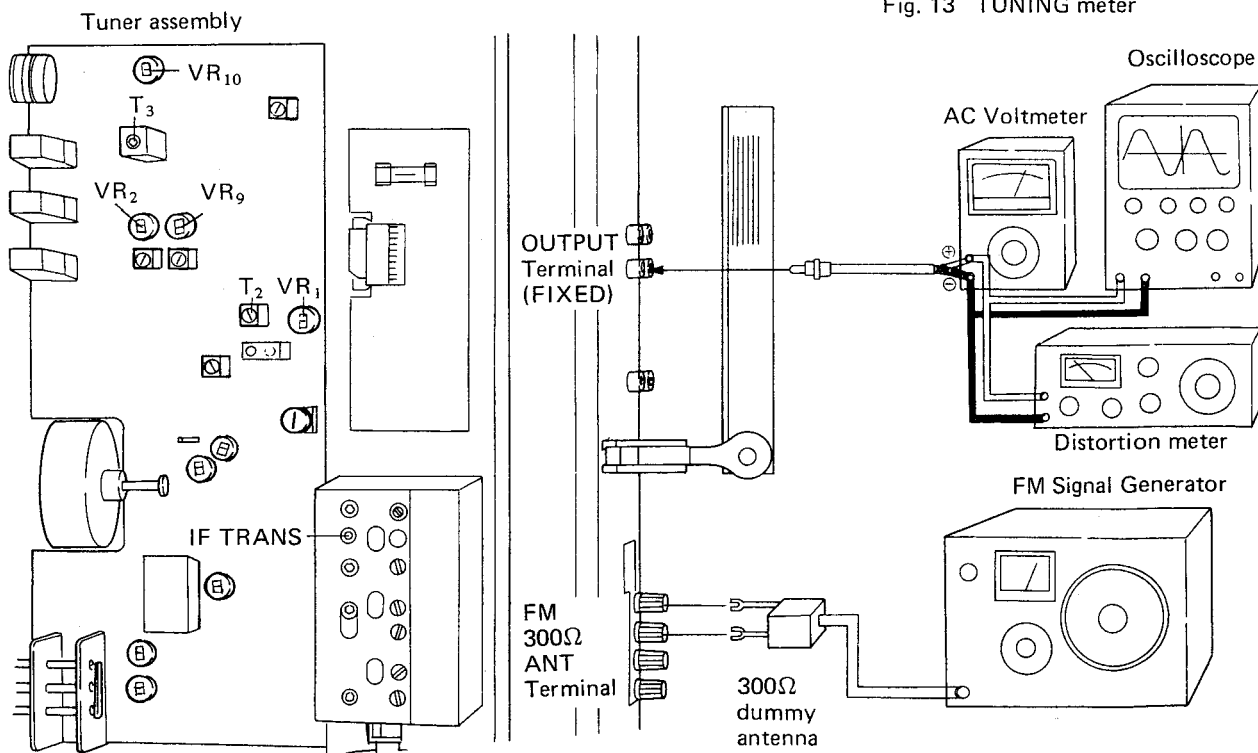

Fig. 12

FM MPX Circuit

1. Connect up the test instruments as shown in Fig. 14.
2. Turn the MUTING and REC LEVEL CHECK switches on the front panel OFF, set the IF BAND switch to the WIDE position, and turn the FUNCTION switch to FM AUTO.
3. Adjust FM SG for zero modulation, and 60dB output.
4. Tune the dial indicator of TX-8500II and FM SG to 98MHz.
5. Connect the PILOT OUT terminal of MPX Signal Generator (MPX SG) to the HORIZONTAL input terminal of an oscilloscope, and terminal no.34 of the tuner assembly to the VERTICAL input terminal (but via a 10:1 probe).
6. Adjust VR₄ to bring the Lissajous waveform shown in the oscilloscope to a halt.
7. With the FM SG acting as an external modulator, apply the MPX SG pilot signal (19kHz), with 7.5kHz deviation, to the input terminal of the FM SG external modulator.
8. Adjust VR₃ in order to reduce the amount of pilot signal leakage appearing at the output terminal of TX-8500II to a minimum.
9. Modulate the MPX SG output with 67.5kHz deviation at 1kHz for L + R, and the pilot signal (19kHz) with 7.5kHz deviation.
10. Next reduce the amount of distortion in the output signal from the TX-8500II to a minimum by adjusting the core of the front-end IF.

NOTE:

Signal at terminal No. 34 is 76kHz sawtooth wave and MPX SG pilot out is a 19kHz sinewave. These form a Lissajous' figure such as shown in Fig. 15.

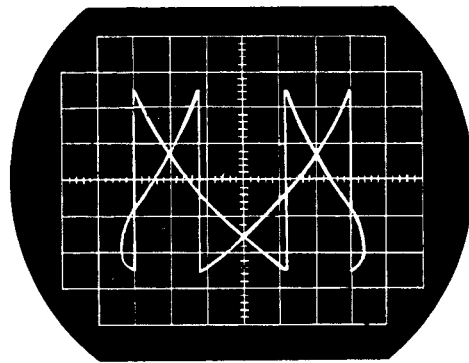

Fig. 15 Lissajous waveform

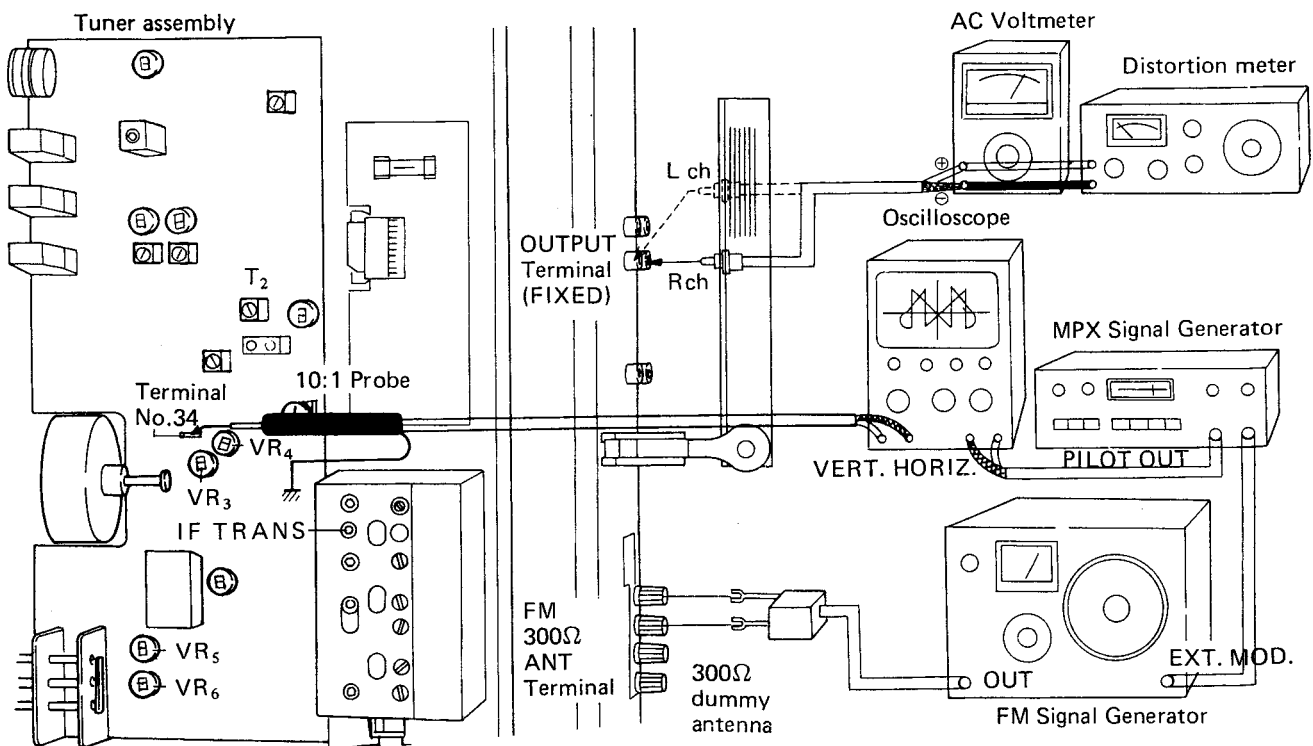

Fig. 14

11. Change the IF BAND switch to the NARROW position, and then adjust the core of T₂ by less than ±90° in order to reduce distortion to a minimum.
12. Change the IF BAND switch back to the WIDE position, and switch main signal of the MPX SG to either L or R.
13. To obtain optimum channel separation, adjust VR₅.
14. Change the IF BAND switch back to the NARROW position again, and again adjust VR₆ to get optimum channel separation.
15. Turn the FUNCTION switch to the NOISE FILTER position, and check that channel separation lies in the 18dB ±3dB range. Also check that the STEREO indicator lamp goes off when in the FM MONO position, and that the signal has become monaural.

Adjustment of the REC LEVEL CHECK Oscillation Level

1. Connect up the test instruments as shown in Fig.16.
2. Turn the FUNCTION switch to FM AUTO.
3. With the FM SG at modulation frequency of 400Hz, 100% modulation, and an output of 60dB, check the output level of TX-8500II.
4. Turn the REC LEVEL CHECK to the ON position, and adjust VR₇ of the AF MPX assembly so that the output level is -6dB below the level found in step 3 above.

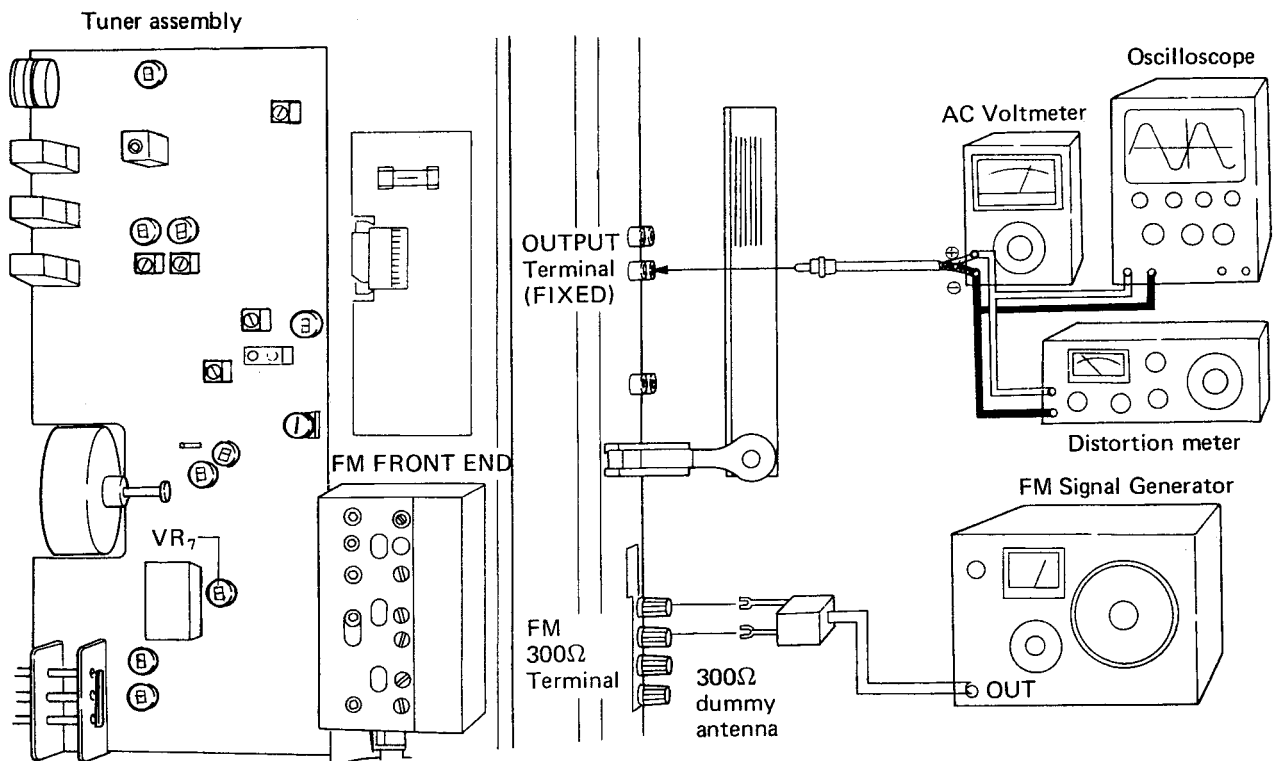

Fig. 16

9.2 AM SECTION

Check that the dial indicator has been adjusted correctly to the starting point.

1. Turn the FUNCTION switch to the AM position.
2. Connect the test instruments as shown in Fig. 17, and adjust the AM Signal Generator (AM SG) to 400Hz modulation frequency, 30% modulation, and 30dB output.
3. Set the dial indicator of TX-8500II and AM SG to 600kHz, and then adjust the cores of T_4 and the bar antenna to gain the maximum output from TX-8500II.
4. Now set the dial indicator and AM SG to 1,400kHz, and again adjust for maximum output, but by means of the AM_2 and AM_1 trimmers.
5. With complete reception of the 600kHz and 1,400kHz signals, repeat steps 3 and 4 to minimize the amount of deviation between the two outputs.

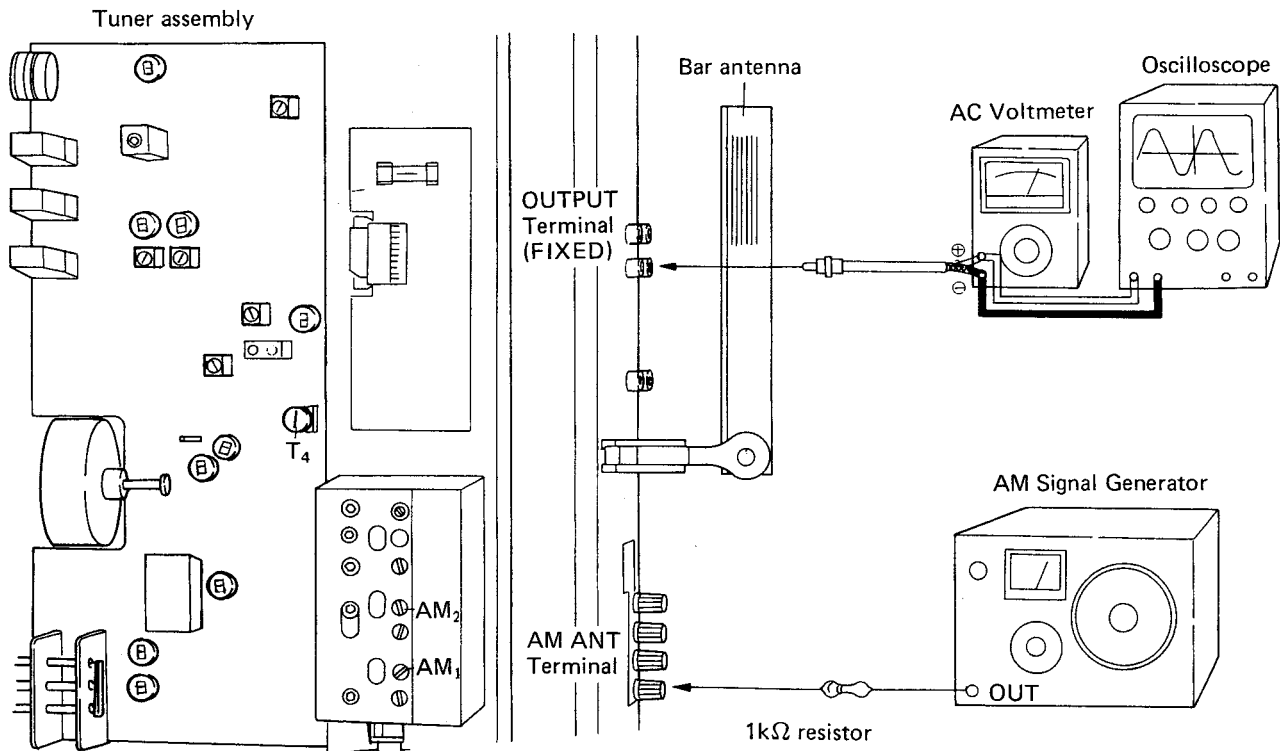
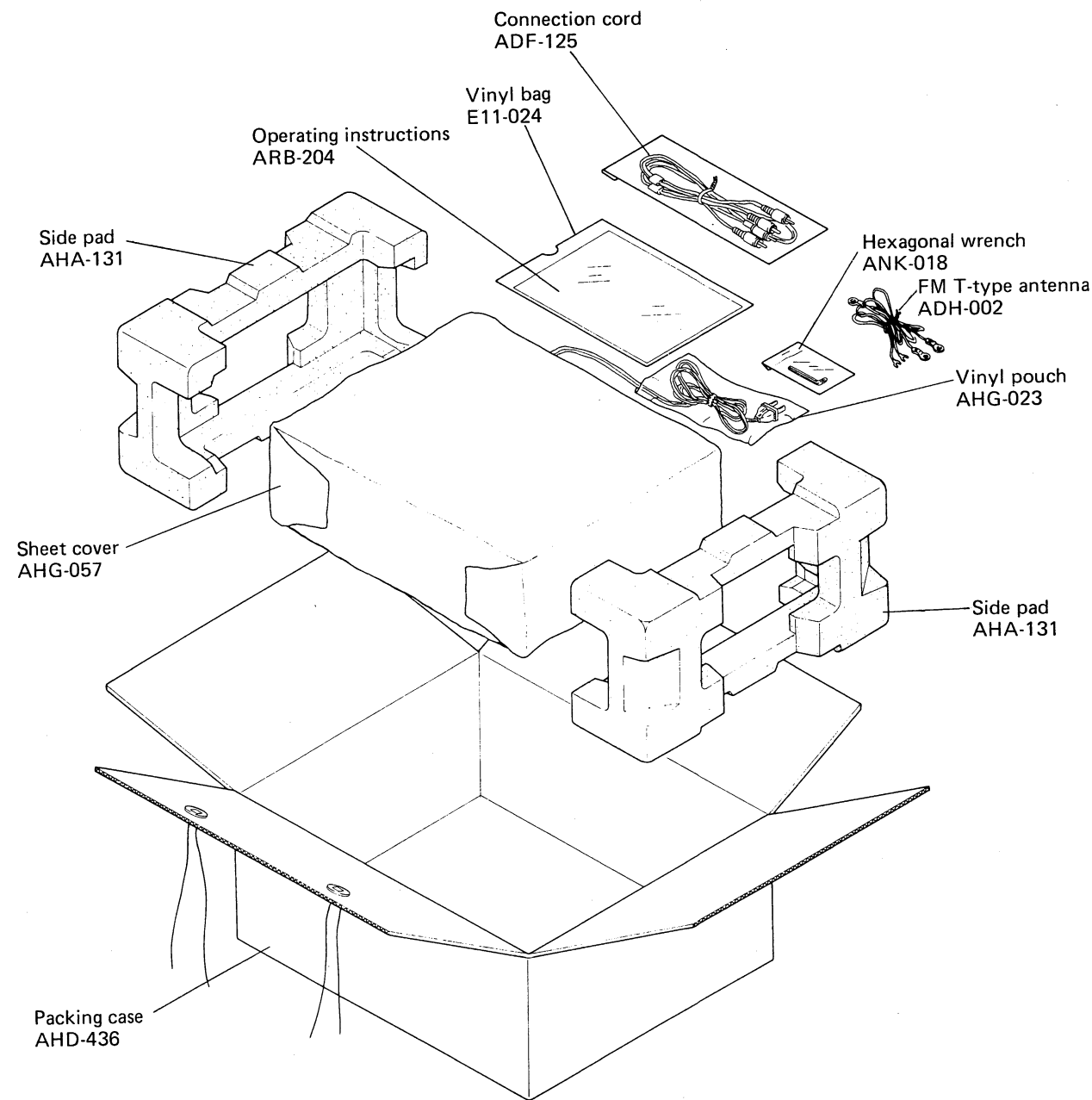

Fig. 17

10. PACKING



11. EXPLODED VIEWS

11.1 NOMENCLATURE OF SCREWS, WASHERS AND NUTS

The following symbols stand for screws, washers and nuts as shown in exploded view.

Symbol	Description	Shape
RT	Brazier head tapping screw	
PT	Pan head tapping screw	
BT	Binding head tapping screw	
CT	Countersunk head tapping screw	
TT	Truss head tapping screw	
OCT	Oval countersunk head tapping screw	
PM	Pan head machine screw	
CM	Countersunk head machine screw	
OCM	Oval countersunk head machine screw	
TM	Truss head machine screw	
BM	Binding head machine screw	
PSA	Pan head screw with spring lock washer	
PSB	Pan head screw with spring lock washer and flat washer	
PSF	Pan head screw with flat washer	

Symbol	Description	Shape
EW	E type washer	
FW	Flat washer	
SW	Spring lock washer	
N	Nut	
WN	Washer faced nut	
ITW	Internal toothed lock washer	
OTW	Outernal toothed lock washer	
SC	Slotted set screw (Cone point)	
SF	Slotted set screw (Flat point)	
HS	Hexagon socket headless set screw	
OCW	Oval countersunk head wood screw	
CW	Countersunk head wood screw	
RW	Round head wood screw	

EXAMPLE

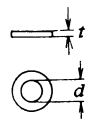
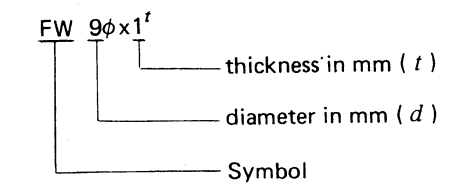
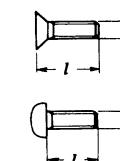
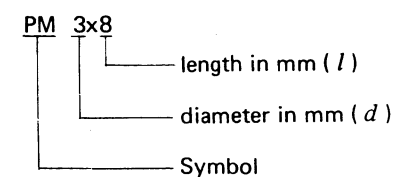

11.2 TOP SIDE

NOTE:
Parts indicated in green type cannot be supplied.

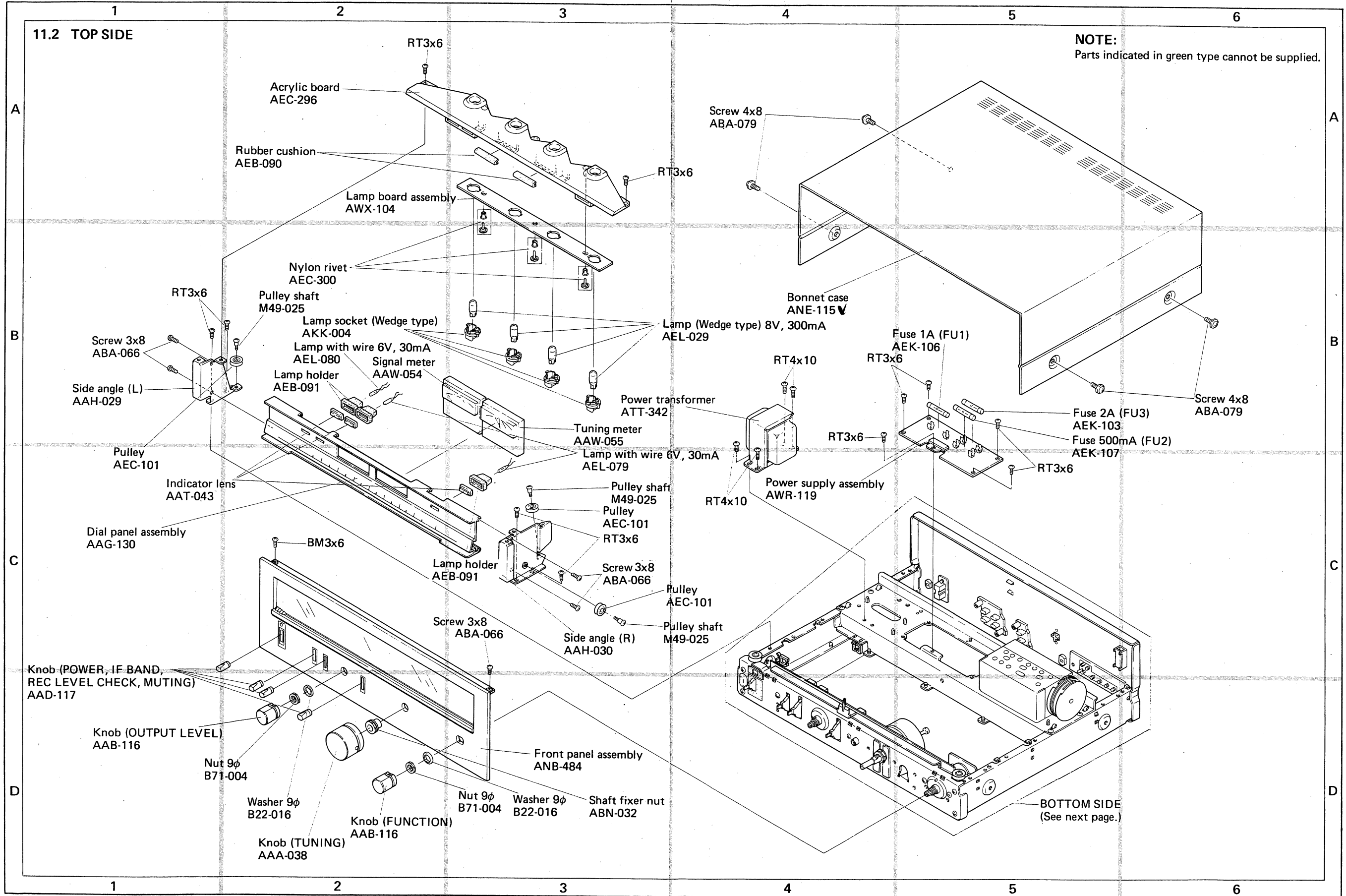

11.3 BOTTOM SIDE

NOTE:
Part indicated in green type cannot be supplied.

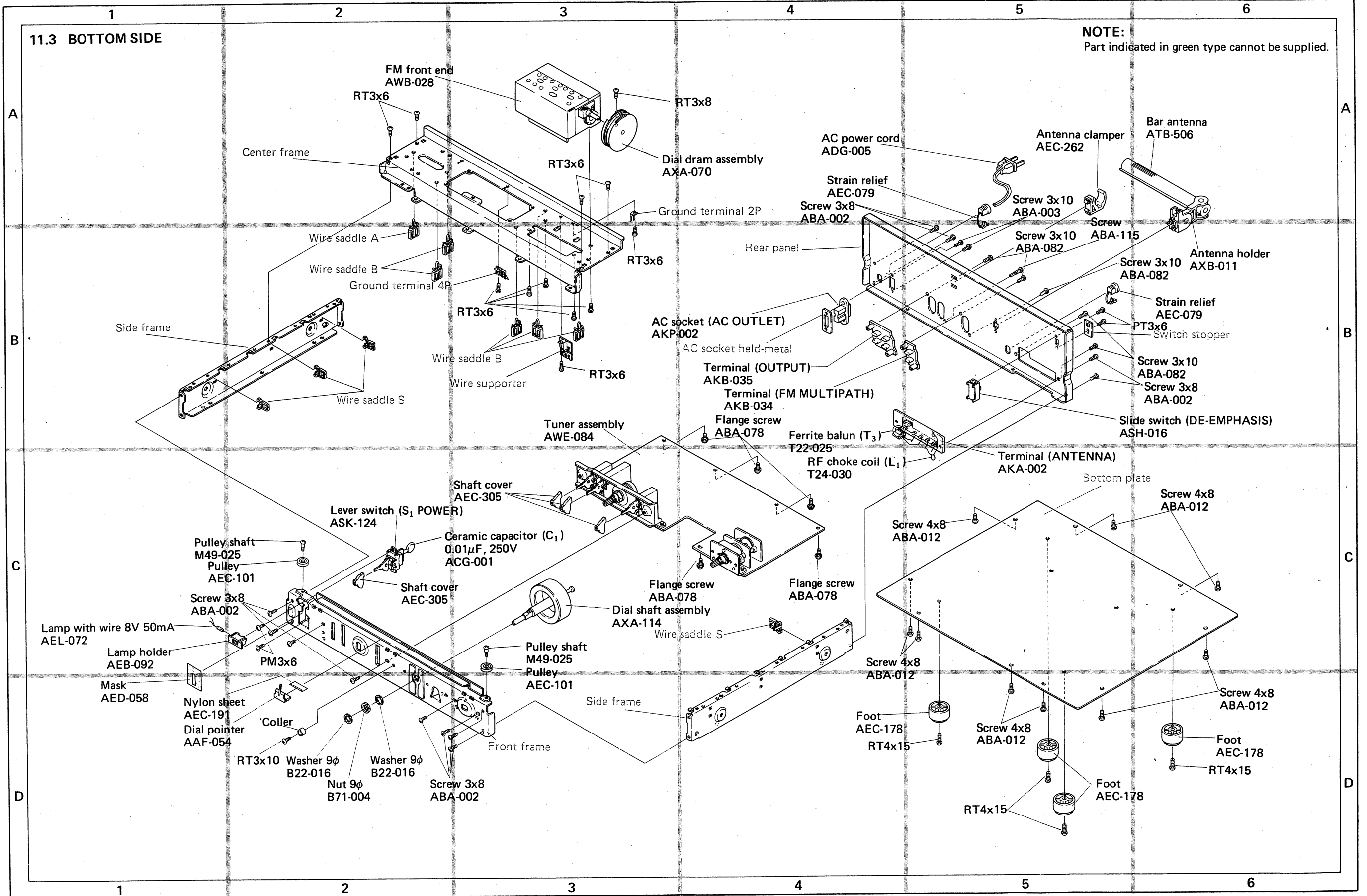

12. SCHEMATIC DIAGRAMS, P.C. BOARD PATTERNS AND PARTS LIST

12.1 SCHEMATIC DIAGRAM AND MISCELLANEOUS PARTS LIST

NOTE:

The indicated semiconductors are representative ones only. Other alternative semiconductors may be used and are listed in the parts list.

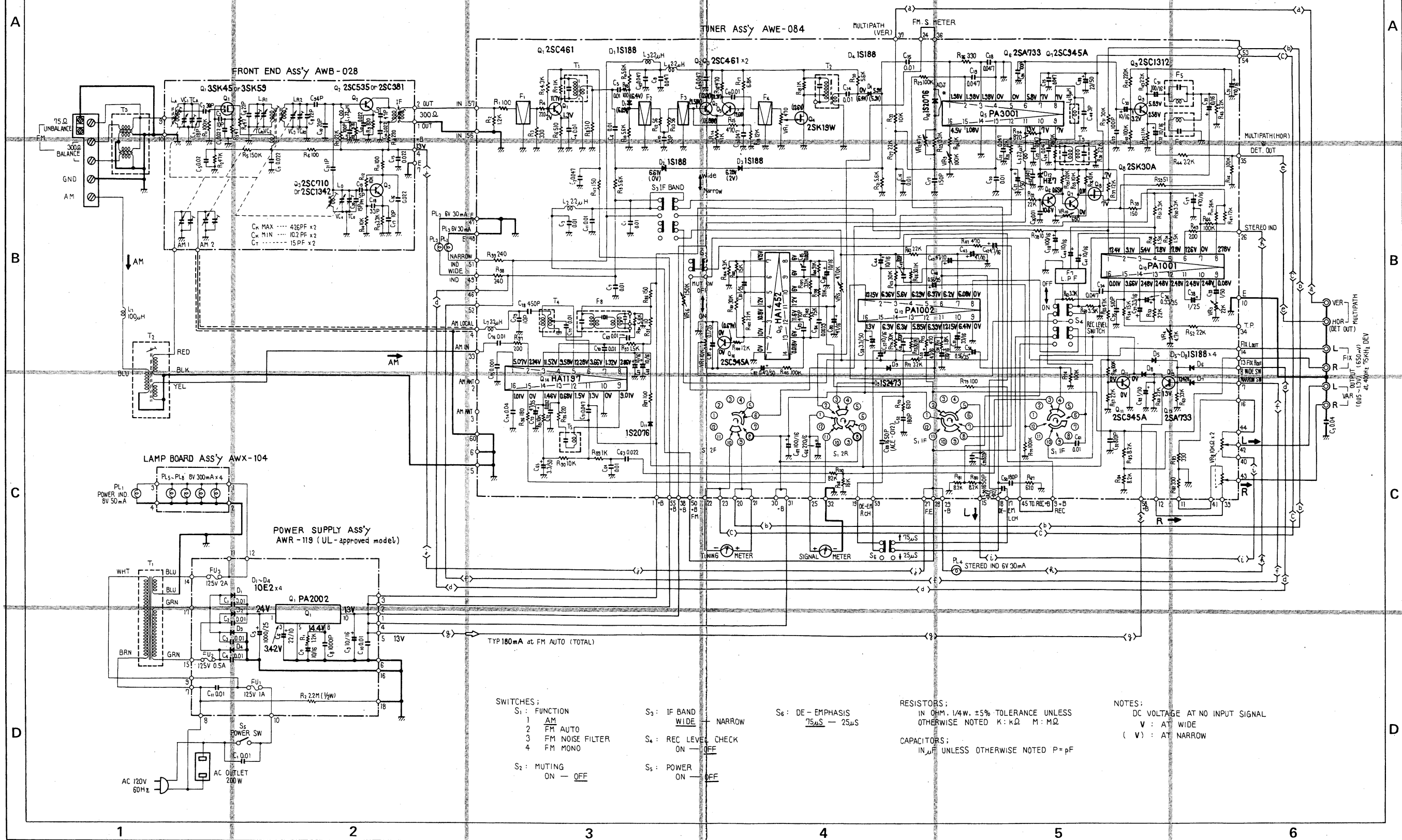

- SWITCHES:**
- S₁: FUNCTION
 - 1 AM
 - 2 FM AUTO
 - 3 FM NOISE FILTER
 - 4 FM MONO
 - S₂: MUTING
 - ON — OFF
 - S₃: IF BAND
 - WIDE — NARROW
 - S₄: REC LEVEL CHECK
 - ON — OFF
 - S₅: POWER
 - ON — OFF

S₆: DE — EMPHASIS
75μS — 25μS

RESISTORS:
IN OHM, 1/4W, ±5% TOLERANCE UNLESS OTHERWISE NOTED K: KΩ M: MΩ

CAPACITORS:
IN μF UNLESS OTHERWISE NOTED P = pF

NOTES:
DC VOLTAGE AT NO INPUT SIGNAL
V : AT WIDE
(V) : AT NARROW

Miscellaneous Parts List

NOTE:

- Capacitors: in μF unless otherwise noted p:pF
- Resistors: in Ω , $\frac{1}{4}W$ unless otherwise noted k:k Ω , M:M Ω

SWITCHES

Symbol	Description	Part No.
S5	Lever switch (POWER)	ASK-124
S6	Slide switch (DE-EMPHASIS)	ASH-016

TRANSFORMERS AND COIL

Symbol	Description	Part No.
T1	Power transformer	ATT-342
T2	Bar antenna	ATB-506
T3	Ferrite balun	T22-025
L1	RF choke coil	T24-030

LAMPS

Symbol	Description	Part No.
PL1	Lamp with wire 8V, 50mA	AEL-072
PL2	Lamp with wire 6V, 30mA	AEL-080
PL3	Lamp with wire 6V, 30mA	AEL-079
PL4	Lamp with wire 6V, 30mA	AEL-079
PL5	Lamp (Wedge type) 8V, 300mA	AEL-029
PL6	Lamp (Wedge type) 8V, 300mA	AEL-029
PL7	Lamp (Wedge type) 8V, 300mA	AEL-029
PL8	Lamp (Wedge type) 8V, 300mA	AEL-029

FUSES

Symbol	Description	Part No.
FU1	Fuse 1A (Primary)	AEK-106
FU2	Fuse 500mA (Secondary)	AEK-107
FU3	Fuse 2A (Secondary)	AEK-103

CAPACITORS

Symbol	Description	Part No.
C1	Ceramic 0.01 250V	ACG-001
C2	Ceramic 0.04 50V	CKDYF 403Z 50

External Appearances of Transistors and ICs

2SC461

2SK19

2SA733
2SC945A

2SK30A

2SC1312

PA1002
PA3001
PA1001
HA1197

HA1452W

PA2002

Circuit Diagrams of ICs

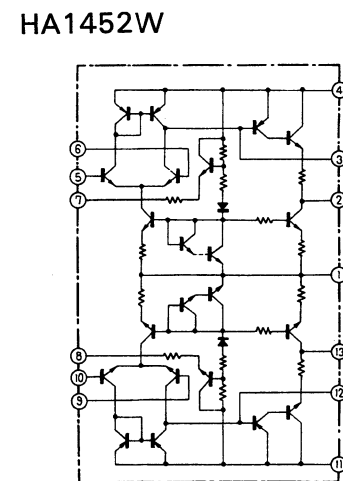

HA1197 (AM IC)

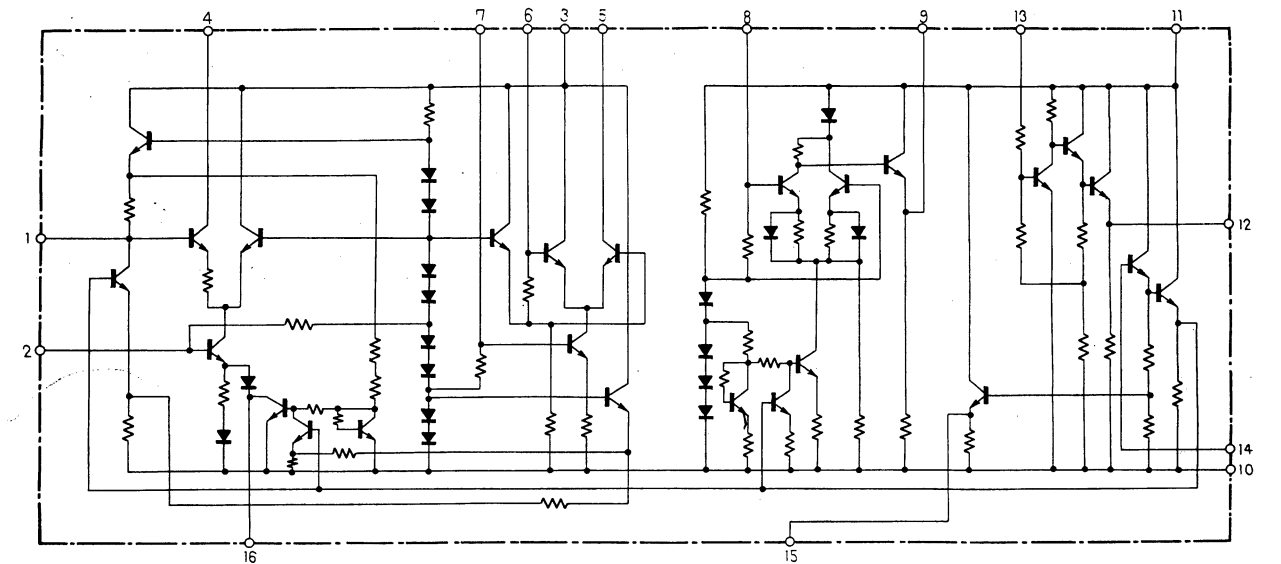

12.2 FM FRONT END (AWB-028)

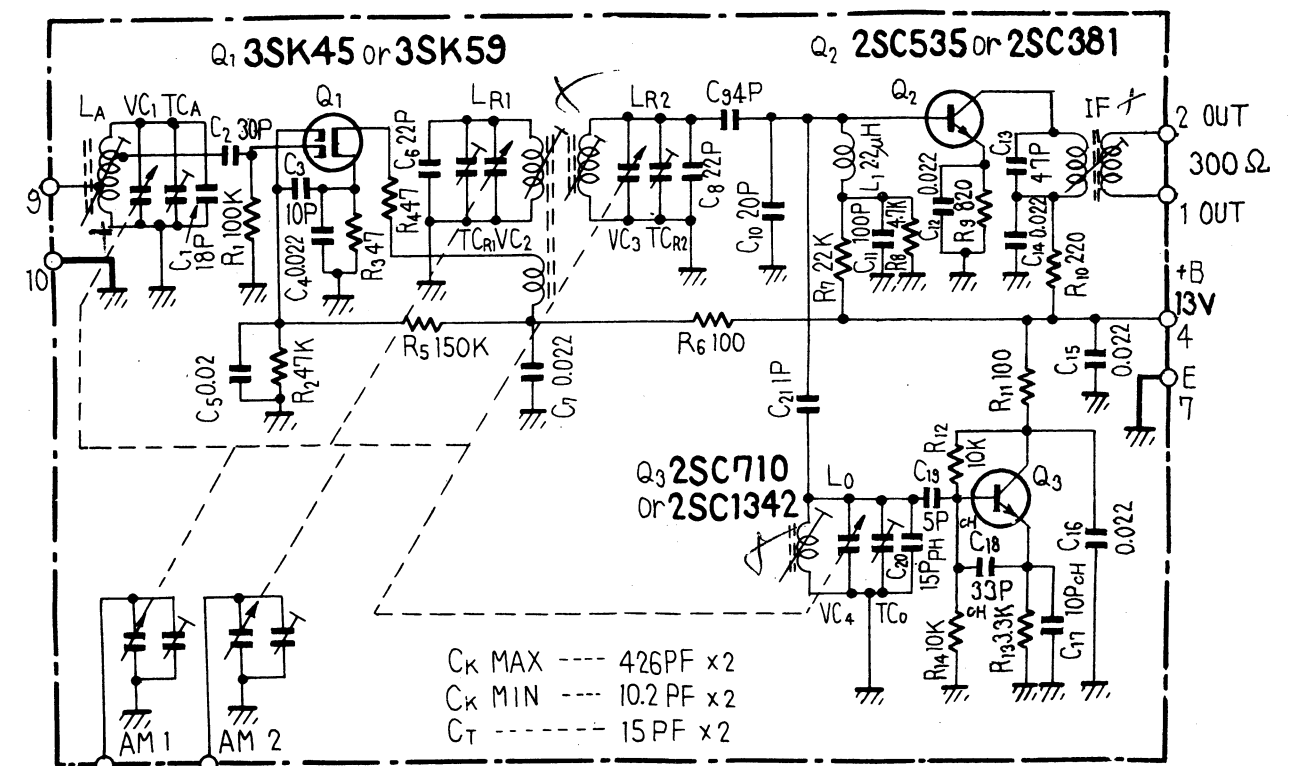

12.3 TUNER ASSEMBLY (AWE-084)

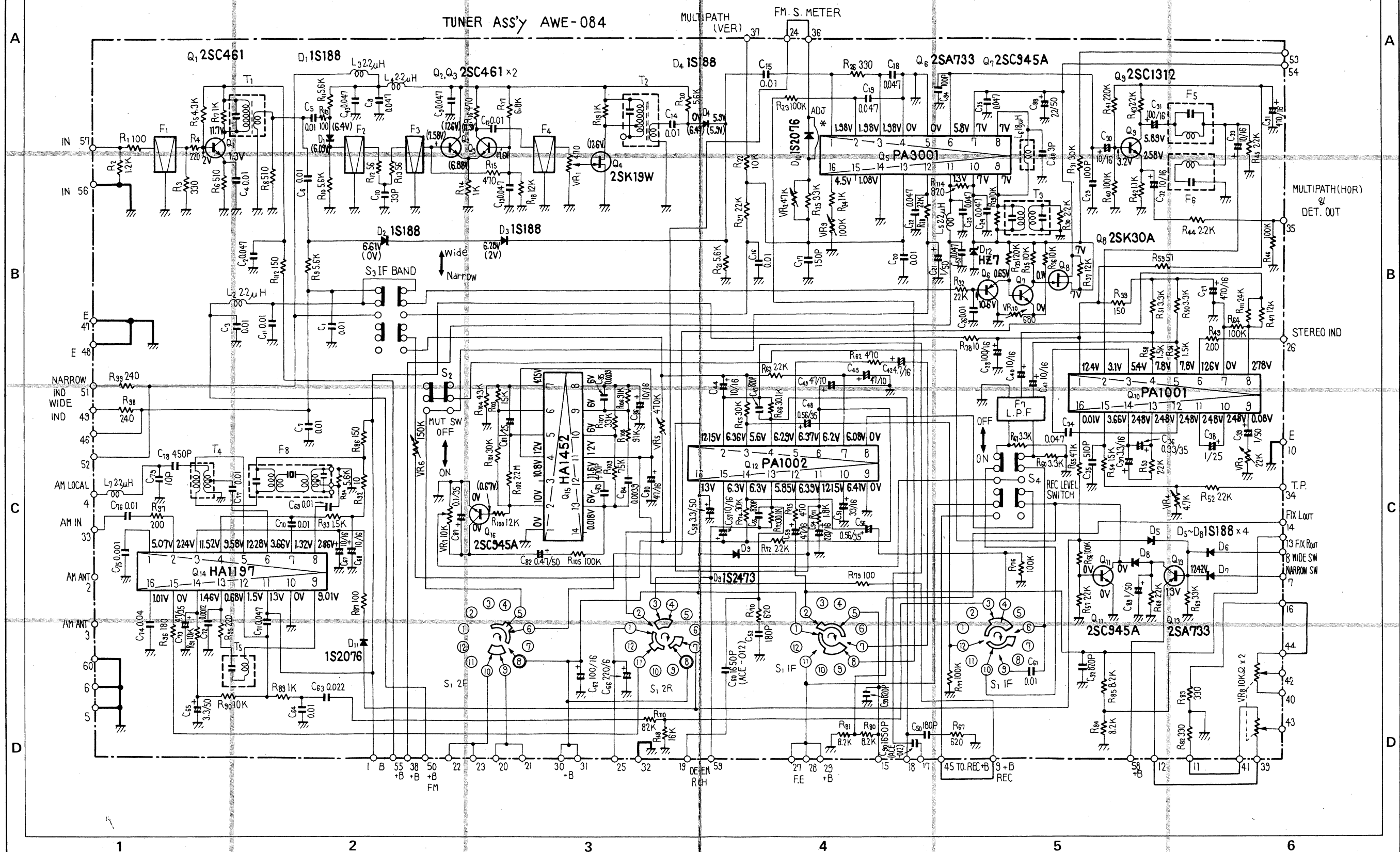

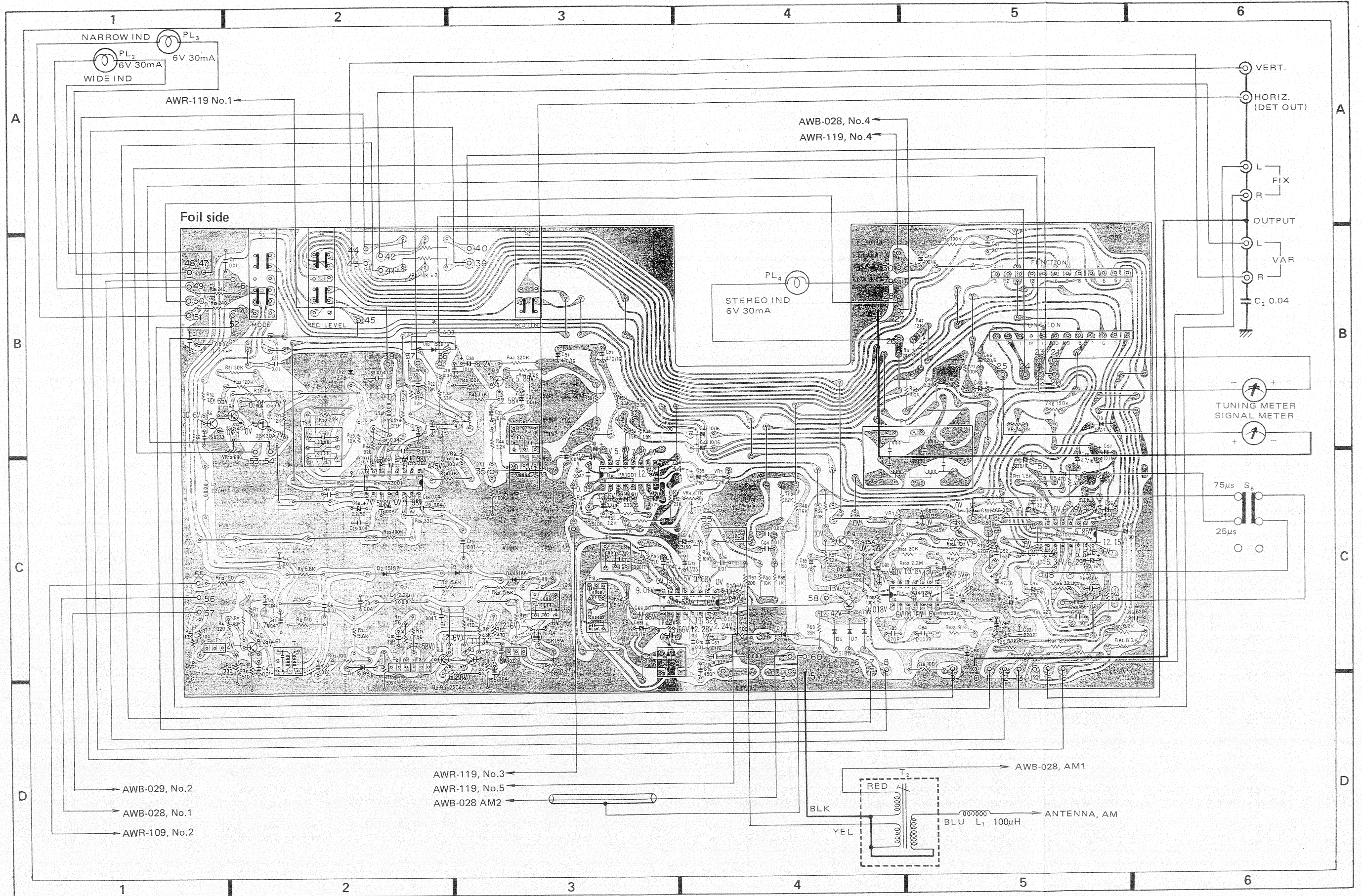

Parts List of Tuner Assembly (AWE-084)

SEMICONDUCTORS

Symbol	Description	Part No.
Q1	Transistor	2SC461-B
Q2	Transistor	2SC461-B
Q3	Transistor	2SC461-B
Q4	FET	2SK19-W
* Q5	IC	PA3001 (PA3001Y)
Q6	Transistor	2SA733-Q
Q7	Transistor	2SC945A-Q
Q8	FET	2SK30A-Y
Q9	Transistor	2SC1312-G
Q10	IC	PA1001
Q11	Transistor	2SC945A-Q
Q12	IC	PA1002
Q13	Transistor	2SA733-Q
Q14	IC	HA1197
Q15	IC	HA1452W
Q16	Transistor	2SC945A-Q
D1	Diode	1S188FM-1
D2	Diode	1S188FM-1
D3	Diode	1S188FM-1
D4	Diode	1S188FM-1
D5	Diode	1S188FM-1
D6	Diode	1S188FM-1
D7	Diode	1S188FM-1
D8	Diode	1S188FM-1
D9	Diode	1S2473
* D10	Diode	1S2076
D11	Diode	1S2076
D12	Zener diode	HZ7-B

TRANSFORMERS, COILS

Symbol	Description	Part No.
T1	FM IF transformer	ATE-023
T2	FM IF transformer	ATE-024
T3	FM IF transformer	T73-035
T4	AM OSC coil	ATB-019
T5	455kHz filter	ATF-038
F1	FM ceramic filter	ATF-013
F2	FM ceramic filter	ATF-013
F3	FM ceramic filter	ATF-013
F4	FM ceramic filter	ATF-013
F5	Anti-birdy filter	ATF-023
F6	Anti-birdy filter	ATF-024
F7	Low pass filter	ATF-036
F8	AM ceramic filter	ATF-034
L2	RF choke coil	T24-028
L3	RF choke coil	T24-028

Symbol	Description	Part No.
L4	RF choke coil	T24-028
L5	RF choke coil	T24-028
L6	RF choke coil	ATH-007
L7	RF choke coil	T24-028

SWITCHES

Symbol	Description	Part No.
S1	Rotary switch (FUNCTION)	ASD-063
S2	Lever switch (FM MUTING)	ASK-109
S3	Lever switch (IF BAND)	ASK-112
S4	Lever switch (REC LEVEL CHECK)	ASK-112

RESISTORS

Symbol	Description	Part No.
R1	Carbon film 100	RD%PS 101J
R2	Carbon film 1.2k	RD%PS 122J
R3	Carbon film 330	RD%PS 331J
R4	Carbon film 220	RD%PS 221J
R5	Carbon film 4.3k	RD%PS 432J
R6	Carbon film 510	RD%PS 511J
R7	Carbon film 1k	RD%PS 102J
R8	Carbon film 510	RD%PS 511J
R9	Carbon film 5.6k	RD%PS 562J
R10	Carbon film 5.6k	RD%PS 562J
R11	Carbon film 5.6k	RD%PS 562J
R12	Carbon film 56	RD%PS 560J
R13	Carbon film 56	RD%PS 560J
R14	Carbon film 1k	RD%PS 102J
R15	Carbon film 470	RD%PS 471J
R16	Carbon film 470	RD%PS 471J
R17	Carbon film 6.8k	RD%PS 682J
R18	Carbon film 12k	RD%PS 123J
R19	Carbon film 1k	RD%PS 102J
R20	Carbon film 5.6k	RD%PS 562J
R21	Carbon film 5.6k	RD%PS 562J
R22	Carbon film 10k	RD%PS 103J
R23	Carbon film 100k	RD%PS 104J
R24	Carbon film 1k	RD%PS 102J
R25	Carbon film 33k	RD%PS 333J
R26	Carbon film 330	RD%PS 331J
R27	Carbon film 22k	RD%PS 223J
R28	Carbon film 2.2k	RD%PS 222J
R29	Carbon film 10k	RD%PS 103J
R30	Carbon film 2.2k	RD%PS 222J
R31	Carbon film 30k	RD%PS 303J
R32	Carbon film 22k	RD%PS 223J

Symbol	Description	Part No.
R33	Carbon film 120k	RD%PS 124J
R34	Carbon film 1.5k	RD%PS 152J
R35	Carbon film 10k	RD%PS 103J
R36	Carbon film 10k	RD%PS 103J
R37	Carbon film 12k	RD%PS 123J
R38	Carbon film 10	RD%PS 100J
R39	Carbon film 150	RD%PS 151J
R40	Carbon film 100k	RD%PS 104J
R41	Carbon film 220k	RD%PS 224J
R42	Carbon film 1.1k	RD%PS 112J
R43	Carbon film 2.2k	RD%PS 222J
R44	Carbon film 2.2k	RD%PS 222J
R45	Carbon film 2.2k	RD%PS 222J
R46	Carbon film 100k	RD%PS 104J
R47	Carbon film 12k	RD%PS 123J
R48	Carbon film 16k	RD%PS 163J
R49	Carbon film 200	RD%PS 201J
R50	Metal film 3.3k $\frac{1}{2}W$	RN%SQ 3301F
R51	Metal film 3.3k $\frac{1}{2}W$	RN%SQ 3301F
R52	Carbon film 22k	RD%PS 223J
R53	Carbon film 2.2k	RD%PS 222J
R54	Carbon film 15k	RD%PS 153J
R55	Carbon film 47k	RD%PS 473J
R56	Carbon film 100k	RD%PS 104J
R57	Carbon film 22k	RD%PS 223J
R58	Carbon film 1.5k	RD%PS 152J
R59	Carbon film 51	RD%PS 510J
R60	Carbon film 3.3k	RD%PS 332J
R61	Carbon film 3.3k	RD%PS 332J
R62	Carbon film 470	RD%PS 471J
R63	Carbon film 2.2k	RD%PS 222J
R64	Carbon film 100k	RD%PS 104J
R65	Carbon film 30k	RD%PS 303J
R66	Metal film 30.1k $\frac{1}{2}W$	RN%SQ 3012F
R67	Carbon film 620	RD%PS 621J
R68	Carbon film 22k	RD%PS 223J
R69	Carbon film 33k	RD%PS 333J
R70	Carbon film 620	RD%PS 621J
R71	Carbon film 1.8k	RD%PS 182J
R72	Carbon film 2.2k	RD%PS 222J
R73	Metal film 30.1k $\frac{1}{2}W$	RN%SQ 3012F
R74	Carbon film 30k	RD%PS 303J
R75	Carbon film 470	RD%PS 471J
R76	Carbon film 100k	RD%PS 104J
R77	Carbon film 100k	RD%PS 104J
R79	Carbon film 100	RD%PS 101J
R80	Carbon film 8.2k	RD%PS 822J
R81	Carbon film 8.2k	RD%PS 822J
R82	Carbon film 330	RD%PS 331J
R83	Carbon film 330	RD%PS 331J
R84	Carbon film 8.2k	RD%PS 822J

Symbol	Description	Part No.
R85	Carbon film 8.2k	RD%PS 822J
R86	Carbon film 150	RD%PS 151J
R87	Carbon film 100	RD%PS 101J
R89	Carbon film 1k	RD%PS 102J
R90	Carbon film 10k	RD%PS 103J
R91	Carbon film 10k	RD%PS 103J
R92	Carbon film 10	RD%PS 100J
R93	Carbon film 1.5k	RD%PS 152J
R94	Carbon film 5.6k	RD%PS 562J
R95	Carbon film 220	RD%PS 221J
R96	Carbon film 180	RD%PS 181J
R97	Carbon film 200	RD%PS 201J
R98	Carbon film 240	RD%PS 241J
R99	Carbon film 240	RD%PS 241J
R100	Carbon film 12k	RD%PS 123J
R101	Carbon film 30k	RD%PS 303J
R102	Carbon film 2.2M	RD%PS 225J
R103	Carbon film 15k	RD%PS 153J
R104	Carbon film 4.3k	RD%PS 432J
R105	Carbon film 100k	RD%PS 104J
R106	Carbon film 91k	RD%PS 913J
R107	Carbon film 33k	RD%PS 333J
R108	Carbon film 91k	RD%PS 913J
R109	Carbon film 75k	RD%PS 753J
R110	Carbon film 82k	RD%PS 823J
R111	Carbon film 24k	RD%PS 243J
R112	Carbon film 150	RD%PS 151J
R113	Carbon film 100	RD%PS 101J
R114	Carbon film 820	RD%PS 821J
VR1	Semi-fixed 470	ACP-006
VR2	Semi-fixed 47k	C92-048
VR3	Semi-fixed 22k	ACP-056
VR4	Semi-fixed 4.7k	C92-051
VR5	Semi-fixed 470k	ACP-011
VR6	Semi-fixed 150k	ACP-057
VR7	Semi-fixed 10k	C92-049
VR8	Variable resistor 10k (OUTPUT LEVEL)	ACV-178
VR9	Semi-fixed 100k	C92-047
VR10	Semi-fixed 680	ACP-013

CAPACITORS

Symbol	Description	Part No.
C1	Ceramic 0.01 50V	CKDYF 103Z 50
C2	Ceramic 0.047 25V	CKDBC 473Z 25
C3	Ceramic 0.01 50V	CKDYB 103K 50
C4	Ceramic 0.01 50V	CKDYB 103K 50
C5	Ceramic 0.01 50V	CKDYF 103Z 50
C6	Ceramic 0.01 50V	CKDYF 103Z 50
C7	Ceramic 0.01 50V	CKDYB 103K 50

Symbol	Description			Part No.
C8	Ceramic	0.047	25V	CKDBC 473Z 25
C9	Ceramic	0.047	25V	CKDBC 473Z 25
C10	Ceramic	33p	50V	CCDSL 330K 50
C11	Ceramic	0.01	50V	CKDYB 103K 50
C12	Ceramic	0.01	50V	CKDYF 103Z 50
C13	Ceramic	0.047	25V	CKDBC 473Z 25
C14	Ceramic	0.01	50V	CKDYF 103Z 50
C15	Ceramic	0.01	50V	CKDYF 103Z 50
C16	Ceramic	0.01	50V	CKDYF 103Z 50
C17	Ceramic	150p	50V	CCDSL 151K 50
C18	Ceramic	0.047	25V	CKDBC 473Z 25
C19	Ceramic	0.047	25V	CKDBC 473Z 25
C20	Ceramic	0.01	50V	CKDYB 103K 50
C21	Electrolytic	1	50V	CEA 010P 50
C22	Ceramic	0.047	25V	CKDBC 473Z 25
C23	Ceramic	0.047	25V	CKDBC 473Z 25
C24	Ceramic	0.047	25V	CKDBC 473Z 25
C25	Ceramic	0.047	25V	CKDBC 473Z 25
C26	Ceramic	0.01	50V	CKDYF 103Z 50
C27	Electrolytic	470	16V	CEA 471P 16
C28	Electrolytic	100	16V	CEA 101P 16
C29	Ceramic	100p	50V	CCDSL 101K 50
C30	Electrolytic	10	16V	CSZA 100M 16
C31	Electrolytic	100	16V	CEA 101P 16
C32	Electrolytic	10	16V	CSZA 100M 16
C33	Electrolytic	10	16V	CEANL 100P 16
C34	Mylar	0.047	50V	CQMA 473K 50
C35	Polystyrene	510p	50V	CQSH 511J 50
C36	Electrolytic	0.33	35V	CSZA R33M 35
C37	Electrolytic	3.3	16V	CSZA 3R3M 16
C38	Electrolytic	1	25V	CSZA 010M 25
C39	Electrolytic	1	50V	CEA 010P 50
C40	Electrolytic	10	16V	CSZA 100M 16
C41	Electrolytic	10	16V	CSZA 100M 16
C42	Electrolytic	4.7	25V	CEANL 4R7P 25
C43	Ceramic	0.047	25V	CKDBC 473Z 25
C44	Electrolytic	10	16V	CSZA 100M 16
C45	Electrolytic	47	10V	CEA 470P 10
C46	Ceramic	3p	50V	CCDSL 030C 50
C47	Polystyrene	820p	50V	CQSA 821G 50
C48	Electrolytic	0.56	35V	CSZA R56K 35
C49	Electrolytic	47	10V	CEA 470P 10
C50	Ceramic	180p	50V	CCDSL 181K 50
C51	Electrolytic	33	16V	ACH-321
C52	Ceramic	180p	50V	CCDSL 181K 50
C53	Ceramic	0.047	25V	CKDBC 473Z 25
C54	Electrolytic	220	16V	CEA 221P 16
C55	Polystyrene	820p	50V	CQSA 821G 50
C56	Electrolytic	0.56	35V	CSZA R56K 35
C57	Electrolytic	10	16V	CSZA 100M 16
C58	Electrolytic	3.3	50V	CEA 3R3P 50

Symbol	Description			Part No.
C59	Electrolytic	4.7	25V	CEANL 4R7P 25
C60	Polystyrene	1650p		ACE-012
C61	Mylar	0.01	50V	CQMA 103J 50
C62	Electrolytic	100	16V	CEA 101P 16
C63	Mylar	0.022	50V	CQMA 223J 50
C64	Mylar	0.01	50V	CQMA 103K 50
C65	Electrolytic	3.3	50V	CEA 3R3P 50
C66	Electrolytic	220	6V	CEA 221P 6
C67	Electrolytic	10	16V	CEA 100P 16
C68	Electrolytic	10	16V	CEA 100P 16
C69	Ceramic	0.01	50V	CKDYF 103Z 50
C70	Ceramic	0.01	50V	CKDYF 103Z 50
C71	Ceramic	0.047	25V	CKDBC 473Z 25
C72	Ceramic	1200p	50V	CKDYB 122K 50
C73	Electrolytic	4.7	35V	CEA 4R7P 35
C74	Ceramic	0.04	50V	CKDYF 403Z 50
C75	Ceramic	0.001	50V	CKDYB 102K 50
C76	Ceramic	0.01	50V	CKDYF 103Z 50
C77	Ceramic	0.01	50V	CKDYF 103Z 50
C78	Polystyrene	450p	50V	CQSA 451J 50
C79	Ceramic	10p	50V	CCDWK 100F 50
C80	Electrolytic	47	16V	CEA 470P 16
C81	Electrolytic	1	25V	CSZA 010M 25
C82	Electrolytic	0.47	50V	CEA R47P 50
C83	Ceramic	470p	50V	CKDYB 471K 50
C84	Mylar	0.0039	50V	CQMA 392J 50
C85	Mylar	0.0039	50V	CQMA 392J 50
C86	Electrolytic	10	16V	CEA 100P 16
C87	Electrolytic	0.1	35V	CSZA 0R1M 35
C88	Electrolytic	2.2	50V	CEA 2R2P 50
C89	Electrolytic	1	50V	CEA 010P 50
C90	Polystyrene	1650p		ACE-012
C91	Electrolytic	470	16V	CEA 471P 16
C92	Ceramic	820p	50V	CKDYB 821K 50
C93	Ceramic	820p	50V	CKDYB 821K 50
C94	Ceramic	100p	50V	CCDSL 101K 50

OTHERS

Symbol	Description	Part No.
	Nut	ABN-027
	Nut	ABN-026
	Screw	ABA-078
	Screw 3x6	ABA-116

* The IC used at Q₅ is either PA3001, or PA3001Y, depending on the model. These two ICs are not interchangeable without a minor alteration to the circuitry. When servicing, follow the instructions described below.

Replacing PA3001 with PA3001Y

Disconnect the jumper wire to the D₁₀ section. Then insert a diode (1S2076), but be careful that the direction is correct.

Replacing PA3001Y with PA3001

Remove diode D₁₀ (1S2076), and connect the gap with a jumper wire.

How to tell PA3001 and PA3001Y apart

PA3001: the characters (PA3001) on the upper surface of the IC are "white".

PA3001Y: either the characters (PA3001) on the upper surface of the IC are "yellow", or the characters PA3001Y have been printed on.

12.4 POWER SUPPLY ASSEMBLY (AWR-119)

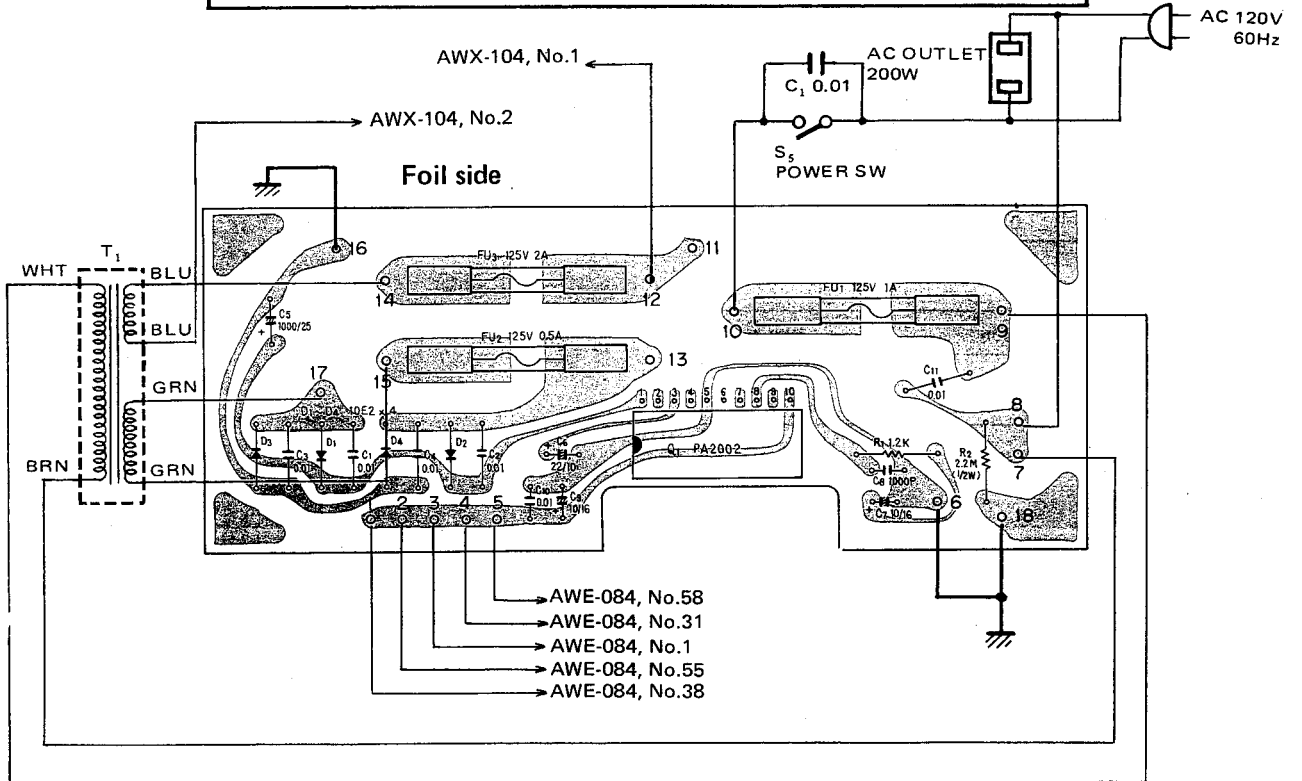
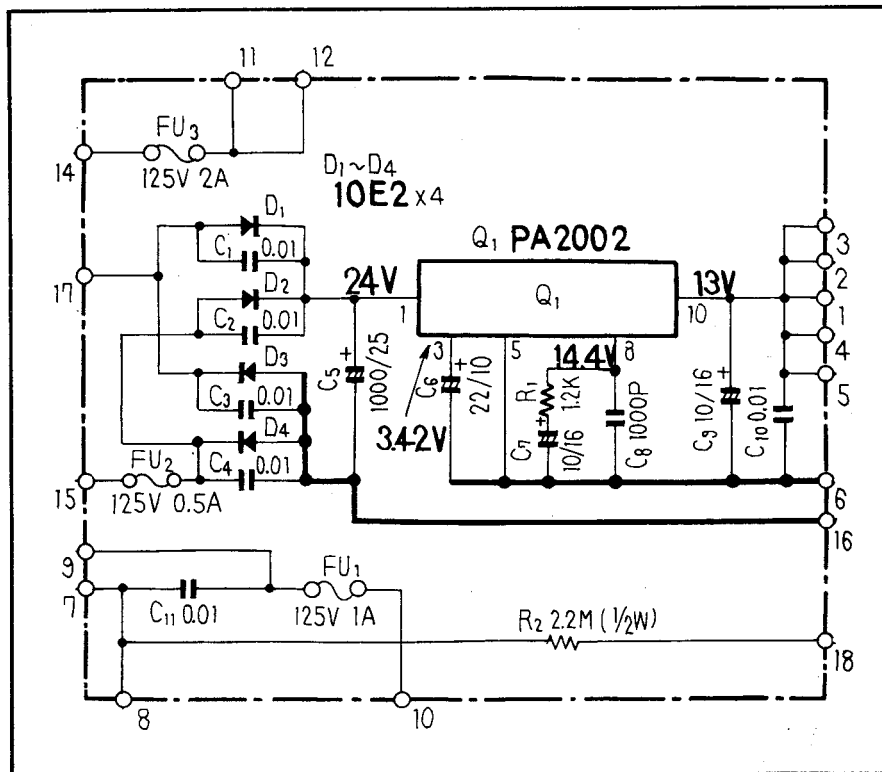

Parts List of Power Supply Assembly (AWR-119)

SEMICONDUCTORS

Symbol	Description	Part No.
Q1	IC	PA2002
D1	Diode	10E2 (SIB01-02)
D2	Diode	10E2 (SIB01-02)
D3	Diode	10E2 (SIB01-02)
D4	Diode	10E2 (SIB01-02)

RESISTORS

Symbol	Description	Part No.
R1	Carbon film 1.2k	RD¼PS 122J
R2	Carbon film 2.2M	RD¼PS 225J

CAPACITORS

Symbol	Description	Part No.
C1	Ceramic 0.01 150V	ACG-004
C2	Ceramic 0.01 150V	ACG-004
C3	Ceramic 0.01 150V	ACG-004
C4	Ceramic 0.01 150V	ACG-004
C5	Electrolytic 1000 25V	CEA 102P 25
C6	Electrolytic 22 10V	CEA 220P 10
C7	Electrolytic 10 16V	CEA 100P 16
C8	Ceramic 0.001 50V	CKDYB 102K 50
C9	Electrolytic 10 16V	CEA 100P 16
C10	Ceramic 0.01 50V	CKDYB 103K 50
C11	Ceramic 0.01 125V	ACG-003

OTHERS

Symbol	Description	Part No.
	Fuse clip	AKR-013
	Fuse clip	AKR-030