

Pioneer

Service Manual

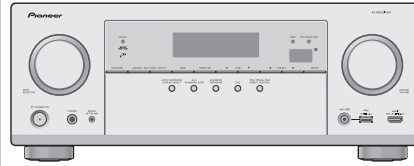

VSX-1023-K

ORDER NO.
RRV4419

AV Receiver

VSX-1023-K

VSX-43

VSX-823-K

THIS MANUAL IS APPLICABLE TO THE FOLLOWING MODEL(S) AND TYPE(S).

Model	Type	Power Requirement	Remarks
VSX-1023-K	CUXESM	AC 120 V	
VSX-43	CUXE	AC 120 V	
VSX-823-K	CUXESM	AC 120 V	

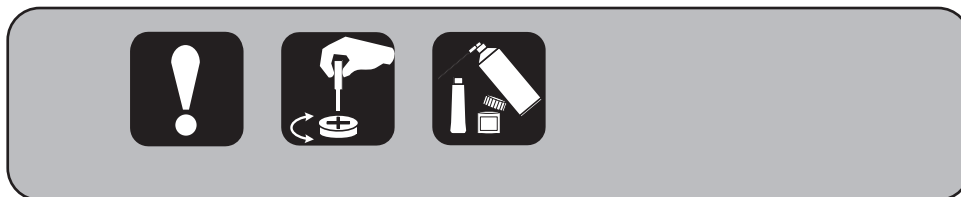

PIONEER CORPORATION 1-1, Shin-ogura, Saiwai-ku, Kawasaki-shi, Kanagawa 212-0031, Japan

PIONEER ELECTRONICS (USA) INC. P.O. Box 1760, Long Beach, CA 90801-1760, U.S.A.

PIONEER EUROPE NV Haven 1087, Keetberglaan 1, 9120 Melsele, Belgium

PIONEER ELECTRONICS ASIACENTRE PTE. LTD. 253 Alexandra Road, #04-01, Singapore 159936

©PIONEER CORPORATION 2013

K-MZV MAR. 2013 Printed in Japan

SAFETY INFORMATION



This service manual is intended for qualified service technicians; it is not meant for the casual do-it-yourselfer. Qualified technicians have the necessary test equipment and tools, and have been trained to properly and safely repair complex products such as those covered by this manual.

Improperly performed repairs can adversely affect the safety and reliability of the product and may void the warranty. If you are not qualified to perform the repair of this product properly and safely, you should not risk trying to do so and refer the repair to a qualified service technician.

WARNING

This product may contain a chemical known to the State of California to cause cancer, or birth defects or other reproductive harm.

Health & Safety Code Section 25249.6 - Proposition 65

(FOR USA MODEL ONLY)

1. SAFETY PRECAUTIONS

The following check should be performed for the continued protection of the customer and service technician.

LEAKAGE CURRENT CHECK

Measure leakage current to a known earth ground (water pipe, conduit, etc.) by connecting a leakage current tester such as Simpson Model 229-2 or equivalent between the earth ground and all exposed metal parts of the appliance (input/output terminals, screwheads, metal overlays, control shaft, etc.). Plug the AC line cord of the appliance directly into a 120 V AC 60 Hz outlet and turn the AC power switch on. Any current measured must not exceed 0.5 mA.

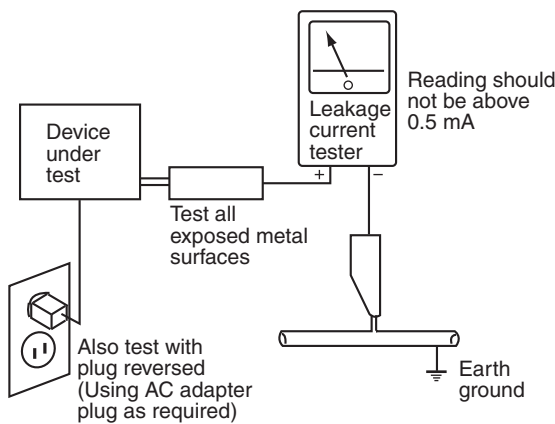

AC Leakage Test

ANY MEASUREMENTS NOT WITHIN THE LIMITS OUTLINED ABOVE ARE INDICATIVE OF A POTENTIAL SHOCK HAZARD AND MUST BE CORRECTED BEFORE RETURNING THE APPLIANCE TO THE CUSTOMER.

2. PRODUCT SAFETY NOTICE

Many electrical and mechanical parts in the appliance have special safety related characteristics. These are often not evident from visual inspection nor the protection afforded by them necessarily can be obtained by using replacement components rated for voltage, wattage, etc. Replacement parts which have these special safety characteristics are identified in this Service Manual.

Electrical components having such features are identified by marking with a ⚠ on the schematics and on the parts list in this Service Manual.

The use of a substitute replacement component which does not have the same safety characteristics as the PIONEER recommended replacement one, shown in the parts list in this Service Manual, may create shock, fire, or other hazards.

Product Safety is continuously under review and new instructions are issued from time to time. For the latest information, always consult the current PIONEER Service Manual. A subscription to, or additional copies of, PIONEER Service Manual may be obtained at a nominal charge from PIONEER.

CONTENTS

SAFETY INFORMATION.....	2	
1. SERVICE PRECAUTIONS.....	5	
1.1 NOTES ON SOLDERING.....	5	A
1.2 NOTES ON REPLACING PARTS.....	5	
1.3 SERVICE NOTICE.....	5	
2. SPECIFICATIONS.....	6	
3. BASIC ITEMS FOR SERVICE.....	7	
3.1 CHECK POINTS AFTER SERVICING.....	7	
3.2 JIGS LIST.....	7	
3.3 PCB LOCATIONS.....	8	
4. BLOCK DIAGRAM.....	10	
4.1 OVERALL WIRING DIAGRAM (for VSX-1023-K, VSX-43).....	10	
4.2 OVERALL WIRING DIAGRAM (for VSX-823-K).....	12	
4.3 D-MAIN BLOCK DIAGRAM.....	14	
4.4 AUDIO BLOCK DIAGRAM (for VSX-1023-K, VSX-43).....	16	B
4.5 AUDIO BLOCK DIAGRAM (for VSX-823-K).....	18	
4.6 POWER SUPPLY BLOCK DIAGRAM.....	20	
4.7 GND BLOCK DIAGRAM (for VSX-1023-K, VSX-43).....	22	
4.8 GND BLOCK DIAGRAM (for VSX-823-K).....	24	
5. DIAGNOSIS.....	26	
5.1 TROUBLESHOOTING.....	26	
5.2 ADAPTER ERROR MESSAGE.....	32	
5.3 USB/iPod ERROR MESSAGE.....	32	
5.4 PROTECTION CIRCUIT.....	33	
5.5 IC INFORMATION.....	37	
6. SERVICE MODE.....	45	C
6.1 TEST MODE.....	45	
6.2 DEFAULT SETTINGS.....	49	
7. DISASSEMBLY.....	50	
8. EACH SETTING AND ADJUSTMENT.....	61	
8.1 ADJUSTMENT REQUIRED WHEN THE UNIT IS REPAIRED OR REPLACED.....	61	
8.2 UPDATING OF THE FIRMWARE.....	62	
8.3 IDLE CURRENT ADJUSTMENT.....	66	
9. EXPLODED VIEWS AND PARTS LIST.....	68	
9.2 EXTERIOR SECTION (VSX-1023-K, VSX-43).....	70	
9.3 EXTERIOR SECTION (VSX-823-K).....	74	
10. SCHEMATIC DIAGRAM.....	78	
10.1 MAIN ASSY (VSX-1023-K, VSX-43).....	78	D
10.2 MAIN ASSY (1/2)(VSX-823-K).....	80	
10.3 MAIN ASSY (2/2)(VSX-823-K).....	82	
10.4 D-MAIN ASSY (1/7).....	84	
10.5 D-MAIN ASSY (2/7).....	86	
10.6 D-MAIN ASSY (3/7).....	88	
10.7 D-MAIN ASSY (4/7).....	90	
10.8 D-MAIN ASSY (5/7).....	92	
10.9 D-MAIN ASSY (6/7).....	94	
10.10 D-MAIN ASSY (7/7).....	96	
10.11 OPTCO ASSY.....	98	
10.12 BRI-1 ASSY (VSX-1023-K, VSX-43 ONLY).....	99	
10.13 CONCT ASSY (VSX-823-K ONLY).....	100	E
10.14 VIDEO ASSY (VSX-1023-K, VSX-43 ONLY).....	101	
10.15 BT and BTCNT ASSYS (VSX-1023-K, VSX-43).....	102	
10.16 BT ASSY (VSX-823-K).....	103	
10.17 BRI-2 ASSY (VSX-1023-K, VSX-43 ONLY).....	103	
10.18 AUDIO ASSY (VSX-1023-K, VSX-43 ONLY).....	104	
10.19 CPU ASSY (VSX-1023-K, VSX-43).....	106	
10.20 CPU ASSY (VSX-823-K).....	108	
10.21 AMP7 ASSY (1/2) (VSX-1023-K, VSX-43).....	110	
10.22 AMP7 ASSY (2/2) (VSX-1023-K, VSX-43).....	112	
10.23 AMP5 ASSY (1/2)(VSX-823-K).....	114	
10.24 AMP5 ASSY (2/2)(VSX-823-K).....	116	
10.25 FHDMI ASSY.....	118	F

- 10.26 INSEL, FRONT and HPMIC ASSYS 120
- 10.27 SMPS ASSY 122
- A 10.28 REG ASSY (VSX-823-K ONLY) 124
- 11. PCB CONNECTION DIAGRAM 126
- 11.1 MAIN ASSY (VSX-1023-K, VSX-43) 126
- 11.2 MAIN ASSY (VSX-823-K) 130
- 11.3 D-MAIN ASSY 134
- 11.4 OPTCO ASSY 138
- 11.5 BRI-1 ASSY (VSX-1023-K, VSX-43 ONLY) 139
- 11.6 CONCT ASSY (VSX-823-K ONLY) 140
- 11.7 VIDEO ASSY (VSX-1023-K, VSX-43 ONLY) 141
- 11.8 BT and BTCNT ASSYS 142
- 11.9 BRI-2 ASSY (VSX-1023-K, VSX-43 ONLY) 143
- B 11.10 AUDIO ASSY (VSX-1023-K, VSX-43 ONLY) 144
- 11.11 CPU ASSY (VSX-1023-K, VSX-43) 146
- 11.12 CPU ASSY (VSX-823-K) 150
- 11.13 AMP7 ASSY (VSX-1023-K, VSX-43) 154
- 11.14 AMP5 ASSY (VSX-823-K) 156
- 11.15 FHDMI, INSEL, FRONT and HPMIC ASSYS 158
- 11.16 SMPS ASSY 162
- 11.17 REG ASSY (VSX-823-K ONLY) 164
- 11.18 WIRE-A, GUIDE and CPU-G ASSYS (VSX-1023-K, VSX-43 ONLY) 165
- 11.19 WG, G-L, G-R and HDC-G ASSYS (VSX-823-K ONLY) 166
- 12. PCB PARTS LIST 167

C

D

E

F

1. SERVICE PRECAUTIONS

1.1 NOTES ON SOLDERING

- For environmental protection, lead-free solder is used on the printed circuit boards mounted in this unit.
Be sure to use lead-free solder and a soldering iron that can meet specifications for use with lead-free solders for repairs accompanied by reworking of soldering.
- Compared with conventional eutectic solders, lead-free solders have higher melting points, by approximately 40 °C.
Therefore, for lead-free soldering, the tip temperature of a soldering iron must be set to around 373 °C in general, although the temperature depends on the heat capacity of the PC board on which reworking is required and the weight of the tip of the soldering iron.

Do NOT use a soldering iron whose tip temperature cannot be controlled.

Compared with eutectic solders, lead-free solders have higher bond strengths but slower wetting times and higher melting temperatures (hard to melt/easy to harden).

The following lead-free solders are available as service parts:

- Parts numbers of lead-free solder:
GYP1006 1.0 in dia.
GYP1007 0.6 in dia.
GYP1008 0.3 in dia.

1.2 NOTES ON REPLACING PARTS

The part listed below is difficult to replace as a discrete component part.

When the part listed in the table is defective, replace whole Assy.

Assy Name	Parts that is Difficult to Replace			
	Ref No.	Function	Part No.	Remarks
D-MAIN Assy	JA1601, JA9601 - JA9605	HDMI Connector	L109100190160-IL	JACK with Cu-through-hole & 21 pin
	JA9620	HDMI Connector	L109100190170-IL	JACK with Cu-through-hole & 21 pin
	JA9202	LAN Connector	G4060RJ450230-IL	JACK with Cu-through-hole & 10 pin
	IC9602	HDMI INTERFACE IC	—————	IC with heat-pad
	IC9002	DSP IC	—————	IC with heat-pad
	IC9204	MEDIA PROCESSOR IC	—————	IC BGA type
	IC9203	LAN PHY IC	—————	IC with heat-pad
	IC9206	APPLE AUTHENTICATION IC	—————	IC with heat-pad
	IC451	3ch SW Power Supply IC	—————	IC with heat-pad
FHDMI Assy	IC809	5 V SW IC	—————	IC with heat-pad
	IC1307	5 V SW Power Supply IC	—————	IC with heat-pad

1.3 SERVICE NOTICE

• Discharging

For more detail, please refer to "7. DISASSEMBLY - 1. Discharging".

2. SPECIFICATIONS

A Amplifier section

Continuous average power output of 80 watts* per channel, min., at 8 ohms, from 20 Hz to 20 000 Hz with no more than 0.08%** total harmonic distortion.

Front (stereo) 80 W + 80 W
 Power output (1 kHz, 6 Ω, 1 %) 140 W per channel
 Guaranteed speaker impedance 6 Ω to 16 Ω

* Measured pursuant to the Federal Trade Commission's Trade Regulation rule on Power Output Claims for Amplifiers

** Measured by Audio Spectrum Analyzer

Audio Section

Input (Sensitivity/Impedance)

LINE 200 mV/47 kΩ

B Signal-to-Noise Ratio (IHF, short circuited, A network)

LINE 98 dB

Signal-to-Noise Ratio [EIA, at 1 W (1 kHz)]

LINE 79 dB

Video Section

Signal level

Composite 1 Vp-p (75 Ω)

Signal Level (VSX-1023)

Component Video Y: 1.0 Vp-p (75 Ω), PB/PR: 0.7 Vp-p (75 Ω)

Corresponding maximum resolution (VSX-1023)

Component Video 1080p (1125p)

C Tuner Section

Frequency Range (FM) 87.5 MHz to 108 MHz

Antenna Input (FM) 75 Ω unbalanced

Frequency Range (AM) 530 kHz to 1700 kHz

Antenna (AM) Loop antenna

Digital In/Out Section

HDMI terminal Type A (19-pin)

HDMI output type 5 V, 100 mA

HDMI input/MHL terminal 5 V, 900 mA

USB terminal USB2.0 High Speed (Type A) 5 V, 2.1 A

iPod terminal USB, and Video (Composite)

ADAPTER PORT terminal 5 V, 100 mA

D Network Section

LAN terminal 10 BASE-T/100 BASE-TX

Integrated control section (VSX-1023, VSX-43)

Control (IR) terminal Ø 3.5 Mini-jack (MONO)

IR signal High Active (High Level: 2.0 V)

(VSX-43)

12 V Trigger terminal ø 3.5 Mini-jack (MONO)

12 V Trigger output type 12 V, Total 150 mA

Miscellaneous

Power Requirements AC 120 V, 60 Hz

Power Consumption 520 W (VSX-1023, VSX-43)

450 W (VSX-823)

E In standby

0.1 W

0.3 W (HDMI Setup – Control : ON)

Dimensions

VSX-1023, VSX-43 435 mm (W) x 168 mm (H) x 342.5 mm (D)

17 3/16 in.(W), 6 5/8 in.(H), 13 1/2 in.(D)

VSX-823 435 mm (W) x 168 mm (H) x 331.5 mm (D)

17 3/16 in.(W), 6 5/8 in.(H), 13 1/16 in.(D)

Weight (without package) 9.2 kg (20 lb 5 oz) (VSX-1023)

Weight (without package) 9.3 kg (20 lb 9 oz) (VSX-43)

8.5 kg (18 lb 12 oz) (VSX-823)

Note

• Specifications and the design are subject to possible modifications without notice, due to improvements.

• This product includes FontAvenue® fonts licensed by NEC Corporation. FontAvenue is a registered trademark of NEC Corporation.

Accessories

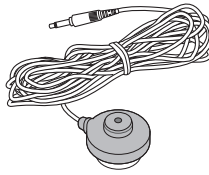

Microphone
(for Auto MCACC setup)
(APM7011)



Dry cell batteries
(AAA size IEC R03) x2



Remote control
(VSX-1023-K, VSX-823-K (AXD7691): 8300769100010-IL)
(VSX-43 (AXD7692): 8300769200010-IL)



AM loop antenna
(E601019000010-IL)



FM wire antenna
(E605010140010-IL)

Warranty card

Quick start guide
(VSX-1023-K, VSX-823-K: 5707000007800-IL)
(VSX-43: 5707000007810-IL)

Safety Brochure

SPEAKER CAUTION Sheet (English only)

Operating instructions (CD-ROM)
(VSX-1023-K, VSX-823-K: 6517000001280-IL)
(VSX-43: 6517000001290-IL)

3. BASIC ITEMS FOR SERVICE

3.1 CHECK POINTS AFTER SERVICING

Items to be checked after servicing

To keep the product quality after servicing, confirm recommended check points shown below.

No.	Procedures	Check points
1	Confirm whether the customer complain has been solved. If the customer complain occurs with the particular source, such as Dolby Digital, DTS, AAC, DVD-A and HDMI, input it for the operation check.	The customer complain must not be reappeared. Video, Audio and operations must be normal.
2	Check the analog audio playback. (Make the analog connections with a DVD player.)	Each channel audio and operations must be normal.
3	Check the digital audio playback. (Make the digital connections with a DVD player.)	Each channel audio and operations must be normal.
4	Check surround playback. (Select Surround mode and check the multichannel operations via the DSP circuit.)	Each channel audio and operations must be normal.
5	Check the video outputs. (Connect with a DVD player.)	Video and operations must be normal.
6	Check the tuner (AM and FM) operations.	Audio and operations must be normal.
7	Check the sound from headphone output.	Sound must be normal, without noise.
8	Check the appearance of the product.	No scratches or dirt on its appearance after receiving it for service.

See the table below for the items to be checked regarding video and audio.

Item to be checked regarding video	Item to be checked regarding audio
Block noise	Distortion
Horizontal noise	Noise
Flicker	Volume too low
Disturbed image (video jumpiness)	Volume too high
Too dark	Volume fluctuating
Too bright	Sound interrupted
Mottled color	

3.2 JIGS LIST

Jigs List

Jig Name	Part No.	Remarks
RS-232C update jig (Jig + 10P FFC)	GGF1642	MAIN microcomputer firmware update (RS-232C ↔ Rear panel)
RS-232C cable (9-pin to 9-pin, straight cable)	(Marketing product)	
Board to board extension jig cable	GGD1846	Diagnosis (D-MAIN Assy ↔ CPU Assy)
Board to board extension jig cable	GGD1847	Diagnosis (D-MAIN Assy ↔ CPU Assy)
Board to board extension jig cable	GGD1848	Diagnosis (D-MAIN Assy ↔ CONCT Assy)
Board to board extension jig cable	GGD1756	Diagnosis (D-MAIN Assy ↔ BRI-1 Assy)
13P extension jig cable	GGD1740	Diagnosis (AMP7 Assy ↔ AUDIO Assy)
3P extension jig cable	GGD1741	Diagnosis (AMP7 Assy ↔ MAIN Assy)
HDMI cable	(Marketing product)	Diagnosis (FRONT Assy ↔ D-MAIN Assy)



Lubricants and Glues List

Name	Part No.	Remarks
Silicon grease	GEM1057	Refer to "9.2 EXTERIOR SECTION".
Silicon adhesive	GYA1011 (KE40RTV-W)	Refer to "9.2 EXTERIOR SECTION".

3.3 PCB LOCATIONS

1

2

3

4

A ■ VSX-1023-K, VSX-43

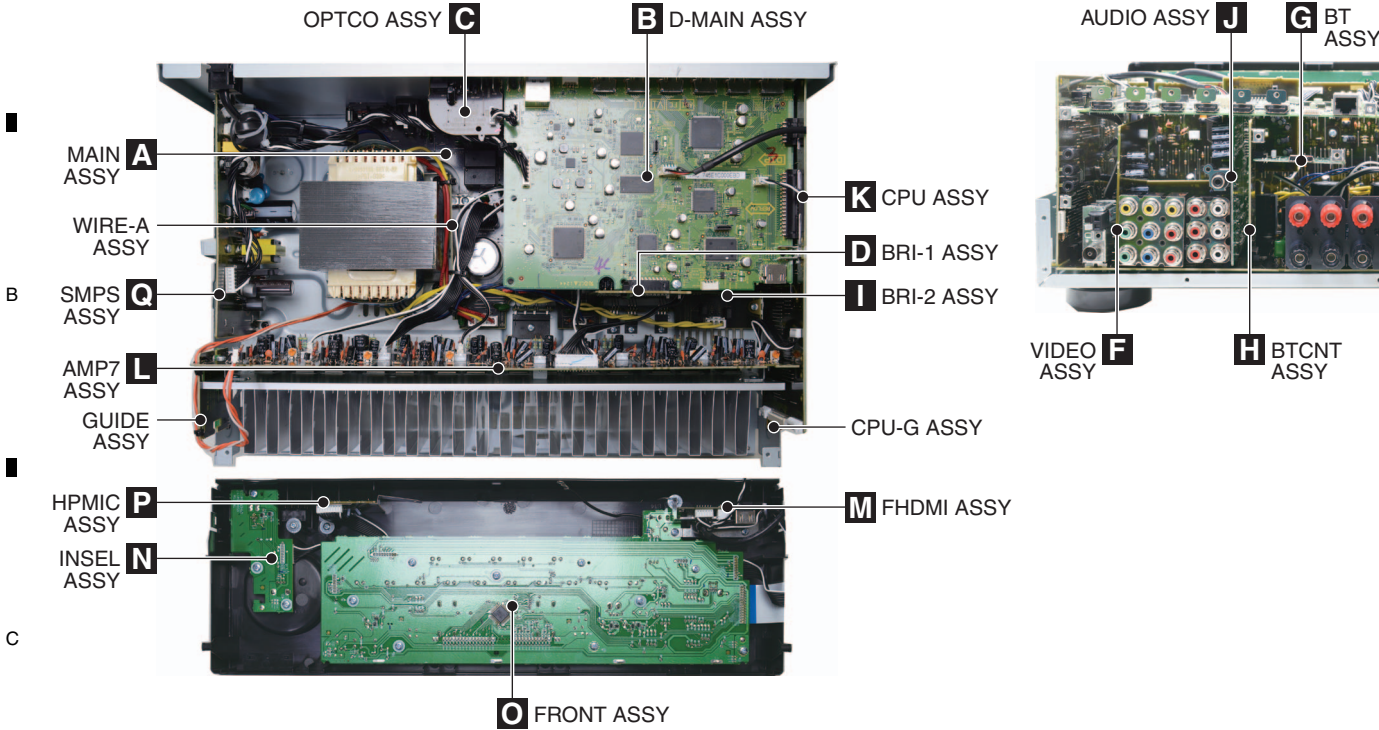

■ VSX-823-K

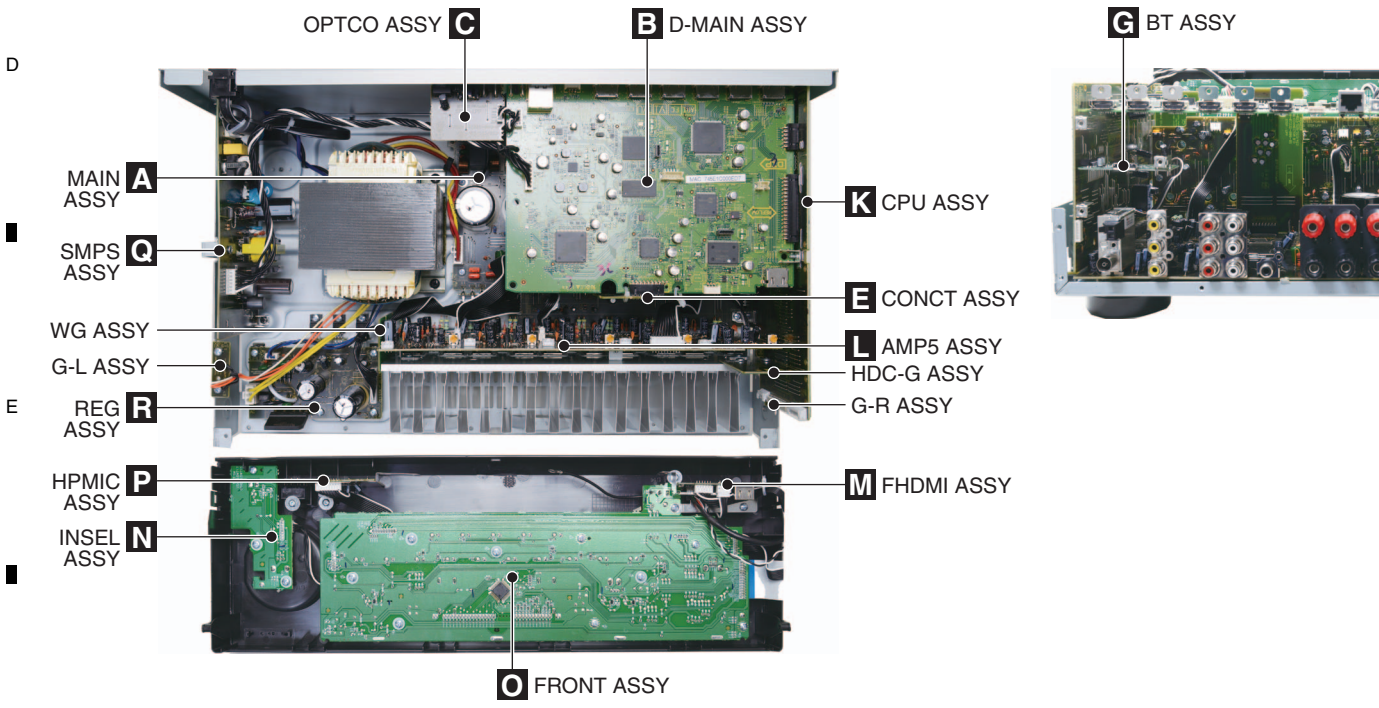

1

2

3

4

NOTES: ● Parts marked by “NSP” are generally unavailable because they are not in our Master Spare Parts List.
 ● The ⚠ mark found on some component parts indicates the importance of the safety factor of the part.
 Therefore, when replacing, be sure to use parts of identical designation.

LIST OF ASSEMBLIES

Mark	Symbol and Description	VSX-1023-K/CUXESM	VSX-43/CUXE	VSX-823-K/CUXESM
NSP	1..PCB TTL ASSY MAIN	7025HK1209010-IL	7025HK1209020-IL	7025HK1210010-IL
	2..MAIN ASSY (PCB SUB ASSY MAIN)	7028073031010-IL	7028073031020-IL	70280733110A0-IL
	2..VIDEO ASSY (PCB SUB ASSY VIDEO)	7028073032020-IL	7028073032020-IL	Not used
	2..OPTCO ASSY (PCB SUB ASSY OPTCO)	7028073033020-IL	7028073033020-IL	70280733130A0-IL
	2..WIRE-A ASSY (PCB SUB ASSY WIRE_A)	7028073035020-IL	7028073035020-IL	Not used
	2..GUIDE ASSY (PCB SUB ASSY GUIDE)	7028073037020-IL	7028073037020-IL	Not used
	2..CPU-G ASSY (PCB SUB ASSY CPU_G)	7028073038020-IL	7028073038020-IL	Not used
	2..BRI-1 ASSY (PCB SUB ASSY BRI-1)	7028073039020-IL	7028073039020-IL	Not used
	2..REG ASSY (PCB SUB ASSY REG)	Not used	Not used	70280733120A0-IL
	2..WG ASSY (PCB SUB ASSY WG)	Not used	Not used	7028073315010-IL
	2..G-L ASSY (PCB SUB ASSY G-L)	Not used	Not used	7028073316010-IL
	2..G-R ASSY (PCB SUB ASSY G-R)	Not used	Not used	7028073317010-IL
	2..HDC-G ASSY (PCB SUB ASSY HDC-G)	Not used	Not used	70280733180A0-IL
NSP	1..PCB TTL ASSY DMAIN	7025HK1209011-IL	7025HK1209021-IL	7025HK1210011-IL
	2..D-MAIN ASSY (PCB SUB ASSY DMAIN)	7028073231040-IL	7028073231040-IL	7028073231020-IL
NSP	1..PCB TTL ASSY CPU	7025HK1209014-IL	7025HK1209024-IL	7025HK1210013-IL
	2..CPU ASSY (PCB SUB ASSY CPU)	7028073021010-IL	7028073021020-IL	70280733310A0-IL
	2..BRI-2 ASSY (PCB SUB ASSY BRI-2)	7028073023020-IL	7028073023020-IL	Not used
	2..BTCNT ASSY (PCB SUB ASSY BTCNT)	7028073024020-IL	7028073024020-IL	Not used
NSP	1..PCB TTL ASSY AUDIO	7025HK1209013-IL	7025HK1209023-IL	Not used
	2..AUDIO ASSY (PCB SUB ASSY AUDIO)	7028073041020-IL	7028073041020-IL	Not used
NSP	1..PCB TTL ASSY AMP7	7025HK1209015-IL	7025HK1209025-IL	Not used
	2..AMP7 ASSY (PCB SUB ASSY AMP7)	7028073051010-IL	7028073051010-IL	Not used
NSP	1..PCB TTL ASSY AMP5	Not used	Not used	7025HK1210014-IL
	2..AMP5 ASSY (PCB SUB ASSY AMP5)	Not used	Not used	70280733410A0-IL
NSP	1..PCB TTL ASSY FHDMI	7025HK1209017-IL	7025HK1209027-IL	7025HK1210016-IL
	2..FHDMI ASSY (PCB SUB ASSY FHDMI)	7028073221040-IL	7028073221040-IL	7028073221040-IL
NSP	1..PCB TTL ASSY BT	7025HK1209018-IL	7025HK1209028-IL	7025HK1210017-IL
	2..BT ASSY (PCB SUB ASSY BT)	7028073211040-IL	7028073211040-IL	7028073211040-IL
NSP	1..PCB TTL ASSY FRONT	7025HK1209012-IL	7025HK1209022-IL	7025HK1210012-IL
	2..FRONT ASSY (PCB SUB ASSY FRONT)	70280733210B0-IL	70280733210D0-IL	70280733210B0-IL
	2..HPMIC ASSY (PCB SUB ASSY HPMIC)	70280733220B0-IL	70280733220D0-IL	70280733220B0-IL
	2..INSEL ASSY (PCB SUB ASSY INSEL)	70280733230B0-IL	70280733230D0-IL	70280733230B0-IL
	2..CONCT ASSY (PCB SUB ASSY CONCT)	Not used	Not used	70280733240B0-IL
NSP	1..PCB TTL ASSY SMPS	7025HK1209016-IL	7025HK1209026-IL	7025HK1210015-IL
⚠	2..SMPS ASSY (PCB SUB ASSY SMPS)	7028073361010-IL	7028073361010-IL	7028073361010-IL

4. BLOCK DIAGRAM

4.1 OVERALL WIRING DIAGRAM (for VSX-1023-K, VSX-43)

A

B

C

D

E

F

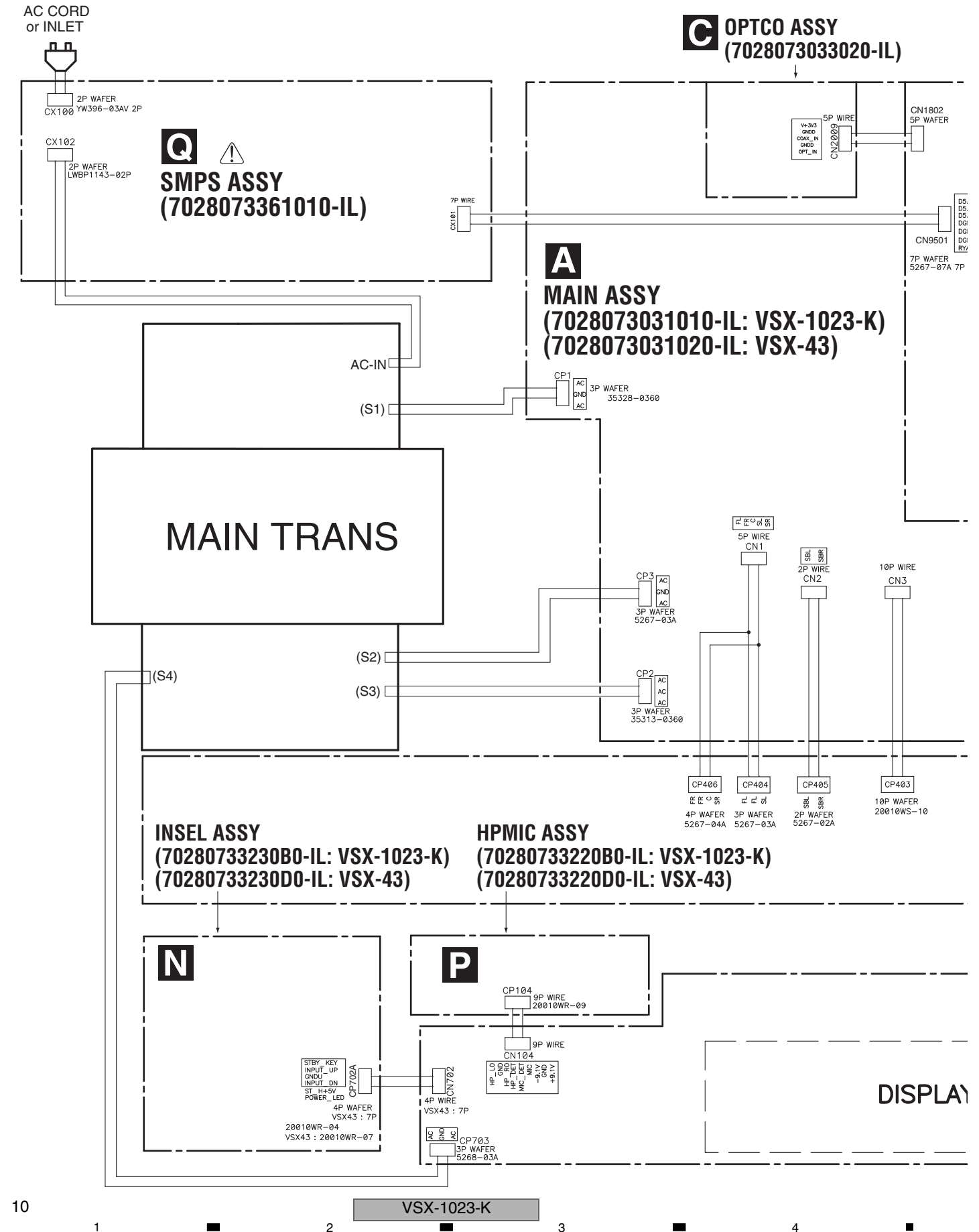

- When ordering service parts, be sure to refer to "EXPLODED VIEWS and PARTS LIST" or "PCB PARTS LIST".
- The Δ mark found on some component parts indicates the importance of the safety factor of the part. Therefore, when replacing, be sure to use parts of identical designation.
-  : The power supply is shown with the marked box.

20-IL)

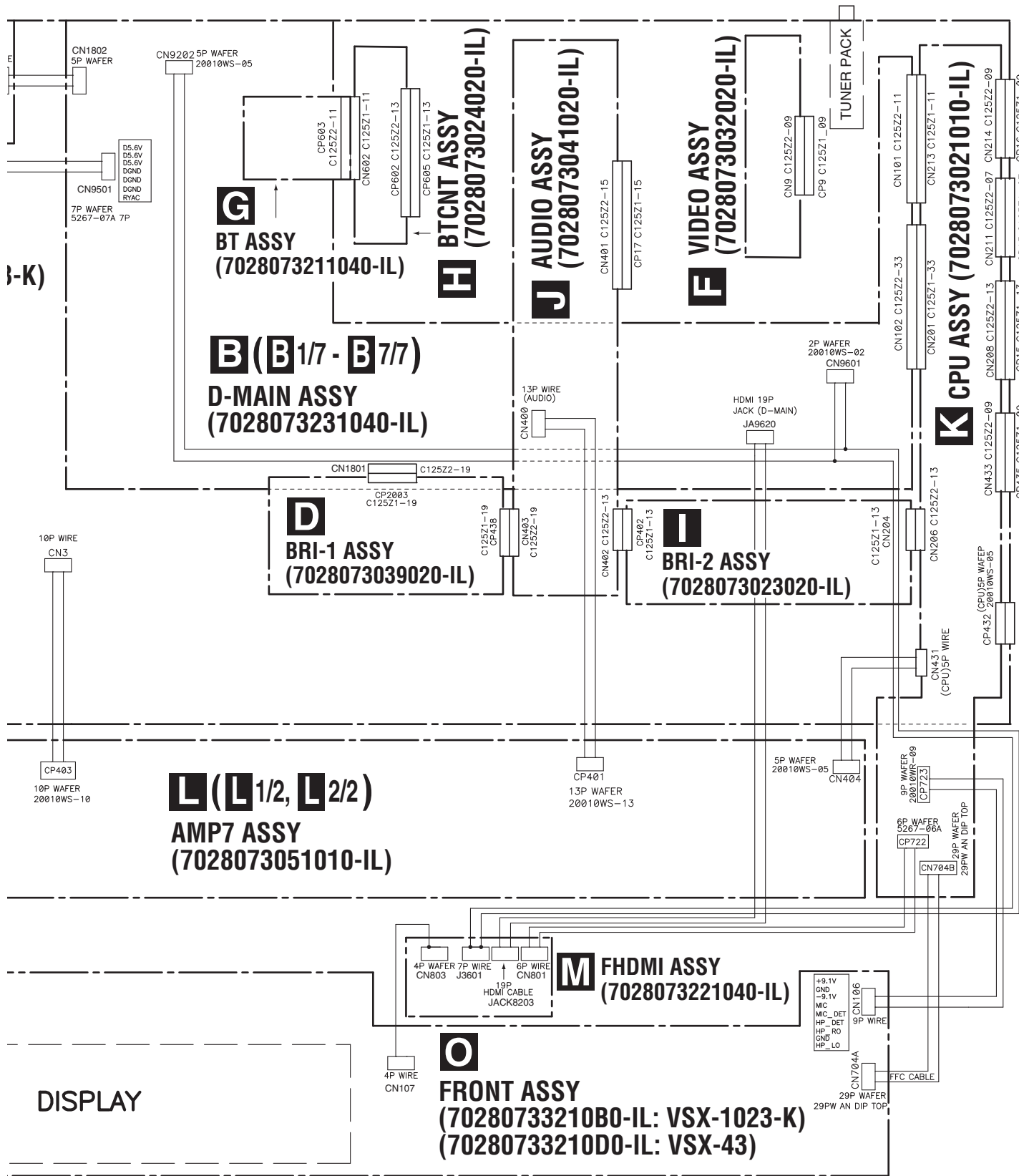

1A0-IL)

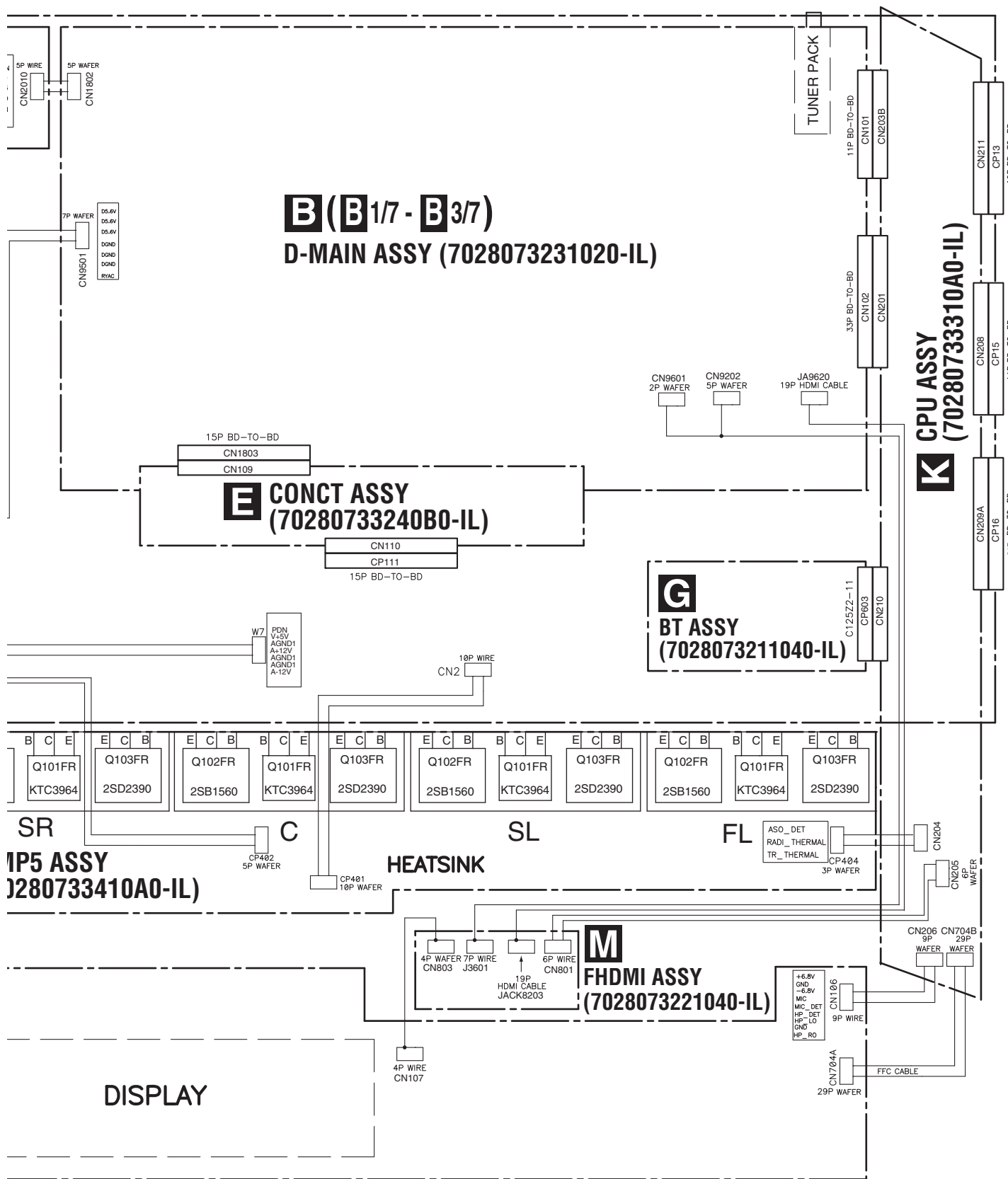

B (B1/7 - B3/7)
D-MAIN ASSY (7028073231020-IL)

E CONCT ASSY (70280733240B0-IL)

G BT ASSY (7028073211040-IL)

K CPU ASSY (70280733310A0-IL)

IP5 ASSY (70280733410A0-IL)

M FHDMI ASSY (7028073221040-IL)

DISPLAY

4.3 D-MAIN BLOCK DIAGRAM

B D-MAIN ASSY

● DMAIN BLOCK

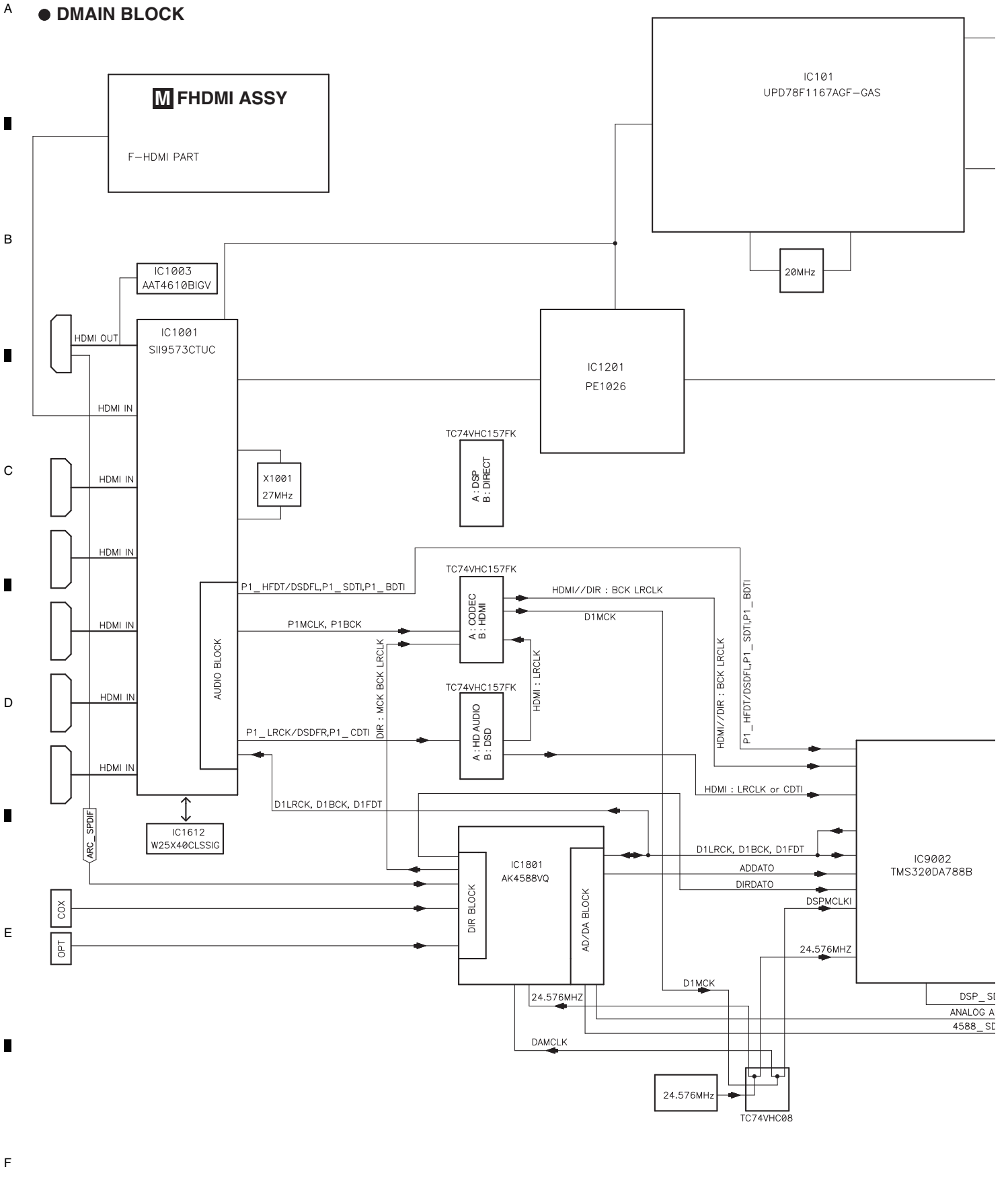

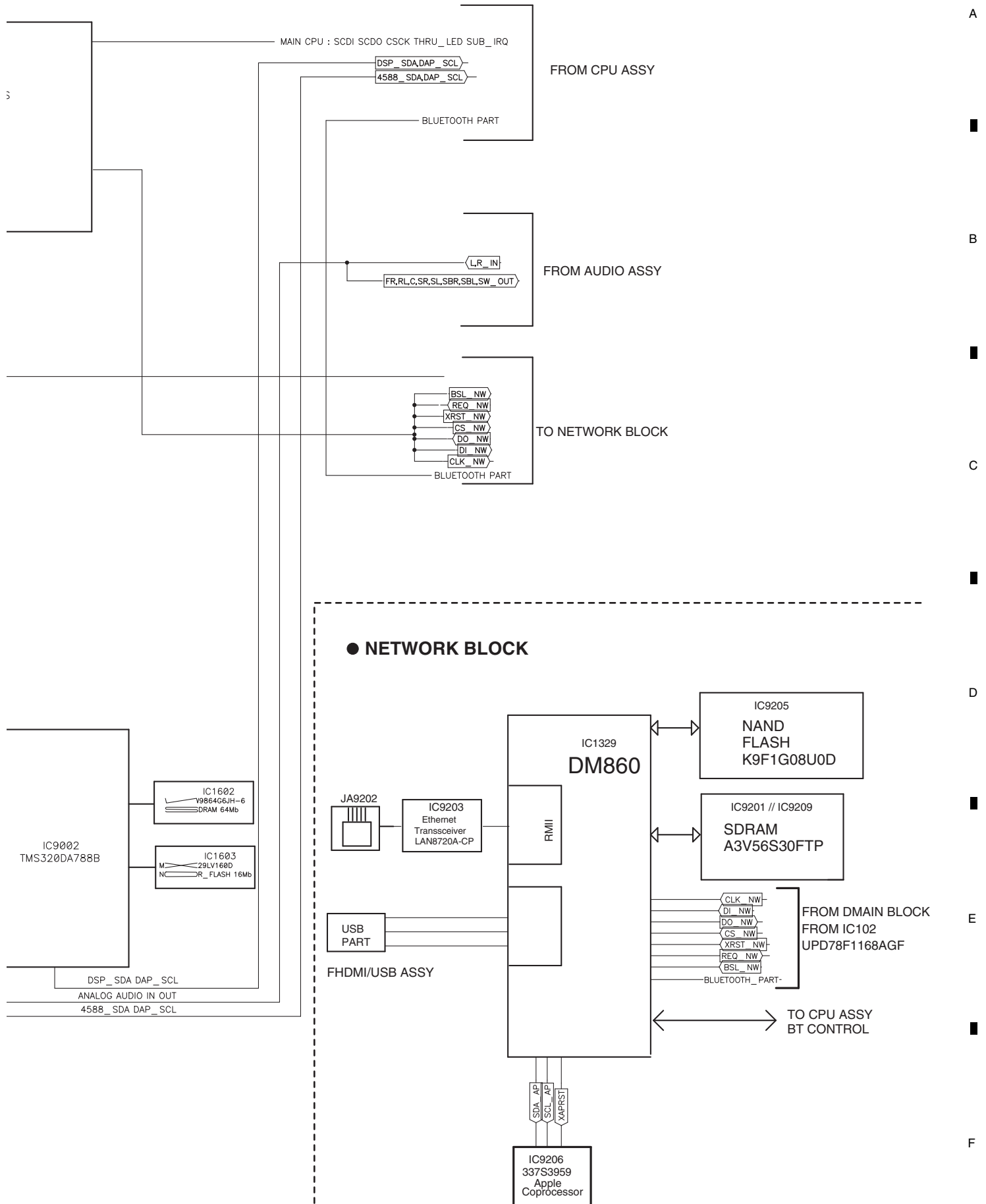

4.4 AUDIO BLOCK DIAGRAM (for VSX-1023-K, VSX-43)

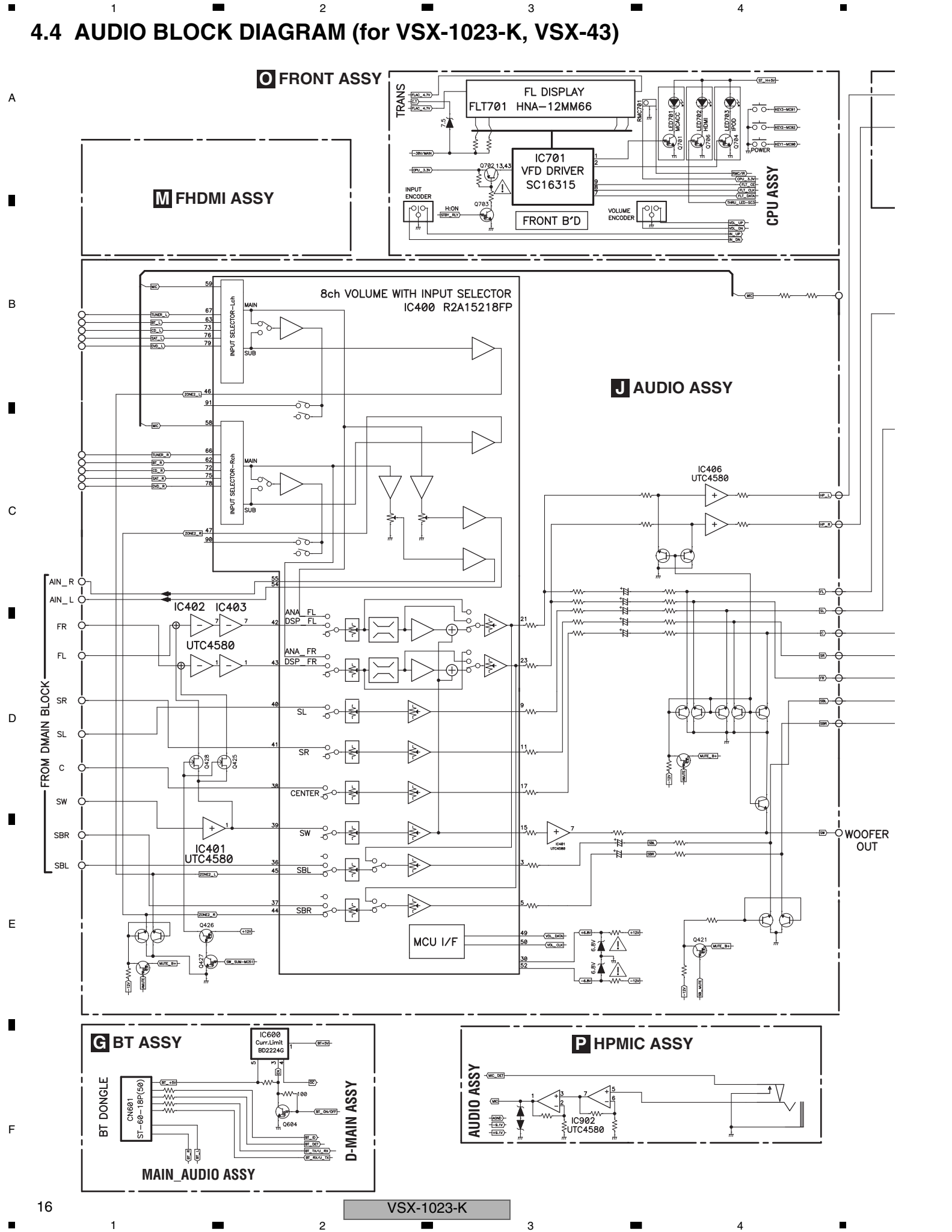

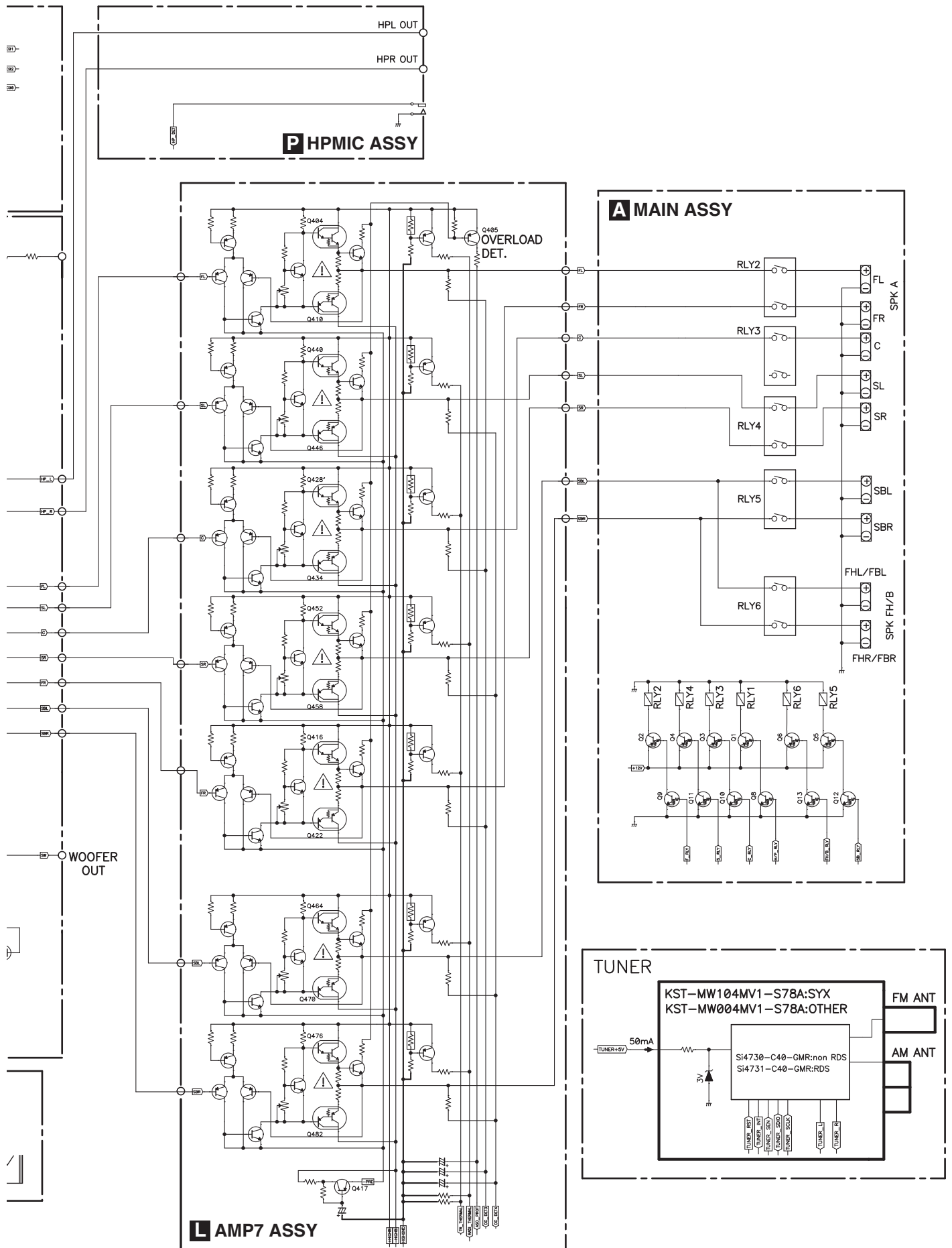

4.5 AUDIO BLOCK DIAGRAM (for VSX-823-K)

A

B

C

D

E

F

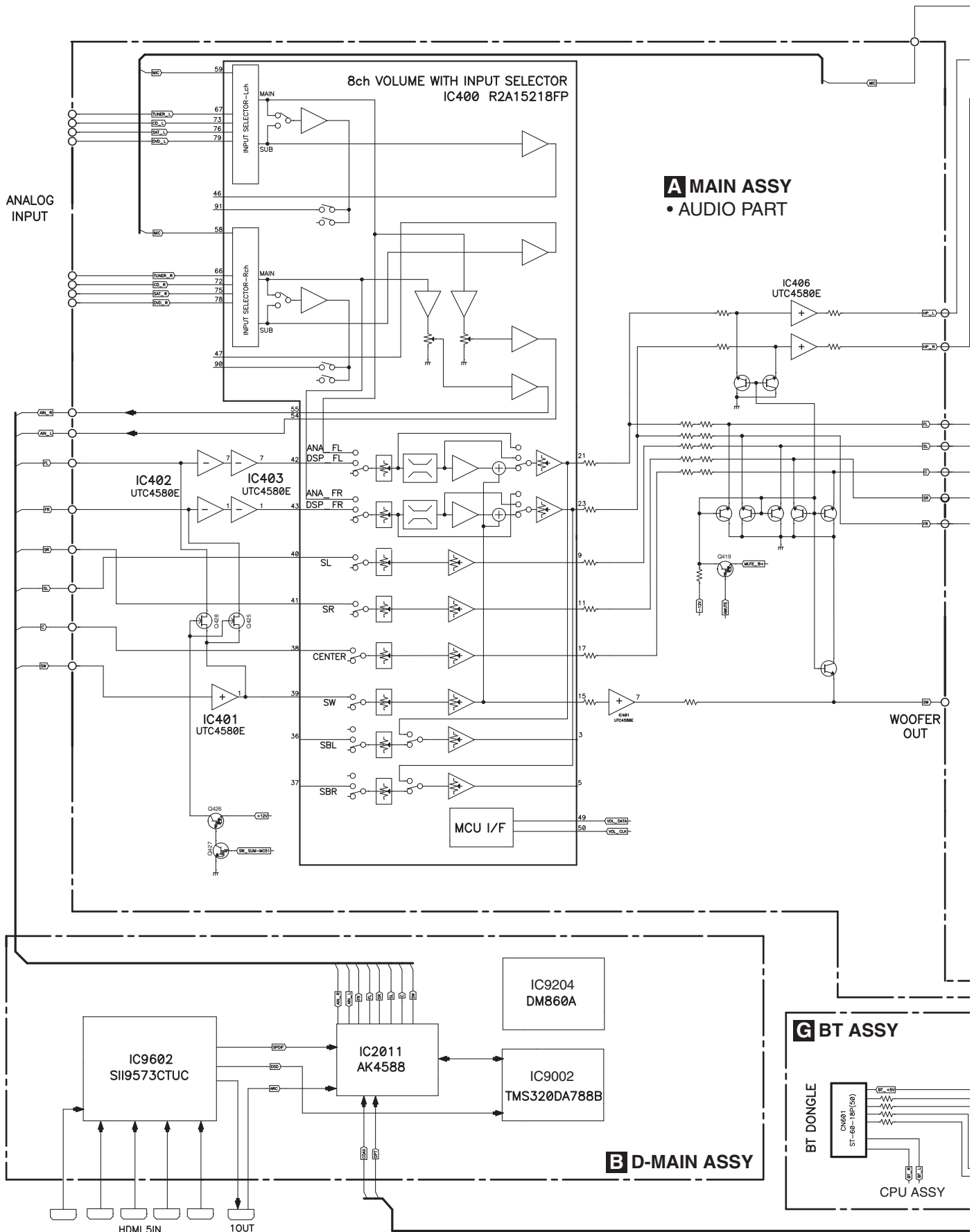

K CPU ASSY

O FRONT ASSY

P HPMIC ASSY

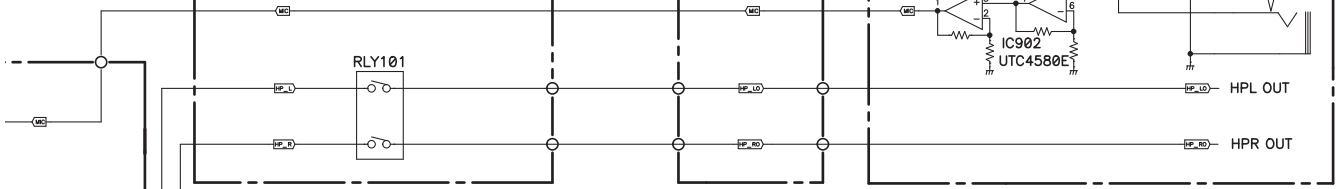

A MAIN ASSY

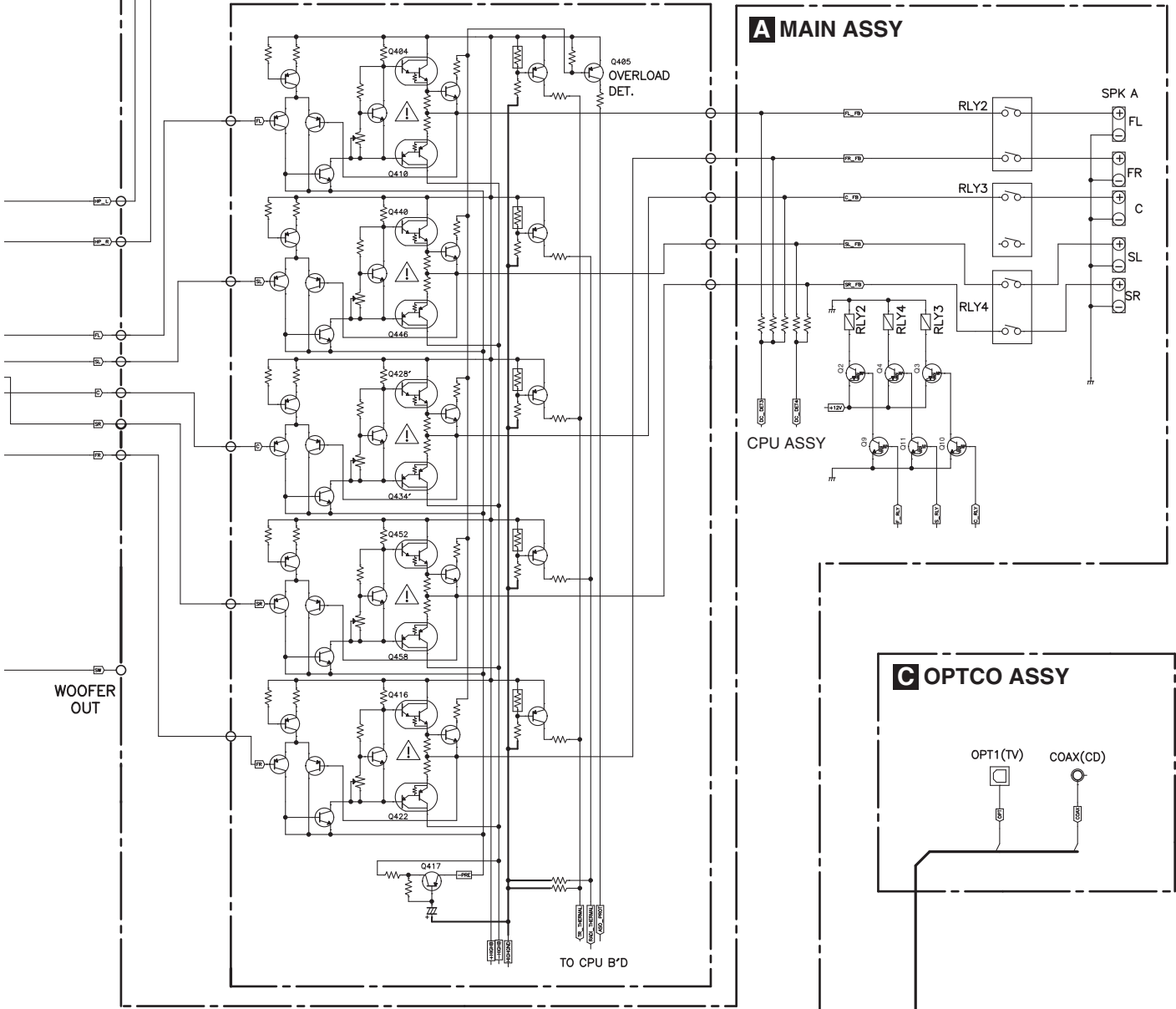

ASSY

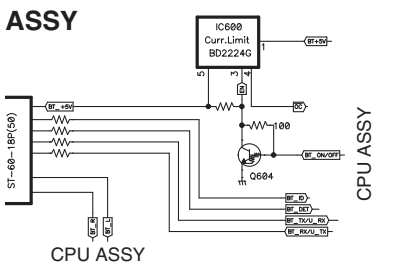

M FHDMI ASSY



4.6 POWER SUPPLY BLOCK DIAGRAM

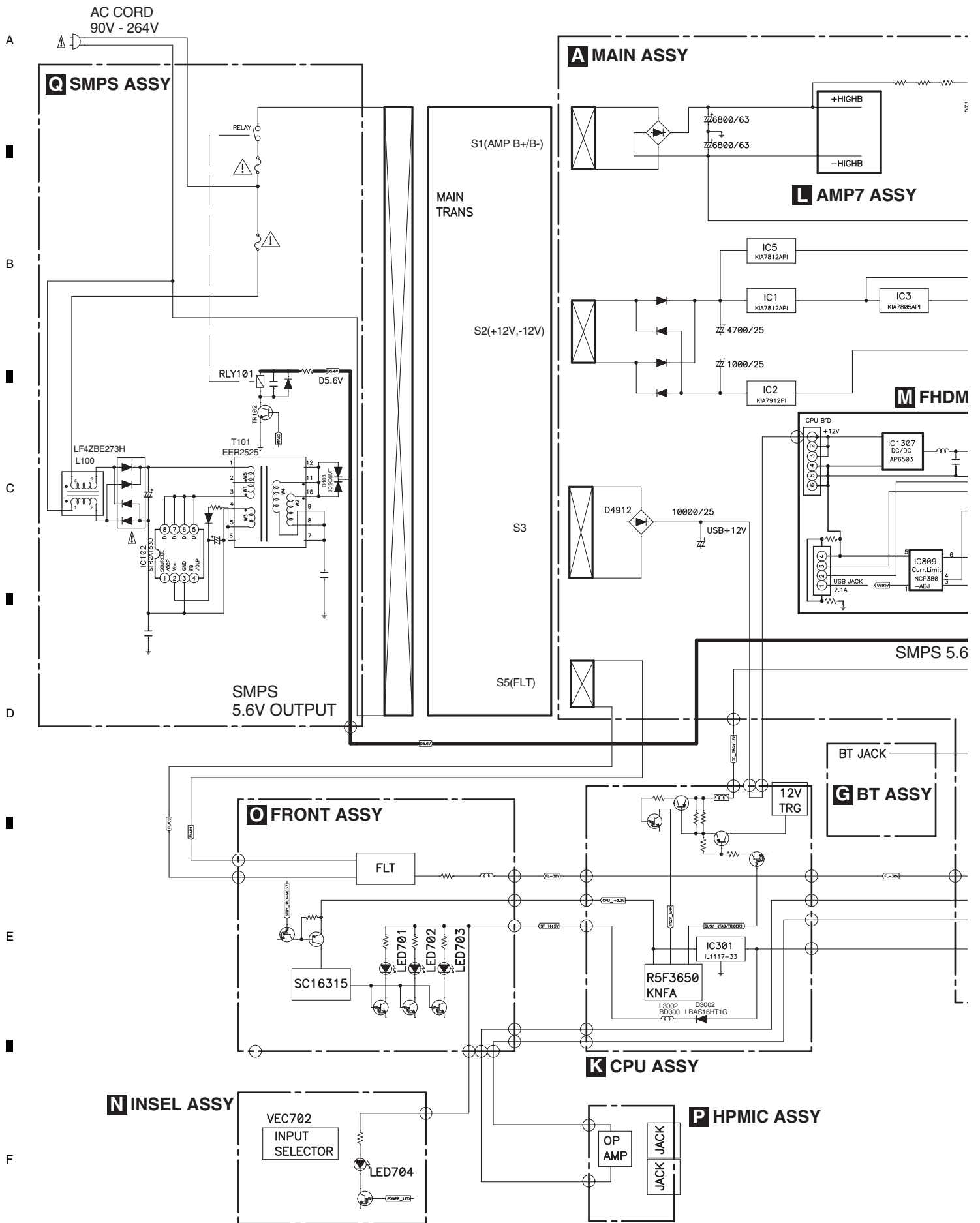

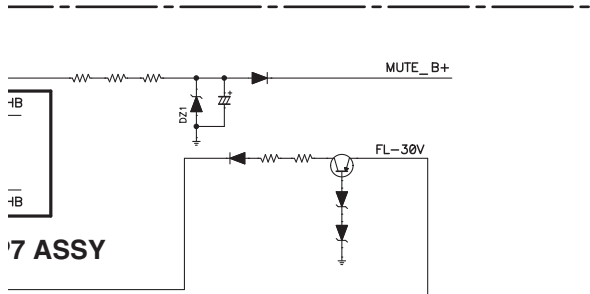

I BRI-2 ASSY

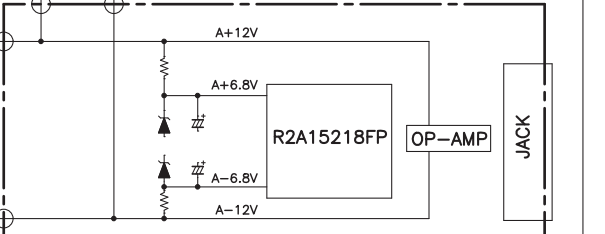
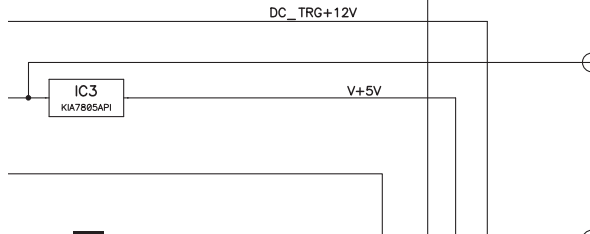
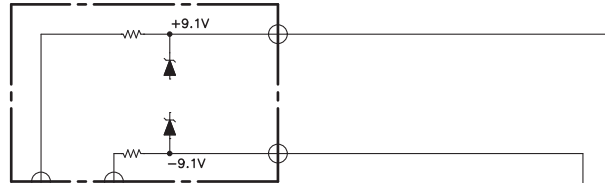

M FHDMI ASSY

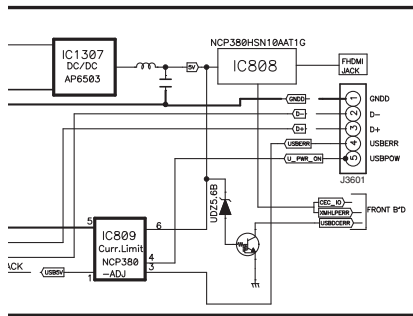

J AUDIO ASSY

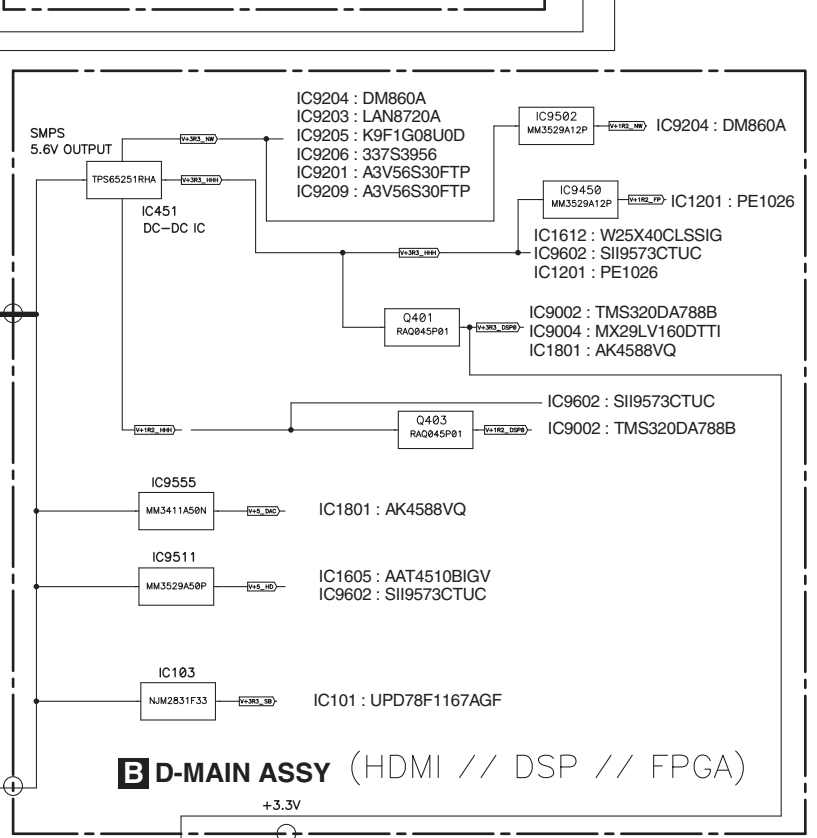

SMPS 5.6V OUTPUT

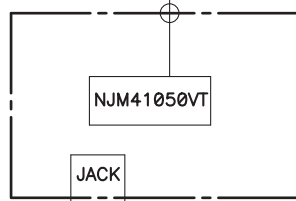
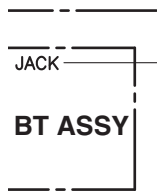

F VIDEO ASSY

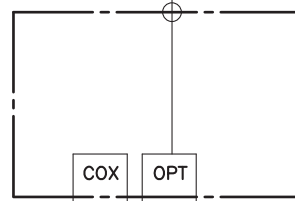

C OPTCO ASSY

4.7 GND BLOCK DIAGRAM (for VSX-1023-K, VSX-43)

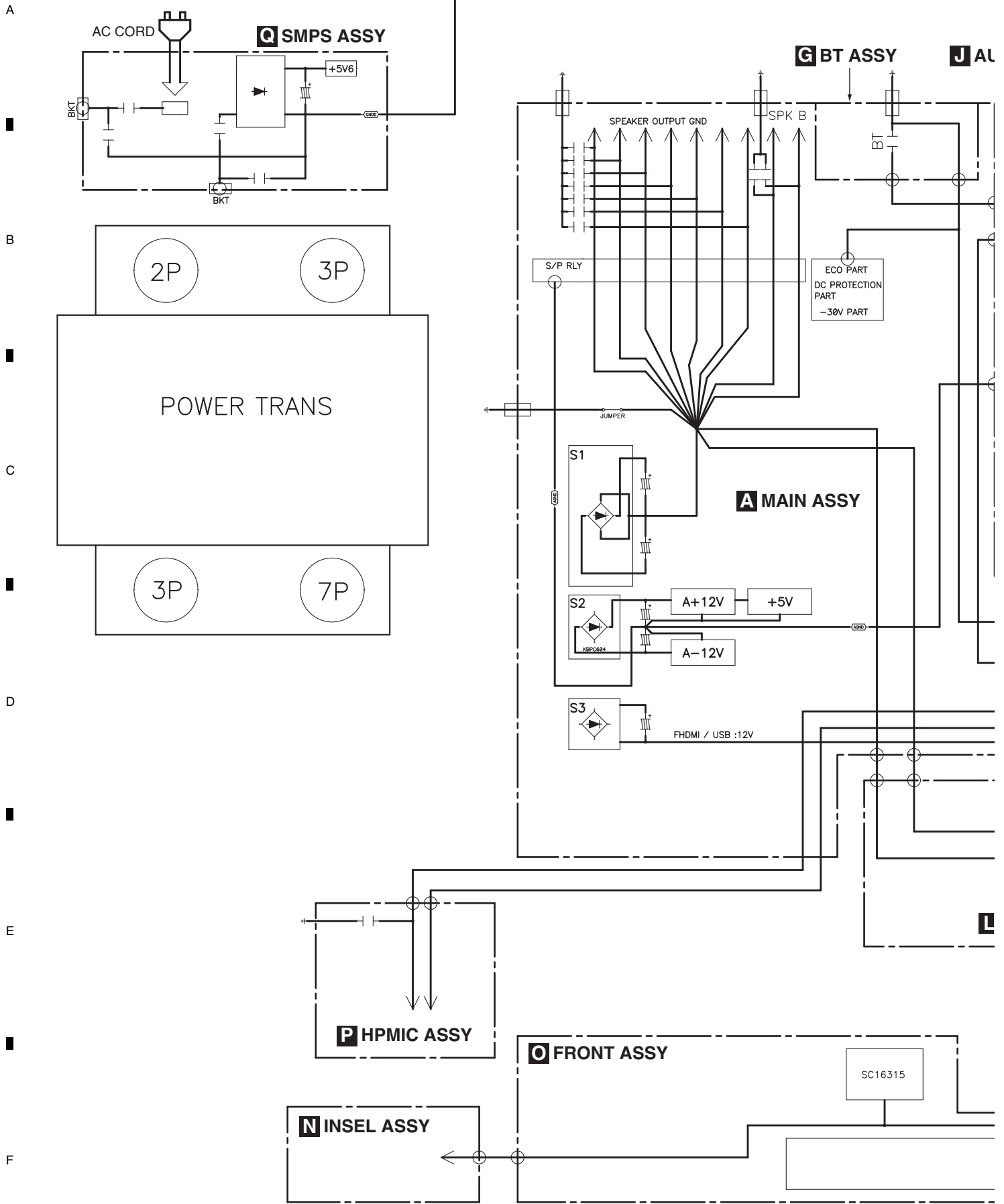

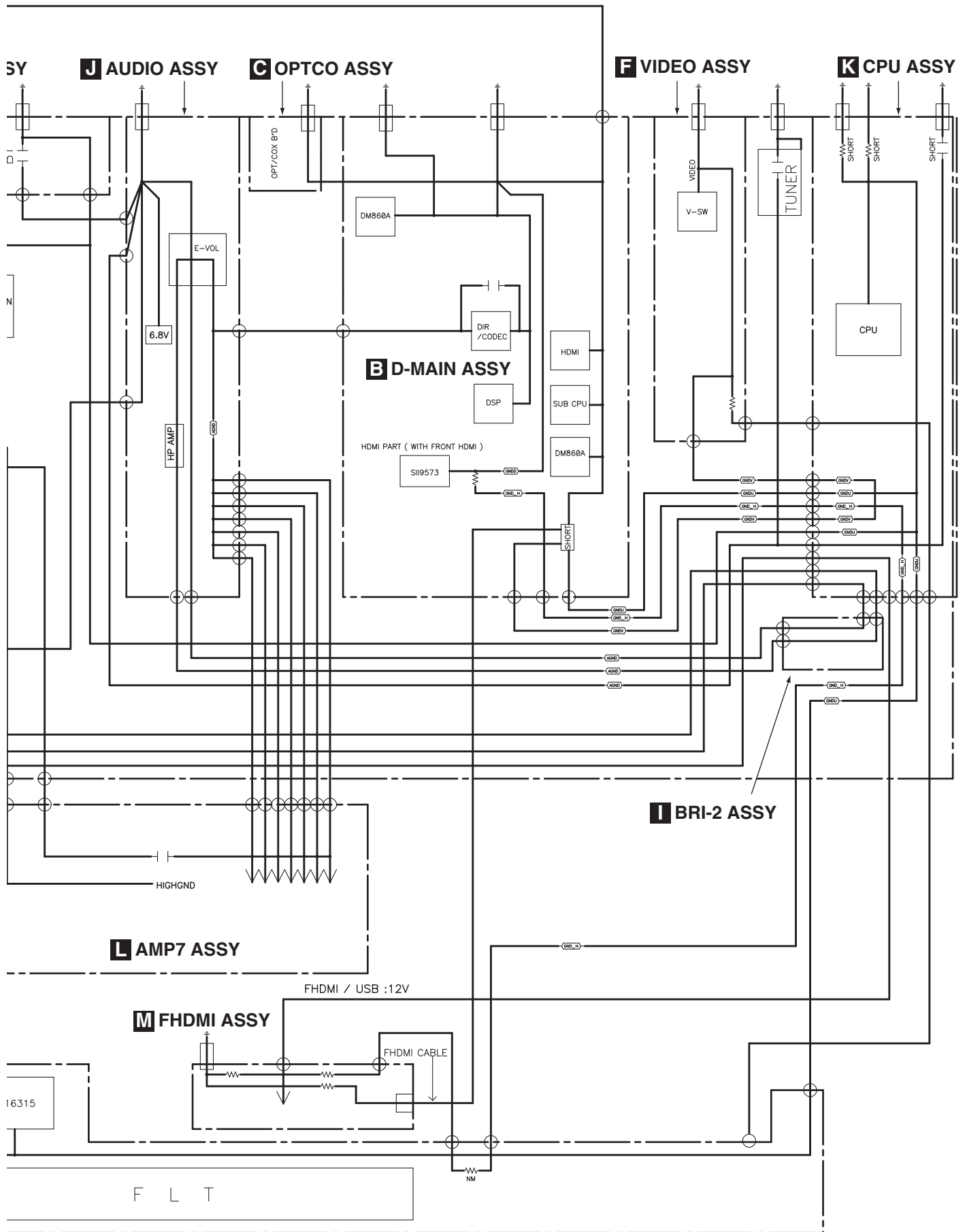

4.8 GND BLOCK DIAGRAM (for VSX-823-K)

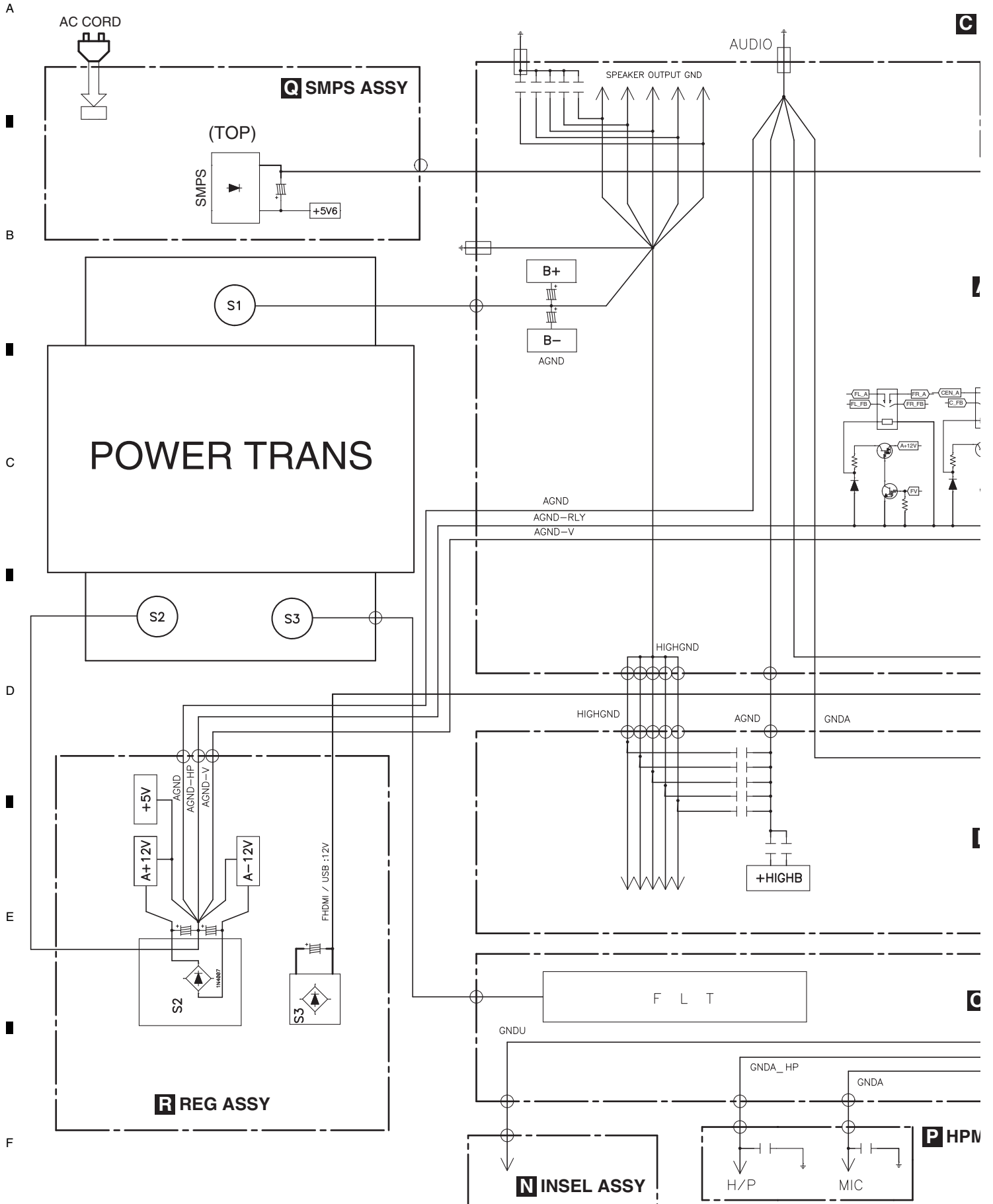

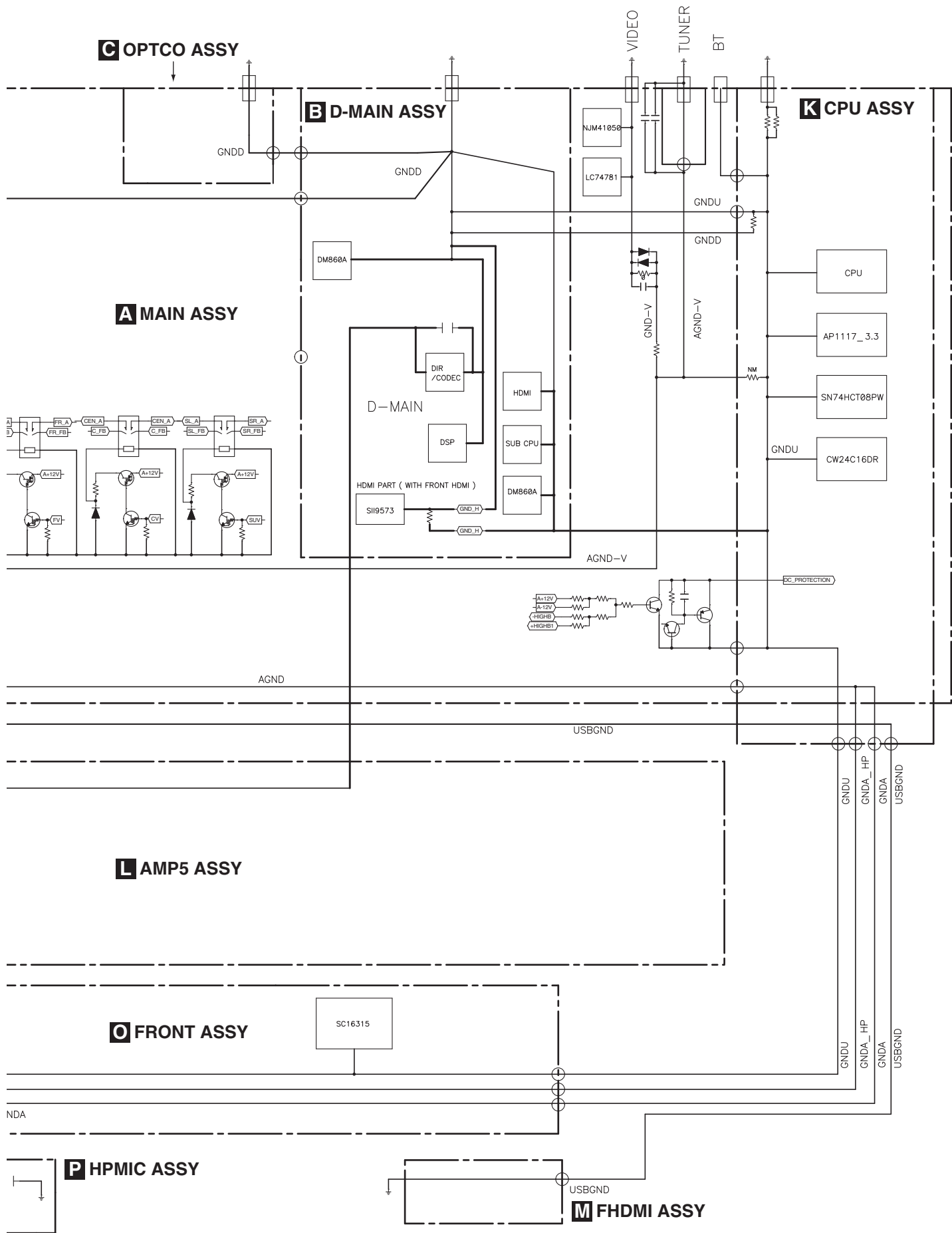

A
B
C
D
E
F

5. DIAGNOSIS

5.1 TROUBLESHOOTING

A Note:*M5; VSX-823-K, VSX-528-K, VSX-528-S
*M7; VSX-1023-K, VSX-43, VSX-828-K, VSX-828-S

No Power

This is just for general reference and does not including every single case.

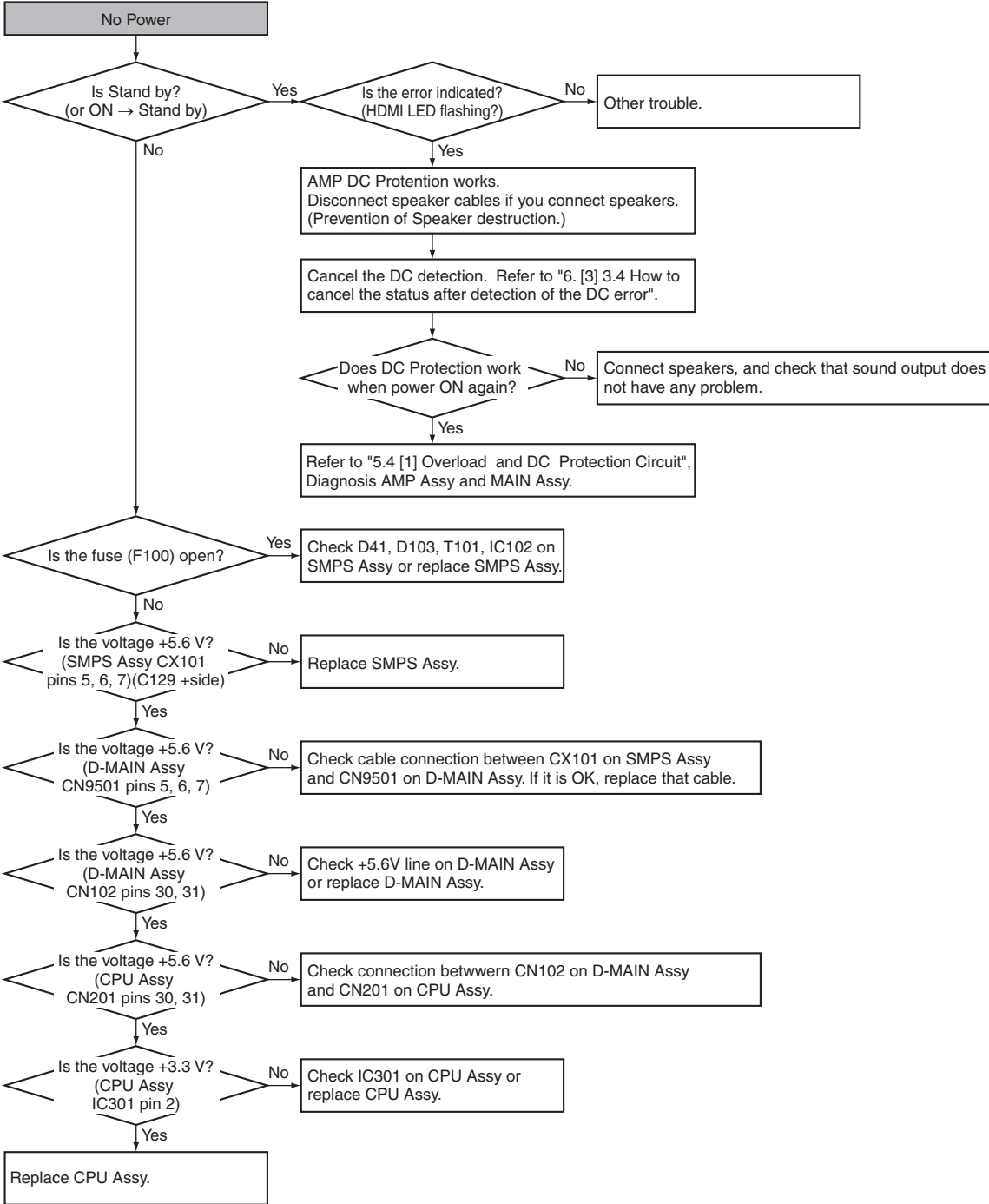

No FL DISPLAY

This is just for general reference and does not including every single case.

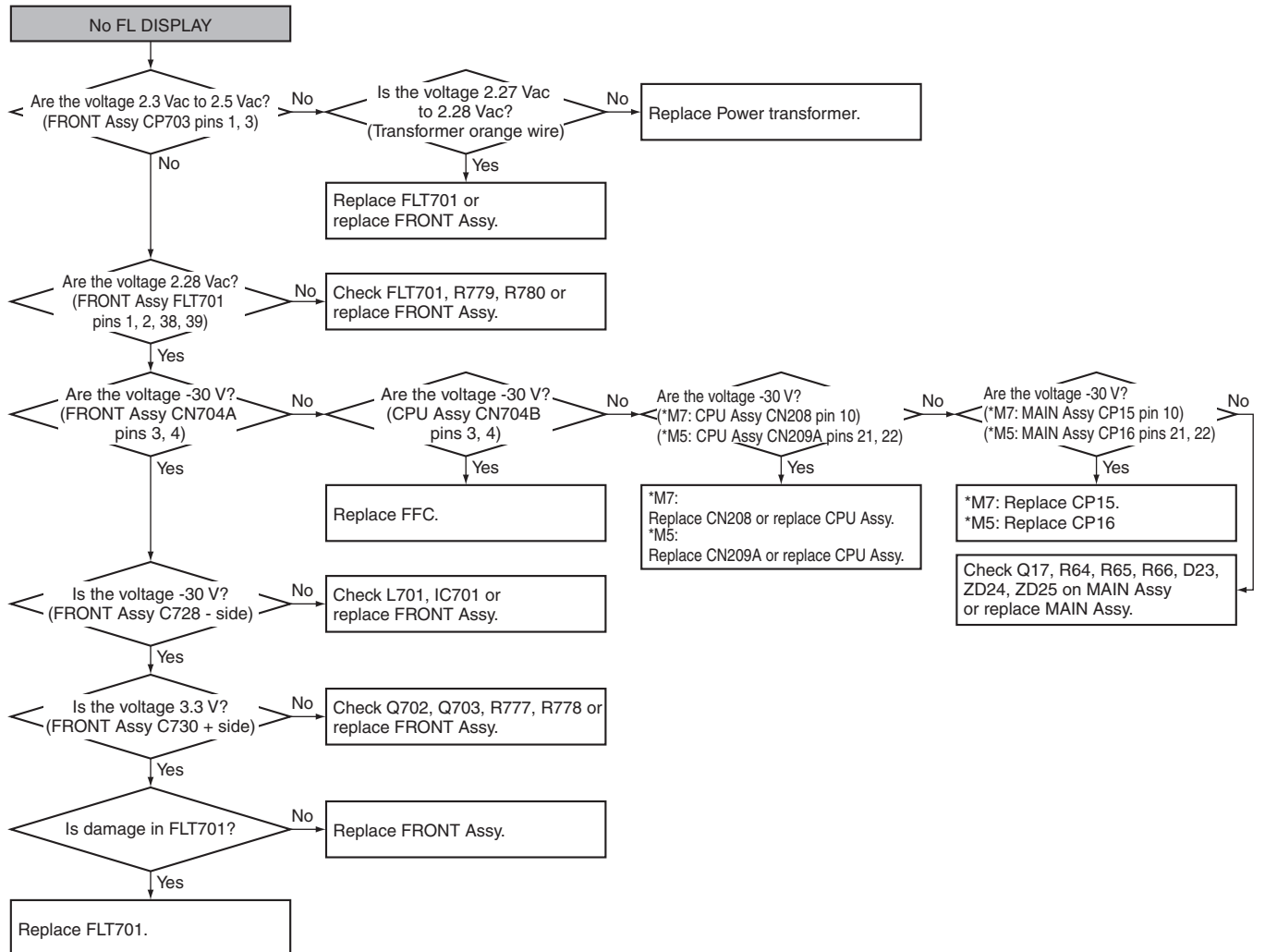

No Sound

This is just for general reference and does not including every single case.

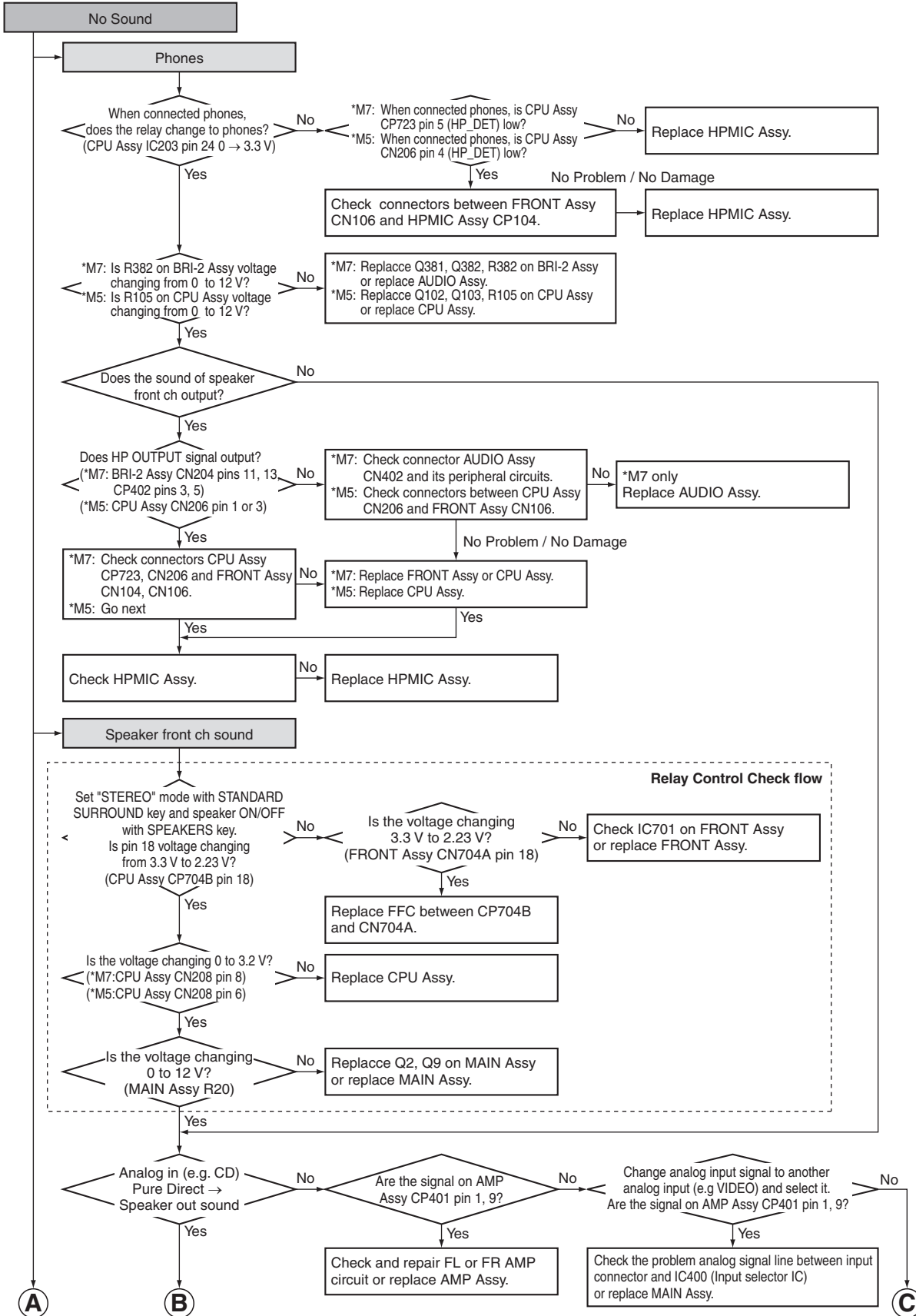

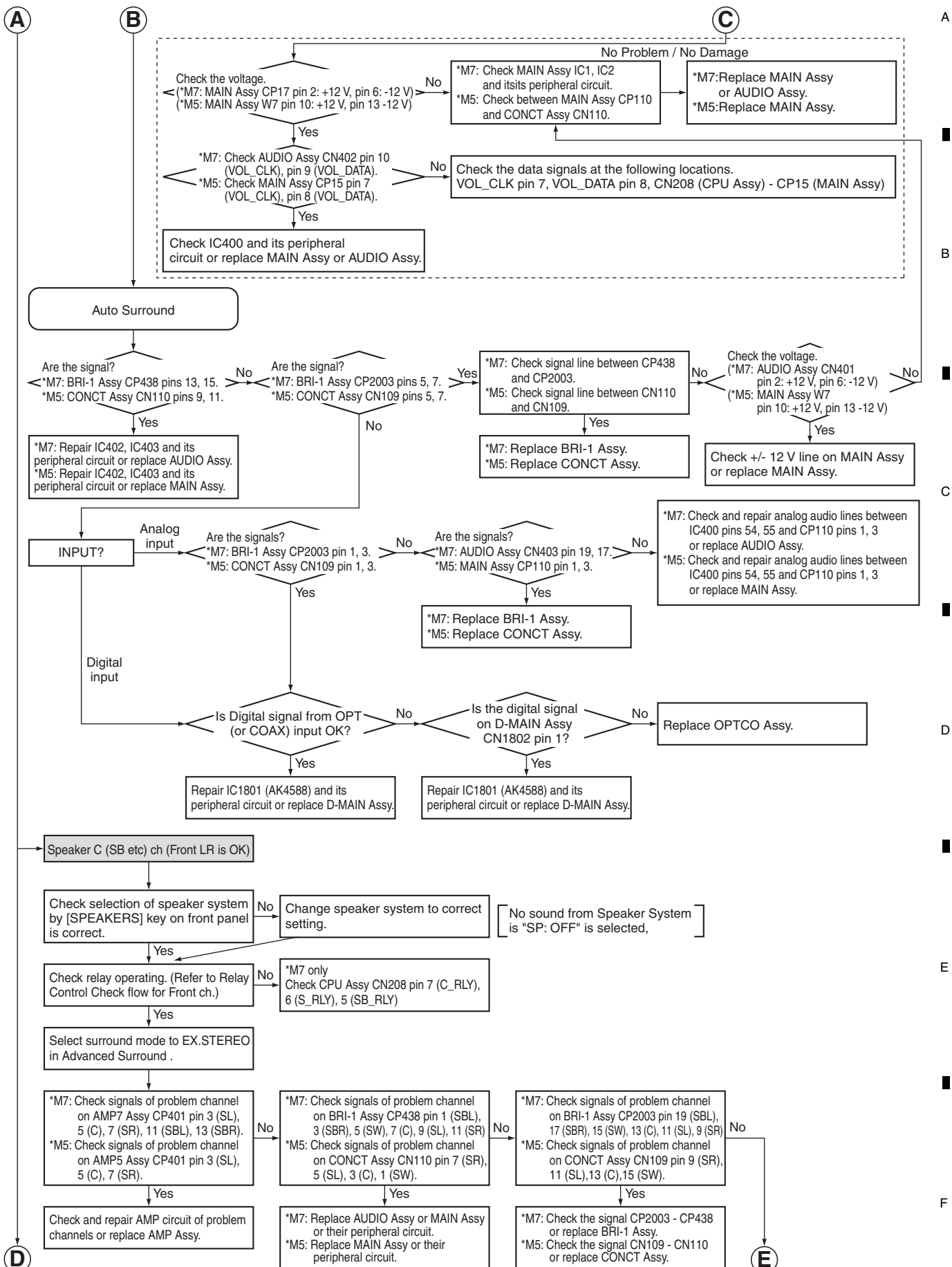

A
B
C
D
E
F

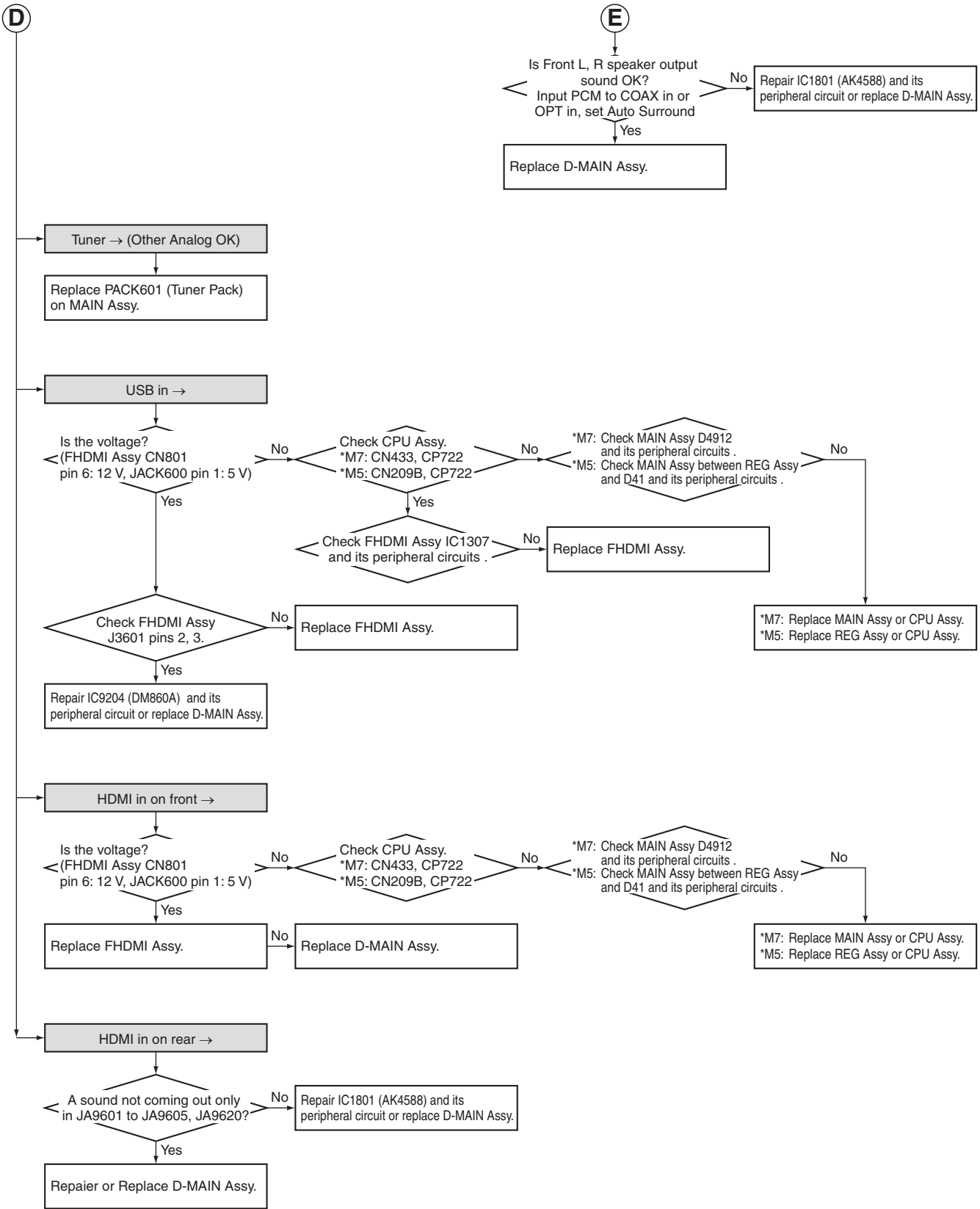

No Picture

This is just for general reference and does not including every single case.

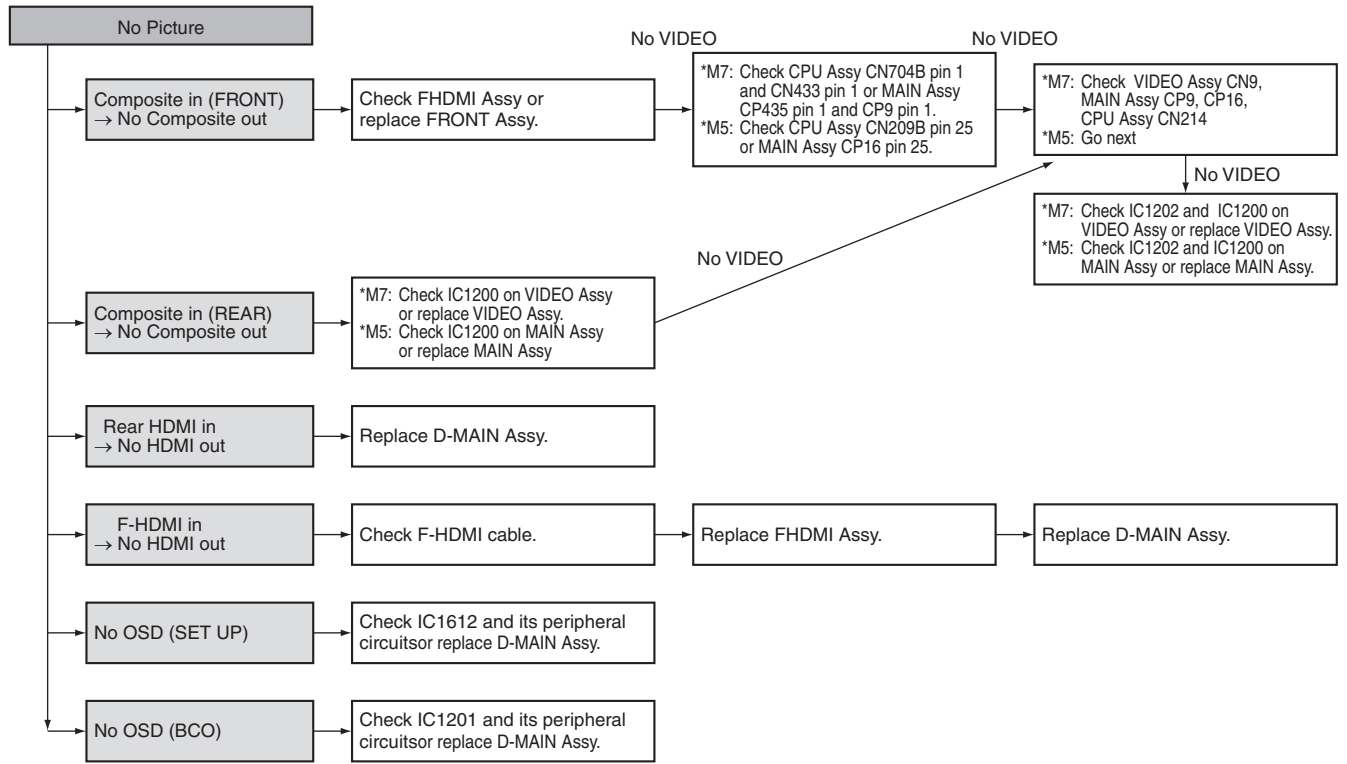

5.2 ADAPTER ERROR MESSAGE

Functional Name

A Adapter port overcurrent detection

Outline

When the BT adapter is inserted in Adapter port, turn off the power of the Adapter port forcibly when it detects an overcurrent. And display ERROR state in FL.

Basic Operation

Front Key Sequence Change	Character Display	Time (sec.)	Icon Display (FL)	LED Display																				
When the overcurrent is detected	<table border="1"> <tr> <td>1</td><td>2</td><td>3</td><td>4</td><td>5</td><td>6</td><td>7</td><td>8</td> <td>1</td><td>2</td> </tr> <tr> <td>A</td><td>D</td><td>P</td><td>E</td><td>R</td><td>R</td><td></td><td></td> <td></td><td></td> </tr> </table> <p>*1</p> <p>Check it after turning the power once off then back on again, and it becomes the normal operation if normal.</p>	1	2	3	4	5	6	7	8	1	2	A	D	P	E	R	R					The display continues until the power is turned off.	—	—
1	2	3	4	5	6	7	8	1	2															
A	D	P	E	R	R																			

*1 Return the "ADP ERR" display to the normal display if you change it into other FUNCTION only in the ADAPTER PORT FUNCTION.

Also display "ADP ERR" if the ADAPTER PORT FUNCTION is ERROR state.

Explain Operation Detail

For detection method

- Confirm a detection port at intervals of 20 msec to 50 msec (*2), and judge it as an overcurrent when you detected an error consecutively three times.

*2 It is assumed that it is fixed value of the 20 msec to 50 msec degree.

5.3 USB/iPod ERROR MESSAGE

Functional Name

E iPod ERROR MESSAGE

Outline

Error message is displayed at abnormality time.

Basic Operation

Front Key Sequence Change	Time (sec)	FL Display
Over Current Error		I:/U: ERR

5.4 PROTECTION CIRCUIT

[1] Overload and DC Protection Circuit

■ for VSX-1023-K, VSX-43

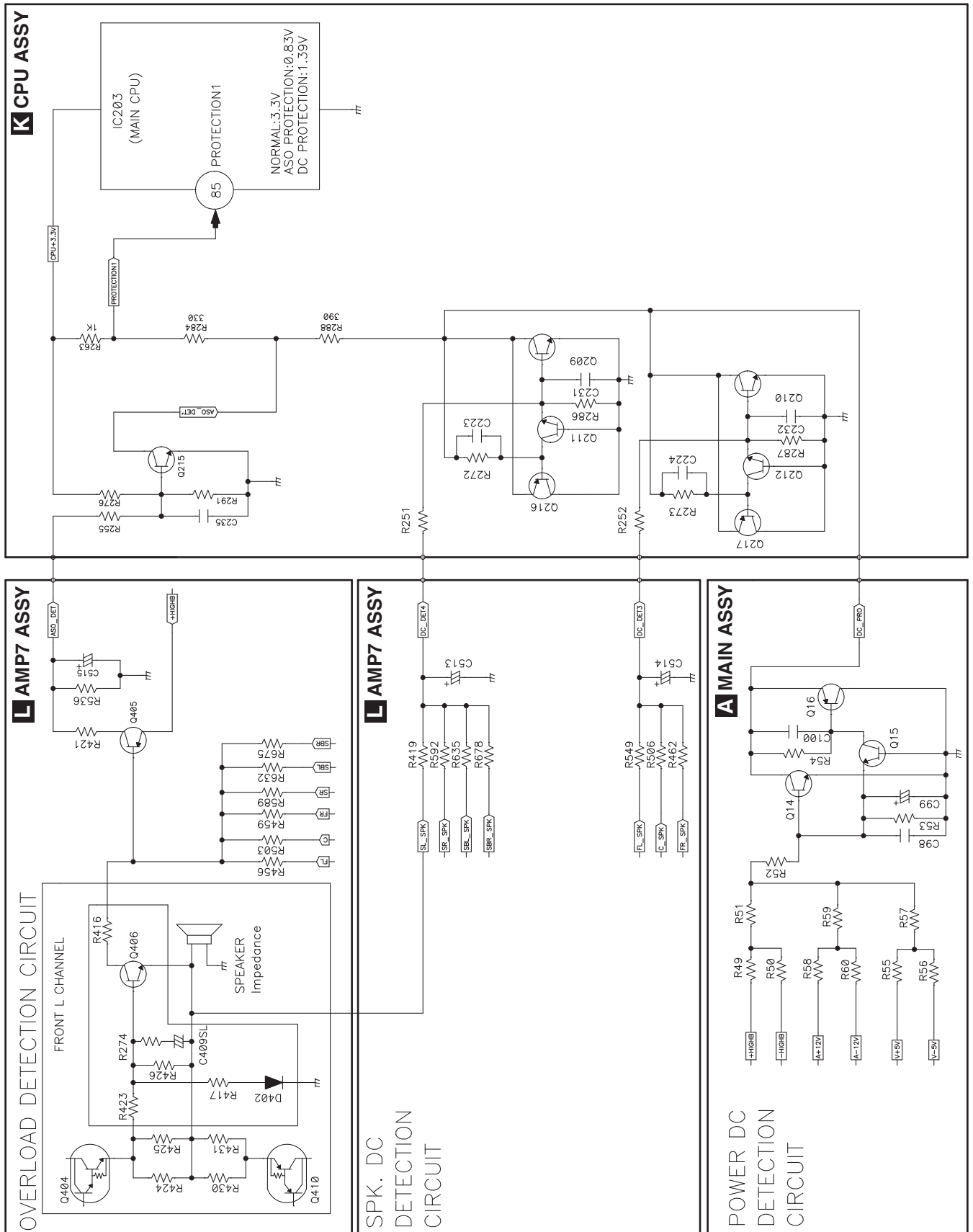

A

for VSX-823-K

B

C

D

E

F

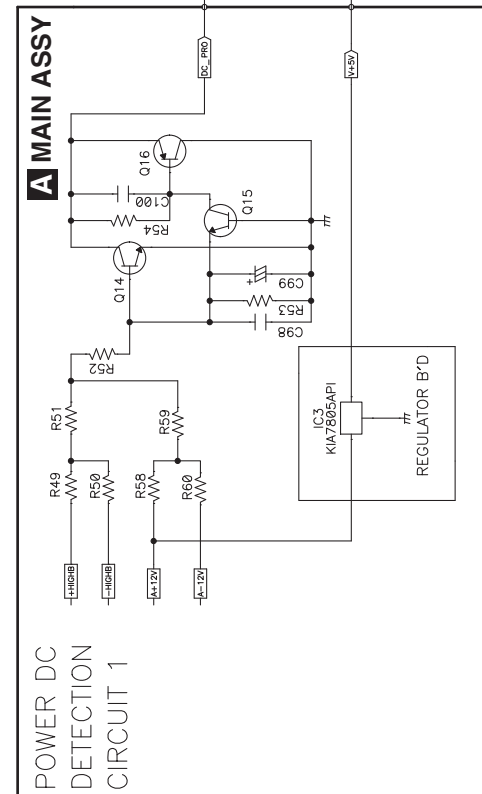
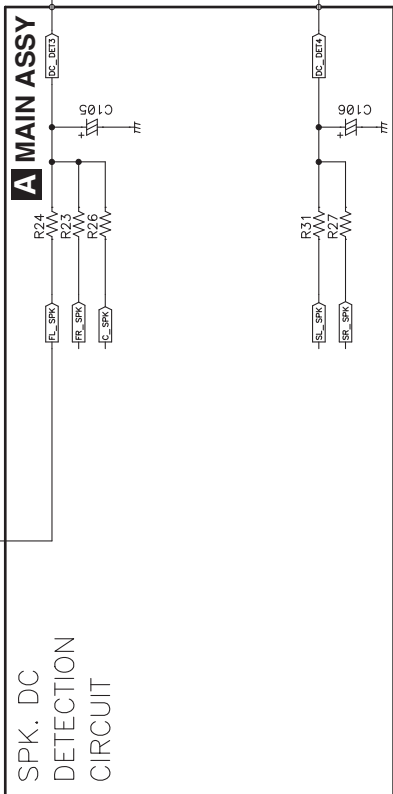
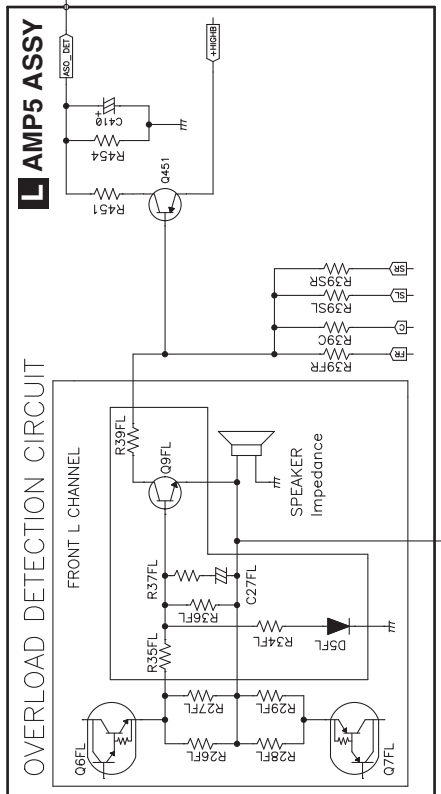
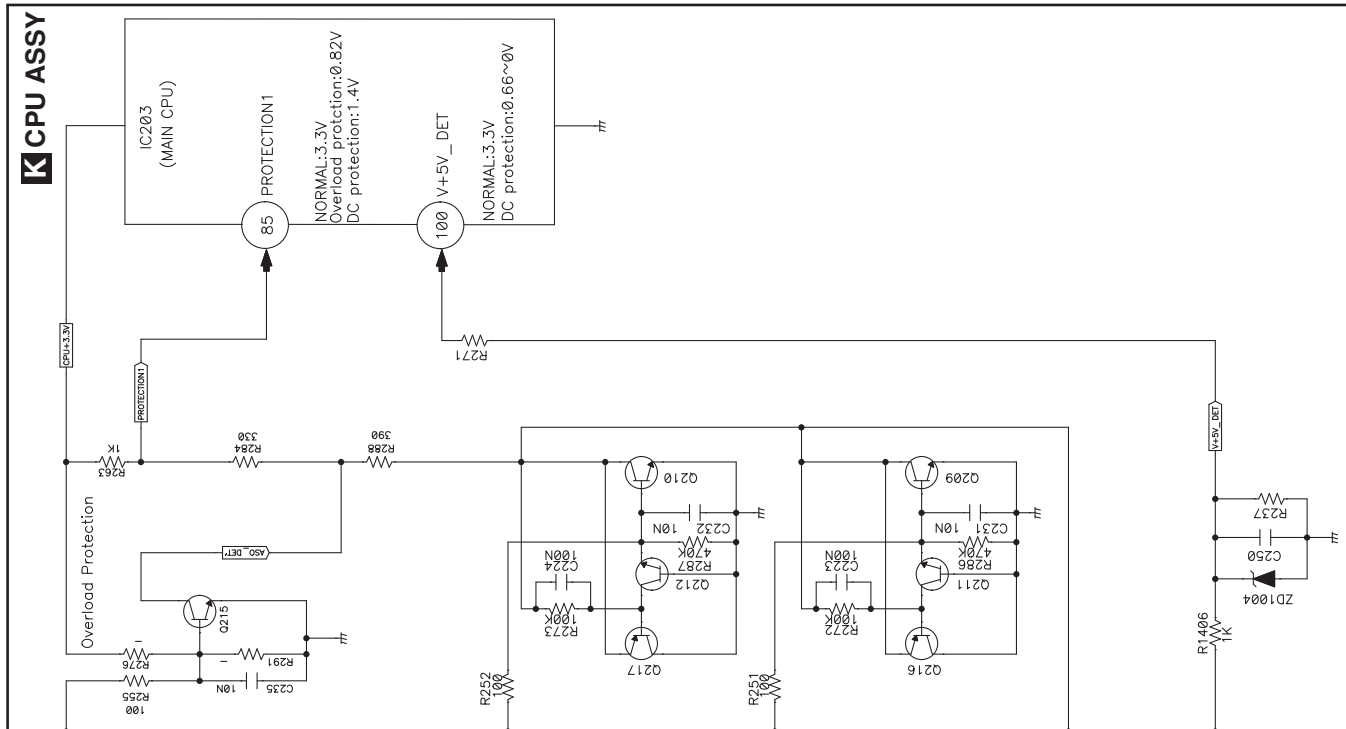

[2] TEMP Protection Circuit

■ for VSX-1023-K, VSX-43

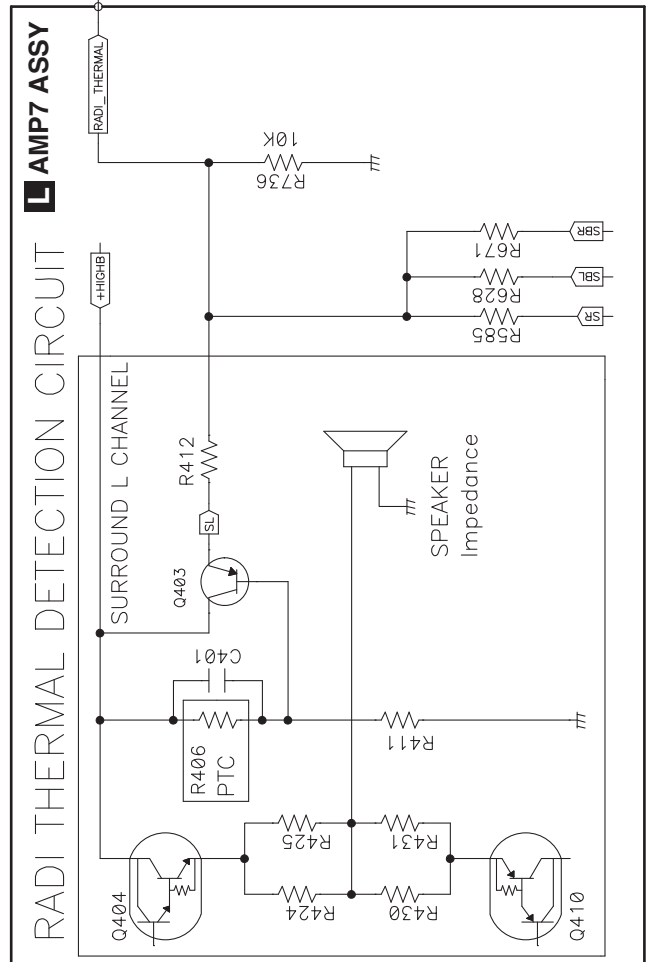
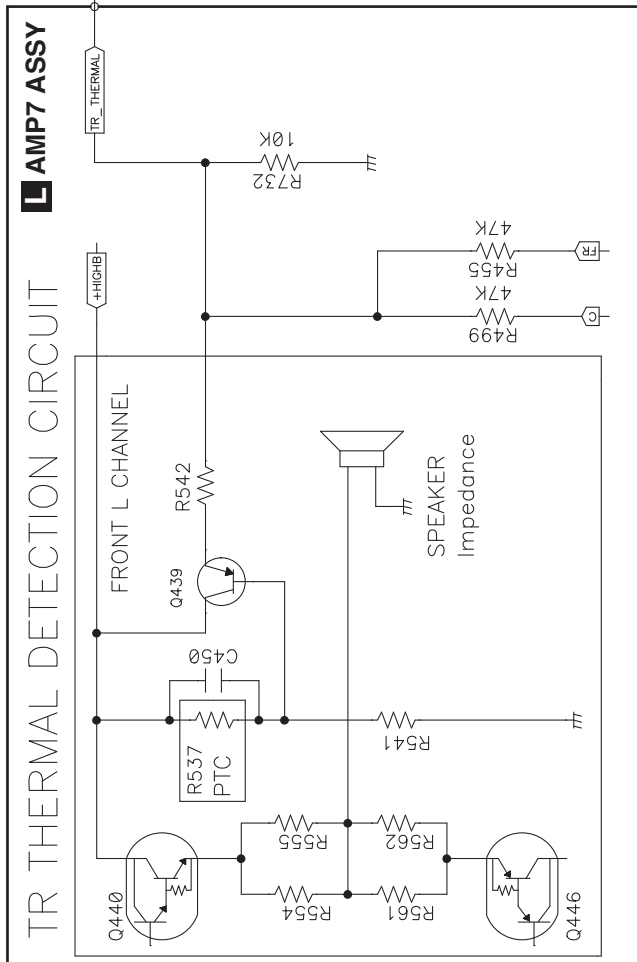
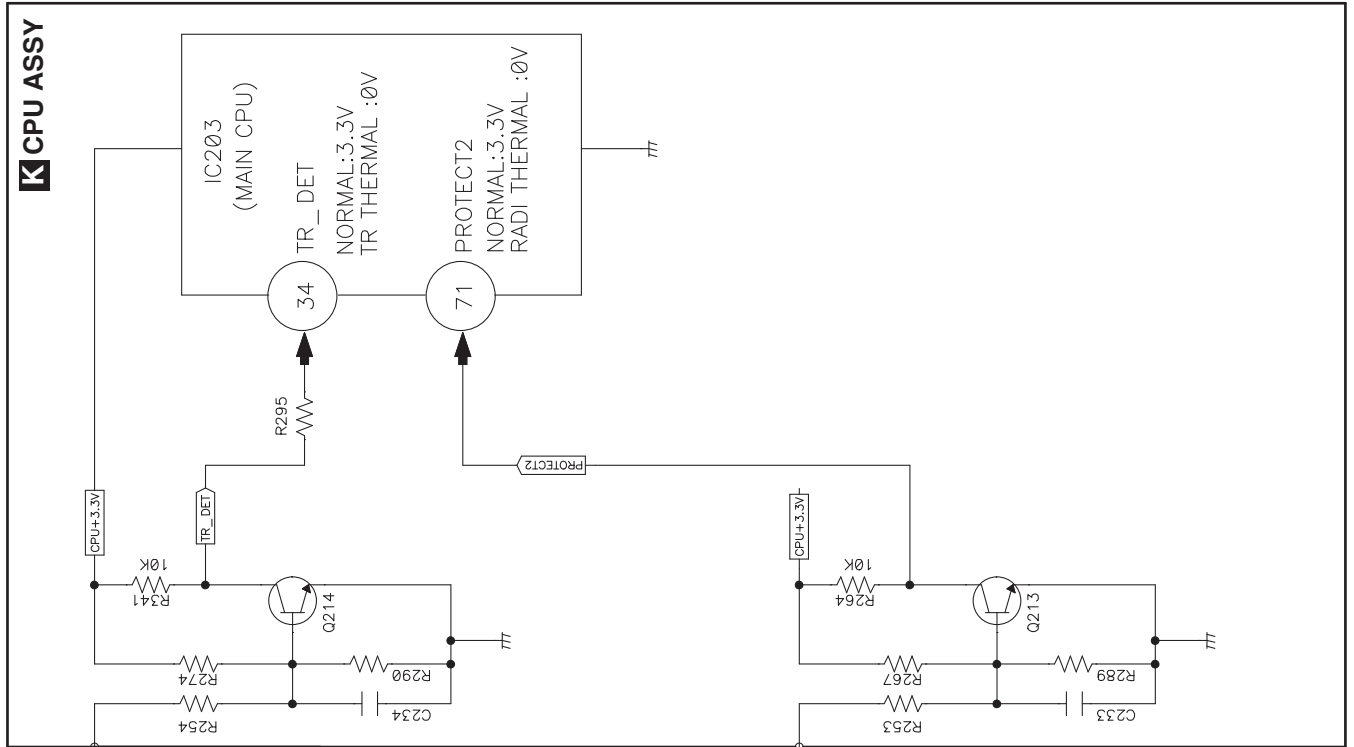

5.5 IC INFORMATION

■ (M3030RFGPFP_256k)(CPU Assy: IC203)(for VSX-1023-K, VSX-43)

MAIN CPU

• Pin Function

No.	Symbol	I/O	Description
1	DIRECT_SEL	O	DIRECT_SEL control pin
2	FLT_CLK	O	FL drive IC output pin of the Clock
3	P9_4		Not used
4	P9_3		Not used
5	POWERDOWN	I	Power down signal input pin
6	40-IR	I	Infra_red signal input
7	RMC	I	Remote control signal input pin
8	GND		Ground
9	CNVSS_UP	I	Switches processor mode
10	24C16_SDA	I/O	Data signal input & output for data backup of main CPU
11	24C16_SCL	O	Clock signal output for data backup of main CPU
12	RESET	I	Main CPU reset signal input pin (active at L)
13	XOUT	O	Output for 16 MHz Crystal
14	GND		Ground
15	XIN	I	Input for 16 MHz Crystal
16	3V3		+3.3 V Power Supply
17	NMI		Pull up
18	TUNER_INT	I	Tuner Interrupt signal input pin
19	4588_INT	I	AK4588 Interrupt signal input pin
20	WOL_NW	I	Output signal for WOL
21	SB_MUTE	O	SB ch. Audio output control pins at Mute Tr (active at L)
22	A_MUTE	O	Audio output control pins at Mute Tr (active at L)
23	HP_DET	I	Monitoring the input pin headphone connection
24	HP_RLY	O	Headphone audio output control pins at Mute Tr (active at L)
25	SW_SUM	O	Output for Sub Woofer SUMMING Control(H:SUMMING)
26	CTL_B	O	IC control signal B output pin for selecting the video input
27	V_POWERSAVE	O	Switches NJM2580M IC POWERSAVE mode
28	CNT_LED	O	Power LED control signal
29	CTL_A	O	IC control signal A output pin for selecting the video input
30	MUTE_B+_CONT	O	Power control pin mute B+
31	U_TX	O	Output for Upgrade (UART)
32	U_RX	I	Input for Upgrade (UART)
33	BUSY_JTAG/TRIGGER1	O	Output for JTAG BUSY/TRIGGER1_ON/OFF SIGNAL
34	SCLK_JTAG/TR_DET'	I	Serial clock input and Protection pin
35	VOL_DATA	O	Data signal output for R2A15219 (I2C)
36	VOL_CLK	O	CLK signal output for R2A15219 (I2C)
37	STBY_RLY	O	Output to ST-BY Relay ON/OFF (active at H)
38	T12V_ERR	I	Input for dc_trg_err condition
39	F_RLY	O	Tr driven control pins at the Front speaker output Relay. (active at H)
40	TUNER_SCLK	O	Clock signal output for Tuner Pack
41	EPM_UP	I	UPGRADE
42	TUNER_SDIO	I/O	Data signal input & output for Tuner Pack
43	TUNER_SEN	O	Output for Tuner Pack Serial Enable Input (active at L)
44	TUNER_RST	O	Output to reset Tuner Pack (active at L)
45	NC		Not used
46	U_CE	O	UPGRADE pin
47	NC		Not used
48	S_RLY	O	Tr driven control pins at the Surround speaker output Relay. (active at H)
49	SB_RLY	O	Tr driven control pins at the Surround Back speaker output Relay. (active at H)
50	FBRL	O	Tr driven control pins at the F.H /B speaker output Relay. (active at H)

A

No.	Symbol	I/O	Description
51	C_RLY	O	Tr driven control pins at the Center speaker output Relay. (active at H)
52	NC		Not used
53	SP_DC	O	HDMI LED on/off control pin if Speaker DC Protection
54	NET_PWR	O	Control pin HDMI IC +5V REG. IC (on: H)
55	DVC_PWR	O	Control pin HDMI IC +1.8V REG. IC (on: H)
56	DIR_PWR	O	Control pin digital +3.3V DC/DC IC (on: H)
57	MIC_DET	I	Monitoring the input pin microphone connection (detection: L)
58	4588_PDN	O	Output for AK4588 power down
59	4588_SDA	I/O	Data signal input & output for AK4588 (I2C)
B 60	4588_SCL	O	Clock signal output for AK4588 (I2C)
61	DSP_SDA	I/O	Data signal Input & output for DA788
62	3V3		+3.3 V Power Supply
63	DSP_SCL	O	Clock signal output for DA788 (SPI)
64	GND		Ground
65	DSP_RST	O	Output to reset DA788
66	NC		Not used
67	DSP_SDOUT	I	Data signal input for DA788 (SPI)
68	DSP_CS	O	Chip select signal output for DA788
69	DSP_RDY	I	SPI Enable signal input from DA788
70	HDMI_SEL	O	IC signal of the control pins at select HDMI or analog audio
C 71	PROTECT2	I	AMP7 Assy input signal of the RADIATOR THERMAL pin (L = PROTECTION)
72	MAIN_IRQ	O	Interrupt signal output pin to sub CPU
73	SUB_ON	O	Control pin SUB CPU IC +3.3 V REG. IC (on: H)
74	SUB_IRQ	I	Interrupt signal output pin to main CPU
75	HD_MUTE	I	Input for HDMI_RX_MUTE condition
76	SUB_PDN	O	Output for sub CPU power down
77	SUB_RST	O	Output to reset sub CPU
78	SCDI_MAIN	I	Data signal input from sub CPU
79	SCDO_MAIN	O	Data signal output to sub CPU
80	CCLK_MAIN	O	Clock signal output for sub CPU
81	SET OPTION	I	Input for Set option
82	STEP OPTION	I	Input for Step (Group) option
D 83	VIDEO_MUTE	O	Output for Video IC MUTE condition
84	FLT_DATA	O	FL drive Ic output pin of the Data
85	PROTECT1	I	AMP7 Assy Protection detection signal input pin (ASO = 0.82 V, DC = 1.39 V)
86	VOL_DN	I	Data input for VOLUME encoder (VOLUME DOWN is counterclockwise direction)
87	VOL_UP	I	Data input for VOLUME encoder (VOLUME UP is clockwise direction)
88	IN_DN	I	Data input for INPUT selector encoder
89	NC		Not used
90	KEY1	I	Data input for Key1 scan
91	KEY3	I	Data input for Key3 scan
92	KEY2	I	Data input for Key2 scan
93	IN_UP	I	Data input for INPUT selector encoder
E 94	FLT_CE	O	Output for chip enable of SC16315
95	NC		Not used
96	GND		Ground
97	USBDCERR	I	Input for usb_dc_err condition
98	3V3		+3.3 V Power Supply
99	3V3		+3.3 V Power Supply
100	V+5V_DET	I	Detection pin V+5V protection

F

■ (M3030RFGPFP_256k)(CPU ASSY: IC203)(for VSX-823-K)

MAIN CPU

• Pin Function

No.	Symbol	I/O	Description
1	DIRECT_SEL	O	DIRECT_SEL control pin
2	CNT_LED	O	LED control signal
3	3959_RST		Not used
4	3959_PWR		Not used
5	POWERDOWN	I	Power down signal input pin
6	NC		Not used
7	RMC	I	Remote control signal input pin
8	GND		Ground
9	CNVSS_UP	I	Switches processor mode
10	24C16_SDA	I/O	Data signal input & output for data backup of main CPU
11	24C16_SCL	O	Clock signal output for data backup of main CPU
12	RESET	I	Main CPU reset signal input pin (active at L)
13	XOUT	O	Output for 16 MHz Crystal
14	GND		Ground
15	XIN	I	Input for 16 MHz Crystal
16	3V3		+3.3 V Power Supply
17	NMI		Pull up
18	TUNER_INT	I	Tuner Interrupt signal input pin
19	4588_INT	I	AK4588 Interrupt signal input pin
20	WOL_NW	I	Output signal for WOL
21	NC		Not used
22	A_MUTE	O	Audio output control pins at Mute Tr (active at L)
23	HP_DET	I	Monitoring the input pin headphone connection
24	HP_RLY	O	Headphone audio output control pins at Mute Tr (active at L)
25	SW_SUM	O	Output for Sub Woofer SUMMING Control (H: SUMMING)
26	CTL_B	O	IC control signal B output pin for selecting the video input
27	NC		Not used
28	OSD/FLT_CLK	O	OSD & FL drive Ic output pin of the Clock
29	CTL_A	O	IC control signal A output pin for selecting the video input
30	MUTE_B+_CONT	O	Power control pin mute B+
31	U_TX	O	Output for Upgrade (UART)
32	U_RX	I	Input for Upgrade (UART)
33	BUSY_JTAG	O	BUSY signal output pin
34	SCLK_JTAG/TR_DET'	I	Serial clock input and Protection pin
35	VOL_DATA	O	Data signal output for R2A15219 (I2C)
36	VOL_CLK	O	CLK signal output for R2A15219 (I2C)
37	STBY_RLY	O	Output to ST-BY Relay ON/OFF (active at H)
38	OSD_RST	O	Not used
39	F_RLY	O	Tr driven control pins at the Front speaker output Relay. (active at H)
40	TUNER_SCLK	O	Clock signal output for Tuner Pack
41	EPM_UP	I	UPGRADE
42	TUNER_SDIO	I/O	Data signal input & output for Tuner Pack
43	TUNER_SEN	O	Output for Tuner Pack Serial Enable Input (active at L)
44	TUNER_RST	O	Output to reset Tuner Pack (active at L)
45	NC		Not used
46	OSD_CE/CE	O	UPGRADE pin
47	NC		Not used
48	S_RLY	O	Tr driven control pins at the Surround speaker output Relay. (active at H)
49	3959_SDA	I/O	Not used
50	3959_SCL	I/O	Not used

A

No.	Symbol	I/O	Description
51	C_RLY	O	Tr driven control pins at the Center speaker output Relay. (active at H)
52	NC		Not used
53	SP_DC	O	HDMI LED on/off control pin if Speaker DC Protection
54	NET_PWR	O	Control pin HDMI IC +5 V REG. IC (on: H)
55	DVC_PWR	O	Control pin HDMI IC +1.8 V REG. IC (on: H)
56	DIR_PWR	O	Control pin digital +3.3 V DC/DC IC (on: H)
57	MIC_DET	I	Monitoring the input pin microphone connection (detection: L)
58	4588_PDN	O	Output for AK4588 power down
59	4588_SDA	I/O	Data signal input & output for AK4588 (I2C)
B 60	4588_SCL	O	Clock signal output for AK4588 (I2C)
61	DSP_SDA	I/O	Data signal Input & output for DA788
62	3V3		+3.3 V Power Supply
63	DSP_SCL	O	Clock signal output for DA788 (SPI)
64	GND		Ground
65	DSP_RST	O	Output to reset DA788
66	NC		Not used
67	DSP_SDOUT	I	Data signal input for DA788 (SPI)
68	DSP_CS	O	Chip select signal output for DA788
69	DSP_RDY	I	SPI Enable signal input from DA788
70	HDMI_SEL	O	IC signal of the control pins at select HDMI or analog audio
C 71	PROTECT2	I	AMP5 Assy input signal of the RADIATOR THERMAL pin (L = PROTECTION)
72	MAIN_IRQ	O	Interrupt signal output pin to sub CPU
73	SUB_ON	O	Control pin sub CPU IC +3.3 V REG. IC (on: H)
74	SUB_IRQ	I	Interrupt signal output pin to main micom
75	HD_MUTE	I	Input for HDMI_RX_MUTE condition
76	SUB_PDN	O	Output for sub CPU power down
77	SUB_RST	O	Output to reset sub CPU
78	SCDI_MAIN	I	Data signal input from sub CPU
79	SCDO_MAIN	O	Data signal output to sub CPU
80	CSCK_MAIN	O	Clock signal output for sub CPU
81	SET OPTION	I	Input for Set option
82	STEP OPTION	I	Input for Step (Group) option
D 83	VIDEO_MUTE	O	Output for Video IC MUTE condition
84	OSD/FLT_DATA	O	OSD or FLT Data pin
85	PROTECT1	I	AMP5 Assy Protection detection signal input pin (ASO = 0.82 V, DC = 1.39 V)
86	VOL_DN	I	Data input for VOLUME encoder (VOLUME DOWN is counterclockwise direction)
87	VOL_UP	I	Data input for VOLUME encoder (VOLUME UP is clockwise direction)
88	IN_DN	I	Data input for INPUT selector encoder
89	NC		Not used
90	KEY1	I	Data input for Key1 scan
91	KEY3	I	Data input for Key3 scan
92	KEY2	I	Data input for Key2 scan
93	IN_UP	I	Data input for INPUT selector encoder
E 94	FLT_CE	O	Output for chip enable of SC16315
95	NC		Not used
96	GND		Ground
97	USBDCERR	I	Input for usb_dc_err condition
98	3V3		+3.3 V Power Supply
99	3V3		+3.3 V Power Supply
100	V+5V_DET	I	Detection pin V+5V protection

F

■(UPD78F1167AGF-GAS)(D-MAIN Assy: IC101)(for VSX-1023-K, VSX-43) SUB CPU

• Pin Function

No.	Symbol	I/O	Description
1	VSCL	O	IIC clock signal output pin (SII9573CTUC-K)
2	VSDA	I/O	IIC data signal in/output pin (SII9573CTUC-K)
3	XHDPP_RST	O	Reset signal output pin for SII9573CTUC-K
4	XRST_NW	O	Reset signal output pin for DM-860A
5	WOL_NW	I	Input signal for WOL
6	P64/xRD	-	Not used
7	P65/WR0	-	Not used
8	P66/WR1	-	Not used
9	XAMUTE_SUB	O	Audio output control pins at Mute Tr (active at L)
10	P77/EX23/KR7/INTP11	-	Not used
11	XHDPP_MUTE	I	Input for HDMI_RX_MUTE condition
12	XMHLPERR	I	Input for MHL ERROR condition
13	HDPP_INT	I	Input for SII9573CTUC-K Interrupt Signal
14	P73/EX19/KR3	-	Not used
15	MHLPOW	O	Output signal for control MHL power
16	P71/EX17/KR1	-	Not used
17	P70/EX16/KR0	-	Not used
18	P06/xWAIT	-	Not used
19	P05/CLKOUT	-	Not used
20	EVSS1	-	Ground
21	P80/EX0	-	Not used
22	P81/EX1	-	Not used
23	P82/EX2	-	Not used
24	P83/EX3	-	Not used
25	P84/EX4	-	Not used
26	P85/EX5	-	Not used
27	P86/EX6	-	Not used
28	CEC_O	O	Output for CEC OPERATION
29	CEC_IO	I/O	Input & Output for CEC Interrupt Signal
30	EVDD1	-	Positive power supply for ports
31	P50/EX8	-	Not used
32	P51/EX9	-	Not used
33	P52/EX10	-	Not used
34	DSD_SEL	O	Output for DSD audio signal selector ic control pin.
35	P54/EX12	-	Not used
36	P55/EX13	-	Not used
37	P56/EX14	-	Not used
38	P57/EX15	-	Not used
39	P17/EX31/TI02/TO02	-	Not used
40	P16/EX30/TI01/TO01/INTP5	-	Not used
41	P15/EX29/RTCDIV/RTCCL	-	Not used
42	232RX	I	Input for Upgrade (UART)
43	232TX	O	Output for Upgrade (UART)
44	DI_NW	O	Data signal Output to DM860A
45	DO_NW	I	Data signal Input from DM860A
46	CLK_NW	O	Clock signal Output to DM860A
47	AVREF1	-	D/A converter reference voltage input
48	P110/AN00	O	Not used
49	CS_NW	O	Output for DM860a chip select
50	AVREF0	-	A/D converter reference voltage input

A

No.	Symbol	I/O	Description
51	AVSS	-	Ground
52	P157/ANI15	-	Not used
53	P156/ANI14	-	Not used
54	P155/ANI13	-	Not used
55	P154/ANI12	-	Not used
56	P153/ANI11	-	Not used
57	P152/ANI10	-	Not used
58	P151/ANI9	-	Not used
59	P150/ANI8	-	Not used
B 60	SUB_IRQ	O	Interrupt Output to main CPU
61	P26/ANI6	-	Not used
62	P25/ANI5	-	Not used
63	FPGA_MUTE	O	Output for FPGA_MUTE condition
64	FPGA_656THRU	O	Output for FPGA_656THRU condition
65	FPGA_NP	O	Switches mode of NTSC,PAL
66	FPGA_RST	O	Reset signal output pin for PE1026A
67	P20/ANI0	-	Not used
68	P130	-	Not used
69	THRU_LED	O	HDMI LED on/off control pin
70	CSCK_MAIN	I	Clock signal Input from main CPU
C 71	SCDO_MAIN	I	Data signal Input from main CPU
72	SCDI_MAIN	O	Data signal Output to main CPU
73	P01/TO00	-	Not used
74	P00/TI00	-	Not used
75	SS_FPGA	-	Not used
76	SO_FPGA	-	Not used
77	SI_FPGA	-	Not used
78	SCK_FPGA	-	Not used
79	P141/PCLBUZ1/INTP7	-	Not used
80	REBOOT_NW	O	Output signal for reboot DM860A
81	MAIN_IRQ	I	Interrupt Input from main CPU
82	REQ_NW	I	Interrupt Input from DM860A
D 83	SUB_PDN	I	Input power down from main CPU
84	P45/SO01	-	Not used
85	P44/SI01	-	Not used
86	P43/SCK01	-	Not used
87	P42/TI04/TO04	-	Not used
88	TOOL1	O	Clock output for debugger
89	TOOL0	I/O	Data I/O for flash memory programmer/debugger
90	XSUB_RST	I	System reset input
91	P124/XT2	-	CRYSTAL connection for sub system clock
92	P123/XT1	-	CRYSTAL connection for sub system clock
93	FLMD0	-	Flash memory programming mode setting
E 94	P122/X2/EXCLK	-	CRYSTAL connection for main system clock
95	P121/X1	-	CRYSTAL connection for main system clock
96	REGC	-	Connecting regulator output (2.5 V) stabilization capacitance for internal operation.
97	VSS	-	Ground
98	EVSS0	-	Ground potential for ports
99	VDD	-	Positive power supply (Connected to +3.3 V)
100	EVDD0	-	Positive power supply for ports (Connected to +3.3 V)

F

■ (UPD78F1167AGF-GAS)(D-MAIN Assy: IC101)(for VSX-823-K)

SUB CPU

• Pin Function

No.	Symbol	I/O	Description
1	VSCL	O	IIC clock signal output pin (SII9573CTUC-K)
2	VSDA	I/O	IIC data signal in/output pin (SII9573CTUC-K)
3	XHDPP_RST	O	Reset signal output pin for SII9573CTUC-K
4	XRST_NW	O	Reset signal output pin for DM-860A
5	WOL_NW	I	input signal for WOL
6	P64/xRD	-	Not used
7	P65/WR0	-	Not used
8	P66/WR1	-	Not used
9	XAMUTE_SUB	O	Audio output control pins at Mute Tr (active at L)
10	P77/EX23/KR7/INTP11	-	Not used
11	XHDPP_MUTE	I	Input for HDMI_RX_MUTE condition
12	XMHLPERR	I	Input for MHL ERROR condition
13	HDPP_INT	I	Input for SII9573CTUC-K Interrupt Signal
14	P73/EX19/KR3	-	Not used
15	MHLPOW	O	Output signal for control MHL power
16	P71/EX17/KR1	-	Not used
17	P70/EX16/KR0	-	Not used
18	P06/xWAIT	-	Not used
19	P05/CLKOUT	-	Not used
20	EVSS1	-	Ground
21	P80/EX0	-	Not used
22	P81/EX1	-	Not used
23	P82/EX2	-	Not used
24	P83/EX3	-	Not used
25	P84/EX4	-	Not used
26	P85/EX5	-	Not used
27	P86/EX6	-	Not used
28	CEC_O	O	Output for CEC OPERATION
29	CEC_IO	I/O	Input & Output for CEC Interrupt Signal
30	EVDD1	-	Positive power supply for ports
31	P50/EX8	-	Not used
32	P51/EX9	-	Not used
33	P52/EX10	-	Not used
34	DSD_SEL	O	Output for DSD audio signal selector ic control pin.
35	P54/EX12	-	Not used
36	P55/EX13	-	Not used
37	P56/EX14	-	Not used
38	P57/EX15	-	Not used
39	P17/EX31/TI02/TO02	-	Not used
40	P16/EX30/TI01/TO01/INTP5	-	Not used
41	P15/EX29/RTCDIV/RTCCCL	-	Not used
42	232RX	I	Input for Upgrade (UART)
43	232TX	O	Output for Upgrade (UART)
44	DI_NW	O	Data signal Output to DM860a
45	DO_NW	I	Data signal Input from DM860a
46	CLK_NW	O	Clock signal Output to DM860a
47	AVREF1	-	D/A converter reference voltage input
48	P110/ANO0	O	Not used
49	CS_NW	O	Output for DM860a chip select
50	AVREF0	-	A/D converter reference voltage input

A

No.	Symbol	I/O	Description
51	AVSS	-	Ground
52	P157/ANI15	-	Not used
53	P156/ANI14	-	Not used
54	P155/ANI13	-	Not used
55	P154/ANI12	-	Not used
56	P153/ANI11	-	Not used
57	P152/ANI10	-	Not used
58	P151/ANI9	-	Not used
59	P150/ANI8	-	Not used
B 60	SUB_IRQ	O	Interrupt Output to main CPU
61	P26/ANI6	-	Not used
62	P25/ANI5	-	Not used
63	FPGA_MUTE	O	Output for FPGA_MUTE condition
64	FPGA_656THRU	O	Output for FPGA_656THRU condition
65	FPGA_NP	O	Switches mode of NTSC, PAL
66	FPGA_RST	O	Reset signal output pin for PE1026A
67	P20/ANI0	-	Not used
68	P130	-	Not used
69	THRU_LED	O	HDMI LED on/off control pin
70	CSCK_MAIN	I	Clock signal Input from main CPU
C 71	SCDO_MAIN	I	Data signal Input from main CPU
72	SCDI_MAIN	O	Data signal Output to main CPU
73	P01/TO00	-	Not used
74	P00/TI00	-	Not used
75	SS_FPGA	-	Not used
76	SO_FPGA	-	Not used
77	SI_FPGA	-	Not used
78	SCK_FPGA	-	Not used
79	P141/PCLBUZ1/INTP7	-	Not used
80	REBOOT_NW	O	Output signal for reboot DM860A
81	MAIN_IRQ	I	Interrupt Input from main CPU
82	REQ_NW	I	Interrupt Input from DM860A
D 83	SUB_PDN	I	Input power down from main CPU
84	P45/SO01	-	Not used
85	P44/SI01	-	Not used
86	P43/SCK01	-	Not used
87	P42/TI04/TO04	-	Not used
88	TOOL1	O	Clock output for debugger
89	TOOL0	I/O	Data I/O for flash memory programmer/debugger
90	XSUB_RST	I	System reset input
91	P124/XT2	-	CRYSTAL connection for sub system clock
92	P123/XT1	-	CRYSTAL connection for sub system clock
93	FLMD0	-	Flash memory programming mode setting
E 94	P122/X2/EXCLK	-	CRYSTAL connection for main system clock
95	P121/X1	-	CRYSTAL connection for main system clock
96	REGC	-	Connecting regulator output (2.5 V) stabilization capacitance for internal operation.
97	VSS	-	Ground
98	EVSS0	-	Ground potential for ports
99	VDD	-	Positive power supply (Connected to +3.3 V)
100	EVDD0	-	Positive power supply for ports (Connected to +3.3 V)

F

5

6

7

8

6. SERVICE MODE

6.1 TEST MODE

[1] Display mode for numbers of protection detections

[Purpose]



The numbers of detections for various protection processes are displayed.

[How to enter/exit]

During Standby mode, simultaneously press and hold the [PRESET ←] and [STANDBY/ON] keys for 2 seconds to enter this mode.

The display will return to the normal indication when no key operation is performed for 5 seconds.

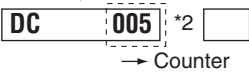
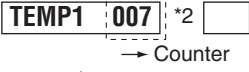
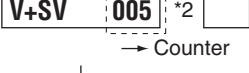
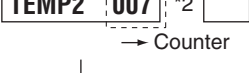
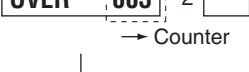
[Basic operations]

Key Operation	FL Display	Time (sec.)	Description of Indications
(STANDBY state)			
[PRESET ←] + [STANDBY/ON] keys (Initial display)		5 (-> normal) *1	Number of DC error detections
[ENTER] key		5 (-> normal) *1	Number of abnormal-temperature error detections
[ENTER] key		5 (-> normal) *1	
[ENTER] key		5 (-> normal) *1	Number of abnormal-temperature error detections
[ENTER] key		5 (-> normal) *1	Number of OVERLOAD error detections
(Initial display)			

*1 "5 (-> normal)" denotes that the display will return to the normal indication when no key operation is performed for 5 seconds.

*2 Variable range: 0 to 255

The above-mentioned Display mode is available only when the product operates properly.

If any protection function is activated while the product is in use, the product cannot be turned ON and enter the above Display mode. In such a case, cancel the protection function, referring to "[3] 3.4 How to cancel the status after detection of the DC error." If a protection function is activated immediately after the previous protection function is canceled, cancel that protection function again then enter STBY mode immediately. You can then see the error logs, following the above procedures, until a next protection function is activated.

VSX-1023-K

5

6

7

8

45

A [2] Reset mode for numbers of protection detections

[Purpose]

For clearing all the counts of protection detections.
(This mode resets the counts of protection detections.)

[How to enter/exit]

During Standby mode, simultaneously press and hold the [ALC/STANDARD SURR] and [STANDBY/ON] keys for 10 seconds to enter this mode.
The display will return to the normal indication when no key operation is performed for 5 seconds.

[Basic operations]

Key Operation	FL Display	Time (sec.)	Description of Indications
(STANDBY state)	<input type="text"/>		
[ALC/STANDARD SURR] + [STANDBY/ON] keys (press and hold the keys for 10 seconds.)	<input type="text" value="CLEAR?"/>	5 (-> normal) *1	
[ENTER] key ↓	↓		
(Counter Clear end)	<input type="text" value="0 K"/>	5 (-> normal) *1	
(Normal display)	<input type="text" value="BD"/> *2	usually	

*1 "5 (-> normal)" denotes that the display will return to the normal indication when no key operation is performed for 5 seconds.

*2 Indication when the BD function is selected

[Detailed explanations]

- When the procedures for Reset mode for numbers of protection detections are completed, all the counters will be reset to "000."
- Prohibitions:
The protection detection counts cannot be cleared (reset to 000) with the MEMORY CLEAR process.
They can only be cleared when the procedures of Reset mode are completed.

[3] The unit's operation when an error is detected

[Purpose]

- The unit's operation when a DC/OVER/TEMP error is detected is described here.
- How to cancel the status after detection of a DC error is described here, because no key input will be accepted after a DC error detection.

[Basic operations]

3.1 DC (AMP is abnormality) error detection

Key Operation	FL Display	Time (sec.)	Description of Indications
(Normal display)	<input type="text" value="BD"/> <input type="checkbox"/>	usually	Normal display
(DC detection)	<input type="text" value="BD"/> <input type="checkbox"/>		
↓ (Auto) (RECEIVER POWER OFF)	<input type="text"/> <input type="checkbox"/>		

If the AC power cord is plugged in while the AVR is prohibited from being ON because of DC detection, the HDMI LED will flash at intervals of 500 msec.

3.2 OVERLOAD (overcurrent) error detection

Key Operation	FL Display	Time (sec.)	Description of Indications
(Normal display)	<input type="text" value="BD"/> <input type="checkbox"/>	usually	Normal display
(OVERLOAD detection)	<input type="text" value="BD"/> <input type="checkbox"/>		
↓ (Auto) (RECEIVER POWER OFF)	<input type="text"/> <input type="checkbox"/>		

3.3 TEMP (AMP overheat) error detection

For detection of a TEMP error, the unit monitors both the TR_DET and PROTECT2 signals. If a TEMP error is detected, the processes shown below will be performed. The processes shown below are rough operational specifications and are not the actual commands from the mounted components.

After a TEMP error is detected, the count of protection activation detections will be updated.

Counter: Temp2 TR_DET
P6_4 (34 pin)
(TRTHER_DET from AMP Assy)

Counter: Temp1 PROTECT2
PL2_1 (71 pin)
(RADI_DET from AMP Assy)

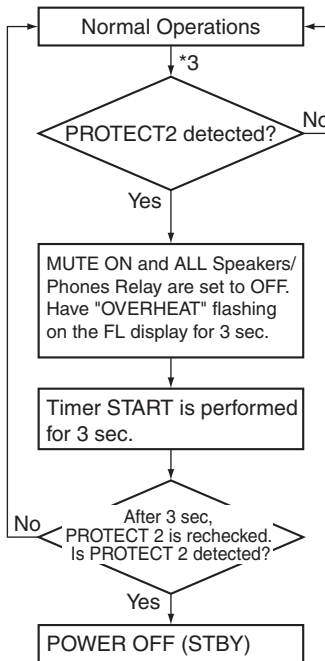
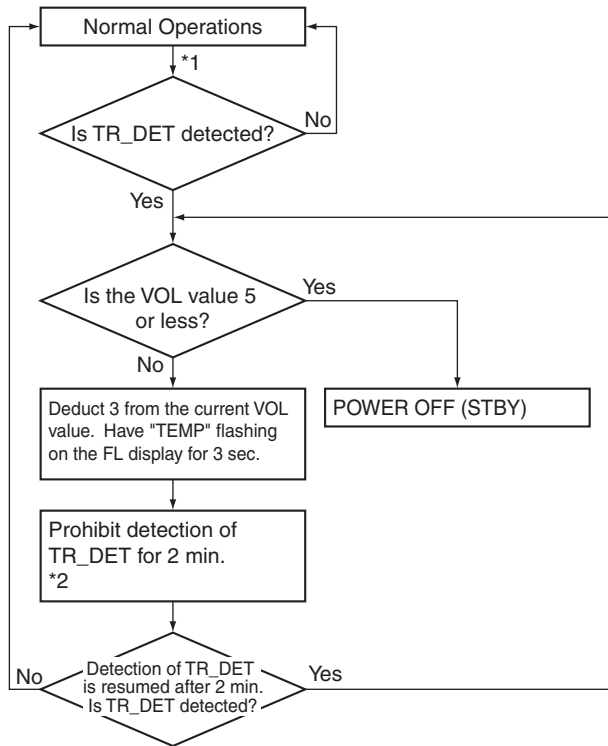



*1: The detection interval must be 1 sec or less.

*2: If PROTECT 2 is detected while TR_DET detection is prohibited for 2 min, the PROTECT 2 function will be activated.

*3: The detection interval must be 1 sec or less.

3.4 How to cancel the status after detection of the DC error

Key Operation	FL Display	Time (sec.)	Description of Indications
(STANDBY state) [ADVANCED SURROUND] + [STANDBY/ON] keys (press and hold the keys for 2 seconds.) ↓ (Normal display)	 	usually	Normal display

[Detailed explanations] Simultaneously holding the [ADVANCED SURROUND] and [STANDBY/ON] keys on the front panel pressed for 2 seconds will cancel Key Input Inhibition mode after a DC error detection and turn the unit ON.

6.2 DEFAULT SETTINGS

■ Resetting the system

Use this procedure to reset all the receiver's settings to the factory default. Use the front panel controls to do this.

- For instructions on resetting the network connection settings.

- 1 Switch the receiver into standby.
- 2 While holding down **BAND**, press and hold **⏻ STANDBY/ON** for about two seconds.
- 3 When you see **RESET?** appear in the display, press **AUTO SURROUND/STREAM DIRECT**.
OK? shows in the display.
- 4 Press **ALC/STANDARD SURR** to confirm.
OK appears in the display to indicate that the receiver has been reset to the factory default settings.

■ Resetting the NETWORK function

Use to reset all network connection settings to their initial, factory-setting condition.

- 1 Press **NETWORK**.
- 2 Press **HOME MENU**.
- 3 Select **'Factory Reset'** from the Network Setup menu.
- 4 Select **'Start'**.
- 5 Select **'OK'** to confirm.
The screen will return automatically to the play screen.

7. DISASSEMBLY

Note:

Even if the unit shown in the photos and illustrations in this manual may differ from your product, the procedures described here are common.

Some connections of the housing wires or connectors may be tight. When disconnecting those wires or connectors, be careful not to damage them.

1. Discharging

[1] MAIN Assy Capacitor (C55, C58)

■ for VSX-1023-K, VSX-43

[Procedures]

- (1) Unplug the power cord.
- (2) Disconnect the 10P connector from CP403 of the AMP7 Assy between CN3 of the MAIN Assy.
- (3) Connect +B and -B terminal of the D7, using resistor leads with 47 - 100 ohms (2 W or higher), for discharging.
 - * Discharging time: 30 - 60 seconds, depending on the level of resistance.
- (4) Check that the voltage between the +B and -B terminals is less than 1 V, using a tester.
 - * Be sure to connect the GND terminal of the tester to the chassis.
 - * If the voltage is still 1 V or higher, repeat Step (3).

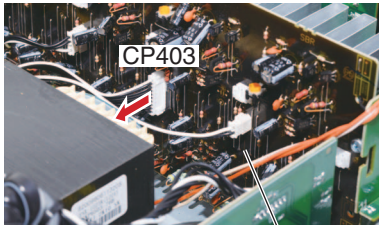

AMP7 Assy

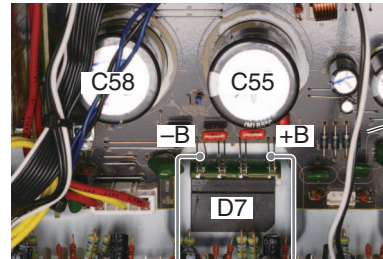

MAIN Assy

47 - 100 ohms
(2 W or higher)

■ for VSX-823-K

[Procedures]

- (1) Unplug the power cord.
- (2) Disconnect the 10P connector from CP403 of the AMP5 Assy between CN3 of the MAIN Assy.
- (3) Disconnect the 7P connector from CP7 of the REG Assy between W7 of the MAIN Assy.
- (4) Connect B+ and B- terminal of the D7, using resistor leads with 47 - 100 ohms (2 W or higher), for discharging.
 - * Discharging time: 30 - 60 seconds, depending on the level of resistance.
- (5) Check that the voltage between the B+ and B- terminals is less than 1 V, using a tester.
 - * Be sure to connect the GND terminal of the tester to the chassis.
 - * If the voltage is still 1 V or higher, repeat Step (4).

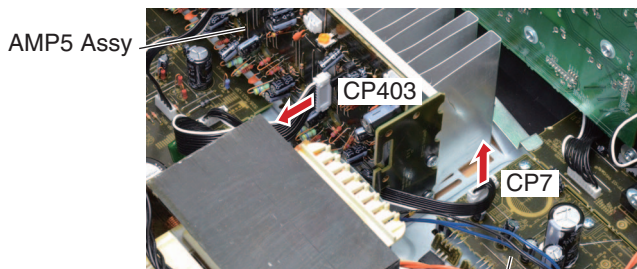

REG Assy

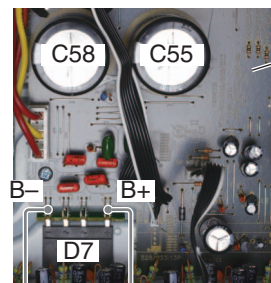

MAIN Assy

47 - 100 ohms
(2 W or higher)

[2] FL-30 V Capacitor (MAIN Assy C101)

[Procedures]

- (1) Unplug the power cord.
- (2) Connect pins 3, 4 (-30V) and pins 5, 6 (GND) of the CN704B on the CPU Assy, using resistor leads with 47-100 ohms (2 W or higher), for discharging.
 - * Discharging time: 5 - 10 seconds, depending on the level of resistance.

- (3) Check that the voltage between the -30V terminal is less than 1 V, using a tester.
 - * Be sure to connect the GND terminal of the tester to the chassis.
 - * If the voltage is still 1 V or higher, repeat Step (2).

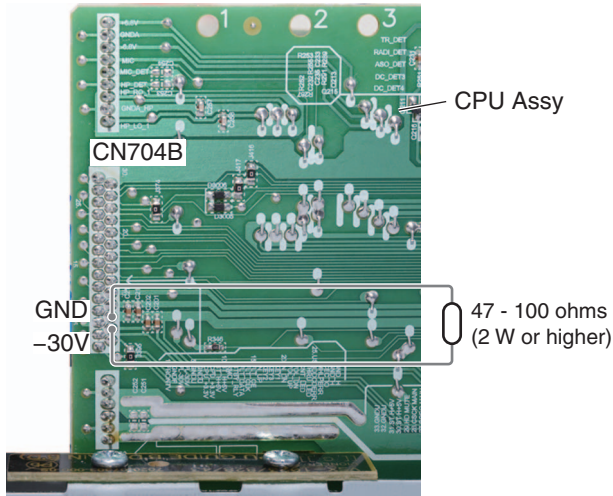

for VSX-1023-K, VSX-43

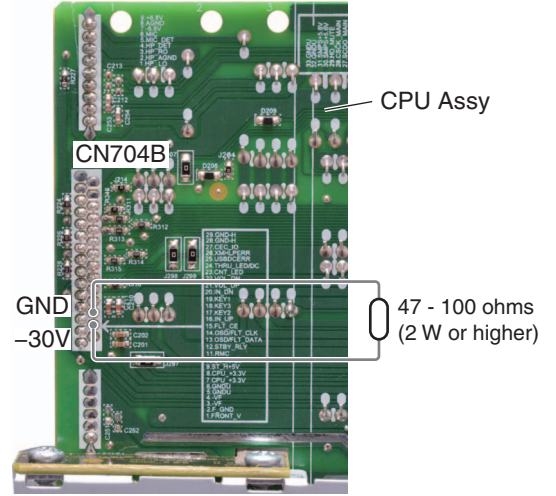

for VSX-823-K

2. Disassembly (VSX-1023-K, VSX-43)

Note:

For performing the diagnosis shown below, the following jigs for service is required:

- Board to board extension jig cable (GGD1846)
- Board to board extension jig cable (GGD1847)
- Board to board extension jig cable (GGD1756)
- 13P extension cable (GGD1740)
- 3P extension cable (GGD1741)
- HDMI cable (marketing product)

[1] Front Panel Section

Remove the cabinet by removing the 10 screws.

- (1) Remove the five screws.
(BBZ30P080FTB)

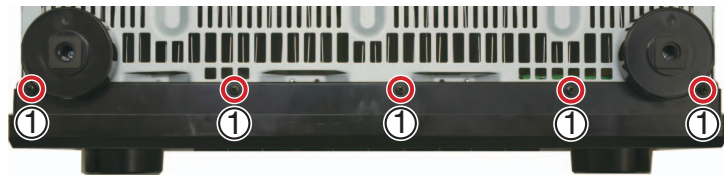

• Bottom view

- (2) Remove the three screws.
(BBZ30P080FTC)

- (3) Remove the two screws.
(1500001206010-IL)

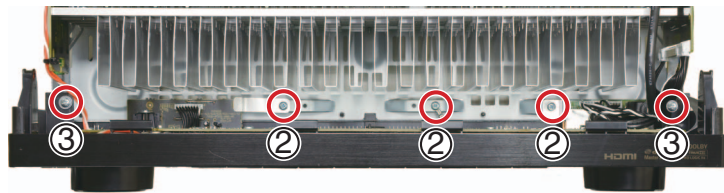

- (4) Release the jumper wire.
(5) Cut the one binder.

- (6) Remove the acetate tape
(JA9620)

- (7) Disconnect the HDMI cable.
(8) Disconnect the one flexible cable and five connectors.
(CN9202, CN9601, CN704B, CP703, CP723, CP722)

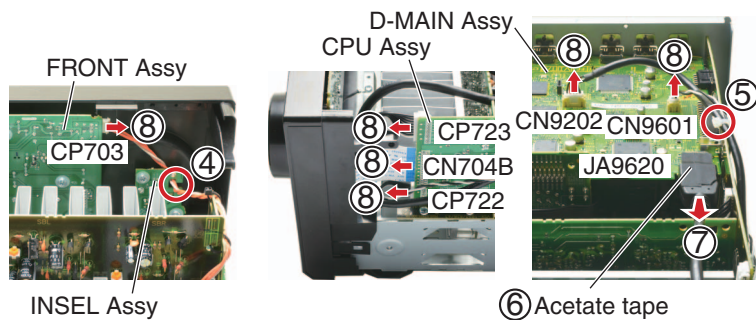

- (9) Unhook the two hooks.
(10) Remove the front panel section.

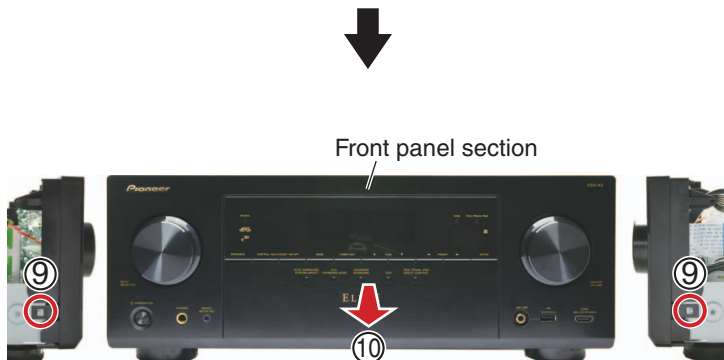

[2] Heatsink Section

Caution: Heatsink section in work becomes hot, and be careful with it.

Remove the cabinet by removing the 10 screws.

- (1) Remove the three screws.
(BBZ30P080FTC)

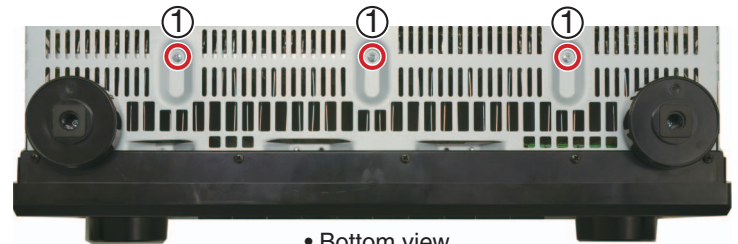

- (2) Remove the four screws.
(BBZ30P080FTC)
(3) Cut the one binder.

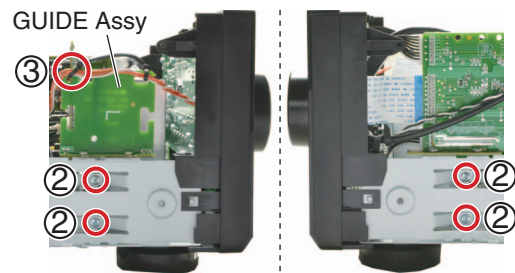

- (4) Remove the acetate tape
(5) Disconnect the HDMI cable.
(JA9620)
(6) Cut the binder.
(7) Disconnect the two connectors.
(CN404, CP401)
(8) Remove the Heatsink section.

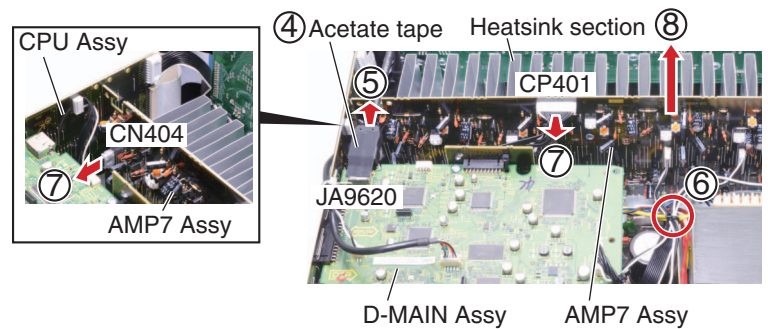

- (9) Arrange the Heatsink section as shown in the photo below.
(10) Connect the two extension jig cables.

Diagnosis

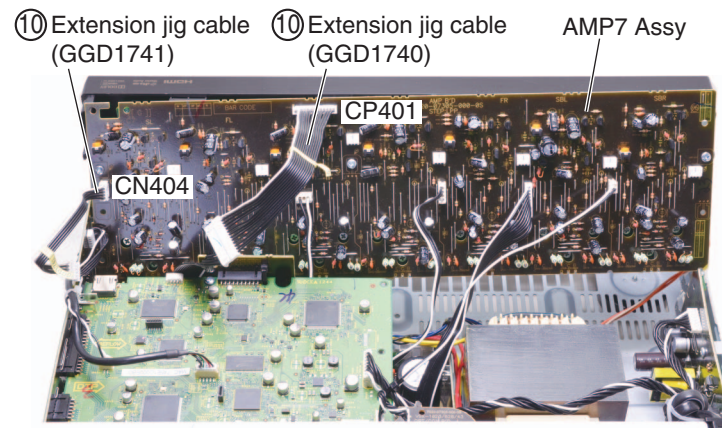

A [3] D-MAIN Assy

Remove the cabinet by removing the 10 screws.

- (1) Remove the two screws.
(BBT30P100FTB)
- (2) Remove the six screws.
(BSZ30P040FTB)

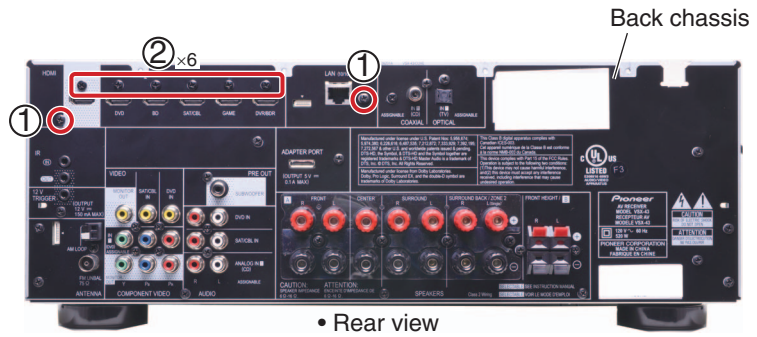

B

- (3) Remove the acetate tape
- (4) Disconnect the HDMI cable.
(JA9620)
- (5) Cut the two binders.
- (6) Remove the two screws.
(BBZ30P080FTC)
- (7) Disconnect the one connector and three B to B connectors.
(CN101, CN102, CN1801, CN1802)

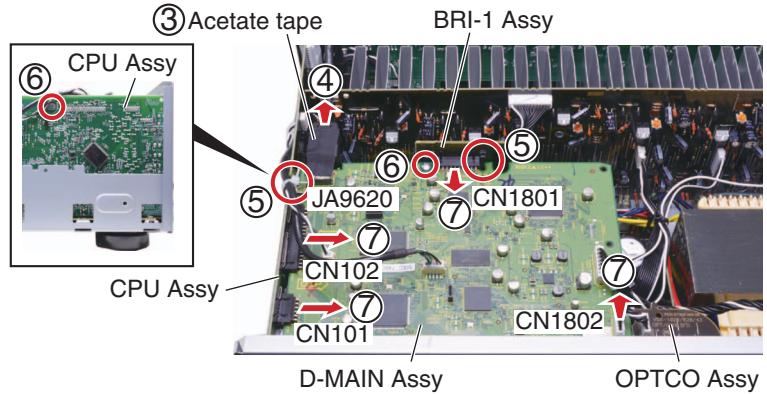

D

- (8) Connect the three extension jig cables.
- (9) Arrange the D-MAIN Assy in the photo below.
- (10) Insert any insulation sheet.
- (11) Connect the HDMI cable (marketing product) from the FHDMI Assy if Front HDMI input needs to be checked.

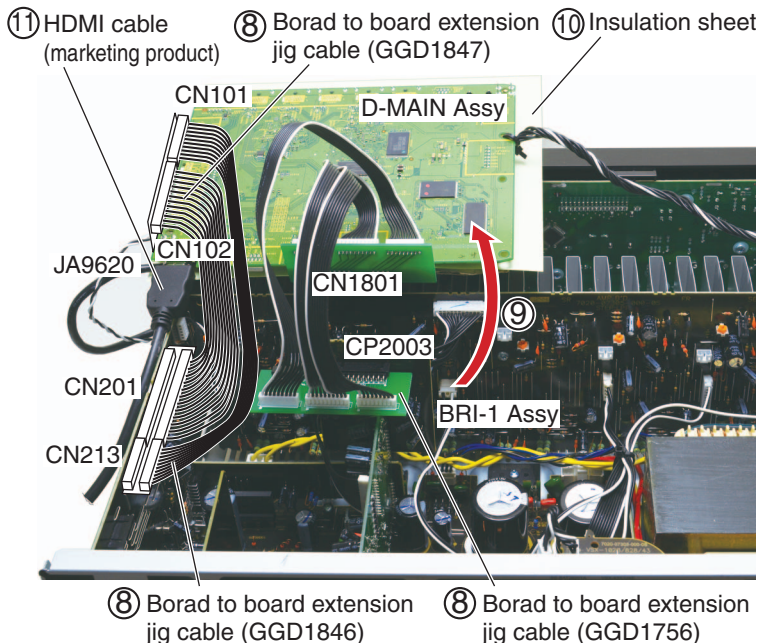

E

Note:
Do not connect the HDMI cable provided with the product to prevent damage to the HDMI connector. Instead, use the another HDMI cable (marketing product) to prevent a load from being applied to the HDMI connector.
D-MAIN Assy works normally even though no connection of HDMI cable. But when checking Front HDMI input, that HDMI connection is required.



F

[4] MAIN Assy

Remove the cabinet by removing the 10 screws.

[4-1] Back chassis, D-MAIN Assy

- (1) Remove the 11 screws.
(BBT30P100FTB)
- (2) Remove the six screws.
(BSZ30P040FTB)
- (3) Remove the D-MAIN Assy.
(See procedure [3].)



[4-2] MAIN Assy

- (1) Remove the CPU-G Assy by removing the two screws.
(BBZ30P080FTC)
- (2) Cut the four binders.
- (3) Disconnect the one flexible cable and 11 connectors.
(CN404, 704B, CP1 to 3, 401, 403 to 406, 722, 723)
- (4) Remove the six screws.
(BBZ30P080FTC)
- (5) Remove the four screws.
(BBZ30P180FTC)
- (6) Remove the MAIN Assy with CPU Assy and back chassis.

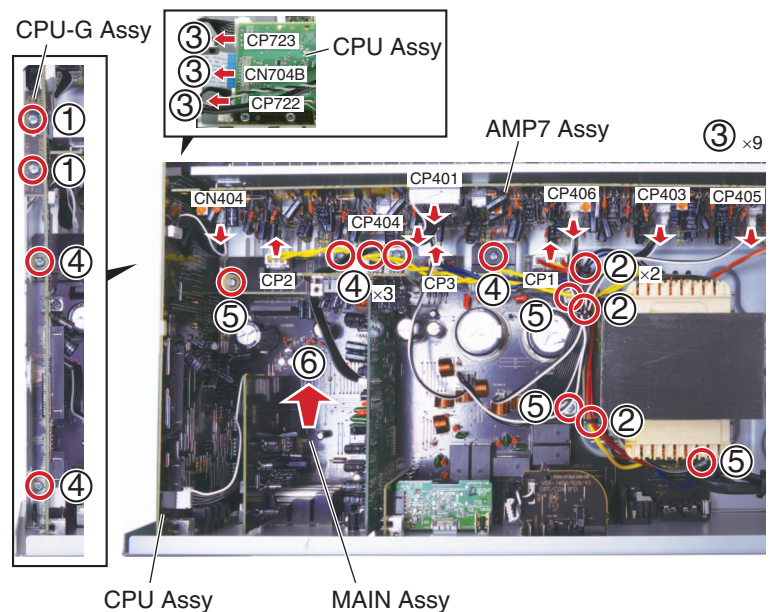

3. Disassembly (VSX-823-K)

Note:

For performing the diagnosis shown below, the following jigs for service is required:

- Board to board extension jig cable (GGD1846)
- Board to board extension jig cable (GGD1847)
- Board to board extension jig cable (GGD1848)
- HDMI cable (marketing product)

[1] Front Panel Section

Remove the cabinet by removing the 10 screws.

- (1) Remove the five screws.
(BBZ30P080FTB)

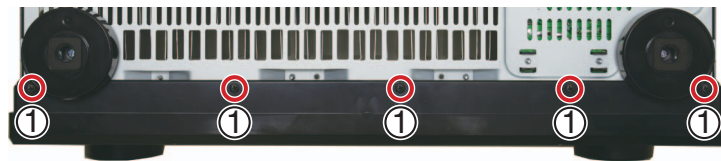

- (2) Remove the three screws.
(BBZ30P080FTC)
- (3) Remove the two screws.
(1500001206010-IL)

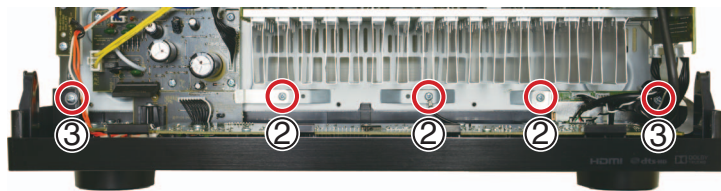

- (4) Release the jumper wire.
- (5) Cut the one binder.
- (6) Remove the acetate tape
(JA9620)
- (7) Disconnect the HDMI cable.
- (8) Disconnect the one flexible cable and five connectors.
(CN205, CN206, CN704B, CN9202, CN9601, CP703)

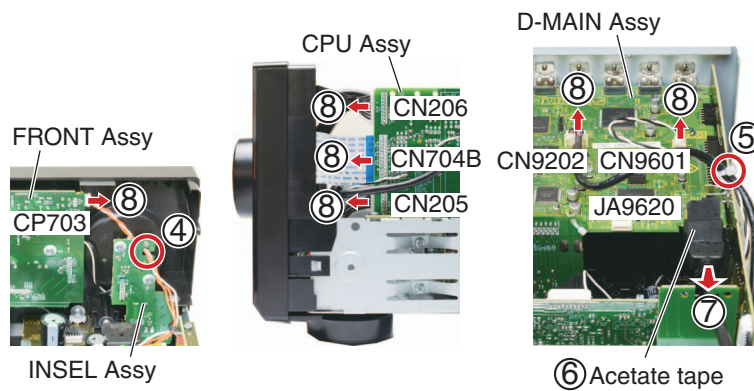

- (9) Unhook the two hooks.
- (10) Remove the front panel section.

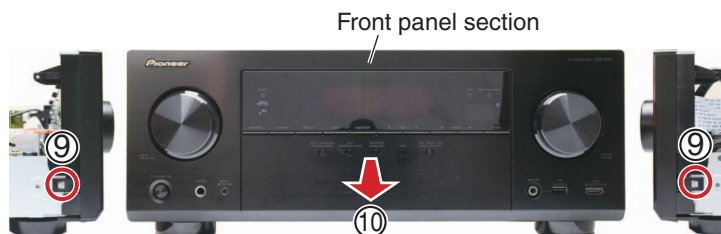

[2] Heatsink Section

Caution: Heatsink section in work becomes hot, and be careful with it.

Remove the cabinet by removing the 10 screws.

- (1) Remove the three screws.
(BBZ30P080FTC)

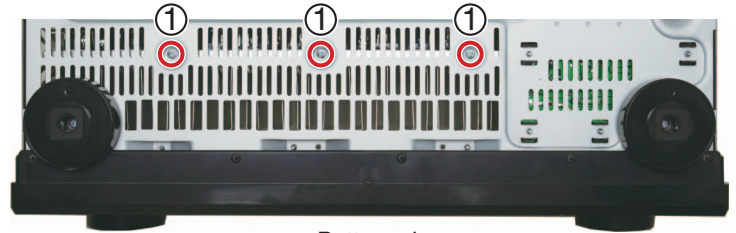

• Bottom view

- (2) Remove the two screws.
(BBZ30P080FTC)
(3) Release the jumper wire.

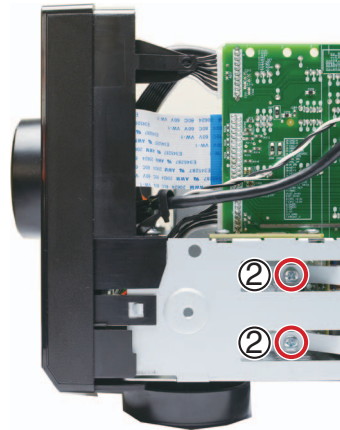

- (4) Remove the acetate tape
(5) Disconnect the HDMI cable.
(JA9620)
(6) Disconnect the four connectors.
(CP401 to CP404)
(7) Remove the heatsink section.

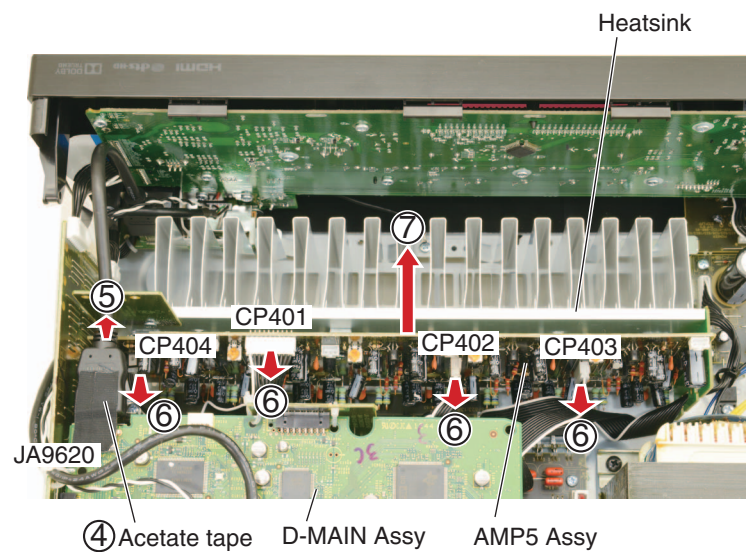

A [3] D-MAIN Assy

Remove the cabinet by removing the 10 screws.

[3-1] Disassembly

- (1) Remove the two screws (BBT30P100FTB)
- (2) Remove the six screws (BSZ30P040FTB)

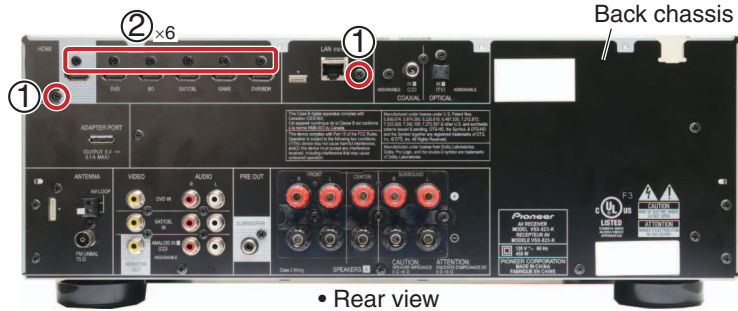

- (3) Remove the acetate tape
- (4) Disconnect the HDMI cable (JA9620)
- (5) Cut the three binders.
- (6) Remove the one screw (BBZ30P080FTC)
- (7) Disconnect the one connector and three B to B connectors (CN101, CN102, CN1802, CN1803)

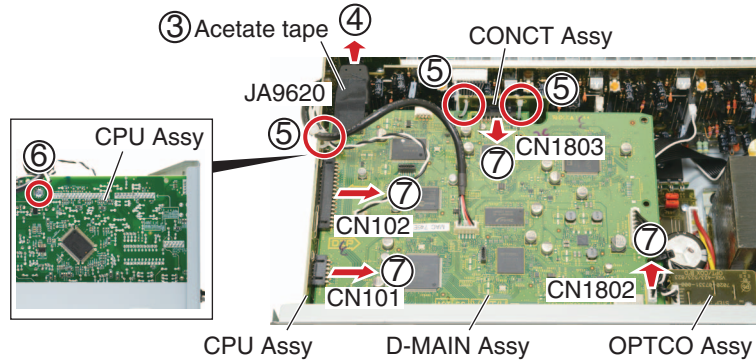

[3-2] Diagnosis of D-MAIN Assy and MAIN Assy

- (1) Connect the three extension jig cables.
- (2) Arrange the D-MAIN Assy in the photo below.
- (3) Insert any insulation sheet.
- (4) Connect the HDMI cable (marketing product) from the FHDMI Assy if Front HDMI input needs to be checked.

Note:
Do not connect the HDMI cable provided with the product to prevent damage to the HDMI connector. Instead, use the another HDMI cable (marketing product) to prevent a load from being applied to the HDMI connector.
D-MAIN Assy works normally even though no connection of HDMI cable. But when checking Front HDMI input, that HDMI connection is required.

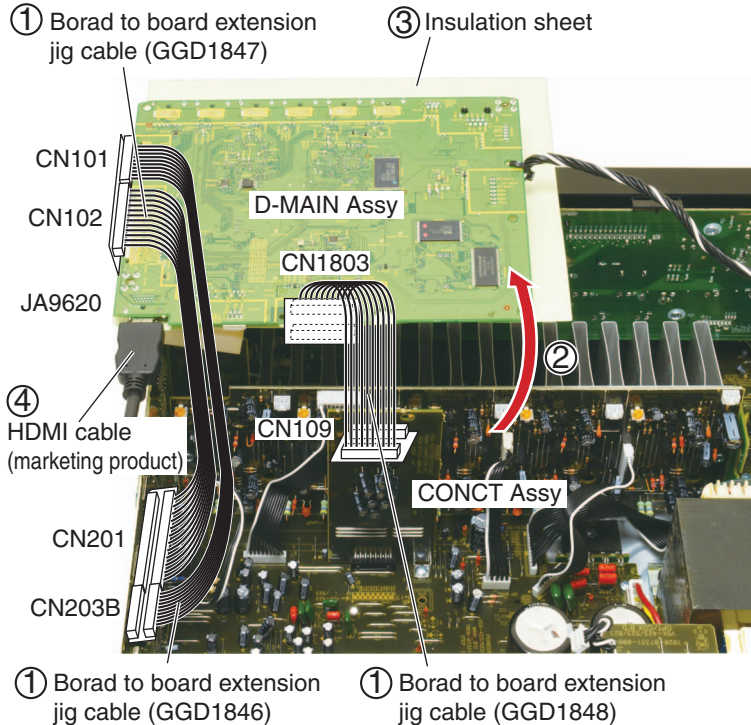

[3-3] Diagnosis of AMP5 Assy

- (1) Disconnect the one extension jig cable.
- (2) Remove the one screw.
(BBZ30P180FTC)
- (3) Remove the CONCT Assy by disconnecting
the one BtoB connector.
(CN110)

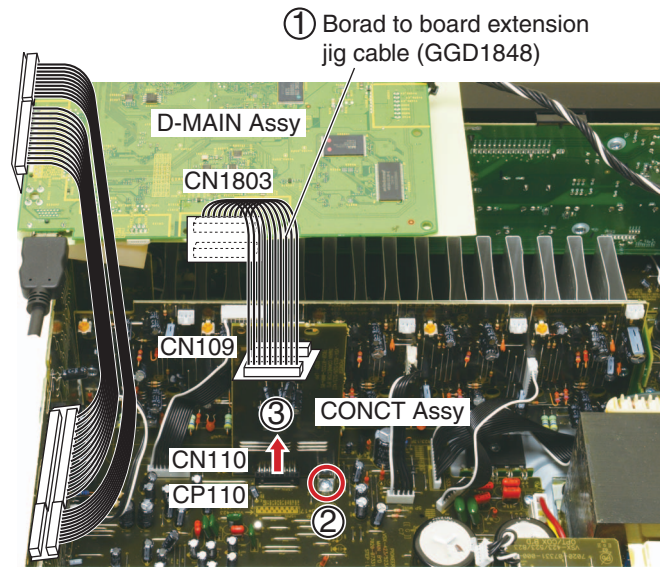

- (4) Reassemble the CONCT Assy to D-MAIN Assy.
- (5) Connect the one extension jig cable.



Diagnosis

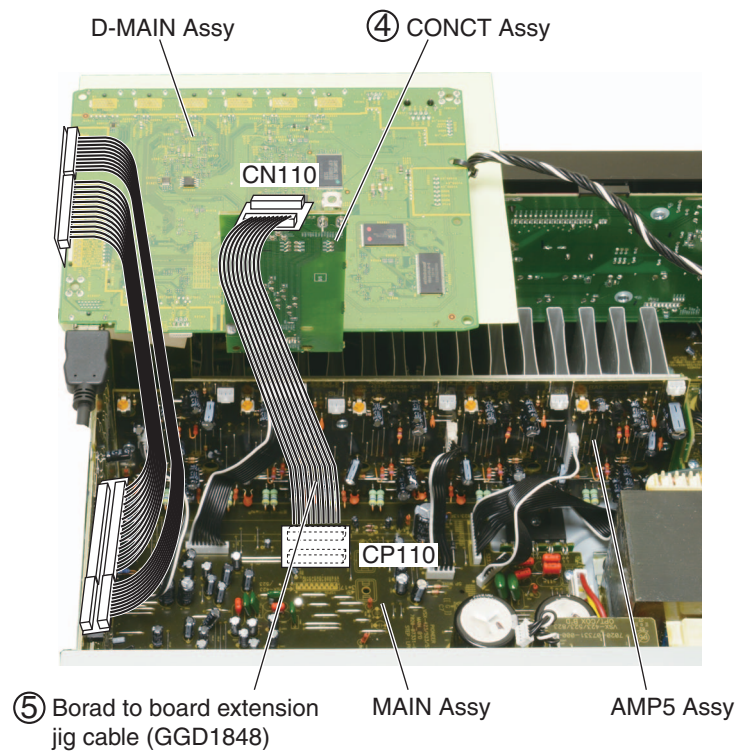

⑤ Borad to board extension
jig cable (GGD1848)

MAIN Assy

AMP5 Assy

A [4] MAIN Assy

Remove the cabinet by removing the 10 screws.

[4-1] Back chassis, D-MAIN Assy

- (1) Remove the 11 screws. (BBT30P100FTB)
- (2) Remove the six screws. (BSZ30P040FTB)
- (3) Remove the D-MAIN Assy. (See procedure [3].)



C [4-2] MAIN Assy

- (1) Remove the CPU-G Assy by removing the two screws. (BBZ30P080FTC)
- (2) Release the jumper wire.
- (3) Disconnect the one flexible cable and eight connectors. (CN205, 206, 704B, CP1, 7, 401 to 404)
- (4) Remove the three screws. (BBZ30P080FTC)
- (5) Remove the four screws. (BBZ30P180FTC)
- (6) Remove the MAIN Assy with CPU Assy and back chassis.

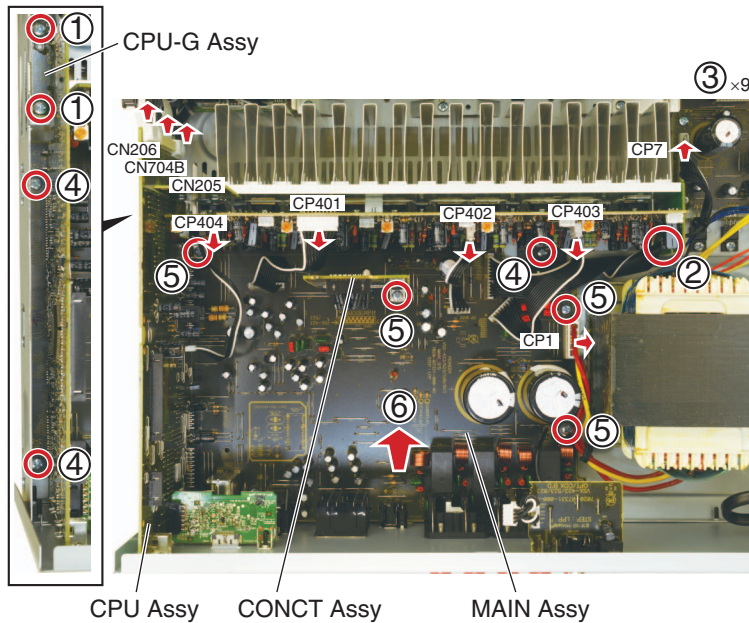

8. EACH SETTING AND ADJUSTMENT



- If the adjustment is shifted or if it becomes necessary to readjust because of part replacement, etc., perform the adjustment as described below.
- Any value changed in Adjustment mode will be stored in memory as soon as it is changed. Before readjustment, take note of the original values for reference in case you need to restore the original settings.
- Use a stable AC power supply.

8.1 ADJUSTMENT REQUIRED WHEN THE UNIT IS REPAIRED OR REPLACED

■ When any of the following assemblies is replaced

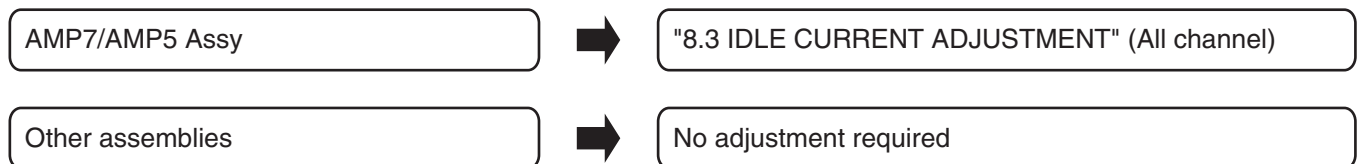

■ When any of the following parts is replaced

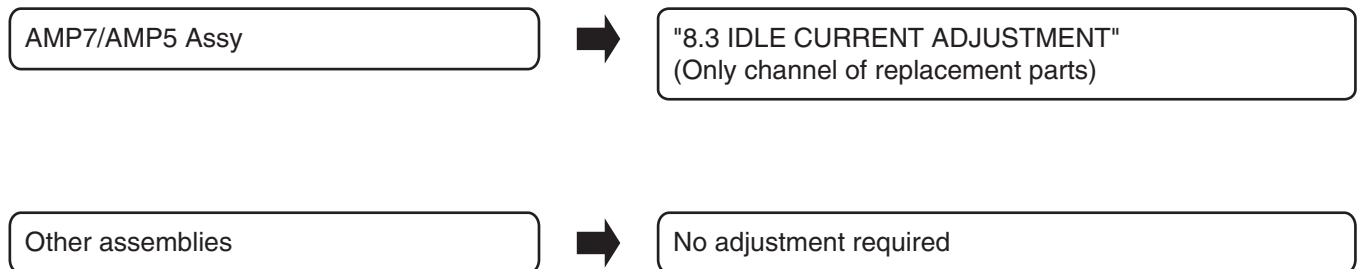

Note 1:

Some parts on D-MAIN and FHDMI Assemblies can not be replaced due to using heat-pad connection between the board. Please refer to [1.2 NOTES ON REPLACING PARTS], when the parts listed in the table is defective, replace whole Assy.

Note 2:

After replacing D-MAIN Assy, the unit needs to reset the system and NETWORK function to factory default. Refer to "Resetting the system" and "Resetting the NETWORK function" on "6.2 DEFAULT SETTINGS", reset the unit.

8.2 UPDATING OF THE FIRMWARE

[Purpose]

Refer to this section when updating the firmware of each microcomputer is required by the service information, etc.

[Necessary Tools and Connections]

- PC with a serial port
- RS-232C cable (9-pin to 9-pin, straight cable) (Marketing product)
- UPDATE jig: GGF1642 (Use FFC of GGF1642. (10P to 10P FFC))
- Firmware

Connect as shown in the figure below.

Insert the FFC with its contact surface facing the Δ mark.

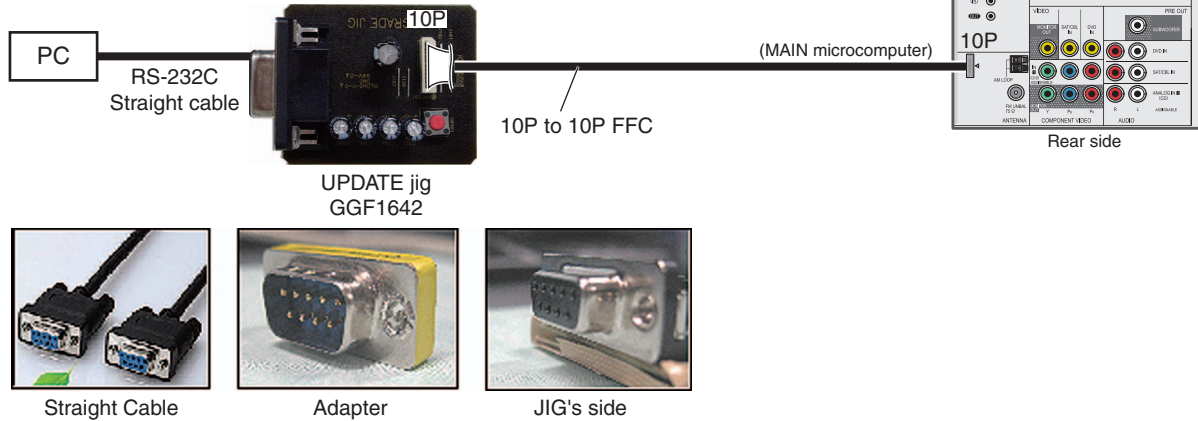

(1) MAIN microcomputer firmware update

[Preestablishment]

- NetworkStandby: OFF
- HDMI Control: OFF
- HDMI StandbyThrough: OFF

[Procedures]

* Store the EPFlash.exe file in the desktop of the PC.

1. Unplug the AC cord.
Connect the FFC cable. (MAIN microcomputer)
Start up application FlashSta on the PC.

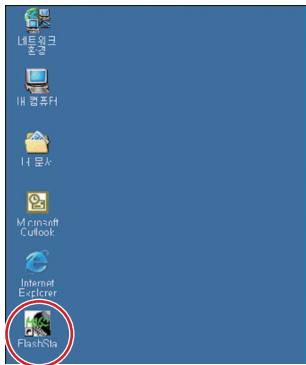

3. Press the OK button.

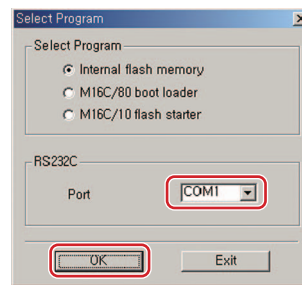

Select for COM port.

[if the following messages are displayed]



Please push the cancel button and press the JIG's RESET button.

And confirm a connection of FFC.

Please return to procedure 1.

4. Select the update file and enter ID.

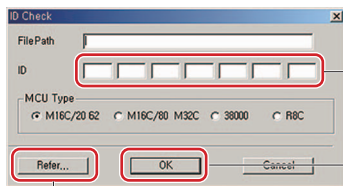

② Enter ID.
Enter "ff" in all field.

③ Press OK button to go to next step.

① Selection of upgrade file

① Select the update file

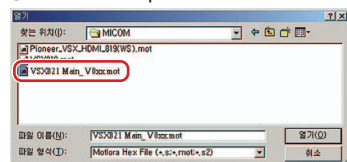

Press the OK button.

Select "VSX_1023Mid_Main Ver***.mot"
or "VSX43_Main_Ver0.60.mot"
"VSX_823Mid_Main Ver***.mot" file to update the MCU.

② Enter ID.

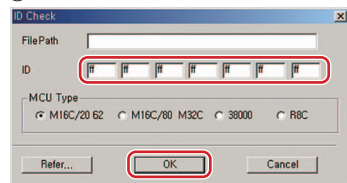

Press the OK button.

5. Set speed update and update the MCU.

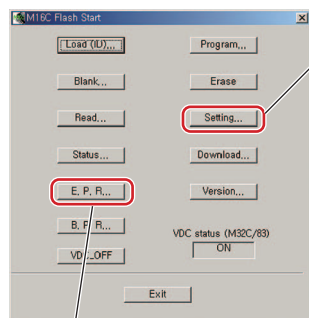

① Set speed of update.

① Set speed of update.
Set Baud rate to 38400.

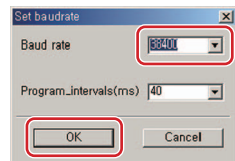

Press the OK button.

② Update the MCU.

E.P.R=>Erase+Program+Read

② Update the MCU

Press the E.P.R ... button

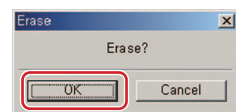

Press OK button.

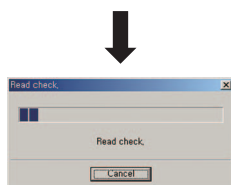
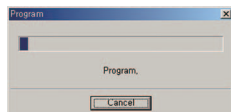

6. Update Finished MAIN microcomputer.



Press the OK button.

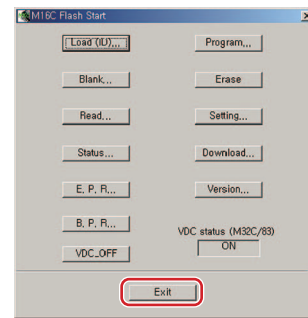

Press the Exit button.
Please wait for until this window disappears.

If the following messages are displayed, shut the update program down, and start the update again from step 1.



Push the JIG's RESET button during 1 sec.
Press the OK button.

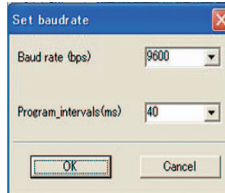

Select the 9600 of the Board rate then press the OK button

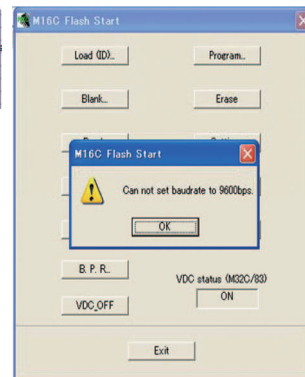
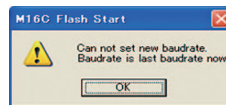

7. Unplug the AC cord.

Disconnect the FFC cable.

A (2) SUB microcomputer firmware update

[Preparations]

Save the firmware file to the "root" of empty USB memory. The file name of the firmware file is "RegM14Sub_V***.bcd". Don't save other files.

- NetworkStandby: OFF
- HDMI Control: OFF
- HDMI StandbyThrough: OFF
- Connect a unit to TV and HDMI, and the GUI output of the unit performs in a state to appear.

[Procedures]

1. Turn on the unit.
2. Set a function for a "NETRADIO".

Note:

Without a network connection, "Server Error" will be displayed on the TV screen. Under this condition, the Service Menu (menu for updating the SUB microcomputer) is not accessible. Set the remote control unit supplied with the unit to Network Function Operation mode then press the ENTER button so that "Empty" is displayed on the screen. Then proceed to Step 3.

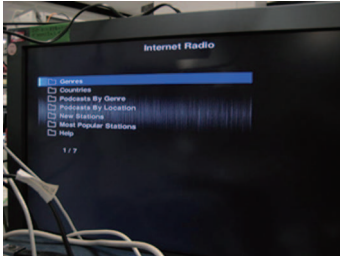

3. Press the "ESC (A85F)" button on the Service remote control unit (GGF1381), then press the "+10 (A81F)" button to enter the service menu (for SUB microcomputer firmware update menu).

When you press other buttons between "ESC" button and "+10" buttons, be invalid.

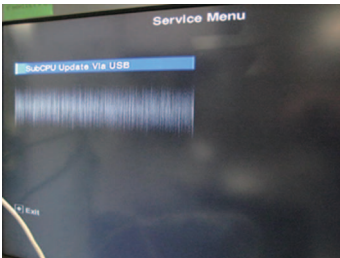

4. Press the "ENTER" button of the remote control unit supplied with Network Function as the state that you can operate.

- (1) When a product can recognize a file, become the following indication.

Select "Start", and press the "ENTER" button.



- (2) When a product cannot recognize a file, become the following indication. Check on USB memory with a file.

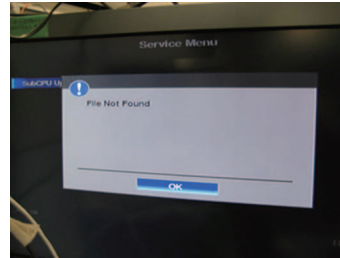

5. Update starts, and "UPDATE" blinks to FL screen and HDMI LED blinks. Be approximately 8 minutes for update at time.

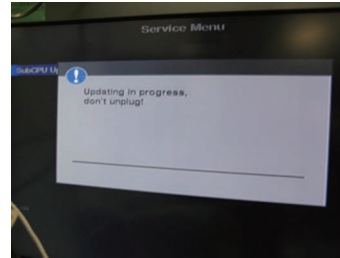

6. When update is completed, "Completed" is displayed by TV screen and HDMI LED lights.

* "UPDATE" blinks to FL display and is displayed. In rare cases, "Completed!" may not be displayed on the TV screen. In such a case, updating is completed if the HDMI LED has become lit. Proceed to Step 7.

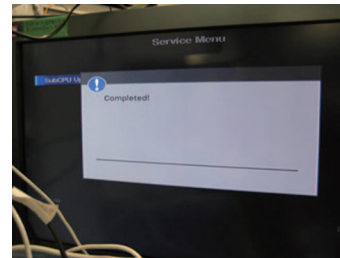

7. Disconnect the AC power cord. (The POWER button does not respond.) Confirm a version of the firm ware of SUB microcomputer.

Note:

Because update is not possible again, never unplug the power cord until the updating process is completed.

(3) USB (BridgeCo) firmware update

[Procedures]

1. Select 'Firmware Update' from the Network Setup menu. The receiver checks whether the USB memory device inserted into the USB port on the receiver's front panel contains updatable software.
2. To update, select 'Start'.
3. When 'Updating in progress, don't unplug!' is displayed, select 'OK'.
 - If 'File Not Found' is displayed, try the following:
 - No update file was found on the USB memory device. Store the file in the USB memory device's root directory.
 - Try disconnecting then reconnecting the USB device or storing the update file again. If the error still occurs, try using a different USB memory device.
4. The software update will start. Please wait. The OSD display will turn off during update and the words 'UPDATE' will flash on the front panel.
5. If 'COMPLETE' is displayed, updating is completed. The screen will return automatically to the play screen.
 - If 'FAIL' is displayed on the front panel display, updating has failed. Try the following:
 - Turn the receiver's power off, then turn it back on and try updating the software again.
 - Try disconnecting then reconnecting the USB device or storing the update file again. If the error still occurs, try using a different USB memory device.

(4) DSP firmware update

[Preestablishment]

- NetworkStandby: OFF
- HDMI Control: OFF
- HDMI StandbyThrough: OFF

[Procedures]

1. Select an Input Function that allows reception via Optical input 1 then set the unit to STBY_Off mode.
2. Press the SPEAKERS and STANDBY/ON keys simultaneously to enter DSP UpDate mode. ("DSP UP" is displayed.)
3. When "PLAY" is displayed, playback of the .wav file starts. (Play the file only once. NEVER repeat playback.) ("PLAY" is displayed.)
4. After playback is finished and "ENTER" is displayed, press the ENTER key on the front panel. ("ENTER" is displayed.)
5. "WRITING" is automatically displayed.
6. After writing is completed, "COMPLETE" is displayed.
7. Turn the unit off then confirm that the version has been updated.

(5) Check to the firmware version

[Preestablishment]

- NetworkStandby: OFF
- HDMI Control: OFF
- HDMI StandbyThrough: OFF

[Procedures]

Make sure that the main unit is in STANDBY mode.

Press and hold the "ENTER" and "STANDBY/ON" keys, then press the "ENTER" key to display each UCOM version.

Each time the "ENTER" key is pressed, then indications on the FL display change as follows:

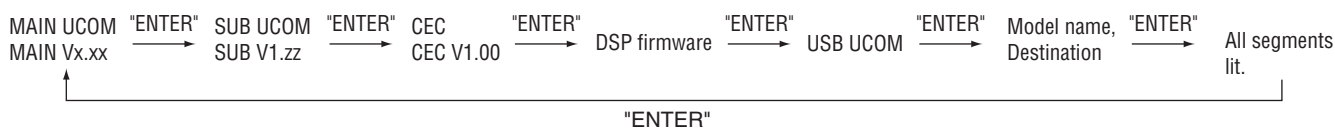

* It may take around 1 minute until the version of the USB microcomputer is displayed. When be not displayed, wait in the state that turned on the power of the product for 1 minute, and please do it from the first procedure again.

Turn the unit off.

8.3 IDLE CURRENT ADJUSTMENT



for VSX-1023-K, VSX-43

When any component parts which are within the red square on the following circuit diagram are replaced, the idle current adjustment of that channel is required. (Idle current adjustment for another channel is not required.)

However, when any capacitors are replaced, the adjustment is not required.

(The following circuit diagram is for SL channel, but another channel also has same circuit diagram and same adjustment is required)

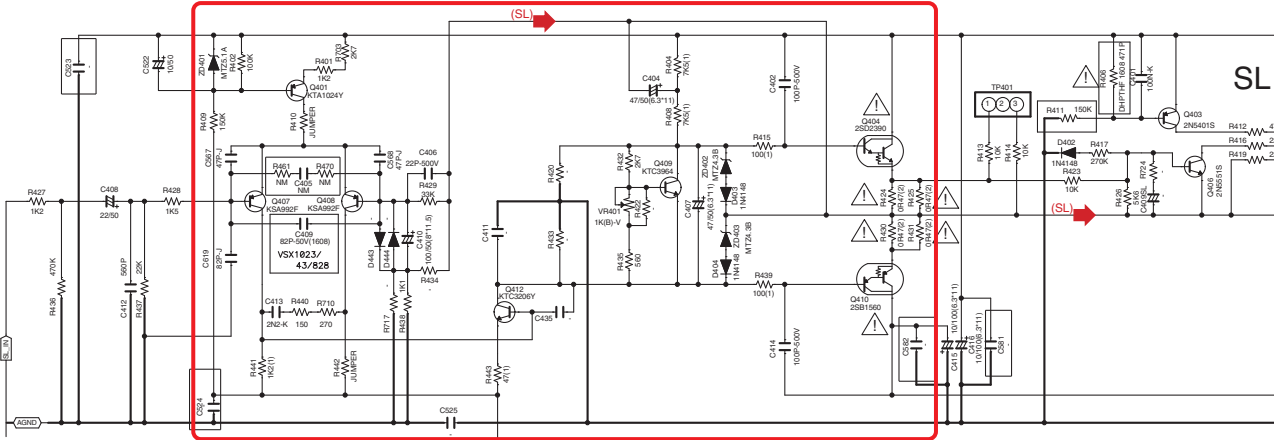

Channel	Measurement Points	Adjustment Points	Procedure
FL	TP404 pin 1 (+) TP404 pin 3 (-)	VR404	① Turn on the power. ② Perform aging for one minute. ③ Connect a digital voltmeter to the measurement point. ④ Turn the adjustment VR so that the voltage becomes in $2.0 \text{ mV} \pm 0.2 \text{ mV}$. (Condition : No signal and no load)
FR	TP402 pin 1 (+) TP402 pin 3 (-)	VR402	
C	TP403 pin 1 (+) TP403 pin 3 (-)	VR403	
SL	TP401 pin 1 (+) TP401 pin 3 (-)	VR401	
SR	TP405 pin 1 (+) TP405 pin 3 (-)	VR405	
SBL	TP406 pin 1 (+) TP406 pin 3 (-)	VR406	
SBR	TP407 pin 1 (+) TP407 pin 3 (-)	VR407	

• Adjustment points and measurement points.... see fig.1.

AMP7 ASSY

SIDE A

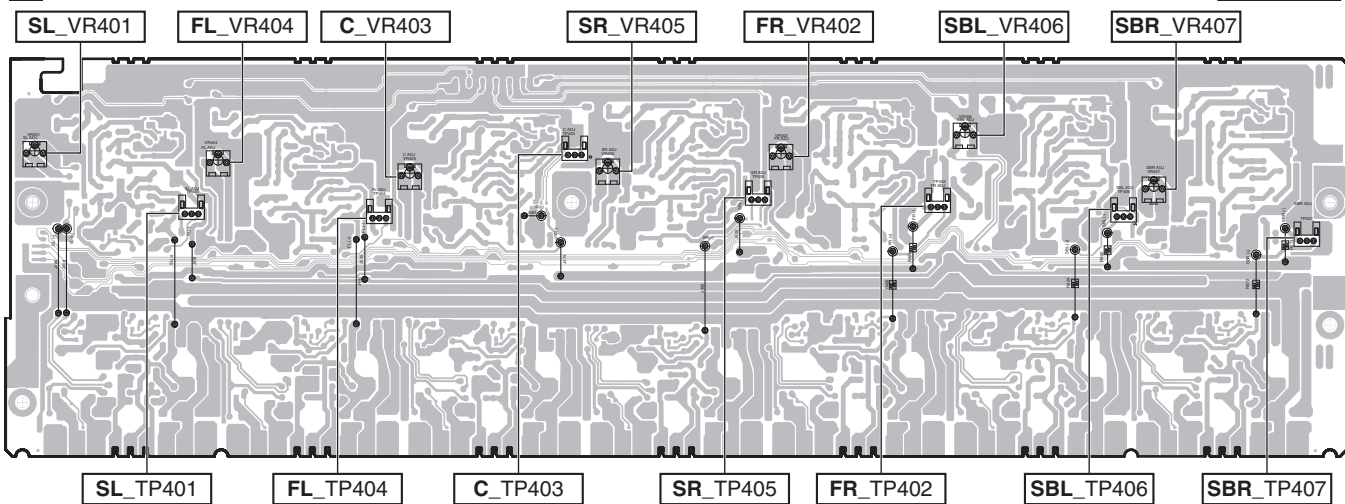
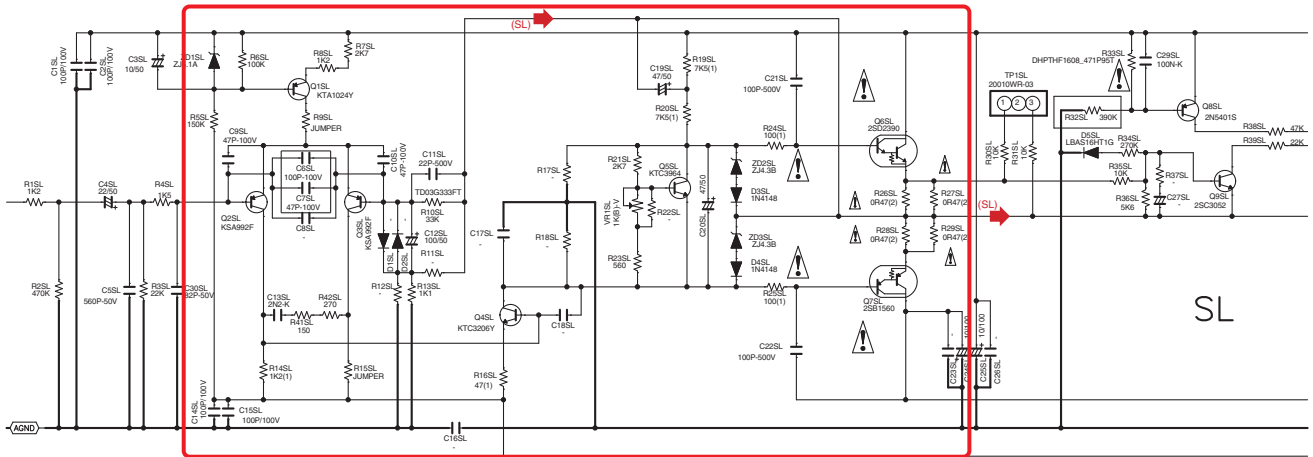

Fig.1



for VSX-823-K

When any component parts which are within the red square on the following circuit diagram are replaced, the idle current adjustment of that channel is required. (Idle current adjustment for another channel is not required.) However, when any capacitors are replaced, the adjustment is not required. (The following circuit diagram is for SL channel, but another channel also has same circuit diagram and same adjustment is required)



Channel	Measurement Points	Adjustment Points	Procedure
FL	TP1FL pin 1 (+) TP1FL pin 3 (-)	VR1FL	① Turn on the power. ② Perform aging for one minute. ③ Connect a digital voltmeter to the measurement point. ④ Turn the adjustment VR so that the voltage becomes in 2.0 mV ± 0.2 mV. (Condition : No signal and no load)
FR	TP1FR pin 1 (+) TP1FR pin 3 (-)	VR1FR	
C	TP1C pin 1 (+) TP1C pin 3 (-)	VR1C	
SL	TP1SL pin 1 (+) TP1SL pin 3 (-)	VR1SL	
SR	TP1SR pin 1 (+) TP1SR pin 3 (-)	VR1SR	

• Adjustment points and measurement points.... see fig.2.

AMP5 ASSY

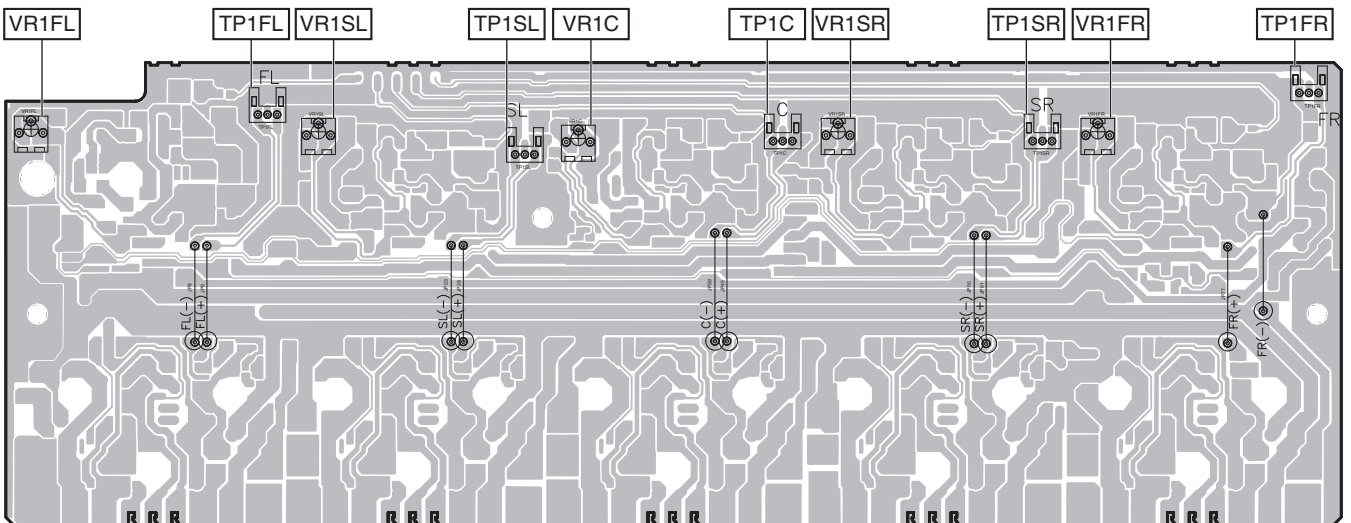

Fig.2

SIDE A

9. EXPLODED VIEWS AND PARTS LIST

- NOTES:
- Parts marked by "NSP" are generally unavailable because they are not in our Master Spare Parts List.
 - The \triangle mark found on some component parts indicates the importance of the safety factor of the part. Therefore, when replacing, be sure to use parts of identical designation.
 - Screws adjacent to ∇ mark on product are used for disassembly.
 - For the applying amount of lubricants or glue, follow the instructions in this manual. (In the case of no amount instructions, apply as you think it appropriate.)

9.1 PACKING SECTION

Poly bag packing style

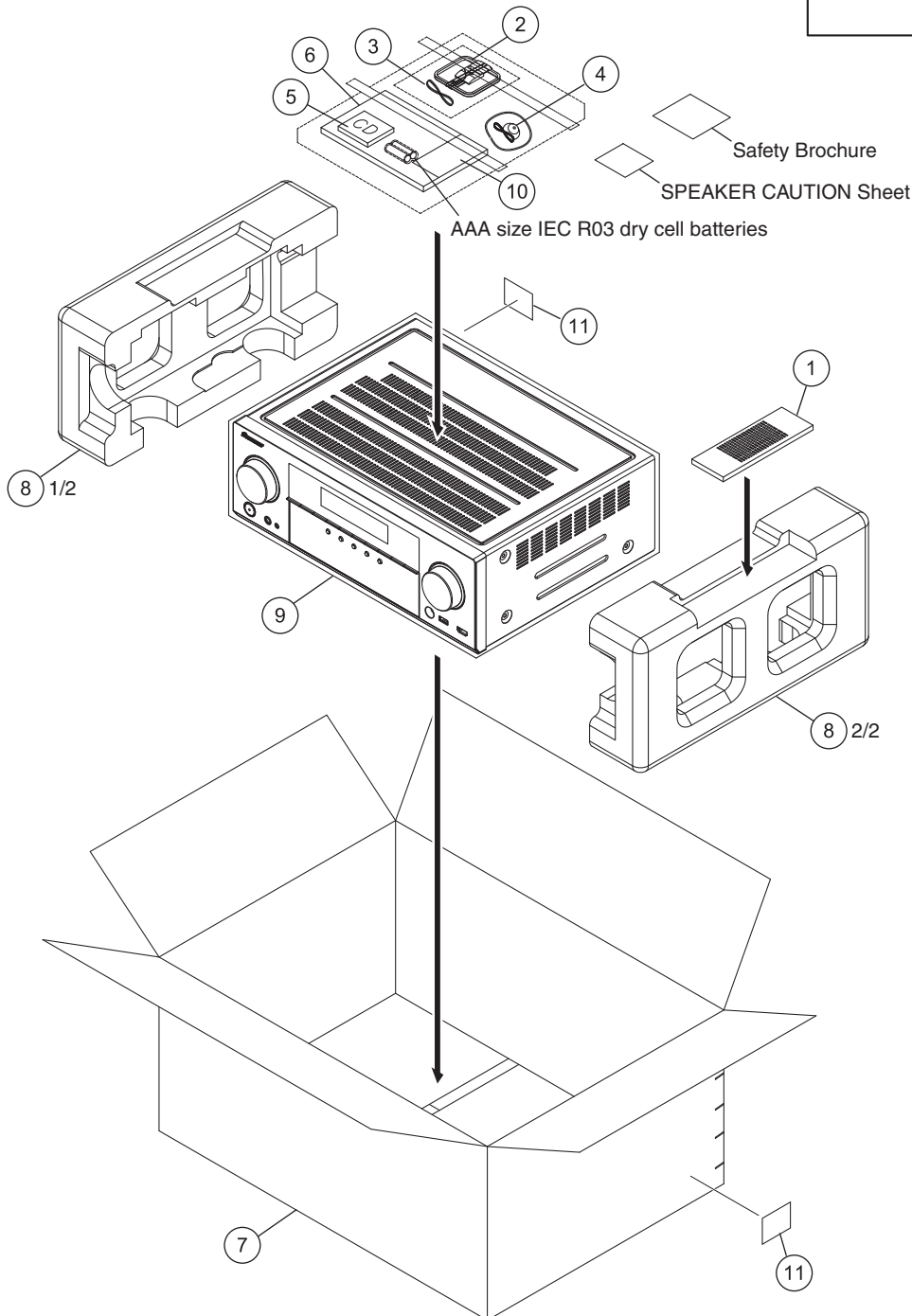
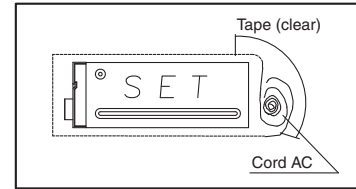

(1) PACKING SECTION PARTS LIST

<u>Mark No.</u>	<u>Description</u>	<u>Part No.</u>
1	Remote Control	See Contrast table (2)
2	AM Loop Antenna	E601019000010-IL
3	FM Wire Antenna	E605010140010-IL
4	Microphone (for Auto MCACC setup)	APM7011
5	Operating Instructions (CD-ROM)	See Contrast table (2)
6	Quick Start Guide	See Contrast table (2)
7	Box, Gift	See Contrast table (2)
8	Cushion, Snow	See Contrast table (2)
9	PE, Sheet	6327040059000-IL
NSP 10	Warranty Card	See Contrast table (2)
NSP 11	Label	VRW1629

(2) CONTRAST TABLE

VSX-1023-K/CUXESM, VSX-43/CUXE and VSX-823-K/CUXESM are constructed the same except for the following:

Mark	No.	Symbol and Description	VSX-1023-K /CUXESM	VSX-43 /CUXE	VSX-823-K /CUXESM
	1	Remote Control	8300769100010-IL	8300769200010-IL	8300769100010-IL
	5	Operating Instructions (CD-ROM)	6517000001280-IL	6517000001290-IL	6517000001280-IL
	6	Quick Start Guide	5707000007800-IL	5707000007810-IL	5707000007800-IL
	7	Box, Gift	6007212380000-IL	60072120700J0-IL	6007212370020-IL
	8	Cushion, Snow	6230213144000-IL	6230213144000-IL	6230213384000-IL
NSP	10	Warranty Card	ARY7172	ARY7177	ARY7172

9.2 EXTERIOR SECTION (VSX-1023-K, VSX-43)

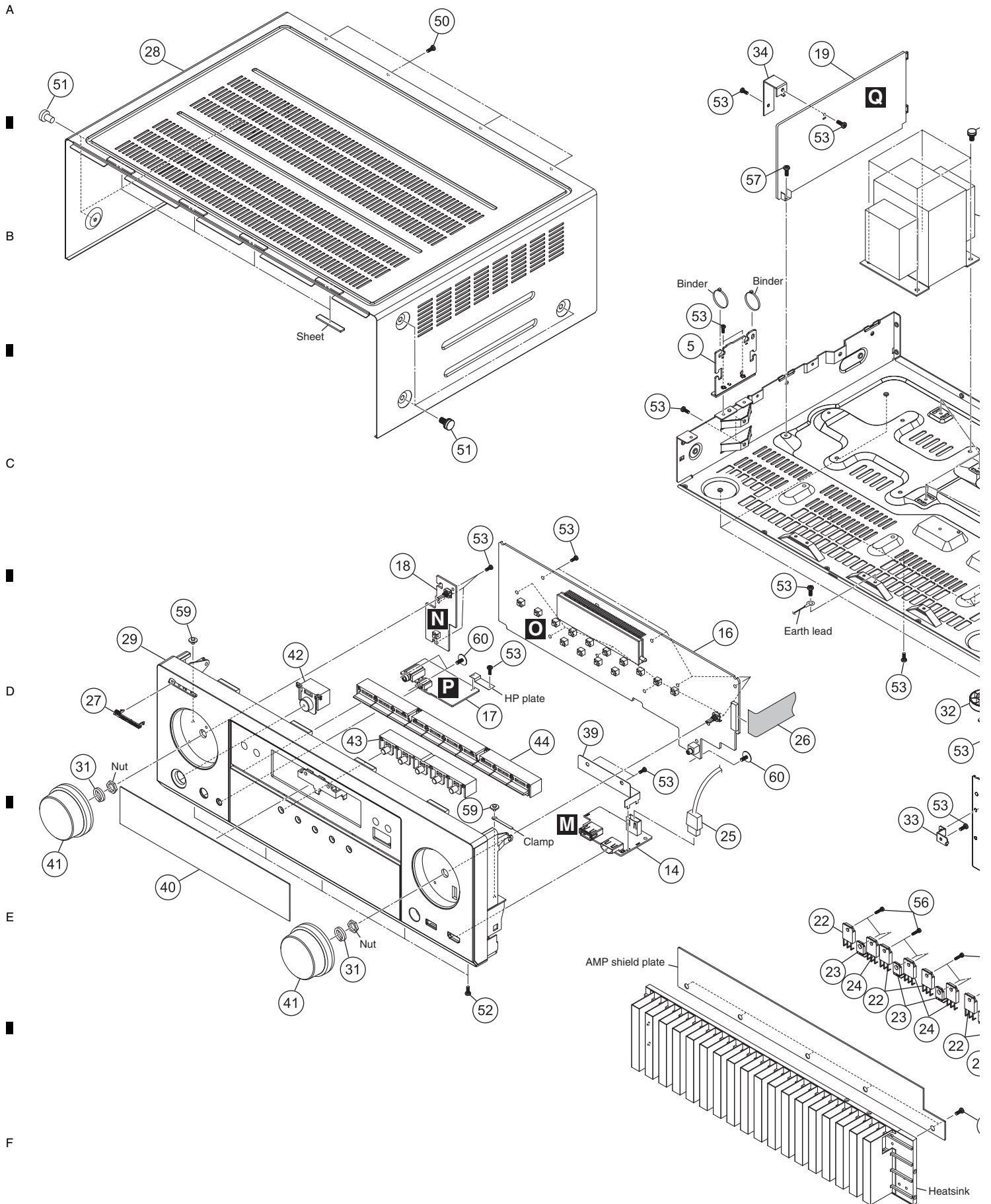

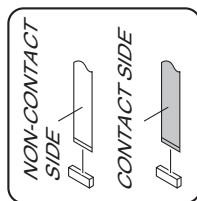
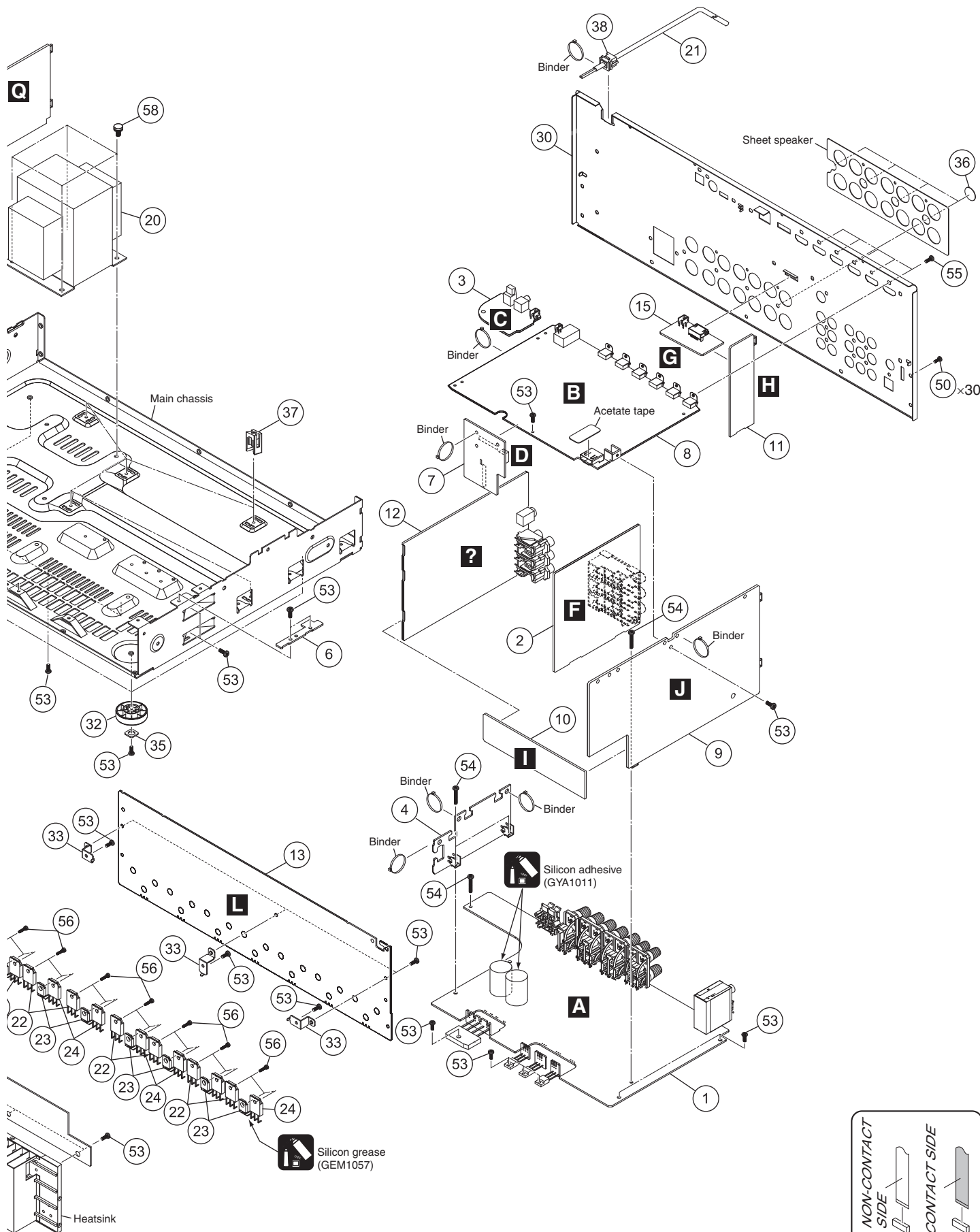

(1) EXTERIOR SECTION PARTS LIST

<u>Mark No.</u>	<u>Description</u>	<u>Part No.</u>	<u>Mark No.</u>	<u>Description</u>	<u>Part No.</u>
A	1 MAIN Assy	See Contrast table (2)	46	•••••	
	2 VIDEO Assy	7028073032020-IL	47	•••••	
	3 OPTCO Assy	7028073033020-IL	48	•••••	
	4 WIRE-A Assy	7028073035020-IL	49	•••••	
	5 GUIDE Assy	7028073037020-IL	50	Screw	BBT30P100FTB
	6 CPU-G Assy	7028073038020-IL	51	Screw	BBT40P080FTB
	7 BRI-1 Assy	7028073039020-IL	52	Screw	BBZ30P080FTB
	8 D-MAIN Assy	7028073231040 -IL	53	Screw	BBZ30P080FTC
	9 CPU Assy	See Contrast table (2)	54	Screw	BBZ30P180FTC
	10 BRI-2 Assy	7028073023020-IL	55	Screw	BSZ30P040FTB
B	11 BTCNT Assy	7028073024020-IL	56	Screw Tapping Assy	B018230141H11-IL
	12 AUDIO Assy	7028073041020-IL	57	Screw, Tap Tite	B020230063B10-IL
	13 AMP7 Assy	7028073051010-IL	58	Screw	B028940101B11-IL
	14 FHDMI Assy	7028073221040-IL	59	Screw	1500001206010-IL
	15 BT Assy	7028073211040-IL	60	Screw	1500001456010-IL
	16 FRONT Assy	See Contrast table (2)			
	17 HPMIC Assy	See Contrast table (2)			
	18 INSEL Assy	See Contrast table (2)			
	⚠ 19 SMPS Assy	7028073361010-IL			
C	⚠ 20 Power Trans 1023CU	8200960611320-IL			
	⚠ 21 Cord Assy	L068125101710-IL			
	⚠ 22 Transistor	J5011560Y0000-IL			
	⚠ 23 Semi, TE/GE NPN 2SC	J502396400010-IL			
	⚠ 24 Transistor	J5032390Y0000-IL			
	⚠ 25 Cable HDMI 230 mm	L304231190050-IL			
	26 Cable, Flat Card 1.0M	N711290822480-IL			
	27 Pioneer Badge B (PLS)	See Contrast table (2)			
	28 Cabinet Assy 1023	3008212006020-IL			
D	29 Front Panel 1023CU	See Contrast table (2)			
	30 Back Chassis	See Contrast table (2)			
	31 Spring	3720210276000-IL			
	32 Foot (PLS)	4000210391000-IL			
	33 Bracket	4010056906010-IL			
	34 Bracket SMPS	401021488600D-IL			
	35 Cushion	4050211605000-IL			
	36 Screw Cover	4050211745100-IL			
	37 Support	4070001601010-IL			
E	38 Stopper	4380040162010-IL			
	39 Plate F/USB	4470212736000-IL			
	40 Window Display	See Contrast table (2)			
	41 Knob	5080212431000-IL			
	42 Button	See Contrast table (2)			
	43 5 Key Button	5090214561000-IL			
	44 10 Key Button	5090214571000-IL			
	45 •••••				

(2) CONTRAST TABLE

VSX-1023-K/CUXESM and VSX-43/CUXE are constructed the same except for the following:

Mark	No.	Symbol and Description	VSX-1023-K /CUXESM	VSX-43 /CUXE
	1	MAIN Assy	7028073031010-IL	7028073031020-IL
	9	CPU Assy	7028073021010-IL	7028073021020-IL
	16	FRONT Assy	70280733210B0-IL	70280733210D0-IL
	17	HPMIC Assy	70280733220B0-IL	70280733220D0-IL
	18	INSEL Assy	70280733230B0-IL	70280733230D0-IL
	27	Pioneer Badge B (PLS)	XAM3006	Not used
	27	Name Plate	Not used	PAM1791
	29	Front Panel 1023CU	3067215881030-IL	3067215891010-IL
	30	Back Chassis	3207214586000-IL	3207214586200-IL
	40	Window Display	50772131130A0-IL	5077213113030-IL
	42	Button	5090213741100-IL	Not used
	42	Standby Button Clear	Not used	5098214551000-IL

A

B

C

D

E

F

9.3 EXTERIOR SECTION (VSX-823-K)

1

2

3

4

A

B

C

D

E

F

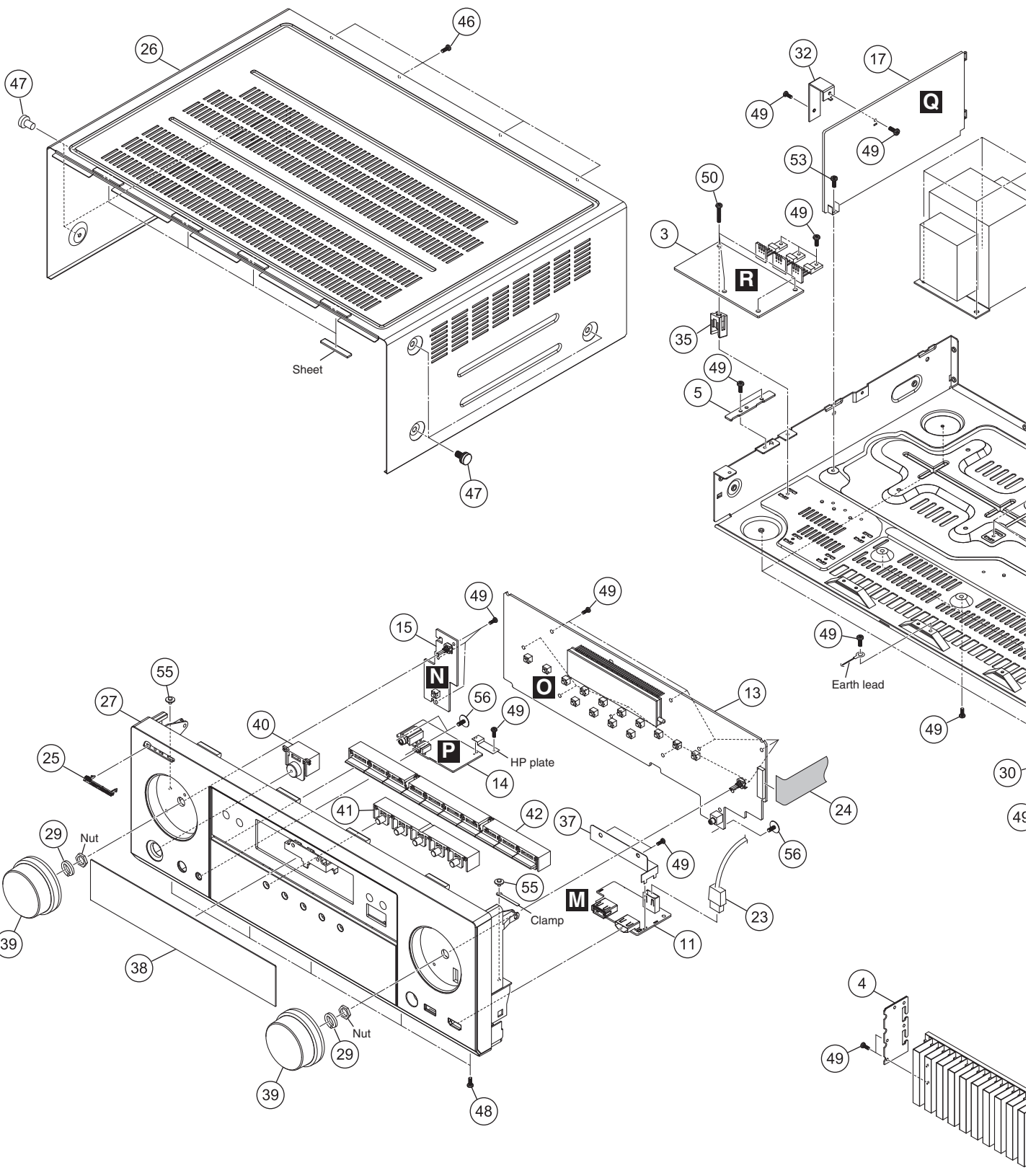

1

2

3

4

A
B
C
D
E
F

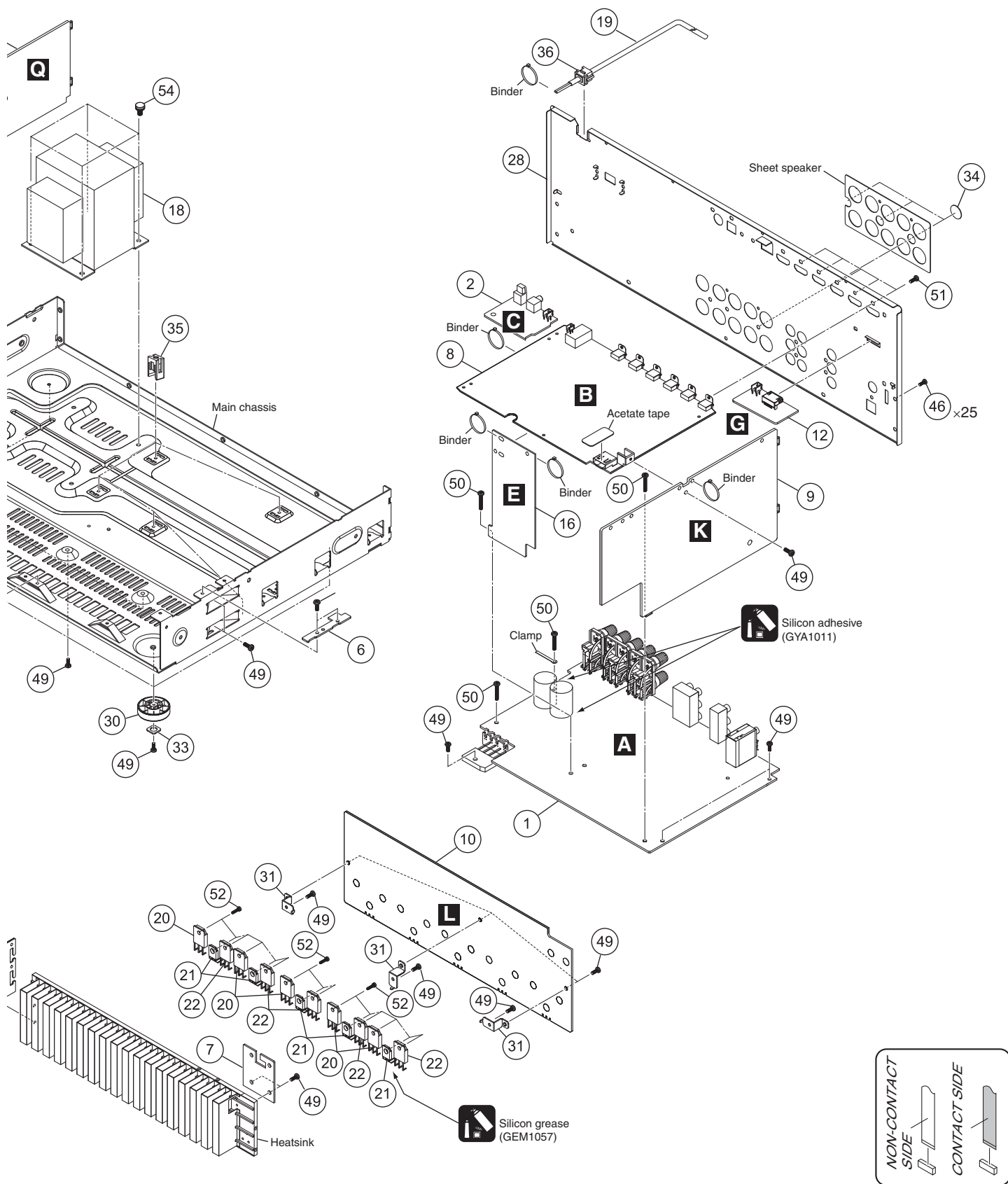

VSX-1023-K

EXTERIOR SECTION PARTS LIST

<u>Mark No.</u>	<u>Description</u>	<u>Part No.</u>	<u>Mark No.</u>	<u>Description</u>	<u>Part No.</u>
A	1 MAIN Assy	70280733110A0-IL	46	Screw	BBT30P100FTB
	2 OPTCO Assy	70280733130A0-IL	47	Screw	BBT40P080FTB
	3 REG Assy	70280733120A0-IL	48	Screw	BBZ30P080FTB
	4 WG Assy	7028073315010-IL	49	Screw	BBZ30P080FTC
	5 G-L Assy	7028073316010-IL	50	Screw	BBZ30P180FTC
	6 G-R Assy	7028073317010-IL	51	Screw	BSZ30P040FTB
	7 HDC-G Assy	70280733180A0-IL	52	Screw Tapping Assy	B018230141H11-IL
	8 D-MAIN Assy	7028073321020-IL	53	Screw, Tap Tite	B020230063B10-IL
	9 CPU Assy	70280733310A0-IL	54	Screw	B028940101B11-IL
	10 AMP5 Assy	70280733410A0-IL	55	Screw	1500001206010-IL
B	11 FHDMI Assy	7028073221040-IL	56	Screw	1500001456010-IL
	12 BT Assy	7028073211040-IL			
	13 FRONT Assy	70280733210B0-IL			
	14 HPMIC Assy	70280733220B0-IL			
	15 INSEL Assy	70280733230B0-IL			
	16 CONCT Assy	70280733240B0-IL			
	⚠ 17 SMPS Assy	7028073361010-IL			
	⚠ 18 Power Trans	8200960611340-IL			
	⚠ 19 Cord Assy	L068125101710-IL			
C	⚠ 20 Transistor	J5011560Y0000-IL			
	⚠ 21 Semi, TE/GE NPN 2SC	J502396400010-IL			
	⚠ 22 Transistor	J5032390Y0000-IL			
	⚠ 23 Cable HDMI 230 mm	L304231190050-IL			
	24 Cable, Flat Card 1.0M	N711290822480-IL			
	25 Pioneer Badge B (PLS)	XAM3006			
	26 Cabinet VSX-523	3008212076000-IL			
	27 Front Panel 823CU	3067215881040-IL			
	28 Back Chassis	3207214576000-IL			
D	29 Spring	3720210276000-IL			
	30 Foot (PLS)	4000210391000-IL			
	31 Bracket	4010056906010-IL			
	32 Bracket SMPS	401021488600D-IL			
	33 Cushion	4050211605000-IL			
	34 Screw Cover	4050211745100-IL			
	35 Support	4070001601010-IL			
	36 Stopper	4380040162010-IL			
	37 Plate F/USB	4470212736000-IL			
E	38 Window Display	5077213113020-IL			
	39 Knob	5080212431000-IL			
	40 Button	5090213741100-IL			
	41 5 Key Button	5090214561000-IL			
	42 10 Key Button	5090214571000-IL			
	43 ●●●●●				
	44 ●●●●●				
	45 ●●●●●				

F



5



6



7



8



A



B



C



D



E



F



5



6

VSX-1023-K



7



8



10. SCHEMATIC DIAGRAM

10.1 MAIN ASSY (VSX-1023-K, VSX-43)

A
B
C
D
E
F

A
MAIN ASSY
(7028073031010-IL: VSX-1023-K)
(7028073031020-IL: VSX-43)

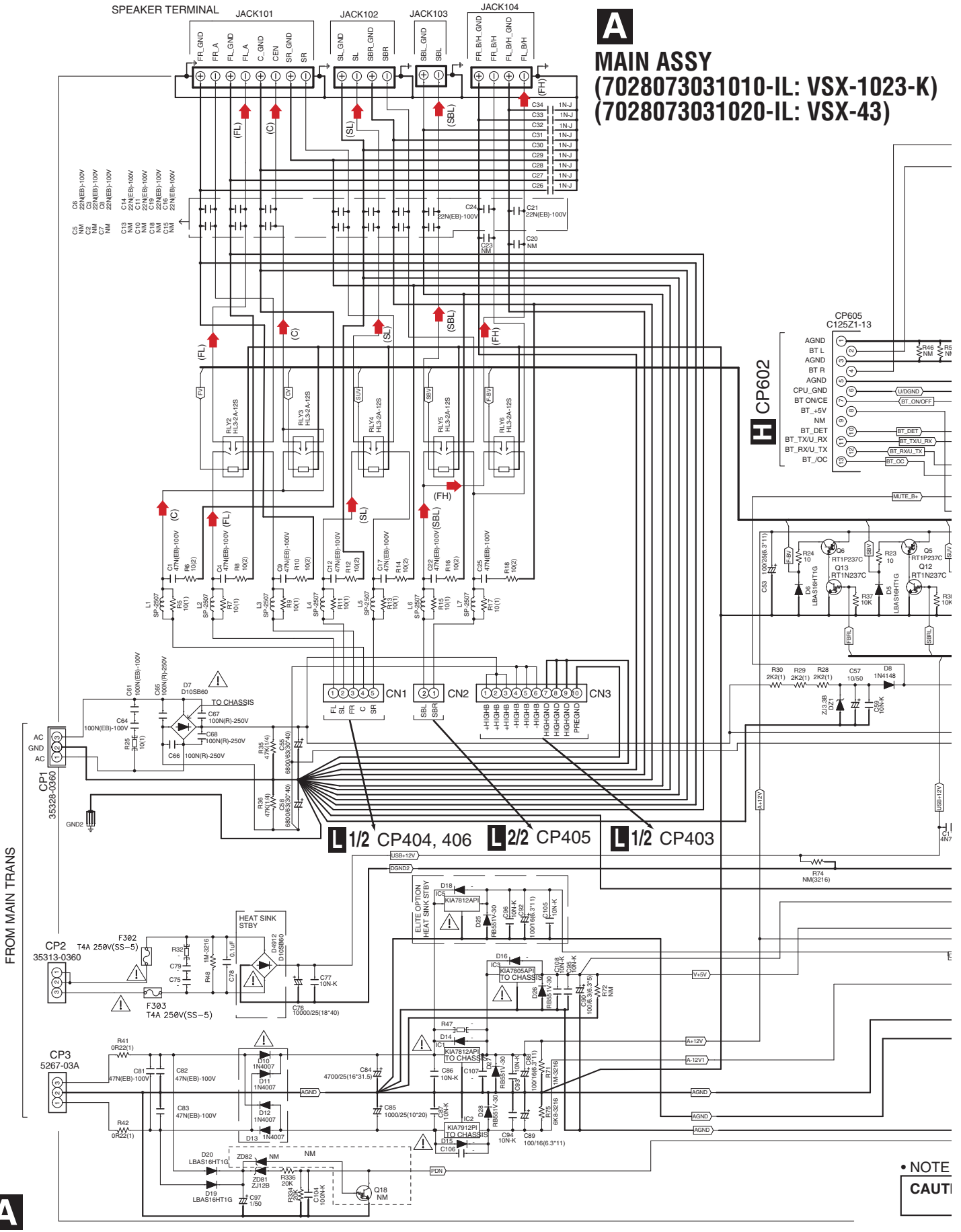

FROM MAIN TRANS

X-1023-K) X-43)

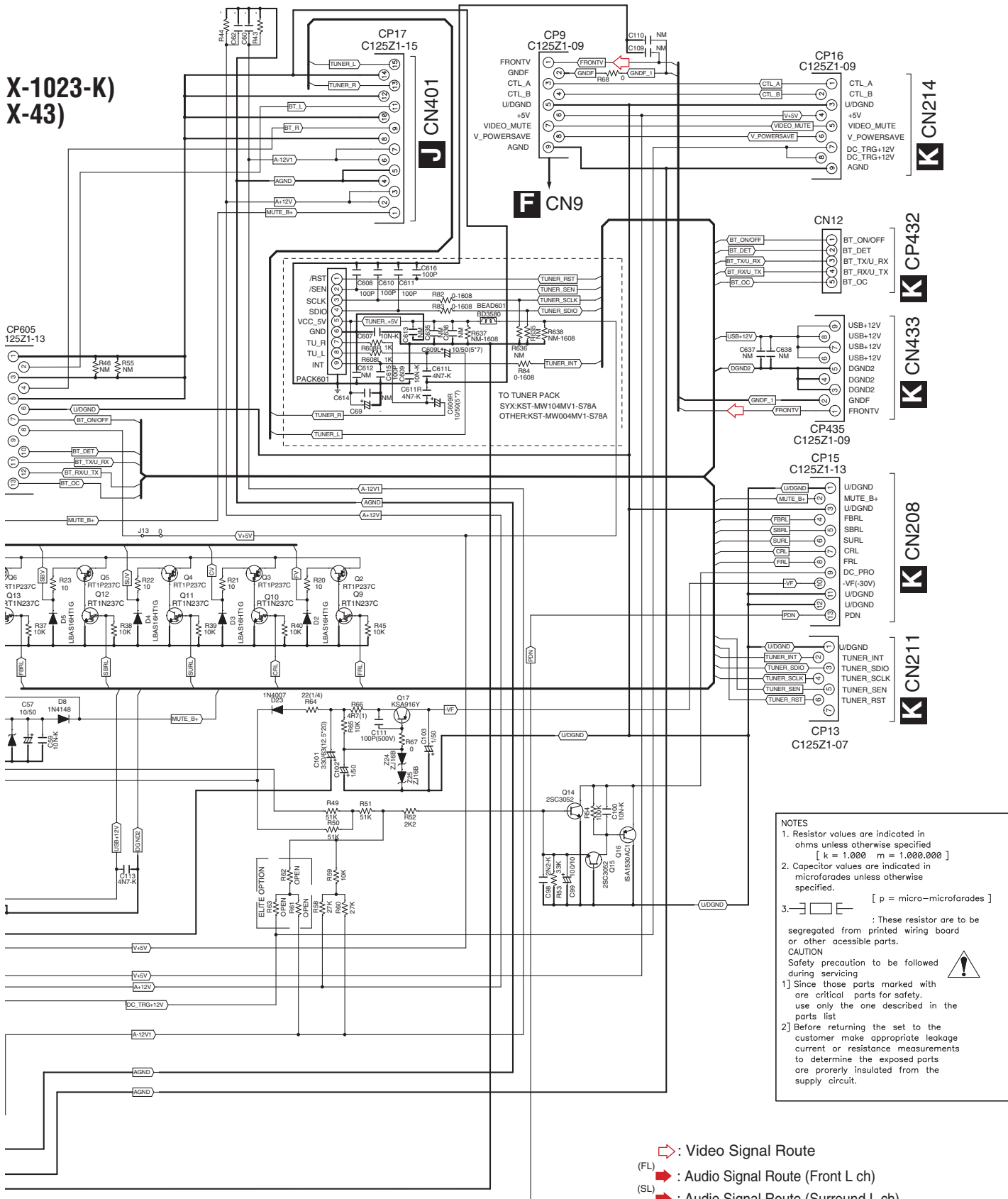

NOTE FOR FUSE REPLACEMENT

CAUTION - FOR CONTINUED PROTECTION AGAINST RISK OF FIRE, REPLACE WITH SAME TYPE AND RATINGS OF FUSE.

NOTES

1. Resistor values are indicated in ohms unless otherwise specified
[k = 1,000 m = 1,000,000]
2. Capacitor values are indicated in microfarads unless otherwise specified.
3. : These resistor are to be segregated from printed wiring board or other accessible parts.
CAUTION
Safety precaution to be followed during servicing

- 1] Since those parts marked with are critical parts for safety, use only the one described in the parts list
- 2] Before returning the set to the customer make appropriate leakage current or resistance measurements to determine the exposed parts are properly insulated from the supply circuit.

- : Video Signal Route
- : Audio Signal Route (Front L ch)
- : Audio Signal Route (Surround L ch)
- : Audio Signal Route (Center ch)
- : Audio Signal Route (Surround Back L ch)
- : Audio Signal Route (Front Height L ch)

10.2 MAIN ASSY (1/2)(VSX-823-K)

SPEAKER TERMINAL
 VSX-523 : ALL Large
 VSX-423 : Front ; Large, Other(Center, Surround) ; Clips

- (FL) : Audio Signal Route (Front L ch)
- (SL) : Audio Signal Route (Surround L ch)
- (C) : Audio Signal Route (Center ch)
- (HPL) : Audio Signal Route (Headphone L ch)

NOTES

- Resistor values are indicated in ohms unless otherwise specified
 [k = 1.000 m = 1.000.000]
- Capacitor values are indicated in microfarads unless otherwise specified.
 [p = micro-microfarades]
- : These resistor are to be segregated from printed wiring board or other accessible parts.
CAUTION
 Safety precaution to be followed during servicing

 1) Since those parts marked with are critical parts for safety, use only the one described in the parts list
 2) Before returning the set to the customer make appropriate leakage current or resistance measurements to determine the exposed parts are properly insulated from the supply circuit.

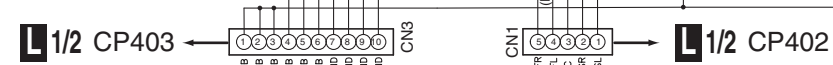
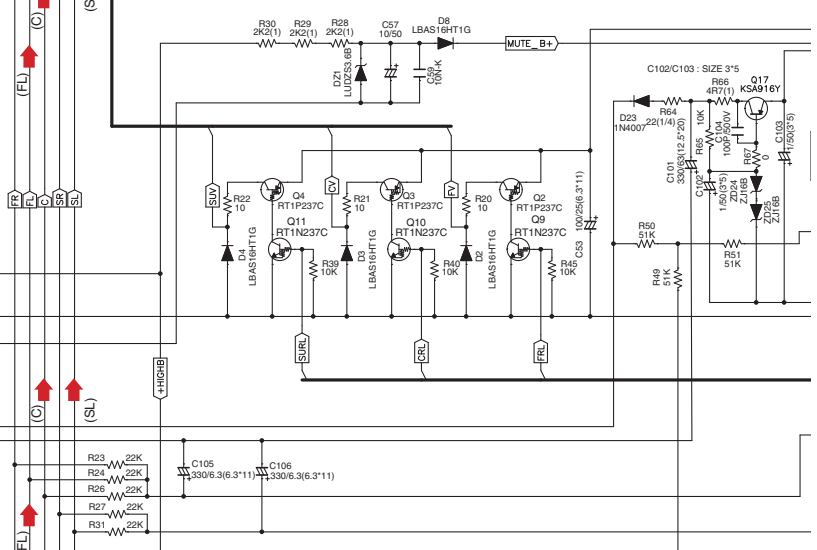
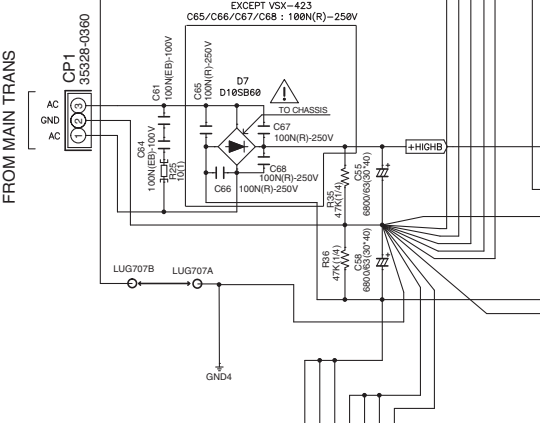
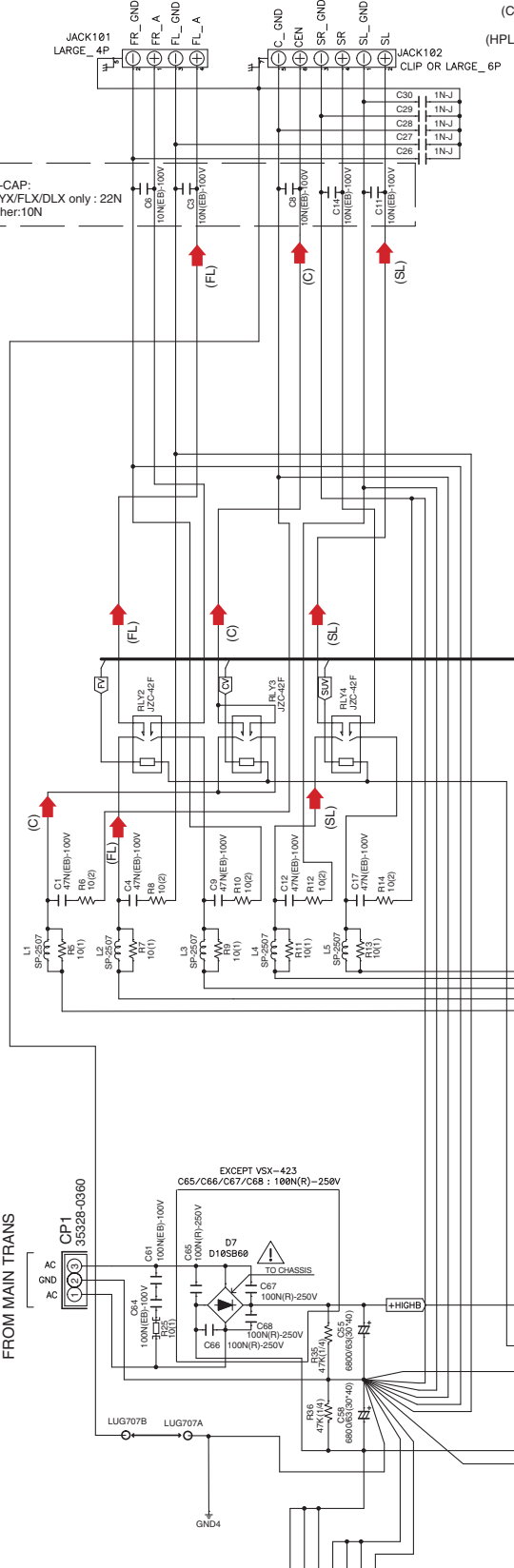
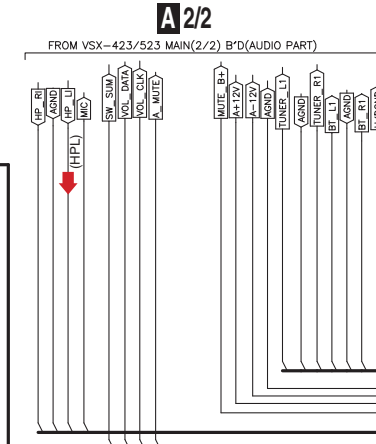
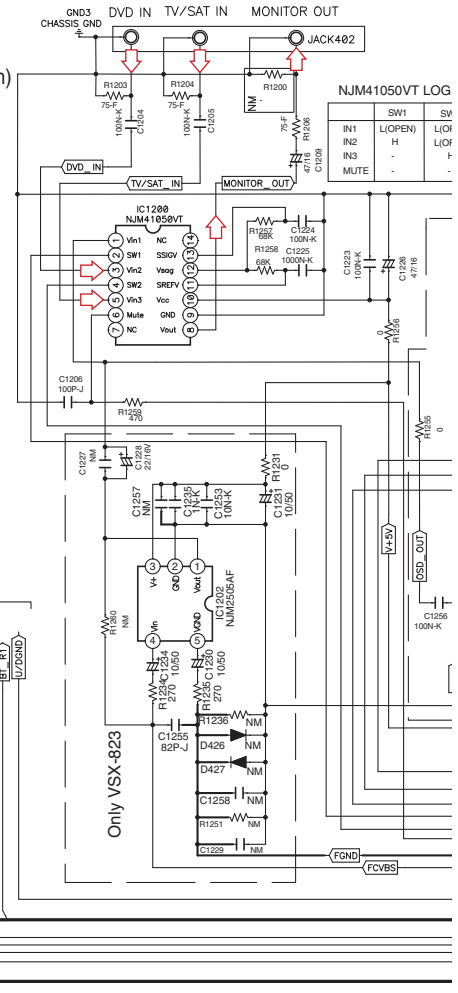

A 1/2

Video Signal Route

A/2 MAIN ASSY (70280733110A0-IL)

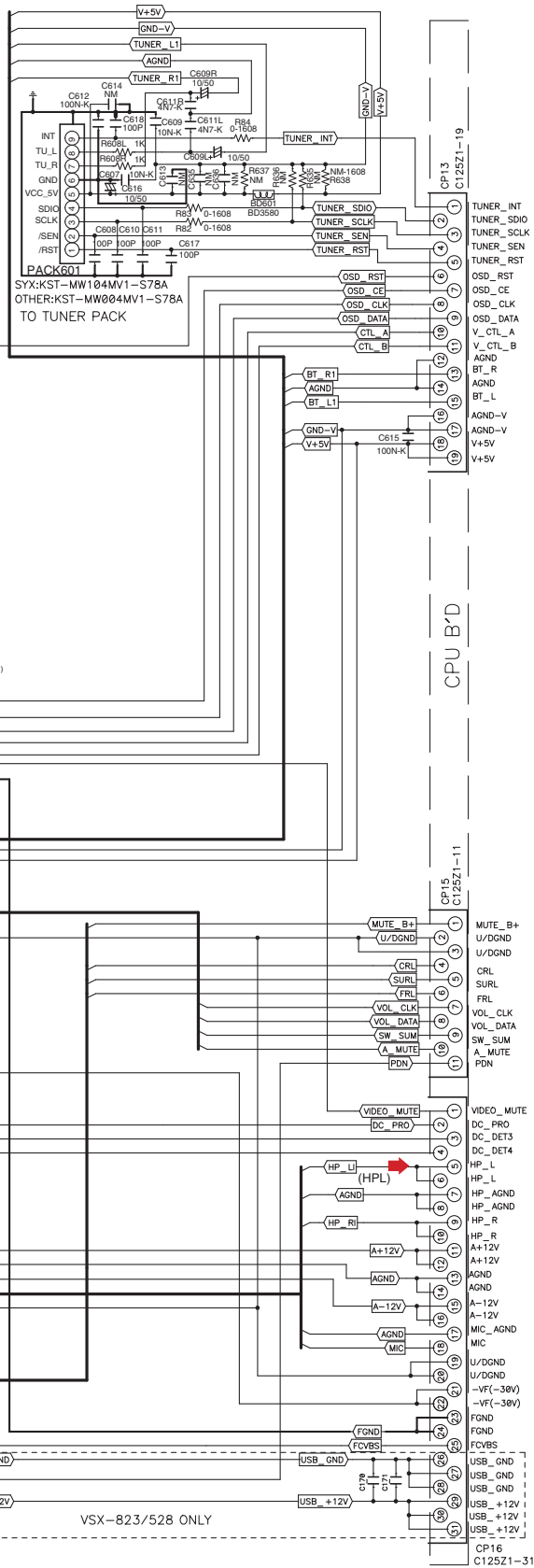
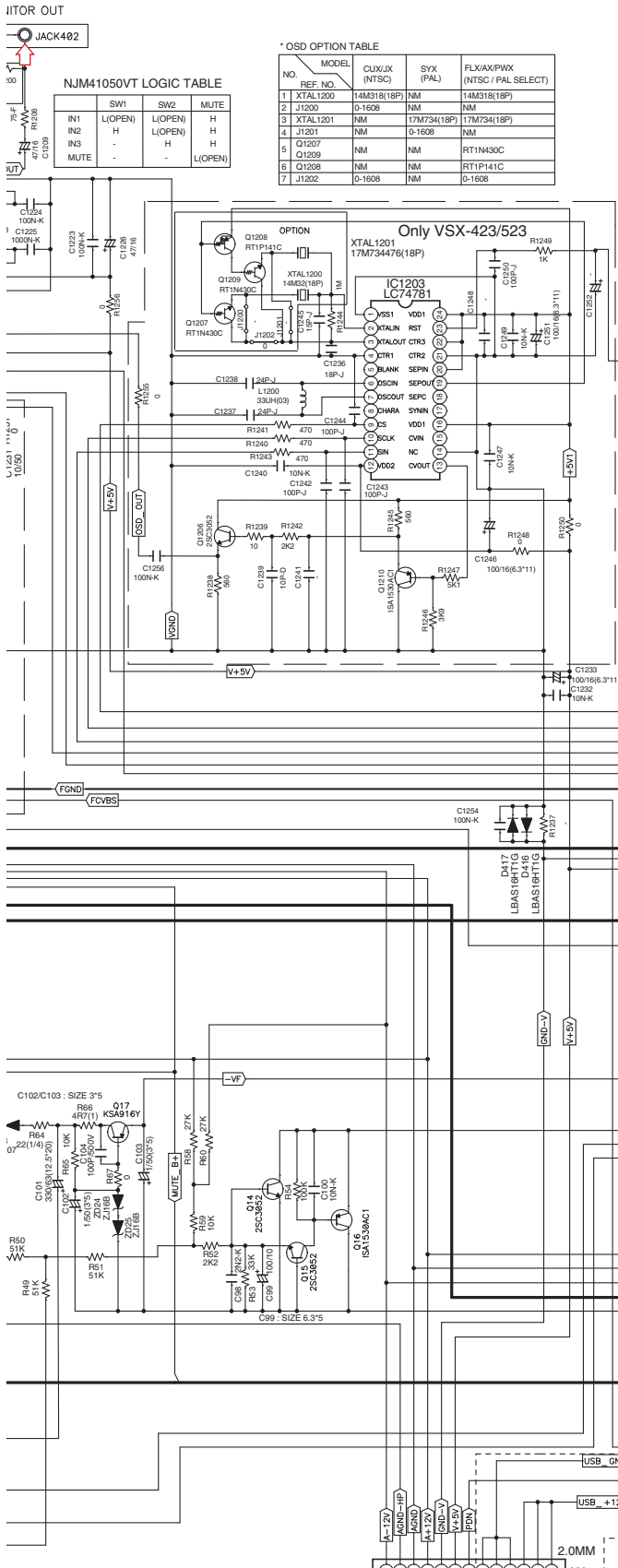

K CN211

K CN208

K CN209A

R CP7

VSX-1023-K

A/2

10.3 MAIN ASSY (2/2)(VSX-823-K)

The Δ mark found on some component parts indicates the importance of the safety factor of the part. Therefore, when replacing, be sure to use parts of identical designation.

A
B
C
D
E
F

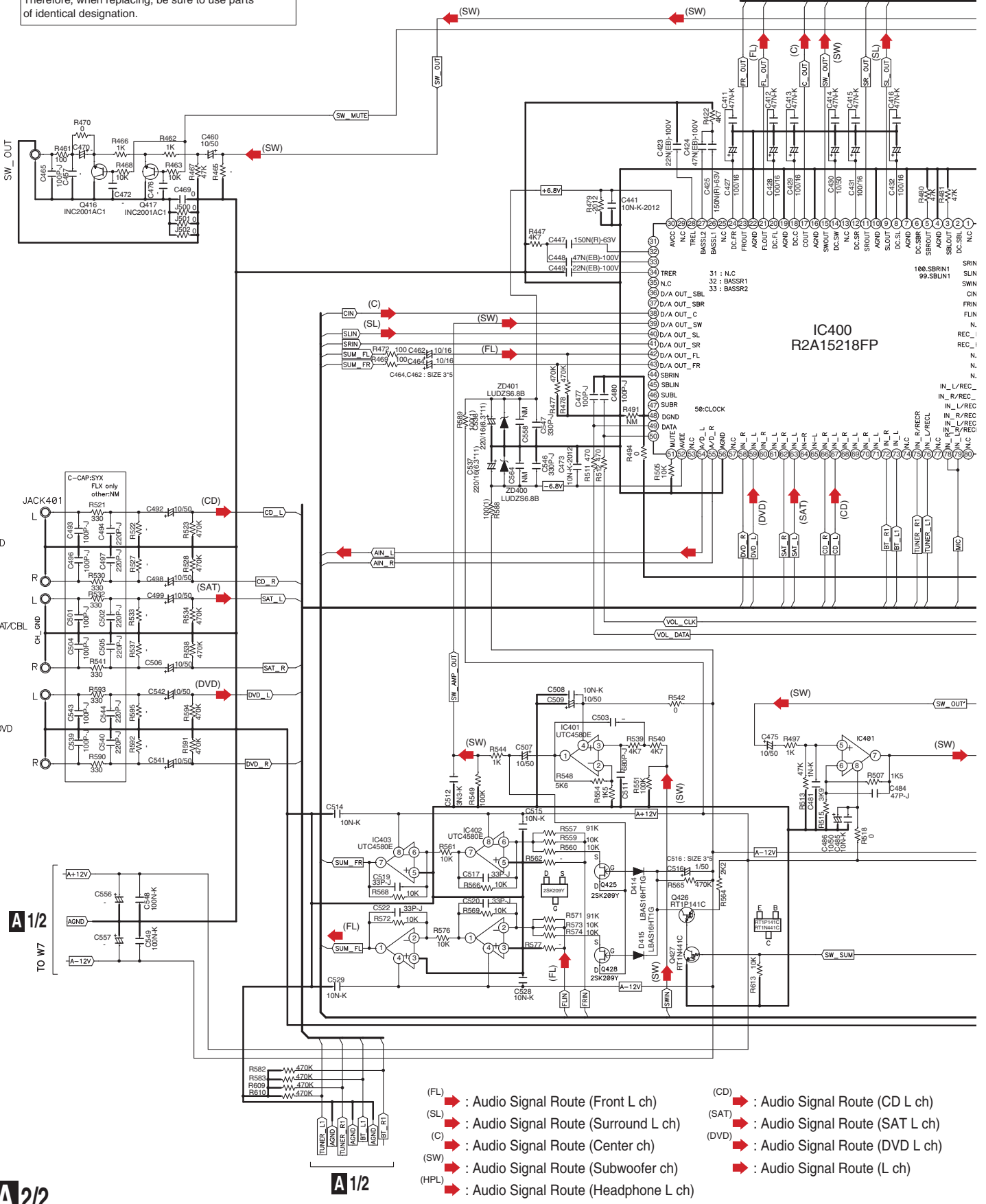

- (FL) \blacktriangleright : Audio Signal Route (Front L ch)
- (SL) \blacktriangleright : Audio Signal Route (Surround L ch)
- (C) \blacktriangleright : Audio Signal Route (Center ch)
- (SW) \blacktriangleright : Audio Signal Route (Subwoofer ch)
- (HPL) \blacktriangleright : Audio Signal Route (Headphone L ch)
- (CD) \blacktriangleright : Audio Signal Route (CD L ch)
- (SAT) \blacktriangleright : Audio Signal Route (SAT L ch)
- (DVD) \blacktriangleright : Audio Signal Route (DVD L ch)
- \blacktriangleright : Audio Signal Route (L ch)

A/2

A/2

A2/2 MAIN ASSY (70280733110A0-IL)

A
B
C
D
E
F

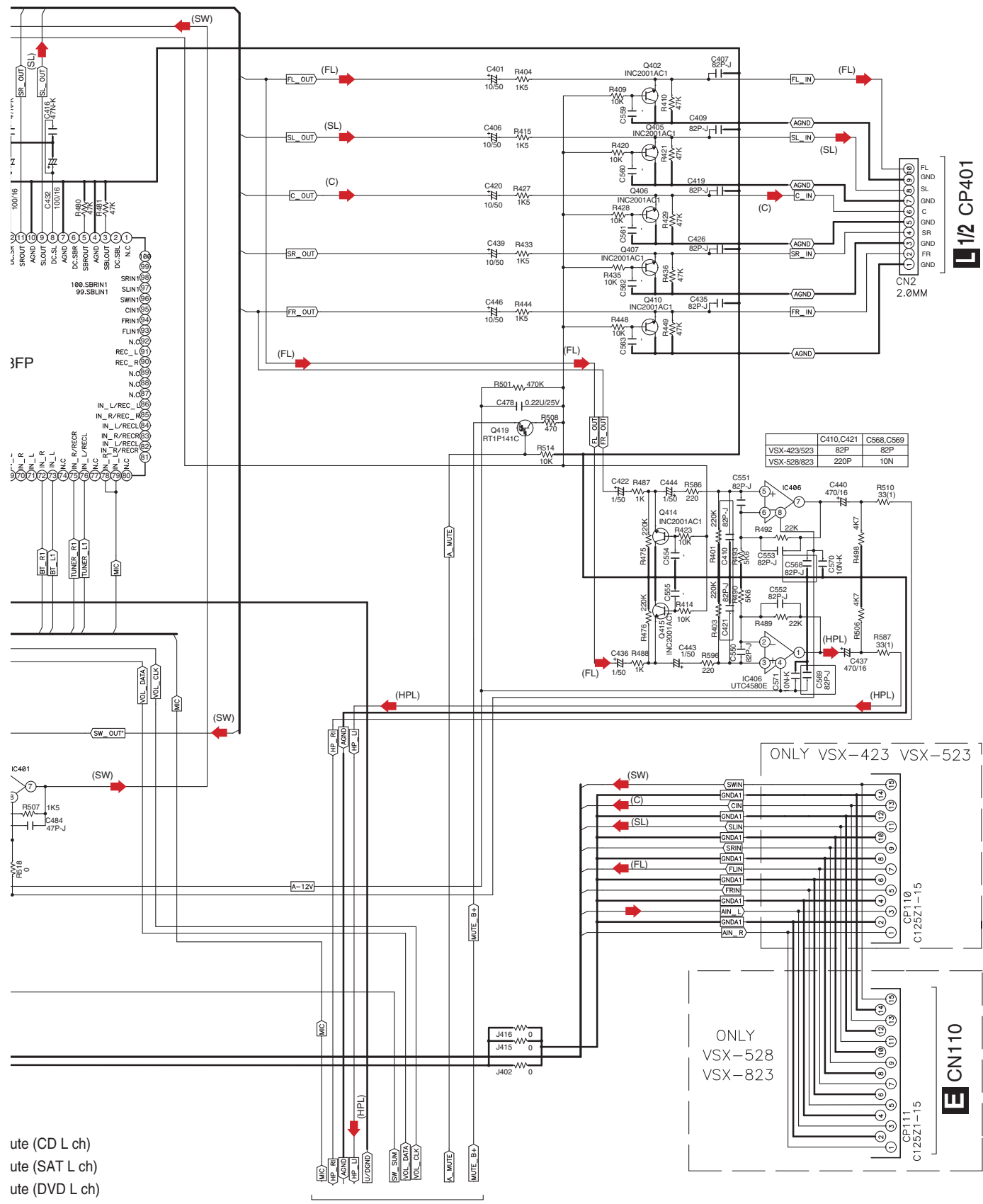

ute (CD L ch)
 ute (SAT L ch)
 ute (DVD L ch)
 ute (L ch)

A1/2

VSX-1023-K

A2/2

10.4 D-MAIN ASSY (1/7)

1

2

3

4

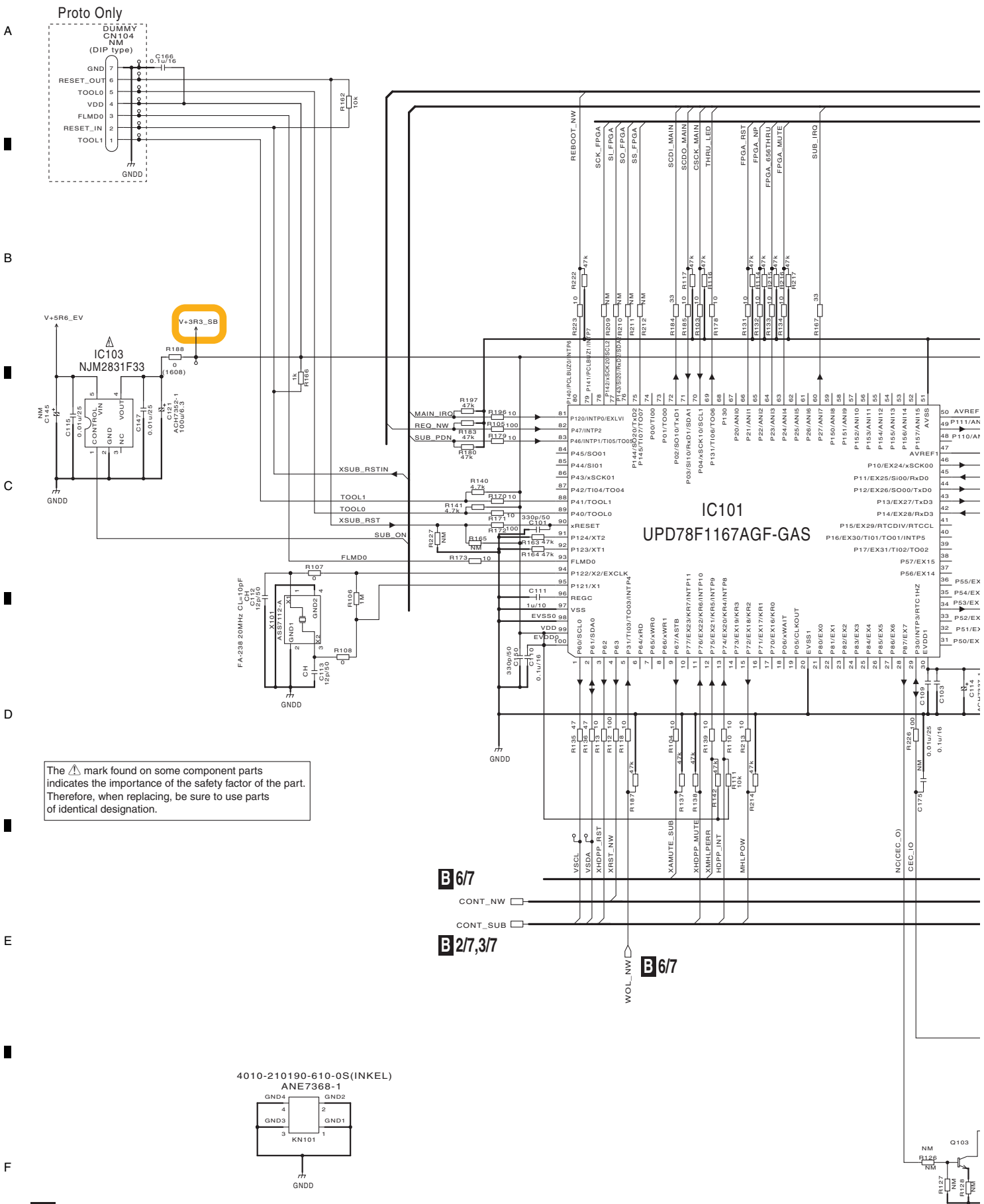

The Δ mark found on some component parts indicates the importance of the safety factor of the part. Therefore, when replacing, be sure to use parts of identical designation.

B17

1

2

3

4

B1/7 D-MAIN ASSY

(VSX-1023-K, VSX-43: 7028073231040-IL)
 (VSX-823-K: 7028073231020-IL)

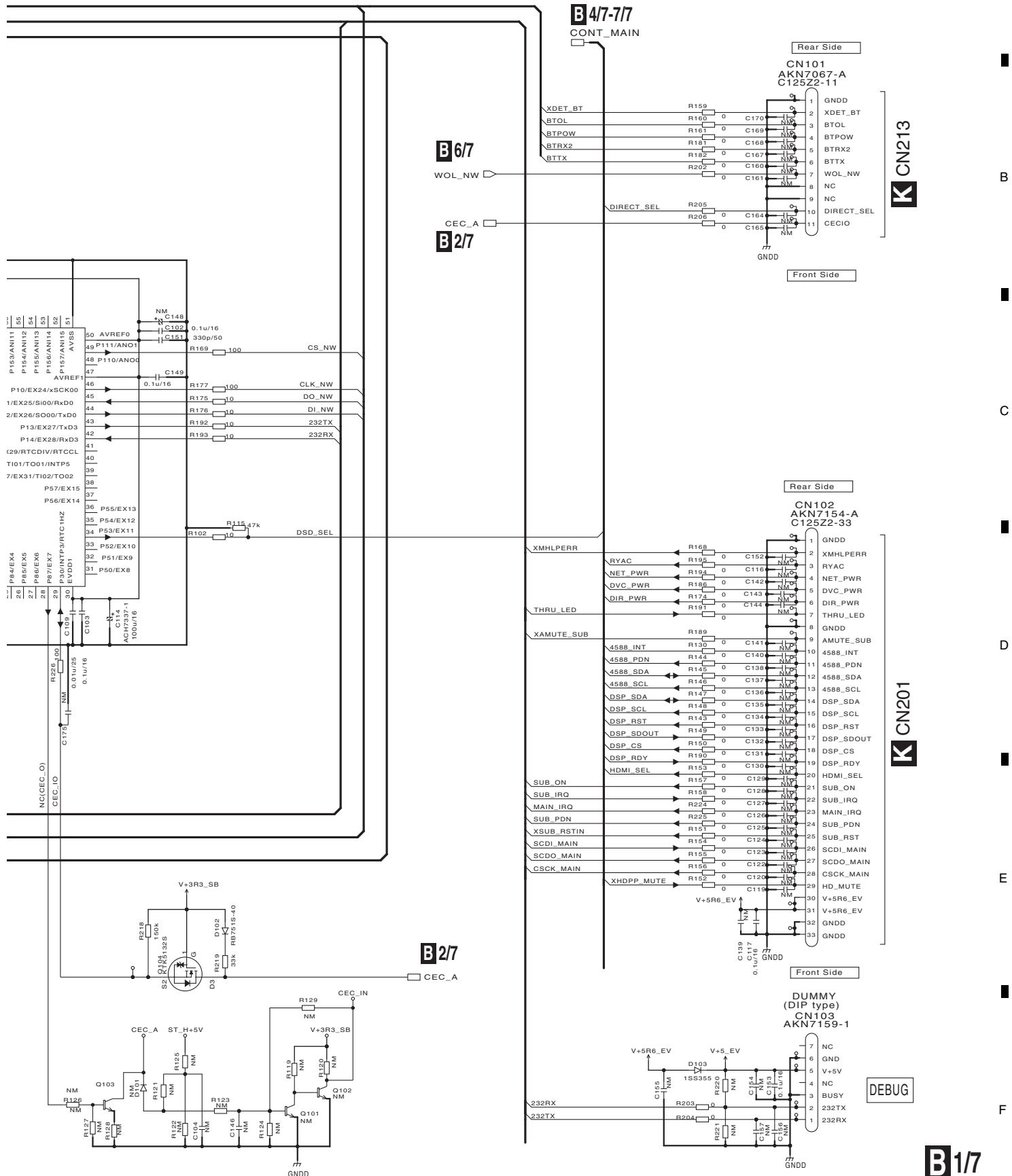

B2/7 D-MAIN ASSY
 (VSX-1023-K, VSX-43: 7028073231040-IL)
 (VSX-823-K: 7028073231020-IL)

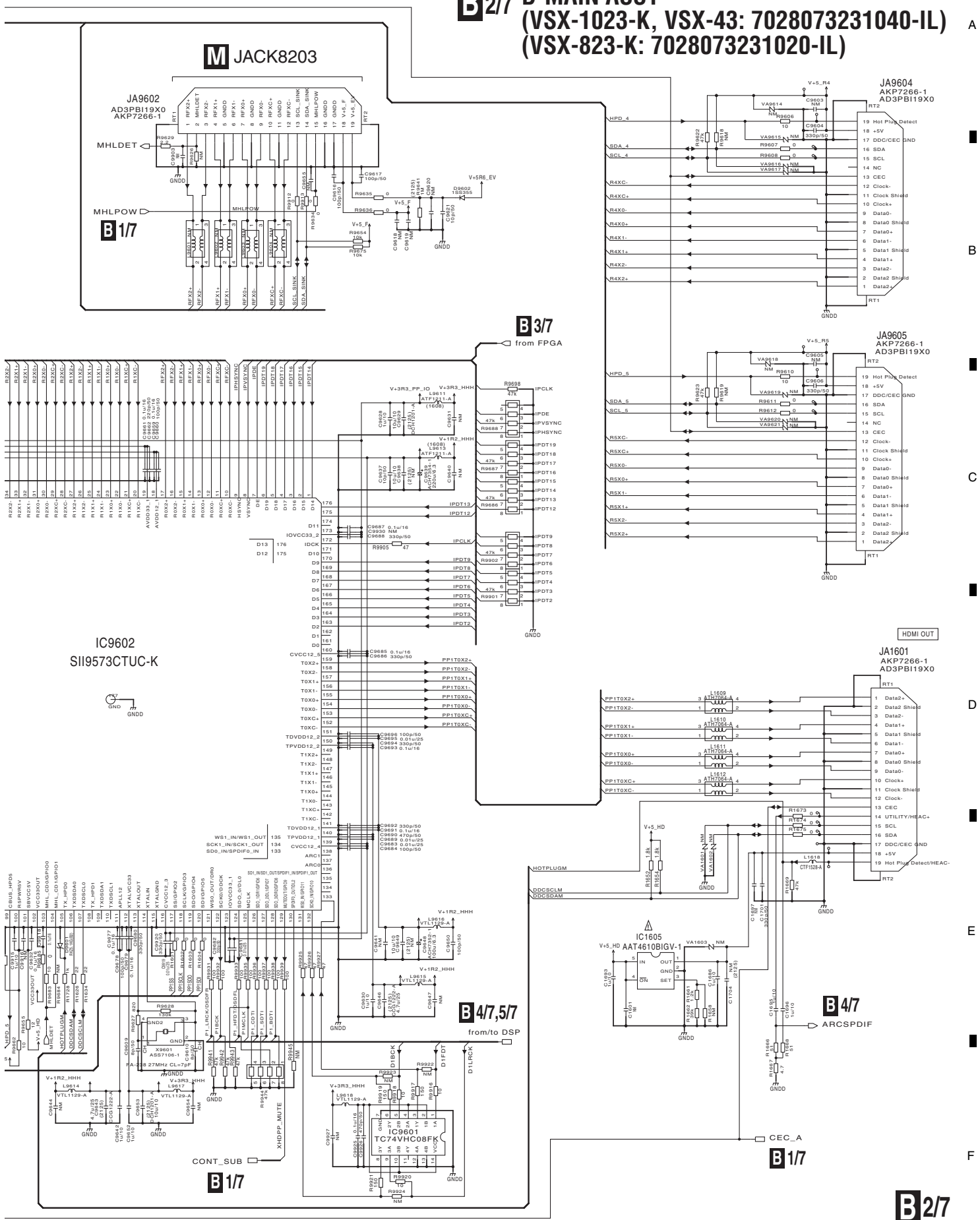

B 47,57
from/to DSP

B 4/7
ARCSPDIF

B 1/7

B 1/7
CEC_A

B3/7 D-MAIN ASSY
 (VSX-1023-K, VSX-43: 7028073231040-IL)
 (VSX-823-K: 7028073231020-IL)

A
B
C
D
E
F

B2/7
to HDMI IN/OUT

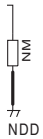
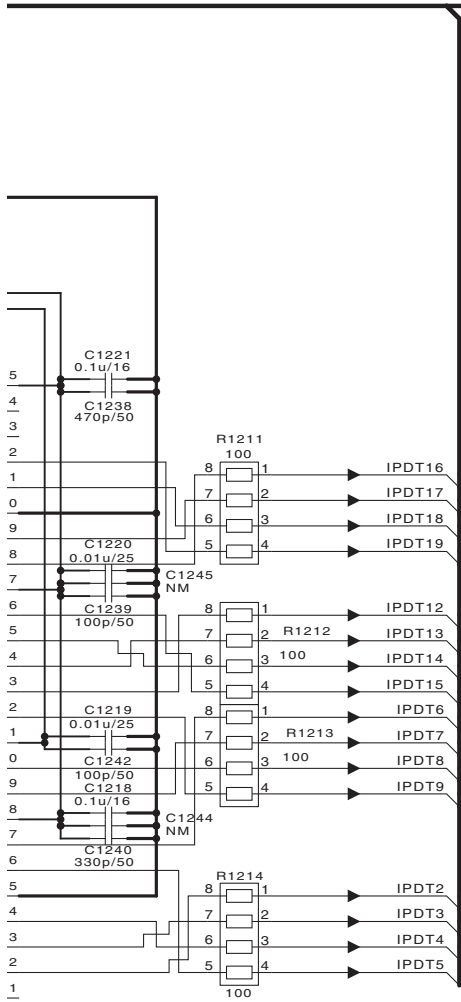

10.7 D-MAIN ASSY (4/7)

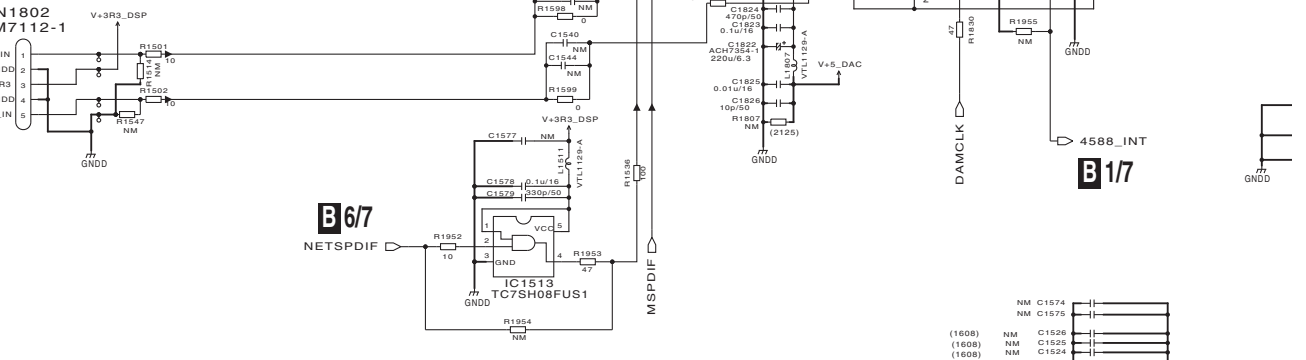
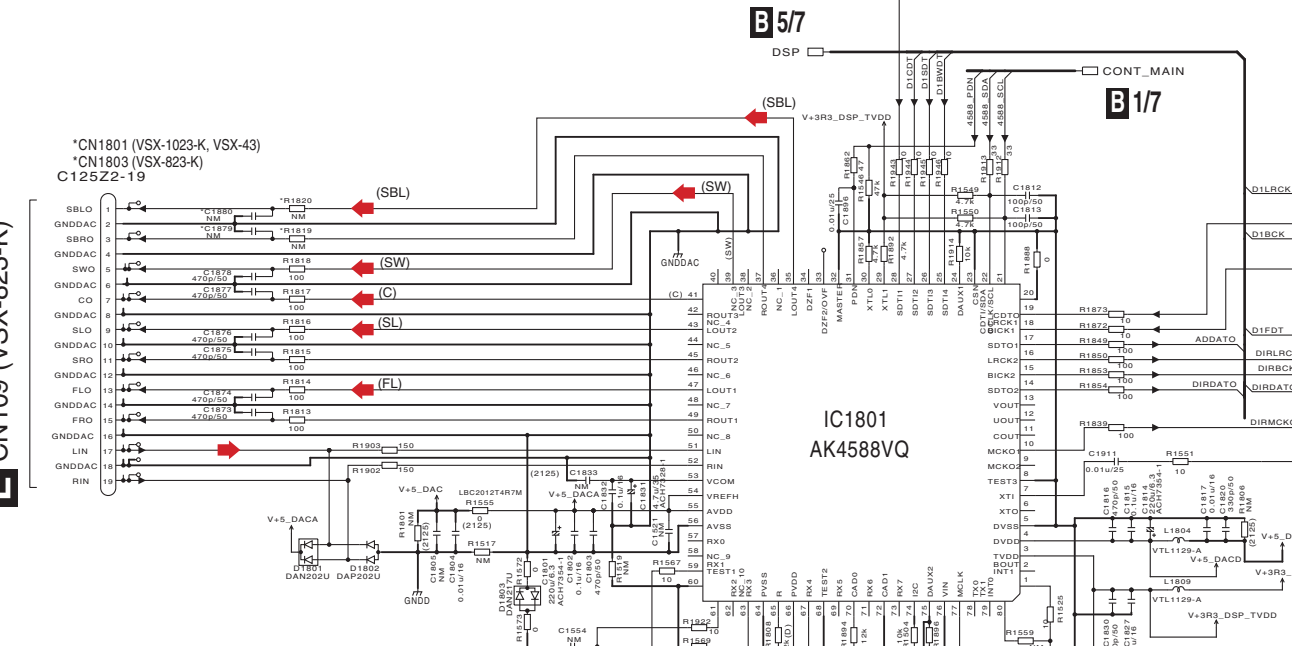
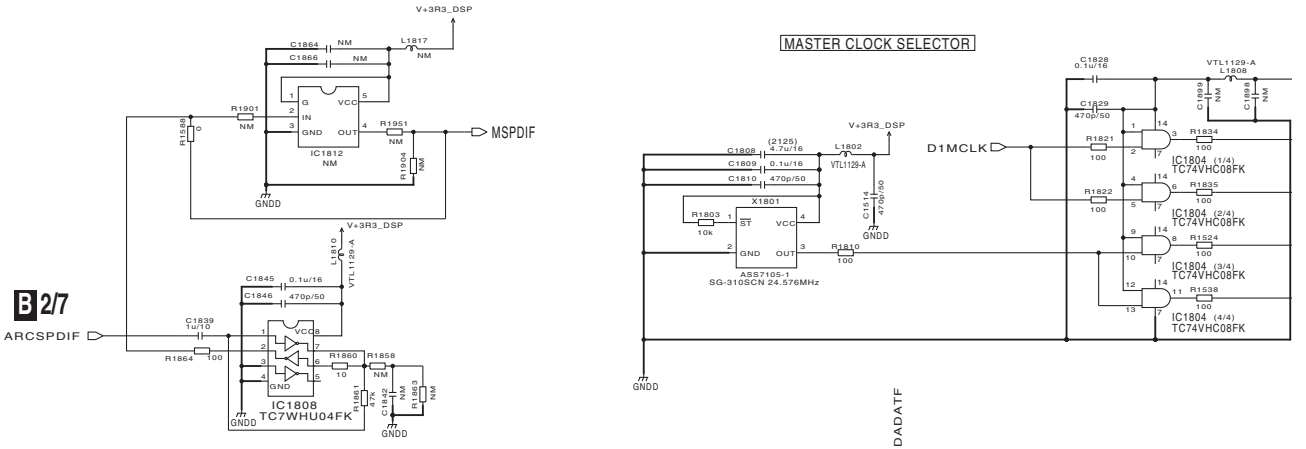

- ➡ : Audio Signal Route (L ch)
- (FL) ➡ : Audio Signal Route (Front L ch)
- (SL) ➡ : Audio Signal Route (Surround L ch)
- (C) ➡ : Audio Signal Route (Center ch)
- (SBL) ➡ : Audio Signal Route (Surround Back L ch)
- (SW) ➡ : Audio Signal Route (Subwoofer ch)

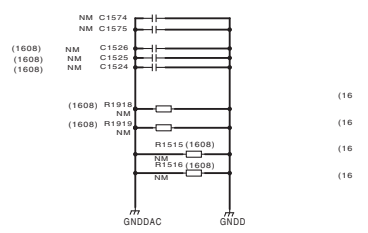

- C** CP2009 (VSX-1023-K, VSX-43)
- C** CP2010 (VSX-823-K)
- D** CP2003 (VSX-1023-K, VSX-43)
- E** CN109 (VSX-823-K)

B4/7 D-MAIN ASSY (VSX-1023-K, VSX-43: 7028073231040-IL) (VSX-823-K: 7028073231020-IL)

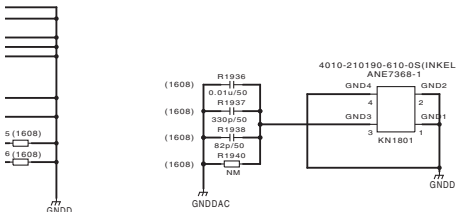
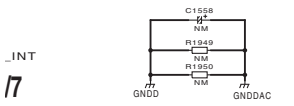
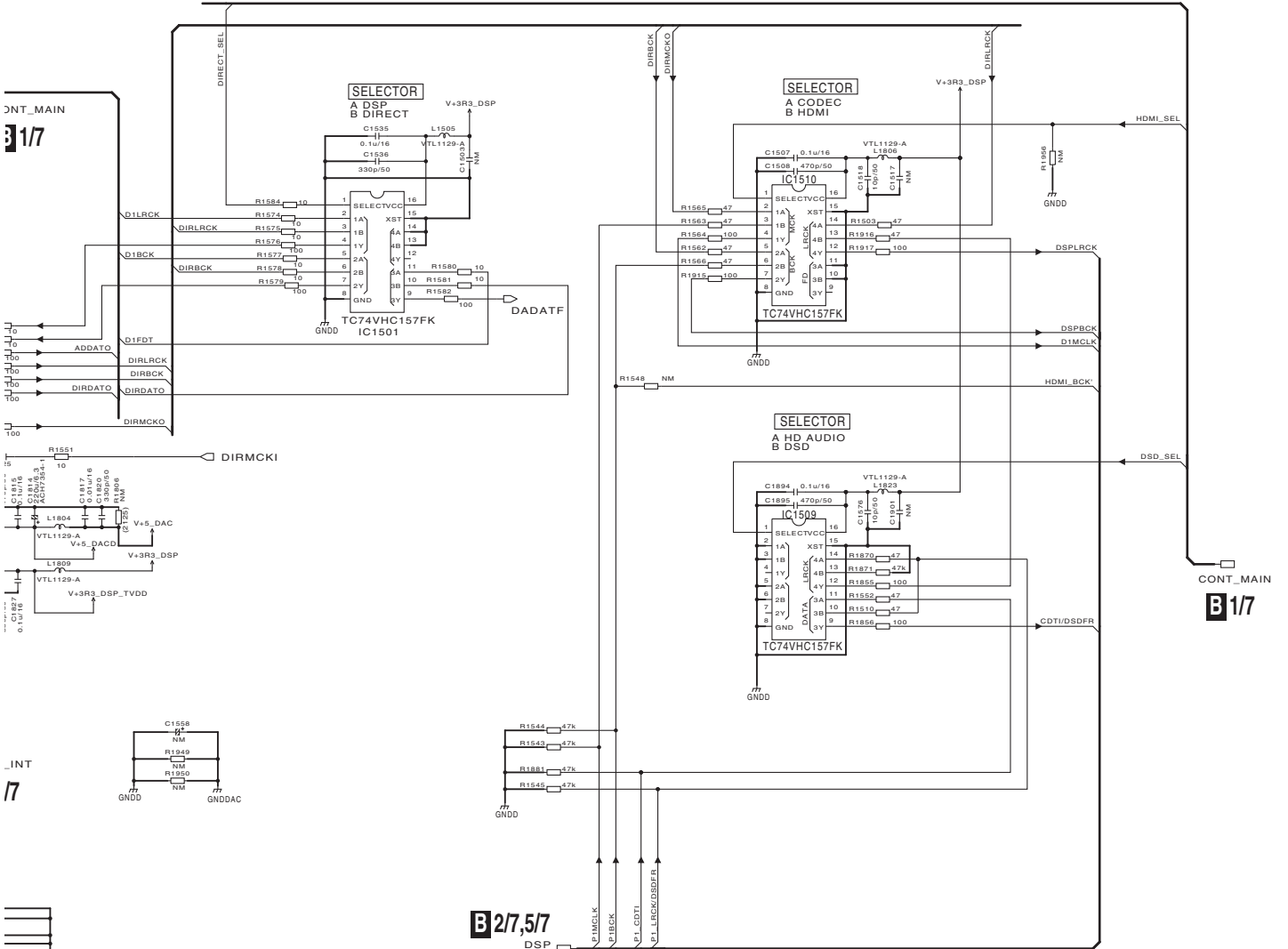
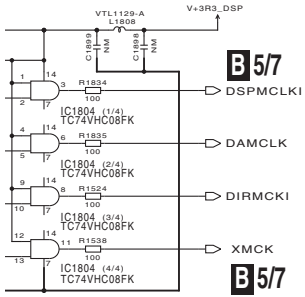

HDMI PCM DATA		HDMI DSD DATA	
HFDT	FL/FR	HFDT	FL
CDTI	C/SW	HDLRCK	FR
SDTI	SL/SR		
BDTI	SBL/SBR		

10.8 D-MAIN ASSY (5/7)

1 2 3 4

A

B

C

D

E

F

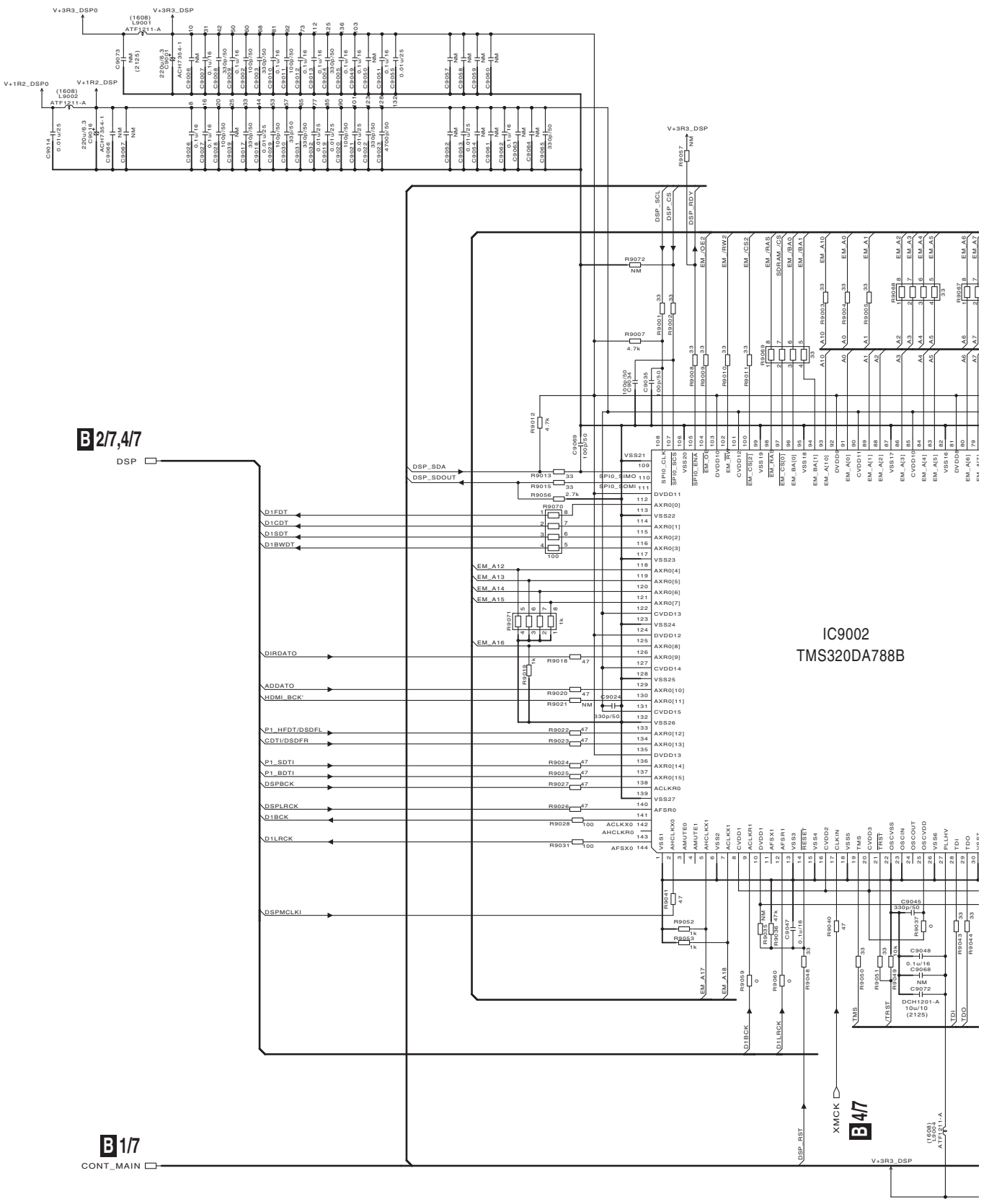

B 2/7,4/7

B 1/7

IC9002
TMS320DA788B

B 4/7

1 2 3 4

B5/7 D-MAIN ASSY

(VSX-1023-K, VSX-43: 7028073231040-IL)
 (VSX-823-K: 7028073231020-IL)

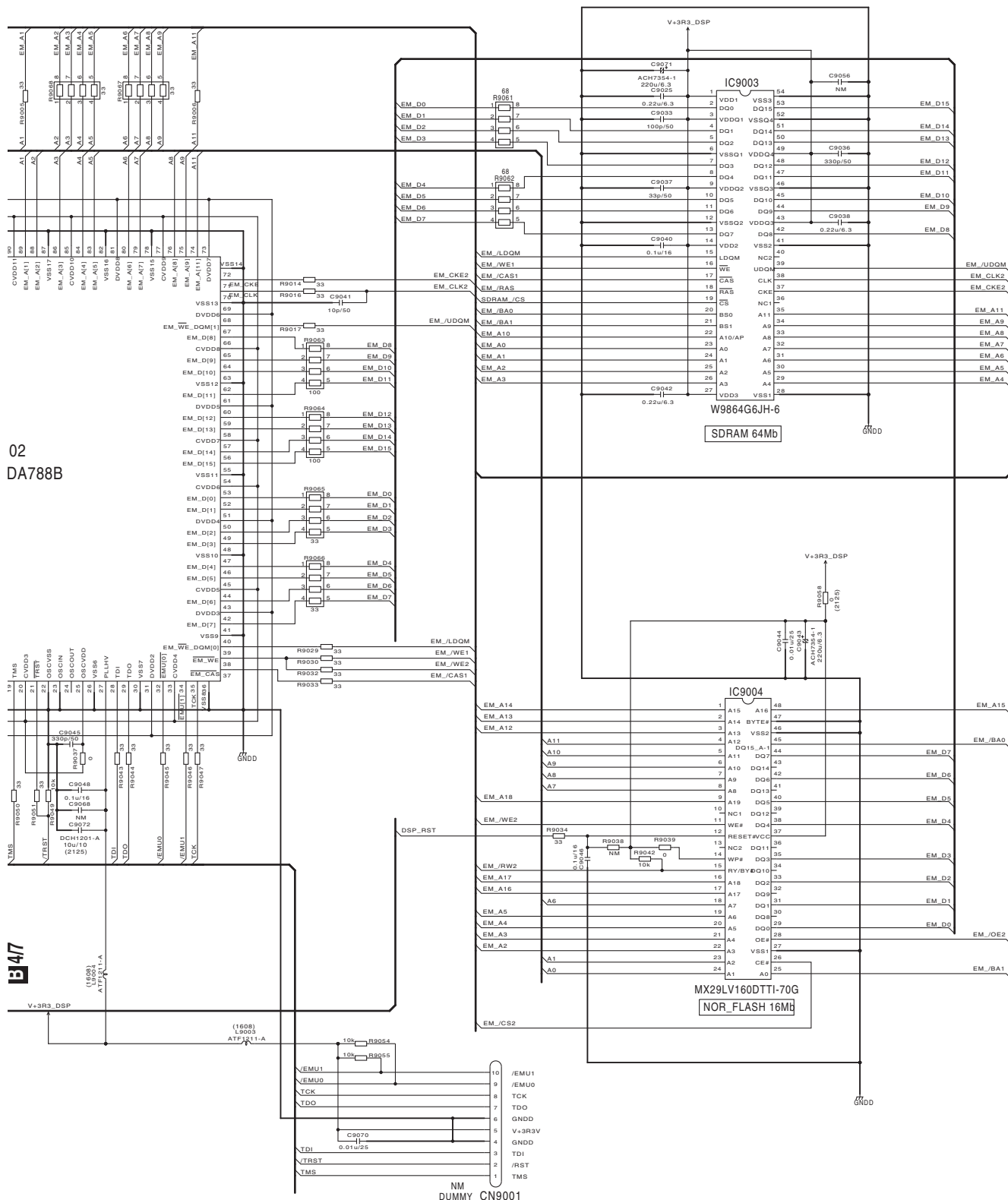

02
DA788B

B47

NM DUMMY CN9001

VSX-1023-K

10.9 D-MAIN ASSY (6/7)

1

2

3

4

A

B

C

D

E

F

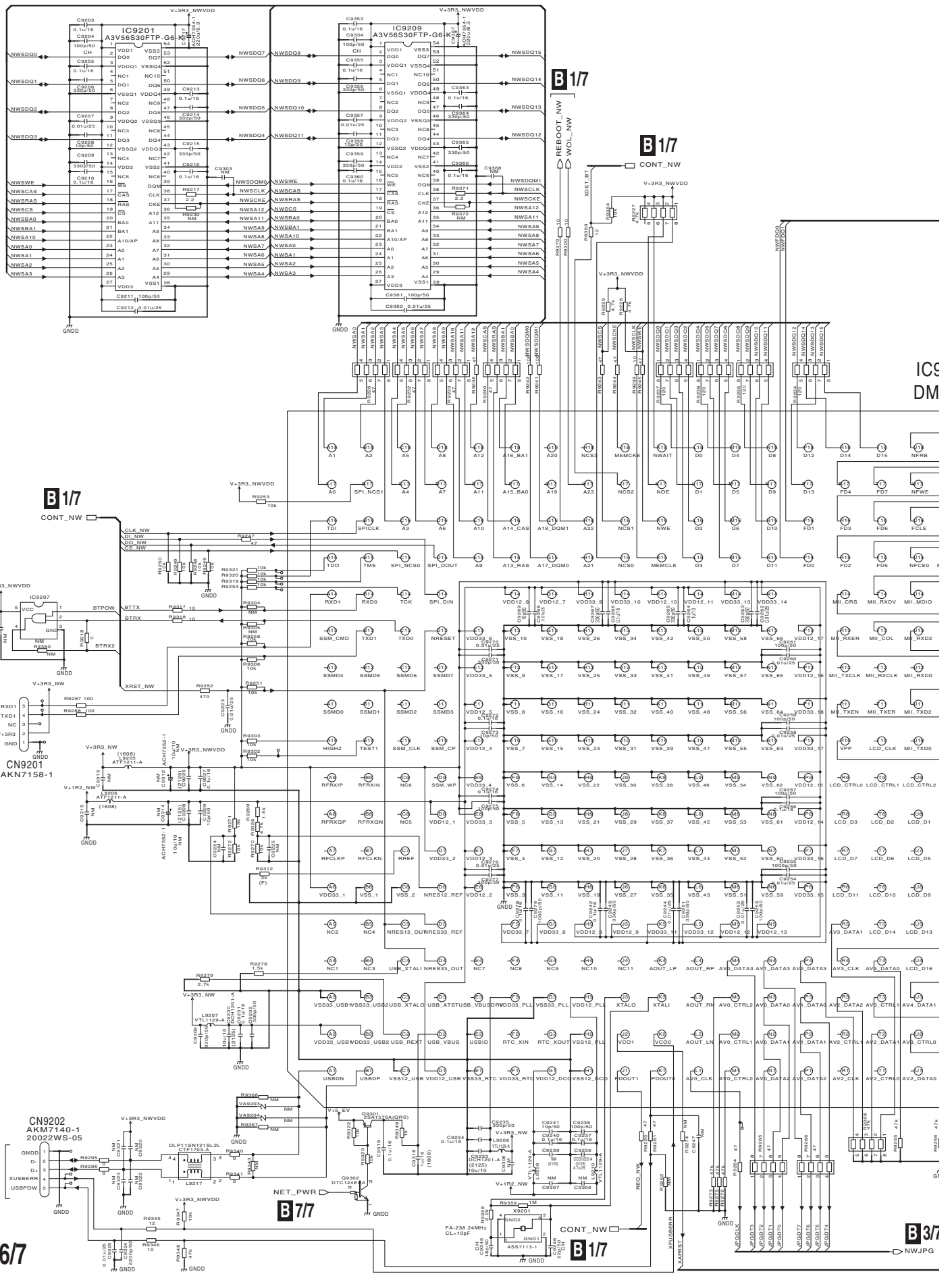

VSX-1023-K

1

2

3

4

B 6/7 D-MAIN ASSY

(VSX-1023-K, VSX-43: 7028073231040-IL)
 (VSX-823-K: 7028073231020-IL)

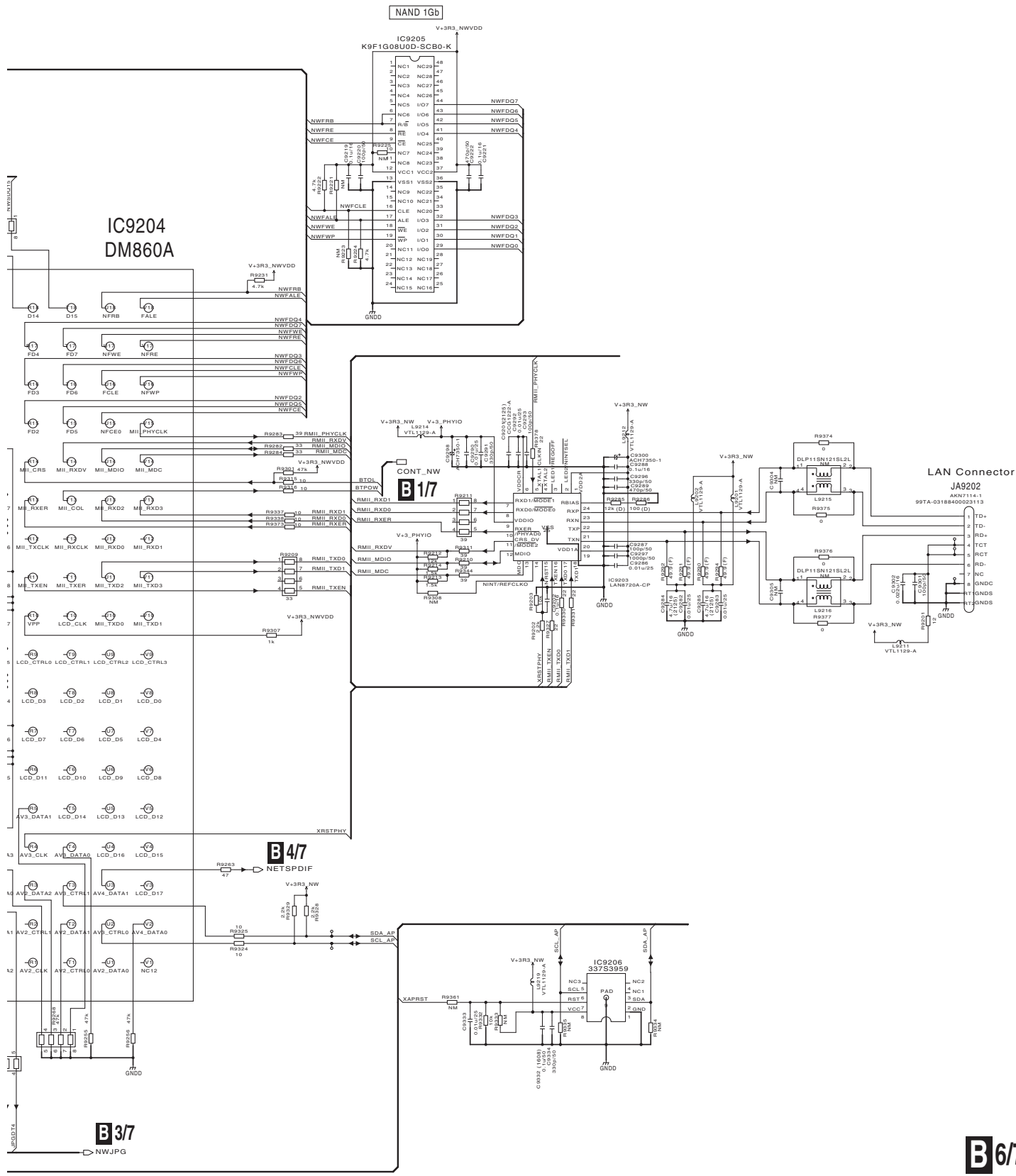

VSX-1023-K

10.10 D-MAIN ASSY (7/7)

1 2 3 4

A

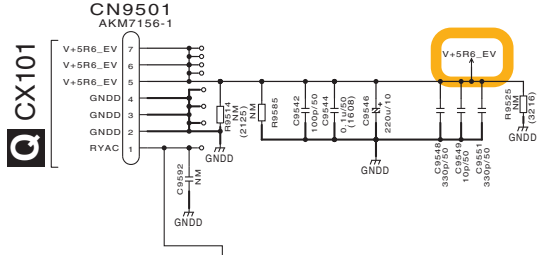

B

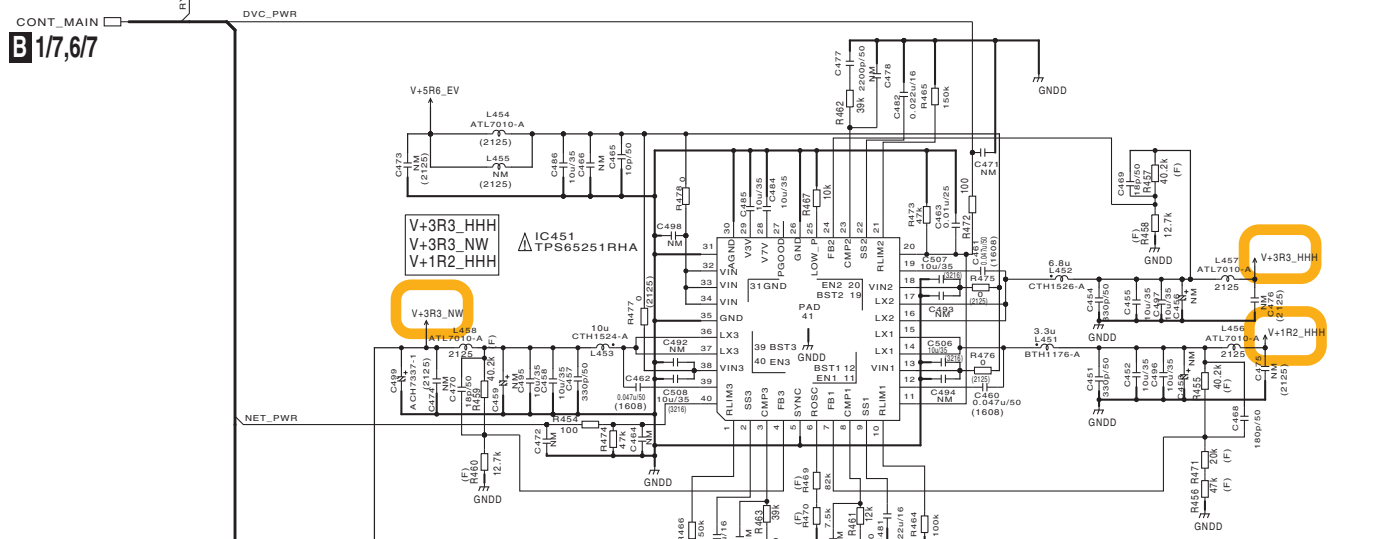

C

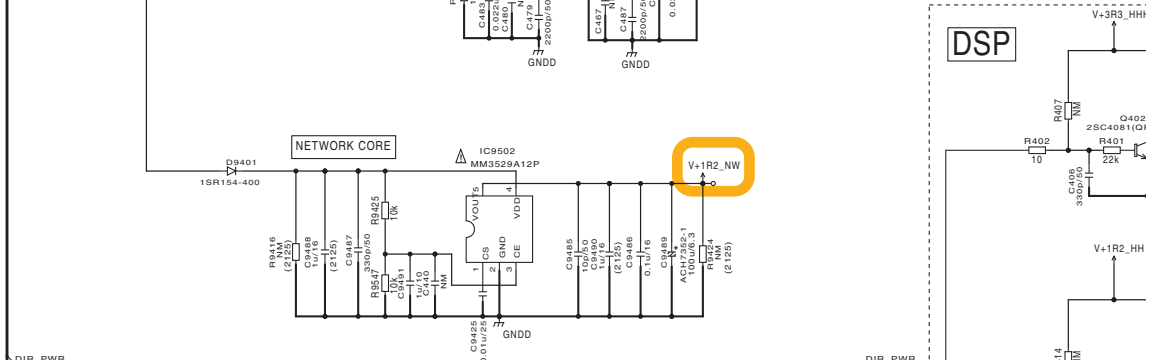

D

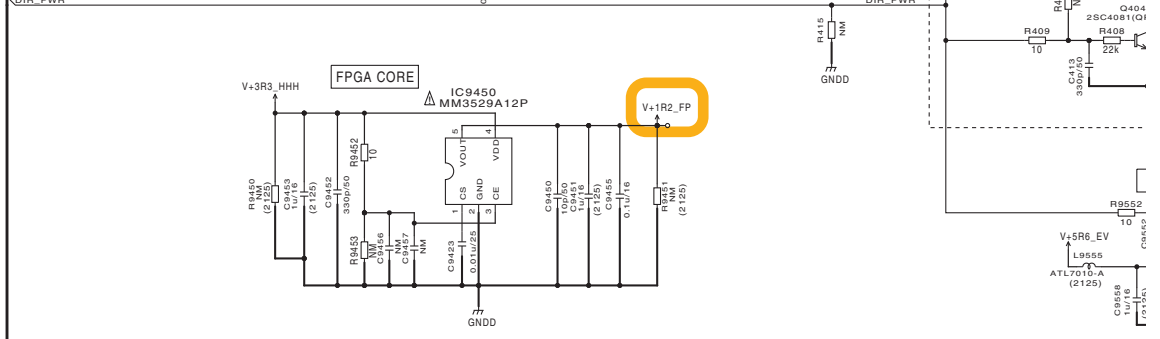

E

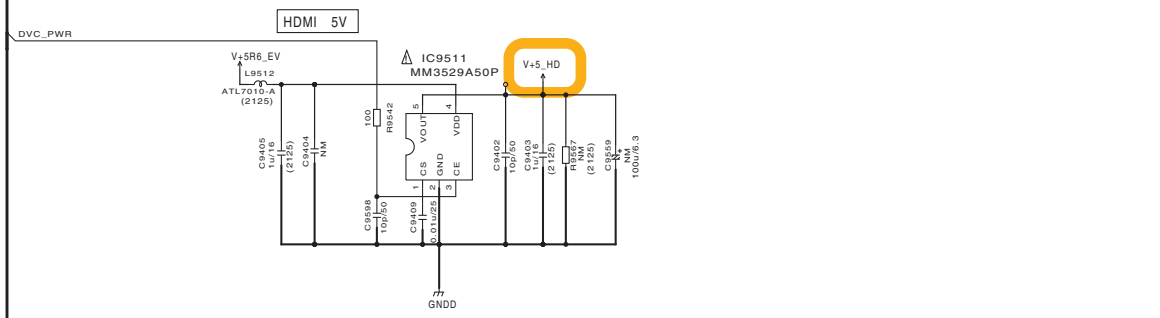

F

B 7/7

1 2 3 4

B77 D-MAIN ASSY (VSX-1023-K, VSX-43: 7028073231040-IL) (VSX-823-K: 7028073231020-IL)

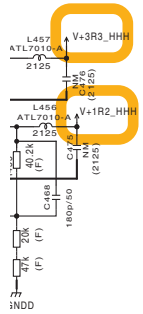
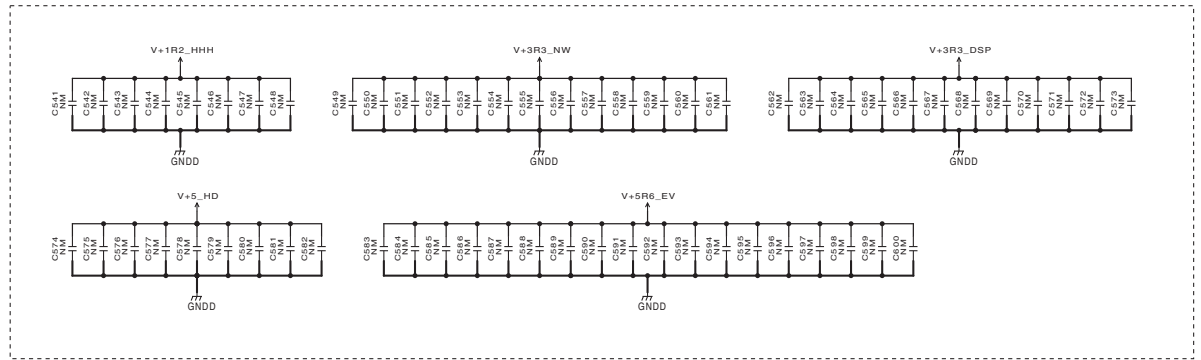

All 1u/10 is DCH1246-A.

The Δ mark found on some component parts indicates the importance of the safety factor of the part. Therefore, when replacing, be sure to use parts of identical designation.

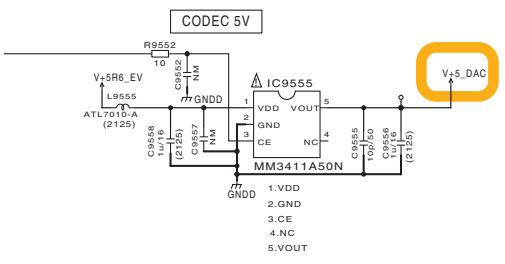
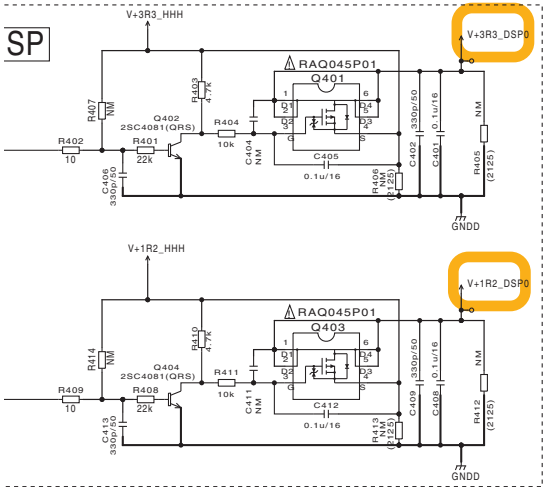

10.11 OPTCO ASSY

OPTCO ASSY (7028073033020-IL)(VSX-1023-K, VSX-43)

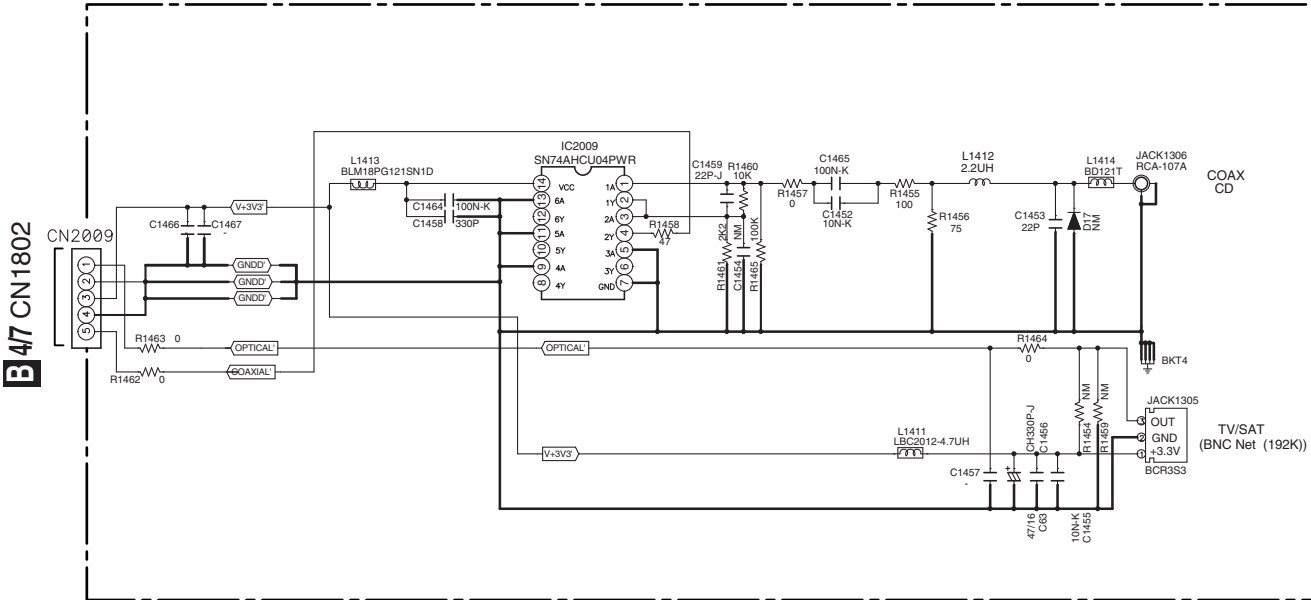

OPTCO ASSY (70280733130A0-IL)(VSX-823-K)

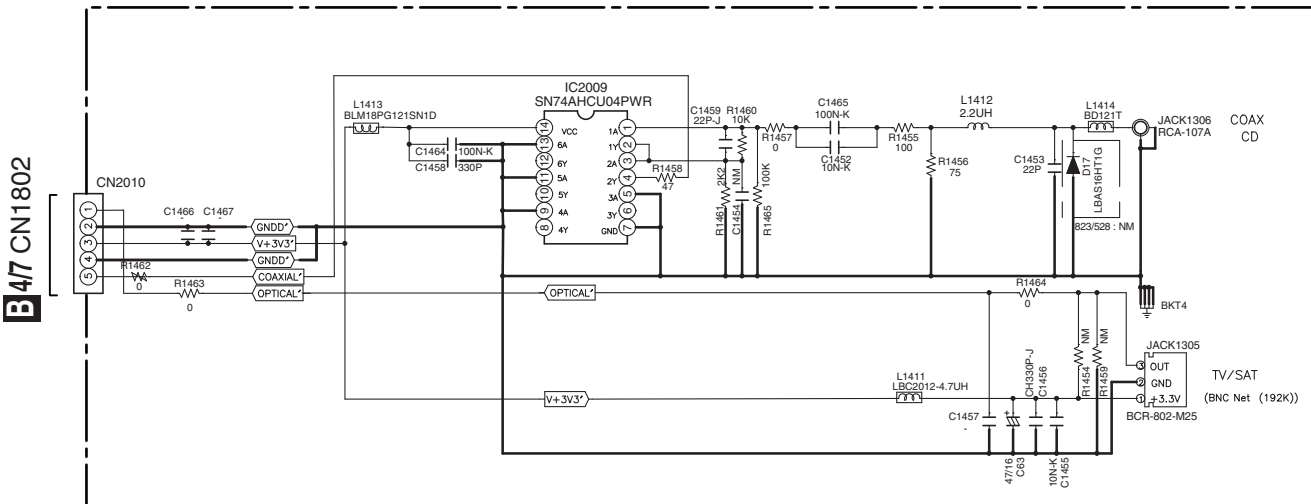

10.12 BRI-1 ASSY (VSX-1023-K, VSX-43 ONLY)

D BRI-1 ASSY (7028073039020-IL)

B 4/7 CN1801

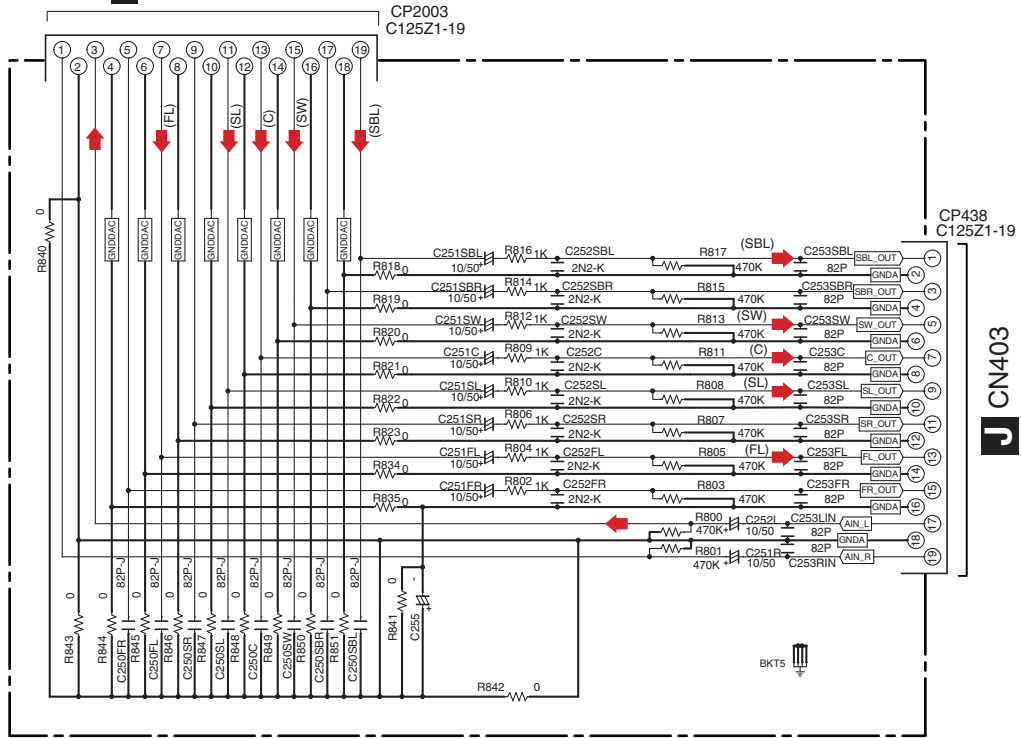

- ➡ : Audio Signal Route (L ch)
- (FL) ➡ : Audio Signal Route (Front L ch)
- (SL) ➡ : Audio Signal Route (Surround L ch)
- (C) ➡ : Audio Signal Route (Center ch)
- (SBL) ➡ : Audio Signal Route (Surround Back L ch)
- (SW) ➡ : Audio Signal Route (Subwoofer ch)

10.13 CONCT ASSY (VSX-823-K ONLY)

CONCT ASSY (70280733240B0-IL)

B 4/7 CN1803

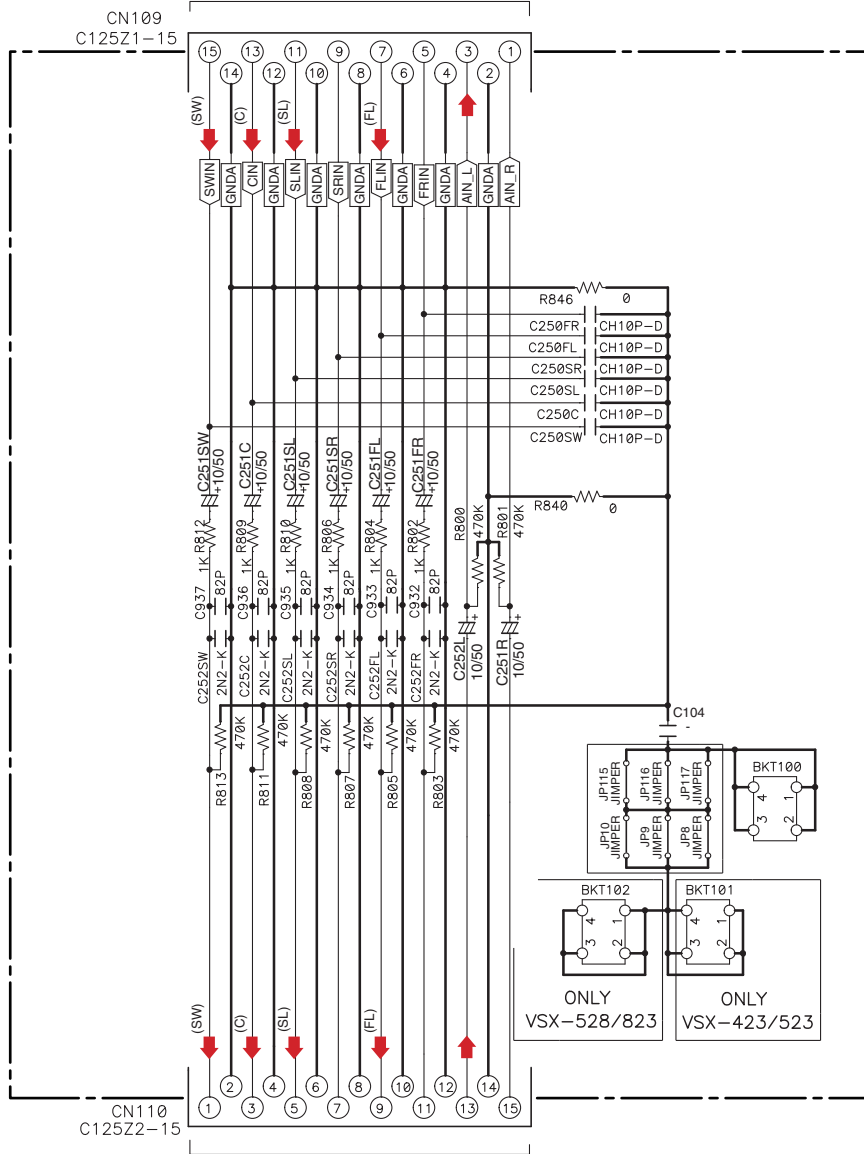

A 2/2 CP111

OPTION

	JP8, JP9, JP10, JP115, JP116, JP117
VSX-423/523	JUMPER
VSX-528/823	NM

- ➡ : Audio Signal Route (L ch)
- (FL) ➡ : Audio Signal Route (Front L ch)
- (SL) ➡ : Audio Signal Route (Surround L ch)
- (C) ➡ : Audio Signal Route (Center ch)
- (SW) ➡ : Audio Signal Route (Subwoofer ch)



10.14 VIDEO ASSY (VSX-1023-K, VSX-43 ONLY)

F VIDEO ASSY (7028073032020-IL)

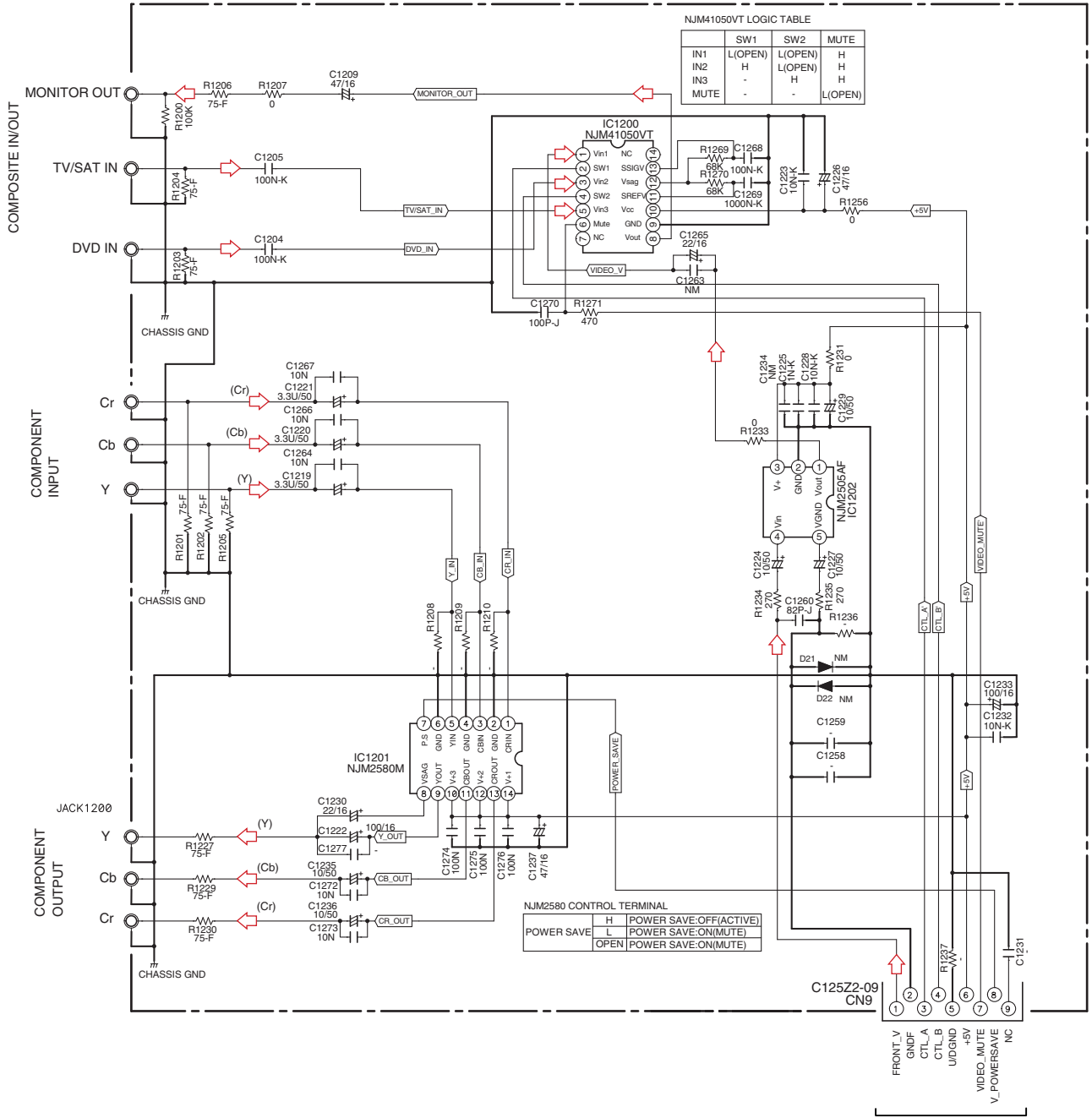

- ◁: Video Signal Route
- (Y) ◁: Video Signal Route (Component Y)
- (Cb) ◁: Video Signal Route (Component Cb)
- (Cr) ◁: Video Signal Route (Component Cr)

A CP9



10.15 BT and BTCNT ASSYS (VSX-1023-K, VSX-43)

G BT ASSY (7028073211040-IL)

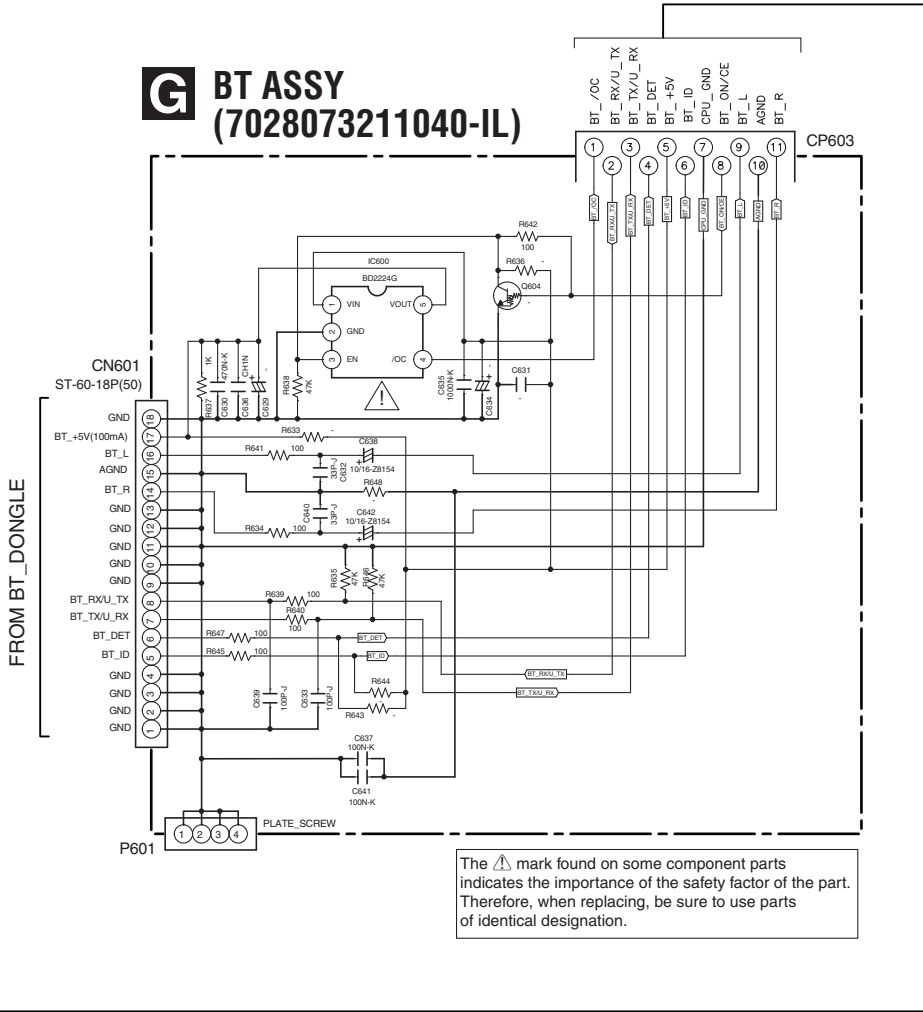

The Δ mark found on some component parts indicates the importance of the safety factor of the part. Therefore, when replacing, be sure to use parts of identical designation.

H BTCNT ASSY (7028073024020-IL)

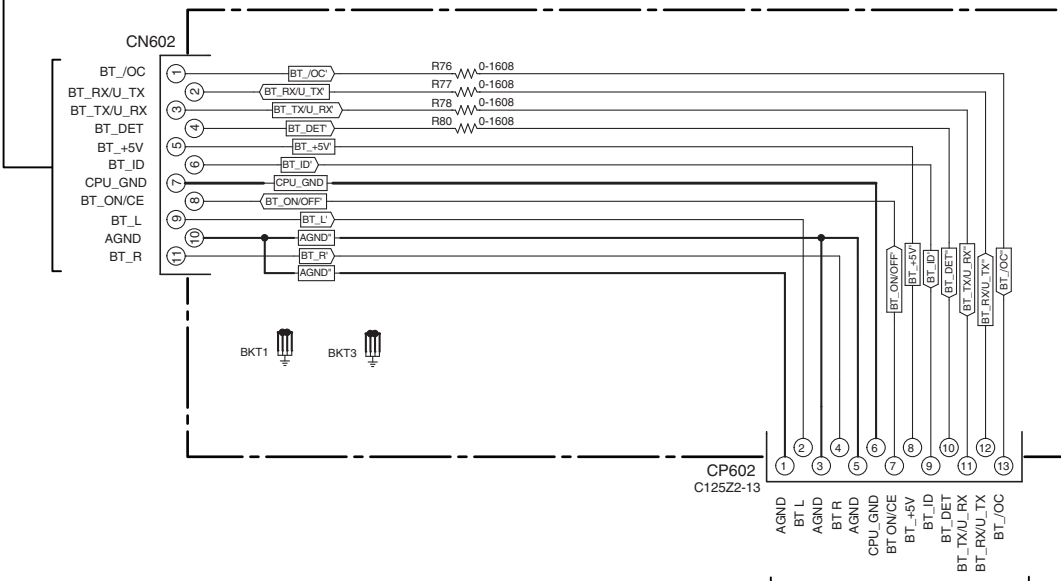

A CP605



10.16 BT ASSY (VSX-823-K)

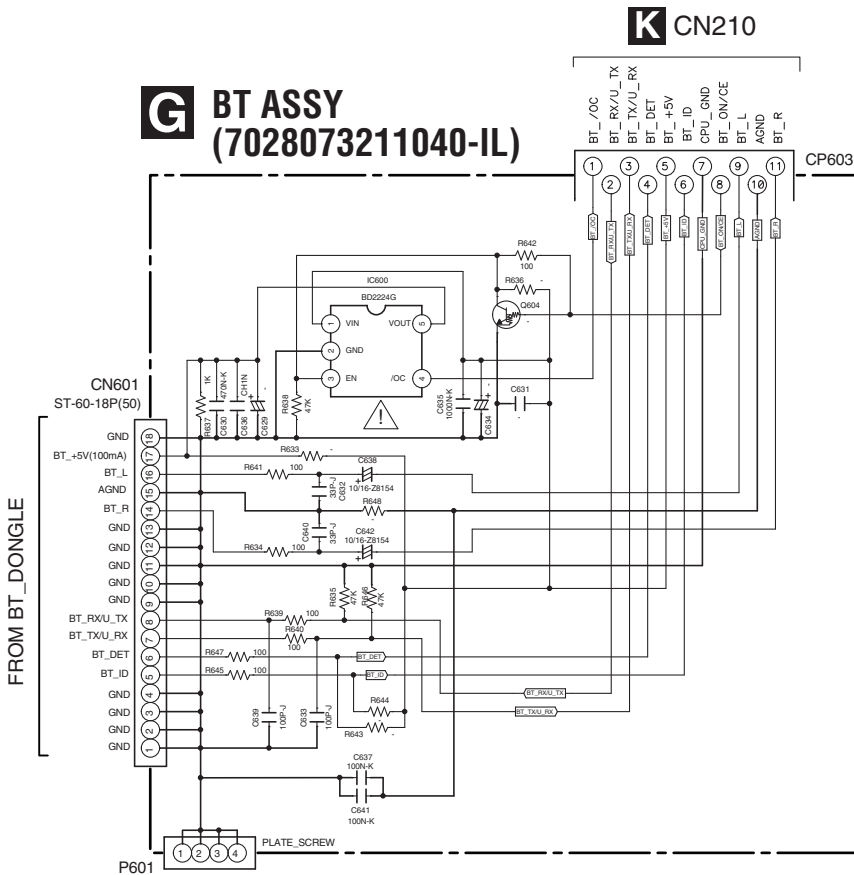

10.17 BRI-2 ASSY (VSX-1023-K, VSX-43 ONLY)

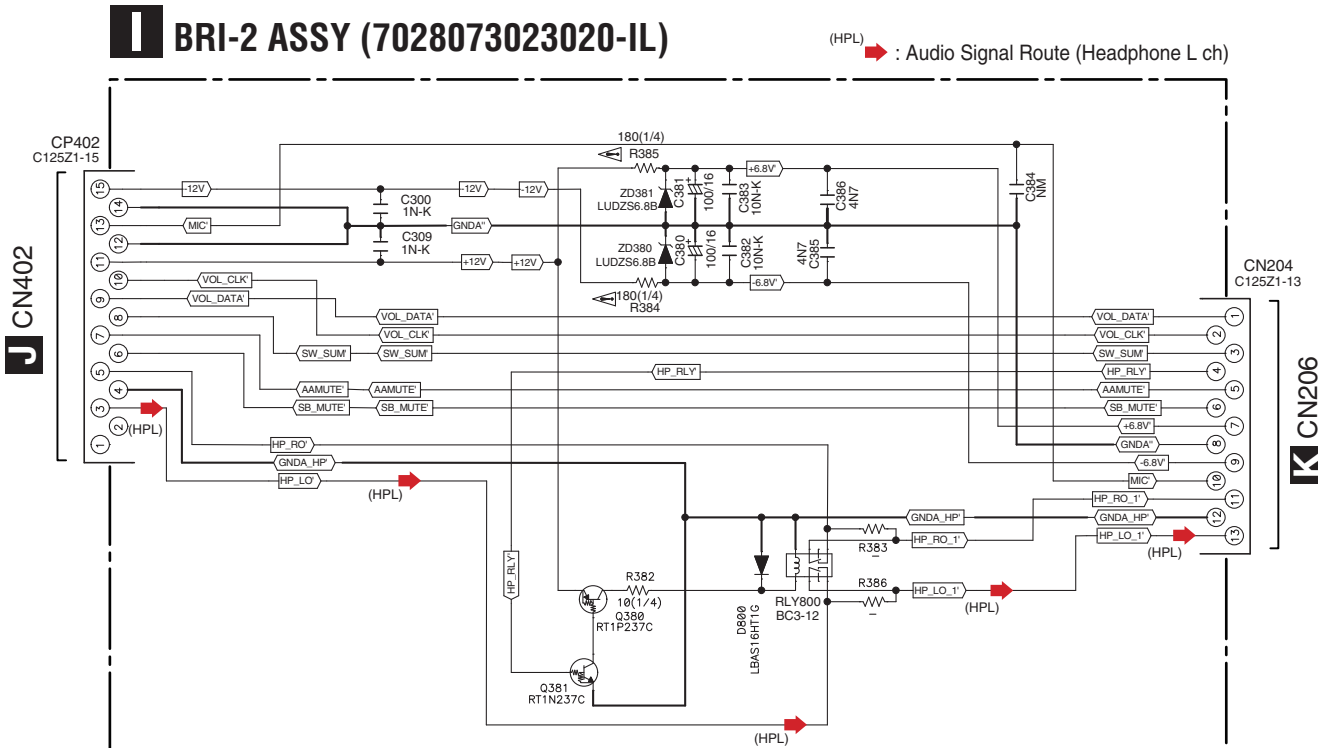

10.18 AUDIO ASSY (VSX-1023-K, VSX-43 ONLY)

The Δ mark found on some component parts indicates the importance of the safety factor of the part. Therefore, when replacing, be sure to use parts of identical designation.

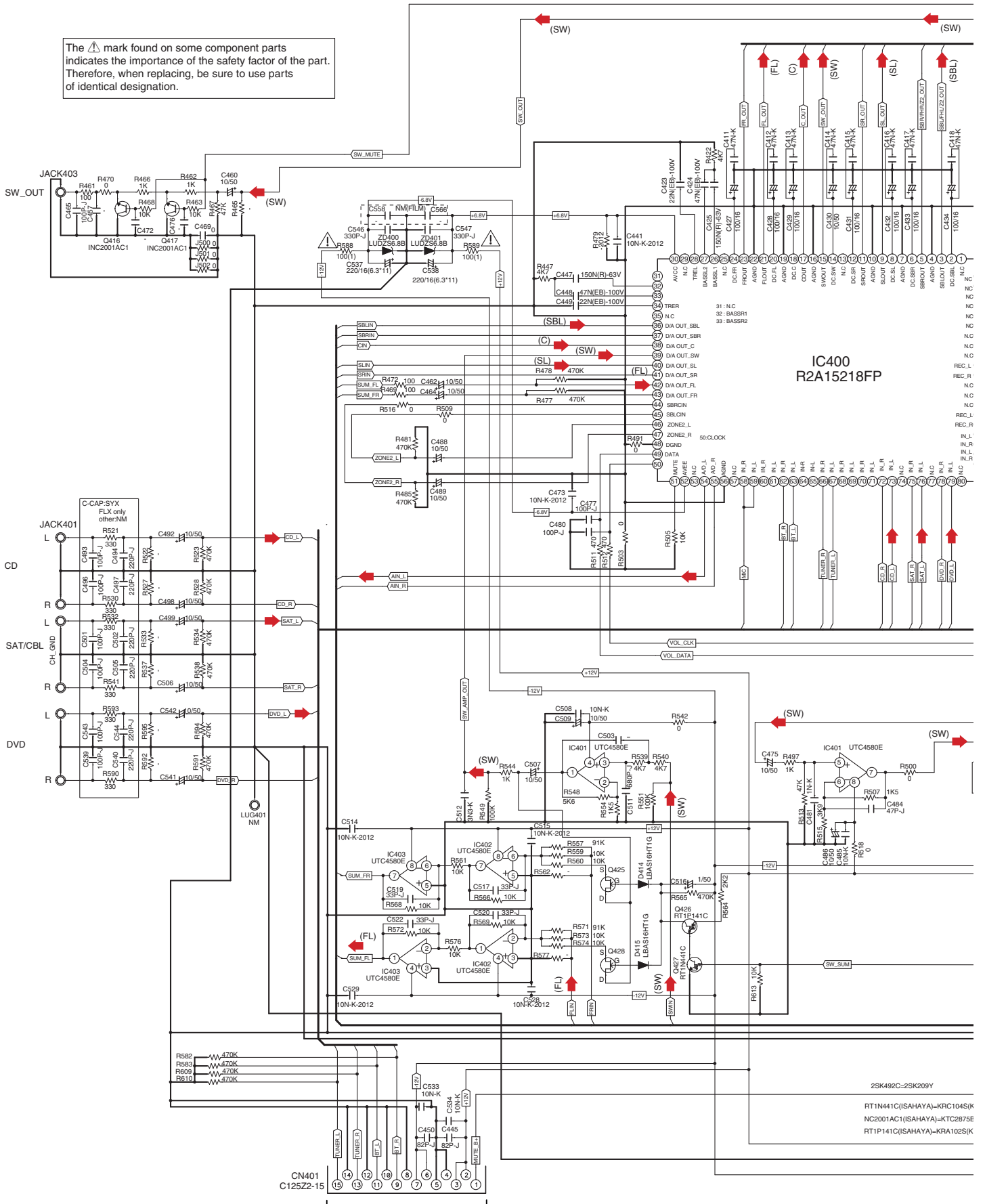

IC400
R2A15218FP

IC401
UTC4580E

- 31: N.C
- 32: BASSR1
- 33: BASSR2
- 34: TRER
- 35: DIA OUT_SBL
- 36: DIA OUT_SBR
- 37: DIA OUT_C
- 38: DIA OUT_SL
- 39: DIA OUT_SR
- 40: DIA OUT_FL
- 41: DIA OUT_FR
- 42: SBRIN
- 43: SBLIN
- 44: ZONE1N
- 45: ZONE1L
- 46: ZONE2N
- 47: ZONE2L
- 48: DGNB
- 49: DATA
- 50: CLOCK
- 51: MUTE
- 52: AVEE
- 53: ADL
- 54: ADL
- 55: ADL
- 56: AGND
- 57: N.C
- 58: N.C
- 59: N.C
- 60: N.C
- 61: N.C
- 62: N.C
- 63: N.C
- 64: N.C
- 65: N.C
- 66: N.C
- 67: N.C
- 68: N.C
- 69: N.C
- 70: N.C
- 71: N.C
- 72: N.C
- 73: N.C
- 74: N.C
- 75: N.C
- 76: N.C
- 77: N.C
- 78: N.C
- 79: N.C
- 80: N.C

2SK492C=2SK209Y
RT1N441C((SAHAYA)=KRC104S(K
NC2001AC1((SAHAYA)=KTC2875E
RT1P141C((SAHAYA)=KRA102S(K

J AUDIO ASSY (7028073041020-IL)

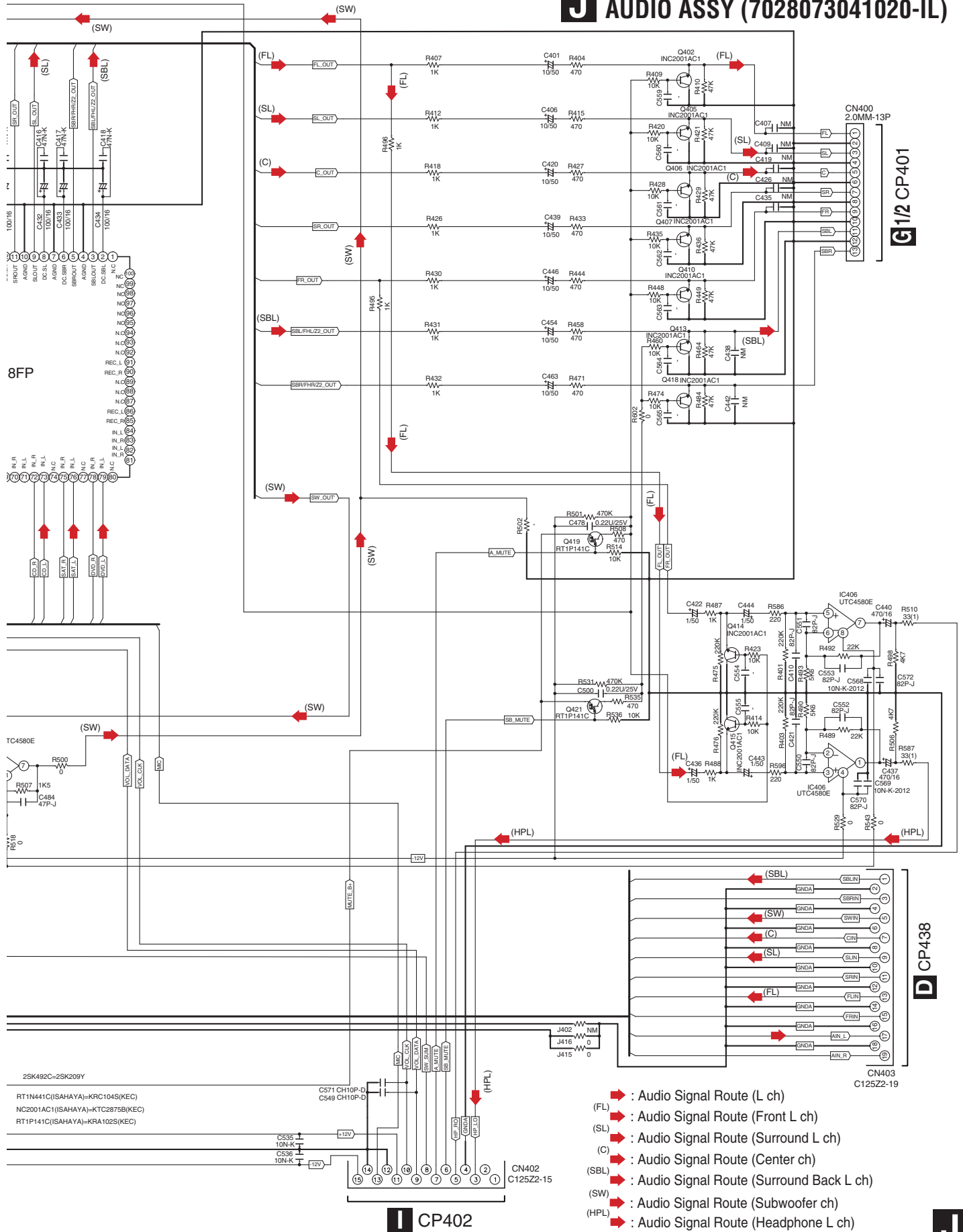

- ➔ : Audio Signal Route (L ch)
- (FL) ➔ : Audio Signal Route (Front L ch)
- (SL) ➔ : Audio Signal Route (Surround L ch)
- (C) ➔ : Audio Signal Route (Center ch)
- (SBL) ➔ : Audio Signal Route (Surround Back L ch)
- (SW) ➔ : Audio Signal Route (Subwoofer ch)
- (HPL) ➔ : Audio Signal Route (Headphone L ch)

CP402

VSX-1023-K

J

10.19 CPU ASSY (VSX-1023-K, VSX-43)

K CPU ASSY (7028073021010-IL)

B17 CN102

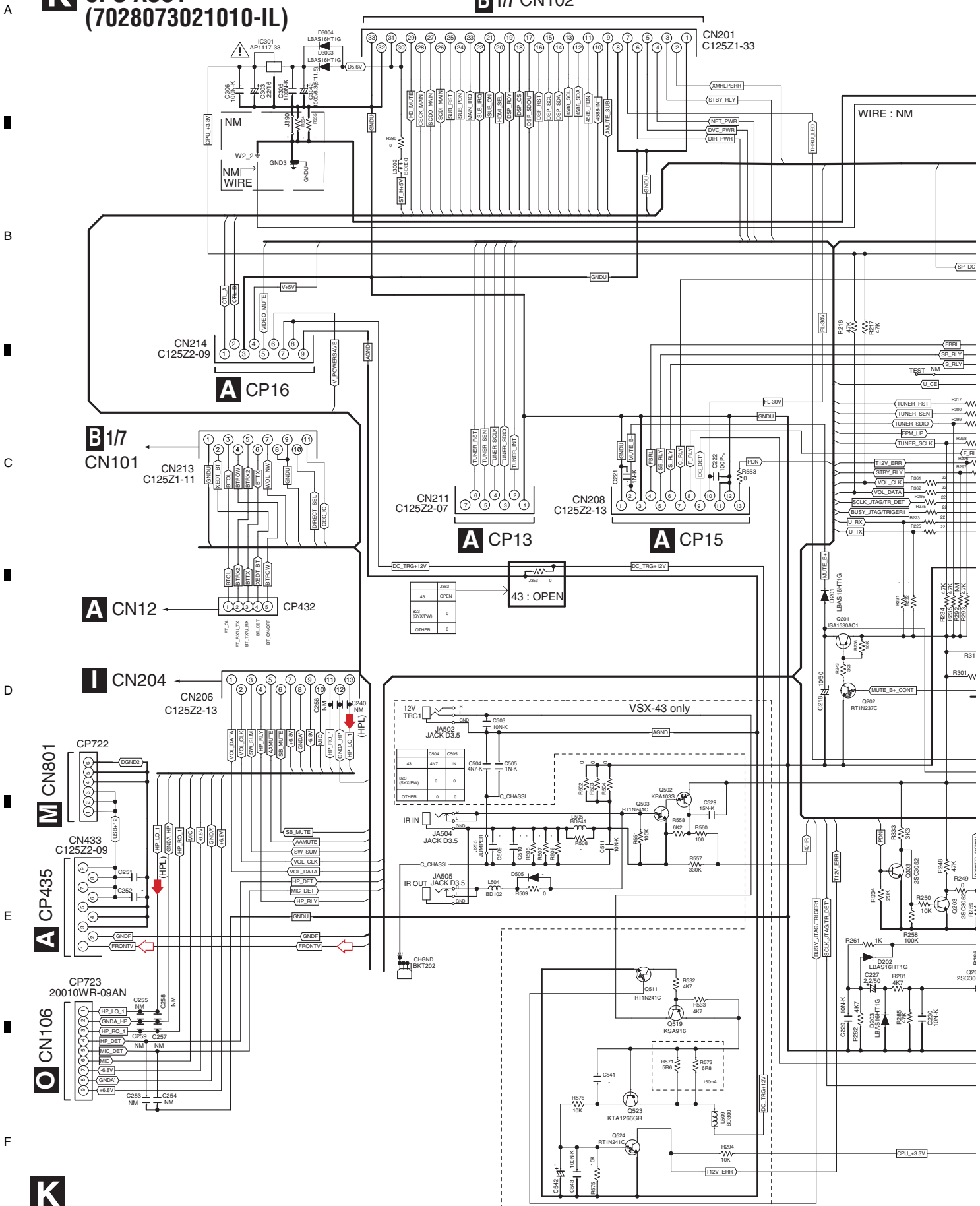

VSX-1023-K

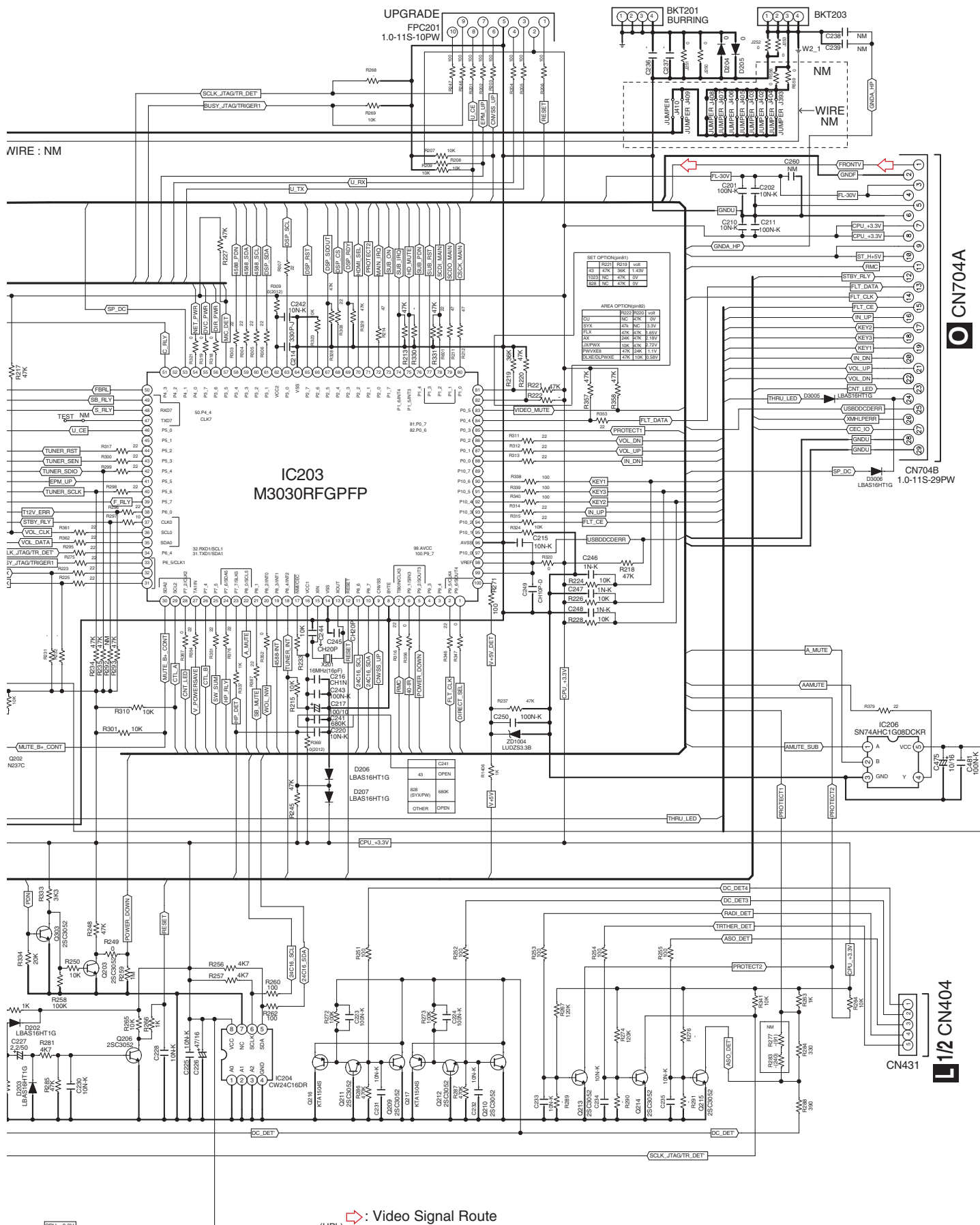

10.20 CPU ASSY (VSX-823-K)

1

2

3

4

A

B

C

D

E

F

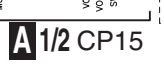
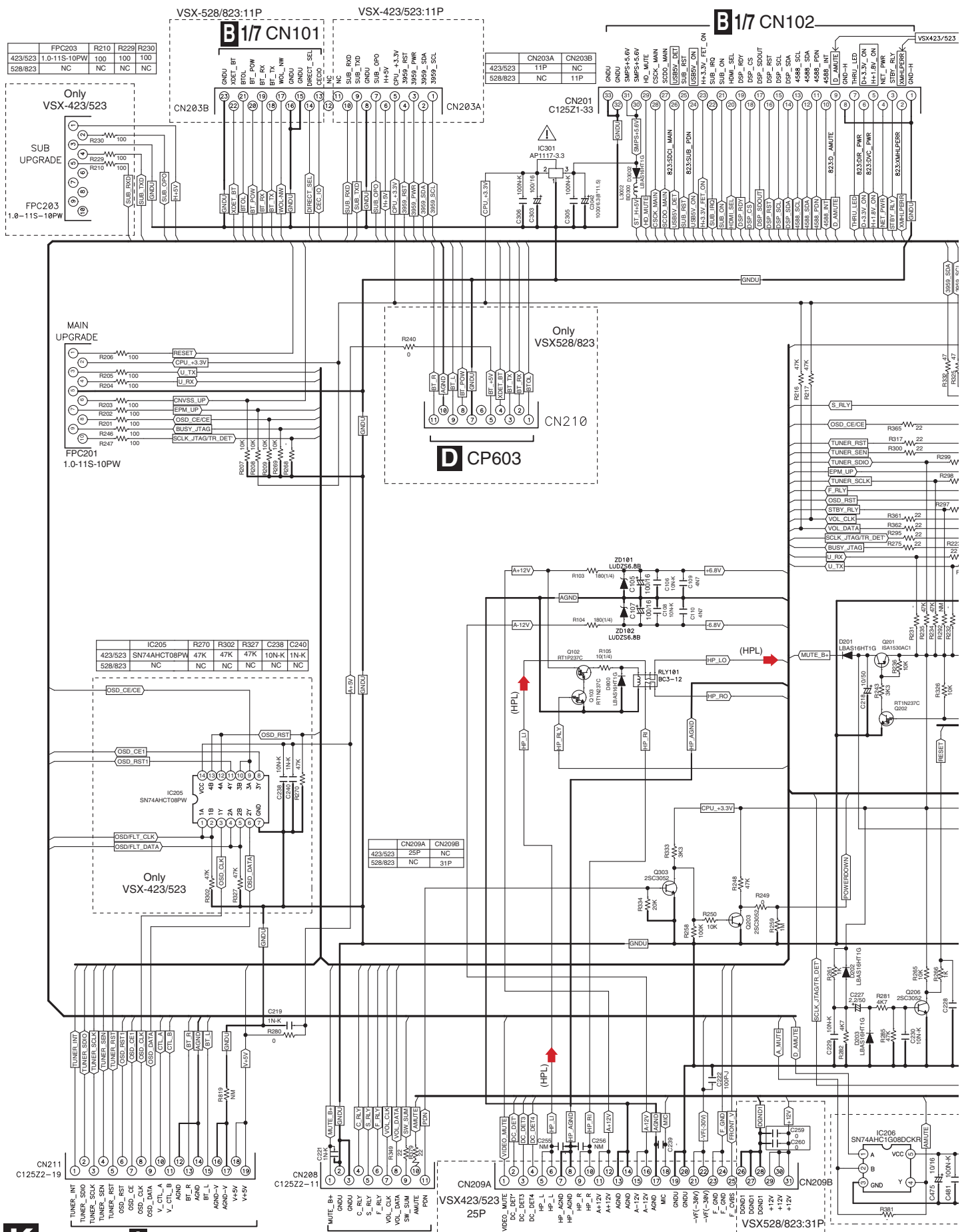

VSX-1023-K

108

1

2

3

4

K CPU ASSY (70280733310A0-IL)

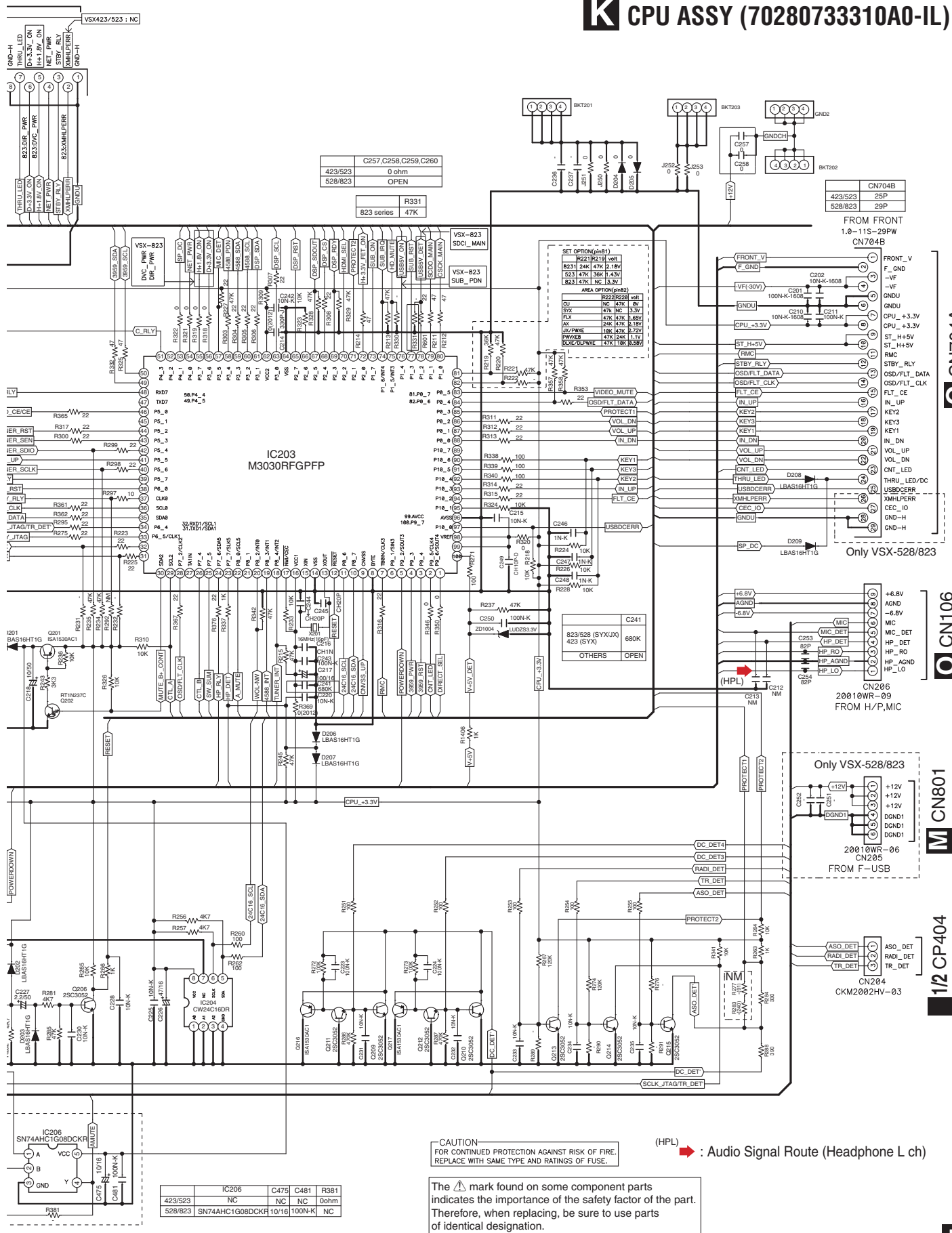

10.21 AMP7 ASSY (1/2) (VSX-1023-K, VSX-43)

A
B
C
D
E
F

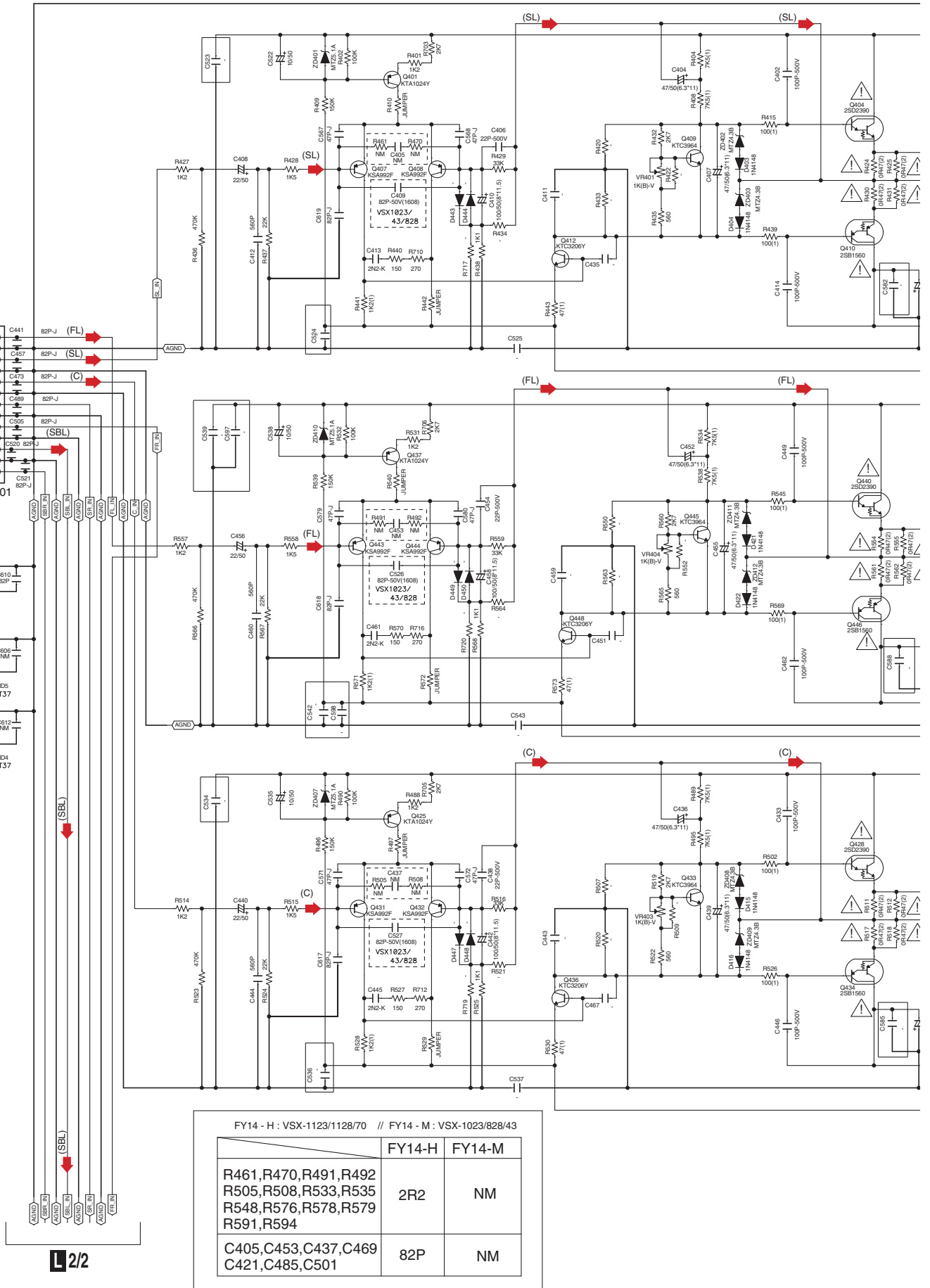

1/2

10.22 AMP7 ASSY (2/2) (VSX-1023-K, VSX-43)

1 2 3 4

A
B
C
D
E
F

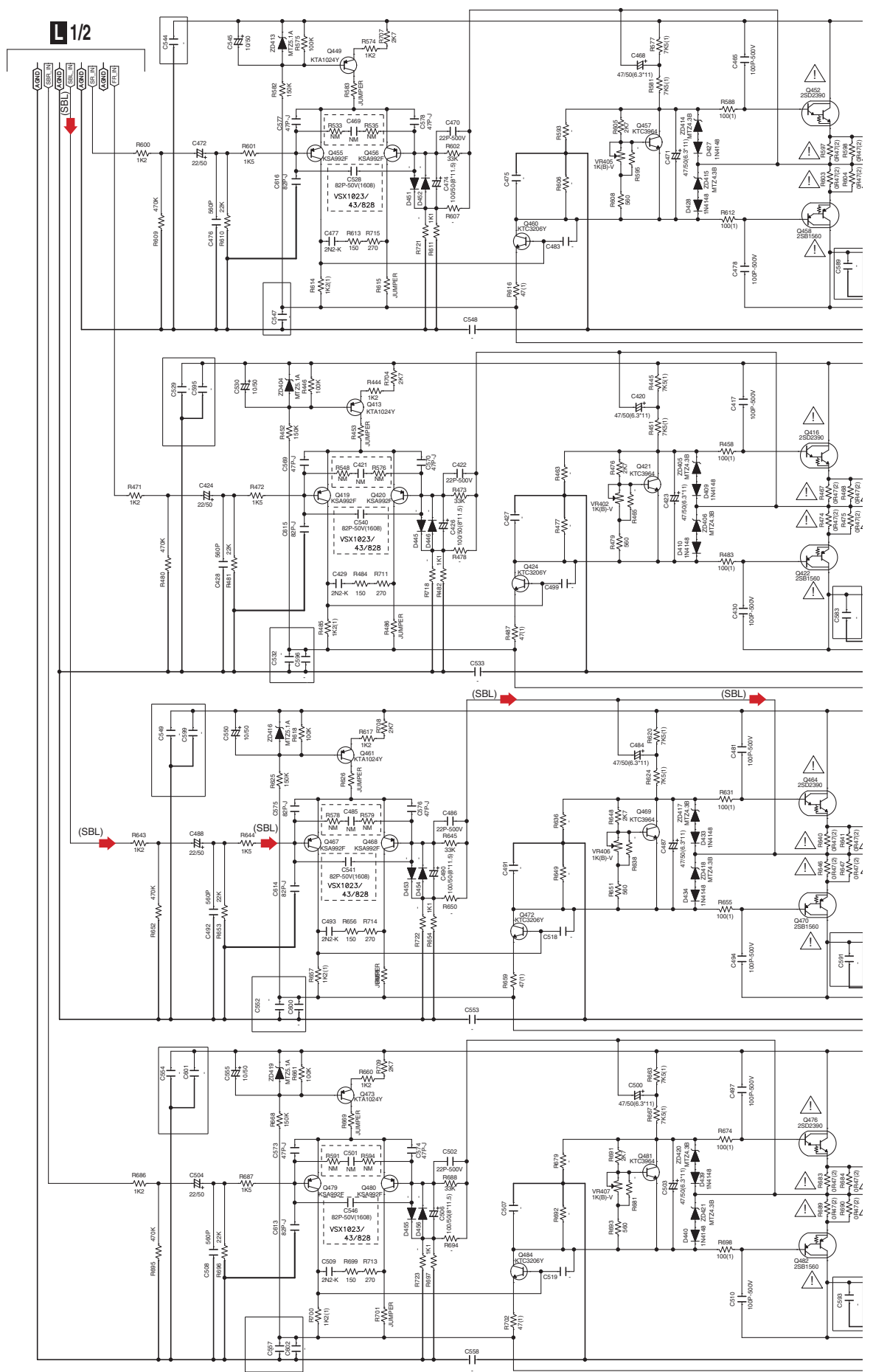

1 2 3 4

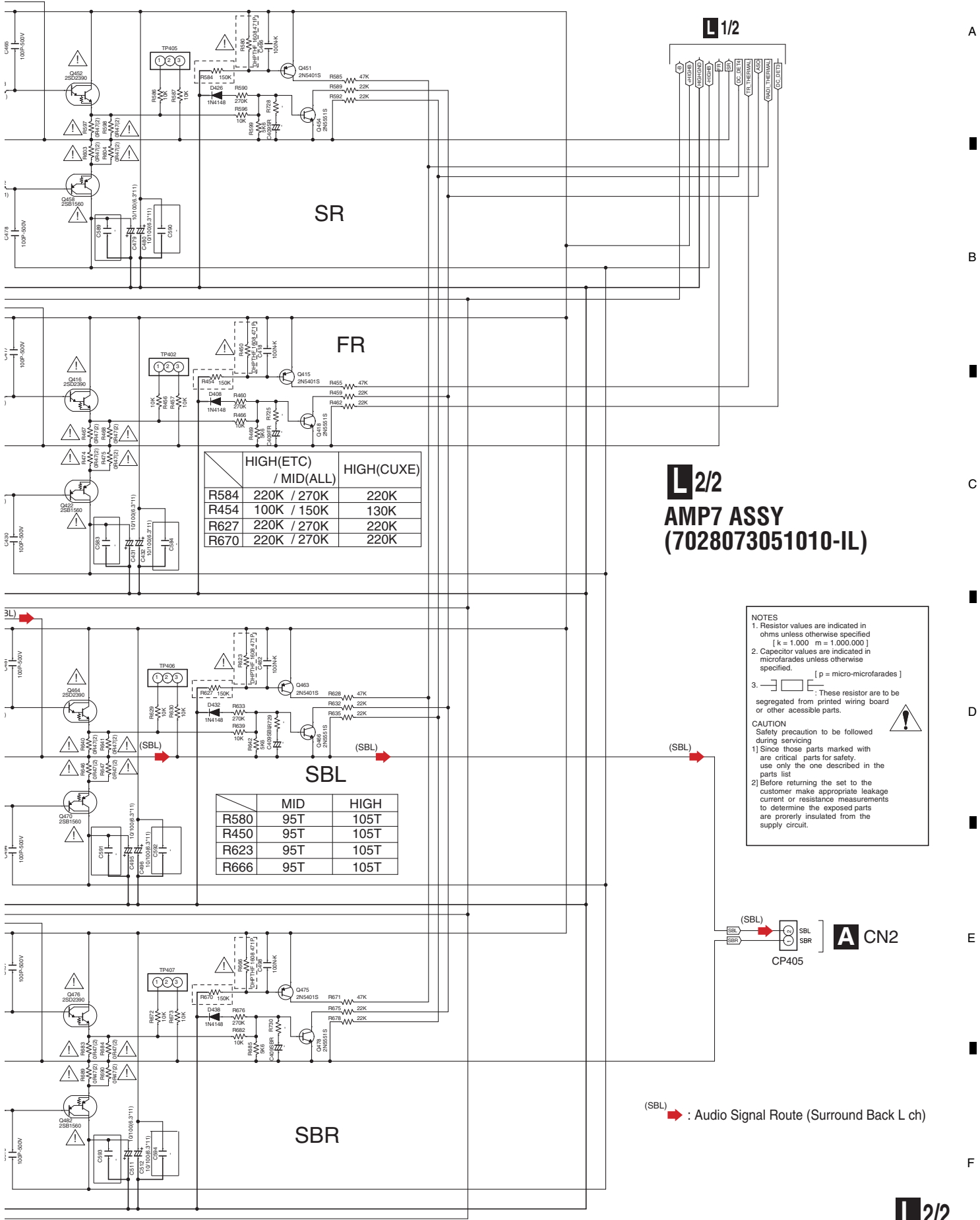

	HIGH(ETC) / MID(ALL)	HIGH(CUXE)
R584	220K / 270K	220K
R454	100K / 150K	130K
R627	220K / 270K	220K
R670	220K / 270K	220K

L 2/2
AMP7 ASSY
(7028073051010-IL)

NOTES

- Resistor values are indicated in ohms unless otherwise specified
 [k = 1,000 m = 1,000,000]
- Capacitor values are indicated in microfarads unless otherwise specified.
 [p = micro-microfarads]
- : These resistor are to be segregated from printed wiring board or other accessible parts.

CAUTION
 Safety precaution to be followed during servicing

- Since those parts marked with are critical parts for safety, use only the one described in the parts list
- Before returning the set to the customer make appropriate leakage current or resistance measurements to determine the exposed parts are properly insulated from the supply circuit.



(SBL) : Audio Signal Route (Surround Back L ch)

10.23 AMP5 ASSY (1/2)(VSX-823-K)

1

2

3

4

A

B

C

D

E

F

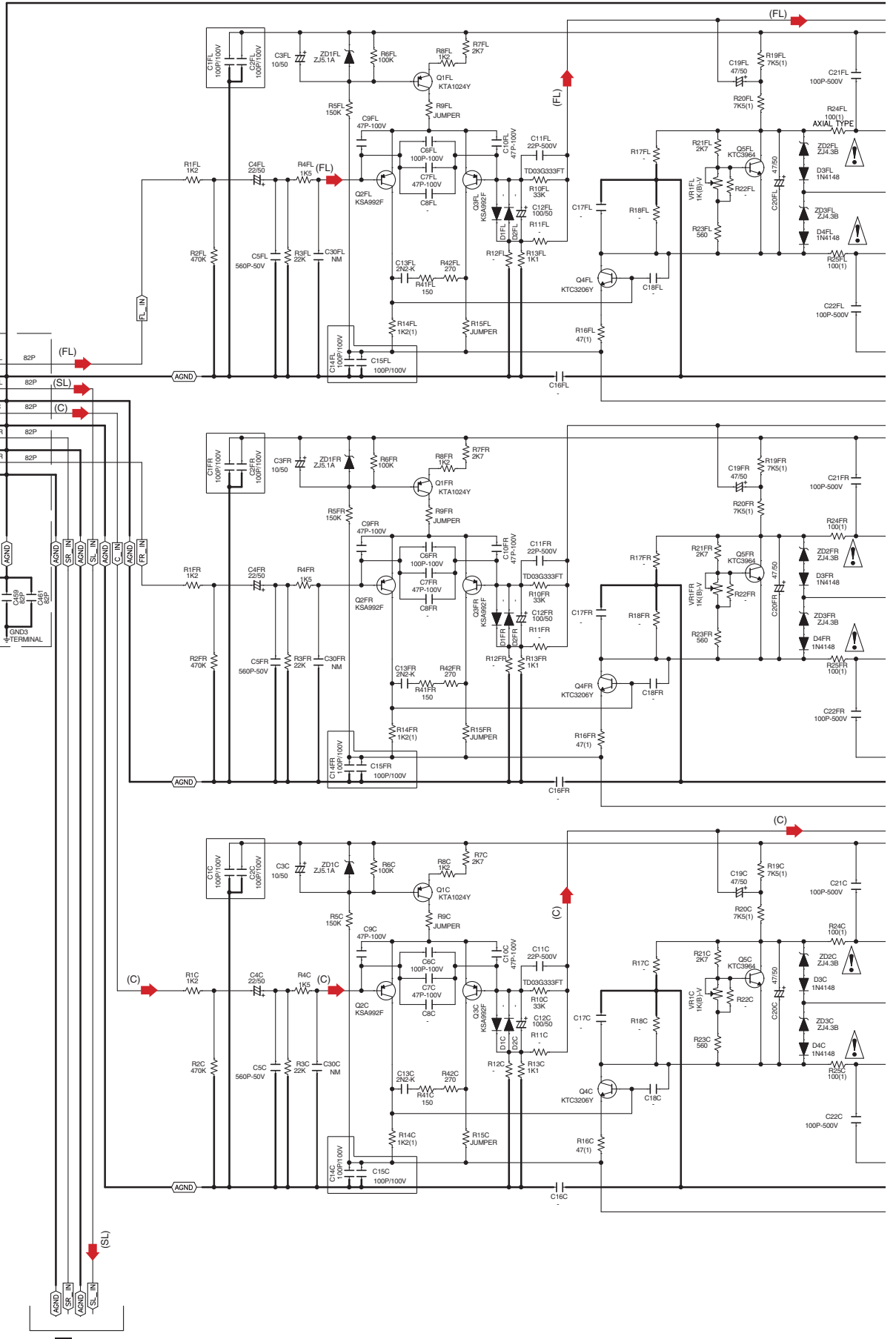
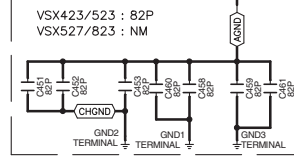
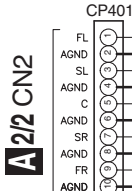

L 1/2

L 2/2

1

2

3

4

L 1/2
AMP5 ASSY
(70280733410A0-IL)

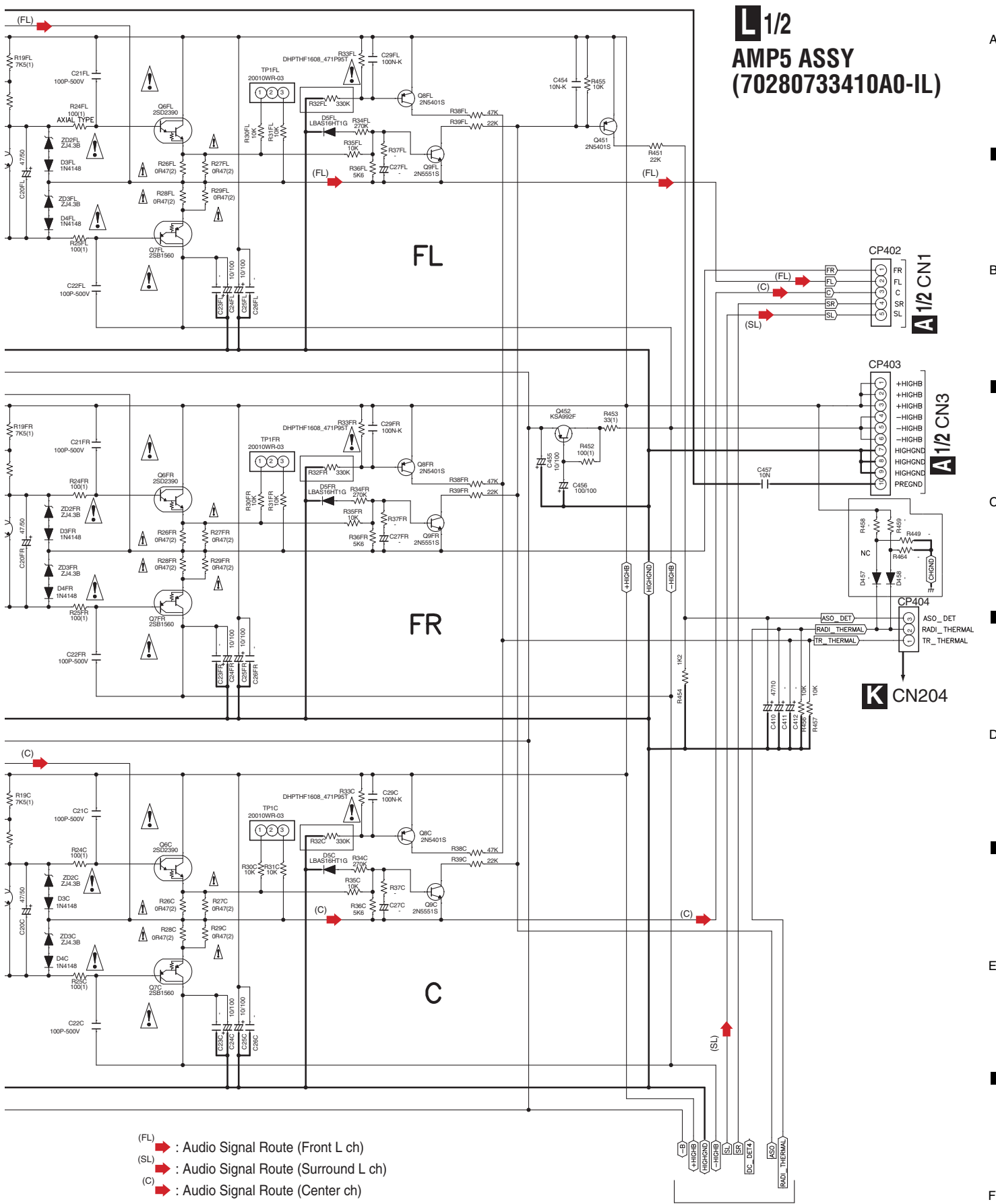

(FL) ➔ : Audio Signal Route (Front L ch)
 (SL) ➔ : Audio Signal Route (Surround L ch)
 (C) ➔ : Audio Signal Route (Center ch)

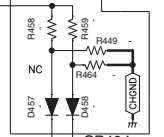
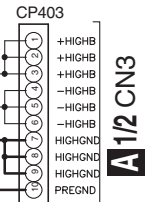
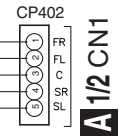

10.24 AMP5 ASSY (2/2)(VSX-823-K)

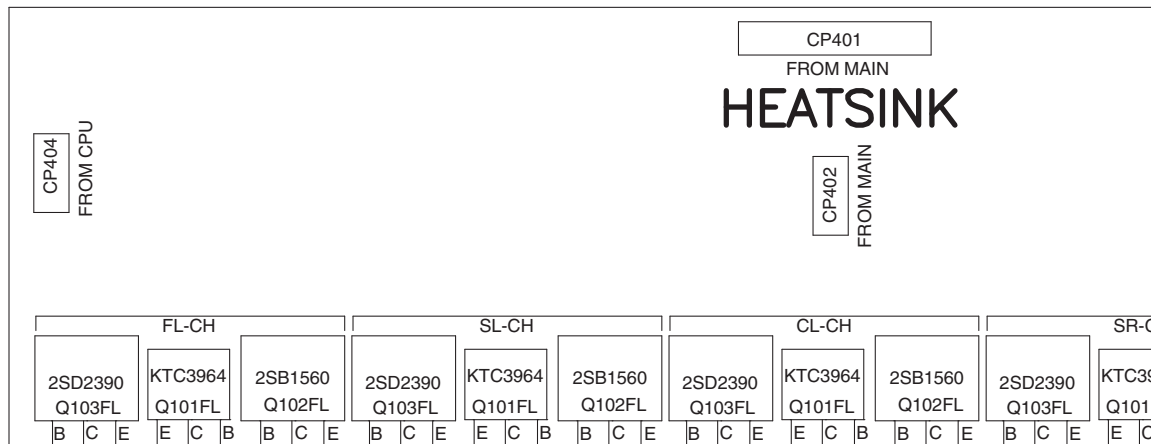
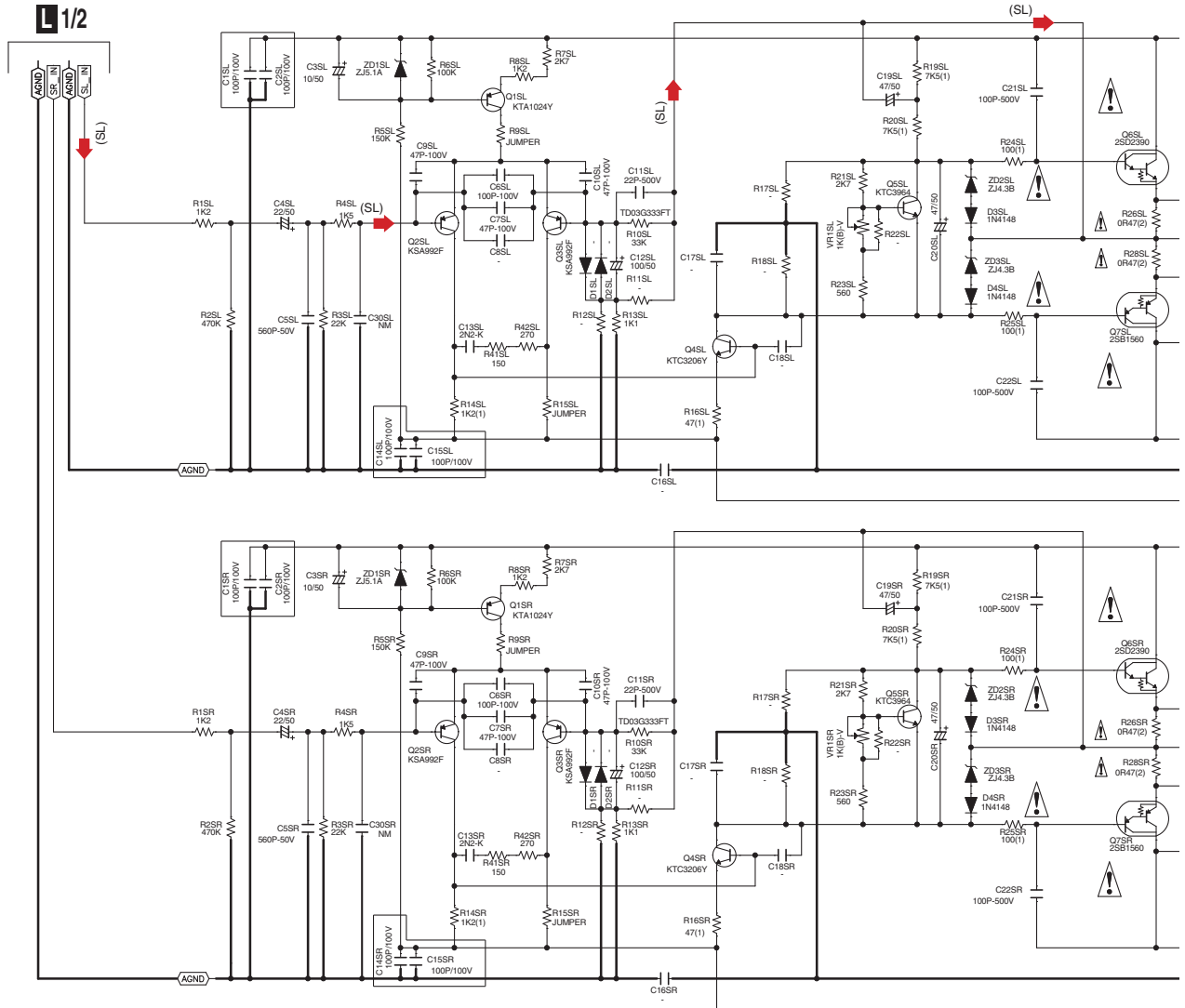

L 2/2 AMP5 ASSY (70280733410A0-IL)

A

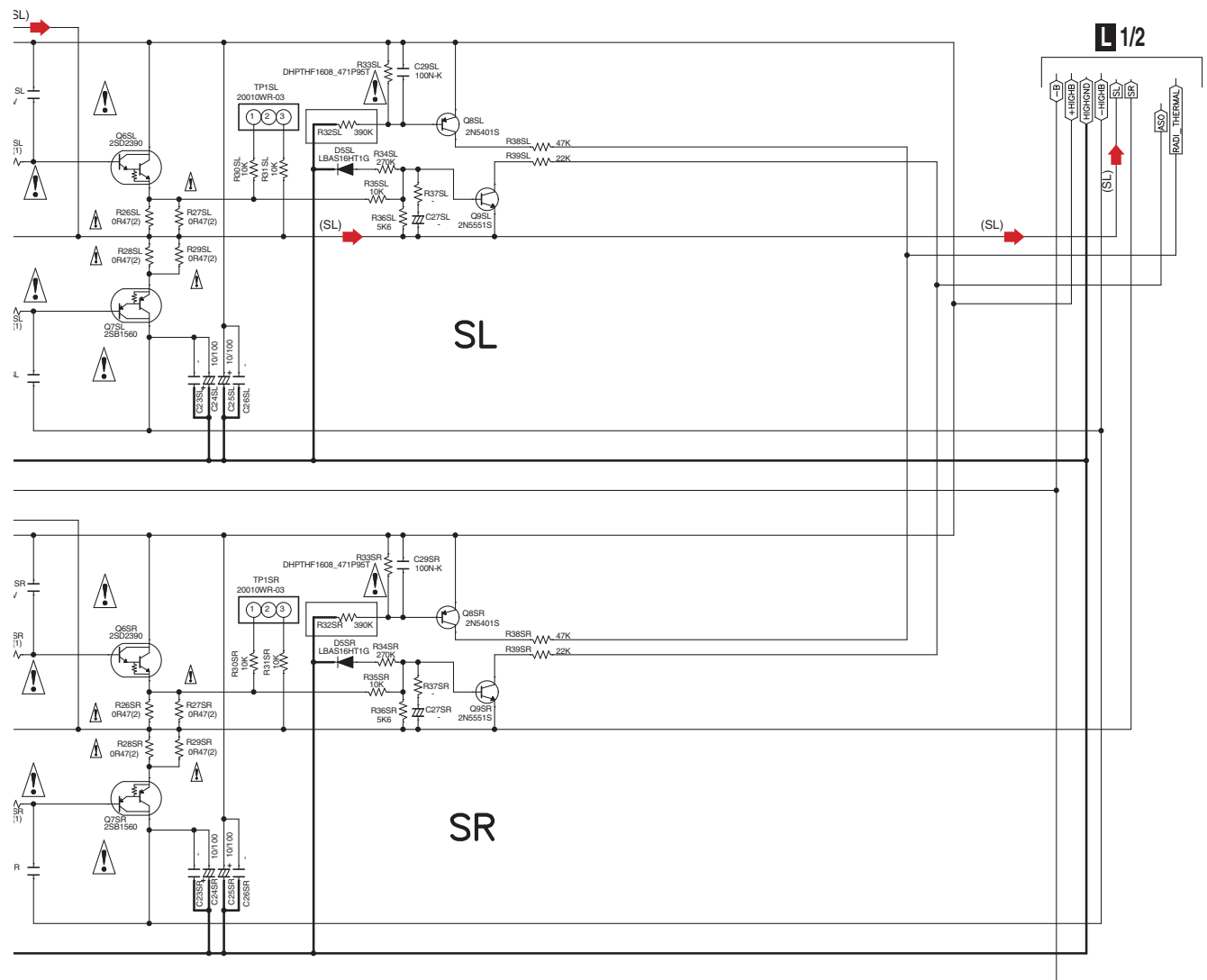

B

C

D

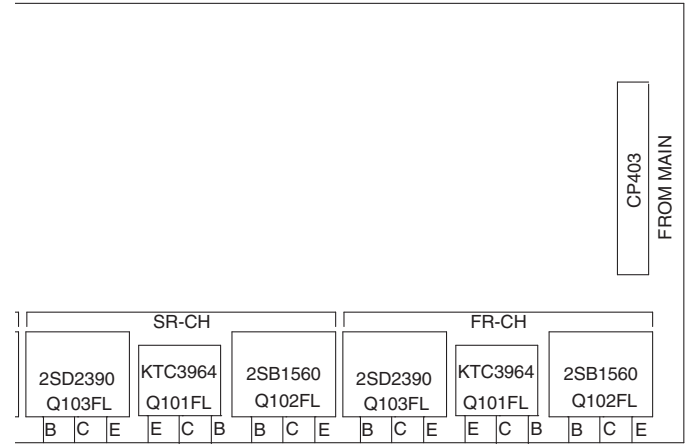

(SL) ➔ : Audio Signal Route (Surround L ch)

E

F

10.25 FHDMI ASSY

FY14 F-HDMI (MHL)

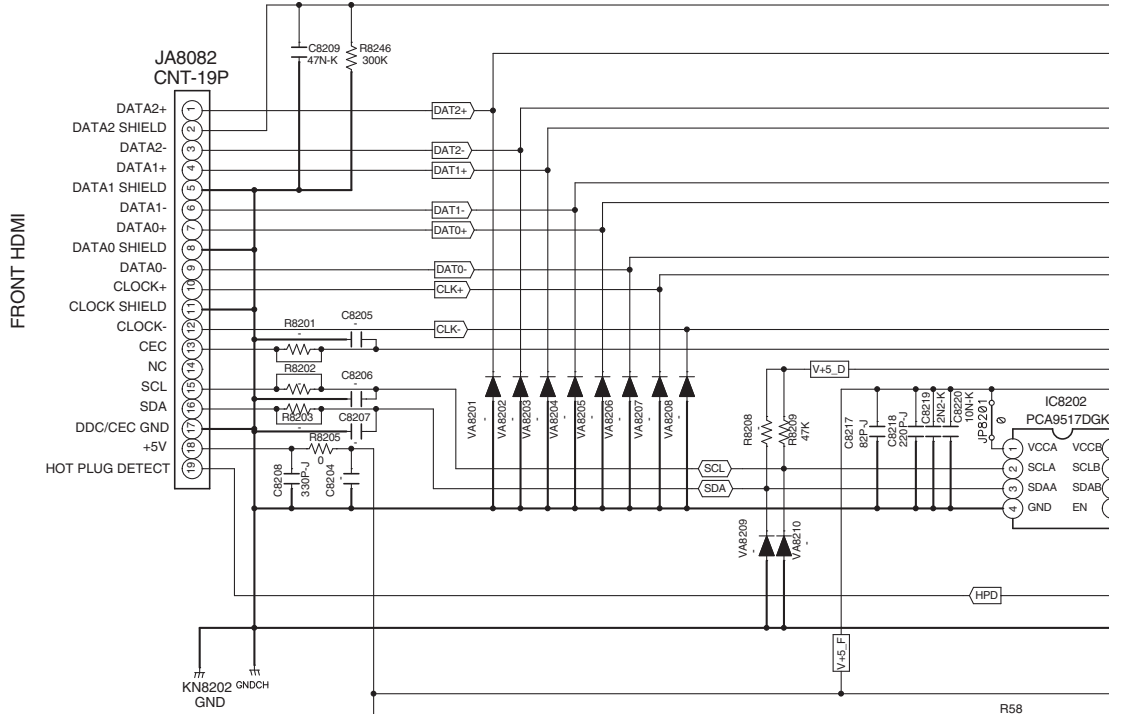

FY14 F-USB

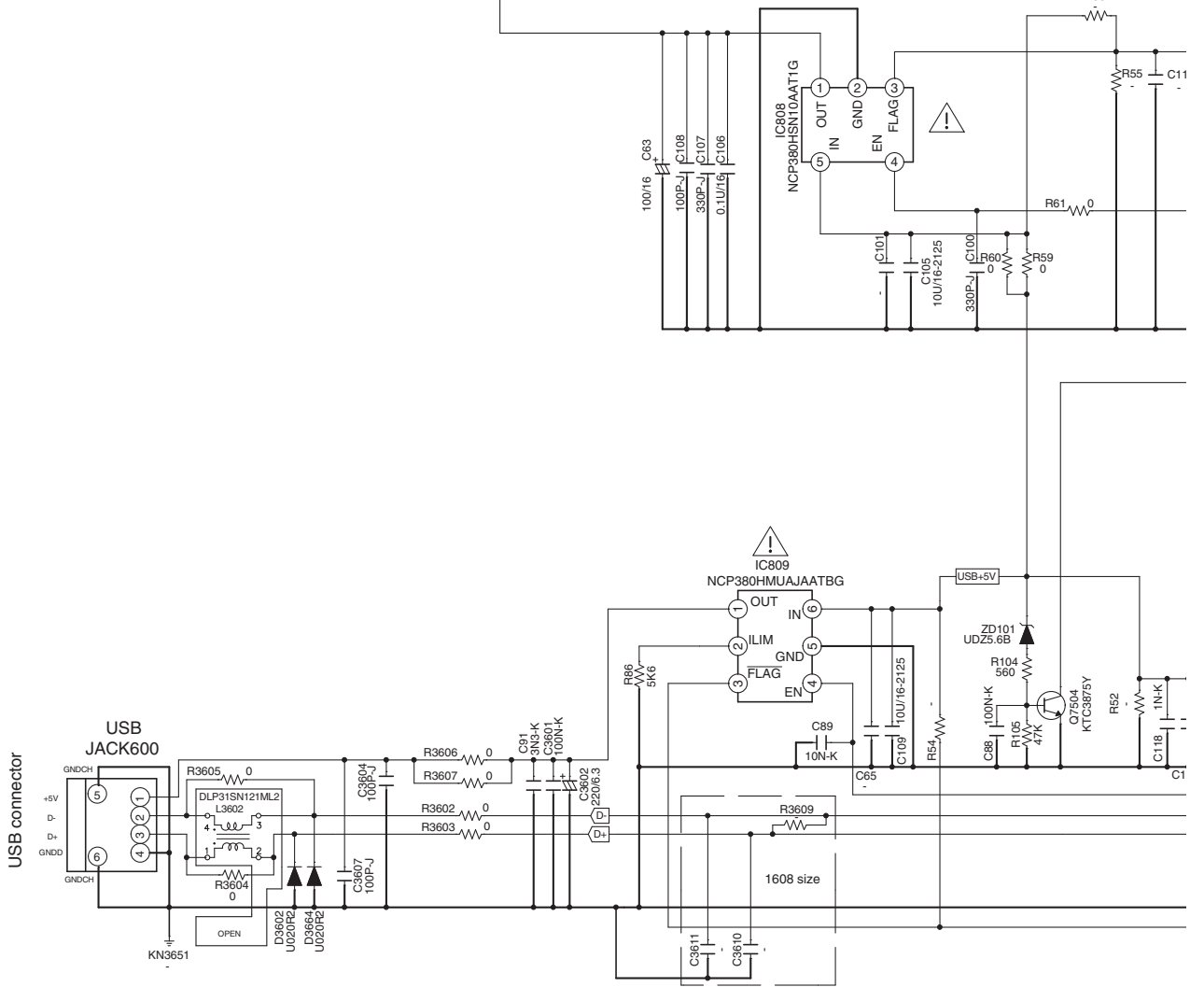

VSX-1023-K



M FHDMI ASSY (7028073221040-IL)

A

B

C

D

E

F

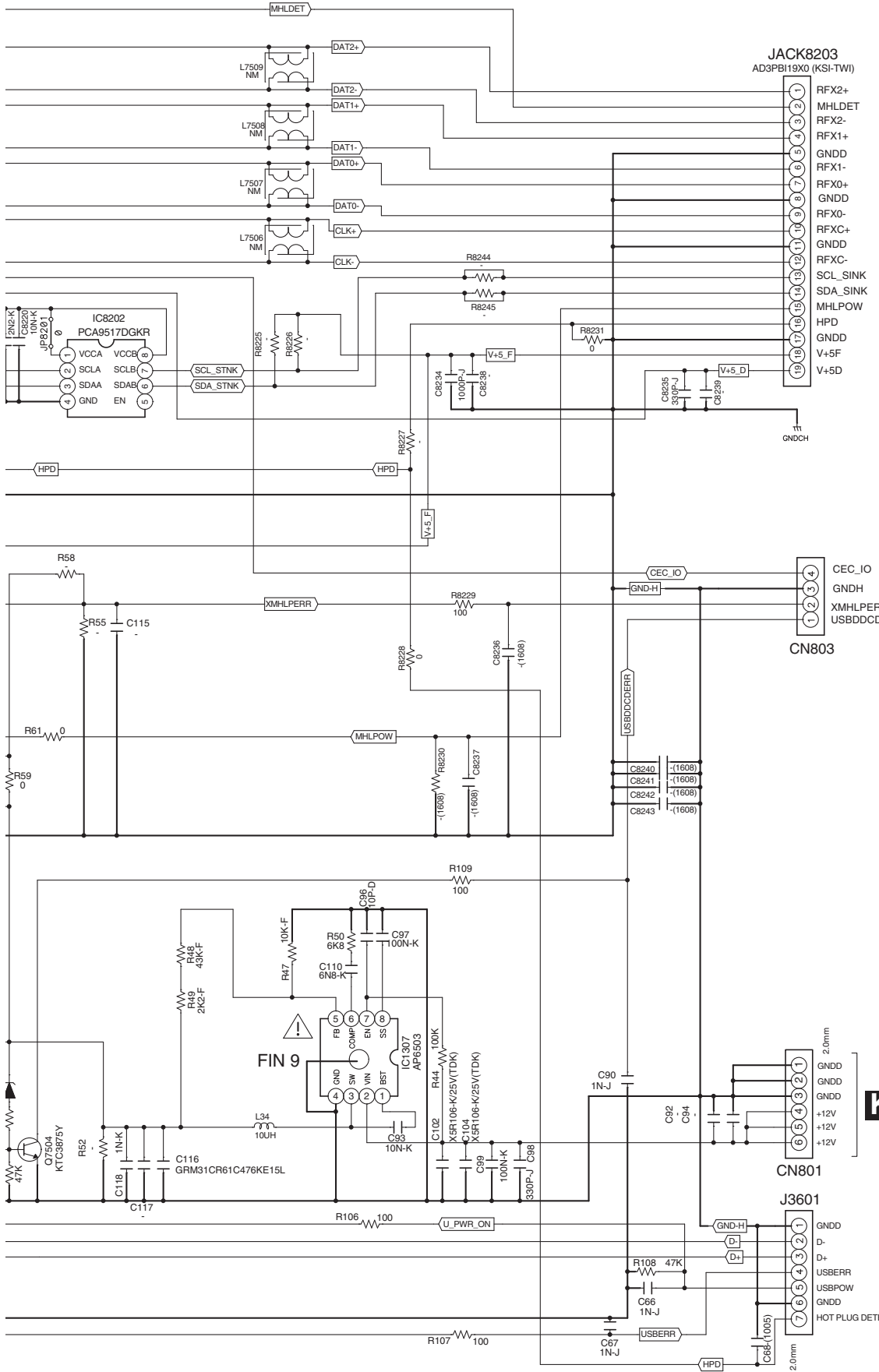

B 2/7 JA9602

O CN107

K CP722

B 6/7 CN9202

B 2/7 CN9601

10.26 INSEL, FRONT and HPMIC ASSYS

FRONT ASSY (VSX-1023-K, VSX-823-K: 70280733210B0-IL) (VSX-43: 70280733210D0-IL)

OPTION

	UXCN	SYX,AX,JXE,FLX,PWX
R779,R780	1(1/4W)	2R2(1/4W)

FROM MAIN TRANS

CP703
5267-3PAN

C737
R787
R788
R789

L700
10UH(02)

FLAC 1
FLAC 2

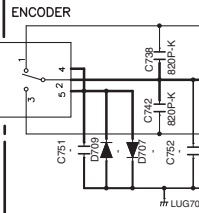
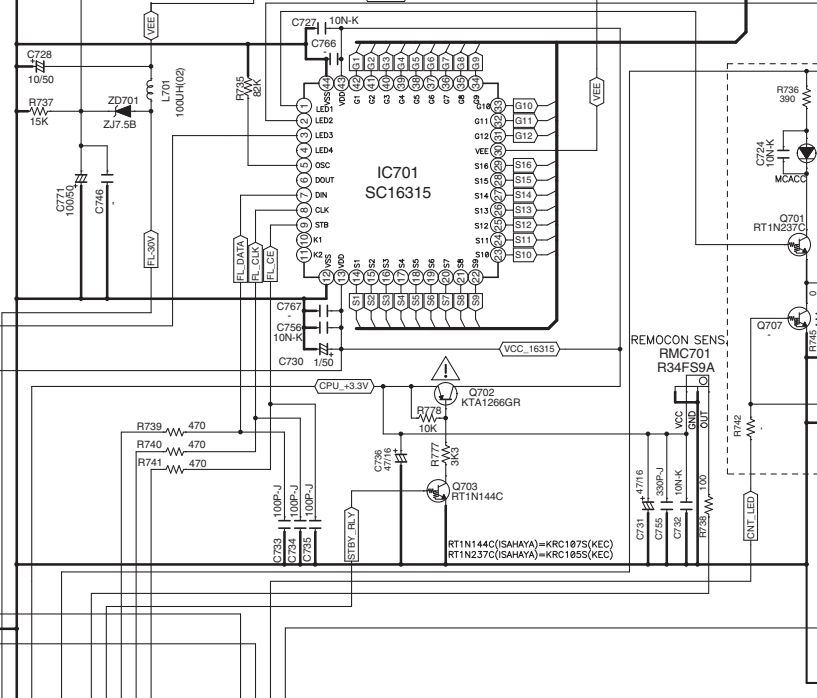
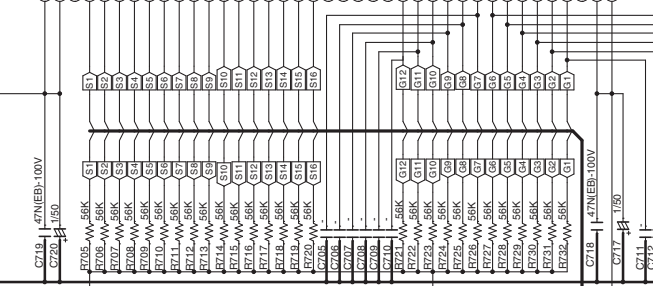
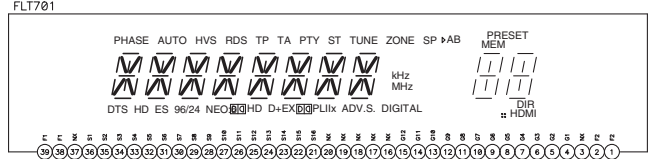

INSEL ASSY (VSX-1023-K, VSX-823-K: 70280733230B0-IL) (VSX-43: 70280733230D0-IL)

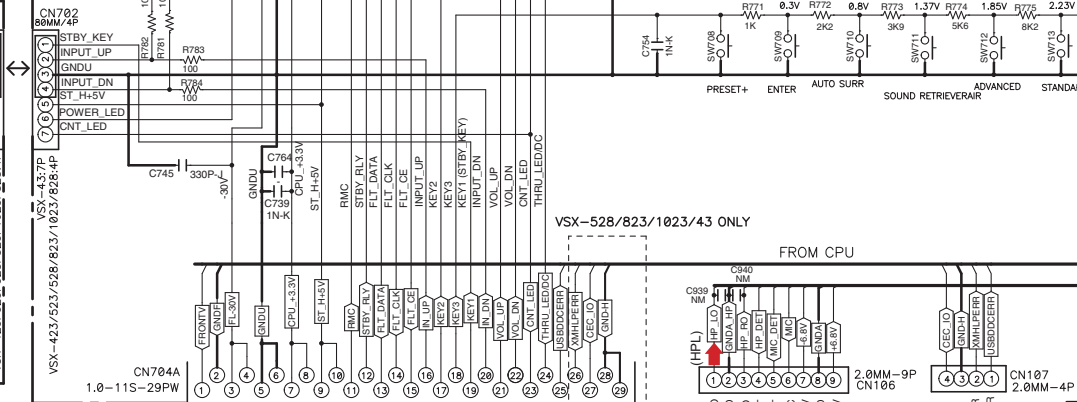
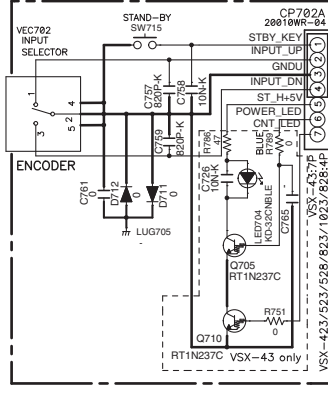

N O
120

K CN704B

VSX-1023-K

K CP723

M CN

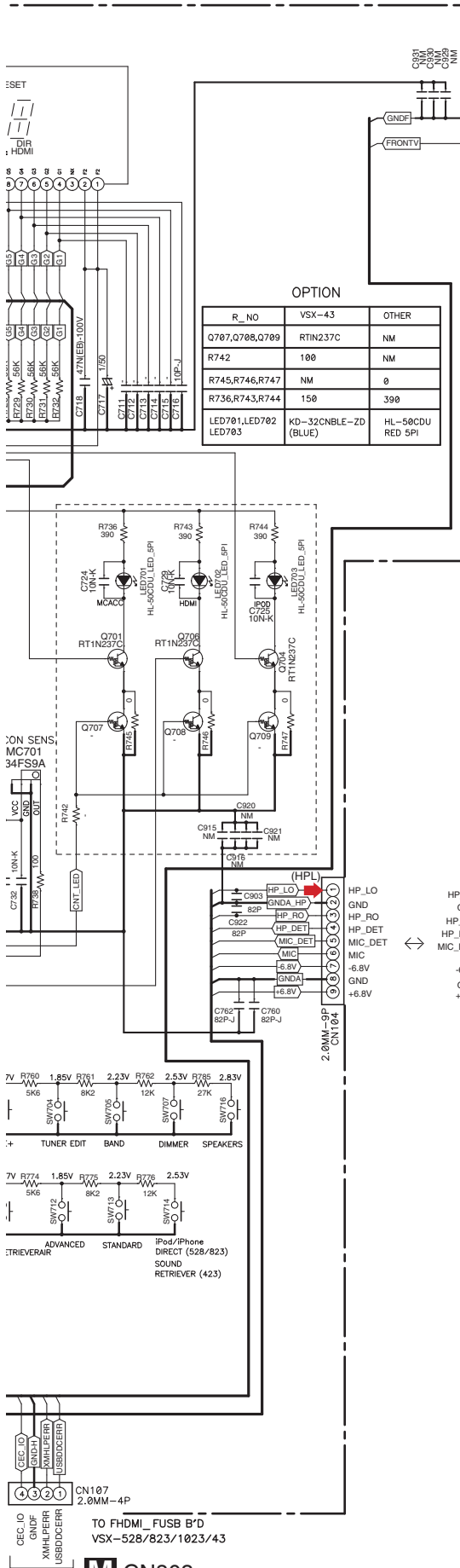

OPTION

R_NO	VSX-43	OTHER
Q707,Q708,Q709	RT1N237C	NM
R742	100	NM
R745,R746,R747	NM	0
R736,R743,R744	150	390
LED701,LED702,LED703	KD-32CNBLE-ZD (BLUE)	HL-50CDU RED SPI

P HPMIC ASSY (VSX-1023-K, VSX-823-K: 70280733220B0-IL) (VSX-43: 70280733220D0-IL)

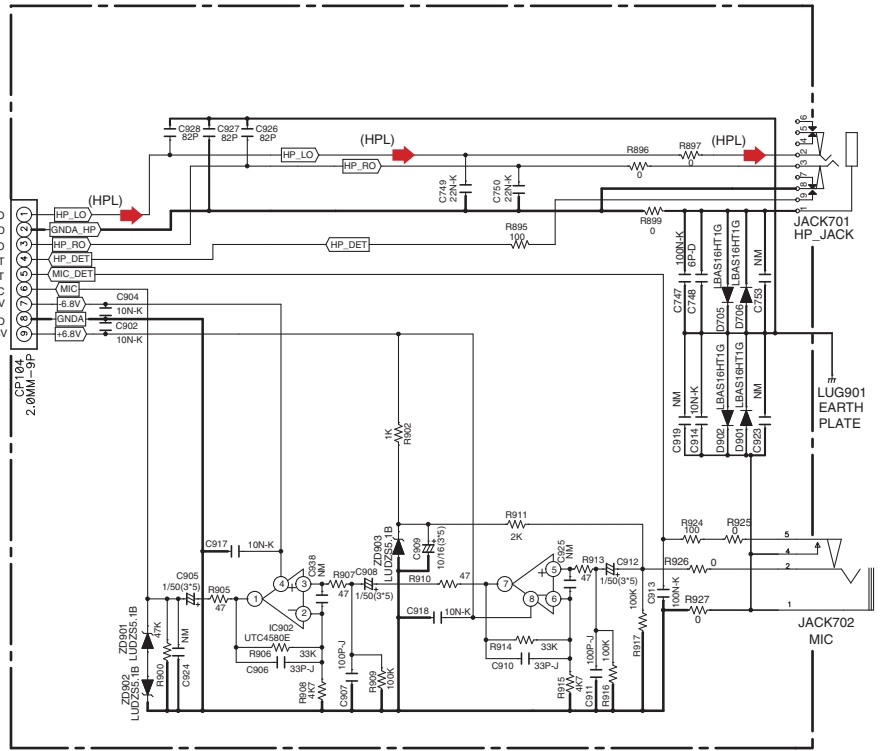

The Δ mark found on some component parts indicates the importance of the safety factor of the part. Therefore, when replacing, be sure to use parts of identical designation.

(HPL) \rightarrow : Audio Signal Route (Headphone L ch)

M CN803

VSX-1023-K

OP

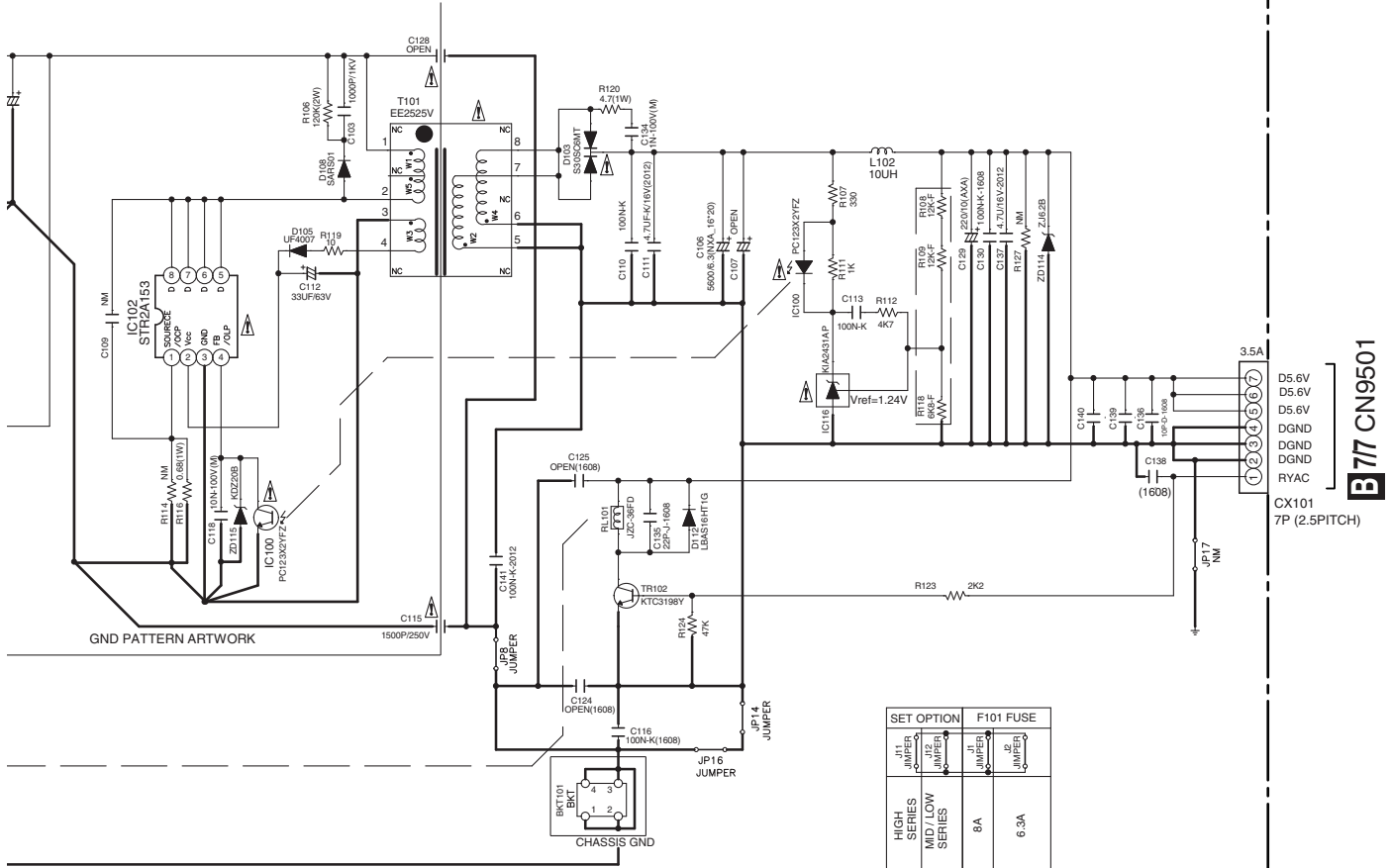

B777 CN9501
 CX101
 7P (2.5PITCH)

SET OPTION	F101 FUSE
J11 JUMPER	8A
J12 JUMPER	6.3A
J13 JUMPER	6.3A
J14 JUMPER	6.3A
J15 JUMPER	6.3A
J16 JUMPER	6.3A
J17 JUMPER	6.3A

NOTES

- Resistor values are indicated in ohms unless otherwise specified [k = 1.000 m = 1.000.000]
- Capacitor values are indicated in microfarads unless otherwise specified. [p = micro-microfarades]
- : These resistor are to be segregated from printed wiring board or other accessible parts.
CAUTION
 Safety precaution to be followed during servicing
 1) Since those parts marked with are critical parts for safety, use only the one described in the parts list
 2) Before returning the set to the customer make appropriate leakage current or resistance measurements to determine the exposed parts are properly insulated from the supply circuit.

INDICATES SAFETY CRITICAL COMPONENTS.
 TO REDUCE THE RISK OF ELECTRIC SHOCK, LEAKAGE CURRENT OR RESISTANCE MEASUREMENTS SHALL BE CARRIED OUT (EXPOSED PARTS ARE ACCEPTABLY INSULATED FROM THE SUPPLY CIRCUIT) BEFORE THE APPLIANCE RETURNED TO THE CUSTOMER.



10.28 REG ASSY (VSX-823-K ONLY)

R REG ASSY (70280733120A0-IL)

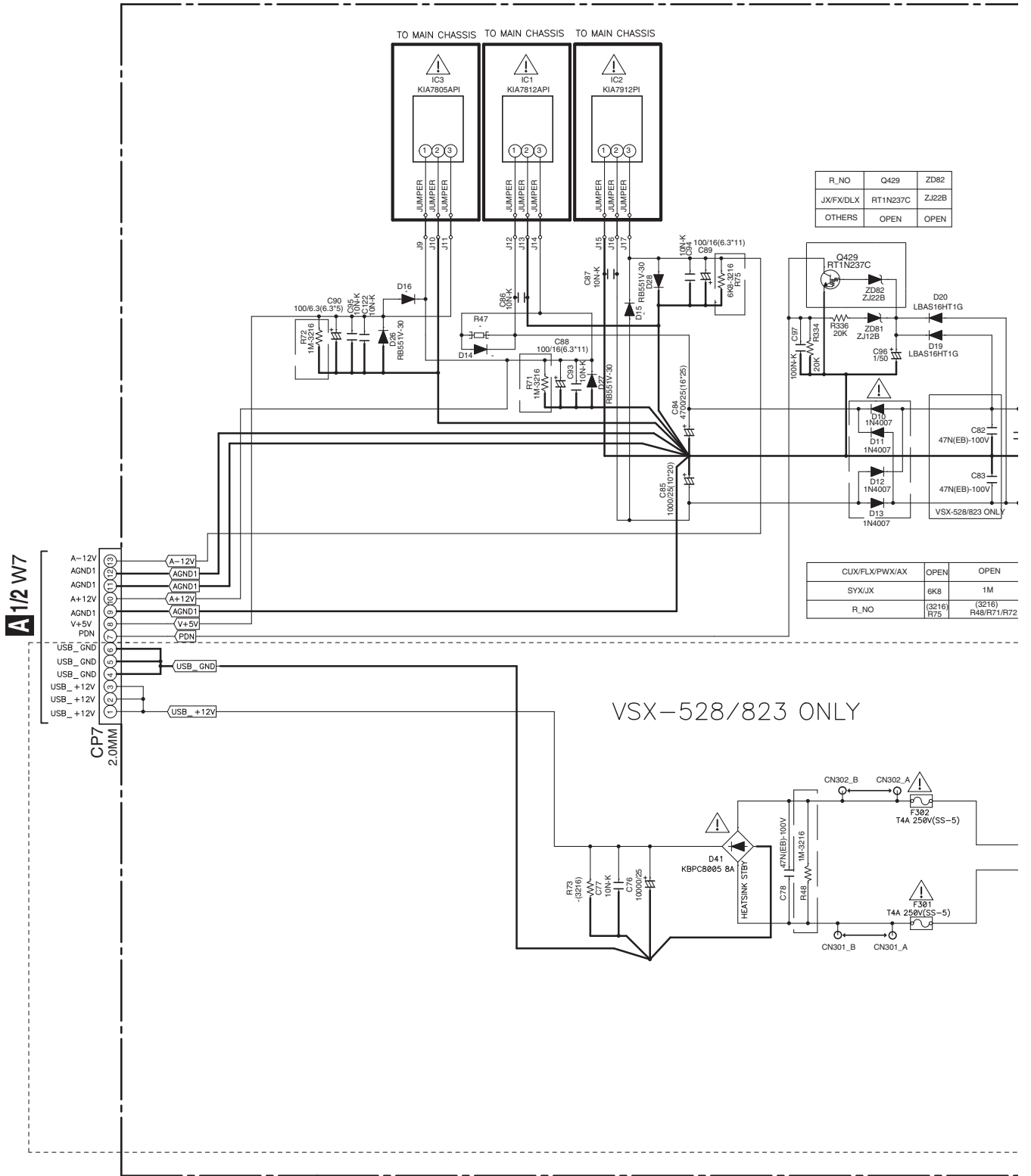

A
B
C
D
E
F

M29	ZD62
N237C	ZJ22B
PEN	OPEN

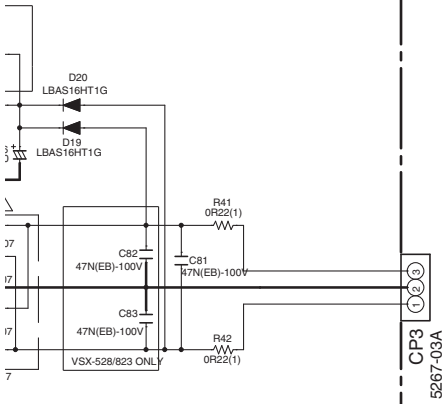

VX/AX	OPEN	OPEN
	6K8	1M
	(3216) R72	(3216) R48/R71/R72

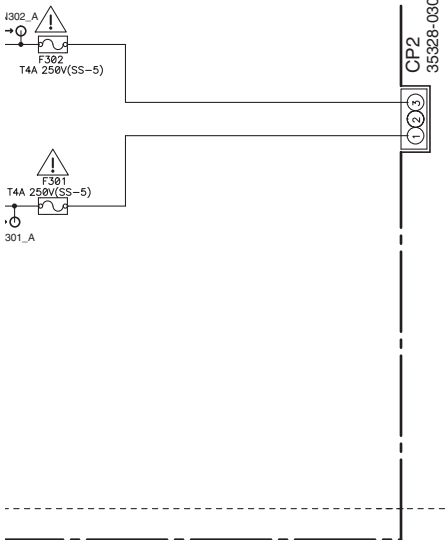

• NOTE FOR FUSE REPLACEMENT

CAUTION - FOR CONTINUED PROTECTION AGAINST RISK OF FIRE, REPLACE WITH SAME TYPE AND RATINGS OF FUSE.

NOTES

1. Resistor values are indicated in ohms unless otherwise specified
[k = 1.000 m = 1.000.000]
2. Capacitor values are indicated in microfarades unless otherwise specified.
3. : These resistor are to be segregated from printed wiring board or other accessible parts.
CAUTION
Safety precaution to be followed during servicing

- 1] Since those parts marked with are critical parts for safety, use only the one described in the parts list
- 2] Before returning the set to the customer make appropriate leakage current or resistance measurements to determine the exposed parts are properly insulated from the supply circuit.

SIDE A

A

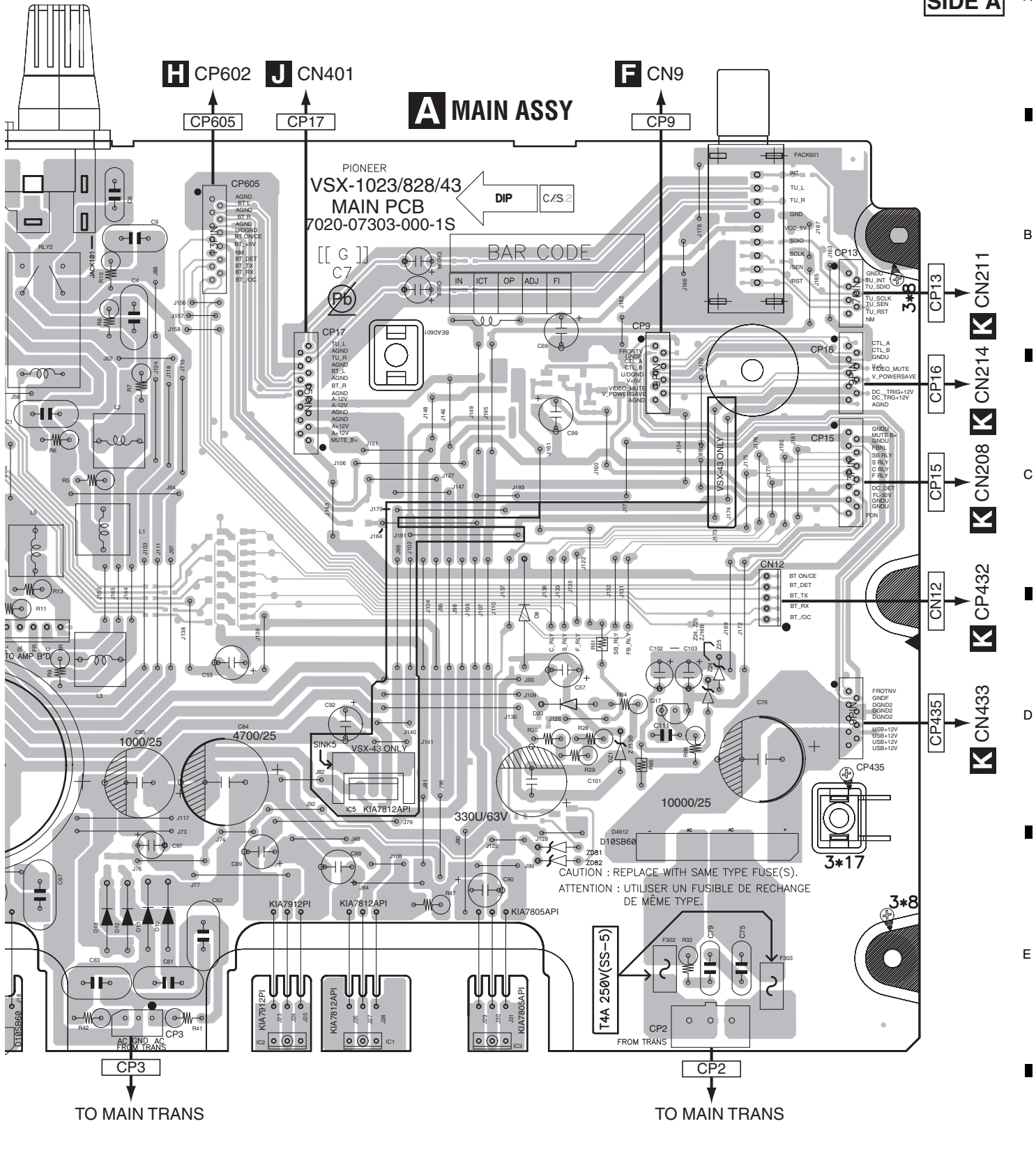

B

C

D

E

F

A

VSX-1023-K

SIDE B

A

B

C

D

E

F

A MAIN ASSY

CP9

CP17

CP605

CP13

CP16

CP15

CN12

CP435

CP2

CP3

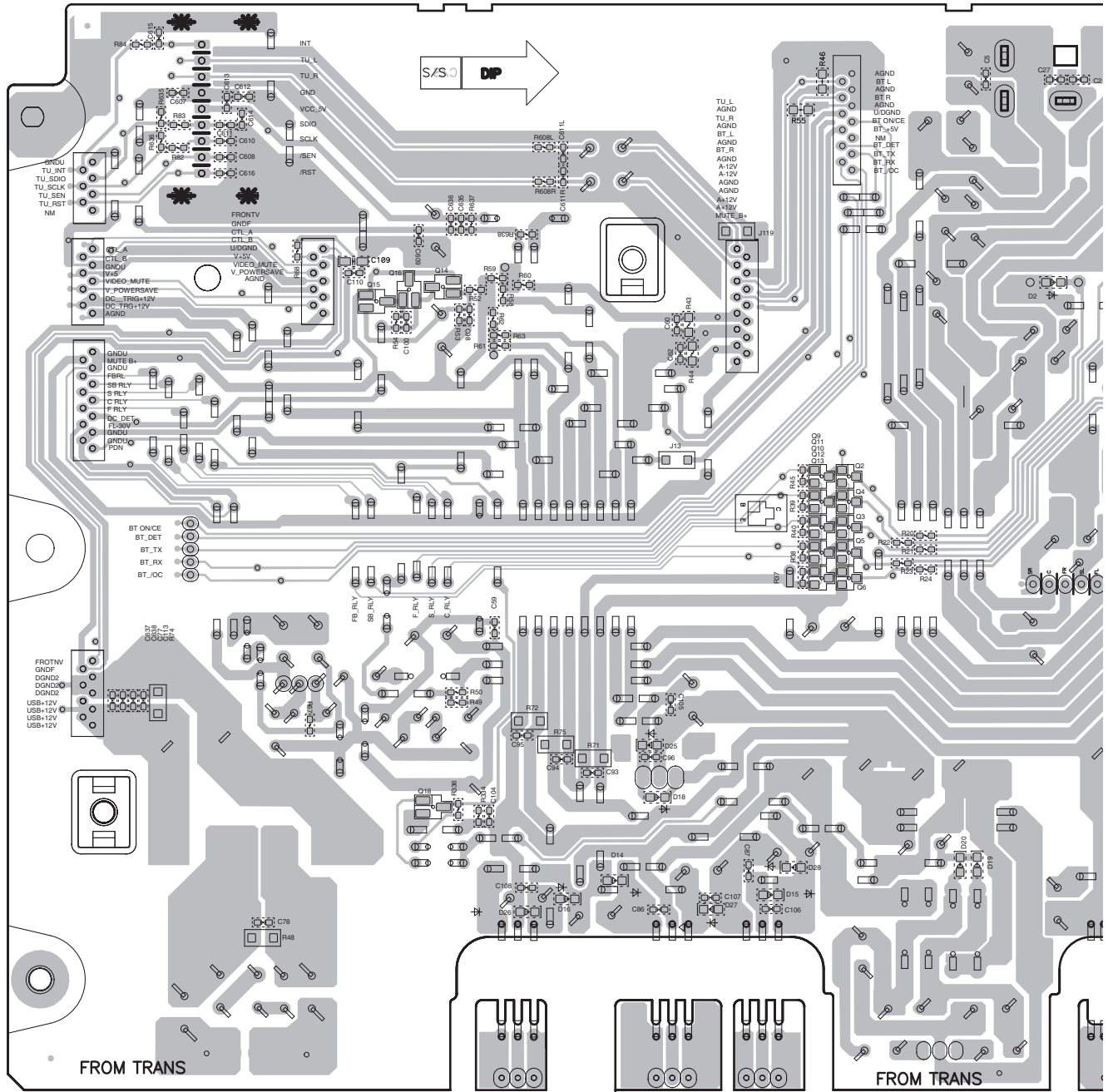

Q15 Q16 Q14
Q18

Q9-Q13 Q2-Q6

A

11.2 MAIN ASSY (VSX-823-K)

SIDE A

A
B
C
D
E
F

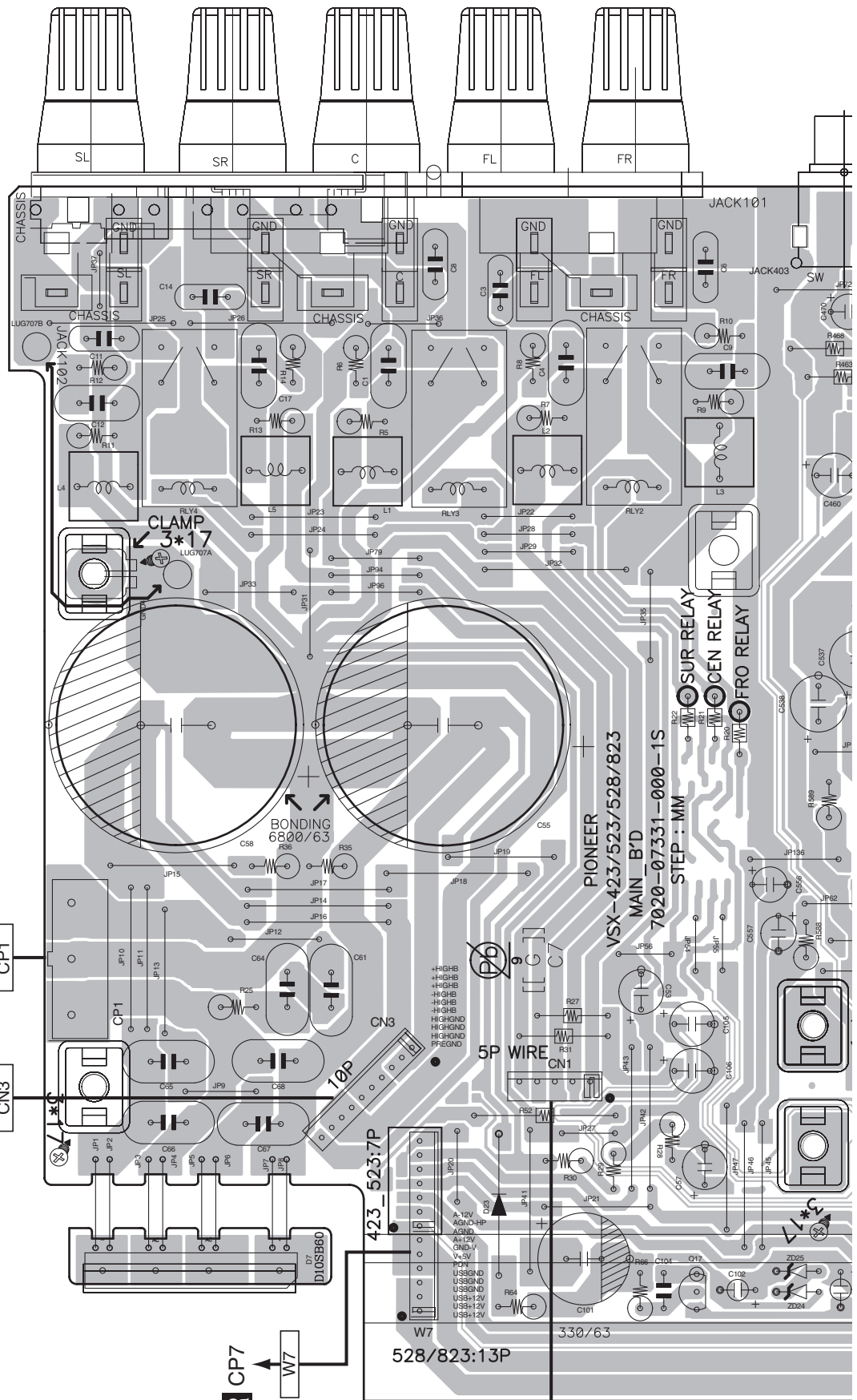

IC1203

CP1 TO MAIN TRANS

CP3

Q17

CP7

W7

528/823:13P

330/63

CN1

CP402

VSX-1023-K

A

11.3 D-MAIN ASSY

SIDE A

B D-MAIN ASSY

C CN2009 (VSX-1023-K, VSX-43)
C CN2010 (VSX-823-K)

C CX101
 [CN9501]

[CN1802]

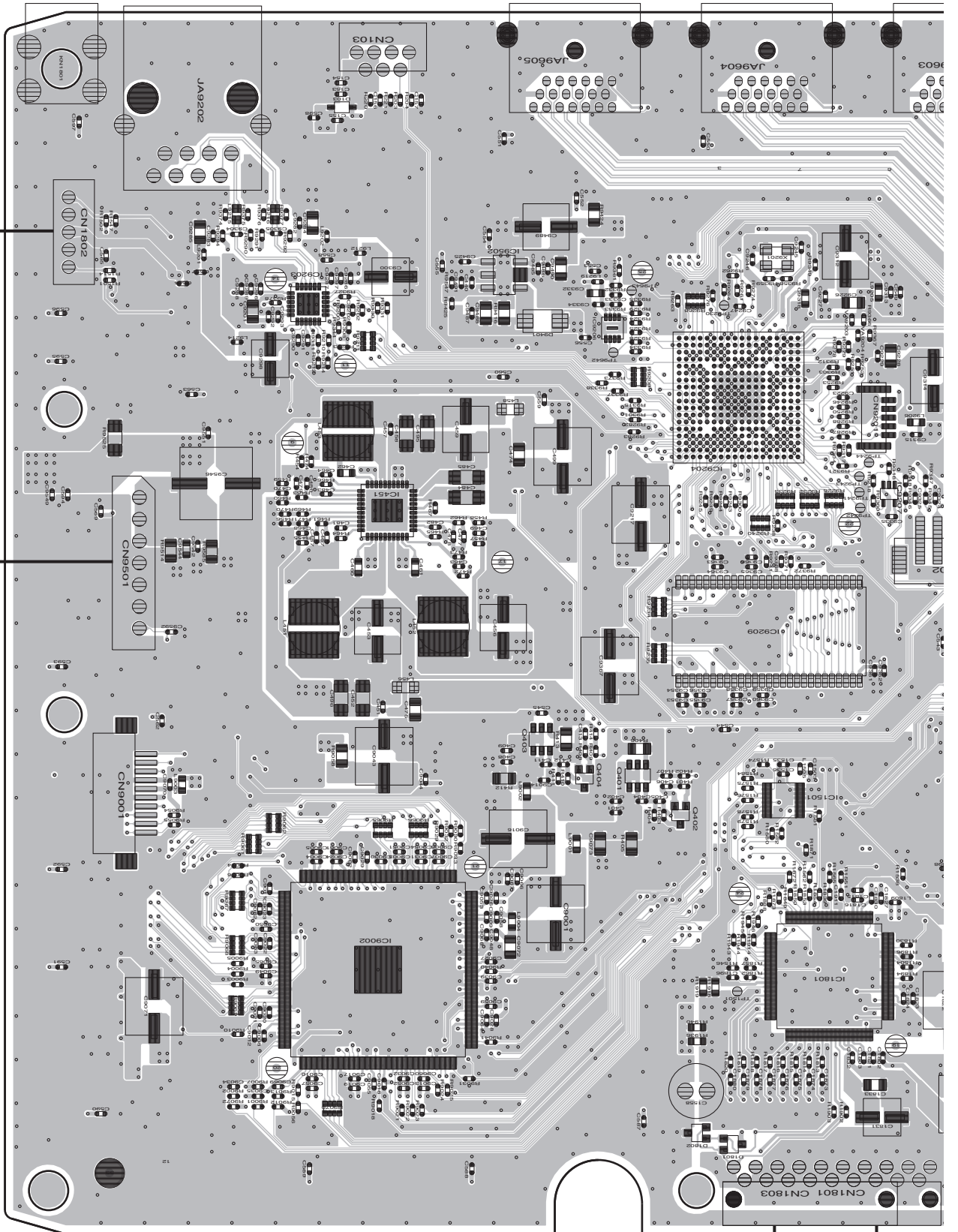

VSX-1023-K, [CN1801] [CN1803] VSX-43

D CP2003 **E** CN109

B

SIDE A

A

B

C

D

E

F

B

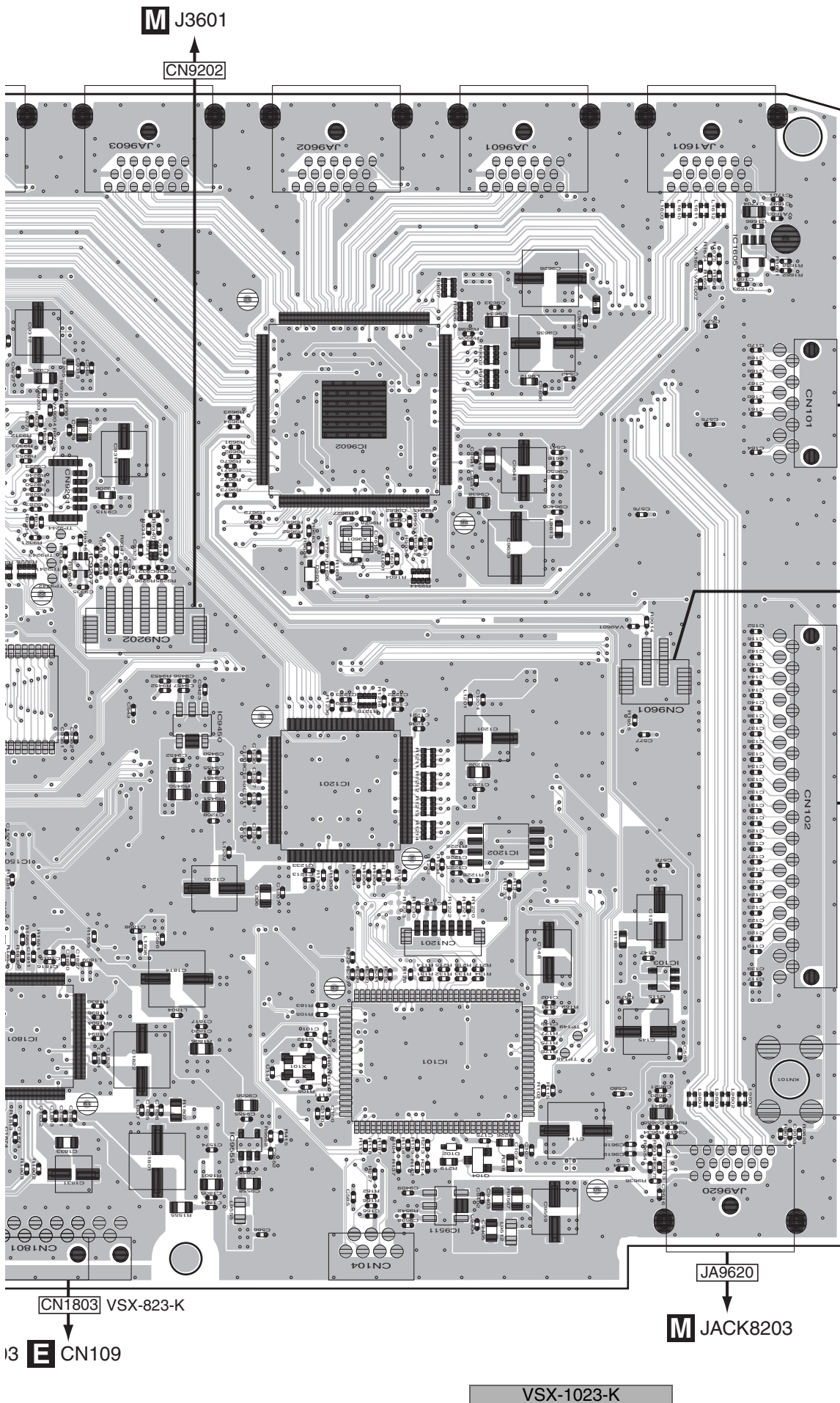

- IC1605
- IC9502
- IC9203
- IC9206
- IC9602
- IC9204
- IC9207
- IC451
- IC9209
- IC9450
- IC1201
- Q403
- Q404
- IC1202
- IC1501
- Q402
- IC103
- IC9002
- IC1801
- IC101
- IC9555
- Q104
- IC9511

M J3601

CN9202

JA9603

JA9602

JA9601

JA1601

CN101

K CN213

CN9601

M J3601

CN102

K CN201

CN1803 VSX-823-K

E CN109

M JACK8203

VSX-1023-K

1

2

3

4

SIDE B

A

B D-MAIN ASSY

CN9202

B

C

D

E

F

CN101

CN9601

CN102

JA9620

CN1801

B

136

VSX-1023-K

1

2

3

4

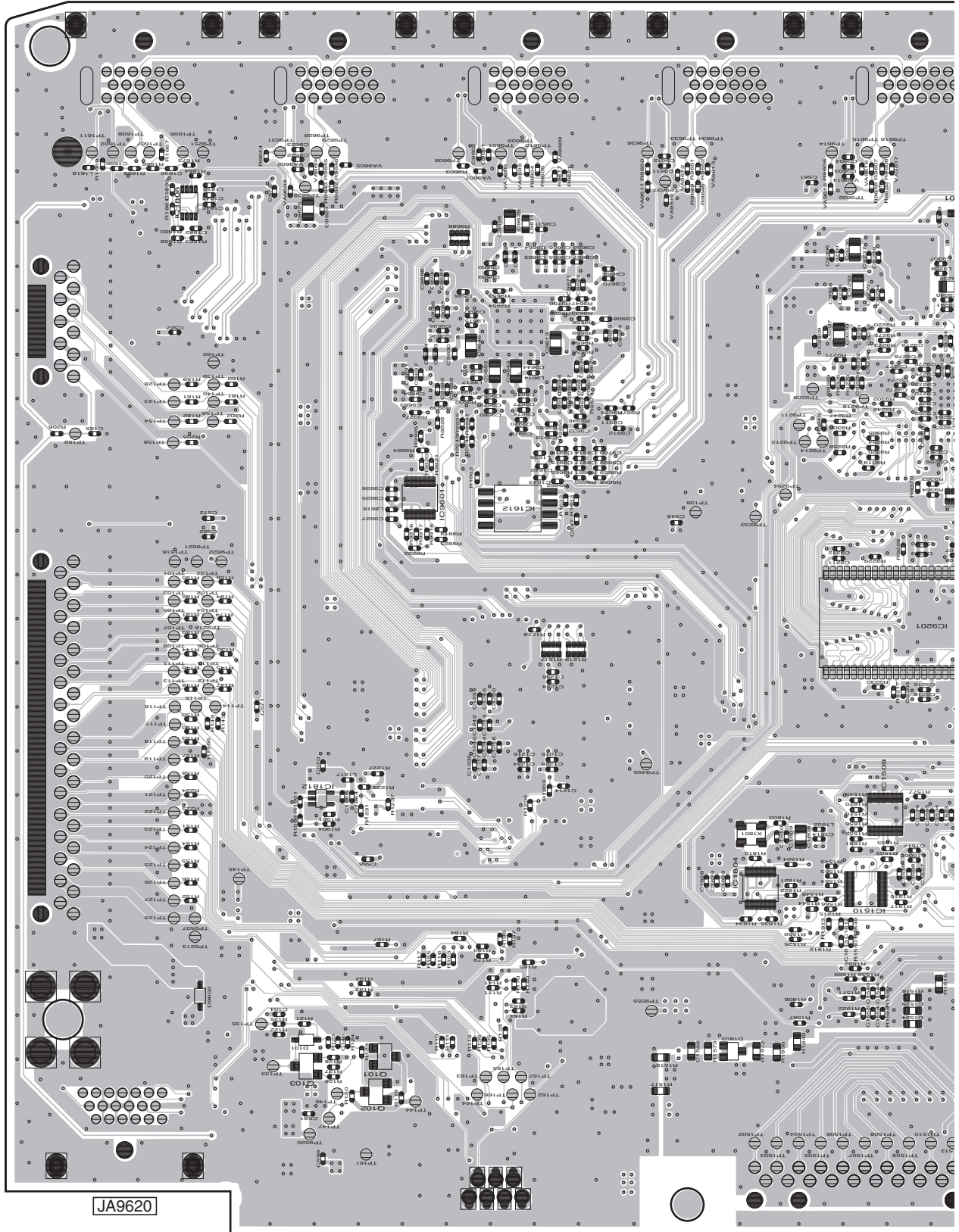

SIDE B

A

B

C

D

E

F

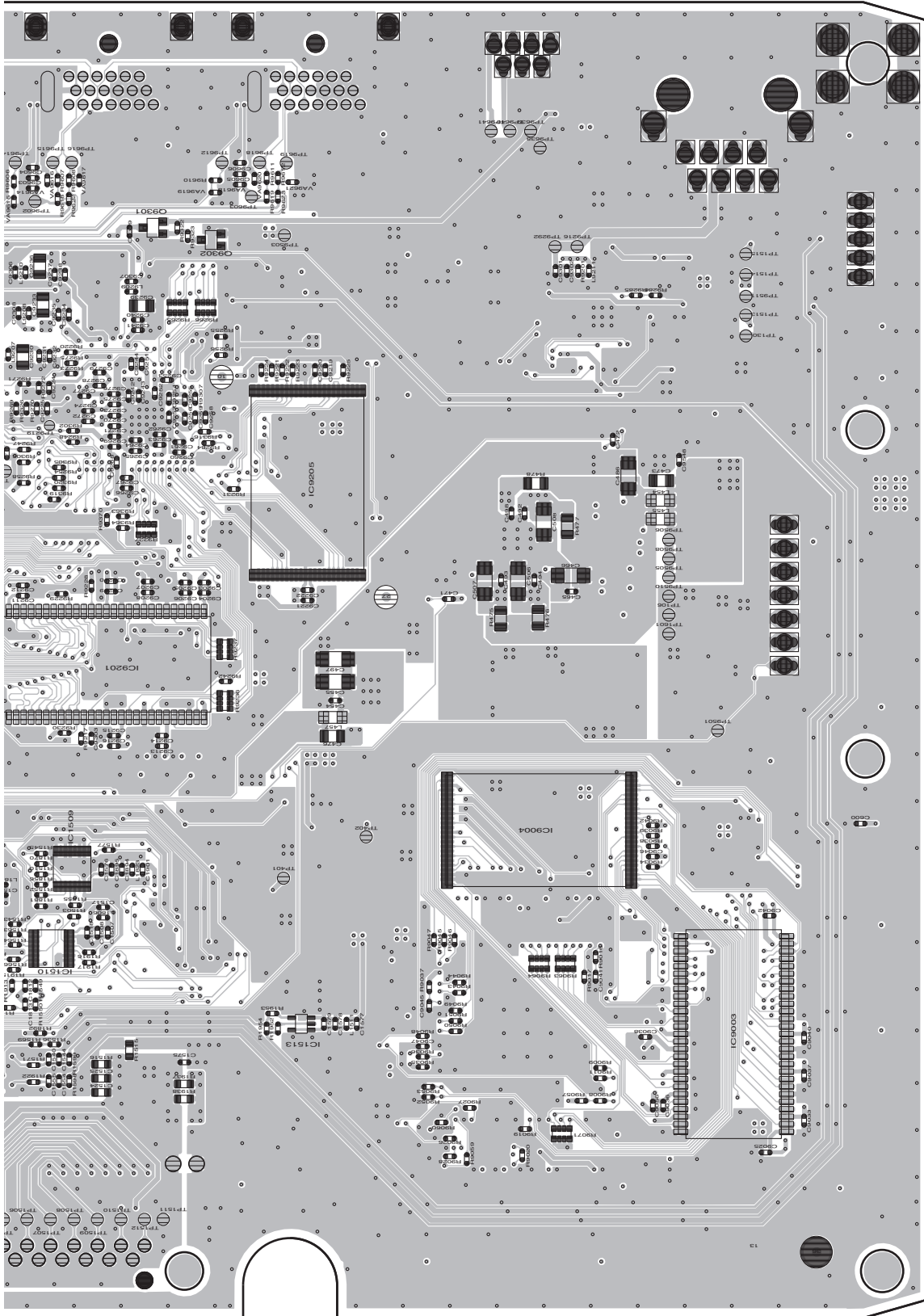

CN1802

CN9501

IC1808
Q9301
Q9302

IC9205

IC9601
IC1612

IC9201

IC9004
IC1812
IC1509

IC1804
IC1510

IC1513
IC9003

Q101
Q103
Q102

CN1801

VSX-1023-K

B

11.4 OPTCO ASSY

SIDE A

SIDE B

VSX-1023-K, VSX-43

C OPTCO ASSY

C OPTCO ASSY

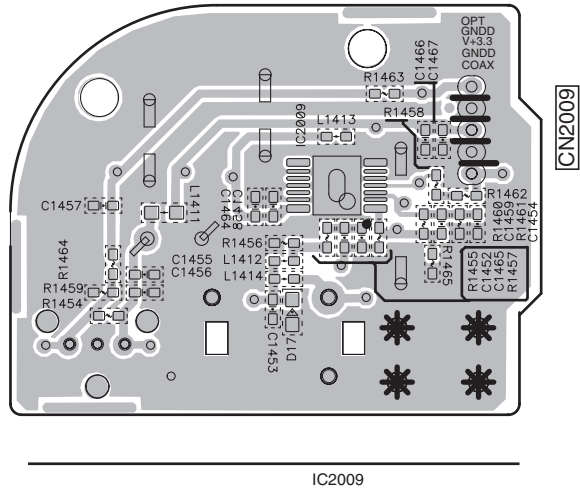
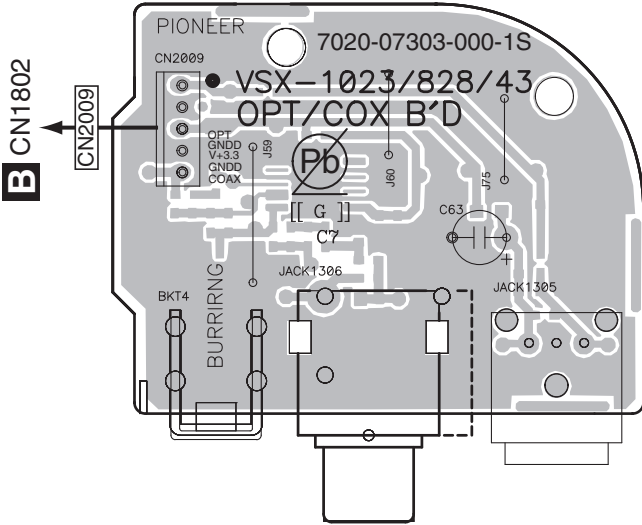

SIDE A

SIDE B

VSX-823-K

C OPTCO ASSY

C OPTCO ASSY

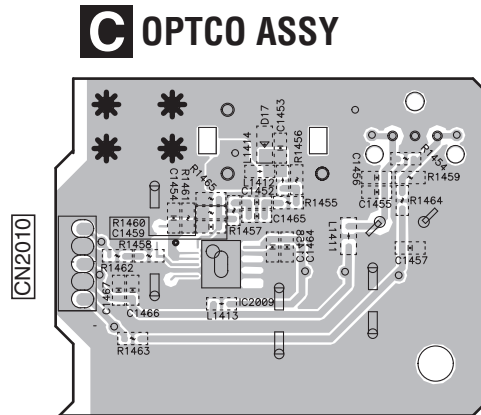
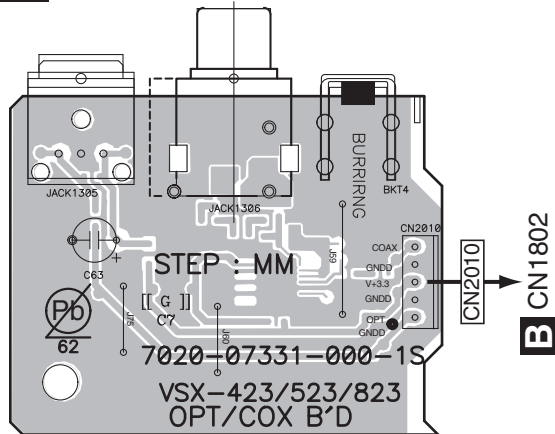

C

11.5 BRI-1 ASSY (VSX-1023-K, VSX-43 ONLY)

SIDE A

SIDE A

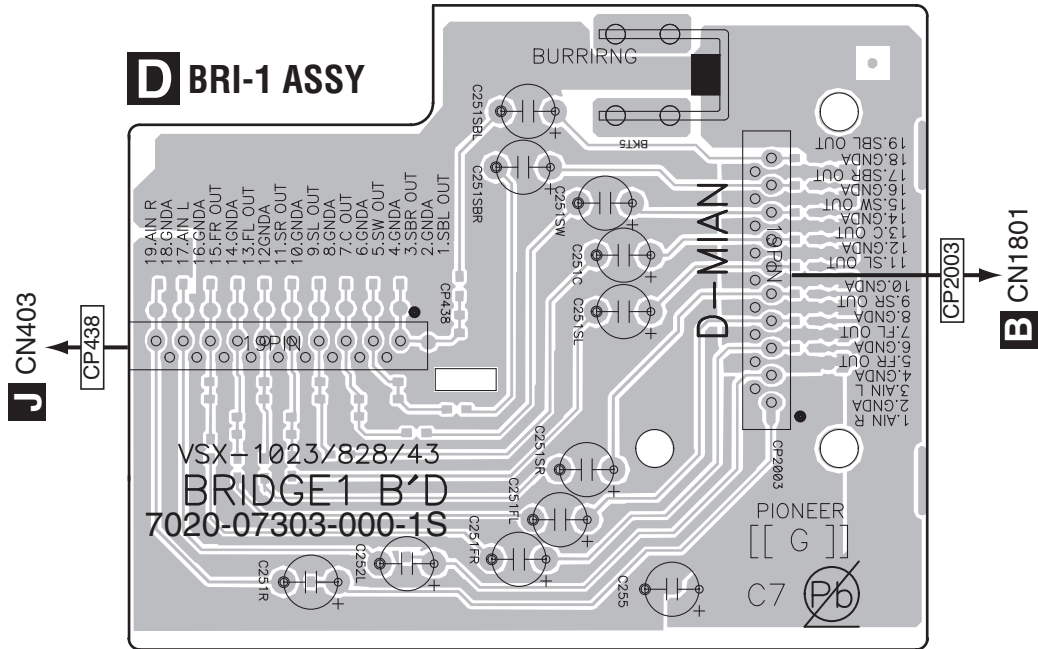

SIDE B

SIDE B

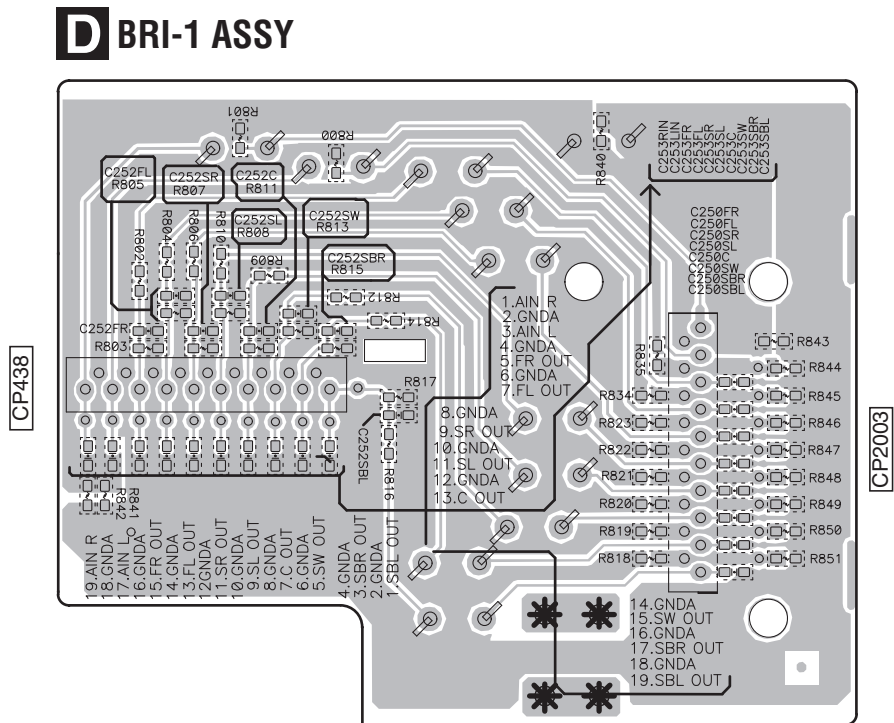

11.6 CONCT ASSY (VSX-823-K ONLY)

SIDE A

SIDE A

CONCT ASSY

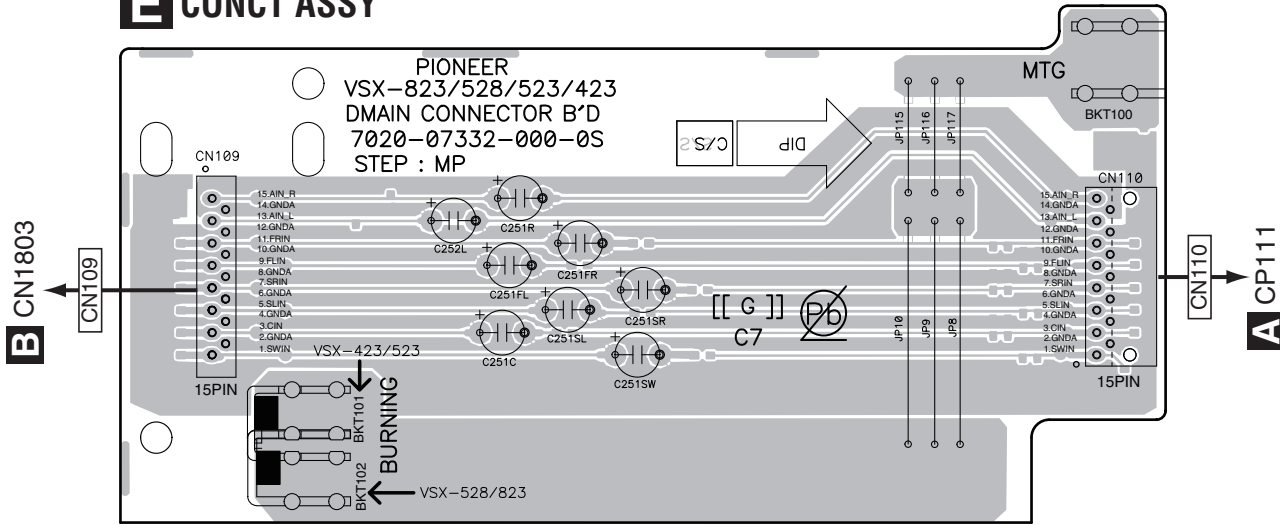

SIDE B

SIDE B

CONCT ASSY

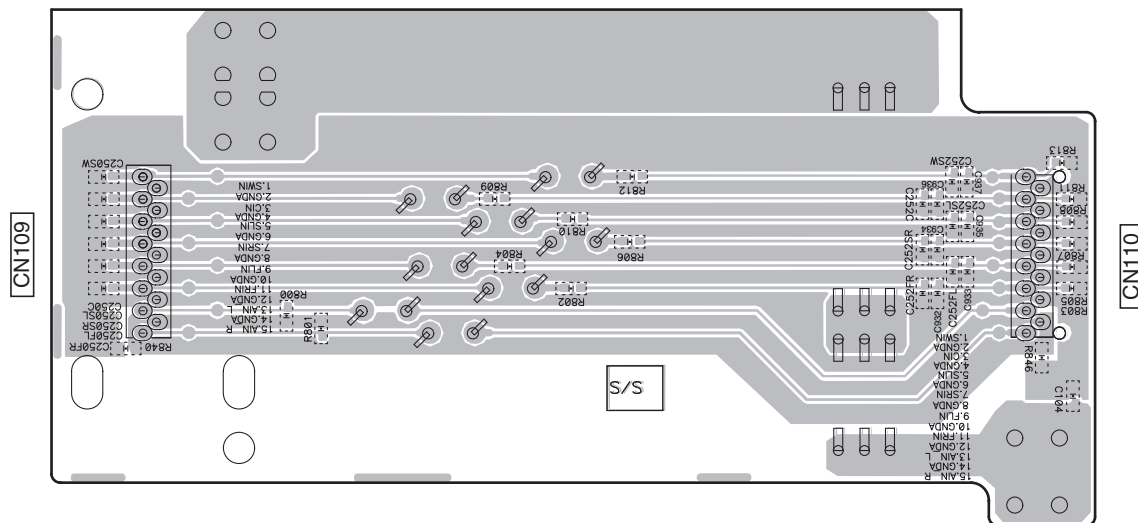

E

11.9 BRI-2 ASSY (VSX-1023-K, VSX-43 ONLY)

SIDE A

SIDE B

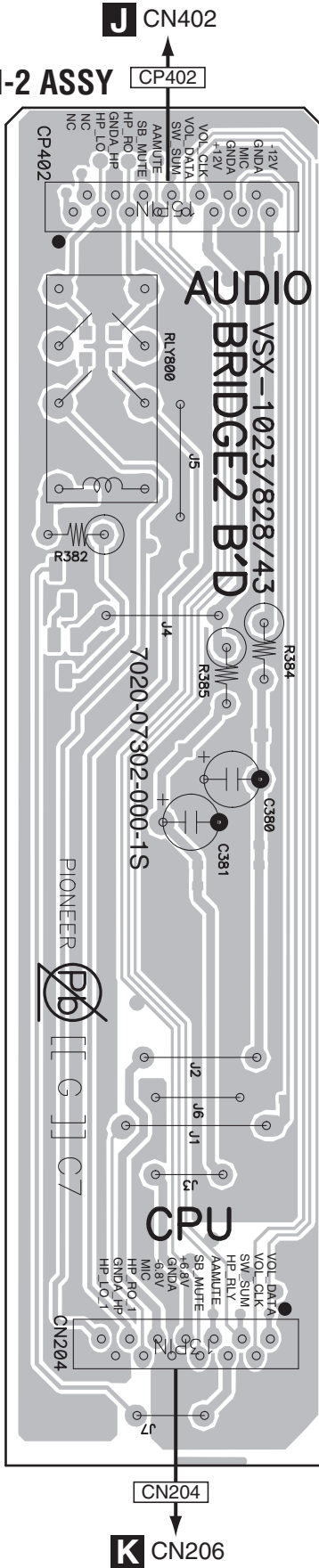

BRI-2 ASSY CP402

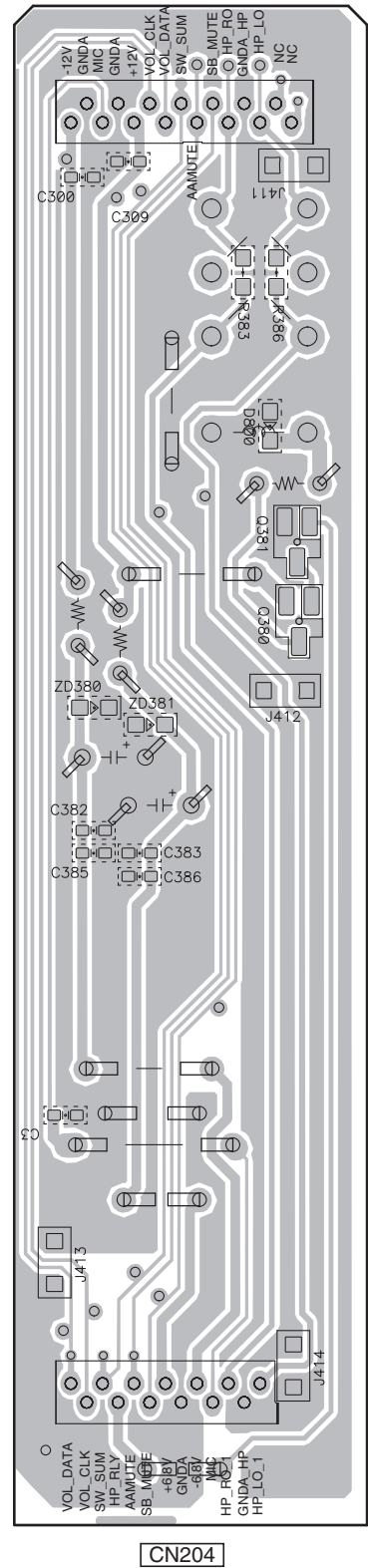

11.10 AUDIO ASSY (VSX-1023-K, VSX-43 ONLY)

SIDE A

SIDE A

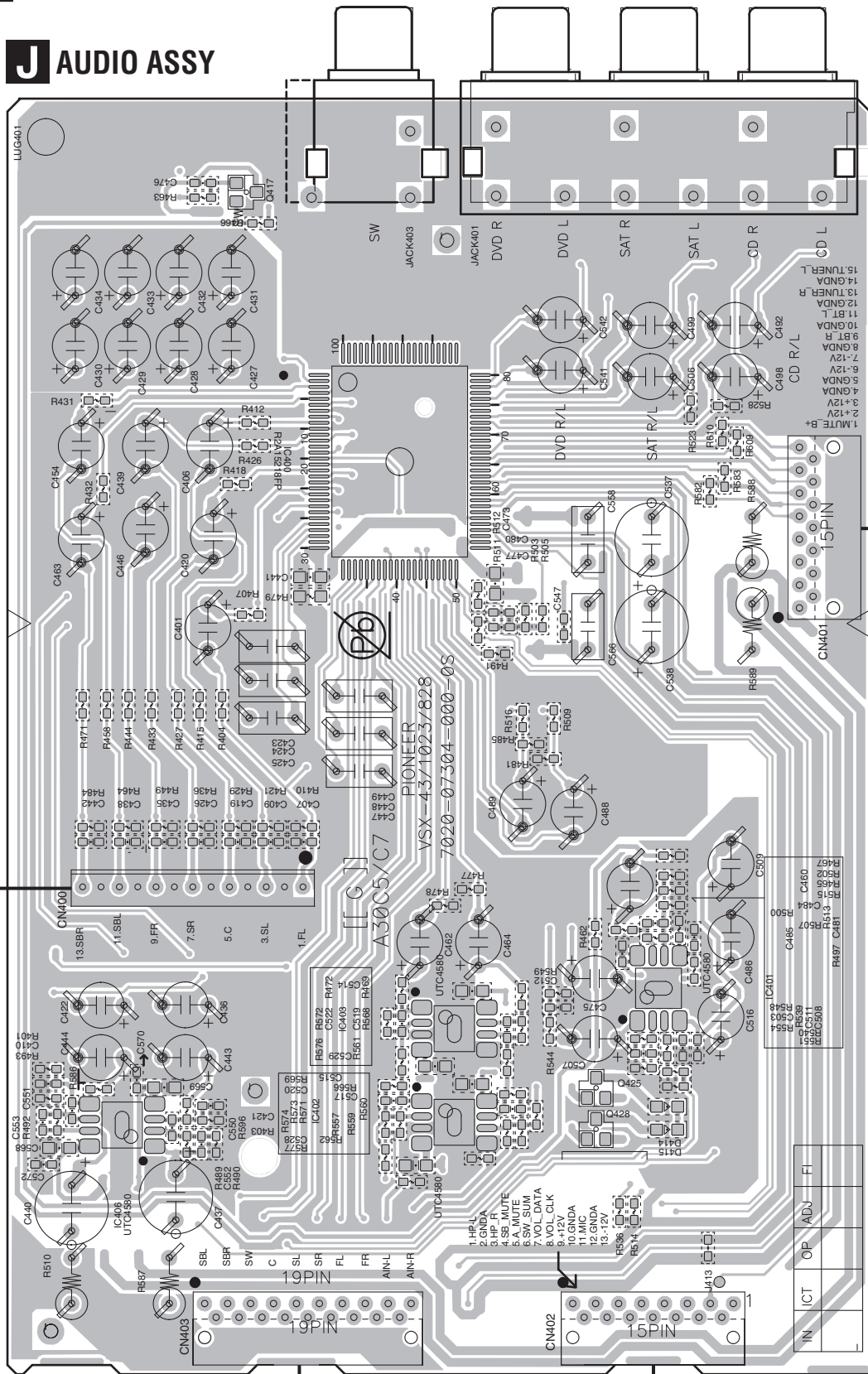

J AUDIO ASSY

A CP17

K CP401

D CP438

I CP402

11.11 CPU ASSY (VSX-1023-K, VSX-43)

SIDE A

K CPU ASSY

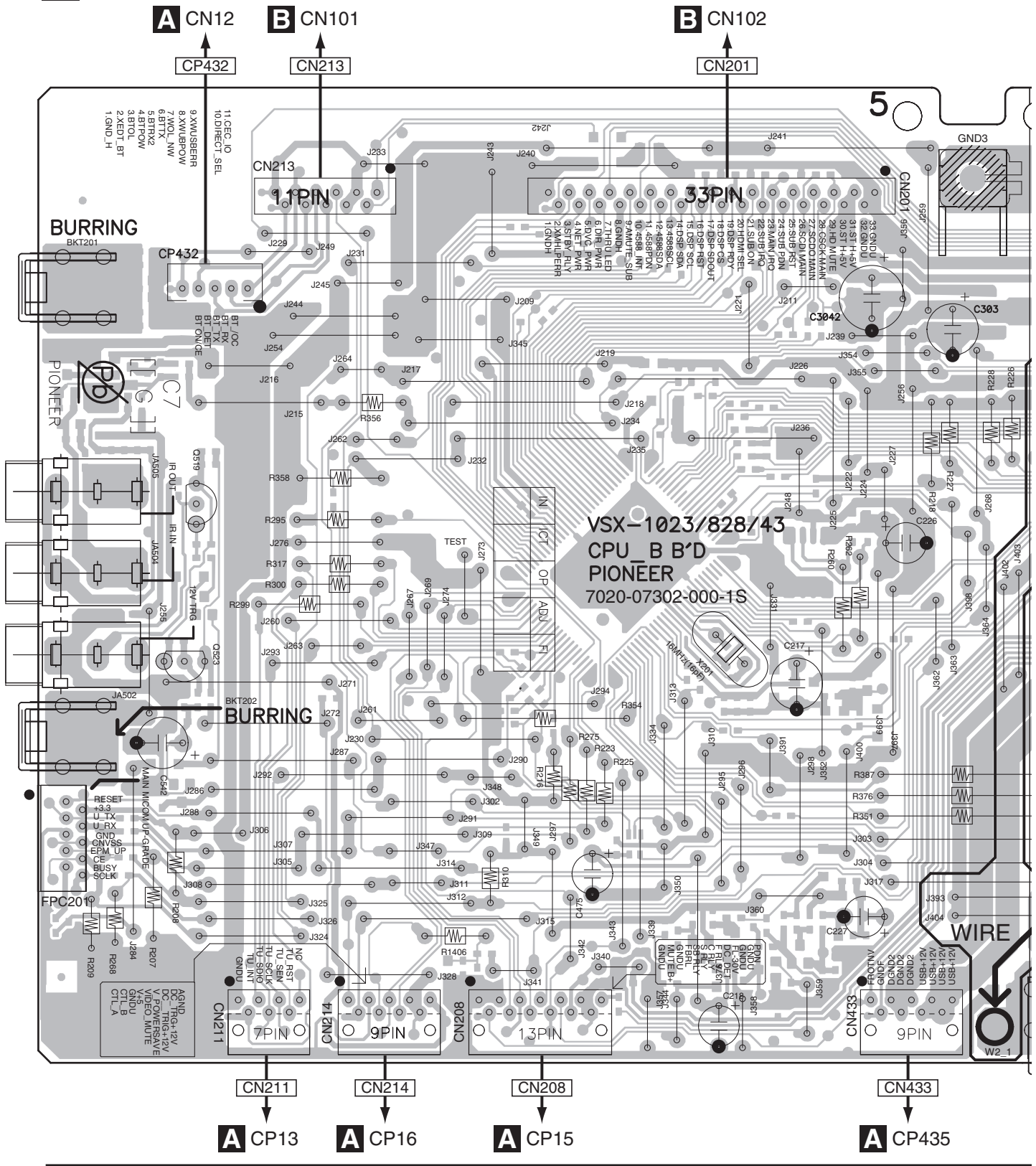

K

SIDE A

A

B

C

D

E

F

K

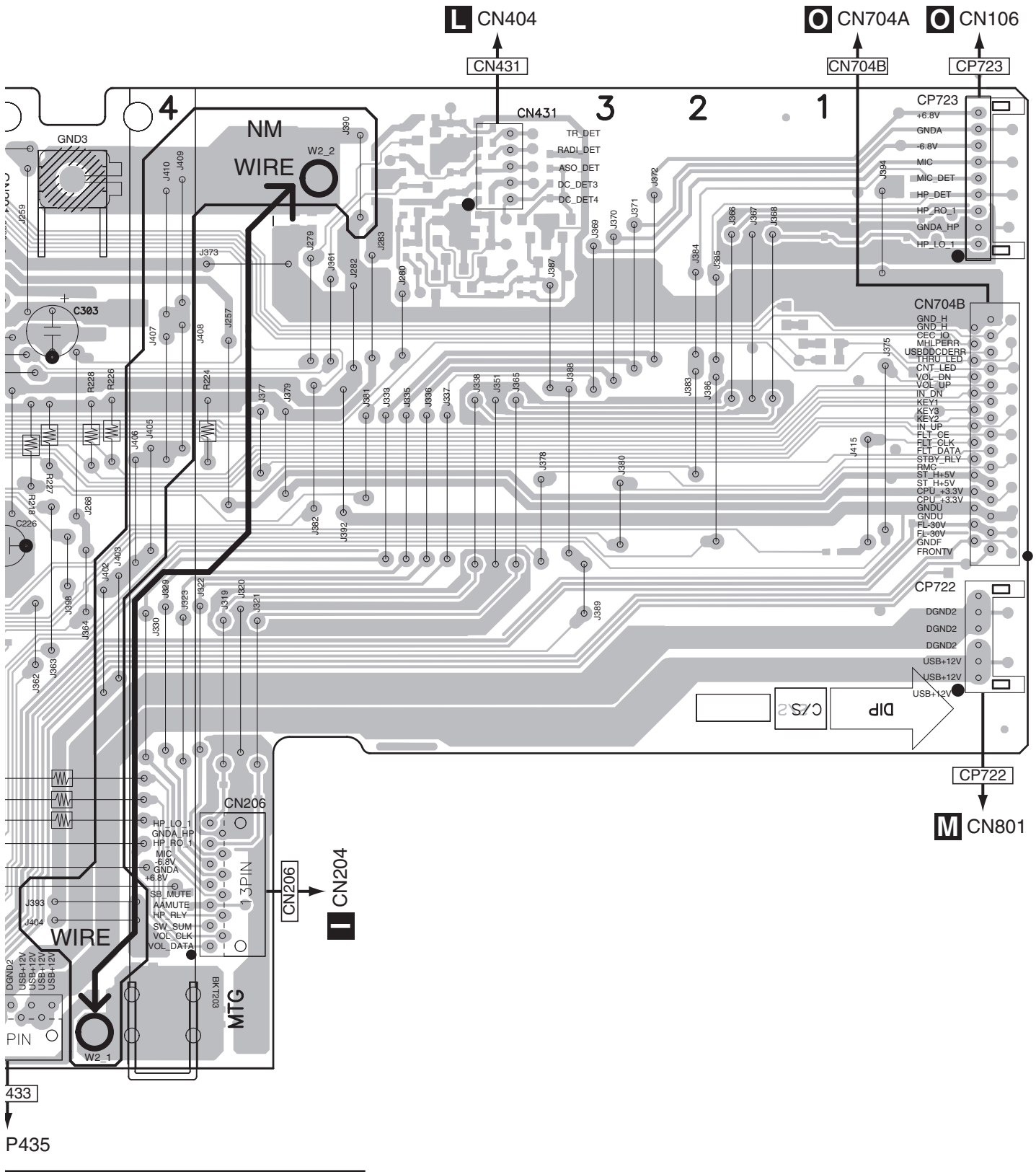

A
B
C
D
E
F
K

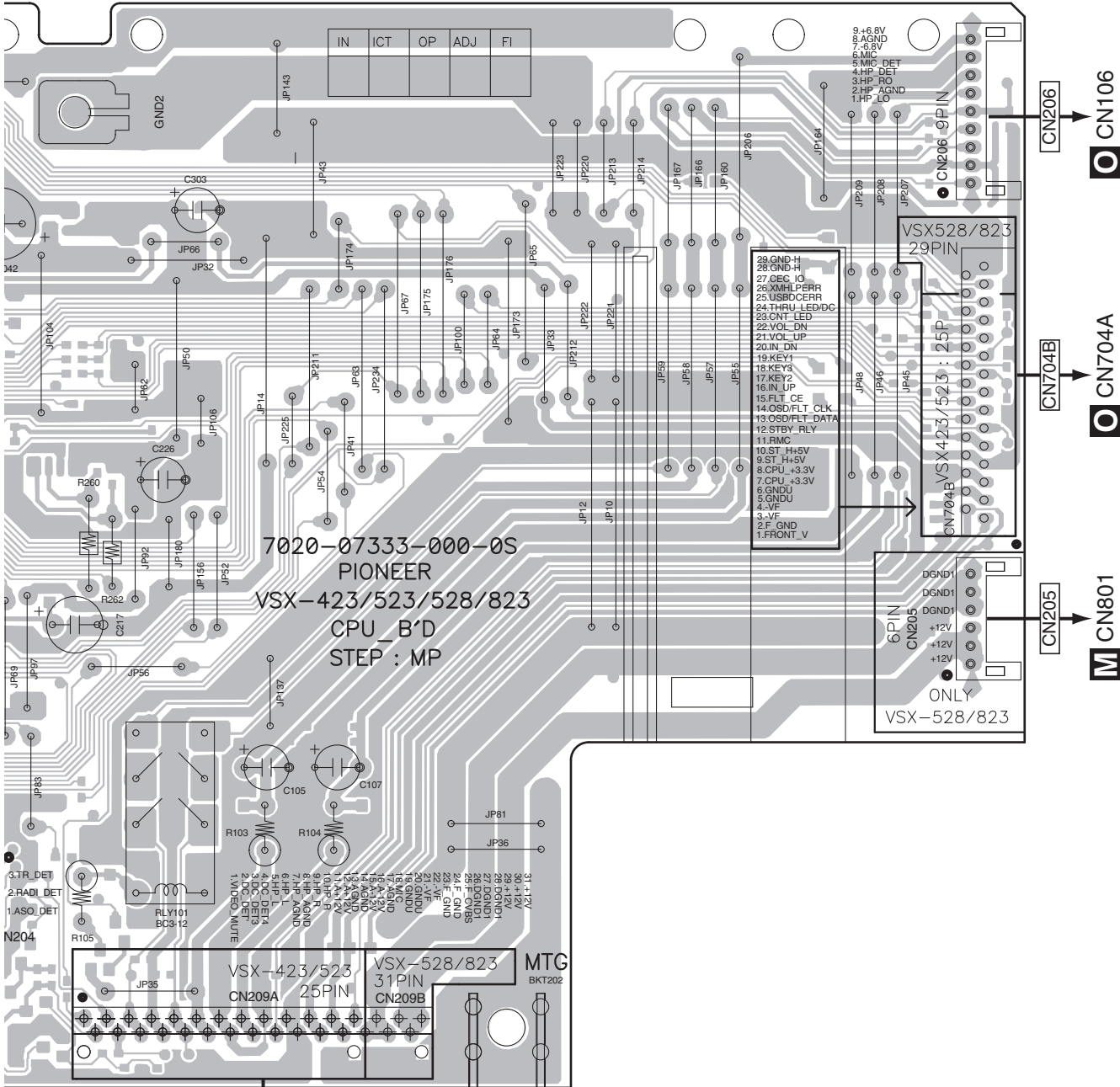

4
04
A CP16

SIDE B

A

B

C

D

E

F

K CPU ASSY

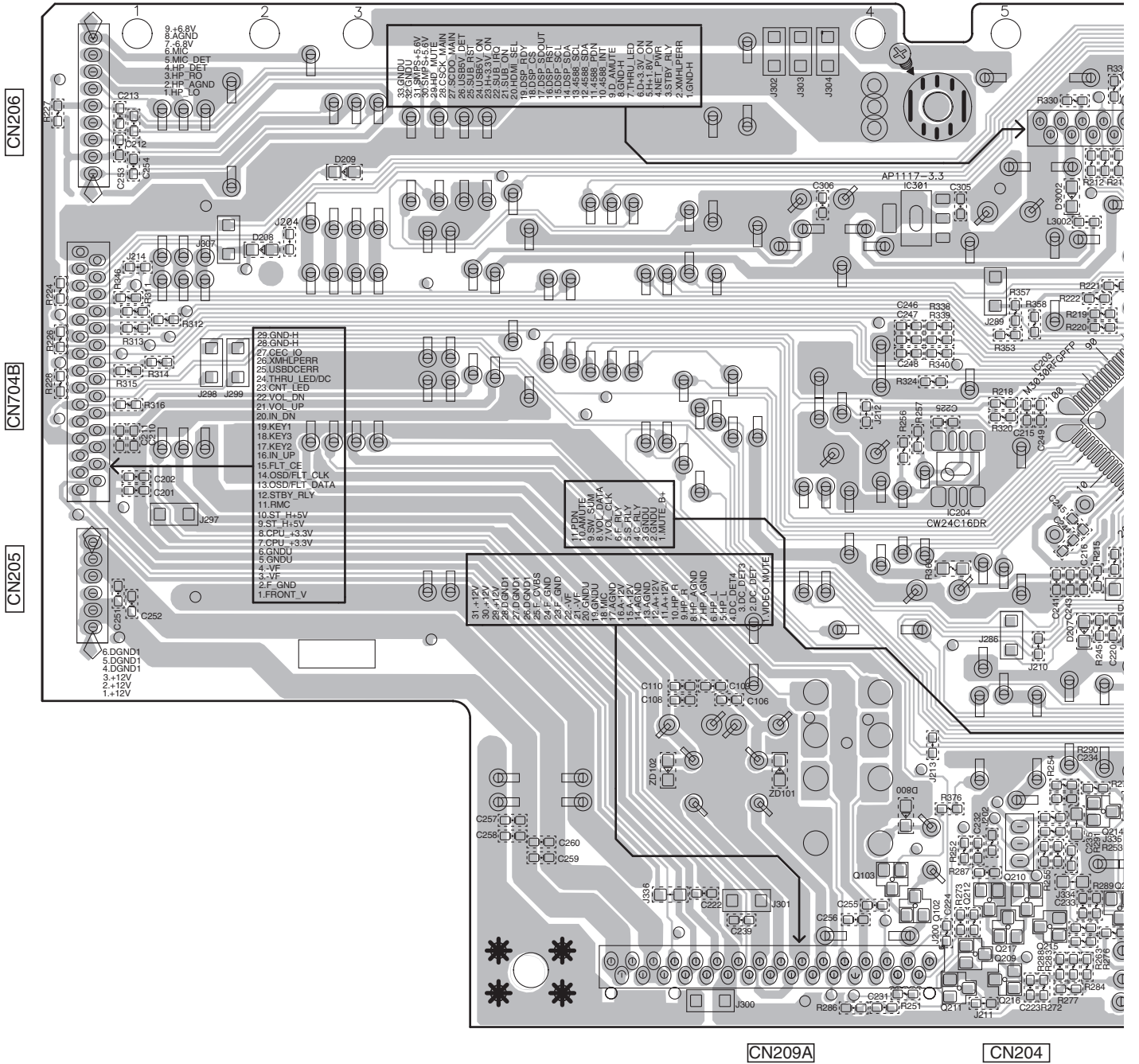

A
B
C
D
E
F

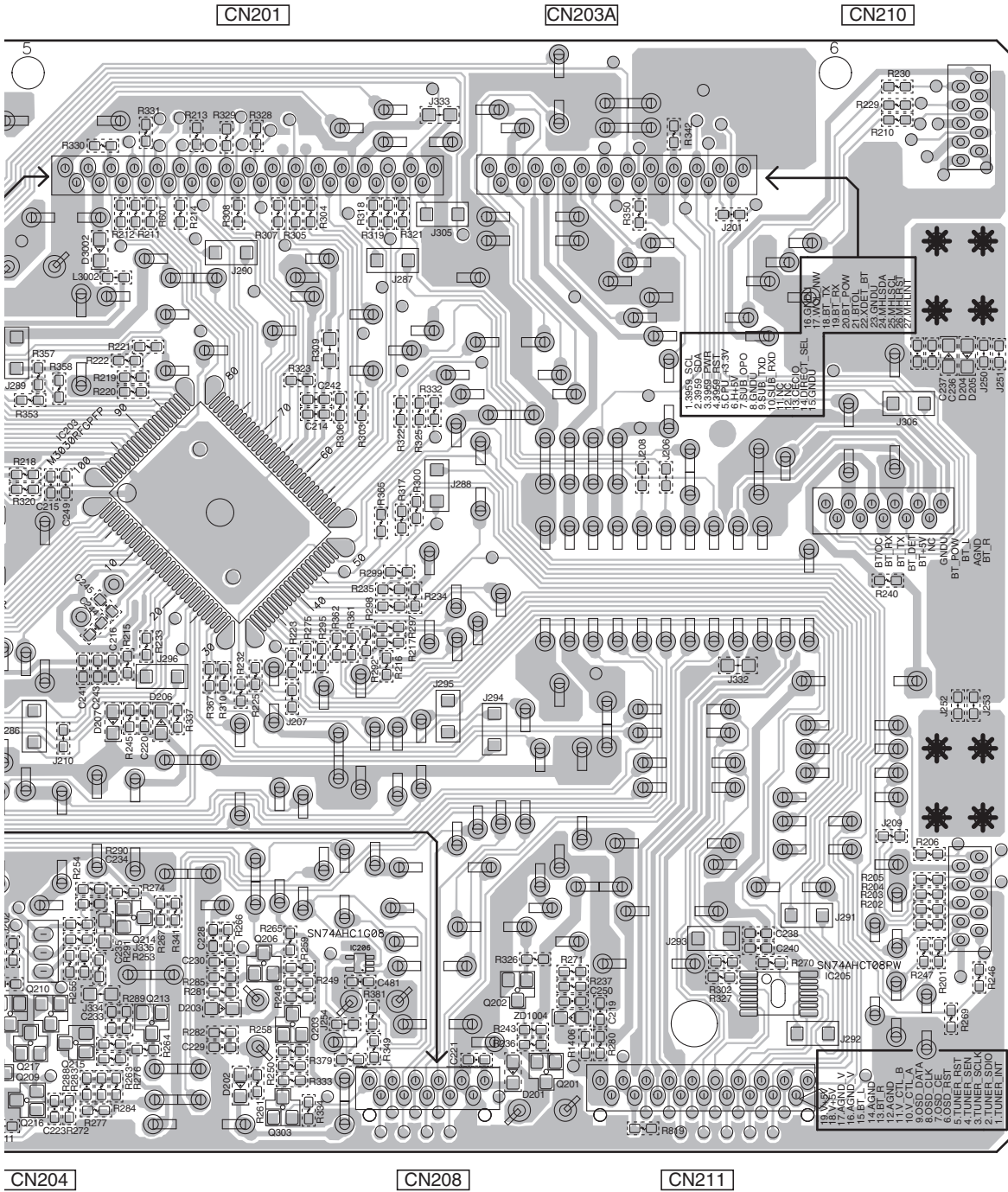

11.13 AMP7 ASSY (VSX-1023-K, VSX-43)

SIDE A

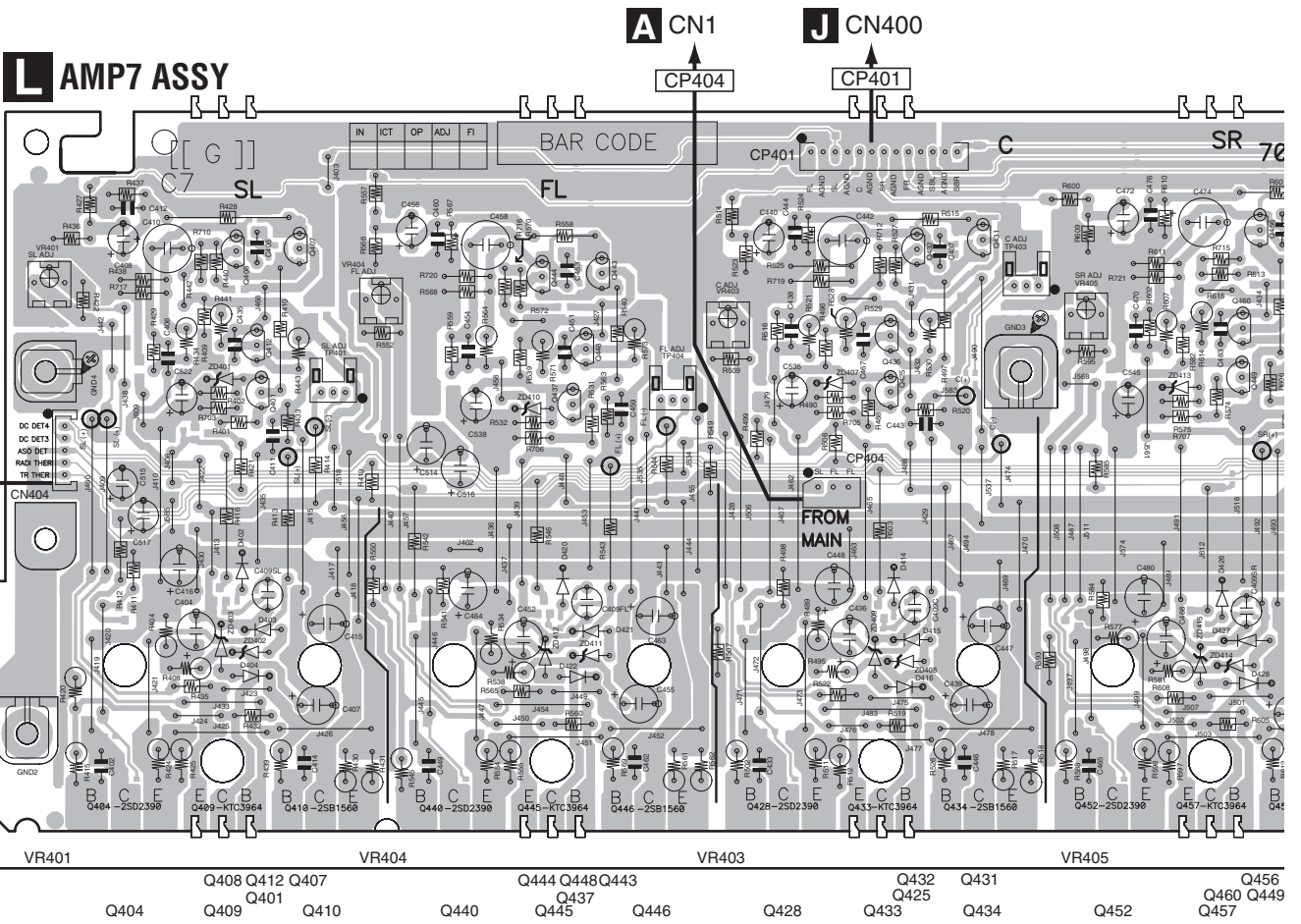

SIDE B

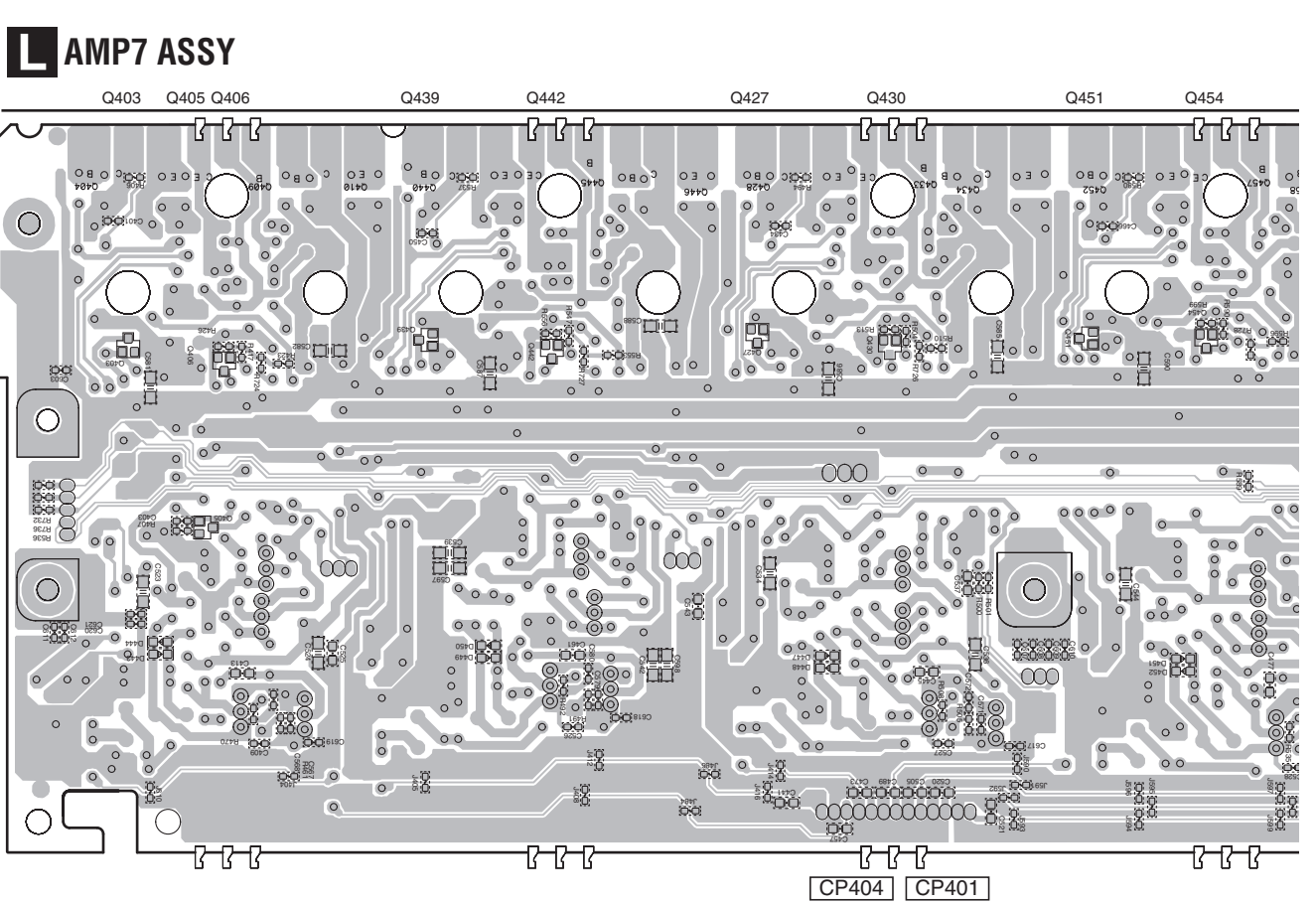

SIDE A

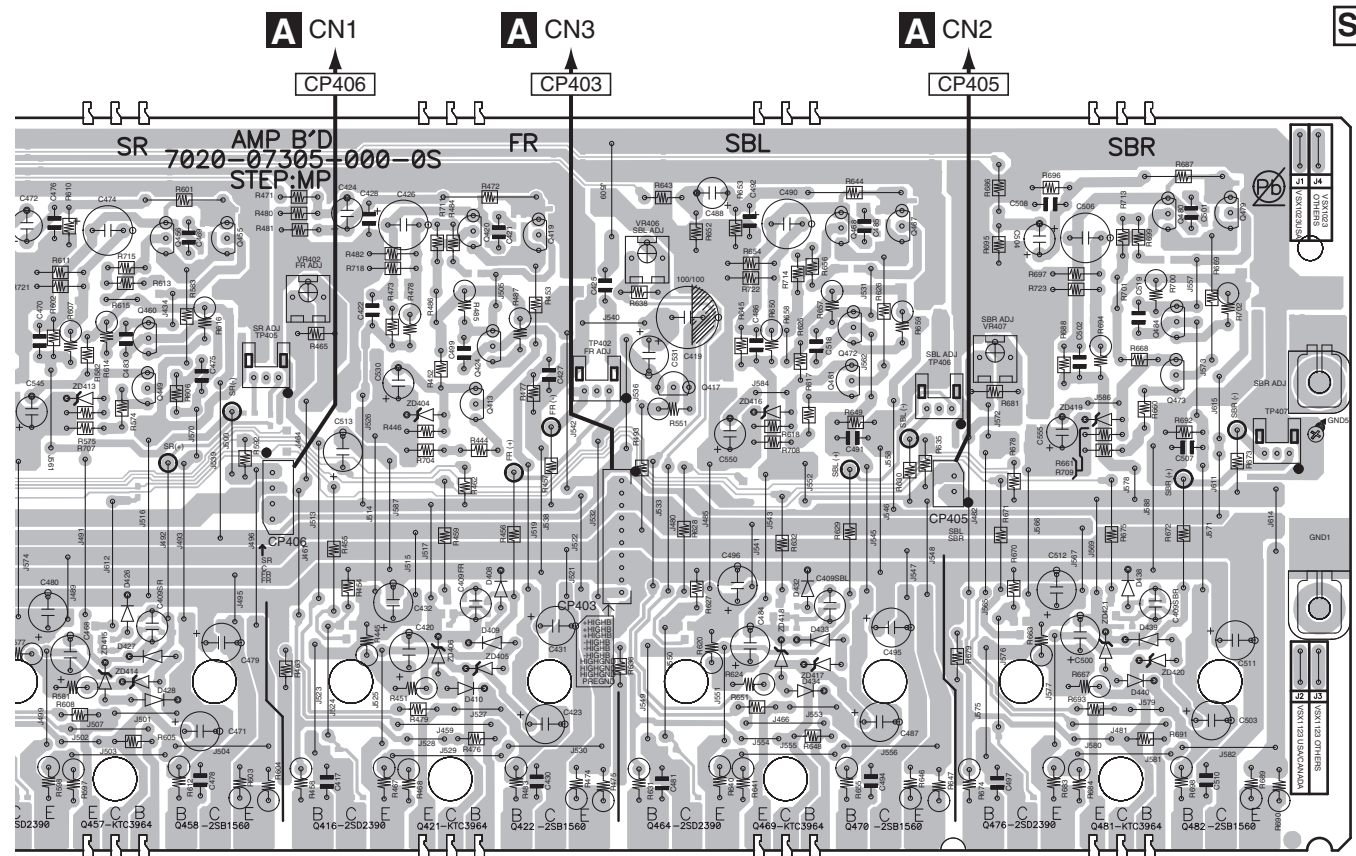

- Q456 Q455
- Q460 Q449
- Q457 Q458
- Q416
- Q420 Q413 Q424
- Q421 Q422
- Q417 Q464
- Q468 Q461 Q467
- Q462 Q472
- Q470
- Q476
- Q480 Q473 Q484
- Q481 Q482

SIDE B

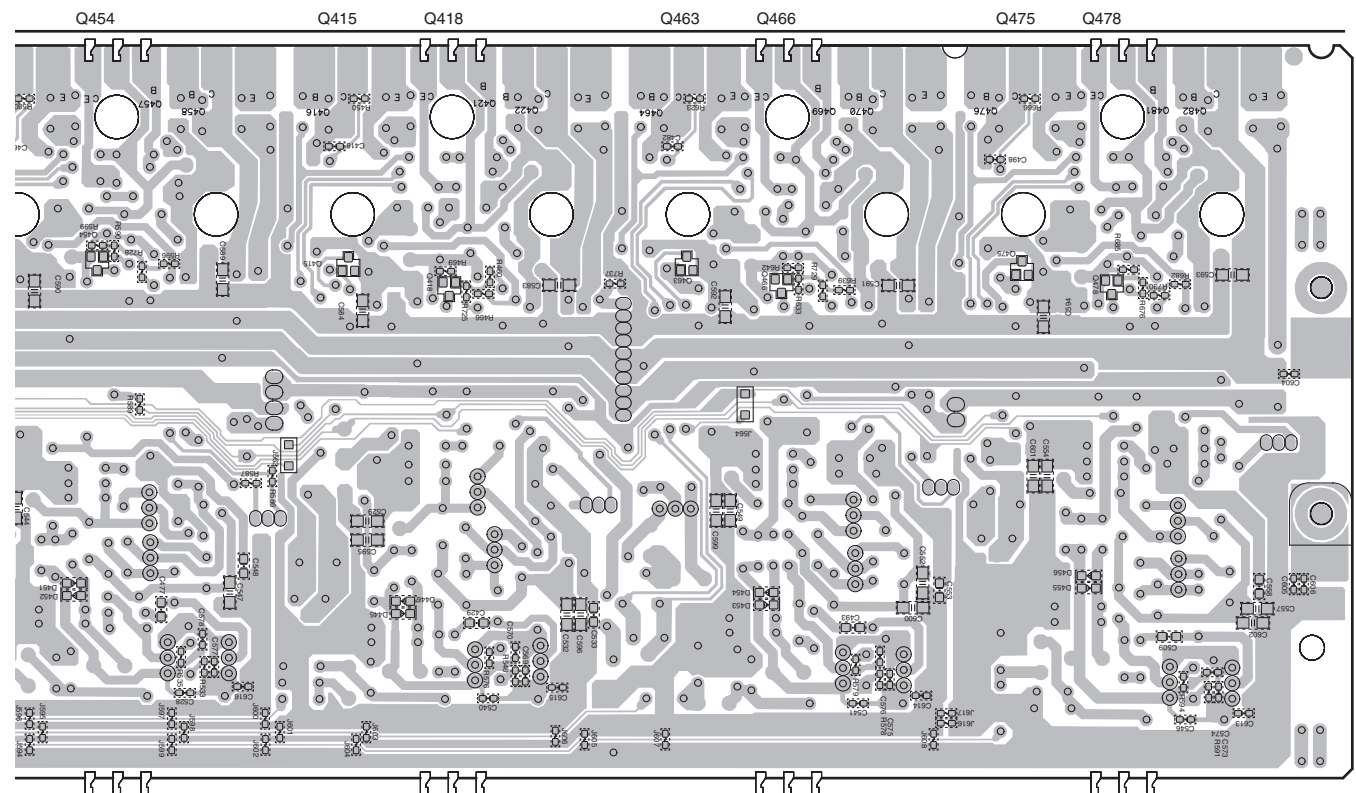

VSX-1023-K

11.14 AMP5 ASSY (VSX-823-K)

SIDE A

AMP5 ASSY

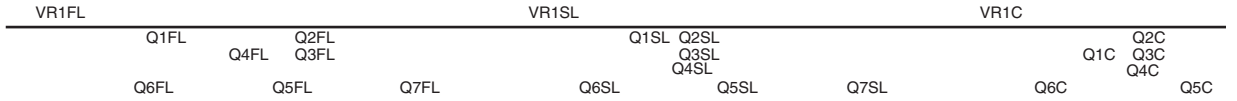
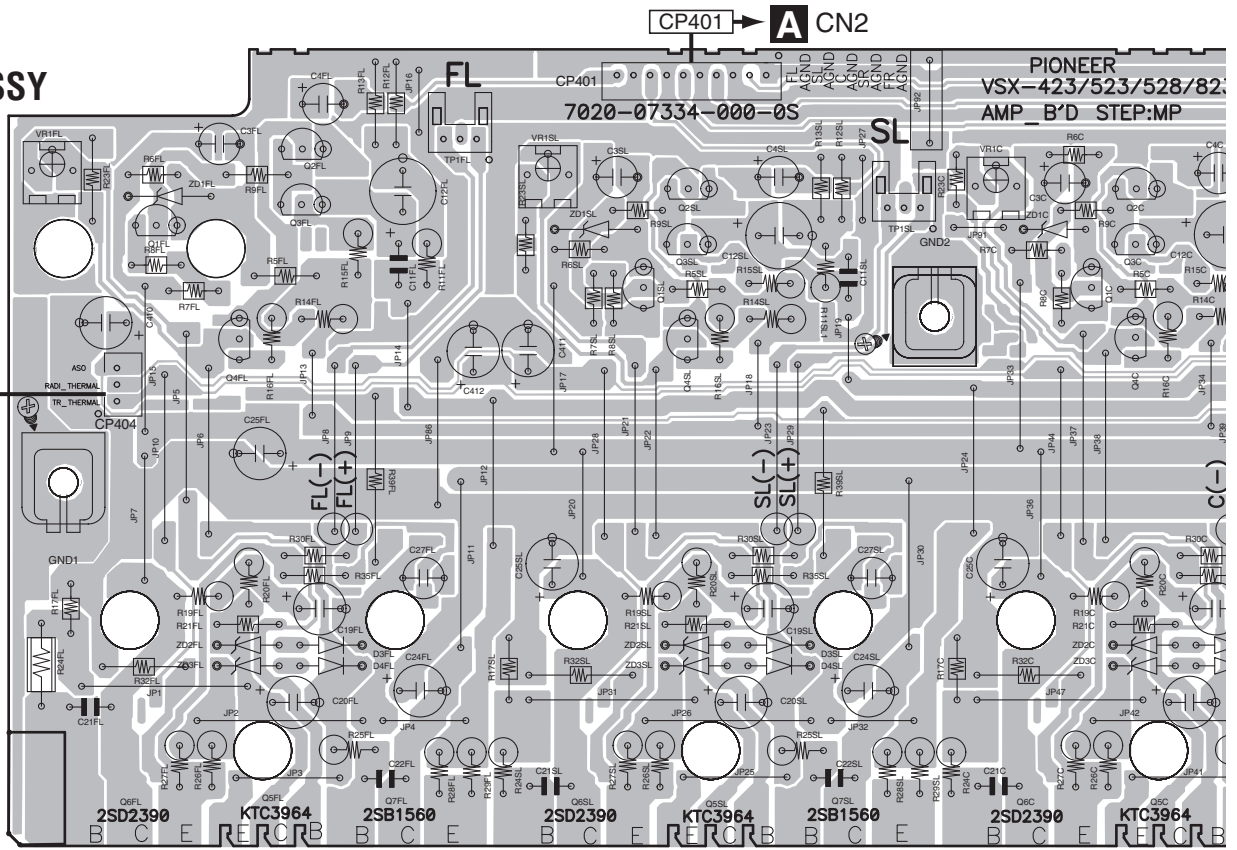

SIDE B

AMP5 ASSY

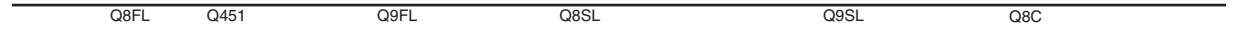
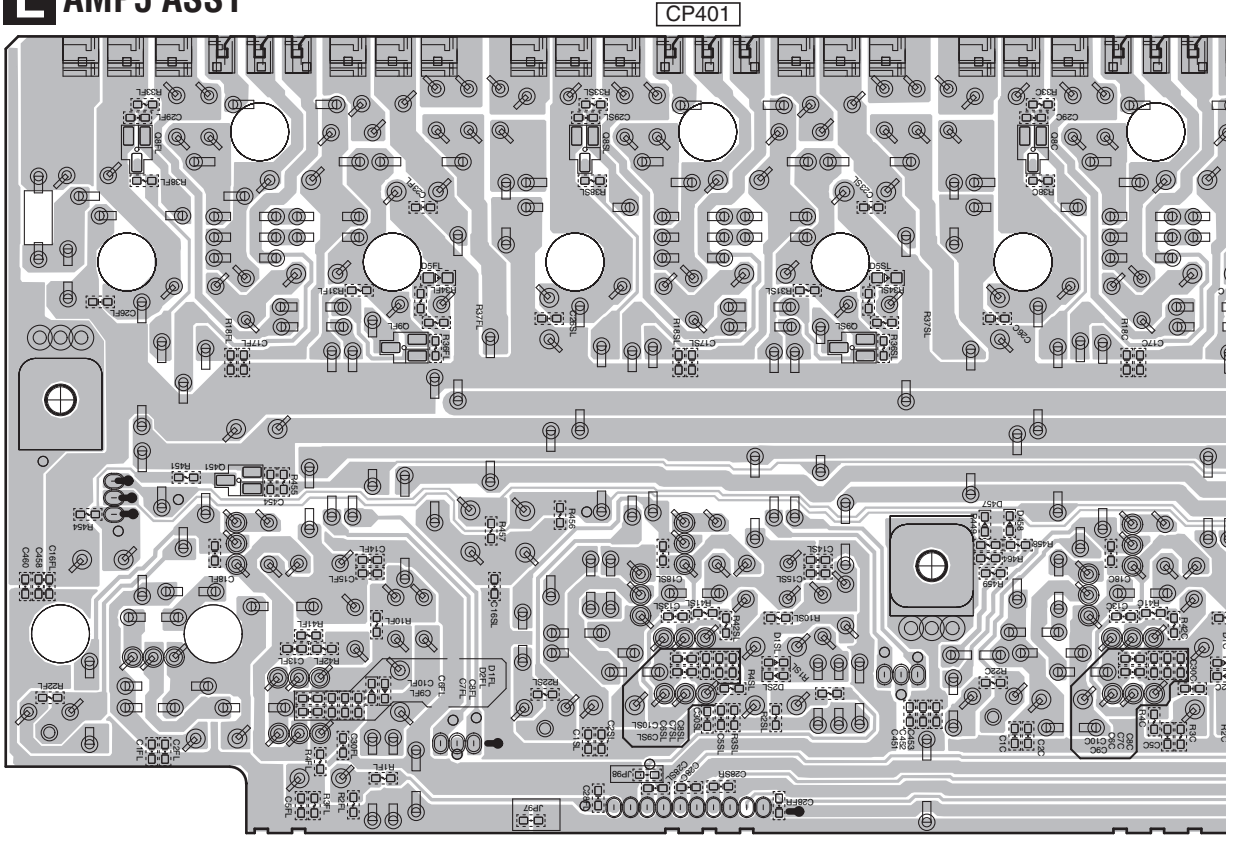

SIDE A

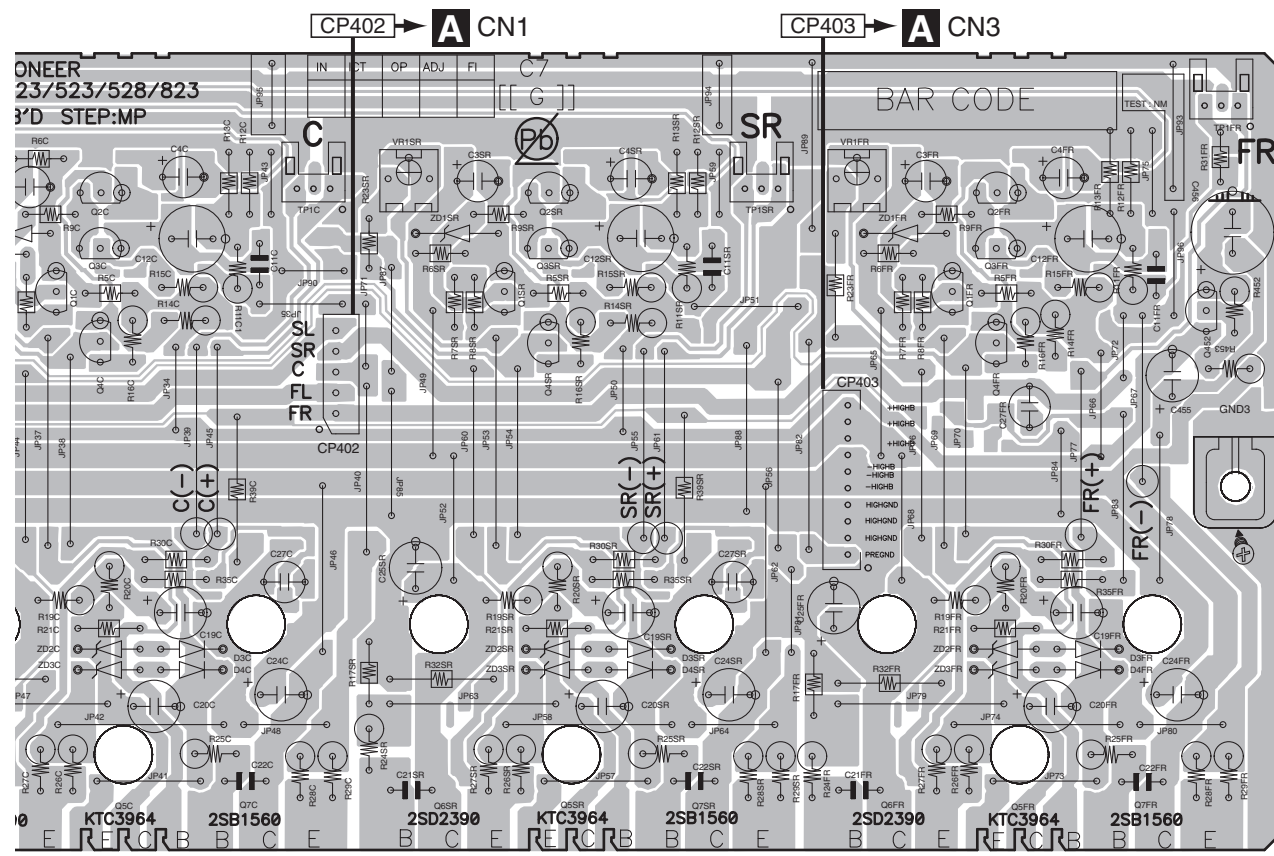

SIDE B

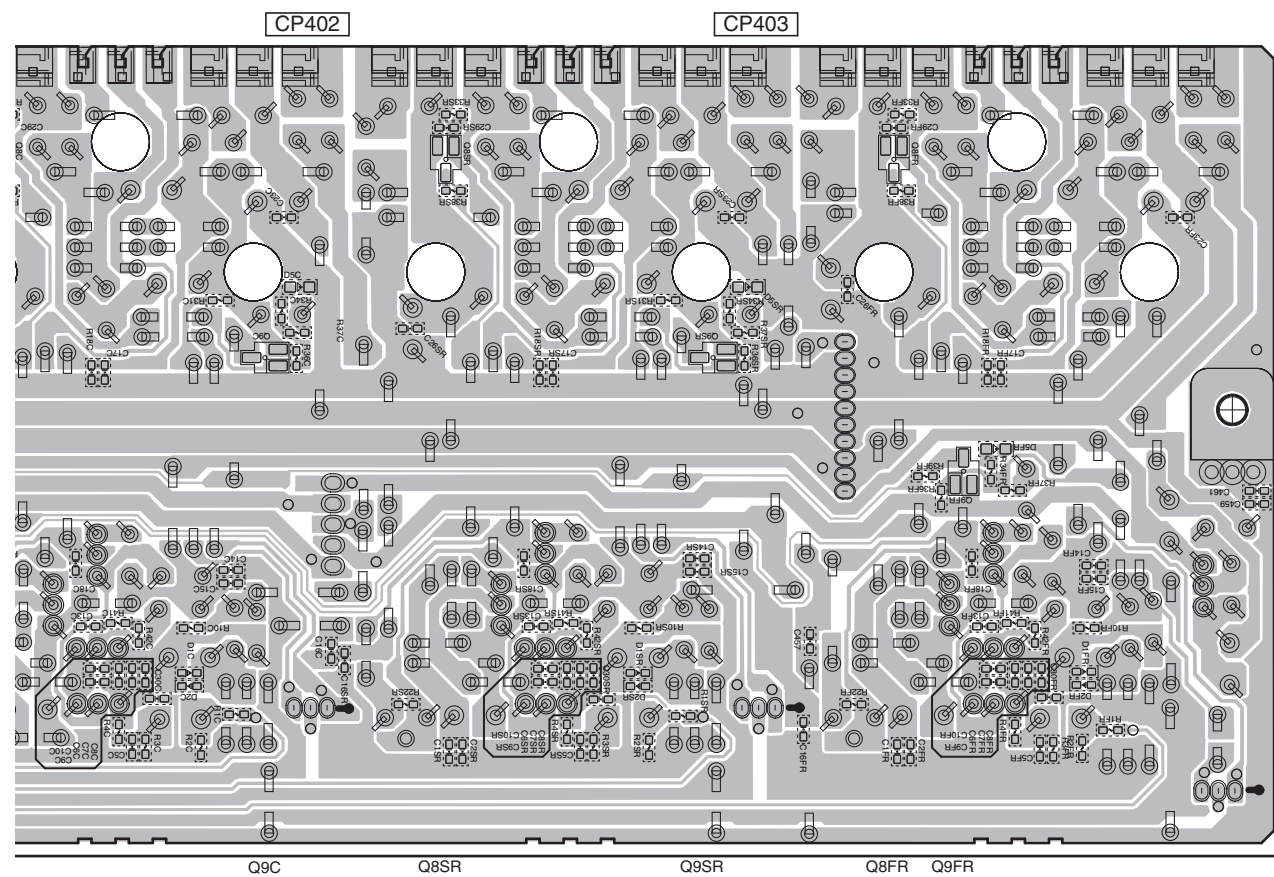

11.15 FHDMI, INSEL, FRONT and HPMIC ASSYS

SIDE A

TO MAIN TRANS

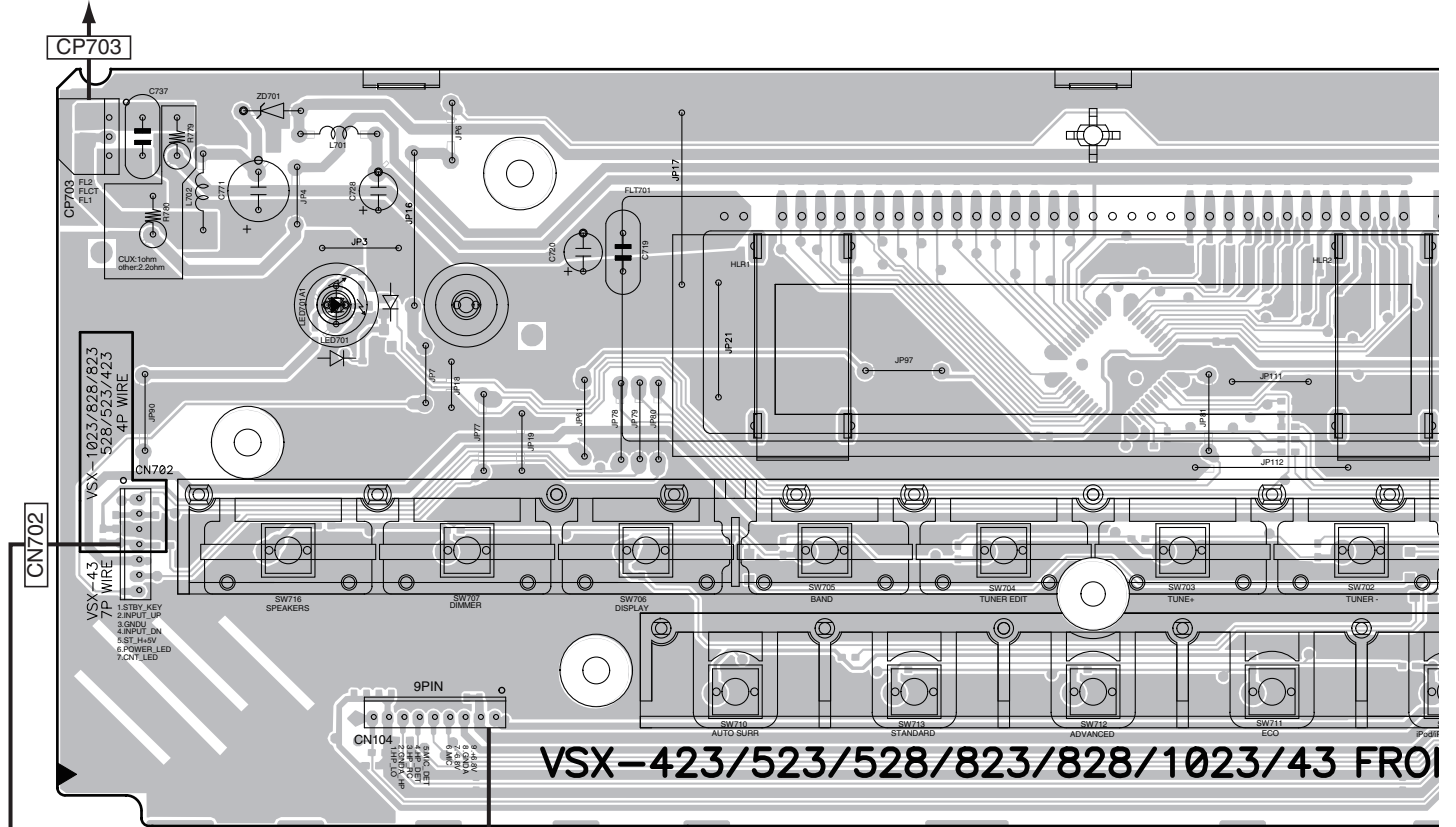

VSX-423/523/528/823/828/1023/43 FRONT ASSY

N INSEL ASSY

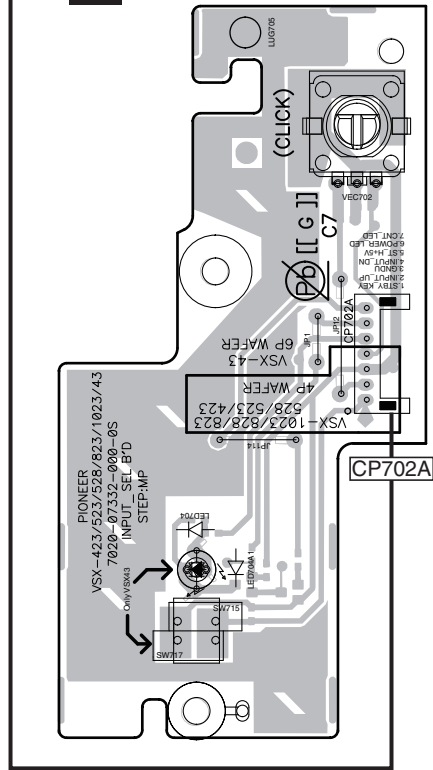

P HPMIC ASSY

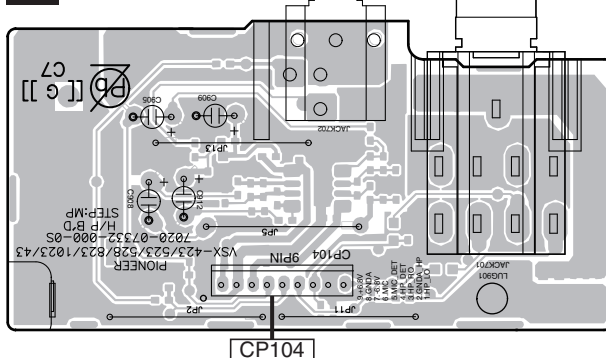

N O P

SIDE A

A

FRONT ASSY

B

C

D

E

F

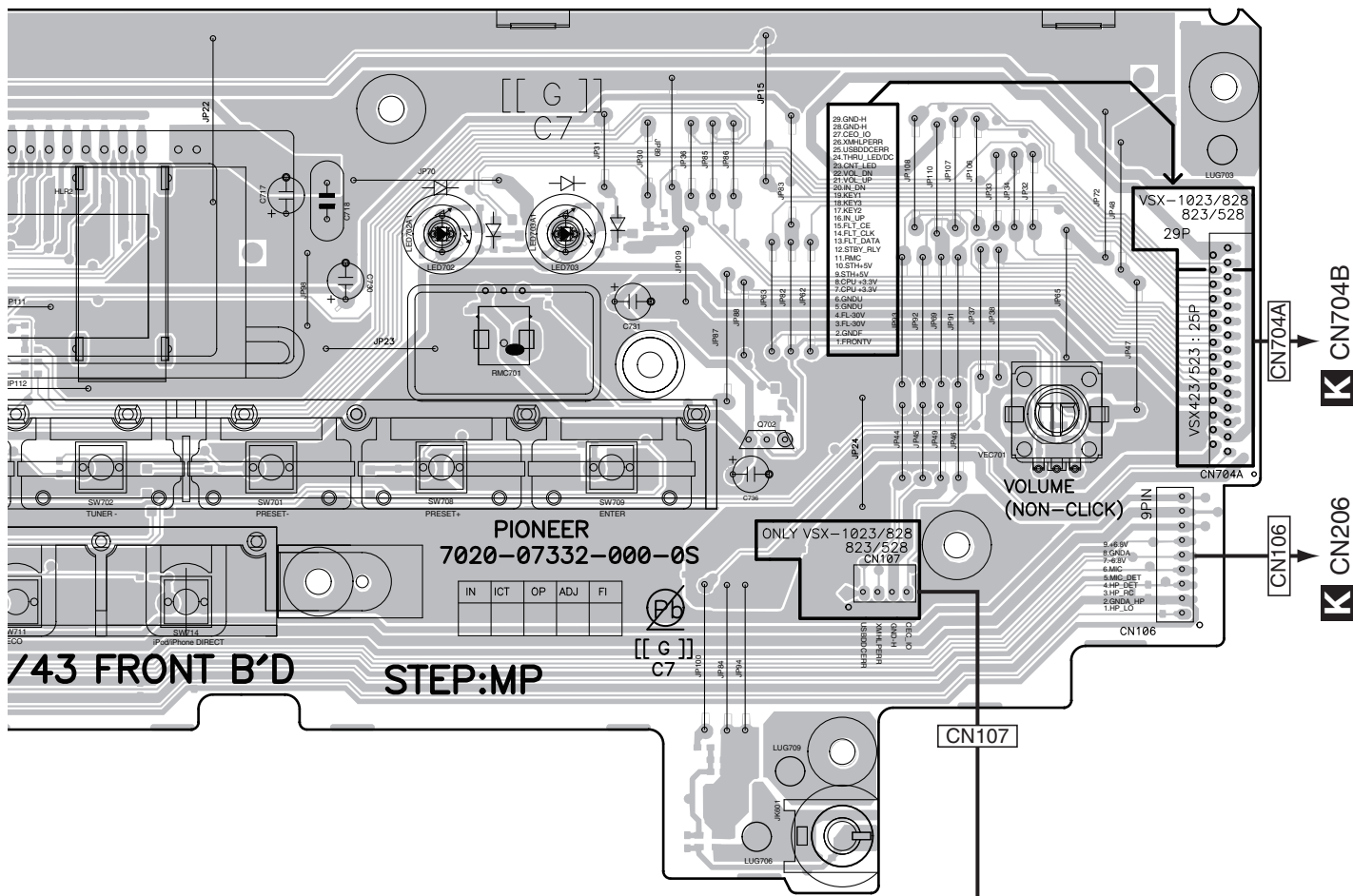

K CN704B

K CN206

K CP722

B JA9602

M FHDMI ASSY

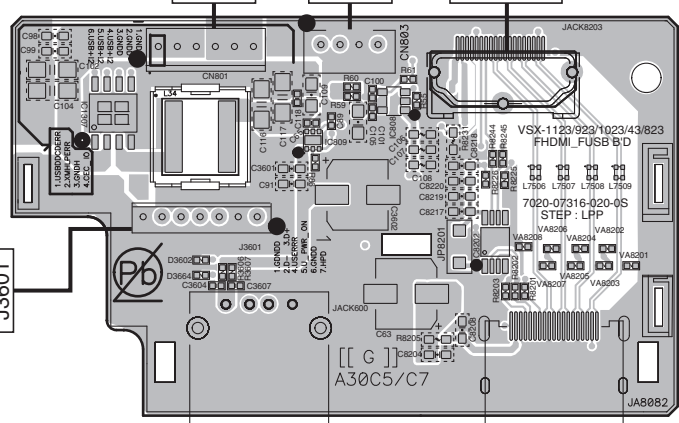

IC808
IC1307
IC809

IC8202

B CN9202, CN9601

VSX-1023-K

M O

SIDE B

IC701

Q701
Q707

A

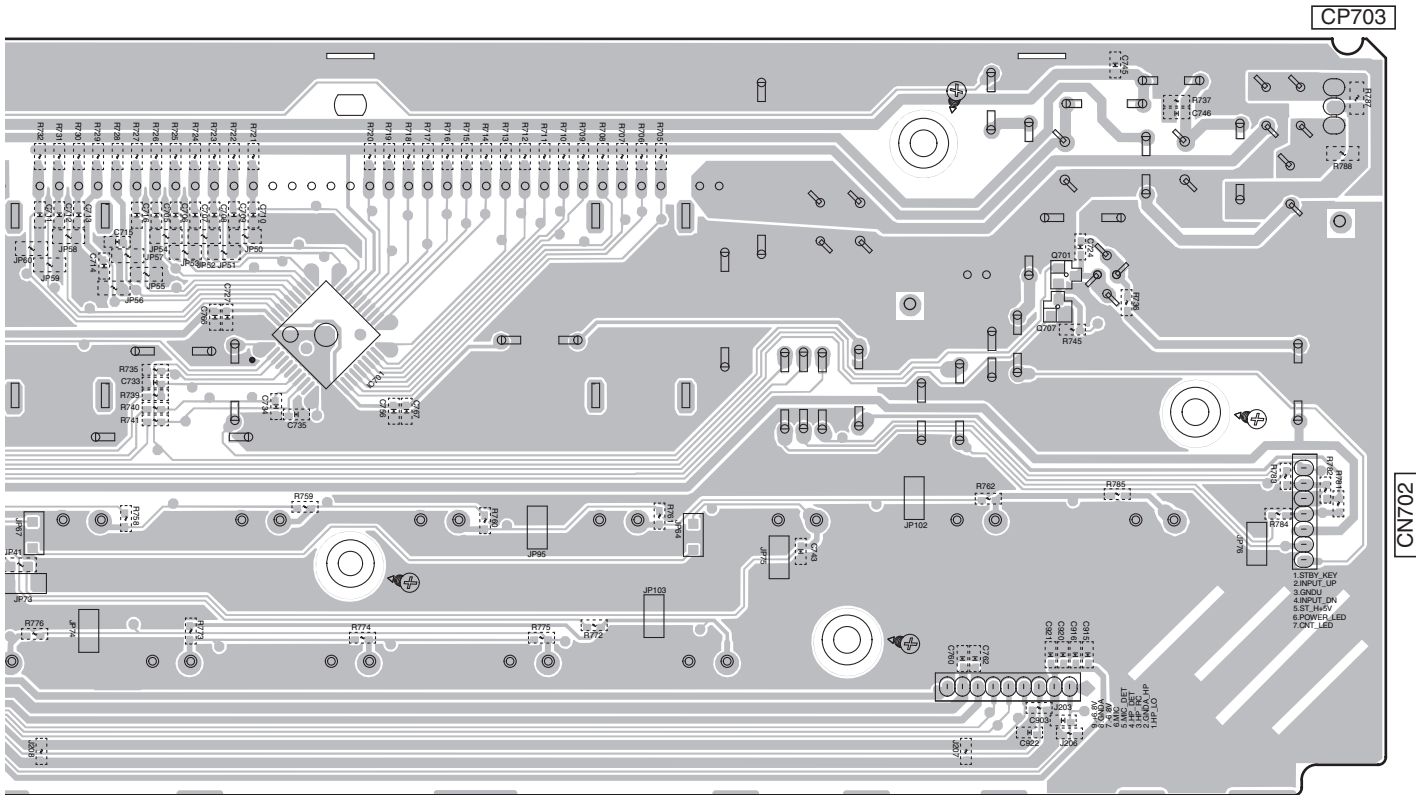

B

C

CN104

N INSEL ASSY

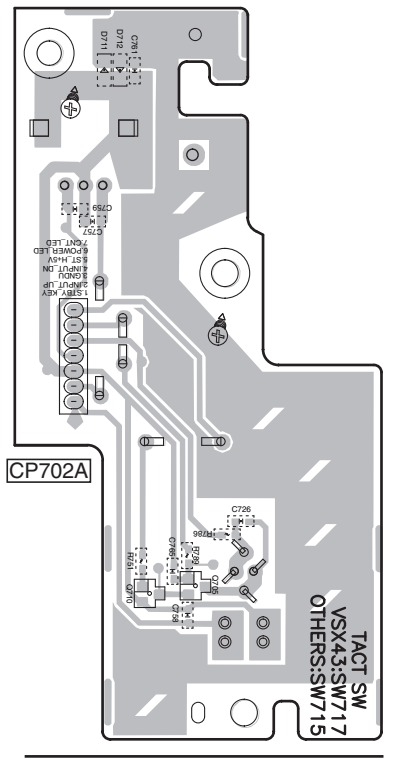

D

E

P HPMIC ASSY

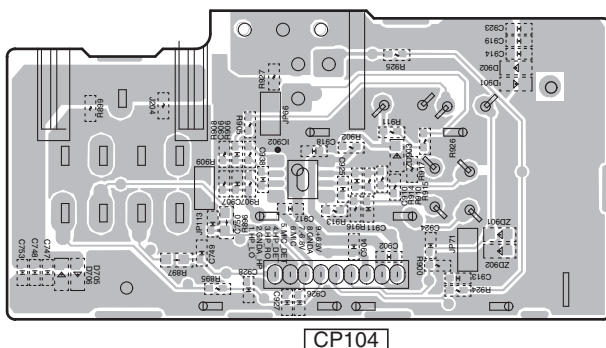

F

IC902

CP702A

Q710 Q705

VSX-1023-K

N O P

SIDE B

SIDE B

A

B

C

D

E

F

SMPS ASSY

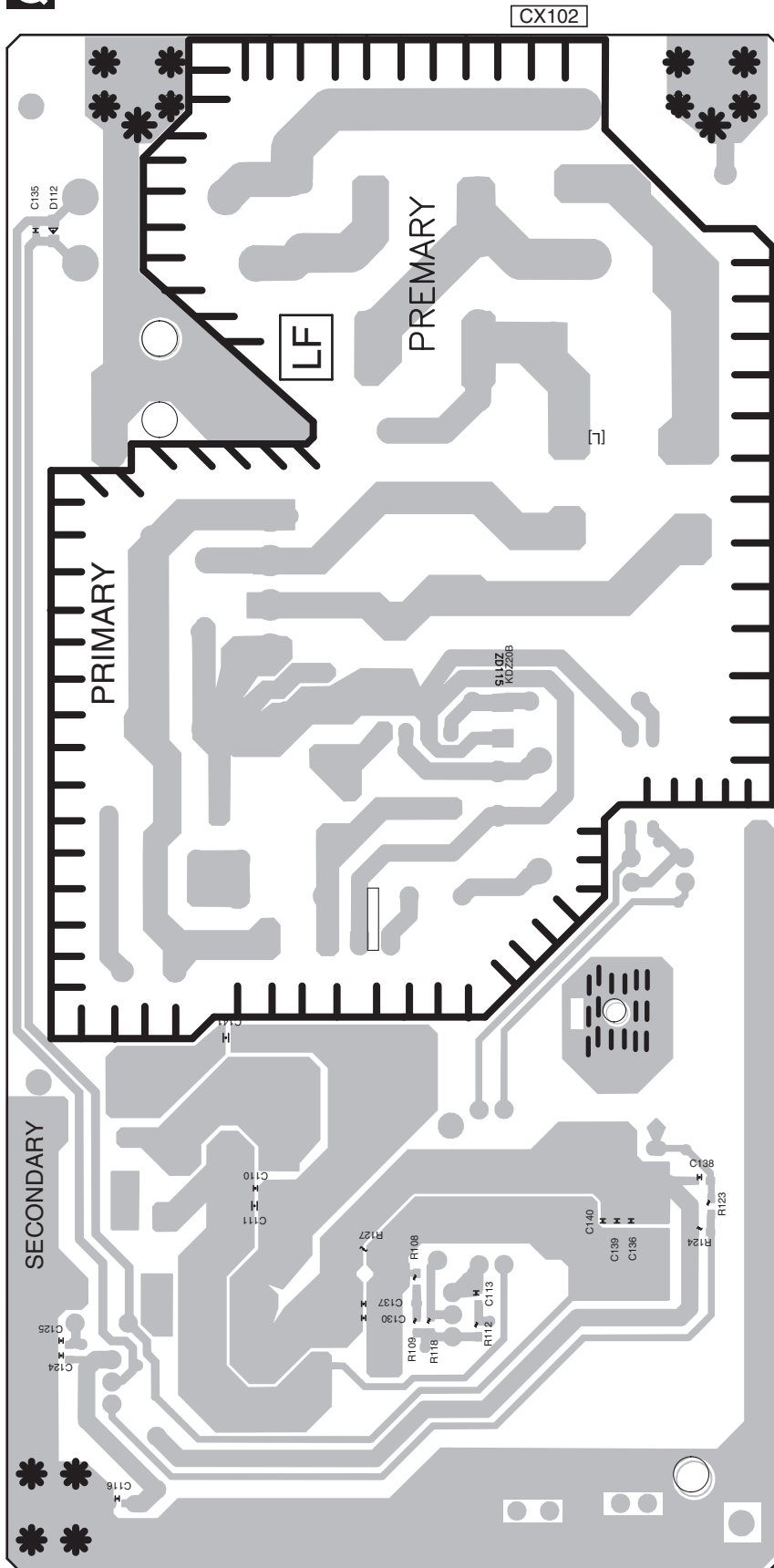

VSX-1023-K



11.17 REG ASSY (VSX-823-K ONLY)

SIDE A

SIDE A

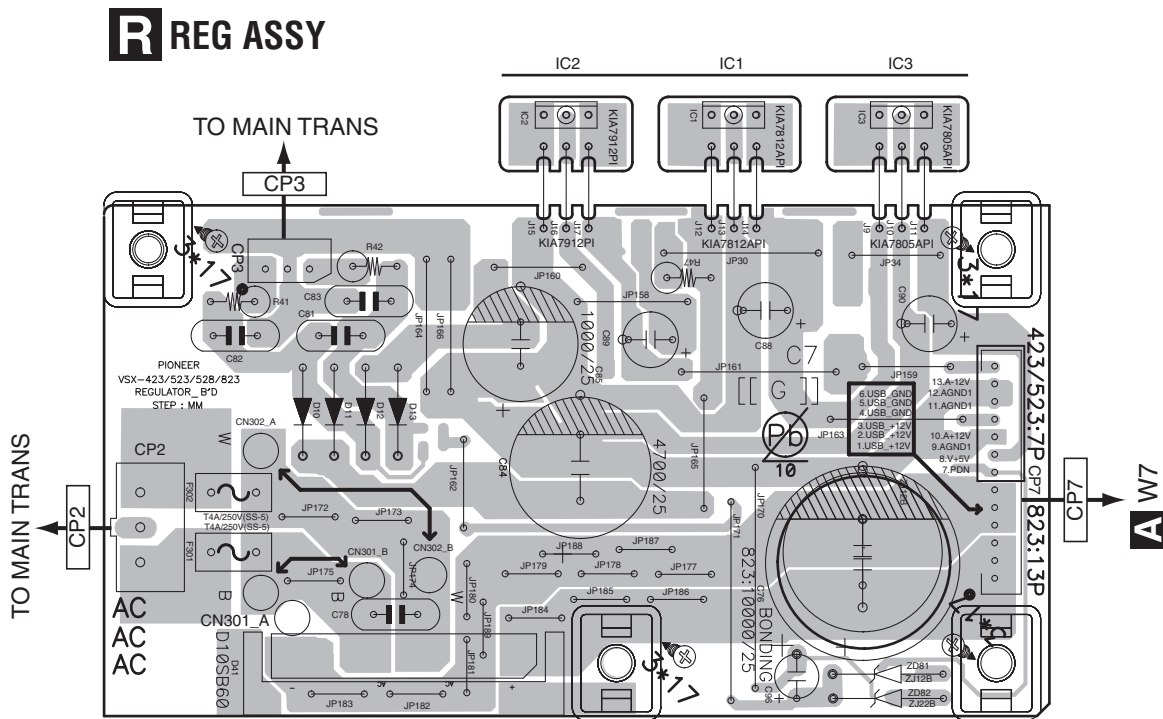

SIDE B

SIDE B

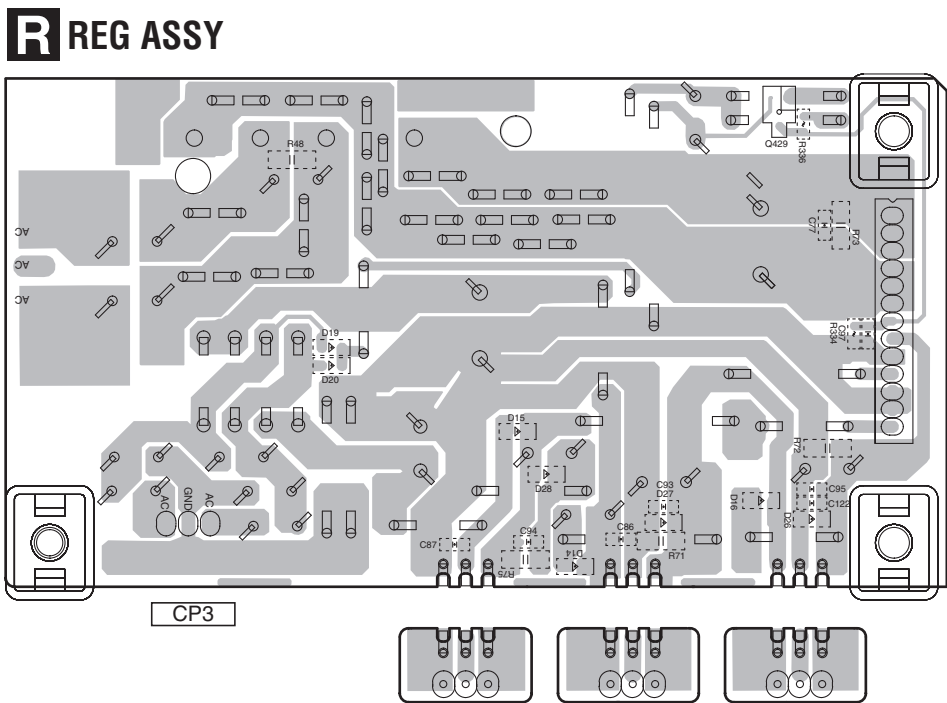

R
164

VSX-1023-K

11.18 WIRE-A, GUIDE and CPU-G ASSYS (VSX-1023-K, VSX-43 ONLY)

SIDE A

SIDE B

WIRE-A ASSY

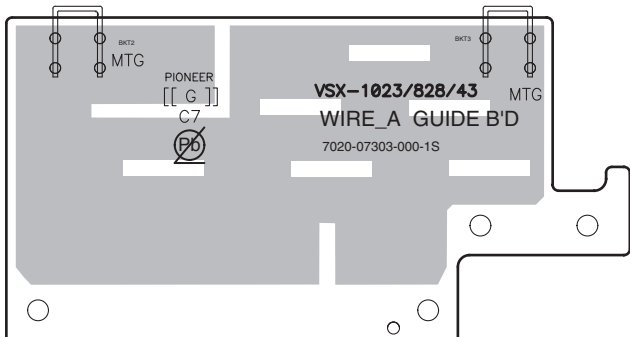

WIRE-A ASSY

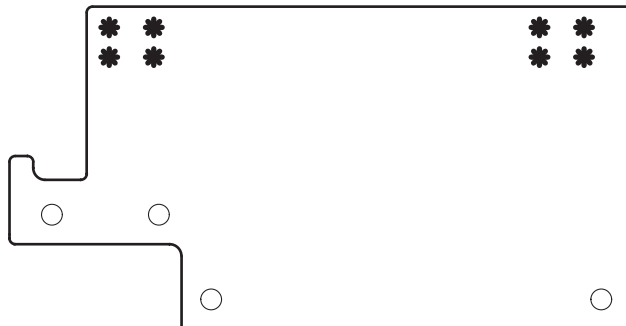

GUIDE ASSY

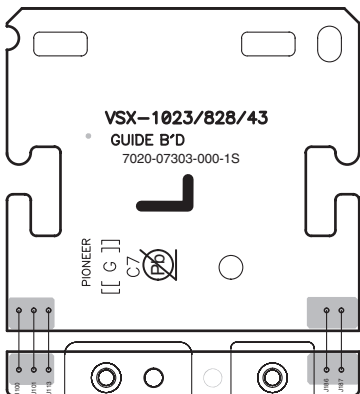

GUIDE ASSY

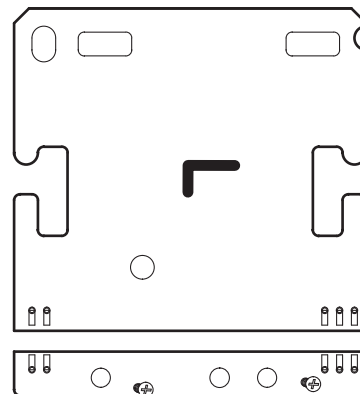

CPU-G ASSY

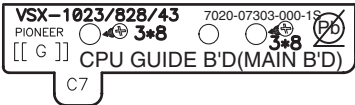

CPU-G ASSY

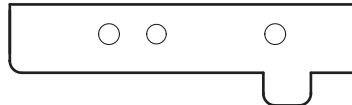

11.19 WG, G-L, G-R and HDC-G ASSYS (VSX-823-K ONLY)

SIDE A

SIDE A

WG ASSY

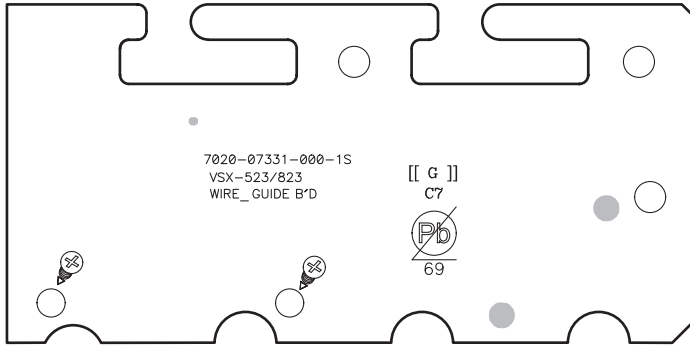

HDC-G ASSY

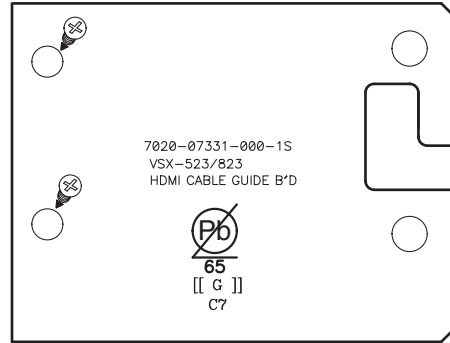

G-L ASSY

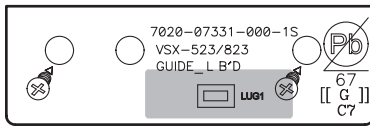

G-R ASSY

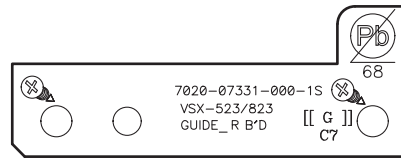

SIDE B

SIDE B

G-L ASSY

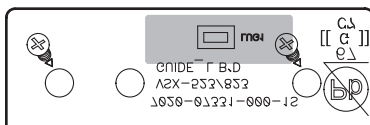

G-R ASSY

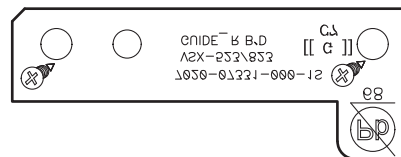

WG ASSY

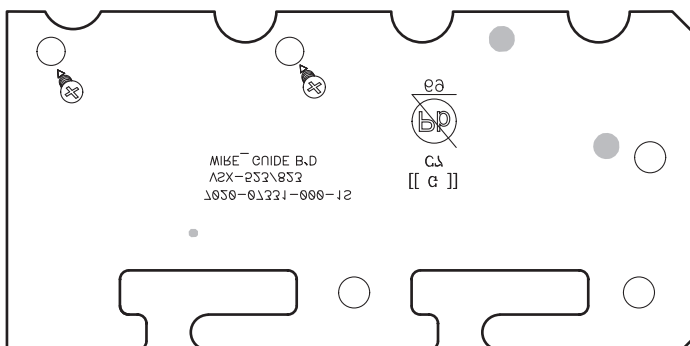

HDC-G ASSY

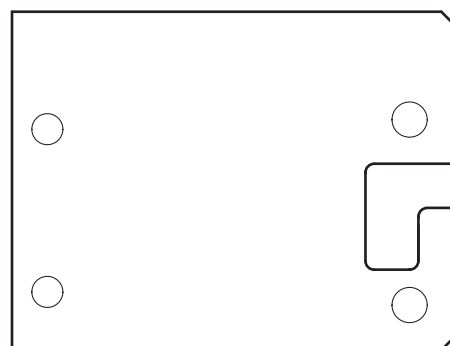

12. PCB PARTS LIST

NOTES: ● Parts marked by "NSP" are generally unavailable because they are not in our Master Spare Parts List.

● The Δ mark found on some component parts indicates the importance of the safety factor of the part. Therefore, when replacing, be sure to use parts of identical designation.

● When ordering resistors, first convert resistance values into code form as shown in the following examples.

Ex.1 When there are 2 effective digits (any digit apart from 0), such as 560 ohm and 47 k ohm (tolerance is shown by J = 5%, and K = 10%).

560 Ω → 56 × 10¹ → 561 RD1/APU 5 6 7 J

47 k Ω → 47 × 10³ → 473 RD1/APU 4 7 3 J

0.5 Ω → R50 RN2H R 5 0 K

1 Ω → 1R0 RSIP 7 R 0 K

Ex.2 When there are 3 effective digits (such as in high precision metal film resistors).

5.62 k Ω → 562 × 10¹ → 5621 RN1/4PC 5 6 2 7 F

● SCHEMATIC DIAGRAM and PCB CONNECTION DIAGRAM → ● PCB PARTS LIST

BKT	→ none	BEAD	→ L	RLY	→ RY	SW	→ S
CLAMP	→ none	F	→ FU	RMC	→ U	VEC	→ S9***
W	→ none	FLT	→ V	RES	→ X	GND	→ KN
LUG	→ none	JACK	→ JA	XTAL	→ X9***		
P	→ none	JACK	→ JA9***	BD	→ L7***		
PACK	→ 9***	JK	→ JA	LED	→ D8***		
CP	→ CN	PT	→ T	Z	→ D9***		
CP	→ CN9***	REG	→ IC	ZD	→ D9***		
CX	→ CN9***	REG	→ IC9***	DZ	→ D9***		
FPC	→ CN9***						

LIST OF ASSEMBLIES

Mark	Symbol and Description	VSX-1023-K/CUXESM	VSX-43/CUXE	VSX-823-K/CUXESM
NSP	1..PCB TTL ASSY MAIN	7025HK1209010-IL	7025HK1209020-IL	7025HK1210010-IL
	2..MAIN ASSY (PCB SUB ASSY MAIN)	7028073031010-IL	7028073031020-IL	70280733110A0-IL
	2..VIDEO ASSY (PCB SUB ASSY VIDEO)	7028073032020-IL	7028073032020-IL	Not used
	2..OPTCO ASSY (PCB SUB ASSY OPTCO)	7028073033020-IL	7028073033020-IL	70280733130A0-IL
	2..WIRE-A ASSY (PCB SUB ASSY WIRE_A)	7028073035020-IL	7028073035020-IL	Not used
	2..GUIDE ASSY (PCB SUB ASSY GUIDE)	7028073037020-IL	7028073037020-IL	Not used
	2..CPU-G ASSY (PCB SUB ASSY CPU_G)	7028073038020-IL	7028073038020-IL	Not used
	2..BRI-1 ASSY (PCB SUB ASSY BRI-1)	7028073039020-IL	7028073039020-IL	Not used
	2..REG ASSY (PCB SUB ASSY REG)	Not used	Not used	70280733120A0-IL
	2..WG ASSY (PCB SUB ASSY WG)	Not used	Not used	7028073315010-IL
	2..G-L ASSY (PCB SUB ASSY G-L)	Not used	Not used	7028073316010-IL
	2..G-R ASSY (PCB SUB ASSY G-R)	Not used	Not used	7028073317010-IL
	2..HDC-G ASSY (PCB SUB ASSY HDC-G)	Not used	Not used	70280733180A0-IL
NSP	1..PCB TTL ASSY DMAIN	7025HK1209011-IL	7025HK1209021-IL	7025HK1210011-IL
	2..D-MAIN ASSY (PCB SUB ASSY DMAIN)	7028073231040-IL	7028073231040-IL	7028073231020-IL
NSP	1..PCB TTL ASSY CPU	7025HK1209014-IL	7025HK1209024-IL	7025HK1210013-IL
	2..CPU ASSY (PCB SUB ASSY CPU)	7028073021010-IL	7028073021020-IL	70280733310A0-IL
	2..BRI-2 ASSY (PCB SUB ASSY BRI-2)	7028073023020-IL	7028073023020-IL	Not used
	2..BTCNT ASSY (PCB SUB ASSY BTCNT)	7028073024020-IL	7028073024020-IL	Not used
NSP	1..PCB TTL ASSY AUDIO	7025HK1209013-IL	7025HK1209023-IL	Not used
	2..AUDIO ASSY (PCB SUB ASSY AUDIO)	7028073041020-IL	7028073041020-IL	Not used
NSP	1..PCB TTL ASSY AMP7	7025HK1209015-IL	7025HK1209025-IL	Not used
	2..AMP7 ASSY (PCB SUB ASSY AMP7)	7028073051010-IL	7028073051010-IL	Not used
NSP	1..PCB TTL ASSY AMP5	Not used	Not used	7025HK1210014-IL
	2..AMP5 ASSY (PCB SUB ASSY AMP5)	Not used	Not used	70280733410A0-IL
NSP	1..PCB TTL ASSY FHDMI	7025HK1209017-IL	7025HK1209027-IL	7025HK1210016-IL
	2..FHDMI ASSY (PCB SUB ASSY FHDMI)	7028073221040-IL	7028073221040-IL	7028073221040-IL
NSP	1..PCB TTL ASSY BT	7025HK1209018-IL	7025HK1209028-IL	7025HK1210017-IL
	2..BT ASSY (PCB SUB ASSY BT)	7028073211040-IL	7028073211040-IL	7028073211040-IL
NSP	1..PCB TTL ASSY FRONT	7025HK1209012-IL	7025HK1209022-IL	7025HK1210012-IL
	2..FRONT ASSY (PCB SUB ASSY FRONT)	70280733210B0-IL	70280733210D0-IL	70280733210B0-IL
	2..HPMIC ASSY (PCB SUB ASSY HPMIC)	70280733220B0-IL	70280733220D0-IL	70280733220B0-IL
	2..INSEL ASSY (PCB SUB ASSY INSEL)	70280733230B0-IL	70280733230D0-IL	70280733230B0-IL
	2..CONCT ASSY (PCB SUB ASSY CONCT)	Not used	Not used	70280733240B0-IL
NSP	1..PCB TTL ASSY SMPS	7025HK1209016-IL	7025HK1209026-IL	7025HK1210015-IL
Δ	2..SMPS ASSY (PCB SUB ASSY SMPS)	7028073361010-IL	7028073361010-IL	7028073361010-IL

CONTRAST OF PCB ASSEMBLIES

A MAIN ASSY

7028073031010-IL and 7028073031020-IL are constructed the same except for the following:

Mark	Symbol and Description	7028073031010-IL	7028073031020-IL
⚠	IC5 Liner regulator IC	Not used	J126781200040-IL
	Heatsink	Not used	2120000818070-IL
	Screw	Not used	B020030081B10-IL

B D-MAIN ASSY

7028073231040-IL and 7028073231020-IL are different in part number, they consist of the same components.

C OPTCO ASSY

7028073033020-IL and 70280733130A0-IL are different in part number, they consist of the same components.

K CPU ASSY

7028073021010-IL and 7028073021020-IL are constructed the same except for the following:

Mark	Symbol and Description	7028073021010-IL	7028073021020-IL
	Q523 Semi, TR/GE PNP 2SA	Not used	J5001266G0050-IL
	Q519 Transistor	Not used	J5000916Y0050-IL
	JA502 Jack, D3.5	Not used	G401PJ3080100-IL

N INSEL ASSY

70280733230B0-IL and 70280733230D0-IL are constructed the same except for the following:

Mark	Symbol and Description	70280733230B0-IL	70280733230D0-IL
	D9704 LED, round	Not used	K500036000160-IL
	S715 Switch	G180501000010-IL	Not used
	S717 Switch	Not used	G180501000010-IL

O FRONT ASSY

70280733210B0-IL and 70280733210D0-IL are constructed the same except for the following:

Mark	Symbol and Description	70280733210B0-IL	70280733210D0-IL
	D701-D703 LED, round	K500052009011-IL	K500036000160-IL
	JA601 TER, RCA 1pin	G600101H0000Y-IL	G600101HG000Y-IL

P HPMIC ASSY

70280733220B0-IL and 70280733220D0-IL are constructed the same except for the following:

Mark	Symbol and Description	70280733220B0-IL	70280733220D0-IL
	JA701 Jack, D6.5	G402PJ612A09Y-IL	G402PJ612AG1Y-IL

Mark No. Description Part No.

PARTS LIST

A MAIN ASSY (VSX-1023-K)

SEMICONDUCTORS

△ IC 1	J126781200040-IL
△ IC 2	J126791200060-IL
△ IC 3	J126780500110-IL
Q 17	J5000916Y0050-IL
△ D 7,4912	K047100600220-IL
△ D 10-13	K000400700220-IL
D 23	K000400700220-IL
D 9001	K06003R344522-IL
D 9024,9025	K06016R044522-IL
D 9081	K06012R044522-IL

MISCELLANEOUS

JA 101 TER,BOARD SCREW 8P	G614108V1010M-IL
JA 102 TER,BOARD SCREW 4P	G612405E0200Y-IL
JA 103 TER,BOARD SCREW 2P	G611201A0200Y-IL
JA 104 TER,BOARD PUSH 4P	G594408SA030Y-IL
RY 2-6 RELAY	G680060103010-IL
CN 9009,9016,9435 CN,WAFER	L109012510920-IL
CN 9013 CN,WAFER	L109012510720-IL
CN 9015,9605 CN,WAFER	L109012511320-IL
CN 9017 CN,WAFER	L109012511520-IL
601 TUNER,FM/AM	E903004100780-IL
△ FU 302,303 FUSE,MICRO (T4A 250 V)	G658402250050-IL

RESISTORS

R 5,7,9,11	C060010065050-IL
R 6,8,10,12	C060010066050-IL
R 13,15,17,25	C060010065050-IL
R 14,16,18	C060010066050-IL
R 41,42	C060R22065050-IL
R 64	C060022063050-IL
R 66	C0604R7065050-IL

CAPACITORS

C 55,58	D040682088010-IL
C 76	D040103084000-IL
C 84	D040472084020-IL
C 85	D040102084060-IL

A MAIN ASSY (VSX-823-K)

SEMICONDUCTORS

IC 400	J084152180010-IL
IC 401-403,406	J121458001010-IL
IC 1200	J127410500010-IL
IC 1202	NJM2505AF
Q 17	J5000916Y0050-IL
△ D 7	K047100600220-IL
D 23	K000400700220-IL

MISCELLANEOUS

JA 101 TER,BOARD SCREW 8P	G614108V1010M-IL
JA 102 TER,BOARD SCREW 2P	G611201A0200Y-IL
JA 401 TER,RCA 6PIN	G603610A0001Y-IL
JA 402 TER,RCA 3PIN	G606305AW140Y-IL
JA 403 TER,RCA 1PIN	G600107A0000Y-IL
RY 2-4 RELAY	G680060103010-IL
CN 9013 CN,WAFER	L109012511920-IL
CN 9015 CN,WAFER	L109012511120-IL

Mark No. Description Part No.

CN 9016 CN,WAFER L109012513120-IL
CN 9111 CN,WAFER L109012511520-IL

601 TUNER,FM/AM E903004100780-IL

RESISTORS

R 5,7,9,11	C060010065050-IL
R 6,8,10,12	C060010066050-IL
R 13,25	C060010065050-IL
R 14	C060010066050-IL
R 64	C060022063050-IL
R 66	C0604R7065050-IL
R 510,587	C000033065520-IL
R 588,589	C060010165060-IL

CAPACITORS

C 55,58 D040682088010-IL

B D-MAIN ASSY

SEMICONDUCTORS

△ IC 103	J126283133010-IL
IC 1201	PE1026A
IC 1501,1509,1510	TC74VHC157FK
IC 1513	TC7SH08FUS1
IC 1804,9601	TC74VHC08FK
△ IC 1605	AAT4610BIGV-1
IC 1801	J080458800010-IL
IC 1808	TC7WHU04FK
IC 9003	J001986466010-IL
IC 9201,9209	A3V56S30FTP-G6
△ IC 9450,9502	MM3529A12P
△ IC 9511	MM3529A50P
△ IC 9555	MM3411A50N
△ Q 401,403	J543045010060-IL

MISCELLANEOUS

JA 1601,9601-9605 CN,WAFER L109100190160-IL
JA 9202 JACK,MODULAR G4060RJ450230-IL
JA 9620 CN,WAFER L109100190170-IL

C OPTCO ASSY

SEMICONDUCTORS

IC 2009 J040740400290-IL

MISCELLANEOUS

JA 1305 MODULE E100802000250-IL
JA 1306 TER,RCA 1PIN G600107A0000Y-IL

D BRI-1 ASSY (VSX-1023-K, VSX-43)

MISCELLANEOUS

CN 9003,9438 CN,WAFER L109012511920-IL

E CONCT ASSY (VSX-823-K)

MISCELLANEOUS

CN 109 CN,WAFER L109012511520-IL

F VIDEO ASSY (VSX-1023-K, VSX-43)

SEMICONDUCTORS

IC 1200 J127410500010-IL
IC 1201 J170258000010-IL
IC 1202 NJM2505AF

Mark	No.	Description	Part No.
------	-----	-------------	----------

MISCELLANEOUS

JA 1200 TER,RCA 9PIN

G607902AA580Y-IL

G **BT ASSY**
SEMICONDUCTORS

△ IC 600

BD2224G

MISCELLANEOUS

CN601 CONNECTOR

CKS5712

H **BTCNT ASSY (VSX-1023-K, VSX-43)**
MISCELLANEOUS

CN602 CN,WAFER

L109012511120-IL

I **BRI-2 ASSY (VSX-1023-K, VSX-43)**
MISCELLANEOUS

RY 800 RELAY

G680240202030-IL

CN204 CN,WAFER

L109012511320-IL

CN9402 CN,WAFER

L109012511520-IL

RESISTORS

R 382

C060010063050-IL

J **AUDIO ASSY (VSX-1023-K, VSX-43)**
SEMICONDUCTORS

IC 400

J084152180010-IL

IC 401-403,406

J121458001010-IL

MISCELLANEOUS

JA 401 TER,RCA 6PIN

G603603A0090Y-IL

JA 403 TER,RCA 1PIN

G600107A0000Y-IL

RESISTORS

R 510,587

C060033065050-IL

R 588,589

C060010165060-IL

K **CPU ASSY (VSX-1023-K)**
SEMICONDUCTORS

IC 204

J000241600170-IL

IC 206

J040741080070-IL

MISCELLANEOUS

JA 504,505 JACK,D3.5

G401PJ3080100-IL

CN201 CN,WAFER

L109012513320-IL

CN213 CN,WAFER

L109012511120-IL

CAPACITORS

C 3042

D040102081070-IL

K **CPU ASSY (VSX-823-K)**
SEMICONDUCTORS

IC 204

J000241600170-IL

IC 206

J040741080070-IL

△ IC 301

J126111733230-IL

MISCELLANEOUS

RY 101 RELAY

G680240202030-IL

X 201 CRYSTAL (16 MHz)

E80016R000030-IL

CN203,210 CN,WAFER

L109012511120-IL

170

Mark	No.	Description	Part No.
------	-----	-------------	----------

RESISTORS

R 103,104

C060018163050-IL

R 105

C060010063050-IL

L **AMP7 ASSY (VSX-1023-K, VSX-43)**
SEMICONDUCTORS

Q 401,413,425,437

J5001024Y0050-IL

Q 407,408,417,419

J5000992FA050-IL

Q 412,424,436,448

J5023206Y0050-IL

Q 420,431,432,443

J5000992FA050-IL

Q 444,455,456,467

J5000992FA050-IL

Q 449,461,473

J5001024Y0050-IL

Q 460,472,484

J5023206Y0050-IL

Q 468,479,480

J5000992FA050-IL

D 9401,9404,9407,9410

K06005R134522-IL

D 9402,9403,9405,9406

K06004R344522-IL

D 9408,9409,9411,9412

K06004R344522-IL

D 9413,9416,9419

K06005R134522-IL

D 9414,9415,9417,9418

K06004R344522-IL

D 9420,9421

K06004R344522-IL

MISCELLANEOUS

VR 401-407 VR,SEMI CARBON MOLD

C541102315000-IL

RESISTORS

△ R 406,450,494,537

F320471000950-IL

△ R 415,439,458,483

C060010165060-IL

△ R 424,425,430,431

N113136647820-IL

R 443,487,530,573

C060047065060-IL

△ R 467,468,474,475

N113136647820-IL

R 493

C060033065060-IL

△ R 502,526,545,569

C060010165060-IL

△ R 511,512,517,518

N113136647820-IL

R 551

C060010165060-IL

△ R 554,555,561,562

N113136647820-IL

△ R 580,623,666

F320471000950-IL

△ R 588,612,631,655

C060010165060-IL

△ R 597,598,603,604

N113136647820-IL

R 616,659,702

C060047065060-IL

△ R 640,641,646,647

N113136647820-IL

△ R 674,698

C060010165060-IL

△ R 683,684,689,690

N113136647820-IL

L **AMP5 ASSY (VSX-823-K)**
SEMICONDUCTORS

Q 1

J5001024Y0050-IL

Q 2,3,452

J5000992FA050-IL

Q 4

J5023206Y0050-IL

D 9001

K06005R134522-IL

D 9002,9003

K06004R344522-IL

MISCELLANEOUS

VR 1 VR,SEMI CARBON MOLD

C541102315000-IL

RESISTORS

R 16

C060047065060-IL

△ R 24,25

C060010165060-IL

△ R 26-29

N113136647820-IL

△ R 33

F320471000950-IL

Mark	No.	Description	Part No.
	R 452		C060010165060-IL
	R 453		C060033065050-IL

M FHDMI ASSY SEMICONDUCTORS

⚠	IC 808	J127380100050-IL
	IC 8202	PCA9517DGK

MISCELLANEOUS

JA 600	CN,PLUG CONTACT	G480400201010-IL
JA 802	CN.WAFER	L109100190140-IL

N INSEL ASSY (VSX-1023-K, VSX-823-K)

MISCELLANEOUS

S 715	SWITCH	G180501000010-IL
S 9702	SW,ENCODER	G121121200230-IL

O FRONT ASSY (VSX-1023-K, VSX-823-K)

SEMICONDUCTORS

	IC 701	J127163150020-IL
⚠	Q 702	J5001266G0050-IL
	D 701-703	K500052009011-IL
	D 9701	K06007R544522-IL

MISCELLANEOUS

JA 601	TER,RCA 1PIN	G600101H0000Y-IL
V 701	DISPLAY,FLT	K530126600011-IL
S 701-714,716	SWITCH	G180501000010-IL
S 9701	SW,ENCODER	G121122400230-IL
1	HOLDER	4320211306000-IL
U 701	MODULE,REMOCON	E940349003810-IL

RESISTORS

⚠	R 779,780	C060001063050-IL
---	-----------	------------------

P HPMIC ASSY (VSX-1023-K, VSX-823-K)

SEMICONDUCTORS

	IC 902	J121458001010-IL
--	--------	------------------

MISCELLANEOUS

JA 701	JACK,D6.5	G402PJ612A09Y-IL
JA 702	JACK,D3.5	G40132340000Y-IL

Q SMPS ASSY

SEMICONDUCTORS

⚠	IC 100	K614123000010-IL
⚠	IC 102	J122201530080-IL
⚠	IC 116	J126243118010-IL
	Q 102	J5023198Y0000-IL
⚠	D 41	K047200600010-IL

⚠	D 103	K120300600010-IL
	D 105	K050400700010-IL
	D 108	K050010010010-IL
	D 9114	K06006R244522-IL
	D 9115	K06620R04P410-IL

MISCELLANEOUS

⚠	L 100	COIL,LINE FILTER	D320201405510-IL
⚠	RY 101	RELAY	G680060103030-IL

Mark	No.	Description	Part No.
⚠	T 101	TRANS,SWITCHING	E060252505510-IL
⚠	CN9100	CN.WAFER 7.92MM	L108396030010-IL
⚠	CN 9102	CN.WAFER 7.92MM	L108011430210-IL

	100,102	BRACKET	4010215796000-IL
	101	BRACKET	4010210196000-IL
⚠	FU 100	FUSE GLASS TUBE 20MM (3.15 A)	N751503151160-IL
⚠	FU 101	FUSE GLASS TUBE 20MM (T8AL/250V)	N751508001160-IL

RESISTORS

⚠	R 100	C060068564520-IL
	R 116	C060R68065050-IL
	R 120	C0604R7065050-IL

CAPACITORS

⚠	C 100	D02110407H010-IL
	C 102	D04010108K000-IL
	C 103	D00810207Q010-IL
⚠	C 104,105	D00847127H010-IL
	C 106	D041562081001-IL
⚠	C 115,132	D00815248H010-IL
⚠	C 117,131,133	D008103589010-IL
	C 129	D041221082230-IL

R REG ASSY (VSX-823-K)

SEMICONDUCTORS

⚠	IC 1	J126781200040-IL
⚠	IC 2	J126791200060-IL
⚠	IC 3	J126780500110-IL
⚠	D 10-13	K000400700220-IL
	D 19,20	K005041480230-IL
⚠	D 41	K047100600220-IL
	D 9081	K06012R044522-IL

MISCELLANEOUS

⚠	FU 301,302	FUSE,MICRO (T4A 250 V)	G658402250050-IL
---	------------	------------------------	------------------

RESISTORS

	R 41,42	C060R22065050-IL
--	---------	------------------

CAPACITORS

	C 76	D040103084000-IL
	C 84	D040472084020-IL
	C 85	D040102084060-IL

WIRE-A ASSY (VSX-1023-K, VSX-43)

There is no service parts.

GUIDE ASSY (VSX-1023-K, VSX-43)

There is no service parts.

CPU-G ASSY (VSX-1023-K, VSX-43)

There is no service parts.

G-L ASSY (VSX-823-K)

There is no service parts.

G-R ASSY (VSX-823-K)

There is no service parts.

HDC-G ASSY (VSX-823-K)

There is no service parts.