

# Pioneer

## Service Manual



VSX-1127-K

ORDER NO.  
RRV4307

AV Receiver

# VSX-1127-K

## VSX-1122-K

## VSX-60

## VSX-1027-K

THIS MANUAL IS APPLICABLE TO THE FOLLOWING MODEL(S) AND TYPE(S).

Model	Type	Power Requirement	Remarks
VSX-1127-K	CUXE	AC 120 V	
VSX-1122-K	CUXESM	AC 120 V	
VSX-60	UXECB	AC 120 V	
VSX-1027-K	CUXE	AC 120 V	

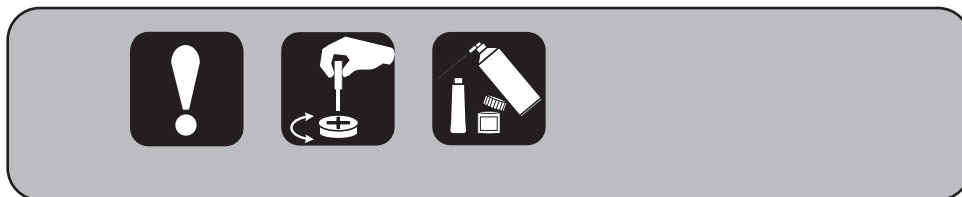

**PIONEER CORPORATION** 1-1, Shin-ogura, Saiwai-ku, Kawasaki-shi, Kanagawa 212-0031, Japan

**PIONEER ELECTRONICS (USA) INC.** P.O. Box 1760, Long Beach, CA 90801-1760, U.S.A.

**PIONEER EUROPE NV** Haven 1087, Keetberglaan 1, 9120 Melsele, Belgium

**PIONEER ELECTRONICS ASIACENTRE PTE. LTD.** 253 Alexandra Road, #04-01, Singapore 159936

©PIONEER CORPORATION 2012

K-MZV MAR. 2012 Printed in Japan

# SAFETY INFORMATION



This service manual is intended for qualified service technicians; it is not meant for the casual do-it-yourselfer. Qualified technicians have the necessary test equipment and tools, and have been trained to properly and safely repair complex products such as those covered by this manual.

Improperly performed repairs can adversely affect the safety and reliability of the product and may void the warranty. If you are not qualified to perform the repair of this product properly and safely, you should not risk trying to do so and refer the repair to a qualified service technician.

## WARNING

This product may contain a chemical known to the State of California to cause cancer, or birth defects or other reproductive harm.

Health & Safety Code Section 25249.6 - Proposition 65

(FOR USA MODEL ONLY)

## 1. SAFETY PRECAUTIONS

The following check should be performed for the continued protection of the customer and service technician.

### LEAKAGE CURRENT CHECK

Measure leakage current to a known earth ground (water pipe, conduit, etc.) by connecting a leakage current tester such as Simpson Model 229-2 or equivalent between the earth ground and all exposed metal parts of the appliance (input/output terminals, screwheads, metal overlays, control shaft, etc.). Plug the AC line cord of the appliance directly into a 120 V AC 60 Hz outlet and turn the AC power switch on. Any current measured must not exceed 0.5 mA.

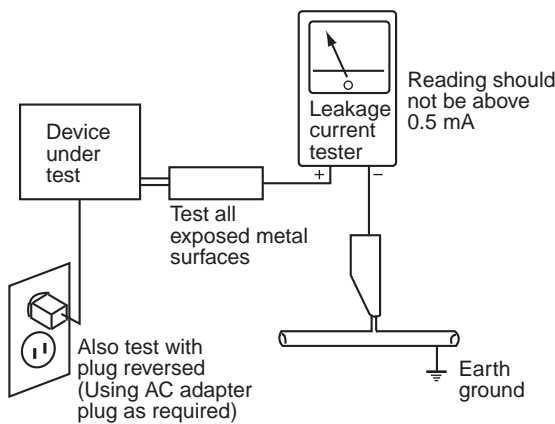

AC Leakage Test

ANY MEASUREMENTS NOT WITHIN THE LIMITS OUTLINED ABOVE ARE INDICATIVE OF A POTENTIAL SHOCK HAZARD AND MUST BE CORRECTED BEFORE RETURNING THE APPLIANCE TO THE CUSTOMER.

## 2. PRODUCT SAFETY NOTICE

Many electrical and mechanical parts in the appliance have special safety related characteristics. These are often not evident from visual inspection nor the protection afforded by them necessarily can be obtained by using replacement components rated for voltage, wattage, etc. Replacement parts which have these special safety characteristics are identified in this Service Manual.

Electrical components having such features are identified by marking with a ⚠ on the schematics and on the parts list in this Service Manual.

The use of a substitute replacement component which does not have the same safety characteristics as the PIONEER recommended replacement one, shown in the parts list in this Service Manual, may create shock, fire, or other hazards.

Product Safety is continuously under review and new instructions are issued from time to time. For the latest information, always consult the current PIONEER Service Manual. A subscription to, or additional copies of, PIONEER Service Manual may be obtained at a nominal charge from PIONEER.

# CONTENTS

SAFETY INFORMATION.....	2	
1. SERVICE PRECAUTIONS.....	5	
1.1 NOTES ON SOLDERING.....	5	A
1.2 NOTES ON REPLACING PARTS.....	5	
1.3 SERVICE NOTICE.....	5	
2. SPECIFICATIONS.....	6	
3. BASIC ITEMS FOR SERVICE.....	9	
3.1 CHECK POINTS AFTER SERVICING.....	9	
3.2 JIGS LIST.....	9	
3.3 PCB LOCATIONS.....	10	
4. BLOCK DIAGRAM.....	12	
4.1 OVERALL WIRING DIAGRAM.....	12	
4.2 AUDIO BLOCK DIAGRAM.....	14	
4.3 D-AUDIO BLOCK DIAGRAM.....	16	
4.4 D-VIDEO BLOCK DIAGRAM.....	18	B
4.5 VIDEO BLOCK DIAGRAM.....	20	
4.6 POWER SUPPLY BLOCK DIAGRAM.....	22	
5. DIAGNOSIS.....	24	
5.1 TROUBLESHOOTING.....	24	
5.2 ERROR INDICATIONS.....	32	
5.3 DETECTION CIRCUIT.....	33	
5.4 IC INFORMATION.....	35	
6. SERVICE MODE.....	38	
6.1 TEST MODE.....	38	
6.2 DEFAULT SETTINGS.....	40	
7. DISASSEMBLY.....	41	
8. EACH SETTING AND ADJUSTMENT.....	48	C
8.1 ADJUSTMENT REQUIRED WHEN THE UNIT IS REPAIRED OR REPLACED.....	48	
8.2 USB BACKUP.....	49	
8.3 UPDATING OF THE FIRMWARE.....	51	
8.4 IDLE CURRENT ADJUSTMENT.....	54	
9. EXPLODED VIEWS AND PARTS LIST.....	56	
9.1 PACKING SECTION.....	56	
9.2 EXTERIOR SECTION.....	58	
10. SCHEMATIC DIAGRAM.....	62	
10.1 AUDIO ASSY.....	62	
10.2 AMP7 ASSY (1/2).....	64	
10.3 AMP7 ASSY (2/2).....	66	
10.4 MAIN ASSY.....	68	D
10.5 D-MAIN ASSY (1/10).....	70	
10.6 D-MAIN ASSY (2/10).....	72	
10.7 D-MAIN ASSY (3/10).....	74	
10.8 D-MAIN ASSY (4/10).....	76	
10.9 D-MAIN ASSY (5/10).....	78	
10.10 D-MAIN ASSY (6/10).....	80	
10.11 D-MAIN ASSY (7/10).....	82	
10.12 D-MAIN ASSY (8/10).....	84	
10.13 D-MAIN ASSY (9/10).....	86	
10.14 D-MAIN ASSY (10/10).....	88	
10.15 IR ASSY.....	90	E
10.16 VIDEO ASSY.....	92	
10.17 BRG ASSY.....	94	
10.18 FRONT and POWER ASSYS.....	96	
10.19 MIC, FVIDEO and HP ASSYS.....	98	
10.20 G-L, G-R, WG-A, WG-B, CCG and BTCNT ASSYS.....	99	
10.21 FHDMI and F-USB ASSYS.....	100	
10.22 SMPS ASSY.....	102	
10.23 BT ASSY.....	104	

- 11. PCB CONNECTION DIAGRAM .....106
  - 11.1 AUDIO ASSY .....106
  - 11.2 AMP7 ASSY .....108
  - 11.3 MAIN ASSY.....110
  - 11.4 D-MAIN ASSY .....114
  - 11.5 IR ASSY .....118
  - 11.6 VIDEO ASSY .....120
  - 11.7 BRG ASSY.....122
  - 11.8 FRONT, POWER, MIC, FVIDEO and HP ASSYS .....124
  - 11.9 G-L, G-R, WG-A and WG-B ASSYS .....128
  - 11.10 CCG and BTCNT ASSYS .....129
  - 11.11 FHDMI and F-USB ASSYS .....130
  - 11.12 BT ASSY .....131
  - 11.13 SMPS ASSY .....132
- 12. PCB PARTS LIST .....134

A

B

C

D

E

F

# 1. SERVICE PRECAUTIONS

## 1.1 NOTES ON SOLDERING

- For environmental protection, lead-free solder is used on the printed circuit boards mounted in this unit.  
Be sure to use lead-free solder and a soldering iron that can meet specifications for use with lead-free solders for repairs accompanied by reworking of soldering.
- Compared with conventional eutectic solders, lead-free solders have higher melting points, by approximately 40 °C.  
Therefore, for lead-free soldering, the tip temperature of a soldering iron must be set to around 373 °C in general, although the temperature depends on the heat capacity of the PC board on which reworking is required and the weight of the tip of the soldering iron.

Do NOT use a soldering iron whose tip temperature cannot be controlled.

Compared with eutectic solders, lead-free solders have higher bond strengths but slower wetting times and higher melting temperatures (hard to melt/easy to harden).

The following lead-free solders are available as service parts:

- Parts numbers of lead-free solder:  
GYP1006 1.0 in dia.  
GYP1007 0.6 in dia.  
GYP1008 0.3 in dia.

## 1.2 NOTES ON REPLACING PARTS

The part listed below is difficult to replace as a discrete component part.  
When the part listed in the table is defective, replace whole Assy.

Assy Name	Parts that is Difficult to Replace			
	Ref No.	Function	Part No.	Remarks
D-MAIN Assy	JA1601, JA9601-JA9607	HDMI Connector	—————	JACK with Cu-through-hole & SMD type
	JA9201	USB Connector	—————	JACK with Cu-through-hole & 6 pin
	JA9202	LAN Connector	—————	JACK with Cu-through-hole & 10 pin
	IC9520	D-MAIN 3.3V Power Supply IC	—————	IC with heat-pad
	IC9521	D-MAIN 3.3V Power Supply IC	—————	IC with heat-pad
	IC9522	D-MAIN 1.8V Power Supply IC	—————	IC with heat-pad
	IC9002	DSP IC	—————	IC with heat-pad
	IC1204	VIDEO FORMAT CONVERTER	—————	IC BGA type
	IC1212	DDR IC	—————	IC BGA type
	IC9203	LAN PHY IC	—————	IC with heat-pad
	IC9204	NETWORK MEDIA PROCESSOR	—————	IC BGA type
	IC1602	HDMI Tx	—————	IC with heat-pad
	IC903	HDMI Rx	—————	IC with heat-pad
IC9602	HDMI SW IC	—————	IC with heat-pad	
F-USB Assy	IC805	USB 5V SW IC	—————	IC with heat-pad
	IC1307	USB 5V SW Power Supply IC	—————	IC with heat-pad

## 1.3 SERVICE NOTICE

### • Discharging

For more detail, please refer to "7. DISASSEMBLY - 1. Discharging".

### • Notes on Ground Points Connection

For more detail, please refer to "7. DISASSEMBLY - 2. Notes on Ground Points Connection".

# 2. SPECIFICATIONS

## ■ VSX-1127-K, VSX-1027-K

### Amplifier section

Continuous average power output of 90 watts\* per channel, min., at 8 ohms, from 20 Hz to 20 000 Hz with no more than 0.08 %\*\* total harmonic distortion.

Front (stereo) ..... 90 W + 90 W  
 Power output (1 kHz, 6 Ω, 1 %, 1 ch driven) ..... 165 W  
 Guaranteed speaker impedance ..... 6 Ω to 16 Ω

\* Measured pursuant to the Federal Trade Commission's Trade Regulation rule on Power Output Claims for Amplifiers  
 \*\* Measured by Audio Spectrum Analyzer

### Audio Section

Input (Sensitivity/Impedance)  
 LINE ..... 315 mV/47 kΩ  
 Signal-to-Noise Ratio (IHF, short circuited, A network)  
 LINE ..... 100 dB  
 Signal-to-Noise Ratio [EIA, at 1 W (1 kHz)]  
 LINE ..... 81 dB

### Tuner Section

Frequency Range (FM) ..... 87.5 MHz to 108 MHz  
 Antenna Input (FM) ..... 75 Ω unbalanced  
 Frequency Range (AM) ..... 530 kHz to 1700 kHz  
 Antenna (AM) ..... Loop antenna (balanced)

### Video Section

Signal level  
 Composite Video ..... 1 Vp-p (75 Ω)  
 Component Video ..... Y: 1.0 Vp-p (75 Ω), PB/PR: 0.7 Vp-p (75 Ω)  
 Corresponding maximum resolution  
 Component Video ..... 1080p (1125p) (Video convert off)

### Digital In/Out Section

HDMI terminal ..... 19-pin (Not DVI)  
 HDMI output type ..... 5 V, 100 mA  
 USB terminal ..... USB2.0 High Speed (Type A) 5 V, 2.1 A  
 iPod terminal ..... USB, and Video (Composite)  
 ADAPTER PORT terminal ..... 5 V, 100 mA  
 WIRELESS LAN ADAPTER terminal ..... 5 V, 600 mA

### Integrated Control Section

Control (IR) terminal ..... ø 3.5 Mini-jack (MONO)  
 IR signal ..... High Active (High Level: 2.0 V)

### Network Section

LAN terminal ..... 10 BASE-T/100 BASE-TX

### Miscellaneous

Power requirements ..... AC 120 V, 60 Hz  
 Power consumption ..... 550 W  
 In standby ..... 0.2 W (HDMI Setup – Control : OFF)  
 0.3 W (HDMI Setup – Control : ON)  
 Dimensions ..... 435 mm (W) x 168 mm (H) x 362.5 mm (D)  
 (17 3/16 in. (W) x 6 5/8 in. (H) x 14 5/16 in. (D))  
 Weight (without package)  
 VSX-1127 ..... 9.9 kg (21.8 lb)  
 VSX-1027 ..... 9.8 kg (21.6 lb)

### Note

- Specifications and the design are subject to possible modifications without notice, due to improvements.
- This product includes FontAvenue® fonts licensed by NEC Corporation. FontAvenue is a registered trademark of NEC Corporation.

## ■ VSX-60

### Amplifier section

Continuous average power output of 90 watts\* per channel, min., at 8 ohms, from 20 Hz to 20 000 Hz with no more than 0.08 %\*\* total harmonic distortion.

Front (stereo) ..... 90 W + 90 W  
 Guaranteed speaker impedance ..... 6 Ω to 16 Ω

\* Measured pursuant to the Federal Trade Commission's Trade Regulation rule on Power Output Claims for Amplifiers  
 \*\* Measured by Audio Spectrum Analyzer

### Audio Section

Input (Sensitivity/Impedance)  
 LINE ..... 315 mV/47 kΩ  
 Output (Level/Impedance)  
 REC ..... 315 mV/2.2 kΩ  
 Signal-to-Noise Ratio (IHF, short circuited, A network)  
 LINE ..... 100 dB  
 Signal-to-Noise Ratio [EIA, at 1 W (1 kHz)]  
 LINE ..... 81 dB

### Tuner Section

Frequency Range (FM) ..... 87.5 MHz to 108 MHz  
 Antenna Input (FM) ..... 75 Ω unbalanced  
 Frequency Range (AM) ..... 530 kHz to 1700 kHz  
 Antenna (AM) ..... Loop antenna (balanced)

### Video Section

Signal level  
 Composite Video ..... 1 Vp-p (75 Ω)  
 Component Video ..... Y: 1.0 Vp-p (75 Ω), PB/PR: 0.7 Vp-p (75 Ω)  
 Corresponding maximum resolution  
 Component Video ..... 1080p (1125p) (Video convert off)

### Digital In/Out Section

HDMI terminal ..... 19-pin (Not DVI)  
 HDMI output type ..... 5 V, 100 mA  
 USB terminal ..... USB2.0 High Speed (Type A) 5 V, 2.1 A  
 iPod terminal ..... USB, and Video (Composite)  
 ADAPTER PORT terminal ..... 5 V, 100 mA  
 WIRELESS LAN ADAPTER terminal ..... 5 V, 600 mA

### Integrated Control Section

Control (IR) terminal ..... ø 3.5 Mini-jack (MONO)  
 IR signal ..... High Active (High Level: 2.0 V)  
 12 V Trigger terminal ..... ø 3.5 Mini-jack (MONO)  
 12 V Trigger output type ..... 12 V, Total 150 mA  
 RS-232C cable type ..... 9-pin, cross type, female-female

### Network Section

LAN terminal ..... 10 BASE-T/100 BASE-TX

### Miscellaneous

Power requirements.....AC 120 V, 60 Hz  
 Power consumption .....550 W  
 In standby.....0.2 W (HDMI Setup – Control : OFF)  
 0.3 W (HDMI Setup – Control : ON)  
 Dimensions..... 435 mm (W) x 168 mm (H) x 362.5 mm (D)  
 (17 3/16 in. (W) x 6 5/8 in. (H) x 14 5/16 in. (D))  
 Weight (without package) .....9.9 kg (22 lb)

### Note

- Specifications and the design are subject to possible modifications without notice, due to improvements.
- This product includes FontAvenue® fonts licensed by NEC Corporation. FontAvenue is a registered trademark of NEC Corporation.

## ■ VSX-1122-K

### Amplifier section

Continuous average power output of 90 watts\* per channel, min., at 8 ohms, from 20 Hz to 20 000 Hz with no more than 0.08 %\*\* total harmonic distortion.

Front (stereo) ..... 90 W + 90 W  
 Power output (1 kHz, 6 Ω, 1 %, 1 ch driven) .....165 W  
 Guaranteed speaker impedance ..... 6 Ω to 16 Ω

\* Measured pursuant to the Federal Trade Commission's Trade Regulation rule on Power Output Claims for Amplifiers

\*\* Measured by Audio Spectrum Analyzer

### Audio Section

Input (Sensitivity/Impedance)

LINE.....315 mV/47 kΩ  
 Signal-to-Noise Ratio (IHF, short circuited, A network)  
 LINE..... 100 dB  
 Signal-to-Noise Ratio [EIA, at 1 W (1 kHz)]  
 LINE..... 81 dB

### Tuner Section

Frequency Range (FM) .....87.5 MHz to 108 MHz  
 Antenna Input (FM)..... 75 Ω unbalanced  
 Frequency Range (AM) ..... 530 kHz to 1700 kHz  
 Antenna (AM) .....Loop antenna (balanced)

### Video Section

Signal level

Composite Video ..... 1 Vp-p (75 Ω)  
 Component Video..... Y: 1.0 Vp-p (75 Ω), PB/PR: 0.7 Vp-p  
 (75 Ω)

Corresponding maximum resolution

Component Video..... 1080p (1125p) (Video convert off)

### Digital In/Out Section

HDMI terminal ..... 19-pin (Not DVI)  
 HDMI output type.....5 V, 100 mA  
 USB terminal ..... USB2.0 High Speed (Type A) 5 V, 2.1 A  
 iPod terminal.....USB, and Video (Composite)  
 ADAPTER PORT terminal .....5 V, 100 mA  
 WIRELESS LAN ADAPTER terminal .....5 V, 600 mA

### Integrated Control Section

Control (IR) terminal .....ø 3.5 Mini-jack (MONO)  
 IR signal..... High Active (High Level: 2.0 V)

### Network Section

LAN terminal..... 10 BASE-T/100 BASE-TX

### Miscellaneous

Power requirements.....AC 120 V, 60 Hz  
 Power consumption .....550 W  
 In standby.....0.2 W (HDMI Setup – Control : OFF)  
 0.3 W (HDMI Setup – Control : ON)  
 Dimensions..... 435 mm (W) x 168 mm (H) x 362.5 mm (D)  
 (17 3/16 in. (W) x 6 5/8 in. (H) x 14 5/16 in. (D))  
 Weight (without package) .....9.9 kg (22 lb)

### Note

- Specifications and the design are subject to possible modifications without notice, due to improvements.
- This product includes FontAvenue® fonts licensed by NEC Corporation. FontAvenue is a registered trademark of NEC Corporation.

*Manufactured under license from Dolby Laboratories. "Dolby", "Pro Logic", "Surround EX", and the double-D symbol are trademarks of Dolby Laboratories.*

*Manufactured under license under U.S. Patent Nos: 5,956,674; 5,974,380; 6,226,616; 6,487,535; 7,212,872; 7,333,929; 7,392,195; 7,272,567 & other U.S. and worldwide patents issued & pending. DTS-HD, the Symbol, & DTS-HD and the Symbol together are registered trademarks & DTS-HD Master Audio is a trademark of DTS, Inc. Product includes software. © DTS, Inc. All Rights Reserved.*

**Accessories**

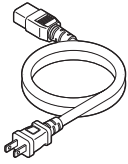

Power cord  
(L068125130010-IL)  
(VSX-60 only)

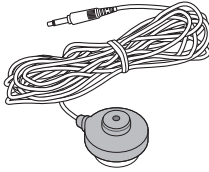

Microphone  
(for Auto MCACC setup)  
(APM7010)

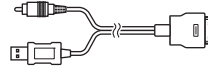

iPod cable  
(L308102013030-IL)



AM loop antenna  
(E601019000010-IL)



FM wire antenna  
(E605010140010-IL)



Remote control (AXD7664)  
(8300766400010-IL)



Dry cell batteries  
(AAA size IEC R03) x2

Warranty card

Quick start guide  
(VSX-1127-K, VSX-1027-K: 5707000006590-IL)  
(VSX-1122-K: 5707000006580-IL)  
(VSX-60: 5707000006600-IL)

Safety Brochure

Operating instructions (CD-ROM)  
(VSX-1127-K, VSX-1027-K: 6517000000550-IL)  
(VSX-1122-K: 6517000000540-IL)  
(VSX-60: 6517000000560-IL)



## 3. BASIC ITEMS FOR SERVICE

### 3.1 CHECK POINTS AFTER SERVICING

#### Items to be checked after servicing

To keep the product quality after servicing, confirm recommended check points shown below.

No.	Procedures	Check points
1	Confirm whether the customer complain has been solved. If the customer complain occurs with the particular source, such as Dolby Digital, DTS, AAC, DVD-A and HDMI, input it for the operation check.	The customer complain must not be reappeared. Video, Audio and operations must be normal.
2	Check the analog audio playback. (Make the analog connections with a DVD player.)	Each channel audio and operations must be normal.
3	Check the digital audio playback. (Make the digital connections with a DVD player.)	Each channel audio and operations must be normal.
4	Check surround playback. (Select Surround mode and check the multichannel operations via the DSP circuit.)	Each channel audio and operations must be normal.
5	Check the video outputs. (Connect with a DVD player.)	Video and operations must be normal.
6	Check the tuner (AM and FM) operations.	Audio and operations must be normal.
7	Check the sound from headphone output.	Sound must be normal, without noise.
8	Check the appearance of the product.	No scratches or dirt on its appearance after receiving it for service.

See the table below for the items to be checked regarding video and audio.

Item to be checked regarding video	Item to be checked regarding audio
Block noise	Distortion
Horizontal noise	Noise
Flicker	Volume too low
Disturbed image (video jumpiness)	Volume too high
Too dark	Volume fluctuating
Too bright	Sound interrupted
Mottled color	

### 3.2 JIGS LIST

#### Jigs List

Jig Name	Part No.	Remarks
13P extension jig cable	GGD1740	Diagnosis (AMP7 Assy ↔ AUDIO Assy)
3P extension jig cable	GGD1741	Diagnosis (AMP7 Assy ↔ MAIN Assy)
Board to board extension jig cable	GGD1736	Diagnosis (D-MAIN Assy ↔ BRG Assy)
Board to board extension jig cable	GGD1798	Diagnosis (D-MAIN Assy ↔ IR Assy)
Board to board extension jig cable	GGD1799	Diagnosis (D-MAIN Assy ↔ IR Assy)
Conversion jig	GGD1802	Diagnosis (D-MAIN Assy ↔ BRG Assy)
Conversion jig	GGD1803	Diagnosis (D-MAIN Assy ↔ IR Assy)

#### Lubricants and Glues List



Name	Part No.	Remarks
Silicon grease	GEM1057	Refer to "9.2 EXTERIOR SECTION".
Silicon adhesive	GYA1011 (KE40RTV-W)	Refer to "9.2 EXTERIOR SECTION".

### 3.3 PCB LOCATIONS

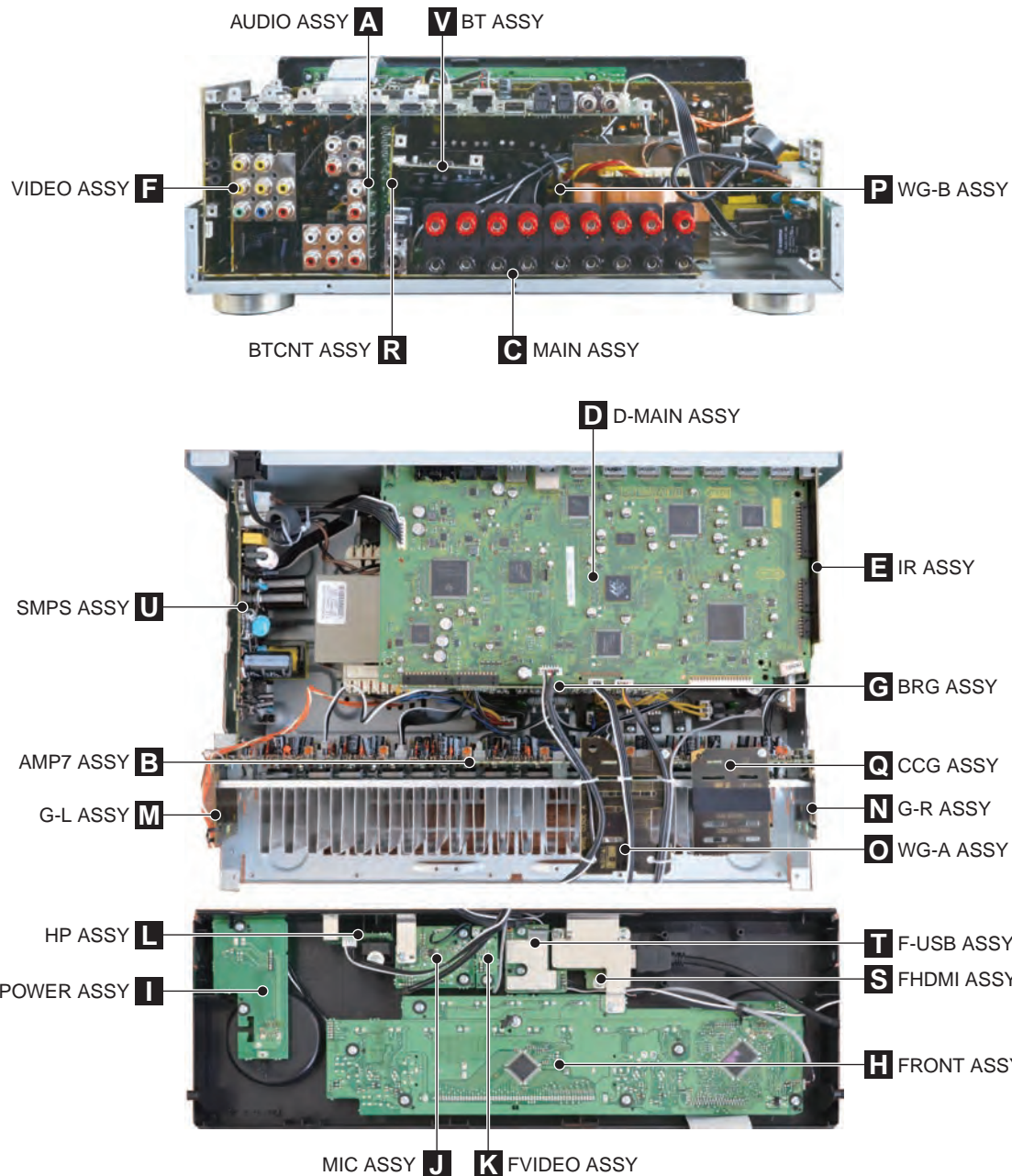

NOTES: ● Parts marked by “NSP” are generally unavailable because they are not in our Master Spare Parts List.  
 ● The  $\triangle$  mark found on some component parts indicates the importance of the safety factor of the part.  
 Therefore, when replacing, be sure to use parts of identical designation.

## LIST OF ASSEMBLIES

Mark	Symbol and Description	VSX-1127-K/CUXE	VSX-1122-K/CUXESM	VSX-60/UXECB	VSX-1027-K/CUXE
NSP	1..PCB TTL ASSY MAIN	7025HK1110020-IL	7025HK1110010-IL	7025HK1110030-IL	7025HK1109010-IL
	2..MAIN ASSY	7028071711010-IL	7028071711010-IL	7028071711040-IL	7028071711010-IL
	2..VIDEO ASSY	7028071712020-IL	7028071712070-IL	7028071712040-IL	7028071712070-IL
	2..G-L ASSY	7028071713040-IL	7028071713040-IL	7028071713040-IL	7028071713040-IL
	2..G-R ASSY	7028071714040-IL	7028071714040-IL	7028071714040-IL	7028071714040-IL
	2..WG-A ASSY	7028071715040-IL	7028071715040-IL	7028071715040-IL	7028071715040-IL
	2..WG-B ASSY	7028071716040-IL	7028071716040-IL	7028071716040-IL	7028071716040-IL
NSP	1..PCB TTL ASSY DMAIN	7025HK1110021-IL	7025HK1110011-IL	7025HK1110031-IL	7025HK1109011-IL
	2..D-MAIN ASSY	7028071752020-IL	7028071752040-IL	7028071752040-IL	7028071752070-IL
NSP	1..PCB TTL ASSY FRONT	7025HK1110022-IL	7025HK1110012-IL	7025HK1110032-IL	7025HK1109012-IL
	2..FRONT ASSY	7028071721050-IL	7028071721010-IL	7028071721040-IL	7028071721060-IL
	2..POWER ASSY	7028071722010-IL	7028071722010-IL	7028071722040-IL	7028071722010-IL
	2..MIC ASSY	7028071723040-IL	7028071723040-IL	7028071723040-IL	7028071723040-IL
	2..FVIDEO ASSY	7028071724040-IL	7028071724040-IL	7028071724040-IL	7028071724040-IL
	2..HP ASSY	7028071725040-IL	7028071725040-IL	7028071725040-IL	7028071725040-IL
NSP	1..PCB TTL ASSY AUDIO	7025HK1110023-IL	7025HK1110013-IL	7025HK1110033-IL	7025HK1109013-IL
	2..AUDIO ASSY	7028071741050-IL	7028071741010-IL	7028071741040-IL	7028071741010-IL
NSP	1..PCB TTL ASSY IR	7025HK1110024-IL	7025HK1110014-IL	7025HK1110034-IL	7025HK1109014-IL
	2..IR ASSY	7028071771010-IL	7028071771010-IL	7028071771040-IL	7028071771010-IL
	2..SMPS ASSY	7028071772010-IL	7028071772010-IL	7028071772040-IL	7028071772010-IL
	2..BRG ASSY	7028071773040-IL	7028071773040-IL	7028071773040-IL	7028071773070-IL
	2..BTCNT ASSY	7028071774040-IL	7028071774040-IL	7028071774040-IL	7028071774040-IL
	2..CCG ASSY	7028071775040-IL	7028071775040-IL	7028071775040-IL	7028071775040-IL
NSP	1..PCB TTL ASSY AMP7	7025HK1110025-IL	7025HK1110015-IL	7025HK1110035-IL	7025HK1109015-IL
	2..AMP7 ASSY	7028071731040-IL	7028071731040-IL	7028071731040-IL	7028071731040-IL
NSP	1..PCB TTL ASSY FHDMI	7025HK1110026-IL	7025HK1110016-IL	7025HK1110036-IL	Not used
	2..FHDMI ASSY	7028071791040-IL	7028071791040-IL	7028071791040-IL	Not used
NSP	1..PCB TTL ASSY F-USB	7025HK1110027-IL	7025HK1110017-IL	7025HK1110037-IL	7025HK1109017-IL
	2..F-USB ASSY	7028071761020-IL	7028071761020-IL	7028071761020-IL	7028071761020-IL
NSP	1..PCB TTL ASSY BT	7025HK1110028-IL	7025HK1110018-IL	7025HK1110038-IL	7025HK1109018-IL
	2..BT ASSY	7028070231010-IL	7028070231010-IL	7028070231010-IL	7028070231010-IL

# 4. BLOCK DIAGRAM

## 4.1 OVERALL WIRING DIAGRAM

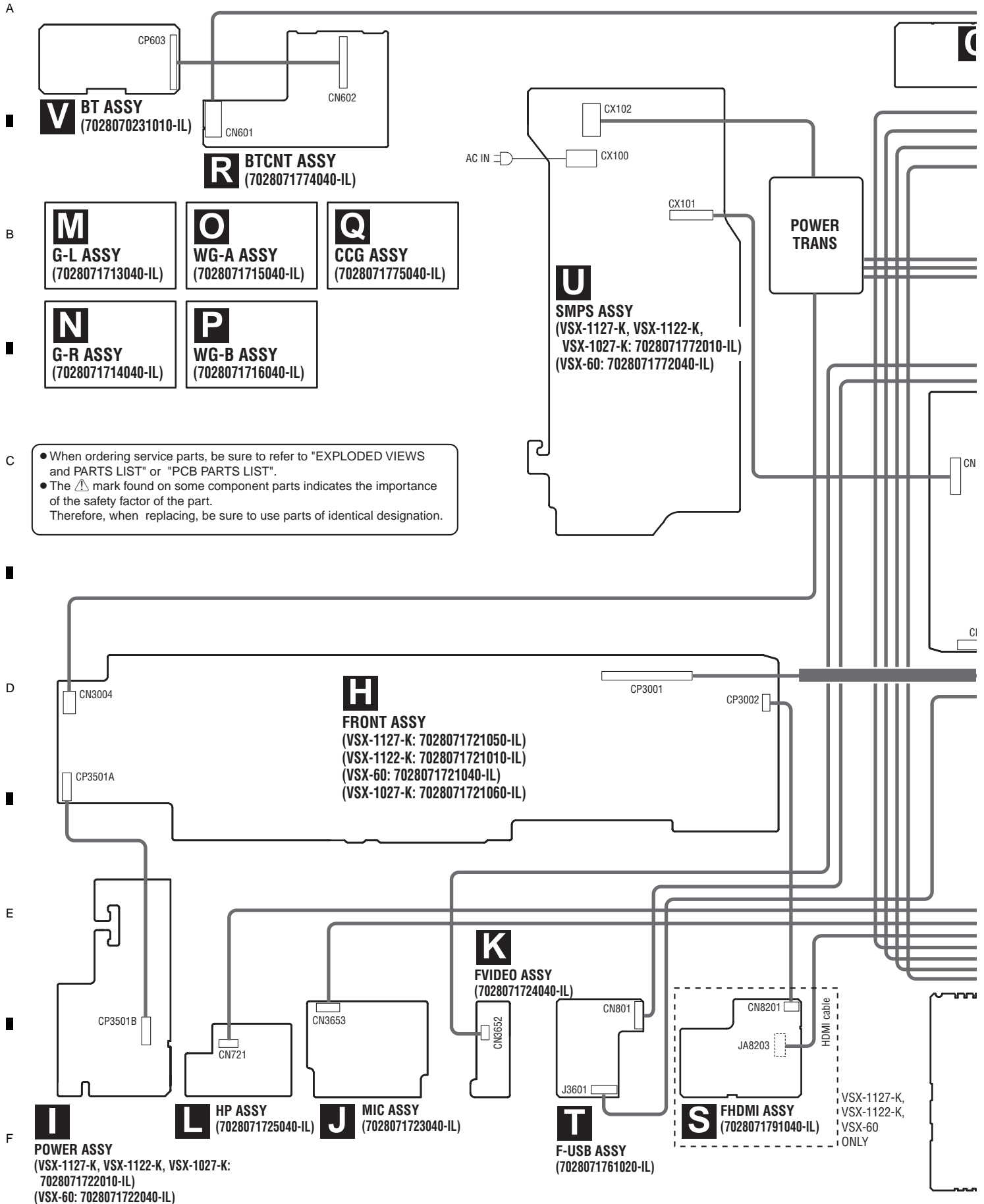

A  
B  
C  
D  
E  
F

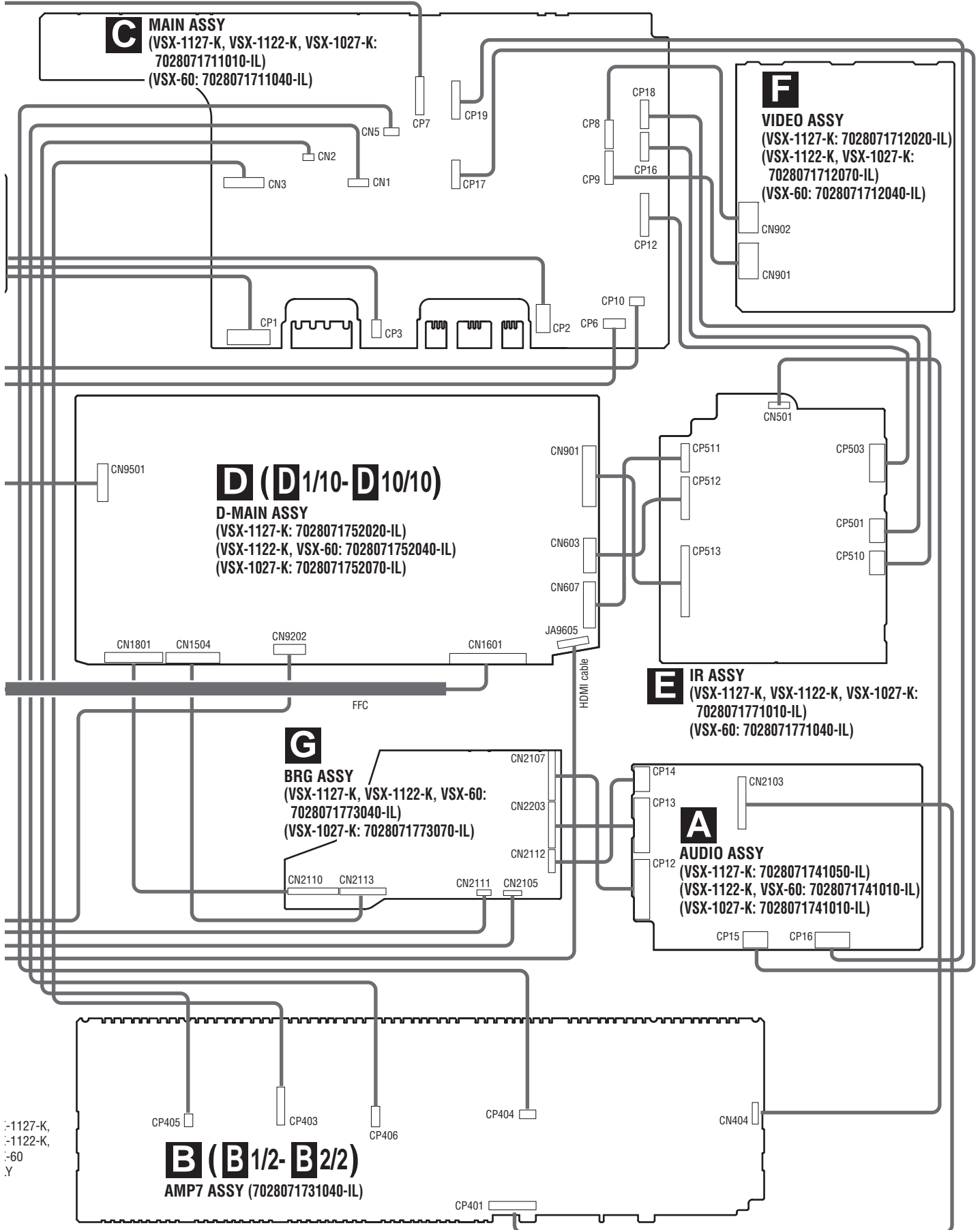

-1127-K,  
-1122-K,  
-60  
Y

# 4.2 AUDIO BLOCK DIAGRAM

1 2 3 4

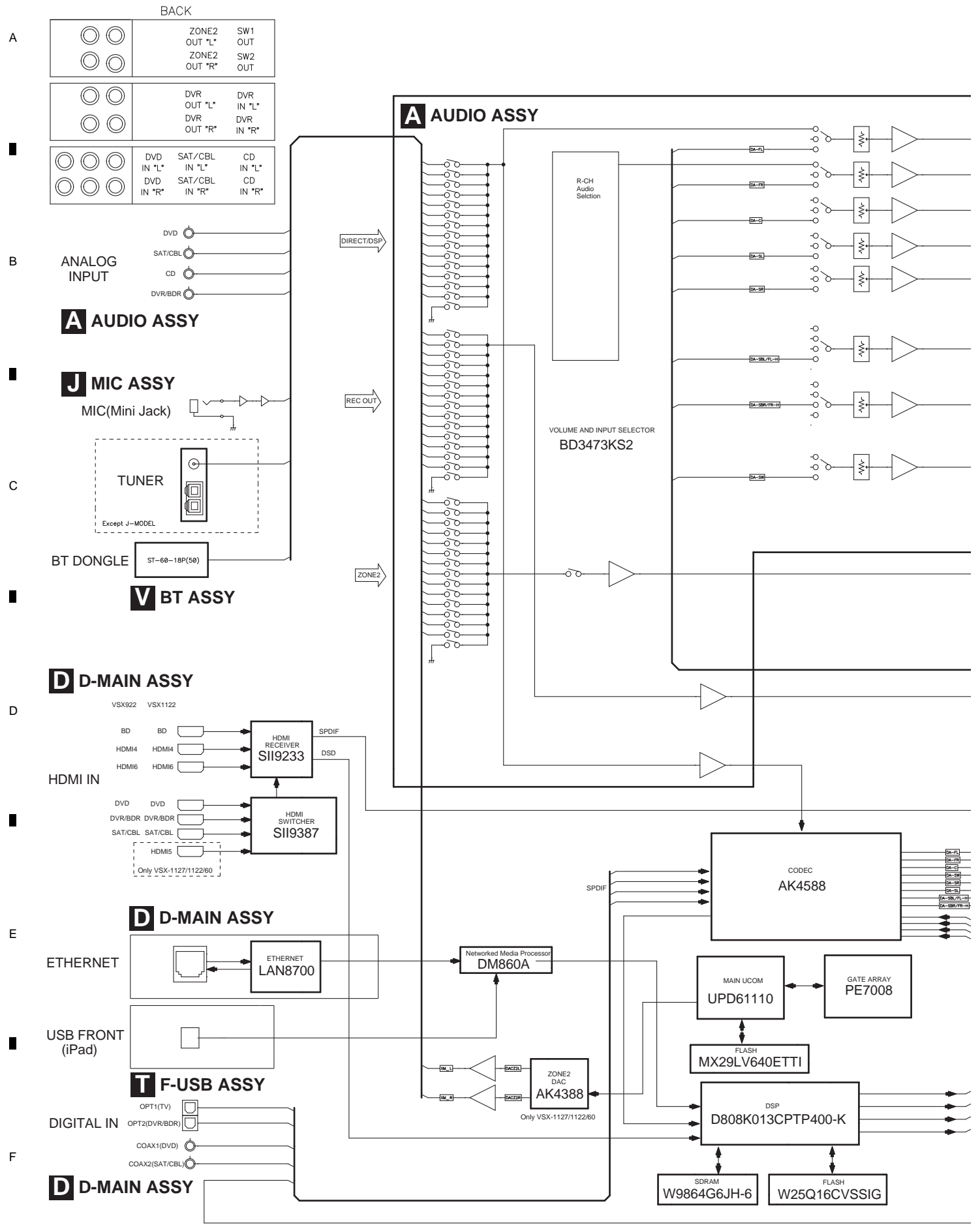

1 2 3 4

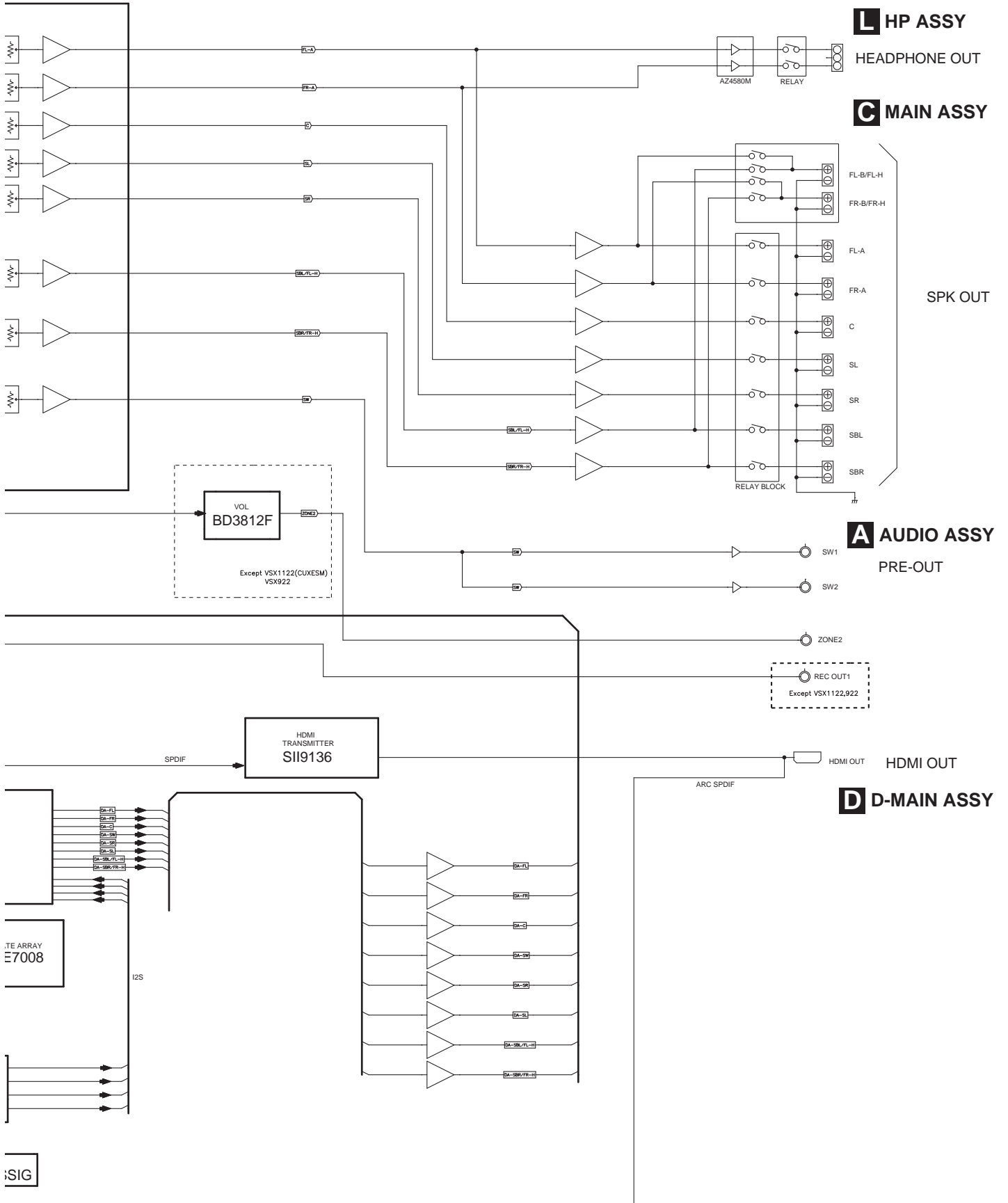

# 4.3 D-AUDIO BLOCK DIAGRAM

## D-MAIN ASSY

A

B

C

D

E

F

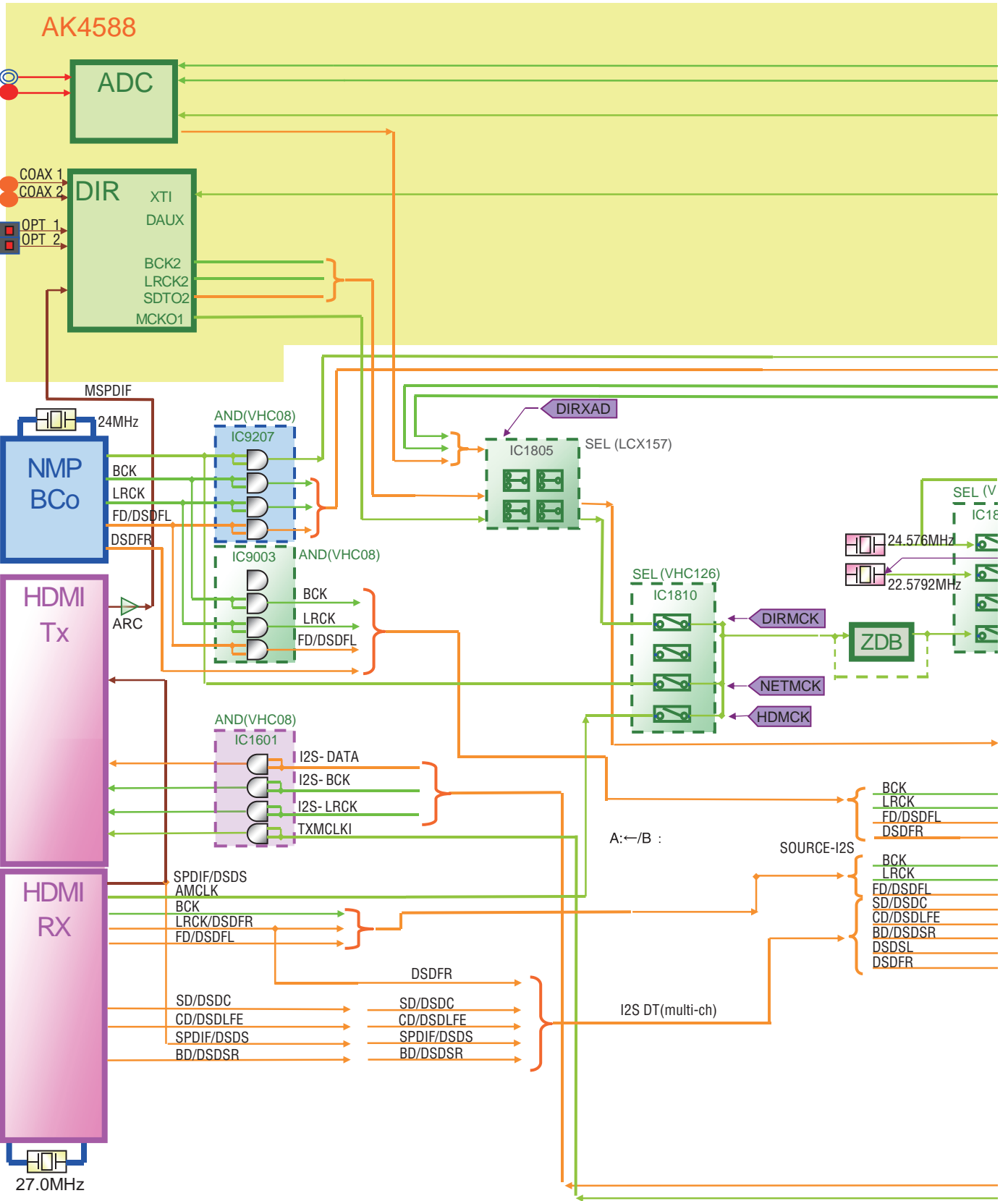



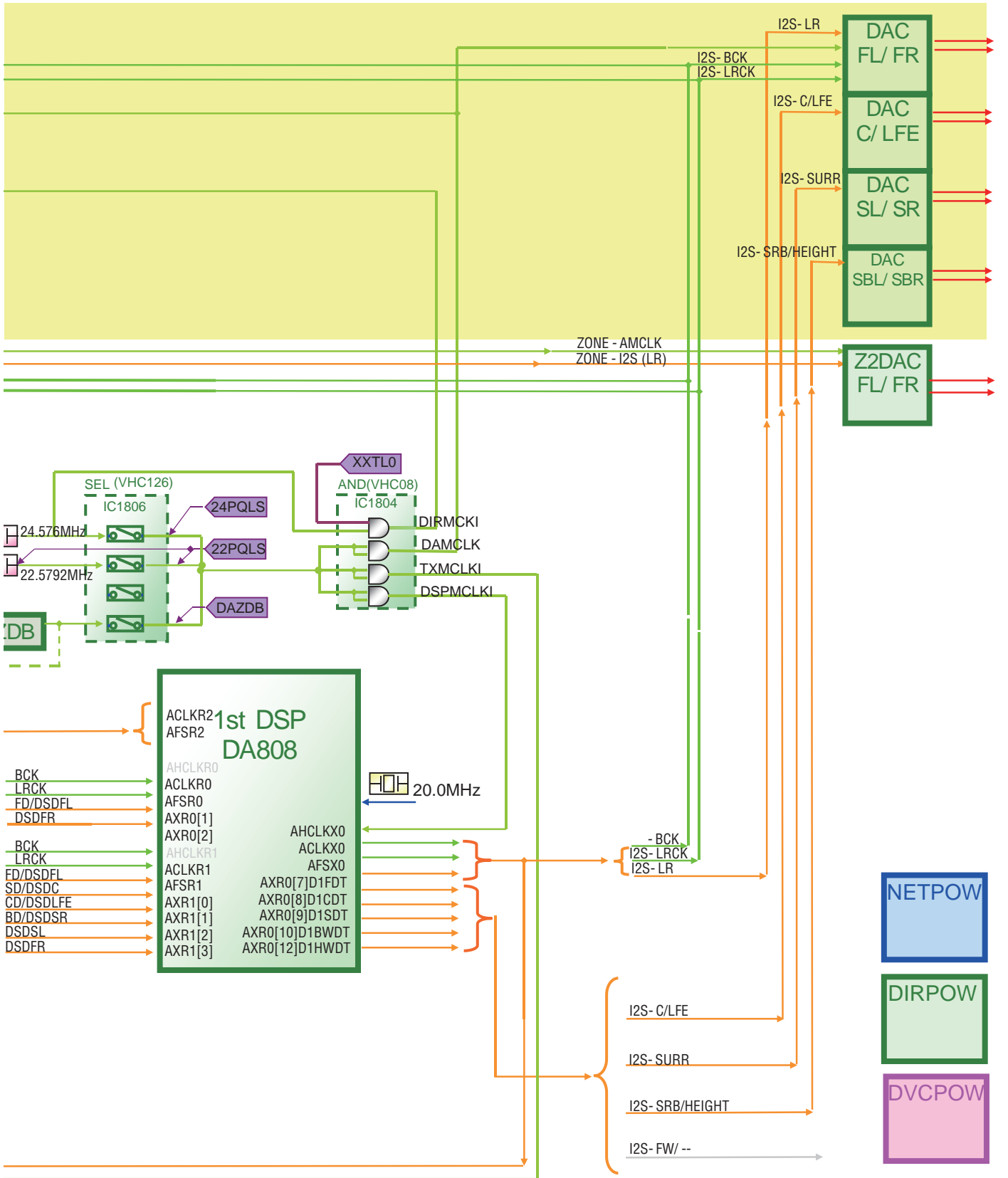

# 4.4 D-VIDEO BLOCK DIAGRAM

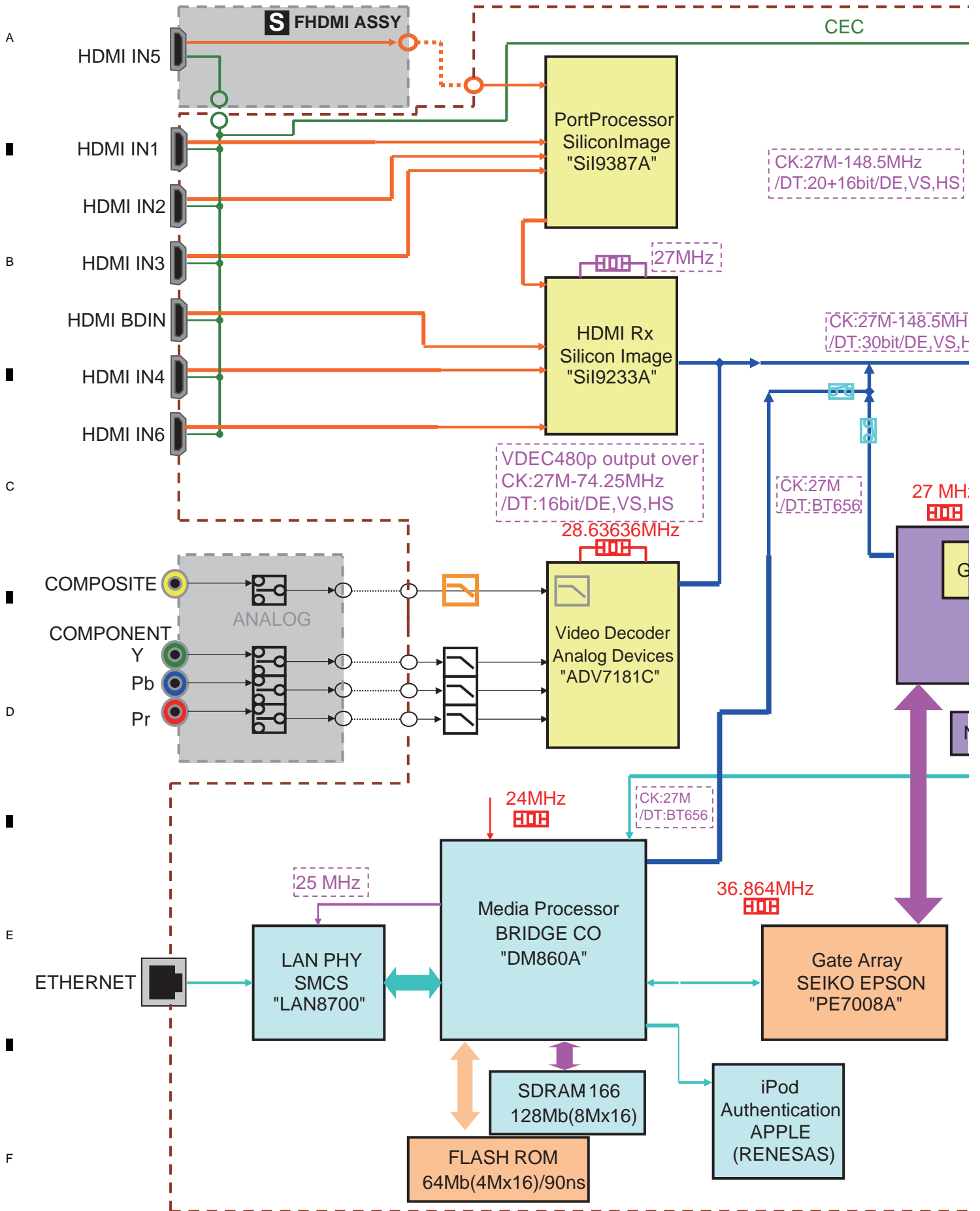

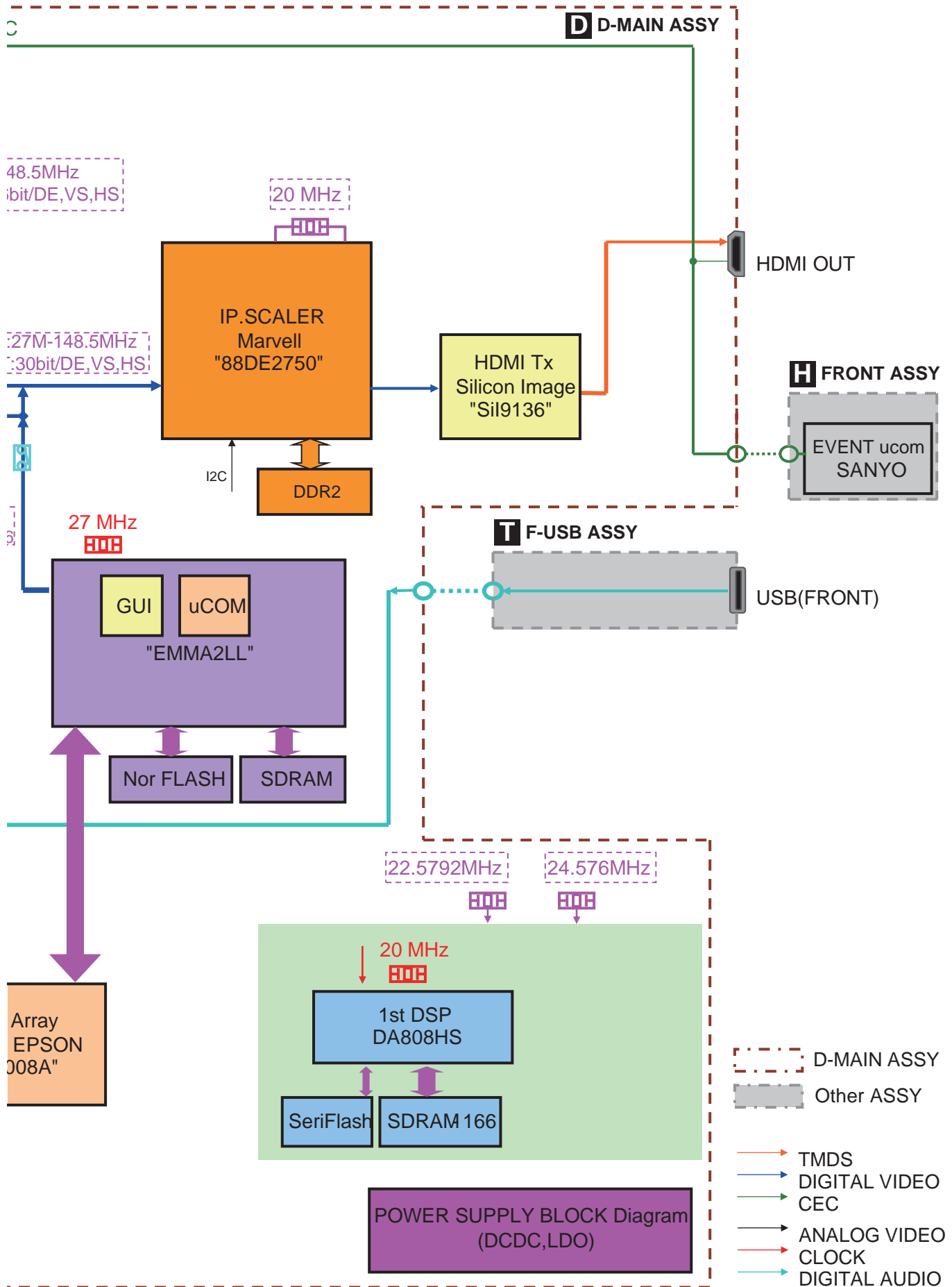

# 4.5 VIDEO BLOCK DIAGRAM

1 2 3 4

## D D-MAIN ASSY

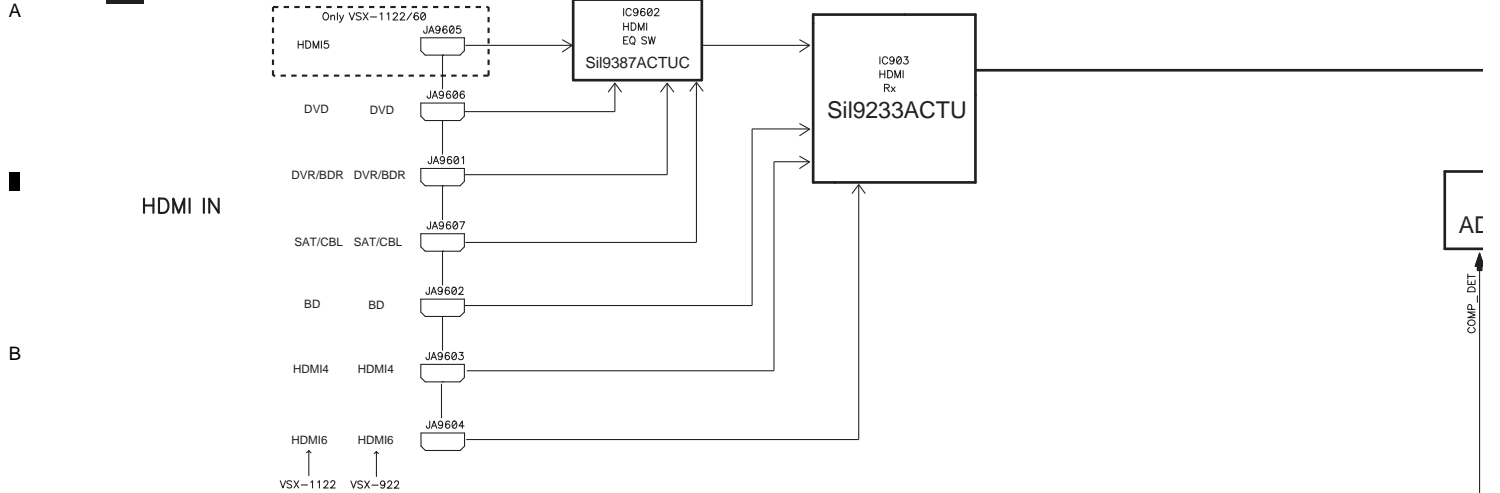

## BACK

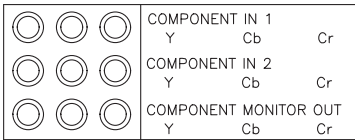
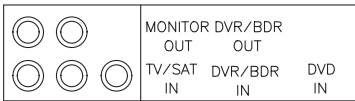

## K FVIDEO ASSY

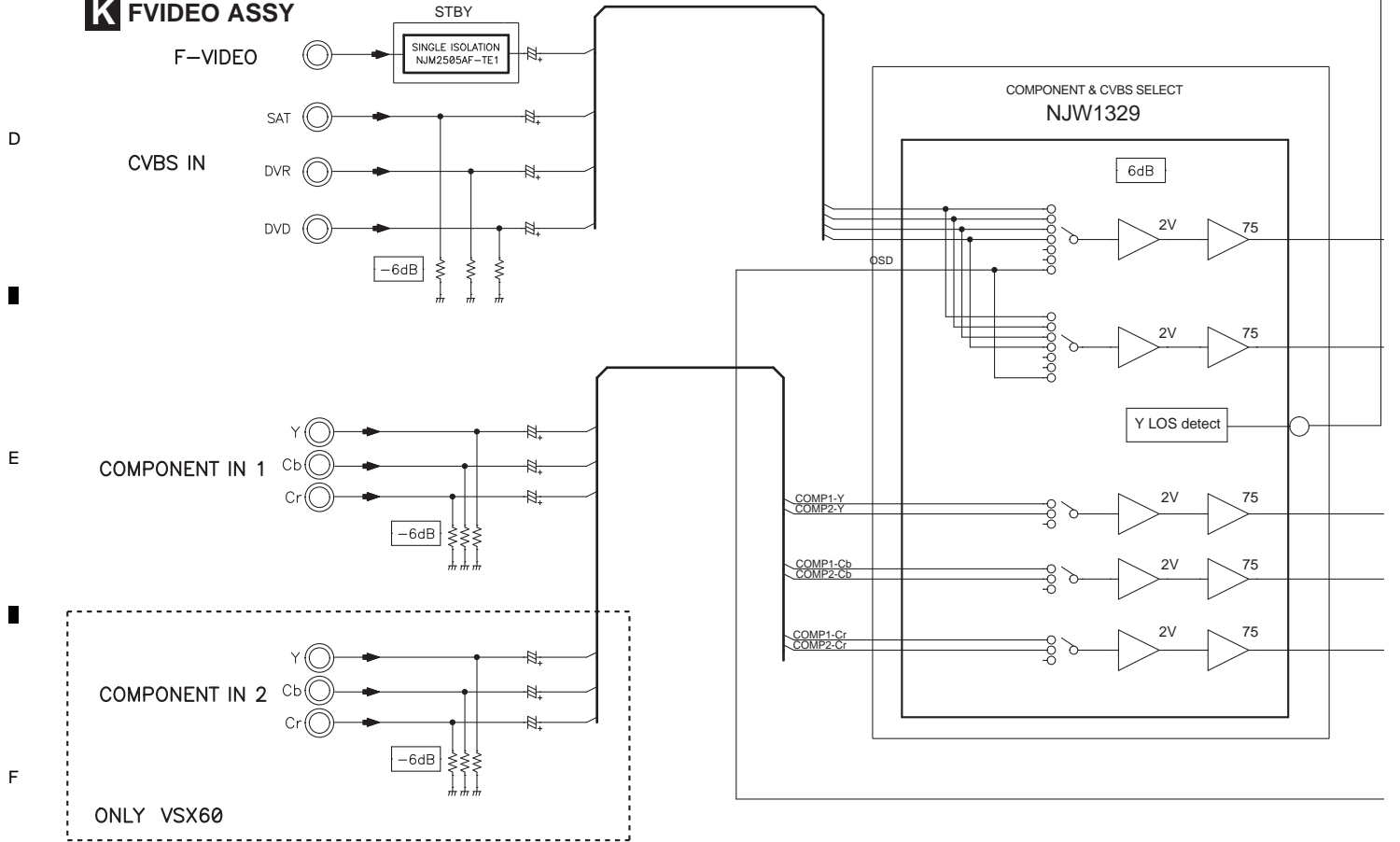

— TMS  
 — Video BUS  
 — Analog Video

A

B

C

D

E

F

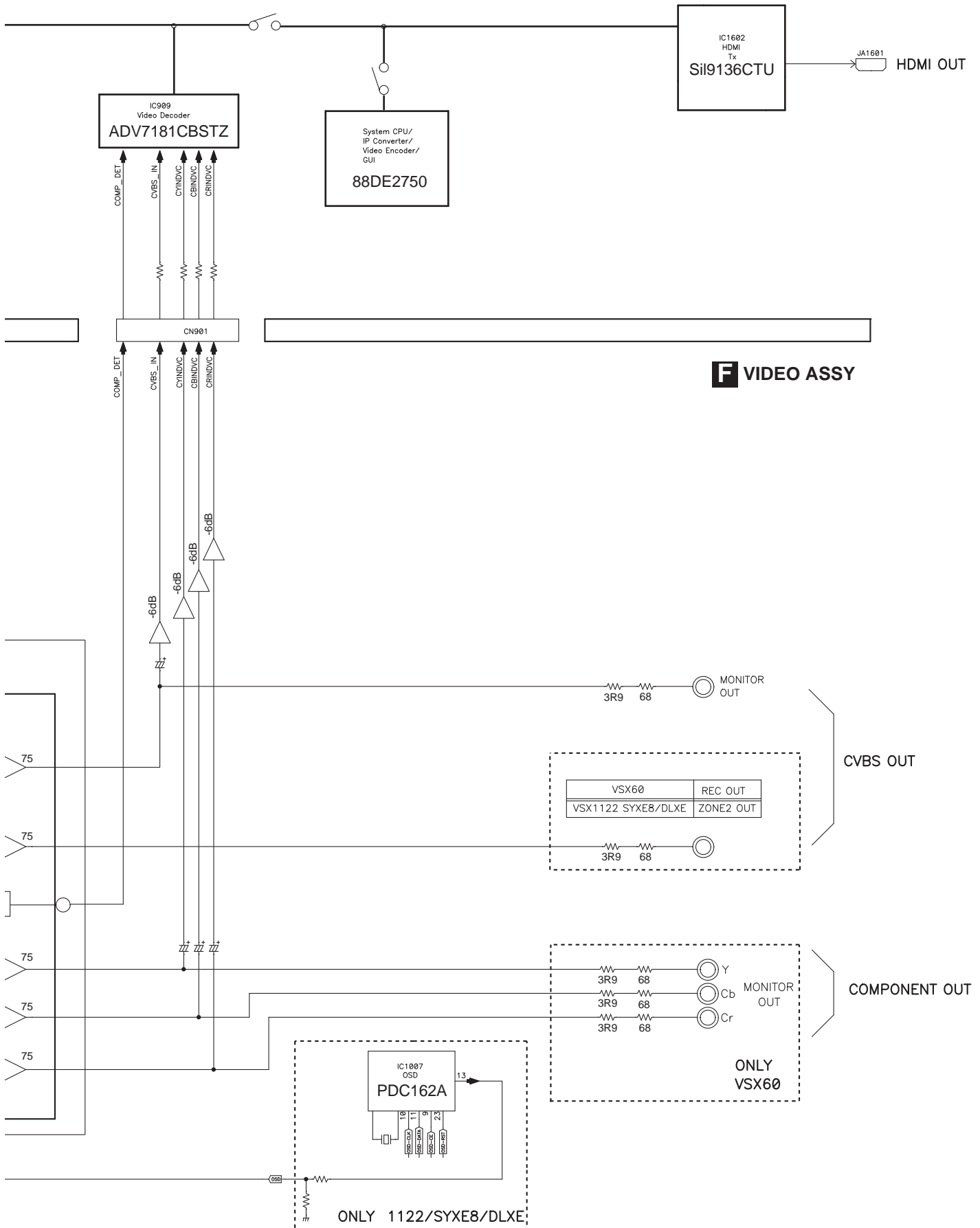

# 4.6 POWER SUPPLY BLOCK DIAGRAM

A  
B  
C  
D  
E  
F

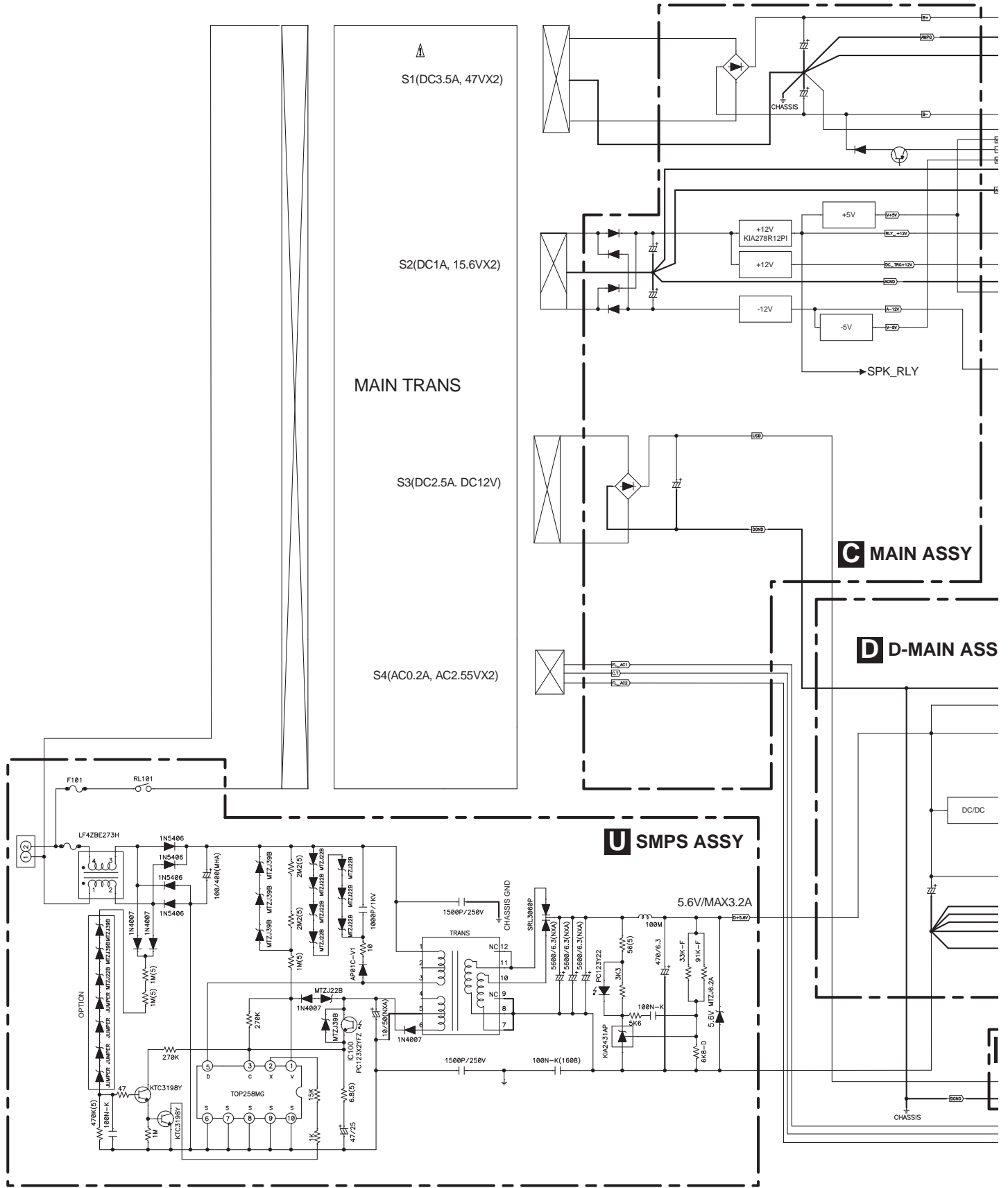

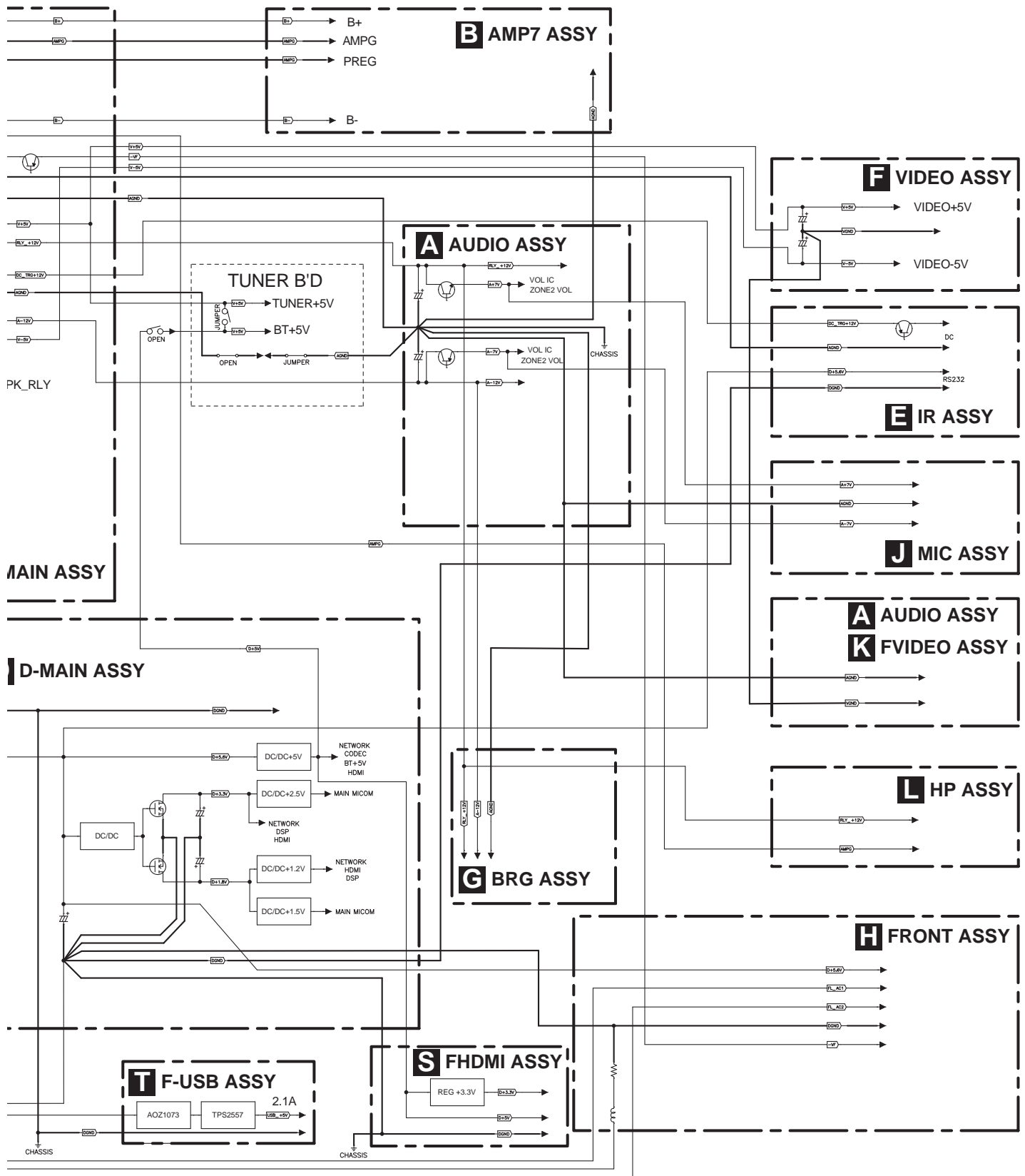

# 5. DIAGNOSIS

## 5.1 TROUBLESHOOTING

### A No Power

This is just for general reference and does not including every single case.

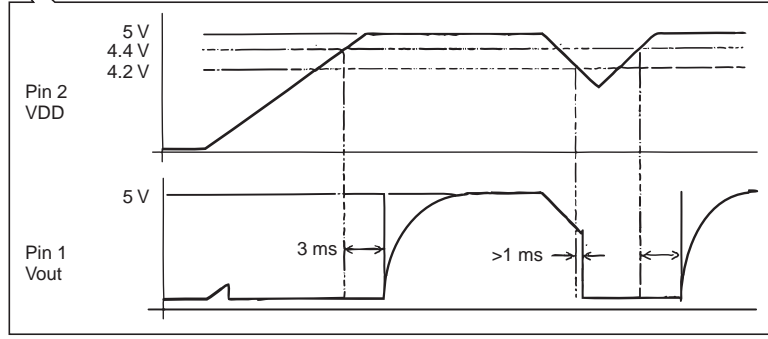
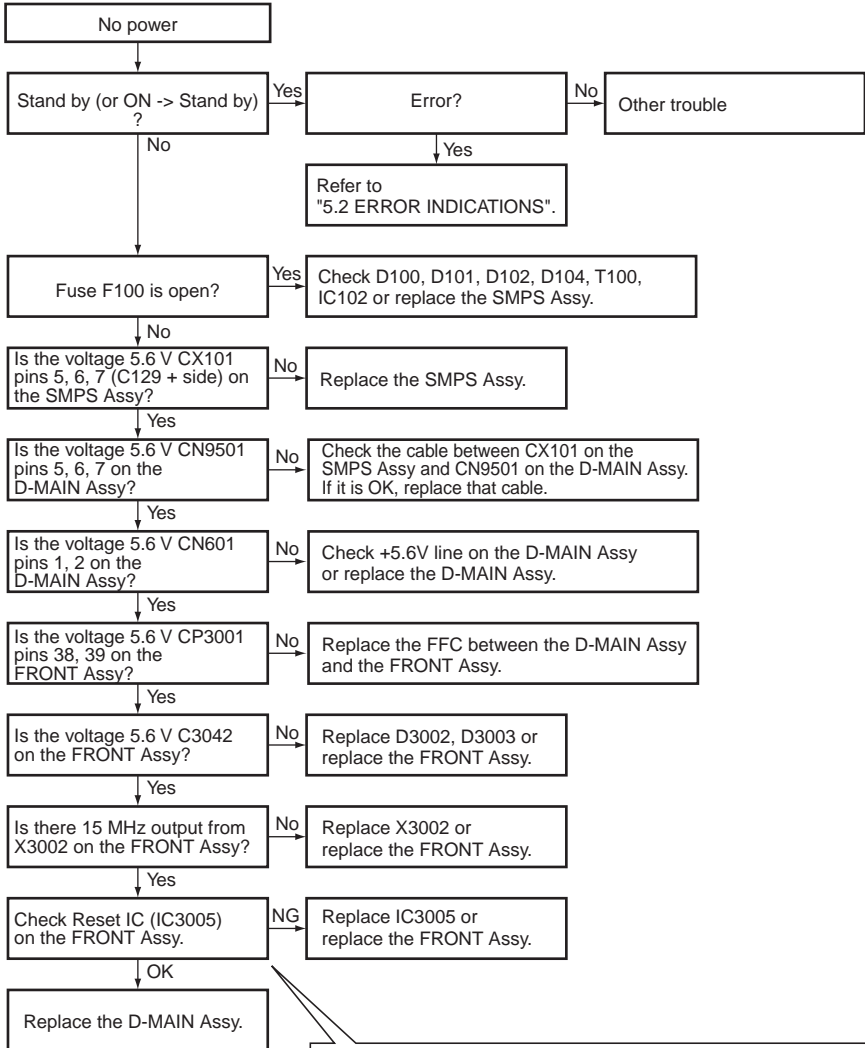



## No FL Display

This is just for general reference and does not including every single case.

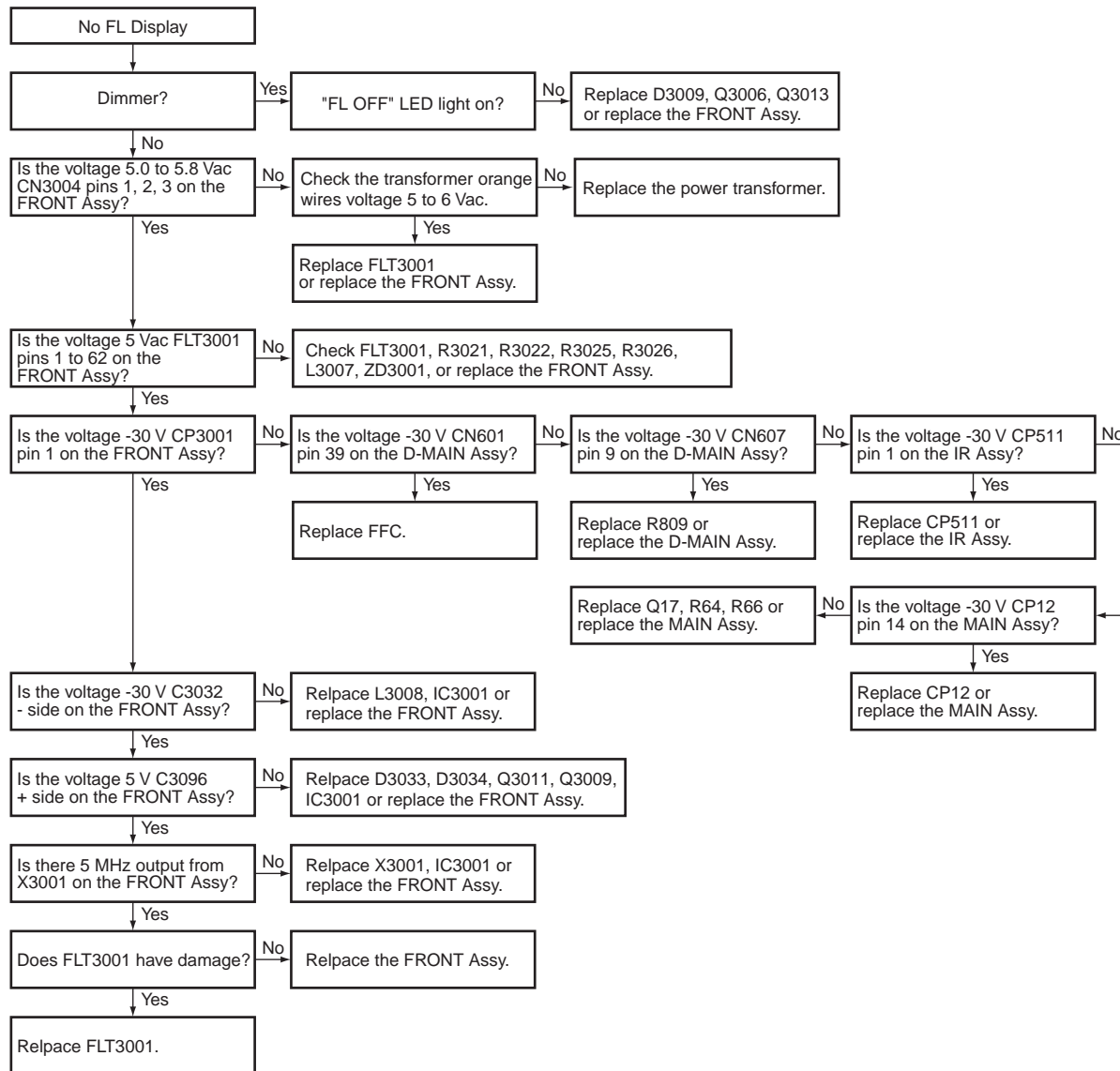

# A No Sound

This is just for general reference and does not including every single case.

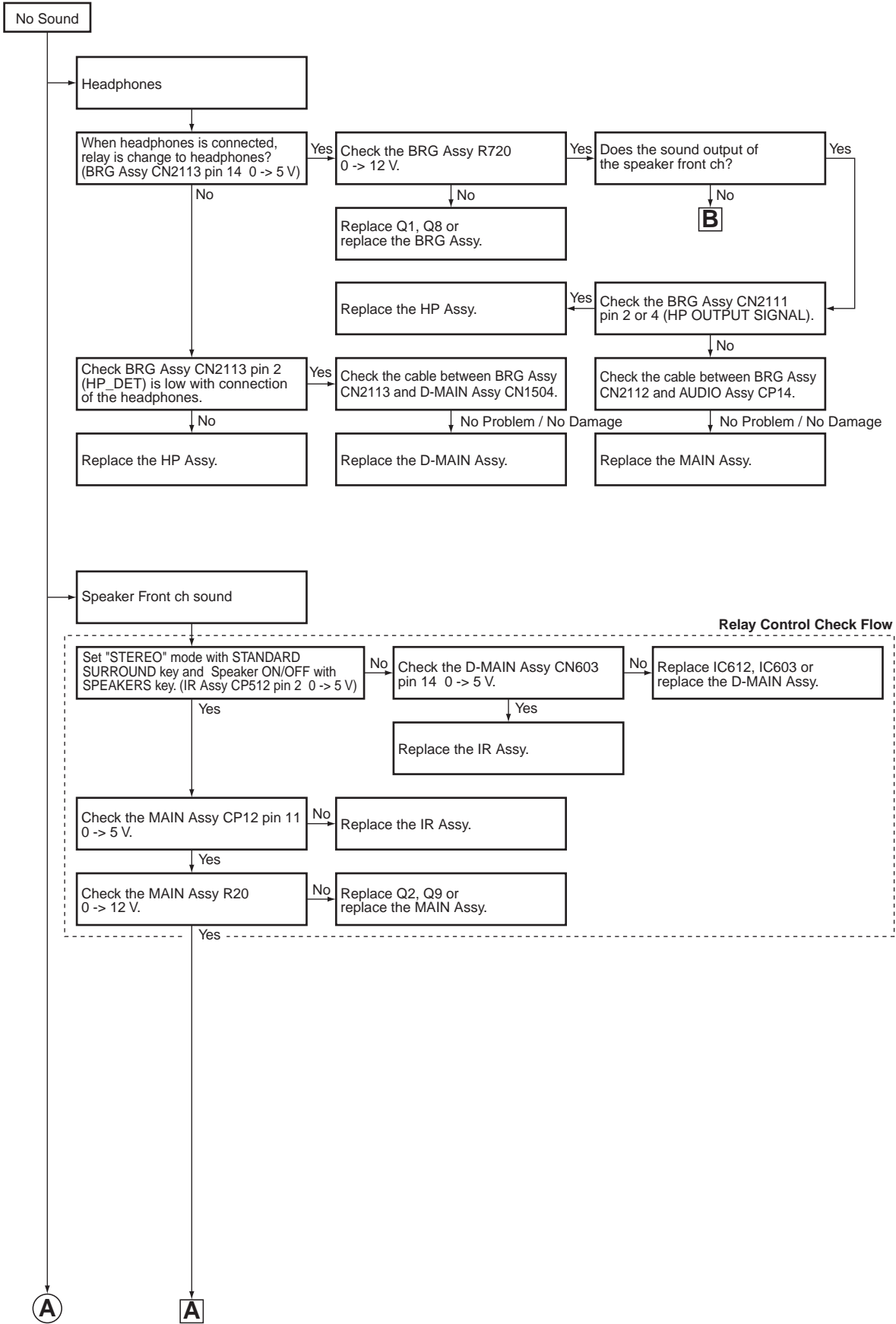

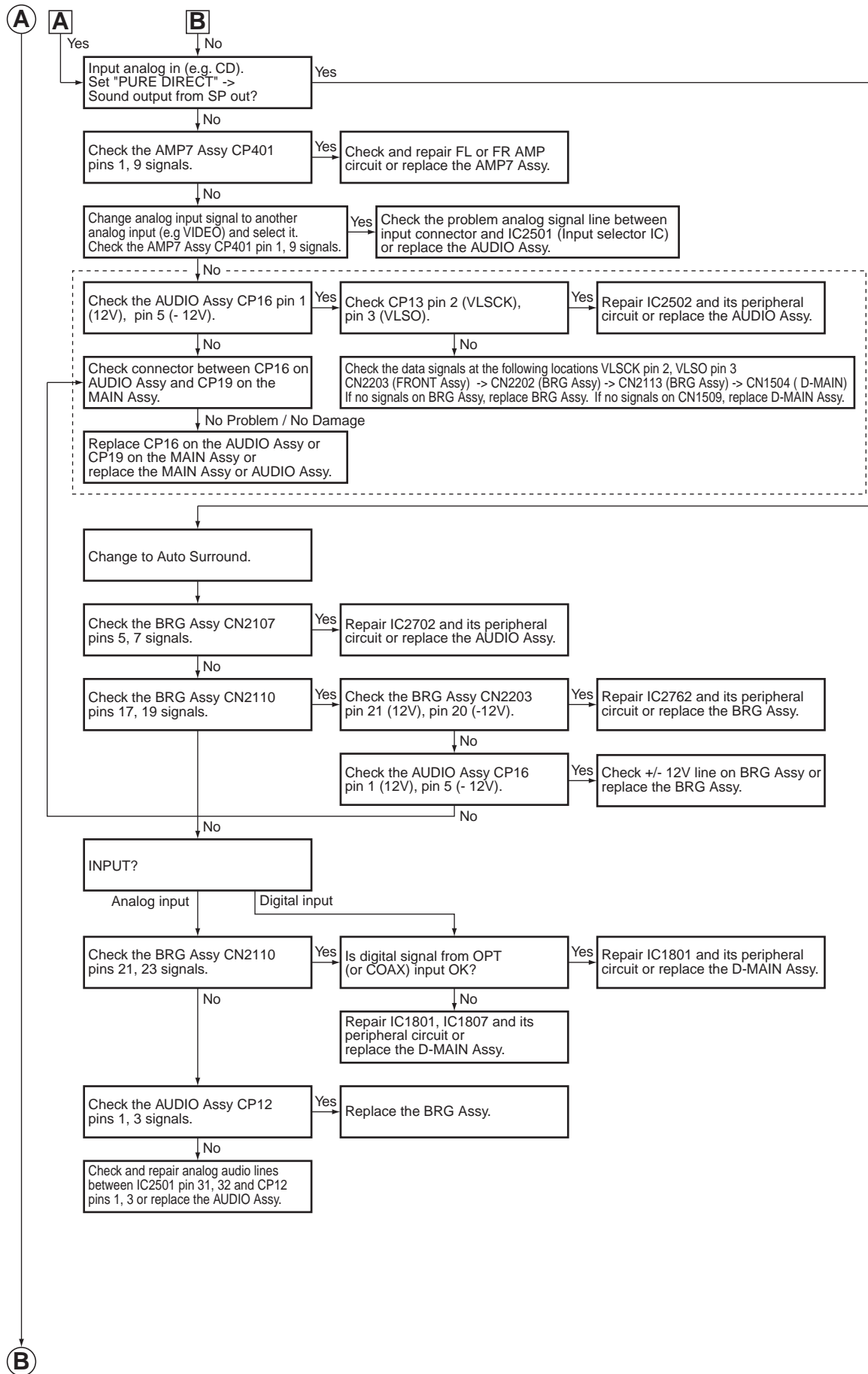

A  
B  
C  
D  
E  
F

B

Speaker C (S SB SP-B etc) ch  
(Front LR is OK)

Check SP System menu is appropriate  
and connected speakers are not  
selected [No] on SP Setting menu.

No  
Change SP System and SP  
Setting to correct setting.

Check Selection of Speaker system  
by [SPEAKERS] key on front panel  
is correct.

No  
Change SP selection to correct  
setting by [SPEAKER] key.

Speaker System Menu	
Setup name	Output sound
Speaker B	SP-B
Normal (SB/FH)	Front High or SB
Normal (SB/FW)	Front Wide or SB

If Speaker System is "Normal (SB/FH)" or "Normal (SB/FW)" and speaker setting by SPEAKER key is "SP: SB ON", there is no sound from FH or FW.

Check relay operating of problem ch.  
(refer to schematic diagram and Relay  
Control Check flow for Front ch)

SP-B no sound

Select Surround mode to  
EX. STEREO in Advanced Surround.

Input analog signals to analog in  
(e.g. CD), SP selection should be  
"SP:B ON", check SBR, SBL channels.

Check signals of problem channel on  
AMP7 Assy CP401 pins 3 (SL), 5 (C),  
7 (SR), 11 (SBL), 13 (SBR) signals.

Yes  
Check and repair AMP circuit of  
problem channels  
or replace the AMP7 Assy.

Check signals on BRG Assy CN2107  
pins 9 (SR), 11 (SL), 13 (SW),  
15 (C), 17 (SBR), 19 (SBL) signals.

Yes  
Replace AUDIO Assy or  
their peripheral circuit.

Check signals on BRG Assy CN2110  
pins 5, 7, 9, 11, 13, 15 signals.  
(Pin assign is same as CN2107)

Yes  
Repair IC2742, IC2704, IC2782  
and their peripheral circuit  
or replace the BRG Assy.

Input PCM to COAX in or OPT in,  
set Auto Surround.  
Is Front LR SP output sound is OK?

Yes  
Replace the D-MAIN Assy.

Repair IC1801 and its peripheral  
circuit or replace the D-MAIN Assy.

C

C

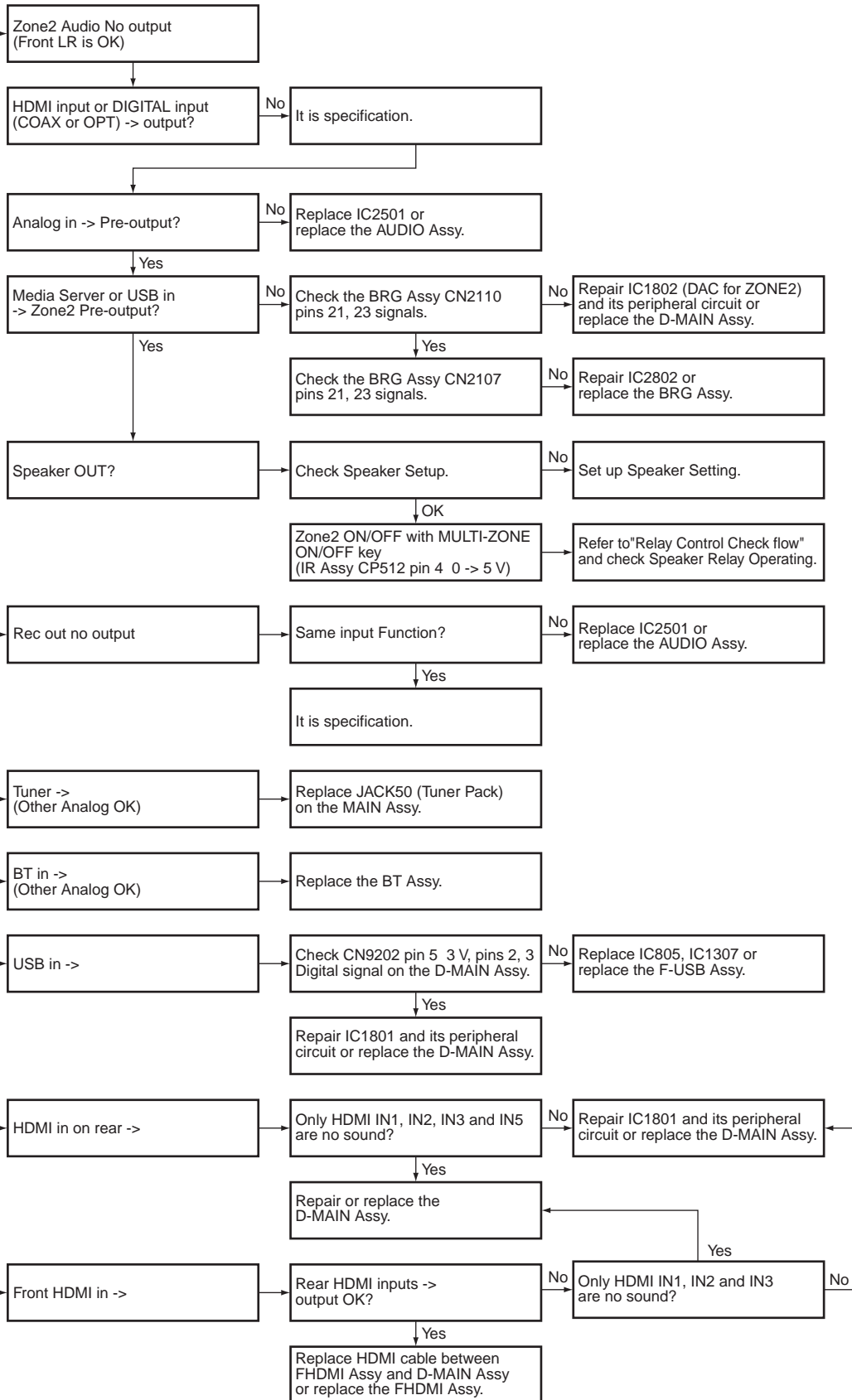

D

A

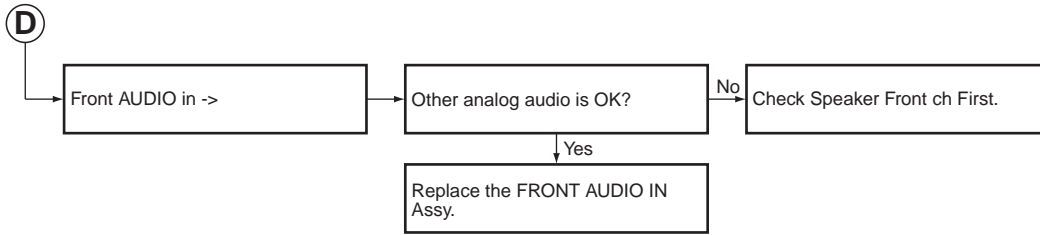

B

### No Picture

This is just for general reference and does not including every single case.

C

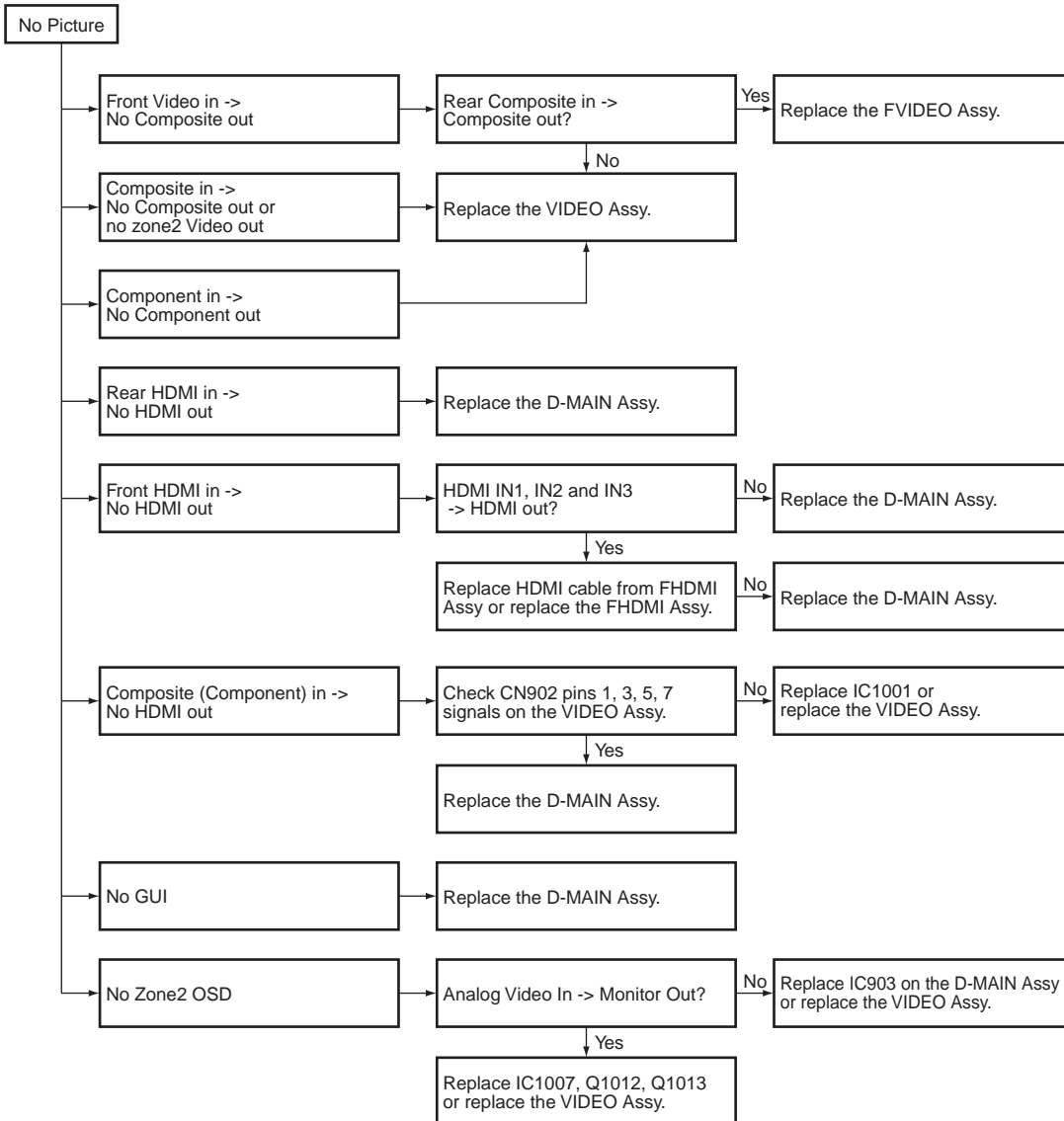

D

E

F

### Others

This is just for general reference and does not including every single case.

#### 12V Trig



No

#### RS-232C



No

#### IR

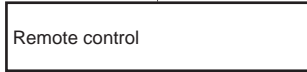

Yes

No

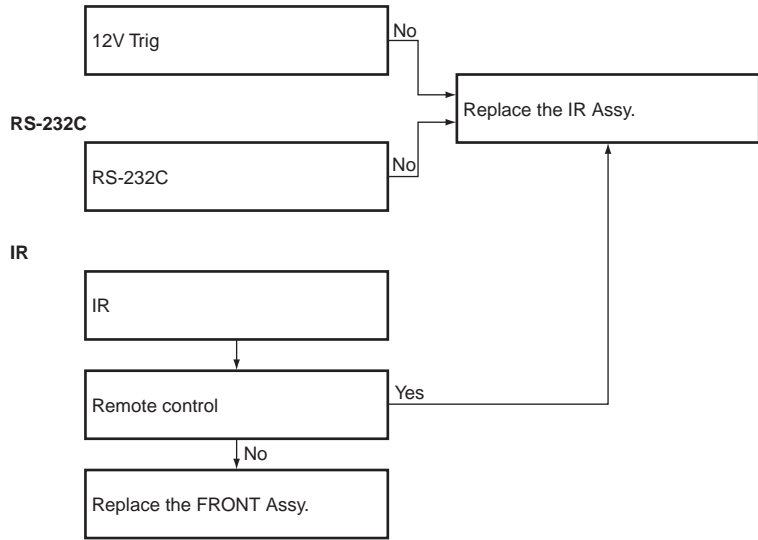
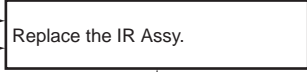

A

B

C

D

E

F

## 5.2 ERROR INDICATIONS

### Error Indications When an Abnormality in The Amplifier System is Detected

#### [Purpose]

Errors upon detection of abnormalities in the amp system are indicated.

#### [Error Indications]

Item	FL Display	LED Flashes	NG Count.	Detection Method	Process After Detection	Description / Remarks
"AMP DC" ("DC output from SP term") detection	Flashing "AMP ERR" for 3 seconds	ADVANCED MCACC LED	DC	XDCERR (Pin 80 of IC3004) Detect "L"	1) Muting on, speaker relay off. 2) "AMP ERR" flashing 3) Shutdown after 3 seconds. 4) "ADVANCED MCACC" LED flashing 5) Power on is not acceptable.	To detect high DC output from amplifier damage (defect status). A process to protect speakers (for protection of connected external devices). For checking, refer to "How to enter release mode" below. If the DC detection port become "H" for 3 seconds, the unit will returns to normal condition automatically.
"AMP overload" detection.	N/A	iPod iPhone iPad LED	OL	XOLERR (Pin 71 of IC3004) Detect "L"	1) Muting on, speaker relay off. 2) Shutdown immediately. 3) "iPod iPhone iPad" LED flashing 4) Power on is acceptable.	To detect overloading (abnormal status) with low-load driving or a short circuit of the speaker terminals (for protection of the amplifier).
"Over Heat" detection.	Flashing "AMP OVERHEAT" for 3 seconds	FL OFF LED	STMP	TEMPERR5 (Pin 72 of IC3004) Detect "H" (REDI_DET)	1) Muting on, speaker relay off, 2) "OVERHEAT" flashing 3) Shutdown after 3 seconds. 4) "FL OFF" LED flashing 5) Power on is acceptable after 1 minute.	To detect overheat of inner temperature.
"Abnormality DC voltage of the Digital power supply" detection	N/A	iPod iPhone iPad LED	DERR	XVDDERR (Pin 70 of IC3004) Detect "L"	1) Muting on, speaker relay off. 2) Shutdown immediately. 3) "iPod iPhone iPad" LED flashing 4) Power on is acceptable.	To detect the abnormality voltage of Digital power supply circuit for the D-MAIN Assy.
"USB Overload" detection	"Over Current" No Flashing	N/A	N/A	USB ERR (VCO0) (Pin K2 of IC9204 (DM860A)) Detect "H"	1) Bass Power off 2) Display "Over Current"	To detect the connected USB device is overload. (over 2.1 A)
"BT Adapter overload" detection.	"ADP OVERLOAD" No Flashing	N/A	N/A	BTOL (MIL_CRS) (Pin R14 of IC9204 (DM860A)) Detect "H"	1) Adapter port power off 2) Display "ADP OVERLOAD"	To detect the connected Blue Tooth Adapter device is overload. (over 100 mA)
"HDCP of HDMI Error" detection	Flashes "HDCP ERROR" for 5 seconds	N/A	N/A	Read Register value	1) Display "HDCP ERROR"	The monitor does not support HDCP type or is in standby mode. (Warning indication for HDMI Simplay)
"Analog Input Over" detection	"OVER" Icon lights 1 second	N/A	N/A	DSP firmware Detect	While the Icon lights 1 second, when there is no ANALOG INPUT OVER detection, the Icon stops lighting and returns to normal display.	To detect the over-input of the analog audio to the A/D converter. When the Icon lights frequently, output level of the source equipment is high and a sound is distorted. Turn on the Analog Att switch.
Analog POWER SUPPLY Error	N/A	FL OFF LED	XPRT	XPROTECT (Pin 83 of IC3004)	1) Muting on, speaker relay off. 2) Shutdown immediately. 3) "FL OFF" LED flashing 4) Power on is acceptable after 1 minute.	Power-on impossible for 1 min.
"Over Heat" detection	N/A (VOL LEVEL)	N/A	N/A	TEMP L (TR_DET) (Pin 81 of IC3004)	VOL 3 dB down	After this error is detected, the system interrupts the OVER HEAT detection for 2 minutes.
"WiFi Over Current" detection	WLAN POW ERR	N/A	N/A	XWUSB ERR (Pin 45 of IC3004)	WUSBPOW is set to L.	To detect the connected WiFi Adapter device is overload. (over 600 mA)

#### [How to Enter Release Mode]

During Standby mode, simultaneously press and hold the "TUNE ↓" and "MULTI-ZONE ON/OFF" keys for 5 seconds.





# A [2] TEMP Protection Circuit

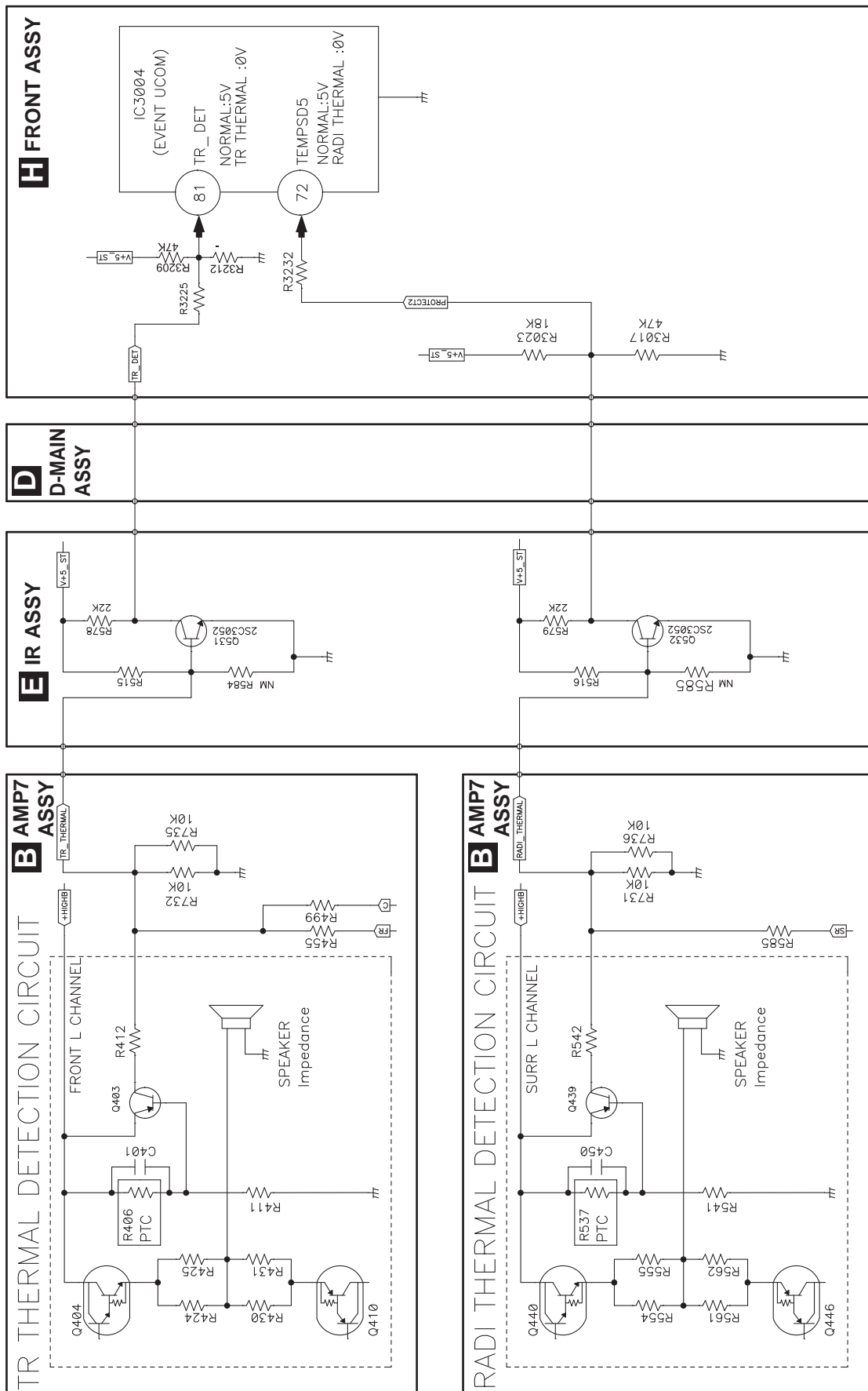

## 5.4 IC INFORMATION

### J171132900010-IL (VIDEO ASSY: IC1001)

IC, MONITOR SW

#### • Pin Arrangement (Top view)

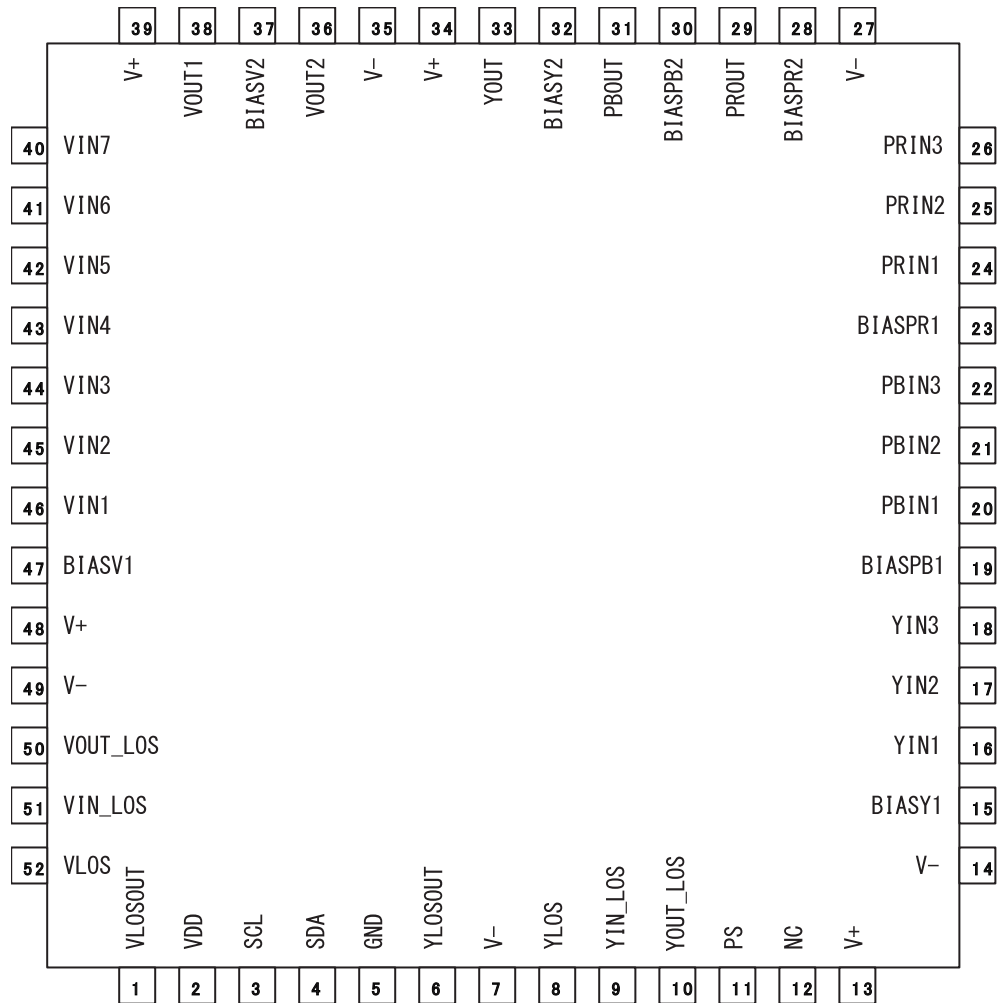

# A • Block Diagram

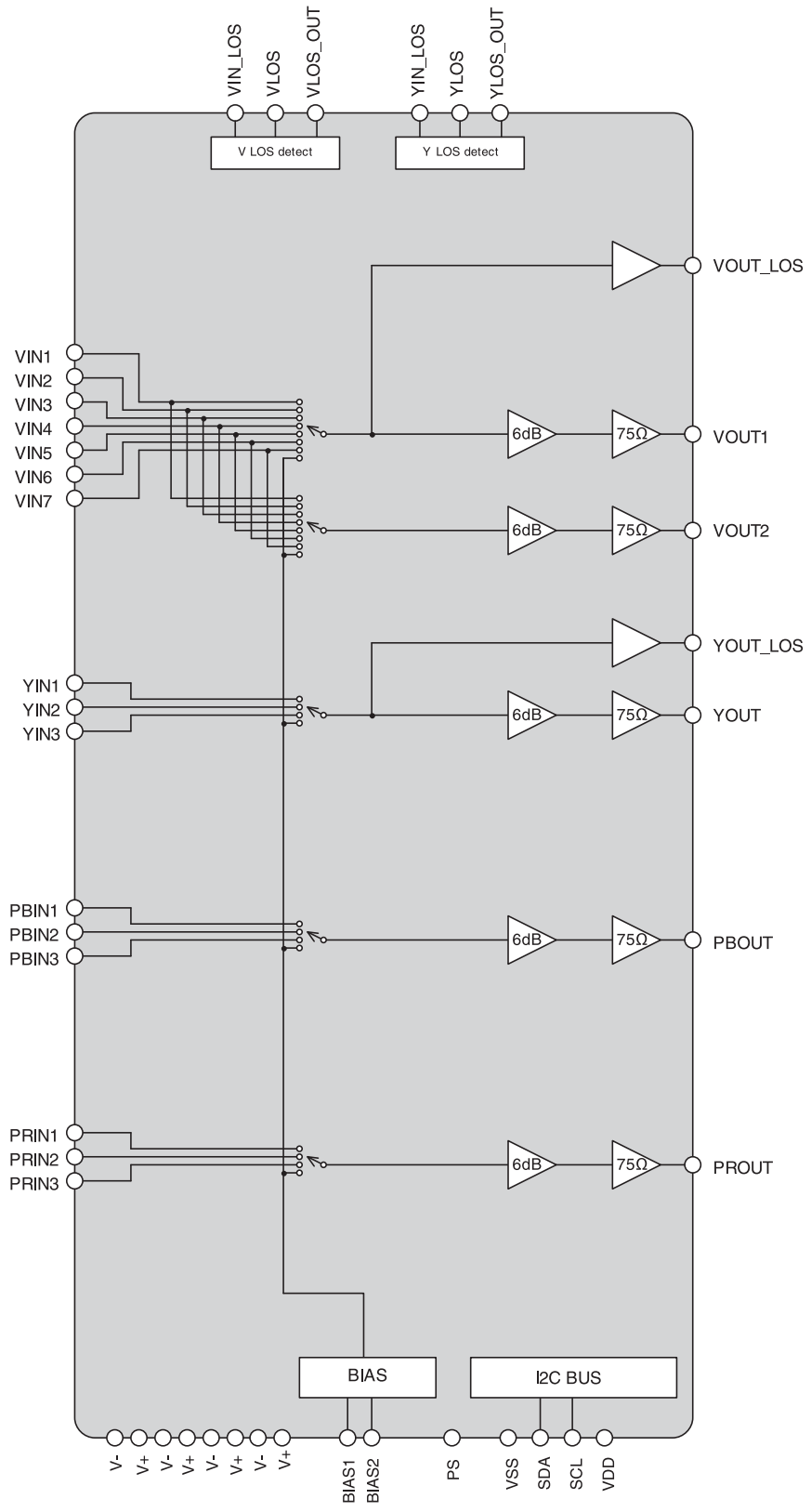

B

C

D

E

F

## ■ (J005251601010S-IL) (D-MAIN ASSY: IC9004)

IC, MEMORY FLASH

### • Pin Arrangement (Top view)

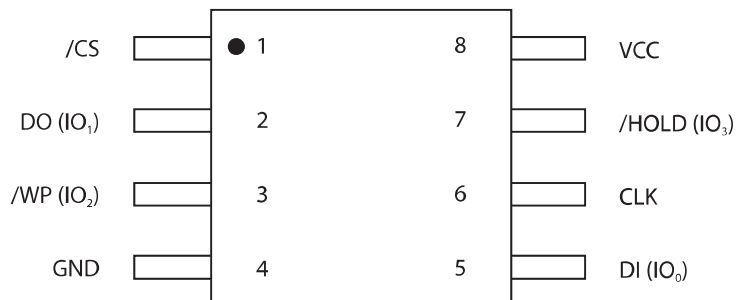

### • Pin Function

PIN NO.	PIN NAME	I/O	FUNCTION
1	/CS	I	Chip Select Input
2	DO (IO <sub>1</sub> )	I/O	Data Output (Data Input Output 1)* <sup>1</sup>
3	/WP (IO <sub>2</sub> )	I/O	Write Protect Input ( Data Input Output 2)* <sup>2</sup>
4	GND		Ground
5	DI (IO <sub>0</sub> )	I/O	Data Input (Data Input Output 0)* <sup>1</sup>
6	CLK	I	Serial Clock Input
7	/HOLD (IO <sub>3</sub> )	I/O	Hold Input (Data Input Output 3)* <sup>2</sup>
8	VCC		Power Supply

\*1 IO<sub>0</sub> and IO<sub>1</sub> are used for Dual and Quad instructions

\*2 IO<sub>0</sub> – IO<sub>3</sub> are used for Quad instructions

# 6. SERVICE MODE

## 6.1 TEST MODE

### A [1] Detected protection history

#### [Purpose]

The numbers of detections for various protection processes are displayed.

#### [How to enter]

During Standby mode, simultaneously press and hold "MULTI-ZONE ON/OFF" and "ENTER" keys for 5 seconds to enter this mode. Turn off the power to this unit by setting the main volume level to "---dB" and Multi-zone to "OFF".

#### [How to exit]

Turning off the power or pressing the RETURN key returns to the normal mode.

#### [Basic operations]

Key operation	FL display
Display number of times DC is detected.	DC : ***
[↓] [↑]	
Display number of times OVERLOAD is detected.	OL : ***
[↓] [↑]	
Display number of times COMBINATION is detected. (Detects DC and OVERLOAD simultaneously)	COM : ***
[↓] [↑]	
Display number of times Power abnormality is detected.	XPRT : ***
[↓] [↑]	
Display number of times AMP overheat is detected.	STMP : ***
[↓] [↑]	
Display number of times Digital Power abnormality is detected.	DERR : ***
[↓] [↑]	
Resetting the number of times error is detected.	RESET ◀HOLD▶
[↓] [↑]	

#### Front Panel Key

- [↓] : TUNE key
- [↑] : TUNE key
- [←] : PRESET key
- [→] : PRESET key

Resetting the number of times error is detected

Key operation	FL display
[←][→]	RESET ◀CLEAR?▶
[ENTER]	RESET ◀RESET▶
Continued	

Key operation	FL display
Display accumulated time & RESET.  [↓] [↑]	1 2 3 4 5 h 2 0 m ◀ H L D ▶
Display CEC(TEST) state.  [↓] [↑]	C E C ◀ OFF ▶
Display FAN(TEST) state. This function does not work on this model.  [↓] [↑]	F A N ◀ OFF ▶
USB Backup state  [↓] [↑]	U S B B A K ◀ H O L D ▶
Display Model Name/Destination state.  [↓] [↑]	V S X - 1 1 2 7 / C U X E
Change cyclically	

**[Description]**

CEC TEST : The function for making the HDMI output terminal to output 4 Hz square wave. If the square wave is output, the CEC line is considered to be normal.

FAN TEST : The function for making the FAN to be forced to rotate.

Resetting the accumulated time

Key operation	FL display
[←][→]	1 2 3 4 5 h 2 0 m ◀ C L ? ▶
[ENTER]	0 h 0 0 m ◀ R S T ▶
Continued	

Display CEC(TEST) state.

Key operation	FL display
[←][→]	C E C ◀ ON ▶
Change cyclically	

**Note:**

In case of US models, [USB Backup] function is not implemented with the first firmware. Before performing the backup function, please check the unit version. If small version number of Main com (EMMA) is smaller than 157, please update to the latest version. If that is 157 or over (e.g. [1-157076014091] ), the backup function is implemented.

Saving and Loading of USB backup state.

Key operation	FL display
[←][→]	(A/V Receiver → USB) U S B B A K ◀ S A V E ? ▶
[←][→]	(USB → A/V Receiver) U S B B A K ◀ L O A D ? ▶
Change cyclically	

Key operation	FL display
[ENTER]	P L E A S E W A I T
SAVE or LOAD is completed. ↓ 5 sec Power OFF (All zone OFF)	C O M P L E T E

A  
B  
C  
D  
E  
F

## 6.2 DEFAULT SETTINGS

1

2

3

4

### A Default system settings

Setting	Default	
Digital Video Converter	ON	
SPEAKERS	SB/FH	
Speaker System	Normal(SB/FH)	
Speaker Setting	Front	SMALL
	Center	SMALL
	FH/FW	SMALL
	Surr	SMALL
	SB	SMALLx2
	SW	YES
Surround Position	IN REAR	
Crossover	80 Hz	
X-Curve	OFF	
DIMMER	Brightest	
<b>HDMI</b>		
HDMI Audio	Amp	
Control	OFF	
Control Mode	--- (OFF)	
ARC (Audio Return Channel)	--- (OFF)	
PQLS	--- (AUTO)	
Standby Through	OFF	
<b>DSP</b>		
Power On Level	LAST	
Volume Limit	OFF	
Mute Level	FULL	
Phase Control	ON	
Auto Sound Retriever	iPod/USB, INTERNET RADIO, SiriusXM, PANDORA, MEDIA SERVER, FAVORITES, ADAPTER PORT input function	ON
	Other input functions	OFF
Sound Delay	0.0 frame	
Dual Mono	CH1	
DRC	AUTO	
SACD Gain	0 dB	
LFE Attenuate	0 dB	
Auto delay	OFF	
Digital Safety	OFF	
Effect Level	ExtendedStereo	90
	Other modes	50
PL II Music Options	Center Width	3
	Dimension	0
	Panorama	OFF
Neo:6 Options	Center Image	Neo:6 CINEMA: 10 Neo:6 MUSIC: 3
	Height Gain	MID
All Inputs	Listening Mode (2 ch/multi ch)	AUTO SURROUND
	Listening Mode (Headphones)	STEREO
<b>MCACC</b>		
MCACC Position Memory	M1: MEMORY 1	
Channel Level (M1 to M6)	0.0 dB	
Speaker Distance (M1 to M6)	10'00"	
Standing Wave (M1 to M6)	ATT of all channels/filters	0.0 dB
	SWch Wide Trim	0.0 dB
EQ Data (M1 to M6)	All channels/bands	0.0 dB
	EQ Wide Trim	0.0 dB

F

### Default input settings

Input function	Input Terminals		
	HDMI	Audio	Component
<b>BD</b>	(BD)		
<b>DVD</b>	IN 1	COAX-1	IN 1
<b>SAT/CBL</b>	IN 2	COAX-2 <a>	●
<b>DVR/BDR</b>	IN 3	OPT-2 <a>	●
<b>HDMI 4</b>	IN 4		
<b>HDMI 5</b>	IN 5 <b>		
<b>HDMI 6</b> <a>	IN 6		
<b>INTERNET RADIO</b>			
<b>SiriusXM</b>			
<b>PANDORA</b>			
<b>MEDIA SERVER</b>			
<b>FAVORITES</b>			
<b>iPod/USB</b>			
<b>TV</b>		OPT-1	
<b>CD</b>		ANALOG-1 <c>	
<b>TUNER</b>			
<b>ADAPTER PORT</b>			

- a VSX-1127 only.  
 b Located on the front panel for the VSX-1127.  
 c Only the **TV** and **CD** inputs can be assigned to **ANALOG-1**.

### Resetting the system

Use this procedure to reset all the receiver's settings to the factory default. Use the front panel controls to do this.

Set MULTI-ZONE to **MULTI ZONE OFF**.

- Disconnect the iPod and USB memory device from the receiver beforehand.
- Set the **Control** with HDMI to **OFF**.

- 1 **Switch the receiver into standby.**
- 2 **While holding down ENTER on the front panel, press  $\odot$  STANDBY/ON.**

The display shows **RESET ◀ NO ▶**.

- 3 **Select 'RESET' using PRESET  $\leftarrow/\rightarrow$ , then press ENTER on the front panel.**

The display shows **RESET? OK**.

- 4 **Press ENTER to confirm.**

**OK** appears in the display to indicate that the receiver has been reset to the factory default settings.

- Note that all settings will be saved, even if the receiver is unplugged.

1

2

3

4



# 7. DISASSEMBLY

## Note:

- (1) Even if the unit shown in the photos and illustrations in this manual may differ from your product, the procedures described here are common.
- (2) For performing the diagnosis shown below, the following jigs for service is required:
  - 13P extension jig cable (GGD1740)
  - 3P extension jig cable (GGD1741)
  - Board to board extension jig cable (GGD1736) + Conversion jig (GGD1802)
  - Board to board extension jig cable (GGD1798) + Conversion jig (GGD1803)
  - Board to board extension jig cable (GGD1799)

## 1. Discharging

### [1] MAIN Assy Capacitor (C55, C58)

#### [Procedures]

- (1) Unplug the power cord.
- (2) Disconnect the 10P connector from CP403 of the AMP7 Assy between CN3 of the MAIN Assy.
- (3) Connect +B and -B terminal of the D7, using resistor leads with 47 - 100 ohms (2 W or higher), for discharging.
  - \* Discharging time: 30 - 60 seconds, depending on the level of resistance.
- (4) Check that the voltage between the +B and -B terminals is less than 1 V, using a tester.
  - \* Be sure to connect the GND terminal of the tester to the chassis.
  - \* If the voltage is still 1 V or higher, repeat Step (3).

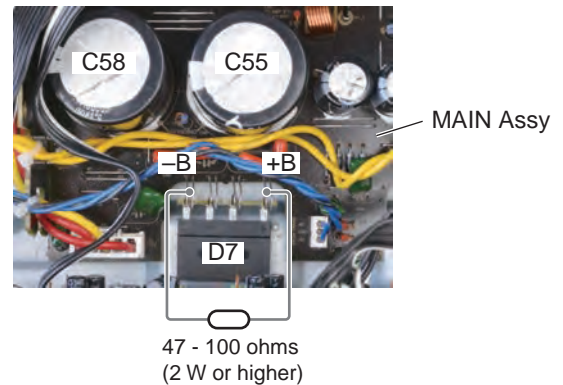
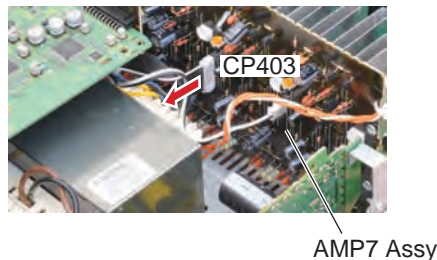

### [2] FL-30 V Capacitor

#### [Procedures]

- (1) Unplug the power cord.
- (2) Connect pin 1 (-30V) and GND terminal (A) of CP3001 on the FRONT Assy, using resistor leads with 47-100 ohms (2 W or higher), for discharging.
  - \* Discharging time: 5 - 10 seconds, depending on the level of resistance.
- (3) Check that the voltage between the -30V terminal is less than 1 V, using a tester.
  - \* Be sure to connect the GND terminal of the tester to the chassis.
  - \* If the voltage is still 1 V or higher, repeat Step (2).

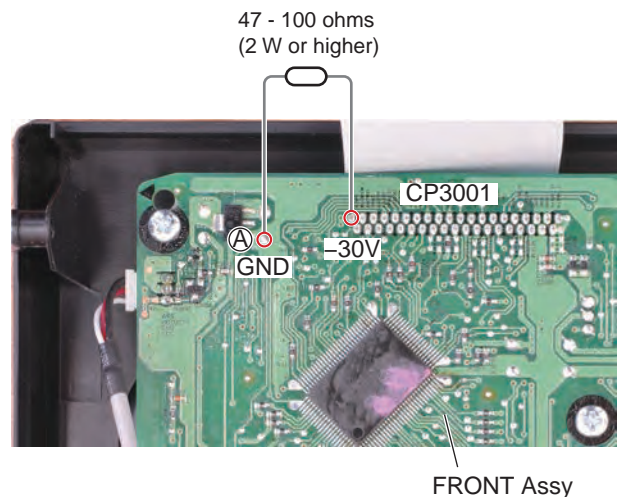

## 2. Notes on Ground Points Connection

### [Note]

During repair, before checking the MAIN Assy, etc., with the rear chassis removed, be sure to connect the GND terminal of the main capacitor to the back chassis (speaker chassis), as shown below, then connect the power cord.

**Without grounding connection, the protection circuit will be activated.  
After repairing, be sure to remove the ground wire before reassembling.**

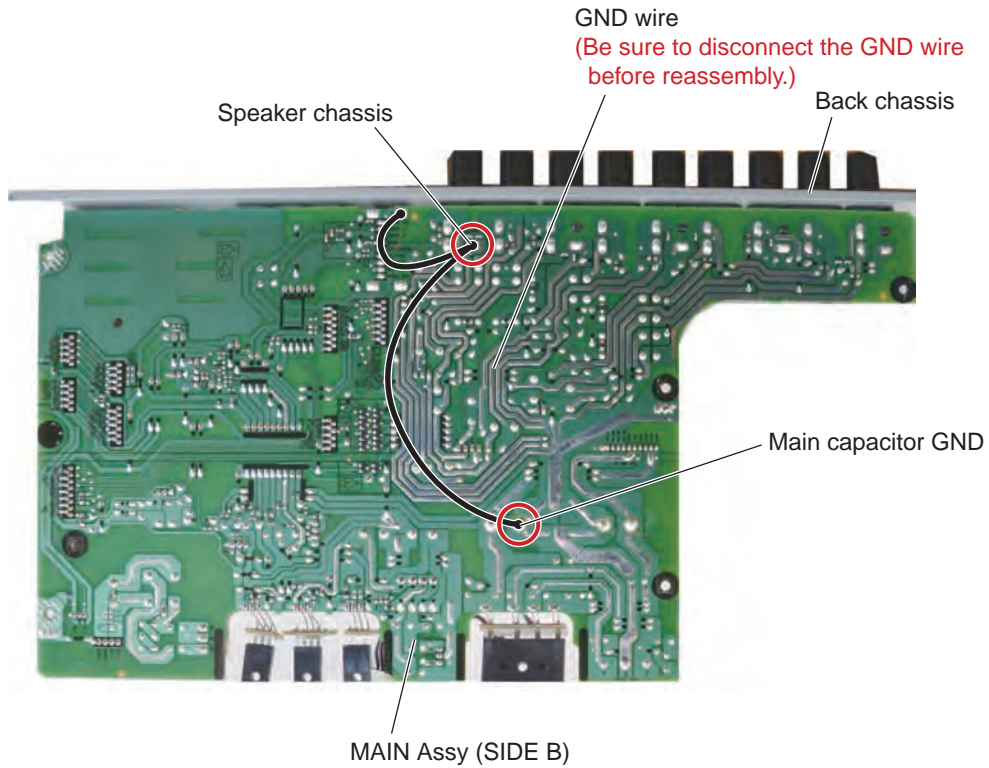

### 3. Disassembly

#### [1] Front Panel Section

Remove the cabinet by removing the 10 screws.

(1) Remove the five screws. (BBZ30P080FTB)

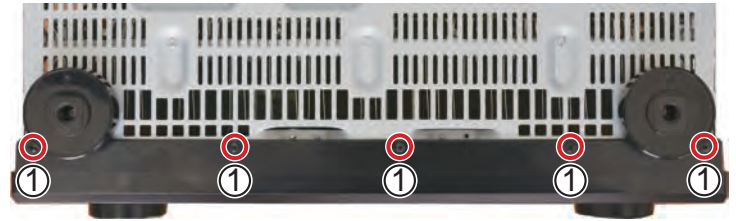

• Bottom view

(2) Remove the one screw.  
(BBZ30P080FTC)

(3) Remove the three screws.  
(1500001206010-IL)

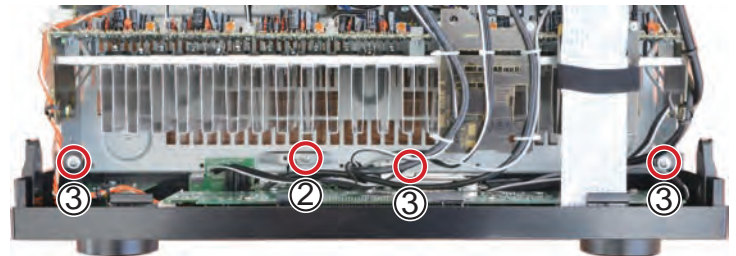

(4) Unhook the two hooks.

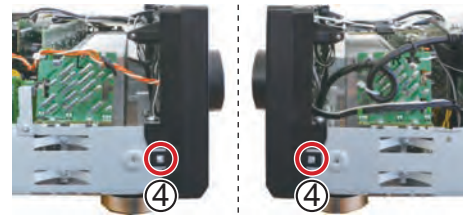

(5) Arrange the front panel section as shown in the photo below.

Front panel section

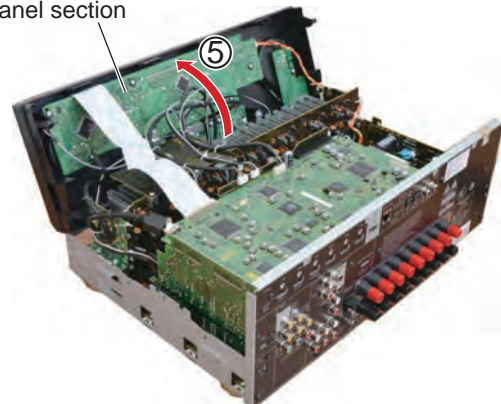

## A [2] Heatsink Section

**Caution:** Heatsink section in work becomes hot, and be careful with it.

Remove the cabinet by removing the 10 screws.

(1) Remove the three screws. (BBZ30P080FTC)

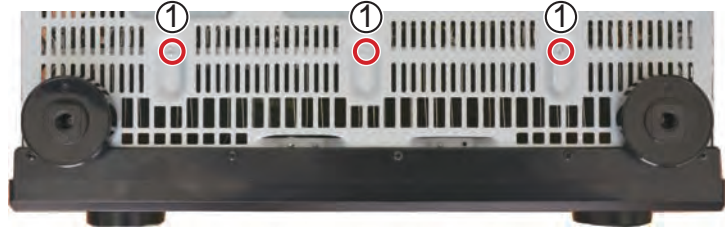

• Bottom view



(2) Remove the four screws. (BBZ30P080FTC)

(3) Cut the two binders.

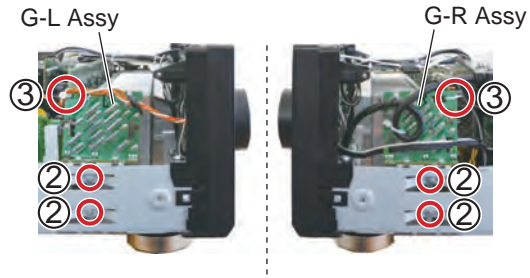

(4) Remove the two screws. (BBZ30P080FTC)

(5) Remove the WG-A and CCG Assemblies.

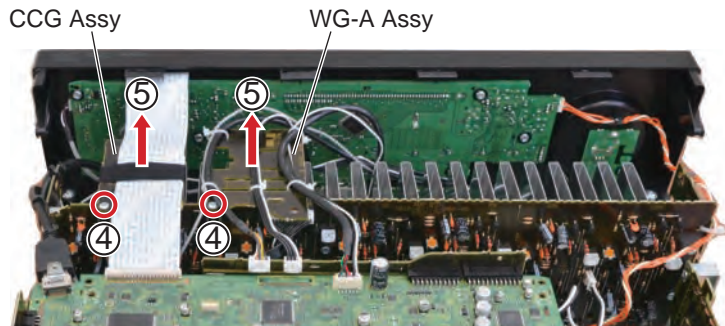

- (6) Disconnect the six connectors.
- (7) Remove the Heatsink section.

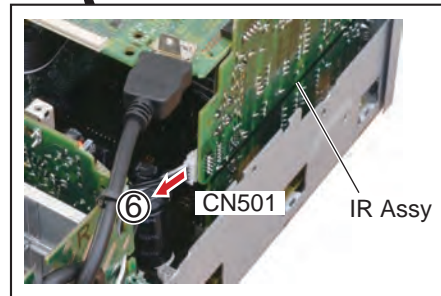
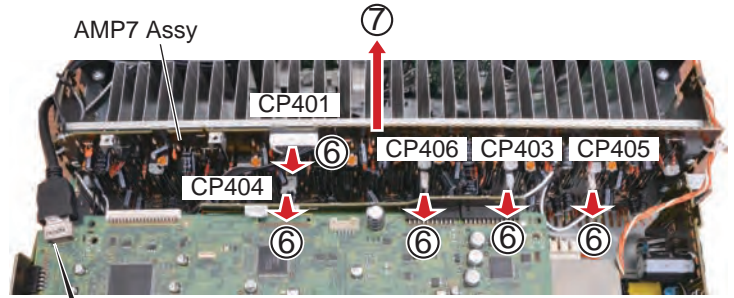

- (8) As shown, arrange the Heatsink section over the WG-A Assy.
- (9) Re-connect the four connectors.
- (10) Connect the two extension jig cables.

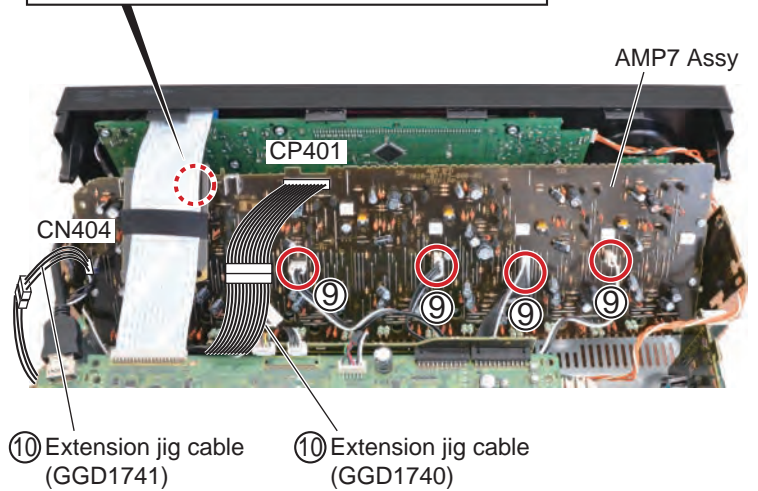
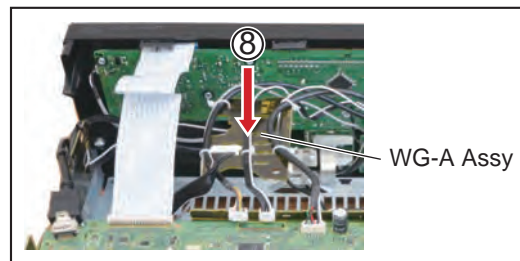

### A [3] D-MAIN Assy

Remove the cabinet by removing the 10 screws.

- (1) Remove the five screws. (BBT30P100FTB)
- (2) Remove the seven screws. (BSZ30P040FTB)

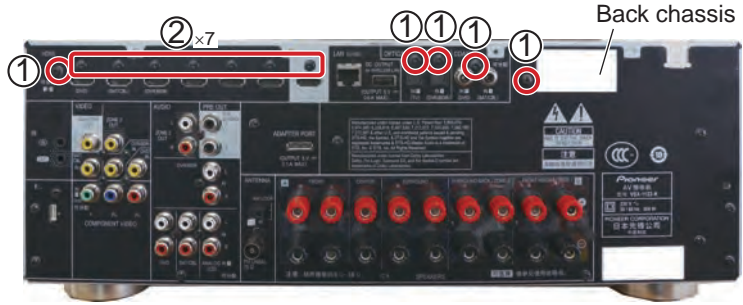

• Rear view



- (3) Disconnect the five B to B connectors. (CN603, 607, 901, 1504, 1801)
- (4) Remove the D-MAIN Assy.

#### • HDMI cable styling

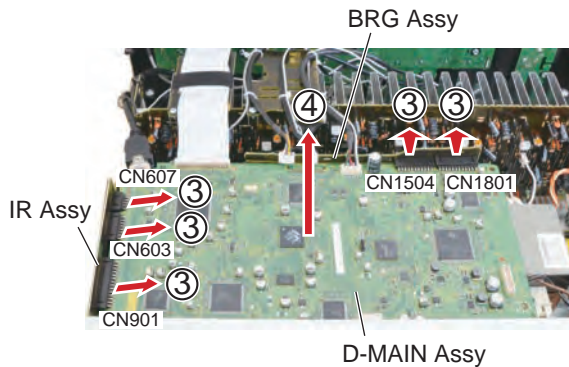
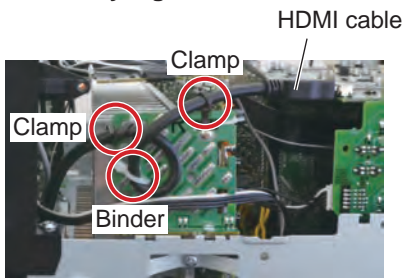

**Note:**  
Make styling so that tension does not hang to the HDMI connector.

- (5) Connect the five extension jig cables.
- (6) Arrange the D-MAIN Assy in the photo below.
- (7) Insert any insulation sheet.

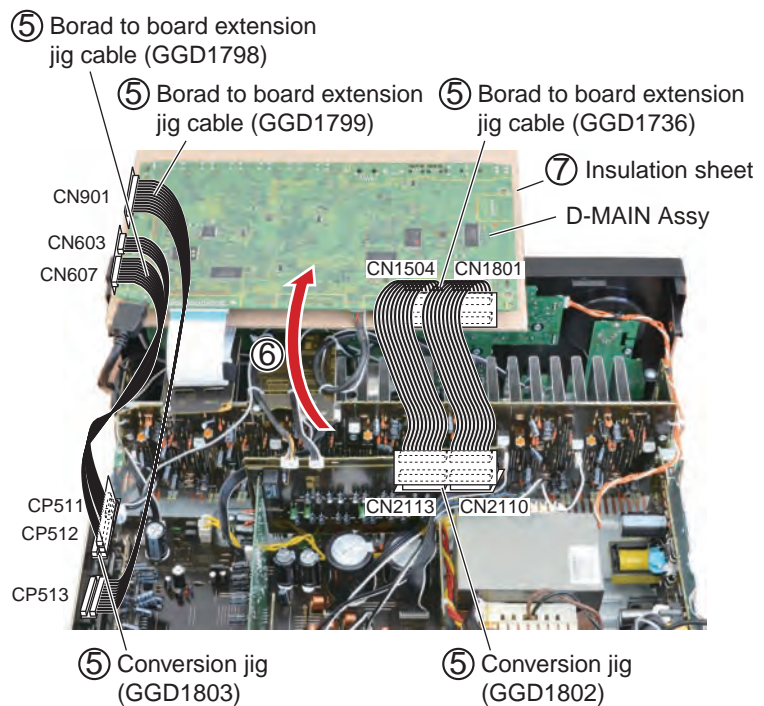

**Note:**  
Confirm that a B to B connector of BRG Assy is connected to AUDIO Assy tightly.

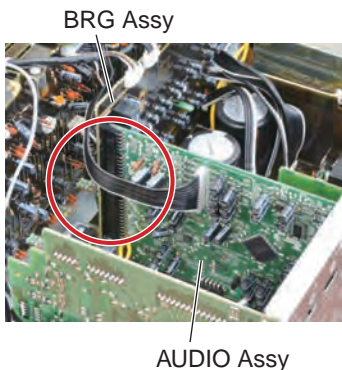

## [4] MAIN Assy

Remove the cabinet by removing the 10 screws.

### [4-1] Back chassis, D-MAIN Assy

- (1) Remove the 15 screws. (BBT30P100FTB)
- (2) Remove the seven screws. (BSZ30P040FTB)
- (3) Remove the D-MAIN Assy.  
(See procedure [3].)

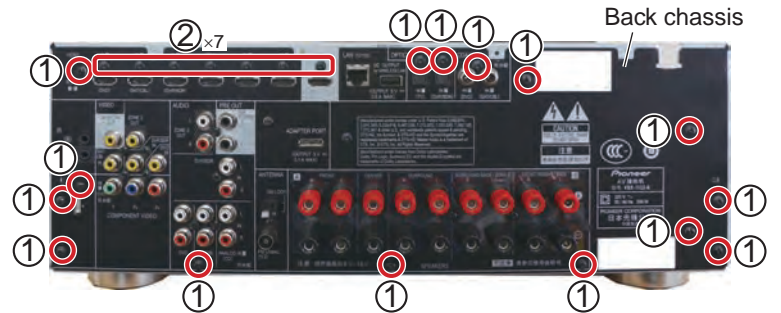

### [4-2] MAIN Assy

- (1) Remove the four screws. (BBZ30P180FTC)
- (2) Remove the six screws. (BBZ30P080FTC)
- (3) Cut the four binders.
- (4) Remove the MAIN Assy with back chassis.

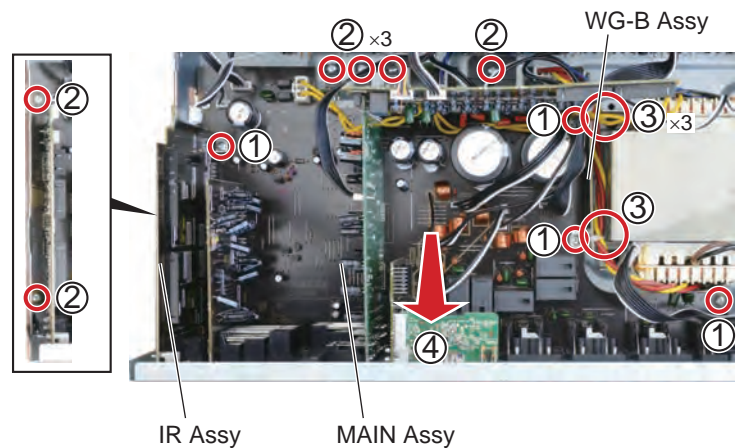

# 8. EACH SETTING AND ADJUSTMENT

A



- If the adjustment is shifted or if it becomes necessary to readjust because of part replacement, etc., perform the adjustment as described below.
- Any value changed in Adjustment mode will be stored in memory as soon as it is changed. Before readjustment, take note of the original values for reference in case you need to restore the original settings.
- Use a stable AC power supply.

B

## 8.1 ADJUSTMENT REQUIRED WHEN THE UNIT IS REPAIRED OR REPLACED

### When any of the following assemblies is replaced

C

AMP7 Assy	➔	"8.4 IDLE CURRENT ADJUSTMENT" (All channel)
D-MAIN Assy	➔	"8.2 USB BACKUP"
Other assemblies	➔	No adjustment required

### When any of the following parts is replaced

D

AMP7 Assy	➔	"8.4 IDLE CURRENT ADJUSTMENT" (Only channel of replacement parts)
Other assemblies	➔	No adjustment required

E

Note:  
Some parts on D-MAIN and F-USB Assemblies can not be replaced due to using heat-pad connection between the board. Please refer to [1.2 NOTES ON REPLACING PARTS], when the parts listed in the table is defective, replace whole Assy.

F



## 8.2 USB BACKUP

### [Introduction]

This model is capable of saving the set values stored in the MAIN Ucom of D-MAIN Assy in the USB and loading them in a new D-MAIN Assy. (Note that MAIN Ucom should normally operate to enable this function.)  
When replacing D-MAIN Assy, execute the above mentioned processes.

### [Data that can be saved/cannot be saved]

The following **data can not be saved**. Data other than these can be saved.

Contents to save	Destination to save
Last memory for turning ON/OFF the Main power and power supply for ZONE2 Last memory for inputting the Main power, ZONE2 Setting for controlling HDMI Remote control ID Setting for Network Standby Data to be save upon the operation of protection circuit Standby Through setting	EVENT Ucom
Settings for HMG Favorite, Recently played, Repeat	BridgeCo IC

(As the data saved by EVENT Ucom is on the FRONT Assy, the data cannot be deleted unless Assy is replaced at the same time.)

### [Requirements for USB memory]

USB memory to be used should meet the following requirements.

- Compatible with USB Mass storage Class
- With a file system of FAT (FAT32)

### [File saving format]

Files are to be saved in the following format:

Example: VSX-1127\_BK01.avr

### [How to save in the USB memory from AV amplifier]

1. Insert the usable USB memory into the USB terminal when the main device is off.
2. Enter the SERVICE MODE and select [USB BAK ◀ HOLD ▶] with ↑↓ keys.  
(See [6.1 TEST MODE] for how to enter the SERVICE MODE.)
3. Select [USB BAK ◀ SAVE? ▶] with ⇐⇒ keys and press [ENTER].  
Note: The system cannot execute SAVE, LOAD until start is completed of BridgeCo.
4. Saving in the USB starts and the main device automatically goes off after the normal completion ([COMPLETE] is displayed.).
5. Remove the USB and saving is finished.

\*1. If the following errors occur after "SAVE" is executed, error message will be displayed and "SAVE" will be stopped and the power will be turned off.

- Ejecting of USB device
- Short capacity of USB device
- Error during writing in the USB device (Read Only or defective Sector, etc.)

\*2. If the same file name exists in the USB, overwriting will be automatically executed.

### [How to write into AV amplifier from the USB memory]

1. Insert the USB with the saved file into the USB terminal when the main device is off.
2. Enter the TEST MODE and select [USB BAK ◀ HOLD ▶] with ↑↓ keys.  
(See [6.1 TEST MODE] for how to enter the TEST MODE.)
3. Select [USB BAK ◀ LOAD? ▶] with ⇐⇒ keys and press [ENTER].
4. Saving in the main device starts and it automatically goes off after the normal completion ([COMPLETE] is displayed.).
5. Remove the USB and loading is finished.

\* If the following errors occur after "LOAD" is executed, error message will be displayed and "LOAD" will be stopped and the power will be turned off.

- No setting file
- Mismatching between the setting file and the specification of the A/V RECEIVER type to be loaded back
- Error due to Checksum, Signature Check, and Size Check
- Ejecting of USB device (during reading of the setting file)

**A Precautions**

- Files are stored in Root of USB memory.
- Files are read from Root of USB memory.
  - ⇒ To make operations such as moving files, be sure to assign the saved file in Root of the USB memory.  
Also please be careful not to assign \*.avr in multiple numbers.
- The time and date of updating for saved file is fixed to "2006/03/08 20:01."
- In principle, please implement Load without making of factory default settings.  
To Load from factory default settings status, please take caution on the following points;

Please be sure to check the HDMI control setting for the user before performing of factory default settings.  
Since the HDMI control setting of default settings is ON, turn OFF the HDMI control setting and Load after performing of factory default settings if the checked user setting is OFF.

(If Load is executed with the setting ON, the assignment information for each HDMI input will be cleared.)

**B**

Procedures for turning OFF the HDMI control setting

⇒ HOME MENU ⇒ 4.System Setup ⇒ e.HDMI Setup ⇒ Control OFF

**Note:**

In case of US models, [USB Backup] function is not implemented with the first firmware.

Before performing the backup function, please check the unit version. If small version number of Main com (EMMA) is smaller than 157, please update to the latest version.

If that is 157 or over (e.g. [1-157076014091] ), the backup function is implemented.

**C****D****E****F**

## 8.3 UPDATING OF THE FIRMWARE

### Workflow

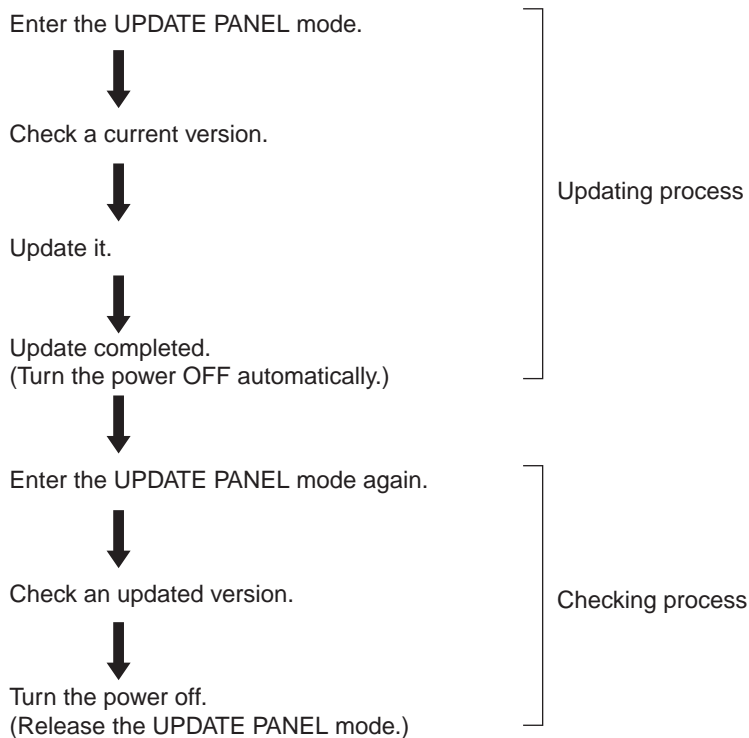

### MAIN com (EMMA), SUB com (EVENT), DSP Flash ROM and BridgeCo IC Update by USB Memory and the Confirmation of the Version

#### ● UPDATE PANEL Mode (Version update)

##### [Preparations]

1. Copy the UPDATE FILE to the root directory of the USB Memory.  
**Note:** NEVER copy several UPDATE FILES to the root directory of the USB Memory.  
 Copy only the corresponding UPDATE FILE.
2. Turn off the power to this unit by setting Multi-Zone to "OFF".
3. Connect the USB Memory to the USB terminal (A type) of the front panel.

##### [Procedure]

1. While holding down "TUNE↑" key on the front panel, press "STANDBY ON/OFF" key and moves to the **UPDATE PANEL mode**.
2. The updating process is as follows.

A

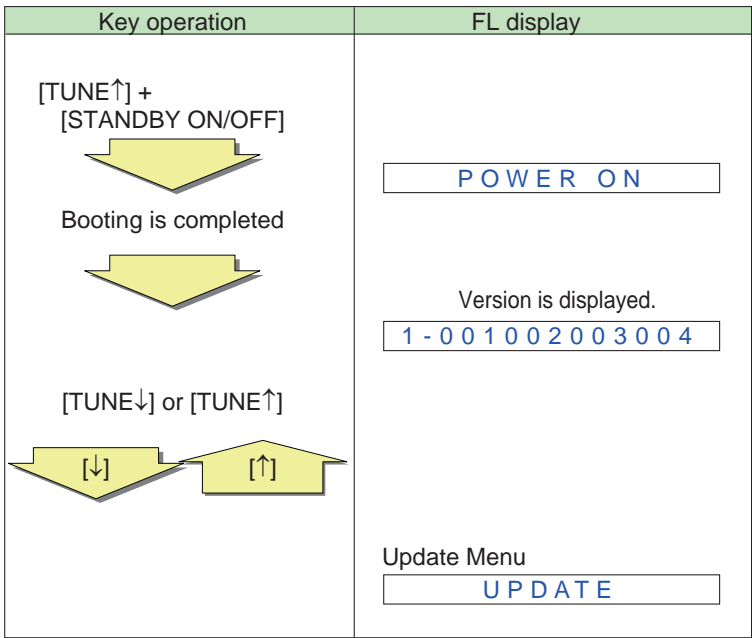

**Front Panel Key**

- [↓] : TUNE key
- [↑] : TUNE key
- [←] : PRESET key
- [→] : PRESET key

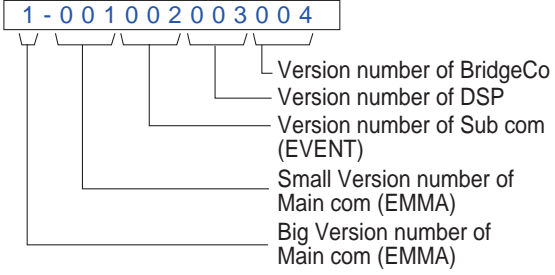

B

C

Do not do time-out during update panel indication.  
 It takes about 45 seconds till version of the BridgeCo is displayed.  
 Meanwhile, version of the BridgeCo is displayed with \*\*\*.

D

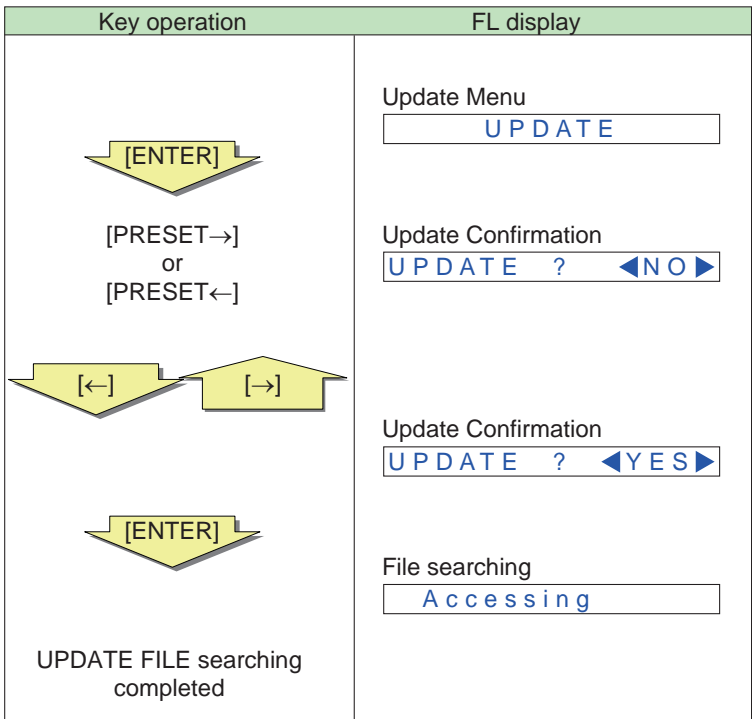

E

F

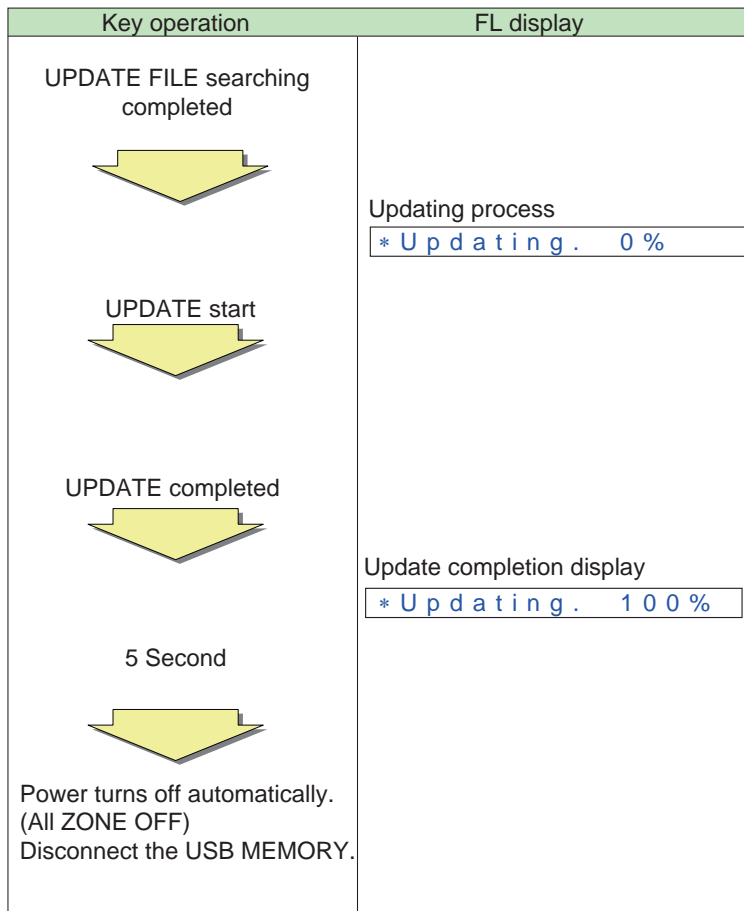

Update time is fluctuated by contents of the update. It will take about 26 minutes at the maximum.  
(Actual time is from 3 minutes to 26 minutes.)

Time required for updating varies, because only the programs that require updating will be updated.

### [Confirmation]

Enter UPDATE PANEL mode and check that the programs have been updated.

# 8.4 IDLE CURRENT ADJUSTMENT



When any component parts which are within the red square on the following circuit diagram are replaced, the idle current adjustment of that channel is required. (Idle current adjustment for another channel is not required.) However, when any capacitors are replaced, the adjustment is not required. (The following circuit diagram is for SL channel, but another channel also has same circuit diagram and same adjustment is required)

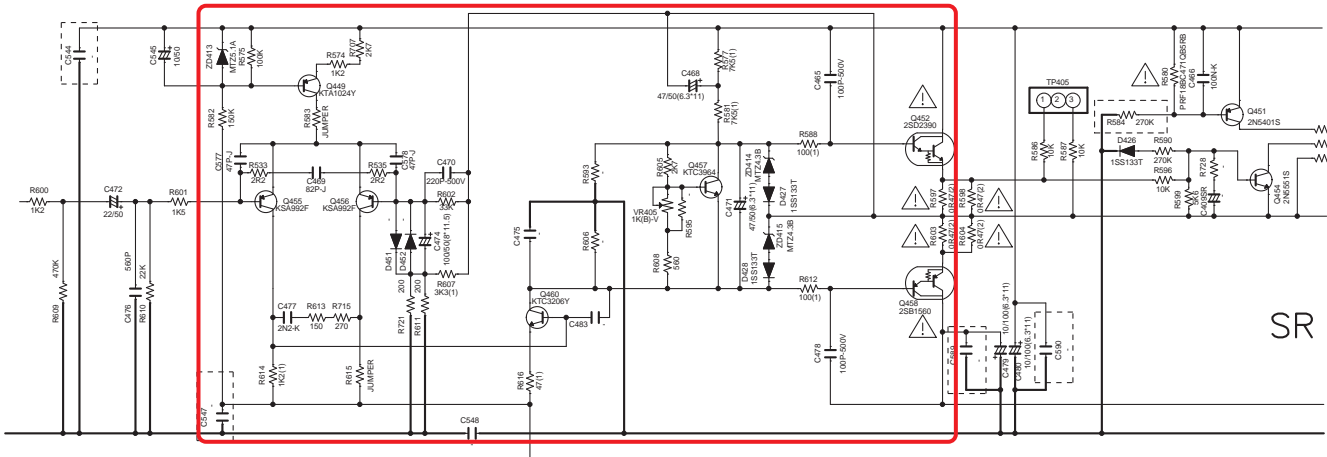

Channel	Measurement Points	Adjustment Points	Procedure
FL	TP404 pin 1 (+) TP404 pin 3 (-)	VR404	① Turn on the power. ② Perform aging for one minute. ③ Connect a digital voltmeter to the measurement point. ④ Turn the adjustment VR so that the voltage becomes in $2.0 \text{ mV} \pm 0.2 \text{ mV}$ . (Condition : No signal and no load)
FR	TP402 pin 1 (+) TP402 pin 3 (-)	VR402	
C	TP403 pin 1 (+) TP403 pin 3 (-)	VR403	
SL	TP401 pin 1 (+) TP401 pin 3 (-)	VR401	
SR	TP405 pin 1 (+) TP405 pin 3 (-)	VR405	
SBL	TP406 pin 1 (+) TP406 pin 3 (-)	VR406	
SBR	TP407 pin 1 (+) TP407 pin 3 (-)	VR407	

• Adjustment points and measurement points.... see fig.1.

## B AMP7 ASSY

SIDE A

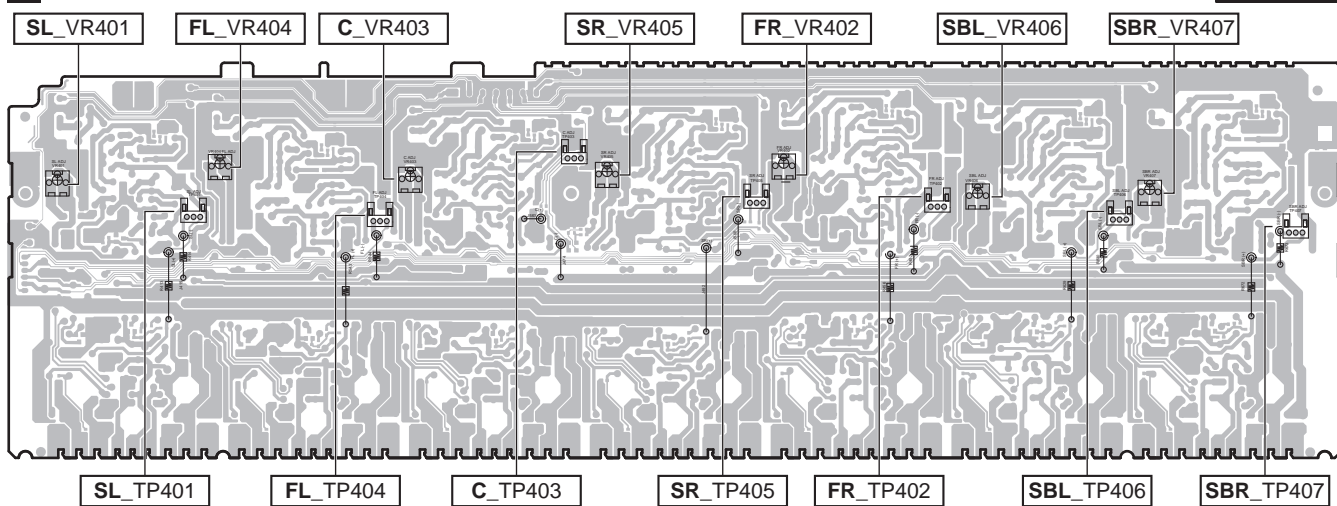

Fig.1



5



6



7



8



A



B



C



D



E



F



5



6

VSX-1127-K



7



8



# 9. EXPLODED VIEWS AND PARTS LIST

NOTES: ● Parts marked by "NSP" are generally unavailable because they are not in our Master Spare Parts List.

- The  $\triangle$  mark found on some component parts indicates the importance of the safety factor of the part. Therefore, when replacing, be sure to use parts of identical designation.
- Screws adjacent to  $\nabla$  mark on product are used for disassembly.
- For the applying amount of lubricants or glue, follow the instructions in this manual. (In the case of no amount instructions, apply as you think it appropriate.)

## 9.1 PACKING SECTION

Poly bag packing style

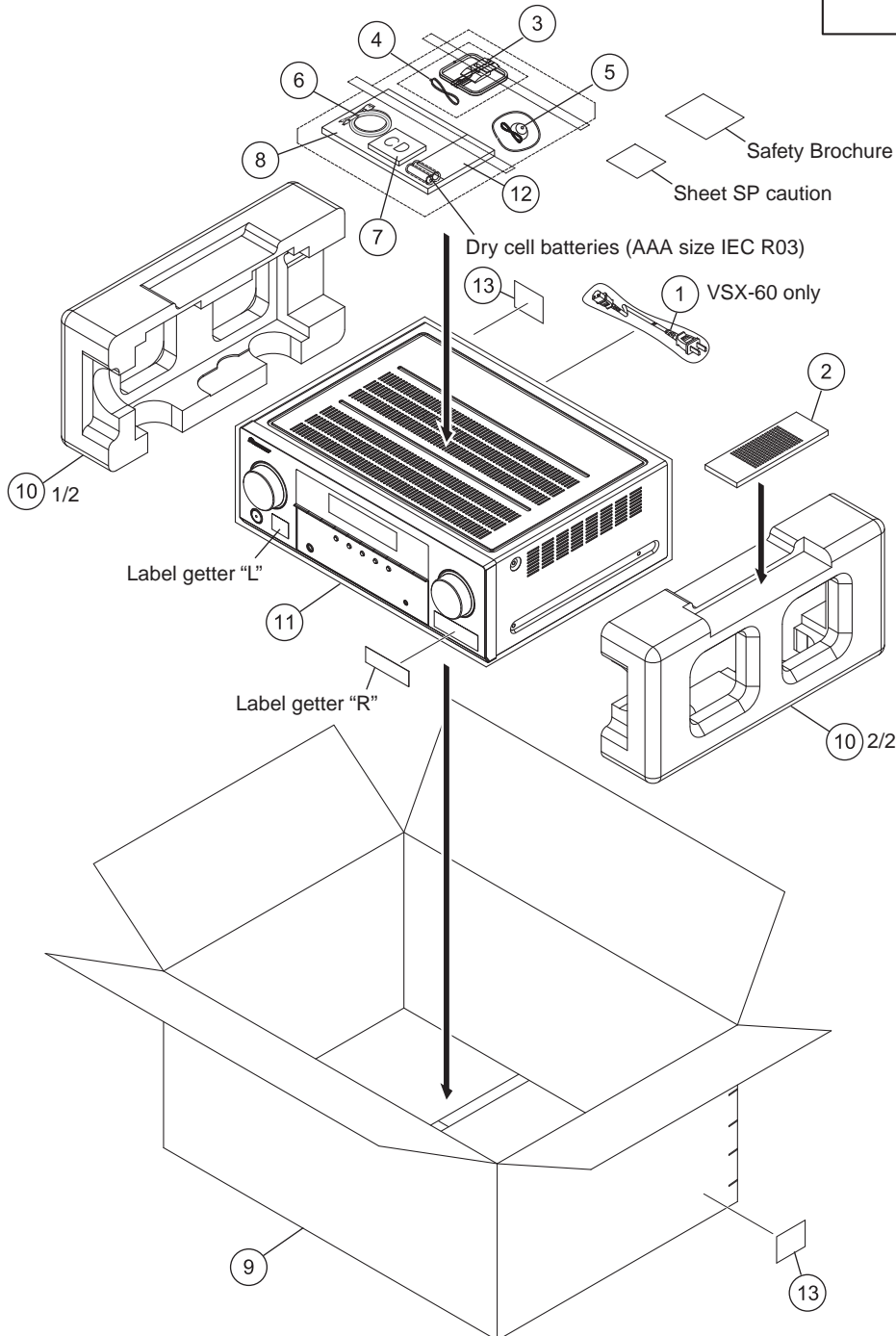
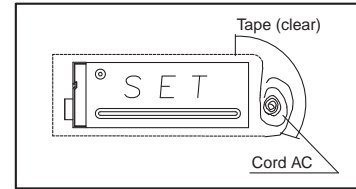



**(1) PACKING SECTION PARTS LIST**

<b>Mark No.</b>	<b>Description</b>	<b>Part No.</b>
⚠	1 Power Cord	See Contrast table (2)
	2 Remote Control	8300766400010-IL
	3 AM Loop Antenna	E601019000010-IL
	4 FM Wire Antenna	E605010140010-IL
	5 Microphone (for Auto MCACC setup)	APM7010
6 iPod Cable	L308102013030-IL	
7 Operating Instructions (CD-ROM)	See Contrast table (2)	
8 Quick Start Guide	See Contrast table (2)	
9 Box, Gift	See Contrast table (2)	
10 Cushion, Snow	6230212914000-IL	
11 PE, Sheet	6327040059000-IL	
NSP 12 Warranty Sheet	See Contrast table (2)	
NSP 13 Label	VRW1629	

**(2) CONTRAST TABLE**

VSX-1127-K/CUXE, VSX-1122-K/CUXESM, VSX-60/UXECB and VSX-1027-K/CUXE are constructed the same except for the following:

<b>Mark</b>	<b>No.</b>	<b>Symbol and Description</b>	<b>VSX-1127-K /CUXE</b>	<b>VSX-1122-K /CUXESM</b>	<b>VSX-60 /UXECB</b>	<b>VSX-1027-K /CUXE</b>
⚠	1	Power Cord	Not used	Not used	L068125130010-IL	Not used
	7	Operating Instructions (CD-ROM)	6517000000550-IL	6517000000540-IL	6517000000560-IL	6517000000550-IL
	8	Quick Start Guide	57070000006590-IL	57070000006580-IL	57070000006600-IL	57070000006590-IL
	9	Box, Gift	6007211820110-IL	6007211820100-IL	6007211820120-IL	6007211820150-IL
NSP	12	Warranty Sheet	ARY7156	ARY7156	ARY7007	ARY7156

# 9.2 EXTERIOR SECTION

1

2

3

4

A

B

C

D

E

F

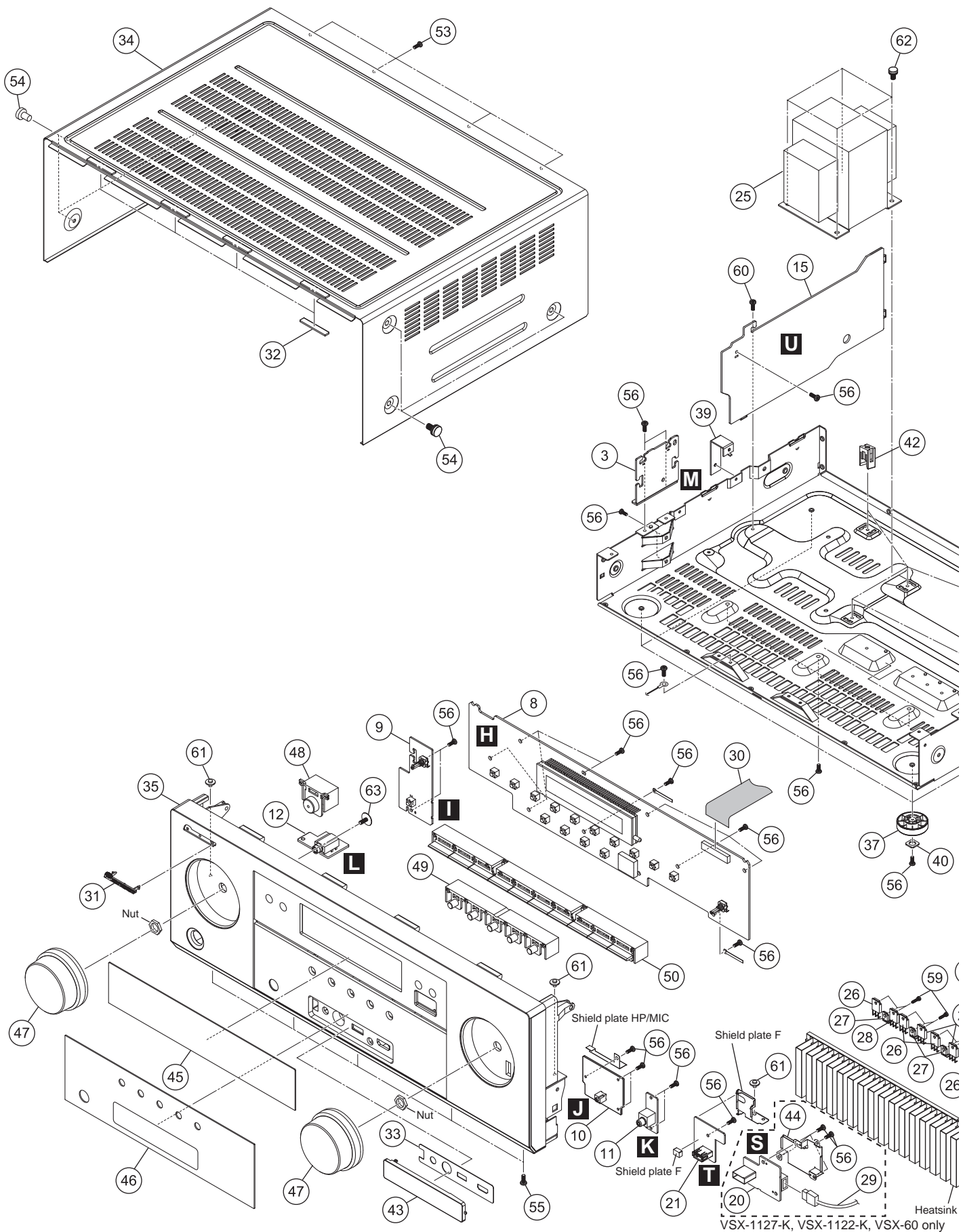

1

2

3

4

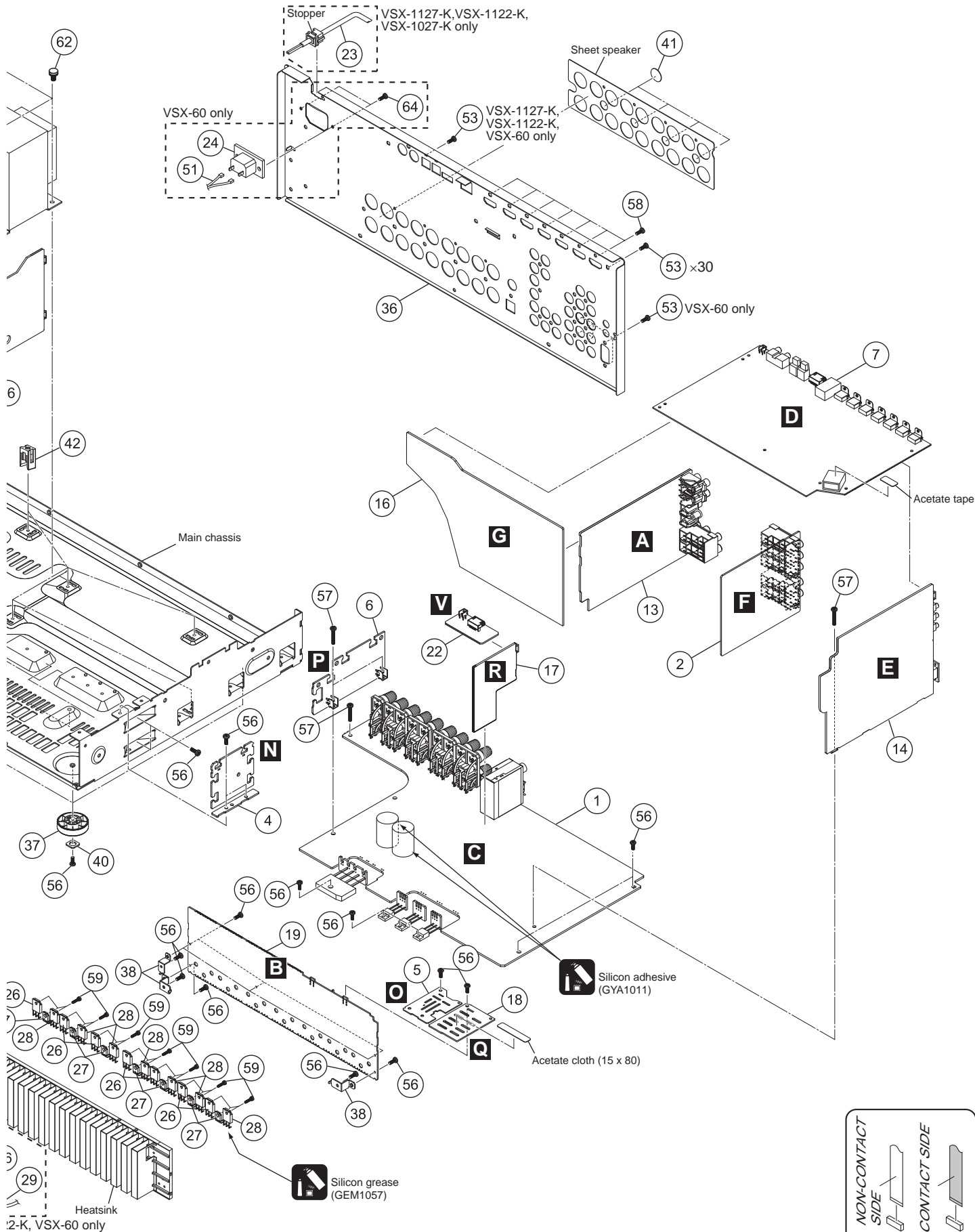

A

B

C

D

E

F

**VSX-1127-K**

**(1) EXTERIOR SECTION PARTS LIST**

<u>Mark No.</u>	<u>Description</u>	<u>Part No.</u>	<u>Mark No.</u>	<u>Description</u>	<u>Part No.</u>
A	1 MAIN Assy	See Contrast table (2)	46	Window Lower	See Contrast table (2)
	2 VIDEO Assy	See Contrast table (2)	47	Knob	5080212431000-IL
	3 G-L Assy	7028071713040-IL	48	Button	See Contrast table (2)
	4 G-R Assy	7028071714040-IL	49	5 Key Button	5090214561000-IL
	5 WG-A Assy	7028071715040-IL	50	10 Key Button	5090214571000-IL
	6 WG-B Assy	7028071716040-IL	51	CN, Wire	See Contrast table (2)
	7 D-MAIN Assy	See Contrast table (2)	52	•••••	
	8 FRONT Assy	See Contrast table (2)	53	Screw	BBT30P100FTB
	9 POWER Assy	See Contrast table (2)	54	Screw	BBT40P080FTB
	10 MIC Assy	7028071723040-IL	55	Screw	BBZ30P080FTB
B	11 FVIDEO Assy	7028071724040-IL	56	Screw	BBZ30P080FTC
	12 HP Assy	7028071725040-IL	57	Screw	BBZ30P180FTC
	13 AUDIO Assy	See Contrast table (2)	58	Screw	BSZ30P040FTB
	14 IR Assy	See Contrast table (2)	59	Screw Tapping Assy	B018230141H11-IL
	15 SMPS Assy	See Contrast table (2)	60	Screw, Tap Tite	B020230063B10-IL
	16 BRG Assy	See Contrast table (2)	61	Screw, Tap Tite	1500001206010-IL
	17 BTCNT Assy	7028071774040-IL	62	Screw	B028940101B11-IL
	18 CCG Assy	7028071775040-IL	63	Screw	1500001456010-IL
	19 AMP7 Assy	7028071731040-IL	64	Screw	See Contrast table (2)
C	20 FHDMI Assy	See Contrast table (2)			
	21 F-USB Assy	7028071761020-IL			
	22 BT Assy	7028070231010-IL			
	⚠ 23 Cord Assy	See Contrast table (2)			
	⚠ 24 Socket, power AC	See Contrast table (2)			
	⚠ 25 Power Trans 1021U	8200960611050-IL			
	⚠ 26 Transistor	J5011560Y0000-IL			
	⚠ 27 Semi, TR/GE NPN 2SC	J502396400010-IL			
	⚠ 28 Transistor	J5032390Y0000-IL			
D	⚠ 29 HDMI Conn-Cable	See Contrast table (2)			
	30 Cable, Flat Card 1.0M	N711392412880-IL			
	31 Pioneer Badge	See Contrast table (2)			
	32 Sheet	1210210235000-IL			
	33 F Input Sheet	See Contrast table (2)			
	34 Cabinet	3007211846000-IL			
	35 Front Panel	See Contrast table (2)			
	36 Back Chassis	See Contrast table (2)			
	37 Foot (PLS)	4000210391000-IL			
E	38 Bracket	4010056906010-IL			
	39 Bracket SMPS	4010214886000-IL			
	40 Cushion	4050211605000-IL			
	41 Screw Cover	4050211745100-IL			
	42 Support	4070001601010-IL			
	43 Front Input Cover	4317215111030-IL			
	44 Front HDMI Plate1122	See Contrast table (2)			
	45 Window Display U	See Contrast table (2)			

**(2) CONTRAST TABLE**

VSX-1127-K/CUXE, VSX-1122-K/CUXESM, VSX-60/UXECB and VSX-1027-K/CUXE are constructed the same except for the following:

Mark	No.	Symbol and Description	VSX-1127-K /CUXE	VSX-1122-K /CUXESM	VSX-60 /UXECB	VSX-1027-K /CUXE
	1	MAIN Assy	7028071711010-IL	7028071711010-IL	7028071711040-IL	7028071711010-IL
	2	VIDEO Assy	7028071712020-IL	7028071712070-IL	7028071712040-IL	7028071712070-IL
	7	D-MAIN Assy	7028071752020-IL	7028071752040-IL	7028071752040-IL	7028071752070-IL
	8	FRONT Assy	7028071721050-IL	7028071721010-IL	7028071721040-IL	7028071721060-IL
	9	POWER Assy	7028071722010-IL	7028071722010-IL	7028071722040-IL	7028071722010-IL
	13	AUDIO Assy	7028071741050-IL	7028071741010-IL	7028071741040-IL	7028071741010-IL
	14	IR Assy	7028071771010-IL	7028071771010-IL	7028071771040-IL	7028071771010-IL
	15	SMPS Assy	7028071772010-IL	7028071772010-IL	7028071772040-IL	7028071772010-IL
	16	BRG Assy	7028071773040-IL	7028071773040-IL	7028071773040-IL	7028071773070-IL
	20	FHDMI Assy	7028071791040-IL	7028071791040-IL	7028071791040-IL	Not used
	23	Cord Assy	L068125101710-IL	L068125101710-IL	Not used	L068125101710-IL
⚠	24	Socket, power AC	Not used	Not used	G430040560021-IL	Not used
⚠	29	HDMI Conn-Cable	ADX7777	ADX7777	ADX7777	Not used
	31	Pioneer Badge	XAM3006	XAM3006	PAM1791	XAM3006
	33	F Input Sheet	1217211162040-IL	1217211162040-IL	1217211162050-IL	1217211792000-IL
	35	Front Panel	3067215111020-IL	3067215111010-IL	3067215121010-IL	3067215491000-IL
	36	Back Chassis	3207214216200S-IL	3207214216000S-IL	3207214216300S-IL	3207214206100S-IL
	44	Front HDMI Plate1122	4470212466000-IL	4470212466000-IL	4470212466000-IL	Not used
	45	Window Display U	5077213113040-IL	5077213113040-IL	5077213113050-IL	5077213113040-IL
	46	Window Lower	5077213123090-IL	5077213123090-IL	50772131230B0-IL	5077213123090-IL
	48	Button	5090213741100-IL	5090213741100-IL	5098214551000-IL	5090213741100-IL
	51	CN, Wire	Not used	Not used	L000800020220-IL	Not used
	64	Screw	Not used	Not used	CBZ30P080FTB	Not used

# 10. SCHEMATIC DIAGRAM

## 10.1 AUDIO ASSY

- When ordering service parts, be sure to refer to "EXPLODED VIEWS and PARTS LIST" or "PCB PARTS LIST".
- The  $\Delta$  mark found on some component parts indicates the importance of the safety factor of the part. Therefore, when replacing, be sure to use parts of identical designation.
- : The power supply is shown with the marked box.

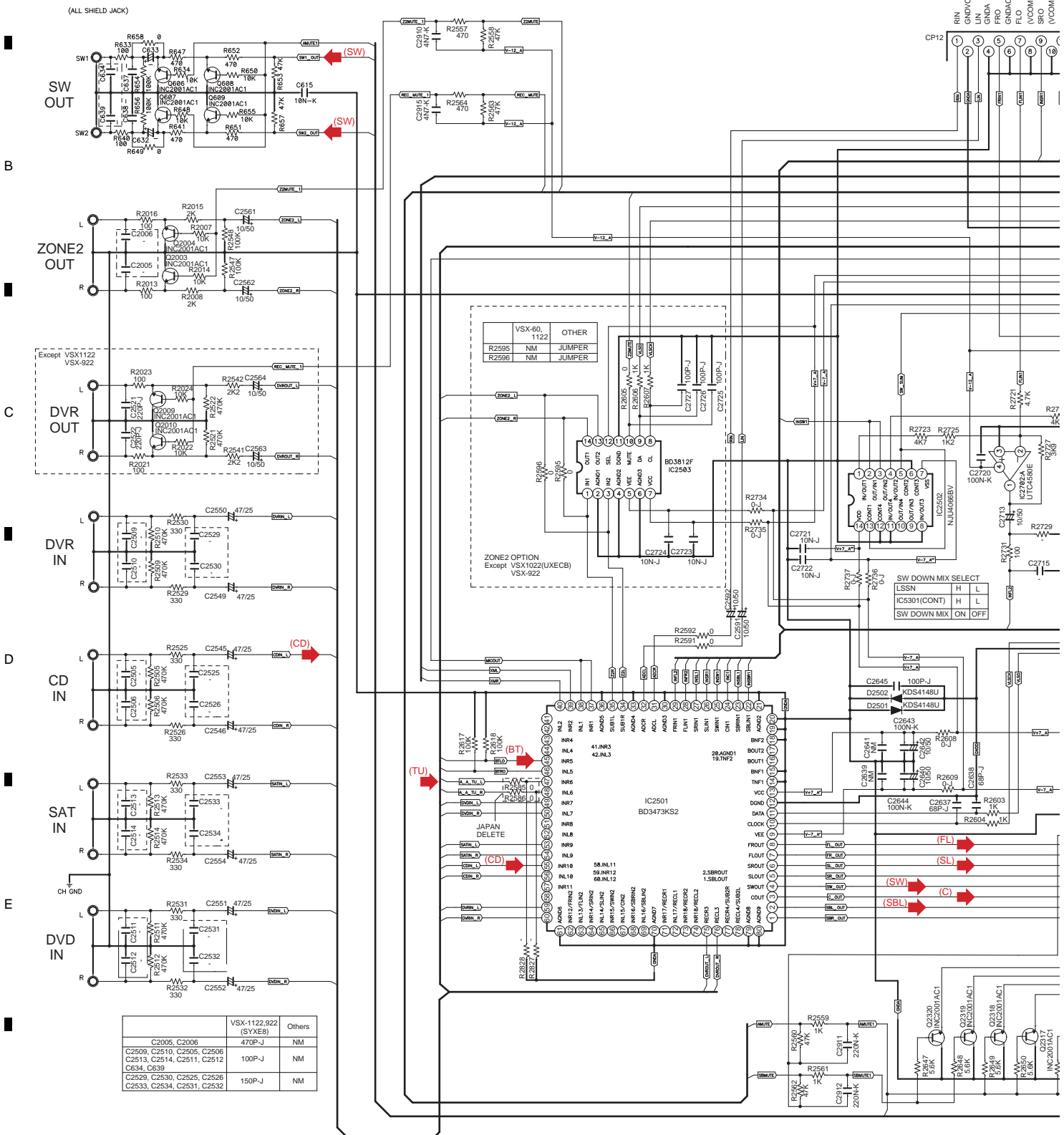

G CN2107

G CN2203

G CN2112

A AUDIO ASSY  
(VSX-1127-K: 7028071741050-IL)  
(VSX-1122-K: 7028071741010-IL)  
(VSX-60: 7028071741040-IL)  
(VSX-1027-K: 7028071741010-IL)

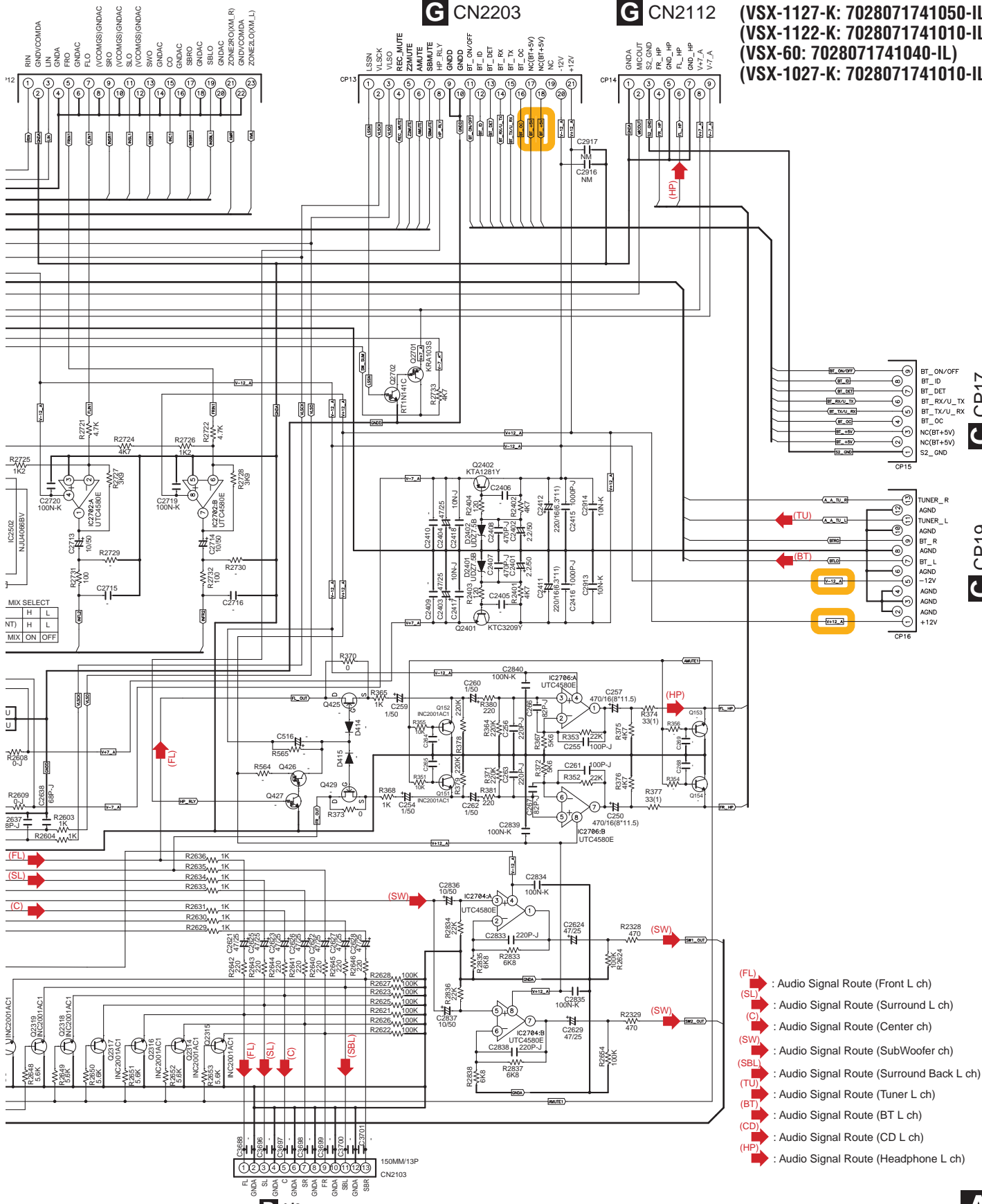

B 1/2 CP401

VSX-1127-K

A

# 10.2 AMP7 ASSY (1/2)

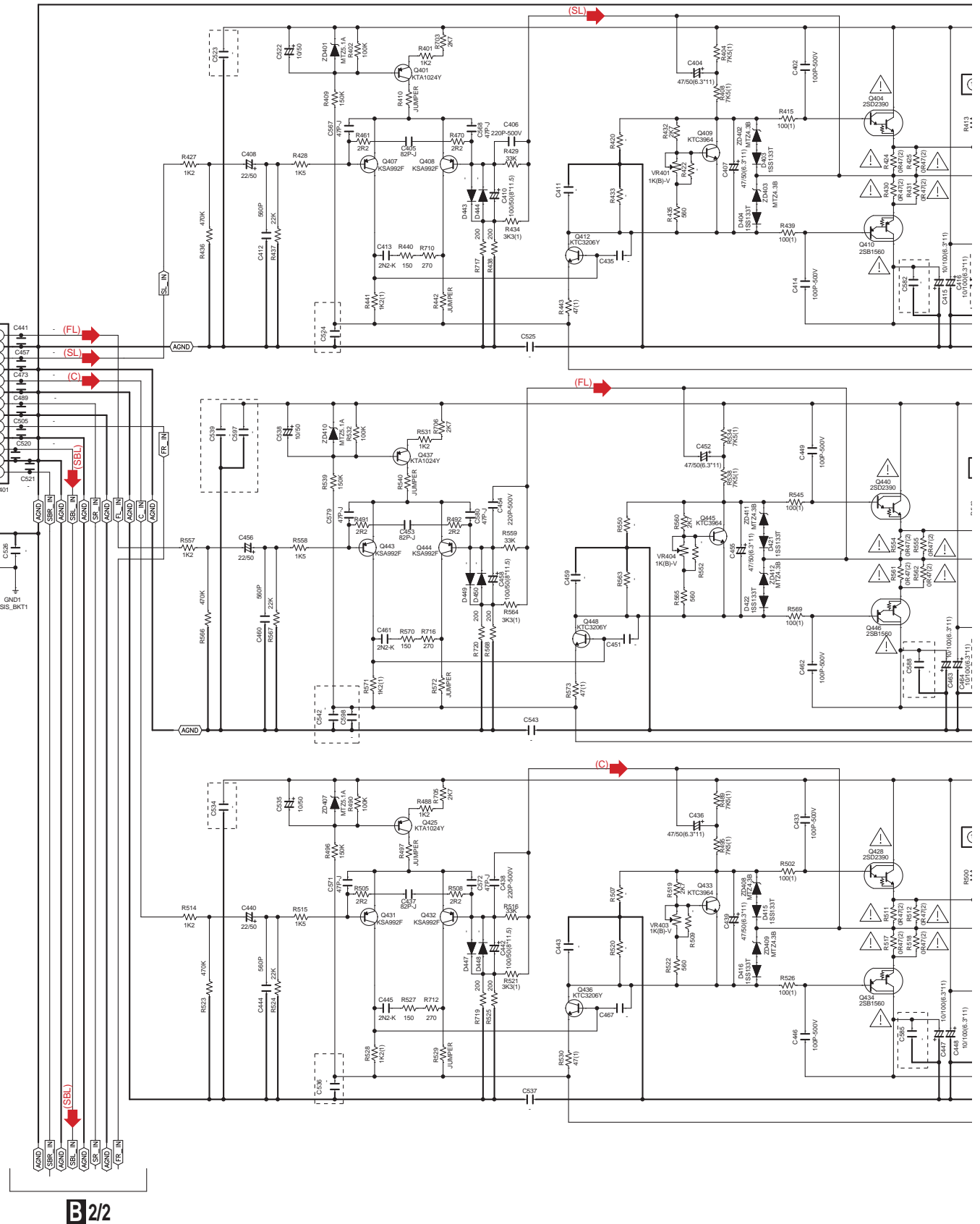

B 1/2



# B 1/2 AMP7 ASSY (7028071731040-IL)

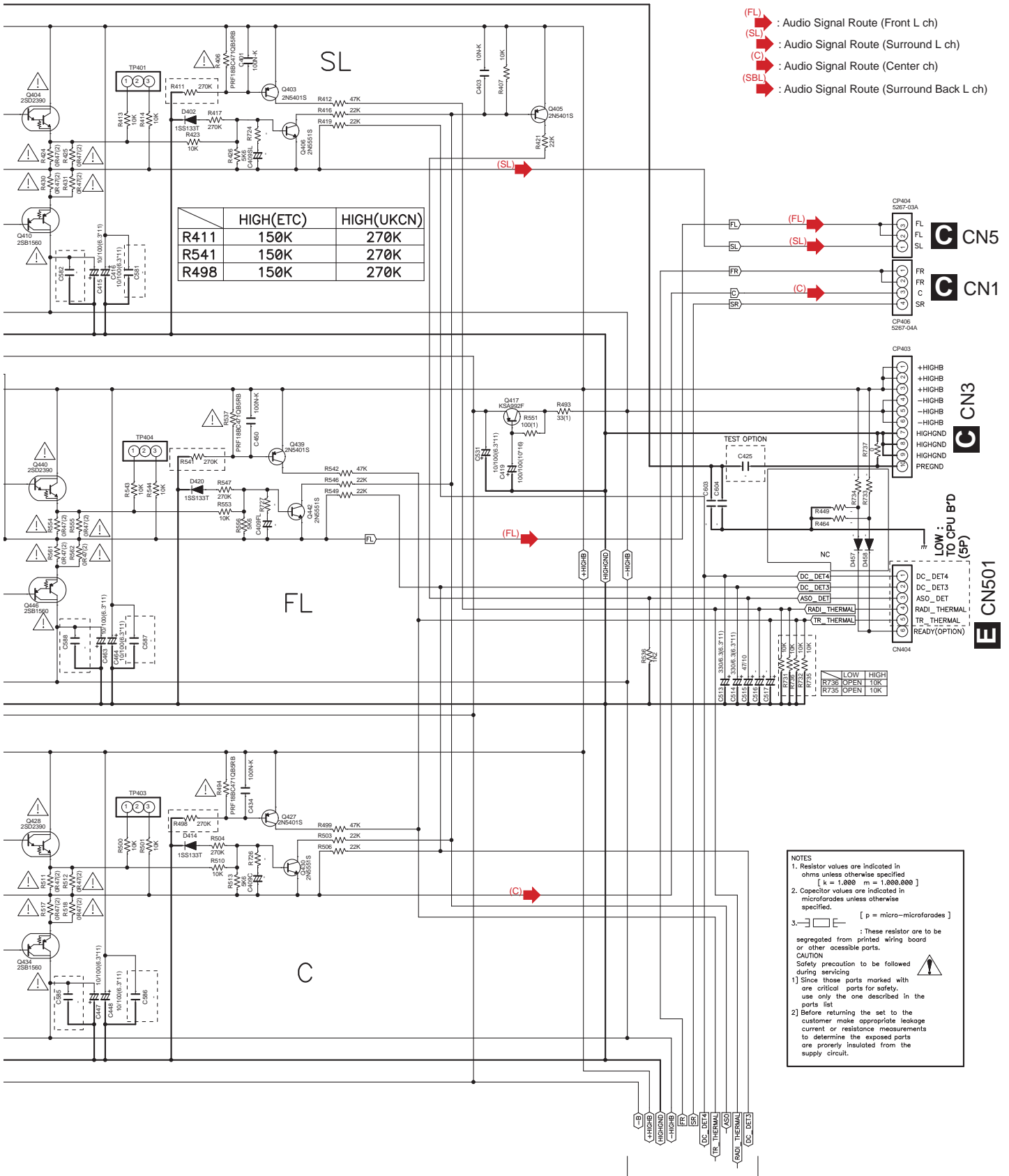

B 2/2

VSX-1127-K

B 1/2

# 10.3 AMP7 ASSY (2/2)

A  
B  
C  
D  
E  
F

1 2 3 4

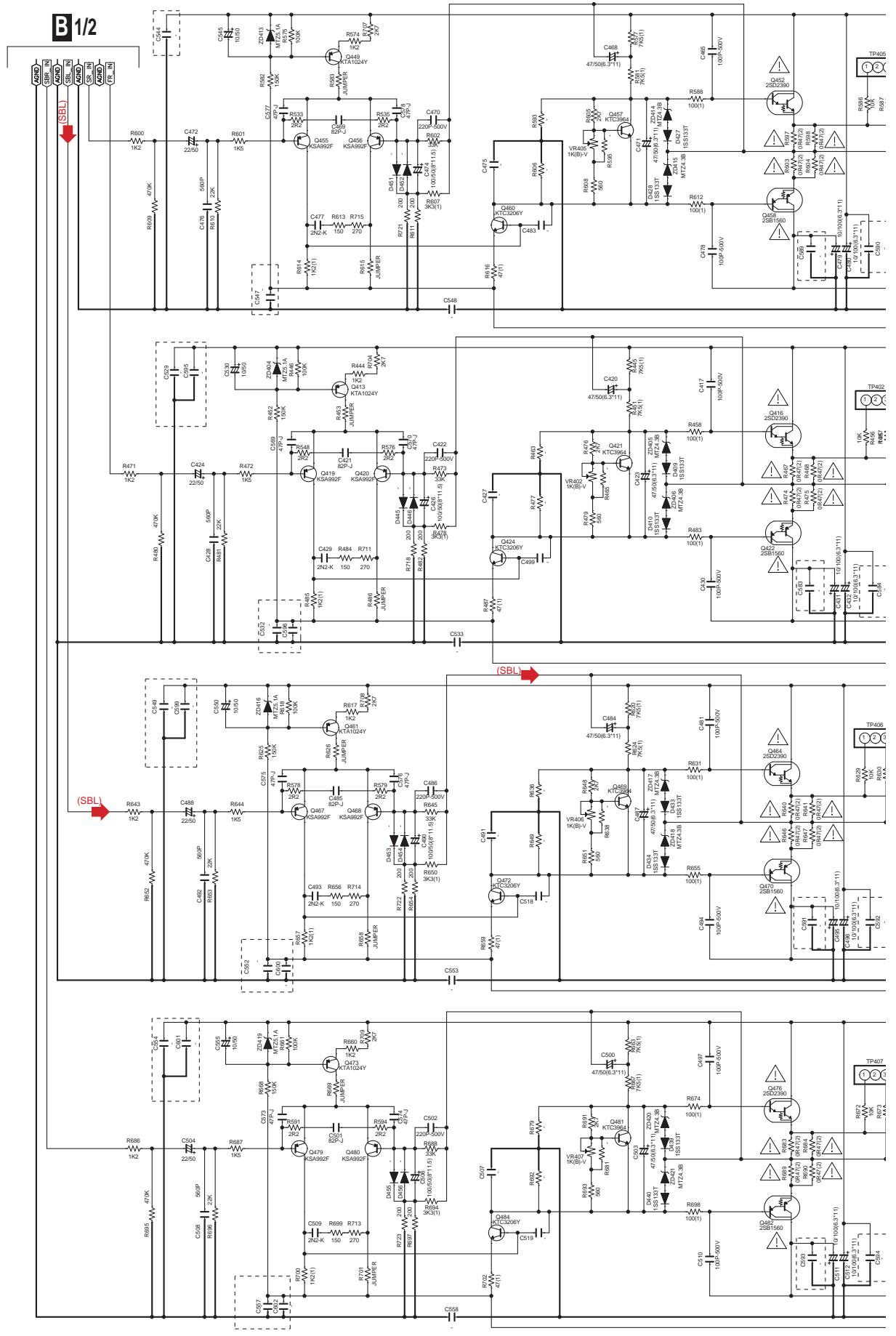

**B 2/2**

VSX-1127-K

1 2 3 4

# B 2/2 AMP7 ASSY (7028071731040-IL)

A  
B  
C  
D  
E  
F

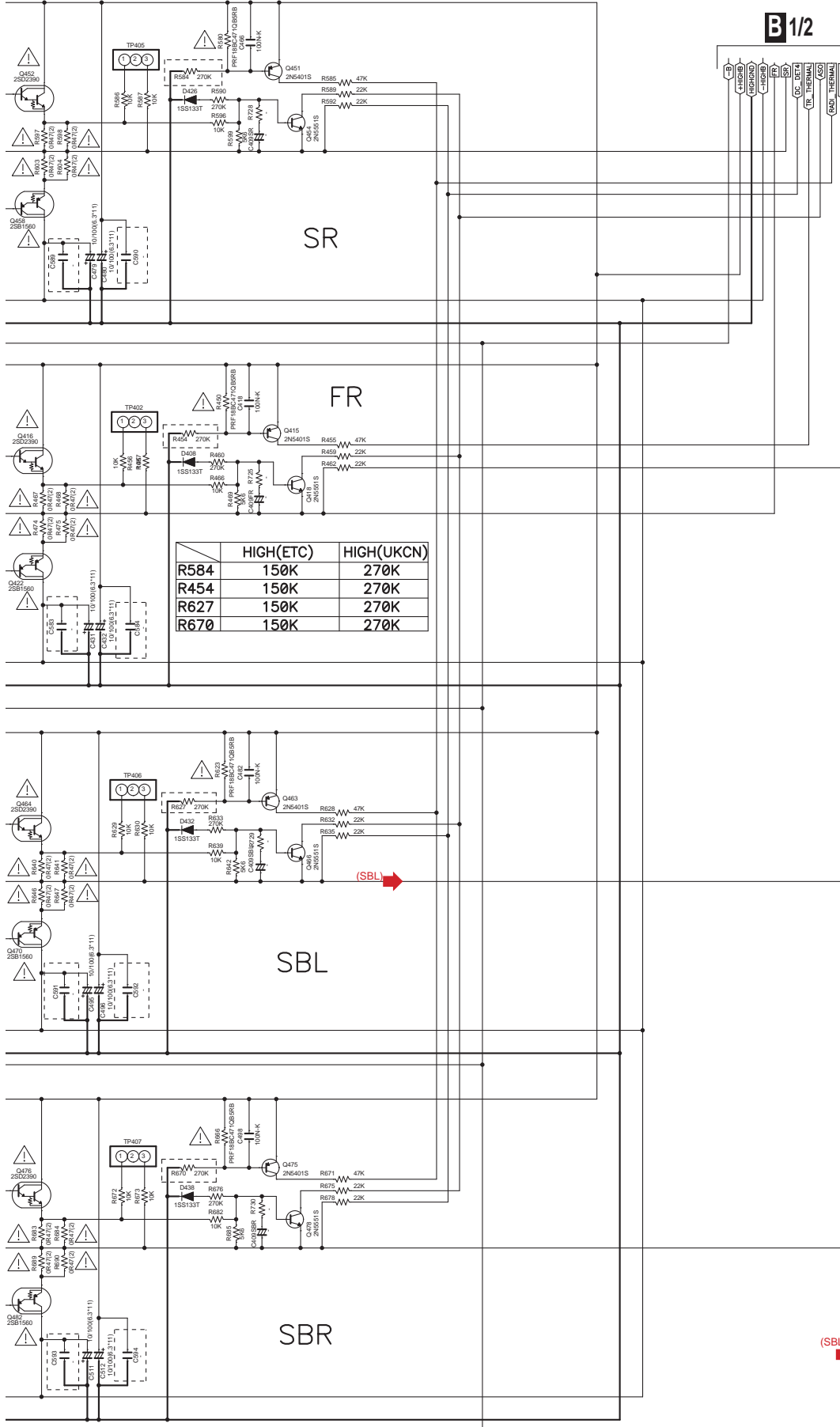

B 1/2

SR

FR

SBL

SBR



(SBL) : Audio Signal Route (Surround Back L ch)

# 10.4 MAIN ASSY

## SPEAKER TERMINAL

**NOTES**

1. Resistor values are indicated in ohms unless otherwise specified [ k = 1,000 m = 1,000,000 ]
2. Capacitor values are indicated in microfarads unless otherwise specified. [ p = micro-microfarads ]
3.  Segregated from this resistor are to be used on critical parts for safety use only the one described in the parts list.

**CAUTION**

Safety precaution to be followed during servicing

- 1] Since those parts marked with one critical parts for safety use only the one described in the parts list.
- 2] Before returning the set to the customer make appropriate leakage current or resistance measurements to determine the exposed parts are properly insulated from the supply circuit.

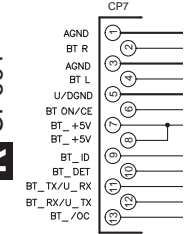
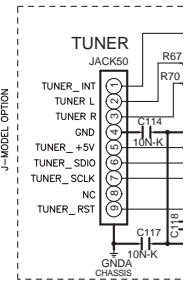

**R** CP601

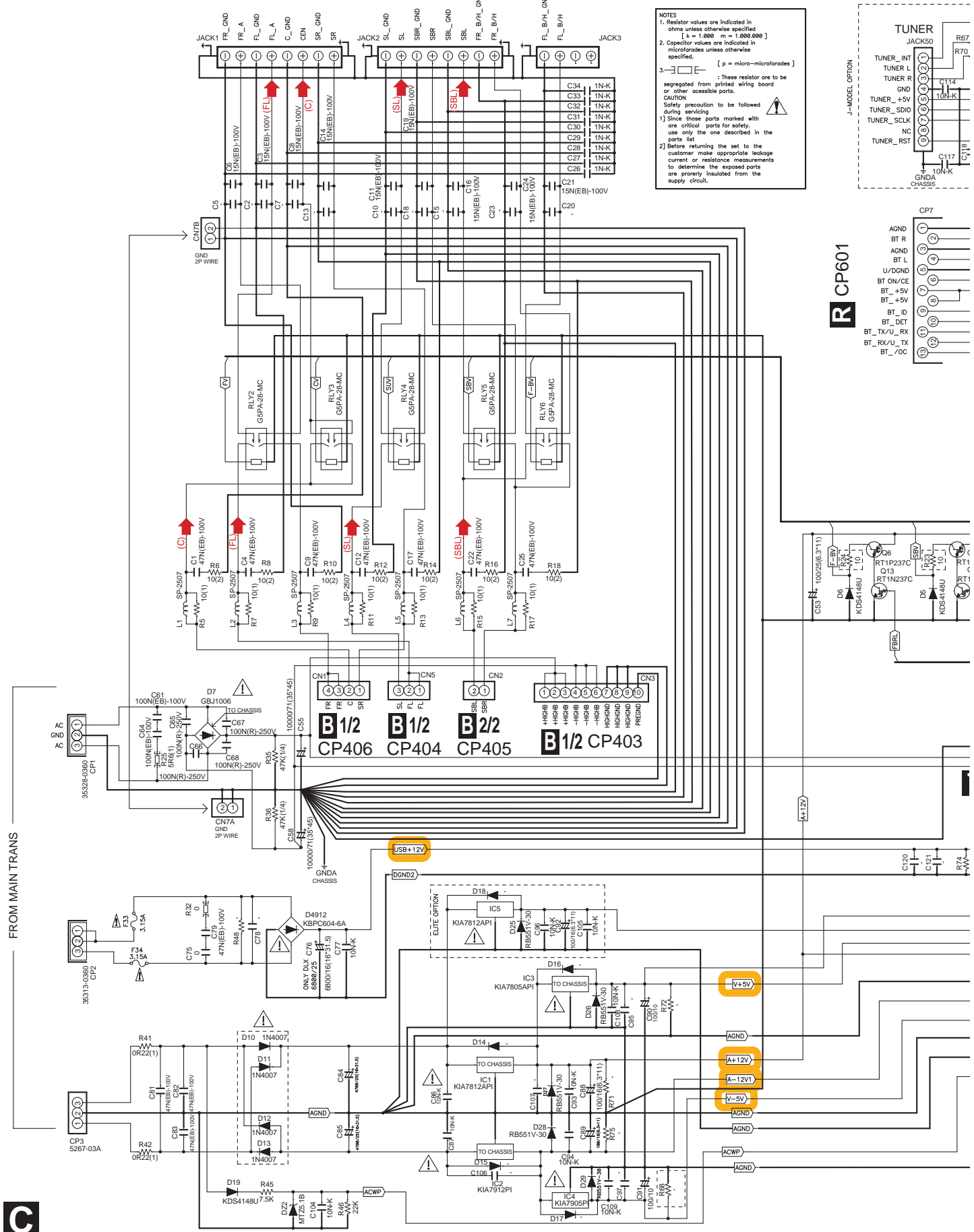

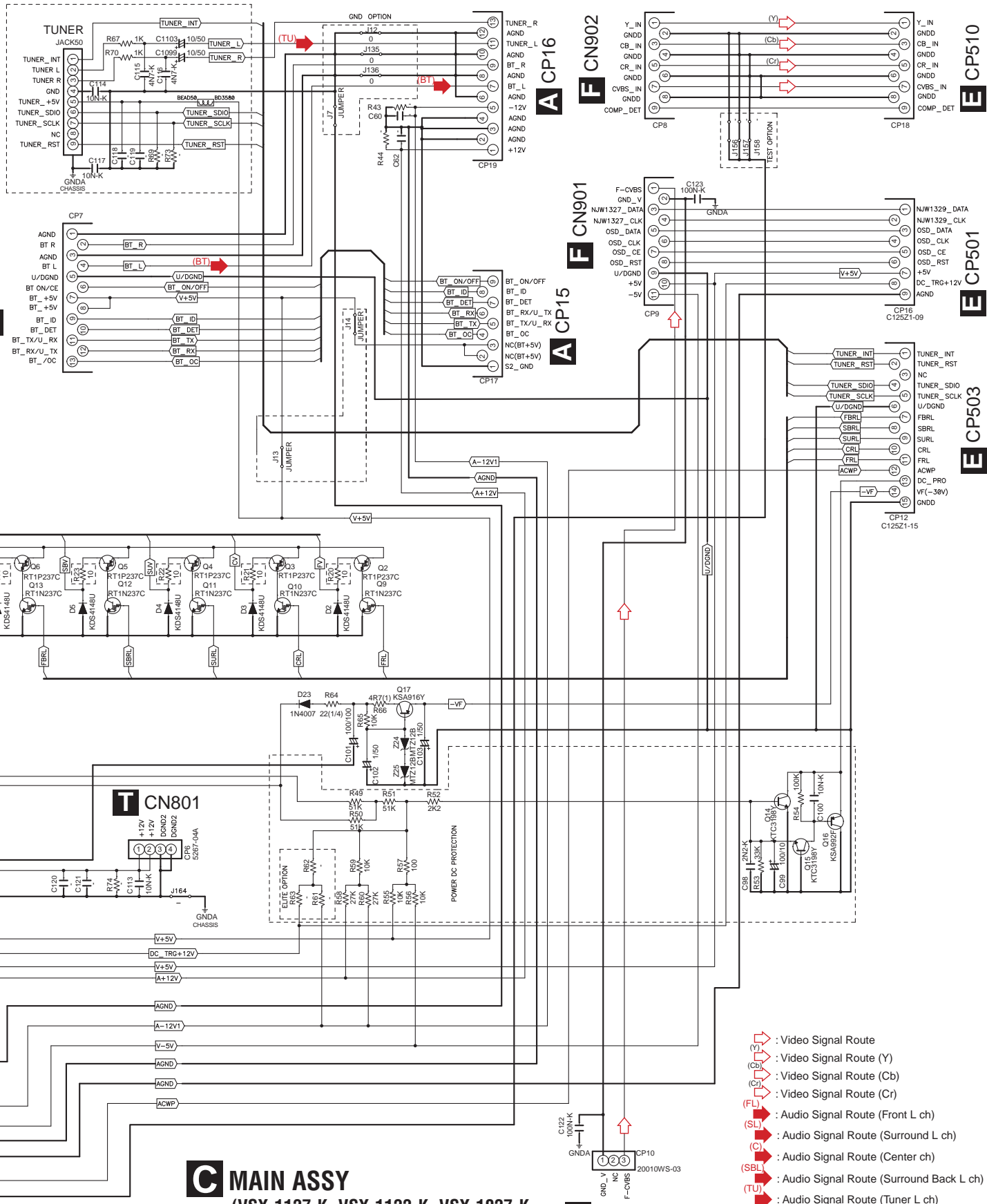

**C MAIN ASSY**  
 (VSX-1127-K, VSX-1122-K, VSX-1027-K  
 : 7028071711010-IL)  
 (VSX-60: 7028071711040-IL)

**K CN3652**

- ↗ : Video Signal Route
- (Y) ↗ : Video Signal Route (Y)
- (Cb) ↗ : Video Signal Route (Cb)
- (Cr) ↗ : Video Signal Route (Cr)
- (FL) ↗ : Audio Signal Route (Front L ch)
- (SL) ↗ : Audio Signal Route (Surround L ch)
- (C) ↗ : Audio Signal Route (Center ch)
- (SBL) ↗ : Audio Signal Route (Surround Back L ch)
- (TU) ↗ : Audio Signal Route (Tuner L ch)
- (BT) ↗ : Audio Signal Route (BT L ch)

# 10.5 D-MAIN ASSY (1/10)

1 2 3 4

A

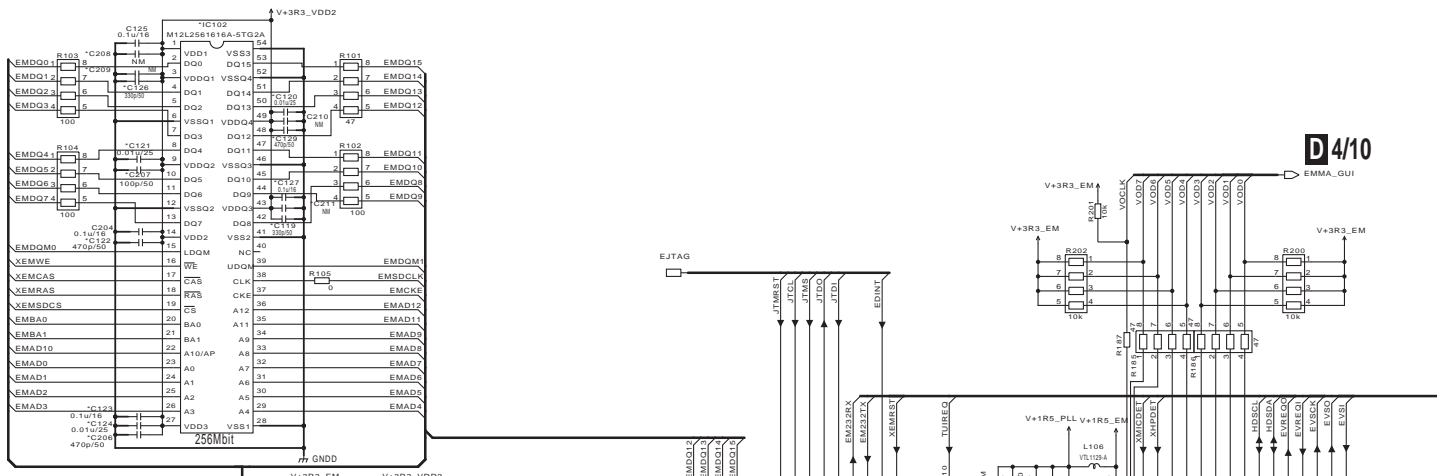

B

C

D

E

F

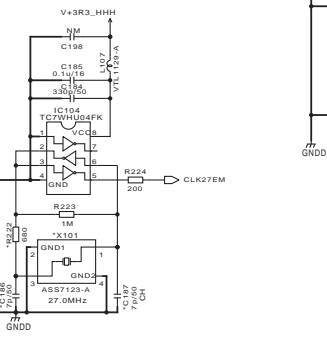

D/110

VSX-1127-K

70

1 2 3 4

**D** 1/10 D-MAIN ASSY

- (VSX-1127-K: 7028071752020-IL)
- (VSX-1122-K: 7028071752040-IL)
- (VSX-60: 7028071752040-IL)
- (VSX-1027-K: 7028071752070-IL)

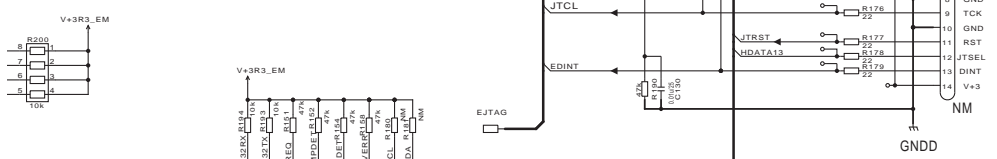

AWX1200: FY13 AVR SEL-LOW  
 AWX9957: VSX-1127/CU,VSX-1122/SY/,DL  
 AWX1223: VSX-1027/CU,VSX-922/SY/,F/,DL/,PW/,A,VSA-922/J  
 AWX1228: VSX-1122/CU,VSX-60/U

Part No.	AWX1200	AWX9957	AWX1223	AWX1228
IC101	1000/4	ACR7352-1	ACR7352-1	ACR7352-1
IC104	1000/4	ACR7352-1	ACR7352-1	ACR7352-1
IC105	1000/50	1000p/50	1000p/50	1000p/50
IC107	1000/4	ACR7352-1	ACR7352-1	ACR7352-1
IC108	1000p/50	1000p/50	1000p/50	1000p/50
IC110	1000/4	ACR7352-1	ACR7352-1	ACR7352-1
IC116	1000/4	ACR7352-1	ACR7352-1	ACR7352-1
IC119	1125/50	1000p/50	1000p/50	1000p/50
IC120	0.01u/25	0.1u/50	0.1u/50	0.1u/50
IC121	0.01u/25	4700p/50	4700p/50	4700p/50
IC122	470p/50	1000p/50	1000p/50	1000p/50
IC123	0.1u/16	0.047u/50	0.047u/50	0.047u/50
IC124	0.01u/25	1000p/50	1000p/50	1000p/50
IC126	100p/50	1000p/50	1000p/50	1000p/50
IC127	0.1u/16	0.01u/25	0.01u/25	0.01u/25
IC129	470p/50	1000p/50	1000p/50	1000p/50
IC133	0.1u/16	0.047u/50	0.047u/50	0.047u/50
IC134	470p/50	1000p/50	1000p/50	1000p/50
IC144	470p/50	1000p/50	1000p/50	1000p/50
IC146	470p/50	1000p/50	1000p/50	1000p/50
IC149	100p/50	1000p/50	1000p/50	1000p/50
IC173	100p/50	1000p/50	1000p/50	1000p/50
IC175	0.1u/16	0.01u/25	0.01u/25	0.01u/25
IC176	100p/50	1000p/50	1000p/50	1000p/50
IC177	100p/50	100p/50	100p/50	100p/50
IC187	10p/50	10p/50	10p/50	10p/50
IC206	470p/50	1000p/50	1000p/50	1000p/50
IC207	100p/50	1000p/50	1000p/50	1000p/50
IC209	100p/50	1000p/50	1000p/50	1000p/50
IC210	100p/50	1000p/50	1000p/50	1000p/50
IC211	100p/50	1000p/50	1000p/50	1000p/50
IC212	100p/50	1000p/50	1000p/50	1000p/50
IC213	100p/50	1000p/50	1000p/50	1000p/50
IC214	100p/50	1000p/50	1000p/50	1000p/50
IC215	100p/50	1000p/50	1000p/50	1000p/50
IC216	100p/50	1000p/50	1000p/50	1000p/50
IC217	100p/50	1000p/50	1000p/50	1000p/50
IC218	100p/50	1000p/50	1000p/50	1000p/50
IC219	100p/50	1000p/50	1000p/50	1000p/50
IC220	100p/50	1000p/50	1000p/50	1000p/50
IC221	100p/50	1000p/50	1000p/50	1000p/50
R222	500	1k	1k	1k
IC102	M1222561616A-9702A	M1222561616A-9702A	M1222561616A-9702A	M1222561616A-9702A
IC103	ABR7122-A	ABR7122-A	ABR7122-A	ABR7122-A

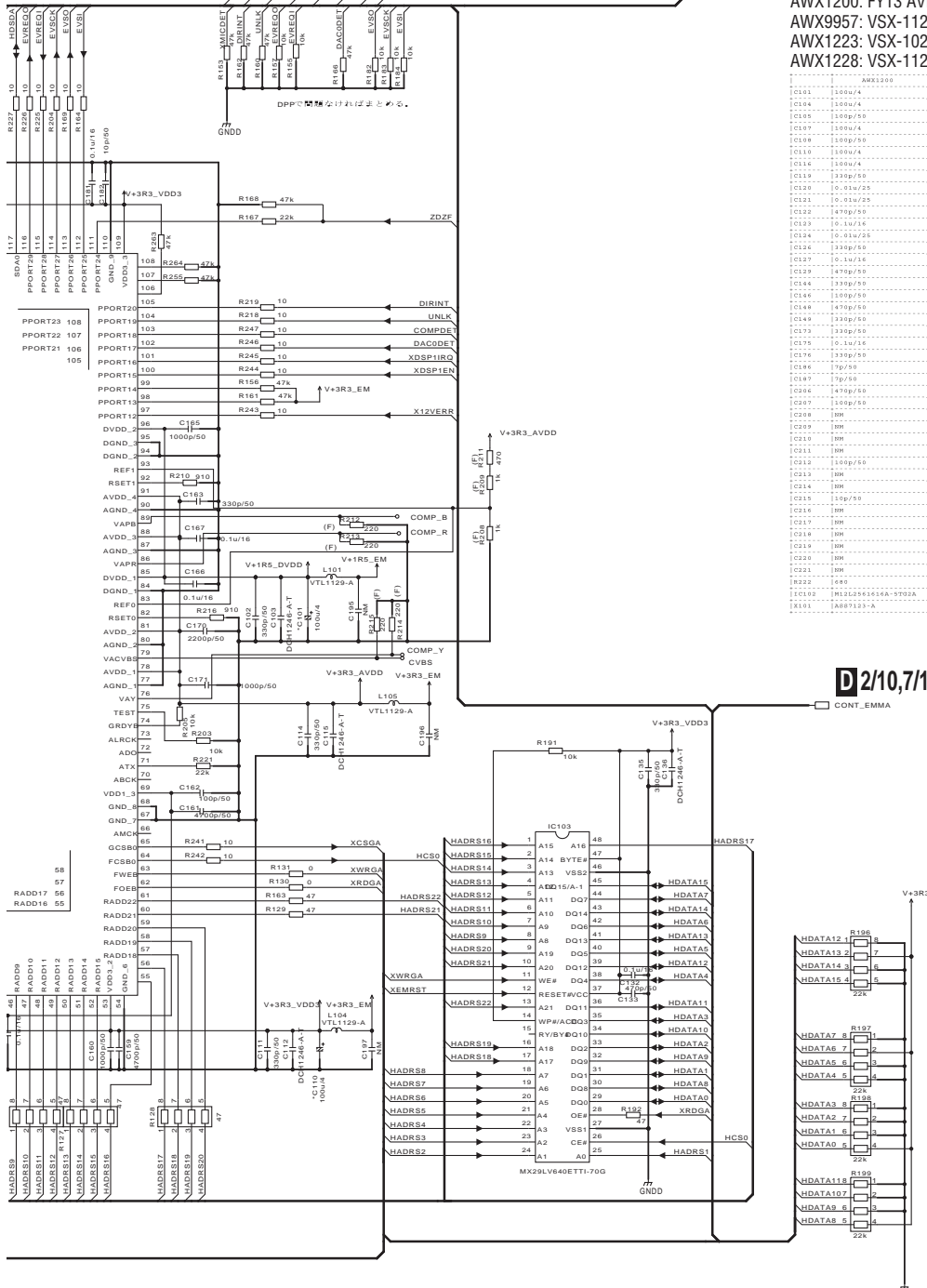

**D** 2/10,7/10,8/10

CONT\_EMMA

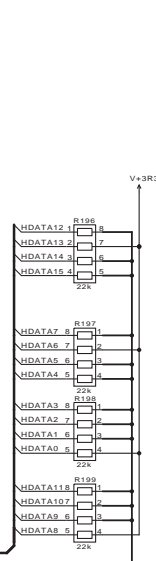

**VSX-1127-K**

# 10.6 D-MAIN ASSY (2/10)

## D 2/10 D-MAIN ASSY

(VSX-1127-K: 7028071752020-IL)  
 (VSX-1122-K: 7028071752040-IL)  
 (VSX-60: 7028071752040-IL)  
 (VSX-1027-K: 7028071752070-IL)

D 1/10,7/10,8/10

D 3/10-10/10

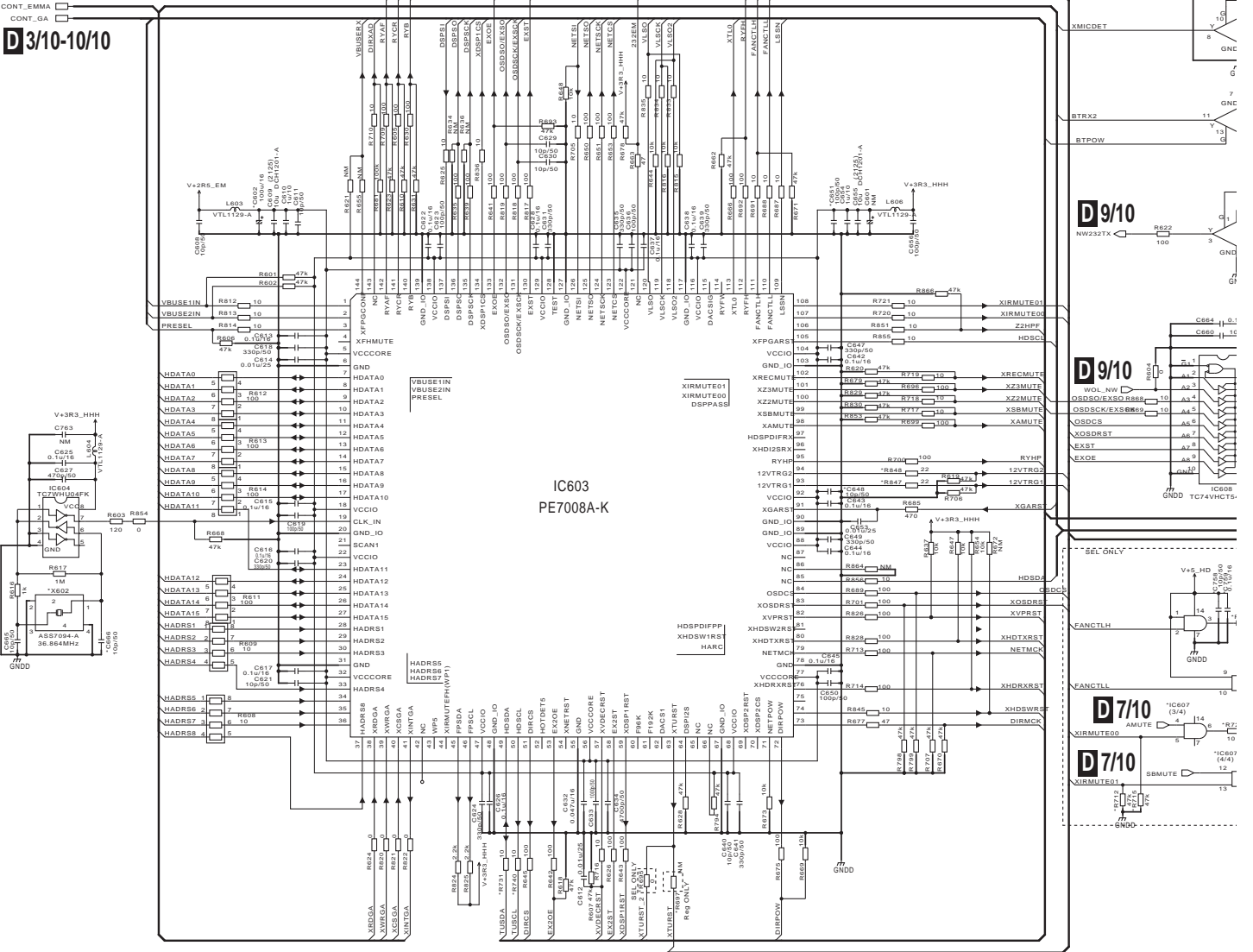

The  $\Delta$  mark found on some component parts should be replaced with same parts (safety regulation authorized) of identical designation.  
 △印の部品は、指定部品（安全規格適合部品）を必ず使用すること。

AKW1200	AKW9057	AKW1223
IC603	10000116	ACW7337-1
IC604	10000116	ACW7337-1
IC605	10000116	ACW7337-1
IC606	10000116	ACW7337-1
IC607	10000116	ACW7337-1
IC608	10000116	ACW7337-1
IC609	10000116	ACW7337-1
IC610	10000116	ACW7337-1
IC611	10000116	ACW7337-1
IC612	10000116	ACW7337-1
IC613	10000116	ACW7337-1
IC614	10000116	ACW7337-1
IC615	10000116	ACW7337-1
IC616	10000116	ACW7337-1
IC617	10000116	ACW7337-1
IC618	10000116	ACW7337-1
IC619	10000116	ACW7337-1
IC620	10000116	ACW7337-1
IC621	10000116	ACW7337-1
IC622	10000116	ACW7337-1
IC623	10000116	ACW7337-1
IC624	10000116	ACW7337-1
IC625	10000116	ACW7337-1
IC626	10000116	ACW7337-1
IC627	10000116	ACW7337-1
IC628	10000116	ACW7337-1
IC629	10000116	ACW7337-1
IC630	10000116	ACW7337-1
IC631	10000116	ACW7337-1
IC632	10000116	ACW7337-1
IC633	10000116	ACW7337-1
IC634	10000116	ACW7337-1
IC635	10000116	ACW7337-1
IC636	10000116	ACW7337-1
IC637	10000116	ACW7337-1
IC638	10000116	ACW7337-1
IC639	10000116	ACW7337-1
IC640	10000116	ACW7337-1
IC641	10000116	ACW7337-1
IC642	10000116	ACW7337-1
IC643	10000116	ACW7337-1
IC644	10000116	ACW7337-1
IC645	10000116	ACW7337-1
IC646	10000116	ACW7337-1
IC647	10000116	ACW7337-1
IC648	10000116	ACW7337-1
IC649	10000116	ACW7337-1
IC650	10000116	ACW7337-1
IC651	10000116	ACW7337-1
IC652	10000116	ACW7337-1
IC653	10000116	ACW7337-1
IC654	10000116	ACW7337-1
IC655	10000116	ACW7337-1
IC656	10000116	ACW7337-1
IC657	10000116	ACW7337-1
IC658	10000116	ACW7337-1
IC659	10000116	ACW7337-1
IC660	10000116	ACW7337-1

D 2/10





# 10.7 D-MAIN ASSY (3/10)

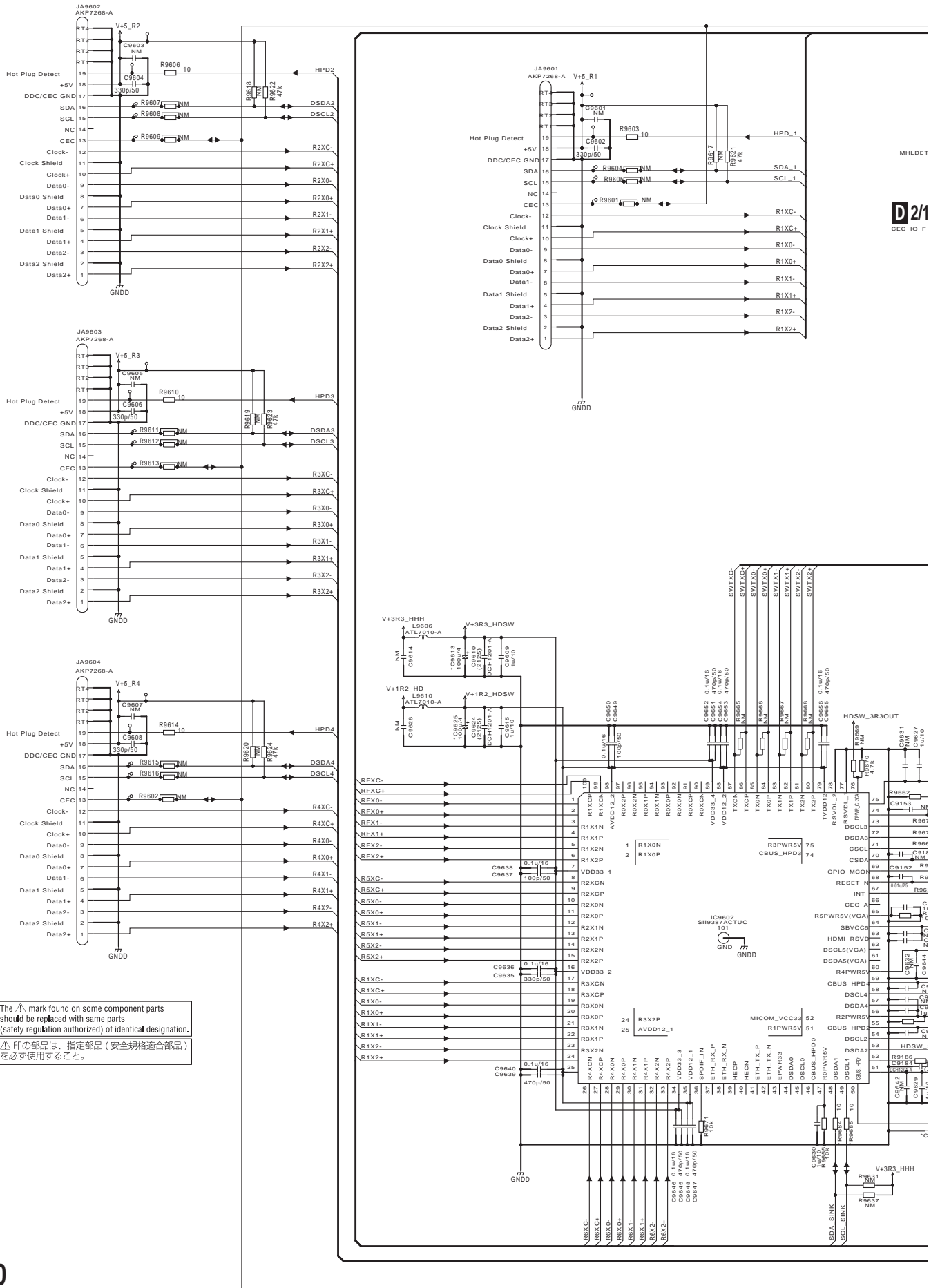

The  $\Delta$  mark found on some component parts should be replaced with same parts (safety regulation authorized) of identical designation.  
 $\Delta$ 印の部品は、指定部品（安全規格適合部品）を必ず使用すること。



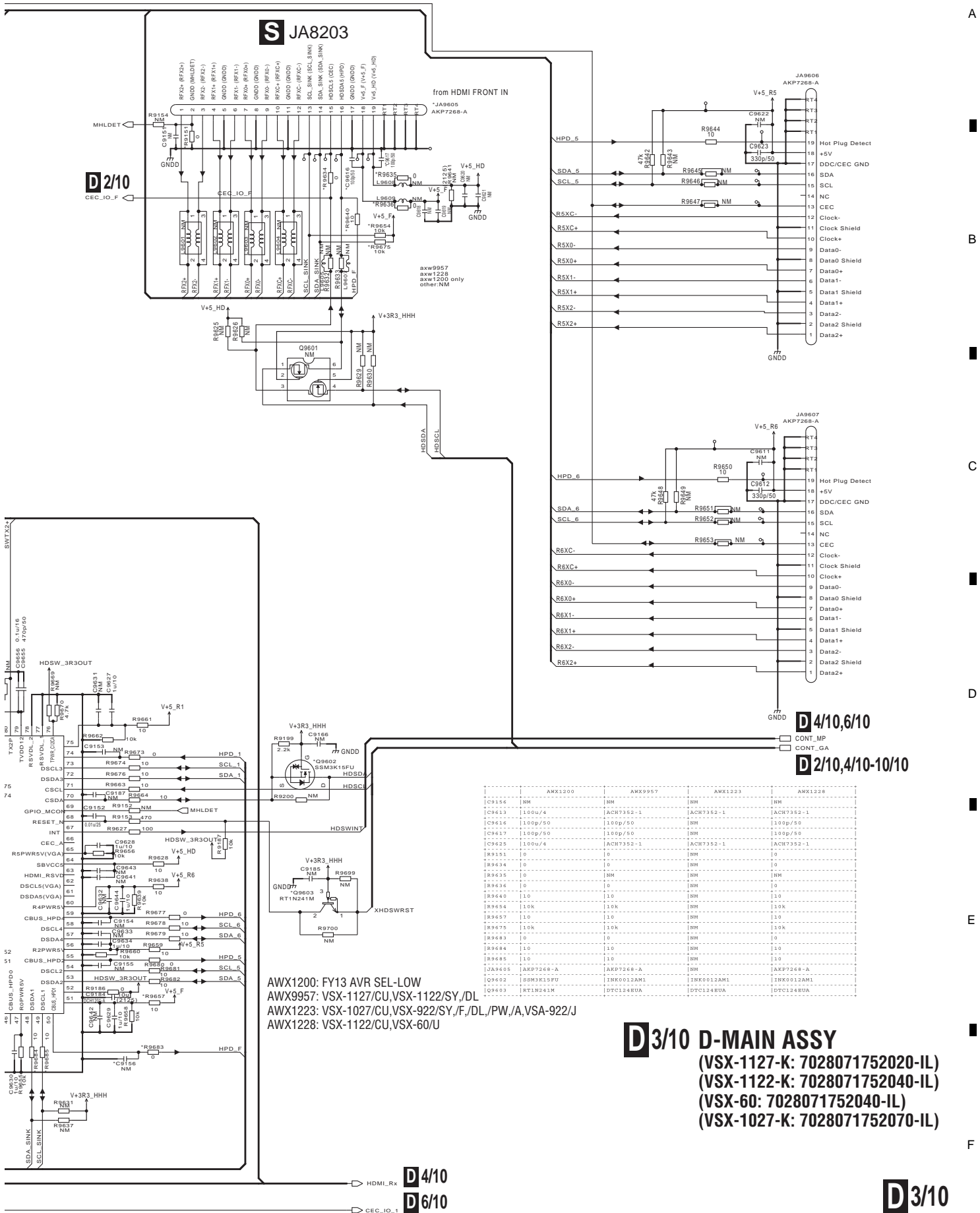

**D 2/10**  
CEC\_IO\_F

**D 4/10,6/10**  
CONT\_MP

**D 2/10,4/10-10/10**  
CONT\_GA

AWX1200: FY13 AVR SEL-LOW  
 AWX9957: VSX-1127/CU,VSX-1122/SY/DL  
 AWX1223: VSX-1027/CU,VSX-922/SY,F,DL/PW,A, VSA-922/J  
 AWX1228: VSX-1122/CU,VSX-60/U

	AWX1200	AWX9957	AWX1223	AWX1228
C9156	NM	NM	NM	NM
C9613	1000u/4	ACR7352-1	ACR7352-1	ACR7352-1
C9616	1000p/50	1000p/50	NM	1000p/50
C9617	1000p/50	1000p/50	NM	1000p/50
C9625	1000u/4	ACR7352-1	ACR7352-1	ACR7352-1
R9151	0	0	0	0
R9634	0	0	0	0
R9635	0	0	0	0
R9636	0	0	0	0
R9640	10	10	10	10
R9654	10k	10k	10k	10k
R9657	10	10	10	10
R9675	10k	10k	10k	10k
R9683	0	0	0	0
R9684	10	10	10	10
R9685	10	10	10	10
J9605	AKP2268-A	AKP2268-A	NM	AKP2268-A
J9602	S8M3K1S9U	INR0012AM1	INR0012AM1	INR0012AM1
Q9603	RT1N241M	DTCL1248UA	DTCL1248UA	DTCL1248UA

**D 3/10 D-MAIN ASSY**  
 (VSX-1127-K: 7028071752020-IL)  
 (VSX-1122-K: 7028071752040-IL)  
 (VSX-60: 7028071752040-IL)  
 (VSX-1027-K: 7028071752070-IL)

**D 4/10**  
**D 6/10**

**D 3/10**

**VSX-1127-K**

# 10.8 D-MAIN ASSY (4/10)

1

2

3

4

A

B

C

D

E

F

**E** CP513

**D** 4/10

76

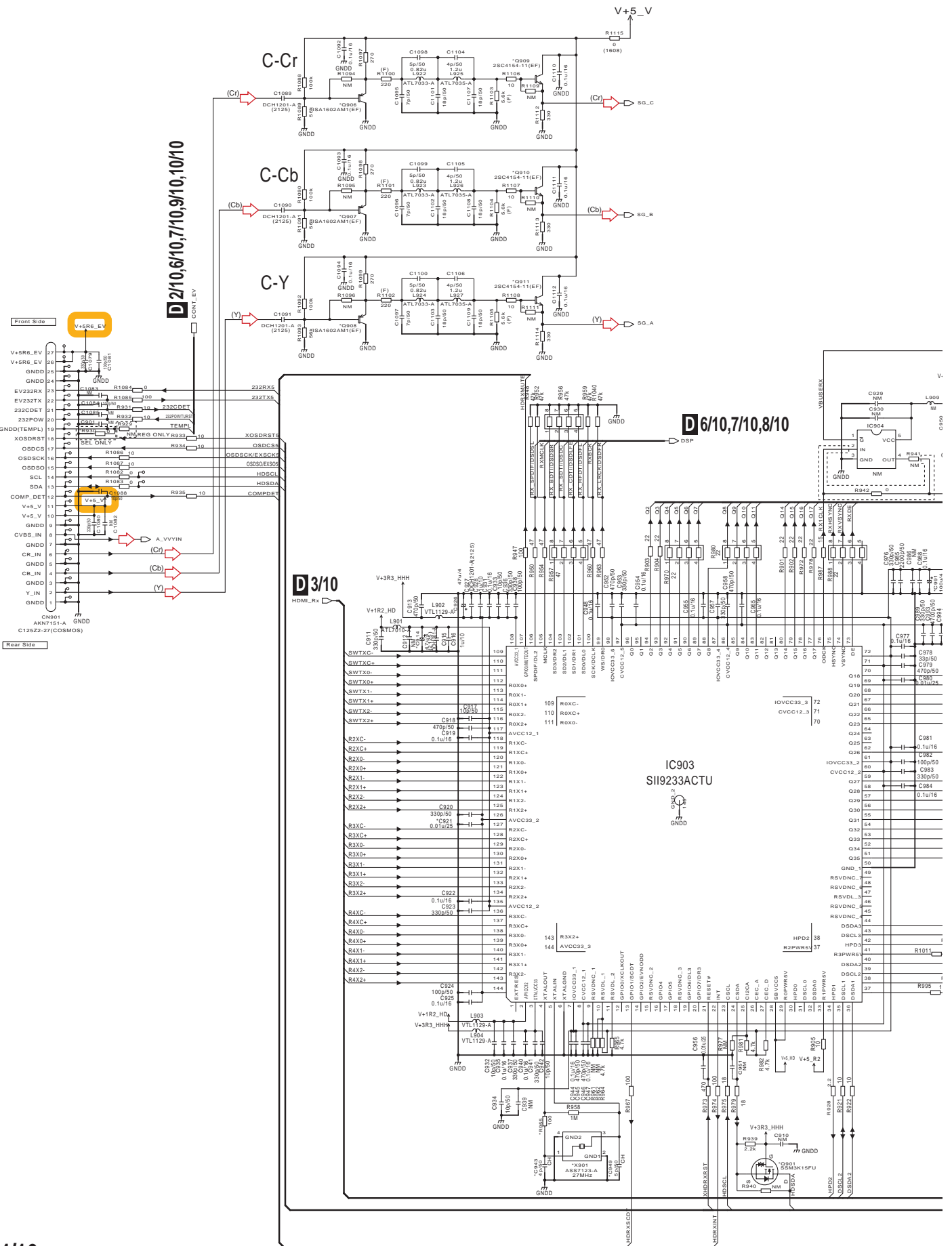

VSX-1127-K

1

2

3

4





AWX1200: FY13 AVR SEL-LOW  
 AWX9957: VSX-1127/CU,VSX-1122/SY,DL  
 AWX1223: VSX-1027/CU,VSX-922/SY,F,DL,/PW,/A,VSA-922/J  
 AWX1228: VSX-1122/CU,VSX-60/U

# D5/10 D-MAIN ASSY

(VSX-1127-K: 7028071752020-IL)  
 (VSX-1122-K: 7028071752040-IL)  
 (VSX-60: 7028071752040-IL)  
 (VSX-1027-K: 7028071752070-IL)

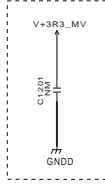

	AWX1200	AWX9957	AWX1223	AWX1228
C1203	100u/4	ACR7354-1	ACH7354-1	ACH7354-1
C1207	220u/4	ACH7354-1	ACH7354-1	ACH7354-1
C1208	220u/4	ACH7354-1	ACH7354-1	ACH7354-1
C1209	0.01u/25	0.1u/16	0.1u/16	0.1u/16
C1210	220u/4	ACH7354-1	ACH7354-1	ACH7354-1
C1215	100u/4	ACH7354-1	ACH7354-1	ACH7354-1
C1218	220u/4	ACH7354-1	ACH7354-1	ACH7354-1
C1219	0.01u/25	100p/50	100p/50	100p/50
C1227	220u/4	ACH7354-1	ACH7354-1	ACH7354-1

## D6/10

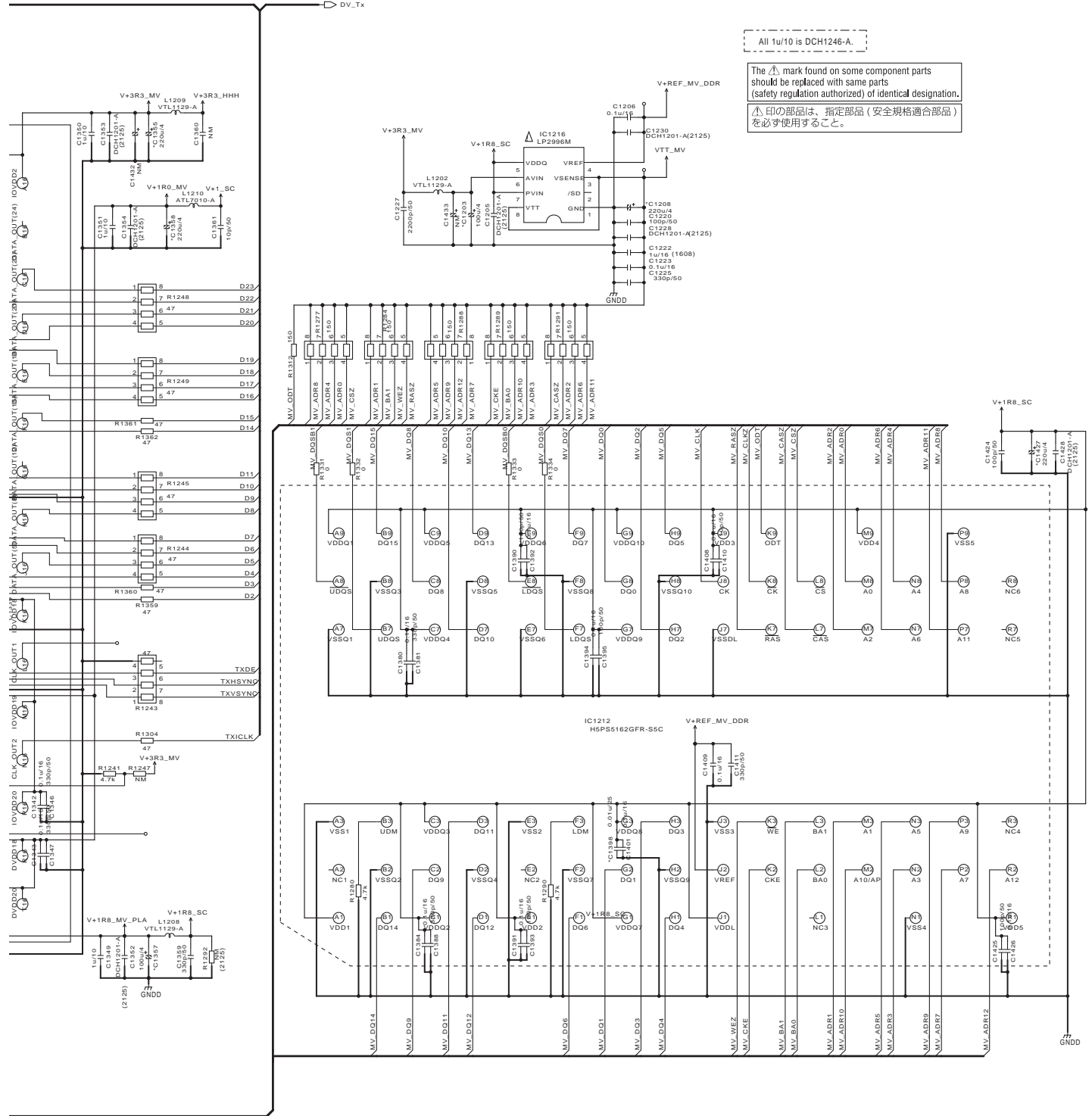

All 1u/10 is DCH1246-A.

The  $\Delta$  mark found on some component parts should be replaced with same parts (safety regulation authorized) of identical designation.  
 △印の部品は、指定部品（安全規格適合部品）を必ず使用すること。

# 10.10 D-MAIN ASSY (6/10)

1

2

3

4

A

B

C

D

E

F

D 5/10

DV\_TX

D 4/10,7/10,8/10

DSP

D 7/10

TXMCLKI

D 6/10

80

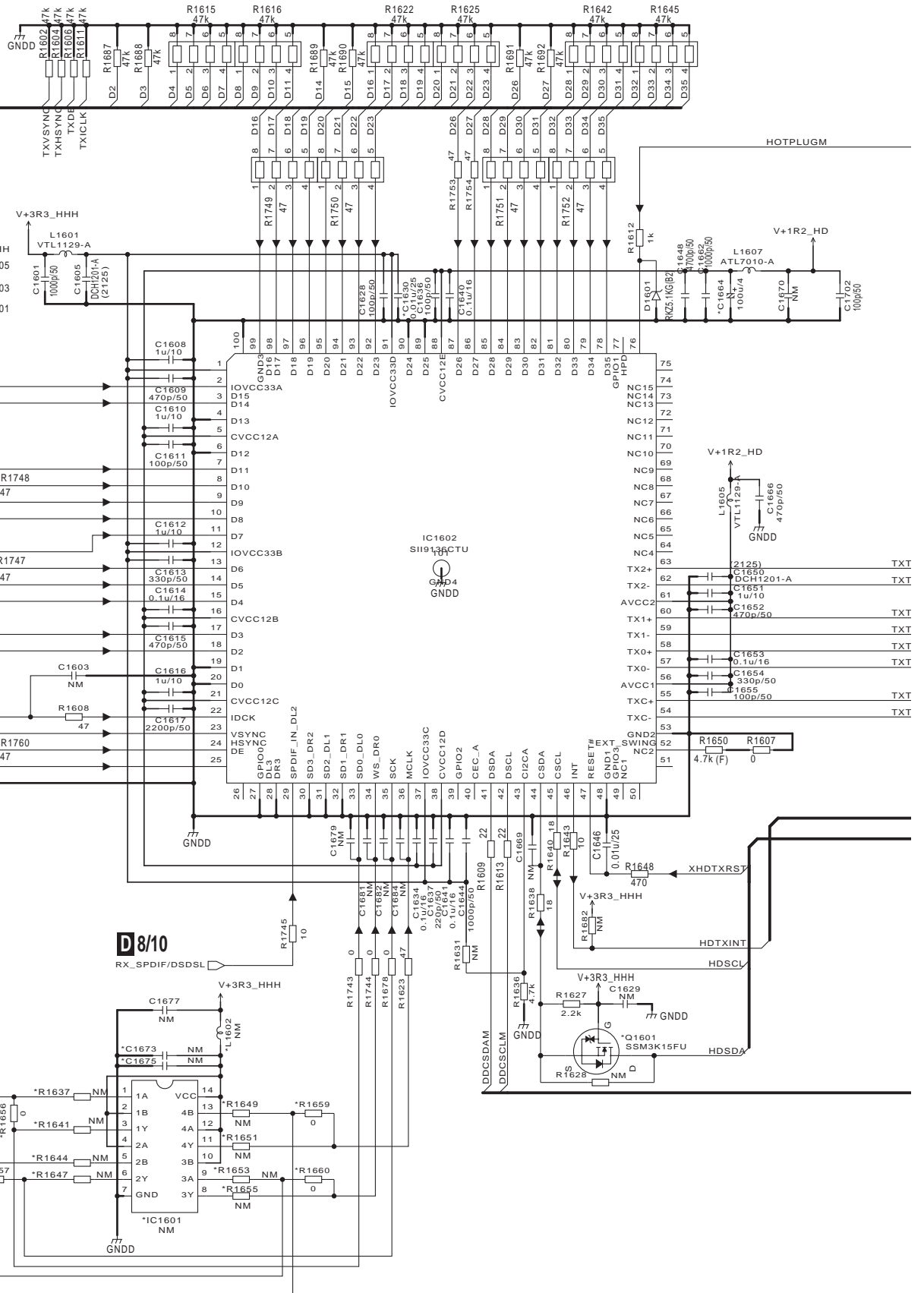

VSX-1127-K

1

2

3

4





# 10.11 D-MAIN ASSY (7/10)

1

2

3

4

D 2/10-6/10,8/10-10/10

MASTER CLOCK SELECTOR

D 2/

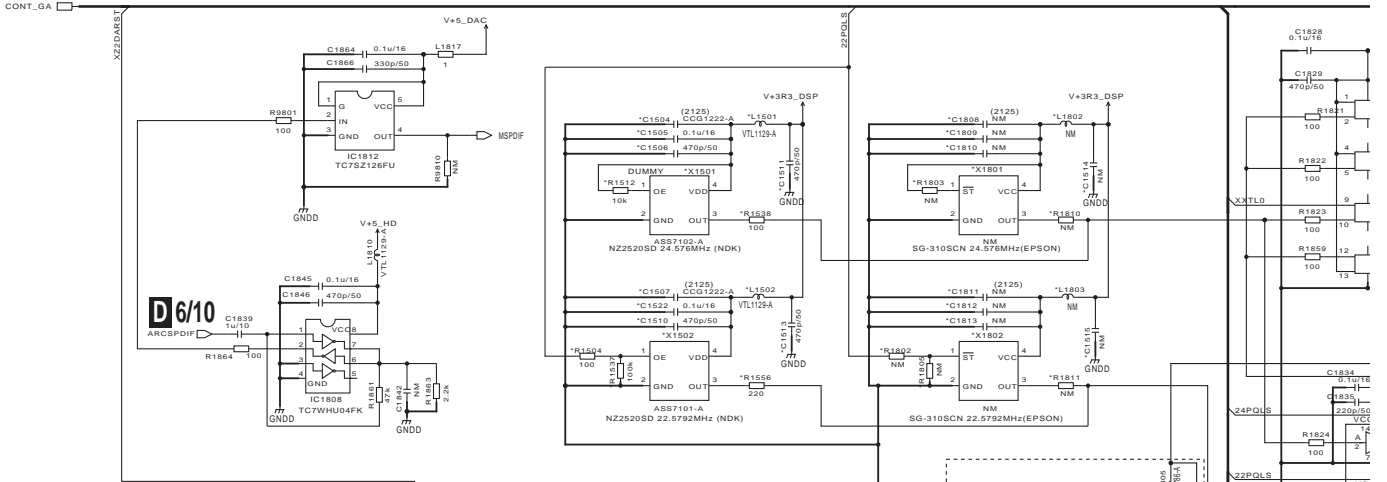

A

B

C

D

E

F

D 9/10

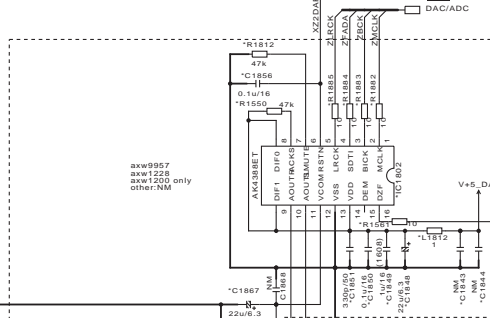

D 4/10,6/10,8/10

D 2/10-6/10,8/10-10/10

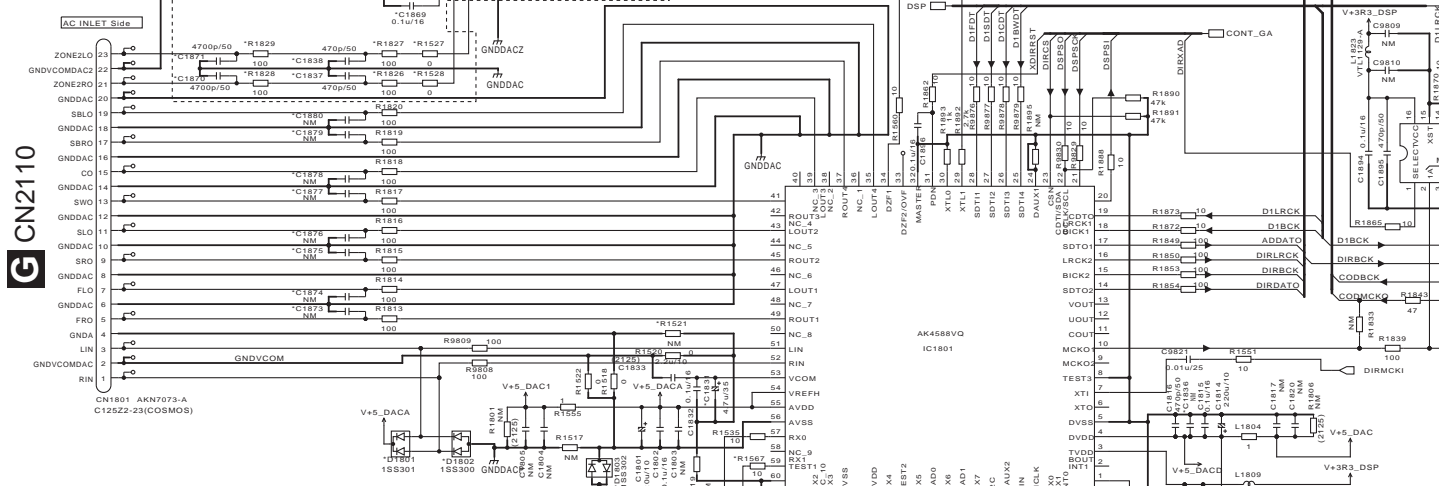

G CN2110

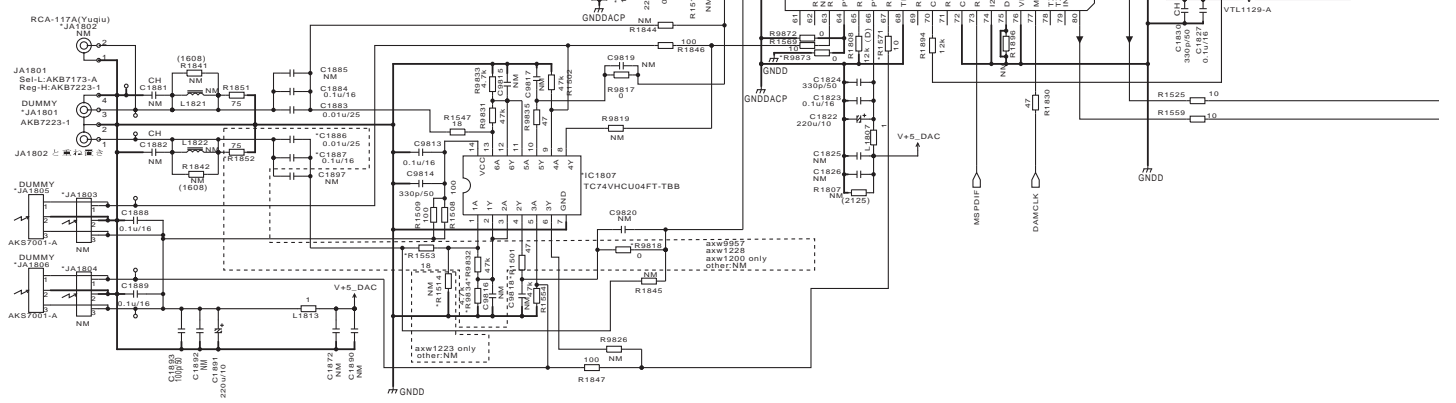

D 7/10

VSX-1127-K

1

2

3

4

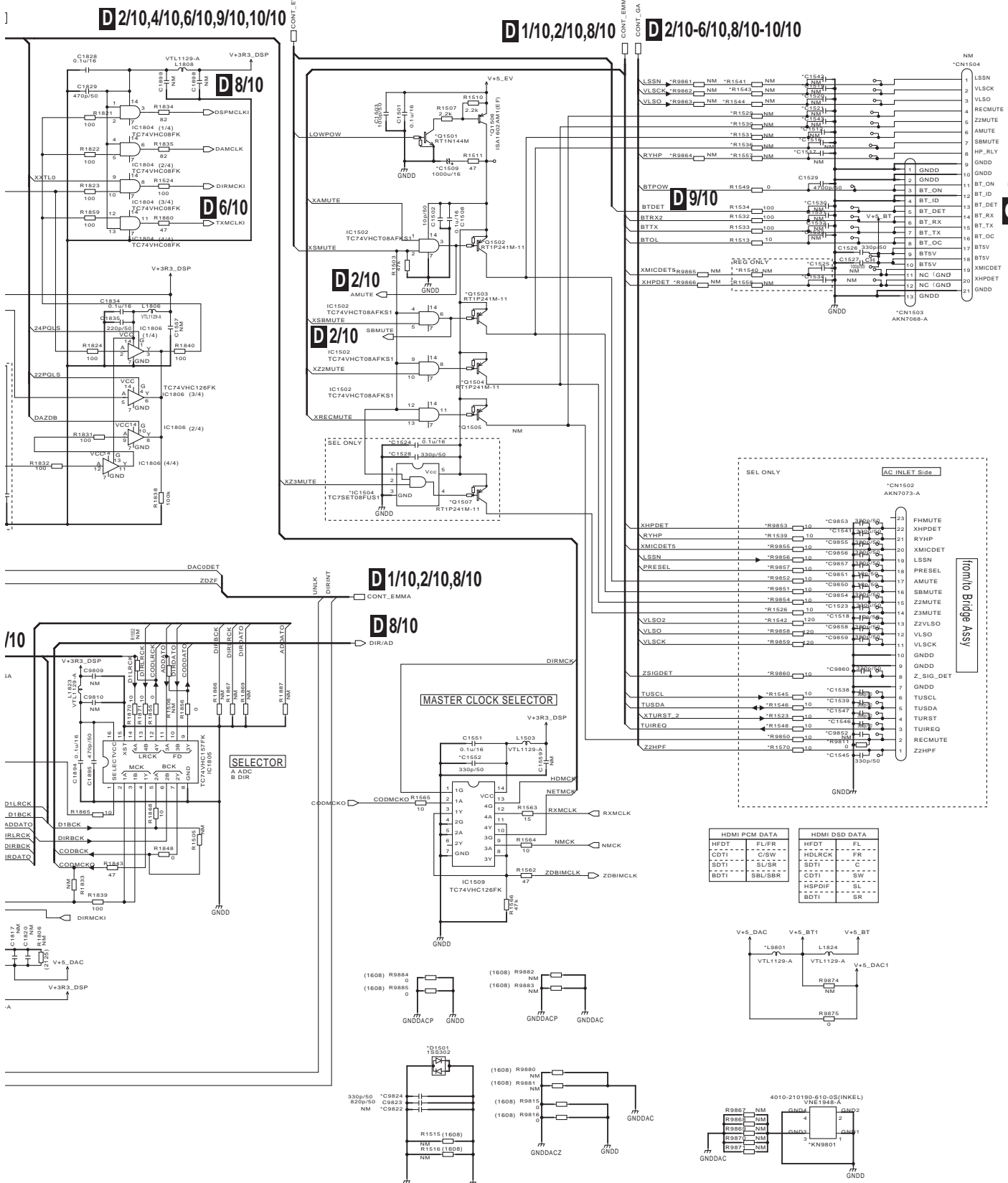

CN2113

G

C

D

E

F

AWX1200: FY13 AVR SEL-LOW  
 AWX9957: VSX-1127/CU,VSX-1122/SY,DL  
 AWX1223: VSX-1027/CU,VSX-922/SY,F,DL,PLW,/A,VSA-922/J  
 AWX1228: VSX-1122/CU,VSX-60/J

VSX-1127-K

D7/10

# 10.12 D-MAIN ASSY (8/10)

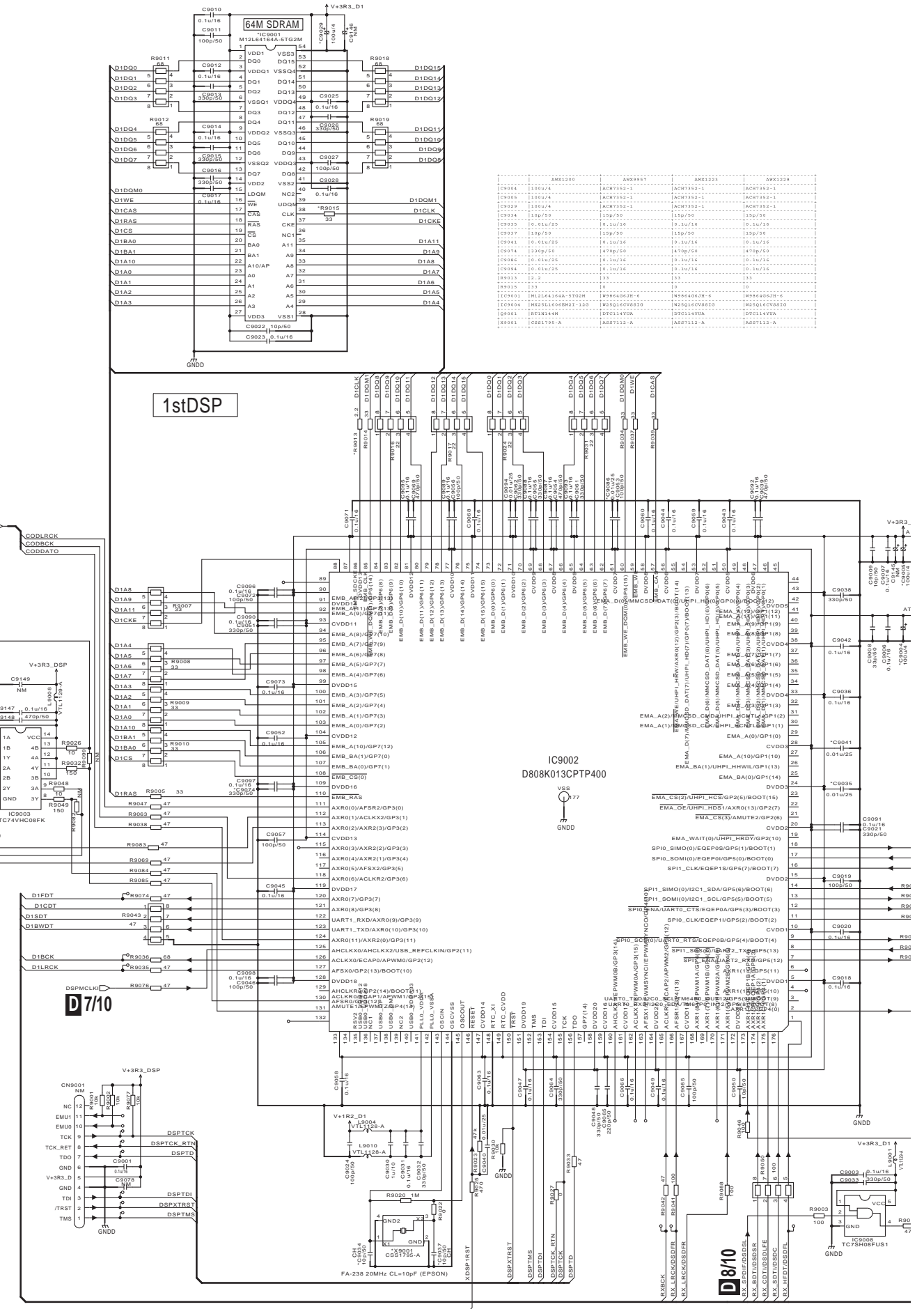











# D10/10 D-MAIN ASSY

(VSX-1127-K: 7028071752020-IL)  
 (VSX-1122-K: 7028071752040-IL)  
 (VSX-60: 7028071752040-IL)  
 (VSX-1027-K: 7028071752070-IL)

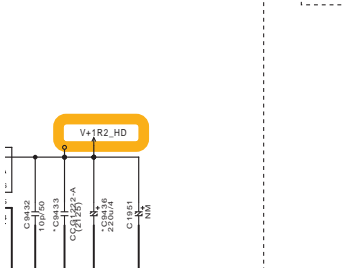
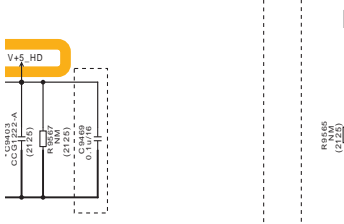
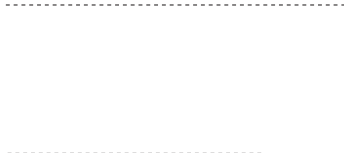
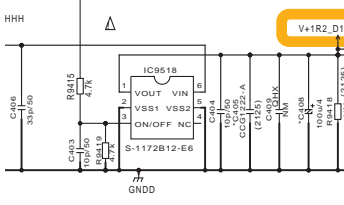
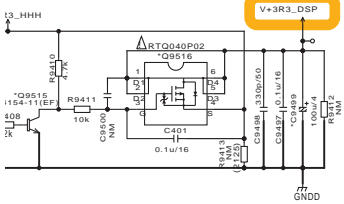
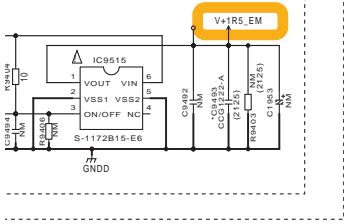
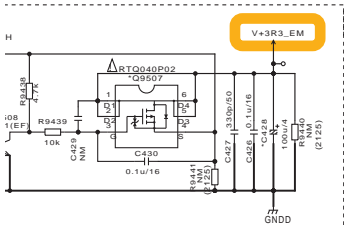

All V+10 is DC11246-A.  
 CCG1222-A is 4.7u/25.

## DSP/CODEC POWER BLOCK

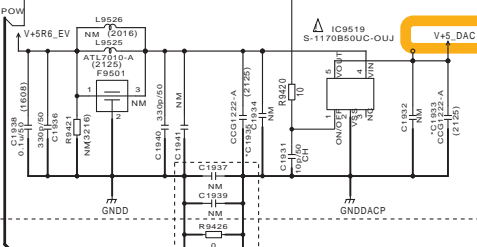

## GA POWER BLOCK

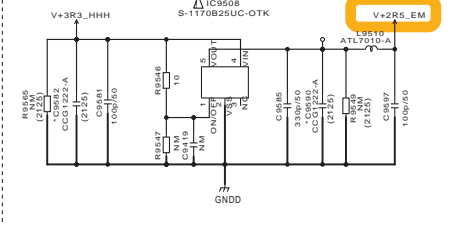

## GA POWER BLOCK

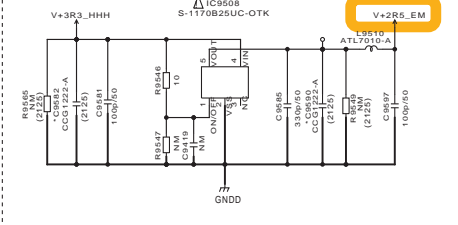

## D2/10

NETPOW5

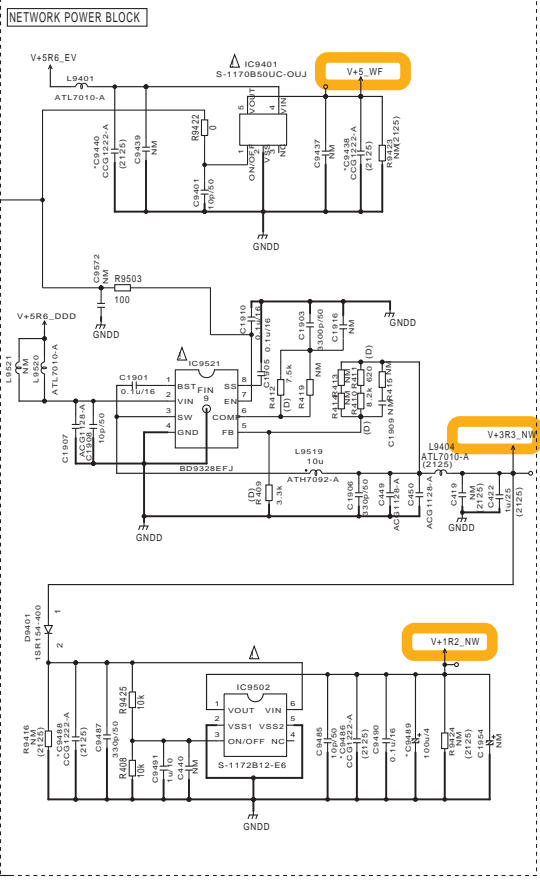

## D2/10-9/10

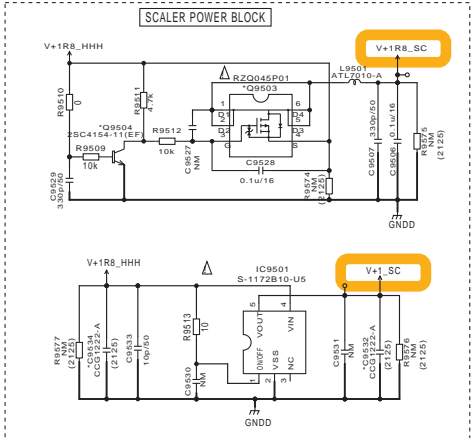

AWX1200: FY13 AVR SEL-LOW  
 AWX9957: VSX-1127/CU, VSX-1122/SY, /DL  
 AWX1223: VSX-1027/CU, VSX-922/SY, /F, /DL, /PW, /A, VSA-922/J  
 AWX1228: VSX-1122/CU, VSX-60/U

The  $\Delta$  mark found on some component parts should be replaced with same parts (safety regulation authorized) of identical designation.  
 $\Delta$  印の部品は、指定部品（安全規格適合部品）を必ず使用すること。

# 10.15 IR ASSY

D4/10 CN901

A  
B  
C  
D  
E  
F

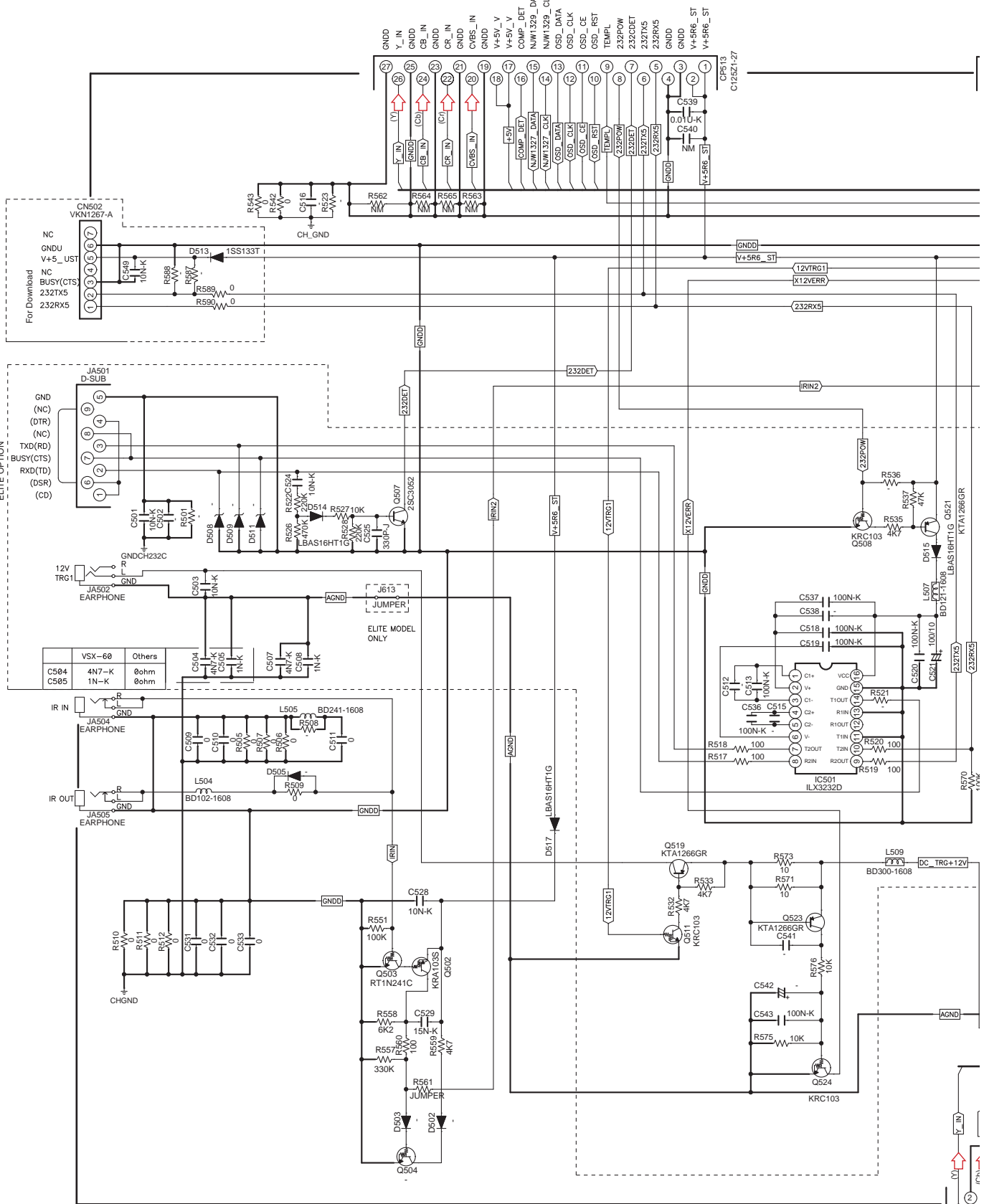

- : Video Signal Route
- : Video Signal Route (Y)
- : Video Signal Route (Cb)
- : Video Signal Route (Cr)

C550	
VSX-60	OTHER
10N-K	0



D 2/10 CN603

D 2/10 CN607

E IR ASSY

(VSX-1127-K, VSX-1122-K, VSX-1027-K : 7028071771010-IL) (VSX-60: 7028071771040-IL)

A B C D E F

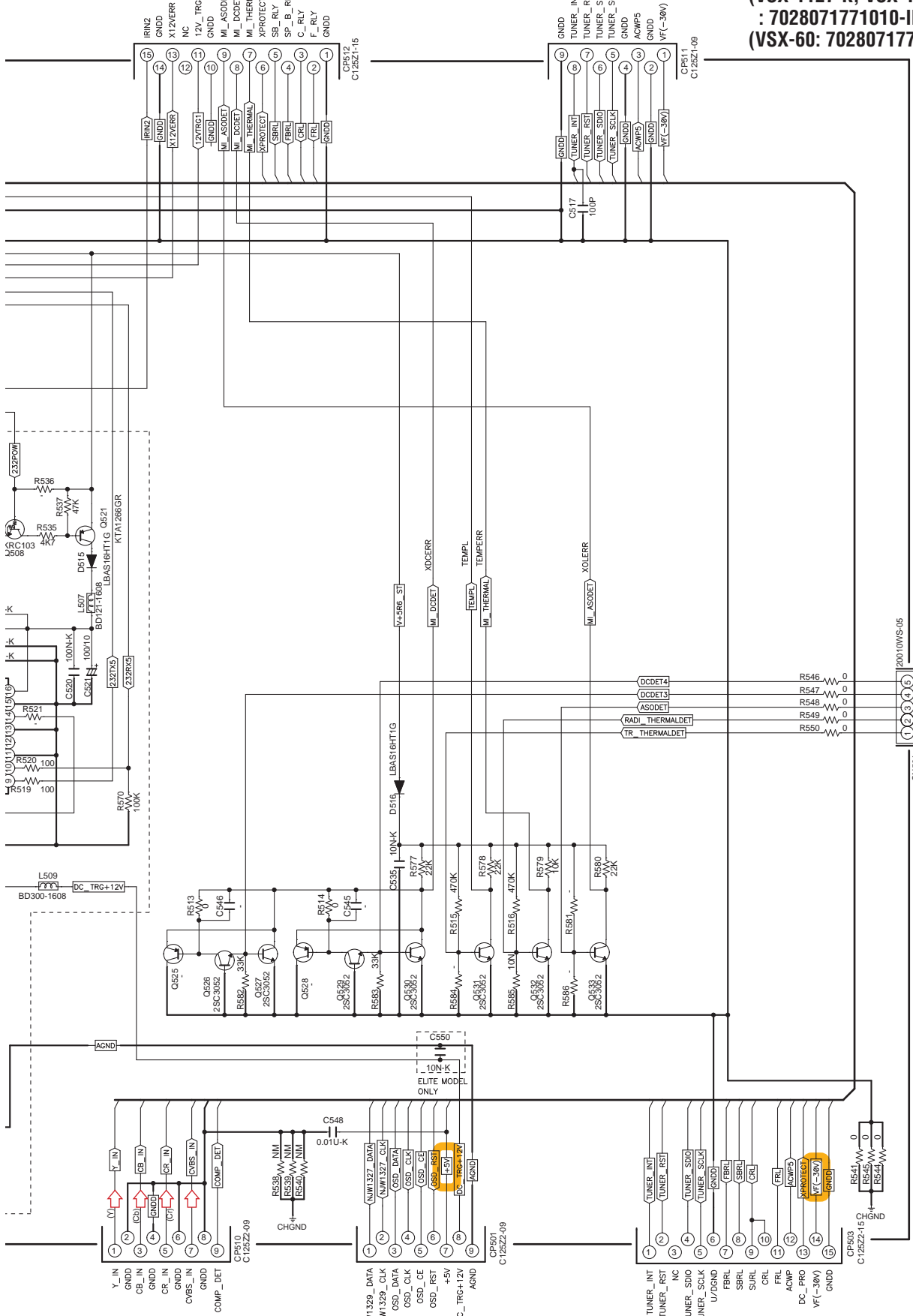

B 1/2 CN404

C CP18

C CP16

C CP12

E

VSX-1127-K

# 10.16 VIDEO ASSY

1 2 3 4

A  
B  
C  
D  
E  
F

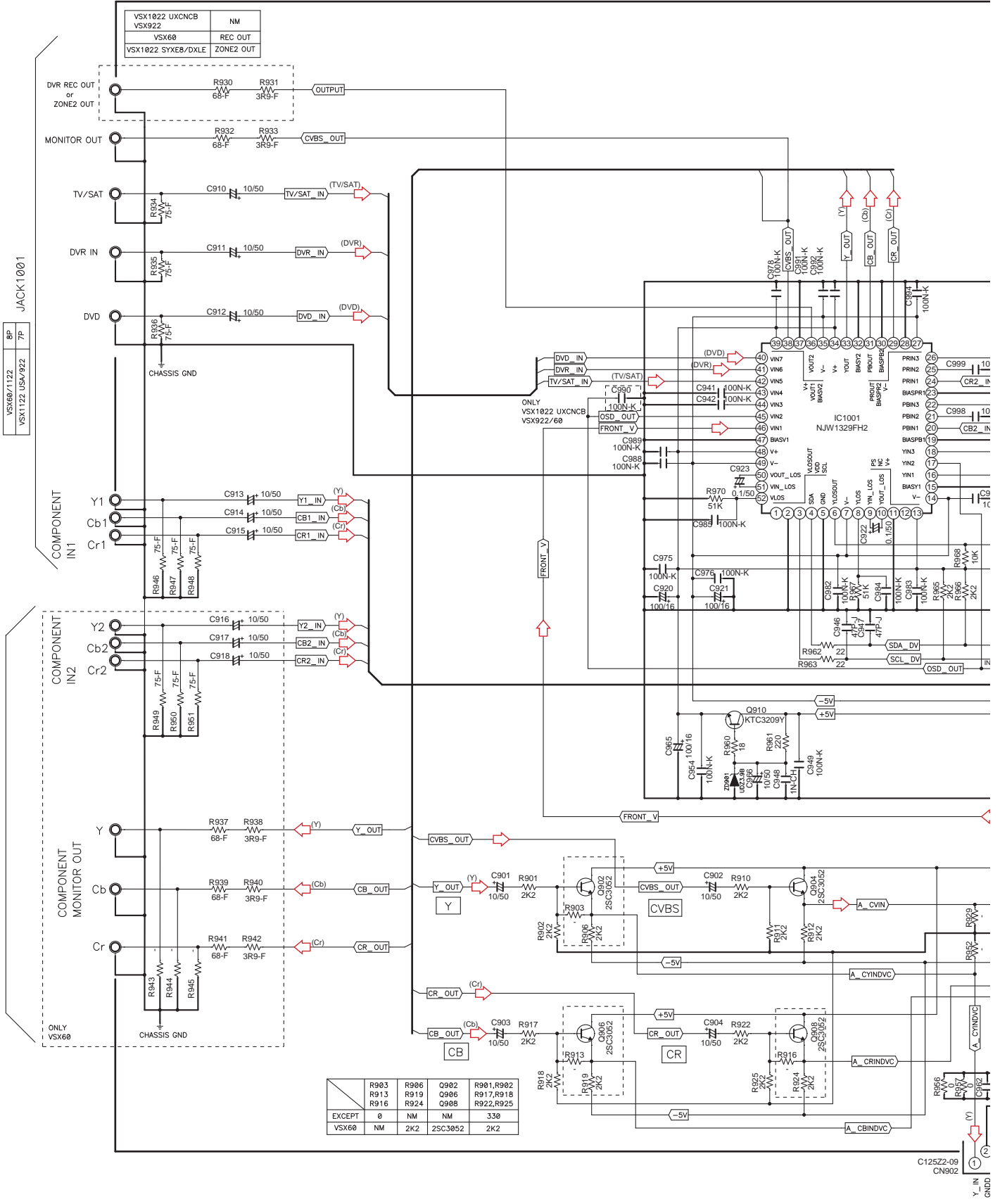

VSX1022 UXCNCB	NM
VSX922	
VSX60	REC OUT
VSX1022 SYXES/DXLE	ZONE2 OUT

VSX60/1122	8P
VSX1122 USA/922	7P

	R903	R906	Q902	R901,R902
	R913	R919	Q906	R917,R918
	R916	R924	Q908	R922,R925
EXCEPT	0	NM	NM	330
VSX60	NM	2K2	2SC3052	2K2

C12522-09  
CN902



1 2 3 4

# F VIDEO ASSY

(VSX-1127-K: 7028071712020-IL)  
 (VSX-1122-K: 7028071712070-IL)  
 (VSX-60: 7028071712040-IL)  
 (VSX-1027-K: 7028071712070-IL)

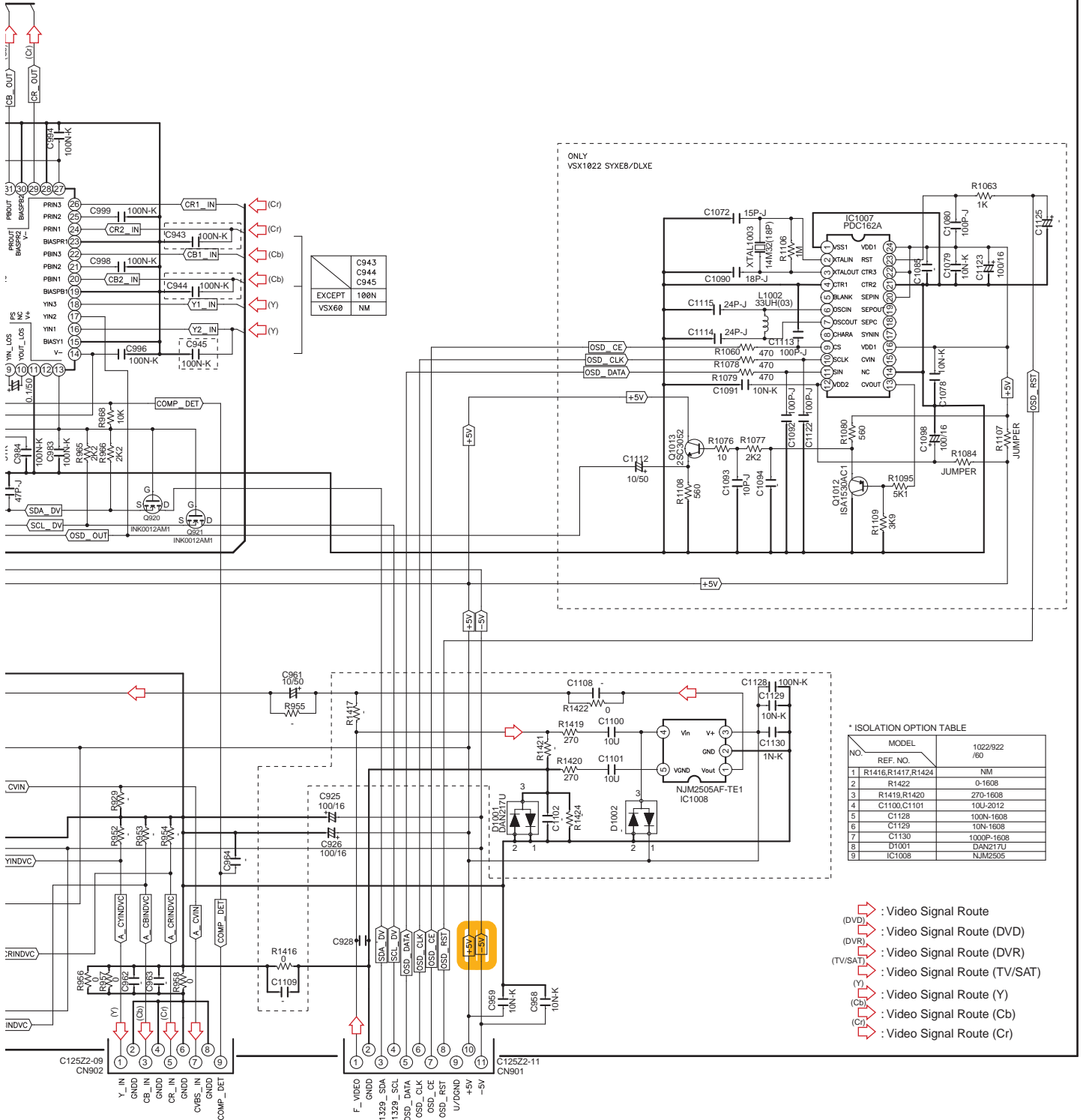

EXCEPT	VSX60	NM
	C943	
	C944	
	C945	

\* ISOLATION OPTION TABLE

NO.	MODEL	1022/922 /60
1	R1416,R1417,R1424	NM
2	R1422	0-1608
3	R1419,R1420	270-1608
4	C1100,C1101	10U-2012
5	C1128	100N-1608
6	C1129	10N-1608
7	C1130	1000P-1608
8	D1001	DAN271U
9	IC1008	NJM2505

CP8

CP9

VSX-1127-K

F

# 10.17 BRG ASSY

**D** 7/10 CN1801

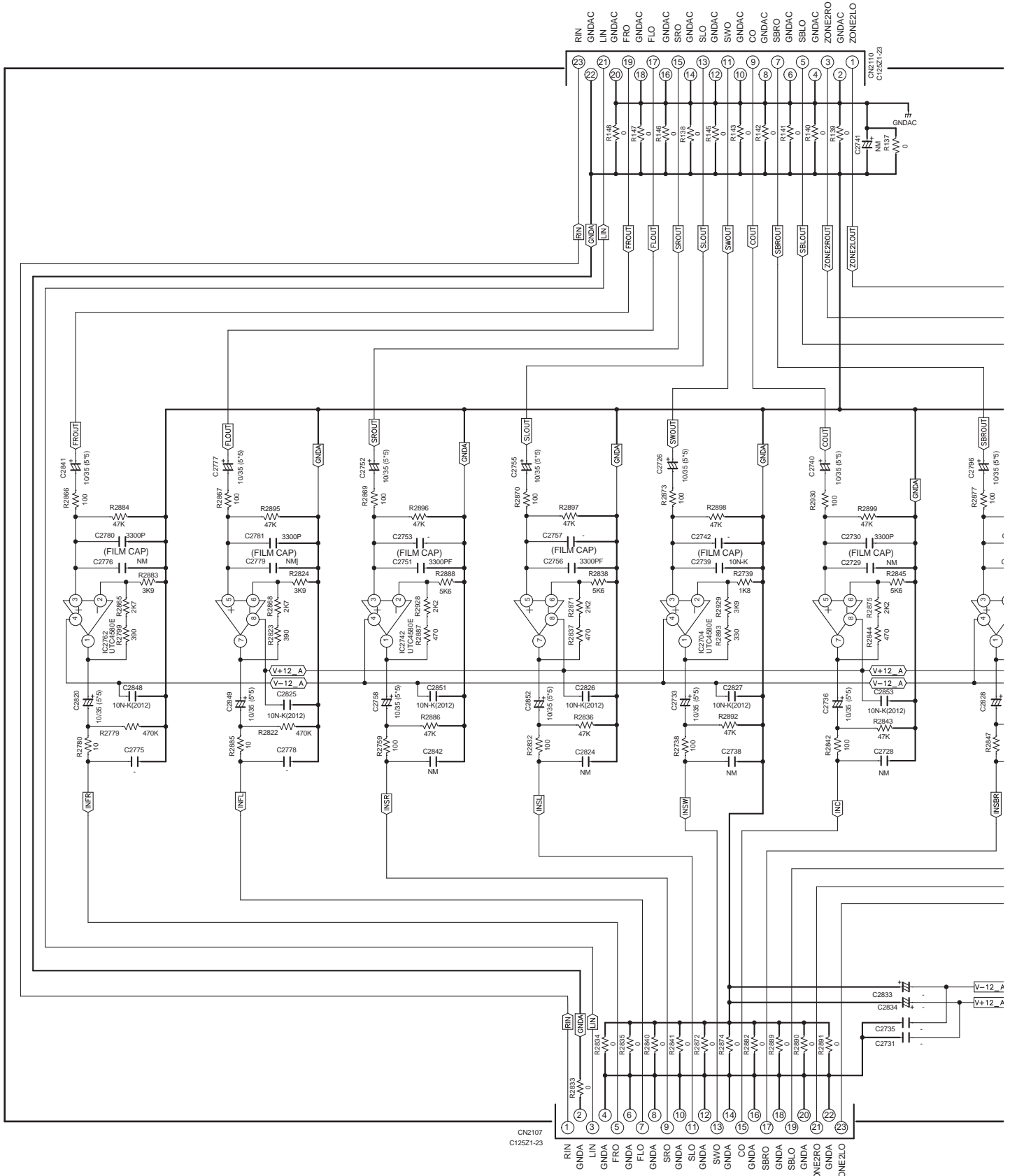

**A** CP12



# BRG ASSY

(VSX-1127-K, VSX-1122-K, VSX-60: 7028071773040-IL)  
(VSX-1027-K: 7028071773070-IL)

## D 7/10 CN1504

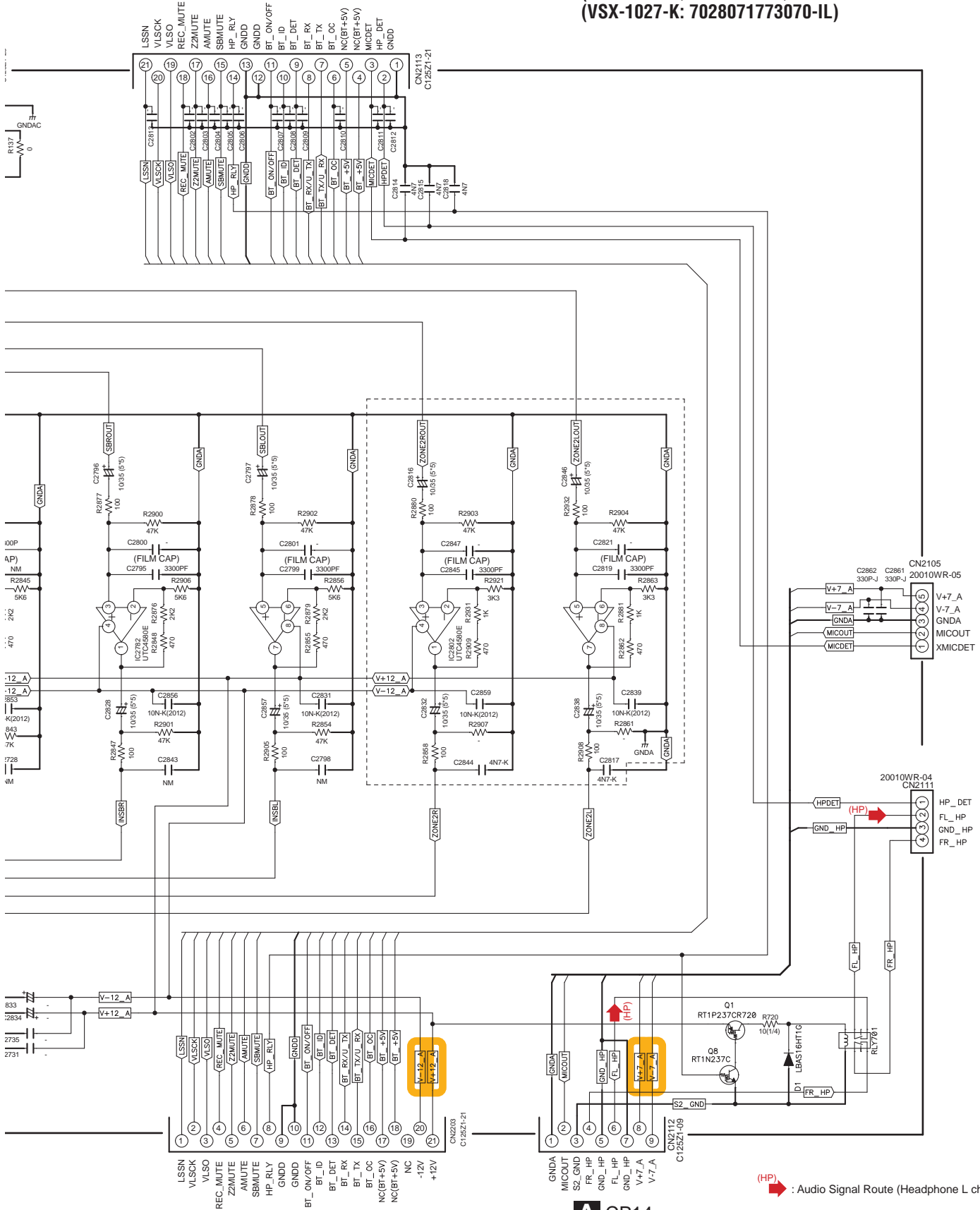

## A CP13

## A CP14

## J CN3653

## L CN721

(HP) : Audio Signal Route (Headphone L ch)

# 10.18 FRONT and POWER ASSYS

## FRONT ASSY (VSX-112) (VSX-112) (VSX-60) (VSX-102)

FLT3001  
HNA-16MM62T  
HNA-16MM62T(SAMSUNG)

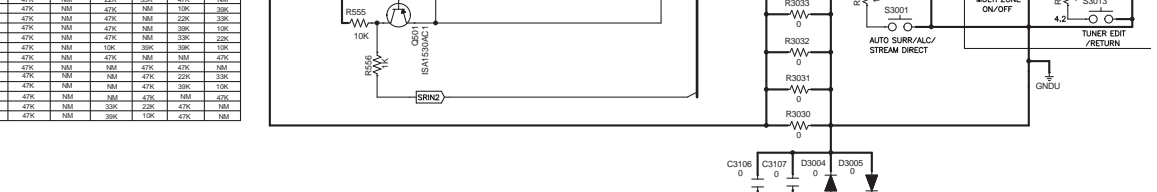
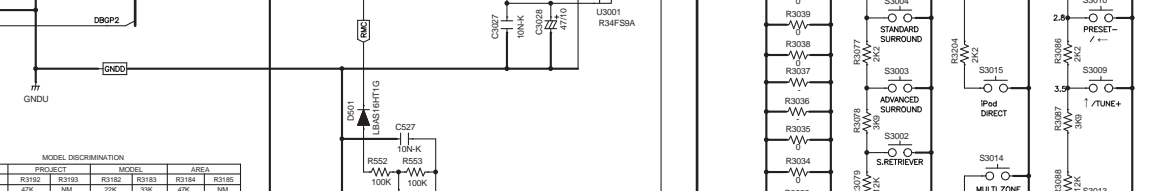
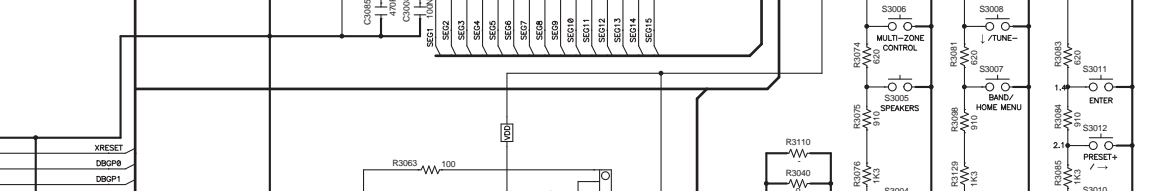
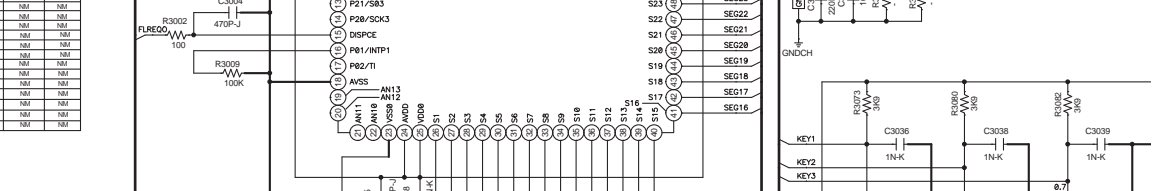
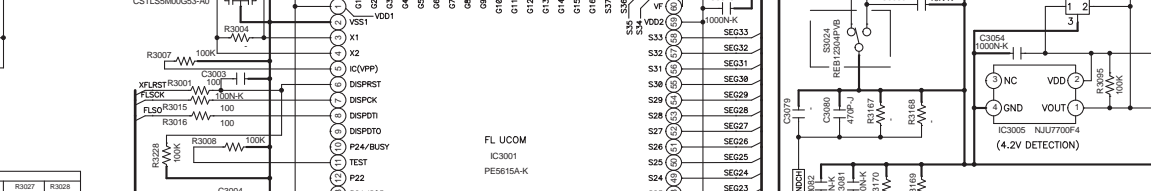
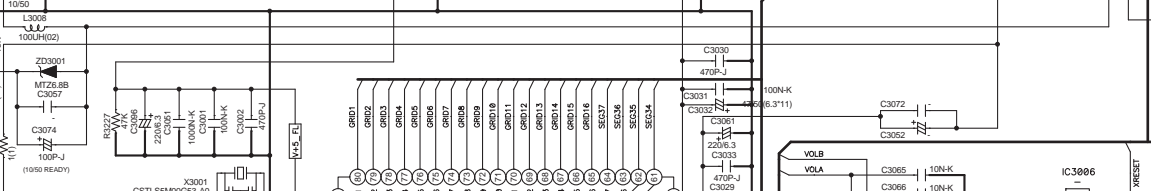
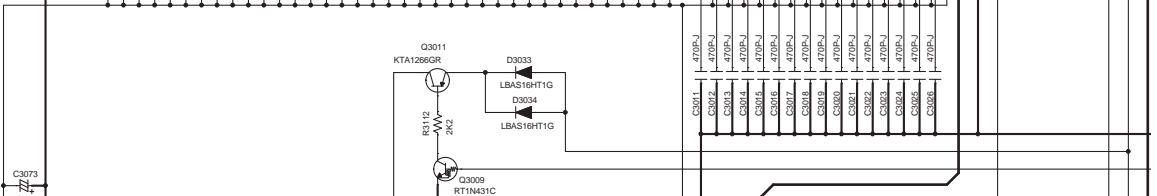
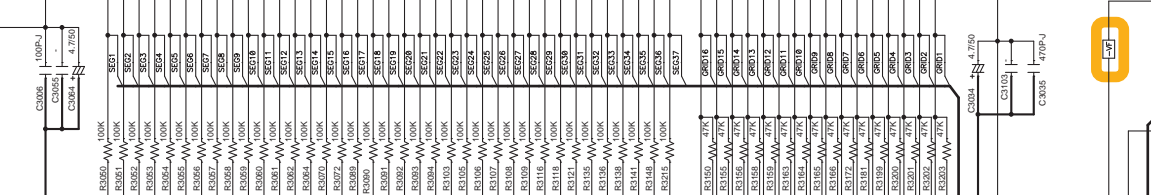
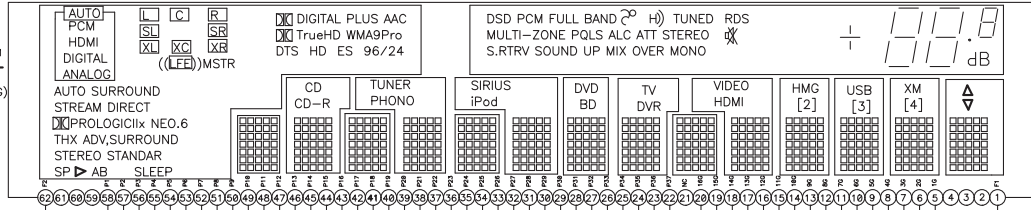

FROM MAIN TRANS

MODEL DISCRIMINATION

MODEL	AREA	R3021	R3022	R3023	R3024	R3025	R3026	R3027	R3028
1097	NA(CLUCE)	0.47(1)	0.47(1)	1(1)	1(1)	1(1)	NM	NM	NM
922	SP(RJSE)	1(1)	1(1)	1(1)	1(1)	1(1)	NM	NM	NM
922	CHA(XES)	1(1)	1(1)	1(1)	1(1)	1(1)	NM	NM	NM
922	GEN(HOLSE)	1(1)	1(1)	1(1)	1(1)	1(1)	NM	NM	NM
922	GEN(LPSE)	1(1)	1(1)	1(1)	1(1)	1(1)	NM	NM	NM
922	ALU(SPARE)	1(1)	1(1)	1(1)	1(1)	1(1)	NM	NM	NM
922	ELU(SYXES)	1(1)	1(1)	1(1)	1(1)	1(1)	NM	NM	NM
1122	NA(CLUCE)	0.47(1)	0.47(1)	1(1)	1(1)	1(1)	NM	NM	NM
1122	CHA(XES)	1(1)	1(1)	1(1)	1(1)	1(1)	NM	NM	NM
1122	GEN(HOLSE)	1(1)	1(1)	1(1)	1(1)	1(1)	NM	NM	NM
1122	ELU(SYXES)	1(1)	1(1)	1(1)	1(1)	1(1)	NM	NM	NM
1127	NA(CLUCE)	0.47(1)	0.47(1)	1(1)	1(1)	1(1)	NM	NM	NM
ELT166	NA(CLUCE)	0.47(1)	0.47(1)	1(1)	1(1)	1(1)	NM	NM	NM

FOR DEBUG & DL

NAME	AREA	R3102	R3103	R3104	R3105	R3106	R3107	R3108
1097	NA(CLUCE)	47K	NM	22K	39K	47K	NM	NM
922	SP(RJSE)	47K	NM	47K	NM	47K	47K	20K
922	CHA(XES)	47K	NM	47K	NM	22K	39K	39K
922	GEN(HOLSE)	47K	NM	47K	NM	39K	19K	19K
922	GEN(LPSE)	47K	NM	47K	NM	39K	22K	22K
922	ALU(SPARE)	47K	NM	10K	39K	39K	19K	19K
922	ELU(SYXES)	47K	NM	47K	NM	47K	NM	NM
1122	NA(CLUCE)	47K	NM	22K	47K	47K	47K	NM
1122	CHA(XES)	47K	NM	47K	47K	22K	39K	39K
1122	GEN(HOLSE)	47K	NM	47K	NM	47K	39K	19K
1122	ELU(SYXES)	47K	NM	47K	47K	47K	47K	47K
1127	NA(CLUCE)	47K	NM	39K	22K	47K	47K	NM
ELT166	NA(CLUCE)	47K	NM	39K	19K	47K	47K	NM



**ASSY (VSX-1127-K: 7028071721050-IL)**  
**(VSX-1122-K: 7028071721010-IL)**  
**(VSX-60: 7028071721040-IL)**  
**(VSX-1027-K: 7028071721060-IL)**

**D2/10 CN601**

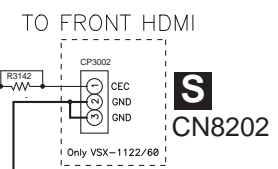
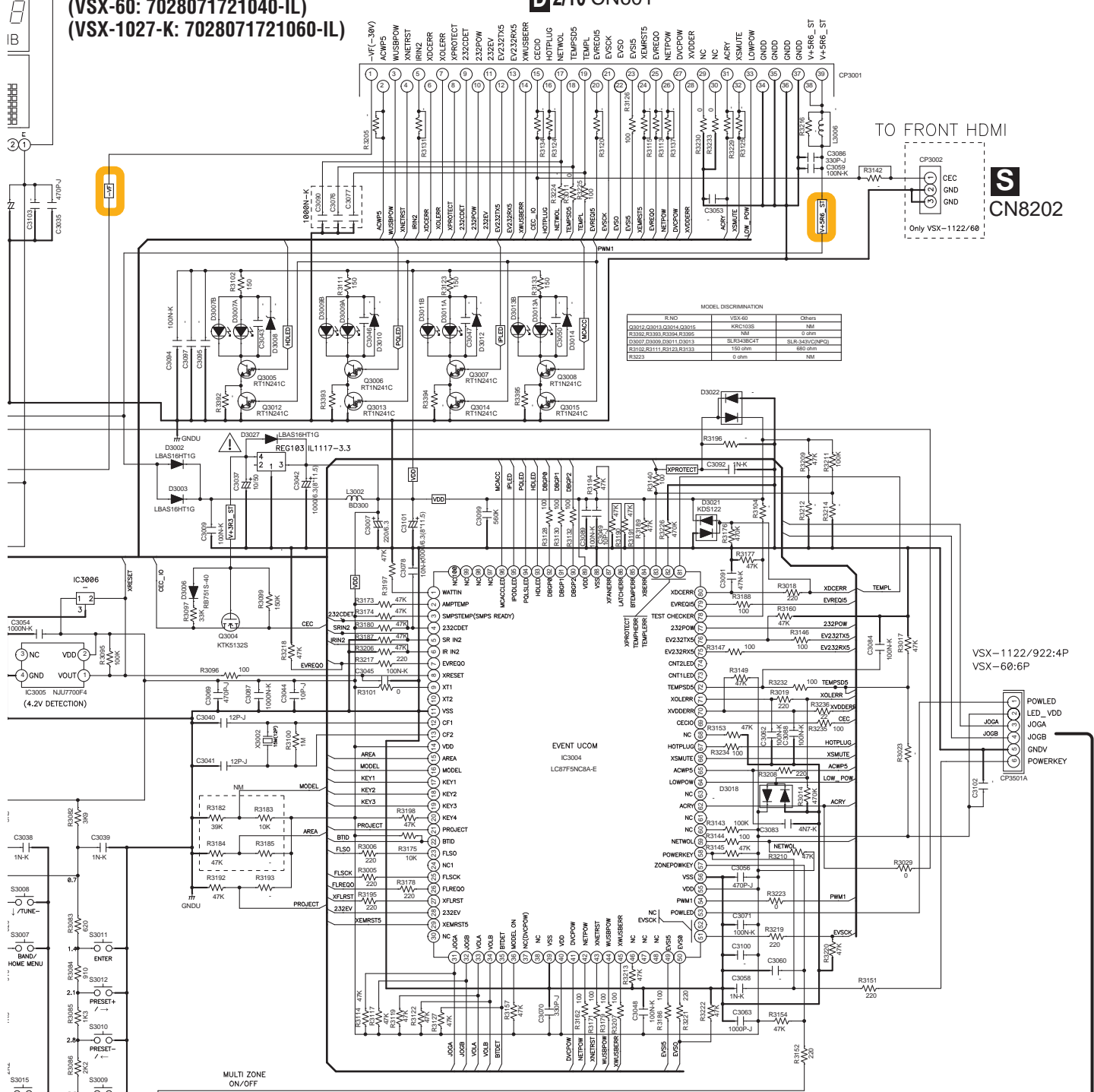

VSX-1122/922:4P  
 VSX-60:6P

**POWER ASSY**  
**(VSX-1127-K, VSX-1122-K,**  
**VSX-1027-K: 7028071722010-IL)**  
**(VSX-60: 7028071722040-IL)**

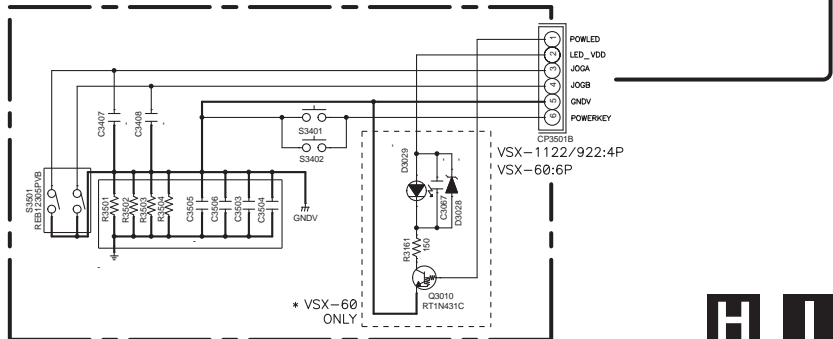

**VSX-1127-K**



# 10.19 MIC, FVIDEO and HP ASSYS

## J MIC ASSY (7028071723040-IL)

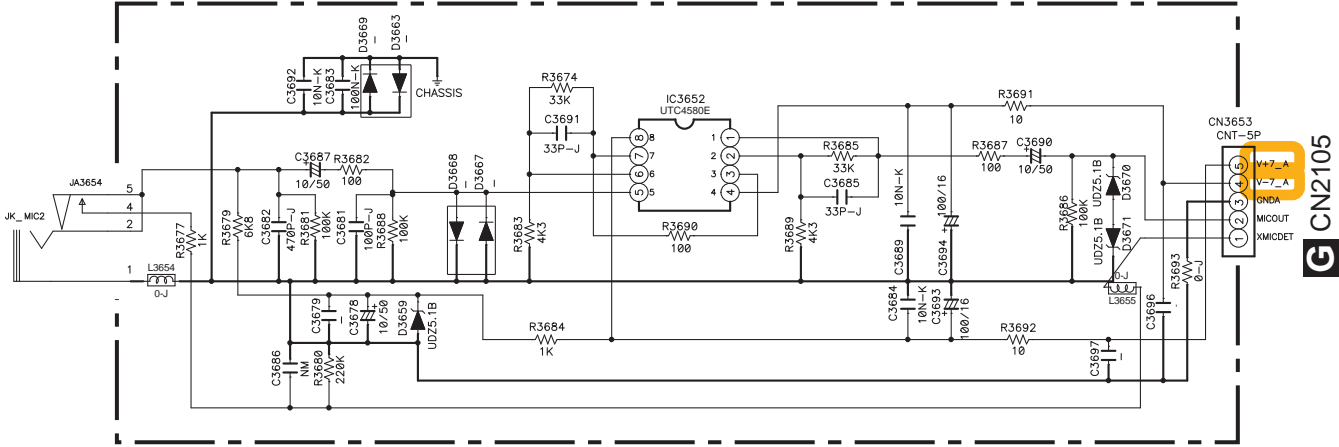

## K FVIDEO ASSY (7028071724040-IL)

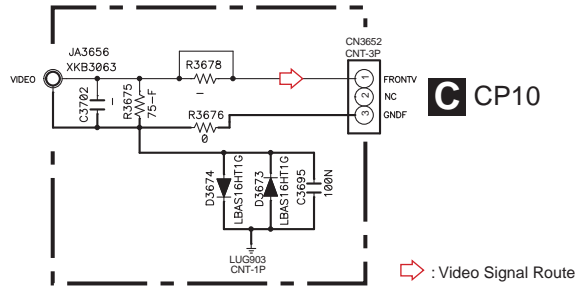

## L HP ASSY (7028071725040-IL)

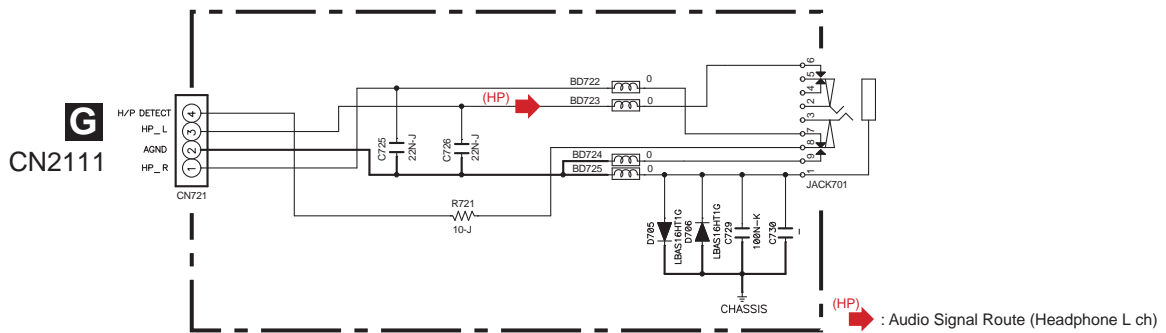

# 10.20 G-L, G-R, WG-A, WG-B, CCG and BTCNT ASSYS

**M** G-L ASSY  
(7028071713040-IL)



**O** WG-A ASSY  
(7028071715040-IL)

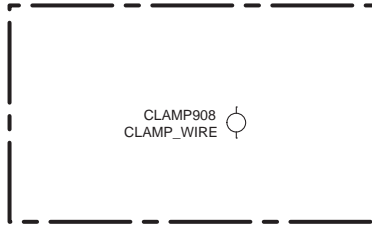

**Q** CCG ASSY  
(7028071775040-IL)



**N** G-R ASSY  
(7028071714040-IL)



**P** WG-B ASSY  
(7028071716040-IL)

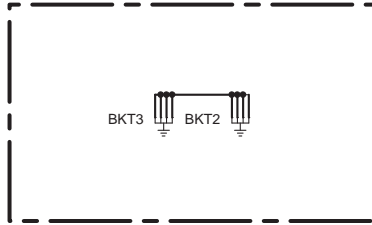

**R** BT CNT ASSY (7028071774040-IL)

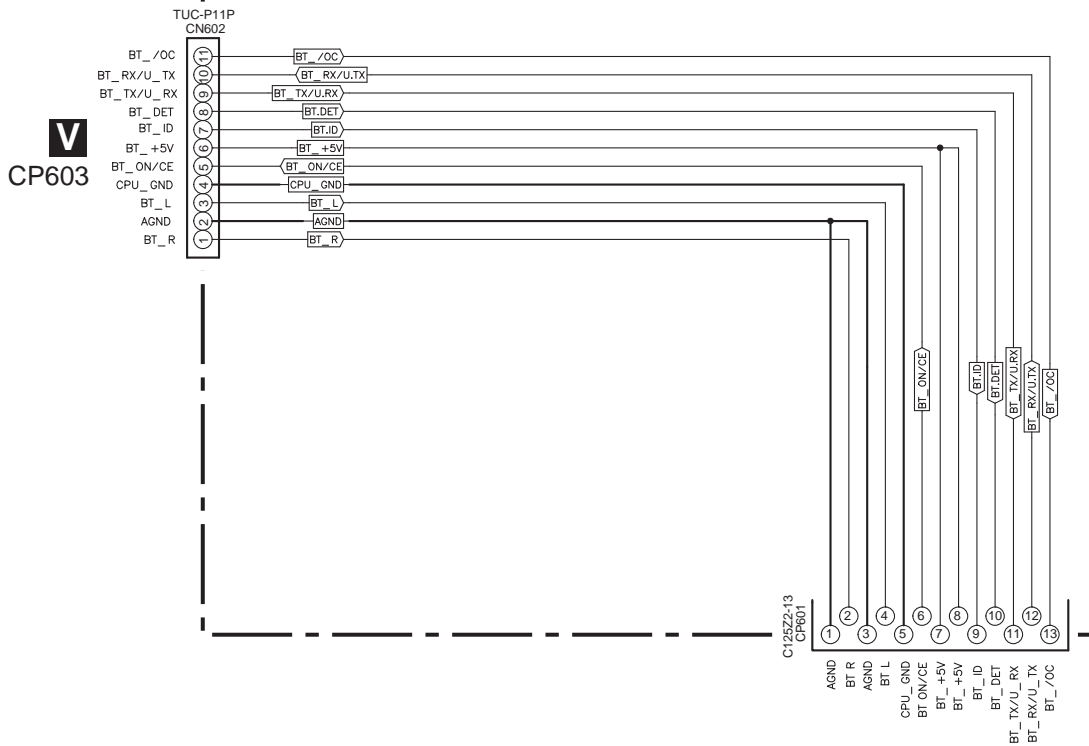

**C** CP7

**M N O P Q R**

# 10.21 FHDMI and F-USB ASSYS

A

## S FHDMI ASSY (7028071791040-IL)

(VSX-1127-K, VSX-1122-K, VSX-60 ONLY)

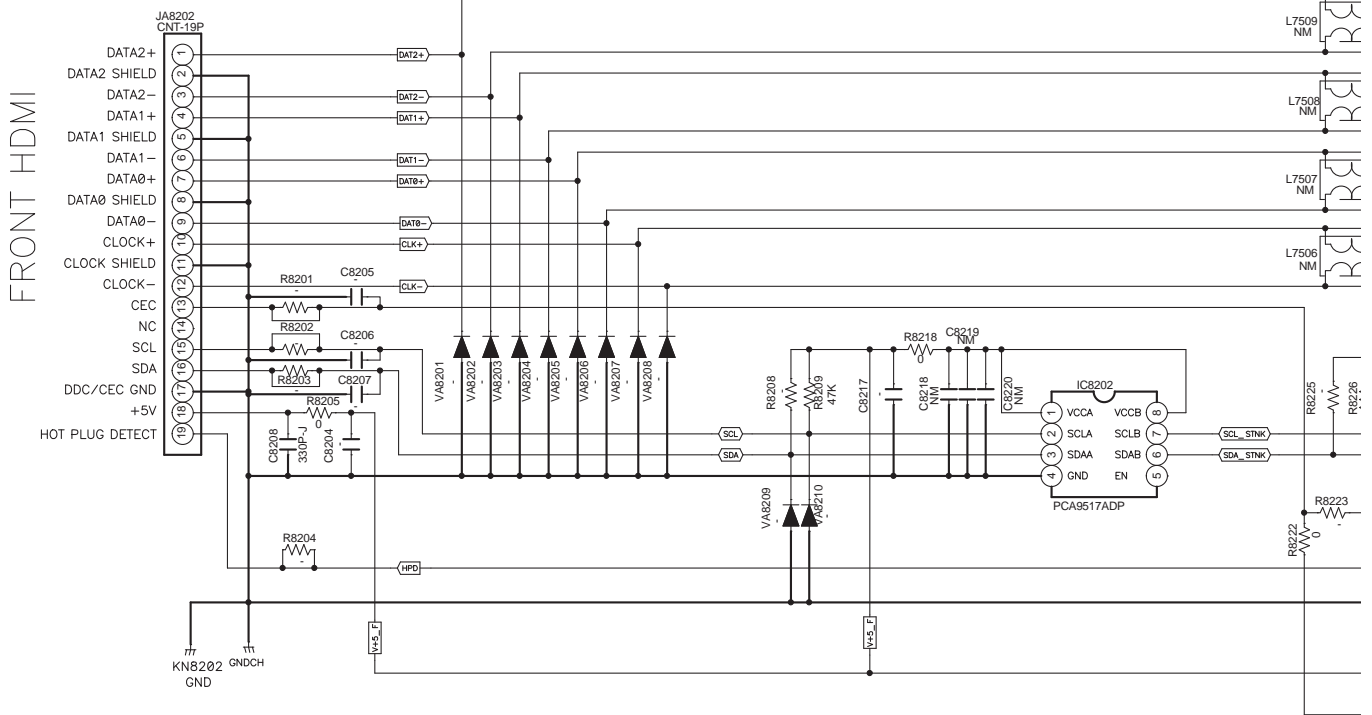

B

C

D

## T F-USB ASSY (7028071761020-IL)

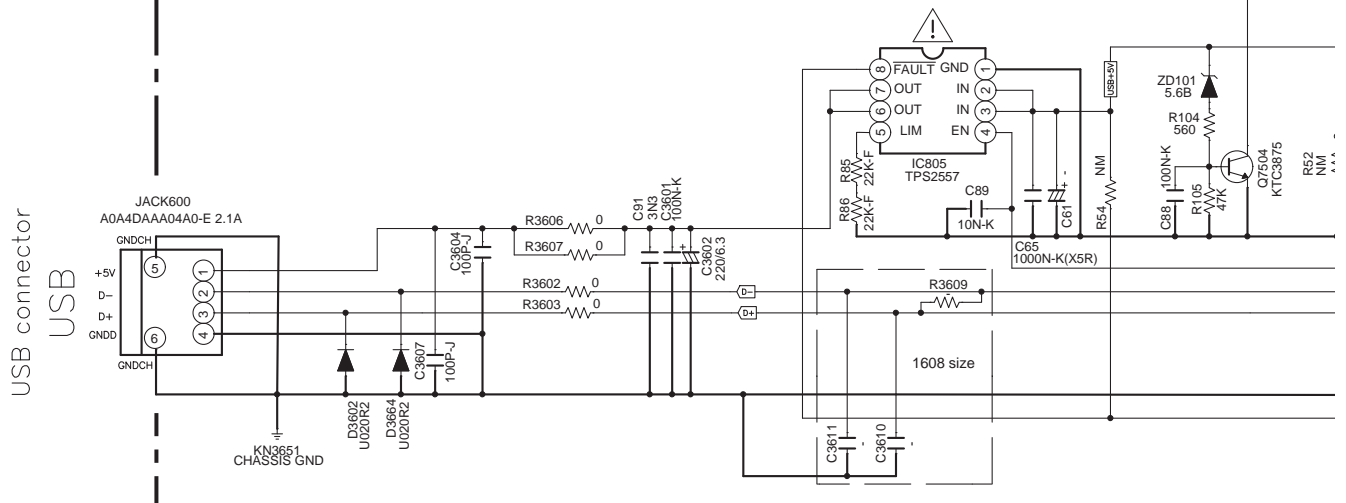

E

F

**S T**

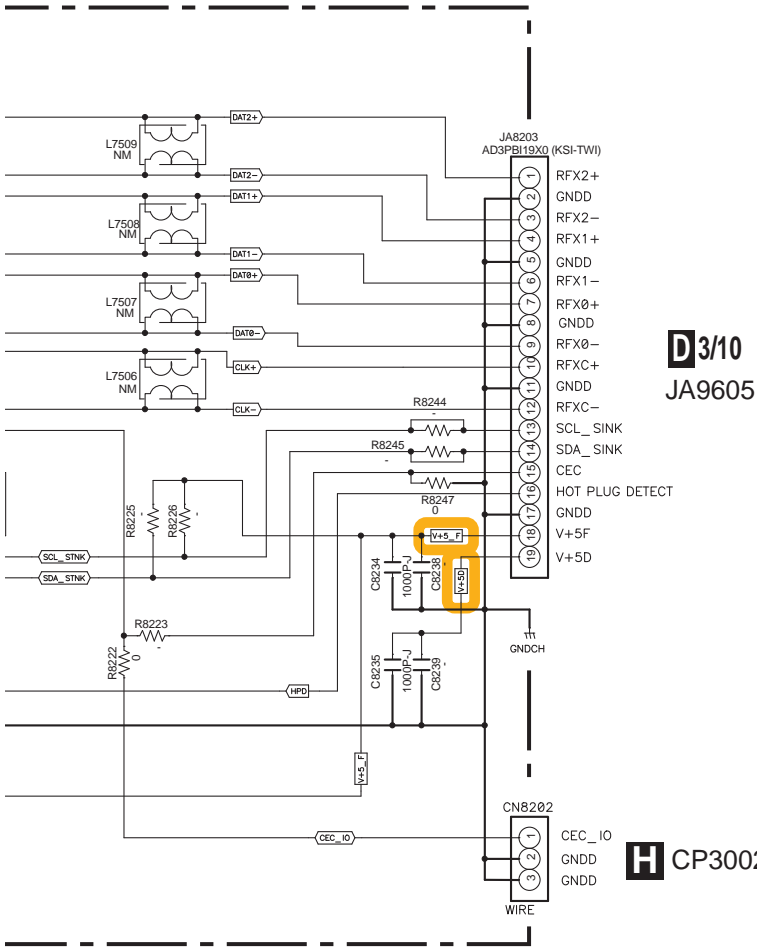

**D3/10**  
JA9605

**H** CP3002

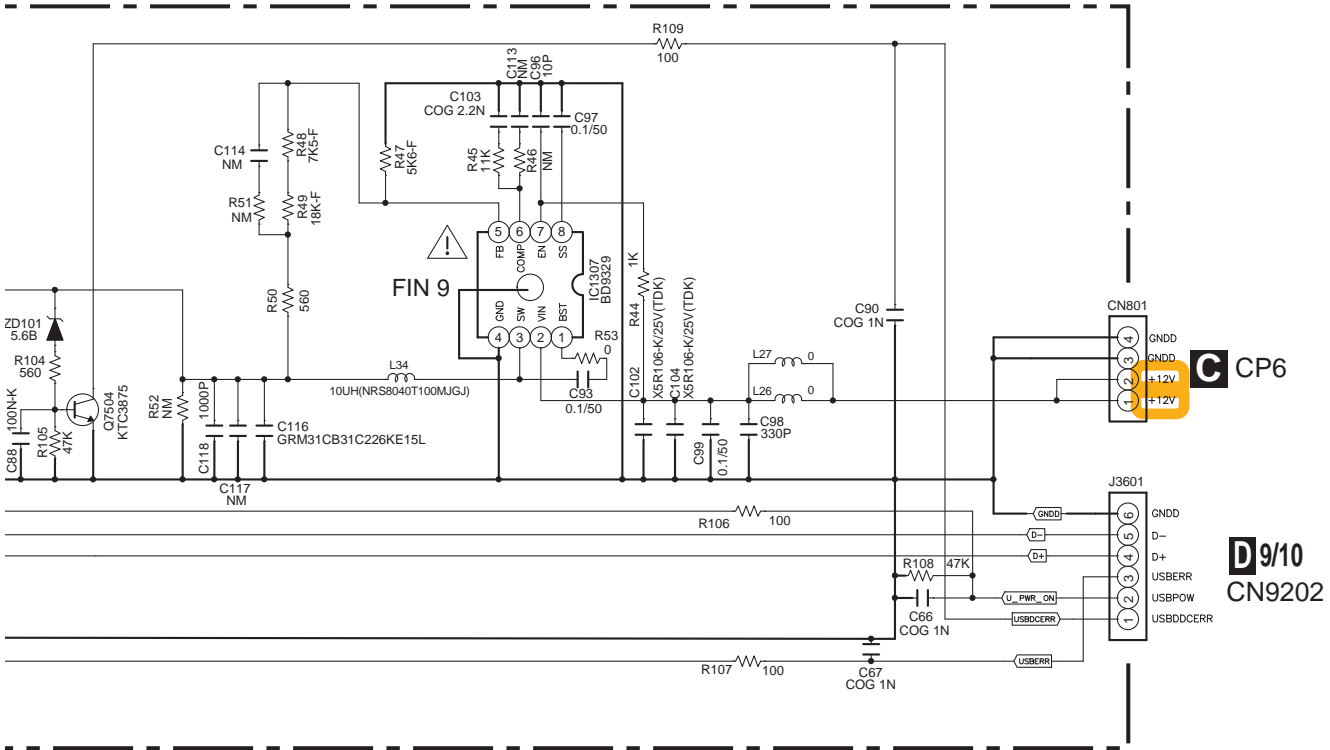

**C** CP6

**D9/10**  
CN9202

# 10.22 SMPS ASSY

A

B

C

D

E

F

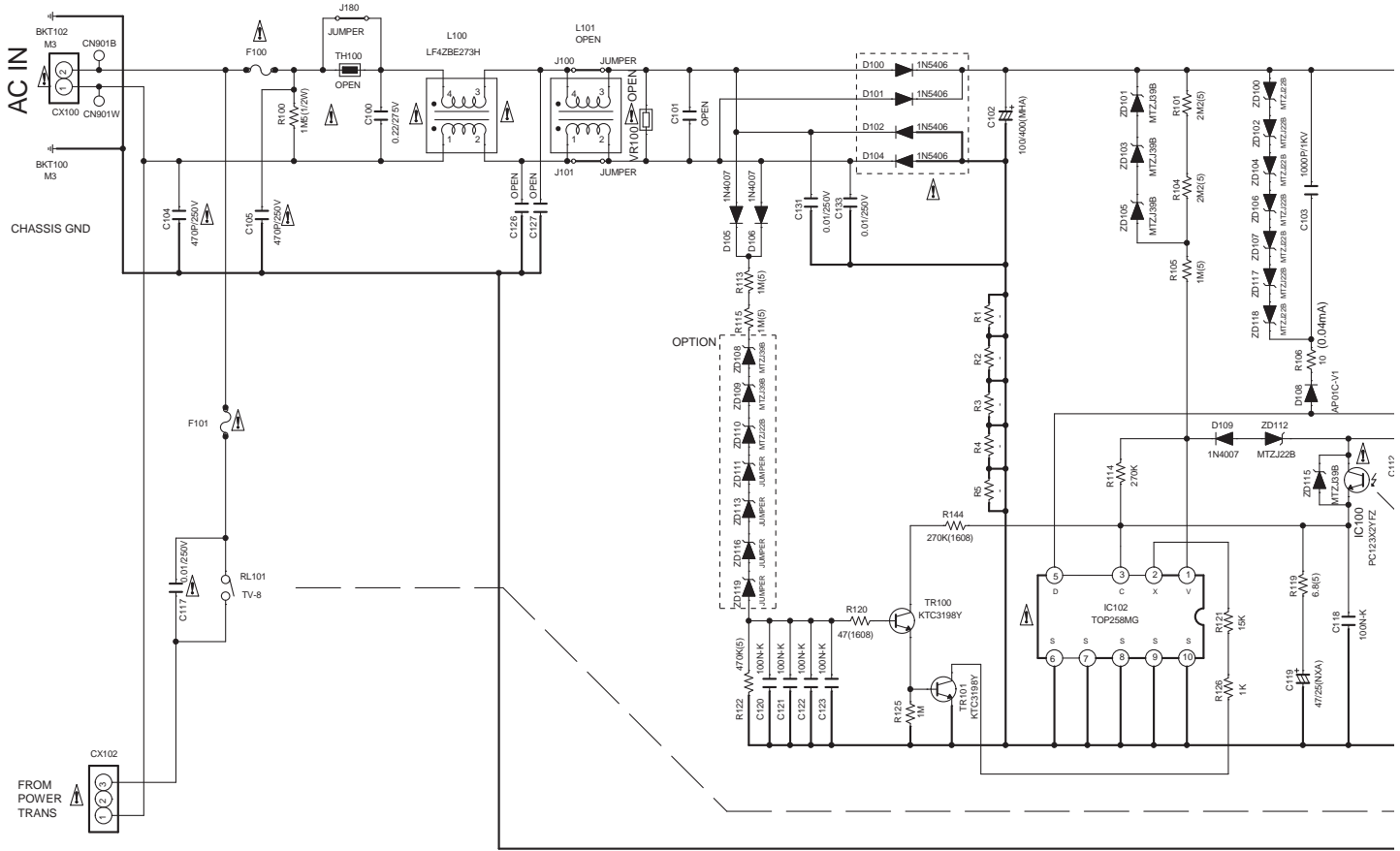

\* OPTION TABLE

\* FUSE OPTION

USA/JAPAN/TAIWAN		OTHER	
F100	F101	F100	F101
3.15A	8A	3.15A	6.3A

	ZD108	ZD109	ZD110	ZD111	ZD113	ZD116	ZD119	ZD101	ZD103	ZD105	R101	R104
USA	MTZJ39B	MTZJ39B	MTZJ22B	JUMPER	JUMPER	JUMPER	JUMPER	MTZJ39B	MTZJ39B	MTZJ39B	2M2 (5)	2M2 (5)
OTHER	1M (5)	1M (5)	MTZJ39B	MTZJ39B	MTZJ39B	MTZJ39B	MTZJ39B	OPEN	OPEN	OPEN	OPEN	OPEN
JAPAN	MTZJ39B	MTZJ39B	JUMPER	JUMPER	JUMPER	JUMPER	JUMPER	MTZJ39B	MTZJ39B	MTZJ39B	2M2 (5)	2M2 (5)
TAIWAN	MTZJ39B	MTZJ39B	MTZJ22B	JUMPER	JUMPER	JUMPER	JUMPER	MTZJ39B	MTZJ39B	MTZJ39B	2M2 (5)	2M2 (5)

	VSX-60	VSX1122/UK	VSX1122/SY.DL	VSX1127	VSX922/SY.DL.FX.PW.JX	VSX922/AX	VS
R5	JUMPER	OPEN	JUMPER	OPEN	JUMPER	OPEN	C
LUG903.904	2P LUG	OPEN	2P LUG	OPEN	2P LUG	OPEN	C
CX100	OPEN	JE202B1T2	OPEN	JE202B1T2	OPEN	JE202B1T2	JE2



1

2

3

4

# U SMPS ASSY

(VSX-1127-K, VSX-1122-K, VSX-1027-K: 7028071772010-IL)  
 (VSX-60: 7028071772040-IL)

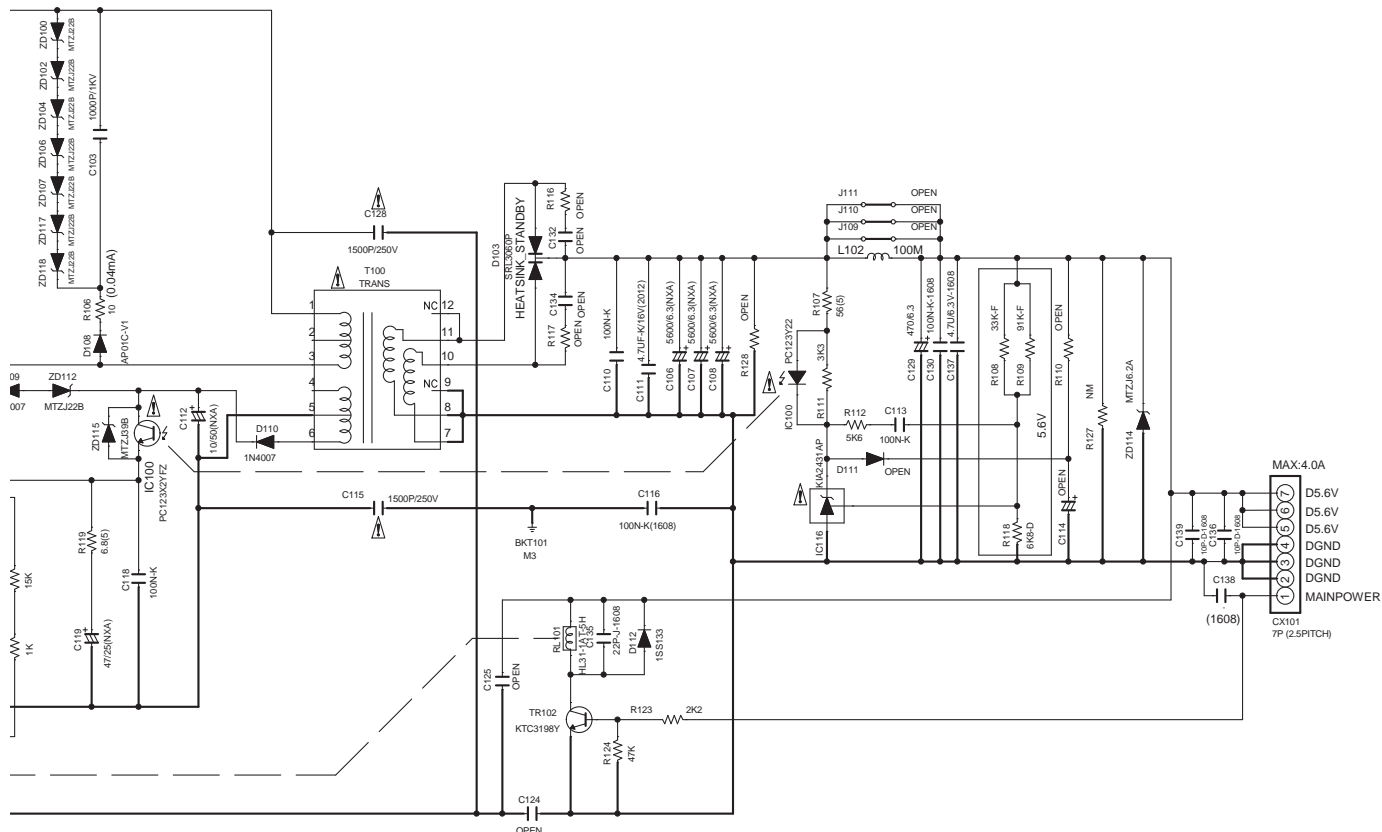

D1010 CN9501

ZD105	R101	R104	R105	R114	R1	R2	R3	R4
1TZX39B	2M2 (5)	2M2 (5)	1M (5)	270K	JUMPER	OPEN	OPEN	OPEN
OPEN	OPEN	OPEN	OPEN	56K	OPEN	JUMPER	OPEN	OPEN
1TZX39B	2M2 (5)	2M2 (5)	1M (5)	270K	OPEN	OPEN	JUMPER	OPEN
1TZX39B	2M2 (5)	2M2 (5)	1M (5)	270K	OPEN	OPEN	OPEN	JUMPER

V <sub>JX</sub>	VSX922/AX	VSX1027
	OPEN	OPEN
	OPEN	OPEN
	JE202B1T2	JE202B1T2

**CAUTION**  
 FOR CONTINUED PROTECTION AGAINST RISK OF FIRE.  
 REPLACE WITH SAME TYPE AND RATINGS OF FUSE.

The mark found on some component parts indicates the importance of the safety factor of the part. Therefore when replacing be sure to use parts of identical designation

**NOTES**

- Resistor values are indicated in ohms unless otherwise specified  
 [ k = 1,000 m = 1,000,000 ]
- Capacitor values are indicated in microfarads unless otherwise specified.
- [ p = micro-microfarades ]

: These resistor are to be segregated from printed wiring board or other accessible parts.

**CAUTION**  
 Safety precaution to be followed during servicing

- Since those parts marked with are critical parts for safety, use only the one described in the parts list
- Before returning the set to the customer make appropriate leakage current or resistance measurements to determine the exposed parts are properly insulated from the supply circuit.

# 10.23 BT ASSY

## V BT ASSY (7028070231010-IL)

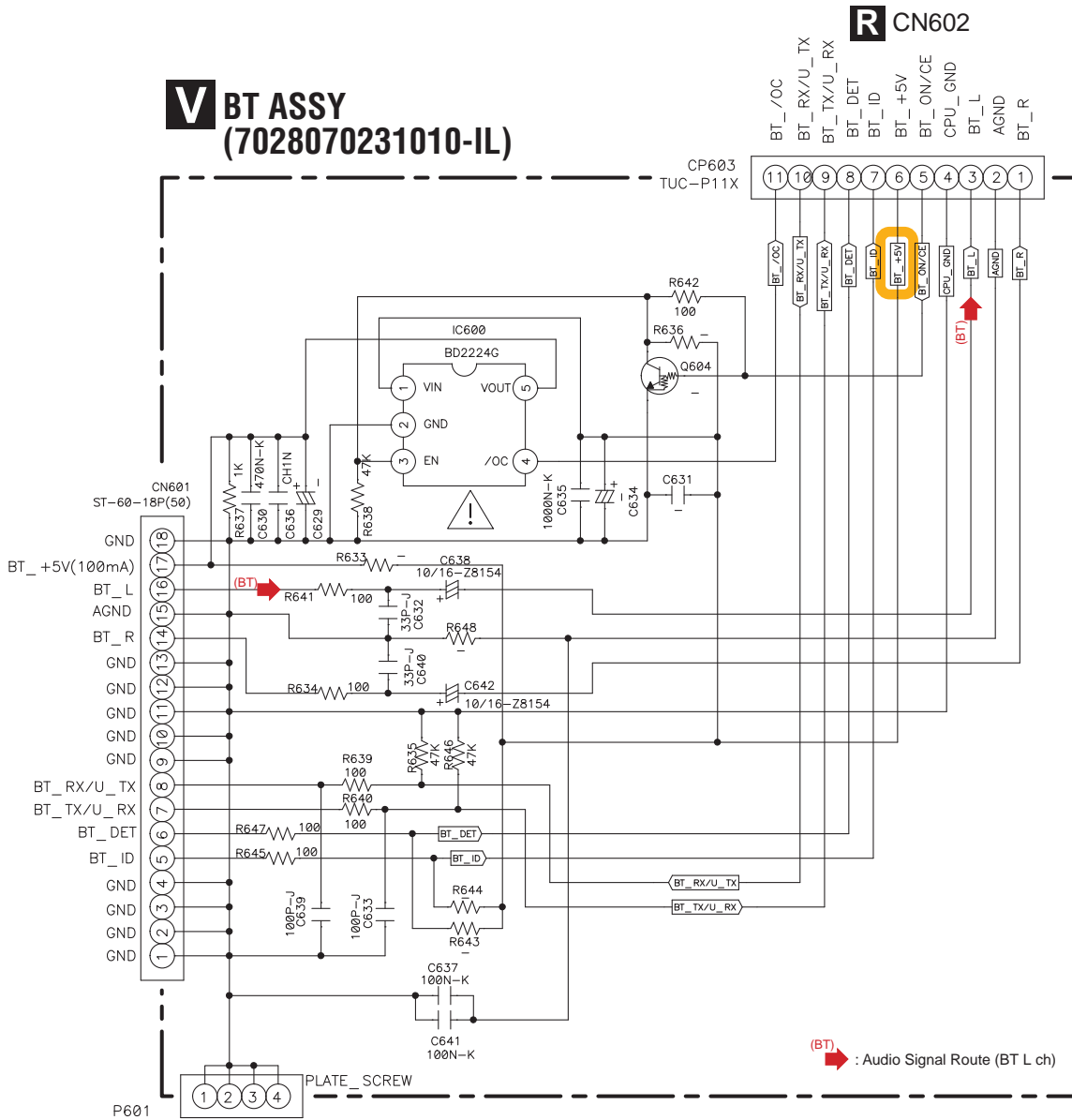





5



6



7



8



A



B



C



D



E



F



5



6

VSX-1127-K



7



8



# 11. PCB CONNECTION DIAGRAM

## 11.1 AUDIO ASSY

**SIDE A**

**NOTE FOR PCB DIAGRAMS :**

1. The parts mounted on this PCB include all necessary parts for several destinations. For further information for respective destinations, be sure to check with the schematic diagram.

2. View point of PCB diagrams.

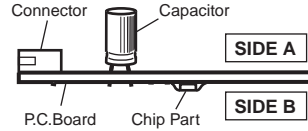

**SIDE A**

### **A** AUDIO ASSY

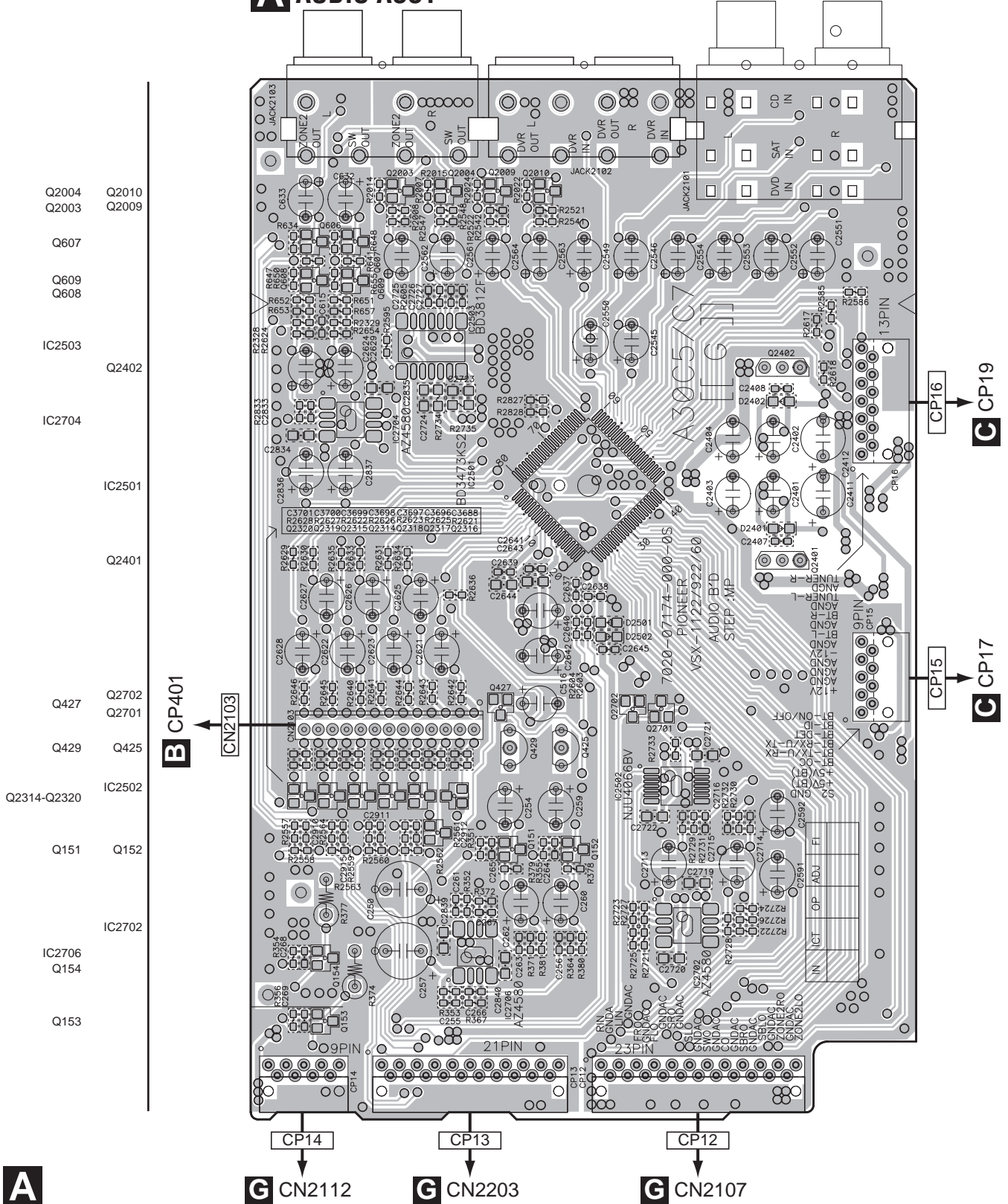

SIDE B

SIDE B

**A** AUDIO ASSY

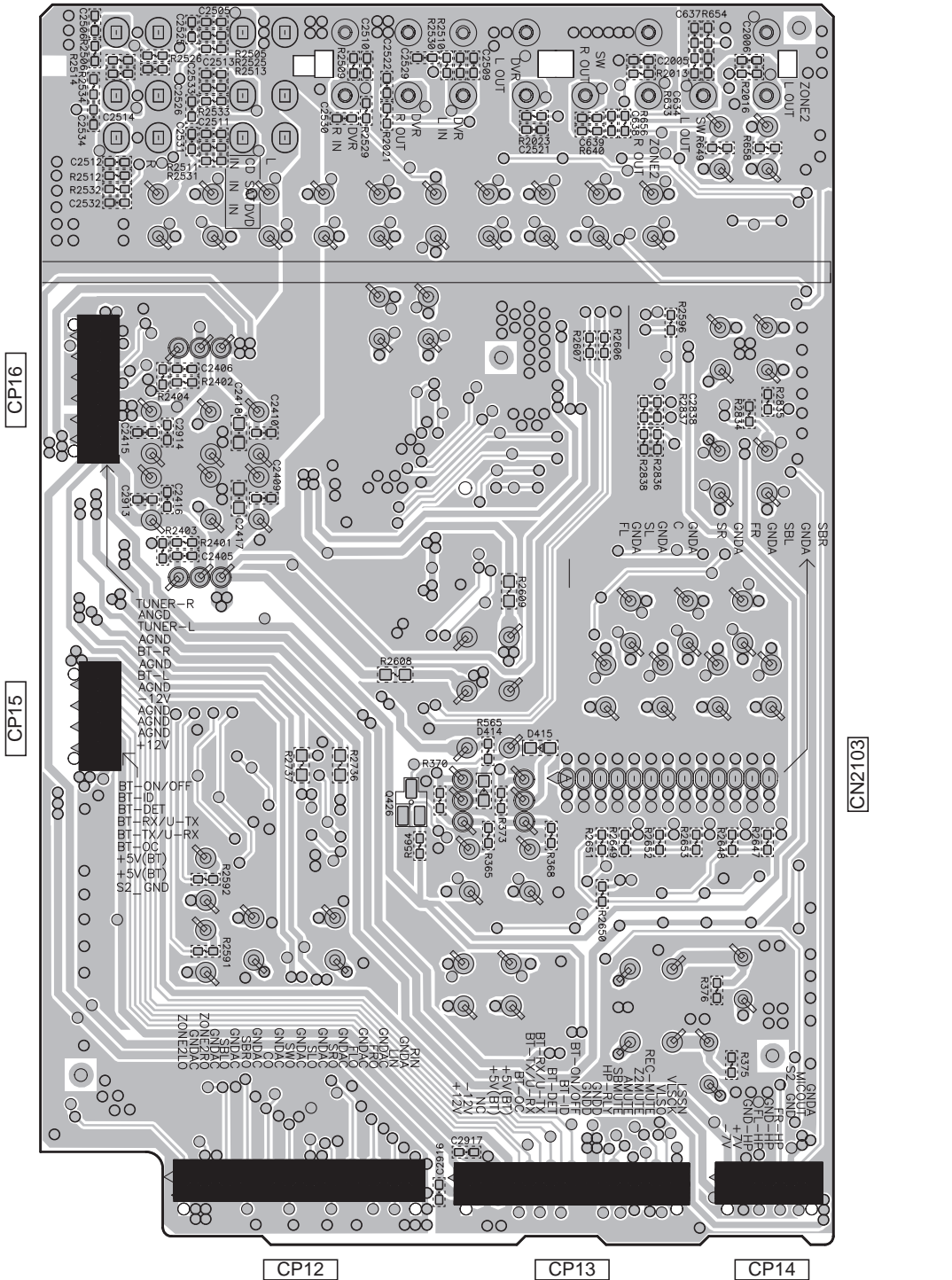

A  
B  
C  
D  
E  
F

VSX-1127-K

**A**

# 11.2 AMP7 ASSY

**SIDE A**

**B AMP7 ASSY**

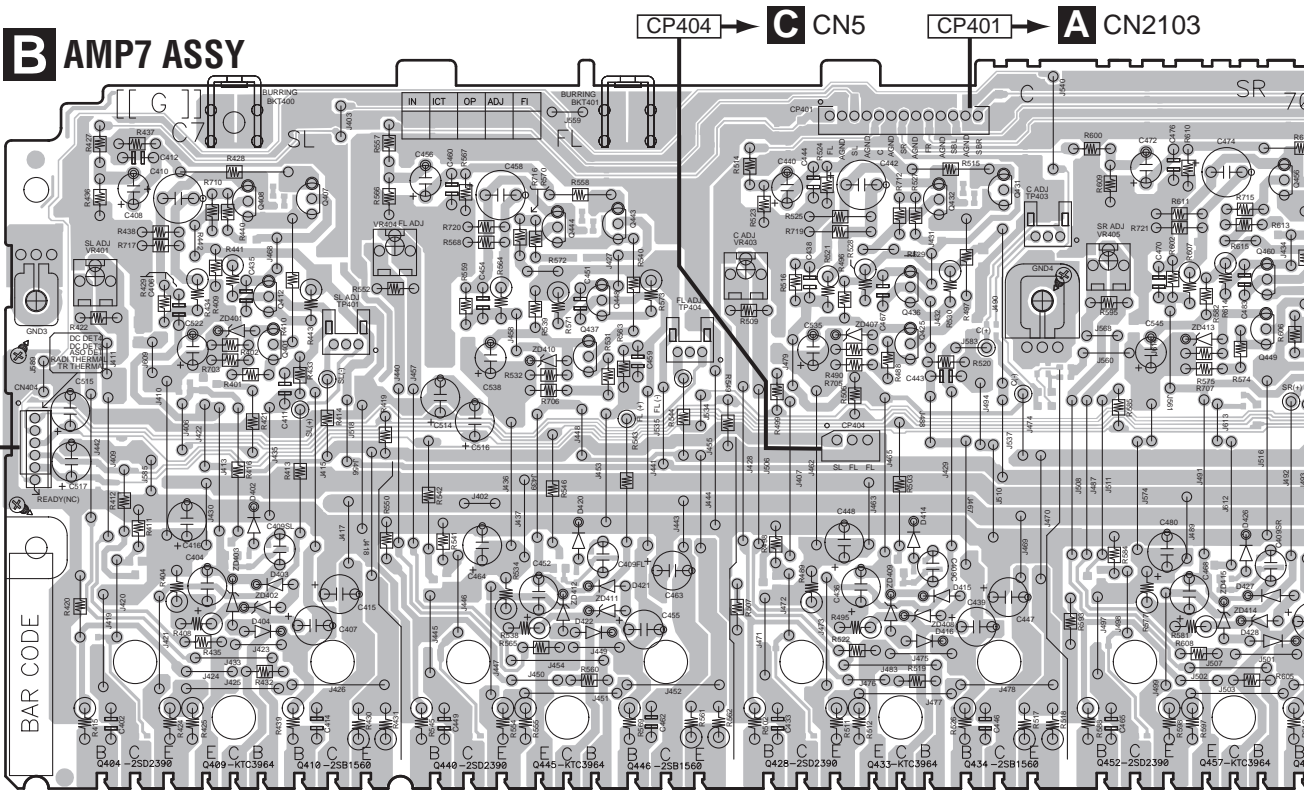

Q408 Q407 Q444 Q443 Q432 Q431 Q456  
 Q412 Q448 Q436 Q431 Q460  
 Q401 Q437 Q425 Q434 Q449  
 Q404 Q409 Q410 Q440 Q445 Q446 Q428 Q433 Q434 Q452 Q457

**SIDE B**

**B AMP7 ASSY**

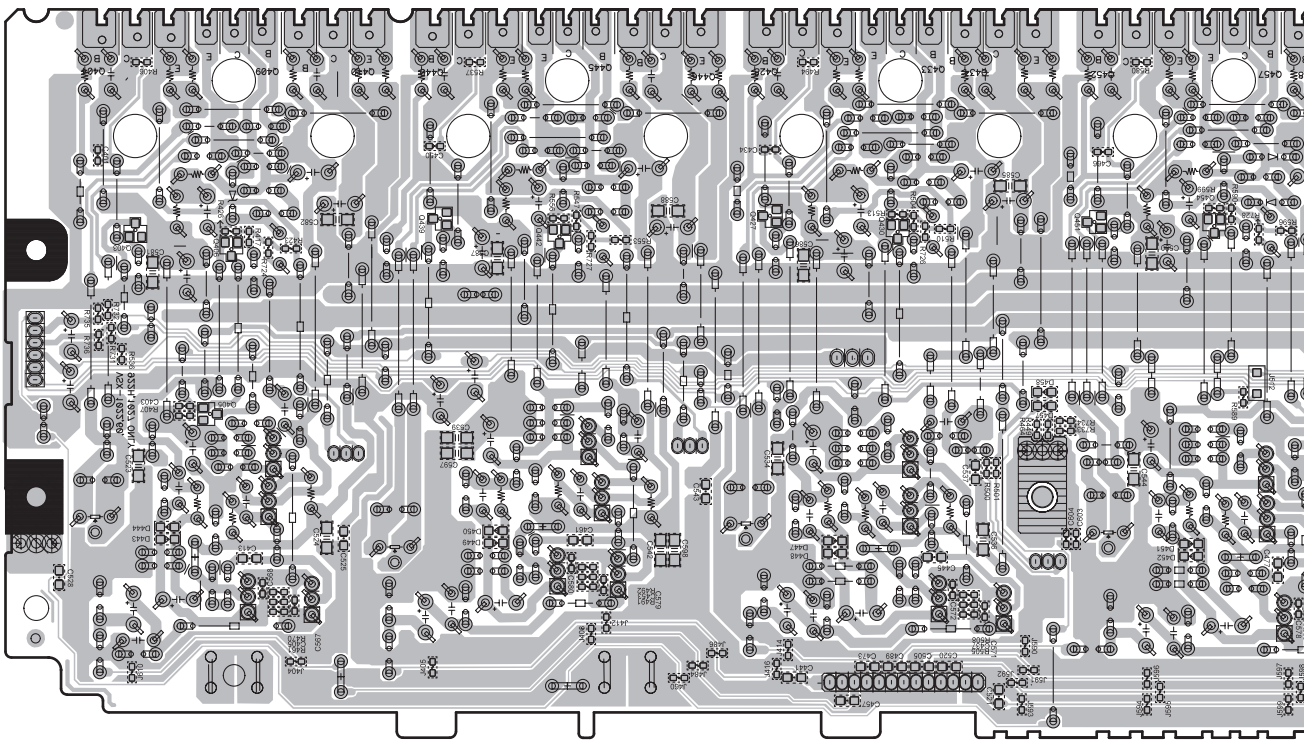

Q403 Q406 Q439 Q442 Q427 Q461 Q454  
 Q405

VSX-1127-K

V2103

CP406

CN1

CP403

CN3

CP405

CN2

SIDE A

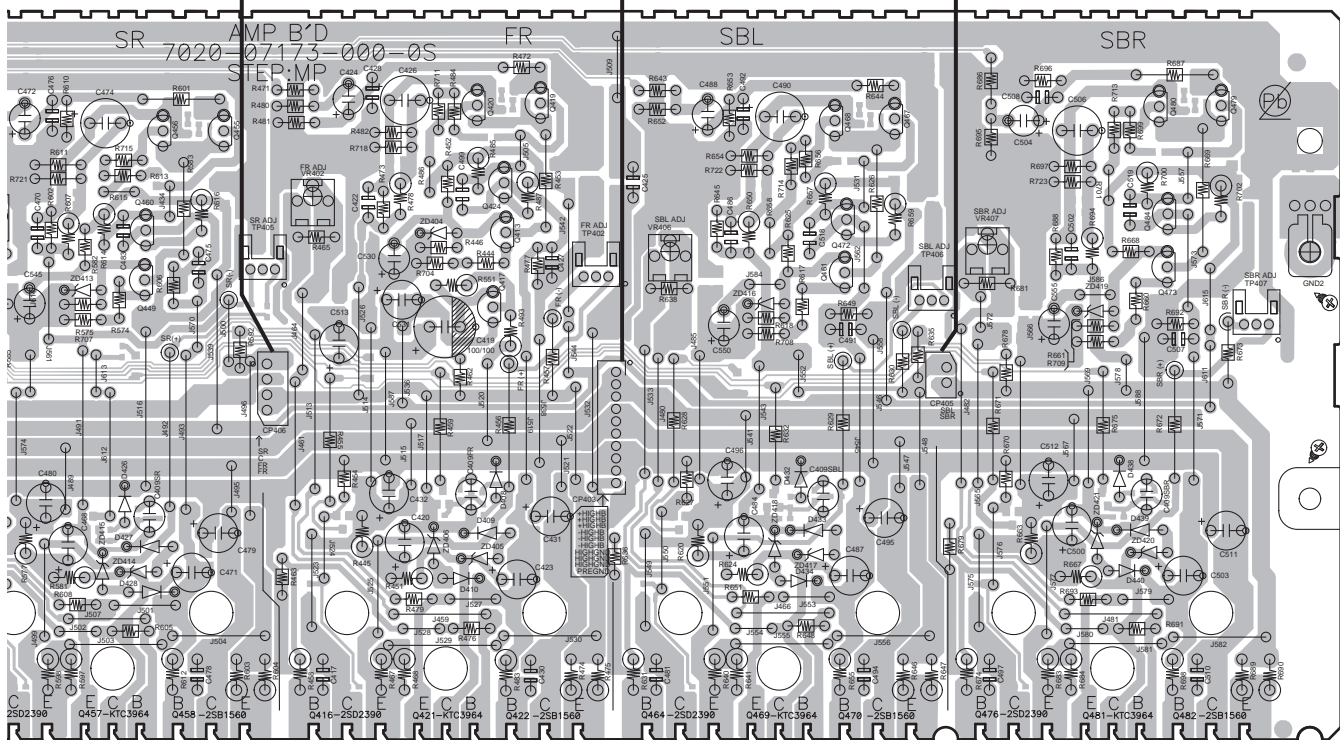

SIDE B

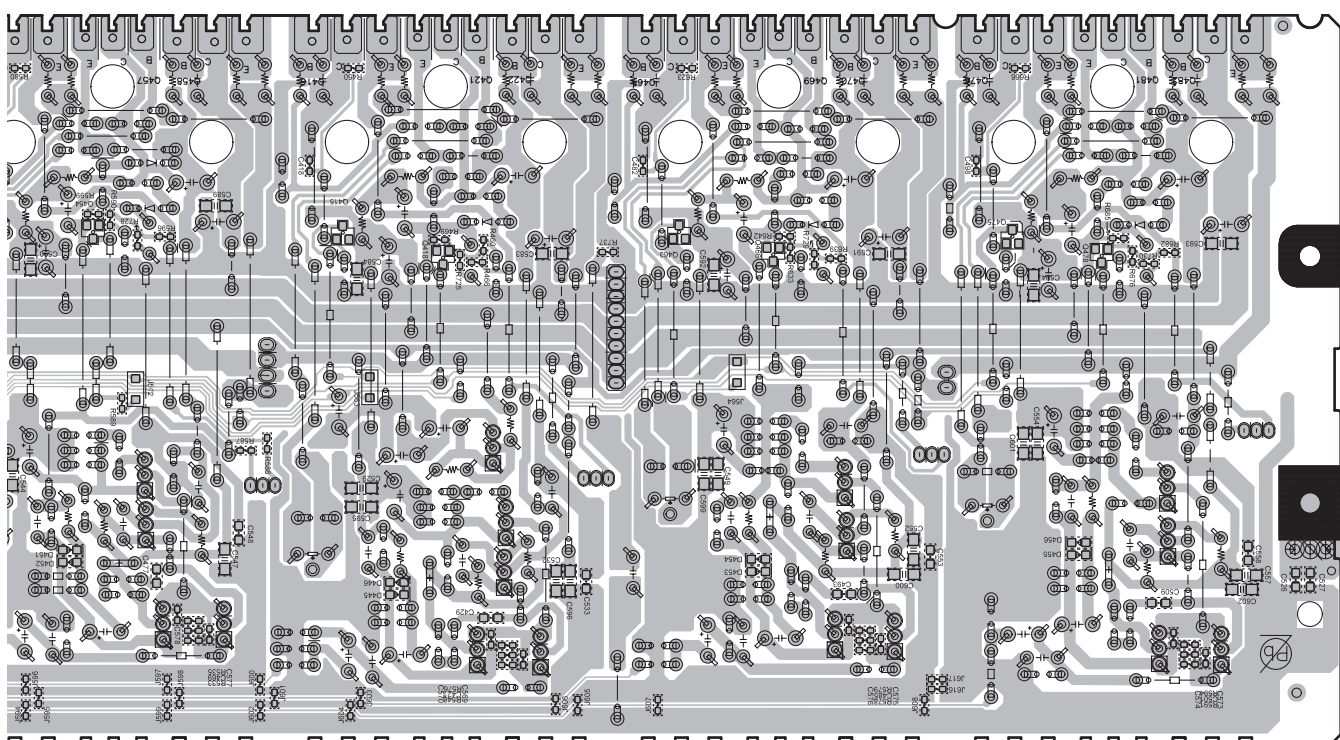

VSX-1127-K

B

# 11.3 MAIN ASSY

**SIDE A**

**C MAIN ASSY**

**B CP404**

CN5

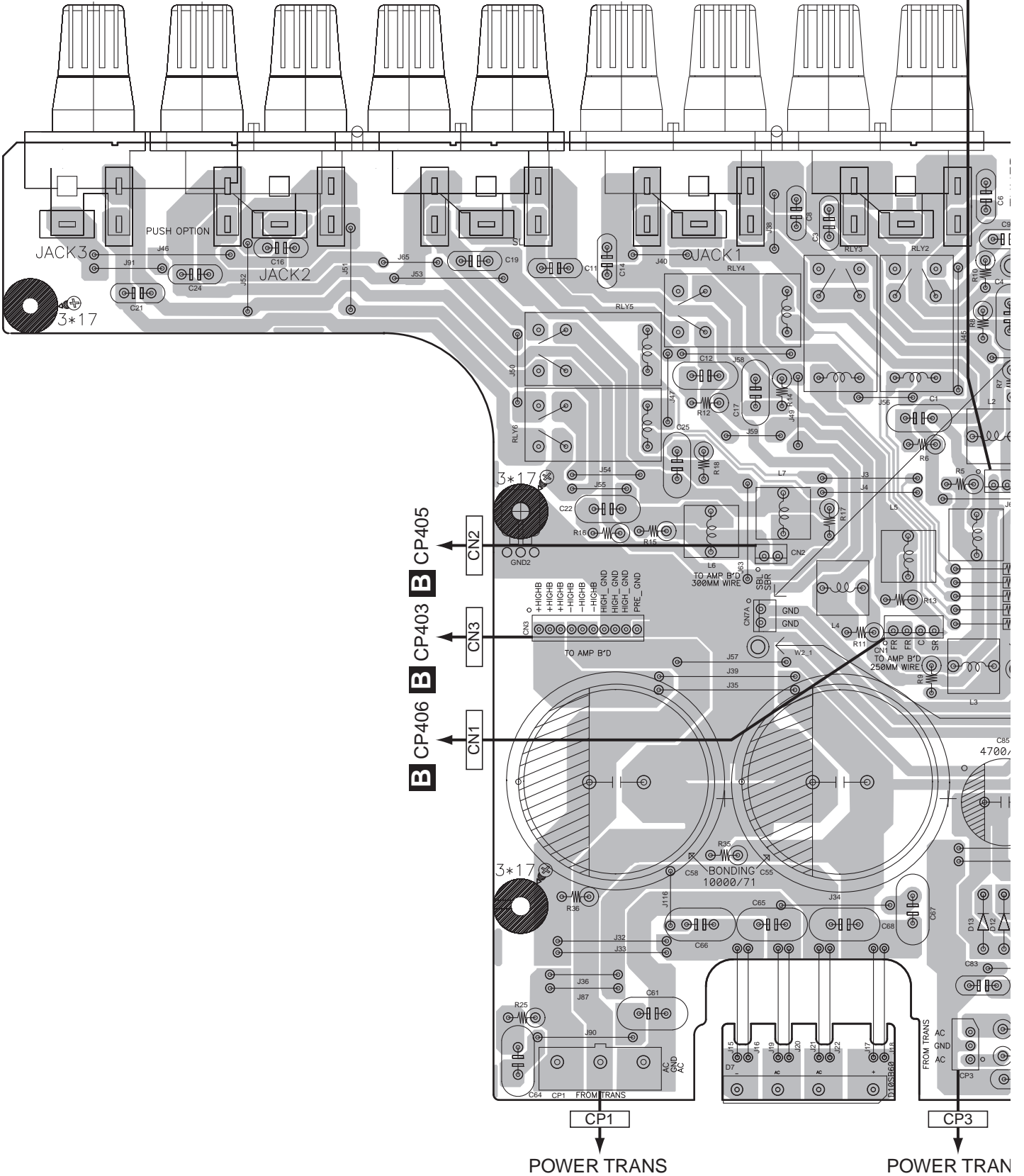

**C**

SIDE A

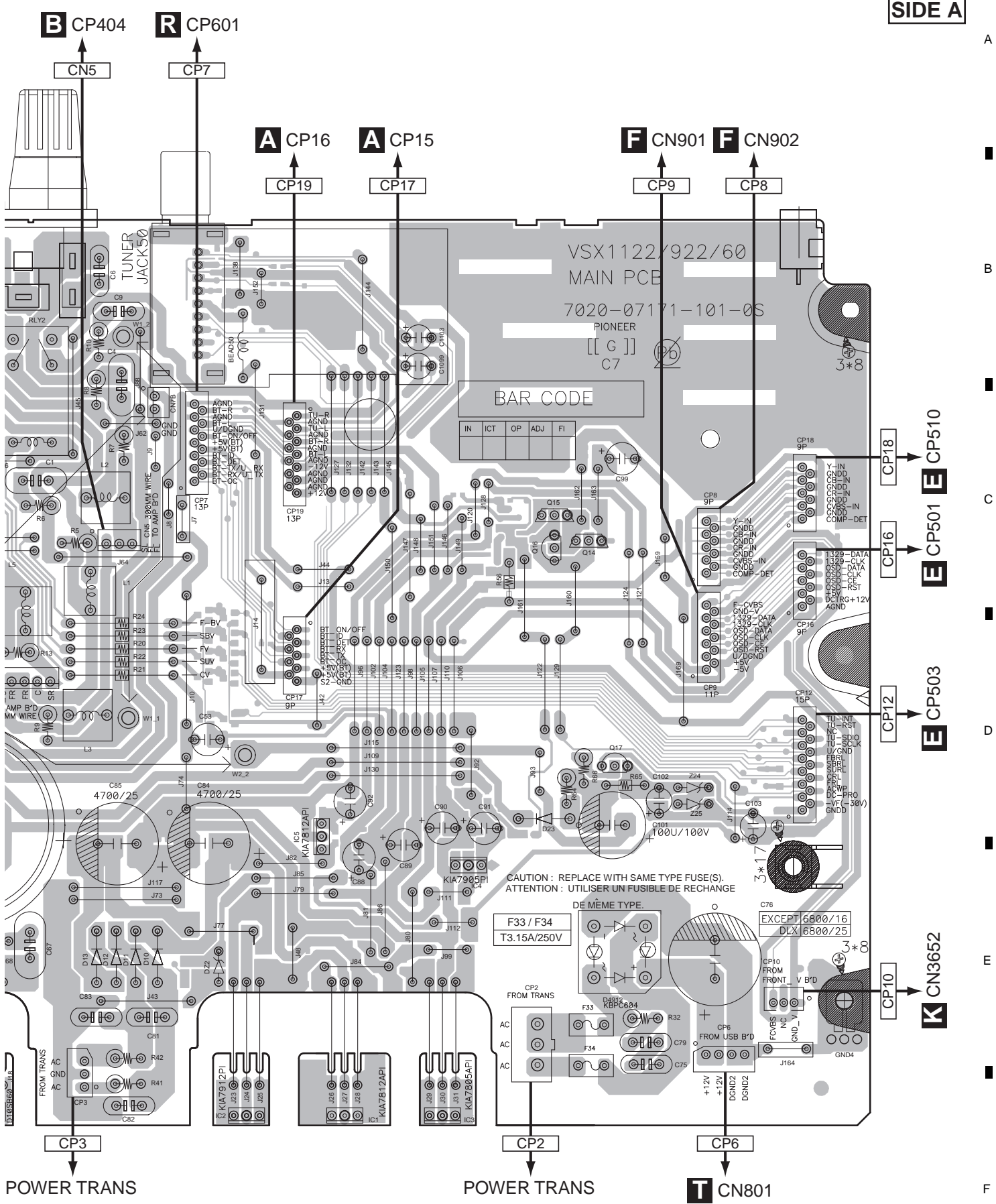

A  
B  
C  
D  
E  
F

E CP501 E CP510  
E CP503  
K CN3652

IC2 IC5 IC1 IC3 IC4 Q16 Q15 Q14 Q17

VSX-1127-K

C

**SIDE B**

**C MAIN ASSY**

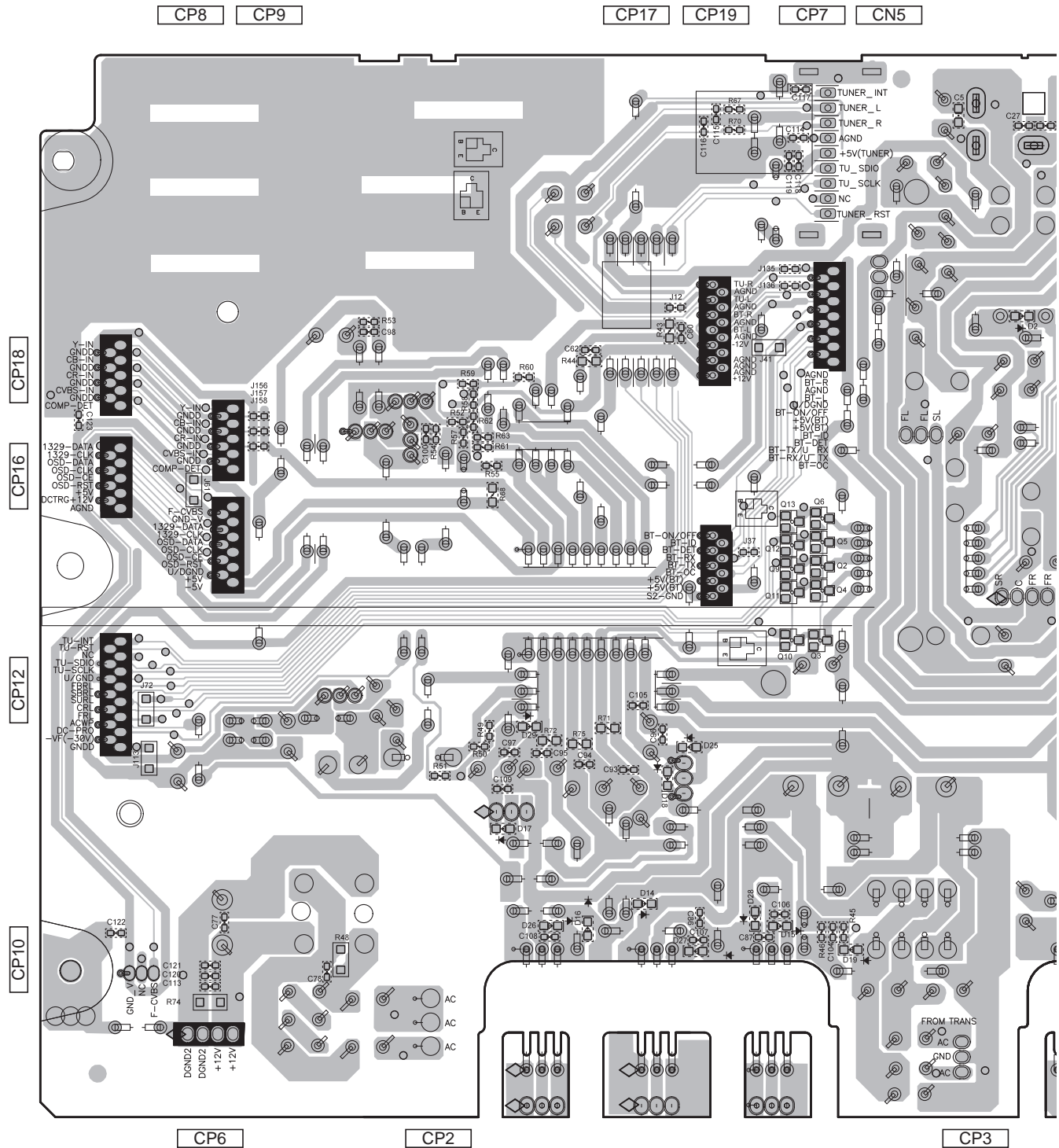

Q9-Q13 Q2-Q6

**C**



**SIDE B**

A

B

C

D

E

F

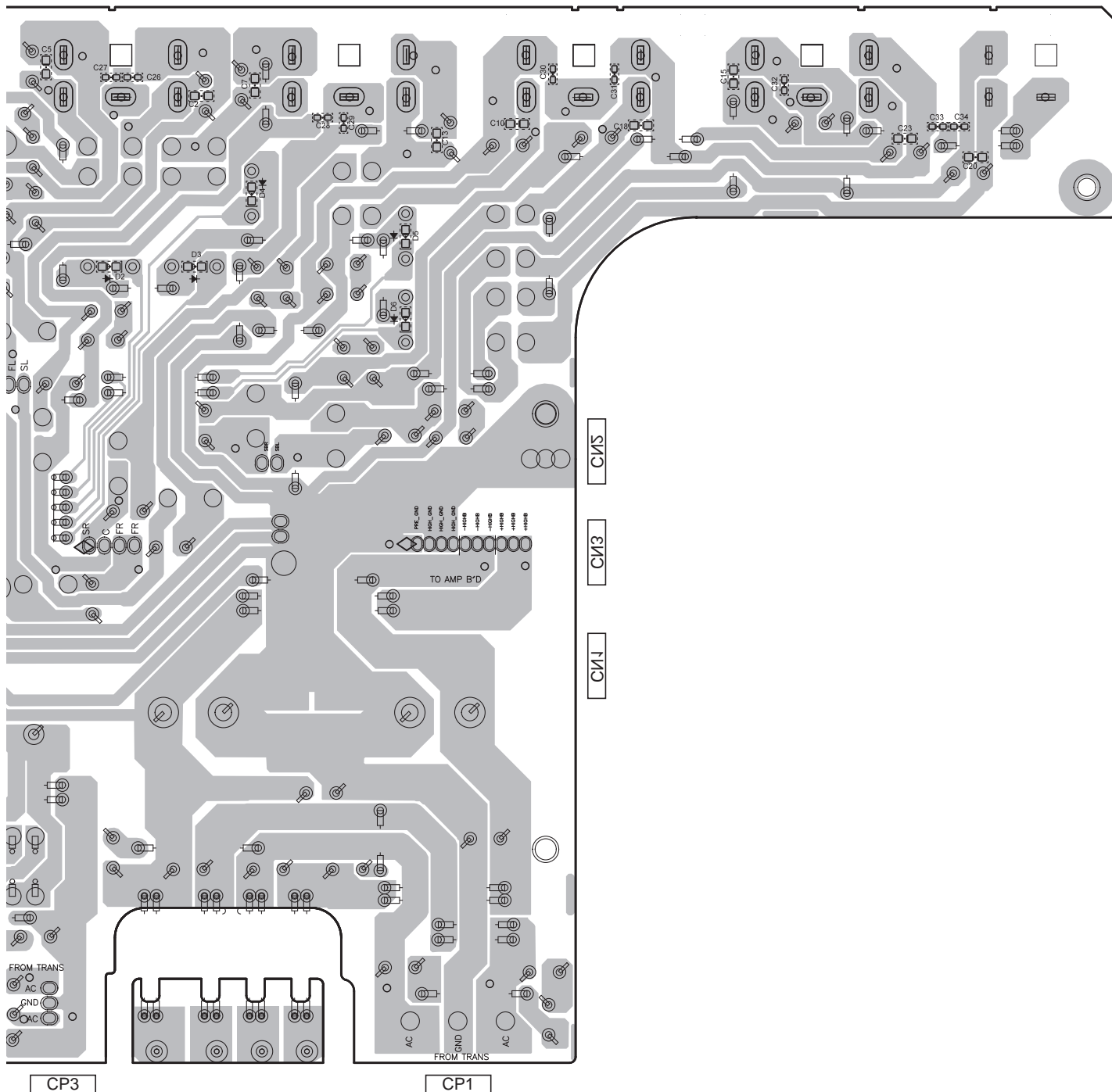



**SIDE A**

A

**G** CN2113

**G** CN2110

CN1504

CN1801

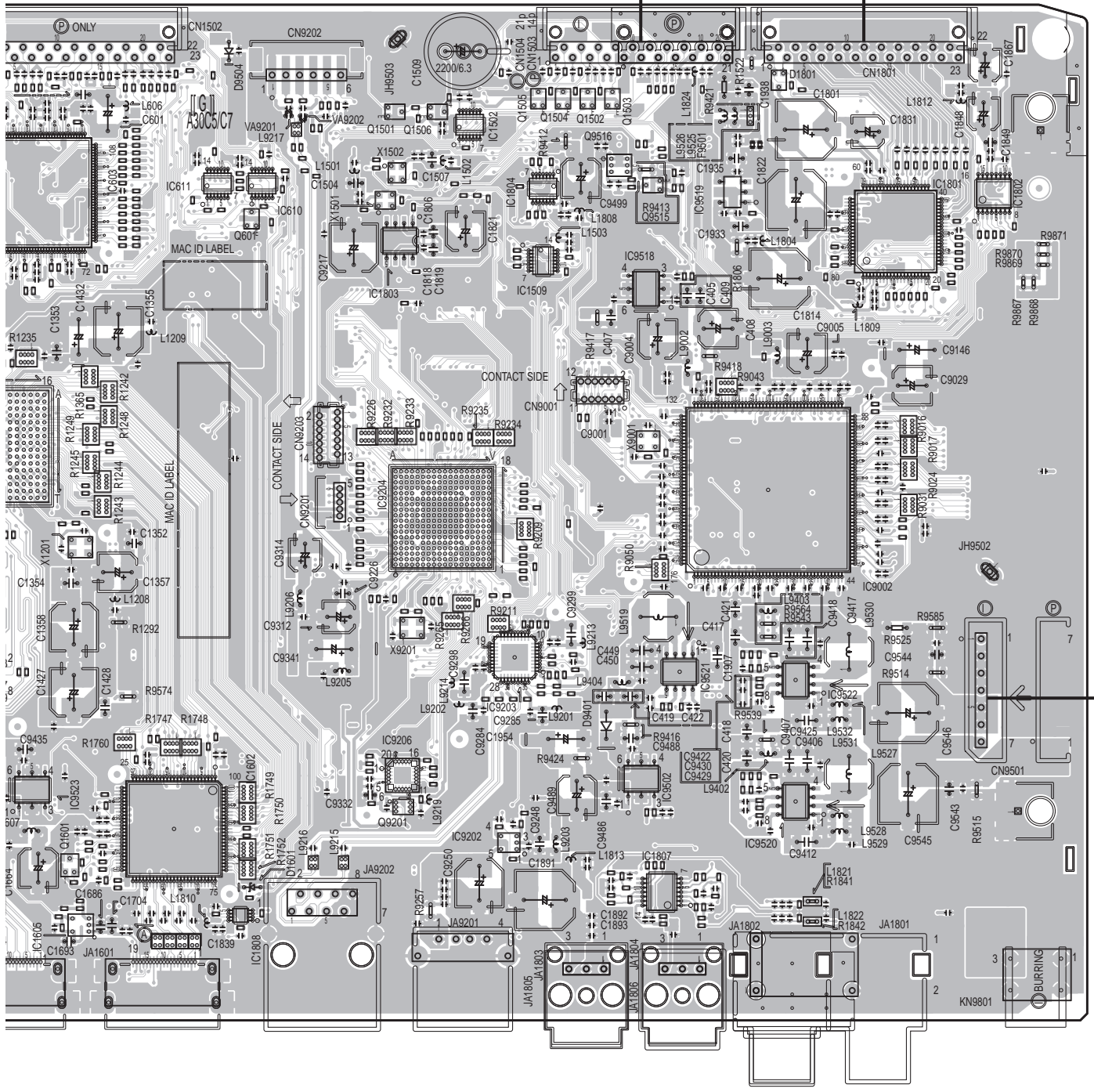

B

C

**U** CX101

D

E

IC603	IC611	IC610	Q1501	Q1506	IC1502	Q1502-Q1505	Q9516	IC9519	IC1801	IC1802
4	Q601		IC1803	IC1509	IC1804	IC9518		IC9002		
IC9523	IC1602		IC9206	IC9204	IC9203	IC9521	IC9002	IC9522		
Q1601	IC1808		Q9201	IC9202		IC1807	IC9520			

F

VSX-1127-K

**D**

SIDE B

# D D-MAIN ASSY

CN1801

CN1504

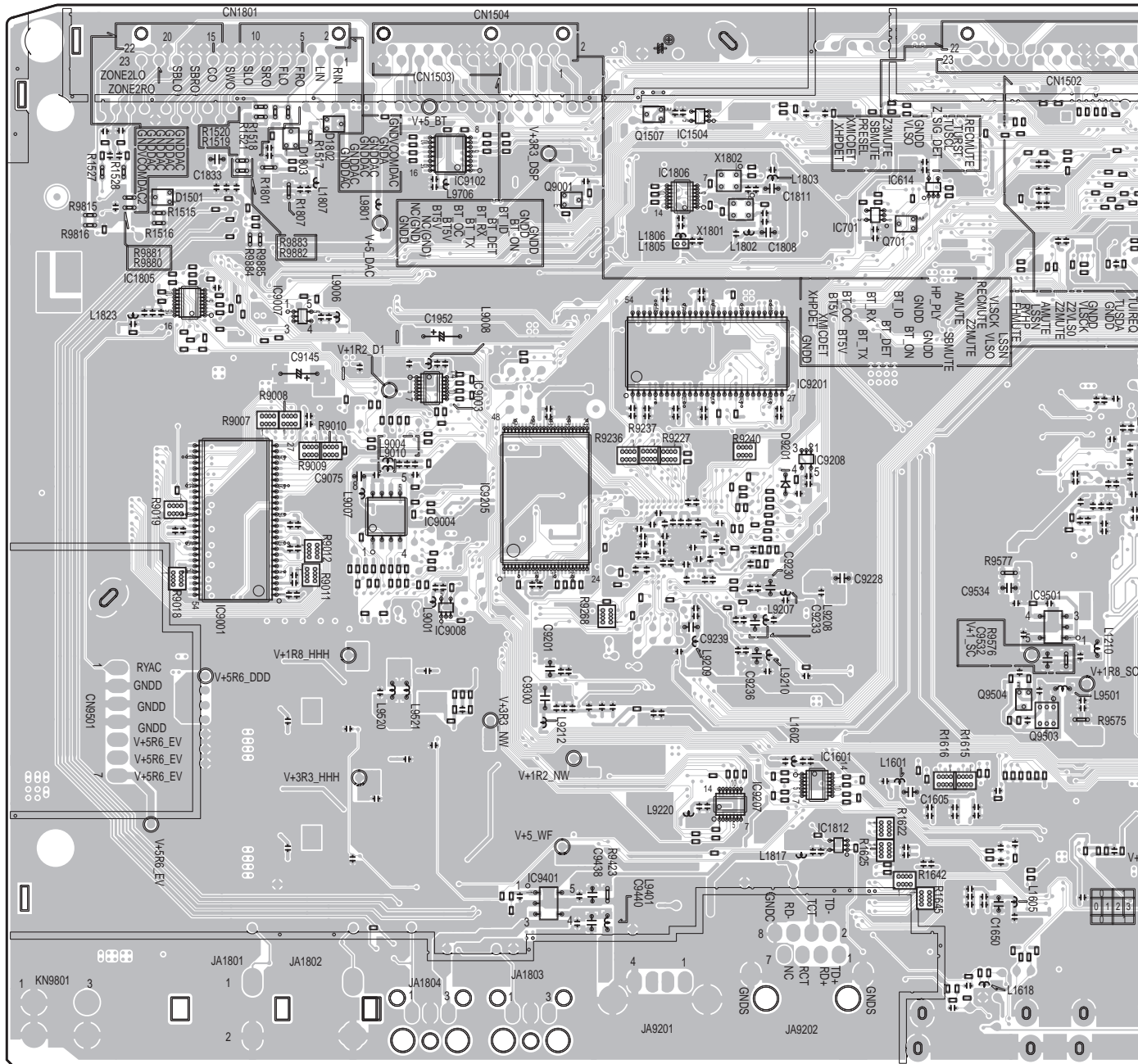

IC1805	IC9007	IC1902	Q1507	IC1504	IC701	IC614
IC9001		IC9003	Q9001	IC1806		Q701
		IC9004	IC9205	IC9201		IC9501
		IC9008	IC9401	IC9207	IC1601	Q9504
					IC1812	Q9503

D

SIDE B

A

B

C

D

E

F

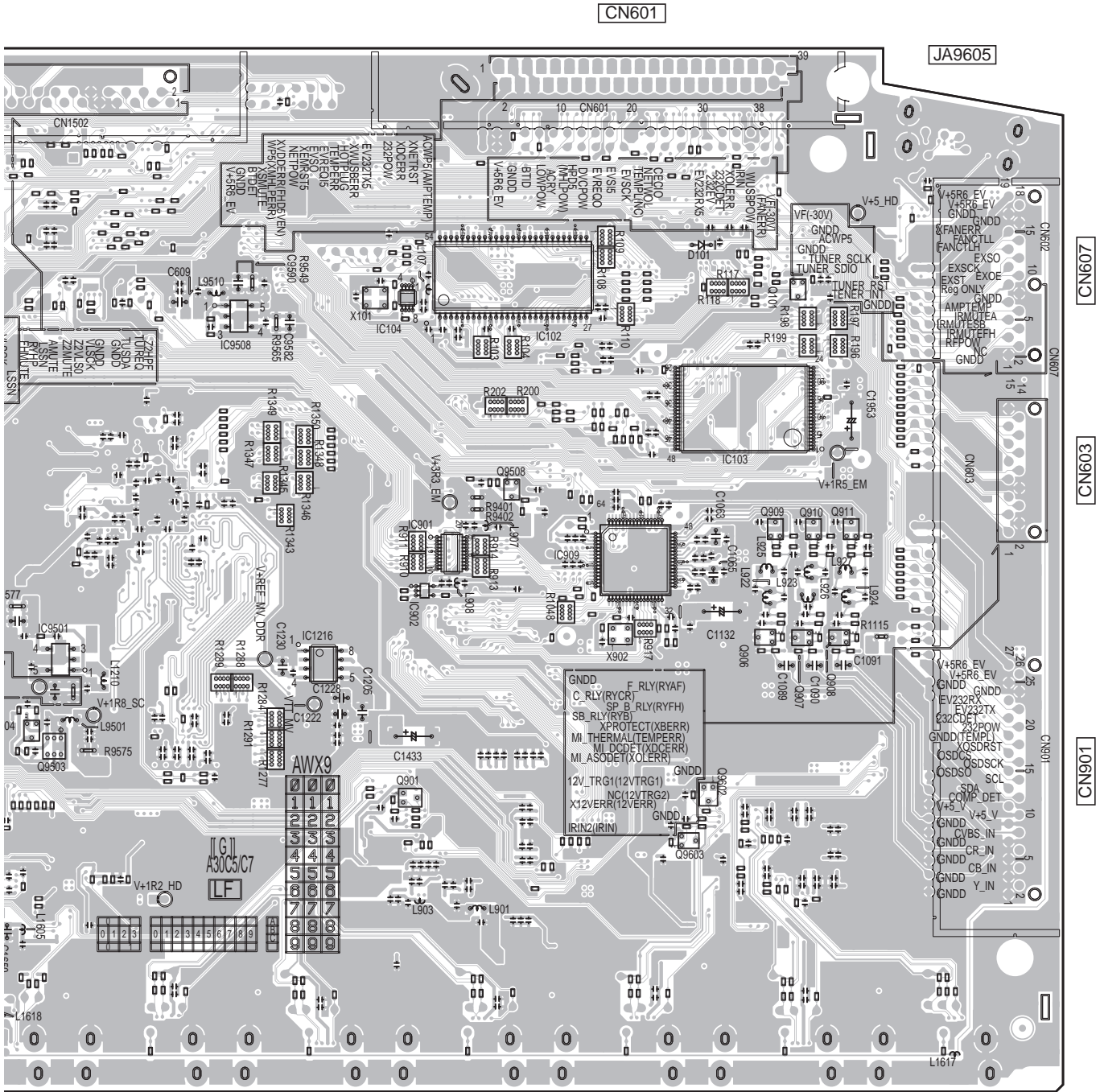

CN601

JA9605

CN607

CN603

CN901

IC9508

IC104

IC901

Q9508

Q101

Q906-Q911

IC9501  
Q9504  
Q9503

IC1216

IC902

Q901

IC909

Q9602

Q9603

IC103

VSX-1127-K

D

# 11.5 IR ASSY

**SIDE A**

**SIDE A**

**E** IR ASSY

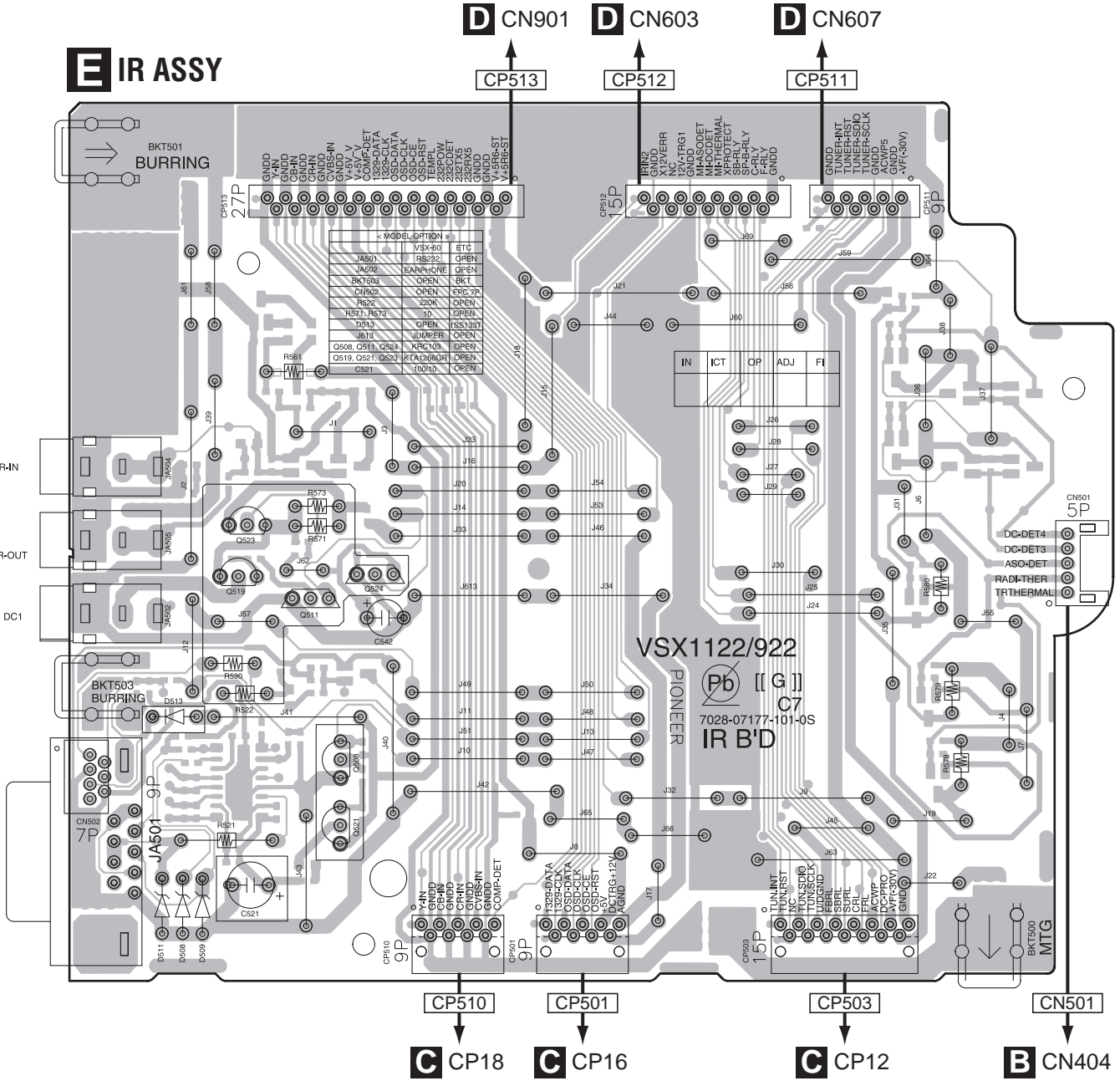

Q523  
Q519 Q511 Q524  
Q508  
Q521

VSX-1122-K



# 11.6 VIDEO ASSY

SIDE A

SIDE A

## VIDEO ASSY

VSX60 ONLY

VSX1122 USA/922 - 7P  
VSX60/1122 - 8P

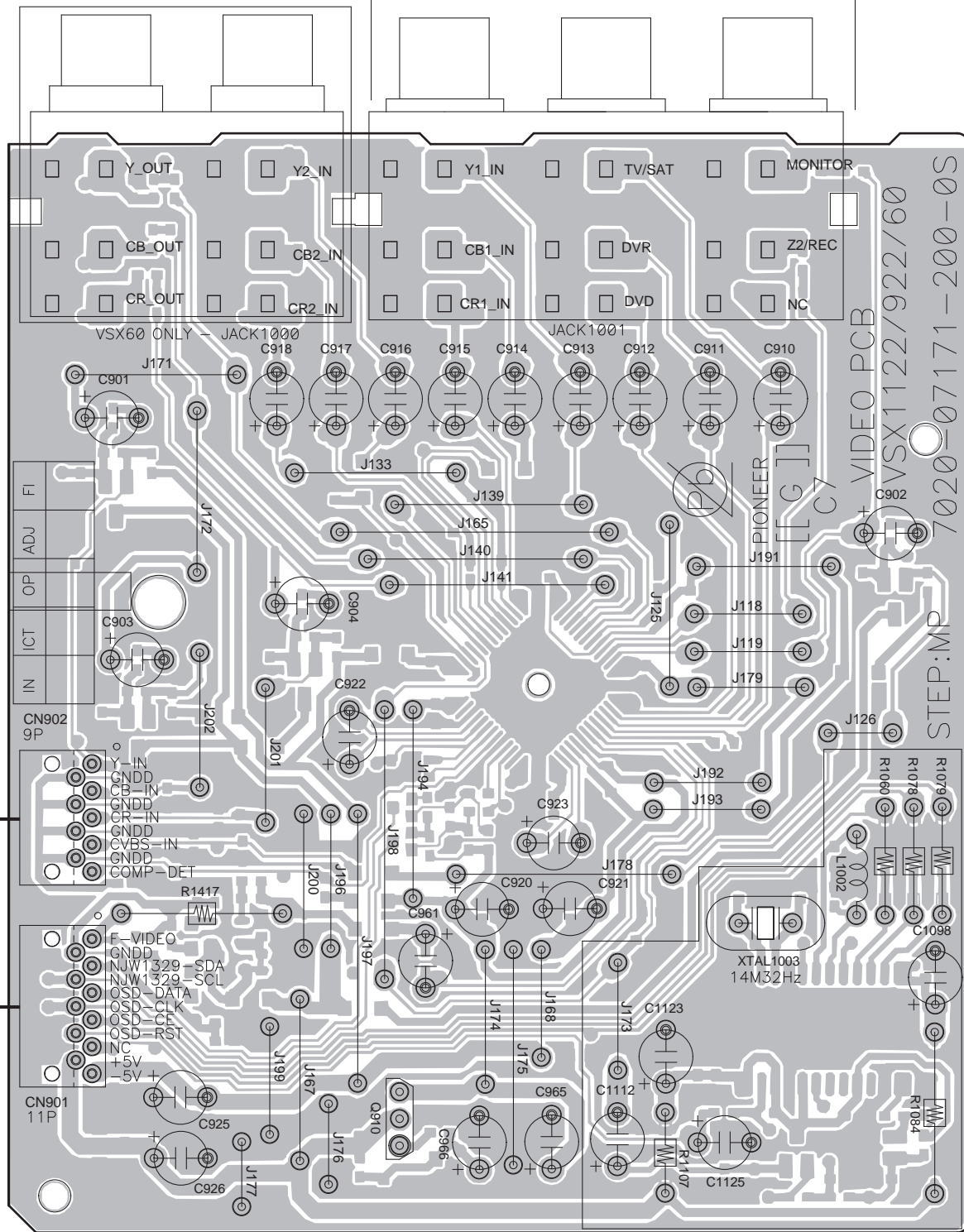

Q910









SIDE B

SIDE B

# BRG ASSY

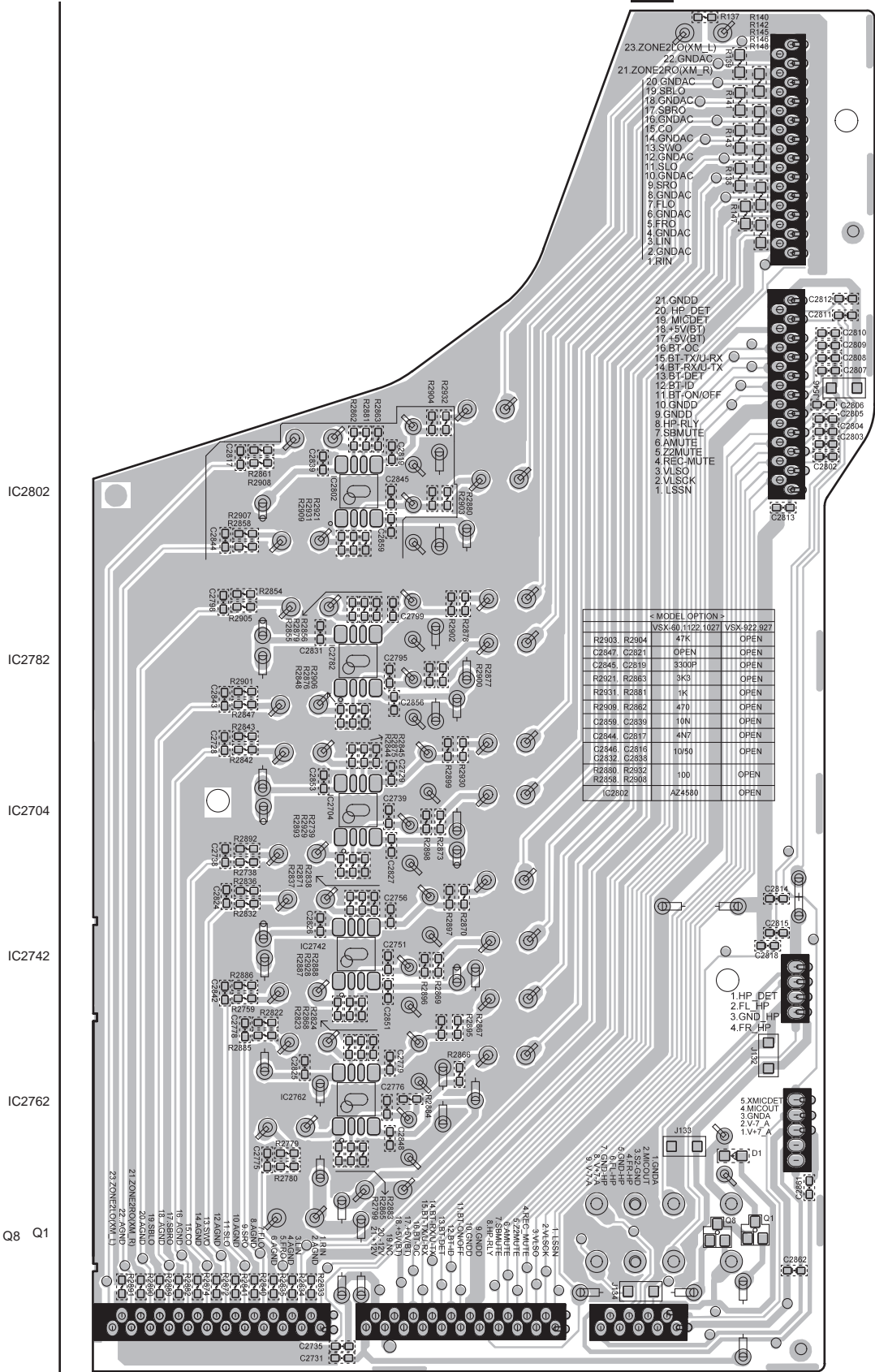

< MODEL OPTION >

VSX-60,1122,1027	VSX-922,927	
R2903, R2904	47K	OPEN
C2847, C2821	OPEN	OPEN
C2845, C2819	3300P	OPEN
R2921, R2863	3K3	OPEN
R2931, R2881	1K	OPEN
R2908, R2862	470	OPEN
C2859, C2839	10N	OPEN
C2844, C2817	4N7	OPEN
C2846, C2816	10*50	OPEN
C2832, C2838		
R2880, R2932	100	OPEN
R2858, R2908		
C2802	AZ4580	OPEN

- 1. HP DET
- 2. FL HP
- 3. GND HP
- 4. FR HP

- 5. XMICDET
- 4. MICOUT
- 3. GND A
- 1. V+7 A

- 1. LSSN
- 2. MSON
- 4. REC-MUTE
- 5. ZMUTE
- 7. SBMUTE
- 8. HP-ALV
- 9. GND0
- 11. BT-ON/OFF
- 12. BT-HP
- 13. BT-DET
- 14. BT-RX/U-RX
- 15. BT-RX/U-TX
- 16. BT-OC
- 17. +5V(BT)
- 18. +5V(BT)
- 19. MICDET
- 20. HP DET
- 21. GND0

- 1. RIN
- 2. GNDAC
- 4. GNDAC
- 5. FRO
- 6. GNDAC
- 7. FLO
- 8. GNDAC
- 9. SRO
- 10. GNDAC
- 11. SLO
- 12. GNDAC
- 13. SWO
- 14. GNDAC
- 15. CO
- 16. GNDAC
- 17. SBRO
- 18. GNDAC
- 19. SBLO
- 20. GNDAC
- 21. ZONE2RO(XM\_R)
- 22. GNDAC
- 23. ZONE2LO(XM\_L)

IC2802

IC2782

IC2704

IC2742

IC2762

Q8 Q1

CN2107

CN2203

CN2112

CN2110

CN2113

CN2111

CN2105

VSX-1127-K



# 11.8 FRONT, POWER, MIC, FVIDEO and HP ASSYS

**SIDE A**

## H FRONT ASSY

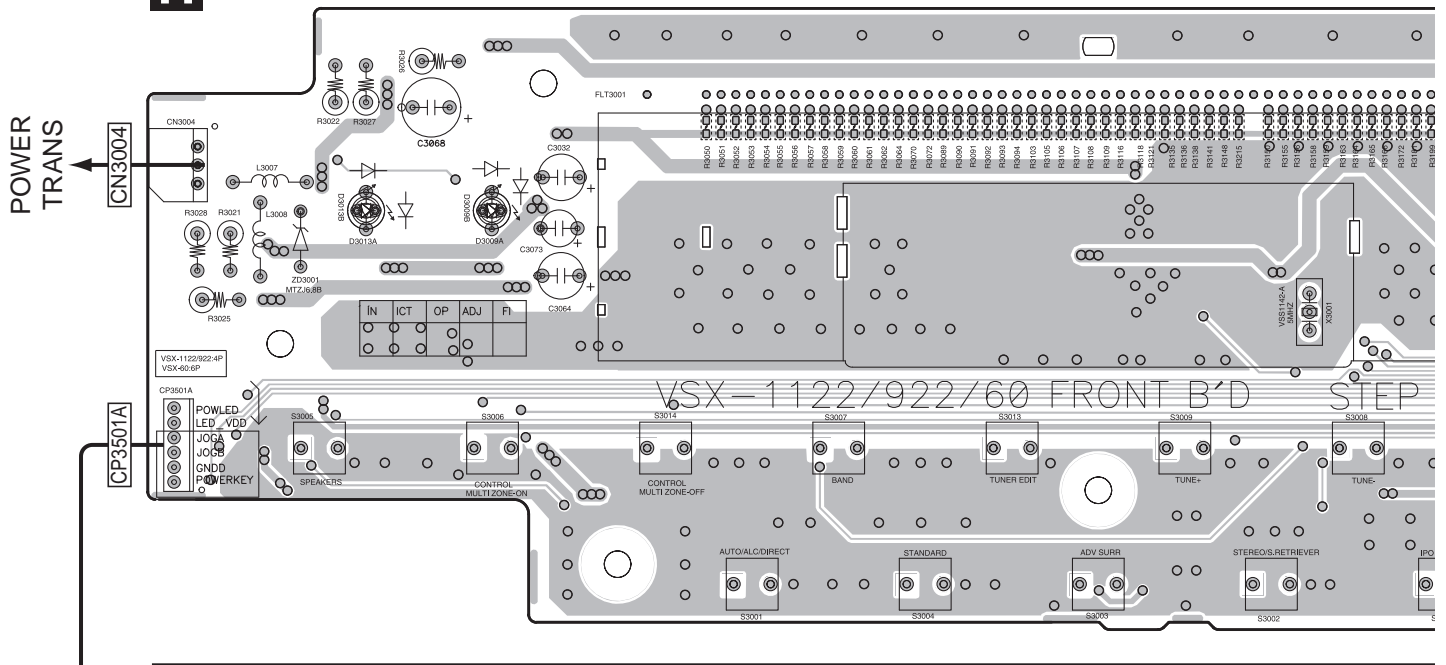

## I POWER ASSY

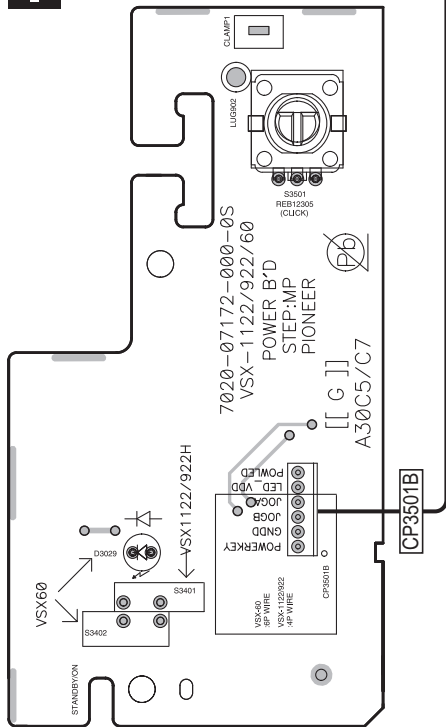

## J MIC ASSY

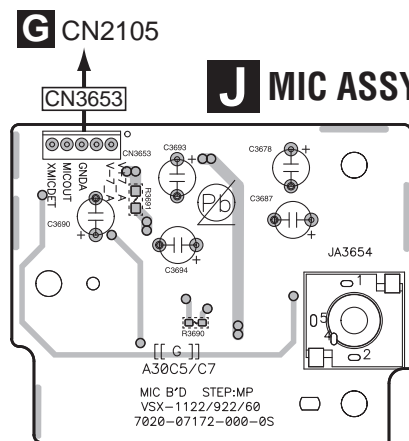

**H I J**

**SIDE A**

**D** CN601

CP3001

CP3002

**S** CN8202

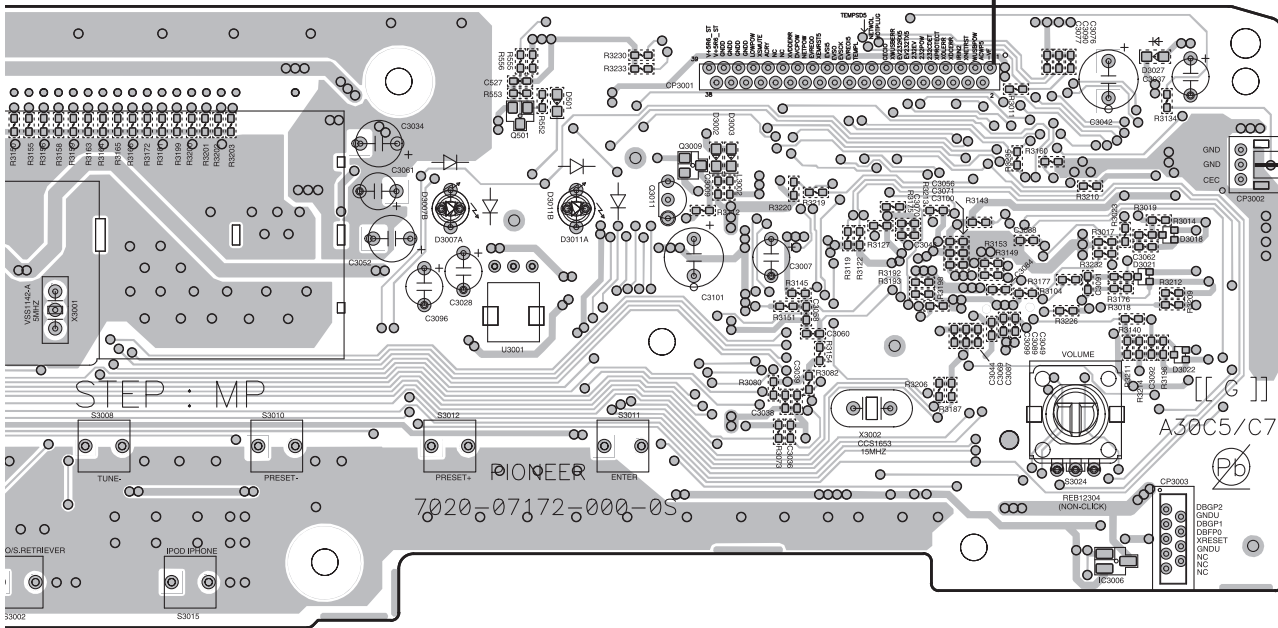

STEP : MP

PIONEER  
7020-07172-000-05

A30C5/C7

Q501

Q3009  
Q3011

IC3006

**K** FVIDEO ASSY

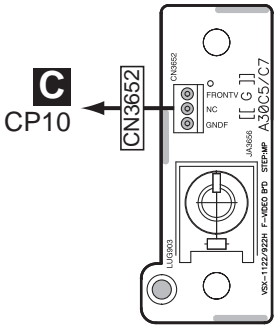

**L** HP ASSY

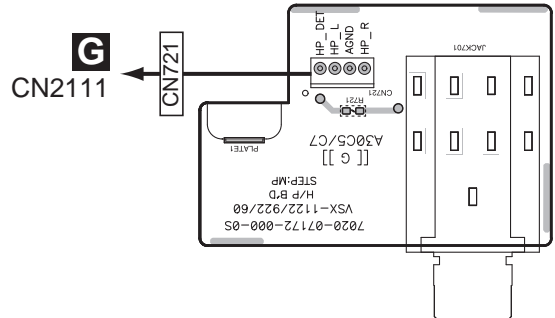

**H K L**

VSX-1127-K

**SIDE B**

A

B

C

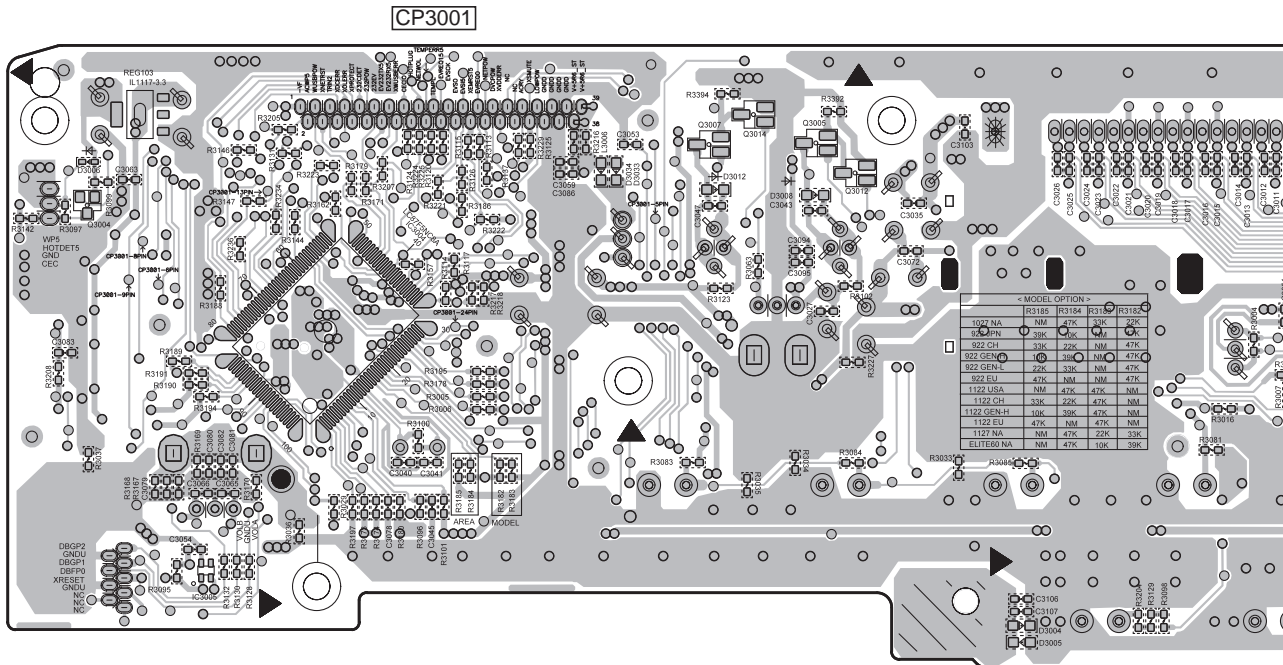

Q3004 REG103

IC3005

IC3004

Q3007 Q3014 Q3005 Q3012

D

E

F

**L HP ASSY**

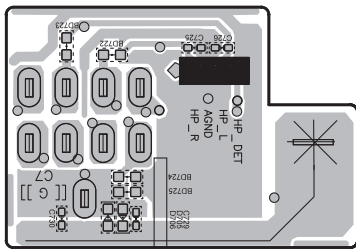

CN721

**K FVIDEO ASSY**

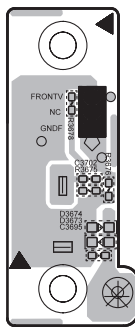

CN3652

SIDE B

# H FRONT ASSY

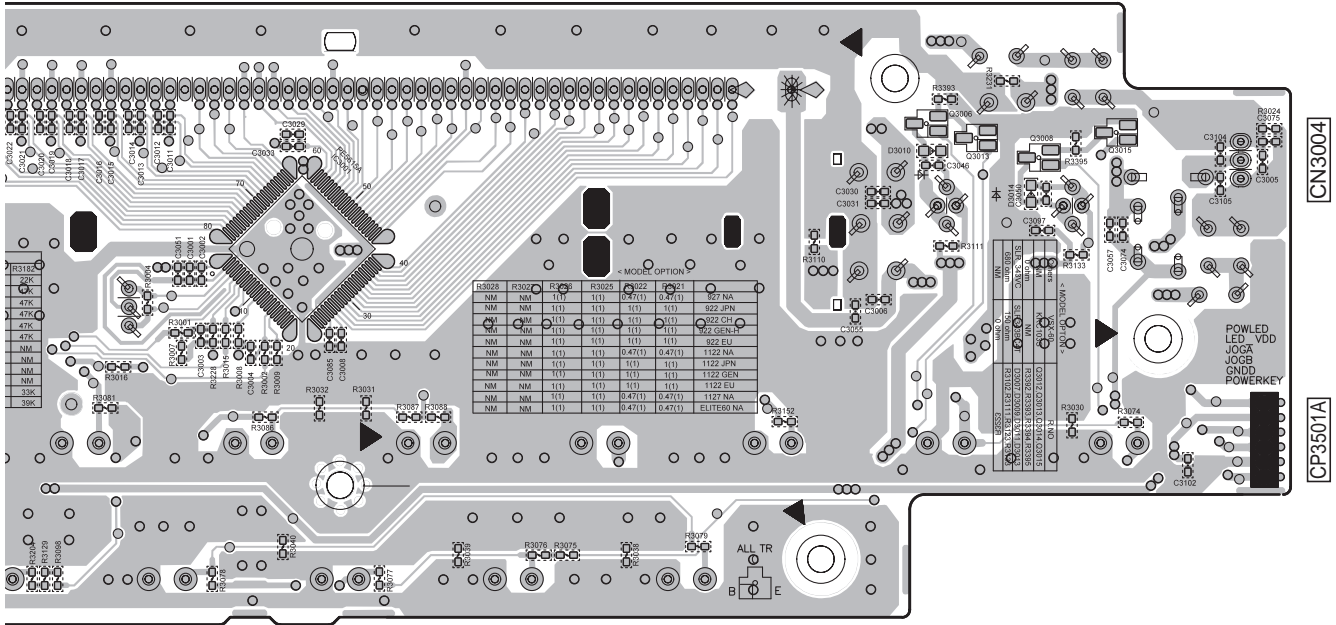

IC3001

Q3006 Q3013 Q3008 Q3015

# J MIC ASSY

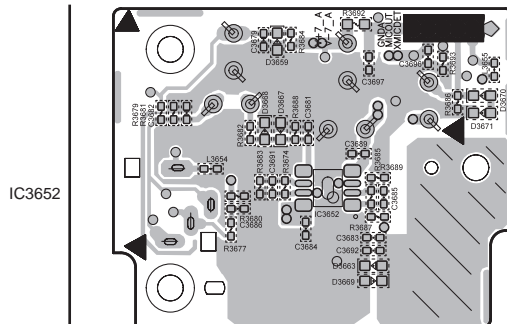

IC3652

CN3653

# I POWER ASSY

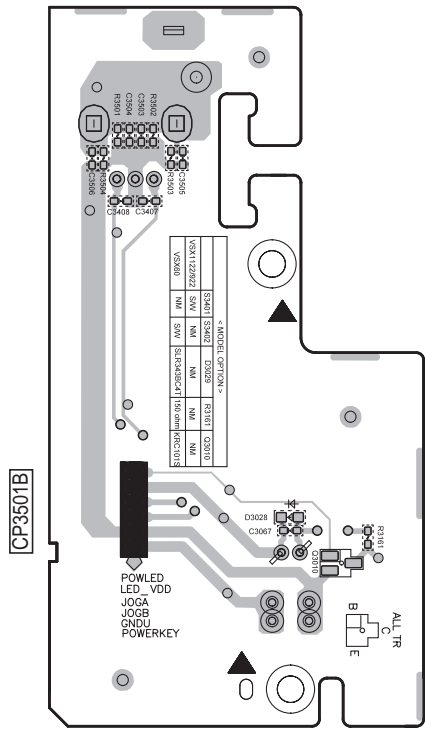

Q3010

# 11.9 G-L, G-R, WG-A and WG-B ASSYS

**SIDE A**

**SIDE B**

A

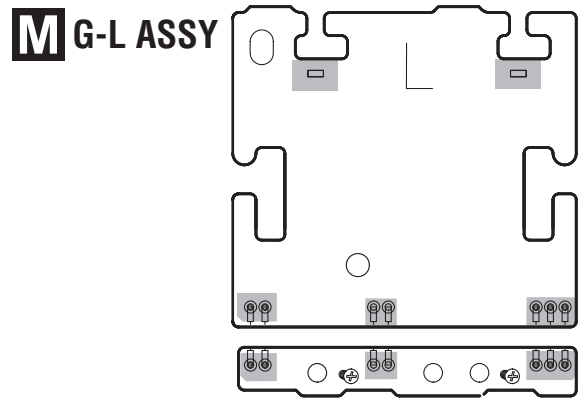
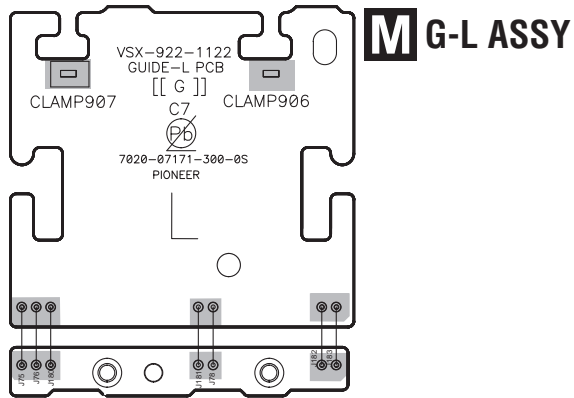

B

C

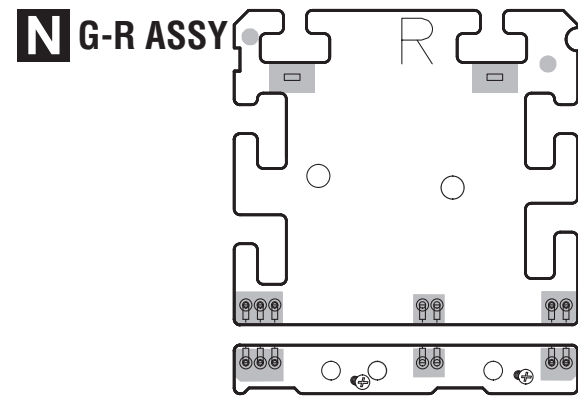
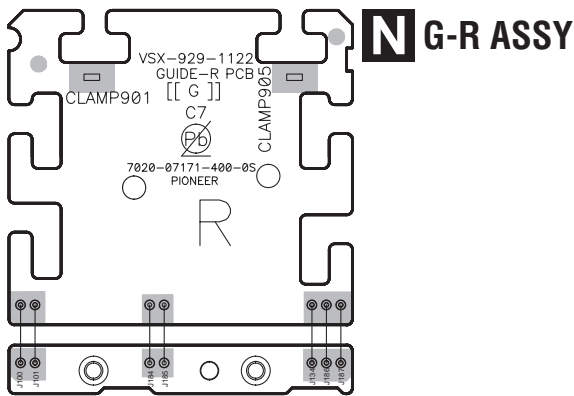

**O WG-A ASSY**

**O WG-A ASSY**

D

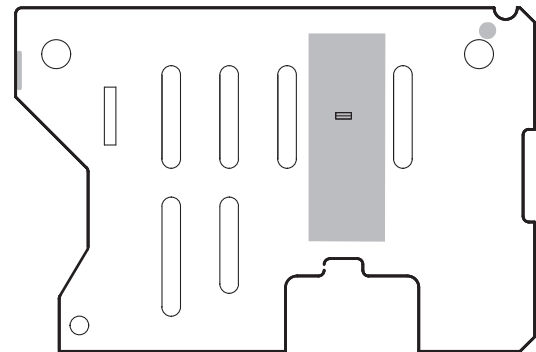
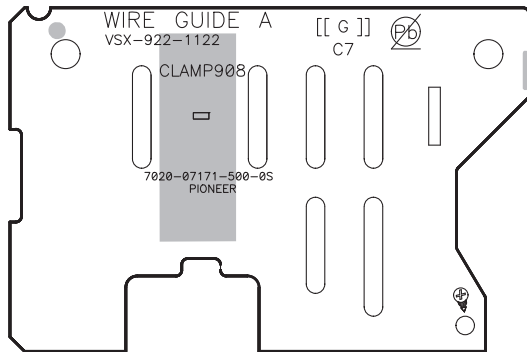

E

**P WG-B ASSY**

**P WG-B ASSY**

F

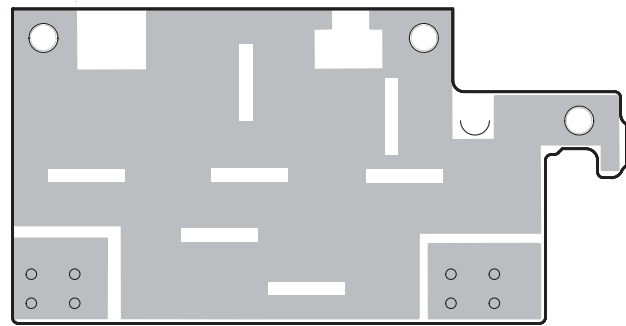
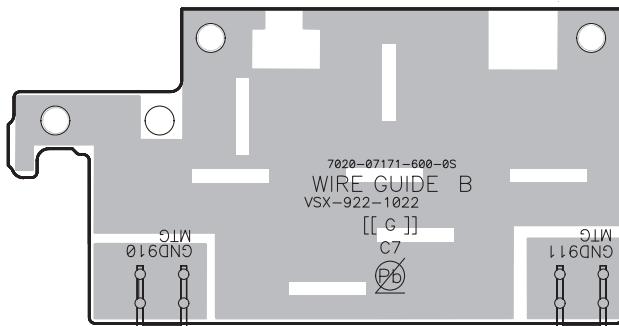

**M N O P**



# 11.10 CCG and BTCNT ASSYS

**SIDE A**

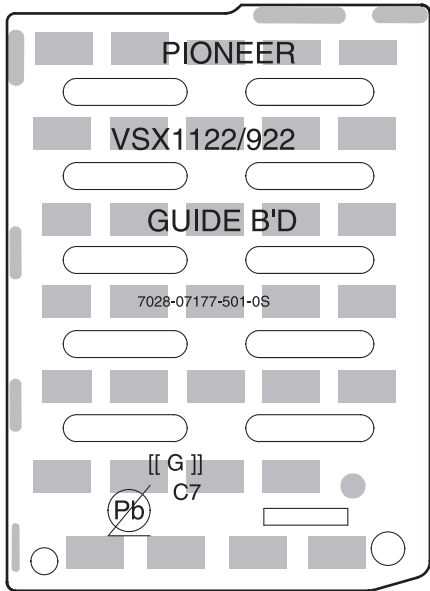

**Q CCG ASSY**

**SIDE A**

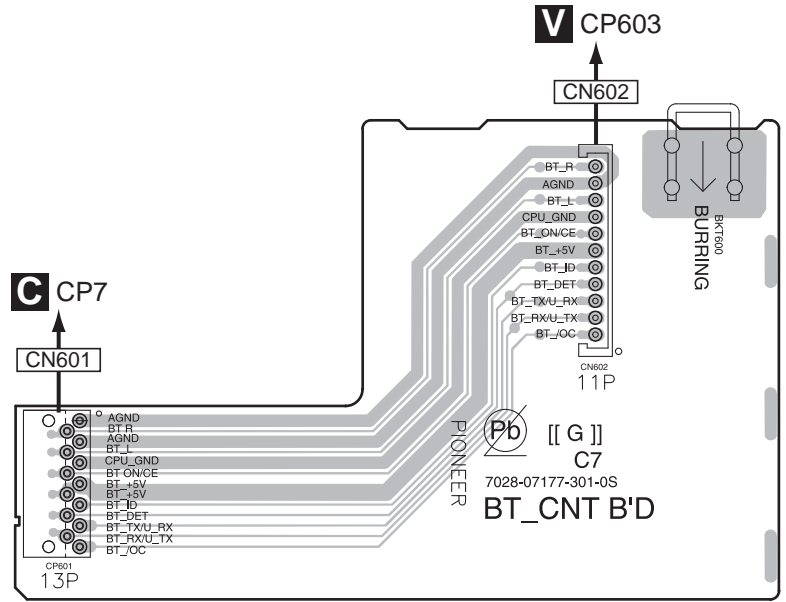

**R BTCNT ASSY**

**SIDE B**

**Q CCG ASSY**

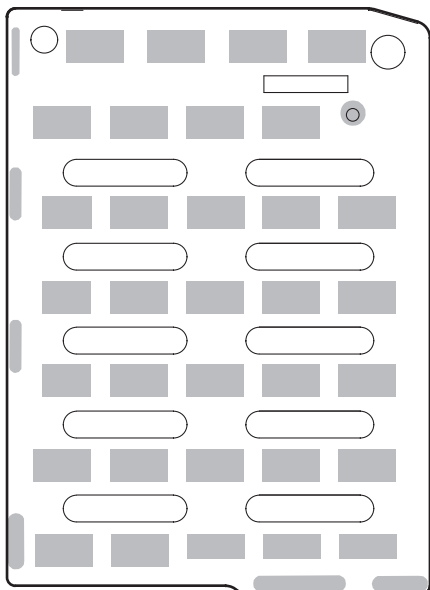

**SIDE B**

**R BTCNT ASSY**

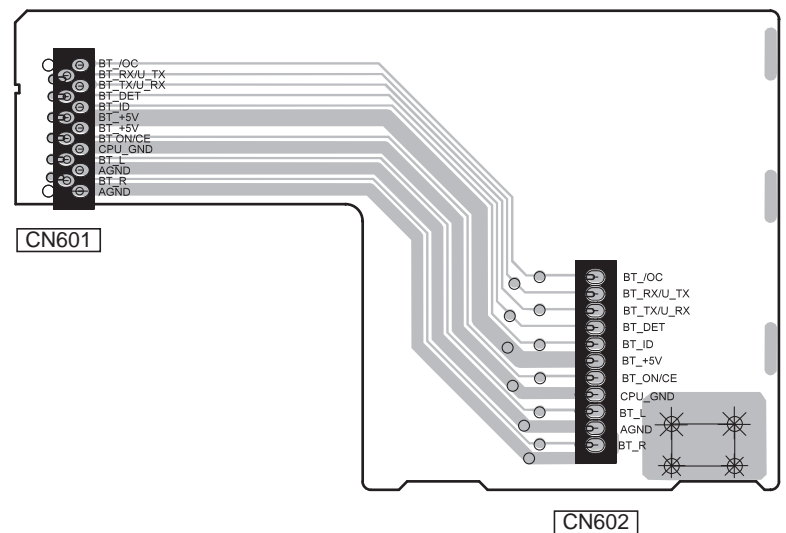

# 11.11 FHDMI and F-USB ASSYS

**SIDE A**

**SIDE A**

**S** FHDMI ASSY

**T** F-USB ASSY

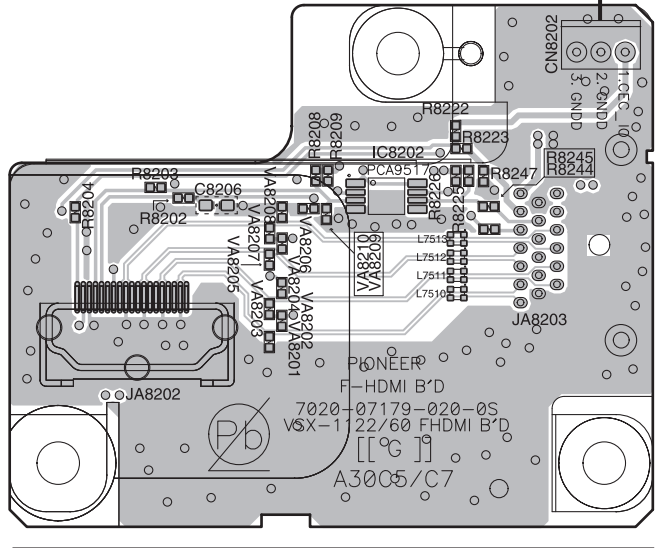

**SIDE B**

**SIDE B**

**S** FHDMI ASSY

**T** F-USB ASSY

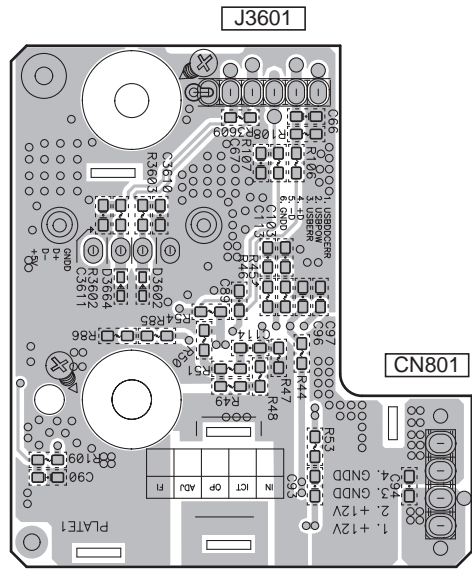
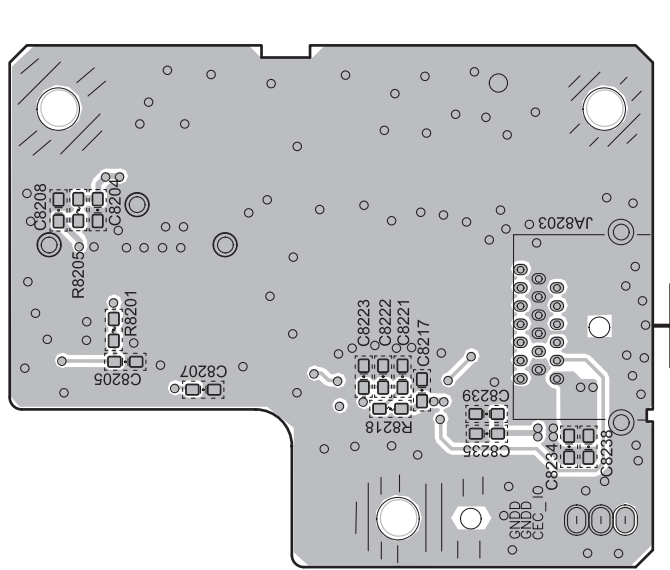

**S** **T**

# 11.12 BT ASSY

**SIDE A**

**SIDE A**

## V BT ASSY

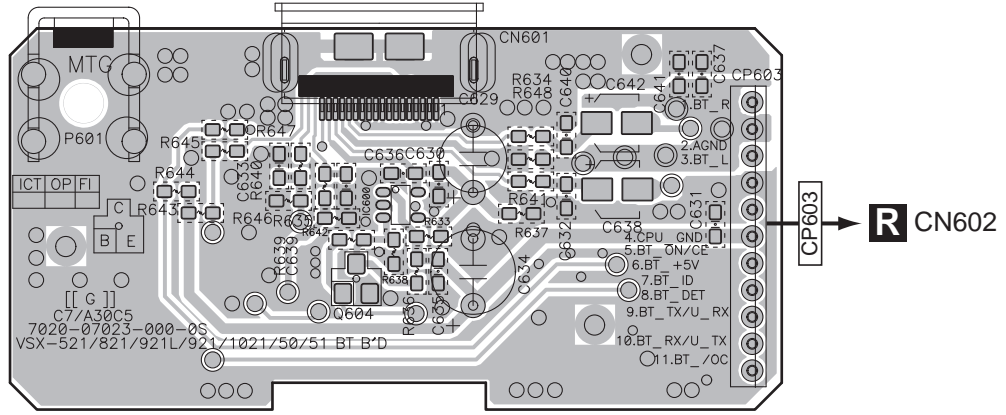

Q604 IC600

**SIDE B**

**SIDE B**

## V BT ASSY

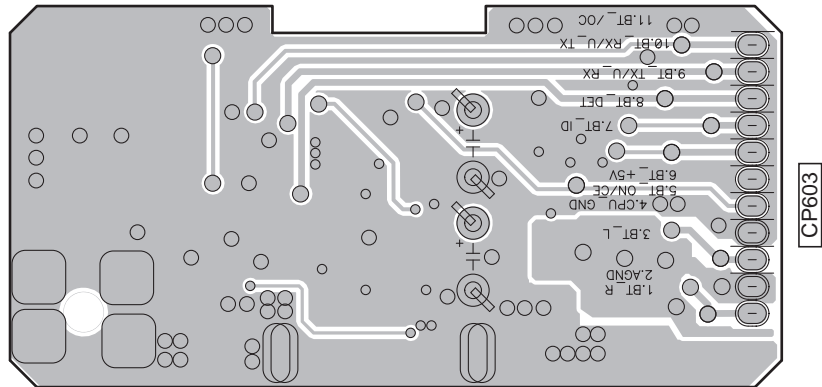

# 11.13 SMPS ASSY

SIDE A

SIDE A

## SMPS ASSY

CAUTION : REPLACE WITH SAME TYPE FUSE(S).  
ATTENTION : UTILISER UN FUSIBLE DE RECHANGE

DE MÊME TYPE.

F101  
T6.3AL/250V

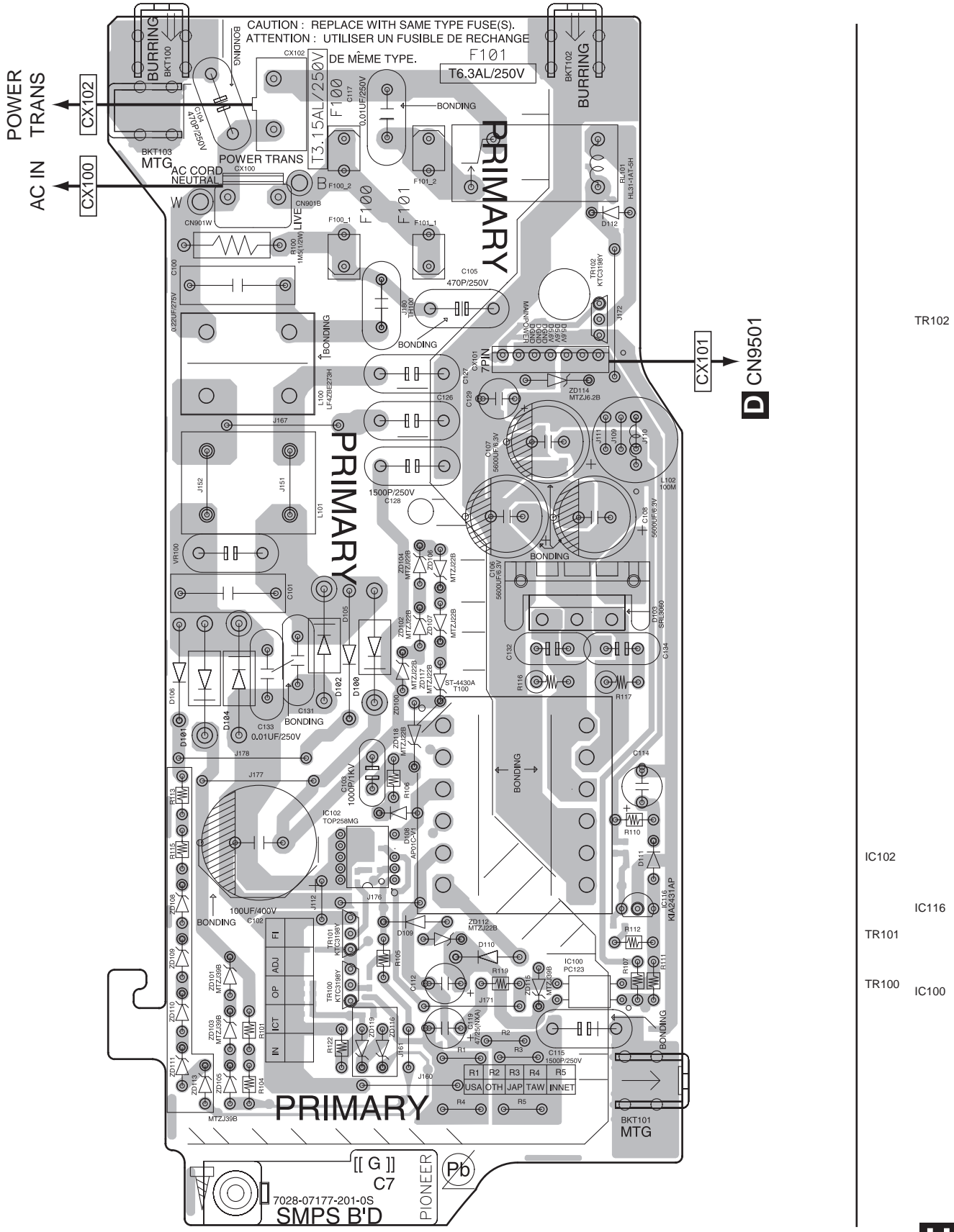

CX101  
D CN9501

TR102

IC102

IC116

TR101

TR100

IC100



SIDE B

SIDE B

# U SMPS ASSY

A

B

C

D

E

F

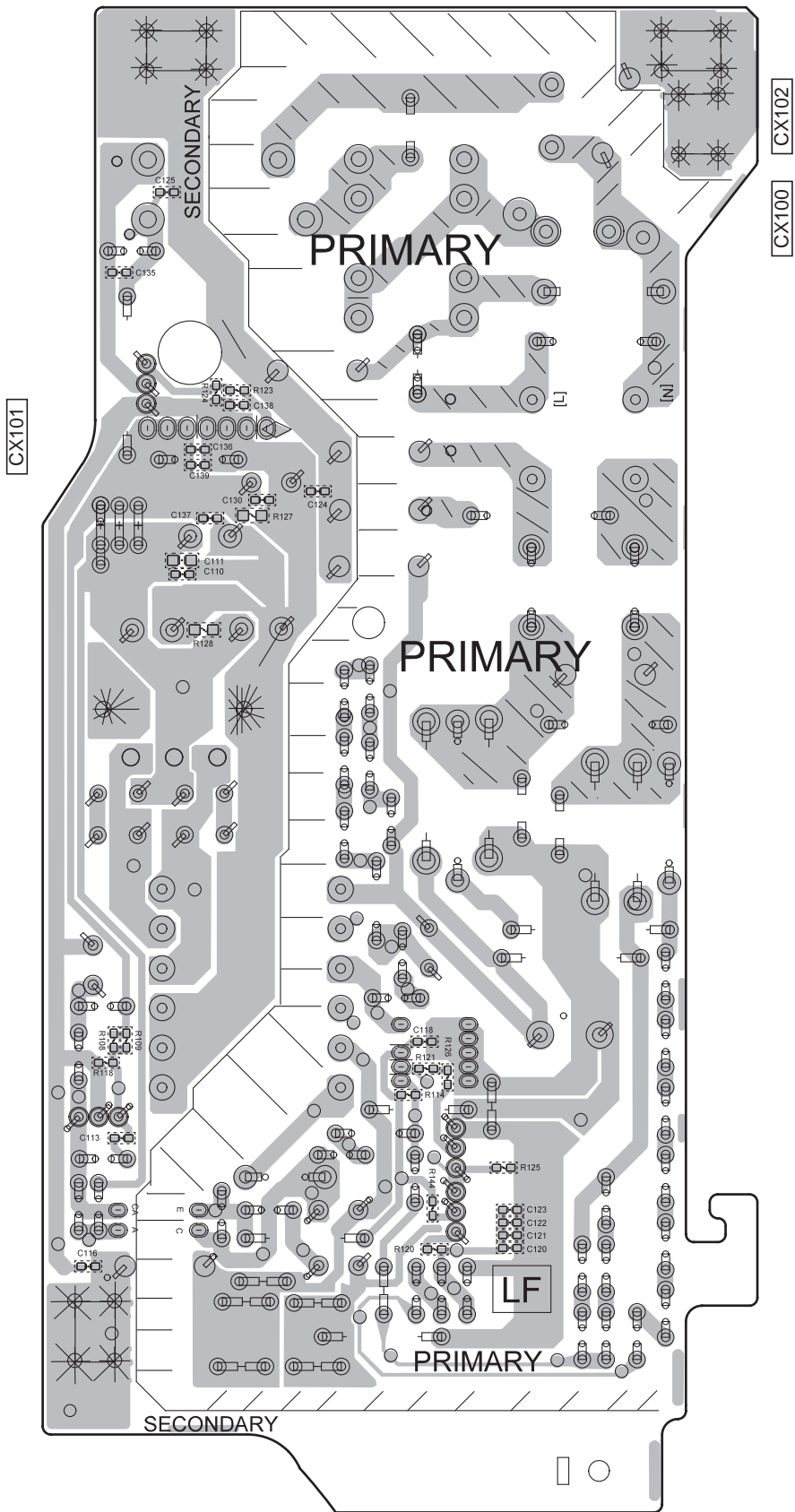

# 12. PCB PARTS LIST

NOTES: ● Parts marked by “NSP” are generally unavailable because they are not in our Master Spare Parts List.

● The  $\Delta$  mark found on some component parts indicates the importance of the safety factor of the part. Therefore, when replacing, be sure to use parts of identical designation.

● When ordering resistors, first convert resistance values into code form as shown in the following examples.

Ex.1 When there are 2 effective digits (any digit apart from 0), such as 560 ohm and 47 k ohm (tolerance is shown by J = 5%, and K = 10%).

560 $\Omega$	→	56 × 10 <sup>1</sup>	→	561	.....	RD1/4PU	5	6	7	J
47 k $\Omega$	→	47 × 10 <sup>3</sup>	→	473	.....	RD1/4PU	4	7	3	J
0.5 $\Omega$	→	R50	.....			RN2H	R	5	0	K
1 $\Omega$	→	1R0	.....			RSIP	T	R	0	K

Ex.2 When there are 3 effective digits (such as in high precision metal film resistors).

5.62 k $\Omega$	→	562 × 10 <sup>1</sup>	→	5621	.....	RN1/4PC	5	6	2	7	F
-----------------	---	-----------------------	---	------	-------	---------	---	---	---	---	---

● Meaning of the figures and others in the parentheses in the parts list.

Example) IC 301 is on the point (face A, 91 of x-axis, and 111 of y-axis) of the corresponding PC board.

IC 301 (A, 91, 111) IC NJM2068V

● SCHEMATIC DIAGRAM and PCB CONNECTION DIAGRAM → ● PCB PARTS LIST

BKT	→	none	BEAD	→	L	RLY	→	RY	SW	→	S
CLAMP	→	none	F	→	FU	RMC	→	U	VEC	→	S9***
W	→	none	FLT	→	V	RES	→	X	GND	→	KN
LUG	→	none	JACK	→	JA	XTAL	→	X9***			
P	→	none	JACK	→	JA9***	BD	→	L7***			
PACK	→	9***	JK	→	JA	LED	→	D8***			
CP	→	CN	PT	→	T	Z	→	D9***			
CP	→	CN9***	REG	→	IC	ZD	→	D9***			
CX	→	CN9***	REG	→	IC9***	DZ	→	D9***			
FPC	→	CN9***									

## LIST OF ASSEMBLIES

Mark	Symbol and Description	VSX-1127-K/CUXE	VSX-1122-K/CUXESM	VSX-60/UXECB	VSX-1027-K/CUXE
NSP	1..PCB TTL ASSY MAIN	7025HK1110020-IL	7025HK1110010-IL	7025HK1110030-IL	7025HK1109010-IL
	2..MAIN ASSY	7028071711010-IL	7028071711010-IL	7028071711040-IL	7028071711010-IL
	2..VIDEO ASSY	7028071712020-IL	7028071712070-IL	7028071712040-IL	7028071712070-IL
	2..G-L ASSY	7028071713040-IL	7028071713040-IL	7028071713040-IL	7028071713040-IL
	2..G-R ASSY	7028071714040-IL	7028071714040-IL	7028071714040-IL	7028071714040-IL
	2..WG-A ASSY	7028071715040-IL	7028071715040-IL	7028071715040-IL	7028071715040-IL
	2..WG-B ASSY	7028071716040-IL	7028071716040-IL	7028071716040-IL	7028071716040-IL
NSP	1..PCB TTL ASSY DMAIN	7025HK1110021-IL	7025HK1110011-IL	7025HK1110031-IL	7025HK1109011-IL
	2..D-MAIN ASSY	7028071752020-IL	7028071752040-IL	7028071752040-IL	7028071752070-IL
NSP	1..PCB TTL ASSY FRONT	7025HK1110022-IL	7025HK1110012-IL	7025HK1110032-IL	7025HK1109012-IL
	2..FRONT ASSY	7028071721050-IL	7028071721010-IL	7028071721040-IL	7028071721060-IL
	2..POWER ASSY	7028071722010-IL	7028071722010-IL	7028071722040-IL	7028071722010-IL
	2..MIC ASSY	7028071723040-IL	7028071723040-IL	7028071723040-IL	7028071723040-IL
	2..FVIDEO ASSY	7028071724040-IL	7028071724040-IL	7028071724040-IL	7028071724040-IL
	2..HP ASSY	7028071725040-IL	7028071725040-IL	7028071725040-IL	7028071725040-IL
NSP	1..PCB TTL ASSY AUDIO	7025HK1110023-IL	7025HK1110013-IL	7025HK1110033-IL	7025HK1109013-IL
	2..AUDIO ASSY	7028071741050-IL	7028071741010-IL	7028071741040-IL	7028071741010-IL
NSP	1..PCB TTL ASSY IR	7025HK1110024-IL	7025HK1110014-IL	7025HK1110034-IL	7025HK1109014-IL
	2..IR ASSY	7028071771010-IL	7028071771010-IL	7028071771040-IL	7028071771010-IL
	2..SMPS ASSY	7028071772010-IL	7028071772010-IL	7028071772040-IL	7028071772010-IL
	2..BRG ASSY	7028071773040-IL	7028071773040-IL	7028071773040-IL	7028071773070-IL
	2..BTCNT ASSY	7028071774040-IL	7028071774040-IL	7028071774040-IL	7028071774040-IL
	2..CCG ASSY	7028071775040-IL	7028071775040-IL	7028071775040-IL	7028071775040-IL
NSP	1..PCB TTL ASSY AMP7	7025HK1110025-IL	7025HK1110015-IL	7025HK1110035-IL	7025HK1109015-IL
	2..AMP7 ASSY	7028071731040-IL	7028071731040-IL	7028071731040-IL	7028071731040-IL
NSP	1..PCB TTL ASSY FHDMI	7025HK1110026-IL	7025HK1110016-IL	7025HK1110036-IL	Not used
	2..FHDMI ASSY	7028071791040-IL	7028071791040-IL	7028071791040-IL	Not used
NSP	1..PCB TTL ASSY F-USB	7025HK1110027-IL	7025HK1110017-IL	7025HK1110037-IL	7025HK1109017-IL
	2..F-USB ASSY	7028071761020-IL	7028071761020-IL	7028071761020-IL	7028071761020-IL
NSP	1..PCB TTL ASSY BT	7025HK1110028-IL	7025HK1110018-IL	7025HK1110038-IL	7025HK1109018-IL
	2..BT ASSY	7028070231010-IL	7028070231010-IL	7028070231010-IL	7028070231010-IL

## CONTRAST OF PCB ASSEMBLIES

### A AUDIO ASSY

7028071741050-IL, 7028071741040-IL and 7028071741010-IL are constructed the same except for the following:

Mark	Symbol and Description	7028071741050-IL	7028071741040-IL	7028071741010-IL
	IC2503 Electric VOL IC (2 ch)	BD3812F	BD3812F	Not used
	JA2102 Ter, RCA 2pin	G601206A0005Y-IL	G602421E0002Y-IL	G601206A0005Y-IL

### C MAIN ASSY

7028071711010-IL and 7028071711040-IL are constructed the same except for the following:

Mark	Symbol and Description	7028071711010-IL	7028071711040-IL
△	IC5 Liner Regulator IC	Not used	J126781200040-IL

### D D-MAIN ASSY

7028071752020-IL, 7028071752040-IL and 7028071752070-IL are constructed the same except for the following:

Mark	Symbol and Description	7028071752020-IL	7028071752040-IL	7028071752070-IL
	IC1802 D/A Converter IC	AK4388ET	AK4388ET	Not used
	IC1803 Zero Delay Buffer	IDT6V60008DCG	Not used	Not used
	IC9207 IC	TC74VHC08FK	TC74VHC08FK	Not used
	JA1801 Pin Jack (2P)	G601206A0700Y-IL	G601206A0700Y-IL	Not used
	JA1802 Ter, RCA 1pin	Not used	Not used	G60011703000Y-IL
	JA1804 Module	E100216500010-IL	E100216500010-IL	Not used

### E IR ASSY

7028071771010-IL and 7028071771040-IL are constructed the same except for the following:

Mark	Symbol and Description	7028071771010-IL	7028071771040-IL
	IC501 IC, Logic-interface	Not used	J046323200020-IL
	Q508, Q511, Q524 Semi, BRT/PNP RC	Not used	J502010300210-IL
	Q519, Q521, Q523 Semi, TR/GE PNP 2SA	Not used	J5001266G0050-IL
	JA501 CN. Wafer Interface	Not used	L103090090040-IL
	JA502 Jack, D3.5	Not used	G401PJ3080100-IL
	503 Bracket	4010210196100-IL	Not used

### F VIDEO ASSY

7028071712020-IL, 7028071712070-IL and 7028071712040-IL are constructed the same except for the following:

Mark	Symbol and Description	7028071712020-IL	7028071712070-IL	7028071712040-IL
	IC1007 Character Generator	PDC162A	Not used	Not used
	X1003 Crystal	E80014R318080-IL	Not used	Not used
	JA1000 Ter, RCA 6pin	Not used	Not used	G603610A0032Y-IL
	JA1001 Ter, RCA 9pin	G607902AA133Y-IL	G607902AA133Y-IL	G607902AA151Y-IL
	JA1001 Ter, RCA 9pin	G607902AA151Y-IL	Not used	Not used

### G BRG ASSY

7028071773040-IL and 7028071773070-IL are constructed the same except for the following:

Mark	Symbol and Description	7028071773040-IL	7028071773070-IL
	IC2802 IC, Linear OP	J121458001010-IL	Not used

### H FRONT ASSY

7028071721050-IL, 7028071721010-IL, 7028071721040-IL and 7028071721060-IL are different in part number, they consist of the same components.

## I POWER ASSY

7028071722010-IL and 7028071722040-IL are constructed the same except for the following:

Mark	Symbol and Description	7028071722010-IL	7028071722040-IL
	D3029 LED, Round	Not used	K500036001120-IL

## U SMPS ASSY

7028071772010-IL and 7028071772040-IL are constructed the same except for the following:

Mark	Symbol and Description	7028071772010-IL	7028071772040-IL
	CN9100 Connector	L108396030010-IL	Not used

Mark	No.	Description	Part No.	Mark	No.	Description	Part No.
------	-----	-------------	----------	------	-----	-------------	----------

### PARTS LIST (VSX-1127-K)

#### A AUDIO ASSY

##### SEMICONDUCTORS

IC 2501	BD3473KS2
IC 2502	J040406600010-IL
IC 2503	BD3812F
IC 2702,2704,2706	J121458001010-IL
Q 2401	J5023209Y0010-IL
Q 2402	J5001281Y0010-IL

##### MISCELLANEOUS

JA 2101 TER,RCA 6PIN	G603610A0001Y-IL
JA 2102 TER,RCA 2PIN	G601206A0005Y-IL
JA 2103 TER,RCA 4PIN	G602421E0046Y-IL

##### RESISTORS

R 374,377	C060033065050-IL
-----------	------------------

#### B AMP7 ASSY

##### SEMICONDUCTORS

Q 401,413,425,437	J5001024Y0050-IL
Q 407,408,417,419	J5000992F0050-IL
Q 412,424,436,448	J5023206Y0050-IL
Q 420,431,432,443	J5000992F0050-IL
Q 444,455,456,467	J5000992F0050-IL
Q 449,461,473	J5001024Y0050-IL
Q 460,472,484	J5023206Y0050-IL
Q 468,479,480	J5000992F0050-IL
D 9401,9404,9407,9410	K06005R134520-IL
D 9402,9403,9405,9406	K06004R344520-IL
D 9408,9409,9411,9412	K06004R344520-IL
D 9413,9416,9419	K06005R134520-IL
D 9414,9415,9418,9418	K06004R344520-IL
D 9420,9421	K06004R344520-IL

##### MISCELLANEOUS

VR 401-407 VR,SEMI CARBON MOLD	C541102315000-IL
400,401 BRACKET	4010210196100-IL

##### RESISTORS

⚠ R 406,450,494,537	F320184710050-IL
⚠ R 424,425,430,431	N113136647820-IL
R 443,487,530,573	C060047065060-IL
⚠ R 467,468,474,475	N113136647820-IL
R 493	C060033065050-IL
⚠ R 511,512,517,518	N113136647820-IL
⚠ R 554,555,561,562	N113136647820-IL
⚠ R 580,623,666	F320184710050-IL
⚠ R 597,598,603,604	N113136647820-IL
R 616,659,702	C060047065060-IL
⚠ R 640,641,646,647	N113136647820-IL
⚠ R 683,684,689,690	N113136647820-IL

##### CAPACITORS

C 419	D04010108C240-IL
-------	------------------

#### C MAIN ASSY

##### SEMICONDUCTORS

⚠ IC 1	J126781200040-IL
⚠ IC 2	J126791200060-IL
⚠ IC 3	J126780500110-IL
⚠ IC 4	J126790500070-IL
Q 14,15	J5023198Y0000-IL
Q 16	J5000992F0050-IL
Q 17	J5000916Y0050-IL
⚠ D 7	K047100600220-IL
⚠ D 10-13,23	K000400700220-IL
⚠ D 4912	K047604000020-IL
D 9002	K06005R144520-IL
D 9024,9025	K06012R044520-IL

##### MISCELLANEOUS

JA 1,2 TER,BOARD SCREW 8P	G614108V1010M-IL
JA 3 TER,BOARD SCREW 2P	G611201A0200Y-IL
JA 50 TUNER,FM/AM	E903004100780-IL
RY 2-6 RELAY	G680120502050-IL
CN 9007,9019 CN,WAFER	L109012511320-IL
CN 9008,9016-9018 CN.WAFER	L109012510920-IL



Mark	No.	Description	Part No.
	CN 9009	CN,WAFER	L109012511120-IL
	CN 9012	CN,WAFER	L109012511520-IL
	2	TERMINAL	3790040886000-IL
⚠	33,34	FUSE,MICRO	G658315250050-IL

**RESISTORS**

R	5,7,9,11	C060010065050-IL
R	6,8,10,12	C060010066050-IL
R	13,15,17	C060010065050-IL
R	14,16,18	C060010066050-IL
R	41,42	C060R22065050-IL
R	25	C0605R6065050-IL
R	64	C060022063050-IL
R	66	C0604R7065050-IL

**CAPACITORS**

C	55,58	D040103089000-IL
C	76	D040682083000-IL
C	84,85	D040472084020-IL
C	101	D04010108C240-IL

**D D-MAIN ASSY  
SEMICONDUCTORS**

IC	101	UPD61110GM-100UEVA
IC	102,9201	J001982566010-IL
IC	104,604,1808	TC7WHU04FK
IC	603	PE7008A
IC	608	TC74VHCT541AFK
IC	610,1509,1806	TC74VHC126FK
IC	611	TC74VHCT126AFK
IC	612,1502	TC74VHCT08AFKS1
IC	613,1601,1804,9003	TC74VHC08FK
IC	614,701,9008,9208	TC7SH08FUS1
IC	901,910	TC74LCX541FK
IC	902,911	TC7SZ125FU
IC	909	ADV7181CBSTZ
⚠	IC 1216	LP2996M
⚠	IC 1403	J040740400270-IL
⚠	IC 1605	AAT4610BIGV-1
IC	1801	AK4588VQ
IC	1802	AK4388ET
IC	1803	IDT6V60008DCG
IC	1805	TC74VHC157FK
IC	1807	J040740400270-IL
IC	1812	TC7SZ126FU
IC	9001	J001986466010-IL
IC	9102	BU4094BCFV
⚠	IC 9202	BD2226G
IC	9206	341S2162
IC	9207	TC74VHC08FK
⚠	IC 9401,9511,9519	S-1170B50UC-OUJ
⚠	IC 9501	S-1172B10-U5
⚠	IC 9502,9518,9523	S-1172B12-E6
⚠	IC 9508	S-1170B25UC-OTK
⚠	IC 9515	S-1172B15-E6
⚠	Q 9503,9507,9516	J543045010060-IL
<b>MISCELLANEOUS</b>	JA 1801	PIN JACK (2P)
	JA 1803,1804	MODULE
	KN 9801	BRACKET
⚠	P 601	SW,POLY
	JA 1801	G601206A0700Y-IL
	JA 1803,1804	E100216500010-IL
	KN 9801	4010210196100-IL
⚠	P 601	G300003500010-IL

Mark	No.	Description	Part No.
		<b>CAPACITORS</b>	
	C	1509	D040222081000-IL

**E IR ASSY  
MISCELLANEOUS**

JA	504,505	JACK,D3.5	G401PJ3080100-IL
CN	9511	CN,WAFER	L109012510920-IL
CN	9512	CN,WAFER	L109012511520-IL
CN	9513	CN,WAFER	L109012512720-IL
	501,503	BRACKET	4010210196100-IL

**F VIDEO ASSY  
SEMICONDUCTORS**

IC	1001	J171132900010-IL
IC	1007	PDC162A
IC	1008	NJM2505AF
Q	910	J5023209Y0010-IL

**MISCELLANEOUS**

JA	1001	TER,RCA 9PIN	G607902AA151Y-IL
JA	1001	TER,RCA 9PIN	G607902AA133Y-IL
X	1003	CRYSTAL	E80014R318080-IL

**G BRG ASSY  
SEMICONDUCTORS**

IC	2704,2742,2762,2782	J121458001010-IL
IC	2802	J121458001010-IL

**MISCELLANEOUS**

RY	701	RELAY	G680240202030-IL
CN	2107,2110	CN,WAFER	L109012512320-IL
CN	2112	CN,WAFER	L109012510920-IL
CN	2113,2203	CN,WAFER	L109012512120-IL

**RESISTORS**

R	720	C060010063050-IL
---	-----	------------------

**H FRONT ASSY  
SEMICONDUCTORS**

IC	3001	PE5615A
IC	3005	J126077004210-IL
⚠	IC 9103	J126111700041-IL
Q	3011	J5001266G0050-IL
D	3007,3009,3011,3013	K500052009011-IL
D	9001	K06006R844520-IL

**MISCELLANEOUS**

V	3001	DISPLAY,FLT	K530166400010-IL
S	3001-3015	SWITCH	G180501000010-IL
S	3024	SW,ENCODER	G121125042011-IL
X	3001	RESONATOR,CERAMIC	E830500000020-IL
X	3002	CRYSTAL	E80015R000020-IL
	3000	FL HOLDER	4320211016000-IL
U	3001	MODULE,REMOCON	E940349003810-IL

**RESISTORS**

R	3021,3022	C060R47065050-IL
R	3025,3026	C060001065060-IL

**Mark No. Description** **Part No.**

**Mark No. Description** **Part No.**

**A I POWER ASSY**  
**MISCELLANEOUS**  
S 3401 SWITCH G180501000010-IL  
S 3501 SW,ENCODER G121125052011-IL

**T F-USB ASSY**  
**MISCELLANEOUS**  
JA 600 CN,PLUG CONTACT G480040000180-IL

**J MIC ASSY**  
**SEMICONDUCTORS**  
IC 3652 J121458001010-IL

**U SMPS ASSY**  
**SEMICONDUCTORS**  
⚠ IC 100 K614123000010-IL  
⚠ IC 102 J122258001010-IL  
⚠ IC 116 J126243118010-IL  
Q 9100-9102 J5023198Y0000-IL  
⚠ D 100-102,104 K040540600030-IL

**MISCELLANEOUS**  
JA 3654 JACK,D3.5 G401PJ354H40Y-IL

⚠ D 103 K120306005510-IL  
D 105,106,109,110 K000400700220-IL  
D 108 K050000015000-IL  
D 9100,9102,9104,9106 K06022R044520-IL  
D 9101,9103,9105,9108 K06039R044520-IL

**K FVIDEO ASSY**  
**MISCELLANEOUS**  
JA 3656 TER,RCA 1PIN G600101HG000Y-IL

D 9107,9110,9112,9117 K06022R044520-IL  
D 9109,9115 K06039R044520-IL  
D 9114 K06006R244520-IL  
D 9118 K06022R044520-IL

**L HP ASSY**  
**MISCELLANEOUS**  
JA 701 JACK,D6.5 G402PJ612AG1Y-IL

**MISCELLANEOUS**  
⚠ L 100 COIL,LINE FILTER D320201405510-IL  
⚠ RY 101 RELAY G680050102020-IL  
⚠ T 100 TRANS,SWITCHING E060283405510-IL  
⚠ CN9100 CONNECTOR L108396030010-IL  
⚠ CN9102 CN.WAFER 7.92MM L108011430210-IL

**M G-L ASSY**  
There is no service parts.

100,102 BRACKET 4010210196100-IL  
⚠ FU 100 FUSE GLASS TUBE 20MM N751503151160-IL  
⚠ FU 101 FUSE GLASS TUBE 20MM N751508001160-IL

**N G-R ASSY**  
There is no service parts.

**RESISTORS**

⚠ R 100 C060015564520-IL  
⚠ R 101 C060022563520-IL  
R 104 C060022563520-IL  
⚠ R 105,113,115 C060010563520-IL

**O WG-A ASSY**  
There is no service parts.

**CAPACITORS**

⚠ C 100 D02122407H010-IL  
C 102 D04010108K000-IL  
C 103 D00810207Q010-IL  
⚠ C 104,105 D00847127H010-IL  
C 106-108 D041562081001-IL

**P WG-B ASSY**  
There is no service parts.

⚠ C 115,128 D00815248H010-IL  
⚠ C 117 D008103589010-IL  
C 131,133 D008103589010-IL

**Q CCG ASSY**  
There is no service parts.

**E R BTCNT ASSY**  
**MISCELLANEOUS**  
CN 602 CN.WAFER 2.0MM L101100041110-IL  
600 BRACKET 4010210196100-IL

**V BT ASSY**  
**SEMICONDUCTORS**  
⚠ IC 600 BD2224G

**S FHDMI ASSY**  
**SEMICONDUCTORS**  
IC 8202 PCA9517DGK

**MISCELLANEOUS**  
CN 601 CONNECTOR CKS5712  
CN 603 CN.WAFER 2.0MM L101100031110-IL  
601 BRACKET 4010210196100-IL

**F MISCELLANEOUS**  
JA 8202 CN.WAFER L109100190060-IL  
JA 8203 CN.WAFER L109100190170-IL