

Pioneer

Service Manual

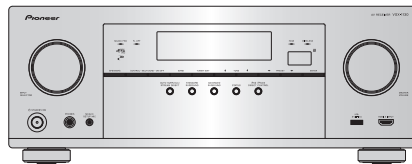

VSX-1130-K

ORDER NO.
RRV4596

AV Receiver

VSX-1130-K

VSX-90

THIS MANUAL IS APPLICABLE TO THE FOLLOWING MODEL(S) AND TYPE(S).

Model	Type	Power Requirement	Remarks
VSX-1130-K	CUXESM	AC 120 V	
VSX-90	CUXE	AC 120 V	

THIS SERVICE MANUAL SHOULD BE USED TOGETHER WITH THE FOLLOWING MANUAL(S).

Model	Order No.	Remarks
VSX-1130-K, VSX-90	RRV4597	SCHEMATIC DIAGRAM, PCB CONNECTION DIAGRAM, PCB PARTS LIST



PIONEER CORPORATION 1-1, Shin-ogura, Saiwai-ku, Kawasaki-shi, Kanagawa 212-0031, Japan

PIONEER ELECTRONICS (USA) INC. P.O. Box 1760, Long Beach, CA 90801-1760, U.S.A.

PIONEER EUROPE NV Haven 1087, Keetberglaan 1, 9120 Melsele, Belgium

PIONEER ELECTRONICS ASIACENTRE PTE. LTD. 253 Alexandra Road, #04-01, Singapore 159936

©PIONEER CORPORATION 2015

K-MZV MAR. 2015 Printed in Japan

SAFETY INFORMATION



This service manual is intended for qualified service technicians; it is not meant for the casual do-it-yourselfer. Qualified technicians have the necessary test equipment and tools, and have been trained to properly and safely repair complex products such as those covered by this manual.

Improperly performed repairs can adversely affect the safety and reliability of the product and may void the warranty. If you are not qualified to perform the repair of this product properly and safely, you should not risk trying to do so and refer the repair to a qualified service technician.

WARNING

This product may contain a chemical known to the State of California to cause cancer, or birth defects or other reproductive harm.

Health & Safety Code Section 25249.6 - Proposition 65

(FOR USA MODEL ONLY)

1. SAFETY PRECAUTIONS

The following check should be performed for the continued protection of the customer and service technician.

LEAKAGE CURRENT CHECK

Measure leakage current to a known earth ground (water pipe, conduit, etc.) by connecting a leakage current tester such as Simpson Model 229-2 or equivalent between the earth ground and all exposed metal parts of the appliance (input/output terminals, screwheads, metal overlays, control shaft, etc.). Plug the AC line cord of the appliance directly into a 120 V AC 60 Hz outlet and turn the AC power switch on. Any current measured must not exceed 0.5 mA.

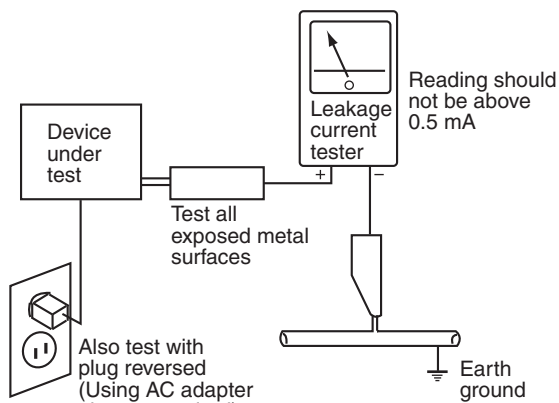

AC Leakage Test

ANY MEASUREMENTS NOT WITHIN THE LIMITS OUTLINED ABOVE ARE INDICATIVE OF A POTENTIAL SHOCK HAZARD AND MUST BE CORRECTED BEFORE RETURNING THE APPLIANCE TO THE CUSTOMER.

2. PRODUCT SAFETY NOTICE

Many electrical and mechanical parts in the appliance have special safety related characteristics. These are often not evident from visual inspection nor the protection afforded by them necessarily can be obtained by using replacement components rated for voltage, wattage, etc. Replacement parts which have these special safety characteristics are identified in this Service Manual.

Electrical components having such features are identified by marking with a ⚠ on the schematics and on the parts list in this Service Manual.

The use of a substitute replacement component which does not have the same safety characteristics as the PIONEER recommended replacement one, shown in the parts list in this Service Manual, may create shock, fire, or other hazards.

Product Safety is continuously under review and new instructions are issued from time to time. For the latest information, always consult the current PIONEER Service Manual. A subscription to, or additional copies of, PIONEER Service Manual may be obtained at a nominal charge from PIONEER.

CONTENTS

SAFETY INFORMATION.....	2
1. SERVICE PRECAUTIONS.....	4
1.1 NOTES ON SOLDERING.....	4
1.2 SERVICE NOTICE.....	4
2. SPECIFICATIONS.....	5
3. BASIC ITEMS FOR SERVICE.....	6
3.1 CHECK POINTS AFTER SERVICING.....	6
3.2 JIGS LIST.....	6
3.3 PCB LOCATIONS.....	7
4. BLOCK DIAGRAM.....	10
4.1 OVERALL WIRING DIAGRAM.....	10
4.2 AUDIO BLOCK DIAGRAM.....	12
4.3 DMAIN BLOCK DIAGRAM (AUDIO).....	14
4.4 VIDEO BLOCK DIAGRAM.....	16
4.5 DMAIN BLOCK DIAGRAM (VIDEO).....	18
4.6 POWER SUPPLY BLOCK DIAGRAM.....	20
4.7 GND BLOCK DIAGRAM.....	22
5. DIAGNOSIS.....	24
5.1 TROUBLESHOOTING.....	24
5.2 CONFIRMATION OF THE NETWORK MODULE.....	30
5.3 ERROR INDICATIONS.....	32
5.4 PROTECTION CIRCUIT.....	34
6. SERVICE MODE.....	36
6.1 TEST MODE.....	36
6.2 DEFAULT SETTINGS.....	38
7. DISASSEMBLY.....	39
8. EACH SETTING AND ADJUSTMENT.....	48
8.1 ADJUSTMENT REQUIRED WHEN THE UNIT IS REPAIRED OR REPLACED.....	48
8.2 USB BACKUP.....	49
8.3 UPDATING OF THE FIRMWARE.....	50
8.4 IDLE CURRENT ADJUSTMENT.....	53
9. EXPLODED VIEWS AND PARTS LIST.....	54
9.1 PACKING SECTION.....	54
9.2 EXTERIOR SECION.....	56

1. SERVICE PRECAUTIONS

1.1 NOTES ON SOLDERING

- A
- For environmental protection, lead-free solder is used on the printed circuit boards mounted in this unit.
Be sure to use lead-free solder and a soldering iron that can meet specifications for use with lead-free solders for repairs accompanied by reworking of soldering.
 - Compared with conventional eutectic solders, lead-free solders have higher melting points, by approximately 40 °C.
Therefore, for lead-free soldering, the tip temperature of a soldering iron must be set to around 373 °C in general, although the temperature depends on the heat capacity of the PC board on which reworking is required and the weight of the tip of the soldering iron.

Do NOT use a soldering iron whose tip temperature cannot be controlled.

- B
- Compared with eutectic solders, lead-free solders have higher bond strengths but slower wetting times and higher melting temperatures (hard to melt/easy to harden).

The following lead-free solders are available as service parts:

- Parts numbers of lead-free solder:
GYP1006 1.0 in dia.
GYP1007 0.6 in dia.
GYP1008 0.3 in dia.

C

1.2 SERVICE NOTICE

■ Discharging

For more detail, please refer to "7. DISASSEMBLY - 1. Discharging".

■ Notice of the Parts exchange

As the screw covers for the speaker terminals are subject to breakage, be careful when removing them.
If a screw cover is broken during removal, replace it with a new one.

- E
- Continuous use of a broken screw cover may cause short-circuiting of speaker terminals.

F

2. SPECIFICATIONS

Amplifier section

Continuous average power output of 100 watts* per channel, min., at 8 ohms, from 20 Hz to 20 000 Hz with no more than 0.08 %** total harmonic distortion.

Front (stereo) 100 W + 100 W
Power output (1 kHz, 6 Ω, 1 %, 1 ch driven) 165 W
Guaranteed speaker impedance 6 Ω to 16 Ω

* Measured pursuant to the Federal Trade Commission's Trade

Regulation rule on Power Output Claims for Amplifiers

** Measured by Audio Spectrum Analyzer

Audio Section

Input (Sensitivity/Impedance)

LINE 315 mV/47 kΩ

Signal-to-Noise Ratio (IHF, short circuited, A network)

LINE 101 dB

Tuner Section

Frequency Range (FM) 87.5 MHz to 108 MHz

Antenna Input (FM) 75 Ω unbalanced

Frequency Range (AM) 530 kHz to 1 700 kHz

Antenna (AM) Loop antenna (balanced)

Video Section

Signal level

Composite Video 1 Vp-p (75 Ω)

Component Video Y: 1.0 Vp-p (75 Ω), PB/PR: 0.7 Vp-p (75 Ω)

Corresponding maximum resolution

Component Video 1080p (1125p)

Bluetooth Section

Version Bluetooth Specification Ver. 2.1 + EDR

Output Bluetooth Specification Class 2

Estimated line-of-sight transmission distance* About 10 m

* The line-of-sight transmission distance is an estimate. Actual

transmission distances supported may differ depending on

surrounding conditions.

Frequency range 2.4 GHz

Supported Bluetooth profiles A2DP, AVRCP

Supported Codec SBC (Subband Codec), AAC

Digital In/Out Section

HDMI terminal 19-pin (Not DVI)

HDMI output type 5 V, 55 mA

HDMI input/MHL terminal 5 V, 900 mA

USB terminal USB2.0 High Speed (Type A) 5 V, 1 A

iPod terminal USB

Integrated Control Section

Control (IR) terminal ø 3.5 Mini-jack (MONO)

IR signal High Active (High Level: 2.0 V)

Network Section (Wired)

LAN terminal 10 BASE-T/100 BASE-TX

Network Section (Wireless)

WLAN standards IEEE 802.11a, IEEE 802.11b,

IEEE 802.11g, IEEE 802.11n

Frequency band

2.4 GHz band (2.412 GHz to 2.462 GHz) Channel 1 to Channel 11

5 GHz band (5.180 GHz to 5.240 GHz, 5.745 GHz to 5.825 GHz) Channel 36 to Channel 48,

Channel 149 to Channel 165

Security Disabled (no encryption)

WEP (Key length: 64 bit/128 bit, Key format: ASCII/Hex)

WPA2 Mixed (WPA/WPA2, Encryption method: TKIP/AES,

Recognition method: PSK)

Miscellaneous

Power requirements AC 120 V, 60 Hz

Power consumption 550 W

In standby 0.1 W

In standby (HDMI control on) 0.3 W

In standby (Network standby on) 2.7 W

In standby (Network standby on, wireless LAN connected) 3.0 W

In standby (HDMI control on, Network standby on) 2.7 W

In standby (HDMI control on, Network standby on, wireless LAN

connected) 3.0 W

Auto power down 15 min, 30 min, 60 min, off (default)

Dimensions 435 mm (W) x 168 mm (H) x 363 mm (D)

(17 3/16 in. (W) x 6 5/8 in. (H) x 14 5/16 in. (D))

Weight (without package) 9.8 kg (21 lb 10 oz)

Accessories

• MCACC Setup microphone (APM7011)

• Remote control unit (8300772300010S)

• AAA size IEC R03 dry cell batteries

• AM loop antenna (E605010140010S)

• FM wire antenna (E605010140010-IL)

• Power cord (VSX-90 only) (L068125130010S)

• CD-ROM (VSX-1130-K/CUXESM: 6517000002141S) (VSX-90/CUXE: 6517000002131S)

• Quick start guide (VSX-1130-K/CUXESM: 5707000009920S) (VSX-90/CUXE: 5707000009900S)

• Safety Brochure

• Warranty sheet

3. BASIC ITEMS FOR SERVICE

3.1 CHECK POINTS AFTER SERVICING

A Items to be checked after servicing

To keep the product quality after servicing, confirm recommended check points shown below.

No.	Procedures	Check points
1	Check the firmware version.	The firmware version must be the latest one. If it is not the latest one, be sure to update it.
2	Confirm whether the customer complain has been solved. If the customer complain occurs with the particular source, such as Dolby Digital, DTS, AAC and HDMI, input it for the operation check.	The customer complain must not be reappeared. Video, Audio and operations must be normal.
3	Check the analog audio playback. (Make the analog connections with a CD/DVD/BD player.)	Each channel audio and operations must be normal.
4	Check the HDMI digital audio playback. (Make the digital connections with a BD player.)	Each channel audio and operations must be normal.
5	Check a supported music file playback (e.g. wav, flac, mp3, etc). (Make the connections with a USB memory or an iOS device)	Audio and operations including OSD output must be normal.
6	Check surround playback. (Select Surround mode and check the multichannel operations via the DSP circuit.)	Each channel audio and operations must be normal.
7	Check the video outputs. (Connect with a BD player.)	Video and operations must be normal.
8	Check the tuner (AM and FM) operations.	Audio and operations must be normal.
9	Check the sound from headphone output.	Sound must be normal, without noise.
10	Check the appearance of the product.	No scratches or dirt on its appearance after receiving it for service.

See the table below for the items to be checked regarding video and audio.

Item to be checked regarding video		Item to be checked regarding audio	
Block noise	Too dark	Distortion	Volume too high
Horizontal noise	Too bright	Noise	Volume fluctuating
Flicker	Mottled color	Volume too low	Sound interrupted
Disturbed image (video jumpiness)			

3.2 JIGS LIST

Jigs List

Jig Name	Part No.	Remarks
13P extension jig cable	GGD1740	Diagnosis (AMP7 Assy ↔ AUDIO Assy)
5P extension jig cable	GGD1741	Diagnosis (AMP7 Assy ↔ CPU Assy)
Board to board extension jig cable (27P)	GGD1873	Diagnosis (DMAIN Assy ↔ BRIDGE Assy)
Board to board extension jig cable (25P)	GGD1874	Diagnosis (DMAIN Assy ↔ BRIDGE Assy)
Board to board extension jig cable (15P)	GGD1848	Diagnosis (DMAIN Assy ↔ CPU Assy)
Board to board extension jig cable (17P)	GGD1889	Diagnosis (DMAIN Assy ↔ CPU Assy)
HDMI cable	(Marketed product)	Diagnosis (FHDMI Assy ↔ DMAIN Assy)
Cable tie (w.1.8 mm x100)	GEC1041	To prevent the BRIDGE Assy from dropping out

Lubricants and Glues List



Name	Part No.	Remarks
Silicon grease	GEM1057	Refer to "9.2 EXTERIOR SECTION".
Silicon adhesive	GYA1011 (KE40RTV-W)	Refer to "9.2 EXTERIOR SECTION".

3.3 PCB LOCATIONS

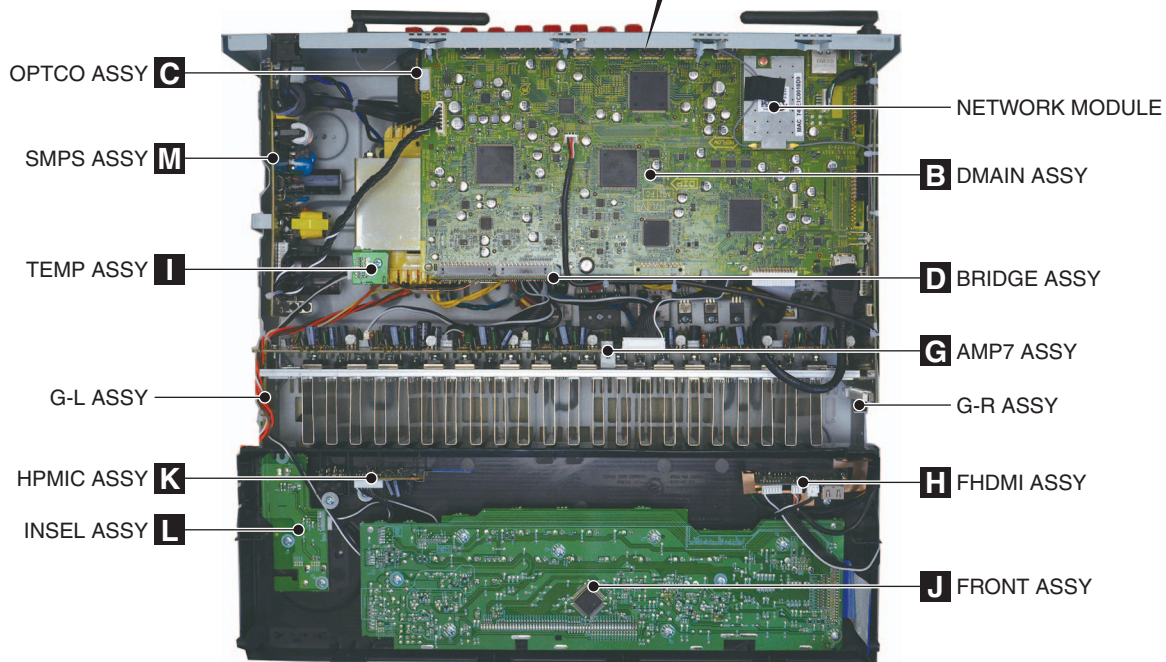
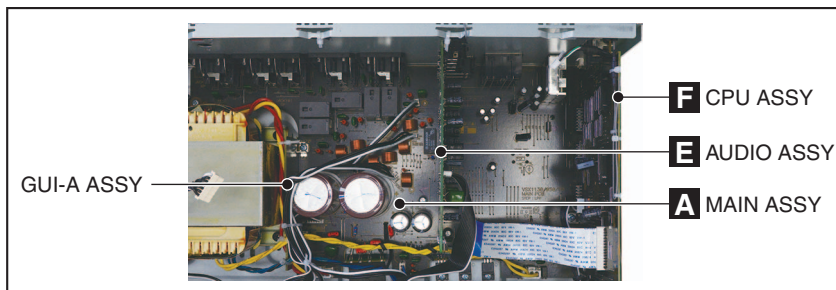

- A **NOTES:**
- Parts marked by “NSP” are generally unavailable because they are not in our Master Spare Parts List.
 - The ⚠ mark found on some component parts indicates the importance of the safety factor of the part. Therefore, when replacing, be sure to use parts of identical designation.

LIST OF ASSEMBLIES

Mark	Symbol and Description	VSX-1130-K /CUXESM	VSX-90 /CUXE
NSP	1..PCB TTL ASSY MAIN	7025HK1401010	7025HK1401020
	2..MAIN ASSY (PCB SUB ASSY MAIN)	7028077811040	7028077811010
	2..BRIDGE ASSY (PCB SUB ASSY BRIDGE)	7028077812020	7028077812010
B	2..GUI-A ASSY (PCB SUB ASSY GUI-A)	7028077813010	7028077813010
	2..G-R ASSY (PCB SUB ASSY G-R)	7028077814010	7028077814010
	2..G-L ASSY (PCB SUB ASSY G-L)	7028077815010	7028077815010
	2..TEMP ASSY (PCB SUB ASSY TEMP)	7028077816010	7028077816010
NSP	1..PCB TTL ASSY DMAIN	7025HK1401012	7025HK1401022
	2..DMAIN ASSY (PCB SUB ASSY DMAIN)	7028077871040	7028077871010
	2..NETWORK MODULE	AXX7293	AXX7293
NSP	1..PCB TTL ASSY FRONT	7025HK1401011	7025HK1401021
	2..FRONT ASSY (PCB SUB ASSY FRONT)	70280777210D0	70280777210A0
	2..INSEL ASSY (PCB SUB ASSY INSEL)	70280777220A0	70280777220A0
C	2..OPTCO ASSY (PCB SUB ASSY OPTCO)	70280777230A0	70280777230A0
	2..HPMIC ASSY (PCB SUB ASSY HPMIC)	70280777240A0	70280777240A0
NSP	1..PCB TTL ASSY CPU	7025HK1401013	7025HK1401023
	2..CPU ASSY (PCB SUB ASSY CPU)	70280777310D0	70280777310A0
NSP	1..PCB TTL ASSY AMP7	7025HK1401014	7025HK1401024
	2..AMP7 ASSY (PCB SUB ASSY AMP7)	7028077751010	7028077751010
NSP	1..PCB TTL ASSY AUDIO	7025HK1401015	7025HK1401025
	2..AUDIO ASSY (PCB SUB ASSY AUDIO)	7028077841040	7028077841010
D			
NSP	1..PCB TTL ASSY SMPS	7025HK1401016	7025HK1401026
	⚠ 2..SMPS ASSY (PCB SUB ASSY SMPS)	702807336108B	702807336106B
NSP	1..PCB TTL ASSY FHDMI	7025HK1401017	7025HK1401027
	2..FHDMI ASSY (PCB SUB ASSY FHDMI)	7028077881010	7028077881010



5



6



7



8



A



B



C



D



E



F



5



6

VSX-1130-K



7



8

9



4. BLOCK DIAGRAM

4.1 OVERALL WIRING DIAGRAM

- When ordering service parts, be sure to refer to "EXPLODED VIEWS and PARTS LIST" or "PCB PARTS LIST".
- The ⚠ mark found on some component parts indicates the importance of the safety factor of the part. Therefore, when replacing, be sure to use parts of identical designation.
- : The power supply is shown with the marked box.

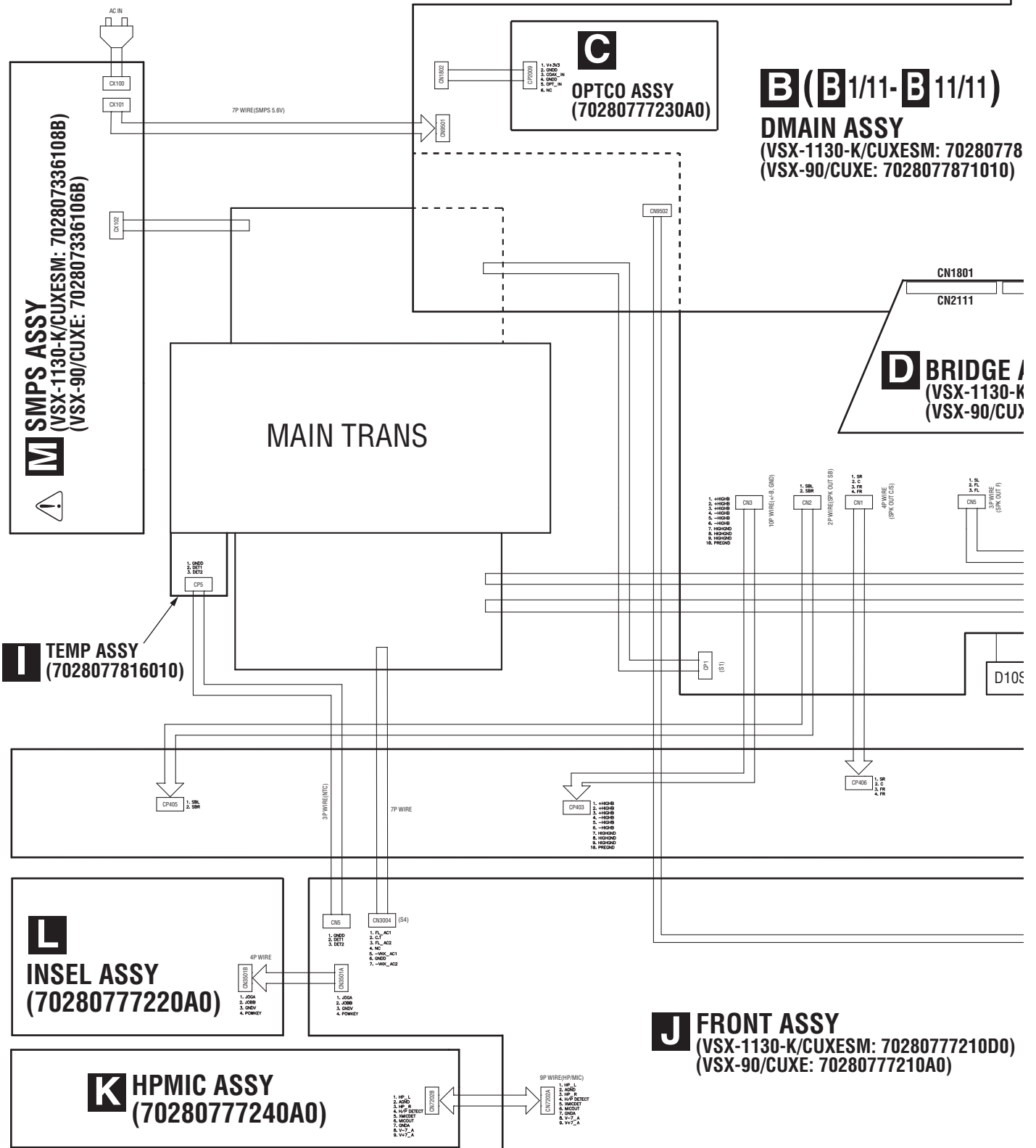

4.2 AUDIO BLOCK DIAGRAM

1

2

3

4

A

B

C

D

E

F

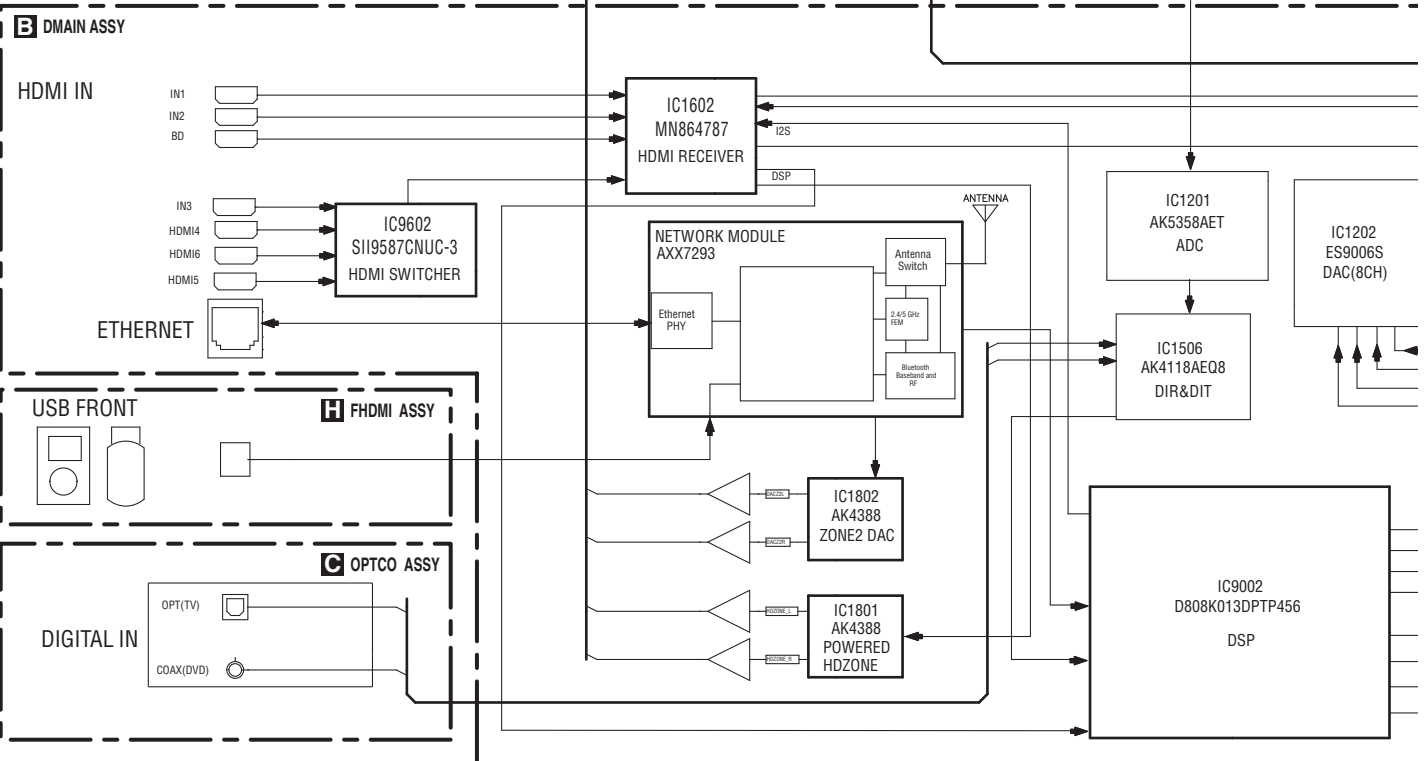
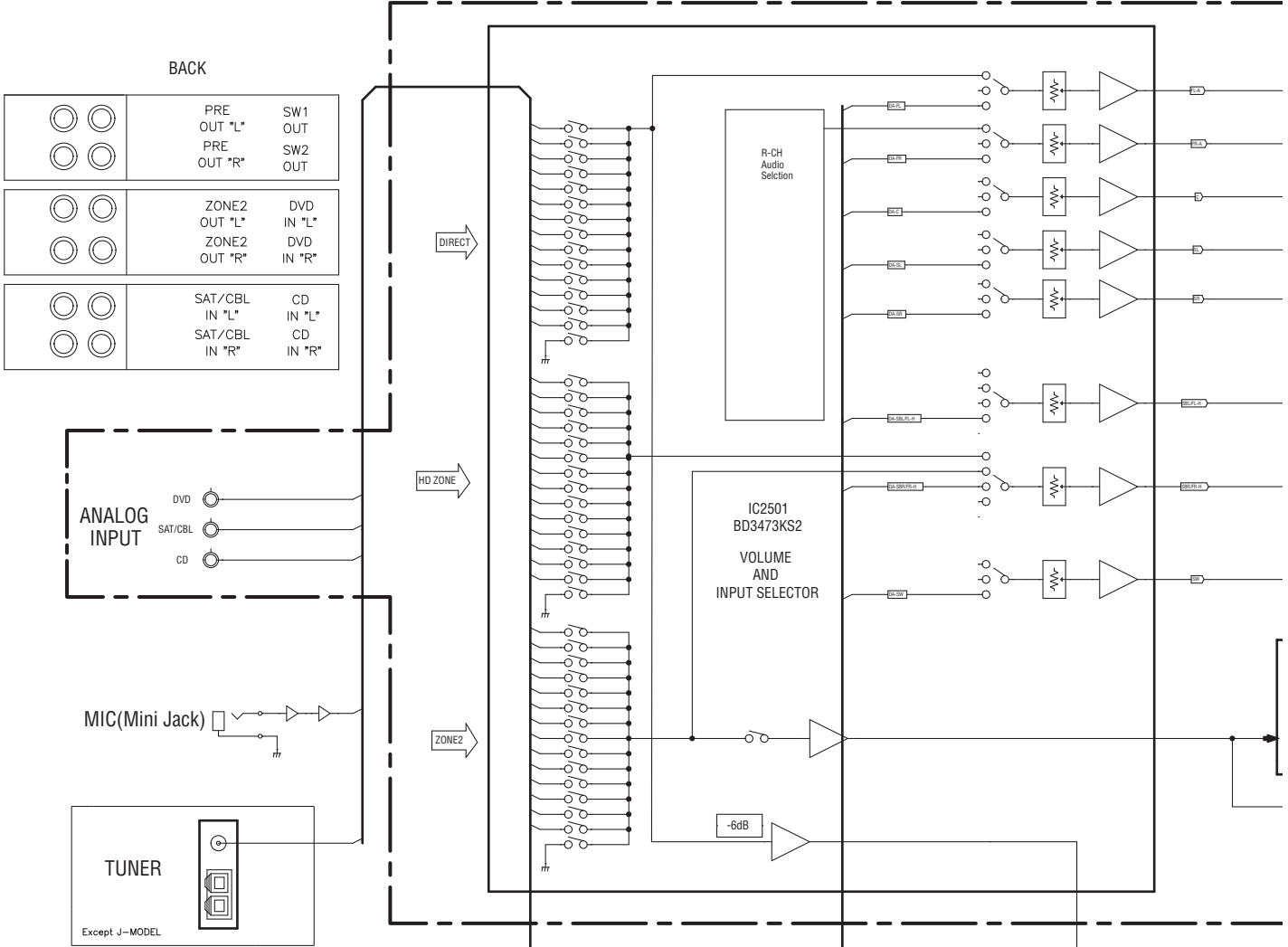

1

2

3

4

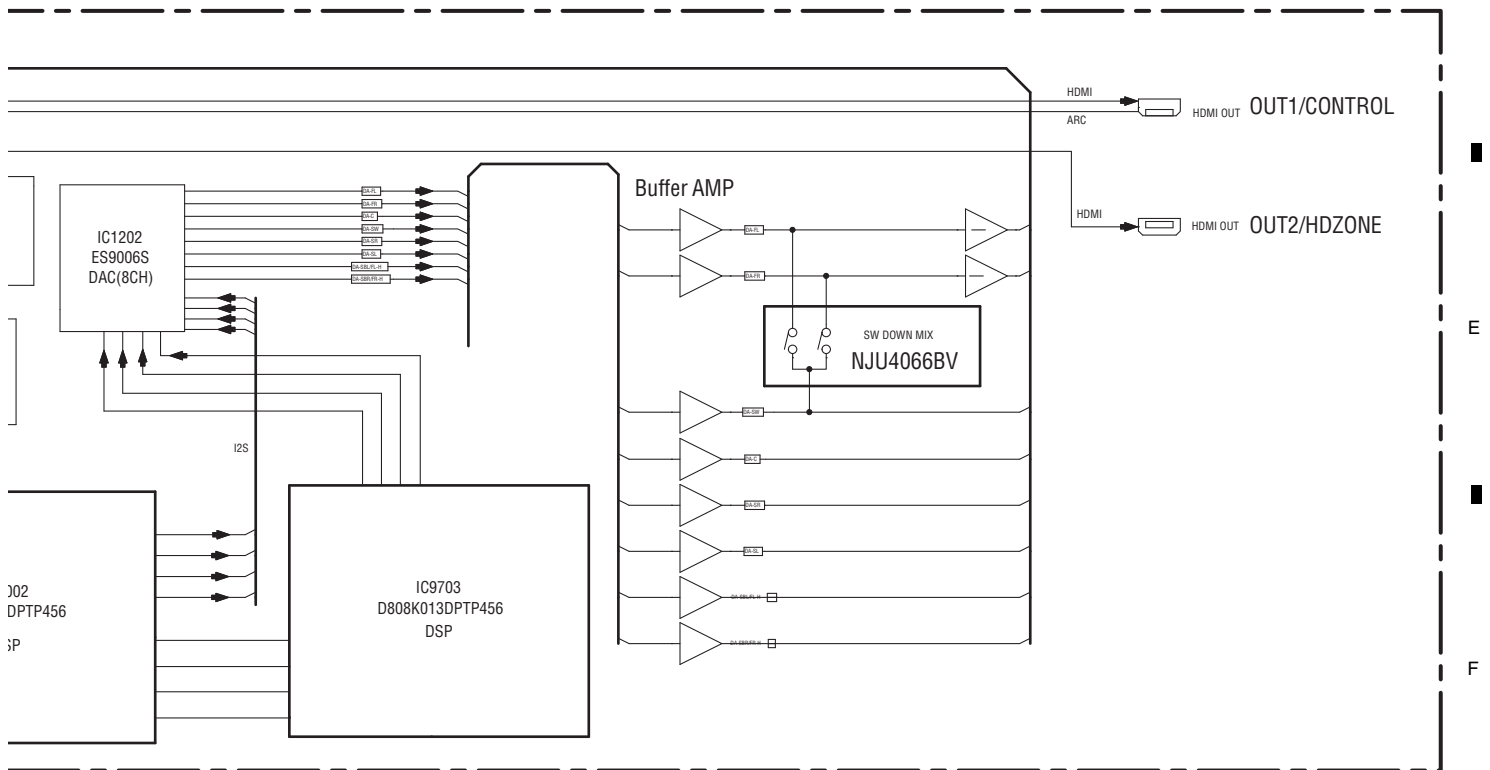
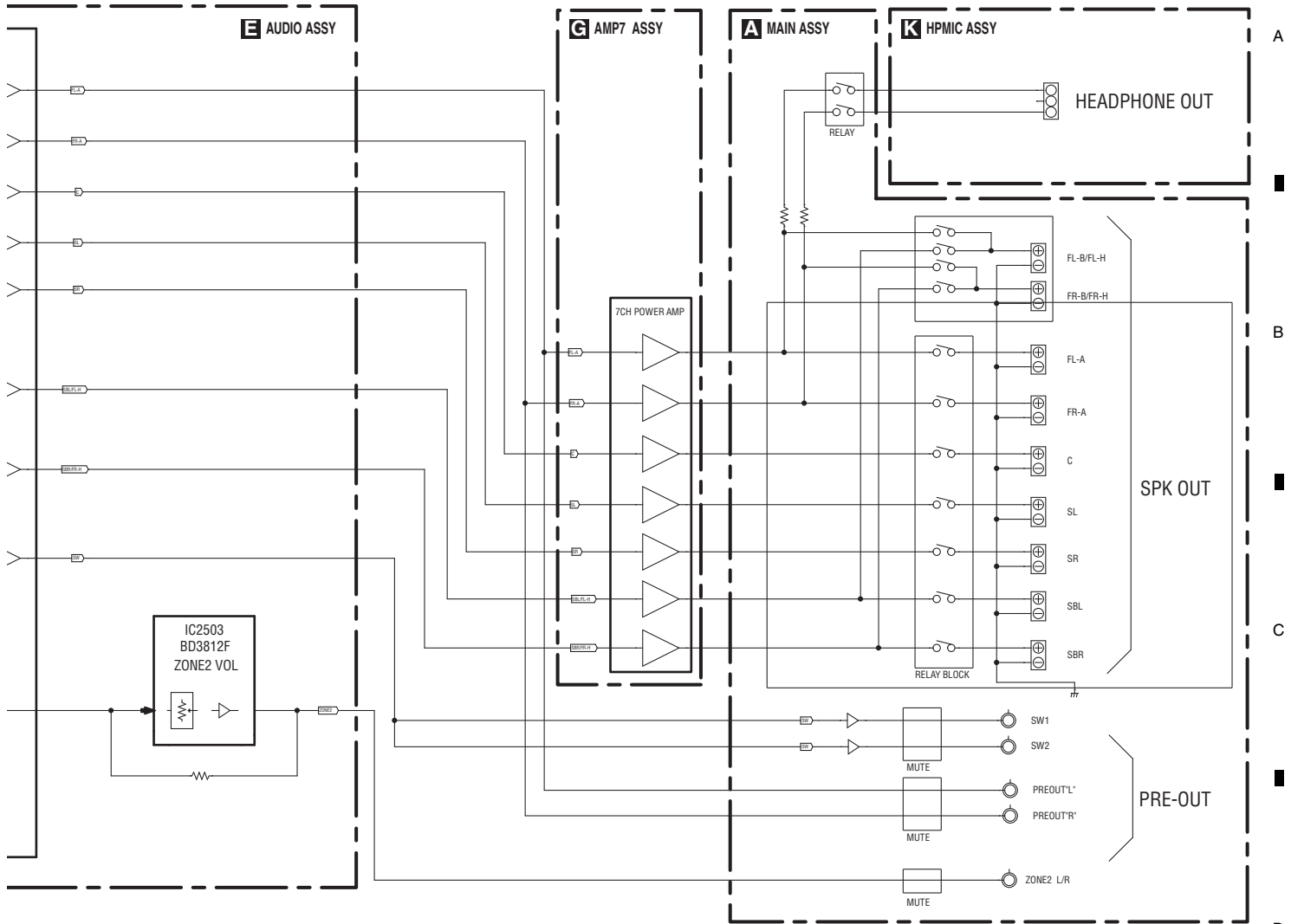

4.3 DMAIN BLOCK DIAGRAM (AUDIO)

B DMAIN ASSY

A

B

C

D

E

F

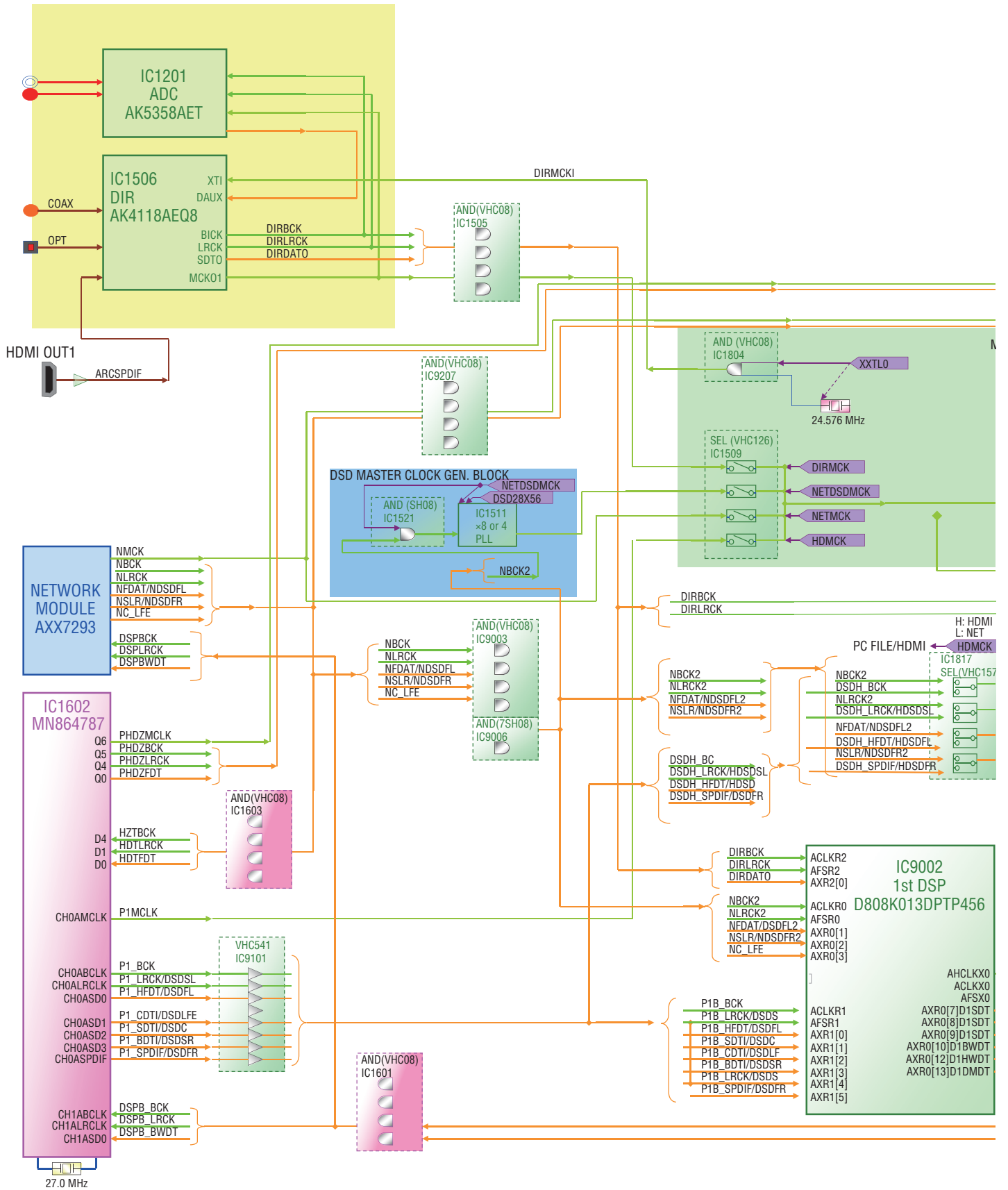

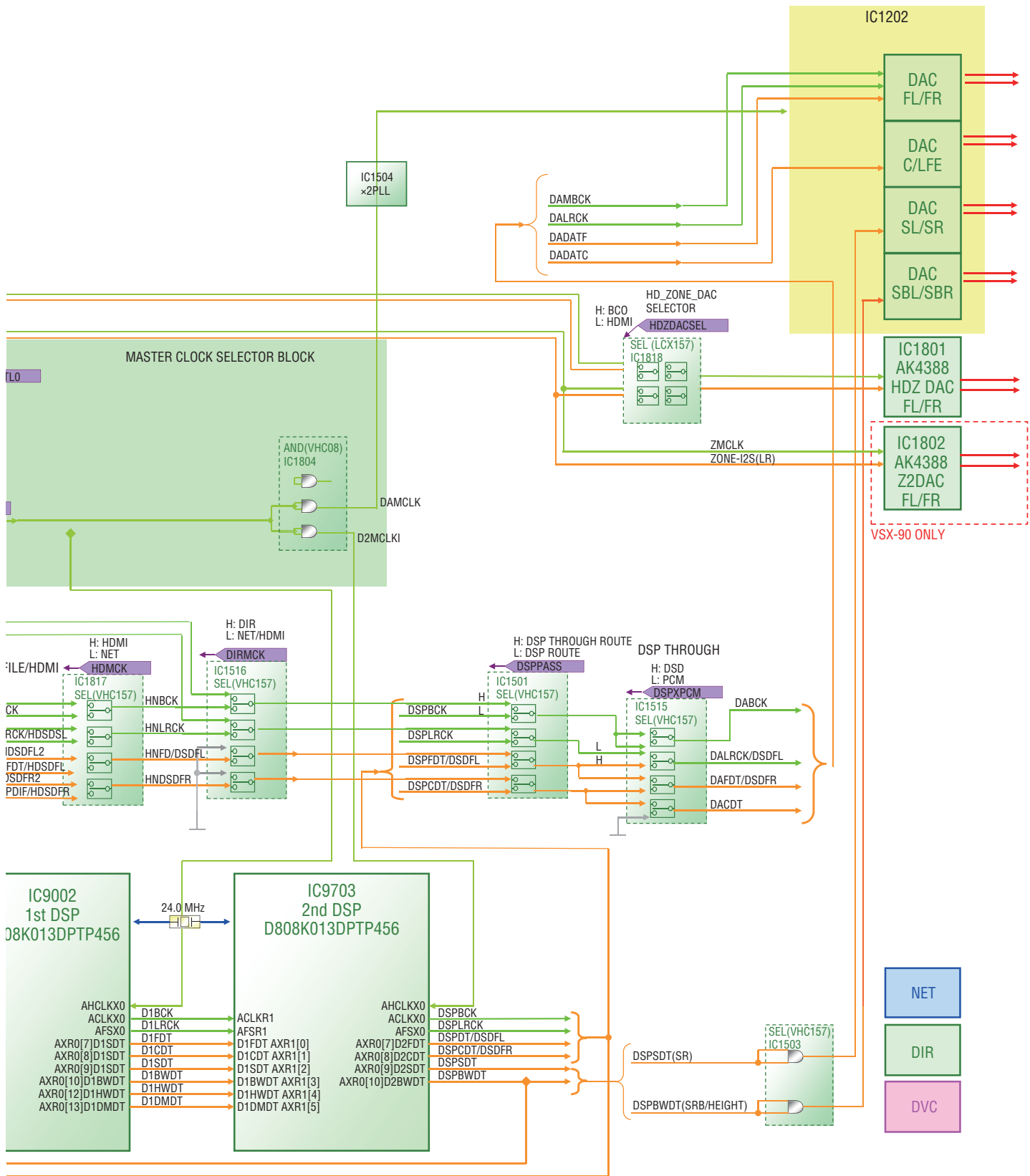

4.4 VIDEO BLOCK DIAGRAM

B DMAIN ASSY

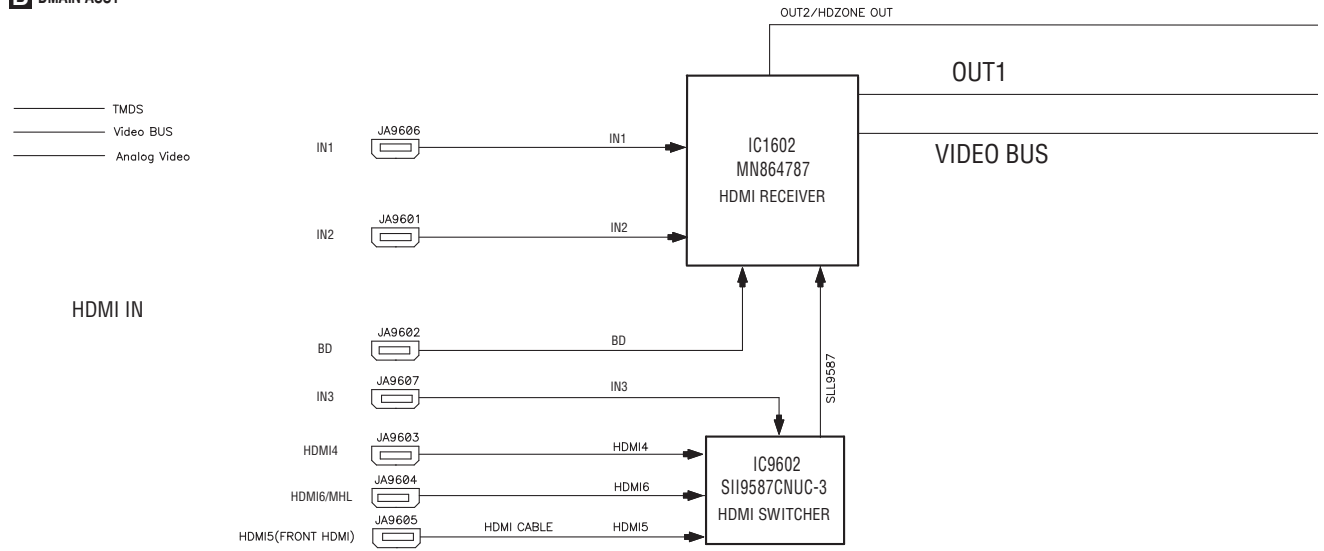

A MAIN ASSY

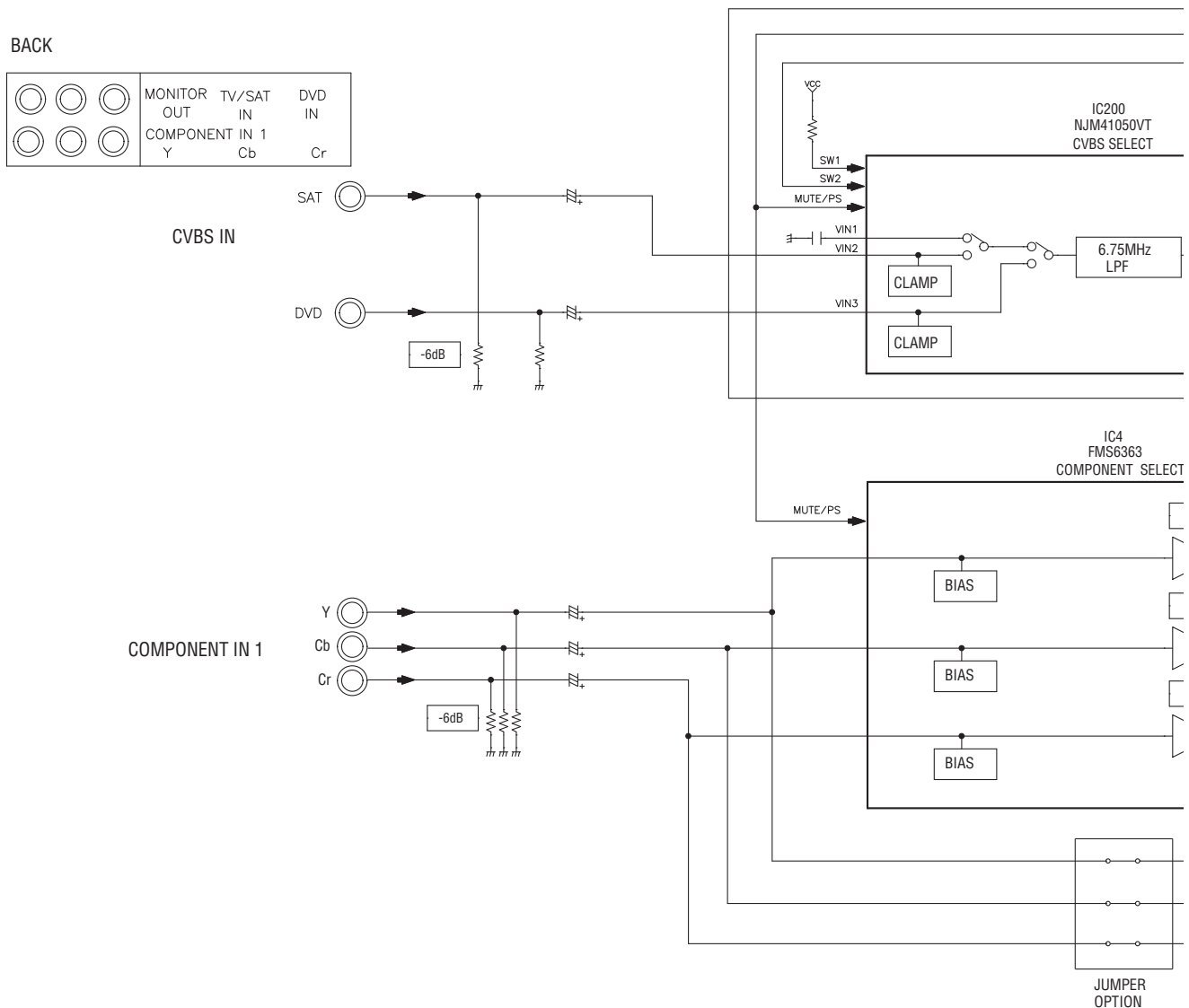

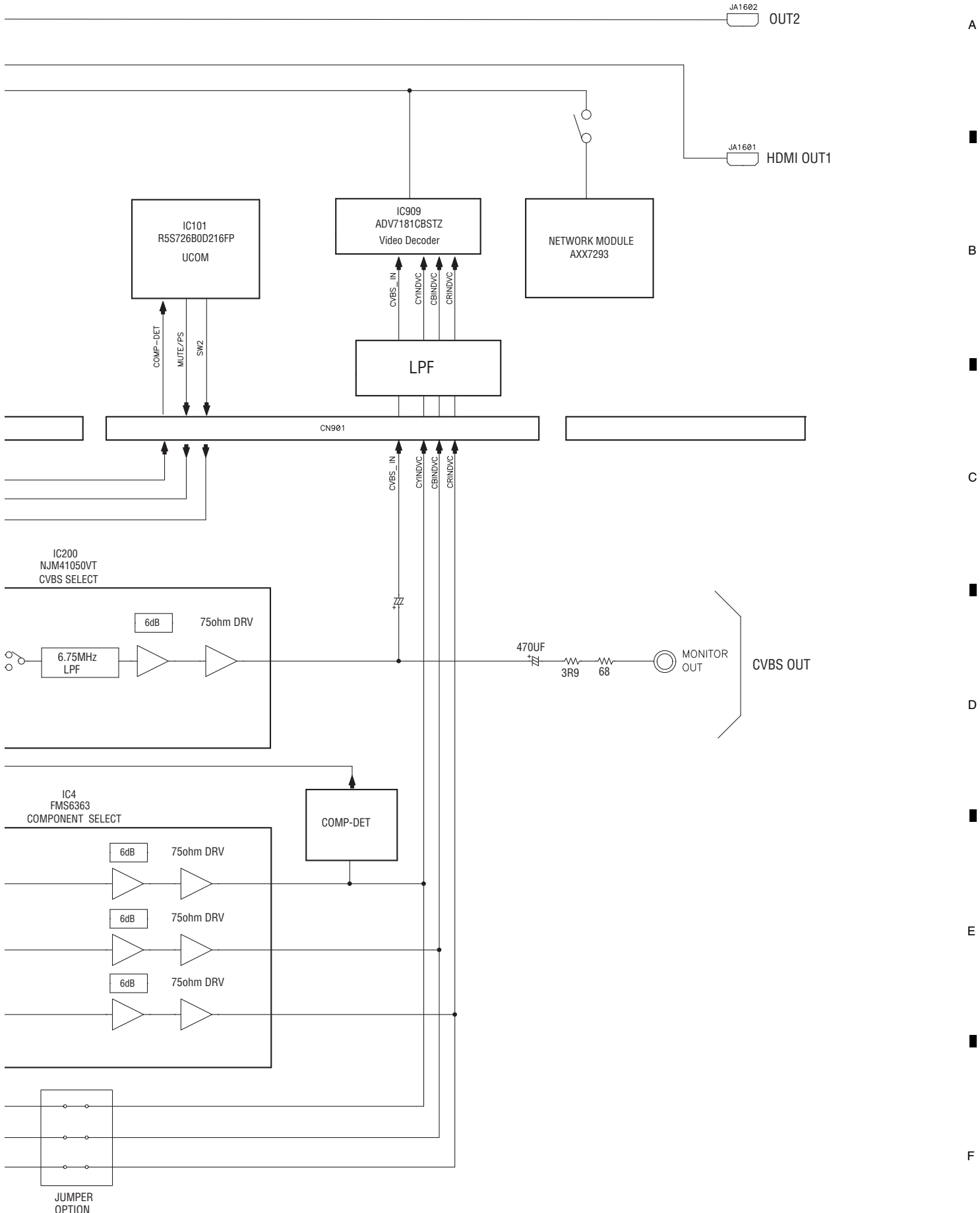

4.5 DMAIN BLOCK DIAGRAM (VIDEO)

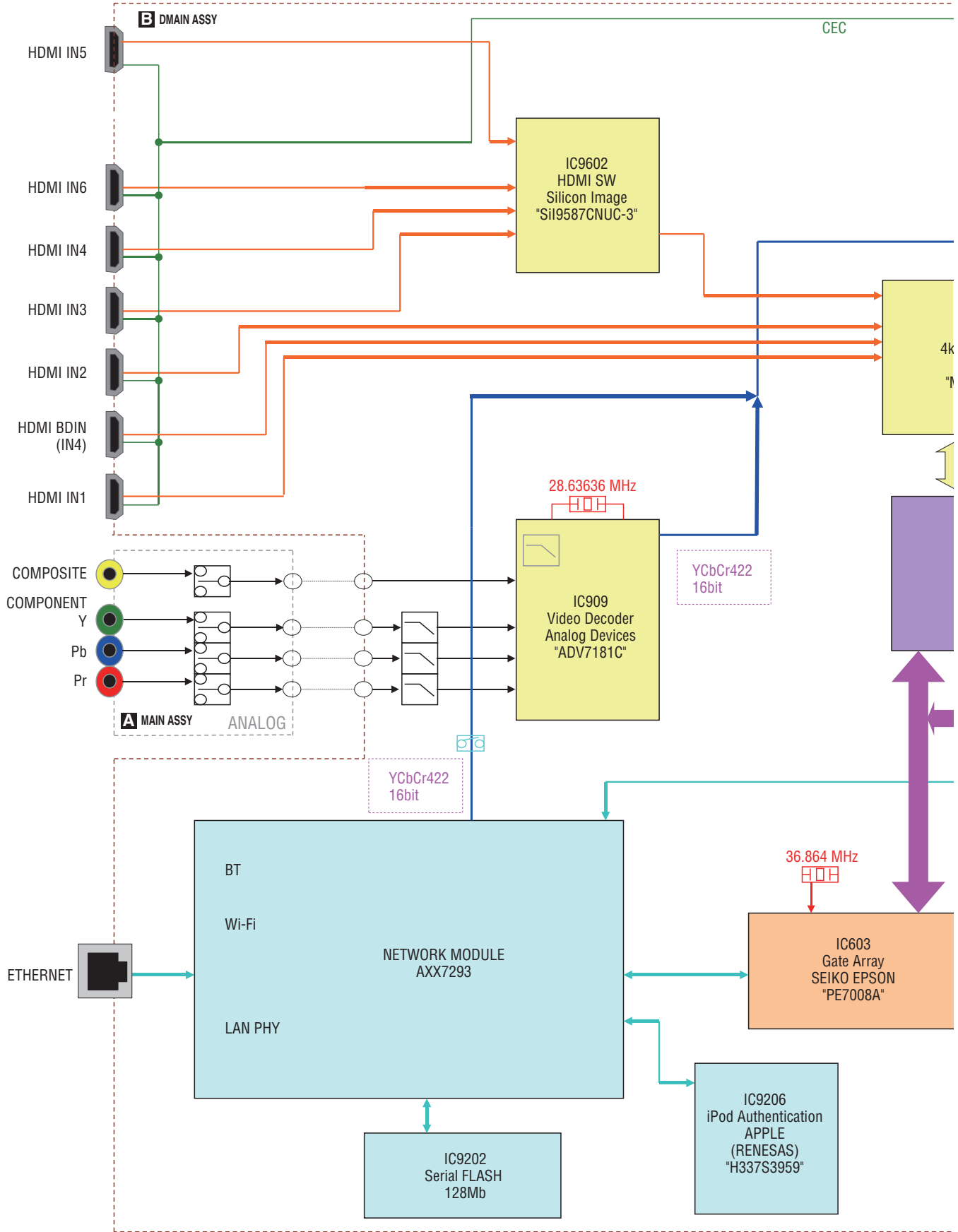

: DMAIN ASSY
 : OTHER ASSY

→ : TMDS
→ : DIGITAL VIDEO
→ : CEC

→ : ANALOG VIDEO
→ : CLOCK
→ : DIGITAL AUDIO

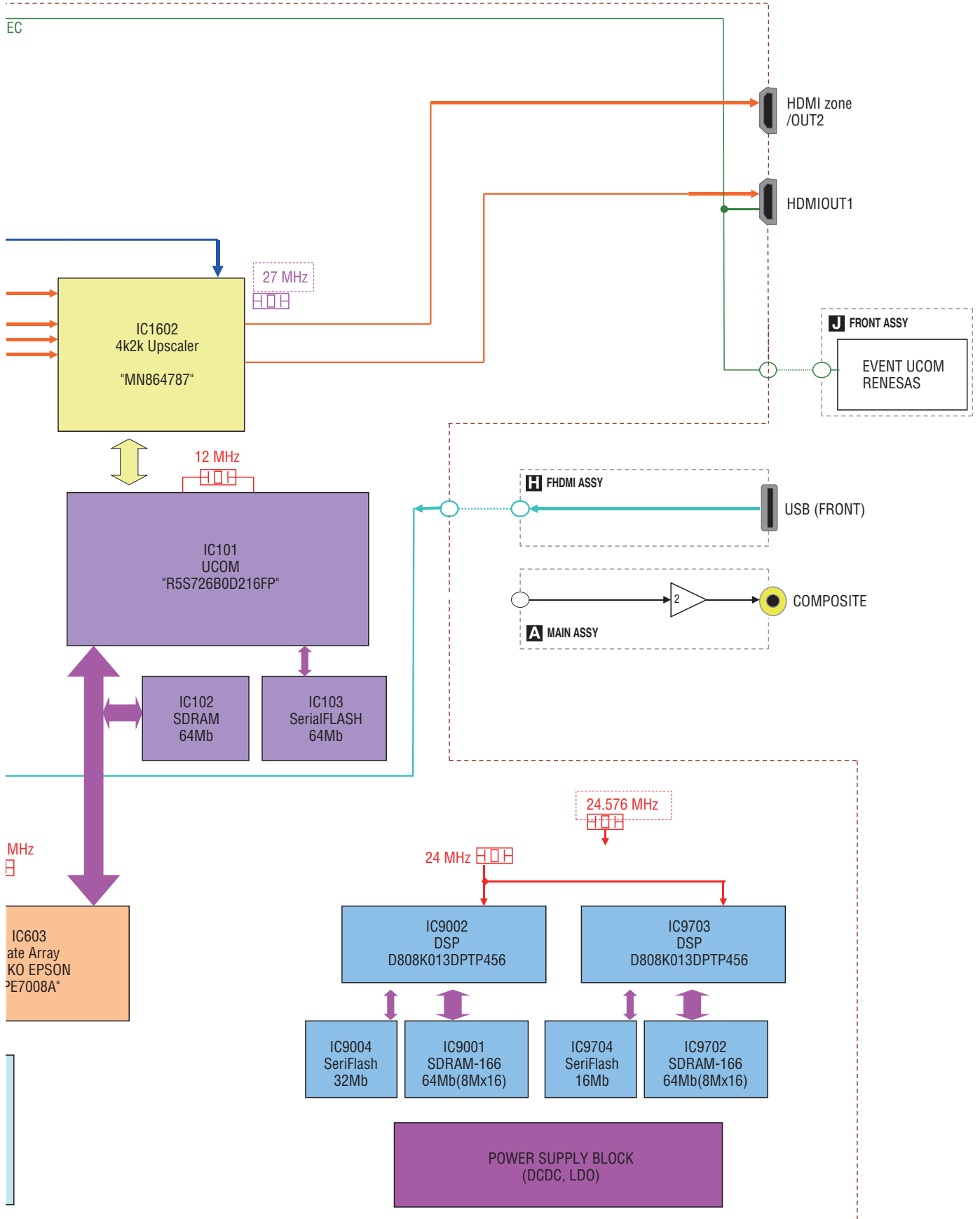

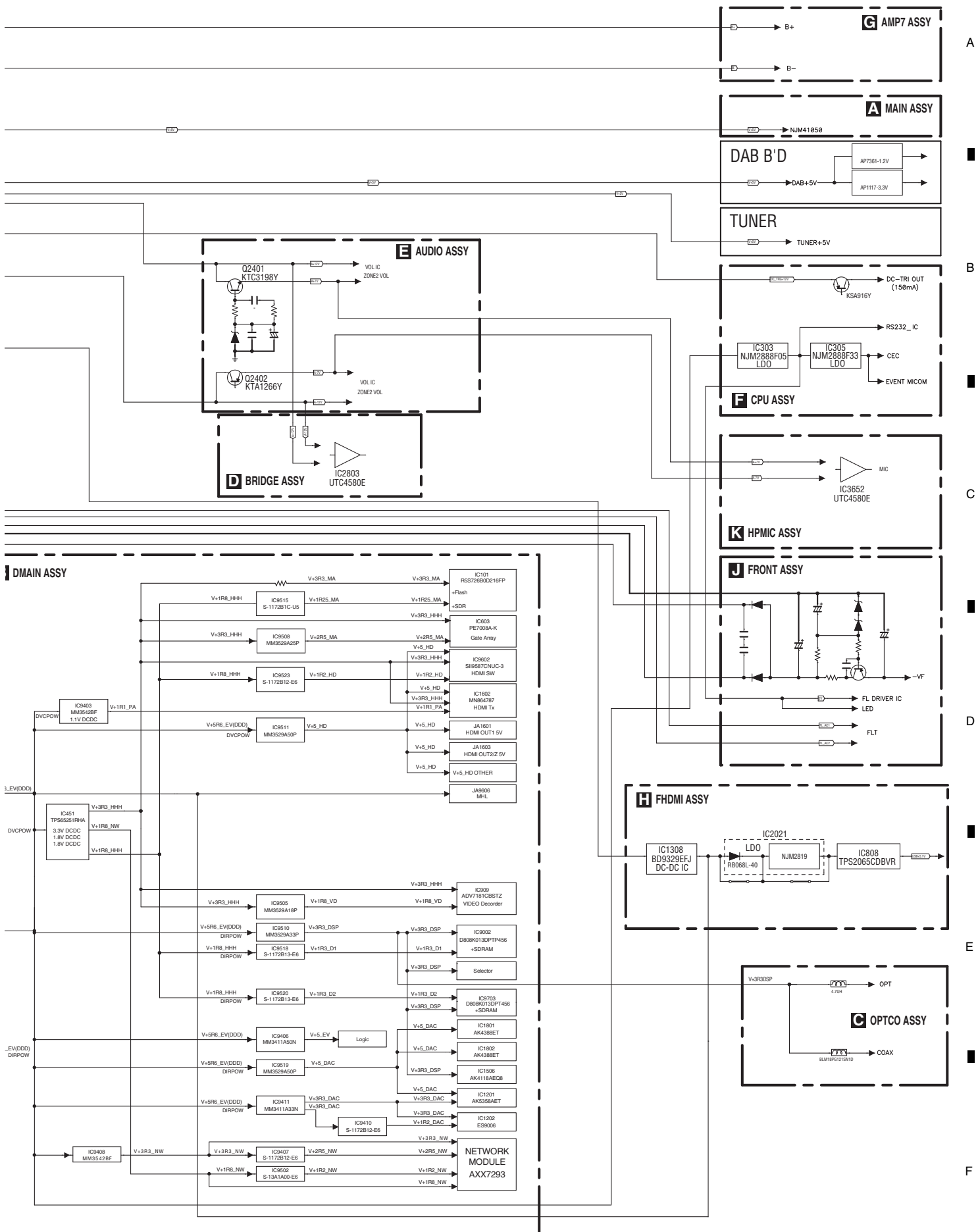

4.7 GND BLOCK DIAGRAM

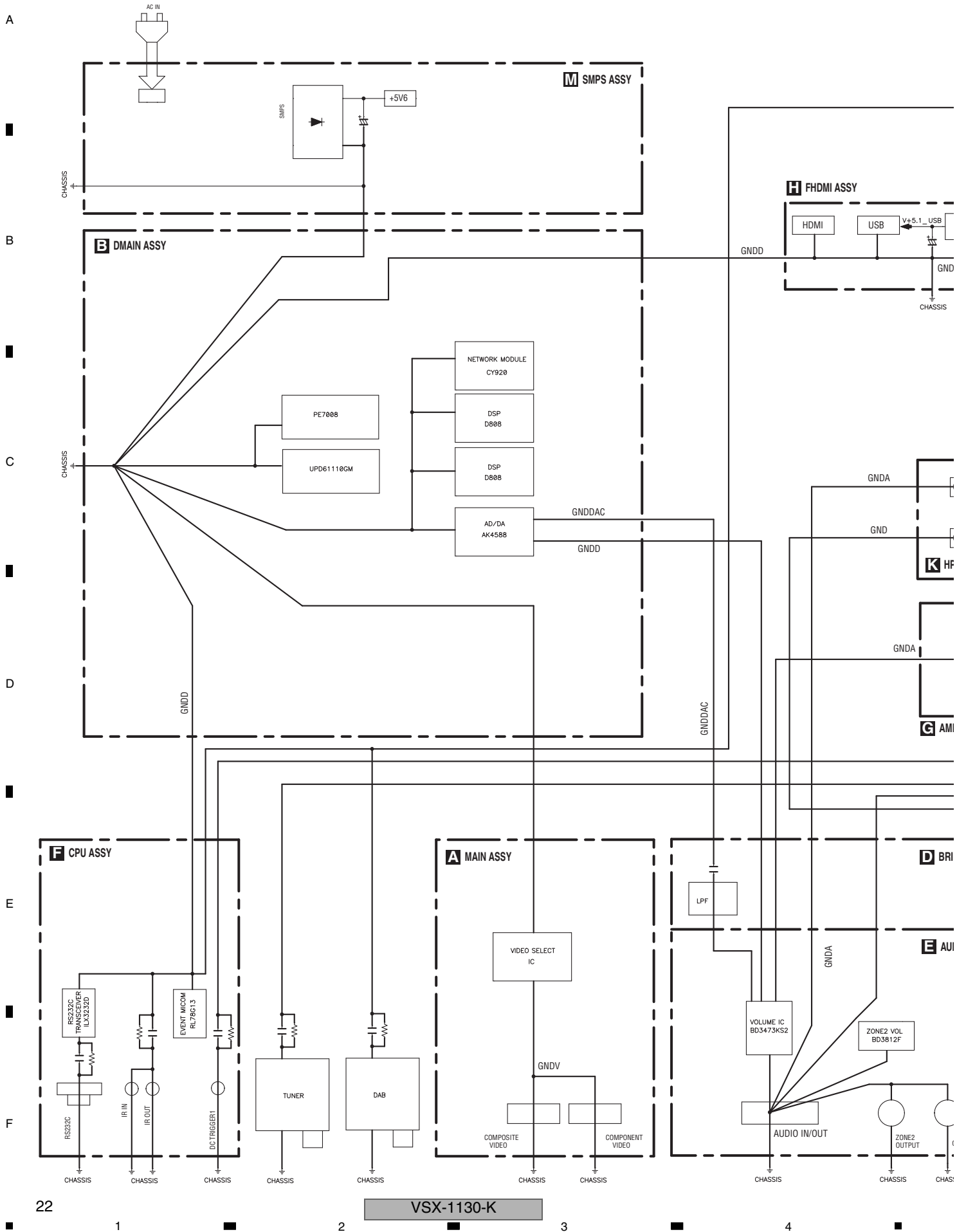

A
B
C
D
E
F

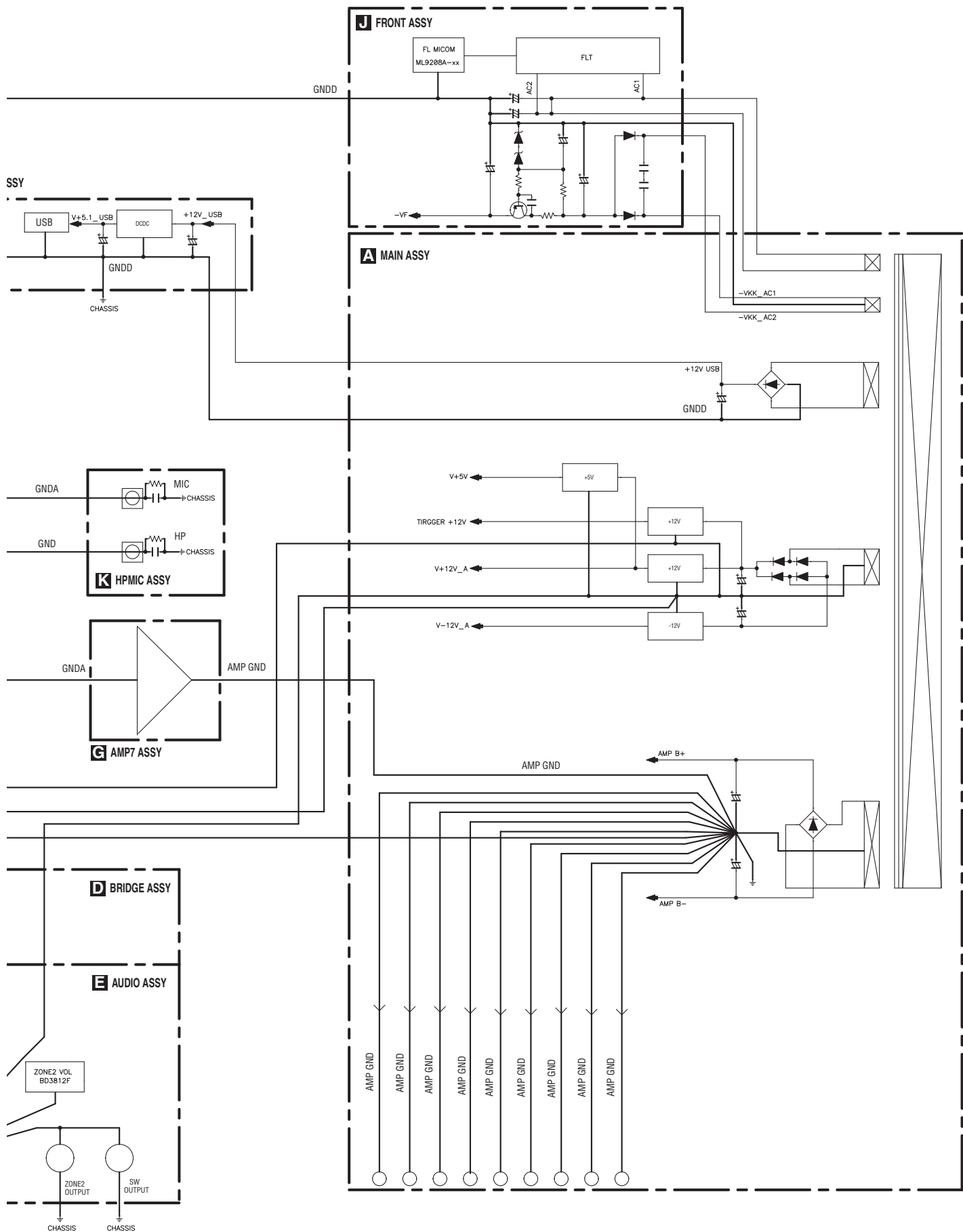

5. DIAGNOSIS

5.1 TROUBLESHOOTING

A No Power

This is just for general reference and does not including every single case.

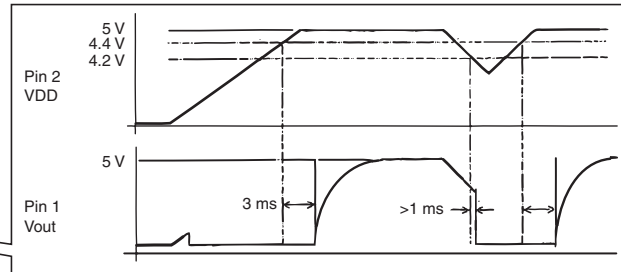
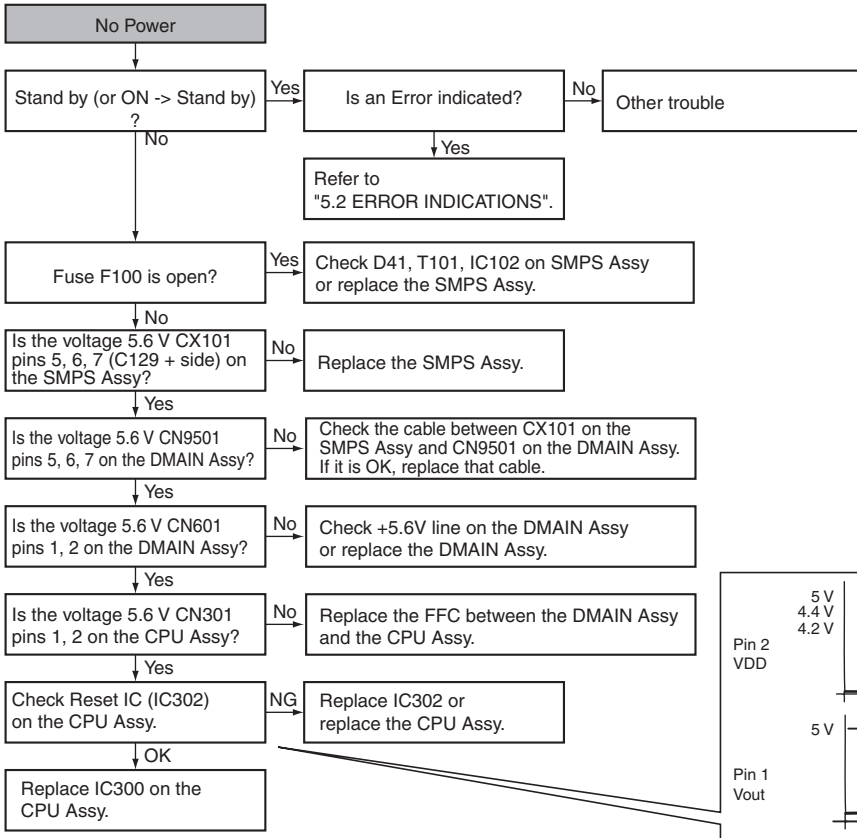

D No FL Display

This is just for general reference and does not including every single case.

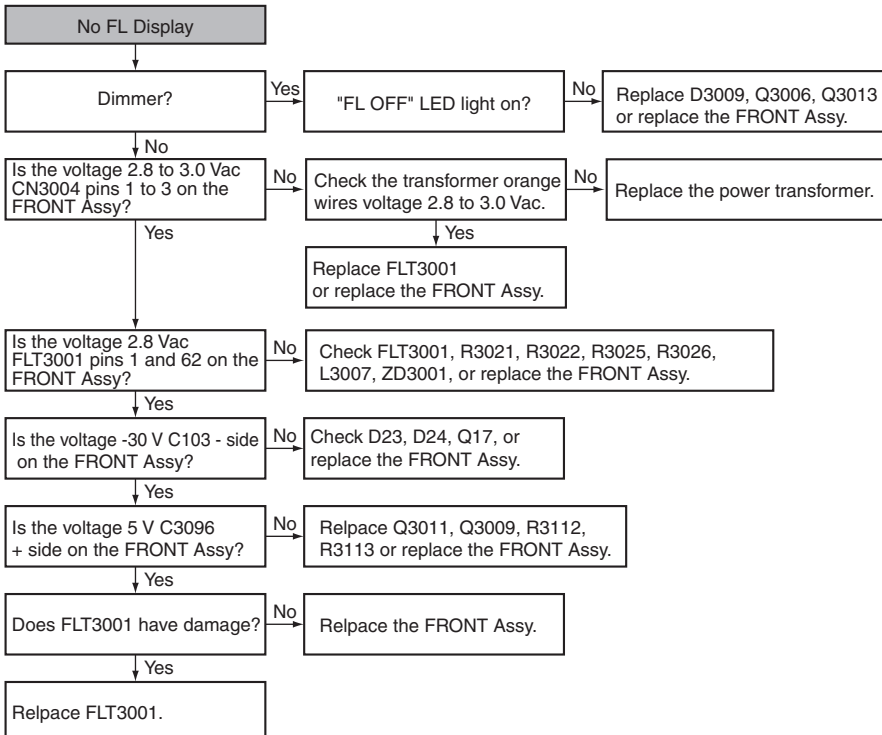

No Sound

This is just for general reference and does not including every single case.

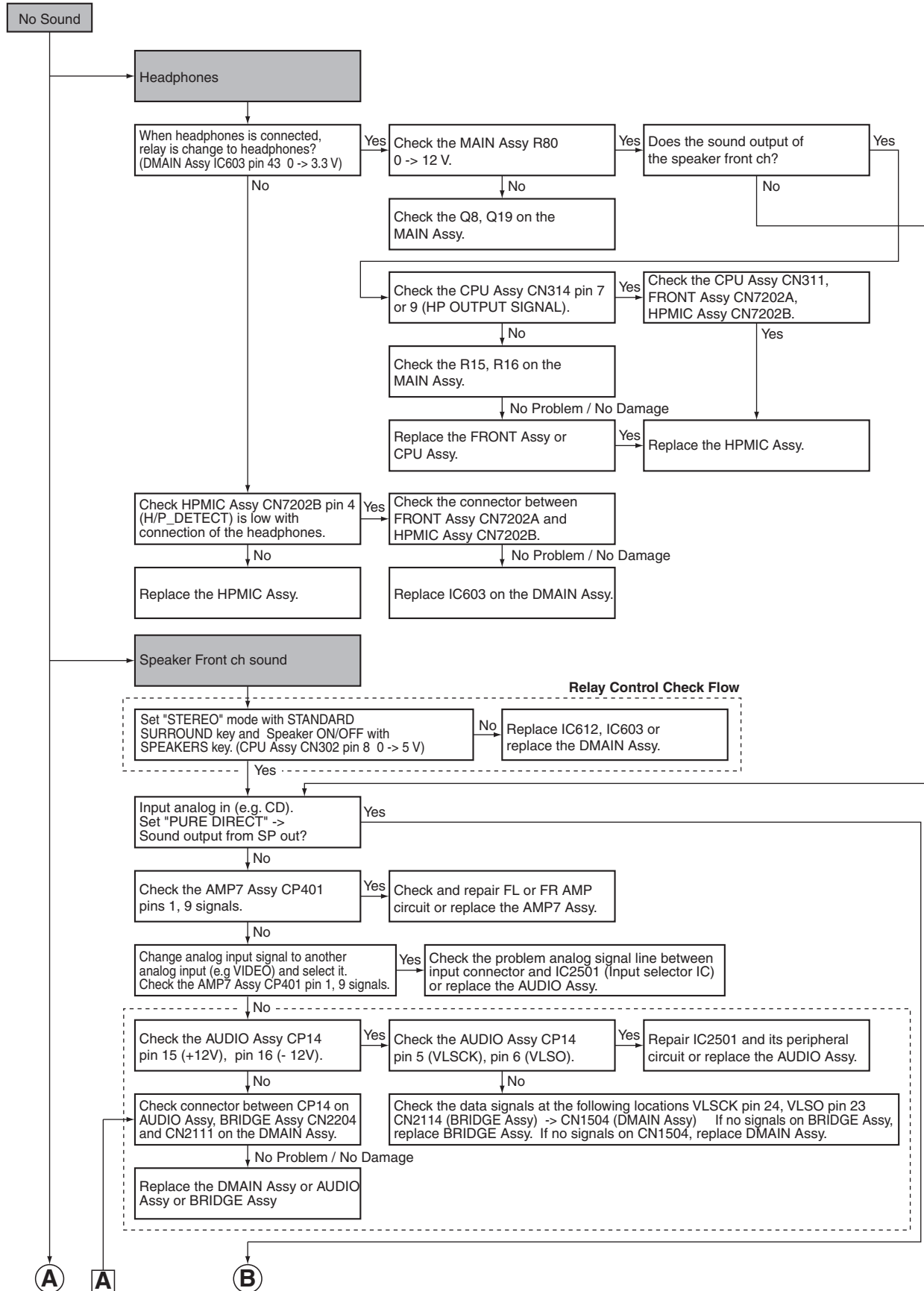

A
B
C
D
E
F

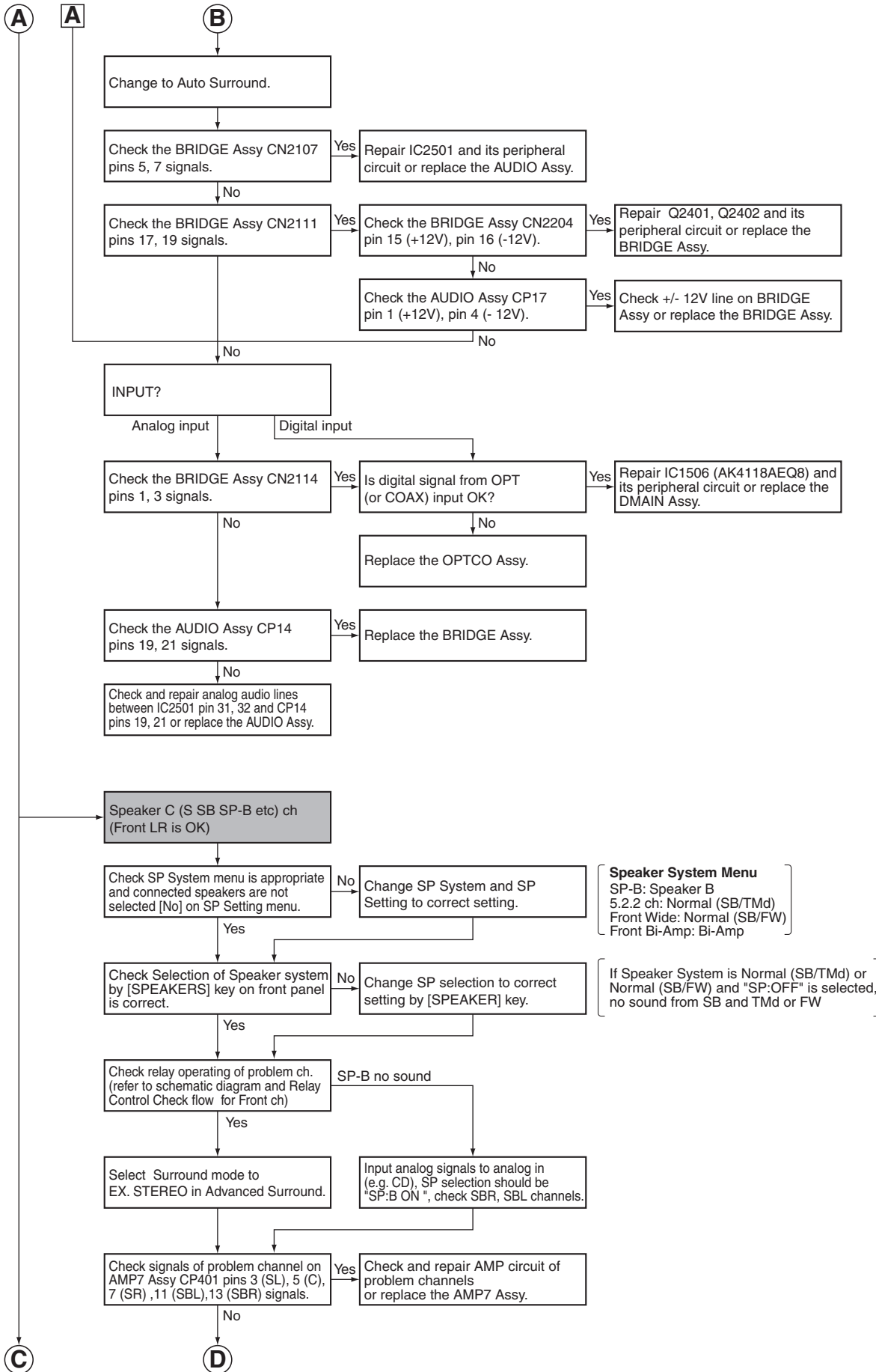

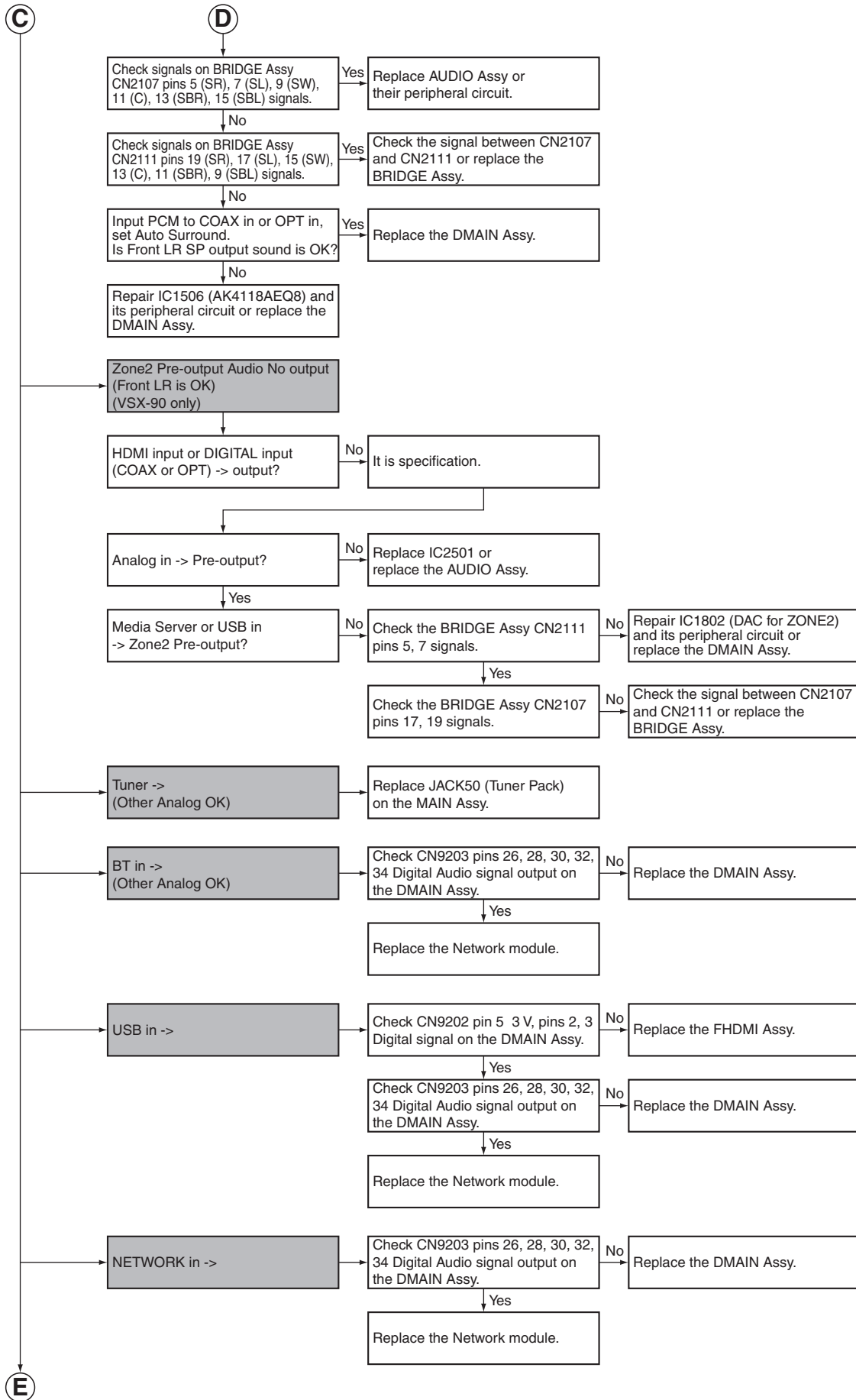

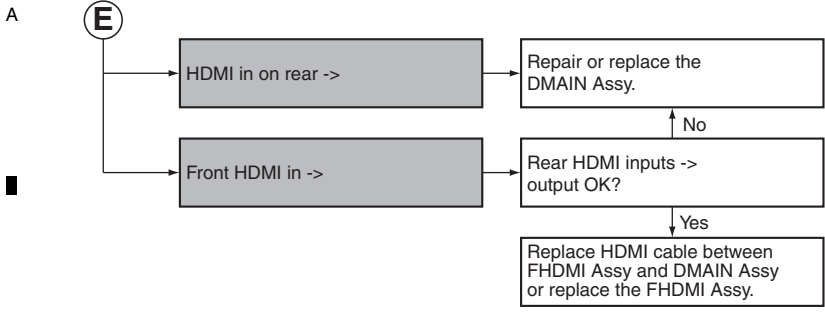

B

No Picture

This is just for general reference and does not including every single case.

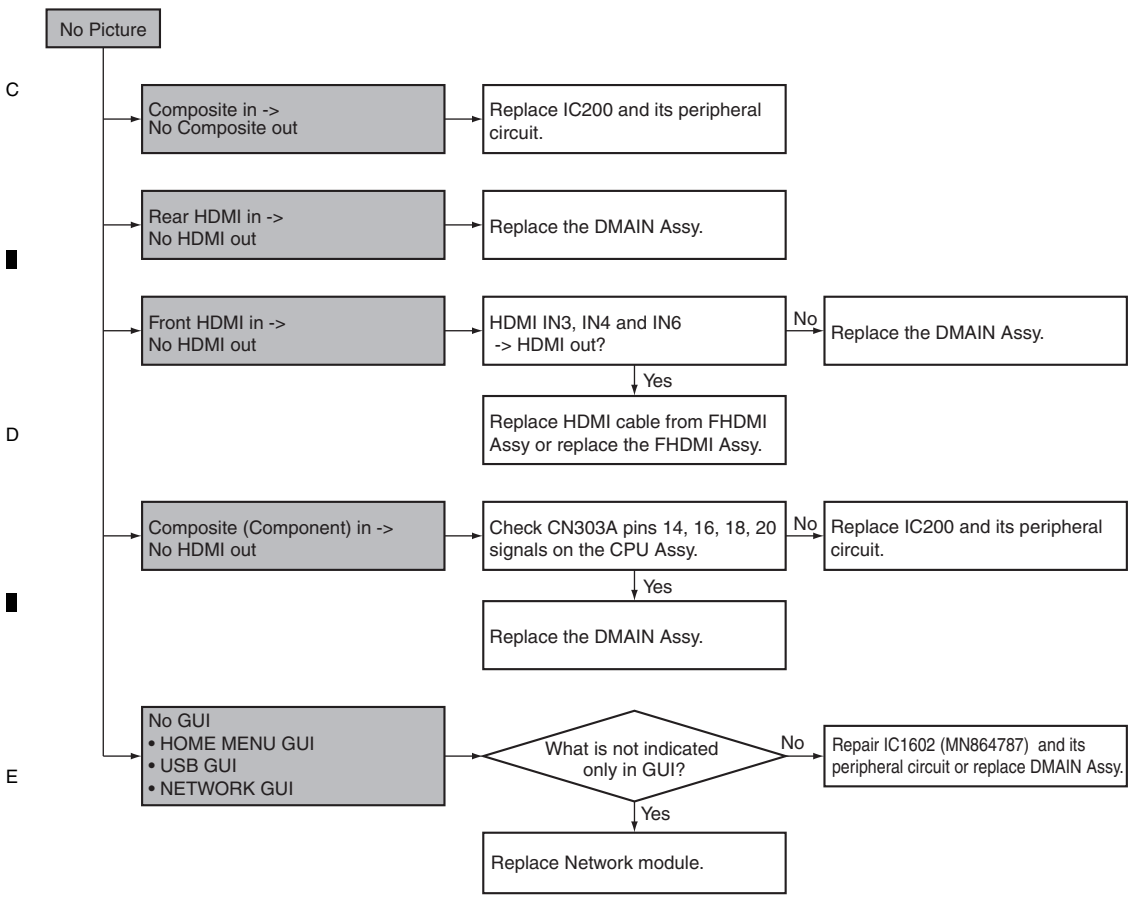

F

Others

This is just for general reference and does not including every single case.

12V Trig



No

RS-232C



No

IR

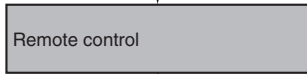
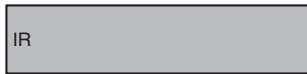

Yes

No

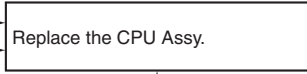

A

B

C

D

E

F

5.2 CONFIRMATION OF THE NETWORK MODULE

A Check if the set SSID of this unit is displayed on a device such as a PC or a smart phone, following the procedures shown below. If the SSID is displayed on the device, the antenna connections of the Network module are normal. If the SSID is not displayed, check the antenna cable connections on the network module.

Procedures:

① Press "Home Menu" button on a remote control and select "Network Connection" from the Network, Bluetooth menu on screen.

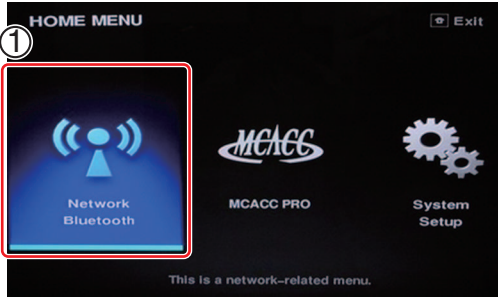

B

③ Select the encryption method to "None" with ← / → from Security Protocol.

④ Select "Frequency Band" at ↓ and select the frequency to "2.4GHz".

⑤ Select "OK" then press ENTER. "Setting change?" window is displayed, then select "YES" and press ENTER.



C

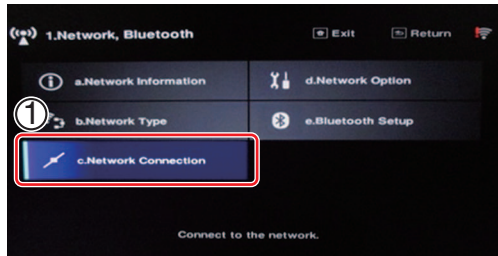

② Select "Wireless Direct" from the Network Connection menu.

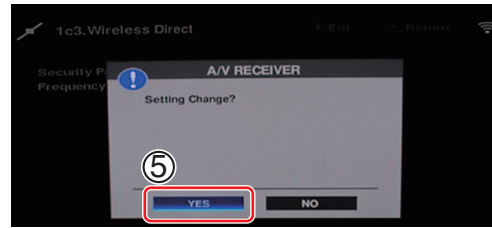

D



⑥ Select the SSID shown on the screen of this receiver. (e.g. WirelessDirectX: XXXXXX)

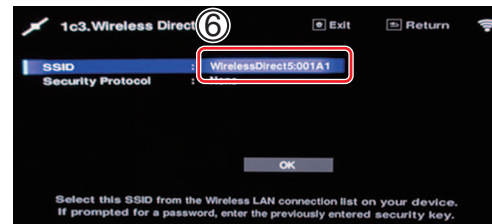

E

F

How to Check on a PC Equipped with a Wireless LAN Device

[Windows 7]

- ① Left-click on the wireless network icon on the system tray.
- ② Check that the above-mentioned SSID (WirelessDirectX:XXXXXX) is displayed on the list that appears.



How to Check on a Smartphone (Example: iPod Touch)

- ① At the top screen of an iPod Touch, select Settings.



- ② Select Wi-Fi.



- ③ Check that the above-mentioned SSID (WirelessDirectX:XXXXXX) is displayed in the "Choose a Network" box.



5.3 ERROR INDICATIONS

■ Error Indications When an Abnormality in The Amplifier System is Detected

[Purpose]

Errors upon detection of abnormalities in the amp system are indicated.

■ [Error Indications]

Item	FL Display	LED Flashes	NG Count.	Detection Method	Process After Detection	Description / Remarks
"AMP DC" ("DC output from SP term") detection	Flashing "AMP ERR" for 3 seconds	ADVANCED MCACC LED	DC	XDCERR (Pin 21 of IC300) Detect "L"	1) Muting on, speaker relay off. 2) "AMP ERR" flashing 3) Shutdown after 3 seconds. 4) "ADVANCED MCACC" LED flashing 5) Power on is not acceptable.	To detect high DC output from amplifier damage (defect status). A process to protect speakers (for protection of connected external devices). For checking, refer to "How to enter release mode" below. If the DC detection port become "H" for 3 seconds, the unit will returns to normal condition automatically.
"AMP overload" detection.	N/A	Wireless LED	OL	XOLERR (Pin 13 of IC300) Detect "L"	1) Muting on, speaker relay off. 2) Shutdown immediately. 3) "Wireless" LED flashing 4) Power on is acceptable.	To detect overloading (abnormal status) with low-load driving or a short circuit of the speaker terminals (for protection of the amplifier).
"Over Heat" detection.	Flashing "AMP OVERHEAT" for 3 seconds	FL OFF LED	STMP	TEMPERR5 (Pin 24 of IC300) Detect "L" (REDI_DET)	1) Muting on, speaker relay off, 2) "AMP OVERHEAT" flashing 3) Shutdown after 3 seconds. 4) "FL OFF" LED flashing 5) Power on is acceptable after 1 minute.	To detect overheat of inner temperature. If the TEMPERR5 port become "H" for 3 seconds, the unit will returns to normal condition automatically.
"Abnormality DC voltage of the Digital power supply" detection	N/A	Wireless LED	DERR	XVDDERR (Pin 60 of IC300) Detect "L"	1) Muting on, speaker relay off. 2) Shutdown immediately. 3) "Wireless" LED flashing 4) Power on is acceptable.	To detect the abnormality voltage of Digital power supply circuit for the DMAIN Assy.
"USB Overload" detection	"Over Current" No Flashing	N/A	N/A	USB ERR (VCO0) (DM920) Detect "L"	1) USB bus Power off 2) Display "Over Current"	To detect the connected USB device is overload. (over 2.1 A)
"HDCP of HDMI Error" detection	Flashes "HDCP ERROR" for 5 seconds	N/A	N/A	Read Register value	1) Display "HDCP ERROR"	The monitor does not support HDCP type or is in standby mode. (Warning indication for HDMI Simplay)
Analog POWER SUPPLY Error	N/A	ADVANCED MCACC LED	XPRT	XPROTECT (Pin 12 of IC300) Detect "L"	1) Muting on, speaker relay off. 2) Shutdown immediately. 3) "ADVANCED MCACC" LED flashing 4) Power on is acceptable after 1 minute.	Power-on impossible for 1 min.
"Temp Over" detection	N/A (VOL LEVEL)	N/A	N/A	TEMP L (TR_DET) (Pin 11 of IC300) Detect "L"	VOL 3 dB down	After this error is detected, the system interrupts the "Temp Over" detection for 2 minutes.

[How to Enter Release Mode]

During Standby mode, simultaneously press and hold the "TUNE ↓" and "MULTI-ZONE ON/OFF" keys for 5 seconds.

Protection Circuit Process List (XMHLPERR)

Item	Purpose	Detection Method	Status of Equipment	Warning Indication	Remarks
MHL Overcurrent detection	Detection of overcurrent in MHL power supply	IC9603 detects MHL circuit overcurrent and XMHLPERR port is set to "L".	Flashes "MHL POW ERR" and stops MHL power supply.	Flashes "MHL POW ERR".	MHL power is not supplied until the MHL equipment is acknowledged after second power-on.

XMHLPERR Circuit

DMAIN ASSY

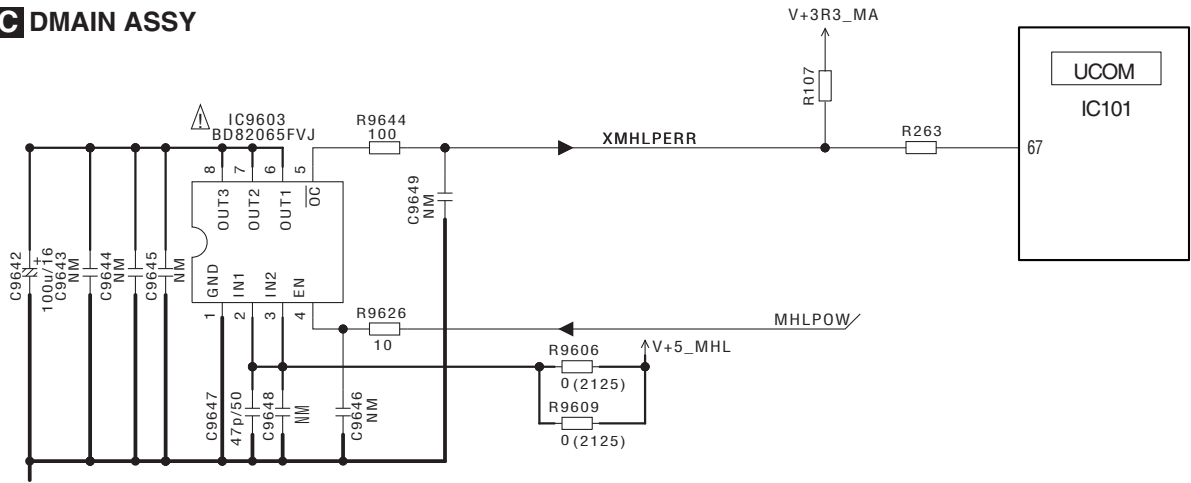

5.4 PROTECTION CIRCUIT

[1] Overload and DC Protection Circuit

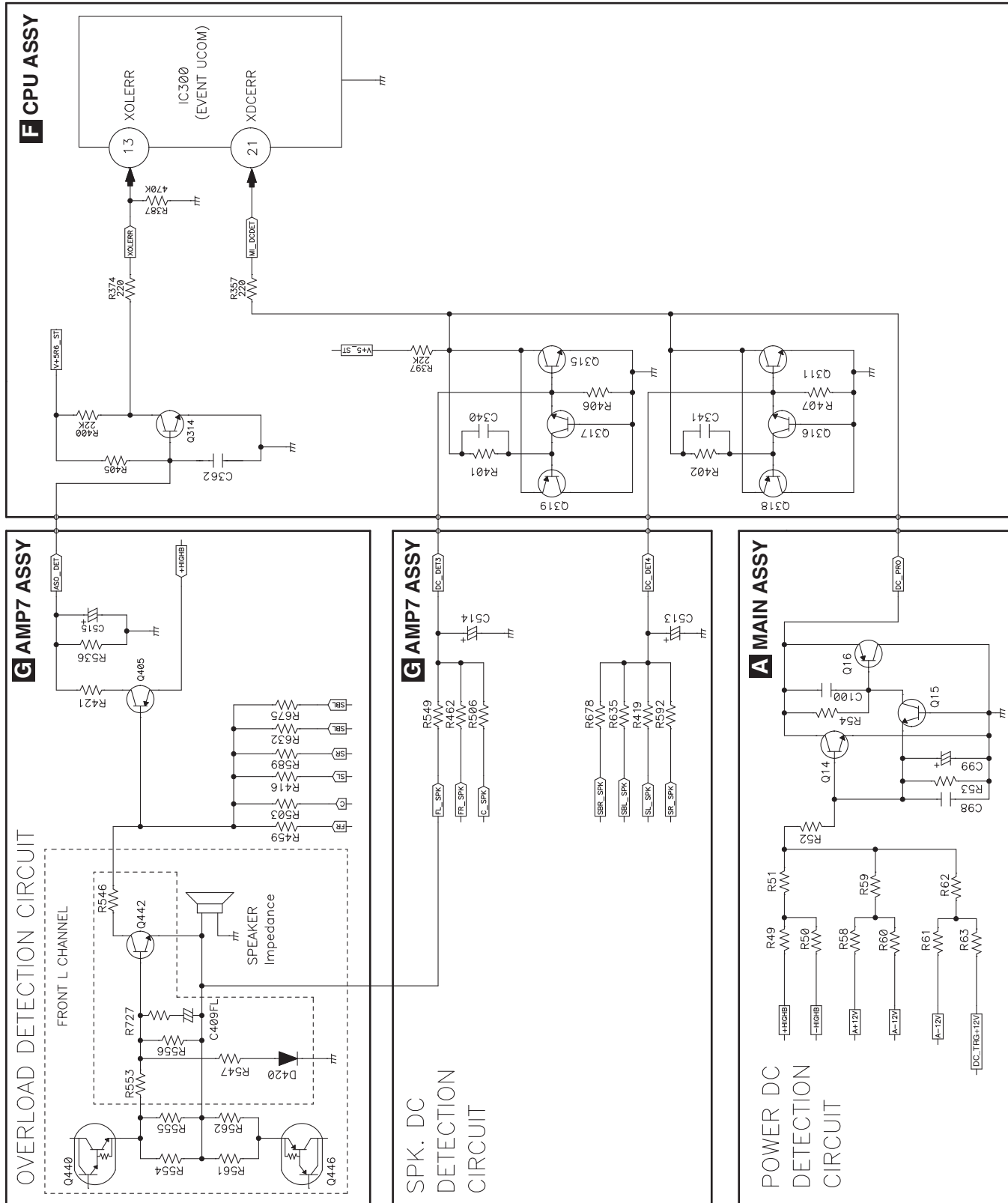

Reference information

- Each DC power supply voltage value that DC PROTECT circuit works
- +HIGH: Less than +54 V (at normal: +63 V)
 - -HIGH: More than -52 V (at normal: -63 V)
 - A+12V: Less than +8 V (at normal: +12 V)
 - A-12V: More than -9 V (at normal: -12V)
 - +12V TRIGGER: Less than +8 V (at normal: +12 V)(VSX-90 only)

[2] TEMP Protection Circuit

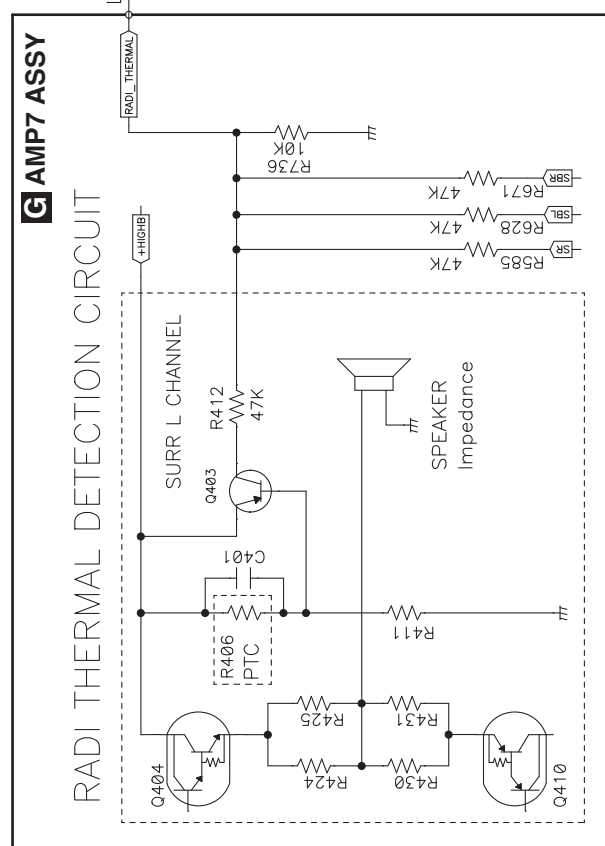
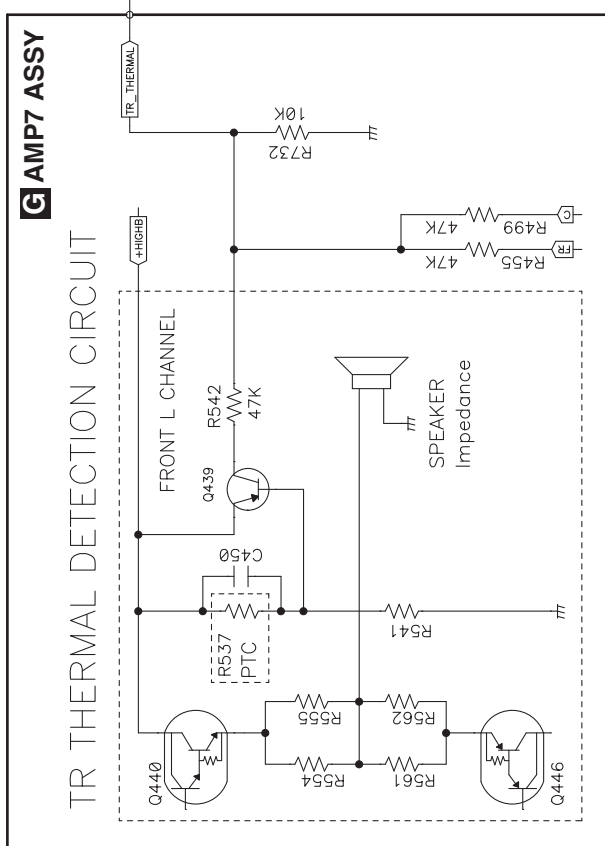
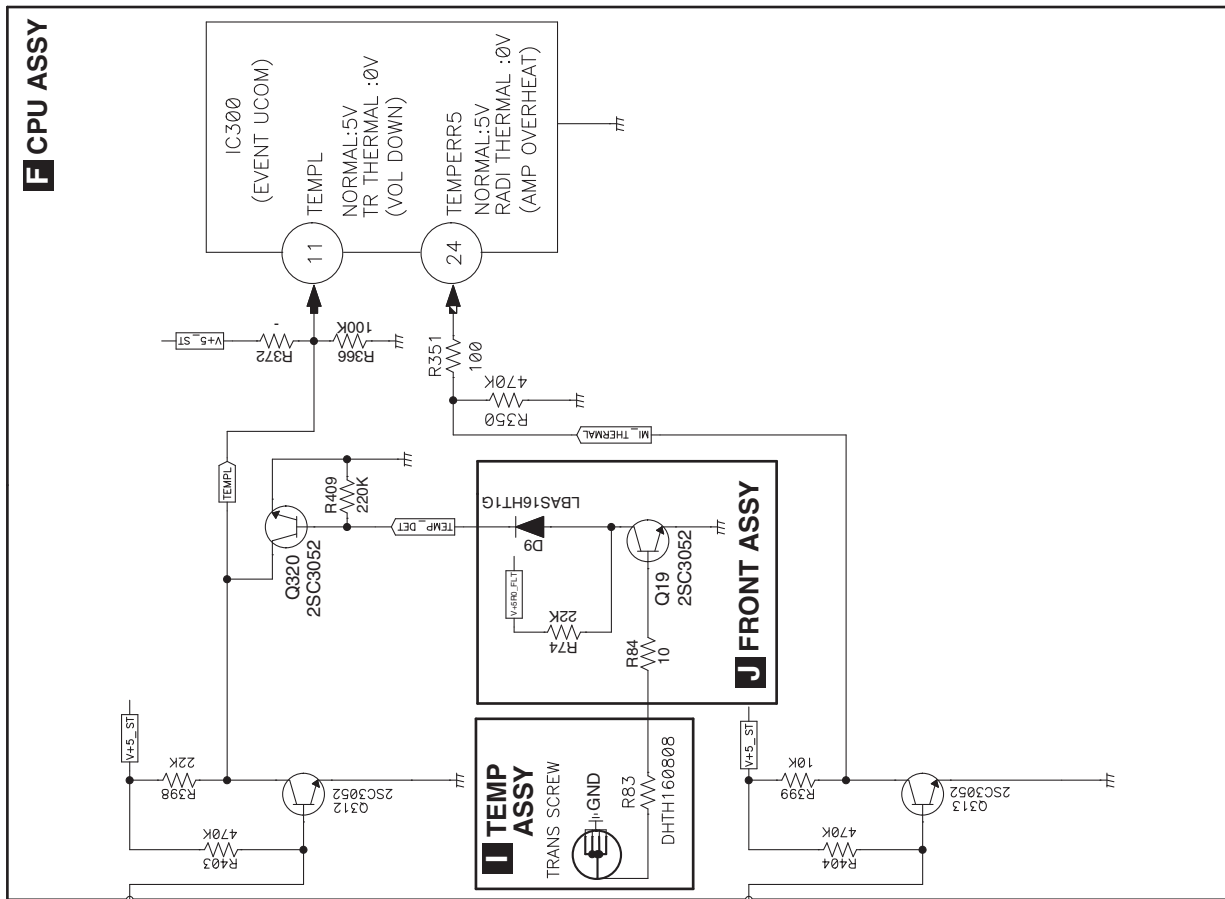

6. SERVICE MODE

6.1 TEST MODE

A [1] Detected protection history

[Purpose]

The numbers of detections for various protection processes are displayed.

[How to enter]

During Standby mode, simultaneously press and hold "MULTI-ZONE ON/OFF" and "ENTER" keys for 5 seconds to enter this mode. Turn off the power to this unit by setting the main volume level to "---dB" and Multi-zone to "OFF".

[How to exit]

Turning off the power or pressing the RETURN key returns to the normal mode.

[Basic operations]

Key operation	FL display
Display number of times DC is detected. [↓] [↑]	DC : ***
Display number of times OVERLOAD is detected. [↓] [↑]	OL : ***
Display number of times COMBINATION is detected. (Detects DC and OVERLOAD simultaneously) [↓] [↑]	COM : ***
Display number of times Power abnormality is detected. [↓] [↑]	XPRT : ***
Display number of times AMP overheat is detected. [↓] [↑]	STMP : ***
Display number of times Digital Power abnormality is detected. [↓] [↑]	DERR : ***
Resetting the number of times error is detected. [↓] [↑]	RESET ◀HOLD▶

Front Panel Key

- [↓] : TUNE key
- [↑] : TUNE key
- [←] : PRESET key
- [→] : PRESET key

Resetting the number of times error is detected

Key operation	FL display
[←][→]	RESET ◀CLEAR?▶
[ENTER]	RESET ◀RESET▶

Continued

Key operation	FL display
Display accumulated time & RESET.	1 2 3 4 5 h 2 0 m ◀ HLD ▶
[↓] [↑]	
Display CEC(TEST) state.	CEC ◀ OFF ▶
[↓] [↑]	
Display FAN(TEST) state. This function does not work on this model.	FAN ◀ OFF ▶
[↓] [↑]	
USB Backup state	USB BAK ◀ HOLD ▶
[↓] [↑]	
Display Wireless disconnection judgement time	WLAN DC ◀ 3 min ▶
[↓] [↑]	
Display Model Name/Destination state.	VSX-1130/CUXESM VSX-90/CUXE
[↓] [↑]	
Change cyclically	

Resetting the accumulated time

Key operation	FL display
[←][→]	1 2 3 4 5 h 2 0 m ◀ CL? ▶
[ENTER]	0 h 0 0 m ◀ RST ▶
Continued	

Display CEC(TEST) state.

Key operation	FL display
[←][→]	CEC ◀ ON ▶
Change cyclically	

Saving and Loading of USB backup state.

Key operation	FL display
[←][→]	(A/V Receiver → USB) USB BAK ◀ SAVE? ▶
[←][→]	(USB → A/V Receiver) USB BAK ◀ LOAD? ▶
Change cyclically	

Key operation	FL display
[ENTER]	PLEASE WAIT
SAVE or LOAD is completed. ↓ 5 sec	COMPLETE
Power OFF (All zone OFF)	

Selecting Wireless disconnection judgement time

Key operation	FL display
[←][→]	WLAN DC ◀ 5 min ▶
↓	<10min>, <15min>, <30min>
[←][→]	WLAN DC ◀ 60 min ▶
Change cyclically	

[Description]
 CEC TEST : The function for making the HDMI output terminal to output 4 Hz square wave. If the square wave is output, the CEC line is considered to be normal.
 FAN TEST : The function for making the FAN to be forced to rotate.

6.2 DEFAULT SETTINGS

A Default system settings

Setting		Default
SPEAKERS		SB/TMd ON
Speaker System		7.2ch/5.2.2ch
Speaker Setting	Front	SMALL
	Center	SMALL
	TMd	SMALL
	FW	SMALL
	Surr	SMALL
	SB	SMALLx2
Surround Position	SW	YES
		ON SIDE
Crossover		80Hz
X-Curve		OFF
DIMMER		Brightest
Inputs		
Input Volume Absorber	All Inputs	0dB
HDMI		
HDMI Audio		AMP
Control		OFF
Control Mode		--- (OFF)
ARC (Audio Return Channel)		--- (OFF)
Standby Through		OFF
4K/60pBD		4:2:0
4K/60pH1 (HDMI IN 1)		4:2:0
4K/60pH2 (HDMI IN 2)		4:2:0
DSP		
Power On Level		LAST
Volume Limit		OFF
Mute Level		FULL
Phase Control		ON
Auto Sound Retriever		OFF
Sound Delay		0 ms
Dual Mono		CH1
DRC		OFF
LFE Attenuate		0dB
Auto delay		OFF
Digital Safety		OFF
Effect Level	ALC (Auto Level Control)	50
Center Spread		OFF
Neo:6 Options	Center Image	Neo:6 CINEMA: 10 Neo:6 MUSIC: 3
All Inputs	Listening Mode (2 ch/multi ch)	AUTO SURROUND
	Listening Mode (Headphones)	STEREO
MCACC		
MCACC Position Memory		M1. MEMORY 1
Channel Level (M1 to M6)		0.0 dB
Speaker Distance (M1 to M6)		10'00"
Standing Wave (M1 to M6)	ATT of all channels/filters	0.0 dB
	SWch Wide Trim	0.0 dB
EQ Data (M1 to M6)	All channels/bands	0.0 dB
	EQ Wide Trim	0.0 dB
Network		
Network Standby		ON
DHCP		ON

Default input settings

Input function	Input Terminals		
	HDMI	Audio	Component
BD	(BD)		
DVD	IN 1	●	●
SAT/CBL	IN 2	COAXIAL	IN
HDMI 1	●		
HDMI 2	●		
HDMI 3	IN 3		
HDMI 4	IN 4		
HDMI 5 (front panel)	IN 5		
HDMI 6/MHL	IN 6		
INTERNET RADIO			
PANDORA			
Spotify			
MEDIA SERVER			
FAVORITES			
iPod/USB			
TV		OPTICAL <a>	
CD		ANALOG-1 	
TUNER			
BT AUDIO			

- a When **ARC** at **HDMI Setup** is set to **ON**, it is not possible to make assignments to the **TV** input's **Audio In** terminals.
- b Only the **TV** and **CD** inputs can be assigned to **ANALOG-1**.

Resetting the system

Use this procedure to reset all the receiver's settings to the factory default. Use the front panel controls to do this.
Set MULTI-ZONE to **MULTI ZONE OFF**.

- Disconnect the iPod and USB memory device from the receiver beforehand.
- Set the **Control** with HDMI to **OFF**.

- 1 **Switch the receiver into standby.**
 - 2 **While holding down ENTER on the front panel, press STANDBY/ON.**
The display shows **RESET ◀ NO ▶**.
 - 3 **Select 'RESET' using PRESET , then press ENTER on the front panel.**
The display shows **RESET? OK**.
 - 4 **Press ENTER to confirm.**
OK appears in the display to indicate that the receiver has been reset to the factory default settings.
- Note that all settings will be saved, even if the receiver is unplugged.

5

6

7

8

7. DISASSEMBLY

Note:

Even if the unit shown in the photos and illustrations in this manual may differ from your product, the procedures described here are common.

Some connections of the housing wires or connectors may be tight. When disconnecting those wires or connectors, be careful not to damage them.

1. Discharging

[1] MAIN Assy Capacitor (C55, C58)

[Procedures]

- (1) Unplug the power cord.
- (2) Disconnect the 10P connector from CP403 of the AMP7 Assy between CN3 of the MAIN Assy.
- (3) Connect +B and -B terminal of the D7, using resistor leads with 47 - 100 ohms (2 W or higher), for discharging.
 - * Discharging time: 30 - 60 seconds, depending on the level of resistance.
- (4) Check that the voltage between the +B and -B terminals is less than 1 V, using a tester.
 - * Be sure to connect the GND terminal of the tester to the chassis.
 - * If the voltage is still 1 V or higher, repeat Step (3).

[2] FL-30 V Capacitor (MAIN Assy C101)

[Procedures]

- (1) Unplug the power cord.
- (2) Connect C101 (-30V) and GND of the FRONT Assy, using resistor leads with 47-100 ohms (2 W or higher), for discharging.
 - * Discharging time: 5 - 10 seconds, depending on the level of resistance.
- (3) Check that the voltage between the -30V terminal is less than 1 V, using a tester.
 - * Be sure to connect the GND terminal of the tester to the chassis.
 - * If the voltage is still 1 V or higher, repeat Step (2).

VSX-1130-K

5

6

7

8

39

2. Disassembly

Note:

For performing the diagnosis shown below, the following jigs for service is required:

- Board to board extension jig cable (27P)(GGD1873)
- Board to board extension jig cable (25P)(GGD1874)
- Board to board extension jig cable (15P)(GGD1848)
- Board to board extension jig cable (17P)(GGD1889)
- 13P extension cable (GGD1740)
- 5P extension cable (GGD1741)
- HDMI cable (marketed product)

[1] Front Panel Section

Remove the cabinet by removing the 10 screws.

- (1) Remove the 5 screws. (BBZ30P080FTB)
- (2) Remove the foot by removing the 1 screw. (BBZ30P080FTC)
- (3) Remove the 1 screw. (BBZ30P080FTC)

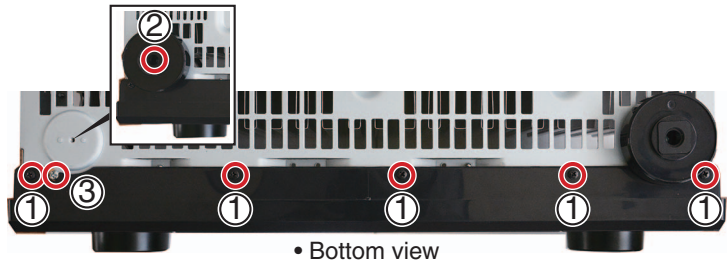

- (4) Remove the 2 screws. (BBZ30P080FTC)
- (5) Remove the 2 screws. (1500001206010-IL)
- (6) Remove the acetate tape.
- (7) Disconnect the HDMI cable. (JA9620)
- (8) Disconnect the 1 flexible cable and 5 connectors. (CN305, 314, 3004, 9202, 9502, CP5)
- (9) Release the 1 jumper wire.
- (10) Cut the 6 cable ties.

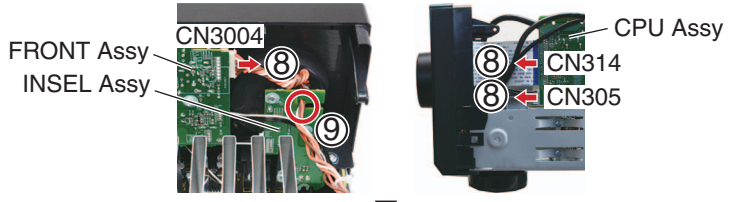
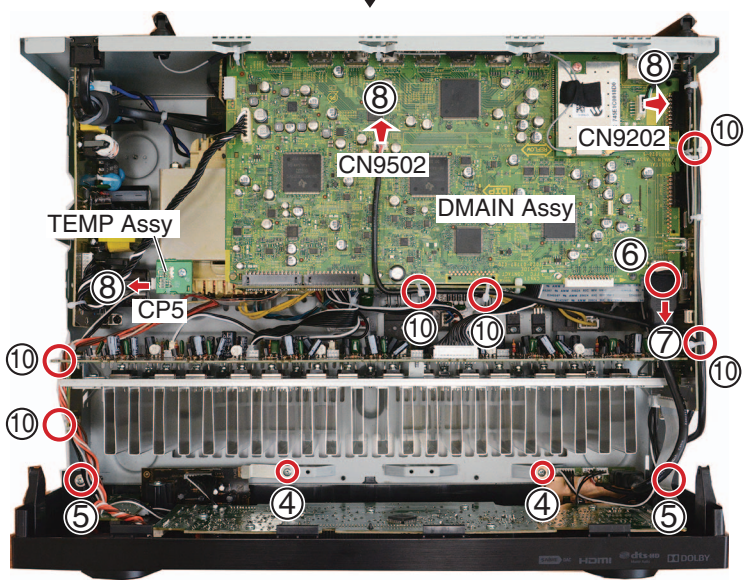

- (11) Unhook the two hooks.
- (12) Remove the front panel section.



[2] Heatsink Section

Caution: Heatsink section in work becomes hot, and be careful with it.

Remove the cabinet by removing the 10 screws.

(1) Remove the 3 screws.
(BBZ30P080FTC)

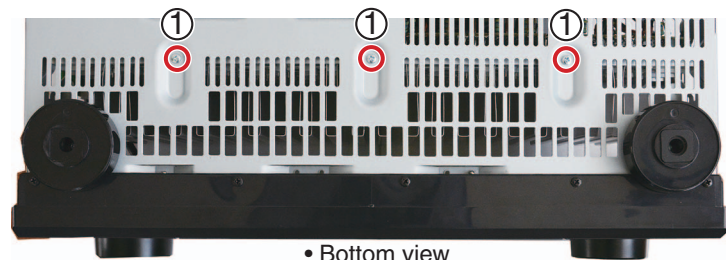

(2) Remove the 4 screws.
(BBZ30P080FTC)

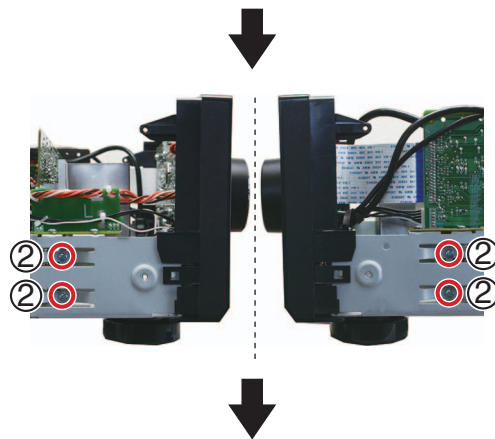

(3) Remove the acetate tape.
(4) Disconnect the HDMI cable.
(JA9620)
(5) Release the jumper wires.
(6) Disconnect the 2 connectors.
(CN404, CP401)
(7) Cut the 1 cable tie.
(8) Remove the Heatsink section.

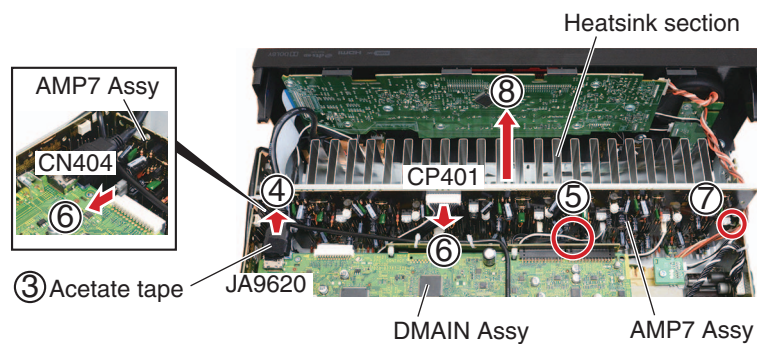

(9) Arrange the Heatsink section as shown in the photo below.
(10) Connect the 2 extension jig cables.

↓

Diagnosis

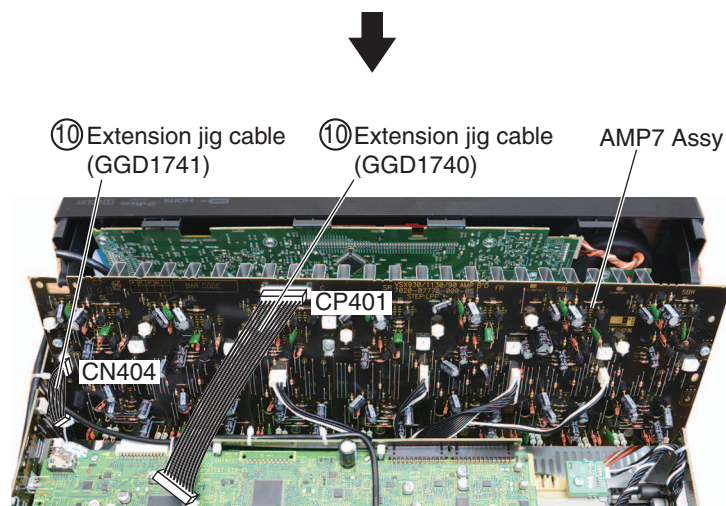

A [3] DMAIN Assy

Remove the cabinet by removing the 10 screws.

[3-1] DMAIN Assy

- (1) Remove the 6 screws. (BBT30P100FTB)
- (2) Remove the 8 screws. (BSZ30P040FTB)

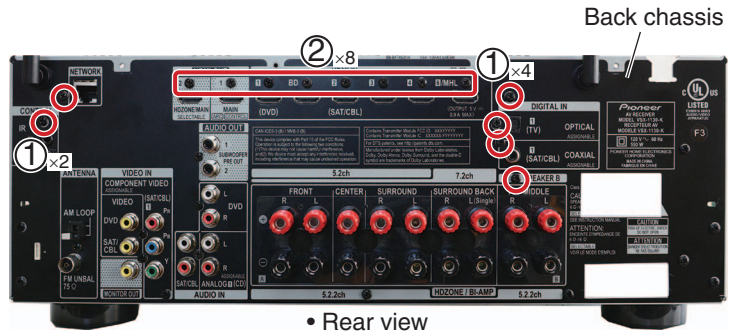

B

C



- (3) Remove the 1 screw. (BBZ30P080FTC)
- (4) Remove the acetate tape.
- (5) Disconnect the HDMI cable. (JA9620)
- (6) Cut the 5 cable ties.
- (7) Remove the acetate tape.

Note:
Also, cleanly remove the tape that secures the antenna cable on the Network module (AXX7293).

- (8) Disconnect the 2 antenna cables.
- (9) Disconnect the 4 B to B connectors. (CN607, 902, 1504, 1801)

Note: Some connections of the housing wires or connectors may be tight. When disconnecting those wires or connectors, be careful not to damage them.

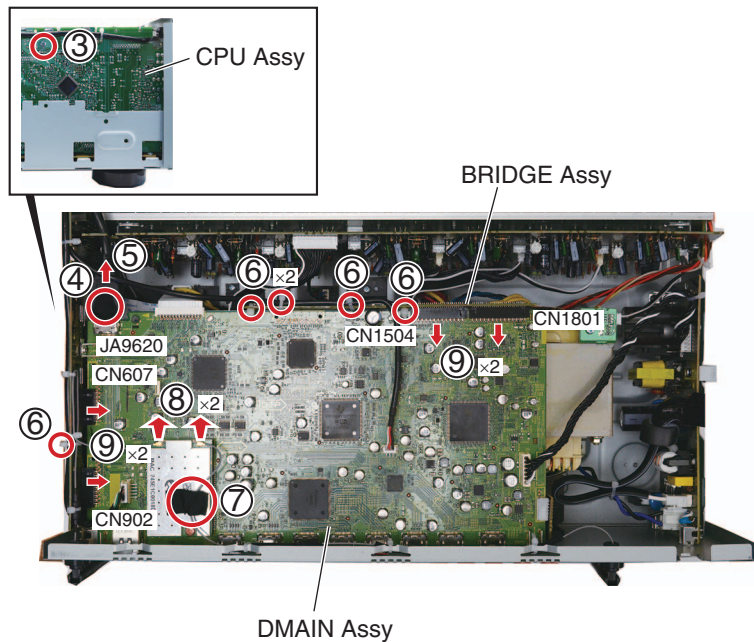

F



[3-2] Diagnosis

- (1) Arrange the DMAIN Assy in the photo below.
- (2) Connect the 4 extension jig cables.
- (3) Insert any insulation sheet.
- (4) Connect the HDMI cable (marketed product) from the FHDMI Assy if Front HDMI input needs to be checked.

Note:

Do not connect the HDMI cable provided with the product to prevent damage to the HDMI connector. Instead, use the another HDMI cable (marketing product) to prevent a load from being applied to the HDMI connector.

DMAIN Assy works normally even though no connection of HDMI cable. But when checking Front HDMI input, that HDMI connection is required.



Diagnosis

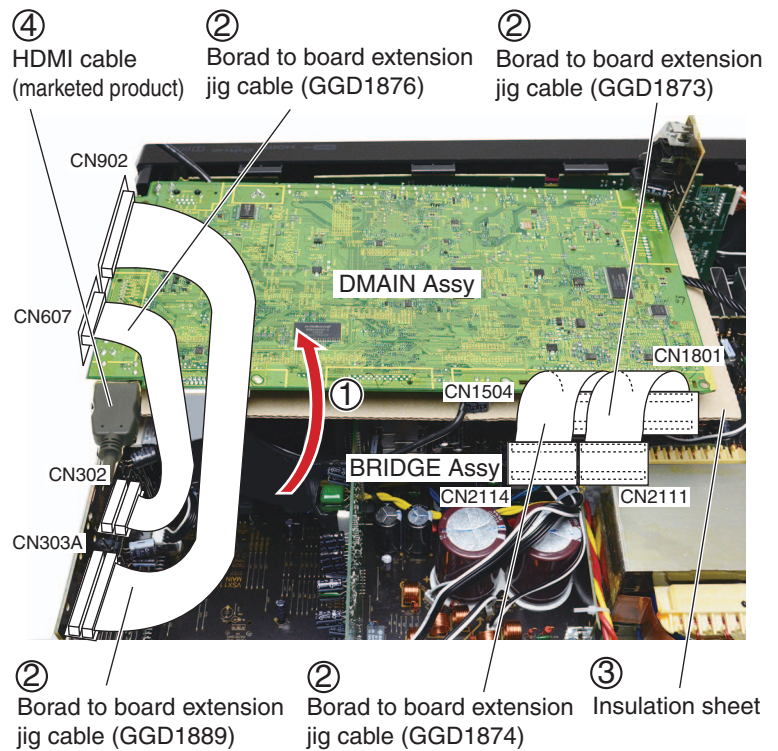

[3-3] Network module (AXX7293)

- (1) Remove the 1 screw.
(BSZ30P040FCC)
- (2) Disconnect the 2 antenna cables.

Note:

After having attached the network module to DMAIN Assy, attach the antenna cables to the network module surely.

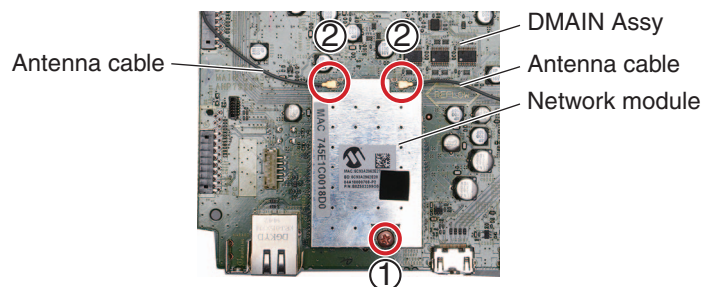

- (3) Insert the tip of a large screwdriver into either part circled in red in the photo.

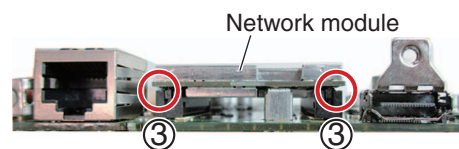

• Rear view



- A (4) Rotate the screwdriver a little to widen the gap between the network module and the connector to several millimeters. Do the same for the other part circled in red.

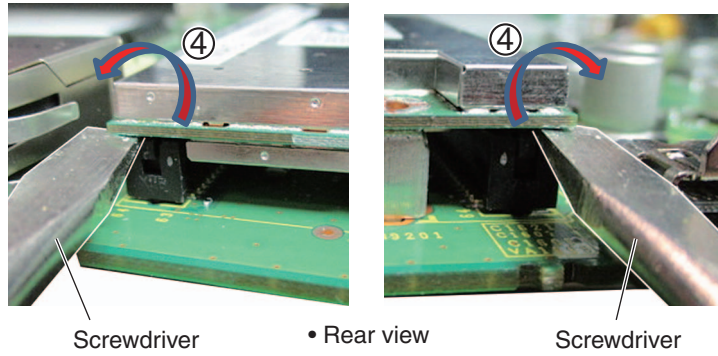

B



- C (5) Insert the tip of the screwdriver into one end of either side of the module then widen the gap to several millimeters.
- (6) Widen the gap in the same way at the middle and the other end of the side of the module so that the gap between the module and the connector is evenly widened.
- (7) Widen the gap in the same way on the opposite side of the module connector.

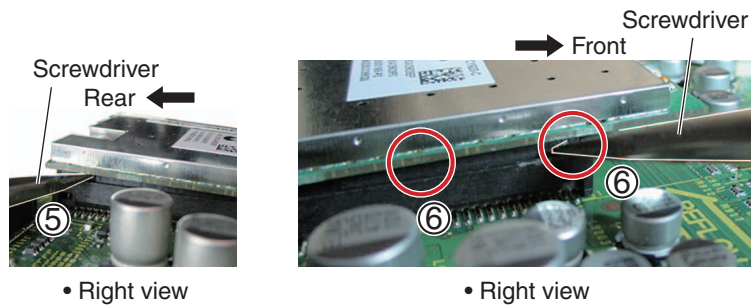

D



- E (8) Repeat Steps (6) and (7) several times to gradually widen the gap between the DMAIN connector and the module then detach the network module.

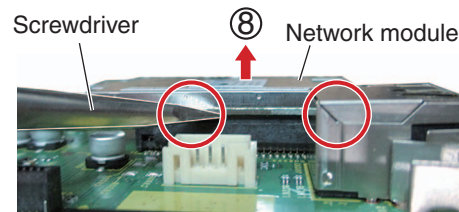

[Note]

If you attempt to forcibly detach the module all at once, the connector of the module will be damaged and the module cannot be reused. Be sure to gradually widen the gap between the connectors from both sides of the module.

After replacing the network module, updating is necessary. Refer to "UPDATA PANEL Mode (Version update)" on "8.3 UPDATING OF THE FIRMWARE".



[4] MAIN Assy

Remove the cabinet by removing the 10 screws.

[4-1] DMAIN Assy

- (1) Remove the DMAIN Assy.
(See procedure [3].)

[4-2] Back chassis

- (1) Remove the 5 screw covers.
(If any cushion is torn, replace it with a new one.)
- (2) Remove the back chassis by remove the 20 screws.
(BBT30P100FTB)

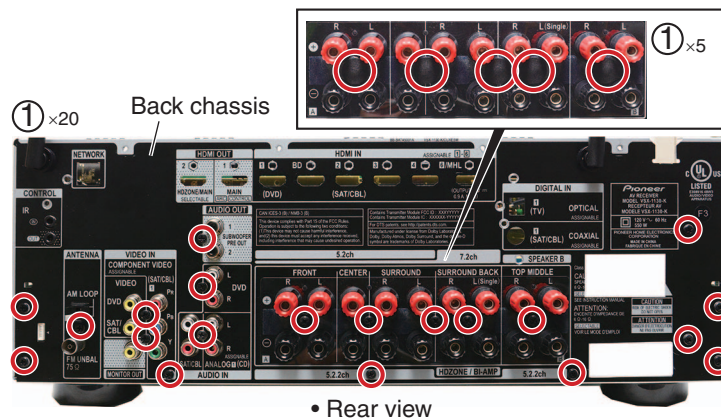

- (3) Cut the 4 cable ties.
(Release the antenna cable (short).)

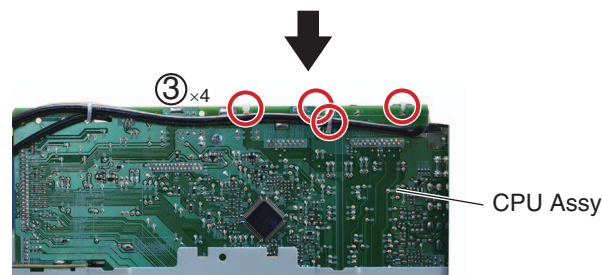

[4-3] AUDIO and BRIDGE Assemblies

- (1) Disconnect the 1 connector.
(CP401)
- (2) Remove the AUDIO and BRIDGE Assemblies by disconnecting the 2 BtoB connectors.
(CP17, 19)

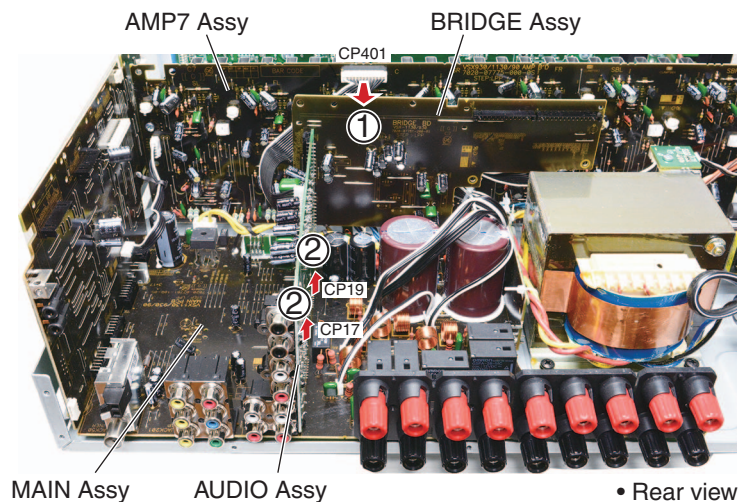

[4-4] CPU Assy

- (1) Remove the G-R Assy by removing the 2 screws.
(BBZ30P080FTC)
- (2) Disconnect the 1 flexible cable and 2 connector.s
(CN305, 314, 404)
- (3) Remove the 1 screw.
(BBZ30P180FTC)
- (4) Remove the CPU Assy by disconnecting the 4 BtoB connectors.
(CN310, 311, 312, 313A)

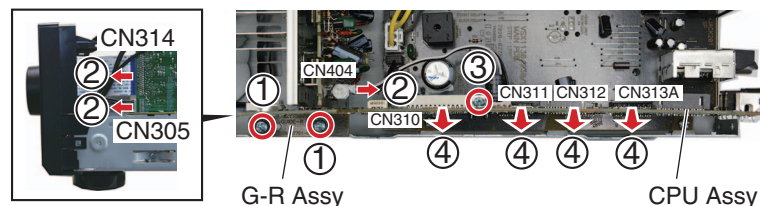

A [4-5] MAIN Assy

- (1) Cut the 3 cable ties.
- (2) Release the 4 jumper wires.
- (3) Disconnect the 7 connectors.
(CP1 to 3, 403 to 406)
- (4) Remove the 6 screws.
(BBZ30P080FTC)
- (5) Remove the 3 screws.
(BBZ30P180FTC)
- (6) Remove the MAIN Assy with GUI-A Assy.

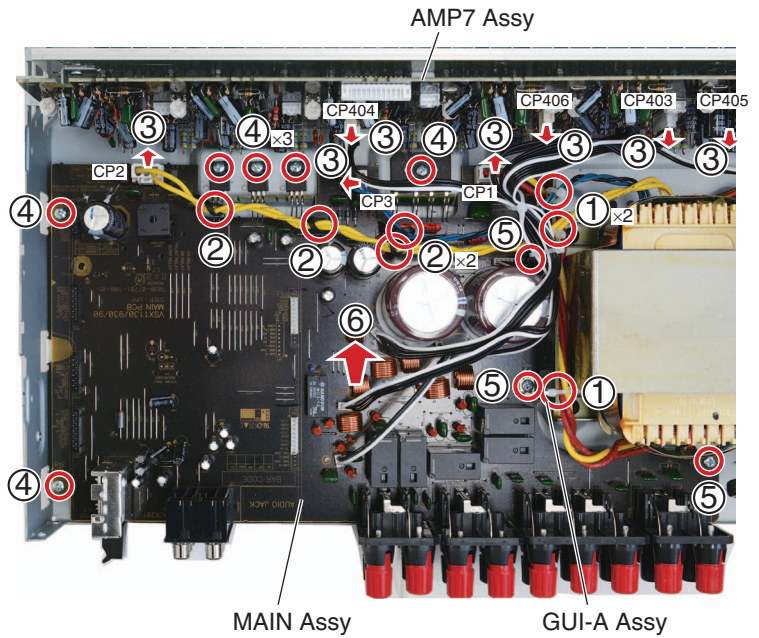

B

C

• Styling of jumper wires

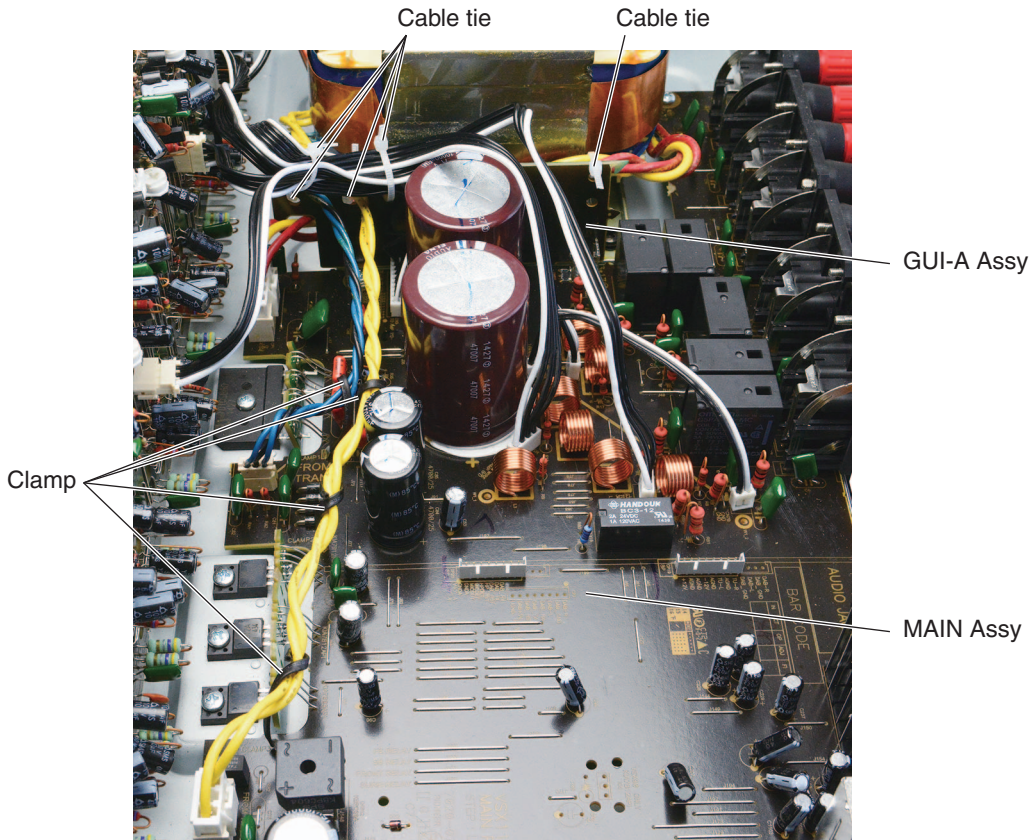

D

E

F

Dressing the Antenna cables

As this capacitor affects sound quality, be sure to avoid passing the antenna cable over the capacitor, as shown in the photo.

Make sure that the antenna cables run transversely near the connectors.

Make sure that the the Front USB cable does not come into contact with the top cover.

Fit the Front USB cable in the cutout of the board.

CPU Assy

Antenna cable (short)

Antenna cable (long)

DMAIN Assy

Antenna

To avoid noise, be careful not to dress the antenna cable close to the capacitor.

Antenna

Wrap the ferrite core attached to the antenna cable with acetate tape then secure it, using hole No. 9, with the aid of a cable tie.

Secure the antenna cable and the Front USB cable, using hole No. 7, with the aid of a cable tie. (Pass the cable tie through the upper and lower holes.)

Secure the cable before connecting it to the connector, using hole No. 12, with the aid of a cable tie.

Secure the antenna cable dressed alongside the CPU Assy, using hole No. 6, with the aid of a cable tie.

Leave some slack in the cable on the transformer side. Secure the cable at the 3 indentations, using cable ties.



When dressing the antenna cable, leave some slack in the cable on the transformer side.

Acetate tape

The sensitivity of the wireless antenna will be affected if the antenna cable comes into direct contact with the Back chassis. Wrap the acetate tape (APPROX 220 mm) around the entire part of the antenna cable close to the Back chassis when replacing this antenna cable.

Note:

There is an acetate tape as a service jig. Part number: GYH1001 Size: 16 mm x 30M (If similar acetate tape is readily available, it can be used to the unit)

Secure the antenna cable to the AXX7293 shield, using the materials indicated below.

Positioning of the materials to be attached is shown below.

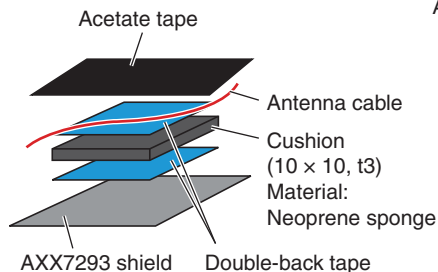

Acetate tape pasting position

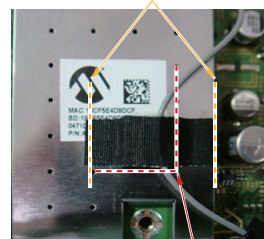

Cushion pasting position

Note:

To detach the cushion, remove it from the AXX7293 shield with the acetate tape and antenna cable attached together. Replace the cushion if it is damaged.

8. EACH SETTING AND ADJUSTMENT

A



- If the adjustment is shifted or if it becomes necessary to readjust because of part replacement, etc., perform the adjustment as described below.
- Any value changed in Adjustment mode will be stored in memory as soon as it is changed. Before readjustment, take note of the original values for reference in case you need to restore the original settings.
- Use a stable AC power supply.

B

8.1 ADJUSTMENT REQUIRED WHEN THE UNIT IS REPAIRED OR REPLACED

■ When any of the following assemblies is replaced

C

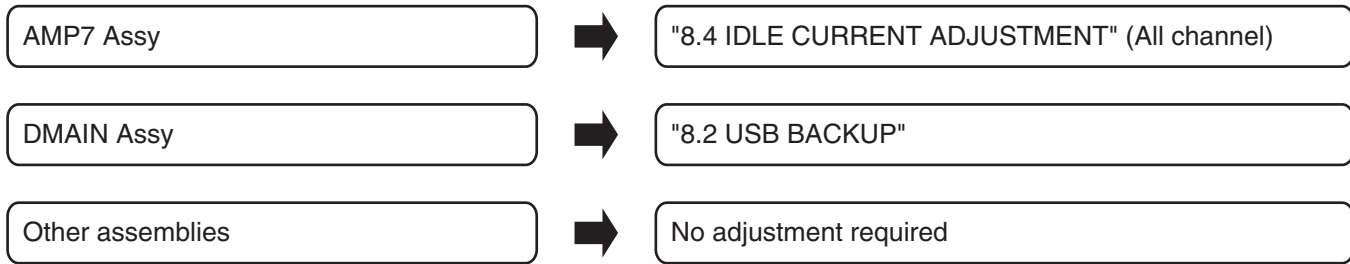

■ When any of the following parts is replaced

D

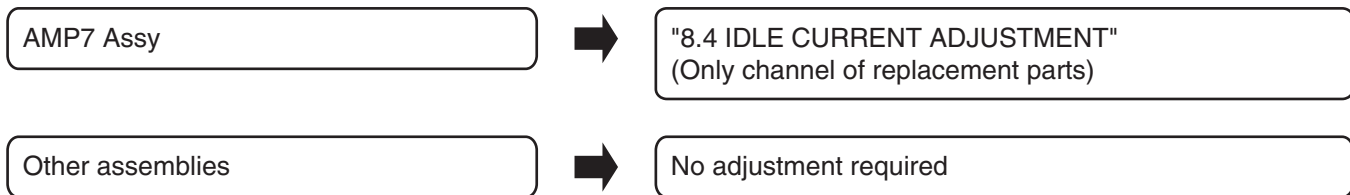

E

Note 1:
After replacing DMAIN Assy, the unit needs to reset factory default settings.
Refer to "Resetting the system" on "6.2 DEFAULT SETTINGS" , reset the unit.

Note 2:
After replacing Network module (AXX7293) or DMAIN Assy, the unit needs to update.
Refer to "UPDATE PANEL Mode (Version update)" on "8.3 UPDATING OF THE FIRMWARE"

Note 3:
After replacing Network module (AXX7293) or DMAIN Assy, the unit needs to test Wi-Fi function.
Refer to "5.2 CONFIRMATION OF THE NETWORK MODULE"

F

8.2 USB BACKUP

[Introduction]

This model is capable of saving the set values stored in the MAIN Ucom of DMAIN Assy in the USB and loading them in a new DMAIN Assy. (Note that MAIN Ucom should normally operate to enable this function.)

When replacing DMAIN Assy, execute the above mentioned processes.

[Data that can be saved/cannot be saved]

The following **data can not be saved**. Data other than these can be saved.

Contents to save	Destination to save
Last memory for turning ON/OFF the Main power and power supply for ZONE2, HDZONE Last memory for inputting the Main power, ZONE2, HDZONE Data to be save upon the operation of protection circuit	EVENT Ucom (IC300)
Internet Radio Last Station, Favorite, etc.	Network module (AXX7293)

(As the data saved by EVENT Ucom is on the CPU Assy, the data cannot be deleted unless Assy is replaced at the same time.)

[Requirements for USB memory]

USB memory to be used should meet the following requirements.

- Compatible with USB Mass storage Class
- With a file system of FAT (FAT32)

[File saving format]

Files are to be saved in the following format:

Example: VSX-1130_BK01.avr

[How to save in the USB memory from AV amplifier]

1. Insert the usable USB memory into the USB terminal when the main device is off.
2. Enter the SERVICE MODE and select [USB BAK ◀ HOLD ▶] with ↑↓ keys.
(See [6.1 TEST MODE] for how to enter the SERVICE MODE.)
3. Select [USB BAK ◀ SAVE? ▶] with ⇐⇒ keys and press [ENTER].
Note: The system cannot execute SAVE, LOAD until start is completed of Network module.
4. Saving in the USB starts and the main device automatically goes off after the normal completion ([COMPLETE] is displayed.)
5. Remove the USB and saving is finished.

*1. If the following errors occur after "SAVE" is executed, error message will be displayed and "SAVE" will be stopped and the power will be turned off.

- Ejecting of USB device
- Short capacity of USB device
- Error during writing in the USB device (Read Only or defective Sector, etc.)

*2. If the same file name exists in the USB, overwriting will be automatically executed.

[How to write into AV amplifier from the USB memory]

1. Insert the USB with the saved file into the USB terminal when the main device is off.
2. Enter the TEST MODE and select [USB BAK ◀ HOLD ▶] with ↑↓ keys.
(See [6.1 TEST MODE] for how to enter the TEST MODE.)
3. Select [USB BAK ◀ LOAD? ▶] with ⇐⇒ keys and press [ENTER].
4. Saving in the main device starts and it automatically goes off after the normal completion ([COMPLETE] is displayed.)
5. Remove the USB and loading is finished.

* If the following errors occur after "LOAD" is executed, error message will be displayed and "LOAD" will be stopped and the power will be turned off.

- No setting file
- Mismatching between the setting file and the specification of the A/V RECEIVER type to be loaded back
- Error due to Checksum, Signature Check, and Size Check
- Ejecting of USB device (during reading of the setting file)

Precautions

- Files are stored in Root of USB memory.
- Files are read from Root of USB memory.
 - ⇒ To make operations such as moving files, be sure to assign the saved file in Root of the USB memory.
- Also please be careful not to assign *.avr in multiple numbers.
- The time and date of updating for saved file is fixed to "2006/03/08 20:01."
- In principle, please implement Load without making of factory default settings.
- Depending on the type of USB memory device, the setting file may not have properly been saved even though [COMPLETE] is displayed after a SAVE process.
Before replacing the DMAIN Assy, perform a LOAD process and check that [COMPLETE] is displayed.

8.3 UPDATING OF THE FIRMWARE

A ■ Workflow

Enter the UPDATE PANEL mode.



Check a current version.



Update it.



Update completed.
(Turn the power OFF automatically.)



Enter the UPDATE PANEL mode again.



Check an updated version.



Turn the power off.
(Release the UPDATE PANEL mode.)

Updating process

Checking process

B

C

■ MAIN com, SUB com (EVENT), DSP Flash ROM and Network module Update by USB Memory and the Confirmation of the Version

● UPDATE PANEL Mode (Version update)

D

[Preparations]





1. Copy the UPDATE FILE to the root directory of the USB Memory.
Note: NEVER copy several UPDATE FILES to the root directory of the USB Memory.
Copy only the corresponding UPDATE FILE.
2. Turn off the power to this unit by setting Multi-Zone to "OFF".
3. Connect the USB Memory to the USB terminal (A type) of the front panel.

[Procedure]

1. While holding down "TUNE↑" key on the front panel, press "STANDBY ON/OFF" key and moves to the **UPDATE PANEL mode**.
2. The updating process is as follows.

E

F



Key operation	FL display
<p>[TUNE↑] + [STANDBY ON/OFF]</p>  <p>Booting is completed</p> 	<p>POWER ON</p>
<p>[TUNE↓] or [TUNE↑]</p>  	<p>Version is displayed.</p> <p>1 - 001002003004</p>
	<p>Update Menu</p> <p>UPDATE</p>

Front Panel Key

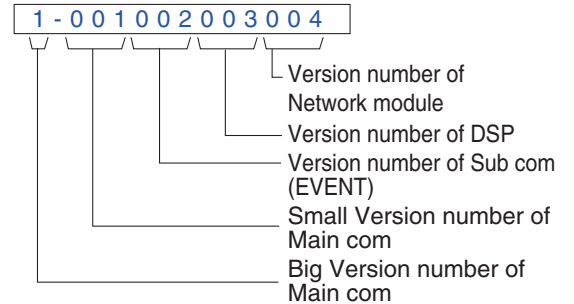
- [↓] : TUNE key
- [↑] : TUNE key
- [←] : PRESET key
- [→] : PRESET key

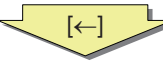
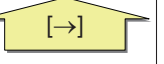

Do not do time-out during update panel indication.
It takes about 45 seconds till version of the Network module is displayed.
Meanwhile, version of the Network module is displayed with ***.

Key operation	FL display
<p>[ENTER]</p> 	<p>Update Menu</p> <p>UPDATE</p>
<p>[PRESET→] or [PRESET←]</p>  	<p>Update Confirmation</p> <p>UPDATE ? ◀NO▶</p>
<p>[ENTER]</p> 	<p>Update Confirmation</p> <p>UPDATE ? ◀YES▶</p>
<p>UPDATE FILE searching completed</p>	<p>File searching</p> <p>Accessing</p>

■

1

■

2

■





3

■

4

■

A

Key operation	FL display
UPDATE FILE searching completed 	Updating process <div style="border: 1px solid black; padding: 2px;">* U p d a t i n g . 0 %</div>
UPDATE start 	
UPDATE completed 	Update completion display <div style="border: 1px solid black; padding: 2px;">* U p d a t i n g . 1 0 0 %</div>
5 Second  Power turns off automatically. (All ZONE OFF) Disconnect the USB MEMORY.	

B

C

Update time is fluctuated by contents of the update. It will take about 26 minutes at the maximum.
 (Actual time is from 3 minutes to 26 minutes.)

D

Time required for updating varies, because only the programs that require updating will be updated.

[Confirmation]

Enter UPDATE PANEL mode and check that the programs have been updated.

E

F

52

1

■

2

VSX-1130-K

■

3

■

4

■

8.4 IDLE CURRENT ADJUSTMENT



When any component parts which are within the red square on the following circuit diagram are replaced, the idle current adjustment of that channel is required. (Idle current adjustment for another channel is not required.) However, when any capacitors are replaced, the adjustment is not required. (The following circuit diagram is for SL channel, but another channel also has same circuit diagram and same adjustment is required)

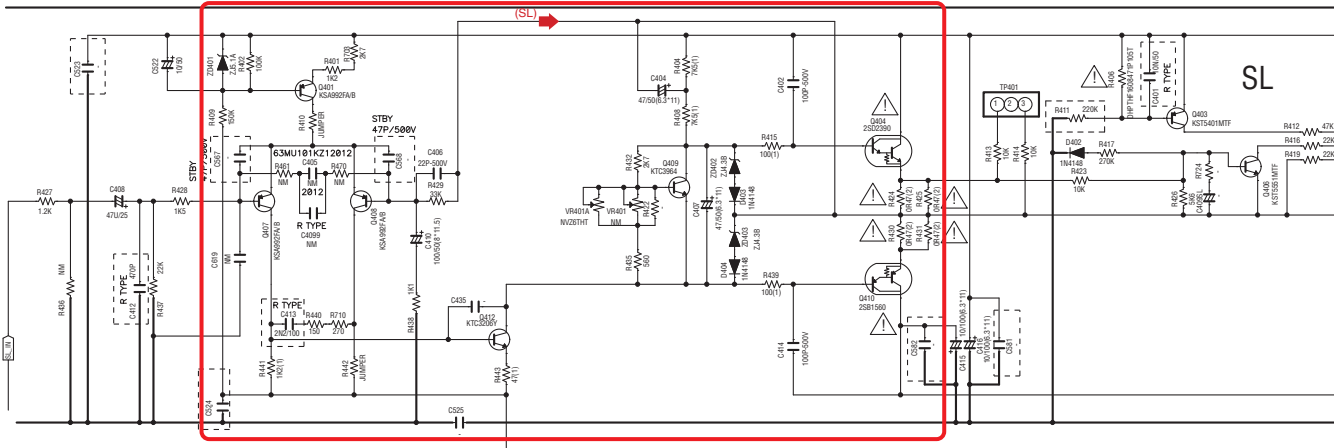

Channel	Measurement Points	Adjustment Points	Procedure
FL	TP404 pin 1 (+) TP404 pin 3 (-)	VR404	① Turn on the power. ② Perform aging for one minute. ③ Connect a digital voltmeter to the measurement point. ④ Turn the adjustment VR so that the voltage becomes in 2.0 mV ± 0.2 mV. (Condition : No signal and no load)
FR	TP402 pin 1 (+) TP402 pin 3 (-)	VR402	
C	TP403 pin 1 (+) TP403 pin 3 (-)	VR403	
SL	TP401 pin 1 (+) TP401 pin 3 (-)	VR401	
SR	TP405 pin 1 (+) TP405 pin 3 (-)	VR405	
SBL	TP406 pin 1 (+) TP406 pin 3 (-)	VR406	
SBR	TP407 pin 1 (+) TP407 pin 3 (-)	VR407	

• Adjustment points and measurement points.... see fig.1.

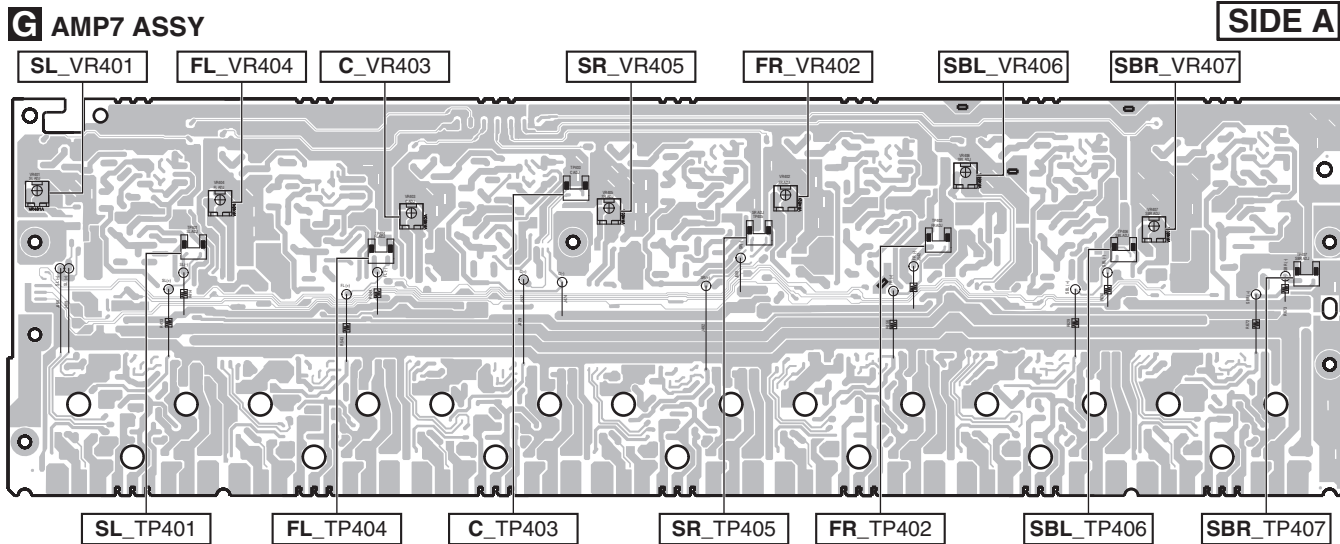

Fig.1

VSX-1130-K

9. EXPLODED VIEWS AND PARTS LIST

NOTES: ● Parts marked by "NSP" are generally unavailable because they are not in our Master Spare Parts List.

- The \triangle mark found on some component parts indicates the importance of the safety factor of the part. Therefore, when replacing, be sure to use parts of identical designation.
- Screws adjacent to ∇ mark on product are used for disassembly.
- For the applying amount of lubricants or glue, follow the instructions in this manual. (In the case of no amount instructions, apply as you think it appropriate.)

9.1 PACKING SECTION

Poly bag packing style

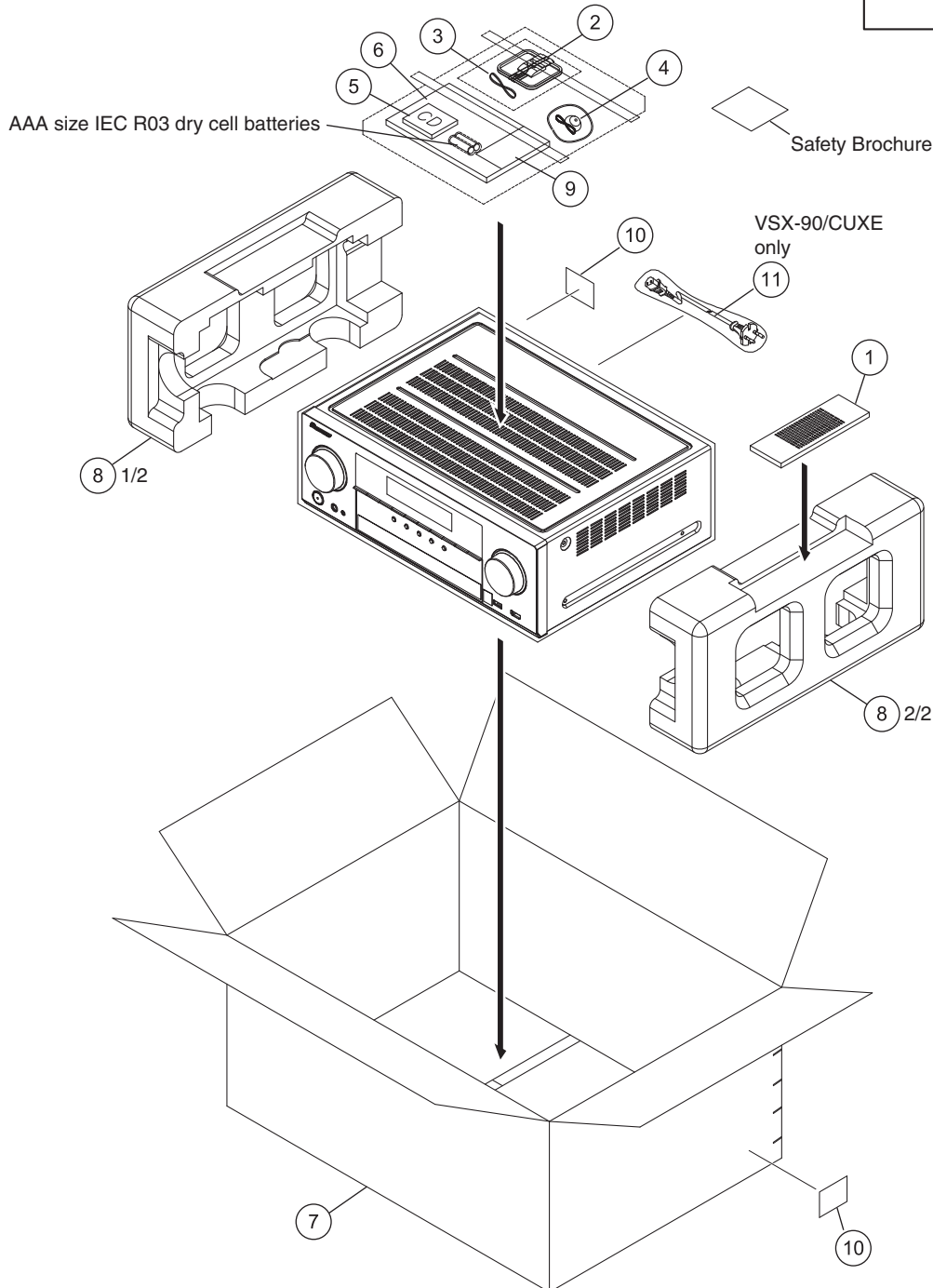
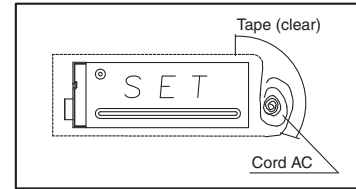

(1) PACKING SECTION PARTS LIST

<u>Mark No.</u>	<u>Description</u>	<u>Part No.</u>
	1 Remote Control Unit (AXD7723)	8300772300010S
	2 AM Loop Antenna	E605010140010S
	3 FM Wire Antenna	E605010140010-IL
	4 MCACC Setup Microphone	APM7011
	5 CD-ROM	See Contrast tabel (2)
	6 Quick Start Guide	See Contrast tabel (2)
	7 Box	See Contrast tabel (2)
	8 Cushion, Snow	6230212914000-IL
NSP	9 Warranty Sheet	See Contrast tabel (2)
NSP	10 Label	VRW1629
⚠	11 Power Cord	See Contrast tabel (2)

(2) CONTRAST TABLE

VSX-1130-K/CUXESM and VSX-90/CUXE are constructed the same except for the following:

Mark	No.	Symbol and Description	VSX-1130-K /CUXESM	VSX-90 /CUXE
	5	CD-ROM	6517000002141S	6517000002131S
	6	Quick Start Guide	5707000009920S	5707000009900S
	7	Box	60072123900B0S	6007211820250S
NSP	9	Warranty Sheet	ARY7172	ARY7177
⚠	11	Power Cord	Not used	L068125130010S

9.2 EXTERIOR SECTION

A

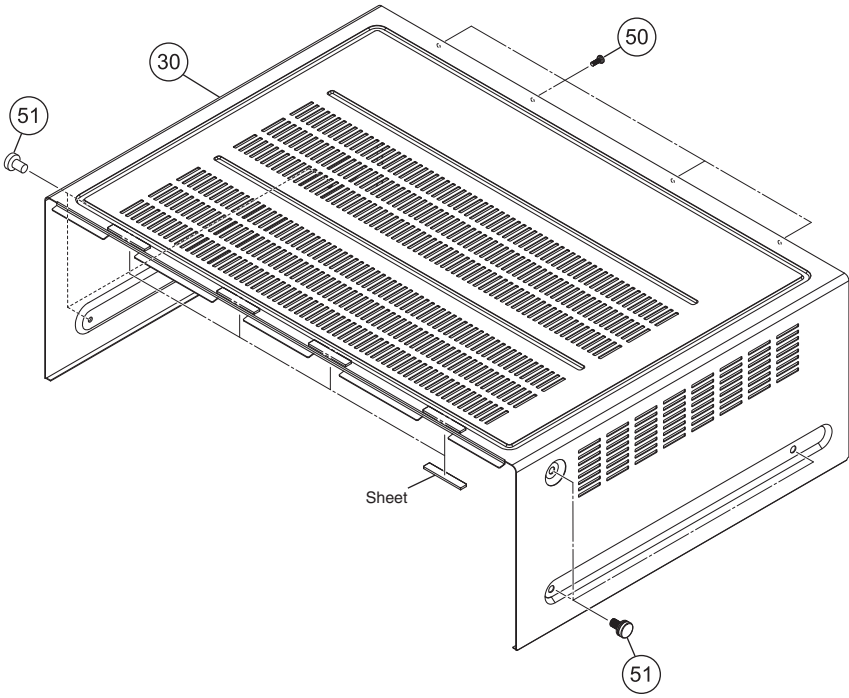

B

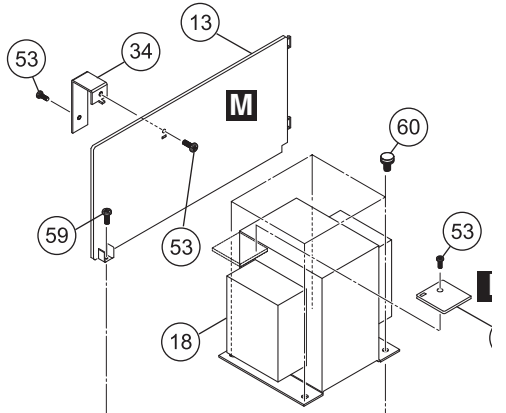

C

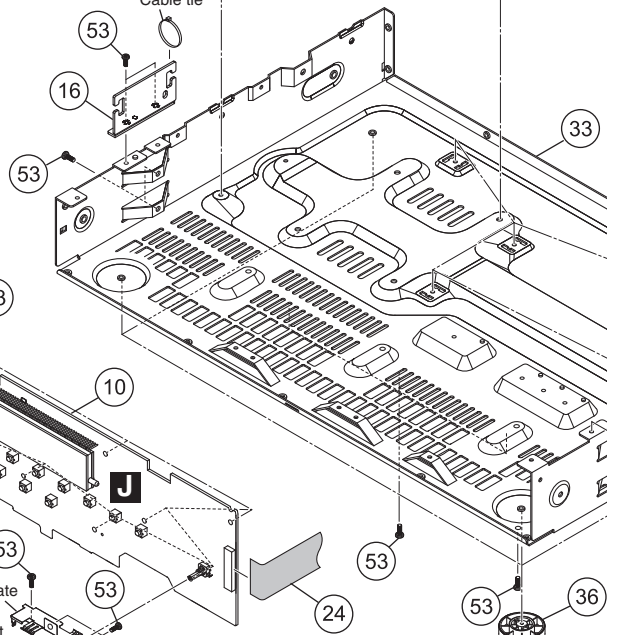

D

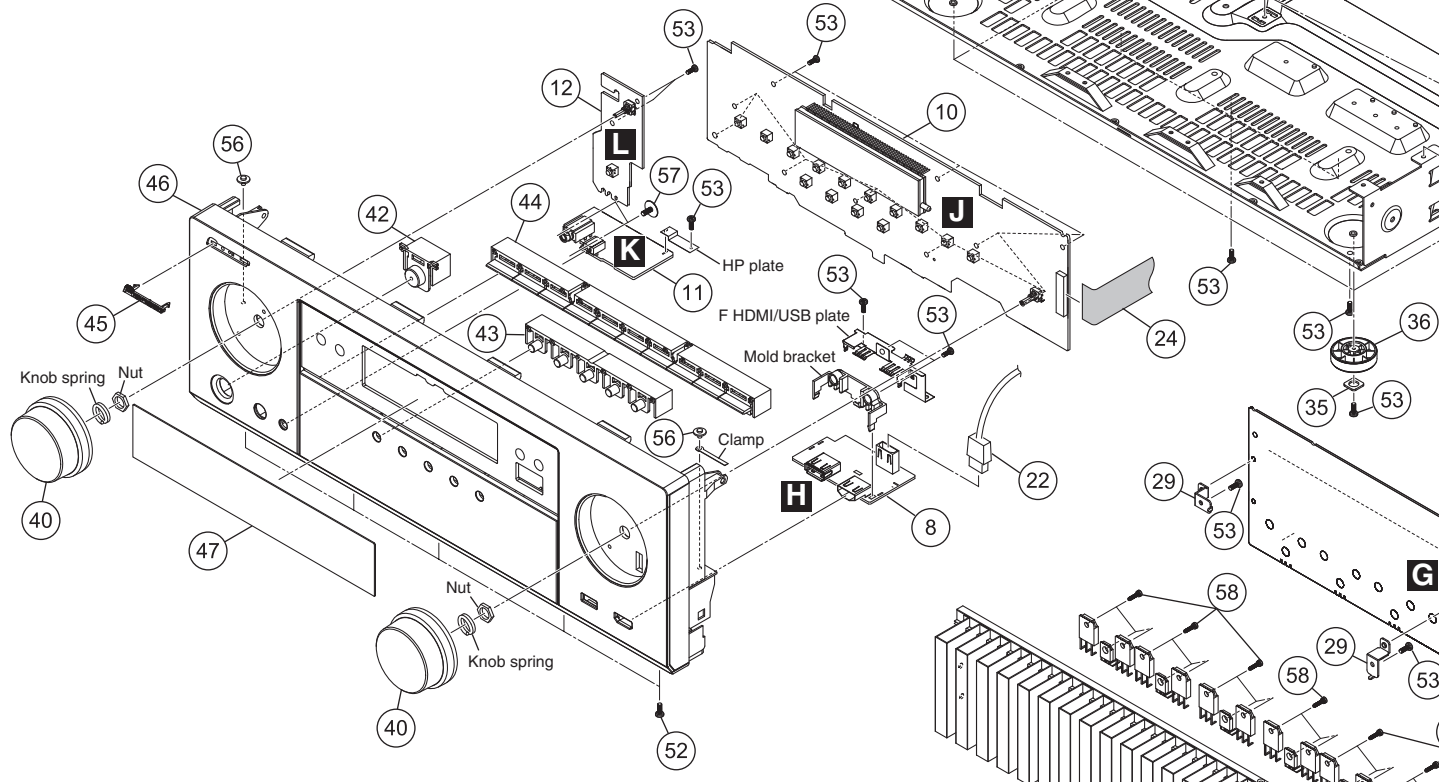

E

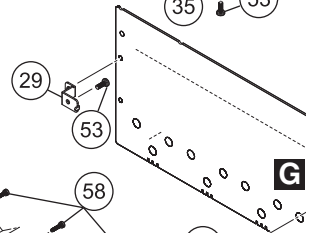

F

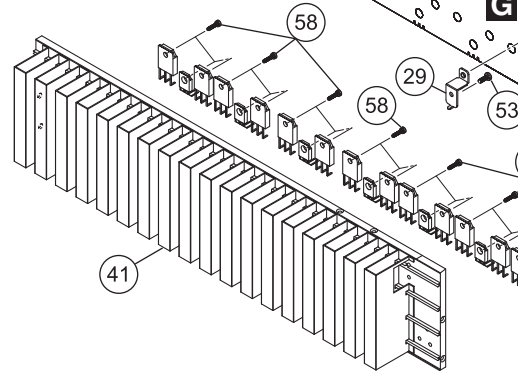

(1) EXTERIOR SECTION PARTS LIST

<u>Mark No.</u>	<u>Description</u>	<u>Part No.</u>	<u>Mark No.</u>	<u>Description</u>	<u>Part No.</u>
A	1 MAIN Assy	See Contrast table (2)	46	Front Panel	See Contrast table (2)
	2 DMAIN Assy	See Contrast table (2)	47	Display Window	See Contrast table (2)
	3 OPTCO Assy	70280777230A0	48	Cushion	AEB7449
	4 BRIDGE Assy	See Contrast table (2)	49	•••••	
	5 AUDIO Assy	See Contrast table (2)	50	Screw	BBT30P100FTB
			51	Screw	BBT40P080FTB
	6 CPU Assy	See Contrast table (2)	52	Screw	BBZ30P080FTB
	7 AMP7 Assy	7028077751010	53	Screw	BBZ30P080FTC
	8 FHDMI Assy	7028077881010	54	Screw	BBZ30P180FTC
	9 TEMP Assy	7028077816010	55	Screw	BSZ30P040FTB
B	10 FRONT Assy	See Contrast table (2)			
			56	Screw	1500001206010-IL
	11 HPMIC Assy	70280777240A0	57	Screw	1500001456010-IL
	12 INSEL Assy	70280777220A0	58	Screw	B018230141H11-IL
⚠	13 SMPS Assy	See Contrast table (2)	59	Screw	B020230063B10-IL
	14 GUI-A Assy	7028077813010	60	Screw	B028940101B11-IL
	15 G-R Assy	7028077814010			
			61	Screw	BSZ30P040FCC
	16 G-L Assy	7028077815010	62	Screw	See Contrast table (2)
	17 Network Module	AXX7293			
⚠	18 Power Trans 1124CU	8200960611510S			
C	⚠ 19 Power Cord	See Contrast table (2)			
	⚠ 20 AC Inlet	See Contrast table (2)			
	21 •••••				
	22 Cable HDMI 230 mm	L304231190240S			
	23 FFC Cable 110 mm	N711271122480S			
	24 FFC Cable 1 mm	N711390922480S			
	25 Other Antenna	ADH7048			
	26 Other Antenna	ADH7049			
	27 Back Chassis	See Contrast table (2)			
D	28 •••••				
	29 HS Bracket	4010056906010S			
	30 Cabinet Assy	3008211846020-IL			
	31 Stopper	See Contrast table (2)			
	32 Screw Cover	4050211745100-IL			
	33 Main Chassis 1130	3200213706101S			
	34 SMPS Bracket	401021488600DS			
	35 Cushion	4050211605000-IL			
	36 Foot (PLS)	4000210391000-IL			
E	37 Speaker Sheet 1130	1210212872000S			
	38 Rubber 10*10*8T	4050215895000S			
	39 Wifi Antenna Bush	2410210171000S			
	40 Knob	5080212431000-IL			
	41 Heatsink	212021217800DS			
	42 Standby Button	5090213741100S			
	43 5 Key Button	5090214561000S			
	44 10 Key Button	5090214571000S			
	45 Pioneer Badge	See Contrast table (2)			
F					

(2) CONTRAST TABLE

VSX-1130-K/CUXESM and VSX-90/CUXE are constructed the same except for the following:

Mark	No.	Symbol and Description	VSX-1130-K /CUXESM	VSX-90 /CUXE
	1	MAIN Assy	7028077811040	7028077811010
	2	DMAIN Assy	7028077871040	7028077871010
	4	BRIDGE Assy	7028077812020	7028077812010
	5	AUDIO Assy	7028077841040	7028077841010
	6	CPU Assy	70280777310D0	70280777310A0
	10	FRONT Assy	70280777210D0	70280777210A0
	13	SMPS Assy	702807336108B	702807336106B
⚠	19	Power Cord	L068125101710S	Not used
⚠	20	AC Inlet	Not used	G430040807010S
⚠	27	Back Chassis	3207215176000S	3207215176400S
	31	Stopper	4380040162010-IL	Not used
	45	Pioneer Badge	XAM3006	PAM1791
	46	Front Panel	3067216111740S	3067216111A20S
	47	Display Window	50772131130P0S	50772131130M0S
	62	Screw	Not used	CBZ30P080FTB

A

B

C

D

E

F