

# Service Manual

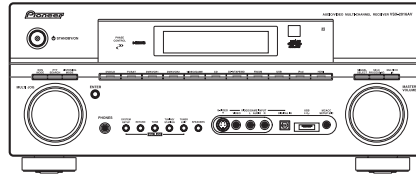

VSX-2016AV-S

ORDER NO.  
**RRV3397**

**AUDIO/VIDEO MULTI-CHANNEL RECEIVER**

# VSX-2016AV-S

## VSX-81TXV

## VSX-81TXV-S

## VSX-9110TXV-K

**THIS MANUAL IS APPLICABLE TO THE FOLLOWING MODEL(S) AND TYPE(S).**

Model	Type	Power Requirement	Remarks
VSX-2016AV-S	HYXJ5	AC 220 V to 230 V	
VSX-81TXV	KUXJCA	AC 120 V	
VSX-81TXV-S	KUXJCA	AC 120 V	
VSX-9110TXV-K	KUXJ	AC 120 V	



For details, refer to "Important Check Points for good servicing".

# SAFETY INFORMATION



This service manual is intended for qualified service technicians ; it is not meant for the casual do-it-yourselfer. Qualified technicians have the necessary test equipment and tools, and have been trained to properly and safely repair complex products such as those covered by this manual.

Improperly performed repairs can adversely affect the safety and reliability of the product and may void the warranty. If you are not qualified to perform the repair of this product properly and safely, you should not risk trying to do so and refer the repair to a qualified service technician.

## WARNING

This product contains lead in solder and certain electrical parts contain chemicals which are known to the state of California to cause cancer, birth defects or other reproductive harm.

Health & Safety Code Section 25249.6 - Proposition 65

## NOTICE

(FOR CANADIAN MODEL ONLY)

Fuse symbols (fast operating fuse) and/or (slow operating fuse) on PCB indicate that replacement parts must be of identical designation.

## REMARQUE

(POUR MODÈLE CANADIEN SEULEMENT)

Les symboles de fusible (fusible de type rapide) et/ou (fusible de type lent) sur CCI indiquent que les pièces de remplacement doivent avoir la même désignation.

(FOR USA MODEL ONLY)

## 1. SAFETY PRECAUTIONS

The following check should be performed for the continued protection of the customer and service technician.

### LEAKAGE CURRENT CHECK

Measure leakage current to a known earth ground (water pipe, conduit, etc.) by connecting a leakage current tester such as Simpson Model 229-2 or equivalent between the earth ground and all exposed metal parts of the appliance (input/output terminals, screwheads, metal overlays, control shaft, etc.). Plug the AC line cord of the appliance directly into a 120V AC 60 Hz outlet and turn the AC power switch on. Any current measured must not exceed 0.5 mA.

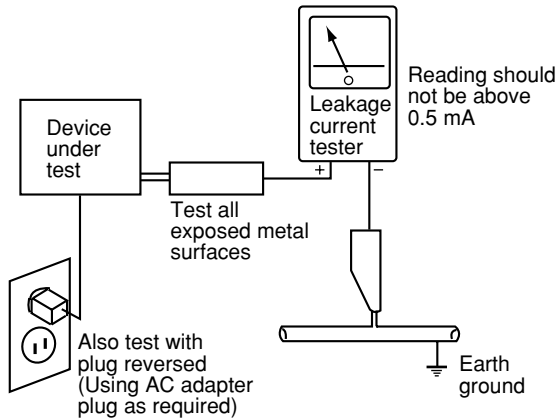

AC Leakage Test

**ANY MEASUREMENTS NOT WITHIN THE LIMITS OUTLINED ABOVE ARE INDICATIVE OF A POTENTIAL SHOCK HAZARD AND MUST BE CORRECTED BEFORE RETURNING THE APPLIANCE TO THE CUSTOMER.**

## 2. PRODUCT SAFETY NOTICE

Many electrical and mechanical parts in the appliance have special safety related characteristics. These are often not evident from visual inspection nor the protection afforded by them necessarily can be obtained by using replacement components rated for voltage, wattage, etc. Replacement parts which have these special safety characteristics are identified in this Service Manual.

Electrical components having such features are identified by marking with a on the schematics and on the parts list in this Service Manual.

The use of a substitute replacement component which does not have the same safety characteristics as the PIONEER recommended replacement one, shown in the parts list in this Service Manual, may create shock, fire, or other hazards.

Product Safety is continuously under review and new instructions are issued from time to time. For the latest information, always consult the current PIONEER Service Manual. A subscription to, or additional copies of, PIONEER Service Manual may be obtained at a nominal charge from PIONEER.

## [Important Check Points for Good Servicing]

In this manual, procedures that must be performed during repairs are marked with the below symbol. Please be sure to confirm and follow these procedures.

### 1. Product safety



Please conform to product regulations (such as safety and radiation regulations), and maintain a safe servicing environment by following the safety instructions described in this manual.

- ① Use specified parts for repair.

Use genuine parts. Be sure to use important parts for safety.

- ② Do not perform modifications without proper instructions.

Please follow the specified safety methods when modification (addition/change of parts) is required due to interferences such as radio/TV interference and foreign noise.

- ③ Make sure the soldering of repaired locations is properly performed.

When you solder while repairing, please be sure that there are no cold solder and other debris. Soldering should be finished with the proper quantity. (Refer to the example)

- ④ Make sure the screws are tightly fastened.

Please be sure that all screws are fastened, and that there are no loose screws.

- ⑤ Make sure each connectors are correctly inserted.

Please be sure that all connectors are inserted, and that there are no imperfect insertion.

- ⑥ Make sure the wiring cables are set to their original state.

Please replace the wiring and cables to the original state after repairs. In addition, be sure that there are no pinched wires, etc.

- ⑦ Make sure screws and soldering scraps do not remain inside the product.

Please check that neither solder debris nor screws remain inside the product.

- ⑧ There should be no semi-broken wires, scratches, melting, etc. on the coating of the power cord.

Damaged power cords may lead to fire accidents, so please be sure that there are no damages. If you find a damaged power cord, please exchange it with a suitable one.

- ⑨ There should be no spark traces or similar marks on the power plug.

When spark traces or similar marks are found on the power supply plug, please check the connection and advise on secure connections and suitable usage. Please exchange the power cord if necessary.

- ⑩ Safe environment should be secured during servicing.

When you perform repairs, please pay attention to static electricity, furniture, household articles, etc. in order to prevent injuries. Please pay attention to your surroundings and repair safely.

### 2. Adjustments



To keep the original performance of the products, optimum adjustments and confirmation of characteristics within specification. Adjustments should be performed in accordance with the procedures/instructions described in this manual.

### 3. Lubricants, Glues, and Replacement parts



Use grease and adhesives that are equal to the specified substance. Make sure the proper amount is applied.

### 4. Cleaning



For parts that require cleaning, such as optical pickups, tape deck heads, lenses and mirrors used in projection monitors, proper cleaning should be performed to restore their performances.

### 5. Shipping mode and Shipping screws



To protect products from damages or failures during transit, the shipping mode should be set or the shipping screws should be installed before shipment. Please be sure to follow this method especially if it is specified in this manual.

# CONTENTS

- 1. SPECIFICATIONS ..... 6
- 2. EXPLODED VIEWS AND PARTS LIST ..... 10
  - 2.1 PACKING SECTION ..... 10
  - 2.2 EXTERIOR SECTION ..... 12
  - 2.3 CHASSIS SECTION ..... 14
  - 2.4 REAR SECTION ..... 16
  - 2.5 POWER AMP SECTION ..... 20
  - 2.6 FRONT PANEL SECTION ..... 22
- 3. BLOCK DIAGRAM AND SCHEMATIC DIAGRAM ..... 24
  - 3.1 BLOCK DIAGRAM for AUDIO BLOCK ..... 24
  - 3.2 BLOCK DIAGRAM for VIDEO BLOCK ..... 26
  - 3.3 OVERALL WIRING DIAGRAM ..... 28
  - 3.4 AUDIO IN ASSY (1/2) ..... 30
  - 3.5 AUDIO IN (2/2) and 12V-REG ASSYS ..... 32
  - 3.6 MAIN CONTROL ASSY (1/3) ..... 34
  - 3.7 MAIN CONTROL (2/3), GUARD-C and GUARD-F ASSYS ..... 36
  - 3.8 MAIN CONTROL ASSY (3/3) ..... 38
  - 3.9 DSP ASSY (1/4) ..... 40
  - 3.10 DSP ASSY (2/4) ..... 42
  - 3.11 DSP ASSY (3/4) ..... 44
  - 3.12 DSP ASSY (4/4) ..... 46
  - 3.13 COMPOSITE ASSY ..... 48
  - 3.14 S-VIDEO and BRIDGE 2 ASSYS ..... 50
  - 3.15 COMPONENT ASSY ..... 52
  - 3.16 DISPLAY, VOLUME and MULTI JOG ASSYS ..... 54
  - 3.17 HEADPHONE, FRONT-IN, PRIMARY and TRANS 1 ASSYS ..... 56
  - 3.18 TRANS 2-1, DIODE 1, VH TR, BRIDGE 1 and PS/SP ASSYS ..... 58
  - 3.19 TRANS 2-2, TRANS SIDE, LOCAL P-SUPPLY, DC/DC, IR I/O and VIDEO CONNECT ASSYS ..... 60
  - 3.20 POWER AMP-L, POSI 1-L and POSI 2-L ASSYS ..... 62
  - 3.21 POWER AMP-R and POSI 1-R ASSYS ..... 64
  - 3.22 POWER AMP IN and POWER PROTECT ASSYS ..... 66
  - 3.23 HDMI & DVC ASSY (1/2) ..... 68
  - 3.24 HDMI & DVC ASSY (2/2) ..... 70
  - 3.25 USB ASSY (VSX-2016AV-S ONLY) ..... 72
- 4. PCB CONNECTION DIAGRAM ..... 74
  - 4.1 AUDIO IN ASSY ..... 76
  - 4.2 12V-REG ASSY ..... 80
  - 4.3 BRIDGE 2 ASSY ..... 81
  - 4.4 MAIN CONTROL ASSY ..... 82
  - 4.5 DSP ASSY ..... 86
  - 4.6 COMPOSITE ASSY ..... 90
  - 4.7 S-VIDEO ASSY ..... 94
  - 4.8 COMPONENT ASSY ..... 98
  - 4.9 DISPLAY ASSY ..... 102
  - 4.10 VOLUME ASSY ..... 106
  - 4.11 HEADPHONE ASSY ..... 107
  - 4.12 MULTIJOG ASSY ..... 108
  - 4.13 FRONT IN ASSY ..... 112
  - 4.14 PRIMARY ASSY ..... 116
  - 4.15 TRANS 1 ASSYS ..... 120
  - 4.16 TRANS 2-1 ASSY ..... 121
  - 4.17 DIODE 1 and VH TR ASSYS ..... 122
  - 4.18 BRIDGE 1 ASSY ..... 123
  - 4.19 PS/SP ASSY ..... 124
  - 4.20 TRANS 2-2 ASSY ..... 128
  - 4.21 POSI 1-L, POSI 2-L and POSI 1-R ASSYS ..... 129
  - 4.22 TRANS SIDE ASSY ..... 130
  - 4.23 IR I/O ASSY ..... 132
  - 4.24 LOCAL P-SUPPLY ASSY ..... 134
  - 4.25 DC/DC ASSY ..... 136
  - 4.26 VIDEO CONNECT ASSY ..... 138
  - 4.27 POWER AMP-L ASSY ..... 140
  - 4.28 POWER AMP-R ASSY ..... 144
  - 4.29 POWER AMP IN ASSY ..... 148
  - 4.30 POWER PROTECT ASSY ..... 150

	5	6	7	8	
	4.31 HDMI & DVC ASSY .....			152	
	4.32 USB ASSY (VSX-2016AV-S ONLY).....			156	
5.	PCB PARTS LIST .....			158	
6.	ADJUSTMENT .....			194	
7.	GENERAL INFORMATION .....			195	A
	7.1 DIAGNOSIS.....			195	
	7.1.1 TEST MODE.....			195	
	7.1.2 PROTECTION CIRCUIT SPECIFICATION .....			198	
	7.1.3 DSP TROUBLESHOOTING .....			200	
	7.1.4 HDMI TROUBLESHOOTING .....			216	
	7.1.5 USB MODULE.....			228	
	7.1.6 HOW TO UPDATE FIRMWARE.....			233	
	7.1.7 HOW TO UPDATE THE FLASH ROMS FOR VARIOUS MICROCOMPUTERS .....			234	
	7.1.8 HOW TO UPDATE THE DSP FLASH ROM BY PLAYING BACK CD.....			236	
	7.1.9 DISASSEMBLY .....			238	
	7.2 PARTS .....			246	B
	7.2.1 IC.....			246	
8.	PANEL FACILITIES .....			261	

# 1. SPECIFICATIONS

## ■ For VSX-2016AV-S

### Amplifier section

#### Continuous Power Output (Stereo)

Front . . . . . 150 W + 150 W (DIN 1 kHz, THD 1 %, 6 Ω)  
120 W + 120 W (DIN 1 kHz, THD 1 %, 8 Ω)

#### Continuous Power Output (Multichannel)

Front . . . . . 150 W + 150 W (DIN 1 kHz, THD 1 %, 6 Ω)  
120 W + 120 W (DIN 1 kHz, THD 1 %, 8 Ω)

Center . . . . . 150 W (DIN 1 kHz, THD 1 %, 6 Ω)  
120 W (DIN 1 kHz, THD 1 %, 8 Ω)

Surround . . . . . 150 W + 150 W (DIN 1 kHz, THD 1 %, 6 Ω)  
120 W + 120 W (DIN 1 kHz, THD 1 %, 8 Ω)

Surround back  
. . . . . 150 W + 150 W (DIN 1 kHz, THD 1 %, 6 Ω)  
120 W + 120 W (DIN 1 kHz, THD 1 %, 8 Ω)

Rated Power Output . . . . . 130 W+130 W  
(20 Hz to 20 kHz, 0.09 %, 6 Ω)

Rated Power Output . . . . . 110 W+110 W  
(20 Hz to 20 kHz, 0.09 %, 8 Ω)

- The above specifications are applicable when the power supply is 230 V.

### Audio Section

#### Input (Sensitivity/Impedance)

LINE . . . . . 335 mV/47 kΩ  
Frequency Response (LINE) . . . . . 5 Hz to 100 000 Hz ±0.3 dB

#### Output (Level/Impedance)

REC . . . . . 335 mV/2.2 kΩ

#### Tone Control

BASS . . . . . ± 6 dB (100 Hz)  
TREBLE . . . . . ± 6 dB (10 kHz)  
LOUDNESS . . . . . +4 dB / +2 dB (100Hz/10 kHz)  
(at volume position -40 dB)

#### Signal-to-Noise Ratio (IHF, short circuited, A network)

LINE . . . . . 103 dB

#### Signal-to-Noise Ratio

[DIN (continuous rated power output/50mW)]

LINE . . . . . 92 dB / 65 dB

### Composite Video / S-Video Section

Input (Sensitivity/Impedance) . . . . . 1 Vp-p/75 Ω

Output (Level/Impedance) . . . . . 1 Vp-p/75 Ω

Signal-to-Noise Ratio . . . . . 65 dB

Frequency Response . . . . . 5 Hz to 10 MHz

### Component Video Section

Input (Sensitivity/Impedance) . . . . . 1 Vp-p/75 Ω

Output (Level/Impedance) . . . . . 1 Vp-p/75 Ω

Signal-to-Noise Ratio . . . . . 65 dB

Frequency Response . . . . . 5 Hz to 100 MHz

### FM Tuner Section

Frequency Range . . . . . 87.5 MHz to 108 MHz

Usable Sensitivity . . . . . Mono: 15.2 dBf, IHF (1.6 μV/75 Ω)

50 dB Quieting Sensitivity . . . . . Mono: 20.2 dBf  
Stereo: 41.2 dBf

Sensitivity (DIN) . . . . . Mono: 1.1 μV (S/N 26 dB)  
Stereo: 50 μV (S/N 46 dB)

Signal-to-Noise Ratio . . . . . Mono: 76 dB (at 85 dBf)  
Stereo: 72 dB (at 85 dBf)

Signal-to-Noise Ratio (DIN) . . . . . Mono: 62 dB  
Stereo: 58 dB

Distortion . . . . . Stereo: 0.6 % (1 kHz)

Alternate Channel Selectivity . . . . . 70 dB (400 kHz)

Stereo Separation . . . . . 40 dB (1 kHz)

Frequency Response . . . . . 30 Hz to 15 kHz ± 1dB

Antenna Input . . . . . 75 Ω unbalanced

### AM Tuner Section

Frequency Range . . . . . 531 kHz to 1602 kHz (9 kHz step)

Sensitivity (IHF, Loop antenna) . . . . . 350 μV/m  
Selectivity . . . . . 30 dB

Signal-to-Noise Ratio . . . . . 50 dB

Antenna . . . . . Loop antenna

### Miscellaneous

Power Requirements . . . . . AC 220 V to 230 V, 50 Hz / 60 Hz

Power Consumption . . . . . 450 W

In standby . . . . . 0.7 W

Dimensions . . . . . 420 (W) mm x 173 (H) mm x 466 (D) mm

Weight (without package) . . . . . 15.3 kg

### Furnished Parts

Setup microphone (for Auto MCACC setup) . . . . . 1

AA/LR6 dry cell batteries . . . . . 2

Remote control unit . . . . . 1

AM loop antenna . . . . . 1

FM wire antenna . . . . . 1

iPod audio control cable . . . . . 1

Warranty card . . . . . 1

These operating instructions



#### Note

- Specifications and the design are subject to possible modifications without notice, due to improvements.

## ■ For VSX-81TXV, VSX-81TXV-S and VSX-9110TXV-K

### Amplifier section (VSX-81TX and VSX-81TXV-S)

Continuous average power output of 110 watts\* per channel, min., at 8 ohms, from 20 Hz to 20 000 Hz with no more than 0.09 %\*\* total harmonic distortion (front).

Continuous Power Output (20 Hz to 20 kHz, 8 Ω, 0.09 %)  
 Front . . . . . 110 W + 110 W  
 Center . . . . . 110 W  
 Surround . . . . . 110 W + 110 W  
 Surround back . . . . . 110 W + 110 W

Continuous Power Output (1 kHz, 6 Ω, 1.0 %)  
 Front . . . . . 150 W + 150 W  
 Center . . . . . 150 W  
 Surround . . . . . 150 W + 150 W  
 Surround back . . . . . 150 W + 150 W

Total harmonic distortion . . . . . 0.09 %  
 (20 Hz to 20 kHz, 110 W, 8 Ω)

\* Measured pursuant to the Federal Trade Commission's Trade Regulation rule on Power Output Claims for Amplifiers

\*\* Measured by Audio Spectrum Analyzer

### Amplifier section (VSX-9110TXV-K)

Continuous average power output of 120 watts\* per channel, min., at 8 ohms, from 20 Hz to 20 000 Hz with no more than 0.2 %\*\* total harmonic distortion (front).

Continuous Power Output (20 Hz to 20 kHz, 8 Ω, 0.2 %)  
 Front . . . . . 120 W + 120 W  
 Center . . . . . 120 W  
 Surround . . . . . 120 W + 120 W  
 Surround back . . . . . 120 W + 120 W

Continuous Power Output (1 kHz, 6 Ω, 1.0 %)  
 Front . . . . . 150 W + 150 W  
 Center . . . . . 150 W  
 Surround . . . . . 150 W + 150 W  
 Surround back . . . . . 150 W + 150 W

Total harmonic distortion . . . . . 0.2 %  
 (20 Hz to 20 kHz, 120 W, 8 Ω)

\* Measured pursuant to the Federal Trade Commission's Trade Regulation rule on Power Output Claims for Amplifiers

\*\* Measured by Audio Spectrum Analyzer

### Audio Section

Input (Sensitivity/Impedance)  
 LINE . . . . . 335 mV/47 kΩ  
 Frequency Response (LINE) . . 5 Hz to 100 000 Hz ±3 dB  
 Output (Level/Impedance)  
 REC . . . . . 335 mV/2.2 kΩ  
 Tone Control  
 BASS . . . . . ± 6 dB (100 Hz)  
 TREBLE . . . . . ± 6 dB (10 kHz)  
 LOUDNESS . . . . . +4 dB / +2 dB (100Hz/10 kHz)  
 (at volume position -40 dB)  
 Signal-to-Noise Ratio (IHF, short circuited, A network)  
 LINE . . . . . 103 dB  
 Signal-to-Noise Ratio [EIA, at 1W (1 kHz)]  
 LINE . . . . . 83 dB

### Composite Video / S-Video Section

Input (Sensitivity/Impedance) . . . . . 1 Vp-p/75 Ω  
 Output (Level/Impedance) . . . . . 1 Vp-p/75 Ω  
 Signal-to-Noise Ratio . . . . . 65 dB  
 Frequency Response . . . . . 5 Hz to 10 MHz

### Component Video Section

Input (Sensitivity/Impedance) . . . . . 1 Vp-p/75 Ω  
 Output (Level/Impedance) . . . . . 1 Vp-p/75 Ω  
 Signal-to-Noise Ratio . . . . . 65 dB  
 Frequency Response . . . . . 5 Hz to 100 MHz

### FM Tuner Section

Frequency Range . . . . . 87.5 MHz to 108 MHz  
 Usable Sensitivity . . . . . Mono: 13.2 dBf, IHF (1.3 μV/75 Ω)  
 50 dB Quietening Sensitivity . . . . . Mono: 20.2 dBf  
 Stereo: 38.6 dBf  
 Signal-to-Noise Ratio . . . . . Mono: 73 dB (at 85 dBf)  
 Stereo: 70 dB (at 85 dBf)  
 Distortion . . . . . Stereo: 0.5 % (1 kHz)  
 Alternate Channel Selectivity . . . . . 60 dB (400 kHz)  
 Stereo Separation . . . . . 40 dB (1 kHz)  
 Frequency Response . . . . . 30 Hz to 15 kHz ± 1 dB  
 Antenna Input . . . . . 75 Ω unbalanced

### AM Tuner Section

Frequency Range . . . . . 530 kHz to 1700 kHz  
 Sensitivity (IHF, Loop antenna) . . . . . 350 μV/m  
 Selectivity . . . . . 25 dB  
 Signal-to-Noise Ratio . . . . . 50 dB  
 Antenna . . . . . Loop antenna

### Miscellaneous

Power Requirements . . . . . AC 120 V, 60 Hz  
 Power Consumption . . . . . 490 W, 650 VA  
 In standby . . . . . 0.65 W  
 AC Outlet . . . . . (switched) 100 W MAX.  
 Dimensions . . . . . 420 (W) mm x 173 (H) mm x 466 (D) mm  
 (16 9/16 (W) in. x 6 13/16 (H) in. x 18 3/8 (D) in.)  
 Weight (without package) . . . . . 15.3 kg (33 lbs 12 oz)

### Furnished Parts

Setup microphone (for Auto MCACC setup) . . . . . 1  
 AA/IEC R6P dry cell batteries . . . . . 2  
 Remote control unit . . . . . 1  
 AM loop antenna . . . . . 1  
 FM wire antenna . . . . . 1  
 iPod audio control cable . . . . . 1  
 Warranty card . . . . . 1  
 These operating instructions



#### Note

- Specifications and the design are subject to possible modifications without notice, due to improvements.

A

### ● Accessories



AM Loop Antenna  
(ATB7013)

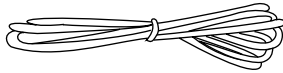

FM Wire Antenna  
(ADH7030)

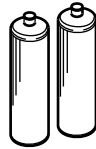

AA/LR6 Dry Cell Batteries  
(VEM1021: VSX-2016AV-S)  
AA/IED R6P Dry Cell Batteries  
(VEM1031: Other models)

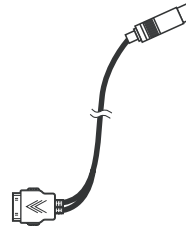

Audio Control Cable for iPod  
(ADE7119)

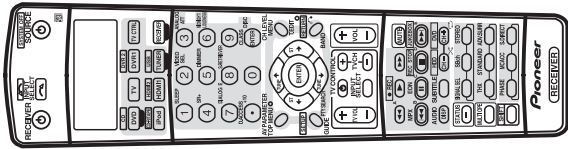

Remote Control Unit  
(AXD7432: VSX-2016AV-S)  
(AXD7431: Other models)

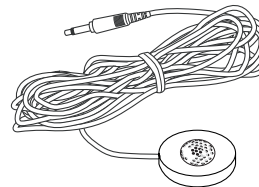

Setup Microphone  
(for Auto MCACC setup)  
(APM7008)

B

C

Windows Media® and the Windows logo are trademarks or registered trademarks of Microsoft Corporation in the United States and/or other countries.

The THX logo is a trademark of THX Ltd. which may be registered in some jurisdictions. All rights reserved.

Manufactured under license from Dolby Laboratories. "Dolby", "Pro Logic", "Surround EX", and the double-D symbol are trademarks of Dolby Laboratories.

"DTS", "DTS-ES", "Neo:6" and "DTS 96/24" are trademarks of Digital Theater Systems, Inc.

E

F



■

5

■

6

■

7

■

8

■

A

■

B

■

C

■

D

■

E

■

F

■

5

■

6

VSX-2016AV-S

■

7

■

8

9

■

# 2. EXPLODED VIEWS AND PARTS LIST

- NOTES:
- Parts marked by "NSP" are generally unavailable because they are not in our Master Spare Parts List.
  - The  $\triangle$  mark found on some component parts indicates the importance of the safety factor of the part. Therefore, when replacing, be sure to use parts of identical designation.
  - Screws adjacent to  $\blacktriangledown$  mark on product are used for disassembly.
  - For the applying amount of lubricants or glue, follow the instructions in this manual. (In the case of no amount instructions, apply as you think it appropriate.)

## 2.1 PACKING SECTION

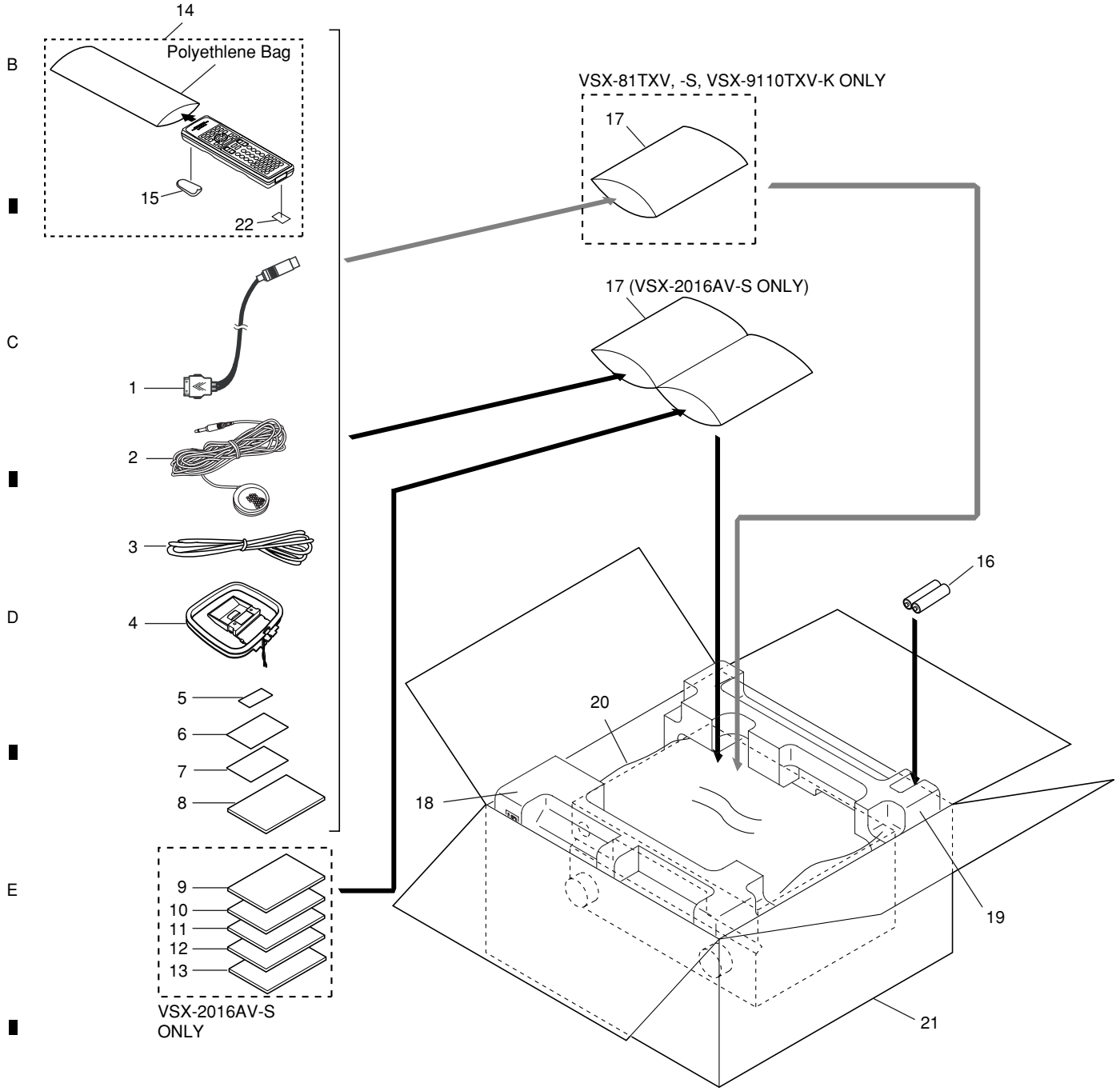

**(1) PACKING SECTION PARTS LIST**

Mark No.	Description	Part No.	Mark No.	Description	Part No.
1	iPod Audio Control Cable	ADE7119	15	Battery Cover	XZN3140
2	Setup Microphone (for Auto MCACC setup)	APM7008	NSP 16	Dry Cell Battery	See Contrast table (2)
3	FM Wire Antenna	ADH7030	NSP 17	Polyethylene Bag	See Contrast table (2)
4	AM Loop Antenna	ATB7013	18	Front Pad	AHA7456
			19	Rear Pad	AHA7457
NSP 5	Warranty Card	See Contrast table (2)	20	Packing Sheet	RHC1023
6	Caution Sheet(Spanish/English)	ARM7083	21	Packing Case	See Contrast table (2)
7	Disclaimer	See Contrast table (2)	22	LABEL (WEEE)	See Contrast table (2)
8	Operating Instructions (English)	See Contrast table (2)			
9	Operating Instructions (French)	See Contrast table (2)			
10	Operating Instructions (German)	See Contrast table (2)			
11	Operating Instructions (Italian)	See Contrast table (2)			
12	Operating Instructions (Spanish)	See Contrast table (2)			
13	Operating Instructions (Dutch)	See Contrast table (2)			
14	Remote Control Unit	See Contrast table (2)			

**(2) CONTRAST TABLE**

VSX-2016AV-S/HYXJ5, VSX-81TXV/KUXJCA, VSX-81TXV-S/KUXJCA and VSX-9110TXV-K/KUXJ are constructed the same except for the following:

Mark	No.	Symbol and Description	VSX-2016AV-S /HYXJ5	VSX-81TXV /KUXJCA	VSX-81TXV-S /KUXJCA	VSX-9110TXV-K /KUXJ	
NSP	5	Warranty Card	ARY7065	ARY7007	ARY7007	ARY7045	
	7	Disclaimer (English/French/German/Italian /Spanish/Dutch)	ARX7081	Not used	Not used	Not used	
	7	Disclaimer (English/French)	Not used	ARX7080	ARX7080	ARX7080	
	8	Operating Instructions (English)	ARB7355	ARB7356	ARB7356	ARB7357	
	9	Operating Instructions (French)	ARC7693	Not used	Not used	Not used	
	10	Operating Instructions (German)	ARC7694	Not used	Not used	Not used	
	11	Operating Instructions (Italian)	ARC7695	Not used	Not used	Not used	
	12	Operating Instructions (Spanish)	ARC7696	Not used	Not used	Not used	
	13	Operating Instructions (Dutch)	ARC7697	Not used	Not used	Not used	
	14	Remote Control Unit	AXD7432	AXD7431	AXD7431	AXD7431	
	NSP	16	Dry Cell Battery AA/LR6	VEM1021	Not used	Not used	Not used
	NSP	16	Dry Cell Battery AA/IEC R6P	Not used	VEM1031	VEM1031	VEM1031
	NSP	17	Polyethylene Bag	AHG7132	AHG7117	AHG7117	AHG7117
21		Packing Case 2016SHY	AHD8437	Not used	Not used	Not used	
21		Packing Case 81KKU	Not used	AHD8428	Not used	Not used	
21		Packing Case 81SKU	Not used	Not used	AHD8432	Not used	
21		Packing Case 9110KKU	Not used	Not used	Not used	AHD8433	
	22	LABEL (WEEE)	ARW7322	Not used	Not used	Not used	

# 2.2 EXTERIOR SECTION

1

2

3

4

A

B

C

D

E

F

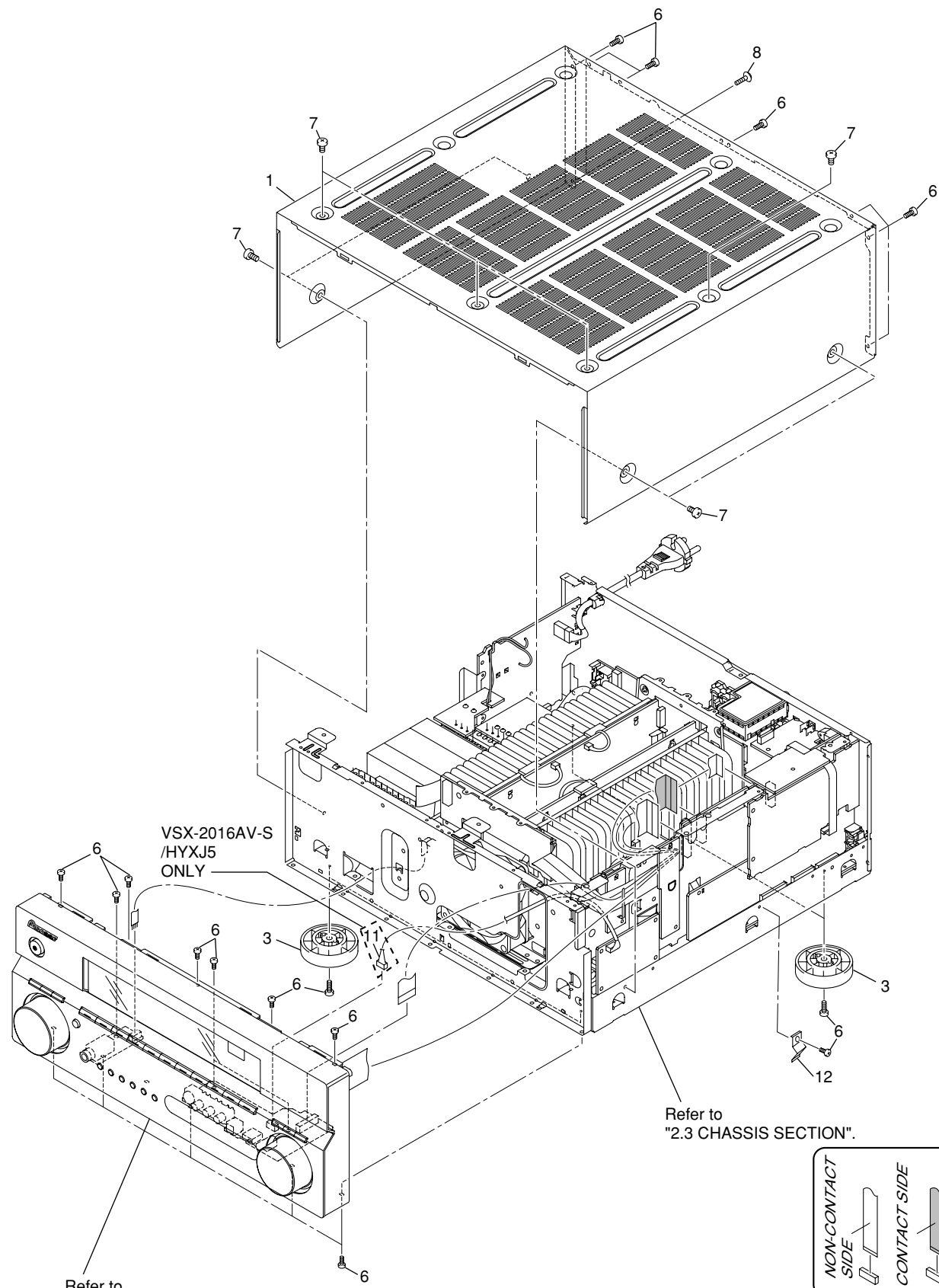

1

2

3

4

5 6 7 8

**(1) EXTERIOR SECTION PARTS LIST**

<u>Mark No.</u>	<u>Description</u>	<u>Part No.</u>
1	Bonnet	See Contrast table (2)
3	Insulator	See Contrast table (2)
6	Screw	BBZ30P080FCC
7	Screw	See Contrast table (2)
8	Screw	IBP30P090FCC
11	4P Shielded Cable	See Contrast table (2)
12	Earth Spring	ABH7245

**(2) CONTRAST TABLE**

VSX-2016AV-S/HYXJ5, VSX-81TXV/KUXJCA, VSX-81TXV-S/KUXJCA and VSX-9110TXV-K/KUXJ are constructed the same except for the following:

Mark	No.	Symbol and Description	VSX-2016AV-S /HYXJ5	VSX-81TXV /KUXJCA	VSX-81TXV-S /KUXJCA	VSX-9110TXV-K /KUXJ
	1	Bonnet 2016S	AZN8020	Not used	AZN8020	Not used
	1	Bonnet 81B	Not used	AZN8021	Not used	AZN8021
	3	Insulator	PNW2766	AMR7198	AMR7198	PNW2766
	7	Screw	BCZ40P060FNI	BCZ40P060FTB	BCZ40P060FNI	BCZ40P060FTB
	11	4P Shielded Cable	XDX3028	Not used	Not used	Not used

# 2.3 CHASSIS SECTION

1 2 3 4

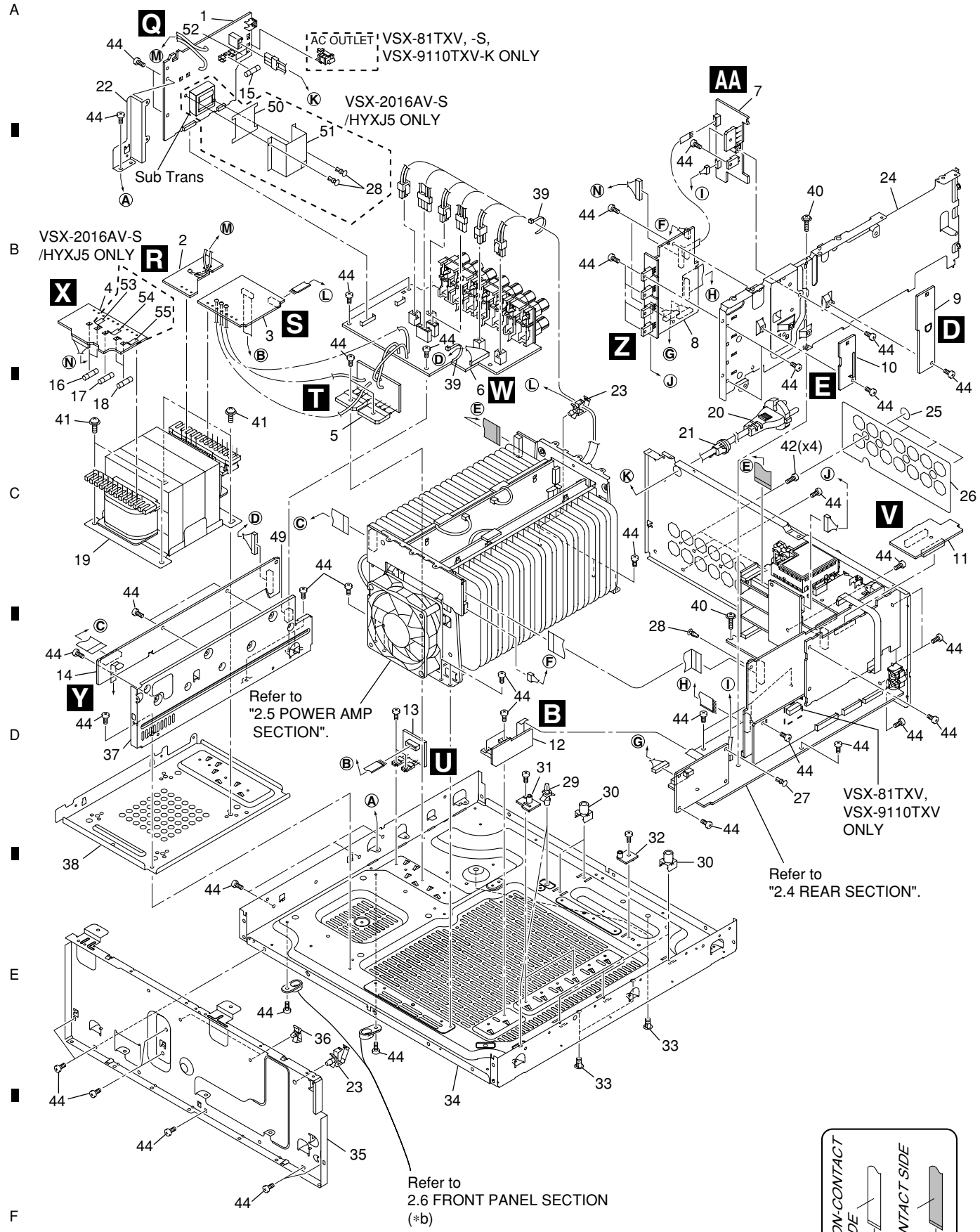

1 2 3 4

**(1) CHASSIS SECTION PARTS LIST**

Mark No.	Description	Part No.	Mark No.	Description	Part No.
1	PRIMARY Assy	See Contrast table (2)	26	SP Sheet 2016	AEC7560
2	TRANS 1 Assy	AWX9038	27	Nyron Rivet	AEC7408
3	TRANS 2-1 Assy	See Contrast table (2)	28	Nyron Rivet	AEC7406
4	TRANS 2-2 Assy	AWX9062	29	Locking Card Spacer	PNW2917
5	DIODE 1 Assy	AWX9060	30	PCB Mold	AMR2534
6	PS/SP Assy	See Contrast table (2)	31	Inter Holder A	AMR7500
7	DC/DC Assy	AWX9015	32	Inter Holder B	AMR7501
8	LOCAL P-SUPPLY Assy	See Contrast table (2)	33	Card Spacer	DNK2769
9	GUARD-C Assy	AWX9051	NSP 34	Under Base 2016	ANA7189
10	GUARD-F Assy	AWX9070	NSP 35	Panel Stay 2016	AND7082
11	BRIDGE 1 Assy	AWX9078	36	Side Clamp	DEC2007
12	12V-REG Assy	AWX9014	37	Under Beam V1	ANG7478
13	VH TR Assy	AWX9061	NSP 38	Trans Frame 74	ANG7539
14	TRANS SIDE Assy	AWX9056	NSP 39	Binder	ZCA-BK1
⚠ 15	Fuse (FU1)	See Contrast table (2)	40	Screw 3x15	ABA7100
⚠ 16	Fuse (FU7,FU8)	See Contrast table (2)	41	Screw	ABA7109
⚠ 17	Fuse (FU4)	See Contrast table (2)	42	Screw	BBT30P100FCC
⚠ 18	Fuse (FU5,FU6)	See Contrast table (2)	44	Screw	BBZ30P080FCC
⚠ 19	Power Transformer (T1501)	See Contrast table (2)	49	Bridge Spacer	AEB7201
⚠ 20	AC Power Cord	See Contrast table (2)	50	Primary Barrier	See Contrast table (2)
21	Cord Stopper	See Contrast table (2)	51	Shield Case	See Contrast table (2)
22	Primary Angle 56	ANG7526	NSP 52	Fuse Card	See Contrast table (2)
NSP 23	Wire Saddle	DEC1450	NSP 53	Fuse Card	See Contrast table (2)
24	DSP Shield 2016	ANG7546	NSP 54	Fuse Card	See Contrast table (2)
25	Cushion Circle 14B	AED7081	NSP 55	Fuse Card	See Contrast table (2)

**(2) CONTRAST TABLE**

VSX-2016AV-S/HYXJ5, VSX-81TXV/KUXJCA, VSX-81TXV-S/KUXJCA and VSX-9110TXV-K/KUXJ are constructed the same except for the following:

Mark	No.	Symbol and Description	VSX-2016AV-S /HYXJ5	VSX-81TXV /KUXJCA	VSX-81TXV-S /KUXJCA	VSX-9110TXV-K /KUXJ
	1	PRIMARY Assy	AWX9035	AWX9034	AWX9034	AWX9034
	3	TRANS 2-1 Assy	AWX9059	AWX9058	AWX9058	AWX9058
	6	PS/SP Assy	AWX9107	AWX9052	AWX9052	AWX9052
	8	LOCAL P-SUPPLY Assy	AWX9064	AWX9063	AWX9063	AWX9063
⚠	15	Fuse (FU1: T5 A L 250 V)	REK1029	Not used	Not used	Not used
⚠	15	Fuse (FU1: 10 A/125 V)	Not used	REK1154	REK1154	REK1154
⚠	16	Fuse (FU7,FU8: T2.5 A L 250 V)	REK1026	Not used	Not used	Not used
⚠	16	Fuse (FU7,FU8: 2.5 A/125 V)	Not used	REK1146	REK1146	REK1146
⚠	17	Fuse (FU4: T4 A L 250 V)	REK1028	Not used	Not used	Not used
⚠	17	Fuse (FU4: 5 A/125 V)	Not used	REK1067	REK1067	REK1067
⚠	18	Fuse (FU5,FU6: T800 mA L 250 V)	REK1021	Not used	Not used	Not used
⚠	18	Fuse (FU5,FU6: 1.25 A/125 V)	Not used	REK1143	REK1143	REK1143
⚠	19	Power Transformer (T1501)	ATS7408	ATS7407	ATS7407	ATS7407
⚠	20	AC Power Cord	VDG1080	VDG1075	VDG1075	VDG1075
	21	Cord Stopper	CM-22B	CM-22C	CM-22C	CM-22C
	50	Primary Barrier	AEC7569	Not used	Not used	Not used
	51	Shield Case	AMR7526	Not used	Not used	Not used
NSP	52	Fuse Card	AAX7098	Not used	Not used	Not used
NSP	53	Fuse Card	AAX7277	Not used	Not used	Not used
NSP	54	Fuse Card	AAX7099	Not used	Not used	Not used
NSP	55	Fuse Card	AAX2367	Not used	Not used	Not used

# 2.4 REAR SECTION

## • VSX-2016AV-S

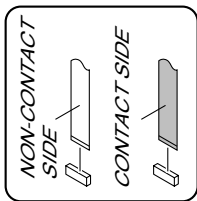
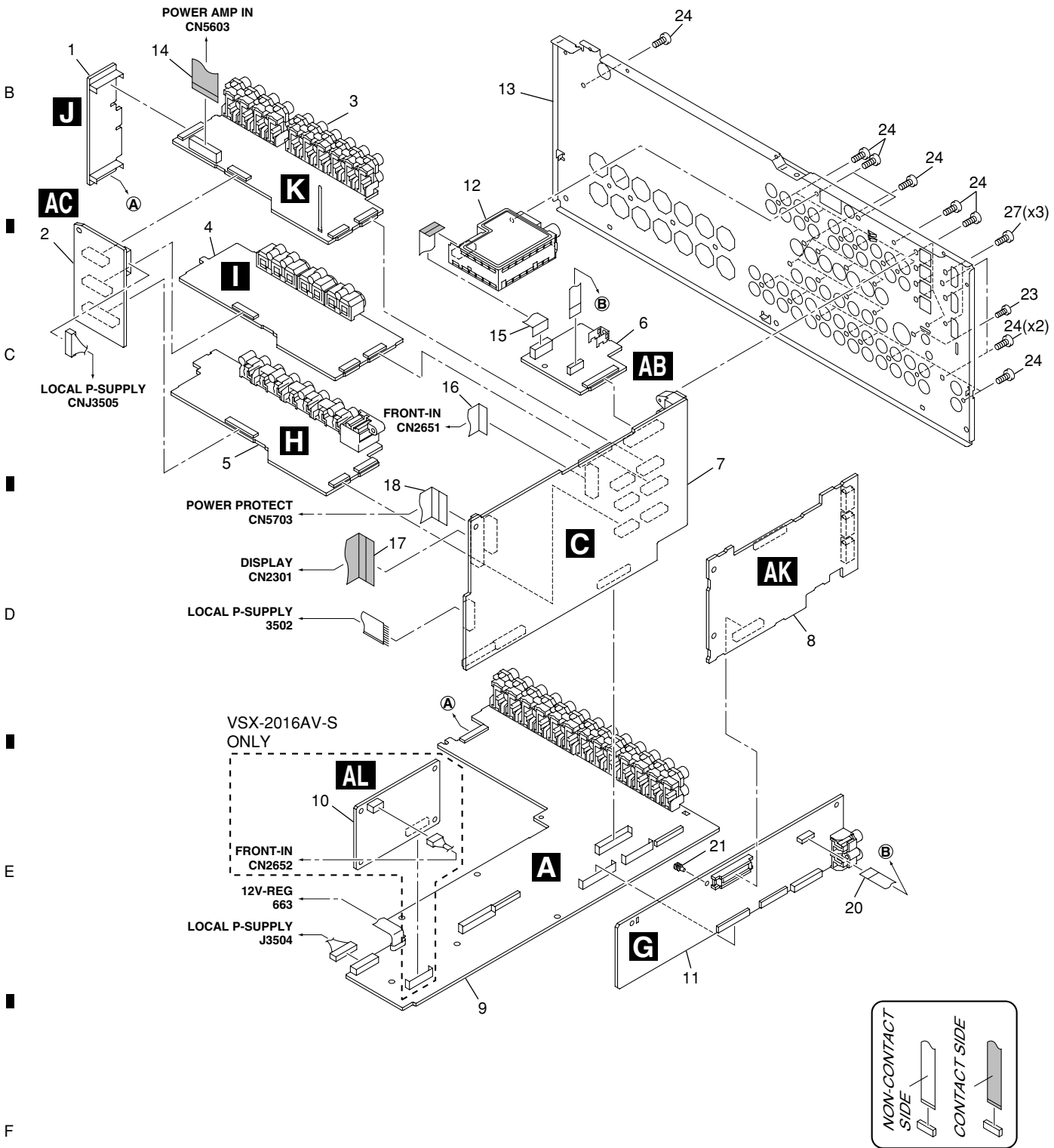



(1) REAR SECTION PARTS LIST

<u>Mark No.</u>	<u>Description</u>	<u>Part No.</u>	
1	BRIDGE 2 Assy	AWX9050	
2	VIDEO CONNECT Assy	AWX9069	A
3	COMPONENT Assy	AWX9031	
4	S-VIDEO Assy	AWX9030	
5	COMPOSITE Assy	AWX9028	
6	IR I/O Assy	AWX9067	
7	MAIN CONTROL Assy	AWX9009	
8	HDMI & DVC Assy	AWQ7037	
9	AUDIO IN Assy	AWX9013	
10	USB Assy	AWX8704	
11	DSP Assy	AWX8698	B
12	FM/AM Tuner Unit	AXX7170	
13	Rear Panel 2016SHY	ANC8377	
14	19P FFC/60V (J58)	ADD7535	
15	11P FFC/60V (J59)	ADD7536	
16	17P FFC/60V (J54)	ADD7540	
17	29P FFC/60V (J55)	ADD7532	
18	19P FFC/60V (J56)	ADD7533	
20	10P FFC/60V (J51)	ADD7528	
21	Card Spacer	AEC7214	
23	Screw	BBZ26P080FCC	C
24	Screw	BBZ30P080FCC	
27	Screw	PMZ30P060FCC	

• VSX-81TXV, -S, VSX-9110TXV-K

A

B

C

D

E

F

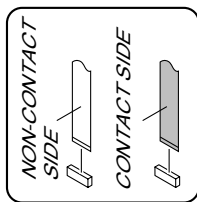
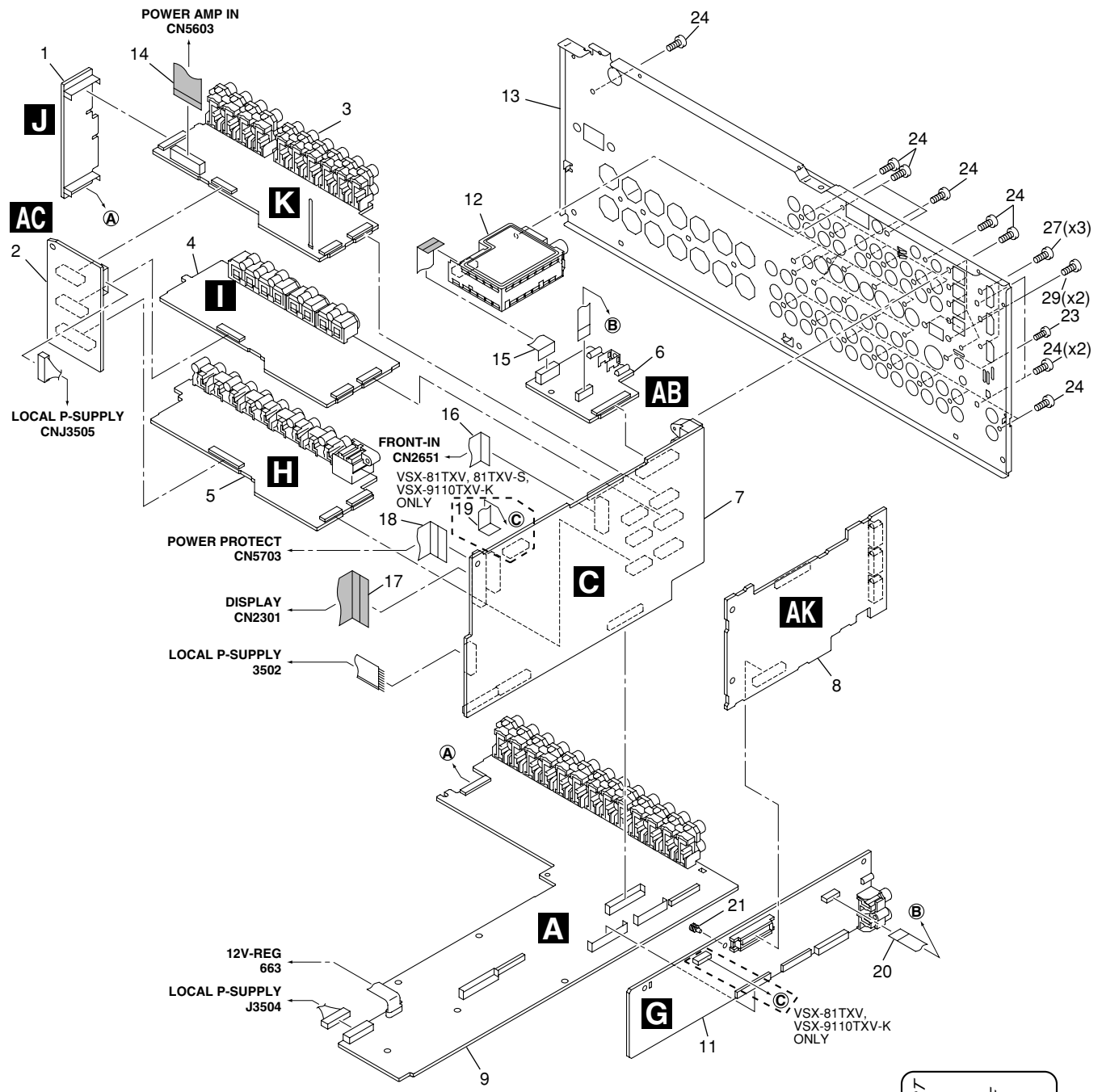

**(1) REAR SECTION PARTS LIST**

<u>Mark No.</u>	<u>Description</u>	<u>Part No.</u>	<u>Mark No.</u>	<u>Description</u>	<u>Part No.</u>
1	BRIDGE 2 Assy	AWX9050			
2	VIDEO CONNECT Assy	AWX9069	16	17P FFC/60V (J54)	ADD7540
3	COMPONENT Assy	See Contrast table (2)	17	29P FFC/60V (J55)	ADD7532
4	S-VIDEO Assy	See Contrast table (2)	18	19P FFC/60V (J56)	ADD7533
5	COMPOSITE Assy	See Contrast table (2)	19	12P FFC/60V (J52)	See Contrast table (2)
			20	10P FFC/60V (J51)	ADD7528
6	IR I/O Assy	See Contrast table (2)			
7	MAIN CONTROL Assy	See Contrast table (2)	21	Card Spacer	AEC7214
8	HDMI & DVC Assy	AWQ7037	23	Screw	BBZ26P080FCC
9	AUDIO IN Assy	See Contrast table (2)	24	Screw	BBZ30P080FCC
			27	Screw	PMZ30P060FCC
11	DSP Assy	See Contrast table (2)	29	Screw 2.85 x 7	ABA7078
12	FM/AM Tuner Unit	See Contrast table (2)			
13	Rear Panel	See Contrast table (2)			
14	19P FFC/60V (J58)	ADD7535			
15	11P FFC/60V (J59)	ADD7536			

**(2) CONTRAST TABLE**

VSX-81TXV/KUXJCA, VSX-81TXV-S/KUXJCA and VSX-9110TXV-K/KUXJ are constructed the same except for the following:

<u>Mark</u>	<u>No.</u>	<u>Symbol and Description</u>	<u>VSX-81TXV /KUXJCA</u>	<u>VSX-81TXV-S /KUXJCA</u>	<u>VSX-9110TXV-K /KUXJ</u>
	3	COMPONENT Assy	AWX9032	AWX9032	AWX9032
	4	S-VIDEO Assy	AWX9029	AWX9029	AWX9029
	5	COMPOSITE Assy	AWX9026	AWX9026	AWX9026
	6	IR I/O Assy	AWX9066	AWX9066	AWX9066
	7	MAIN CONTROL Assy	AWX9008	AWX9008	AWX9008
	9	AUDIO IN Assy	AWX9012	AWX9012	AWX9012
	11	DSP Assy	AWX8697	AWX8697	AWX8697
	12	FM/AM Tuner Unit	AXX7172	AXX7172	AXX7172
	13	Rear Panel 81KKU	ANC8378	Not used	Not used
	13	Rear Panel 81SKU	Not used	ANC8379	Not used
	13	Rear Panel 9110KKU	Not used	Not used	ANC8380
	19	12P FFC/60V (J52)	ADD7529	ADD7529	ADD7529

# 2.5 POWER AMP SECTION

A

B

C

D

E

F

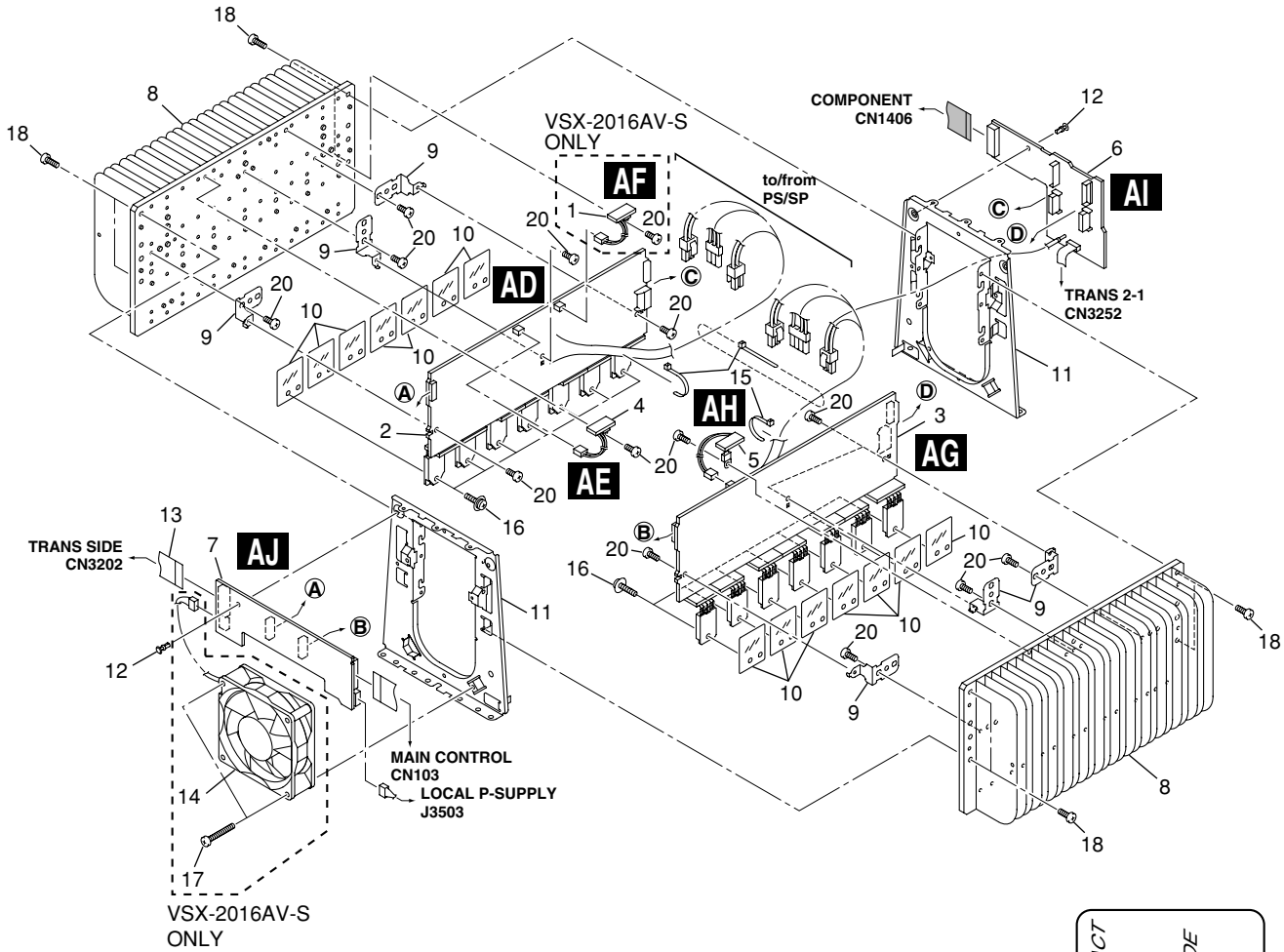

**(1) POWER AMP SECTION PARTS LIST**

<u>Mark No.</u>	<u>Description</u>	<u>Part No.</u>	<u>Mark No.</u>	<u>Description</u>	<u>Part No.</u>
1	POSI 2-L Assy	See Contrast table (2)	11	H.S. Angle 2016	ANG7547
2	POWER AMP-L Assy	See Contrast table (2)	12	Nyron Rivet	AEC7408
3	POWER AMP-R Assy	See Contrast table (2)	13	17P FFC/60V (J57)	ADD7534
4	POSI 1-L Assy	See Contrast table (2)	⚠ 14	DC Fan Motor	See Contrast table (2)
5	POSI 1-R Assy	See Contrast table (2)	NSP 15	Binder	ZCA-BK1
6	POWER AMP IN Assy	AWX9075	16	Screw 3X19	ABA7085
7	POWER PROTECT Assy	See Contrast table (2)	17	Screw	See Contrast table (2)
NSP 8	Heat Sink 45	ANH7152	18	Screw	BBT30P100FCC
9	PCB Angle 45	ANG7406	20	Screw	BBZ30P080FCC
10	Mica Sheet 45	AEE7047			

**(2) CONTRAST TABLE**

VSX-2016AV-S/HYXJ5, VSX-81TXV/KUXJCA, VSX-81TXV-S/KUXJCA and VSX-9110TXV-K/KUXJ are constructed the same except for the following:

<u>Mark</u>	<u>No.</u>	<u>Symbol and Description</u>	<u>VSX-2016AV-S /HYXJ5</u>	<u>VSX-81TXV /KUXJCA</u>	<u>VSX-81TXV-S /KUXJCA</u>	<u>VSX-9110TXV-K /KUXJ</u>
	1	POSI 2-L Assy	AWX9082	Not used	Not used	Not used
	2	POWER AMP-L Assy	AWX9072	AWX9071	AWX9071	AWX9071
	3	POWER AMP-R Assy	AWX9073	AWX9106	AWX9106	AWX9106
	4	POSI 1-L Assy	AWX9081	AWX9080	AWX9080	AWX9080
	5	POSI 1-R Assy	AWX9084	AWX9083	AWX9083	AWX9083
	7	POWER PROTECT Assy	AWX9077	AWX9076	AWX9076	AWX9076
⚠	14	DC Fan Motor	AXM7029	Not used	Not used	Not used
	17	Screw	BBZ30P300FTC	Not used	Not used	Not used

# 2.6 FRONT PANEL SECTION

A

B

C

D

E

F

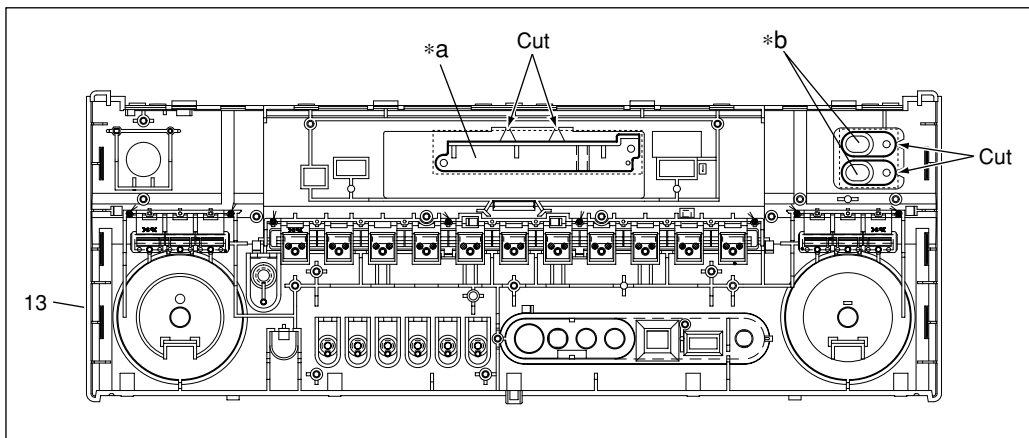
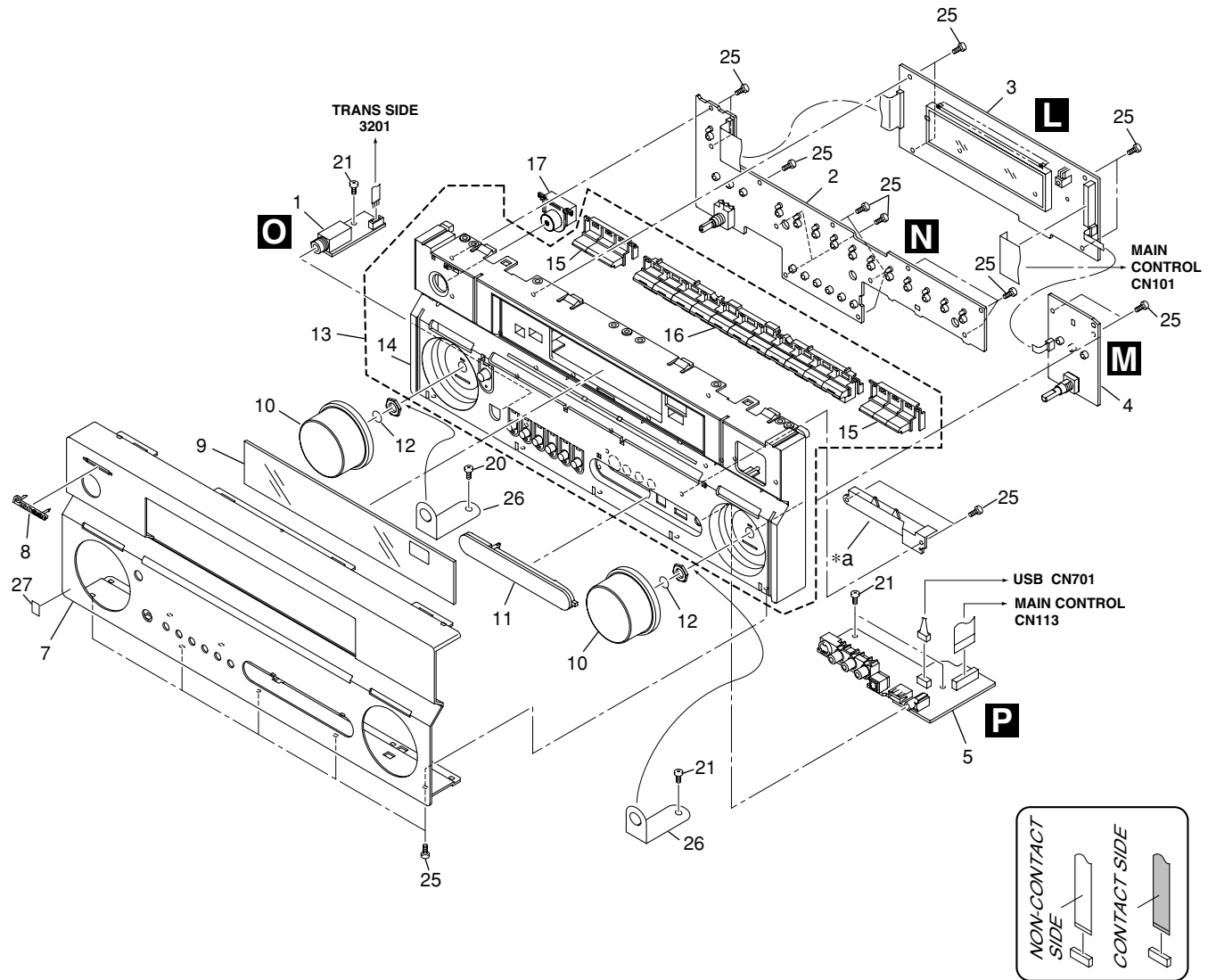

**(1) FRONT PANEL SECTION PARTS LIST**

<u>Mark No.</u>	<u>Description</u>	<u>Part No.</u>	<u>Mark No.</u>	<u>Description</u>	<u>Part No.</u>
1	HEADPHONE Assy	AWX9049	NSP 16	Func BTN Assy	See Contrast table (2)
2	MULTI JOG Assy	See Contrast table (2)	17	STDBY BTN Assy	See Contrast table (2)
3	DISPLAY Assy	See Contrast table (2)	21	Screw	BBZ30P080FCC
4	VOLUME Assy	See Contrast table (2)	25	Screw	PPZ30P080FNI
5	FRONT-IN Assy	See Contrast table (2)	26	Earth Plate	See Contrast table (2)
7	F Panel	See Contrast table (2)	NSP 27	Energy Star Label	See Contrast table (2)
8	Pioneer Name Plate	See Contrast table (2)			
9	Window	See Contrast table (2)			
10	Rotary Knob	See Contrast table (2)			
11	Input Cover	See Contrast table (2)			
12	Ring	ABH7213			
13	P Base Assy	See Contrast table (2)			
NSP 14	P Base	See Contrast table (2)			
NSP 15	Side Button	See Contrast table (2)			

**(2) CONTRAST TABLE**

VSX-2016AV-S/HYXJ5, VSX-81TXV/KUXJCA, VSX-81TXV-S/KUXJCA and VSX-9110TXV-K/KUXJ are constructed the same except for the following:

<u>Mark No.</u>	<u>Symbol and Description</u>	<u>VSX-2016AV-S /HYXJ5</u>	<u>VSX-81TXV /KUXJCA</u>	<u>VSX-81TXV-S /KUXJCA</u>	<u>VSX-9110TXV-K /KUXJ</u>
2	MULTI JOG Assy	AWX9112	AWX9045	AWX9112	AWX9045
3	DISPLAY Assy	AWX9103	AWX9040	AWX9040	AWX9040
4	VOLUME Assy	AWX9111	AWX9044	AWX9111	AWX9044
5	FRONT-IN Assy	AWX9048	AWX9047	AWX9047	AWX9047
7	F Panel 2016SHY	ANB7400	Not used	Not used	Not used
7	F Panel 81KKU	Not used	ANB7397	Not used	Not used
7	F Panel 81SKU	Not used	Not used	ANB7398	Not used
7	F Panel 9110KKU	Not used	Not used	Not used	ANB7399
8	Pioneer Name Plate	VAM1129	VAM1109	VAM1129	Not used
8	Pioneer Badge B	Not used	Not used	Not used	XAM3006
9	Window 2016HY	AAK8330	Not used	AAK8330	AAK8330
9	Window 81K	Not used	AAK8331	Not used	Not used
10	Rotary Knob P	AAA7033	Not used	AAA7033	Not used
10	Rotary Knob B	Not used	AAA7024	Not used	AAA7024
11	Input Cover V3S	XAK3533	Not used	XAK3533	Not used
11	Input Cover 81K	Not used	AAK8355	Not used	Not used
13	P Base 2016SHY Assy	AXG7287	Not used	Not used	Not used
13	P Base 81KKU Assy	Not used	AXG7290	Not used	Not used
13	P Base 81SKU Assy	Not used	Not used	AXG7308	Not used
13	P Base 9110KKU Assy	Not used	Not used	Not used	AXG7309
NSP	14 P Base 2016SHY	AMB7920	Not used	Not used	Not used
NSP	14 P Base 81KKU	Not used	AMB7919	Not used	Not used
NSP	14 P Base 81SKU	Not used	Not used	AMB7925	Not used
NSP	14 P Base 9110KKU	Not used	Not used	Not used	AMB7921
NSP	15 Side Button S	AAD7760	Not used	AAD7760	Not used
NSP	15 Side Button K	Not used	AAD7761	Not used	AAD7761
NSP	16 Func BTN S Assy	AAD7757	Not used	AAD7757	Not used
NSP	16 Func BTN K Assy	Not used	AAD7758	Not used	AAD7758
	17 STDBY BTN 915P Assy	XAD3217	Not used	XAD3217	Not used
	17 STDBY BTN 915K Assy	Not used	XAD3216	Not used	XAD3216
	26 Earth Plate	ABK7062	Not Used	ABK7062	Not used
NSP	27 Energy Ster Label	Not used	AAX8022	AAX8022	AAX8022

# 3. BLOCK DIAGRAM AND SCHEMATIC DIAGRAM

## 3.1 BLOCK DIAGRAM for AUDIO BLOCK

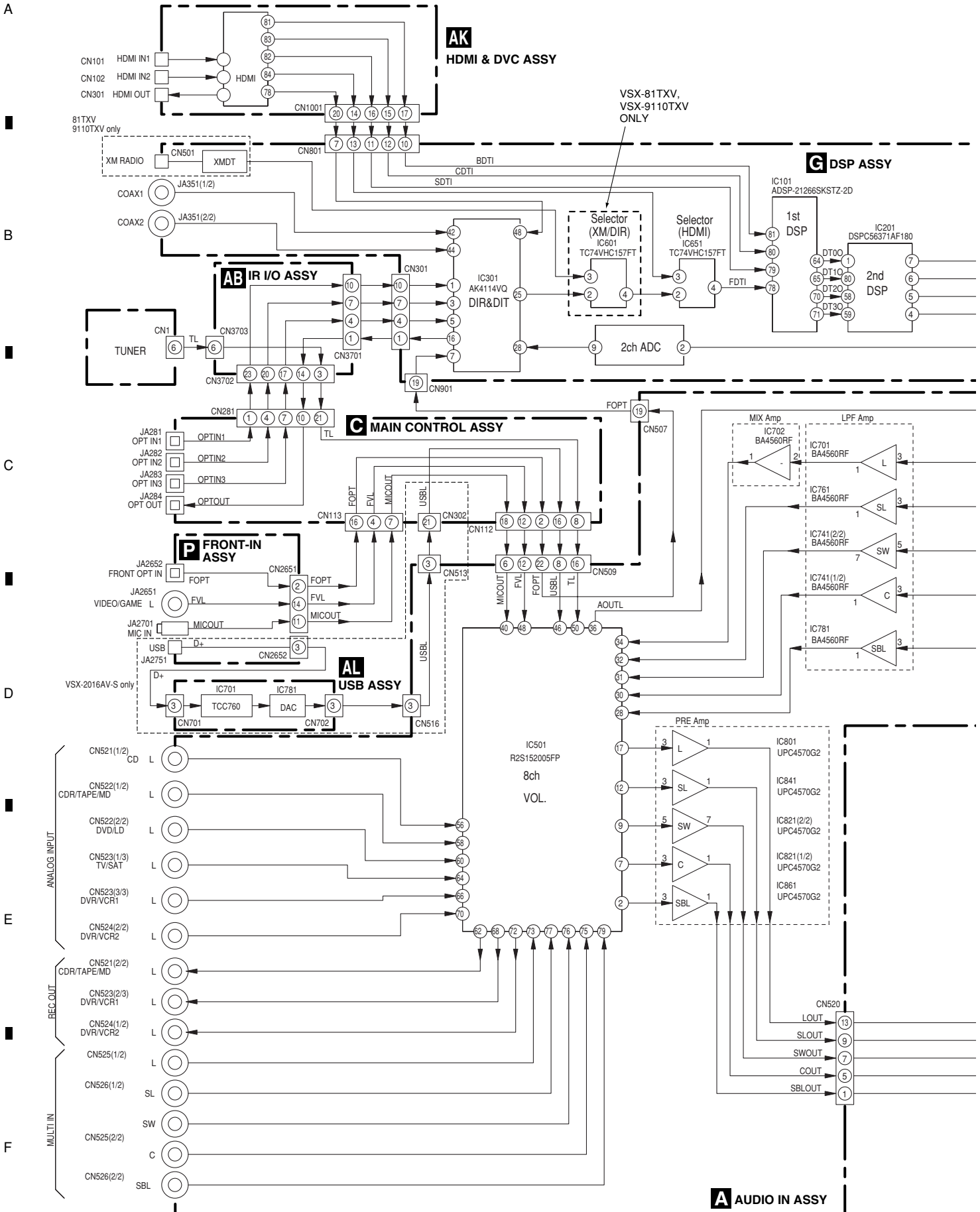



A  
B  
C  
D  
E  
F

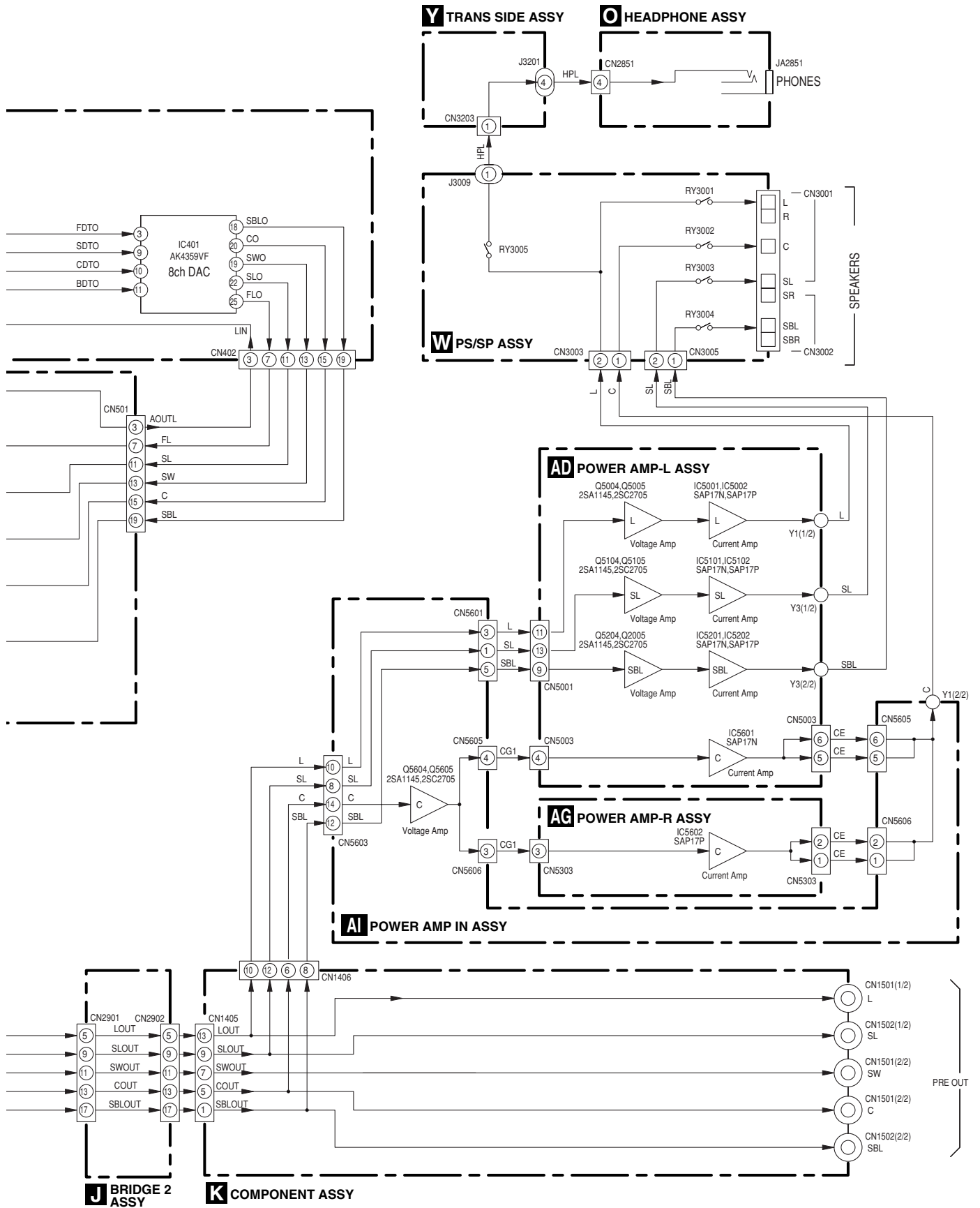

# 3.2 BLOCK DIAGRAM for VIDEO BLOCK

A  
B  
C  
D  
E  
F

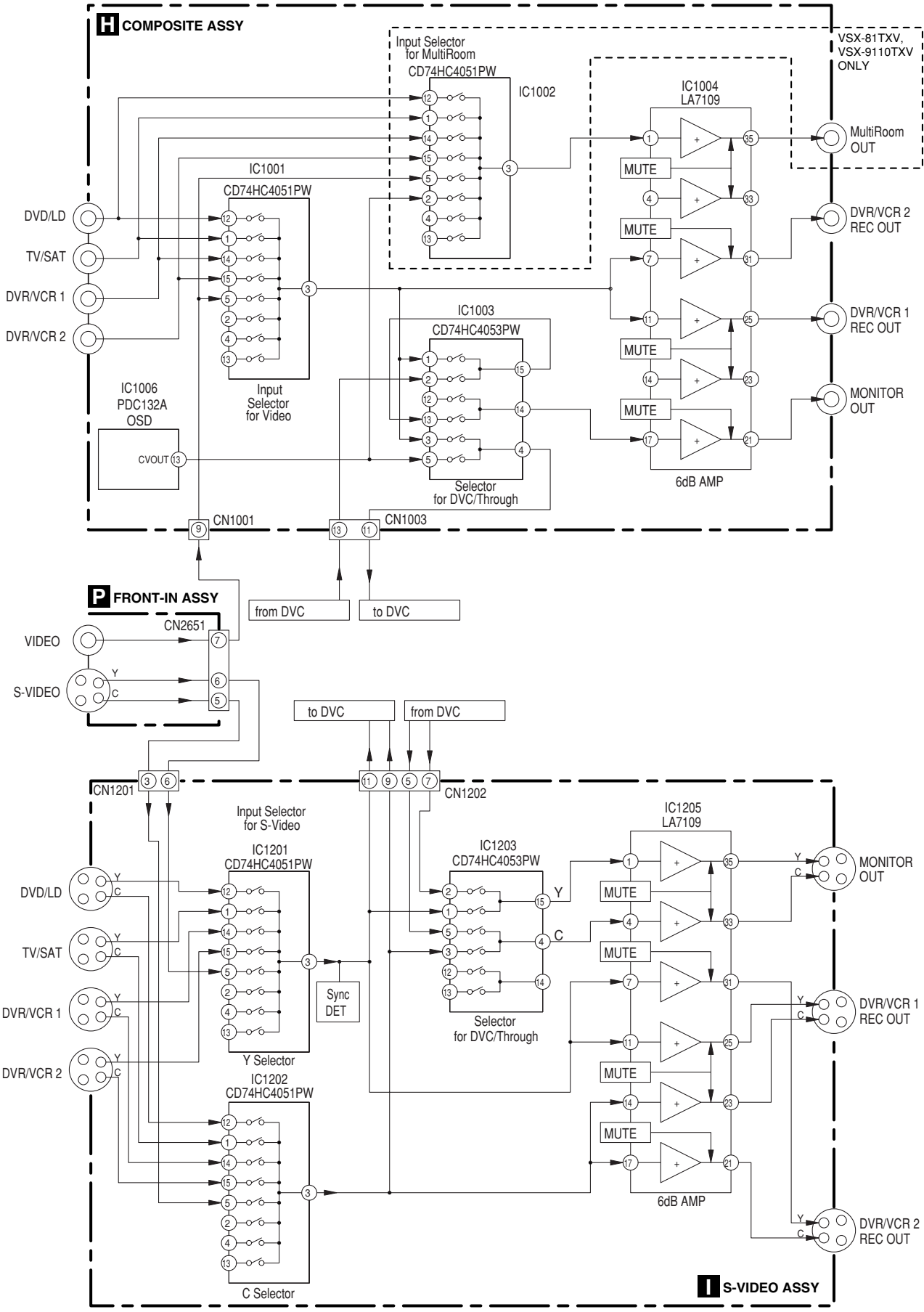

A  
B  
C  
D  
E  
F

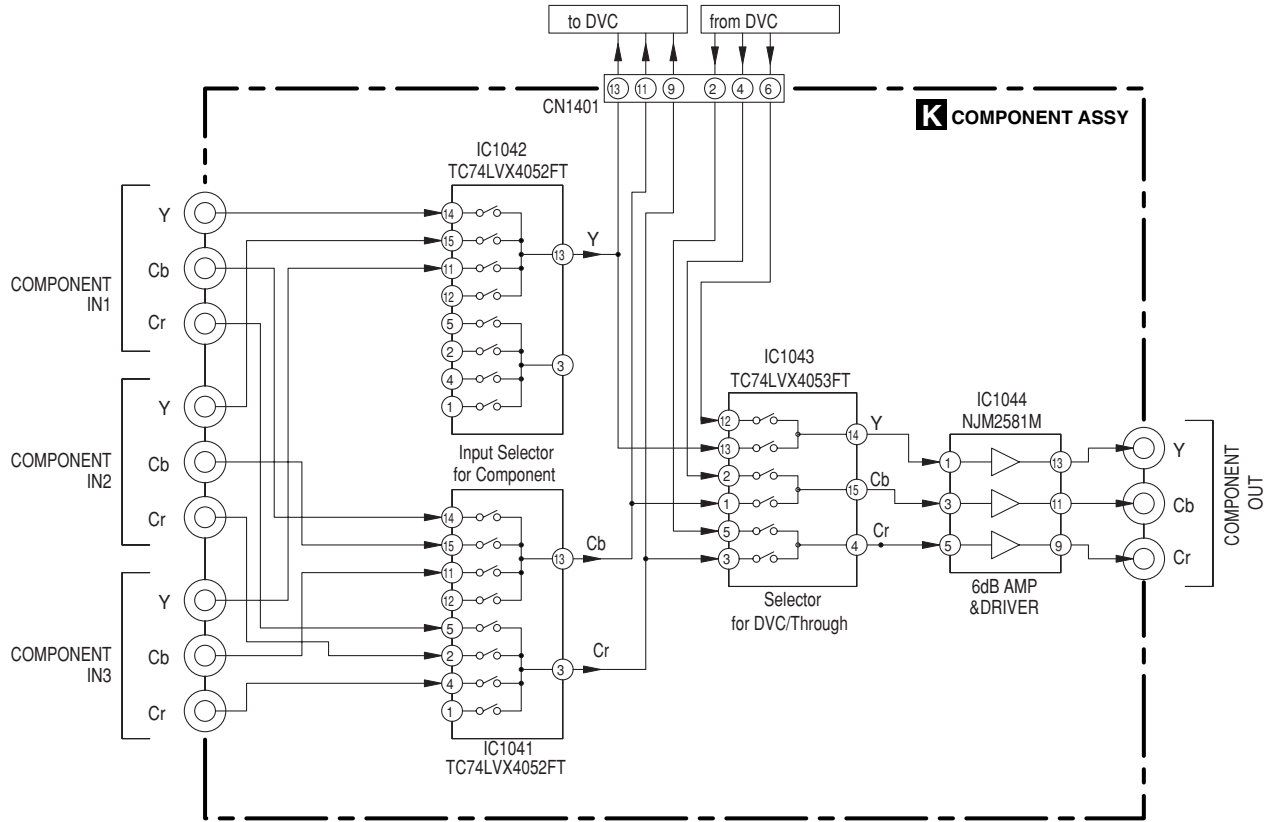



- When ordering service parts, be sure to refer to "EXPLODED VIEWS and PARTS LIST" or "PCB PARTS LIST".
- The ⚠ mark found on some component parts indicates the importance of the safety factor of the part. Therefore, when replacing, be sure to use parts of identical designation.
-  : The power supply is shown with the marked box.

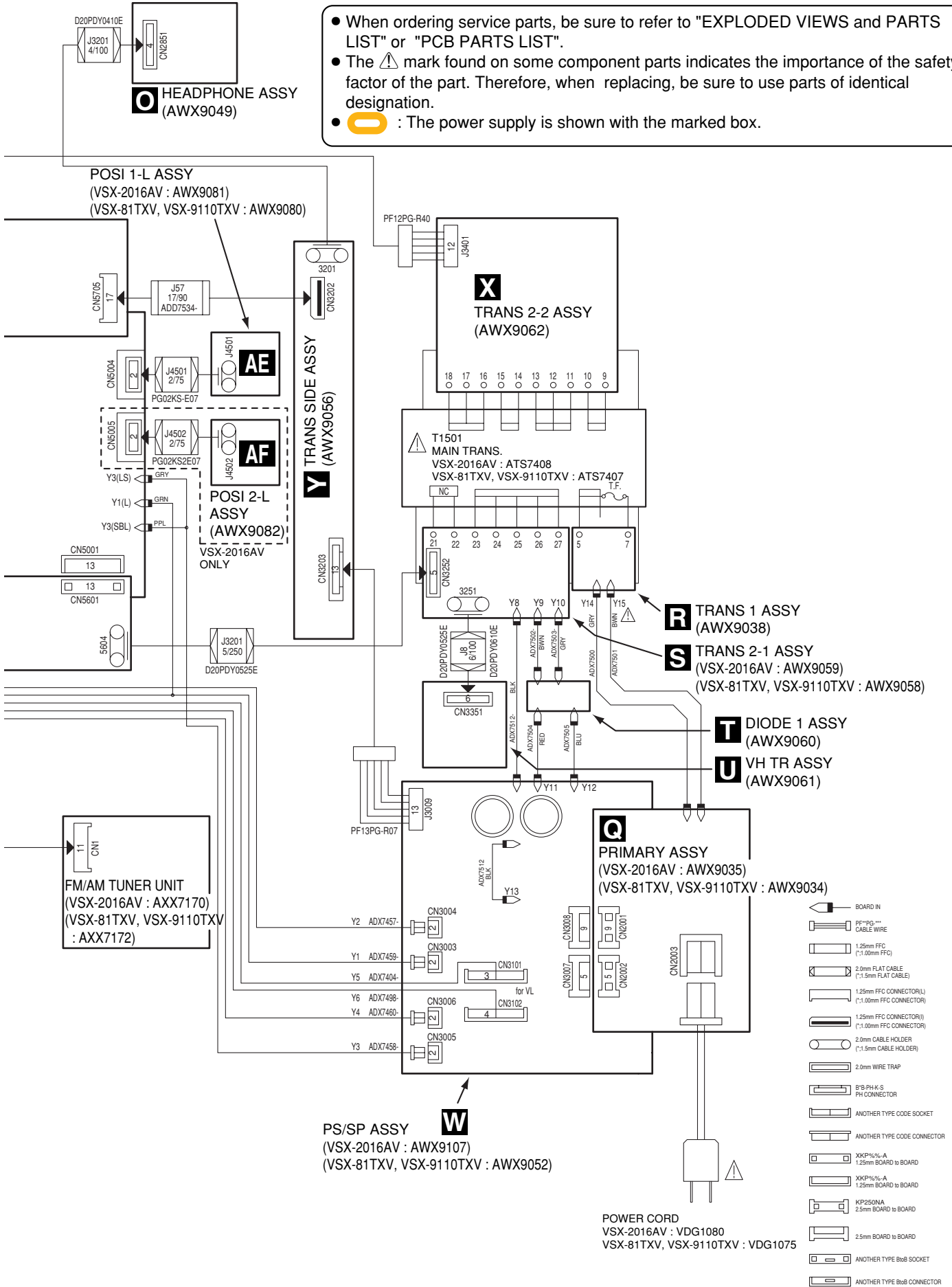

# 3.4 AUDIO IN ASSY (1/2)

1

2

3

4

A

B

C

D

E

F

A 2/2

A 2/2

A 2/2

G 1/4 CN402

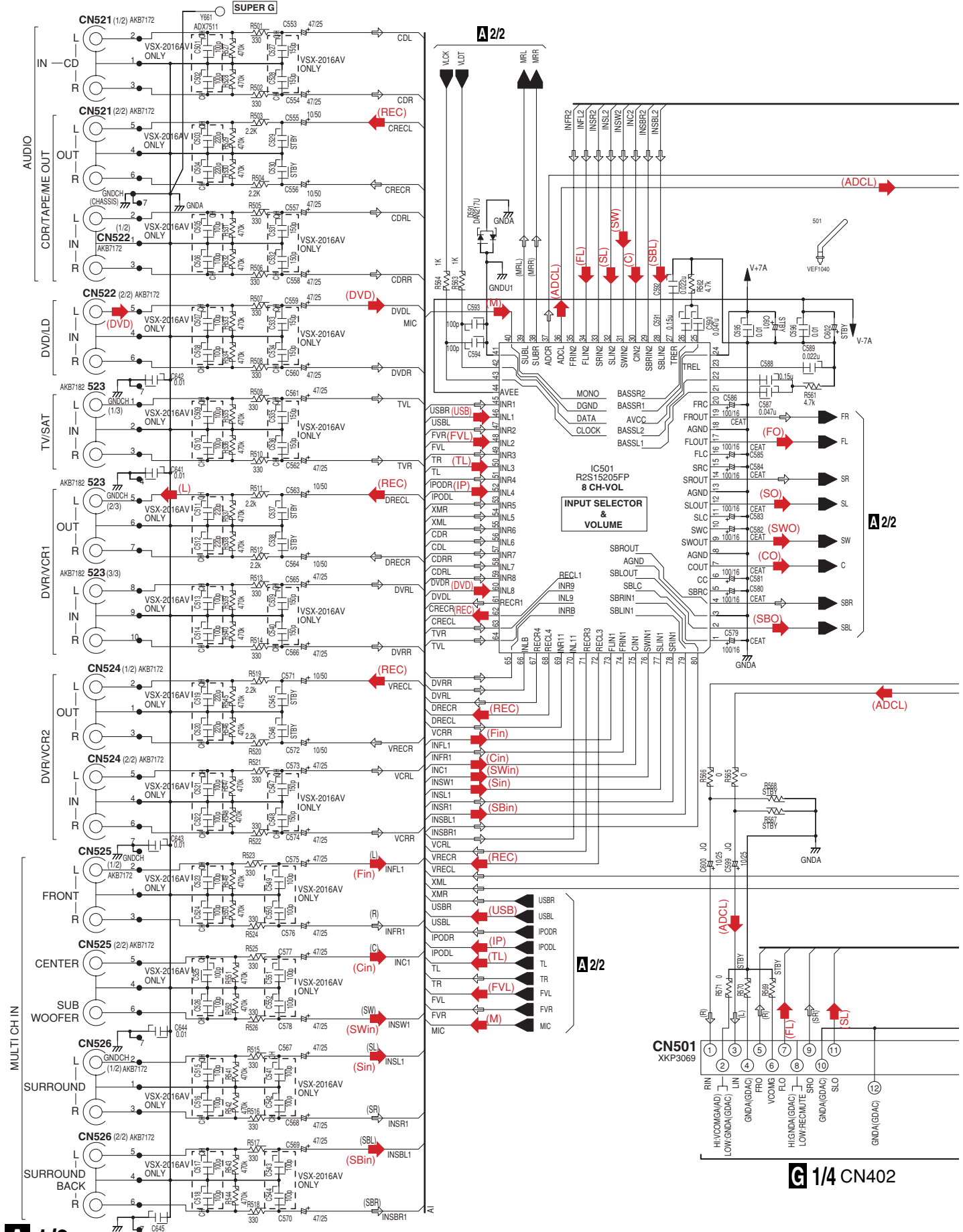

A 1/2

VSX-2016AV-S

1

2

3

4

# A 1/2 AUDIO IN ASSY

(VSX-2016AV : AWX9013)  
 (VSX-81TXV, VSX-9110TXV : AWX9012)

A  
B  
C  
D  
E  
F

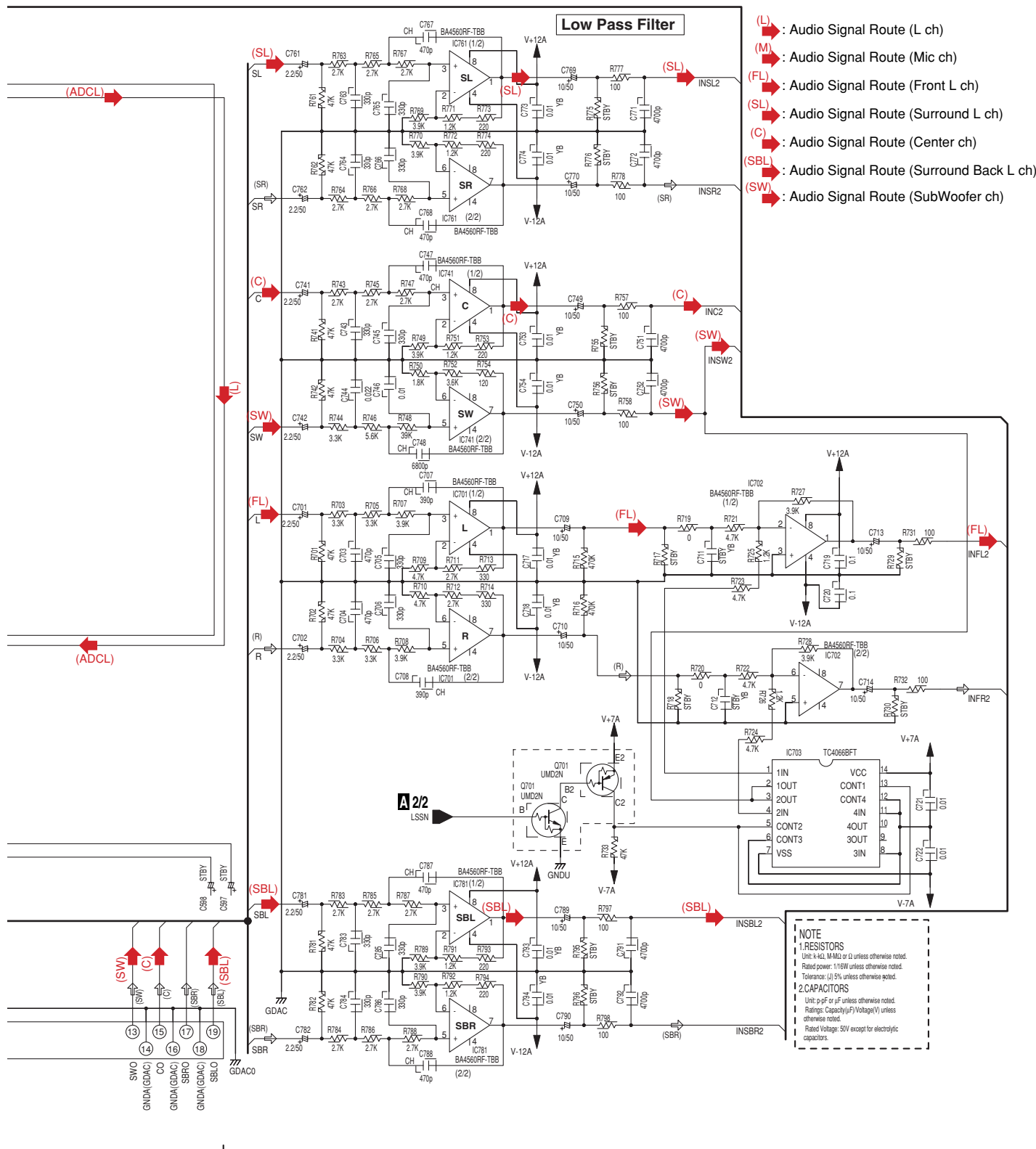

# 3.5 AUDIO IN (2/2) and 12V-REG ASSYS

A  
B  
C  
D  
E  
F

1 2 3 4

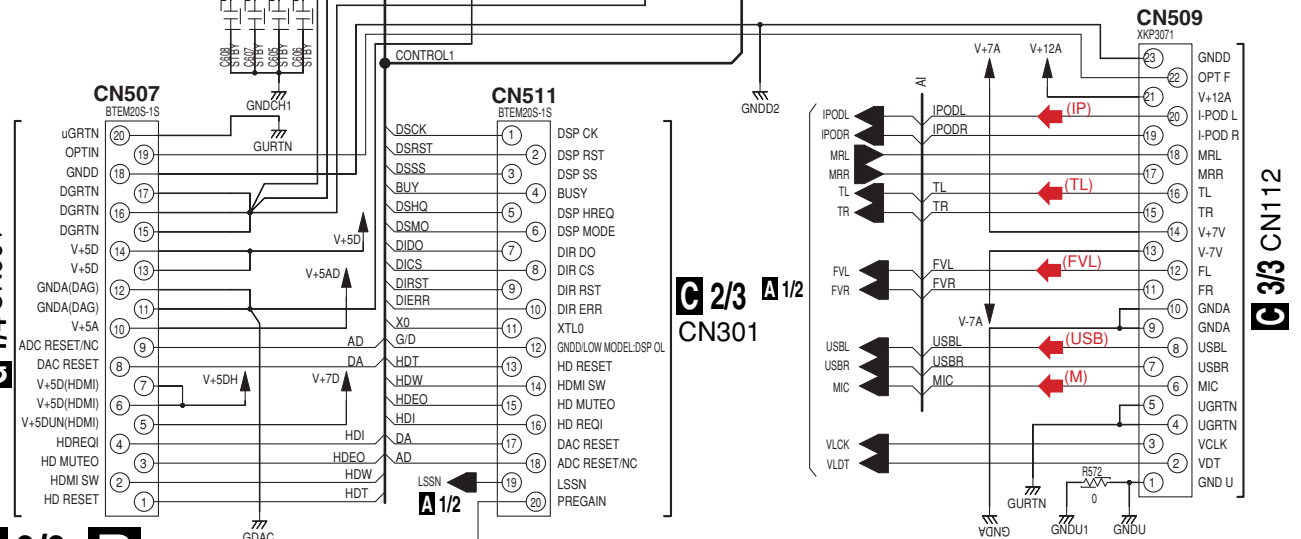
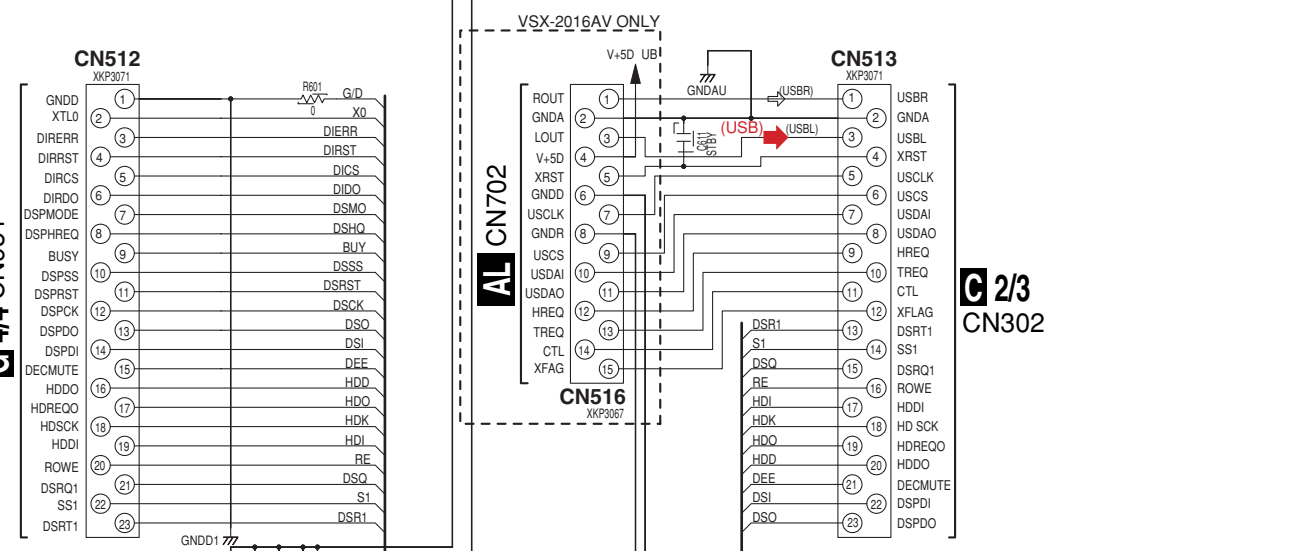
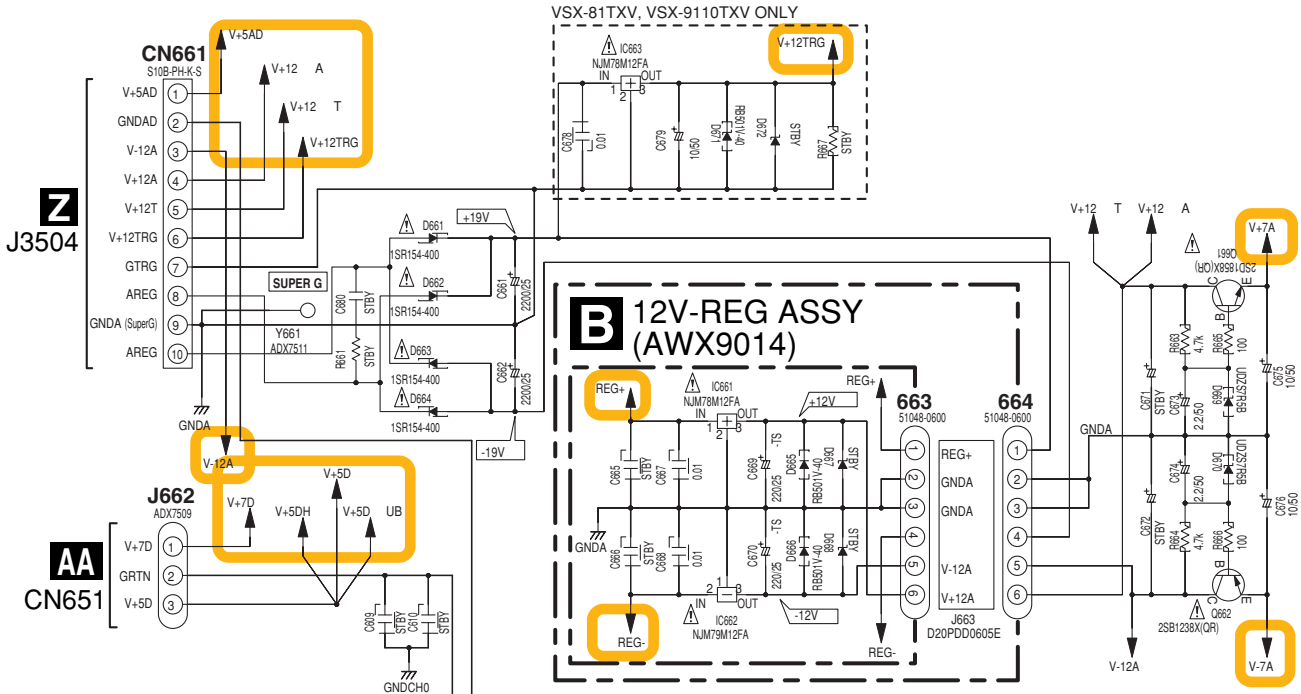

1 2 3 4



# A 2/2 AUDIO IN ASSY

(VSX-2016AV : AWX9013)  
 (VSX-81TXV, VSX-9110TXV : AWX9012)

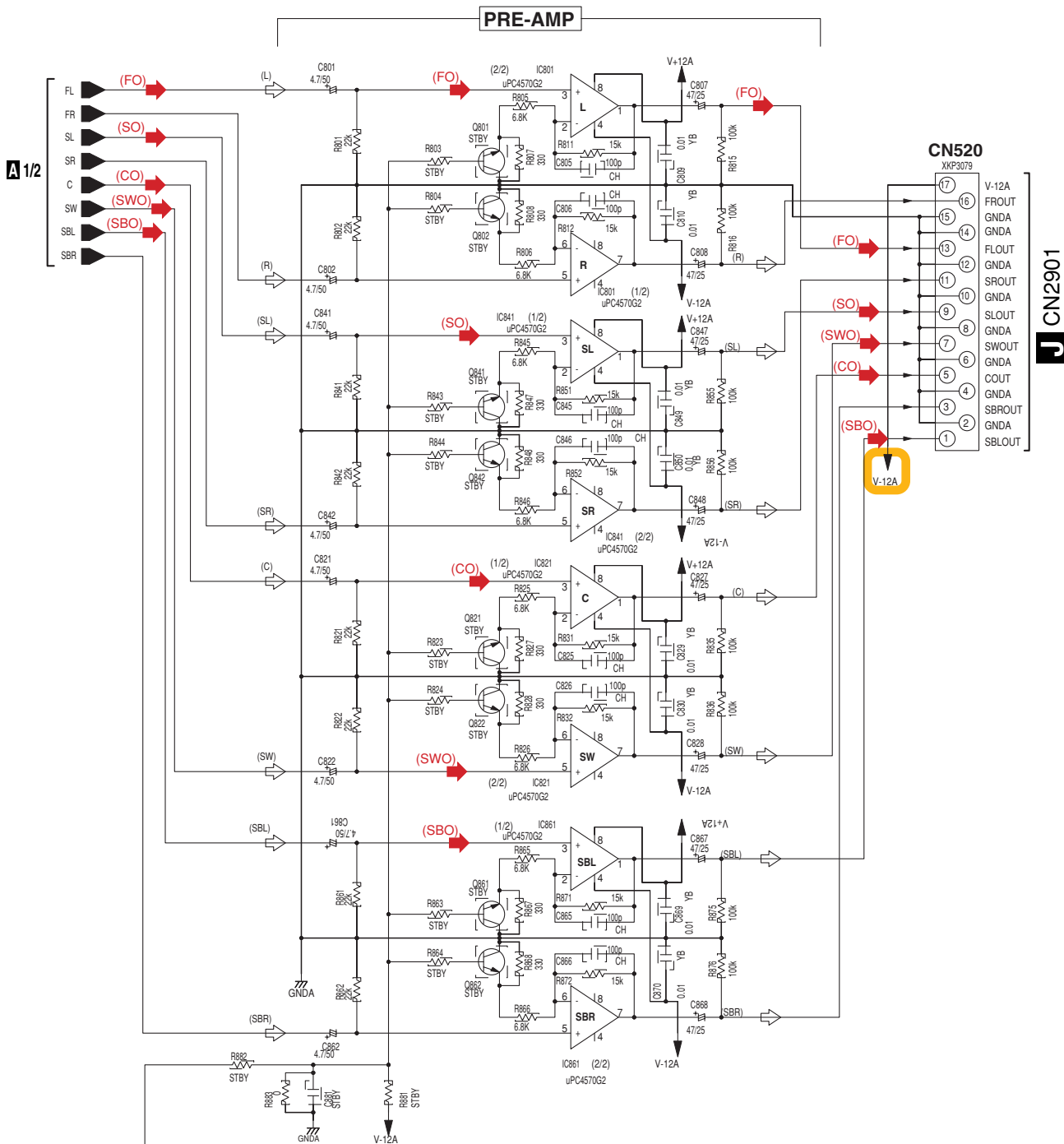

- (L) : Audio Signal Route (L ch)
- (M) : Audio Signal Route (Mic ch)
- (FL) : Audio Signal Route (Front L ch)
- (SL) : Audio Signal Route (Surround L ch)
- (C) : Audio Signal Route (Center ch)
- (SBL) : Audio Signal Route (Surround Back L ch)
- (SW) : Audio Signal Route (SubWoofer ch)

**NOTE**

**1.RESISTORS**  
 Unit: k-kΩ, M-MΩ or Ω unless otherwise noted.  
 Rated power: 1/16W unless otherwise noted.  
 Tolerance: (±) 5% unless otherwise noted.

**2.CAPACITORS**  
 Unit: p-pF or μF unless otherwise noted.  
 Ratings: Capacity(μF)/Voltage(V) unless otherwise noted.  
 Rated Voltage: 50V except for electrolytic capacitors.

# 3.6 MAIN CONTROL ASSY (1/3)

## C 1/3 MAIN CONTROL ASSY (VSX-2016AV : AWX9009) (VSX-81TXV, VSX-9110TXV : AWX9008)

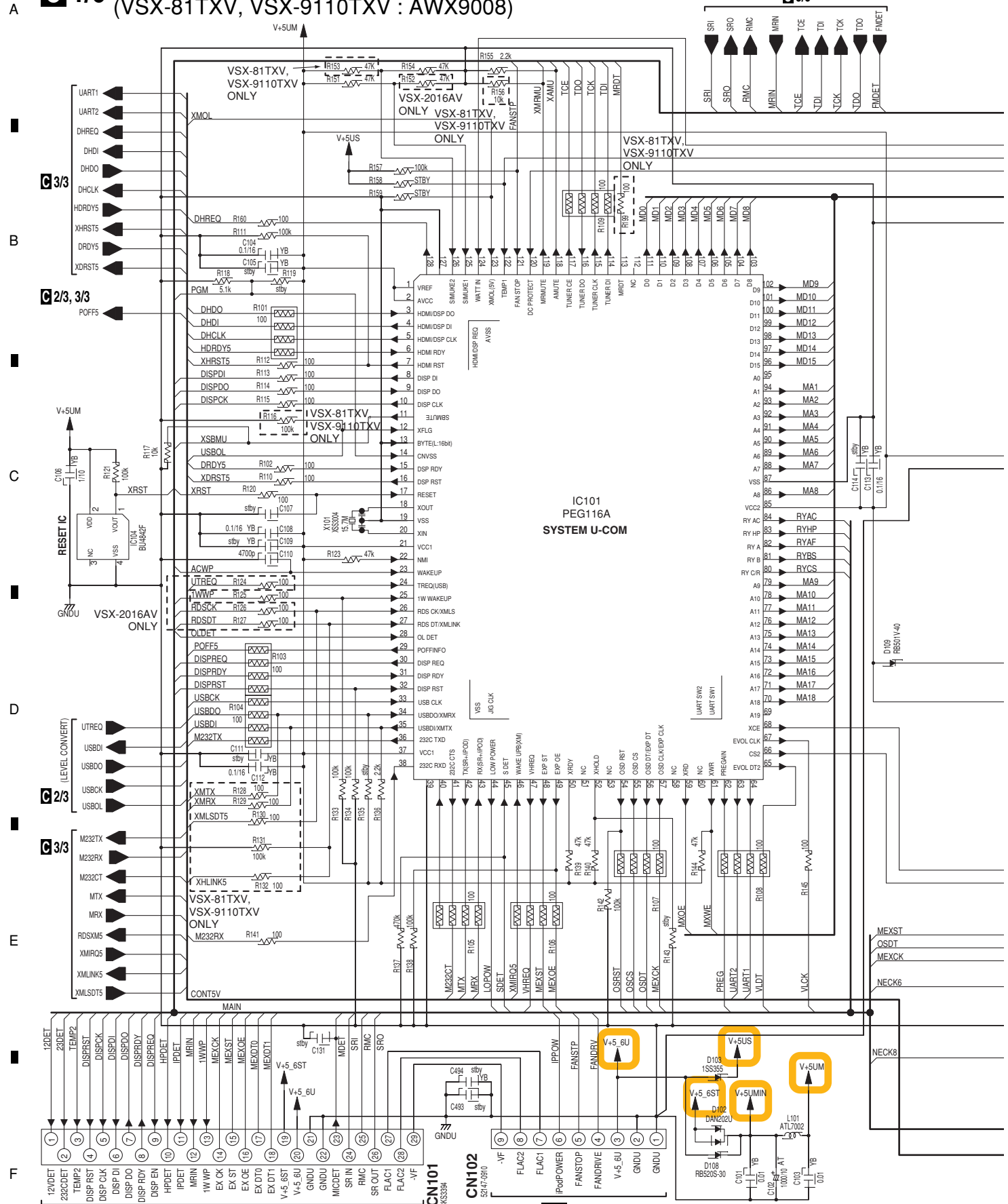

C 1/3

L CN2301

Z 3502

# AJ CN5703

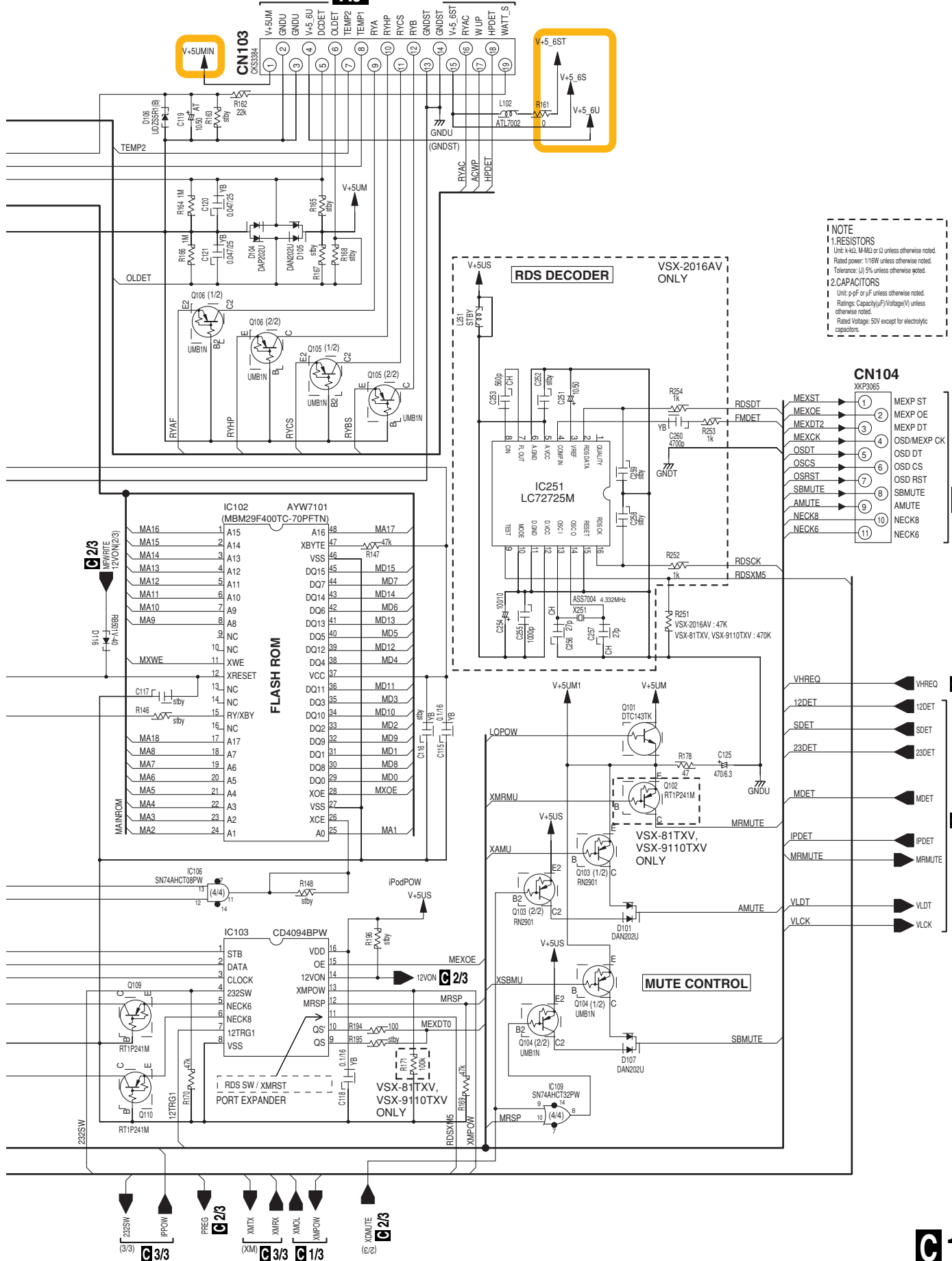

**NOTE**

**1.RESISTORS**  
 Unit: k=K, M=M or Ω unless otherwise noted.  
 Rated power: 1/16W unless otherwise noted.  
 Tolerance: (J) 5% unless otherwise noted.

**2.CAPACITORS**  
 Unit: p=pF or μF unless otherwise noted.  
 Ratings: Capacity(μF)/Voltage(V) unless otherwise noted.  
 Rated Voltage: 50V except for electrolytic capacitors.

A  
B  
C  
D  
E  
F

232SW (3/3) C 3/3  
 IPPOW  
 PREG C 2/3  
 XMTX (XM) C 3/3  
 XMRX C 1/3  
 XMXL  
 XMPOW  
 XMUTE (C/2) C 2/3



A  
B  
C  
D  
E  
F

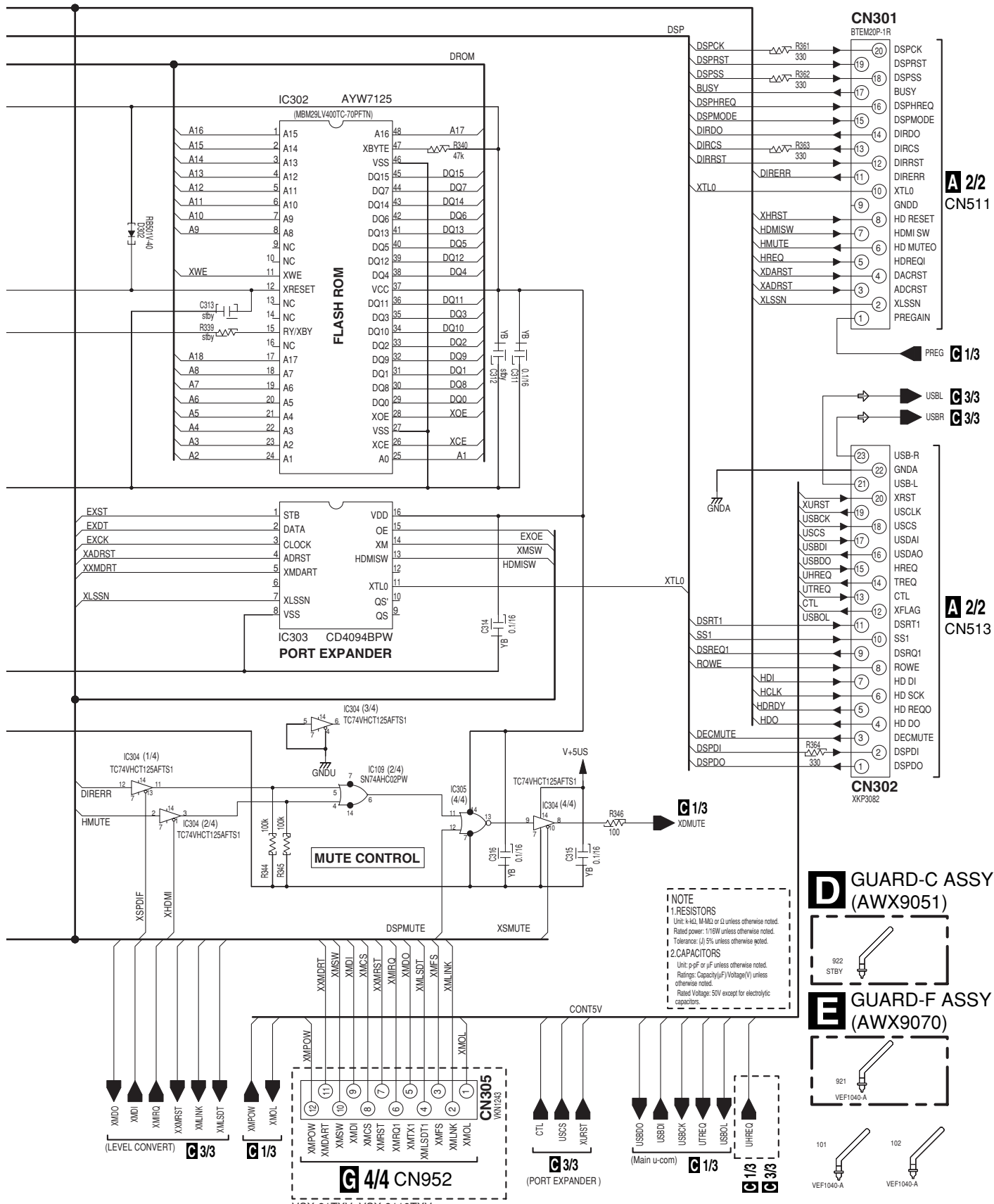

A 2/2 CN511

C 1/3

C 3/3

C 3/3

A 2/2 CN513

**NOTE**

**1.RESISTORS**  
 Unit: k $\Omega$ , M $\Omega$  or  $\Omega$  unless otherwise noted.  
 Rated power: 1/16W unless otherwise noted.  
 Tolerance: (J) 5% unless otherwise noted.

**2.CAPACITORS**  
 Unit: pF or  $\mu$ F unless otherwise noted.  
 Ratings: Capacity( $\mu$ F)/Voltage(V) unless otherwise noted.  
 Rated Voltage: 50V except for electrolytic capacitors.

D GUARD-C ASSY (AWX9051)

E GUARD-F ASSY (AWX9070)

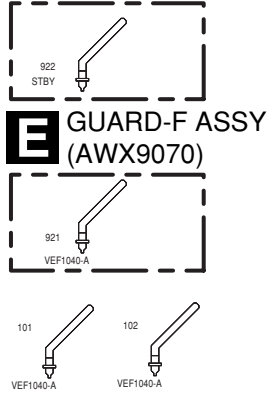

G 4/4 CN952

C 3/3 (PORT EXPANDER)

C 1/3 (Main u-com)

C 1/3

C 3/3

C 2/3 D E



C 1/3

C 3/3

**MAIN CONTROL ASSY**  
 (VSX-2016AV : AWX9009)  
 (VSX-81TXV, VSX-9110TXV : AWX9008)

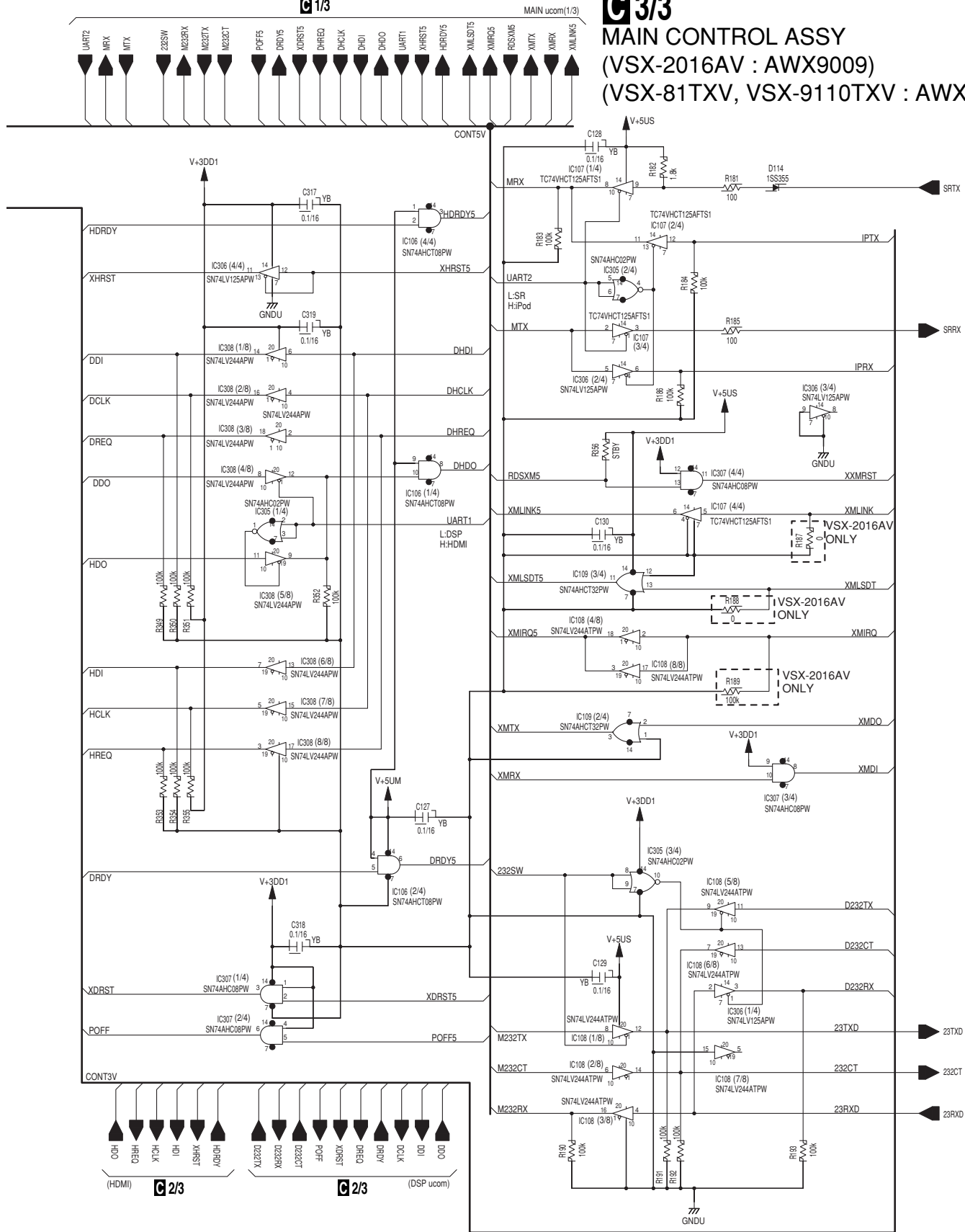

- (L) : Audio Signal Route (L ch)
- (M) : Audio Signal Route (Mic ch)
- (D) : Audio Data Route
- (V) : Video Signal Route
- (SY) : S-Video Signal Route (Y ch)
- (SC) : S-Video Signal Route (C ch)

# 3.9 DSP ASSY (1/4)

**G 1/4** DSP ASSY  
 (VSX-2016AV : AWX8698)  
 (VSX-81TXV, VSX-9110TXV : AWX8697)

A  
B  
C  
D  
E  
F

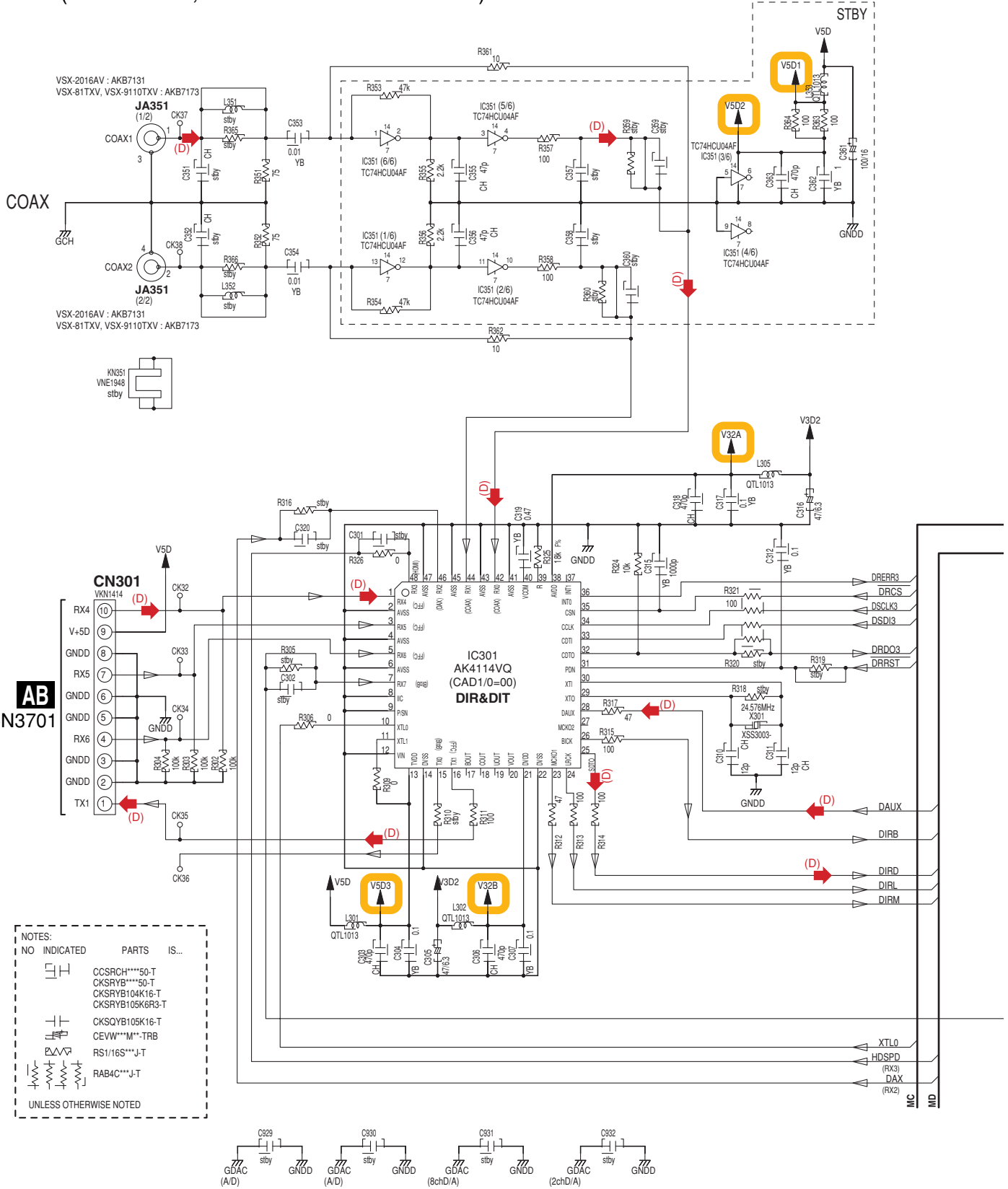

**G 1/4**



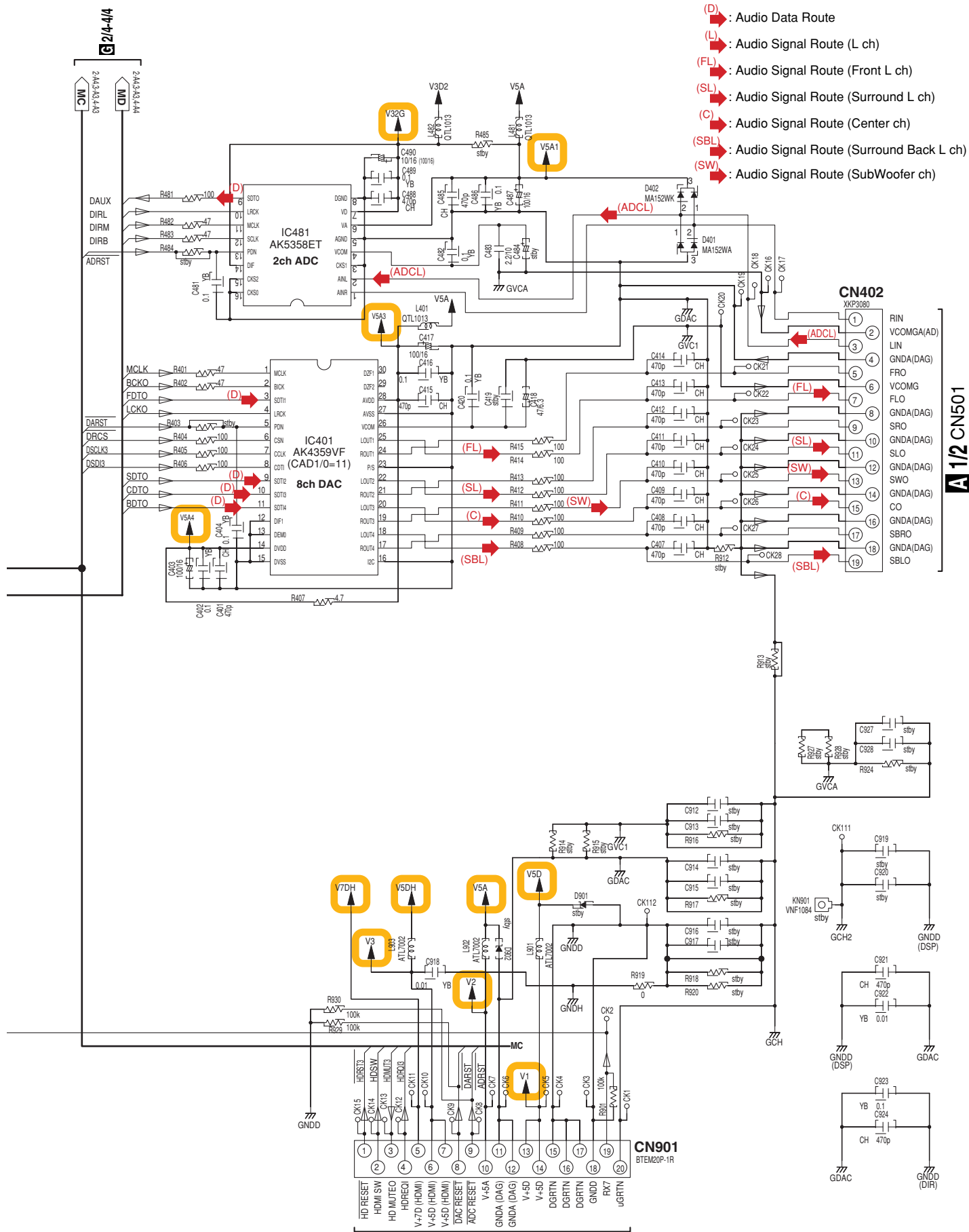

A

B

C

D

E

F

A 2/2 CN507

G 1/4

VSX-2016AV-S





# 3.11 DSP ASSY (3/4)

**G 3/4** DSP ASSY  
 (VSX-2016AV : AWX8698)  
 (VSX-81TXV, VSX-9110TXV : AWX8697)

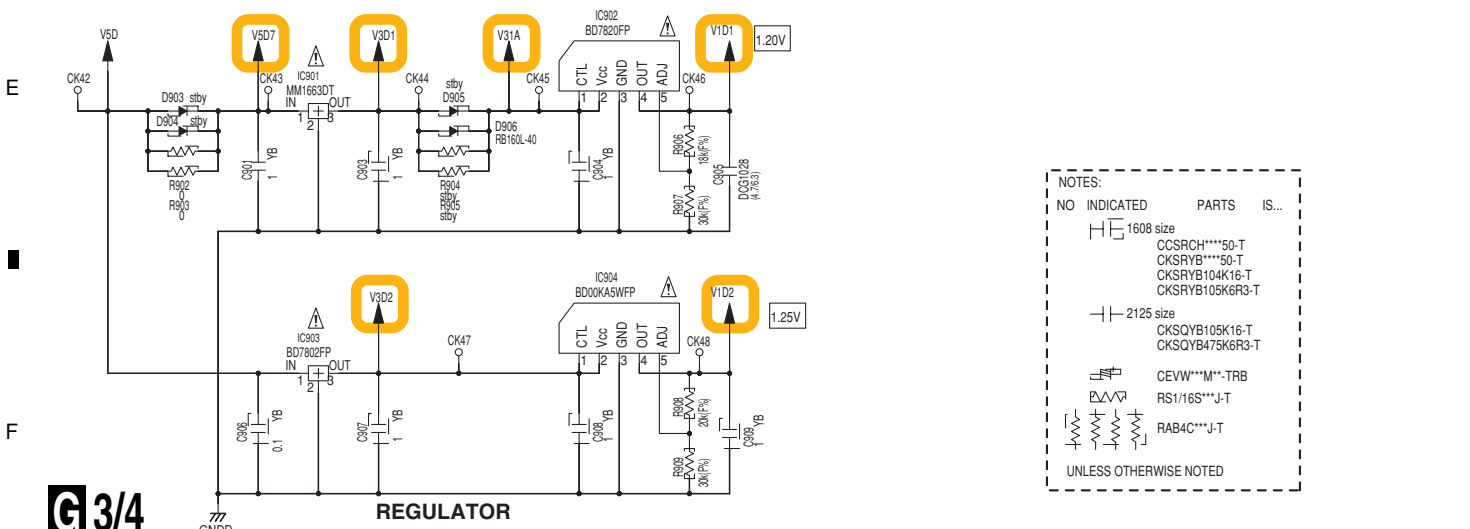
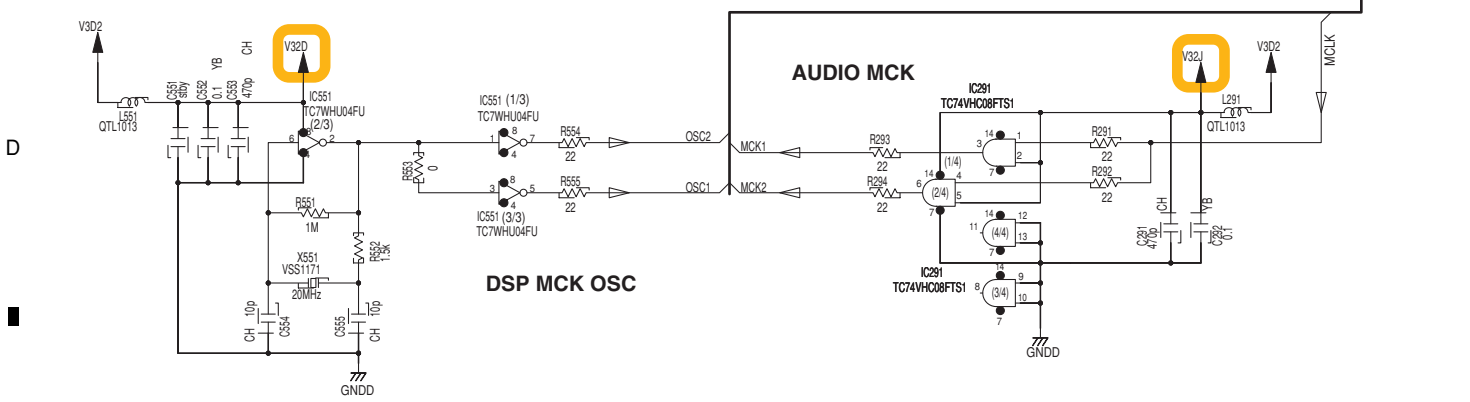
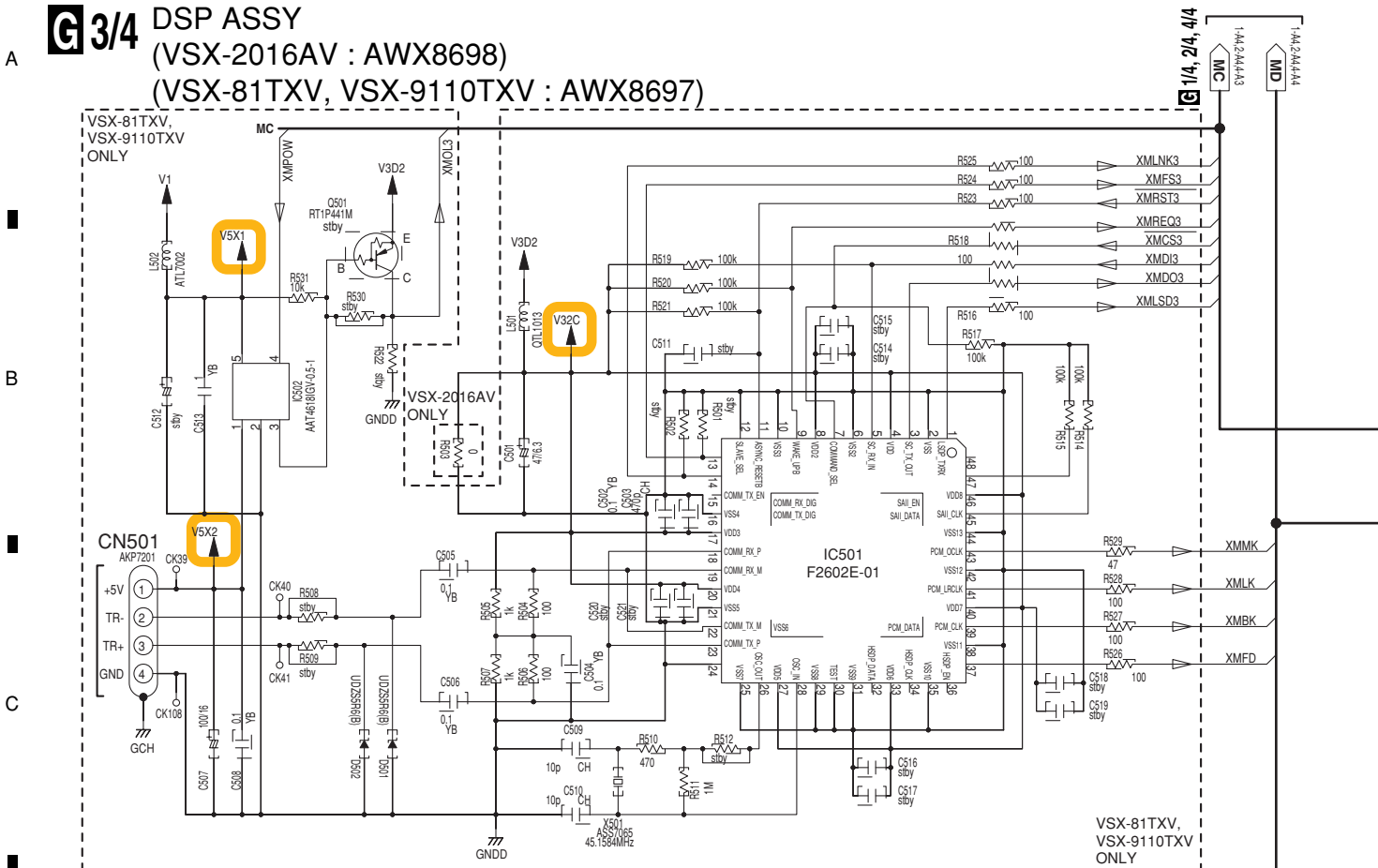

- NOTES:
- NO INDICATED PARTS IS...
  - 1608 size
  - CCSRCH\*\*\*50-T
  - CKSRVB\*\*\*50-T
  - CKSRVB104K16-T
  - CKSRVB105K6R3-T
  - 2125 size
  - CKSQYB105K16-T
  - CKSQYB475K6R3-T
  - CEVW\*\*\*TRB
  - RS1/16S\*\*\*J-T
  - RABAC\*\*\*J-T
  - UNLESS OTHERWISE NOTED

**G 3/4**

VSX-2016AV-S

(D) : Audio Data Route

\*\* AROUND R247  
The connective is not 'CDT' but 'SDT'.  
But now the connection of PCB is like this.  
If this route is used, it should correct the PCB  
(NOW NO USE THIS ROUTE)

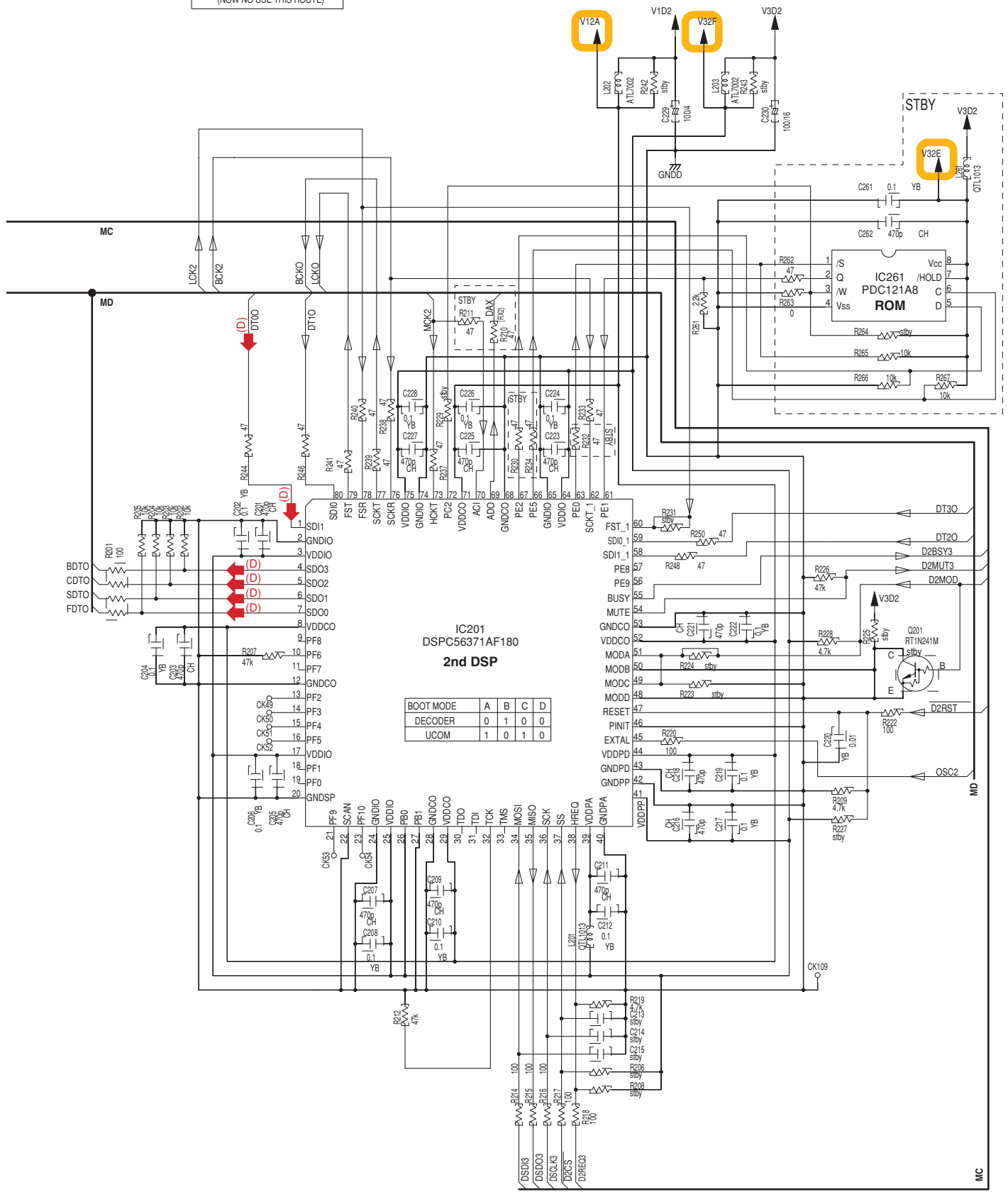

A  
B  
C  
D  
E  
F

### 3.12 DSP ASSY (4/4)

**G 4/4** DSP ASSY  
 (VSX-2016AV : AWX8698)  
 (VSX-81TXV, VSX-9110TXV : AWX8697)

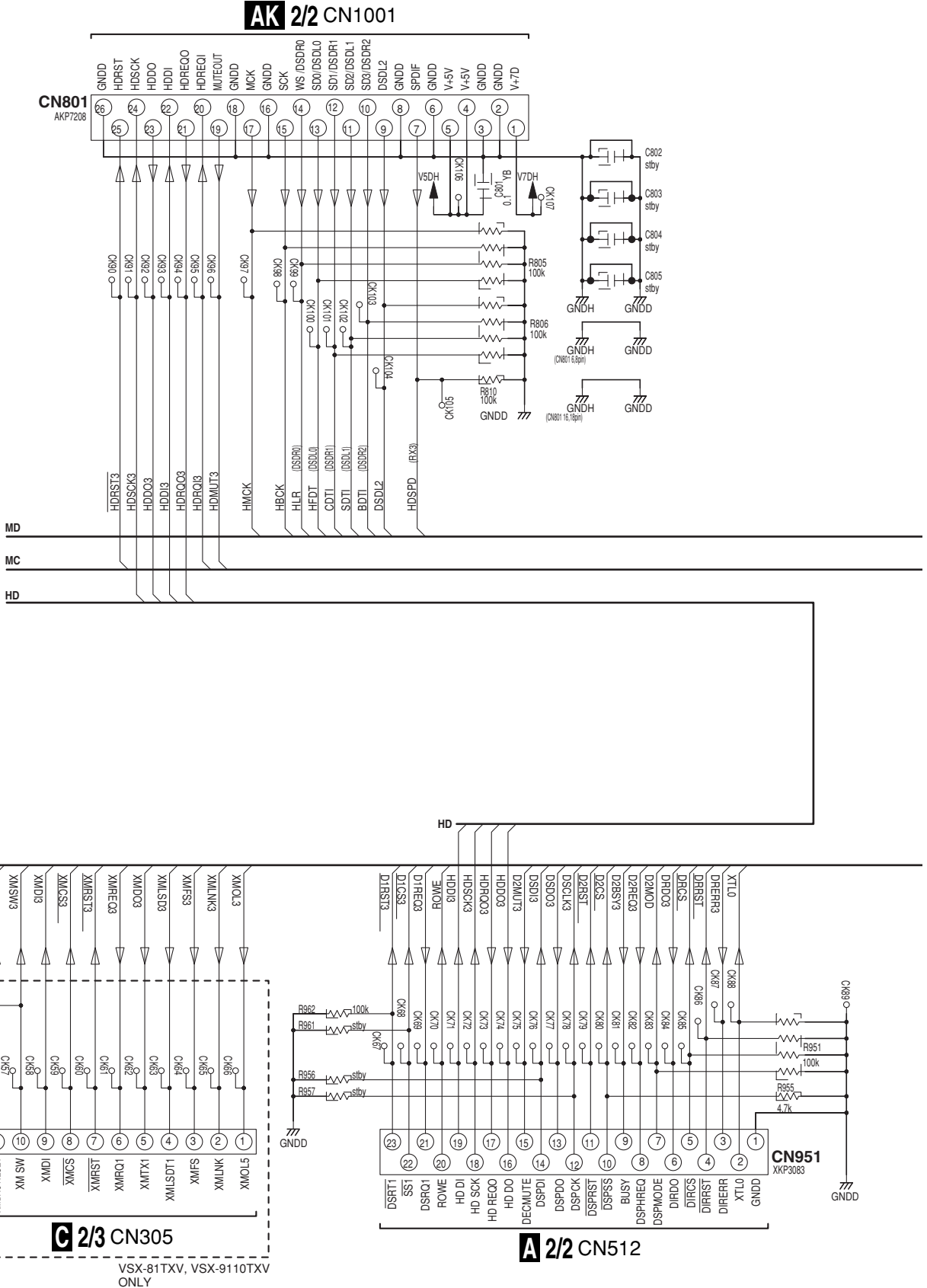

**G 4/4**

(D) : Audio Data Route

A

B

C

D

E

F

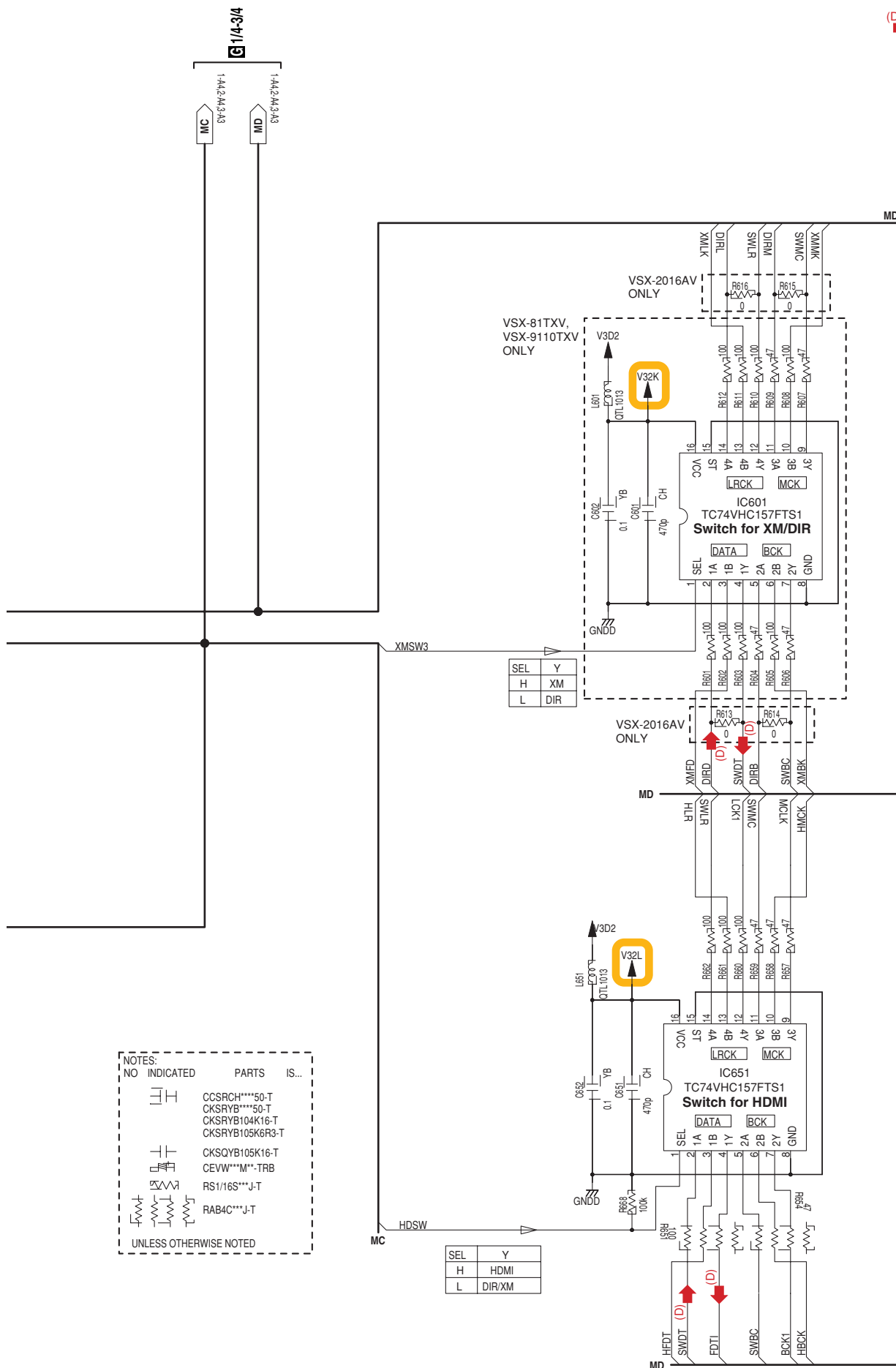

NOTES:

NO	INDICATED	PARTS	IS...
		CCSRCH****50-T	
		CKSRYPB****50-T	
		CKSRYPB104K16-T	
		CKSRYPB105K6R3-T	
		CKSQYB105K16-T	
		CEVW***M*-TRB	
		RS1/16S***J-T	
		RAB4C***J-T	

UNLESS OTHERWISE NOTED

# 3.13 COMPOSITE ASSY

**COMPOSITE ASSY**  
 (VSX-2016AV : AWX9028)  
 (VSX-81TXV, VSX-9110TXV : AWX9026)

IC1001 INPUT SELECTOR FOR VIDEO

51C	51B	51A	OUT
L	L	L	MUTE
L	L	H	DVR/VCR1
L	H	L	DVR/VCR2
L	H	H	DVD
H	L	L	TV
H	L	H	VIDEO
H	H	L	MUTE
H	H	H	MUTE

IC1003 SELECTOR FOR DVCorTHRU

SWB	SWC	OUT
H	H	THRU
L	H	DVC
L	L	OSD

A  
B  
C  
D  
E  
F

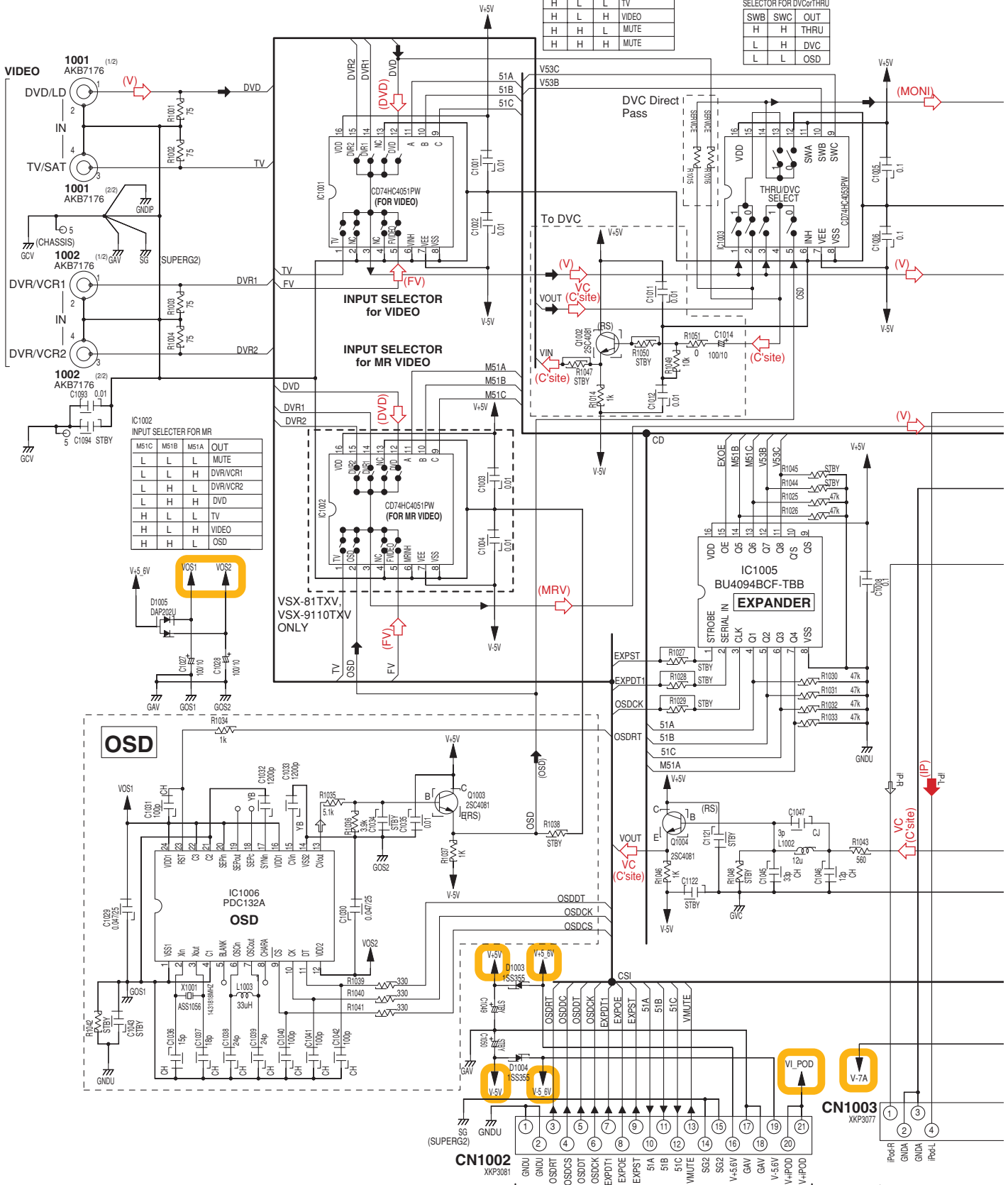

AC CN3802



Video Signal Route

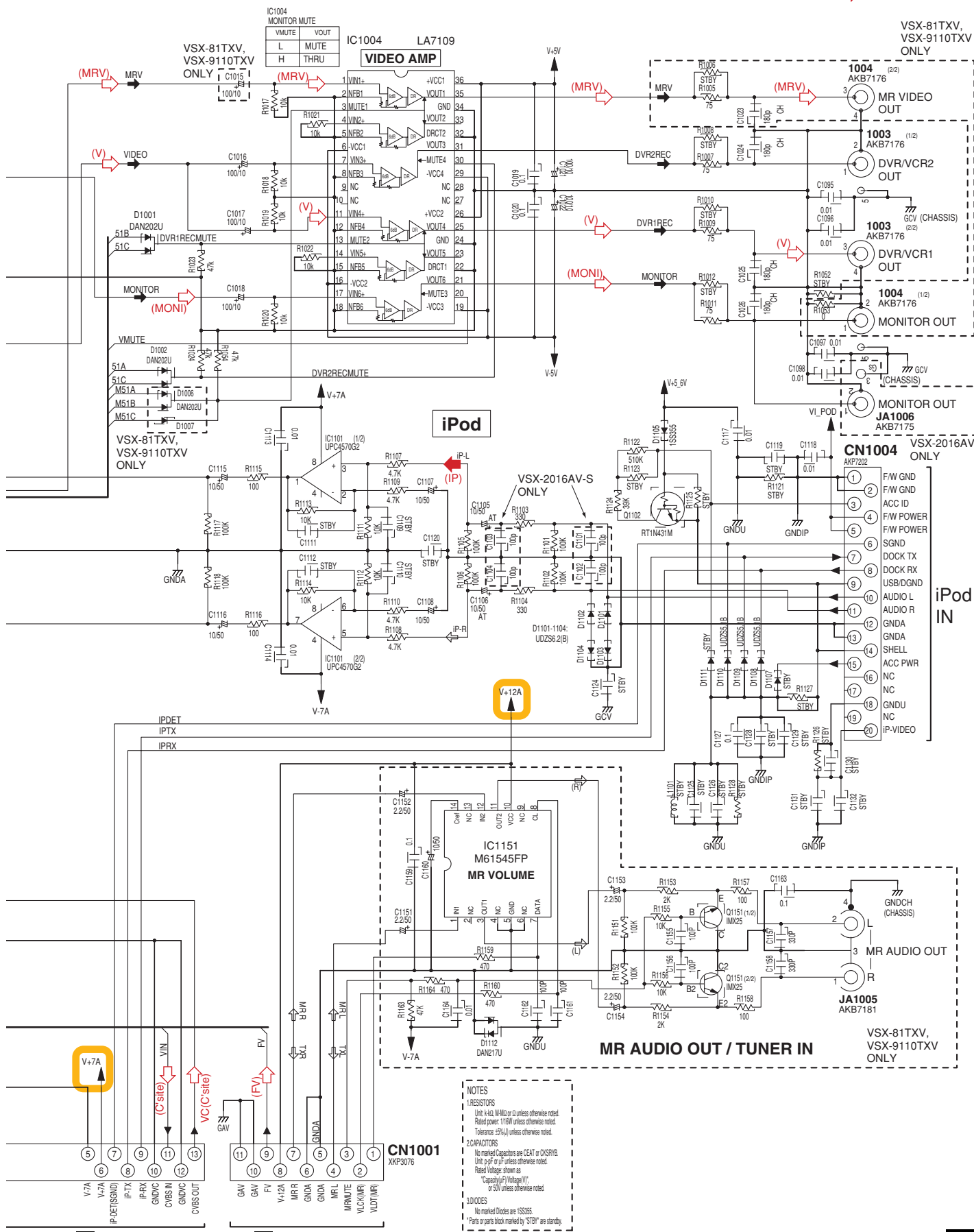

**NOTES**

1. RESISTORS  
 Unit: k Ω, M Ω or Ω unless otherwise noted.  
 Rated power: 1/16W unless otherwise noted.  
 Tolerance: ±5% unless otherwise noted.

2. CAPACITORS  
 No marked Capacitors are CEAT or CDSR/B.  
 Unit: p, µF or nF unless otherwise noted.  
 Rated Voltage: shown as  
 \*Capacity (µF) Voltage(V)  
 or µF unless otherwise noted.

3. DIODES  
 No marked Diodes are 1SS385.  
 \*Parts or parts block marked by "STBY" are standby.

C 3/3 CN111

C 3/3 CN110

VSX-2016AV-S



# 3.14 S-VIDEO and BRIDGE 2 ASSYS

**S-VIDEO ASSY (VSX-2016AV : AWX9030)  
(VSX-81TXV, VSX-9110TXV : AWX9029)**

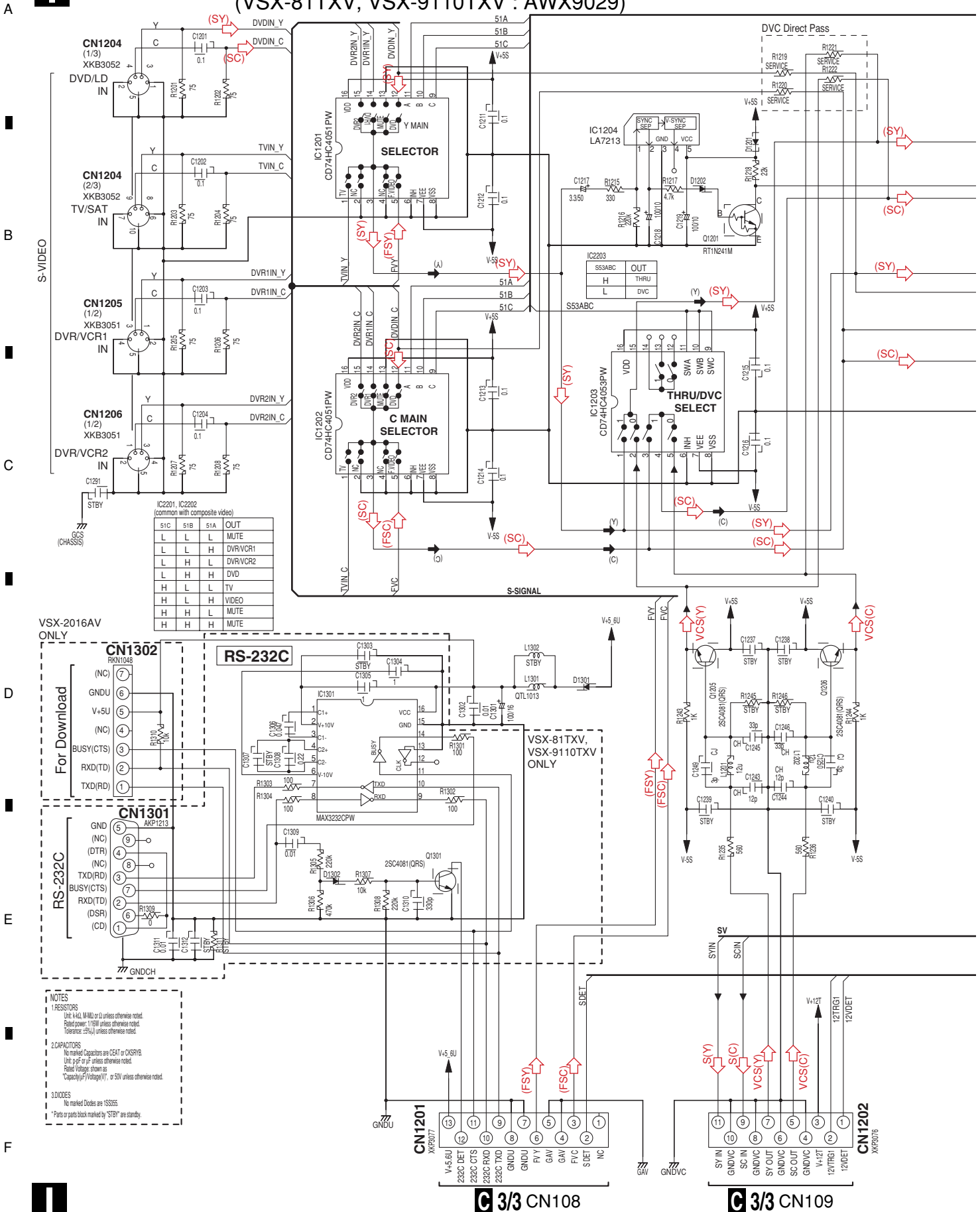

**C 3/3 CN108**

**C 3/3 CN109**

VSX-2016AV-S

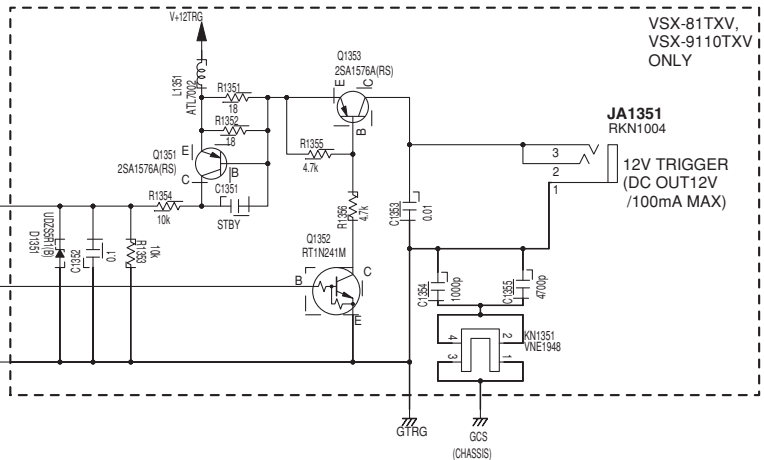
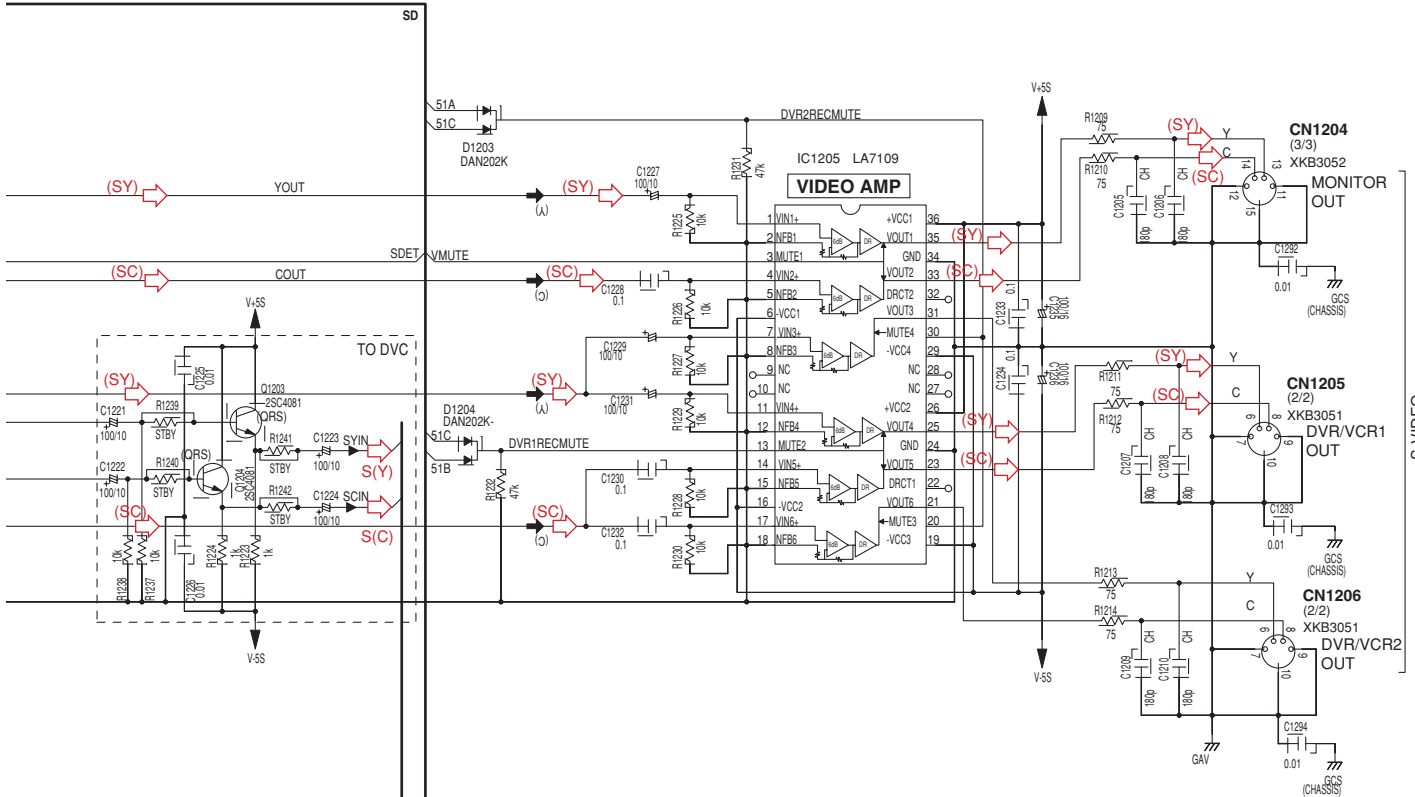

**J BRIDGE 2 ASSY (AWX9050)**

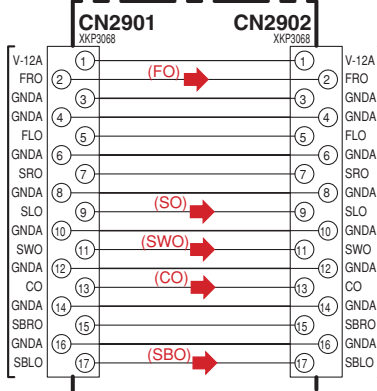

- (FL) : Audio Signal Route (Front L ch)
- (SL) : Audio Signal Route (Surround L ch)
- (C) : Audio Signal Route (Center ch)
- (SBL) : Audio Signal Route (Surround Back L ch)
- (SW) : Audio Signal Route (SubWoofer ch)
- (SY) : S-Video Signal Route (Y ch)
- (SC) : S-Video Signal Route (C ch)

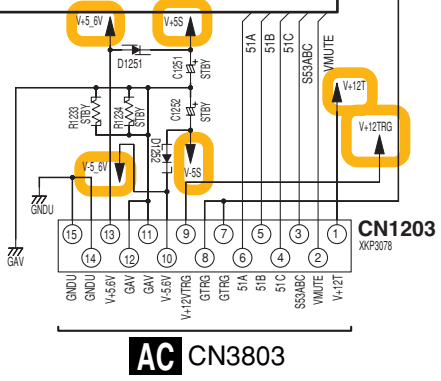

**A 2/2**  
CN520

**K**  
CN1405

**AC** CN3803

# 3.15 COMPONENT ASSY

## K COMPONENT ASSY (VSX-2016AV : AWX9031) (VSX-81TXV, VSX-9110TXV : AWX9032)

IC2491 & IC2492			IC2404	
CSW1	CSW1	Selector	C53B	Selector
L	L	D	L	DVC
H	L	Comp In 1	H	THRU
L	H	Comp In 2		
H	H	Comp In 3		

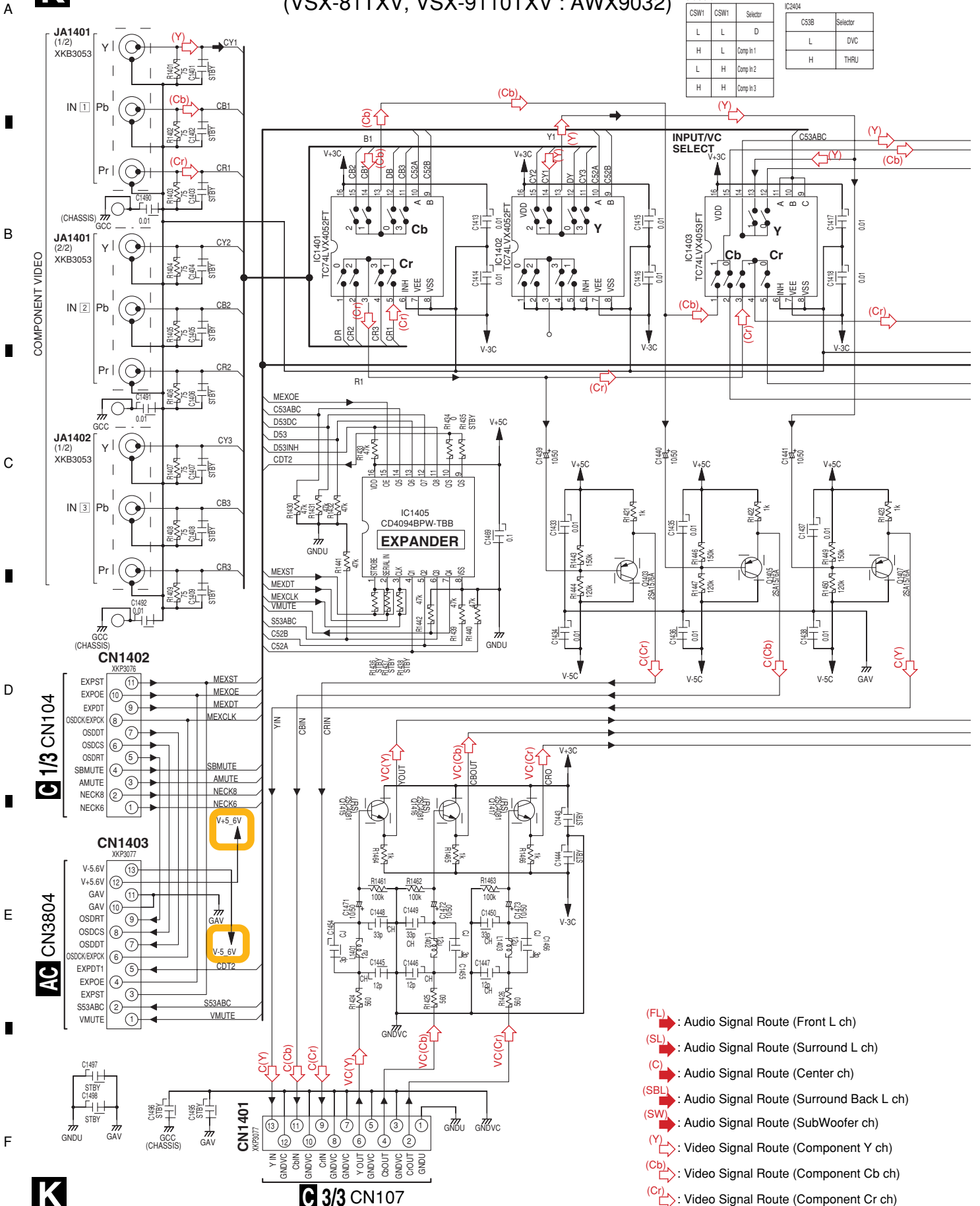

- (FL) : Audio Signal Route (Front L ch)
- (SL) : Audio Signal Route (Surround L ch)
- (C) : Audio Signal Route (Center ch)
- (SBL) : Audio Signal Route (Surround Back L ch)
- (SW) : Audio Signal Route (SubWoofer ch)
- (Y) : Video Signal Route (Component Y ch)
- (Cb) : Video Signal Route (Component Cb ch)
- (Cr) : Video Signal Route (Component Cr ch)

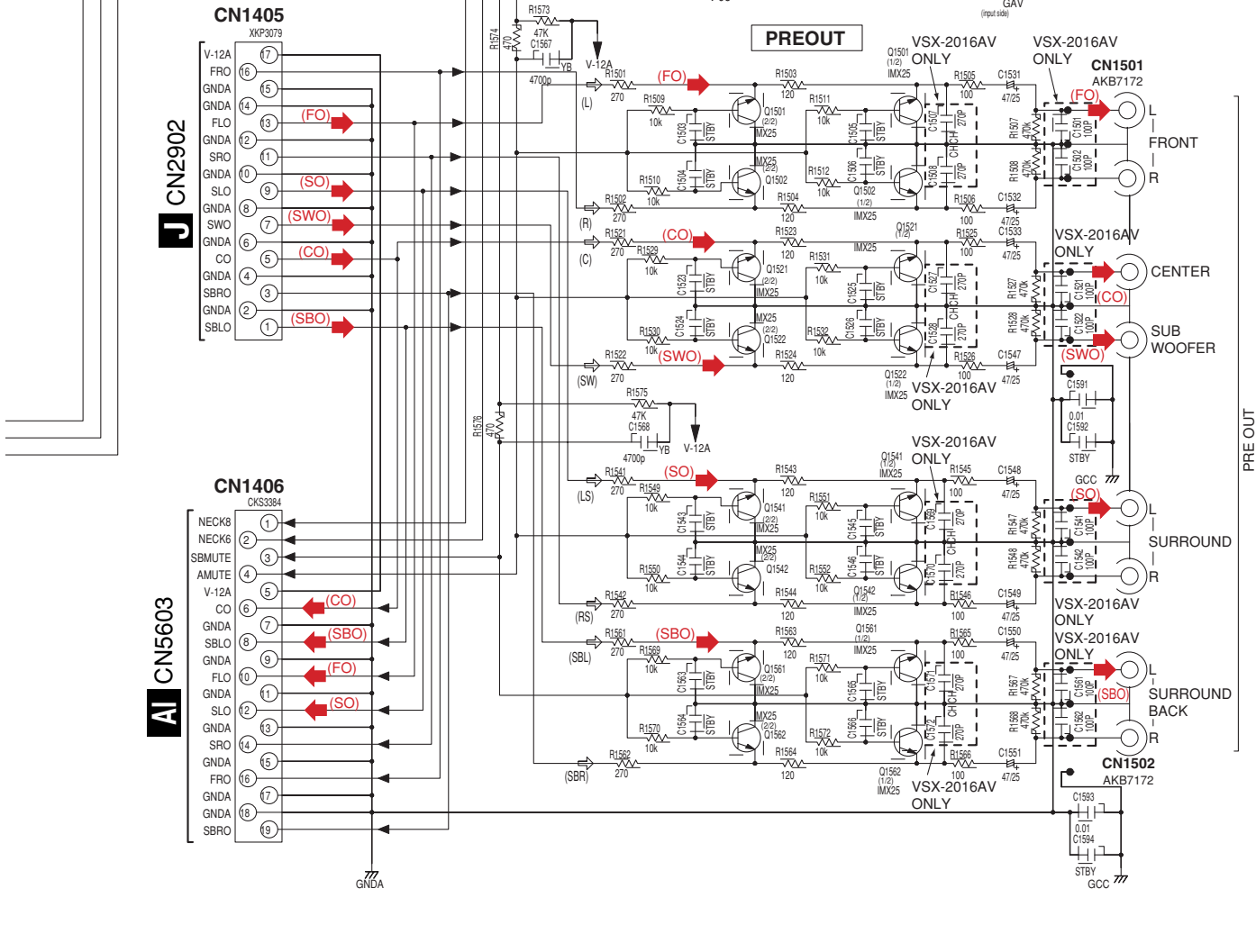
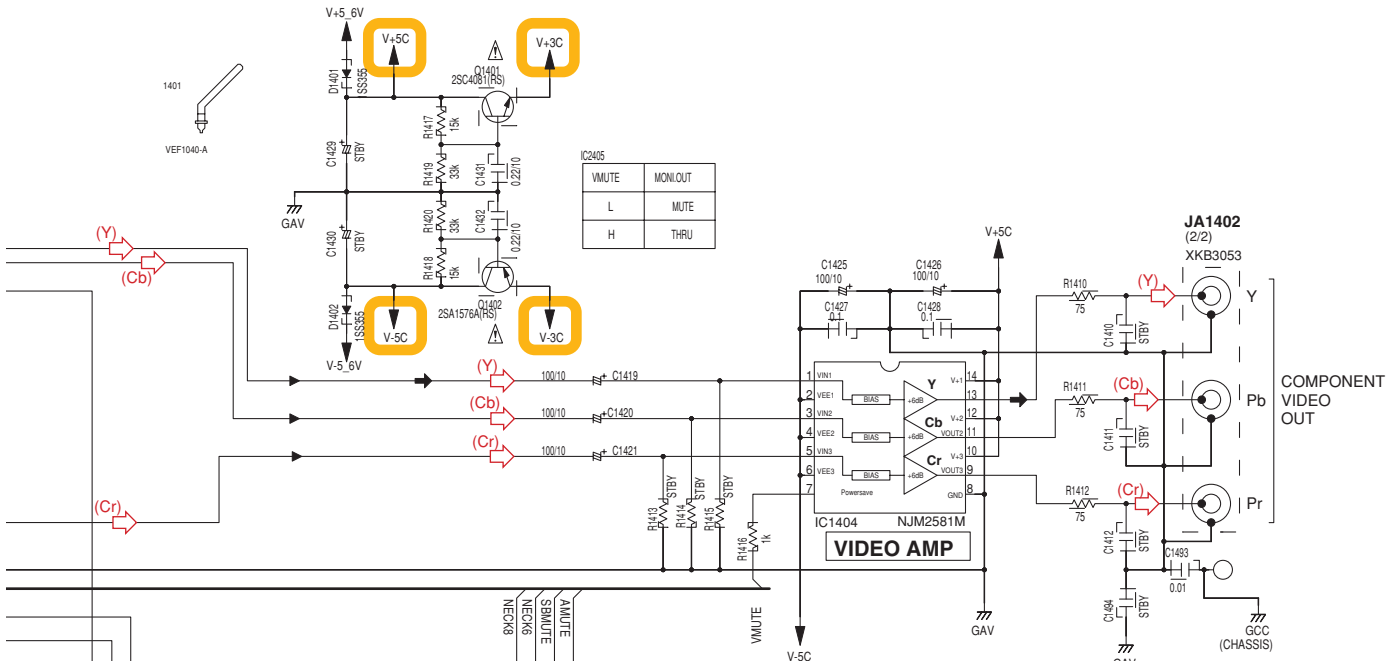

**NOTES**

**RESISTORS**  
 Unit: k- $\Omega$ , M-M $\Omega$  or  $\Omega$  unless otherwise noted.  
 Rated power: 1/10W unless otherwise noted.  
 Tolerance:  $\pm 5\%$  unless otherwise noted.

**DIODES**  
 No marked Diodes are 1SS335.  
 Parts or parts blocks marked by "STBY" are standby.

**CAPACITORS**  
 No marked Capacitors are CEAT or OXSRVB.  
 Unit:  $\mu$ F or pF unless otherwise noted.  
 Rated Voltage: shown as "Capacity(Volts)" or 50V unless otherwise noted.



# 3.16 DISPLAY, VOLUME and MULTI JOG ASSYS

**DISPLAY ASSY**  
 (VSX-2016AV : AWX9103)  
 (VSX-81TXV, VSX-9110TXV : AWX9040)

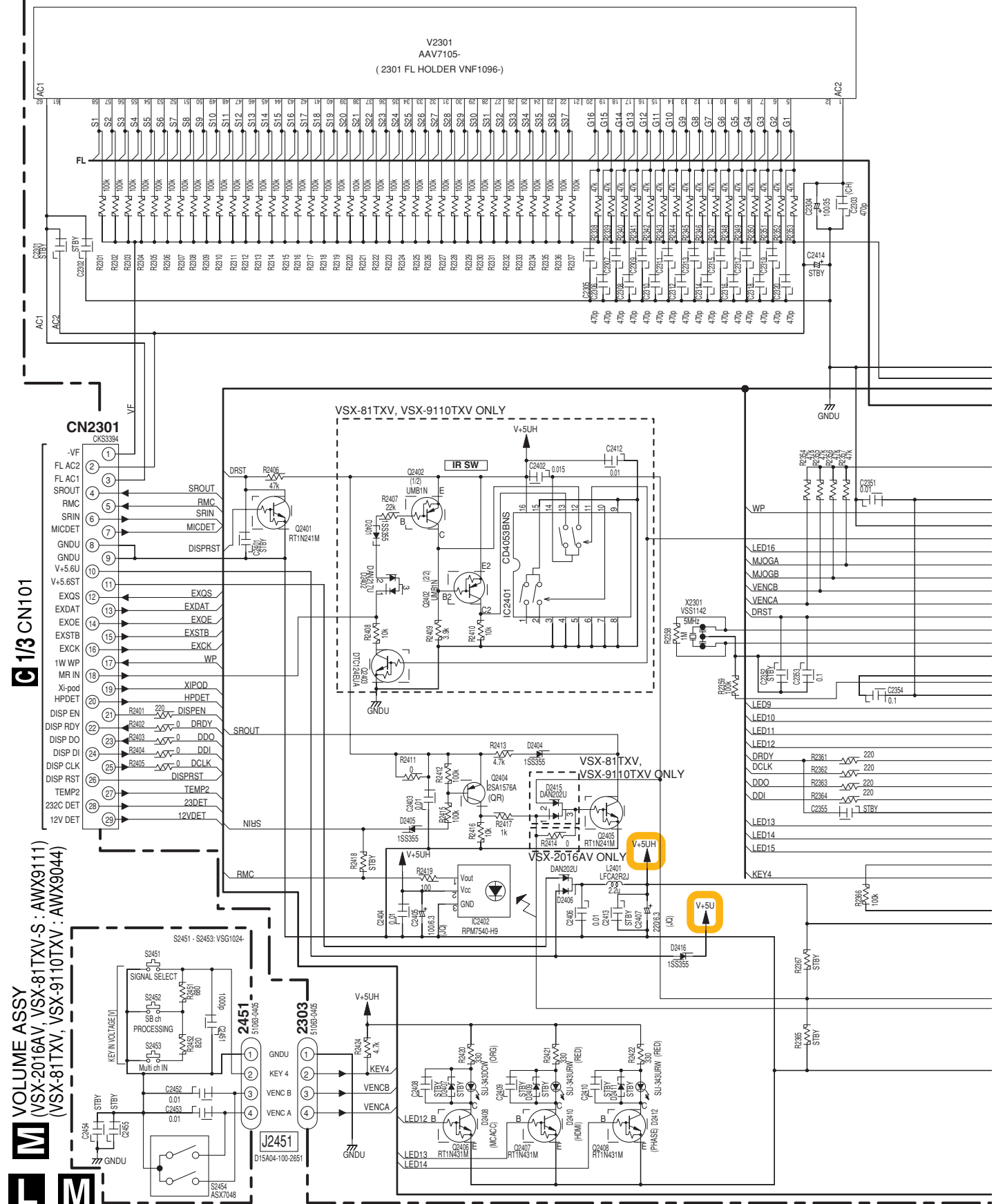

**VOLUME ASSY**  
 (VSX-2016AV, VSX-81TXV-S : AWX9111)  
 (VSX-81TXV, VSX-9110TXV : AWX9044)

VSX-2016AV-S

**N** MULTI JOG ASSY  
 (VSX-2016AV, VSX-81TXV-S : AWX9112)  
 (VSX-81TXV, VSX-9110TXV : AWX9045)

**VOLUME ASSY**  
 S2451 : SIGNAL SELECT  
 S2452 : SBCh PROCESSING  
 S2453 : MULTI CH IN  
 S2454 : MASTER VOLUME

**MULTI JOG ASSY**  
 S2501 : MULTI JOG  
 S2551 : DVR/VCR2  
 S2552 : VIDEO/GAME  
 S2553 : CD  
 S2554 : CD-R/TAPE/MD  
 S2555 : FM/AM  
 S2556 : USB (XM)  
 S2557 : iPod  
 S2558 : HDMI  
 S2561 : ENTER  
 S2562 : SYSTEM SETUP  
 S2563 : RETURN  
 S2564 : TONE  
 S2565 : TUNING/STATION  
 S2566 : TUNER EDIT  
 S2567 : SPEAKERS  
 S2571 : ○ STANDBY/ON  
 S2572 : EON MODE (MULTI ROOM ON/OFF)  
 S2573 : PTY SEARCH (MULTI ROOM CONTROL)  
 S2574 : LISTENING MODE  
 S2575 : DVD/LD  
 S2576 : TV/SAT  
 S2577 : DVR/VCR1

**NOTE**  
 1.RESISTORS  
 Unit: k-Ω, M-Ω or Ω unless otherwise noted.  
 Rated power: 1/10W unless otherwise noted.  
 Tolerance: (J) ±5% unless otherwise noted.  
 2.CAPACITORS  
 Unit: pF or μF unless otherwise noted.  
 Ratings: Capacity(μF)/Voltage(V) unless otherwise noted.  
 Rated Voltage: 50V except for electrolytic capacitors.  
 3.DIODES  
 Indicated in 1SS355.  
 4.TACT SWITCHES  
 Indicated in VSG1024.

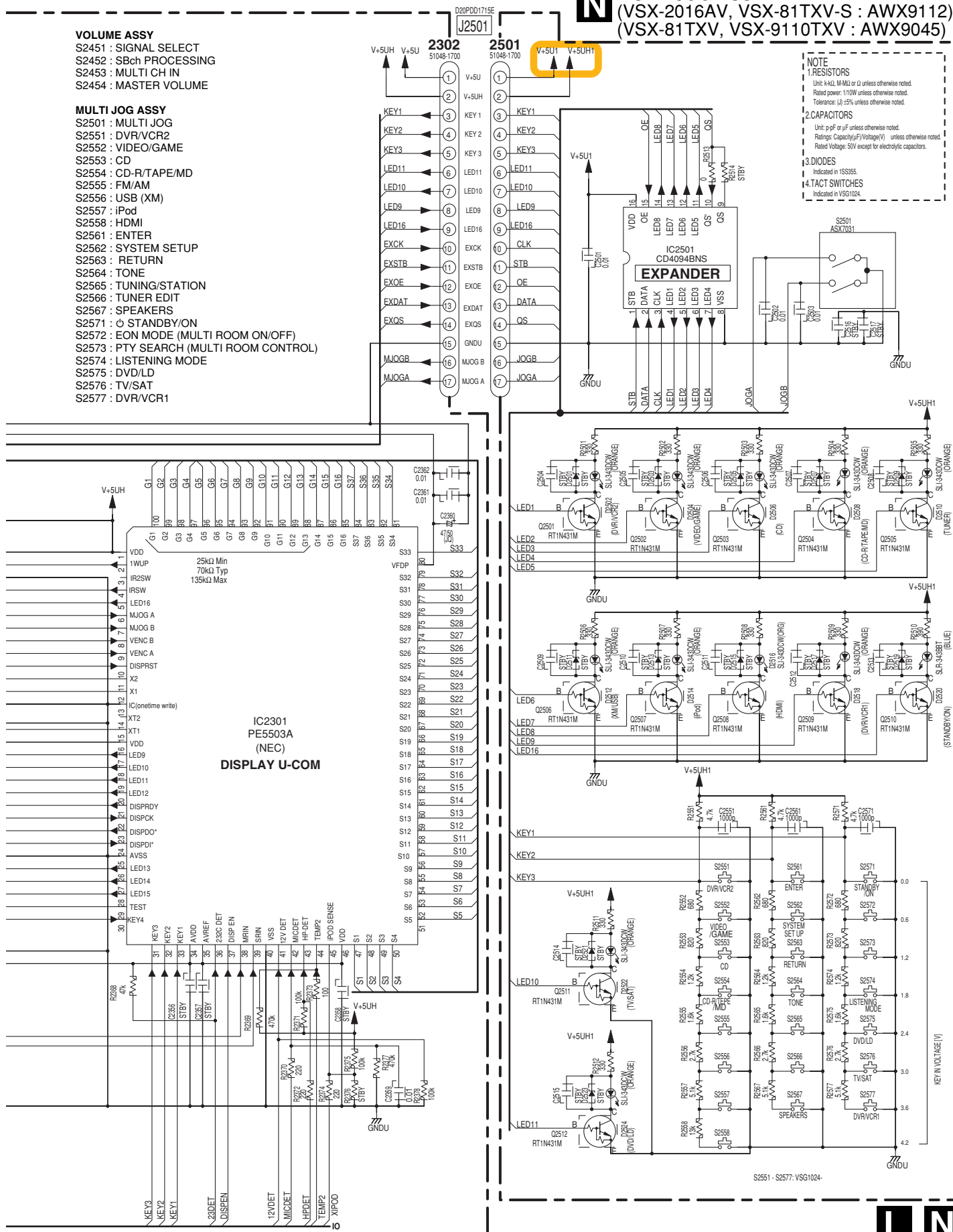







# 3.18 TRANS 2-1, DIODE 1, VH TR, BRIDGE 1 and PS/SP ASSYS

## S TRANS 2-1 ASSY (VSX-2116AV : AWX9059) (VSX-81TXV, VSX-9110TXV : AWX9058)

CAUTION : FOR CONTINUED PROTECTION AGAINST RISK OF FIRE. REPLACE ONLY WITH SAME TYPE NO. 491007 MFD, BY LITTELFUSE INK. FOR IC3251 and IC3252.

## T DIODE 1 ASSY (AWX9060)

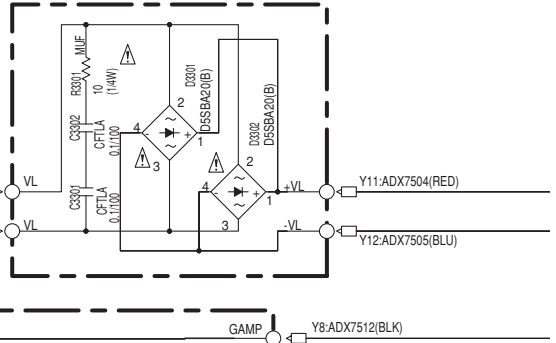

## V BRIDGE 1 ASSY (AWX9078)

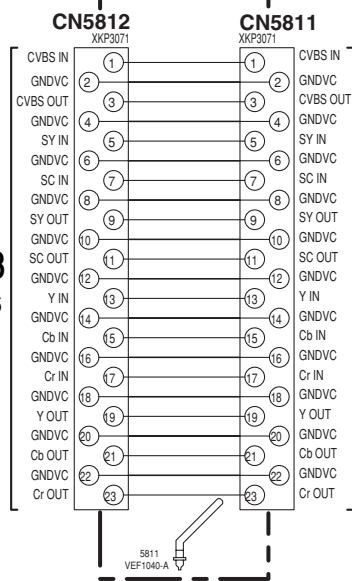

**C 3/3**  
CN106

**AK 2/2**  
CN1002

## U

## VH TR ASSY (AWX9061)

CAUTION : FOR CONTINUED PROTECTION AGAINST RISK OF FIRE. REPLACE ONLY WITH SAME TYPE NO. ICP-N15, MFD BY ROHM CO., LTD. FOR IC3351 and IC3352.

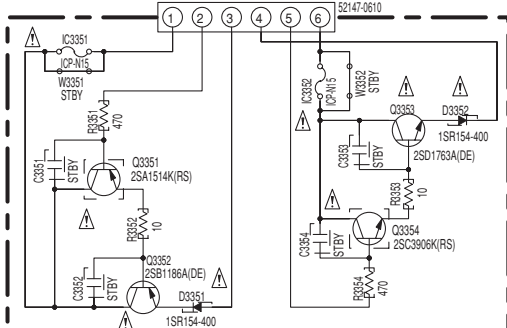

**AI**  
5604

**W** PS/SP ASSY  
 (VSX-2116AV : AWX9107)  
 (VSX-81TXV, VSX-9110TXV : AWX9052)

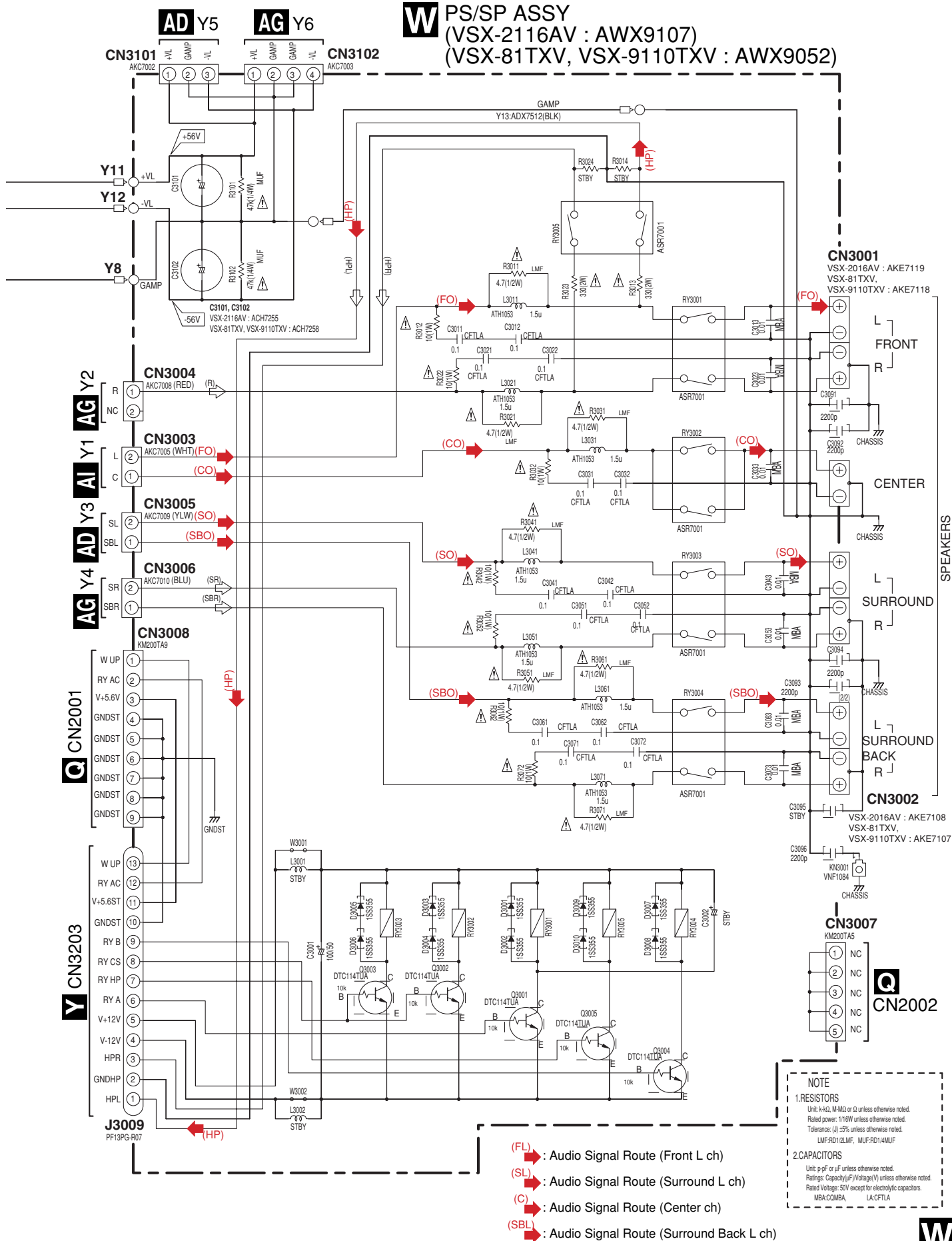

**NOTE**

**1.RESISTORS**  
 Unit: k-kΩ, M-MΩ or Ω unless otherwise noted.  
 Rated power: 1/8W unless otherwise noted.  
 Tolerance: (J) ±5% unless otherwise noted.  
 LMF:RD1/2LMF, MUF:RD1/4MUF

**2.CAPACITORS**  
 Unit: p-pF or μF unless otherwise noted.  
 Ratings: Capacity(μF)/Voltage(V) unless otherwise noted.  
 Rated Voltage: 50V except for electrolytic capacitors.  
 MBA:COMBA, LA:CFLTA

- (FL) : Audio Signal Route (Front L ch)
- (SL) : Audio Signal Route (Surround L ch)
- (C) : Audio Signal Route (Center ch)
- (SBL) : Audio Signal Route (Surround Back L ch)



# 3.19 TRANS 2-2, TRANS SIDE, LOCAL P-SUPPLY, DC/DC, IR I/O and VIDEO CONNECT ASSYS

## Z LOCAL P-SUPPLY ASSY (VSX-2016AV : AWX9064) (VSX-81TXV, VSX-9110TXV : AWX9063)

NOTE FOR FUSE REPLACEMENT

**CAUTION** -FOR CONTINUED PROTECTION AGAINST RISK OF FIRE. REPLACE WITH SAME TYPE AND RATINGS ONLY.

A  
B  
C  
D  
E  
F

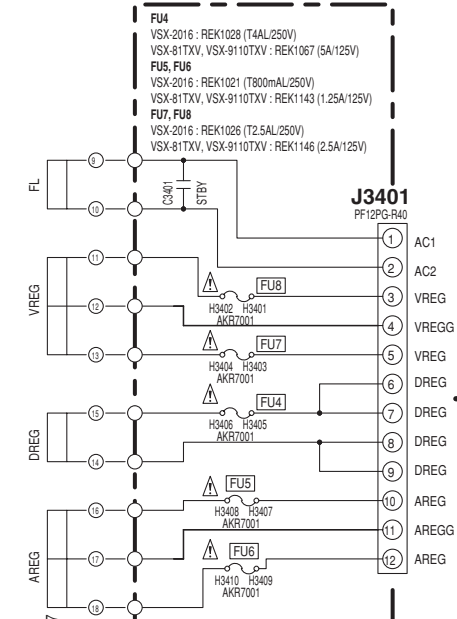

### X TRANS 2-2 ASSY (AWX9062)

**NOTE 1. RESISTORS**  
Unit: k-Ω, M-Ω or Ω unless otherwise noted.  
Rated power: 1/8W unless otherwise noted.  
Tolerance: ±1% unless otherwise noted.

**2. CAPACITORS**  
Unit: μF or pF unless otherwise noted.  
Ratings: Capacity (μF) Voltage (V) unless otherwise noted.  
Rated Voltage: 50V except for electrolytic capacitors.

T1501 MAIN TRANS.  
VSX-2016AV : ATS7408  
VSX-81TXV, VSX-9110TXV : ATS7407

### Y TRANS SIDE ASSY (AWX9056)

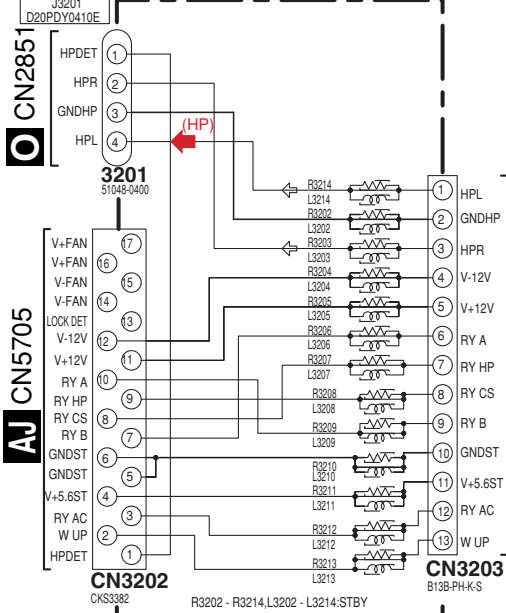

### X Y Z AA

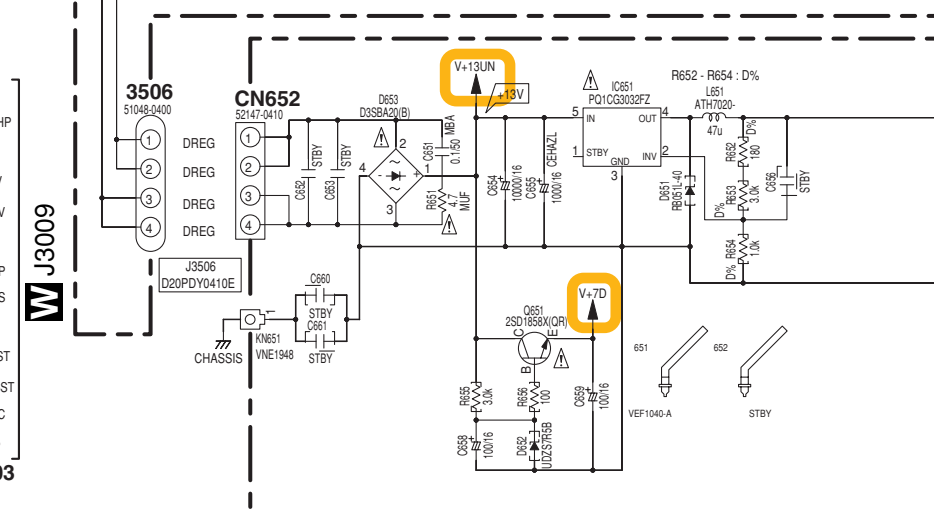
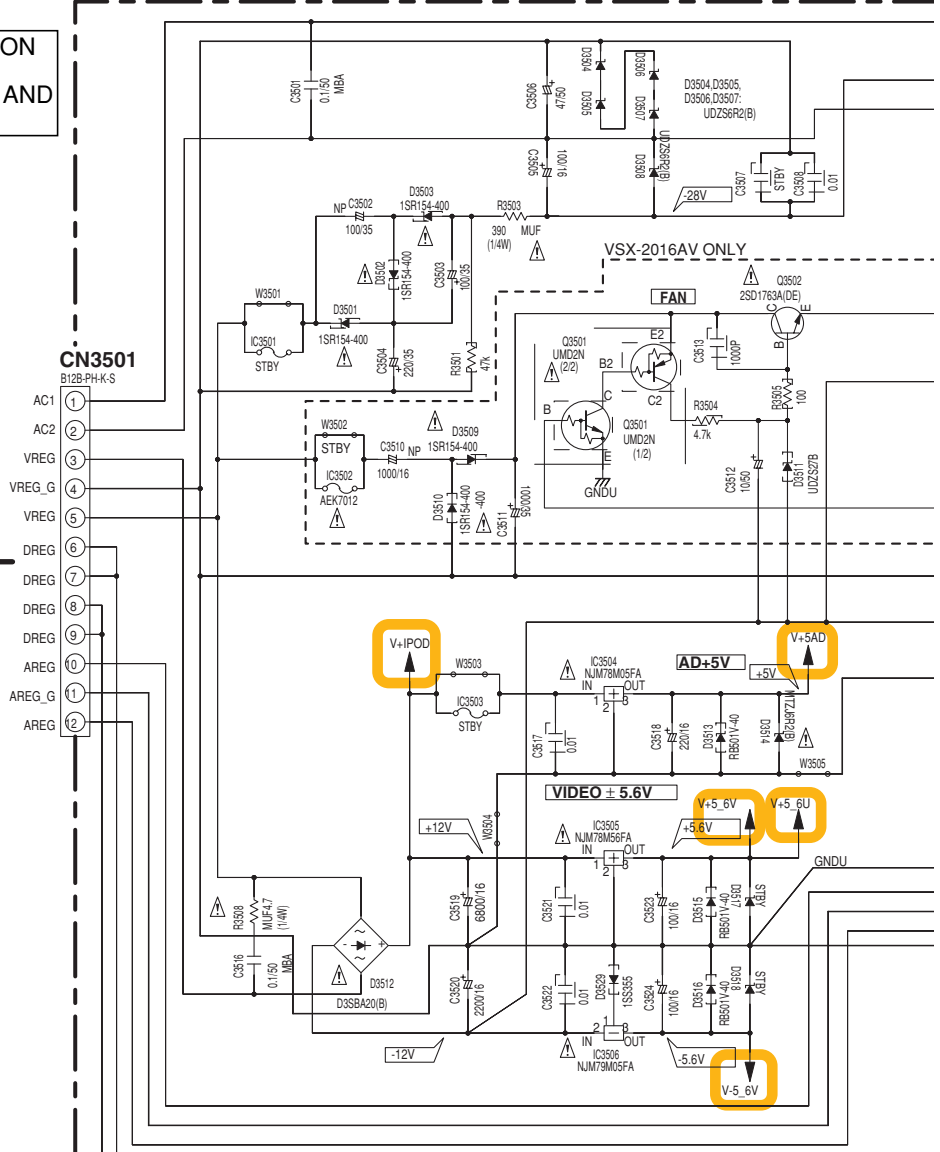

### AA DC/DC ASSY (AWX9015)



# 3.20 POWER AMP-L, POSI 1-L and POSI 2-L ASSYS

## AD POWER AMP-L ASSY (VSX-2016AV : AWX9072) (VSX-81TXV, VSX-9110TXV : AWX9071)

A  
B  
C  
D  
E  
F

**AE**  
POSI 1-L ASSY  
(VSX-2016AV : AWX9081)  
(VSX-81TXV, VSX-9110TXV : AWX9080)

**AF**  
POSI 2-L ASSY  
(AWX9082)

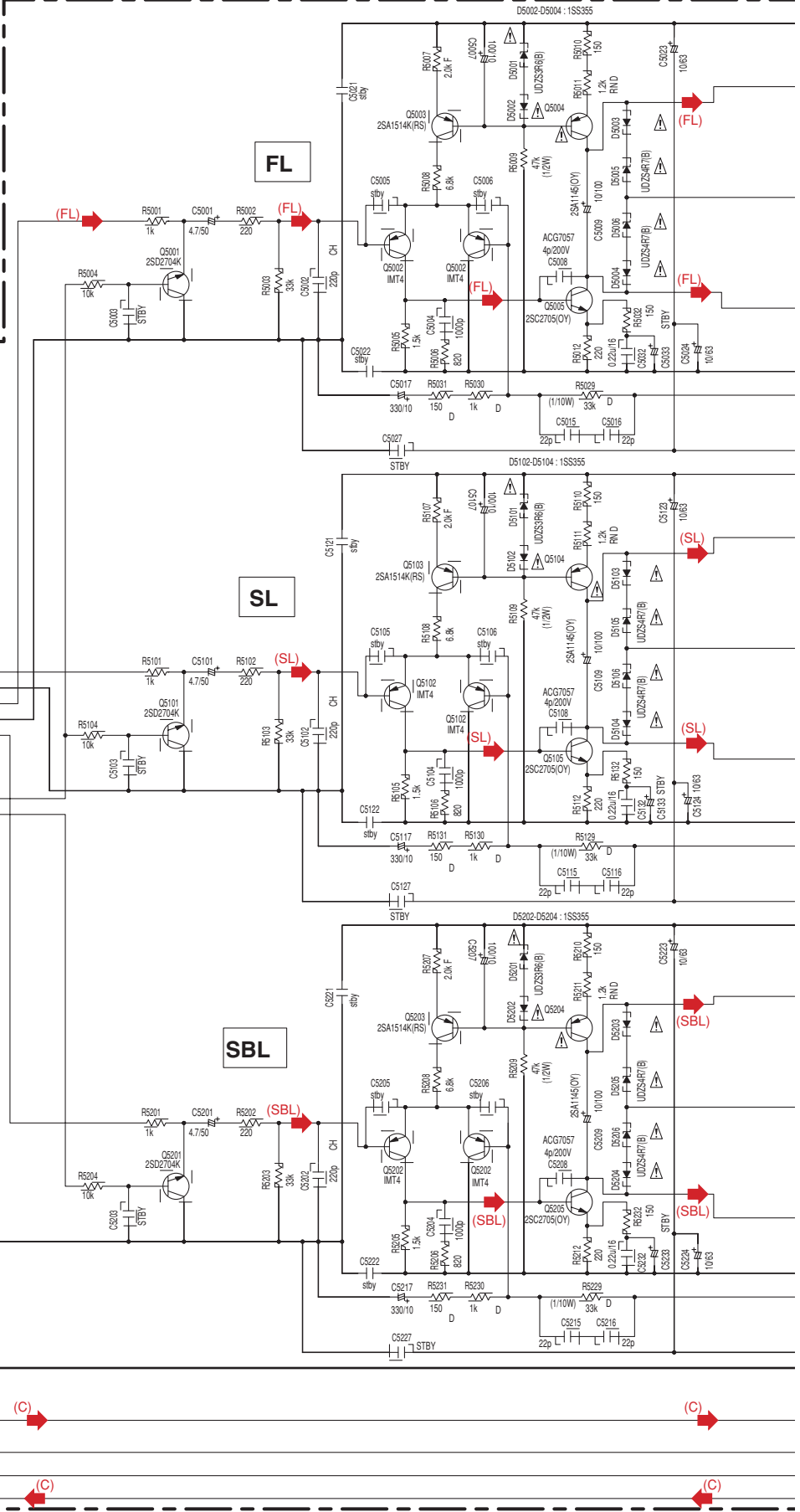
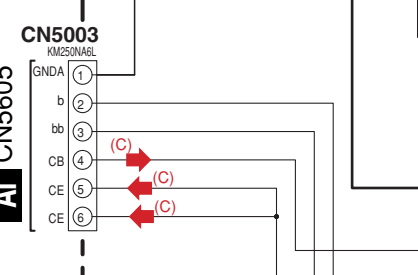
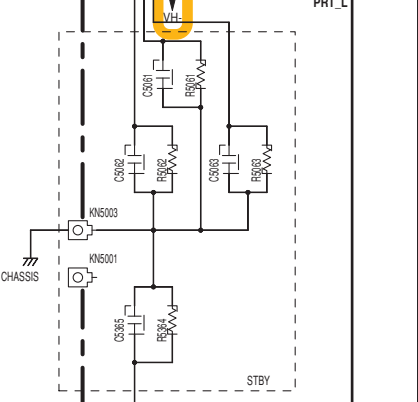
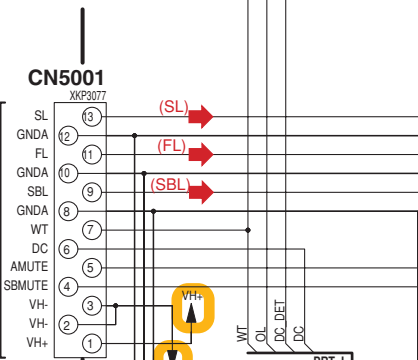
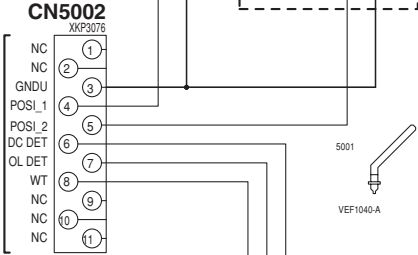
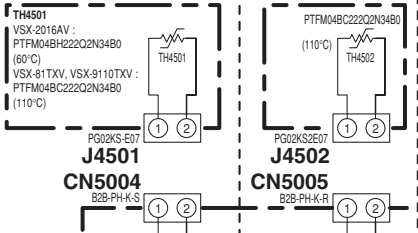

**AD AE AF**

1 2 3 4

- (FL) : Audio Signal Route (Front L ch)
- (SL) : Audio Signal Route (Surround L ch)
- (C) : Audio Signal Route (Center ch)
- (SBL) : Audio Signal Route (Surround Back L ch)

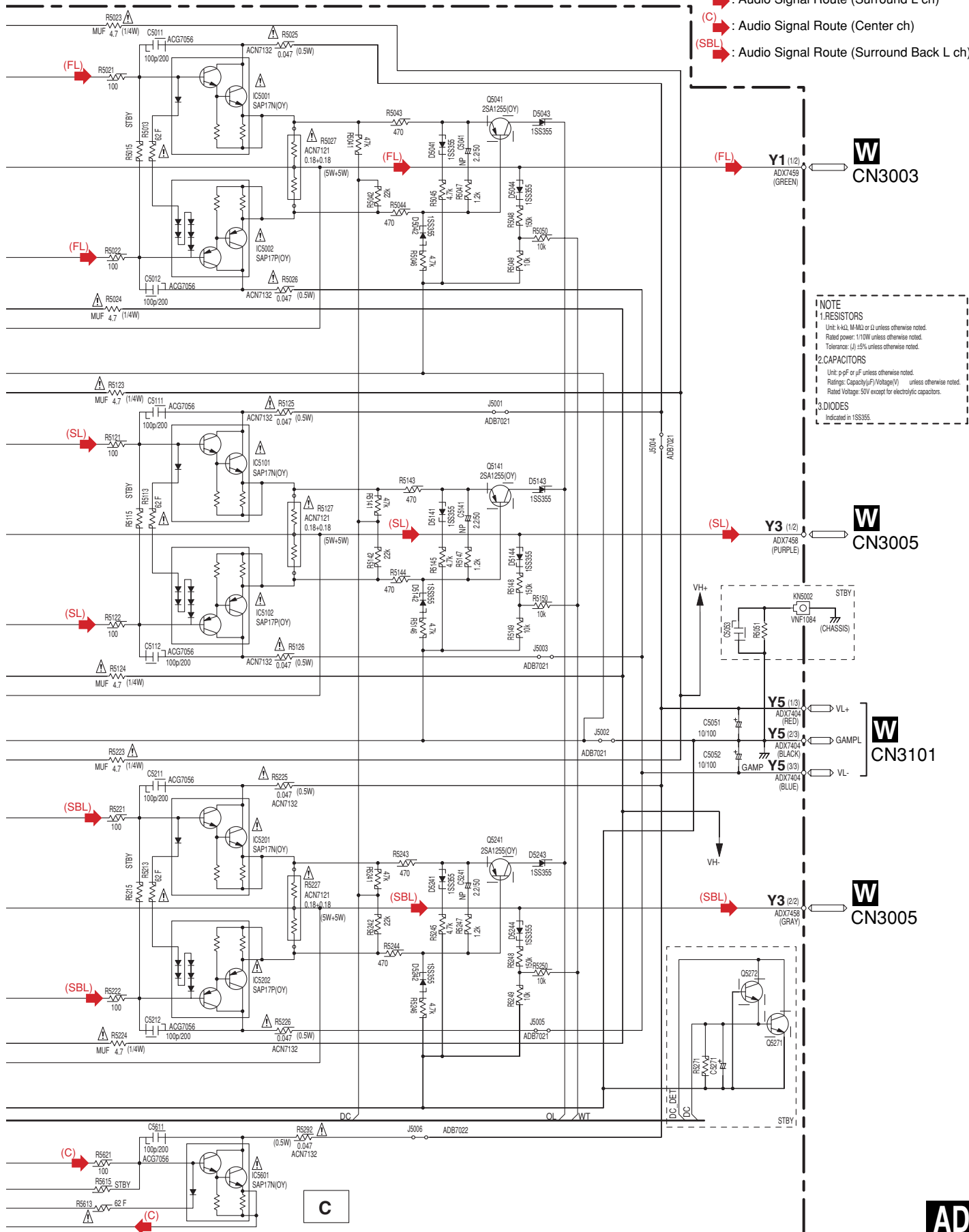

**NOTE**

**1.RESISTORS**  
Unit: k-kΩ, M-MΩ or Ω unless otherwise noted.  
Rated power: 1/10W unless otherwise noted.  
Tolerance: (J) ±5% unless otherwise noted.

**2.CAPACITORS**  
Unit: p-pF or μF unless otherwise noted.  
Rating: Capacity(μF) Voltage(V) unless otherwise noted.  
Rated Voltage: 50V except for electrolytic capacitors.

**3.DIODES**  
Indicated in 1SS335.

**W**  
CN3003

**W**  
CN3005

**W**  
CN3101

**W**  
CN3005

**C**



# 3.21 POWER AMP-R and POSI 1-R ASSYS

## AG POWER AMP-R ASSY (VSX-2016AV : AWX9073) (VSX-81TXV, VSX-9110TXV : AWX9106)

### AH

POSI 1-R ASSY  
(VSX-2016AV : AWX9084)  
(VSX-81TXV, VSX-9110TXV : AWX9083)

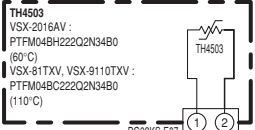

J4551  
CN5304  
B2B-PH-K-S

CN5302  
XKP3076

AJ CN5702

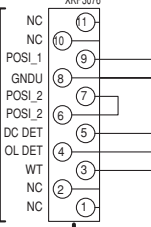

CN5301  
XKP3077

AI CN5602

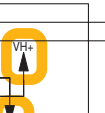
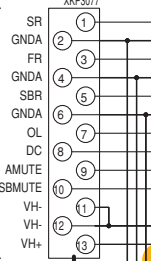

FR

SR

SBR

C

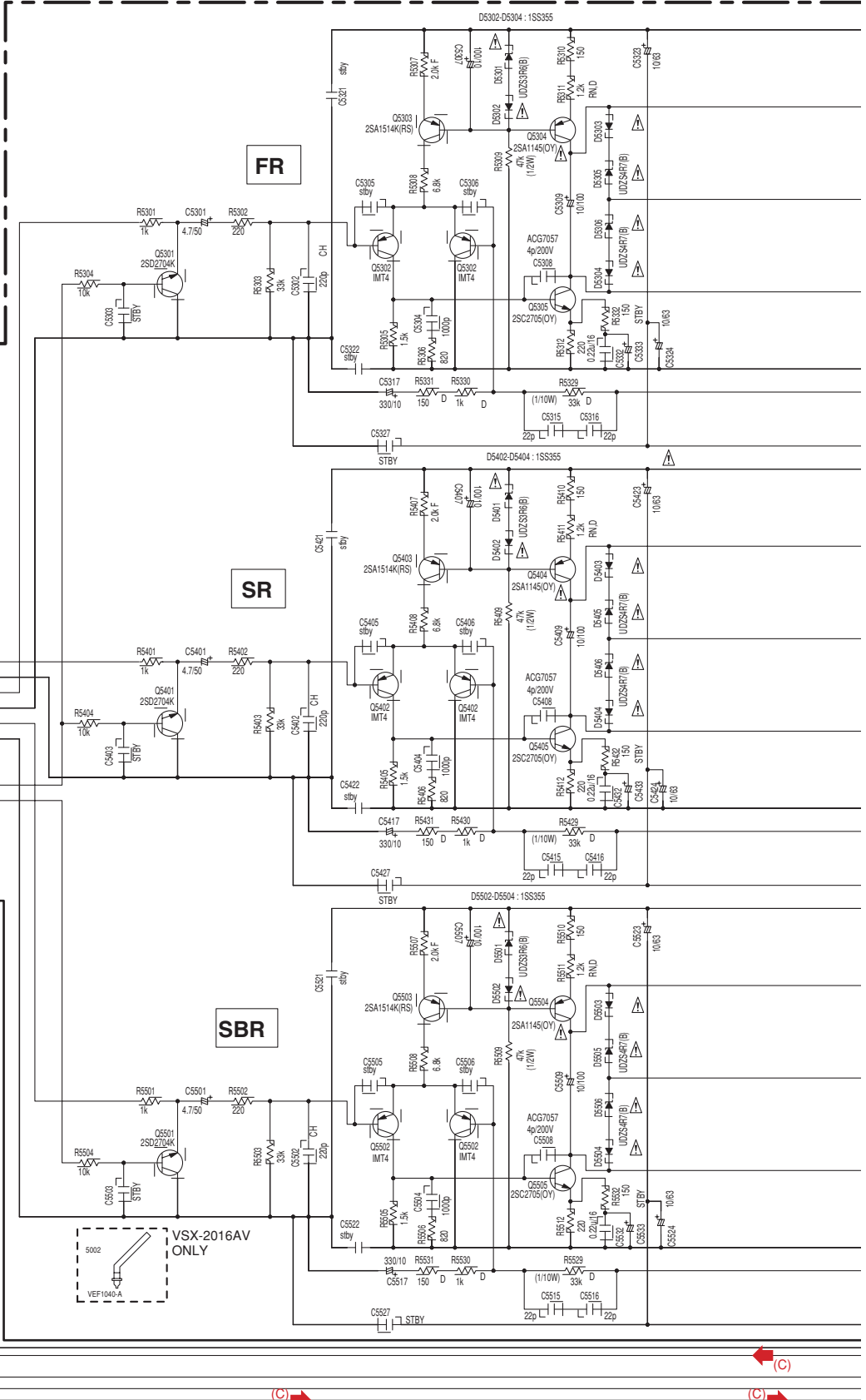

CN5303  
KM250NABL

AI CN5606

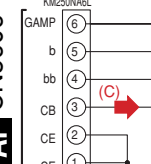



(C) : Audio Signal Route (Center ch)

A

B

C

D

E

F

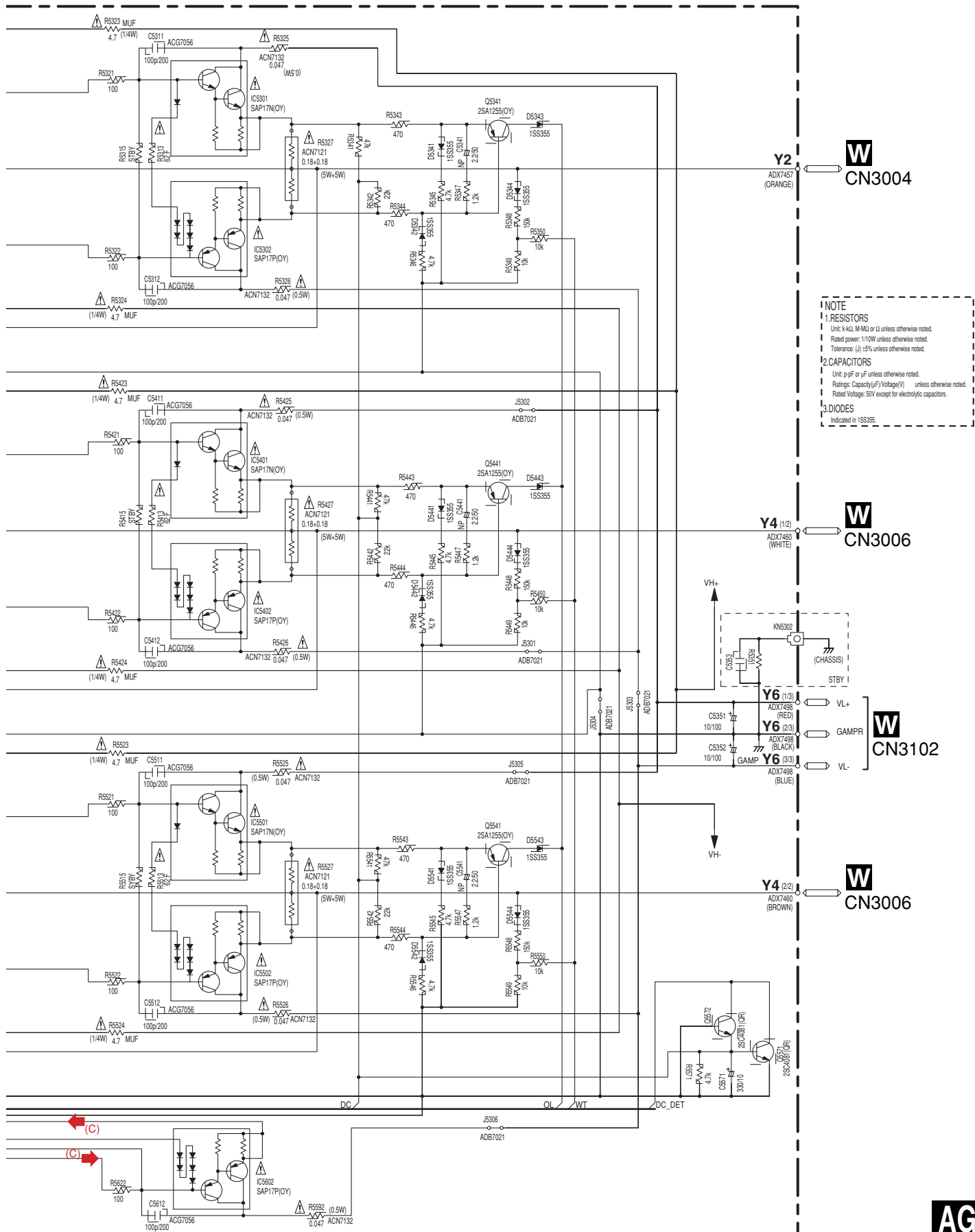

**NOTE**

1. RESISTORS  
 Unit: k- $\Omega$ , M- $\Omega$  or  $\Omega$  unless otherwise noted.  
 Rated power: 1/10W unless otherwise noted.  
 Tolerance:  $\pm 5\%$  unless otherwise noted.

2. CAPACITORS  
 Unit: p-pF or  $\mu$ F unless otherwise noted.  
 Rating: Capacity( $\mu$ F)/Voltage(V) unless otherwise noted.  
 Rated Voltage: 35V except for electrolytic capacitors.

3. DIODES  
 Indicated in 1SS355.

**W** CN3004  
ADX7457 (ORANGE)

**W** CN3006  
ADX7456 (WHITE)

**W** CN3102

Y6 (1/3) ADX7496 (RED)  
 Y6 (2/3) ADX7496 (BLACK)  
 Y6 (3/3) ADX7496 (BLUE)

**W** CN3006  
ADX7456 (BROWN)

# 3.22 POWER AMP IN and POWER PROTECT ASSYS

1 2 3 4

A  
B  
C  
D  
E  
F

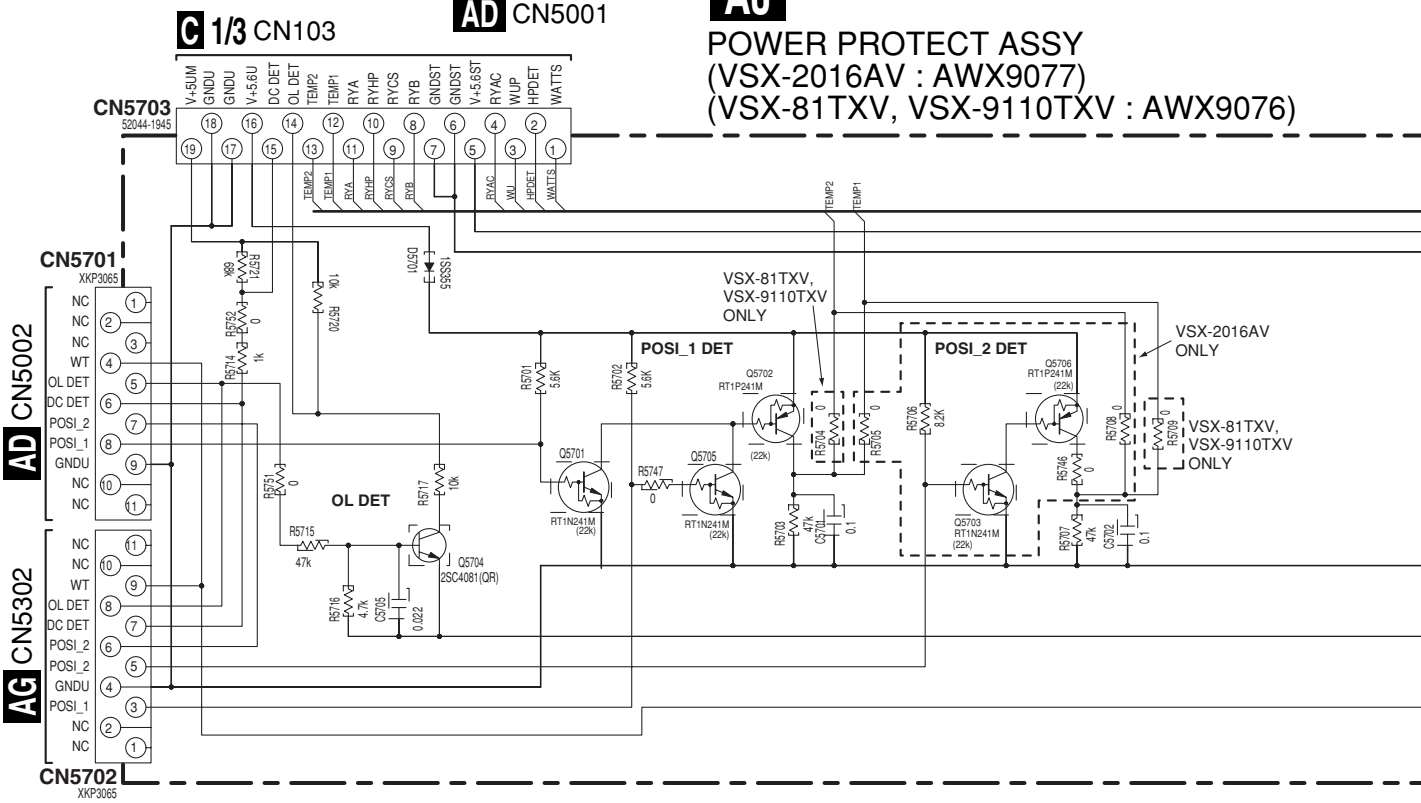
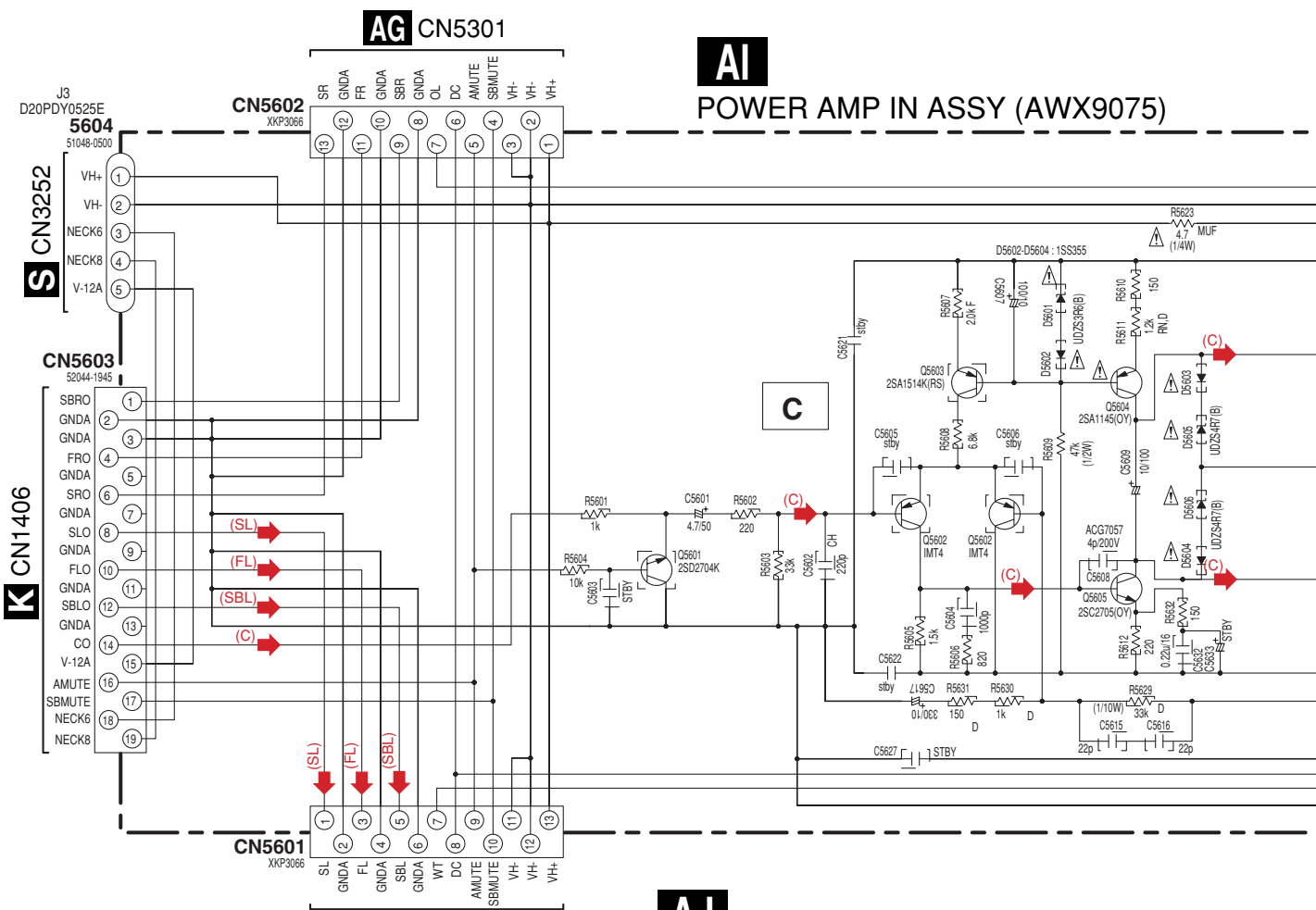

**AI AJ**

VSX-2016AV-S

1 2 3 4

- (FL) : Audio Signal Route (Front L ch)
- (SL) : Audio Signal Route (Surround L ch)
- (C) : Audio Signal Route (Center ch)
- (SBL) : Audio Signal Route (Surround Back L ch)

A  
B  
C  
D  
E  
F

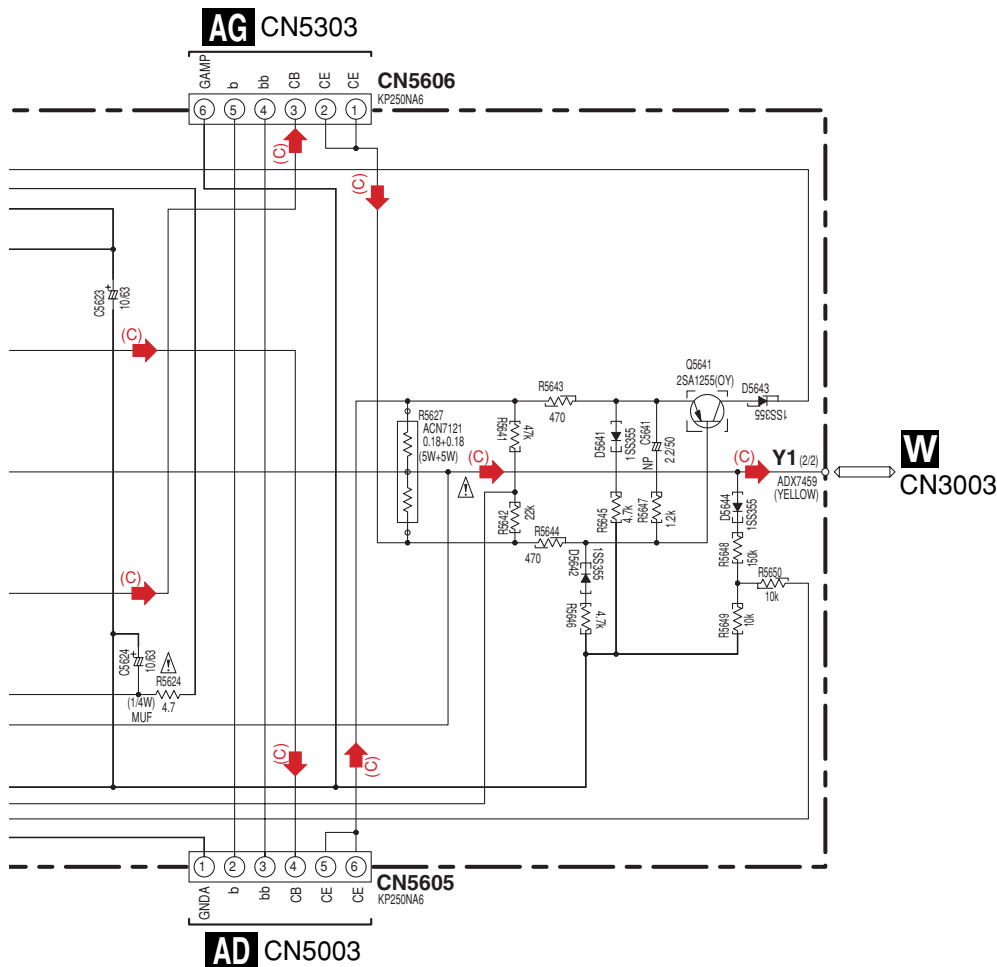

**NOTE**  
**1.RESISTORS**  
 Unit: k-kΩ, M-MΩ or Ω unless otherwise noted.  
 Rated power: 1/16W unless otherwise noted.  
 Tolerance: (J) ±5% unless otherwise noted.  
**2.CAPACITORS**  
 Unit: p-pF or μF unless otherwise noted.  
 Ratings: Capacity(μF)/Voltage(V) unless otherwise noted.  
 Rated Voltage: 50V expect for electrolytic capacitors.

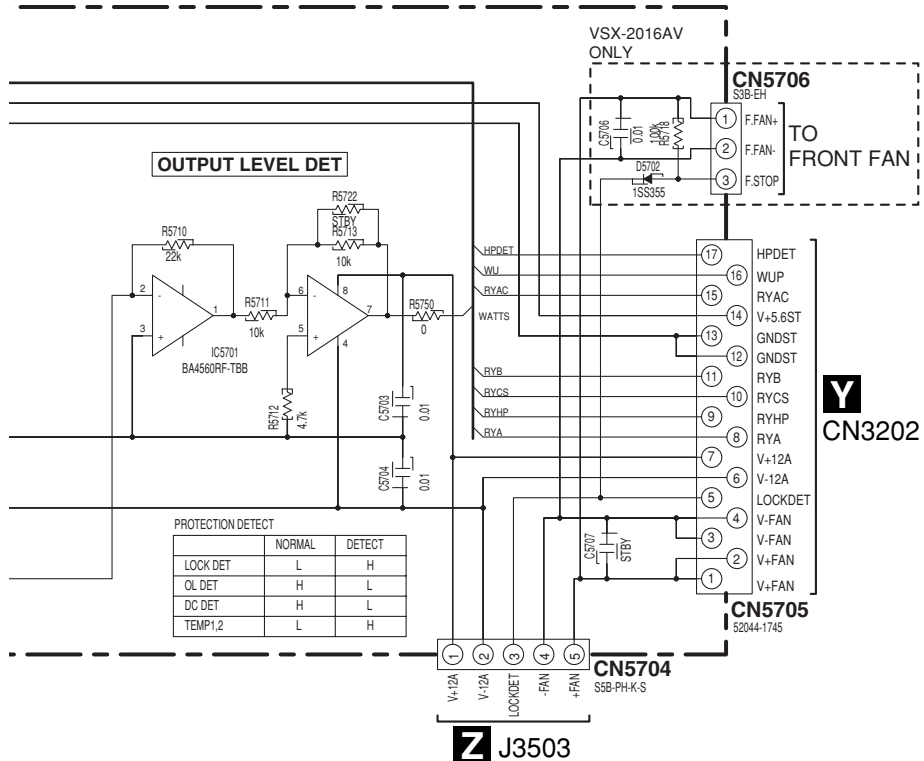

**AI AJ**

# 3.23 HDMI & DVC ASSY (1/2)

## AK 1/2 HDMI & DVC ASSY (AWQ7037)

A  
B  
C  
D  
E  
F

1 2 3 4

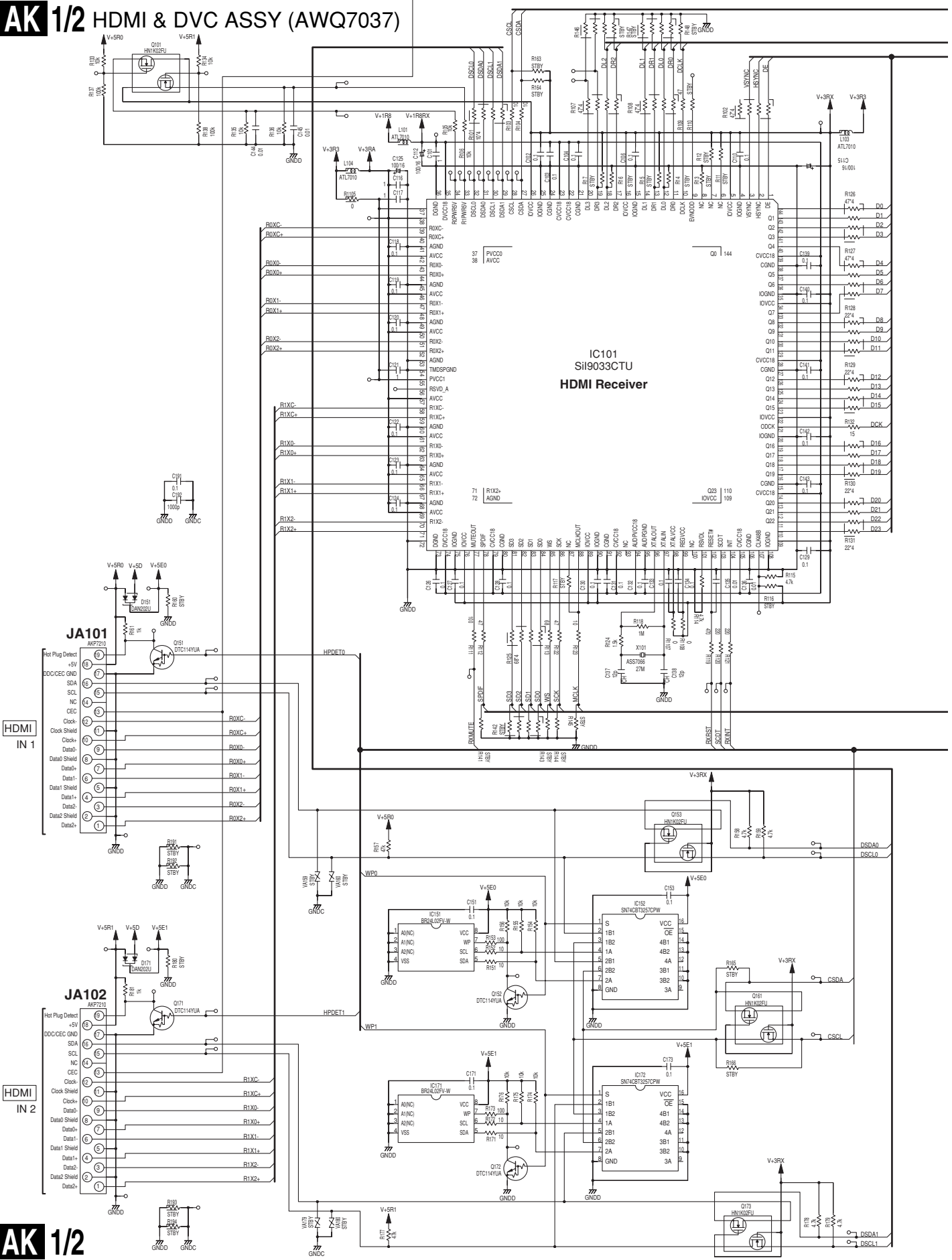

## AK 1/2

VSX-2016AV-S

1 2 3 4

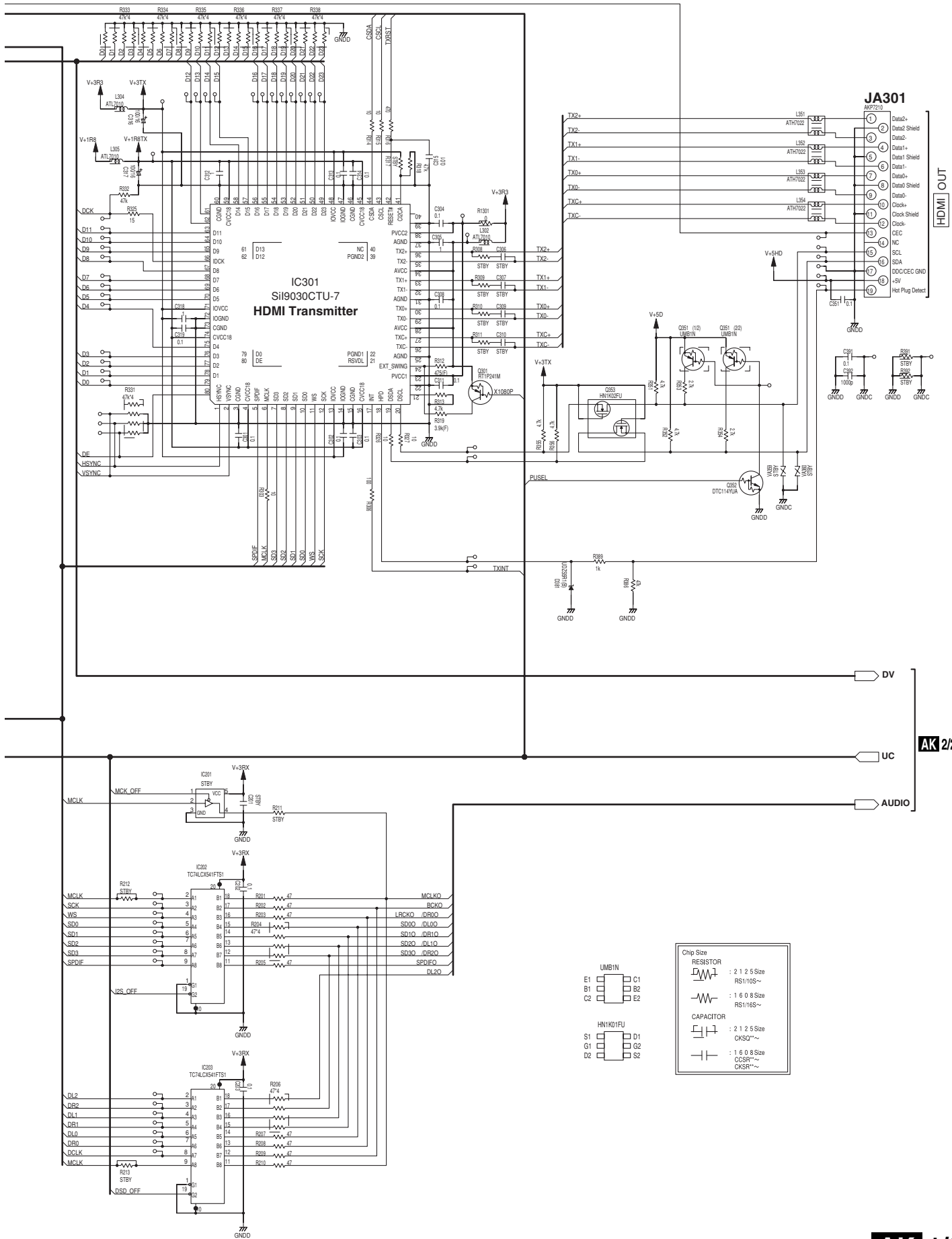



# AK 2/2 HDMI & DVC ASSY (AWQ7037)

A

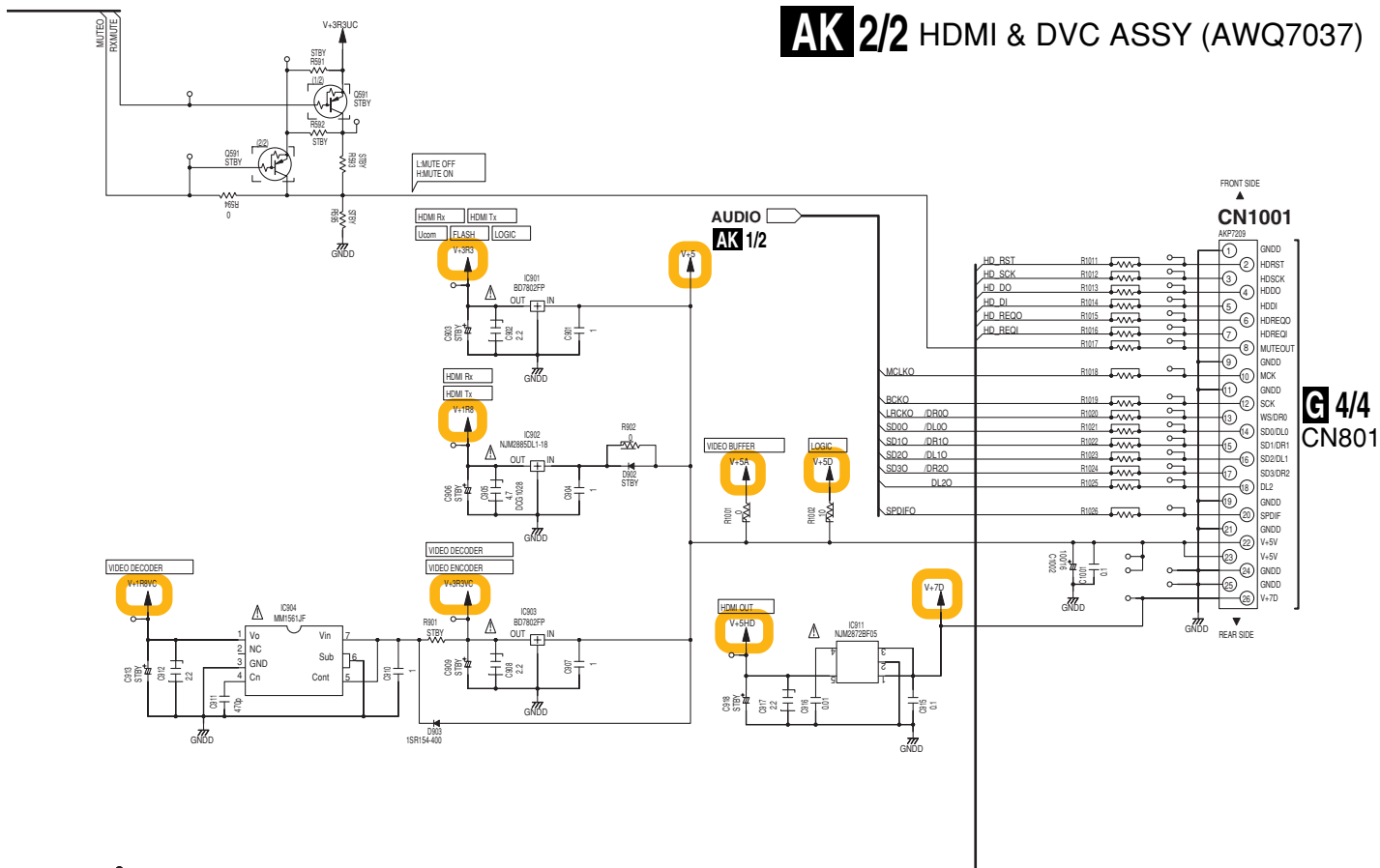

B

C

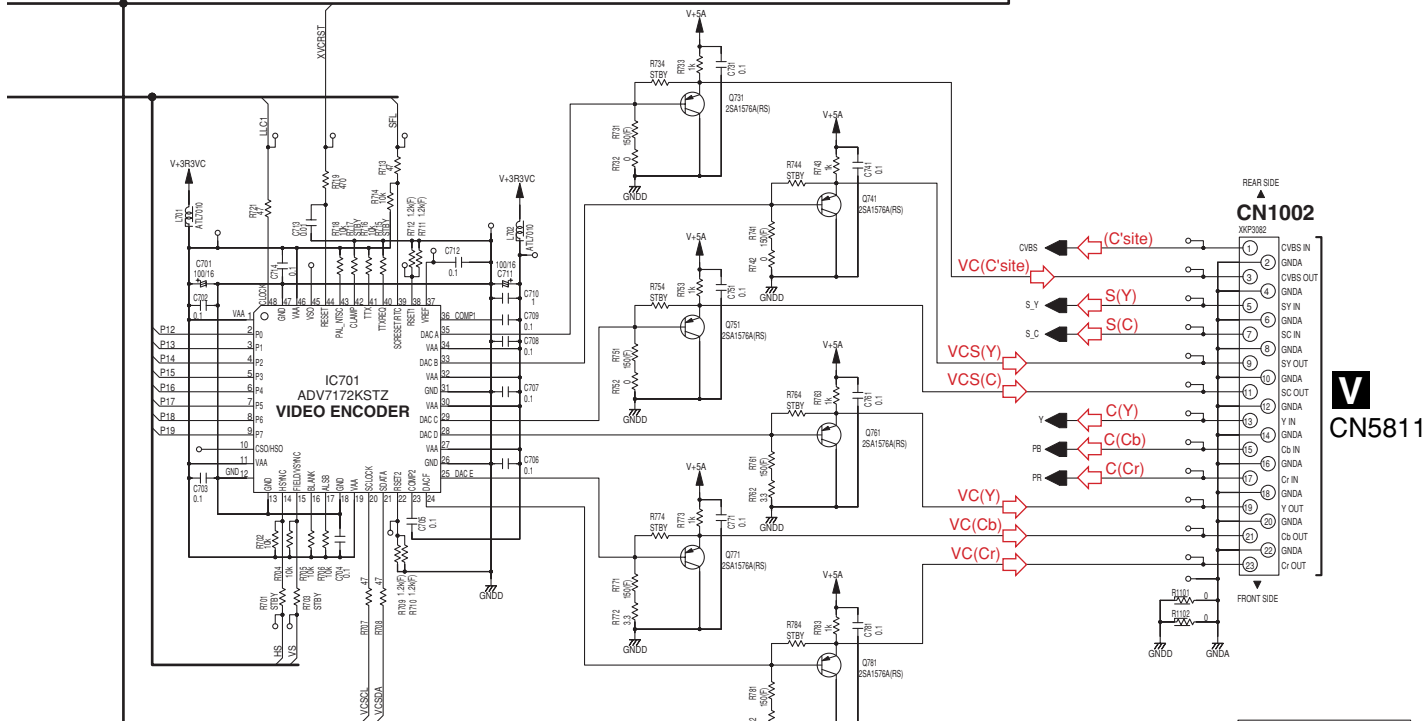

D

E

F

Chip Size	
RESISTOR	
	: 2 1 2 5 Size RS1/10S~
	: 1 6 0 8 Size RS1/16S~
CAPACITOR	
	: 2 1 2 5 Size CKSQ~
	: 1 6 0 8 Size CCSR~
	: CKSR~

## AK 2/2

# 3.25 USB ASSY (VSX-2016AV-S ONLY)

## AL USB ASSY (AWX8704)

A

B

C

D

E

F

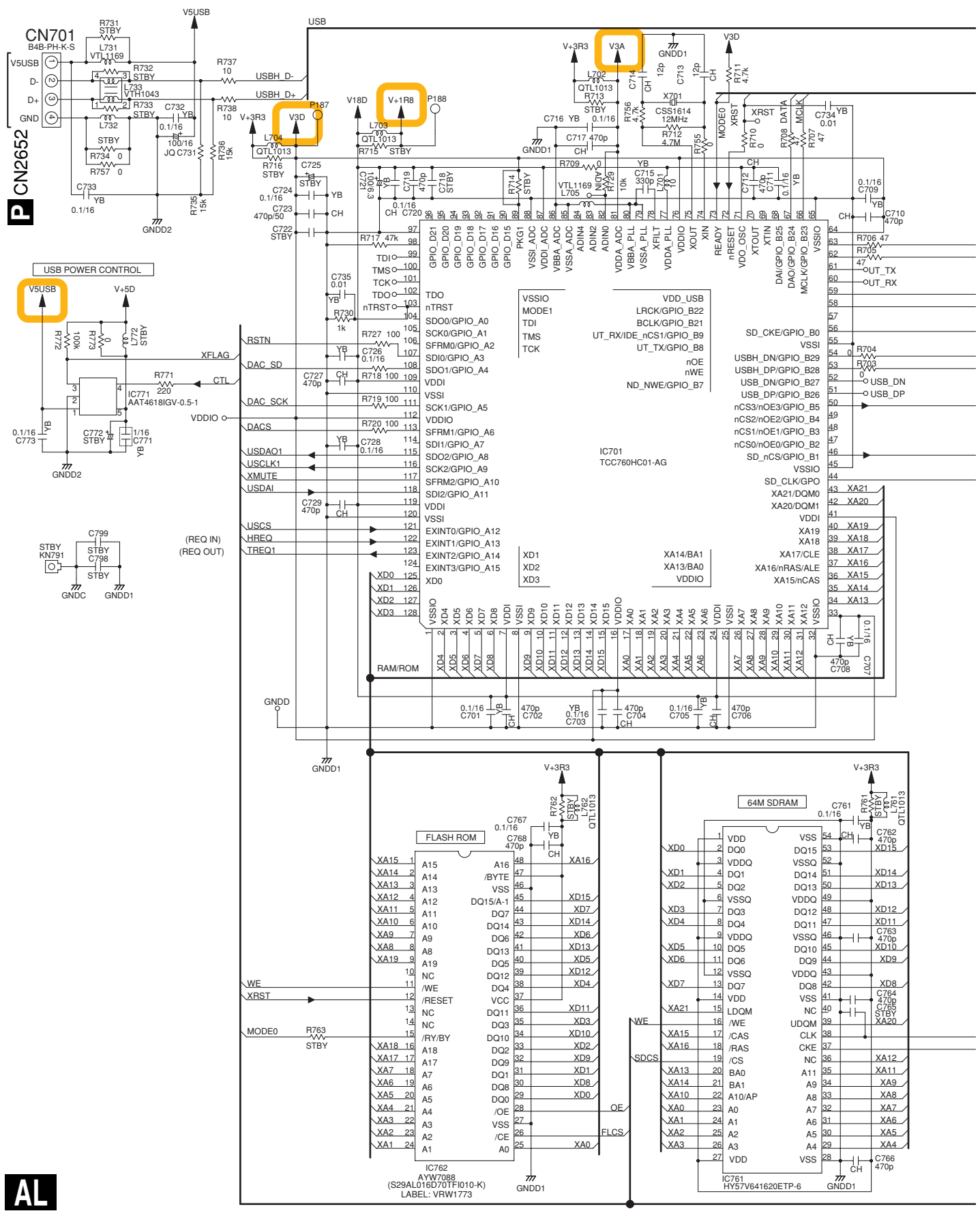



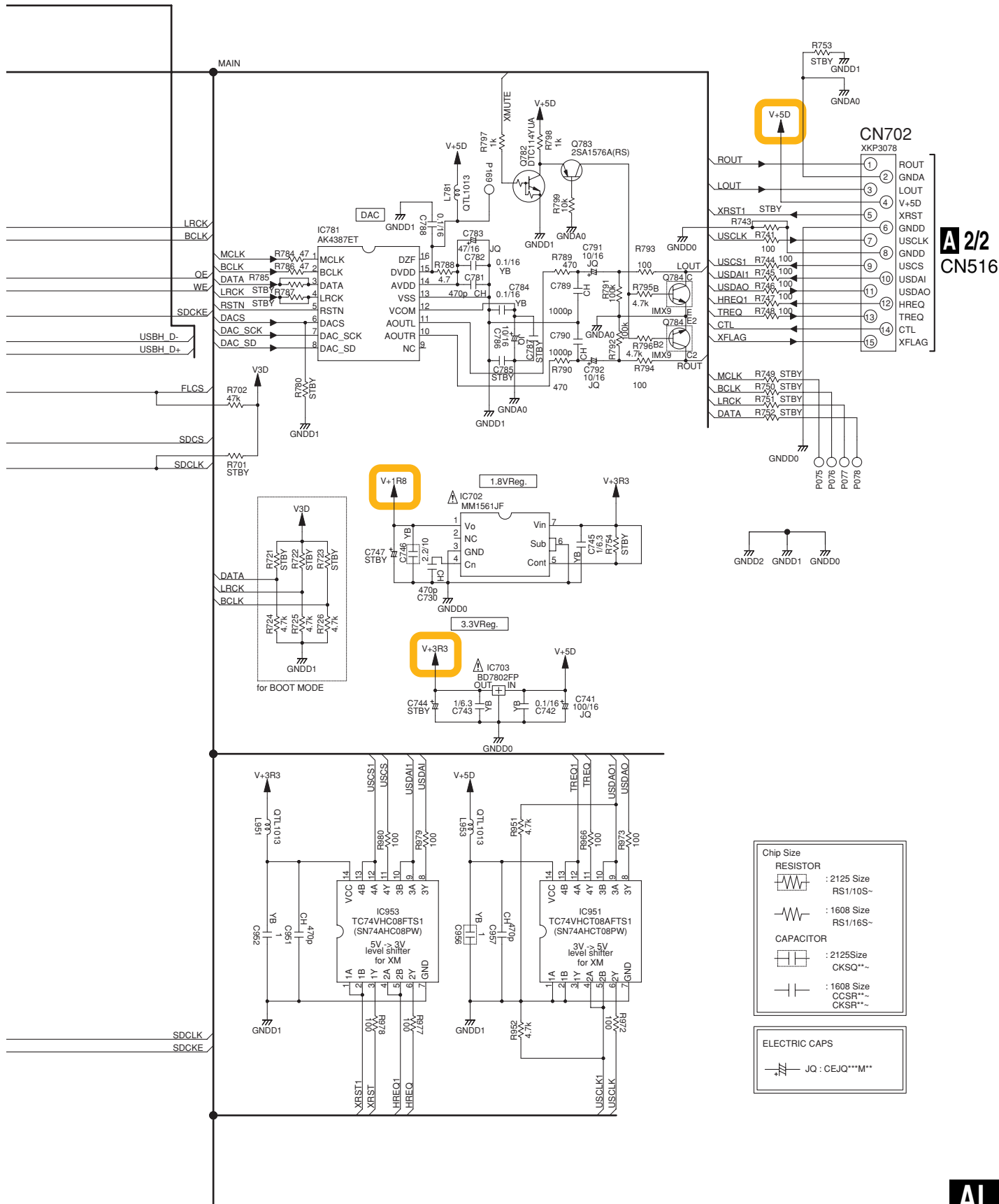







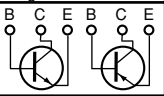

A 2/2  
CN516

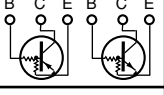
# 4. PCB CONNECTION DIAGRAM

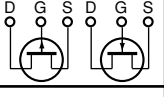
## NOTE FOR PCB DIAGRAMS :

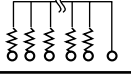
1. Part numbers in PCB diagrams match those in the schematic diagrams.
2. A comparison between the main parts of PCB and schematic diagrams is shown below.

Symbol In PCB Diagrams	Symbol In Schematic Diagrams	Part Name
		Transistor
		Transistor with resistor
		Field effect transistor
		Resistor array
		3-terminal regulator

3. The parts mounted on this PCB include all necessary parts for several destinations.  
For further information for respective destinations, be sure to check with the schematic diagram.
4. View point of PCB diagrams.

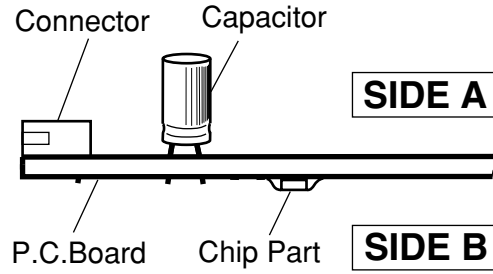

■

5

■

6

■

7

■

8

■

A

■

B

■

C

■

D

■

E

■

F

■

5

■

6

VSX-2016AV-S

■

7

■

8

■

# 4.1 AUDIO IN ASSY

**SIDE A**

## **A** AUDIO IN ASSY

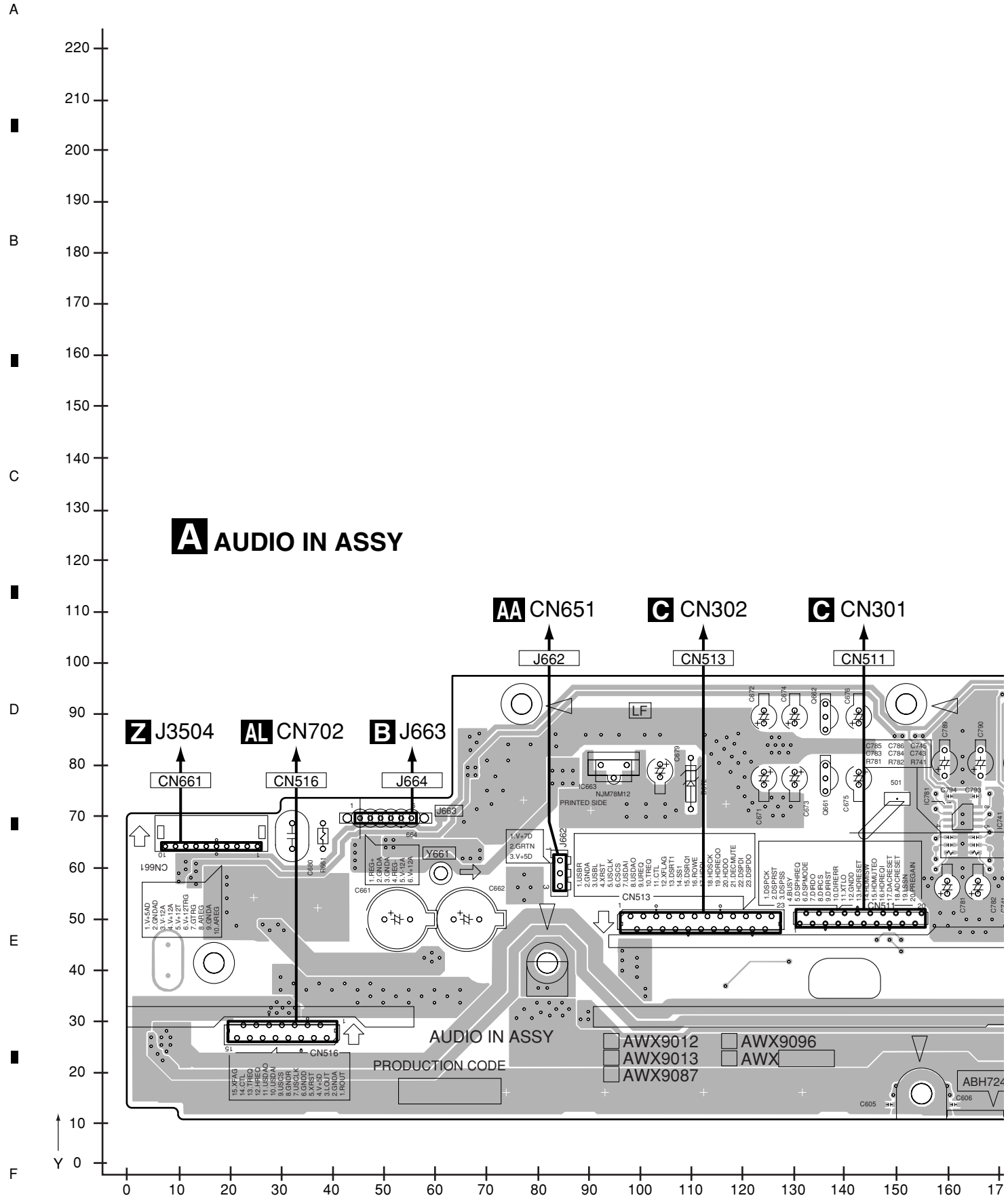





SIDE B

A  
B  
C  
D  
E  
F

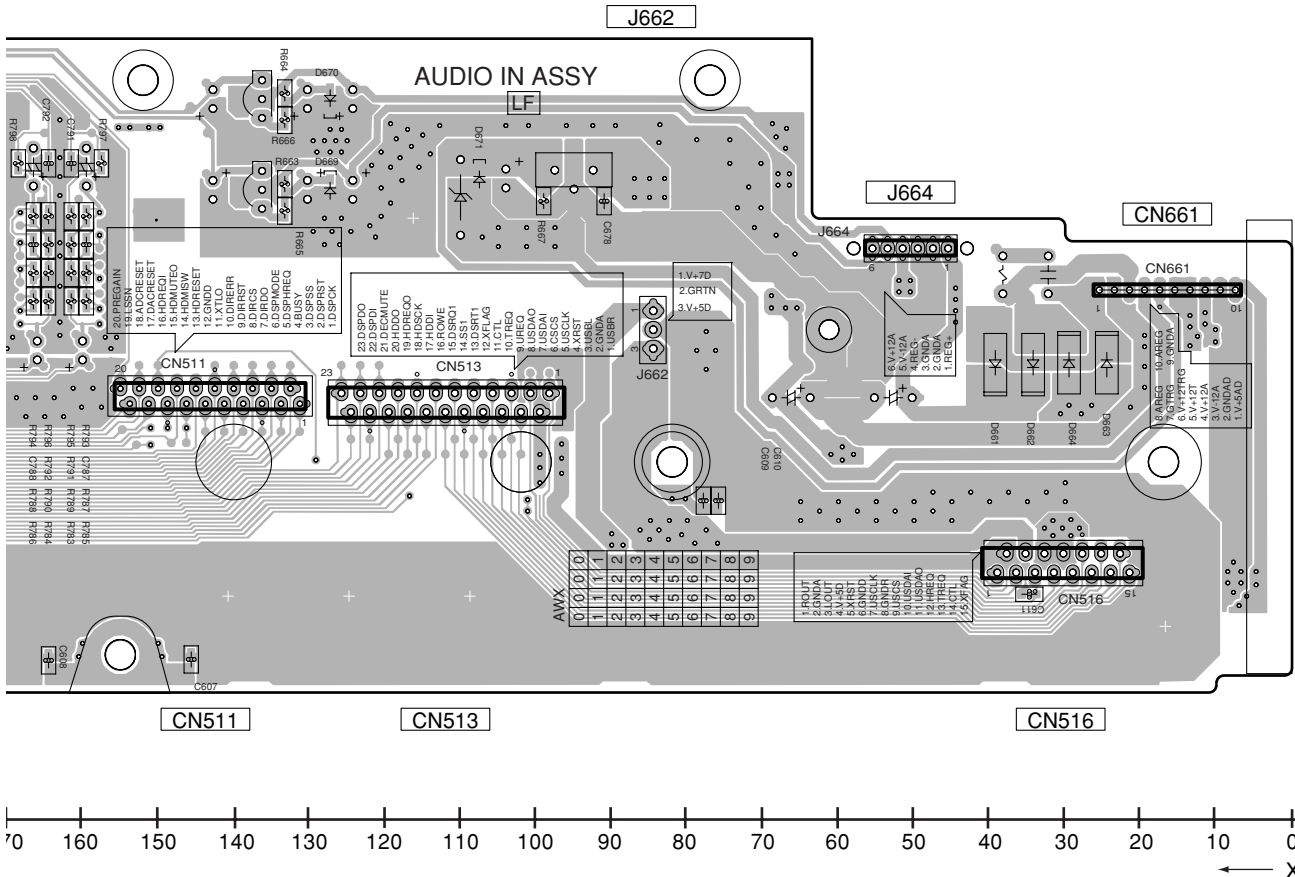

# 4.2 12V-REG ASSY

**SIDE A**

**SIDE A**

## **B** 12V-REG ASSY

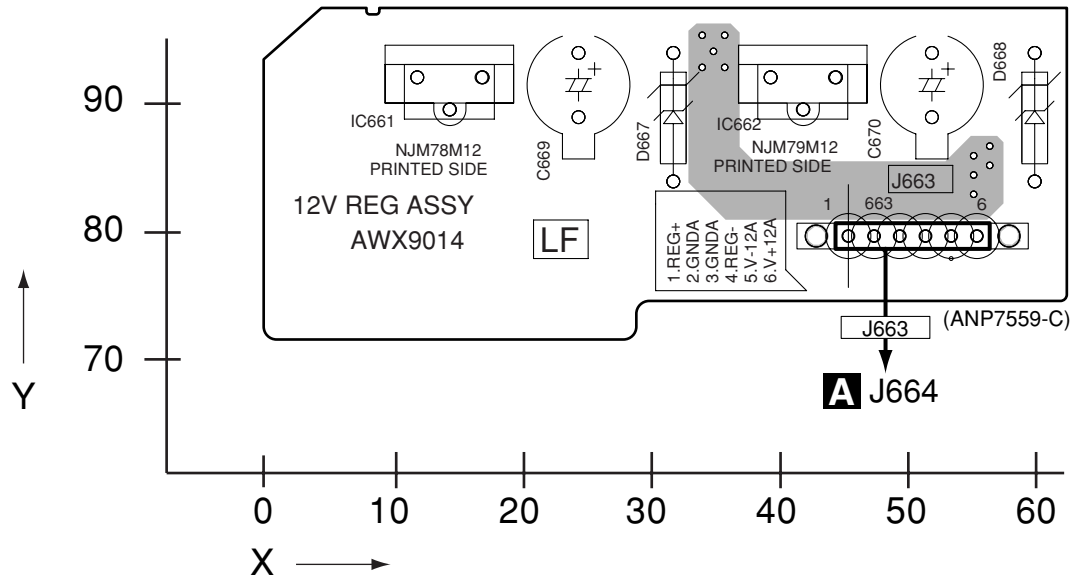

**SIDE B**

**SIDE B**

## **B** 12V-REG ASSY

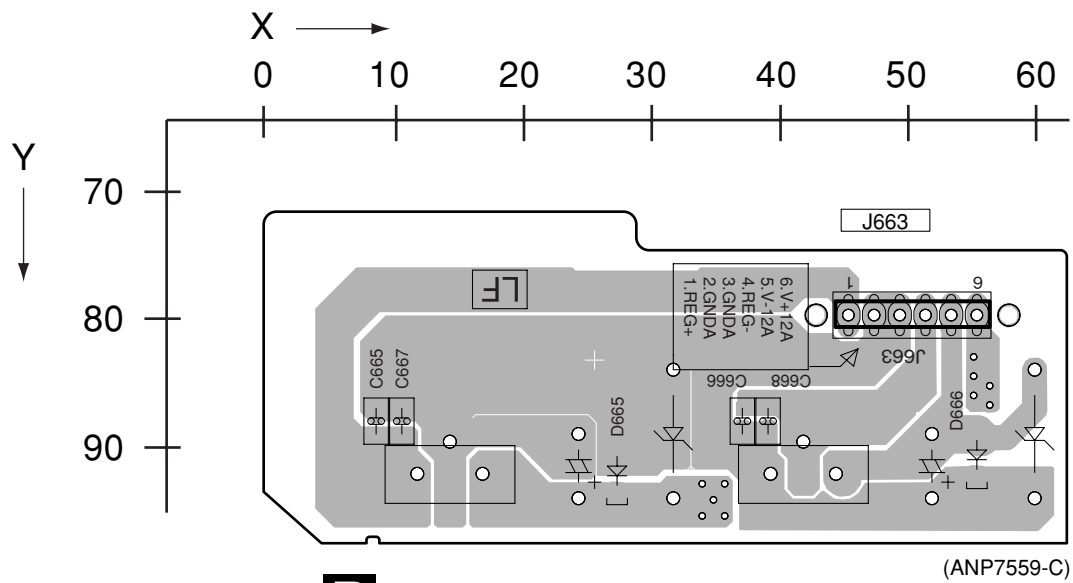

**B**

**B**



### 4.3 BRIDGE 2 ASSY

**SIDE A**

**SIDE A**

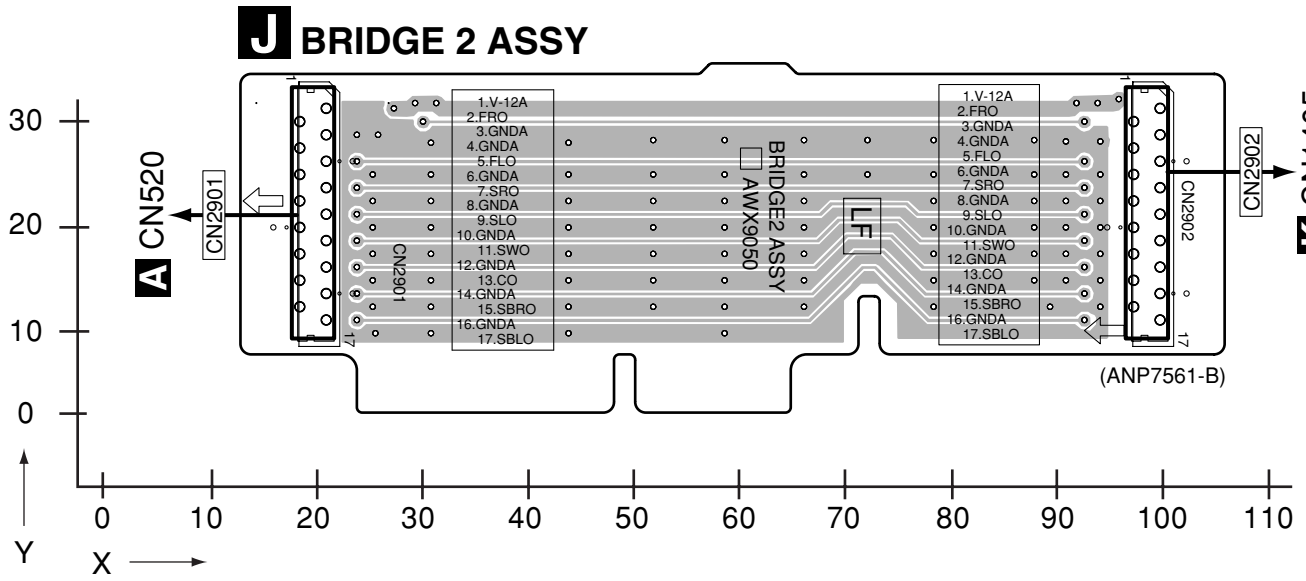

**SIDE B**

**SIDE B**

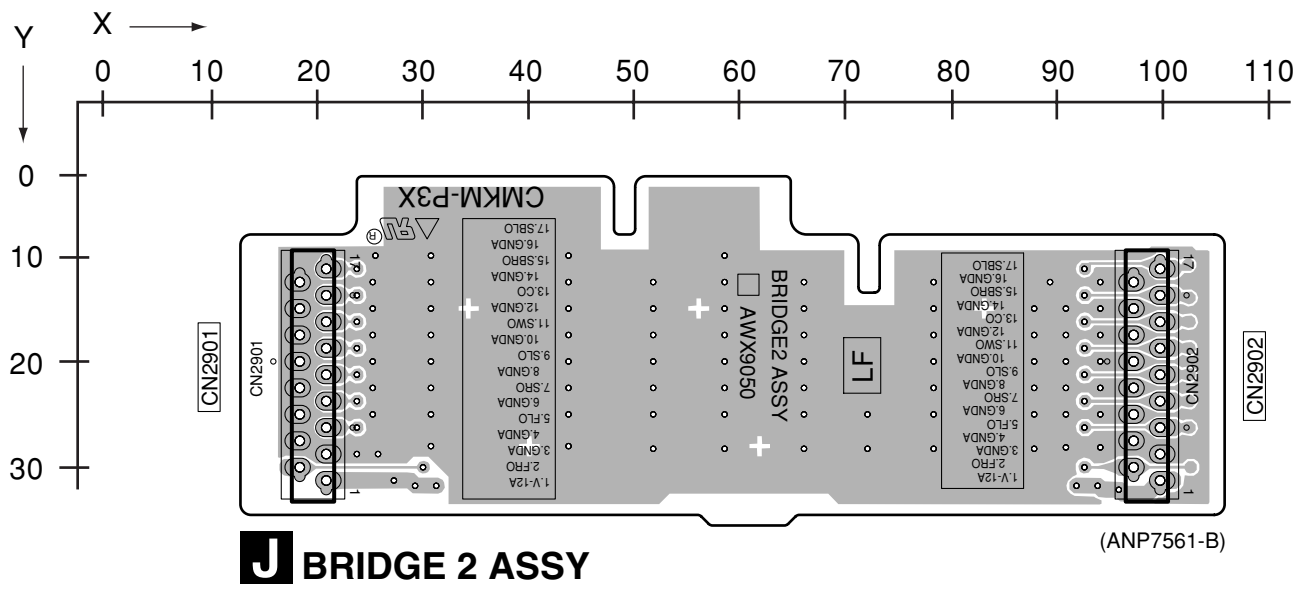

**J**

**J**



**SIDE A**

A  
B  
C  
D  
E  
F

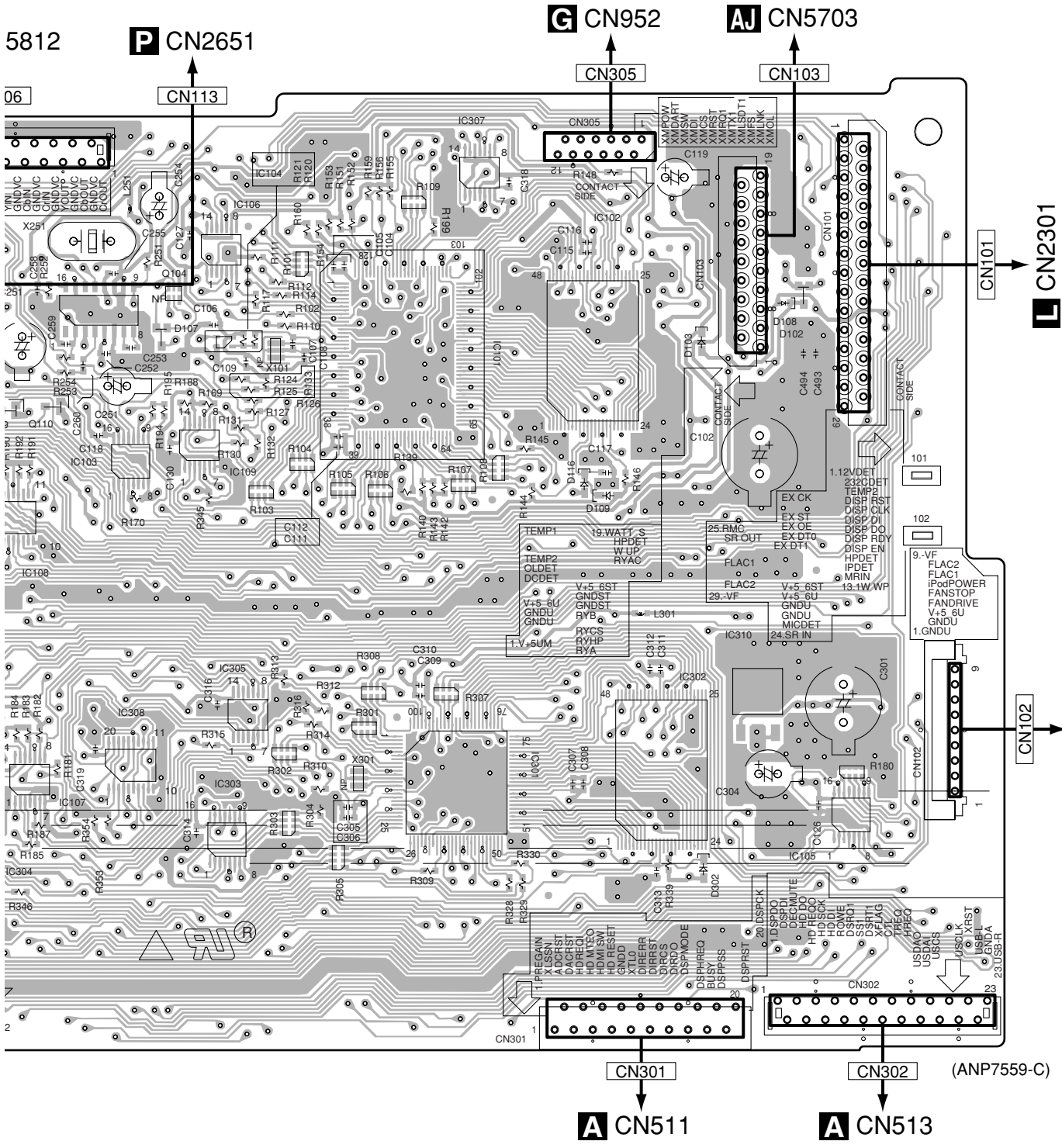

100 110 120 130 140 150 160 170 180 190 200 210 220 230

SIDE B

# C MAIN CONTROL ASSY

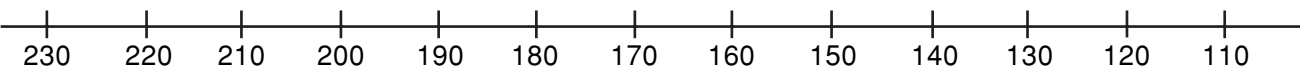
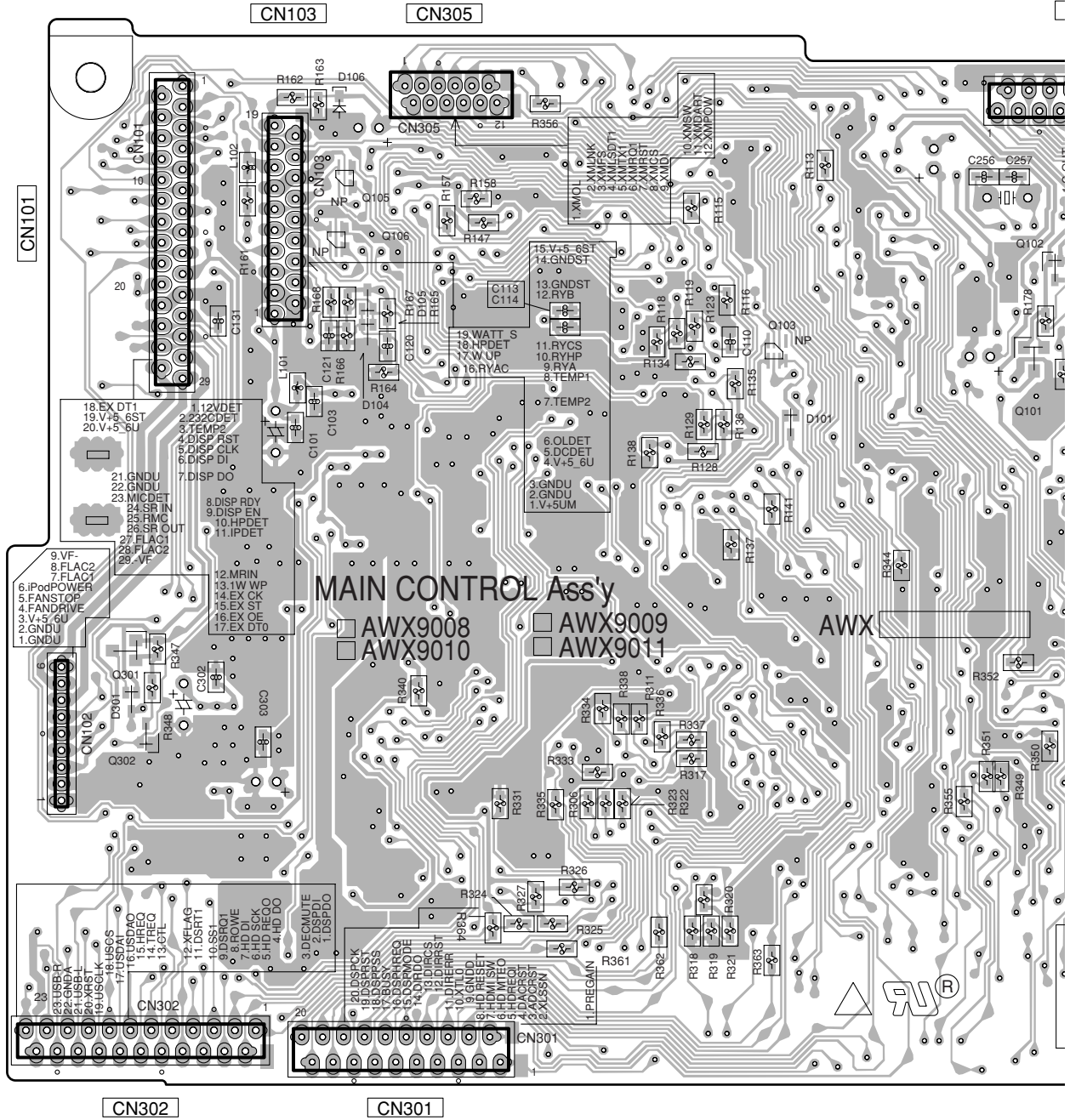

C

SIDE B

A

B

C

D

E

F

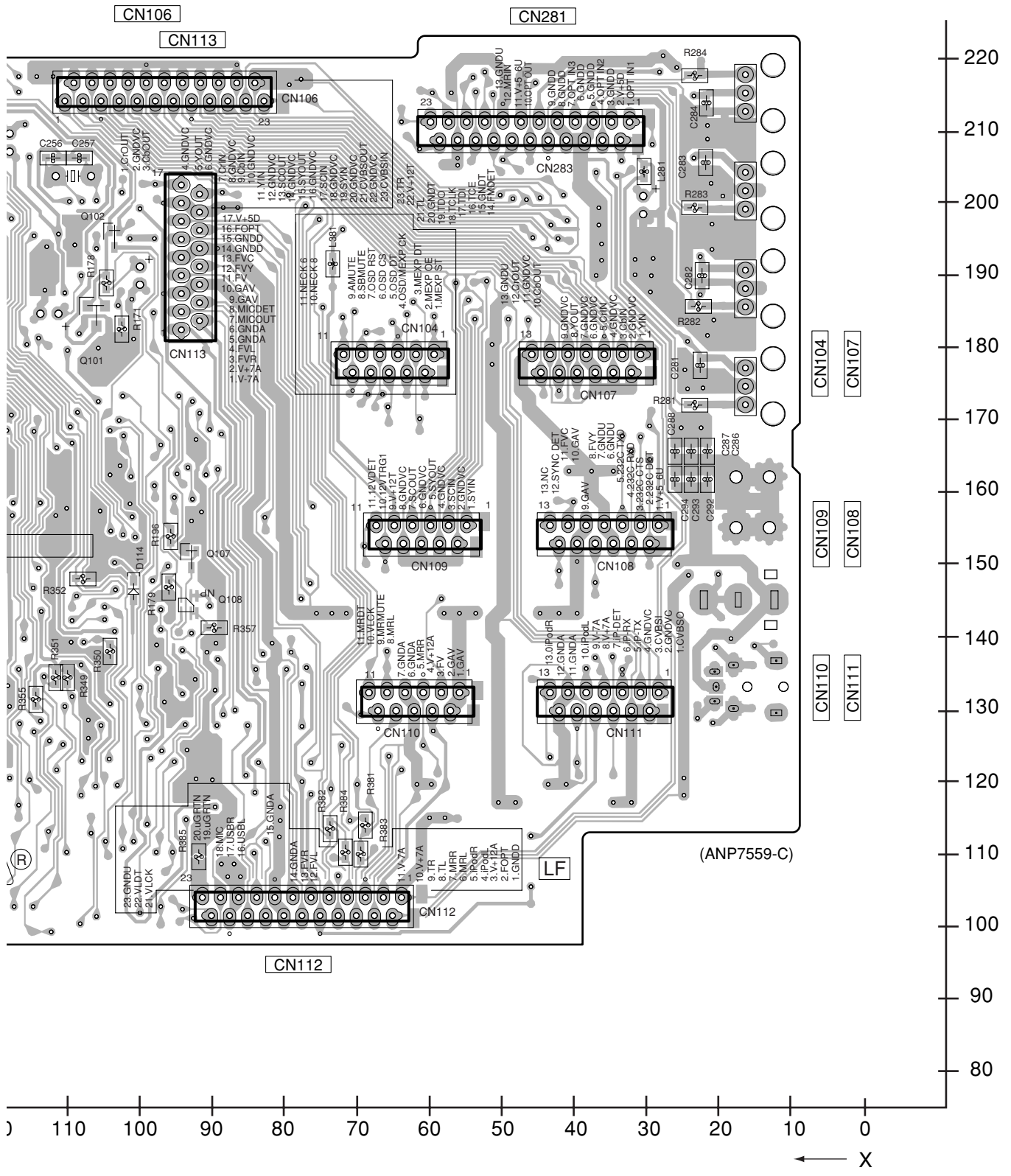



**SIDE A**

A

B

C

D

E

F

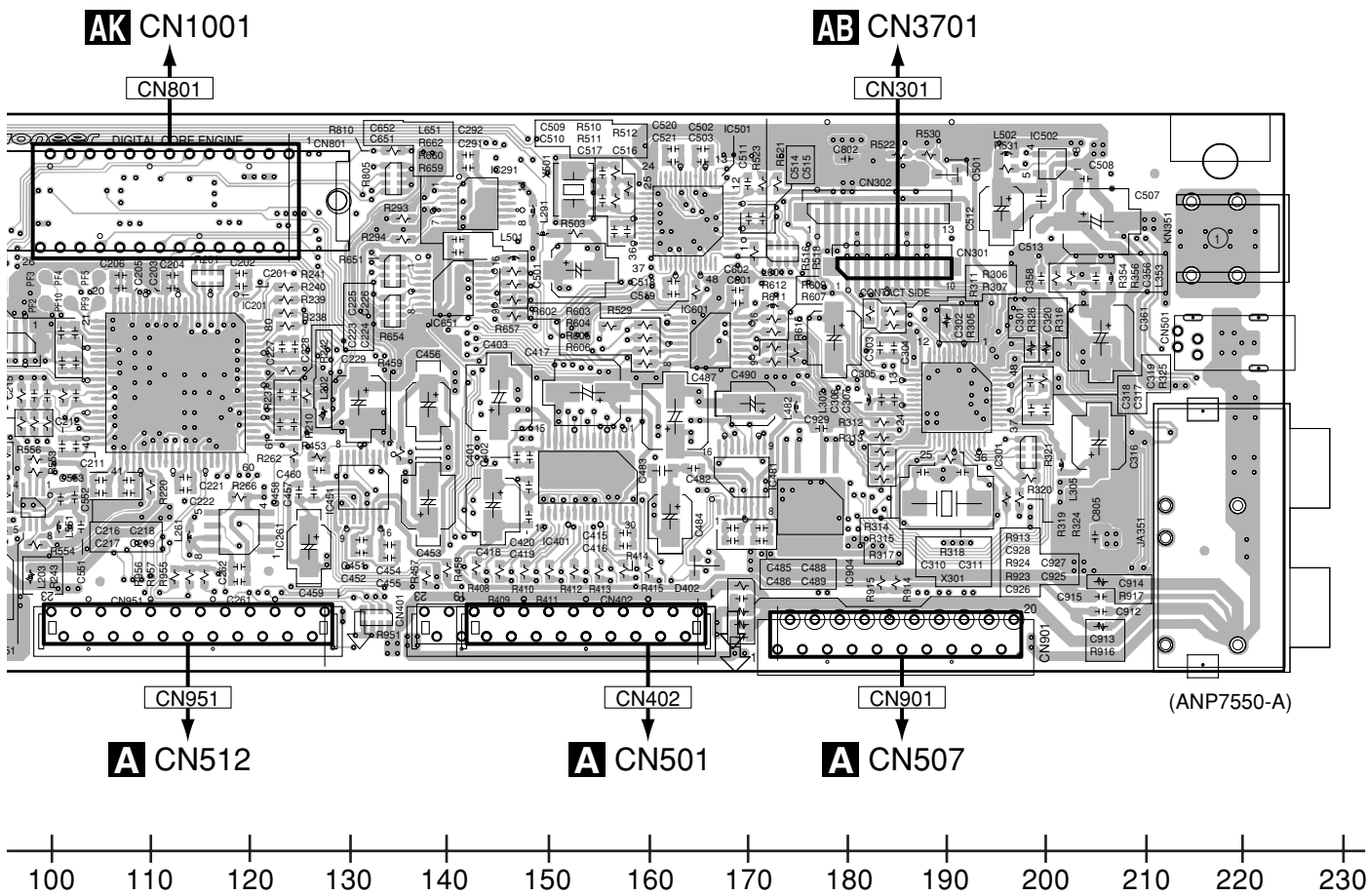

SIDE B

A

B

C

D

E

F

# G DSP ASSY

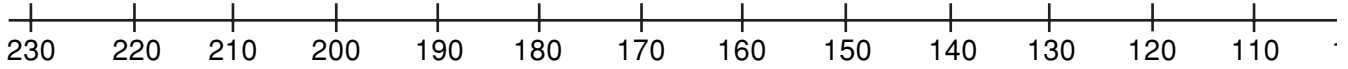
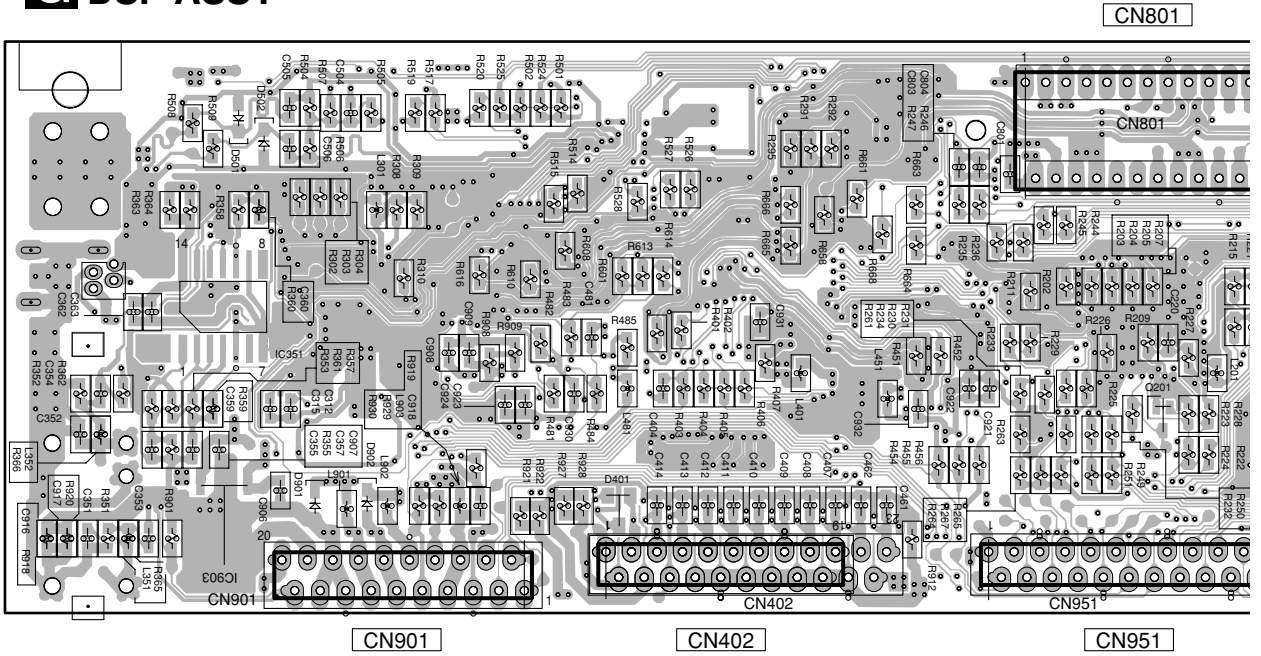



SIDE B

A

B

C

D

E

F

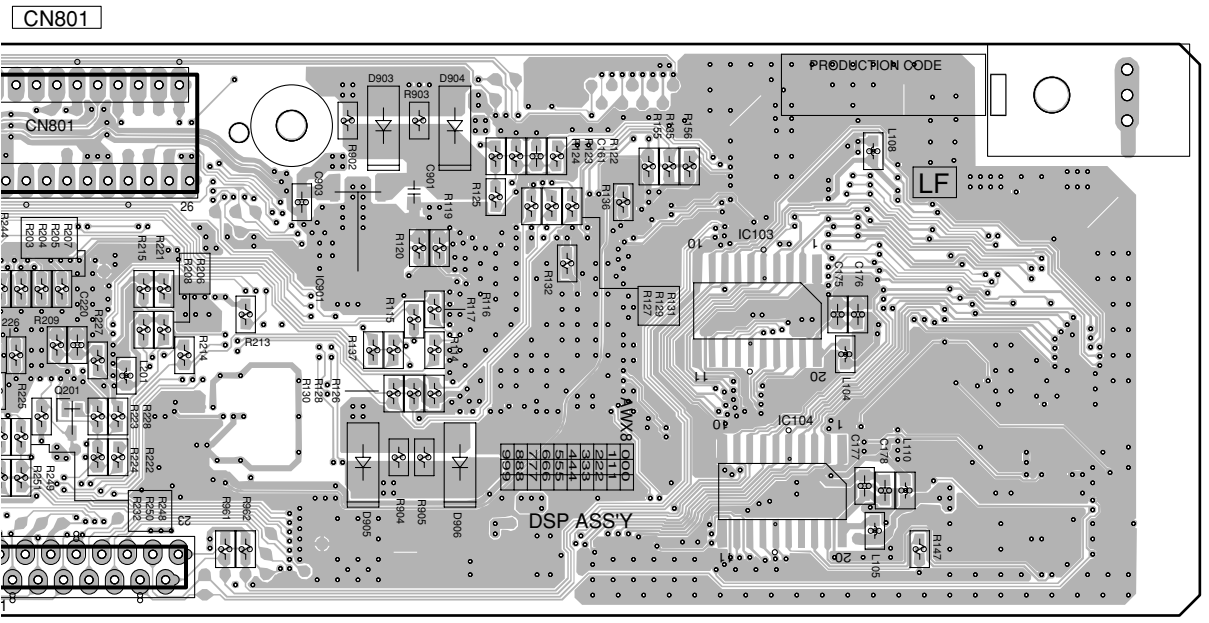

(ANP7550-A)

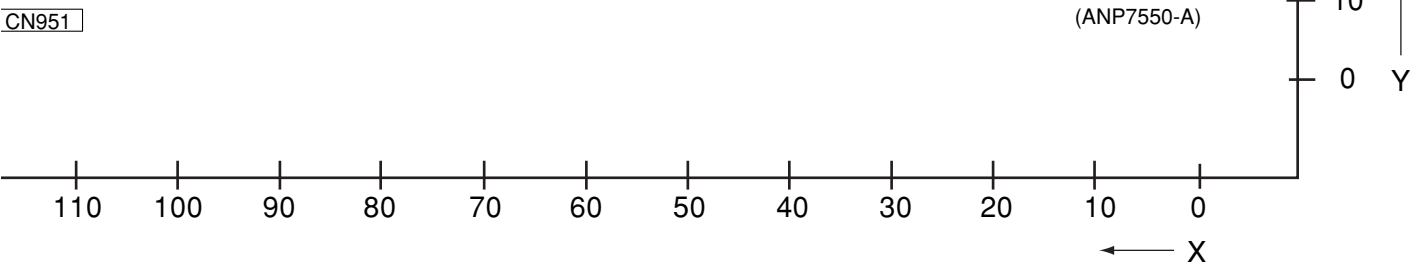





SIDE B

# H COMPOSITE ASSY

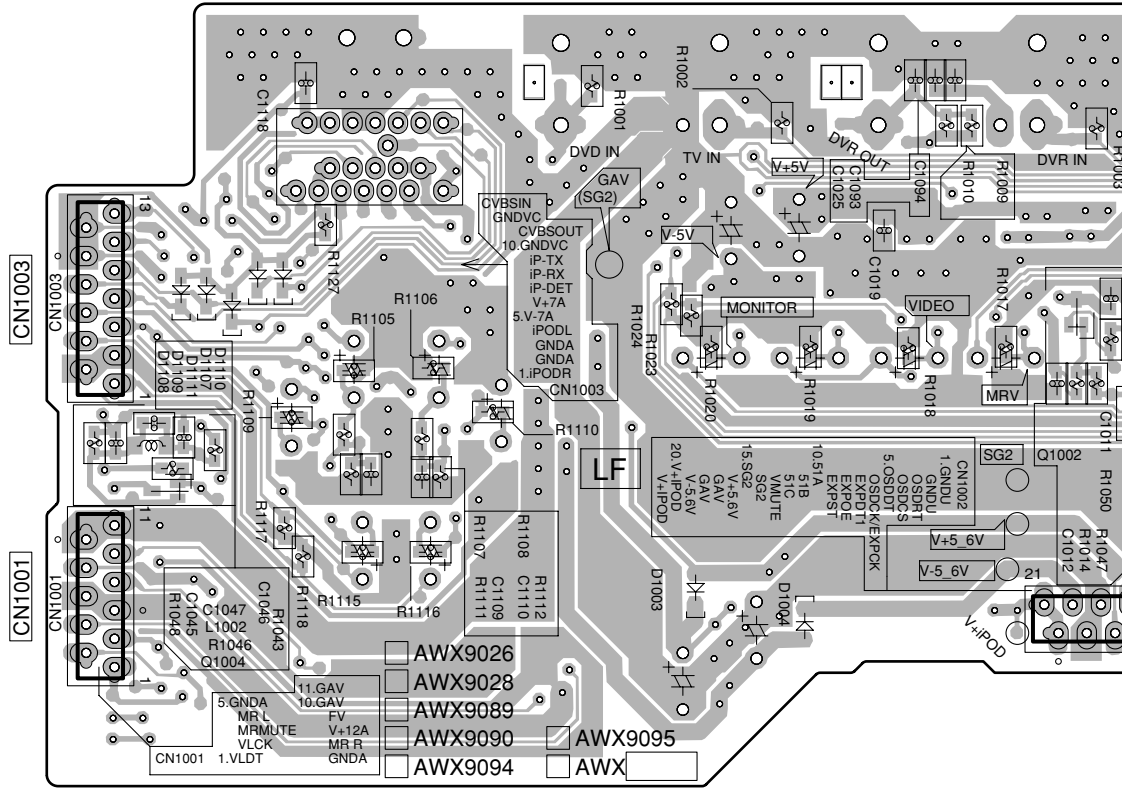

(ANP7561-B)

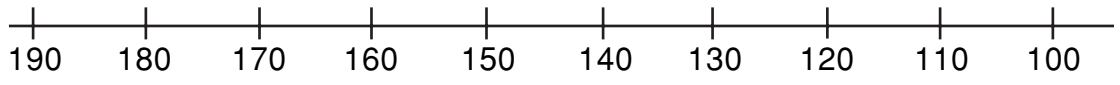

A  
B  
C  
D  
E  
F



**SIDE B**

A

B

C

D

E

F

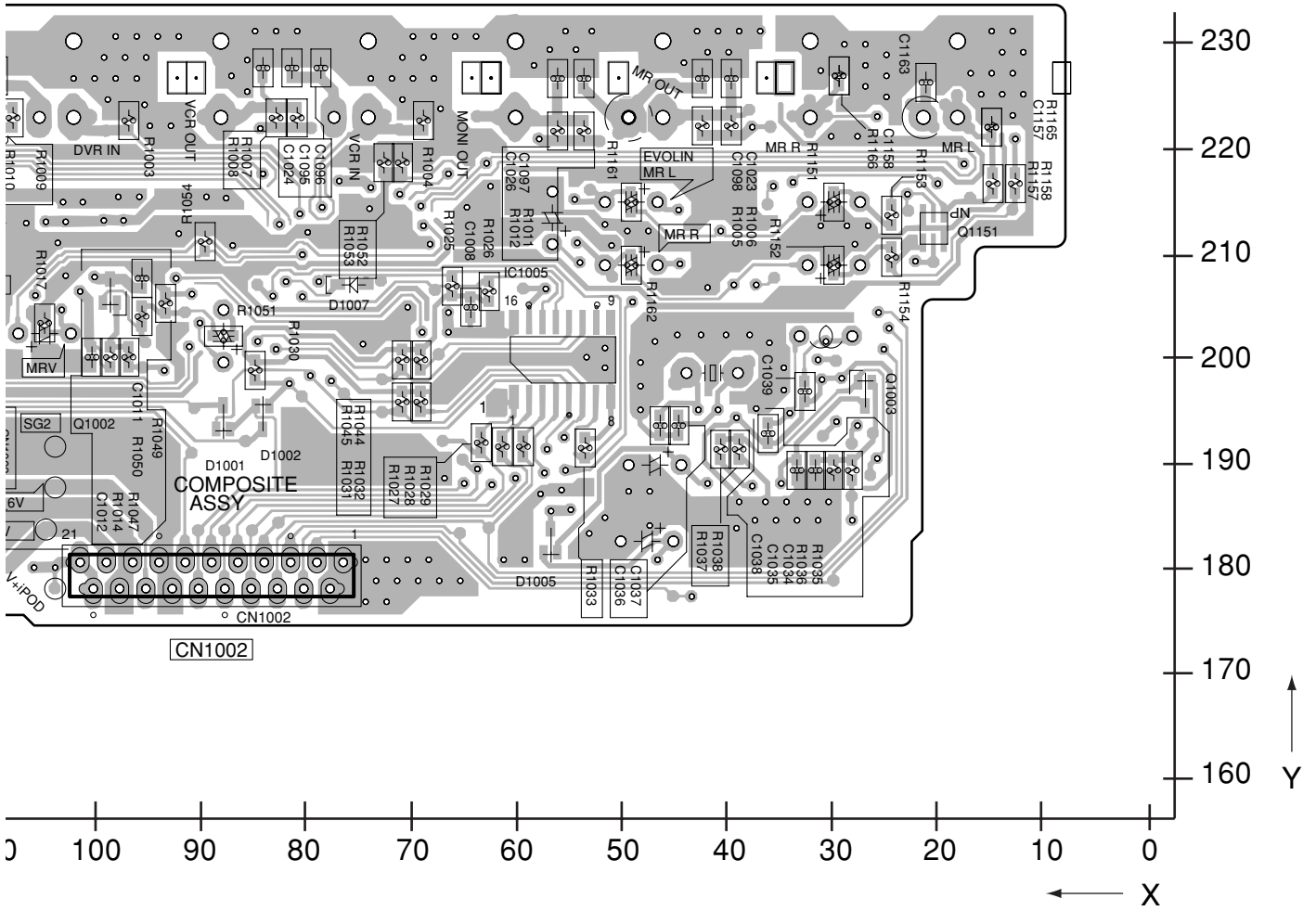

# 4.7 S-VIDEO ASSY

**SIDE A**

## S-VIDEO ASSY

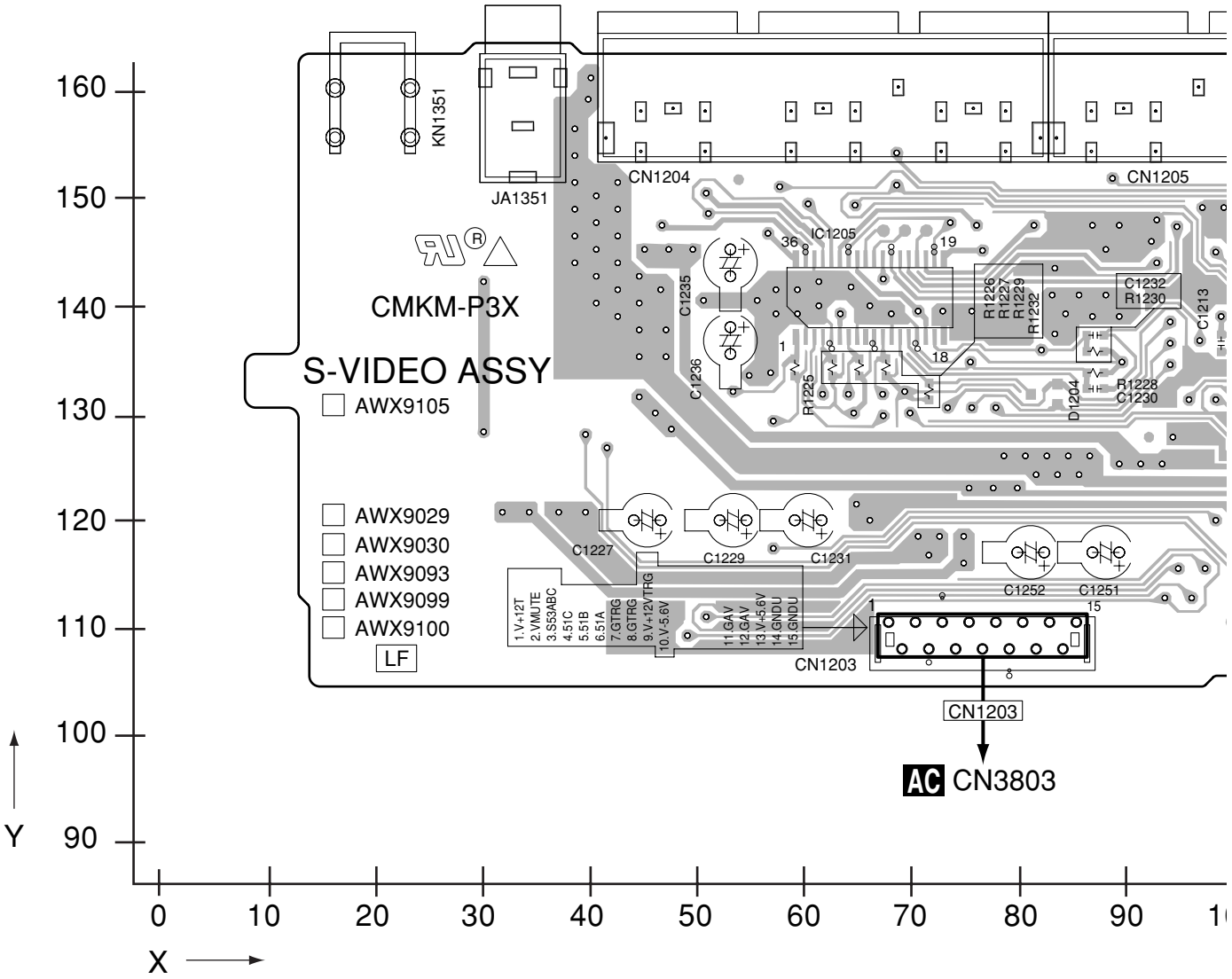



**SIDE B**

A

# S-VIDEO ASSY

B

C

D

E

F

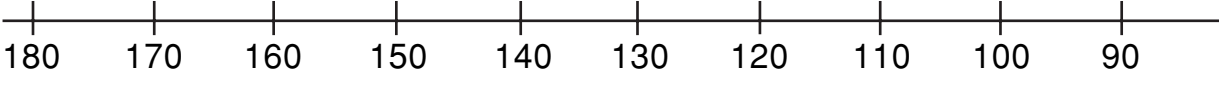
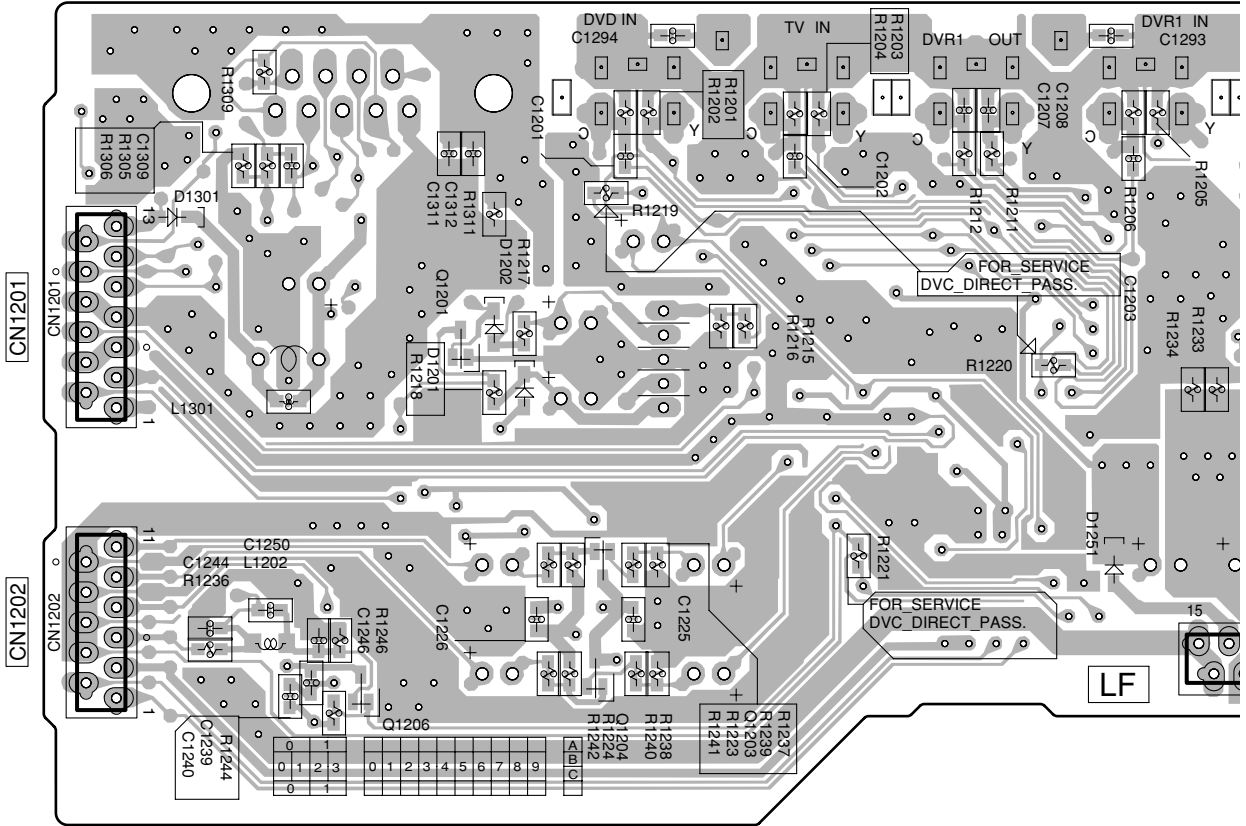



SIDE B

A

B

C

D

E

F

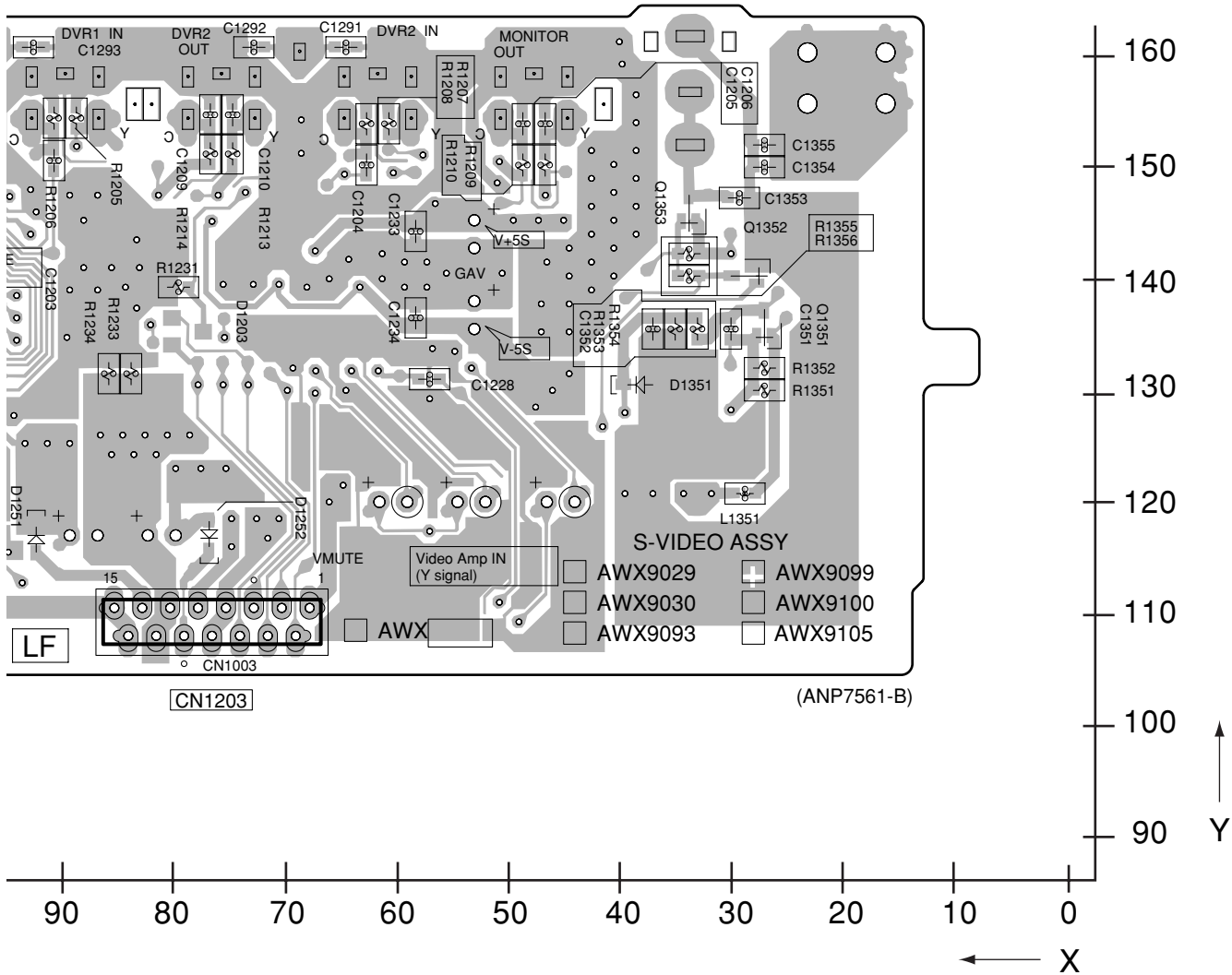

# 4.8 COMPONENT ASSY

**SIDE A**

## **K** COMPONENT ASSY

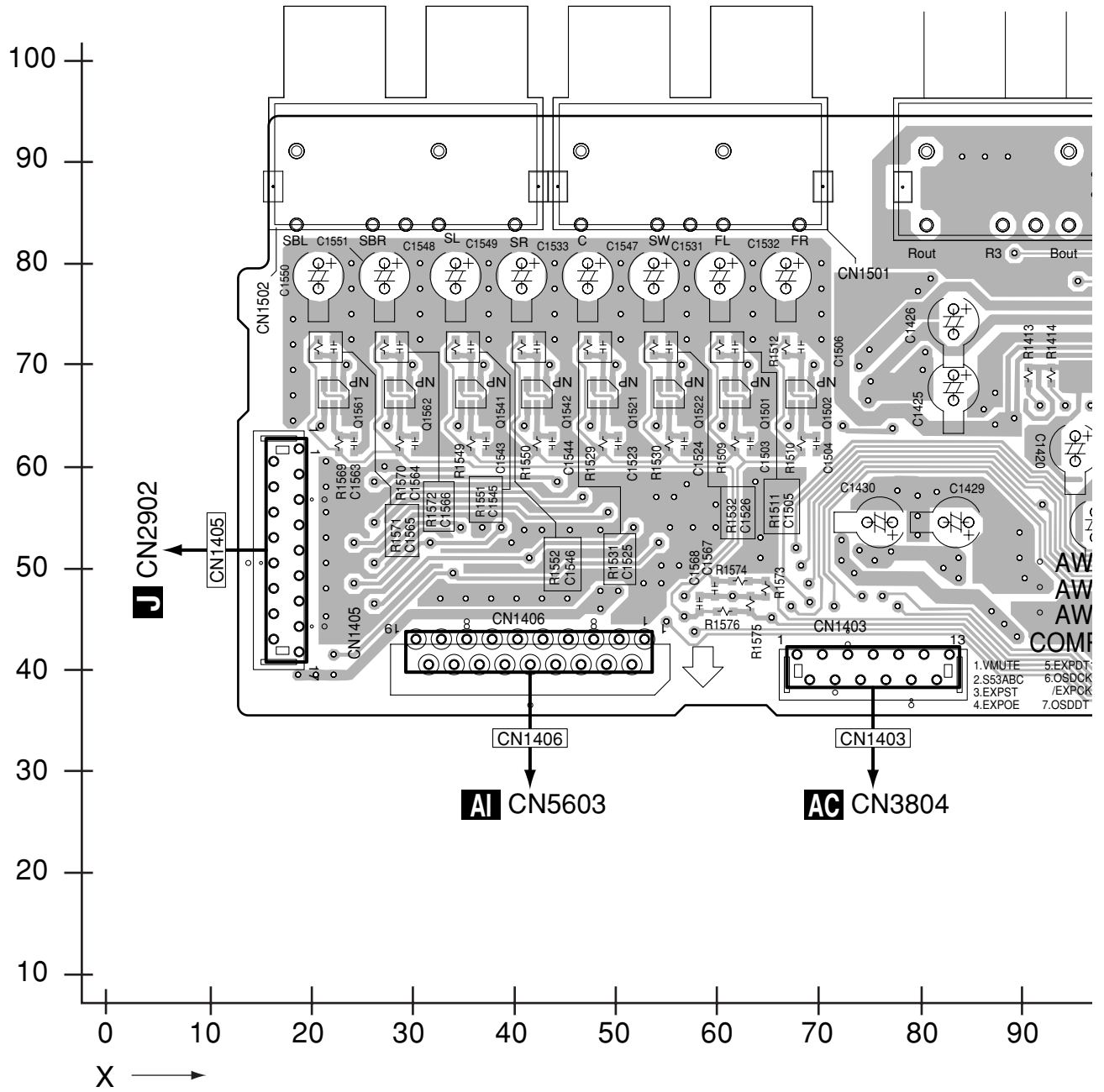

**K**

A

B

C

D

E

F

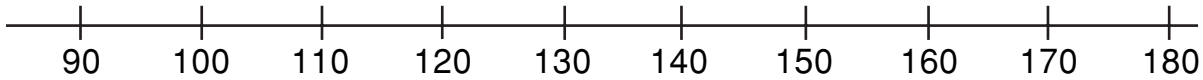
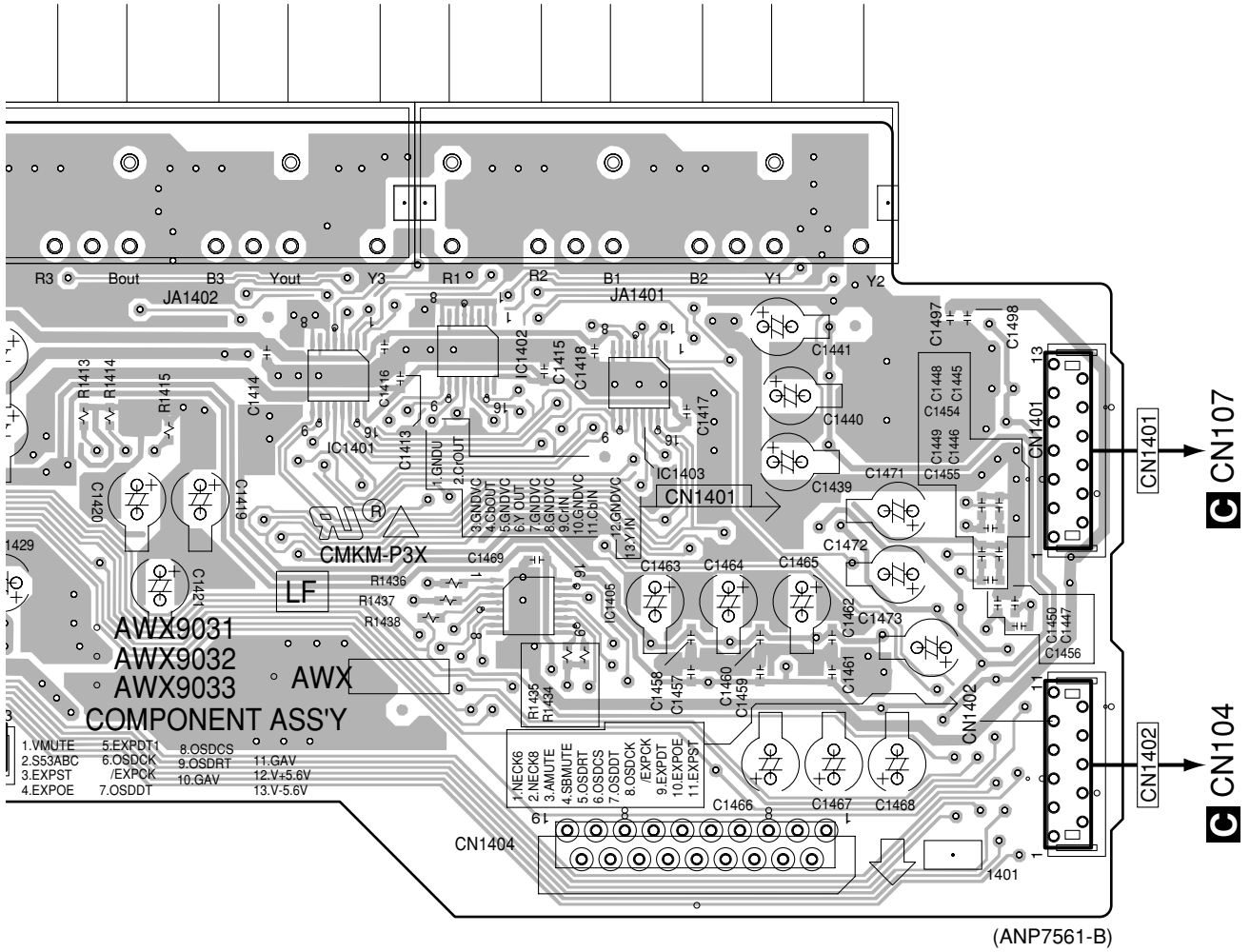

5

6

7

8

SIDE B

A

B

C

D

E

F

# K COMPONENT ASSY

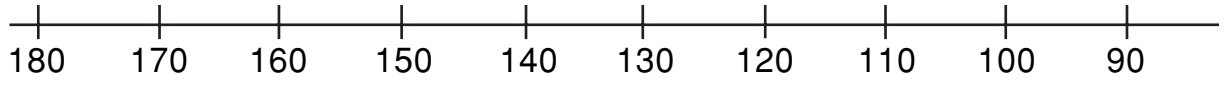
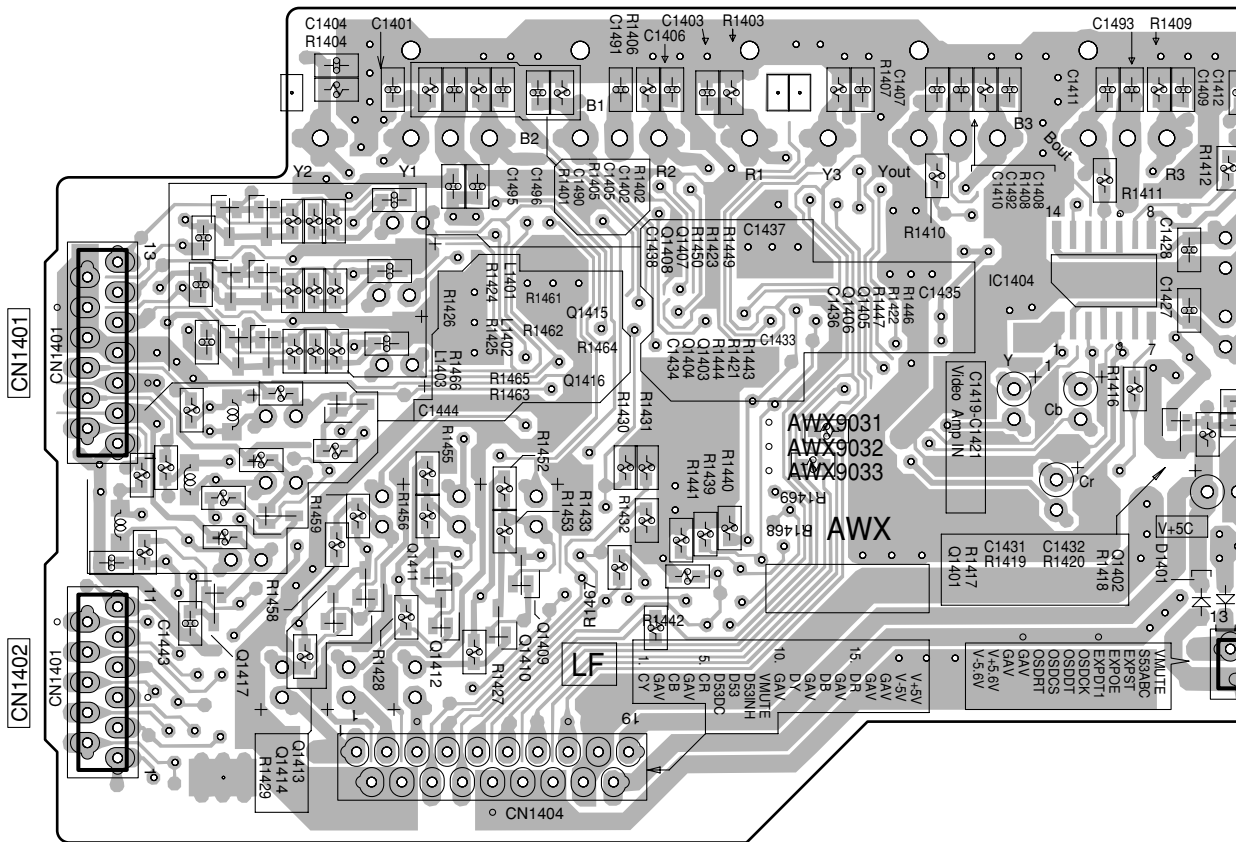

SIDE B

A  
B  
C  
D  
E  
F

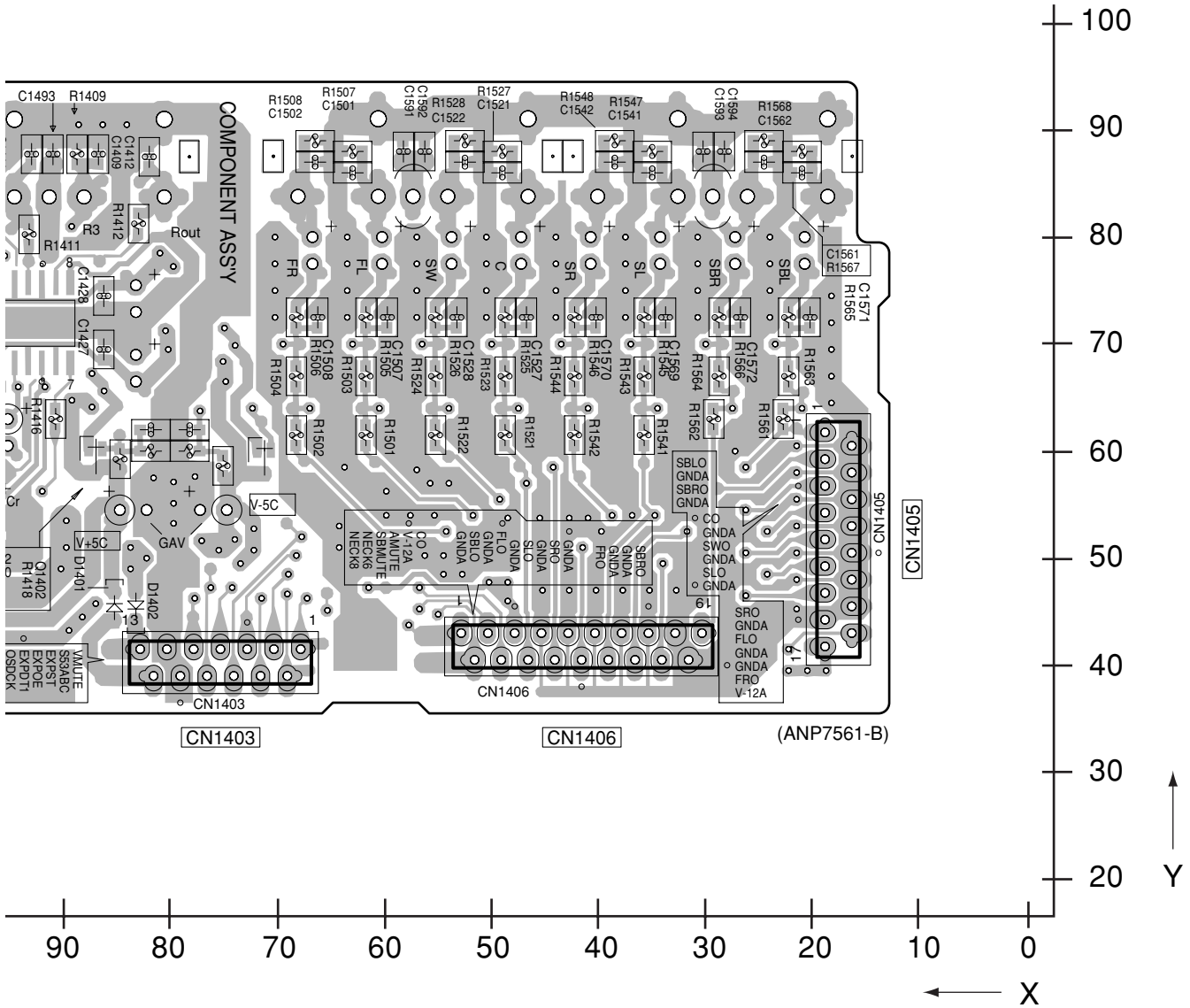





SIDE B

# DISPLAY ASSY

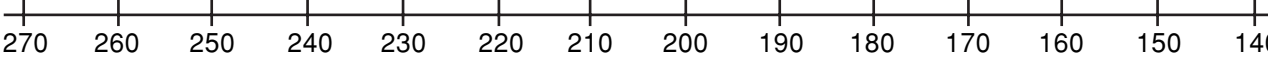
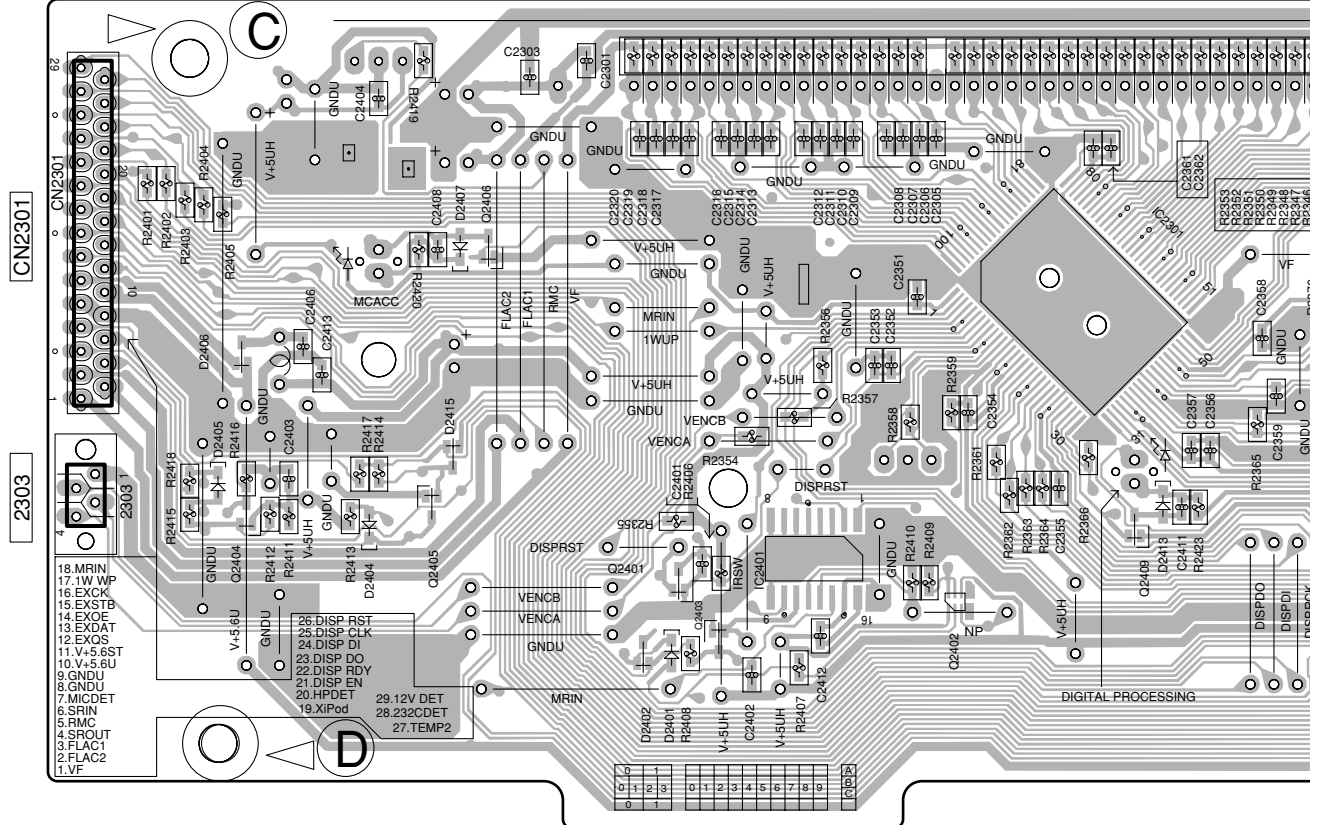





# 4.10 VOLUME ASSY

**SIDE A**

**SIDE A**

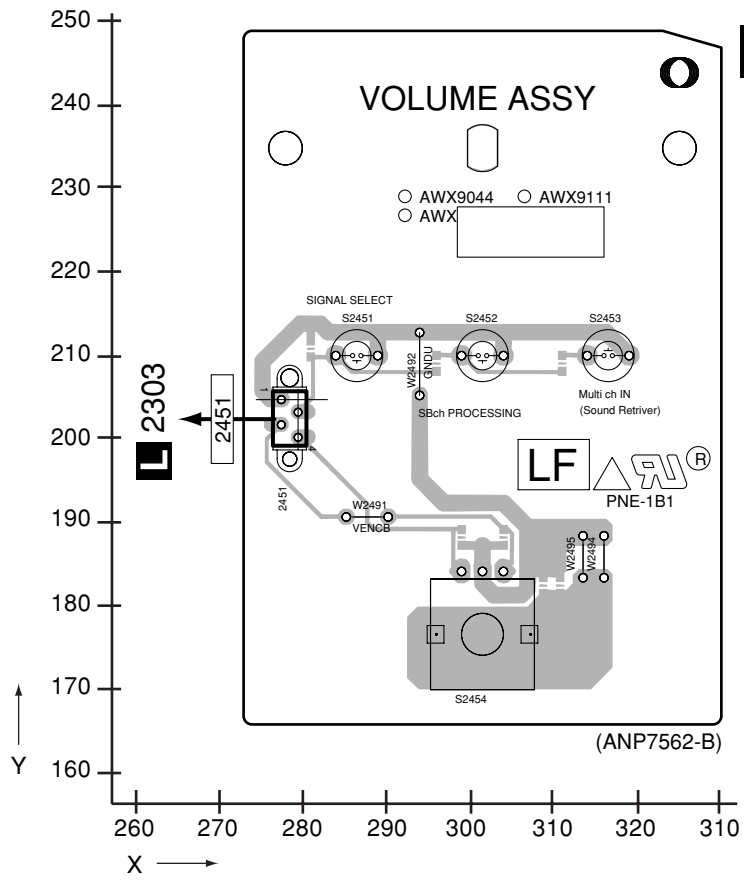

**M** VOLUME ASSY

**SIDE B**

**SIDE B**

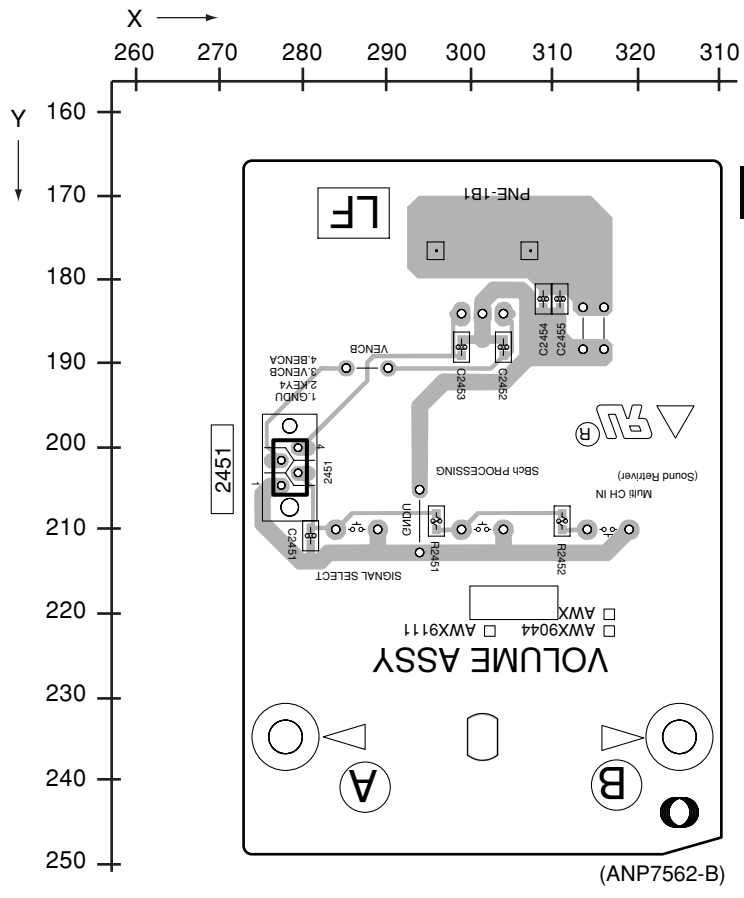

**M** VOLUME ASSY

4.11 HEADPHONE ASSY

SIDE A

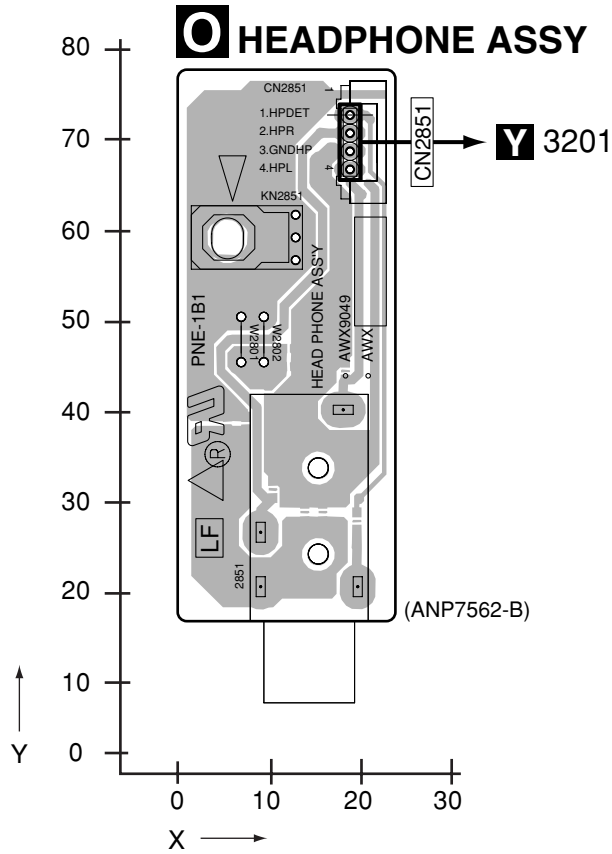

SIDE A

SIDE B

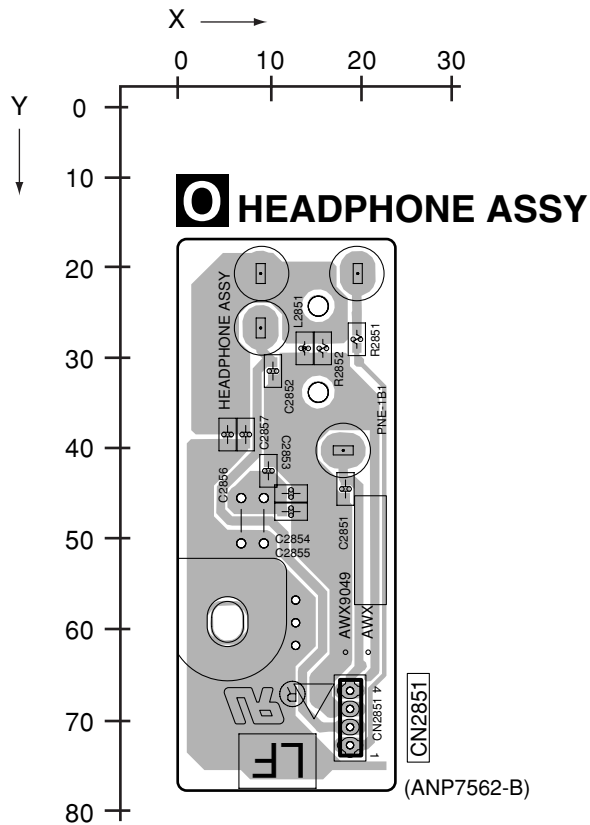

SIDE B



# 4.12 MULTIJOG ASSY

**SIDE A**

## MULTI JOG ASSY

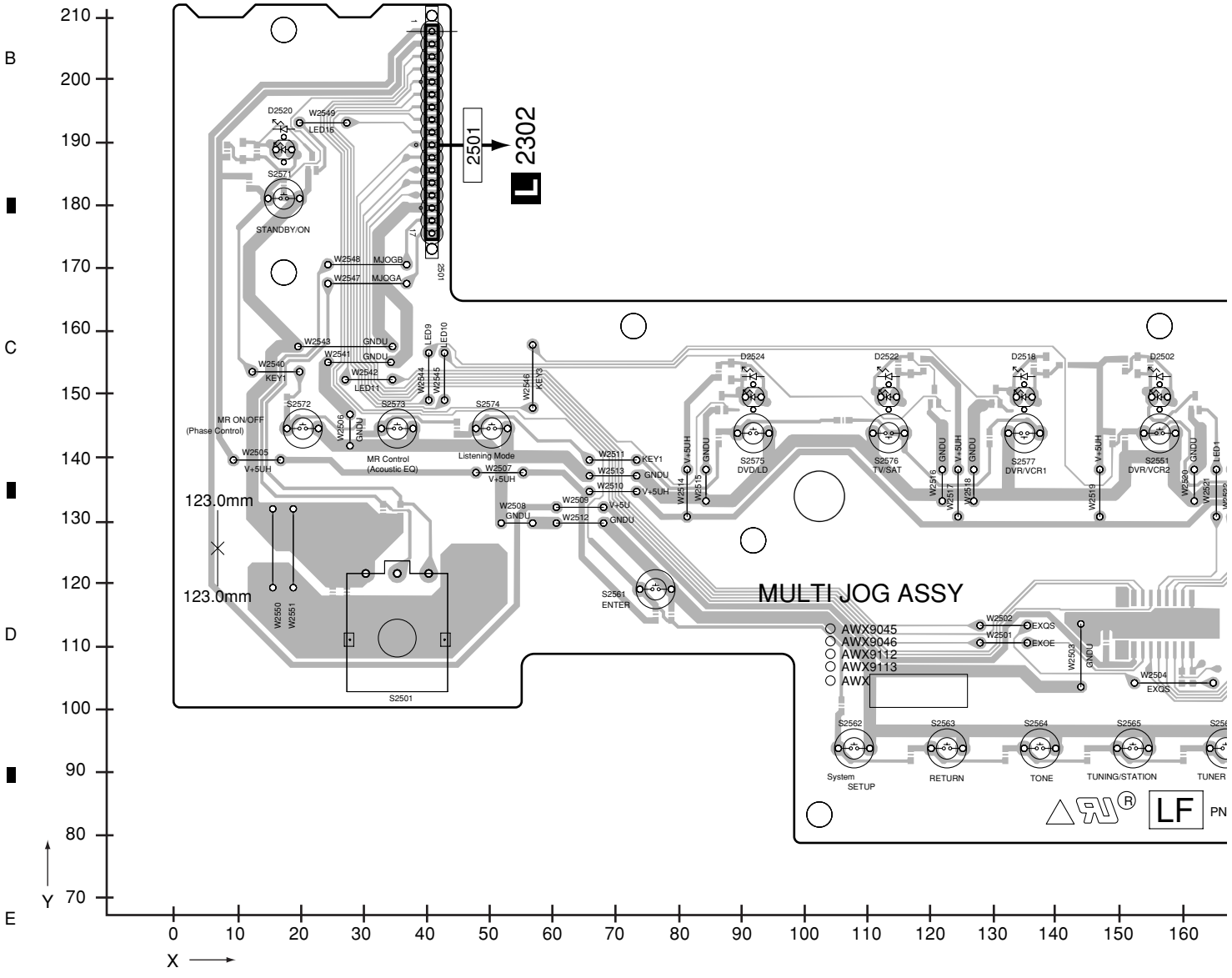

SIDE A

A

B

C

D

E

F

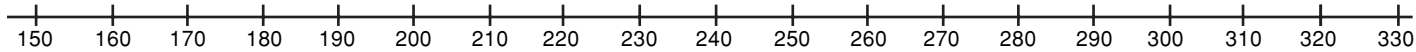
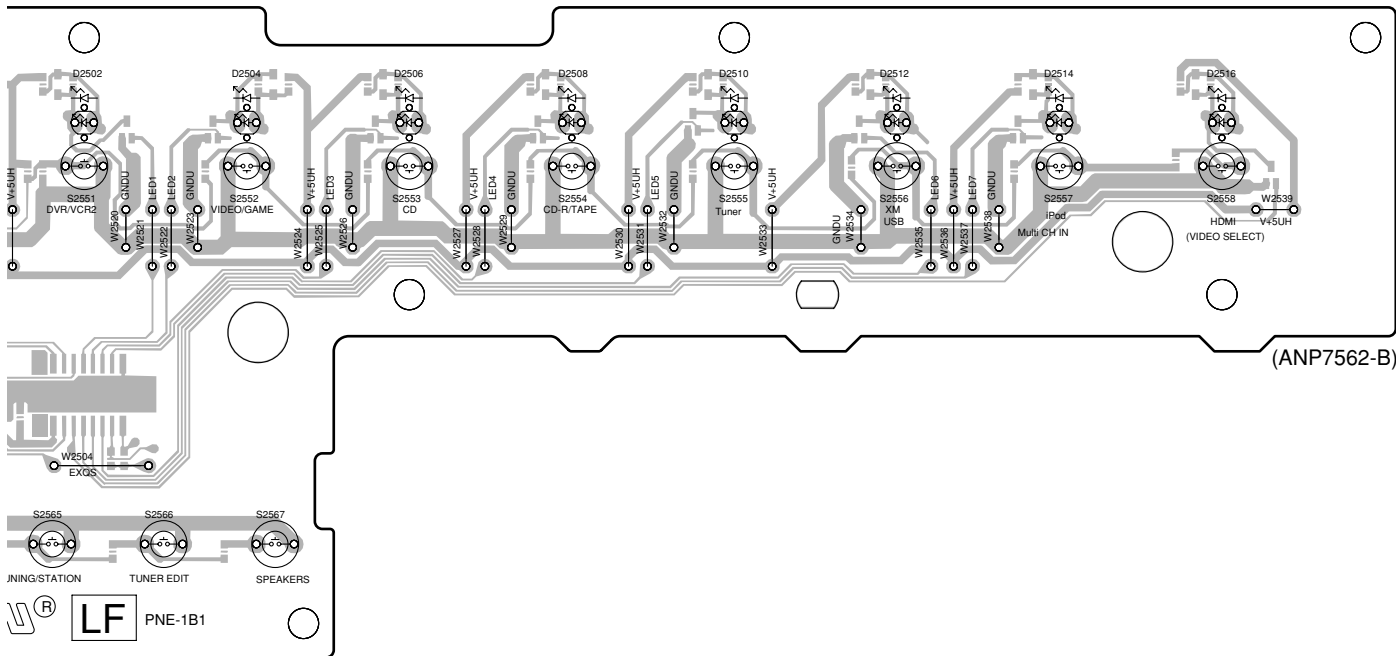

**SIDE B**

A

B

# **N** MULTI JOG ASSY

C

D

E

F

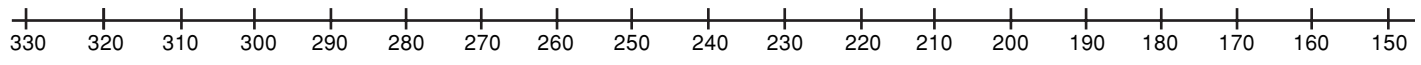
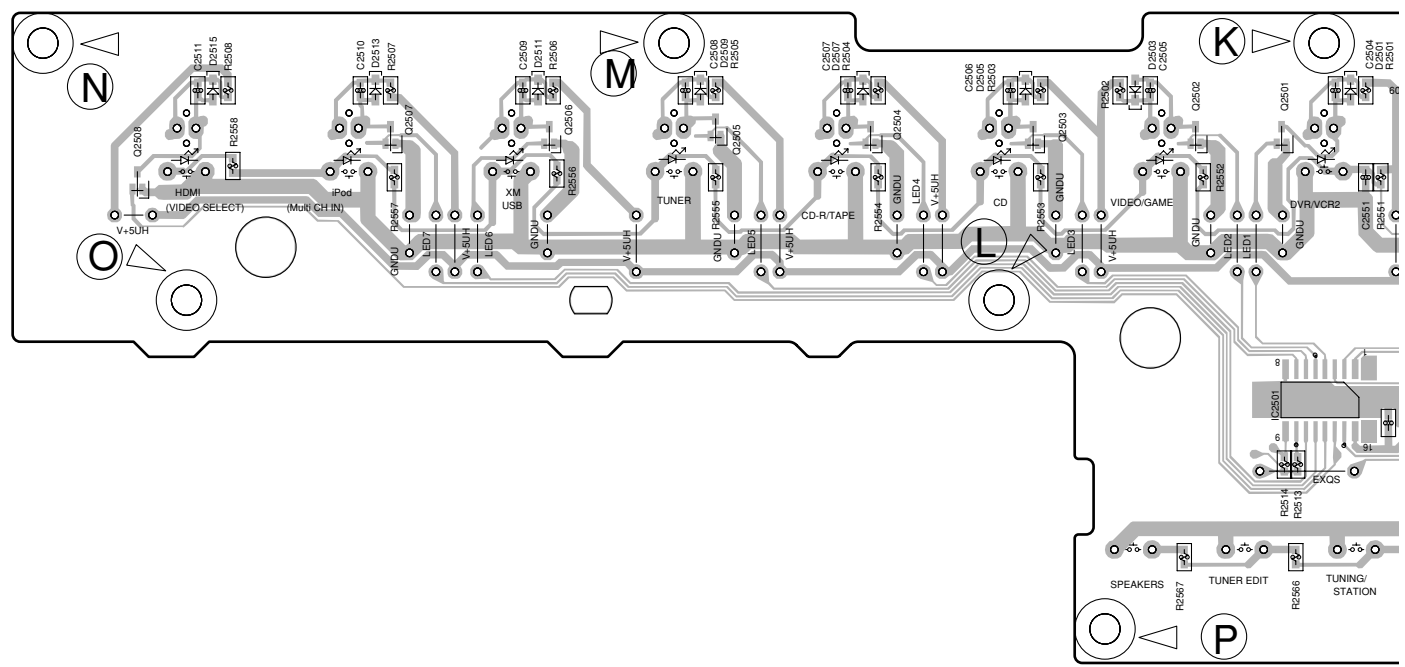



# 4.13 FRONT IN ASSY

**SIDE A**

## **P** FRONT-IN ASSY

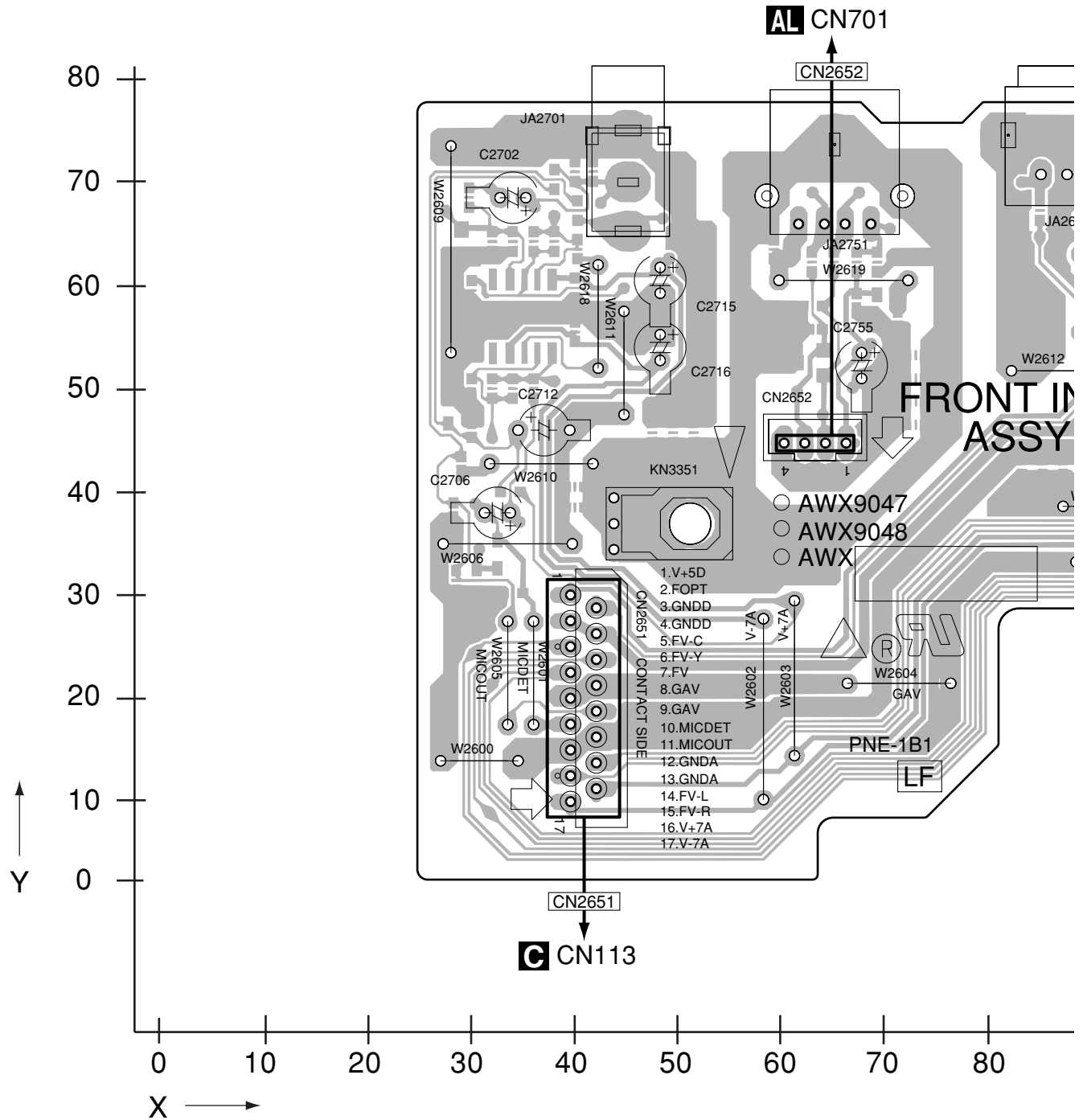

**P**



**SIDE A**

A

B

C

D

E

F

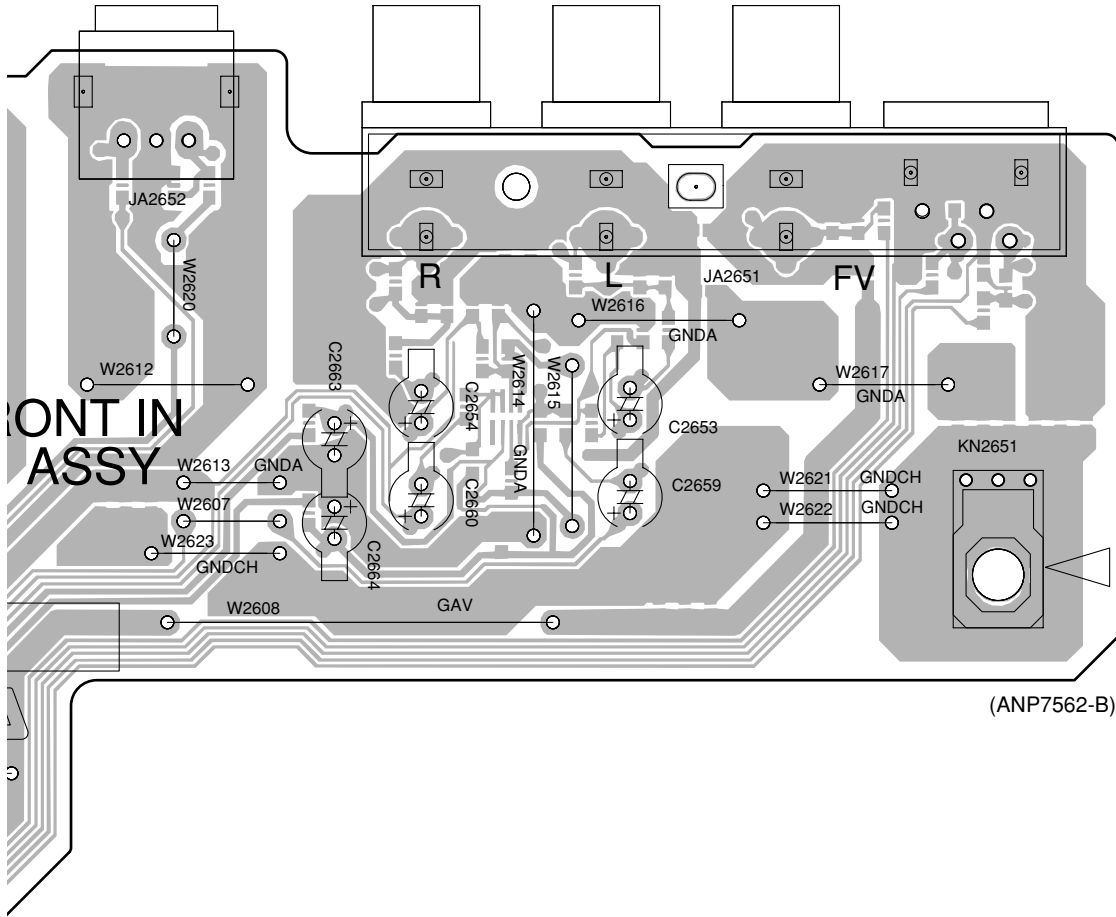

(ANP7562-B)

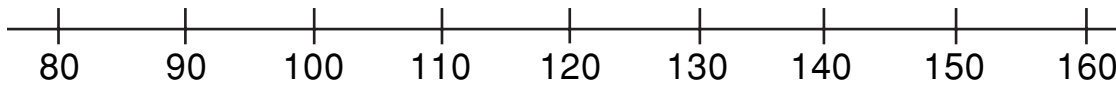

SIDE B

**P** FRONT-IN ASSY

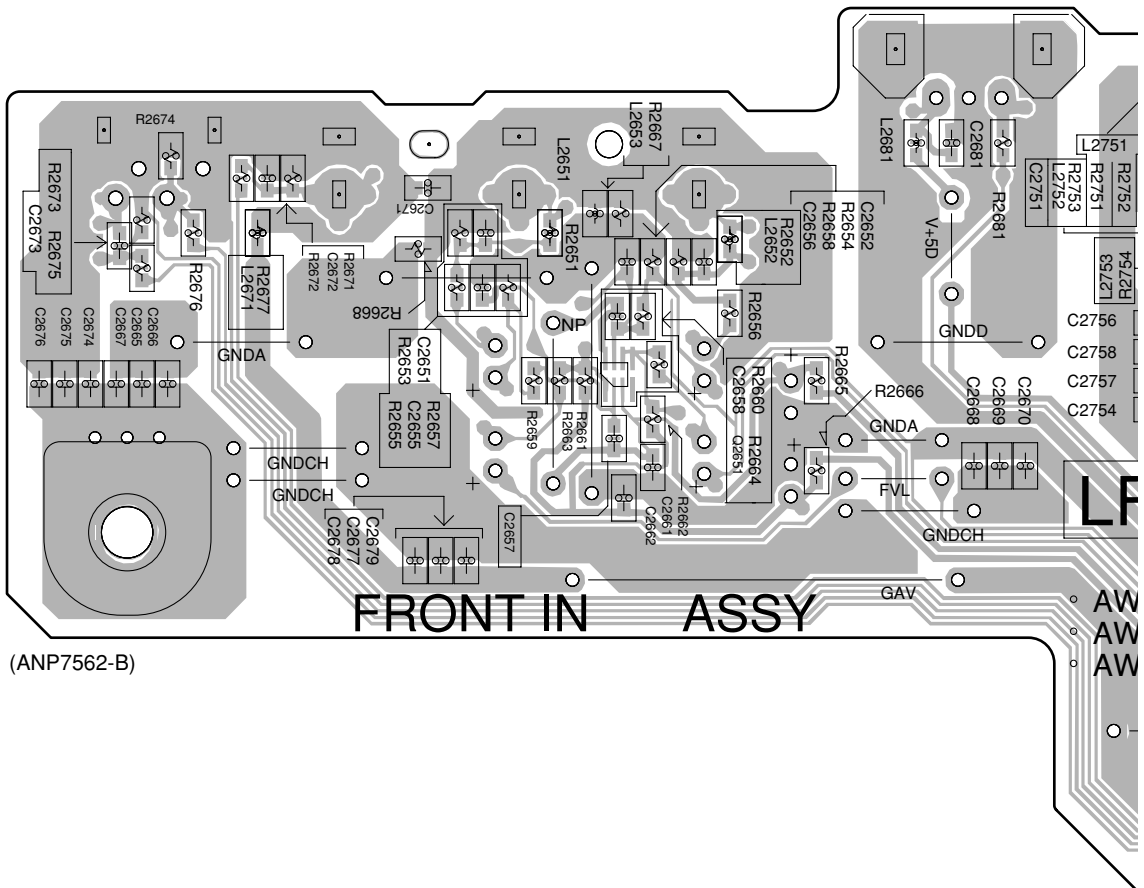

(ANP7562-B)

FRONT IN ASSY

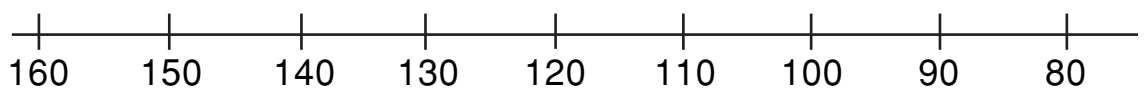

**P**

**SIDE B**

A

B

C

D

E

F

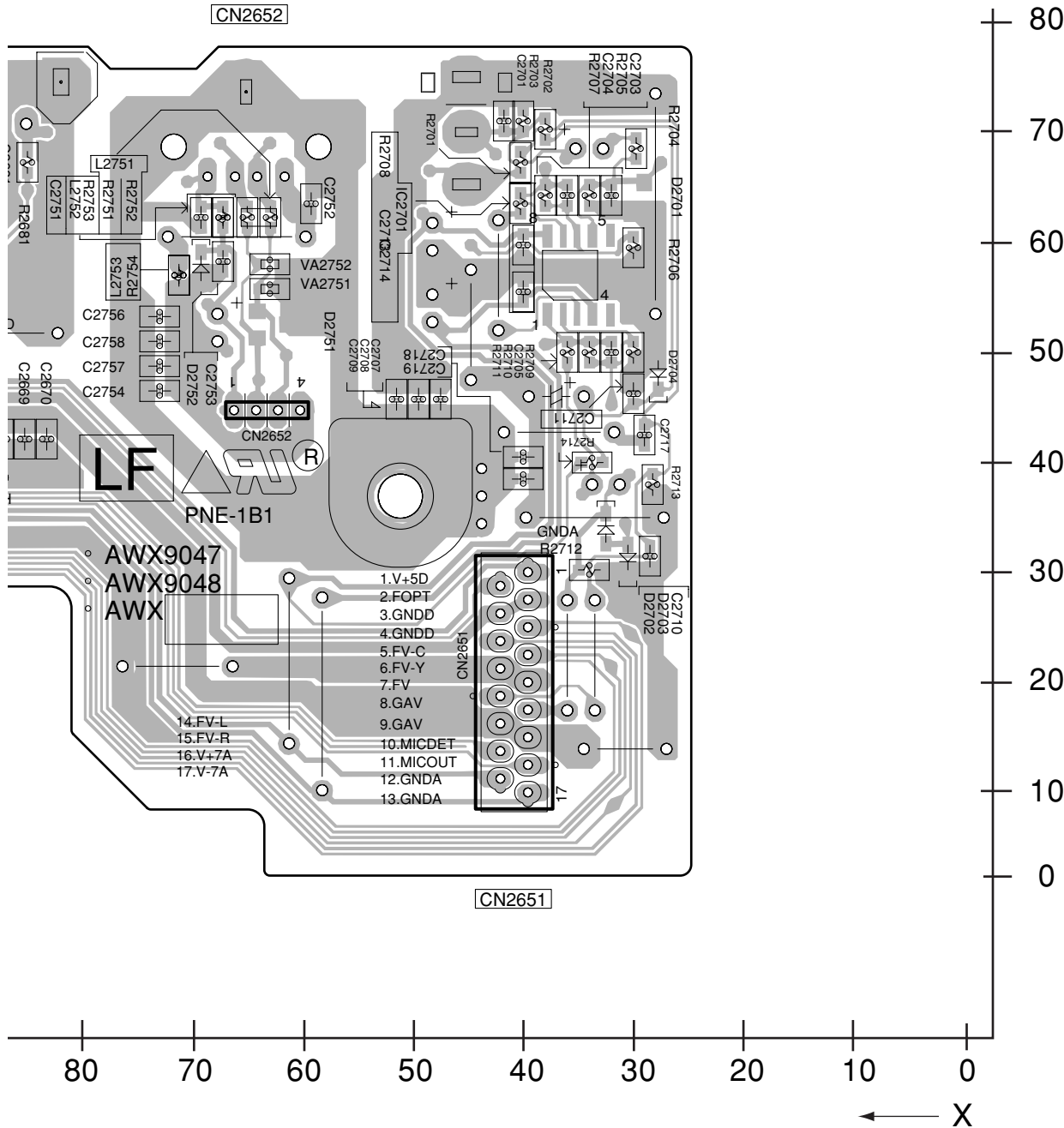

1 2 3 4

# 4.14 PRIMARY ASSY

**SIDE A**

## **Q** PRIMARY ASSY

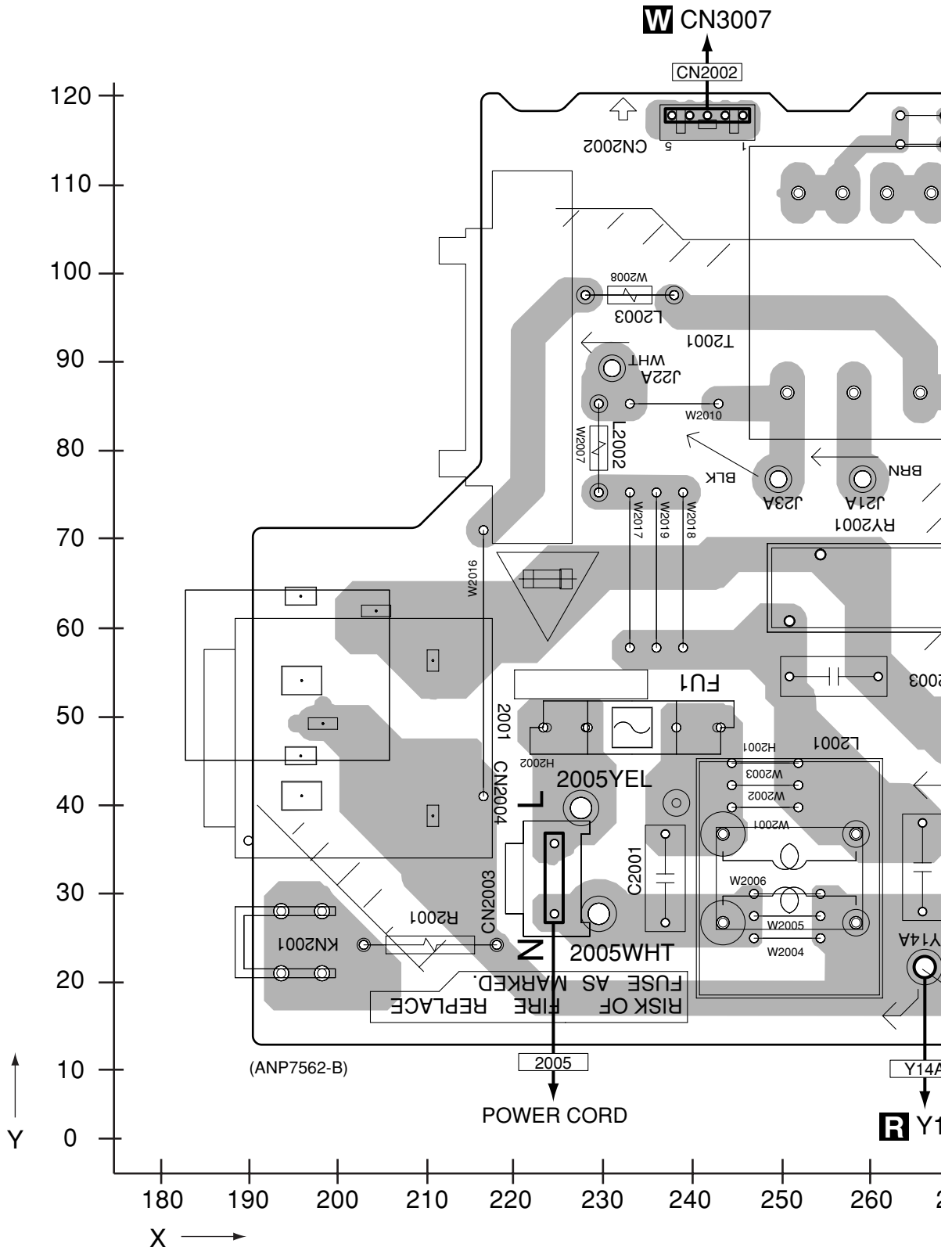



**SIDE B**

**Q PRIMARY ASSY**

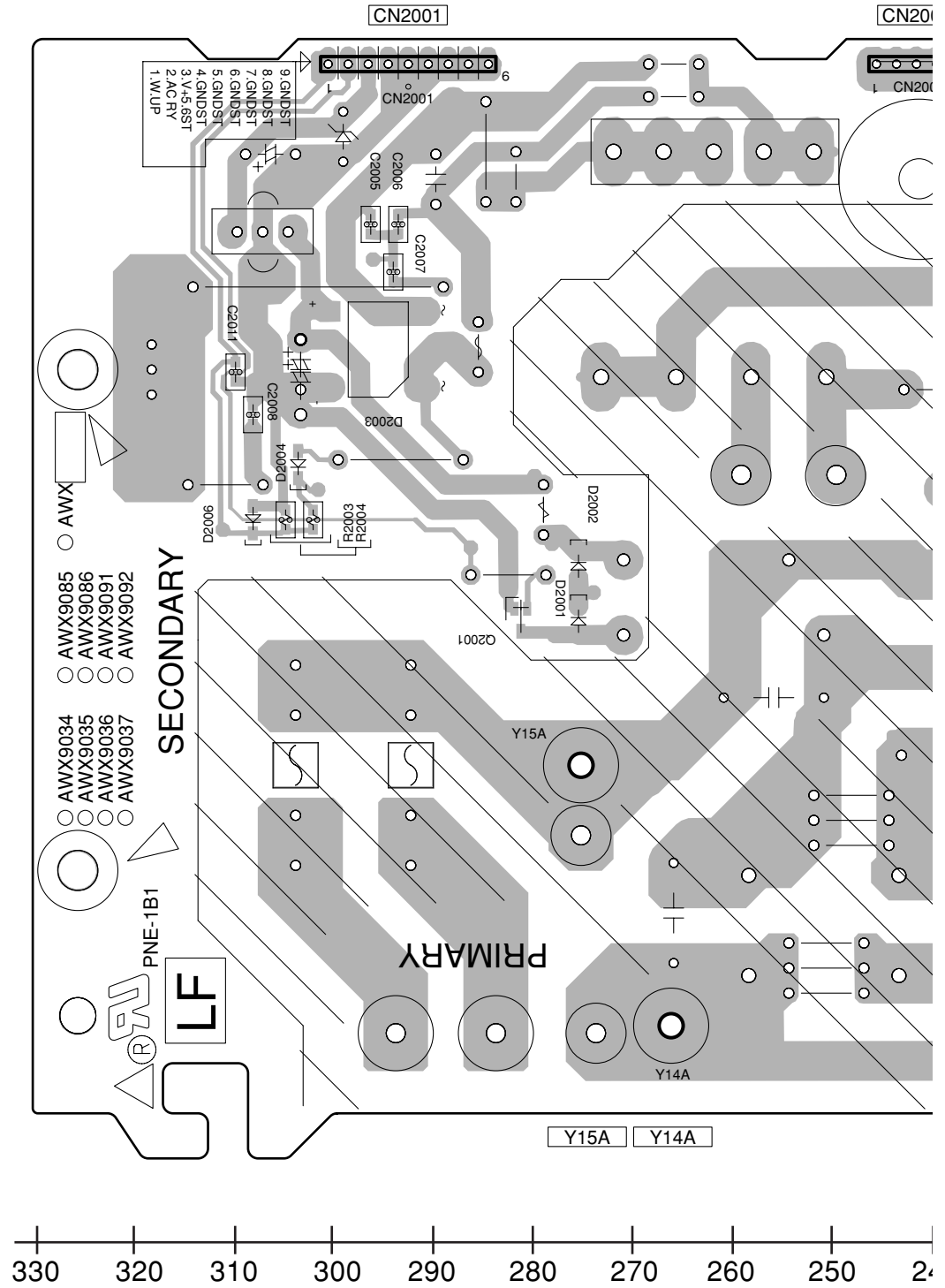

330 320 310 300 290 280 270 260 250 240

A  
B  
C  
D  
E  
F

**Q**

**SIDE B**

A  
B  
C  
D  
E  
F

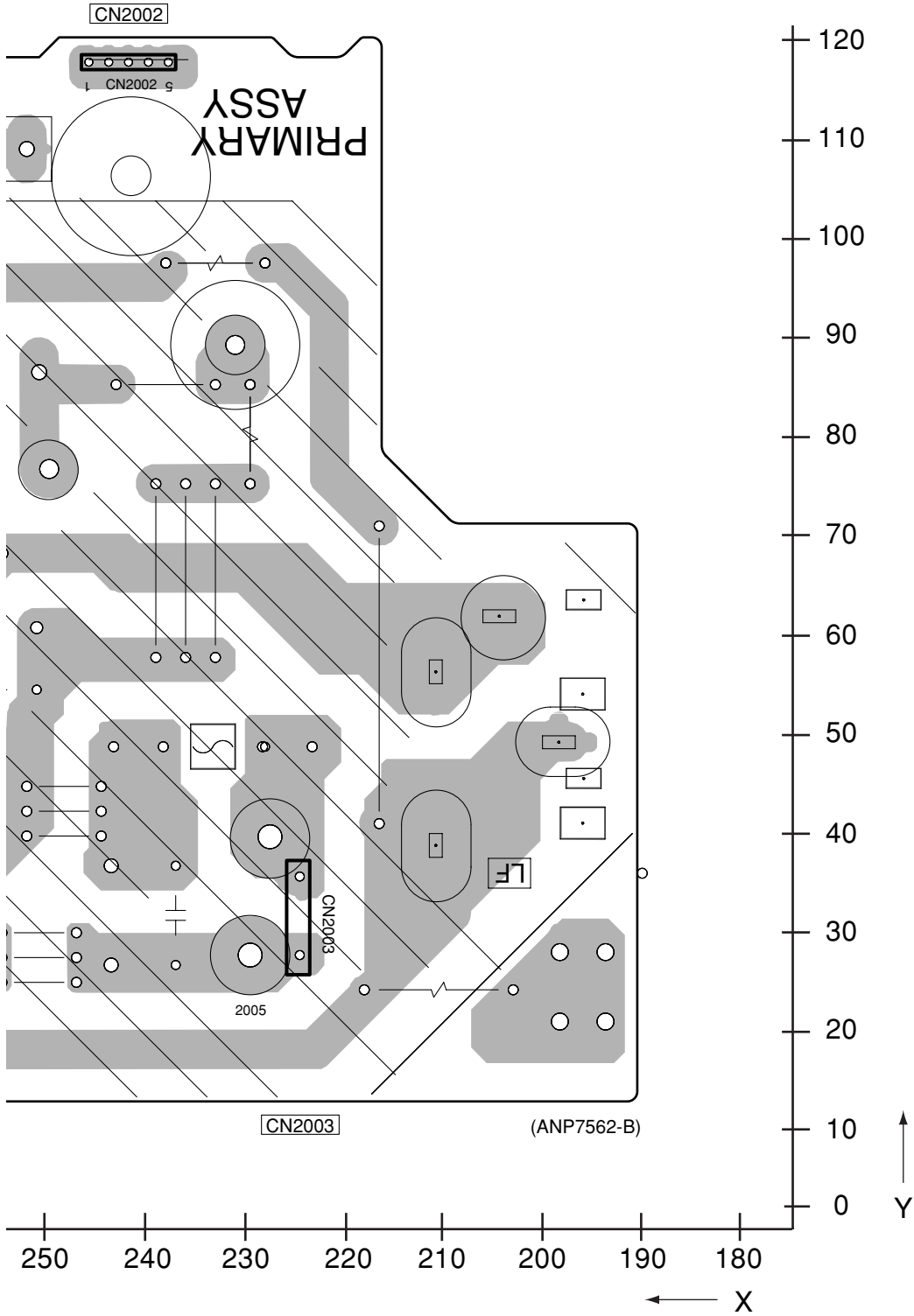

# 4.15 TRANS 1 ASSYS

**SIDE A**

**SIDE A**

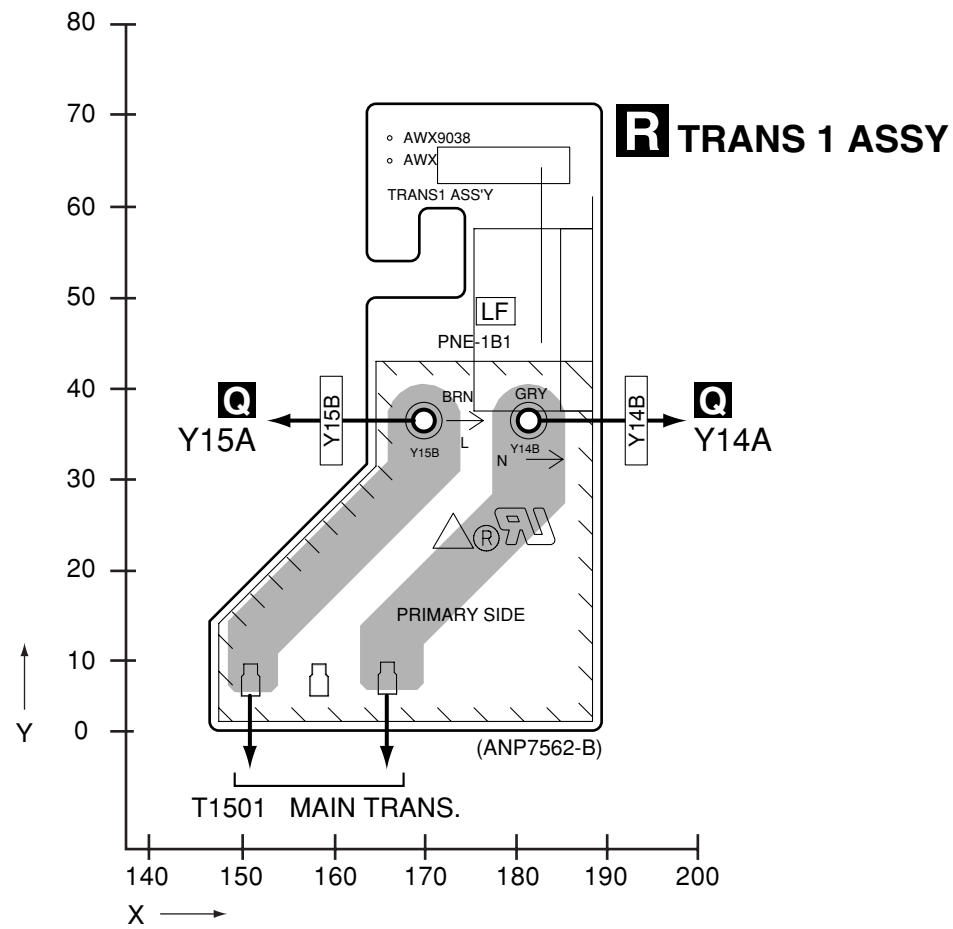

**SIDE B**

**SIDE B**

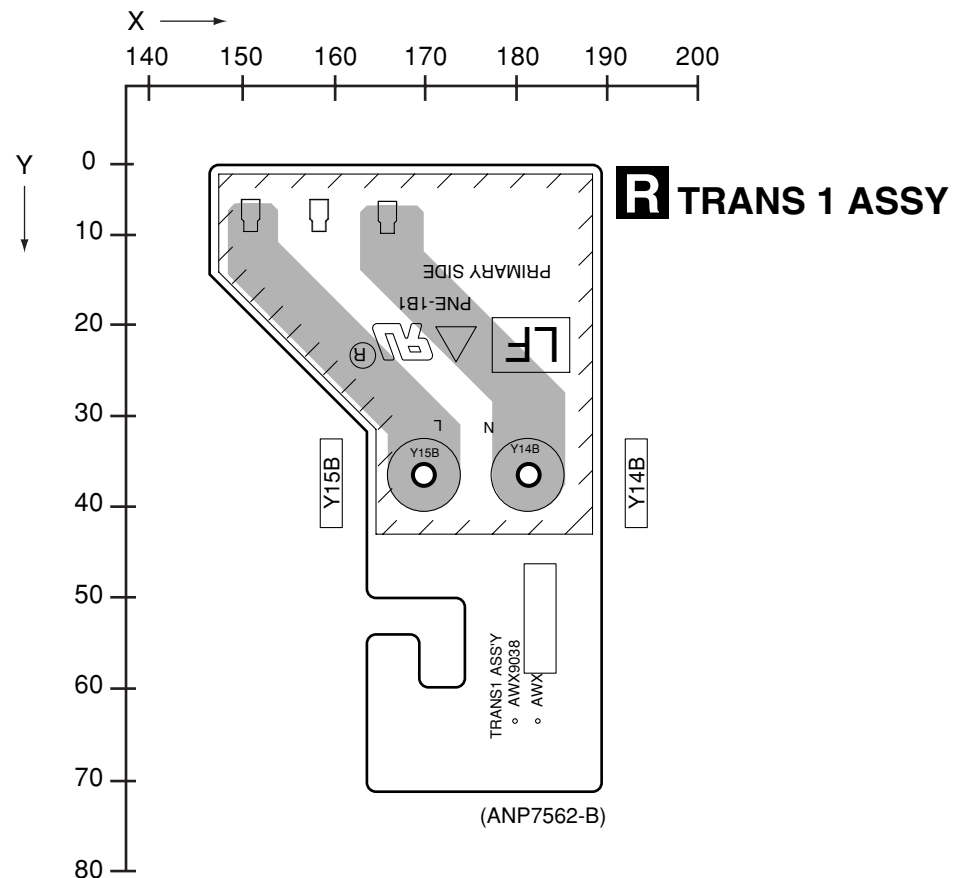

**R**

**R**



# 4.16 TRANS 2-1 ASSY

**SIDE A**

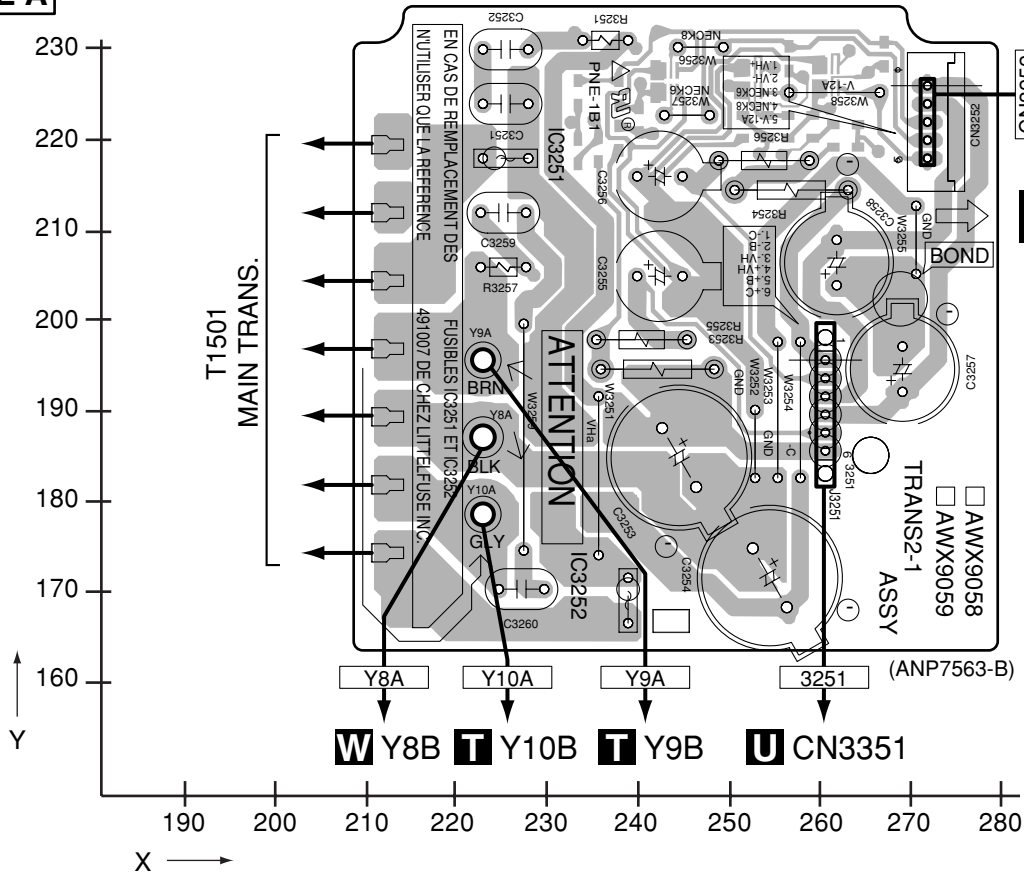

**SIDE A**

**A** 5604  
**S** TRANS 2-1 ASSY

**SIDE B**

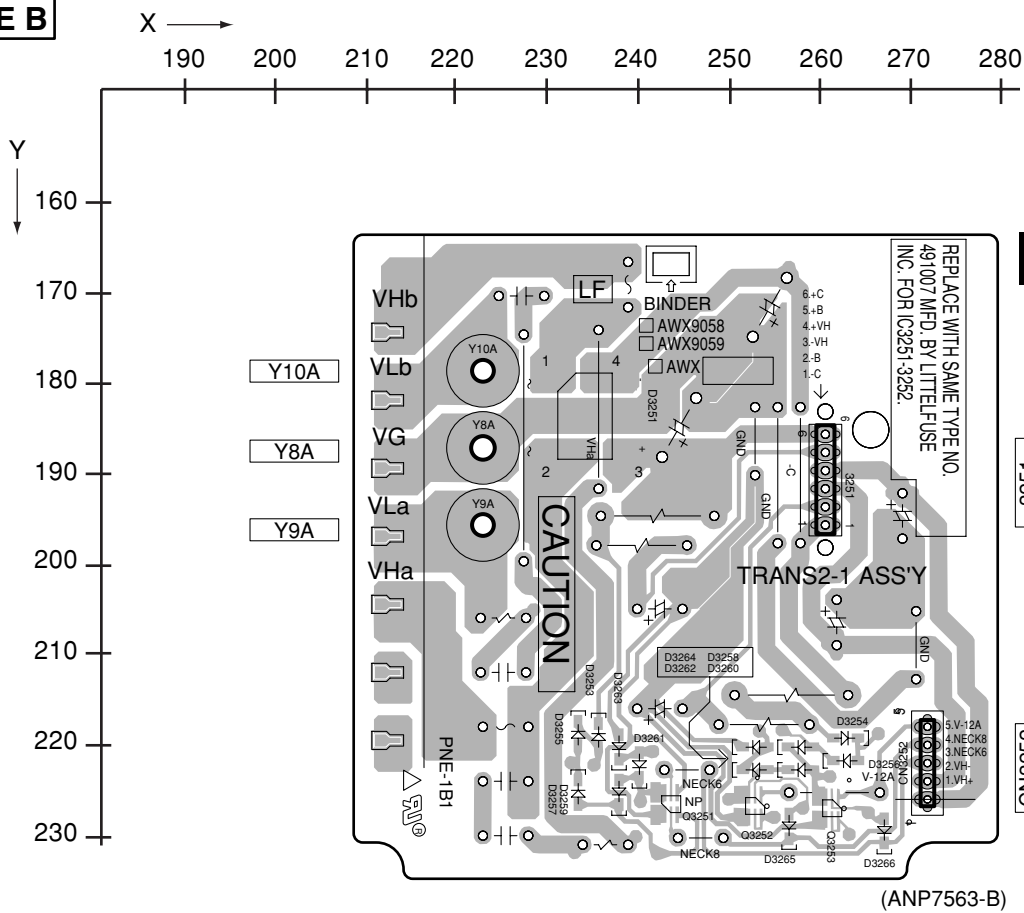

**SIDE B**

**S** TRANS 2-1 ASSY

**S**

**S**

# 4.17 DIODE 1 and VH TR ASSYS

**SIDE A**

**SIDE B**

A

B

C

D

E

F

**T DIODE 1 ASSY**

**T DIODE 1 ASSY**

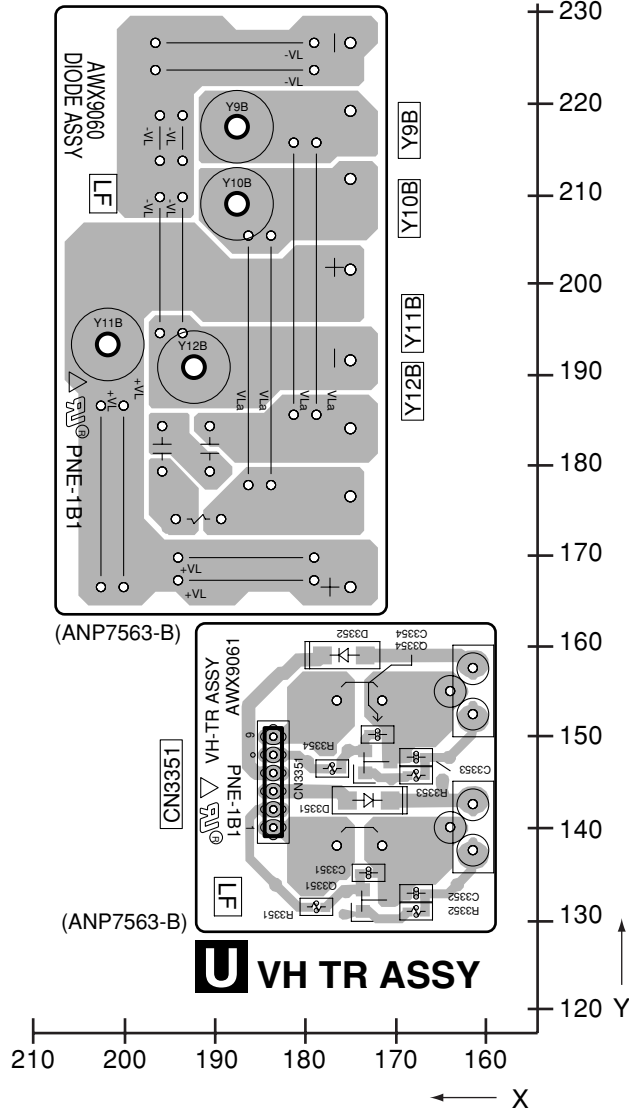
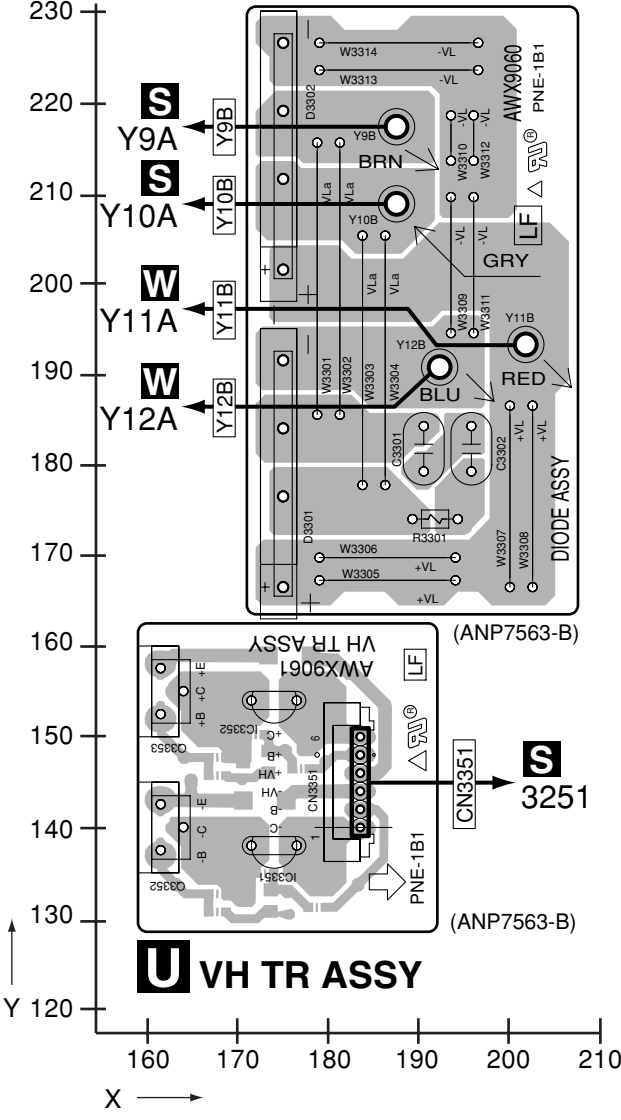

4.18 BRIDGE 1 ASSY

SIDE A

SIDE A

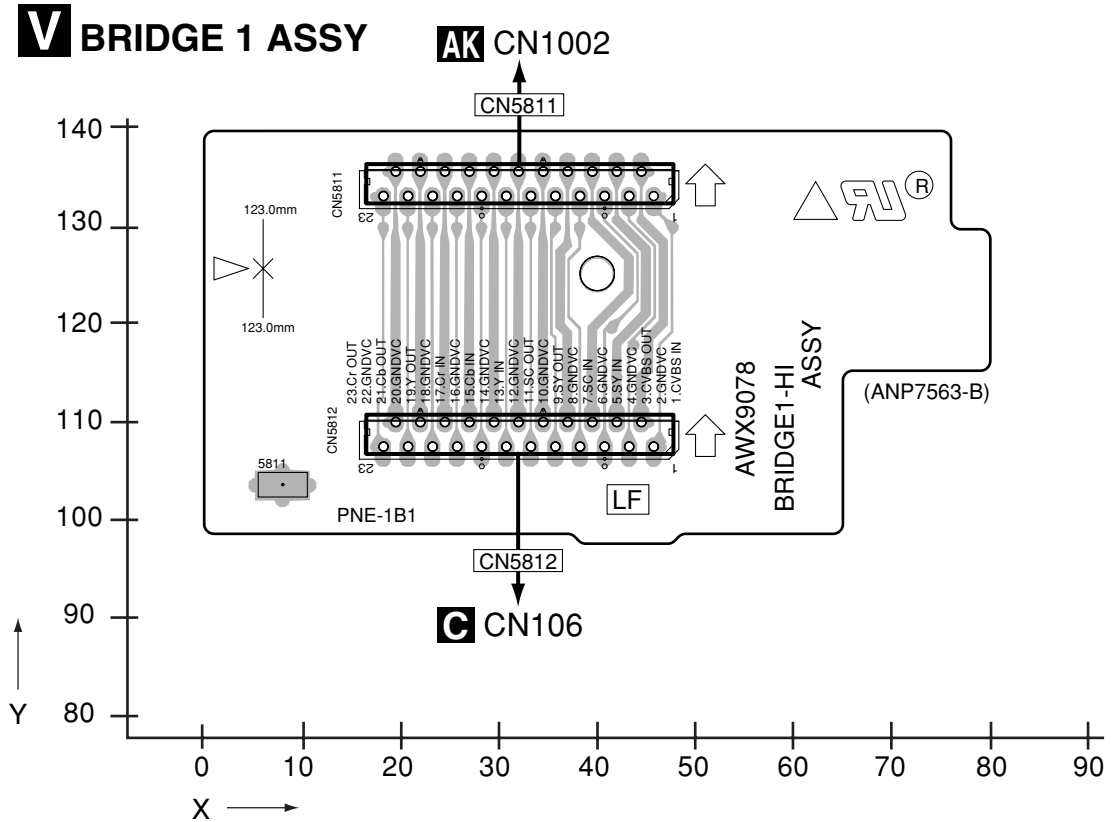

SIDE B

SIDE B

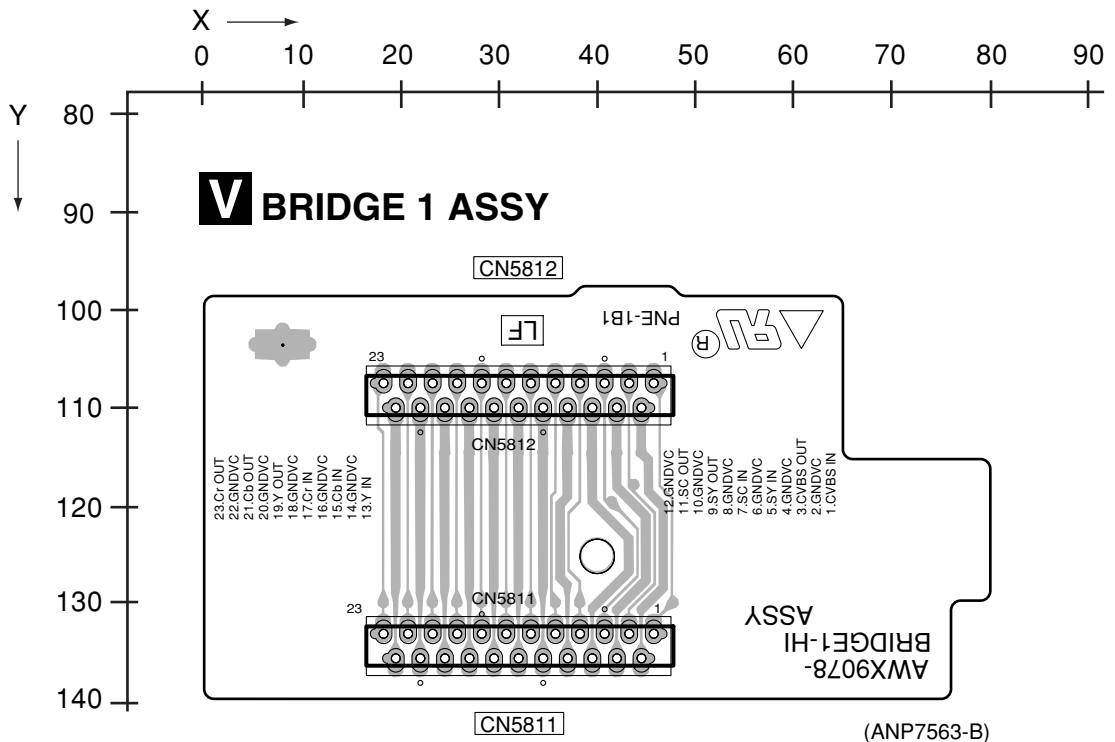

V

V



A  
B  
C  
D  
E  
F

Y11B S Y8A T Y12B AD Y5  
Y8B Y12A CN3101

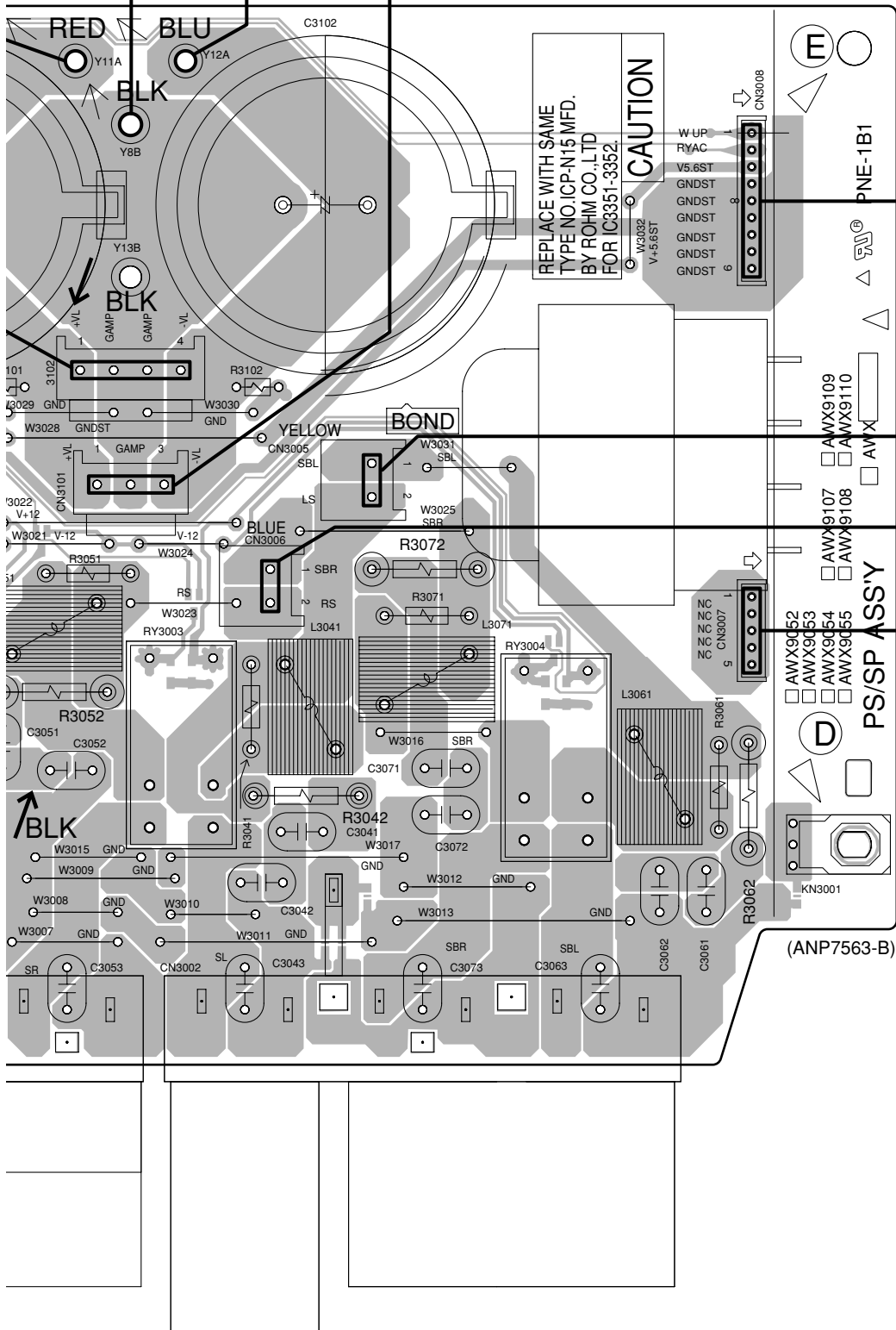

Q CN2001

AD Y3

AG Y4

Q CN2002

230 240 250 260 270 280 290 300 310 320 320

SIDE B

# W PS/SP ASSY

Y12A Y8B Y11A

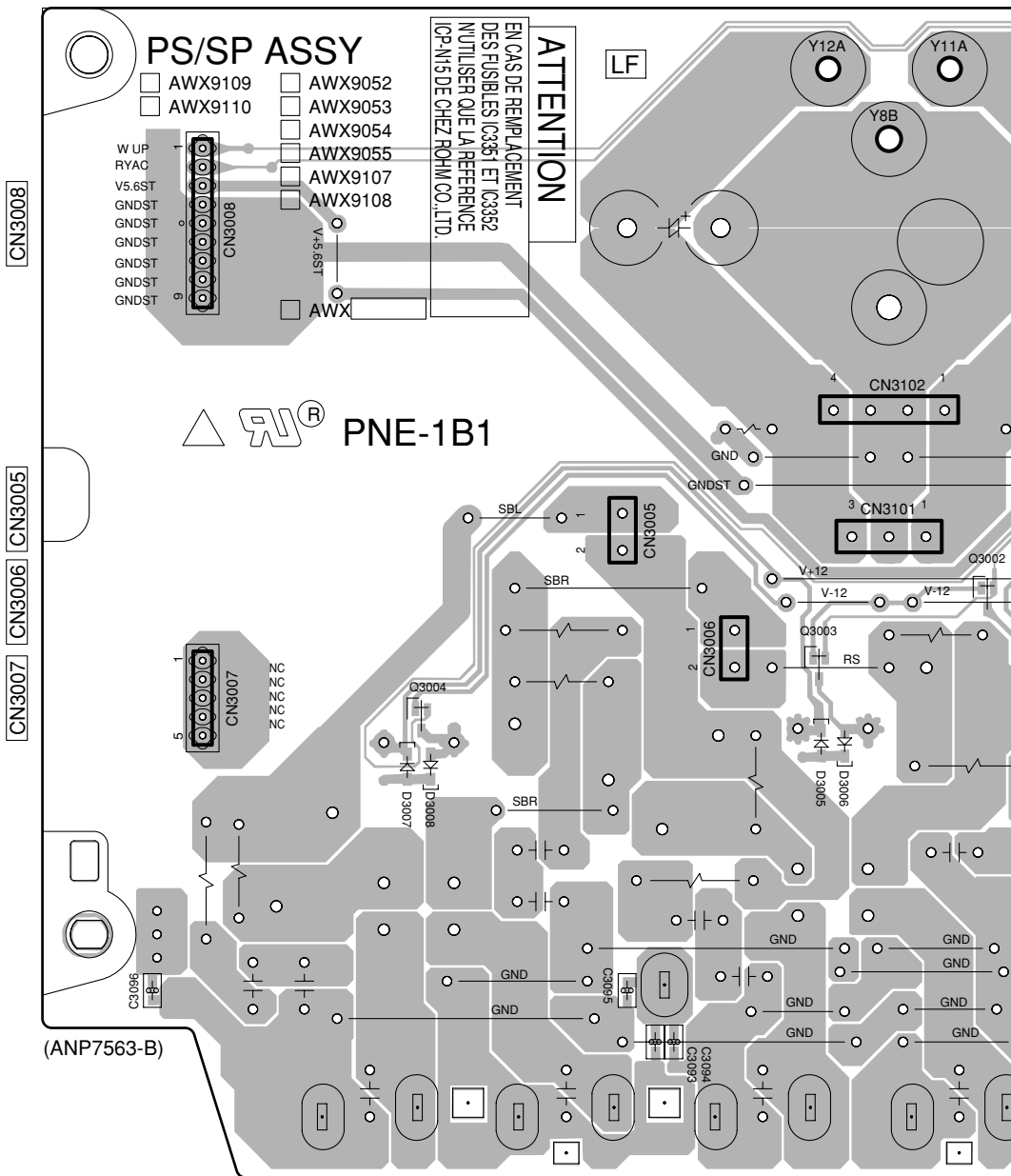

SIDE B

A

B

C

D

E

F

Y8B Y11A

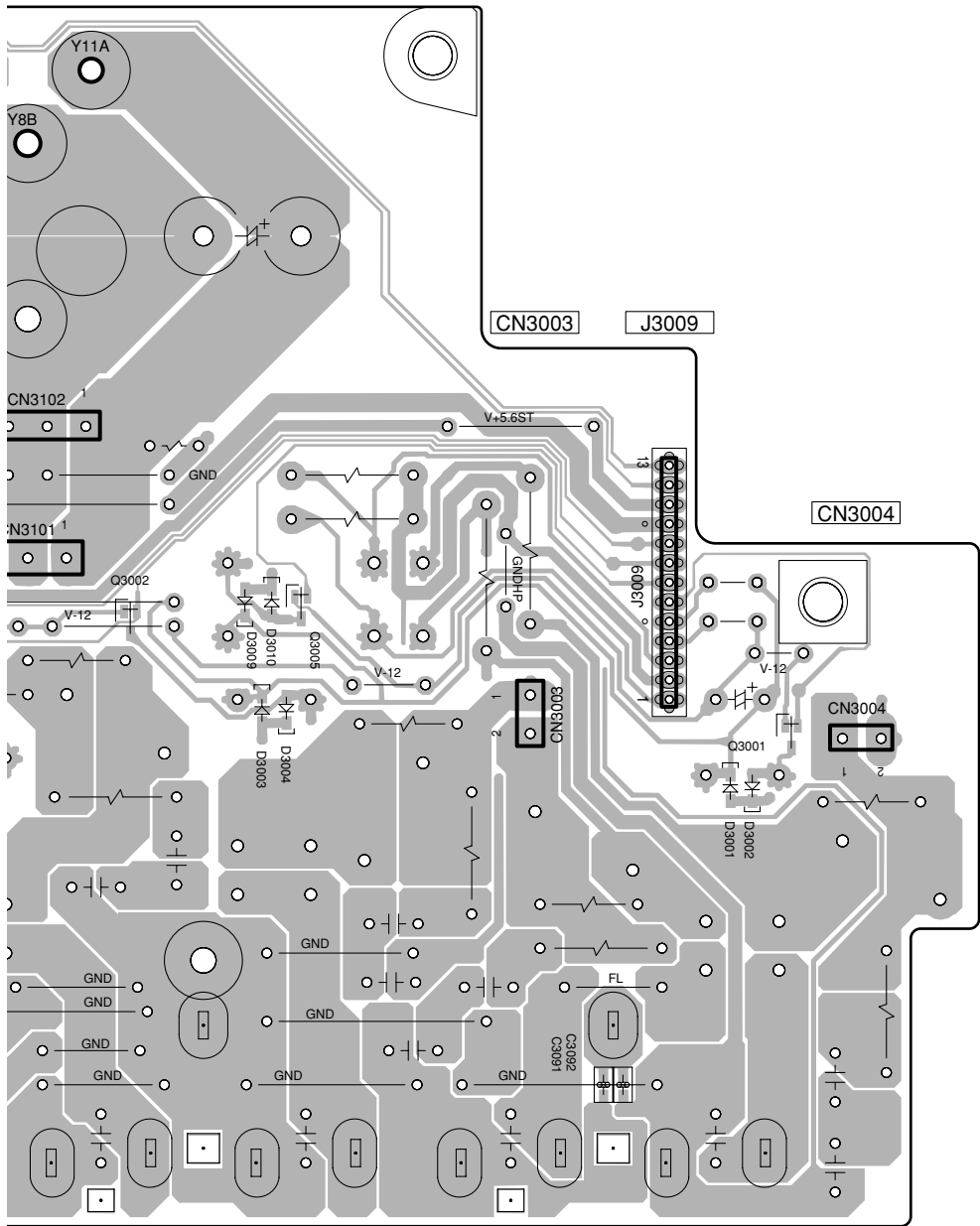

02 CN3101

240 230 220 210 200 190 180 170 160 150 140

X

160 150 140 130 120 110 100 90 80 70 60 50 40 30 20 10 0 Y

VSX-2016AV-S



# 4.20 TRANS 2-2 ASSY

**SIDE A**

**SIDE A**

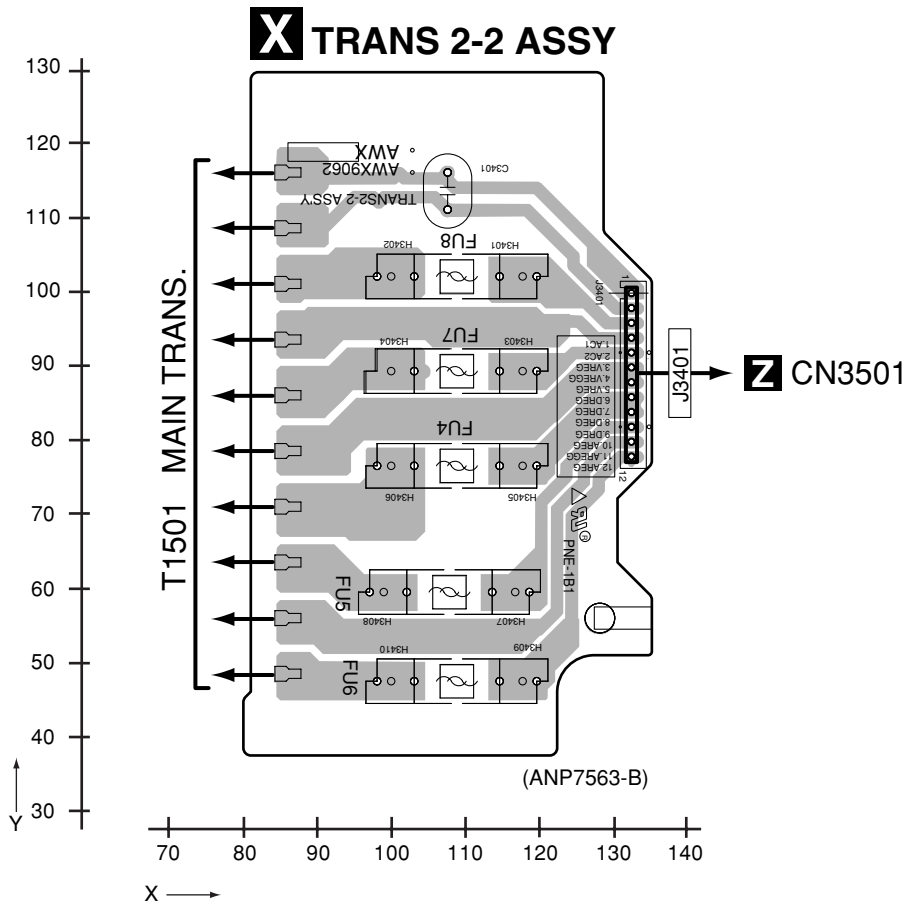

**SIDE B**

**SIDE B**

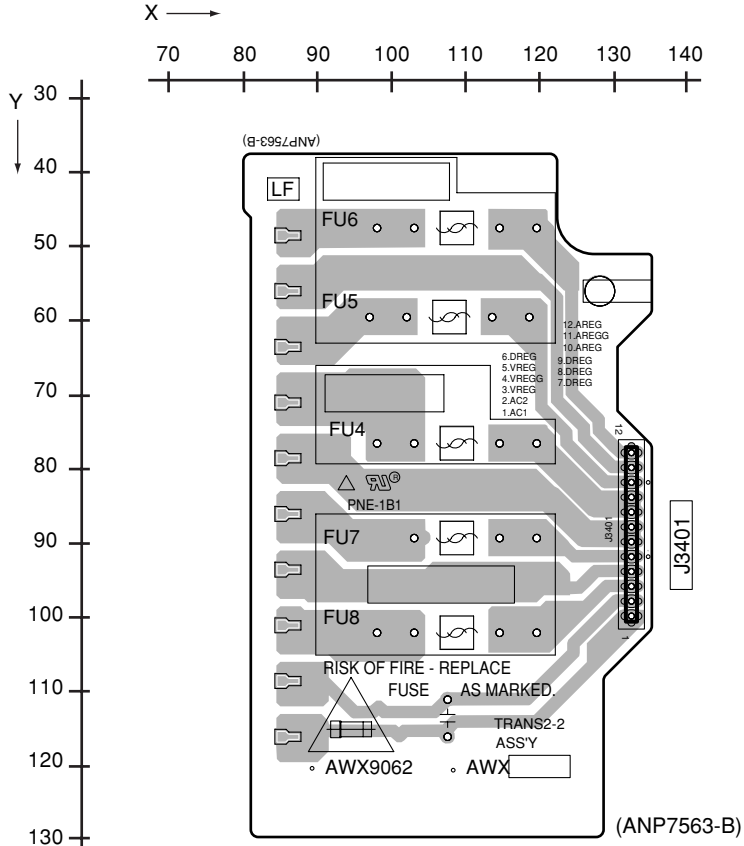

**X TRANS 2-2 ASSY**

**X**





# 4.22 TRANS SIDE ASSY

**SIDE A**

## Y TRANS SIDE ASSY

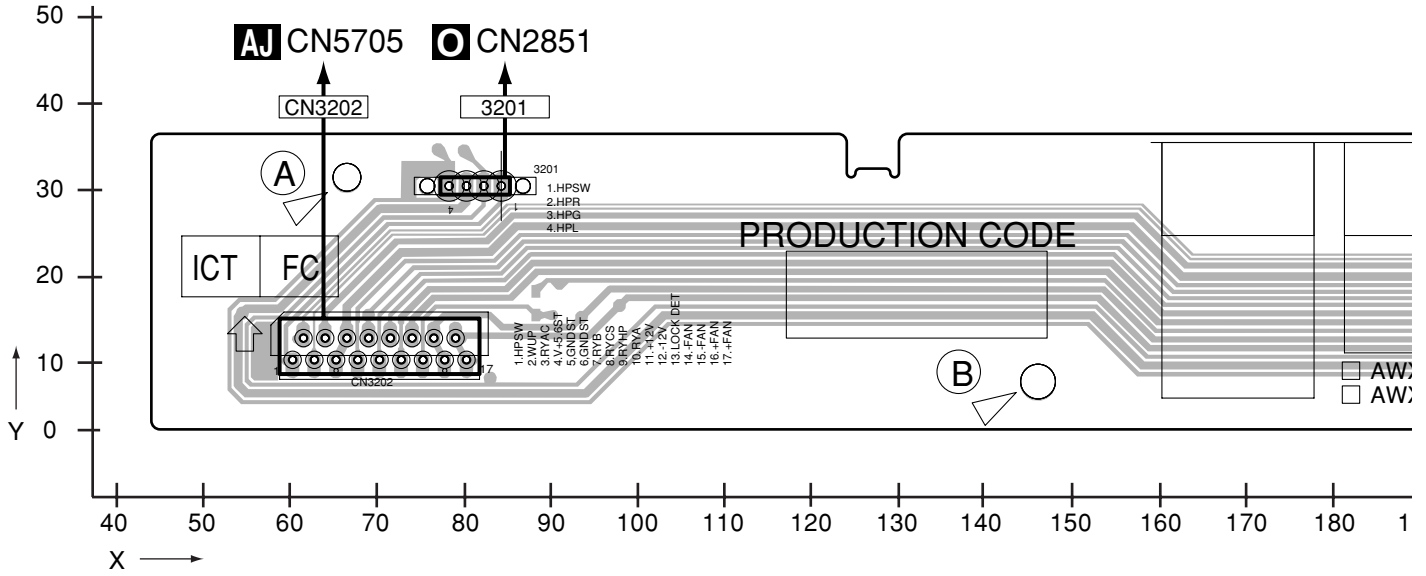

**SIDE B**

## Y TRANS SIDE ASSY

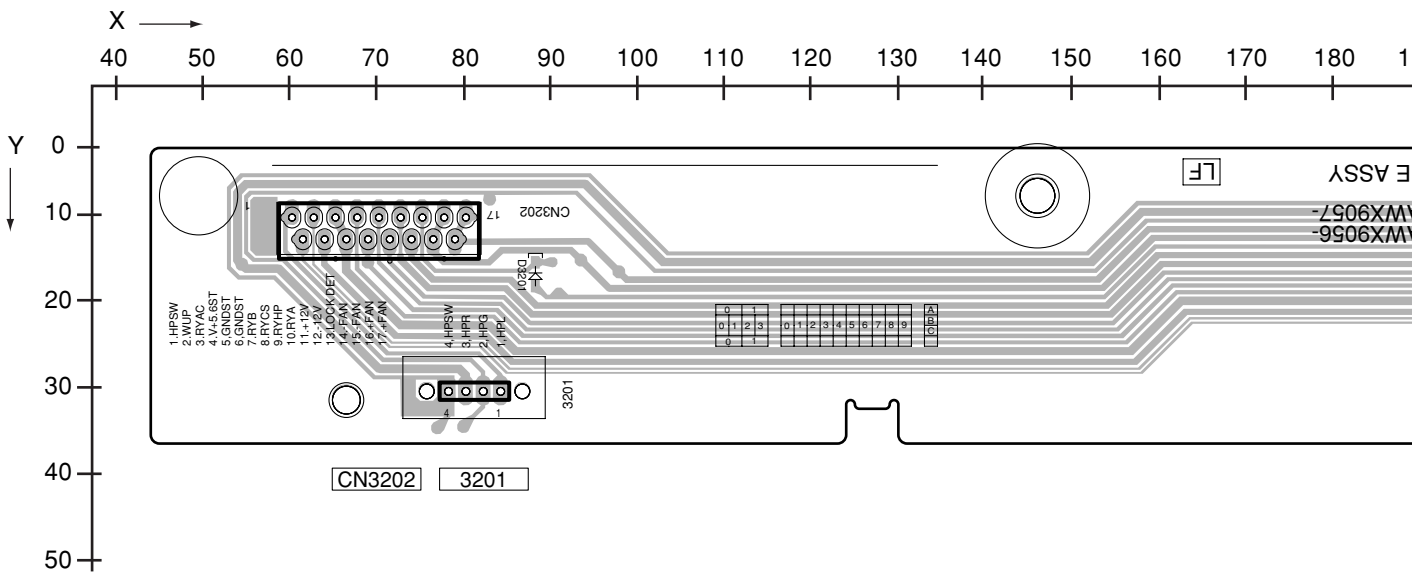

**Y**

**SIDE A**

A

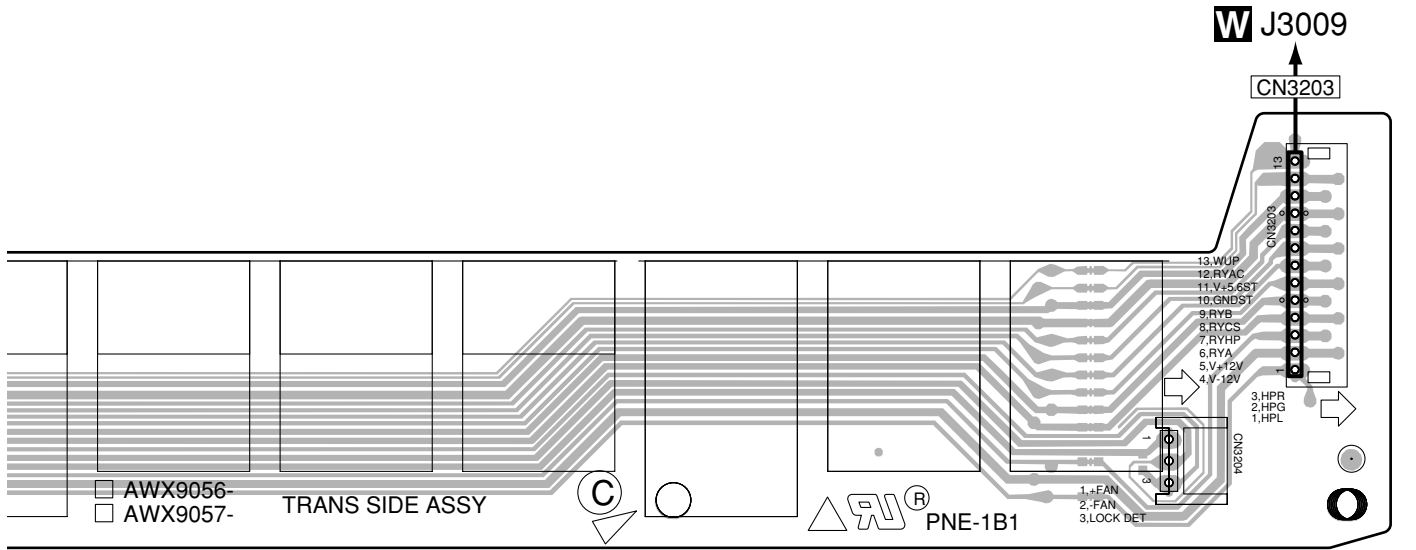

B

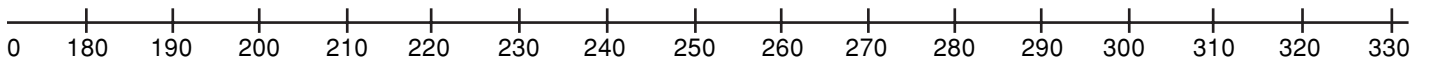

C

**SIDE B**

D

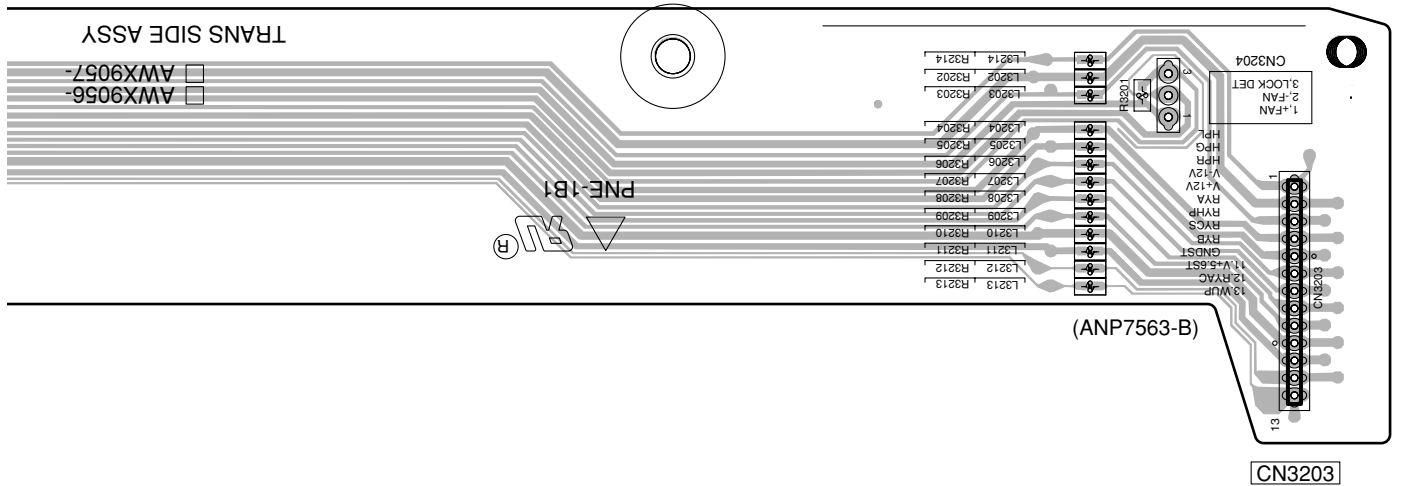
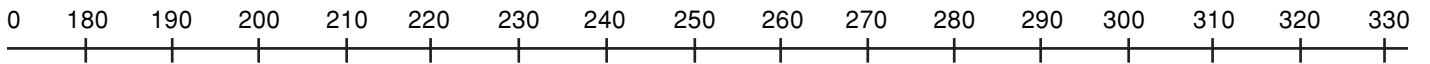

E

F



# 4.23 IR I/O ASSY

**SIDE A**

**SIDE A**

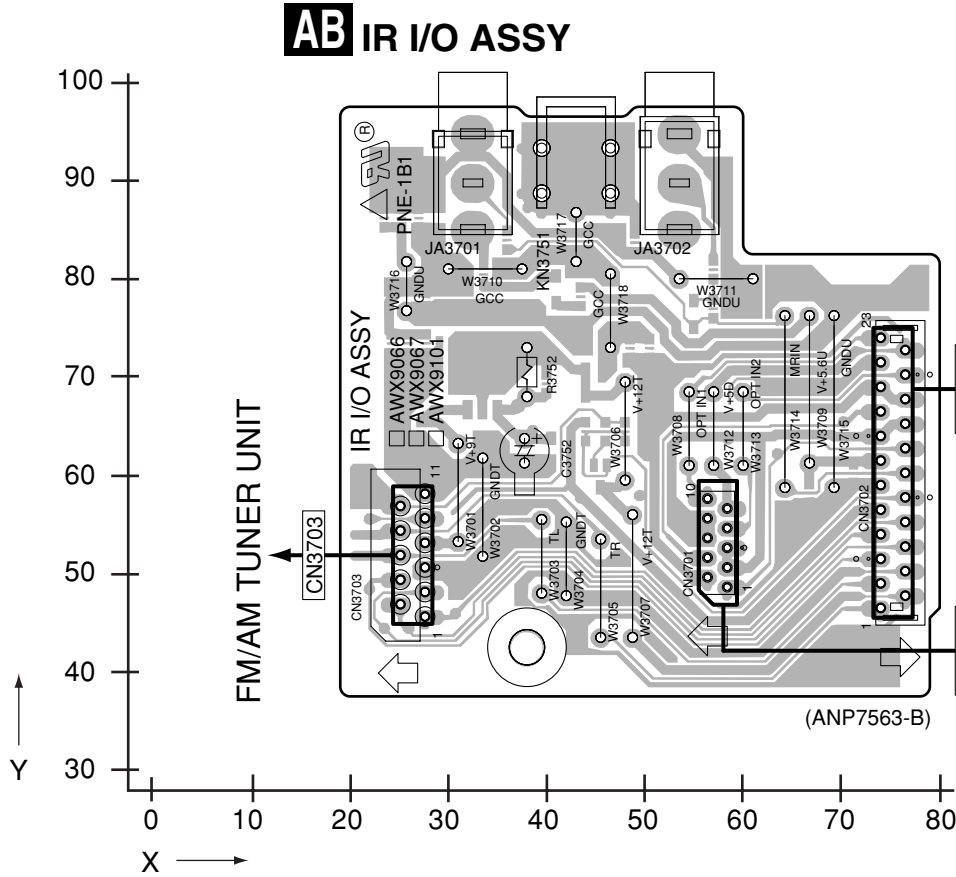

**SIDE B**

**SIDE B**

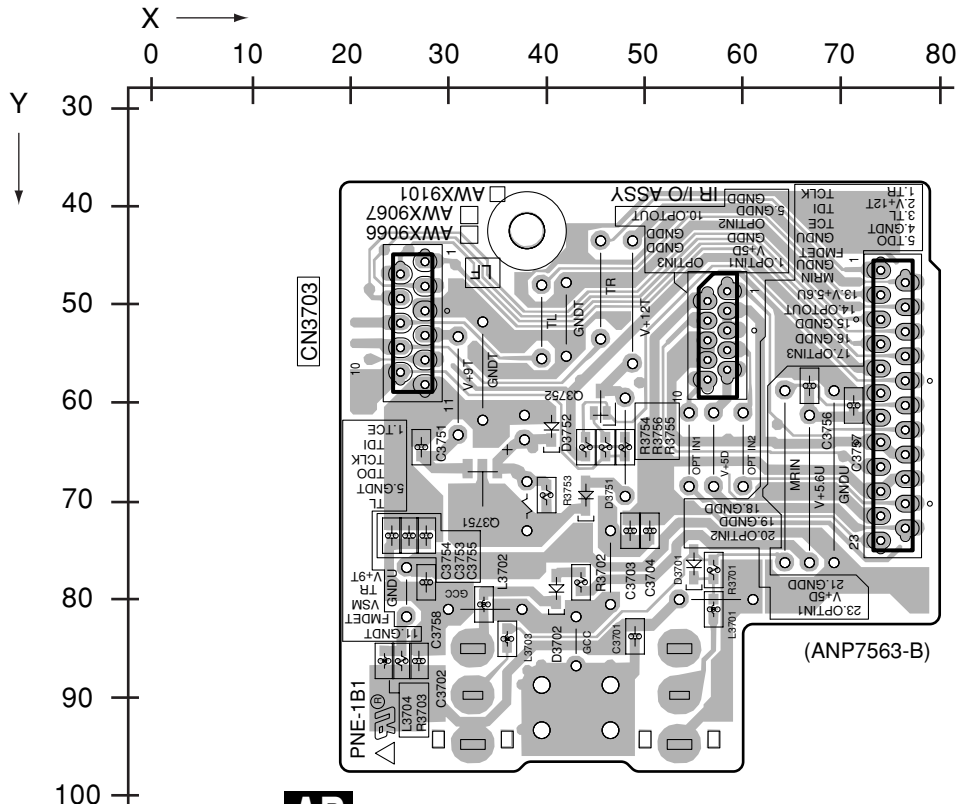

**AB**

**AB IR I/O ASSY**

**AB**

■

5

■

6

■

7

■

8

■

A

■

B

■

C

■

D

■

E

■

F

■

5

■

6

VSX-2016AV-S

■

7

■

8

■

# 4.24 LOCAL P-SUPPLY ASSY

**SIDE A**

**SIDE A**

## Z LOCAL P-SUPPLY ASSY

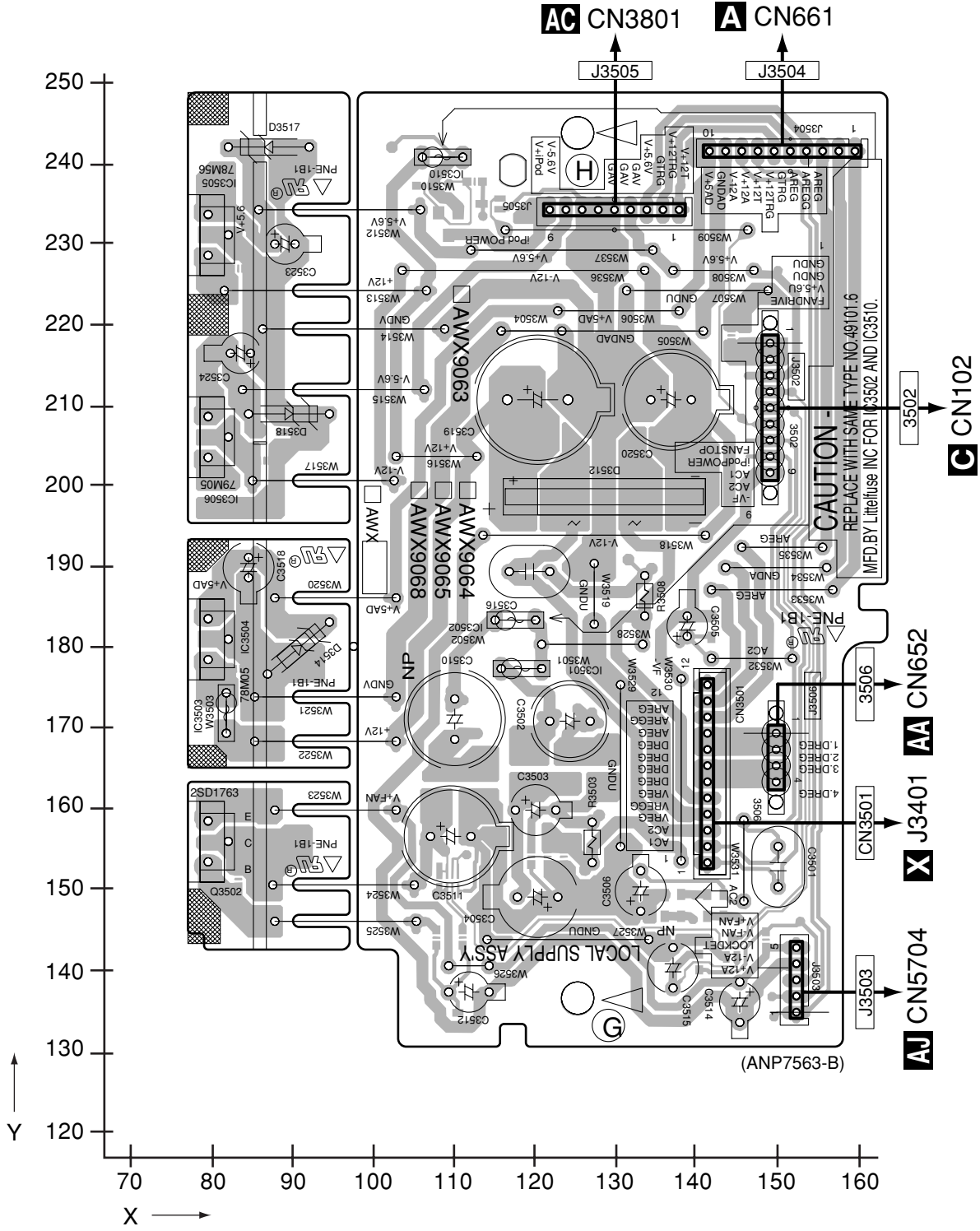

SIDE B

SIDE B

A

# Z LOCAL P-SUPPLY ASSY

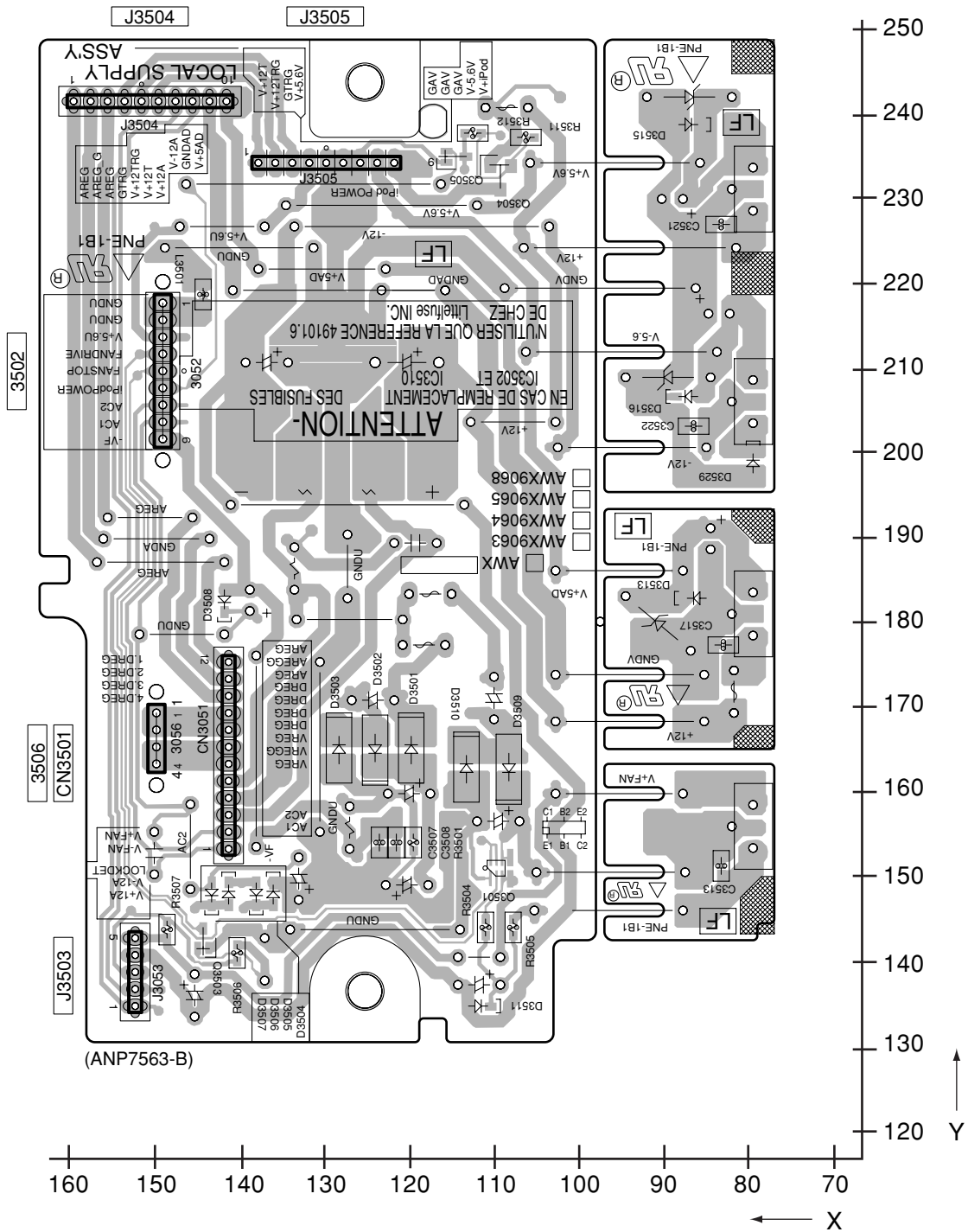

B

C

D

E

F

Z

Z

# 4.25 DC/DC ASSY

**SIDE A**

**SIDE A**

## AA DC/DC ASSY

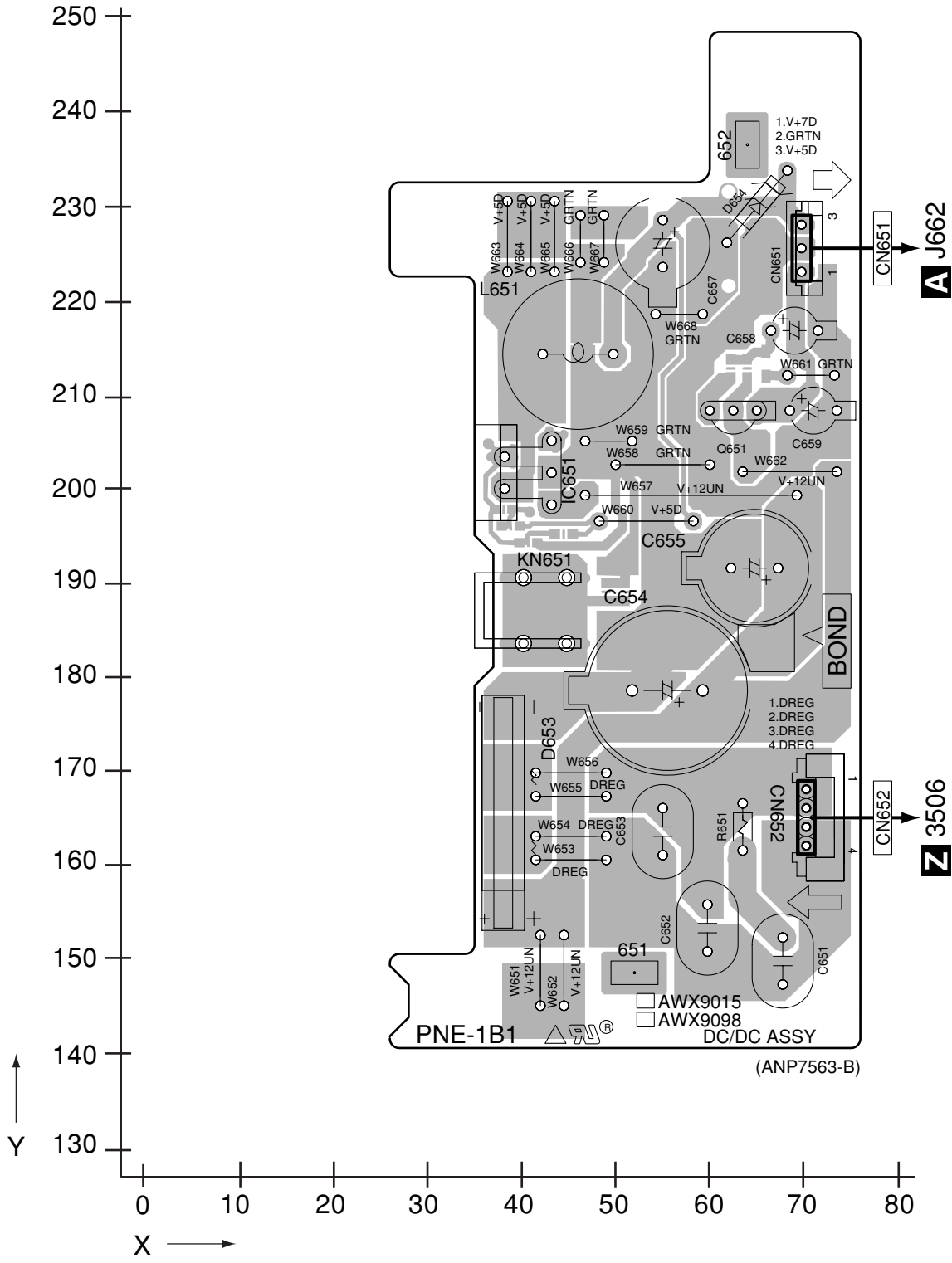

**AA**

**AA**



SIDE B

SIDE B

# AA DC/DC ASSY

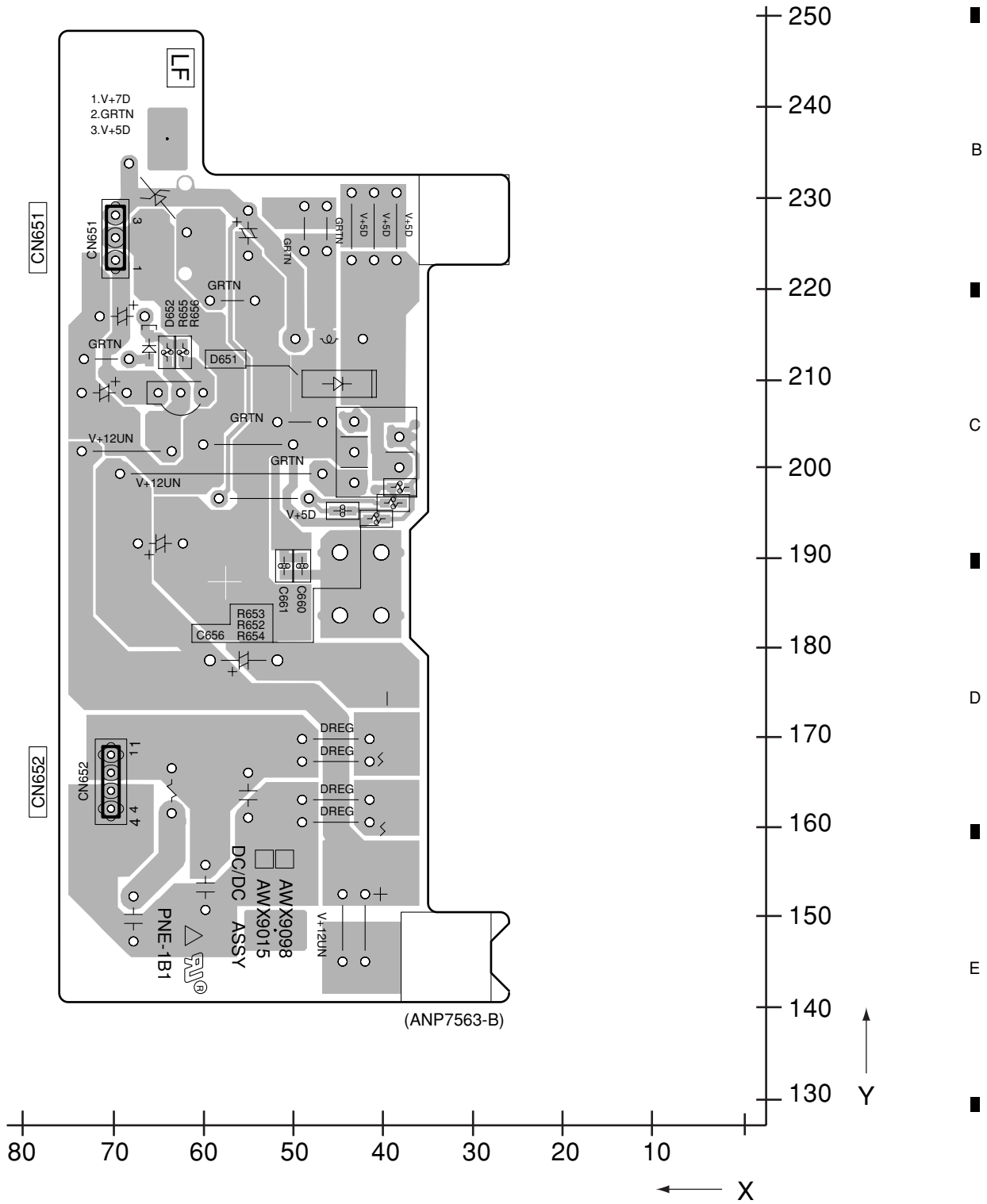

AA

AA





1 2 3 4

# 4.27 POWER AMP-L ASSY

**SIDE A**

## **AD** POWER AMP-L ASSY

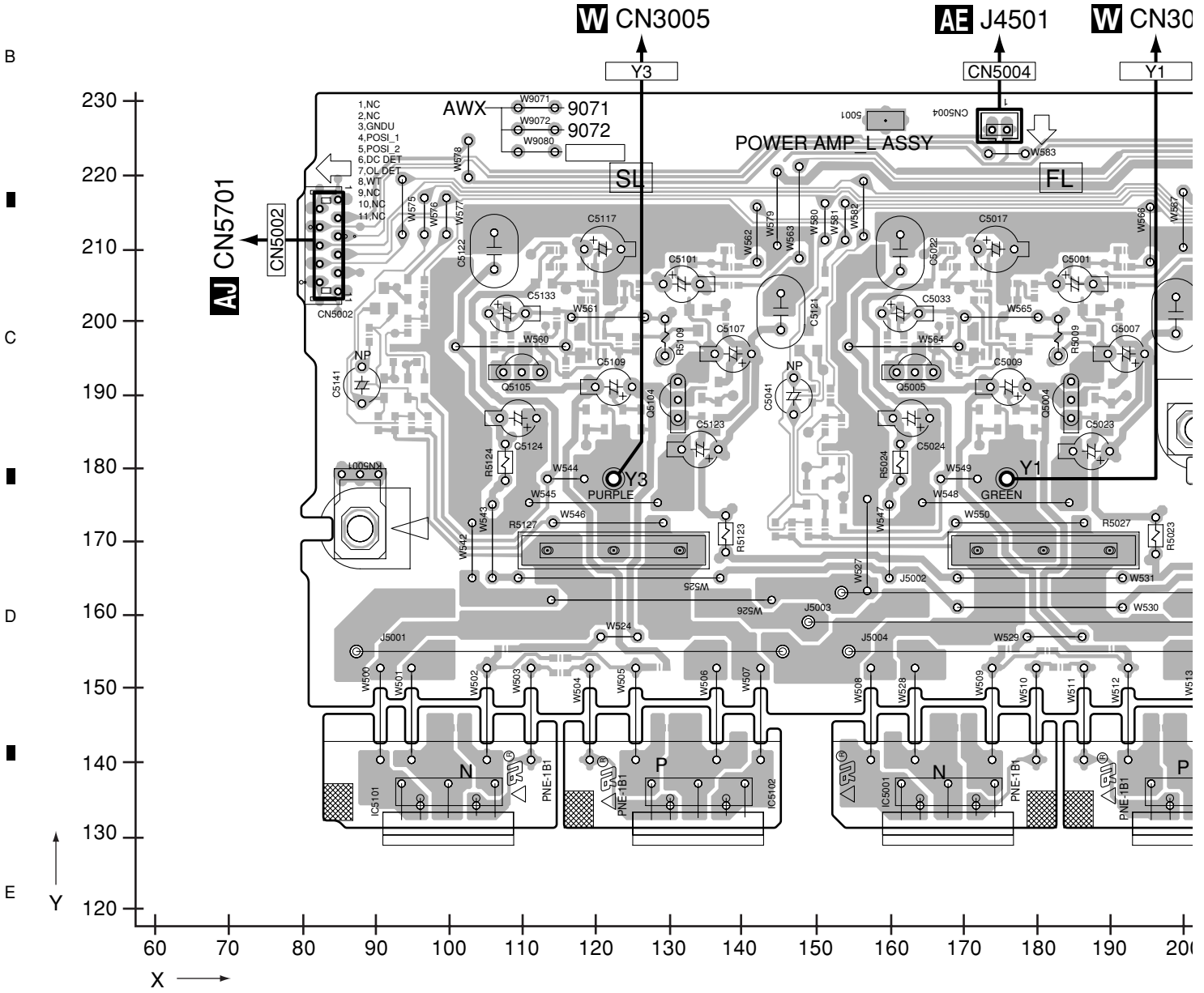

SIDE A

A

B

C

D

E

F

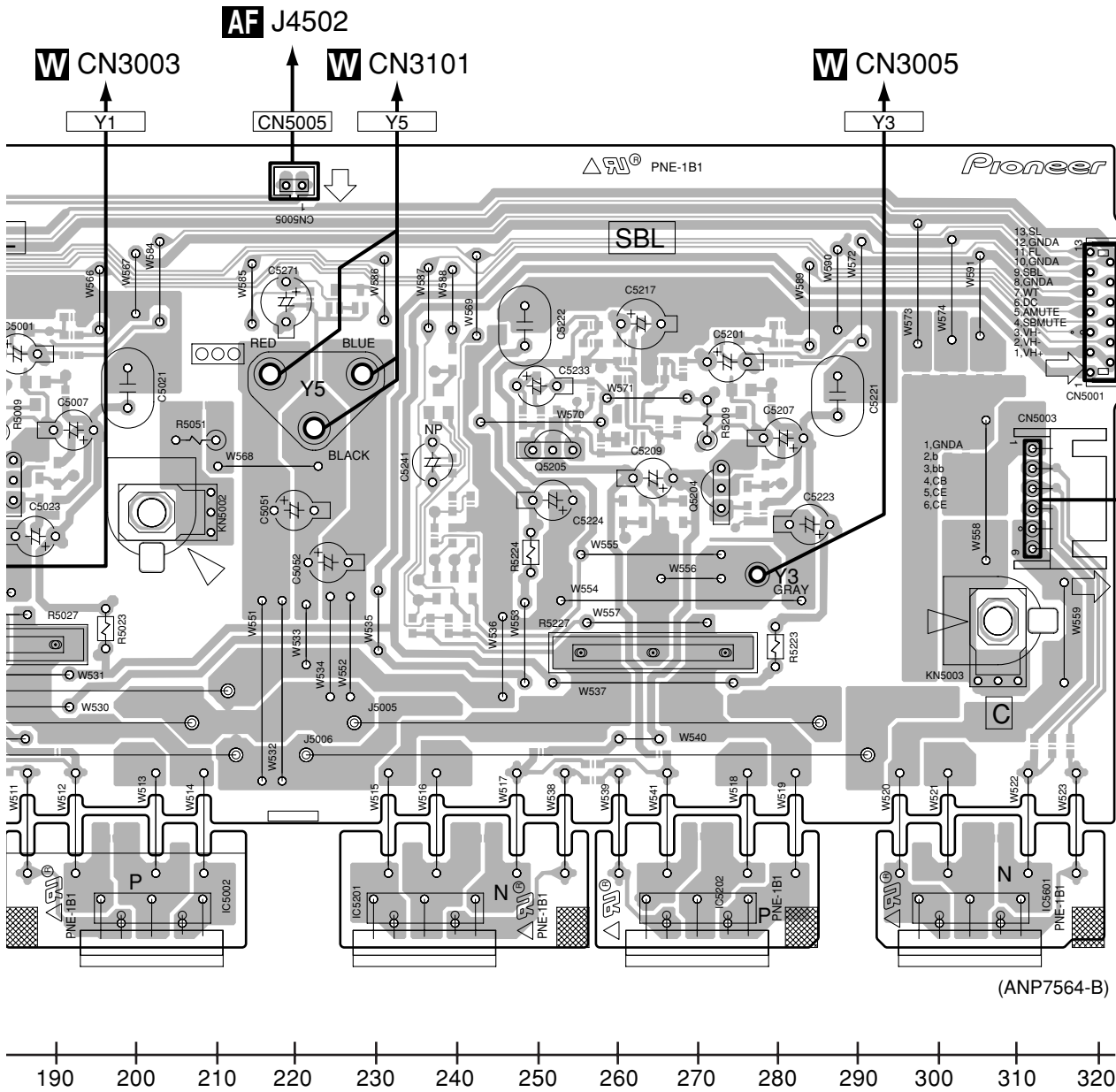

SIDE B

A

B

C

D

E

F

# AD POWER AMP-L ASSY

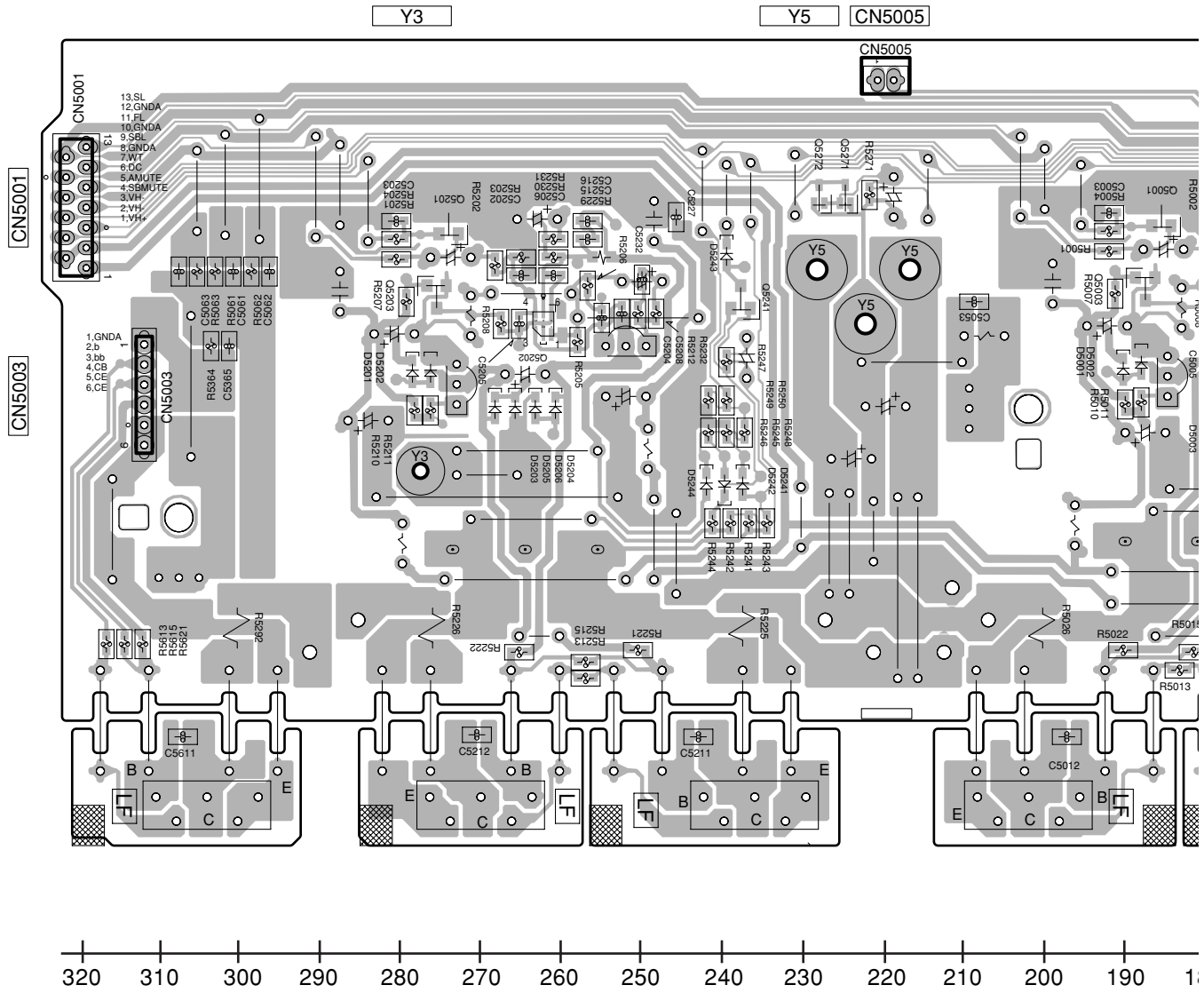

SIDE B

A

B

C

D

E

F

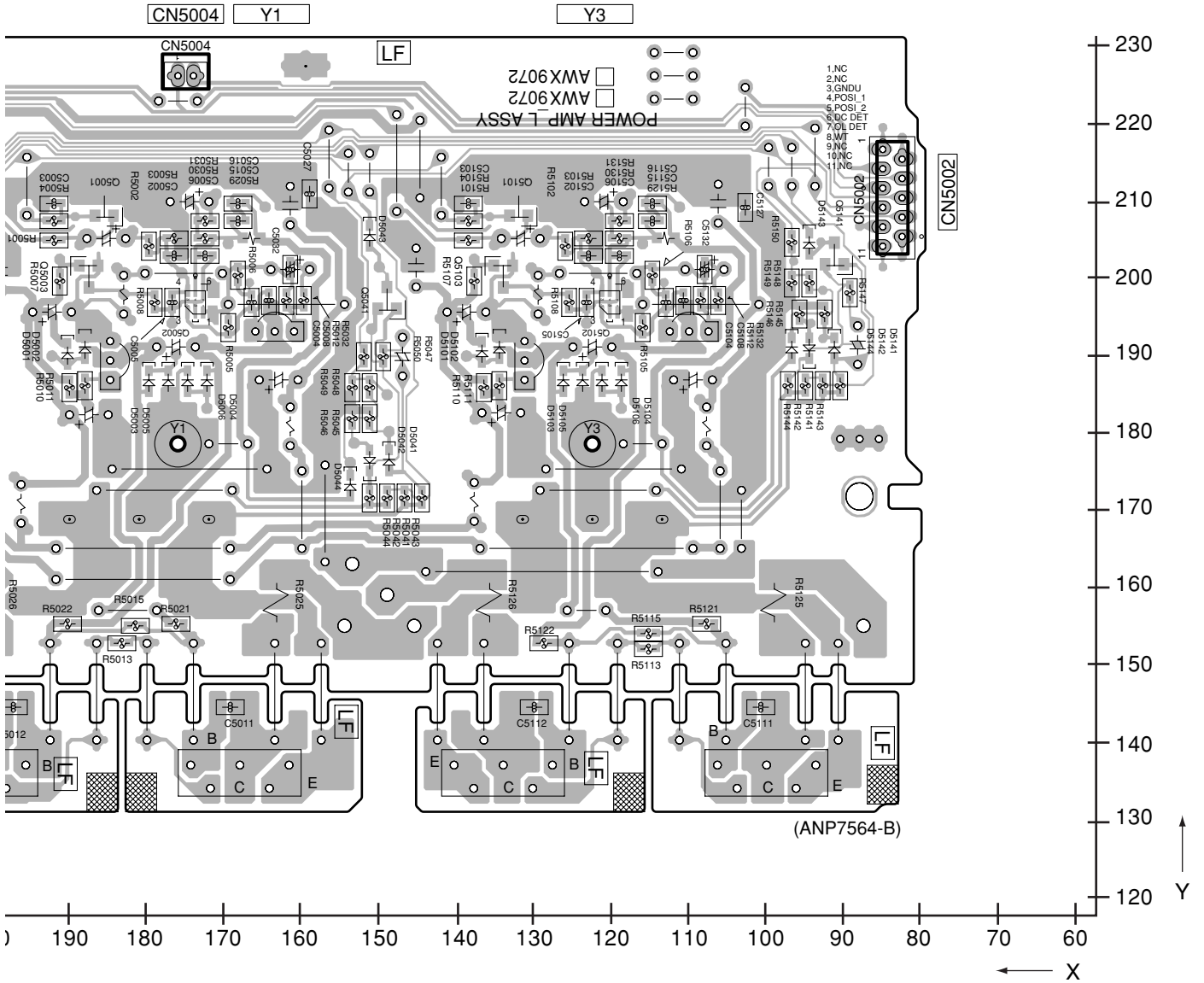

# 4.28 POWER AMP-R ASSY

**SIDE A**

## AG POWER AMP-R ASSY

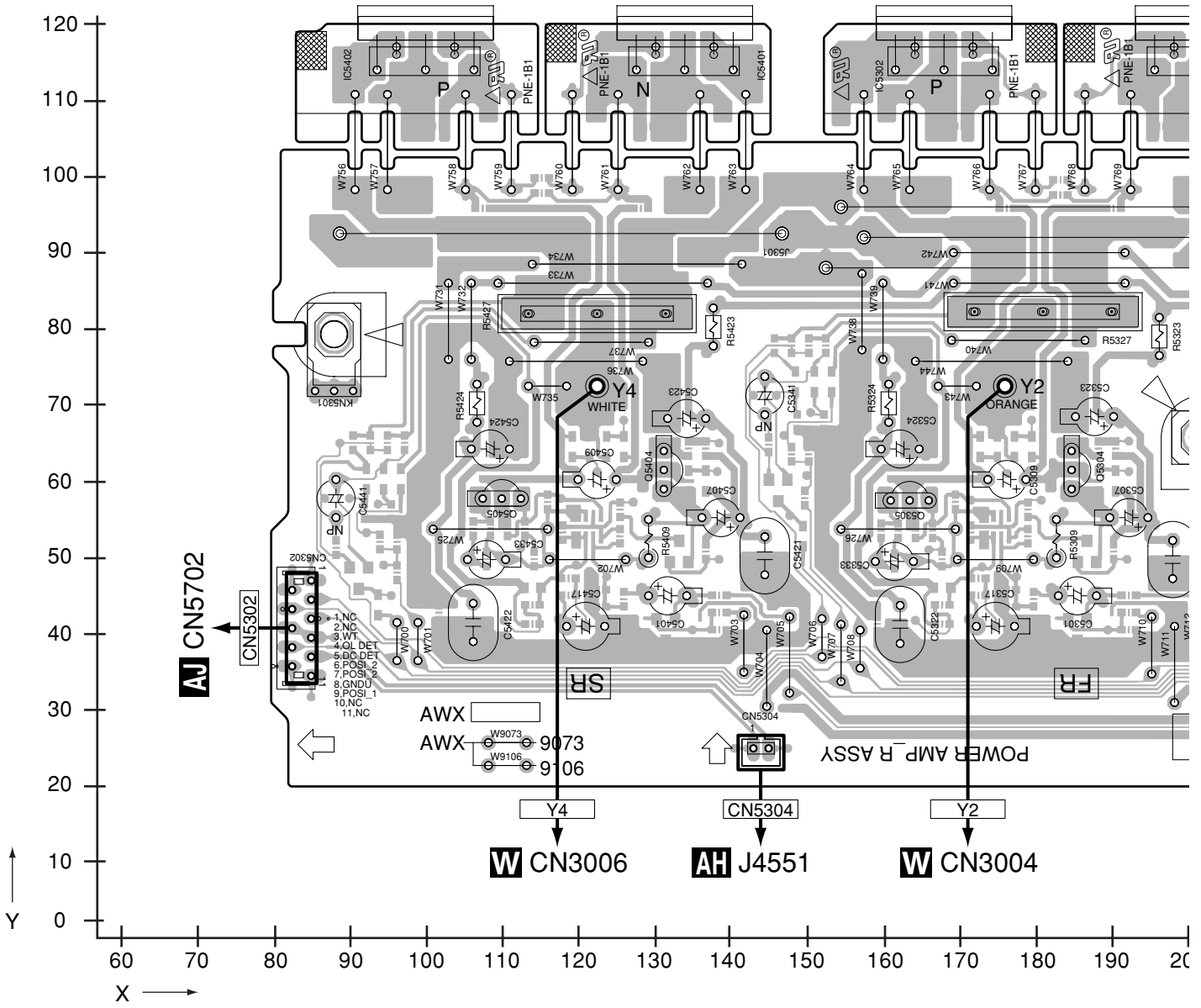



SIDE A

A

B

C

D

E

F

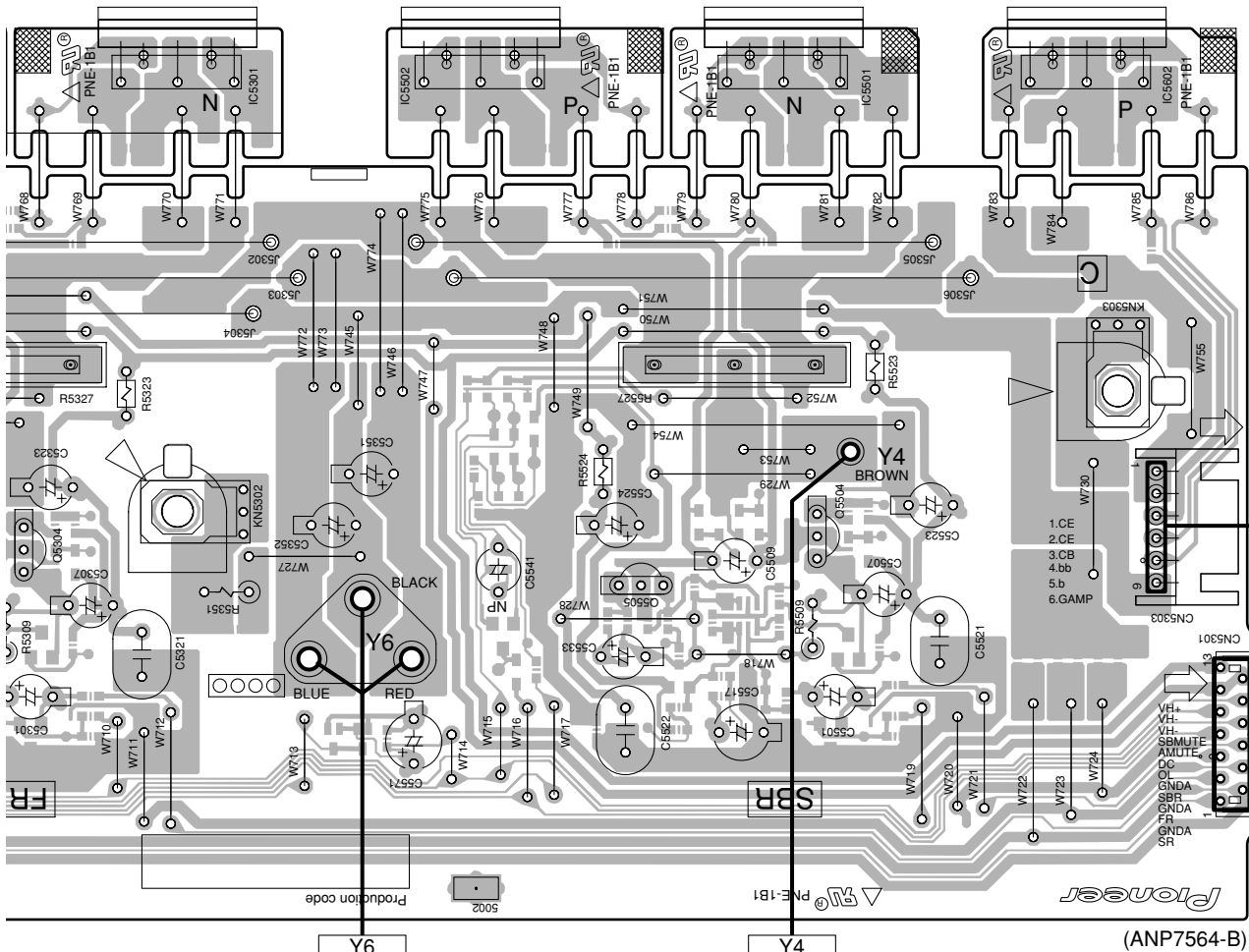

W CN3102

W CN3006

A CN5602 A CN5606

CN5303

CN5301

(ANP7564-B)

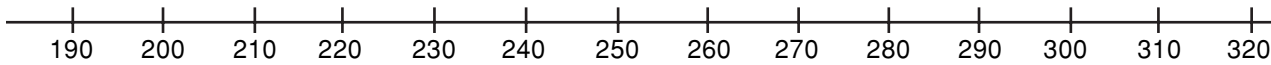

SIDE B

A

# AG POWER AMP-R ASSY

B

C

D

E

F

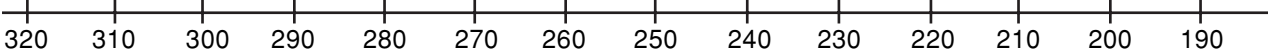
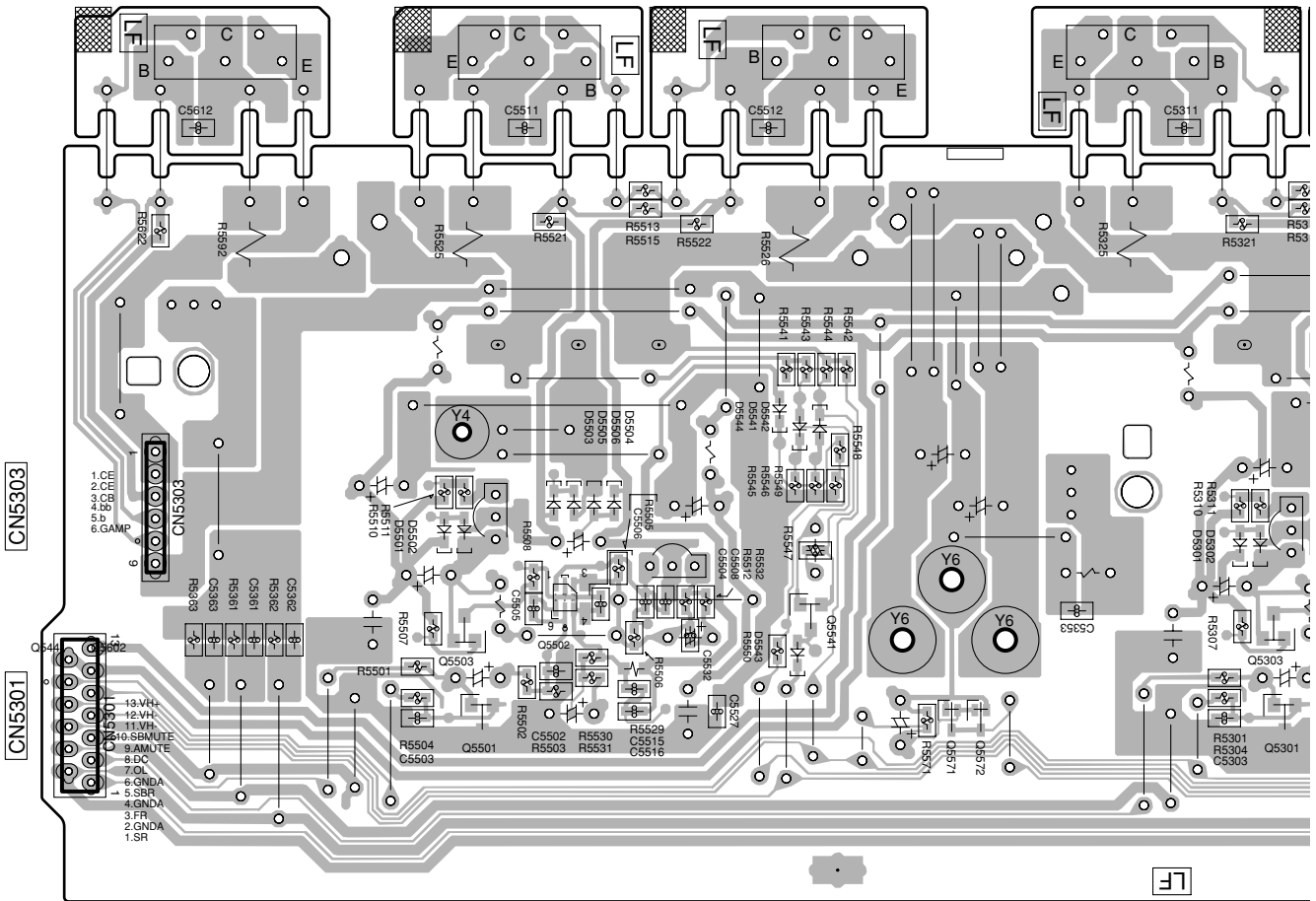

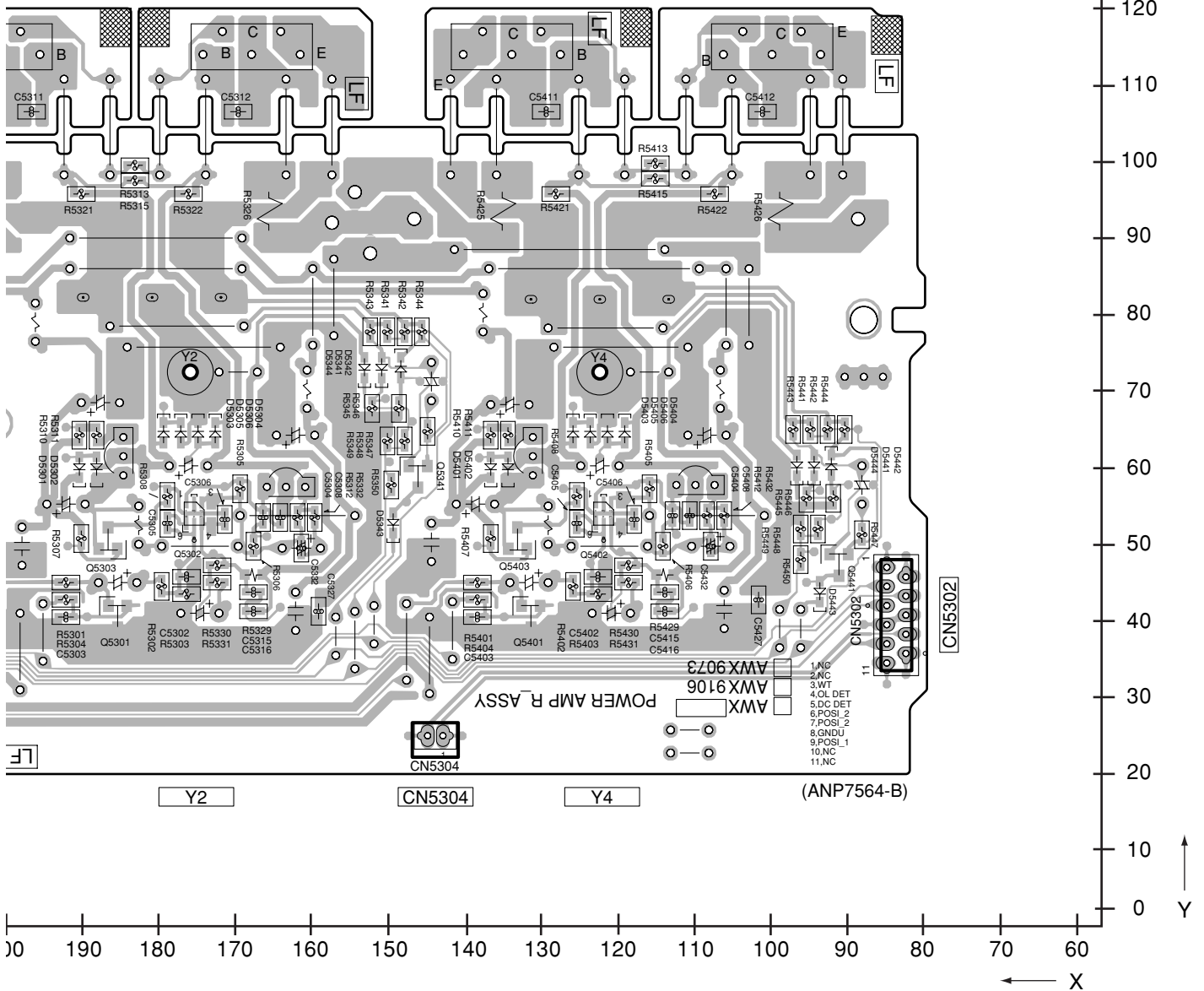

# 4.29 POWER AMP IN ASSY

**SIDE A**

**SIDE A**

## AI POWER AMP IN ASSY

A  
B  
C  
D  
E  
F

150  
140  
130  
120  
110  
100  
90  
80  
70  
60  
50  
40  
30  
20  
10  
0

0 10 20 30 40 50 60 70 80

X →

↑ Y

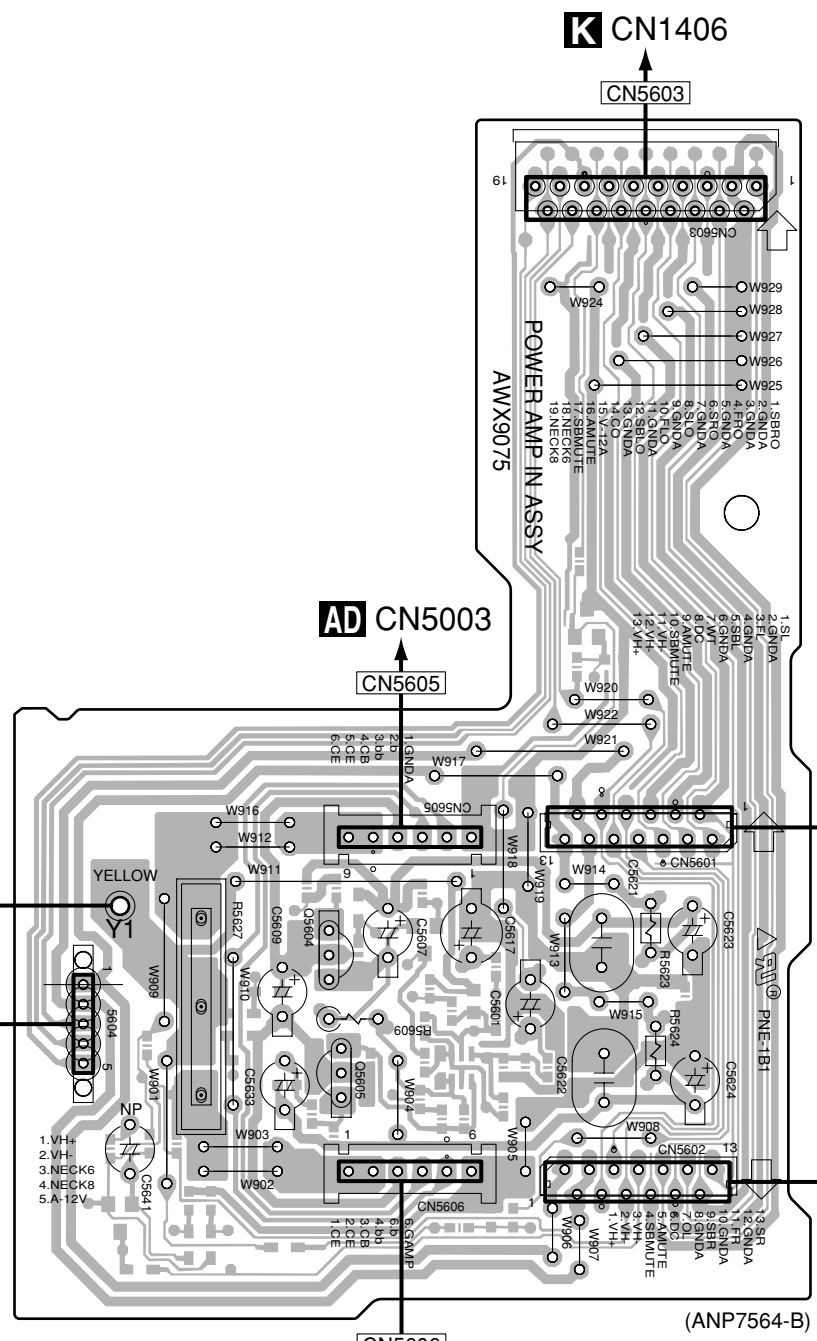

**AI**

**AI**

SIDE B

SIDE B

A

# AI POWER AMP IN ASSY

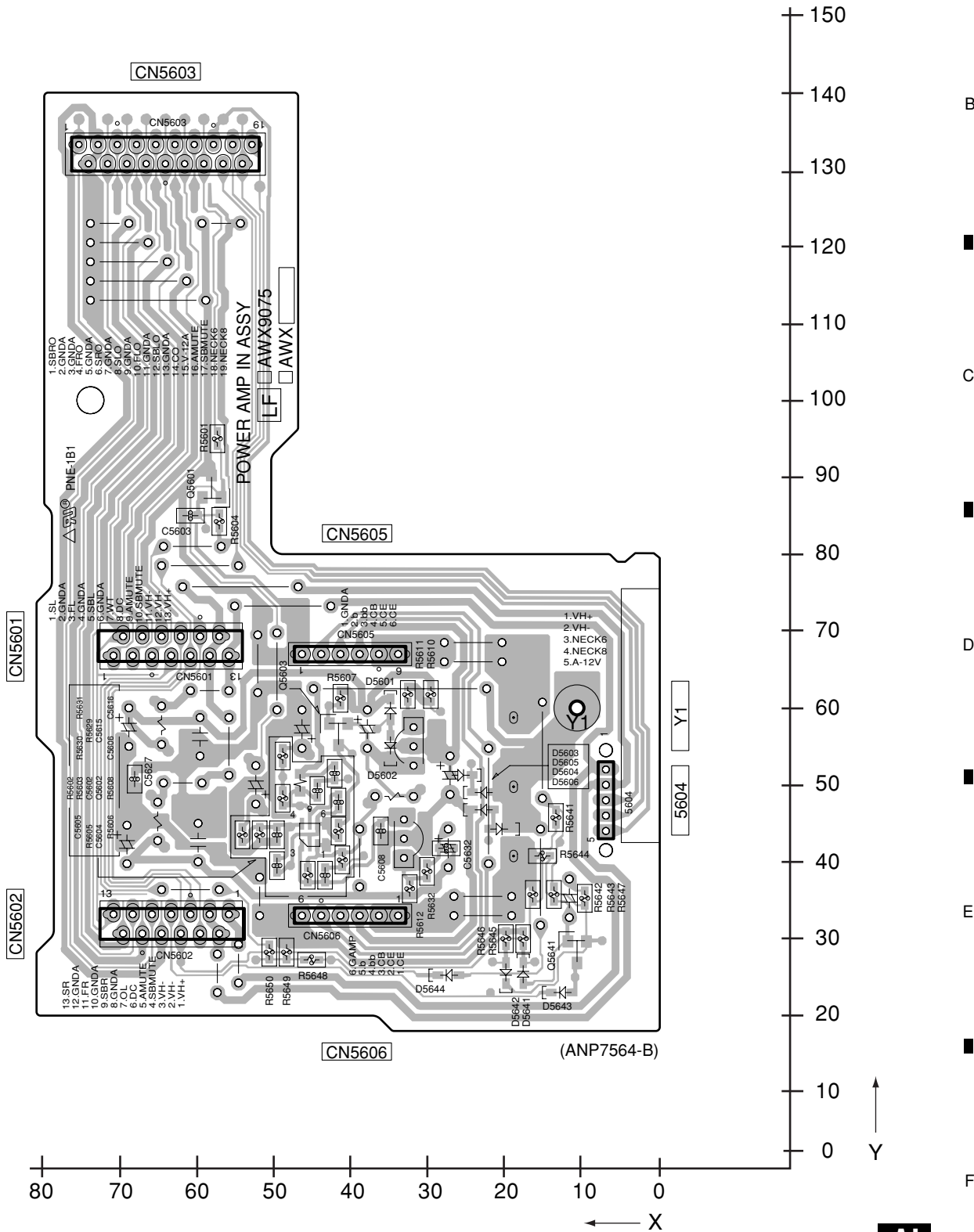

AI

AI

# 4.30 POWER PROTECT ASSY

SIDE A

SIDE A

## AJ POWER PROTECT ASSY

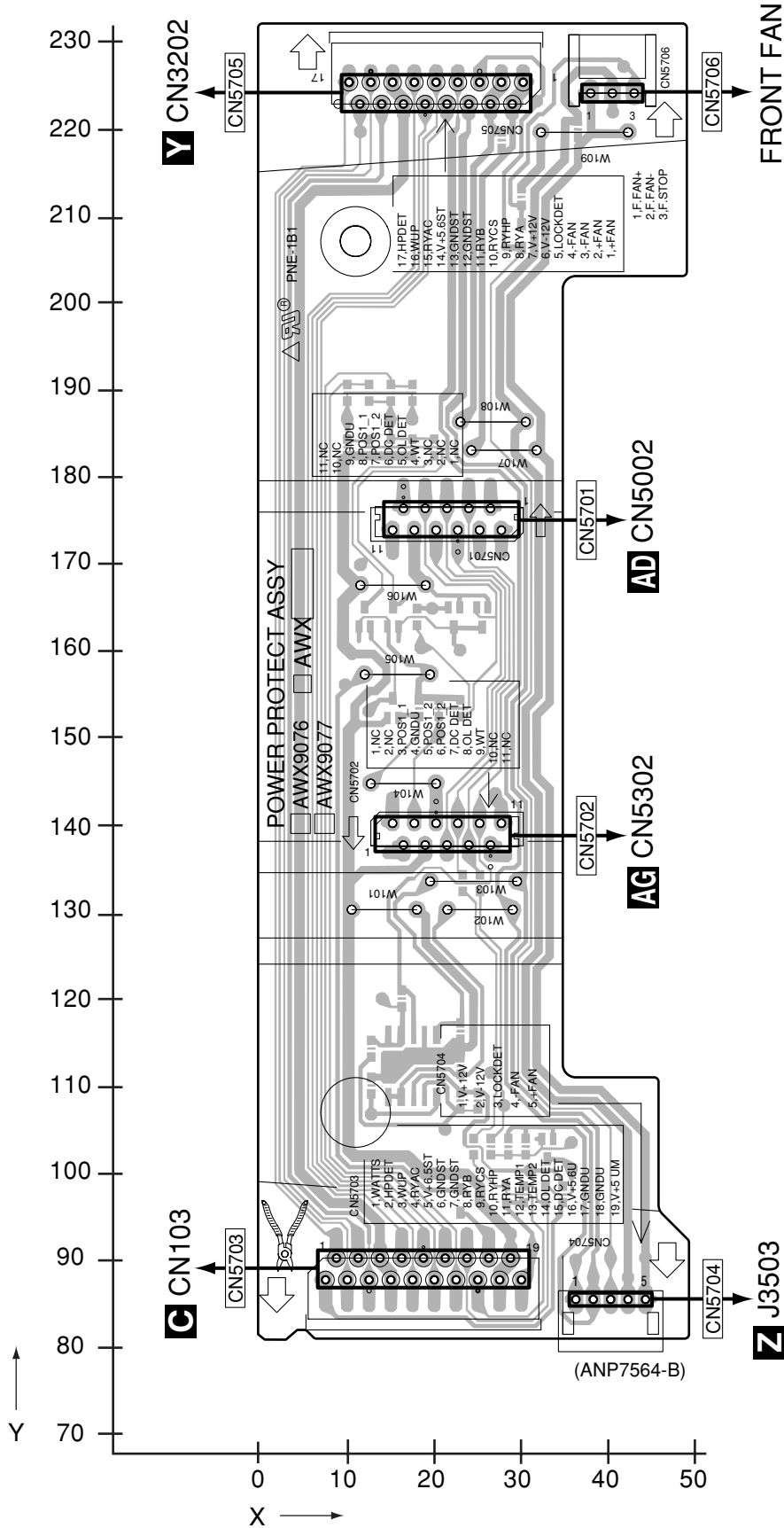



# 4.31 HDMI & DVC ASSY

**SIDE A**

## **AK** HDMI & DVC ASSY

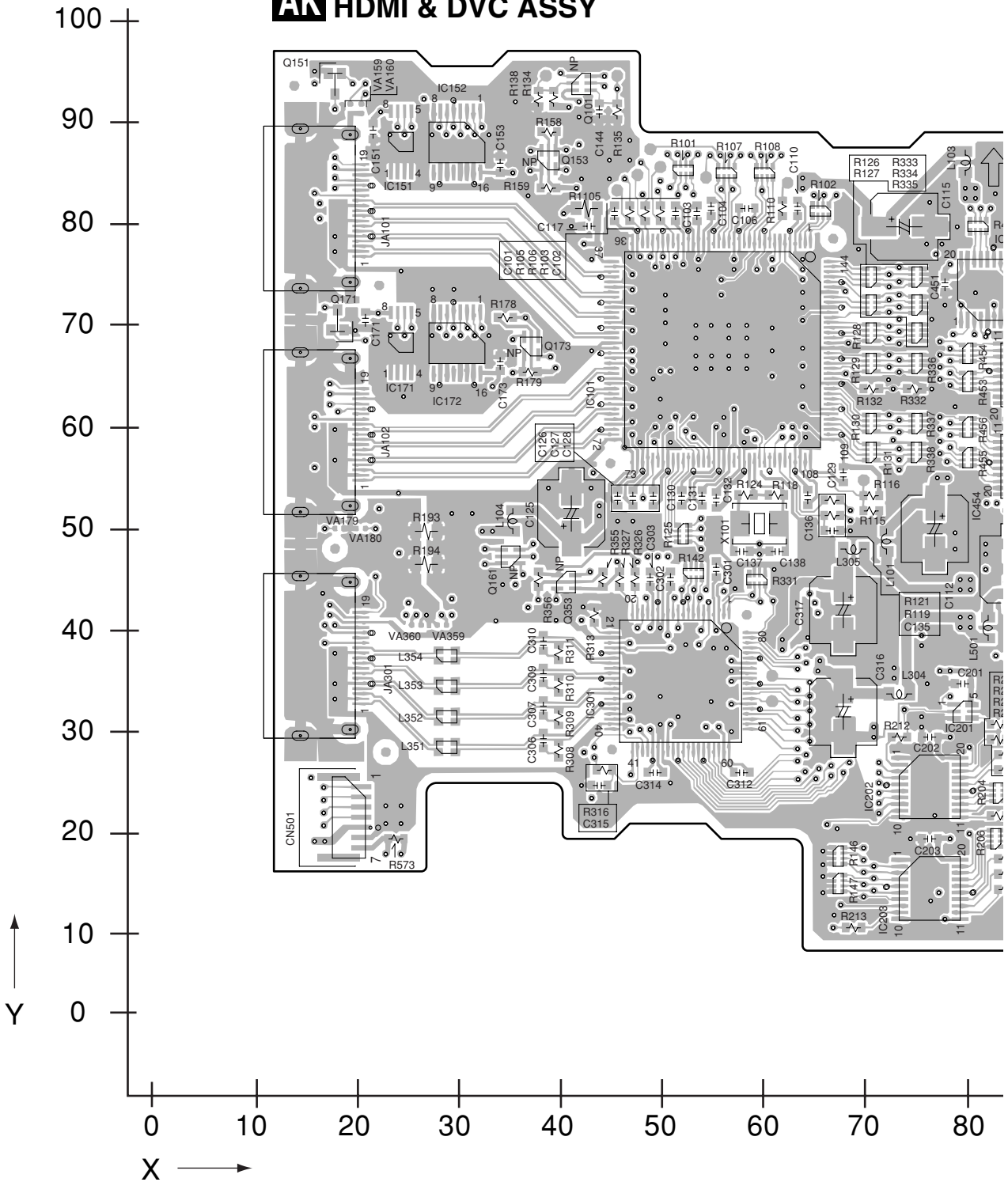

**AK**



SIDE A

A

B

C

D

E

F

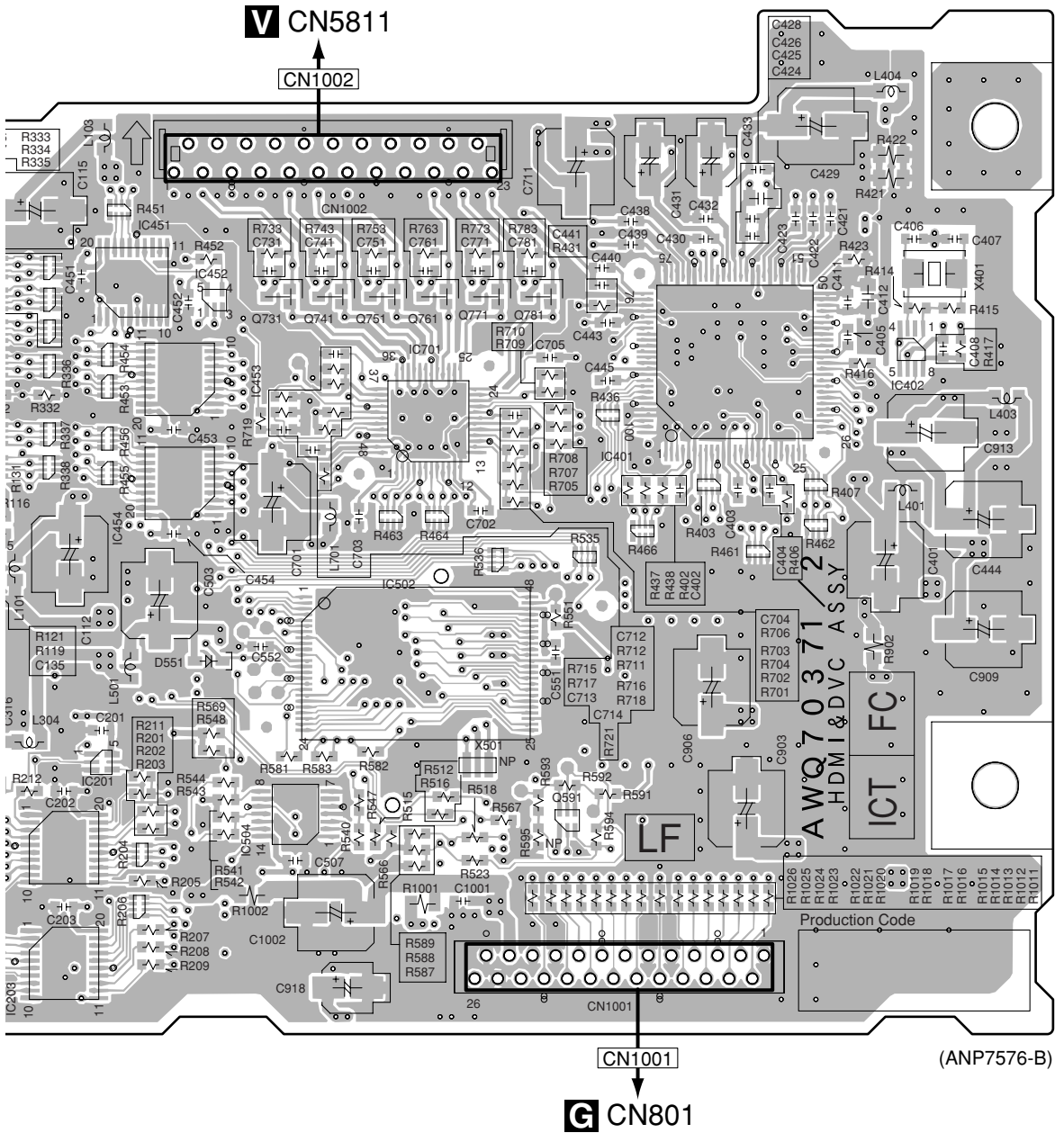

(ANP7576-B)

80 90 100 110 120 130 140 150 160

**G** CN801

**SIDE B**

A

B

C

D

E

F

**AK** HDMI & DVC ASSY

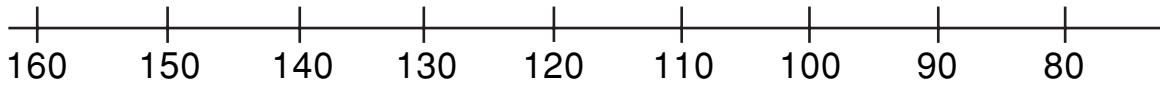
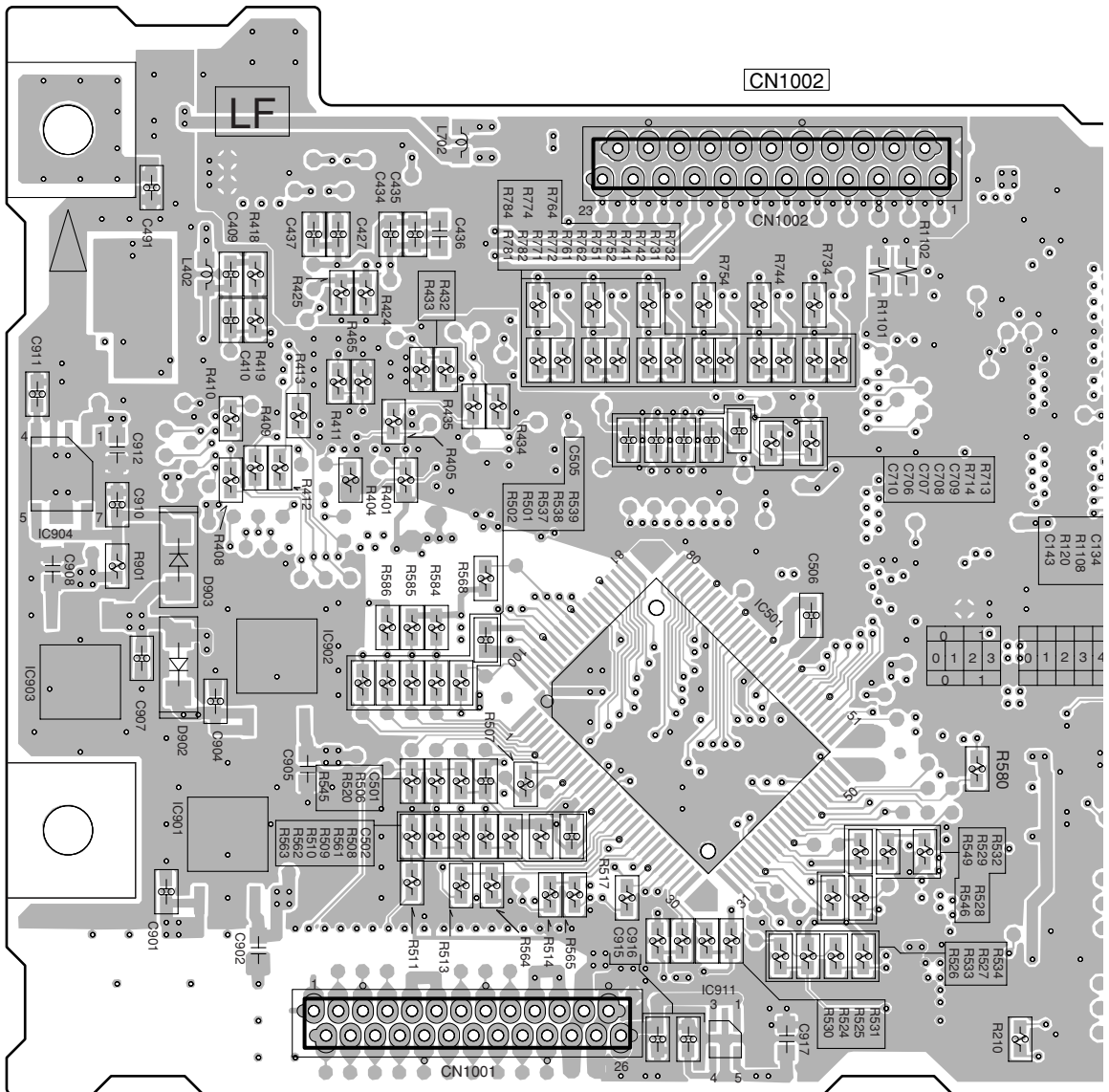

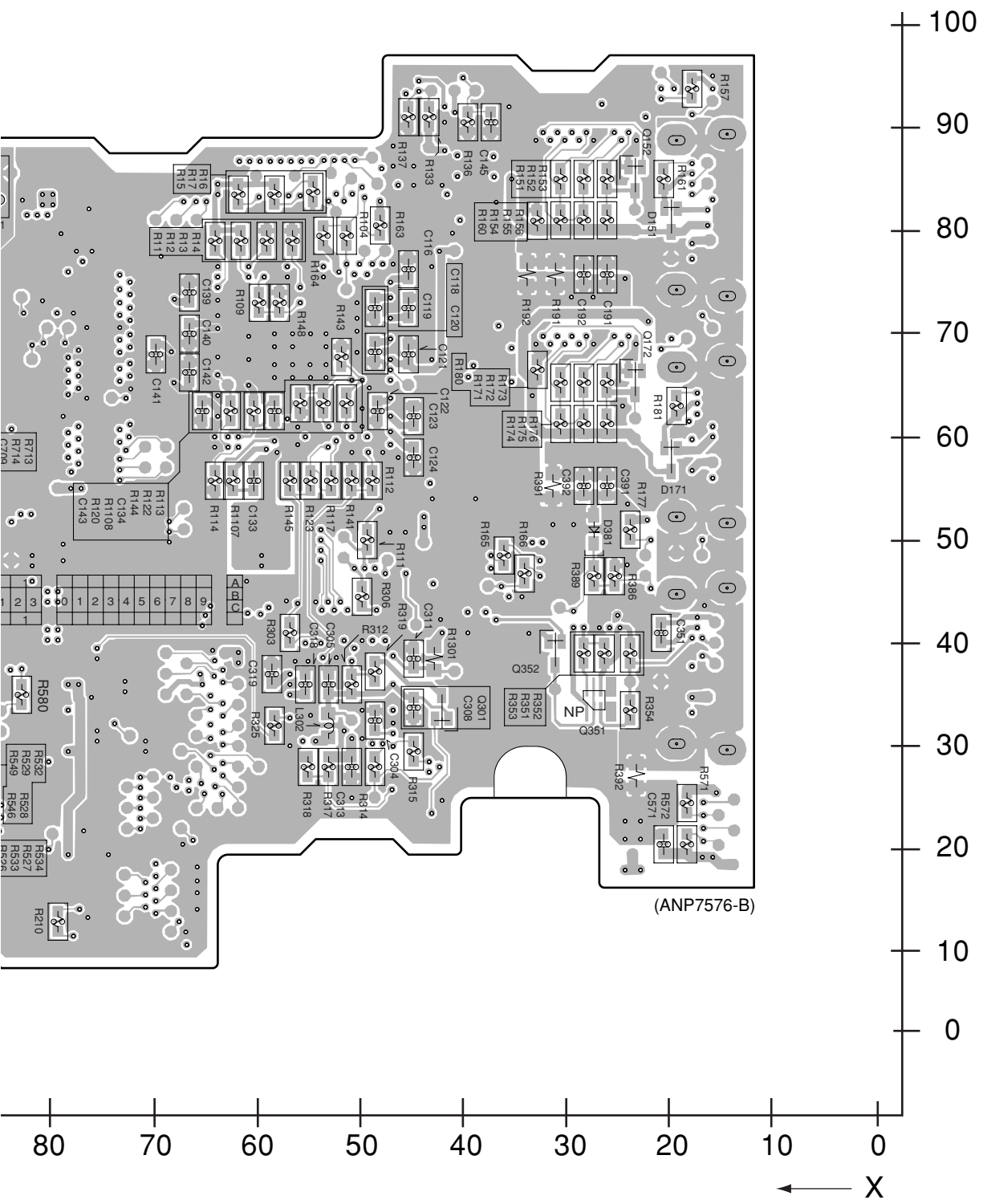

# 4.32 USB ASSY (VSX-2016AV-S ONLY)

**SIDE A**

**SIDE A**

A

B

C

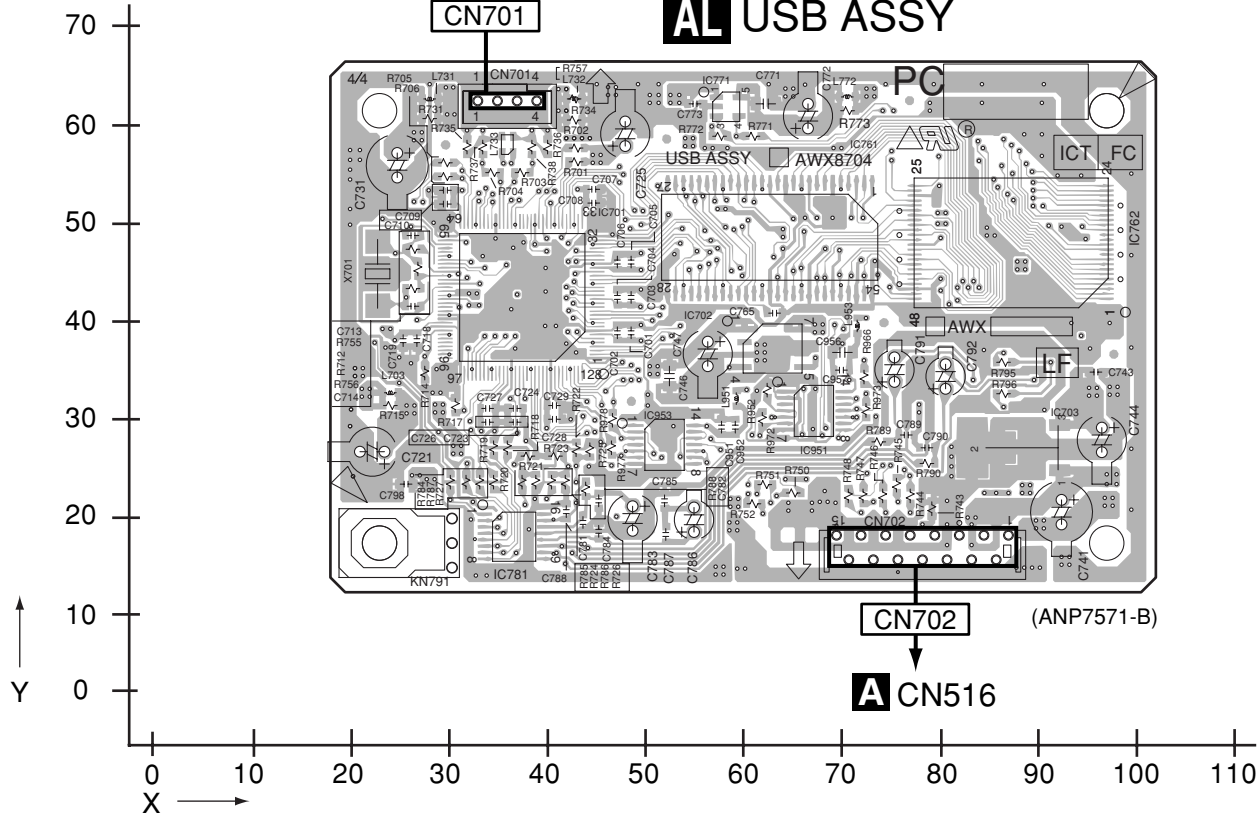

**SIDE B**

**SIDE B**

D

E

F

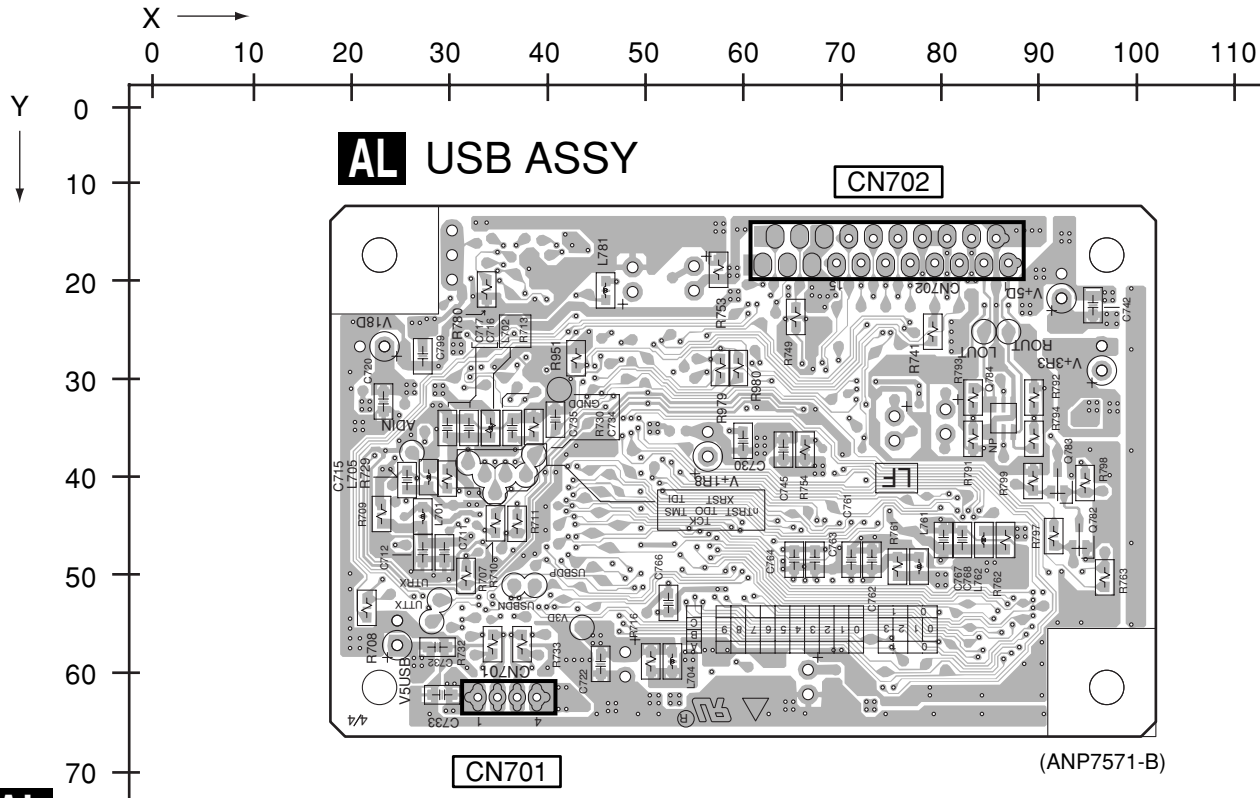

■

5

■

6

■

7

■

8

■

A

■

B

■

C

■

D

■

E

■

F

■

5

■

6

VSX-2016AV-S

■

7

■

8

■

# 5. PCB PARTS LIST

NOTES: ● Parts marked by "NSP" are generally unavailable because they are not in our Master Spare Parts List.

● The  $\Delta$  mark found on some component parts indicates the importance of the safety factor of the part. Therefore, when replacing, be sure to use parts of identical designation.

● When ordering resistors, first convert resistance values into code form as shown in the following examples.

Ex.1 When there are 2 effective digits (any digit apart from 0), such as 560 ohm and 47k ohm (tolerance is shown by J=5%, and K=10%).

560  $\Omega$   $\rightarrow$   $56 \times 10^1$   $\rightarrow$  561 ..... RD1/4PU 5 6 1 J  
 47k  $\Omega$   $\rightarrow$   $47 \times 10^3$   $\rightarrow$  473 ..... RD1/4PU 4 7 3 J  
 0.5  $\Omega$   $\rightarrow$  R50 ..... RN2H R 5 0 K  
 1  $\Omega$   $\rightarrow$  1R0 ..... RS1P 1 R 0 K

Ex.2 When there are 3 effective digits (such as in high precision metal film resistors).

5.62k  $\Omega$   $\rightarrow$   $562 \times 10^1$   $\rightarrow$  5621 ..... RN1/4PC 5 6 2 1 F

● Meaning of the figures and others in the parentheses in the parts list.

Example) IC 301 is on the point (face A, 91 of x-axis, and 111 of y-axis) of the corresponding PC board.

IC 301 (A, 91, 111) IC NJM2068V

## LIST OF WHOLE PCB ASSEMBLIES

Mark	Symbol and Description	VSX-2016AV-S /HYXJ5	VSX-81TXV /KUXJCA	VSX-81TXV-S /KUXJCA	VSX-9110TXV-K /KUXJ
NSP	1..MAIN ASSY	AWK7889	AWK7888	AWK7888	AWK7888
	2..MAIN CONTROL ASSY	AWX9009	AWX9008	AWX9008	AWX9008
	2..AUDIO IN ASSY	AWX9013	AWX9012	AWX9012	AWX9012
	2..12V-REG ASSY	AWX9014	AWX9014	AWX9014	AWX9014
	2..GUARD-C ASSY	AWX9051	AWX9051	AWX9051	AWX9051
	2..GUARD-F ASSY	AWX9070	AWX9070	AWX9070	AWX9070
1..DSP ASSY	AWX8698	AWX8697	AWX8697	AWX8697	
NSP	1..VIDEO ASSY	AWK7898	AWK7897	AWK7897	AWK7897
	2..COMPOSITE ASSY	AWX9028	AWX9026	AWX9026	AWX9026
	2..S-VIDEO ASSY	AWX9030	AWX9029	AWX9029	AWX9029
	2..COMPONENT ASSY	AWX9031	AWX9032	AWX9032	AWX9032
	2..BRIDGE 2 ASSY	AWX9050	AWX9050	AWX9050	AWX9050
NSP	1..COMPLEX ASSY	AWK7902	AWK7901	AWK7943	AWK7901
	2..PRIMARY ASSY	AWX9035	AWX9034	AWX9034	AWX9034
	2..TRANS 1 ASSY	AWX9038	AWX9038	AWX9038	AWX9038
	2..DISPLAY ASSY	AWX9103	AWX9040	AWX9040	AWX9040
	2..VOLUME ASSY	AWX9111	AWX9044	AWX9111	AWX9044
	2..MULTI JOG ASSY	AWX9112	AWX9045	AWX9112	AWX9045
	2..FRONT-IN ASSY	AWX9048	AWX9047	AWX9047	AWX9047
	2..HEADPHONE ASSY	AWX9049	AWX9049	AWX9049	AWX9049
NSP	1..SECONDARY ASSY	AWK7911	AWK7910	AWK7910	AWK7910
	2..PS/SP ASSY	AWX9107	AWX9052	AWX9052	AWX9052
	2..TRANS SIDE ASSY	AWX9056	AWX9056	AWX9056	AWX9056
	2..TRANS 2-1 ASSY	AWX9059	AWX9058	AWX9058	AWX9058
	2..DIODE 1 ASSY	AWX9060	AWX9060	AWX9060	AWX9060
	2..VH TR ASSY	AWX9061	AWX9061	AWX9061	AWX9061
	2..TRANS 2-2 ASSY	AWX9062	AWX9062	AWX9062	AWX9062
	2..LOCAL P-SUPPLY ASSY	AWX9064	AWX9063	AWX9063	AWX9063
	2..IR I/O ASSY	AWX9067	AWX9066	AWX9066	AWX9066
	2..VIDEO CONNECT ASSY	AWX9069	AWX9069	AWX9069	AWX9069
	2..DC/DC ASSY	AWX9015	AWX9015	AWX9015	AWX9015
	2..BRIDGE 1 ASSY	AWX9078	AWX9078	AWX9078	AWX9078
	NSP	1..POWER AMP ASSY	AWK7920	AWK7919	AWK7919
2..POWER AMP-L ASSY		AWX9072	AWX9071	AWX9071	AWX9071
2..POWER AMP-R ASSY		AWX9073	AWX9106	AWX9106	AWX9106
2..POWER AMP IN ASSY		AWX9075	AWX9075	AWX9075	AWX9075
2..POWER PROTECT ASSY		AWX9077	AWX9076	AWX9076	AWX9076
2..POSI 1-L ASSY		AWX9081	AWX9080	AWX9080	AWX9080
2..POSI 2-L ASSY		AWX9082	Not used	Not used	Not used
2..POSI 1-R ASSY		AWX9084	AWX9083	AWX9083	AWX9083
1..HDMI & DVC ASSY		AWQ7037	AWQ7037	AWQ7037	AWQ7037
1..USB ASSY		AWX8704	Not used	Not used	Not used

## ■ CONTRAST OF PCB ASSEMBLIES

### **A** AUDIO IN ASSY

AWX9013 and AWX9012 are constructed the same except for the following :

Mark	Symbol and Description	AWX9013	AWX9012
	IC663	Not used	NJM78M12FA
	D671	Not used	RB501V-40
	C501, C502, C505-C510, C513-C518	CCSRCH101J50	Not used
	C521-C526, C541-C544, C549-C552	CCSRCH101J50	Not used
	C503, C504, C511, C512, C519, C520	CCSRCH221J50	Not used
	C527, C528, C531-C536, C539, C540	CCSRCH151J50	Not used
	C547, C548	CCSRCH151J50	Not used
	C678	Not used	CKSRYB103K50
	C679	Not used	CEAT100M50
	CN516 15P PLUG	XKP3067	Not used

### **C** MAIN CONTROL ASSY

AWX9009 and AWX9008 are constructed the same except for the following :

Mark	Symbol and Description	AWX9009	AWX9008
	IC251	LC72725M	Not used
	Q102	Not used	RT1P241M
	C251	CEAT100M50	Not used
	C253	CCSRCH561J50	Not used
	C254	CEAT101M10	Not used
	C255	CKSRYB102K50	Not used
	C256, C257	CCSRCH270J50	Not used
	C260	CKSRYB472K50	Not used
	R116, R131	Not used	RS1/16S104J
	R124, R126, R127, R171	RS1/16S101J	Not used
	R128-R130, R132, R199, R333	Not used	RS1/16S101J
	R152	RS1/16S473J	Not used
	R153	Not used	RS1/16S473J
	R156	Not used	RS1/16S103J
	R187, R188	RS1/16S0R0J	Not used
	R189	RS1/16S104J	Not used
	R251	RS1/16S473J	RS1/16S474J
	R252-R254	RS1/16S102J	Not used
	R383, R384	Not used	RS1/16S0R0J
	CN305 12P CONNECTOR	Not used	VKN1243
	X251 CRYSTAL RESONATOR (4.332 MHz)	ASS7004	Not used

### **G** DSP ASSY

AWX8698 and AWX8697 are constructed the same except for the following :

Mark	Symbol and Description	AWX8698	AWX8797
	IC501	Not used	F2602E-01
	IC502	Not used	AAT4618IGV-0.5-1
	IC601	Not used	TC74VHC157FTS1
	D501, D502	Not used	UDZS5R6(B)
	L501, L601 CHIP SOLID INDUCTOR	Not used	QTL1013
	L502 CHIP SOLID INDUCTOR	Not used	ATL7002
	C501	Not used	CEVW470M6R3
	C502, C504-C506, C508, C602	Not used	CKSRYB104K16
	C503, C601	Not used	CCSRCH471J50
	C507	Not used	CEVW101M16
Mark	Symbol and Description	AWX8698	AWX8797
	C509, C510	Not used	CCSRCH100D50
	C513	Not used	CKSQYB105K16
	R503, R613-R616	RS1/16S0R0J	Not used

Mark	Symbol and Description	AWX8698	AWX8797
A	R504, R506, R516, R523-R526, R528 R601-R603, R605, R608, R610-R612	Not used Not used	RS1/16S101J RS1/16S101J
	R505, R507 R510 R511 R514, R515, R517, R519-R521 R518	Not used Not used Not used Not used Not used	RS1/16S102J RS1/16S471J RS1/16S105J RS1/16S104J RAB4C101J
	R527, R529, R604, R606, R607, R609 R531 R964 X501 CRYSTAL RESONATOR (45.1584 MHz) CN501 4P SOCKET	Not used Not used Not used Not used Not used	RS1/16S470J RS1/16S103J RAB4C104J ASS7065 AKP7201
	CN952 12P CONNECTOR JA351	Not used AKB7131 (JACK)	VKN1416 AKB7173 (PIN JACK 2P)

## H COMPOSITE ASSY

AWX9028 and AWX9026 are constructed the same except for the following :

Mark	Symbol and Description	AWX9028	AWX9026
C	IC1002 IC1151 Q1151 D1006 D1007	Not used Not used Not used Not used Not used	CD74HC4051PW M61545FP IMX25 DAN202U 1SS355
	D1112 C1003, C1004, C1164 C1015 C1023 C1101-C1104	Not used Not used Not used Not used CCSRCH101J50	DAN217U CKSRYB103K50 CEAT101M10 CCSRCH181J50 Not used
	C1151-C1154 C1155, C1156, C1161, C1162 C1157, C1158 C1159, C1163 C1160	Not used Not used Not used Not used Not used	CEAT2R2M50 CCSRCH101J50 CCSRCH331J50 CKSRYB104K50 CEAT100M50
	R1005 R1053 R1151, R1152 R1153, R1154 R1155, R1156	Not used Not used Not used Not used Not used	RS1/16S750J RS1/16S0R0J RS1/16S104J RS1/16S202J RS1/16S103J
	R1157, R1158 R1159, R1160, R1164 R1163 1004 PIN JACK (2P) 1005 PIN JACK (2P) JA1006 PIN JACK (1P)	Not used Not used Not used Not used Not used Not used AKB7175	RS1/16S101J RS1/16S471J RS1/16S473J AKB7176 AKB7181 Not used

## I S-VIDEO ASSY

AWX9030 and AWX9029 are constructed the same except for the following :

Mark	Symbol and Description	AWX9030	AWX9029
F	IC1301 Q1301 Q1351, Q1353 Q1352 D1302	Not used Not used Not used Not used Not used	MAX3232CPW 2SC4081(QRS) 2SA1576A(RS) RT1N241M 1SS355
	D1351 L1351 CHIP SOLID INDUCTOR C1304, C1305 C1306 C1308	Not used Not used Not used Not used Not used	UDZS5R1(B) ATL7002 CKSRYB105K10 CKSRYB473K50 CKSRYB224K16



Mark	Symbol and Description	AWX9030	AWX9029
	C1309, C1311, C1353	Not used	CKSRYB103K50
	C1310	Not used	CCSRCH331J50
	C1352	Not used	CKSRYB104K16
	C1354	Not used	CKSRYB102K50
	C1355	Not used	CKSRYB472K50
	R1301-R1304	Not used	RS1/16S101J
	R1305, R1308	Not used	RS1/16S224J
	R1306	Not used	RS1/16S474J
	R1307, R1353, R1354	Not used	RS1/16S103J
	R1309	Not used	RS1/16S0R0J
	R1310	RS1/16S103J	Not used
	R1351, R1352	Not used	RS1/16S180J
	R1355, R1356	Not used	RS1/16S472J
	CN1301 9P D-SUB SOCKET	Not used	AKP1213
	CN1302 07P CONNECTOR	RKN1048	Not used
	JA1351 JACK	Not used	RKN1004
	KN1351 SCREW PLATE	Not used	VNE1948

## **K** COMPONENT ASSY

AWX9031 and AWX9032 are constructed the same except for the following :

Mark	Symbol and Description	AWX9031	AWX9032
	C1501, C1502, C1521, C1522, C1541, C1542	CCSRCH101J50	Not used
	C1561, C1562	CCSRCH101J50	Not used
	C1507, C1508, C1527, C1528, C1569-C1572	CCSRCH271J50	Not used

## **L** DISPLAY ASSY

AWX9103 and AWX9040 are constructed the same except for the following :

Mark	Symbol and Description	AWX9103	AWX9040
	IC2401	Not used	CD4053BNS
	Q2402	Not used	UMB1N
	Q2403	Not used	DTC124EUA
	D2401	Not used	1SS355
	D2402	Not used	DAN217U
	D2415	Not used	DAN202U
	C2402	Not used	CKSRYB153K50
	C2412	Not used	CKSRYB103K50
	R2407	Not used	RS1/16S223J
	R2408, R2410	Not used	RS1/16S103J
	R2409	Not used	RS1/16S392J
	R2414	RS1/16S0R0J	Not used

## **M** VOLUME ASSY

AWX9111 and AWX9044 are different in part number, but construction is the same.

## **N** MULTI JOG ASSY

AWX9112 and AWX9045 are different in part number, but construction is the same.

## **P** FRONT-IN ASSY

AWX9048 and AWX9047 are constructed the same except for the following :

Mark	Symbol and Description	AWX9048	AWX9047
	L2752, L2753 CHIP FERRITE BEAD	VTL1169	Not used
	C2673	CKSRYB104K16	CKSRYB104K25
	C2753, C2756	CKSRYB104K16	Not used
	C2755	CEAT101M16	Not used
	C2757	CCSRCH471J50	Not used

Mark	Symbol and Description	AWX9048	AWX9047
	R2751, R2752 CN2652 CONNECTOR JA2751 USB CONNECTOR	RS1/16S0R0J B4B-PH-K-S XKP3086	Not used Not used Not used

## Q PRIMARY ASSY

AWX9035 and AWX9034 are constructed the same except for the following :

Mark	Symbol and Description	AWX9035	AWX9034
⚠	RY2001	ASR7013	ASR7022
⚠	T2001 STANDBY TRANSFORMER	ATT7040	ATT7043
⚠	R2001 (2.2 M, 1/2 W)	Not used	RCN1080
	R2002	RD1/4MUF101J	RD1/4MUF220J
⚠	2001 AC SOCKET 1P	Not used	AKP1033

## S TRANS 2-1 ASSY

AWX9059 and AWX9058 are constructed the same except for the following :

Mark	Symbol and Description	AWX9059	AWX9058
	D3253	UDZS8R2(B)	UDZS10(B)
	D3254	UDZS7R5(B)	UDZS9R1(B)
	D3255	UDZS9R1(B)	UDZS10(B)
	D3256	UDZS8R2(B)	UDZS9R1(B)
	D3263	UDZS13(B)	UDZS10(B)
	D3264	UDZS15(B)	UDZS12(B)

## W PS/SP ASSY

AWX9107 and AWX9052 are constructed the same except for the following :

Mark	Symbol and Description	AWX9107	AWX9052
	C3101, C3102	ACH7255	ACH7258
	CN3001 SPEAKER TERMINAL 8P	AKE7119	AKE7118
	CN3002 SPEAKER TERMINAL 6P	AKE7108	AKE7107

## Z LOCAL P-SUPPLY ASSY

AWX9064 and AWX9063 are constructed the same except for the following :

Mark	Symbol and Description	AWX9064	AWX9063
⚠	IC3502 (1.6A)	AEK7012	Not used
⚠	Q3501	UMD2N	Not used
⚠	Q3502	2SD1763A(DE)	Not used
	Q3503	DTC124EUA	Not used
⚠	D3509, D3510	1SR154-400	Not used
	D3511	UDZS27(B)	Not used
	C3510	CEANP102M16	Not used
	C3511	CEAT102M35	Not used
	C3512, C3514	CEAT100M50	Not used
	C3513	CKSRYB102K50	Not used

Mark	Symbol and Description	AWX9064	AWX9063
	C3515	CEANP470M25	Not used
	R3504	RS1/16S472J	Not used
	R3505	RS1/16S101J	Not used
	R3506	RS1/16S222J	Not used

## AB IR I/O ASSY

AWX9067 and AWX9066 are constructed the same except for the following :

Mark	Symbol and Description	AWX9067	AWX9066
	D3702	Not used	1SS355
	L3701, L3703 INDUCTOR	Not used	CTF1473
	L3702 CHIP SOLID INDUCTOR	Not used	QTL1013
	L3704 INDUCTOR	Not used	CTF1385
	C3758	Not used	CKSRYB103K50

Mark	Symbol and Description	AWX9067	AWX9066
	R3701 R3702 R3703, R3755 JA3701 CONNECTOR JA3702 JACK	Not used Not used RS1/16S0R0J Not used Not used	RS1/16S0R0J RS1/16S102J Not used CKS4124 RKN1004

## **AD** POWER AMP-L ASSY

AWX9072 and AWX9071 are constructed the same except for the following :

Mark	Symbol and Description	AWX9072	AWX9071
	CN5005 CONNECTOR	B2B-PH-K-R	Not used

## **AE** POSI 1-L ASSY

AWX9081 and AWX9080 are constructed the same except for the following :

Mark	Symbol and Description	AWX9081	AWX9080
	TH4501 POSISTOR	PTFM04BH222Q2N34B0	PTFM04BC222Q2N34B0

## **AG** POWER AMP-R ASSY

AWX9073 and AWX9106 are constructed the same except for the following :

Mark	Symbol and Description	AWX9073	AWX9106
	5002 PCB BINDER	VEF1040	Not used

## **AH** POSI 1-R ASSY

AWX9084 and AWX9083 are constructed the same except for the following :

Mark	Symbol and Description	AWX9084	AWX9083
	TH4503 POSISTOR	PTFM04BH222Q2N34B0	PTFM04BC222Q2N34B0

## **AJ** POWER PROTECT ASSY

AWX9077 and AWX9076 are constructed the same except for the following :

Mark	Symbol and Description	AWX9077	AWX9076
	Q5703 Q5706 D5702 C5706 R5704, R5709  R5705, R5708, R5746 R5706 R5718 CN5706 3 PIN CONNECTOR	RT1N241M RT1P241M 1SS355 CKSRYB103K50 Not used  RS1/16S0R0J RS1/16S822J RS1/16S104J S3B-EH	Not used Not used Not used Not used RS1/16S0R0J  Not used Not used Not used Not used

1 2 3 4

**PCB PARTS LIST FOR VSX-2016AV-S/HYXJ5 UNLESS OTHERWISE NOTED**

Mark No.	Description	Part No.	Mark No.	Description	Part No.
<b>MAIN ASSY (AWK7889)</b>			R 511	(B,302,128)	RS1/16S222J
<b>MISCELLANEOUS</b>			R 512	(B,302,118)	RS1/16S222J
J 663	JUMPER WIRE	D20PDD0605E	R 513	(B,302,142)	RS1/16S331J
<b>A AUDIO IN ASSY</b>			R 514	(B,302,135)	RS1/16S331J
<b>MISCELLANEOUS</b>			R 515	(B,302,209)	RS1/16S331J
IC 501	(A,262,69) 8CH E-VOL	R2S15205FP	R 516	(B,302,202)	RS1/16S331J
IC 701	(A,205,68) OP-AMP IC	BA4560RF	R 517	(B,302,222)	RS1/16S331J
IC 702	(A,220,73) OP-AMP IC	BA4560RF	R 518	(B,302,216)	RS1/16S331J
IC 703	(A,220,56) IC	TC4066BFT	R 519	(B,302,155)	RS1/16S222J
IC 741	(A,177,68) OP-AMP IC	BA4560RF	R 520	(B,302,148)	RS1/16S222J
IC 761	(A,191,68) OP-AMP IC	BA4560RF	R 521	(B,302,168)	RS1/16S331J
IC 781	(A,163,68) OP-AMP IC	BA4560RF	R 522	(B,302,161)	RS1/16S331J
IC 801	(A,264,170) OP-AMP IC	UPC4570G2	R 523	(B,302,182)	RS1/16S331J
IC 821	(A,264,139) OP-AMP IC	UPC4570G2	R 524	(B,302,176)	RS1/16S331J
IC 841	(A,264,155) OP-AMP IC	UPC4570G2	R 525	(B,302,195)	RS1/16S331J
IC 861	(A,264,123) OP-AMP IC	UPC4570G2	R 526	(B,302,189)	RS1/16S331J
Q 661	(A,136,78) TRANSISTOR	2SD1858X	R 527	(B,309,56)	RS1/16S474J
Q 662	(A,136,90) TRANSISTOR	2SB1238X	R 528	(B,309,51)	RS1/16S474J
Q 701	(A,224,50) TRANSISTOR	UMD2N	R 529	(B,309,69)	RS1/16S474J
D 591	(B,231,52) DIODE	DAN217U	R 530	(B,309,64)	RS1/16S474J
△D 661	(B,39,52) DIODE	1SR154-400	R 531	(B,309,84)	RS1/16S474J
△D 662	(B,34,52) DIODE	1SR154-400	R 532	(B,309,79)	RS1/16S474J
△D 663	(B,25,52) DIODE	1SR154-400	R 533	(B,309,97)	RS1/16S474J
△D 664	(B,30,52) DIODE	1SR154-400	R 534	(B,309,92)	RS1/16S474J
D 669	(B,127,75) DIODE	UDZS7R5(B)	R 535	(B,309,110)	RS1/16S474J
D 670	(B,127,87) DIODE	UDZS7R5(B)	R 536	(B,309,107)	RS1/16S474J
J 662	(A,85,59) 3P HOUSING WIRE ASSY	ADX7509	R 537	(B,309,128)	RS1/16S474J
CN501	(A,258,24) 19P PLUG	XKP3069	R 538	(B,309,118)	RS1/16S474J
CN507	(A,266,24) B TO B CONNECTOR	BTEM20S-1S	R 539	(B,309,140)	RS1/16S474J
CN509	(A,234,48) 23P PLUG	XKP3071	R 540	(B,309,134)	RS1/16S474J
CN511	(A,131,47) B TO B CONNECTOR	BTEM20S-1S	R 541	(B,309,210)	RS1/16S474J
CN512	(A,220,24) 23P PLUG	XKP3071	R 542	(B,309,205)	RS1/16S474J
CN513	(A,98,48) 23P PLUG	XKP3071	R 543	(B,309,223)	RS1/16S474J
CN516	(A,39,24) 15P PLUG	XKP3067	R 544	(B,309,218)	RS1/16S474J
CN520	(A,282,208) 17P SOCKET	XKP3079	R 545	(B,309,154)	RS1/16S474J
CN521	(A,317,60) PIN JACK (4P)	AKB7172	R 546	(B,309,149)	RS1/16S474J
CN522	(A,317,88) PIN JACK (4P)	AKB7172	R 547	(B,309,167)	RS1/16S474J
CN524	(A,317,158) PIN JACK (4P)	AKB7172	R 548	(B,309,162)	RS1/16S474J
CN525	(A,317,186) PIN JACK (4P)	AKB7172	R 549	(B,309,182)	RS1/16S474J
CN526	(A,317,214) PIN JACK (4P)	AKB7172	R 550	(B,309,177)	RS1/16S474J
CN661	(A,26,62) CONNECTOR POST	S10B-PH	R 551	(B,309,195)	RS1/16S474J
523	(A,317,123) PIN JACK (6P)	AKB7182	R 552	(B,309,190)	RS1/16S474J
Y 661	AVG14 BOARD IN	ADX7511	R 561	(A,246,87)	RS1/16S472J
501	(A,150,71) PCB BINDER	VEF1040	R 562	(A,244,75)	RS1/16S472J
664	(A,46,67) 6P CABLE HOLDER	51048-0600	R 563	(A,244,58)	RS1/16S102J
<b>RESISTORS</b>			R 564	(A,244,57)	RS1/16S102J
R 501	(B,303,54)	RS1/16S331J	R 565	(B,268,42)	RS1/16S0R0J
R 502	(B,302,43)	RS1/16S331J	R 566	(B,275,42)	RS1/16S0R0J
R 503	(B,302,71)	RS1/16S222J	R 571	(B,256,33)	RS1/16S0R0J
R 504	(B,302,64)	RS1/16S222J	R 572	(B,234,53)	RS1/16S0R0J
R 505	(B,302,84)	RS1/16S331J	R 601	(B,222,22)	RS1/16S0R0J
R 506	(B,302,77)	RS1/16S331J	R 663	(B,133,76)	RS1/16S472J
R 507	(B,302,97)	RS1/16S331J	R 664	(B,133,88)	RS1/16S472J
R 508	(B,302,90)	RS1/16S331J	R 665	(B,133,72)	RS1/16S101J
R 509	(B,302,110)	RS1/16S331J	R 666	(B,133,84)	RS1/16S101J
R 510	(B,302,103)	RS1/16S331J			

5		6		7		8	
Mark No.	Description	Part No.	Mark No.	Description	Part No.		
R 701	(A,203,61)	RS1/16S473J	R 778	(B,197,79)	RS1/16S101J		
R 702	(A,208,61)	RS1/16S473J	R 781	(A,161,61)	RS1/16S473J		
R 703	(B,204,60)	RS1/16S332J	R 782	(A,166,61)	RS1/16S473J		
R 704	(B,207,60)	RS1/16S332J	R 783	(B,162,60)	RS1/16S272J		A
R 705	(B,202,60)	RS1/16S332J	R 784	(B,165,60)	RS1/16S272J		
R 706	(B,209,60)	RS1/16S332J	R 785	(B,160,60)	RS1/16S272J		
R 707	(B,202,64)	RS1/16S392J	R 786	(B,167,60)	RS1/16S272J		
R 708	(B,209,64)	RS1/16S392J	R 787	(B,160,64)	RS1/16S272J		
R 709	(B,204,64)	RS1/16S472J	R 788	(B,167,64)	RS1/16S272J		
R 710	(B,207,64)	RS1/16S472J	R 789	(B,162,64)	RS1/16S392J		
R 711	(B,204,68)	RS1/16S272J	R 790	(B,165,64)	RS1/16S392J		
R 712	(B,207,68)	RS1/16S272J	R 791	(B,162,68)	RS1/16S122J		
R 713	(B,202,72)	RS1/16S331J	R 792	(B,165,68)	RS1/16S122J		
R 714	(B,209,72)	RS1/16S331J	R 793	(B,160,72)	RS1/16S221J		
R 715	(B,204,72)	RS1/16S474J	R 794	(B,167,72)	RS1/16S221J		B
R 716	(B,207,72)	RS1/16S474J	R 797	(B,158,79)	RS1/16S101J		
R 719	(B,223,80)	RS1/16S0R0J	R 798	(B,169,79)	RS1/16S101J		
R 720	(B,216,80)	RS1/16S0R0J	R 801	(B,262,165)	RS1/16S223J		
R 721	(B,223,77)	RS1/16S472J	R 802	(B,262,176)	RS1/16S223J		
R 722	(B,216,77)	RS1/16S472J	R 805	(A,266,165)	RS1/16S682J		
R 723	(A,226,70)	RS1/16S472J	R 806	(A,266,175)	RS1/16S682J		
R 724	(A,213,70)	RS1/16S472J	R 807	(A,269,168)	RS1/16S331J		
R 725	(A,226,74)	RS1/16S122J	R 808	(A,269,173)	RS1/16S331J		
R 726	(A,213,74)	RS1/16S122J	R 811	(A,263,165)	RS1/16S153J		
R 727	(B,223,73)	RS1/16S392J	R 812	(A,263,175)	RS1/16S153J		
R 728	(B,216,73)	RS1/16S392J	R 815	(B,262,194)	RS1/16S104J		C
R 731	(B,225,66)	RS1/16S101J	R 816	(B,262,186)	RS1/16S104J		
R 732	(B,214,66)	RS1/16S101J	R 821	(B,262,134)	RS1/16S223J		
R 733	(A,226,48)	RS1/16S473J	R 822	(B,262,144)	RS1/16S223J		
R 741	(A,175,61)	RS1/16S473J	R 825	(A,266,134)	RS1/16S682J		
R 742	(A,180,61)	RS1/16S473J	R 826	(A,266,144)	RS1/16S682J		
R 743	(B,176,60)	RS1/16S272J	R 827	(A,269,137)	RS1/16S331J		
R 744	(B,179,60)	RS1/16S332J	R 828	(A,269,142)	RS1/16S331J		
R 745	(B,174,60)	RS1/16S272J	R 831	(A,263,134)	RS1/16S153J		
R 746	(B,181,60)	RS1/16S562J	R 832	(A,263,144)	RS1/16S153J		
R 747	(B,174,64)	RS1/16S272J	R 835	(B,275,194)	RS1/16S104J		D
R 748	(B,181,64)	RS1/16S393J	R 836	(B,275,186)	RS1/16S104J		
R 749	(B,176,64)	RS1/16S392J	R 841	(B,262,149)	RS1/16S223J		
R 750	(B,179,64)	RS1/16S182J	R 842	(B,262,160)	RS1/16S223J		
R 751	(B,176,68)	RS1/16S122J	R 845	(A,266,150)	RS1/16S682J		
R 752	(B,179,68)	RS1/16S362J	R 846	(A,266,160)	RS1/16S682J		
R 753	(B,174,72)	RS1/16S221J	R 847	(A,269,152)	RS1/16S331J		
R 754	(B,181,72)	RS1/16S121J	R 848	(A,269,157)	RS1/16S331J		
R 757	(B,172,79)	RS1/16S101J	R 851	(A,263,150)	RS1/16S153J		
R 758	(B,183,79)	RS1/16S101J	R 852	(A,263,160)	RS1/16S153J		
R 761	(A,189,61)	RS1/16S473J	R 855	(B,269,194)	RS1/16S104J		E
R 762	(A,194,61)	RS1/16S473J	R 856	(B,269,186)	RS1/16S104J		
R 763	(B,190,60)	RS1/16S272J	R 861	(B,262,118)	RS1/16S223J		
R 764	(B,193,60)	RS1/16S272J	R 862	(B,262,129)	RS1/16S223J		
R 765	(B,188,60)	RS1/16S272J	R 865	(A,266,118)	RS1/16S682J		
R 766	(B,195,60)	RS1/16S272J	R 866	(A,266,128)	RS1/16S682J		
R 767	(B,188,64)	RS1/16S272J	R 867	(A,269,121)	RS1/16S331J		
R 768	(B,195,64)	RS1/16S272J	R 868	(A,269,126)	RS1/16S331J		
R 769	(B,190,64)	RS1/16S392J	R 871	(A,263,118)	RS1/16S153J		
R 770	(B,193,64)	RS1/16S392J	R 872	(A,263,128)	RS1/16S153J		
R 771	(B,190,68)	RS1/16S122J	R 875	(B,282,194)	RS1/16S104J		
R 772	(B,193,68)	RS1/16S122J	R 876	(B,282,186)	RS1/16S104J		F
R 773	(B,188,72)	RS1/16S221J	R 883	(A,253,116)	RS1/16S0R0J		
R 774	(B,195,72)	RS1/16S221J					
R 777	(B,186,79)	RS1/16S101J					

**Mark No. Description****Part No.****Mark No. Description****Part No.****CAPACITORS**

A	C 501 (B,307,56)	CCSRCH101J50	C 562 (A,300,103) ELECT. CAPACITOR	CEAT470M25
	C 502 (B,307,51)	CCSRCH101J50	C 563 (A,300,131)	CEAT100M50
	C 503 (B,307,69)	CCSRCH221J50	C 564 (A,300,120)	CEAT100M50
	C 504 (B,307,64)	CCSRCH221J50	C 565 (A,300,144) ELECT. CAPACITOR	CEAT470M25
	C 505 (B,307,84)	CCSRCH101J50	C 566 (A,300,135) ELECT. CAPACITOR	CEAT470M25
	C 506 (B,307,79)	CCSRCH101J50	C 567 (A,300,210) ELECT. CAPACITOR	CEAT470M25
	C 507 (B,307,97)	CCSRCH101J50	C 568 (A,300,201) ELECT. CAPACITOR	CEAT470M25
	C 508 (B,307,92)	CCSRCH101J50	C 569 (A,293,210) ELECT. CAPACITOR	CEAT470M25
	C 509 (B,307,110)	CCSRCH101J50	C 570 (A,293,201) ELECT. CAPACITOR	CEAT470M25
	C 510 (B,307,107)	CCSRCH101J50	C 571 (A,300,157)	CEAT100M50
	C 511 (B,307,128)	CCSRCH221J50	C 572 (A,300,148)	CEAT100M50
	C 512 (B,307,118)	CCSRCH221J50	C 573 (A,300,170) ELECT. CAPACITOR	CEAT470M25
B	C 513 (B,307,140)	CCSRCH101J50	C 574 (A,300,161) ELECT. CAPACITOR	CEAT470M25
	C 514 (B,307,134)	CCSRCH101J50	C 575 (A,300,184) ELECT. CAPACITOR	CEAT470M25
	C 515 (B,307,210)	CCSRCH101J50	C 576 (A,300,175) ELECT. CAPACITOR	CEAT470M25
	C 516 (B,307,205)	CCSRCH101J50	C 577 (A,300,197) ELECT. CAPACITOR	CEAT470M25
	C 517 (B,307,223)	CCSRCH101J50	C 578 (A,300,188) ELECT. CAPACITOR	CEAT470M25
	C 518 (B,307,218)	CCSRCH101J50	C 579 (A,270,87)	CEAT101M16
	C 519 (B,307,154)	CCSRCH221J50	C 580 (A,268,95)	CEAT101M16
	C 520 (B,307,149)	CCSRCH221J50	C 581 (A,264,87)	CEAT101M16
	C 521 (B,307,167)	CCSRCH101J50	C 582 (A,262,95)	CEAT101M16
	C 522 (B,307,162)	CCSRCH101J50	C 583 (A,258,87)	CEAT101M16
	C 523 (B,307,182)	CCSRCH101J50	C 584 (A,256,95)	CEAT101M16
C	C 524 (B,307,177)	CCSRCH101J50	C 585 (A,252,87)	CEAT101M16
	C 525 (B,307,195)	CCSRCH101J50	C 586 (A,250,95)	CEAT101M16
	C 526 (B,307,190)	CCSRCH101J50	C 587 (A,247,84)	CKSRYP473K50
	C 527 (B,297,49)	CCSRCH151J50	C 588 (A,246,84)	CKSRYP154K10
	C 528 (B,298,44)	CCSRCH151J50	C 589 (A,244,84)	CKSRYP223K50
	C 531 (B,297,83)	CCSRCH151J50	C 590 (A,247,76)	CKSRYP473K50
	C 532 (B,298,79)	CCSRCH151J50	C 591 (A,247,74)	CKSRYP154K10
	C 533 (B,297,96)	CCSRCH151J50	C 592 (A,244,73)	CKSRYP223K50
	C 534 (B,298,92)	CCSRCH151J50	C 593 (A,248,59)	CCSRCH101J50
	C 535 (B,297,109)	CCSRCH151J50	C 594 (A,247,59)	CCSRCH101J50
	C 536 (B,298,105)	CCSRCH151J50	C 595 (A,247,79)	CKSRYP103K50
D	C 539 (B,297,141)	CCSRCH151J50	C 596 (A,247,78)	CKSRYP103K50
	C 540 (B,298,137)	CCSRCH151J50	C 599 (A,269,35)	CEJQ100M25
	C 541 (B,297,209)	CCSRCH101J50	C 600 (A,274,35)	CEJQ100M25
	C 542 (B,298,203)	CCSRCH101J50	C 641 (B,309,114)	CKSRYP103K50
	C 543 (B,300,222)	CCSRCH101J50	C 642 (B,309,88)	CKSRYP103K50
	C 544 (B,300,216)	CCSRCH101J50	C 643 (B,309,214)	CKSRYP103K50
	C 547 (B,297,167)	CCSRCH151J50	C 644 (B,309,158)	CKSRYP103K50
	C 548 (B,298,163)	CCSRCH151J50	C 645 (B,309,186)	CKSRYP103K50
	C 549 (B,297,182)	CCSRCH101J50	C 661 (A,50,48) ELECT. CAPACITOR	CEAT222M25
	C 550 (B,298,177)	CCSRCH101J50	C 662 (A,64,48) ELECT. CAPACITOR	CEAT222M25
	C 551 (B,297,194)	CCSRCH101J50	C 673 (A,130,76)	CEAT2R2M50
E	C 552 (B,297,190)	CCSRCH101J50	C 674 (A,130,86)	CEAT2R2M50
	C 553 (A,300,51) ELECT. CAPACITOR	CEAT470M25	C 675 (A,143,76)	CEAT100M50
	C 554 (A,300,42) ELECT. CAPACITOR	CEAT470M25	C 676 (A,143,86)	CEAT100M50
	C 555 (A,300,73)	CEAT100M50	C 701 (A,202,53)	CEAT2R2M50
	C 556 (A,300,64)	CEAT100M50	C 702 (A,208,53)	CEAT2R2M50
	C 557 (A,300,86) ELECT. CAPACITOR	CEAT470M25	C 703 (A,203,62)	CCSRCH471J50
	C 558 (A,300,77) ELECT. CAPACITOR	CEAT470M25	C 704 (A,208,62)	CCSRCH471J50
	C 559 (A,300,99) ELECT. CAPACITOR	CEAT470M25	C 705 (A,203,64)	CCSRCH331J50
	C 560 (A,300,90) ELECT. CAPACITOR	CEAT470M25	C 706 (A,208,64)	CCSRCH331J50
	C 561 (A,300,112) ELECT. CAPACITOR	CEAT470M25	C 707 (B,202,68)	CCSRCH391J50
F			C 708 (B,209,68)	CCSRCH391J50
			C 709 (A,202,76)	CEAT100M50
			C 710 (A,209,76)	CEAT100M50
			C 713 (A,223,69)	CEAT100M50
			C 714 (A,216,69)	CEAT100M50

5		6		7		8		
Mark No.	Description	Part No.	Mark No.	Description	Part No.	Mark No.	Description	
C 717	(A,208,72)	CKSRYP103K50	C 827	(A,273,192) ELECT. CAPACITOR	CEAT470M25			
C 718	(A,203,72)	CKSRYP103K50	C 828	(A,273,185) ELECT. CAPACITOR	CEAT470M25			
C 719	(A,217,77)	CKSRYP104K50	C 829	(A,260,137)	CKSRYP103K50			
C 720	(A,222,77)	CKSRYP104K50	C 830	(A,260,142)	CKSRYP103K50		A	
C 721	(A,224,53)	CKSRYP103K50	C 841	(A,259,108)	CEAT4R7M50			
C 722	(A,215,56)	CKSRYP103K50	C 842	(A,259,101)	CEAT4R7M50			
C 741	(A,174,53)	CEAT2R2M50	C 845	(A,263,148)	CCSRCH101J50			
C 742	(A,180,53)	CEAT2R2M50	C 846	(A,263,161)	CCSRCH101J50			
C 743	(A,175,62)	CCSRCH331J50	C 847	(A,266,192) ELECT. CAPACITOR	CEAT470M25			
C 744	(A,180,62)	CKSRYP223K50	C 848	(A,266,185) ELECT. CAPACITOR	CEAT470M25			
C 745	(A,175,64)	CCSRCH331J50	C 849	(A,260,152)	CKSRYP103K50			
C 746	(A,180,64)	CKSRYP103K50	C 850	(A,260,157)	CKSRYP103K50			
C 747	(B,174,68)	CCSRCH471J50	C 861	(A,271,108)	CEAT4R7M50			
C 748	(B,181,68)	CKSRYP682K50	C 862	(A,271,101)	CEAT4R7M50			
C 749	(A,174,76)	CEAT100M50	C 865	(A,263,117)	CCSRCH101J50		B	
C 750	(A,181,76)	CEAT100M50	C 866	(A,263,129)	CCSRCH101J50			
C 751	(B,176,79)	CKSRYP472K50	C 867	(A,279,192) ELECT. CAPACITOR	CEAT470M25			
C 752	(B,179,79)	CKSRYP472K50	C 868	(A,279,185) ELECT. CAPACITOR	CEAT470M25			
C 753	(A,180,72)	CKSRYP103K50	C 869	(A,260,121)	CKSRYP103K50			
C 754	(A,175,72)	CKSRYP103K50	C 870	(A,260,126)	CKSRYP103K50			
C 761	(A,188,53)	CEAT2R2M50	<b>B 12V-REG ASSY</b> <b>MISCELLANEOUS</b> IC 661 (A,12,90) REGULATOR IC NJM78M12FA IC 662 (A,39,90) REGULATOR IC NJM79M12FA D 665 (B,28,90) CHIP DIODE RB501V-40 D 666 (B,56,88) CHIP DIODE RB501V-40 663 (A,46,77) 6P CABLE HOLDER 51048-0600					
C 762	(A,194,53)	CEAT2R2M50						
C 763	(A,189,62)	CCSRCH331J50						
C 764	(A,194,62)	CCSRCH331J50						
C 765	(A,189,64)	CCSRCH331J50						
C 766	(A,194,64)	CCSRCH331J50						
C 767	(B,188,68)	CCSRCH471J50						
C 768	(B,195,68)	CCSRCH471J50						
C 769	(A,188,76)	CEAT100M50						
C 770	(A,195,76)	CEAT100M50						
C 771	(B,190,79)	CKSRYP472K50	<b>CAPACITORS</b> C 667 (B,11,86) CKSRYP103K50 C 668 (B,39,86) CKSRYP103K50 C 669 (A,25,92) CEAT221M25 C 670 (A,52,92) CEAT221M25					
C 772	(B,193,79)	CKSRYP472K50						
C 773	(A,194,72)	CKSRYP103K50						
C 774	(A,189,72)	CKSRYP103K50						
C 781	(A,160,53)	CEAT2R2M50						
C 782	(A,166,53)	CEAT2R2M50						
C 783	(A,161,62)	CCSRCH331J50						
C 784	(A,166,62)	CCSRCH331J50						
C 785	(A,161,64)	CCSRCH331J50						
C 786	(A,166,64)	CCSRCH331J50						
C 787	(B,160,68)	CCSRCH471J50	<b>C MAIN CONTROL ASSY)</b> <b>MISCELLANEOUS</b> IC 101 (A,150,186) CPU PEG116A IC 102 (A,175,187) FLASH ROM AYW7121 IC 103 (A,114,172) LOGIC IC CD4094BPW IC 104 (A,127,188) RESET IC BU4842F IC 105 (A,209,126) LOGIC IC CD4094BPW IC 106 (A,126,200) LOGIC IC SN74AHCT08PW IC 107 (A,101,131) IC TC74VHCT125AFTS1 IC 108 (A,99,165) LOGIC IC SN74LV244ATPW IC 109 (A,123,174) LOGIC IC SN74AHCT32PW IC 251 (A,110,192) RDS DECORDER IC LC72725M IC 301 (A,157,130) CPU PEG117A IC 302 (A,184,132) FLASH ROM AYW7125 IC 303 (A,127,123) LOGIC IC CD4094BPW IC 304 (A,95,113) IC TC74VHCT125AFTS1 IC 305 (A,130,139) LOGIC IC SN74AHC02PW IC 306 (A,94,131) LOGIC IC SN74LV125APW IC 307 (A,160,210) LOGIC IC SN74AHC08PW IC 308 (A,114,132) LOGIC IC SN74LV244APW △ IC 310 (A,197,141) IC NJM2391DL1-33 Q 101 (B,106,182) TRANSISTOR DTC143TK					
C 788	(B,167,68)	CCSRCH471J50						
C 789	(A,160,76)	CEAT100M50						
C 790	(A,167,76)	CEAT100M50						
C 791	(B,162,79)	CKSRYP472K50						
C 792	(B,165,79)	CKSRYP472K50						
C 793	(A,166,72)	CKSRYP103K50						
C 794	(A,161,72)	CKSRYP103K50						
C 801	(A,253,108)	CEAT4R7M50						
C 802	(A,253,101)	CEAT4R7M50						
C 805	(A,263,164)	CCSRCH101J50						
C 806	(A,263,176)	CCSRCH101J50						
C 807	(A,260,192) ELECT. CAPACITOR	CEAT470M25						
C 808	(A,260,185) ELECT. CAPACITOR	CEAT470M25						
C 809	(A,260,168)	CKSRYP103K50						
C 810	(A,260,173)	CKSRYP103K50						
C 821	(A,265,108)	CEAT4R7M50						
C 822	(A,265,101)	CEAT4R7M50						
C 825	(A,263,133)	CCSRCH101J50						
C 826	(A,263,145)	CCSRCH101J50						







**Mark No. Description****Part No.****Mark No. Description****Part No.****D GUARD-C ASSY**

GUARD-C Assy has no service part.

**E GUARD-F ASSY****MISCELLANEOUS**

921 (A,245,238) PCB BINDER

VEF1040

**G DSP ASSY****MISCELLANEOUS**

IC 101 (A,65,37) DSP IC

ADSP-21266SKSTZ-2D

IC 103 (B,43,38) LOGIC IC (LATCHES)

TC74VHC573FS1

IC 104 (B,41,21) LOGIC IC (LATCHES)

TC74VHC573FS1

IC 105 (A,16,16) 2 TO 4 LINE DECODER

TC7W139FU

IC 106 (A,15,37) FLASH ROM

AYW7128

IC 107 (A,33,49) SRAM (4M)

CY7C1049C3312VXC

IC 109 (A,8,19) 1 CHIP OR GATE

TC7SH32FUS1

IC 201 (A,113,37) DSP IC

DSPC56371AF180

IC 291 (A,143,55) IC

TC74VHC08FTS1

IC 301 (A,191,36) DA I/F TRANCEIVER

AK4114VQ

IC 401 (A,154,28) AUDIO 8CH DAC

AK4359VF

IC 481 (A,170,28) AD CONVERTER IC

AK5358ET

IC 551 (A,98,25) LOGIC IC

TC7WHU04FU

IC 651 (A,141,47) IC

TC74VHC157FTS1

△ IC 901 (B,83,45) REGULATOR IC

MM1663DT

△ IC 902 (A,82,16) REGULATOR IC

BD7820FP

△ IC 903 (B,203,16) REGULATOR IC

BD7802FP

△ IC 904 (A,176,25) LDO REGULATOR

BD00KA5WFP

D 401 (B,164,18) DIODE

MA152WA

D 402 (A,166,19) DIODE

MA152WK

D 906 (B,73,23) DIODE

RB160L-40

L 101 (A,73,57) CHIP SOLID INDUCTOR

QTL1013

L 102 (A,67,18) CHIP SOLID INDUCTOR

ATL7002

L 104 (B,35,34) CHIP SOLID INDUCTOR

QTL1013

L 105 (B,32,17) CHIP SOLID INDUCTOR

QTL1013

L 106 (A,13,20) CHIP SOLID INDUCTOR

QTL1013

L 107 (A,19,23) CHIP SOLID INDUCTOR

QTL1013

L 108 (B,32,54) CHIP SOLID INDUCTOR

QTL1013

L 201 (B,105,32) CHIP SOLID INDUCTOR

QTL1013

L 202 (A,127,34) CHIP SOLID INDUCTOR

ATL7002

L 203 (A,98,18) CHIP SOLID INDUCTOR

ATL7002

L 291 (A,149,55) CHIP SOLID INDUCTOR

QTL1013

L 301 (B,188,48) CHIP SOLID INDUCTOR

QTL1013

L 302 (A,182,36) CHIP SOLID INDUCTOR

QTL1013

L 305 (A,202,29) CHIP SOLID INDUCTOR

QTL1013

L 401 (B,146,32) CHIP SOLID INDUCTOR

QTL1013

L 481 (B,163,30) CHIP SOLID INDUCTOR

QTL1013

L 482 (A,175,35) CHIP SOLID INDUCTOR

QTL1013

L 551 (A,101,23) CHIP SOLID INDUCTOR

QTL1013

L 651 (A,147,50) CHIP SOLID INDUCTOR

QTL1013

L 901 (B,191,19) CHIP SOLID INDUCTOR

ATL7002

L 902 (B,187,19) CHIP SOLID INDUCTOR

ATL7002

L 903 (B,179,19) CHIP SOLID INDUCTOR

ATL7002

JA351 (A,225,22) JACK

AKB7131

X 301 (A,190,25) CRYSTAL RESONATOR

XSS3003

X 551 (A,91,28) CRYSTAL RESONATOR  
CN301 (A,185,49) 10P CONNECTOR  
CN402 (A,165,14) 19P SOCKET  
CN801 (A,124,60) 26P PLUG  
CN901 (A,173,11) B TO B CONNCTORVSS1171  
VKN1414  
XKP3080  
AKP7208  
BTEM20P-1R

CN951 (A,128,14) 23P SOCKET

XKP3083

**RESISTORS**

R 101 (A,44,45)

RAB4C472J

R 103 (A,46,39)

RS1/16S101J

R 104 (A,46,38)

RS1/16S472J

R 105 (A,46,35)

RAB4C470J

R 106 (A,50,24)

RAB4C470J

R 107 (A,49,21)

RS1/16S470J

R 108 (A,52,17)

RS1/16S470J

R 109 (A,54,18)

RS1/16S470J

R 110 (A,57,18)

RAB4C470J

R 111 (A,62,18)

RAB4C470J

R 112 (A,72,19)

RAB4C220J

R 113 (A,84,31)

RAB4C101J

R 114 (B,75,34)

RS1/16S220J

R 115 (B,79,34)

RS1/16S220J

R 116 (B,75,38)

RS1/16S101J

R 117 (B,77,37)

RS1/16S101J

R 118 (A,80,40)

RS1/16S101J

R 119 (B,75,44)

RS1/16S472J

R 120 (B,77,44)

RS1/16S472J

R 122 (B,63,53)

RS1/16S101J

R 125 (B,69,49)

RS1/16S101J

R 127 (B,66,48)

RS1/16S101J

R 129 (B,64,48)

RS1/16S101J

R 131 (B,62,48)

RS1/16S101J

R 132 (B,62,43)

RS1/16S100J

R 135 (B,52,52)

RS1/16S472J

R 136 (B,57,49)

RS1/16S101J

R 137 (B,81,34)

RS1/16S101J

R 145 (A,41,41)

RAB4C470J

R 146 (A,41,29)

RAB4C470J

R 147 (B,27,15)

RS1/16S470J

R 148 (A,41,16)

RAB4C470J

R 149 (A,14,20)

RS1/16S470J

R 150 (A,16,20)

RS1/16S470J

R 153 (A,8,21)

RS1/16S470J

R 154 (A,9,14)

RS1/16S472J

R 155 (B,54,52)

RS1/16S472J

R 156 (B,50,52)

RS1/16S472J

R 201 (A,116,48)

RAB4C101J

R 202 (B,120,40)

RS1/16S103J

R 203 (B,118,40)

RS1/16S103J

R 204 (B,116,40)

RS1/16S103J

R 205 (B,114,40)

RS1/16S103J

R 207 (B,112,40)

RS1/16S473J

R 209 (B,112,35)

RS1/16S472J

R 212 (A,101,36)

RS1/16S473J

R 214 (B,100,34)

RS1/16S101J

R 215 (B,104,40)

RS1/16S101J

R 216 (A,98,33)

RS1/16S101J

R 217 (A,100,33)

RS1/16S101J



	<u>Mark No.</u>	<u>Description</u>	<u>Part No.</u>	<u>Mark No.</u>	<u>Description</u>	<u>Part No.</u>
A	C 126	(A,60,21)	CKSRYB104K16	C 188	(A,9,16)	CKSRYB104K16
	C 127	(A,64,23)	CCSRCH471J50	C 201	(A,119,47)	CCSRCH471J50
	C 128	(A,64,21)	CKSRYB104K16	C 202	(A,119,48)	CKSRYB104K16
	C 129	(A,67,23)	CCSRCH471J50	C 203	(A,112,47)	CCSRCH471J50
	C 130	(A,67,21)	CKSRYB104K16	C 204	(A,112,48)	CKSRYB104K16
	C 131	(A,69,23)	CCSRCH471J50	C 205	(A,107,47)	CCSRCH471J50
	C 132	(A,69,21)	CKSRYB104K16	C 206	(A,107,48)	CKSRYB104K16
	C 133	(A,73,23)	CCSRCH471J50	C 207	(A,103,42)	CCSRCH471J50
	C 134	(A,73,21)	CKSRYB104K16	C 208	(A,101,42)	CKSRYB104K16
	C 135	(A,76,24)	CCSRCH471J50	C 209	(A,103,39)	CCSRCH471J50
B	C 136	(A,76,23)	CKSRYB104K16	C 210	(A,101,39)	CKSRYB104K16
	C 137	(A,79,26)	CCSRCH471J50	C 211	(A,103,31)	CCSRCH471J50
	C 138	(A,81,26)	CKSRYB104K16	C 212	(A,101,31)	CKSRYB104K16
	C 139	(A,79,28)	CCSRCH471J50	C 216	(A,105,28)	CCSRCH471J50
	C 140	(A,81,28)	CKSRYB104K16	C 217	(A,105,26)	CKSRYB104K16
	C 141	(A,79,32)	CCSRCH471J50	C 218	(A,108,28)	CCSRCH471J50
	C 142	(A,81,32)	CKSRYB104K16	C 219	(A,108,26)	CKSRYB104K16
	C 143	(A,79,35)	CCSRCH471J50	C 220	(B,110,35)	CKSRYB103K50
	C 144	(A,81,35)	CKSRYB104K16	C 221	(A,114,28)	CCSRCH471J50
	C 145	(A,79,43)	CCSRCH471J50	C 222	(A,114,27)	CKSRYB104K16
C	C 146	(A,81,43)	CKSRYB104K16	C 223	(A,123,33)	CCSRCH471J50
	C 147	(A,79,38)	CCSRCH471J50	C 224	(A,125,33)	CKSRYB104K16
	C 148	(A,81,38)	CKSRYB104K16	C 225	(A,123,36)	CCSRCH471J50
	C 149	(A,79,45)	CCSRCH471J50	C 226	(A,125,36)	CKSRYB104K16
	C 150	(A,81,45)	CKSRYB104K16	C 227	(A,123,41)	CCSRCH471J50
	C 151	(A,79,48)	CCSRCH471J50	C 228	(A,125,41)	CKSRYB104K16
	C 152	(A,81,48)	CKSRYB104K16	C 229	(A,131,35) CHIP ELECT. CAPACITOR	CEVW101M4
	C 153	(A,77,52)	CCSRCH471J50	C 230	(A,93,17)	CEVW101M16
	C 154	(A,77,53)	CKSRYB104K16	C 291	(A,142,59)	CCSRCH471J50
	C 155	(A,74,52)	CCSRCH471J50	C 292	(A,142,60)	CKSRYB104K16
D	C 156	(A,74,53)	CKSRYB104K16	C 303	(A,183,41)	CCSRCH471J50
	C 157	(A,71,52)	CCSRCH471J50	C 304	(A,185,41)	CKSRYB104K16
	C 158	(A,71,53)	CKSRYB104K16	C 305	(A,179,42)	CEVW470M6R3
	C 159	(A,68,52)	CCSRCH471J50	C 306	(A,184,36)	CCSRCH471J50
	C 160	(A,68,53)	CKSRYB104K16	C 307	(A,185,36)	CKSRYB104K16
	C 161	(B,65,53)	CKSRYB103K50	C 310	(A,188,28)	CCSRCH120J50
	C 162	(A,66,52)	CCSRCH471J50	C 311	(A,192,28)	CCSRCH120J50
	C 163	(A,66,53)	CKSRYB104K16	C 312	(B,196,28)	CKSRYB104K16
	C 164	(A,63,52)	CCSRCH471J50	C 315	(B,198,28)	CKSRYB102K50
	C 165	(A,63,53)	CKSRYB104K16	C 316	(A,205,31)	CEVW470M6R3
E	C 166	(A,60,52)	CCSRCH471J50	C 317	(A,200,35)	CKSRYB104K16
	C 167	(A,60,53)	CKSRYB104K16	C 318	(A,199,35)	CCSRCH471J50
	C 168	(A,57,52)	CCSRCH471J50	C 319	(A,199,38)	CKSRYB474K10
	C 169	(A,57,53)	CKSRYB104K16	C 353	(B,210,16)	CKSRYB103K50
	C 170	(A,54,52)	CCSRCH471J50	C 354	(B,215,30)	CKSRYB103K50
	C 171	(A,54,53)	CKSRYB104K16	C 401	(A,147,30)	CCSRCH471J50
	C 174	(A,22,17)	CEVW101M16	C 402	(A,148,30)	CKSRYB104K16
	C 175	(B,36,38)	CCSRCH471J50	C 403	(A,145,36)	CEVW101M16
	C 176	(B,34,38)	CKSRYB104K16	C 404	(B,160,30)	CKSRYB104K16
	C 177	(B,33,21)	CCSRCH471J50	C 407	(B,143,19)	CCSRCH471J50
F	C 178	(B,31,21)	CKSRYB104K16	C 408	(B,145,19)	CCSRCH471J50
	C 179	(A,14,16)	CCSRCH471J50	C 409	(B,148,19)	CCSRCH471J50
	C 180	(A,12,16)	CKSRYB104K16	C 410	(B,150,19)	CCSRCH471J50
	C 181	(A,15,25)	CCSRCH471J50	C 411	(B,153,19)	CCSRCH471J50
	C 182	(A,15,23)	CKSRYB104K16	C 412	(B,155,19)	CCSRCH471J50
	C 183	(A,40,49)	CCSRCH471J50	C 413	(B,158,19)	CCSRCH471J50
	C 184	(A,42,49)	CKSRYB104K16	C 414	(B,160,19)	CCSRCH471J50
	C 185	(A,26,51)	CCSRCH471J50	C 415	(A,158,22)	CCSRCH471J50
	C 186	(A,24,51)	CKSRYB104K16	C 416	(A,158,21)	CKSRYB104K16
	C 187	(A,9,17)	CCSRCH471J50	C 417	(A,154,36)	CEVW101M16

5		6		7		8	
Mark No.	Description	Part No.	Mark No.	Description	Part No.	Mark No.	Description
C 418	(A,145,25)	CEVW470M6R3	JA 1006(A,57,233)	PIN JACK (1P)	AKB7175		
C 420	(A,148,27)	CKSRYP104K16	X 1001(A,44,196)	CRYSTAL (14.31818M)	ASS1056		
C 481	(B,167,35)	CKSRYP104K16	CN1001(A,184,173)	11P SOCKET	XKP3076		
C 482	(A,165,29)	CKSRYP104K16	CN1002(A,77,178)	21P SOCKET	XKP3081		A
C 483	(A,162,29)	CKSQYB225K10	CN1003(A,184,198)	13P SOCKET	XKP3077		
C 485	(A,169,23)	CCSRCH471J50	CN1004(A,161,233)	20P SOCKET	AKP7202		
C 486	(A,169,21)	CKSRYP104K16	1003(A,78,233)	PIN JACK (2P)	AKB7176		
C 487	(A,163,34)	CEVW101M16	1001(A,134,233)	PIN JACK (2P)	AKB7176		
C 488	(A,172,23)	CCSRCH471J50	1002(A,106,233)	PIN JACK (2P)	AKB7176		
C 489	(A,172,21)	CKSRYP104K16					
C 490	(A,171,35)	CEVW100M16					
C 552	(A,102,26)	CKSRYP104K16	<b>RESISTORS</b>				
C 553	(A,101,26)	CCSRCH471J50	R 1001(B,142,224)		RS1/16S750J		
C 554	(A,94,26)	CCSRCH100D50	R 1002(B,125,221)		RS1/16S750J		
C 555	(A,94,30)	CCSRCH100D50	R 1003(B,97,220)		RS1/16S750J		B
			R 1004(B,69,220)		RS1/16S750J		
			R 1007(B,81,220)		RS1/16S750J		
C 651	(A,141,50)	CCSRCH471J50	R 1009(B,108,220)		RS1/16S750J		
C 652	(A,141,52)	CKSRYP104K16	R 1011(B,54,219)		RS1/16S750J		
C 801	(B,126,51)	CKSRYP104K16	R 1014(B,99,198)		RS1/16S102J		
C 901	(B,77,50)	CKSQYB105K16	R 1017(B,105,201)		RS1/16S103J		
C 903	(B,88,49)	CKSRYP105K6R3	R 1018(B,114,201)		RS1/16S103J		
C 904	(A,83,21)	CKSRYP105K6R3	R 1019(B,122,201)		RS1/16S103J		
C 905	(A,73,15) CHIP CERAMIC C.	DCG1028	R 1020(B,131,201)		RS1/16S103J		
C 906	(B,197,20)	CKSRYP104K16	R 1021(A,108,203)		RS1/16S103J		
C 907	(B,203,24)	CKSRYP105K6R3	R 1022(A,117,203)		RS1/16S103J		
C 908	(B,181,34)	CKSRYP105K6R3	R 1023(B,133,204)		RS1/16S473J		C
C 909	(B,179,34)	CKSRYP105K6R3	R 1024(B,135,205)		RS1/16S473J		
C 918	(B,177,19)	CKSRYP103K50	R 1025(B,66,204)		RS1/16S473J		
C 921	(B,128,30)	CCSRCH471J50	R 1026(B,63,204)		RS1/16S473J		
C 922	(B,130,30)	CKSRYP103K50	R 1030(B,85,196)		RS1/16S473J		
C 923	(B,173,29)	CKSRYP104K16	R 1031(B,71,193)		RS1/16S473J		
C 924	(B,175,29)	CCSRCH471J50	R 1032(B,69,193)		RS1/16S473J		
			R 1033(B,54,189)		RS1/16S473J		
			R 1034(A,42,177)		RS1/16S102J		
			R 1035(B,28,187)		RS1/16S512J		
			R 1036(B,30,187)		RS1/16S392J		
			R 1037(B,41,189)		RS1/16S102J		D
			R 1039(A,25,193)		RS1/16S331J		
			R 1040(A,25,196)		RS1/16S331J		
			R 1041(A,27,196)		RS1/16S331J		
			R 1043(B,175,192)		RS1/16S561J		
			R 1046(B,179,190)		RS1/16S102J		
			R 1049(B,94,203)		RS1/16S103J		
			R 1051(B,88,200)		RS1/16S0R0J		
			R 1054(B,90,209)		RS1/16S473J		
			R 1101(A,162,205)		RS1/16S104J		
D 1001	(B,88,192) DIODE	DAN202U	R 1102(A,158,206)		RS1/16S104J		E
D 1002	(B,84,192) DIODE	DAN202U	R 1103(A,164,205)		RS1/16S331J		
D 1003	(B,132,179) DIODE	1SS355	R 1104(A,155,205)		RS1/16S331J		
D 1004	(B,123,176) DIODE	1SS355	R 1105(B,163,199)		RS1/16S104J		
D 1005	(B,57,180) DIODE	DAP202U	R 1106(B,156,199)		RS1/16S104J		
D 1101	(A,163,208) DIODE	UDZS6R2(B)	R 1107(B,163,193)		RS1/16S472J		
D 1102	(A,157,208) DIODE	UDZS6R2(B)	R 1108(B,157,193)		RS1/16S472J		
D 1103	(A,163,210) DIODE	UDZS6R2(B)	R 1109(B,168,195)		RS1/16S472J		
D 1104	(A,157,209) DIODE	UDZS6R2(B)	R 1110(B,150,195)		RS1/16S472J		
D 1105	(A,172,201) DIODE	1SS355	R 1111(B,163,190)		RS1/16S103J		
D 1108	(B,178,206) DIODE	UDZS5R1(B)					
D 1109	(B,176,206) DIODE	UDZS5R1(B)					
D 1110	(B,169,207) DIODE	UDZS5R1(B)					F
L 1002	(B,180,192) CHIP COIL	LCTAW120J2520					
L 1003	(A,33,200) AXIAL INDUCTOR	LAU330J					

**H** **COMPOSITE ASSY**  
**MISCELLANEOUS**

IC 1001	(A,74,199) IC	CD74HC4051PW
IC 1003	(A,92,208) IC	CD74HC4053PW
IC 1004	(A,112,209) VIDEO AMP IC	LA7109
IC 1005	(B,56,197) PORT EXPANDER	BU4094BCF
IC 1006	(A,36,184) CHARACTER GENERATOR	PDC132A
IC 1101	(A,159,189) OP-AMP IC	UPC4570G2
Q 1002	(B,99,204) TRANSISTOR	2SC4081
Q 1003	(B,27,194) TRANSISTOR	2SC4081
Q 1004	(B,179,188) TRANSISTOR	2SC4081
Q 1102	(A,173,207) DIGITAL TR (SC-70)	RT1N431M
D 1001	(B,88,192) DIODE	DAN202U
D 1002	(B,84,192) DIODE	DAN202U
D 1003	(B,132,179) DIODE	1SS355
D 1004	(B,123,176) DIODE	1SS355
D 1005	(B,57,180) DIODE	DAP202U
D 1101	(A,163,208) DIODE	UDZS6R2(B)
D 1102	(A,157,208) DIODE	UDZS6R2(B)
D 1103	(A,163,210) DIODE	UDZS6R2(B)
D 1104	(A,157,209) DIODE	UDZS6R2(B)
D 1105	(A,172,201) DIODE	1SS355
D 1108	(B,178,206) DIODE	UDZS5R1(B)
D 1109	(B,176,206) DIODE	UDZS5R1(B)
D 1110	(B,169,207) DIODE	UDZS5R1(B)
L 1002	(B,180,192) CHIP COIL	LCTAW120J2520
L 1003	(A,33,200) AXIAL INDUCTOR	LAU330J

**Mark No. Description****Part No.****Mark No. Description****Part No.**

R 1112(B,155,189)  
R 1113(A,165,188)  
R 1114(A,154,189)  
R 1115(B,162,183)  
R 1116(B,156,183)

RS1/16S103J  
RS1/16S103J  
RS1/16S103J  
RS1/16S101J  
RS1/16S101J

C 1105(A,163,201)  
C 1106(A,155,201)  
C 1107(A,168,197)  
C 1108(A,150,197)  
C 1113(A,157,193)

CEAT100M50  
CEAT100M50  
CEAT100M50  
CEAT100M50  
CKSRBY103K50

R 1117(B,169,185)  
R 1118(B,167,182)  
R 1122(A,170,205)  
R 1124(A,170,208)

RS1/16S104J  
RS1/16S104J  
RS1/16S514J  
RS1/16S393J

C 1114(A,162,193)  
C 1115(A,162,180)  
C 1116(A,156,180)  
C 1117(A,174,198)  
C 1118(B,167,224)

CKSRBY103K50  
CEAT100M50  
CEAT100M50  
CKSRBY103K50  
CKSRBY103K50

C 1127(A,171,220)

CKSRBY104K50

**CAPACITORS**

C 1001(A,75,202)  
C 1002(A,73,204)  
C 1005(A,91,212)  
C 1006(A,94,212)  
C 1008(B,65,202)

CKSRBY103K50  
CKSRBY103K50  
CKSRBY104K50  
CKSRBY104K50  
CKSRBY104K50

C 1011(B,96,205)  
C 1012(B,101,198)  
C 1014(A,88,197)  
C 1016(A,116,200)  
C 1017(A,125,200)

CKSRBY103K50  
CKSRBY103K50  
CEAT101M10  
CEAT101M10  
CEAT101M10

C 1018(A,134,200)  
C 1019(B,116,211)  
C 1020(A,120,208)  
C 1021(A,123,214)  
C 1022(A,129,214)

CEAT101M10  
CKSRBY104K50  
CKSRBY104K50  
CEAT101M10  
CEAT101M10

C 1024(B,84,225)  
C 1025(B,113,224)  
C 1026(B,56,224)  
C 1027(A,45,180)  
C 1028(A,45,187)

CCSRCH181J50  
CCSRCH181J50  
CCSRCH181J50  
CEAT101M10  
CEAT101M10

C 1029(A,45,177)  
C 1030(A,27,185)  
C 1031(A,39,177)  
C 1032(A,35,177)  
C 1033(A,31,177)

CKSRBY473K25  
CKSRBY473K25  
CCSRCH101J50  
CKSRBY122K50  
CKSRBY122K50

C 1035(B,34,187)  
C 1036(B,47,191)  
C 1037(B,45,191)  
C 1038(B,36,190)  
C 1039(B,33,194)

CKSRBY103K50  
CCSRCH150J50  
CCSRCH180J50  
CCSRCH240J50  
CCSRCH240J50

C 1040(A,31,193)  
C 1041(A,28,193)  
C 1042(A,27,193)  
C 1045(B,184,192)  
C 1046(B,178,193)

CCSRCH101J50  
CCSRCH101J50  
CCSRCH101J50  
CCSRCH330J50  
CCSRCH120J50

C 1047(B,180,194)  
C 1093(B,111,224)  
C 1095(B,82,225)  
C 1096(B,79,225)  
C 1097(B,54,224)

CCSRCH3R0C50  
CKSRBY103K50  
CKSRBY103K50  
CKSRBY103K50  
CKSRBY103K50

C 1098(B,43,224)  
C 1101(A,162,206)  
C 1102(A,158,205)  
C 1103(A,160,200)  
C 1104(A,158,200)

CKSRBY103K50  
CCSRCH101J50  
CCSRCH101J50  
CCSRCH101J50  
CCSRCH101J50

C 1211(B,103,149)  
C 1212(B,105,149)  
C 1213(B,75,149)  
C 1214(B,77,149)  
C 1215(B,123,134)

CKSRBY103K50  
CKSRBY103K50  
CKSRBY103K50  
CKSRBY103K50  
CKSRBY103K50

**S-VIDEO ASSY  
MISCELLANEOUS**

IC 1201(A,115,134) IC  
IC 1202(A,103,134) IC  
IC 1203(A,111,119) IC  
IC 1204(A,130,136) IC  
IC 1205(A,66,138) VIDEO AMP IC

CD74HC4051PW  
CD74HC4051PW  
CD74HC4053PW  
LA7213  
LA7109

Q 1201(B,147,133) TRANSISTOR  
Q 1203(B,135,115) TRANSISTOR  
Q 1204(B,135,106) TRANSISTOR  
Q 1205(A,148,117) TRANSISTOR  
Q 1206(B,155,104) TRANSISTOR

RT1N241M  
2SC4081  
2SC4081  
2SC4081  
2SC4081

D 1201(B,141,129) DIODE  
D 1202(B,144,134) DIODE  
D 1203(B,79,133) DIODE  
D 1204(A,83,129) DIODE  
D 1251(B,93,114) DIODE

1SS355  
1SS355  
DAN202K  
DAN202K  
1SS355

D 1252(B,77,115) DIODE  
D 1301(B,170,143) DIODE  
L 1201(A,155,109) CHIP COIL  
L 1202(B,162,108) CHIP COIL  
L 1301(B,161,128) CHIP SOLID INDUCTOR

1SS355  
1SS355  
LCTAW120J2520  
LCTAW120J2520  
QTL1013

CN1201(A,175,128) 13P SOCKET  
CN1202(A,175,104) 11P SOCKET  
CN1203(A,68,108) 15P SOCKET  
CN1204SOCKET  
CN1205(A,97,163) SOCKET

XKP3077  
XKP3076  
XKP3078  
XKB3052  
XKB3051

CN1206(A,125,163) SOCKET  
CN1302(A,175,152) 07P CONNECTOR

XKB3051  
RKN1048

**RESISTORS**

R 1201(B,131,152)  
R 1202(B,133,152)  
R 1203(B,117,152)  
R 1204(B,119,152)  
R 1205(B,89,152)

RS1/16S750J  
RS1/16S750J  
RS1/16S750J  
RS1/16S750J  
RS1/16S750J

R 1206(B,91,152)  
R 1207(B,61,151)  
R 1208(B,63,151)  
R 1209(B,47,148)  
R 1210(B,49,148)

RS1/16S750J  
RS1/16S750J  
RS1/16S750J  
RS1/16S750J  
RS1/16S750J

R 1211(B,103,149)  
R 1212(B,105,149)  
R 1213(B,75,149)  
R 1214(B,77,149)  
R 1215(B,123,134)

RS1/16S750J  
RS1/16S750J  
RS1/16S750J  
RS1/16S750J  
RS1/16S331J

5	6	7	8
Mark No.	Description	Part No.	Mark No. Description Part No.
R 1216(B,125,134)		RS1/16S224J	C 1243(A,155,113) CCSRCH120J50
R 1217(B,141,134)		RS1/16S472J	C 1244(B,167,109) CCSRCH120J50
R 1218(B,144,129)		RS1/16S223J	C 1245(A,152,112) CCSRCH330J50
R 1223(B,137,115)		RS1/16S102J	C 1246(B,158,108) CCSRCH330J50
R 1224(B,138,106)		RS1/16S102J	C 1249(A,155,107) CCSRCJ3R0C50
R 1225(A,59,132)		RS1/16S103J	C 1250(B,162,111) CCSRCJ3R0C50
R 1226(A,63,132)		RS1/16S103J	C 1292(B,73,158) CKSRYB103K50
R 1227(A,65,132)		RS1/16S103J	C 1293(B,93,158) CKSRYB103K50
R 1228(A,87,131)		RS1/16S103J	C 1294(B,129,158) CKSRYB103K50
R 1229(A,68,132)		RS1/16S103J	C 1301(A,158,138) CEAT101M16
R 1230(A,87,133)		RS1/16S103J	C 1302(A,153,141) CKSRYB103K50
R 1231(B,80,137)		RS1/16S473J	
R 1232(A,72,130)		RS1/16S473J	
R 1235(A,155,111)		RS1/16S561J	
R 1236(B,167,108)		RS1/16S561J	
R 1237(B,130,115)		RS1/16S103J	
R 1238(B,130,106)		RS1/16S103J	
R 1243(A,145,119)		RS1/16S102J	
R 1244(B,157,102)		RS1/16S102J	
R 1310(A,175,147)		RS1/16S103J	

### CAPACITORS

C 1201(B,133,148)		CKSRYB104K16
C 1202(B,119,148)		CKSRYB104K16
C 1203(B,91,148)		CKSRYB104K16
C 1204(B,63,148)		CKSRYB104K16
C 1205(B,49,151)		CCSRCH181J50
C 1206(B,47,151)		CCSRCH181J50
C 1207(B,105,152)		CCSRCH181J50
C 1208(B,103,152)		CCSRCH181J50
C 1209(B,77,152)		CCSRCH181J50
C 1210(B,75,152)		CCSRCH181J50
C 1211(A,111,134)		CKSRYB104K16
C 1212(A,119,132)		CKSRYB104K16
C 1213(A,99,134)		CKSRYB104K16
C 1214(A,107,131)		CKSRYB104K16
C 1215(A,115,115)		CKSRYB104K16
C 1216(A,108,121)		CKSRYB104K16
C 1217(A,132,141)	ELECT. CAPACITOR	CEAT3R3M50
C 1218(A,138,135)		CEAT101M10
C 1219(A,138,128)		CEAT101M10
C 1221(A,125,115)		CEAT101M10
C 1222(A,125,106)		CEAT101M10
C 1223(A,145,115)		CEAT101M10
C 1224(A,145,106)		CEAT101M10
C 1225(B,132,110)		CKSRYB103K50
C 1226(B,140,110)		CKSRYB103K50
C 1227(A,47,118)		CEAT101M10
C 1228(B,57,129)		CKSRYB104K16
C 1229(A,55,118)		CEAT101M10
C 1230(A,87,130)		CKSRYB104K16
C 1231(A,62,118)		CEAT101M10
C 1232(A,87,135)		CKSRYB104K16
C 1233(B,59,142)		CKSRYB104K16
C 1234(B,59,134)		CKSRYB104K16
C 1235(A,53,143)		CEAT101M16
C 1236(A,53,136)		CEAT101M16

### J BRIDGE 2 ASSY MISCELLANEOUS

CN2901(A,21,29)	17P PLUG	XKP3068
CN2902(A,100,29)	17P PLUG	XKP3068

### K COMPONENT ASSY MISCELLANEOUS

IC 1401(A,113,70)	MULTIPLEXER (4CHx2)	TC74LVX4052FT
IC 1402(A,124,72)	MULTIPLEXER (4CHx2)	TC74LVX4052FT
IC 1403(A,139,69)	MULTIPLEXER (2CHx3)	TC74LVX4053FT
IC 1404(B,93,70)	VIDEO IC	NJM2581M
IC 1405(A,129,50)	LOGIC IC	CD4094BPW
Q 1401(B,87,57)	TRANSISTOR	2SC4081
Q 1402(B,71,57)	TRANSISTOR	2SA1576A
Q 1403(B,163,64)	TRANSISTOR	2SA1576A
Q 1405(B,163,69)	TRANSISTOR	2SA1576A
Q 1407(B,163,74)	TRANSISTOR	2SA1576A
Q 1415(B,156,59)	TRANSISTOR	2SC4081
Q 1416(B,162,50)	TRANSISTOR	2SC4081
Q 1417(B,167,42)	TRANSISTOR	2SC4081
Q 1501(A,62,65)	TRANSISTOR	IMX25
Q 1502(A,68,65)	TRANSISTOR	IMX25
Q 1521(A,49,65)	TRANSISTOR	IMX25
Q 1522(A,55,65)	TRANSISTOR	IMX25
Q 1541(A,36,65)	TRANSISTOR	IMX25
Q 1542(A,42,65)	TRANSISTOR	IMX25
Q 1561(A,22,65)	TRANSISTOR	IMX25
Q 1562(A,29,65)	TRANSISTOR	IMX25
D 1401(B,85,43)	DIODE	1SS355
D 1402(B,83,43)	DIODE	1SS355
L 1401(B,166,58)	CHIP COIL	LCTAW120J2520
L 1402(B,169,53)	CHIP COIL	LCTAW120J2520
L 1403(B,175,49)	CHIP COIL	LCTAW120J2520
JA 1401(A,141,94)	6P RCA PIN JACK	XKB3053
JA 1402(A,99,94)	6P RCA PIN JACK	XKB3053
CN1401(A,175,56)	13P SOCKET	XKP3077
CN1402(A,175,30)	11P SOCKET	XKP3076
CN1403(A,68,39)	13P SOCKET	XKP3077
CN1405(A,19,59)	17P SOCKET	XKP3079
CN1406(A,53,41)	CONNECTOR	CKS3384
CN1501(A,58,94)	PIN JACK (4P)	AKB7172
CN1502(A,30,94)	PIN JACK (4P)	AKB7172
1401(A,166,28)	PCB BINDER	VEF1040

**Mark No. Description****Part No.****Mark No. Description****Part No.****RESISTORS**

A	R 1401(B,149,85)	RS1/16S750J
	R 1402(B,138,85)	RS1/16S750J
	R 1403(B,124,85)	RS1/16S750J
	R 1404(B,157,85)	RS1/16S750J
	R 1405(B,145,85)	RS1/16S750J
	R 1406(B,131,85)	RS1/16S750J
	R 1407(B,115,85)	RS1/16S750J
	R 1408(B,103,85)	RS1/16S750J
	R 1409(B,89,85)	RS1/16S750J
	R 1410(B,107,78)	RS1/16S750J
	R 1411(B,93,78)	RS1/16S750J
	R 1412(B,83,79)	RS1/16S750J
B	R 1416(B,91,61)	RS1/16S102J
	R 1417(B,85,57)	RS1/16S153J
	R 1418(B,75,56)	RS1/16S153J
	R 1419(B,82,58)	RS1/16S333J
	R 1420(B,78,58)	RS1/16S333J
	R 1421(B,159,64)	RS1/16S102J
	R 1422(B,159,69)	RS1/16S102J
	R 1423(B,159,74)	RS1/16S102J
	R 1424(B,169,59)	RS1/16S561J
	R 1425(B,171,54)	RS1/16S561J
	R 1426(B,173,53)	RS1/16S561J
C	R 1430(B,133,54)	RS1/16S473J
	R 1431(B,131,54)	RS1/16S473J
	R 1432(B,131,50)	RS1/16S473J
	R 1433(B,134,46)	RS1/16S473J
	R 1434(A,134,46)	RS1/16S0R0J
	R 1439(B,126,49)	RS1/16S473J
	R 1440(B,124,49)	RS1/16S473J
	R 1441(B,128,48)	RS1/16S473J
	R 1442(B,128,45)	RS1/16S473J
	R 1443(B,157,64)	RS1/16S154J
	R 1444(B,160,64)	RS1/16S124J
D	R 1446(B,157,69)	RS1/16S154J
	R 1447(B,161,69)	RS1/16S124J
	R 1449(B,157,74)	RS1/16S154J
	R 1450(B,161,74)	RS1/16S124J
	R 1461(B,162,60)	RS1/16S104J
	R 1462(B,163,55)	RS1/16S104J
	R 1463(B,166,48)	RS1/16S104J
	R 1464(B,157,55)	RS1/16S102J
	R 1465(B,166,52)	RS1/16S102J
	R 1466(B,173,47)	RS1/16S102J
E	R 1501(B,62,59)	RS1/16S271J
	R 1502(B,68,59)	RS1/16S271J
	R 1503(B,62,65)	RS1/16S121J
	R 1504(B,68,65)	RS1/16S121J
	R 1505(B,62,70)	RS1/16S101J
	R 1506(B,68,70)	RS1/16S101J
	R 1507(B,63,86)	RS1/16S474J
	R 1508(B,67,87)	RS1/16S474J
	R 1509(A,62,60)	RS1/16S103J
	R 1510(A,68,60)	RS1/16S103J
F	R 1511(A,60,69)	RS1/16S103J

	R 1512(A,67,69)	RS1/16S103J
	R 1521(B,49,59)	RS1/16S271J
	R 1522(B,55,59)	RS1/16S271J
	R 1523(B,49,65)	RS1/16S121J
	R 1524(B,55,65)	RS1/16S121J
	R 1525(B,49,70)	RS1/16S101J
	R 1526(B,55,70)	RS1/16S101J
	R 1527(B,49,86)	RS1/16S474J
	R 1528(B,53,87)	RS1/16S474J
	R 1529(A,49,60)	RS1/16S103J
	R 1530(A,55,60)	RS1/16S103J
	R 1531(A,47,69)	RS1/16S103J
	R 1532(A,54,69)	RS1/16S103J
	R 1541(B,36,59)	RS1/16S271J
	R 1542(B,42,59)	RS1/16S271J
	R 1543(B,36,65)	RS1/16S121J
	R 1544(B,42,65)	RS1/16S121J
	R 1545(B,36,70)	RS1/16S101J
	R 1546(B,42,70)	RS1/16S101J
	R 1547(B,35,86)	RS1/16S474J
	R 1548(B,39,87)	RS1/16S474J
	R 1549(A,36,60)	RS1/16S103J
	R 1550(A,42,60)	RS1/16S103J
	R 1551(A,34,69)	RS1/16S103J
	R 1552(A,41,69)	RS1/16S103J
	R 1561(B,23,61)	RS1/16S271J
	R 1562(B,29,61)	RS1/16S271J
	R 1563(B,22,65)	RS1/16S121J
	R 1564(B,29,65)	RS1/16S121J
	R 1565(B,22,70)	RS1/16S101J
	R 1566(B,29,70)	RS1/16S101J
	R 1567(B,21,86)	RS1/16S474J
	R 1568(B,25,87)	RS1/16S474J
	R 1569(A,23,60)	RS1/16S103J
	R 1570(A,29,60)	RS1/16S103J
	R 1571(A,21,69)	RS1/16S103J
	R 1572(A,27,69)	RS1/16S103J
	R 1573(A,65,46)	RS1/16S473J
	R 1574(A,62,46)	RS1/16S471J
	R 1575(A,63,44)	RS1/16S473J
	R 1576(A,61,43)	RS1/16S471J

**CAPACITORS**

	C 1413(A,118,70)	CKSRYB103K50
	C 1414(A,107,72)	CKSRYB103K50
	C 1415(A,131,70)	CKSRYB103K50
	C 1416(A,117,73)	CKSRYB103K50
	C 1417(A,143,67)	CKSRYB103K50
	C 1418(A,135,72)	CKSRYB103K50
	C 1419(A,101,61)	CEAT101M10
	C 1420(A,95,61)	CEAT101M10
	C 1421(A,97,53)	CEAT101M10
	C 1425(A,83,67)	CEAT101M10
	C 1426(A,83,73)	CEAT101M10
	C 1427(B,86,67)	CKSRYB104K25
	C 1428(B,86,72)	CKSRYB104K25
	C 1431(B,82,60)	CKSRYB224K10
	C 1432(B,78,60)	CKSRYB224K10



5  
**Mark No. Description**

C 1433(B,153,64)  
 C 1434(B,168,64)  
 C 1435(B,153,70)  
 C 1436(B,168,69)  
 C 1437(B,152,76)

C 1438(B,168,73)  
 C 1439(A,151,63)  
 C 1440(A,151,68)  
 C 1441(A,150,74)  
 C 1445(A,170,59)

C 1446(A,170,55)  
 C 1447(A,172,50)  
 C 1448(A,169,59)  
 C 1449(A,169,55)  
 C 1450(A,170,50)

C 1454(A,170,57)  
 C 1455(A,170,52)  
 C 1456(A,172,48)  
 C 1469(A,130,54)  
 C 1471(A,163,58)

C 1472(A,163,53)  
 C 1473(A,166,46)  
 C 1490(B,147,85)  
 C 1491(B,133,85)  
 C 1492(B,105,85)

C 1493(B,91,85)  
 C 1501(B,63,84)  
 C 1502(B,67,85)  
 C 1507(B,60,70)  
 C 1508(B,66,70)

C 1521(B,49,84)  
 C 1522(B,53,85)  
 C 1527(B,47,70)  
 C 1528(B,53,70)  
 C 1531(A,60,78) ELECT. CAPACITOR

C 1532(A,67,78) ELECT. CAPACITOR  
 C 1533(A,47,78) ELECT. CAPACITOR  
 C 1541(B,35,84)  
 C 1542(B,39,85)  
 C 1547(A,54,78) ELECT. CAPACITOR

C 1548(A,34,78) ELECT. CAPACITOR  
 C 1549(A,41,78) ELECT. CAPACITOR  
 C 1550(A,21,78) ELECT. CAPACITOR  
 C 1551(A,27,78) ELECT. CAPACITOR  
 C 1561(B,21,84)

C 1562(B,25,85)  
 C 1567(A,60,46)  
 C 1568(A,58,44)  
 C 1569(B,34,70)  
 C 1570(B,40,70)

C 1571(B,20,70)  
 C 1572(B,27,70)  
 C 1591(B,58,86)  
 C 1593(B,30,86)

**COMPLEX ASSY  
 MISCELLANEOUS**

△ Y 14 AWG18 BOARD IN  
 △ Y 15 AWG18 BOARD IN

6  
**Part No.**

CKSRYP103K50  
 CKSRYP103K50  
 CKSRYP103K50  
 CKSRYP103K50  
 CKSRYP103K50

CKSRYP103K50  
 CEAT100M50  
 CEAT100M50  
 CEAT100M50  
 CCSRCH120J50

CCSRCH120J50  
 CCSRCH120J50  
 CCSRCH330J50  
 CCSRCH330J50  
 CCSRCH330J50

CCSRCJ3R0C50  
 CCSRCH330J50  
 CCSRCH330J50  
 CKSRYP104K50  
 CEAT100M50

CEAT100M50  
 CEAT100M50  
 CKSRYP103K50  
 CKSRYP103K50  
 CKSRYP103K50

CKSRYP103K50  
 CCSRCH101J50  
 CCSRCH101J50  
 CCSRCH271J50  
 CCSRCH271J50

CCSRCH101J50  
 CCSRCH101J50  
 CCSRCH271J50  
 CCSRCH271J50  
 CEAT470M25

CEAT470M25  
 CEAT470M25  
 CCSRCH101J50  
 CCSRCH101J50  
 CEAT470M25

CEAT470M25  
 CEAT470M25  
 CEAT470M25  
 CEAT470M25  
 CCSRCH101J50

CCSRCH101J50  
 CKSRYP472K50  
 CKSRYP472K50  
 CCSRCH271J50  
 CCSRCH271J50

CCSRCH271J50  
 CCSRCH271J50  
 CKSRYP103K50  
 CKSRYP103K50

ADX7500  
 ADX7501

7  
**Mark No. Description**

**DISPLAY ASSY  
 MISCELLANEOUS**

IC 2301(B,164,214) DISPLAY U-COM PE5503A  
 IC 2402(A,237,230) REMOTE RECEIVER UNIT RPM7540-H9  
 Q 2401(B,205,185) TRANSISTOR RT1N241M  
 Q 2404(B,251,192) TRANSISTOR 2SA1576A  
 Q 2405(B,231,192) TRANSISTOR RT1N241M

Q 2406(B,225,220) DIGITAL TR (SC-70) RT1N431M  
 Q 2407(B,70,220) DIGITAL TR (SC-70) RT1N431M  
 Q 2408(B,65,214) DIGITAL TR (SC-70) RT1N431M  
 D 2404(B,238,190) DIODE 1SS355  
 D 2405(B,254,195) DIODE 1SS355

D 2406(B,252,209) DIODE DAN202U  
 D 2408(A,237,220) LED (ORANGE) SLI-343DCW(STU)  
 D 2410(A,76,218) LED (RED) SLI-343URW(RST)  
 D 2412(A,58,214) LED (RED) SLI-343URW(RST)  
 D 2416(B,53,227) DIODE 1SS355

L 2401(A,248,205) RADIAL INDUCTOR LFCA2R2J  
 V 2301(A,218,237) FL TUBE AAV7105  
 X 2301(A,179,197) CERAMIC (5M) VSS1142  
 CN2301(A,269,204) CONNECTOR CKS3394  
 2302(A,48,221) 17P CABLE HOLDER 51048-1700

2301(A,157,201) FL HOLDER (FE) VNF1096  
 2303(A,267,196) CABLE HOLDER (4P) 51063-0405

**RESISTORS**

R 2301(B,104,240) RS1/16S104J  
 R 2302(B,106,240) RS1/16S104J  
 R 2303(B,108,240) RS1/16S104J  
 R 2304(B,110,240) RS1/16S104J  
 R 2305(B,112,240) RS1/16S104J

R 2306(B,114,240) RS1/16S104J  
 R 2307(B,116,240) RS1/16S104J  
 R 2308(B,118,240) RS1/16S104J  
 R 2309(B,120,240) RS1/16S104J  
 R 2310(B,122,240) RS1/16S104J

R 2311(B,124,240) RS1/16S104J  
 R 2312(B,126,240) RS1/16S104J  
 R 2313(B,128,240) RS1/16S104J  
 R 2314(B,130,240) RS1/16S104J  
 R 2315(B,132,240) RS1/16S104J

R 2316(B,134,240) RS1/16S104J  
 R 2317(B,136,240) RS1/16S104J  
 R 2318(B,138,240) RS1/16S104J  
 R 2319(B,140,240) RS1/16S104J  
 R 2320(B,142,240) RS1/16S104J

R 2321(B,144,240) RS1/16S104J  
 R 2322(B,146,240) RS1/16S104J  
 R 2323(B,148,240) RS1/16S104J  
 R 2324(B,150,240) RS1/16S104J  
 R 2325(B,152,240) RS1/16S104J

R 2326(B,154,240) RS1/16S104J  
 R 2327(B,156,240) RS1/16S104J  
 R 2328(B,158,240) RS1/16S104J  
 R 2329(B,160,240) RS1/16S104J  
 R 2330(B,162,240) RS1/16S104J

**Mark No. Description****Part No.****Mark No. Description****Part No.**

R 2331(B,164,240)  
R 2332(B,166,240)  
R 2333(B,168,240)  
R 2334(B,170,240)  
R 2335(B,172,240)

RS1/16S104J  
RS1/16S104J  
RS1/16S104J  
RS1/16S104J  
RS1/16S104J

R 2422(B,64,219)  
R 2424(B,135,193)

RS1/16S331J  
RS1/16S472J

**CAPACITORS**

C 2303(B,221,238)  
C 2304(A,230,236) ELECT. CAPACITOR  
C 2305(B,178,231)  
C 2306(B,180,231)  
C 2307(B,182,231)

CCSRCH471J50  
CEAT101M35  
CCSRCH471J50  
CCSRCH471J50  
CCSRCH471J50

R 2336(B,174,240)  
R 2337(B,176,240)  
R 2338(B,180,240)  
R 2339(B,182,240)  
R 2340(B,184,240)

RS1/16S104J  
RS1/16S104J  
RS1/16S473J  
RS1/16S473J  
RS1/16S473J

C 2308(B,183,231)  
C 2309(B,187,231)  
C 2310(B,189,231)  
C 2311(B,190,231)  
C 2312(B,192,231)

CCSRCH471J50  
CCSRCH471J50  
CCSRCH471J50  
CCSRCH471J50  
CCSRCH471J50

R 2341(B,186,240)  
R 2342(B,188,240)  
R 2343(B,190,240)  
R 2344(B,192,240)  
R 2345(B,194,240)

RS1/16S473J  
RS1/16S473J  
RS1/16S473J  
RS1/16S473J  
RS1/16S473J

C 2313(B,196,231)  
C 2314(B,197,231)  
C 2315(B,199,231)  
C 2316(B,201,231)  
C 2317(B,204,231)

CCSRCH471J50  
CCSRCH471J50  
CCSRCH471J50  
CCSRCH471J50  
CCSRCH471J50

R 2346(B,196,240)  
R 2347(B,198,240)  
R 2348(B,200,240)  
R 2349(B,202,240)  
R 2350(B,204,240)

RS1/16S473J  
RS1/16S473J  
RS1/16S473J  
RS1/16S473J  
RS1/16S473J

C 2318(B,206,231)  
C 2319(B,208,231)  
C 2320(B,209,231)  
C 2351(B,180,215)  
C 2353(B,185,207)

CCSRCH471J50  
CCSRCH471J50  
CCSRCH471J50  
CKSRYP103K50  
CKSRYP104K25

R 2351(B,206,240)  
R 2352(B,208,240)  
R 2353(B,210,240)  
R 2354(B,198,200)  
R 2355(B,206,191)

RS1/16S473J  
RS1/16S473J  
RS1/16S473J  
RS1/16S473J  
RS1/16S473J

C 2354(B,175,202)  
C 2359(B,142,204)  
C 2360(A,87,231) ELECT. CAPACITOR  
C 2361(B,161,230)  
C 2362(B,160,230)

CKSRYP104K25  
CKSRYP103K50  
CEJQ470M50  
CKSRYP103K50  
CKSRYP103K50

R 2356(B,190,207)  
R 2357(B,193,202)  
R 2358(B,181,201)  
R 2359(B,176,202)  
R 2361(B,172,197)

RS1/16S473J  
RS1/16S473J  
RS1/16S105J  
RS1/16S104J  
RS1/16S221J

C 2403(B,247,195)  
C 2404(B,237,236)  
C 2405(A,247,235)  
C 2406(B,245,209)  
C 2407(A,229,210)

CKSRYP103K50  
CKSRYP103K50  
CEJQ101M6R3  
CKSRYP103K50  
CEJQ221M6R3

R 2362(B,170,194)  
R 2363(B,169,194)  
R 2364(B,167,194)  
R 2366(B,162,198)  
R 2368(B,126,199)

RS1/16S221J  
RS1/16S221J  
RS1/16S221J  
RS1/16S104J  
RS1/16S473J

**M VOLUME ASSY  
MISCELLANEOUS**

J 2451 JUMPER WIRE  
S 2451(A,289,207) SWITCH  
S 2452(A,304,207) SWITCH  
S 2453(A,314,207) SWITCH  
S 2454(A,302,174) ROTARY ENCODER

D15A04-100-2651  
VSG1024  
VSG1024  
VSG1024  
ASX7048

2451(A,278,202) CABLE HOLDER (4P) 51063-0405

**RESISTORS**

R 2451(B,296,206)  
R 2452(B,311,206)

RS1/16S681J  
RS1/16S821J

**CAPACITORS**

C 2451(B,281,208)  
C 2452(B,304,186)  
C 2453(B,299,186)

CKSRYP102K50  
CKSRYP103K50  
CKSRYP103K50

R 2411(B,247,191)  
R 2412(B,249,192)  
R 2413(B,240,191)  
R 2414(B,237,196)  
R 2415(B,257,192)

RS1/16S0R0J  
RS1/16S104J  
RS1/16S472J  
RS1/16S0R0J  
RS1/16S104J

R 2416(B,251,195)  
R 2417(B,239,196)  
R 2419(B,232,240)  
R 2420(B,233,220)  
R 2421(B,72,225)

RS1/16S103J  
RS1/16S102J  
RS1/16S101J  
RS1/16S331J  
RS1/16S331J

5	6	
Mark No.	Description	Part No.
<b>N MULTI JOG ASSY</b>		
<b>MISCELLANEOUS</b>		
	IC 2501(B,157,111) LOGIC IC	CD4094BNS
Q	2501(B,162,146) DIGITAL TR (SC-70)	RT1N431M
Q	2502(B,174,146) DIGITAL TR (SC-70)	RT1N431M
Q	2503(B,195,146) DIGITAL TR (SC-70)	RT1N431M
Q	2504(B,217,146) DIGITAL TR (SC-70)	RT1N431M
Q	2505(B,237,147) DIGITAL TR (SC-70)	RT1N431M
Q	2506(B,259,146) DIGITAL TR (SC-70)	RT1N431M
Q	2507(B,280,146) DIGITAL TR (SC-70)	RT1N431M
Q	2508(B,314,140) DIGITAL TR (SC-70)	RT1N431M
Q	2509(B,131,147) DIGITAL TR (SC-70)	RT1N431M
Q	2510(B,22,184) DIGITAL TR (SC-70)	RT1N431M
Q	2511(B,121,147) DIGITAL TR (SC-70)	RT1N431M
Q	2512(B,87,146) DIGITAL TR (SC-70)	RT1N431M
D	2502(A,155,147) LED (ORANGE)	SLI-343DCW(STU)
D	2504(A,177,147) LED (ORANGE)	SLI-343DCW(STU)
D	2506(A,198,147) LED (ORANGE)	SLI-343DCW(STU)
D	2508(A,220,147) LED (ORANGE)	SLI-343DCW(STU)
D	2510(A,241,147) LED (ORANGE)	SLI-343DCW(STU)
D	2512(A,263,147) LED (ORANGE)	SLI-343DCW(STU)
D	2514(A,284,147) LED (ORANGE)	SLI-343DCW(STU)
D	2516(A,306,147) LED (ORANGE)	SLI-343DCW(STU)
D	2518(A,134,147) LED (ORANGE)	SLI-343DCW(STU)
D	2520(A,16,186) LED (BLUE)	SLR-343BBT(HJKL)
D	2522(A,112,147) LED (ORANGE)	SLI-343DCW(STU)
D	2524(A,91,147) LED (ORANGE)	SLI-343DCW(STU)
J	2501 JUMPER WIRE	D20PDD1715E
S	2501(A,36,119) ROTARY ENCODER	ASX7031
S	2551(A,154,141) SWITCH	VSG1024
S	2552(A,181,141) SWITCH	VSG1024
S	2553(A,202,141) SWITCH	VSG1024
S	2554(A,224,141) SWITCH	VSG1024
S	2555(A,245,141) SWITCH	VSG1024
S	2556(A,267,141) SWITCH	VSG1024
S	2557(A,288,141) SWITCH	VSG1024
S	2558(A,310,141) SWITCH	VSG1024
S	2561(A,74,117) SWITCH	VSG1024
S	2562(A,106,91) SWITCH	VSG1024
S	2563(A,120,91) SWITCH	VSG1024
S	2564(A,135,91) SWITCH	VSG1024
S	2565(A,150,91) SWITCH	VSG1024
S	2566(A,165,91) SWITCH	VSG1024
S	2567(A,179,91) SWITCH	VSG1024
S	2571(A,15,179) SWITCH	VSG1024
S	2572(A,18,142) SWITCH	VSG1024
S	2573(A,33,142) SWITCH	VSG1024
S	2574(A,48,142) SWITCH	VSG1024
S	2575(A,90,141) SWITCH	VSG1024
S	2576(A,116,141) SWITCH	VSG1024
S	2577(A,138,141) SWITCH	VSG1024
	2501(A,41,205) 17P CABLE HOLDER	51048-1700
<b>RESISTORS</b>		
R	2501(B,151,152)	RS1/16S331J
R	2502(B,184,152)	RS1/16S331J
R	2503(B,194,152)	RS1/16S331J
R	2504(B,216,152)	RS1/16S331J
R	2505(B,237,152)	RS1/16S331J

7	8	
Mark No.	Description	Part No.
R	2506(B,259,152)	RS1/16S331J
R	2507(B,280,152)	RS1/16S331J
R	2508(B,302,152)	RS1/16S331J
R	2509(B,142,152)	RS1/16S331J
R	2510(B,9,186)	RS1/16S391J
R	2511(B,119,152)	RS1/16S331J
R	2512(B,87,151)	RS1/16S331J
R	2513(B,160,103)	RS1/16S0R0J
R	2551(B,149,141)	RS1/16S472J
R	2552(B,173,141)	RS1/16S681J
R	2553(B,194,141)	RS1/16S821J
R	2554(B,216,141)	RS1/16S122J
R	2555(B,237,141)	RS1/16S162J
R	2556(B,258,141)	RS1/16S472J
R	2557(B,280,141)	RS1/16S512J
R	2558(B,301,142)	RS1/16S133J
R	2561(B,77,113)	RS1/16S472J
R	2562(B,106,98)	RS1/16S681J
R	2563(B,117,90)	RS1/16S821J
R	2564(B,132,90)	RS1/16S122J
R	2565(B,145,90)	RS1/16S162J
R	2566(B,160,90)	RS1/16S272J
R	2567(B,175,90)	RS1/16S512J
R	2571(B,12,181)	RS1/16S472J
R	2572(B,18,146)	RS1/16S681J
R	2573(B,30,142)	RS1/16S821J
R	2574(B,45,142)	RS1/16S122J
R	2575(B,87,141)	RS1/16S162J
R	2576(B,106,143)	RS1/16S272J
R	2577(B,130,141)	RS1/16S512J
<b>CAPACITORS</b>		
C	2501(B,148,108)	CKSRYB103K50
C	2502(B,36,129)	CKSRYB103K50
C	2503(B,33,129)	CKSRYB103K50
C	2551(B,151,141)	CKSRYB102K50
C	2561(B,79,113)	CKSRYB102K50
C	2571(B,18,181)	CKSRYB102K50
<b>HEADPHONE ASSY</b>		
<b>MISCELLANEOUS</b>		
	KN2851(A,13,54) WRAPPING TERMINAL	VNF1084
	CN2851(A,19,70) 4P JUMPER CONNECTOR	52147-0410
	2851(A,15,14) PHONE JACK	AKN7029
<b>RESISTORS</b>		
R	2851(B,20,26)	RS1/16S102J
R	2852(B,16,27)	RS1/16S0R0J
<b>CAPACITORS</b>		
C	2851(B,19,42)	CKSRYB392K50
C	2852(B,11,29)	CKSRYB392K50
C	2853(B,10,40)	CCSRCH471J50
C	2854(B,13,43)	CKSRYB103K50
C	2855(B,13,45)	CKSRYB104K16

**Mark No. Description****Part No.****Mark No. Description****Part No.****P FRONT-IN ASSY  
MISCELLANEOUS**

A	IC 2701(B,36,55) OP-AMP IC	BA4560RF
	Q 2651(B,116,47) CHIP TRANSISTOR	HN1C01FU
	D 2701(B,29,62) DIODE	DAN217
	D 2702(B,33,32) DIODE	UDZS5R1(B)
	D 2703(B,31,29) DIODE	UDZS5R1(B)
	D 2704(B,28,46) DIODE	UDZS5R1(B)
	L 2653(B,117,59) INDUCTOR	CTF1385
	L 2671(B,143,58) INDUCTOR	CTF1385
	L 2681(B,92,65) CHIP SOLID INDUCTOR	QTL1013
	L 2752(B,68,60) CHIP FERRITE BEADS	VTL1169
B	L 2753(B,72,55) CHIP FERRITE BEADS	VTL1169
	JA2651(A,109,69) PIN JACK (4P)	XKX3003
	JA2652(A,88,77) OPTICAL IN MODULE	GP1FM513RZ
	JA2701(A,45,73) JACK	RKN1004
	JA2751(A,65,76) USB CONNECTOR	XKP3086
	KN2651(A,156,42) WRAPPING TERMINAL	VNF1084
	KN3351(A,44,37) WRAPPING TERMINAL	VNF1084
	CN2651(A,40,28) CONNECTOR	CKS3382
	CN2652(A,67,42) CONNECTOR	B4B-PH

**RESISTORS**

C	R 2651(B,121,58)	RS1/16S0R0J
	R 2652(B,107,57)	RS1/16S0R0J
	R 2653(B,128,58)	RS1/16S104J
	R 2654(B,111,56)	RS1/16S104J
	R 2655(B,128,54)	RS1/16S221J
	R 2656(B,107,52)	RS1/16S221J
	R 2657(B,124,54)	RS1/16S104J
	R 2658(B,113,56)	RS1/16S104J
	R 2659(B,122,46)	RS1/16S221J
	R 2660(B,113,51)	RS1/16S221J
D	R 2661(B,118,46)	RS1/16S153J
	R 2662(B,113,43)	RS1/16S153J
	R 2663(B,120,46)	RS1/16S101J
	R 2664(B,112,48)	RS1/16S101J
	R 2665(B,100,46)	RS1/16S470J
	R 2666(B,100,39)	RS1/16S470J
	R 2668(B,131,57)	RS1/16S0R0J
	R 2671(B,141,62)	RS1/16S750J
	R 2672(B,145,62)	RS1/16S0R0J
	R 2673(B,152,59)	RS1/16S750J
	R 2674(B,150,64)	RS1/16S750J
	R 2675(B,152,55)	RS1/16S0R0J
E	R 2676(B,148,58)	RS1/16S0R0J
	R 2681(B,85,65)	RS1/16S101J
	R 2701(B,41,65)	RS1/16S102J
	R 2702(B,38,68)	RS1/16S682J
	R 2703(B,40,69)	RS1/16S104J
	R 2704(B,30,66)	RS1/16S101J
	R 2705(B,34,62)	RS1/16S104J
	R 2706(B,30,57)	RS1/16S472J
	R 2707(B,38,62)	RS1/16S333J
	R 2708(B,41,61)	RS1/16S101J
	R 2709(B,30,48)	RS1/16S472J
F	R 2710(B,34,48)	RS1/16S333J
	R 2711(B,36,48)	RS1/16S101J

R 2712(B,34,28)	RS1/16S104J
R 2714(B,34,38)	RS1/16S102J
R 2751(B,65,60)	RS1/16S0R0J
R 2752(B,63,60)	RS1/16S0R0J

**CAPACITORS**

C 2651(B,126,58)	CCSRCH221J50
C 2652(B,109,56)	CCSRCH221J50
C 2653(A,125,47)	CEAT100M50
C 2654(A,109,46)	CEAT100M50
C 2655(B,126,54)	CCSRCH101J50
C 2656(B,115,56)	CCSRCH101J50
C 2659(A,125,39) ELECT. CAPACITOR	CEAT470M25
C 2660(A,109,39) ELECT. CAPACITOR	CEAT470M25
C 2661(B,113,40)	CKSRYB103K50
C 2662(B,115,37)	CKSRYB103K50
C 2663(A,102,46) ELECT. CAPACITOR	CEAT330M25
C 2664(A,102,40) ELECT. CAPACITOR	CEAT330M25
C 2665(B,152,46)	CKSRYB103K50
C 2666(B,150,46)	CKSRYB223K50
C 2671(B,130,61)	CKSRYB103K50
C 2672(B,143,62)	CKSRYB102K50
C 2673(B,154,57)	CKSRYB104K16
C 2674(B,156,46)	CKSRYB103K50
C 2675(B,158,46)	CKSRYB223K50
C 2681(B,89,65)	CKSRYB104K16
C 2701(B,42,69)	CCSRCH471J50
C 2702(A,36,66)	CEAT100M50
C 2703(B,32,62)	CCSRCH101J50
C 2704(B,36,62)	CCSRCH330J50
C 2705(B,32,48)	CCSRCH330J50
C 2706(A,34,36)	CEAT100M50
C 2707(B,48,43)	CKSRYB103K50
C 2709(B,52,43)	CKSRYB223K50
C 2712(A,35,44)	CEAT100M50
C 2713(B,40,57)	CKSRYB103K50
C 2714(B,40,53)	CKSRYB103K50
C 2715(A,49,59)	CEAT100M50
C 2716(A,49,53)	CEAT100M50
C 2718(B,40,38)	CKSRYB102K50
C 2719(B,40,36)	CCSRCH221J50
C 2753(B,68,56)	CKSRYB104K16
C 2755(A,68,51)	CEAT101M16
C 2756(B,73,51)	CKSRYB104K16
C 2757(B,73,46)	CCSRCH471J50

**Q PRIMARY ASSY  
MISCELLANEOUS**

⚠ IC 2001(A,305,99) REGULATOR IC	NJM78M56FA
Q 2001(B,281,60) DIGITAL TR (SC-70)	RT1N431M
D 2001(B,276,60) DIODE	1SS355
D 2002(B,276,65) DIODE	1SS355
⚠ D 2003(B,296,87) BRIDGE DIODE	S1WB(A)60SD
D 2004(B,304,75) DIODE	1SS355
D 2006(B,308,70) DIODE	UDZS5R1(B)
⚠ L 2001(A,244,24) LINE FILTER	XTF3004
H 2001(A,243,46) FUSE CLIP	AKR7001
H 2002(A,223,46) FUSE CLIP	AKR7001

Mark No.	Description	Part No.
	KN2001(A,194,19) SCREW PLATE	VNE1948
△	RY2001(A,251,58) JOE LOW POWER RELAY	ASR7013
△	T 2001(A,273,84) STANDBY TRANSFORMER	ATT7040
	CN2001(A,301,115) 9P SOCKET	KP200TA9L
	CN2002(A,246,115) 5P SOCKET	KP200TA5L
△	CN2003(A,225,25) AC CORD SOCKET	RKP1751

### RESISTORS

R	2002(A,279,68) CARBON FILM	RD1/4MUF101J
R	2003(B,305,70)	RS1/16S103J
R	2004(B,302,70)	RS1/16S332J

### CAPACITORS

△	C 2002(A,266,26) FILM (0.01, 275 V)	ACE7013
△	C 2003(A,251,52) 10000P, 250 V	XCG3009
	C 2004(A,290,106) FILM CAPACITOR	CQMBA103J50
	C 2009(A,303,88) ELECT. CAPACITOR	CEAT332M25
	C 2010(A,309,106)	CEAT221M25
	C 2011(B,310,85)	CKSRYB103K50

## R TRANS 1 ASSY

TRANS 1 Assy has no service part.

## SECONDARY ASSY

### MISCELLANEOUS

Y	9 AWG18 BOARD IN	ADX7502
Y	10 AWG18 BOARD IN	ADX7503
Y	11 AWG18 BOARD IN	ADX7504
Y	12 AWG18 BOARD IN	ADX7505

## S TRANS 2-1 ASSY

### MISCELLANEOUS

△	IC 3251(A,228,215) PROTECTOR (7A)	AEK7021
△	IC 3252(A,239,164) PROTECTOR (7A)	AEK7021
	Q 3251(B,244,224) CHIP TRANSISTOR	RN1901
	Q 3252(B,253,224) TRANSISTOR	UMD2N
	Q 3253(B,261,224) TRANSISTOR	UMD2N
△	D 3251(B,234,181) BRIDGE DIODE	S1WB(A)60SD
	D 3253(B,236,216) DIODE	UDZS8R2(B)
	D 3254(B,263,217) DIODE	UDZS7R5(B)
	D 3255(B,233,216) DIODE	UDZS9R1(B)
	D 3256(B,263,219) DIODE	UDZS8R2(B)
	D 3257(B,233,223) DIODE	UDZS9R1(B)
	D 3258(B,258,218) DIODE	UDZS8R2(B)
	D 3259(B,238,223) DIODE	UDZS6R8(B)
	D 3260(B,258,220) DIODE	UDZS6R8(B)
	D 3261(B,240,220) DIODE	UDZS12(B)
	D 3262(B,253,220) DIODE	UDZS12(B)
	D 3263(B,238,218) DIODE	UDZS13(B)
	D 3264(B,253,218) DIODE	UDZS15(B)
	D 3265(B,257,226) DIODE	UDZS13(B)
	D 3266(B,267,227) DIODE	UDZS13(B)
J	3251 JUMPER WIRE	D20PDY0610E
	3251(A,261,193) 6P CABLE HOLDER	51048-0600

Mark No.	Description	Part No.
<b>RESISTORS</b>		
△	R 3253(A,248,192) METAL OXIDE	RS1LMF472J
△	R 3254(A,263,212) METAL OXIDE	RS1LMF472J
△	R 3255(A,245,195) CARBON FILM	RD1/2LMF332J
△	R 3256(A,259,215) CARBON FILM	RD1/2LMF332J

### CAPACITORS

C	3253(A,243,186) ELECT. CAPACITOR	CEAT471M2A
C	3254(A,253,172) ELECT. CAPACITOR	CEAT471M2A
C	3255(A,240,202) ELECT. CAPACITOR	CEAT101M63
C	3256(A,240,213) ELECT. CAPACITOR	CEAT101M63
C	3257(A,269,190) ELECT. CAPACITOR	CEAT221M2A
C	3258(A,262,201) ELECT. CAPACITOR	CEAT221M2A

## T DIODE 1 ASSY

### MISCELLANEOUS

△	D 3301(A,175,164) DIODE	D5SBA20(B)
△	D 3302(A,175,199) DIODE	D5SBA20(B)

### RESISTORS

△	R 3301(A,194,172) CARBON FILM	RD1/4MUF100J
---	-------------------------------	--------------

### CAPACITORS

C	3301(A,191,182) FILM CAPACITOR	CFTLA104J2A
C	3302(A,196,177) FILM CAPACITOR	CFTLA104J2A

## U VH TR ASSY

### MISCELLANEOUS

△	IC 3351(A,177,136) IC PROTECTOR	ICP-N15
△	IC 3352(A,177,152) IC PROTECTOR	ICP-N15
	Q 3351(B,172,130) CHIP TRANSISTOR	2SA1514K
△	Q 3352(A,162,135) TRANSISTOR	2SB1186A
△	Q 3353(A,162,150) TRANSISTOR	2SD1763A
	Q 3354(B,172,145) CHIP TRANSISTOR	2SC3906K
△	D 3351(B,173,141) DIODE	1SR154-400
△	D 3352(B,176,157) DIODE	1SR154-400
	CN3351(A,184,138) 6P JUMPER CONNECTOR	52147-0610

### RESISTORS

R	3351(B,179,129)	RS1/16S471J
R	3352(B,168,128)	RS1/16S100J
R	3353(B,168,143)	RS1/16S100J
R	3354(B,177,144)	RS1/16S471J

## V BRIDGE 1 ASSY

### MISCELLANEOUS

	CN5811(A,46,130) 23P PLUG	XKP3071
	CN5812(A,46,105) 23P PLUG	XKP3071
	5811(A,8,101) PCB BINDER	VEF1040

**Mark No. Description****Part No.****Mark No. Description****Part No.****W PS/SP ASSY  
MISCELLANEOUS**

A	Q 3001(B,161,85) CHIP TRANSISTOR	DTC114TUA
	Q 3002(B,229,97) CHIP TRANSISTOR	DTC114TUA
	Q 3003(B,247,90) CHIP TRANSISTOR	DTC114TUA
	Q 3004(B,290,84) CHIP TRANSISTOR	DTC114TUA
	Q 3005(B,212,99) CHIP TRANSISTOR	DTC114TUA

	D 3001(B,168,80) DIODE	1SS355
	D 3002(B,165,80) DIODE	1SS355
	D 3003(B,216,88) DIODE	1SS355
	D 3004(B,213,88) DIODE	1SS355
	D 3005(B,247,82) DIODE	1SS355

B	D 3006(B,244,82) DIODE	1SS355
	D 3007(B,291,79) DIODE	1SS355
	D 3008(B,289,79) DIODE	1SS355
	D 3009(B,217,99) DIODE	1SS355
	D 3010(B,215,99) DIODE	1SS355

	L 3011(A,188,78) COIL	ATH1053
	L 3021(A,146,69) COIL	ATH1053
	L 3031(A,199,83) COIL	ATH1053
	L 3041(A,258,82) COIL	ATH1053
	L 3051(A,236,90) COIL	ATH1053

	L 3061(A,299,74) COIL	ATH1053
	L 3071(A,280,84) COIL	ATH1053
C	J 3009(A,174,89) CONNECTOR ASSY	PF13PG-R07
	KN3001(A,318,64) WRAPPING TERMINAL	VNF1084
	RY3001(A,163,81) RELAY	ASR7001

	RY3002(A,211,89) RELAY	ASR7001
	RY3003(A,242,83) RELAY	ASR7001
	RY3004(A,286,82) RELAY	ASR7001
	RY3005(A,219,103) RELAY	ASR7001
	CN3001(A,190,33) SPEAKER TERMINAL 8-P	AKE7119

	CN3002(A,274,33) SPEAKER TERMINAL 6-P	AKE7108
	CN3007(A,313,90) 5P PLUG	KM200TA5
D	CN3008(A,313,145) 9P PLUG	KM200TA9
	Y 13 AWG14 BOARD IN	ADX7512
	Y 8 AWG14 BOARD IN	ADX7512

**RESISTORS**

	△ R 3011(A,187,68) METAL OXIDE	RS1/2LMF4R7J
	△ R 3012(A,175,64) METAL OXIDE	RS1LMF100J
	△ R 3013(A,193,94) METAL OXIDE	RS2LMF331J
	△ R 3021(A,148,79) METAL OXIDE	RS1/2LMF4R7J
	△ R 3022(A,152,51) METAL OXIDE	RS1LMF100J

	△ R 3023(A,188,97) METAL OXIDE	RS2LMF331J
E	△ R 3031(A,196,87) METAL OXIDE	RS1/2LMF4R7J
	△ R 3032(A,194,67) METAL OXIDE	RS1LMF100J
	△ R 3041(A,254,82) METAL OXIDE	RS1/2LMF4R7J
	△ R 3042(A,267,67) METAL OXIDE	RS1LMF100J

	△ R 3051(A,240,93) METAL OXIDE	RS1/2LMF4R7J
	△ R 3052(A,237,79) METAL OXIDE	RS1LMF100J
	△ R 3061(A,309,63) METAL OXIDE	RS1/2LMF4R7J
	△ R 3062(A,313,73) METAL OXIDE	RS1LMF100J
	△ R 3071(A,280,88) METAL OXIDE	RS1/2LMF4R7J

	△ R 3072(A,268,94) METAL OXIDE	RS1LMF100J
	R 3101(A,222,115) CARBON FILM	RD1/4MUF473J
F	R 3102(A,252,115) CARBON FILM	RD1/4MUF473J

**CAPACITORS**

	C 3001(A,164,89)	CEAT101M50
	C 3011(A,190,60)	CFTLA104J50
	C 3012(A,203,53)	CFTLA104J50
	C 3013(A,190,42) FILM CAPACITOR	CQ MBA103J50
	C 3021(A,157,48)	CFTLA104J50

	C 3022(A,157,39)	CFTLA104J50
	C 3023(A,169,42) FILM CAPACITOR	CQ MBA103J50
	C 3031(A,205,66)	CFTLA104J50
	C 3032(A,200,60)	CFTLA104J50
	C 3033(A,211,42) FILM CAPACITOR	CQ MBA103J50

	C 3041(A,257,63)	CFTLA104J50
	C 3042(A,253,57)	CFTLA104J50
	C 3043(A,253,42) FILM CAPACITOR	CQ MBA103J50
	C 3051(A,224,70)	CFTLA104J50
	C 3052(A,230,70)	CFTLA104J50

	C 3053(A,232,42) FILM CAPACITOR	CQ MBA103J50
	C 3061(A,308,58)	CFTLA104J50
	C 3062(A,302,53)	CFTLA104J50
	C 3063(A,295,42) FILM CAPACITOR	CQ MBA103J50
	C 3071(A,274,70)	CFTLA104J50

	C 3072(A,279,65)	CFTLA104J50
	C 3073(A,274,42) FILM CAPACITOR	CQ MBA103J50
	C 3091(B,181,50)	CKSRYB222K50
	C 3092(B,179,50)	CKSRYB222K50
	C 3093(B,265,50)	CKSRYB222K50

	C 3094(B,263,50)	CKSRYB222K50
	C 3096(B,318,55)	CKSRYB222K50
	C 3101(A,212,137)	ACH7255
	C 3102(A,258,137)	ACH7255

**X TRANS 2-2 ASSY  
MISCELLANEOUS**

	H 3401(A,120,100) FUSE CLIP	AKR7001
	H 3402(A,98,100) FUSE CLIP	AKR7001
	H 3403(A,120,87) FUSE CLIP	AKR7001
	H 3404(A,98,87) FUSE CLIP	AKR7001
	H 3405(A,120,74) FUSE CLIP	AKR7001

	H 3406(A,98,74) FUSE CLIP	AKR7001
	H 3407(A,119,57) FUSE CLIP	AKR7001
	H 3408(A,97,57) FUSE CLIP	AKR7001
	H 3409(A,120,45) FUSE CLIP	AKR7001
	H 3410(A,98,45) FUSE CLIP	AKR7001

	J 3401(A,132,97) CONNECTOR ASSY	PF12PG-R40
--	---------------------------------	------------

**Y TRANS SIDE ASSY  
MISCELLANEOUS**

	J 3201 JUMPER WIRE	D20PDY0410E
	CN3202(A,60,8) CONNECTOR	CKS3382
	CN3203(A,319,21) CONNECTOR	B13B-PH
	3201(A,84,28) 4P CABLE HOLDER	51048-0400

Mark No.	Description	Part No.
<b>Z</b>	<b>LOCAL P-SUPPLY ASSY</b>	
	<b>MISCELLANEOUS</b>	
△ IC	3502(A,120,181) PROTECTOR (1.6A)	AEK7012
△ IC	3504(A,80,176) IC	NJM78M05FA
△ IC	3505(A,80,226) REGULATOR IC	NJM78M56FA
△ IC	3506(A,80,201) IC	NJM79M05FA
△ IC	3510(A,111,238) PROTECTOR (1.6A)	AEK7012
Q	3501(B,110,149) TRANSISTOR	UMD2N
△ Q	3502(A,80,151) TRANSISTOR	2SD1763A
Q	3503(B,144,140) DIGITAL TRANSISTOR	DTC124EUA
Q	3504(B,109,230) CHIP TRANSISTOR	RSR015P03
Q	3505(B,115,232) DIGITAL TRANSISTOR	DTC124EUA
△ D	3501(B,120,163) DIODE	1SR154-400
△ D	3502(B,124,163) DIODE	1SR154-400
△ D	3503(B,128,163) DIODE	1SR154-400
D	3504(B,136,146) DIODE	UDZS6R2(B)
D	3505(B,138,146) DIODE	UDZS6R2(B)
D	3506(B,141,146) DIODE	UDZS6R2(B)
D	3507(B,143,146) DIODE	UDZS6R2(B)
D	3508(B,142,180) DIODE	UDZS6R2(B)
△ D	3509(B,108,160) DIODE	1SR154-400
△ D	3510(B,113,160) DIODE	1SR154-400
D	3511(B,112,132) DIODE	UDZS27(B)
D	3512(A,117,196) DIODE	D3SBA20(B)
△ D	3513(B,86,180) CHIP DIODE	RB501V-40
△ D	3514(A,95,181) DIODE	MTZJ6R2(B)
D	3515(B,87,236) CHIP DIODE	RB501V-40
D	3516(B,87,204) CHIP DIODE	RB501V-40
D	3529(B,80,196) DIODE	1SS355
J	3502 9P JUMPER WIRE	D20PDY0915E
J	3503(A,152,132) CONNECTOR ASSY	PF05PG-Q15
J	3504(A,160,239) CONNECTOR ASSY	PF10PG-R07
J	3505(A,138,232) CONNECTOR ASSY	PF09PG-R37
J	3506 JUMPER WIRE	D20PDY0410E
CN	3501(A,141,151) CONNECTOR	B12B-PH
	3502(A,149,215) 9P CABLE HOLDER	51048-0900
	3506(A,150,167) 4P CABLE HOLDER	51048-0400
	<b>RESISTORS</b>	
R	3501(B,120,152)	RS1/16S473J
△ R	3503(A,127,156) CARBON FILM	RD1/4MUF391J
R	3504(B,111,142)	RS1/16S472J
R	3505(B,108,142)	RS1/16S101J
R	3506(B,140,139)	RS1/16S222J
△ R	3508(A,134,181) CARBON FILM	RD1/4MUF4R7J
R	3511(B,106,235)	RS1/16S103J
R	3512(B,113,235)	RS1/16S101J
	<b>CAPACITORS</b>	
C	3501(A,150,148) FILM CAPACITOR	CQ MBA104J50
C	3502(A,122,168) ELECT. CAPACITOR	CEANP101M35
C	3503(A,118,157) ELECT. CAPACITOR	CEAT101M35
C	3504(A,123,147)	CEAT221M35
C	3505(A,139,179)	CEAT101M16
C	3506(A,133,145)	CEAT470M50
C	3508(B,122,152)	CKSRYB103K50
C	3510(A,110,171) ELECT. CAPACITOR	CEANP102M16
C	3511(A,107,154) ELECT. CAPACITOR	CEAT102M35
C	3512(A,109,135)	CEAT100M50

Mark No.	Description	Part No.
C	3513(B,83,149)	CKSRYB102K50
C	3514(A,145,136)	CEAT100M50
C	3515(A,137,140) ELECT. CAPACITOR	CEANP470M25
C	3516(A,122,187) FILM CAPACITOR	CQ MBA104J50
C	3517(B,83,175)	CKSRYB103K50
C	3518(A,85,189)	CEAT221M16
C	3519(A,117,208) ELECT. CAPACITOR	CEAT682M16
C	3520(A,134,208) ELECT. CAPACITOR	CEAT222M16
C	3521(B,83,224)	CKSRYB103K50
C	3522(B,87,201)	CKSRYB103K50
C	3523(A,88,227)	CEAT101M16
C	3524(A,85,214)	CEAT101M16
	<b>AA DC/DC ASSY</b>	
	<b>MISCELLANEOUS</b>	
△ IC	651 (A,43,196) REGULATOR IC	PQ1CG3032FZ
Q	651 (A,65,206) TRANSISTOR	2SD1858X
△ D	651 (B,45,207) DIODE	RB051L-40
△ D	652 (B,66,211) DIODE	UDZS7R5(B)
△ D	653 (A,38,152) DIODE	D3SBA20(B)
△ D	654 (A,68,231) DIODE	MTZJ6R2(B)
L	651 (A,50,212) INDUCTOR	ATH7020
KN	651 (A,40,181) SCREW PLATE	VNE1948
CN	651 (A,70,221) 3P TOP POST	B3B-EH
CN	652 (A,70,166) 4P JUMPER CONNECTOR	52147-0410
	651 (A,52,146) PCB BINDER	VEF1040
	<b>RESISTORS</b>	
△ R	651 (A,64,164) CARBON FILM	RD1/4MUF4R7J
R	652 (B,39,194) CHIP METAL FILM R	RN1/16SE1800D
R	653 (B,38,195)	RN1/16SE3001D
R	654 (B,41,192)	RN1/16SE1001D
R	655 (B,64,210)	RS1/16S302J
R	656 (B,62,210)	RS1/16S101J
	<b>CAPACITORS</b>	
C	651 (A,68,150) FILM CAPACITOR	CQ MBA104J50
C	654 (A,59,176) ELECT. CAPACITOR	CEAT103M16
C	655 (A,67,189) ELECT. CAPACITOR	CEHAZL102M16
C	657 (A,55,226) ELECT. CAPACITOR	CEHAZL102M6R3
C	658 (A,67,214)	CEAT101M16
C	659 (A,69,206)	CEAT101M16
	<b>AB IR I/O ASSY</b>	
	<b>MISCELLANEOUS</b>	
Q	3751(B,34,66) TRANSISTOR	2SD1664
D	3752(B,41,60) DIODE	UDZS10(B)
KN	3751(A,40,91) SCREW PLATE	VNE1948
CN	3701(A,58,46) 10P CONNECTOR	VKN1241
CN	3702(A,74,44) 23P SOCKET	XKP3082
CN	3703(A,28,43) CONNECTOR	CKS3376
	<b>RESISTORS</b>	
R	3703(B,25,84)	RS1/16S0R0J
R	3752(A,38,66) CARBON FILM RESISTOR	RD1/4MUF391J
R	3755(B,48,62)	RS1/16S0R0J

**Mark No. Description****Part No.****Mark No. Description****Part No.****CAPACITORS**

C 3701(B,49,81)	CKSRYB104K50
C 3702(B,27,84)	CCSRCH471J50
C 3752(A,38,61)	CEAT101M16
C 3753(B,26,71)	CKSRYB103K50
C 3754(B,24,71)	CKSRYB104K50
C 3755(B,28,71)	CKSRYB105K10
C 3756(B,67,56)	CKSRYB103K50
C 3757(B,71,58)	CCSRCH471J50

D 5001(B,190,188)	CHIP ZENER DIODE	UDZS3R6(B)
D 5002(B,188,188)	DIODE	1SS355
D 5003(B,180,184)	DIODE	1SS355
D 5004(B,172,184)	DIODE	1SS355
D 5005(B,177,184)	DIODE	UDZS4R7(B)
D 5006(B,175,184)	DIODE	UDZS4R7(B)
D 5041(B,149,174)	DIODE	1SS355
D 5042(B,151,174)	DIODE	1SS355
D 5043(B,151,203)	DIODE	1SS355
D 5044(B,154,171)	DIODE	1SS355

**AC VIDEO CONNECT ASSY****MISCELLANEOUS**

CN3801(A,288,240)	CONNECTOR POST	S9B-PH
CN3802(A,298,175)	21P PLUG	XKP3070
CN3803(A,305,198)	15P PLUG	XKP3067
CN3804(A,308,222)	13P PLUG	XKP3066

D 5101(B,137,188)	CHIP ZENER DIODE	UDZS3R6(B)
D 5102(B,135,188)	DIODE	1SS355
D 5103(B,126,184)	DIODE	1SS355
D 5104(B,119,184)	DIODE	1SS355
D 5105(B,124,184)	DIODE	UDZS4R7(B)

D 5106(B,121,184)	DIODE	UDZS4R7(B)
D 5141(B,91,188)	DIODE	1SS355
D 5142(B,95,188)	DIODE	1SS355
D 5143(B,95,202)	DIODE	1SS355
D 5144(B,97,188)	DIODE	1SS355

**POWER AMP ASSY****MISCELLANEOUS**

J 3	JUMPER WIRE	D20PDY0525E
Y 5	LEAD WITH HOUSING	ADX7404
Y 4	LEAD WITH HOUSING	ADX7460
Y 3	LEAD WITH HOUSING	ADX7458
Y 2	LEAD WITH HOUSING	ADX7457

D 5201(B,279,187)	CHIP ZENER DIODE	UDZS3R6(B)
D 5202(B,276,187)	DIODE	1SS355
D 5203(B,268,183)	DIODE	1SS355
D 5204(B,261,183)	DIODE	1SS355
D 5205(B,266,183)	DIODE	UDZS4R7(B)

Y 1	LEAD WITH HOUSING	ADX7459
Y 6	LEAD WITH HOUSING	ADX7498

D 5206(B,263,183)	DIODE	UDZS4R7(B)
D 5241(B,238,173)	DIODE	1SS355
D 5242(B,240,173)	DIODE	1SS355
D 5243(B,240,202)	DIODE	1SS355
D 5244(B,242,173)	DIODE	1SS355

**AD POWER AMP-L ASSY****MISCELLANEOUS**

△IC 5001(A,174,135)	DARLINGTON POWER IC	SAP17N(OY)
△IC 5002(A,208,135)	DARLINGTON POWER IC	SAP17P(OY)
△IC 5101(A,106,135)	DARLINGTON POWER IC	SAP17N(OY)
△IC 5102(A,140,135)	DARLINGTON POWER IC	SAP17P(OY)
△IC 5201(A,242,135)	DARLINGTON POWER IC	SAP17N(OY)

CN5001(A,319,200)	13P SOCKET	XKP3077
CN5002(A,85,214)	11P SOCKET	XKP3076
CN5003(A,312,191)	PLUG 6-P	KM250NA6L
CN5004(A,176,224)	CONNECTOR POST	B2B-PH
5001(A,160,225)	PCB BINDER	VEF1040

△IC 5202(A,276,135)	DARLINGTON POWER IC	SAP17P(OY)
△IC 5601(A,310,135)	DARLINGTON POWER IC	SAP17N(OY)
Q 5001(B,186,207)	CHIP TRANSISTOR	2SD2704K
Q 5002(B,174,194)	TRANSISTOR	IMT4
Q 5003(B,188,198)	CHIP TRANSISTOR	2SA1514K

**RESISTORS**

R 5001(B,192,202)		RS1/16S102J
R 5002(B,180,202)		RS1/16S221J
R 5003(B,177,203)		RS1/16S333J
R 5004(B,192,205)		RS1/16S103J
R 5005(B,170,191)		RS1/16S152J

Q 5004(A,185,184)	TRANSISTOR	2SA1145
Q 5005(A,161,191)	TRANSISTOR	2SC2705
Q 5041(B,149,195)	CHIP TR	2SA1255
Q 5101(B,132,207)	CHIP TRANSISTOR	2SD2704K
Q 5102(B,120,194)	TRANSISTOR	IMT4

R 5006(B,168,198)		RS1/16S821J
R 5007(B,191,197)		RS1/16S2001F
R 5008(B,179,194)		RS1/16S682J
R 5009(A,183,193)	CARBON FILM	RD1/2VM473J
R 5010(B,190,183)		RS1/16S151J

Q 5103(B,134,198)	CHIP TRANSISTOR	2SA1514K
Q 5104(A,131,184)	TRANSISTOR	2SA1145
Q 5105(A,108,191)	TRANSISTOR	2SC2705
Q 5141(B,91,201)	CHIP TR	2SA1255
Q 5201(B,274,206)	CHIP TRANSISTOR	2SD2704K

R 5011(B,188,184)		RN1/16SE1201D
R 5012(B,162,195)		RS1/16S221J
R 5013(B,183,150)	CHIP RESISTOR	RS1/16S62R0F
R 5021(B,176,153)		RS1/16S101J
R 5022(B,190,153)		RS1/16S101J

Q 5202(B,262,193)	TRANSISTOR	IMT4
Q 5203(B,276,197)	CHIP TRANSISTOR	2SA1514K
Q 5204(A,273,183)	TRANSISTOR	2SA1145
Q 5205(A,250,191)	TRANSISTOR	2SC2705
Q 5241(B,238,197)	CHIP TR	2SA1255

△R 5023(A,196,166)	CARBON FILM	RD1/4MUF4R7J
△R 5024(A,162,176)	CARBON FILM	RD1/4MUF4R7J
△R 5025(B,163,156)	CHIP (0.047, 0.5 W)	ACN7132
△R 5026(B,200,156)	CHIP (0.047, 0.5 W)	ACN7132
△R 5027(A,190,166)	RESISTOR (0.18, 5 W)	ACN7121





**Mark No. Description****Part No.****Mark No. Description****Part No.**

C 5132(B,108,199) CKSRYB224K16  
 C 5141(A,88,191) CEANP2R2M50  
 C 5201(A,271,202) CEAT4R7M50  
 A C 5202(B,265,199) CCSRCH221J50  
 C 5204(B,255,194) CKSRYB102K50

Q 5571(B,223,38) TRANSISTOR 2SC4081  
 Q 5572(B,220,38) TRANSISTOR 2SC4081  
 D 5301(B,191,58) CHIP ZENER DIODE UDZS3R6(B)  
 D 5302(B,188,58) DIODE 1SS355  
 D 5303(B,180,62) DIODE 1SS355

C 5207(A,283,192) CEAT101M10  
 C 5208(B,253,195) CERAMIC (4P, 200 V) ACG7057  
 C 5209(A,267,187) ELECT. CAPACITOR CEAT100M2A  
 C 5211(B,243,142) CERAMIC (100P, 200 V) ACG7056  
 C 5212(B,271,142) CERAMIC (100P, 200 V) ACG7056

D 5304(B,173,62) DIODE 1SS355  
 D 5305(B,177,62) DIODE UDZS4R7(B)  
 D 5306(B,175,62) DIODE UDZS4R7(B)  
 D 5341(B,151,71) DIODE 1SS355  
 D 5342(B,149,71) DIODE 1SS355

C 5215(B,257,204) CCSRCH220J50  
 C 5216(B,257,206) CCSRCH220J50  
 C 5217(A,261,206) CEAT331M10  
 C 5223(A,287,181) CEAT100M63  
 B C 5224(A,255,184) CEAT100M63

D 5343(B,150,50) DIODE 1SS355  
 D 5344(B,153,71) DIODE 1SS355  
 D 5401(B,137,58) CHIP ZENER DIODE UDZS3R6(B)  
 D 5402(B,135,58) DIODE 1SS355  
 D 5403(B,126,62) DIODE 1SS355

C 5232(B,250,199) CKSRYB224K16  
 C 5241(A,237,192) CEANP2R2M50  
 C 5611(B,307,142) CERAMIC (100P, 200 V) ACG7056

D 5404(B,119,62) DIODE 1SS355  
 D 5405(B,124,62) DIODE UDZS4R7(B)  
 D 5406(B,122,62) DIODE UDZS4R7(B)  
 D 5441(B,95,58) DIODE 1SS355  
 D 5442(B,92,58) DIODE 1SS355

**AE POSI 1-L ASSY****MISCELLANEOUS**

△ TH4501(A,54,223) POSISTOR PTFM04BH222Q2N34B0  
 J 4501(A,66,220) CONNECTOR ASSY PG02KS-E07

D 5443(B,94,41) DIODE 1SS355  
 D 5444(B,97,58) DIODE 1SS355  
 D 5501(B,280,59) CHIP ZENER DIODE UDZS3R6(B)  
 D 5502(B,277,59) DIODE 1SS355  
 D 5503(B,267,62) DIODE 1SS355

**AF POSI 2-L ASSY****MISCELLANEOUS**

△ TH4502(A,79,235) POSISTOR PTFM04BC222Q2N34B0  
 J 4502(A,76,223) CONNECTOR ASSY PG02KS2E07

D 5504(B,261,62) DIODE 1SS355  
 D 5505(B,265,62) DIODE UDZS4R7(B)  
 D 5506(B,263,62) DIODE UDZS4R7(B)  
 D 5541(B,240,71) DIODE 1SS355  
 D 5542(B,238,71) DIODE 1SS355

**AG POWER AMP-R ASSY****MISCELLANEOUS**

△ IC 5301(A,196,111) DARLINGTON POWER IC SAP17N(OY)  
 D △ IC 5302(A,162,111) DARLINGTON POWER IC SAP17P(OY)  
 △ IC 5401(A,128,111) DARLINGTON POWER IC SAP17N(OY)  
 △ IC 5402(A,94,111) DARLINGTON POWER IC SAP17P(OY)  
 △ IC 5501(A,264,111) DARLINGTON POWER IC SAP17N(OY)

D 5543(B,240,45) DIODE 1SS355  
 D 5544(B,242,73) DIODE 1SS355  
 CN5301(A,319,31) 13P SOCKET XKP3077  
 CN5302(A,85,45) 11P SOCKET XKP3076  
 CN5303(A,312,68) PLUG 6-P KM250NA6L

△ IC 5502(A,230,111) DARLINGTON POWER IC SAP17P(OY)  
 △ IC 5602(A,298,111) DARLINGTON POWER IC SAP17P(OY)  
 Q 5301(B,186,38) CHIP TRANSISTOR 2SD2704K  
 Q 5302(B,176,52) TRANSISTOR IMT4  
 Q 5303(B,187,48) CHIP TRANSISTOR 2SA1514K

CN5304(A,143,23) CONNECTOR POST B2B-PH  
 5002(A,236,21) PCB BINDER VEF1040

**RESISTORS**

Q 5304(A,185,62) TRANSISTOR 2SA1145  
 Q 5305(A,161,55) TRANSISTOR 2SC2705  
 E Q 5341(B,146,56) CHIP TR 2SA1255  
 Q 5401(B,132,38) CHIP TRANSISTOR 2SD2704K  
 Q 5402(B,122,52) TRANSISTOR IMT4

R 5301(B,192,43) RS1/16S102J  
 R 5302(B,180,42) RS1/16S221J  
 R 5303(B,177,41) RS1/16S333J  
 R 5304(B,192,40) RS1/16S103J  
 R 5305(B,170,55) RS1/16S152J

Q 5403(B,133,48) CHIP TRANSISTOR 2SA1514K  
 Q 5404(A,131,62) TRANSISTOR 2SA1145  
 Q 5405(A,108,55) TRANSISTOR 2SC2705  
 Q 5441(B,91,45) CHIP TR 2SA1255  
 Q 5501(B,275,38) CHIP TRANSISTOR 2SD2704K

R 5306(B,168,47) RS1/16S821J  
 R 5307(B,190,48) RS1/16S2001F  
 R 5308(B,179,54) RS1/16S682J  
 R 5309(A,183,48) CARBON FILM RD1/2VM473J  
 R 5310(B,191,62) RS1/16S151J

Q 5502(B,266,52) TRANSISTOR IMT4  
 Q 5503(B,277,48) CHIP TRANSISTOR 2SA1514K  
 Q 5504(A,274,63) TRANSISTOR 2SA1145  
 F Q 5505(A,252,55) TRANSISTOR 2SC2705  
 Q 5541(B,239,49) CHIP TR 2SA1255

R 5311(B,188,62) RN1/16SE1201D  
 R 5312(B,162,51) RS1/16S221J  
 R 5313(B,183,97) CHIP RESISTOR RS1/16S62R0F  
 R 5321(B,190,93) RS1/16S101J  
 R 5322(B,176,93) RS1/16S101J

△ R 5323(A,196,79) CARBON FILM RD1/4MUF4R7J  
 △ R 5324(A,161,70) CARBON FILM RD1/4MUF4R7J  
 △ R 5325(B,203,91) CHIP (0.047, 0.5 W) ACN7132  
 △ R 5326(B,166,91) CHIP (0.047, 0.5 W) ACN7132  
 △ R 5327(A,172,80) RESISTOR (0.18, 5 W) ACN7121



**Mark No. Description****Part No.****Mark No. Description****Part No.**

C 5432(B,108,47) CKSRYB224K16  
 C 5441(A,88,53) CEANP2R2M50  
 C 5501(A,273,43) CEAT4R7M50  
 A C 5502(B,267,43) CCSRCH221J50  
 C 5504(B,257,51) CKSRYB102K50

R 5606(B,41,38) RS1/16S821J  
 R 5607(B,42,59) RS1/16S2001F  
 R 5608(B,42,42) RS1/16S682J  
 R 5609(A,32,46) CARBON FILM RD1/2VM473J  
 R 5610(B,30,59) RS1/16S151J

C 5507(A,284,54) CEAT101M10  
 C 5508(B,255,51) CERAMIC (4P, 200 V) ACG7057  
 C 5509(A,267,58) ELECT. CAPACITOR CEAT100M2A  
 C 5511(B,271,104) CERAMIC (100P, 200 V) ACG7056  
 C 5512(B,243,104) CERAMIC (100P, 200 V) ACG7056

R 5611(B,33,59) RN1/16SE1201D  
 R 5612(B,33,34) RS1/16S221J  
 ⚠ R 5623(A,65,58) CARBON FILM RD1/4MUF4R7J  
 ⚠ R 5624(A,65,40) CARBON FILM RD1/4MUF4R7J  
 ⚠ R 5627(A,19,56) RESISTOR (0.18, 5 W) ACN7121

C 5515(B,258,41) CCSRCH220J50  
 C 5516(B,258,39) CCSRCH220J50  
 C 5517(A,263,39) CEAT331M10  
 C 5523(A,289,64) CEAT100M63  
 B C 5524(A,254,62) CEAT100M63

R 5629(B,47,48) RN1/10SE3302D  
 R 5630(B,49,46) RN1/16SE1001D  
 R 5631(B,49,51) RN1/16SE1500D  
 R 5632(B,30,36) RS1/16S151J  
 R 5641(B,14,43) RS1/16S473J

C 5532(B,252,47) CKSRYB224K16  
 C 5541(A,238,54) CEANP2R2M50  
 C 5571(A,229,35) CEAT331M10  
 C 5612(B,307,104) CERAMIC (100P, 200 V) ACG7056

R 5642(B,17,33) RS1/16S223J  
 R 5643(B,14,33) RS1/16S471J  
 R 5644(B,15,38) RS1/16S471J  
 R 5645(B,18,28) RS1/16S472J  
 R 5646(B,20,28) RS1/16S472J

**AH POSI 1-R ASSY****MISCELLANEOUS**

⚠ TH4503(A,54,235) POSISTOR PTFM04BH222Q2N34B0  
 J 4551(A,66,232) CONNECTOR ASSY PG02KS-E07

R 5647(B,10,33) RS1/16S122J  
 R 5648(B,45,25) RS1/16S154J  
 R 5649(B,49,26) RS1/16S103J  
 R 5650(B,51,26) RS1/16S103J

**CAPACITORS**

C 5601(A,53,45) CEAT4R7M50  
 C 5602(B,50,41) CCSRCH221J50  
 C 5604(B,44,36) CKSRYB102K50  
 C 5607(A,38,57) CEAT101M10  
 C 5608(B,36,42) CERAMIC (4P, 200 V) ACG7057

C 5609(A,27,51) ELECT. CAPACITOR CEAT100M2A  
 C 5615(B,45,47) CCSRCH220J50  
 C 5616(B,42,49) CCSRCH220J50  
 C 5617(A,47,52) CEAT331M10  
 C 5623(A,69,58) CEAT100M63

C 5624(A,69,42) CEAT100M63  
 C 5632(B,28,39) CKSRYB224K16  
 C 5641(A,12,35) CEANP2R2M50

**AI POWER AMP IN ASSY****MISCELLANEOUS**

Q 5601(B,58,86) CHIP TRANSISTOR 2SD2704K  
 Q 5602(B,46,41) TRANSISTOR IMT4  
 Q 5603(B,42,54) CHIP TRANSISTOR 2SA1514K  
 Q 5604(A,32,55) TRANSISTOR 2SA1145  
 Q 5605(A,33,38) TRANSISTOR 2SC2705

Q 5641(B,11,26) CHIP TR 2SA1255  
 D 5601(B,35,57) CHIP ZENER DIODE UDZS3R6(B)  
 D 5602(B,35,53) DIODE 1SS355  
 D 5603(B,26,49) DIODE 1SS355  
 D 5604(B,23,44) DIODE 1SS355

D 5605(B,23,47) DIODE UDZS4R7(B)  
 D 5606(B,21,42) DIODE UDZS4R7(B)  
 D 5641(B,18,23) DIODE 1SS355  
 D 5642(B,20,23) DIODE 1SS355  
 D 5643(B,13,21) DIODE 1SS355

D 5644(B,28,23) DIODE 1SS355  
 E CN5601(A,71,64) 13P PLUG XKP3066  
 CN5602(A,56,31) 13P PLUG XKP3066  
 CN5603(A,76,131) 19P CONNECTOR 52044-1945  
 CN5605(A,47,65) SOCKET 6-P KP250NA6

CN5606(A,34,31) SOCKET 6-P KP250NA6  
 5604(A,7,50) 5P CABLE HOLDER 51048-0500

**RESISTORS**

R 5601(B,58,93) RS1/16S102J  
 R 5602(B,54,41) RS1/16S221J  
 R 5603(B,52,41) RS1/16S333J  
 R 5604(B,57,82) RS1/16S103J  
 F R 5605(B,46,36) RS1/16S152J

**AJ POWER PROTECT ASSY****MISCELLANEOUS**

IC 5701(B,19,110) OP-AMP IC BA4560RF  
 Q 5701(B,26,161) TRANSISTOR RT1N241M  
 Q 5702(B,16,161) DIGITAL TR (SC-70) RT1P241M  
 Q 5703(B,16,151) TRANSISTOR RT1N241M  
 Q 5704(B,33,100) TRANSISTOR 2SC4081

Q 5705(B,23,161) TRANSISTOR RT1N241M  
 Q 5706(B,12,161) DIGITAL TR (SC-70) RT1P241M  
 D 5701(B,23,94) DIODE 1SS355  
 D 5702(B,30,205) DIODE 1SS355  
 CN5701(A,28,171) 11P PLUG XKP3065

CN5702(A,15,138) 11P PLUG XKP3065  
 CN5703(A,8,85) 19P CONNECTOR 52044-1945  
 CN5704(A,37,83) CONNECTOR S5B-PH  
 CN5705(A,30,223) 17P CONNECTOR 52044-1745  
 CN5706(A,38,222) 3PIN CONNECTOR S3B-EH

5	6
Mark No. Description	Part No.
<b>RESISTORS</b>	
R 5701(B,23,151)	RS1/16S562J
R 5702(B,21,151)	RS1/16S562J
R 5703(B,10,181)	RS1/16S473J
R 5705(B,18,187)	RS1/16S0R0J
R 5706(B,19,151)	RS1/16S822J
R 5707(B,18,181)	RS1/16S473J
R 5708(B,13,187)	RS1/16S0R0J
R 5710(B,17,118)	RS1/16S223J
R 5711(B,13,112)	RS1/16S103J
R 5712(B,13,108)	RS1/16S472J
R 5713(B,23,106)	RS1/16S103J
R 5714(B,24,131)	RS1/16S102J
R 5715(B,27,101)	RS1/16S473J
R 5716(B,29,101)	RS1/16S472J
R 5717(B,33,95)	RS1/16S103J
R 5718(B,30,210)	RS1/16S104J
R 5720(B,31,95)	RS1/16S103J
R 5721(B,29,95)	RS1/16S683J
R 5746(B,20,181)	RS1/16S0R0J
R 5747(B,18,161)	RS1/16S0R0J
R 5750(B,35,95)	RS1/16S0R0J
R 5751(B,26,131)	RS1/16S0R0J
R 5752(B,25,101)	RS1/16S0R0J

**CAPACITORS**

C 5701(B,13,181)	CKSRYB104K50
C 5702(B,15,181)	CKSRYB104K50
C 5703(B,23,110)	CKSRYB103K50
C 5704(B,23,114)	CKSRYB103K50
C 5705(B,31,101)	CKSRYB223K50
C 5706(B,37,217)	CKSRYB103K50

**AK HDMI & DVC ASSY MISCELLANEOUS**

IC 101 (A,56,65) HDMI RECEIVER	SI19033CTU
IC 151 (A,25,86) EEPROM	BR24L02FV-W
IC 152 (A,30,86) LOGIC IC	SN74CBT3257CPW
IC 171 (A,25,66) EEPROM	BR24L02FV-W
IC 172 (A,30,66) LOGIC IC	SN74CBT3257CPW
IC 202 (A,77,22) IC	TC74LCX541FTS1
IC 203 (A,77,12) IC	TC74LCX541FTS1
IC 301 (A,52,33) HDMI TRANSMITTER	SI19030CTU-7
IC 401 (A,135,64) VIDEO DECODER	ADV7401BSTZ-80
IC 402 (A,150,65) IC	TC7WU04FU
IC 452 (A,90,70) IC	TC7SZ125FU
IC 453 (A,87,63) IC	TC74LCX541FTS1
IC 454 (A,87,54) IC	TC74LCX541FTS1
IC 501 (B,107,36) CPU	PEG118A
IC 502 (A,107,38) FLASH ROM	AYW7123
IC 504 (A,97,25) IC	TC74VHC125FTS1
IC 701 (A,108,59) VIDEO ENCODER IC	ADV7172KSTZ
△ IC 901 (B,144,27) REGULATOR IC	BD7802FP
△ IC 902 (B,140,41) IC	NJM2885DL1-18
△ IC 903 (B,156,40) REGULATOR IC	BD7802FP

7	8
Mark No. Description	Part No.
△ IC 904 (B,158,57) REGULATOR IC	MM1561JF
△ IC 911 (B,104,11) REGULATOR IC	NJM2872BF05
Q 101 (A,42,91) DUAL MOS FET	HN1K02FU
Q 151 (A,18,91) CHIP TRANSISTOR	DTC114YUA
Q 152 (B,24,83) CHIP TRANSISTOR	DTC114YUA
Q 153 (A,39,84) DUAL MOS FET	HN1K02FU
Q 161 (A,35,45) DUAL MOS FET	HN1K02FU
Q 171 (A,18,68) CHIP TRANSISTOR	DTC114YUA
Q 172 (B,24,63) CHIP TRANSISTOR	DTC114YUA
Q 173 (A,37,65) DUAL MOS FET	HN1K02FU
Q 301 (B,42,31) DIGITAL TR (SC-70)	RT1P241M
Q 351 (B,28,32) CHIP TR (PNP X 2)	UMB1N
Q 352 (B,31,37) CHIP TRANSISTOR	DTC114YUA
Q 353 (A,41,42) DUAL MOS FET	HN1K02FU
Q 731 (A,95,70) TRANSISTOR	2SA1576A
Q 741 (A,100,70) TRANSISTOR	2SA1576A
Q 751 (A,104,70) TRANSISTOR	2SA1576A
Q 761 (A,109,70) TRANSISTOR	2SA1576A
Q 771 (A,113,70) TRANSISTOR	2SA1576A
Q 781 (A,118,70) TRANSISTOR	2SA1576A
D 151 (B,20,79) DIODE	DAN202U
D 171 (B,20,55) DIODE	DAN202U
D 381 (B,28,49) DIODE	UDZS5R1(B)
D 551 (A,89,38) CHIP DIODE	RB501V-40
D 903 (B,148,50) DIODE	1SR154-400
L 101 (A,72,46) CHIP BEADS	ATL7010
L 103 (A,80,84) CHIP BEADS	ATL7010
L 104 (A,36,48) CHIP BEADS	ATL7010
L 302 (B,53,30) CHIP BEADS	ATL7010
L 304 (A,74,31) CHIP BEADS	ATL7010
L 305 (A,69,46) CHIP BEADS	ATL7010
△ L 351 (A,29,26) COIL	ATH7022
△ L 352 (A,29,29) COIL	ATH7022
△ L 353 (A,29,32) COIL	ATH7022
△ L 354 (A,29,35) COIL	ATH7022
L 401 (A,149,53) CHIP BEADS	ATL7010
L 402 (B,146,73) CHIP BEADS	ATL7010
L 403 (A,158,61) CHIP BEADS	ATL7010
L 404 (A,148,88) CHIP BEADS	ATL7010
L 501 (A,82,38) CHIP BEADS	ATL7010
L 701 (A,100,51) CHIP BEADS	ATL7010
L 702 (B,125,84) CHIP BEADS	ATL7010
JA 101 (A,16,79) HDMI CONNECTOR	AKP7210
JA 102 (A,16,57) HDMI CONNECTOR	AKP7210
JA 301 (A,16,35) HDMI CONNECTOR	AKP7210
X 101 (A,60,48) CRYSTAL (27M)	ASS7066
X 401 (A,152,72) CRYSTAL (28.63636M)	ASS7067
X 501 (A,112,29) CERAMIC (15.7M)	XSS3004
CN501 (A,18,19) 07P CONNECTOR	RKN1048
CN1001(A,137,13) 26P SOCKET	AKP7209
CN1002(A,86,81) 23P SOCKET	XKP3082

**RESISTORS**

R 101 (A,52,83) RESISTOR ARRAY	RAB4CQ100J
R 102 (A,66,79) RESISTOR ARRAY	RAB4CQ470J
R 103 (A,50,79)	RS1/16S100J
R 104 (B,52,77)	RS1/16S100J
R 105 (A,47,79)	RS1/16S103J

	<b>Mark No.</b>	<b>Description</b>	<b>Part No.</b>	<b>Mark No.</b>	<b>Description</b>	<b>Part No.</b>
	R 106	(A,49,79)	RS1/16S103J	R 303	(B,57,39)	RS1/16S100J
	R 107	(A,57,83) RESISTOR ARRAY	RAB4CQ470J	R 306	(B,50,42)	RS1/16S101J
	R 108	(A,60,83) RESISTOR ARRAY	RAB4CQ470J	R 312	(B,51,34) CHIP RESISTOR	RS1/16S4750F
A	R 109	(B,60,71)	RS1/16S470J	R 313	(A,44,39)	RS1/16S472J
	R 111	(B,50,48)	RS1/16S101J	R 314	(B,49,26)	RS1/16S100J
	R 112	(B,49,53)	RS1/16S470J	R 315	(B,45,27)	RS1/16S100J
	R 113	(B,52,61)	RS1/16S680J	R 316	(A,45,24)	RS1/16S471J
	R 114	(B,64,53)	RS1/16S472J	R 318	(B,55,26)	RS1/16S472J
	R 115	(A,71,49)	RS1/16S472J	R 319	(B,49,35)	RS1/16S3901F
	R 118	(A,61,51)	RS1/16S105J	R 325	(B,59,30)	RS1/16S150J
	R 119	(A,67,49)	RS1/16S471J	R 326	(A,48,43)	RS1/16S100J
	R 120	(B,63,60)	RS1/16S221J	R 327	(A,46,43)	RS1/16S100J
	R 121	(A,67,50)	RS1/16S221J	R 331	(A,60,43) RESISTOR ARRAY	RAB4CQ473J
B	R 122	(B,54,61)	RS1/16S470J	R 332	(A,75,61)	RS1/16S473J
	R 123	(B,55,53)	RS1/16S100J	R 333	(A,75,72) RESISTOR ARRAY	RAB4CQ473J
	R 124	(A,58,51)	RS1/16S152J	R 334	(A,75,70) RESISTOR ARRAY	RAB4CQ473J
	R 125	(A,52,47) RESISTOR ARRAY	RAB4CQ680J	R 335	(A,75,67) RESISTOR ARRAY	RAB4CQ473J
	R 126	(A,71,72) RESISTOR ARRAY	RAB4CQ470J	R 336	(A,75,64) RESISTOR ARRAY	RAB4CQ473J
	R 127	(A,71,70) RESISTOR ARRAY	RAB4CQ470J	R 337	(A,75,58) RESISTOR ARRAY	RAB4CQ473J
	R 128	(A,71,67) RESISTOR ARRAY	RAB4CQ220J	R 338	(A,75,55) RESISTOR ARRAY	RAB4CQ473J
	R 129	(A,71,64) RESISTOR ARRAY	RAB4CQ220J	R 351	(B,27,37)	RS1/16S472J
	R 130	(A,71,58) RESISTOR ARRAY	RAB4CQ220J	R 352	(B,24,37)	RS1/16S472J
	R 131	(A,71,55) RESISTOR ARRAY	RAB4CQ220J	R 353	(B,29,37)	RS1/16S272J
	R 132	(A,71,61)	RS1/16S150J	R 354	(B,24,31)	RS1/16S272J
C	R 133	(B,44,89)	RS1/16S103J	R 355	(A,44,43)	RS1/16S472J
	R 134	(A,40,90)	RS1/16S103J	R 356	(A,38,43)	RS1/16S472J
	R 135	(A,46,89)	RS1/16S103J	R 386	(B,26,44)	RS1/16S473J
	R 136	(B,40,88)	RS1/16S103J	R 389	(B,28,44)	RS1/16S102J
	R 137	(B,46,89)	RS1/16S104J	R 403	(A,132,54) RESISTOR ARRAY	RAB4CQ470J
	R 138	(A,38,90)	RS1/16S104J	R 404	(B,134,56)	RS1/16S330J
	R 151	(B,31,83)	RS1/16S100J	R 405	(B,131,61)	RS1/16S330J
	R 152	(B,29,83)	RS1/16S100J	R 406	(A,139,52)	RS1/16S330J
	R 153	(B,26,83)	RS1/16S101J	R 407	(A,142,54) RESISTOR ARRAY	RAB4CQ560J
	R 154	(B,31,79)	RS1/16S103J	R 408	(B,144,56)	RS1/16S560J
	R 155	(B,29,79)	RS1/16S103J	R 409	(B,142,57)	RS1/16S560J
D	R 156	(B,26,79)	RS1/16S103J	R 410	(B,144,61)	RS1/16S103J
	R 157	(B,18,91)	RS1/16S473J	R 411	(B,135,64)	RS1/16S100J
	R 158	(A,39,87)	RS1/16S472J	R 412	(B,140,57)	RS1/16S560J
	R 159	(A,39,81)	RS1/16S472J	R 413	(B,138,61)	RS1/16S560J
	R 161	(B,21,83)	RS1/16S102J	R 414	(A,150,69)	RS1/16S105J
	R 171	(B,31,63)	RS1/16S100J	R 415	(A,153,69)	RS1/16S101J
	R 172	(B,29,63)	RS1/16S100J	R 416	(A,146,64)	RS1/16S101J
	R 173	(B,26,63)	RS1/16S101J	R 417	(A,154,65)	RS1/16S0R0J
	R 174	(B,31,59)	RS1/16S103J	R 418	(B,142,73)	RS1/16S132J
	R 175	(B,29,59)	RS1/16S103J	R 419	(B,142,69)	RS1/16S391J
E	R 176	(B,26,59)	RS1/16S103J	R 421	(A,148,80)	RS1/10S0R0J
	R 177	(B,24,49)	RS1/16S473J	R 422	(A,148,82)	RS1/10S0R0J
	R 178	(A,35,68)	RS1/16S472J	R 423	(A,145,73)	RS1/16S103J
	R 179	(A,37,63)	RS1/16S472J	R 424	(B,133,71)	RS1/16S272J
	R 181	(B,20,61)	RS1/16S102J	R 425	(B,135,71)	RS1/16S272J
	R 201	(A,83,27)	RS1/16S470J	R 431	(A,123,69)	RS1/16S471J
	R 202	(A,84,25)	RS1/16S470J	R 432	(B,126,65)	RS1/16S103J
	R 203	(A,84,24)	RS1/16S470J	R 434	(B,122,62)	RS1/16S330J
	R 204	(A,83,22) RESISTOR ARRAY	RAB4CQ470J	R 435	(B,124,62)	RS1/16S330J
	R 205	(A,83,19)	RS1/16S470J	R 436	(A,124,60) RESISTOR ARRAY	RAB4CQ470J
F	R 206	(A,83,17) RESISTOR ARRAY	RAB4CQ470J	R 452	(A,89,73)	RS1/16S330J
	R 207	(A,84,15)	RS1/16S470J	R 453	(A,80,62) RESISTOR ARRAY	RAB4CQ680J
	R 208	(A,84,14)	RS1/16S470J	R 454	(A,80,65) RESISTOR ARRAY	RAB4CQ680J
	R 209	(A,84,12)	RS1/16S470J	R 455	(A,80,55) RESISTOR ARRAY	RAB4CQ680J
	R 210	(B,80,11)	RS1/16S470J	R 456	(A,80,58) RESISTOR ARRAY	RAB4CQ680J



	<u>Mark No.</u>	<u>Description</u>	<u>Part No.</u>	<u>Mark No.</u>	<u>Description</u>	<u>Part No.</u>	
A	C 133	(B,61,53)	CKSRYB104K16	C 430	(A,132,75)	CKSRYB104K16	
	C 134	(B,59,60)	CKSRYB104K16	C 431	(A,127,82)	CEVW100M16	
	C 135	(A,67,47)	CKSRYB103K50	C 432	(A,132,77)	CKSRYB104K16	
	C 136	(A,65,51)	CKSRYB103K50	C 433	(A,132,82)	CEVW100M16	
	C 137	(A,58,45)	CCSRCH120J50	C 434	(B,131,76)	CKSRYB103K50	
B	C 138	(A,62,45)	CCSRCH120J50	C 435	(B,129,76)	CKSRYB104K16	
	C 139	(B,67,72)	CKSRYB104K16	C 436	(B,127,76)	DCH1201	
	C 140	(B,67,68)	CKSRYB104K16	C 437	(B,137,76)	CKSRYB104K16	
	C 141	(B,70,66)	CKSRYB104K16	C 438	(A,126,76)	CKSRYB104K16	
	C 142	(B,67,64)	CKSRYB104K16	C 439	(A,126,74)	CKSRYB104K16	
C	C 143	(B,66,60)	CKSRYB104K16	C 440	(A,123,72)	CKSRYB104K16	
	C 144	(A,44,89)	CKSRYB103K50	C 441	(A,123,71)	CKSRYB102K50	
	C 145	(B,38,88)	CKSRYB103K50	C 443	(A,124,68)	CKSRYB103K50	
	C 151	(A,22,87)	CKSRYB104K16	C 444	(A,156,51)	CEVW101M16	
	C 153	(A,34,83)	CKSRYB104K16	C 445	(A,124,63)	CKSRYB104K16	
D	C 171	(A,21,68)	CKSRYB104K16	C 452	(A,87,69)	CKSRYB104K16	
	C 173	(A,34,64)	CKSRYB104K16	C 453	(A,86,58)	CKSRYB104K16	
	C 191	(B,26,73)	CKSRYB104K16	C 454	(A,86,49)	CKSRYB104K16	
	C 192	(B,29,73)	CKSRYB102K50	C 501	(B,123,32)	CKSRYB103K50	
	C 202	(A,77,27)	CKSRYB104K16	C 502	(B,116,27)	CKSRYB104K16	
E	C 203	(A,77,17)	CKSRYB104K16	C 503	(A,85,44)	CEVW101M16	
	C 301	(A,56,44)	CKSRYB104K16	C 505	(B,123,43)	CKSRYB104K16	
	C 302	(A,51,43)	CKSRYB104K16	C 506	(B,97,45)	CKSRYB104K16	
	C 303	(A,49,43)	CKSRYB104K16	C 507	(A,97,21)	CKSRYB104K16	
	C 304	(B,49,30)	CKSRYB104K16	C 551	(A,119,39)	CKSRYB104K16	
F	C 305	(B,53,34)	CKSRYB105K10	C 552	(A,94,40)	CKSRYB104K16	
	C 308	(B,45,31)	CKSRYB104K16	C 571	(B,21,18)	CKSRYB104K16	
	C 311	(B,45,36)	CKSRYB104K16	C 701	(A,95,52)	CEVW101M16	
	C 312	(A,58,24)	CKSRYB105K10	C 702	(A,113,51)	CKSRYB104K16	
	C 313	(B,51,26)	CKSRYB104K16	C 703	(A,102,51)	CKSRYB104K16	
G	C 314	(A,50,24)	CKSRYB104K16	C 704	(A,116,60)	CKSRYB104K16	
	C 315	(A,44,22)	CKSRYB103K50	C 705	(A,119,65)	CKSRYB104K16	
	C 316	(A,68,30)	CEVW101M16	C 706	(B,109,59)	CKSRYB104K16	
	C 317	(A,68,40)	CEVW101M16	C 707	(B,107,59)	CKSRYB104K16	
	C 318	(B,56,34)	CKSRYB105K10	C 708	(B,105,59)	CKSRYB104K16	
H	C 319	(B,59,35)	CKSRYB104K16	C 709	(B,102,60)	CKSRYB104K16	
	C 351	(B,21,39)	CKSRYB104K16	C 710	(B,111,59)	CKSRYB105K10	
	C 391	(B,26,53)	CKSRYB104K16	C 711	(A,121,81)	CEVW101M16	
	C 392	(B,29,53)	CKSRYB102K50	C 712	(A,100,65)	CKSRYB104K16	
	C 401	(A,148,47)	CEVW101M16	C 713	(A,96,58)	CKSRYB103K50	
I	C 402	(A,130,53)	CKSRYB104K16	C 714	(A,98,57)	CKSRYB104K16	
	C 403	(A,135,53)	CKSRYB105K10	C 731	(A,94,72)	CKSRYB104K16	
	C 404	(A,138,53)	CKSRYB104K16	C 741	(A,99,72)	CKSRYB104K16	
	C 405	(A,144,66)	CKSRYB104K16	C 751	(A,103,72)	CKSRYB104K16	
	C 406	(A,150,75)	CCSRCH7R0D50	C 761	(A,108,72)	CKSRYB104K16	
J	C 407	(A,154,75)	CCSRCH7R0D50	C 771	(A,112,72)	CKSRYB104K16	
	C 408	(A,153,65)	CKSRYB104K16	C 781	(A,117,72)	CKSRYB104K16	
	C 409	(B,144,73)	CHIP CAPACITOR	CKSRYB823K25	C 901	(B,149,23)	CKSRYB105K10
	C 410	(B,144,69)	CKSRYB103K50	C 902	(B,142,18)	CKSQYB225K10	
	C 411	(A,144,69)	CKSRYB471K50	C 904	(B,145,38)	CKSRYB105K10	
K	C 412	(A,146,70)	CKSQYB225K10	C 905	(B,138,33)	CHIP CERAMIC C.	
	C 421	(A,143,77)	CKSRYB104K16	C 907	(B,151,42)	DCG1028	
	C 422	(A,141,77)	CKSRYB104K16	C 908	(B,158,49)	CKSRYB105K10	
	C 423	(A,140,77)	CKSRYB104K16	C 910	(B,153,54)	CKSQYB225K10	
	C 424	(A,136,75)	CKSRYB103K50	C 911	(B,160,63)	CKSRYB471K50	
L	C 425	(A,136,77)	CKSRYB104K16	C 912	(B,153,59)	CKSQYB225K10	
	C 426	(A,137,78)	DCH1201	C 915	(B,109,11)	CKSRYB104K16	
	C 427	(B,135,76)	CKSRYB104K16	C 916	(B,107,11)	CKSRYB103K50	
	C 428	(A,137,81)	CKSRYB104K16	C 917	(B,99,11)	CKSQYB225K10	
	C 429	(A,142,85)	CEVW101M16	C 1001	(A,111,18)	CKSRYB104K16	





**Mark No. Description****Part No.****6. ADJUSTMENT**

- There is no information to be shown in this chapter.

A

C 723 (A,37,27)  
 C 724 (A,37,29)  
 C 726 (A,34,27)  
 C 727 (A,34,29)  
 C 728 (A,41,28)

CCSRCH471J50  
 CKSRYB104K16  
 CKSRYB104K16  
 CCSRCH471J50  
 CKSRYB104K16

C 729 (A,41,29)  
 C 730 (B,60,34)  
 C 731 (A,25,55)  
 C 732 (B,29,55)  
 C 733 (B,29,60)

CCSRCH471J50  
 CCSRCH471J50  
 CEJQ101M16  
 CKSRYB104K16  
 CKSRYB104K16

B

C 734 (B,41,32)  
 C 735 (B,37,33)  
 C 741 (A,92,19)  
 C 742 (B,96,20)  
 C 743 (A,96,32)

CKSRYB103K50  
 CKSRYB103K50  
 CEJQ101M16  
 CKSRYB104K16  
 CKSRYB105K6R3

C 745 (B,64,35)  
 C 746 (A,53,32)  
 C 761 (B,71,46)  
 C 762 (B,73,46)  
 C 763 (B,67,46)

CKSRYB105K6R3  
 CKSQYB225K10  
 CKSRYB104K16  
 CCSRCH471J50  
 CCSRCH471J50

C

C 764 (B,65,46)  
 C 766 (B,52,50)  
 C 767 (B,80,44)  
 C 768 (B,82,44)  
 C 771 (A,62,60)

CCSRCH471J50  
 CCSRCH471J50  
 CKSRYB104K16  
 CCSRCH471J50  
 CKSQYB105K16

C 773 (A,55,60)  
 C 781 (A,44,17)  
 C 782 (A,45,19)  
 C 783 (A,49,19)  
 C 784 (A,45,16)

CKSRYB104K16  
 CCSRCH471J50  
 CKSRYB104K16  
 CEJQ470M16  
 CKSRYB104K16

C 786 (A,55,16)  
 C 788 (A,42,18)  
 C 789 (A,77,26)  
 C 790 (A,79,25)  
 C 791 (A,75,31)

CEJQ100M16  
 CKSRYB104K16  
 CKSRYB102K50  
 CKSRYB102K50  
 CEJQ100M16

D

C 792 (A,81,31)  
 C 951 (A,58,27)  
 C 952 (A,59,27)  
 C 956 (A,70,34)  
 C 957 (A,70,33)

CEJQ100M16  
 CCSRCH471J50  
 CKSRYB105K10  
 CKSQYB105K10  
 CCSRCH471J50

E

F

# 7. GENERAL INFORMATION

## 7.1 DIAGNOSIS

### 7.1.1 TEST MODE

#### Version indication

##### [Purpose]

The versions for various microcomputers and DSP firmware are displayed.

##### [How to enter/exit]

During Standby mode, simultaneously press and hold the STANDBY/ON and MULTI CH IN keys for 5 seconds to enter this mode. This mode is automatically exited when the indications of all versions have finished.

##### [Basic operations]

FL Display	Description of Version Indications	Duration (sec.)	Devices that can be considered generally normal, with the corresponding indications
POWER OFF ↓ M1.000 F1.000 ↓ D1.000 H1.000 ↓ f1.000 s1.000 ↓ USB 2006. 1. 9 ↓ Normal display	Mx.xxx : Main microcomputer Fx.xxx : Display microcomputer  Dx.xxx : DSP microcomputer Hx.xxx : HDMI microcomputer  fx.xxx : 1st DSP firmware sx.xxx : 2nd DSP firmware  USB xxxx.xx.xx : USB firmware	5  5  5  5	Main microcomputer and display microcomputer  DSP microcomputer and HDMI microcomputer  1st DSP firmware : Flash ROM (IC106) near the DSP IC 2nd DSP firmware : Flash ROM within the DSP IC (IC201)  USB firmware : Flash ROM (IC762) near the USB IC (IC701)

##### [Notes]

1. If the version indication becomes "\*\*\*," a failure in communications between the corresponding microcomputers or a failure in the corresponding microcomputers is likely.
2. In this submode, the user settings will not be cleared.
3. If the USB firmware version indication becomes "\*\*\*," return the unit to Normal mode, switch Function to USB, then reenter Test mode and check the USB firmware version. If the indication becomes "\*\*\*\*" again, communication between the main microcomputer and the USB firmware is in failure.

## ■ Detected protection history

### [Purpose]

The numbers of detections for various protection processes are displayed.

### [How to enter/exit]

During Standby mode, simultaneously press and hold the DVR/VCR1 and ENTER keys for 5 seconds to enter this mode. This mode is automatically exited when all the indications have finished.

### [Basic operations]

FL Display	Description of Indications	Duration (sec.)
POWER OFF ↓ DC : 000	Number of DC detections	3
↓ OVER: 010	Number of overload detections	3
↓ CON : 002	Number of detections of cord disconnection (DC and OL DET line) (simultaneous detections of DC and OVERLOAD)	3
↓ FAN : 002	Number of detections of fan abnormalities	3
↓ TEMP: 255	Number of detections of abnormal temperature	3
↓ Normal display		

### [Description]

When the keys are pressed, the numbers of DC detections, overload detections, detections of connectors disconnection inside unit (It is detected by both DC and OVERLOAD detections.), detections of fan abnormalities, and detections of abnormal temperature are displayed for 3 seconds each, in that order.

The maximum value of each detections is 255.

## ■ Error indications when an abnormality in the amplifier system is detected

### [Purpose]

An error message is displayed when an abnormality in the amplifier system is detected.

### [Error Messages]

FL Display	Status	Duration (sec.)
AMP ERROR	When AMP DC is detected	Flashes 3 times.
FAN STOP	When stopping of the fan is detected	Flashes 3 times.
OVERHEAT	When a thermal shutdown (abnormal temperature), etc. is detected	Flashes 3 times.
12V TRG ERR KUXJ and KUXJCA types only	When the 12-V trigger circuit is short-circuited	Flashes
XM ANT ERR KUXJ and KUXJCA types only	The power supply of the XM antenna is abnormally	Flashes

### [Description]

**AMP ERROR** : After a failure in the amplifier block or high DC output is detected, the shutdown process starts, then the power will be shut off. Then the MCACC LED will flash. The power cannot be turned on again. If you wish to turn on the unit after a shutdown activated by DC detection, enter Test mode, by proceeding with the steps described in "How to enter release mode" below.

**FAN STOP** : The fan does not function.

**OVERHEAT** : The temperature of the amplifier is abnormally high.

After a failure is detected, the shutdown process starts, then the power will be off. The power can be turned on again in Normal mode.

**12V TRG ERR** : The 12-V trigger output is short-circuited.  
(KUXJ and KUXJCA types only)

**XM ANT ERR** : The power supply of the XM antenna is abnormally.  
(KUXJ and KUXJCA types only)

### [How to enter release mode]

Press and hold **DVR/VCR2** and **ENTER** keys on the front panel simultaneously for 5 seconds in standby mode.

# 7.1.2 PROTECTION CIRCUIT SPECIFICATION

## ● Protection Circuit Process List

Item	Purpose	Detection Method	Process	Warning Indication	Remarks
DC detection	To detect amplifier damage (defect status) A process to protect speakers (for protection of connected external devices)	Detects when the DC_PROTECT port becomes "L". (Pin 120 of IC101)	Turns muting on and speaker relay off, then turns off the power after 3 seconds. Then flashes MCACC indicator.	Flashing "AMP ERR" for 3 seconds.	Once detected and turned the power off, input a key never again. If the DC_DET port becomes "H" within 3 seconds, the unit returns to normal condition automatically.
AMP overload	To detect overloading (abnormal status) With low-load driving or a short circuit of the speaker terminals (for protection of the amplifier)	Detects when the OL_DET port becomes "L" (checks by interrupt). (Pin 28 of IC101)	Turns muting on and speaker relay off, and immediately turns off the power. Then flashes PHASE CONTROL indicator.	None	
Overheat detection	Self reset type protection feature by temperature-rise of heat sink	Detects when the TEMP2 port becomes "H". (Pin 44 of IC2301)	Turns muting on and speaker relay off, then turns off the power after 3 seconds.	Flashing "OVERHEAT" for 3 seconds.	If the TEMP2 port becomes "L" within 3 seconds, the unit returns to normal condition automatically.
12V trigger failure detection	To detect the shortcircuit of 12V trigger output (load more than 50mA) (for protection of the amplifier)	Detects when the 12VDET port becomes "H". (Pin 44 of IC2301)	Turns 12V trigger output to off.	Flashing "12V ERR"	Continue showing warning. Release the FL indication by switching the INPUT SEL or the turns the power off.

## ● DC Detection Circuit

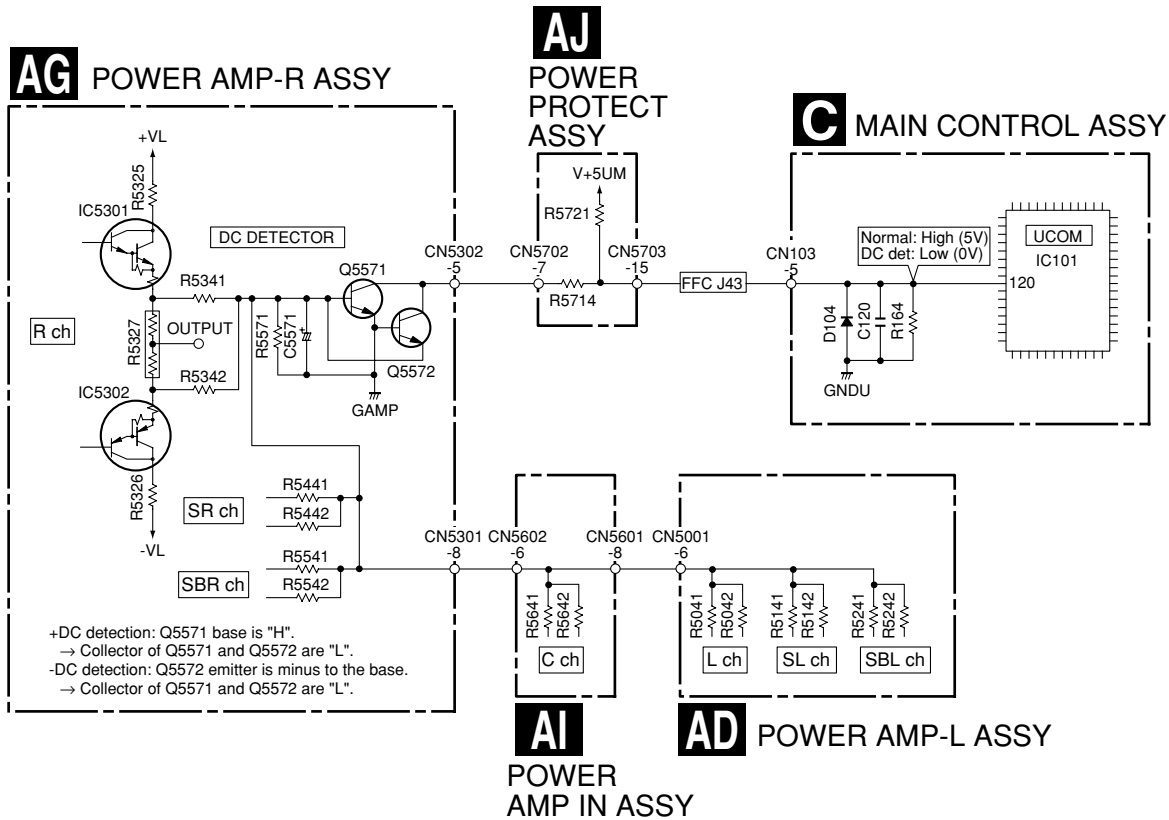

# ● OL (Over Load) Detection Circuit

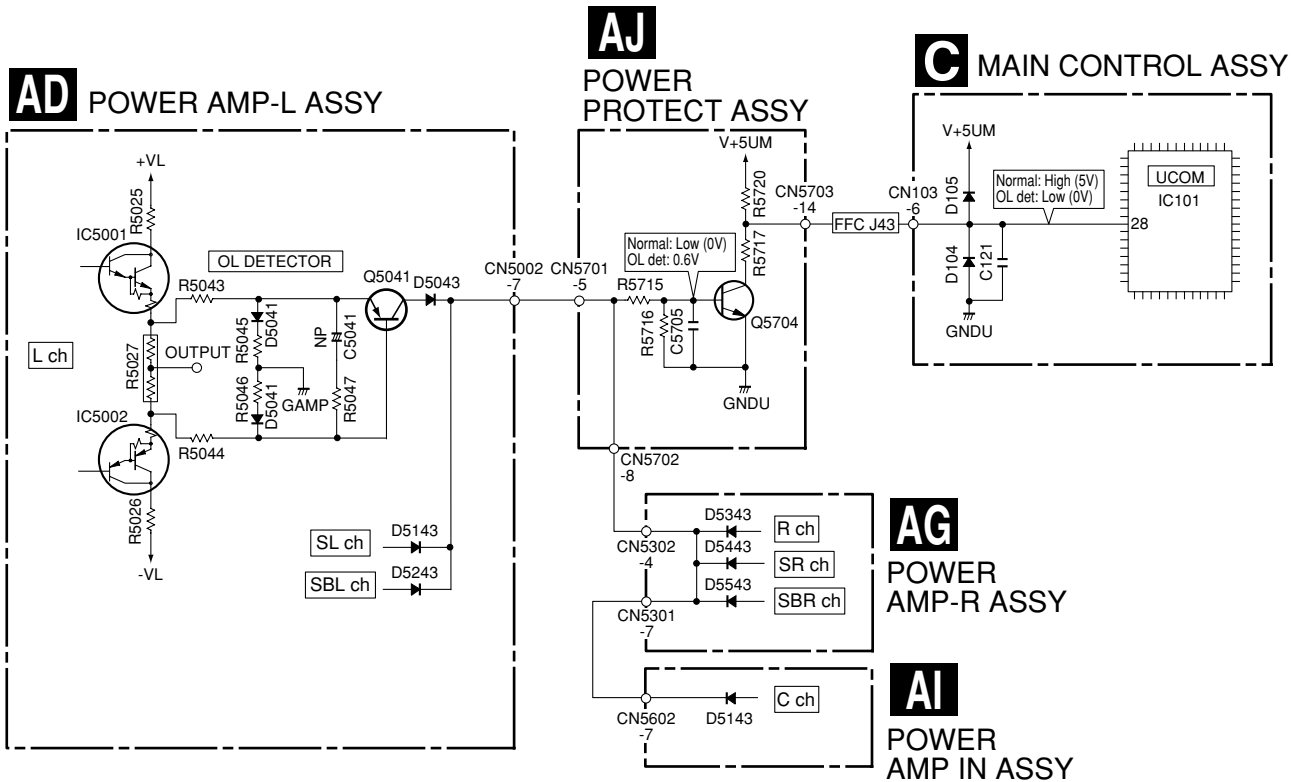

# 7.1.3 DSP TROUBLESHOOTING

## ■ Simplified diagnosis

Herein is described how to easily diagnose a defective part in the DSP Assy, only with operations of the main unit.

- If the sound is not output when Sound Delay is ON  
If the sound is output without a problem when Sound Delay is OFF (0.0 fr) but an abnormality in the sound is detected when Sound Delay is ON (0.1 to 6.0 fr), it is most likely that SRAM (IC107) or DECODER IC (IC105) in the 1st DSP block is in failure.

## ■ Troubleshooting

- It is assumed that there is no loose connection or damage in the LCRs.
- : KUXJ and KUXJCA types only

### Step 0: Preliminary confirmation

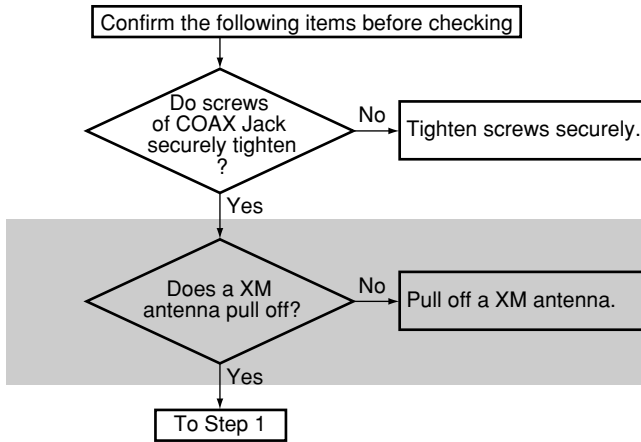

### Step 1: Connections

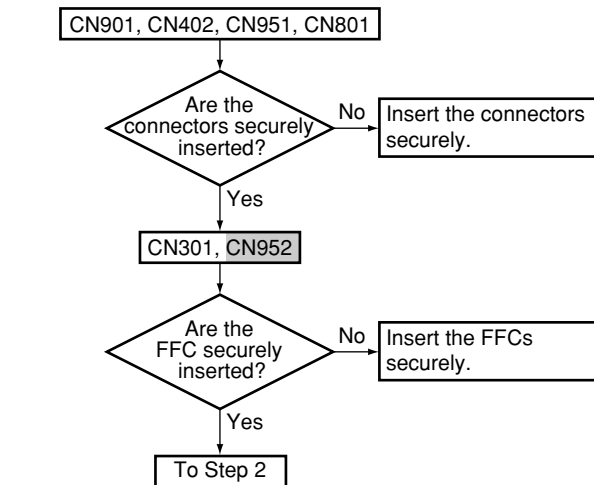

### Step 2: Power supply

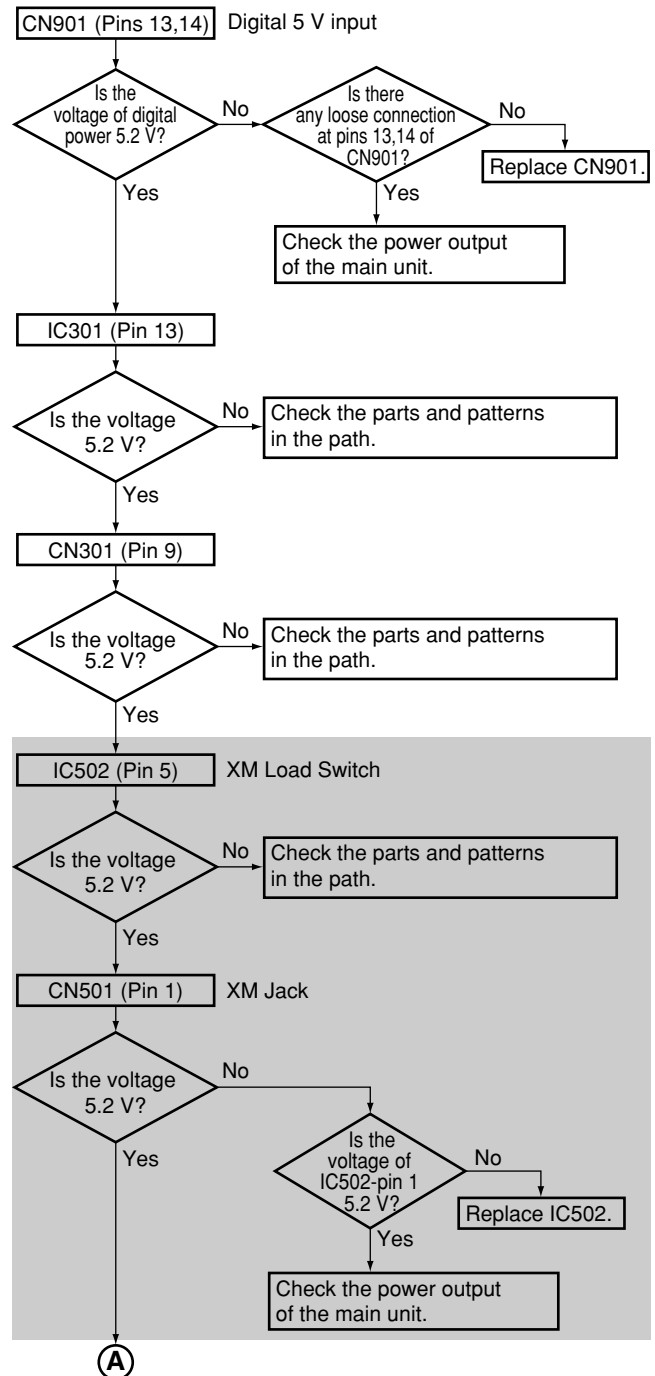



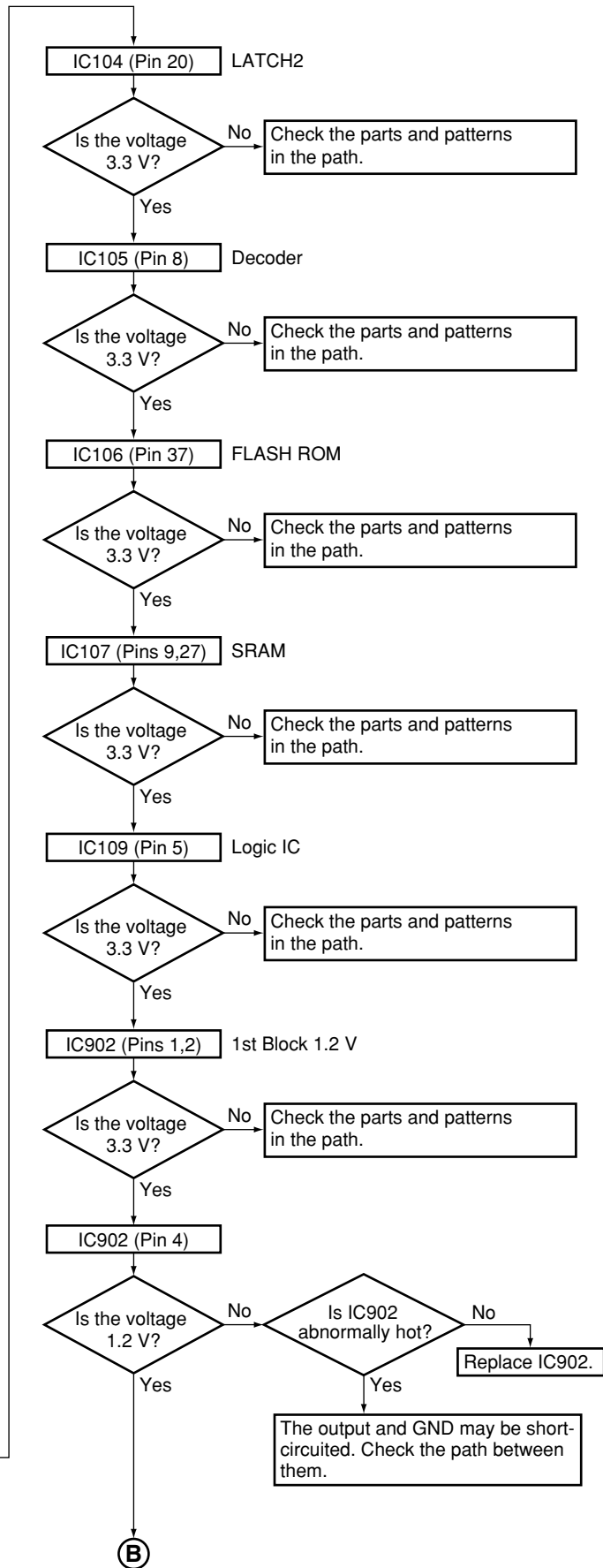
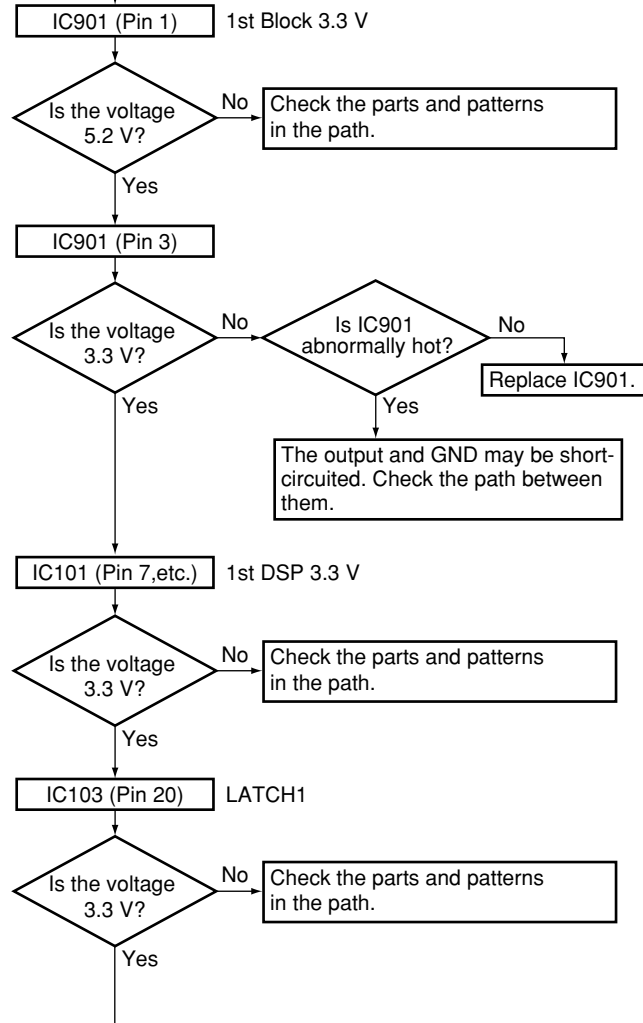
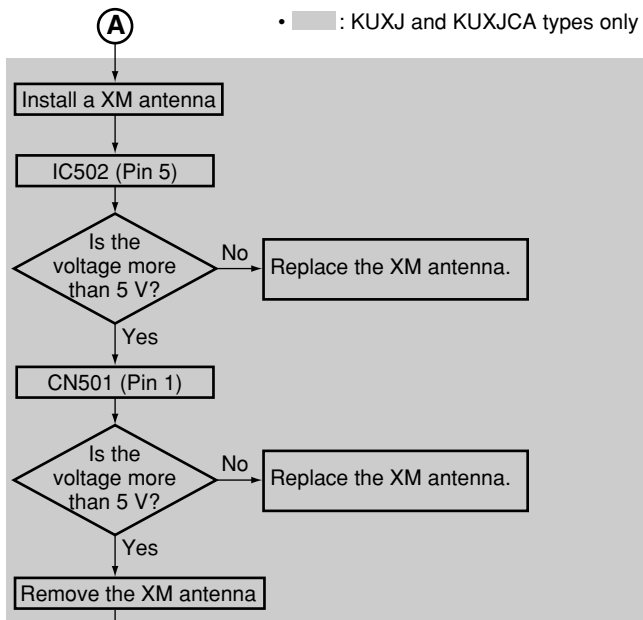

A **(B)** ■ : KUXJ and KUXJCA types only

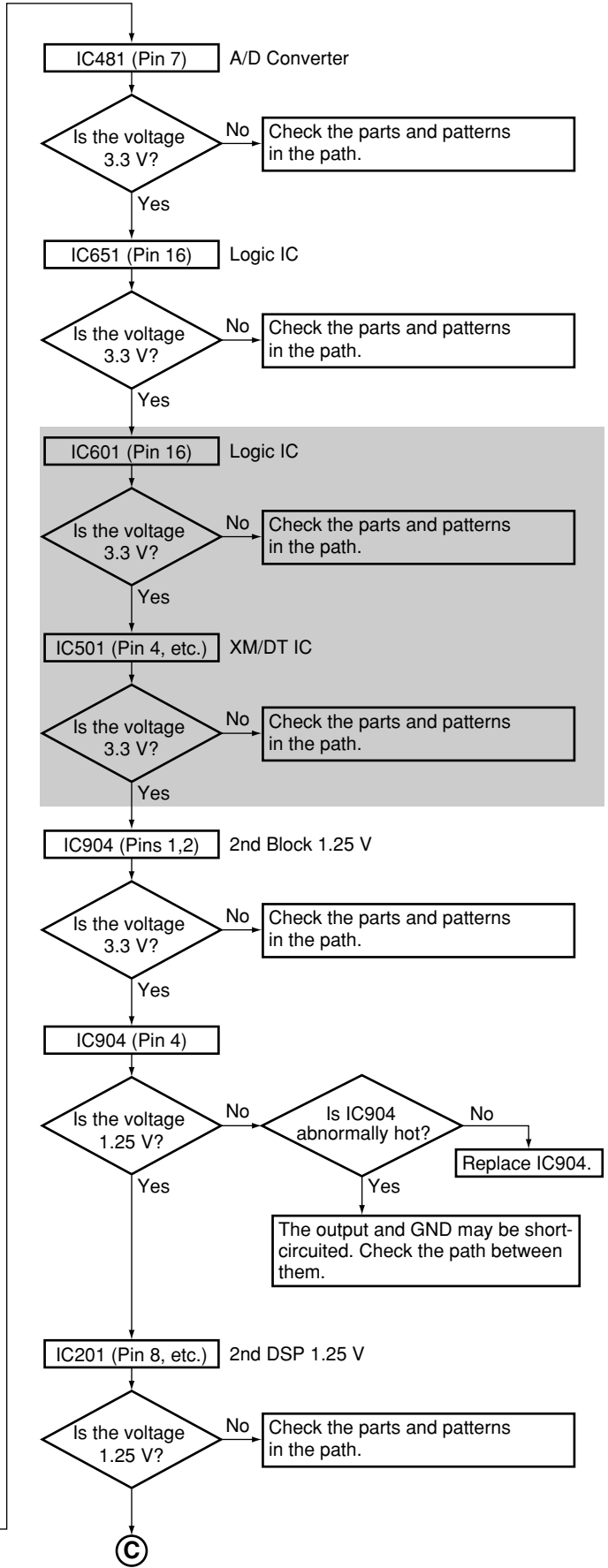
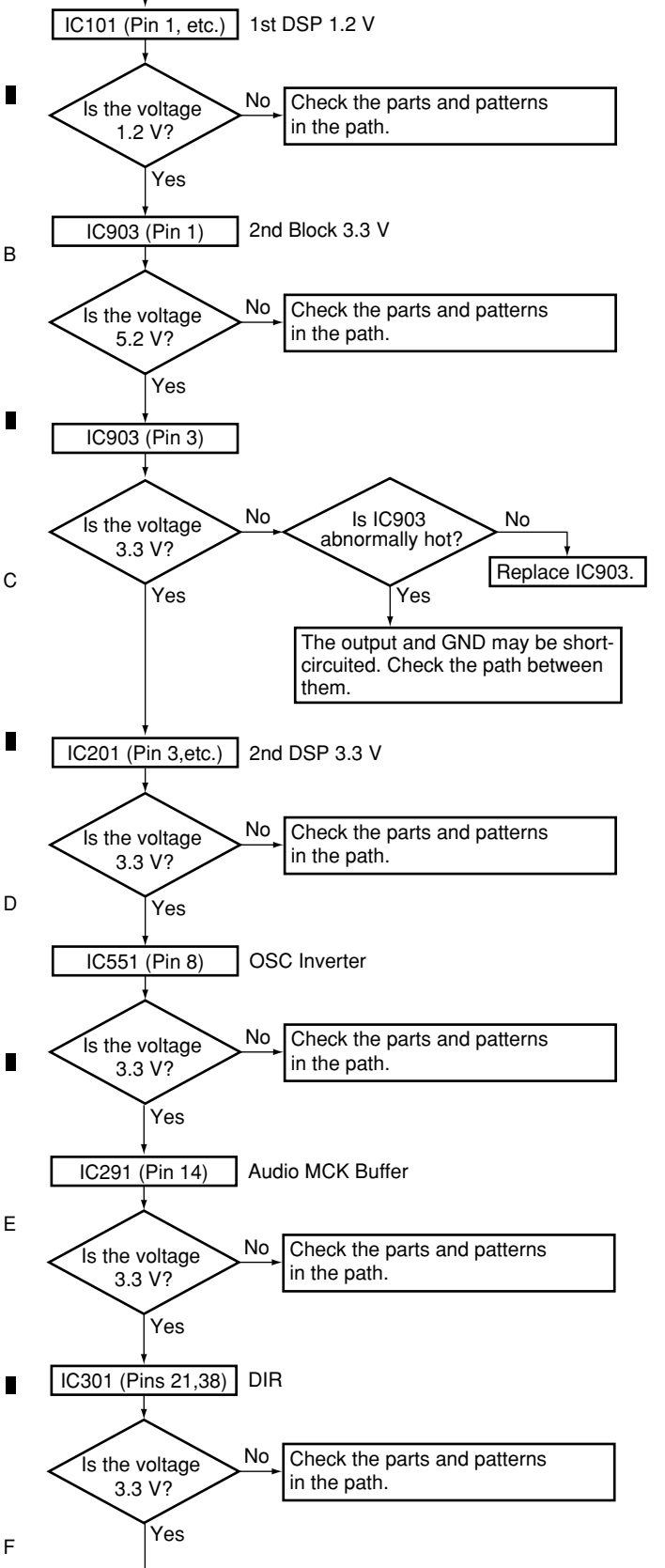

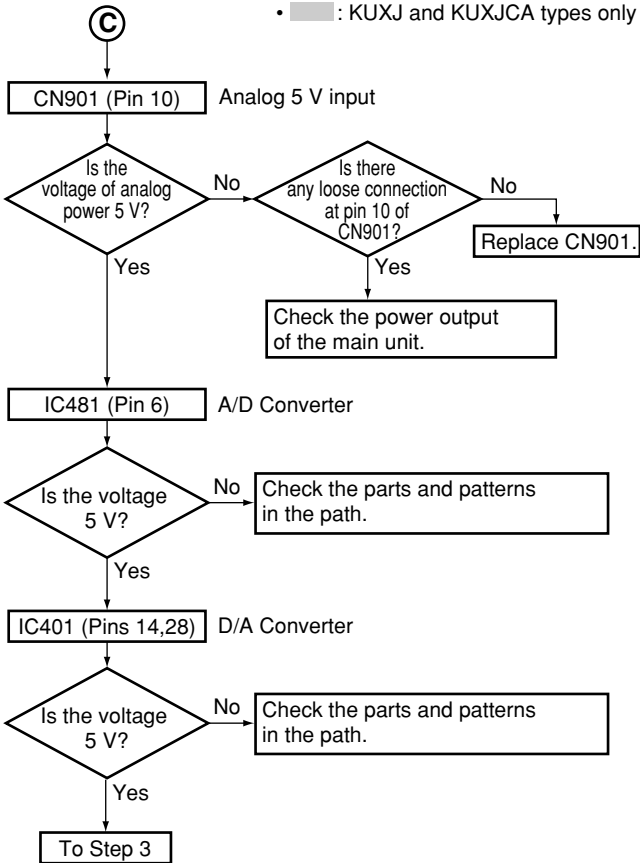

### Step 3: Operating Master Clock

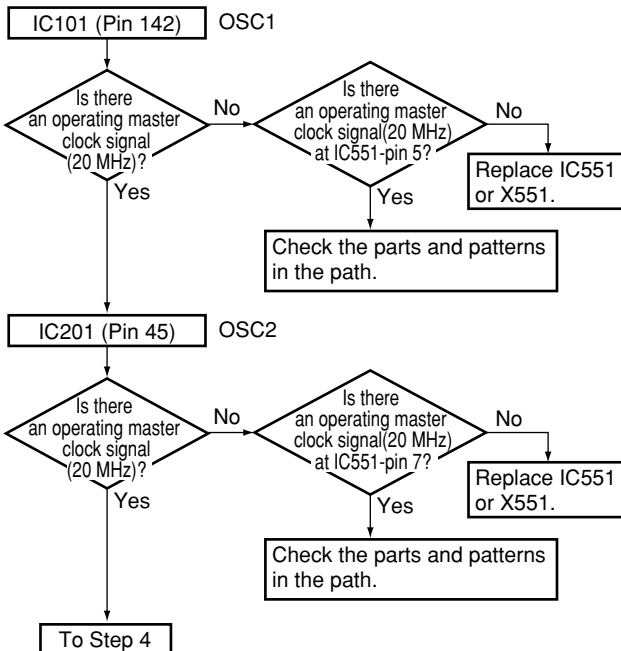

### Step 4: Audio Clock (Until Switch)

- When a sound is not out with the digital (COAX, OPT IN) signal input. → Go to Step 4-1
- When a sound is not out with the analog signal input. → Go to Step 4-2
- When a sound is not out with the HDMI. (It is assumption that failure diagnosis of HDMI assy completed) When the source is DVD-A or PCM96k → Go to Step 4-3-1 When the source is compression or less than PCM48k → Go to Step 4-3-2
- When a sound is not out with the XM Radio. → Go to Step 4-4

#### Step 4-1: When a sound is not out with the digital (COAX, OPT IN) signal input

Check that changes by pulling out and inserting the digital input lines. (Function is able to change the assignment. Therefore it is not specified.)

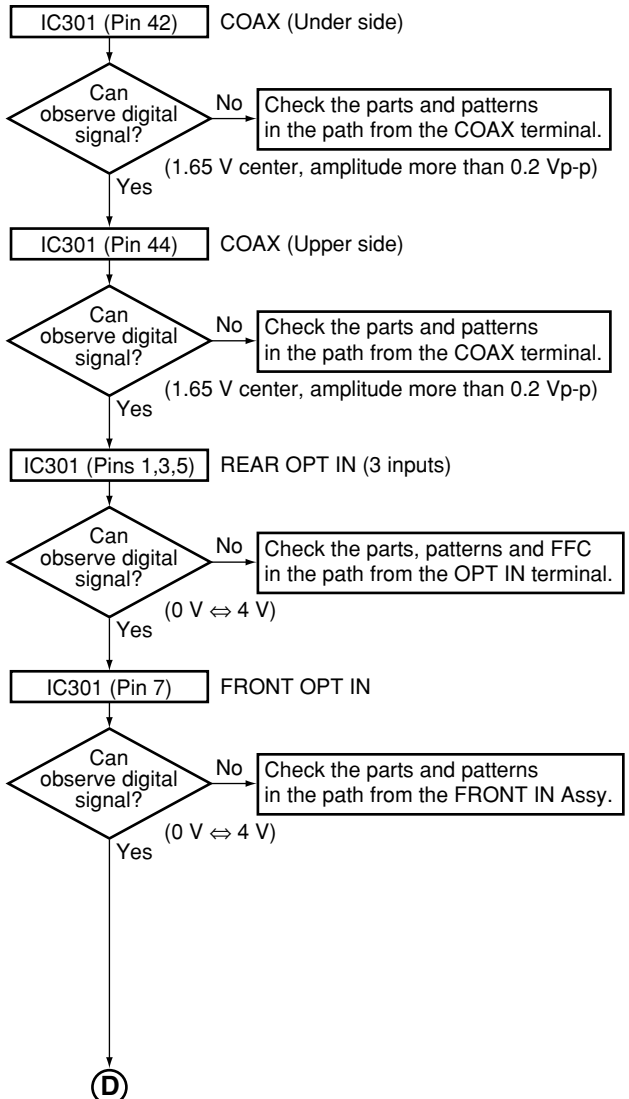

A **D**   : KUXJ and KUXJCA types only

Input a digital signal and check with the state which selected the function.

IC601 (Pin 1) XMSW3

Is the voltage 0 V? No Check the path to the microcomputer.

Yes

IC651 (Pin 1) HDSW

Is the voltage 0 V? No Check the path to the microcomputer.

Yes

IC301 (Pin 23) DIRM

Is there a master clock output (24.576 MHz)? No Is the voltage of IC301-pin 31 3.3 V? No Check the path to the microcomputer.

Yes

Is the oscillation of IC301-pin 29 stopped? No

Is the output of IC301-pin 36 (DRERR3) 0 V? No Replace IC301 or IC651 (IC601).

IC601 (Pin 11)

Is there a master clock input (24.576 MHz)? No Is there abnormality at the parts and patterns in the input path? No Replace IC301 or IC601.

Yes

IC651 (Pin 11)

Is there a master clock input (24.576 MHz)? No Is there abnormality at the parts and patterns in the input path? No Replace IC301 (IC601) or IC651.

Yes

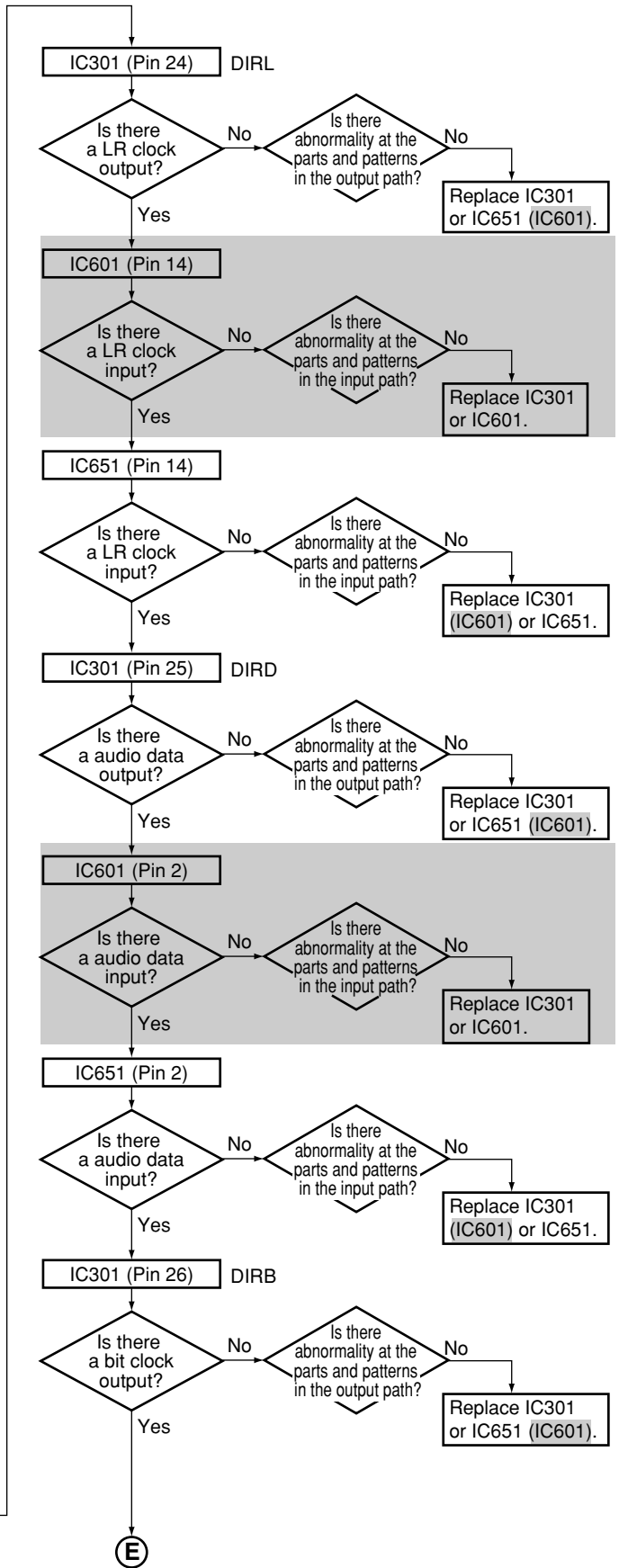

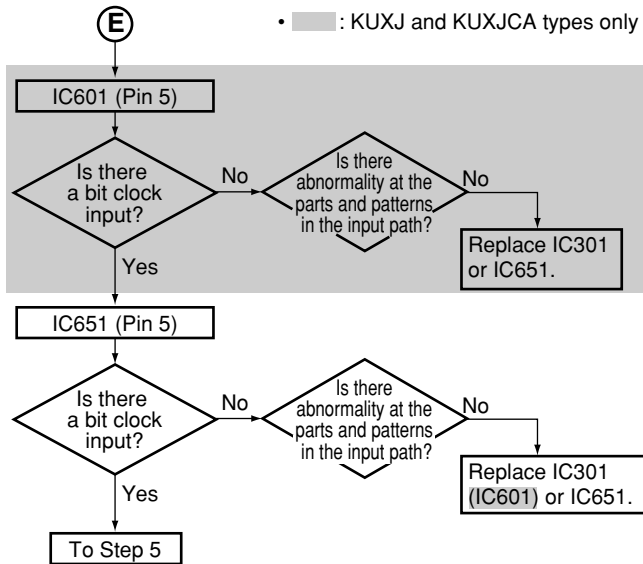

**Step 4-2: When a sound is not out with the analog signal input**

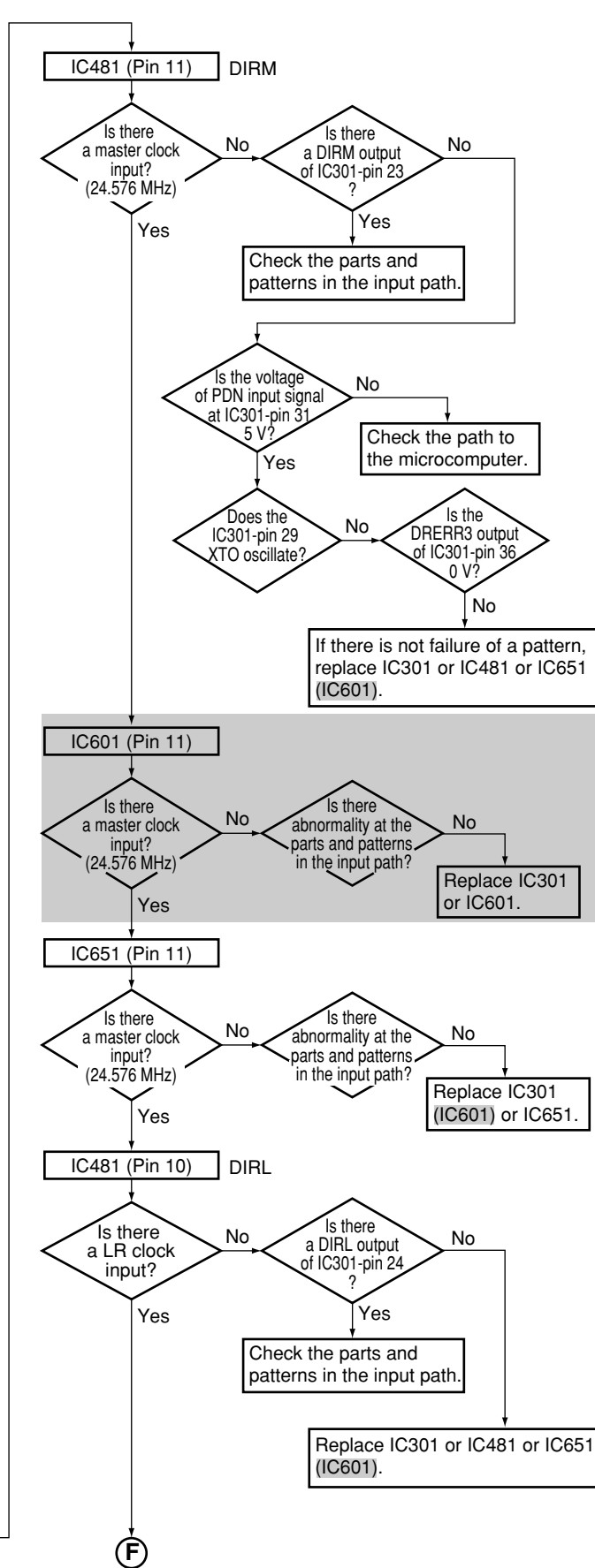
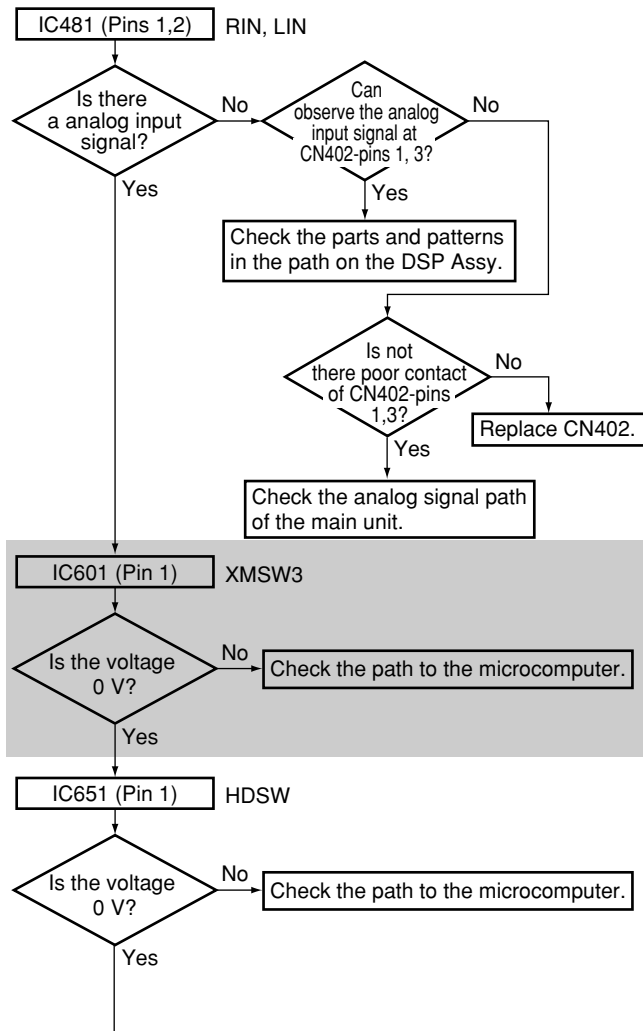

A • ■ : KUXJ and KUXJCA types only

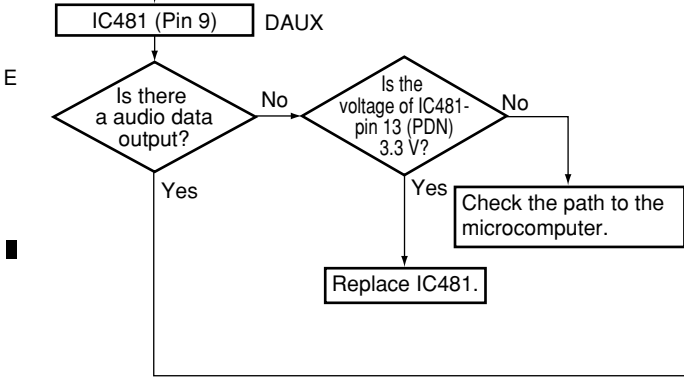
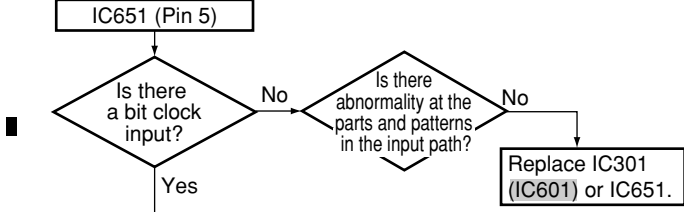
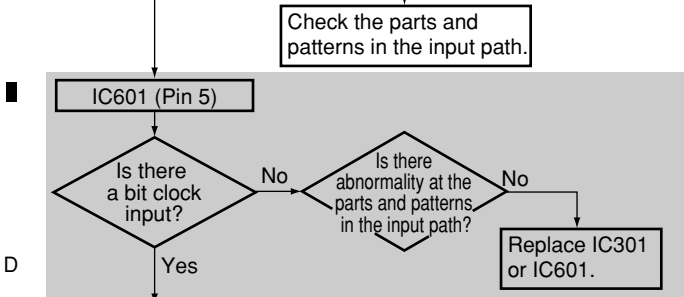
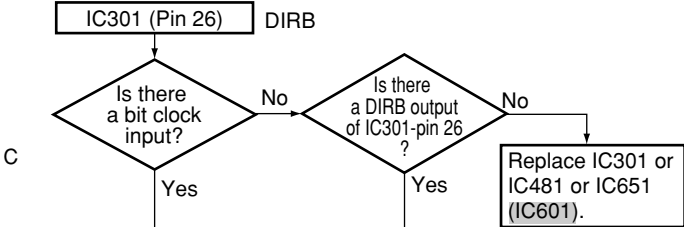
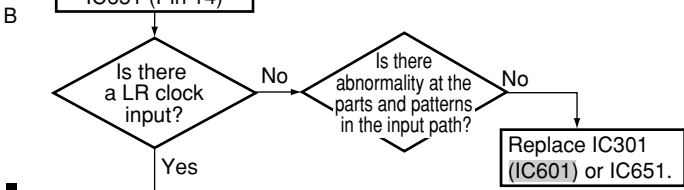
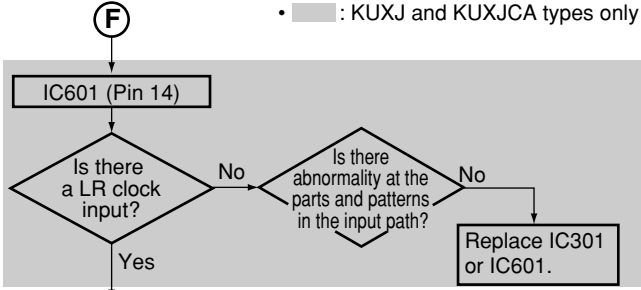

F

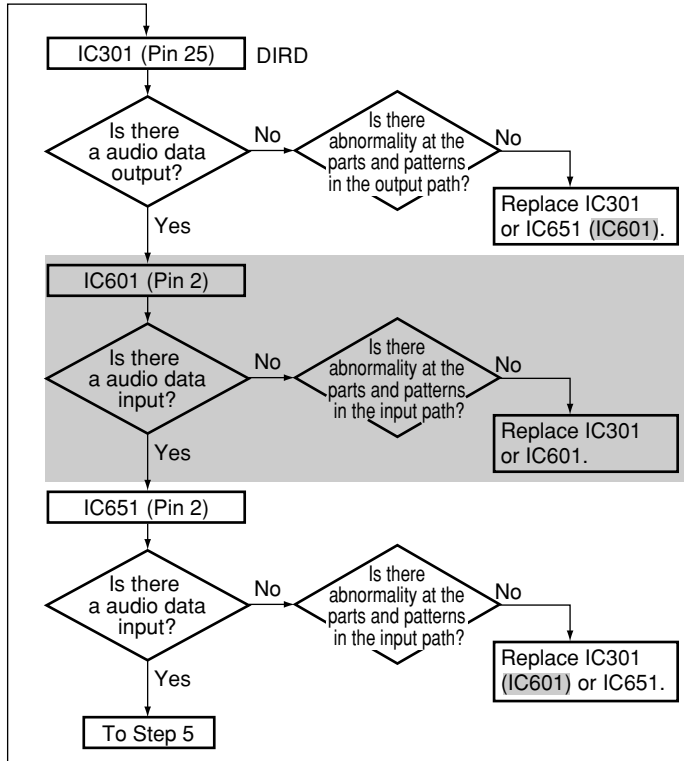

**Step 4-3-1: When a sound is not out with the HDMI (When the source is DVD-A or PCM96k)**

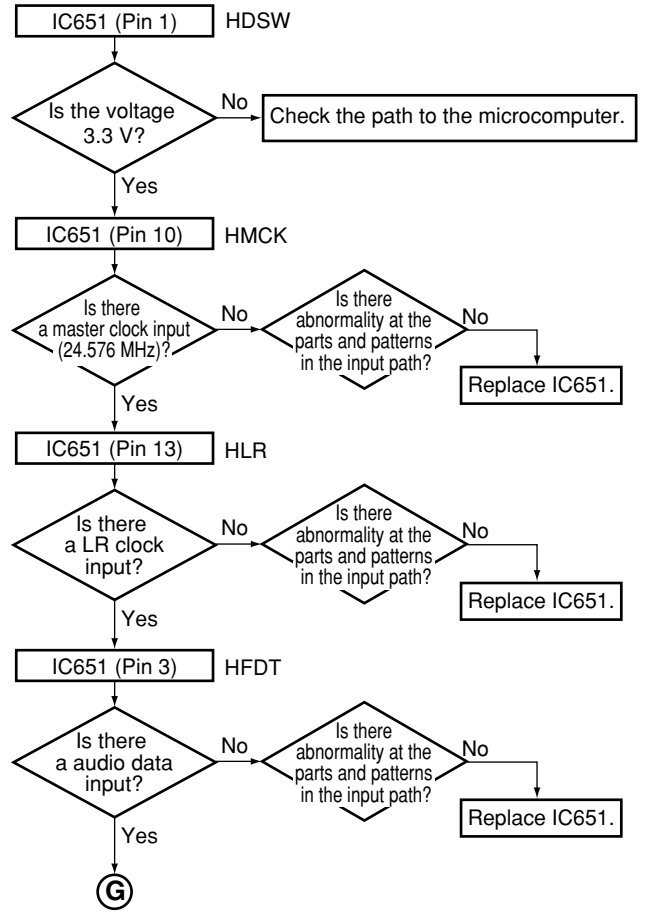

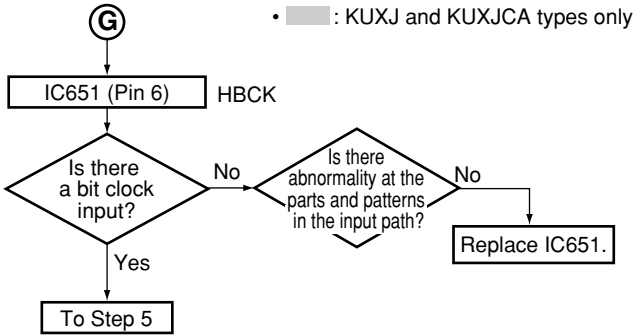

**Step 4-3-2: When a sound is not out with the HDMI (When the source is compression or less than PCM48k)**

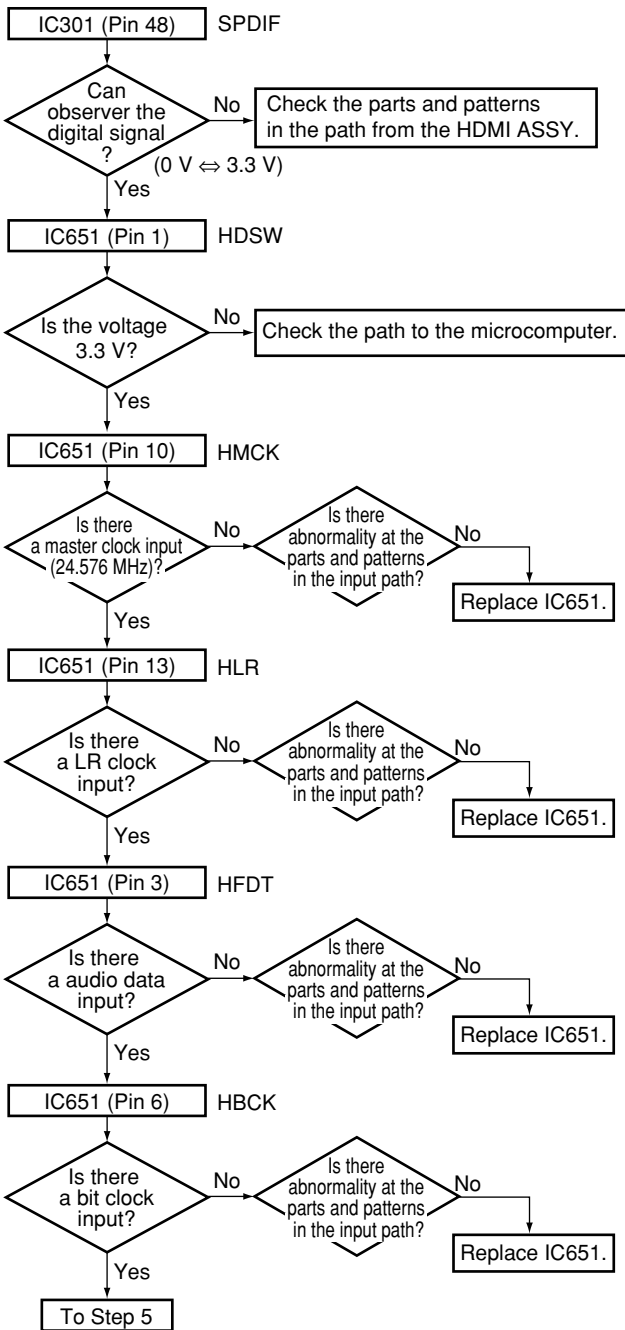

**Step 4-4: When a sound is not out with the XM Radio**

Insert the XM Antenna and check it.

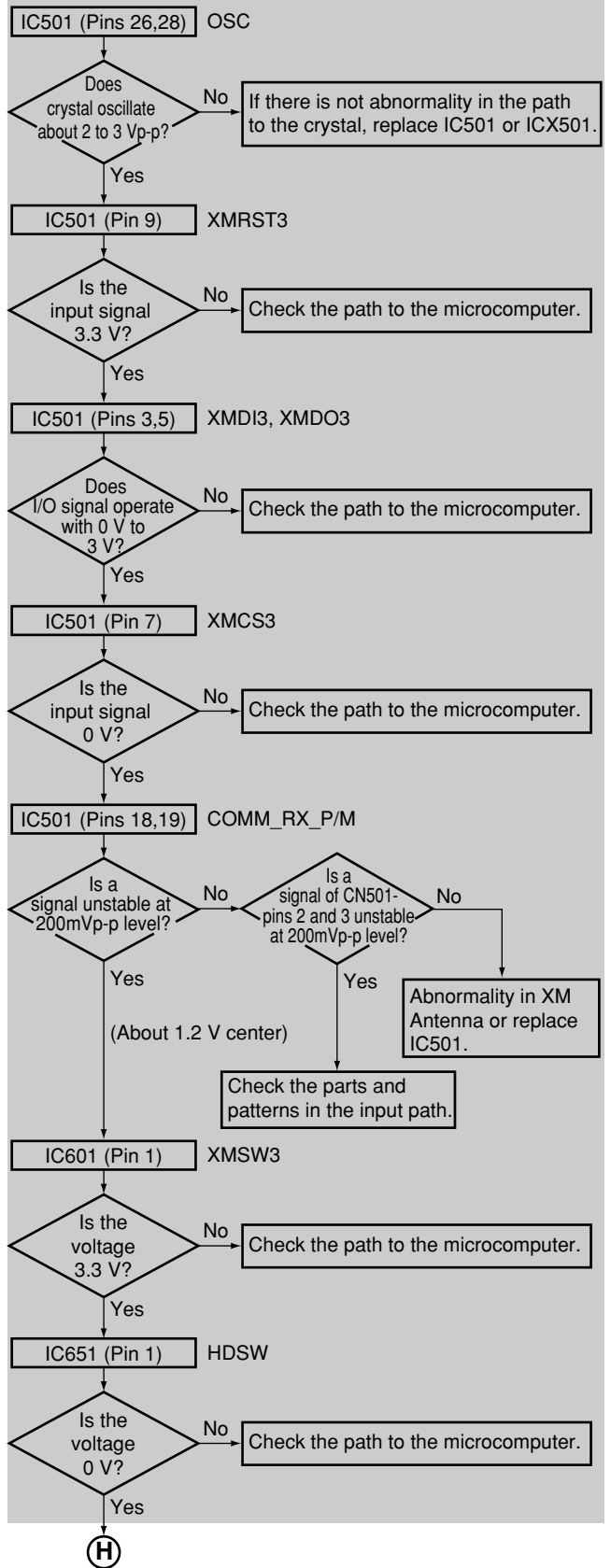

A

(H)

• ■ : KUXJ and KUXJCA types only

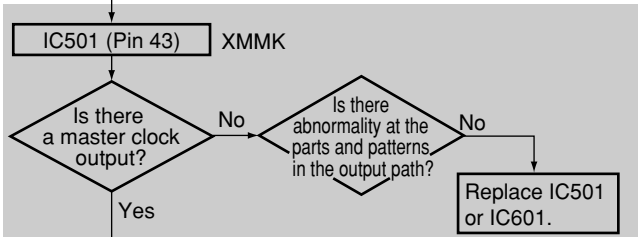

B

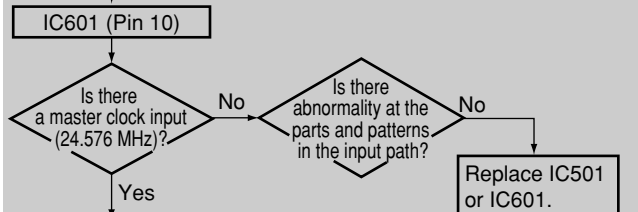

C

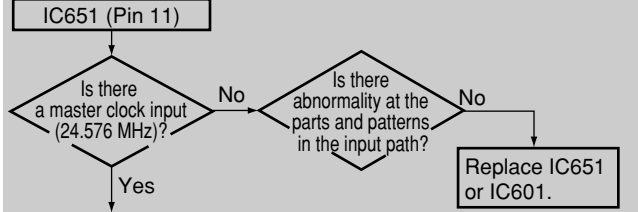

D

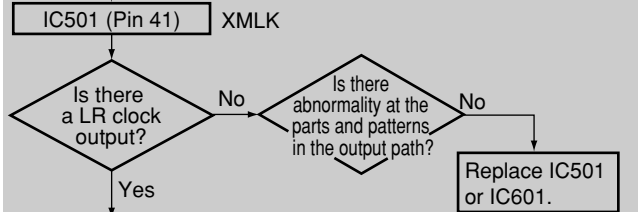

E

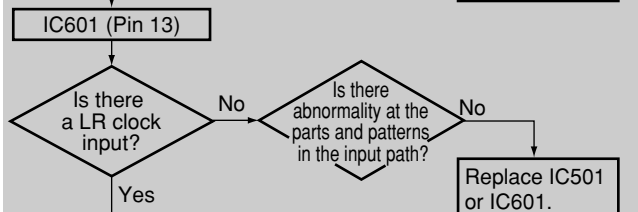

F

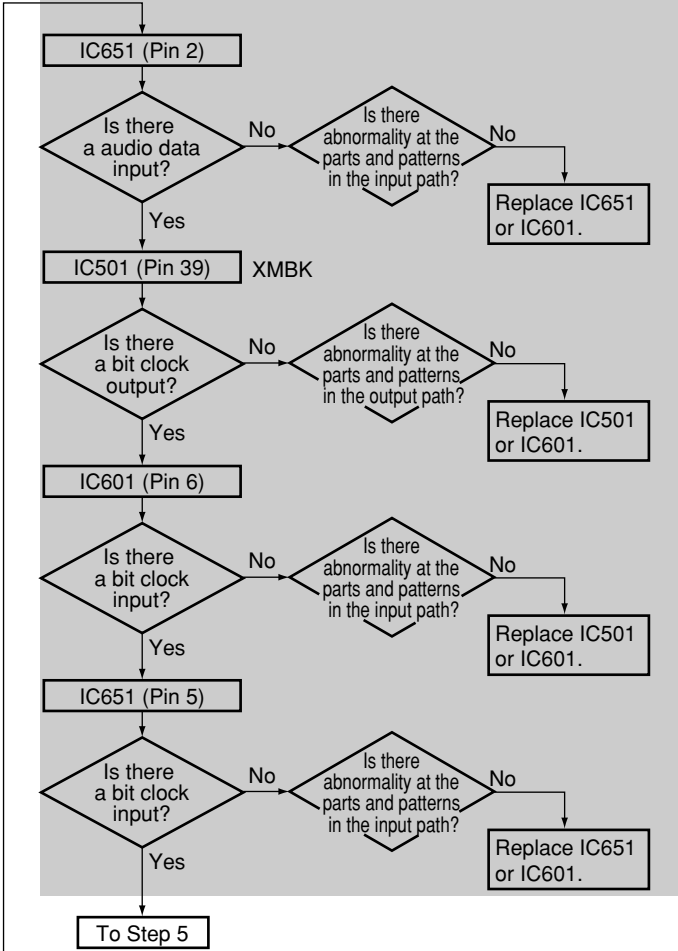
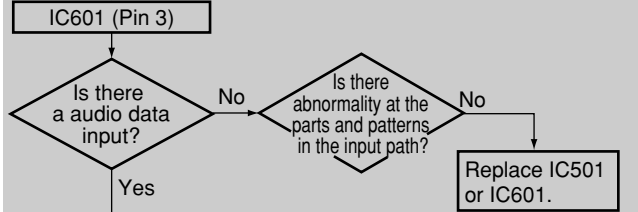
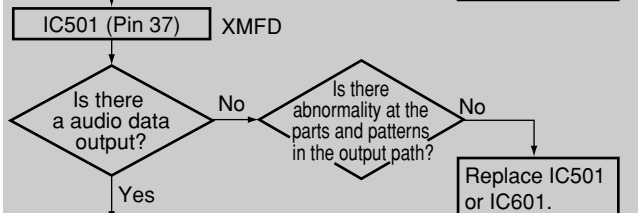
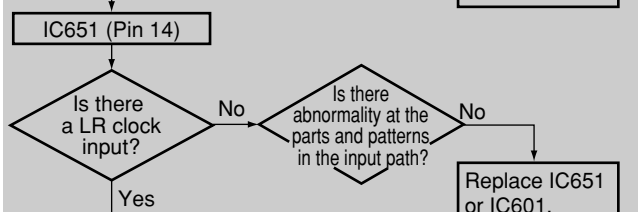

Step 5: Audio Clock (1st DSP from Switch)

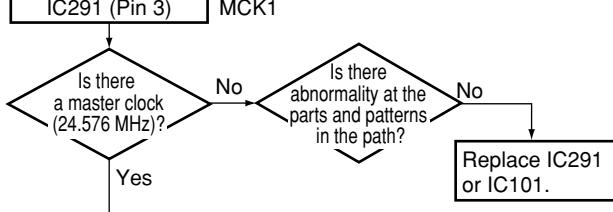
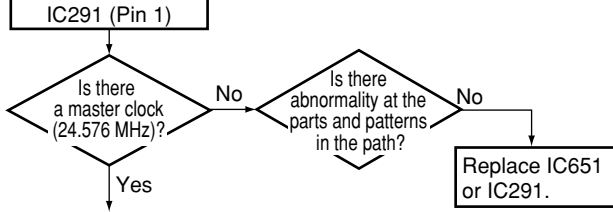
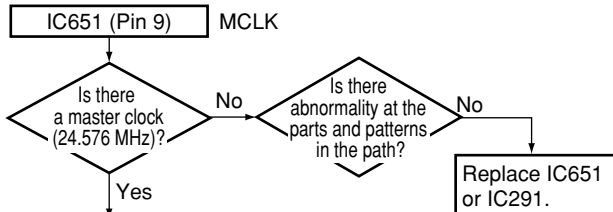

(I)



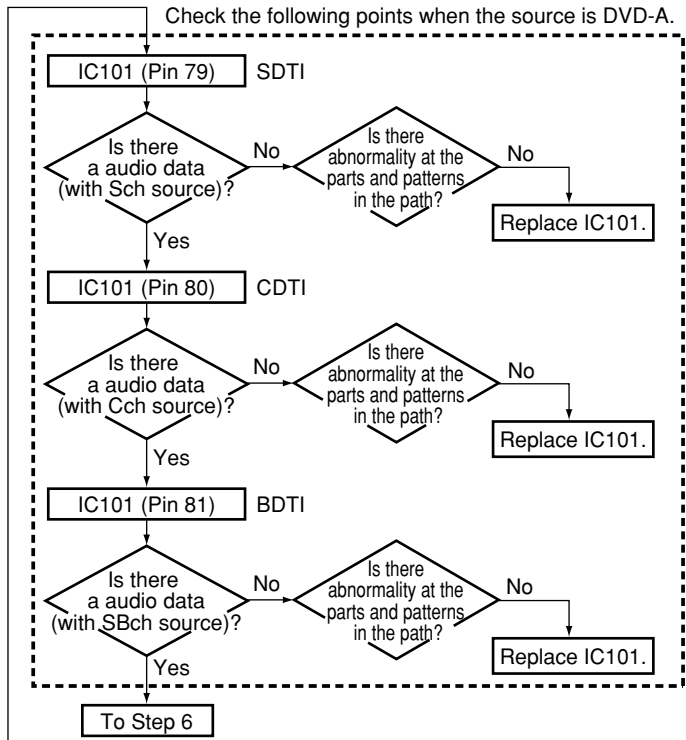
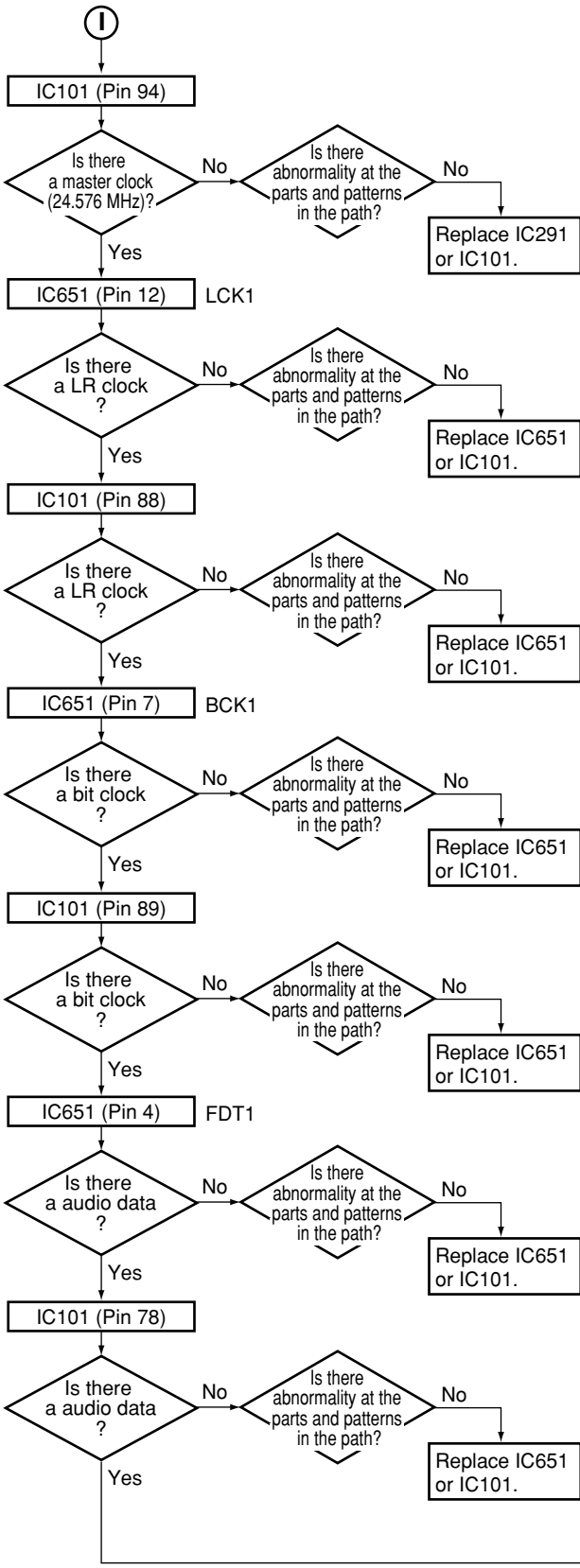

**Step 6: Audio Clock (2nd DSP from 1st DSP)**

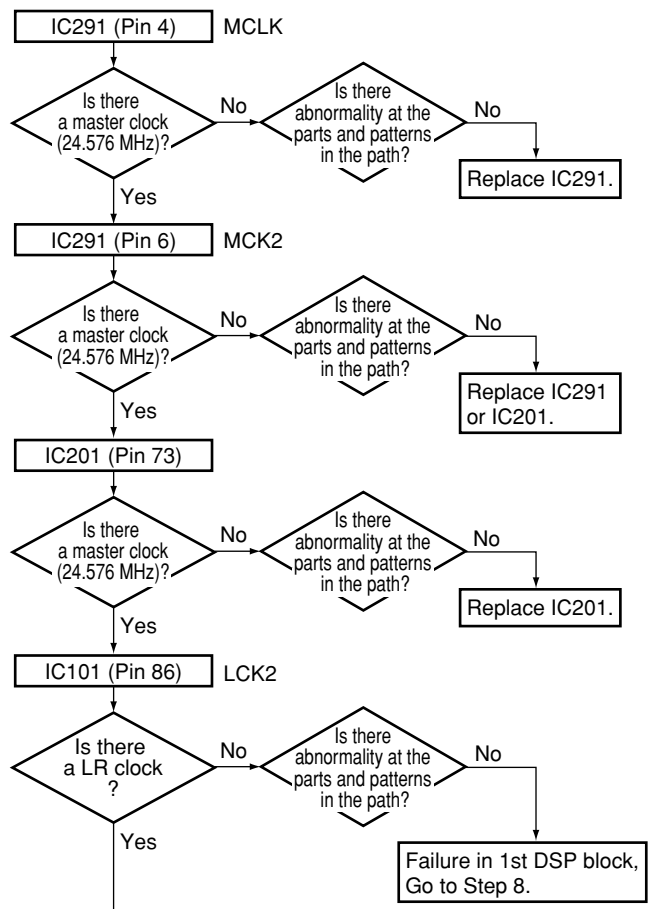

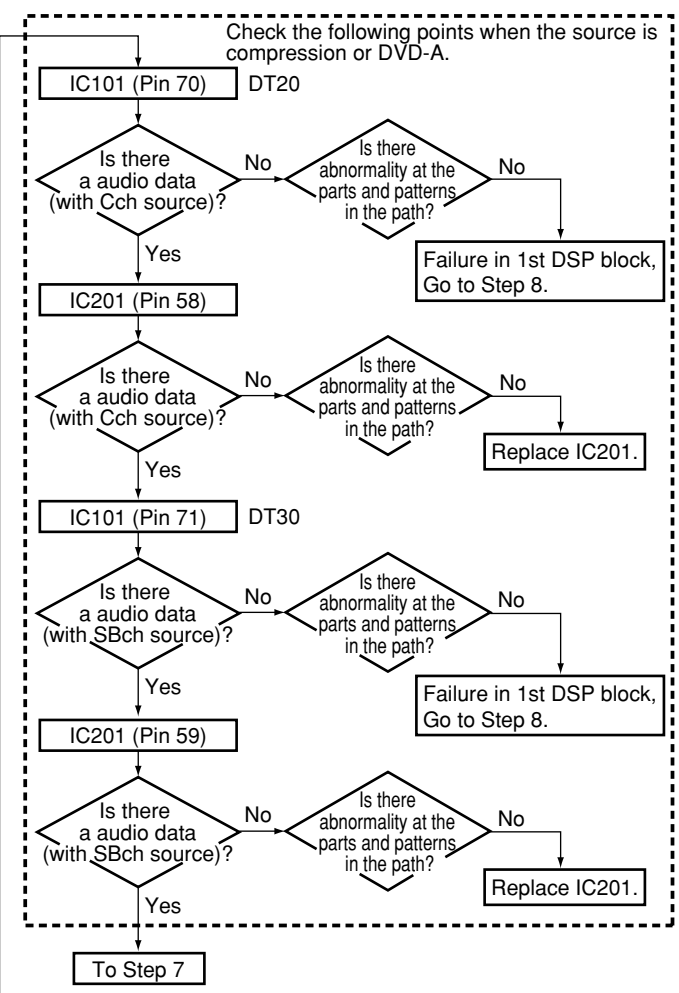
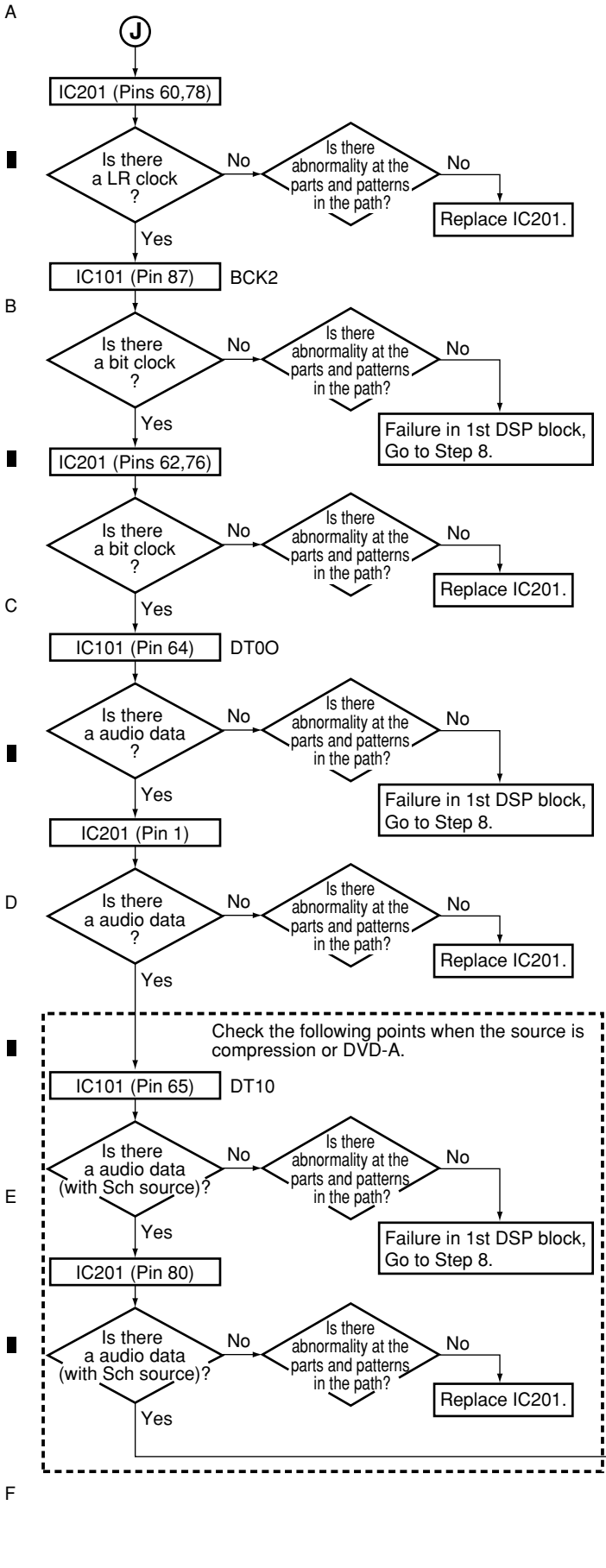

**Step 7: Audio Clock (DAC output from 2nd DSP)**

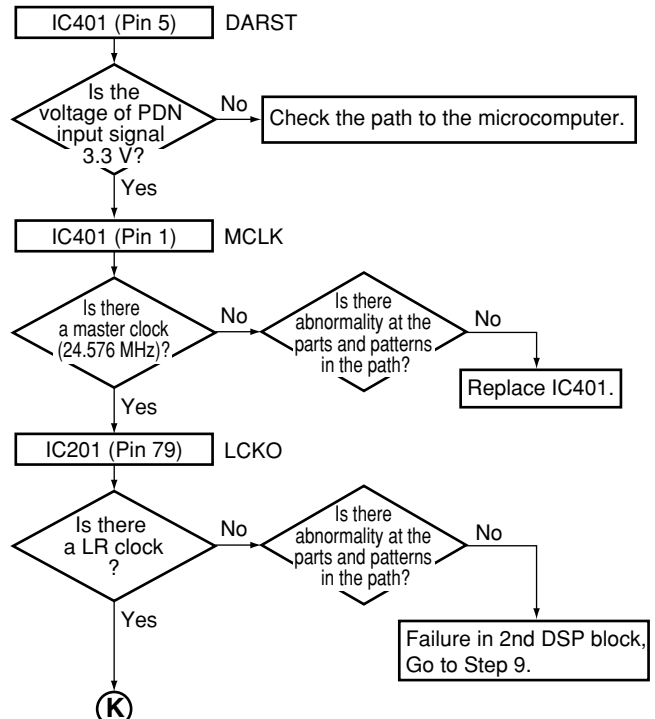

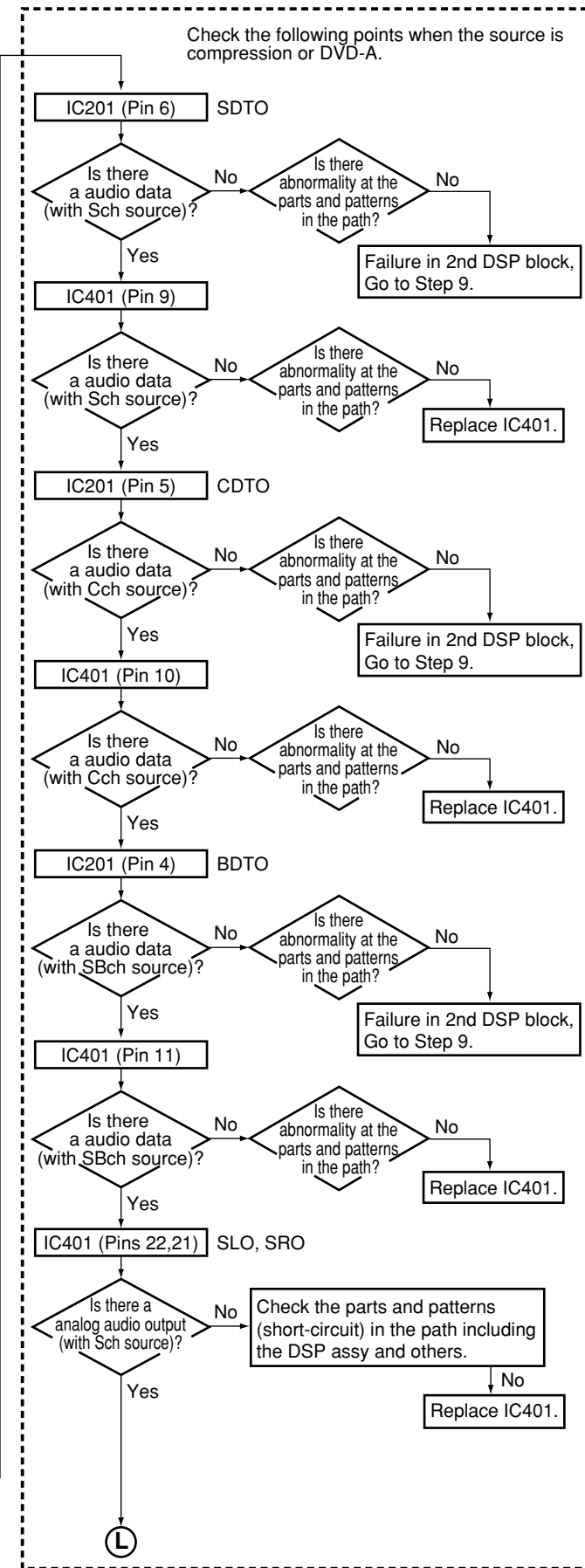
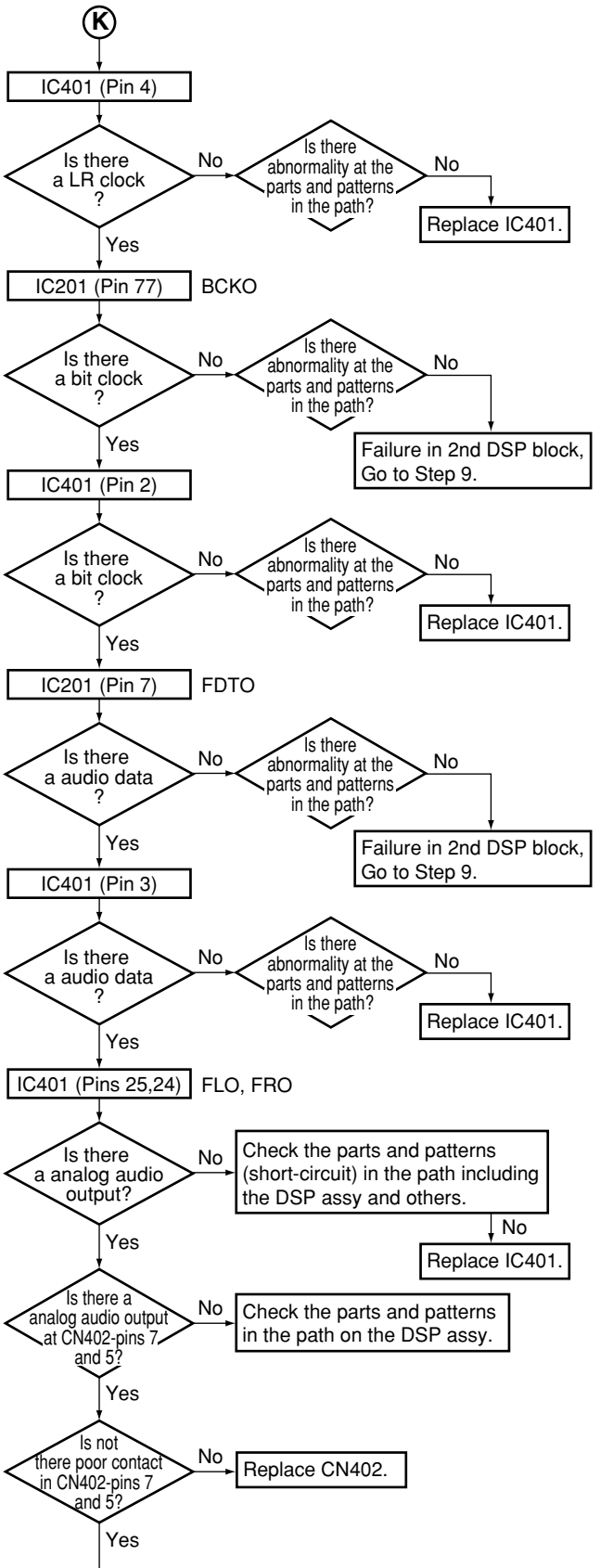

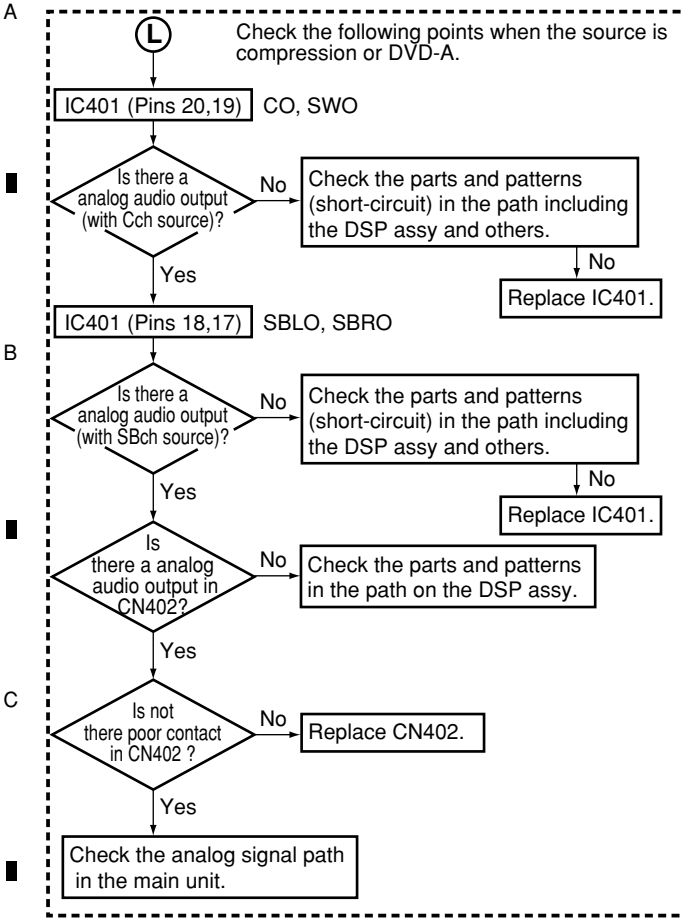

**Step 8: 1st DSP**

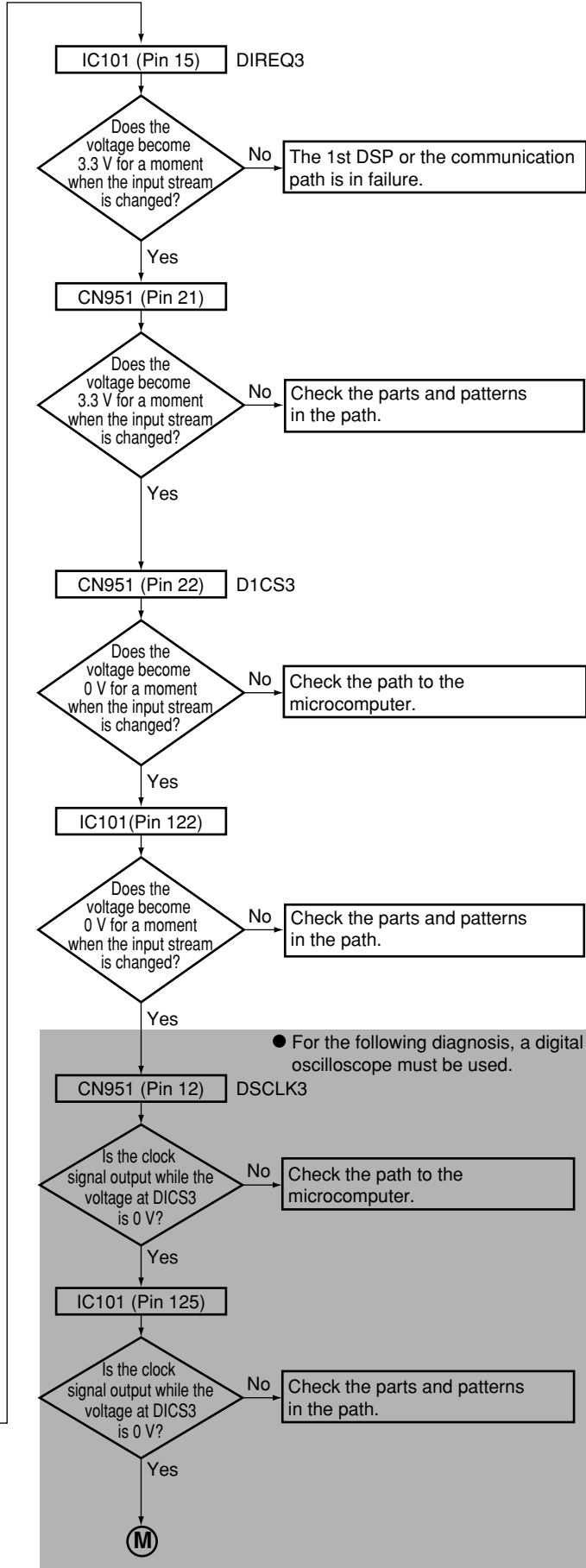
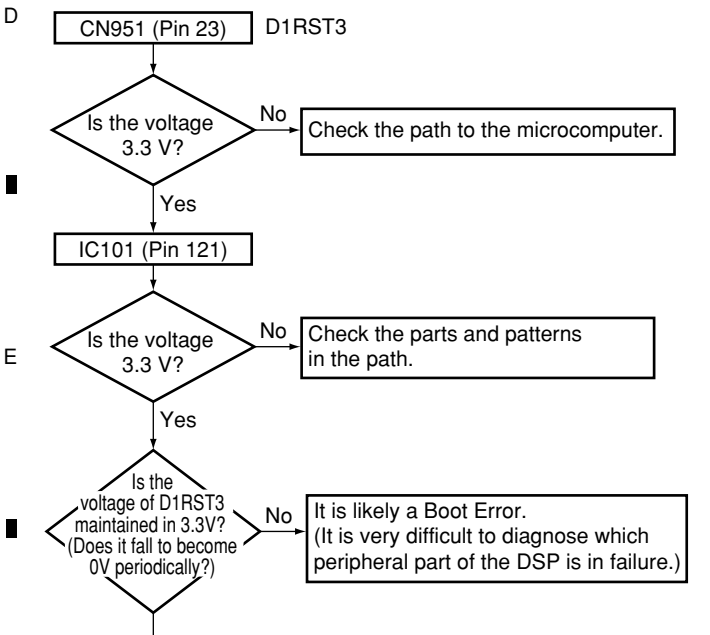

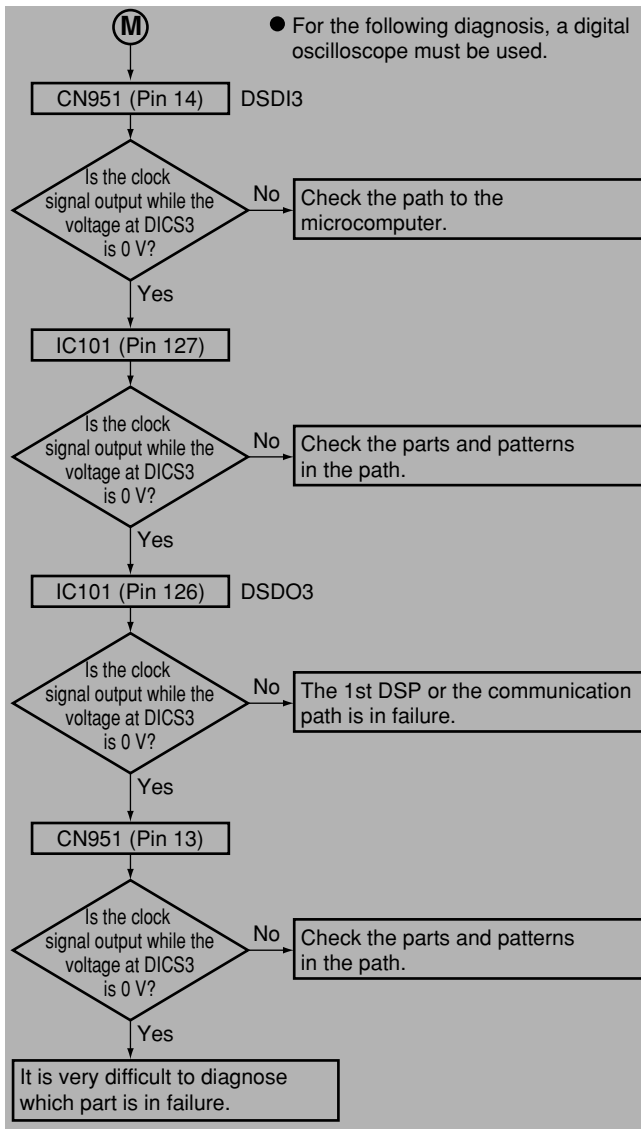

**Step 9: 2nd DSP**

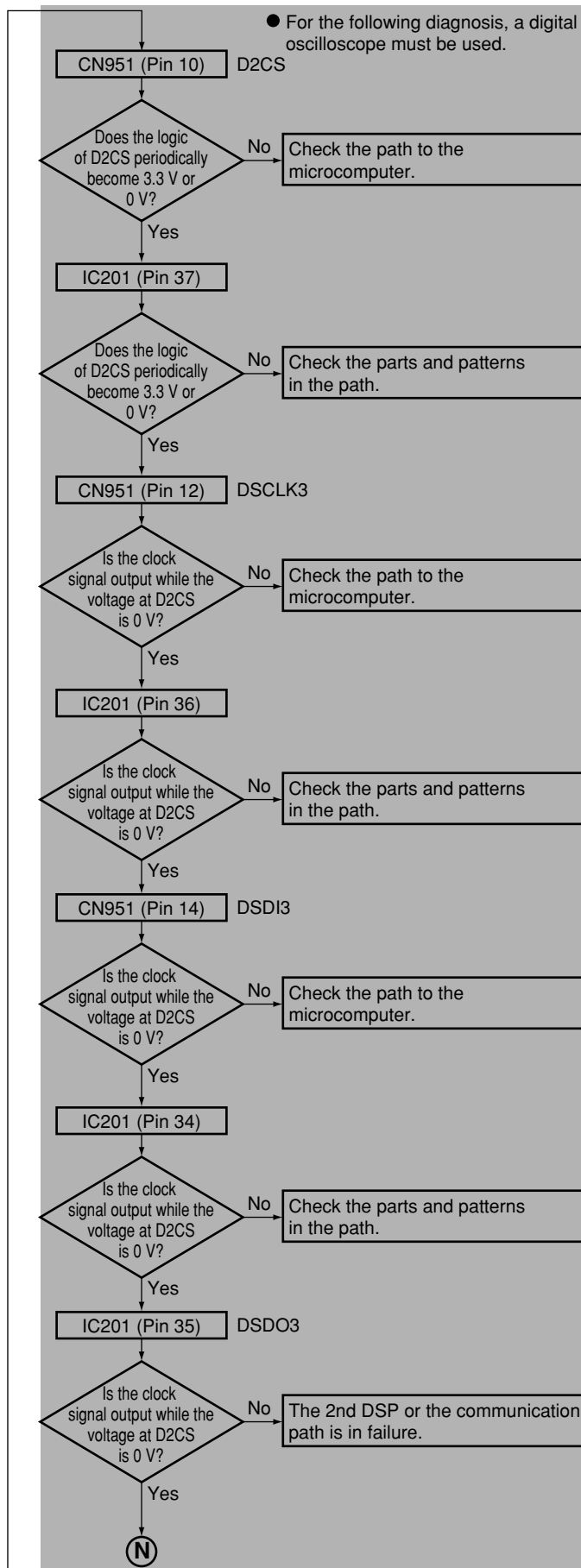
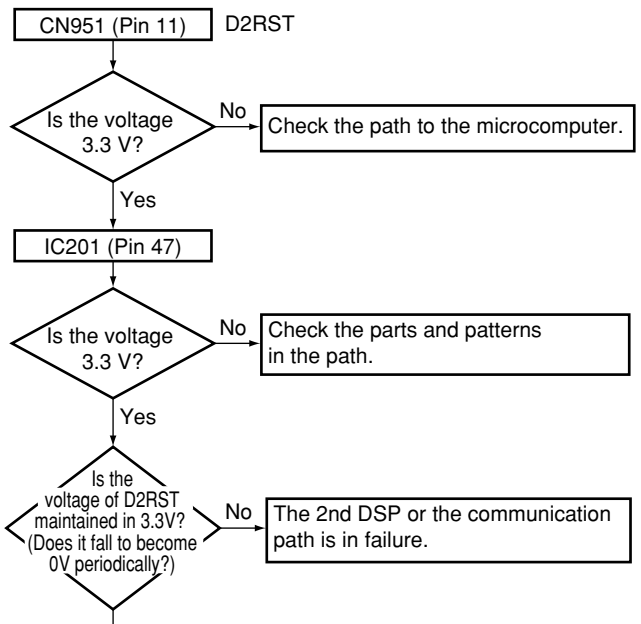

A  
B  
C  
D  
E  
F

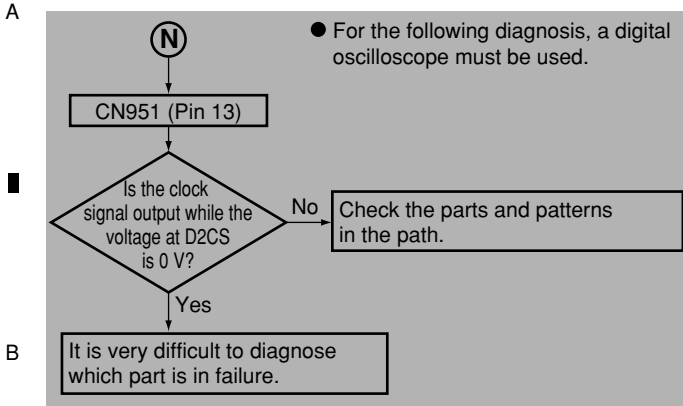

**DSP Block Diagram**

**• Signal Block**

■ : KUXJ and KUXJCA types only

- : I2S MCLK
- : I2S DATA (2ch)
- - -> : I2S DATA (compression or 2ch)
- - -> : I2S LRCK, MBCK
- - -> : Control/Memory bus line
- ⇄ : Analog audio signal
- : SPDIF, operating clock

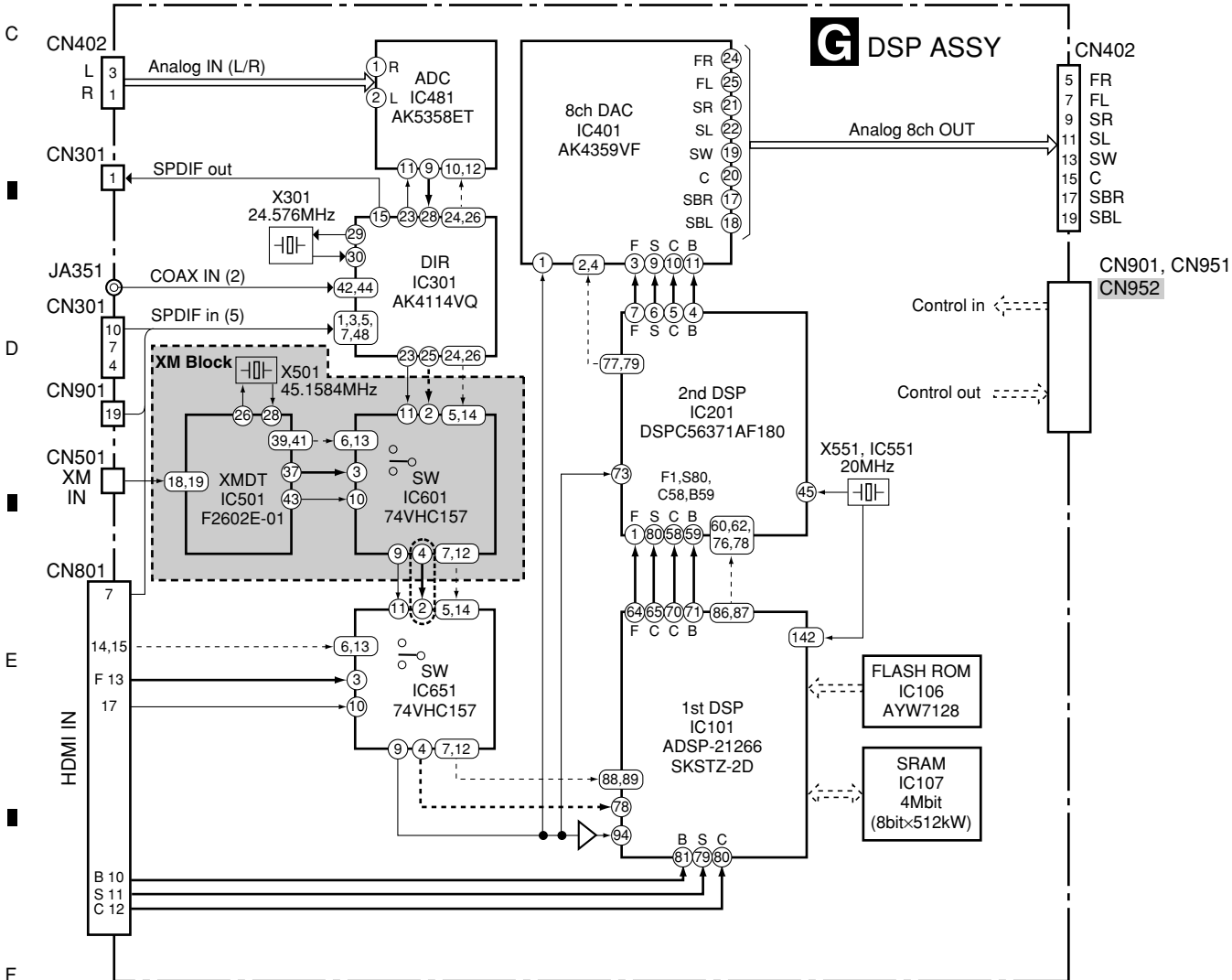

### • Power Block and GND Map

•  : KUXJ and KUXJCA types only

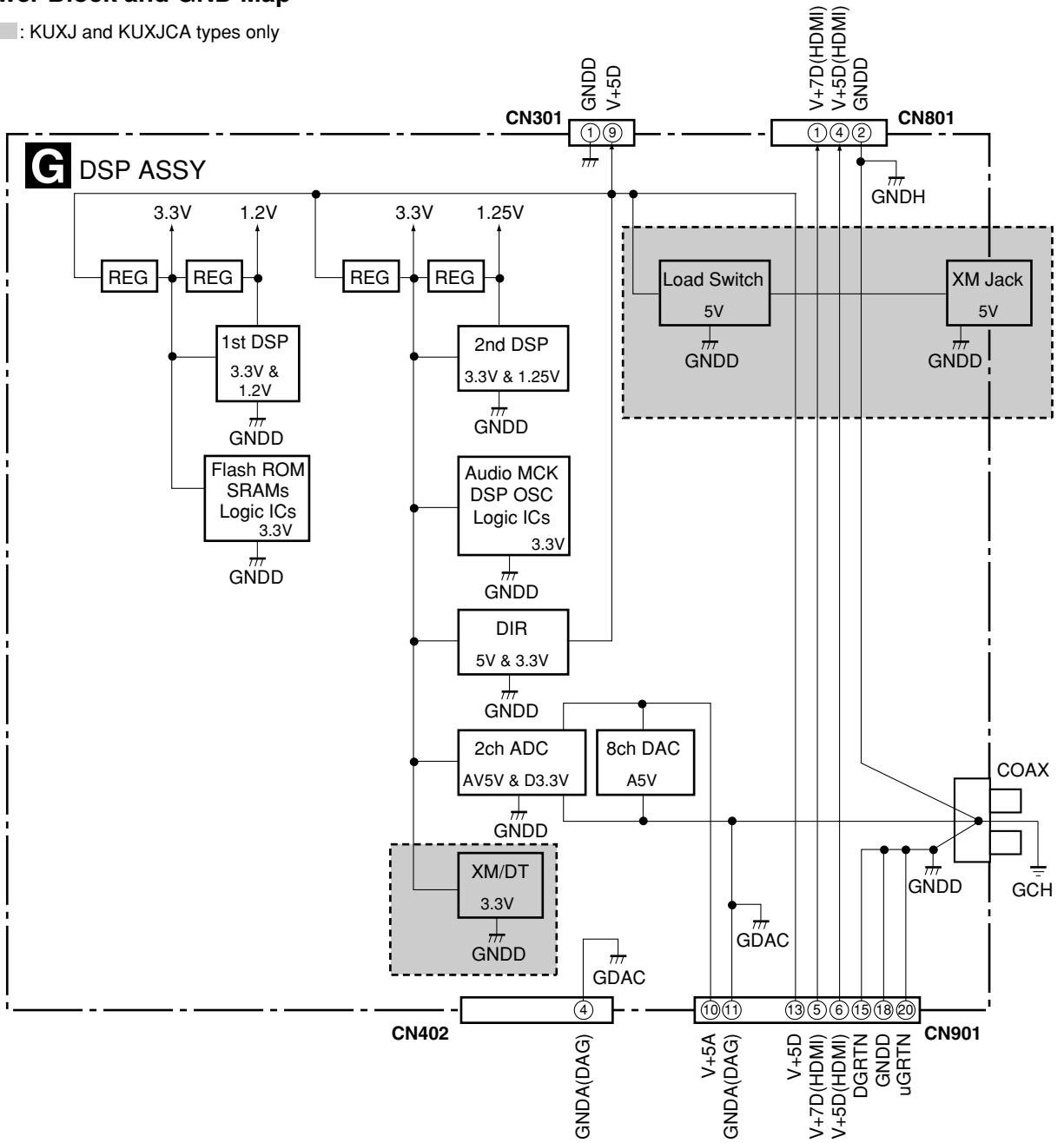

## 7.1.4 HDMI TROUBLESHOOTING

### HDMI Simple Diagnosis

Please refer to the one point trouble shooting first before checking the flow chart on the next page.

#### HDMI

Symptom	Remedy
The HDMI indicator blinks continuously.	Check all the points below.
No picture or sound.	<ul style="list-style-type: none"> <li>This receiver is HDCP-compatible. Check that the components you are connecting are also HDCP-compatible. If they are not, please connect them using the component, S-video or composite video jacks.</li> <li>Depending on the connected source component, it's possible that it will not work with this receiver (even if it is HDCP-compatible). In this case, connect using the component, S-video or composite video jacks between source and receiver.</li> <li>If the problem still persists when connecting your HDMI component directly to your monitor, please consult the component or monitor manual or contact the manufacturer for support.</li> </ul>
No picture.	<ul style="list-style-type: none"> <li>To see the on-screen display, you must also connect the receiver and TV with a composite, component, or S-video cable.</li> <li>Depending in the output settings of the source component, it may be outputting a video format that can't be displayed. Change the output settings of the source, or connect using the component, S-video or composite jacks.</li> </ul>
No sound, or sound suddenly ceases.	<ul style="list-style-type: none"> <li>Check that the HDMI AV setting is set to <b>AMP/THROUGH</b>.</li> <li>If the component is a DVI device, use a separate connection for the audio.</li> <li>Check the audio output settings of the source component.</li> </ul>
Noisy or distorted picture.	<ul style="list-style-type: none"> <li>If the problem still persists when connecting your HDMI component directly to your monitor, please consult the component or monitor manual or contact the manufacturer for support.</li> </ul>

#### 1. Causes for noncompletion of HDMI authentication between the source equipment and this unit (the HDMI indicator is unlit or flashes)

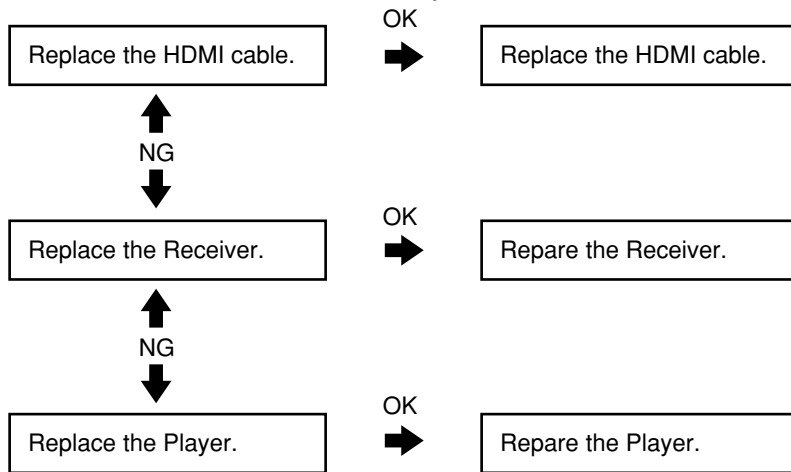

#### 2. Causes for noncompletion of HDMI authentication between the monitor and this unit (no display or sound from the monitor)

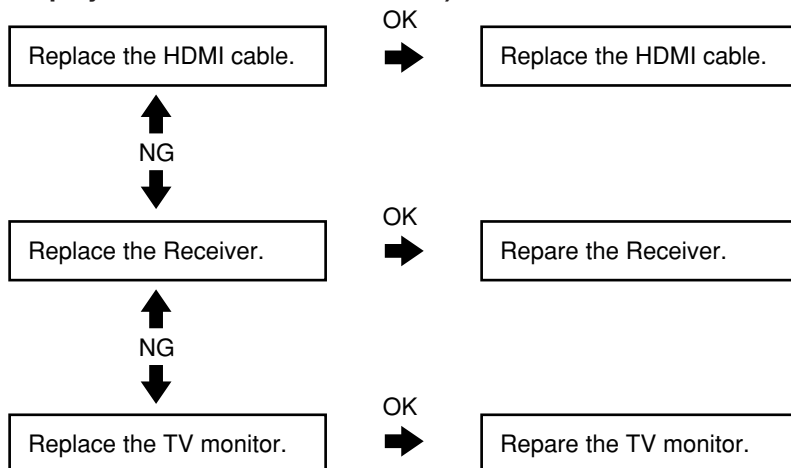



## HDMI Troubleshooting

- The parts marked like **V+5** in the following chart are located in "HDMI & DVC Assy Check Points".

### Common section

#### Step 1-1: Connections

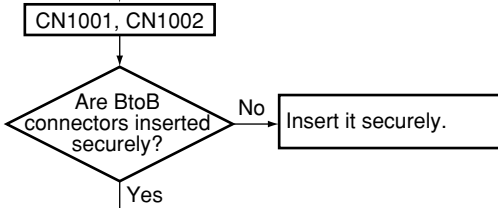

#### Step 1-2: Power supply

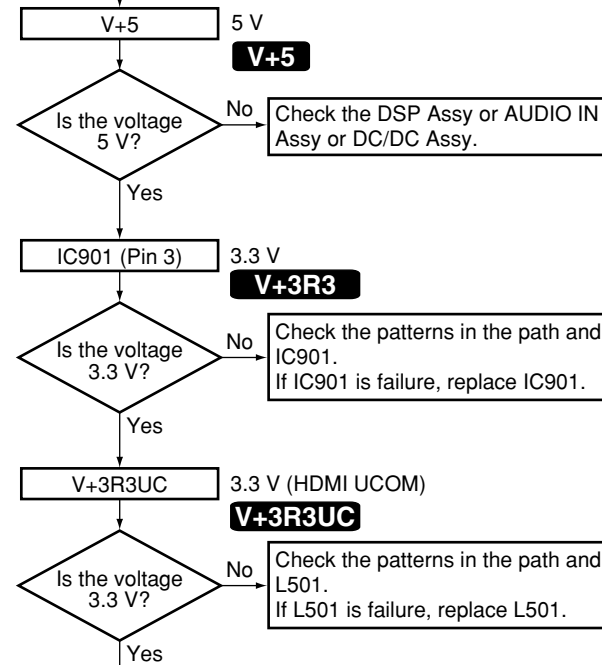

#### Step 1-3: Reset

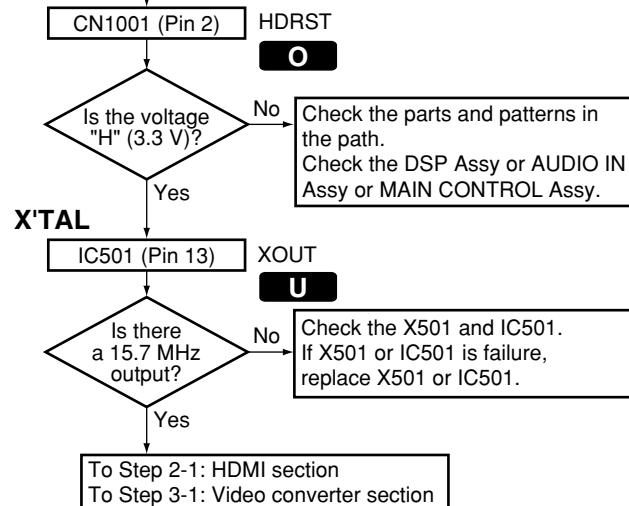

### HDMI section

#### Step 2-1: Power supply

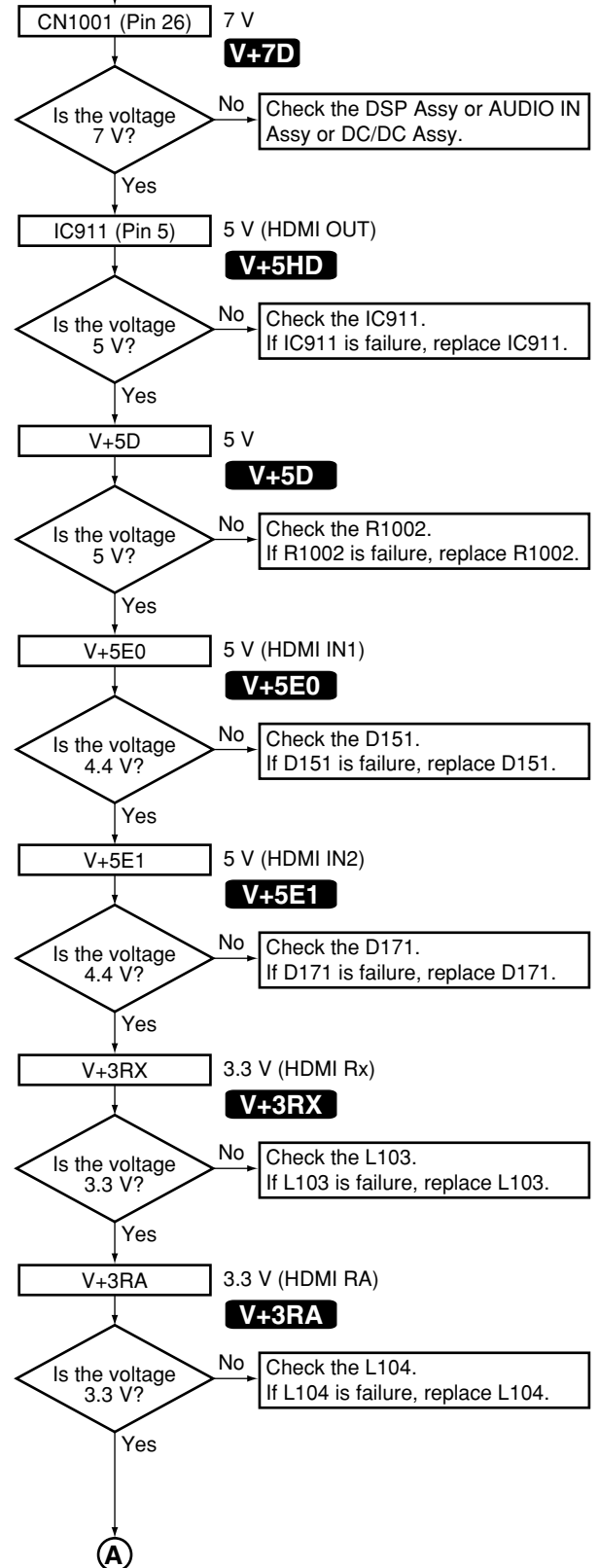

A

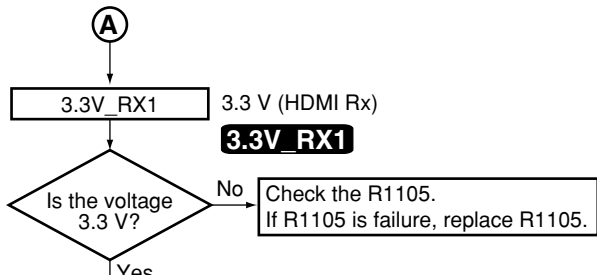

B

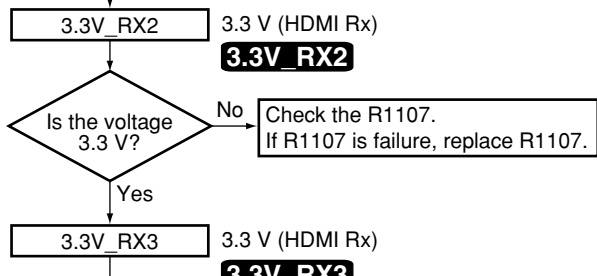

C

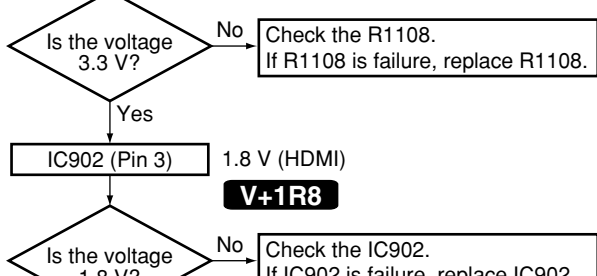

D

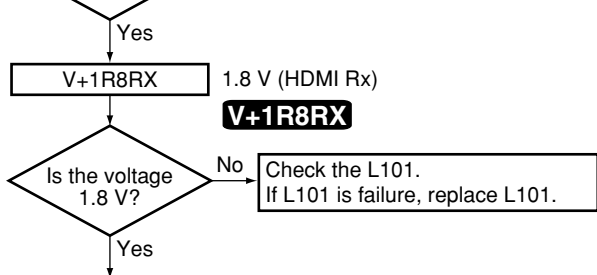

E

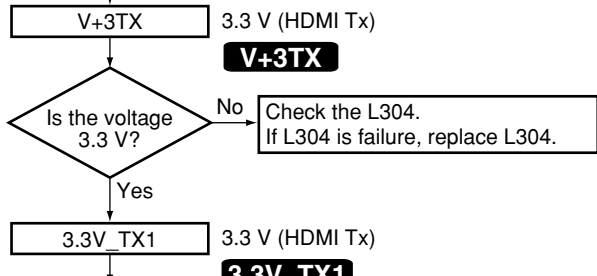

F

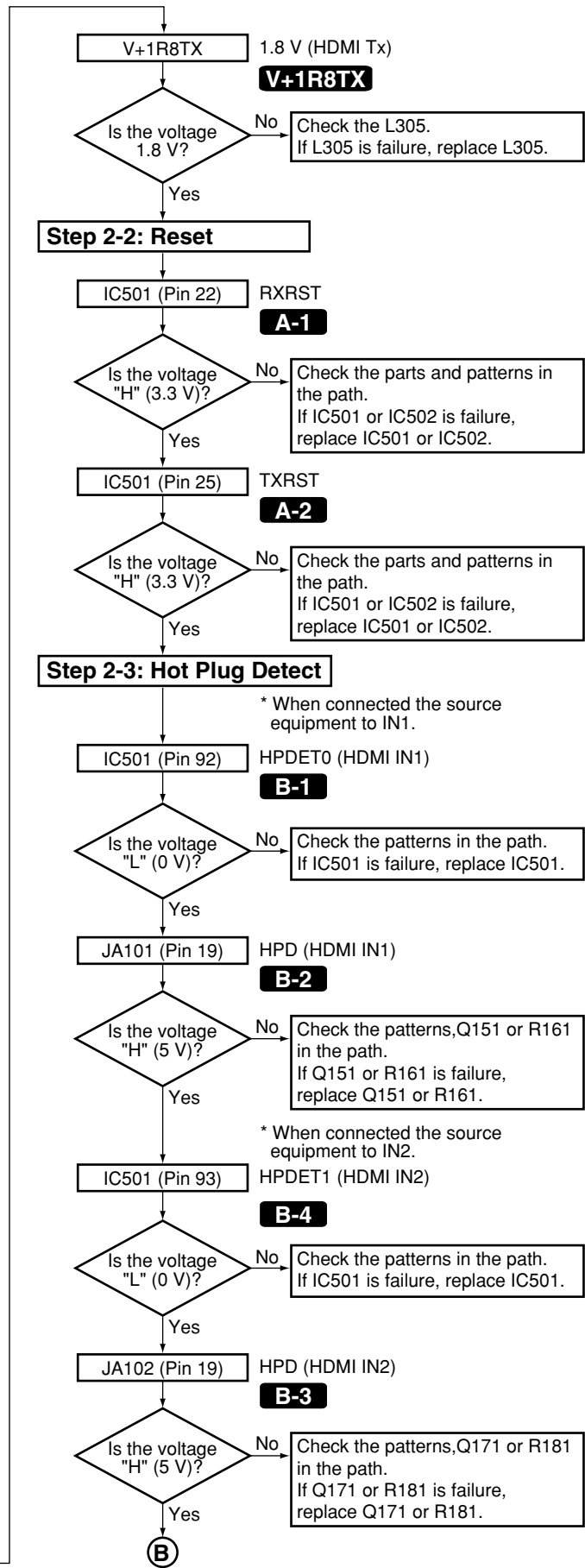
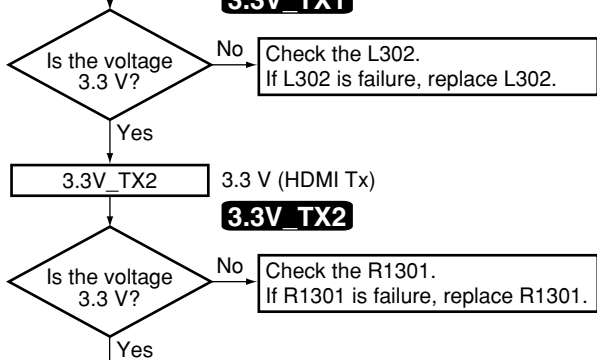

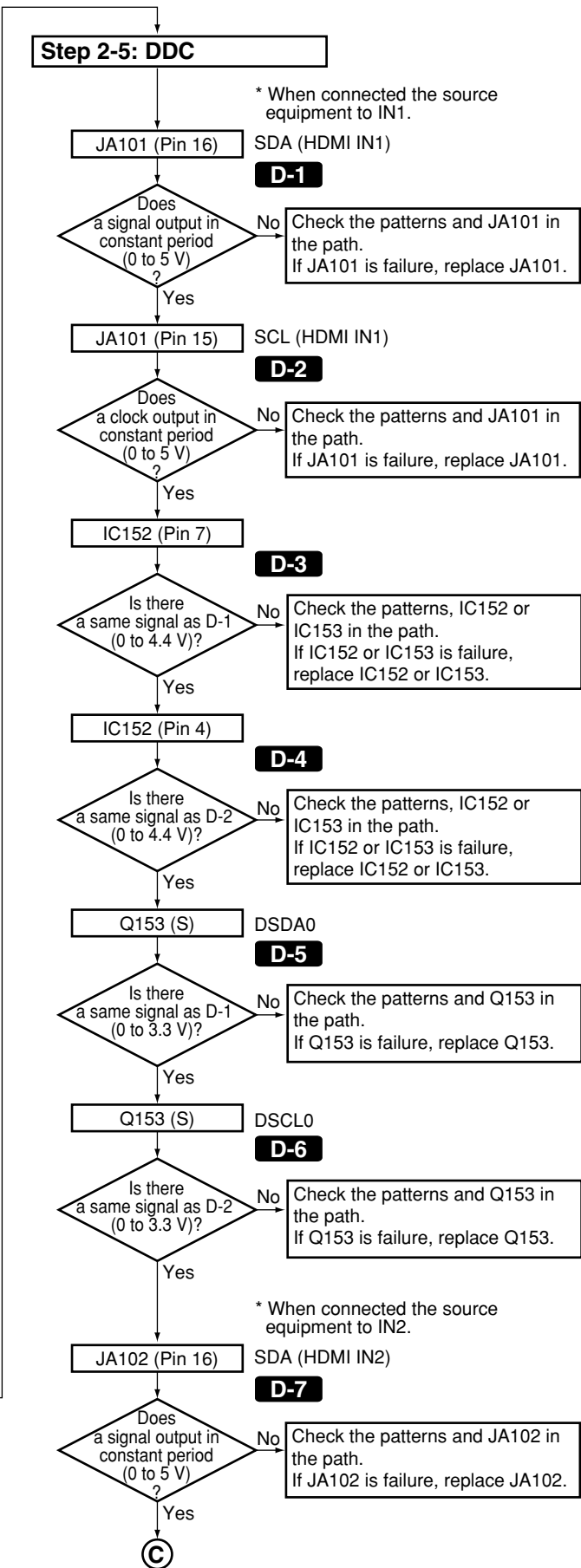
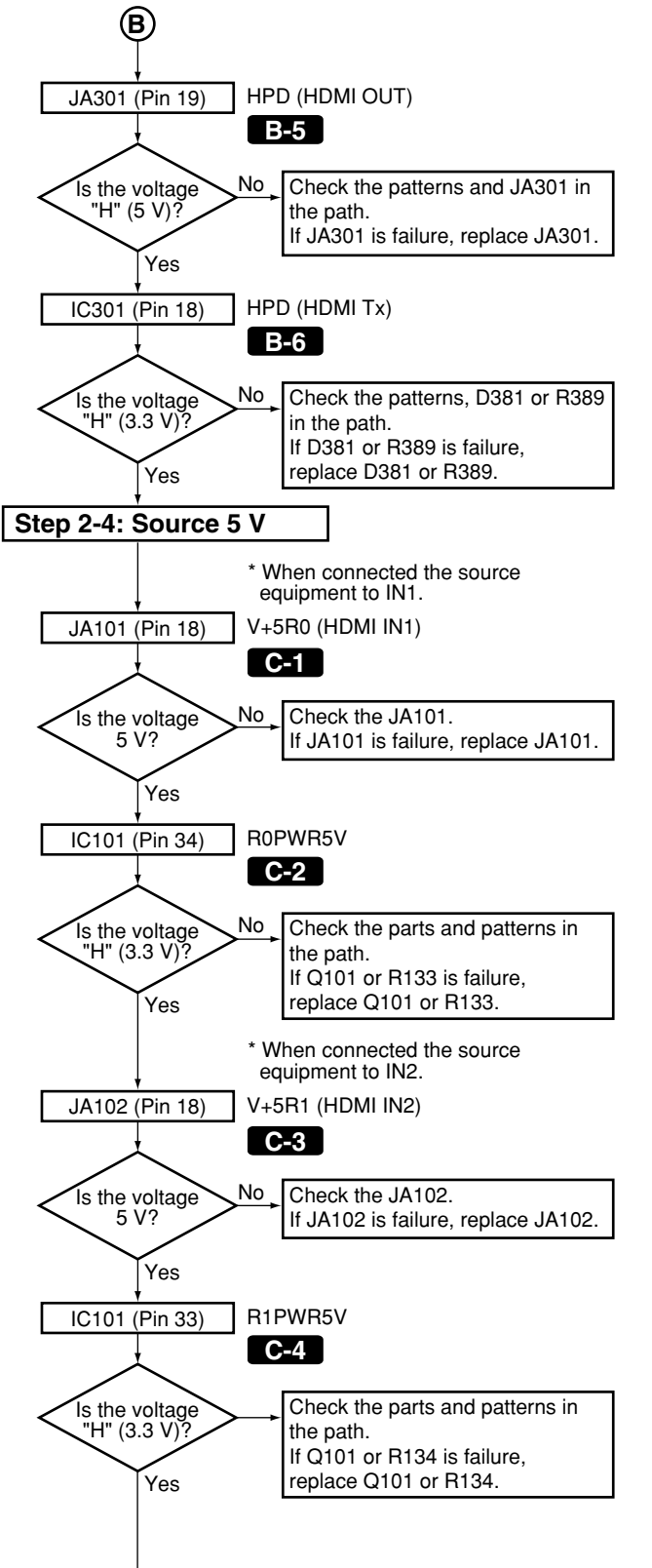

A  
B  
C  
D  
E  
F

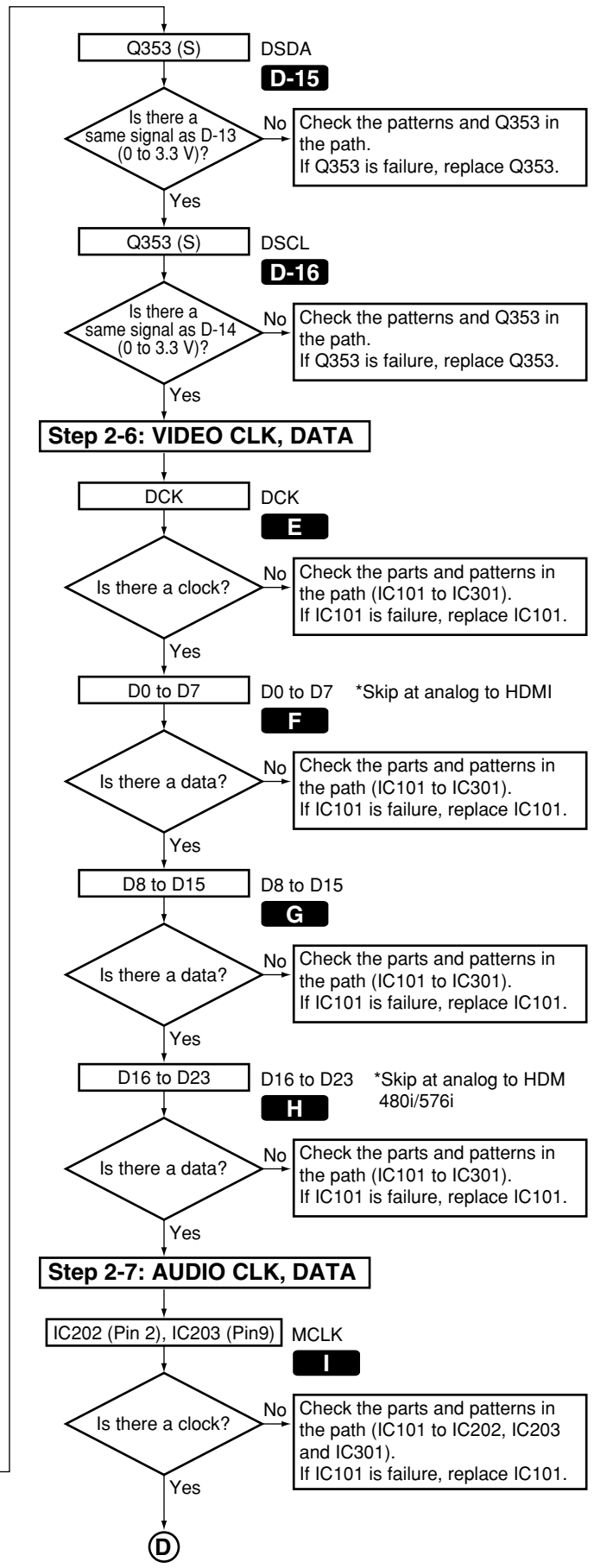
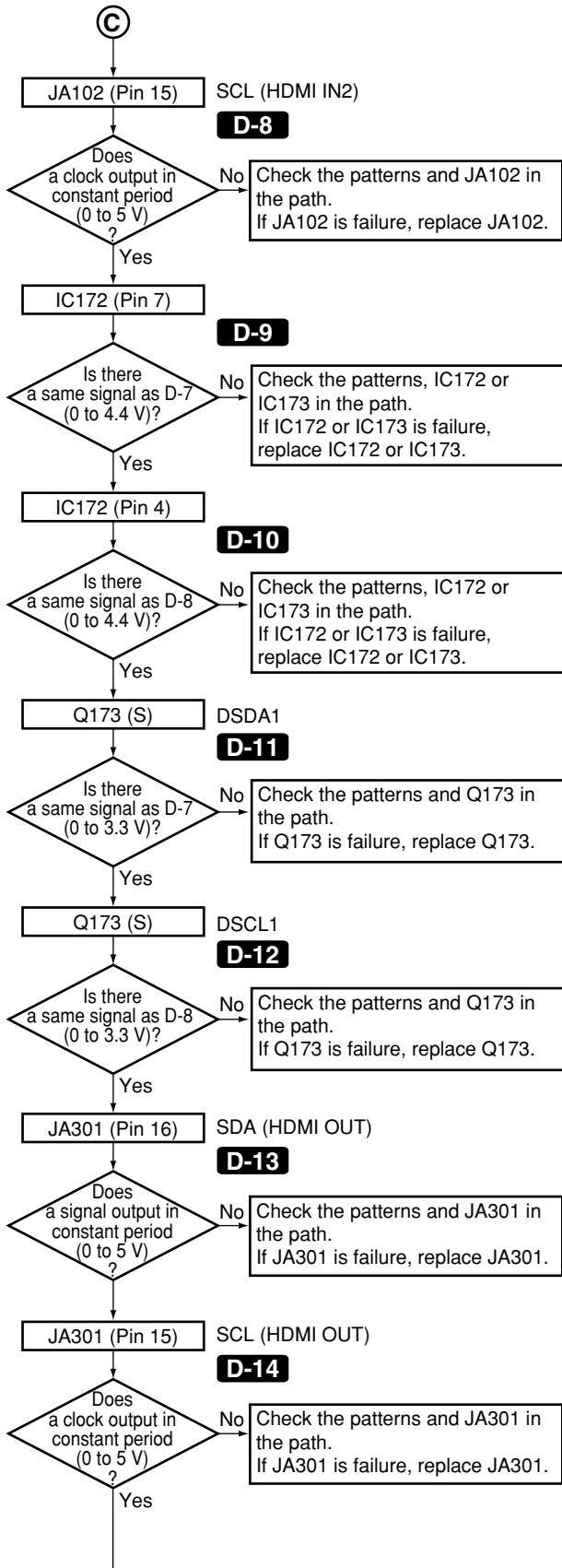

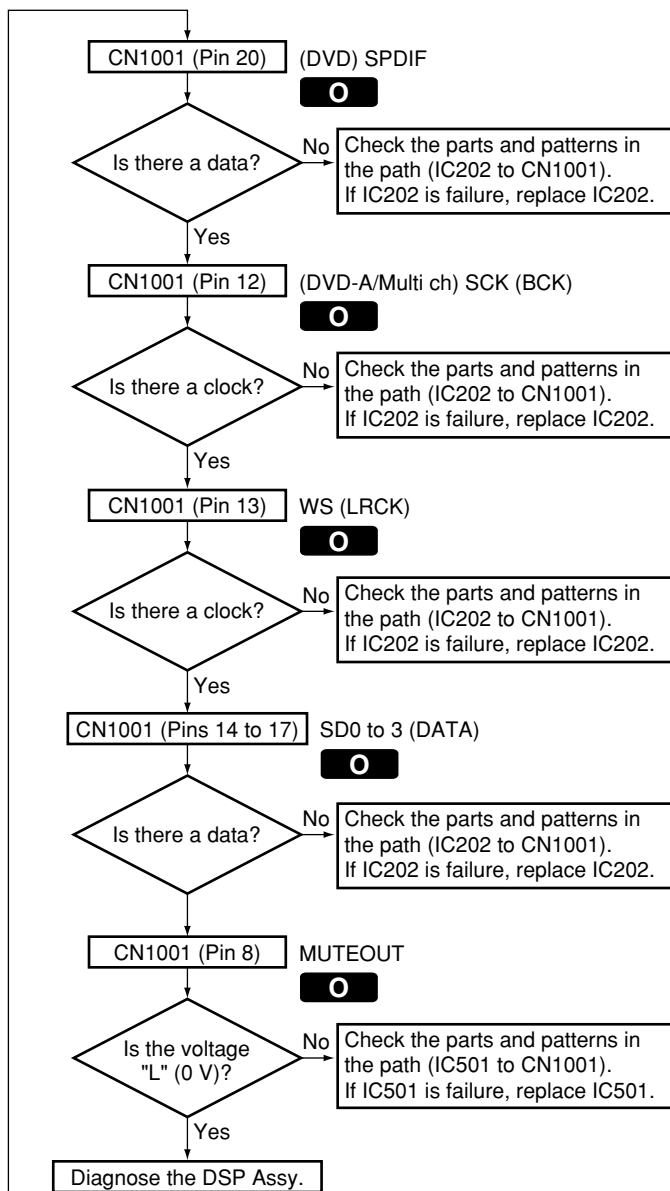
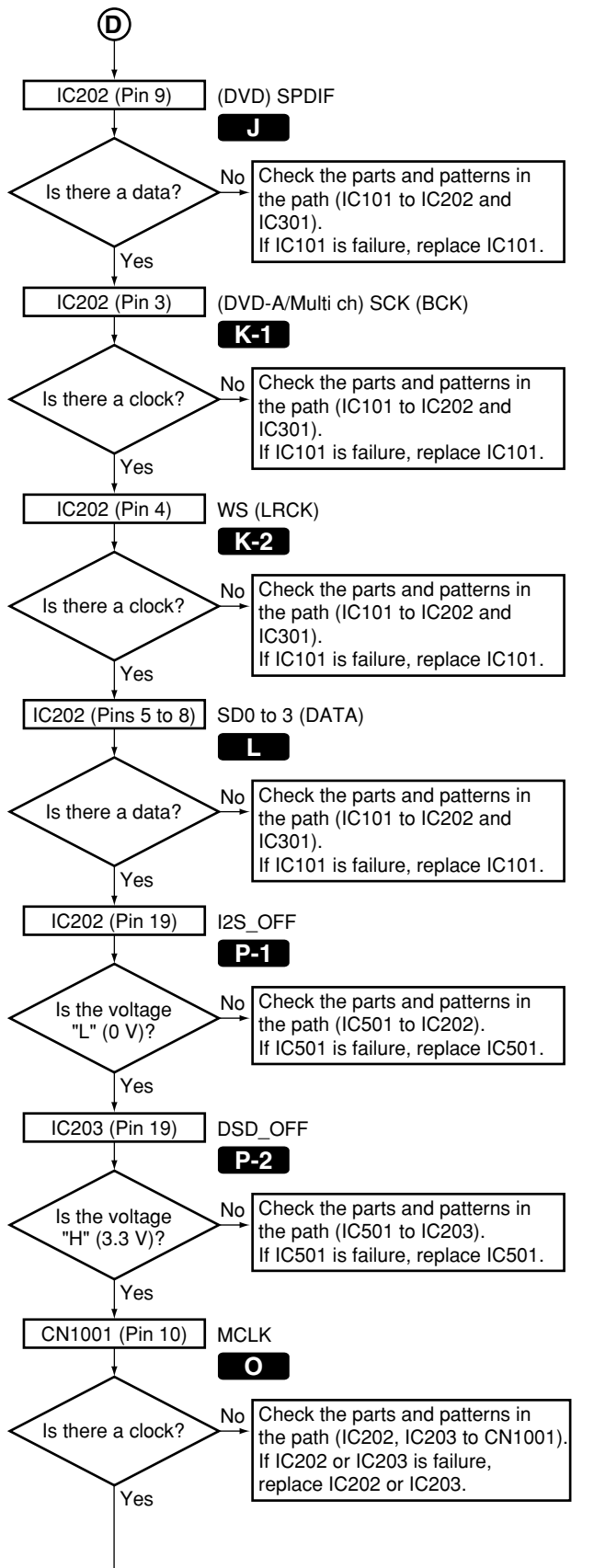

A  
B  
C  
D  
E  
F

A

### Video converter section

#### Step 3-1: Power Supply

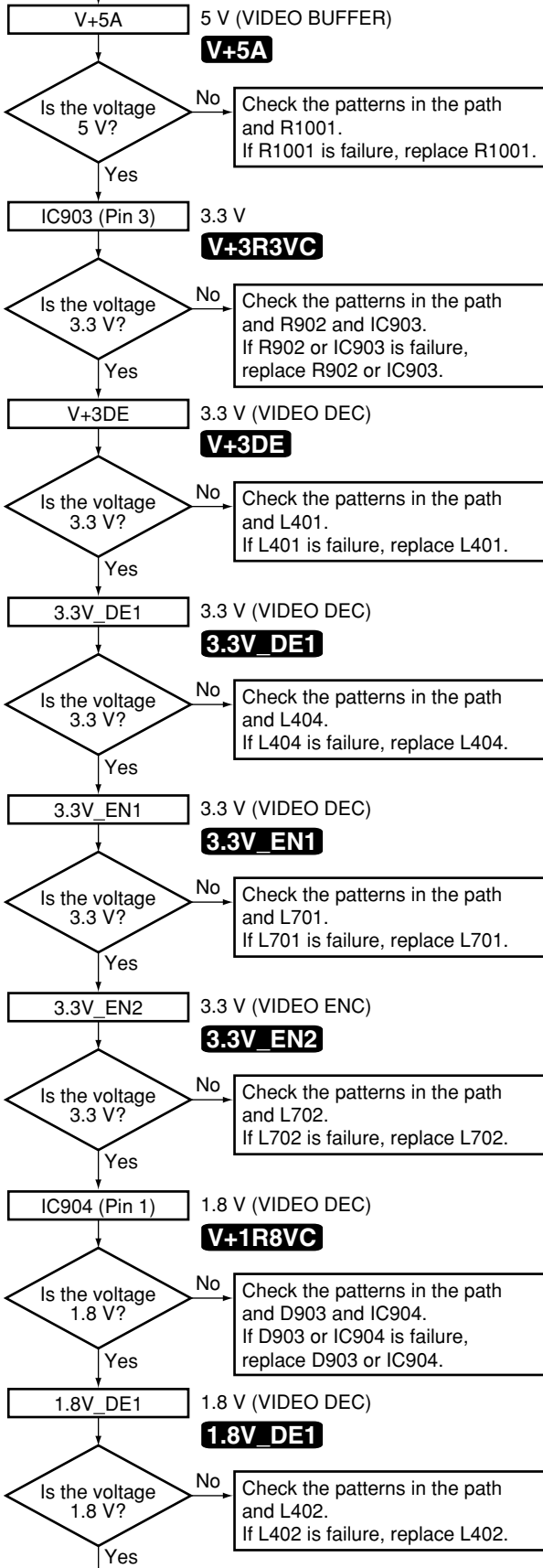

B

C

D

E

F

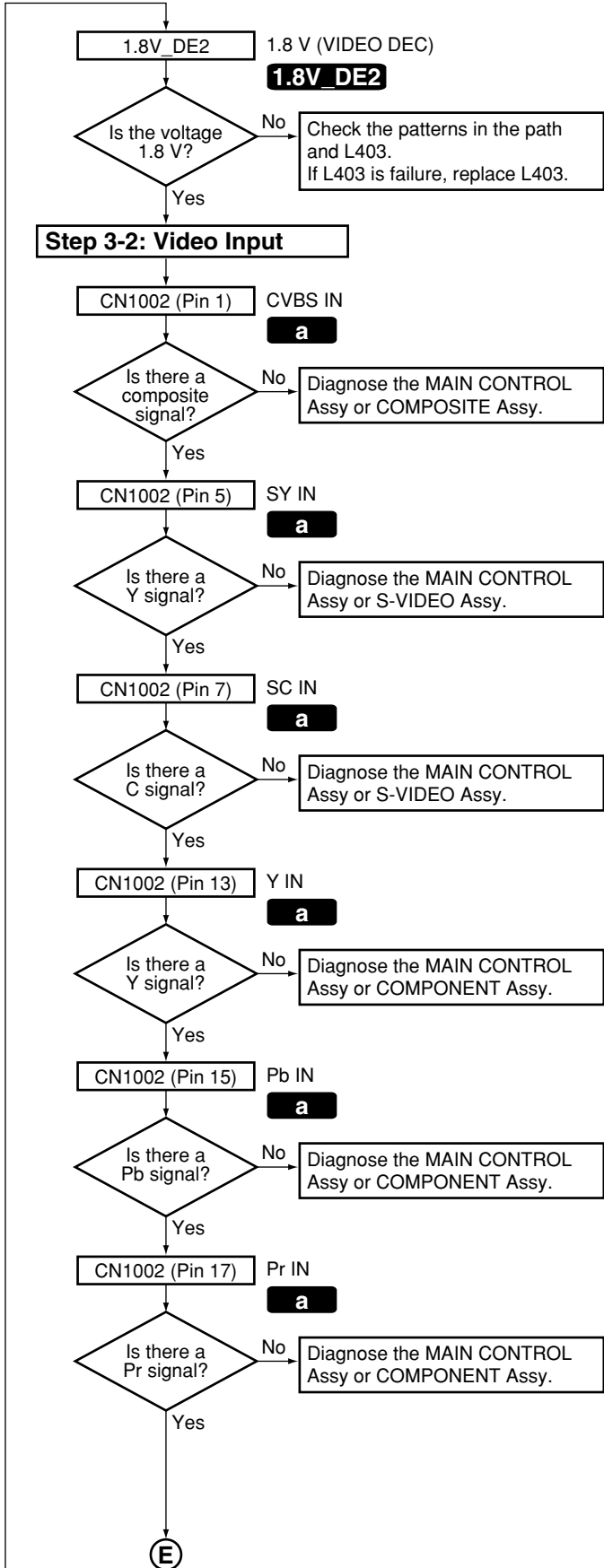

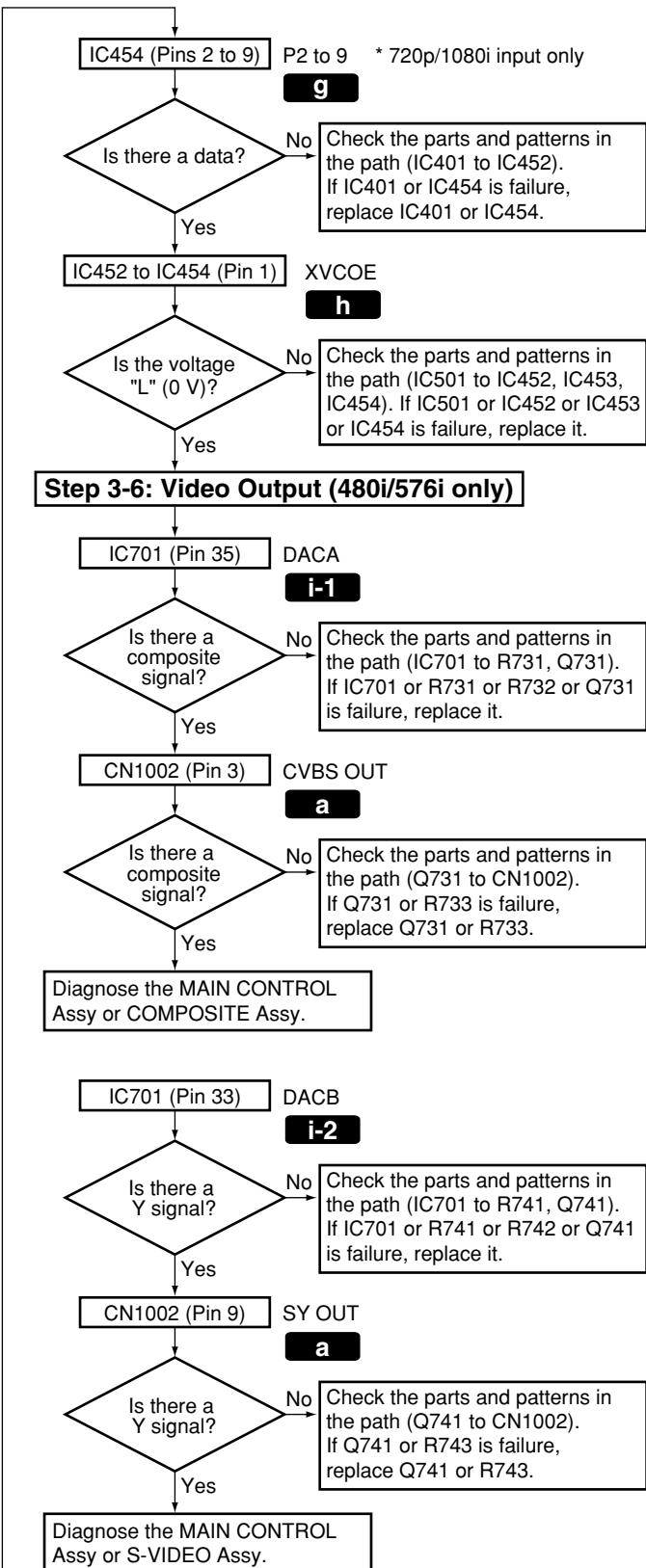
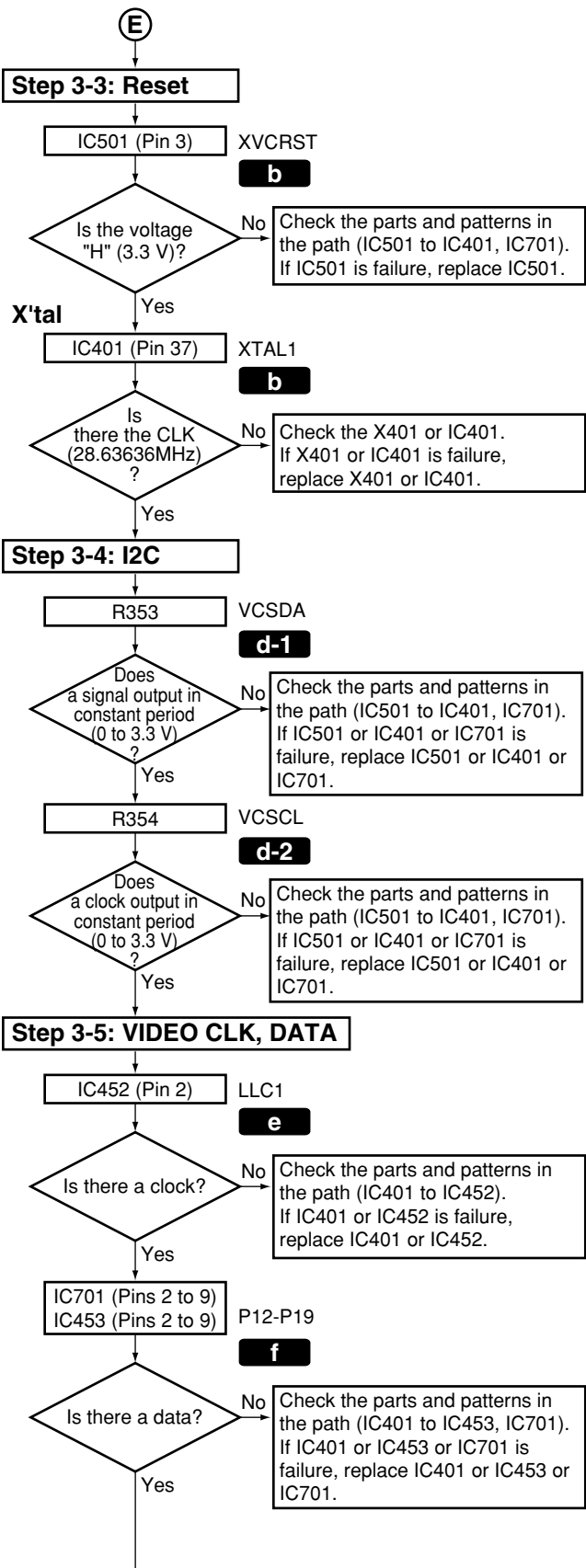

A

B

C

D

E

F

A

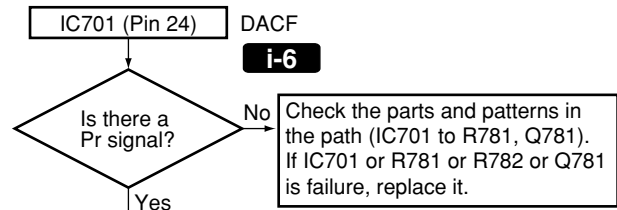
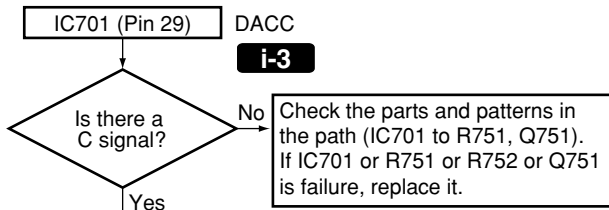

B

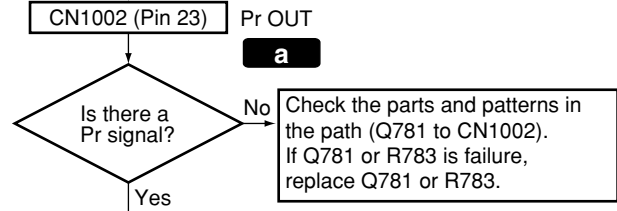
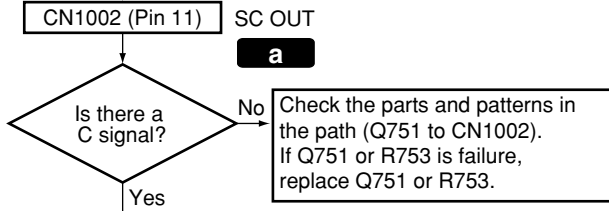

Diagnose the MAIN CONTROL Assy or S-VIDEO Assy.

Diagnose the MAIN CONTROL Assy or COMPONENT Assy.

C

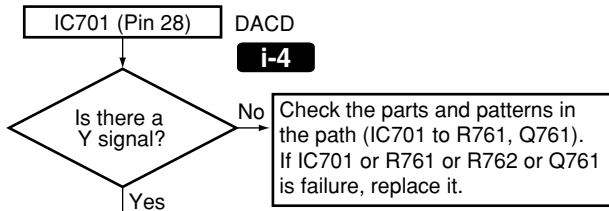

D

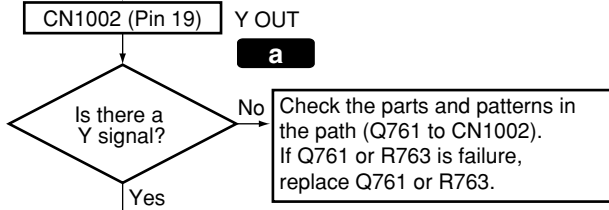

Diagnose the MAIN CONTROL Assy or COMPONENT Assy.

E

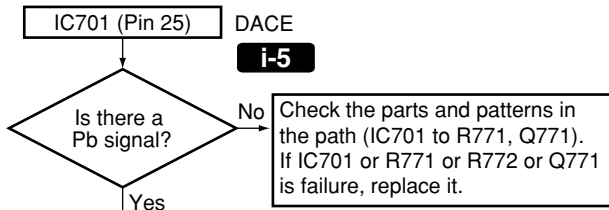

F

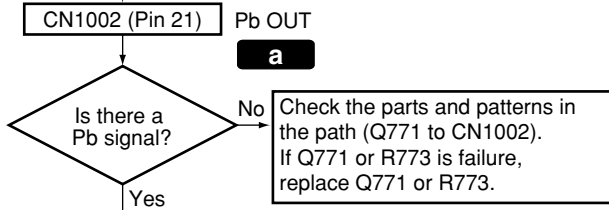

Diagnose the MAIN CONTROL Assy or COMPONENT Assy.



### ■ HDMI & DVC Assy Check Points (Power supply section)

**AK** HDMI & DVC ASSY

SIDE B

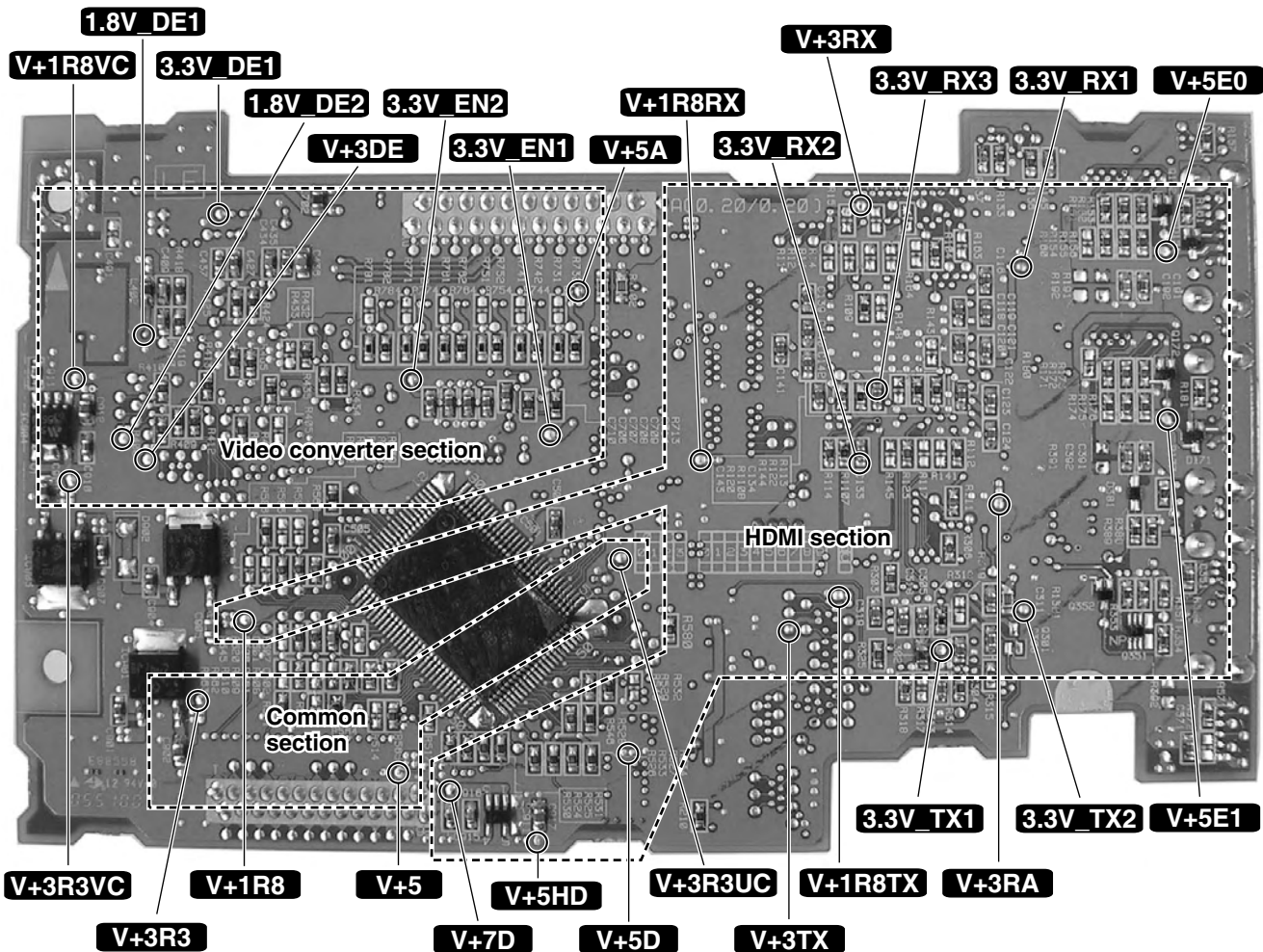

A  
B  
C  
D  
E  
F

# A ■ HDMI & DVC Assy Check Points (Signal section)

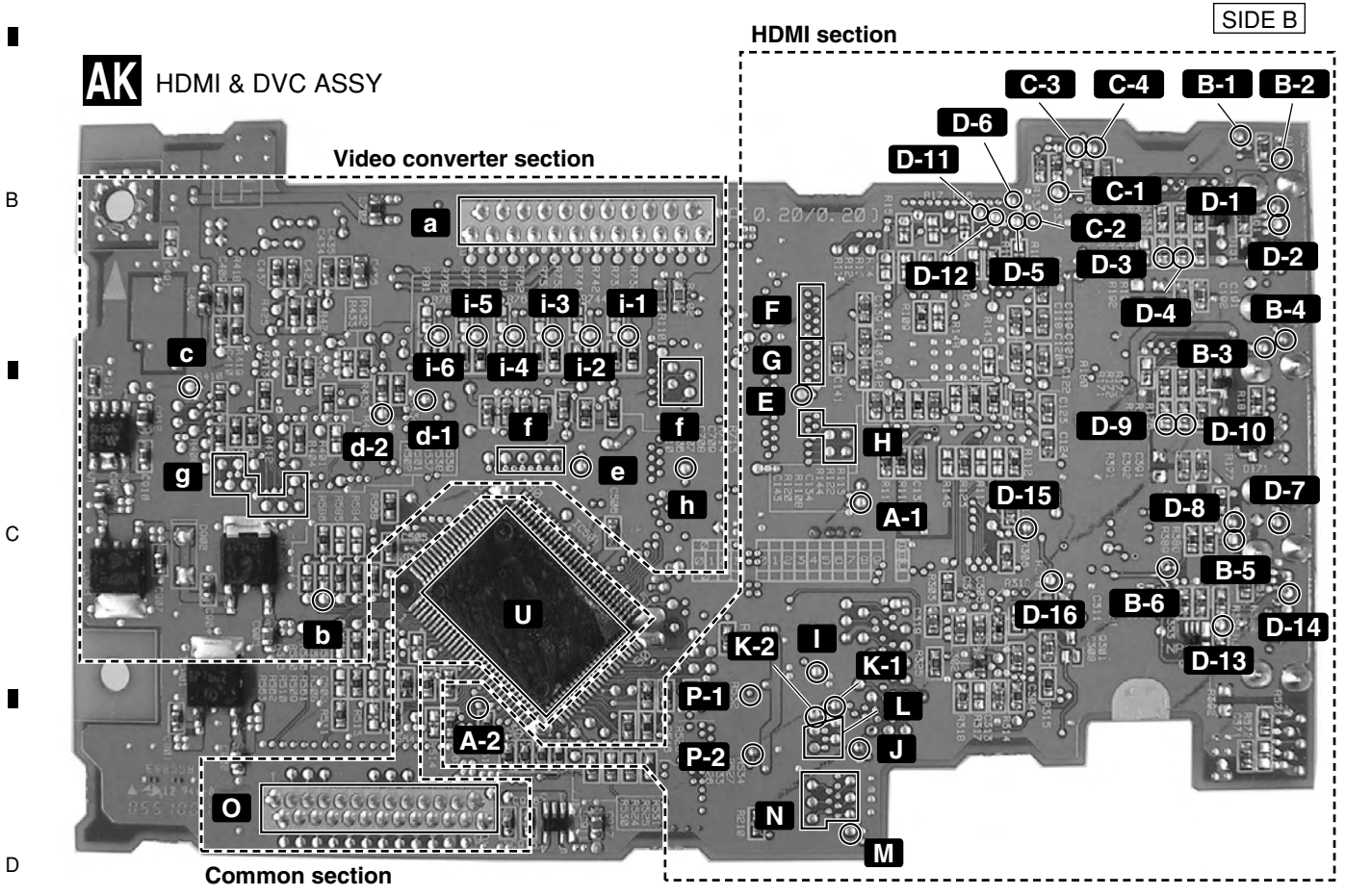

# Block Diagram of the HDMI & DVC Assy

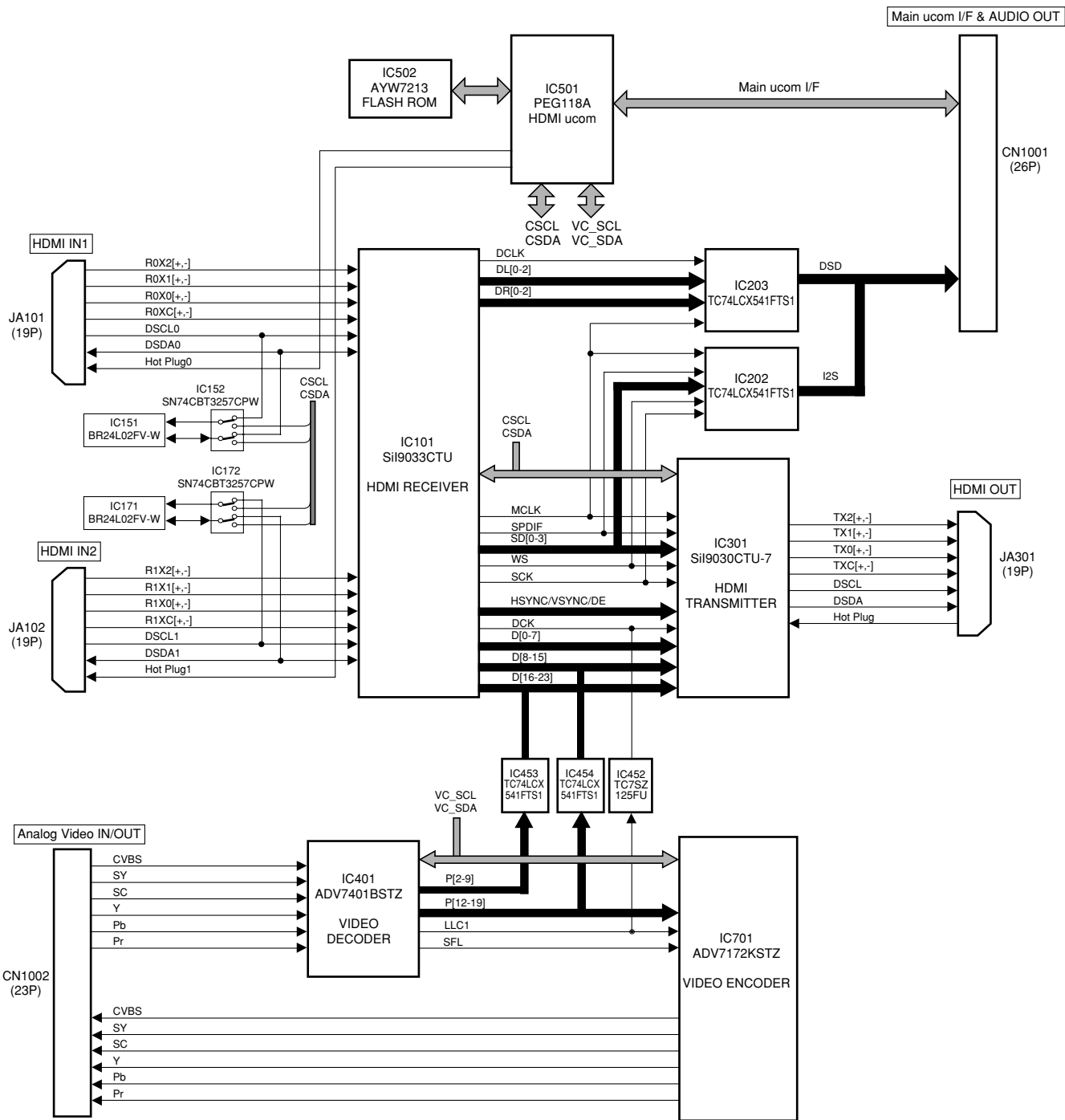

A  
B  
C  
D  
E  
F

**Description of Error Indications**

FL Display	Error Content	Possible causes and actions to be taken
USB ERROR1 USB ERR1	Detection of overcurrent to a USB device	Overcurrent (500 mA or more) is consumed at the connected USB device. • Some USB devices, such as a portable HDD, need more current than that this unit supplies. (Use the AC adaptor for the connected USB device.) • The USB power is short-circuited.
USB ERROR2 USB ERR2	Detection of a medium not supported	A USB device that this unit does not support (other than the Mass Storage Class) is connected (such as a mouse, printer, or digital camera). • Connect a mass storage class USB device.
USB ERROR3 USB ERR3	Communication error with the system microcomputer	Communication between TCC760HC01-AG (IC701) and PEG116A (IC101) failed. • Defective connection (connectors) inside this unit • See STEP 3 of Troubleshooting.

**Operations when overcurrent to a USB device is detected**

- Overcurrent to a USB device is detected at the port for the microcomputer.
- The power supply to the USB device is stopped.
- Control of 5 V power is disabled at the port for the microcomputer.
- Change of indications on the FL display

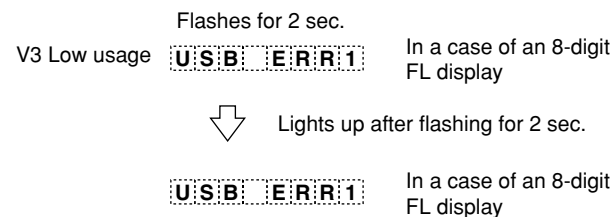

- To supply power to the USB module again:
  - Turn the power to the unit off then back on.
  - Set the function setting to anything other than USB then back to USB.
  - Press the USB play key on the remote control unit.

- After overcurrent is detected, if the USB play key is pressed while the error indication is displayed, power supply to the USB module is restored. If overcurrent is no longer detected, the indications shown below are displayed (normal indication):



In this state, flashing of "USB ERROR1" stops, but playback will not start. To start playback, press the USB play key again.

In the above case, if overcurrent is detected again, the above procedures 1 through 4 are repeated.

**In a case where a medium not supported is connected**

- Change of indications on the FL displays

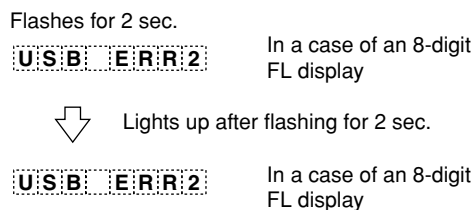

If overcurrent is detected before detection of a non-supported medium, the error indication "USB ERROR1" remains, as the power supply to the USB module is stopped.

**On supported media**

The formats of supported media that can be played back on this unit are MP3, WMA, and AAC. Some media in MPEG4 can also be played back. As AAC derives from MPEG4 codec, playback of media in AAC codec of MPEG4 is possible.

## Block Diagram of the USB Assy

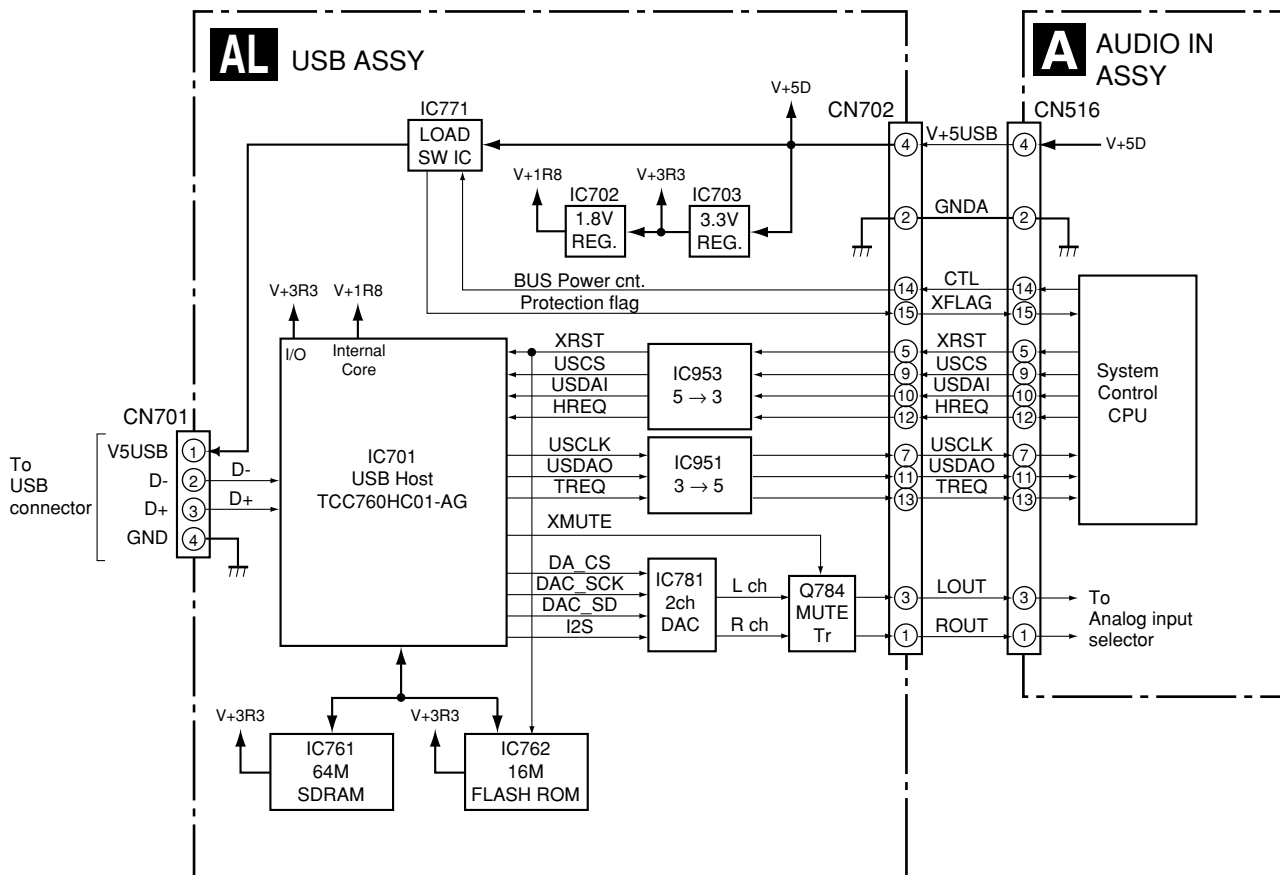

Main parts	Purpose
<b>TCC760HC01-AG</b>	: USB Host control decoder (MP3/WMA/MPEG-4AAC)
<b>16M FLASH ROM</b>	: Firmware is stored
<b>64M SDRAM</b>	: Temporary storage area of decoding music file
<b>LOAD SWITCH</b>	: Current limitation to USB device power
<b>2ch DAC</b>	: D/A converter for analog output

A

# ■ USB Troubleshooting

## Step 1: Connectors

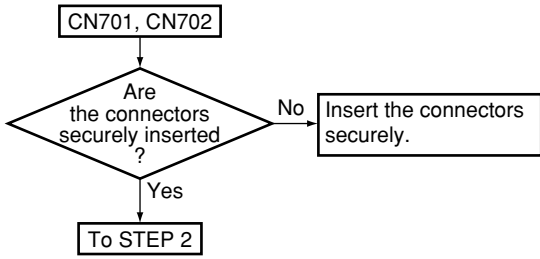

B

## Step 2: Power supply

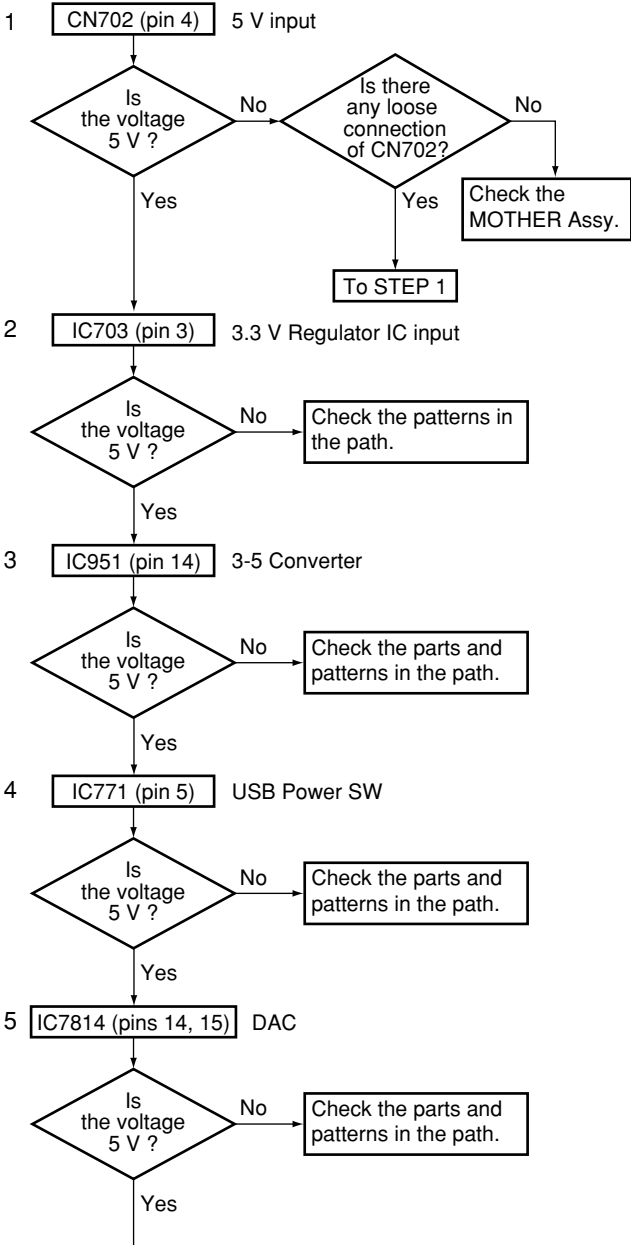

C

D

E

F

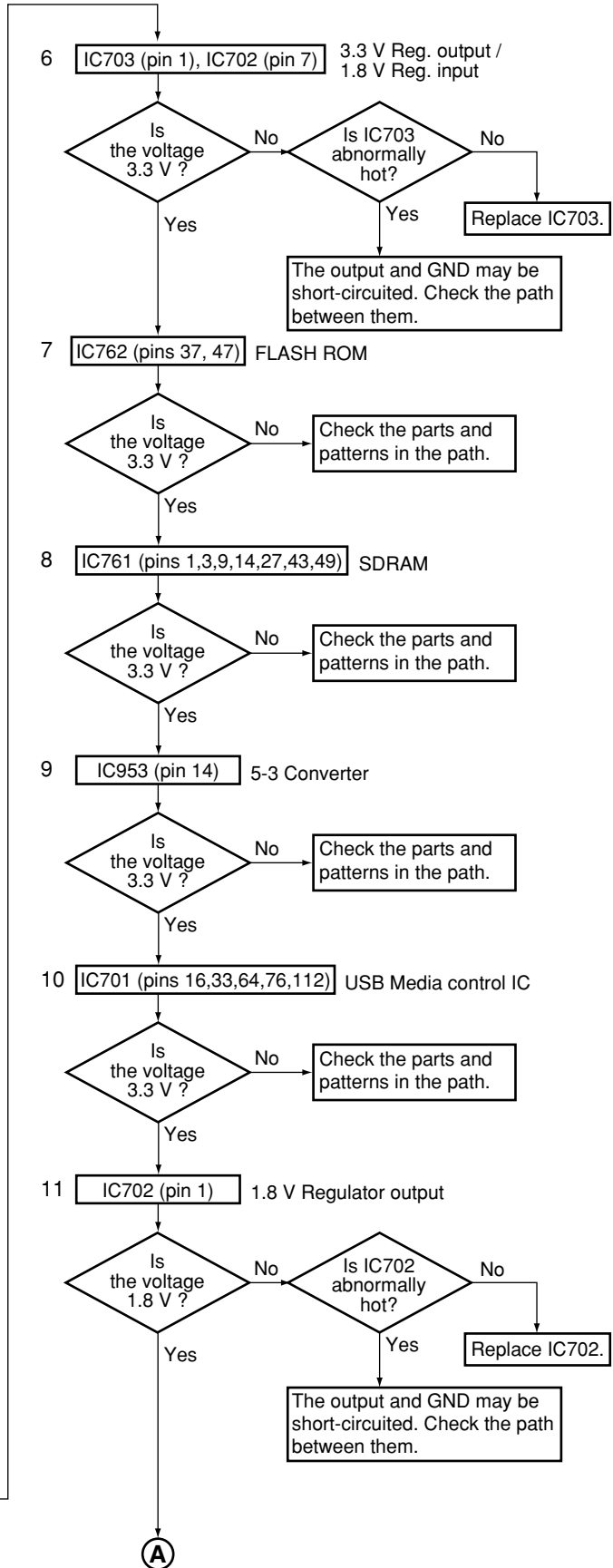

A

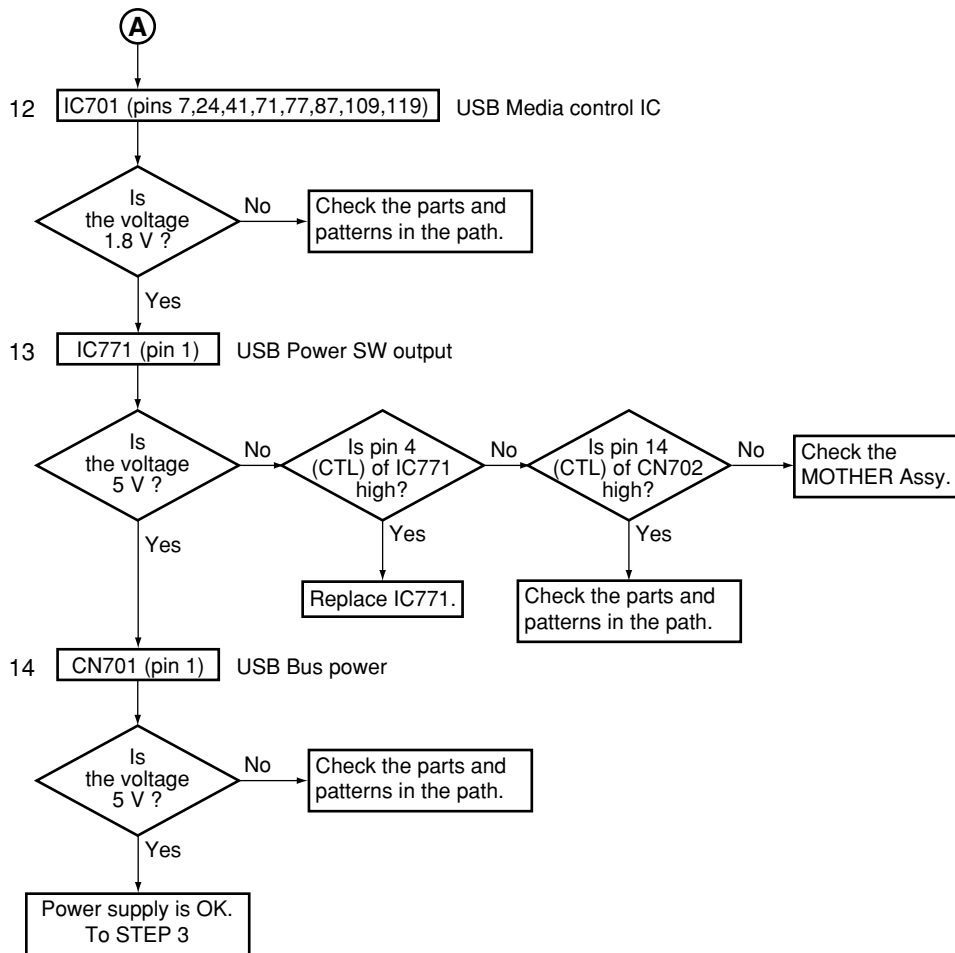

**Step 3: Operation of USB Media control IC**

**Note:** Please confirm it with the USB memory connected for the content.

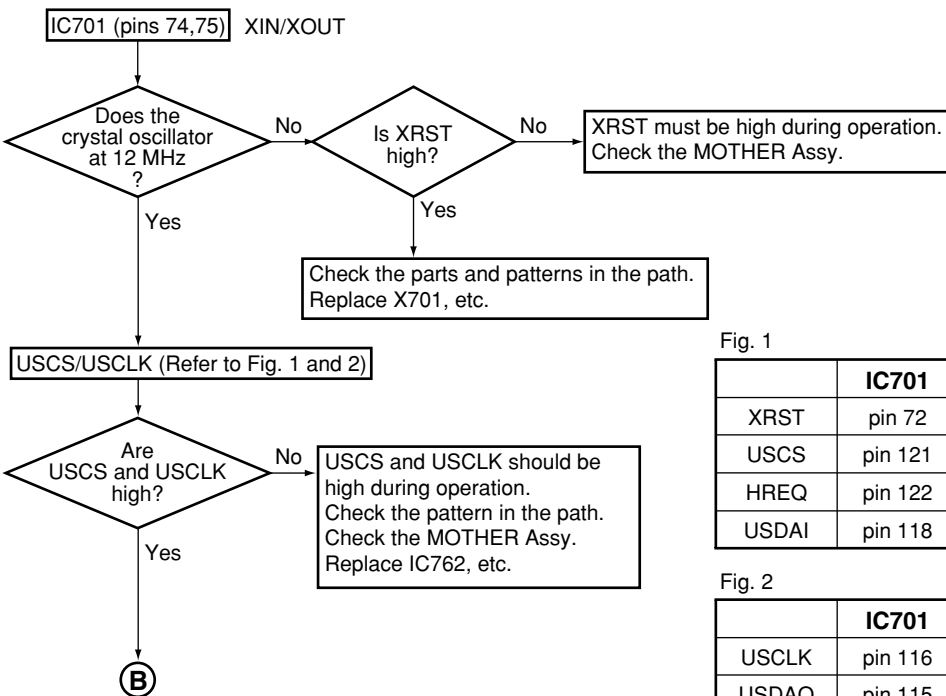

Fig. 1

	IC701	IC953 (5 V → 3 V)	CN702
XRST	pin 72	pin 3	pins 1,2 pin 5
USCS	pin 121	pin 11	pins 12,13 pin 9
HREQ	pin 122	pin 6	pins 4,5 pin 12
USDAI	pin 118	pin 8	pins 9,10 pin 10

Fig. 2

	IC701	IC951 (3 V → 5 V)	CN702
USCLK	pin 116	pins 4,5	pin 6 pin 7
USDAO	pin 115	pins 9,10	pin 8 pin 11
TREQ	pin 123	pins 12,13	pin 11 pin 13

A

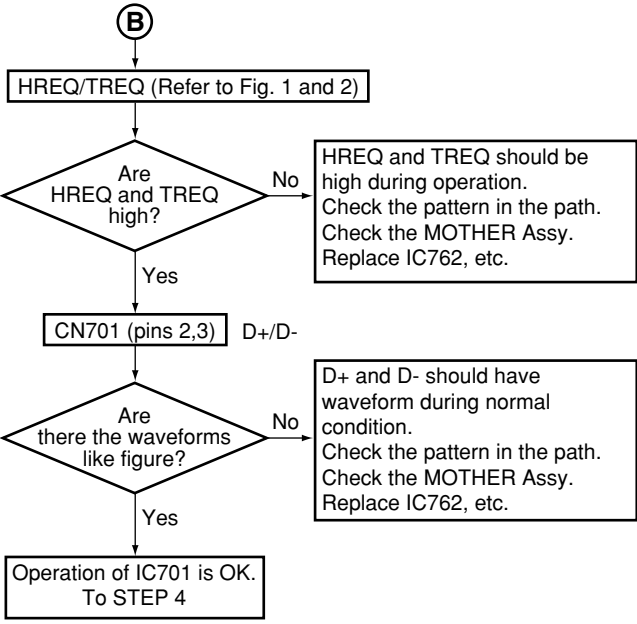
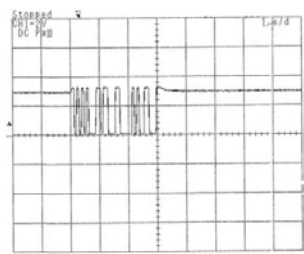
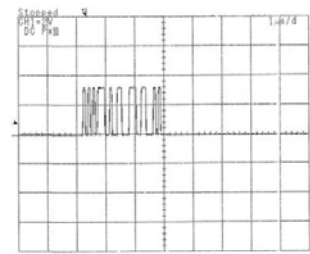

Fig. D+



X: 1 μsec/div, Y: 2 V/div

Fig. D-



X: 1 μsec/div, Y: 2 V/div

C

**Step 4: Audio Out check**

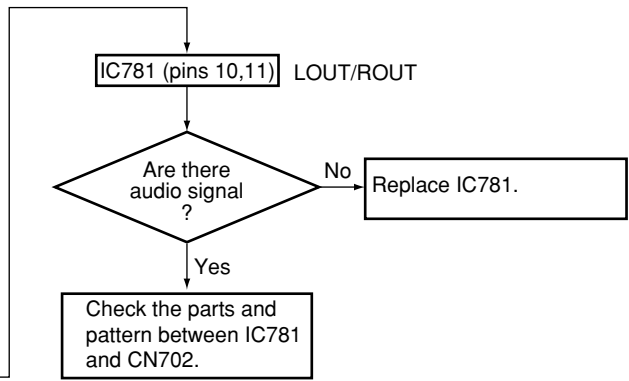
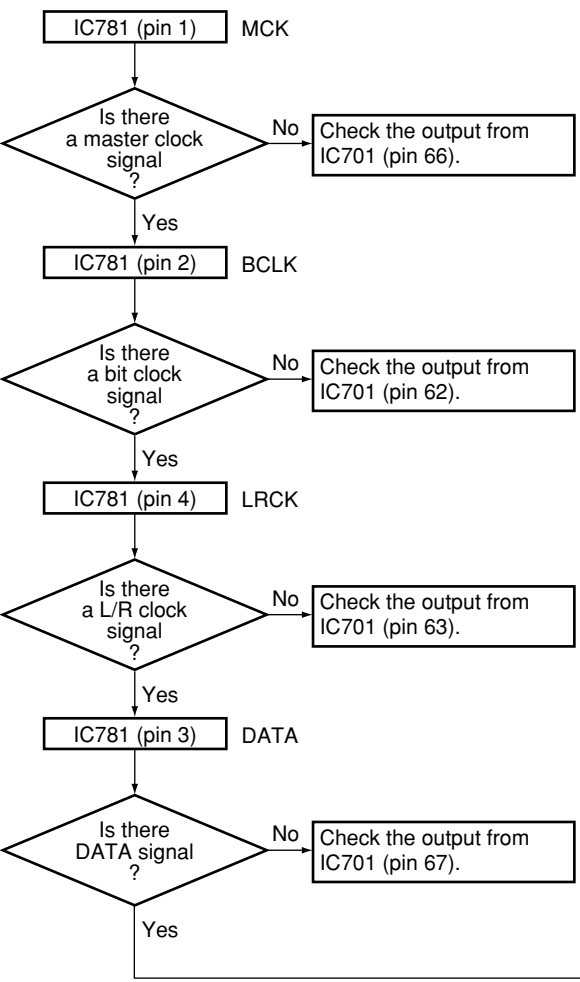



### ■ Explanation

With this unit, updating of the firmware of the USB module can be performed, using a USB memory stick. However, if the hardware of the flash memory that stores the firmware or the firmware itself has a problem, updating cannot be performed in a manner described below. In such a case, replacement of the flash memory is required.

### ■ Procedures

1. Turn the unit on then set the function setting to USB function.
2. Insert the USB memory stick that contains the "player.rom" file.\*
3. "LOADING" is indicated on the FL display.
4. "UPDATE" is indicated on the FL display.
5. Wait until "FINISH" is indicated on the FL display.
6. Remove the USB memory stick then set the function setting to anything other than USB.
7. Return the function setting to USB function and wait for about 5 seconds in order to obtain the version data of the USB firmware.
8. Turn the unit off (Standby mode).
9. Check the version ("U\_xxxxx" is suffixed to the version indication).  
If the version is not updated, the data for the new version may not have been obtained in Step 7. Repeat Step 7 and the subsequent steps.

#### Notes \* :

- Never reinsert the USB memory stick that contains the "player.rom" file.
- In a rare case, depending on the type of USB memory stick, the above-mentioned updating procedures are not possible. In such a case, try with other type of USB memory stick.

#### Importance:

- Never change the function setting or turn the power off during the process of Steps 3 through 5. If you do, loading of the firmware will fail, and updating procedures cannot be continued. In such a case, replacement of the flash memory is required.

## 7.1.7 HOW TO UPDATE THE FLASH ROMS FOR VARIOUS MICROCOMPUTERS

### HDMI, MAIN and DSP microcomputer

#### [Purpose]

Refer to this section when updating of a Flash ROM is required by the service information, etc.

#### [Tools to be used]

- PC with a serial port
- RS-232C cable (cf. following note)
- Program for updating (ufu.exe)
- RS-232C I/F jig (GGF1348)
- Firmware ("mot" extension)
- 7-pin FFC (VDA1681)

#### Note;

Please use a RS-232C cable properly as follows.

For updating HDMI microcomputer

--> straight cable (PC terminal-9pin male) [Connections A]

For updating MAIN microcomputer or DSP microcomputer

--> cross cable (PC terminal-25pin female) [Connections B]

#### [Connections A]

(HDMI microcomputer)

#### - HY and KU models -

Connect as indicated in the figure below:

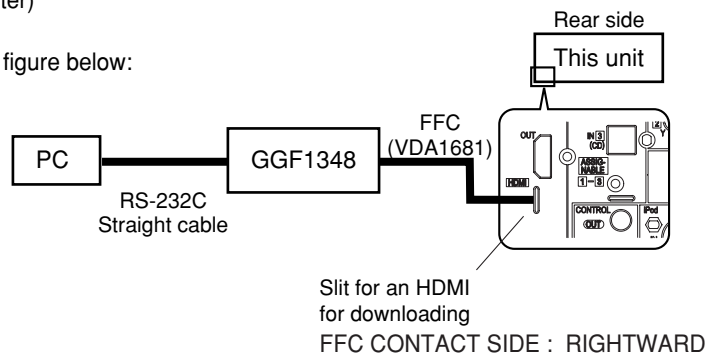

#### [Connections A]

(MAIN microcomputer)

(DSP microcomputer)

#### - HY models -

Connect as indicated in the figure below:

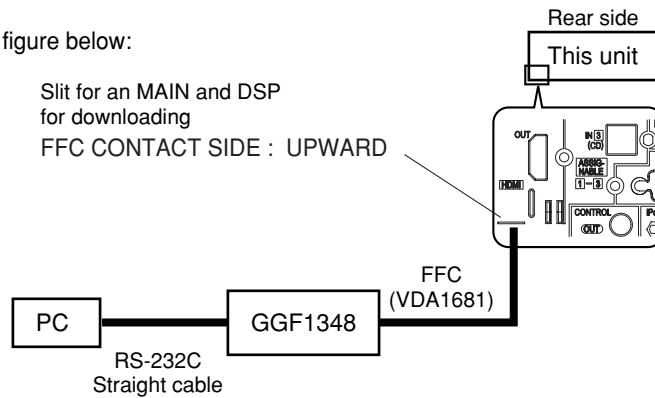

#### [Connections B]

(MAIN microcomputer)

(DSP microcomputer)

#### - KU models -

Connect as indicated in the figure below:

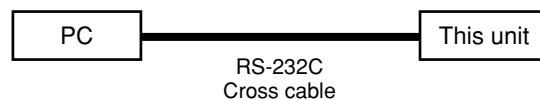

**[Note]**

**Do NOT disconnect the AC power cords of this unit nor the PC.**

**[Procedures]**

- Turn off the power to this unit by setting the main volume level to "---dB."
- Connect the 232C I/F jigs and the PC, as indicated in "Connections."
- (HDMI microcomputer) :  
Simultaneously press and hold the ENTER and FM/AM keys for about 5 seconds.  
(MAIN microcomputer) :  
Simultaneously press and hold the ENTER and HDMI keys for about 5 seconds.  
(DSP microcomputer) :
  - KU models  
Simultaneously press and hold the ENTER and XM keys for about 5 seconds.
  - HY models  
Simultaneously press and hold the ENTER and USB keys for about 5 seconds.
- The unit is turned on, and "HDMI DOWNLOAD", "MAIN DOWNLOAD" or "DSPM DOWNLOAD" is displayed.
- Double-click on "ufu.exe".
- Check that "Full" is selected in MODE SELECT.
- Select the firm ware file with "mot" extension.
- Select the communication speed.
  - Basic speed: 19200
  - Data transfer speed: 57600
- Click on "START" button.
- (HDMI microcomputer) :  
"Completed" is displayed for about 1 minutes in the "ufu.exe" window.  
(MAIN microcomputer), (DSP microcomputer) :  
"Completed" is displayed for about 3 minutes in the "ufu.exe" window.
- Disconnect then reconnect the AC power cord of the unit. If the unit is not reset, retry from Step 2.

- Reset the receiver.

**Note:** Note that all the data the receiver retains will be cleared.

- Check the version.

Following the procedures described in "Version indication" in "7.1.1 TEST MODE," check that the version has been changed to a new one.

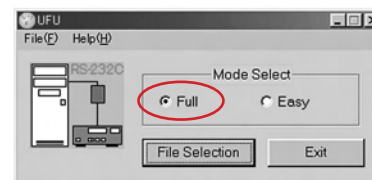

Check that "Full" is selected in MODE SELECT.

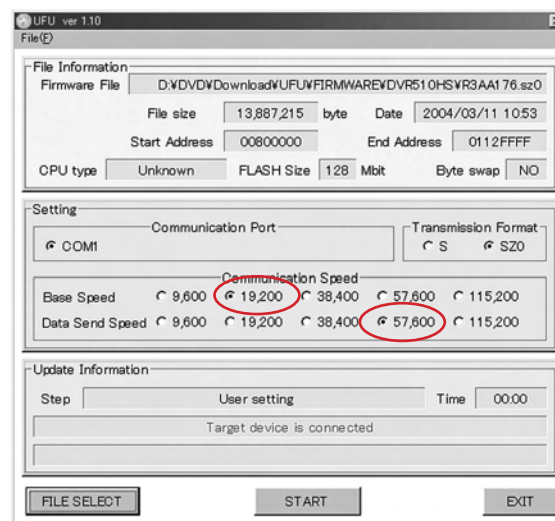

Select the communication speed.

- Basic speed: 19200
- Data transfer speed: 57600

**[ Resetting the receiver ]**

- Reset the receiver.

**Note:** Note that all the data the receiver retains will be cleared.

**Resetting the receiver**

Use this procedure to reset all the receiver's settings to the factory default. Use the front panel controls to do this.

**1 Switch the receiver into standby.****2 While holding down the front panel AV PARAMETER button, press and hold STANDBY/ON for about three seconds.**

The display shows **RESET?**.

**3 Press the front panel ENTER button.**

The display shows **RESET OK?**.

**4 Press SETUP to confirm.**

OK appears in the display to indicate that the receiver has been reset to the factory default settings.

• Note that all settings will be saved, even if the receiver is unplugged.



**[Procedures]**

2. Check the versions of the DSP and microcomputer.  
Check the versions by referring to "Version indication" in "7.1.1 TEST MODE."
3. Connect a CD or DVD player.
  - (1) Connect the CD or DVD player to be used for updating to any digital input connector of this unit.
  - (2) With the INPUT SELECTOR, select the input being used.
4. Check if the digital signal is locked (received).
  - (1) Play back a stream for updating with the player.
  - (2) Set the receiver to normal setting, "Signal Select" to Auto, then check on the Signal Select indicator whether the input is set to Auto and Digital.
5. Start up this unit in writing mode.
  - (1) Relocate the CD playback starting point to the beginning (time: 0:00) of the track No and pause playback.
  - (2) Set the volume of the receiver to  $-\infty$  dB and set the receiver to STANDBY OFF.
  - (3) Simultaneously press and hold the ENTER and iPOD keys until "DSPF DOWNLOAD" is displayed on the FL display. The unit enters writing mode.
6. Play back the track on CD disc.
  - (1) Release Pause mode of the player and play back the track where the DSP program stream signal to be burned is stored.
  - (2) After 5-10 seconds, the HDMI indicator starts flashing. Be sure to check that it is flashing.
  - (3) Flashing indicates that a correct stream is being received and that updating is in progress.

**Note:** Do NOT turn off the unit while the HDMI indicator is flashing. If the unit is turned off, be sure to go back to Step 5. (As the Flash ROM goes into unusual status if the power is off during rewriting, the unit may not start properly.) Even in such a case, you can restore the unit by performing Steps 5 to 8.
7. Wait until rewriting is completed.
  - (1) Basically, wait until "OK" is displayed on the FL display. It takes about 2 minutes for updating.
  - (2) After confirming that "OK" is displayed, stop or pause the player then after 5 seconds set the player to STANDBY OFF.
8. Check the version of the program after updating.
  - (1) Check the version by simultaneously pressing and holding the STANDBY/ON and MULTI CH IN keys.
  - (2) For confirmation, check basic operations.

## 7.1.9 DISASSEMBLY

**Note 1:** Even if the unit shown in the photos and illustrations in this manual may differ from your product, the procedures described here are common.

**Note 2:** For performing the diagnosis shown below, the following jigs for service is required:

- 11P board to board extension jig cable (GGD1482)
- 13P board to board extension jig cable (GGD1483)
- 15P board to board extension jig cable (GGD1484)
- 21P board to board extension jig cable (GGD1485)

### 1. Before the Power Amp Block is removed

Before the Power Amp Block is removed, discharge C3257 and C3258 on the TRANS 2-1 Assy, as indicated below. If you don't, the IC protectors (IC3351 and IC3352) on the VH TR Assy may be open, and DC voltage may be generated at the power amplifier output, which will result in "AMP ERR."

#### [Procedure]

- ① Unplug the AC power cord.
- ② Discharge C3257 and C3258 on the TRANS 2-1 Assy.  
**Note:** For discharging, use a load of 100Ω, 3W or more, to protect the IC protectors. Do NOT discharge instantly by short-circuiting.
- ③ Check that the voltage between the electrodes of each C3257 and C3258 is 1V or less.
- ④ Reassembling the Power Amp Block.

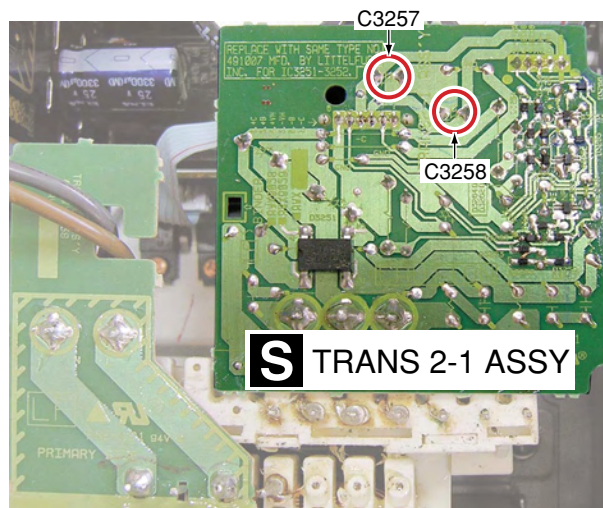
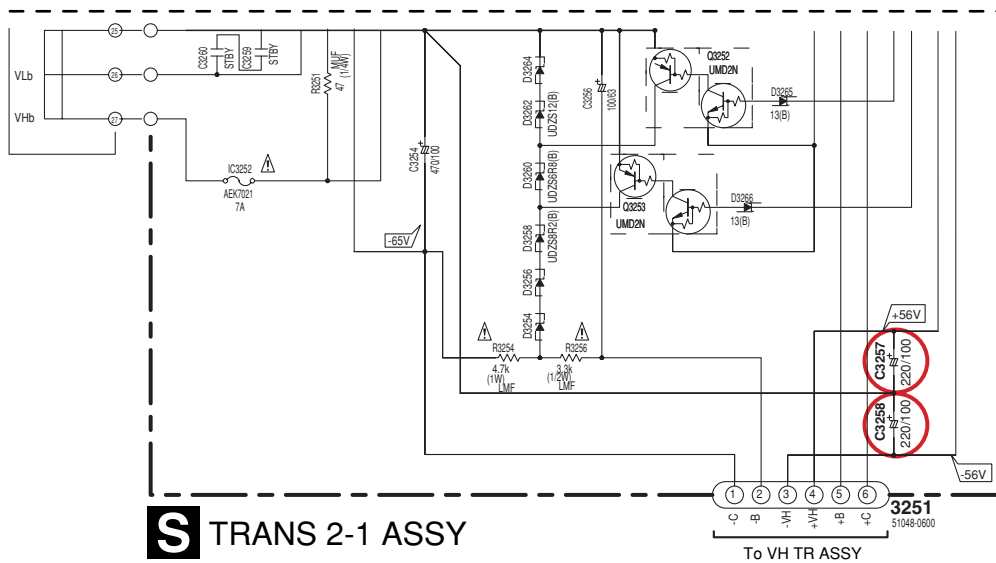

## 2. PCB Location

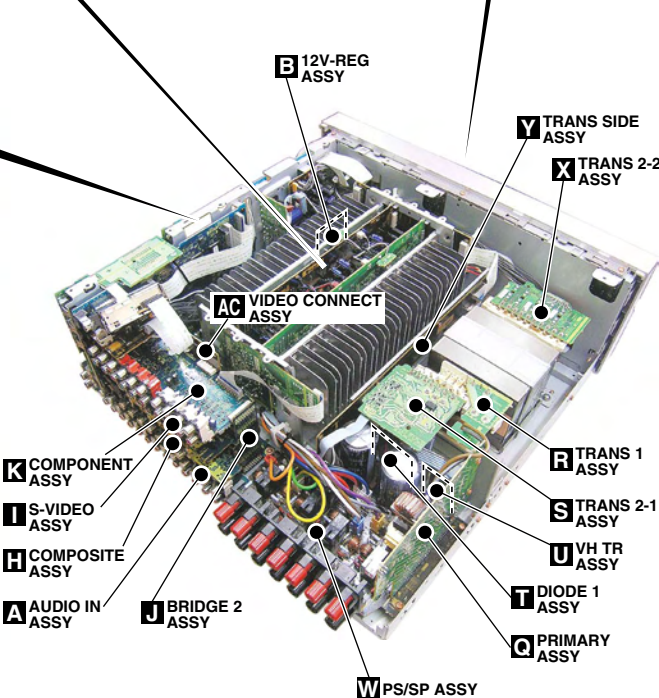
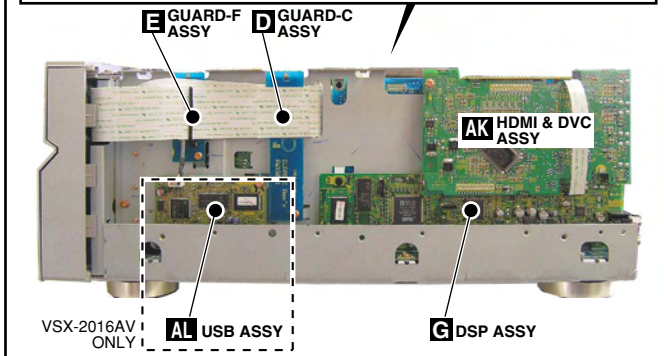
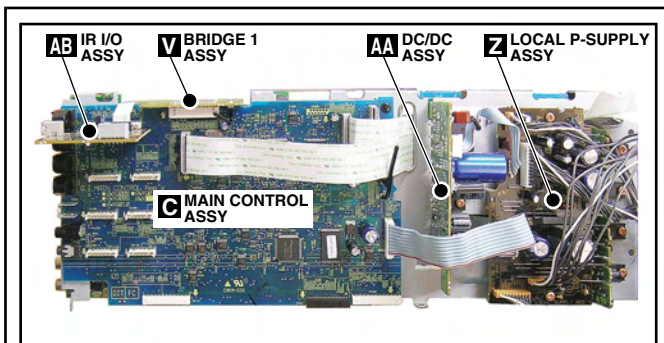
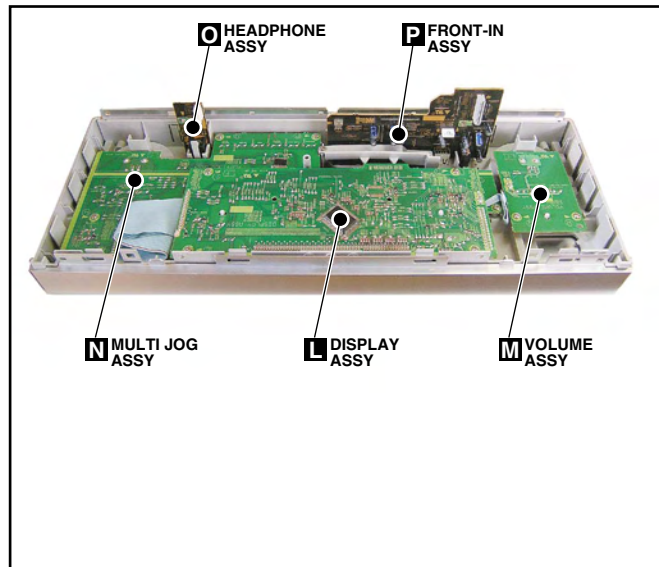
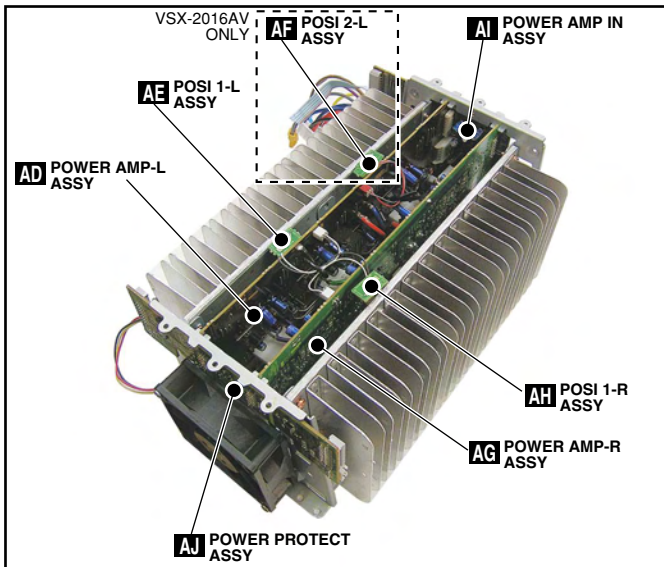

### 3. Disassembly

#### 1 Bonnet

① Remove the eight screws.

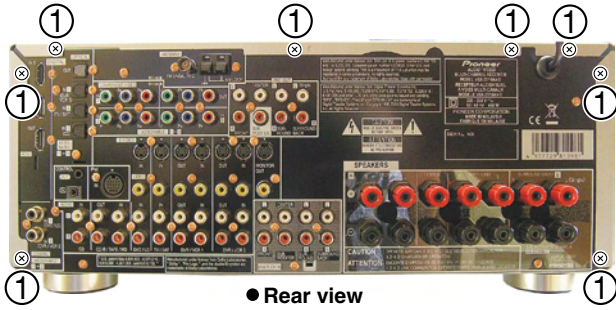

② Remove the eight screws.

③ Remove the bonnet.

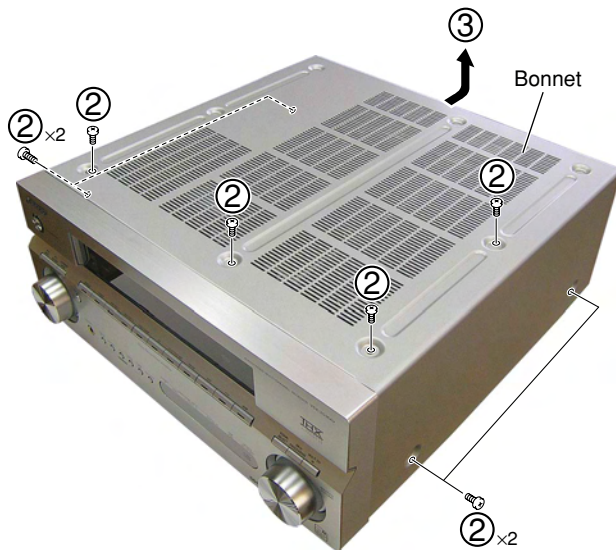

#### 2 Power Amp Block

##### Caution:

Before removing the Power Amp Block, discharge C3257 and C3258 on the TRANS 2-1 Assy. Refer to "1. Before the Power Amp Block is removed".

① Remove the seven screws.

② Disconnect the three flexible cables and the one connector.

③ Disconnect the one jumper wire.

④ Disconnect the six connectors.

⑤ Remove the power amp block.

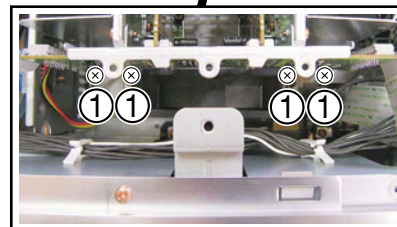
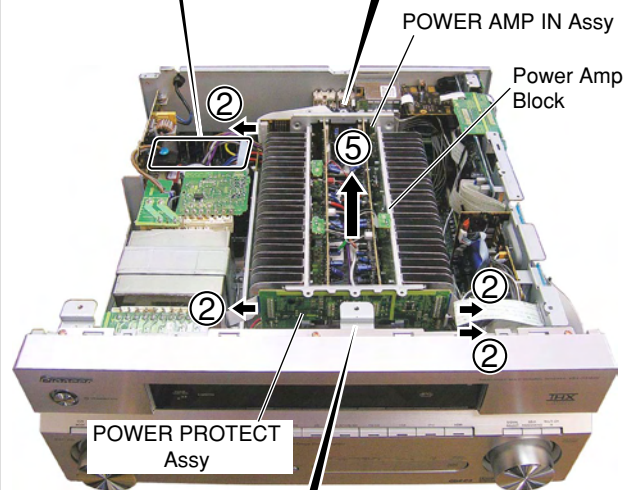
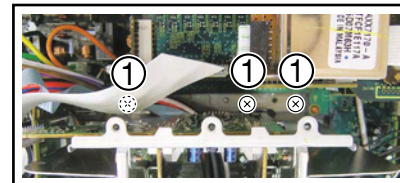
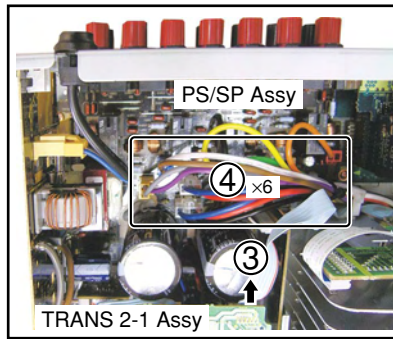



### 3 Replacing the Power Transistor

#### ● POWER PROTECT Assy

- ① Remove the one nylon rivet.
- ② Disconnect the one connector. (VSX-2016AV only)
- ③ Remove the POWER PROTECT Assy by removing the two connectors.

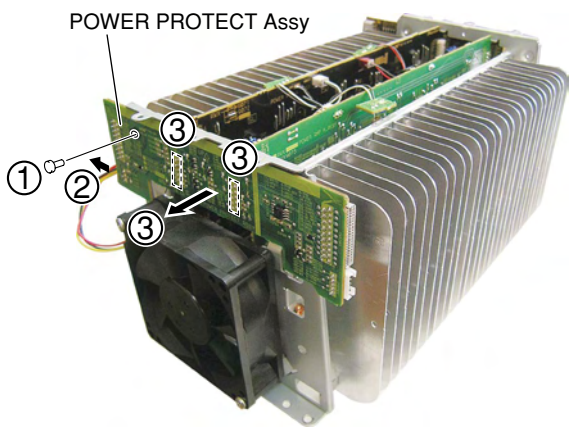

#### ● HS Angle 2016

- ① Remove the four screws.
- ② Remove the HS angle 2016.

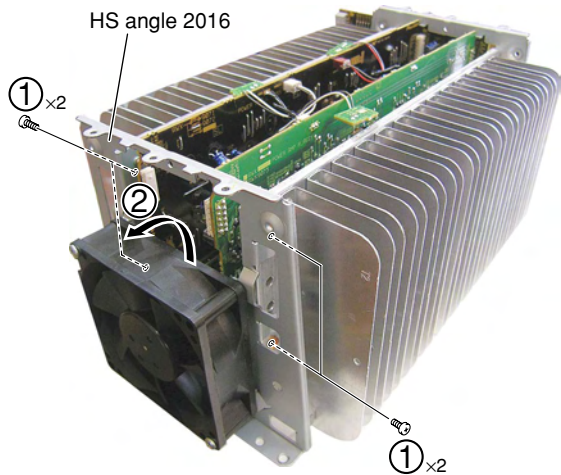

#### ● POWER AMP IN Assy

- ① Remove the one nylon rivet.
- ② Remove the POWER AMP IN Assy by removing the four connectors.

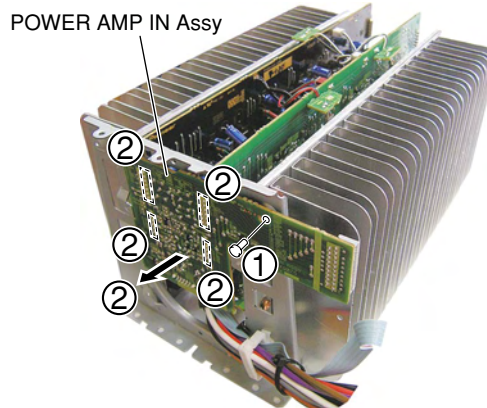

#### ● HS Angle 2016

- ① Remove the four screws.
- ② Release the clamber.
- ③ Remove the HS angle 2016.

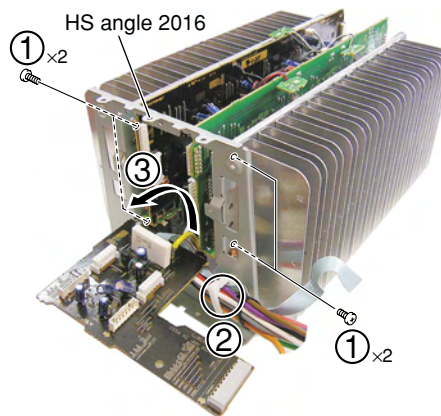

#### ● Replacing the Power Transistor

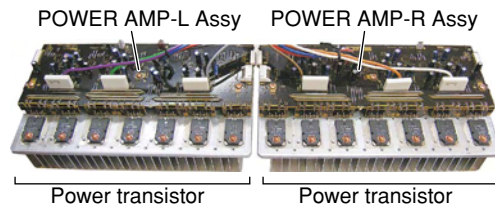

**Replace**



# 4 Replacing the AUDIO IN Assy

## ● Rear Panel

- ① Disconnect the one connector.
- ② Remove the four cushion circle 14B.
- ③ Remove the four screws.
- ④ Remove the one screw.  
(KU model: Remove the three screws.)
- ⑤ Remove the three screws.

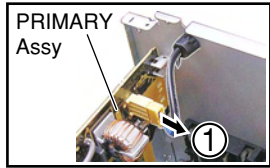

## ● Rear view

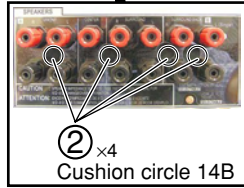
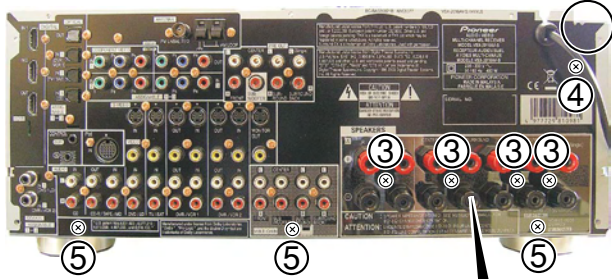

- ⑥ Remove the one screw.
- ⑦ Remove the three screws.
- ⑧ Remove the 32 screws.  
(KU model: Remove the 34 screws.)
- ⑨ Remove the rear panel.

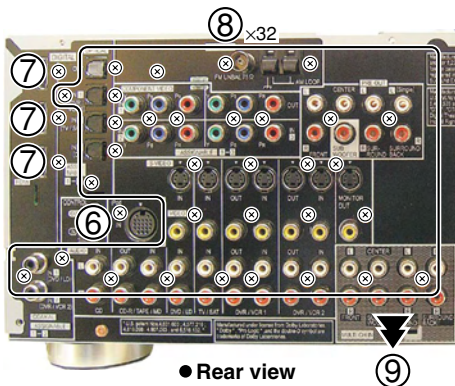

● Rear view



## ● FM/AM TUNER Unit

- ① Remove the FM/AM TUNER Unit by removing the one flexible cable.

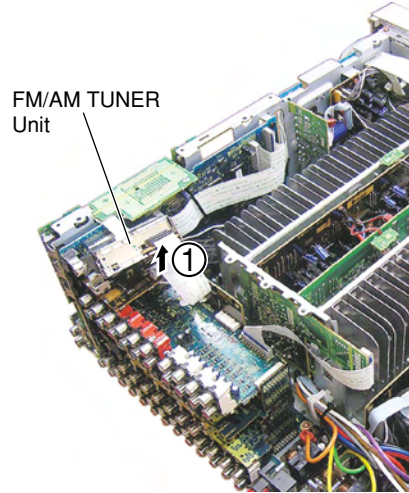

## ● PCB Assys

- ① Disconnect cables, connectors, as required.
- ② First remove the BRIDGE 2 Assy, then remove the COMPOSITE, S-VIDEO, COMPONENT and VIDEO CONNECT Assys.

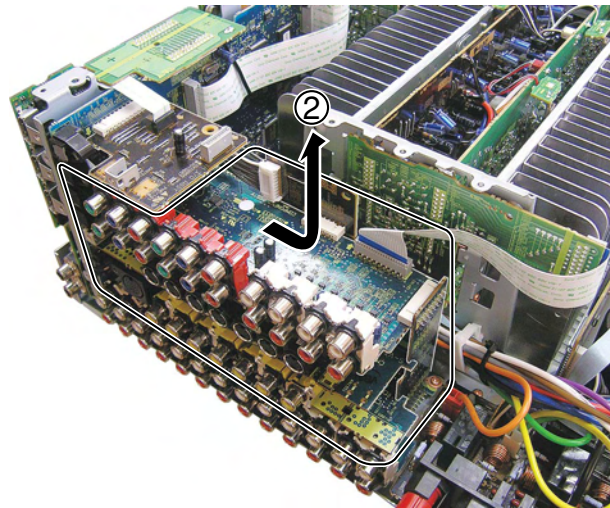

### ● DSP Shield Section

- ① Remove the one screw.
- ② Remove the two screws.
- ③ Disconnect cables, connectors, as required.
- ④ Remove the DSP shield 2016 with PCB Assemblies..

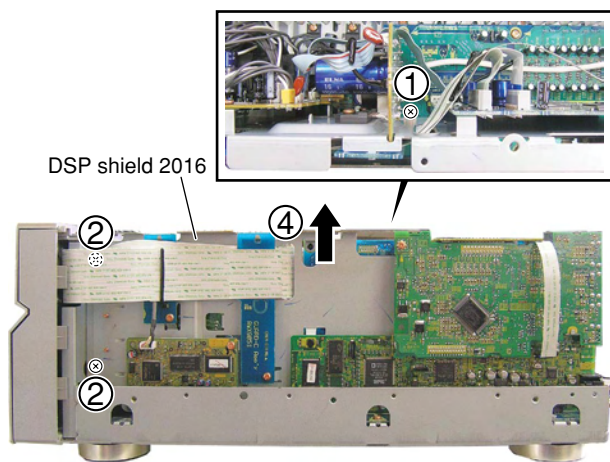

### ● AUDIO IN Assy

- ① Remove the two screws.
- ② Remove the five screws.
- ③ Release the locking card spacer.
- ④ Disconnect cables, connectors, as required.
- ⑤ Remove the AUDIO IN Assy.

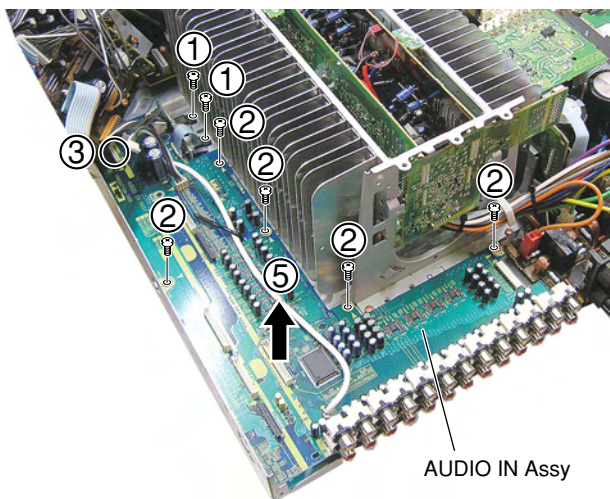

## 4. Diagnosis

### 1 Preparations

- ① Remove the bonnet.
  - ② Remove the rear panel.
- 
- ① Remove the BRIDGE 2 Assy.
  - ② Remove the VIDEO CONNECT Assy.
  - ③ Remove the COMPONENT, S-VIDEO, COMPOSITE Assys.

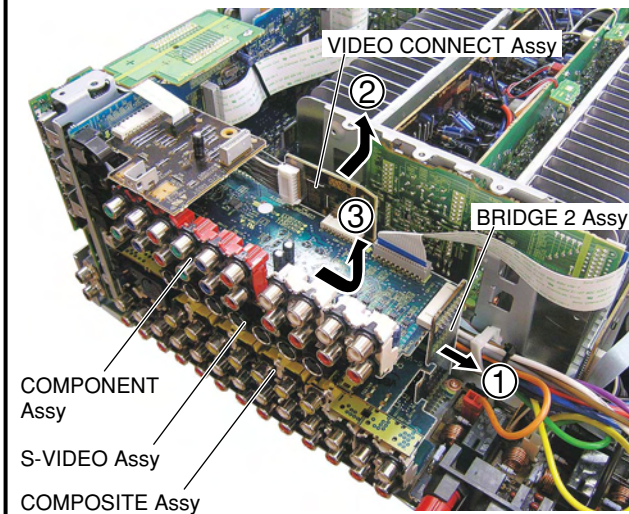

- ④ Connect the earth points to chassis as follows.
  - Ⓐ Pin jack (GND) on the DSP Assy ↔ chassis
  - Ⓑ Pin jack (L side GND) on the AUDIO IN Assy ↔ chassis
  - Ⓒ Pin jack (Yellow GND) on the COMPOSITE Assy ↔ chassis
  - Ⓓ Speaker terminal (L side black) ↔ chassis

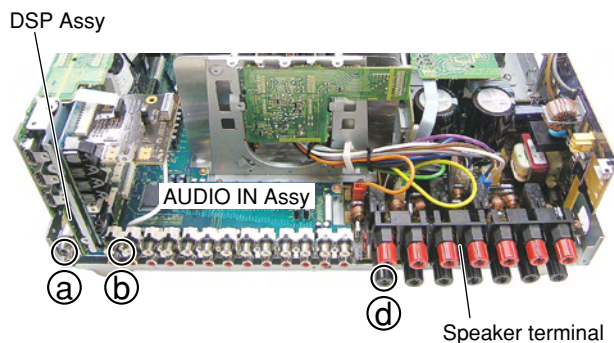

A

## 2 Diagnosis

### ● COMPONENT Assy

#### Jig cable

- 11P board to board extension jig cable (GGD1482)
- 13P board to board extension jig cable (GGD1483) ×2

- ① Connect the three extension jig cables.
- ② Reassembling the S-VIDEO and COMPOSITE Assys.
- ③ Reassembling the VIDEO CONNECT Assy.
- ④ Connect the one flexible cable.
- ⑤ Insert the insulation sheet.
- ⑥ Arrange the unit as shown in the photo below.

B

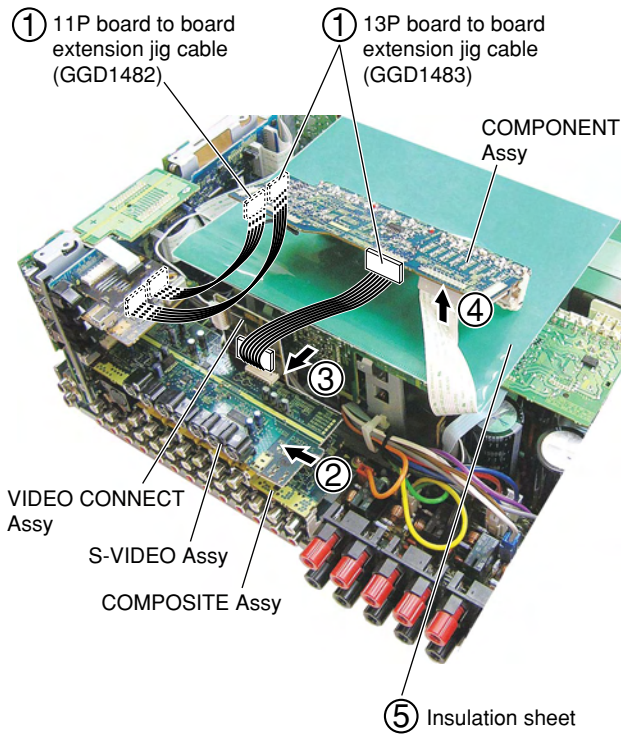

C

D

E

F



### ● S-VIDEO Assy

#### Jig cable

- 11P board to board extension jig cable (GGD1482)
- 13P board to board extension jig cable (GGD1483)
- 15P board to board extension jig cable (GGD1484)

- ① Connect the three extension jig cables.
- ② Reassembling the COMPONENT and COMPOSITE Assys.
- ③ Reassembling the BRIDGE 2 and VIDEO CONNECT Assys.
- ④ Connect the one flexible cable.

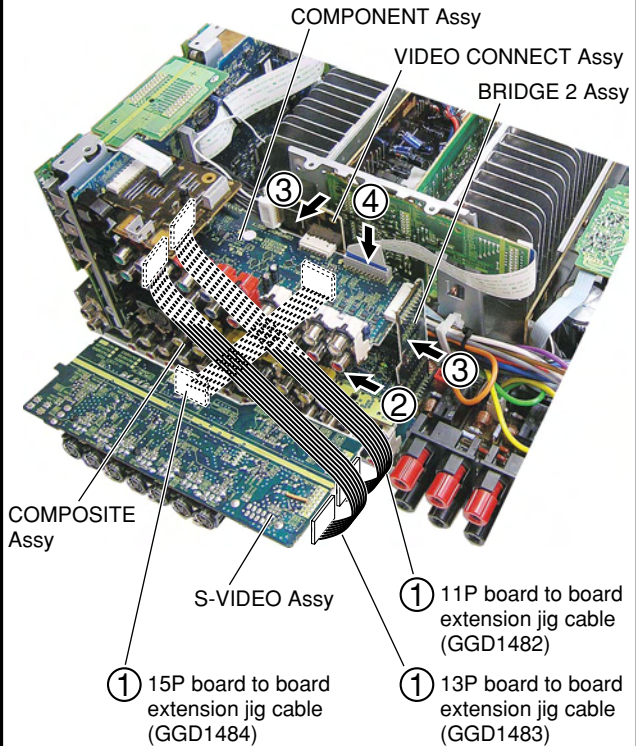

### ● COMPOSITE Assy

#### Jig cable

- 11P board to board extension jig cable (GGD1482)
- 13P board to board extension jig cable (GGD1483)
- 21P board to board extension jig cable (GGD1485)

- ① Connect the three extension jig cables.
- ② Reassembling the COMPONENT and S-VIDEO Assys.
- ③ Reassembling the BRIDGE 2 and VIDEO CONNECT Assys.
- ④ Connect the one flexible cable.

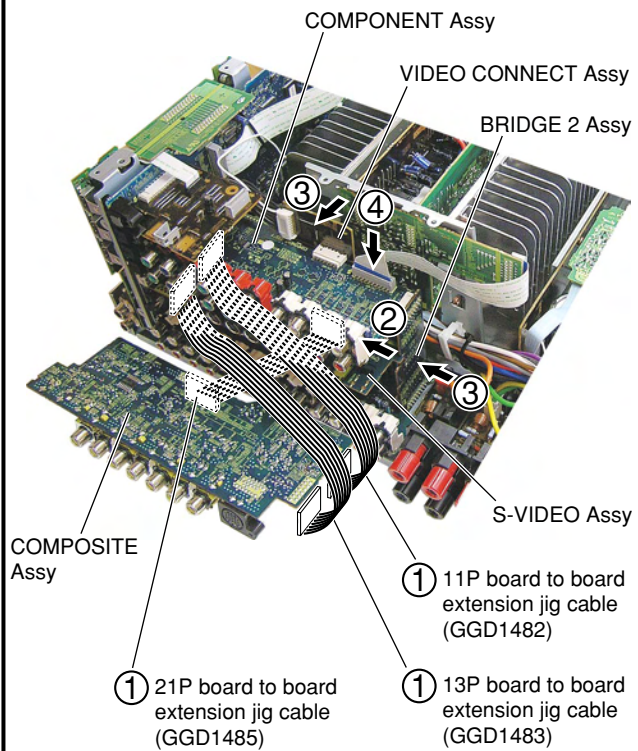

↓

**Diagnosis**

## 7.2 PARTS

### 7.2.1 IC

The information shown in the list is basic information and may not correspond exactly to that shown in the schematic diagrams.

#### ● List of IC

M61545FP, LA7109, PDC132A, PEG118A, PEG116A, TCC760HC01-AG, AAT4618IGV-0.5-1

#### ■ M61545FP (COMPOSITE ASSY : IC1151)

• 2 ch Electronic Volume IC

#### ● Block Diagram

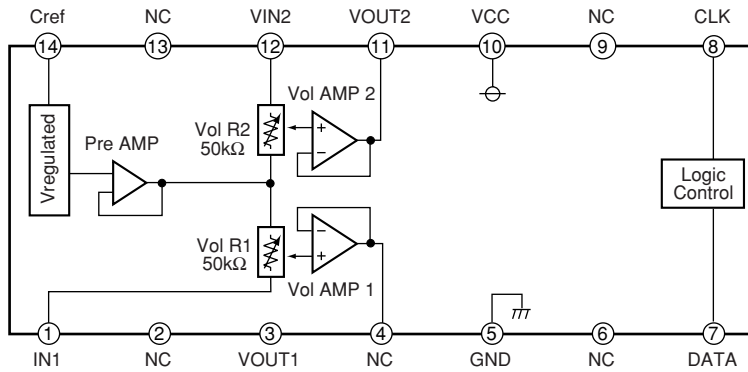

#### ● Pin Function

No.	Pin Name	I/O	Pin Function
1	VIN1	I	1-ch input
2	NC	-	Non connection
3	VOUT1	O	1-ch output
4	NC	-	Non connection
5	GND	-	Ground
6	NC	-	Non connection
7	DATA	I	Control data input Inputs data in synchronization with clock.
8	CLK	I	Clock input pin for transferring serial data
9	NC	-	Non connection
10	VCC	-	Power supply
11	VOUT2	O	2-ch output
12	VIN2	I	2-ch input
13	NC	-	Non connection
14	Cref	I	Vref filter

## LA7109 (COMPOSITE ASSY : IC1004), (S-VIDEO ASSY : IC1205)

• Video Amp IC

### ● Block Diagram

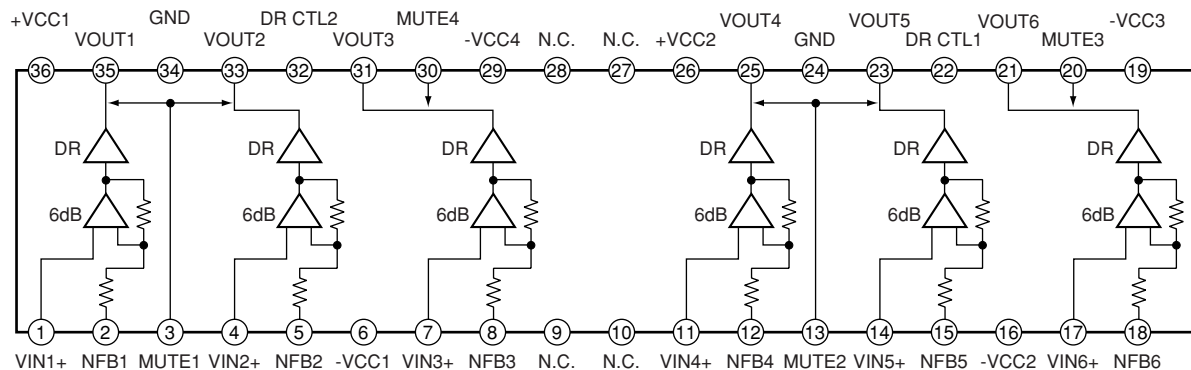

### ● Pin Function

No.	Pin Name	I/O	Pin Function	No.	Pin Name	I/O	Pin Function
1	VIN1+	I	Input pin	19	-VCC3	-	-VCC power supply
2	NFB1	I	Negative feedback pin of amp	20	MUTE3	I	Changeover pin of mute ability
3	MUTE1	I	Changeover pin of mute ability	21	VOUT6	O	Output pin
4	VIN2+	I	Input pin	22	DR CTL1	I	Changeover pin of drive ability
5	NFB2	I	Negative feedback pin of amp	23	VOUT5	O	Output pin
6	-VCC1	-	-VCC power supply	24	GND	-	Ground
7	VIN3+	I	Input pin	25	VOUT4	O	Output pin
8	NFB3	I	Negative feedback pin of amp	26	+VCC2	-	+VCC power supply
9	N.C.	-	Recommend connecting to -Vcc	27	N.C.	-	Recommend connecting to -Vcc
10	N.C.	-	Recommend connecting to -Vcc	28	N.C.	-	Recommend connecting to -Vcc
11	VIN4+	I	Input pin	29	-VCC4	-	-VCC power supply
12	NFB4	I	Negative feedback pin of amp	30	MUTE4	I	Changeover pin of mute ability
13	MUTE2	I	Changeover pin of mute ability	31	VOUT3	O	Output pin
14	VIN5+	I	Input pin	32	DR CTL2	I	Changeover pin of drive ability
15	NFB5	I	Negative feedback pin of amp	33	VOUT2	O	Output pin
16	-VCC2	-	-VCC power supply	34	GND	-	Ground
17	VIN6+	I	Input pin	35	VOUT1	O	Output pin
18	NFB6	I	Negative feedback pin of amp	36	+VCC1	-	+VCC power supply

# A ■ PDC132A (COMPOSITE ASSY : IC1006)

• Character Generator IC

## ● Pin Arrangement (Top view)

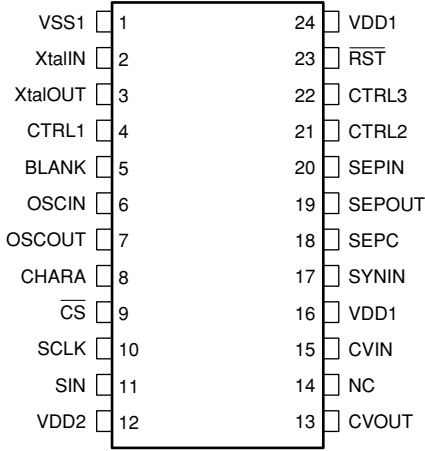

## C ● Block Diagram

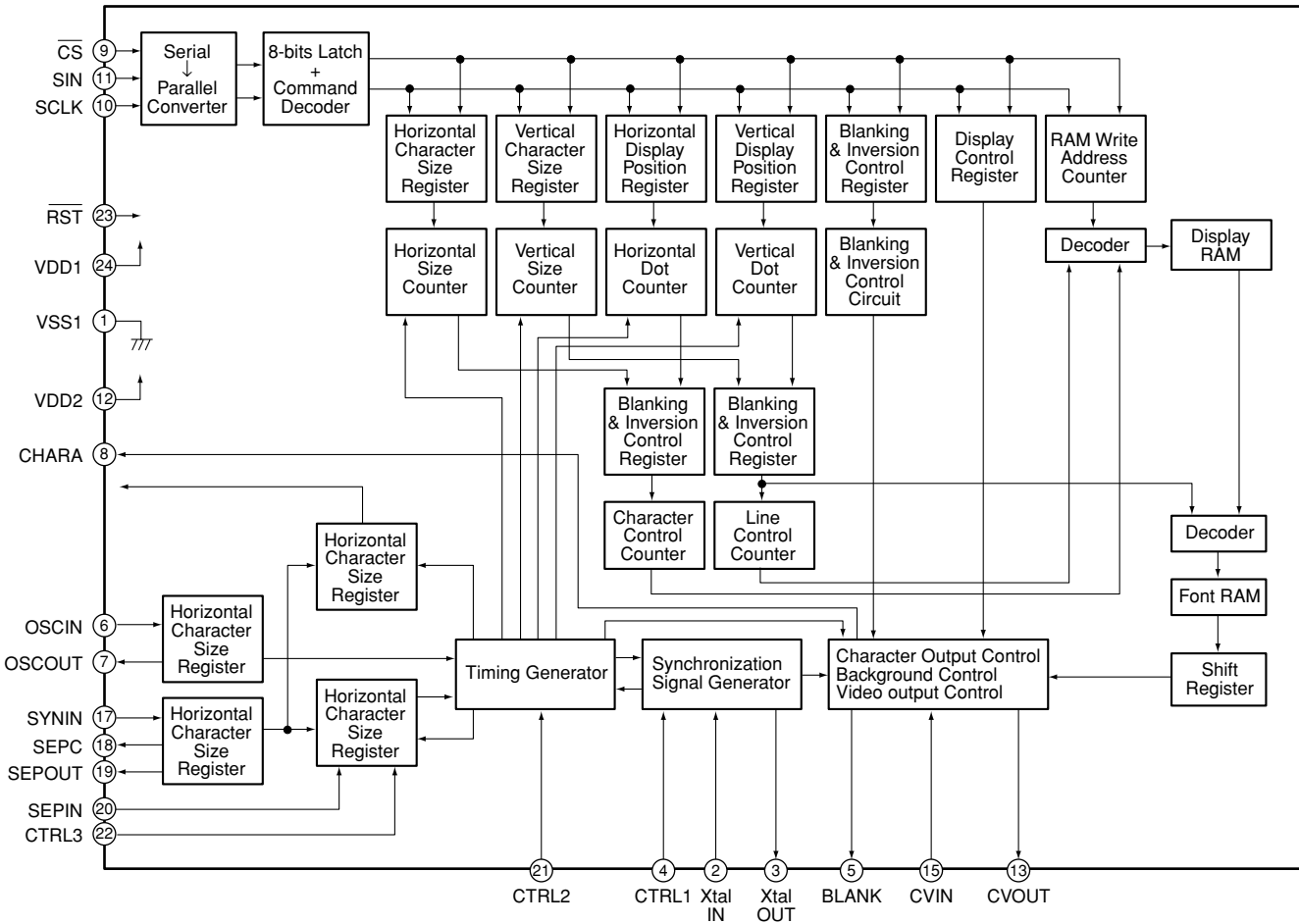



## ● Pin Function

No.	Pin Name	I/O	Pin Function
1	VSS1	–	Digital ground
2	XtalIN	I	Crystal oscillator connection (2fsc or 4fsc)
3	XtalOUT	O	Crystal oscillator connection (2fsc or 4fsc)
4	CTRL1	I	Crystal oscillator input switching L: crystal oscillator mode, H: external clock mode
5	BLANK	O	Blank signal output Outputs a composite sync signal when MOD0 is high.
6	OSCIN	I	Connections for the coil and capacitor that form the oscillator that generates the character output dot clock.
7	OSCOUT	O	Connections for the coil and capacitor that form the oscillator that generates the character output dot clock.
8	CHARA	I	Character signal output
9	$\overline{CS}$	I	Enable input for serial data input Serial data input is enabled when low. A pull-up resistor is built in (hysteresis input).
10	SCLK	I	Clock input for serial data I/O A pull-up resistor is built in (hysteresis input).
11	SIN	I	Serial data input A pull-up resistor is built in (hysteresis input).
12	VDD2	–	Analog power supply
13	CVOUT	O	Composite video signal output
14	NC	–	Must be either connected to ground or left open.
15	CVIN	I	Composite video signal input
16	VDD1	–	+5 V digital power supply
17	SYNIN	I	Video signal input for the built-in sync separator circuit
18	SEPC	O	Built-in sync separator circuit bias voltage monitor pin
19	SEPOUT	O	Built-in sync separator circuit composite sync signal output
20	SEPIN	I	Inputs a vertical synchronization signal created by integrating the SEPOUT pin output signal.
21	CTRL2	I	The setting indicated by this pin takes priority in switching between the NTSC, PAL, PAL-M and PAL-N formats. A low level selects NTSC after a reset. The microprocessor command NTSC, PAL, PAL-M, or PAL-N setting is valid. High = PAL-M format.
22	CTRL3	I	Controls whether or not the $\overline{VSYNC}$ signal is input to the SEPIN input. Low = $\overline{VSYNC}$ input, high = $\overline{VSYNC}$ not input.
23	$\overline{RST}$	I	System reset input
24	VDD1	–	+5 V digital power supply

A

# PEG118A (HDMI & DVC ASSY : IC501)

• HDMI Microcomputer

## ● Pin Arrangement (Top view)

B

C

D

E

F

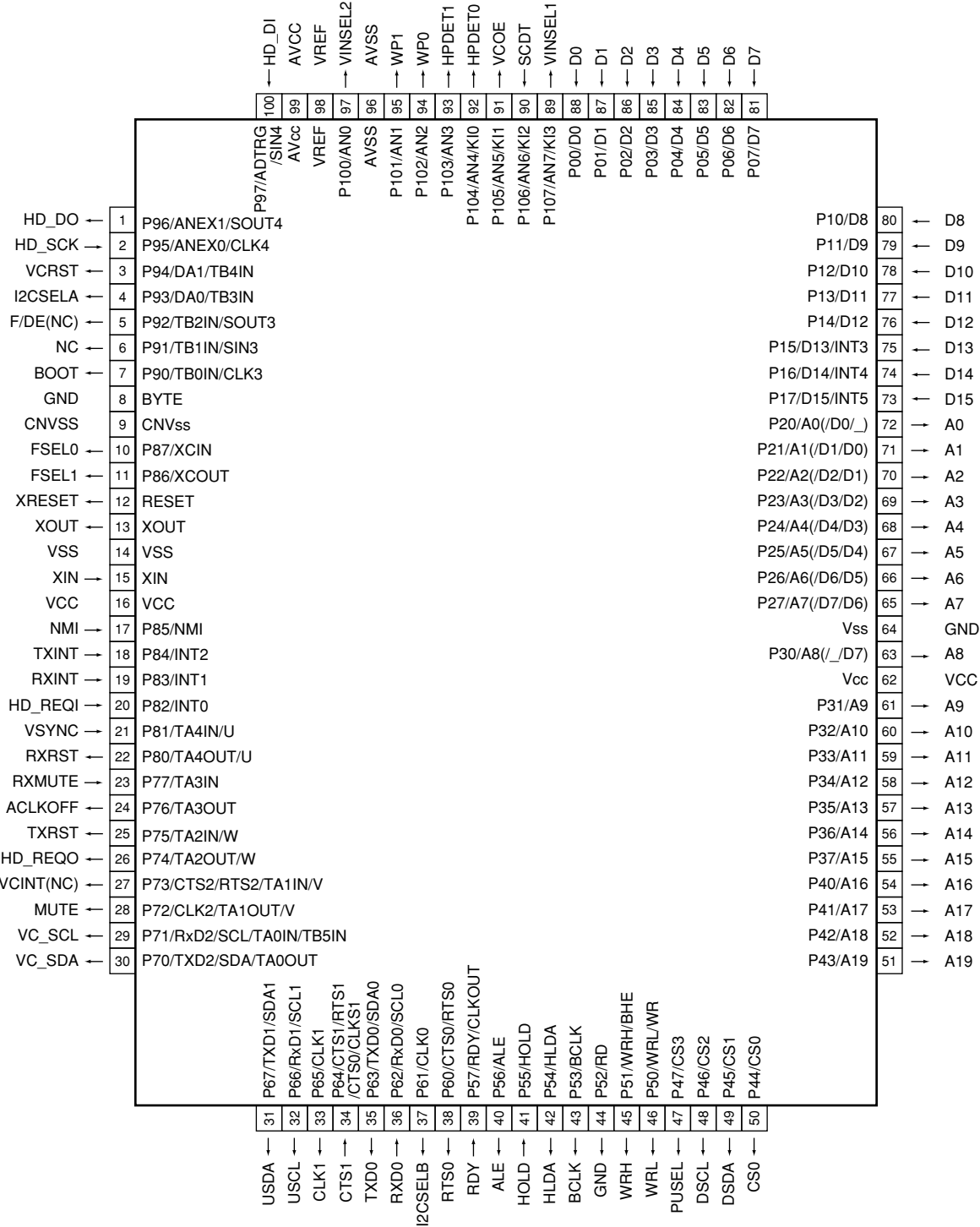

### ● Pin Function

No.	Mark	Pin Name	I/O	Pin Function
1	P96/ANEX1/SOUT4	HD_DO	O	Main controller communication DATA OUT
2	P95/ANEX0/CLK4	HD_SCK	I	Main controller communication CLOCK IN
3	P94/DA1/TB4IN	VCRST	O	ADV7401/ADV7172 RESET, (L: RESET)
4	P93/DA0/TB3IN	/1080P	O	TMDS amplitude switch (L:1080p, H: excepting 1080p)
5	P92/TB2IN/SOUT3	NC	O	OPEN
6	P91/TB1IN/SIN3	NC	O	OPEN
7	P90/TB0IN/CLK3	NC	O	OPEN
8	BYTE	BYTE	-	GND
9	CNVss	CNVSS	-	GND
10	P87/XCIN	NC	O	OPEN
11	P86/XCOUT	NC	O	OPEN
12	RESET	XRESET	I	Main controller communication RESET input (L: RESET)
13	XOUT	XOUT	O	XTAL
14	VSS	VSS	-	GND
15	XIN	XIN	I	XTAL
16	VCC	VCC	-	Power supply 3.3V
17	P85/NMI	NMI	I	Pull up with Vcc
18	P84/INT2	TXINT	I	SiI9030 interrupt
19	P83/INT1	RXINT	I	SiI9033 interrupt
20	P82/INT0	HD_REQI	I	Main controller communication REQ IN
21	P81/TA4IN/U	VSYNC	I	SiI9033 VSYNC input
22	P80/TA4OUT/U	RXRST	O	SiI9033 RESET (L: RESET)
23	P77/TA3IN	RXMUTE	I	SiI9033 MUTE IN
24	P76/TA3OUT	MCK_OFF	O	AUDIO MCK OFF (not used)
25	P75/TA2IN/W	TXRST	O	SiI9030 RESET (L: RESET)
26	P74/TA2OUT/W	HD_REQO	O	Main controller communication REQ OUT
27	P73/CTS2/RTS2/TA1IN/V	VCINT(NC)	O	ADV7401 interrupt (not used)
28	P72/CLK2/TA1OUT/V	MUTE	O	AUDIO MUTE (H: MUTE)
29	P71/RxD2/SCL/TA0IN/TB5IN	VC_SCL	O	I2C SCL(ADV7401/ADV7172)
30	P70/TXD2/SDA/TA0OUT	VC_SDA	O	I2C SDA(ADV7401/ADV7172)
31	P67/TXD1/SDA1	CSDA	O	I2C SDA(SiI9033/SiI9030)
32	P66/RxD1/SCL1	CSCL	O	I2C SCL(SiI9033/SiI9030)
33	P65/CLK1	CLK1(NC)	O	OPEN
34	P64/CTS1/RTS1/CTS0/CLKS1	CTS1(NC)	O	OPEN
35	P63/TXD0/SDA0	TXD0	O	RS232C TXD
36	P62/RxD0/SCL0	RXD0	I	RS232C RXD
37	P61/CLK0	NC	O	OPEN
38	P60/CTS0/RTS0	RTS0	O	RS232C RTS
39	P57/RDY/CLKOUT	RDY	I	Pull up with Vcc
40	P56/ALE	ALE	O	OPEN
41	P55/HOLD	HOLD	I	Pull up with Vcc
42	P54/HLDA	HLDA	O	OPEN
43	P53/BCLK	BCLK	O	Pull up with Vcc
44	P52/RD	RD	O	FLASH ROM I/F RD
45	P51/WRH/BHE	BHE	O	OPEN
46	P50/WRL/WR	WR	O	FLASH ROM I/F WR
47	P47/CS3	PUSEL	O	DDC communication pull-up resistor switch (L: Normal operation)
48	P46/CS2	NC	O	OPEN

A

No.	Mark	Pin Name	I/O	Pin Function	
49	P45/CS1	NC	O	OPEN	
50	P44/CS0	CS0	O	FLASH ROM I/F CS	
51	P43/A19	NC	O	OPEN	
52	P42/A18	A18	O	FLASH ROM I/F	
53	P41/A17	A17	O	FLASH ROM I/F	
54	P40/A16	A16	O	FLASH ROM I/F	
55	P37/A15	A15	O	FLASH ROM I/F	
56	P36/A14	A14	O	FLASH ROM I/F	
B	57	P35/A13	A13	O	FLASH ROM I/F
58	P34/A12	A12	O	FLASH ROM I/F	
59	P33/A11	A11	O	FLASH ROM I/F	
60	P32/A10	A10	O	FLASH ROM I/F	
61	P31/A9	A9	O	FLASH ROM I/F	
62	Vcc	VCC	–	Power supply 3.3V	
63	P30/A8(Ⓢ/D7)	A8	O	FLASH ROM I/F	
64	Vss	GND	–	GND	
65	P27/A7(/D7/D6)	A7	O	FLASH ROM I/F	
66	P26/A6(/D6/D5)	A6	O	FLASH ROM I/F	
C	67	P25/A5(/D5/D4)	A5	O	FLASH ROM I/F
68	P24/A4(/D4/D3)	A4	O	FLASH ROM I/F	
69	P23/A3(/D3/D2)	A3	O	FLASH ROM I/F	
70	P22/A2(/D2/D1)	A2	O	FLASH ROM I/F	
71	P21/A1(/D1/D0)	A1	O	FLASH ROM I/F	
72	P20/A0(/D0/Ⓢ)	NC	O	OPEN	
73	P17/D15/INT5	D15	I	FLASH ROM I/F	
74	P16/D14/INT4	D14	I	FLASH ROM I/F	
75	P15/D13/INT3	D13	I	FLASH ROM I/F	
76	P14/D12	D12	I	FLASH ROM I/F	
77	P13/D11	D11	I	FLASH ROM I/F	
D	78	P12/D10	D10	I	FLASH ROM I/F
79	P11/D9	D9	I	FLASH ROM I/F	
80	P10/D8	D8	I	FLASH ROM I/F	
81	P07/D7	D7	I	FLASH ROM I/F	
82	P06/D6	D6	I	FLASH ROM I/F	
83	P05/D5	D5	I	FLASH ROM I/F	
84	P04/D4	D4	I	FLASH ROM I/F	
85	P03/D3	D3	I	FLASH ROM I/F	
86	P02/D2	D2	I	FLASH ROM I/F	
E	87	P01/D1	D1	I	FLASH ROM I/F
88	P00/D0	D0	I	FLASH ROM I/F	
89	P107/AN7/KI3	I2S_OFF	O	Audio data control I2S data OFF (H: OFF)	
90	P106/AN6/KI2	SCDT	I	SiI9033 SCDT input	
91	P105/AN5/KI1	VCOE	O	Video data select (L: HDMI, H: Analog VIDEO)	
92	P104/AN4/KI0	HPDET0	O	Hot Plug Detect control (IN1)	
93	P103/AN3	HPDET1	O	Hot Plug Detect control (IN2)	
94	P102/AN2	WP0	O	EDID1 E2PROM WP control (L: Normal operation, H: Writing)	
95	P101/AN1	WP1	O	EDID2 E2PROM WP control (L: Normal operation, H: Writing)	
96	AVSS	AVSS	–	GND	
F	97	P100/AN0	DSD_OFF	O	Audio data control DSD data OFF (H: OFF)
98	VREF	VREF	–	Reference voltage 3.3V	
99	AVcc	AVCC	–	Power supply 3.3V	
100	P97/ADTRG/SIN4	HD_DI	I	Main controller communication (DATA IN)	

# PEG116A (MAIN CONTROL ASSY : IC101)

• Main Microcomputer

## ● Pin Arrangement (Top view)

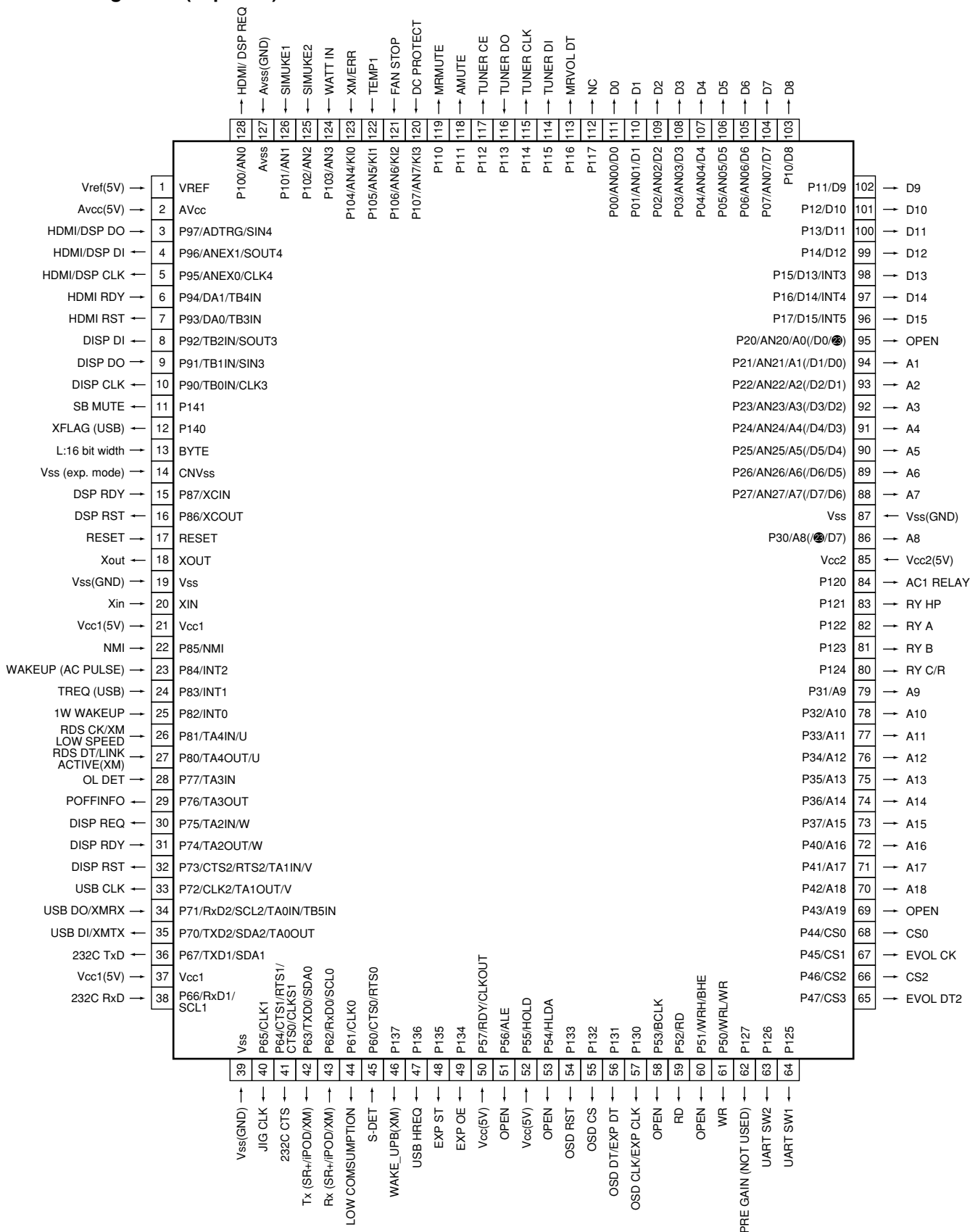

## ● Pin Function

No.	Mark	Pin Name	I/O	Pin Function
1	VREF	Vref(5V)	–	Reference voltage (5V)
2	AVcc	Avcc(5V)	–	Power supply (5V)
3	P97/ADTRG/SIN4	HDMI / DSP DO	I	Data input for HDMI/DSP microcomputer
4	P96/ANEX1/SOUT4	HDMI / DSP DI	O/L	Data output for HDMI/DSP microcomputer
5	P95/ANEX0/CLK4	HDMI / DSP CLK	O/L	Clock output for HDMI/DSP microcomputer
6	P94/DA1/TB4IN	HDMI RDY	I	Ready input for HDMI microcomputer
7	P93/DA0/TB3IN	HDMI RST	O/L	Reset output for HDMI microcomputer
8	P92/TB2IN/SOUT3	DISP DI	O/L	Communication data output of the display microcomputer
9	P91/TB1IN/SIN3	DISP DO	I	Communication data input of the display microcomputer
10	P90/TB0IN/CLK3	DISP CLK	O/L	Communication clock output of the display microcomputer
11	P141	SB MUTE	O/L	MUTE for SB ch (L: MUTE)
12	P140	XFLAG (USB)	I	Error signal from the USB module
13	BYTE	L: 16 bit	–	Bus width setting of the external flash L= 16bit, H= 8bit
14	CNVss	Vss(EXP mode)	–	Shift from the single chip mode to the memory expansion mode Set to VCC at internal FLASH rewriting.
15	P87/XCIN	DSP RDY	I	Microcomputer communication Request input to the main microcomputer
16	P86/XCOUT	DSP RST	O/L	DSP controller communication
17	RESET	RESET	I	Reset input from the main microcomputer
18	XOUT	Xout	O	Connect a ceramic resonator (15.7 MHz)
19	Vss	Vss(GND)	–	Ground
20	XIN	Xin	I	Connect a ceramic resonator
21	Vcc1	Vcc1(5V)	–	Power supply Vcc1(5V)
22	P85/NMI	NMI	I	47k pull-up
23	P84/INT2	WAKEUP(AC PULSE)	( I )	AC pulse input
24	P83/INT1	TREQ(USB)	I	Communication request signal from the USB module
25	P82/INT0	1W WAKEUP	I	Display microcomputer communication
26	P81/TA4IN/U	RDS CK(XM) LOW SPEED	I	(RDS model) CLOCK IN/(XM) Low speed Data Part
27	P80/TA4OUT/U	RDS DT/LINK ACTIVE(XM)	I	(RDS model) DATA IN/(XM) LINK active indicator
28	P77/TA3IN	OL DET	I	OVERLOAD detection (L: abnormal)
29	P76/TA3OUT	POFFINFO	O/L	Notify power off to DSP controller (an outlet comes off)
30	P75/TA2IN/W	DISP REQ	O/L	Display microcomputer communication
31	P74/TA2OUT/W	DISP RDY	I	Display microcomputer communication
32	P73/CTS2/RTS2/TA1IN/V	DISP RST	O/H	Display microcomputer communication
33	P72/CLK2/TA1OUT/V	USBCLK	I	Communication clock input with the USB module
34	P71/RxD2/SCL2/TA0IN/TB5IN	USBDO/XM Rx	I	Communication data input with the USB module/XM communication data input
35	P70/TXD2/SDA2/TA0OUT	USBDI/XM Tx	O/L	Communication data output with the USB module/XM communication data output
36	P67/TXD1/SDA1	232C TxD	O/L	RS-232C open
37	Vcc1	Vcc1(5V)	–	Power supply (5V)
38	P66/RxD1/SCL1	232C RxD	I	RS-232C open
39	Vss	Vss(GND)	–	Ground
40	P65/CLK1	JIG CLK	–	RS-232C open
41	P64/CTS1/RTS1/CTS0/CLKS1	232C CTS	O/L	RS-232C
42	P63/TXD0/SDA0	Tx(SR+/iPOD)	O/L	SR+/iPod communication data output
43	P62/RxD0/SCL0	Rx(SR+/iPOD)	I	SR+/iPod communication data input
44	P61/CLK0	LOW CONSUMPTION	O/L	AMUTE power ON/OFF (ON: H)
45	P60/CTS0/RTS0	S-DET	I	S-VIDEO detection (H)
46	P137	WAKE_UPB(XM)	I	For XMDT communication
47	P136	USB HREQ	O/L	Communication enabling signal to the USB module
48	P135	EXP ST	O/L	Expansion IC communication

No.	Mark	Pin Name	I/O	Pin Function
49	P134	EXP OE	O/L	Expansion IC communication
50	P57/RDY/CLKOUT	Vcc(5V)	I	Power supply Vcc (5V)
51	P56/ALE	OPEN	O/L	NC (open at memory expansion mode)
52	P55/HOLD	Vcc(5V)	I	Power supply Vcc (5V)
53	P54/HLDA	OPEN	O/L	NC (open at memory expansion mode)
54	P133	OSD RST	O/L	OSD communication
55	P132	OSD CS	O/L	OSD communication
56	P131	OSD DT/EXP DT	O/L	OSD communication and expansion IC communication
57	P130	OSD CLK/EXP CLK	O/L	OSD communication and expansion IC communication
58	P53/BCLK	OPEN	O/L	NC (open at memory expansion mode)
59	P52/RD	RD	O/L	FLASH MEMORY I/F READ
60	P51/WRH/BHE	OPEN	O/L	FLASH MEMORY I/F WRITE
61	P50/WRL/WR	WR	O/L	FLASH MEMORY I/F WRITE
62	P127	PREGAIN	O/L	PREGAIN not used
63	P126	UART SW2	O/L	L: Select SR+ path, H: Select iPod or XM path
64	P125	UART SW1	O/L	L: Select DSP microcomputer path, H: Select HDMI microcomputer path
65	P47/CS3	EVOL DT2	O/L	Electronic VOL & function IC communication
66	P46/CS2	CS2	O/L	Electronic VOL & function IC communication
67	P45/CS1	EVOL CK	O/L	Electronic VOL & function IC communication
68	P44/CS0	CS0	O/L	FLASH MEMORY CE control
69	P43/A19	OPEN	O/L	FLASH MEMORY communication address output
70	P42/A18	A18	O/L	FLASH MEMORY communication address output
71	P41/A17	A17	O/L	FLASH MEMORY communication address output
72	P40/A16	A16	O/L	FLASH MEMORY communication address output
73	P37/A15	A15	O/L	FLASH MEMORY communication address output
74	P36/A14	A14	O/L	FLASH MEMORY communication address output
75	P35/A13	A13	O/L	FLASH MEMORY communication address output
76	P34/A12	A12	O/L	FLASH MEMORY communication address output
77	P33/A11	A11	O/L	FLASH MEMORY communication address output
78	P32/A10	A10	O/L	FLASH MEMORY communication address output
79	P31/A9	A9	O/L	FLASH MEMORY communication address output
80	P124	RY C/R	O/L	Center, surround SP relay (ON: H)
81	P123	RY B	O/L	SP-B relay (ON: H)
82	P122	RY A	O/L	SP-A relay (ON: H)
83	P121	RY HP	O/L	HP relay (ON: H)
84	P120	AC1 RELAY	O/L	AC relay (ON: H)
85	Vcc2	Vcc2(5V)	-	Power supply Vcc1 (5V)
86	P30/A8/(D7)	A8	O/L	FLASH MEMORY communication address output
87	Vss	Vss(GND)	-	Ground Vss(GND)
88	P27/AN27/A7/(D7/D6)	A7	O/L	FLASH MEMORY communication address output
89	P26/AN26/A6/(D6/D5)	A6	O/L	FLASH MEMORY communication address output
90	P25/AN25/A5/(D5/D4)	A5	O/L	FLASH MEMORY communication address output
91	P24/AN24/A4/(D4/D3)	A4	O/L	FLASH MEMORY communication address output
92	P23/AN23/A3/(D3/D2)	A3	O/L	FLASH MEMORY communication address output
93	P22/AN22/A2/(D2/D1)	A2	O/L	FLASH MEMORY communication address output
94	P21/AN21/A1/(D1/D0)	A1	O/L	FLASH MEMORY communication address output
95	P20/AN20/A0/(D0)	OPEN	O/L	FLASH MEMORY communication address output
96	P17/D15/INT5	D15	O/L	FLASH MEMORY communication data input/output

A

No.	Mark	Pin Name	I/O	Pin Function
97	P16/D14/INT4	D14	O/L	FLASH MEMORY communication data input/output
98	P15/D13/INT3	D13	O/L	FLASH MEMORY communication data input/output
99	P14/D12	D12	O/L	FLASH MEMORY communication data input/output
100	P13/D11	D11	O/L	FLASH MEMORY communication data input/output
101	P12/D10	D10	O/L	FLASH MEMORY communication data input/output
102	P11/D9	D9	O/L	FLASH MEMORY communication data input/output
103	P10/D8	D8	O/L	FLASH MEMORY communication data input/output
104	P07/AN07/D7	D7	O/L	FLASH MEMORY communication data input/output
105	P06/AN06/D6	D6	O/L	FLASH MEMORY communication data input/output
106	P05/AN05/D5	D5	O/L	FLASH MEMORY communication data input/output
107	P04/AN04/D4	D4	O/L	FLASH MEMORY communication data input/output
108	P03/AN03/D3	D3	O/L	FLASH MEMORY communication data input/output
109	P02/AN02/D2	D2	O/L	FLASH MEMORY communication data input/output
110	P01/AN01/D1	D1	O/L	FLASH MEMORY communication data input/output
111	P00/AN00/D0	D0	O/L	FLASH MEMORY communication data input/output
112	P117	NC	O/L	NC
113	P116	MRVOL DT	O/L	EVOL communication data for SUBROOM
114	P115	TUNER DI	O/L	TUNER module communication
115	P114	TUNER CLK	O/L	TUNER module communication
116	P113	TUNER DO	I	TUNER module communication
117	P112	TUNER CE	O/L	TUNER module communication
118	P111	AMUTE	O/L	AMUTE (L: MUTE, H: MUTE OFF)
119	P110	MRMUTE	O/L	MR MUTE (L: MUTE, H: MUTE OFF)
120	P107/AN7/KI3	DC PROTECT	I	DC abnormality detection (L detection)
121	P106/AN6/KI2	FAN STOP	I	FAN STOP detection (L at FAN rotation: abnormality)
122	P105/AN5/KI1	TEMP1	I	Temperature detection (H: high temperature)
123	P104/AN4/KI0	XM/ERR	I	XM Error
124	P103/AN3	WATT IN	I	(A/D) Voltage detection for limiter control
125	P102/AN2	SIMUKE2	I	(A/D) Destination distinction
126	P101/AN1	SIMUKE1	I	(A/D) Destination distinction
127	Avss	Avss(GND)	–	Ground Vss (GND)
128	P100/AN0	HDMI/ DSP REQ	O/L	REQ output for HDMI/DSP microcomputer

E

F



# TCC760HC01-AG (USB ASSY : IC701)

• USB Media Control IC

## • Pin Arrangement (Top view)

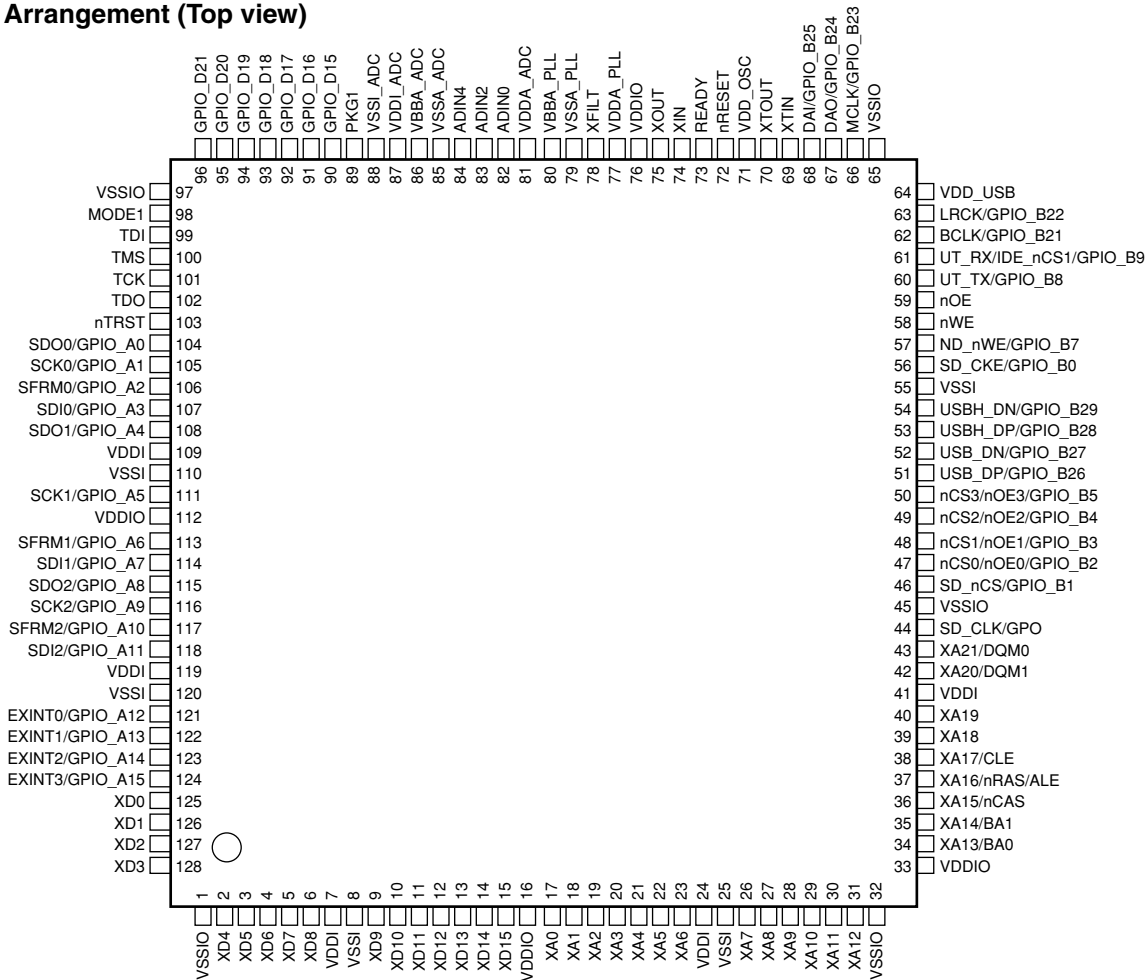

## • Block Diagram

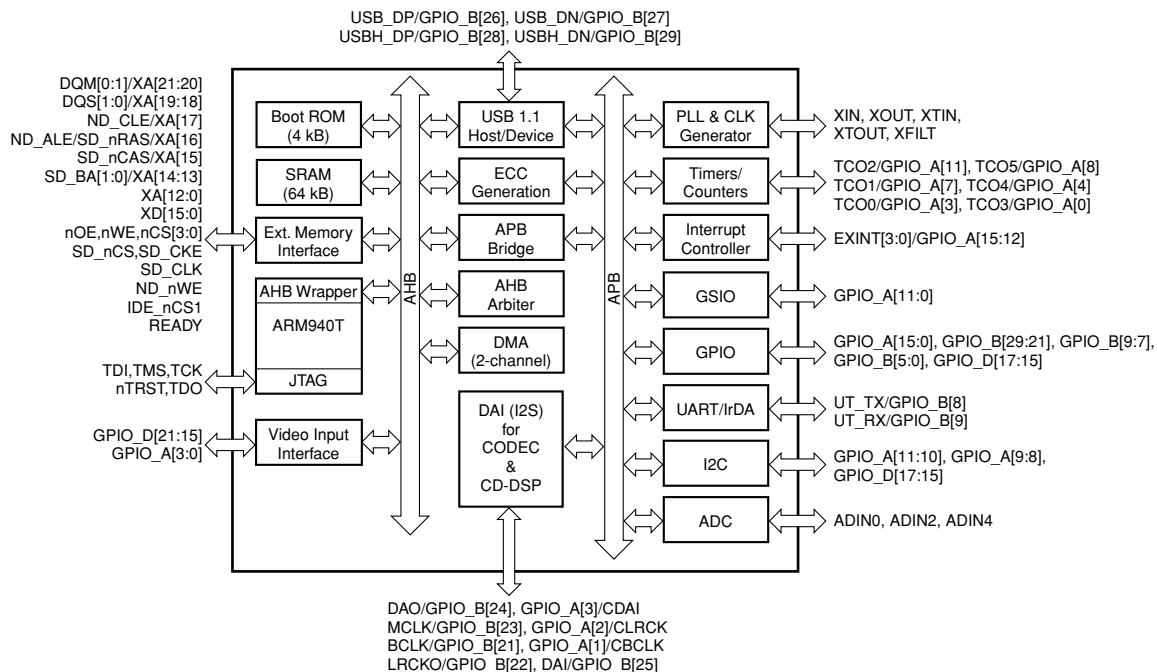

## ● Pin Functions

No.	Pin Name	I/O	Pin Function
1	VSSIO	–	Digital ground for I/O
2	XD4	I/O	External bus data bit [4]
3	XD5	I/O	External bus data bit [5]
4	XD6	I/O	External bus data bit [6]
5	XD7	I/O	External bus data bit [7]
6	XD8	I/O	External bus data bit [8]
7	VDDI	–	Digital power supply for internal core (1.8 V)
8	VSSI	–	Digital ground for internal
9	XD9	I/O	External bus data bit [9]
10	XD10	I/O	External bus data bit [10]
11	XD11	I/O	External bus data bit [11]
12	XD12	I/O	External bus data bit [12]
13	XD13	I/O	External bus data bit [13]
14	XD14	I/O	External bus data bit [14]
15	XD15	I/O	External bus data bit [15]
16	VDDIO	–	Digital power supply for I/O (1.8 V to 3.3 V)
17	XA0	I/O	External bus address bit [0]
18	XA1	I/O	External bus address bit [1]
19	XA2	I/O	External bus address bit [2]
20	XA3	I/O	External bus address bit [3]
21	XA4	I/O	External bus address bit [4]
22	XA5	I/O	External bus address bit [5]
23	XA6	I/O	External bus address bit [6]
24	VDDI	–	Digital power supply for internal core (1.8 V)
25	VSSI	–	Digital ground for internal
26	XA7	I/O	External bus address bit [7]
27	XA8	I/O	External bus address bit [8]
28	XA9	I/O	External bus address bit [9]
29	XA10	I/O	External bus address bit [10]
30	XA11	I/O	External bus address bit [11]
31	XA12	I/O	External bus address bit [12]
32	VSSIO	–	Digital ground for I/O
33	VDDIO	–	Digital power supply for I/O (1.8 V to 3.3 V)
34	XA13/BA0	I/O	External bus address bit [13] / SDRAM bank address 0
35	XA14/BA1	I/O	External bus address bit [14] / SDRAM bank address 1
36	XA15/nCAS	I/O	External bus address bit [15] / SDRAM CAS signal
37	XA16/nRAS/ALE	I/O	External bus address bit [16] / SDRAM RAS signal / ALE for NAND flash
38	XA17/CLE	I/O	External bus address bit [17] / CLE for NAND flash
39	XA18	I/O	External bus address bit [18]
40	XA19	I/O	External bus address bit [19]
41	VDDI	–	Digital power supply for internal core (1.8 V)
42	XA20/DQM1	I/O	External bus address bit [20] / Data I/O mask 1
43	XA21/DQM0	I/O	External bus address bit [21] / Data I/O mask 0
44	SD_CLK/GPO	I/O	SDRAM clock / GPO, SD_CLK can be used as a general purpose output.
45	VSSIO	–	Digital ground for I/O
46	SD_nCS/GPIO_B1	I/O	Chip select signal for SDRAM, active low / GPIO_B[1]
47	nCS0/nOE0/GPIO_B2	I/O	External bus chip select [0] / NAND flash output enable [0] / GPIO_B[2]
48	nCS1/nOE1/GPIO_B3	I/O	External bus chip select [1] / NAND flash output enable [1] / GPIO_B[3]
49	nCS2/nOE2/GPIO_B4	I/O	External bus chip select [2] / NAND flash output enable [2] / GPIO_B[4]
50	nCS3/nOE3/GPIO_B5	I/O	External bus chip select [3] / NAND flash output enable [3] / GPIO_B[5]

No.	Pin Name	I/O	Pin Function
51	USB_DP/GPIO_B26	I/O	USB function D+ signal / GPIO_B[26]
52	USB_DN/GPIO_B27	I/O	USB function D- signal / GPIO_B[27]
53	USBH_DP/GPIO_B28	I/O	USB host D+ signal / GPIO_B[28]
54	USBH_DN/GPIO_B29	I/O	USB host D- signal / GPIO_B[29]
55	VSSI	–	Digital ground for internal
56	SD_CKE/GPIO_B0	I/O	SDRAM clock enable signal, active high / GPIO_B[0]
57	ND_nWE/GPIO_B7	I/O	NAND flash WE, active low / GPIO_B[7]
58	nWE	I/O	Static memory write enable signal, active low
59	nOE	I/O	Static memory output enable signal, active low
60	UT_TX/GPIO_B8	I/O	UART or IrDA TX data / GPIO_B[8]
61	UT_RX/IDE_nCS1/GPIO_B9	I/O	UART or IrDA RX data / IDE chip select 1 / GPIO_B[9]
62	BCLK/GPIO_B21	I/O	I2S bit clock / GPIO_B[21]
63	LRCK/GPIO_B22	I/O	I2S word clock / GPIO_B[22]
64	VDD_USB	–	Power supply for USB I/O (3.3 V)
65	VSSIO	–	Digital ground for I/O
66	MCLK/GPIO_B23	I/O	I2S system clock / GPIO_B[23]
67	DAO/GPIO_B24	I/O	I2S digital audio data output / GPIO_B[24]
68	DAI/GPIO_B25	I/O	I2S digital audio data input / GPIO_B[25]
69	XTIN	I	Sub crystal oscillator input (32.768 kHz)
70	XTOUT	O	Sub crystal oscillator output (32.768 kHz)
71	VDD_OSC	–	Digital power supply for oscillators (1.8 V)
72	nRESET	I	System reset, active low
73	READY	I	Ready information from external device
74	XIN	I	Main crystal oscillator input for PLL (12 MHz)
75	XOUT	O	Main crystal oscillator output for PLL (12 MHz)
76	VDDIO	–	Digital power supply for I/O (1.8 V to 3.3 V)
77	VDDA_PLL	–	Analog and digital power supply for PLL (1.8 V)
78	XFILT	AO	PLL filter output
79	VSSA_PLL	–	Analog ground for PLL
80	VBBA_PLL	–	Analog ground for PLL
81	VDDA_ADC	–	Analog power supply for ADC (3.3 V)
82	ADIN0	AI	General purpose multi-channel ADC input 0
83	ADIN2	AI	General purpose multi-channel ADC input 2
84	ADIN4	AI	General purpose multi-channel ADC input 4
85	VSSA_ADC	–	Analog ground for ADC
86	VBBA_ADC	–	Analog ground for ADC
87	VDDI_ADC	–	Digital power supply for ADC (1.8 V)
88	VSSI_ADC	–	Digital ground for ADC
89	PKG1	I	Package ID 1, pull-up for normal operation
90	GPIO_D15	I/O	GPIO_D[15]
91	GPIO_D16	I/O	GPIO_D[16]
92	GPIO_D17	I/O	GPIO_D[17]
93	GPIO_D18	I/O	GPIO_D[18]
94	GPIO_D19	I/O	GPIO_D[19]
95	GPIO_D20	I/O	GPIO_D[20]
96	GPIO_D21	I/O	GPIO_D[21]
97	VSSIO	–	Digital ground for I/O
98	MODE1	I	Mode select input 1, Pull-down for normal operation.
99	TDI	I	JTAG serial data input for ARM940T
100	TMS	I	JTAG test mode select for ARM940T

A

No.	Pin Name	I/O	Pin Function
101	TCK	I	JTAG test clock for ARM940T
102	TDO	I/O	JTAG serial data output for ARM940T
103	nTRST	I	JTAG reset signal for ARM940T, active low
104	SDO0/GPIO_A0	I/O	Serial data output 0 / GPIO_A[0]
105	SCK0/GPIO_A1	I/O	Serial clock input 0 / GPIO_A[1]
106	SFRM0/GPIO_A2	I/O	Serial frame 0 / GPIO_A[2]
107	SDI0/GPIO_A3	I/O	Serial data input 0 / GPIO_A[3]
108	SDO1/GPIO_A4	I/O	Serial data output 1 / GPIO_A[4]
109	VDDI	-	Digital power supply for internal core (1.8 V)
110	VSSI	-	Digital ground for internal
111	SCK1/GPIO_A5	I/O	Serial clock input 1 / GPIO_A[5]
112	VDDIO	-	Digital power supply for I/O (1.8 V to 3.3 V)
113	SFRM1/GPIO_A6	I/O	Serial frame 1 / GPIO_A[6]
114	SDI1/GPIO_A7	I/O	Serial data input 1 / GPIO_A[7]
115	SDO2/GPIO_A8	I/O	Serial data output 2 / GPIO_A[8]
116	SCK2/GPIO_A9	I/O	Serial clock input 2 / GPIO_A[9]
117	SFRM2/GPIO_A10	I/O	Serial frame 2 / GPIO_A[10]
118	SDI2/GPIO_A11	I/O	Serial data input 2 / GPIO_A[11]
119	VDDI	-	Digital power supply for internal core (1.8 V)
120	VSSI	-	Digital ground for internal
121	EXINT0/GPIO_A12	I/O	External interrupt request [0] / GPIO_A[12]
122	EXINT1/GPIO_A13	I/O	External interrupt request [1] / GPIO_A[13]
123	EXINT2/GPIO_A14	I/O	External interrupt request [2] / GPIO_A[14]
124	EXINT3/GPIO_A15	I/O	External interrupt request [3] / GPIO_A[15]
125	XD0	I/O	External bus data bit [0]
126	XD1	I/O	External bus data bit [1]
127	XD2	I/O	External bus data bit [2]
128	XD3	I/O	External bus data bit [3]

D

## ■ AAT4618IGV-0.5-1 (USB ASSY : IC771)

• Load Switching IC

### ● Pin Arrangement (Top view)

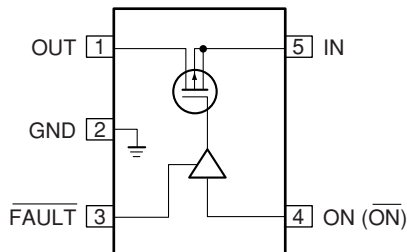

### ● Pin Function

No.	Pin Name	I/O	Pin Function
1	OUT	O	P-channel MOS FET drain
2	GND	-	Ground
3	FAULT	O	Open-drain FAULT output
4	ON (ON)	I	Enable input: 4618 active low, 4618- active high
5	IN	I	P-channel MOS FET source

F

# 8. PANEL FACILITIES

## Front panel (VSX-2016AV-S/HYXJ5)

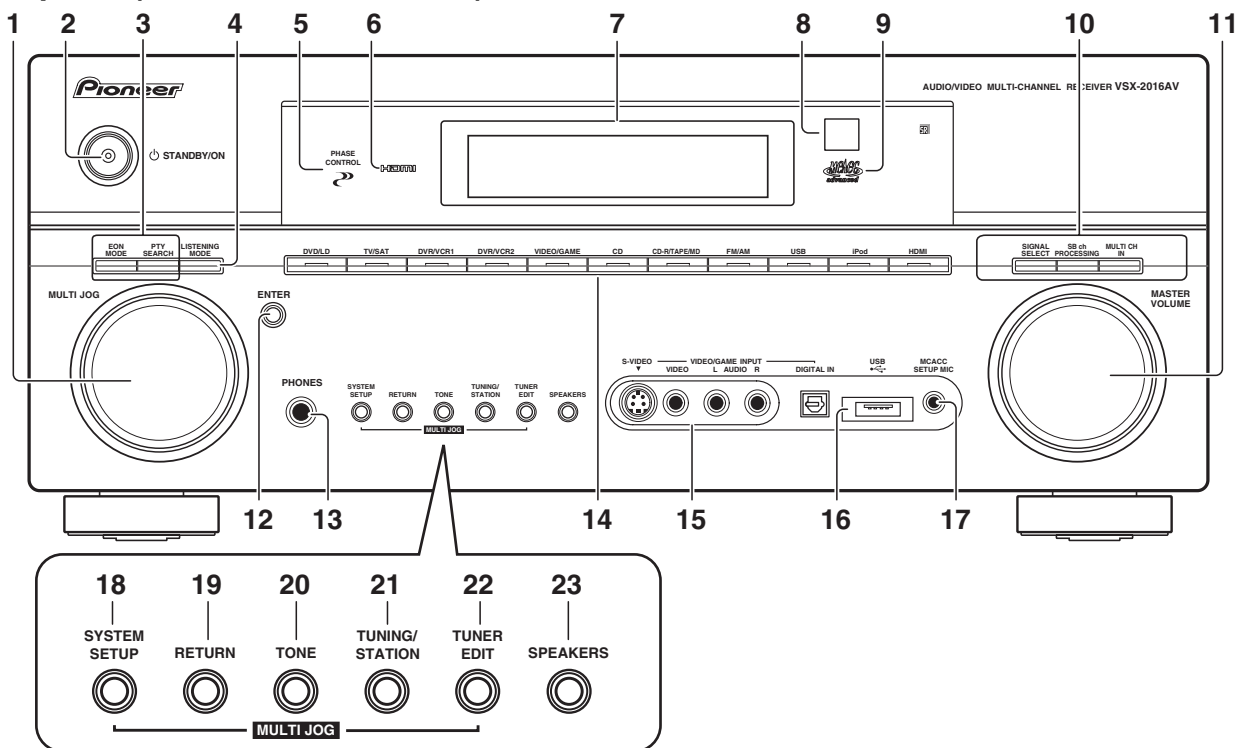

### 1 MULTI JOG dial

Use the **MULTI JOG** dial to select various settings and menu options.

### 2 STANDBY/ON

Switches the receiver between on and standby. Power indicator lights when the receiver is on.

### 3 EON MODE

Use to search for programs that are broadcasting traffic or news information.

#### PTY SEARCH

Use this button to search for RDS program types.

### 4 LISTENING MODE

Use with the **MULTI JOG** dial to select the various listening modes.

### 5 PHASE CONTROL indicator

Lights when Phase Control is switched on.

### 6 HDMI indicator

Blinks when connecting an HDMI-equipped component; lights when the component is connected.

### 7 Character display

### 8 Remote sensor

Receives the signals from the remote control.

### 9 MCACC indicator

Lights when one of the MCACC presets is selected.

### 10 SIGNAL SELECT

Use to select an input signal.

**SBch PROCESSING** - Selects the surround back channel mode or virtual surround back mode.

**MULTI CH IN** - Press to select the multichannel analog inputs.

### 11 MASTER VOLUME dial

### 12 ENTER

### 13 PHONES jack

Use to connect headphones. When the headphones are connected, there is no sound output from the speakers.

### 14 Input source buttons

Press to select an input source.

### 15 VIDEO/GAME INPUT

### 16 USB interface

Connect a USB audio device for playback.

### 17 MCACC SETUP MIC jack

Use to connect the supplied microphone.

### 18 SYSTEM SETUP

Press to access the System Setup menu.

### 19 RETURN

Press to confirm and exit the current menu screen.

### 20 TONE

Press this button to access the bass and treble controls, which you can then adjust with the **MULTI JOG** dial.

### 21 TUNING/STATION

Use to find radio frequencies and to select preset stations.

### 22 TUNER EDIT

Use with the **MULTI JOG** dial to memorize and name stations for recall.

### 23 SPEAKERS

Use to change the speaker system.

## Front panel (VSX-81TXV, VSX-81TXV-S, VSX-9110TXV-K)

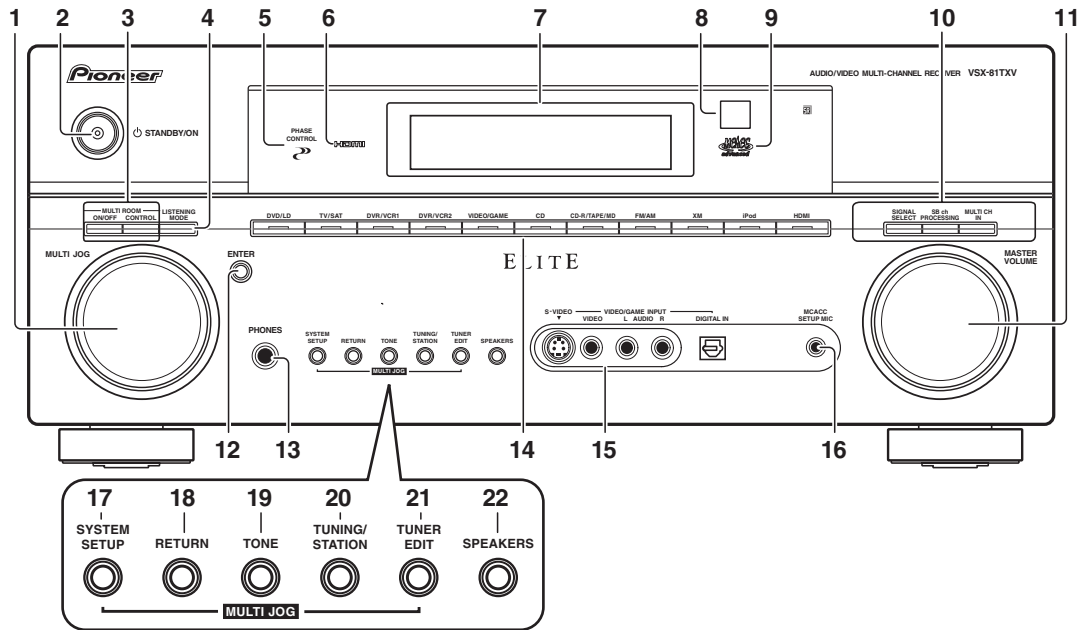

### 1 MULTI JOG dial

Use the **MULTI JOG** dial to select various settings and menu options.

### 2 STANDBY/ON

Switches the receiver between on and standby. Power indicator lights when the receiver is on.

### 3 MULTI ROOM controls

If you've made multi-room connections (see Multi-room listening) use these controls to control the sub room from the main room (see Using the multi-room controls).

### 4 LISTENING MODE

Use with the **MULTI JOG** dial to select the various listening modes.

### 5 PHASE CONTROL indicator

Lights when Phase Control is switched on.

### 6 HDMI indicator

Blinks when connecting an HDMI-equipped component; lights when the component is connected.

### 7 Character display

See Display.

### 8 Remote sensor

Receives the signals from the remote control (see Operating range of remote control unit).

### 9 MCACC indicator

Lights when one of the MCACC presets is selected.

### 10 SIGNAL SELECT

Use to select an input signal.

**SBch PROCESSING** – Selects the surround back channel mode or virtual surround back mode.

**MULTI CH IN** – Press to select the multichannel analog inputs.

### 11 MASTER VOLUME dial

### 12 ENTER

### 13 PHONES jack

Use to connect headphones. When the headphones are connected, there is no sound output from the speakers.

### 14 Input source buttons

Press to select an input source.

### 15 VIDEO/GAME INPUT

See Connecting a component to the front panel inputs.

### 16 MCACC SETUP MIC jack

Use to connect the supplied microphone.

### 17 SYSTEM SETUP

Press to access the System Setup menu.

### 18 RETURN

Press to confirm and exit the current menu screen.

### 19 TONE

Press this button to access the bass and treble controls, which you can then adjust with the **MULTI JOG** dial.

### 20 TUNING/STATION

Use to find radio frequencies and to select preset stations.

### 21 TUNER EDIT

Use with the **MULTI JOG** dial to memorize and name stations for recall.

### 22 SPEAKERS

Use to change the speaker system.

## Rear panel (VSX-2016AV-S/HYXJ5)

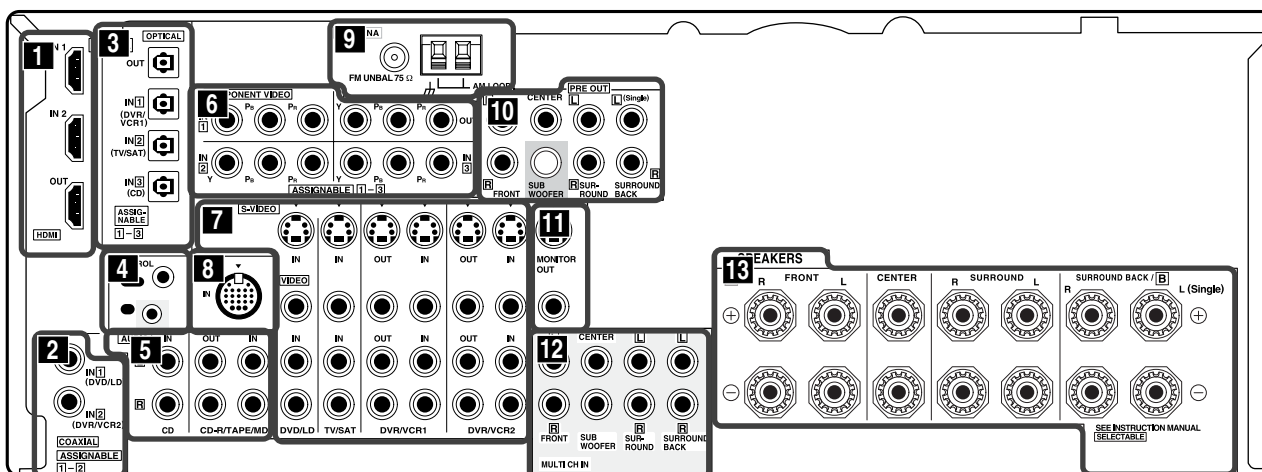

### Caution

- Before making or changing the connections, switch off the power and disconnect the power cord from the power outlet. Plugging in should be the final step.

#### 1 HDMI connectors (x3)

Two inputs and one output for high-quality audio/video connection to compatible HDMI devices.

→ Connecting using HDMI.

#### 2 Coaxial digital audio inputs (x2)

Use for digital audio sources, including DVD players/recorders, digital satellite receivers, CD players, etc.

#### 3 Optical digital audio output / input(s) (x4)

Use the **OUT** jack for recording to a CD or MiniDisc recorder.

→ Connecting digital audio sources.

Use the **IN** jacks for digital audio sources, including DVD players/recorders, digital satellite receivers, CD players, etc.

#### 4 Control input/output

Use to connect other Pioneer components so that you can control all your equipment from a single IR remote sensor.

→ Operating other Pioneer components with this unit's sensor.

#### 5 Stereo analog audio source inputs/outputs (x3)

Use for connection to audio sources such as CD players, tape decks, turntables, etc.

→ Connecting analog audio sources.

#### 6 Component video connections (x4)

Use the inputs to connect any video source that has component video output, such as a DVD recorder. Use the output for connection to a monitor or TV.

→ Using the component video jacks.

#### 7 Audio/video source inputs/outputs (x6)

Use for connection to audio/visual sources, such as DVD players/recorders, VCRs, etc. Each set of inputs has jacks for composite video, S-video and stereo analog audio.

→ Connecting a DVD/HDD recorder, VCR and other video sources.

#### 8 iPod input terminal

Use to connect your Apple iPod as an audio source.

→ Connecting an iPod.

#### 9 AM and FM antenna terminals

Use to connect indoor or outdoor antennas for radio broadcasts.

→ Connecting antennas.

#### 10 Multichannel pre-amplifier outputs

Use to connect separate amplifiers for front, center, surround, surround back and subwoofer channels.

→ Connecting additional amplifiers.

#### 11 Composite and S-video monitor outputs

Use to connect monitors and TVs.

→ Connecting your TV and DVD recorder.

#### 12 Multichannel analog audio inputs

7.1 channel inputs for connection to a DVD player with multichannel analog outputs.

→ Connecting the multichannel analog inputs.

#### 13 Speaker terminals

Use for connection to the main front, center, surround and surround back speakers.

→ Installing your speaker system.

## Rear panel (VSX-81TXV, VSX-81TXV-S, VSX-9110TXV-K)

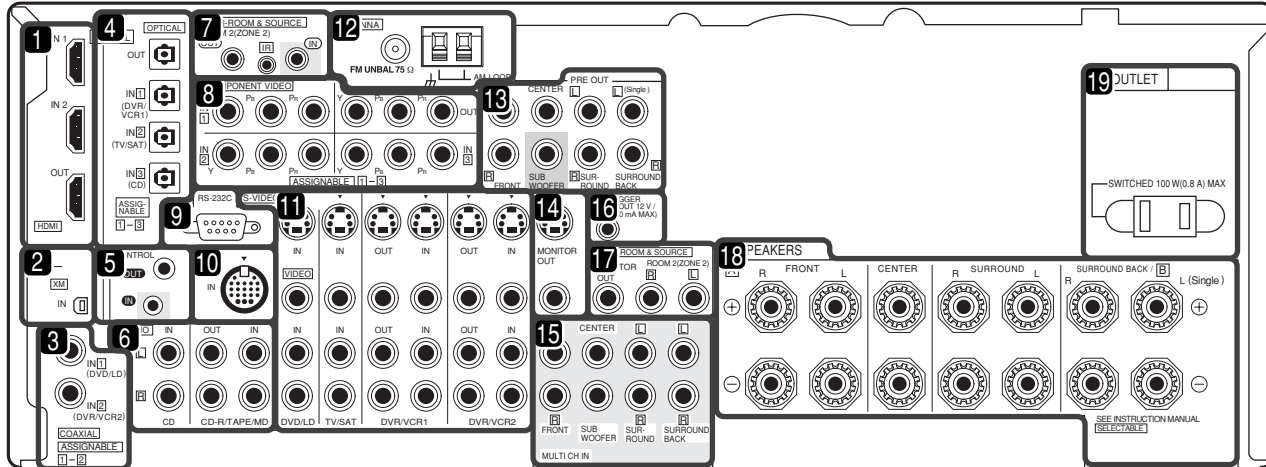

VSX-81TXV, VSX-81TXV-S, VSX-9110TXV-K

### Caution

- Before making or changing the connections, switch off the power and disconnect the power cord from the power outlet. Plugging in should be the final step.

#### 1 HDMI connectors (x3)

Two inputs and one output for high-quality audio/video connection to compatible HDMI devices.

→ Connecting using HDMI.

#### 2 XM Radio input

→ See Using XM Radio.

#### 3 Coaxial digital audio inputs (x2)

Use for digital audio sources, including DVD players/recorders, digital satellite receivers, CD players, etc.

→ See also The Input Setup menu to assign the inputs.

#### 4 Optical digital audio output / input(s) (x4)

Use the **OUT** jack for recording to a CD or MiniDisc recorder. → Connecting digital audio sources.

Use the **IN** jacks for digital audio sources, including DVD players/recorders, digital satellite receivers, CD players, etc.

→ See also The Input Setup menu to assign the inputs.

#### 5 Control input/output

Use to connect other Pioneer components so that you can control all your equipment from a single IR remote sensor.

→ Operating other Pioneer components with this unit's sensor.

#### 6 Stereo analog audio source inputs/outputs (x3)

Use for connection to audio sources such as CD players, tape decks, turntables, etc.

→ Connecting analog audio sources.

#### 7 Remote input (multi-room and source)

Use for connection to an external remote control sensor for use in a multi-room setup, for example.

→ Connecting an IR receiver.

#### 8 Component video connections (x4)

Use the inputs to connect any video source that has component video output, such as a DVD recorder. Use the output for connection to a monitor or TV.

→ Using the component video jacks.

#### 9 RS-232C connector

Use for connection to a PC for graphical output when using Advanced MCACC.

→ Connecting a PC for Advanced MCACC output.

#### 10 iPod input terminal

Use to connect your Apple iPod as an audio source.

→ Connecting an iPod.

#### 11 Audio/video source inputs/outputs (x6)

Use for connection to audio/visual sources, such as DVD players/recorders, VCRs, etc. Each set of inputs has jacks for composite video, S-video and stereo analog audio.

→ Connecting a DVD/HDD recorder, VCR and other video sources.

#### 12 AM and FM antenna terminals

Use to connect indoor or outdoor antennas for radio broadcasts.

→ Connecting antennas.

#### 13 Multichannel pre-amplifier outputs

Use to connect separate amplifiers for front, center, surround, surround back and subwoofer channels.

→ Connecting additional amplifiers (see also Installing your speaker system for powered subwoofer connection).

#### 14 Composite and S-video monitor outputs

Use to connect monitors and TVs.

→ Connecting your TV and DVD player.

#### 15 Multichannel analog audio inputs

7.1 channel inputs for connection to a DVD player with multichannel analog outputs.

→ Connecting the multichannel analog inputs.

#### 16 12V trigger jack (total 50 mA max.)

Use to switch components in your system on and off according to the input function of the receiver.

→ Switching components on and off using the 12 volt trigger.

#### 17 Multi-room and source outputs

Use to connect a second amplifier in a separate room.

→ Multi-room listening.

#### 18 Speaker terminals

Use for connection to the main front, center, surround and surround back speakers.

→ Installing your speaker system.

#### 19 Switched AC power outlet (100 W/0.8 A max.)

Use to power another component in the system. Power to the outlet switches on and off with the receiver.

→ AC outlet.



## Display (VSX-2016AV-S/HYXJ5)

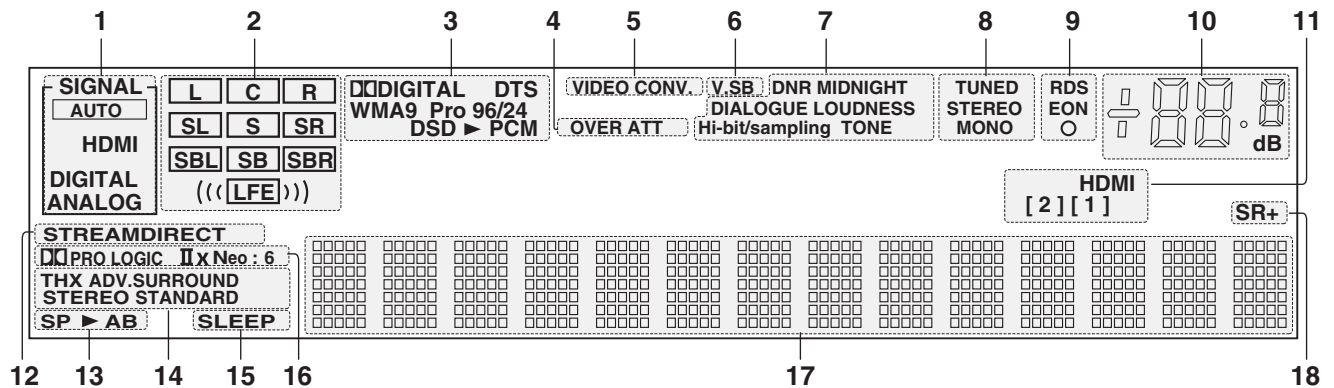

### 1 SIGNAL indicators

Light to indicate the currently selected input signal.  
**AUTO** lights when the receiver is set to select the input signal automatically.

### 2 Program format indicators

These change according to which channels are active in digital sources.

- L** - Left front channel
- C** - Center channel
- R** - Right front channel
- SL** - Left surround channel
- S** - Surround channel (mono)
- SR** - Right surround channel
- SBL** - Left surround back channel
- SB** - Surround back channel (mono)
- SBR** - Right surround back channel
- LFE** - Low frequency effects channel (the ((( ))) indicators light when an LFE signal is being input)

### 3 Digital format indicators

Light when a signal encoded in the corresponding format is detected ( **DSD ▶ PCM** lights during DSD (Direct Stream Digital) to PCM conversion with SACDs).

### 4 OVER / ATT

**OVER** lights to indicate that the level of an analog source is too high. **ATT** lights when you use the attenuator (**ANALOG ATT**) to reduce it.

### 5 VIDEO CONV.

Lights when digital video conversion is enabled.

### 6 V.SB

Lights during Virtual surround back processing.

### 7 Sound processing indicators

Light according to the active AV parameter(s).

### 8 TUNER indicators

**TUNED** - Lights when a broadcast is being received.  
**STEREO** - Lights when a stereo FM broadcast is being received in auto stereo mode.  
**MONO** - Lights when the mono mode is set using the **MPX** button.

### 9 EON / RDS indicators

**EON** - Lights when the EON mode is set (flashes during EON reception). The **○** indicator lights when the current station carries the EON service.  
**RDS** - Lights when an RDS broadcast is received.

### 10 Master volume level

### 11 HDMI connection indicators

Light to indicate the HDMI input currently selected.

### 12 STREAM DIRECT

Lights when Direct / Pure Direct is selected.

### 13 Speaker indicators

Indicate the current speaker system, **A** and/or **B**.

### 14 Listening mode indicators

**THX** - Lights when a Home THX mode is selected.  
**ADV. SURROUND** - Lights when an Advanced Surround mode has been selected.  
**STEREO** - Lights when stereo listening is switched on.  
**STANDARD** - Lights when a Standard Surround mode is switched on.

### 15 SLEEP

Lights when the receiver is in sleep mode.

### 16 Matrix decoding format indicators

**PRO LOGIC IIx** - This lights to indicate **PRO LOGIC II** / **PRO LOGIC IIx** decoding.  
**Neo:6** - When one of the Neo:6 modes of the receiver is on, this lights to indicate Neo:6 processing.

### 17 Character display

Displays various system information.

### 18 SR+

Lights when the SR+ mode is switched on.

## Display (VSX-81TXV, VSX-81TXV-S, VSX-9110TXV-K)

A

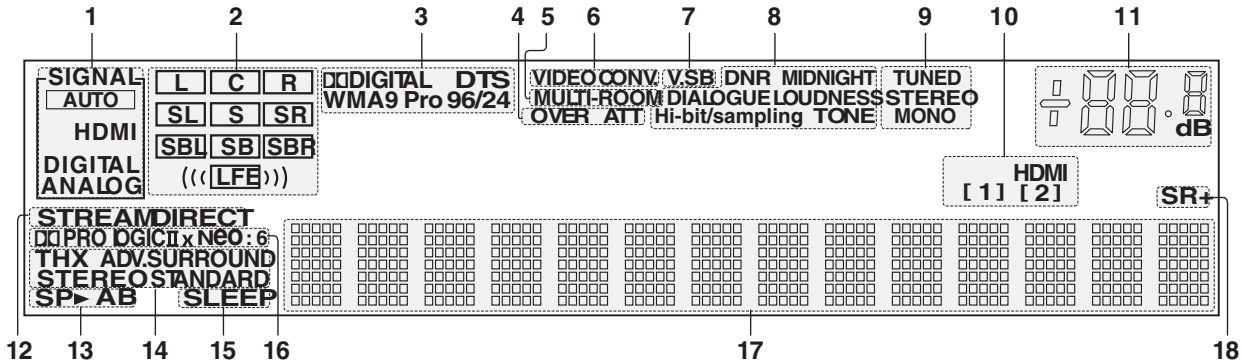

B

### 1 SIGNAL indicators

Light to indicate the currently selected input signal.  
**AUTO** lights when the receiver is set to select the input signal automatically.

### 2 Program format indicators

These change according to which channels are active in digital sources.

**L** – Left front channel

**C** – Center channel

**R** – Right front channel

**SL** – Left surround channel

**S** – Surround channel (mono)

**SR** – Right surround channel

**SBL** – Left surround back channel

**SB** – Surround back channel (mono)

**SBR** – Right surround back channel

**LFE** – Low frequency effects channel (the ((( ))) indicators light when an LFE signal is being input)

### 3 Digital format indicators

Light when a signal encoded in the corresponding format is detected.

### 4 OVER / ATT

**OVER** lights to indicate that the level of an analog source is too high. **ATT** lights when you use the attenuator (**ANALOG ATT**) to reduce it.

### 5 MULTI-ROOM

Lights when the multi-room feature is active.

### 6 VIDEO CONV.

Lights when digital video conversion is enabled.

### 7 V.SB

Lights during Virtual surround back processing.

### 8 Sound processing indicators

Light according to the active AV parameter(s).

### 9 TUNER indicators

**TUNED** – Lights when a broadcast is being received.

**STEREO** – Lights when a stereo FM broadcast is being received in auto stereo mode.

**MONO** – Lights when the mono mode is set using the **MPX** button.

### 10 HDMI connection indicators

Light to indicate the HDMI input currently selected.

### 11 Master volume level

### 12 STREAM DIRECT

Lights when Direct / Pure Direct is selected.

### 13 Speaker indicators

Indicate the current speaker system, **A** and/or **B**.

### 14 Listening mode indicators

**THX** – Lights when a Home THX mode is selected.

**ADV. SURROUND** – Lights when an Advanced Surround mode has been selected.

**STEREO** – Lights when stereo listening is switched on (see Listening in stereo).

**STANDARD** – Lights when a Standard Surround mode is switched on (see Listening in surround sound).

### 15 SLEEP

Lights when the receiver is in sleep mode.

### 16 Matrix decoding format indicators

**PRO LOGIC IIx** – This lights to indicate **PRO** Logic II / **PRO** Logic IIx decoding.

**Neo:6** – When one of the Neo:6 modes of the receiver is on, this lights to indicate Neo:6 processing.

### 17 Character display

Displays various system information.

### 18 SR+

Lights when the SR+ mode is switched on.

F

## Remote control (VSX-2016AV-S/HYXJ5)

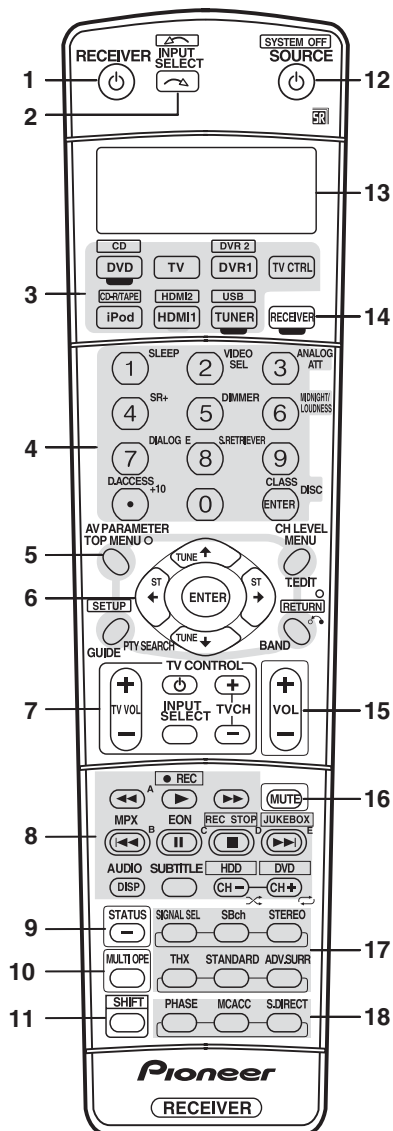

The remote has been conveniently color-coded according to component control using the following system (press the corresponding input source button to access):

- **Green** - Receiver controls (see below)
- **Red** - DVD controls
- **Blue** - Tuner controls
- **White** - Other controls

### 1 RECEIVER

This switches between standby and on for this receiver.

### 2 INPUT SELECT

Use to select the input source (use **SHIFT** for **INPUT SELECT** ).

### 3 Input source buttons

Press to select control of other components.

### 4 Number buttons and other receiver/component controls

Use the number buttons to directly select a radio frequency or the tracks on a CD, DVD, etc.

**DISC (ENTER)** can be used to enter commands for TV or DTV, and also to select a disc in a multi-CD player.

Press **RECEIVER** first to access:

**SLEEP** - Use to put the receiver in sleep mode and select the amount of time before sleep.

**VIDEO SEL** - Press repeatedly to select the video source.

**ANALOG ATT** - Attenuates (lowers) the level of an analog input signal to prevent distortion.

**SR+** - Switches the SR+ mode on/off.

**DIMMER** - Dims or brightens the display.

**MIDNIGHT/LOUDNESS** - Use Midnight when listening to movie soundtracks at low volume. Use Loudness to boost the bass and treble at low volume.

**DIALOG E** - Use to make dialog stand out when watching TV or a movie.

**S. RETRIEVER** - Press to restore CD quality sound to compressed audio sources.

Press **TUNER** first to access:

**D.ACCESS** - After pressing, you can access a radio station directly using the number buttons.

**CLASS** - Switches between the three banks (classes) of radio station presets.

### 5 Tuner/component control buttons/SETUP

These button controls can be accessed after you have selected the corresponding input source button (**DVD**, **DVR1**, **TV**, etc.). Press **RECEIVER** first to access the following controls:

**AV PARAMETER** - Use to access the AV options.

**SETUP** - Use to access the System Setup menu.

**CH LEVEL** - Press repeatedly to select a channel, then use **←/→** to adjust the level.

**RETURN** - Press to confirm and exit the current menu screen (also use to return to the previous menu with DVDs or to select closed captioning with DTV).

### 6 (TUNE/ST) / ENTER

Use the arrow buttons when setting up your surround sound system and the AV options. Also used to control DVD menus/options and for deck 1 of a double cassette deck player. Use the **TUNE ↑/↓** buttons to find radio frequencies and use **ST ←/→** to find preset stations.

### 7 TV CONTROL buttons

These buttons are dedicated to control the TV assigned to the **TV CTRL** button. Thus if you only have one TV to hook up to this system assign it to the **TV CTRL** input source button. If you have two TVs, assign the main TV to the **TV CTRL** button.

**TV ** - Use to turn on/off the power of the TV.

**TV VOL +/-** - Use to adjust the volume on your TV.

**INPUT SELECT** - Use to select the TV input signal.

**TV CH +/-** - Use to select channels.

A

## 8 Component control buttons

The main buttons (▶, ■, etc.) are used to control a component after you have selected it using the input source buttons.

The controls above these buttons can be accessed after you have selected the corresponding input source button (for example **DVD**, **DVR1** or **TV**). The following controls can be accessed when listening to the built-in tuner:

**MPX** - Switches between stereo and mono reception of FM broadcasts. If the signal is weak then switching to mono will improve the sound quality.

**DISP** - Switches between named station presets and radio frequencies. Also used to display RDS information.

**EON** - Use to search for programs that are broadcasting traffic or news information.

B

## 9 STATUS

Press to check selected receiver settings.

## 10 MULTI OPE

Use this button to perform multi operations.

C

## 11 SHIFT

Press to access the controls outlined in white boxes (for example, **INPUT SELECT** ) , or to display the currently selected input source in the remote control LCD.

## 12 SOURCE

Press to turn on/off other components connected to the receiver.

## 13 Character display (LCD)

This display shows information when transmitting control signals.

D

The following commands are shown when you're setting the remote to control other components:

**SETUP** - Indicates the setup mode, from which you choose the options below.

**PRESET** - See Selecting preset codes directly.

**LEARNING** - See Programming signals from other remote controls.

**MULTI OP** - See Multi Operation and System Off.

**SYS OFF** - See Multi Operation and System Off.

**DIRECT F** - See Direct function.

**RENAME** - See Renaming input source names.

E

**ERASE** - See Erasing one of the remote control button settings.

**RESET** - See Resetting the remote control presets.

**READ ID** - See Confirming preset codes.

## 14 RECEIVER

Switches the remote to control the receiver (used to select the green commands above the number buttons (**ANALOG ATT**, etc)). Also use this button to set up surround sound.

## 15 VOL +/-

Use to set the listening volume.

F

## 16 MUTE

Mutes the sound or restores the sound if it has been muted (adjusting the volume also restores the sound).

## 17 Receiver controls

**SIGNAL SEL** - Use to select an input signal.

**SBch** - Use to select the surround/virtual back channel mode.

**STEREO** - Switches between direct and stereo playback. Direct playback bypasses the tone controls and any other signal processing for the most accurate reproduction of a source.

**THX** - Press to select a Home THX listening mode.

**STANDARD** - Press for Standard decoding and to switch between the various  Pro Logic IIx and Neo: 6 options.

**ADV.SURR** - Use to switch between the various surround modes.

## 18 PHASE

Press to switch on/off Phase Control.

**MCACC** - Press to switch between MCACC presets.

**S.DIRECT** - Press to select Auto Surround or Stream Direct listening.

## Remote control (VSX-81TXV, VSX-81TXV-S, VSX-9110TXV-K)

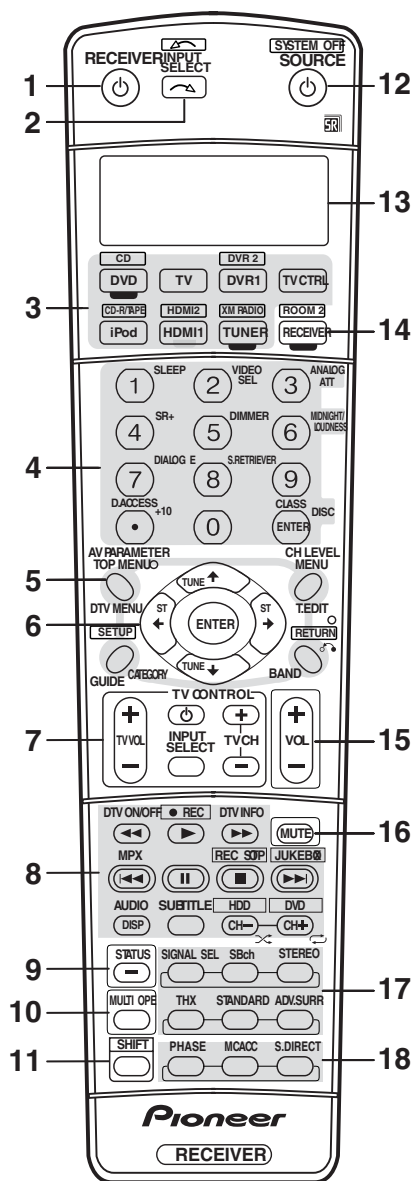

The remote has been conveniently color-coded according to component control using the following system (press the corresponding input source button to access):

- **Green** – Receiver controls (see below)
- **Red** – DVD controls
- **Blue** – Tuner/XM Radio controls
- **Yellow** – iPod controls
- **White** – Other controls

### 1 RECEIVER

This switches between standby and on for this receiver.

### 2 INPUT SELECT

Use to select the input source (use **SHIFT** for **INPUT SELECT** ).

### 3 Input source buttons

Press to select control of other components (see Controlling the rest of your system).

### 4 Number buttons and other receiver/component controls

Use the number buttons to directly select a radio frequency or the tracks on a CD, DVD, etc.

**DISC (ENTER)** can be used to enter commands for TV or DTV, and also to select a disc in a multi-CD player.

Press **RECEIVER** first to access:

**SLEEP** – Use to put the receiver in sleep mode and select the amount of time before sleep.

**VIDEO SEL** – Press repeatedly to select the video source.

**ANALOG ATT** – Attenuates (lowers) the level of an analog input signal to prevent distortion.

**SR+** – Switches the SR+ mode on/off.

**DIMMER** – Dims or brightens the display.

**MIDNIGHT/LOUDNESS** – Use Midnight when listening to movie soundtracks at low volume. Use Loudness to boost the bass and treble at low volume.

**DIALOG E** – Use to make dialog stand out when watching TV or a movie.

**S. RETRIEVER** – Press to restore CD quality sound to compressed audio sources.

Press **TUNER** first to access:

**D.ACCESS** – After pressing, you can access a radio station directly using the number buttons.

**CLASS** – Switches between the three banks (classes) of radio station presets.

### 5 Tuner/component control buttons/SETUP

These button controls can be accessed after you have selected the corresponding input source button (**DVD**, **DVR1**, **TV**, etc.). The **BAND** and **T.EDIT** tuner controls are explained from. Press **RECEIVER** first to access the following controls:

**AV PARAMETER** – Use to access the AV options.

**SETUP** – Use to access the System Setup menu.

**CH LEVEL** – Press repeatedly to select a channel, then use **←/→** to adjust the level.

**RETURN** – Press to confirm and exit the current menu screen (also use to return to the previous menu with DVDs or to select closed captioning with DTV).

### 6 (TUNE/ST) /ENTER

Use the arrow buttons when setting up your surround sound system and the AV options.

Also used to control DVD menus/options and for deck 1 of a double cassette deck player. Use the **TUNE ↓/↑** buttons to find radio frequencies and use **ST ←/→** to find preset stations.

### 7 TV CONTROL buttons

These buttons are dedicated to control the TV assigned to the **TV CTRL** button. Thus if you only have one TV to hook up to this system assign it to the **TV CTRL** input source button. If you have two TVs, assign the main TV to the **TV CTRL** button.

**TV ** – Use to turn on/off the power of the TV.

**TV VOL +/-** – Use to adjust the volume on your TV.

**INPUT SELECT** – Use to select the TV input signal.

**TV CH +/-** – Use to select channels.

A

## 8 Component control buttons

The main buttons (▶, ■, etc.) are used to control a component after you have selected it using the input source buttons.

The controls above these buttons can be accessed after you have selected the corresponding input source button (for example **DVD**, **DVR1** or **TV**). The following controls can be accessed when listening to the built-in tuner:

**MPX** – Switches between stereo and mono reception of FM broadcasts. If the signal is weak then switching to mono will improve the sound quality.

**DISP** – Switches between named station presets and radio frequencies.

## 9 STATUS

Press to check selected receiver settings.

## 10 MULTI OPE

Use this button to perform multi operations.

## 11 SHIFT

Press to access the controls outlined in white boxes (for example, **INPUT SELECT** ) , or to display the currently selected input source in the remote control LCD.

## 12 SOURCE

Press to turn on/off other components connected to the receiver.

## 13 Character display (LCD)

This display shows information when transmitting control signals.

The following commands are shown when you're setting the remote to control other components (see Controlling the rest of your system):

**SETUP** – Indicates the setup mode, from which you choose the options below

**PRESET** – See Selecting preset codes directly.

**LEARNING** – See Programming signals from other remote controls.

**MULTI OP** – See Multi Operation and System Off.

**SYS OFF** – See Multi Operation and System Off.

**DIRECT F** – See Direct function.

**RENAME** – See Renaming input source names.

**ERASE** – See Erasing one of the remote control button settings.

**RESET** – See Resetting the remote control presets.

**READ ID** – See Confirming preset codes.

## 14 RECEIVER

Switches the remote to control the receiver (used to select the green commands above the number buttons (**ANALOG ATT**, etc)). Also use this button to set up surround sound . With **SHIFT**, this selects the multi-room control.

## 15 VOL +/-

Use to set the listening volume.

## 16 MUTE

Mutes the sound or restores the sound if it has been muted (adjusting the volume also restores the sound).

## 17 Receiver controls

**SIGNAL SEL** – Use to select an input signal.

**SBch** – Use to select the surround/virtual back channel mode.

**STEREO** – Switches between direct and stereo playback. Direct playback bypasses the tone controls and any other signal processing for the most accurate reproduction of a source.

**THX** – Press to select a Home THX listening mode.

**STANDARD** – Press for Standard decoding and to switch between the various  Pro Logic IIx and Neo:6 options.

**ADV.SURR** – Use to switch between the various surround modes.

**18 PHASE** – Press to switch on/off Phase Control.

**MCACC** – Press to switch between MCACC presets.

**S.DIRECT** – Press to select Auto Surround or Stream Direct listening.

D

E

F

■

5

■

6

■

7

■

8

■

A

■

B

■

C

■

D

■

E

■

F

■

5

■

6

VSX-2016AV-S

■

7

■

8

■

## ■ Jigs list

A

Name	Jig No.	Remarks
11P board to board extension jig cable	GGD1482	Diagnosis
13P board to board extension jig cable	GGD1483	Diagnosis
15P board to board extension jig cable	GGD1484	Diagnosis
21P board to board extension jig cable	GGD1485	Diagnosis
RS-232C I/F jig	GGF1348	Update the Flash ROMS
7-pin FFC	VDA1681	Update the Flash ROMS

B

## ■ CLEANING



Before shipping out the product, be sure to clean the following positions by using the prescribed cleaning tools:

Position to be cleaned	Cleaning tools
Fans	Cleaning paper : GED-008

C

D

E

F