

 **PIONEER®**

Service Manual

**CIRCUIT DESCRIPTIONS
REPAIR & ADJUSTMENTS**

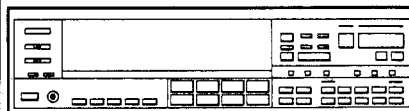

**ORDER NO.
ARP1243-A**

AUDIO/VIDEO STEREO RECEIVER

VSX-4000(BK)

MODEL VSX-4000(BK) COMES IN TWO VERSIONS DISTINGUISHED AS FOLLOWS:

Type	Power requirement	Export destination
KUC	AC120V only	U.S.A and Canada
S/G	AC110V, 120V, 220V, 240V (Switchable)	U.S.Military

- This service manual is applicable to the KUC and S/G types.
- As to the S/G type, please refer to pages 32.
- As to the circuit descriptions, please refer to the VSX-5000(BK) service manual (ARP1241).

CONTENTS

1. SAFETY INFORMATION	2
2. EXPLODED VIEW AND PARTS LIST	3
3. PACKING	6
4. P.C. BOARDS CONNECTION DIAGRAM.	7
5. SCHEMATIC DIAGRAM	15
6. ELECTRICAL PARTS LIST	23
7. ADJUSTMENTS	27
8. REMOTE CONTROL UNIT	29
9. FOR S/G TYPE	32

PIONEER ELECTRONIC CORPORATION 4-1, Meguro 1-Chome, Meguro-ku, Tokyo 153, Japan
PIONEER ELECTRONICS SERVICE INC. P.O. Box 1760, Long Beach, California 90801 U.S.A. | TEL: (213) 420-5700
PIONEER ELECTRONIC (EUROPE) N.V. Keetberglaan 1, 2740 Beveren, Belgium | TEL: 03/775-28-08
PIONEER ELECTRONICS AUSTRALIA PTY. LTD. 178-184 Boundary Road, Braeside, Victoria 3195, Australia
TEL: (03) 580-9911

SI© AUG. 1986 Printed

1. SAFETY INFORMATION

1. SAFETY PRECAUTIONS

The following check should be performed for the continued protection of the customer and service technician.

LEAKAGE CURRENT CHECK

Measure leakage current to a known earth ground (water pipe, conduit, etc.) by connecting a leakage current tester such as Simpson Model 229-2 or equivalent between the earth ground and all exposed metal parts of the appliance (input/output terminals, screwheads, metal overlays, control shaft, etc.). Plug the AC line cord of the appliance directly into a 120V AC 60Hz outlet and turn the AC power switch on. Any current measured must not exceed 0.5mA.

ANY MEASUREMENTS NOT WITHIN THE LIMITS OUTLINED ABOVE ARE INDICATIVE OF A POTENTIAL SHOCK HAZARD AND MUST BE CORRECTED BEFORE RETURNING THE APPLIANCE TO THE CUSTOMER.

2. PRODUCT SAFETY NOTICE

Many electrical and mechanical parts in the appliance have special safety related characteristics. These are often not evident from visual inspection nor the protection afforded by them necessarily can be obtained by using replacement components rated for voltage, wattage, etc. Replacement parts which have these special safety characteristics are identified in this Service Manual.

Electrical components having such features are identified by marking with a Δ on the schematics and on the parts list in this Service Manual.

The use of a substitute replacement component which does not have the same safety characteristics as the PIONEER recommended replacement one, shown in the parts list in this Service Manual, may create shock, fire, or other hazards.

Product Safety is continuously under review and new instructions are issued from time to time. For the latest information, always consult the current PIONEER Service Manual. A subscription to, or additional copies of, PIONEER Service Manual may be obtained at a nominal charge from PIONEER.

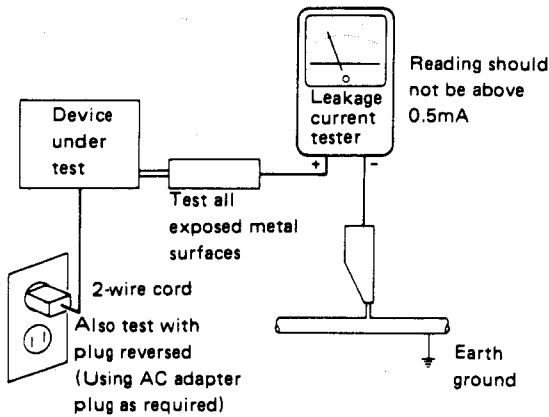

AC Leakage Test

4. P.C. BOARD CONNECTION DIAGRAM

External Appearance of Transistor and ICs

2SA933S
2SC1740S
2SC2668

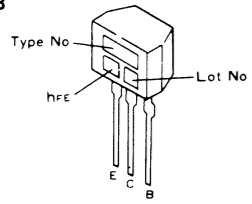

2SK161
2SK241-Y

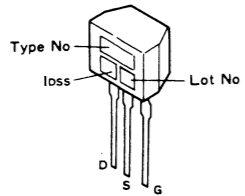

M5201P

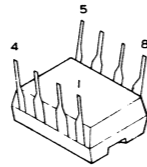

μPC78M05H
μPC78M12H

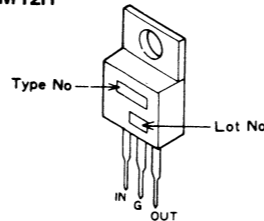

2SA968
2SB834
2SC2238
2SD880

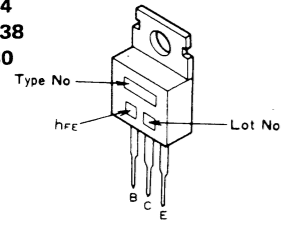

LM7001

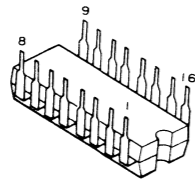

M5218P
M5218PF
M5220P
M51848P
MN3007

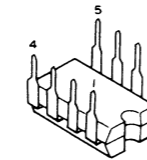

2SA1490(C)
2SC3854(C)

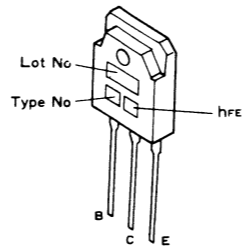

2SA979

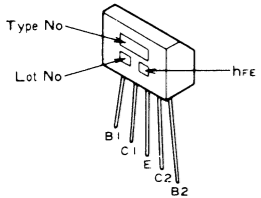

CX-789

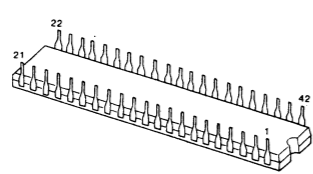

PD0012A

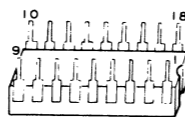

PD3068

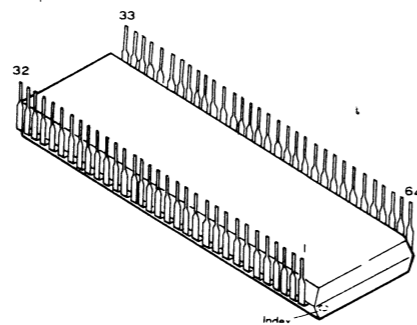

2SA1145
2SC2240
2SC2705

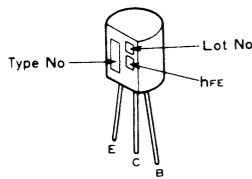

LA1265S

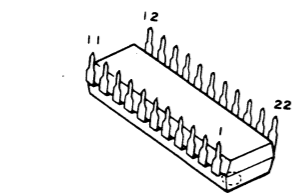

RN1201
RN1203
RN2203
RN2201

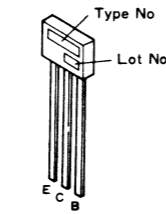

TC9163N

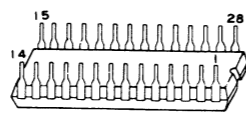

2SA1237

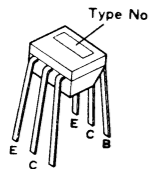

LA7580

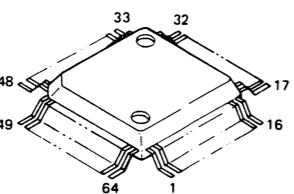

2SC2786

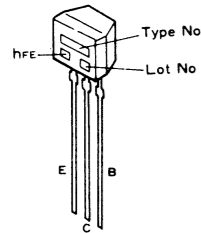

PA0016
TC4066BP
TC4069UBP
μPD4066BC

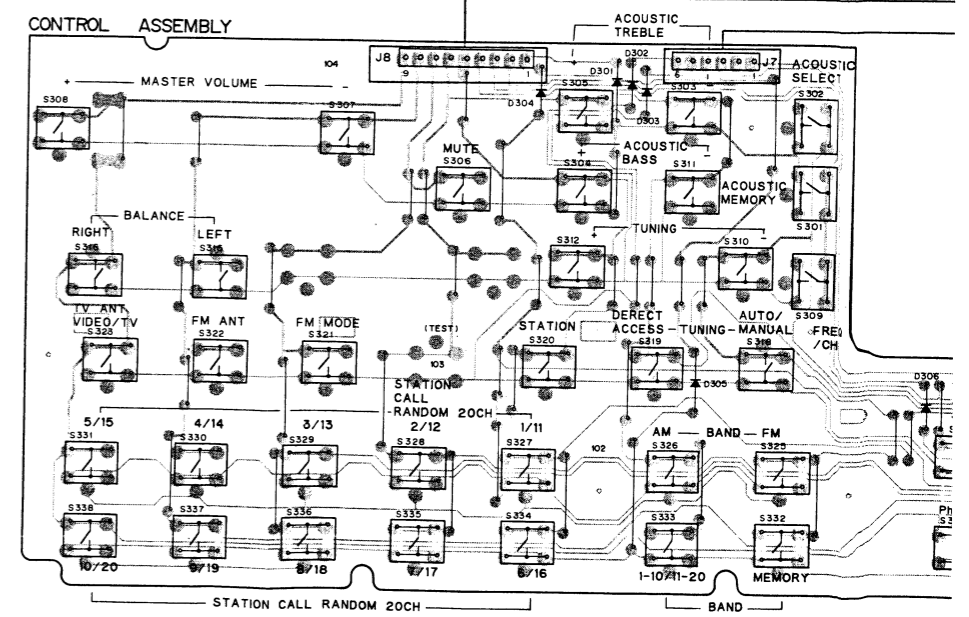
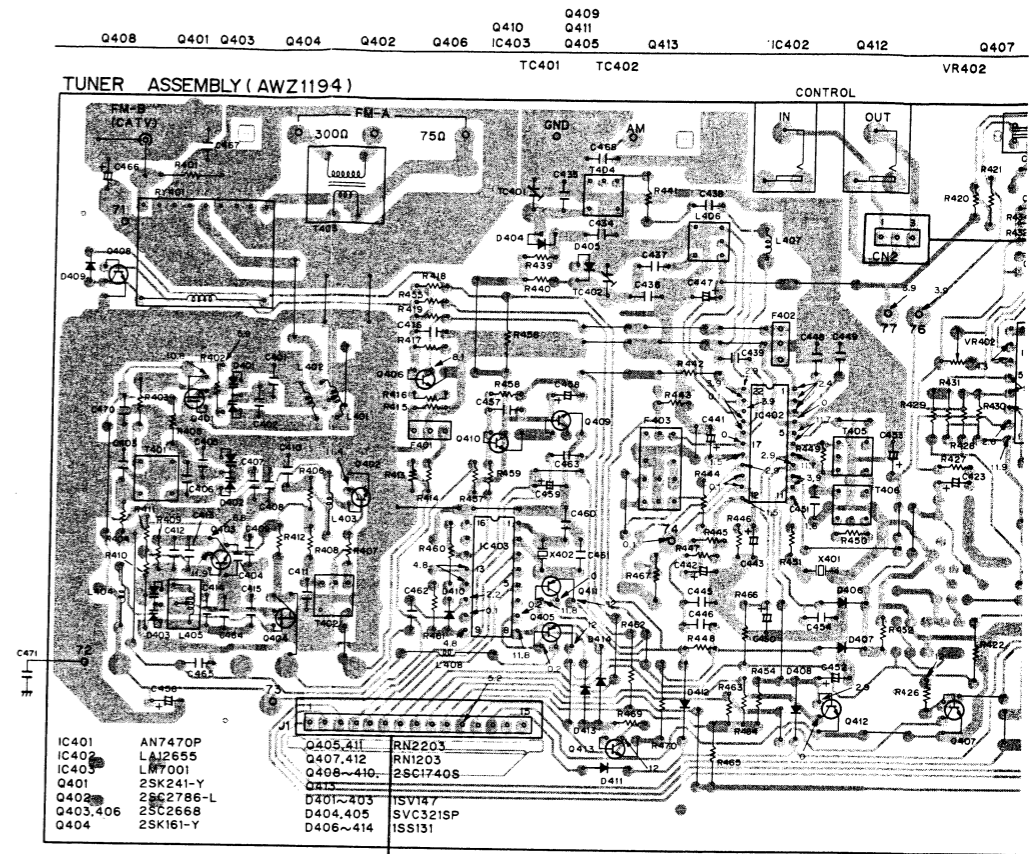
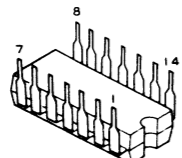

NOTES:

- Parts without part number cannot be supplied.
- The Δ mark found on some component parts indicates the importance of the safety factor of the part. Therefore, when replacing, be sure to use parts of identical designation.
- For your Parts Stock Control, the fast moving items are indicated with the marks $\Delta\Delta$ and Δ .
 $\Delta\Delta$ GENERALLY MOVES FASTER THAN Δ
 This classification shall be adjusted by each distributor because it depends on model number, temperature, humidity, etc.
- Parts marked by "⊙" are not always kept in stock. Their delivery time may be longer than usual or they may be unavailable.

3. PACKING

Parts List

Mark	No.	Part No.	Description
	1	AHA1020	Front pad
	2	AHA1021	Rear pad
	3	AHD1105	Packing case
	4	AEA1002	Antenna set
	5	ARB1030	Operating instruction (ENGLISH)
	51		Packing sheet
	52		Battery assembly

Parts List

Mark	No.	Part No.	Description	Mark	No.	Part No.	Description
	1	AWZ1194	Tuner assembly		36	AEC-898	Rivet
	2	AWZ1104	Signal assembly		37	AEP-818	Mica sheet
	3		38
	4	AWZ1105	AF Video assembly		39	ABA-176	Screw
$\Delta\Delta$	5	2SA1490(C)	Transistor (Q1, Q3)		40	ABA-258	Screw
$\Delta\Delta$	6	2SC3854(C)	Transistor (Q2, Q4)	Δ	41	ADG-089	AC power cord
	7		42
$\Delta\Delta$	8	CKDYF473Z50	Ceramic capacitor (C2)		43	BBZ30P080FZK	Screw
$\Delta\Delta$	9	ATS1033	Power transformer (AC120V, T1)		44
$\Delta\Delta$	10	ATT1016	Power transformer (AC120V, T2)		45
$\Delta\Delta$	11	AKX1004	Line voltage selector (S1)		46	FBT40P080FZK	Screw
$\Delta\Delta$	12	AEK-108	Fuse (AC125V, 5A, FU1)		47	VBZ40P080FMC	Screw
$\Delta\Delta$	13	AEK-100	Fuse (AC125V, 4A, FU3, FU4)		48	VMZ30P060FMC	Screw
$\Delta\Delta$	14	AEK-008	Battery		49	AKP-515	AC socket (AC OUTLET)
	15	AEC-784	Leg assembly		101		Control assembly
	16	AMR1049	Lamp assembly		102		LCD assembly
	17	AEL1020	Lamp with lead wire		103		Remote control assembly
	18	AAD1046	Knob A (VCR1)		104		SP. Switch assembly
	19	AAD1047	Knob B (VCR2)		105		Head phone terminal assembly
	20	AAD1048	Knob C (VDP/VCR3)		106		Power switch assembly
	21	AAD1049	Knob D (VIDEO SIGNAL SELECTOR)		107	
	22	AAD1050	Knob E (TAPE1)		108		Chassis
	23	AAD1051	Knob E (TAPE2)		109		Rear panel
	24	AAD1052	Knob G (CD)		110		Bottom plate
	25	AAD1053	Knob H (PHONO)		111		P.C.B holder
	26	AAH1005	Aluminum panel LU		112		Head phone holder
	27	AAH1009	Aluminum panel LD		113		Heat sink
	28	AAH1010	Aluminum panel RU		114		Rubber (A)
	29	AAH1008	Aluminum panel RD		115		Rubber (B)
	30	AAK1117	Acrylic panel				
	31	AAM-030	Function board				
	32	AAY-157	Push knob (SPEAKERS)				
	33	AMB1084	Front panel				
	34	AMR1105	IR Filter				
	35	ANE1043	Bonnet case				

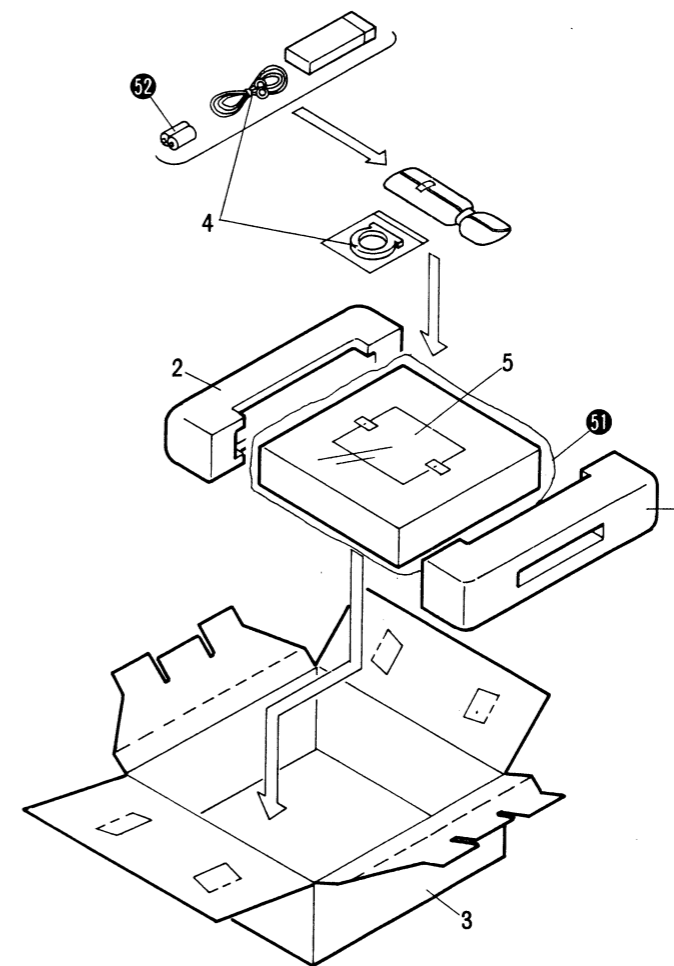

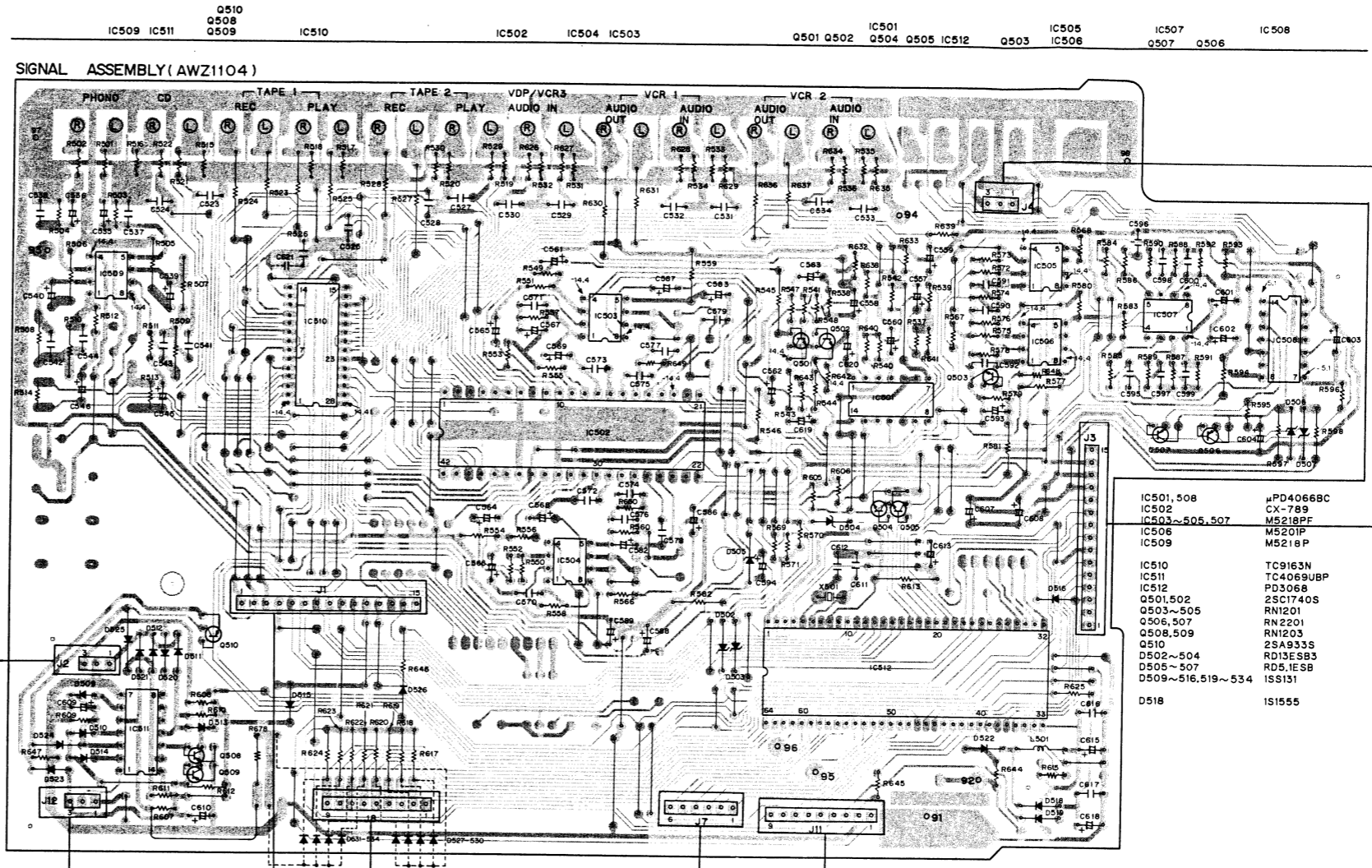
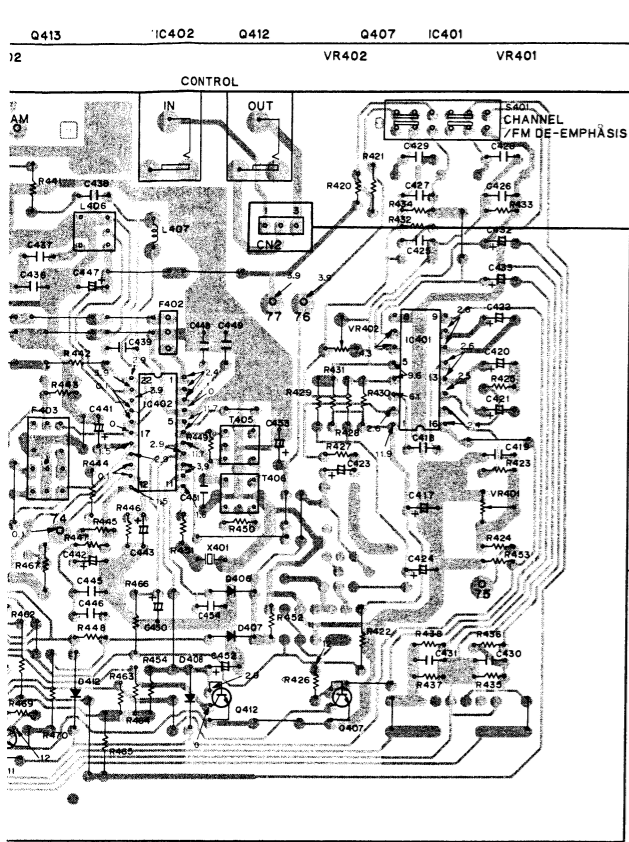

IC501, 508	μPD40668C
IC502	CX-789
IC503~505, 507	M5218PF
IC506	M5201P
IC509	M5218P
IC510	TC9163N
IC511	TC4069UBP
IC512	PD3068
Q501, 502	2SC1740S
Q503~505	RN1201
Q506, 507	RN2201
Q508, 509	RN1203
Q510	2SA933S
D502~504	RD13E9B3
D505~507	RD51E5B
D509~516, 519~534	ISS131
D518	IS1555

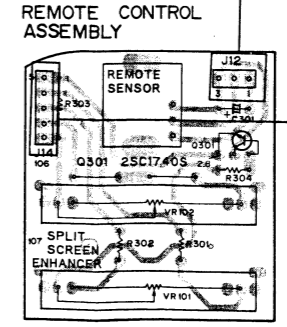
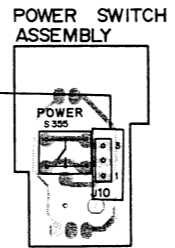
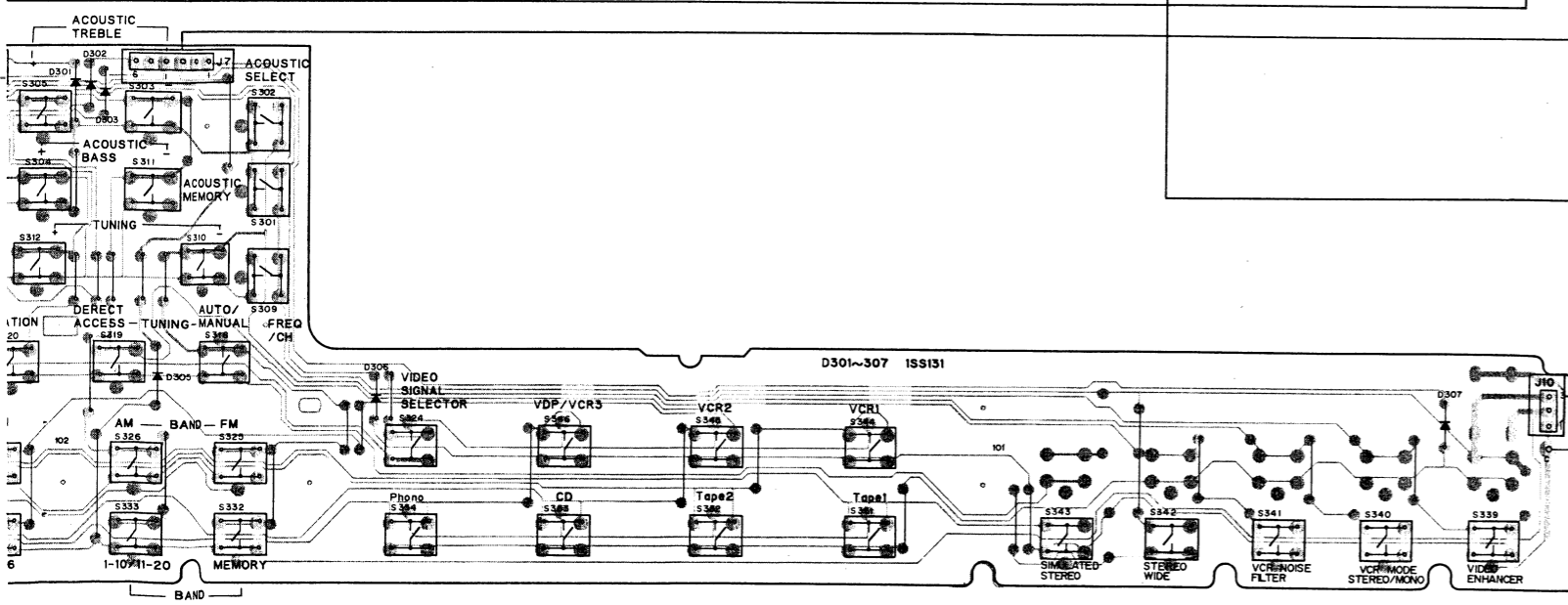

Q112 Q110 Q109 Q103 Q101
 Q116 Q111 Q115 Q114 Q102 Q113
 Q107 Q108 Q118 IC104 Q201 Q128 Q129
 Q202 Q119 Q205 Q209 Q216 IC101 IC106
 Q212 Q208 IC202 Q206 Q210 Q214 Q209 Q216 IC201 Q213 Q210 Q211 IC105 Q122 Q215 Q217 Q221 Q218 Q219 Q220 IC203 IC204 Q223 Q222 Q226 Q225 IC206

AF VIDEO ASSEMBLY (AWZ1105)

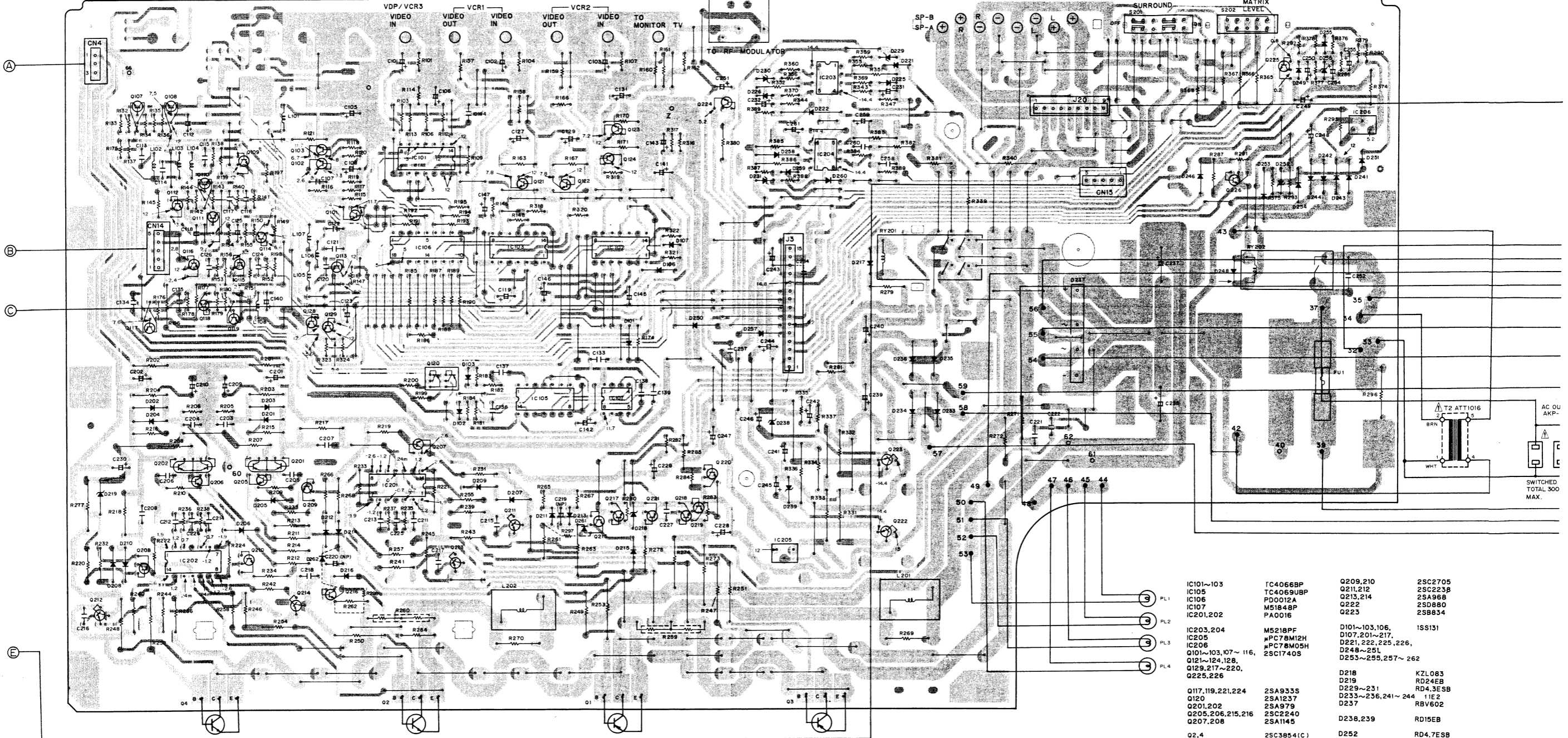

IC101~103	IC4056BP	Q209,210	25C2705
IC105	TC4069UBP	Q211,212	25C223B
IC106	P00012A	Q213,214	25A968
IC107	M51848P	Q222	25D880
IC201,202	PA0016	Q223	25B834
IC203,204	M5218PF	D101~103,106,	1SS131
IC205	PC78M12H	D107,201~217,	
IC206	PC78M05H	D221,222,225,226,	
Q101~103,107~116,	25C1740S	D248~25L	
Q121~124,128,		D253~255,257~262	
Q129,217~220,			
Q225,226			
Q117,119,221,224	25A933S	D218	K2L083
Q120	25A1237	D219	RD24EB
Q201,202	25A979	D229~231	RD4.3E5B
Q205,206,215,216	25C2240	D233~236,241~244	1IE2
Q207,208	25A1145	D237	RBV602
Q2,4	25C3854(C)	D238,239	RD15EB
Q1,3	25A1490(C)	D252	RD4.7E5B
		D256	RD5.6E5B

LCD ASSEMBLY

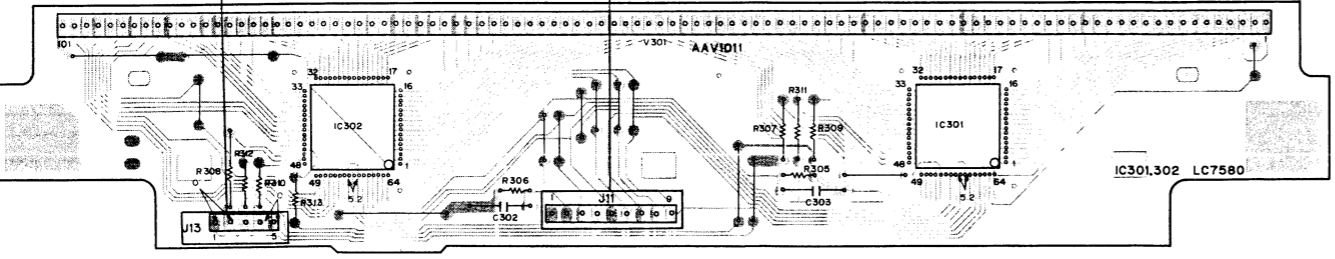

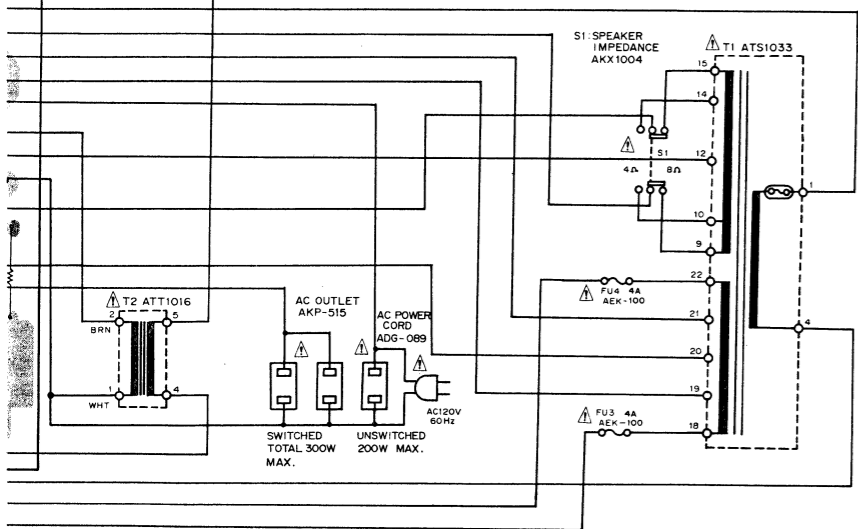
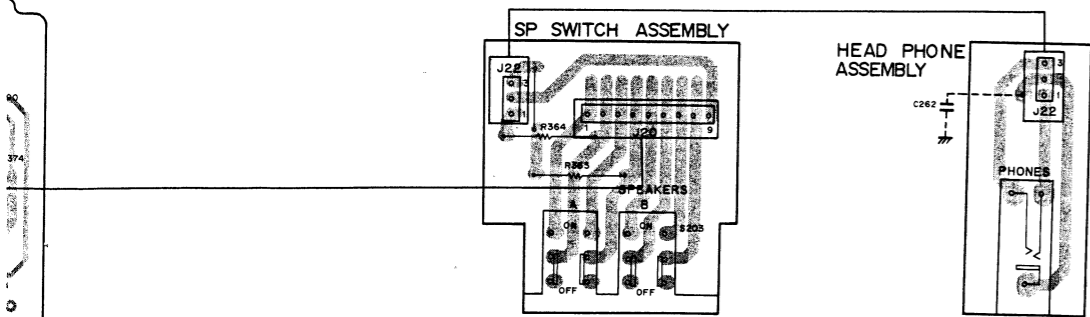

25C2705
 25C2239
 25A968
 25D880
 25B834

06. ISS131
 217.
 225, 226,

257~262

KZL083
 RD24EB
 RD4.3ESB
 241~244 11E2
 RBV602

RD15EB
 RD4.7ESB
 RD5.6ESB

A

B

C

D

5. SCHEMATIC DIAGRAM

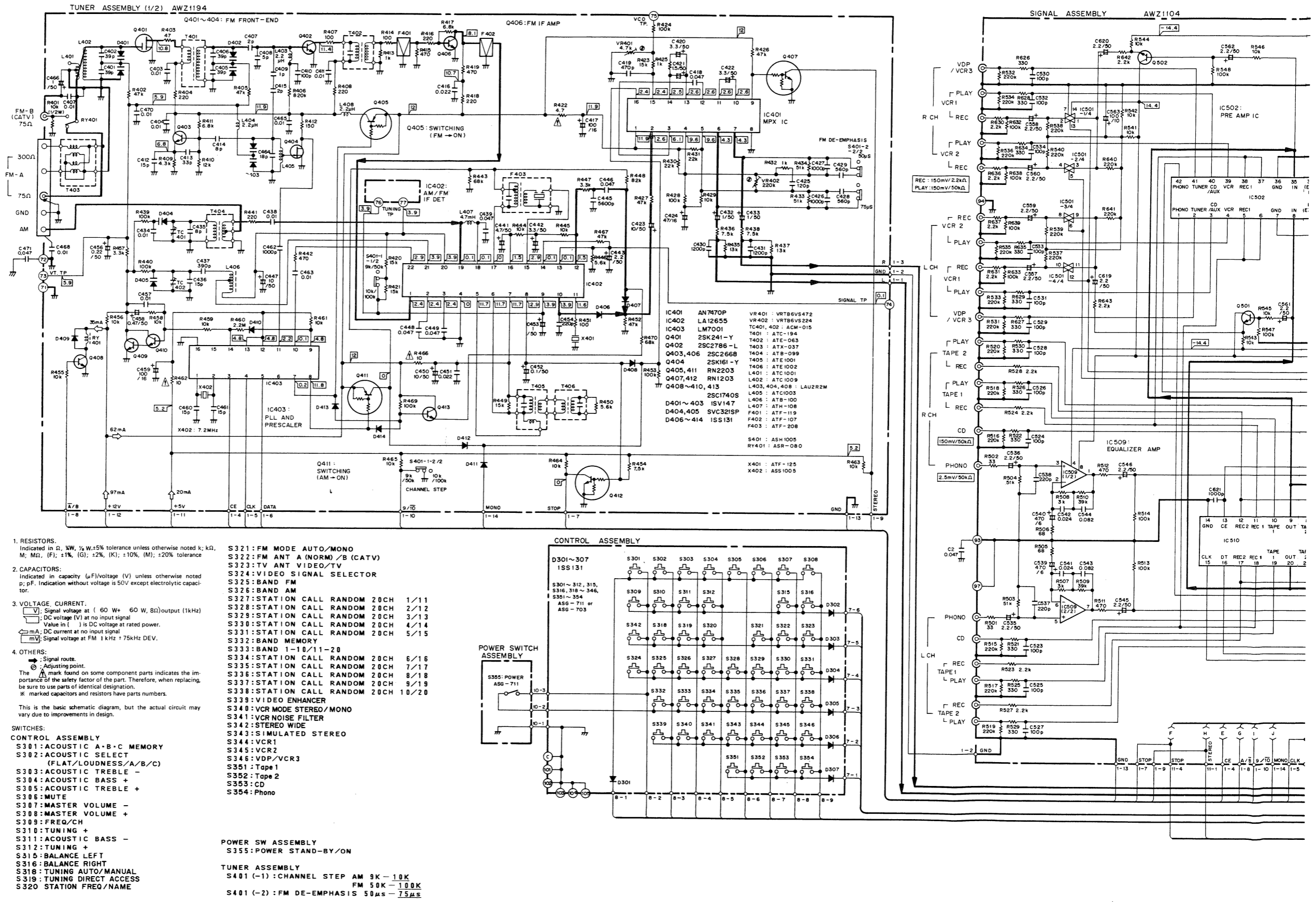

- 1. RESISTORS.**
Indicated in Ω, kW, ¼ W, ½ W, 1 W, 5% tolerance unless otherwise noted k; kΩ, M; MΩ, (F); ±1%, (G); ±2%, (K); ±10%, (M); ±20% tolerance
- 2. CAPACITORS:**
Indicated in capacity (μF)/voltage (V) unless otherwise noted p, pF. Indication without voltage is 50V except electrolytic capacitor.
- 3. VOLTAGE, CURRENT.**
V: Signal voltage at (60 W ± 60 W, 8Ω) output (1kHz)
DC voltage (V) at no input signal
Value in [] is DC voltage at rated power.
mA: DC current at no input signal
mV: Signal voltage at FM 1kHz ± 75kHz DEV.
- 4. OTHERS:**
Signal route
Adjusting point
The mark found on some component parts indicates the importance of the safety factor of the part. Therefore, when replacing, be sure to use parts of identical designation.
marked capacitors and resistors have parts numbers.
- This is the basic schematic diagram, but the actual circuit may vary due to improvements in design.
- SWITCHES:**
- CONTROL ASSEMBLY**
S301: ACOUSTIC A-B-C MEMORY
S302: ACOUSTIC SELECT (FLAT/LOUDNESS/A/B/C)
S303: ACOUSTIC TREBLE -
S304: ACOUSTIC BASS +
S305: ACOUSTIC TREBLE +
S306: MUTE
S307: MASTER VOLUME -
S308: MASTER VOLUME +
S309: FREQ/CH
S310: TUNING +
S311: ACOUSTIC BASS -
S312: TUNING +
S315: BALANCE LEFT
S316: BALANCE RIGHT
S318: TUNING AUTO/MANUAL
S319: TUNING DIRECT ACCESS
S320: STATION FREQ/NAME
- S321: FM MODE AUTO/MONO
S322: FM ANT A (NORM)/B (CATV)
S323: TV ANT VIDEO/TV
S324: VIDEO SIGNAL SELECTOR
S325: BAND FM
S326: BAND AM
S327: STATION CALL RANDOM 20CH 1/11
S328: STATION CALL RANDOM 20CH 2/12
S329: STATION CALL RANDOM 20CH 3/13
S330: STATION CALL RANDOM 20CH 4/14
S331: STATION CALL RANDOM 20CH 5/15
S332: BAND MEMORY
S333: BAND 1-10/11-20
S334: STATION CALL RANDOM 20CH 6/16
S335: STATION CALL RANDOM 20CH 7/17
S336: STATION CALL RANDOM 20CH 8/18
S337: STATION CALL RANDOM 20CH 9/19
S338: STATION CALL RANDOM 20CH 10/20
S339: VIDEO ENHANCER
S340: VCR MODE STEREO/MONO
S341: VCR NOISE FILTER
S342: STEREO WIDE
S343: SIMULATED STEREO
S344: VCR1
S345: VCR2
S346: VDP/VCR3
S351: Tape 1
S352: Tape 2
S353: CD
S354: Phono
- POWER SW ASSEMBLY**
S355: POWER STAND-BY/ON

The underlined indicates the switch position.

A
B
C
D

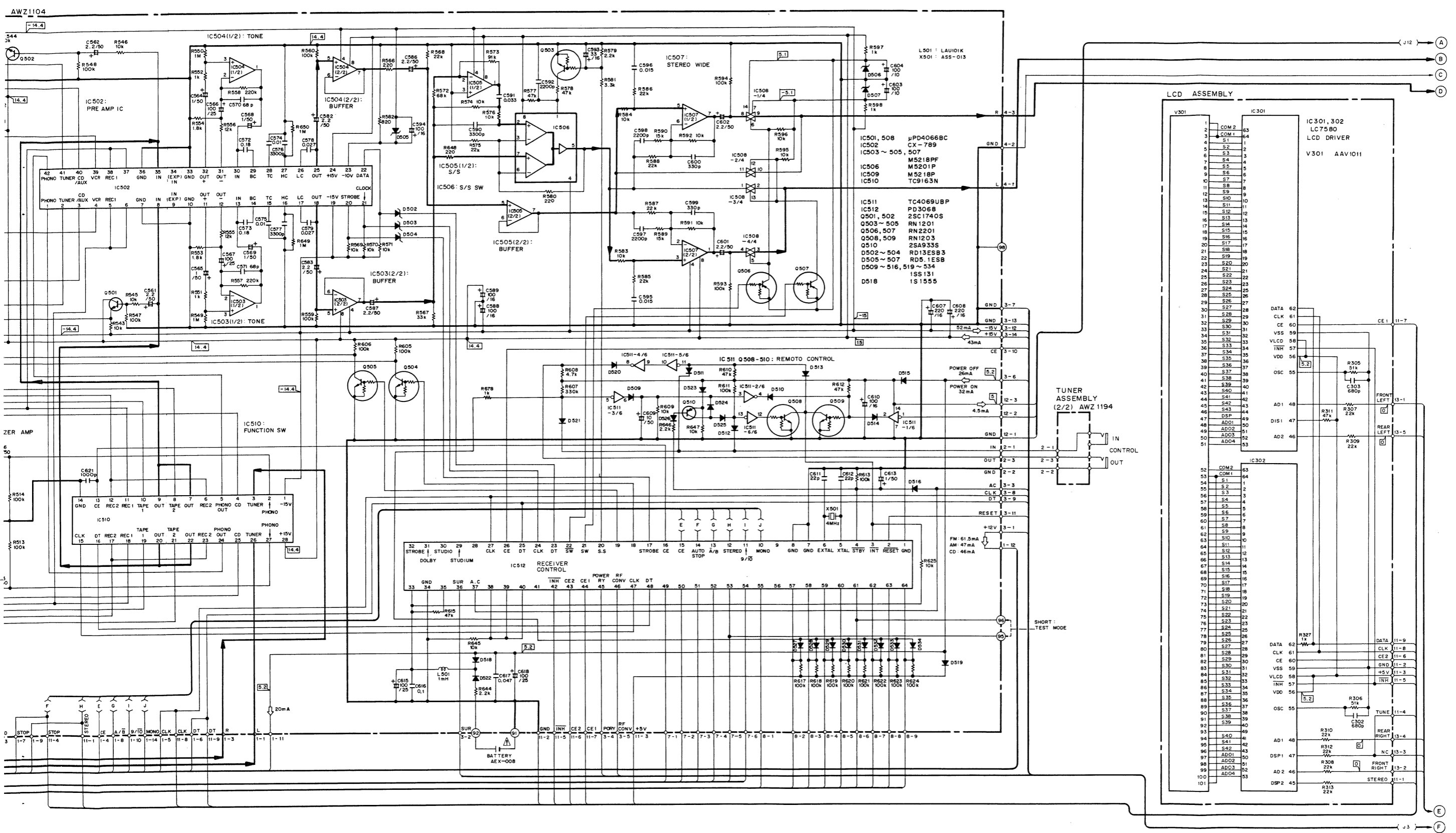

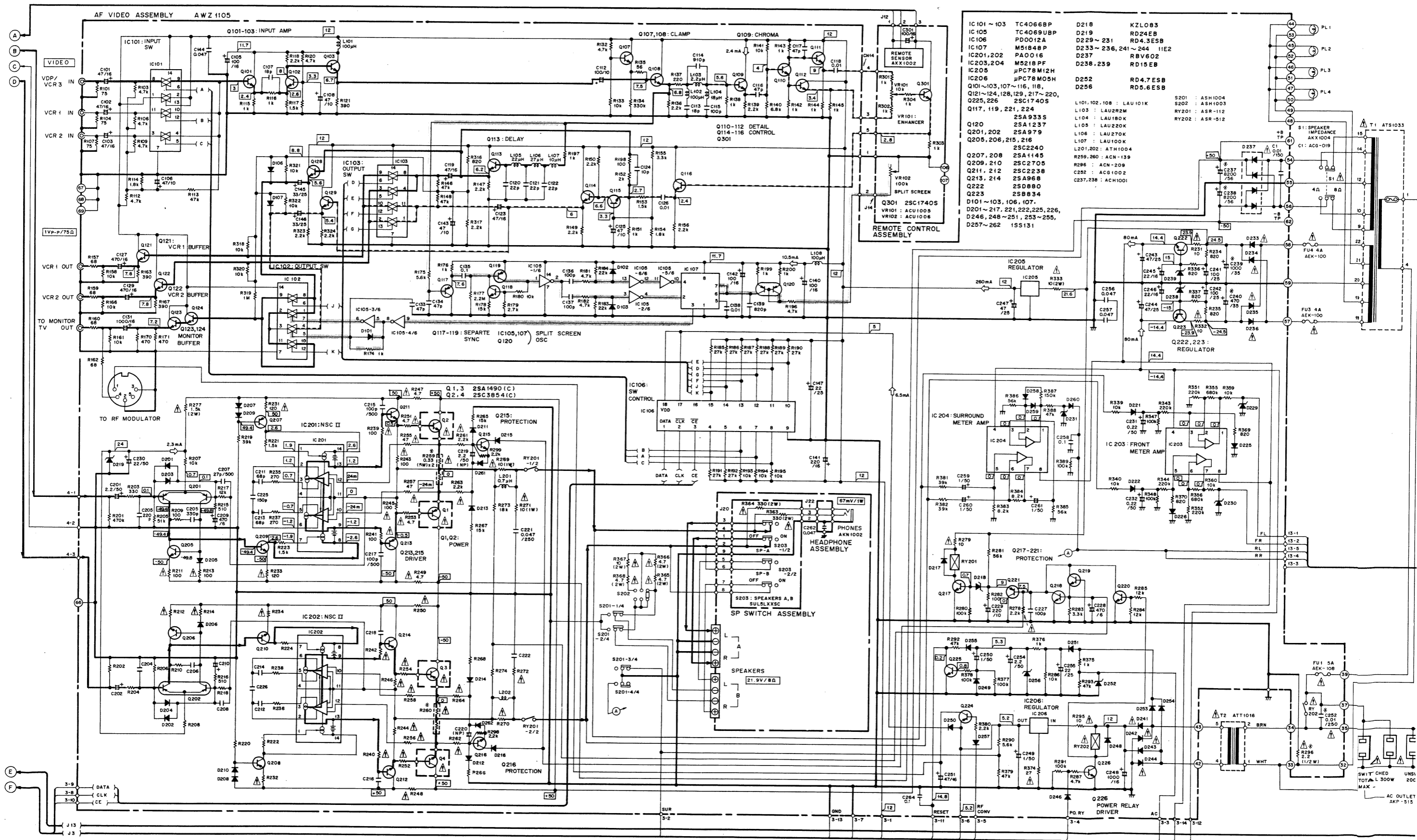

IC101 ~ 103	TC4066BP	D218	KZL083
IC105	TC4069UBP	D219	RD24EB
IC106	P00012A	D229 ~ 231	RD4.3ESB
IC107	M51848P	D233 ~ 236, 241 ~ 244	11E2
IC201,202	PA0016	D237	RBV602
IC203,204	M5218PF	D238,239	RD15EB
IC205	μPC78M12H		
IC206	μPC78M05H	D252	RD4.7ESB
Q101~103,107~116, 118,		D256	RD5.6ESB
Q121~124,128,129, 217~220,			
Q225,226	2SC1740S		
Q117, 119, 221, 224			
Q120	2SA933S		
Q201, 202	2SA1237		
Q205, 206, 215, 216	2SA979		
Q207, 208	2SA1145		
Q209, 210	2SC2705		
Q211, 212	2SC2238		
Q213, 214	2SA968		
Q222	2SD880		
Q223	2SB834		
D101~103, 106, 107,			
D201~217, 221,222,225,226,			
D246, 248~251, 253~255,			
D257~262	15S131		

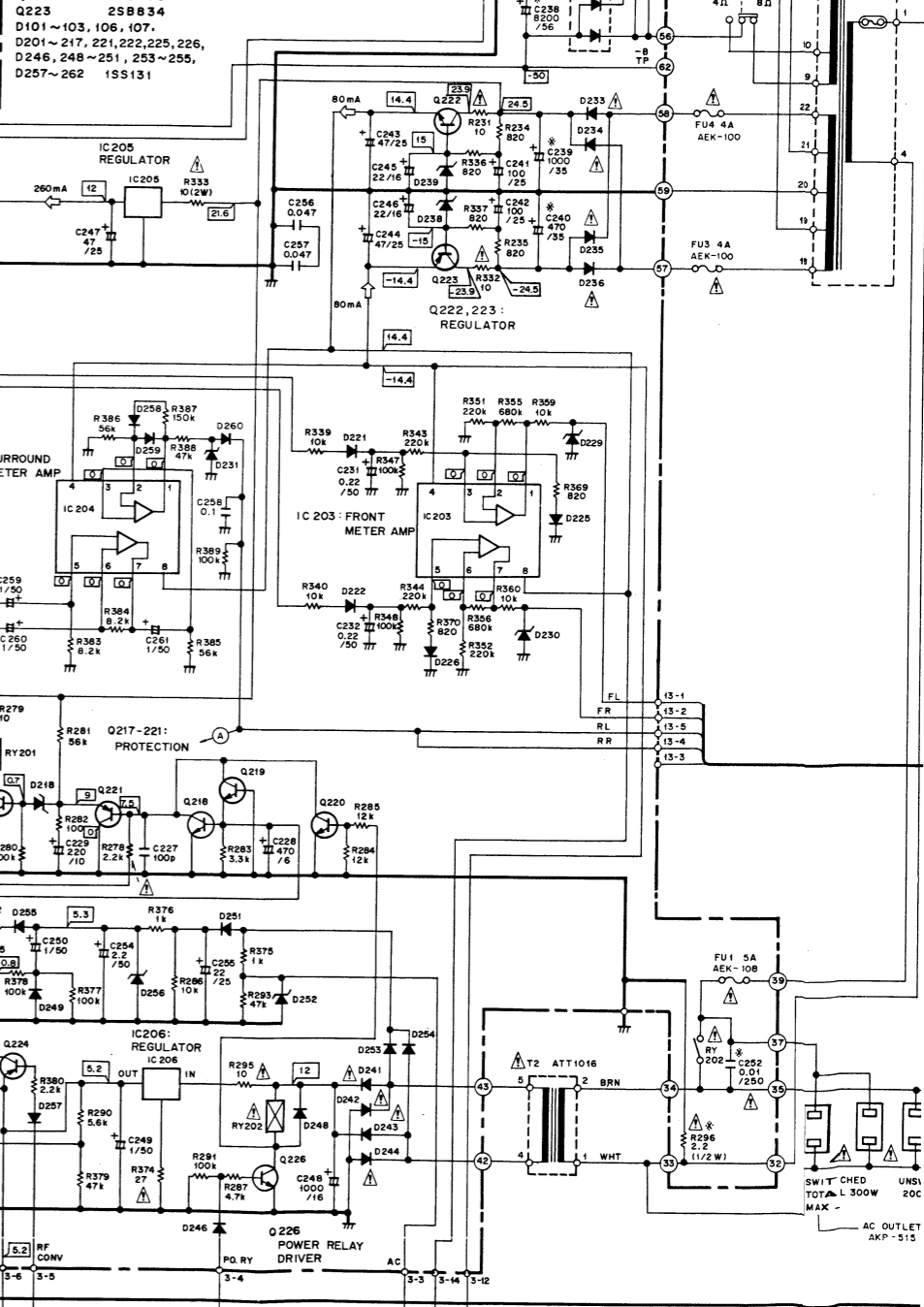

NOTE:
 The indicated semiconductors are representative ones only. Other alternative semiconductors may be used and are listed in the parts list.

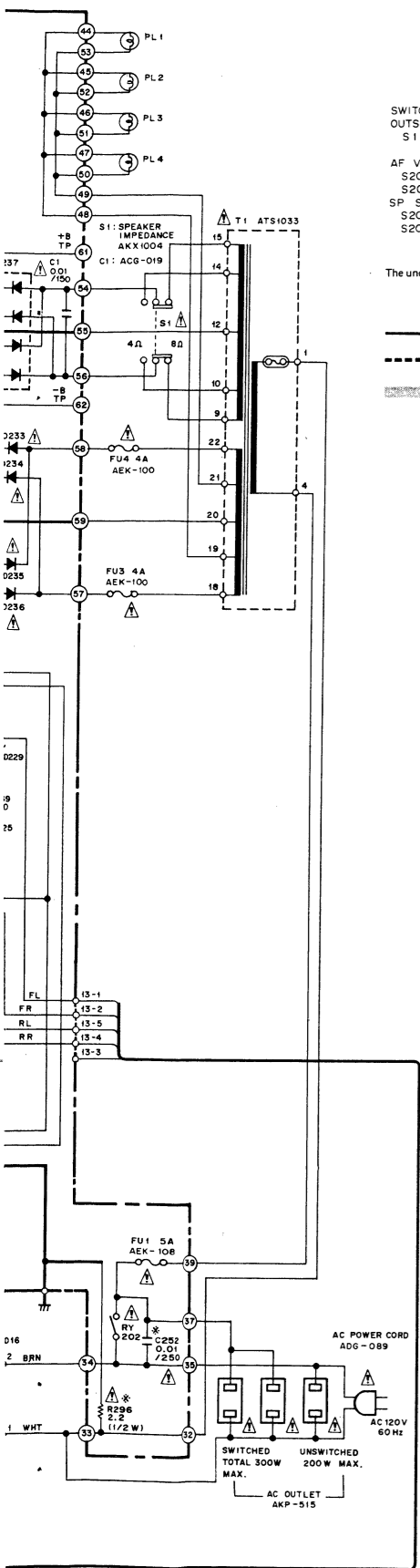

SWITCHES
 OUTSIDE OF P.C BOARD ASSEMBLY
 S1: SPEAKER IMPEDANCE SELECTOR A, B
 4Ω - 8Ω
 AF VIDEO ASSEMBLY
 S201: SURROUND ON - OFF
 S202: MATRIX LEVEL HI - M.L. - Lo
 SP SW ASSEMBLY
 S203 (1/2): SPEAKERS A ON - OFF
 S203 (2/2): SPEAKERS B ON - OFF

The underlined indicates the switch position.

— VIDEO SIGNAL (ORIGINAL SIGNAL)
 - - - ENHANCER SIGNAL
 SPRIT SCREEN CONTROL SIGNAL

A

B

C

D

OTHERS

Mark	Symbol & Description	Part No.
*	X501 Crystal resonator Terminal (4P) Terminal (6P)	ASS-013 AKB1007 AKB1008

**AF Video Assembly (AWZ1105)
SEMICONDUCTORS**

Mark	Symbol & Description	Part No.
**	IC107	M51848P
**	IC203, IC204	M5218PF
**	IC201, IC202	PA0016
**	IC106	PDO012A
**	IC101—IC103	TC4066BP
**	IC105	TC4069UBP
**	IC206	μ PC78M05H
**	IC205	μ PC78M12H
**	Q207, Q208	2SA1145
**	Q120	2SA1237
**	Q117, Q119, Q221, Q224	2SA933S
**	Q213A, Q214A	2SA968
**	Q201B, Q202B	2SA979
**	Q223	2SB834
**	Q101—Q103, Q107—Q116, Q121—Q124, Q128, Q129, Q217—Q220, Q225, Q226, Q118	2SC1740S
**	Q211A, Q212A	2SC2238
**	Q205, Q206, Q215, Q216	2SC2240
**	Q209, Q210	2SC2705
**	Q222	2SD880
**	D218	KZL083
Δ *	D237	RBV602
*	D238, D239	RD15EB
*	D219	RD24EB
*	D229—D231	RD4.3ESB
*	D252	RD4.7ESB
*	D256	RD5.6ESB
*	D101—D103, D106, D107, D201—D217, D221, D222, D225, D226, D246, D248—D251, D253—D255, D257—D262	1SS131
*	D233—D236, D241—D244	11E2

SWITCHES AND RELAYS

Mark	Symbol & Description	Part No.
**	S201 (SURROUND SW)	ASH1004
**	S202 (MATRIX LEVEL)	ASH1003
*	RY201	ASR-112
Δ *	RY202	ASR-512

COILS

Mark	Symbol & Description	Part No.
	L201, L202 Choke coil (0.7mH)	ATH1004
	L107 Inductor (10 μ H)	LAU100K
	L101, L102, L108 Inductor (100 μ H)	LAU101K
	L104 Inductor (18 μ H)	LAU180K

Mark	Symbol & Description	Part No.
	L103 Inductor (2.2 μ H)	LAU2R2M
	L105 Inductor (22 μ H)	LAU220K
	L106 Inductor (27 μ H)	LAU270K

CAPACITORS

Mark	Symbol & Description	Part No.
Δ	C252 (0.01 μ F/AC120V) C237, C238 (8200/56) C124	ACG1002 ACH1001 CCCCH100D50
Δ	C115 C1 Ceramic capacitor (0.01 μ F/AC150V)	CCCCH101J50 ACG-019
	C113 C120—C122 C136, C137, C227 C215—C218 C225, C226	CCCCH180J50 CCCCH220J50 CCCSL101J50 CCCSL101K500 CCCSL151J50
	C107 C203, C204 C207, C208 C116, C117, C133, C134 C211—C214	CCCSL180J50 CCCSL221J50 CCCSL270K500 CCCSL470J50 CCCSL680J50
	C219, C220 C231, C232 C249, C250, C259—C261 C112 C105, C140, C142	CEANP2R2M100 CEASR22M50 CEAS010M50 CEAS101M10 CEAS101M16
	C241, C242 C248, C131 C239 C201, C202, C254 C245, C246	CEAS101M25 CEAS102M16 CEAS102M35 CEAS2R2M50 CEAS220M16
	C147 C230 C229 C141 C145, C146	CEAS220M25 CEAS220M50 CEAS221M10 CEAS221M16 CEAS330M25
	C255 C106, C108, C125, C143 C101—C103, C119, C123, C251 C243, C244, C247 C127, C129	CEAS4R7M50 CEAS220M25 CEAS470M16 CEAS470M25 CEAS471M16
	C240 C209, C210, C228 C205, C206 C118, C126, C138 C144, C257	CEAS471M35 CEAS471M6 CKCYB331K50 CKCYX103M25 CKDYF473Z50
	C258 C135 C221, C222 C139 C114 C264	CKDYX104M25 CQMA104J50 CQMA473K250 CQSA821J50 CQSA911J50 CKCYX104M25

RESISTORS

NOTE: When ordering resistors, convert the resistance value into code form, and then rewrite the part no. as before.

Mark	Symbol & Description	Part No.
Δ	R259, R260 (0.33 Ω 5Wx2)	ACN-139
Δ	R296 (2.2M Ω)	ACN-209

Mark	Symbol & Description	Part No.
Δ	R279	RD1/4PMFL100J
Δ	R211—R214, R239—R246, R255—R258, R261—R264, R278, R295, R331, R332, R374	RD1/4PMF \square \square \square J

Mark	Symbol & Description	Part No.
	R121, R163, R167, R170, R171, R177, R201—R204, R207—R210, R215—R224, R251—R254	RD1/4PM \square \square \square J
Δ	R231—R234	RFA1/4PS121J
Δ	R247—R250	RFA1/4PS4R7J
Δ	R269—R272	RS1LMF100J
Δ	R333, R367	RS2LMF100J
Δ	R277	RS2LMF152J
Δ	R365, R366, R368	RS2LMF4R7J
	Other resistors	RD1/8PM \square \square \square J

OTHERS

Mark	Symbol & Description	Part No.
	Pin jack (1P)	AKB1010
	Terminal (SPEAKERS) (8P)	AKE-111
	DIN socket (5P)	AKP-081

**Control Assembly
SEMICONDUCTORS**

Mark	Symbol & Description	Part No.
*	D301—D307	1SS131

SWITCHES

Mark	Symbol & Description	Part No.
**	S301—S312, S315, S316, S318—S346, S351—S354 Tact switch (ACOUSTIC MEMORY, ACOUSTIC, TREBLE-, BASS, MUTE, VOLUME-, VOLUME, FREQICH, TUNE-, BASS-, TUNE, BLANCE LEFT, BLANCE RIGHT, EXPANDER, AUTO/MANU, DIRECT, STATION NAME, FM MONO, CATV, TV/VIDEO, V.SEL, FM, AM, 1, 2, 3, 4, 5, MEMORY, 1-10/11-20, 6, 7, 8, 9, 10, V.ADP, ENHANCER, VCR MODE, NOISE FILTER, SIMULATED STEREO, VCR1, VCR2, VDP, STUDIO, STADIUM, DOLBY, TAPE1, TAPE2, CD, PHONO)	ASG-711 (ASG-703)

**LCD Assembly
SEMICONDUCTORS**

Mark	Symbol & Description	Part No.
**	IC301, IC302	LC7580

CAPACITORS

Mark	Symbol & Description	Part No.
	C302, C303	CKPYB681K50

RESISTORS

NOTE: When ordering resistors, convert the resistance value into code form, and then rewrite the part no. as before.

Mark	Symbol & Description	Part No.
	All resistors	RD1/8PM \square \square \square J

OTHERS

Mark	Symbol & Description	Part No.
*	V301 Indicator	AAV1011

**Remote Control Assembly
SEMICONDUCTOR**

Mark	Symbol & Description	Part No.
**	Q301	2SC1740S

CAPACITORS

Mark	Symbol & Description	Part No.
	C301	CEAS101M16

RESISTORS

Mark	Symbol & Description	Part No.
*	VR101 Semi-fixed (100k)	ACU1005
*	VR102 Semi-fixed (100k)	ACU1006
	R301—R304	RD1/8PM102J

CAPACITORS

Mark	Symbol & Description	Part No.
	C301	CEAS101M16

OTHERS

Mark	Symbol & Description	Part No.
	Remote control sensor unit	AXX1002

**SP switch Assembly
SWITCH**

Mark	Symbol & Description	Part No.
**	S203 Push switch (SPEAKER)	SUL5LXXSC

RESISTORS

Mark	Symbol & Description	Part No.
Δ	R363, R364	RS2LMF331J

Headphone Assembly

Mark	Symbol & Description	Part No.
	Jack (PHONE)	AKN1002

Power switch Assembly

Mark	Symbol & Description	Part No.
**	S355 Tact switch (POWER)	ASG-711 (ASG-703)

7. ADJUSTMENTS

FM Tuner Section

- Connect the FM signal generator (FM SG) to the FM ANTENNA 300Ω terminal through a 300Ω dummy antenna.
- Set the AUTO/MANUAL switch to the MANUAL position and the FUNCTION switch to the FM.

FM MONO ADJUSTMENT

Step	FM SG (1 kHz±75 kHz dev.)		Frequency display	Adjustment point	Adjustment procedure
	Frequency	Level			
1	No signal		87.5 MHz	—	Check pin 73 (3.4±1.5V) of tuner assembly. Check pin 73 (8.7 ^{+2.5V} _{-2.0V}) of tuner assembly.
2			108.0 MHz		
3	98 MHz	20~30 dB	98 MHz	T401, L402 T402	Set the output from pin 74 of tuner assembly to maximum level.
4	98 MHz	60 dB	98 MHz	T405	Adjust voltage across pins 76 and 77 of tuner assembly to T meter center. (±10 mV)
5	98 MHz	60 dB	98 MHz	T406	Minimize distortion.
6	Repeat steps 4 and 5 until both specification ratings are satisfied.				

FM MPX ADJUSTMENT

7	98 MHz	80 dB	98 MHz	VR401	Adjust the frequency at pin 75 of tuner assembly to 75.8 kHz (±100 Hz)
	No modulation				
8	98 MHz	60 dB	98 MHz	T402	Minimize distortion in both left and right channel outputs (adjust T402 to within ±90°)
	Stereo modulation*				
9	98 MHz	60 dB	98 MHz	VR402	Maximize separation.
	Stereo modulation*				
10	98 MHz	10 dB	98 MHz	—	Confirm that TUNER IND and STEREO IND are extinguished.
	Stereo modulation*				

* Stereo modulation: Main 1 kHz L+R ±68.25 kHz dev. Pilot 19 kHz ±6.75 kHz dev.

AM (MW) Tuner Section

- Connect loop antenna to the AM signal generator (AM SG), and connect the Loop antenna (of the set) to AM ANTENNA terminal.
- Set the FUNCTION switch to the AM (MW) .

Step	AM SG (400Hz, 30% MOD)		Frequency display	Adjustment point	Adjustment procedure
	Frequency	Level			
1	No signal		531 kHz	L406	Set pin 73 of tuner assembly to 1.2V (±0.05V) Set pin 73 tuner assembly to 10.0V (±0.1V)
2			1602 kHz	TC402	
3	Repeat steps 1 and 2 until both specification ratings are satisfied.				
4	603 kHz	40 dB	603 kHz	T404	Set the output from pin 74 of tuner assembly to maximum level.
5	1395 kHz	40 dB	1395 kHz	TC401	
6	Repeat steps 4 and 5 until both specification ratings are satisfied.				
7	999 kHz	55 dB	999kHz	Confirm that TUNER IND becomes lit.	

- The distance between AM SG side loop antenna A and the receiver side (VSX-4000(BK)) loop antenna B, that is, from the center of A side loop antenna to that of B side loop antenna should be 60 cm.

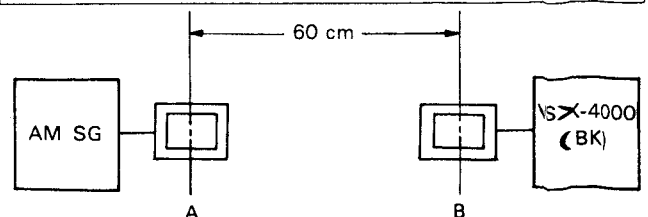

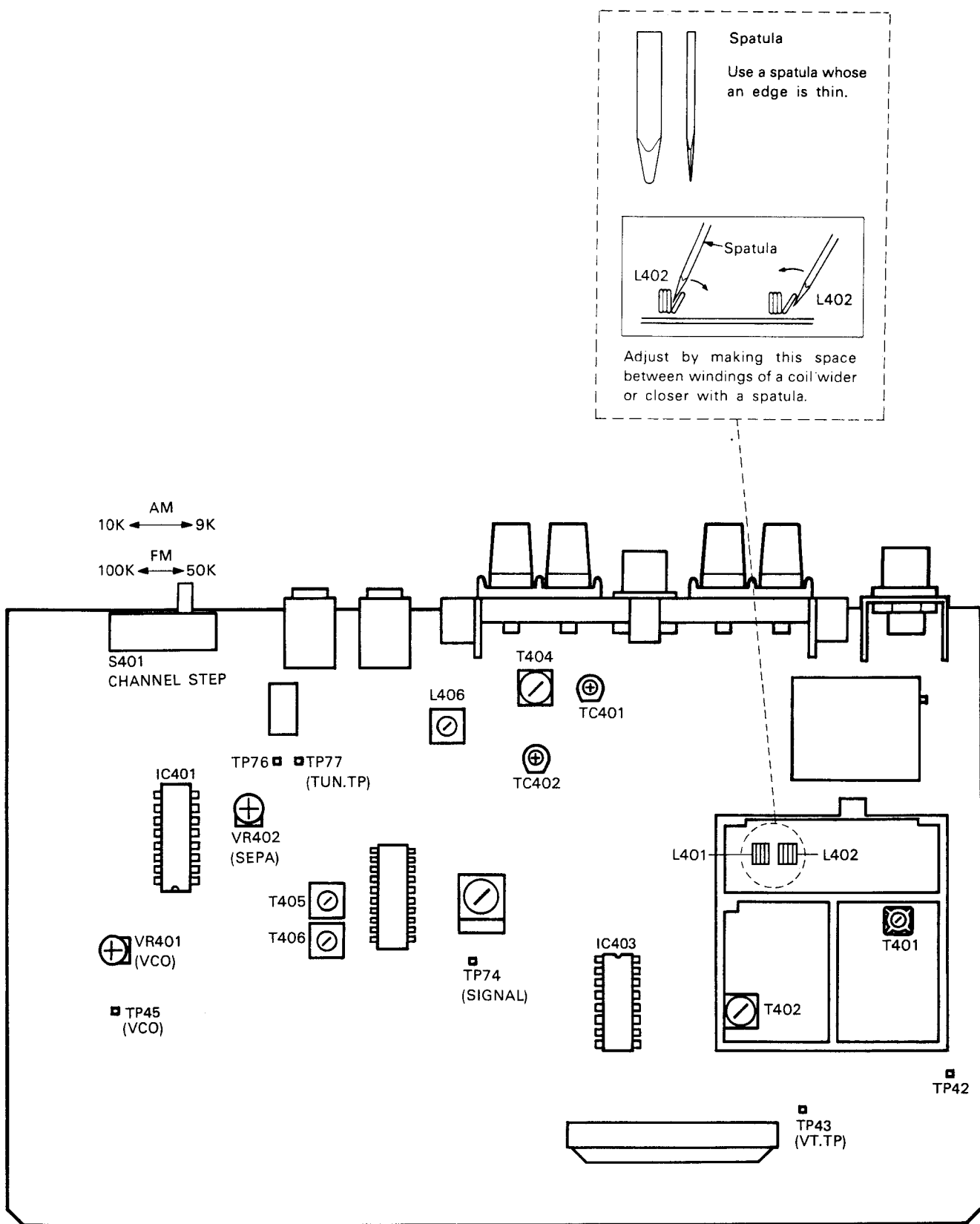
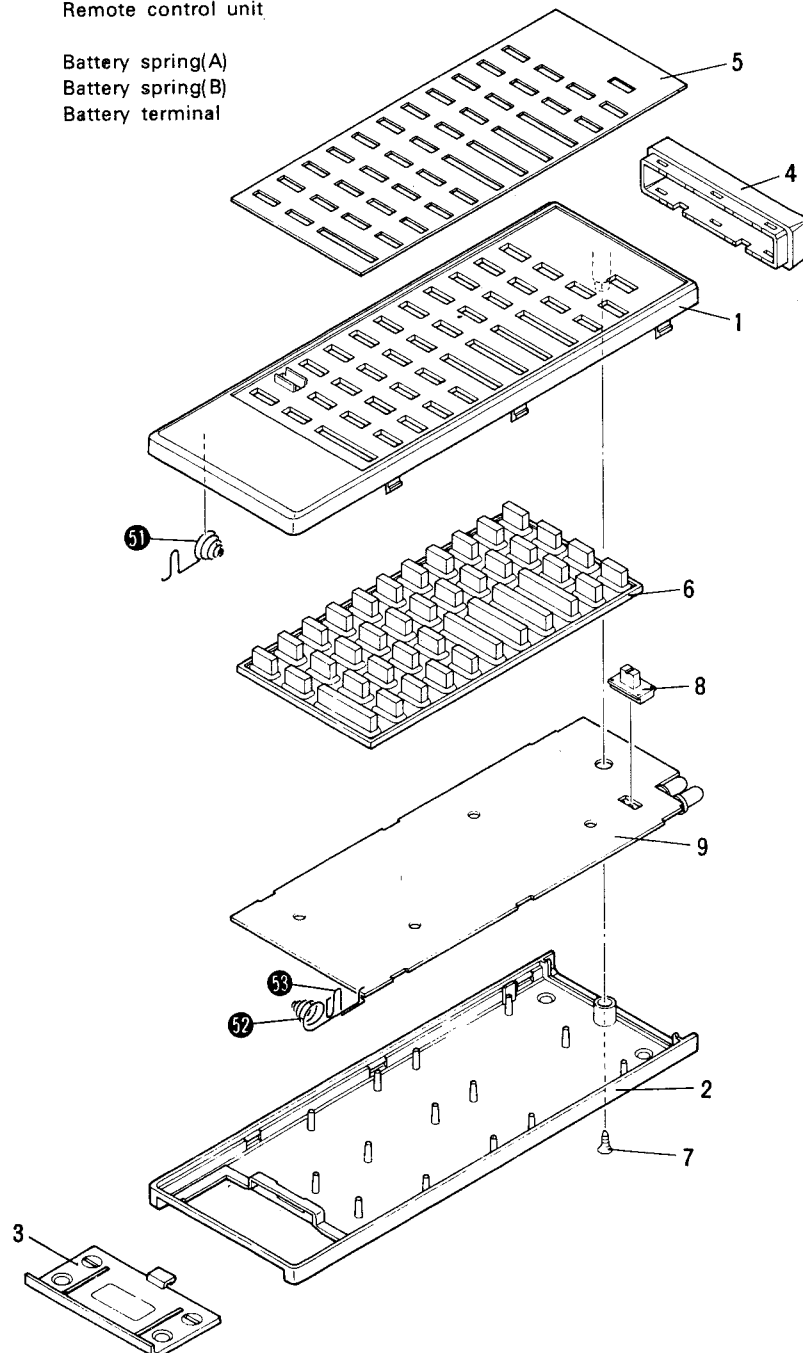

Fig. 7-1 Adjustment points

8. REMOTE CONTROL UNIT

8.1 EXPLODED VIEW

Parts List			
Mark	No.	Part No.	Description
	1	AZH1019	Case(A)
	2	AZH1016	Case(B)
	3	AZH1017	Case(C)
	4	AZN1200	Filter
	5	AZA1037	Plate
	6	AZA1036	Rubber switch
	7	AZB1057	Screw
	8	AZS1021	Knob(POWER)
	9		Remote control unit
51			Battery spring(A)
52			Battery spring(B)
53			Battery terminal



8.2 ELECTRICAL PARTS LIST

NOTES:

- When ordering resistors, first convert resistance values into code form as shown in the following examples.
Ex. 1 When there are 2 effective digits (any digit apart from 0), such as 560 ohm and 47k ohm (tolerance is shown by J=5%, and K=10%).
 560Ω 56×10^1 561.....RD¼PS $\begin{matrix} \text{5} & \text{6} & \text{1} \\ \text{J} \end{matrix}$
 $47k\Omega$ 47×10^3 473.....RD¼PS $\begin{matrix} \text{4} & \text{7} & \text{3} \\ \text{J} \end{matrix}$
 0.5Ω 0R5RN2H $\begin{matrix} \text{0} & \text{5} \\ \text{K} \end{matrix}$
 1Ω 010RS1P $\begin{matrix} \text{0} & \text{1} & \text{0} \\ \text{K} \end{matrix}$
- *Ex. 2* When there are 3 effective digits (such as in high precision metal film resistors).
 $5.62k\Omega$ 562×10^1 5621RN¼SR $\begin{matrix} \text{5} & \text{6} & \text{2} & \text{1} \\ \text{F} \end{matrix}$
- The Δ mark found on some component parts indicates the importance of the safety factor of the part. Therefore, when replacing, be sure to use parts of identical designation.
- For your Parts Stock Control, the fast moving items are indicated with the marks **★★** and **★**.
★★ GENERALLY MOVES FASTER THAN ★
 This classification shall be adjusted by each distributor because it depends on model number, temperature, humidity, etc.
- Parts marked by "⊙" are not always kept in stock. Their delivery time may be longer than usual or they may be unavailable.

Remote control unit Assembly (ADX1007)

SEMICONDUCTORS

Mark	Symbol & Description	Part No.
★★	IC1	PD5039
★★	Q1	2SC2021
★★	Q2	2SC2673
★	D1, D2 LED	SE303A

SWITCH

Mark	Symbol & Description	Part No.
★★	SW1 Slide switch (POWER)	SSSS21507

CAPACITORS

Mark	Symbol & Description	Part No.
	C1	CEJA470M6
	C3, C4	CCDSL101J50
	C5	CKDYB472K59

RESISTORS

NOTE: When ordering resistors, convert the resistance value into code form, and then rewrite the part no. as before.

Mark	Symbol & Description	Part No.
	R5, R6	RD1/8PM2R7J
	Other resistors	RD1/8PM□□□J

OTHER

Mark	Symbol & Description	Part No.
★	X1 Ceramic resonator	CSB480EB

8.3 SCHEMATIC DIAGRAM

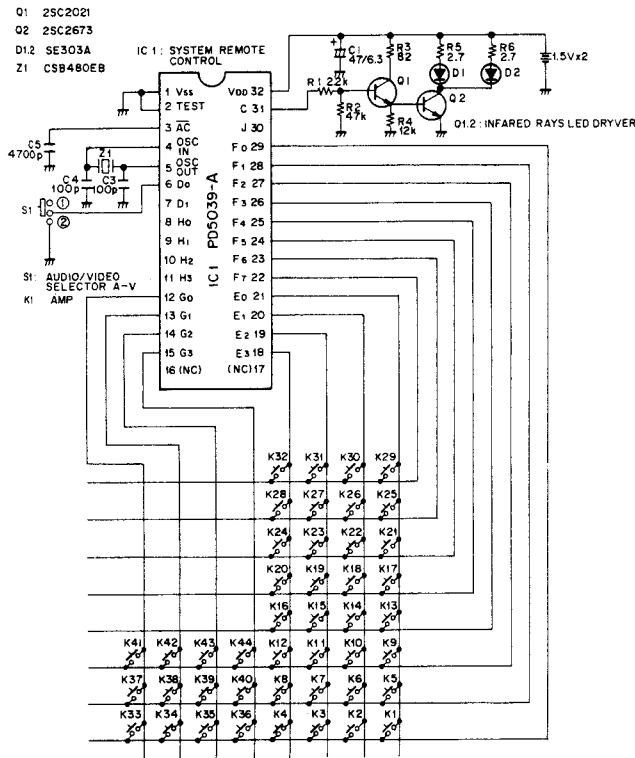

NOTE:

The indicated semiconductors are representative ones only. Other alternative semiconductors may be used and are listed in the parts list.

- RESISTORS:**
Indicated in Ω , 1/4W, 1/6W and 1/8W, $\pm 5\%$ tolerance unless otherwise noted k; k Ω , M; M Ω , (F); $\pm 1\%$, (G); $\pm 2\%$, (K); $\pm 10\%$, (M); $\pm 20\%$ tolerance
 - CAPACITORS:**
Indicated in capacity (μ F)/voltage (V) unless otherwise noted p; pF. Indication without voltage is 50V except electrolytic capacitor.
 - VOLTAGE, CURRENT:**
 - \square : DC voltage (V) at no input signal Value in () is DC voltage at rated power.
 - \square mA: DC current at no input signal
 - \square mV: Signal voltage at FM 400 Hz \pm 75 kHz DEV.
 - OTHERS:**
 - \rightarrow : Signal route.
 - \odot : Adjusting point.
- The Δ mark found on some component parts indicates the importance of the safety factor of the part. Therefore, when replacing, be sure to use parts of identical designation.
 * marked capacitors and resistors have parts numbers.
 The underlined indicates the switch position.

This is the basic schematic diagram, but the actual circuit may vary due to improvements in design.
 THE UNDERLINED INDICATES THE SWITCH POSITION

8.4 P.C. BOARD PATTERN

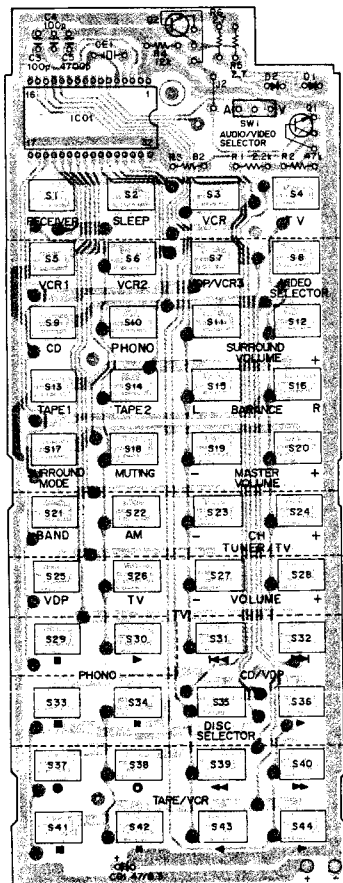

Key No	SW No.
K1	S1
K2	S2
K3	S3
K4	S4
K5	S5
K6	S6
K7	S7
K8	S8
K9	S9
K10	S10
K11	S11
K12	S12
K13	S13
K14	S14
K15	S15
K16	S16
K17	S17
K18	S18
K19	S19
K20	S20
K21	S21
K22	S22
K23	S23
K24	S24
K25	S25
K26	S26
K27	S27
K28	S28
K29	S29
K30	S30
K31	S31
K32	S32
K33	S33
K34	S34
K35	S35
K36	S36
K37	S37
K38	S38
K39	S39
K40	S40
K41	S41
K42	S42
K43	S43
K44	S44

External Appearance of Transistors and ICs

2SC2021

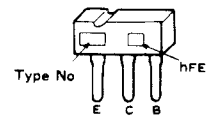

2SC2673

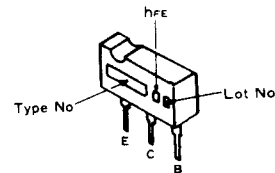

PD5039

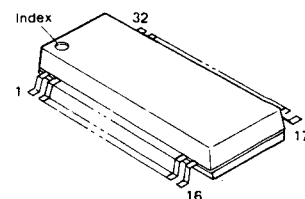

9. FOR S/G TYPE

CONTRAST OF MISCELLANEOUS PARTS

The VSX-4000(BK)/S/G type is the same as the VSX-4000(BK)/KUC type except for following sections.

Mark	Symbol & Description	Parts No.		Remarks
		VSX-4000(BK) KUC type	VSX-4000(BK) S/G type	
⚠ ★★	S2 Line voltage selector (A)	AKX1004	
⚠ ★★	S3 Line voltage selector (B)	AKX-507	
⚠ ★★	FU1 Fuse (8A)	AEK-304	
⚠ ★★	FU1, FU2 Fuse (4A)	AEK-100	
⚠	AC Power cord (AC120V) (AC110V/120V/220V/240V)	ADG-089 ADG-087	
⚠ ★	T1 Power transformer (AC120V) (AC110V/120V/220V/240V)	ATS1033 ATS1034	
⚠ ★	T2 Power transformer AC120V) (AC110V/120V/220V/240V)	ATT1016 ATT1017	
	Packing case	AHD1103	AHD1104	

