

Service Manual

PIONEER®
The Art of Entertainment

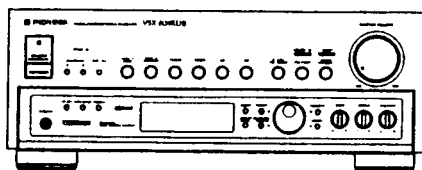

ORDER NO.
RRV1323

AUDIO/VIDEO STEREO RECEIVER

VSX-804RDS

THIS MANUAL IS APPLICABLE TO THE FOLLOWING MODEL(S) AND TYPE(S).

Type	Model	Power Requirement	The voltage can be converted by the following method.
	VSX-804RDS		
HBWXJ	○	AC230V	AC240V, *
HEZXJ	○	AC220-230V	AC240V, *

*: Alter the wiring of the Power-supply block at the primary winding of Power transformer referring to the "Line Voltage Selection" described in Service Manual.

CONTENTS

1. BLOCK DIAGRAM	2	5. ADJUSTMENTS	44
2. EXPLODED VIEWS, PACKING AND PARTS LIST	3	6. IC INFORMATION	46
3. SCHEMATIC AND PCB CONNECTION DIAGRAMS	10	7. DISASSEMBLY	48
4. PCB PARTS LIST	39	8. FL INFORMATION	50
		9. PANEL FACILITIES	51
		10. SPECIFICATIONS	55

PIONEER ELECTRONIC CORPORATION 4-1, Meguro 1-Chome, Meguro-ku, Tokyo 153, Japan
PIONEER ELECTRONICS SERVICE INC. P.O. Box 1760, Long Beach, California 90801, U.S.A.
PIONEER ELECTRONICS OF CANADA, INC. 300 Allstate Parkway Markham, Ontario L3R 0P2, Canada
PIONEER ELECTRONIC [EUROPE] N.V. Haven 1087 Keetberglaan 1, 9120 Melsele, Belgium
PIONEER ELECTRONICS AUSTRALIA PTY. LTD. 178-184 Boundary Road, Braeside, Victoria 3195, Australia, TEL: [03] 580-9911
 © **PIONEER ELECTRONIC CORPORATION 1995**

T-DFY APR. 1995 Printed in Japan

1. BLOCK DIAGRAM

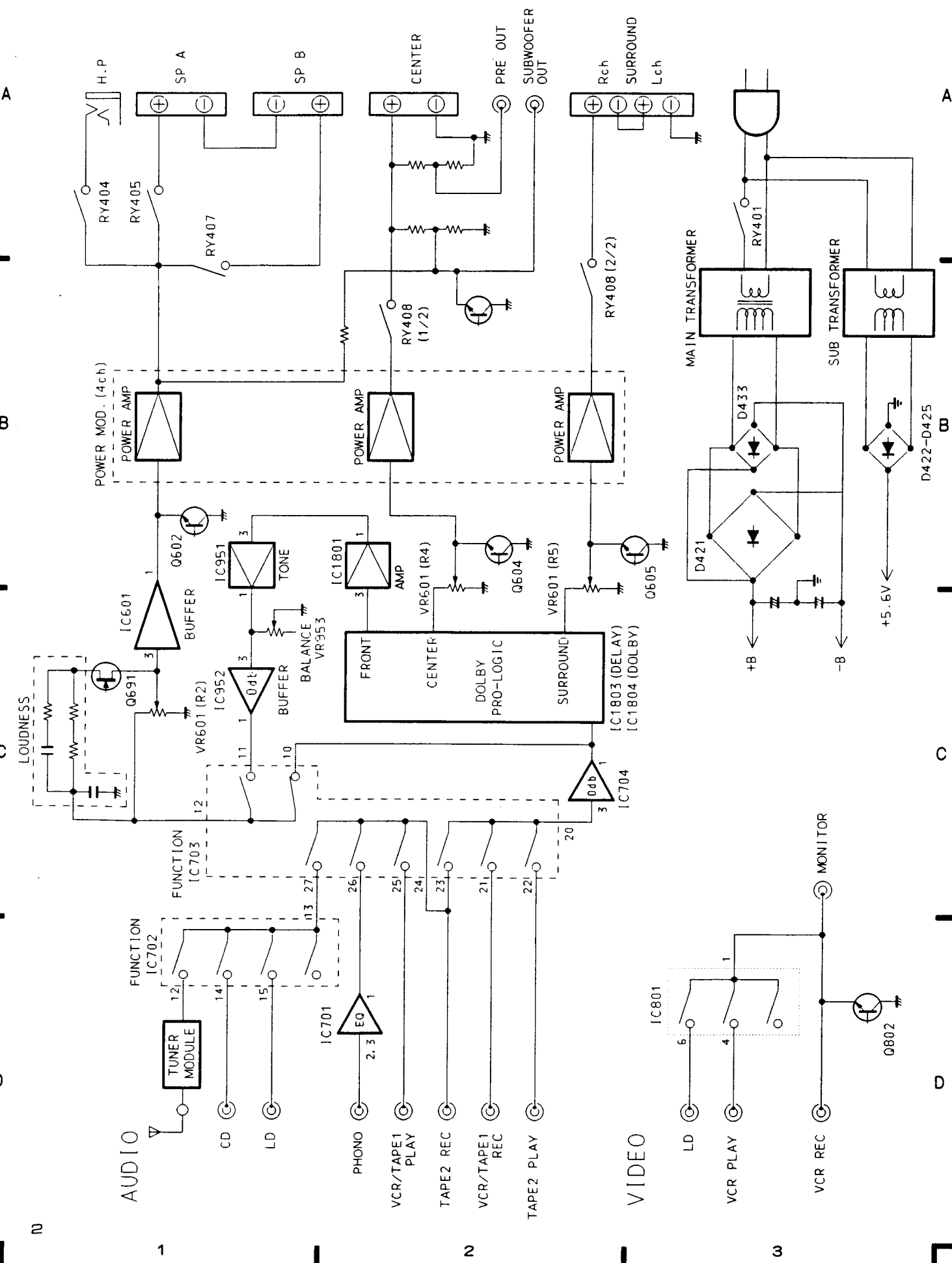

2. EXPLODED VIEWS, PACKING AND PARTS LIST

NOTES :

- Parts marked by "NSP" are generally unavailable because they are not in our Master Spare Parts List.
- The Δ mark found on some component parts indicates the importance of the safety factor of the part. Therefore, when replacing, be sure to use parts of identical designation.
- Parts marked by "☉" are not always kept in stock. Their delivery time may be longer than usual or they may be unavailable.

2.1 PACKING

■ CONTRAST OF HBWXJ TYPE AND HEZXJ TYPE

VSX – 804RDS/HBWXJ and HEZXJ have the same construction except for the following:

Mark	No.	Description	Part No.		Remarks
			VSX – 804RDS		
			HBWXJ	HEZXJ	
	1	Operating instructions (Dutch/Swedish/Spanish/Portuguese)	Not used	ARC7068	
	1	Operating instructions (French/German/Italian)	Not used	ARC7067	

■ PARTS LIST FOR HBWXJ TYPE

Mark	No.	Description	Parts No.
	1	OPERATING INSTRUCTIONS (English)	ARB7026
	2	REMOTE CONTROL UNIT (CU – VSX094)	AXD7047
	3	FM ANTENNA	ADH7001
NSP	4	BATTERY (R6P, AA)	VEM – 013
	5	LOOP ANTENNA	ATB7004
	6	SIDE PAD L	AHA7044
	7	SIDE PAD R	AHA7045
	8	PACKING CASE	AHD7117
	9	PACKING SHEET	AHG7010
	10	BATTERY COVER	AZA7031

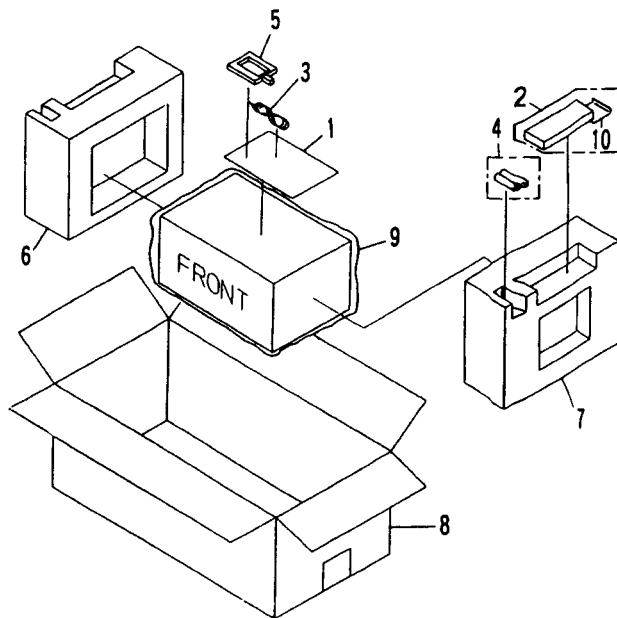

2.2 EXTERIOR

■ CONTRAST OF HBWXJ TYPE AND HEZXJ TYPE

VSX-804RDS/HBWXJ and HEZXJ have the same construction except for the following:

Mark	No.	Description	Part No.		Remarks
			VSX-804RDS		
			HBWXJ	HEZXJ	
△	5	AC power cord	PDG1055	ADG1131	For AC power cord
	8	Rear panel	ANC7203	ANC7174	
△	57	Fuse (T5A/250V)	PEK1003	Not used	

■ PARTS LIST FOR HBWXJ TYPE

Mark	No.	Description	Parts No.	Mark	No.	Description	Parts No.
△	1	POWER TRANSFORMER (T1)	ATS7069		36	REG. ASSY	AWZ7735
△	2	FUSE (T1.25A, FU3, FU4)	AEK1055		37	FL AND UCOM ASSY	AWZ7614
	3		NSP	38	H.P. ASSY	AWZ7615
△	4	FUSE (T5A, FU1)	AEK1061		39	SCREW	ABA7009
△	5	AC POWER CORD	PDG1055		40	SCREW	ABA1147
	6	FLEXIBLE CABLE (J14)	ADD7005		41	SCREW	BBZ30P080FZK
NSP	7	CHASSIS	ANA7016		42	SCREW	BBZ30P200FMC
	8	REAR PANEL	ANC7203		43	SCREW	BPZ26P080FMC
	9		NSP	44	WASHER	AEE7002
	10	INSULATOR	PNW1912		45	SCREW	BBZ30P080FMC
	11	PCB SUPPORT	AEC1581	NSP	46	ADHESIVE DOUBLE COATED TAPE	AEH1025
	12	RUBBER SPACER	AEC7034				
	13	CORD STOPPER	AEC-882	NSP	47	SP ASSY	AWZ7613
	14	PCB MOLD	AMR2533		48	LED LENS	PNW2019
	15			49	
					50	
	16	SUB PANEL	AAP7011				
	17	FRONT PANEL	AMB7181		51	PVC SHEET	AEC7024
	18	IR FILTER	AAK7123		52	PUSH RIVET	AEC7025
	19	FL PANEL	AAK7127		53	SCREW	ABA1047
	20	JOG RING	AAK7129		54	CERAMIC CAPACITOR (C11)	CKDYF103Z50
					55	CERAMIC CAPACITOR (C12)	CKDYF47Z250
	21	NAME PLATE	PAM1608				
	22	ROUND KNOB L	AAB1390	NSP	56	PCB HOLDER	ANG7040
	23	ROUND KNOB S	AAB7047	△	57	FUSE (T5A/250V)	PEK1003
	24	JOG KNOB	AAB7048				
	25	FUNCTION BUTTON	AAD7156				
	26	ILLUMI BUTTON	AAD7157				
	27	POWER BUTTON	AAD7158				
	28	HINGE BUTTON A	AAD7159				
	29	HINGE BUTTON B	AAD7160				
	30	SURROUND BUTTON	AAD7161				
	31	BONNET CASE	ANE7047				
	32	FM/AM TUNER MODULE/HEZ	AXQ7041				
	33	PS AND FUNC ASSY	AWZ7611				
	34	VOL. ASSY	AWZ7612				
NSP	35	TRANS ASSY	AWZ7924				

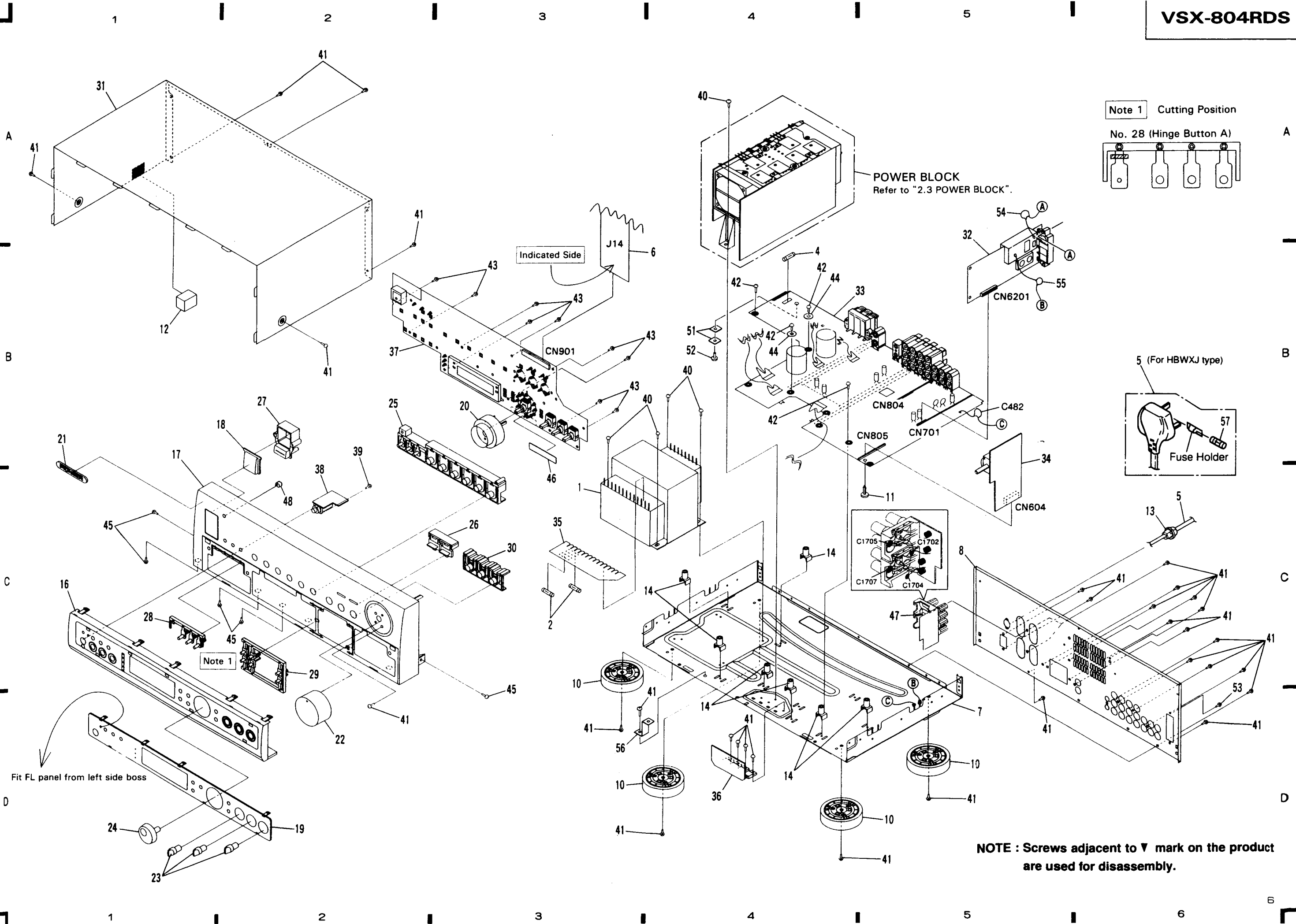

Note 1 Cutting Position

No. 28 (Hinge Button A)

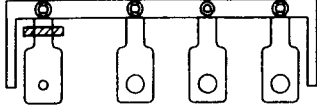

5 (For HBWXJ type)

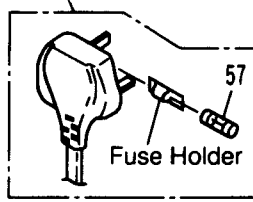

Fit FL panel from left side boss

NOTE : Screws adjacent to ▼ mark on the product are used for disassembly.

2.3 POWER BLOCK

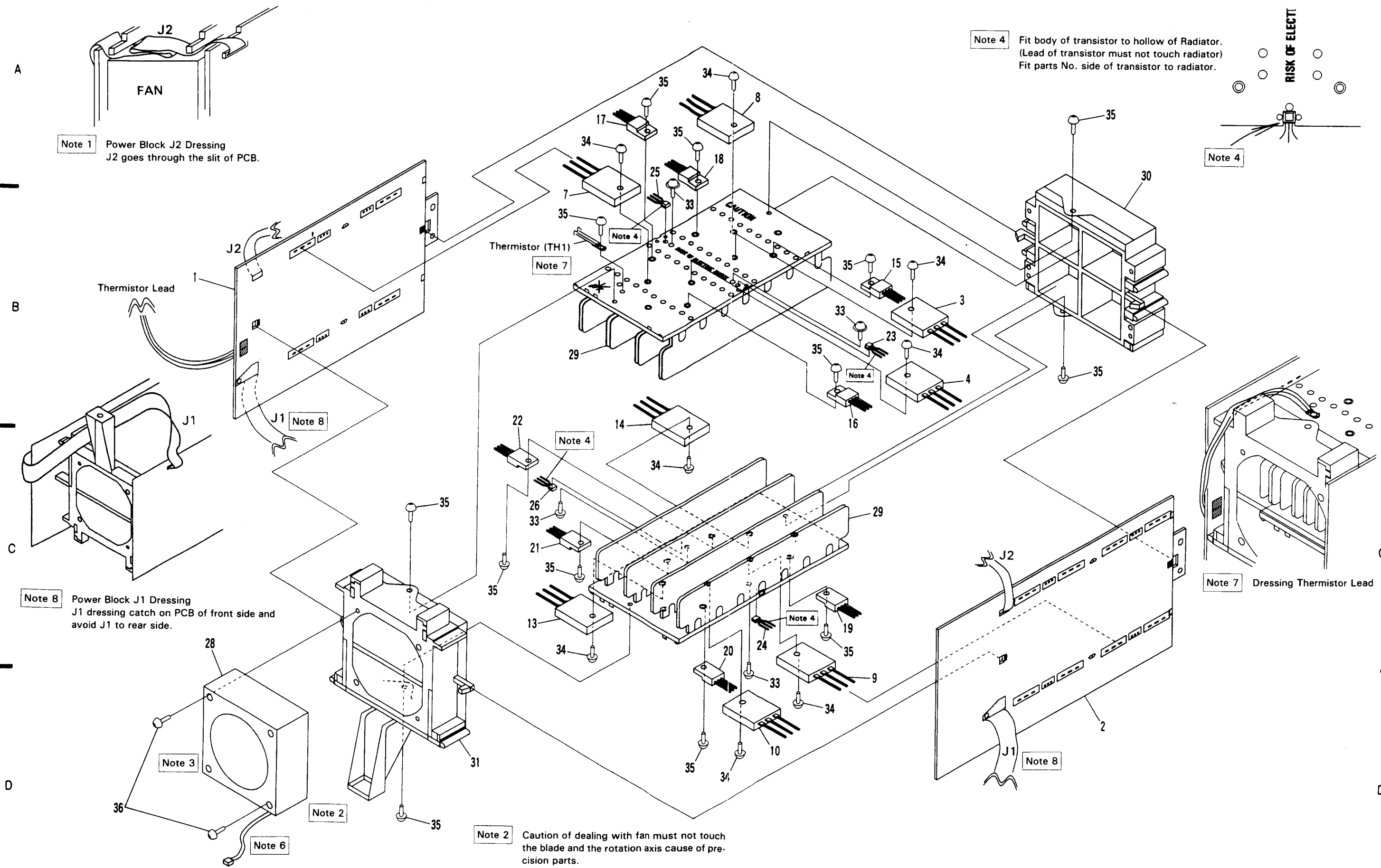

Note 1 Power Block J2 Dressing
J2 goes through the slit of PCB.

Note 4 Fit body of transistor to hollow of Radiator.
(Lead of transistor must not touch radiator)
Fit parts No. side of transistor to radiator.

Note 4

Note 7 Dressing Thermistor Lead

Note 8 Power Block J1 Dressing
J1 dressing catch on PCB of front side and
avoid J1 to rear side.

Note 2 Caution of dealing with fan must not touch
the blade and the rotation axis cause of pre-
cision parts.

Note 3 Set side without fan guard facing out side
(The other side of parts No. side).

Note 6 Install fan motor to do right-down fan lead.

3. SCHEMATIC AND PCB CONNECTION DIAGRAMS

3.1 OVERALL SCHEMATIC DIAGRAM

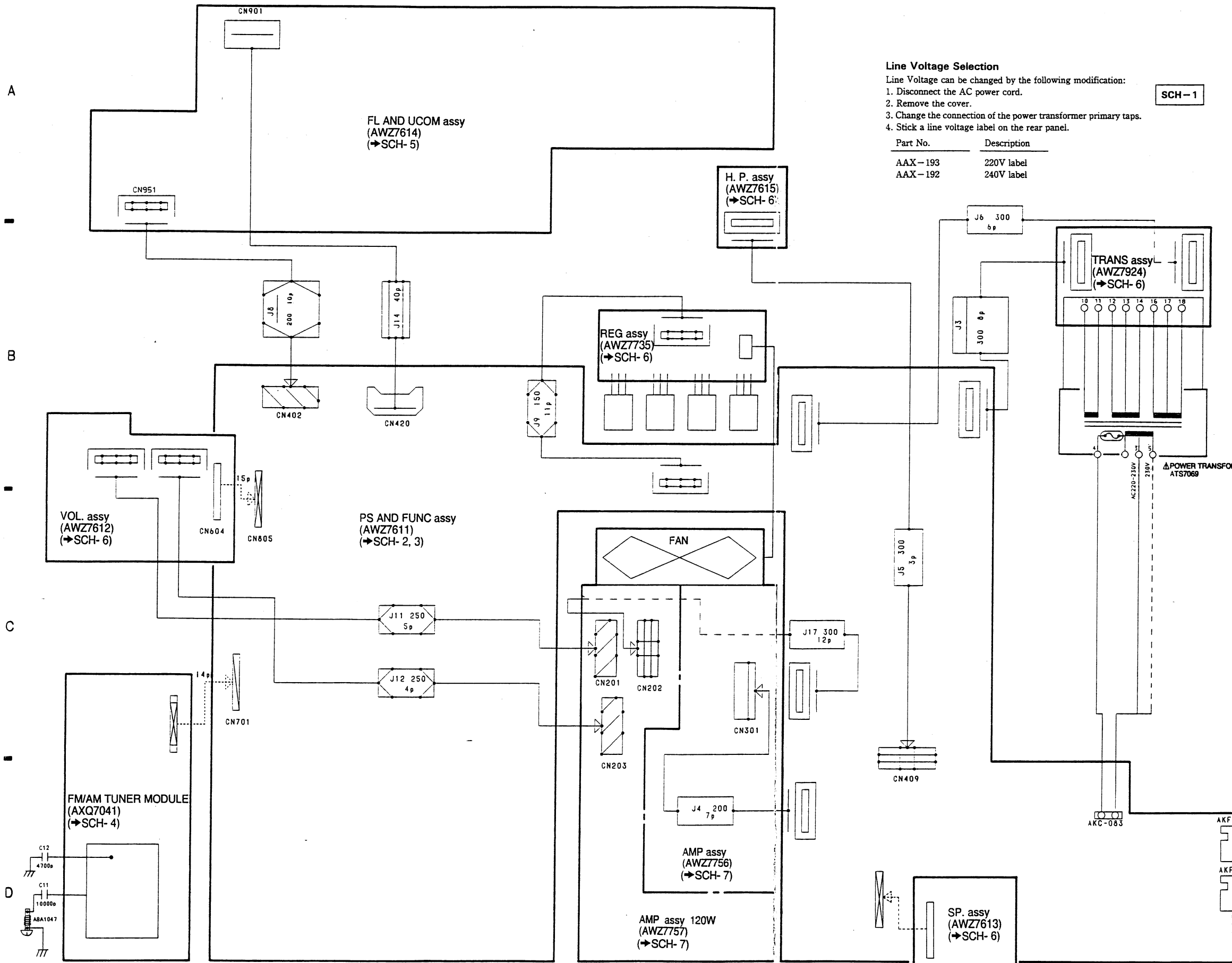

Line Voltage Selection
 Line Voltage can be changed by the following modification:
 1. Disconnect the AC power cord.
 2. Remove the cover.
 3. Change the connection of the power transformer primary taps.
 4. Stick a line voltage label on the rear panel.

Part No.	Description
AAX-193	220V label
AAX-192	240V label

NOTE FOR SCHEMATIC DIAGRAMS (Type 1A)

- When ordering service parts, be sure to refer to "PARTS LIST of EXPLODED VIEWS" or "PCB PARTS LIST".**
- Since these are basic circuits, some parts of them or the values of some components may be changed for improvement.
- RESISTORS:**
 Unit: k: kΩ, M: MΩ, or Ω unless otherwise noted.
 Rated power: 1/4W, 1/6W, 1/8W, 1/10W unless otherwise noted.
 Tolerance: (F): ±1%, (G): ±2%, (K): ±10%, (M): ±20% or ±5% unless otherwise noted.
- CAPACITORS:**
 Unit: p: pF or μF unless otherwise noted.
 Ratings: capacitor (μF)/ voltage (V) unless otherwise noted.
 Rated voltage: 50V except for electrolytic capacitors.
- COILS:**
 Unit: m: mH or μH unless otherwise noted.
- VOLTAGE AND CURRENT:**
 : Signal voltage at rated output.
 or - V :
 DC voltage (V) at no input signal unless otherwise noted.
 Value in () is DC voltage at rated power.
 mA or - mA :
 DC current at no input signal unless otherwise noted.
- OTHERS:**
 • ⊕ or ⊙ : Adjusting point.
 • ⊖ : Measurement point.
 • The Δ mark found on some component parts indicates the importance of the safety factor of the parts. Therefore, when replacing, be sure to use parts of identical designation.
- SCH-□ ON THE SCHEMATIC DIAGRAM:**
 • SCH-□ indicates the drawing number of the schematic diagram. (SCH stands for schematic diagram.)
- SWITCHES** (Underline indicates switch position):

- FL AND UCOM assy**
- S901 POWER
 - S903 SPEAKER A
 - S904 SPEAKER B
 - S905 RETURN
 - S907 RF ATT
 - S908 MPX MODE
 - S909 FM/AM
 - S912 TAPE1/VCR
 - S913 TAPE2/MONITOR
 - S914 PHONO
 - S915 TUNER
 - S916 LD
 - S917 CD
 - S918 LOUDNESS
 - S919 DIRECT
 - S921 3CH LOGIC
 - S922 SFC MODE
 - S923 PRO- LOGIC
 - S924 MEMORY
 - S925 ENTER
 - S926 SELECT
 - S927 CHARACTER/SEARCH
 - S928 CLASS
 - S929 DISPLAY MODE
 - S941 MULTI JOG

Δ AC POWER CORD
 HBWXJ TYPE : PDG1055
 HEZJ TYPE : ADG1131

AKF-116
 HBWXJ TYPE : AC230V/50/60Hz
 HEZJ TYPE : 220-230V/50/60Hz

SCH-1

OVERALL SCHEMATIC DIAGRAM

SCH-1

OVERALL SCHEMATIC DIAGRAM

■ PARTS LIST FOR HBWXJ TYPE

Mark	No.	Description	Parts No.
	1	AMP ASSY	AWZ7756
	2	AMP ASSY 120W	AWZ7757
△	3	TRANSISTOR (Q3)	2SA1302
△	4	TRANSISTOR (Q4)	2SA1302
	5	
	6	
△	7	TRANSISTOR (Q11)	2SA1302
△	8	TRANSISTOR (Q12)	2SA1302
△	9	TRANSISTOR (Q1)	2SC3281
△	10	TRANSISTOR (Q2)	2SC3281
	11	
	12	
△	13	TRANSISTOR (Q9)	2SC3281
△	14	TRANSISTOR (Q10)	2SC3281
△	15	TRANSISTOR (Q23)	2SA1837
△	16	TRANSISTOR (Q24)	2SA1837
△	17	TRANSISTOR (Q33)	2SA1837
△	18	TRANSISTOR (Q34)	2SA1837
△	19	TRANSISTOR (Q21)	2SC4793
△	20	TRANSISTOR (Q22)	2SC4793
△	21	TRANSISTOR (Q31)	2SC4793
△	22	TRANSISTOR (Q32)	2SC4793
△	23	TRANSISTOR (Q209)	2SC1740S
△	24	TRANSISTOR (Q210)	2SC1740S
△	25	TRANSISTOR (Q309)	2SC1740S
△	26	TRANSISTOR (Q310)	2SC1740S
	27	
	28	FAN MOTOR	AXM7005
NSP	29	RADIATOR	ANH7011
	30	EXHAUST MOLD	AMR7035
	31	RADIATOR MOLD	AMR7036
	32	
	33	SCREW	ABA-283
	34	SCREW	ABA1037
	35	SCREW	BBZ30P080FZK
	36	SCREW	BPZ30P350FZK

3.2 PS AND FUNC ASSY

*Video SW IC(LA7952)

Pin No.	Voltage
1	+6.3V
2	0
3	+4.9V
4	+5.1V
5	0
6	+5.0V
7	+12.1V
8	+5.1V
9	+5.1V

PS AND FUNC assy (1/2) (AWZ7811)

IC801: VIDEO AMP

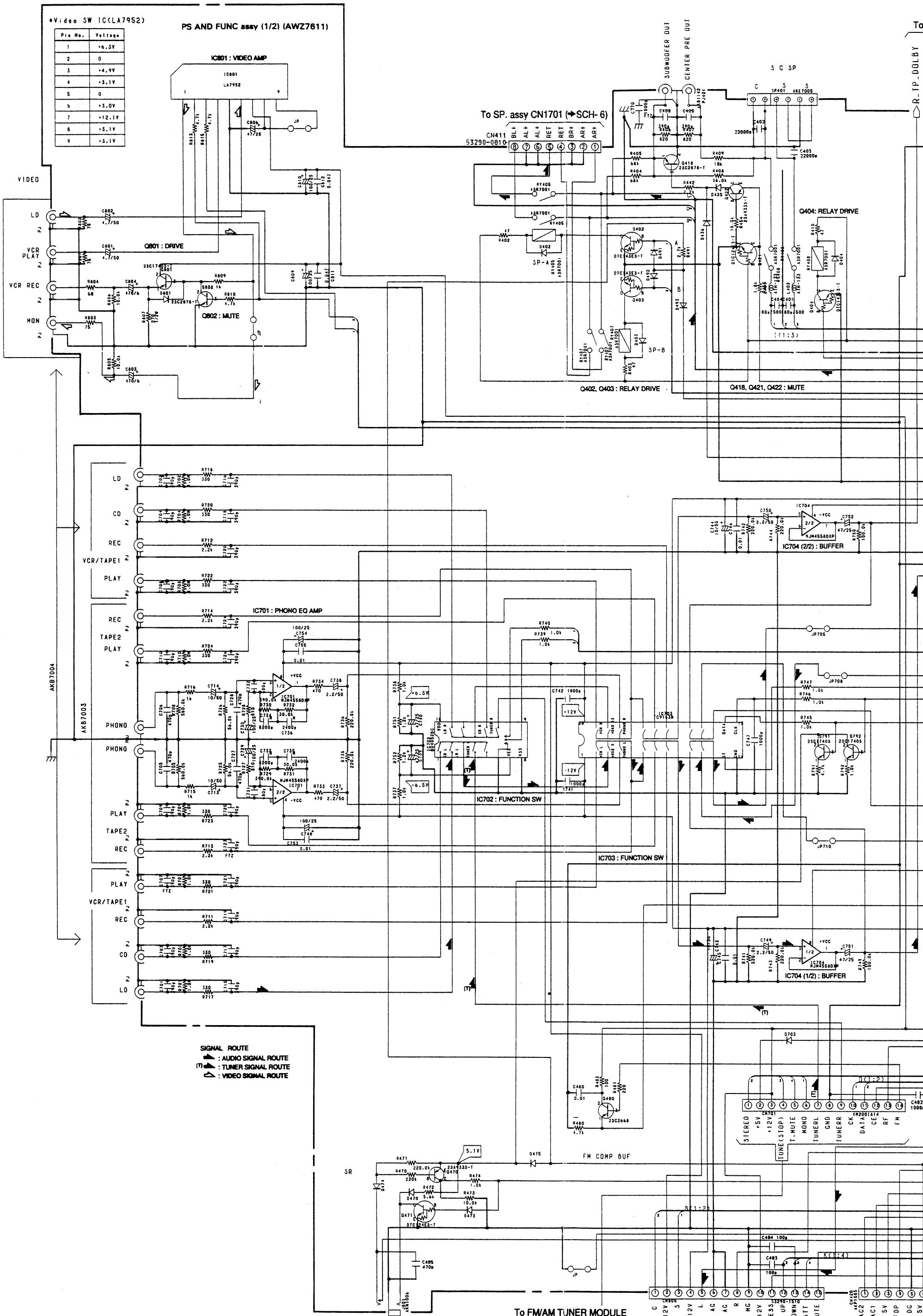

SIGNAL ROUTE
 ▲: AUDIO SIGNAL ROUTE
 ▢: TUNER SIGNAL ROUTE
 ▽: VIDEO SIGNAL ROUTE

SCH-2

PS AND FUNC ASSY (1/2)

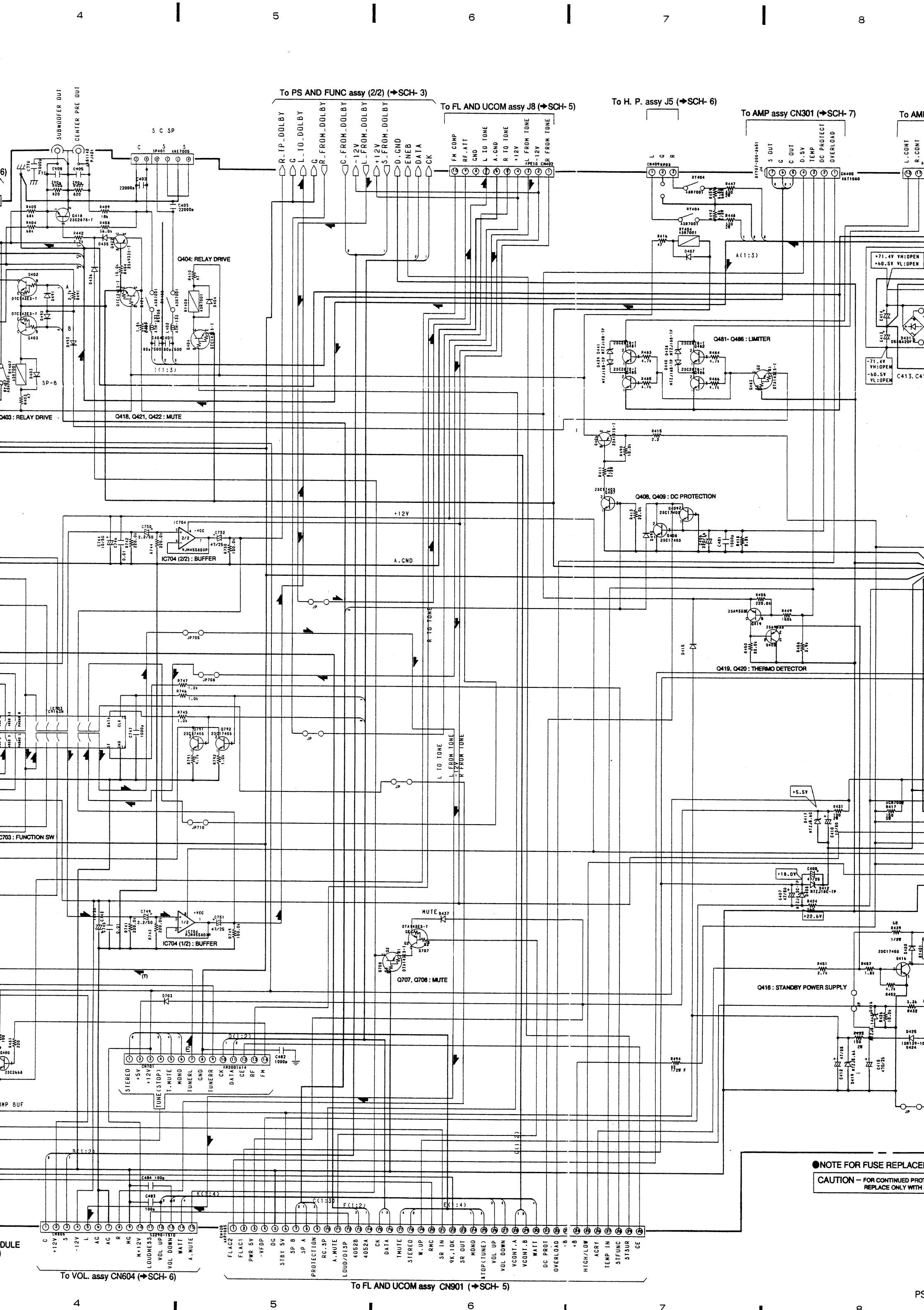

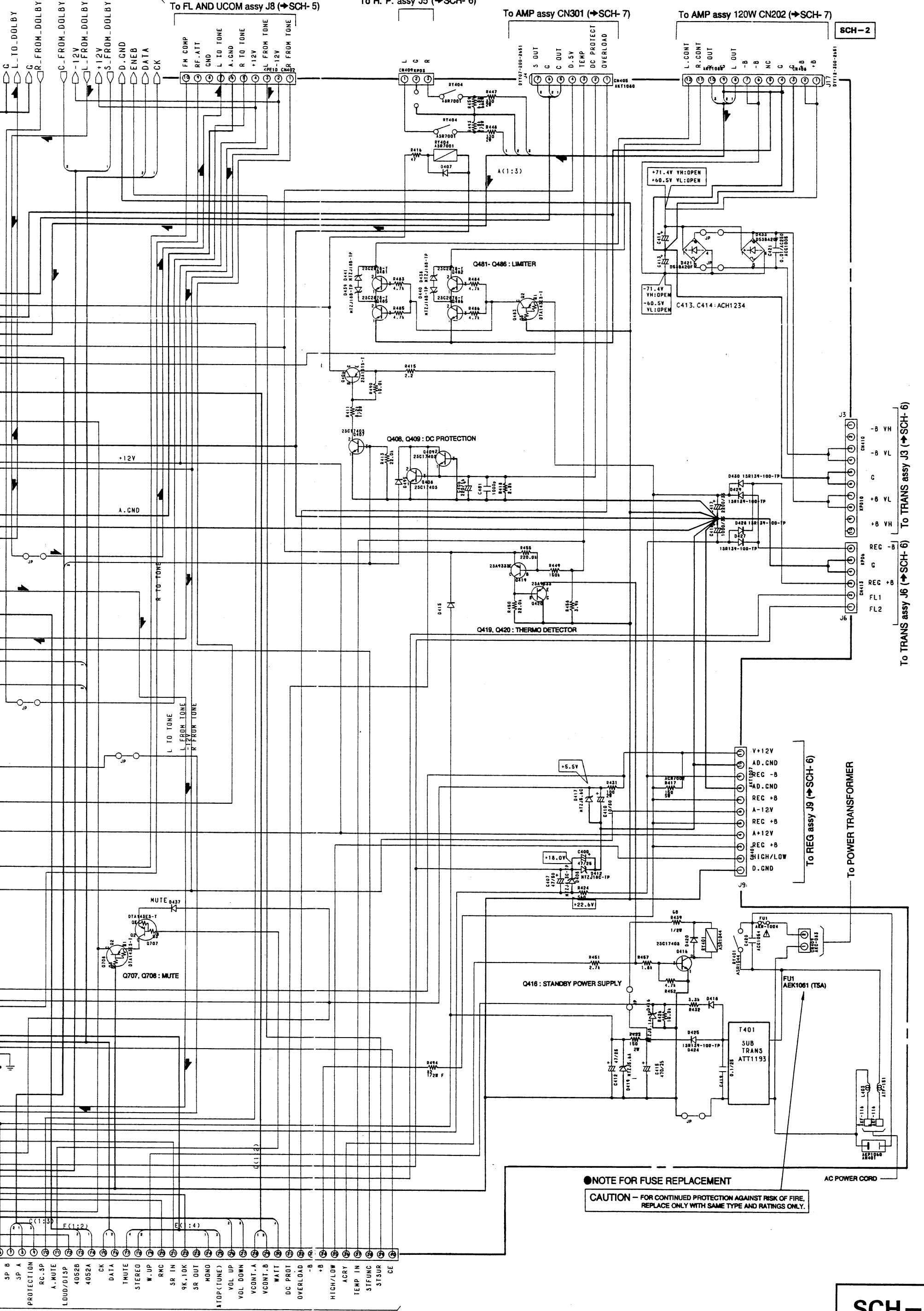

NOTE FOR FUSE REPLACEMENT
 CAUTION - FOR CONTINUED PROTECTION AGAINST RISK OF FIRE,
 REPLACE ONLY WITH SAME TYPE AND RATINGS ONLY.

A
B
C
D
E
F

SP B
SP A
PROTECTION
RC.SP
A.MUTE
4052B
4052A
CK
DATA
THUTE
STEREO
W.UP
RMC
SR IN
9K.10K
SR OUT
HONO
STOP(TONE)
VOL UP
VOL DOWN
VCONT.A
VCONT.B
WAIT
DC PROT
OVERLOAD
+B
+B
HIGH/LOW
ACRY
TEMP IN
STFUNC
STSUR
CE

To TRANS assy J3 (SCH- 6)
 -B VH
 -B VL
 C
 +B VL
 +B VH
 REC -B
 REC +B
 FL1
 FL2

To REG assy J9 (SCH- 6)

To POWER TRANSFORMER

A

B

C

D

PS AND FUNC assy (2/2) (AWZ7611)

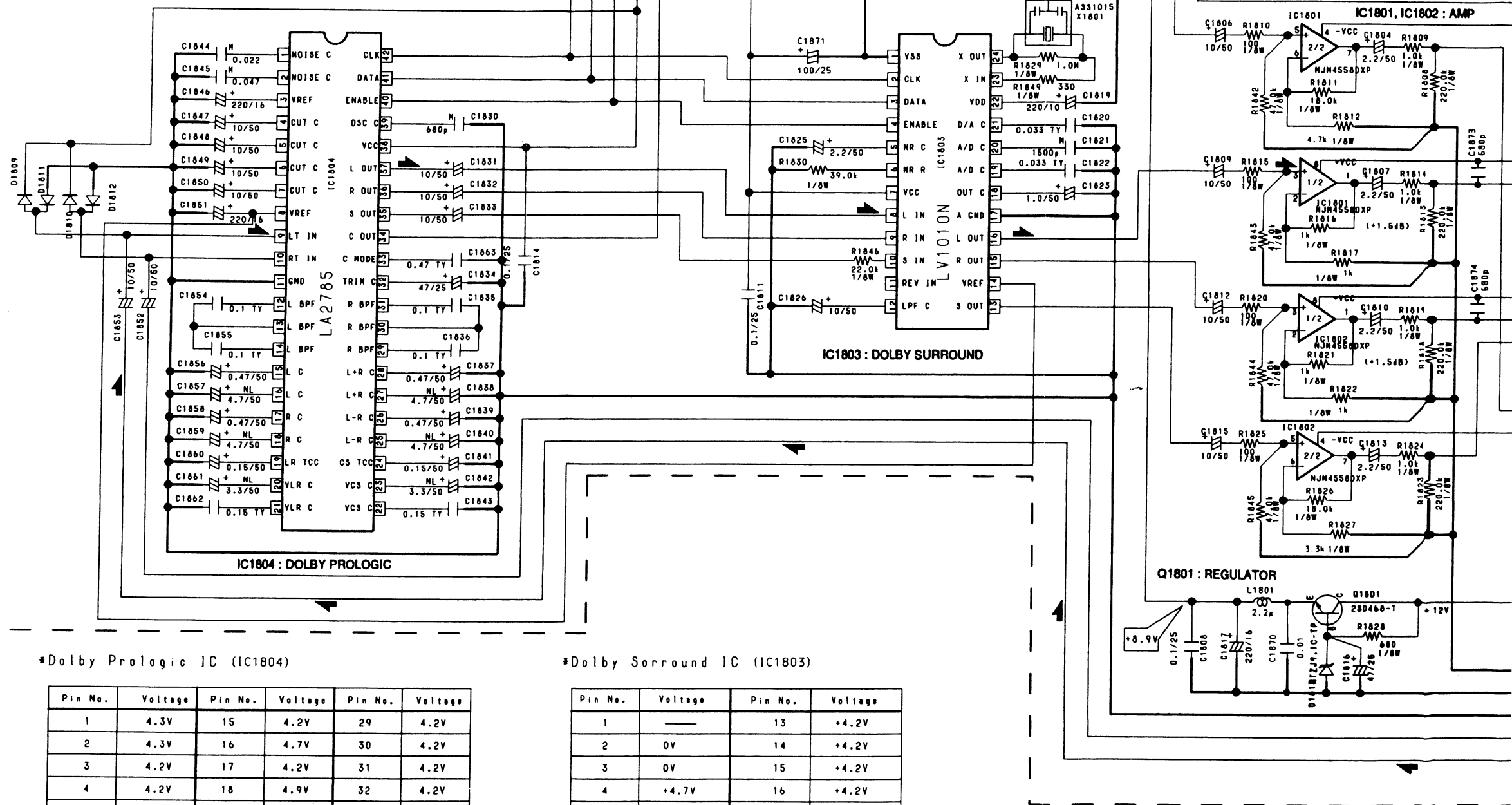

*Dolby Prologic IC (IC1804)

Pin No.	Voltage	Pin No.	Voltage	Pin No.	Voltage
1	4.3V	15	4.2V	29	4.2V
2	4.3V	16	4.7V	30	4.2V
3	4.2V	17	4.2V	31	4.2V
4	4.2V	18	4.9V	32	4.2V
5	4.2V	19	4.2V	33	4.2V
6	4.2V	20	4.2V	34	4.2V
7	4.2V	21	4.2V	35	4.2V
8	4.2V	22	4.2V	36	4.2V
9	4.2V	23	4.2V	37	4.2V
10	4.2V	24	4.2V	38	6.4V
11	0V	25	4.9V	39	—
12	4.2V	26	4.2V	40	4.7V
13	4.2V	27	4.7V	41	0V
14	4.2V	28	4.2V	42	0V

*Dolby Surround IC (IC1803)

Pin No.	Voltage	Pin No.	Voltage
1	—	13	+4.2V
2	0V	14	+4.2V
3	0V	15	+4.2V
4	+4.7V	16	+4.2V
5	+2.4V	17	—
6	+0.7V	18	+4.2V
7	+6.4V	19	+4.2V
8	+4.2V	20	+4.2V
9	+4.2V	21	+4.2V
10	+4.2V	22	+4.8V
11	+4.2V	23	—
12	+4.2V	24	—

SIGNAL ROUTE
▶ : AUDIO SIGNAL ROUTE

SCH-3

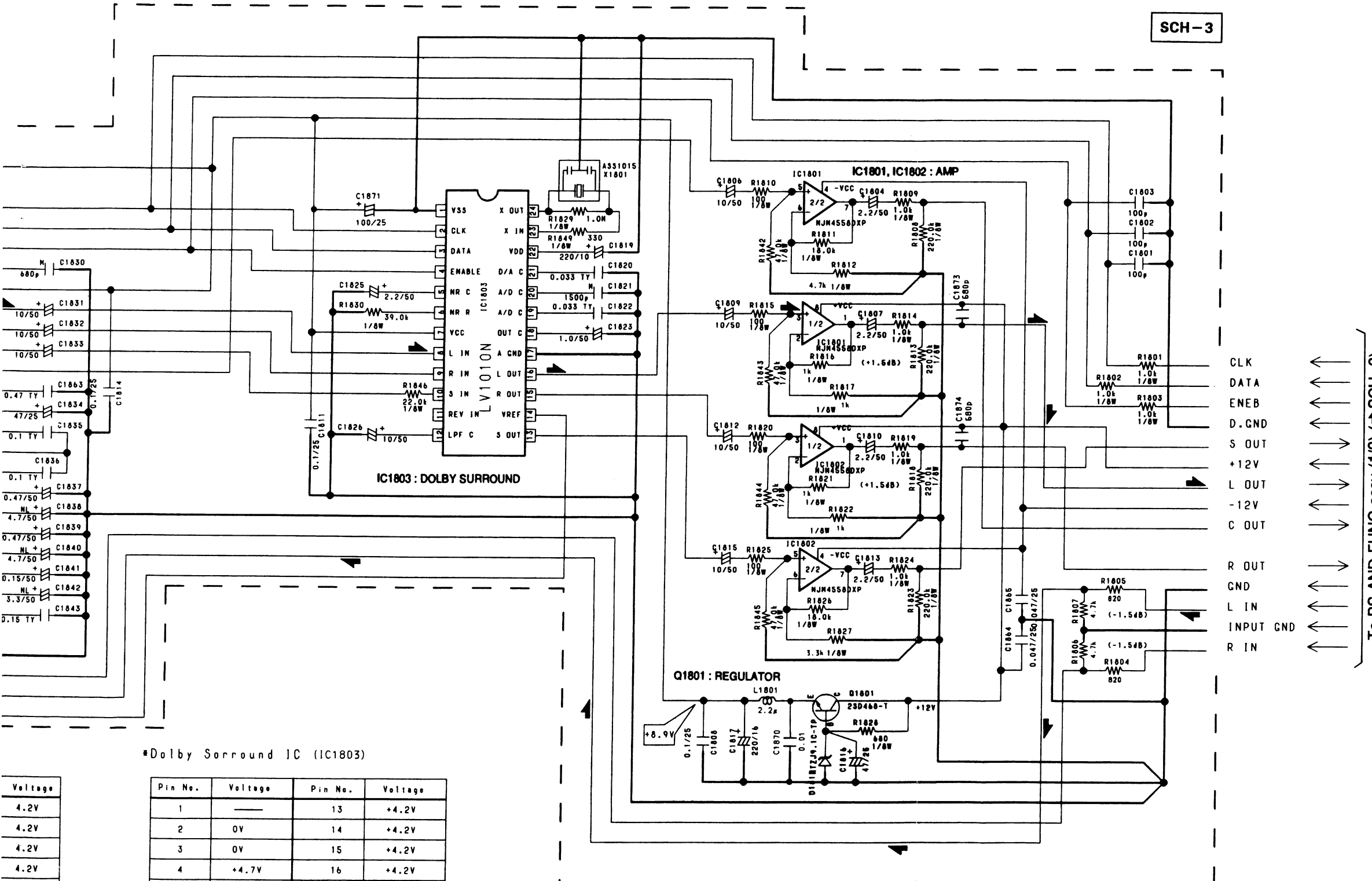

To PS AND FUNC assy (1/2) (→SCH-2)

*Dolby Surround IC (IC1803)

Voltage	Pin No.	Voltage	Pin No.	Voltage
4.2V	1	—	13	+4.2V
4.2V	2	0V	14	+4.2V
4.2V	3	0V	15	+4.2V
4.2V	4	+4.7V	16	+4.2V
4.2V	5	+2.4V	17	—
4.2V	6	+0.7V	18	+4.2V
4.2V	7	+8.4V	19	+4.2V
4.2V	8	+4.2V	20	+4.2V
4.2V	9	+4.2V	21	+4.2V
4.2V	10	+4.2V	22	+4.8V
—	11	+4.2V	23	—
4.7V	12	+4.2V	24	—
0V				
0V				

SIGNAL ROUTE
 ▲ : AUDIO SIGNAL ROUTE

- CLK
- DATA
- ENEB
- D. GND
- S OUT
- +12V
- L OUT
- 12V
- C OUT
- R OUT
- GND
- L IN
- INPUT GND
- R IN

SCH-3

• This diagram is viewed from the mounted parts side.

PS AND FUNC assy

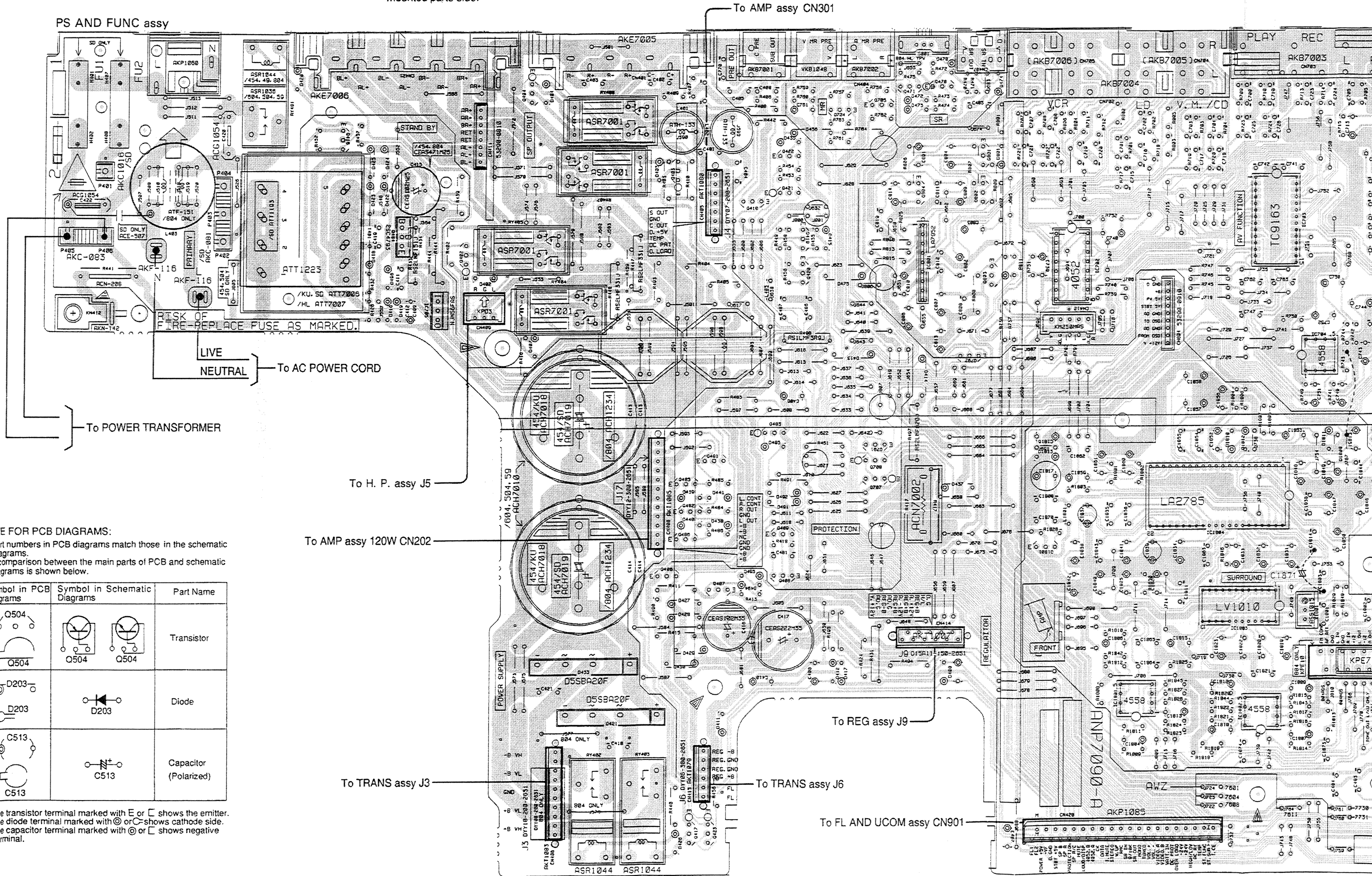

NOTE FOR PCB DIAGRAMS:

1. Part numbers in PCB diagrams match those in the schematic diagrams.
2. A comparison between the main parts of PCB and schematic diagrams is shown below.

Symbol in PCB Diagrams	Symbol in Schematic Diagrams	Part Name
		Transistor
		Diode
		Capacitor (Polarized)

3. The transistor terminal marked with E or \square shows the emitter.
4. The diode terminal marked with \odot or \square shows cathode side.
5. The capacitor terminal marked with \ominus or \square shows negative terminal.

The parts mounted on this PCB include all necessary parts for several destinations. For further information for respective destinations, be sure to check with the schematic diagram.

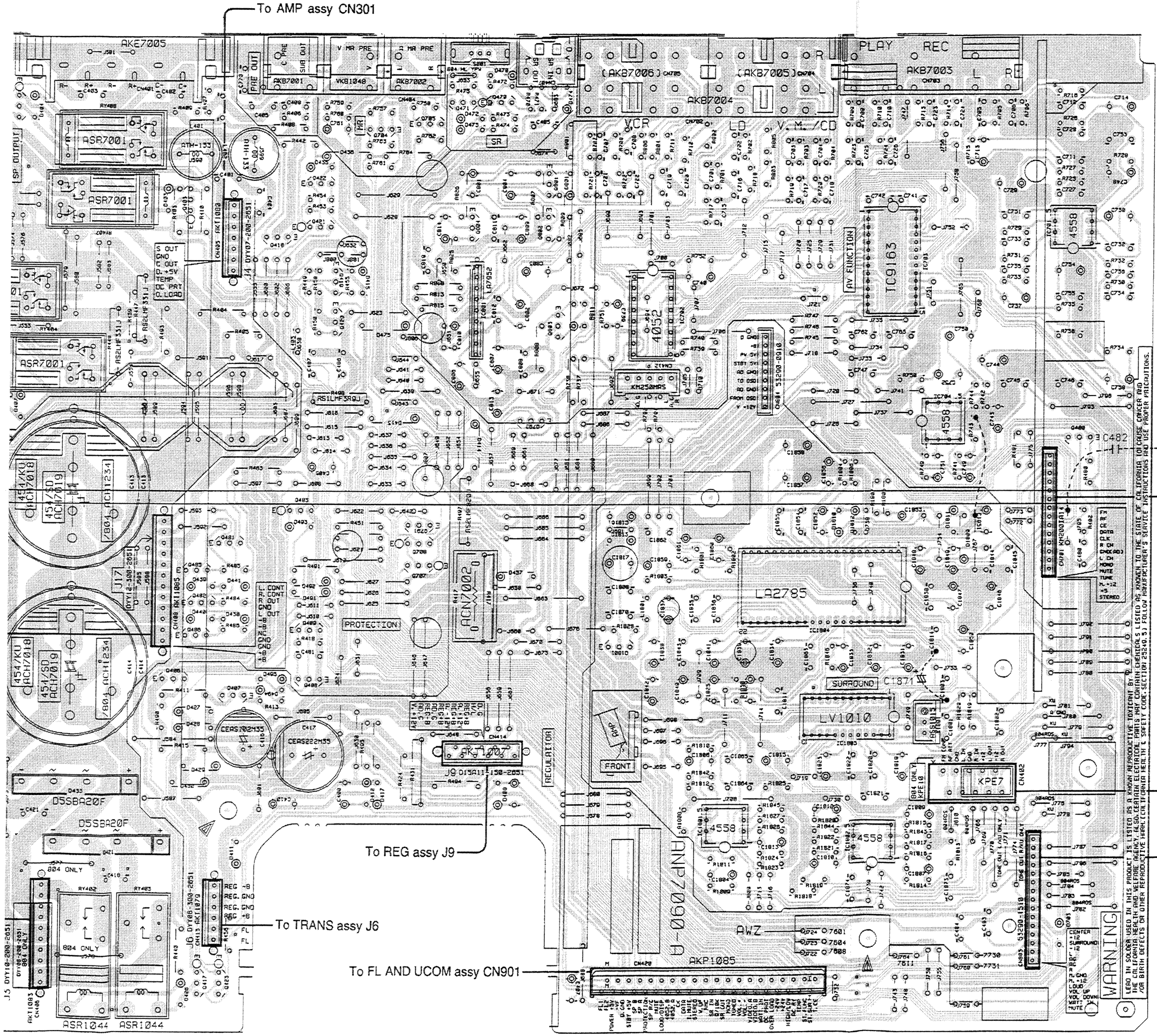

- G404 G470
G471
G705
G704
- G416 G422 G801
G403 G421 G802 IC701
G418 G804
G419 IC703
- G484 G402 IC801
IC702
G803
G420 IC705
G792 IC704
G480
- CHASIS
- G483 To FM/AM TUNER MODULE CN6201
- G481 G791
G706
- G485 G707
- G482 IC1804
- G486 Q1801
G409
- G408 IC1803
G406
G407
- To FL AND UCOM assy J8
- IC1801
IC1802 To VOL. assy CN604
- G417
G423

A
B
C
D

4

5

6

7

8

9

4

5

6

7

8

9

from the

To AMP assy CN301

To REG assy J9

To TRANS assy J6

To FL AND UCOM assy CN901

WARNING
LEAD IN SOLDER USED IN THIS PRODUCT IS LISTED AS A KNOWN REPRODUCTIVE TOXICANT BY THE CALIFORNIA HEALTH AND WELFARE AGENCY. ALSO, CERTAIN ELECTRICAL PARTS LISTED AS KNOWN TO THE STATE OF CALIFORNIA TO CAUSE CANCER AND FOR BIRTH DEFECTS OR OTHER REPRODUCTIVE HARM. FOR FURTHER INFORMATION, SEE THE SAFETY CODE, SECTION 25240.5, FOLLOW MANUFACTURER'S SERVICE INSTRUCTIONS AND USE PROPER PRECAUTIONS.

3.3 FM/AM TUNER MODULE/HEZ

SCH-4

FM/AM TUNER MODULE/HEZ (AXQ7041)

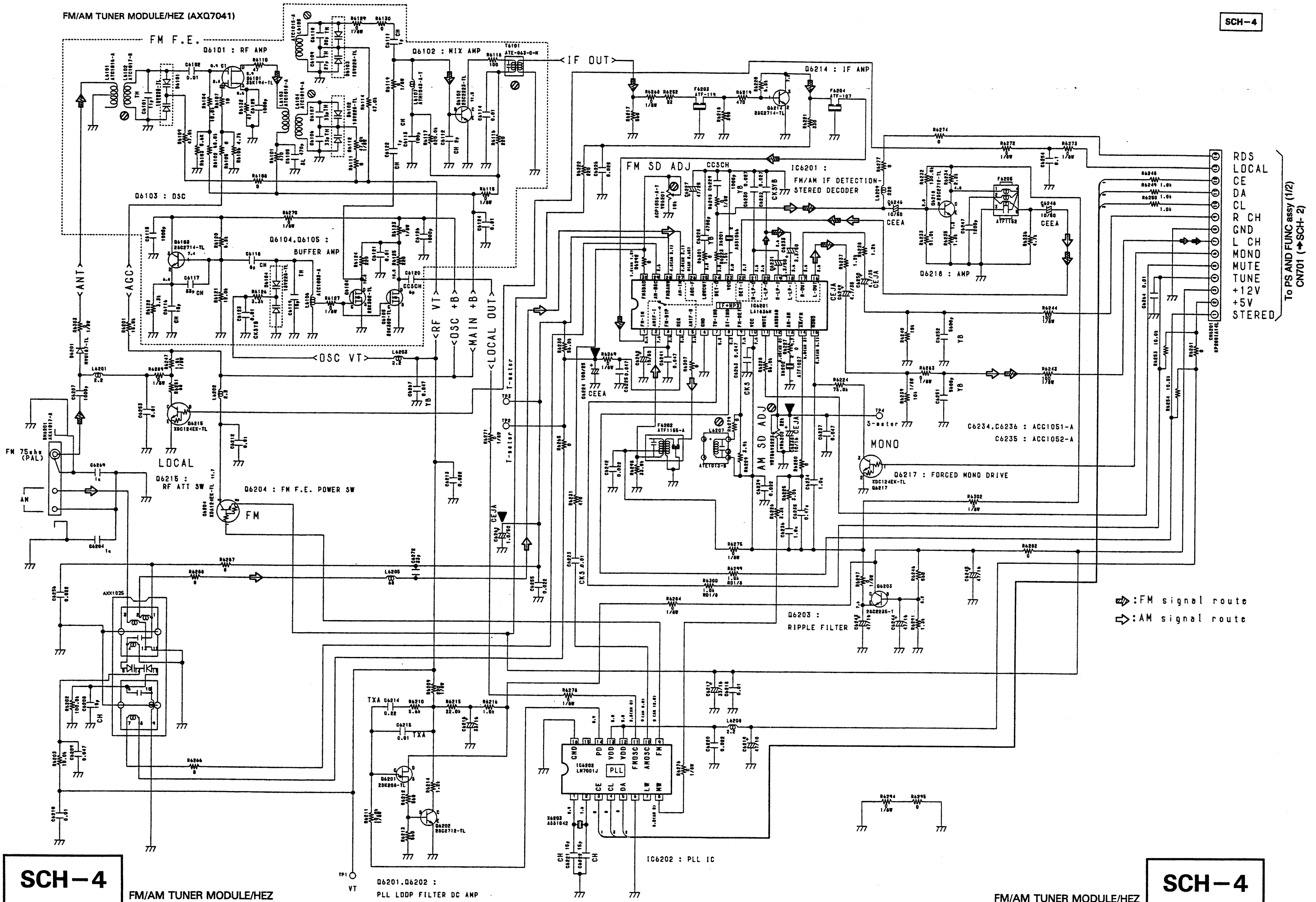

RDS LOCAL
CE
DA
CL
R CH
GND
L CH
MONO
MUTE
TUNE
+12V
+5V
STEREO

To PS AND FUNC assy (1/2)
CN701 (→SCH-2)

→: FM signal route
⇨: AM signal route

SCH-4

SCH-4

1

2

3

4

5

6

FM/AM TUNER MODULE/HEZ

FM/AM TUNER MODULE/HEZ

SCH-4

This diagram is viewed from the mounted parts side.

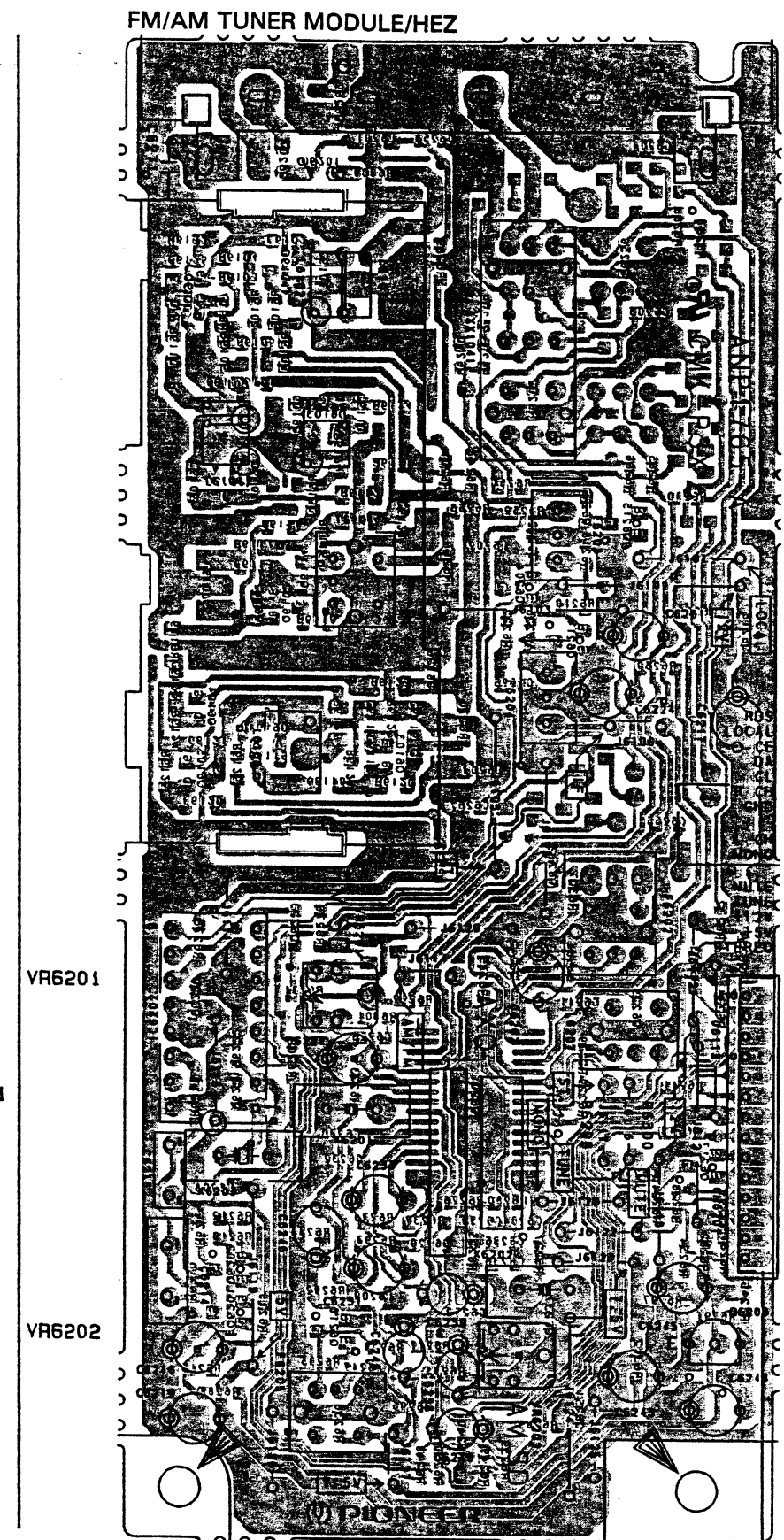
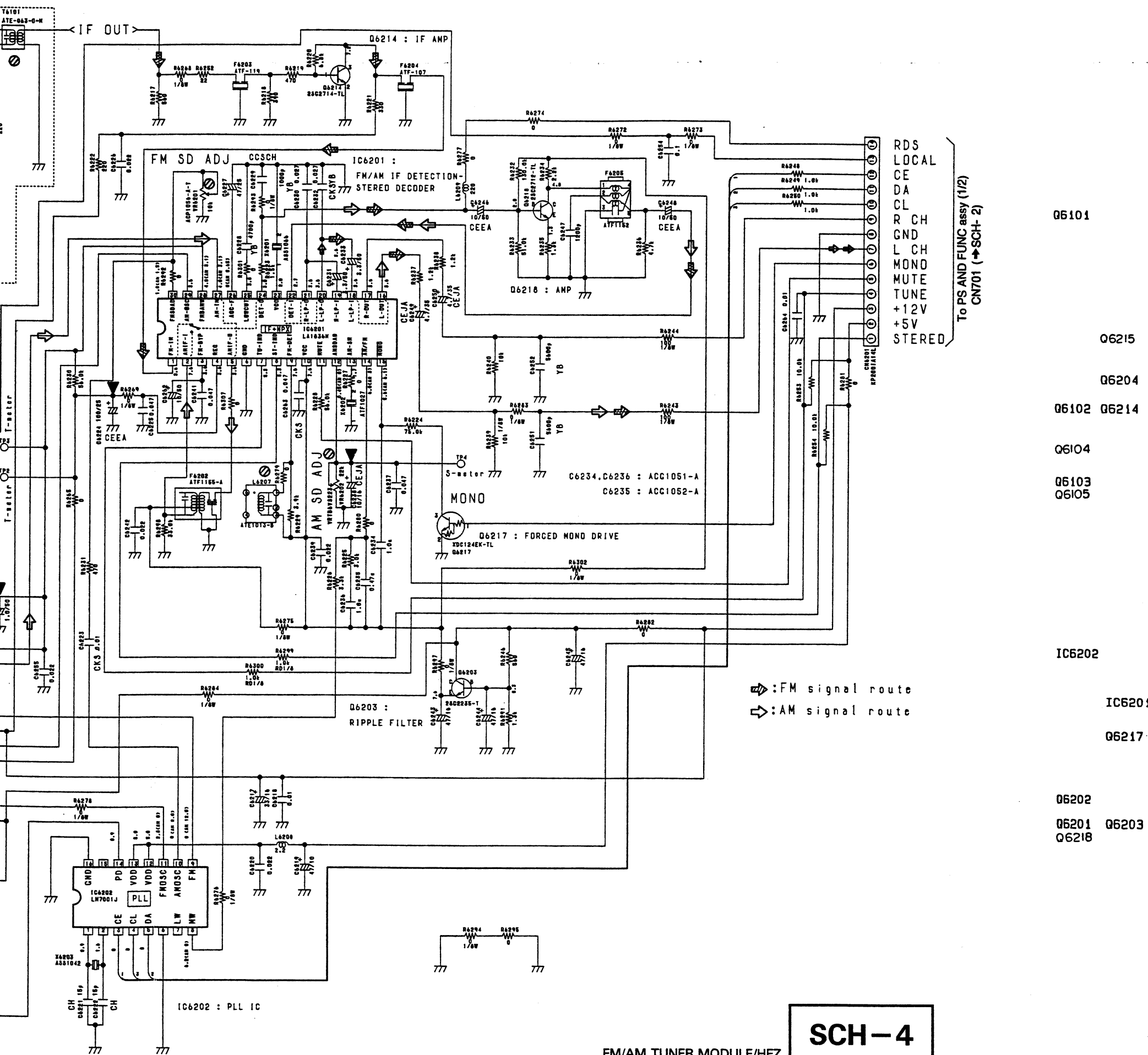

SCH-4

To PS AND FUNC assy (1/2) CN420 (→SCH- 2)

- T.CE
- ST.SUR
- ST.FUNC
- TEMP IN
- AC RY
- High/Low
- +24
- 24
- OVERLOAD
- DC PROT
- WAIT.IN
- V.CONT B
- V.CONT A
- VOL-
- VOL+
- STOP
- MOND
- SR OUT
- 9K/10K
- SR IN
- RMC
- W.UP
- STEREO
- T.MUTE
- DATA
- CK
- 4052.A
- 4052.B
- DISP/LOUD
- MUTE
- RC.SP
- PROTECTION
- SP.A
- SP.B
- STBY 5V
- D.C
- VFDP
- PWR 5V
- FL.AC1
- FL.AC2

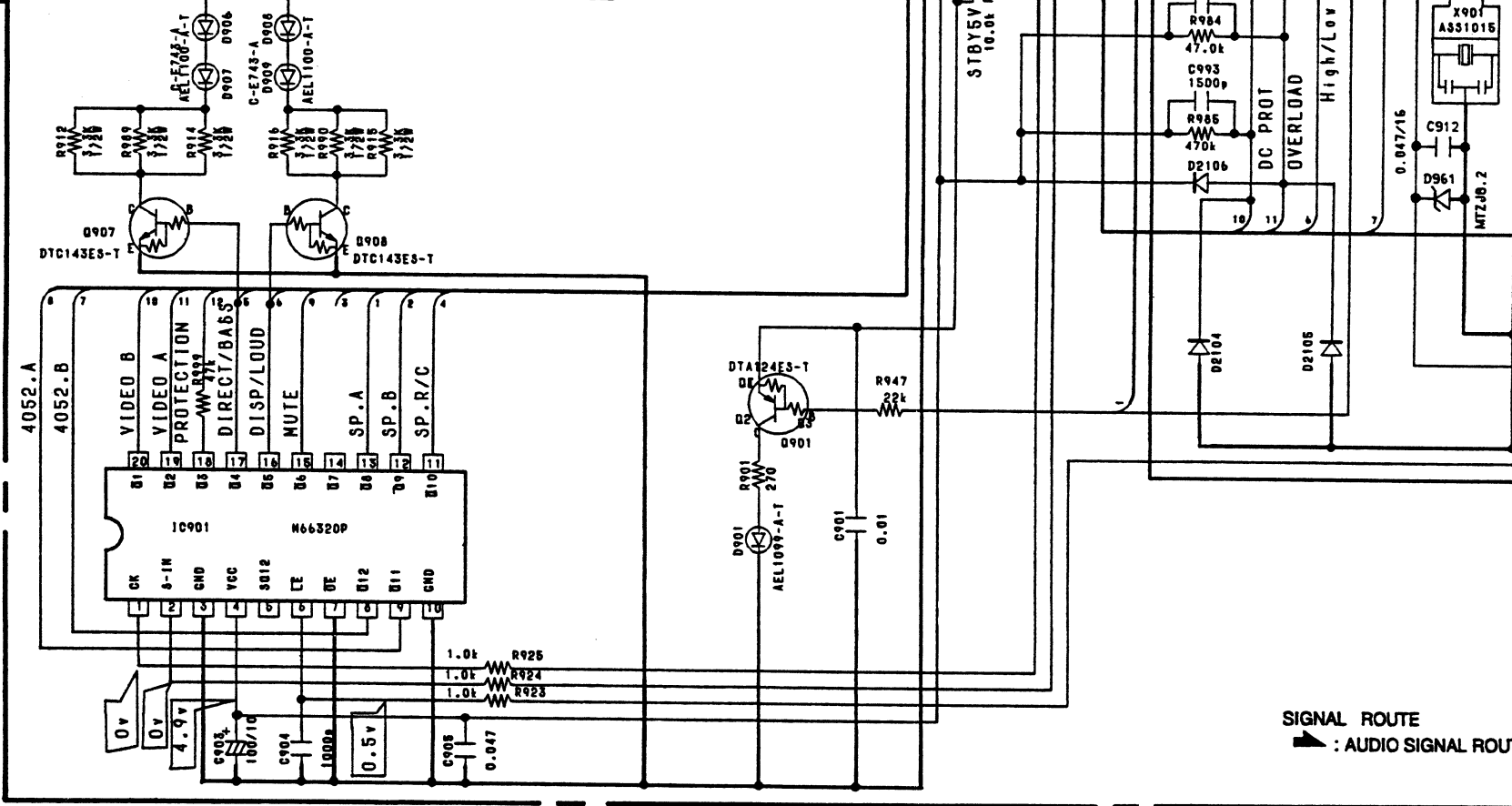
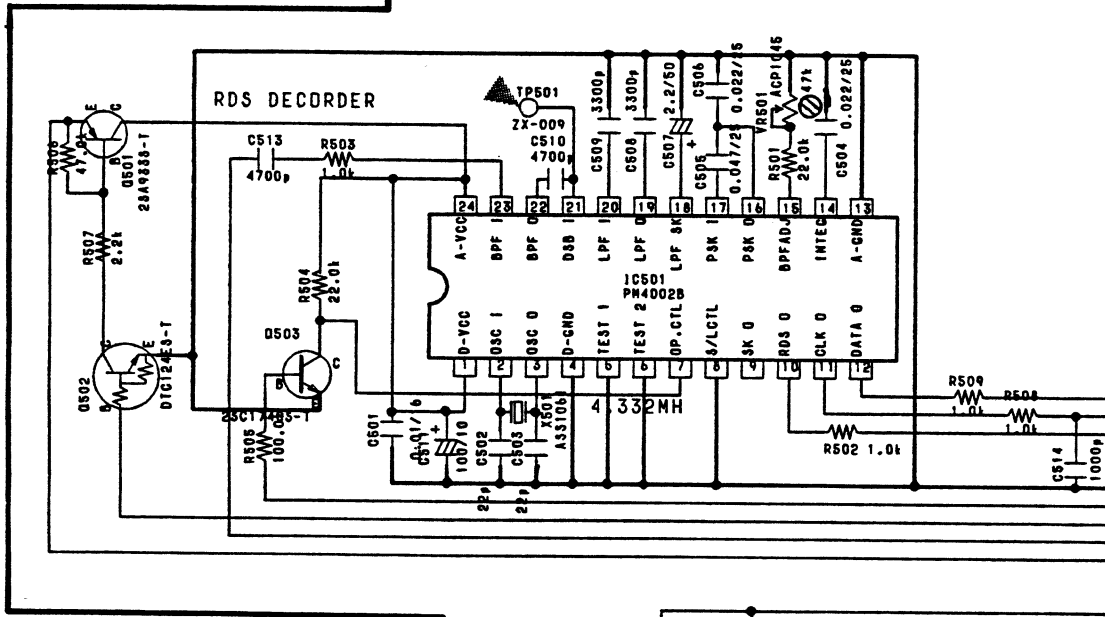
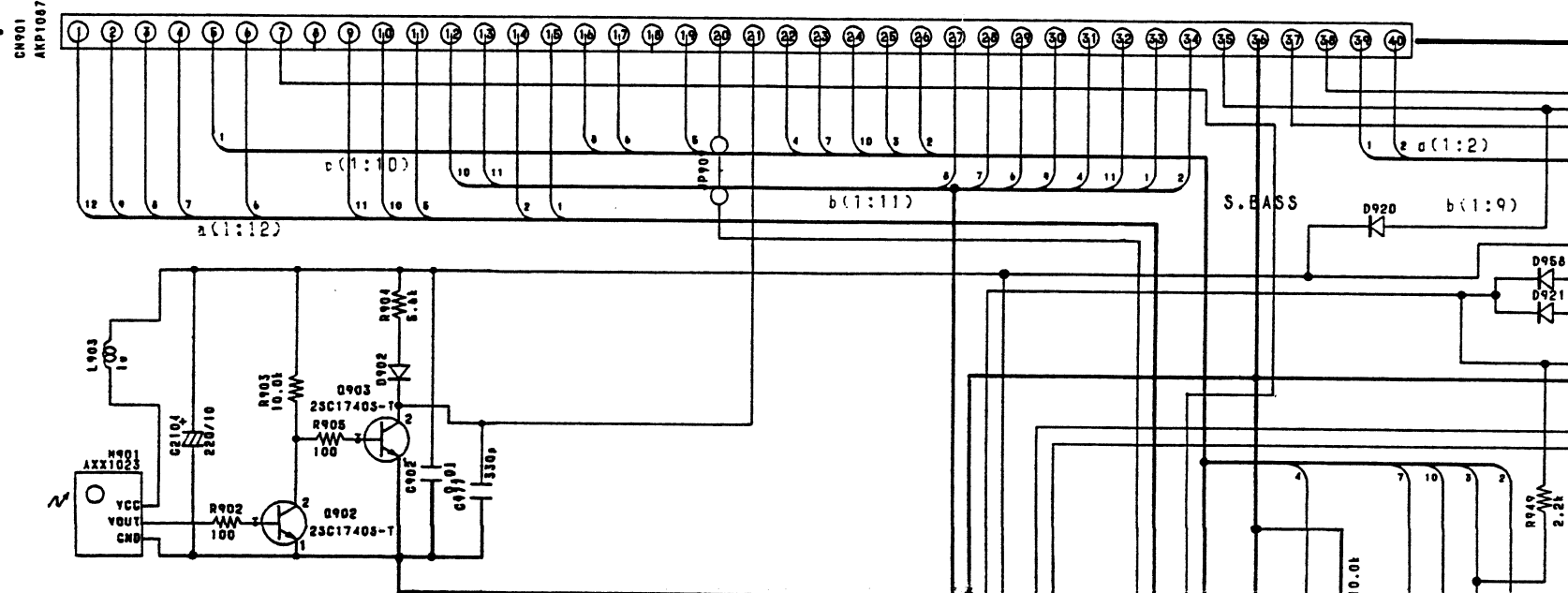

SIGNAL ROUTE
▲ : AUDIO SIGNAL ROUTE

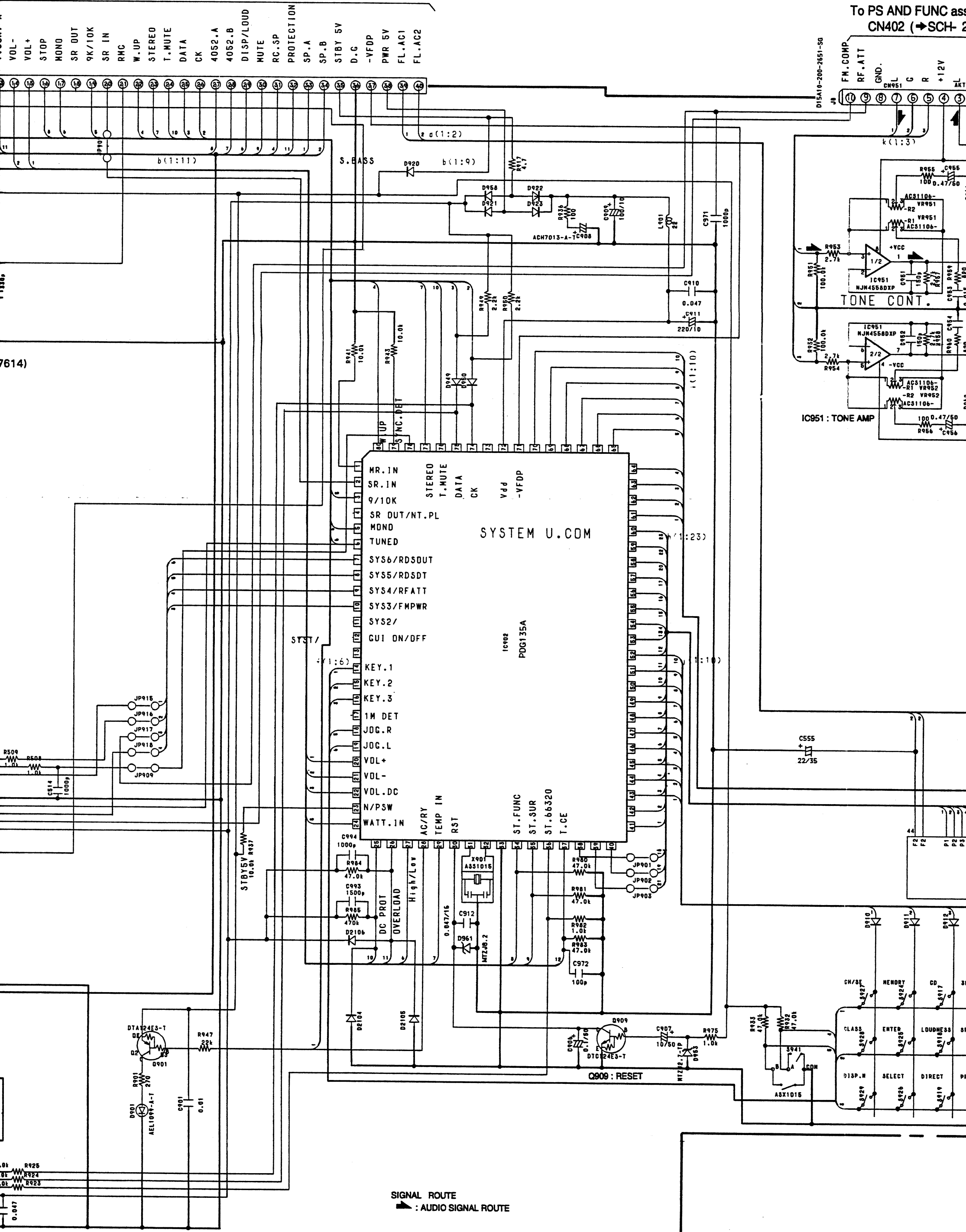

SIGNAL ROUTE
▲ : AUDIO SIGNAL ROUTE

To PS AND FUNC assy (1/2)
CN402 (→SCH- 2)

SCH-5

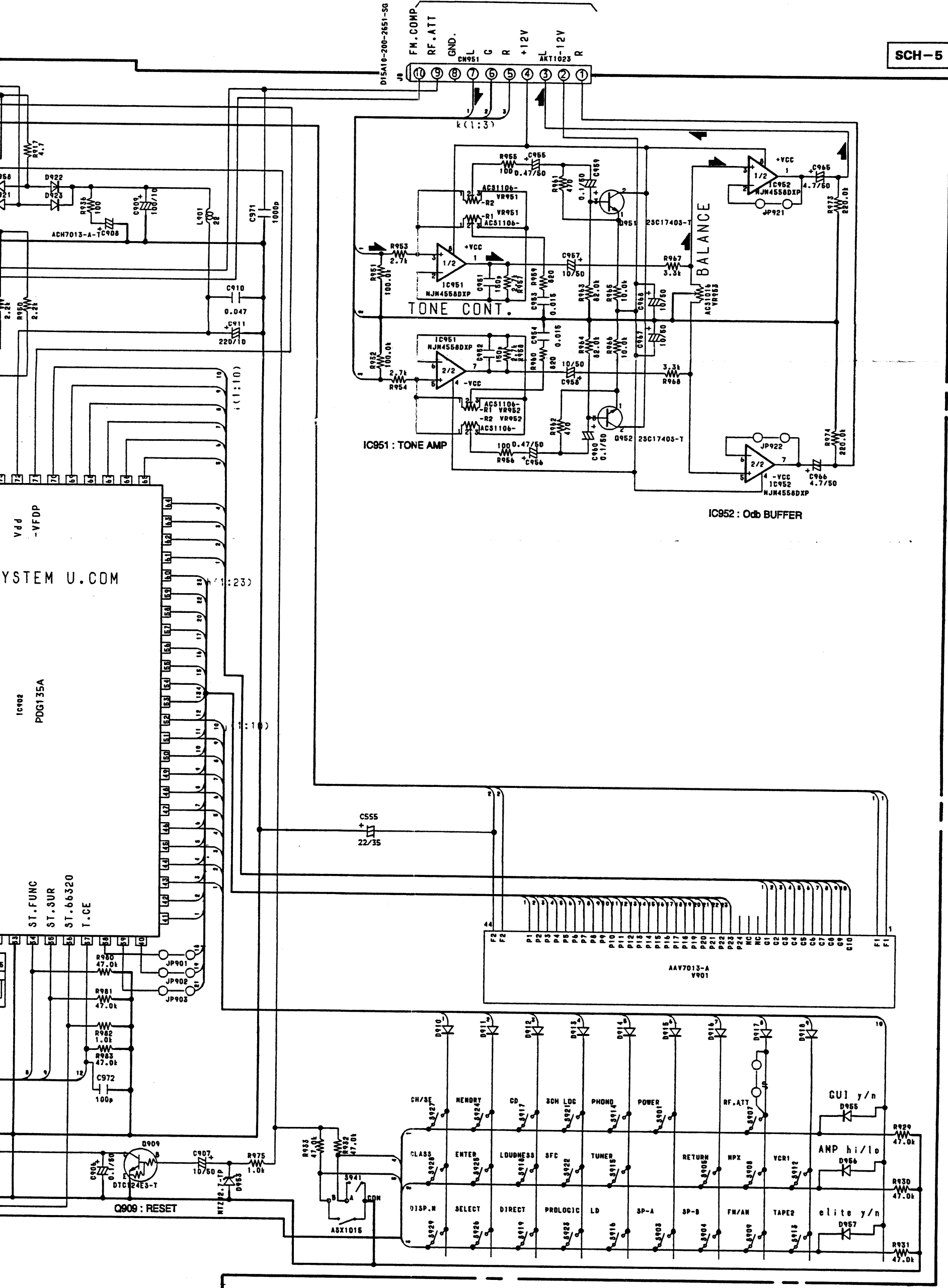

A
B
C
D
E
F

SCH-5

FL AND UCOM ASSY

The parts mounted on this PCB include all necessary parts for several destinations.
 For further information for respective destinations, be sure to check with the schematic diagram.

FL AND UCOM assy

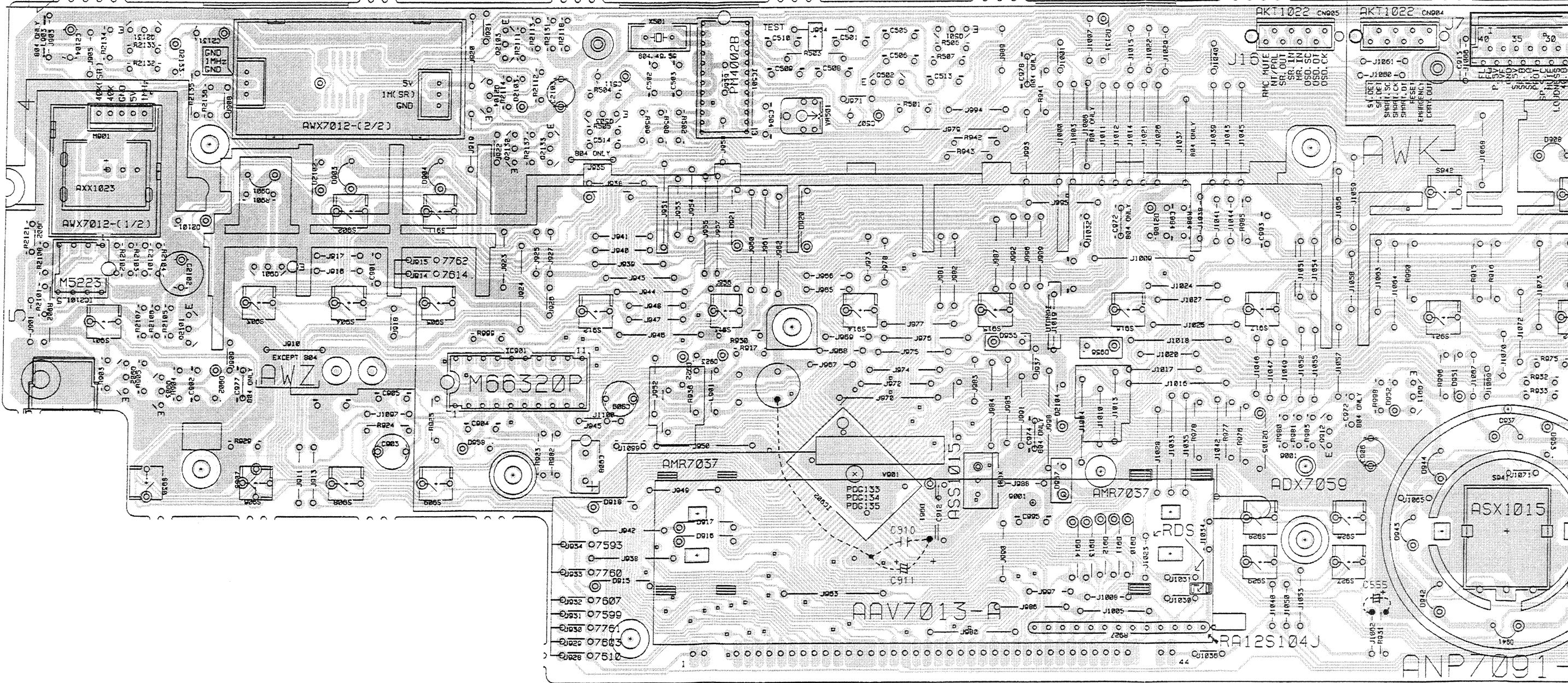

IC2101 Q2131 Q901 Q2104 Q2103 Q2132 Q2133 Q503 Q2106 IC501 VR501 Q502 Q501 IC902 Q912 Q911
 Q902 Q903 Q2101 IC901

• This diagram is viewed from the mounted parts side.

The parts mounted on this PCB include all necessary parts for several destinations. For further information for respective destinations, be sure to check with the schematic diagram.

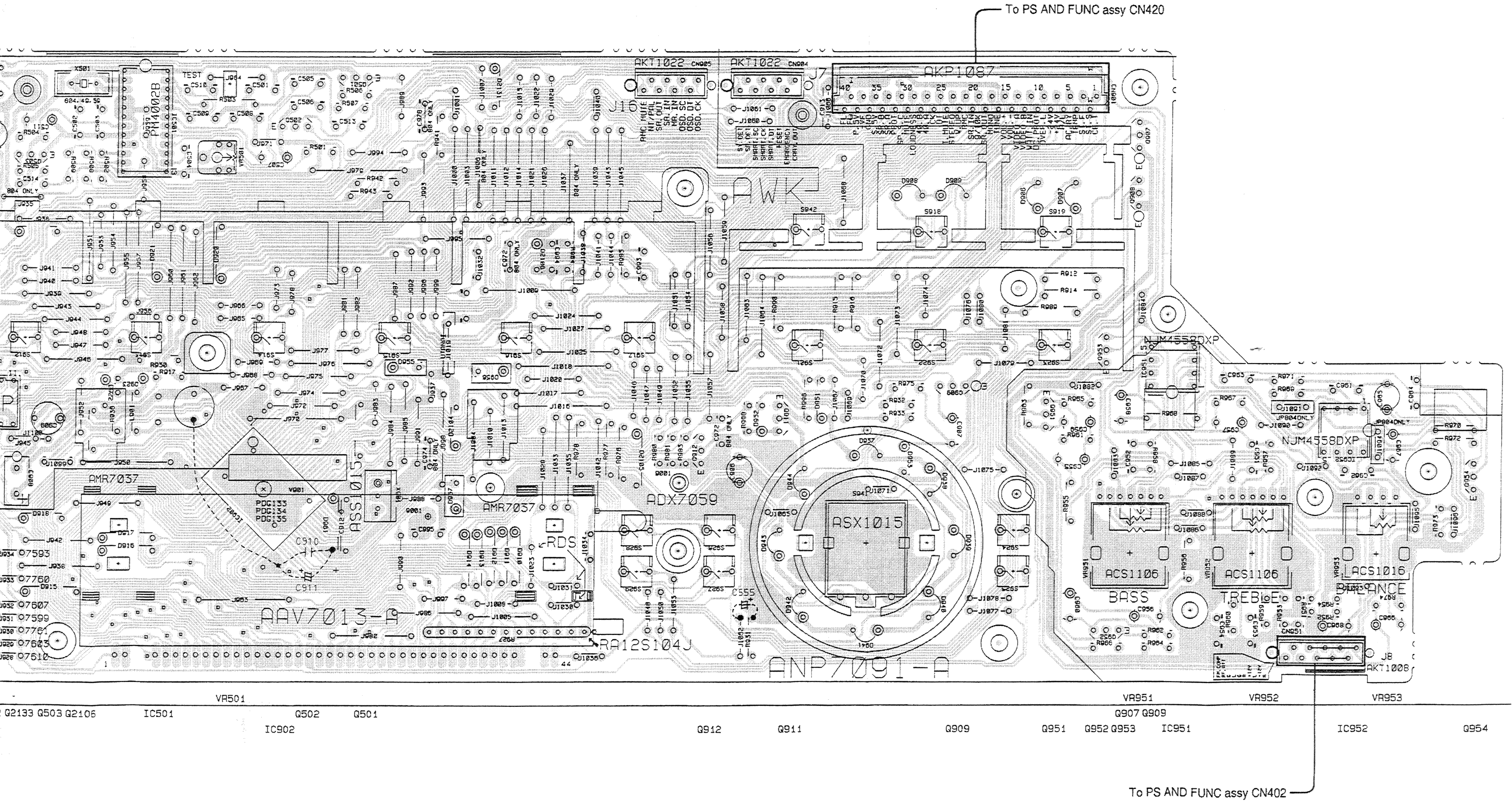

To PS AND FUNC assy CN420

To PS AND FUNC assy CN402

• This diagram is viewed from the mounted parts side.

A

To PS AND FUNC assy (1/2)
CN409 (→SCH- 2)

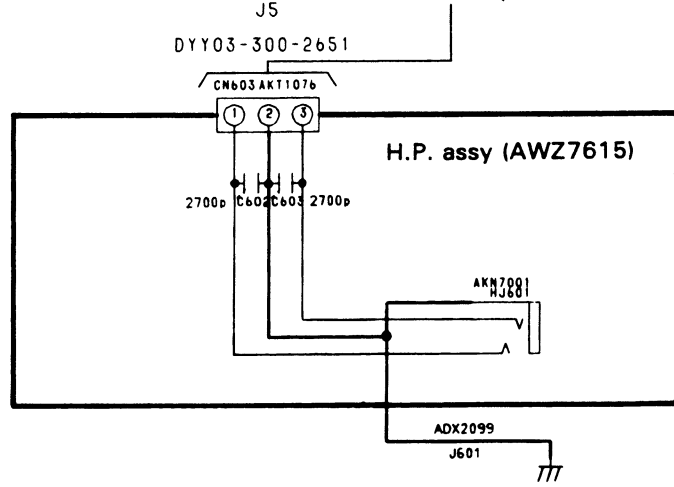

B

To PS AND FUNC assy (1/2)
CN411 (→SCH- 2)

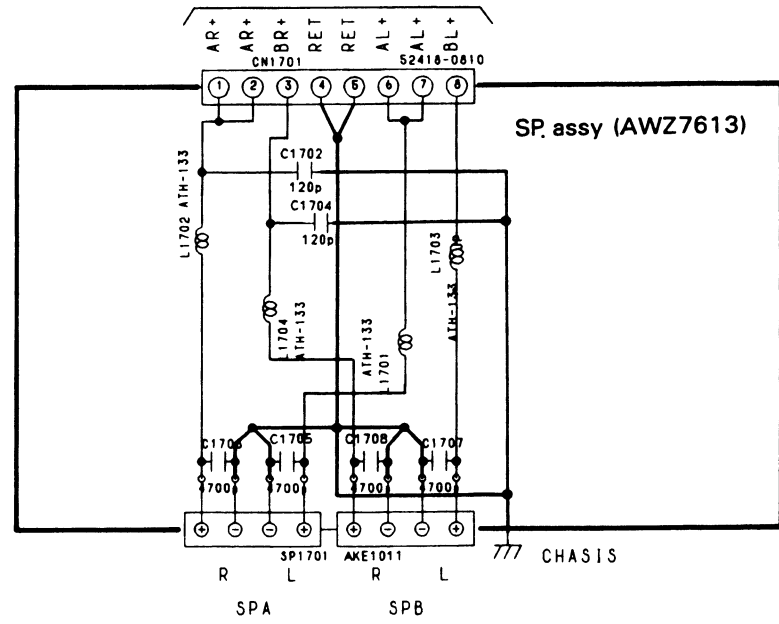

D

●NOTE FOR FUSE REPLACEMENT

CAUTION - FOR CONTINUED PROTECTION AGAINST RISK OF FIRE,
REPLACE ONLY WITH SAME TYPE AND RATINGS ONLY.

To PS AND FUNC assy (1/2)
J3 (→SCH-2)

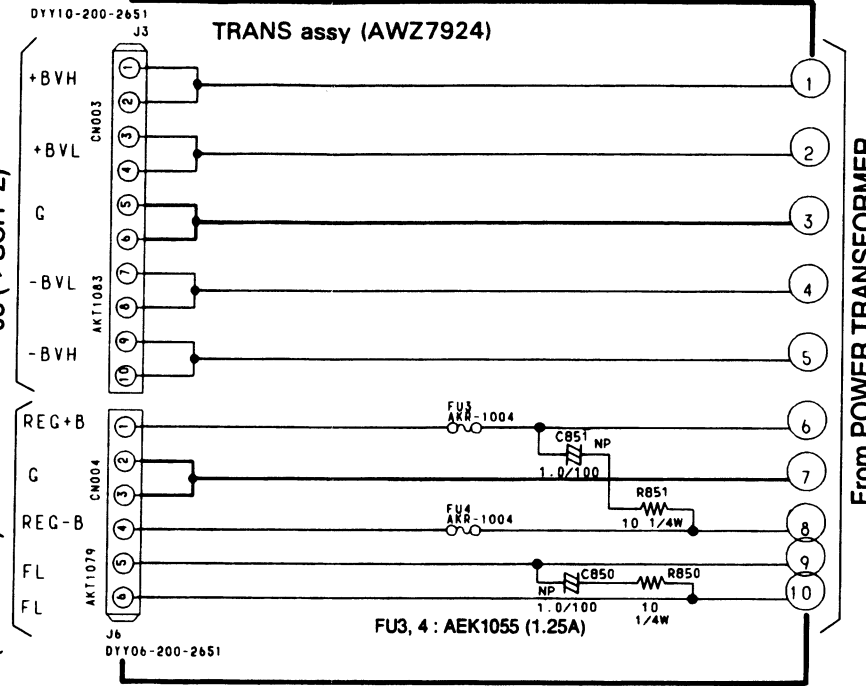

To PS AND FUNC assy (1/2)
J9 (→SCH- 2)

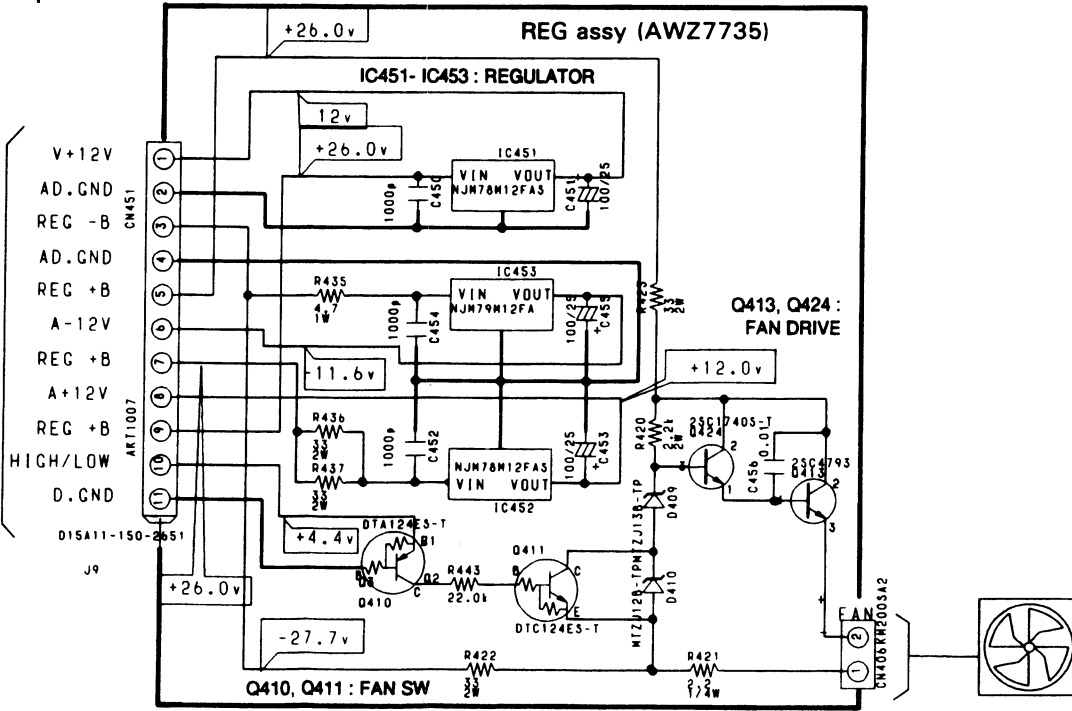

SCH-6

VOL. ASSY, TRANS ASSY, REG ASSY,
H. P. ASSY, SP ASSY

30

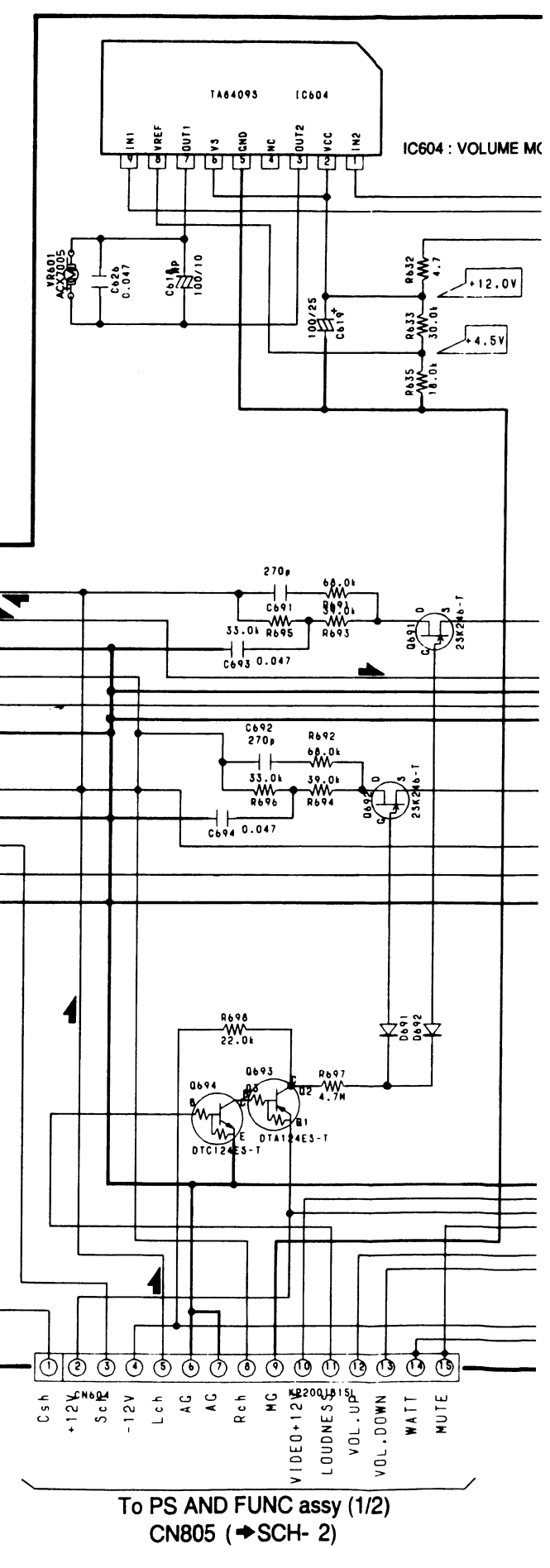

●NOTE FOR FUSE REPLACEMENT
CAUTION - FOR CONTINUED PROTECTION AGAINST RISK OF FIRE,
 REPLACE ONLY WITH SAME TYPE AND RATINGS ONLY.

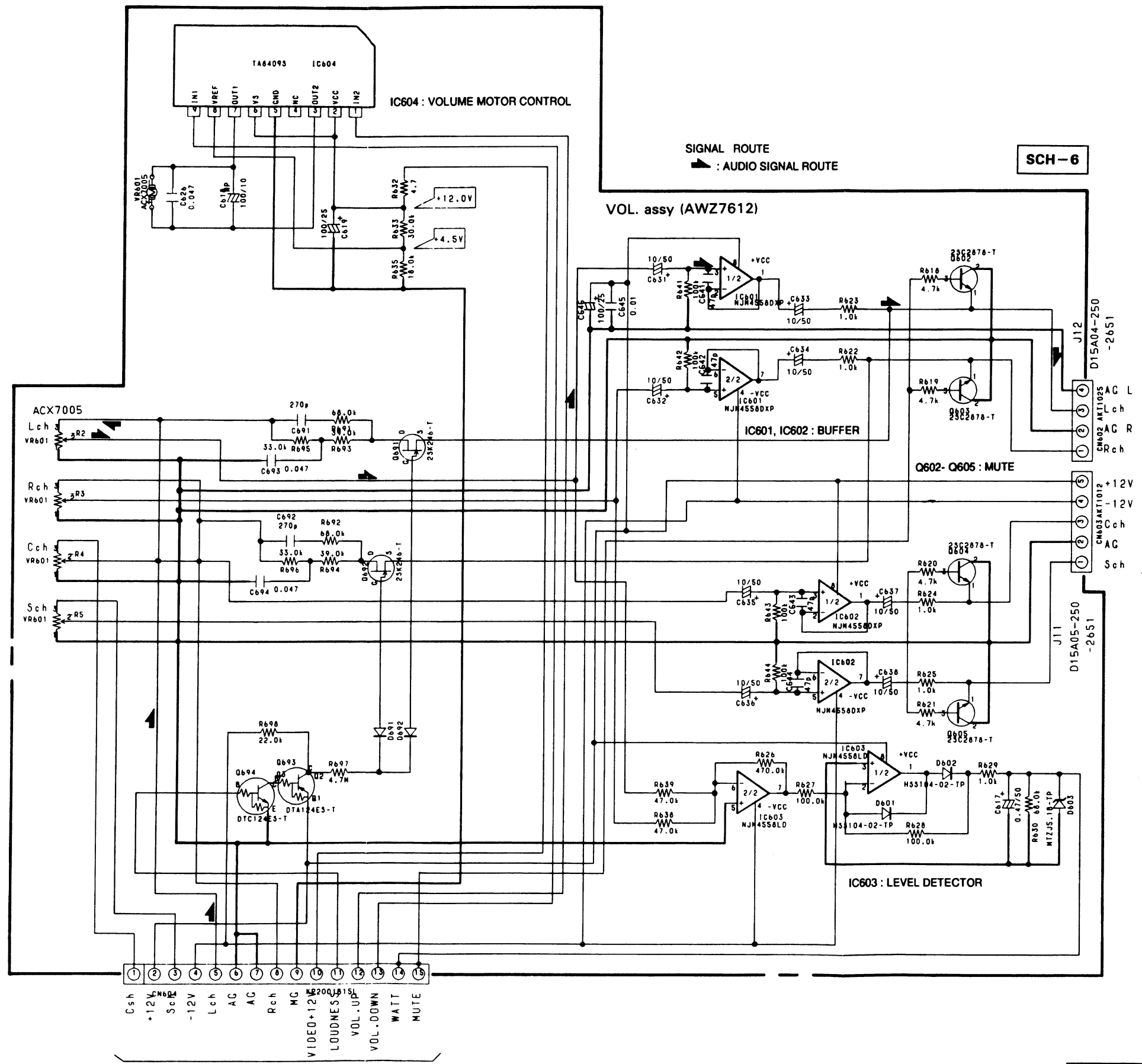
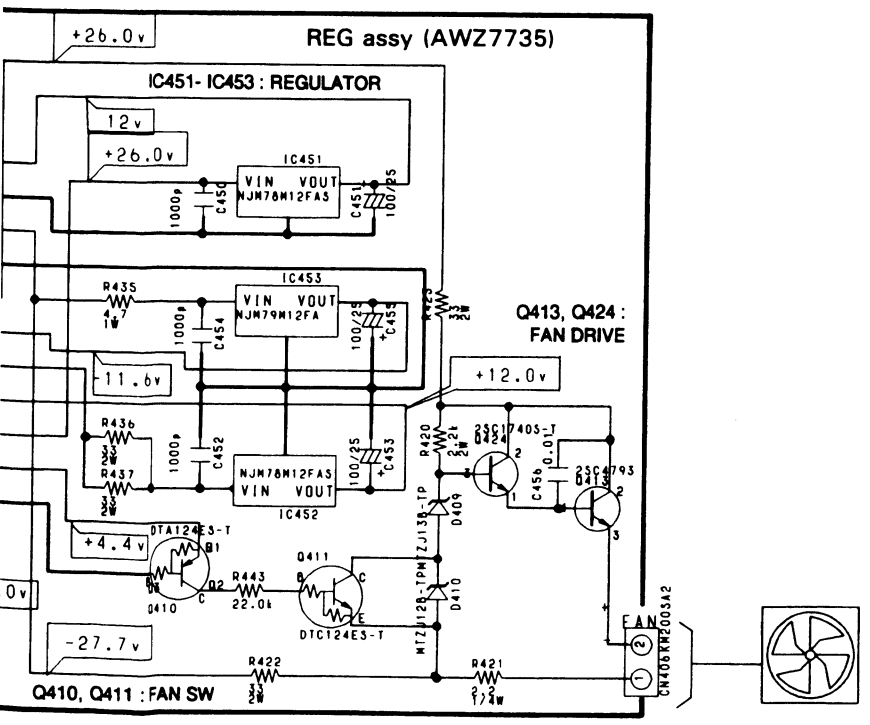
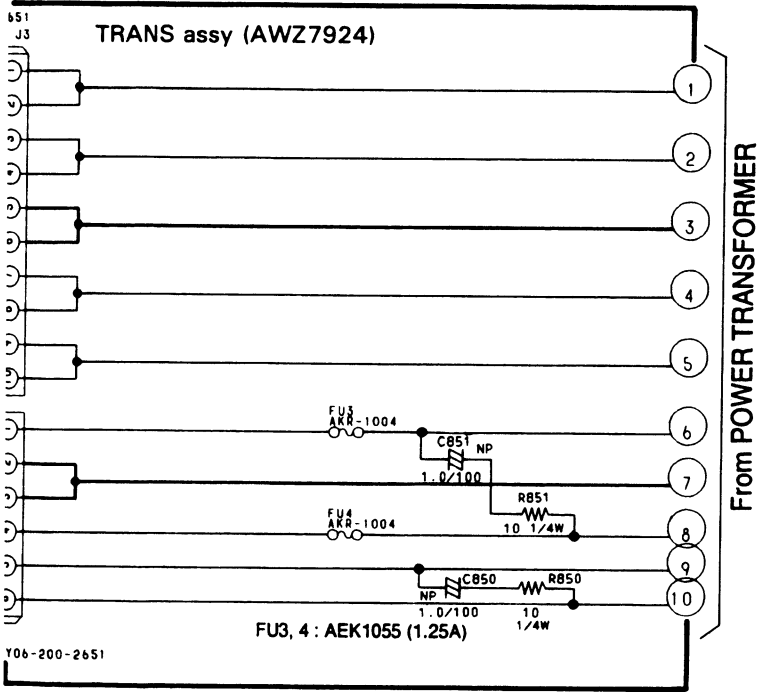

To PS AND FUNC assy (1/2)
 CN805 (→SCH- 2)

To AMP assy 120W
 CN201 (→SCH- 7)

To AMP assy 120W
 CN203 (→SCH- 7)

VOL. ASSY, TRANS ASSY, REG ASSY,
 H. P. ASSY, SP ASSY

SCH-6

A

B

C

D

• This diagram is viewed from the mounted parts side.

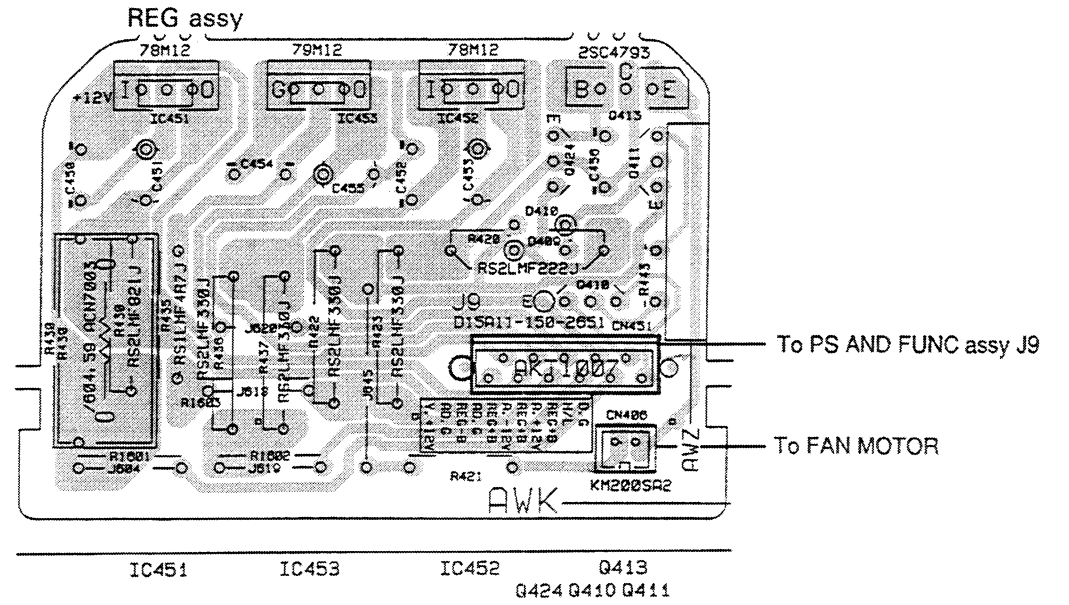
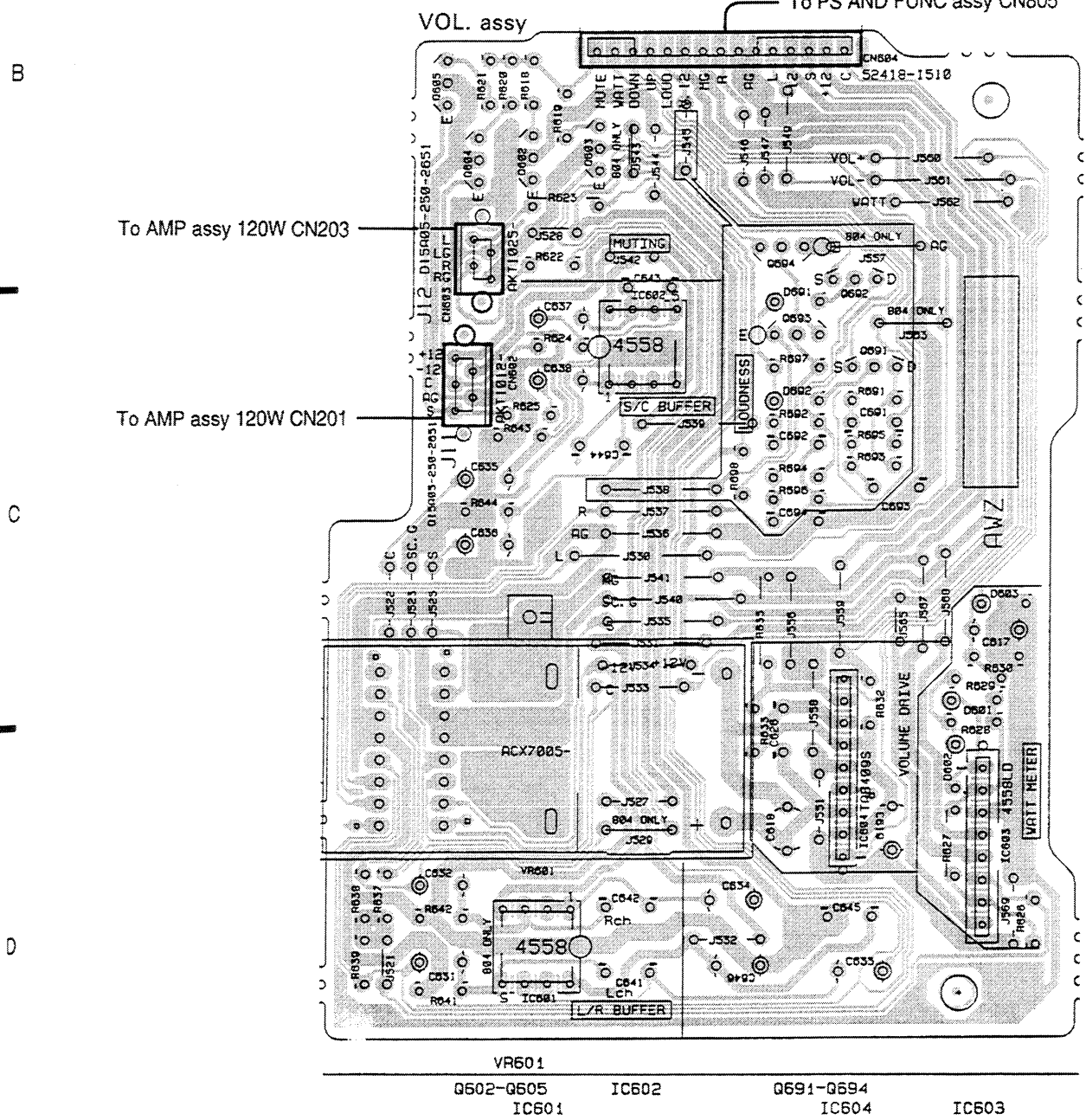
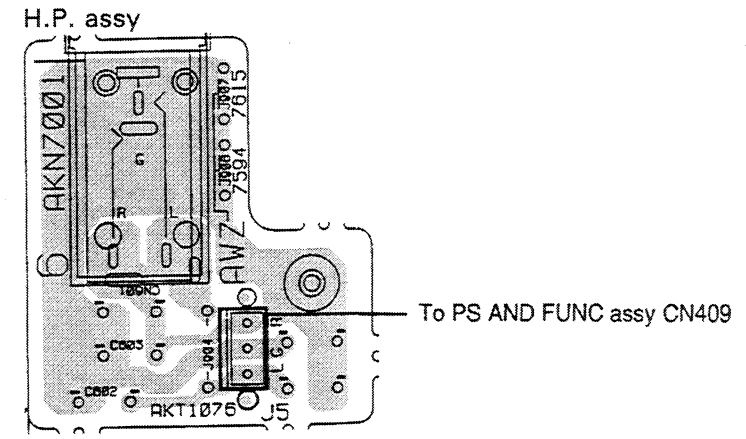
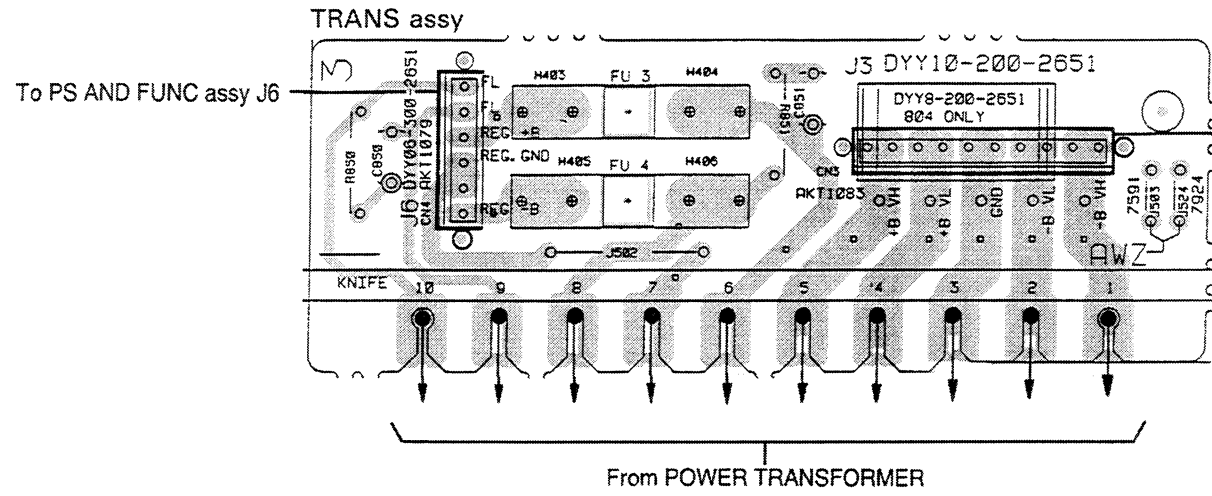

To PS AND FUNC assy CN411

The parts mounted on this PCB include all necessary parts for several destinations. For further information for respective destinations, be sure to check with the schematic diagram.

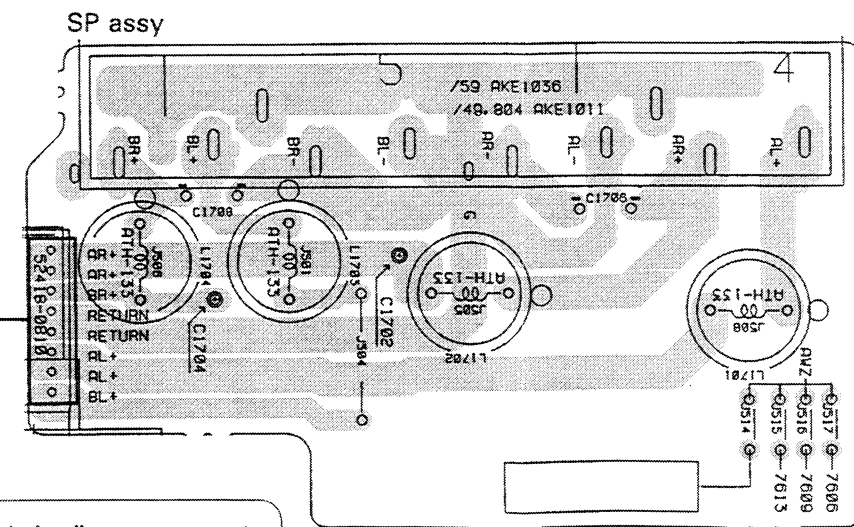

A

B

C

D

A

B

C

D

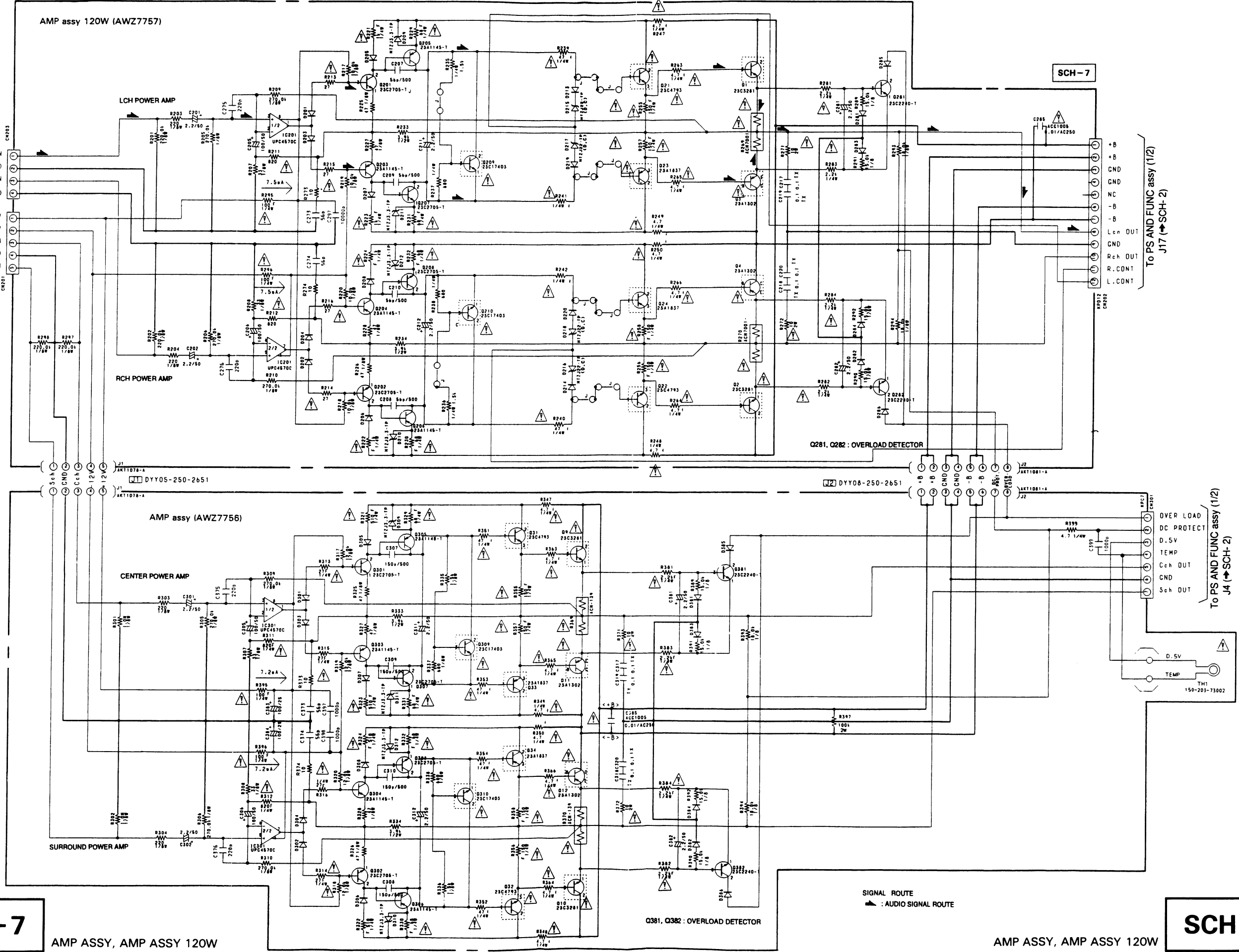

SCH-7

SCH-7

AMP ASSY, AMP ASSY 120W

AMP ASSY, AMP ASSY 120W

Q381, Q382 : OVERLOAD DETECTOR

SIGNAL ROUTE
▲ : AUDIO SIGNAL ROUTE

To PS AND FUNC assy (1/2)
J4 (SCH-2)

OVER LOAD
DC PROTECT
D.5V
TEMP
Cch OUT
GND
Sch OUT

D.5V
TEMP
TH1
150-201-73002

To PS AND FUNC assy (1/2)
J17 (SCH-2)

+B
+B
GND
GND
NC
-B
-B
Lch OUT
GND
Rch OUT
R.CONT
L.CONT

To VOL. assy
J11 (SCH-6)

Lch IN
GND
Rch IN
GND
+12V
-12V
Cch IN
GND
Sch IN

J1 AKT1078-A
J2 DYY05-250-2651
J3 AKT1078-A

J4 AKT1081-A
J5 DYY08-250-2651
J6 AKT1081-A

AMP assy (AWZ7756)

CENTER POWER AMP

SURROUND POWER AMP

AMP assy 120W (AWZ7757)

LCH POWER AMP

RCH POWER AMP

SCH-7

SCH-7

SCH-7

AMP ASSY, AMP ASSY 120W

AMP ASSY, AMP ASSY 120W

Q381, Q382 : OVERLOAD DETECTOR

SIGNAL ROUTE
▲ : AUDIO SIGNAL ROUTE

To PS AND FUNC assy (1/2)
J4 (SCH-2)

OVER LOAD
DC PROTECT
D.5V
TEMP
Cch OUT
GND
Sch OUT

D.5V
TEMP
TH1
150-201-73002

To PS AND FUNC assy (1/2)
J17 (SCH-2)

+B
+B
GND
GND
NC
-B
-B
Lch OUT
GND
Rch OUT
R.CONT
L.CONT

To VOL. assy
J11 (SCH-6)

Lch IN
GND
Rch IN
GND
+12V
-12V
Cch IN
GND
Sch IN

J1 AKT1078-A
J2 DYY05-250-2651
J3 AKT1078-A

J4 AKT1081-A
J5 DYY08-250-2651
J6 AKT1081-A

AMP assy (AWZ7756)

CENTER POWER AMP

SURROUND POWER AMP

AMP assy 120W (AWZ7757)

LCH POWER AMP

RCH POWER AMP

SCH-7

SCH-7

SCH-7

AMP ASSY, AMP ASSY 120W

AMP ASSY, AMP ASSY 120W

Q381, Q382 : OVERLOAD DETECTOR

SIGNAL ROUTE
▲ : AUDIO SIGNAL ROUTE

• This diagram is viewed from the mounted parts side.

A

A

B

B

C

C

D

D

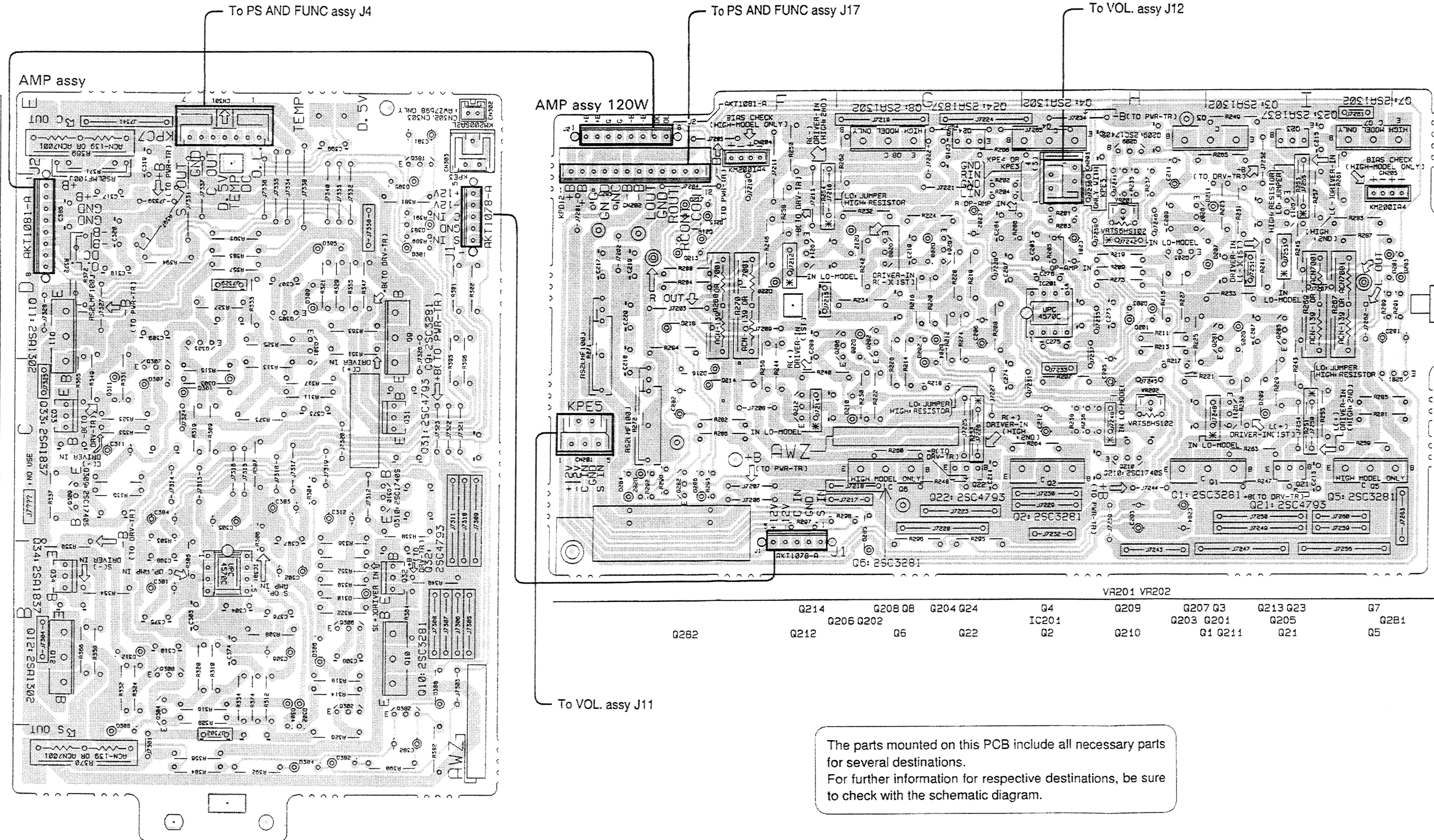

The parts mounted on this PCB include all necessary parts for several destinations. For further information for respective destinations, be sure to check with the schematic diagram.

Q381
Q305
Q11 Q9
Q303 Q301
Q307
Q33 Q31
Q309 Q310
IC301 Q32
Q34
Q305
Q12 Q10
Q308
Q302 Q382
Q304

Q282
Q214 Q208 Q8 Q204 Q24 Q4 Q201 Q209 Q207 Q3 Q213 Q23 Q7
Q212 Q206 Q202 Q5 Q22 IC201 Q210 Q203 Q201 Q205 Q21 Q211 Q21 Q21
Q281 Q5

4. PCB PARTS LIST

NOTES :

- Parts marked by "NSP" are generally unavailable because they are not in our Master Spare Parts List.
- The Δ mark found on some component parts indicates the importance of the safety factor of the part. Therefore, when replacing, be sure to use parts of identical designation.
- Parts marked by "⊙" are not always kept in stock. Their delivery time may be longer than usual or they may be unavailable.
- When ordering resistors, first convert resistance values into code form as shown in the following examples.

Ex. 1 When there are 2 effective digits (any digit apart from 0), such as 560 ohm and 47k ohm (tolerance is shown by J = 5%, and K = 10%).

560Ω → 56 × 10¹ → 561 RD1/8PM 5 6 1 J
 47kΩ → 47 × 10³ → 473 RD1/4PS 4 7 3 J
 0.5Ω → 0R5 RN2H 0 R 5 K
 1Ω → 010 RS1P 0 1 0 K

Ex. 2 When there are 3 effective digits (such as in high precision metal film resistors).

5.62kΩ → 562 × 10¹ → 5621 RM1/4PC 5 6 2 1 F

Mark	No.	Description	Parts No.	Mark	No.	Description	Parts No.
------	-----	-------------	-----------	------	-----	-------------	-----------

LIST OF ASSEMBLIES

		FM/AM TUNER MODULE/HEZ	AXQ7041
NSP		MOTHER ASSY	AWK7134
		— PS AND FUNC ASSY	AWZ7611
		— VOL. ASSY	AWZ7612
NSP		— SP ASSY	AWZ7613
		— REG. ASSY	AWZ7735
NSP		— TRANS ASSY	AWZ7924
NSP		FL AND AMP ASSY	AWK7135
		— FL AND UCOM ASSY	AWZ7614
NSP		— H.P. ASSY	AWZ7615
		— AMP ASSY	AWZ7756
		— AMP ASSY 120W	AWZ7757

FM/AM TUNER MODULE/HEZ

SEMICONDUCTORS

IC6201	LA1836M
IC6202	LM7001J
Q6102	2SC2223
Q6203	2SC2235
Q6202, Q6218	2SC2712
Q6103, Q6214	2SC2714
Q6201	2SK208
Q6104, Q6105	2SK302
Q6101	3SK194
Q6204	XDA124EK
Q6215, Q6217	XDC124EK
D6101 - D6104	1SV228
D6201	HVU187

COILS AND FILTERS

L6106	ATC1003
L6105	ATC1015
L6101	ATC1016
L6102	ATC1017
L6103	ATC1018
L6104	ATC1019
T6101 (10.7MHz)	ATE - 063
L6207 (10.7MHz)	ATE1013
F6204	ATF - 107
F6203	ATF - 119

F6205	ATF1152
F6202 (450kHz)	ATF1155
L6107 (2.2μH)	ATH1043
L6209	LCTA221J3225
L6201 - L6203, L6208	LCTA2R2J3225
L6205	LCTA680J3225

CAPACITORS

C6204, C6234, C6236, C6254, C6269 (1μF/16V)	ACG1051
C6120	CCSCH060D50
C6229	CCSCH102J50
C6111, C6122	CCSQCH010C50
C6112	CCSQCH020C50
C6118	CCSQCH080D50
C6113	CCSQCH101J50
C6116, C6208, C6221, C6222	CCSQCH150J50
C6117	CCSQCH330J50
C6272	CCSLSL330J50
C6105	CCSLSL471J50
C6101	CCSQTH110J50
C6119	CCSQTH150J50
C6109	CCSQTH270J50
C6107, C6110	CCSQTH300J50
C6106	CCSQTH330J50
C6231, C6233, C6262	CEAS100M50
C6216, C6217	CEAS330M16
C6219	CEAS470M10
C6243 - C6245	CEAS470M16
C6227	CEAS470M25
C6246, C6248	CSEA100M50
C6224	CSEA101M25
C6261	CEJA010M50
C6238	CEJA100M16
C6249, C6250	CEJA4R7M35
C6215	CFTXA103J50
C6214	CFTXA224J50
C6115, C6125, C6126, C6207	CKSQYB102K50
C6102, C6114, C6121, C6124, C6210	CKSQYB103K50
C6253, C6264	CKSQYB103K50
C6247	CKSQYB122K50
C6213	CKSQYB223K50
C6230	CKSQYB273K50
C6228	CKSQYB472K50

Mark	No.	Description	Parts No.
	C6209, C6237, C6267		CKSQYB473K50
	C6251, C6252		CKSQYB562K50
	C6212, C6218		CKSQYF103Z50
	C6220, C6226, C6239, C6242		CKSQYF223Z50
	C6255, C6256		CKSQYF223Z50
	C6235		CKSQYF224Z25
	C6225, C6241		CKSQYF473Z50
	C6123		CKSYB103K50
	C6232		CKSYB273K50
	C6223		CKSYF103Z50
	C6263		CKSYF473Z50

RESISTORS

VR6201 (10k Ω)	ACP1056
VR6202	VRTB6VS223
R6299, R6300	RD1/8PM102J
R6115, R6119, R6123, R6127, R6129	RS1/8S000J
R6268 - R6273, R6275, R6276, R6278	RS1/8S000J
R6283, R6284, R6289, R6293, R6294	RS1/8S000J
R6297, R6302, R6303	RS1/8S000J
R6243, R6244	RS1/8S101J
R6211, R6239	RS1/8S103J
R6237	RS1/8S122J
R6247	RS1/8S152J
R6209	RS1/8S221J
R6112	RS1/8S473J
Other Resistors	RS1/10S□□□□

OTHERS

BN6201 2P TERMINAL WITH PAL	AKA1017
X6203 CRYSTAL RESONATOR (7.200MHz)	ASS1042
X6201 CRYSTAL RESONATOR (456kHz)	ASS1066
X6202 CERAMIC RESONATOR (450kHz) AM RF TUNING BLOCK	ATF1027 AXX1025
CN6201 14P SOCKET	KP200IA14L

PS AND FUNC ASSY SEMICONDUCTORS

IC702	BU4052BC
IC1804	LA2785
IC801	LA7952
IC1803	LV1010N
IC1801, IC1802, IC701, IC704	NJM4558D - D
IC703	TC9163AN
Q406	2SA1515
Q419, Q420, Q422, Q470	2SA933S
Q407 - Q409, Q416, Q791, Q792	2SC1740S
Q801	2SC1740S
Q480	2SC2668
Q418, Q481, Q482, Q485, Q486	2SC2878
Q802	2SC2878
Q1801	2SD468
Q483, Q707, Q708	DTA143ES
Q421, Q471	DTC124ES
Q402 - Q404	DTC143ES
D425, D427 - D430	ISR139 - 100
D1809 - D1812, D402 - D404, D407	1SS252
D415, D418, D420, D435 - D437	1SS252
D470, D473 - D475, D491 - D495	1SS252
D703, D801	1SS252
D421, D433	D5SBA20 (B)
D438 - D441	MTZJ18B
D412	MTZJ18C

Mark	No.	Description	Parts No.
	D408		MTZJ4.3C
	D416		MTZJ5.1A
	D419		MTZJ5.6A
	D417		MTZJ5.6C
	D1813		MTZJ9.1C

COILS AND FILTERS

L403	ATF - 151
L401, L402 (1 μ H)	ATH - 133
L1801	LAU2R2J

TRANSFORMERS

T401	ATT1193
------	---------

SWITCHES AND RELAYS

RY401	ASR1044
RY404, RY405, RY407, RY408	ASR7001

CAPACITORS

C422 (0.022 μ F/400V)	ACG1030
C420 (0.01 μ F/400V)	ACG1054
C413, C414 (10000 μ F/56V)	ACH1234
C1801 - C1803	CCCCH101J50
C483, C484	CCCSL101J50
C401, C404	CCCSL181K500
C1842, C1861	CEANL3R3M50
C1838, C1840, C1857, C1859	CEANL4R7M50
C1823	CEAS010M50
C1806, C1809, C1812, C1815, C1826	CEAS100M50
C1831 - C1833, C1847 - C1850	CEAS100M50
C1852, C1853, C410, C713, C714	CEAS100M50
C743, C744	CEAS100M50
C729, C730, C748, C754	CEAS101M25
C809, C810	CEAS101M25
C416	CEAS102M35
C1819	CEAS221M10
C1817, C1846, C1851, C406	CEAS221M16
C417	CEAS222M35
C1804, C1807, C1810, C1813, C1825	CEAS2R2M50
C737, C738, C749, C750	CEAS2R2M50
C1816, C1834, C400, C412	CEAS470M25
C739, C740, C751, C752, C806	CEAS470M25
C407	CEAS470M50
C415	CEAS471M25
C803, C804	CEAS471M6
C801, C802	CEAS4R7M50
C1841, C1860	CEASR15M50
C1837, C1839, C1856, C1858	CEASR47M50
C1835, C1836, C1854, C1855	CFTXA104J50
C1843, C1862	CFTXA154J50
C1820, C1822	CFTXA333J50
C1863	CFTXA474J50
C481, C741, C742, C747, C770	CKCYB102K50
C480	CKCYB103K50
C485, C705, C706, C727, C728	CKCYB471K50
C1870, C745, C746, C753, C755	CKCYF103Z50
C402, C403	CQPA223F100
C811, C812	CKCYF473Z50
C1808, C1811, C1814, C419	CKCYX104M25
C1864, C1865	CKCYX473M25
C405, C408, C701 - C704	CKDYB391K50
C707 - C710, C715 - C726	CKDYB391K50
C731, C732	CKDYB681K50
C1821	CQMA152J50
C1873, C1874	CKCYB681K50

Mark	No.	Description	Parts No.	Mark	No.	Description	Parts No.
	C1844		CQMA223J50	SP ASSY			
	C735, C736		CQMA242J50	COILS AND FILTERS			
	C1845		CQMA473J50			L1701-L1704 (1/H)	ATH-133
	C1830		CQMA681J50	CAPACITORS			
	C733, C734		CQMA822J50			C1702, C1704	CCDSL121K500
						C1705, C1707	CKDYB472K500
						C1706, C1708	CKCYF472Z50
	C421, C481		CQMXA104J100	OTHERS			
RESISTORS						CN1701 8P SOCKET	52418-0810
	R417 (150Ω)		ACN7002			SPEAKER TERMINAL 8-P	AKE1011
	R807		RD1/2PM271J	REG. ASSY			
	R439		RD1/2PM680J	SEMICONDUCTORS			
	R459, R493		RD1/2PM682J			IC451, IC452	NJM78M12FAS
	R494		RD1/2PMF820J			IC453	NJM79M12FA
						Q424	2SC1740S
	R431		RS2LMF101J			Q413	2SC4793
	R433		RS2LMF151J			Q410	DTA124ES
	R447, R448		RS2LMF331J			Q411	DTC124ES
	Other Resistors		RD1/8PM□□□□J			D410	MTZJ12B
						D409	MTZJ13B
OTHERS				CAPACITORS			
	CN411 8P PLUG		53290-0810			C451, C453, C455	CEAS101M25
	CN805 15P PLUG		53290-1510			C450, C452, C454	CKCYF102Z50
	CN404 2P PIN JACK		AKB7036			C456	CKCYF103Z50
	CN703 6P PIN JACK		AKB7003	RESISTORS			
	CN702 PIN JACK (12P)		AKB7004			R421	RD1/4PMF2R2J
						R435	RS1LMF4R7J
	CN401 SPEAKER TERMINAL 6-P		AKE7005			R420	RS2LMF222J
	CN407 JACK		AKN1006			R422, R423, R436, R437	RS2LMF330J
	CN420 40P SOCKET		AKP1085			Other Resistors	RD1/8PM□□□□J
	CABLE HOLDER		AKT1007	OTHERS			
	CABLE HOLDER (6P)		AKT1079			CABLE HOLDER	AKT1007
	CABLE HOLDER (7P)		AKT1080	TRANS ASSY			
	CABLE HOLDER (12P)		AKT1085	CAPACITORS			
	X1801 CERAMIC RESONATOR (8MHz)		ASS1015			C850, C851	CEANP010M100
	CN701 14P PLUG		KM200LA14	RESISTORS			
	CN402 CONNECTOR (10P)		KPE10			R850, R851	RFAI/4PS100J
VOL. ASSY				OTHERS			
SEMICONDUCTORS						CABLE HOLDER (6P)	AKT1079
	IC601, IC603		NJM4558D-D	FL AND UCOM ASSY			
	IC602		NJM4558LD	SEMICONDUCTORS			
	IC604		TA8409S			IC901	M66320P
	Q602-Q605		2SC2878			IC951, IC952	NJM4558D-D
	Q691, Q692		2SK246			IC902	PDG135A
						IC501	PM4002B
	Q693		DTA124ES			Q501	2SA933S
	Q694		DTC124ES	RESISTORS			
	D601, D602, D691, D692		ISS252			Q503, Q902, Q903, Q951, Q952	2SC1740S
	D603		MTZJ5.1B			Q901	DTA124ES
CAPACITORS						Q502, Q909	DTC124ES
	C691, C692		CCCSL271J50			Q907, Q908	DTC143ES
	C641-C644		CCCSL470J50			D2104-D2106, D902, D910-D918	ISS252
	C618		CEANP101M10	OTHERS			
	C631-C638		CEAS100M50			D920-D923, D958	ISS252
	C619, C646		CEAS101M25			D901	AEL1099
						D906-D909	AEL1100
	C617		CEASR47M50			D953	MTZJ2.7
	C693, C694		CFTXA473J50			D961	MTZJ3.2
	C645		CKCYF103Z50	RESISTORS			
	C626		CKCYF473Z50			VR601 (100kΩ)	
						Other Resistors	
RESISTORS						Other Resistors	
	VR601 (100kΩ)		ACX7005	OTHERS			
	Other Resistors		RD1/8PM□□□□J			CN604 15P SOCKET	52418-1510
						CABLE HOLDER	AKT1012
OTHERS							

Mark	No.	Description	Parts No.
COILS AND FILTERS			
	L903		LAU010K
	L901		LAU220K
SWITCHES AND RELAYS			
	S901, S903 - S905, S907 - S909		ASG1034
	S912 - S919, S921 - S929		ASG1034
	S941		ASX1015
CAPACITORS			
	C908		ACH7013
	C951, C952		CCCSL151J50
	C502, C503		CCDCH220J50
	C906		CEAS0R1M50
	C907, C968		CEAS100M50
	C511, C903		CEAS101M10
	C2104		CEAS221M10
	C507		CEAS2R2M50
	C966		CEAS4R7M50
	C959, C960		CEJA0R1M50
	C967		CEJA100M16
	C957, C958		CEJA100M50
	C909		CEJA101M10
	C911		CEJA221M6
	C965		CEJA4R7M35
	C955, C956		CEJAR47M50
	C953, C954		CFTXA153J50
	C994		CKCYB102K50
	C993		CKCYB152K50
	C977		CKCYB331K50
	C905, C910		CKCYF473Z50
	C902		CKCYX103M25
	C508, C509		CKDYB332K50
	C510, C513		CKDYB472K50
	C904		CKDYF102Z50
	C504, C506		CKDYX223M25
	C505		CKDYX473M25
	C972		CKPUYB101K50
	C912		CKPUYF473Z16
	C514, C913, C971		CKPUYB102K50
	C901		CKPUYF103Z25
	C501		CKPUYY103M16
	C978		CKCYB471K50
RESISTORS			
	VR501 (47k Ω)		ACP1045
	VR953 (500k Ω - B)		ACS1016
	VR951, VR952 (30k Ω - B5 x 2)		ACS1106
	R912, R914 - R916, R989, R990		RD1/2PM332J
	Other Resistors		RD1/8PM□□□J
OTHERS			
	V901 FL TUBE		AAV7013
	CN901 40P SOCKET		AKP1087
	X901 CERAMIC RESONATOR (8MHz)		ASS1015
	X501 CRYSTAL RESONATOR (4.332MHz)		ASS1061
	REMOTE RECEIVER UNIT		AXX1023
H.P. ASSY			
CAPACITORS			
	C602, C603		CKCYB272K50

Mark	No.	Description	Parts No.
OTHERS			
	JACK		AKN7001
	CABLE HOLDER (3P)		AKT1076
AMP ASSY			
SEMICONDUCTORS			
	IC301		UPC4570C
	Q303 - Q306		2SA1145
	Q381, Q382		2SC2240
	Q301, Q302, Q307, Q308		2SC2705
	D301 - D308, D381 - D386		1SS252
	D309 - D312		MTZJ3.3
	TH1		150 - 203 - 73002
CAPACITORS			
	C385 (0.01 μ F/150V)		ACG1005
	C307 - C310		CCCSL151K500
	C375, C376		CCCSL221J50
	C373, C374		CCCSL560J50
	C383, C384		CEAS101M25
	C305, C306		CEAS101M50
	C301, C302, C311, C312		CEAS2R2M50
	C381, C382		CEAS2R2M50
	C317 - C320		CFTXA104J50
	C399		CKCYB102K50
	C397, C398		CKCYF102Z50
RESISTORS			
	R369, R370 (0.33 Ω , 5W)		ACN7001
	R333, R334		RD1/2PM392J
	R373, R374		RD1/4PMF100J
	R395, R396		RD1/4PMF101J
	R355 - R358		RD1/4PMF151J
	R313 - R316		RD1/4PMF270J
	R321 - R324		RD1/4PMF511J
	R329 - R332		RD1/4PMF680J
	R381 - R384		RD1/4PMFL222J
	R351 - R354		RF1/4PS470J
	R347 - R350, R363 - R366, R399		RF1/4PS4R7J
	R371, R372		RS2LMF100J
	R397		RS2LMF104J
	Other Resistors		RD1/8PM□□□J
OTHERS			
	CABLE HOLDER (8P)		AKT1081
AMP ASSY 120W			
SEMICONDUCTORS			
	IC201		UPC4570C
	Q203 - Q206		2SA1145
	Q281, Q282		2SC2240
	Q201, Q202, Q207, Q208		2SC2705
	D201 - D208, D213, D214		1SS252
	D219, D220, D281 - D286		1SS252
	D215 - D218		MTZJ22D
	D209 - D212		MTZJ3.3
CAPACITORS			
	C285 (0.01 μ F/150V)		ACG1005
	C275, C276		CCCSL221J50
	C273, C274		CCCSL560J50
	C207 - C210		CCCSL560K500
	C205, C206		CEAS101M50

Mark	No.	Description	Parts No.
	C201, C202, C211, C212		CEAS2R2M50
	C281, C282		CEAS2R2M50
	C217 - C220		CFTXA104J50
	C297		CKCYF103Z50
RESISTORS			
	R269, R270 (0.33Ω, 5W)		ACN7001
	R233, R234		RD1/2PM392J
	R273, R274		RD1/4PMF100J
	R295, R296		RD1/4PMF101J
	R221 - R224		RD1/4PMF102J
	R255 - R258		RD1/4PMF151J
	R229 - R232		RD1/4PMF680J
△	R281 - R284		RD1/4PMFL222J
	R239 - R242		RF1/4PS470J
	R247 - R250, R263 - R266		RF1/4PS4R7J
	R235, R236		RN1/4PC1501F
	R237, R238		RN1/4PC6800F
	R271, R272		RS2LMF100J
	Other Resistors		RD1/8PM□□□J
OTHERS			
	CABLE HOLDER (8P)		AKT1081
CN203	CONNECTOR (4P)		KPE4
CN201	CONNECTOR (5P)		KPE5

5. ADJUSTMENTS

■ ADJUSTMENT OF FM TUNER SECTION

- Set the FM/AM selector to FM BAND.
- Connect the wiring as shown in Fig. 5-1.

Step No.	Adjustment Title	FM SG (1kHz, ± 75 kHz dev.)		Reception Frequency Display	Adjustment Location	Specifications
		Frequency (MHz)	Level (dB μ V)			
1	Center Adjustment	98	80	98 MHz	L6207	Adjust so that the DC voltage between IC6201-Pin 4 and Pin 28 (or \oplus leads of C6224 and C6261) becomes $0V \pm 50mV$.
2	Front End Sensitivity Adjustment	106	Low input (0 to 30)	106 MHz	L6104 L6105 L6102 T6101	After adjusting L6104 and L6105 so that the DC voltage between IC6201-Pin 12 and GND (or \oplus leads of C6238 and GND) becomes at maximum level, adjust T6101 and L6102.
3	Stereo Distortion	98	80	98 MHz	T6101	Minimize the distortion with 1/8 rotation of the core.
4	TUNED IND. Lighting Level	98	15 (± 2 dB)	98 MHz	VR6201	Adjust so that the indicator of TUNED IND. starts to light up.
5	SK Level Adjustment	88 EXTERNAL *1 (RDS SG)	60	88 MHz (RF ATT ON)	VR501	Adjust so that the output level 57 kHz between TP501 and GND becomes maximum. (Refer to Fig. 5-2)

*1: RDS SG (AUDIO, PILOT, RDS, BK and DK: OFF, SK: ON)

Notes:

- Before adjusting, make sure there is no gap between L6101 and L6102 and between L6103 and L6104. If there is a gap between them, bring them into contact with each other first, and then make adjustments.
- Make indicator adjustments in order of AM \rightarrow FM.
- Adjustment sequence : L6104 \rightarrow L6105 \rightarrow L6102 \rightarrow T6101

■ ADJUSTMENT OF AM TUNER SECTION

- Set the FM/AM selector to AM BAND.
- Connect the wiring as shown in Fig. 5-1.

Step No.	Adjustment Title	AM SG (400Hz, 30% Mod.)		Reception Frequency Display	Adjustment Location	Specifications
		Frequency (kHz)	Level (dB μ V/m)			
1	TUNED IND. Lighting Level	999*1	47 (± 2 dB)	999 kHz*1	VR6202	Adjust so that the indicator of TUNED IND. starts to light up.

*1: For the area using 10 kHz step, frequencies should be 1000 kHz.

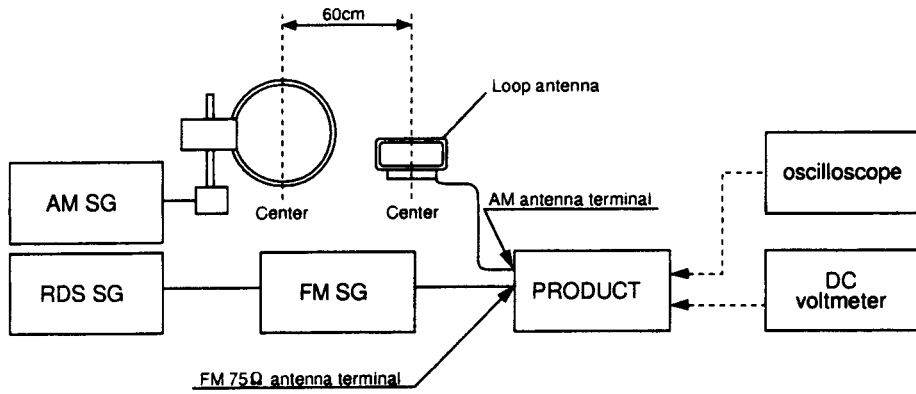

Fig. 5-1 AM and FM Adjustment Wiring Diagram

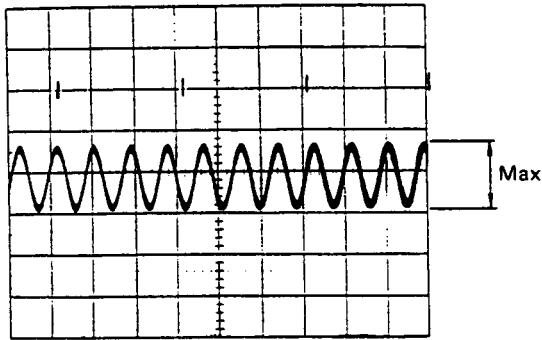
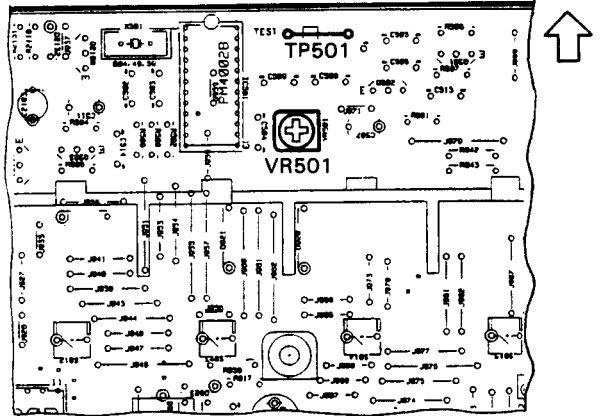

Photo 1
Fig. 5-2 Waveform

FL AND UCOM Assy



FM/AM TUNER MODULE/HEZ

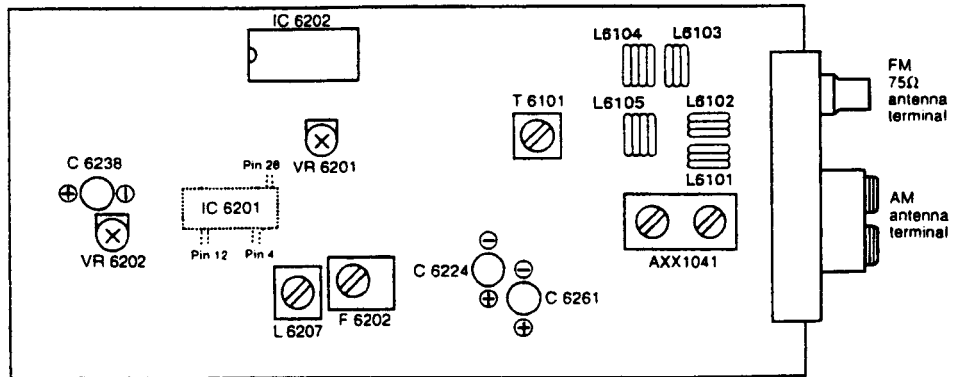

Fig. 5-3 Adjustment Points

6. IC INFORMATION

- The information shown in the list is basic information and may not correspond exactly to that shown in the schematic diagrams.

■ PDG135A (IC902: FL AND UCOM ASSY)

- System Micro-computer
- Pin Assignment (Top View)

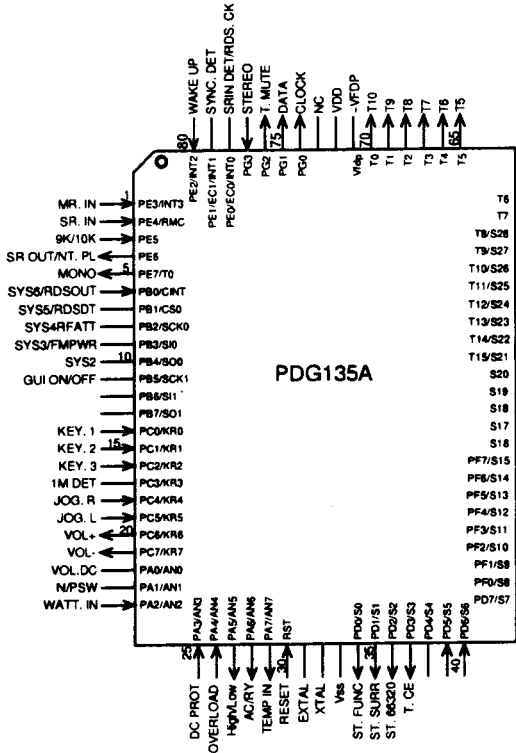

● Pin Function

No.	Pin Name	I/O	Description	Act.
1	MR. IN PE3/INT3	I	Remote control signal input from Multi-room	H
2	SR. IN PE4/RMC	I	Remote control signal input	H
3	9k/10k PE5	I	Switching destination (9k/10k) H: 10k, L: 9k	-
4	SR OUT/NT. PL PE6	O	Remote control signal output	-
5	MONO PE7/T0	O	TUNER: Execution MONO output	H
6	TUNED PB0/CINT	I	TUNER: TUNED input	L
7	SYS6/RDSOUT PB1/CS0	-	---	-
8	SYS5/RDSDT PB2/SCK0	-	---	-
9	SYS4/RFATT PB3/SI0	-	---	-
10	SYS3/FMPWR PB4/SO0	-	---	-

No.	Pin Name	I/O	Description	Act.
11	SYS2/ PB5/SCK1	-	---	-
12	GUI ON/OFF PB6/SI1	-	---	-
13	PB7/SO1	-	---	-
14	KEY. 1 PC0/KR0	I	KEY SCAN input 1	-
15	KEY. 2 PC1/KR1	I	KEY SCAN input 2	-
16	KEY. 3 PC2/KR2	I	KEY SCAN input 3	-
17	1M DET PC3/KR3	-	---	-
18	JOG. R PC4/KR4	I	JOG input UP: JOG1 DOWN: JOG2	-
19	JOG. L PC5/KR5	I	JOG input UP: JOG1 DOWN: JOG2	-
20	VOL + PC6/KR6	O	MASTER VOLUME UP output	H
21	VOL - PC7/KR7	O	MASTER VOLUME DOWN out-put	H
22	VOL. DC PA0/AN0	-	---	-
23	N/PSW PA1/AN1	-	---	-
24	WATT. IN PA2/AN2	I	WATT input (A/D) for fan	-
25	DC PROT PA3/AN3	I	DC input (A/D) for protection	-
26	OVERLOAD PA4/AN4	I	OVER/LOAD input (A/D) for protection	-
27	High/Low PA5/AN5	O	Switching fan rotation L: High, H: Low	-
28	AC/RV PA6/AN6	O	POWER relay ON/OFF	H
29	TEMP IN PA7/AN7	O	TEMP input (A/D) for fan	-
30	RESET RST	I	RESET input	L
31	EXTAL	-	Oscillator (8MHz)	-
32	XTAL	-		-
33	Vss	-	GND	-
34	ST. FUNC PD0/S0	I	STROB output for TC9163	H

No.	Pin Name	I/O	Description	Act.
35	ST. SURR PD1/S1	I	Chip/Enable output for LV1010 (DSP)	L
36	ST. 66320 PD2/S2	I	Chip/Enable output for M66320	H
37	T. CE PD3/S3	I	Chip/Enable output for LM7001 (PLL)	L
38	PD4/S4	-	-----	-
39	PD5/S5	I	-----	-
40	PD6/S6	I	-----	-
41	S4 PD7/S7	O	FL segment output 4	-
42	S5 PF0/S8	O	FL segment output 5/Key scan output 1	-
49	S12 PF7/S15		FL segment output 12/Key scan output 8	-
50	S13	O	FL segment output 13/Key scan output 9	-
52	S15		FL segment output 15/Key scan output 11	-
53	S16	O	FL segment output 16	-
54	S17	O	FL segment output 17	-
55	S18 T15/S21	O	FL segment output 18	-
60	S23 T10/S26		FL segment output 23	-

No.	Pin Name	I/O	Description	Act.
61	T1 T9/S27	O	FL timing output 1	-
62	T2 T8/S28	O	FL timing output 2	-
63	T3	O	FL timing output 3	-
70	T10		FL timing output 10	-
71	-VFDP Vfdp	-	FL driver power supply	-
72	VDD	-	+5V power supply	-
73	NC	-	-----	-
74	CLOCK PG0	O	CLOCK output for TC9163/M66320/LM7001/LV1010	-
75	DATA PG1	O	DATA output for TC9163/M66320/LM7001/LV1010	-
76	T. MUTE PG2	O	TUNER: MUTE	H
77	STEREO PG3	I	TUNER: STEREO input	H
78	SRin DET/RDS. CK PE0/EC0/INT0	-	-----	-
79	SYNC. DET PE1/EC1/INT1	-	-----	-
80	WAKE UP PE2/INT2	I	WAKE-UP (AC pulse for BACK-UP) input	-

7. DISASSEMBLY

CAUTION !

You will get an electric shock if you touch the Radiator (Heat-sink) when the power cord is connected to the power source. Also, the Electrolytic Capacitor contains a charge even when the power cord is unplugged, so the charge must be removed when the bonnet has been taken off.

< Removing the Charge >

- ① Connect the Radiator (top side) and either the Chassis or the Rear panel for 2 to 3 seconds with a Resistor of more than 5W/10Ω.
- ② Connect the +B lead on the J2 and either the Chassis or the Rear panel for 2 to 3 seconds with a Resistor of more than 5W/10Ω.

7.1 PS AND FUNC ASSY

1. Remove the Bonnet case.
2. Remove the two screws ①.
3. Remove the screw ②.
4. Remove the four screws ③ holding the PS AND FUNC assy.
5. Remove the Round knob L and remove the screw ④ between the volume and the front panel.
6. Remove the VOL assy from the PS AND FUNC assy.
7. Remove the rear panel, and power block from the chassis at the same time, according to the Fig. 1

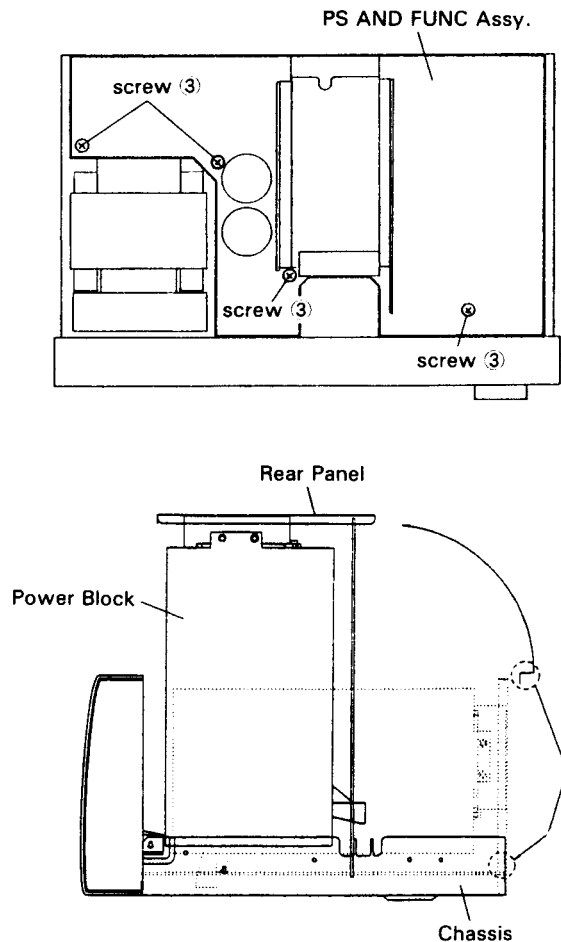
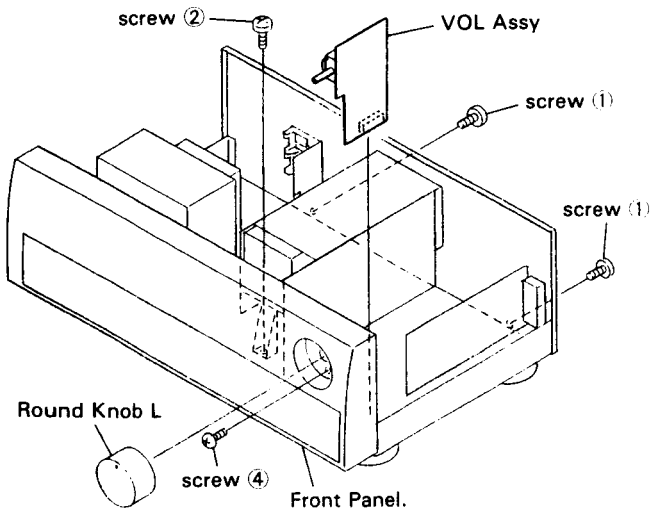
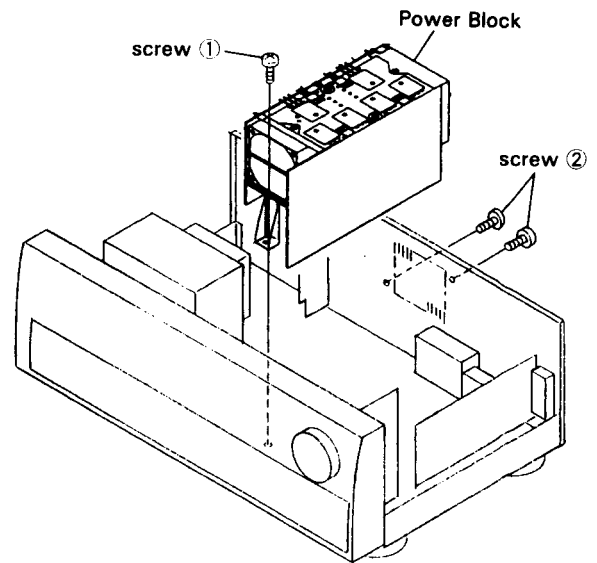

Fig. 1

7.2 POWER BLOCK

1. Remove the Bonnet case.
2. Remove the screw ①.
3. Remove the two screws ②.



7.3 FL AND UCOM ASSY

1. Remove the Bonnet case.
2. Remove the five screws ①.
3. Remove the Round knob L and remove the screw ② between the volume and the front panel.
4. Remove the front panel from the chassis (watching out for the claw on the front panel bottom).
5. Remove the three round knob S (BASS, TREBLE, BALANCE).
6. Remove the screws in Fig. 2 and remove the FL AND UCOM assy.

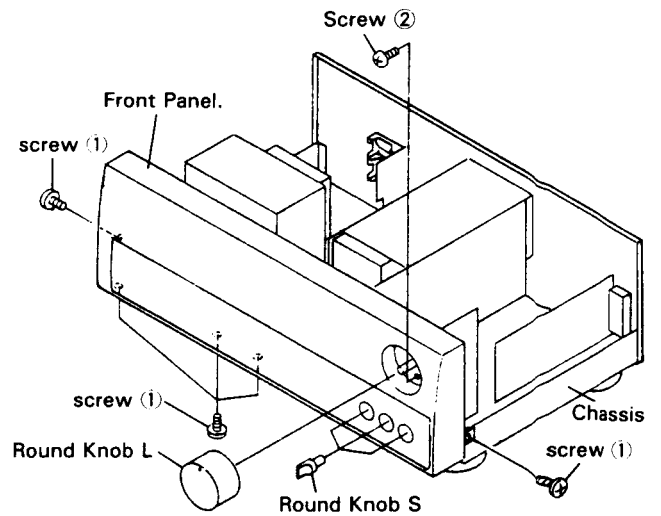

< Location of the FL AND UCOM assy Fixing \$crews >

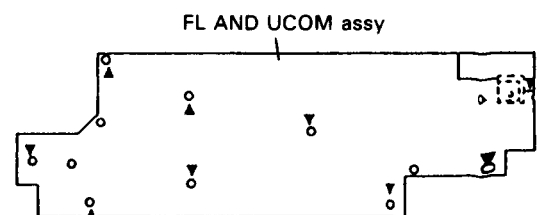
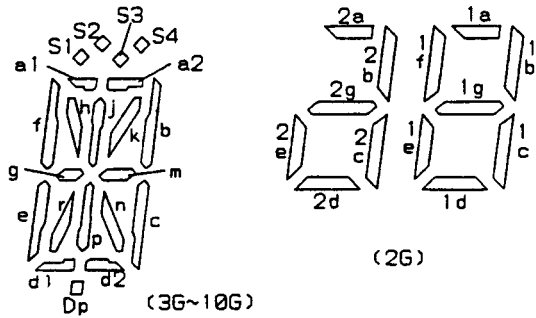
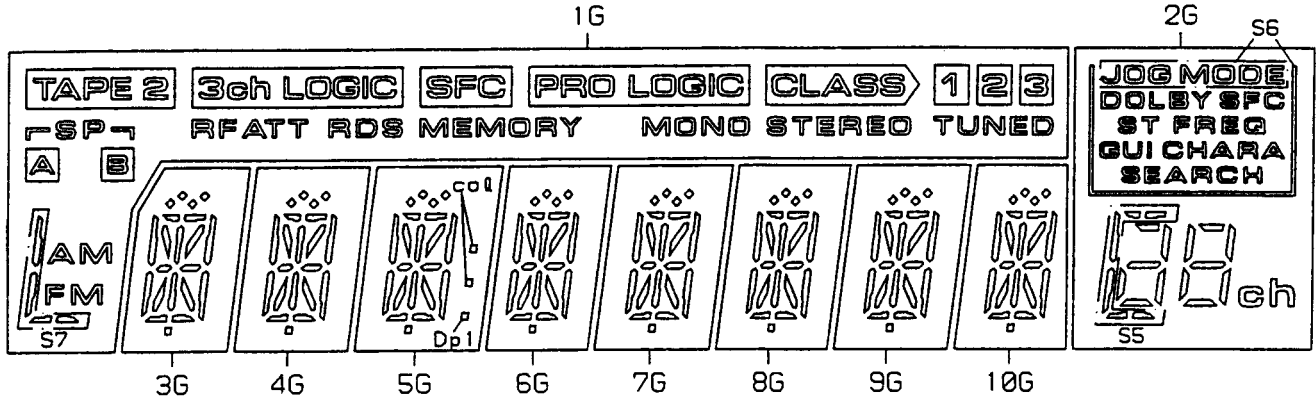

Fig. 2

8. FL INFORMATION

AAV7013 (V901: FL AND UCOM ASSY)

- FL TUBE
- Grid Assignment



● Anode Connection

	1G	2G	3G, 4G	5G	6G~10G
P1	S7	S5	a1	a1	a1
P2	FM	2a, 2d	a2	a2	a2
P3	AM	2b	h	h	h
P4	A	2g	j	j	j
P5	B	2c	k	k	k
P6	SP	2e	b	b	b
P7	TAPE 2	1a	f	f	f
P8	RFATT	1b	m	m	m
P9	3ch LOGIC	1f	g	g	g
P10	RDS	1g	c	c	c
P11	SFC	1c	e	e	e
P12	MEMORY	1e	r	r	r
P13	PRO LOGIC	1d	p	p	p
P14	MONO	ch	n	n	n
P15	TUNED	S6	d1	d1	d1
P16	3	SFC	d2	d2	d2
P17	2	FREQ	Dp	Dp	Dp
P18	1	CHARA	S3	S3	S3
P19	CLASS	SEARCH	S1	S1	S1
P20	STEREO	GUI	S4	S4	S4
P21	-	-	S2	S2	S2
P22	-	DOLBY	-	col	-
P23	-	ST	-	Dp1	-

● Pin Assignment

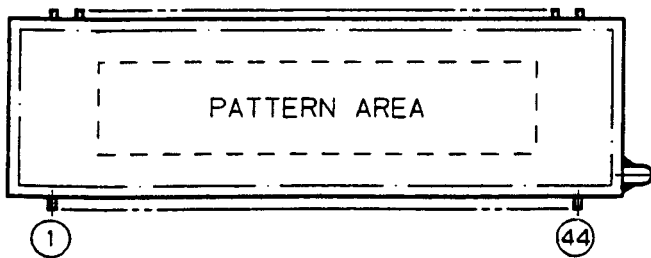

● Pin Connection

PIN NO.	1	2	3	4	5	6	7	8	9	10	11	12	13	14	15	16	17	18	19	20	21	22	23	24	25	26	27	28	29	30	31	32	33	34	35	36	37	38	39	40	41	42	43	44				
CONNECTION	F	F	N	N	0	9	8	7	6	5	4	3	2	1	N	N	N	2	2	2	2	2	2	2	2	2	3	3	3	3	3	3	3	3	3	3	4	4	4	4	4	4	4	4	4	4	4	4
	1	1	P	P	G	G	G	G	G	G	G	G	G	C	C	C	3	2	1	0	9	8	7	6	5	4	3	2	1	0	9	8	7	6	5	4	3	2	1	P	P	N	N	F	F	F	F	

NOTE 1) F1, F2 --- Filament
 2) NP ----- No pin
 3) NC ----- No connection
 4) DL ----- Datum Line
 5) 1G~10G --- Grid

9. PANEL FACILITIES

FRONT PANEL FACILITIES

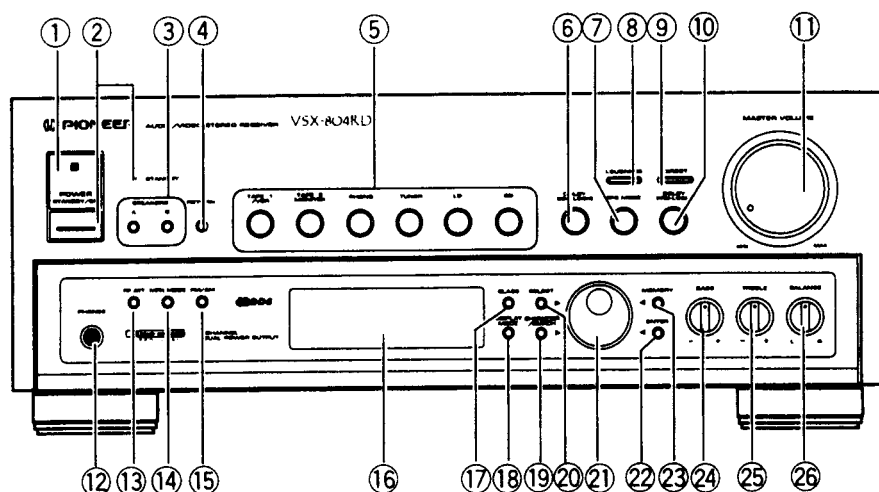

① Remote sensor

② POWER STANDBY/ON switch, STANDBY indicator

This is the switch for electric power.

ON : When set to the ON position, power is supplied and the unit becomes operational.

STANDBY : When set to STANDBY position, the main power flow is cut and the unit is no longer fully operational. A minute flow of power feeds the unit to maintain operation readiness.

The STANDBY indicator lights when the power is set to STANDBY, and goes out when set to ON.

[Timer ON/OFF possible]

When the unit is switched ON, ON/OFF control can be performed by means of the optional timer.

NOTE:

When the power is initially turned ON, muting will be applied to prevent sound from being output for about 5 seconds.

③ SPEAKERS buttons (A, B)

ON/OFF switches for the A and B speaker systems.

④ RETURN button

Press this button to return the receiver to the initial state. TUNER is selected at this initial state. Adjust the sound level by using the MASTER VOLUME control.

- TAPE 2 MONITOR OFF
- SFC MODE OFF
- LOUDNESS OFF
- MUTING OFF
- FUNCTION TUNER
- DIRECT OFF

And SPEAKERS buttons switch as follows.

Before pressing the RETURN button	After pressing
Both A and B are off	→ Only A is on
Only A is on	→ No change
Only B is on	→ Both A and B are on
Both A and B are on	→ No change

NOTE:

Press the RETURN button, and the frequency last selected is received. If reception of the frequency last selected is not possible, the mode automatically switches to AUTO TUNING.

⑤ Input selector buttons

TAPE 1/VCR

: Press when performing playback on a VCR unit or cassette deck.

TAPE 2 MONITOR

: Press when performing playback on a second cassette deck and when monitoring recording.

PHONO

: Press when playing records on a turntable.

TUNER

: Press when listening to radio broadcasts.

LD

: Press when performing playback on an LD player.

CD

: Press when playing compact discs on a CD player.

⑥ DOLBY 3CH LOGIC button

Select this setting when stereo-source regeneration and rear speakers are not connected and you wish to use the front L, front R, and center speakers to enjoy audio/visual material bearing the  mark.

⑦ SFC MODE button

Each time you press it, the mode and the display indications change as follows.

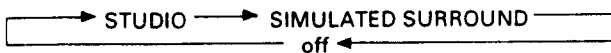

⑧ LOUDNESS button

Use when listening at low volume levels.

ON : Boosts low and high frequencies to produce a fuller sense of sound, particularly at low volume levels.

OFF : Normal position.

NOTE:

This button does not operate when the DIRECT button is in the on position.

⑨ DIRECT button

Press this to listen to source sound without passing the audio signal through sound quality and balance adjusting circuitry. The surround mode, LOUDNESS, and rear and center speakers are automatically switched off.

⑩ DOLBY PRO-LOGIC button

Switches DOLBY PRO-LOGIC SURROUND on and off.

⑪ MASTER VOLUME control

Use to simultaneously adjust the sound volume from the front, center, and rear speakers.

⑫ PHONES jack

Connect the plug on your headphones to this jack. Set SPEAKERS A and B switches to OFF if you want to cut the sound from speakers and listen only through the headphones.

⑬ RF ATT button

Set this button to on when receiving strong FM signals (nearby stations) to reduce sound distortion (RF ATT indicator lights). Normally, this button should be set to off.

This button does not affect AM reception.

⑭ MPX MODE button

Use to select the auto stereo mode or monaural mode when listening to FM broadcasts. The monaural mode has been selected when the MONO indicator in the display section is lit.

Auto stereo mode:

Normally, leave in this mode for reception. When a stereo FM broadcast is received, it will be automatically reproduced in stereo.

Monaural mode:

When receiving distant stations or stations with weak broadcast signals, the input signal may be weak, thus resulting in increased noise during FM stereo broadcasts. In this event, setting the receiver to the monaural mode will reduce the noise. In this case, however, FM stereo broadcasts will be reproduced in monaural sound.

NOTE:

This button has no effect on reception of AM broadcasts.

⑮ FM/AM button

Use this to switch between FM and AM frequency band reception.

⑯ Display section

⑰ CLASS button

Use to switch between preset memory classes 1 to 3. In each class, one station can be memorized in each of the 1 to 10 stations, enabling a total of 30 stations to be memorized.

⑱ DISPLAY MODE buttons

Use this to switch between display modes. Each time you press it, the display changes as follows.

<FM reception>

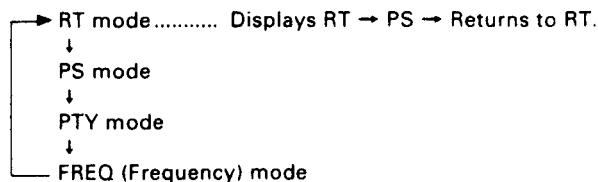

<AM reception>

(in the case of memorized broadcasting station names)

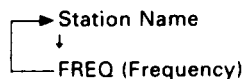

⑲ CHARACTER/SEARCH button

When receiving an AM broadcast, or when in the FM RT, PS modes:

Press this button; "INPUT" is displayed, and the mode switches to manual station name input.

When in the FM PTY mode:

Press this button; "SEARCH" is displayed, and the mode switches to program type search.

NOTE:

This button does not function in the frequency mode.

⑳ SELECT button

Press this button to switch to the station mode. Then you can turn the multi-jog to select a station.

When in the Frequency mode, tuning the multi-jog raises or lowers the frequency.

㉑ Multi-jog

Use during tuner operation to select frequencies and station numbers. In the Manual Name input mode and PTY search mode, use to select characters and program types.

㉒ ENTER button

Press this button when you are in the frequency preset mode, and the displayed frequency is memorized in the selected station. (Station indications stop flashing and stay lit.)

㉓ MEMORY button

Press this button to switch to the frequency preset mode.

㉔ BASS control

Use to adjust the low-frequency level. Turn clockwise to boost bass, and counterclockwise to attenuate bass.

㉕ TREBLE control

Use to adjust the high-frequency level. Turn clockwise to boost treble, and counterclockwise to attenuate treble.

㉖ BALANCE control

Use to adjust the sound volume balance between left and right speakers.

L: Decrease the sound on the right side.

R: Decrease the sound on the left side.

Usually, left and right volume levels should be the same.

DISPLAY SECTION

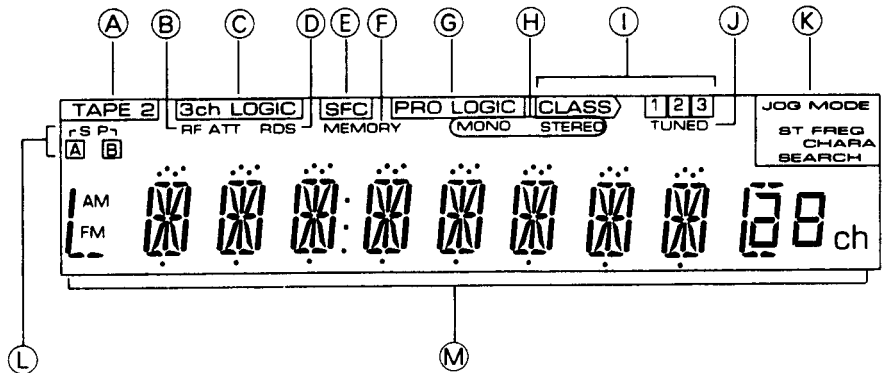

- (A) TAPE 2 indicator**
Lights up when the input selector is set to TAPE 2 MONITOR on.
- (B) RF ATT indicator**
Stays lit while RF ATT button is on.
- (C) DOLBY 3CH LOGIC indicator**
- (D) RDS indicator**
Lights when an RDS broadcast is received.
- (E) SFC indicator**
This lights when an SFC mode (STUDIO, SIMULATED SURROUND) is selected.
- (F) MEMORY indicator**
- (G) DOLBY PRO-LOGIC indicator**
- (H) MONO/STEREO indicator**
MONO : Lights up when the FM MONO mode is selected with the MPX MODE button.
STEREO : Lights up when a stereo FM broadcast is being received.

- (I) CLASS indicator**
Indicates the class selected by the CLASS button. The current CLASS is displayed.
- (J) TUNED indicator**
Lights up when a station is tuned.
- (K) JOG MODE indicator**
ST, FREQ:
When operating the TUNER with the multi-jog, this indicates the station mode (ST) or the frequency mode (FREQ).
CHARA:
Lights up when entering characters with the operation of Manual Station Name Memory.
SEARCH:
Lights up in the PTY search mode.
- (L) SP (SPEAKERS) A, B indicators**
Indicates which speaker system (or systems) are switched on.
- (M) Character display**

REAR PANEL FACILITIES

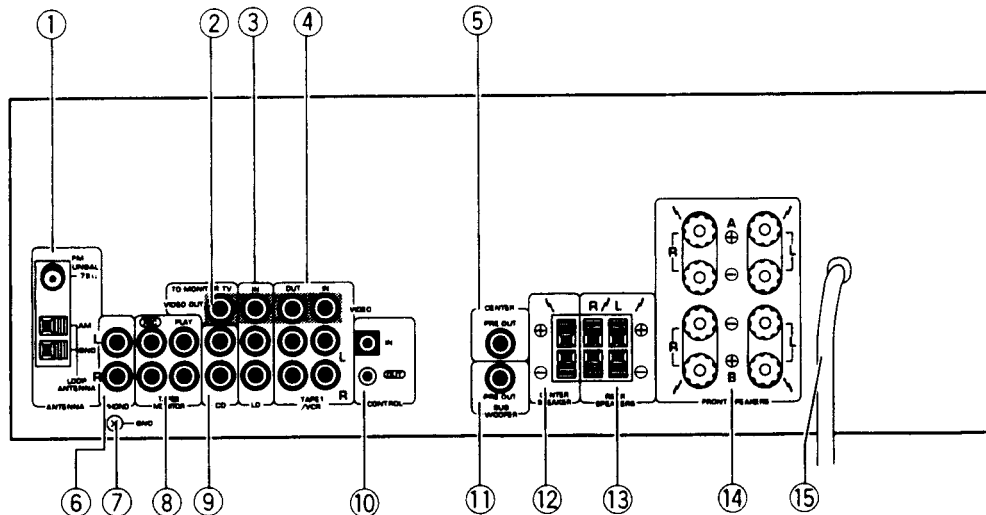

① FM/AM ANTENNA terminals

Use these antenna terminals for reception of normal FM and AM broadcasts.

② VIDEO OUT (TO MONITOR TV) jack

Connect to monitor TV or to TV sets with video input terminals for watching program materials from a VCR or LD player connected to this unit.

③ LD input jacks

Connect to an LD player's output jacks (audio, video).

④ TAPE 1/VCR jacks

Connect to the first cassette deck or a VCR. With a VCR, also connect the video jacks.

⑤ CENTER PRE OUT jack

When a separate power amplifier is used to drive the surround center speaker, connect the power amplifier to this jack.

⑥ PHONO input jacks

Connect to the output cables from a turntable.

⑦ GND terminal

Connect the turntable ground lead to this terminal.

⑧ TAPE 2 MONITOR jacks

Connect to audio components such as a second cassette deck or a graphic equalizer.

⑨ CD input jacks

Connect to the output jacks of a compact disc player.

⑩ CONTROL IN/OUT jacks

IN : Connect this jack to other Pioneer components when using those components to control this unit.

OUT : Connect this jack to other Pioneer components when using the remote control of this unit to control the other components.

NOTE:

The receiver's remote sensor does not function when a plug is inserted in the IN jack. To operate, point the remote control unit at the remote sensor on the component to which the receiver's IN jack is connected.

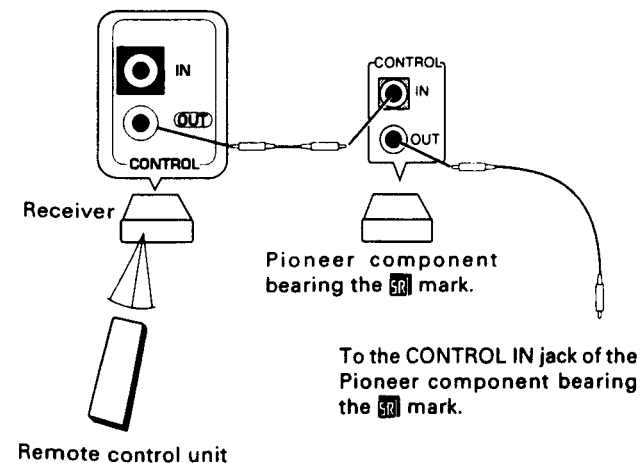

⑪ SUB WOOFER PRE OUT jack

If you want to boost the low frequencies, connect to a subwoofer power amplifier.

⑫ CENTER SPEAKER terminals

Connect the center speaker to these terminals.

NOTE:

Do not allow any of the cord's conductors to protrude from the terminals or touch any other conductors. Malfunctioning or breakdowns may occur when conductors come into contact with each other. Use a center speaker with an impedance of 8Ω to 16Ω.

⑬ REAR SPEAKERS terminals

Connect the rear speakers to these terminals.

NOTE:

Do not allow any of the cord's conductors to protrude from the terminals or touch any other conductors. Malfunctioning or breakdowns may occur when conductors come into contact with each other. Use rear speakers with an impedance of 8Ω to 16Ω.
 Be sure to connect two speakers (L, R). There will be no sound if only one speaker is connected.

⑭ FRONT SPEAKERS terminals

A : Connect to the first set of speakers.

B : Connect to the second set of speakers.

NOTE:

Do not allow any of the cord's conductors to protrude from the terminals or touch any other conductors. Malfunctioning or breakdowns may occur when conductors come into contact with each other. Use front speakers with an impedance of 8Ω to 16Ω.

⑮ Power cord

10. SPECIFICATIONS

Amplifier section

Continuous power output (DIN, 2 channels driven)	
Front (1 kHz, T.H.D 1 %, 4 Ω)	120 W + 120 W
Continuous power output (2 channels driven)*	
Front (20 Hz — 20,000 Hz, T.H.D 0.09 %, 8 Ω)	75 W + 75 W
Continuous power output (DIN, 4 channels driven)	
Front	80 W + 80 W (1 kHz, 1 %, 4 Ω)
Center	80 W (1 kHz, 1 %, 4 Ω)
Rear	80 W (1 kHz, 1 %, 4 Ω)
Total Harmonic Distortion (both channels driven)*	
Front (20 Hz — 20,000 Hz, 8 Ω, 50 W OUTPUT)	0.09 %
Dynamic Power (2 Ω/4 Ω/8 Ω)	180 W/150 W/100 W

● Above specifications are for when power supply is 230 V.

Input (Sensitivity/Impedance)

PHONO MM	2.8 mV/47 kΩ
CD, TAPE 1/VCR, TAPE 2, LD	200 mV/47 kΩ
Phono Overload Level (T.H.D. 0.1 %, 1 kHz)	
PHONO MM	100 mV

Frequency Response

PHONO MM	20 Hz to 20,000 Hz ±0.3 dB
CD, TAPE 1/VCR, TAPE 2, LD	5 Hz to 100,000 Hz ±0.3 dB

Output (Level/Impedance)

TAPE 1/VCR REC, TAPE 2 REC	200 mV/2.2 kΩ
VCR OUT	200 mV/2.2 kΩ

Tone Control

BASS	±8 dB (150 Hz)
TREBLE	±8 dB (10 kHz)
LOUDNESS	+6 dB (100 Hz at -40 dB) +4 dB (10 kHz at -40 dB)

Signal-to-Noise Ratio (IHF, short circuited, A network)

PHONO MM	74 dB
CD, TAPE 1/VCR, TAPE 2, LD	96 dB

Signal-to-Noise Ratio

[DIN (Continuous rated power output/50 mW)]

PHONO MM	67/61 dB
CD, TAPE 1/VCR, TAPE 2, LD	82/62 dB

* Measured by Audio Spectrum Analyzer.

VIDEO Section

Input (Sensitivity/Impedance)

VCR, LD	1 Vp-p/75 Ω
---------	-------------

Output (Level/Impedance)

VCR	1 Vp-p/75 Ω
-----	-------------

Frequency Response

VCR, LD → MONITOR	5 Hz to 7 MHz ±0.3 dB
-------------------	-----------------------

Signal-to-Noise Ratio 55 dB

Cross Talk 55 dB

FM Tuner Section

Frequency Range	87.5 MHz to 108 MHz
Usable Sensitivity	Mono: 14.2 dBf, IHF (1.4 μV/75 Ω)
Sensitivity (DIN)	
Mono	1.0 μV/75 Ω
Stereo	50 μV/75 Ω
Signal-to-Noise Ratio	Mono: 74 dB (at 80 dBf) Stereo: 72 dB (at 80 dBf)

Signal-to-Noise Ratio (DIN)

Mono	60 dB
Stereo	58 dB

Distortion Stereo: 0.6 % (1 kHz)

Alternate Channel Selectivity 65 dB (400 kHz)

Stereo Separation 40 dB (1 kHz)

Frequency Response 30 Hz to 15 kHz (±1) dB

Antenna Input 75 Ω unbalanced

AM Tuner Section

Frequency range	531 kHz to 1,602 kHz (9 kHz step)
Sensitivity (IHF, Loop antenna)	350 μV/m
Selectivity	25 dB
Signal-to-Noise Ratio	45 dB
Antenna	AM loop antenna

Miscellaneous

Power requirements a.c. 220—230 Volts, 50/60 Hz

Power consumption 700 W

In Standby Condition 3 W

Dimensions 420 (W) x 155 (H) x 315 (D) mm

Weight (without package) 9.4 kg

Furnished Parts

FM antenna	1
AM Loop antenna	1
Dry cell batteries (AA/R6P)	2
Remote control unit	1
Operating Instructions	1

NOTE:

Specifications and the design are subject to possible modifications without notice, due to improvements.