

Pioneer

Service Manual

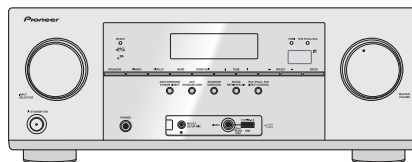

VSX-1022-K

ORDER NO.
RRV4306

AV Receiver

VSX-1022-K

VSX-42

VSX-822-K

THIS MANUAL IS APPLICABLE TO THE FOLLOWING MODEL(S) AND TYPE(S).

Model	Type	Power Requirement	Remarks
VSX-1022-K	CUXESM	AC 120 V	
VSX-42	UXECB	AC 120 V	
VSX-822-K	CUXESM	AC 120 V	

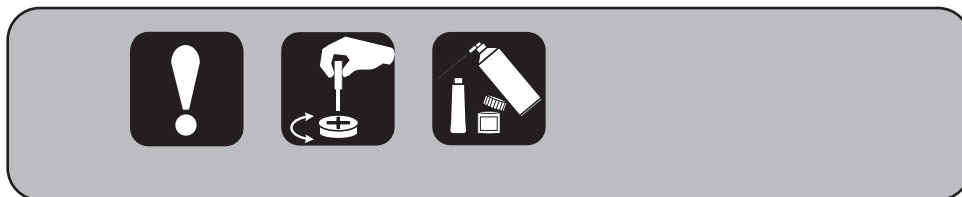

PIONEER CORPORATION 1-1, Shin-ogura, Saiwai-ku, Kawasaki-shi, Kanagawa 212-0031, Japan

PIONEER ELECTRONICS (USA) INC. P.O. Box 1760, Long Beach, CA 90801-1760, U.S.A.

PIONEER EUROPE NV Haven 1087, Keetberglaan 1, 9120 Melsele, Belgium

PIONEER ELECTRONICS ASIACENTRE PTE. LTD. 253 Alexandra Road, #04-01, Singapore 159936

©PIONEER CORPORATION 2012

SAFETY INFORMATION



This service manual is intended for qualified service technicians; it is not meant for the casual do-it-yourselfer. Qualified technicians have the necessary test equipment and tools, and have been trained to properly and safely repair complex products such as those covered by this manual.

Improperly performed repairs can adversely affect the safety and reliability of the product and may void the warranty. If you are not qualified to perform the repair of this product properly and safely, you should not risk trying to do so and refer the repair to a qualified service technician.

WARNING

This product may contain a chemical known to the State of California to cause cancer, or birth defects or other reproductive harm.

Health & Safety Code Section 25249.6 - Proposition 65

(FOR USA MODEL ONLY)

1. SAFETY PRECAUTIONS

The following check should be performed for the continued protection of the customer and service technician.

LEAKAGE CURRENT CHECK

Measure leakage current to a known earth ground (water pipe, conduit, etc.) by connecting a leakage current tester such as Simpson Model 229-2 or equivalent between the earth ground and all exposed metal parts of the appliance (input/output terminals, screwheads, metal overlays, control shaft, etc.). Plug the AC line cord of the appliance directly into a 120 V AC 60 Hz outlet and turn the AC power switch on. Any current measured must not exceed 0.5 mA.

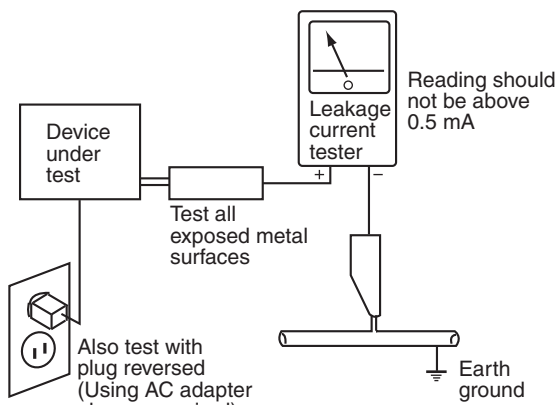

AC Leakage Test

ANY MEASUREMENTS NOT WITHIN THE LIMITS OUTLINED ABOVE ARE INDICATIVE OF A POTENTIAL SHOCK HAZARD AND MUST BE CORRECTED BEFORE RETURNING THE APPLIANCE TO THE CUSTOMER.

2. PRODUCT SAFETY NOTICE

Many electrical and mechanical parts in the appliance have special safety related characteristics. These are often not evident from visual inspection nor the protection afforded by them necessarily can be obtained by using replacement components rated for voltage, wattage, etc. Replacement parts which have these special safety characteristics are identified in this Service Manual.

Electrical components having such features are identified by marking with a ⚠ on the schematics and on the parts list in this Service Manual.

The use of a substitute replacement component which does not have the same safety characteristics as the PIONEER recommended replacement one, shown in the parts list in this Service Manual, may create shock, fire, or other hazards.

Product Safety is continuously under review and new instructions are issued from time to time. For the latest information, always consult the current PIONEER Service Manual. A subscription to, or additional copies of, PIONEER Service Manual may be obtained at a nominal charge from PIONEER.

CONTENTS

SAFETY INFORMATION.....	2	
1. SERVICE PRECAUTIONS.....	5	
1.1 NOTES ON SOLDERING.....	5	A
1.2 NOTES ON REPLACING PARTS.....	5	
1.3 SERVICE NOTICE.....	5	
2. SPECIFICATIONS.....	6	
3. BASIC ITEMS FOR SERVICE.....	8	
3.1 CHECK POINTS AFTER SERVICING.....	8	
3.2 JIGS LIST.....	8	
3.3 PCB LOCATIONS.....	9	
4. BLOCK DIAGRAM.....	12	
4.1 OVERALL WIRING DIAGRAM.....	12	
4.2 AUDIO BLOCK DIAGRAM (VSX-1022-K, VSX-42).....	14	
4.3 AUDIO BLOCK DIAGRAM (VSX-822-K).....	16	
4.4 D-MAIN BLOCK DIAGRAM.....	18	B
4.5 D-AUDIO BLOCK DIAGRAM.....	20	
4.6 D-MAIN BLOCK DIAGRAM (1/2).....	22	
4.7 D-MAIN BLOCK DIAGRAM (2/2).....	24	
4.8 CPU BLOCK DIAGRAM.....	26	
4.9 VIDEO BLOCK DIAGRAM.....	28	
4.10 POWER SUPPLY BLOCK DIAGRAM.....	30	
5. DIAGNOSIS.....	32	
5.1 TROUBLESHOOTING.....	32	
5.2 ADAPTER ERROR MESSAGE.....	44	
5.3 USB/iPod ERROR MESSAGE.....	44	
5.4 DETECTION CIRCUIT.....	45	
5.5 IC INFORMATION.....	47	C
6. SERVICE MODE.....	51	
6.1 SERVICE MODE.....	51	
7. DISASSEMBLY.....	55	
8. EACH SETTING AND ADJUSTMENT.....	64	
8.1 ADJUSTMENT REQUIRED WHEN THE UNIT IS REPAIRED OR REPLACED.....	64	
8.2 UPDATING OF THE FIRMWARE.....	65	
8.3 IDLE CURRENT ADJUSTMENT.....	69	
9. EXPLODED VIEWS AND PARTS LIST.....	72	
9.1 PACKING SECTION.....	72	
9.2 EXTERIOR SECTION.....	74	
10. SCHEMATIC DIAGRAM.....	78	D
10.1 AUDIO ASSY.....	78	
10.2 AMP7 ASSY (1/2)(VSX-1022-K, VSX-42).....	80	
10.3 AMP7 ASSY (2/2)(VSX-1022-K, VSX-42).....	82	
10.4 AMP5 ASSY (1/2)(VSX-822-K).....	84	
10.5 AMP5 ASSY (2/2)(VSX-822-K).....	86	
10.6 MAIN ASSY.....	88	
10.7 D-MAIN ASSY (1/7)(VSX-1022-K, VSX-42).....	90	
10.8 D-MAIN ASSY (2/7)(VSX-1022-K, VSX-42).....	92	
10.9 D-MAIN ASSY (3/7)(VSX-1022-K, VSX-42).....	94	
10.10 D-MAIN ASSY (4/7)(VSX-1022-K, VSX-42).....	96	
10.11 D-MAIN ASSY (5/7)(VSX-1022-K, VSX-42).....	98	
10.12 D-MAIN ASSY (6/7)(VSX-1022-K, VSX-42).....	100	
10.13 D-MAIN ASSY (7/7)(VSX-1022-K, VSX-42).....	102	E
10.14 D-MAIN ASSY (1/7)(VSX-822-K).....	104	
10.15 D-MAIN ASSY (2/7)(VSX-822-K).....	106	
10.16 D-MAIN ASSY (3/7)(VSX-822-K).....	108	
10.17 D-MAIN ASSY (4/7)(VSX-822-K).....	110	
10.18 D-MAIN ASSY (5/7)(VSX-822-K).....	112	
10.19 D-MAIN ASSY (6/7)(VSX-822-K).....	114	
10.20 D-MAIN ASSY (7/7)(VSX-822-K).....	116	
10.21 CPU ASSY.....	118	
10.22 VIDEO, G-L, G-R, WG-A and WG-B ASSYS.....	120	
10.23 BT CNT, OPTCO, BRG-1 and BRG-2 ASSYS.....	122	
10.24 BT and F-USB ASSYS.....	124	F
10.25 FRONT, INSEL, HP, MIC, FVIDEO and WG ASSYS.....	126	
10.26 STBY ASSY.....	128	

- 11. PCB CONNECTION DIAGRAM130
 - 11.1 AUDIO ASSY130
 - A 11.2 AMP7 ASSY (VSX-1022-K, VSX-42)132
 - 11.3 AMP5 ASSY (VSX-822-K)134
 - 11.4 MAIN ASSY136
 - 11.5 D-MAIN ASSY140
 - 11.6 CPU ASSY144
 - 11.7 VIDEO ASSY146
 - 11.8 G-L, G-R, WG-A and WG-B ASSYS148
 - 11.9 BT CNT and OPTCO ASSYS149
 - 11.10 BRG-1 and BRG-2 ASSYS150
 - 11.11 BT and F-USB ASSYS151
 - 11.12 FRONT, INSEL, HP, MIC, FVIDEO and WG ASSYS152
 - B 11.13 STBY ASSY156
- 12. PCB PARTS LIST157

C

D

E

F

1. SERVICE PRECAUTIONS

1.1 NOTES ON SOLDERING

- For environmental protection, lead-free solder is used on the printed circuit boards mounted in this unit.
Be sure to use lead-free solder and a soldering iron that can meet specifications for use with lead-free solders for repairs accompanied by reworking of soldering.
- Compared with conventional eutectic solders, lead-free solders have higher melting points, by approximately 40 °C.
Therefore, for lead-free soldering, the tip temperature of a soldering iron must be set to around 373 °C in general, although the temperature depends on the heat capacity of the PC board on which reworking is required and the weight of the tip of the soldering iron.

Do NOT use a soldering iron whose tip temperature cannot be controlled.

Compared with eutectic solders, lead-free solders have higher bond strengths but slower wetting times and higher melting temperatures (hard to melt/easy to harden).

The following lead-free solders are available as service parts:

- Parts numbers of lead-free solder:
 - GYP1006 1.0 in dia.
 - GYP1007 0.6 in dia.
 - GYP1008 0.3 in dia.

1.2 NOTES ON REPLACING PARTS

The part listed below is difficult to replace as a discrete component part.
When the part listed in the table is defective, replace whole Assy.

Assy Name	Parts that is Difficult to Replace			Remarks
	Ref No.	Function	Part No.	
D-MAIN Assy	JA1001 - JA1007	HDMI Connector	—————	JACK with Cu-through-hole & 21 pin
	JA9202	LAN Connector	—————	JACK with Cu-through-hole & 10 pin
	IC9501	D-MAIN 3.3V Power Supply IC	—————	IC with heat-pad
	IC9502	D-MAIN 1.2V Power Supply IC	—————	IC with heat-pad
	IC9503	D-MAIN 1.8V Power Supply IC	—————	IC with heat-pad
	IC9504	D-MAIN 3.3V Power Supply IC	—————	IC with heat-pad
	IC9506	D-MAIN 5V Power Supply IC	—————	IC with heat-pad
	IC101	D-MAIN 5V Power Supply IC	—————	IC with heat-pad
	IC103	D-MAIN 3.3V Power Supply IC	—————	IC with heat-pad
	IC1601	DSP IC	—————	IC with heat-pad
	IC9203	LAN PHY IC	—————	IC with heat-pad
	IC9204	NETWORK MEDIA PROCESSOR	—————	IC BGA type
	IC1001	HDMI INTERFACE IC	—————	IC with heat-pad
F-USB Assy	IC805	USB 5V SW IC	—————	IC with heat-pad
	IC1307	USB 5V SW Power Supply IC	—————	IC with heat-pad

1.3 SERVICE NOTICE

• Discharging

For more detail, please refer to "7. DISASSEMBLY - 1. Discharging".

• Notes on Ground Points Connection

For more detail, please refer to "7. DISASSEMBLY - 2. Notes on Ground Points Connection".

2. SPECIFICATIONS

■ VSX-1022-K, VSX-822-K

Amplifier section

Continuous average power output of 80 watts* per channel, min., at 8 ohms, from 20 Hz to 20 000 Hz with no more than 0.08 %** total harmonic distortion.

Front (stereo) 80 W + 80 W
Power output (1 kHz, 6 Ω, 1 %) 140 W per channel
Guaranteed speaker impedance 6 Ω to 16 Ω

* Measured pursuant to the Federal Trade Commission's Trade Regulation rule on Power Output Claims for Amplifiers

** Measured by Audio Spectrum Analyzer

Audio Section

Input (Sensitivity/Impedance)

LINE 200 mV/47 kΩ
Signal-to-Noise Ratio (IHF, short circuited, A network)
LINE 98 dB

Signal-to-Noise Ratio [EIA, at 1 W (1 kHz)]
LINE 79 dB

Video Section

Signal level

Composite 1 Vp-p (75 Ω)

Tuner Section

Frequency Range (FM) 87.5 MHz to 108 MHz
Antenna Input (FM) 75 Ω unbalanced
Frequency Range (AM) 530 kHz to 1700 kHz
Antenna (AM) Loop antenna

Digital In/Out Section

HDMI terminal Type A (19-pin)
HDMI output type 5 V, 100 mA
USB terminal USB2.0 Full Speed (Type A)
iPod terminal USB, and Video (Composite)
ADAPTER PORT terminal 5 V, 100 mA

Network Section

LAN terminal 10 BASE-T/100 BASE-TX

Miscellaneous

Power Requirements AC 120 V, 60 Hz
Power Consumption 520 W (VSX-1022)
450 W (VSX-822)
In standby 0.4 W (Control OFF)
Dimensions 435 mm (W) x 168 mm (H) x 342.5 mm (D)
173/16 in. (W) x 65/8 in. (H) x 145/16 in. (D)
Weight (without package) 9.3 kg (20 lb 9 oz) (VSX-1022)
8.9 kg (19 lb 10 oz) (VSX-822)

Note

- Specifications and the design are subject to possible modifications without notice, due to improvements.
- This product includes FontAvenue® fonts licensed by NEC Corporation. FontAvenue is a registered trademark of NEC Corporation.

■ VSX-42

Amplifier section

Continuous average power output of 80 watts* per channel, min., at 8 ohms, from 20 Hz to 20 000 Hz with no more than 0.08 %** total harmonic distortion.

Front (stereo) 80 W + 80 W
Guaranteed speaker impedance 6 Ω to 16 Ω

* Measured pursuant to the Federal Trade Commission's Trade Regulation rule on Power Output Claims for Amplifiers

** Measured by Audio Spectrum Analyzer

Audio Section

Input (Sensitivity/Impedance)

LINE 200 mV/47 kΩ
Signal-to-Noise Ratio (IHF, short circuited, A network)
LINE 98 dB
Signal-to-Noise Ratio [EIA, at 1 W (1 kHz)]
LINE 79 dB

Video Section

Signal level

Composite 1 Vp-p (75 Ω)

Tuner Section

Frequency Range (FM) 87.5 MHz to 108 MHz
Antenna Input (FM) 75 Ω unbalanced
Frequency Range (AM) 530 kHz to 1700 kHz
Antenna (AM) Loop antenna

Digital In/Out Section

HDMI terminal Type A (19-pin)
HDMI output type 5 V, 100 mA
USB terminal USB2.0 Full Speed (Type A)
iPod terminal USB, and Video (Composite)
ADAPTER PORT terminal 5 V, 100 mA

Network Section

LAN terminal 10 BASE-T/100 BASE-TX

Integrated control section

Control (IR) terminal Ø 3.5 Mini-jack (MONO)
IR signal High Active (High Level: 2.0 V)
12 V Trigger terminal Ø 3.5 Mini-jack (MONO)
12 V Trigger output type 12 V, 50 mA

Miscellaneous

Power Requirements AC 120 V, 60 Hz
Power Consumption 520 W
In standby 0.4 W (Control OFF)
Dimensions 435 mm (W) x 168 mm (H) x 342.5 mm (D)
173/16 in. (W) x 65/8 in. (H) x 145/16 in. (D)
Weight (without package) 9.3 kg (20 lb 9 oz)

Note

- Specifications and the design are subject to possible modifications without notice, due to improvements.
- This product includes FontAvenue® fonts licensed by NEC Corporation. FontAvenue is a registered trademark of NEC Corporation.

Manufactured under license from Dolby Laboratories. "Dolby", "Pro Logic", "Surround EX", and the double-D symbol are trademarks of Dolby Laboratories.

Manufactured under license under U.S. Patent Nos: 5,956,674; 5,974,380; 6,226,616; 6,487,535; 7,212,872; 7,333,929; 7,392,195; 7,272,567 & other U.S. and worldwide patents issued & pending. DTS-HD, the Symbol, & DTS-HD and the Symbol together are registered trademarks & DTS-HD Master Audio is a trademark of DTS, Inc. Product includes software. © DTS, Inc. All Rights Reserved.

Accessories

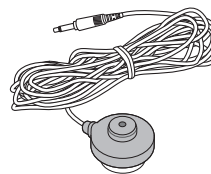

Microphone
(for Auto MCACC setup)
(APM7010)

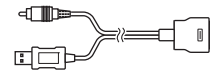

iPod cable
(L308102013030-IL)



Remote control (AXD7661)
(VSX-1022-K, VSX-822-K: 8300766100010-IL)



Remote control (AXD7662)
(VSX-42: 8300766200010-IL)



Dry cell batteries
(AAA size IEC R03) x2



AM loop antenna
(E601019000010-IL)



FM wire antenna
(E605010140010-IL)

Warranty card

Quick start guide
(VSX-1022-K: 5707000006490-IL)
(VSX-42: 5707000006500-IL)
(VSX-822-K: 5707000006490-IL)

Safety Brochure

Operating instructions (CD-ROM)
(VSX-1022-K, VSX-822-K: 6517000000490-IL)
(VSX-42: 6517000000510-IL)

3. BASIC ITEMS FOR SERVICE

3.1 CHECK POINTS AFTER SERVICING

A Items to be checked after servicing

To keep the product quality after servicing, confirm recommended check points shown below.

No.	Procedures	Check points
1	Confirm whether the customer complain has been solved. If the customer complain occurs with the particular source, such as Dolby Digital, DTS, AAC, DVD-A and HDMI, input it for the operation check.	The customer complain must not be reappeared. Video, Audio and operations must be normal.
2	Check the analog audio playback. (Make the analog connections with a DVD player.)	Each channel audio and operations must be normal.
3	Check the digital audio playback. (Make the digital connections with a DVD player.)	Each channel audio and operations must be normal.
4	Check surround playback. (Select Surround mode and check the multichannel operations via the DSP circuit.)	Each channel audio and operations must be normal.
5	Check the video outputs. (Connect with a DVD player.)	Video and operations must be normal.
6	Check the tuner (AM and FM) operations.	Audio and operations must be normal.
7	Check the sound from headphone output.	Sound must be normal, without noise.
8	Check the appearance of the product.	No scratches or dirt on its appearance after receiving it for service.

C See the table below for the items to be checked regarding video and audio.

Item to be checked regarding video	Item to be checked regarding audio
Block noise	Distortion
Horizontal noise	Noise
Flicker	Volume too low
Disturbed image (video jumpiness)	Volume too high
Too dark	Volume fluctuating
Too bright	Sound interrupted
Mottled color	

3.2 JIGS LIST

Jigs List

Jig Name	Part No.	Remarks
RS-232C update jig (Jig + 10P FFC)	GGF1642	MAIN microcomputer firmware update (RS-232C ↔ Rear panel)
RS-232C cable (9-pin to 9-pin, straight cable)	(Marketing product)	
9P extension jig cable	GGD1739	Diagnosis (AMP5 Assy ↔ AUDIO Assy)
13P extension jig cable	GGD1740	Diagnosis (AMP7 Assy ↔ AUDIO Assy)
3P extension jig cable	GGD1741	Diagnosis (AMP7 Assy ↔ MAIN Assy)
Board to board extension jig cable	GGD1756	Diagnosis (D-MAIN Assy ↔ BRG-A Assy)
Board to board extension jig cable	GGD1770	Diagnosis (D-MAIN Assy ↔ CPU Assy)
Board to board extension jig cable	GGD1800	Diagnosis (D-MAIN Assy ↔ CPU Assy)
25P extension jig FFC	GGD1801	Diagnosis (FRONT Assy ↔ CPU Assy)

Lubricants and Glues List



Name	Part No.	Remarks
Silicon grease	GEM1057	Refer to "9.2 EXTERIOR SECTION".
Silicon adhesive	GYA1011 (KE40RTV-W)	Refer to "9.2 EXTERIOR SECTION".

3.3 PCB LOCATIONS

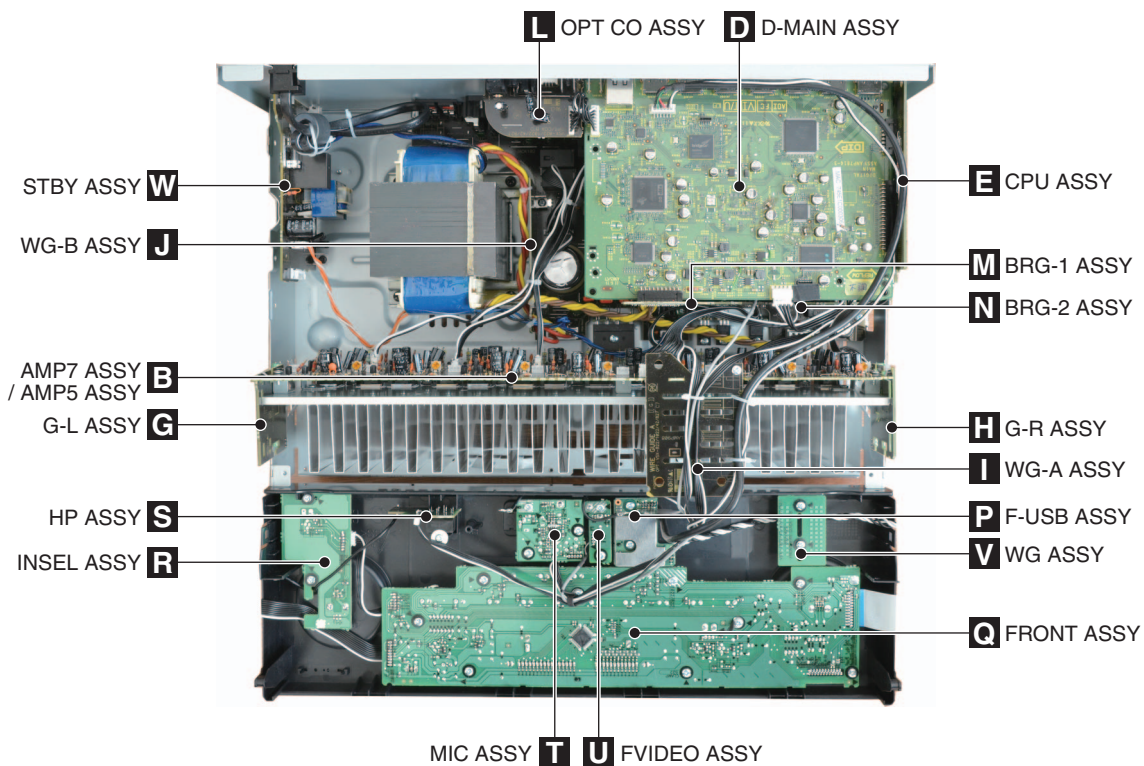
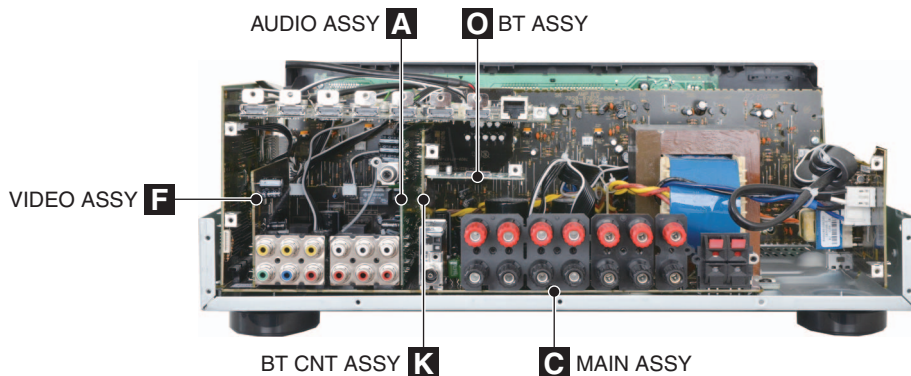

- A **NOTES:**
- Parts marked by “NSP” are generally unavailable because they are not in our Master Spare Parts List.
 - The \triangle mark found on some component parts indicates the importance of the safety factor of the part. Therefore, when replacing, be sure to use parts of identical designation.

LIST OF ASSEMBLIES

Mark	Symbol and Description	VSX-1022-K/ CUXESM	VSX-42/ UXECB	VSX-822-K/ CUXESM
NSP	1..PCB TTL ASSY MAIN	7025HK1108010-IL	7025HK1108020-IL	7025HK1107010-IL
	2..MAIN ASSY	7028071611030-IL	7028071611050-IL	7028071611010-IL
	2..BTCNT ASSY	7028071612050-IL	7028071612050-IL	7028071612050-IL
	2..OPTCO ASSY	7028071613050-IL	7028071613050-IL	7028071613050-IL
	2..G-R ASSY	7028071614050-IL	7028071614050-IL	7028071614050-IL
B	2..G-L ASSY	7028071615050-IL	7028071615050-IL	7028071615050-IL
	2..WG-A ASSY	7028071616050-IL	7028071616050-IL	7028071616050-IL
	2..WG-B ASSY	7028071617050-IL	7028071617050-IL	7028071617050-IL
NSP	1.PCB TTL ASSY FRONT	7025HK1108011-IL	7025HK1108021-IL	7025HK1108011-IL
	2..FRONT ASSY	7028071621030-IL	7028071621050-IL	7028071621030-IL
	2..HP ASSY	7028071622030-IL	7028071622050-IL	7028071622030-IL
	2..INSEL ASSY	7028071623030-IL	7028071623050-IL	7028071623030-IL
	2..MIC ASSY	7028071624050-IL	7028071624050-IL	7028071624050-IL
	2..FVIDEO ASSY	7028071626030-IL	7028071626050-IL	7028071626030-IL
	2..WG ASSY	7028071627060-IL	7028071627060-IL	7028071627060-IL
	2..WG ASSY	7028071627060-IL	7028071627060-IL	7028071627060-IL
NSP	1..PCB TTL ASSY VIDEO	7025HK1108012-IL	7025HK1108022-IL	7025HK1107012-IL
	2..VIDEO ASSY	7028071671030-IL	7028071671030-IL	7028071671010-IL
	2..STBY ASSY	7028071672030-IL	7028071672030-IL	7028071672010-IL
	2..BRG-1 ASSY	7028071673030-IL	7028071673030-IL	7028071673030-IL
	2..BRG-2 ASSY	7028071674030-IL	7028071674050-IL	7028071674030-IL
NSP	1..PCB TTL ASSY AUDIO	7025HK1108013-IL	7025HK1108023-IL	7025HK1107013-IL
	2..AUDIO ASSY	7028071641030-IL	7028071641050-IL	7028071641010-IL
NSP	1..PCB TTL ASSY DMAIN	7025HK1108014-IL	7025HK1108024-IL	7025HK1107014-IL
	2..D-MAIN ASSY	7028071691050-IL	7028071691050-IL	7028071691010-IL
NSP	1..PCB TTL ASSY CPU	7025HK1108015-IL	7025HK1108025-IL	7025HK1107015-IL
	2..CPU ASSY	7028071681030-IL	7028071681050-IL	7028071681010-IL
NSP	1..PCB TTL ASSY AMP7	7025HK1108017-IL	7025HK1108017-IL	Not used
	2..AMP7 ASSY	7028070253010-IL	7028070253010-IL	Not used
NSP	1..PCB TTL ASSY AMP5	Not used	Not used	7025HK1107017-IL
	2..AMP5 ASSY	Not used	Not used	7028070245010-IL
NSP	1..PCB TTL ASSY BT	7025HK1009019-IL	7025HK1009019-IL	7025HK1009019-IL
	2..BT ASSY	7028070231010-IL	7028070231010-IL	7028070231010-IL
NSP	1..PCB TTL ASSY F-USB	7025HK1108016-IL	7025HK1108016-IL	7025HK1108016-IL
	2..F-USB ASSY	7028071781030-IL	7028071781030-IL	7028071781030-IL



5



6



7



8



A



B



C



D



E



F



5



6

VSX-1022-K



7



8

11



4. BLOCK DIAGRAM

4.1 OVERALL WIRING DIAGRAM

- When ordering service parts, be sure to refer to "EXPLODED VIEWS and PARTS LIST" or "PCB PARTS LIST".
- The mark found on some component parts indicates the importance of the safety factor of the part. Therefore, when replacing, be sure to use parts of identical designation.

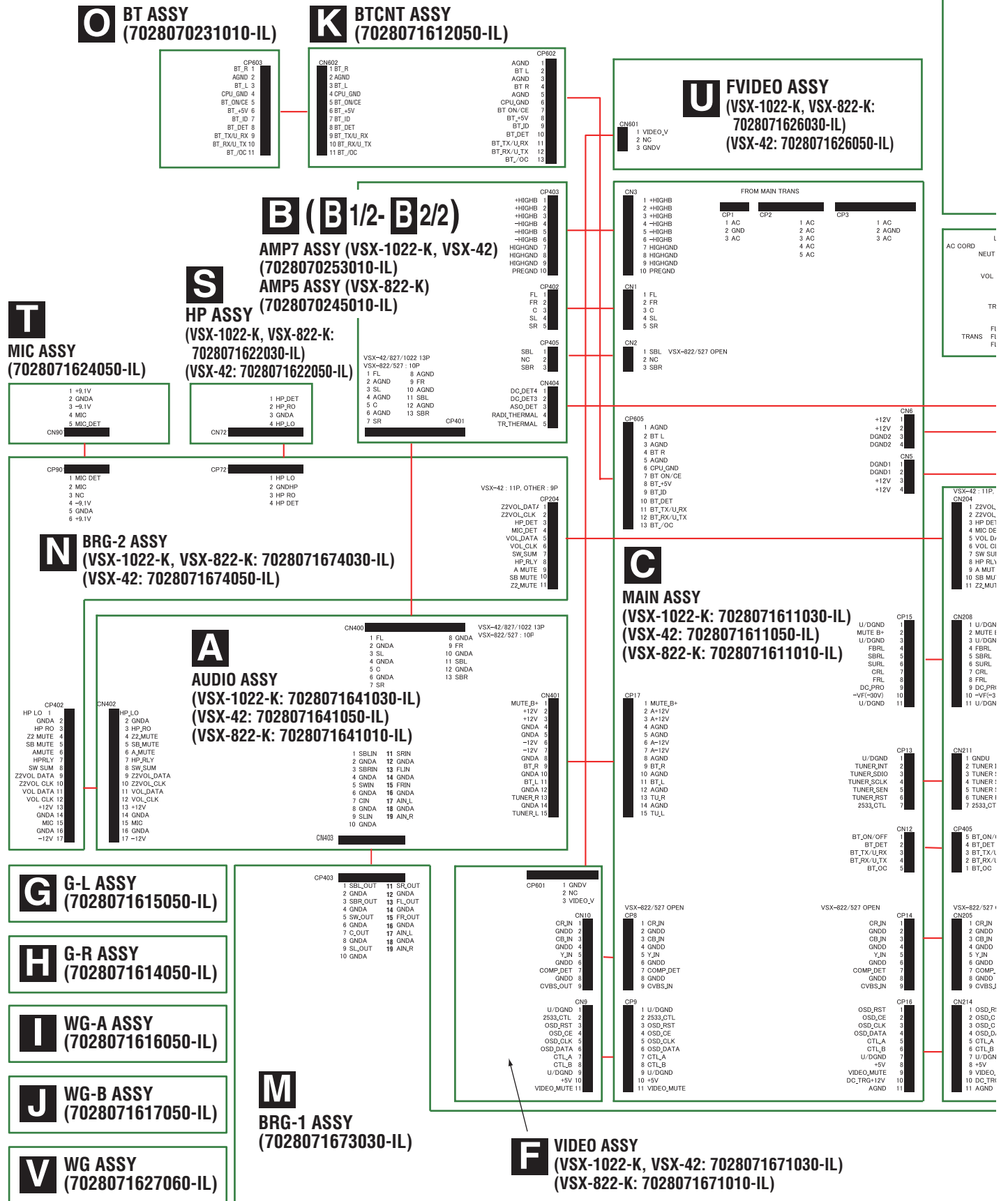

R INSEL ASSY
 (VSX-1022-K, VSX-822-K: 7028071623030-IL)
 (VSX-42: 7028071623050-IL)

Q FRONT ASSY
 (VSX-1022-K, VSX-822-K: 7028071621030-IL)
 (VSX-42: 7028071621050-IL)

- | | | |
|--------------|--------------|--------------------|
| 1 HDMI+12V | 1 -30V | 13 STBY_RLY |
| 2 STBY_RLY | 2 -30V | 14 FLR_DATA |
| 3 PDN | 3 GNDU | 15 FLT_CLK |
| 4 CPU_ST_VCC | 4 CPU_ST_VCC | 16 FLT_CE |
| 5 CPU+3.3V | 5 CPU+3.3V | 17 INPUT_UP |
| 6 GNDU | 6 GNDU | 18 KEY2 |
| 7 FL2 | 7 GNDU | 19 KEY3 |
| 8 FLCT | 8 CPU+3.3V | 20 KEY1 (STBY_KEY) |
| 9 FL1 | 9 CPU+3.3V | 21 INPUT_DN |
| | 10 ST_H+5V | 22 VOL_UP |
| | 11 POWERDOWN | 23 VOL_DN |
| | 12 RMC | 24 CNT_LED |
| | | 25 THRU_LED |



W STBY ASSY
 (VSX-1022-K, VSX-42: 7028071672030-IL)
 (VSX-822-K: 7028071672010-IL)

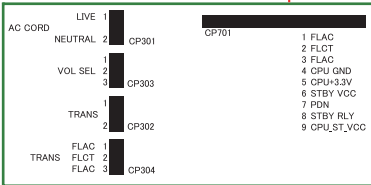

P F-USB ASSY
 (7028071781030-IL)

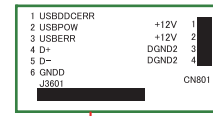

L OPTCO ASSY
 (7028071613050-IL)

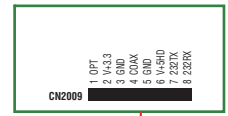

D (D1/7- D7/7)

D-MAIN ASSY
 (VSX-1022-K, VSX-42: 7028071691050-IL)
 (VSX-822-K: 7028071691010-IL)

E CPU ASSY
 (VSX-1022-K: 7028071681030-IL)
 (VSX-42: 7028071681050-IL)
 (VSX-822-K: 7028071681010-IL)

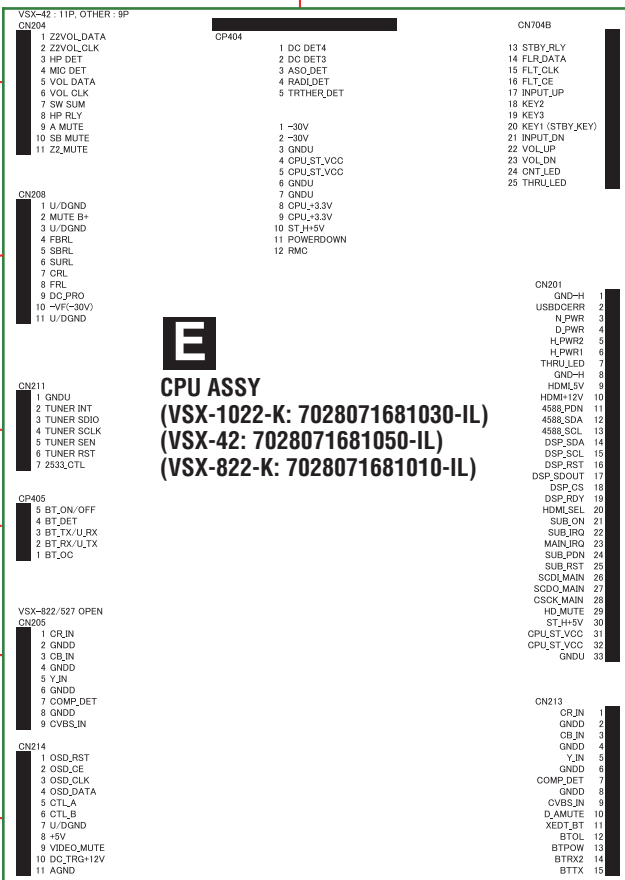

4.2 AUDIO BLOCK DIAGRAM (VSX-1022-K, VSX-42)

P F-USB ASSY

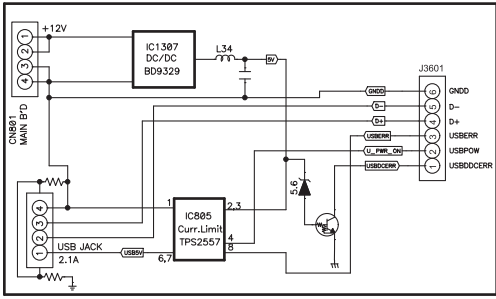

Q FRONT ASSY

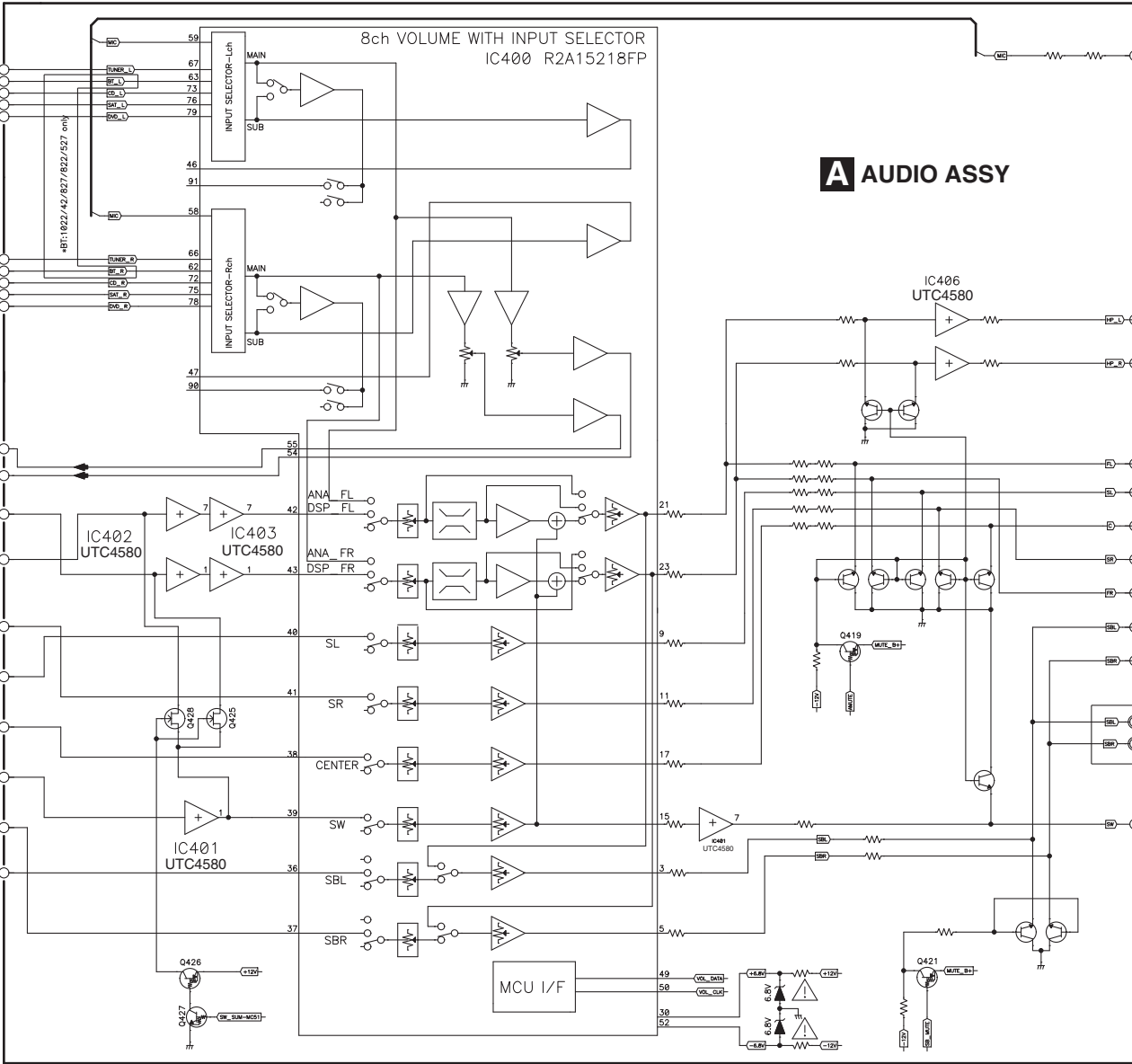
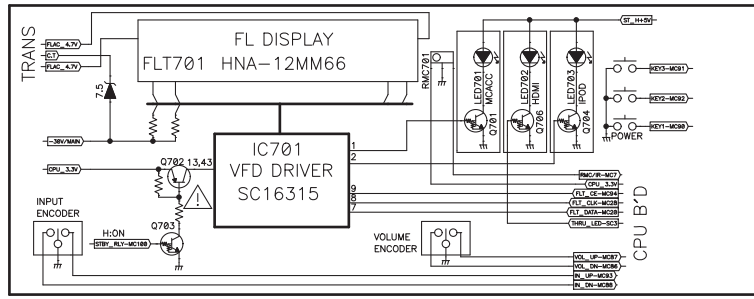

A AUDIO ASSY

O BT ASSY

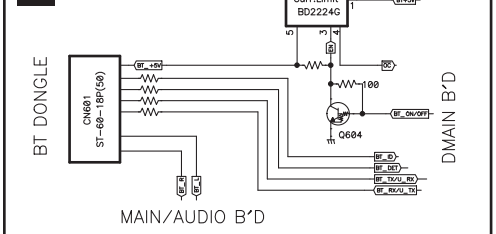

T MIC ASSY

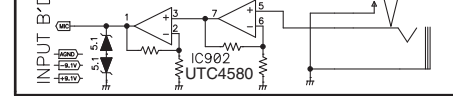

U FVIDEO ASSY

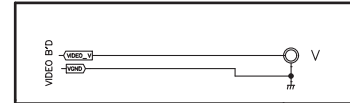

S HP ASSY

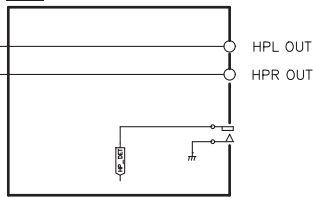

P F-USB ASSY

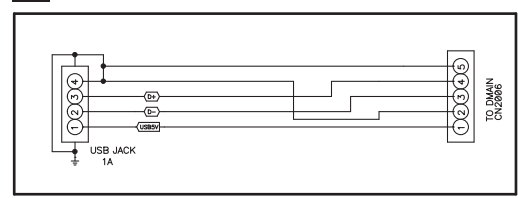

B AMP7 ASSY

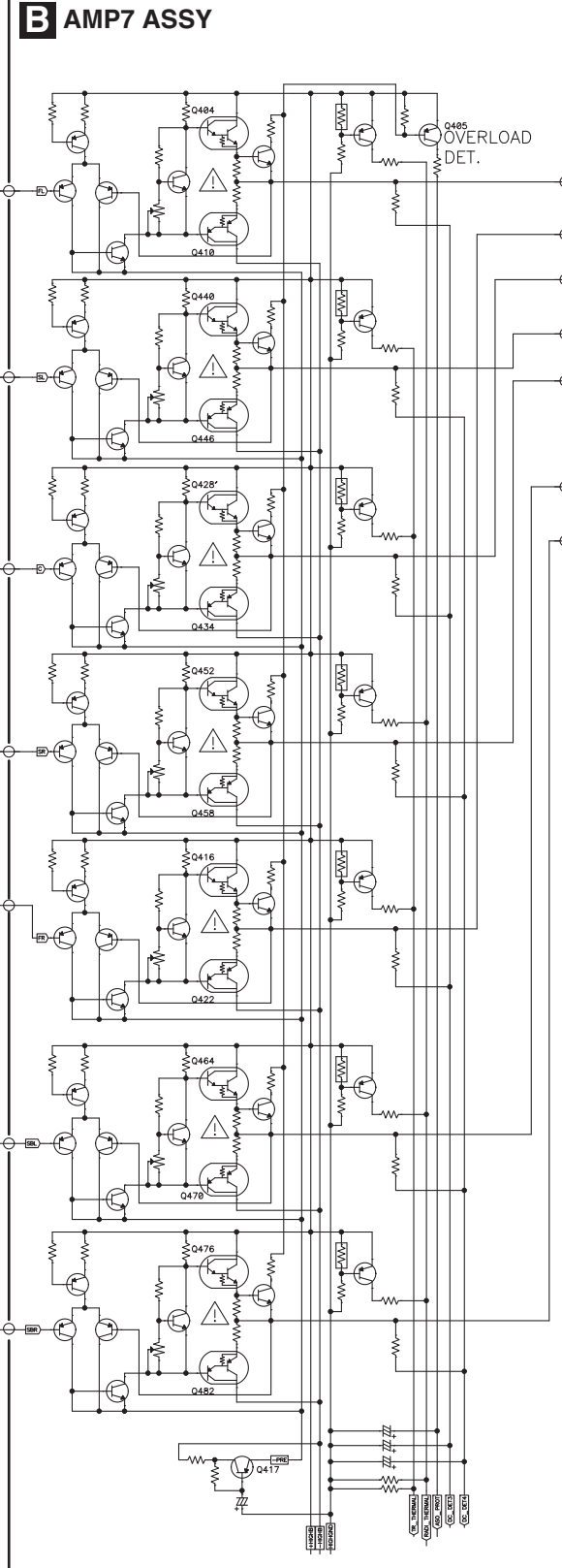

C MAIN ASSY

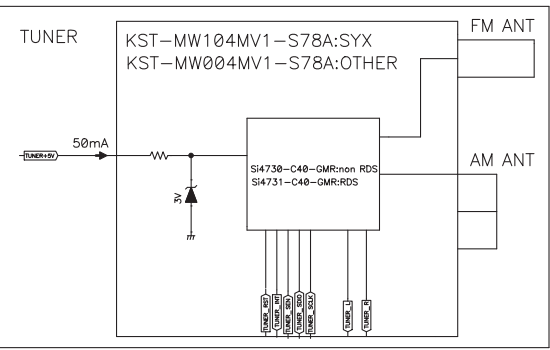
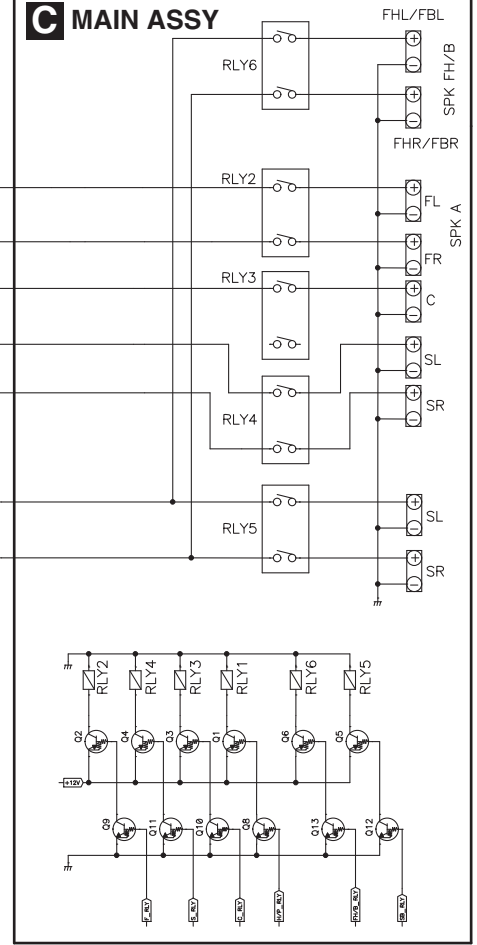

4.3 AUDIO BLOCK DIAGRAM (VSX-822-K)

P F-USB ASSY

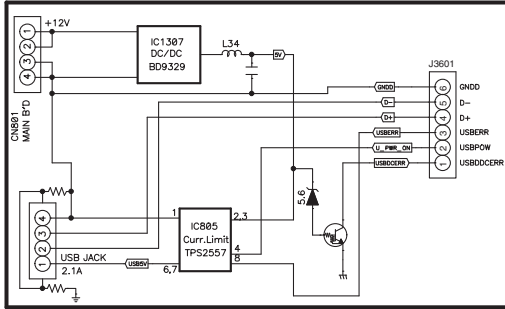

Q FRONT ASSY

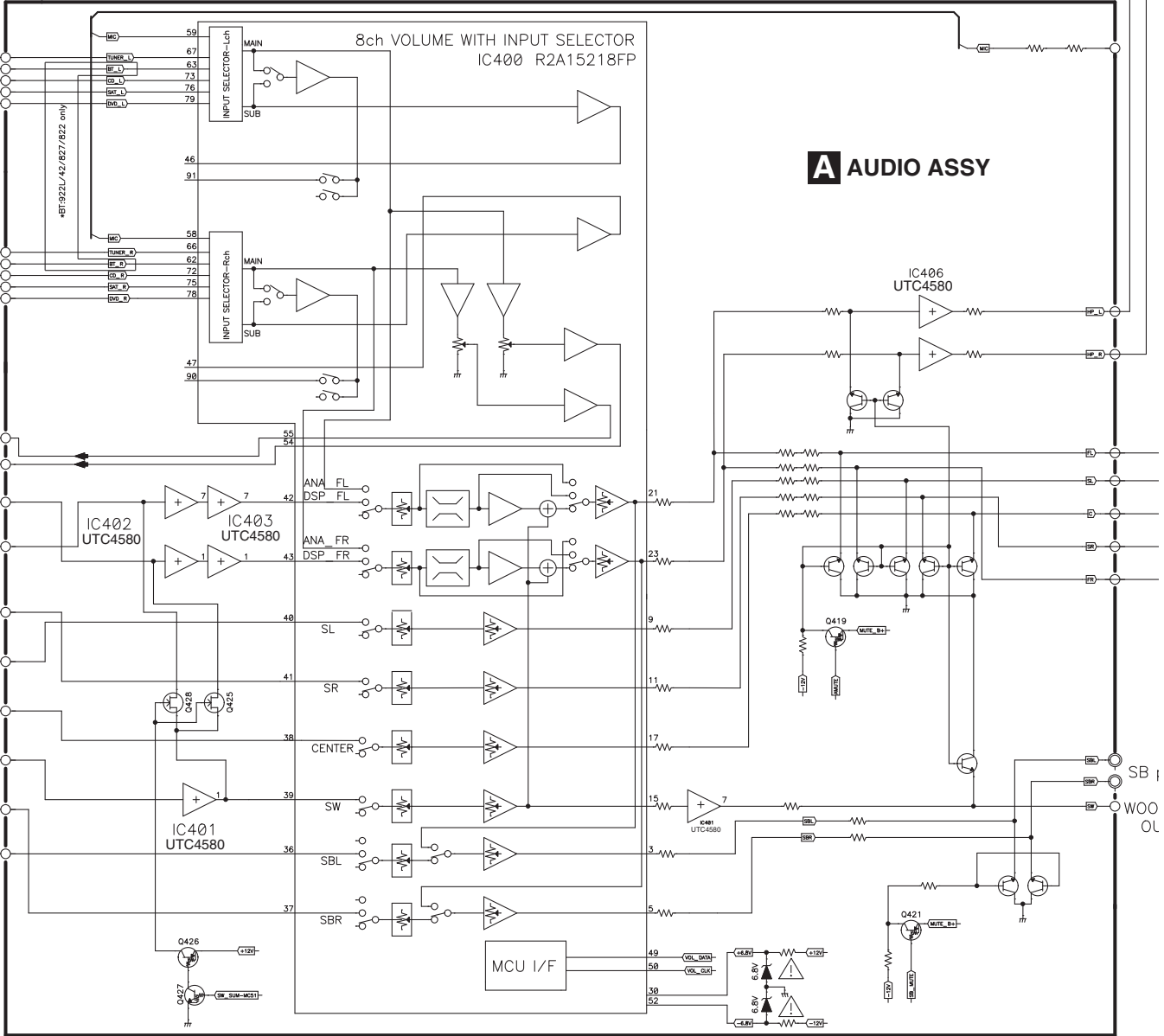
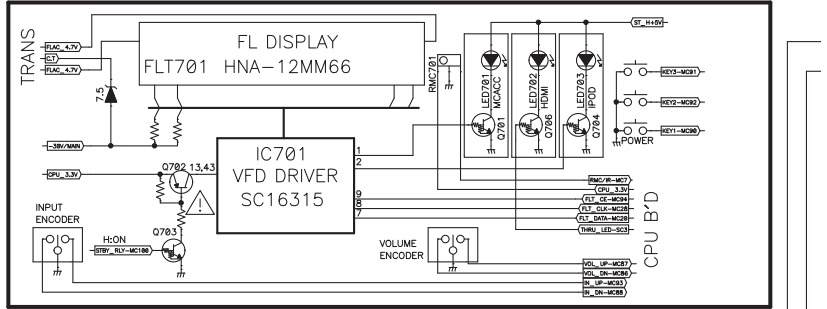

O BT ASSY

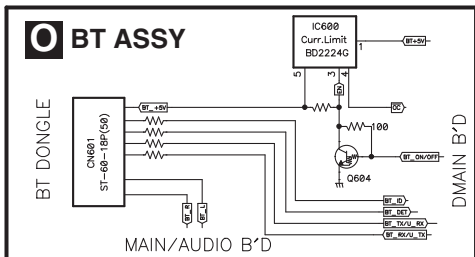

T MIC ASSY

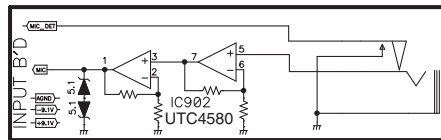

U FVIDEO ASSY

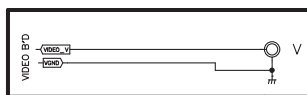

S HP ASSY

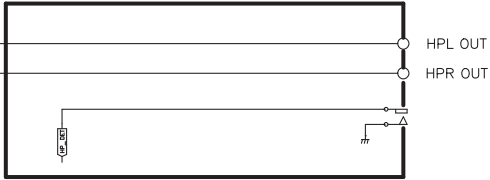

P F-USB ASSY

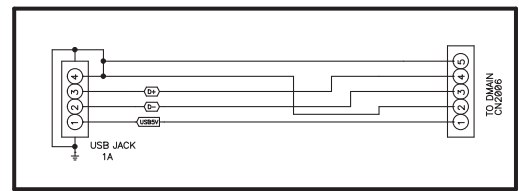

B AMP5 ASSY

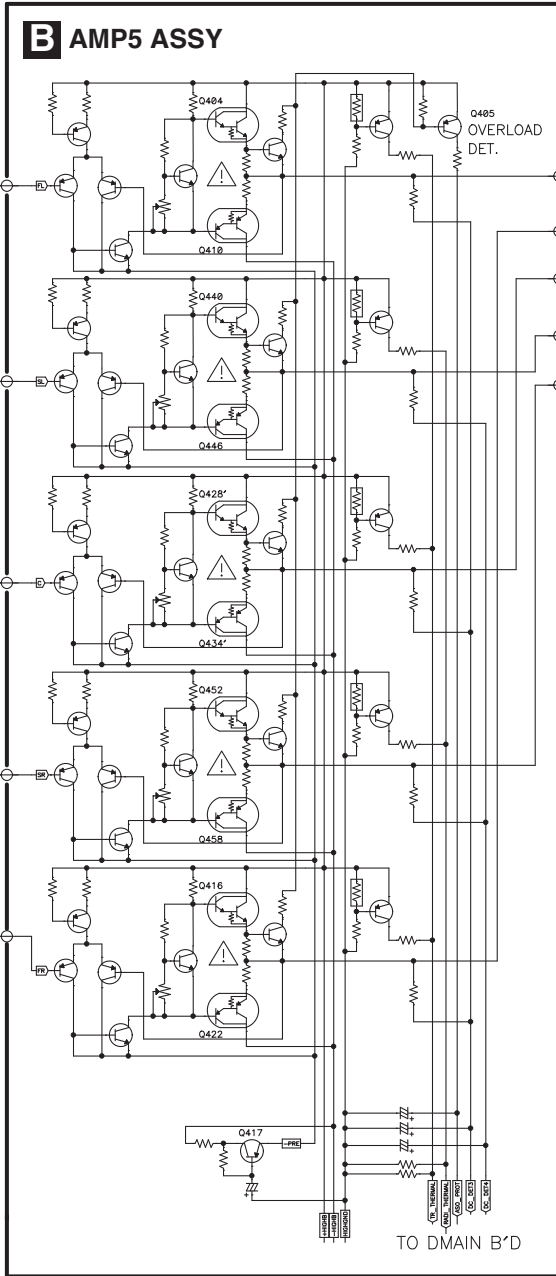

C MAIN ASSY

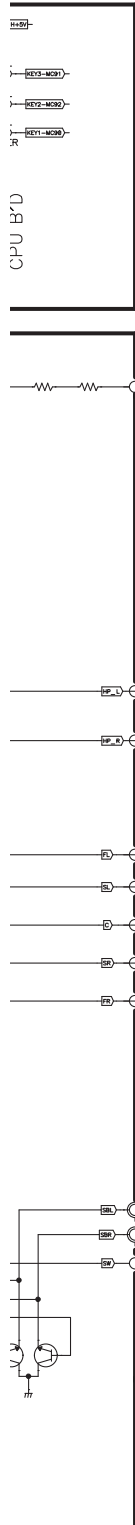
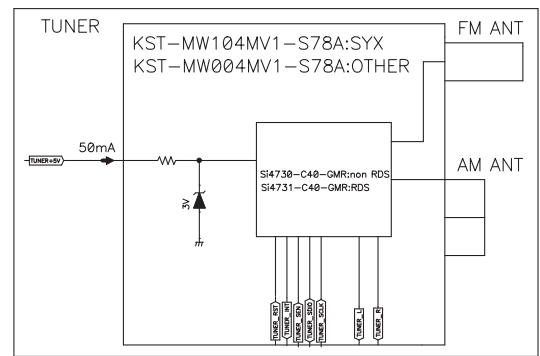
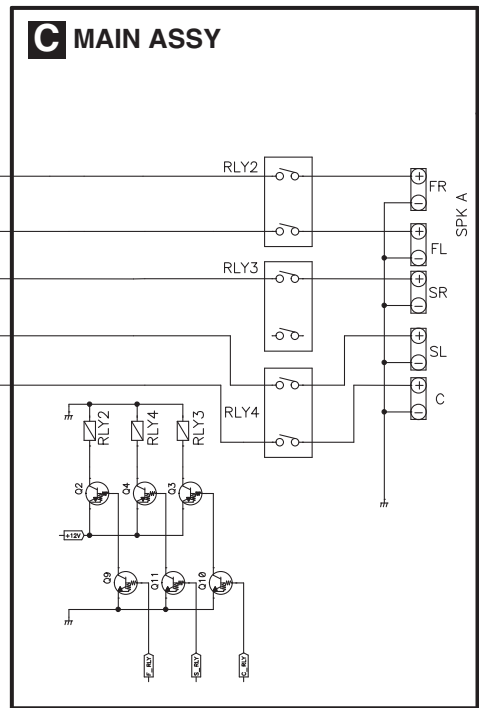

Y

A

B

C

D

E

F

4.4 D-MAIN BLOCK DIAGRAM

A
B
C
D
E
F

- D-MAIN ASSY
- other ASSY
- TMD5
- CEC
- DIGITAL VIDEO
- ANALOG VIDEO/AUDIO
- SPDIF
- DIGITAL AUDIO
- CLOCK

- HDMI DVD_IN
- HDMI SAT/CBL_IN
- HDMI BD_IN
- HDMI GAME_IN
- HDMI DVR/BDR_IN
- HDMI VIDEO_IN

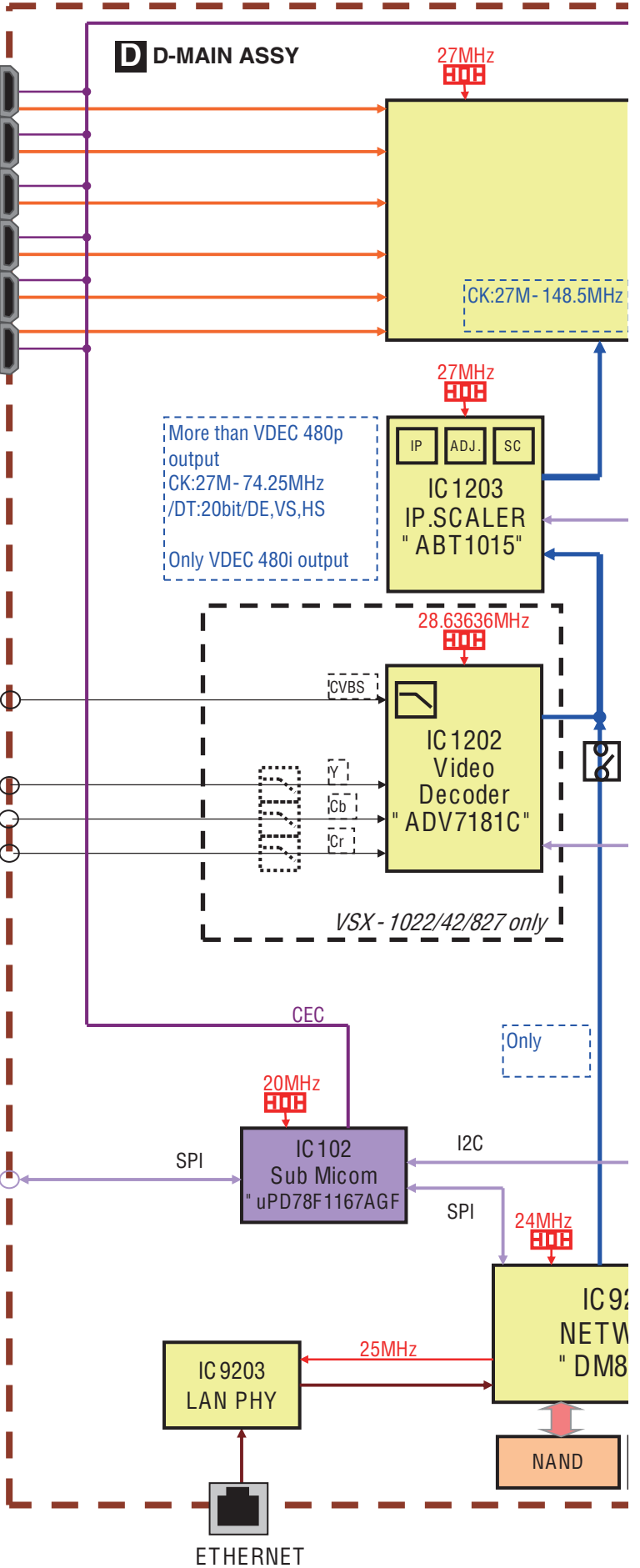
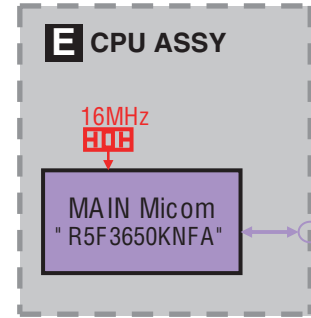
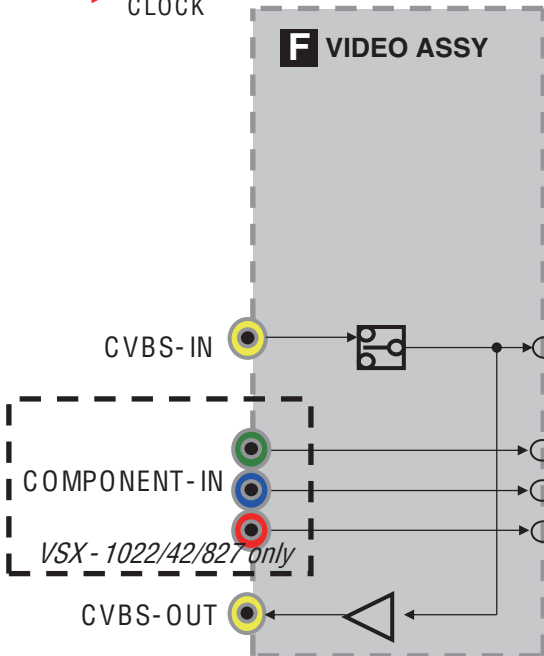

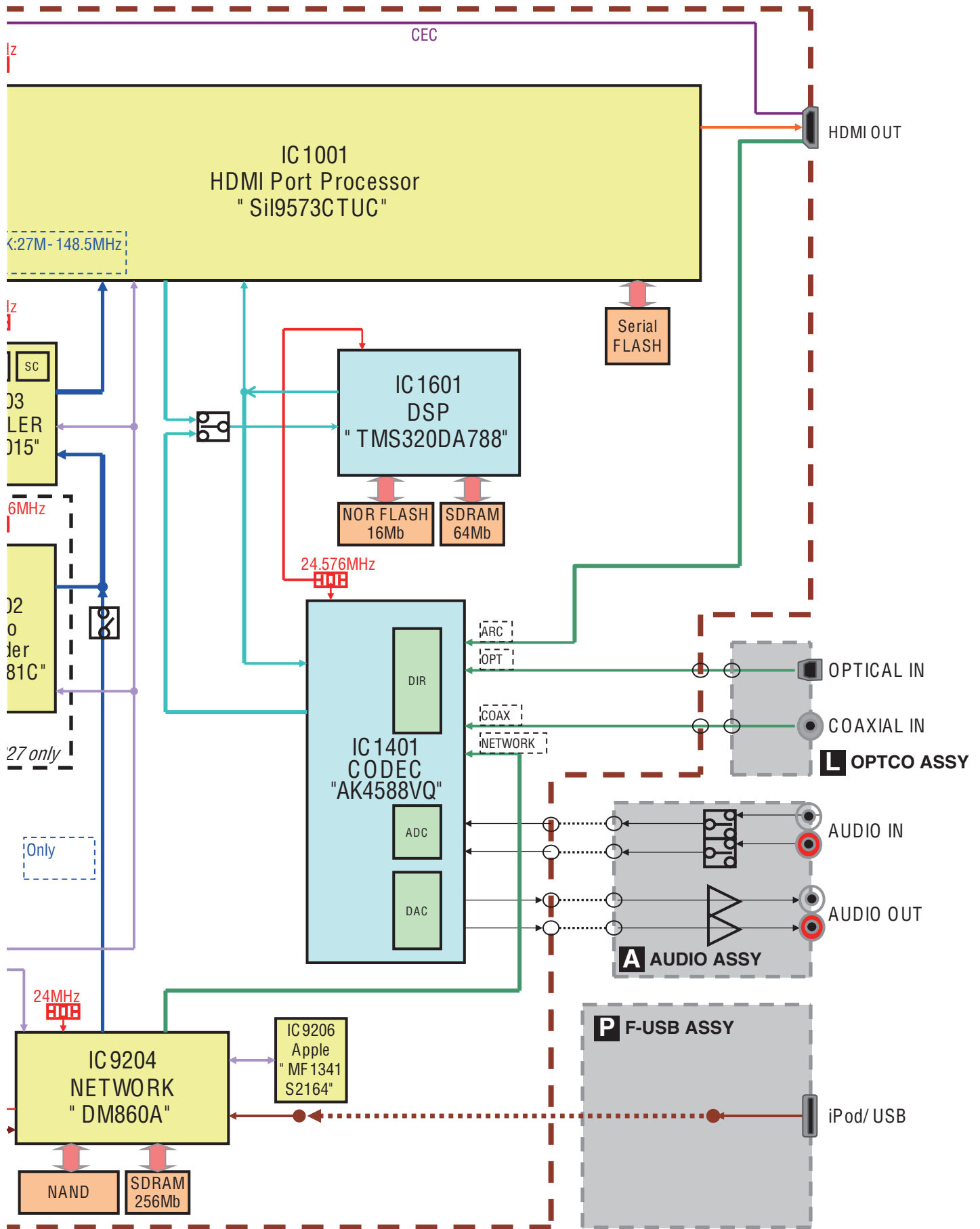

4.5 D-AUDIO BLOCK DIAGRAM

D MAIN ASSY

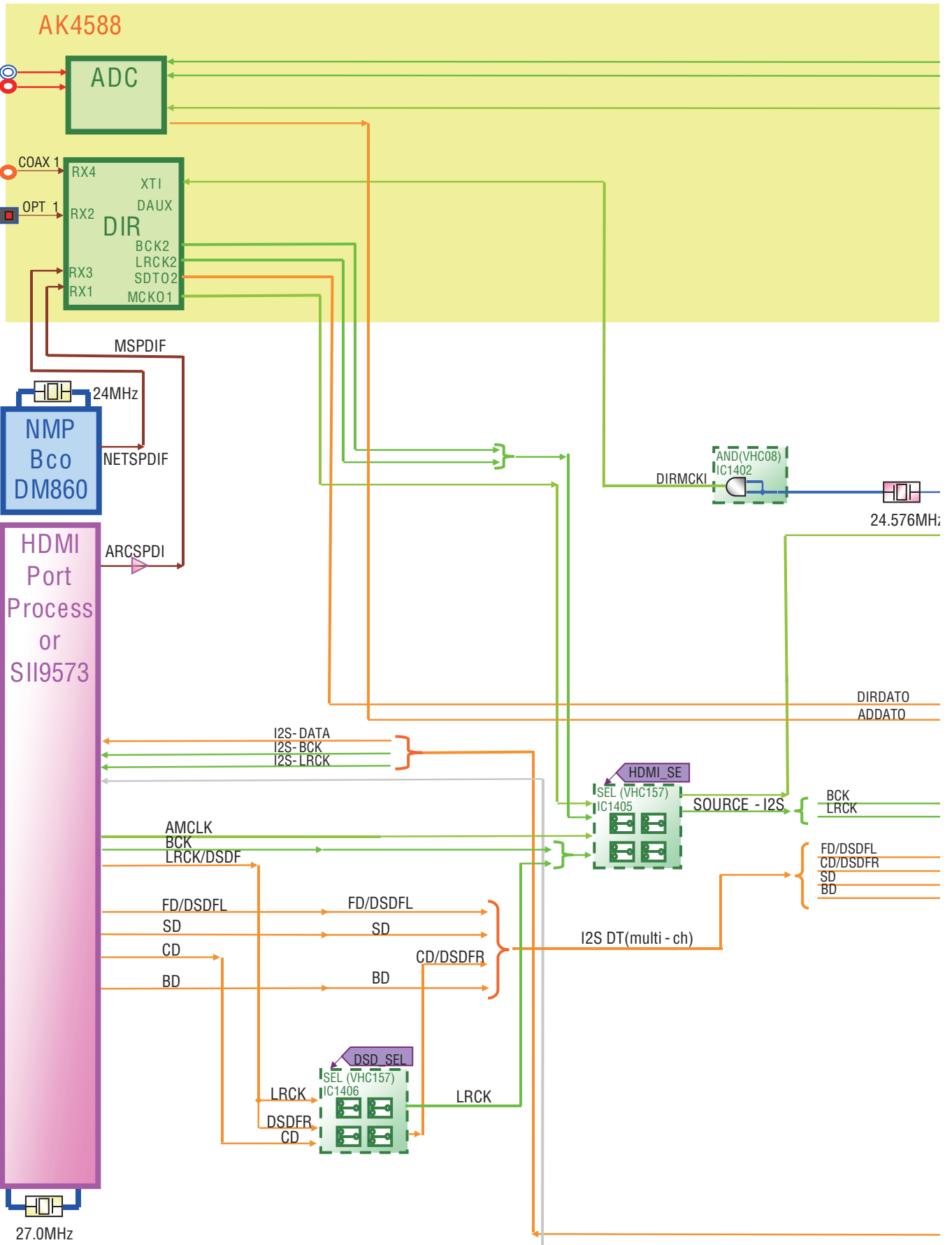

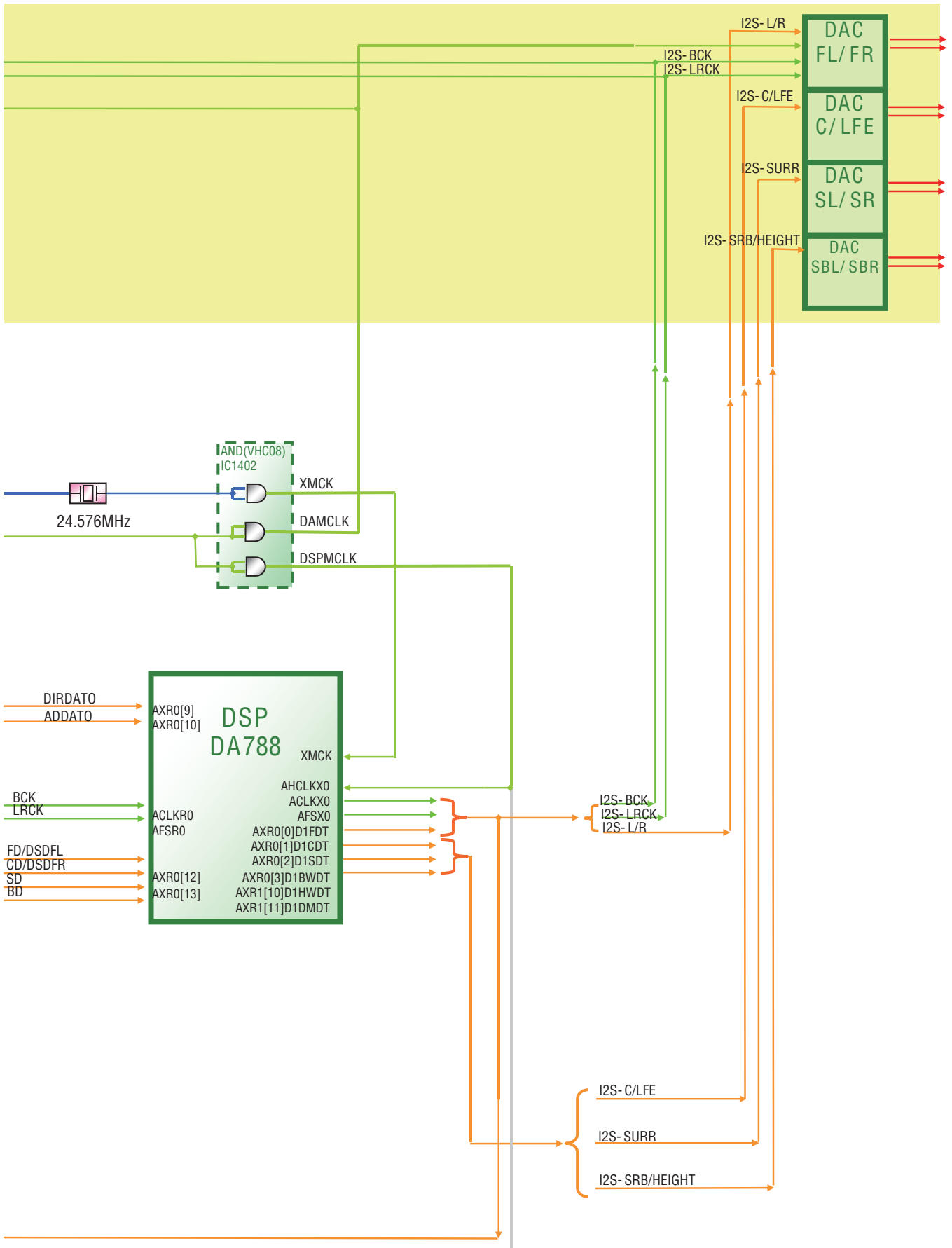

4.6 D-MAIN BLOCK DIAGRAM (1/2)

D D-MAIN ASSY

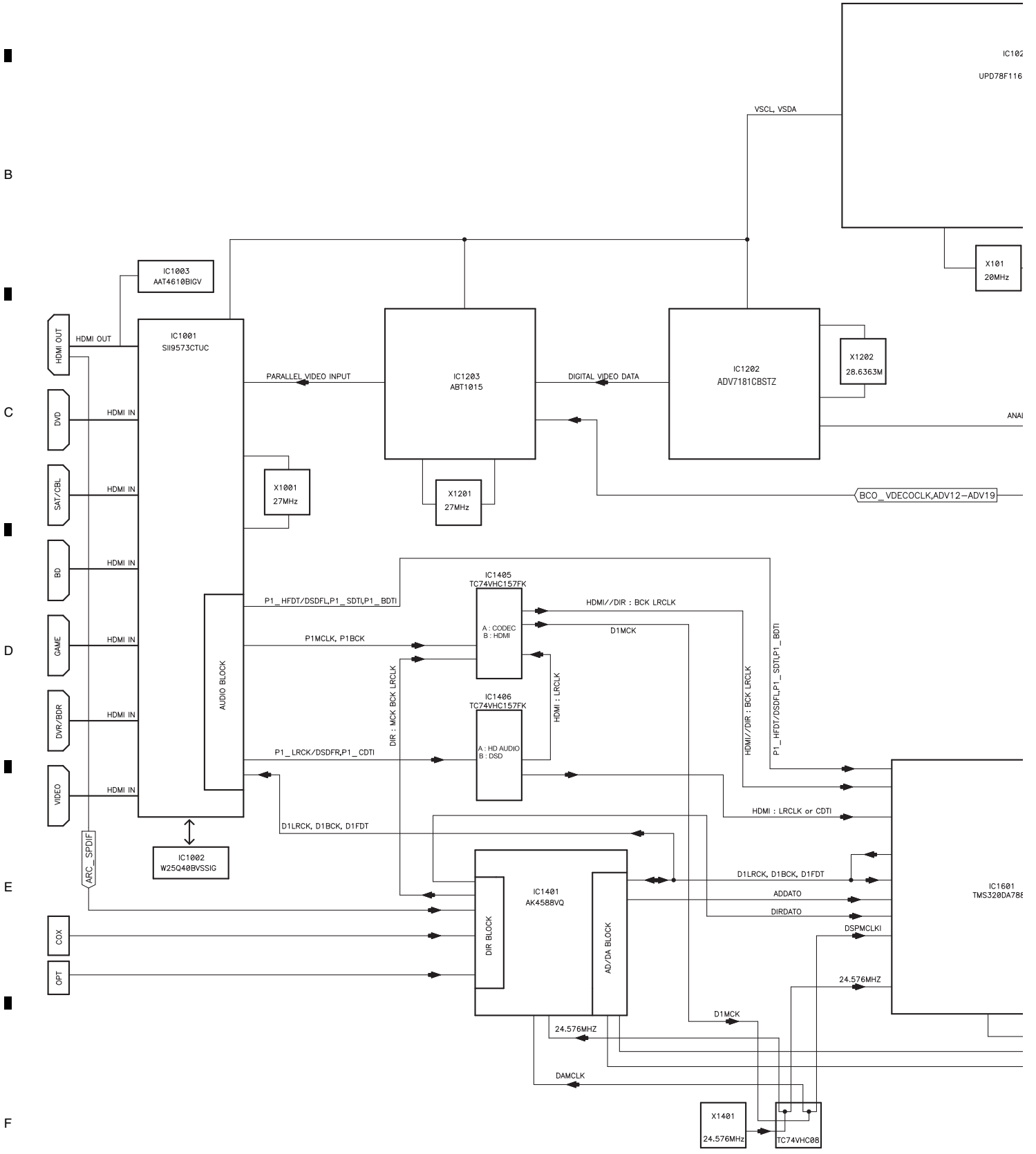

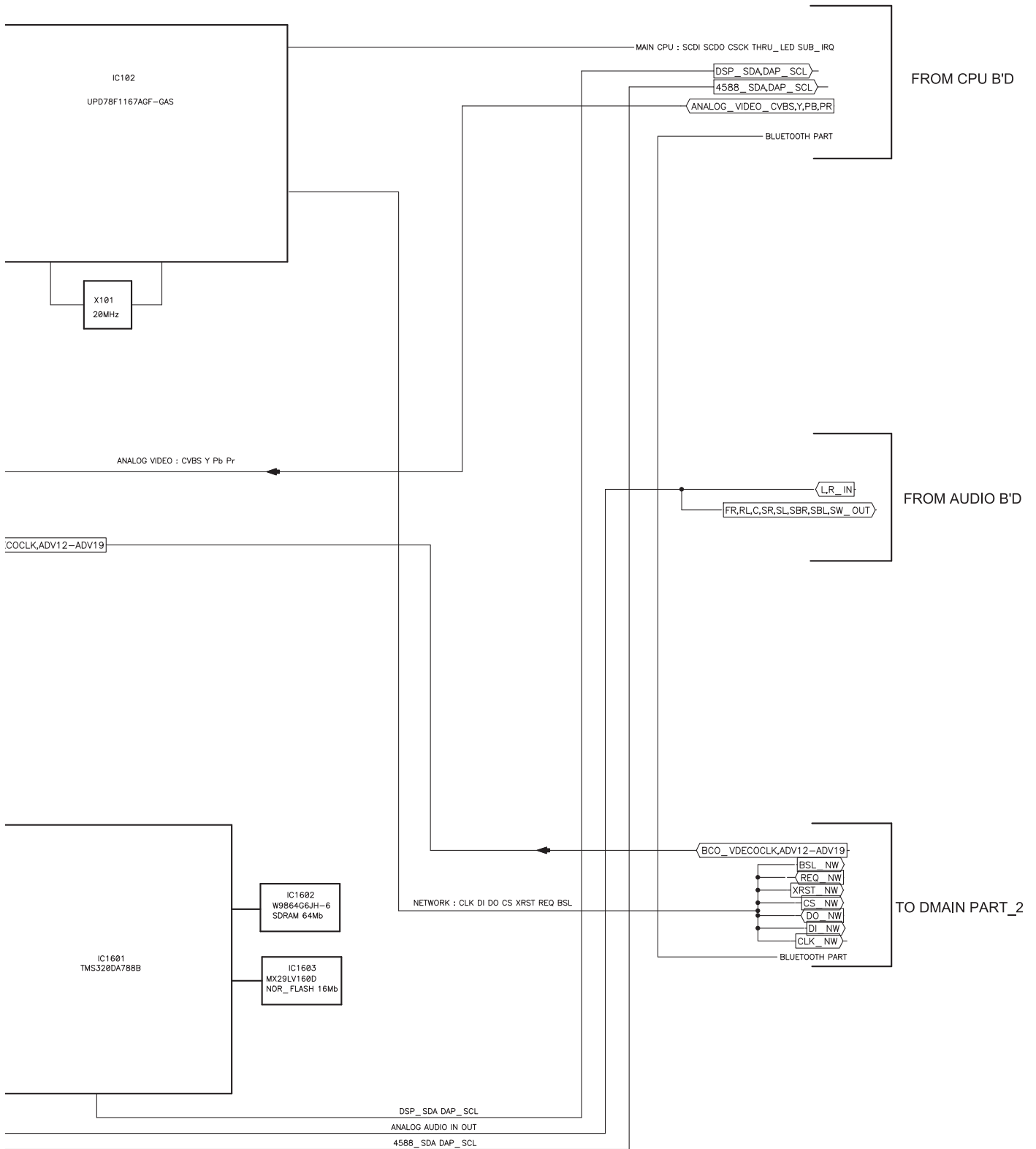

4.7 D-MAIN BLOCK DIAGRAM (2/2)

A

B

C

D

E

F

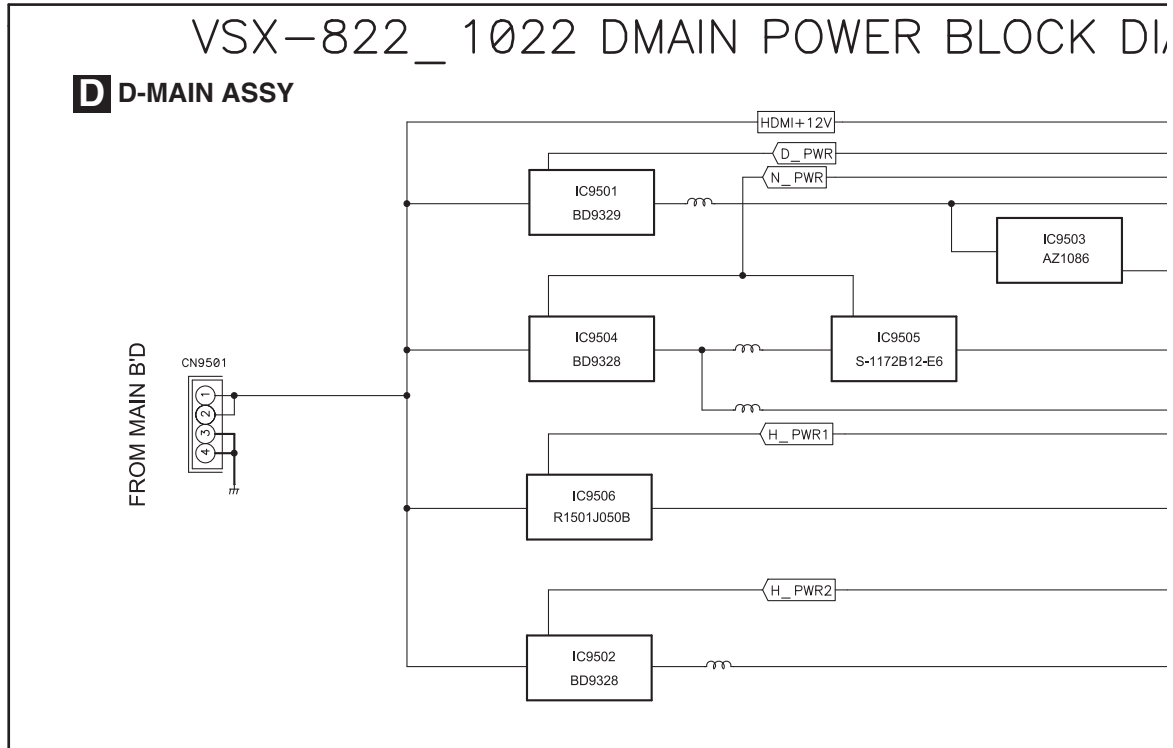
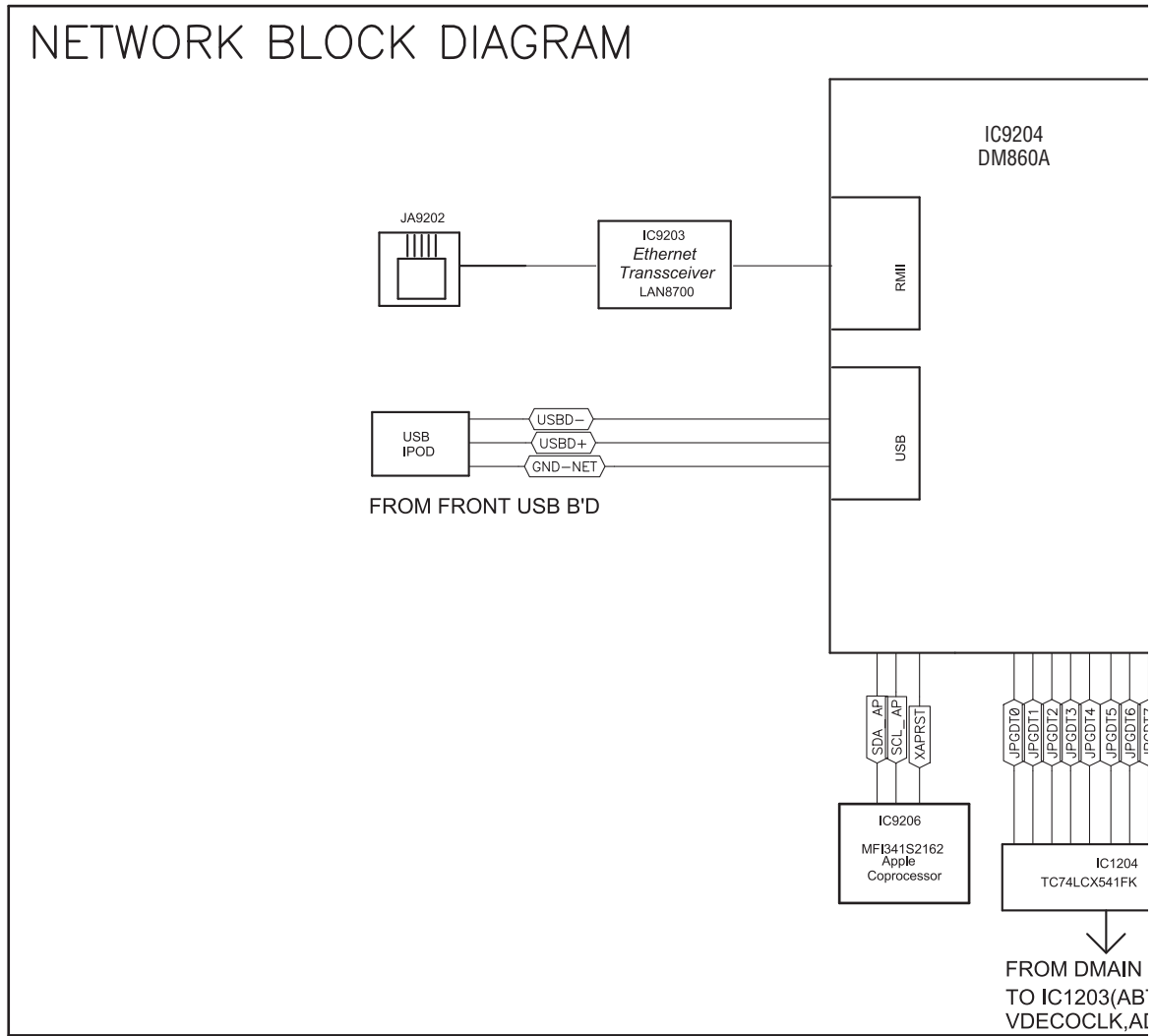

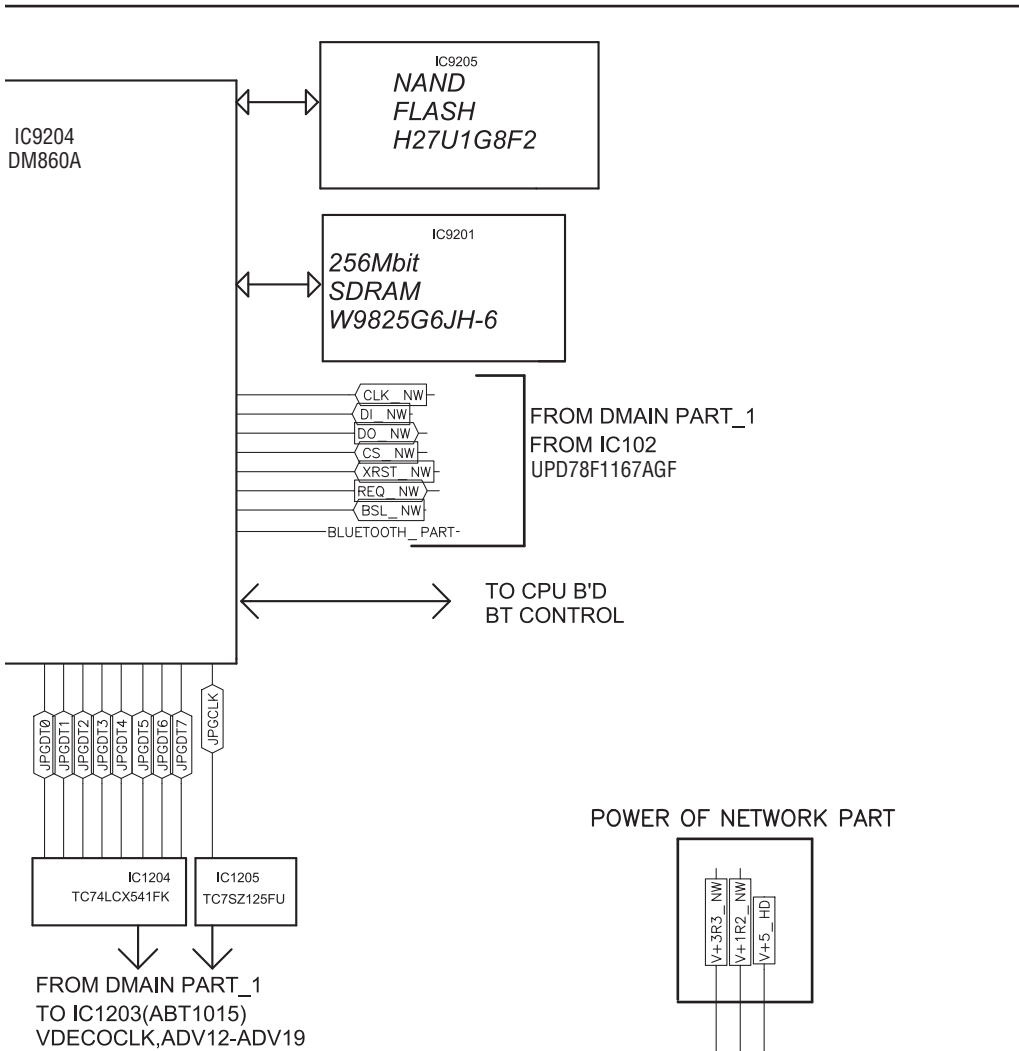

LOCK DIAGRAM

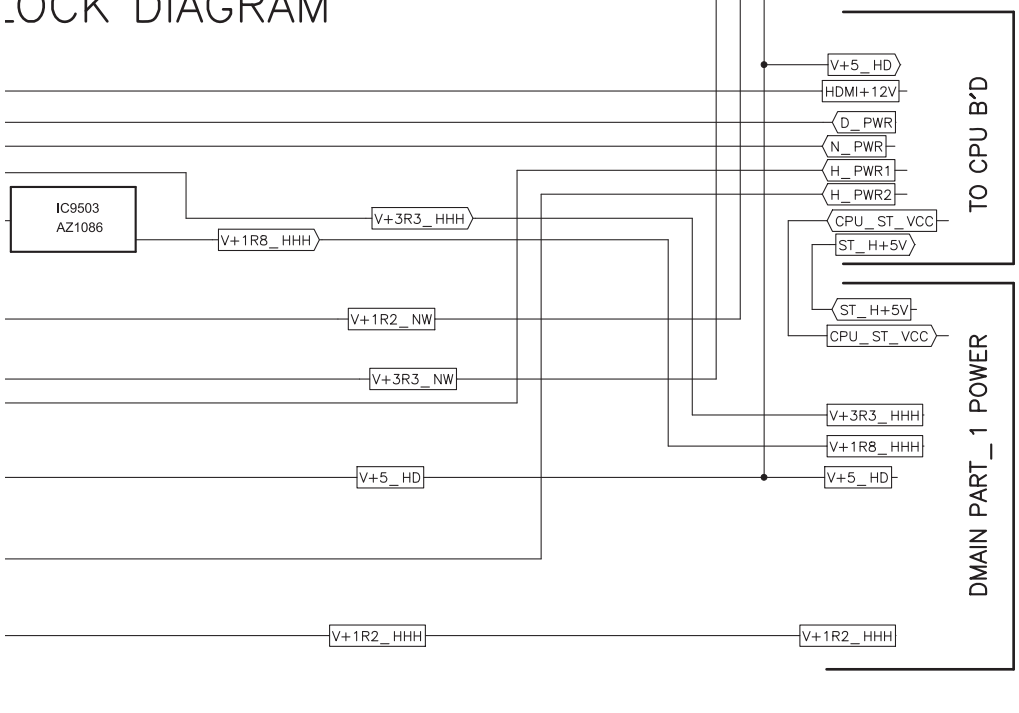

4.8 CPU BLOCK DIAGRAM

E CPU ASSY

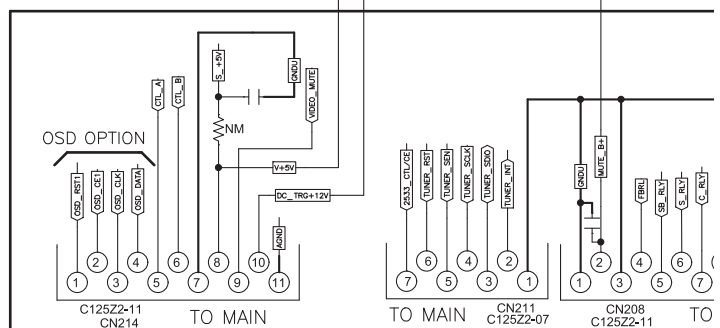
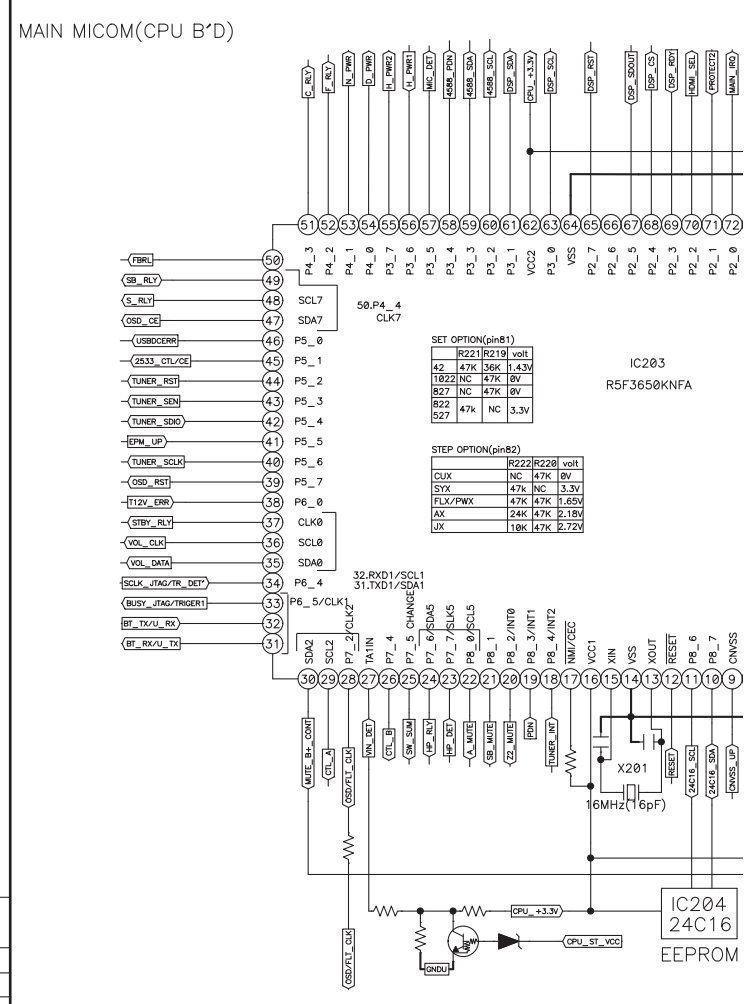
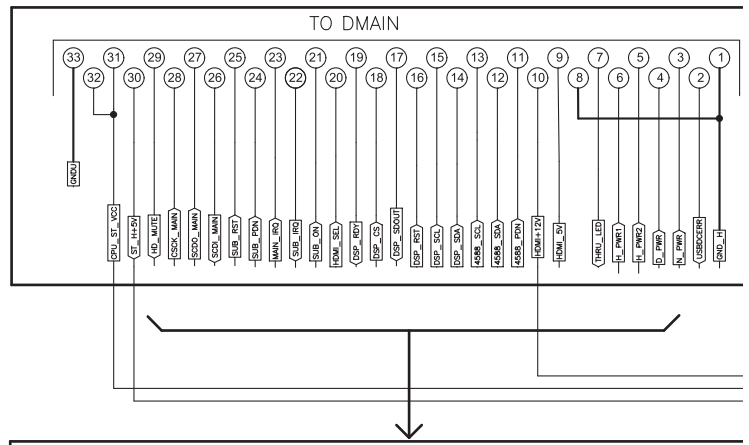
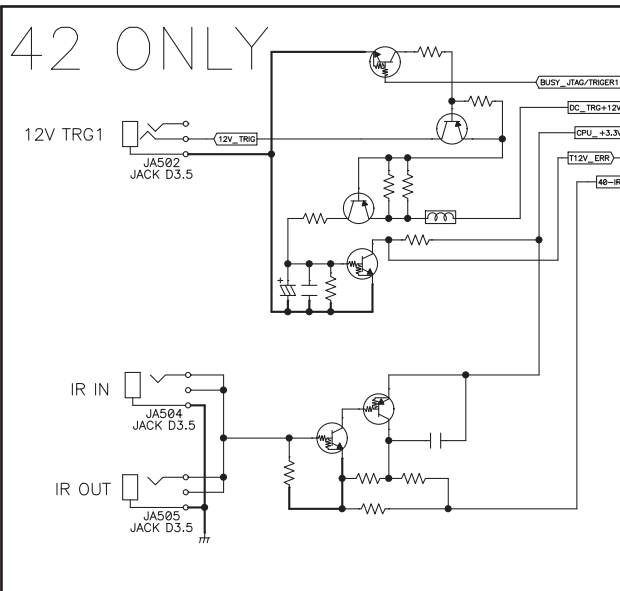
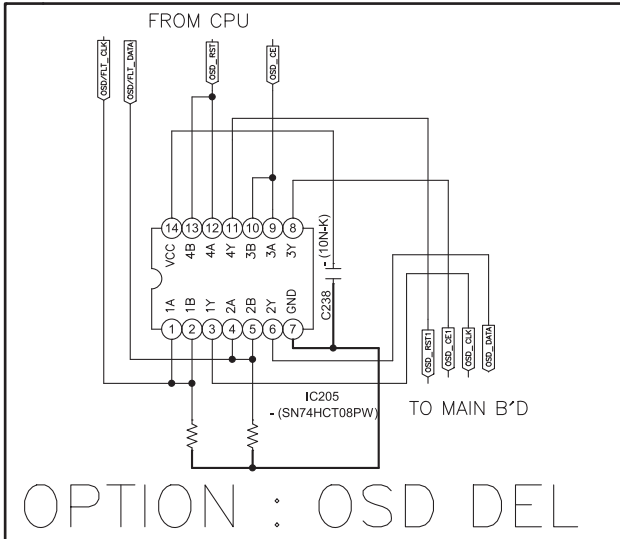

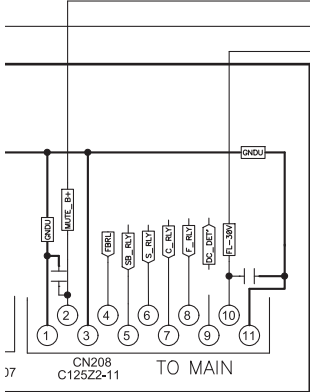
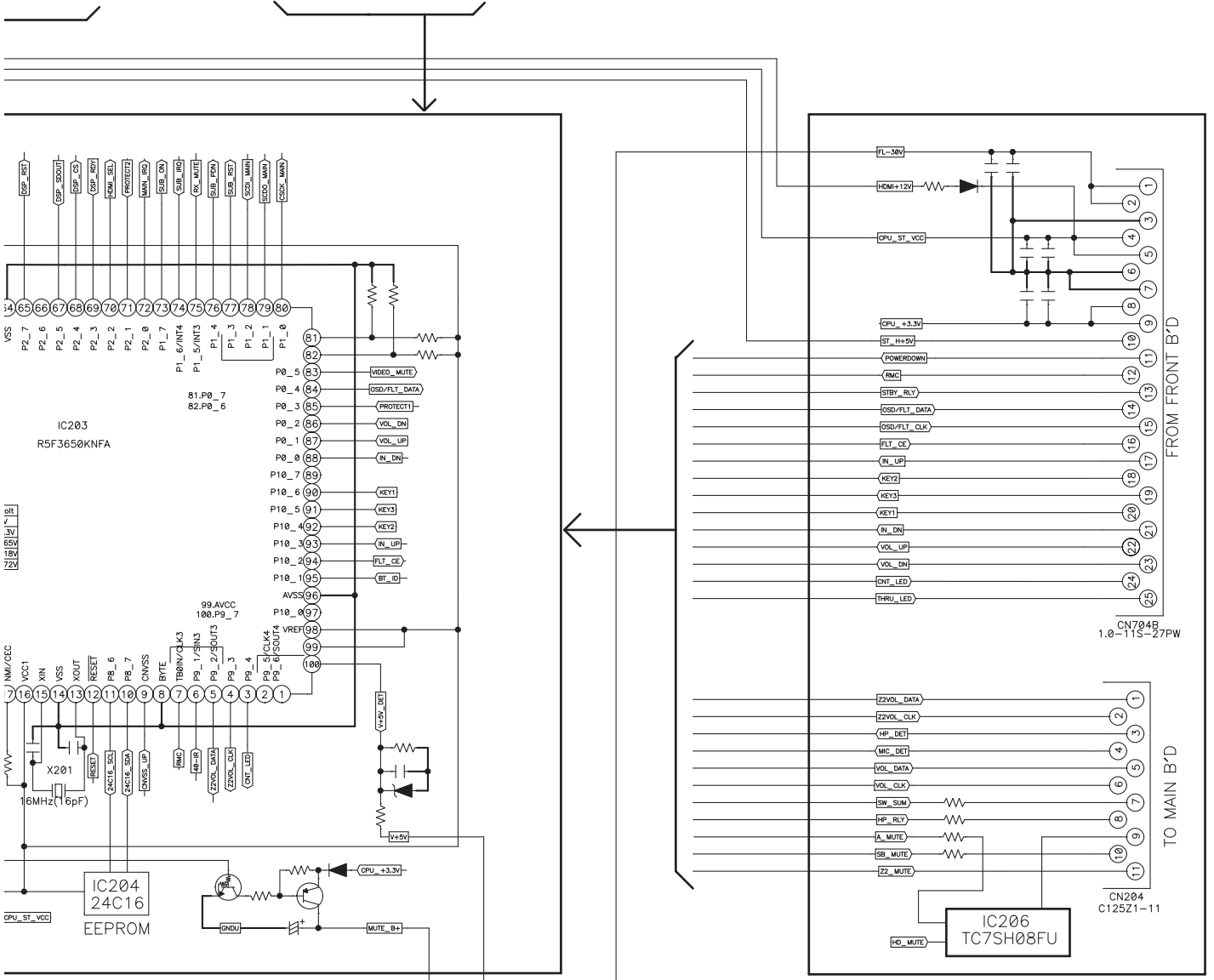
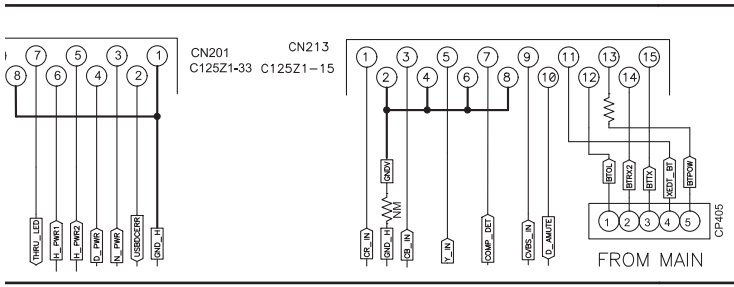

The  mark found on some component parts indicates the importance of the safety factor of the part. Therefore when replacing be sure to use parts of identical designation

4.9 VIDEO BLOCK DIAGRAM

F VIDEO ASSY

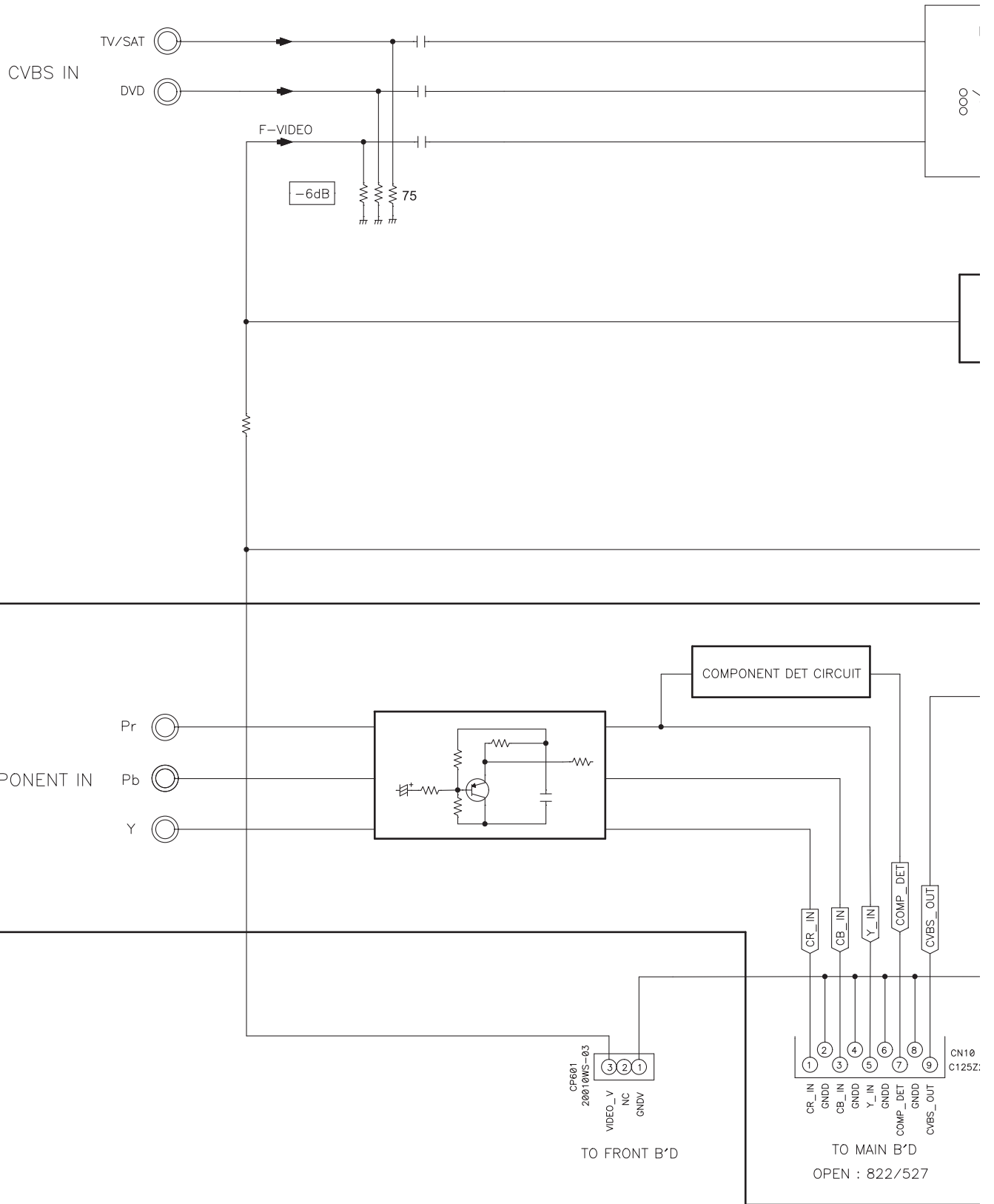

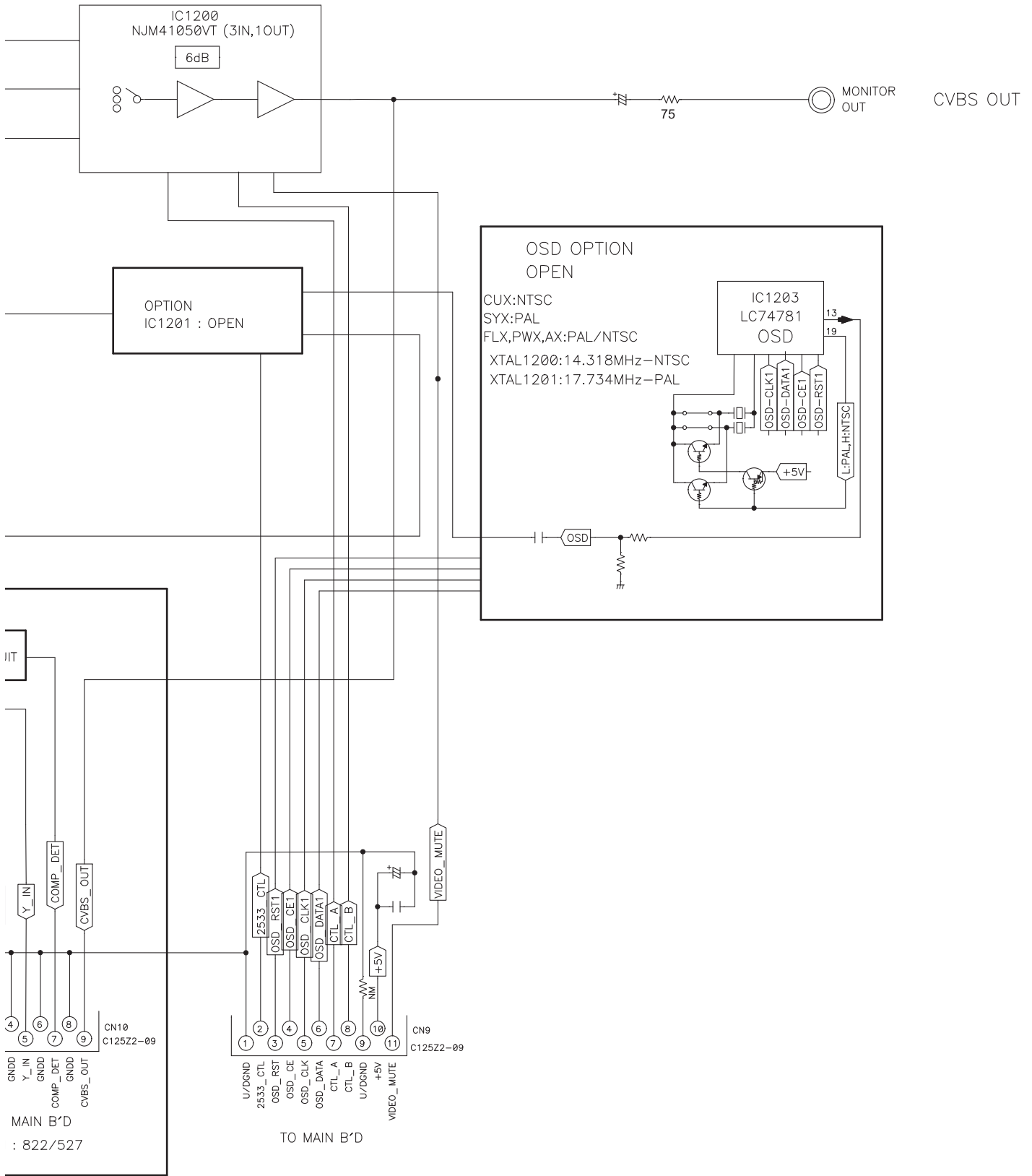

4.10 POWER SUPPLY BLOCK DIAGRAM

1 2 3 4

A
B
C
D
E
F

C MAIN ASSY

The  mark found on some component parts indicates the importance of the safety factor of the part. Therefore when replacing be sure to use parts of identical designation

MAIN TRANS

S1(AMP B+/B-)

S2(+12V,-12V)

S3

S4

S5(FLT)

SUB TRANS

W STBY ASSY

AC CORD

RELAY

RLY301

0.301

STBY-RLY-6801

ZZ 6800/63

ZZ 6800/63

42 ONLY

IC5 KIA7812API

IC1 KIA7812API

ZZ 4700/25

ZZ 1000/25

IC2 KIA7912PI

AUDIO JACK

D9

6800/16 ZZ

D9

6800/16 ZZ

FILAMENT AC4.7V

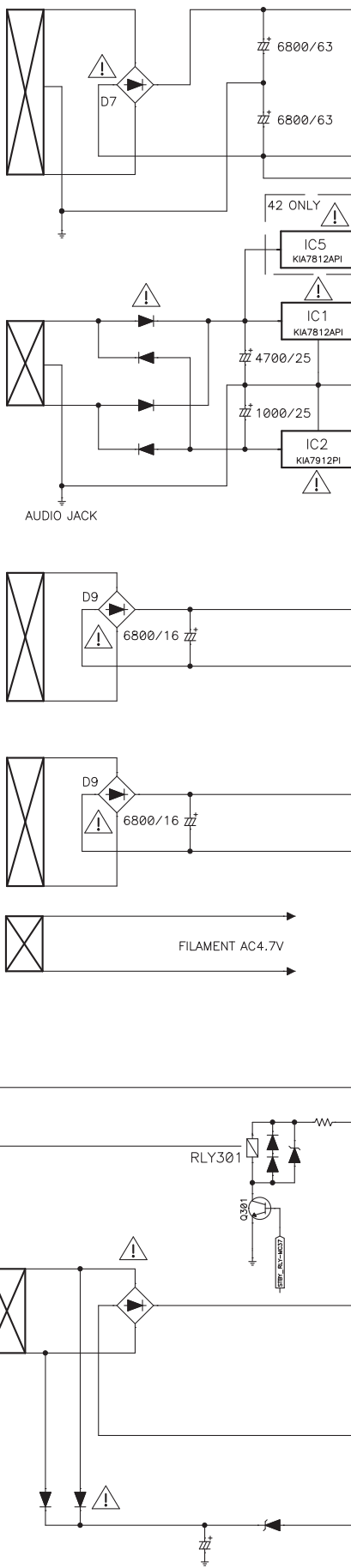
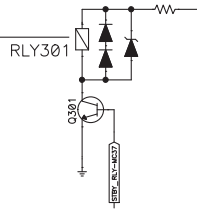

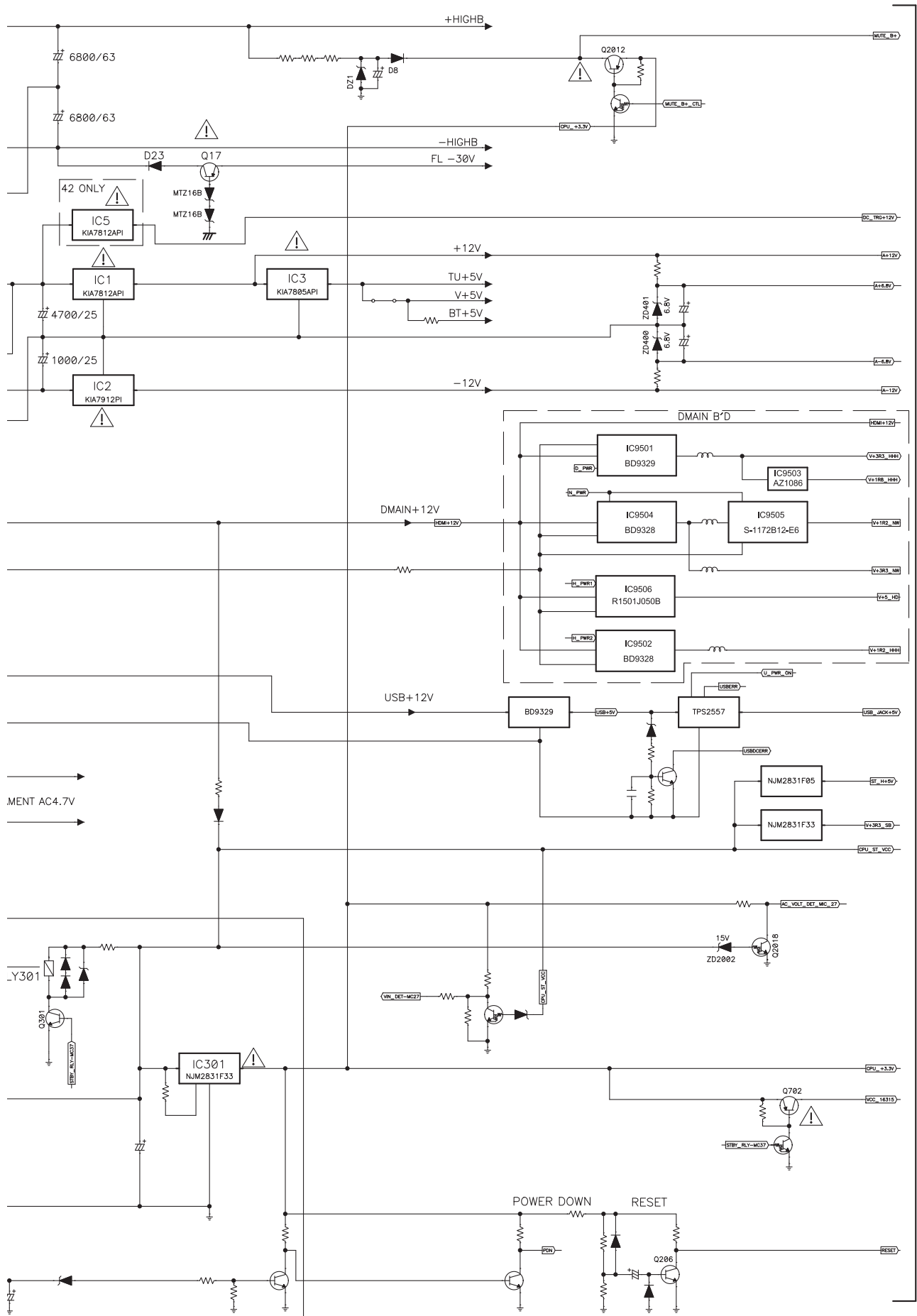

5. DIAGNOSIS

5.1 TROUBLESHOOTING

[1] DSP TROUBLESHOOTING

■ TROUBLESHOOTING FOR ALL DESTINATION

Step 0: Preliminary confirmation

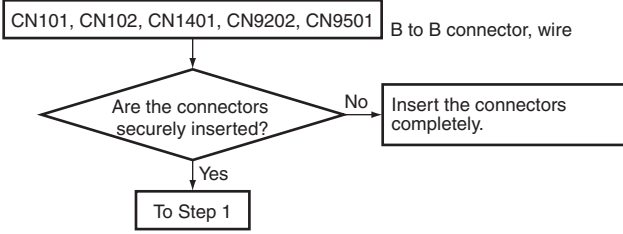

Step 1: Fixed board

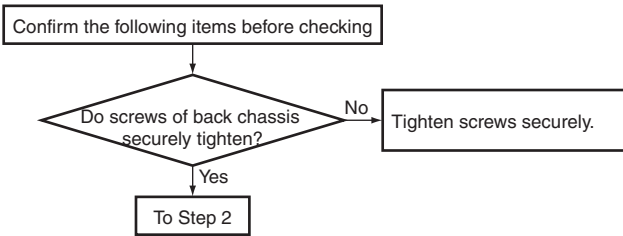

Step 2: Power supply

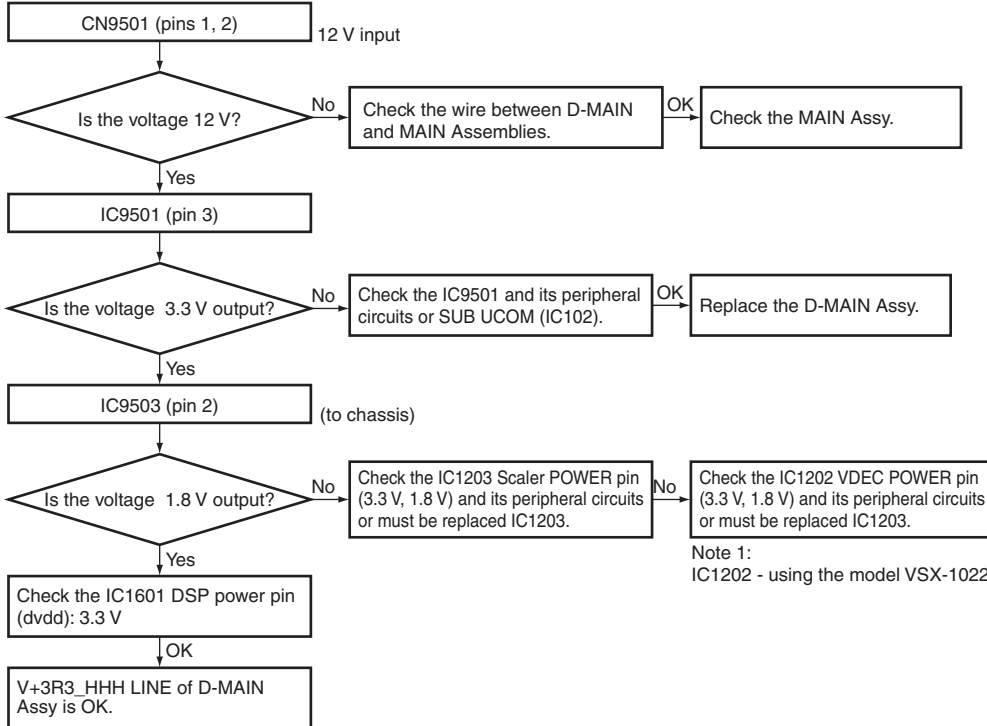

Step 3: Power supply

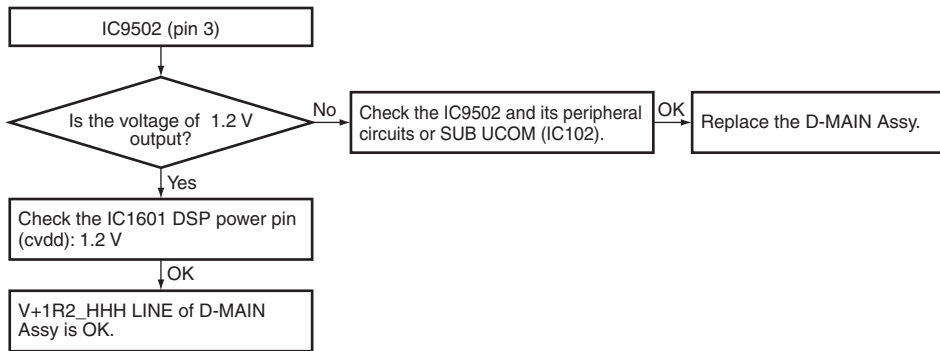

Step 4: Power supply

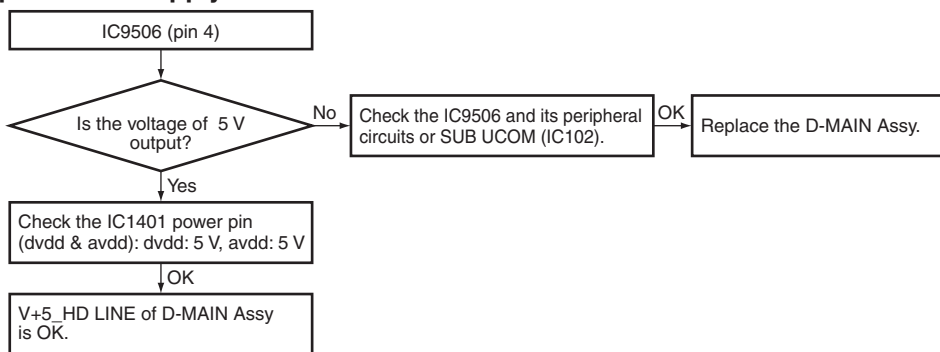

Step 5: Power supply

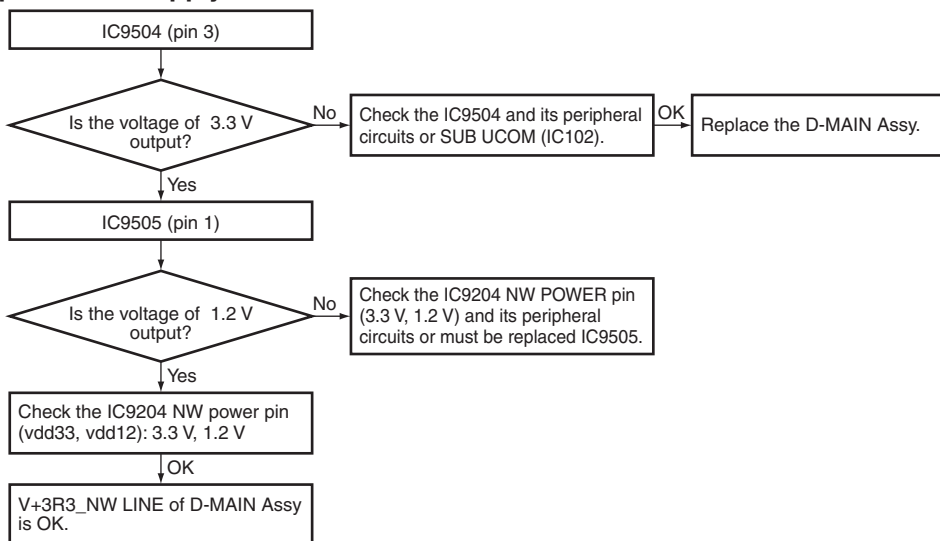

A Step 6: X'tal

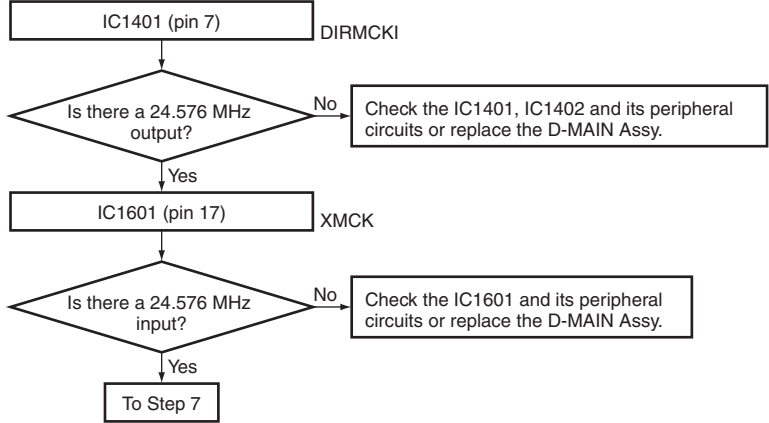

B

Step 7: DIR

Check that the S/PDIF signal is input.
 Check that changes by pulling out and inserting the digital input lines.

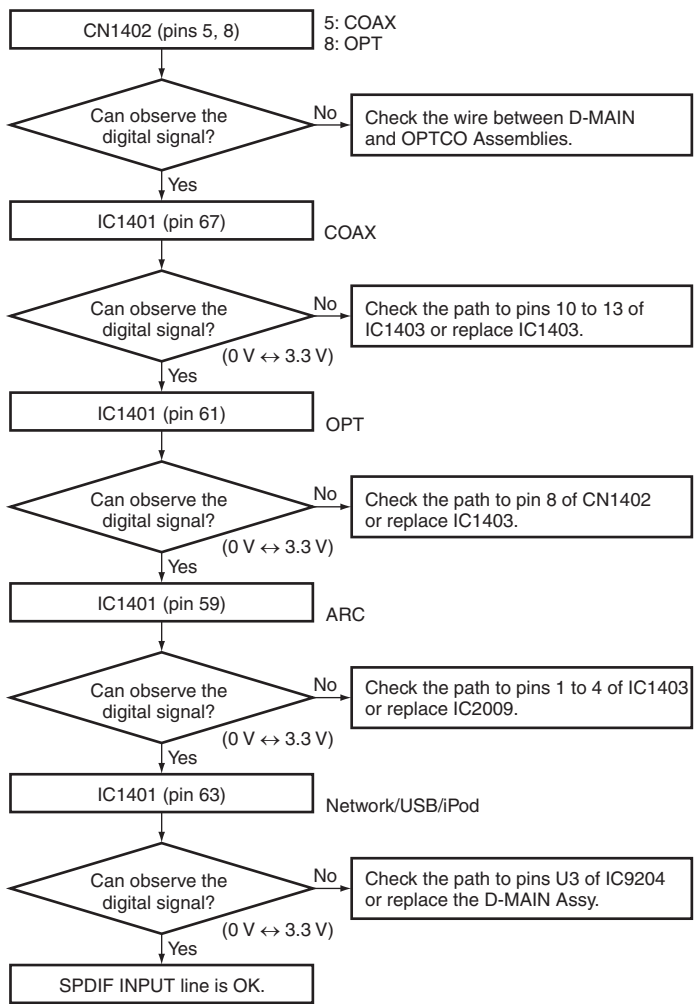

C

D

E

F

Check that the data and clock signals are output.

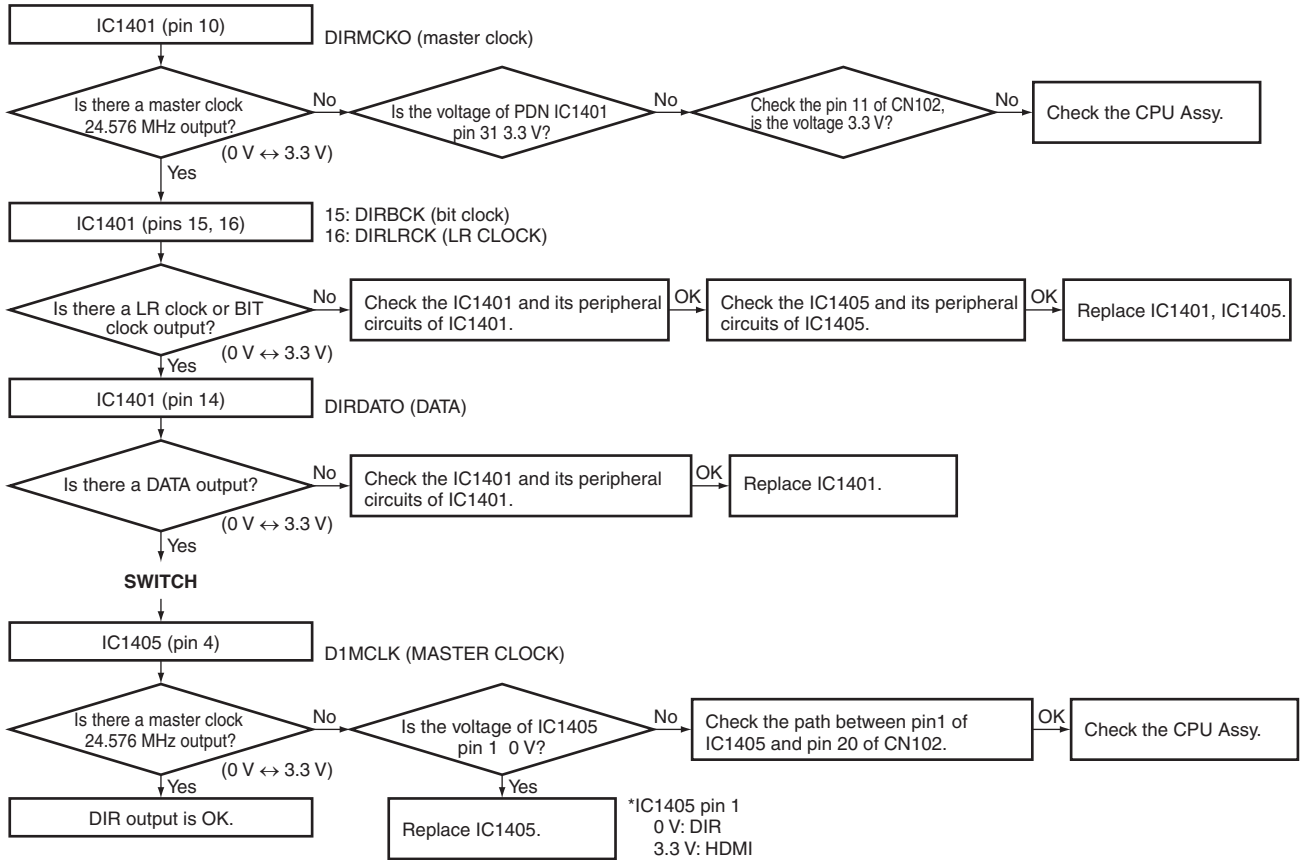

Step 8: ADC

Check that the ANALOG input to DSP mode.

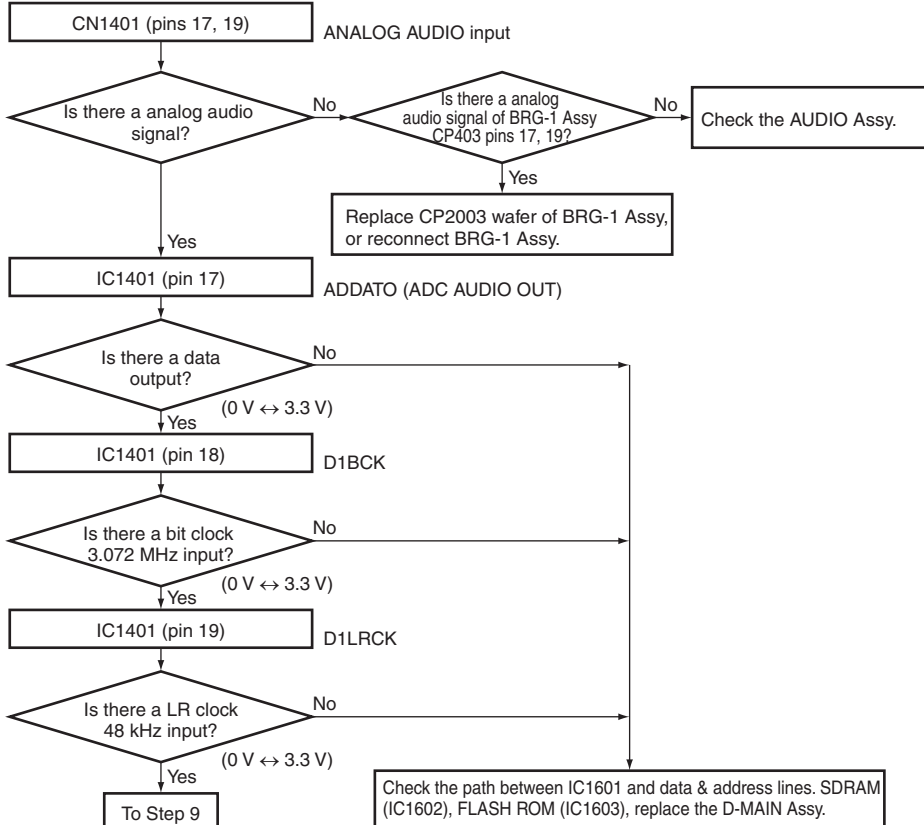

A Step 9: DSP mode audio output

Digital output of each CH when inputting the digital signal with audio.

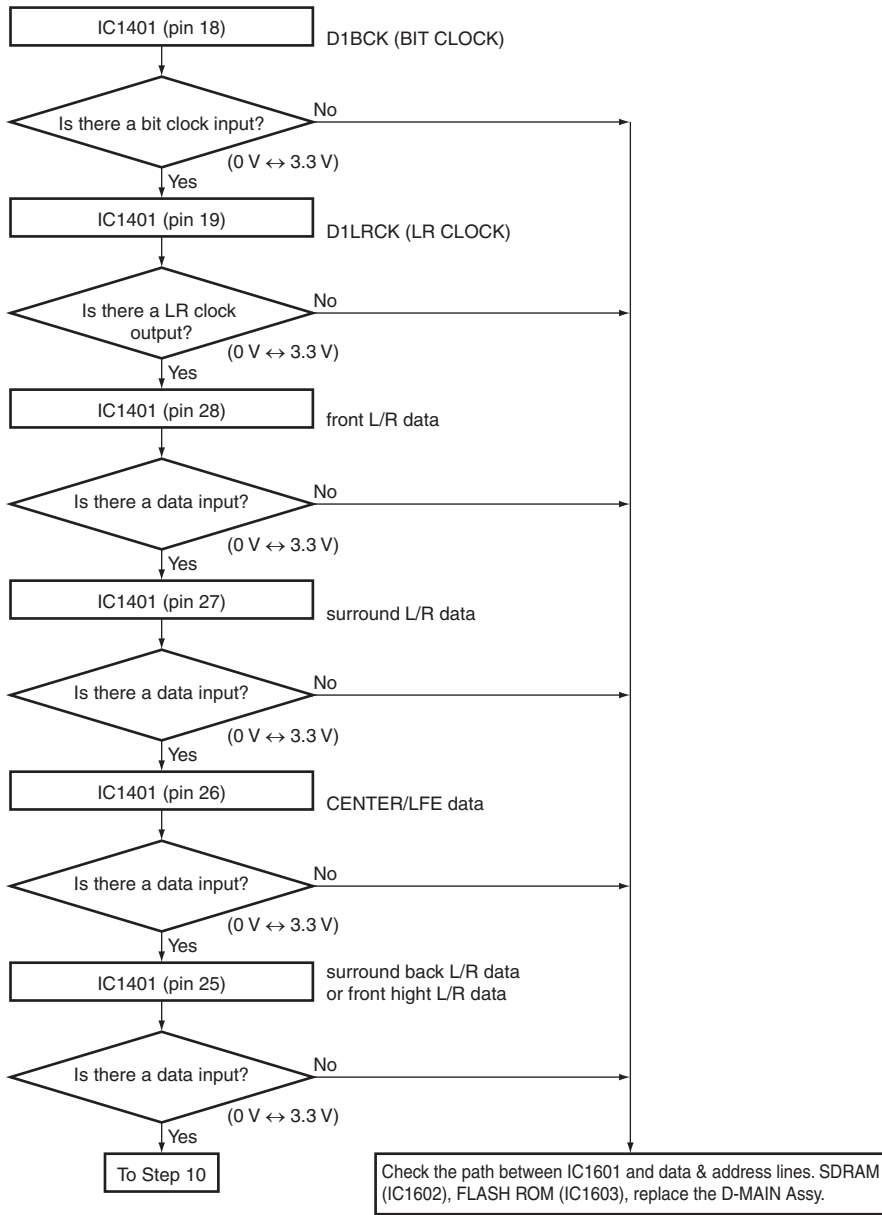

B

C

D

E

F

Step 10: CODEC output (ANALOG AUDIO OUT)

Analog output of each CH when inputting the digital signal with audio.

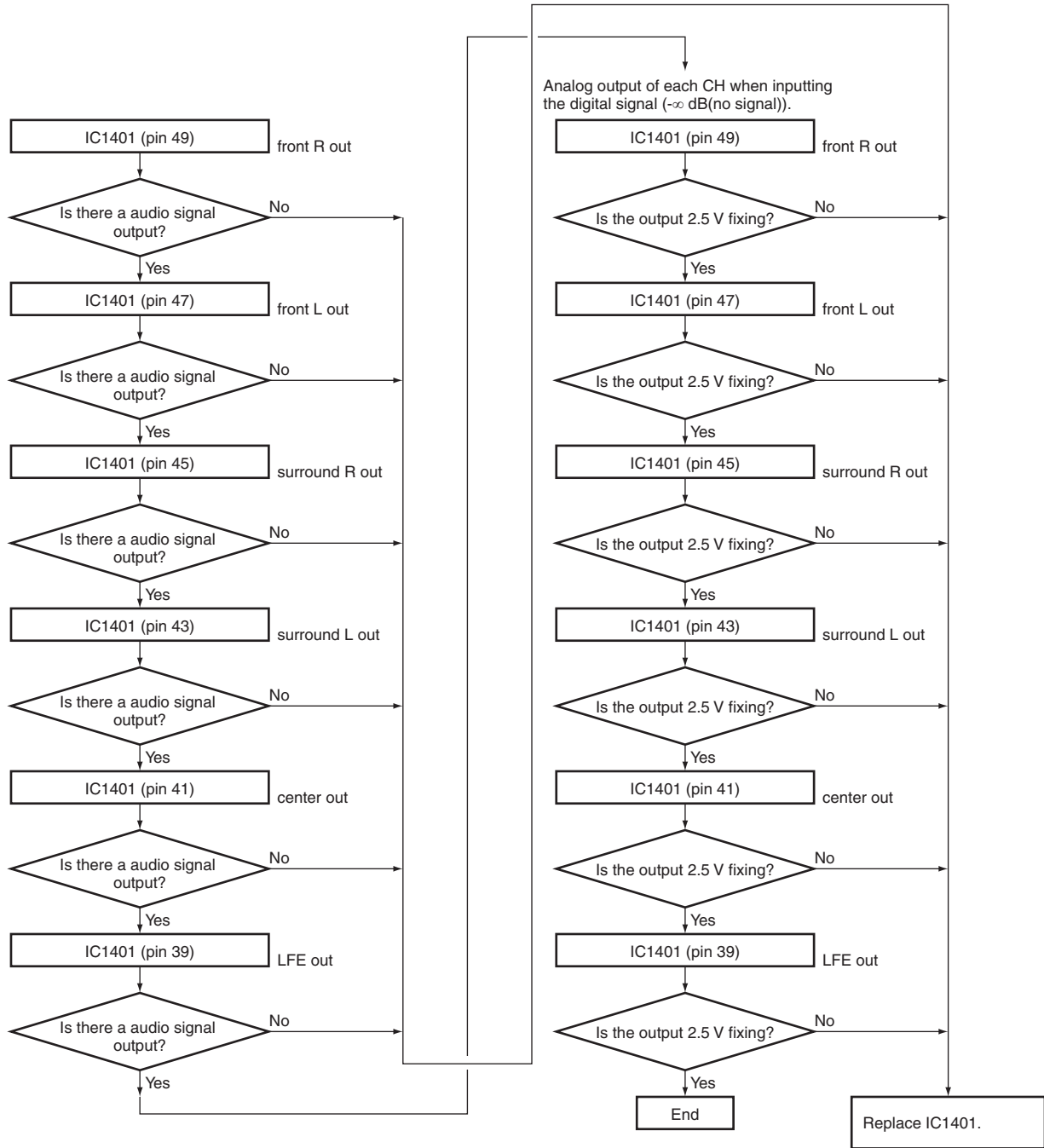

A [2] HDMI TROUBLESHOOTING

■ HDMI Troubleshooting

Cause for noncompletion of HDMI authentication between the source equipment and this unit.
(the HDMI indicator is unlit or flasher)

■ HDMI Simple Diagnosis

Causes for no display or sound from the monitor

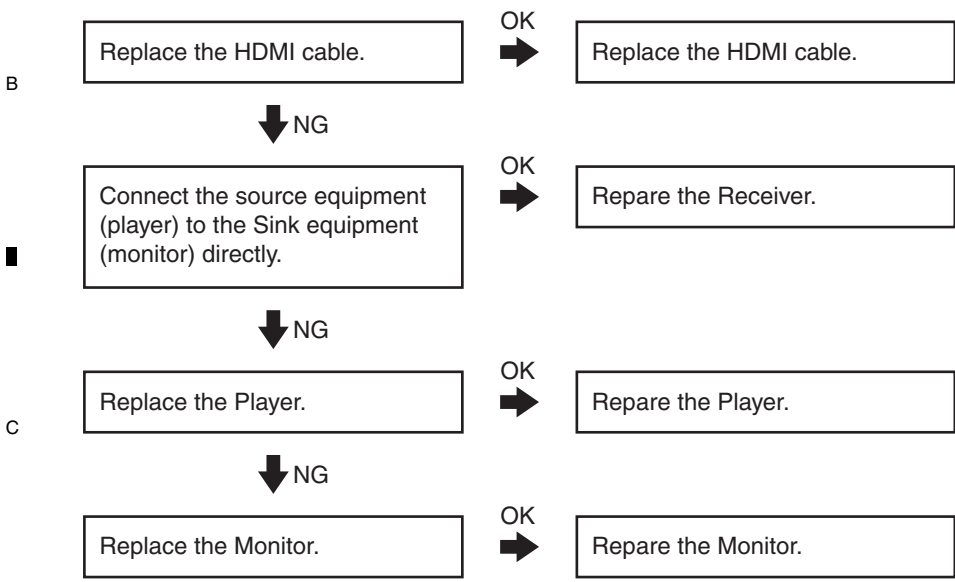

Step 0: Preliminary confirmation

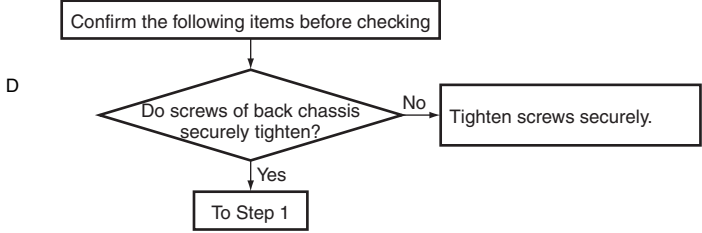

Step 1: Connect the HDMI equipment

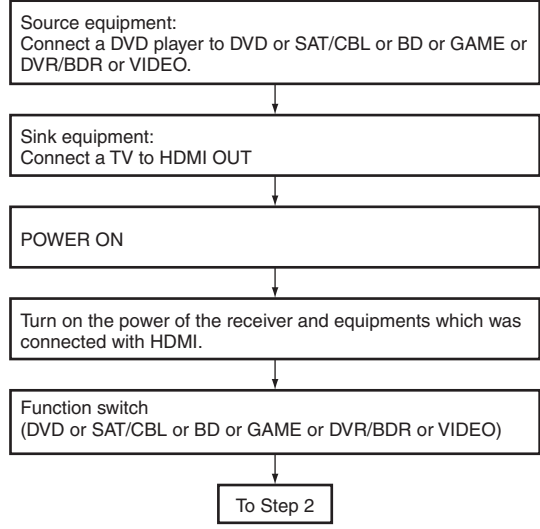

F

Step 2: Power supply

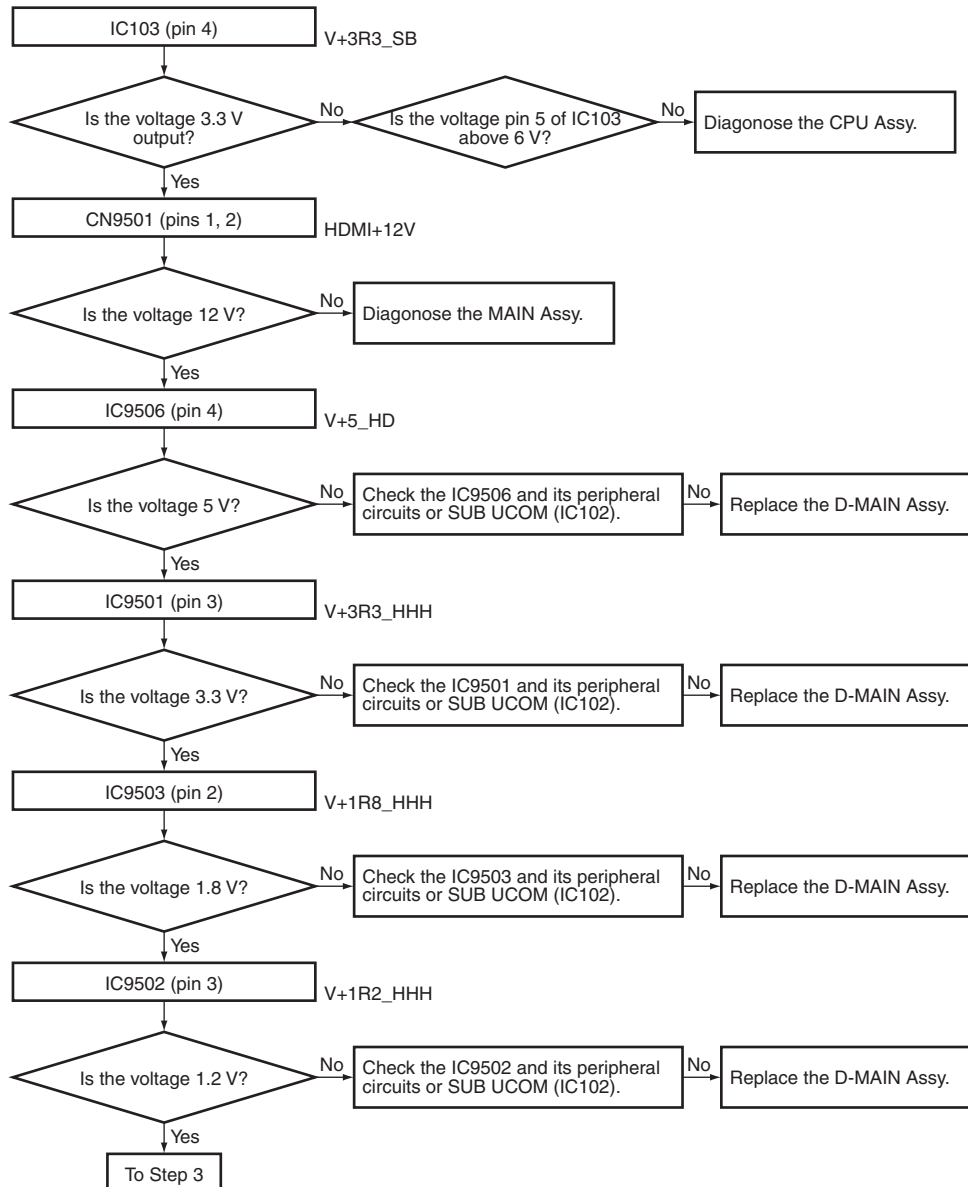

A Step 3: Diagnosis

Each data lines confirmation checks it after standby off/on.

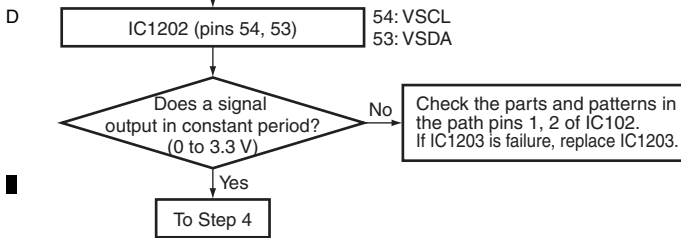
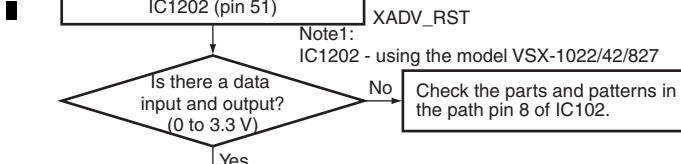
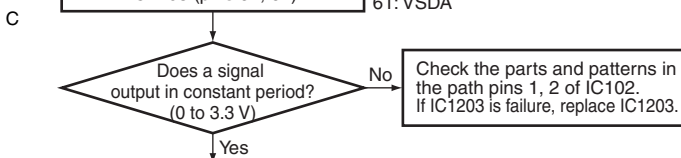
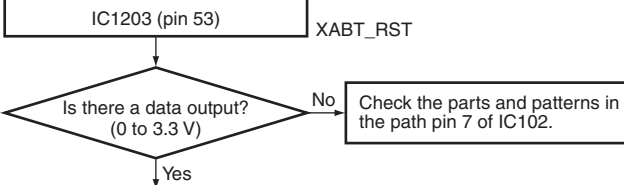
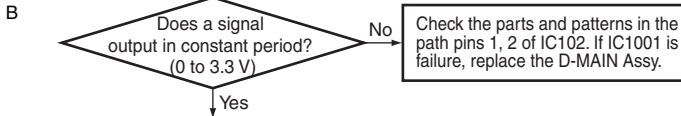
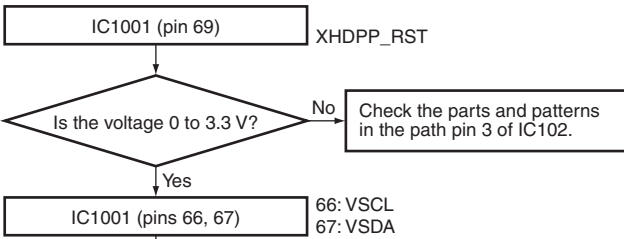

Step 4: X'TAL

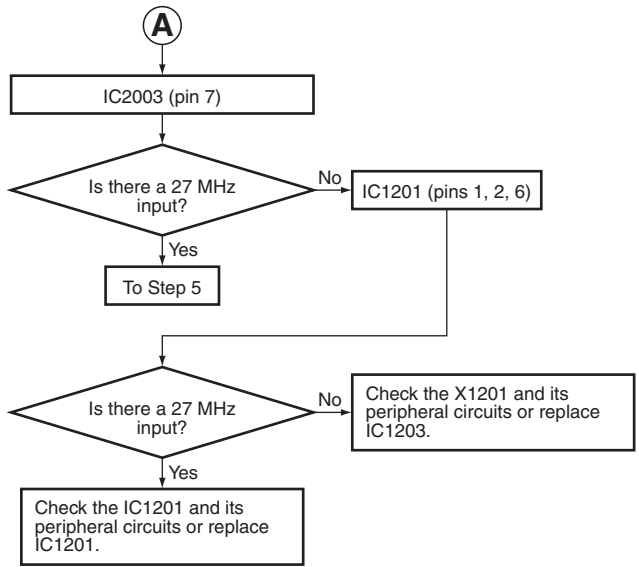
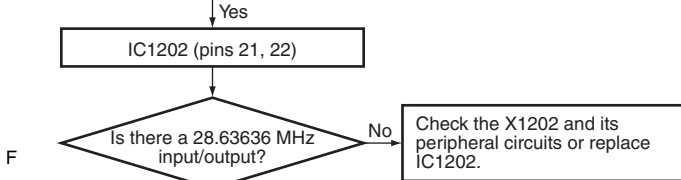
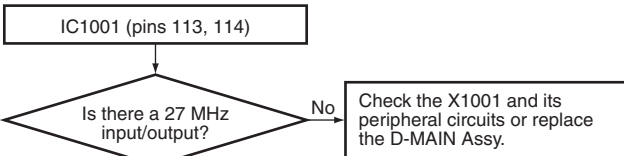

Step 5: ANALOG UP (VSX-1022/42/827 only)

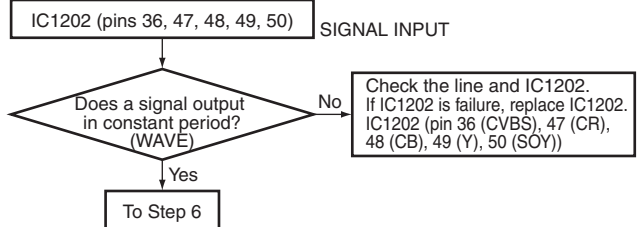
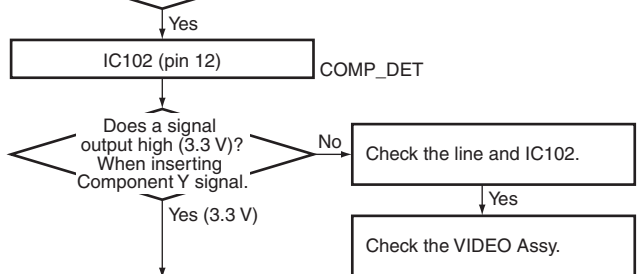
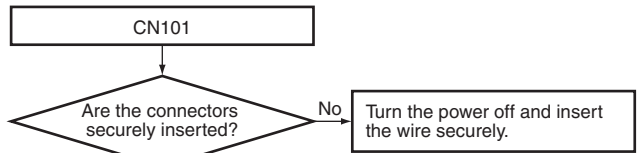

Step 6: TMDS

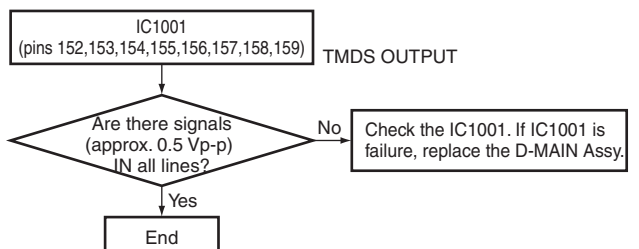

Step 7: HDMI AUDIO

*play is Dolby thru HD @ dts master audio source

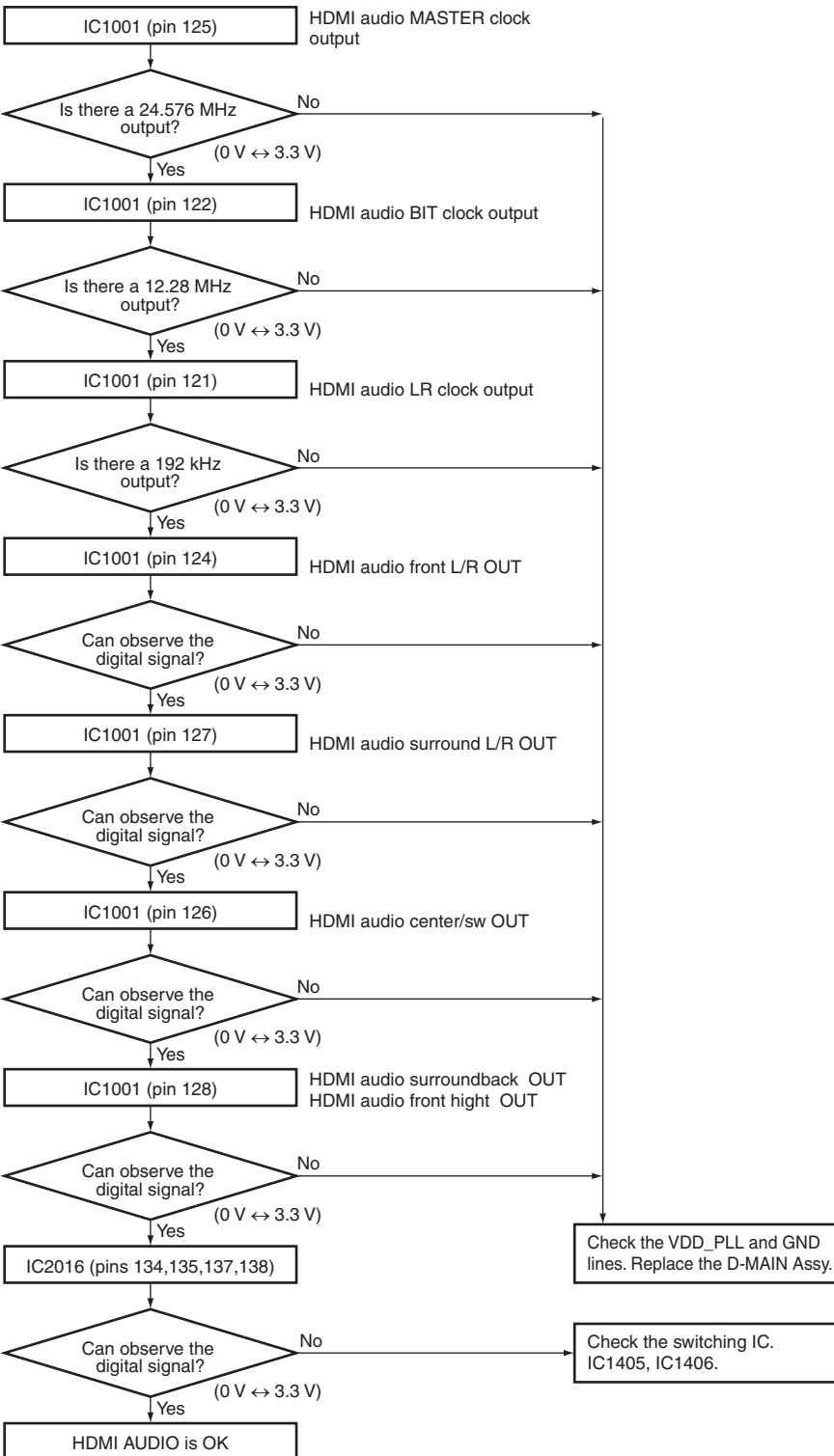

A [3] iPod TROUBLESHOOTING

Step 0: iPod/USB Power supply

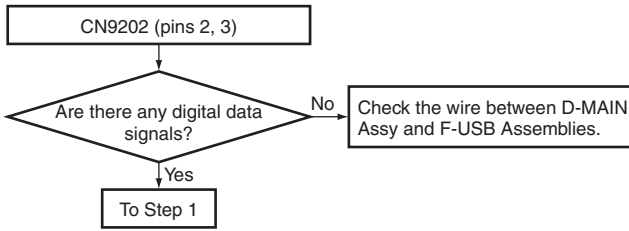

Step 1: Diagnosis

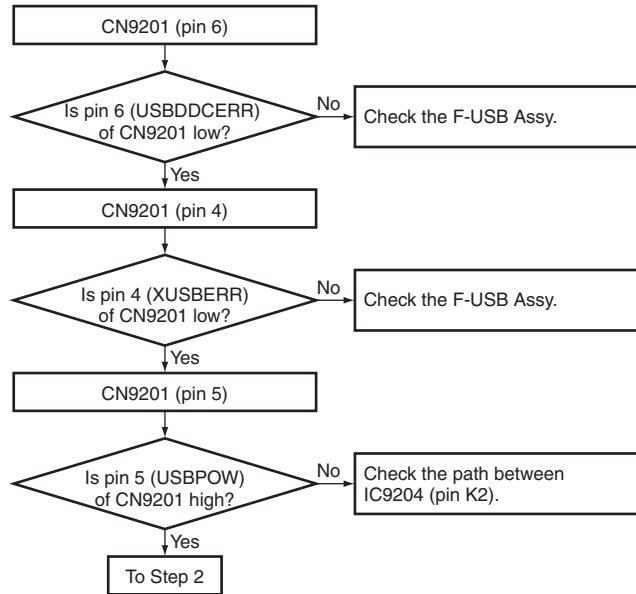

Step 2: Operation of iPod (Authentication process)

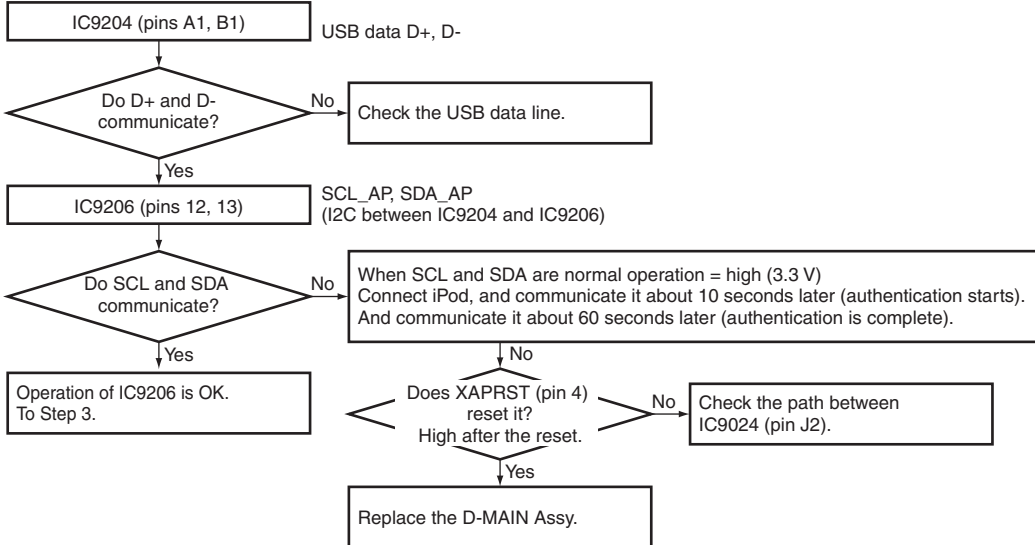

Step 3: Audio out check

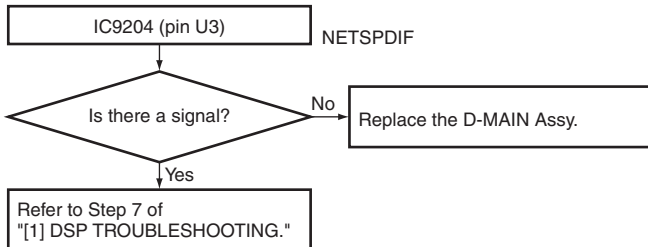

[4] BT (Bluetooth) TROUBLESHOOTING

Step 0: Preliminary confirmation

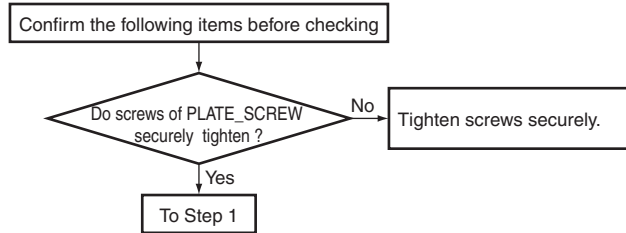

Step 1: BT_DET

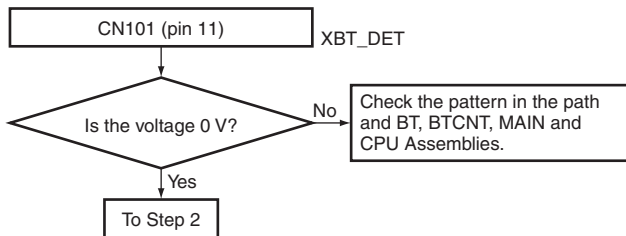

Step 2: Diagnosis

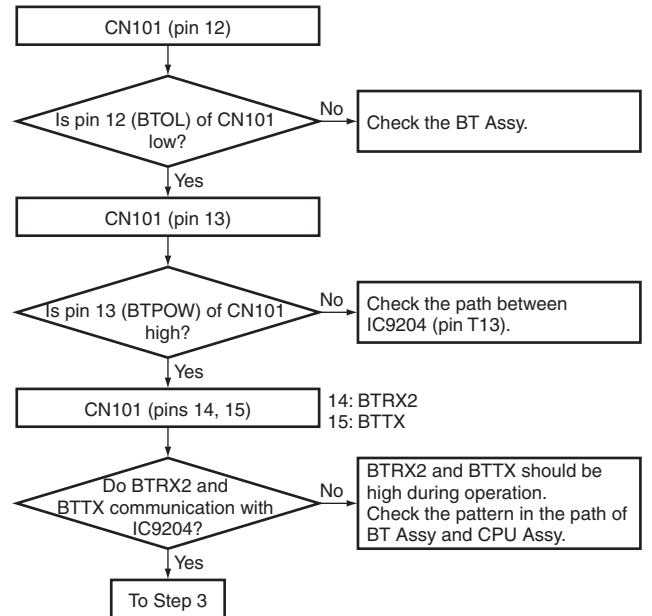

Step 3: Audio out check

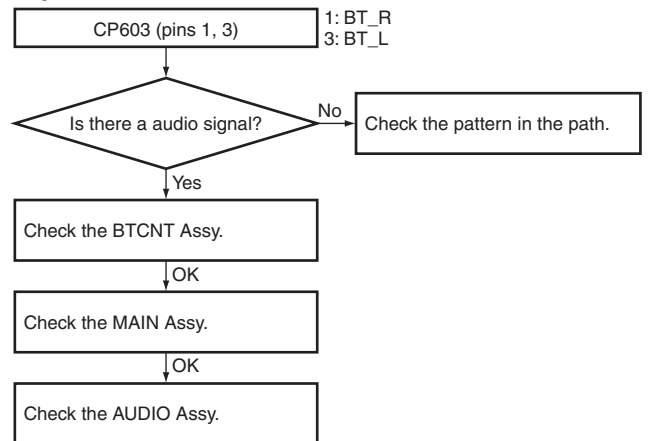

5.2 ADAPTER ERROR MESSAGE

Functional Name

Adapter port overcurrent detection

Outline

When the BT adapter is inserted in Adapter port, turn off the power of the Adapter port forcibly when it detects an overcurrent. And display ERROR state in FL.

Basic Operation

Front Key Sequence Change	Character Display	Time (sec.)	Icon Display (FL)	LED Display																				
When the overcurrent is detected	<table border="1"> <tr> <td>1</td><td>2</td><td>3</td><td>4</td><td>5</td><td>6</td><td>7</td><td>8</td> <td>1</td><td>2</td> </tr> <tr> <td>A</td><td>D</td><td>P</td><td>E</td><td>R</td><td>R</td><td></td><td></td> <td></td><td></td> </tr> </table> <p>*1</p> <p>Check it after turning the power once off then back on again, and it becomes the normal operation if normal.</p>	1	2	3	4	5	6	7	8	1	2	A	D	P	E	R	R					The display continues until the power is turned off.	—	—
1	2	3	4	5	6	7	8	1	2															
A	D	P	E	R	R																			

*1 Return the "ADP ERR" display to the normal display if you change it into other FUNCTION only in the ADAPTER PORT FUNCTION.

Also display "ADP ERR" if the ADAPTER PORT FUNCTION is ERROR state.

Explain Operation Detail

For detection method

- Confirm a detection port at intervals of 20 msec to 50 msec (*2), and judge it as an overcurrent when you detected an error consecutively three times.

*2 It is assumed that it is fixed value of the 20 msec to 50 msec degree.

5.3 USB/iPod ERROR MESSAGE

Functional Name

iPod ERROR MESSAGE

Outline

Error message is displayed at abnormality time.

Basic Operation

Front Key Sequence Change	Time (sec)	FL Display
Over Current Error		I//U: ERR

5.4 DETECTION CIRCUIT

[1] Overload and DC Protection Circuit

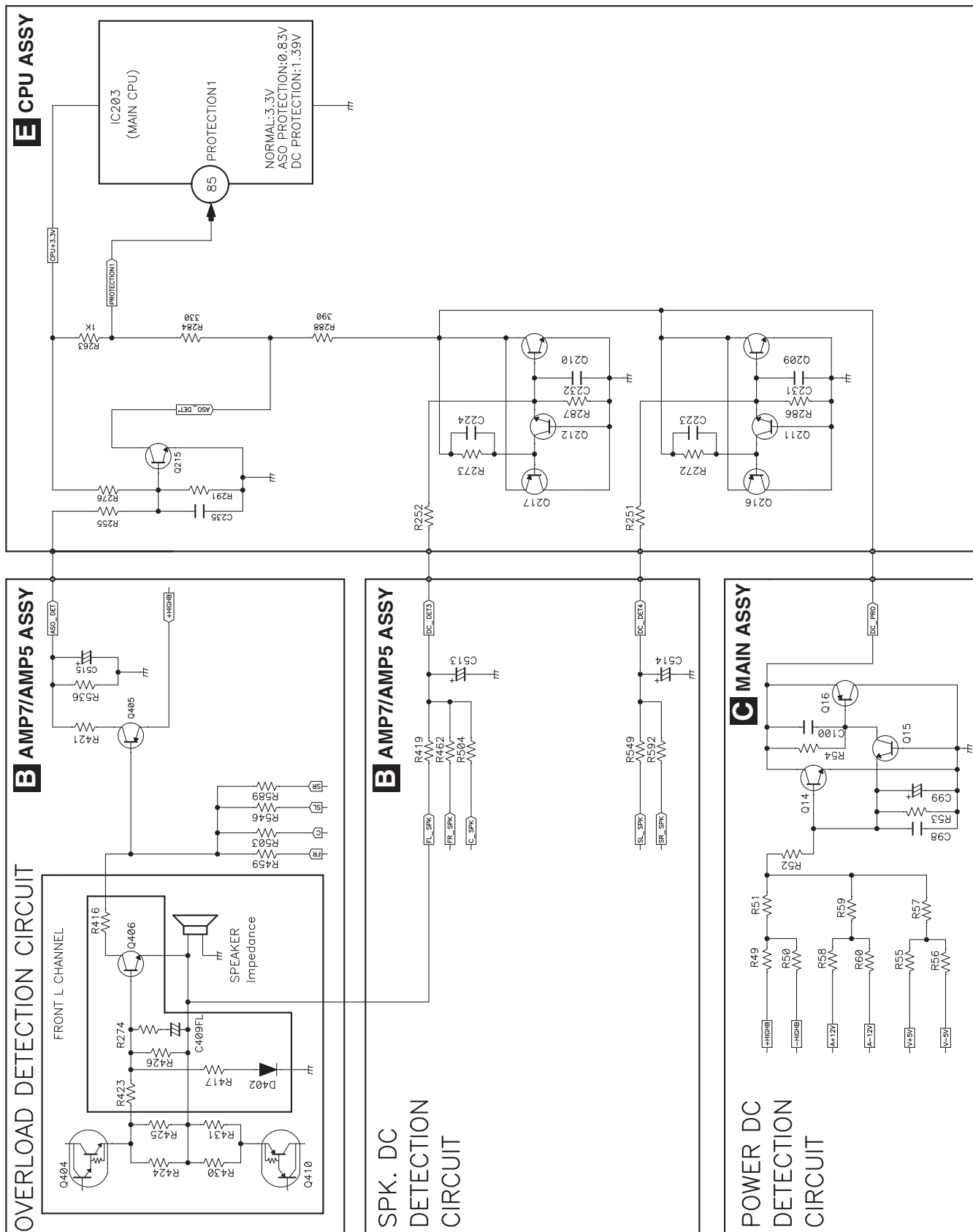

A [2] TEMP Protection Circuit

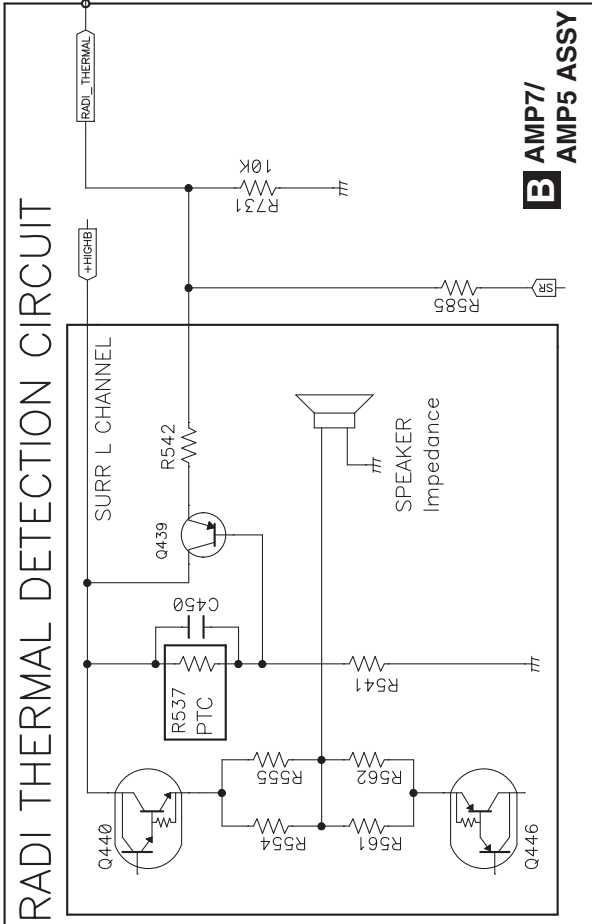
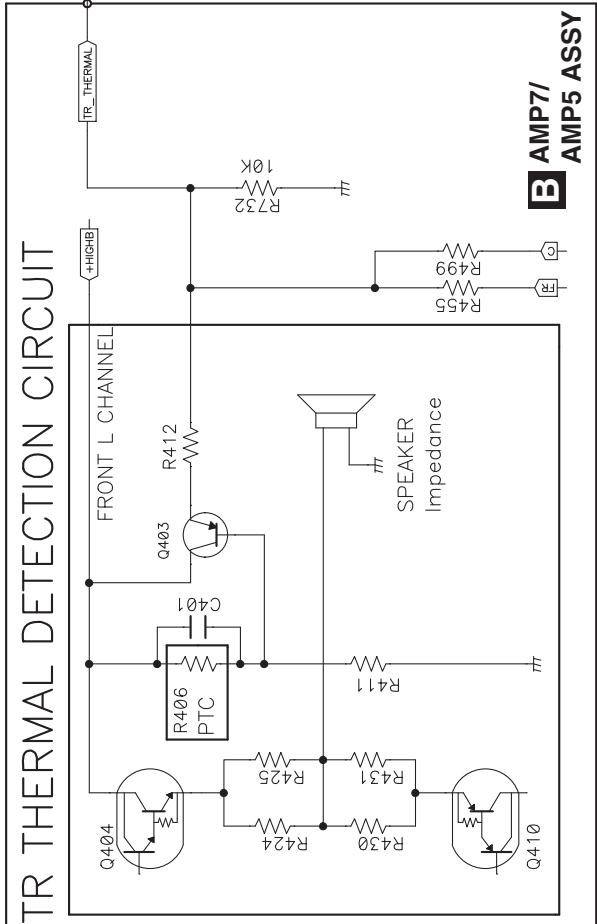
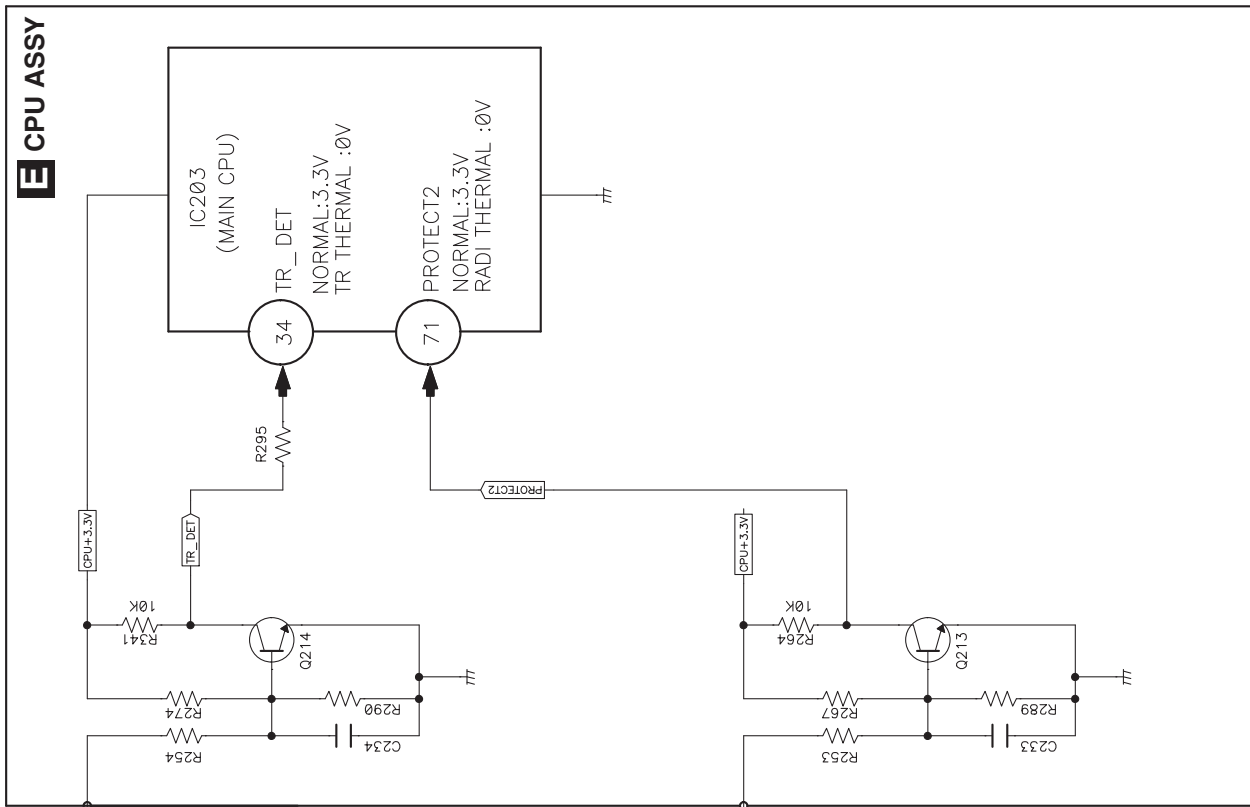

5.5 IC INFORMATION

■ (R5F3650KNFA)(CPU ASSY: IC203)

MAIN Microcomputer

• Pin Function

No.	Symbol	I/O	Description
1	P9_6/SOUT4	O	Not used
2	P9_5/CLK4	O	Not used
3	CNT_LED	O	Power LED control signal
4	Z2VOL_CLK	O	CLK signal output for BD3812F (I2C)
5	Z2VOL_DATA	O	Data signal output for BD3812F (I2C)
6	40-IR	I	Infra_red signal input
7	RMC	I	Remote control signal input pin
8	GNDU	I	The data bus is 16 bits long when the this pin is held "L" (GND)
9	CNVSS_UP	I	Switches processor mode
10	24C16_SDA	I/O	Data signal input & output for data backup of MAIN UCOM
11	24C16_SCL	O	Clock signal output for data backup of MAIN UCOM
12	/RESET	I	UCOM reset signal input pin (active at L)
13	XOUT	O	Output for 16 MHz Crystal
14	VSS	-	Ground
15	XIN	I	Input for 16 MHz Crystal
16	VCC1	-	+3.3 V power supply
17	/NMI	I	Input pin for the NMI interrupt
18	TUNER_INT	I	Tuner Interrupt signal input pin
19	PDN	I	Power down signal input pin
20	Z2_MUTE	O	Z2 ch. Audio output control pins at Mute Tr (active at L)
21	SB_MUTE	O	SB ch. Audio output control pins at Mute Tr (active at L)
22	A_MUTE	O	Audio output control pins at Mute Tr (active at L)
23	HP_DET	I	Monitoring the input pin headphone connection
24	HP_RLY	O	Headphone audio output control pins at Mute Tr (active at L)
25	SW_SUM	O	Output for Sub Woofer SUMMING Control(H:SUMMING)
26	CTL_B	O	IC control signal B output pin for selecting the video input
27	VIN_DET	I	Input for st_pwr condition
28	OSD/FLT_CLK	O	OSD & FL drive Ic output pin of the Data
29	CTL_A	O	ICcontrol signal A output pin for selecting the video input
30	MUTE_B+_CONT	O	Power control pin mute B+
31	BT_RX/U_TX	O	Data signal output from BLUETOOTH Antenna
32	BT_TX/U_RX	I	Data signal input from BLUETOOTH Antenna
33	BUSY_JTAG/TRIGGER1	O	Output for JTAG BUSY/TRIGGER1_ON/OFF SIGNAL
34	SCLK_JTAG/TR_DET'	I	CLOCK SIGNAL Input for SCLK_JTAG/TR_DET'
35	VOL_DATA	O	Data signal output for R2A15219 (I2C)
36	VOL_CLK	O	CLK signal output for R2A15219 (I2C)
37	STBY_RLY	O	Output to ST-BY Relay ON/OFF (active at H)
38	T12V_ERR	I	Input for dc_trg_err condition
39	OSD_RST	O	OSD IC Reset signal output pin
40	TUNER_SCLK	O	Clock signal output for Tuner Pack
41	EPM_UP	I	UPGRADE
42	TUNER_SDIO	I/O	Data signal input & output for Tuner Pack
43	TUNER_SEN	O	Output for Tuner Pack Serial Enable Input (active at L)
44	TUNER_RST	O	Output to reset Tuner Pack (active at L)
45	2533_CTL/CE	O	Output for NJM2533 control on/off signal
46	USBDCERR	O	Input for usb_dc_err condition
47	OSD_CE	O	OSD IC enable signal output pin
48	S_RLY	O	Tr driven control pins at the Surround speaker output Relay. (active at H)
49	SB_RLY	O	Tr driven control pins at the Surround Back speaker output Relay. (active at H)
50	FBRL	O	Tr driven control pins at the F.H /B speaker output Relay. (active at H)

A • Pin Function

No.	Symbol	I/O	Description
51	C_RLY	O	Tr driven control pins at the Center speaker output Relay.(active at H)
52	F_RLY	O	Tr driven control pins at the Front speaker output Relay. (active at H)
53	N_PWR	O	Control pin digital +3.3 V DC/DC IC (on: H)
54	D_PWR	O	Control pin digital +3.3 V DC/DC IC (on: H)
55	H_PWR2	O	Control pin digital +1.2 V DC/DC IC (on: H)
56	H_PWR1	O	Control pin HDMI IC +5.0 V REG. IC (on: H)
57	MIC_DET	O	Monitoring the input pin microphone connection (detection: L)
58	4588_PDN	O	Output for AK4588 power down
59	4588_SDA	O	Data signal output for AK4588 (I2C)
60	4588_SCL	O	Clock signal output for AK4588 (I2C)
61	DSP_SDA	O	Data signal output for DA787 (DA789) (I2C)
62	VCC2	-	+3.3 V power supply
63	DSP_SCL	O	Clock signal output for DA787 (DA789) (I2C)
64	VSS	-	Ground
65	DSP_RST	O	Output to reset DA787(DA788)
66	NC	-	Not used
67	DSP_SDOOUT	I	Data signal Input from DA787 (DA788)
68	DSP_CS	O	Output for DA787 (DA788) chip select
69	DSP_RDY	I	Input for DA787 (DA788) SPI Enable
70	HDMI_SEL	O	IC signal of the control pins at select HDMI or analog audio
71	PROTECT2	I	AMP Assy input signal of the RADIATOR THERMAL pin (L= PROTECTION)
72	MAIN_IRQ	O	Interrupt Output to SUB UCOM
73	SUB_ON	O	Output for SUB UCOM Power ON/OFF cotrol pin
74	SUB_IRQ	I	Interrupt Input from SUB UCOM
75	HD_MUTE	I	Input for HDMI_RX_MUTE condition
76	SUB_PDN	O	Output for SUB UCOM power down
77	SUB_RST	O	Output to reset SUB UCOM
78	SCDI_MAIN	I	Data signal input from SUB UCOM
79	SCDO_MAIN	O	Data signal output to SUB UCOM
80	CSCK_MAIN	O	Clock signal output for SUB UCOM
81	SET OPTION	I	Input for Set option
82	STEP OPTION	I	Input for Step (Group) option
83	VIDEO_MUTE	O	Output for NJM41050 mute cotrol pin
84	OSD/FLT_DATA	O	OSD & FL drive Ic output pin of the Data
85	PROTECT1	I	AMP Assy Protection detection signal input pin (ASO= 0.82 V, DC= 1.39 V)
86	VOL_DN	I	Data input for VOLUME encoder (VOLUME DOWN is counterclockwise direction)
87	VOL_UP	I	Data input for VOLUME encoder (VOLUME UP is clockwise direction)
88	IN_DN	I	Data input for INPUT selector encoder
89	NC	-	Not used
90	KEY1	I	Data input for Key1 scan
91	KEY3	I	Data input for Key3 scan
92	KEY2	I	Data input for Key2scan
93	IN_UP	I	Data input for INPUT selector encoder
94	FLT_CE	O	Output for chip enable of SC16315
95	NC	O	Not used
96	GND	-	Ground
97	NC	O	Not used
98	VREF	-	Reference voltage (Connected to +3.3 V)
99	AVCC	-	+3.3 V power supply
100	V+5V_DET	I	Output to ST-BY Relay ON/OFF (active at H)

■ (UPD78F1167AGF-GAS(D-MAIN ASSY: IC102)

SUB Microcomputer

• Pin Function

No.	Symbol	I/O	Description
1	VSCL	O	IIC clock signal output pin (SII9573CTUC-K)
2	VSDA	I/O	IIC data signal in/output pin (SII9573CTUC-K)
3	XHDPP_RST	O	Reset signal output pin for SII9573CTUC-K
4	XRST_NW	O	Reset signal output pin for DM-860A
5	P31/TI03/TO03/INTP4	–	Not used
6	P64/xRD	–	Not used
7	XABT_RST	O	Reset signal output pin for ABT1015
8	XADV_RST	O	Reset signal output pin for ADV7181CBSTZ
9	XAMUTE_SUB	O	Audio output control pins at Mute Tr (active at L)
10	P77/EX23/KR7/INTP11	–	Not used
11	XHDPP_MUTE	I	Input for HDMI_RX_MUTE condition
12	COMP_DET	I	Input for comp_video condition
13	HDPP_INT	I	Input for SII9573CTUC-K Interrupt Signal
14	P73/EX19/KR3	–	Not used
15	P72/EX18/KR2	–	Not used
16	P71/EX17/KR1	–	Not used
17	P70/EX16/KR0	–	Not used
18	P06/xWAIT	–	Not used
19	P05/CLKOUT	–	Not used
20	EVSS1	–	Ground
21	P80/EX0	–	Not used
22	P81/EX1	–	Not used
23	P82/EX2	–	Not used
24	P83/EX3	–	Not used
25	P84/EX4	–	Not used
26	P85/EX5	–	Not used
27	P86/EX6	–	Not used
28	CEC_O	O	Output for CEC OPERATION
29	CECI_INT	I	Input for CEC Interrupt Signal
30	EVDD1	–	Positive power supply for ports
31	P50/EX8	–	Not used
32	ABT_3V_ON	O	Output for ABT1015 Power ON/OFF control pin
33	XNWJPG_SEL	O	Output for TC74LCX541FK enable
34	DSD_SEL	O	Output for DSD audio signal selector ic control pin.
35	P54/EX12	–	Not used
36	CEC_PWR	O	Output for NJM2831 enable
37	P56/EX14	–	Not used
38	P57/EX15	–	Not used
39	P17/EX31/TI02/TO02	–	Not used
40	P16/EX30/TI01/TO01/INTP5	–	Not used
41	P15/EX29/RTCDIV/RTCCL	–	Not used
42	232RX	I	Input for Upgrade (UART)
43	232TX	O	Output for Upgrade (UART)
44	DI_NW	O	Data signal Output to DM860a
45	DO_NW	I	Data signal Input from DM860a
46	CLK_NW	O	Clock signal Output to DM860a
47	AVREF1	–	D/A converter reference voltage input
48	BSL_NW	O	Not used
49	CS_NW	O	Output for DM860a chip select
50	AVREF0	–	A/D converter reference voltage input

A • Pin Function

No.	Symbol	I/O	Description
51	AVSS	–	Ground
52	P157/ANI15	–	Not used
53	P156/ANI14	–	Not used
54	P155/ANI13	–	Not used
55	P154/ANI12	–	Not used
56	P153/ANI11	–	Not used
57	P152/ANI10	–	Not used
58	P151/ANI9	–	Not used
59	P150/ANI8	–	Not used
60	SUB_IRQ	O	Interrupt Output to MAIN microcomputer
61	P26/ANI6	–	Not used
62	P25/ANI5	–	Not used
63	P24/ANI4	–	Not used
64	P23/ANI3	–	Not used
65	P22/ANI2	–	Not used
66	P21/ANI1	–	Not used
67	P20/ANI0	–	Not used
68	P130	–	Not used
69	THRU_LED	O	HDMI LED on/off control pin
70	CCLK_MAIN	I	Clock signal Input from MAIN microcomputer
71	SCDO_MAIN	I	Data signal Input from MAIN microcomputer
72	SCDI_MAIN	O	Data signal Output to MAIN microcomputer
73	P01/TO00	–	Not used
74	P00/TI00	–	Not used
75	P145/TI07/TO07	–	Not used
76	P144/SO20/TxD2	–	Not used
77	P143/SI20/RxD2/SDA2	–	Not used
78	P142/SCK20/SCL2	–	Not used
79	P141/PCLBUZ1/INTP7	–	Not used
80	P140/PCLBUZ0/INTP6	–	Not used
81	MAIN_IRQ	I	Interrupt Input from MAIN microcomputer
82	REQ_NW	I	Interrupt Input from dm860a
83	SUB_PDN	I	Input power down from MAIN microcomputer
84	P45/SO01	–	Not used
85	P44/SI01	–	Not used
86	P43/SCK01	–	Not used
87	P42/TI04/TO04	–	Not used
88	TOOL1	O	Clock output for debugger
89	TOOL0	I/O	Data I/O for flash memory programmer/debugger
90	XSUB_RST	I	System reset input
91	P124/XT2	–	CRYSTAL connection for sub system clock
92	P123/XT1	–	CRYSTAL connection for sub system clock
93	FLMD0	–	Flash memory programming mode setting
94	P122/X2/EXCLK	–	CRYSTAL connection for main system clock
95	P121/X1	–	CRYSTAL connection for main system clock
96	REGC	–	Connecting regulator output (2.5 V) stabilization capacitance for internal operation.
97	VSS	–	Ground
98	EVSS0	–	Ground potential for ports
99	VDD	–	Positive power supply (Connected to +3.3 V)
100	EVDD0	–	Positive power supply for ports (Connected to +3.3 V)

5

6

7

8

6. SERVICE MODE

6.1 SERVICE MODE

[1] Display mode for numbers of protection detections

[Purpose]





The numbers of detections for various protection processes are displayed.

[How to enter/exit]

During Standby mode, simultaneously press and hold the [PRESET ←] and [STANDBY/ON] keys for 2 seconds to enter this mode.

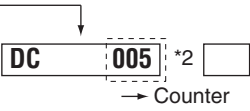
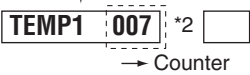
The display will return to the normal indication when no key operation is performed for 5 seconds.

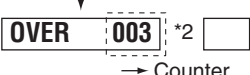
[Basic operations]

Key Operation	FL Display	Time (sec.)	Description of Indications
(STANDBY state)			
[PRESET ←] + [STANDBY/ON] keys (Initial display)		5 (-> normal) *1	Number of DC error detections
[ENTER] key		5 (-> normal) *1	Number of abnormal-temperature error detections
[ENTER] key		5 (-> normal) *1	
[ENTER] key		5 (-> normal) *1	Number of abnormal-temperature error detections
[ENTER] key		5 (-> normal) *1	Number of OVERLOAD error detections
(Initial display)			

*1 "5 (-> normal)" denotes that the display will return to the normal indication when no key operation is performed for 5 seconds.

*2 Variable range: 0 to 255

The above-mentioned Display mode is available only when the product operates properly.

If any protection function is activated while the product is in use, the product cannot be turned ON and enter the above Display mode. In such a case, cancel the protection function, referring to "3.4 How to cancel the status after detection of the DC error." If a protection function is activated immediately after the previous protection function is canceled, cancel that protection function again then enter STBY mode immediately. You can then see the error logs, following the above procedures, until a next protection function is activated.

VSX-1022-K

5

6

7

8

51

A [2] Reset mode for numbers of protection detections

[Purpose]

For clearing all the counts of protection detections.
(This mode resets the counts of protection detections.)

[How to enter/exit]

During Standby mode, simultaneously press and hold the [ALC/STANDARD SURR] and [STANDBY/ON] keys for 10 seconds to enter this mode.
The display will return to the normal indication when no key operation is performed for 5 seconds.

[Basic operations]

Key Operation	FL Display	Time (sec.)	Description of Indications
(STANDBY state)	<input type="text"/>		
[ALC/STANDARD SURR] + [STANDBY/ON] keys (press and hold the keys for 10 seconds.)	<input type="text" value="CLEAR?"/>	5 (-> normal) *1	
[ENTER] key ↓	↓		
(Counter Clear end)	<input type="text" value="0 K"/>	5 (-> normal) *1	
(Normal display)	<input type="text" value="BD"/> *2	usually	

*1 "5 (-> normal)" denotes that the display will return to the normal indication when no key operation is performed for 5 seconds.

*2 Indication when the BD function is selected

[Detailed explanations]

- When the procedures for Reset mode for numbers of protection detections are completed, all the counters will be reset to "000."
- Prohibitions:
The protection detection counts cannot be cleared (reset to 000) with the MEMORY CLEAR process.
They can only be cleared when the procedures of Reset mode are completed.

[3] The unit's operation when a error is detected

[Purpose]

- The unit's operation when a DC/OVER/TEMP error is detected is described here.
- How to cancel the status after detection of a DC error is described here, because no key input will be accepted after a DC error detection.

[Basic operations]

3.1 DC (AMP is abnormality) error detection

Key Operation	FL Display	Time (sec.)	Description of Indications
(Normal display)	BD <input type="checkbox"/>	usually	Normal display
(DC detection)	BD <input type="checkbox"/>		
↓ (Auto) (RECEIVER POWER OFF) *1, *2	<input type="checkbox"/>		

3.2 OVERLOAD (overcurrent) error detection

Key Operation	FL Display	Time (sec.)	Description of Indications
(Normal display)	BD <input type="checkbox"/>	usually	Normal display
(OVERLOAD detection)	BD <input type="checkbox"/>		
↓ (Auto) (RECEIVER POWER OFF) *1	<input type="checkbox"/>		

3.3 TEMP (AMP overheat) error detection

For detection of a TEMP error, the unit monitors both the TR_DET and PROTECT2 signals. If a TEMP error is detected, the processes shown below will be performed. The processes shown below are rough operational specifications and are not the actual commands from the mounted components.

After a TEMP error is detected, the count of protection activation detections will be updated.

Counter: Temp2 TR_DET
P6_4 (34 pin)
(TRTHER_DET from AMP Assy)

Counter: Temp1 PROTECT2
PL2_1 (71 pin)
(RADI_DET from AMP Assy)

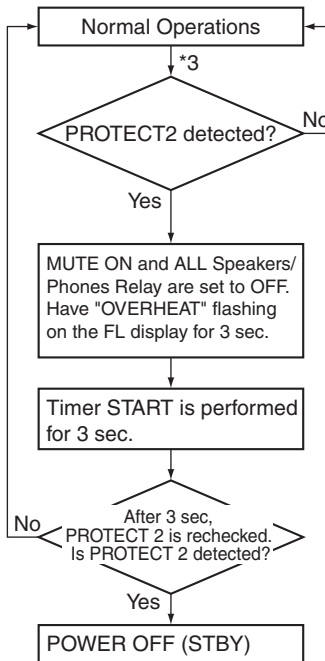
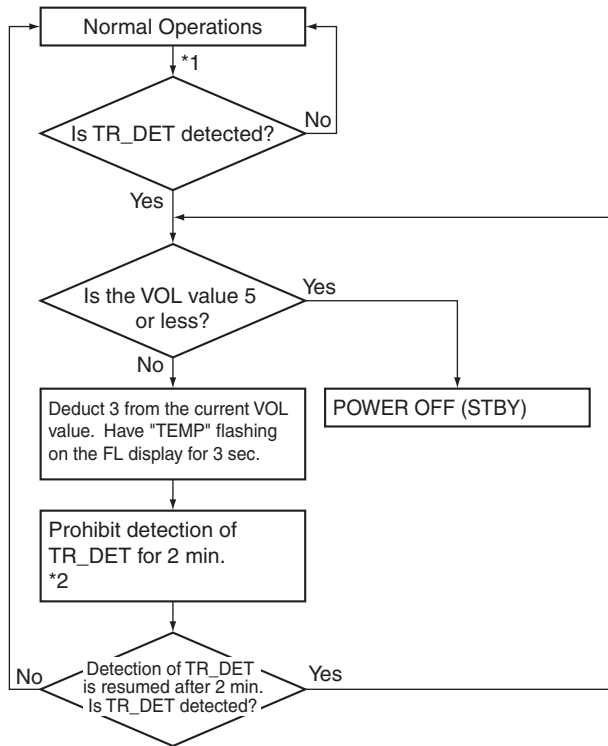

*1: The detection interval must be 1 sec or less.

*2: If PROTECT 2 is detected while TR_DET detection is prohibited for 2 min, the PROTECT 2 function will be activated.

*3: The detection interval must be 1 sec or less.

3.4 How to cancel the status after detection of the DC error

Key Operation	FL Display	Time (sec.)	Description of Indications
(STANDBY state) [ADVANCED SURROUND] + [STANDBY/ON] keys (press and hold the keys for 2 seconds.) ↓ (Normal display)		usually	Normal display

[Detailed explanations] Simultaneously holding the [ADVANCED SURROUND] and [STANDBY/ON] keys on the front panel pressed for 2 seconds will cancel Key Input Inhibition mode after a DC error detection and turn the unit ON.

7. DISASSEMBLY

Note:

- (1) Even if the unit shown in the photos and illustrations in this manual may differ from your product, the procedures described here are common.
- (2) For performing the diagnosis shown below, the following jigs for service is required:
 - 9P extension jig cable (GGD1739)
 - 13P extension jig cable (GGD1740)
 - 3P extension jig cable (GGD1741)
 - Board to board extension jig cable (GGD1756)
 - Board to board extension jig cable (GGD1770)
 - Board to board extension jig cable (GGD1800)
 - 25P extension jig FFC (GGD1801)

1. Discharging

[1] MAIN Assy Capacitor (C55, C58)

[Procedures]

- (1) Unplug the power cord.
- (2) Disconnect the 10P connector from CP403 of the AMP7/AMP5 Assy between CN3 of the MAIN Assy.
- (3) Connect +B and -B terminal of the D7, using resistor leads with 47 - 100 ohms (2 W or higher), for discharging.
 - * Discharging time: 30 - 60 seconds, depending on the level of resistance.
- (4) Check that the voltage between the +B and -B terminals is less than 1 V, using a tester.
 - * Be sure to connect the GND terminal of the tester to the chassis.
 - * If the voltage is still 1 V or higher, repeat Step (3).



AMP7/AMP5 Assy

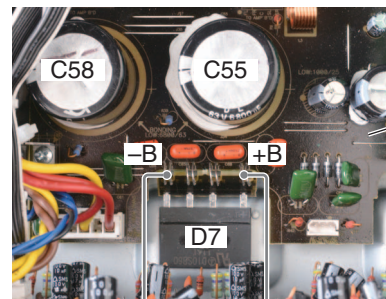

MAIN Assy

47 - 100 ohms
(2 W or higher)

[2] FL-30 V Capacitor (MAIN Assy C101)

[Procedures]

- (1) Unplug the power cord.
- (2) Connect pin 1 (-30V) and pin 2 (GND) of CN704B on the CPU Assy, using resistor leads with 47-100 ohms (2 W or higher), for discharging.
 - * Discharging time: 5 - 10 seconds, depending on the level of resistance.
- (3) Check that the voltage between the -30V terminal is less than 1 V, using a tester.
 - * Be sure to connect the GND terminal of the tester to the chassis.
 - * If the voltage is still 1 V or higher, repeat Step (2).

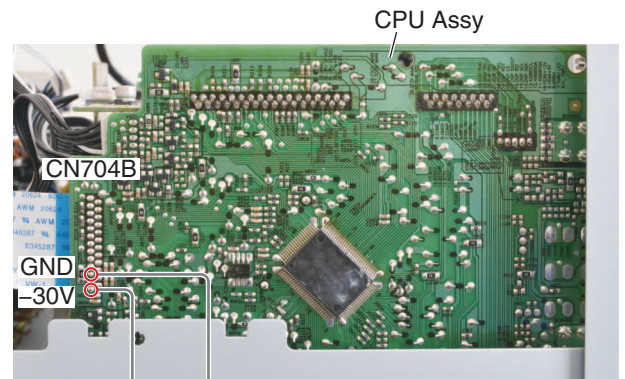

CPU Assy

47 - 100 ohms
(2 W or higher)

2. Notes on Ground Points Connection

[Note]

During repair, before checking the MAIN Assy, etc., with the rear chassis removed, be sure to connect the GND terminal of the main capacitor to the back chassis (speaker chassis), as shown below, then connect the power cord.

**Without grounding connection, the protection circuit will be activated.
After repairing, be sure to remove the ground wire before reassembling.**

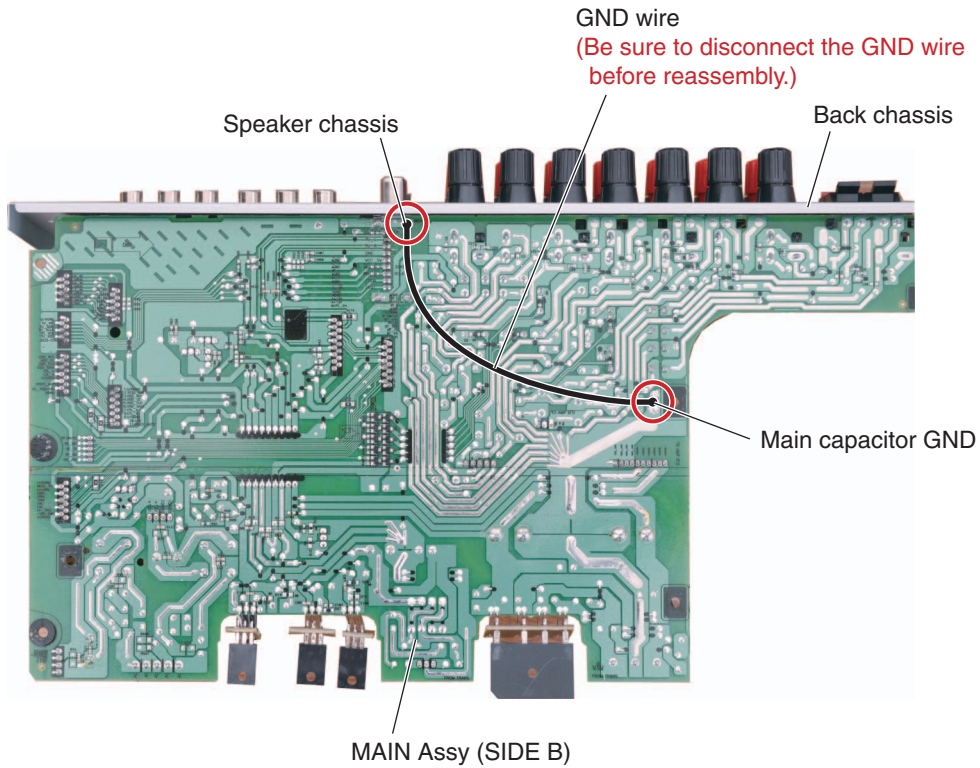

3. Disassembly

[1] Front Panel Section

Remove the cabinet by removing the 10 screws.

(1) Remove the five screws. (BBZ30P080FTB)

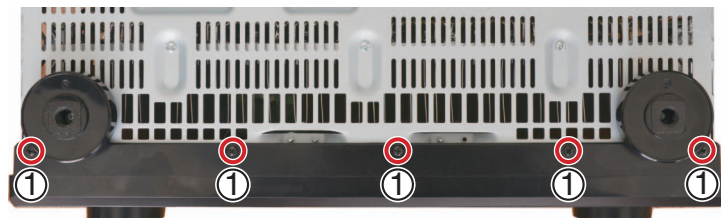

• Bottom view

(2) Remove the two screws.

(BBZ30P080FTC)

(3) Remove the three screws.

(1500001206010-IL)

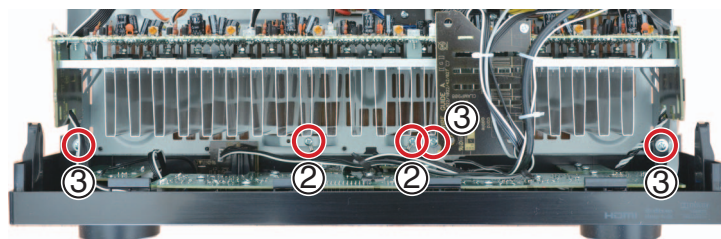

(4) Remove the tape.

(5) Unhook the two hooks.

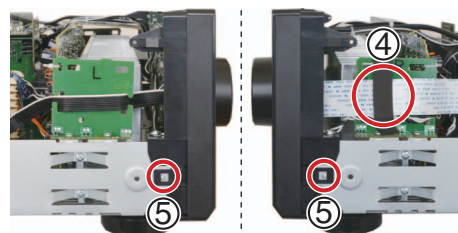

(6) Arrange the front panel section as shown in the photo below.

Front panel section

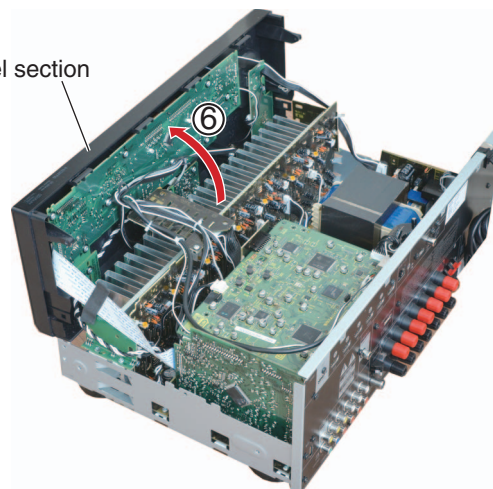

A [2] Heatsink Section

Caution: Heatsink section in work becomes hot, and be careful with it.

Remove the cabinet by removing the 10 screws.

(1) Remove the three screws. (BBZ30P080FTC)

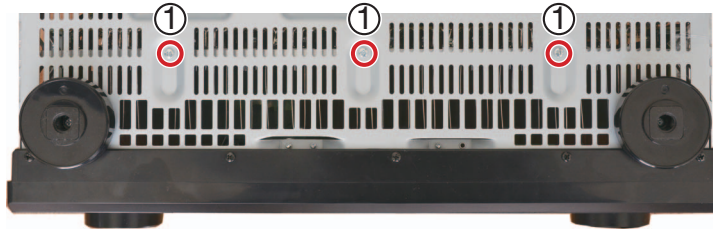

• Bottom view



(2) Remove the four screws. (BBZ30P080FTC)

(3) Cut the two binders.

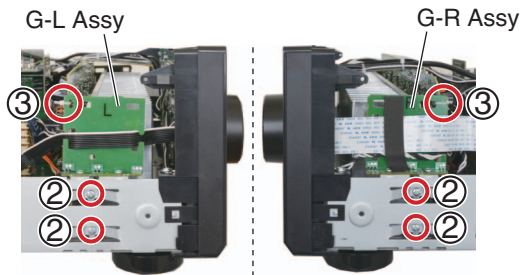

(4) Remove the one screw. (BBZ30P080FTC)

(5) Remove the WG-A Assy.

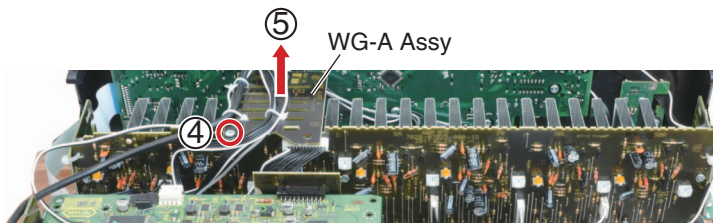

- (6) Cut the two binders.
- (7) Disconnect the five connectors.
(VSX-1022-K, VSX-42: CP401 to CP405)
Disconnect the four connectors.
(VSX-822-K: CP401 to CP404)
- (8) Remove the Heatsink section.

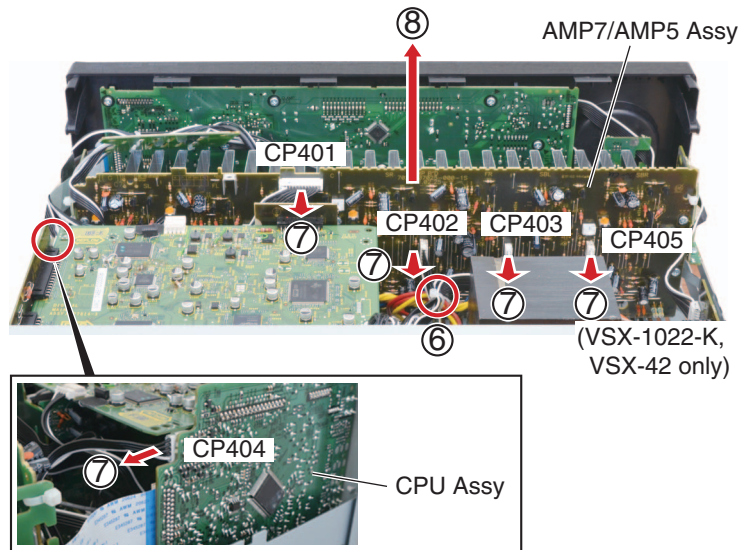

- (9) As shown, arrange the Heatsink section over the WG-A Assy.
- (10) Re-connect the three connectors.
(VSX-1022-K, VSX-42)
- (11) Connect the two extension jig cables.
(VSX-1022-K, VSX-42)
Connect the one extension jig cable.
(VSX-822-K)

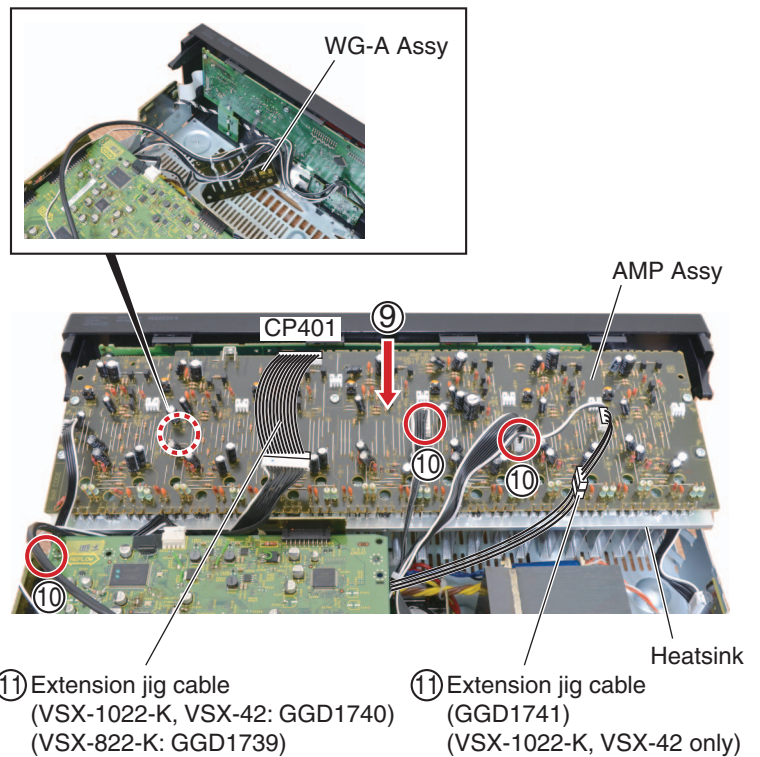

Note:
AMP5 Assy: GGD1739
AMP7 Assy: GGD1740 + GGD1741

A [3] D-MAIN Assy

Remove the cabinet by removing the 10 screws.

- (1) Remove the five screws. (BBT30P100FTB)
- (2) Remove the seven screws. (BSZ30P040FTB)

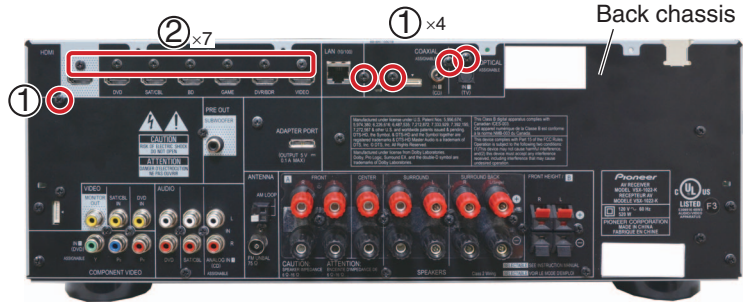

• Rear view

- (3) Disconnect the three B to B connectors. (CN101, CN102, CN1401)
- (4) Remove the D-MAIN and OPTCO Assemblies.

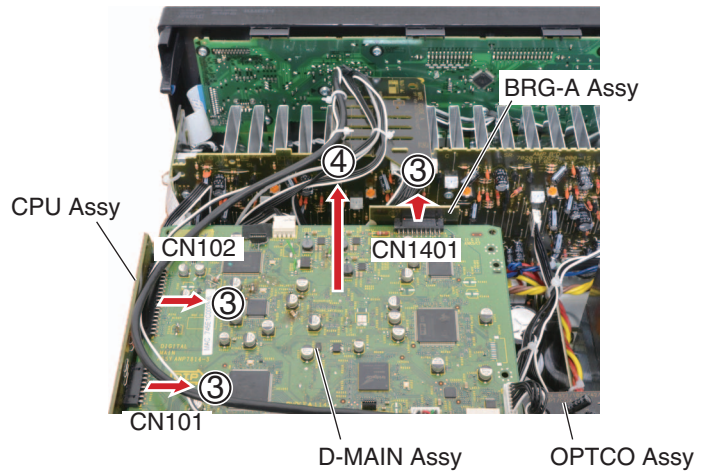

- (6) Connect the three extension jig cables.
- (7) Arrange the D-MAIN and OPTCO Assemblies in the photo below.
- (8) Insert any insulation sheet.

Note:
9 pin connector on GGD1756 is not used in this case.

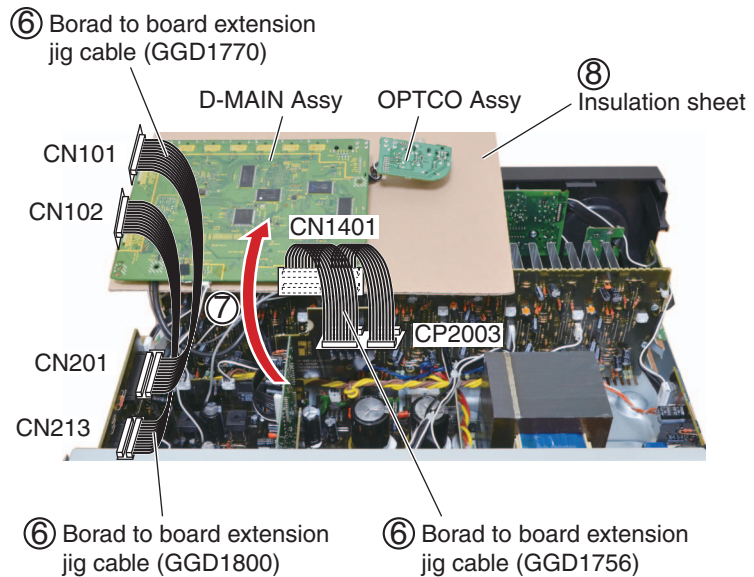

[4] MAIN Assy

Remove the cabinet by removing the 10 screws.

[4-1] Back chassis, D-MAIN Assy

- (1) Remove the 15 screws. (BBT30P100FTB)
- (2) Remove the seven screws. (BSZ30P040FTB)
- (3) Remove the D-MAIN Assy.
(See procedure [3].)

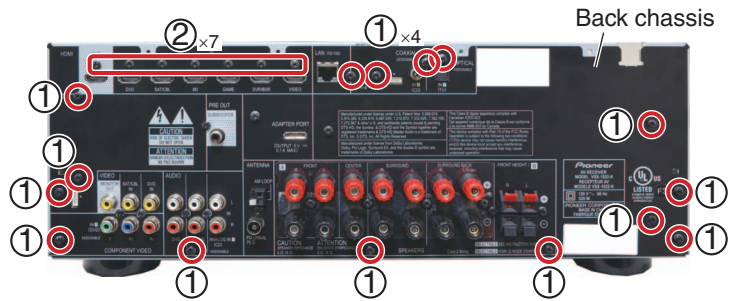

[4-2] MAIN Assy

- (1) Remove the four screws. (BBZ30P180FTC)
- (2) Remove the two screws. (BBZ30P080FTC)
- (3) Cut the four binders.

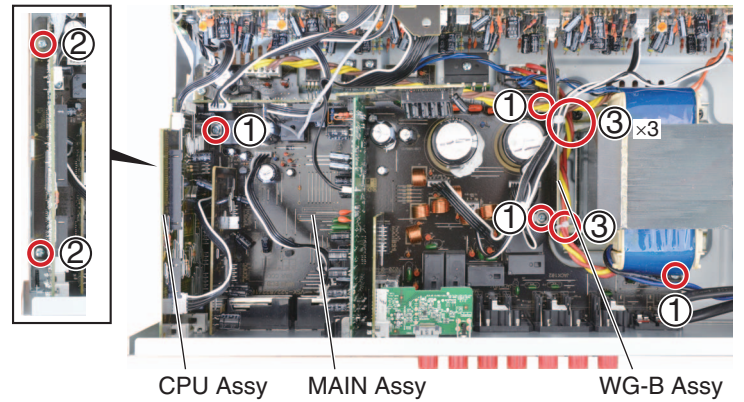

- (4) Remove the four screws. (BBZ30P080FTC)

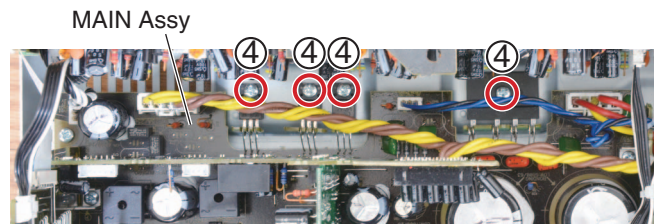

- (5) Arrange the unit as shown in the photo below.
- (6) Connect the chassis ground.
See "2. Notes on Ground Points Connection".

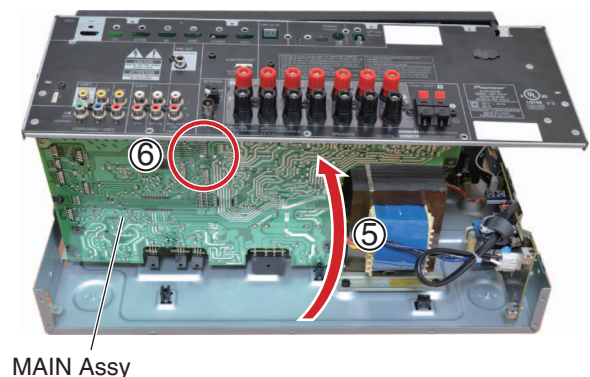

A [4-3] Regulator ICs and Rectifier diode

- (1) Remove the support.
- (2) Tighten then loosen the screw in each of the four holes for temporary joining that are located on the rear side of the main chassis. (This is for shaving the thread grooves to facilitate attachment in the next step.)

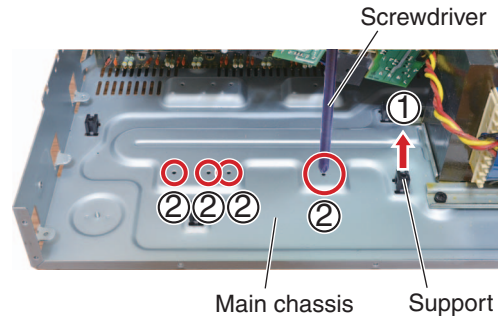

B



C

- (3) Attach the three regulator ICs and a rectifier diode to the holes tapped in Step (2). Be sure to place them in a direction perpendicular to the board and take care that the jumper wires will not become distorted.

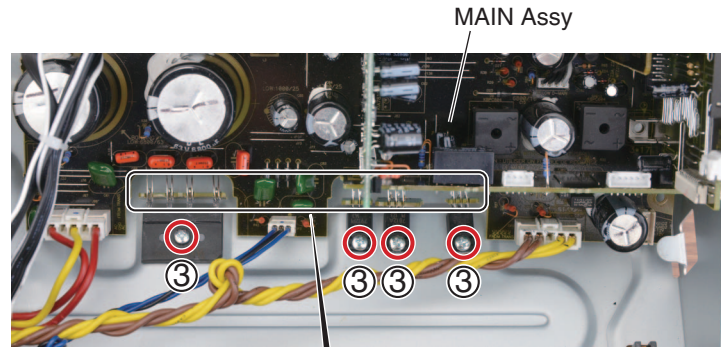

D

Note:
While securing the regulator ICs and rectifier diode to the holes for temporary joining, tighten the screws while holding the regulator ICs and rectifier diode with your fingers so that the jumper wires will not become distorted.

E



F

[4-4] Diagnosis

- (1) Connect the CP401 on the AMP Assy with extension jig cable. (See procedure [2].)
- (2) Reassemble the D-MAIN Assy to the rear panel or put it on the AMP Assy with extension jig cables. (See procedure [3].)
- (3) Connect the extension jig FFC.
- (4) Insert any insulation sheet between AMP Assy and MAIN Assy.

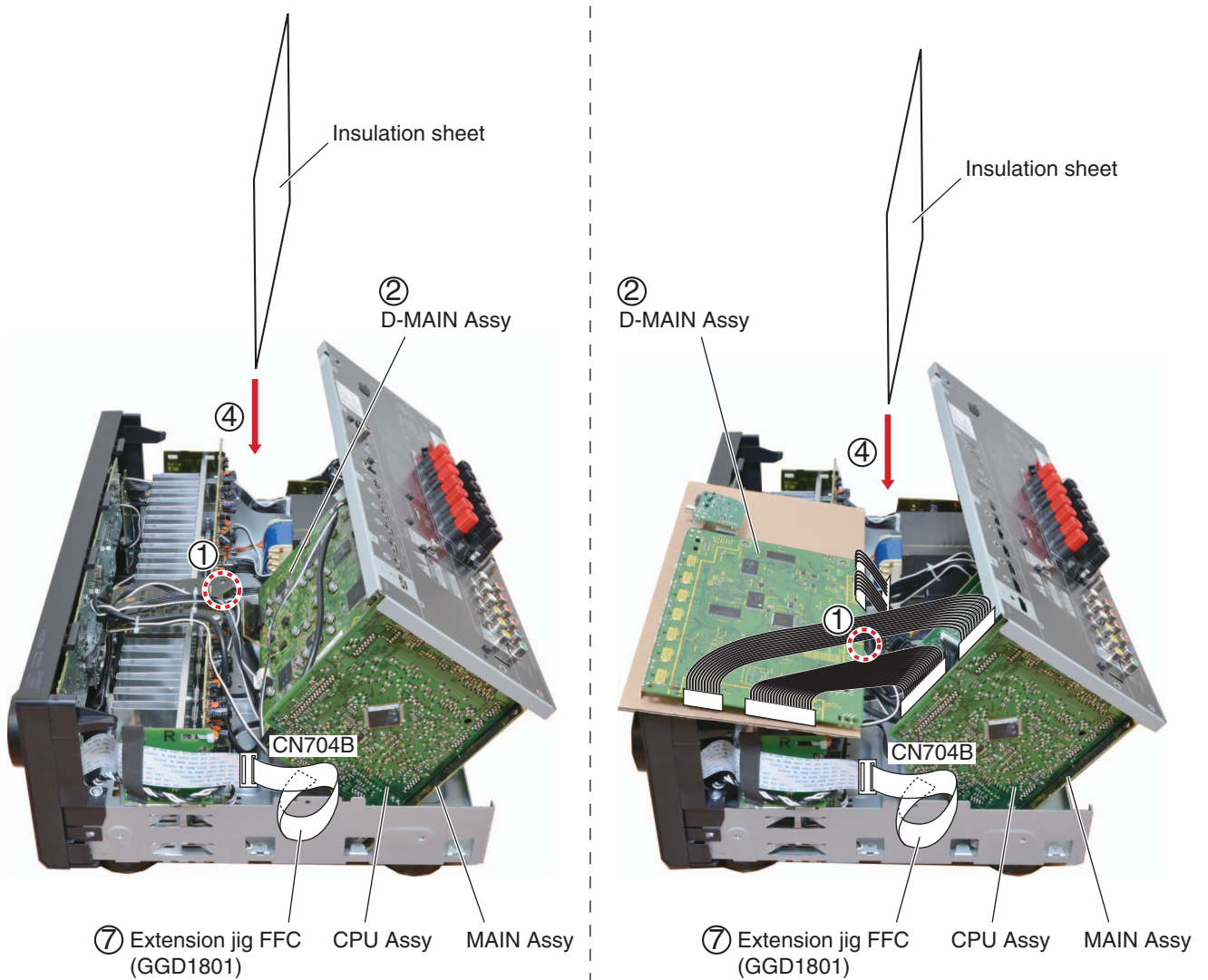

8. EACH SETTING AND ADJUSTMENT



A

- If the adjustment is shifted or if it becomes necessary to readjust because of part replacement, etc., perform the adjustment as described below.
- Any value changed in Adjustment mode will be stored in memory as soon as it is changed. Before readjustment, take note of the original values for reference in case you need to restore the original settings.
- Use a stable AC power supply.

B

8.1 ADJUSTMENT REQUIRED WHEN THE UNIT IS REPAIRED OR REPLACED

■ When any of the following assemblies is replaced

C

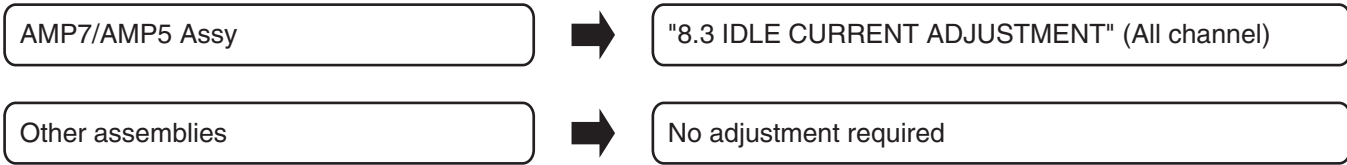

■ When any of the following parts is replaced

D

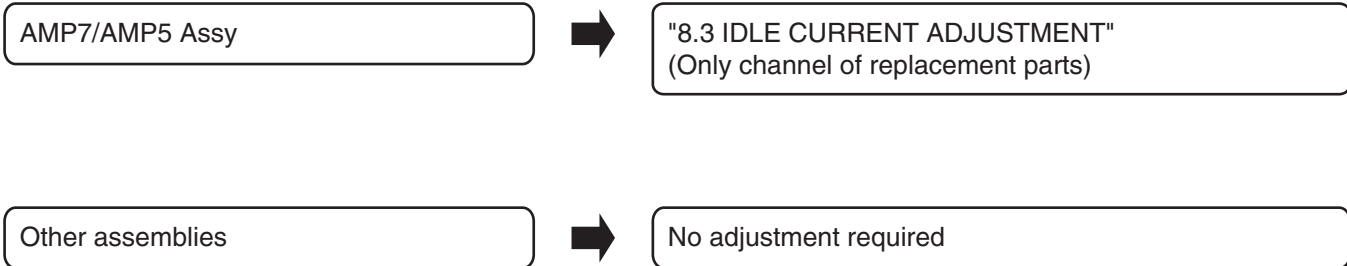

Note:

Some parts on D-MAIN and F-USB Assemblies can not be replaced due to using heat-pad connection between the board. Please refer to [1.2 NOTES ON REPLACING PARTS], when the parts listed in the table is defective, replace whole Assy.

E

F

8.2 UPDATING OF THE FIRMWARE

[Purpose]

Refer to this section when updating the firmware of each microcomputer is required by the service information, etc.

[Necessary Tools and Connections]

- PC with a serial port
- RS-232C cable (9-pin to 9-pin, straight cable) (Marketing product)
- UPDATE jig: GGF1642 (Use FFC of GGF1642. (10P to 10P FFC))
- Firmware

Connect as shown in the figure below.

Insert the FFC with its contact surface facing the Δ mark.

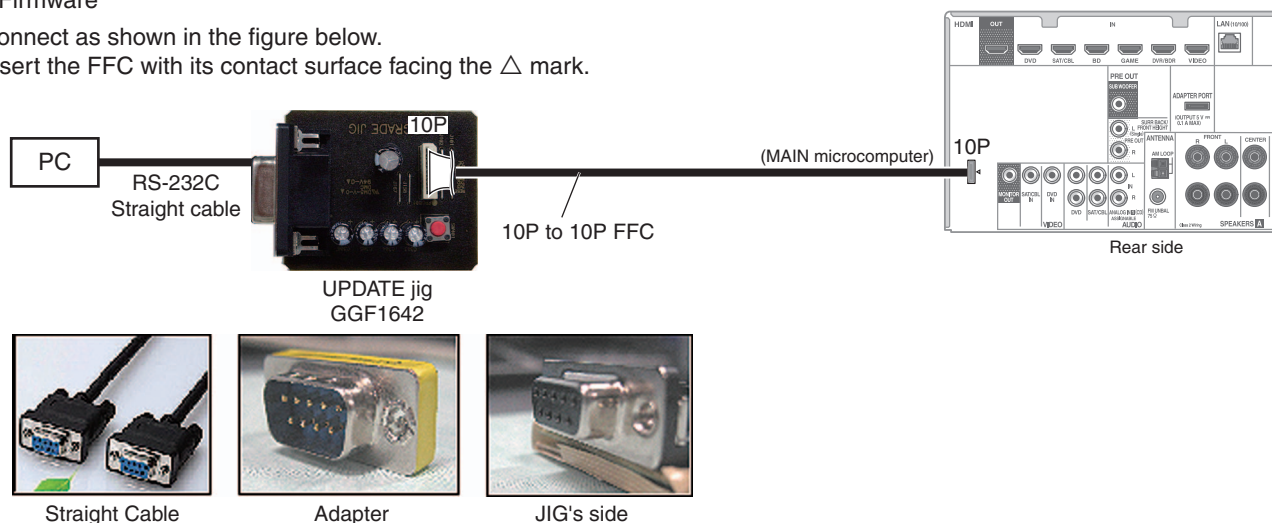

(1) MAIN microcomputer firmware update

[Preestablishment]

- NetworkStandby: OFF
- HDMI Control: OFF
- HDMI StandbyThrough: OFF (North America model only)

[Procedures]

1. Unplug the AC cord.

Connect the FFC cable. (MAIN microcomputer)
Start up application FlashSta on the PC.

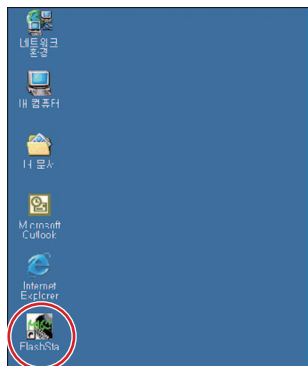

2. Plug the AC cord. (STANDBY mode)

For updating of the MAIN microcomputer, proceed with the following steps in STANDBY mode.

3. Press the OK button.

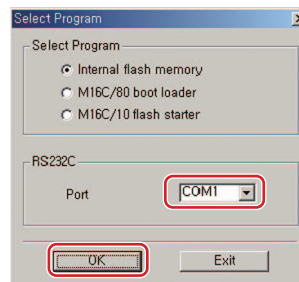

Select for COM port.

[if the following messages are displayed]



Please push the cancel button and press the JIG's RESET button.

And confirm a connection of FFC.

Please return to procedure 1.

4. Select the update file and enter ID.

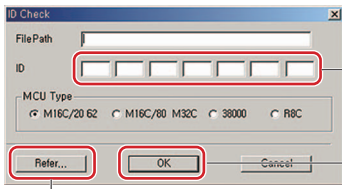

② Enter ID.
Enter "ff" in all field.
③ Press OK button to go to next step.

① Selection of upgrade file

① Select the update file

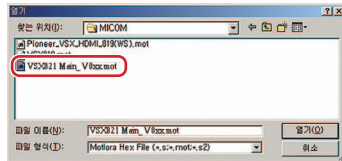

Select "VSX_1022Mid_Main Ver***.mot" or "VSX42_Main_Ver0.60.mot" "VSX_822Mid_Main Ver***.mot" file to update the MCU.



Press the OK button.

② Enter ID.

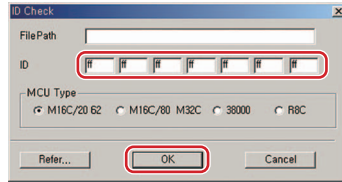

Press the OK button.

6. Update Finished MAIN microcomputer.



Press the OK button.

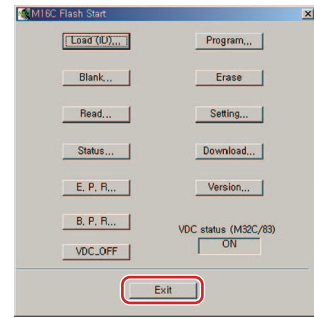

Press the Exit button. Please wait for until this window disappears.

If the following messages are displayed, shut the update program down, and start the update again from step 1.



Push the JIG's RESET button during 1 sec. Press the OK button.

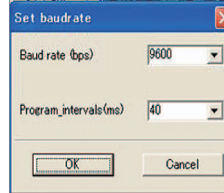

Select the 9600 of the Board rate then press the OK button

5. Set speed update and update the MCU.

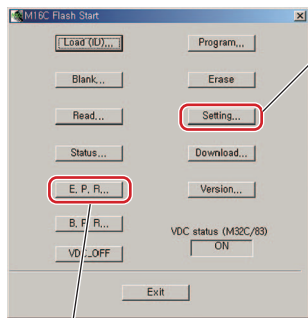

① Set speed of update.

① Set speed of update. Set Baud rate to 38400.

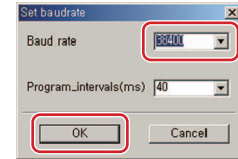

Press the OK button.

② Update the MCU. E.P.R=>Erase+Program+Read

② Update the MCU Press the E.P.R ... button

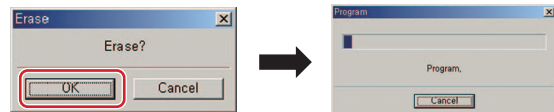

Press OK button.

7. Unplug the AC cord. Disconnect the FFC cable.

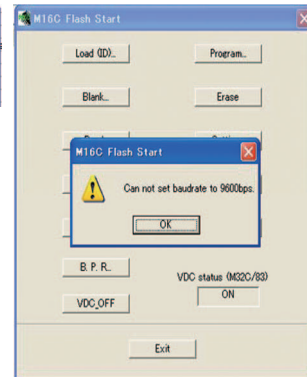

(2) SUB microcomputer firmware update

[Preparations]

Save the firmware file to the "root" of empty USB memory.

The file name of the firmware file is "RegM13Sub_V***.bcd". Don't save other files.

- NetworkStandby: OFF
- HDMI Control: OFF
- HDMI StandbyThrough: OFF (North America model only)
- Connect a unit to TV and HDMI, and the GUI output of the unit performs in a state to appear.

[Procedures]

1. Turn on the unit.
2. Set a function for a "NETRADIO".

Note:

Without a network connection, "Server Error" will be displayed on the TV screen. Under this condition, the Service Menu (menu for updating the SUB microcomputer) is not accessible. Set the remote control unit supplied with the unit to Network Function Operation mode then press the ENTER button so that "Empty" is displayed on the screen. Then proceed to Step 3.

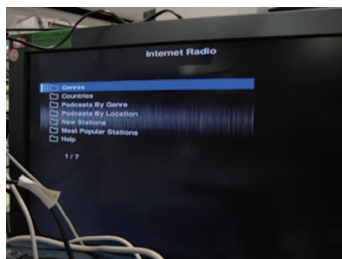

3. Press the "ESC (A85F)" button on the Service remote control unit (GGF1381), then press the "+10 (A81F)" button to enter the service menu (for SUB microcomputer firmware update menu).

When you press other buttons between "ESC" button and "+10" buttons, be invalid.

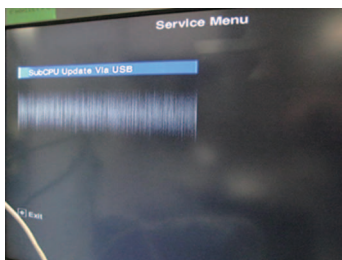

4. Press the "ENTER" button of the remote control unit supplied with Network Function as the state that you can operate.

- (1) When a product can recognize a file, become the following indication.

Select "Start", and press the "ENTER" button.

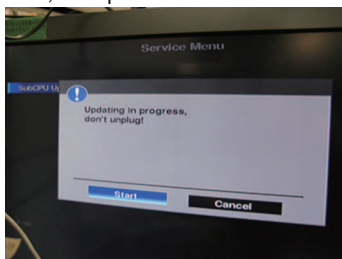

- (2) When a product cannot recognize a file, become the following indication. Check on USB memory with a file.

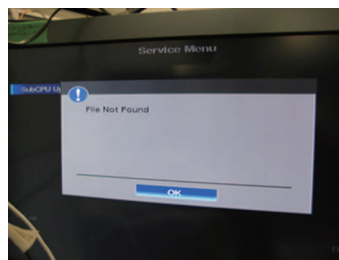

5. Update starts, and "UPDATE" blinks to FL screen and HDMI LED blinks. Be approximately 8 minutes for update at time.

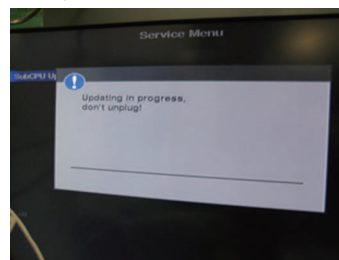

6. When update is completed, "Completed" is displayed by TV screen and HDMI LED lights.

* "UPDATE" blinks to FL display and is displayed. In rare cases, "Completed!" may not be displayed on the TV screen. In such a case, updating is completed if the HDMI LED has become lit. Proceed to Step 7.

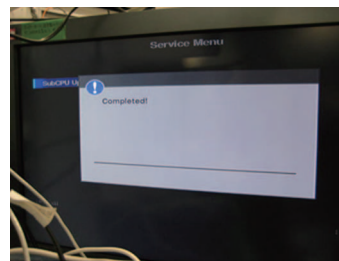

7. Disconnect the AC power cord. (The POWER button does not respond.) Confirm a version of the firm ware of SUB microcomputer.

Note:

Because update is not possible again, never unplug the power cord until the updating process is completed.

A (3) USB (BridgeCo) firmware update

[Procedures]

1. Select 'Firmware Update' from the Network Setup menu. The receiver checks whether the USB memory device inserted into the USB port on the receiver's front panel contains updatable software.
2. To update, select 'Start'.
3. When 'Updating in progress, don't unplug!' is displayed, select 'OK'.
 - If 'File Not Found' is displayed, try the following:
 - No update file was found on the USB memory device. Store the file in the USB memory device's root directory.
 - Try disconnecting then reconnecting the USB device or storing the update file again. If the error still occurs, try using a different USB memory device.
4. The software update will start. Please wait. The OSD display will turn off during update and the words 'UPDATE' will flash on the front panel.
5. If 'COMPLETE' is displayed, updating is completed. The screen will return automatically to the play screen.
 - If 'FAIL' is displayed on the front panel display, updating has failed. Try the following:
 - Turn the receiver's power off, then turn it back on and try updating the software again.
 - Try disconnecting then reconnecting the USB device or storing the update file again. If the error still occurs, try using a different USB memory device.

B (4) DSP firmware update

[Preestablishment]

- NetworkStandby: OFF
- HDMI Control: OFF
- HDMI StandbyThrough: OFF (North America model only)

[Procedures]

1. Select an Input Function that allows reception via Optical input 1 then set the unit to STBY_Off mode.
2. Press the SPEAKERS and STANDBY/ON keys simultaneously to enter DSP UpDate mode. ("DSP UP" is displayed.)
3. When "PLAY" is displayed, playback of the .wav file starts. (Play the file only once. NEVER repeat playback.) ("PLAY" is displayed.)
4. After playback is finished and "ENTER" is displayed, press the ENTER key on the front panel. ("ENTER" is displayed.)
5. "WRITING" is automatically displayed.
6. After writing is completed, "COMPLETE" is displayed.
7. Turn the unit off then confirm that the version has been updated.

C (5) Check to the firmware version

[Preestablishment]

- NetworkStandby: OFF
- HDMI Control: OFF
- HDMI StandbyThrough: OFF (North America model only)

[Procedures]

Make sure that the main unit is in STANDBY mode.

Press and hold the "ENTER" and "STANDBY/ON" keys, then press the "ENTER" key to display each UCOM version.

Each time the "ENTER" key is pressed, then indications on the FL display change as follows:

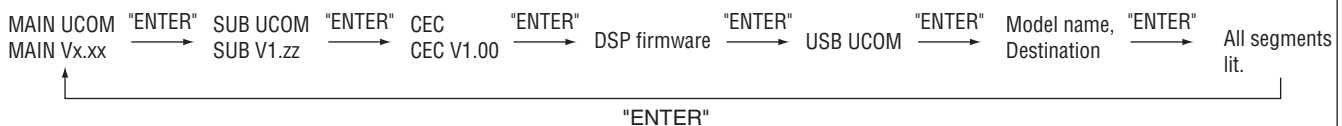

- * It may take around 1 minute until the version of the USB microcomputer is displayed. When be not displayed, wait in the state that turned on the power of the product for 1 minute, and please do it from the first procedure again.

Turn the unit off.

8.3 IDLE CURRENT ADJUSTMENT



for VSX-1022-K, VSX-42

When any component parts which are within the red square on the following circuit diagram are replaced, the idle current adjustment of that channel is required. (Idle current adjustment for another channel is not required.) However, when any capacitors are replaced, the adjustment is not required.

(The following circuit diagram is for SL channel, but another channel also has same circuit diagram and same adjustment is required)

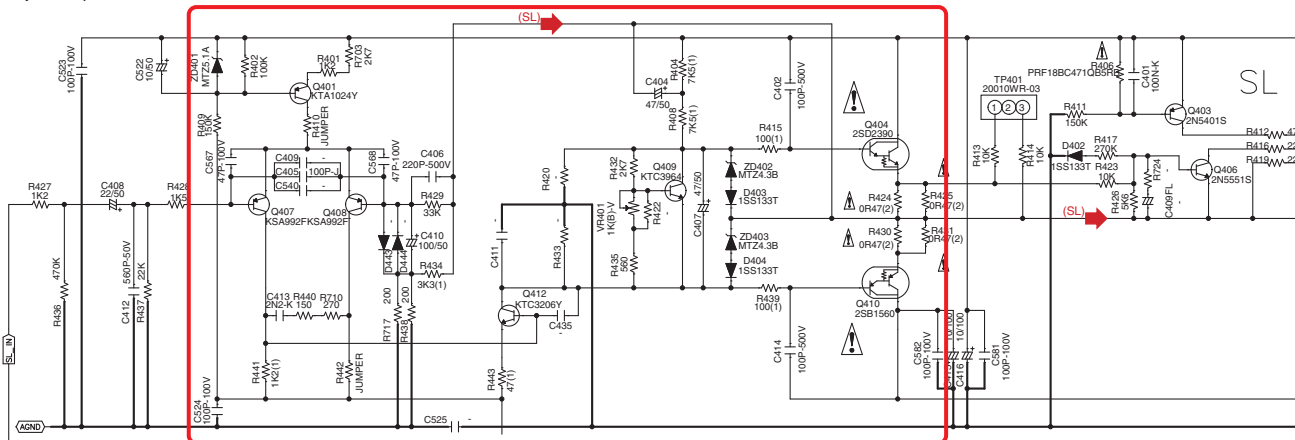

Channel	Measurement Points	Adjustment Points	Procedure
FL	TP404 pin 1 (+) TP404 pin 3 (-)	VR404	① Turn on the power. ② Perform aging for one minute. ③ Connect a digital voltmeter to the measurement point. ④ Turn the adjustment VR so that the voltage becomes in 2.0 mV ± 0.2 mV. (Condition : No signal and no load)
FR	TP402 pin 1 (+) TP402 pin 3 (-)	VR402	
C	TP403 pin 1 (+) TP403 pin 3 (-)	VR403	
SL	TP401 pin 1 (+) TP401 pin 3 (-)	VR401	
SR	TP405 pin 1 (+) TP405 pin 3 (-)	VR405	
SBL	TP406 pin 1 (+) TP406 pin 3 (-)	VR406	
SBR	TP407 pin 1 (+) TP407 pin 3 (-)	VR407	

• Adjustment points and measurement points.... see fig.1.

B AMP7 ASSY

SIDE A

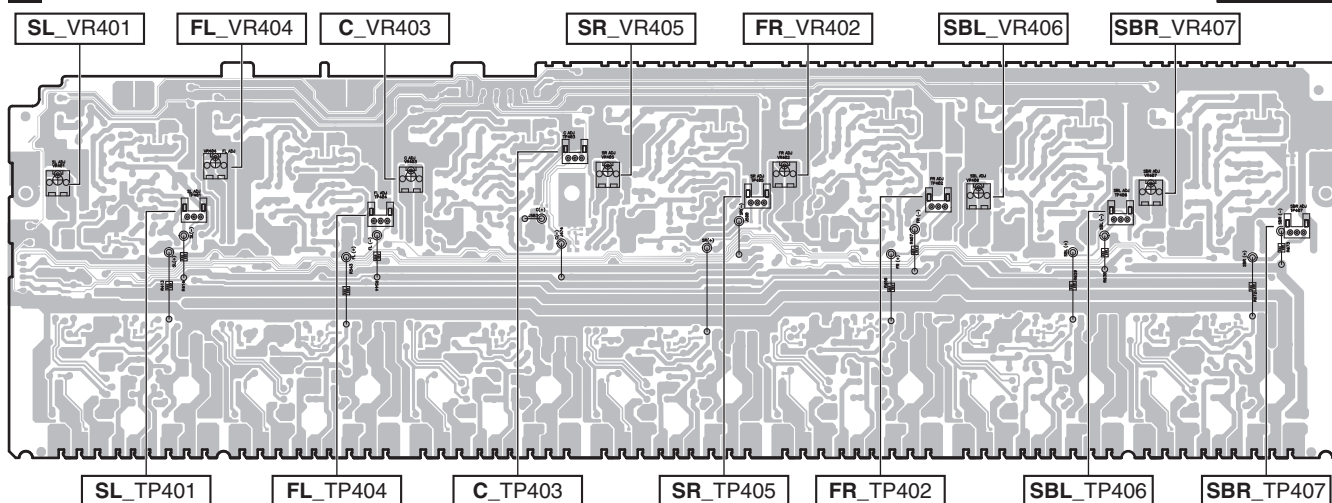

Fig.1

VSX-1022-K



for VSX-822-K

When any component parts which are within the red square on the following circuit diagram are replaced, the idle current adjustment of that channel is required. (Idle current adjustment for another channel is not required.)

However, when any capacitors are replaced, the adjustment is not required.

(The following circuit diagram is for SL channel, but another channel also has same circuit diagram and same adjustment is required)

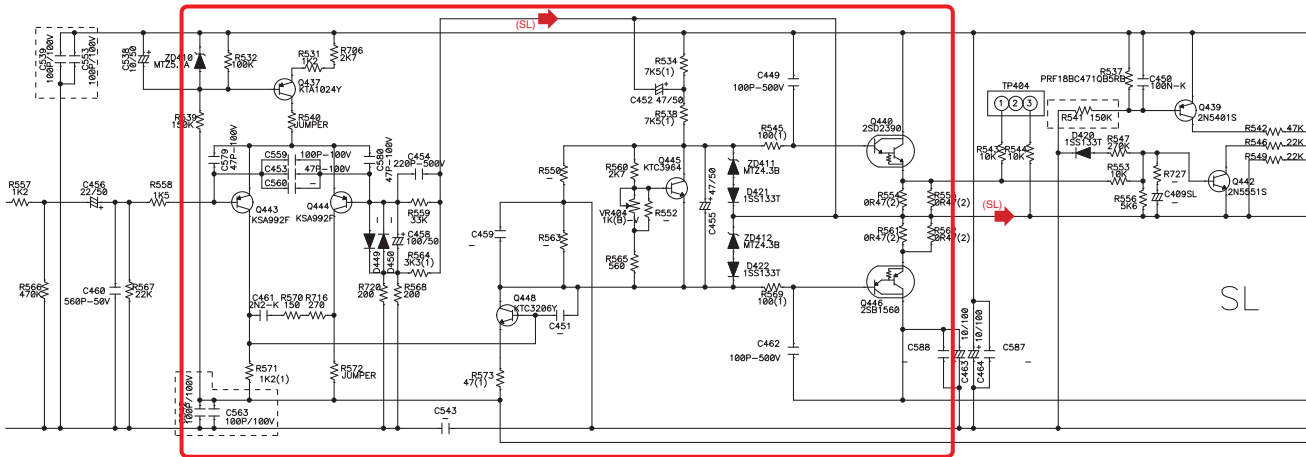

Channel	Measurement Points	Adjustment Points	Procedure
FL	TP401 pin 1 (+) TP401 pin 3 (-)	VR401	① Turn on the power. ② Perform aging for one minute. ③ Connect a digital voltmeter to the measurement point. ④ Turn the adjustment VR so that the voltage becomes in 2.0 mV ± 0.2 mV. (Condition : No signal and no load)
FR	TP402 pin 1 (+) TP402 pin 3 (-)	VR402	
C	TP403 pin 1 (+) TP403 pin 3 (-)	VR403	
SL	TP404 pin 1 (+) TP404 pin 3 (-)	VR404	
SR	TP405 pin 1 (+) TP405 pin 3 (-)	VR405	

• Adjustment points and measurement points.... see fig.2.

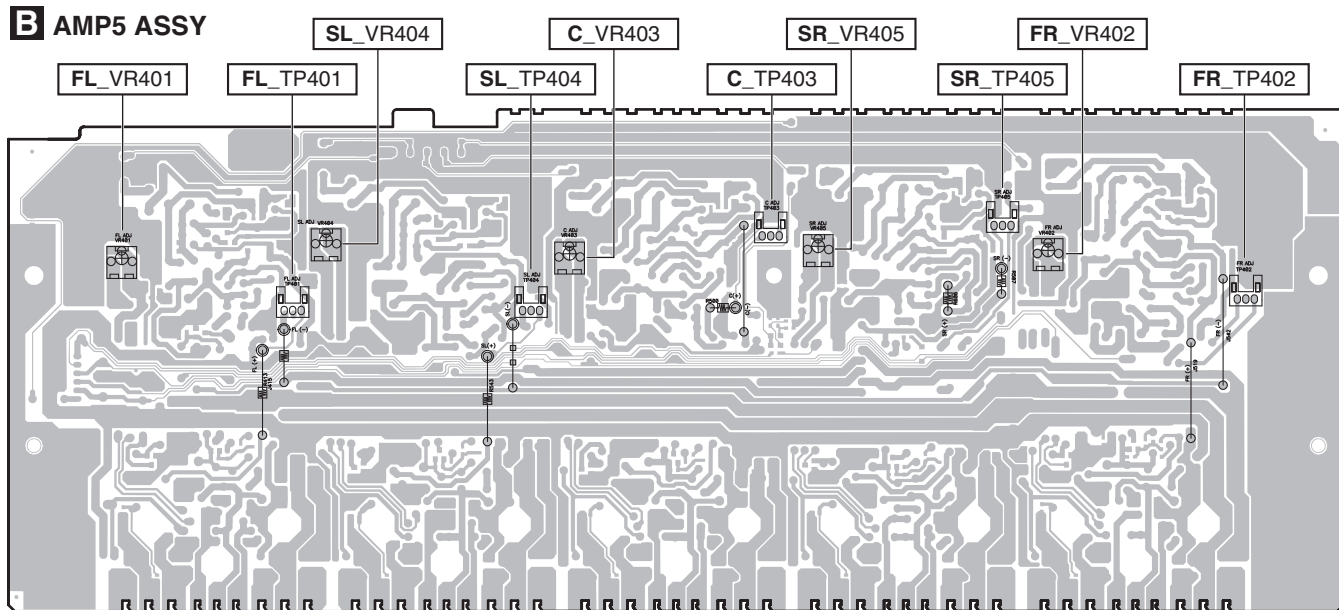

Fig.2

SIDE A



5



6



7



8



A



B



C



D



E



F



5



6

VSX-1022-K



7



8



9. EXPLODED VIEWS AND PARTS LIST

- NOTES:
- Parts marked by "NSP" are generally unavailable because they are not in our Master Spare Parts List.
 - The \triangle mark found on some component parts indicates the importance of the safety factor of the part. Therefore, when replacing, be sure to use parts of identical designation.
 - Screws adjacent to ∇ mark on product are used for disassembly.
 - For the applying amount of lubricants or glue, follow the instructions in this manual. (In the case of no amount instructions, apply as you think it appropriate.)

9.1 PACKING SECTION

Poly bag packing style

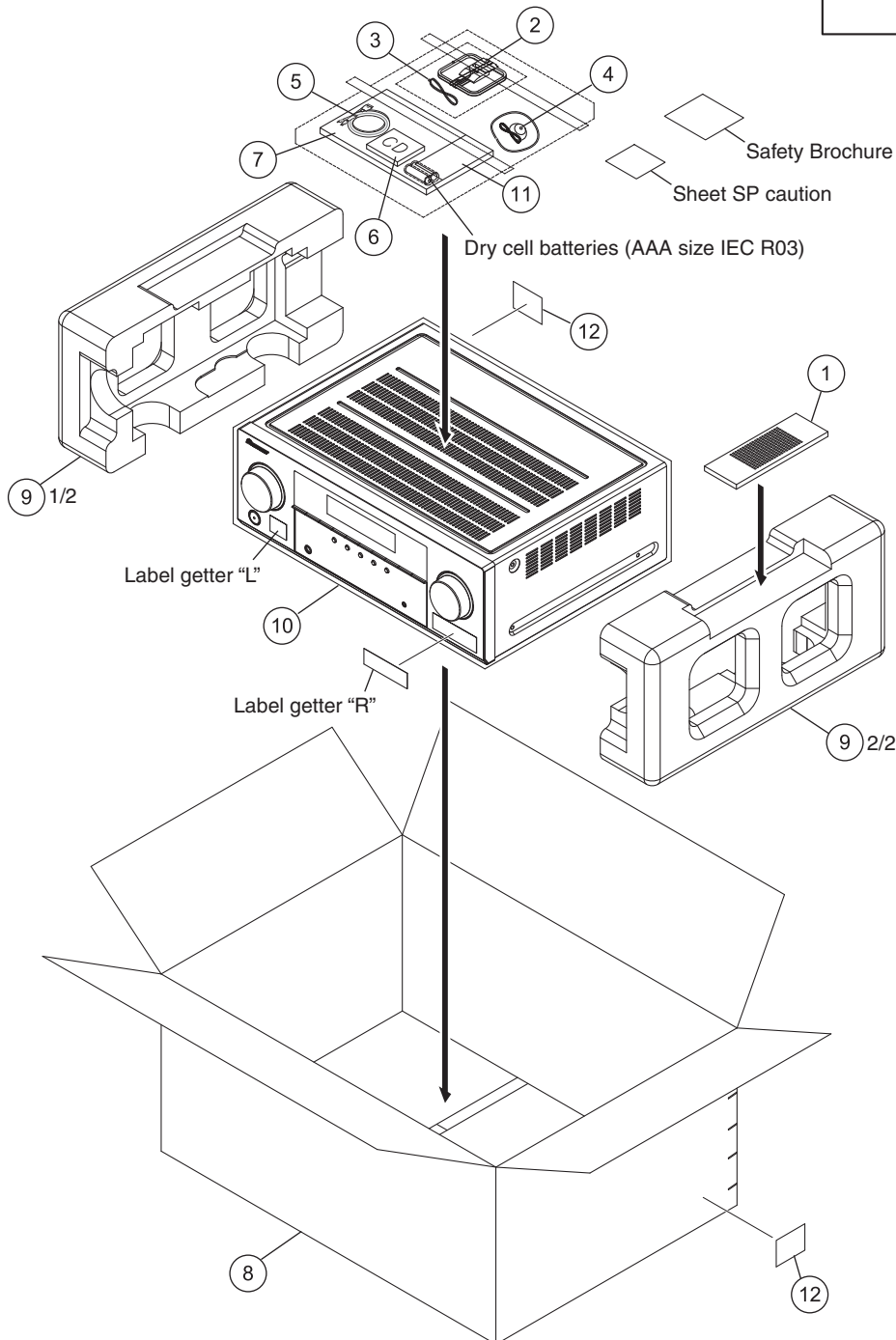
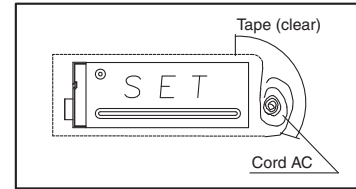

(1) PACKING SECTION PARTS LIST

<u>Mark No.</u>	<u>Description</u>	<u>Part No.</u>
1	Remote Control	See Contrast table (2)
2	AM Loop Antenna	E601019000010-IL
3	FM Wire Antenna	E605010140010-IL
4	Microphone (for Auto MCACC setup)	APM7010
5	iPod Cable	L308102013030-IL
6	Operating Instructions (CD-ROM)	See Contrast table (2)
7	Quick Start Guide	See Contrast table (2)
8	Box, Gift	See Contrast table (2)
9	Cushion, Snow VSX-522	6230213144000-IL
10	PE, Sheet	6327040059000-IL
NSP 11	Warranty Card	See Contrast table (2)
NSP 12	Label	VRW1629

(2) CONTRAST TABLE

VSX-1022-K/CUXESM, VSX-42/UXECB and VSX-822-K/CUXESM are constructed the same except for the following:

Mark	No.	Symbol and Description	VSX-1022-K /CUXESM	VSX-42 /UXECB	VSX-822-K /CUXESM
	1	Remote Control	8300766100010-IL	8300766200010-IL	8300766100010-IL
	6	Operating Instructions (CD-ROM)	6517000000490-IL	6517000000510-IL	6517000000490-IL
	7	Quick Start Guide	5707000006490-IL	5707000006500-IL	5707000006490-IL
	8	Box, Gift	6007212070050-IL	6007212070060-IL	6007212070090-IL
NSP	11	Warranty Card	ARY7156	ARY7007	ARY7156

9.2 EXTERIOR SECTION

1

2

3

4

A

B

C

D

E

F

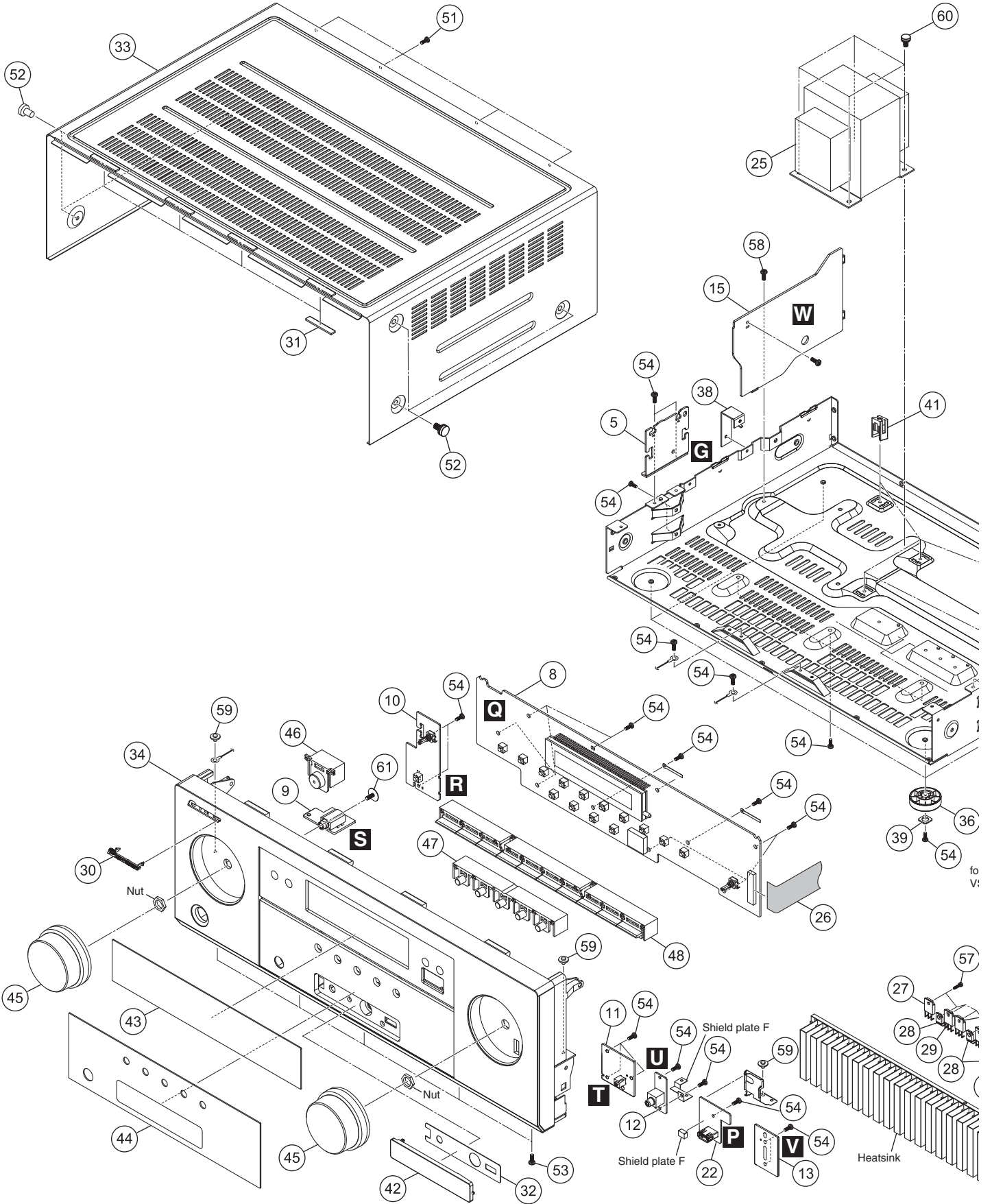

1

2

3

4

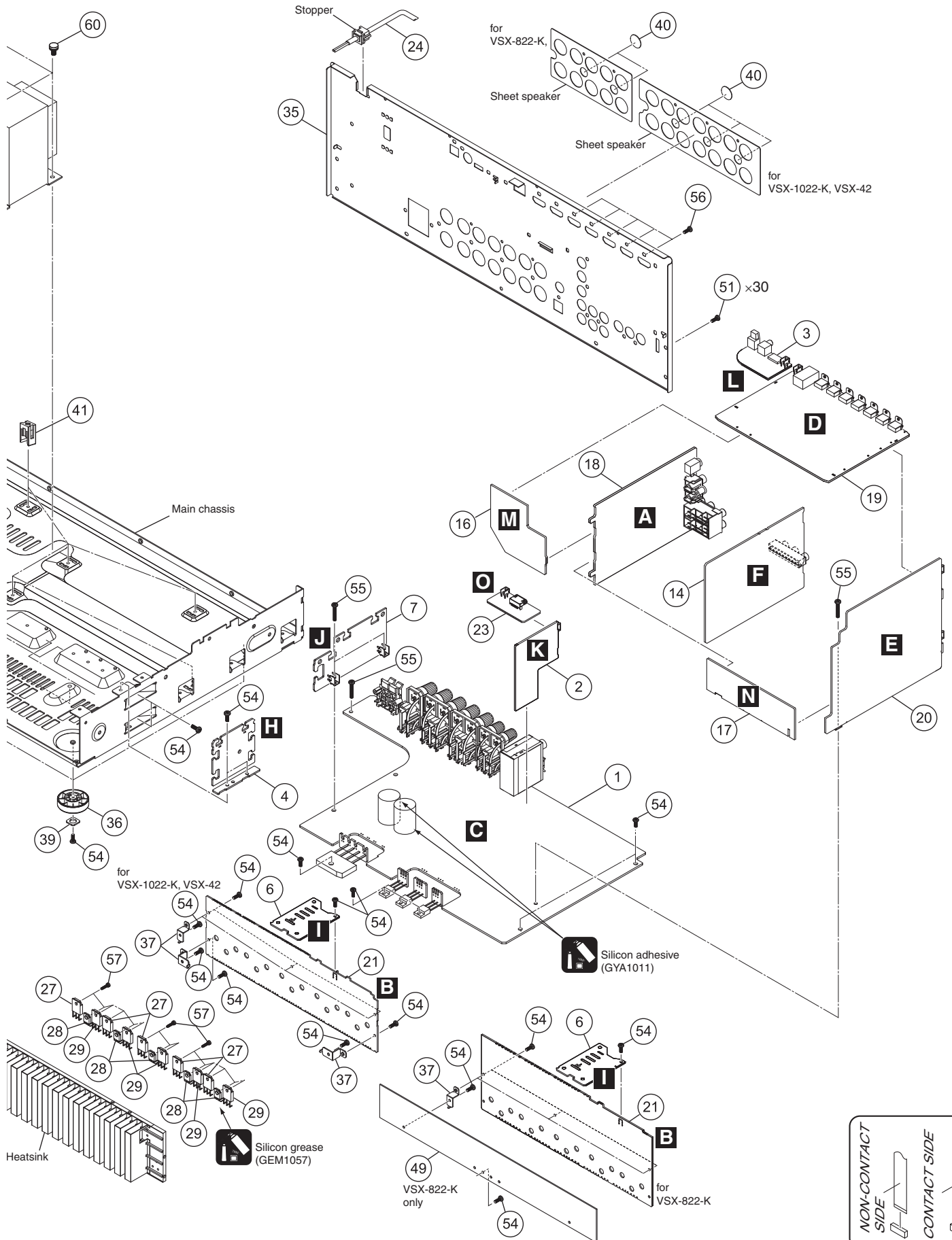

A

B

C

D

E

F

VSX-1022-K

(1) EXTERIOR SECTION SECTION PARTS LIST

	<u>Mark No.</u>	<u>Description</u>	<u>Part No.</u>	<u>Mark No.</u>	<u>Description</u>	<u>Part No.</u>
A	1	MAIN Assy	See Contrast table (2)	46	Button	See Contrast table (2)
	2	BTCNT Assy	7028071612050-IL	47	5 Key Button	5090214561000-IL
	3	OPTCO Assy	7028071613050-IL	48	10 Key Button	5090214571000-IL
	4	G-R Assy	7028071614050-IL	49	Shield AMP PCB	See Contrast table (2)
	5	G-L Assy	7028071615050-IL	50	•••••	
	6	WG-A Assy	7028071616050-IL	51	Screw	BBT30P100FTB
	7	WG-B Assy	7028071617050-IL	52	Screw	BBT40P080FTB
	8	FRONT Assy	See Contrast table (2)	53	Screw	BBZ30P080FTB
	9	HP Assy	See Contrast table (2)	54	Screw	BBZ30P080FTC
	10	INSEL Assy	See Contrast table (2)	55	Screw	BBZ30P180FTC
B	11	MIC Assy	7028071624050-IL	56	Screw	BSZ30P040FTB
	12	FVIDEO Assy	See Contrast table (2)	57	Screw Tapping Assy	B018230141H11-IL
	13	WG Assy	7028071627060-IL	58	Screw, Tap Tite	B020230063B10-IL
	14	VIDEO Assy	See Contrast table (2)	59	Screw, Tap Tite	1500001206010-IL
	15	STBY Assy	See Contrast table (2)	60	Screw	B028940101B11-IL
	16	BRG-1 Assy	7028071673030-IL	61	Screw	1500001456010-IL
	17	BRG-2 Assy	See Contrast table (2)			
	18	AUDIO Assy	See Contrast table (2)			
	19	D-MAIN Assy	See Contrast table (2)			
C	20	CPU Assy	See Contrast table (2)			
	21	AMP Assy	See Contrast table (2)			
	22	F-USB Assy	7028071781030-IL			
	23	BT Assy	7028070231010-IL			
	⚠ 24	Cord Assy	L068125101710-IL			
	⚠ 25	Power Trans	See Contrast table (2)			
	26	Cable Flat Card 1.0	N711251722480-IL			
	⚠ 27	Transistor	J5011560Y0000-IL			
	⚠ 28	Semi, Tr/Ge NPN 2SC	J502396400010-IL			
D	⚠ 29	Transistor	J5032390Y0000-IL			
	30	Pioneer Badge	See Contrast table (2)			
	31	Sheet	1210210235000-IL			
	32	F Input Sheet	See Contrast table (2)			
	33	Cabinet VSX-522	3007212006000-IL			
	34	Front Panel	See Contrast table (2)			
	35	Back Chassis	See Contrast table (2)			
	36	Foot (PLS)	4000210391000-IL			
	37	Bracket	4010056906010-IL			
E	38	Bracket SMPS	4010214886000-IL			
	39	Cushion	4050211605000-IL			
	40	Screw Cover	4050211745100-IL			
	41	Support	4070001601010-IL			
	42	Front Input Cover	4317215111030-IL			
	43	Window Display U	See Contrast table (2)			
	44	Window Lower	See Contrast table (2)			
	45	Knob	5080212431000-IL			

(2) CONTRAST TABLE

VSX-1022-K/CUXESM, VSX-42/UXECB and VSX-822-K/CUXESM are constructed the same except for the following:

Mark	No.	Symbol and Description	VSX-1022-K /CUXESM	VSX-42 /UXECB	VSX-822-K /CUXESM
	1	MAIN Assy	7028071611030-IL	7028071611050-IL	7028071611010-IL
	8	FRONT Assy	7028071621030-IL	7028071621050-IL	7028071621030-IL
	9	HP Assy	7028071622030-IL	7028071622050-IL	7028071622030-IL
	10	INSEL Assy	7028071623030-IL	7028071623050-IL	7028071623030-IL
	12	FVIDEO Assy	7028071626030-IL	7028071626050-IL	7028071626030-IL
	14	VIDEO Assy	7028071671030-IL	7028071671030-IL	7028071671010-IL
	15	STBY Assy	7028071672030-IL	7028071672030-IL	7028071672010-IL
	17	BRG-2 Assy	7028071674030-IL	7028071674050-IL	7028071674030-IL
	18	AUDIO Assy	7028071641030-IL	7028071641050-IL	7028071641010-IL
	19	D-MAIN Assy	7028071691050-IL	7028071691050-IL	7028071691010-IL
	20	CPU Assy	7028071681030-IL	7028071681050-IL	7028071681010-IL
	21	AMP7 Assy	7028070253010-IL	7028070253010-IL	Not used
	21	AMP5 Assy	Not used	Not used	7028070245010-IL
⚠	25	Power Trans	8200960611140-IL	8200960611140-IL	8200960611180-IL
	30	Pioneer Badge	XAM3006	PAM1791	XAM3006
	32	F Input Sheet	1217211792000-IL	1217211792010-IL	1217211792000-IL
	34	Front Panel	3067215491010-IL	3067215501000-IL	3067215491020-IL
	35	Back Chassis	3207214196000S-IL	3207214196200S-IL	3207214186000S-IL
	43	Window Display U	5077213113020-IL	5077213113030-IL	5077213113020-IL
	44	Window Lower	5077213123060-IL	5077213123040-IL	5077213123060-IL
	46	Button	5090213741100-IL	5098214551000-IL	5090213741100-IL
	49	Shield AMP PCB	Not used	Not used	4010215676000-IL

10. SCHEMATIC DIAGRAM

10.1 AUDIO ASSY

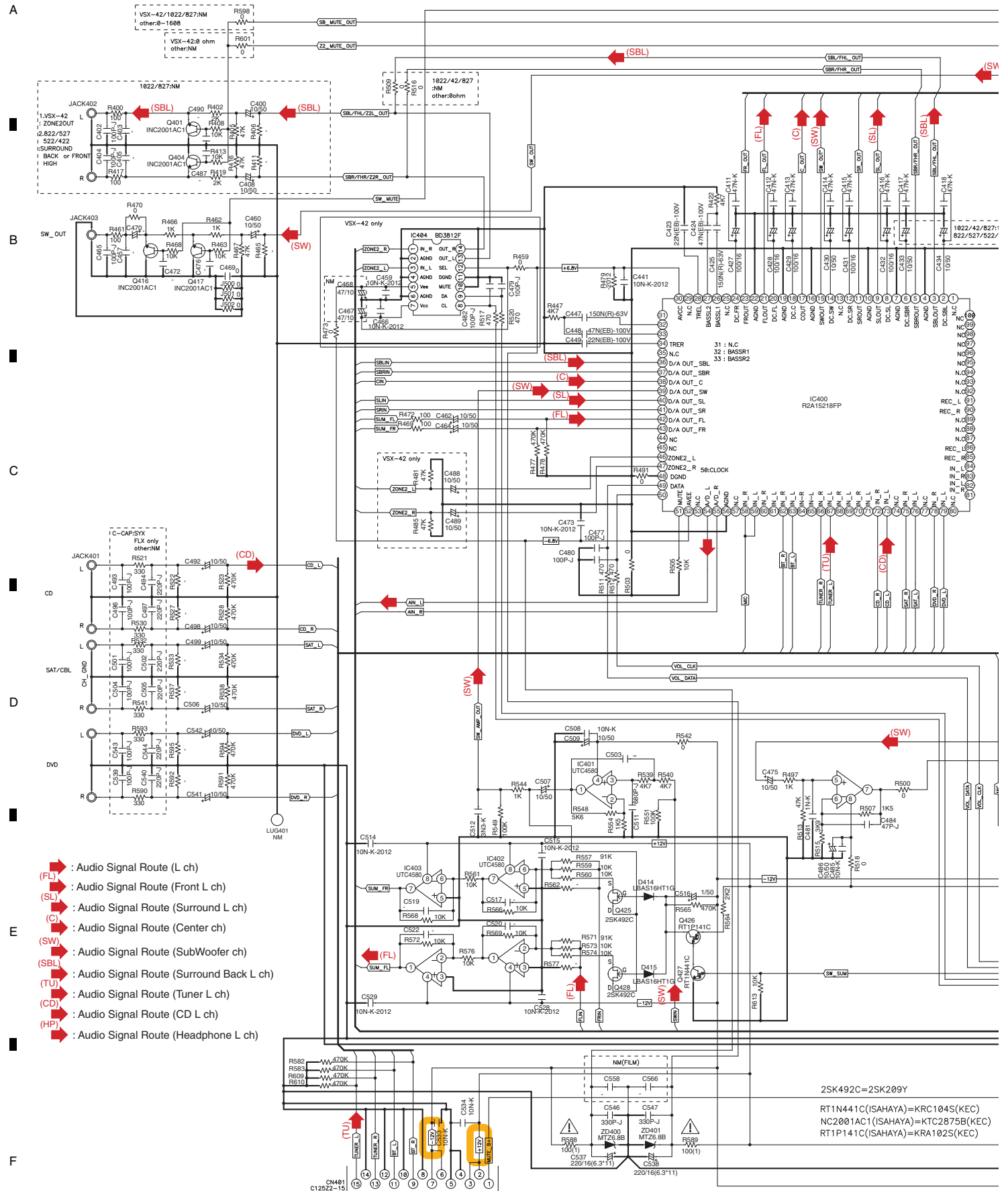

- (FL) : Audio Signal Route (L ch)
- (FR) : Audio Signal Route (Front L ch)
- (SL) : Audio Signal Route (Surround L ch)
- (SR) : Audio Signal Route (Surround R ch)
- (C) : Audio Signal Route (Center ch)
- (SW) : Audio Signal Route (SubWoofer ch)
- (SBL) : Audio Signal Route (Surround Back L ch)
- (SBR) : Audio Signal Route (Surround Back R ch)
- (TU) : Audio Signal Route (Tuner L ch)
- (CD) : Audio Signal Route (CD L ch)
- (HP) : Audio Signal Route (Headphone L ch)

A

C CP17

A AUDIO ASSY (VSX-1022-K: 7028071641030-IL) (VSX-42: 7028071641050-IL) (VSX-822-K: 7028071641010-IL)

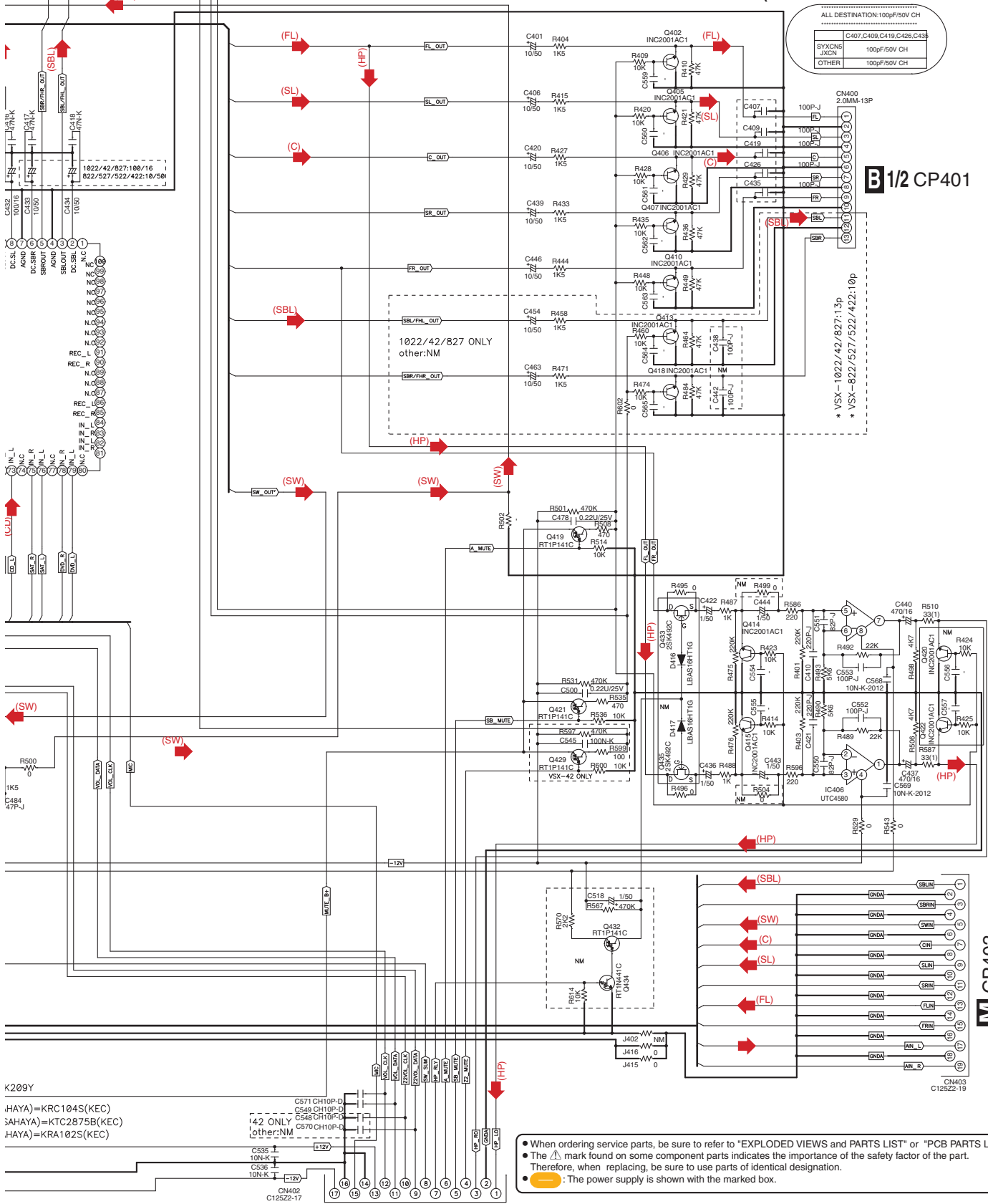

A
B
C
D
E
F



10.2 AMP7 ASSY (1/2)(VSX-1022-K, VSX-42)

B 1/2 AMP7 ASSY (7028070253010-IL)

A
B
C
D
E
F

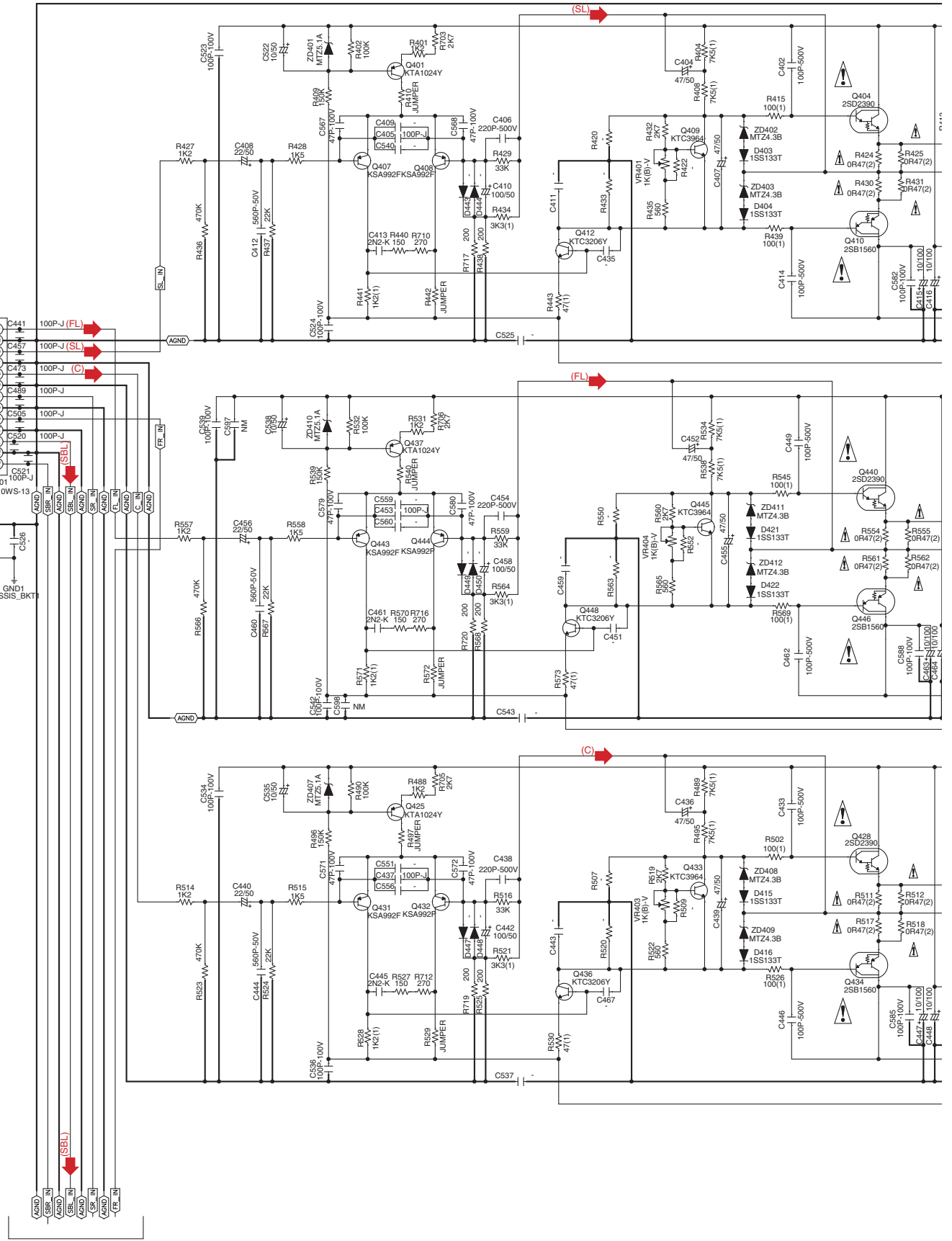

B 2/2

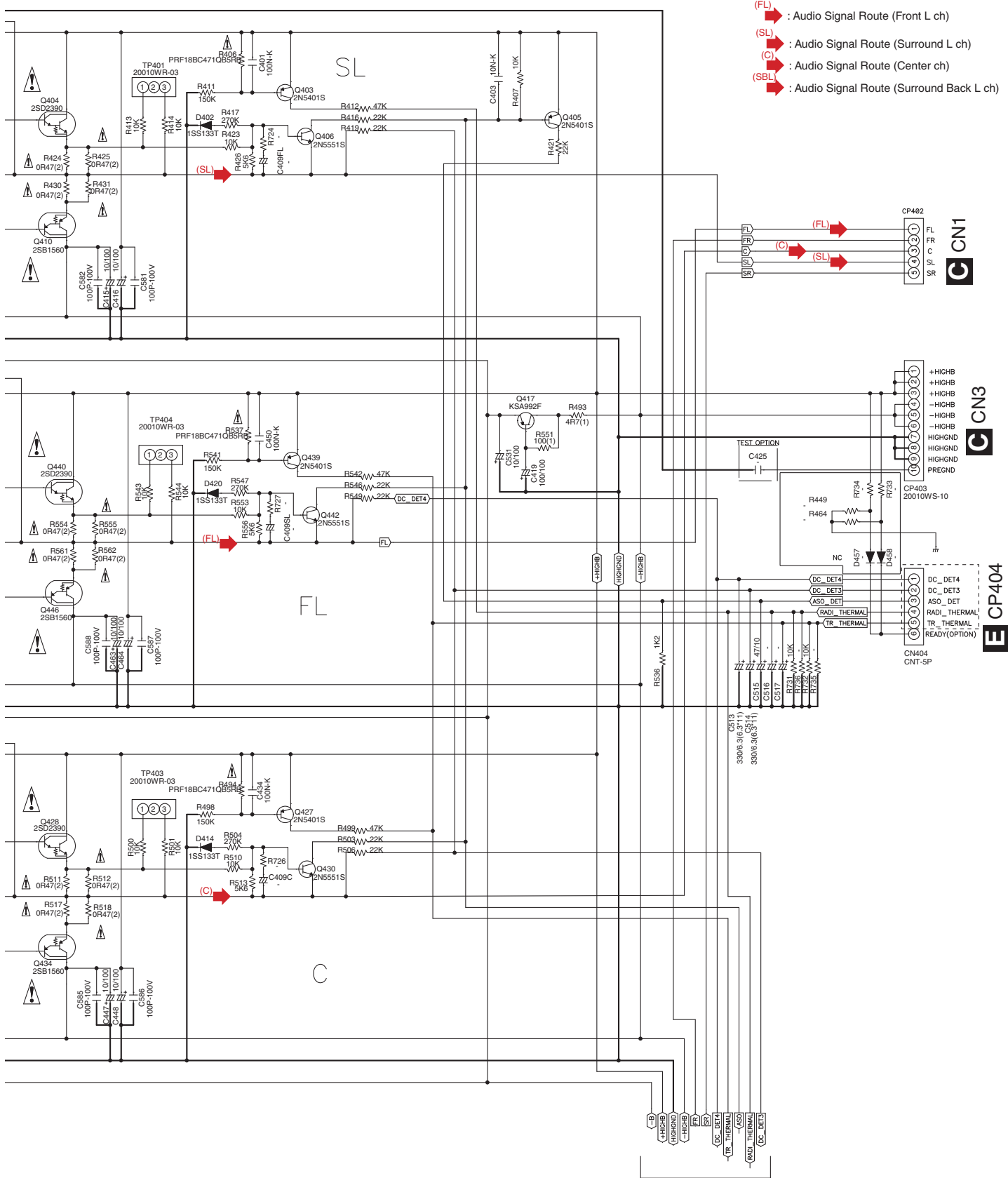

- (FL) : Audio Signal Route (Front L ch)
- (SL) : Audio Signal Route (Surround L ch)
- (C) : Audio Signal Route (Center ch)
- (SBL) : Audio Signal Route (Surround Back L ch)

B 2/2

10.3 AMP7 ASSY (2/2)(VSX-1022-K, VSX-42)

B1/2

A
B
C
D
E
F

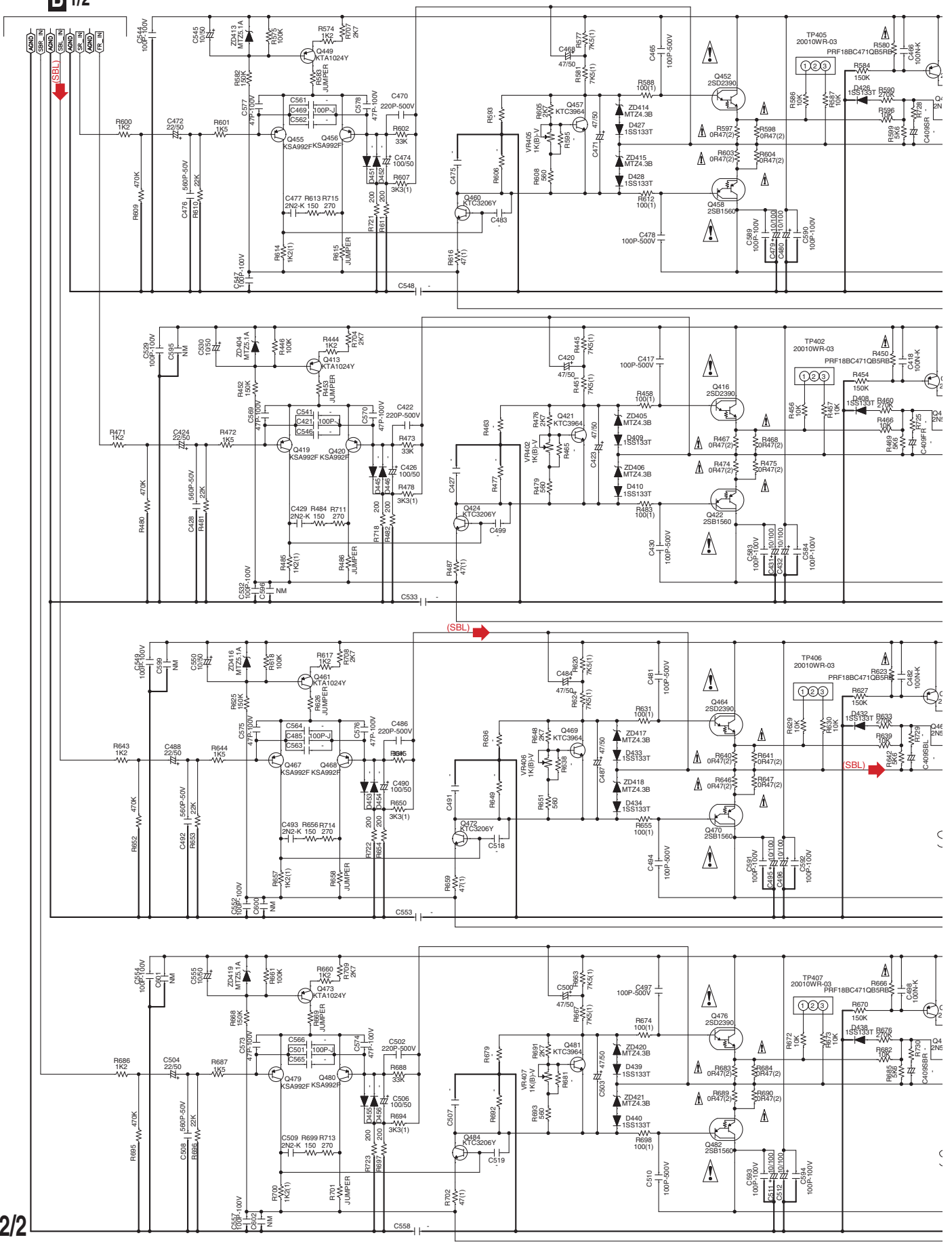

B2/2

VSX-1022-K

1

2

3

4

B 2/2 AMP7 ASSY (7028070253010-IL)

A
B
C
D
E
F

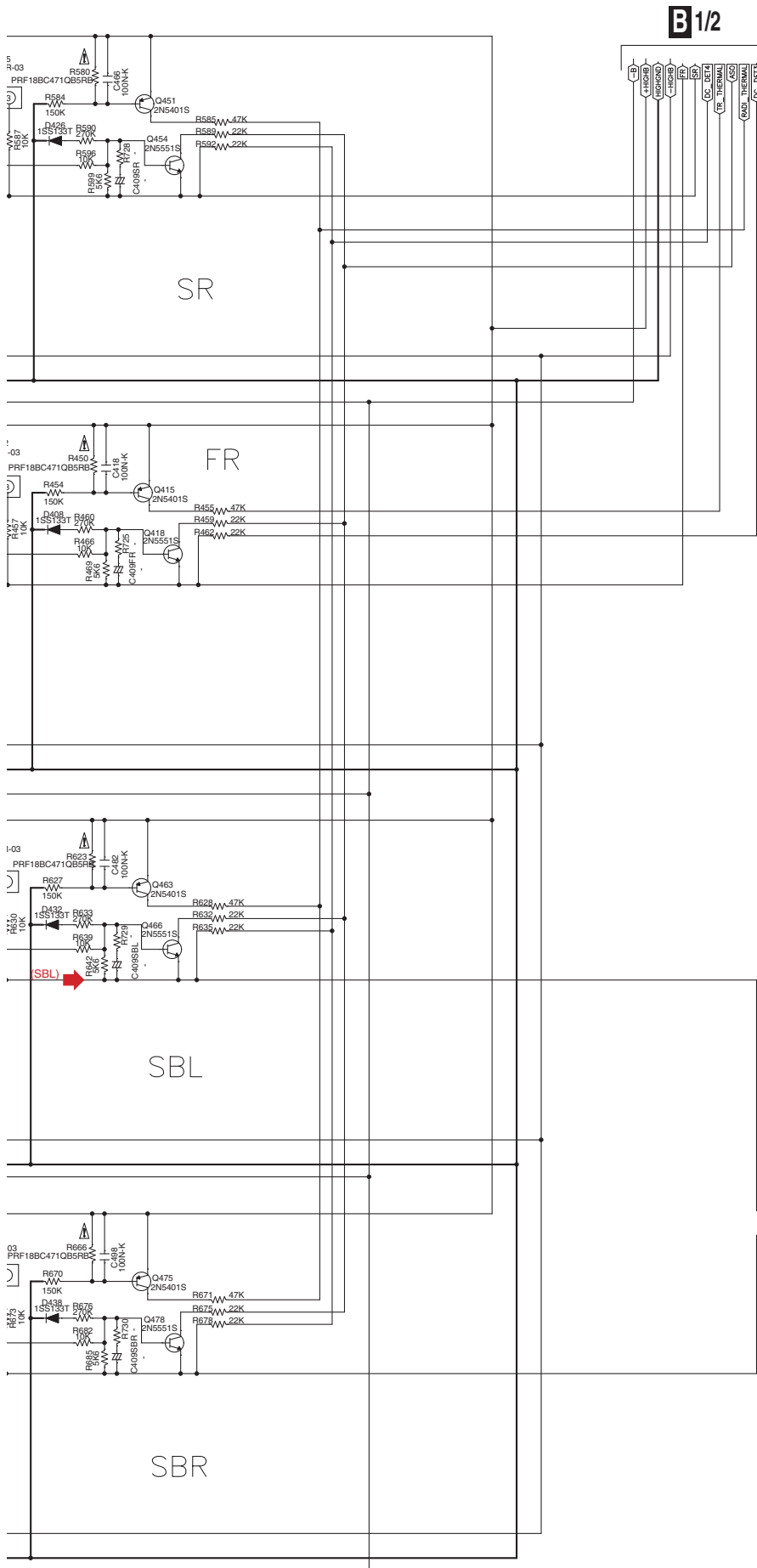

(SBL) : Audio Signal Route (Surround Back L ch)

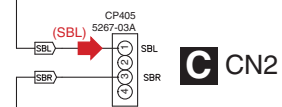

10.4 AMP5 ASSY (1/2)(VSX-822-K)

B 1/2 AMP5 ASSY (7028070245010-IL)

A
B
C
D
E
F

A CN400

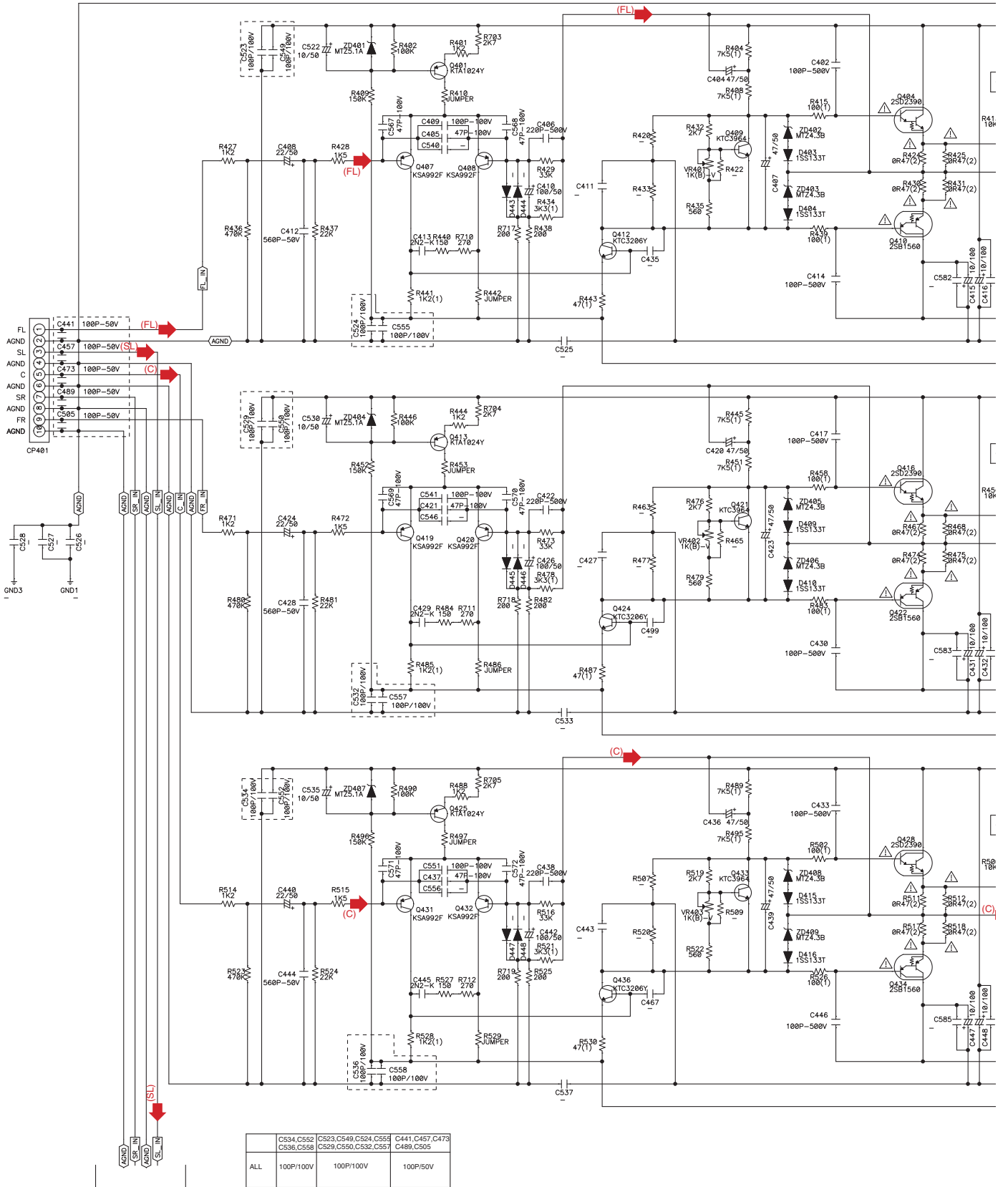

	C534, C552 C536, C558	C523, C549, C524, C556 C529, C550, C532, C557	C441, C457, C473 C489, C505
ALL	100P/100V	100P/100V	100P/50V

B 2/2

B 1/2

A
B
C
D
E
F

- (FL) : Audio Signal Route (Front L ch)
- (SL) : Audio Signal Route (Surround L ch)
- (C) : Audio Signal Route (Center ch)

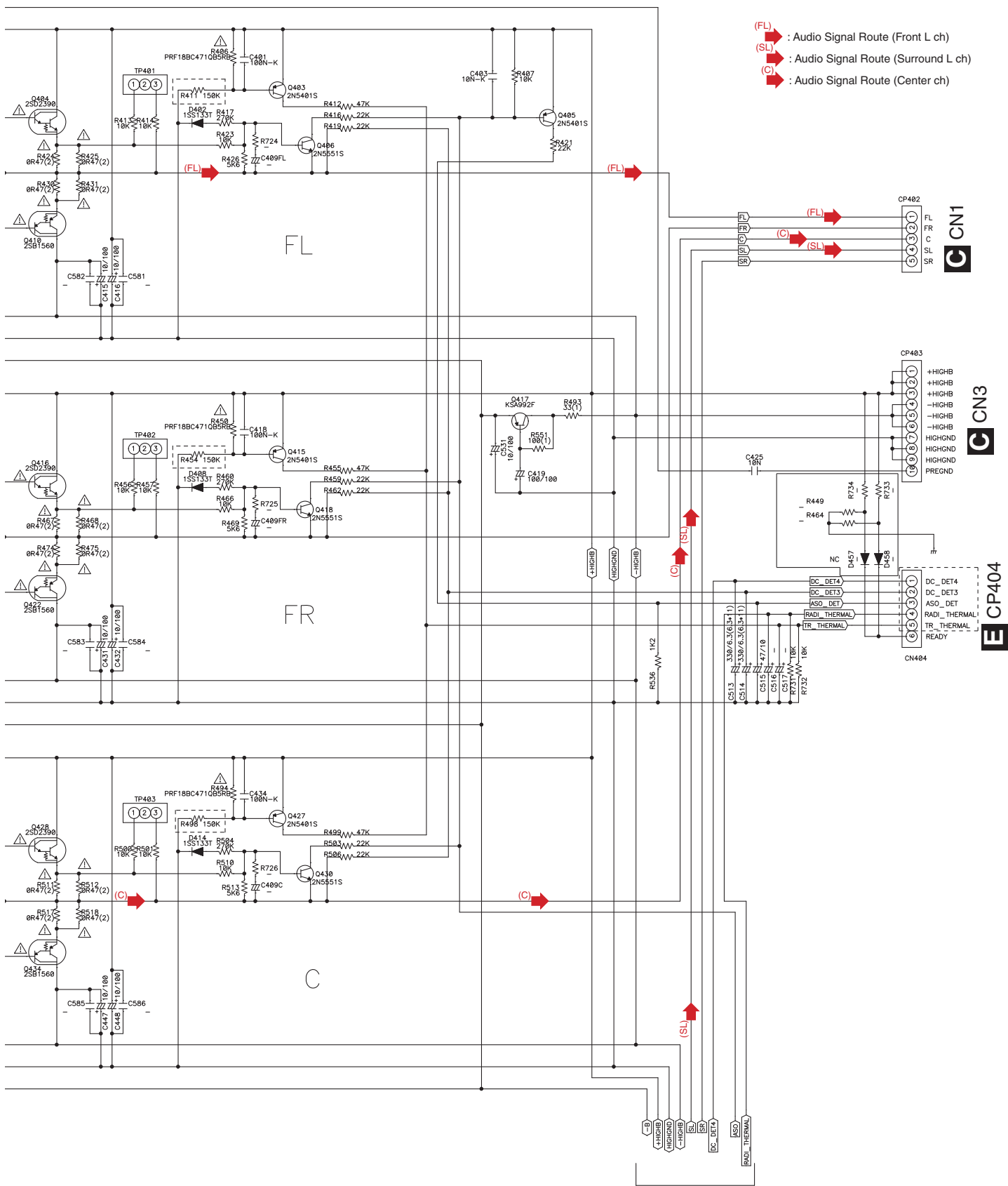

10.5 AMP5 ASSY (2/2)(VSX-822-K)

B2/2 AMP5 ASSY (7028070245010-IL)

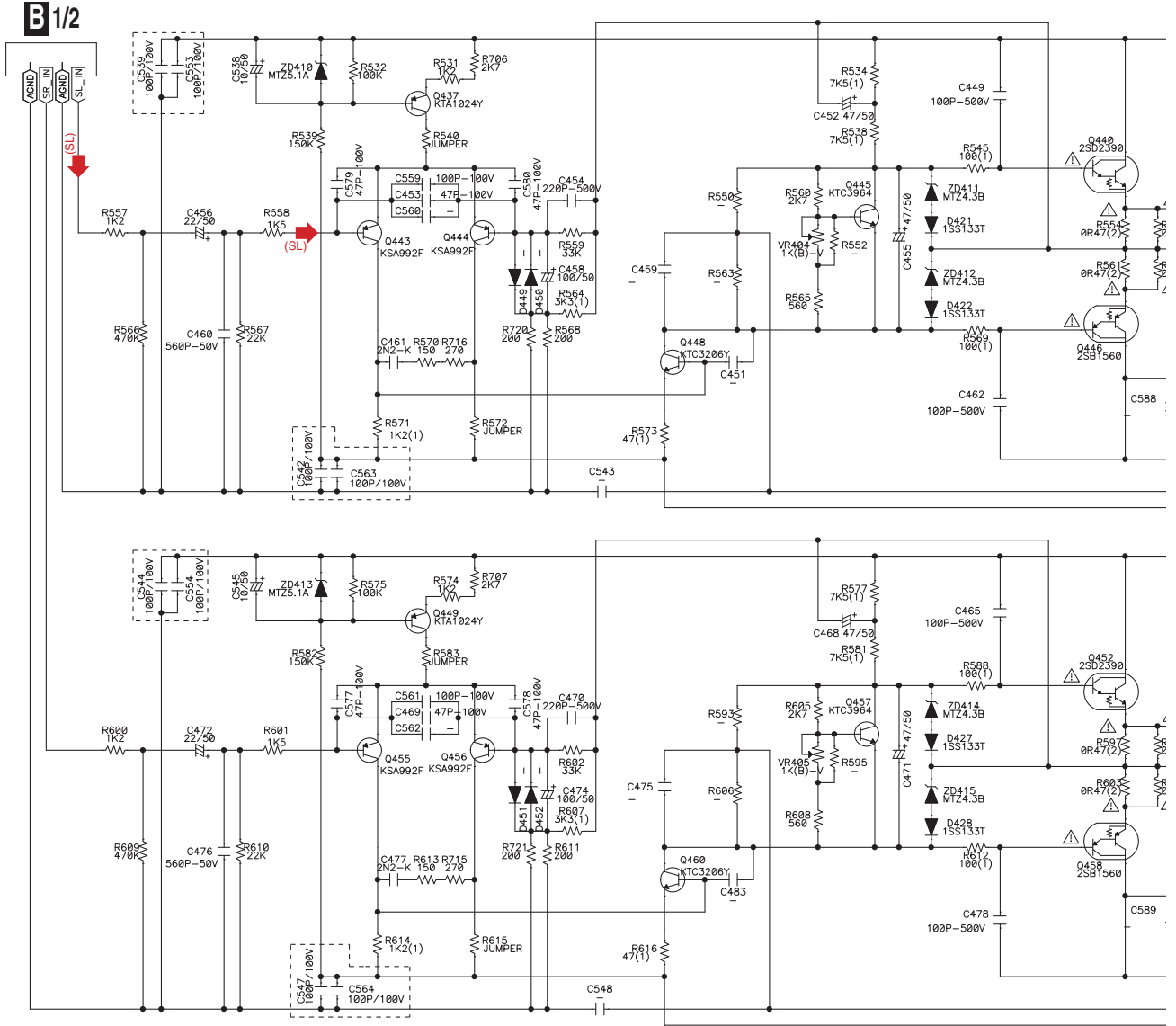

	C539, C553, C542, C563 C544, C554, C547, C564
ALL	100P/100V

10.6 MAIN ASSY

1 2 3 4

A
B
C
D
E
F

SPEAKER TERMINAL

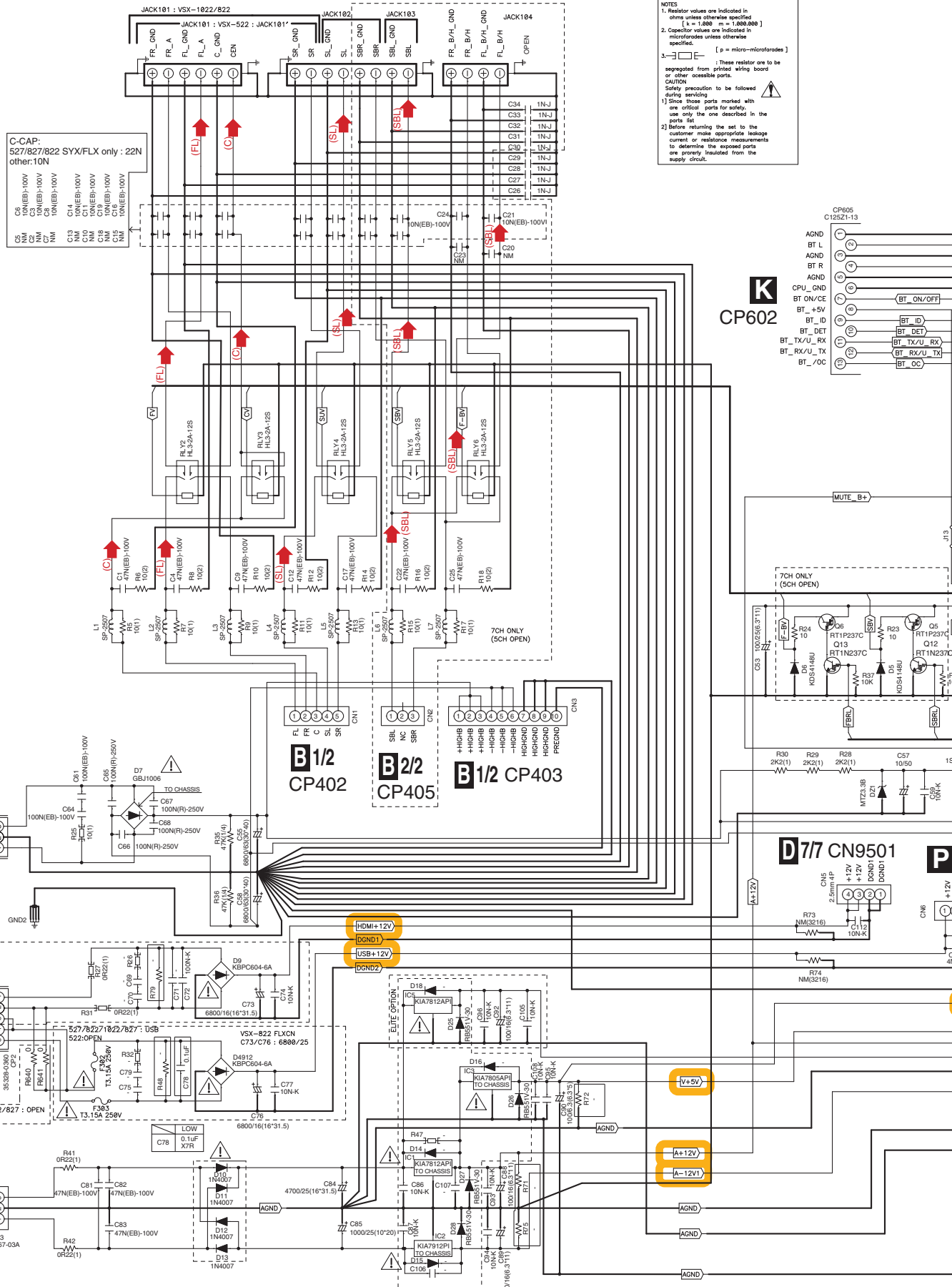

NOTES

1. Resistor values are indicated in ohms unless otherwise specified. [k = 1,000 m = 1,000,000]
2. Capacitor values are indicated in microfarads unless otherwise specified. [p = micro-microfarads]
3. : These resistors are to be segregated from printed wiring board or other accessible parts. CAUTION: Safety precautions to be followed during servicing.

1) Since those parts marked with one critical ports for safety, use only the one described in the parts list.

2) Before returning the set to the customer make appropriate leakage current or resistance measurements to determine the exposed parts are properly insulated from the supply circuit.

1 2 3 4

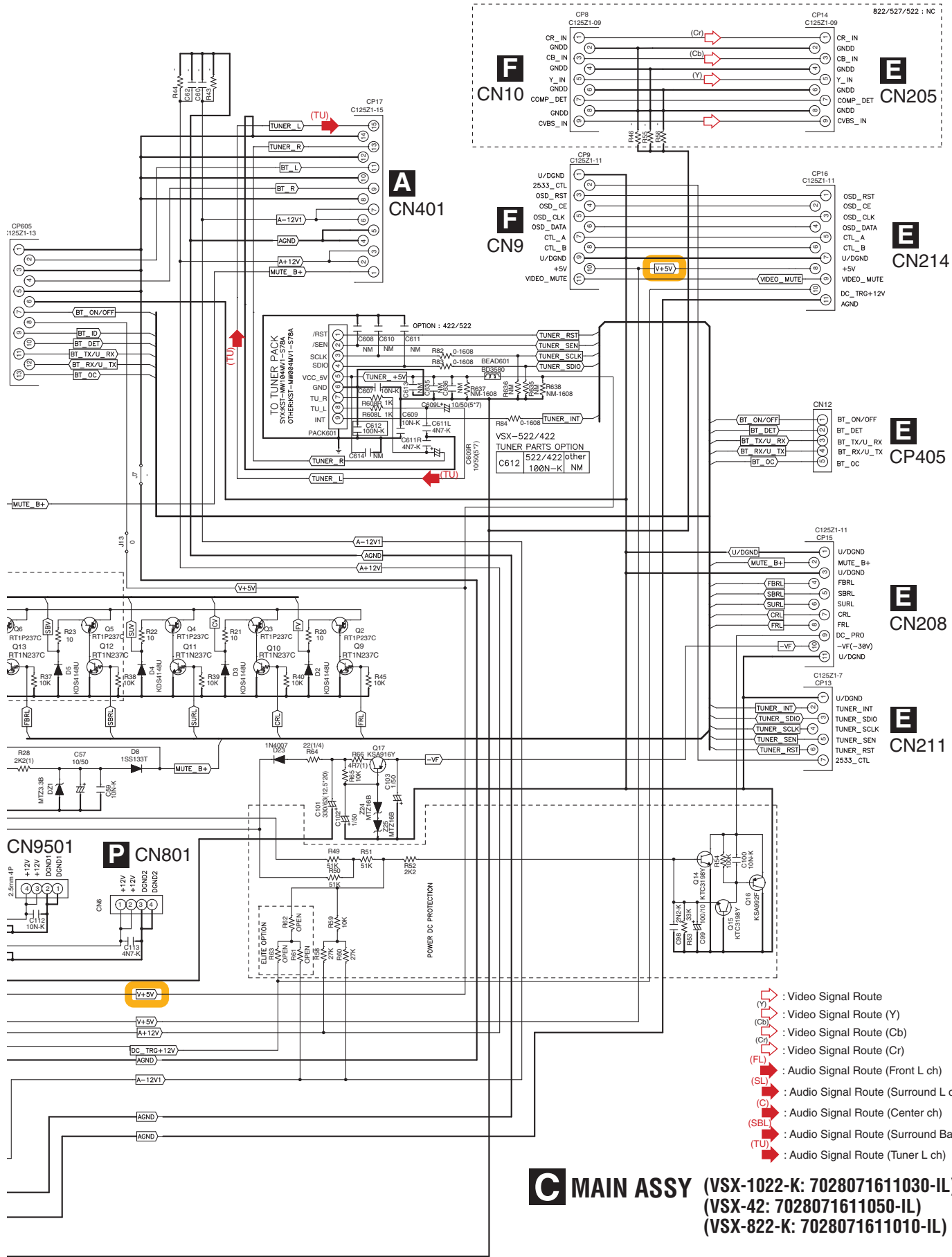

C MAIN ASSY (VSX-1022-K: 7028071611030-IL)
 (VSX-42: 7028071611050-IL)
 (VSX-822-K: 7028071611010-IL)

10.7 D-MAIN ASSY (1/7)(VSX-1022-K, VSX-42)

A

B

C

D

E

F

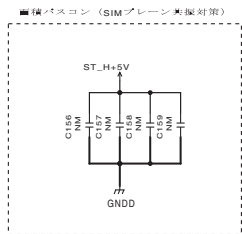
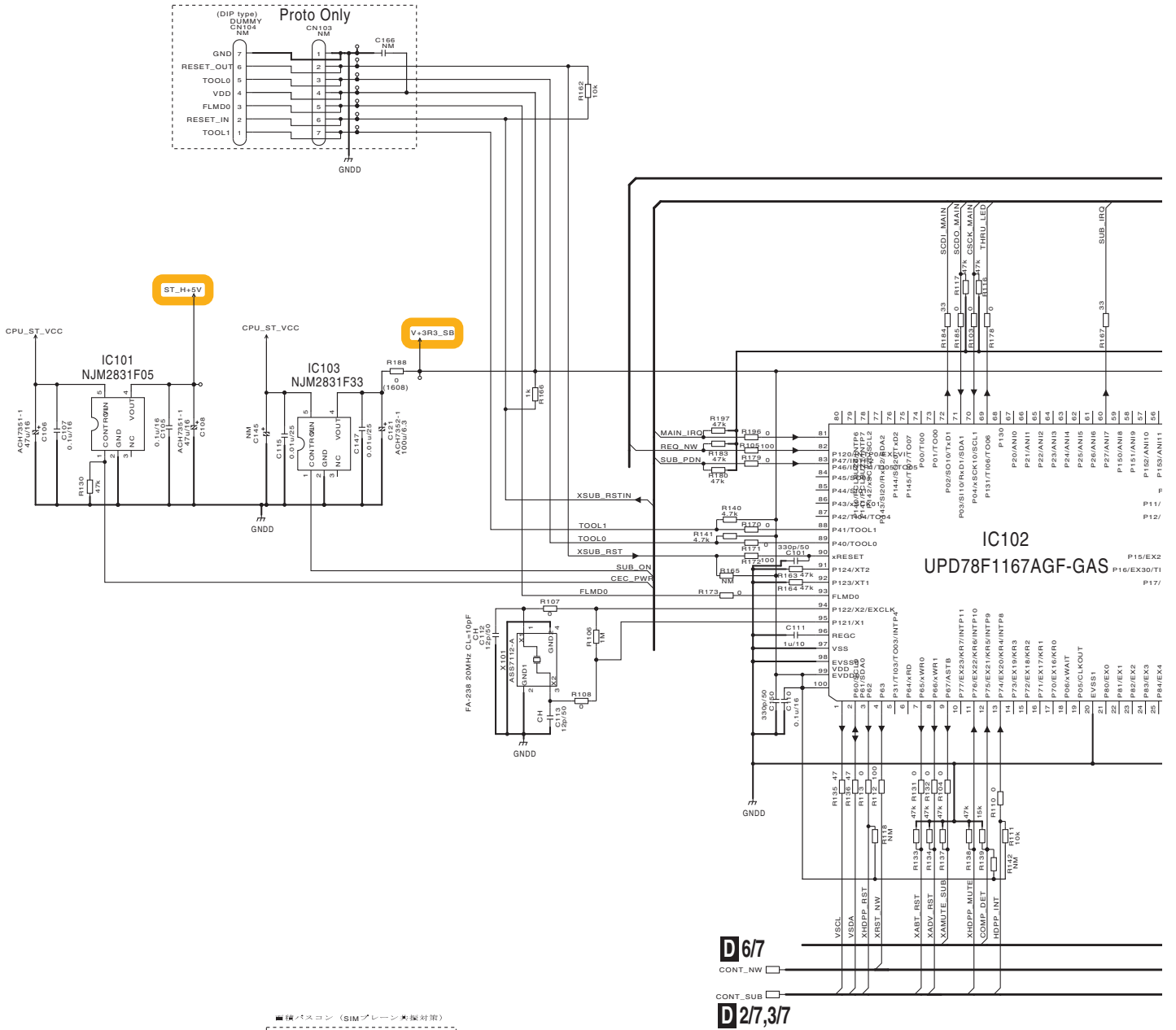

D17

10.8 D-MAIN ASSY (2/7)(VSX-1022-K, VSX-42)

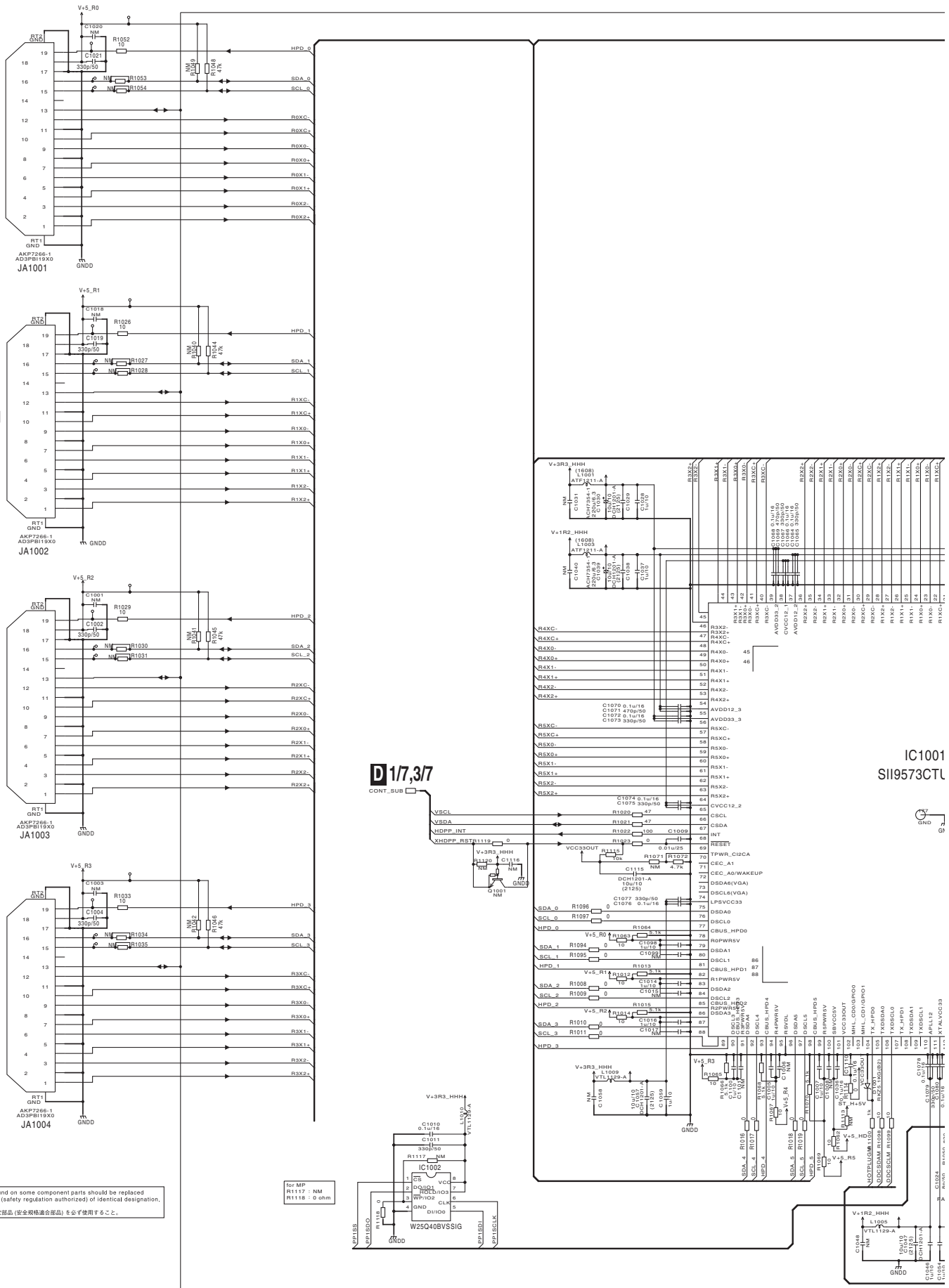

The Δ mark found on some component parts should be replaced with same parts (safety regulation authorized) of identical designation.
 △印の部品は検査部品(安全規格適合部品)を必ず使用すること。

For MP
 R1117 NM
 R1118 0 ohm



10.9 D-MAIN ASSY (3/7)(VSX-1022-K, VSX-42)

1

2

3

4

A

B

C

D

E

F

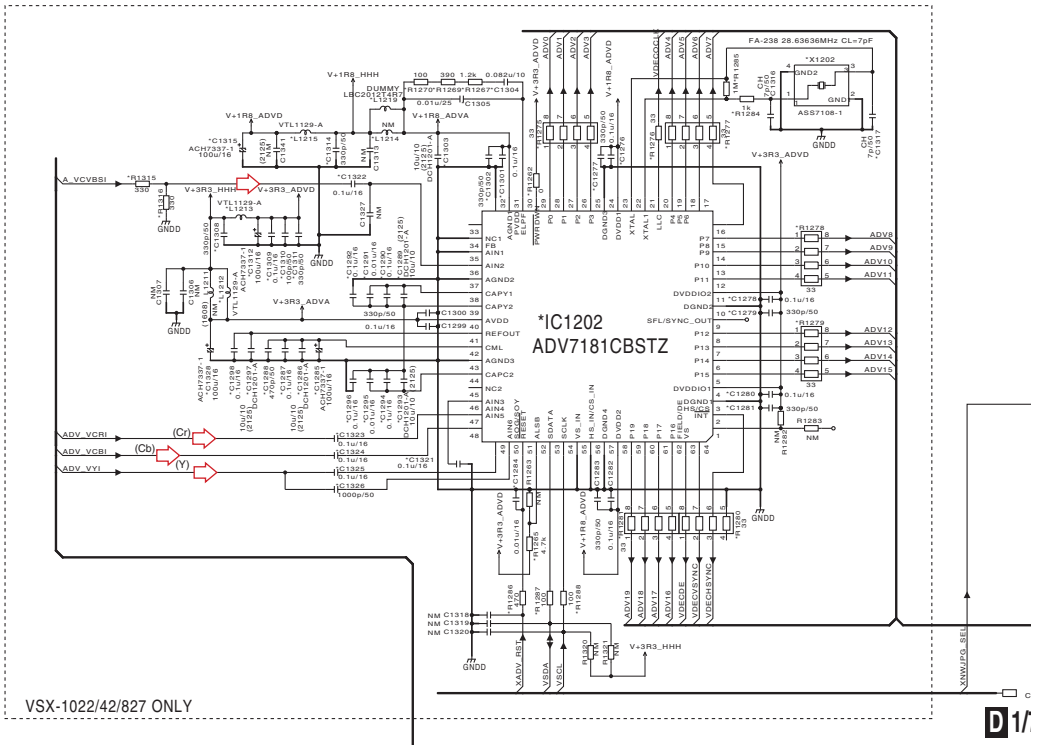

D17,217,417,517,717

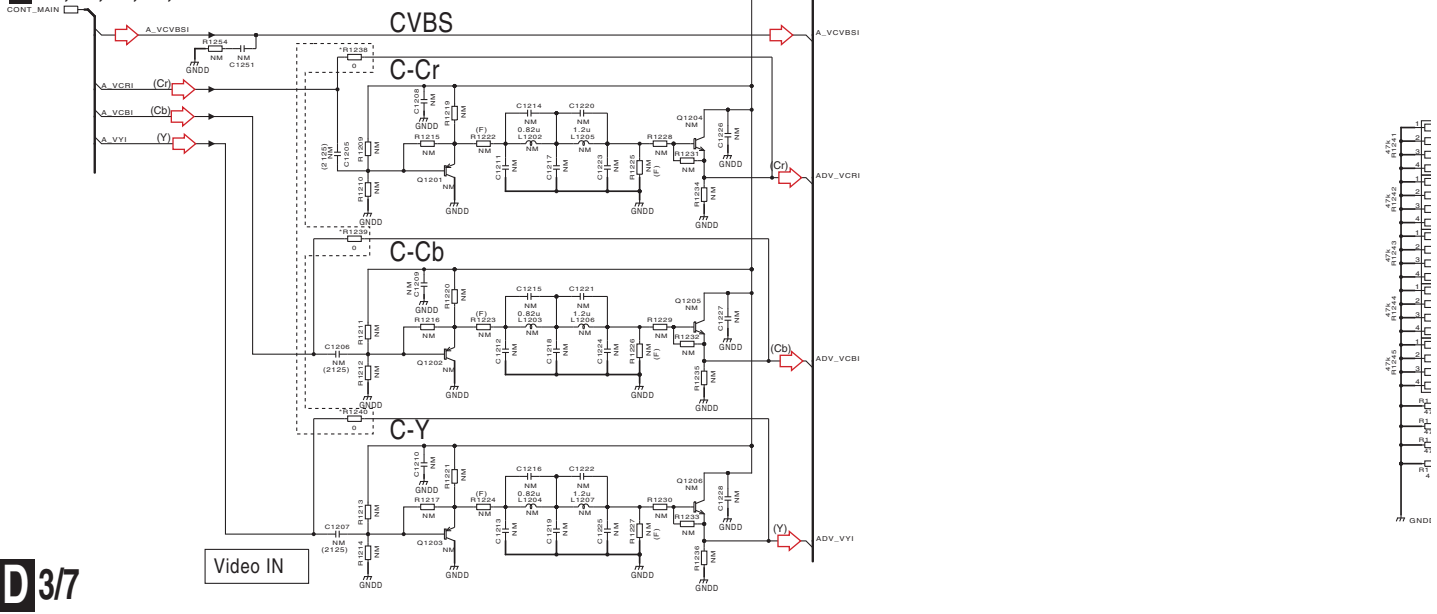

VSX-1022-K



1

2

3

4

D3/7 D-MAIN ASSY (7028071691050-IL)

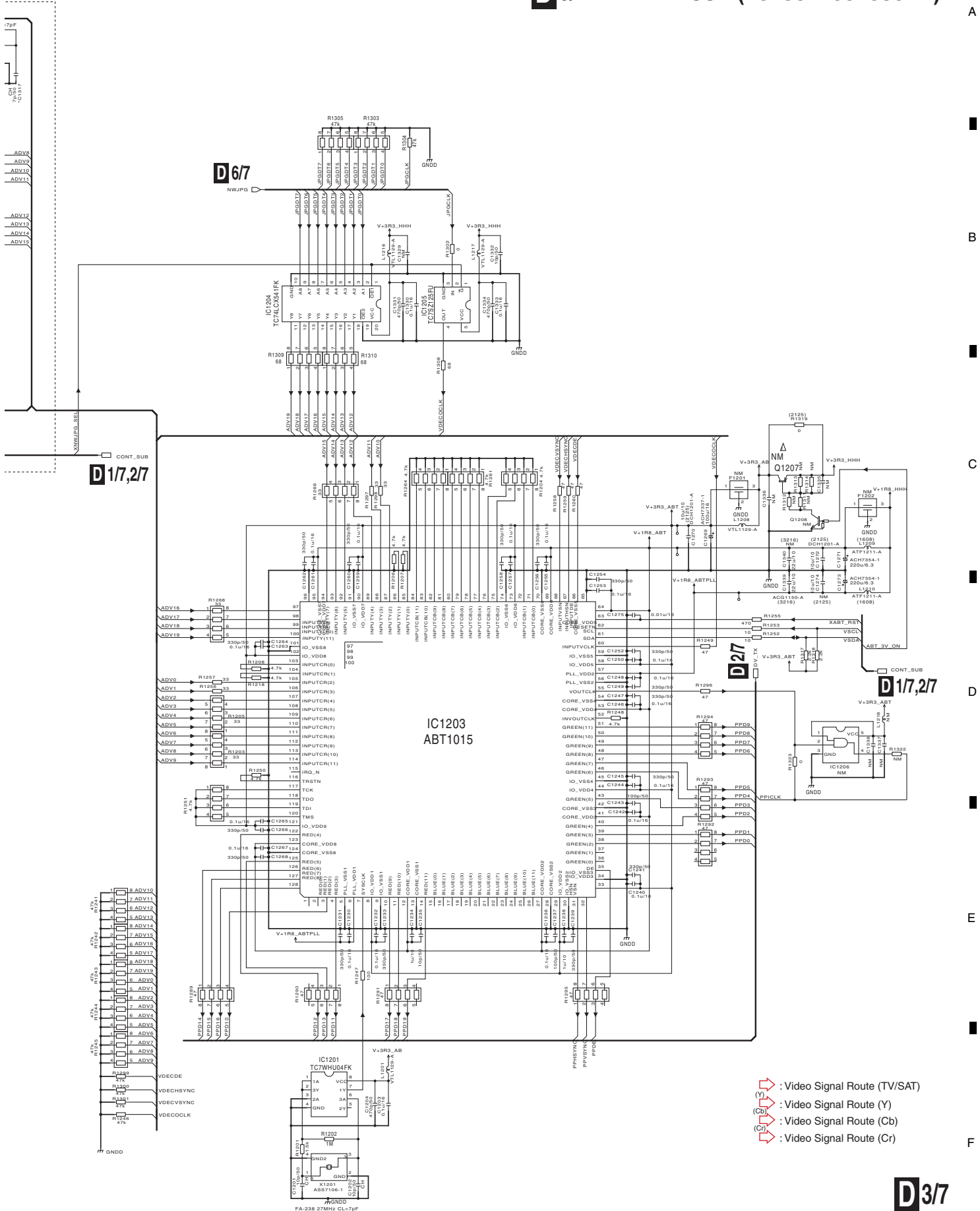

- (V) : Video Signal Route (TV/SAT)
- (Y) : Video Signal Route (Y)
- (Cb) : Video Signal Route (Cb)
- (Cr) : Video Signal Route (Cr)

VSX-1022-K



10.10 D-MAIN ASSY (4/7)(VSX-1022-K, VSX-42)

1 2 3 4

MASTER CLOCK SELECTOR

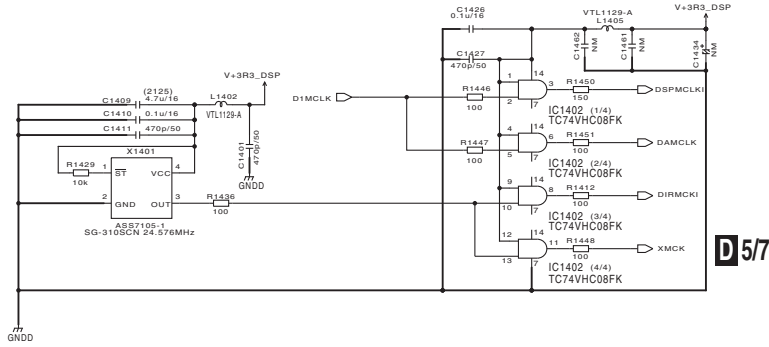

D 5/7

D 2/7,5/7

D 1/7,2/7,3/7,5/7,7/7

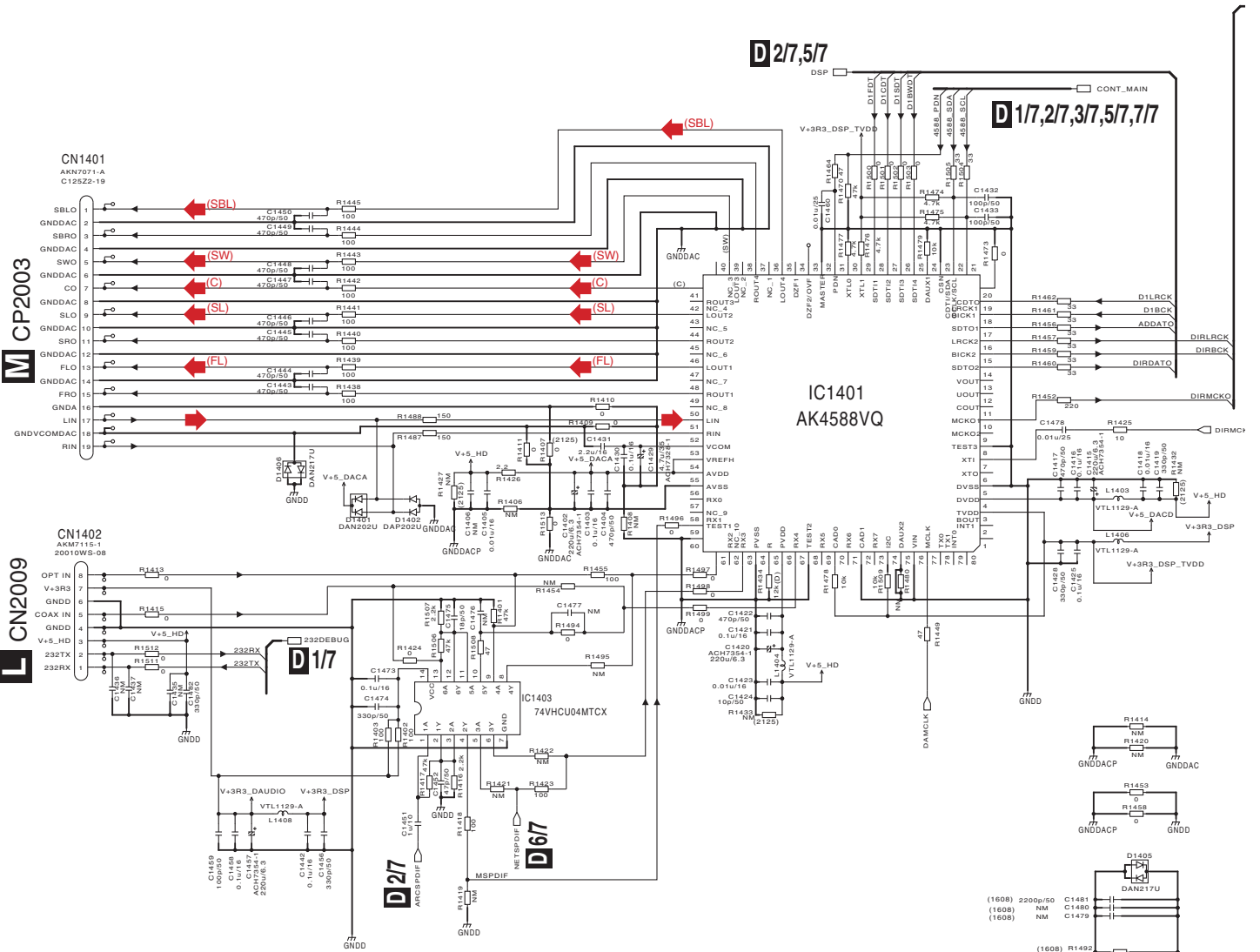

The Δ mark found on some component parts should be replaced with same parts (safety regulation authorized) of identical designation.
 △印の部品は指定部品(安全規格適合部品)を必ず使用すること。

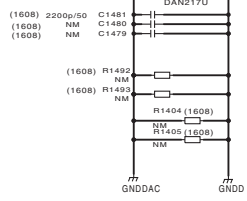

D 4/7

1 2 3 4

D4/7 D-MAIN ASSY (7028071691050-IL)

A

B

C

D

E

F

- ▶ : Audio Signal Route (L ch)
- (FL) ▶ : Audio Signal Route (Front L ch)
- (SL) ▶ : Audio Signal Route (Surround L ch)
- (C) ▶ : Audio Signal Route (Center ch)
- (SW) ▶ : Audio Signal Route (SubWoofer ch)
- (SBL) ▶ : Audio Signal Route (Surround Back L ch)

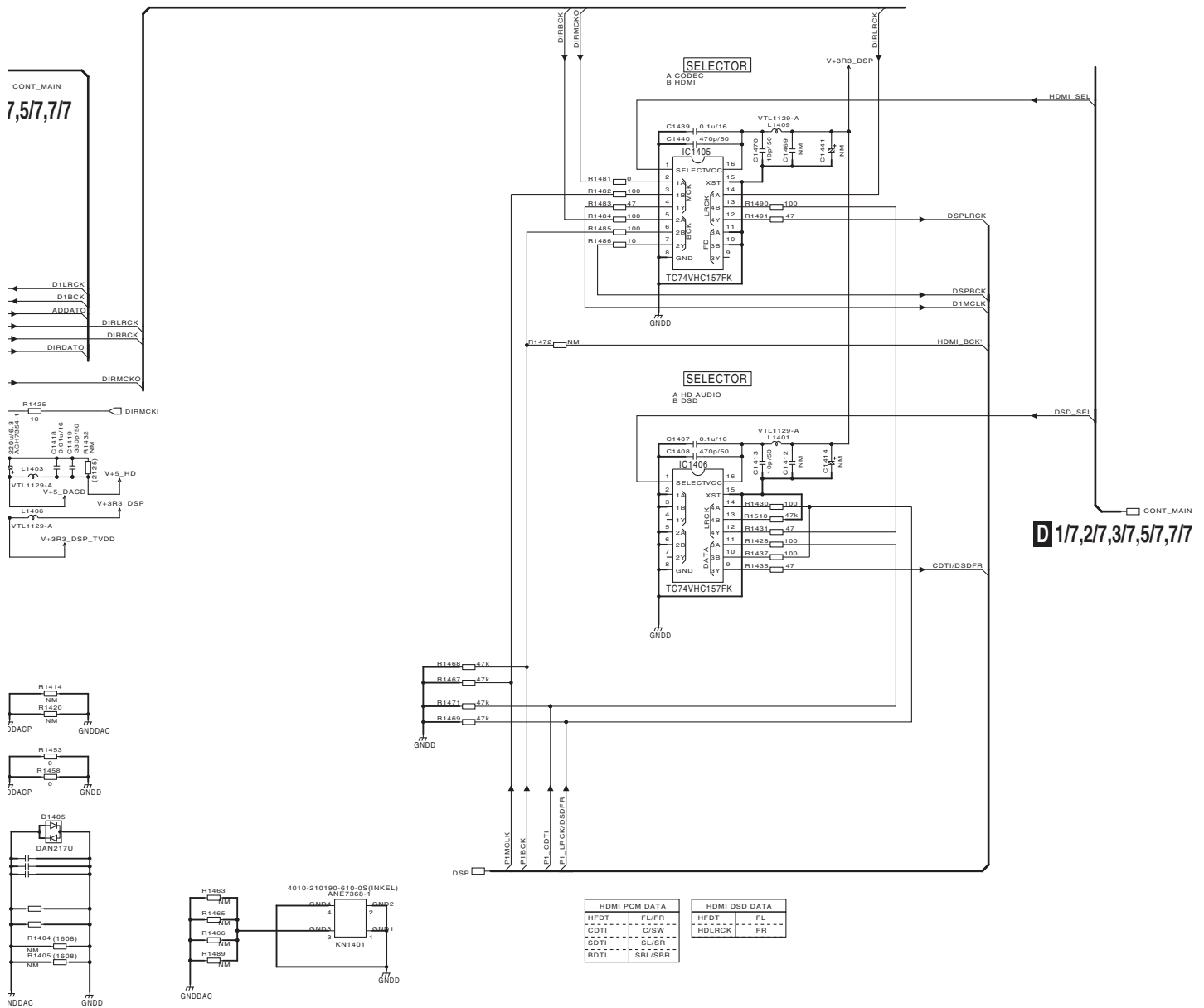

10.11 D-MAIN ASSY (5/7)(VSX-1022-K, VSX-42)

A
B
C
D
E
F

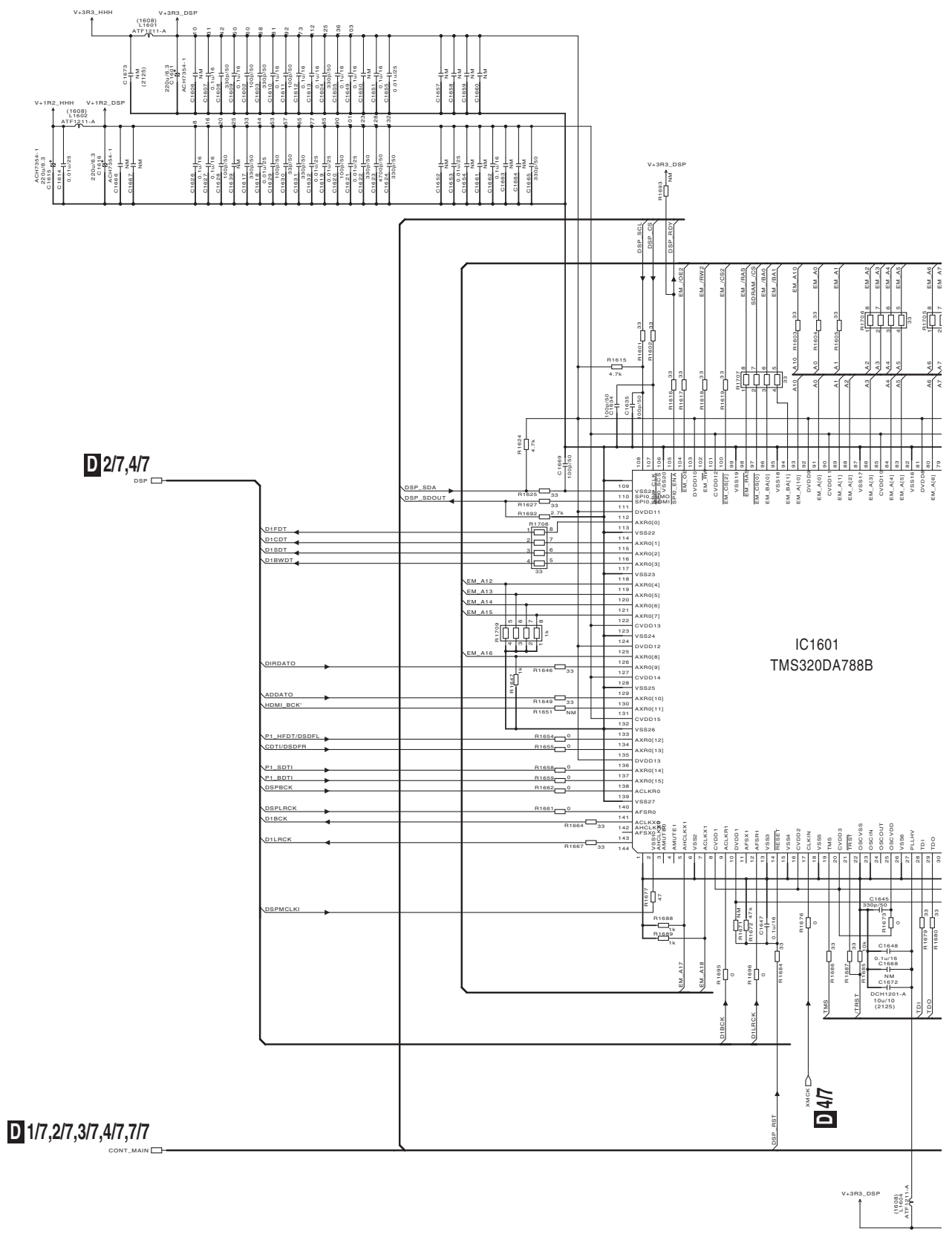

1

2

3

4

D5/7 D-MAIN ASSY (7028071691050-IL)

A
B
C
D
E
F

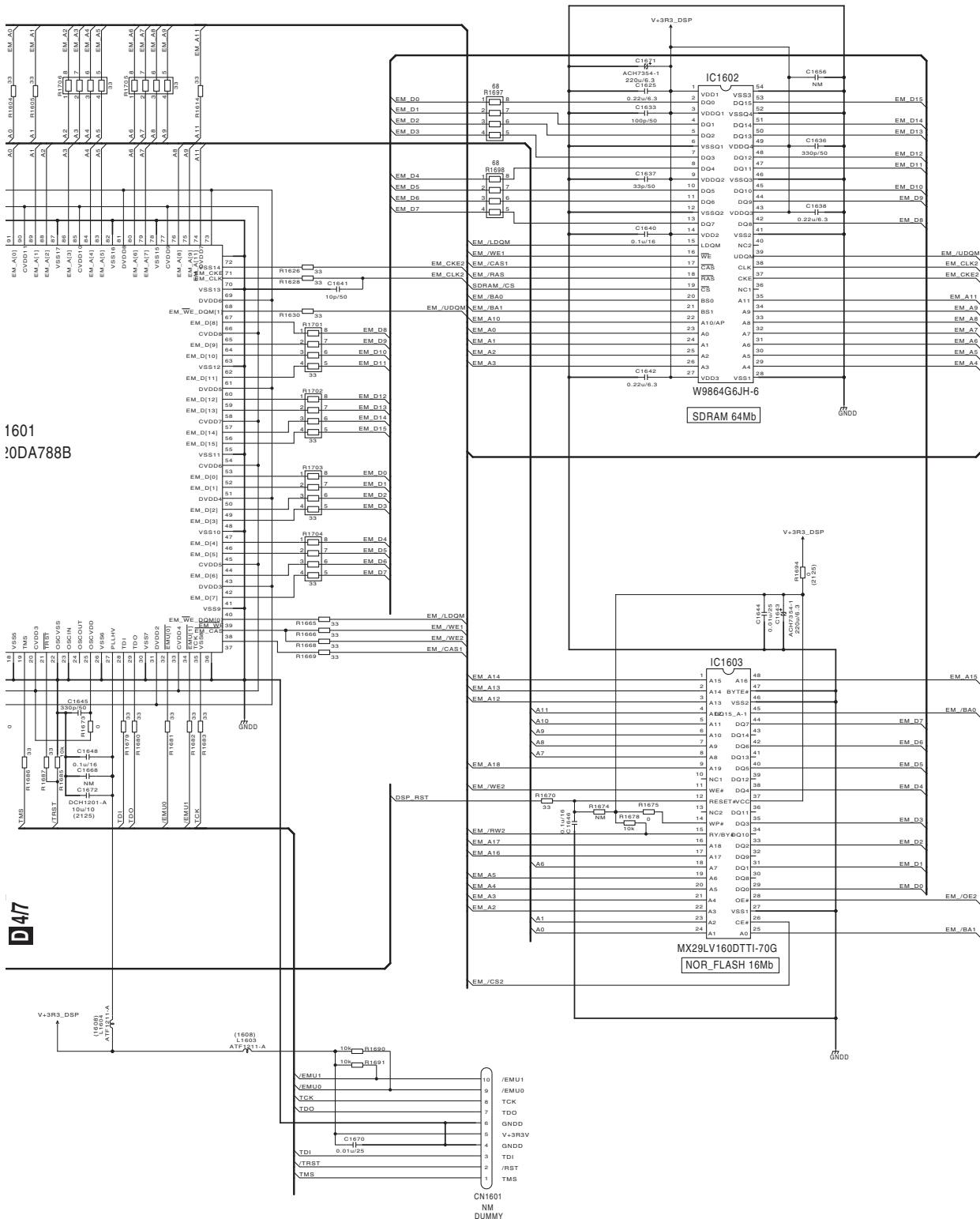

10.12 D-MAIN ASSY (6/7)(VSX-1022-K, VSX-42)

A

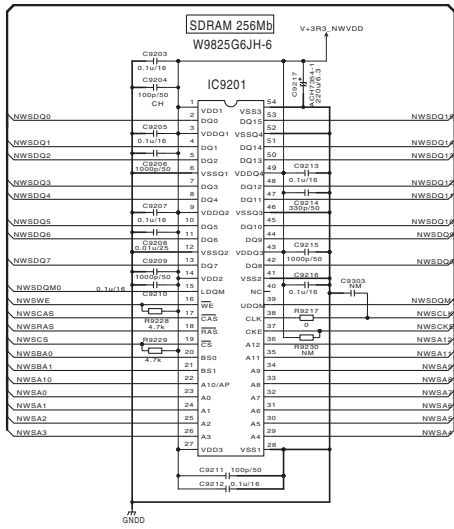

B

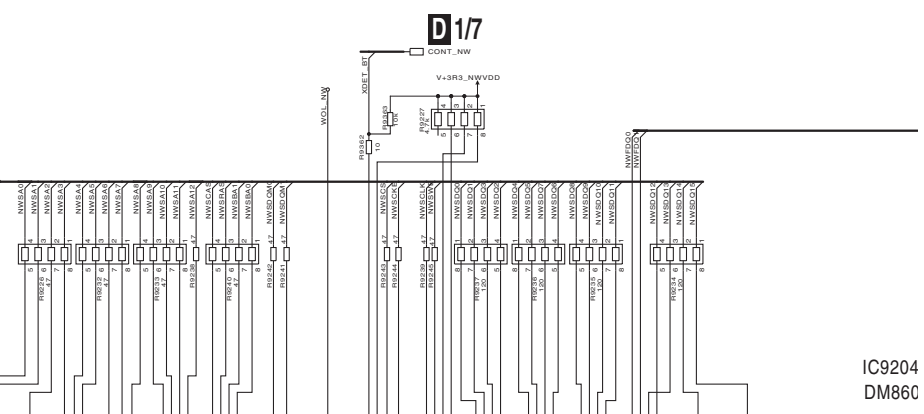

C

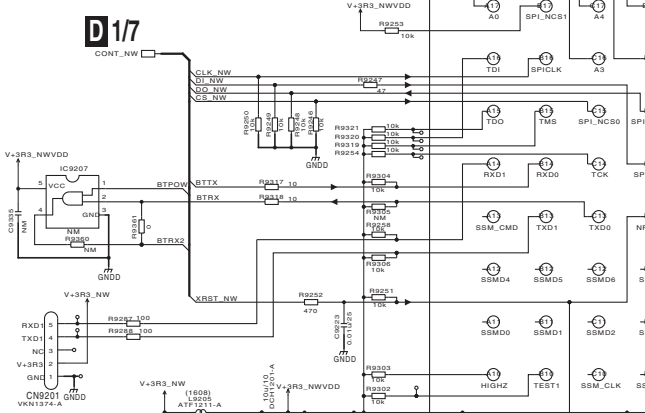

D

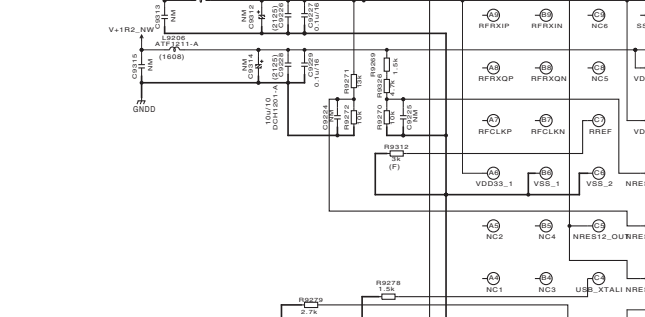

E

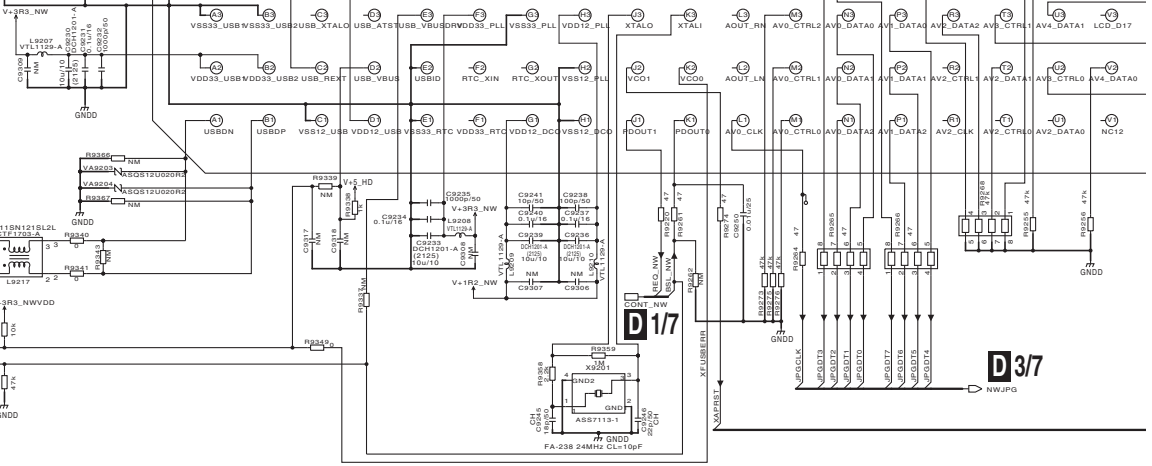

F

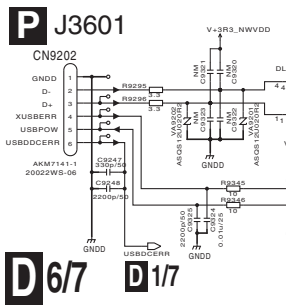

1

2

3

4

D6/7 D-MAIN ASSY (7028071691050-IL)

A

B

C

D

E

F

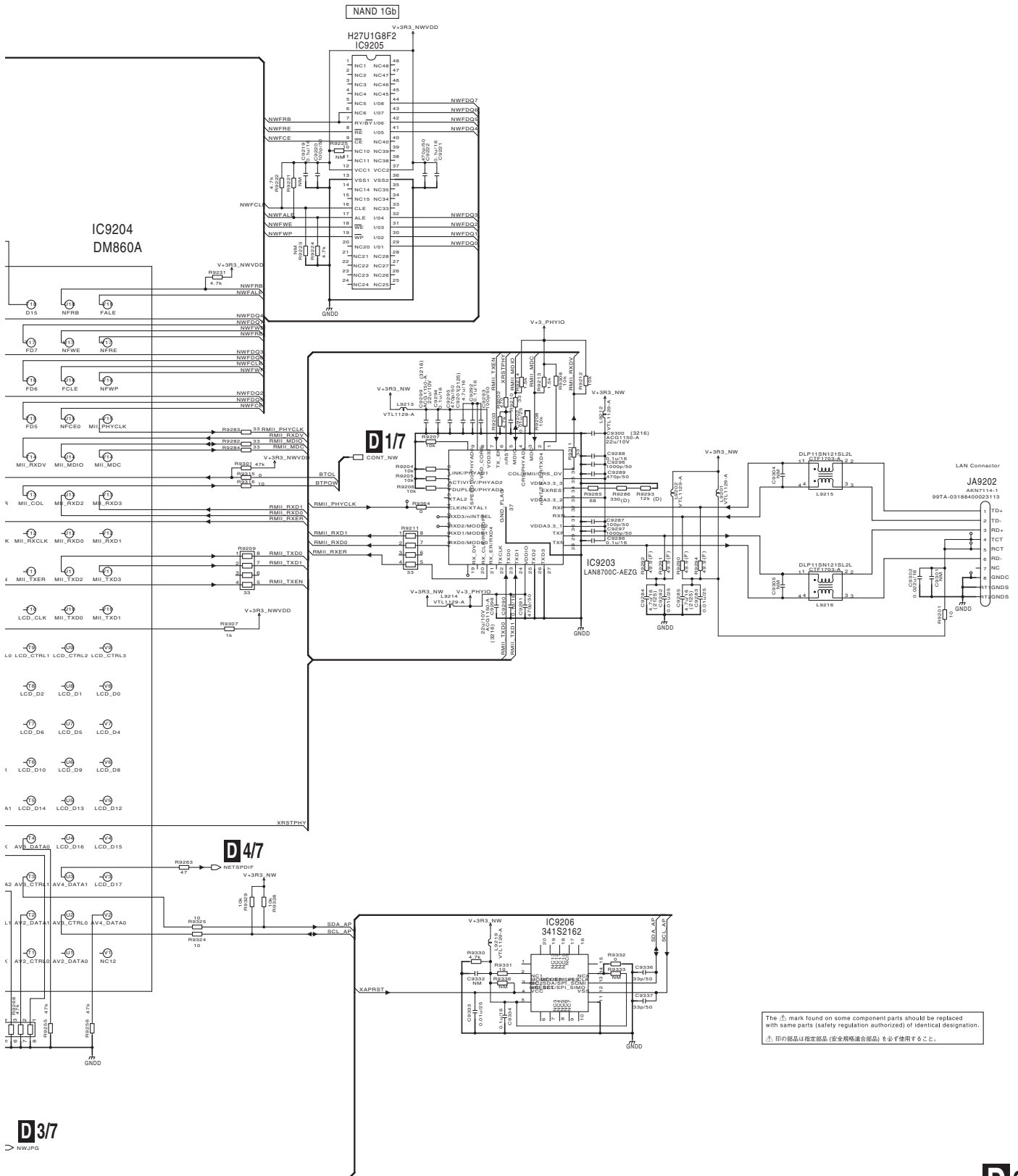

The Δ mark found on some component parts should be replaced with same parts (safety regulation authorized) of identical designation.
 Δ 印の部品は指定部品 (安全規格適合部品) を必ず使用する。こと。

D37
 > NWJPG

VSX-1022-K

10.13 D-MAIN ASSY (7/7)(VSX-1022-K, VSX-42)

A
B
C
D
E
F

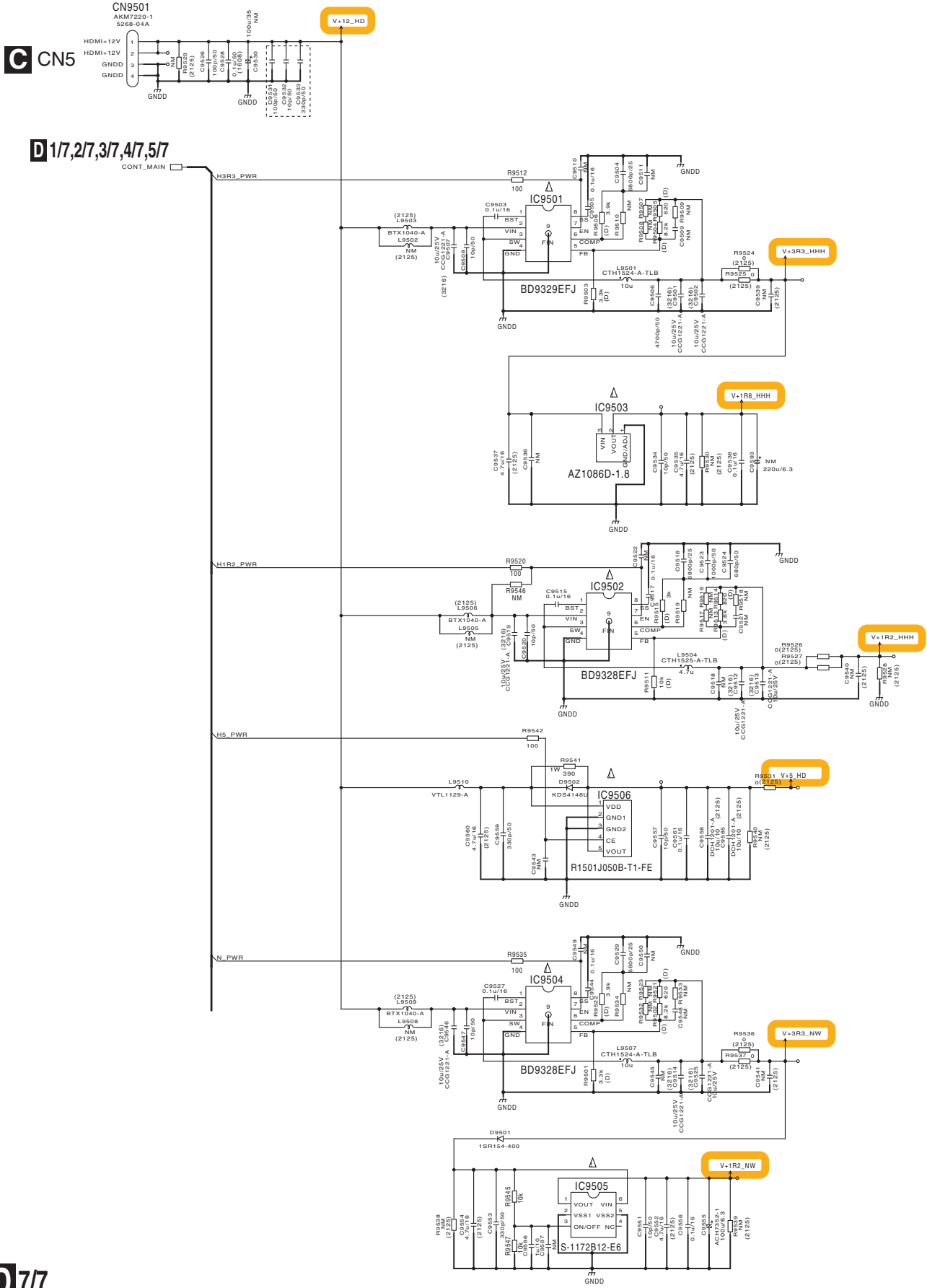

D77 D-MAIN ASSY (7028071691050-IL)

A

B

C

D

E

F



161429

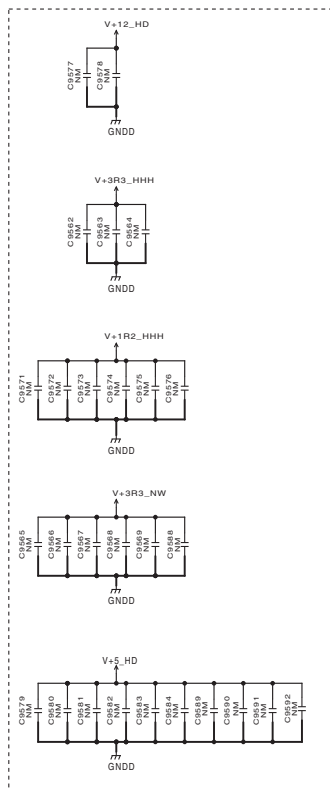

All 1u/10 is DCH1246-A.

The Δ mark found on some component parts should be replaced with same parts (safety regulation authorized) of identical designation.
△印の部品は指定部品(安全規格適合部品)を必ず使用すること。



10.14 D-MAIN ASSY (1/7)(VSX-822-K)

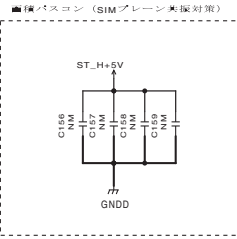
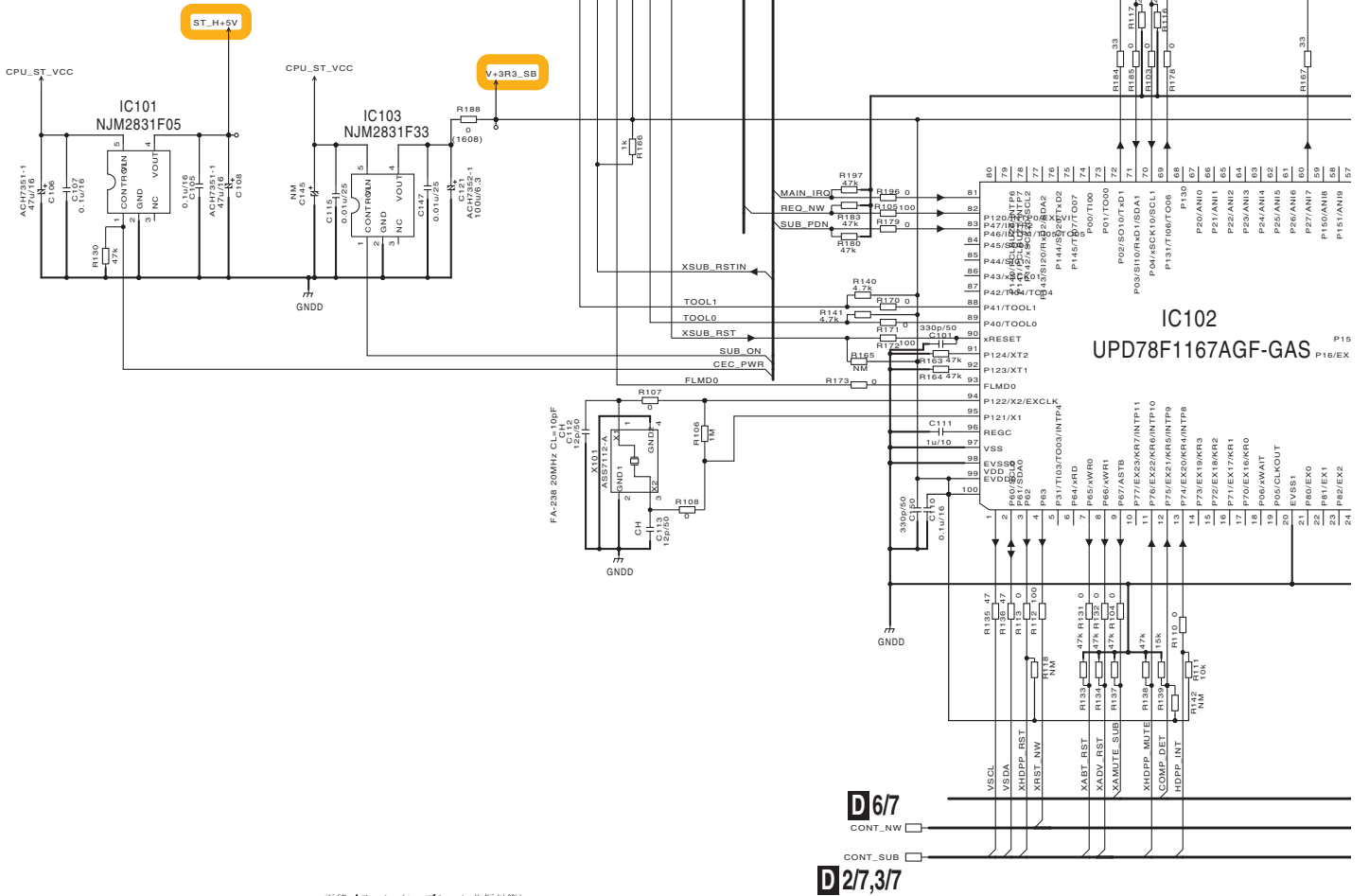
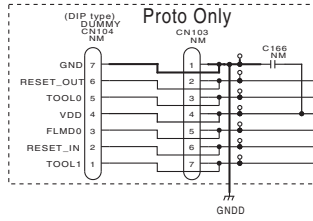

D17 D-MAIN ASSY (7028071691010-IL)

A
B
C
D
E
F

D 2/7,3/7,4/7,5/7,7/7

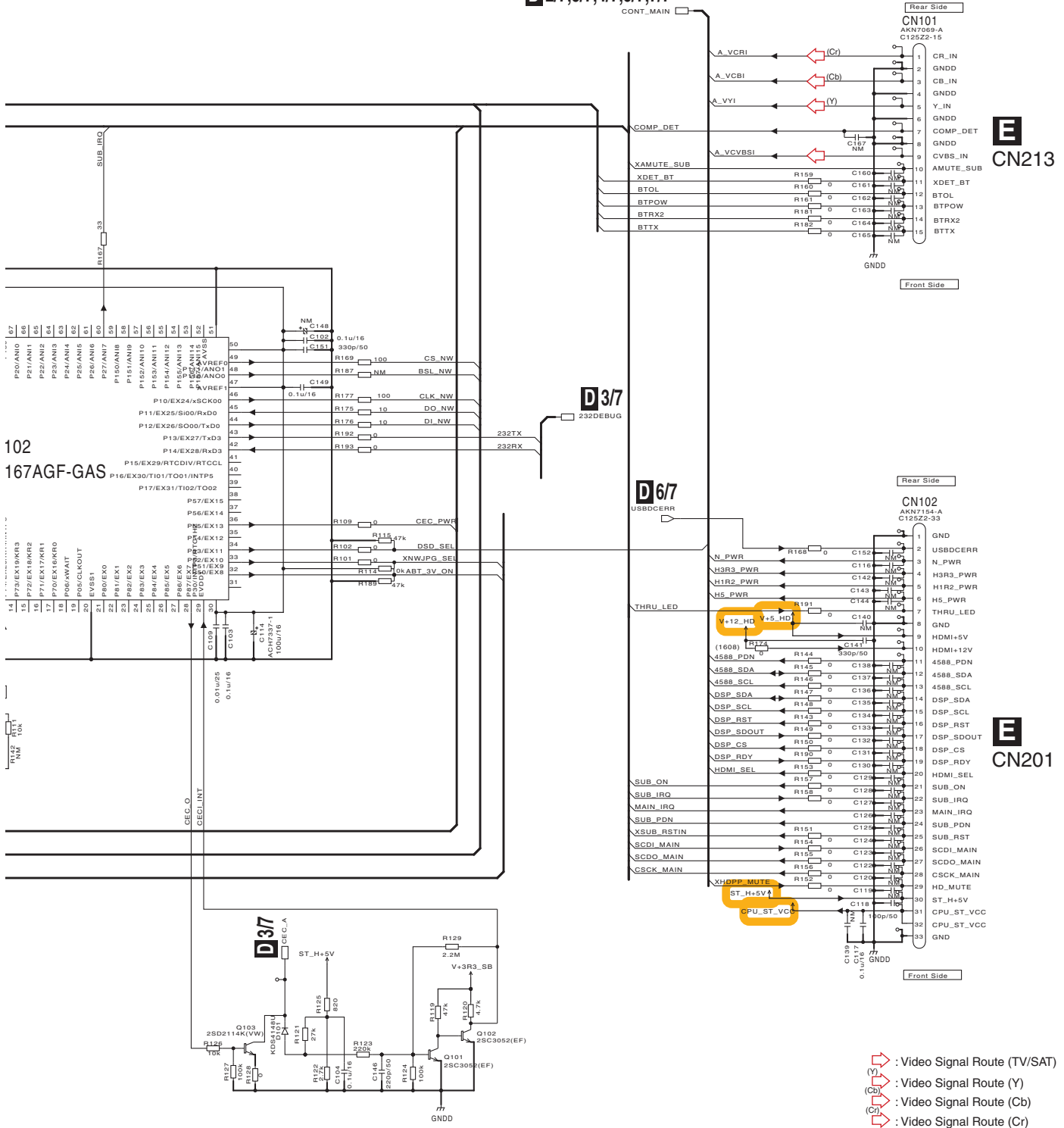

102
167AGF-GAS

E
CN213

E
CN201

VSX-1022-K

D17

10.15 D-MAIN ASSY (2/7)(VSX-822-K)

1 2 3 4

A

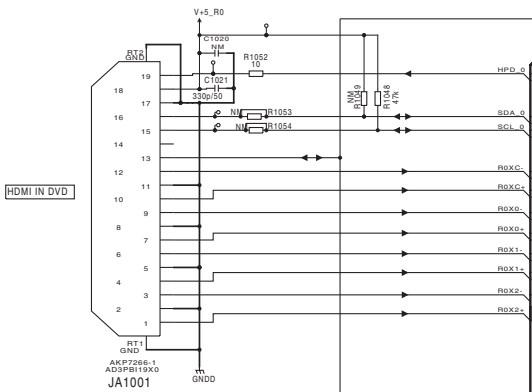

B

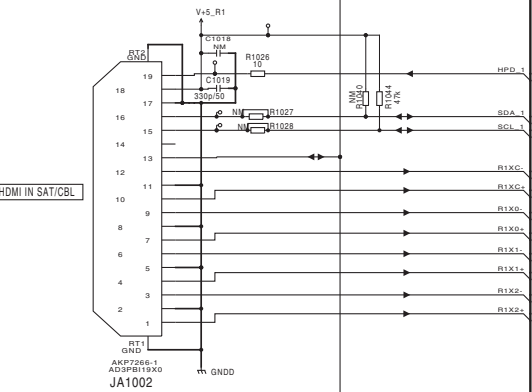

C

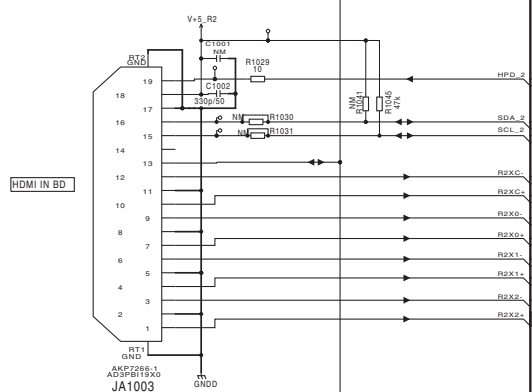

D

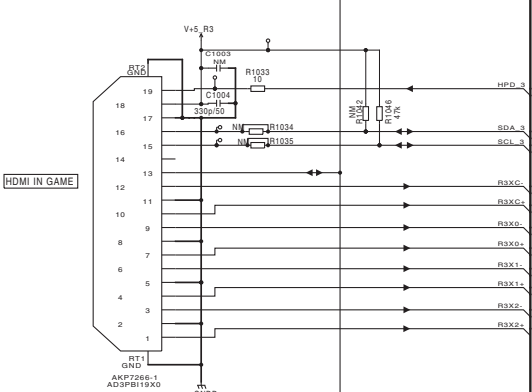

F

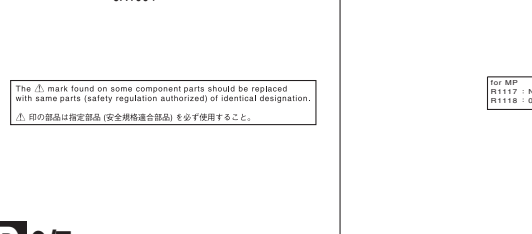

The Δ mark found on some component parts should be replaced with same parts (safety regulation authorized) of identical designation.
 △印の部品は指定部品(安全規格適合部品)を必ず使用すること。
 For MP
 R1117 : NM
 R1118 : 0 ohm

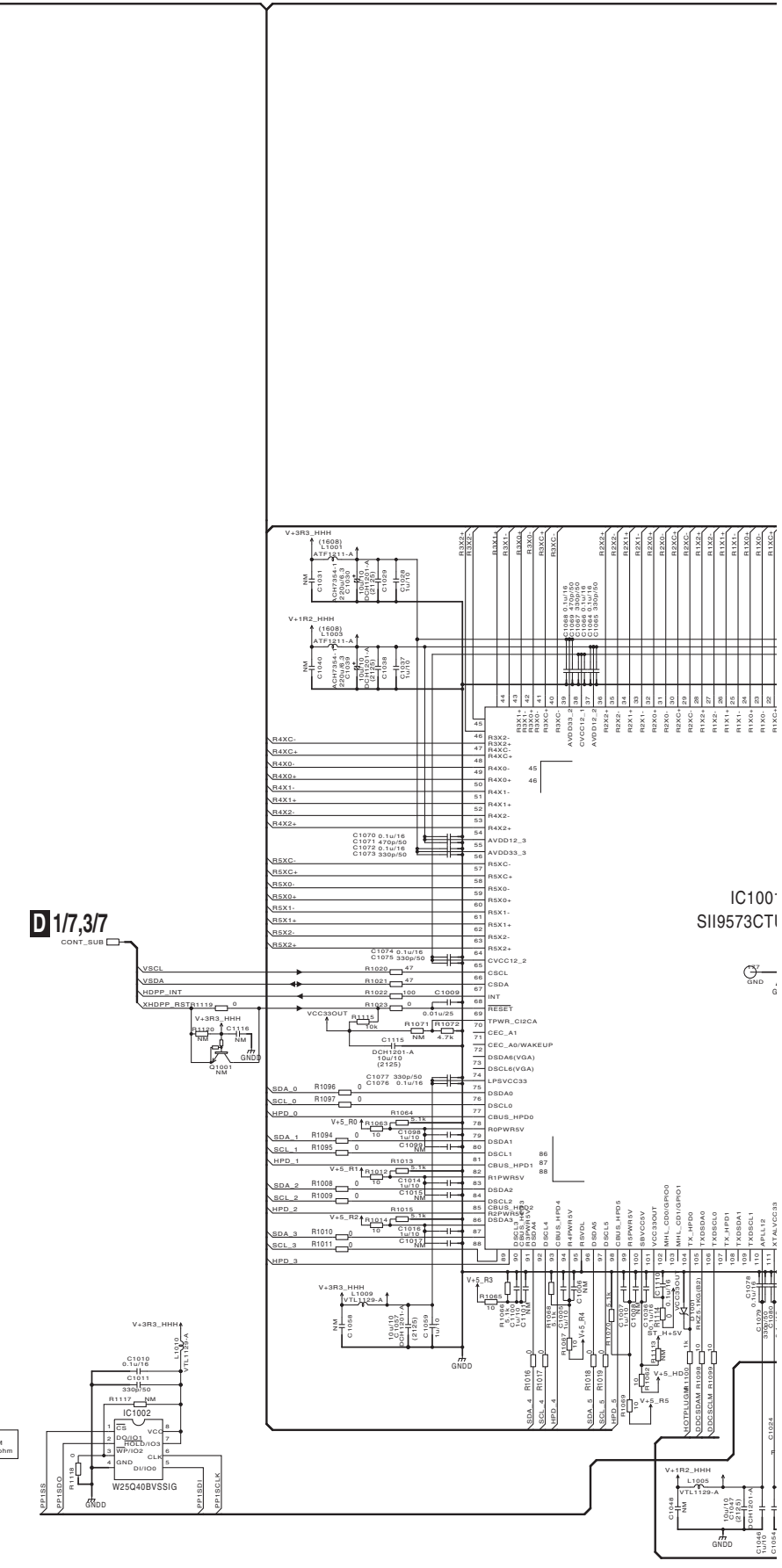

D17,3/7
CONT. SUB

IC100
SII9573CTI

D2/7

1 2 3 4

10.16 D-MAIN ASSY (3/7)(VSX-822-K)

A
B
C
D
E
F

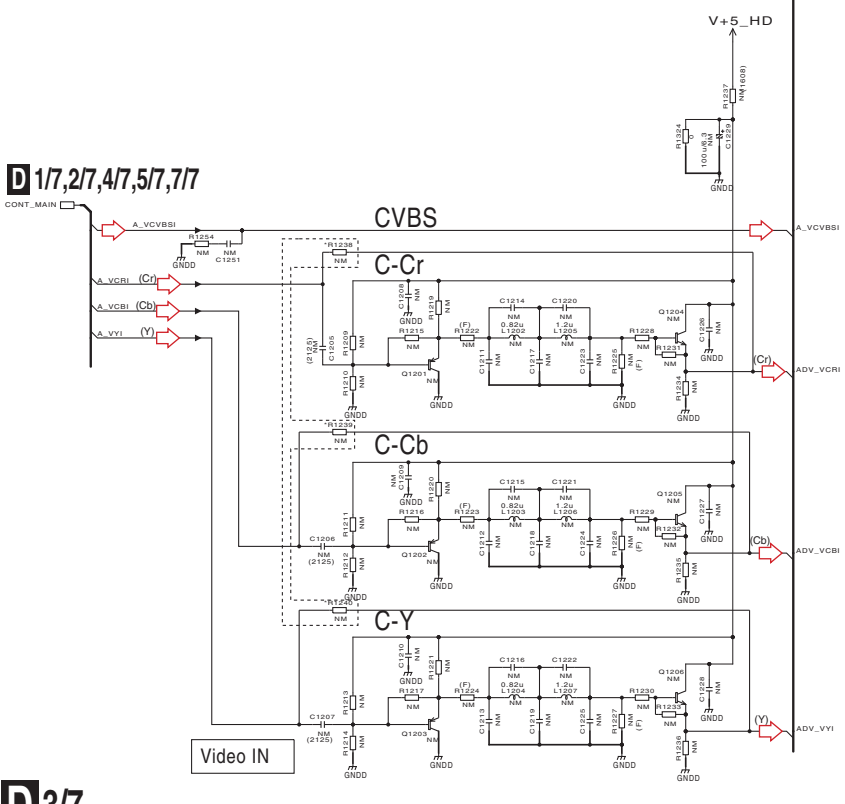
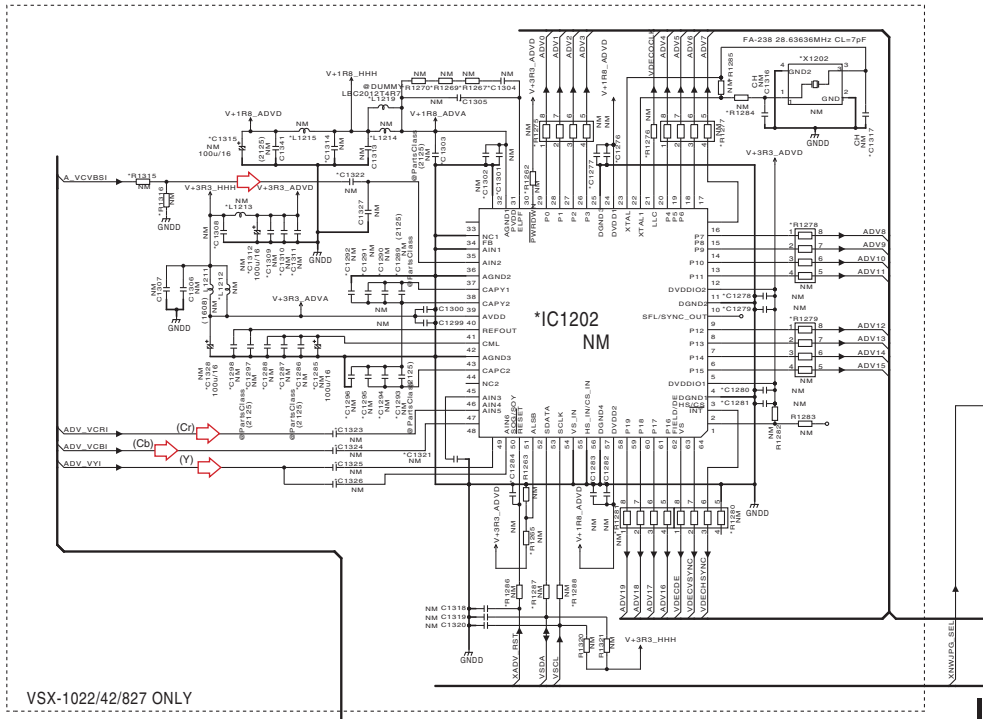

VSX-1022-K

D 117,217,417,517,717

D3/7

4/20
4/20
4/20
4/20

D3/7 D-MAIN ASSY (7028071691010-IL)

A
B
C
D
E
F

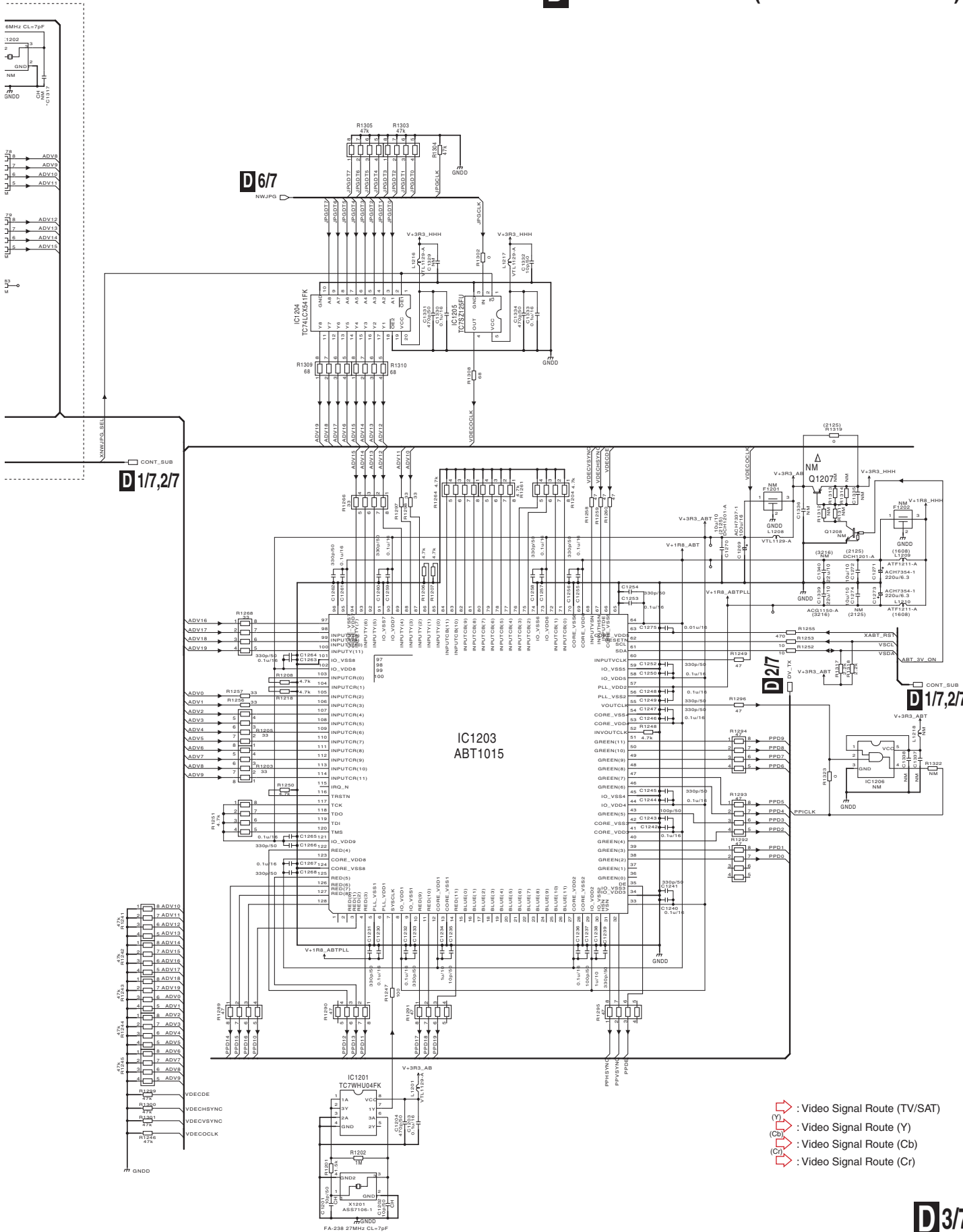

- (TV/SAT) : Video Signal Route (TV/SAT)
- (Y) : Video Signal Route (Y)
- (Cb) : Video Signal Route (Cb)
- (Cr) : Video Signal Route (Cr)

VSX-1022-K



10.17 D-MAIN ASSY (4/7)(VSX-822-K)

A

B

C

D

E

F

MASTER CLOCK SELECTOR

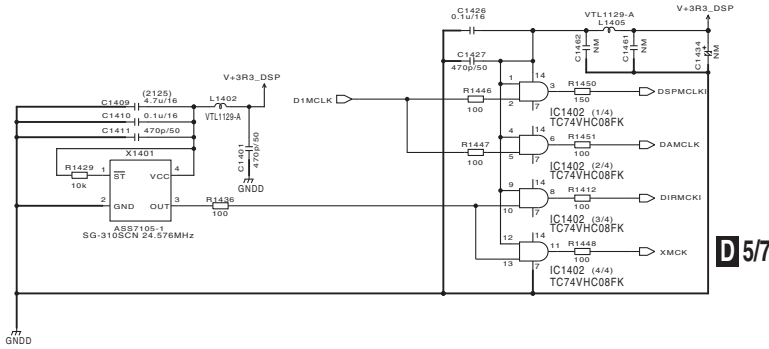

D 5/7

D 2/7, 5/7

D 1/7, 2/7, 3/7, 5/7, 7/7

M CP2003

L CN2009

D 1/7

D 2/7

D 6/7

IC1401
AK4588VQ

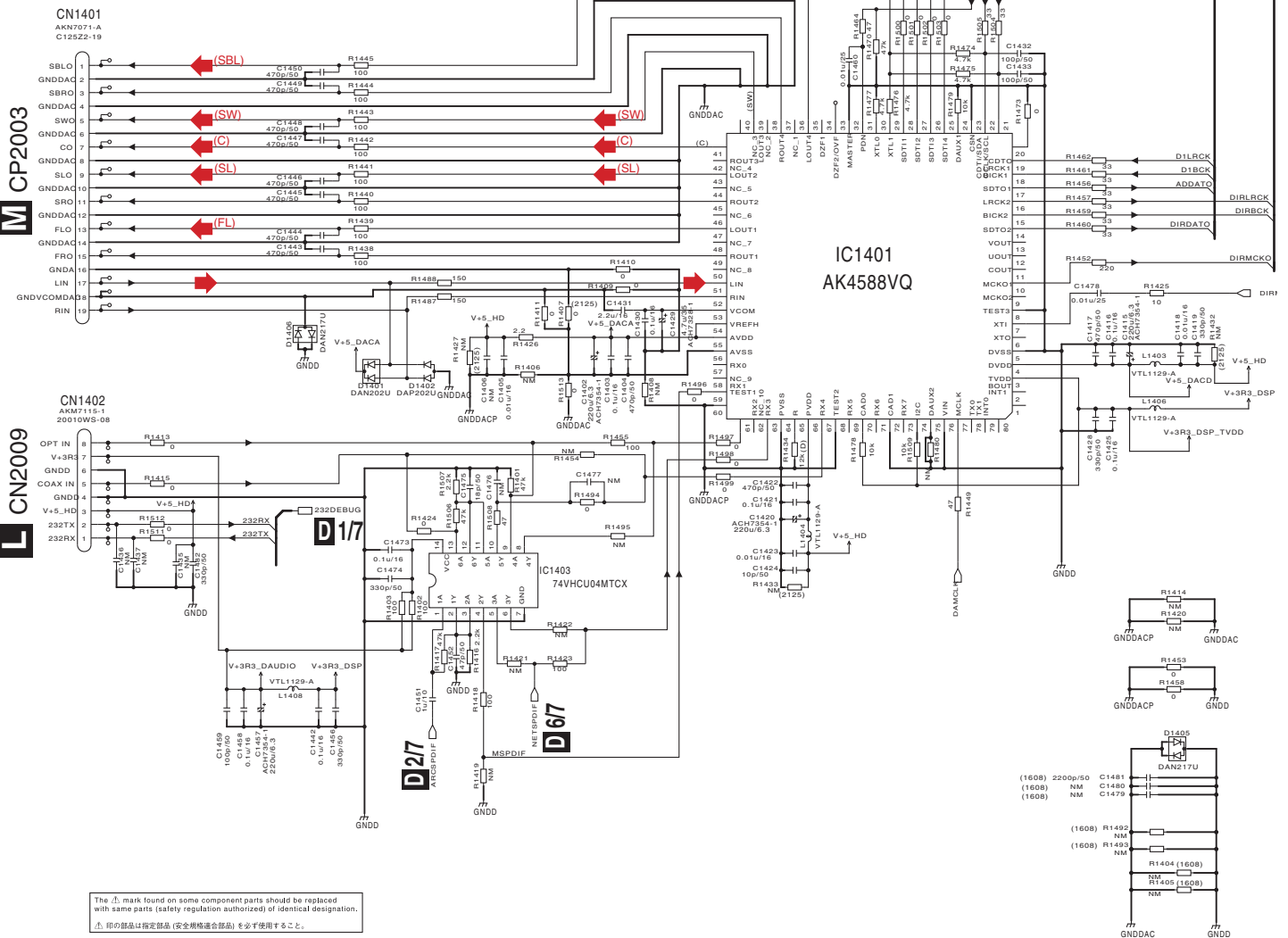

The Δ mark found on some component parts should be replaced with same parts (safety regulation authorized) of identical designation.
△印の部品は指定部品(安全規格適合部品)を必ず使用すること。

D 4/7

D4/7 D-MAIN ASSY (7028071691010-IL)

A

B

C

D

E

F

- ▶ : Audio Signal Route (L ch)
- (FL) ▶ : Audio Signal Route (Front L ch)
- (SL) ▶ : Audio Signal Route (Surround L ch)
- (C) ▶ : Audio Signal Route (Center ch)
- (SW) ▶ : Audio Signal Route (SubWoofer ch)
- (SBL) ▶ : Audio Signal Route (Surround Back L ch)

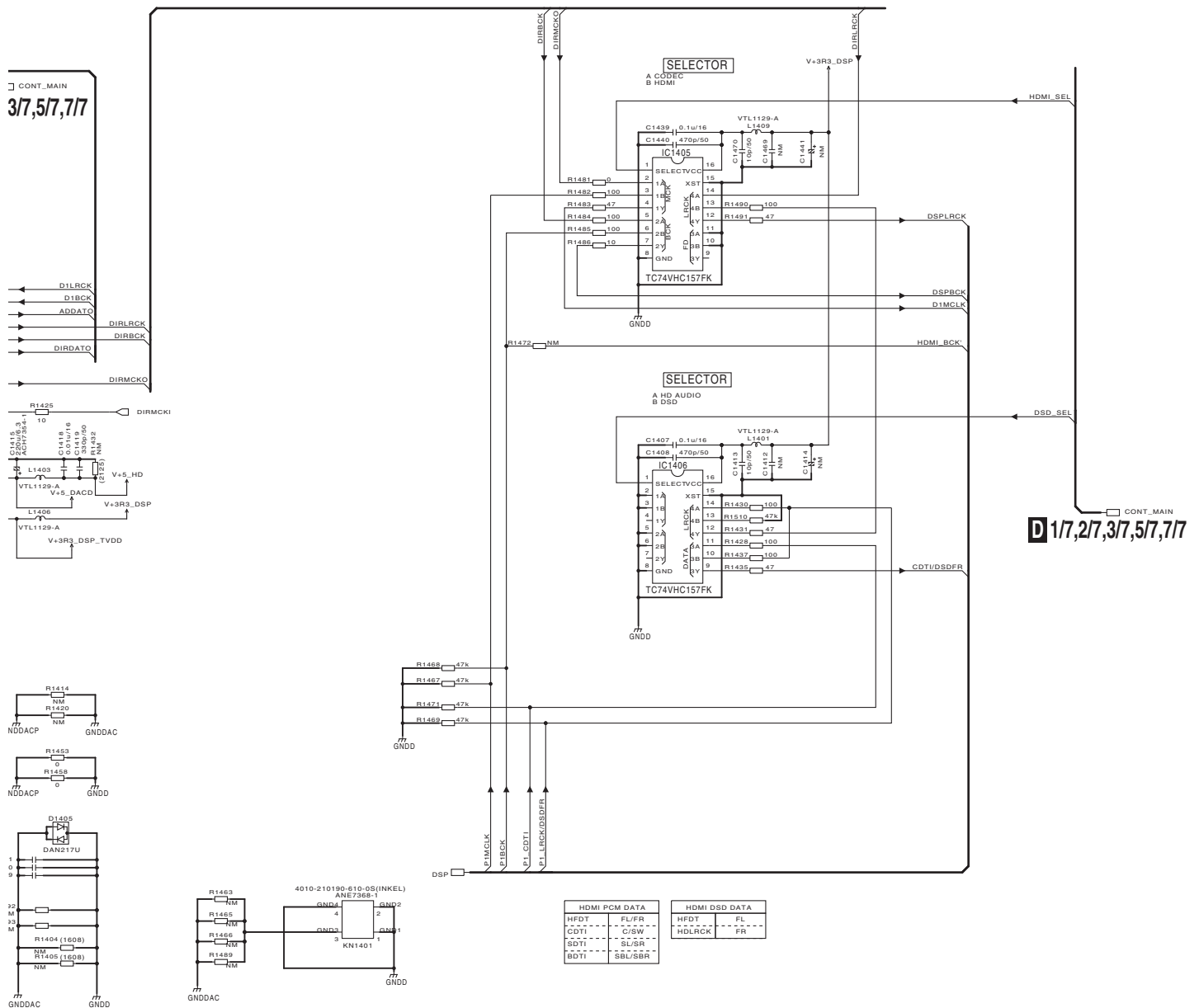

D5/7 D-MAIN ASSY (7028071691010-IL)

A
B
C
D
E
F

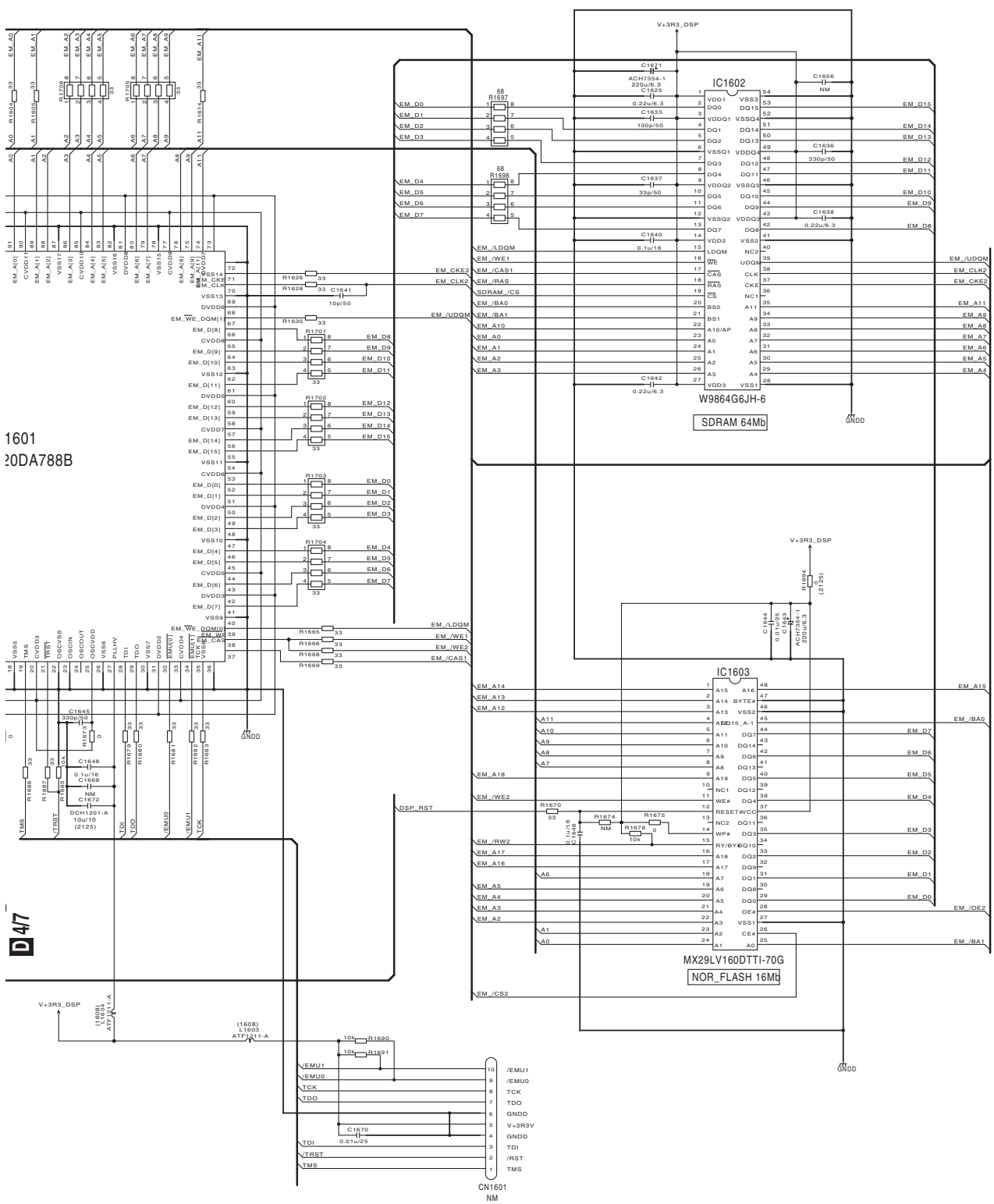

1601
20DA788B

D47

VSX-1022-K

D5/7

10.19 D-MAIN ASSY (6/7)(VSX-822-K)

1 2 3 4

A

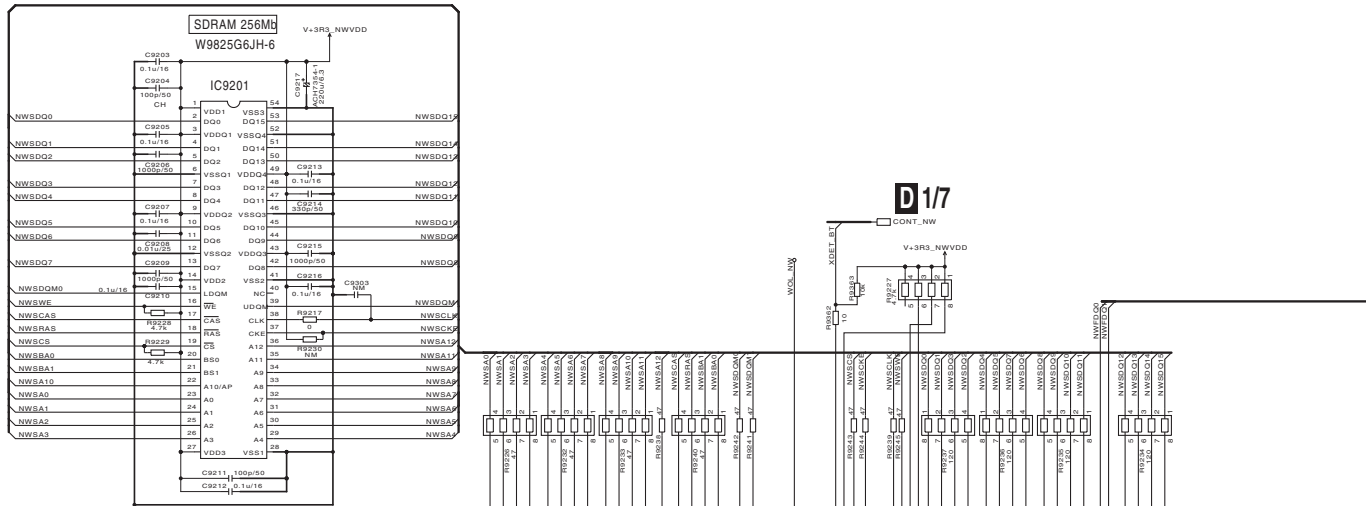

B

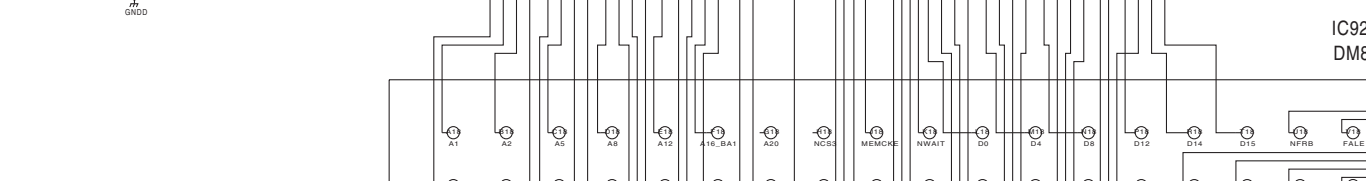

C

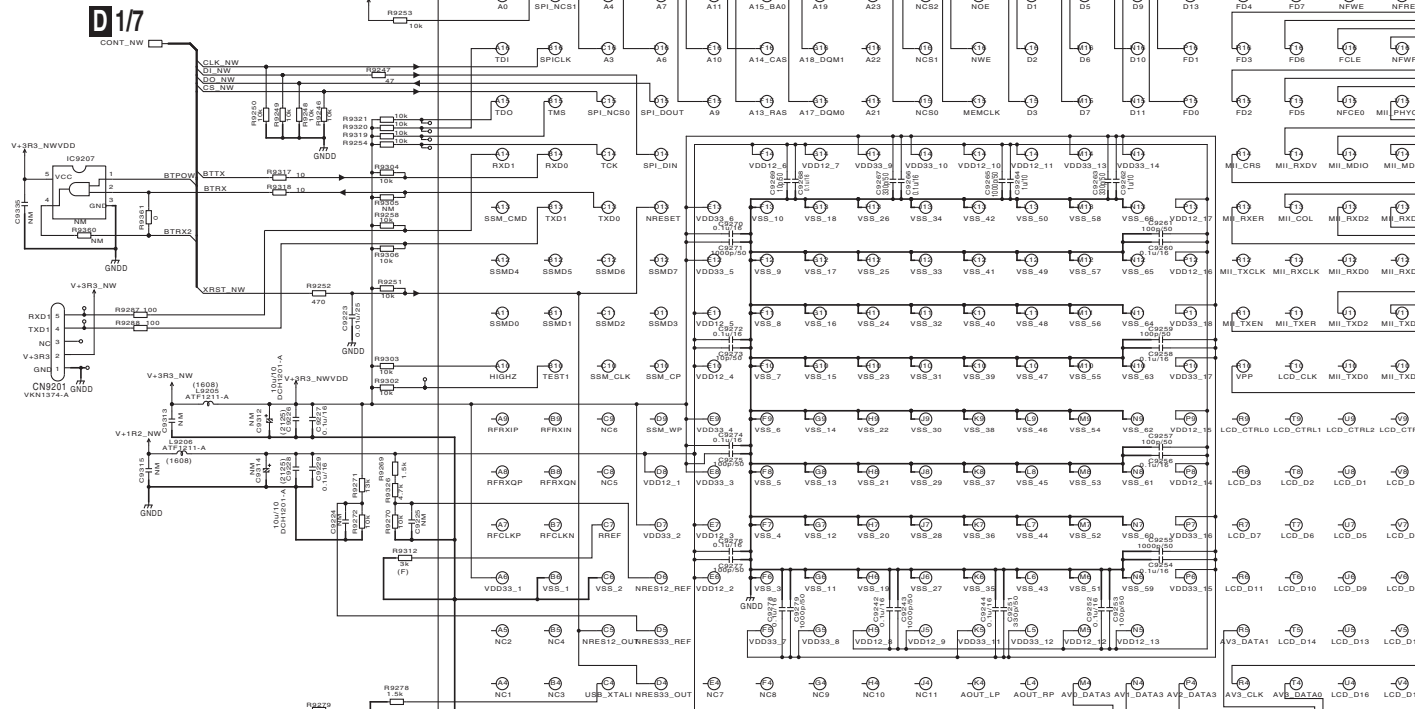

D

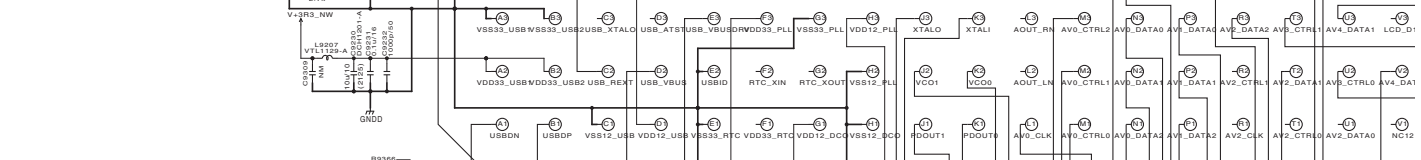

E

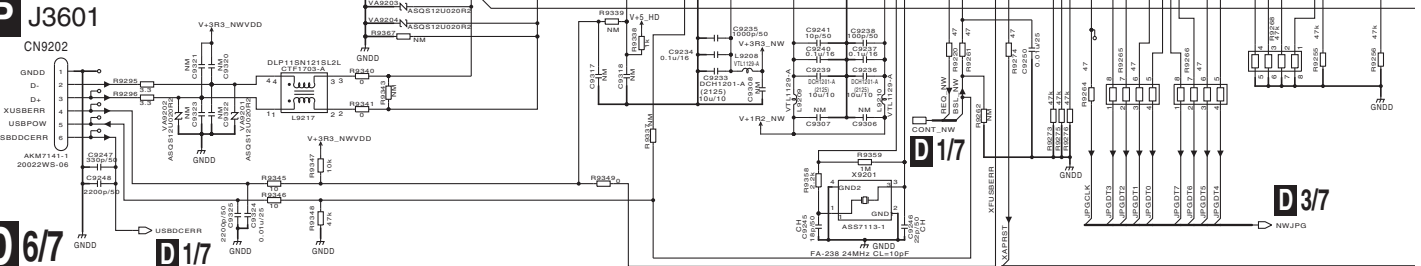

F



10.20 D-MAIN ASSY (7/7)(VSX-822-K)

1 2 3 4

A

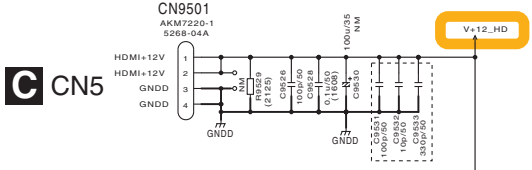

D 1/7,2/7,3/7,4/7,5/7

B

C

D

E

F

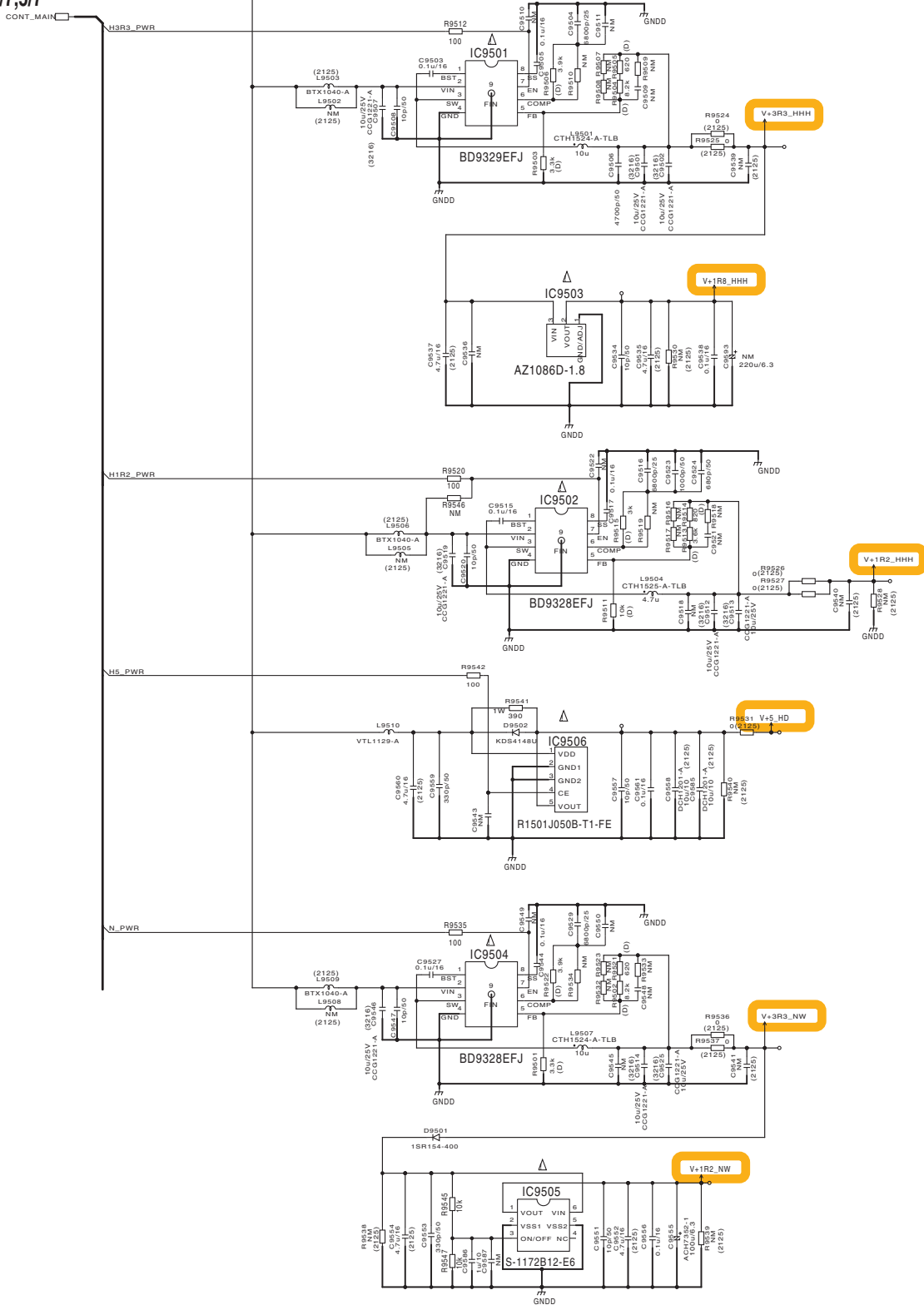

D 7/7

1 2 3 4

D77 D-MAIN ASSY (7028071691010-IL)

A

B

C

D

E

F

32_HHH
NM 10
(2125)

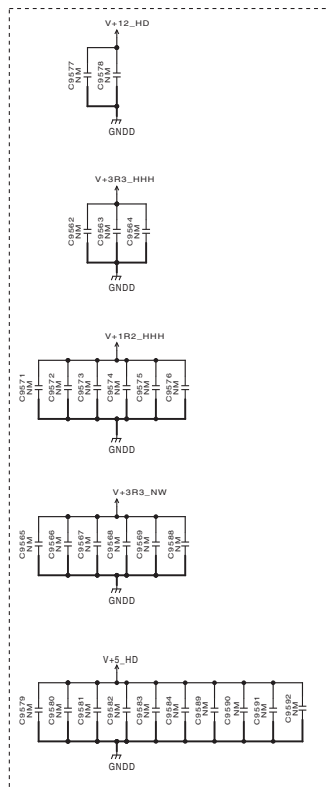

All 1u/10 is DCH1246-A.

The Δ mark found on some component parts should be replaced with same parts (safety regulation authorized) of identical designation.
△印の部品は指定部品(安全規格適合部品)を必ず使用すること。

10.21 CPU ASSY

CPU ASSY

(VSX-1022-K: 7028071681030-IL)

(VSX-42: 7028071681050-IL)

(VSX-822-K: 7028071681010-IL)

D I7 CN102

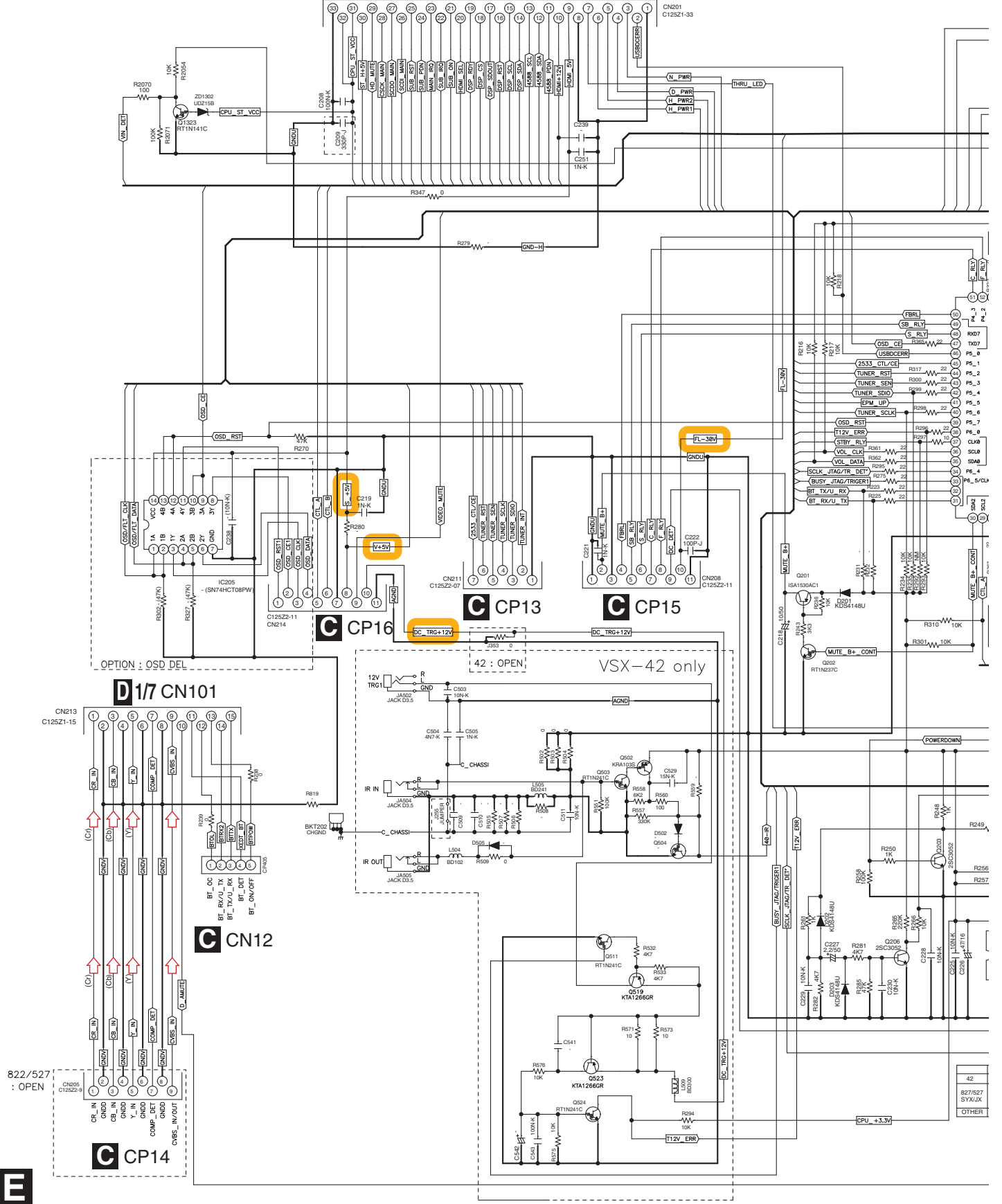

VSX-1022-K

A
B
C
D
E
F

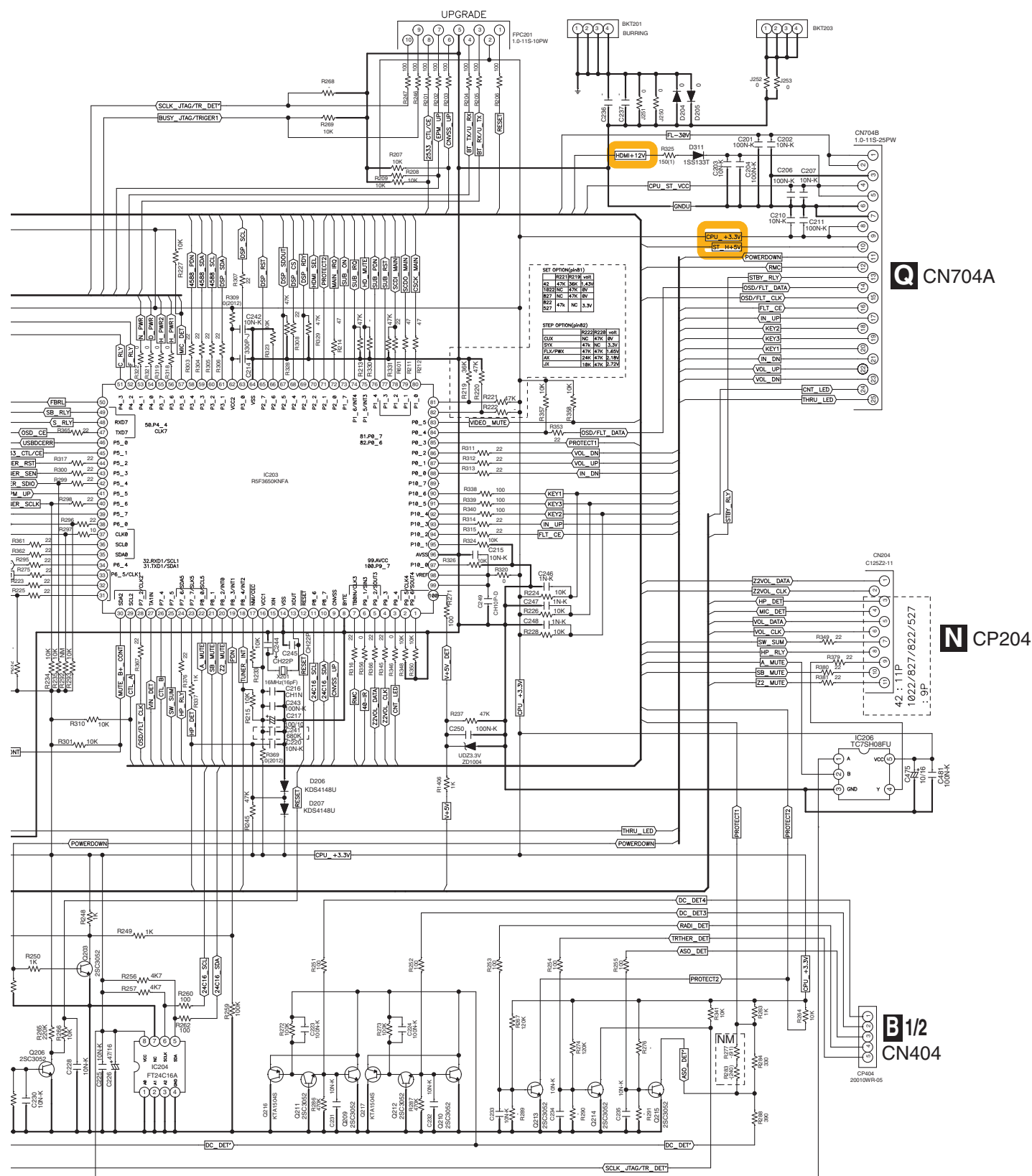

C504	C505	J255	C209	C222	C241	J353
42	4N7	1N	JUMPER	1N-K	1N-K	OPEN
827/527	SYX/JX	0	0	JUMPER 330P-J	100P-J	680K
0	0	0	0	OPEN	1N-K	OPEN

CAUTION
FOR CONTINUED PROTECTION AGAINST RISK OF FIRE.
REPLACE WITH SAME TYPE AND RATINGS OF FUSE.

The Δ mark found on some component parts indicates the importance of the safety factor of the part. Therefore when replacing be sure to use parts of identical designation

- \rightarrow : Video Signal Route (TV/SAT)
- (Y) : Video Signal Route (Y)
- (Cb) : Video Signal Route (Cb)
- (Cr) : Video Signal Route (Cr)

VSX-1022-K

Q CN704A

N CP204

B 1/2 CN404



10.22 VIDEO, G-L, G-R, WG-A and WG-B ASSYS

F VIDEO ASSY (VSX-1022-K, VSX-42: 7028071671030-IL) (VSX-822-K: 7028071671010-IL)

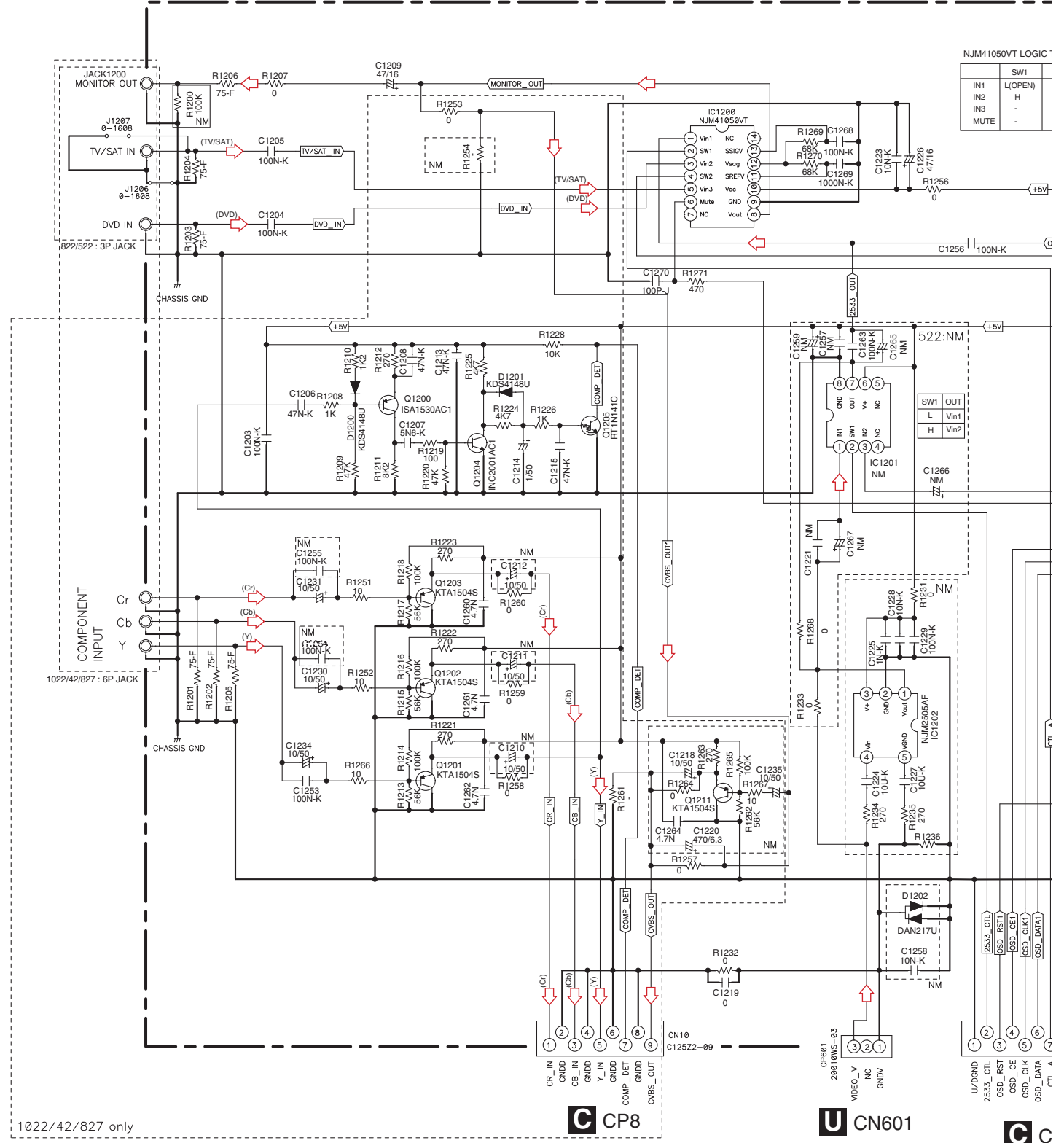

1022/42/827 only



A
B
C
D
E
F

NJM41050VT LOGIC TABLE

	SW1	SW2	MUTE
IN1	L(OPEN)	L(OPEN)	H
IN2	H	L(OPEN)	H
IN3	-	H	H
MUTE	-	-	L(OPEN)

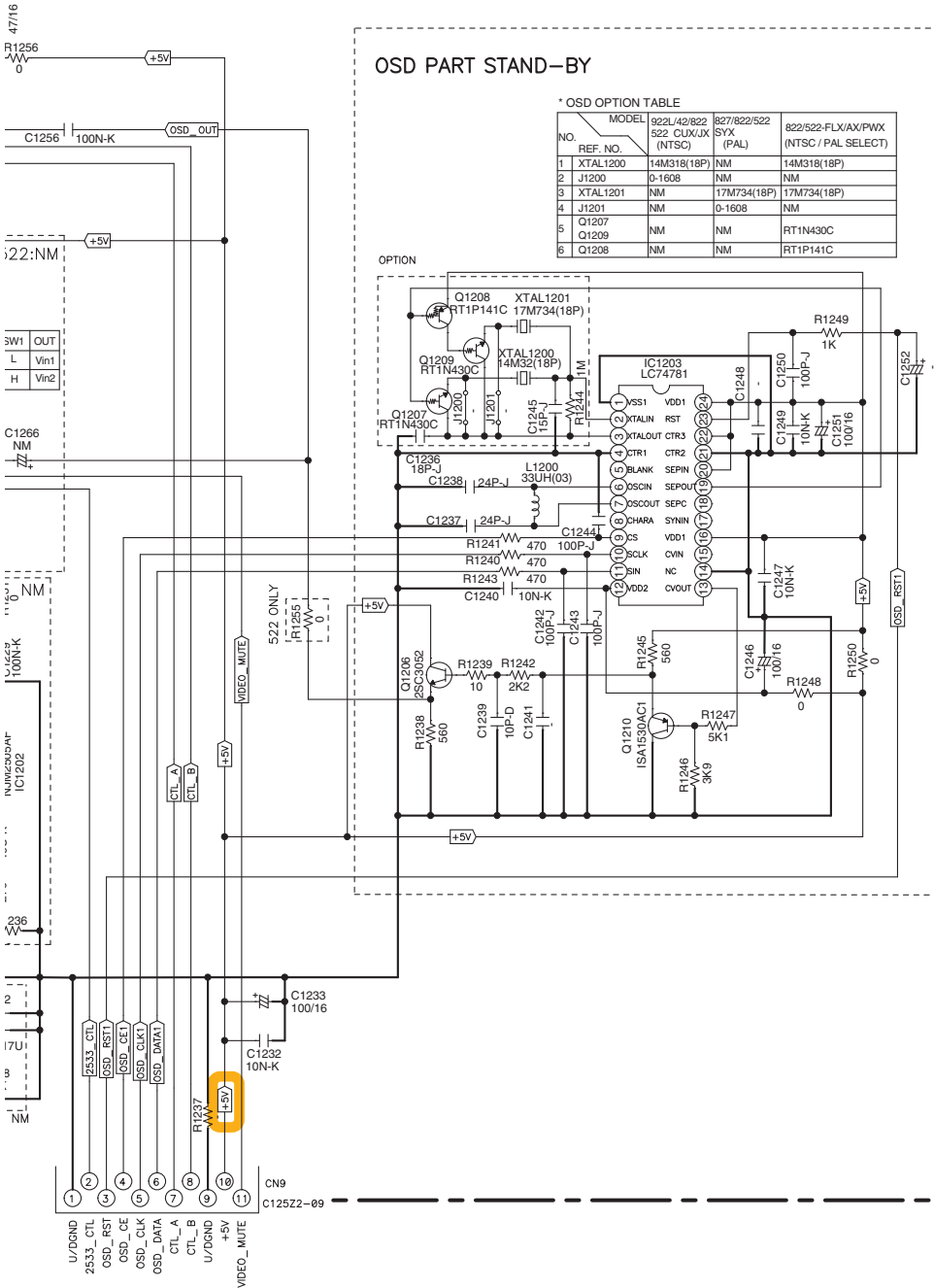

OSD PART STAND-BY

* OSD OPTION TABLE

NO.	MODEL	922L/42/822	827/822/522	822/522-FLX/AX/PWX
REF. NO.	522 CLX/JX (NTSC)	522 CLX/JX (PAL)	522 CLX/JX (NTSC / PAL SELECT)	
1	XTAL1200	14M318(18P)	NM	14M318(18P)
2	J1200	0-1608	NM	NM
3	XTAL1201	NM	17M734(18P)	17M734(18P)
4	J1201	NM	0-1608	NM
5	Q1207	NM	NM	RT1N430C
6	Q1208	NM	NM	RT1P141C

G G-L ASSY
(7028071615050-IL)

H G-R ASSY
(7028071614050-IL)

I WG-A ASSY
(7028071616050-IL)

J WG-B ASSY
(7028071617050-IL)

CLAMP908
CLAMP_WIRE

BKT3
BKT2

- Video Signal Route
- (DVD) Video Signal Route (DVD)
- (TV/SAT) Video Signal Route (TV/SAT)
- (Y) Video Signal Route (Y)
- (Cb) Video Signal Route (Cb)
- (Cr) Video Signal Route (Cr)

C CP9

10.23 BT CNT, OPTCO, BRG-1 and BRG-2 ASSYS

K BT CNT ASSY (7028071612050-IL)

CP603

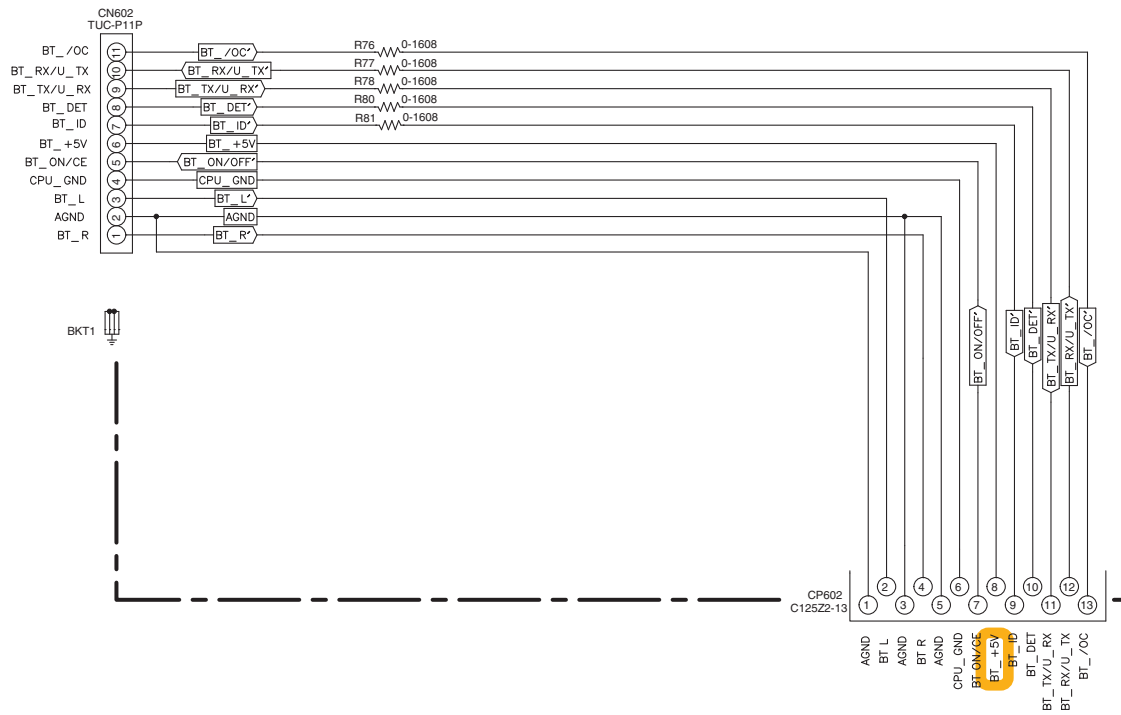

CP605

L OPTCO ASSY (7028071613050-IL)

TV/SAT (96k)

COAX CD

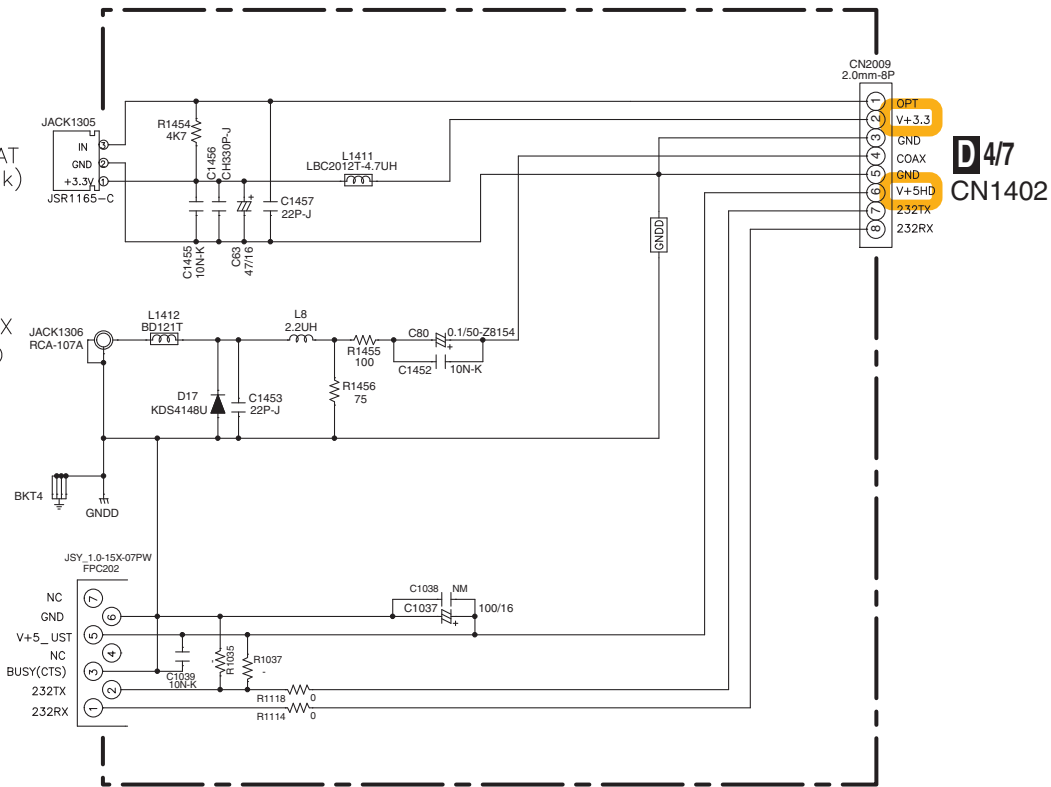

CN402

K L

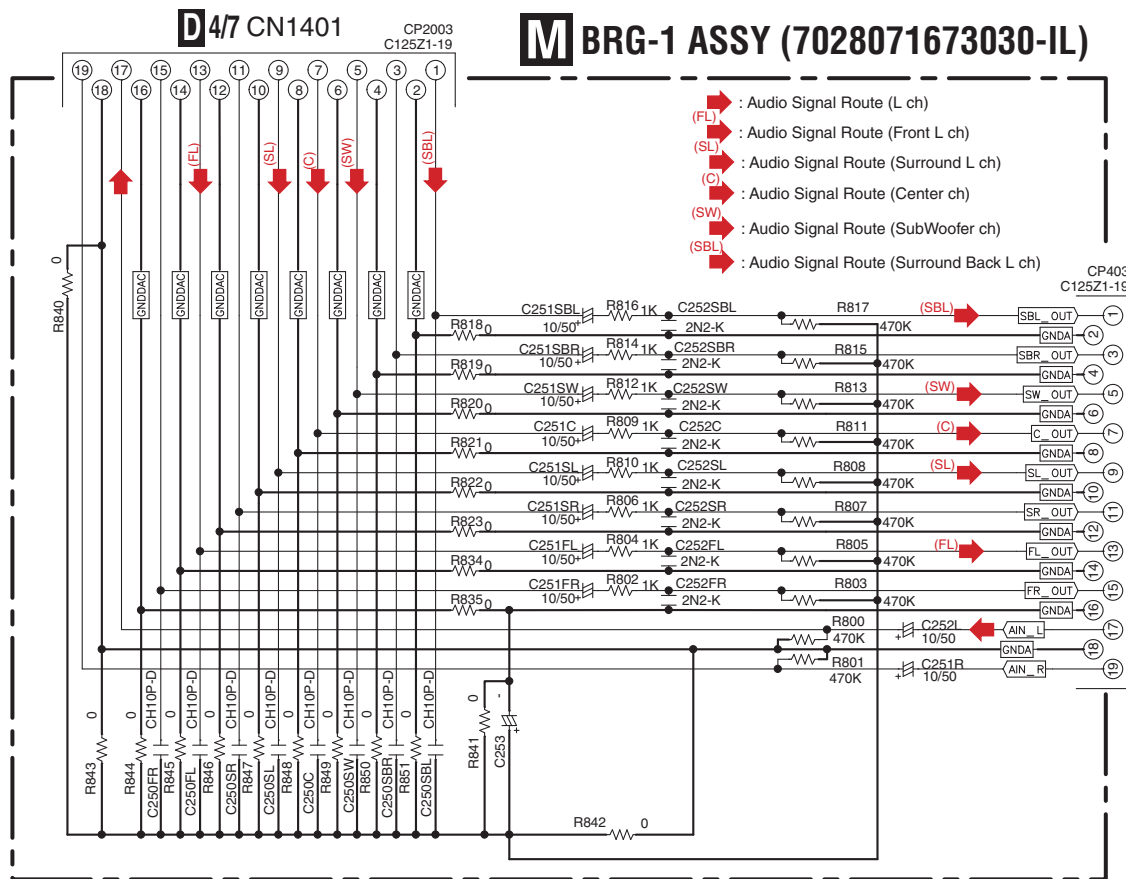

A CN403

**N BRG-2 ASSY (VSX-1022-K, VSX-822-K: 7028071674030-IL)
(VSX-42: 7028071674050-IL)**

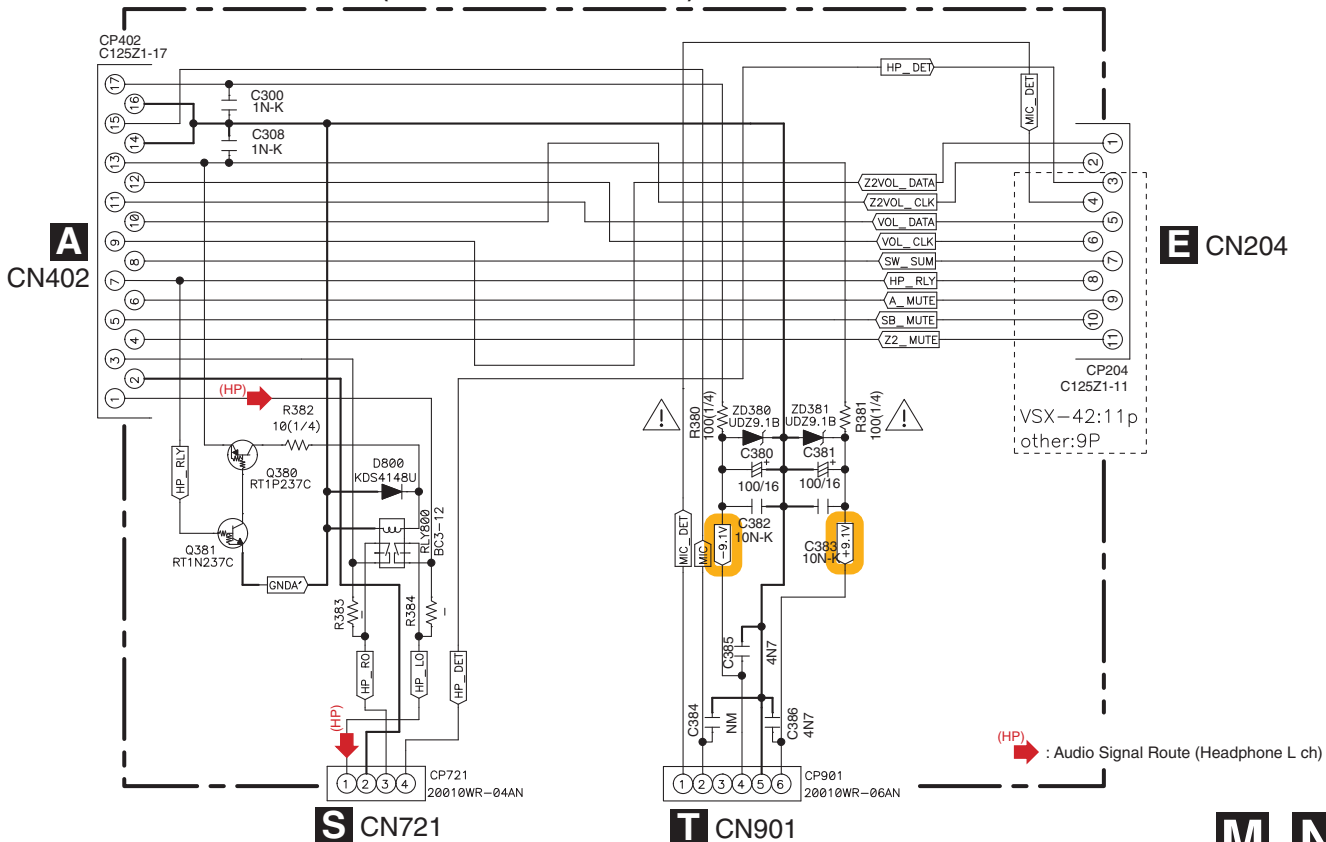

VSX-1022-K

M N

10.24 BT and F-USB ASSYS

K CN602

O BT ASSY
(7028070231010-IL)

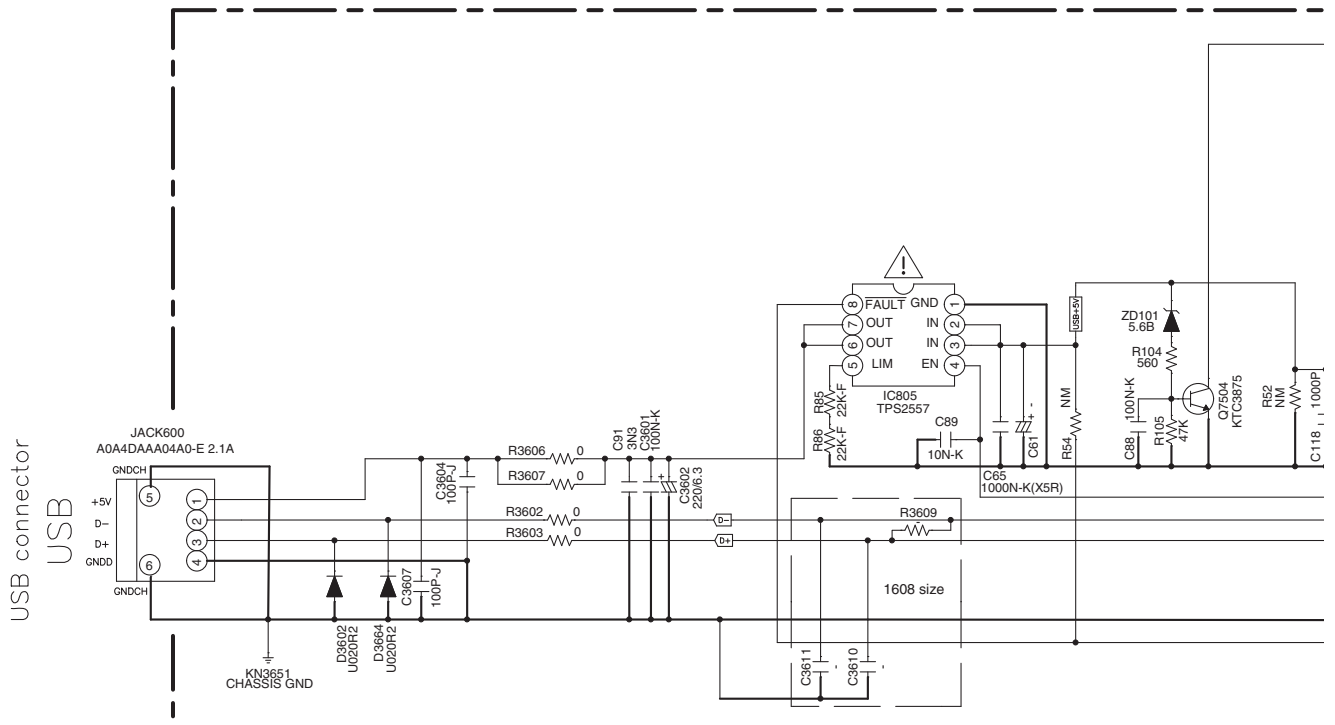
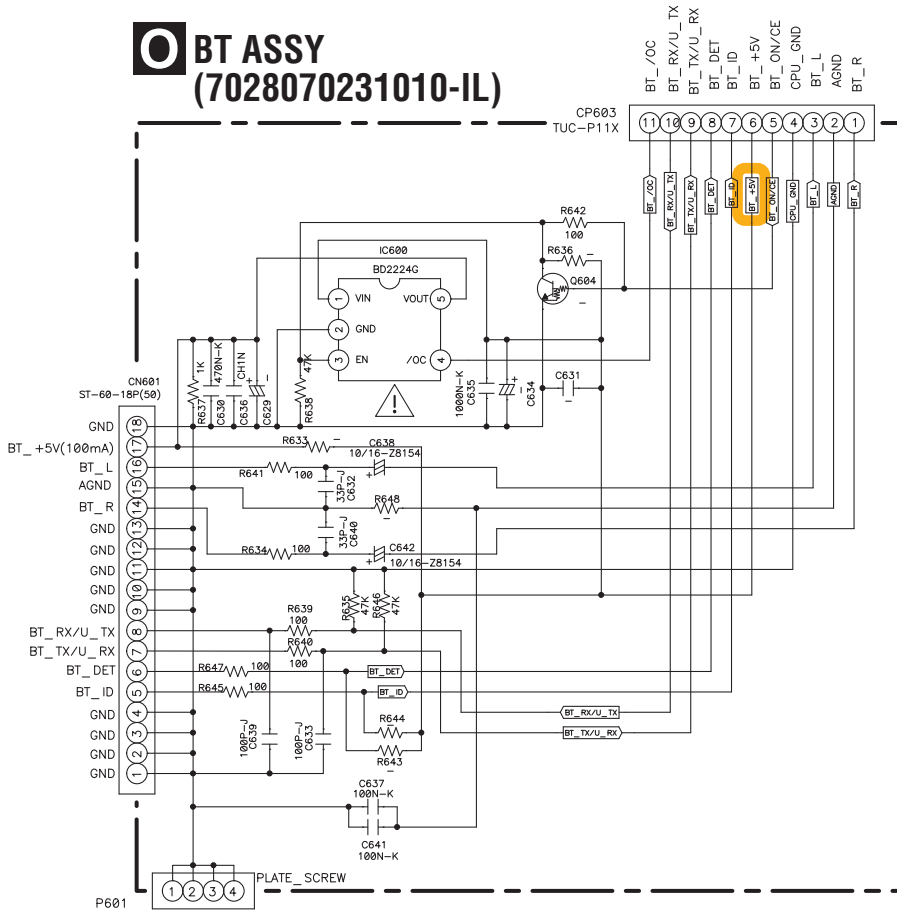

O P

P F-USB ASSY (7028071781030-IL)

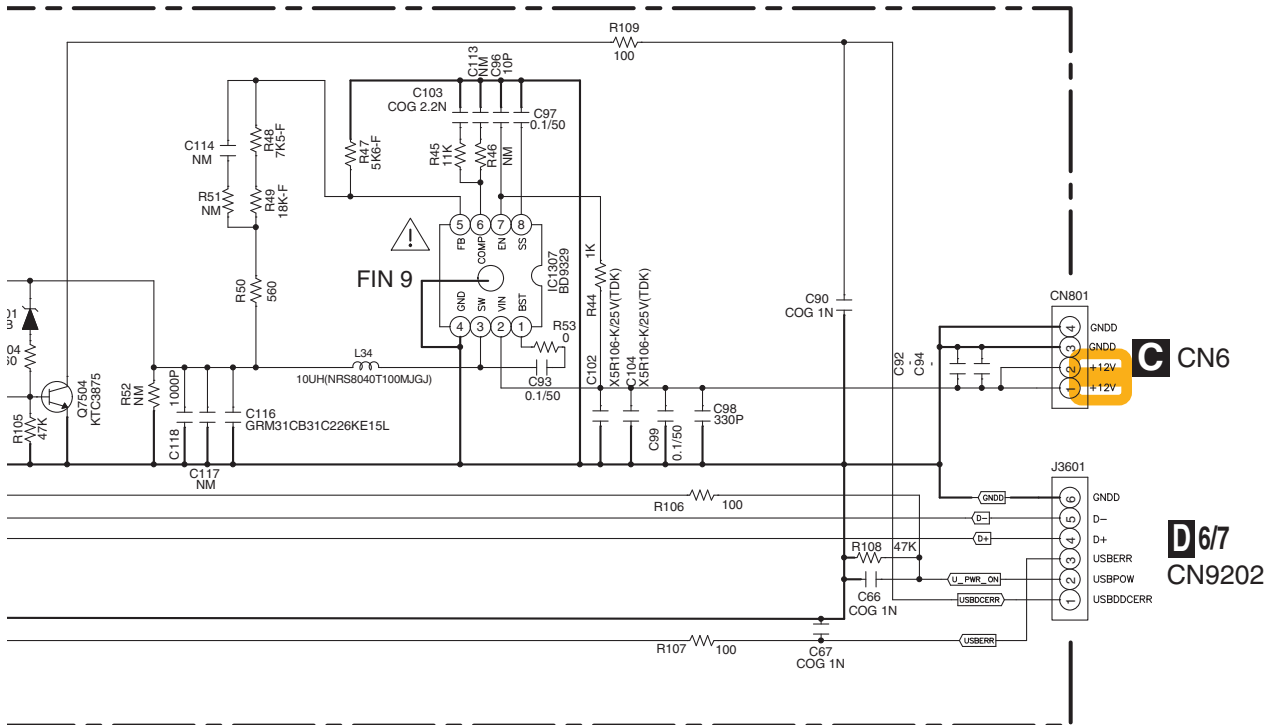

10.25 FRONT, INSEL, HP, MIC, FVIDEO and WG ASSYS

Q FRONT ASSY (VSX-1022-K, VSX-822-K: 7028071621030-IL) (VSX-42: 7028071621050-IL)

The Δ mark found on some component parts indicates the importance of the safety factor of the part. Therefore when replacing be sure to use parts of identical designation.

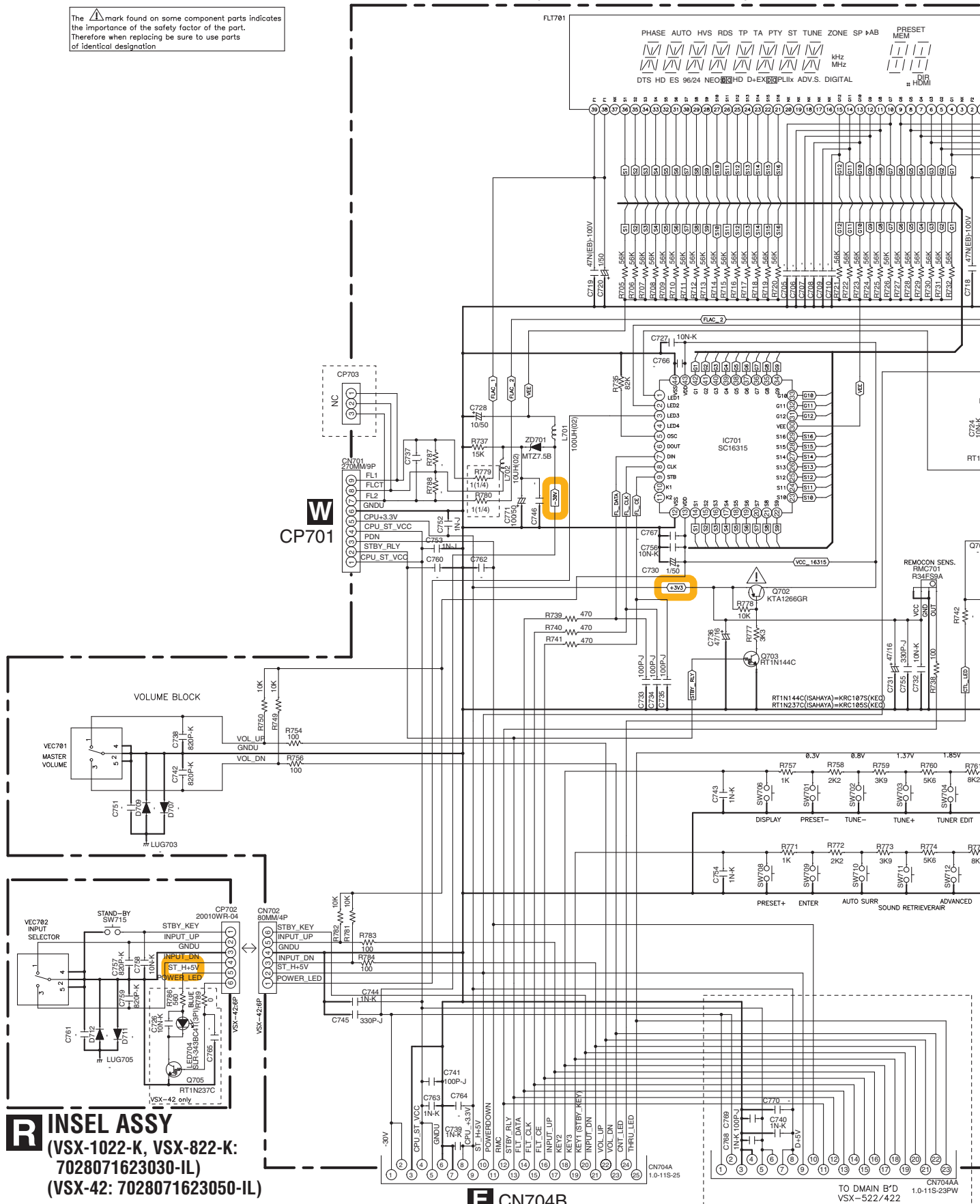

R INSEL ASSY (VSX-1022-K, VSX-822-K: 7028071623030-IL) (VSX-42: 7028071623050-IL)

Q R

L)

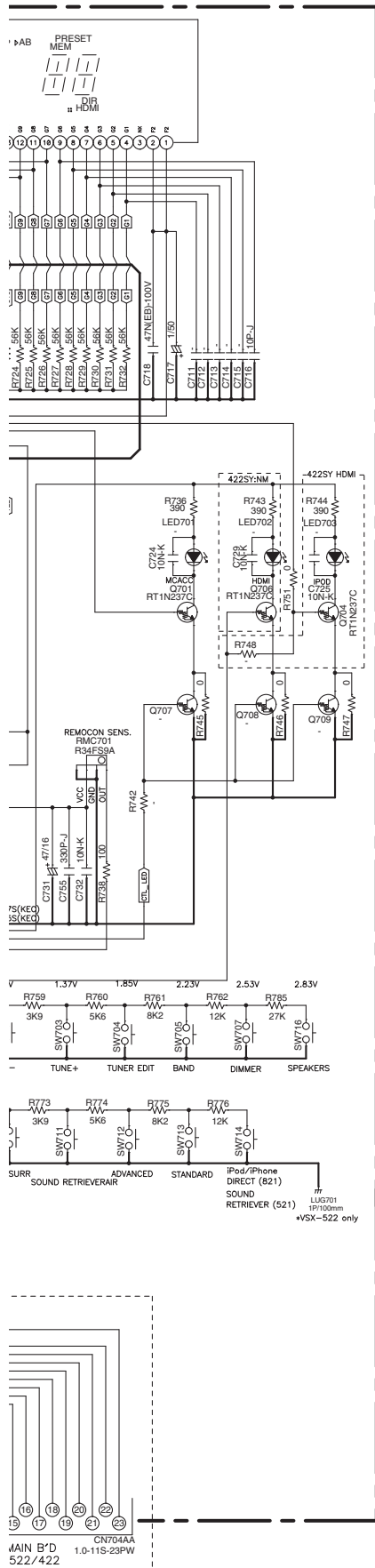

S HP ASSY
 (VSX-1022-K, VSX-822-K: 7028071622030-IL)
 (VSX-42: 7028071622050-IL)

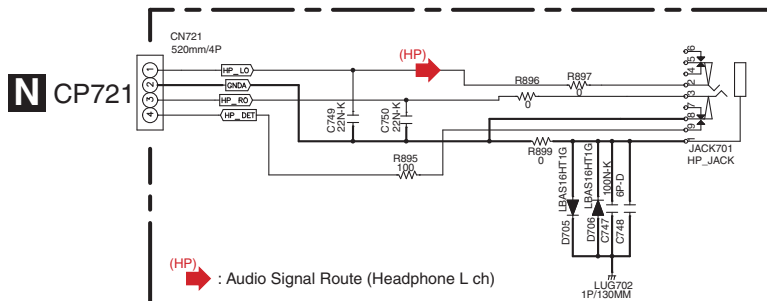

T MIC ASSY (7028071624050-IL)

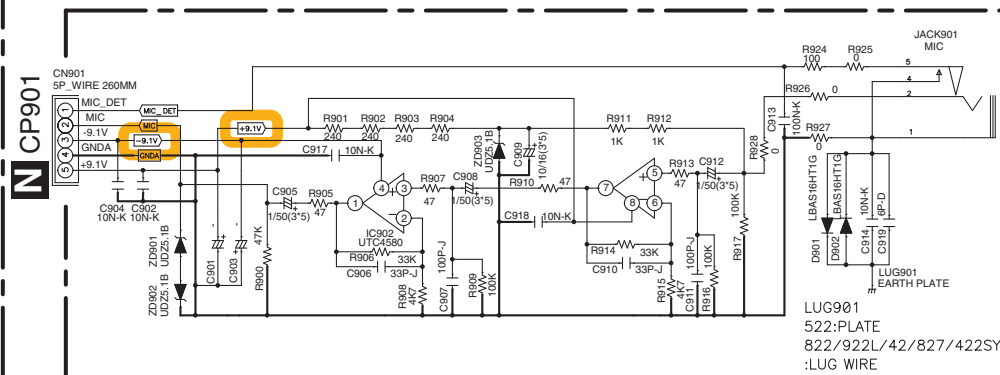

OPTION

	UXCN	SYXAA, JXE, FLX, PWX	
R779, R780	(1/4W)	2R2 (1/4W)	
Q787, Q788, Q789	RT1N237C	NM	422 SY
R742	15K	NM	
R745, R746, R747	NM	0	0
R735, R744	15K	330	330
R743	15K	330	330
LED781, LED783	SLR3438C41	HL-58CDU	HL-58CDU
LED782	SLR3438C41	HL-58CDU	HL-58CDU
R748	NM	3M	0-1600
R751	0-1600	0-1600	NM
C729	10N-K	10N-K	NM
Q786	RT1N237C	RT1N237C	NM
JP34	NM	NM	0-3216

U FVIDEO ASSY (VSX-1022-K, VSX-822-K: 7028071626030-IL)
 (VSX-42: 7028071626050-IL)

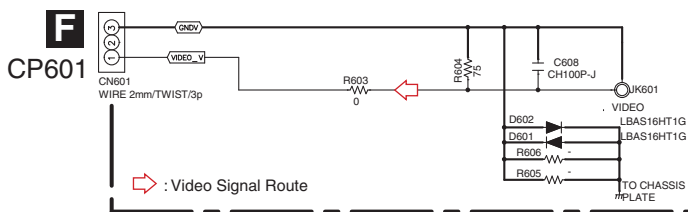

V WG ASSY (7028071627060-IL)

Q S T U V

10.26 STBY ASSY

W STBY ASSY (VSX-1022-K, VSX-42: 7028071672030-IL) (VSX-822-K: 7028071672010-IL)

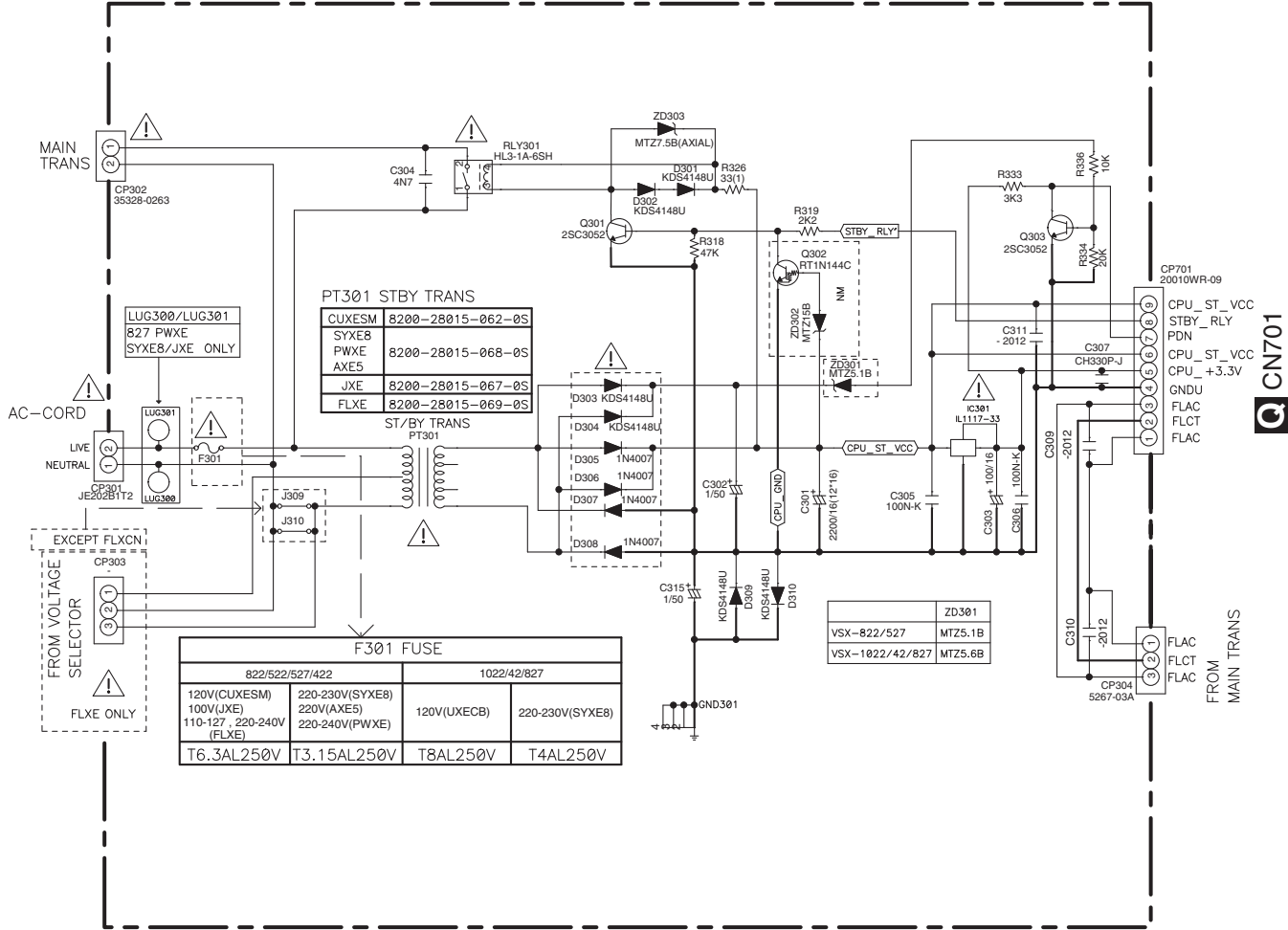

CAUTION
FOR CONTINUED PROTECTION AGAINST RISK OF FIRE,
REPLACE WITH SAME TYPE AND RATINGS OF FUSE.

The mark found on some component parts indicates the importance of the safety factor of the part. Therefore when replacing be sure to use parts of identical designation

NOTES

1. Resistor values are indicated in ohms unless otherwise specified
[k = 1,000 m = 1,000,000]
2. Capacitor values are indicated in microfarads unless otherwise specified.
[p = micro-microfarads]
3. : These resistor are to be segregated from printed wiring board or other accessible parts.
CAUTION
Safety precaution to be followed during servicing

1] Since those parts marked with are critical parts for safety, use only the one described in the parts list

2] Before returning the set to the customer make appropriate leakage current or resistance measurements to determine the exposed parts are properly insulated from the supply circuit.



5



6



7



8



A



B



C



D



E



F



5



6

VSX-1022-K



7



8



11. PCB CONNECTION DIAGRAM

11.1 AUDIO ASSY

SIDE A

NOTE FOR PCB DIAGRAMS :

1. The parts mounted on this PCB include all necessary parts for several destinations. For further information for respective destinations, be sure to check with the schematic diagram.

2. View point of PCB diagrams.

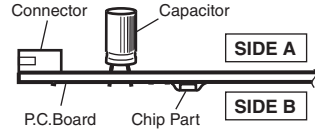

SIDE A

A AUDIO ASSY

B
C
D
E
F

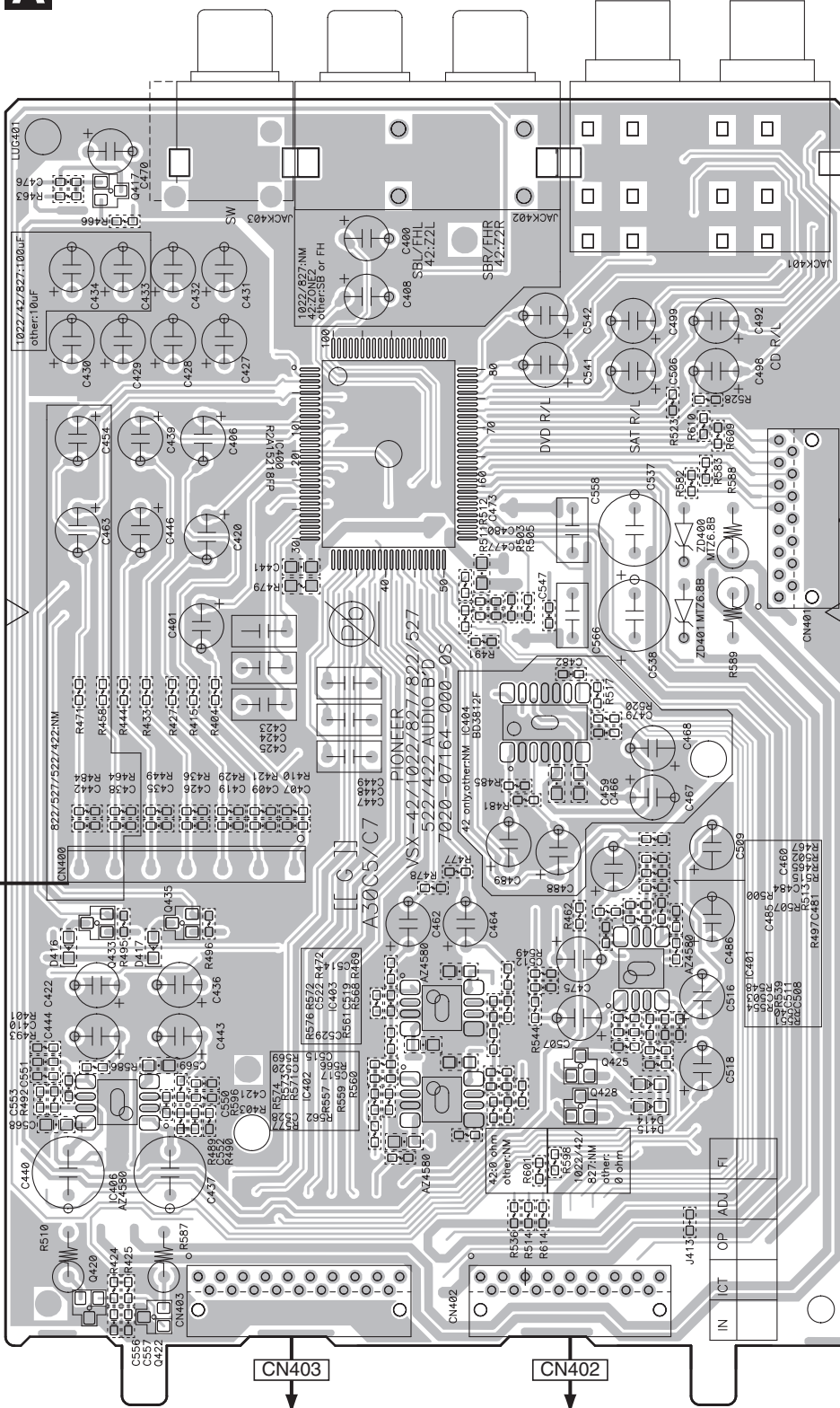

B CP401

CN400

M CP403

N CP402

CN401

C CP17

A

A AUDIO ASSY

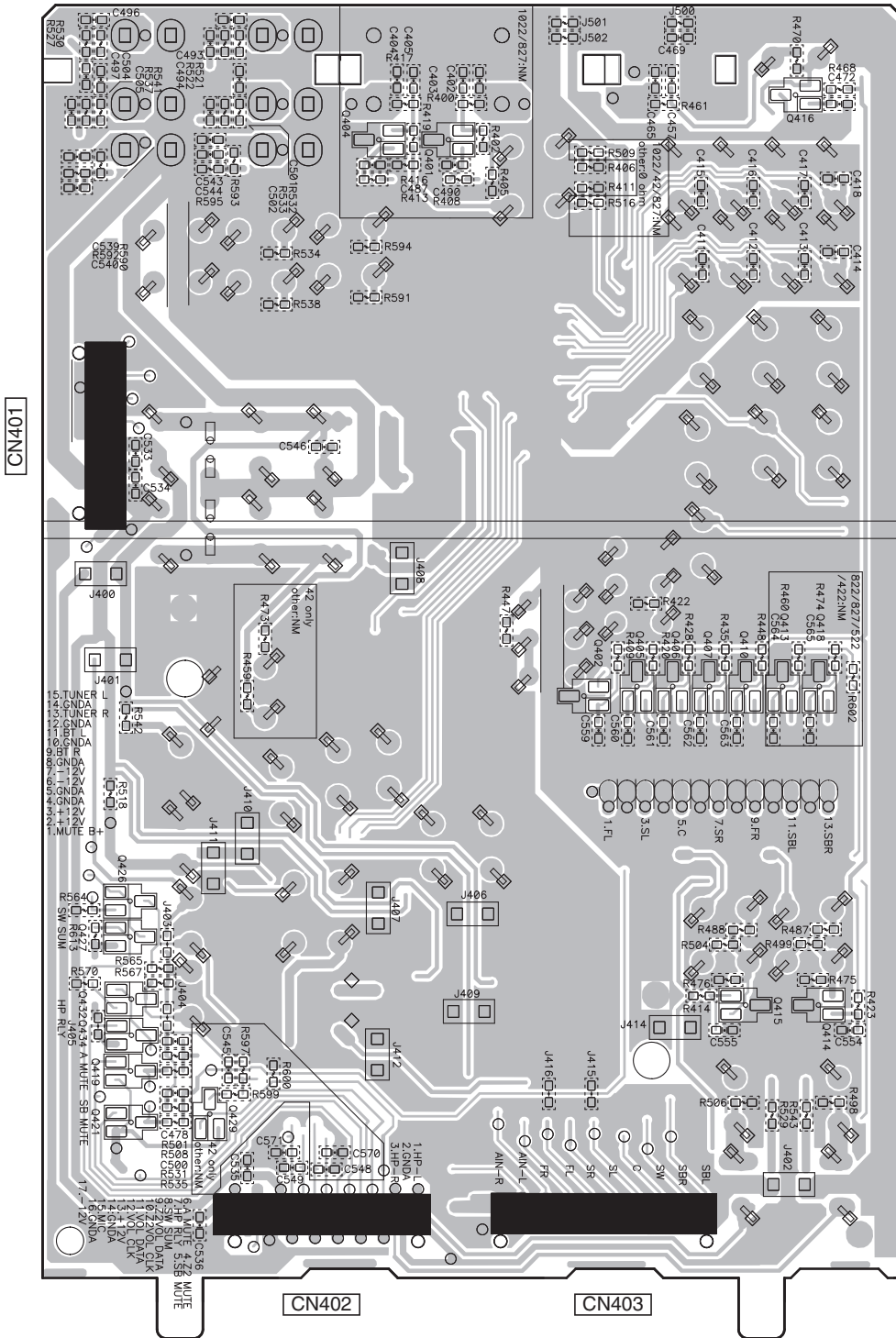

- Q402
- Q410
- Q413
- Q418
- Q405-Q407
- Q426
- Q427
- Q432
- Q415
- Q414
- Q434
- Q419
- Q421
- Q429

11.2 AMP7 ASSY (VSX-1022-K, VSX-42)

SIDE A

B AMP7 ASSY

CP401 → **A** CN400

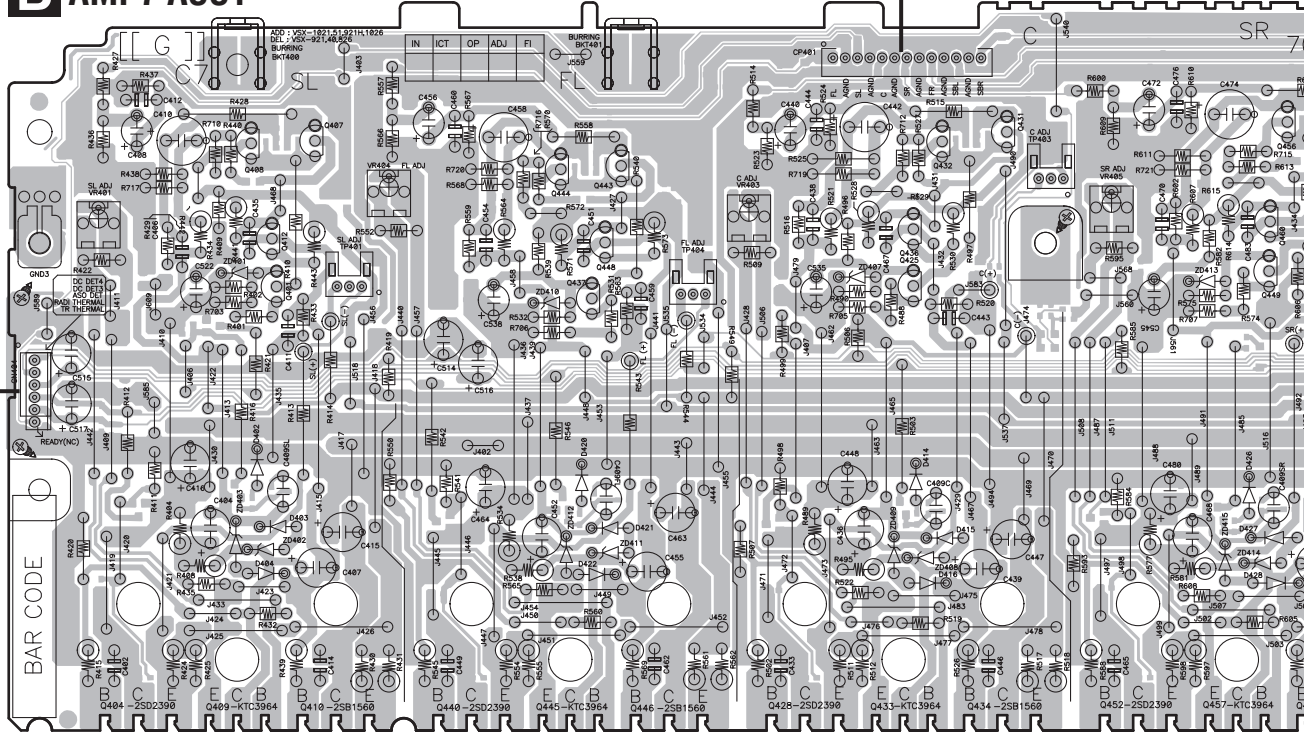

Q408	Q407	Q444	Q443	Q432	Q431	Q456
Q412	Q401	Q448	Q437	Q436	Q460	Q460
Q404	Q409	Q410	Q440	Q445	Q446	Q449
Q440	Q445	Q446	Q428	Q433	Q434	Q452
						Q457

SIDE B

B AMP7 ASSY

CP401

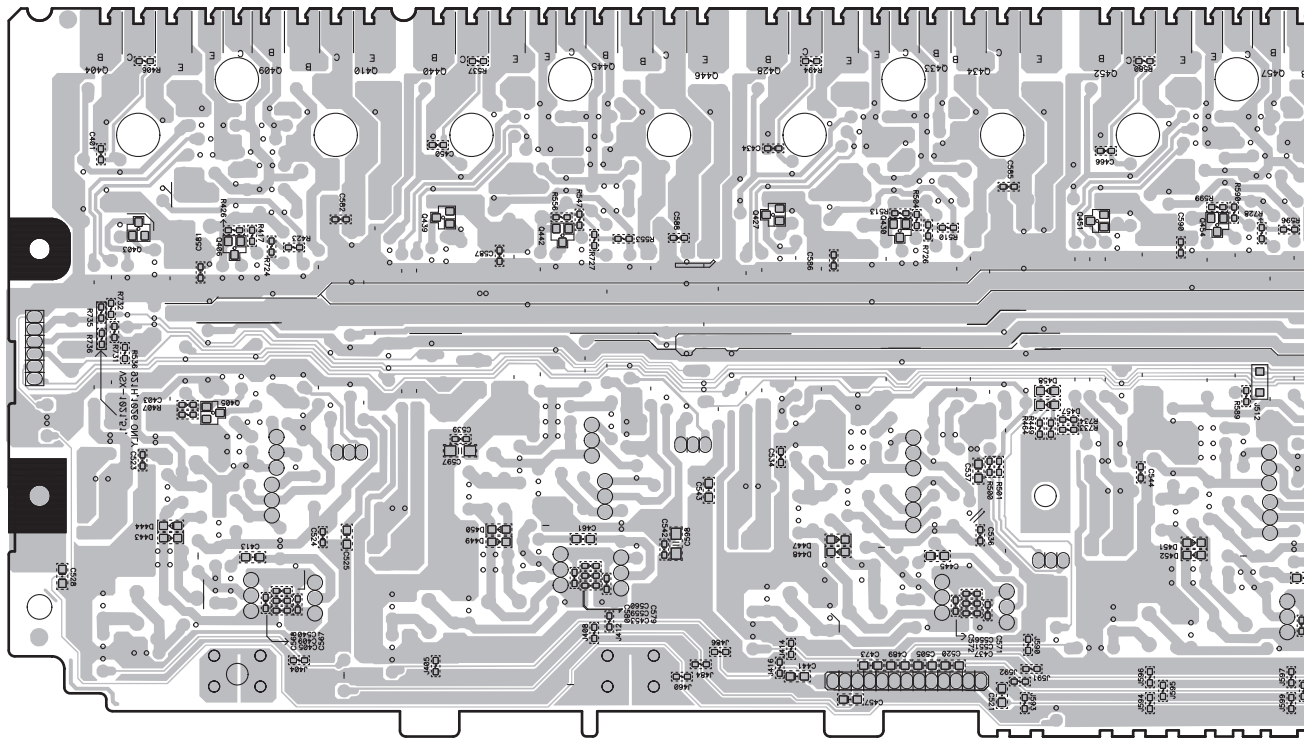

Q403	Q406	Q439	Q442	Q427	Q430	Q451	Q454
Q405							

B

SIDE A

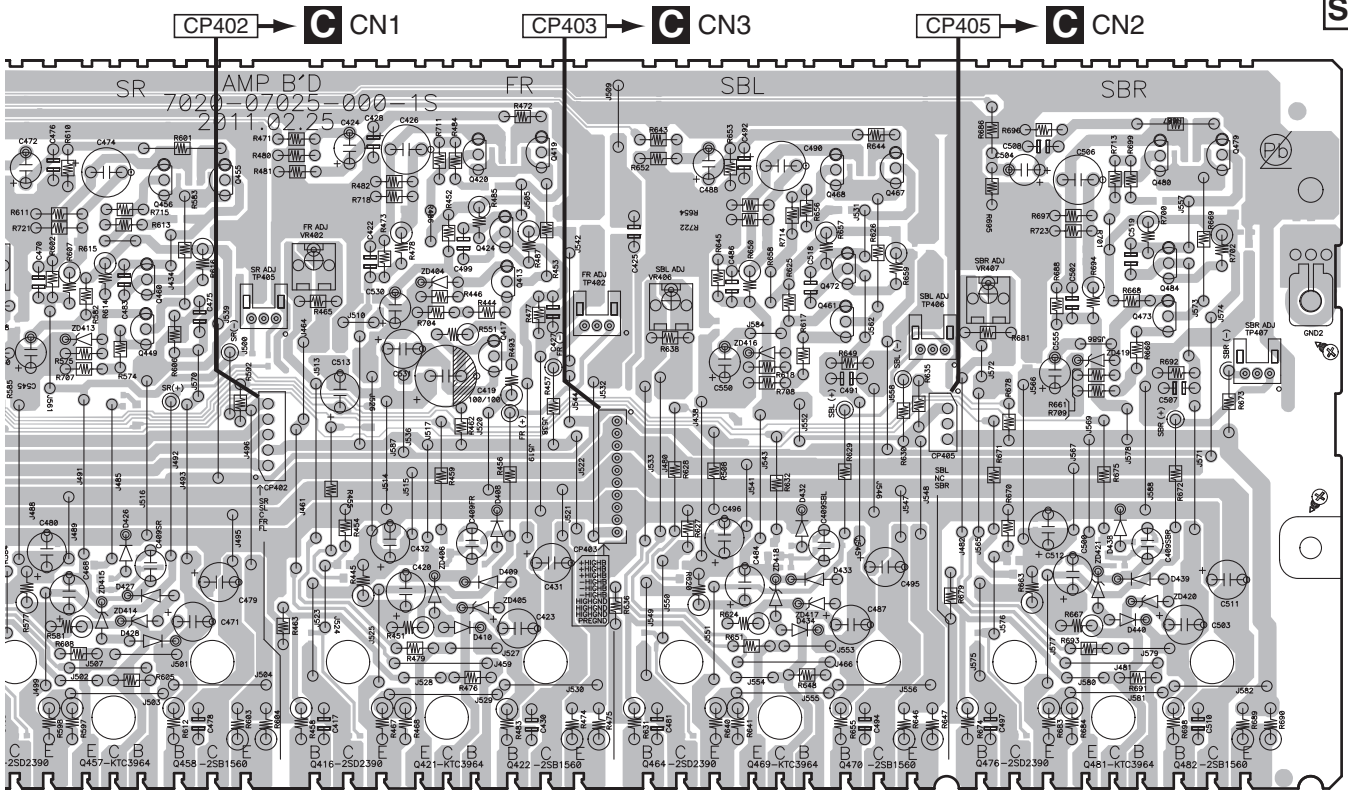

452 Q457 Q458 Q416 Q421 Q422 Q464 Q469 Q470 Q476 Q481 Q482

SIDE B

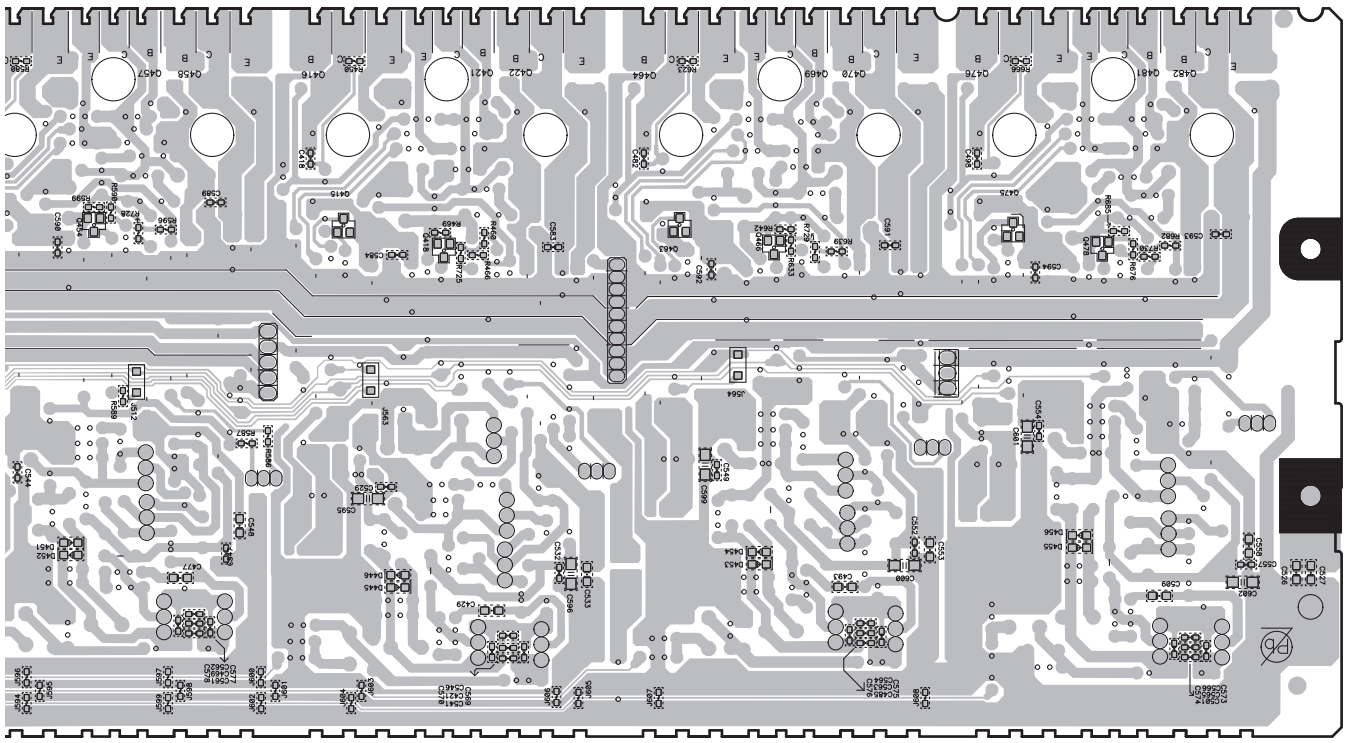

Q454 Q415 Q418 Q463 Q466 Q475 Q478

VSX-1022-K

B

11.3 AMP5 ASSY (VSX-822-K)

SIDE A

B AMP5 ASSY

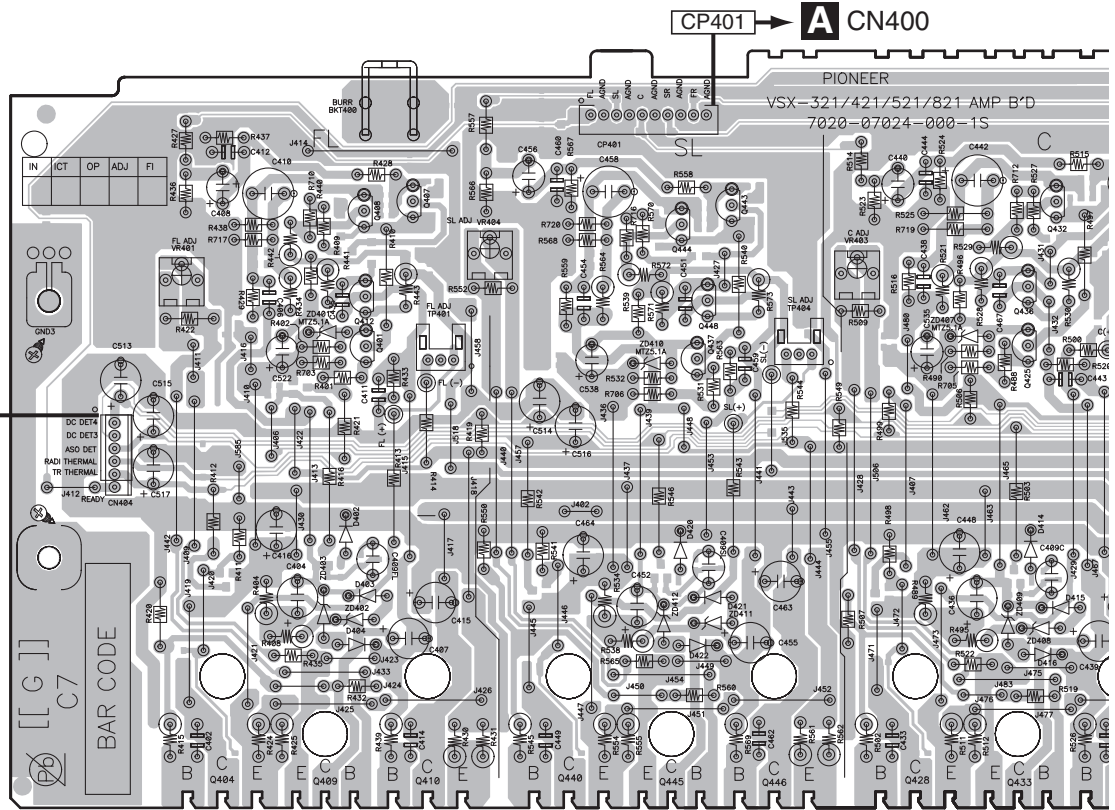

Q408 Q407 Q444 Q443 Q432
 Q412 Q448 Q436
 Q401 Q437 Q425
 Q404 Q409 Q410 Q440 Q445 Q446 Q428 Q443 Q

SIDE B

B AMP5 ASSY

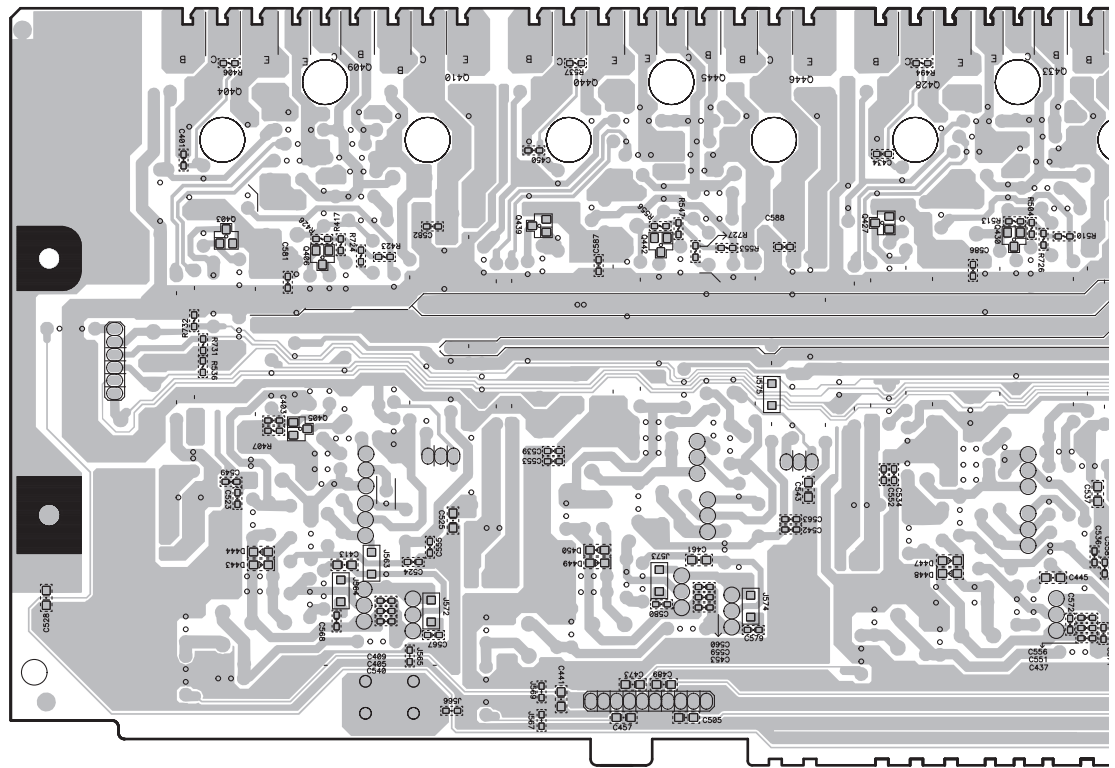

Q403 Q406 Q439 Q442 Q427 Q430
 Q405 Q445

B

CP402 → **C** CN1 CP403 → **C** CN3

SIDE A

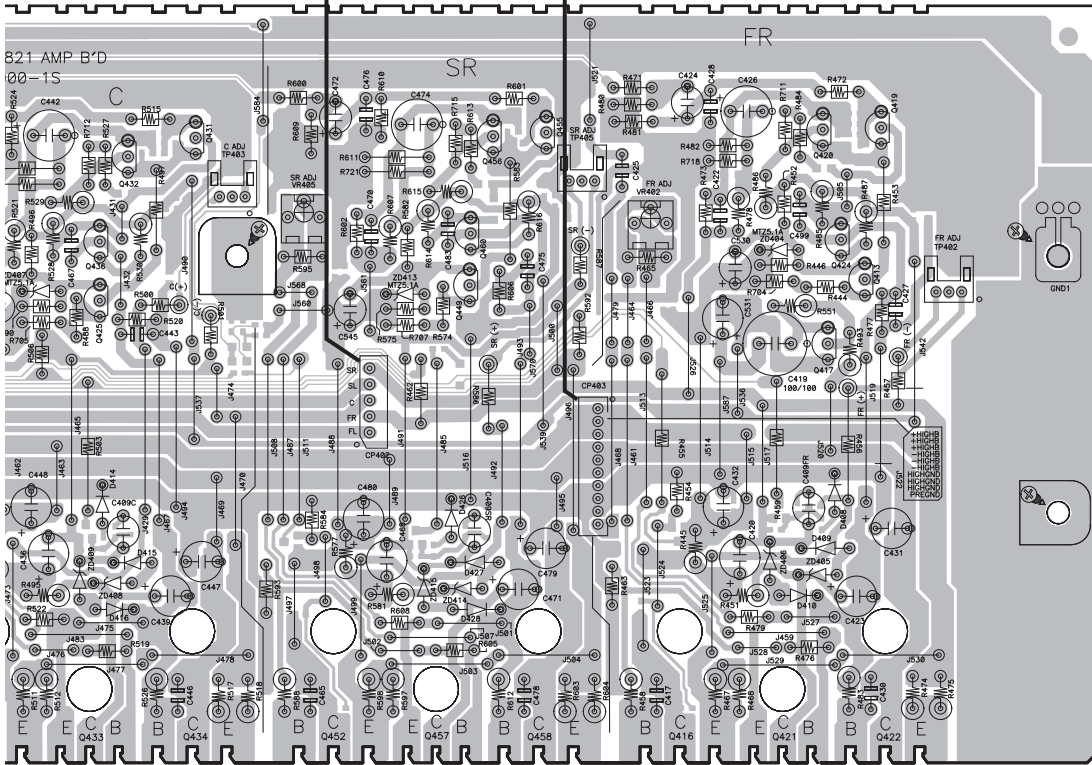

A
B
C

Q432 Q431 Q456 Q455 Q420 Q419
 Q436 Q425 Q443 Q434 Q452 Q457 Q458 Q416 Q421 Q422
 Q460 Q449 Q424 Q417 Q413

SIDE B

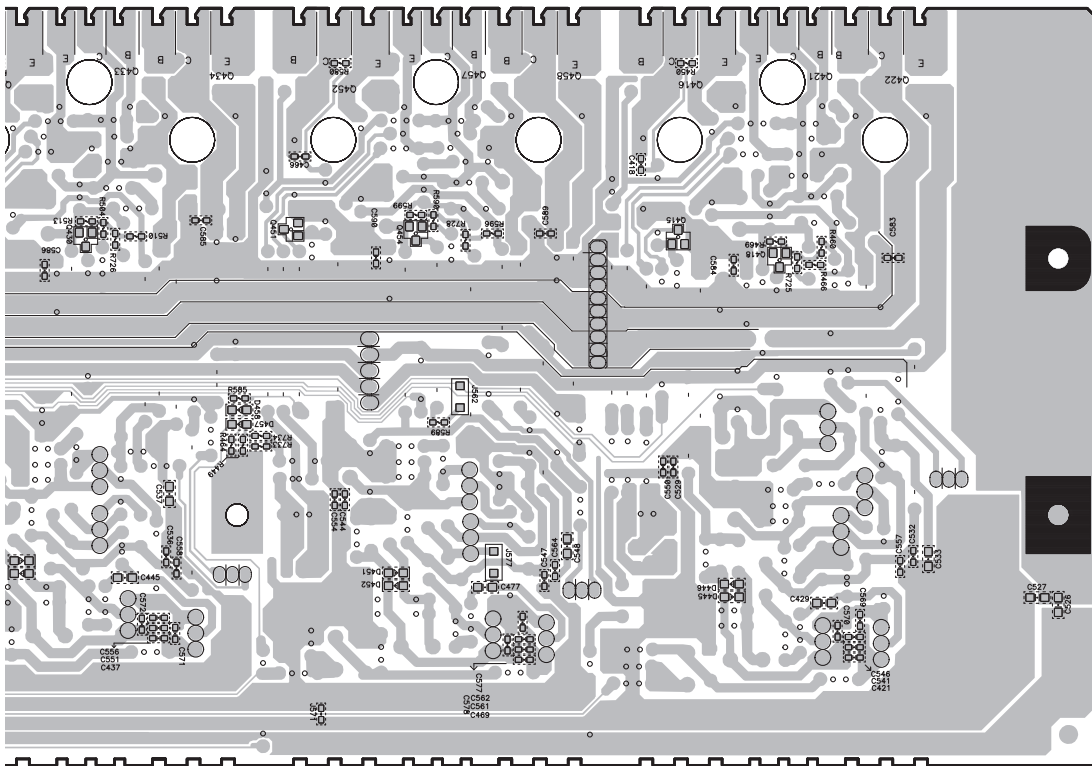

D
E
F

CP402 CP403

Q430 Q451 Q454 Q415 Q418

VSX-1022-K

B

11.4 MAIN ASSY

SIDE A

C MAIN ASSY

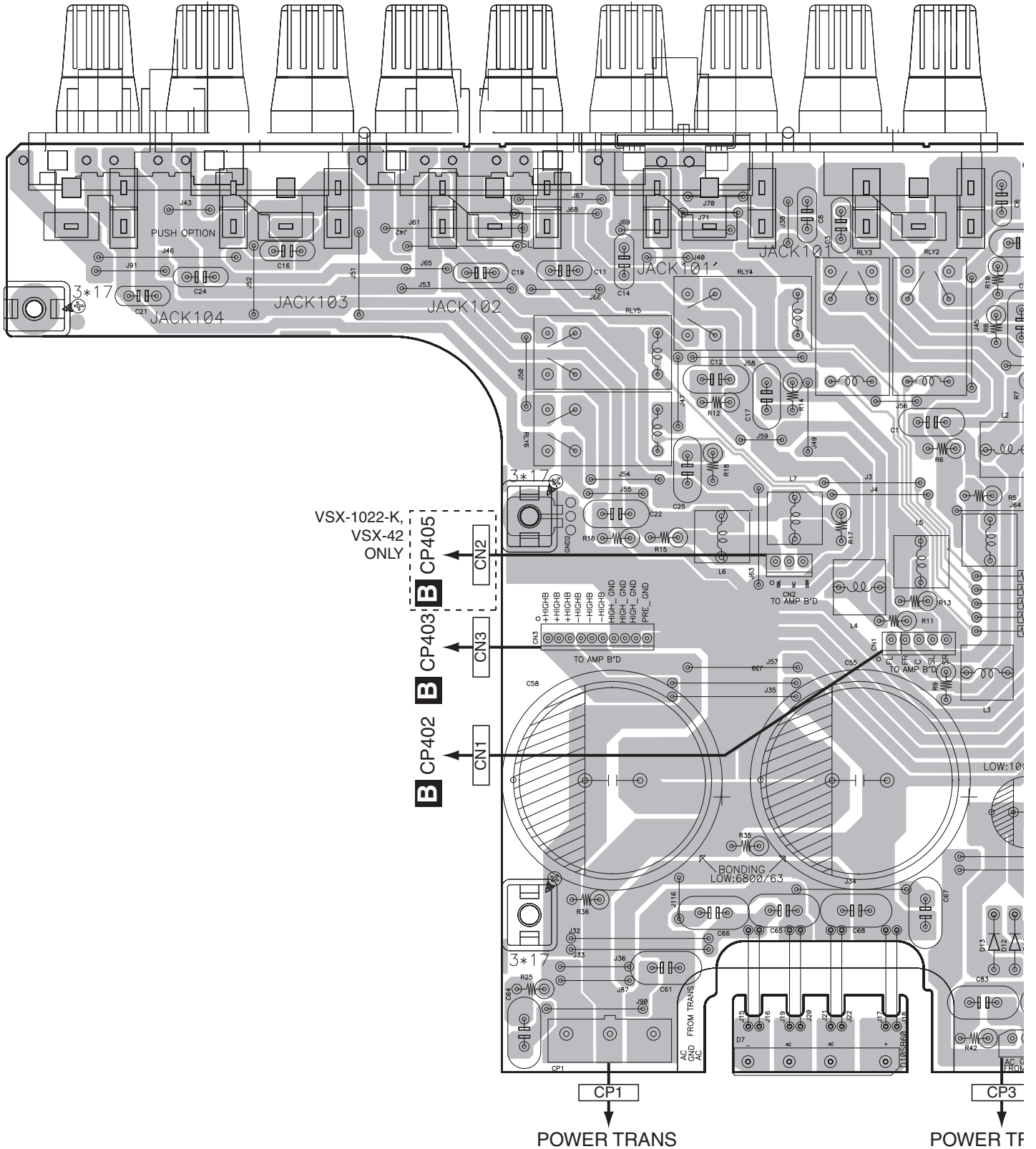

C

SIDE A

A
B
C
D
E
F

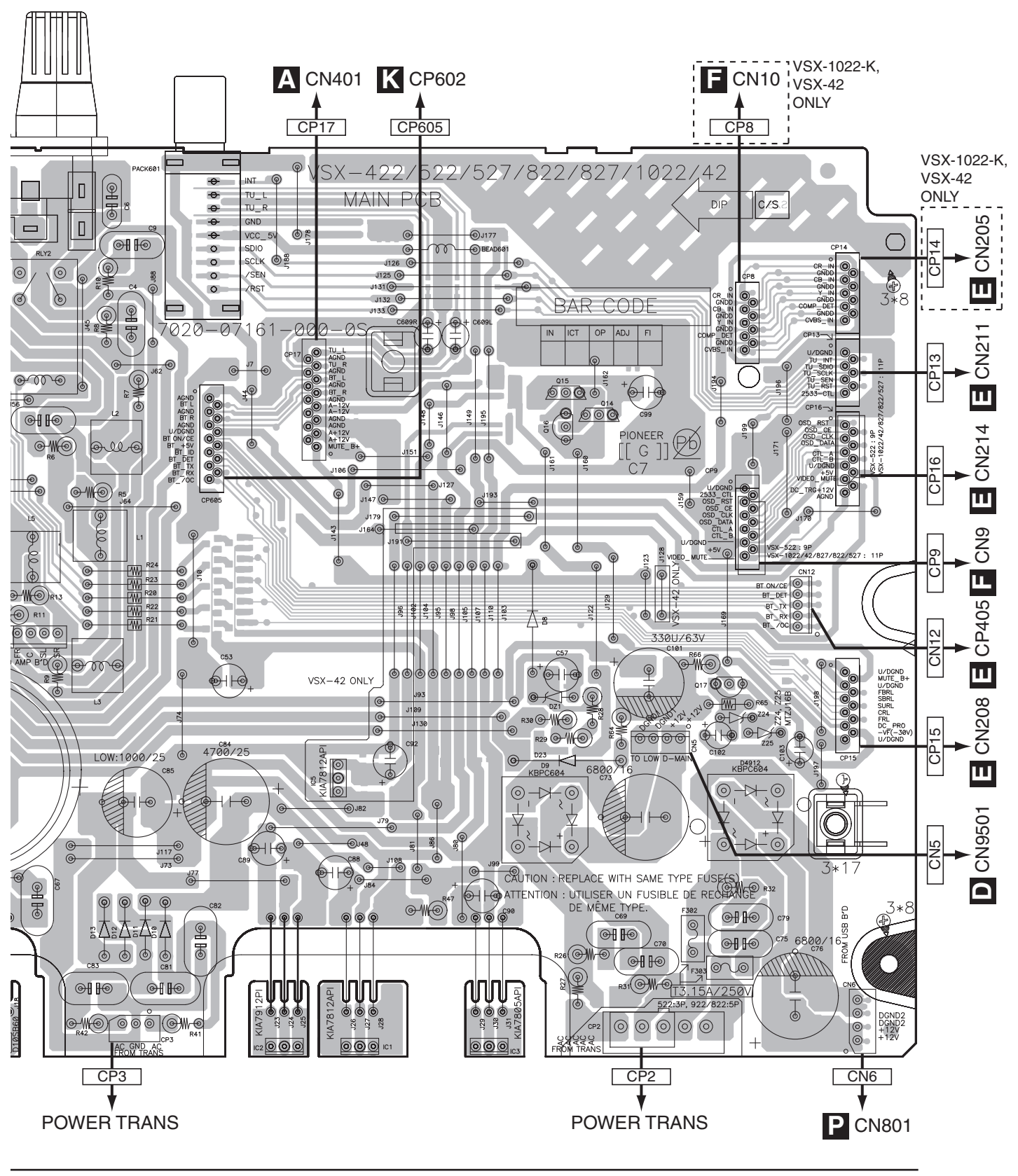

POWER TRANS

POWER TRANS

P CN801

C

VSX-1022-K

SIDE B

A

B

C

D

E

F

C MAIN ASSY

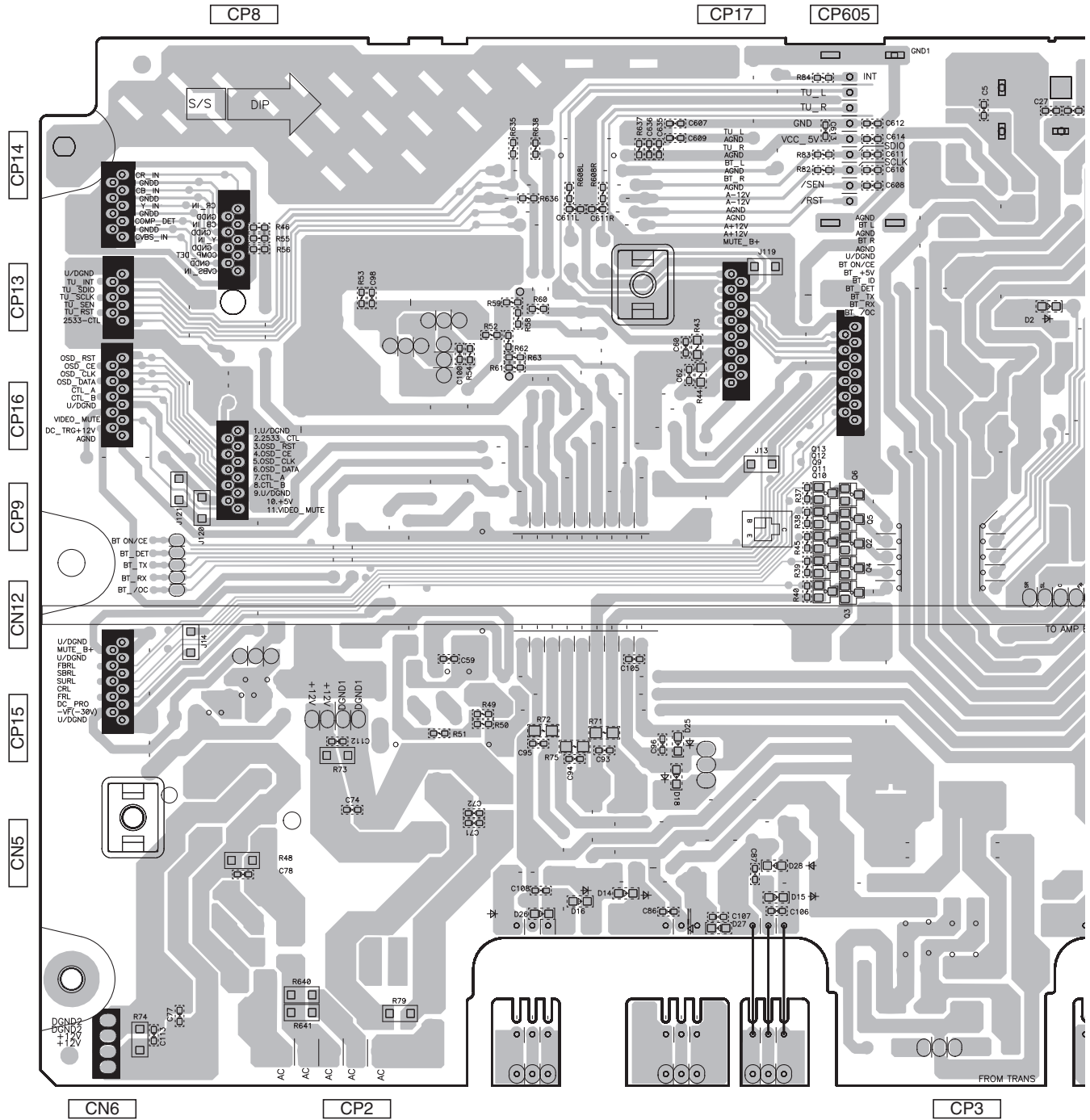

Q9-Q13 Q2-Q6

C

SIDE B

A

B

C

D

E

F

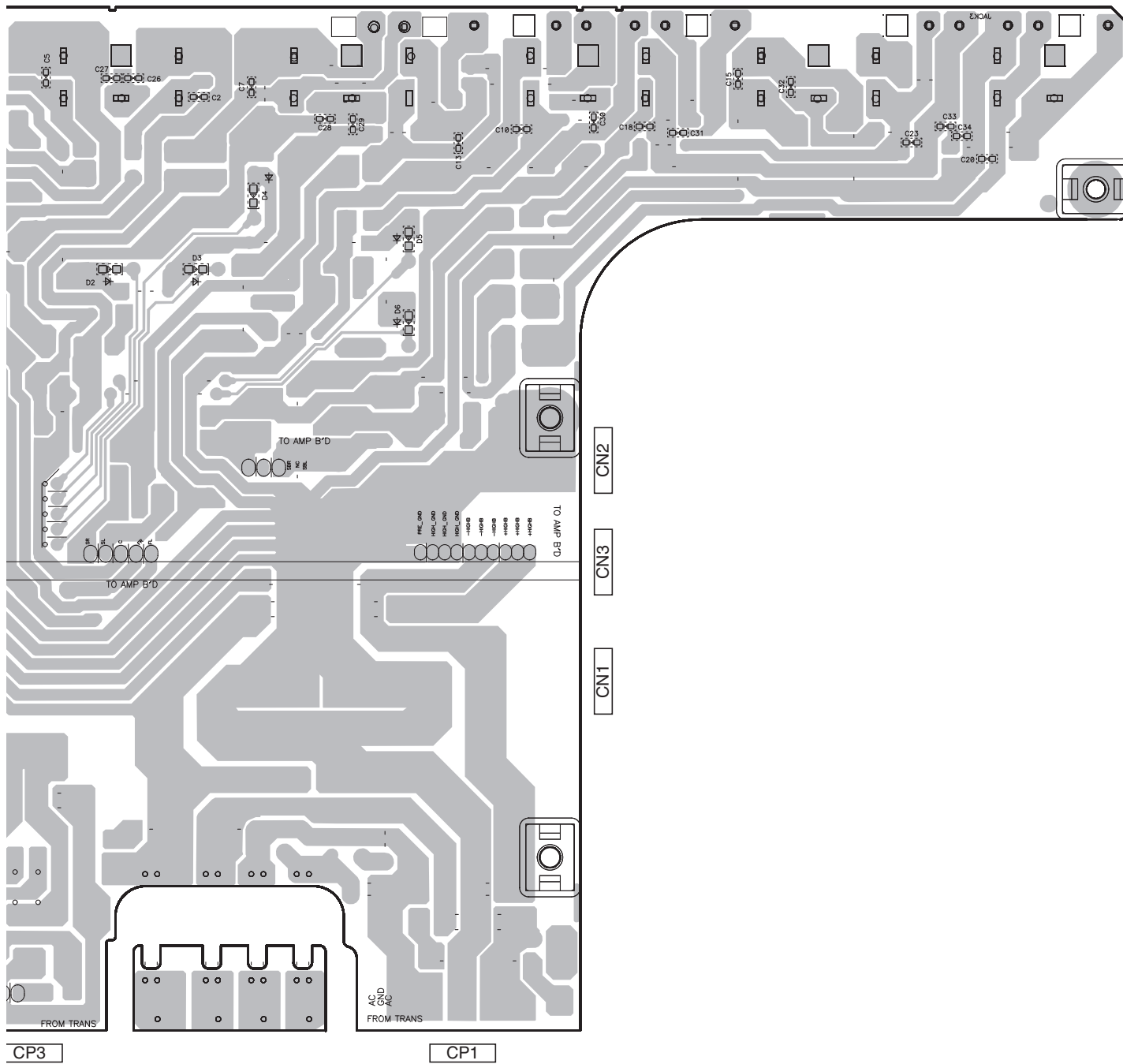

11.5 D-MAIN ASSY

SIDE A

D D-MAIN ASSY

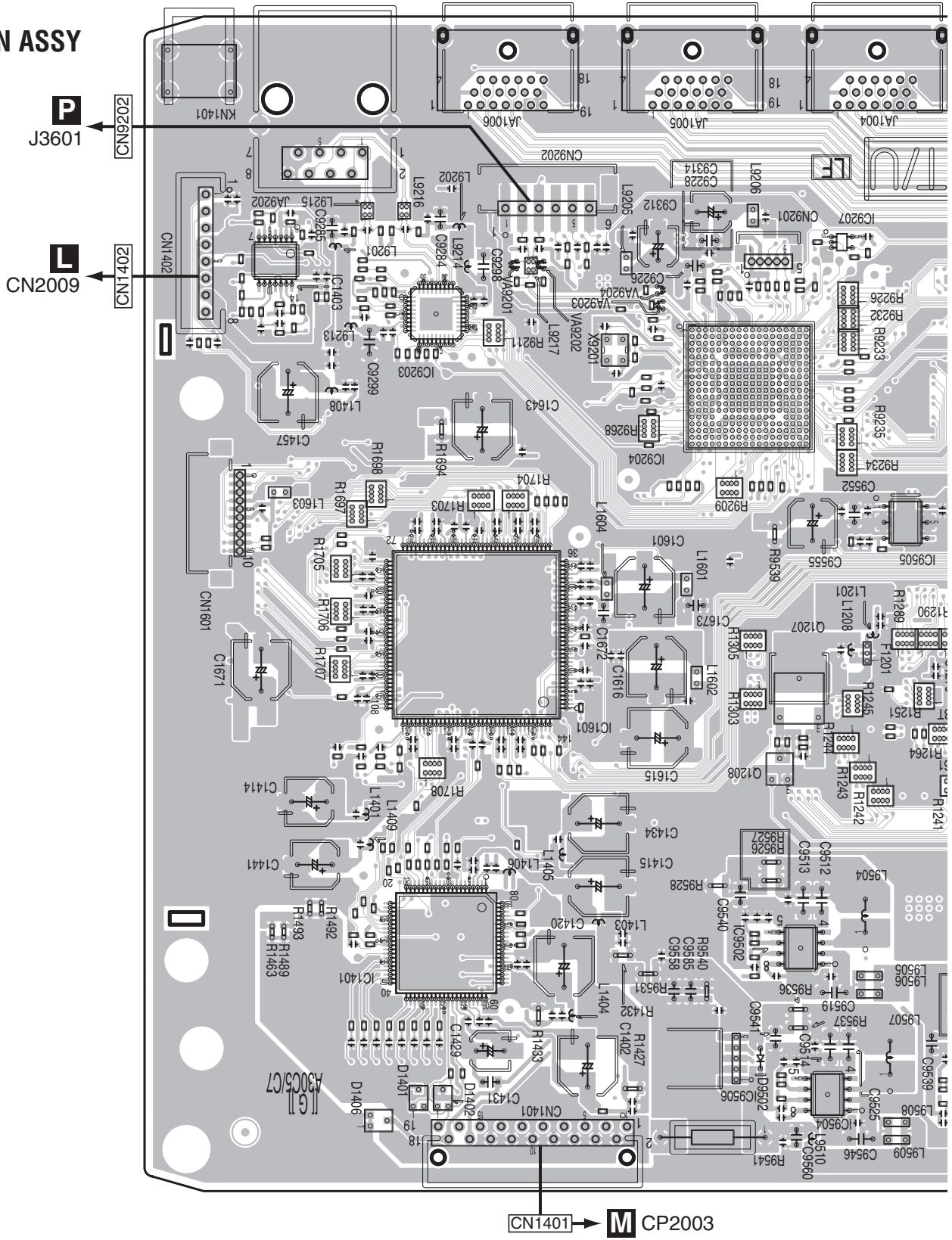

IC1403	IC9203	IC9204	IC9207	IC9505
	IC1601		Q1207	
	IC1401		Q1208	IC9502
			IC9506	IC9504

VSX-1022-K

D
140

1 2 3 4

1 2 3 4

SIDE A

A
B
C
D
E
F

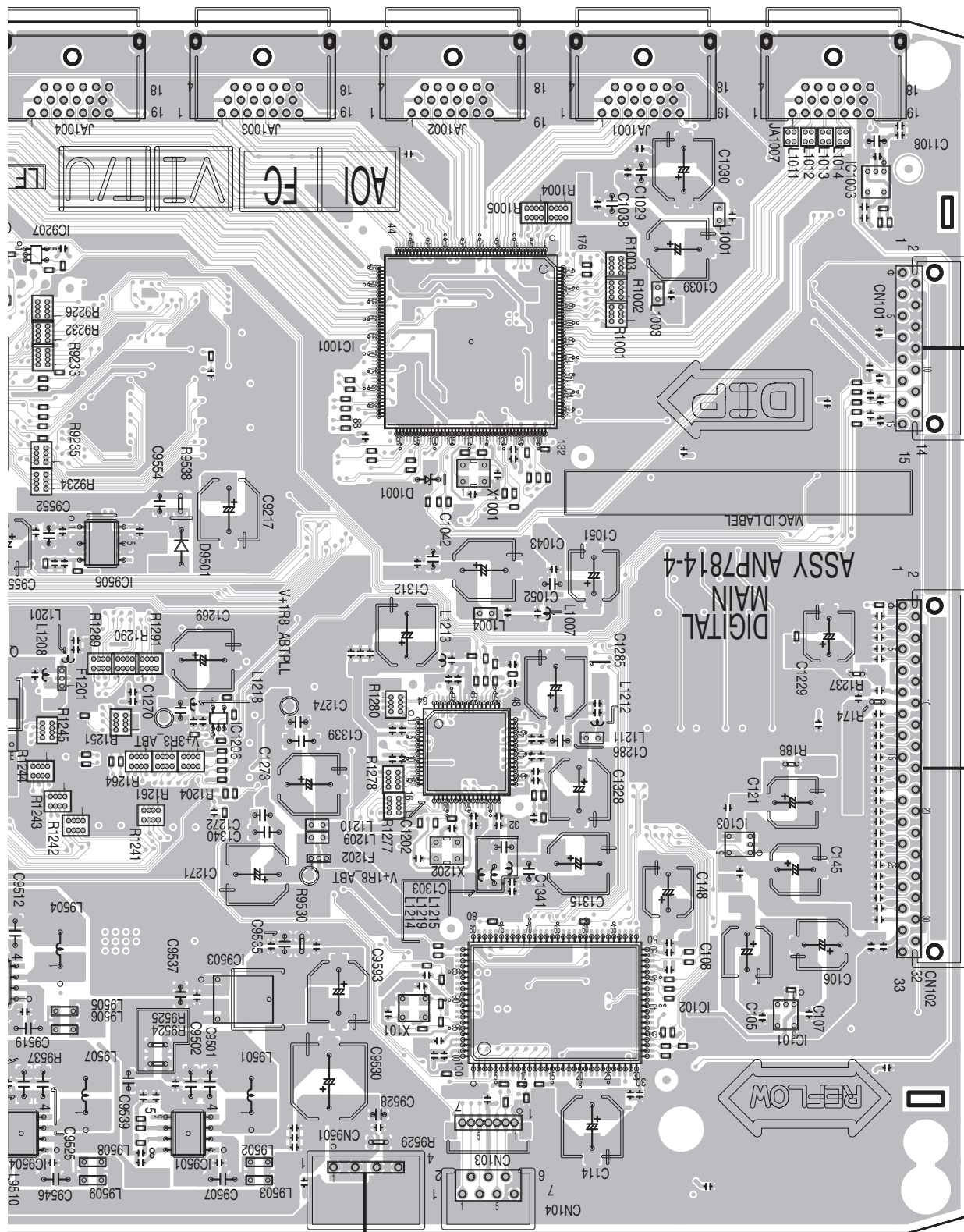

E CN213

E CN201

C CN5 ← CN501

IC9207		IC1001		IC1003
IC9505	IC1206	IC1202	IC103	
2 IC9503		IC102	IC101	
C9504	IC9501			

VSX-1022-K

D

5 6 7 8

SIDE B

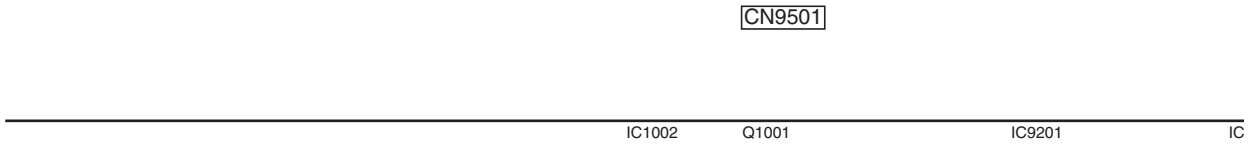
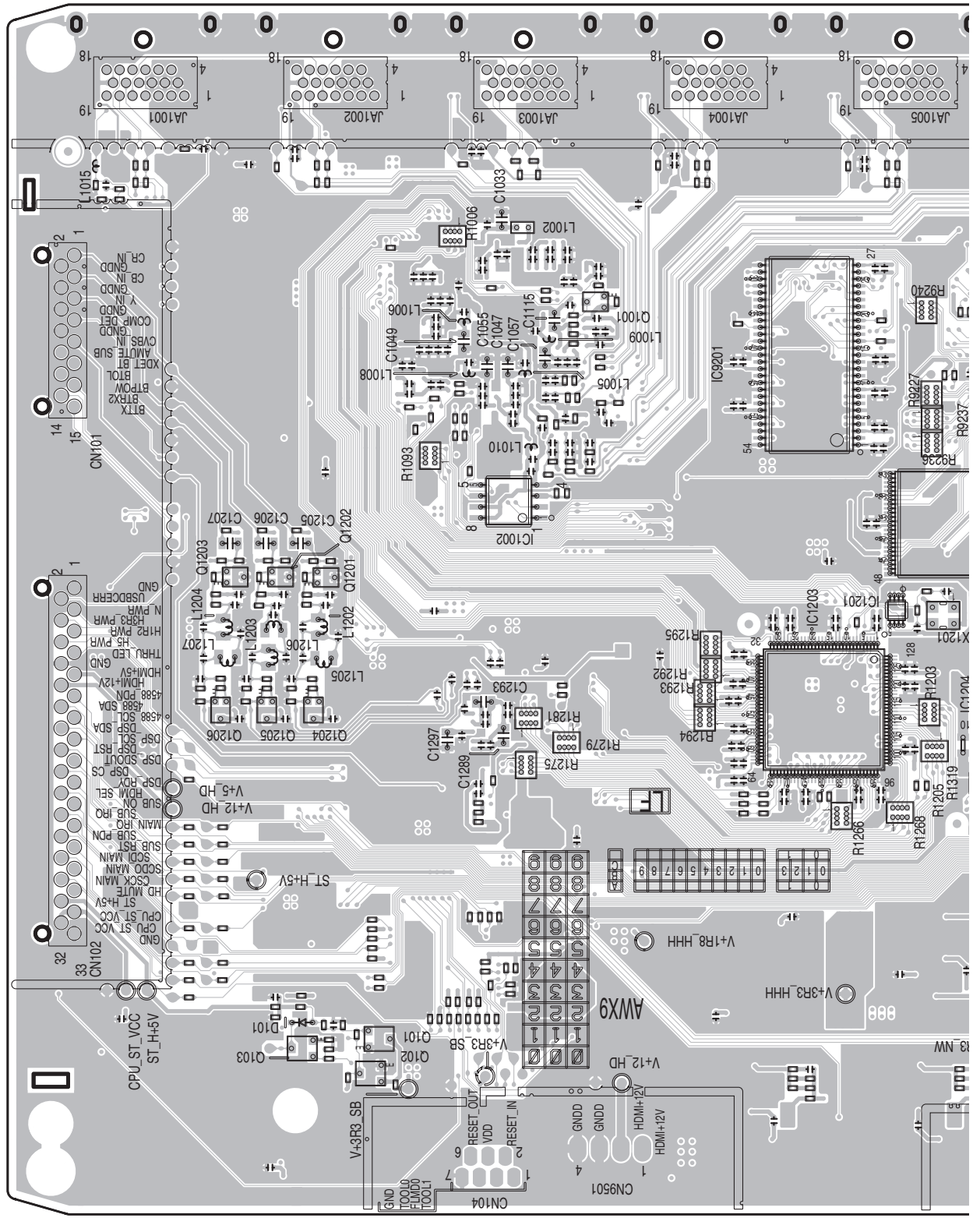

VSX-1022-K

D D-MAIN ASSY

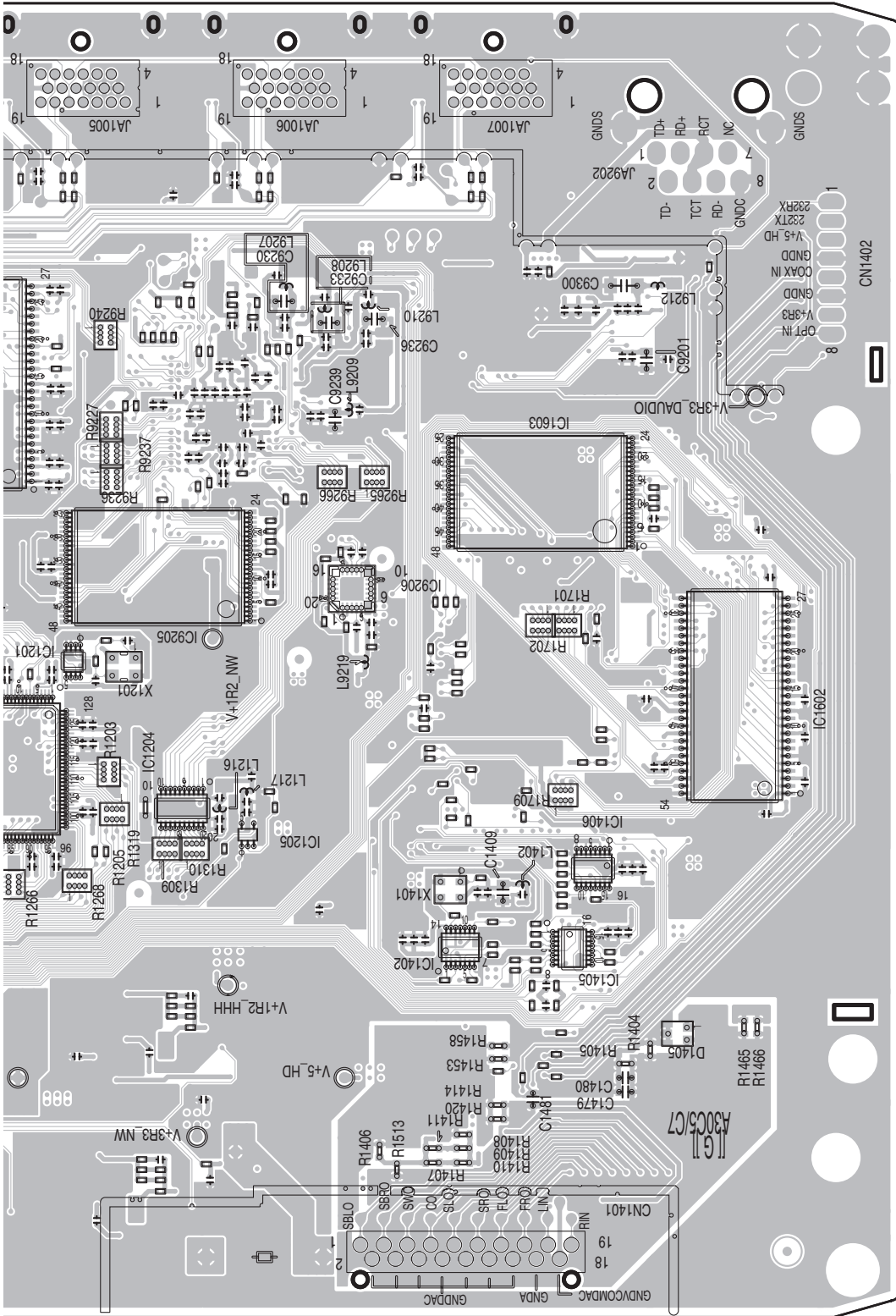

IC1201	IC1204	IC1205	IC1402	IC1405	IC1406	IC1602	IC1603	IC9205	IC9206
03									

11.6 CPU ASSY

SIDE A

SIDE A

CPU ASSY

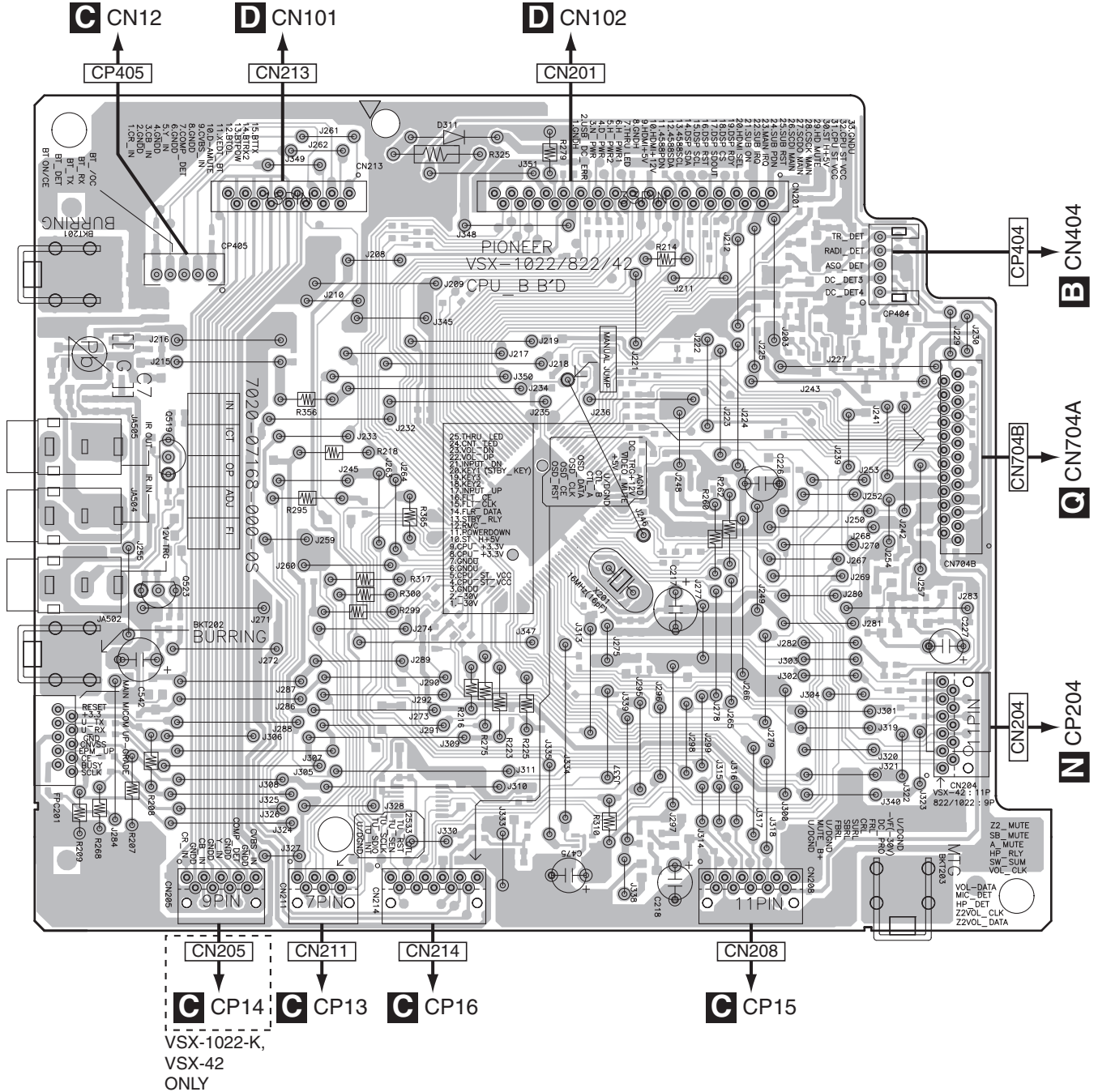

Q519
Q523



SIDE B

SIDE B

A

E CPU ASSY

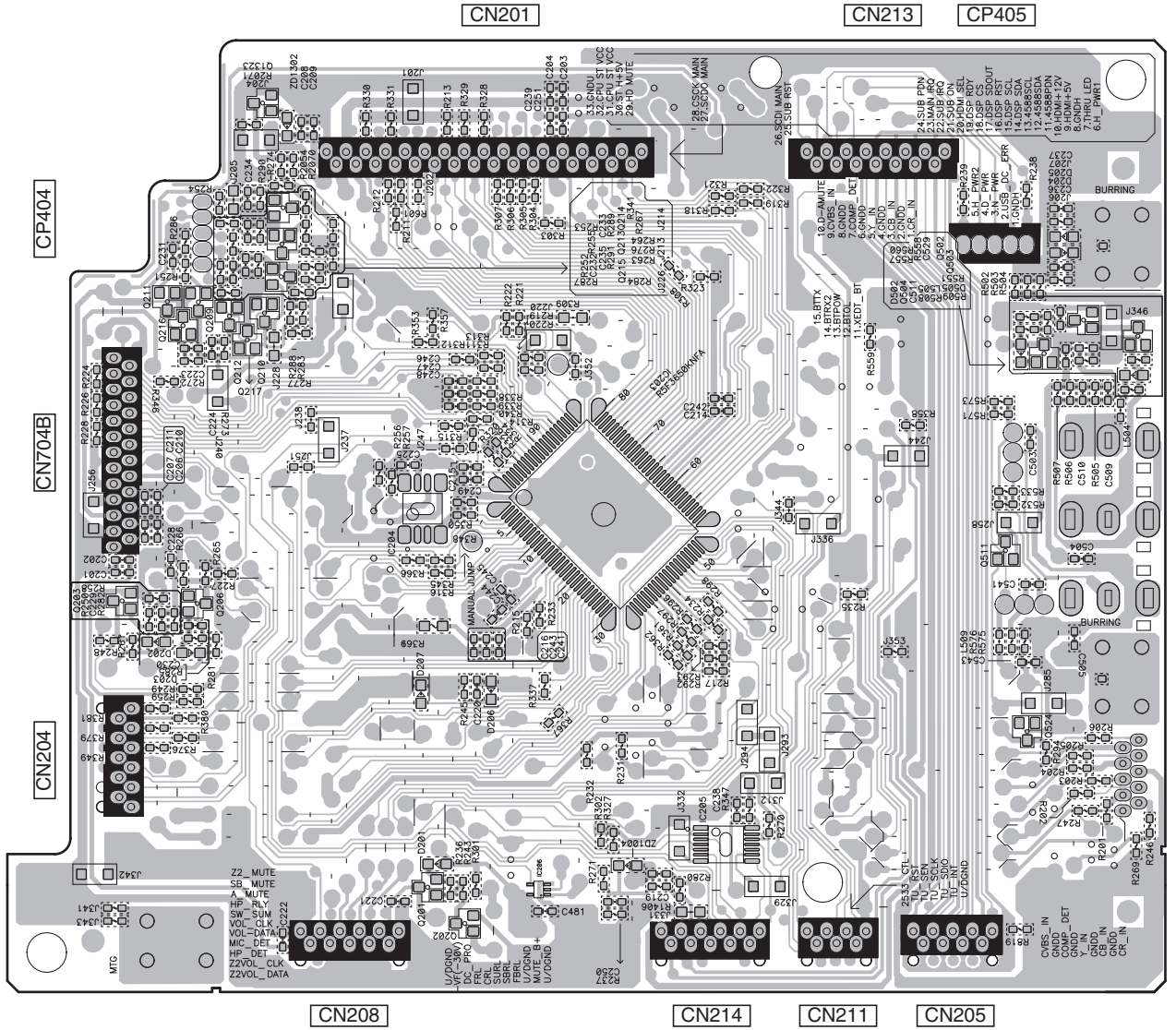

B

C

D

E

- Q1323
- Q213-Q215
- Q504 Q502 Q503
- Q209-Q212
- Q216 Q217
- IC204
- IC203
- Q511
- Q203 Q206
- Q201 Q202
- IC205
- Q524

F

VSX-1022-K



11.7 VIDEO ASSY

SIDE A

SIDE A

F VIDEO ASSY

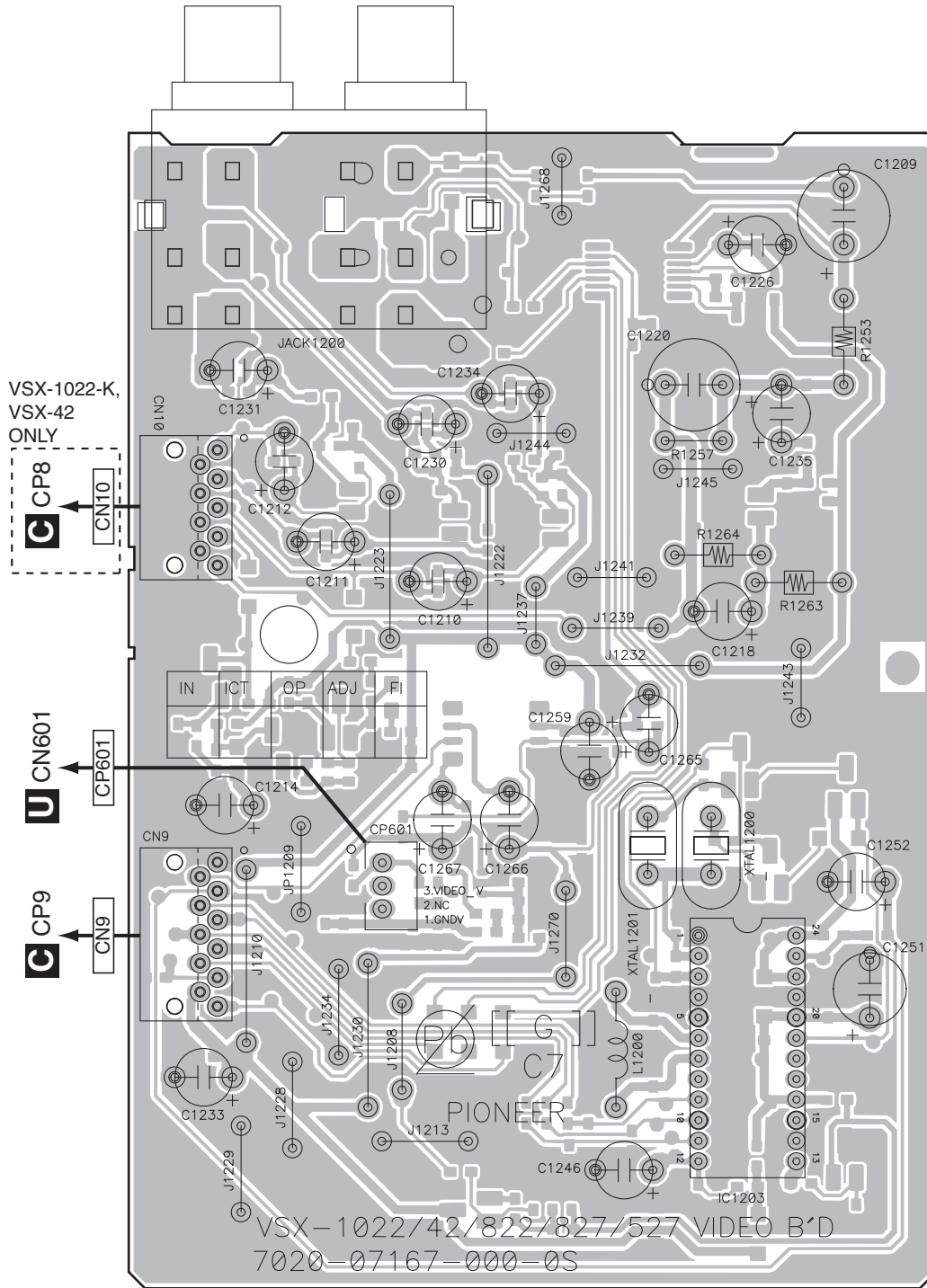

SIDE B

SIDE B

A

F VIDEO ASSY

B

C

D

E

F

IC200

Q1211 Q1203
Q1201 Q1202

Q1205
IC1201 Q1200
Q1209 Q1204
Q1208

Q1207 IC1202

Q1210
Q1206

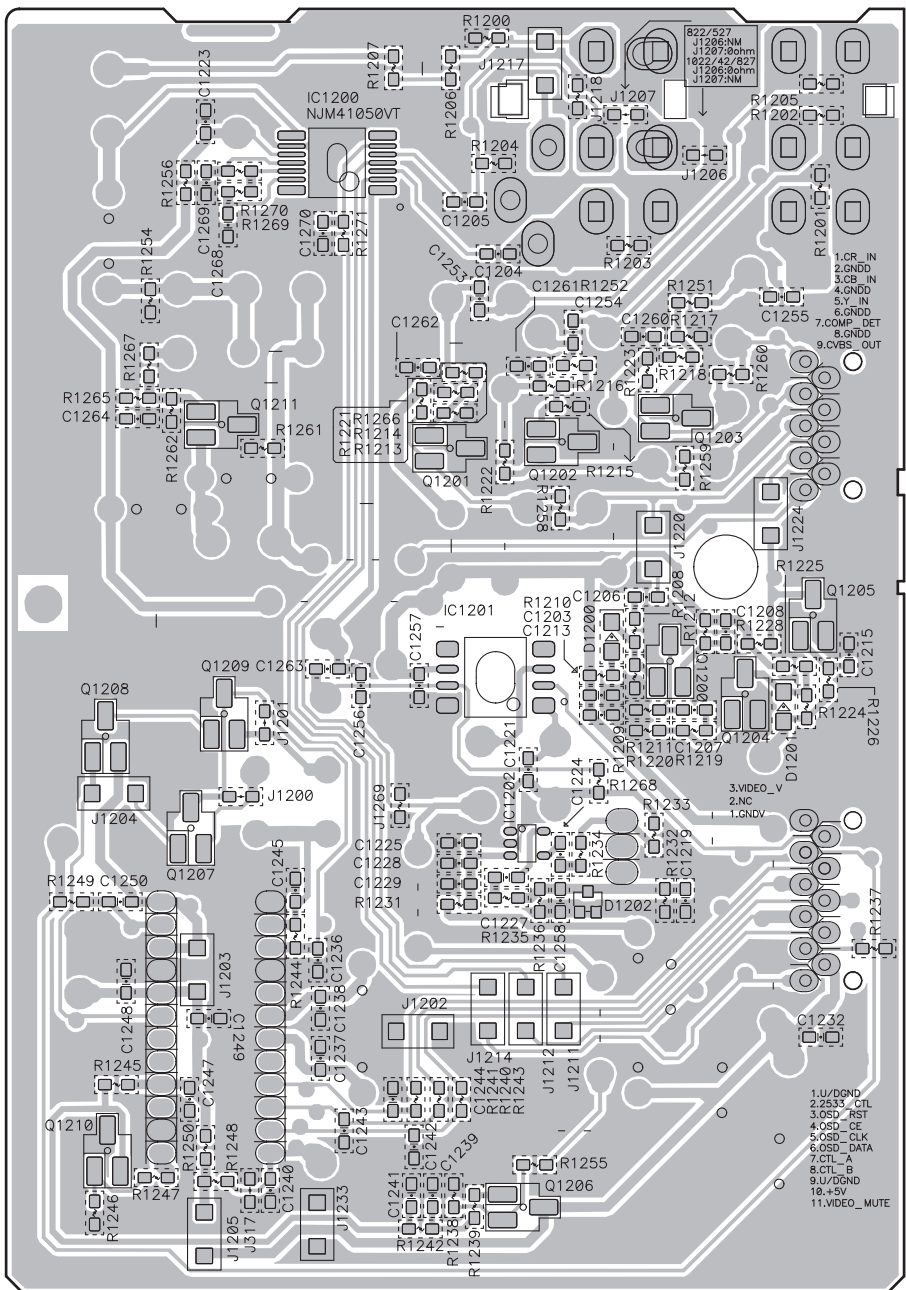

CN10

CP601

CN9

11.8 G-L, G-R, WG-A and WG-B ASSYS

SIDE A

SIDE B

A

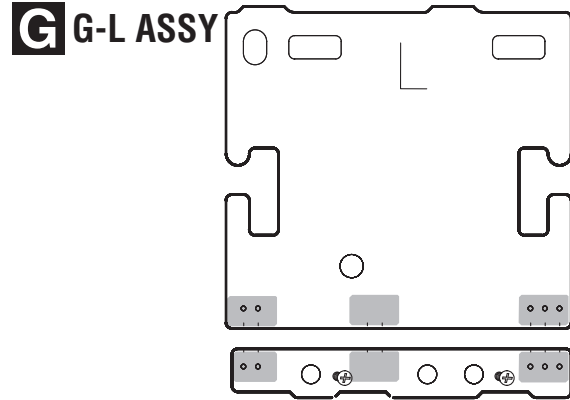
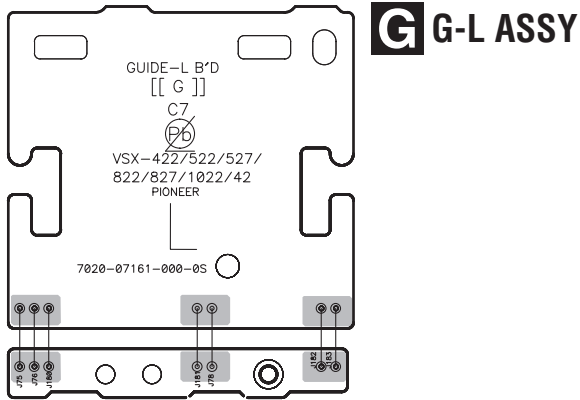

B

C

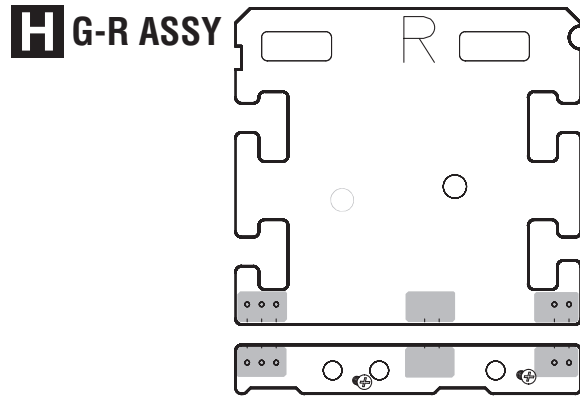
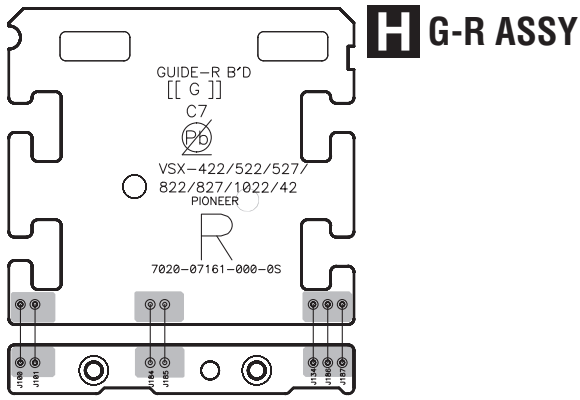

D

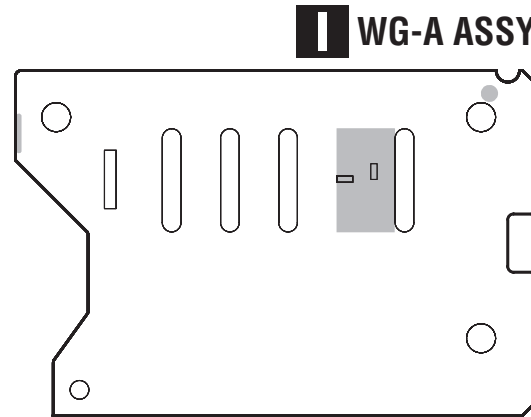
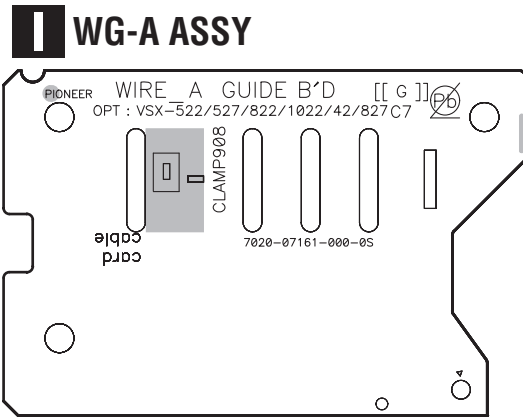

E

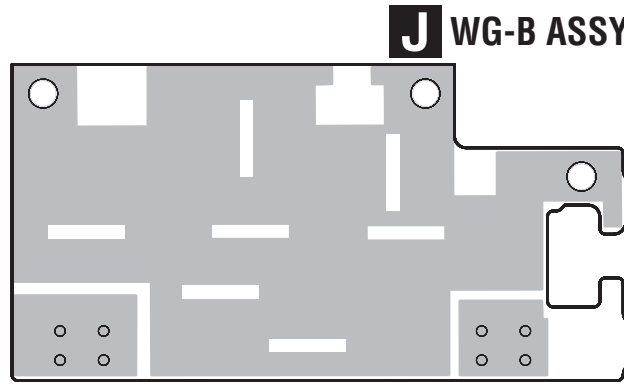
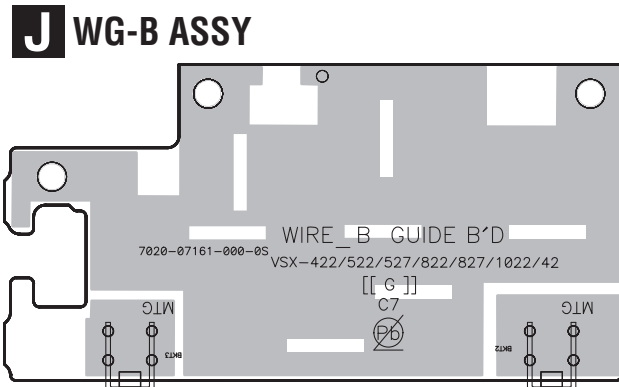

G H I J

11.9 BT CNT and OPTCO ASSYS

SIDE A

K BT CNT ASSY

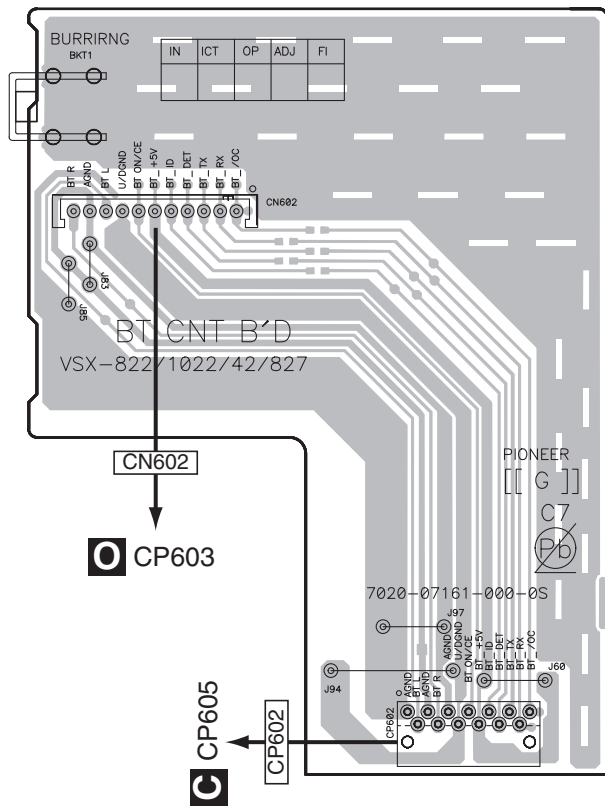

SIDE A

L OPTCO ASSY

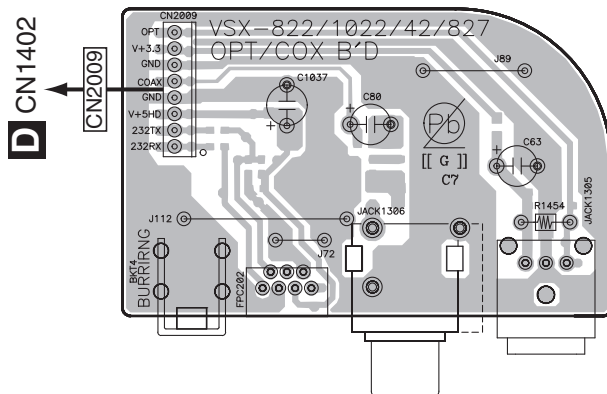

A

B

C

SIDE B

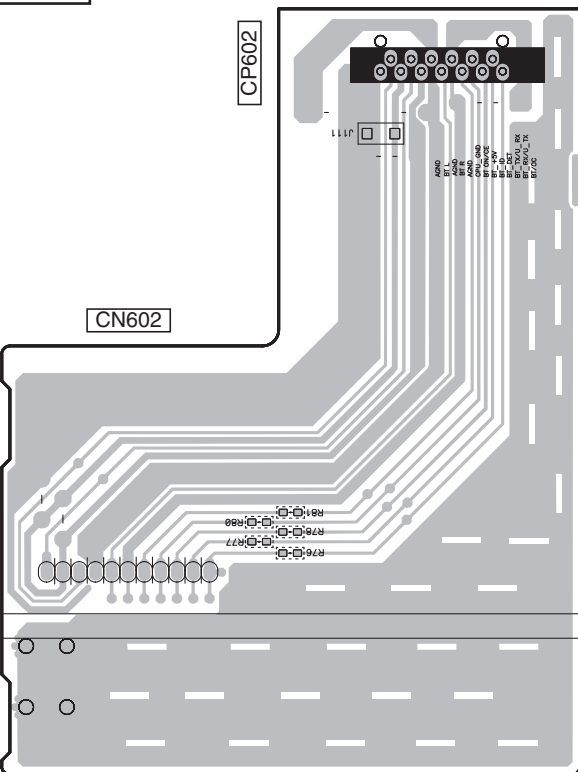

SIDE B

L OPTCO ASSY

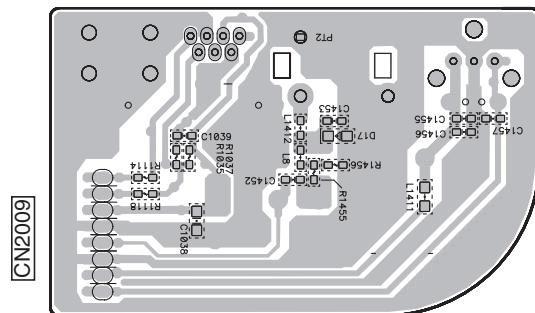

D

E

F

K BT CNT ASSY

K L

11.10 BRG-1 and BRG-2 ASSYS

SIDE A

SIDE A

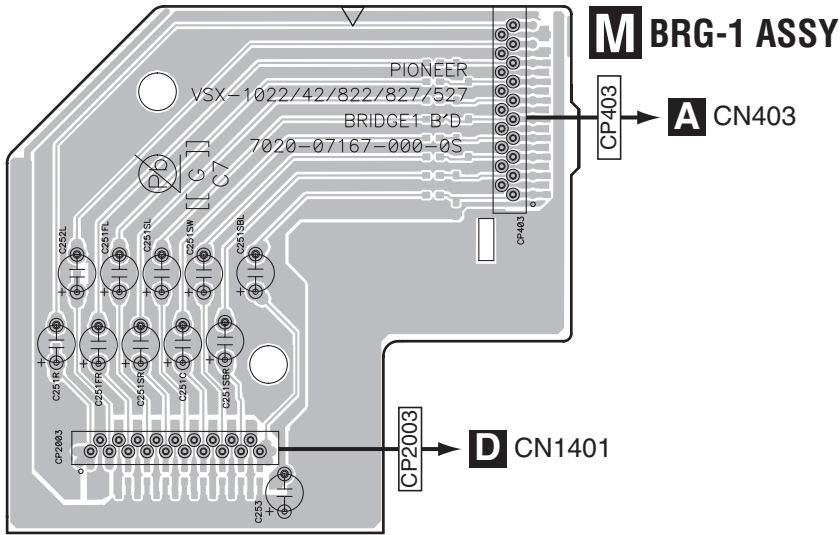

N BRG-2 ASSY

A CN402

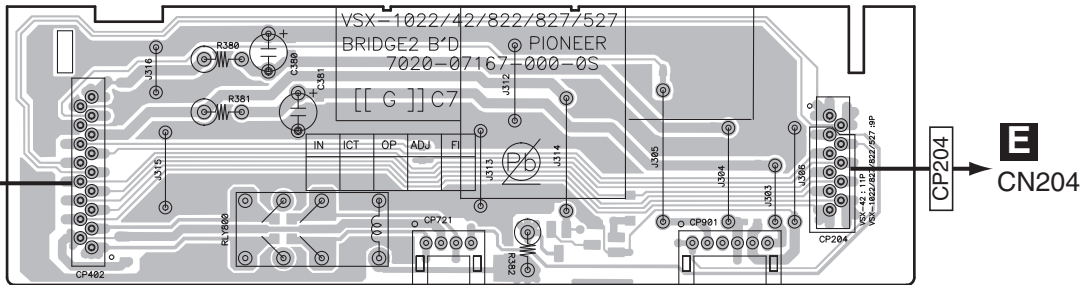

SIDE B

SIDE B

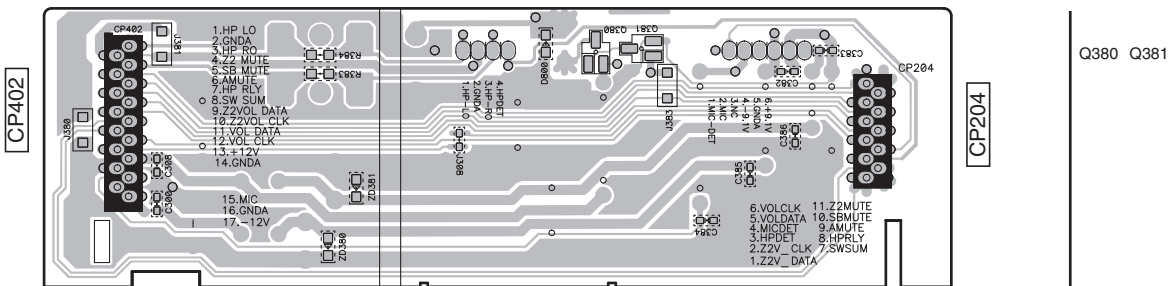

N BRG-2 ASSY

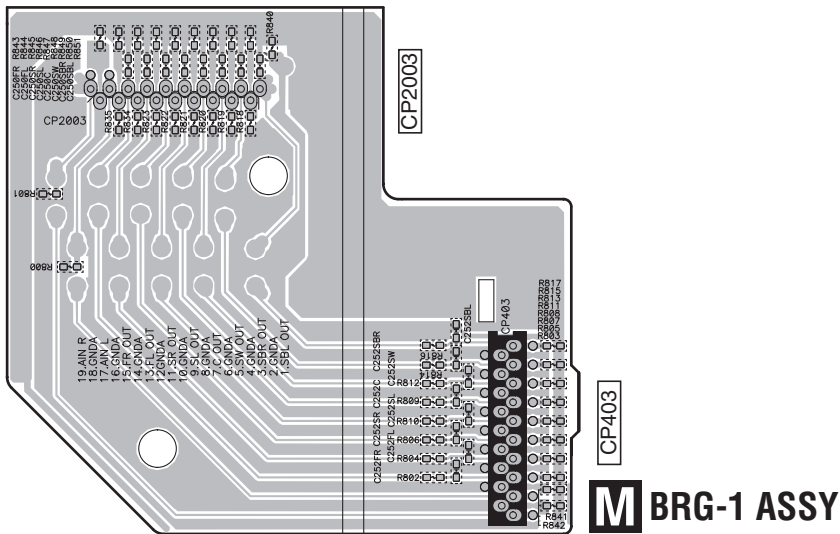

M N

11.12 FRONT, INSEL, HP, MIC, FVIDEO and WG ASSYS

SIDE A

Q FRONT ASSY

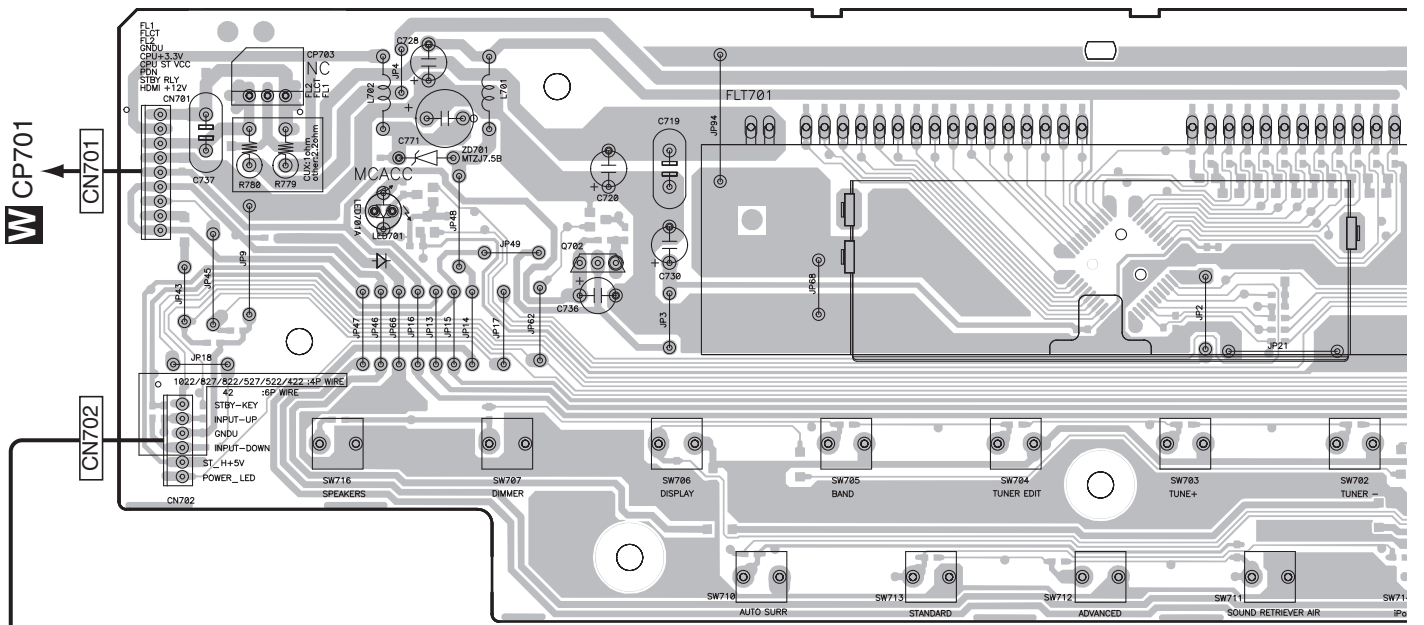

Q702

R INSEL ASSY

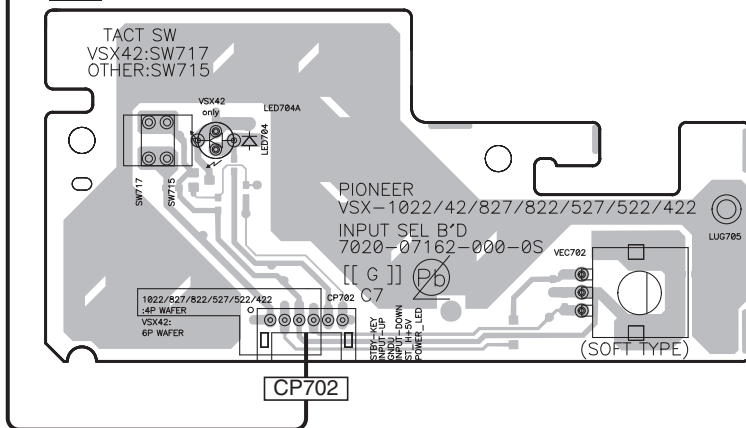

S HP ASSY

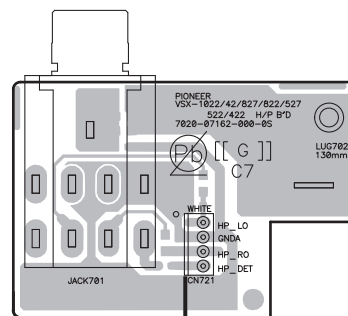

N CP721

Q R S

SIDE A

A

B

C

D

E

F

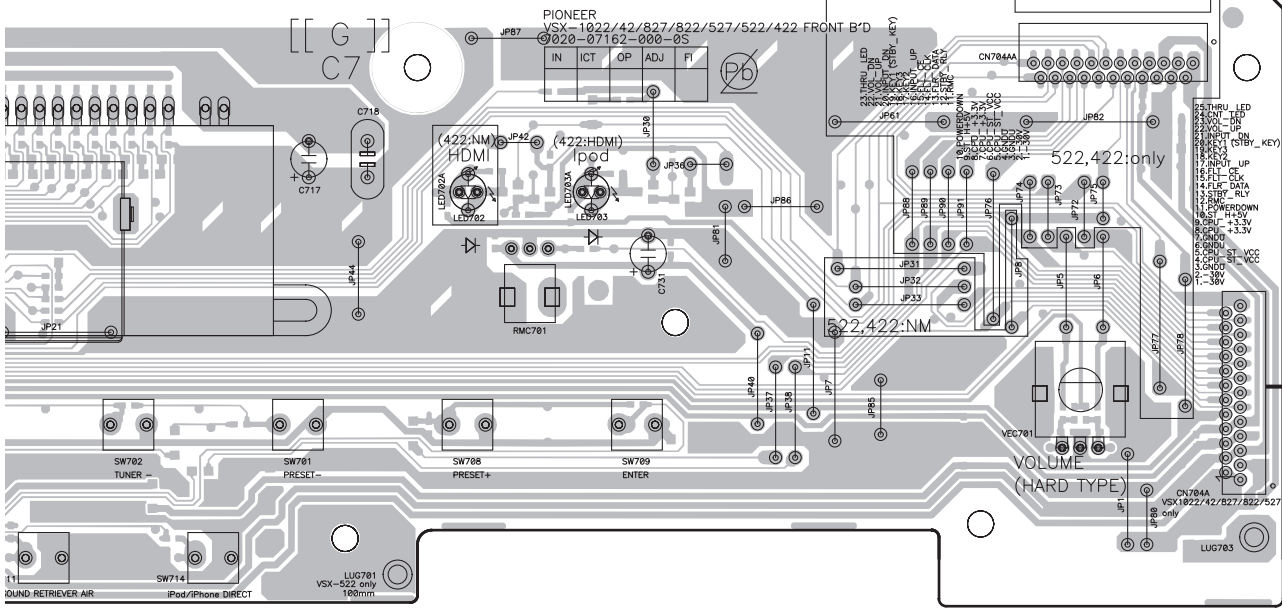

SIDE B

Q FRONT ASSY

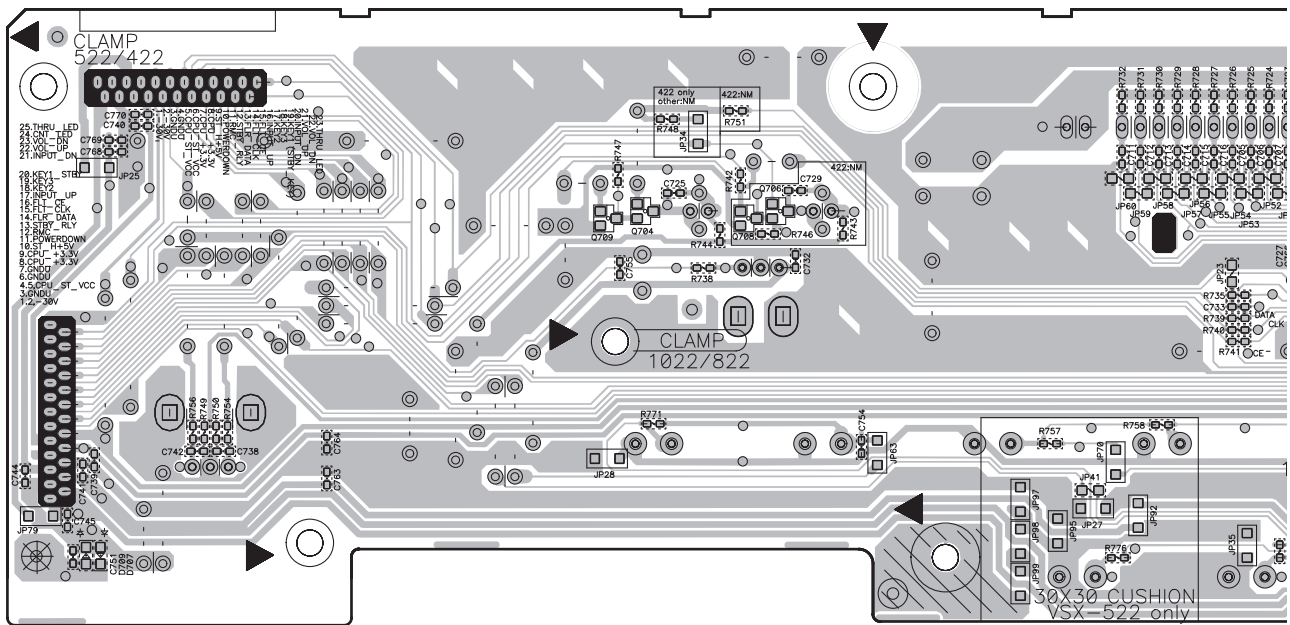

CN704A

Q709 Q704 Q708 Q706

V WG ASSY

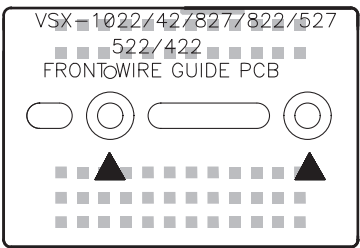

U FVIDEO ASSY

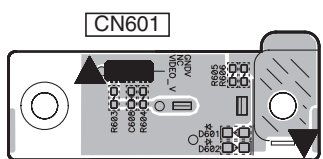

T MIC ASSY

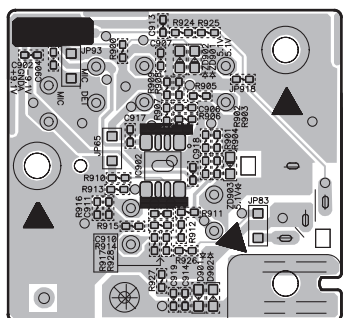

IC902

Q T U V

SIDE B

A

B

C

D

E

F

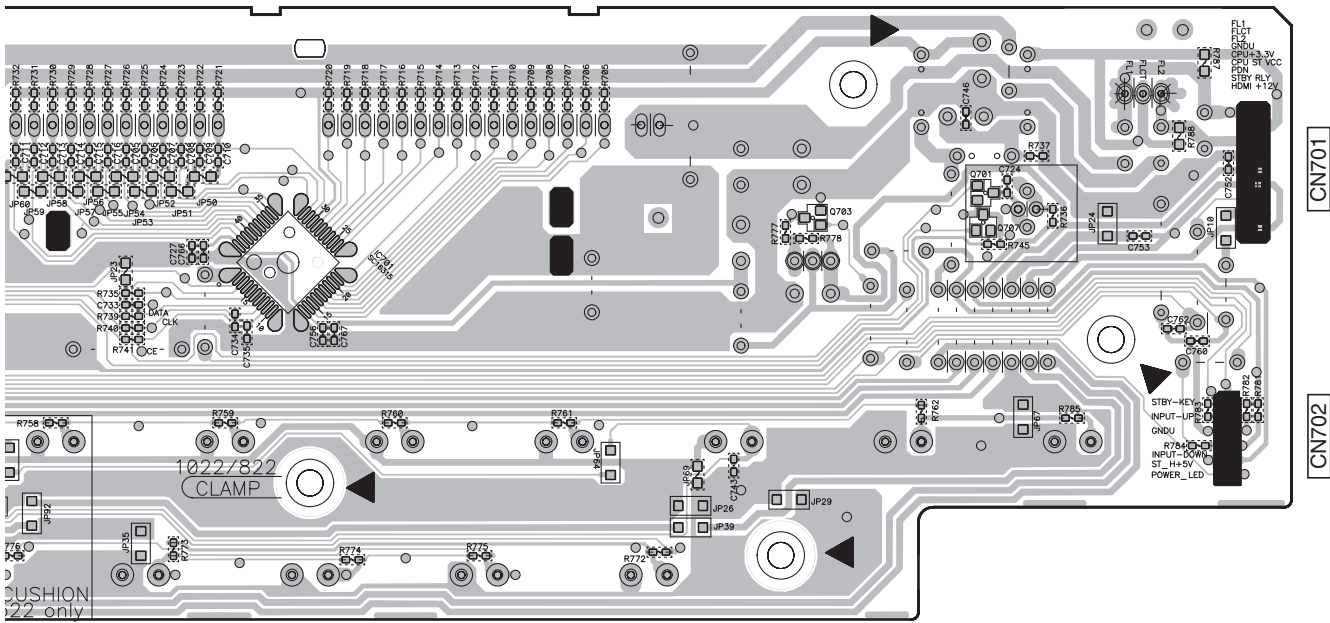

IC701

Q703

Q701
Q707

S HP ASSY

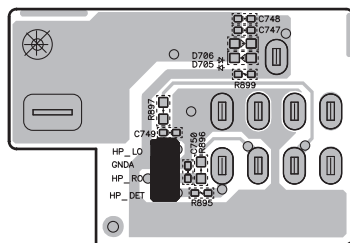

R INSEL ASSY

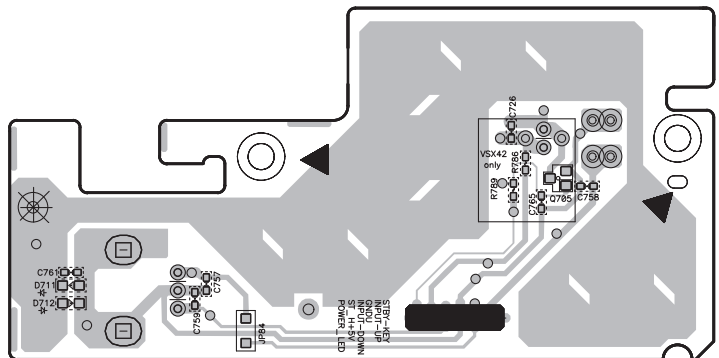

Q705

VSX-1022-K

Q R S

11.13 STBY ASSY

SIDE A

SIDE A

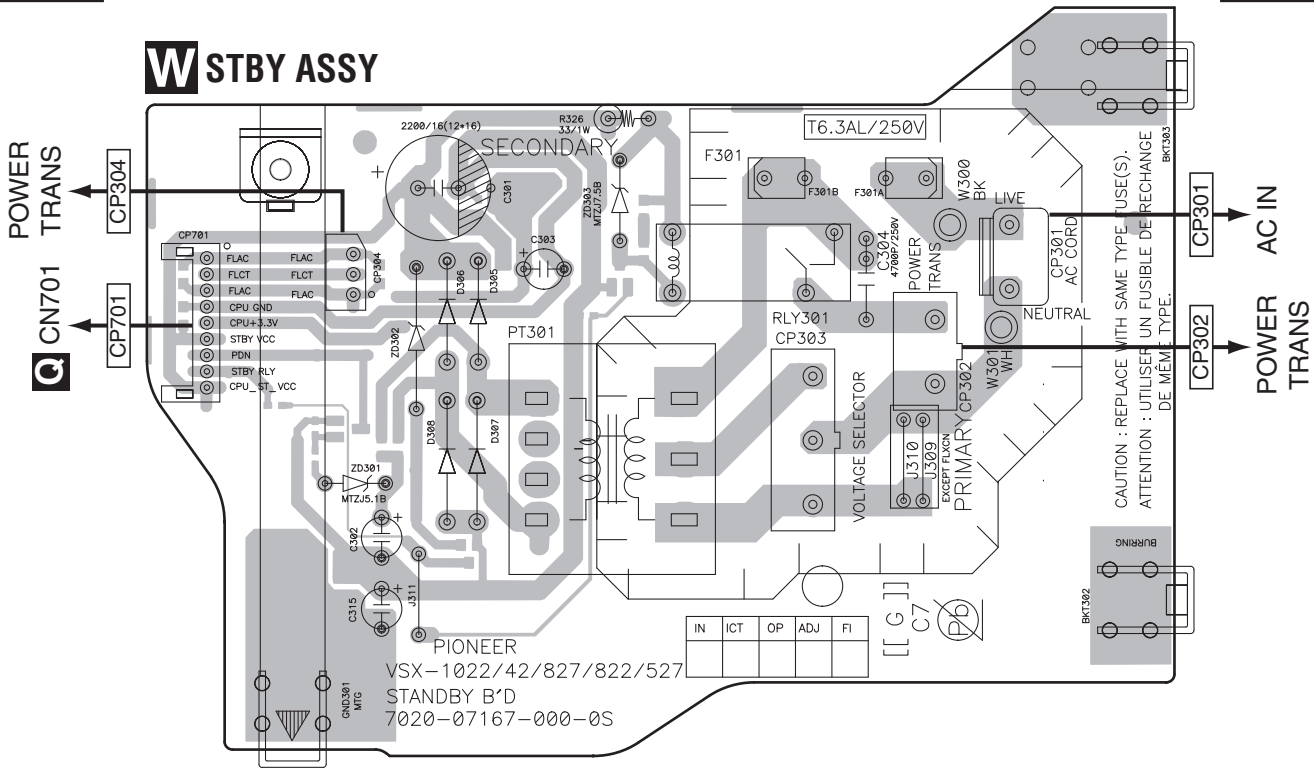

SIDE B

SIDE B

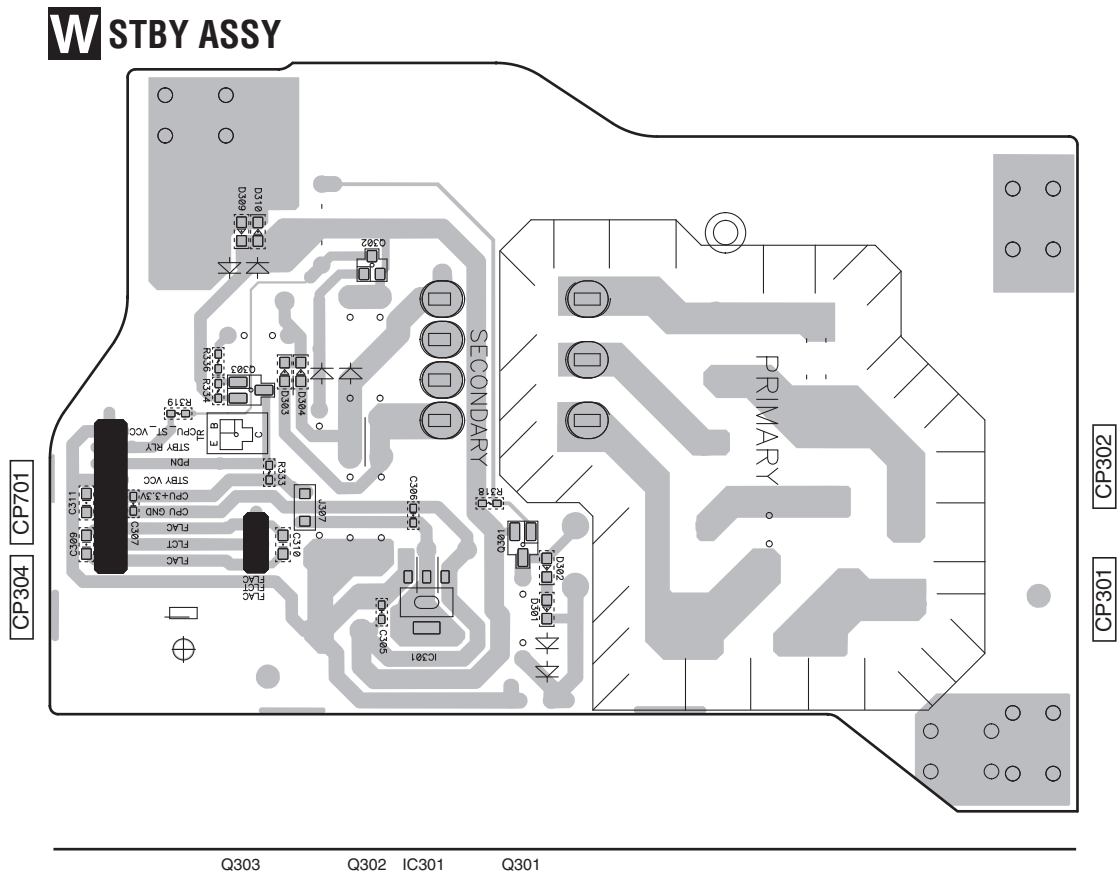

W

12. PCB PARTS LIST

NOTES: ● Parts marked by "NSP" are generally unavailable because they are not in our Master Spare Parts List.

● The Δ mark found on some component parts indicates the importance of the safety factor of the part. Therefore, when replacing, be sure to use parts of identical designation.

● When ordering resistors, first convert resistance values into code form as shown in the following examples.

Ex.1 When there are 2 effective digits (any digit apart from 0), such as 560 ohm and 47 k ohm (tolerance is shown by J = 5%, and K = 10%).

560 Ω \rightarrow 56 $\times 10^1$ \rightarrow 561 RD1/APU [5] [6] [7] J

47 k Ω \rightarrow 47 $\times 10^3$ \rightarrow 473 RD1/APU [4] [7] [3] J

0.5 Ω \rightarrow R50 RN2H [R] [5] [0] K

1 Ω \rightarrow 1R0 RS1P [7] [R] [0] K

Ex.2 When there are 3 effective digits (such as in high precision metal film resistors).

5.62 k Ω \rightarrow 562 $\times 10^1$ \rightarrow 5621 RN1/4PC [5] [6] [2] [7] F

● Meaning of the figures and others in the parentheses in the parts list.

Example) IC 301 is on the point (face A, 91 of x-axis, and 111 of y-axis) of the corresponding PC board.

IC 301 (A, 91, 111) IC NJM2068V

● SCHEMATIC DIAGRAM and PCB CONNECTION DIAGRAM \rightarrow ● PCB PARTS LIST

BKT	\rightarrow none	BEAD	\rightarrow L	RLY	\rightarrow RY	SW	\rightarrow S
CLAMP	\rightarrow none	F	\rightarrow FU	RMC	\rightarrow U	VEC	\rightarrow S9***
W	\rightarrow none	FLT	\rightarrow V	RES	\rightarrow X	GND	\rightarrow KN
LUG	\rightarrow none	JACK	\rightarrow JA	XTAL	\rightarrow X9***		
P	\rightarrow none	JACK	\rightarrow JA9***	BD	\rightarrow L7***		
PACK	\rightarrow 9***	JK	\rightarrow JA	LED	\rightarrow D8***		
CP	\rightarrow CN	PT	\rightarrow T	Z	\rightarrow D9***		
CP	\rightarrow CN9***	REG	\rightarrow IC	ZD	\rightarrow D9***		
FPC	\rightarrow CN9***	REG	\rightarrow IC9***	DZ	\rightarrow D9***		

LIST OF ASSEMBLIES

Mark	Symbol and Description	VSX-1022-K /CUXESM	VSX-42 /JXECB	VSX-822-K /CUXESM
NSP	1..PCB TTL ASSY MAIN	7025HK1108010-IL	7025HK1108020-IL	7025HK1107010-IL
	2..MAIN ASSY	7028071611030-IL	7028071611050-IL	7028071611010-IL
	2..BTCNT ASSY	7028071612050-IL	7028071612050-IL	7028071612050-IL
	2..OPTCO ASSY	7028071613050-IL	7028071613050-IL	7028071613050-IL
	2..G-R ASSY	7028071614050-IL	7028071614050-IL	7028071614050-IL
	2..G-L ASSY	7028071615050-IL	7028071615050-IL	7028071615050-IL
	2..WG-A ASSY	7028071616050-IL	7028071616050-IL	7028071616050-IL
	2..WG-B ASSY	7028071617050-IL	7028071617050-IL	7028071617050-IL
NSP	1.PCB TTL ASSY FRONT	7025HK1108011-IL	7025HK1108021-IL	7025HK1108011-IL
	2..FRONT ASSY	7028071621030-IL	7028071621050-IL	7028071621030-IL
	2..HP ASSY	7028071622030-IL	7028071622050-IL	7028071622030-IL
	2..INSEL ASSY	7028071623030-IL	7028071623050-IL	7028071623030-IL
	2..MIC ASSY	7028071624050-IL	7028071624050-IL	7028071624050-IL
	2..FVIDEO ASSY	7028071626030-IL	7028071626050-IL	7028071626030-IL
	2..WG ASSY	7028071627060-IL	7028071627060-IL	7028071627060-IL
NSP	1..PCB TTL ASSY VIDEO	7025HK1108012-IL	7025HK1108022-IL	7025HK1107012-IL
	2..VIDEO ASSY	7028071671030-IL	7028071671030-IL	7028071671010-IL
	2..STBY ASSY	7028071672030-IL	7028071672030-IL	7028071672010-IL
	2..BRG-1 ASSY	7028071673030-IL	7028071673030-IL	7028071673030-IL
	2..BRG-2 ASSY	7028071674030-IL	7028071674050-IL	7028071674030-IL
NSP	1..PCB TTL ASSY AUDIO	7025HK1108013-IL	7025HK1108023-IL	7025HK1107013-IL
	2..AUDIO ASSY	7028071641030-IL	7028071641050-IL	7028071641010-IL
NSP	1..PCB TTL ASSY DMAIN	7025HK1108014-IL	7025HK1108024-IL	7025HK1107014-IL
	2..D-MAIN ASSY	7028071691050-IL	7028071691050-IL	7028071691010-IL
NSP	1..PCB TTL ASSY CPU	7025HK1108015-IL	7025HK1108025-IL	7025HK1107015-IL
	2..CPU ASSY	7028071681030-IL	7028071681050-IL	7028071681010-IL
NSP	1..PCB TTL ASSY AMP7	7025HK1108017-IL	7025HK1108017-IL	Not used
	2..AMP7 ASSY	7028070253010-IL	7028070253010-IL	Not used
NSP	1..PCB TTL ASSY AMP5	Not used	Not used	7025HK1107017-IL
	2..AMP5 ASSY	Not used	Not used	7028070245010-IL
NSP	1..PCB TTL ASSY BT	7025HK1009019-IL	7025HK1009019-IL	7025HK1009019-IL
	2..BT ASSY	7028070231010-IL	7028070231010-IL	7028070231010-IL
NSP	1..PCB TTL ASSY F-USB	7025HK1108016-IL	7025HK1108016-IL	7025HK1108016-IL
	2..F-USB ASSY	7028071781030-IL	7028071781030-IL	7028071781030-IL

CONTRAST OF PCB ASSEMBLIES

A AUDIO ASSY

7028071641030-IL, 7028071641050-IL and 7028071641010-IL are constructed the same except for the following:

Mark	Symbol and Description	7028071641030-IL	7028071641030-IL	7028071641030-IL
	JA402 Ter, RCA 2pin	Not used	Not used	G601206A0005Y-IL

B MAIN ASSY

7028071611030-IL, 7028071611050-IL and 7028071611010-IL are constructed the same except for the following:

Mark	Symbol and Description	7028071611030-IL	7028071611050-IL	7028071611010-IL
⚠	IC5 Liner Regulator IC	Not used	J126781200040-IL	Not used
	R15, R17 R, metal Film 100PPM	C060010065050-IL	C060010065050-IL	Not used
	R16, R18 R, metal Film 100PPM	C060010066050-IL	C060010066050-IL	Not used
	RY5, RY6 Relay	G680120502050-IL	G680120502050-IL	Not used
	CN9008, CN9014 CN. wafer	L109012510920-IL	L109012510920-IL	Not used
	JA104 Ter, board Push 4p	G594408SA030Y-IL	G594408SA030Y-IL	Not used
	JA103 Ter, board Screw 2p	G611201A0200Y-IL	G611201A0200Y-IL	Not used
	JA102 Ter, board Screw 4p	G612405E0200Y-IL	G612405E0200Y-IL	G611201A0200Y-IL

C D-MAIN ASSY

7028071691050-IL and 7028071691010-IL are constructed the same except for the following:

Mark	Symbol and Description	7028071691050-IL	7028071691010-IL
	IC1202 Video Decoder IC	ADV7181CBSTZ-K	Not used

D CPU ASSY

7028071681030-IL, 7028071681050-IL and 7028071681010-IL are different in part number, they consist of the same components.

E VIDEO ASSY

7028071671030-IL and 7028071671010-IL are constructed the same except for the following:

Mark	Symbol and Description	7028071671030-IL	7028071671010-IL
	JA1200 Ter, RCA 6pin	G603610A0051Y-IL	G606305AW140Y-IL

F BRG-2 ASSY

7028071674030-IL and 7028071674050-IL are constructed the same except for the following:

Mark	Symbol and Description	7028071674030-IL	7028071674050-IL
	CN204 CN. wafer	L109012510920-IL	L109012511120-IL

G FRONT ASSY

7028071621030-IL and 7028071621050-IL are constructed the same except for the following:

Mark	Symbol and Description	7028071621030-IL	7028071621050-IL
	D9701 - D9703 LED, round	K500052009011-IL	K500036001120-IL

H INSEL ASSY

7028071623030-IL and 7028071623050-IL are constructed the same except for the following:

Mark	Symbol and Description	7028071623030-IL	7028071623050-IL
	D9704 LED, round	Not used	K500036001120-IL

S HP ASSY

7028071622030-IL and 7028071622050-IL are constructed the same except for the following:

Mark	Symbol and Description	7028071622030-IL	7028071622050-IL
	JA701 Jack, d6.5	G402PJ612A09Y-IL	G402PJ612AG1Y-IL

U FVIDEO ASSY

7028071626030-IL and 7028071626050-IL are constructed the same except for the following:

Mark	Symbol and Description	7028071626030-IL	7028071626050-IL
	JA601 Ter, RCA 1pin	G600101H0000Y-IL	G600101HG000Y-IL

W STBY ASSY

7028071672030-IL and 7028071672010-IL are constructed the same except for the following:

Mark	Symbol and Description	7028071672030-IL	7028071672010-IL
	D9301 D, zener	K06005R644520-IL	K06005R144520-IL
⚠	FU301 Fuse Glass Tube 20mm	N751508001160-IL	N751506301160-IL

Mark	No.	Description	Part No.	Mark	No.	Description	Part No.
------	-----	-------------	----------	------	-----	-------------	----------

PARTS LIST (VSX-1022-K)

A AUDIO ASSY **SEMICONDUCTORS**

IC 400	J084152180010-IL
IC 401-403,406	J121458001010-IL
D 9400,9401	K06006R844520-IL

MISCELLANEOUS

JA 401 TER,RCA 6PIN	G603610A0001Y-IL
JA 403 TER,RCA 1PIN	G600107A0000Y-IL

RESISTORS

R 510,587	C060033065050-IL
⚠ R 588,589	C060010165060-IL

B AMP7 ASSY (VSX-1022-K, VSX-42) **SEMICONDUCTORS**

Q 401,413,425,437	J5001024Y0050-IL
Q 407,408,417,419	J5000992F0050-IL
Q 412,424,436,448	J5023206Y0050-IL
Q 420,431,432,443	J5000992F0050-IL
Q 444,455,456,467	J5000992F0050-IL

Q 449,461,473	J5001024Y0050-IL
Q 460,472,484	J5023206Y0050-IL
Q 468,479,480	J5000992F0050-IL
D 9401,9404,9407,9410	K06005R134520-IL
D 9402,9403,9405,9406	K06004R344520-IL

D 9408,9409,9411,9412	K06004R344520-IL
D 9413,9416,9419	K06005R134520-IL
D 9414,9415,9417,9418	K06004R344520-IL
D 9420,9421	K06004R344520-IL

MISCELLANEOUS

VR 401-407 VR,SEMI CARBON MOLD 401 BRACKET	C541102315000-IL 4010210196100-IL
---	--------------------------------------

RESISTORS

⚠ R 406,450,494,537	F320184710050-IL
⚠ R 424,425,430,431	N113136647820-IL
R 443,487,530,573	C060047065060-IL
⚠ R 467,468,474,475	N113136647820-IL

R 493	C060033065050-IL
-------	------------------

⚠ R 511,512,517,518	N113136647820-IL
⚠ R 554,555,561,562	N113136647820-IL
⚠ R 580,623,666	F320184710050-IL
⚠ R 597,598,603,604	N113136647820-IL
R 616,659,702	C060047065060-IL

⚠ R 640,641,646,647	N113136647820-IL
⚠ R 683,684,689,690	N113136647820-IL

CAPACITORS

C 419	D04010108C240-IL
-------	------------------

B AMP5 ASSY (VSX-822-K) **SEMICONDUCTORS**

Q 401,413,425,437	J5001024Y0050-IL
Q 407,408,417,419	J5000992F0050-IL
Q 412,424,436,448	J5023206Y0050-IL
Q 420,431,432,443	J5000992F0050-IL
Q 444,455,456	J5000992F0050-IL

Q 449	J5001024Y0050-IL
Q 460	J5023206Y0050-IL
D 9401,9404,9407,9410	K06005R134520-IL
D 9402,9403,9405,9406	K06004R344520-IL
D 9408,9409,9411,9412	K06004R344520-IL

D 9413	K06005R134520-IL
D 9414,9415	K06004R344520-IL

MISCELLANEOUS

VR 401-405 VR,SEMI CARBON MOLD 400 BRACKET	C541102315000-IL 4010210196100-IL
---	--------------------------------------

RESISTORS

⚠ R 406,450,494,537	F320184710050-IL
⚠ R 424,425,430,431	N113136647820-IL
R 443,487,530,573	C060047065060-IL
⚠ R 467,468,474,475	N113136647820-IL
R 493	C060033065050-IL

⚠ R 511,512,517,518	N113136647820-IL
⚠ R 554,555,561,562	N113136647820-IL
⚠ R 580	F320184710050-IL

Mark	No.	Description	Part No.
△	R	597,598,603,604	N113136647820-IL
	R	616	C060047065060-IL

Mark	No.	Description	Part No.
	IC	1403	J040740400270-IL
	IC	1405,1406	TC74VHC157FK

CAPACITORS

C	419	D04010108C240-IL
---	-----	------------------

IC	1602	J001986466010-IL	
IC	9201	J001982566010-IL	
IC	9206	341S2162	
△	IC	9505	S-1172B12-E6

**MISCELLANEOUS**

1401	BRACKET	4010210196100-IL
------	---------	------------------

E CPU ASSY SEMICONDUCTORS

IC	204	J000241600170-IL
IC	206	TC7SH08FUS1

MISCELLANEOUS

X	201	CRYSTAL (16 MHz)	E80016R000030-IL
CN	201	CN,WAFER	L109012513320-IL
CN	213	CN,WAFER	L109012511520-IL
	201,202	BRACKET	4010210196100-IL

F VIDEO ASSY SEMICONDUCTORS

IC	1200	J127410500010-IL
----	------	------------------

MISCELLANEOUS

JA	1200	TER,RCA 6PIN	G603610A0051Y-IL
----	------	--------------	------------------

G G-L ASSY

There is no service parts.

H G-R ASSY

There is no service parts.

I WG-A ASSY

There is no service parts.

J WG-B ASSY

There is no service parts.

K BT CNT ASSY**MISCELLANEOUS**

CN	602	CN,WAFER 2.0MM	L101100041110-IL
----	-----	----------------	------------------

L OPTCO ASSY**MISCELLANEOUS**

JA	1305	OPTICAL RECEIVER	E100116500040-IL
JA	1306	TER,RCA 1PIN	G600107A0000Y-IL

C MAIN ASSY**SEMICONDUCTORS**

△	IC	1	J126781200040-IL
△	IC	2	J126791200060-IL
△	IC	3	J126780500110-IL
	Q	14,15	J5023198Y0000-IL
	Q	16	J5000992F0050-IL

B	Q	17	J5000916Y0050-IL
	D	7	K047100600220-IL
△	D	9,4912	K047604000020-IL
△	D	10-13	K000400700220-IL
	D	23	K000400700220-IL

	D	9001	K06003R344520-IL
	D	9024,9025	K06016R044520-IL

MISCELLANEOUS

JA	101	TER,BOARD SCREW 8P	G614108V1010M-IL	
JA	102	TER,BOARD SCREW 4P	G612405E0200Y-IL	
JA	103	TER,BOARD SCREW 2P	G611201A0200Y-IL	
JA	104	TER,BOARD PUSH 4P	G594408SA030Y-IL	
	RY	2-6	RELAY	G680120502050-IL

	CN	9008,9014	CN,WAFER	L109012510920-IL
	CN	9009,9015,9016	CN,WAFER	L109012511120-IL
	CN	9013	CN,WAFER	L109012510720-IL
	CN	9017	CN,WAFER	L109012511520-IL
	CN	9605	CN,WAFER	L109012511320-IL

	601	TUNER,FM/AM	E903004100780-IL	
△	FU	302,303	FUSE,MICRO	G658315250050-IL

RESISTORS

R	5,7,9,11	C060010065050-IL
R	6,8,10,12	C060010066050-IL
R	13,15,17,25	C060010065050-IL
R	14,16,18	C060010066050-IL
R	27,31,41,42	C060R22065050-IL

R	64	C060022063050-IL
R	66	C0604R7065050-IL

CAPACITORS

C	55,58	D040682088010-IL
C	73,76	D040682083000-IL
C	84	D040472084020-IL
C	85	D040102084060-IL
C	101	D040331088230-IL

D D-MAIN ASSY**SEMICONDUCTORS**

△	IC	1003	AAT4610BIGV-1
	IC	1201	TC7WHU04FK
	IC	1202	ADV7181CBSTZ
	IC	1203	ABT1015
	IC	1204	TC74LCX541FK

	IC	1205	TC7SZ125FU
	IC	1401	AK4588VQ
	IC	1402	TC74VHC08FK

Mark	No.	Description	Part No.
------	-----	-------------	----------

M BRG-1 ASSY

MISCELLANEOUS

CN 403,2003 CN,WAFER

L109012511920-IL

N BRG-2 ASSY

MISCELLANEOUS

RY 800 RELAY
CN 204 CN,WAFER
CN 402 CN,WAFER

G680240202030-IL
L109012510920-IL
L109012511720-IL

RESISTORS

R 382

C060010063050-IL

O BT ASSY

SEMICONDUCTORS

⚠ IC 600

BD2224G

MISCELLANEOUS

CN 601 CONNECTOR
CN 603 CN,WAFER 2.0MM
601 BRACKET

CKS5712
L101100031110-IL
4010210196100-IL

P F-USB ASSY

MISCELLANEOUS

JA 600 CN,PLUG CONTACT

G480040000180-IL

Q FRONT ASSY

SEMICONDUCTORS

IC 701
⚠ Q 702
D 8701
D 9701-9703

J127163150010-IL
J5001266G0050-IL
K06007R544520-IL
K500052009011-IL

MISCELLANEOUS

H 701 FL HOLDER
V 701 DISPLAY,FLT
S 701-714,716 SWITCH
S 9701 SW,ENCODER
U 701 MODULE,REMOCON

4320211016000-IL
K530126600010-IL
G180501000010-IL
G121125042011-IL
E940349003810-IL

RESISTORS

R 779,780

C060001063050-IL

R INSEL ASSY

MISCELLANEOUS

S 715 SWITCH
S 9702 SW,ENCODER

G180501000010-IL
G121125052011-IL

S HP ASSY

MISCELLANEOUS

JA 701 JACK,D6.5

G402PJ612A09Y-IL

T MIC ASSY

SEMICONDUCTORS

IC 902

J121458001010-IL

Mark	No.	Description	Part No.
------	-----	-------------	----------

MISCELLANEOUS

JA 901 JACK,D3.5

G401PJ354H40Y-IL

U FVIDEO ASSY

MISCELLANEOUS

JA 601 TER,RCA 1PIN

G600101H0000Y-IL

V WG ASSY

There is no service parts.

W STBY ASSY

SEMICONDUCTORS

⚠ IC 301
⚠ D 303,304
⚠ D 305-307
D 308
D 9301

J126111700041-IL
K005041480230-IL
K000400700220-IL
K000400700220-IL
K06005R644520-IL

D 9303

K06007R544520-IL

MISCELLANEOUS

⚠ RY 301 RELAY
⚠ T 301 POWER TRANS
⚠ CN 301 CONNECTOR
⚠ CN 302 CN,WAFER 7.92MM
302,303 BRACKET

G680060102020-IL
8200280150620-IL
L108396030010-IL
L108011430210-IL
4010210196100-IL

⚠ FU 301 FUSE GLASS TUBE 20MM

N751508001160-IL

RESISTORS

⚠ R 326

C060033065050-IL

CAPACITORS

C 301
⚠ C 304

D040222083010-IL
D00847208H010-IL