

# Pioneer

## Service Manual

ORDER NO.  
**RRV4530**

AV Receiver

# VSX-824-K

## VSX-529-K

## VSX-529-S

**THIS MANUAL IS APPLICABLE TO THE FOLLOWING MODEL(S) AND TYPE(S).**

Model	Type	Power Requirement	The voltage can be converted by the following method.
VSX-824-K	SYXEV8	AC 220 V to 230 V	-----
VSX-529-K	SYXEV8	AC 220 V to 230 V	-----
VSX-529-S	SYXEV8	AC 220 V to 230 V	-----
VSX-824-K	DLXEV	AC 110 V to 127 V/220 V to 240 V	With the voltage selector
VSX-824-K	FXEV	AC 110 V to 127 V/220 V to 240 V	With the voltage selector
VSX-824-K	AXEV5	AC 220 V	-----

**This service manual should be used together with the following manual(s).**

Model No.	Order No.	Remarks
VSX-824-K/CUXEVSM	RRV4520	
VSX-824-K, VSX-1024-K, VSX-1029-K, VSX-44, VSA-824	RRV4526	SCHEMATIC DIAGRAM, PCB CONNECTION DIAGRAM, PCB PARTS LIST

**For SPECIFICATIONS and PANEL FACILITIES, refer to the operating instructions.**

**PIONEER CORPORATION** 1-1, Shin-ogura, Saiwai-ku, Kawasaki-shi, Kanagawa 212-0031, Japan  
**PIONEER ELECTRONICS (USA) INC.** P.O. Box 1760, Long Beach, CA 90801-1760, U.S.A.  
**PIONEER EUROPE NV** Haven 1087, Keetberglaan 1, 9120 Melsele, Belgium  
**PIONEER ELECTRONICS ASIACENTRE PTE. LTD.** 253 Alexandra Road, #04-01, Singapore 159936

©PIONEER CORPORATION 2014

K-ZZZ JUNE 2014 Printed in Japan

# 1. CONTRAST OF MISCELLANEOUS PARTS

NOTES: ● Parts marked by "NSP" are generally unavailable because they are not in our Master Spare Parts List.

● The  $\Delta$  mark found on some component parts indicates the importance of the safety factor of the part. Therefore, when replacing, be sure to use parts of identical designation.

● Screws adjacent to  $\nabla$  mark on product are used for disassembly.

● For the applying amount of lubricants or glue, follow the instructions in this manual.

(In the case of no amount instructions, apply as you think it appropriate.)

● Nos. indicate the pages and Nos. in the service manual for the base model.

● When ordering resistors, first convert resistance values into code form as shown in the following examples.

Ex.1 When there are 2 effective digits (any digit apart from 0), such as 560 ohm and 47k ohm (tolerance is shown by J=5%, and K=10%).

560 $\Omega$   $\rightarrow$  56 x 10<sup>1</sup>  $\rightarrow$  561 ..... RD1/4PU5 6 1 J  
 47k $\Omega$   $\rightarrow$  47 x 10<sup>3</sup>  $\rightarrow$  473 ..... RD1/4PU4 7 3 J  
 0.5 $\Omega$   $\rightarrow$  R50 ..... RN2HR 5 0 K  
 1 $\Omega$   $\rightarrow$  1R0 ..... RS1P 1 R 0 K

Ex.2 When there are 3 effective digits (such as in high precision metal film resistors).

5.62k $\Omega$   $\rightarrow$  562 x 10<sup>1</sup>  $\rightarrow$  5621 ..... RN1/4PC 5 6 2 1 F

## CONTRAST TABLE

### VSX-824-K/SYXEV8, VSX-529-K/SYXEV8 and VSX-529-S/SYXEV8

VSX-824-K/CUXEVSM, VSX-824-K/SYXEV8, VSX-529-K/SYXEV8 and VSX-529-S/SYXEV8 are constructed the same except for the following:

Mark	No.	Symbol and Description	VSX-824-K /CUXEVSM	VSX-824-K /SYXEV8	VSX-529-K /SYXEV8	VSX-529-S /SYXEV8	Remarks
<b>PCB ASSEMBLIES</b>							
NSP	P76-1 P76-2	1..PCB TTL ASSY MAIN	7025HK1310010	7025HK1310090	7025HK1310030	7025HK1310040	
		2..MAIN Assy	7028074511010	7028074511030	7028074511030	7028074511030	
		2..REG Assy	7028074512010	7028074512030	7028074512030	7028074512030	
NSP	P76-4	1..PCB TTL ASSY DMAIN 2..DMAIN Assy	7025HK1310011 7028074571010	7025HK1310091 7028074571030	7025HK1310031 7028074571050	7025HK1310041 7028074571050	
NSP	P76-5	1..PCB TTL ASSY FRONT 2..FRONT Assy	7025HK1310012 7028074521010	7025HK1310092 7028074521030	7025HK1310032 7028074521030	7025HK1310042 7028074521030	
NSP	P76-10	1..PCB TTL ASSY CPU 2..CPU Assy	7025HK1310013 7028074531010	7025HK1310093 7028074531030	7025HK1310033 7028074531020	7025HK1310043 7028074531020	
NSP	P76-14	1..PCB TTL ASSY AMP5	7025HK1310014	7025HK1310094	7025HK1310034	7025HK1310044	
NSP	$\Delta$ P76-16	1..PCB TTL ASSY SMPS 2..SMPS Assy	7025HK1310015 702807336104A	7025HK1310095 702807336101A	7025HK1310035 702807336101A	7025HK1310045 702807336101A	
NSP	P76-17	1..PCB TTL ASSY FHDMI 2..FHDMI Assy	7025HK1310016 7028074581010	7025HK1310096 7028074581030	7025HK1310036 7028074581030	7025HK1310046 7028074581030	
NSP	P76-18	1..PCB TTL ASSY BT 2..BT Assy	7025HK1310017 70280732110H0	Not used Not used	7025HK1310037 70280732110H0	7025HK1310047 70280732110H0	
NSP	P76-18	1..PCB TTL ASSY IN BT 2..INNER BT Assy	Not used Not used	7025HK1310097 7028074551020	Not used Not used	Not used Not used	
<b>PACKING SECTION</b>							
NSP	P73-5	Operating Instructions (CD-ROM)	6517000001710S	6517000001750S	6517000001750S	6517000001750S	
NSP		Operating Instructions_VSX-1024 (En)(pdf)	ARB7543	Not used	Not used	Not used	
NSP		Operating Instructions_VSX-1024 (Frca)(pdf)	ARC8299	Not used	Not used	Not used	
NSP		Operating Instructions_VSX-1024 (Es)(pdf)	ARC8300	Not used	Not used	Not used	
NSP		Operating Instructions_VSX-424 (En)(pdf)	Not used	ARB7549	ARB7549	ARB7549	
NSP		Operating Instructions_VSX-424 (Fr)(pdf)	Not used	ARC8315	ARC8315	ARC8315	
NSP		Operating Instructions_VSX-424 (Es)(pdf)	Not used	ARC8316	ARC8316	ARC8316	
NSP		Operating Instructions_VSX-424 (De)(pdf)	Not used	ARC8317	ARC8317	ARC8317	
NSP		Operating Instructions_VSX-424 (It)(pdf)	Not used	ARC8318	ARC8318	ARC8318	
NSP		Operating Instructions_VSX-424 (NI)(pdf)	Not used	ARC8319	ARC8319	ARC8319	
NSP		Operating Instructions_VSX-424 (Ru)(pdf)	Not used	ARC8320	ARC8320	ARC8320	

Mark	No.	Symbol and Description	VSX-824-K /CUXEVSM	VSX-824-K /SYXEV8	VSX-529-K /SYXEV8	VSX-529-S /SYXEV8	Remarks
NSP		Operating Instructions_VSX-824,529 (En)(pdf)	Not used	ARB7548	ARB7548	ARB7548	
NSP		Operating Instructions_VSX-824,529 (Fr)(pdf)	Not used	ARC8309	ARC8309	ARC8309	
NSP		Operating Instructions_VSX-824,529 (Es)(pdf)	Not used	ARC8310	ARC8310	ARC8310	
NSP		Operating Instructions_VSX-824,529 (De)(pdf)	Not used	ARC8311	ARC8311	ARC8311	
NSP		Operating Instructions_VSX-824,529 (It)(pdf)	Not used	ARC8312	ARC8312	ARC8312	
NSP		Operating Instructions_VSX-824,529 (Nl)(pdf)	Not used	ARC8313	ARC8313	ARC8313	
NSP		Operating Instructions_VSX-824,529 (Ru)(pdf)	Not used	ARC8314	ARC8314	ARC8314	
	P73-6	Quick Start Guide	5707000008940S	5707000008980S	5707000008980S	5707000008980S	
	P73-7	Box	6007212580000S	6007212580040S	6007212580020S	6007212580030S	
NSP	P73-10	Warranty Card	ARY7172	ARY7158	ARY7158	ARY7158	
⚠		Power Cord	Not used	L068250160020-IL	L068250160020-IL	L068250160020-IL	
		<b>EXTERIOR SECION (VSX-824-K)</b>					
⚠	P76-19	Power Trans	8200960612450S	8200960612460S	8200960612460S	8200960612460S	
⚠	P76-20	Cord Assy	L068125101710-IL	Not used	Not used	Not used	
	P76-26	Pioneer Badge B	XAM3006	XAM3006	XAM3006	Not used	
	P76-26	Pioneer Name Plate	Not used	Not used	Not used	VAM1129	
	P76-29	Cabinet	3008212076000V	3008212076000V	3008212076000V	3008212076010-IL	
	P76-30	Panel	3067216111000S	306721611100S	306721611110S	3067216111200S	
	P76-31	Back Chassis	3207214886000S	3207214886400S	3207214886100S	3207214886110S	
	P76-32	Spring	3720210276000-IL	Not used	Not used	Not used	
	P76-32	Spring Knob	Not used	3720210556000S	3720210556000S	3720210556000S	
	P76-33	Foot	4000210391010S	4000210391010S	4000210391010S	4007210391010S	
	P76-42	Knob	5080212431000-IL	5080212431000-IL	5080212431000-IL	5087212431100-IL	
	P76-43	Button	5090213741100-IL	5090213741100-IL	5090213741100-IL	5097213741000-IL	
	P76-44	5 Key Button	5090214561200S	5090214561200S	5090214561200S	5097214561300S	
⚠	P76-49	Screw	BBT40P080FTB	BBT40P080FTB	BBT40P080FTB	1500040083B10SV	
		Socket, Power AC	Not used	G430040560021-IL	G430040560021-IL	G430040560021-IL	No. 60
		BT Cover	Not used	4310216061100S	Not used	Not used	No. 61

Notes : The numbers in the remarks column correspond to the numbers on the "EXPLODED VIEWS".

For PCB ASSEMBLIES, Refer to "CONTRAST OF PCB ASSEMBLIES", "PCB PARTS LIST", "3. SCHEMATIC DIAGRAM" and "4. PCB CONNECTION DIAGRAM".

**VSX-824-K/DLXEV, VSX-824-K/FXEV and VSX-824-K/AXEV5**

VSX-824-K/CUXEVSM, VSX-824-K/DLXEV, VSX-824-K/FXEV and VSX-824-K/AXEV5 are constructed the same except for the following:

Mark	No.	Symbol and Description	VSX-824-K /CUXEVSM	VSX-824-K /DLXEV	VSX-824-K /FXEV	VSX-824-K /AXEV5	Remarks
<b>PCB ASSEMBLIES</b>							
NSP	P76-1 P76-2	1..PCB TTL ASSY MAIN 2..MAIN Assy 2..REG Assy	7025HK1310010 7028074511010 7028074512010	7025HK1310060 7028074511010 7028074512070	7025HK1310070 7028074511070 7028074512070	7025HK1310080 7028074511010 7028074512010	
NSP	P76-4	1..PCB TTL ASSY DMAIN 2..DMAIN Assy	7025HK1310011 7028074571010	7025HK1310061 7028074571020	7025HK1310071 7028074571020	7025HK1310081 7028074571020	
NSP	P76-5	1..PCB TTL ASSY FRONT 2..FRONT Assy	7025HK1310012 7028074521010	7025HK1310062 7028074521030	7025HK1310072 7028074521030	7025HK1310082 7028074521030	
NSP	P76-10	1..PCB TTL ASSY CPU 2..CPU Assy	7025HK1310013 7028074531010	7025HK1310063 7028074531070	7025HK1310073 7028074531080	7025HK1310083 7028074531090	
NSP		1..PCB TTL ASSY AMP5	7025HK1310014	7025HK1310064	7025HK1310074	7025HK1310084	
NSP ⚠	P76-16	1..PCB TTL ASSY SMPS 2..SMPS Assy	7025HK1310015 702807336104A	7025HK1310065 7028074591060	7025HK1310075 7028074591060	7025HK1310085 702807336103A	
NSP	P76-17	1..PCB TTL ASSY FHDMI 2..FHDMI Assy	7025HK1310016 7028074581010	7025HK1310066 7028074581030	7025HK1310076 7028074581030	7025HK1310086 7028074581030	
NSP		1..PCB TTL ASSY BT	7025HK1310017	7025HK1310067	7025HK1310077	7025HK1310087	
NSP		1..PCB TTL ASSY V SEL 2..V SEL Assy	Not used Not used	7025HK1310068 7028067621060	7025HK1310078 7028067621060	Not used Not used	No. 62
<b>PACKING SECTION</b>							
NSP	P73-5	Operating Instructions (CD-ROM)	6517000001710S	6517000001771S	6517000001771S	Not used	
NSP		Operating Instructions_VSX-1024 (En)(pdf)	ARB7543	Not used	Not used	Not used	
NSP		Operating Instructions_VSX-1024 (Frca)(pdf)	ARC8299	Not used	Not used	Not used	
NSP		Operating Instructions_VSX-1024 (Es)(pdf)	ARC8300	Not used	Not used	Not used	
NSP		Operating Instructions_VSX-524 (En)(pdf)	Not used	ARB7551	ARB7551	Not used	
NSP		Operating Instructions_VSX-524 (Es)(pdf)	Not used	ARC8323	ARC8323	Not used	
NSP		Operating Instructions_VSX-524 (Zhtw)(pdf)	Not used	ARC8324	ARC8324	Not used	
NSP		Operating Instructions_VSX-824 (En)(pdf)	Not used	ARB7550	ARB7550	Not used	
NSP		Operating Instructions_VSX-824 (Es)(pdf)	Not used	ARC8321	ARC8321	Not used	
NSP		Operating Instructions_VSX-824 (Zhtw)(pdf)	Not used	ARC8322	ARC8322	Not used	
NSP	P73-6	Quick Start Guide	5707000008940S	5707000009001S	5707000009001S	Not used	
NSP		Operating Instructions (Zhch)	Not used	Not used	Not used	5707000009030S	
NSP	P73-7	Box	6007212580000S	6007212370210S	6007212370220S	6007212370230S	
NSP ⚠	P73-10	Warranty Card	ARY7172	Not used	Not used	ARY7137	
		Power Cord	Not used	L068250160020-IL	L068125070060-IL	Not used	
		Tuner Isolator	Not used	Not used	Not used	L170200060010-IL	
<b>EXTERIOR SECION (VSX-824-K)</b>							
⚠	P76-19	Power Trans	8200960612450S	8200960612480S	8200960612480S	8200960612490S	
⚠	P76-20	Cord Assy	L068125101710-IL	Not used	Not used	L068250101710-IL	
	P76-30	Panel	3067216111000S	3067216111100S	3067216111100S	3067216111100S	
	P76-31	Back Chassis 824	3207214886000S	3207214886300S	3207214886300S	3207214886020S	
	P76-32	Spring	3720210276000-IL	Not used	Not used	Not used	
	P76-32	Spring Knob	Not used	3720210556000S	3720210556000S	3720210556000S	
	P76-39	Stopper	4380040162010-IL	Not used	Not used	4380040162010-IL	
⚠		Socket, Power AC	Not used	G430040560021-IL	G430040560021-IL	Not used	No. 60

Notes : The numbers in the remarks column correspond to the numbers on the "EXPLODED VIEWS".  
For PCB ASSEMBLIES, Refer to "CONTRAST OF PCB ASSEMBLIES", "PCB PARTS LIST".

5 6 7 8

**EXPLODED VIEWS**  
**EXTERIOR SECTION (VSX-824-K)**

**CONTRAST OF PCB ASSEMBLIES**

**A F MAIN ASSY**

7028074511010, 7028074511030 and 7028074511070 are constructed the same with the exception of some components, including the following:

Mark	Symbol and Description	7028074511010	7028074511030	7028074511070	Remarks
	PACK601 TUNER,FM/AM	E903004100781S	E903104100781S	E903004100781S	

Note: This list is not complete. Only components that are available as service part are listed!

**B F D-MAIN ASSY**

7028074571010, 7028074571030, 7028074571050 and 7028074571020 are constructed the same with the exception of some components, including the following:

Mark	Symbol and Description	7028074571010	7028074571030	7028074571050	7028074571020	Remarks
⚠	IC2021	NJM2819ADL3-05	Not used	Not used	Not used	

Note: This list is not complete. Only components that are available as service part are listed!

**J F CPU ASSY**

7028074531010, 7028074531030, 7028074531020, 7028074531070, 7028074531080 and 7028074531090 are constructed the same with the exception of some components, including the following:

Mark	Symbol and Description	7028074531010	7028074531030	7028074531020	Remarks
	CN211	L109012511140S	L109012511340S	L109012511140S	

Mark	Symbol and Description	7028074531070	7028074531080	7028074531090	Remarks
	CN211	L109012511140S	L109012511140S	L109012511140S	

Note: This list is not complete. Only components that are available as service part are listed!

VSX-824-K

5 6 7 8

5

**L F FHDMI ASSY**

7028074581010 and 7028074581030 are constructed the same with the exception of some components, including the following:

Mark	Symbol and Description	7028074581010	7028074581030	Remarks
⚠	IC2021	NJM2819ADL3-515H	Not used	

Note: This list is not complete. Only components that are available as service part are listed!

**N F FRONT ASSY**

7028074521010 and 7028074521030 are constructed the same with the exception of some components, including the following:

Mark	Symbol and Description	7028074521010	7028074521030	Remarks
⚠	R779, R780	C060001063050-IL	C0602R2063050-IL	

Note: This list is not complete. Only components that are available as service part are listed!

**Q F SMPS ASSY**

702807336104A, 702807336101A, 7028074591060 and 702807336103A are constructed the same with the exception of some components, including the following:

Mark	Symbol and Description	702807336104A	702807336101A	Remarks
⚠	FU101 FUSE GLASS TUBE 20mm (T8AL/250V)	N751508001160-IL	Not used	
⚠	FU101 FUSE GLASS TUBE 20mm (T6.3AL/250V)	Not used	N751506301160-IL	

Mark	Symbol and Description	7028074591060	702807336103A	Remarks
⚠	FU101 FUSE GLASS TUBE 20mm (T8AL/250V)	N751508001160-IL	Not used	
⚠	FU101 FUSE GLASS TUBE 20mm (T6.3AL/250V)	Not used	N751506301160-IL	

Note: This list is not complete. Only components that are available as service part are listed!

**R F REG ASSY**

7028074512010, 7028074512030 and 7028074512070 are constructed the same with the exception of some components, including the following:

Mark	Symbol and Description	7028074512010	7028074512030	7028074512070	Remarks
	D9082 (ZD82)	Not used	Not used	K06022R044522-IL	

The mounting positions of the additional parts are described in the circuit diagram and PCB diagram of the parent manual.

Note: This list is not complete. Only components that are available as service part are listed!

**PCB PARTS LIST**

**Mark No. Description** \_\_\_\_\_ **Part No.** \_\_\_\_\_

**G F INNER BT ASSY****SEMICONDUCTORS**

IC 632	J121210080010S
⚠ IC 634	J126288833010S

**CAPACITORS**

C 655, 656	D040102081070-IL
------------	------------------

**S F V SEL ASSY****MISCELLANEOUS**

⚠ S 601 SW.SLIDE	G060329140000-IL
⚠ CN 601 CN.WAFER 7.92MM	L108011430510-IL
1 SUPPORTER	4070210192000-IL
2 SPACER(PLS)	4300210062000-IL
⚠ FU 601 FUSE GLASS TUBE 20MM	N751503151160-IL

## 2. DIAGNOSIS

### 2.1 Pairing this unit and Bluetooth wireless technology device (VSX-824-K/SYXEV8)

#### Pairing with the unit (Initial registration)

In order for the unit to playback music stored on a Bluetooth capable device, pairing must first be performed. Pairing should be performed when first using the unit with the Bluetooth capable device, or when the pairing data on the device has been erased for any reason. Pairing is a step required to allow communication using Bluetooth wireless technology to be carried out.

- Pairing is performed the first time that you use the unit and the Bluetooth capable device together.
- In order to allow communication using Bluetooth wireless technology to take place, pairing must be performed on both the unit and the Bluetooth capable device.
- After pressing the **BT ADPT** and switching to **BT AUDIO** input, perform the pairing procedure on the Bluetooth capable device. If pairing has been performed correctly, you will not need to perform the pairing procedures for the unit as shown below.

Please refer to the user's manual for your Bluetooth capable device for more details.

**1 Press  STANDBY/ON and turn the power to the unit on.**

**2 Press BT ADPT.**

The unit switches to **BT AUDIO** and **WAITING DEVICE** will be displayed on the front panel of the unit.

**3 Turn on the power to the Bluetooth capable device that you wish to pair with, and perform pairing procedure on it.**

Pairing will start.

- Place the Bluetooth capable device close to the unit.
- Please refer to the user's manual for your Bluetooth capable device for details on when pairing can be performed and the procedures required for pairing.
- When PIN code entry is requested, enter **0000**. (This unit does not accept any PIN code setting other than **0000**.)

**4 Confirm on the Bluetooth capable device that pairing has been completed.**

If pairing with the Bluetooth capable device has been completed correctly, **CONNECTED** will be displayed on the front panel of the unit.

# 3. SCHEMATIC DIAGRAM

## 3.1 INNER BT ASSY

### GF INNER BT ASSY

VSX-824/SYXEV8 INNER BT B'D

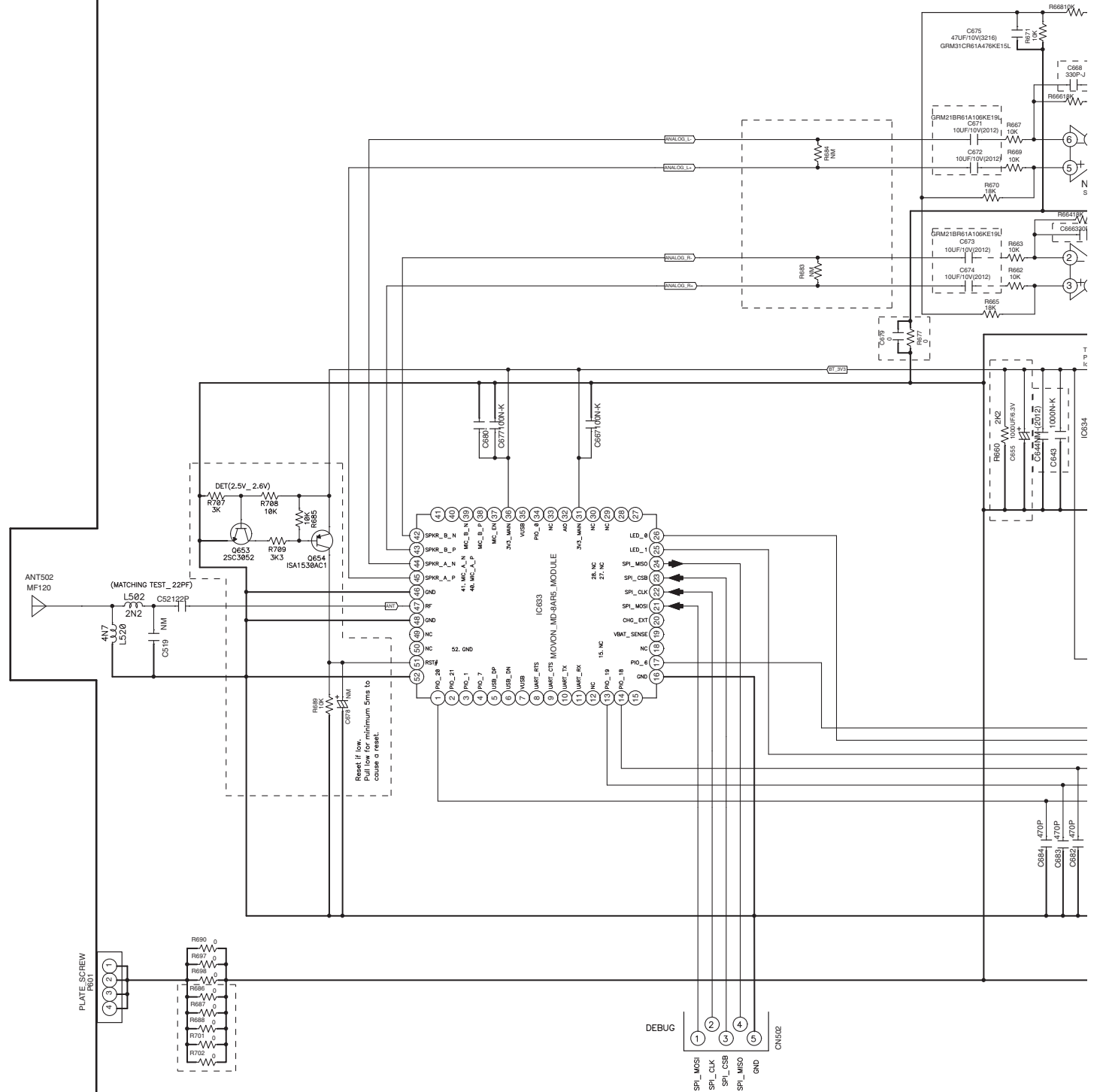



**J** CN211

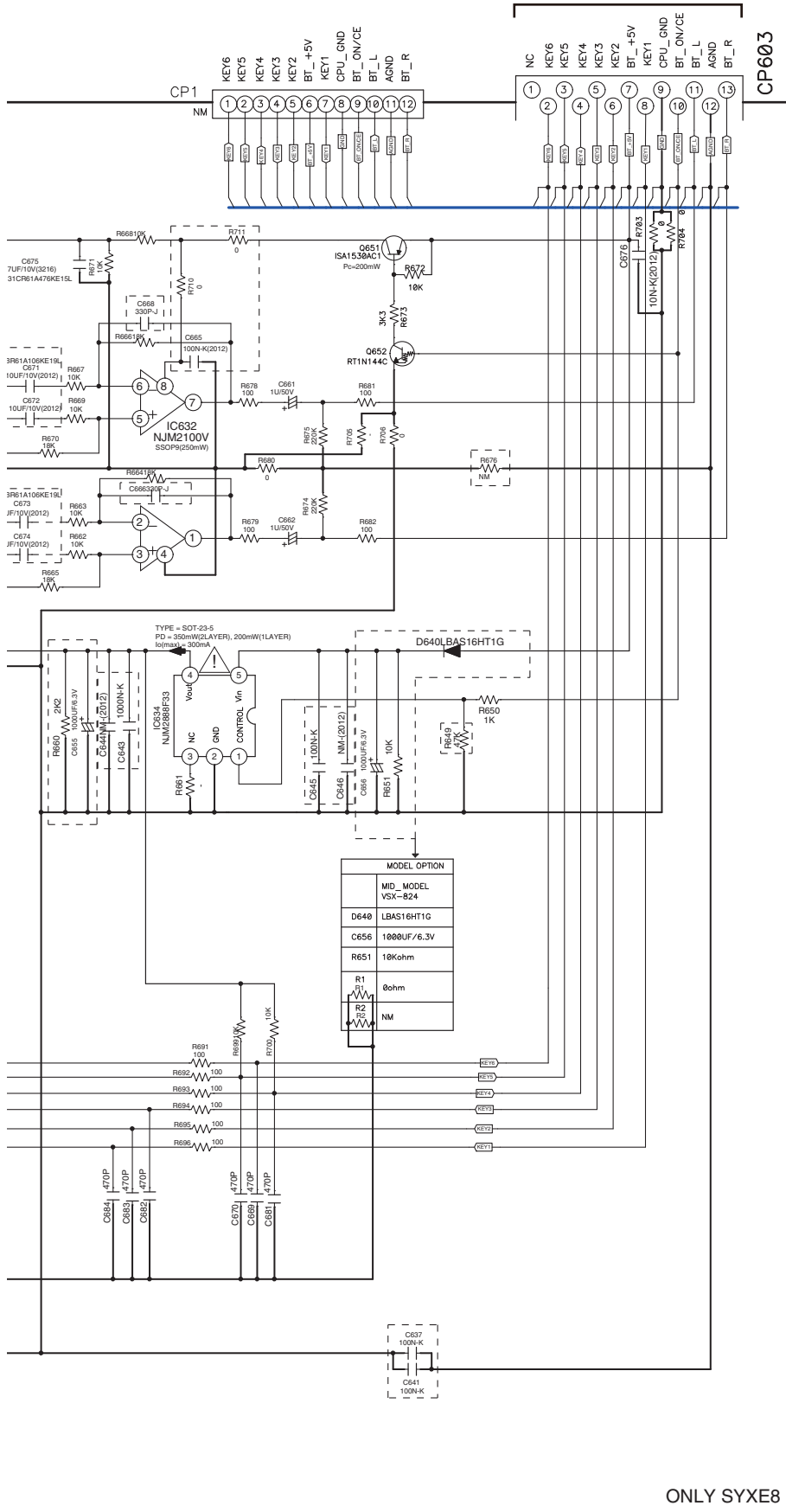

BT READY	BT_/OC BT_RX/LL_TX BT_TX/LL_RX BT_DET BT_+5V BT_ID CPU_GND BT_ON/CE BT_L AGND BT_R
INNER BT	NC KEY6 KEY5 KEY4 KEY3 KEY2 BT_+5V KEY1 CPU_GND BT_ON/CE BT_L AGND BT_R

MODEL OPTION

	C645	C646	C643	C644	R649	R676	C637	C641
MID	100N-K	NM	1000N-K	NM	47K	NM	100N-K	100N-K

MODEL OPTION	
MID_MODEL	VSX-824
D640	LBAS16HT1G
C656	1000UF/6.3V
R651	10Kohm
R1	0ohm
R2	NM

(MODULE KEY CONTROL)

S : Short Key, L : Long Key

	KEY1	KEY2	KEY3	KEY4	KEY5	KEY6
PLAY	S					
PAUSE	S					
STOP	L					
FF		L				
FR			L			
FWD SKIP		S				
REV SKIP			S			
PAIRING MODE	S					
BT STATE	READY			L	L	
	PAIRING			L	H	
	CONNECTED			H	L	
	PLAYING			H	H	
DEC OPEN/CLOSE						OPEN-->H CLOSE-->L
		MAIN --> BT			BT --> MAIN	

ONLY SYXE8

# 3.2 V SEL ASSY

## SF V SEL ASSY

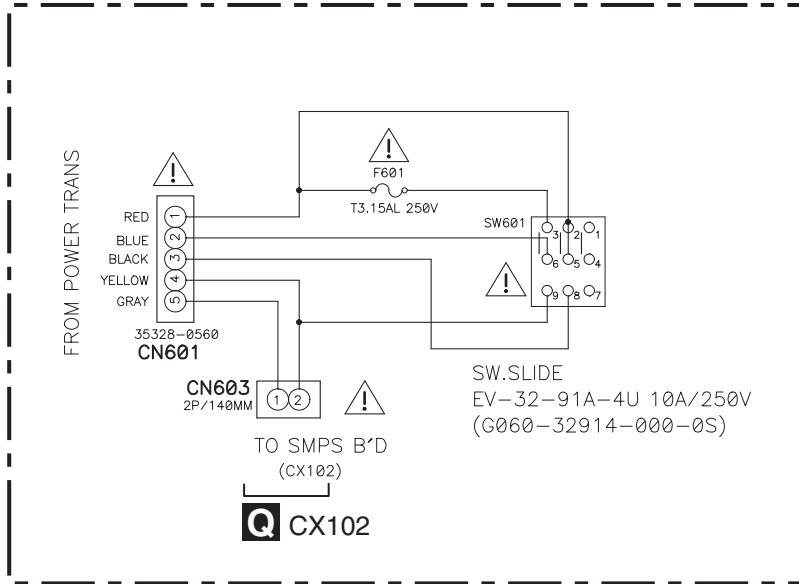

**CAUTION**  
FOR CONTINUED PROTECTION AGAINST RISK OF FIRE,  
REPLACE WITH SAME TYPE AND RATINGS OF FUSE.

The mark found on some component parts indicates the importance of the safety factor of the part. Therefore when replacing be sure to use parts of identical designation.

**NOTES**

1. Resistor values are indicated in ohms unless otherwise specified [ k = 1,000 m = 1,000,000 ]
2. Capacitor values are indicated in microfarads unless otherwise specified. [ p = micro-microfarads ]

3. : These resistor are to be segregated from printed wiring board or other accessible parts.

**CAUTION**

Safety precaution to be followed during servicing

- 1] Since those parts marked with are critical parts for safety, use only the one described in the parts list
- 2] Before returning the set to the customer make appropriate leakage current or resistance measurements to determine the exposed parts are properly insulated from the supply circuit.

# 4. PCB CONNECTION DIAGRAM

## 4.1 INNER BT ASSY

SIDE A

SIDE A

**GF** INNER BT ASSY

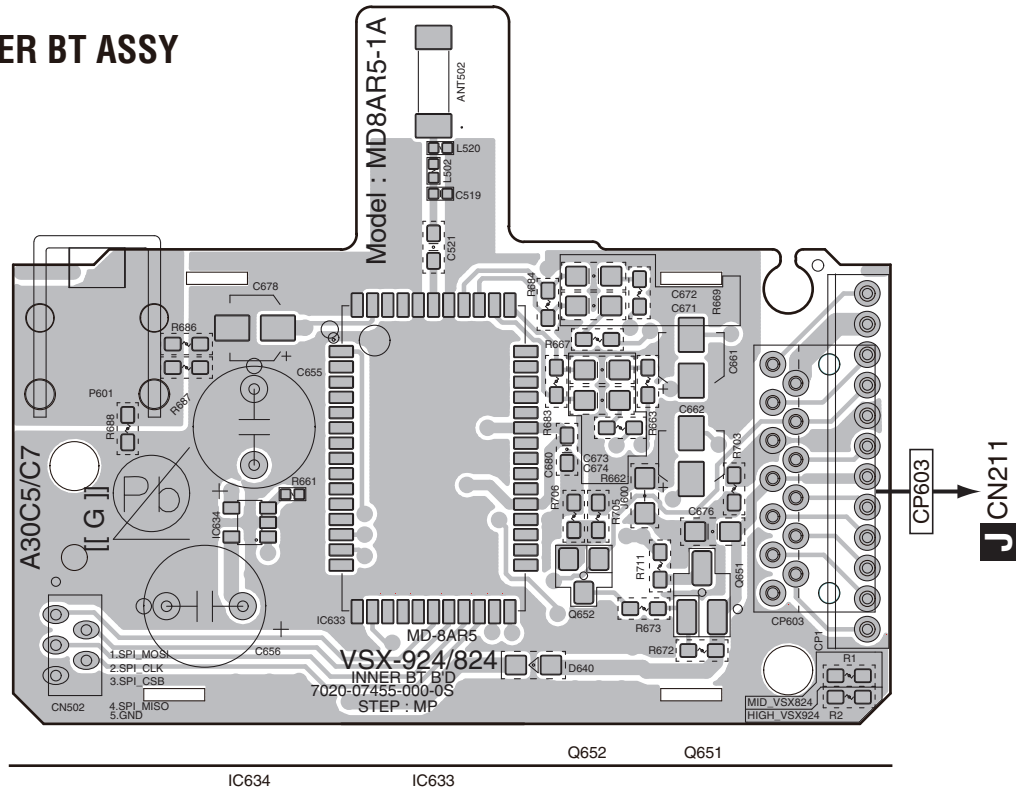

SIDE B

SIDE B

**GF** INNER BT ASSY

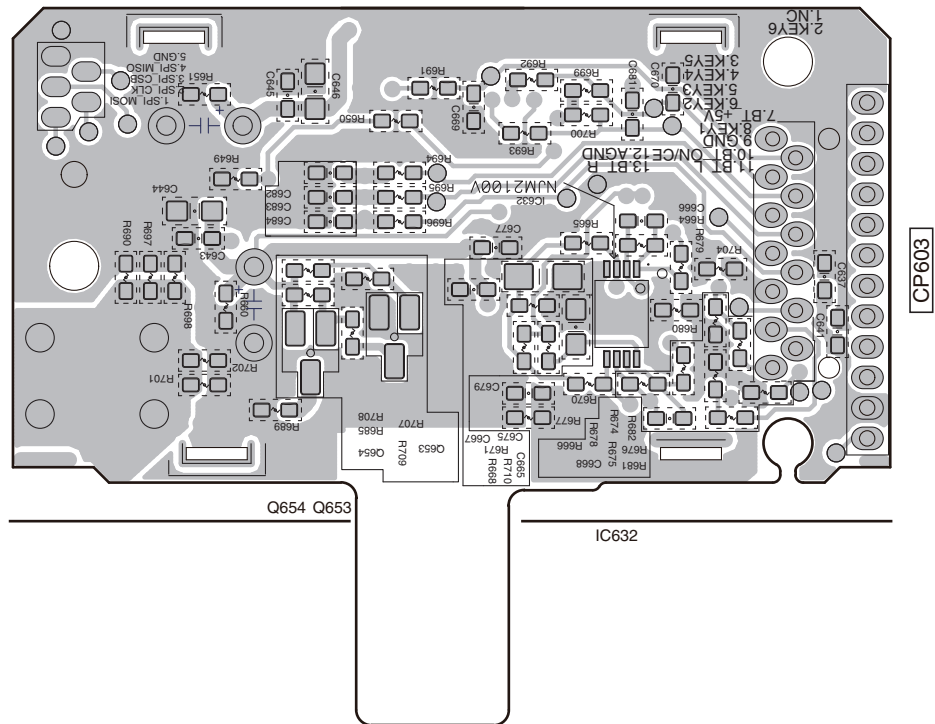

**GF**

**GF**

VSX-824-K