

Service Manual

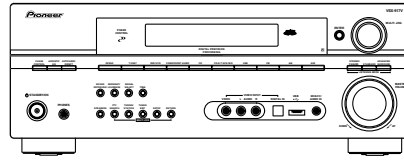

VSX-917V-K

ORDER NO.
RRV3559

AUDIO/VIDEO MULTI-CHANNEL RECEIVER

VSX-917V-K

VSX-917V-S
VSX-817-K
VSX-817-S

THIS MANUAL IS APPLICABLE TO THE FOLLOWING MODEL(S) AND TYPE(S).

Model	Type	Power Requirement	Remarks
VSX-917V-K	MYXJ5	AC 220 V to 230 V	
VSX-917V-S	MYXJ5	AC 220 V to 230 V	
VSX-817-K	MYXJ5	AC 220 V to 230 V	
VSX-817-S	MYXJ5	AC 220 V to 230 V	



For details, refer to "Important Check Points for Good Servicing".

SAFETY INFORMATION



This service manual is intended for qualified service technicians; it is not meant for the casual do-it-yourselfer. Qualified technicians have the necessary test equipment and tools, and have been trained to properly and safely repair complex products such as those covered by this manual.

Improperly performed repairs can adversely affect the safety and reliability of the product and may void the warranty. If you are not qualified to perform the repair of this product properly and safely, you should not risk trying to do so and refer the repair to a qualified service technician.

WARNING

This product contains lead in solder and certain electrical parts contain chemicals which are known to the state of California to cause cancer, birth defects or other reproductive harm.

Health & Safety Code Section 25249.6 – Proposition 65



NOTICE

(FOR CANADIAN MODEL ONLY)

Fuse symbols  (fast operating fuse) and/or  (slow operating fuse) on PCB indicate that replacement parts must be of identical designation.

REMARQUE

(POUR MODÈLE CANADIEN SEULEMENT)

Les symboles de fusible  (fusible de type rapide) et/ou  (fusible de type lent) sur CCI indiquent que les pièces de remplacement doivent avoir la même désignation.

(FOR USA MODEL ONLY)

1. SAFETY PRECAUTIONS

The following check should be performed for the continued protection of the customer and service technician.

LEAKAGE CURRENT CHECK

Measure leakage current to a known earth ground (water pipe, conduit, etc.) by connecting a leakage current tester such as Simpson Model 229-2 or equivalent between the earth ground and all exposed metal parts of the appliance (input/output terminals, screwheads, metal overlays, control shaft, etc.). Plug the AC line cord of the appliance directly into a 120V AC 60 Hz outlet and turn the AC power switch on. Any current measured must not exceed 0.5 mA.

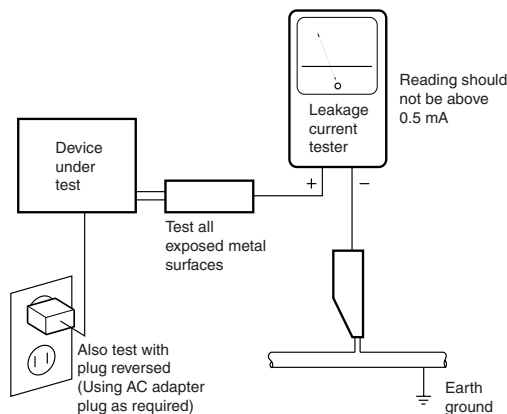

AC Leakage Test

ANY MEASUREMENTS NOT WITHIN THE LIMITS OUTLINED ABOVE ARE INDICATIVE OF A POTENTIAL SHOCK HAZARD AND MUST BE CORRECTED BEFORE RETURNING THE APPLIANCE TO THE CUSTOMER.

2. PRODUCT SAFETY NOTICE

Many electrical and mechanical parts in the appliance have special safety related characteristics. These are often not evident from visual inspection nor the protection afforded by them necessarily can be obtained by using replacement components rated for voltage, wattage, etc. Replacement parts which have these special safety characteristics are identified in this Service Manual.

Electrical components having such features are identified by marking with a Δ on the schematics and on the parts list in this Service Manual.

The use of a substitute replacement component which does not have the same safety characteristics as the PIONEER recommended replacement one, shown in the parts list in this Service Manual, may create shock, fire, or other hazards.

Product Safety is continuously under review and new instructions are issued from time to time. For the latest information, always consult the current PIONEER Service Manual. A subscription to, or additional copies of, PIONEER Service Manual may be obtained at a nominal charge from PIONEER.

[Important Check Points for Good Servicing]

In this manual, procedures that must be performed during repairs are marked with the below symbol. Please be sure to confirm and follow these procedures.

1. Product safety



Please conform to product regulations (such as safety and radiation regulations), and maintain a safe servicing environment by following the safety instructions described in this manual.

- ① Use specified parts for repair.

Use genuine parts. Be sure to use important parts for safety.

- ② Do not perform modifications without proper instructions.

Please follow the specified safety methods when modification (addition/change of parts) is required due to interferences such as radio/TV interference and foreign noise.

- ③ Make sure the soldering of repaired locations is properly performed.

When you solder while repairing, please be sure that there are no cold solder and other debris. Soldering should be finished with the proper quantity. (Refer to the example)

- ④ Make sure the screws are tightly fastened.

Please be sure that all screws are fastened, and that there are no loose screws.

- ⑤ Make sure each connectors are correctly inserted.

Please be sure that all connectors are inserted, and that there are no imperfect insertion.

- ⑥ Make sure the wiring cables are set to their original state.

Please replace the wiring and cables to the original state after repairs. In addition, be sure that there are no pinched wires, etc.

- ⑦ Make sure screws and soldering scraps do not remain inside the product.

Please check that neither solder debris nor screws remain inside the product.

- ⑧ There should be no semi-broken wires, scratches, melting, etc. on the coating of the power cord.

Damaged power cords may lead to fire accidents, so please be sure that there are no damages. If you find a damaged power cord, please exchange it with a suitable one.

- ⑨ There should be no spark traces or similar marks on the power plug.

When spark traces or similar marks are found on the power supply plug, please check the connection and advise on secure connections and suitable usage. Please exchange the power cord if necessary.

- ⑩ Safe environment should be secured during servicing.

When you perform repairs, please pay attention to static electricity, furniture, household articles, etc. in order to prevent injuries. Please pay attention to your surroundings and repair safely.

2. Adjustments



To keep the original performance of the products, optimum adjustments and confirmation of characteristics within specification. Adjustments should be performed in accordance with the procedures/instructions described in this manual.

3. Lubricants, Glues, and Replacement parts



Use grease and adhesives that are equal to the specified substance. Make sure the proper amount is applied.

4. Cleaning



For parts that require cleaning, such as optical pickups, tape deck heads, lenses and mirrors used in projection monitors, proper cleaning should be performed to restore their performances.

5. Shipping mode and Shipping screws



To protect products from damages or failures during transit, the shipping mode should be set or the shipping screws should be installed before shipment. Please be sure to follow this method especially if it is specified in this manual.

CONTENTS

- SAFETY INFORMATION 2
- 1. SPECIFICATIONS 5
- A 2. EXPLODED VIEWS AND PARTS LIST 6
 - 2.1 PACKING SECTION 6
 - 2.2 EXTERIOR SECTION..... 8
 - 2.3 FRONT PANEL SECTION 12
- 3. BLOCK DIAGRAM AND SCHEMATIC DIAGRAM 14
 - 3.1 BLOCK DIAGRAM 14
 - 3.2 OVERALL WIRING CONNECTION DIAGRAM..... 16
 - 3.3 MAIN ASSY (1/3) 18
 - 3.4 MAIN ASSY (2/3) 20
 - 3.5 MAIN ASSY (3/3) 22
 - 3.6 DSP ASSY (1/2) 24
 - 3.7 DSP ASSY (2/2)..... 26
 - B 3.8 POWER PACK (1/2), TRANS2 and TRANS3 ASSYS 28
 - 3.9 POWER PACK ASSY (2/2) 30
 - 3.10 COMPONENT VIDEO, HEAD PHONE and 5.1CH INPUT ASSYS 32
 - 3.11 FRONT DISPLAY, ROTARY ENCODER and POWER KEY ASSYS..... 34
 - 3.12 S.VIDEO, TRANS4 and REGULATOR ASSYS 36
 - 3.13 COMP VIDEO and BOARD TO BOARD ASSYS 38
 - 3.14 VIDEO, DIGITAL INPUT, FRONT VIDEO and PRIMARY ASSYS 40
 - 3.15 FRONT IN ASSY 42
 - 3.16 HDMI & DVC ASSY (VSX-917V ONLY) 44
 - 3.17 USB ASSY 46
 - 4. PCB CONNECTION DIAGRAM 48
 - 4.1 USB ASSY 49
 - C 4.2 MAIN ASSY 50
 - 4.3 DSP ASSY 54
 - 4.4 TRANS2 and TRANS3 ASSYS 55
 - 4.5 POWER PACK ASSY 56
 - 4.6 COMPONENT VIDEO ASSY 60
 - 4.7 HEADPHONE and 5.1CH INPUT ASSYS 61
 - 4.8 FRONT DISPLAY ASSY 62
 - 4.9 ROTARY ENCODER and POWER KEY ASSYS 66
 - 4.10 S.VIDEO ASSY 68
 - 4.11 TRANS4 and REGULATOR ASSYS 69
 - 4.12 COMP VIDEO and BOARD TO BOARD ASSYS (VSX-917V ONLY) 70
 - 4.13 VIDEO ASSY (VSX-817 ONLY) 72
 - D 4.14 DIGITAL INPUT and FRONT VIDEO ASSYS 73
 - 4.15 PRIMARY ASSY 74
 - 4.16 FRONT IN ASSY 76
 - 4.17 HDMI&DVC ASSY (VSX-917V ONLY) 77
 - 5. PCB PARTS LIST 78
 - 6. ADJUSTMENT 99
 - 7. GENERAL INFORMATION 100
 - 7.1 DIAGNOSIS 100
 - 7.1.1 DSP TROUBLESHOOTING 100
 - 7.1.2 HDMI TROUBLESHOOTING (VSX-917V ONLY) 108
 - 7.1.3 DISASSEMBLY 116
 - E 7.2 PARTS 120
 - 7.2.1 IC 120
 - 7.3 EXPLANATION 125
 - 7.3.1 DETECTION CIRCUIT 125
 - 7.3.2 AMPLIFIER SYSTEM PROTECTION OPERATION SPECIFICATION..... 127
 - 7.3.3 AMPLIFIER FAILURE DIAGNOSIS FLOW CHART 129
 - 8. PANEL FACILITIES 130

1. SPECIFICATIONS

VSX-917V

Amplifier section

- **Continuous power output (stereo)**
Front 100 W + 100 W
(DIN 1 kHz, THD 1.0 %, 8 Ω)
- **Rated power output (surround / 20 Hz to 20 kHz, THD 0.08 %, 8 W)**
Front 90 W per channel
Center 90 W
Surround 90 W per channel
Surround Back 90 W per channel
- **Rated power output (surround / 1 kHz, THD 1 %, 8 Ω)**
Front 110 W per channel
Center 110 W
Surround 110 W per channel
Surround Back 110 W per channel

Audio section

- **Input (Sensitivity/Impedance)**
CD, DVR/VCR, CD-R/TAPE/MD,
DVD/LD, TV/SAT 200 mV/47 kΩ
- **Frequency response**
CD, DVR/VCR, CD-R/TAPE/MD, DVD/LD,
TV/SAT 5 Hz to 100 000 Hz ± 3 dB
- **Output (Level/Impedance)**
DVR/VCR REC, CD-R/TAPE/
MD REC 200 mV/2.2 kΩ
- **Tone control**
Bass ± 6 dB (100 Hz)
Treble ± 6 dB (10 kHz)
Loudness +10 dB/+5 dB (100 Hz/10 kHz)
(at volume level -50 dB)
- **Signal-to-Noise Ratio DIN (Continuous rated power output / 50 mW)**
CD, DVR/VCR, CD-R/TAPE/MD,
DVD/LD, TV/SAT 88 dB/64 dB

Video Section

- **Input (Sensitivity/Impedance)**
DVR/VCR, DVD/LD, TV/SAT 1 Vp-p/75 Ω
- **Output (Level/Impedance)**
DVR/VCR, MONITOR OUT 1 Vp-p/75 Ω
- **Frequency response**
DVR/VCR, DVD/LD,
TV/SAT \Leftrightarrow MONITOR 5 Hz to 7 MHz ± 3 dB
Signal-to-Noise Ratio 55 dB
Crosstalk 50 dB



Note

- Specifications and the design are subject to possible modifications without notice, due to improvements.

Manufactured under license from Dolby Laboratories. "Dolby", "Pro Logic", "Surround EX", and the double-D symbol are trademarks of Dolby Laboratories.

"DTS" and "DTS-ES | Neo:6" are registered trademarks of DTS, Inc. "96/24" is a trademark of DTS, Inc.

Accessories

AM loop antenna (ATB7013)

FM wire antenna (ADH7030)

Microphone (for Auto MCACC setup) (APM7008)

Remote control (VSX-917V : XXD3128) (VSX-817 : XXD3133)

AA size IEC R6 Dry cell batteries (x2)

Component video section

- **Input (Sensitivity/Impedance)**
DVD/LD, TV/SAT, DVR/VCR 1 Vp-p/75 Ω
- **Output (Level/Impedance)**
MONITOR OUT 1 Vp-p/75 Ω
- **Frequency response**
DVD/LD, TV/SAT,
DVR/VCR \Leftrightarrow MONITOR 5 Hz to 40 MHz ± 3 dB
Signal-to-Noise Ratio 60 dB

FM Tuner Section

- Frequency Range 87.5 MHz to 108 MHz
Usable Sensitivity Mono: 13.2 dBf, IHF
(1.3 μ V/75 Ω)
50 dB Quieting Sensitivity Mono: 20.2 dBf
Stereo: 38.6 dBf
Signal-to-Noise Ratio. . . . Mono: 73 dB (at 85 dBf)
Stereo: 70 dB (at 85 dBf)
Distortion Stereo: 0.5 % (1 kHz)
Alternate Channel Selectivity 60 dB (400 kHz)
Stereo Separation. 40 dB (1 kHz)
Frequency Response 30 Hz to 15 kHz
(± 1 dB)
Antenna Input (DIN) 75 Ω unbalanced

AM Tuner Section

- Frequency Range. 531 kHz to 1602 kHz
Sensitivity (IHF, Loop antenna). 350 μ V/m
Signal-to-Noise Ratio 50 dB
Antenna Loop antenna



Miscellaneous

- Power requirements
..... AC 220 V to 230 V, 50 Hz/60 Hz
Power consumption. 395 W
In standby. 0.5 W
Dimensions
..... 420 (W) mm x 158 (H) mm x 352.5 (D) mm
Weight (without package). 8.8 kg (VSX-917V)
Weight (without package). 8.5 kg (VSX-817)

Furnished Parts

- Microphone (for Auto MCACC setup). 1
Dry cell batteries (AA size IEC R6) 2
Remote control 1
AM loop antenna 1
FM wire antenna 1
Warranty card 1
Operating instructions

2. EXPLODED VIEWS AND PARTS LIST

- NOTES:
- Parts marked by "NSP" are generally unavailable because they are not in our Master Spare Parts List.
 - The  mark found on some component parts indicates the importance of the safety factor of the part. Therefore, when replacing, be sure to use parts of identical designation.
 - Screws adjacent to  mark on product are used for disassembly.
 - For the applying amount of lubricants or glue, follow the instructions in this manual. (In the case of no amount instructions, apply as you think it appropriate.)

2.1 PACKING SECTION

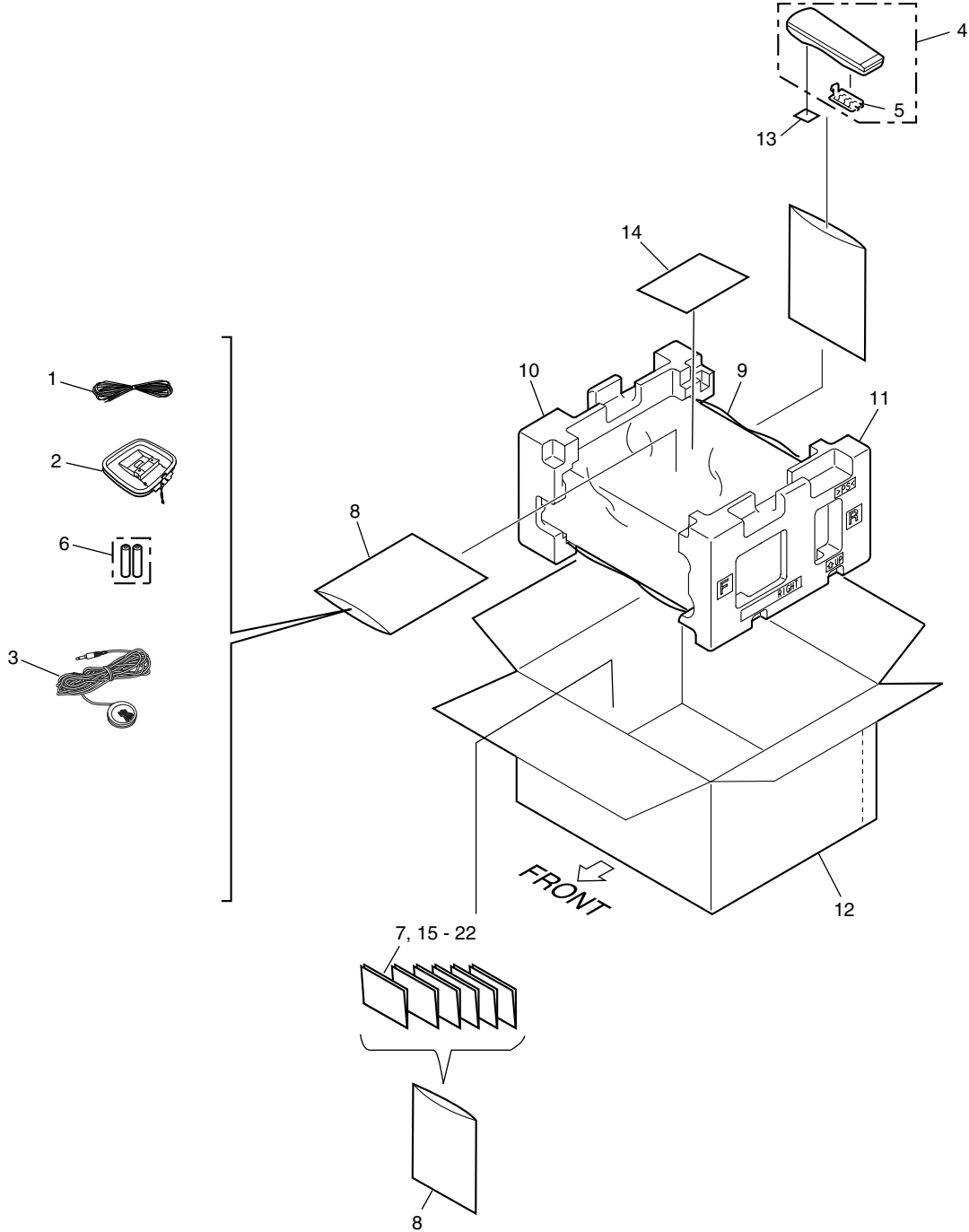

(1) PACKING SECTION PARTS LIST

<u>Mark No.</u>	<u>Description</u>	<u>Part No.</u>
1	FM Wire Antenna	ADH7030
2	AM Loop Antenna	ATB7013
3	Microphone (for Auto MCACC setup)	APM7008
4	Remote Control	See Contrast table (2)
5	Battery Cover	See Contrast table (2)
NSP 6	Dry Cell Battery (AA, R6)	See Contrast table (2)
7	Operating Instructions (English)	See Contrast table (2)
NSP 8	Polyethylene Bag (0.06*230*340)	Z21-038
9	Packing Sheet	AHG7069
10	Left Pad V3	XHA3158
11	Right Pad V3	XHA3159
12	Packing Case	See Contrast table (2)
13	Label (WEEE)	ARW7322
NSP 14	Warranty Card	ARY7065
15	Operating Instructions (Italian)	See Contrast table (2)
16	Operating Instructions (Dutch)	See Contrast table (2)
17	Operating Instructions(Spanish)	See Contrast table (2)
18	Operating Instructions (French)	See Contrast table (2)
19	Operating Instructions(German)	See Contrast table (2)
20	Operating Instructions (English/Italian)	See Contrast table (2)
21	Operating Instructions (Dutch/Spanish)	See Contrast table (2)
22	Operating Instructions (French/German)	See Contrast table (2)

(2) CONTRAST TABLE

VSX-917V-K/MYXJ5, VSX-917V-S/MYXJ5, VSX-817-K/MYXJ5 and VSX-817-S/MYXJ5 are constructed the same except for the following:

Mark	No.	Symbol and Description	VSX-917V-K /MYXJ5	VSX-917V-S /MYXJ5	VSX-817-K /MYXJ5	VSX-817-S /MYXJ5
NSP	4	Remote Control	XXD3128	XXD3128	XXD3133	XXD3133
	5	Battery Cover	XZN3140	XZN3140	AZN7933	AZN7933
	6	Dry Cell Battery (AA, R6)	XEX3001	XEX3001	XEX3002	XEX3002
	7	Operating Instructions (English)	XRB3074	XRB3074	Not used	Not used
	12	Packing Case	XHD3665	XHD3666	XHD3674	XHD3675
	15	Operating Instructions (Italian)	XRC3269	XRC3269	Not used	Not used
	16	Operating Instructions (Dutch)	XRC3270	XRC3270	Not used	Not used
	17	Operating Instructions (Spanish)	XRC3271	XRC3271	Not used	Not used
	18	Operating Instructions (French)	XRC3272	XRC3272	Not used	Not used
	19	Operating Instructions (German)	XRC3273	XRC3273	Not used	Not used
	20	Operating Instructions (English/Italian)	Not used	Not used	XRE3142	XRE3142
	21	Operating Instructions (Dutch/Spanish)	Not used	Not used	XRC3267	XRC3267
	22	Operating Instructions (French/German)	Not used	Not used	XRC3268	XRC3268

2.2 EXTERIOR SECTION

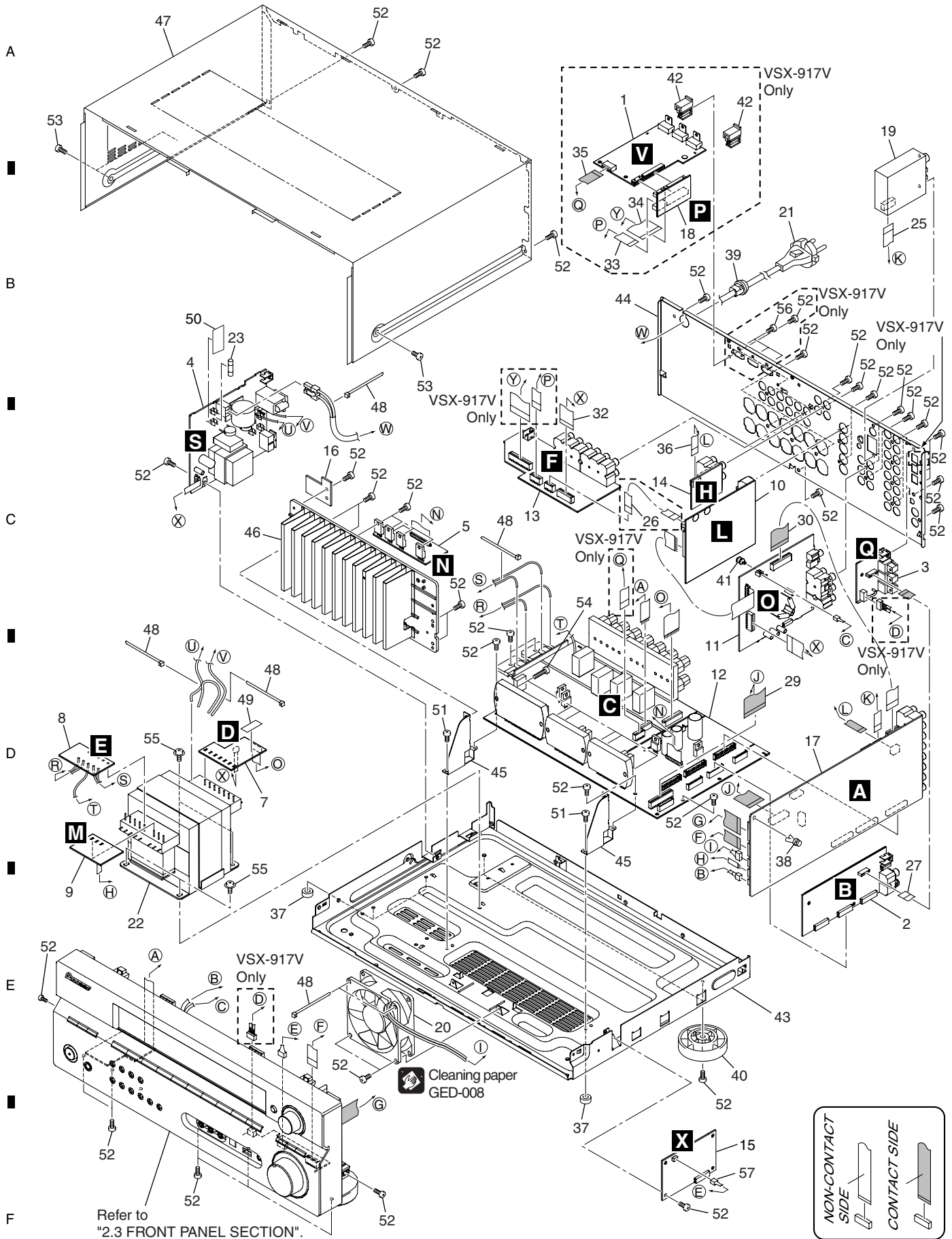

(1) EXTERIOR SECTION PARTS LIST

<u>Mark No.</u>	<u>Description</u>	<u>Part No.</u>	<u>Mark No.</u>	<u>Description</u>	<u>Part No.</u>
1	HDMI & DVC Assy	See Contrast table (2)	NSP 46	Heatsink	XNH3043
2	DSP Assy	AWX8810	47	Bonnet	See Contrast table (2)
3	DIGITAL INPUT Assy	See Contrast table (2)	NSP 48	Binder (BK-1)	ZCA-BK1
4	PRIMARY Assy	XWZ4216	49	ICP Label	XAX3121
5	REGULATOR Assy	See Contrast table (2)	50	Fuse Card	AAAX7493
6	•••••		51	Screw	BBZ30P060FCC
7	TRANS2 Assy	See Contrast table (2)	52	Screw	BBZ30P080FNI
8	TRANS3 Assy	XWZ4246	53	Screw	See Contrast table (2)
9	TRANS4 Assy	XWZ4225	54	Screw	BBZ30P140FTC
10	S.VIDEO Assy	See Contrast table (2)	55	Screw	BBZ40P080FNI
11	COMP VIDEO Assy	See Contrast table (2)	56	Screw	See Contrast table (2)
12	POWER PACK Assy	See Contrast table (2)	57	4P Shielded Cable	XDX3028
13	COMPONENT VIDEO Assy	See Contrast table (2)			
14	5.1CH INPUT Assy	XWZ4249			
15	USB Assy	AWX8704			
16	BIND Assy	XWZ4252			
17	MAIN Assy	See Contrast table (2)			
18	BOARD TO BOARD Assy	See Contrast table (2)			
19	FM/AM TUNER Unit	AXX7170			
⚠ 20	DC Fan Motor	XXM3012			
⚠ 21	AC Power Cord	VDG1080			
⚠ 22	Power Transformer (T1501)	See Contrast table (2)			
⚠ 23	Fuse (FU1 : T3.15 A)	REK1027			
24	•••••				
25	11P Flexible Cable/30V	XDD3189			
26	7P Flexible Cable/30V	See Contrast table (2)			
27	10P Flexible Cable/30V	XDD3196			
28	•••••				
29	25P Flexible Cable/30V	XDD3201			
30	21P Flexible Cable/30V	See Contrast table (2)			
31	•••••				
32	15P Flexible Cable/30V	See Contrast table (2)			
33	9P Flexible Cable/30V	See Contrast table (2)			
34	23P Flexible Cable/30V	See Contrast table (2)			
35	9P Flexible Cable/30V	See Contrast table (2)			
36	7P Flexible Cable/30V	XDD3235			
NSP 37	Spacer	AEB7092			
38	Push Rivet	AEC7205			
39	Cord Stopper	CM-22B			
40	Insulator	PNW2766			
NSP 41	Card Spacer	See Contrast table (2)			
42	HDMI Support	See Contrast table (2)			
NSP 43	Chassis 816	XNA3026			
44	Rear Panel	See Contrast table (2)			
45	Heatsink Angle V3	XNG3145			

(2) CONTRAST TABLE

VSX-917V-K/MYXJ5, VSX-917V-S/MYXJ5, VSX-817-K/MYXJ5 and VSX-817-S/MYXJ5 are constructed the same except for the following:

Mark	No.	Symbol and Description	VSX-917V-K /MYXJ5	VSX-917V-S /MYXJ5	VSX-817-K /MYXJ5	VSX-817-S /MYXJ5
A	1	HDMI & DVC Assy	AWQ7039	AWQ7039	Not used	Not used
	3	DIGITAL INPUT Assy	XWZ4213	XWZ4213	XWZ4212	XWZ4212
	5	REGULATOR Assy	XWZ4221	XWZ4221	XWZ4223	XWZ4223
	7	TRANS2 Assy	XWZ4282	XWZ4282	XWZ4245	XWZ4245
	10	S.VIDEO Assy	XWZ4228	XWZ4228	Not used	Not used
	11	COMP VIDEO Assy	XWZ4267	XWZ4267	Not used	Not used
	11	VIDEO Assy	Not used	Not used	XWZ4209	XWZ4209
	12	POWER PACK Assy	XWZ4240	XWZ4240	XWZ4236	XWZ4236
	13	COMPONENT VIDEO Assy	XWZ4248	XWZ4248	XWZ4247	XWZ4247
	17	MAIN Assy	XWK3308	XWK3308	XWK3304	XWK3304
B	18	BOARD TO BOARD Assy	XWZ4268	XWZ4268	Not used	Not used
	22	Power Transformer (T1501)	XTS3108	XTS3108	XTS3109	XTS3109
	26	7P Flexible Cable/30V	XDD3191	XDD3191	Not used	Not used
	30	21P Flexible Cable/30V	XDD3221	XDD3221	Not used	Not used
	30	13P Flexible Cable/30V	Not used	Not used	XDD3220	XDD3220
	32	15P Flexible Cable/30V	XDD3223	XDD3223	Not used	Not used
	32	7P Flexible Cable/30V	Not used	Not used	XDD3235	XDD3235
	33	9P Flexible Cable/30V	XDD3224	XDD3224	Not used	Not used
	34	23P Flexible Cable/30V	XDD3225	XDD3225	Not used	Not used
	35	9P Flexible Cable/30V	XDD3226	XDD3226	Not used	Not used
C	NSP	41 Card Spacer	REC1156	REC1156	Not used	Not used
	NSP	41 PCB Spacer (3x6)	Not used	Not used	AEC7156	AEC7156
		42 HDMI Support	XMR3107	XMR3107	Not used	Not used
		44 Rear Panel	XNC3468	XNC3469	XNC3478	XNC3479
		47 Bonnet	XZN3183	XZN3184	XZN3183	XZN3184
		53 Screw	BBZ30P080FTB	BBZ30P080FNI	BBZ30P080FTB	BBZ30P080FNI
D	56	Screw	PMZ30P060FCC	PMZ30P060FCC	Not used	Not used

■

5

■

6

■

7

■

8

■

A

■

B

■

C

■

D

■

E

■

F

■

5

■

6

VSX-917V-K

■

7

■

8

11

■

2.3 FRONT PANEL SECTION

A

B

C

D

E

F

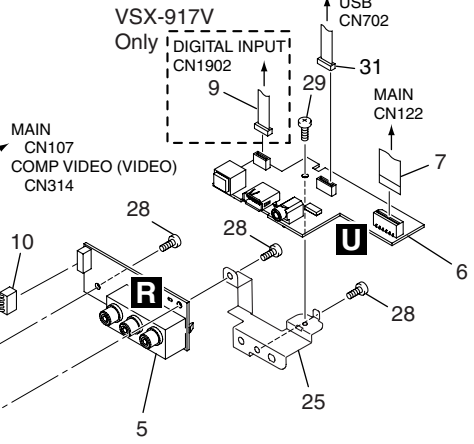
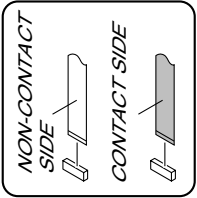
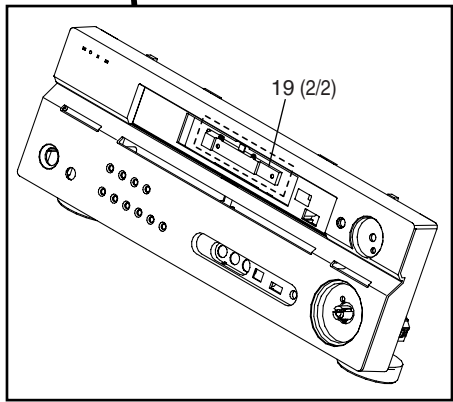
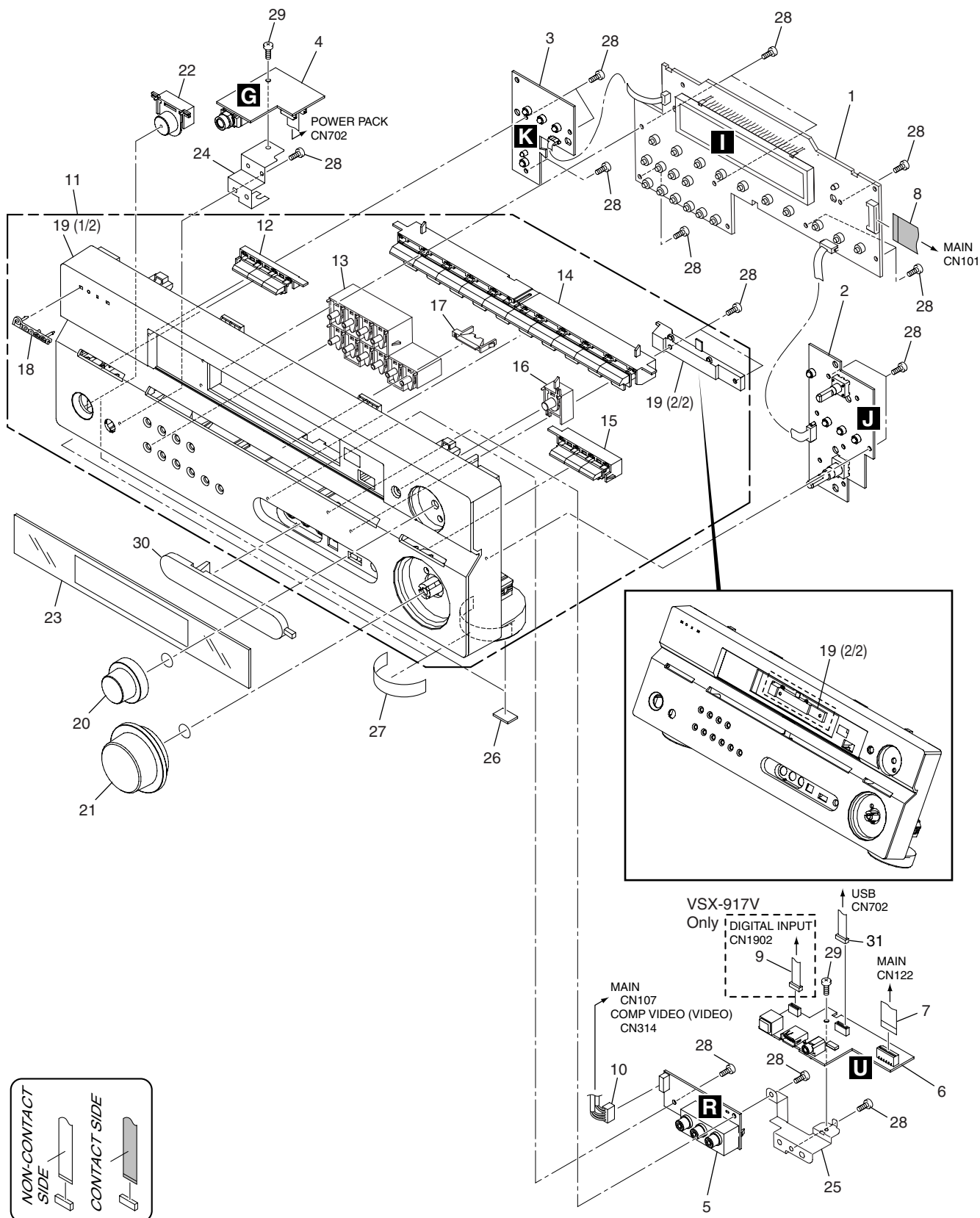

(1) FRONT PANEL SECTION PARTS LIST

<u>Mark No.</u>	<u>Description</u>	<u>Part No.</u>	<u>Mark No.</u>	<u>Description</u>	<u>Part No.</u>
1	FRONT DISPLAY Assy	See Contrast table (2)	21	VOL Knob	See Contrast table (2)
2	ROTARY ENCODER Assy	XWZ4205	22	STANDBY Button Assy	See Contrast table (2)
3	POWER KEY Assy	See Contrast table (2)	23	D Panel MCACC/CL/PC	See Contrast table (2)
4	HEADPHONE Assy	XWZ4265	24	Earth Plate HP V2 (M)	XNG3131
5	FRONT VIDEO Assy	XWZ4214	25	Earth Plate FR V3	XNG3144
6	FRONT IN Assy	See Contrast table (2)	26	Rubber Sheet	AEB1111
7	11P Flexible Cable/30V	XDD3218	NSP 27	Gold Foil Label	XAX3487
8	17P Flexible Cable/30V	XDD3200	28	Screw	BPZ30P080FTC
9	5P Shield Cable	See Contrast table (2)	29	Screw	BBZ30P080FNI
10	5P Shield Cable	XDX3054	30	Input Cover	See Contrast table (2)
NSP 11	Front Panel Assy	See Contrast table (2)	31	4P Shielded Cable	XDX3028
12	TUNER Button	See Contrast table (2)			
13	SUB Button	See Contrast table (2)			
14	FUNCTION Button	See Contrast table (2)			
15	LISTEN Button	See Contrast table (2)			
16	JOG Button	See Contrast table (2)			
17	C Lens V3	See Contrast table (2)			
18	Pioneer Name Plate	See Contrast table (2)			
19	Front Panel	See Contrast table (2)			
20	JOG Knob	See Contrast table (2)			

(2) CONTRAST TABLE

VSX-917V-K/MYXJ5, VSX-917V-S/MYXJ5, VSX-817-K/MYXJ5 and VSX-817-S/MYXJ5 are constructed the same except for the following:

<u>Mark</u>	<u>No.</u>	<u>Symbol and Description</u>	<u>VSX-917V-K /MYXJ5</u>	<u>VSX-917V-S /MYXJ5</u>	<u>VSX-817-K /MYXJ5</u>	<u>VSX-817-S /MYXJ5</u>
NSP	1	FRONT DISPLAY Assy	XWZ4204	XWZ4204	XWZ4226	XWZ4226
	3	POWER KEY Assy	XWZ4254	XWZ4254	XWZ4206	XWZ4206
	6	FRONT IN Assy	XWK3314	XWK3314	XWK3312	XWK3312
	9	5P Shield Cable	XDX3027	XDX3027	Not used	Not used
	11	Front Panel Assy	XXG3280	XXG3281	XXG3288	XXG3289
	12	TUNER Button	XAD3230	XAD3248	XAD3230	XAD3248
	13	SUB Button	XAD3231	XAD3249	XAD3231	XAD3249
	14	FUNCTION Button	XAD3232	XAD3250	XAD3232	XAD3250
	15	LISTEN Button	XAD3233	XAD3251	XAD3233	XAD3251
	16	JOG Button	XAD3240	XAD3252	XAD3240	XAD3252
	17	C Lens V3	XAK3534	XAK3534	Not used	Not used
	18	Pioneer Name Plate	XAM3006	VAM1129	XAM3006	VAM1129
	19	Front Panel	XMB3250	XMB3251	XMB3258	XMB3259
	20	JOG Knob	XAB3052	XAB3054	XAB3052	XAB3055
	21	VOL Knob	XAB3053	XAB3056	XAB3053	XAB3057
	22	STANDBY Button Assy	XAD3216	XAD3217	XAD3202	XAD3203
	23	D Panel MCACC/CL/PC	XAK3567	XAK3567	XAK3568	XAK3568
	30	Input Cover	XAK3532	XAK3533	XAK3532	XAK3589

3. BLOCK DIAGRAM AND SCHEMATIC DIAGRAM

3.1 BLOCK DIAGRAM

A

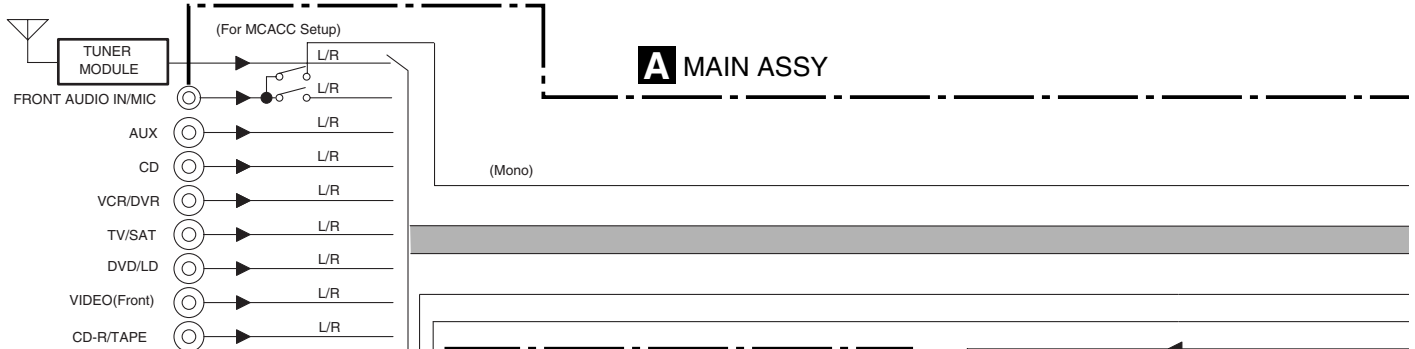

B

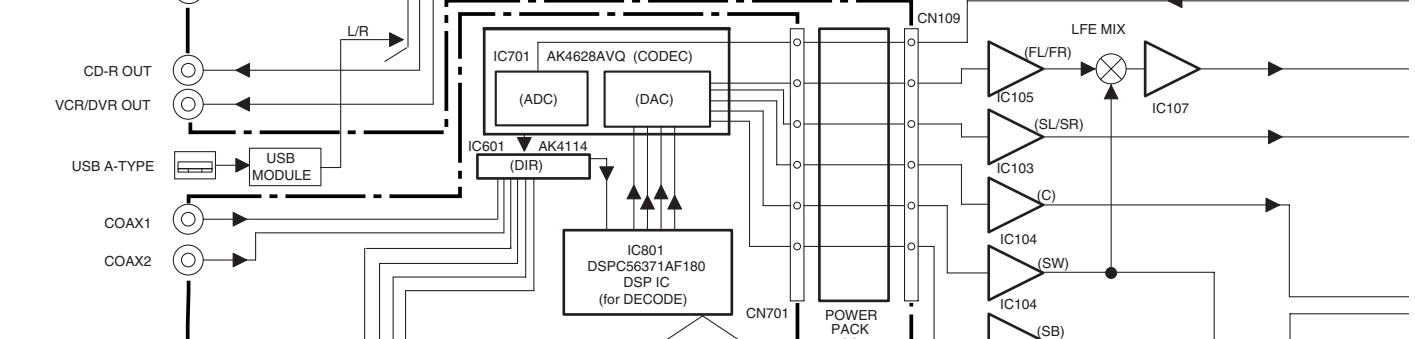

C

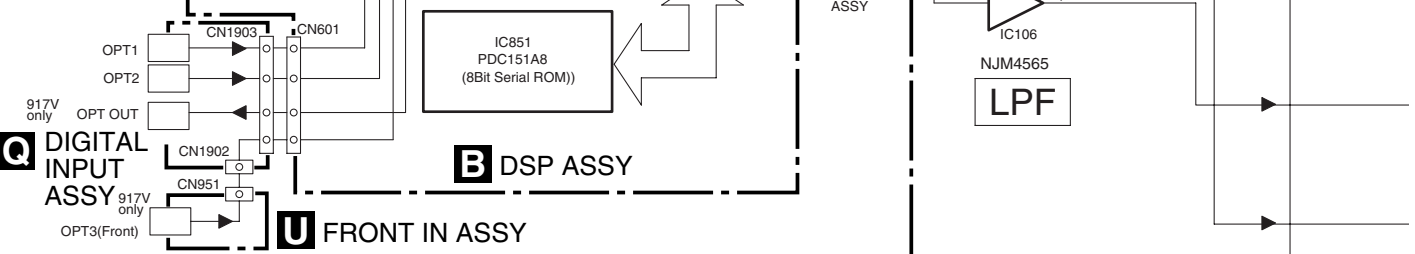

D

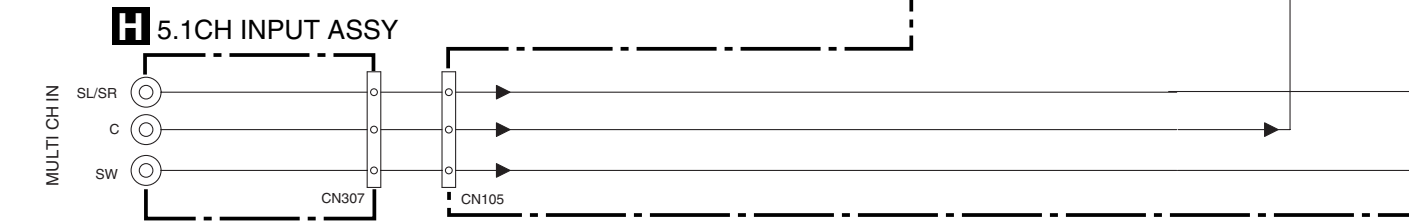

E

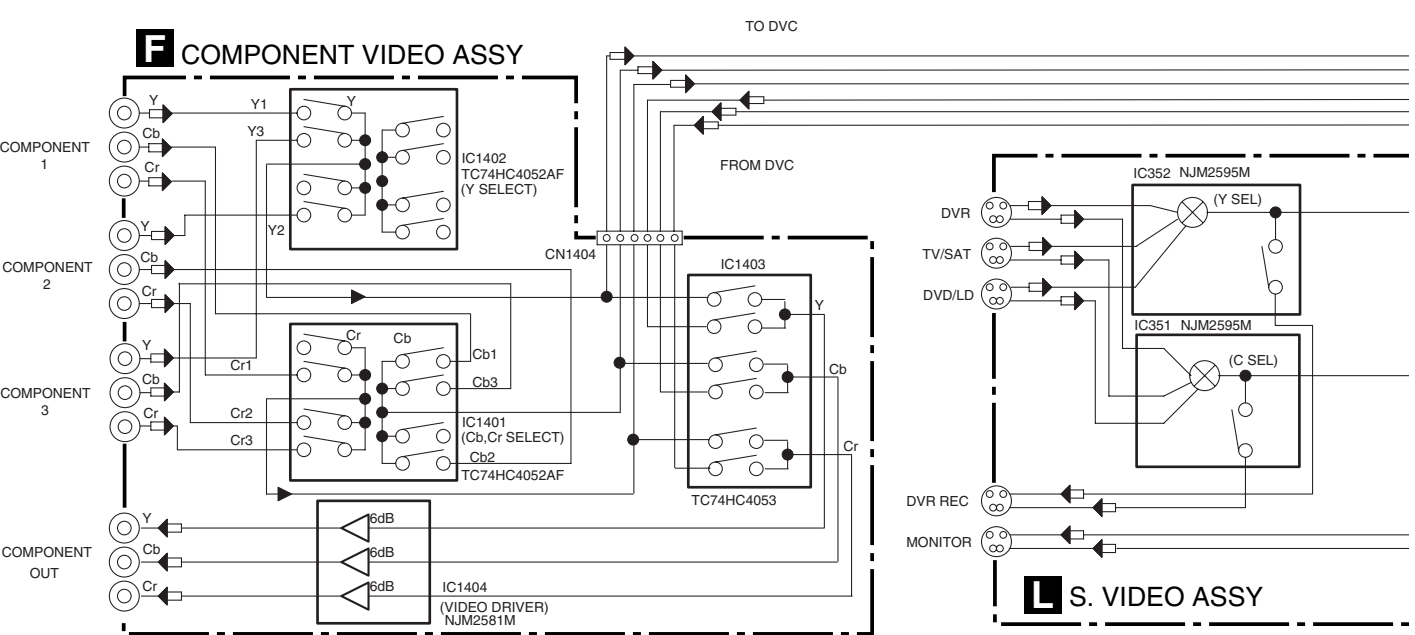

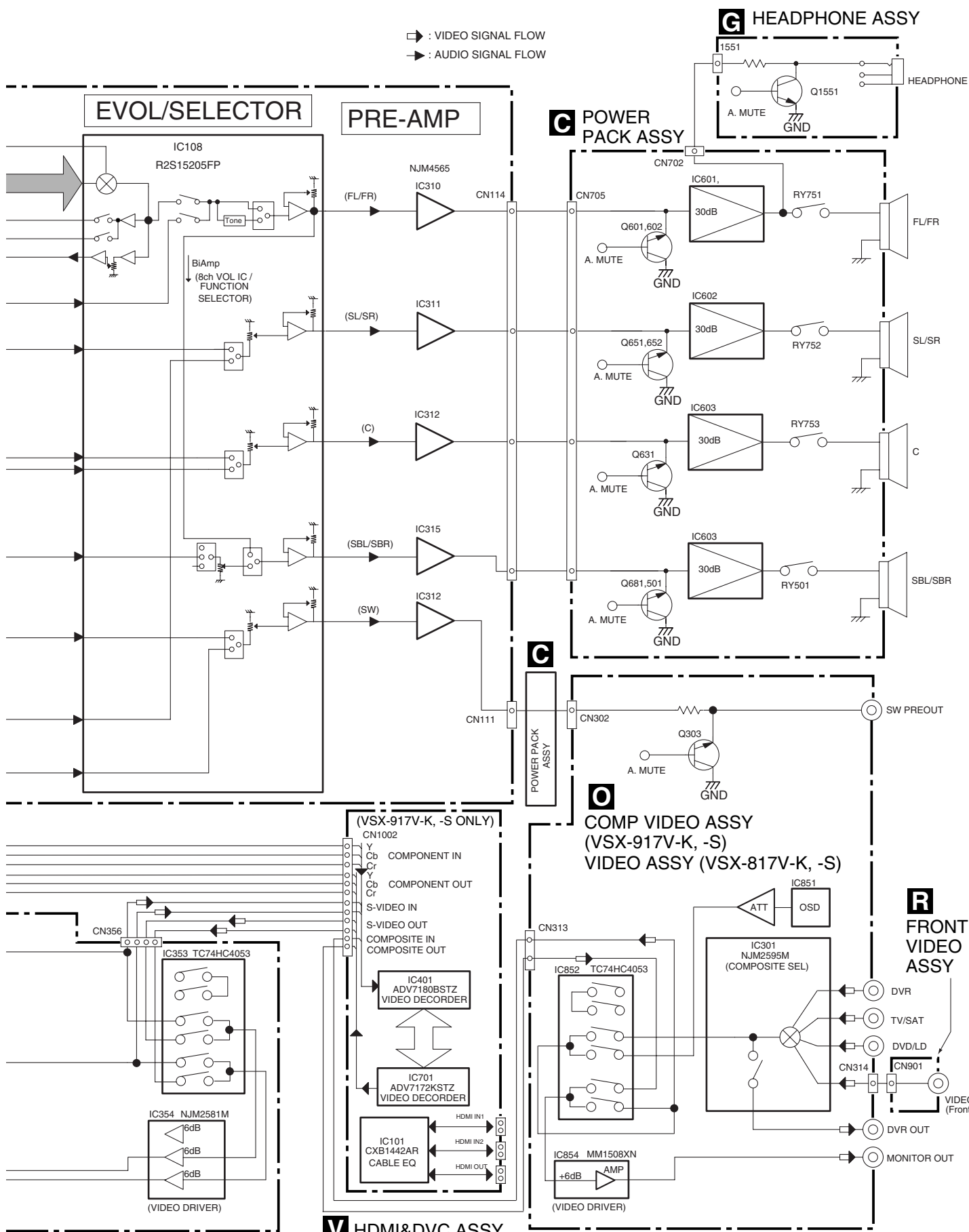

F

⇒ : VIDEO SIGNAL FLOW
 → : AUDIO SIGNAL FLOW

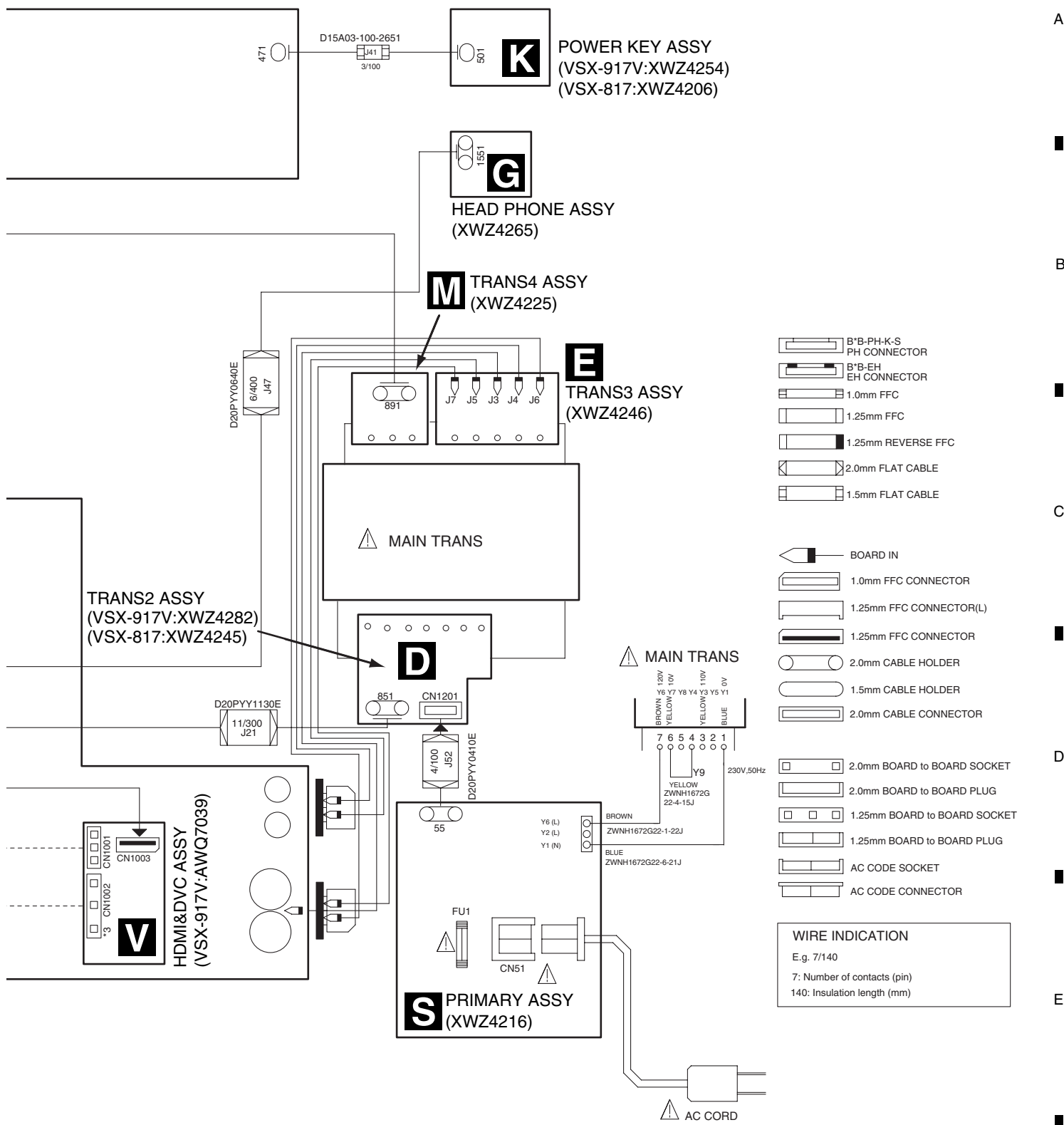

A
B
C
D
E
F



- When ordering service parts, be sure to refer to "EXPLODED VIEWS and PARTS LIST" or "PCB PARTS LIST".
- The ⚠ mark found on some component parts indicates the importance of the safety factor of the part. Therefore, when replacing, be sure to use parts of identical designation.
-  : The power supply is shown with the marked box.

3.3 MAIN ASSY (1/3)

A 1/3 MAIN ASSY (VSX-917V:XWK3308) (VSX-817 : XWK3304)

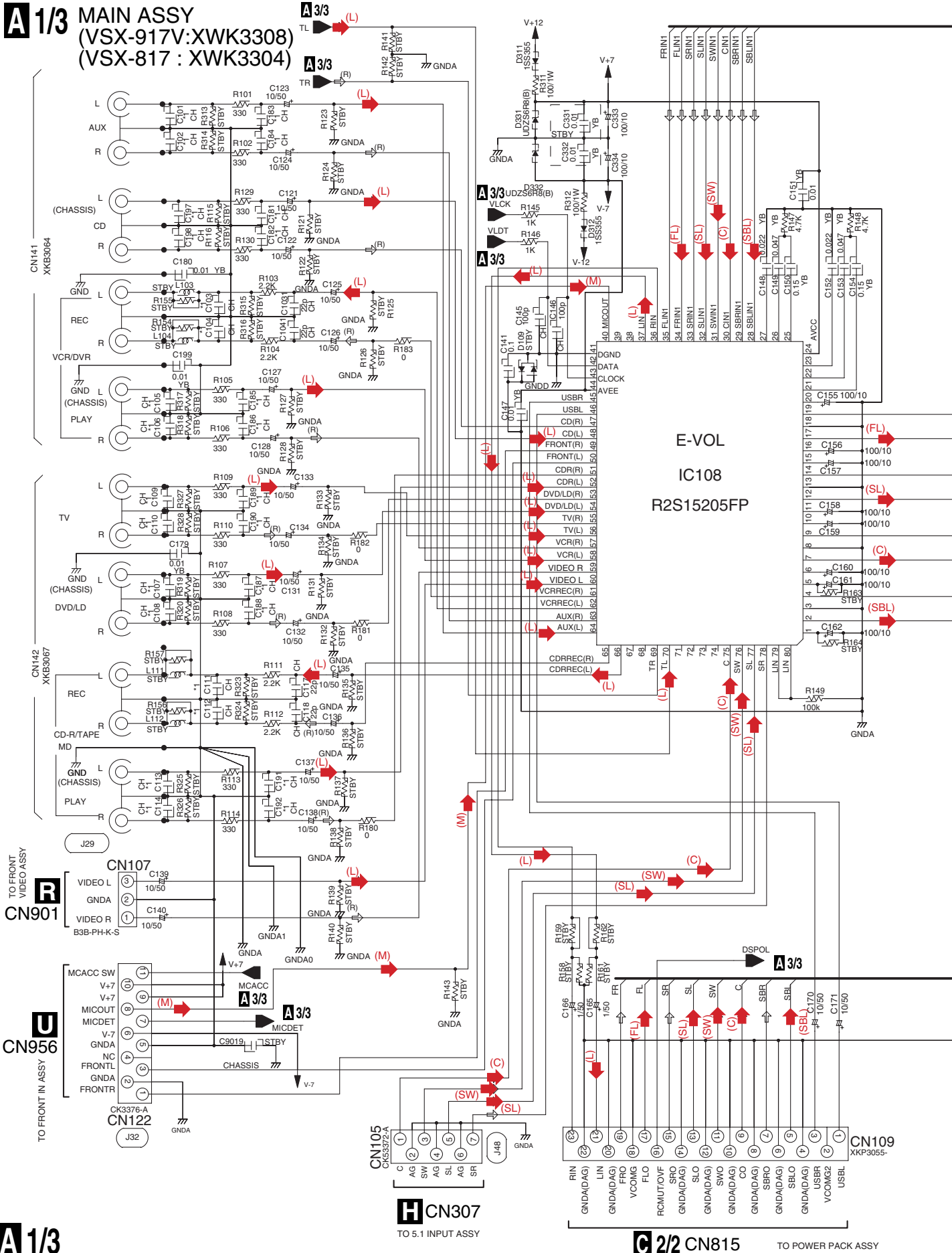

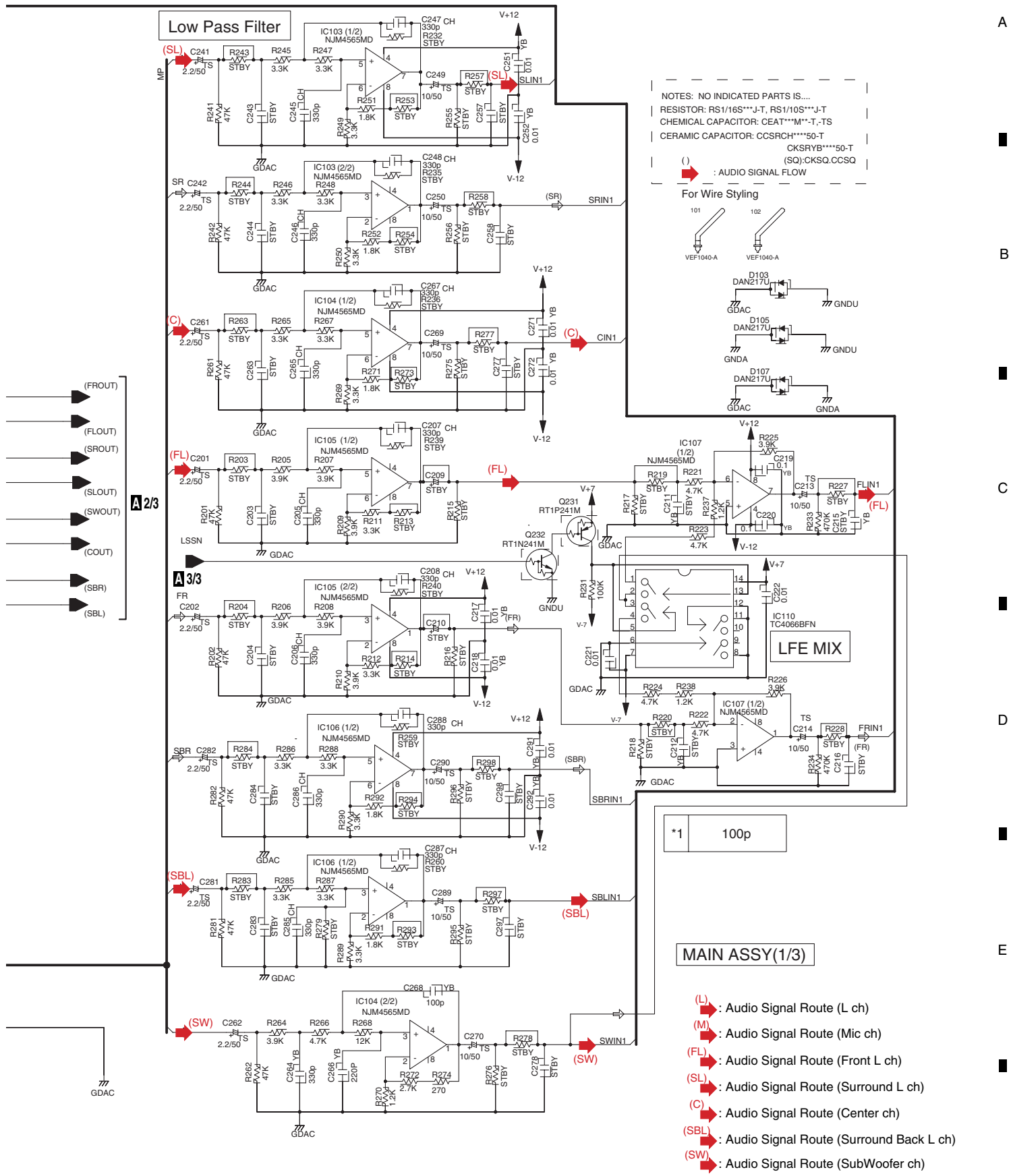

A

B

C

D

E

F

3.4 MAIN ASSY (2/3)

A 2/3 MAIN ASSY (VSX-917V:XWK3308) (VSX-817:XWK3304)

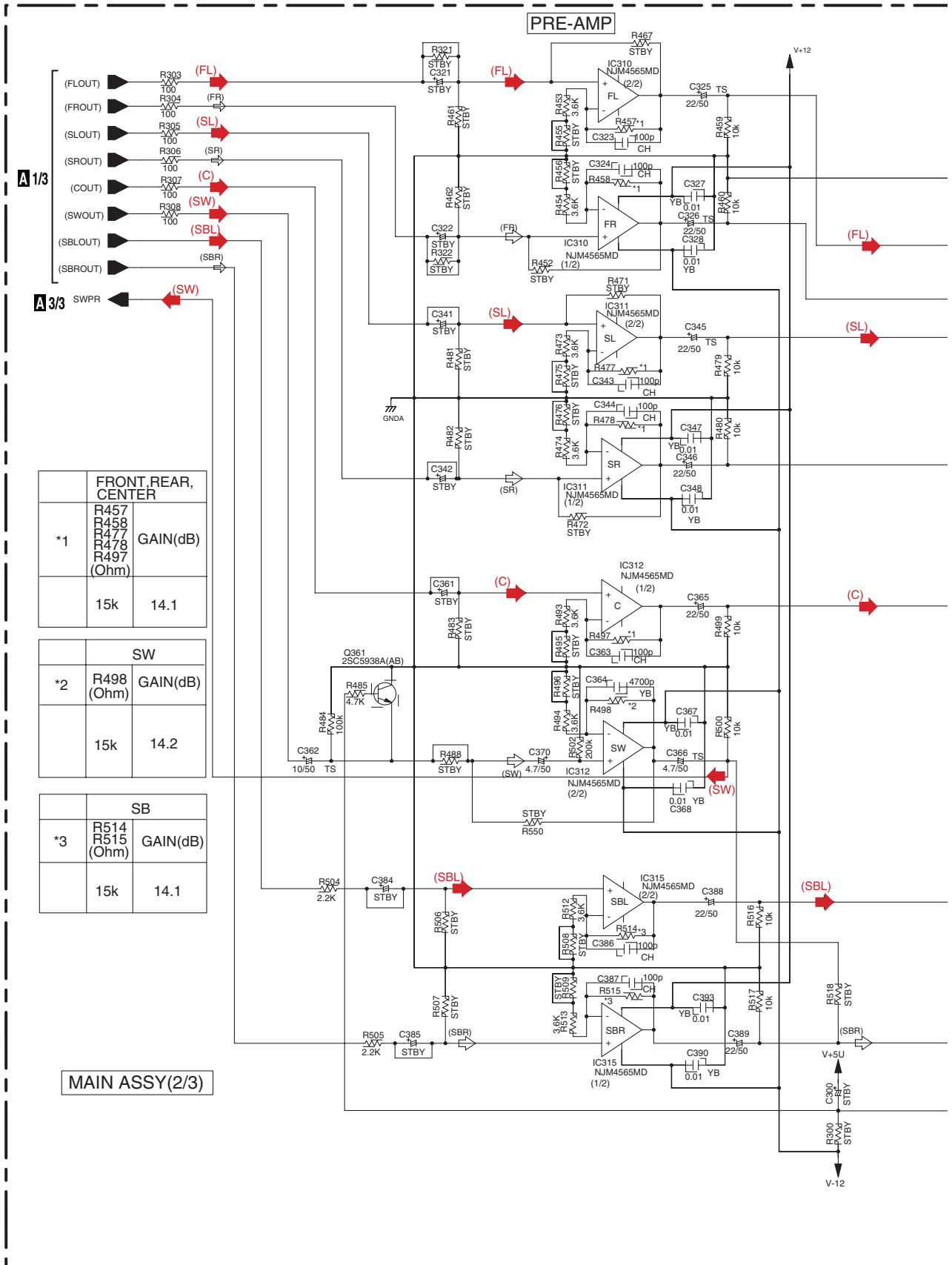

A 2/3

- (FL) : Audio Signal Route (Front L ch)
- (SL) : Audio Signal Route (Surround L ch)
- (C) : Audio Signal Route (Center ch)
- (SBL) : Audio Signal Route (Surround Back L ch)
- (SW) : Audio Signal Route (SubWoofer ch)

NOTE
1.RESISTORS
 Unit: k-k Ω , M-M Ω or Ω unless otherwise noted.
 Rated power: 1/16W unless otherwise noted.
 Tolerance: (J) \pm 5% unless otherwise noted.
2.CAPACITORS
 Unit: p-pF or μ F unless otherwise noted.
 Ratings: Capacity(μ F)/Voltage(V) unless otherwise noted.
 Rated Voltage: 50V expect for electrolytic capacitors.
 JA:CEJA
 : AUDIO SIGNAL FLOW

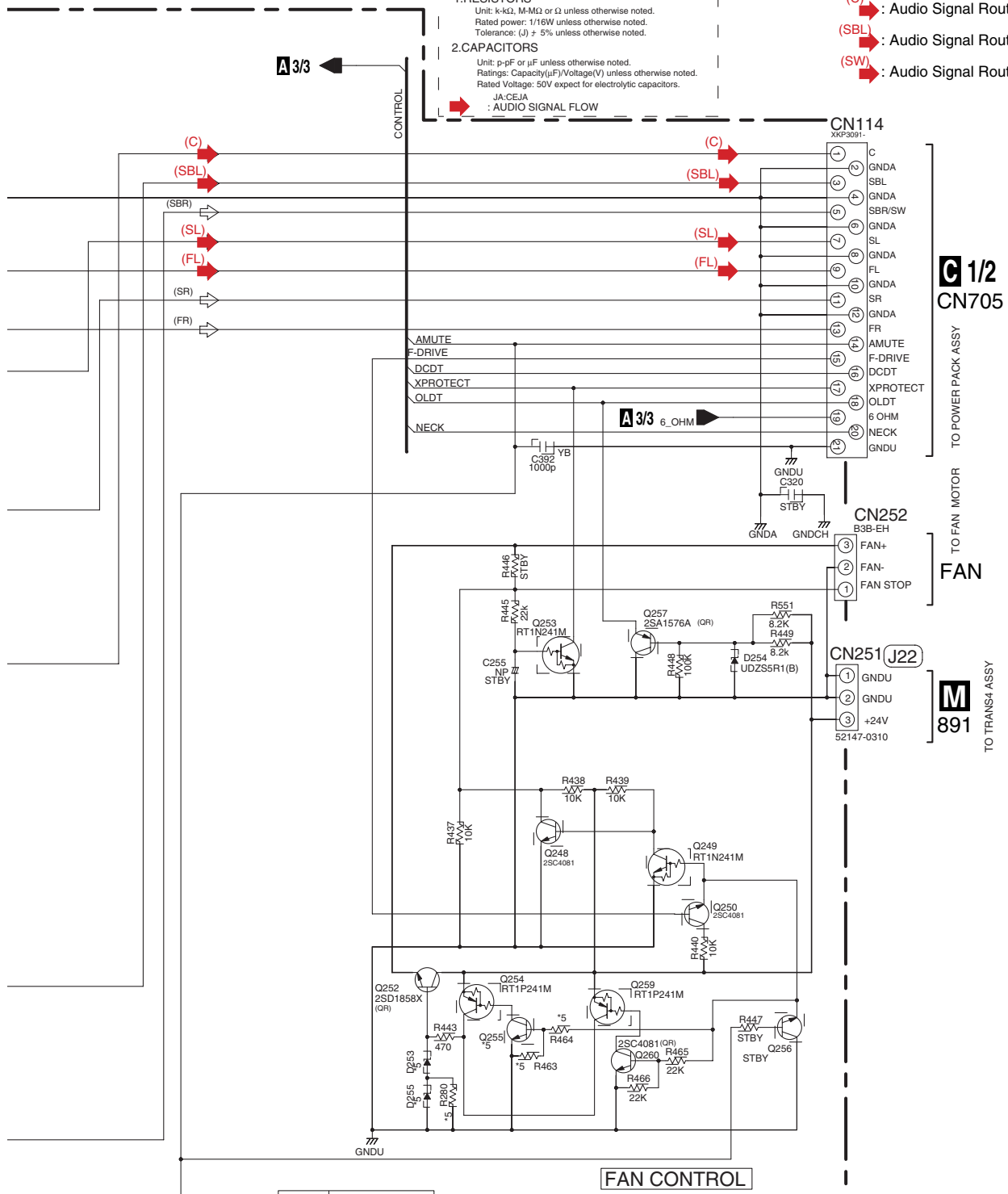

*5	
D253	UDZS13(B)
D255	UDZS13(B)
R280	-
Q255	2SC4081(QR)
R463	22K
R464	22K

FAN CONTROL

3.5 MAIN ASSY (3/3)

A 3/3 MAIN ASSY (VSX-917V:XWK3308) (VSX-817V:XWK3304)

TO FM/AM TUNER UNIT

Except VSX-917V VSX-917V Only

CN312
CN303
TO Composite Video Assy

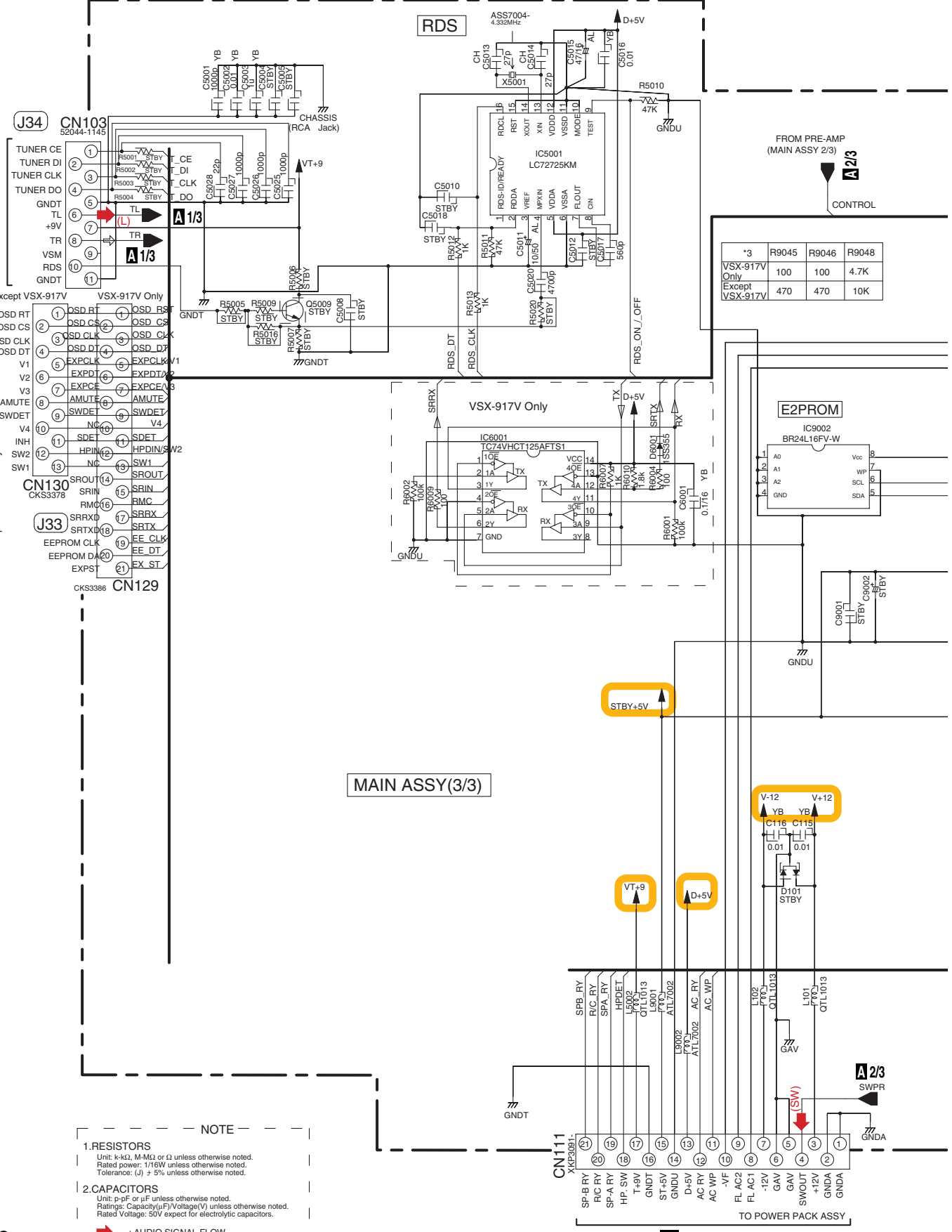

*3	R9045	R9046	R9048
VSX-917V Only	100	100	4.7K
Except VSX-917V	470	470	10K

NOTE

1. RESISTORS
Unit: k- Ω , M- Ω or Ω unless otherwise noted.
Rated power: 1/4W unless otherwise noted.
Tolerance: (J) \pm 5% unless otherwise noted.

2. CAPACITORS
Unit: p-pF or μ F unless otherwise noted.
Ratings: Capacity(μ F)/Voltage(V) unless otherwise noted.
Rated Voltage: 50V expect for electrolytic capacitors.

: AUDIO SIGNAL FLOW

MAIN ASSY(3/3)

C 2/2 CN816

A 3/3

- (L) : Audio Signal Route (L ch)
- (SW) : Audio Signal Route (SubWoofer ch)
- (V) : Video Signal Route

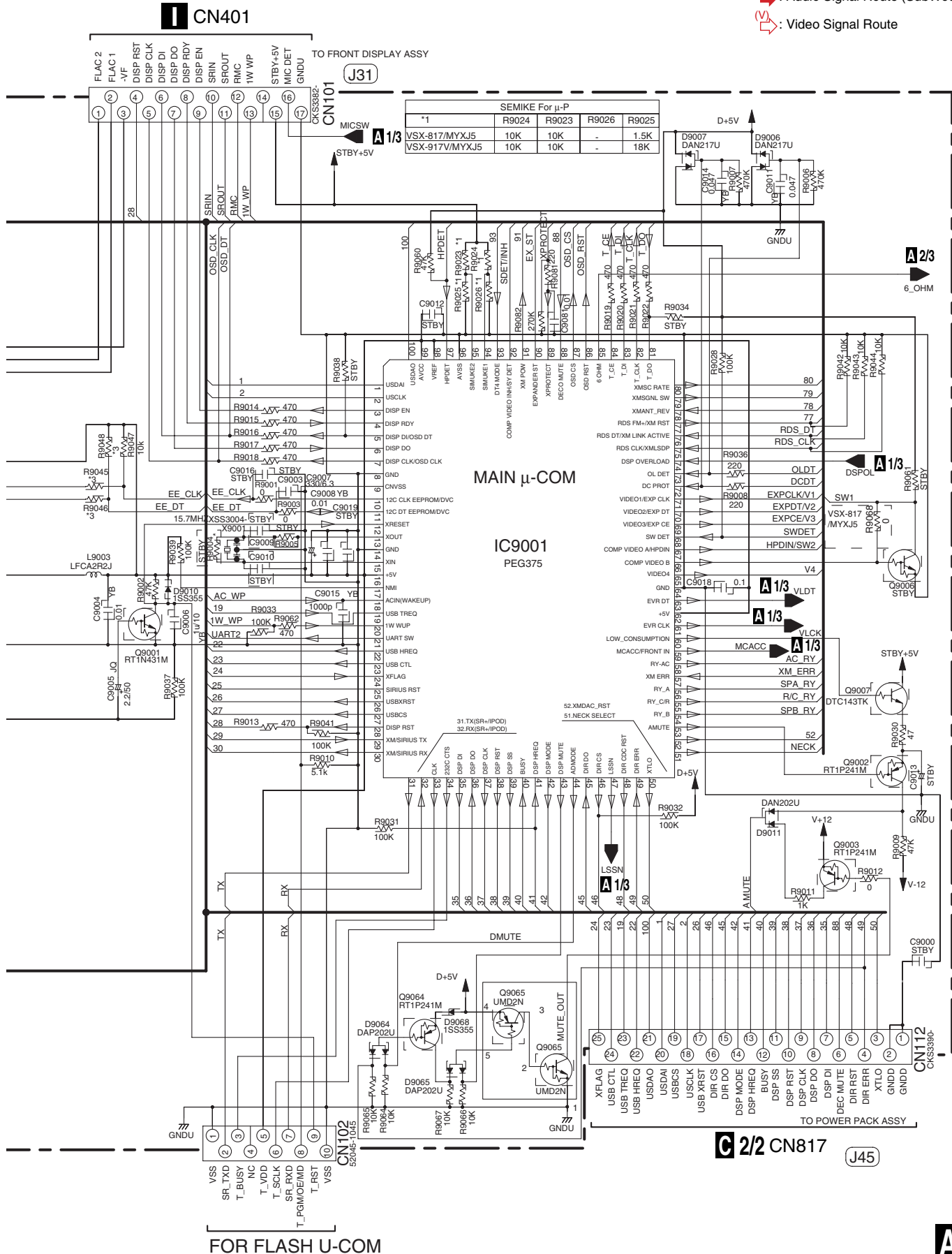

A

B

C

D

E

F

3.6 DSP ASSY (1/2)

B 1/2 DSP ASSY (AWX8810)

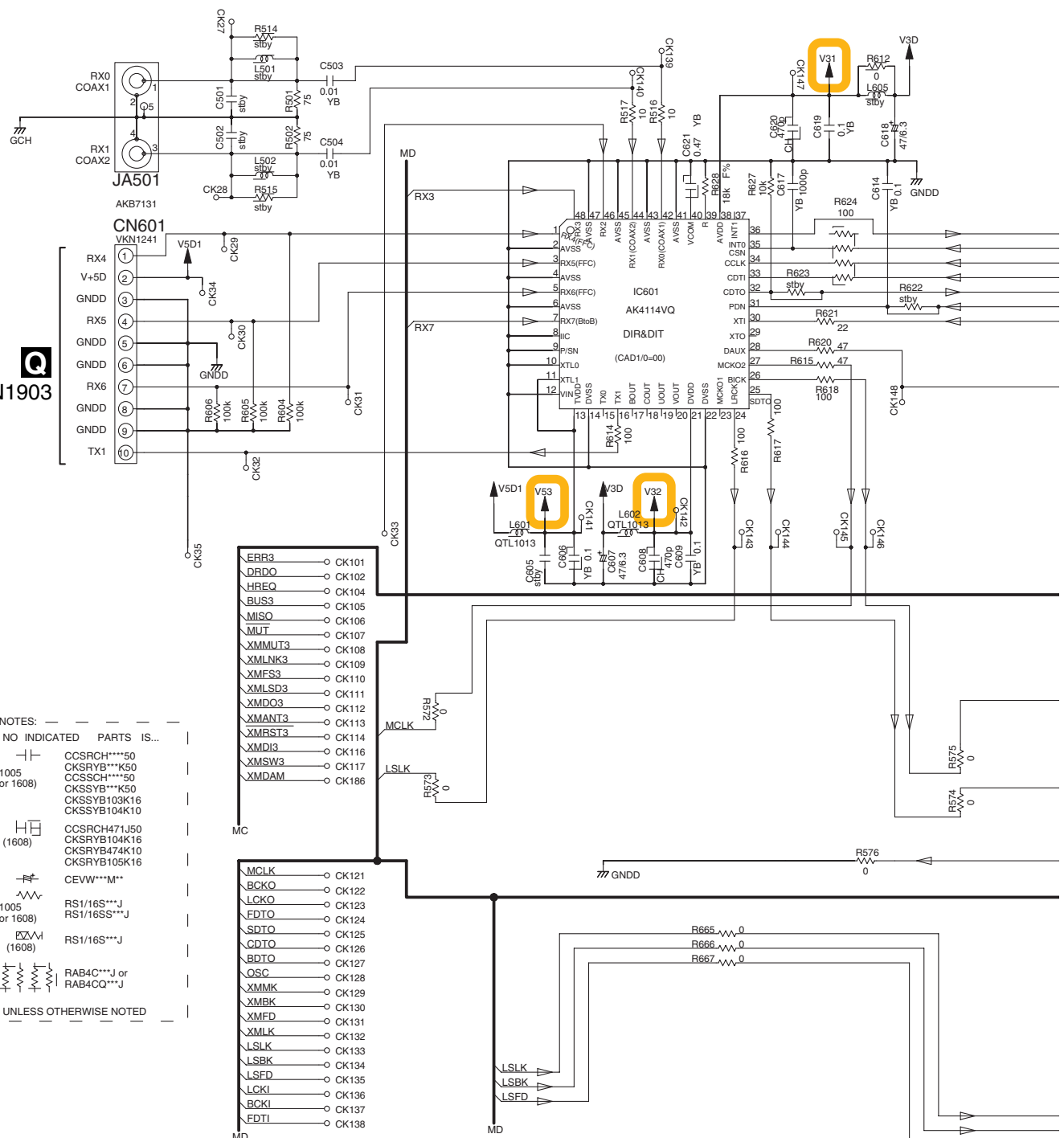

- NOTES: — — — — —
 NO INDICATED PARTS IS...
- CCSRCH***50
 - CKSRYB***K50
 - CCSRCH***50
 - CKSSYB***K50
 - CKSSYB103K16
 - CKSSYB104K10
 - CCSRCH471J50
 - CKSRYB104K16
 - CKSRYB474K10
 - CKSRYB105K16
 - CEVW***M**
 - RS1/16S***J
 - RS1/16SS***J
 - RS1/16S***J
 - RAB4C***J or RAB4CQ***J
- UNLESS OTHERWISE NOTED

- ERR3 ○ CK101
- DRDO ○ CK102
- HRREQ ○ CK104
- BUS3 ○ CK105
- MISO ○ CK106
- MUT ○ CK107
- XMMUT3 ○ CK108
- XMLNK3 ○ CK109
- XMFS3 ○ CK110
- XMLSD3 ○ CK111
- XMDO3 ○ CK112
- XMANT3 ○ CK113
- XMRST3 ○ CK114
- XMDI3 ○ CK116
- XMSW3 ○ CK117
- XMDAM ○ CK186
- MCLK ○ CK121
- BCKO ○ CK122
- LCKO ○ CK123
- FDTO ○ CK124
- SDTO ○ CK125
- CDTO ○ CK126
- BDTO ○ CK127
- OSC ○ CK128
- XMMK ○ CK129
- XMBK ○ CK130
- XMFD ○ CK131
- XMLK ○ CK132
- LSLK ○ CK133
- LSBK ○ CK134
- LSFD ○ CK135
- LCKI ○ CK136
- BCKI ○ CK137
- FDTI ○ CK138

- (L) : Audio Signal Route (L ch)
- (FL) : Audio Signal Route (Front L ch)
- (SL) : Audio Signal Route (Surround L ch)
- (C) : Audio Signal Route (Center ch)
- (SBL) : Audio Signal Route (Surround Back L ch)
- (SW) : Audio Signal Route (SubWoofer ch)

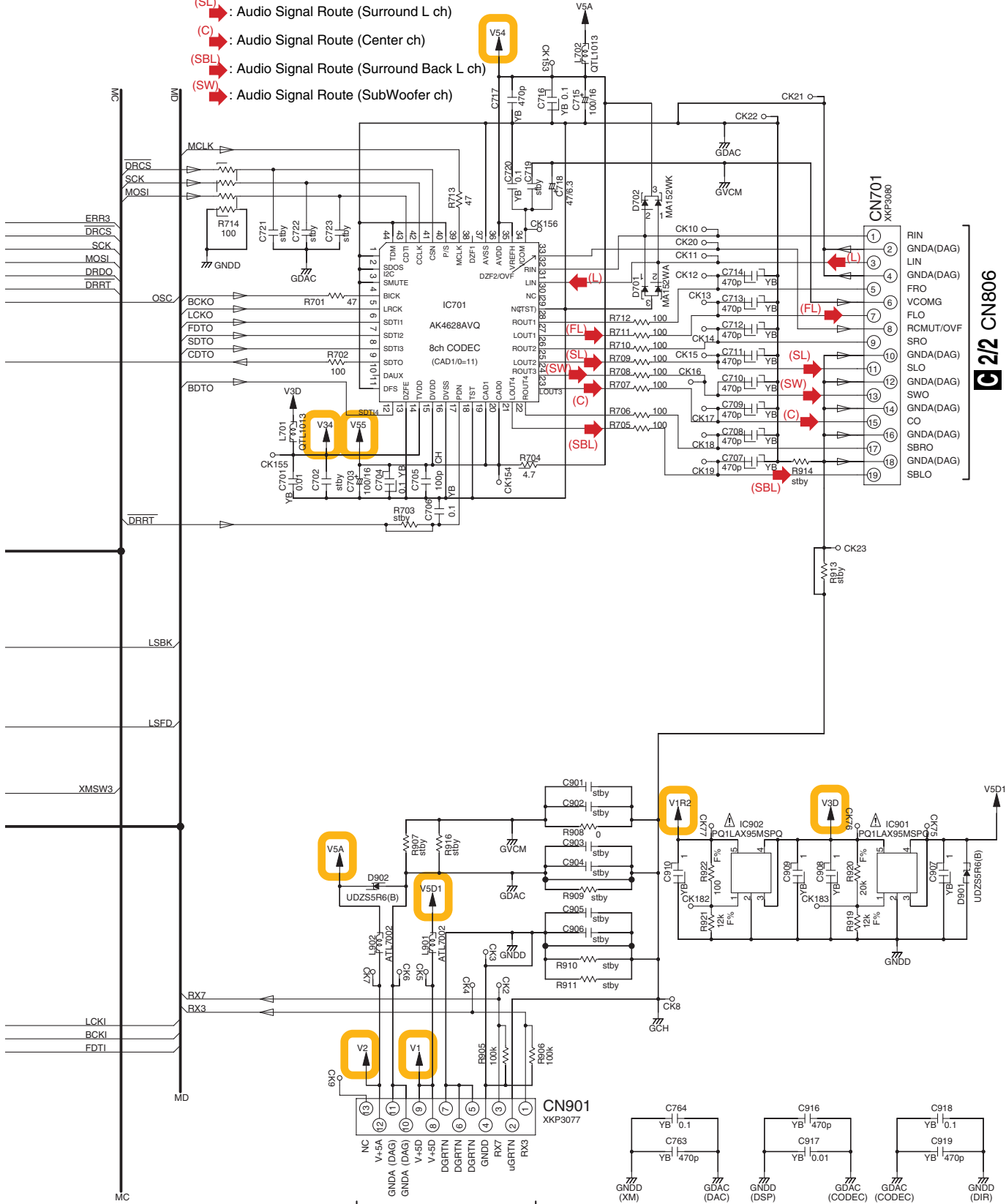

C 2/2 CN806

C 2/2 CN805

B 1/2

3.7 DSP ASSY (2/2)

B 2/2 DSP ASSY (AWX8810)

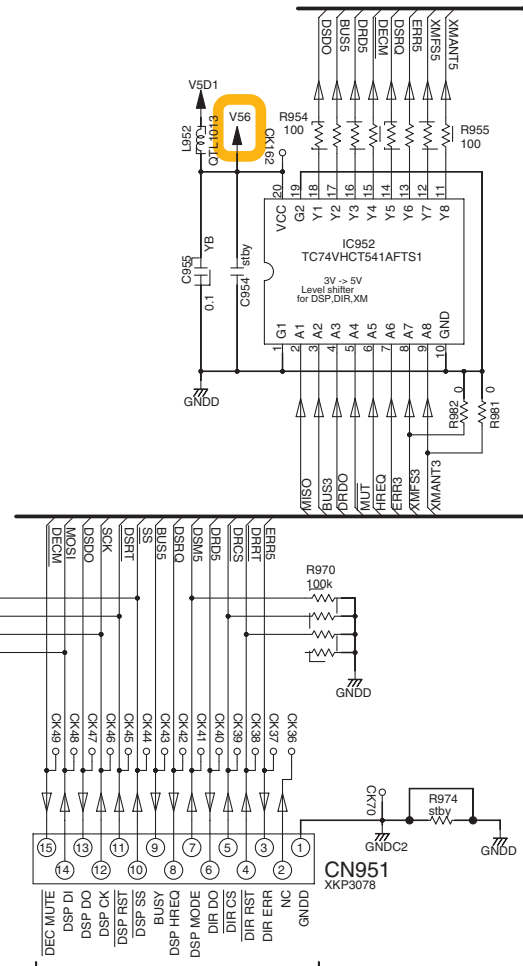
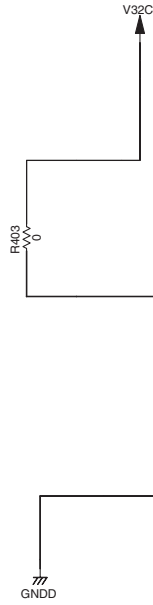

C 2/2 CN807

B 2/2

A
B
C
D
E
F

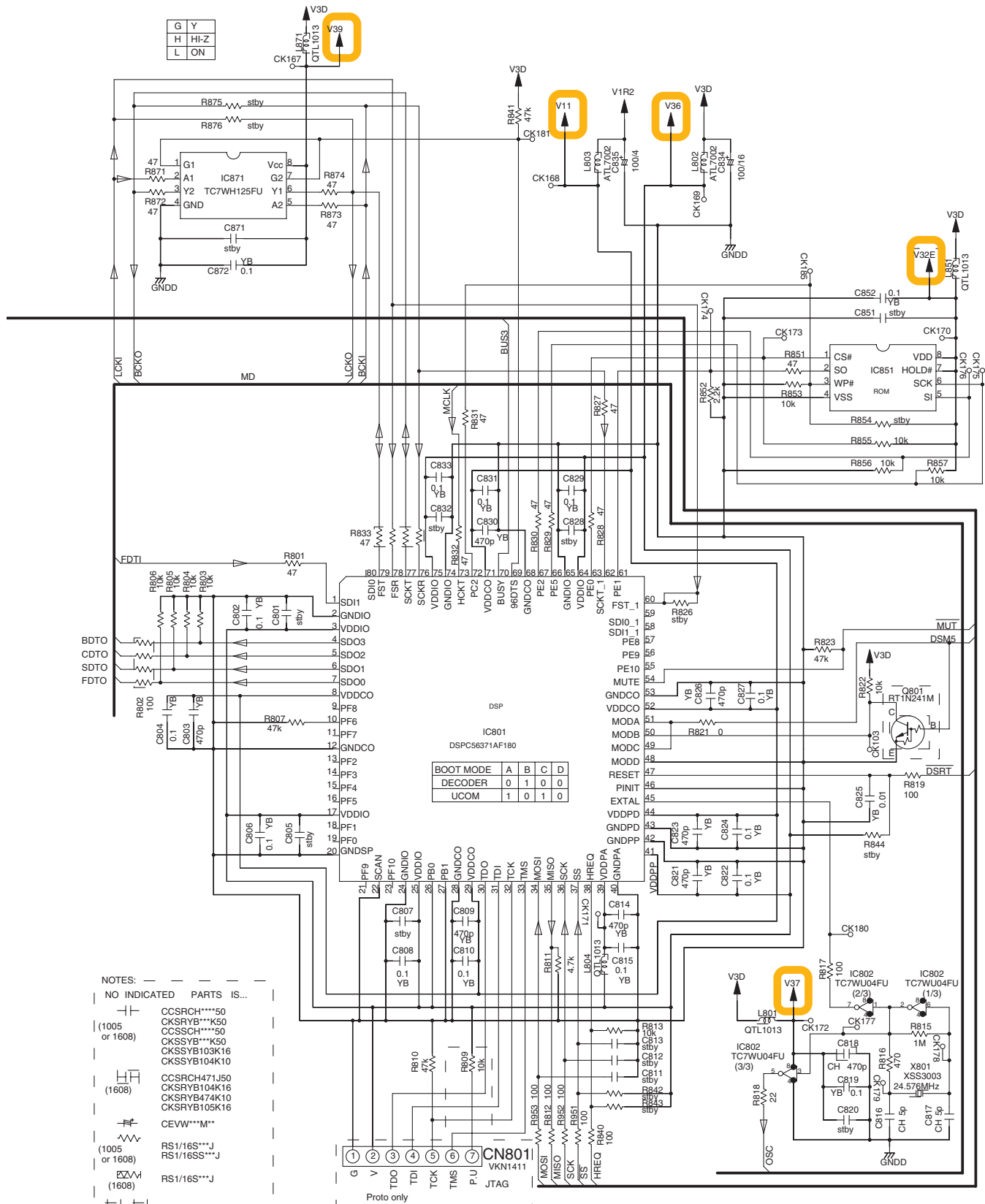

NOTES:

- NO INDICATED PARTS IS...
- CCSRCH***50
- CKSRYPB***K50
- CCSSCH***50
- CKSSYPB***K50
- CKSSYB103K16
- CKSSYB104K10
- CCSRCH471J50
- CKSRYPB104K16
- CKSRYPB474K10
- CKSRYPB105K16
- CEVW***M**
- RS1/16S***J
- RS1/16SS***J
- RS1/16S***J
- RAB4C***J or RAB4CQ***J

UNLESS OTHERWISE NOTED

3.8 POWER PACK (1/2), TRANS2 and TRANS3 ASSYS

C 1/2 POWER PACK ASSY (VSX-917V: XWZ4240) (VSX-817: XWZ4236)

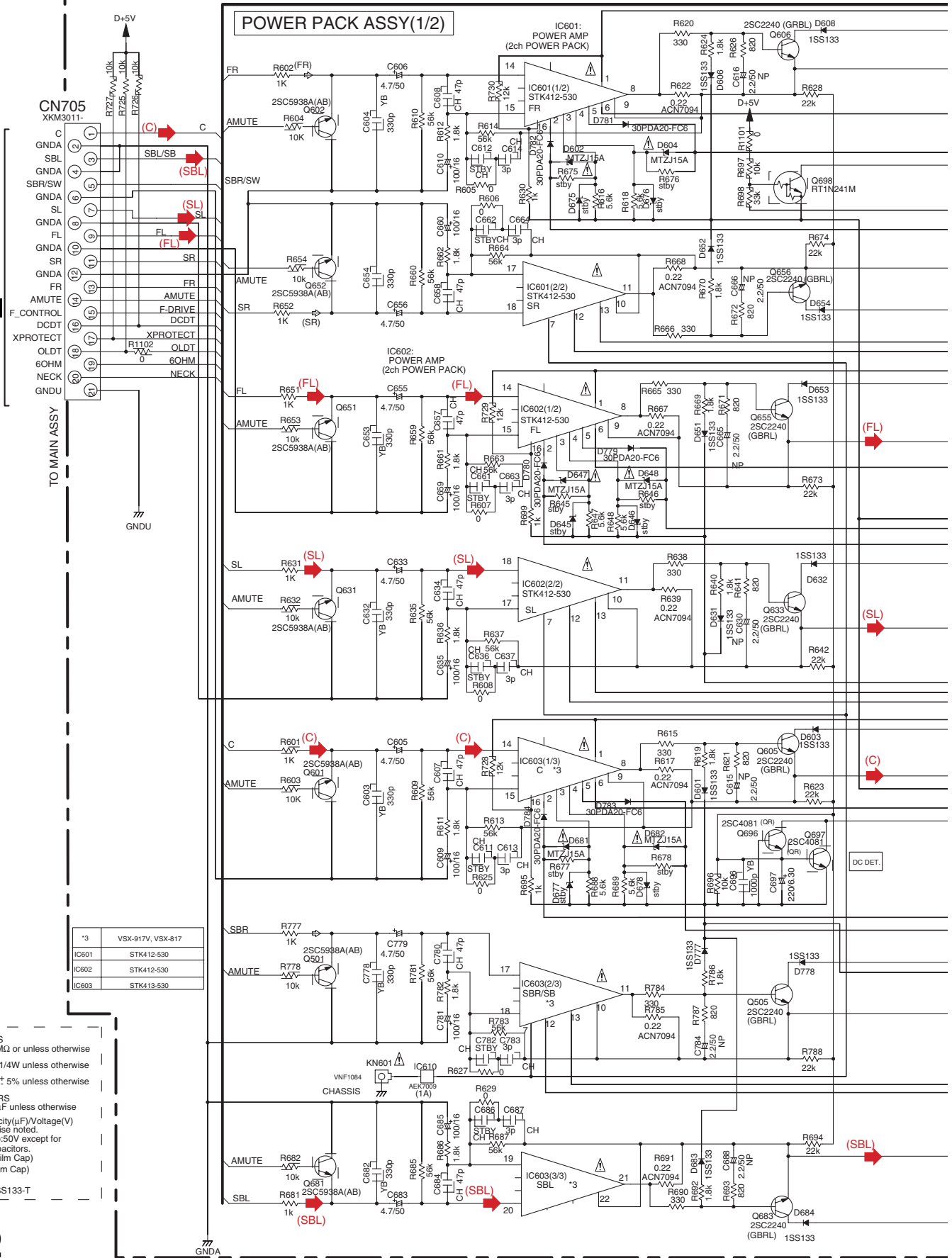

*3	VSX-917V, VSX-817
IC601	STK412-530
IC602	STK412-530
IC603	STK413-530

- NOTE**
- RESISTORS
Unit: k- Ω , M-M Ω or unless otherwise noted.
Rated power: 1/4W unless otherwise noted.
Tolerance: (J) \pm 5% unless otherwise noted.
 - CAPACITORS
Unit: p-pF or μ F unless otherwise noted.
Ratings: Capacity (μ F)/Voltage (V) unless otherwise noted.
Rated Voltage: 50V except for electrolytic capacitors.
BA: COMBA (Film Cap)
M: CQMA (Film Cap)
 - DIODES
Indicated in 1SS133-T



CAUTION : FOR CONTINUED PROTECTION AGAINST RISK OF FIRE. REPLACE ONLY WITH SAME TYPE NO. ICP-N10, MFD BY ROHM CO., LTD. FOR IC701 and IC702.

CAUTION : FOR CONTINUED PROTECTION AGAINST RISK OF FIRE. REPLACE ONLY WITH SAME TYPE NO. AEK7021 MFD, BY LITTELFUSE INK. FOR IC853.

*1	R701	R703	R707	R709	R721
	R702	R704	R708	R710	R722
	MYXJ5	6.8k	100k	120k	— 8.2k

E TRANS3 ASSY (XWZ4246)

D

TRANS2 ASSY (VSX-917V:XWZ4282) (VSX-817:XWZ4245)

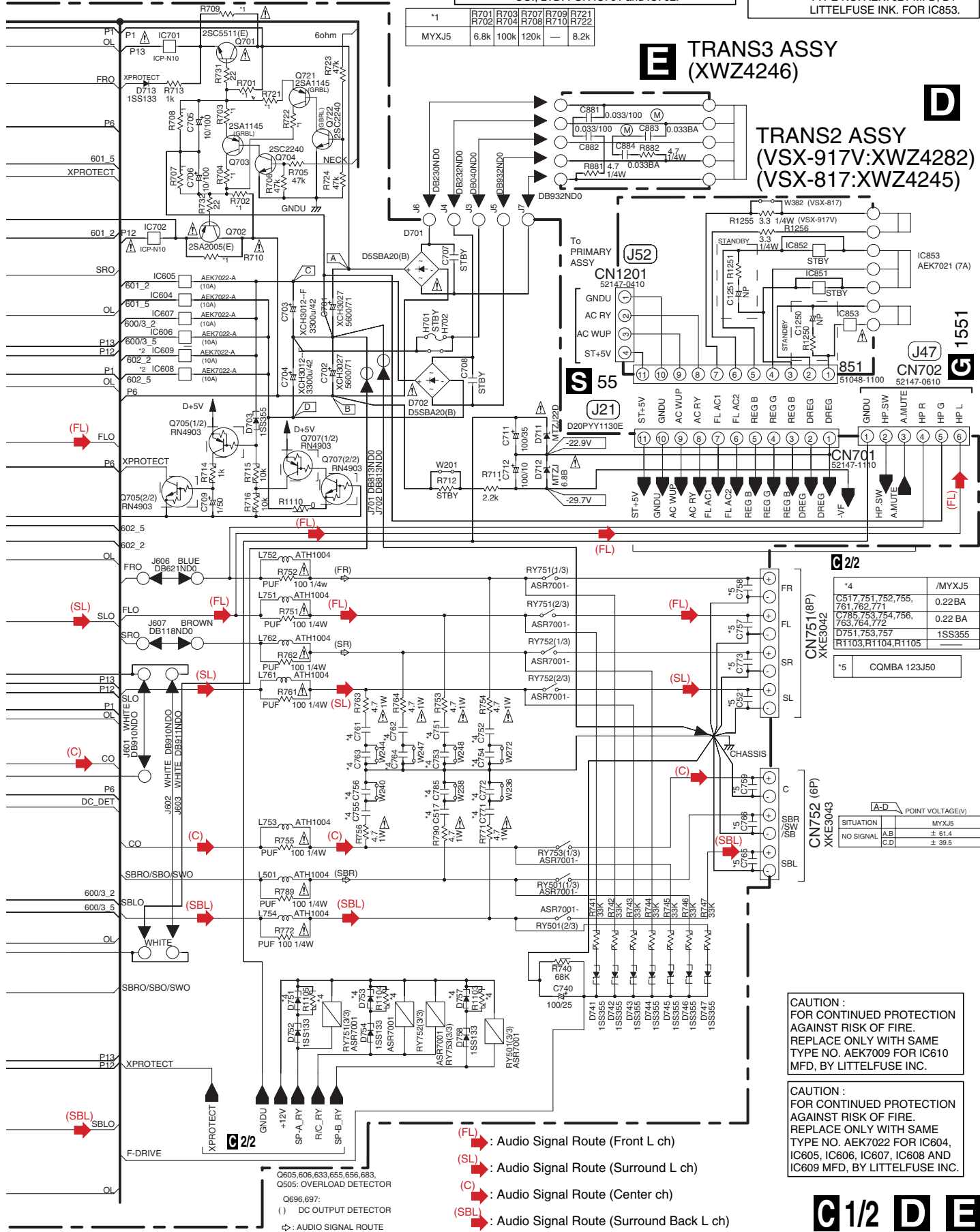

S 55

G 1551

G 2/2

*4	CS17,751,752,755,761,762,771	0.22BA
	CT85,753,754,756,763,764,772	0.22 BA
	D751,753,772	1SS355
	R1103,R1104,R1105	1SS355
*5	COMBA 123J50	

C 1/2

SITUATION	POINT VOLTAGE(V)	
	A/B	MYXJ5
NO SIGNAL	C/D	± 61.4
		± 39.5

- (FL) : Audio Signal Route (Front L ch)
- (SL) : Audio Signal Route (Surround L ch)
- (C) : Audio Signal Route (Center ch)
- (SBL) : Audio Signal Route (Surround Back L ch)

Q605,606,633,655,656,683, Q605: OVERLOAD DETECTOR
Q696,697: DC OUTPUT DETECTOR
⇨: AUDIO SIGNAL ROUTE

CAUTION : FOR CONTINUED PROTECTION AGAINST RISK OF FIRE. REPLACE ONLY WITH SAME TYPE NO. AEK7009 FOR IC610 MFD, BY LITTELFUSE INC.

CAUTION : FOR CONTINUED PROTECTION AGAINST RISK OF FIRE. REPLACE ONLY WITH SAME TYPE NO. AEK7022 FOR IC604, IC605, IC606, IC607, IC608 AND IC609 MFD, BY LITTELFUSE INC.

C 1/2 **D** **E**

3.9 POWER PACK ASSY (2/2)

C 2/2 POWER PACK ASSY (VSX-917V:XWZ4240) (VSX-817:XWZ4236)

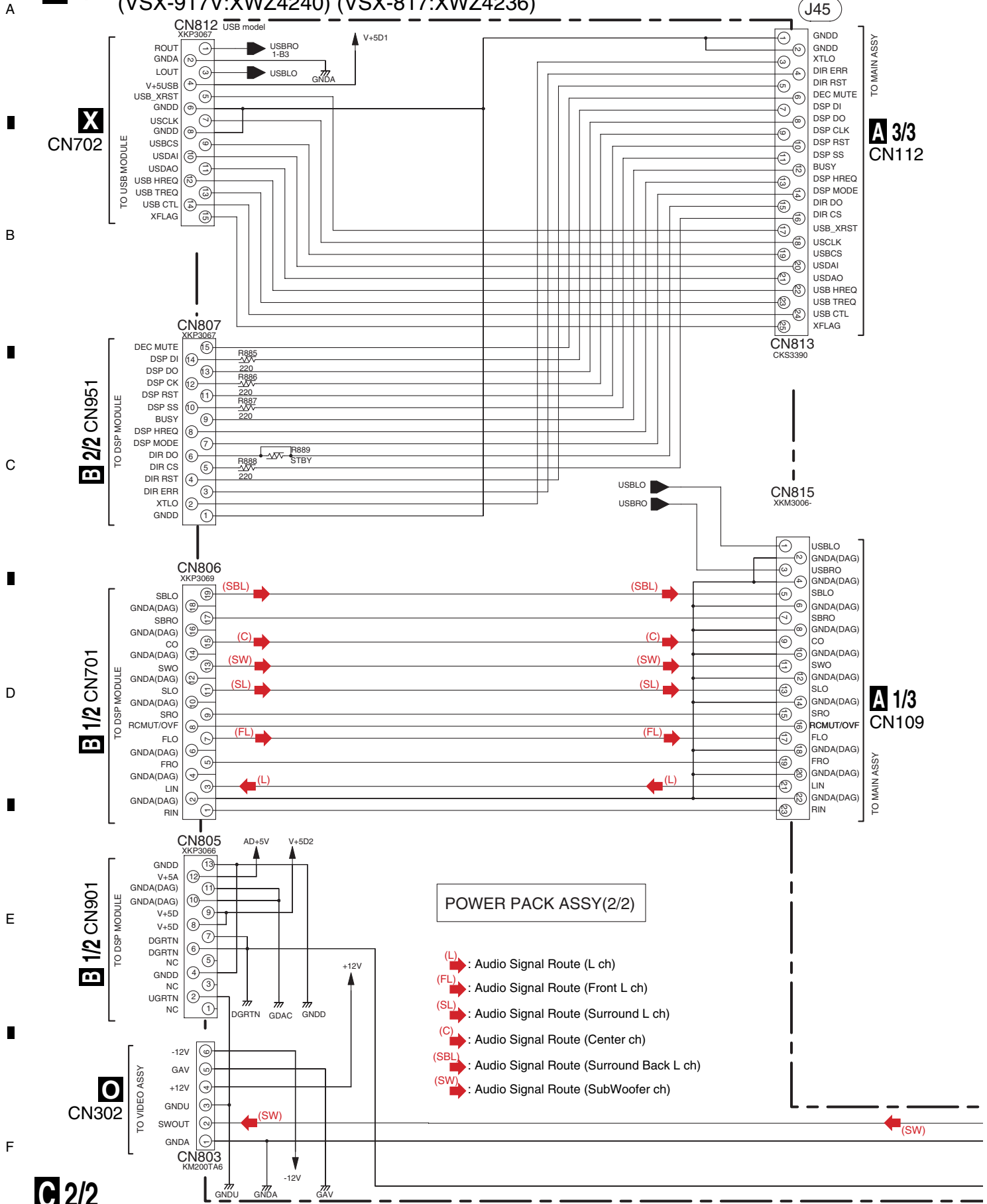

POWER PACK ASSY(2/2)

- (L) : Audio Signal Route (L ch)
- (FL) : Audio Signal Route (Front L ch)
- (SL) : Audio Signal Route (Surround L ch)
- (C) : Audio Signal Route (Center ch)
- (SBL) : Audio Signal Route (Surround Back L ch)
- (SW) : Audio Signal Route (SubWoofer ch)

*4	VSX-917V /MYXJ5	VSX-817 /MYXJ5
W80	X	X
W81	O	X

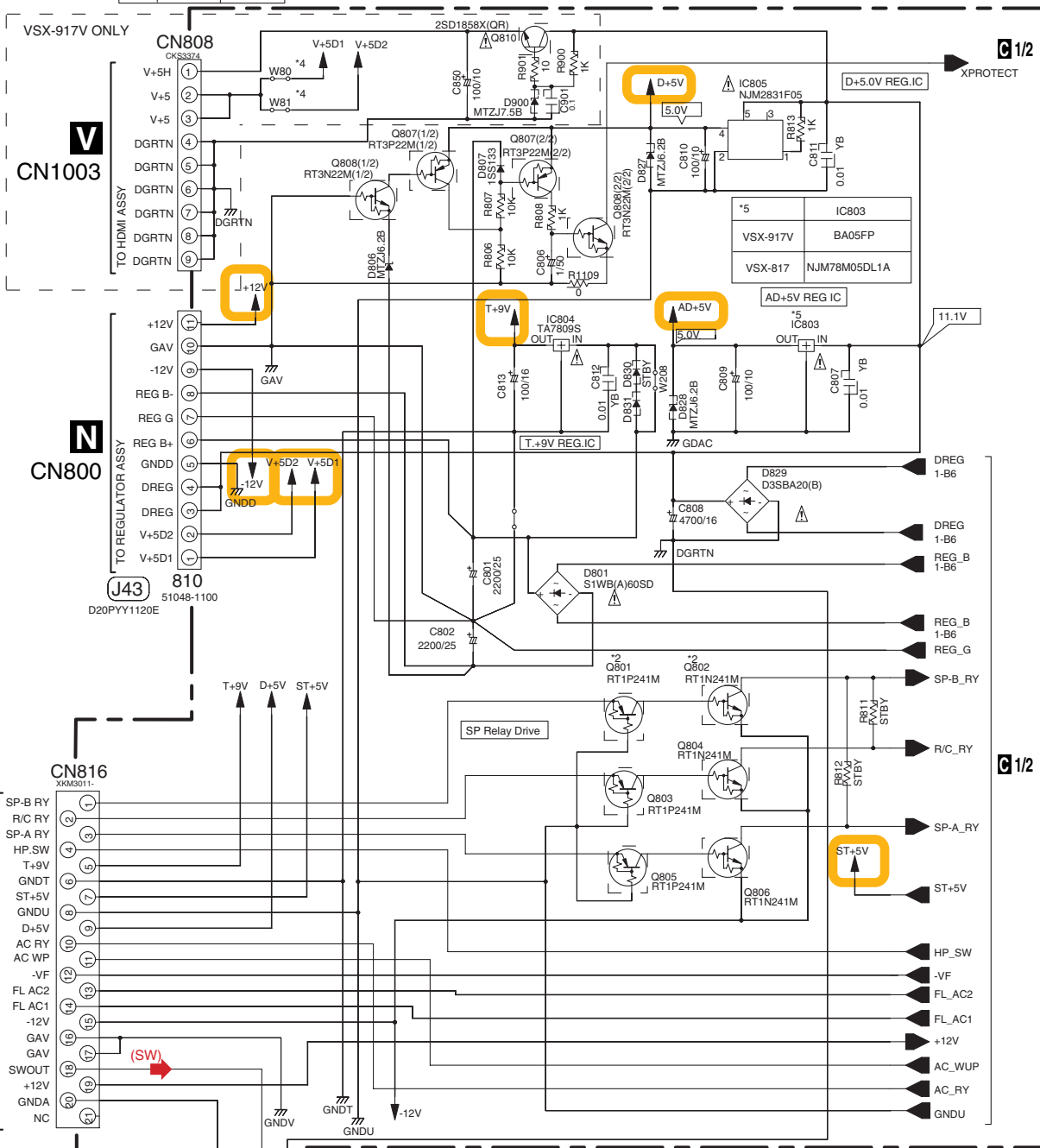

*2	VSX-917V, VSX-817
Q801 Q802	O

NOTE

1. RESISTORS
Unit:k- Ω ,M-M Ω or unless otherwise noted.
Rated power:1/4W unless otherwise noted.
Tolerance:(J) \pm 5% unless otherwise noted.

2. CAPACITORS
Unit: p-pF or μ F unless otherwise noted.
Ratings:Capacity(μ F)/Voltage(V)
unless otherwise noted.
Rated Voltage:50V except for
electrolytic capacitors.

A 3/3 CN111

V CN1003

N CN800

J43 810
D20PYY1120E

C 1/2

C 1/2

C 2/2

3.10 COMPONENT VIDEO, HEAD PHONE and 5.1CH INPUT ASSYS

COMPONENT VIDEO ASSY (VSX-917V:XWZ4248) (VSX-817:XWZ4247)

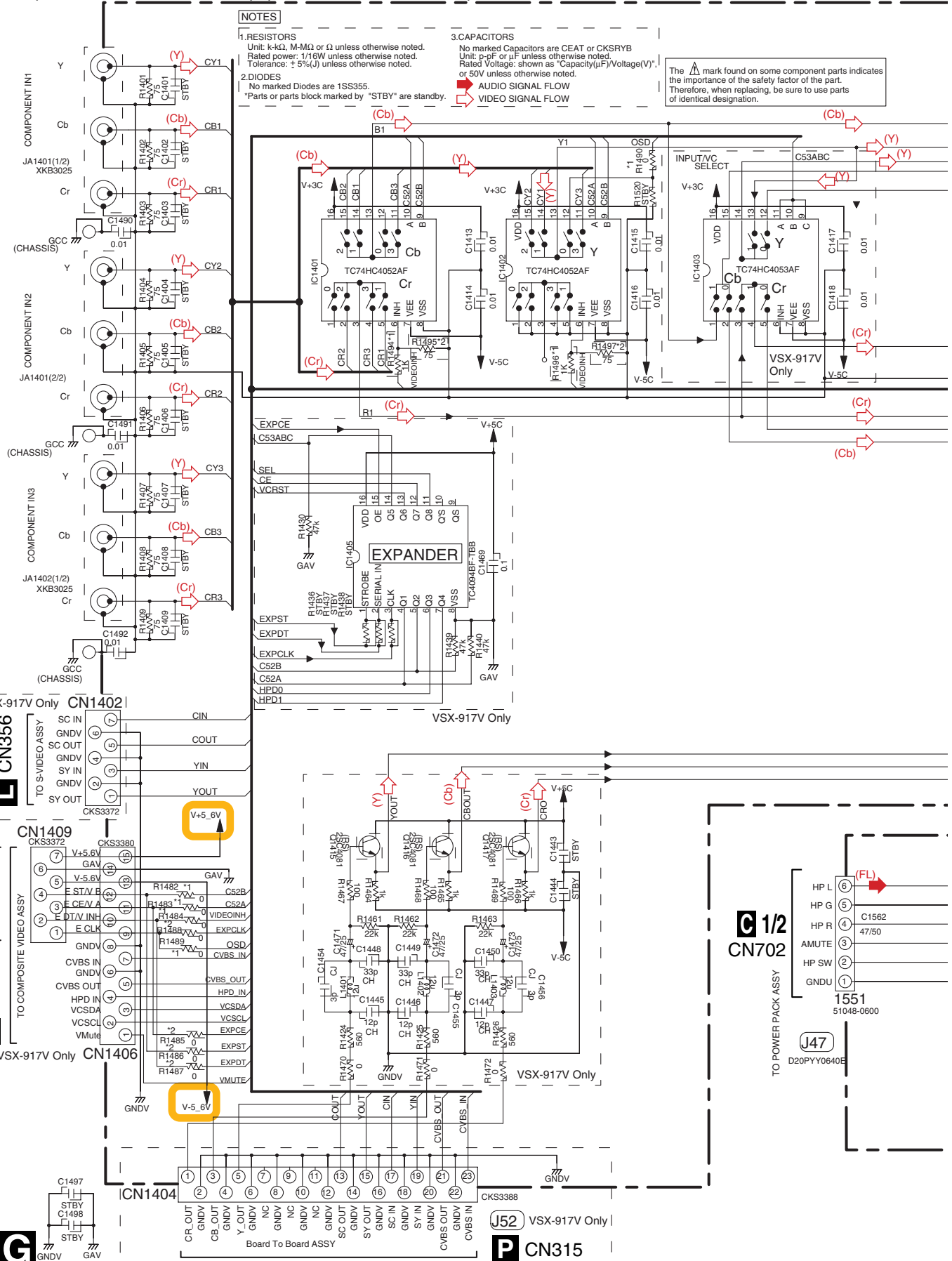

(Y) : Video Signal Route (Component Y ch)
 (Cb) : Video Signal Route (Component Cb ch)
 (Cr) : Video Signal Route (Component Cr ch)

	VSX-817	VSX-917V
*1	○	X
*2	X	○

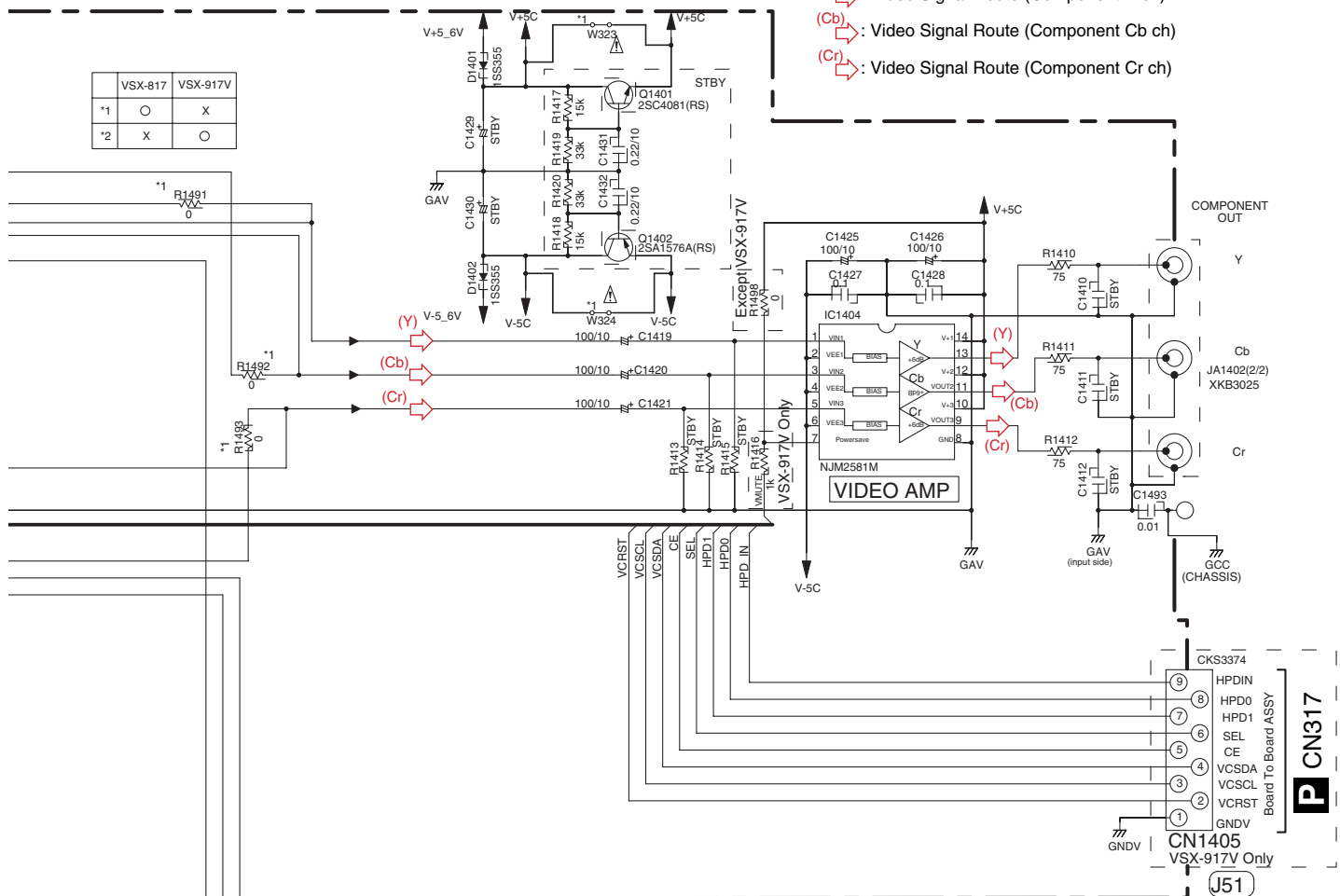

G HEAD PHONE ASSY (XWZ4265)

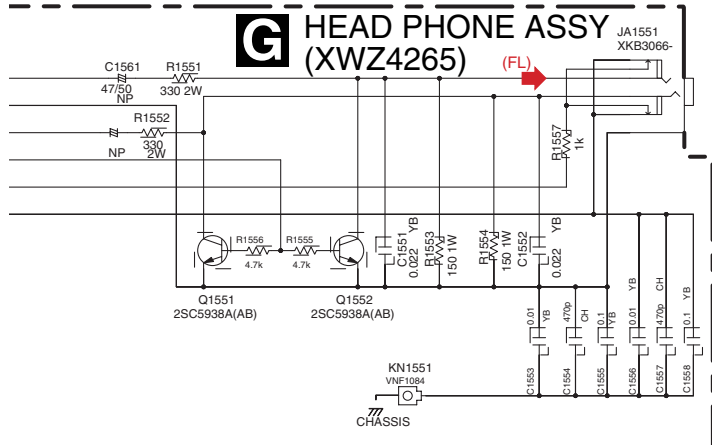

H 5.1CH INPUT ASSY (XWZ4249)

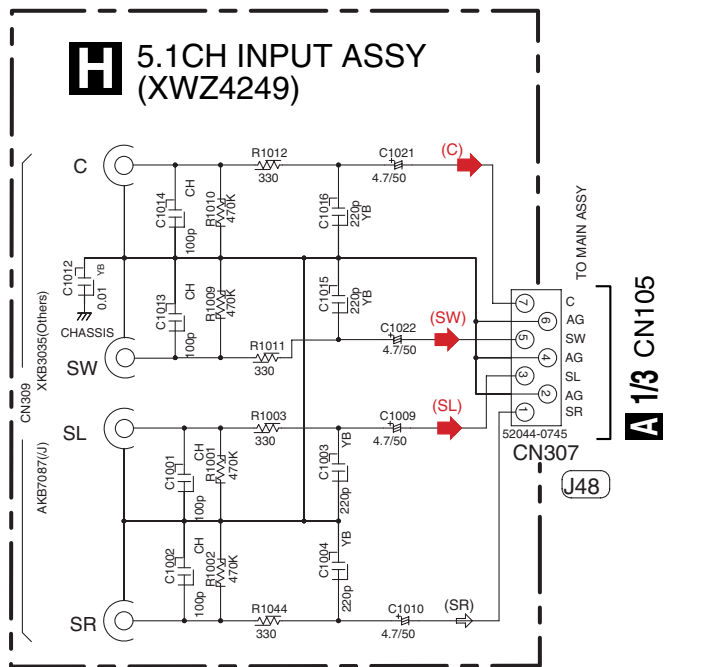

(FL) : Audio Signal Route (Front L ch)
 (SL) : Audio Signal Route (Surround L ch)
 (C) : Audio Signal Route (Center ch)
 (SW) : Audio Signal Route (SubWoofer ch)

F G H

3.11 FRONT DISPLAY, ROTARY ENCODER and POWER KEY ASSYS

J ROTARY ENCODER ASSY (XWZ4205)

I FRONT DISPLAY ASSY (VSX-917V:XWZ4204) (VSX-817:XWZ4226)

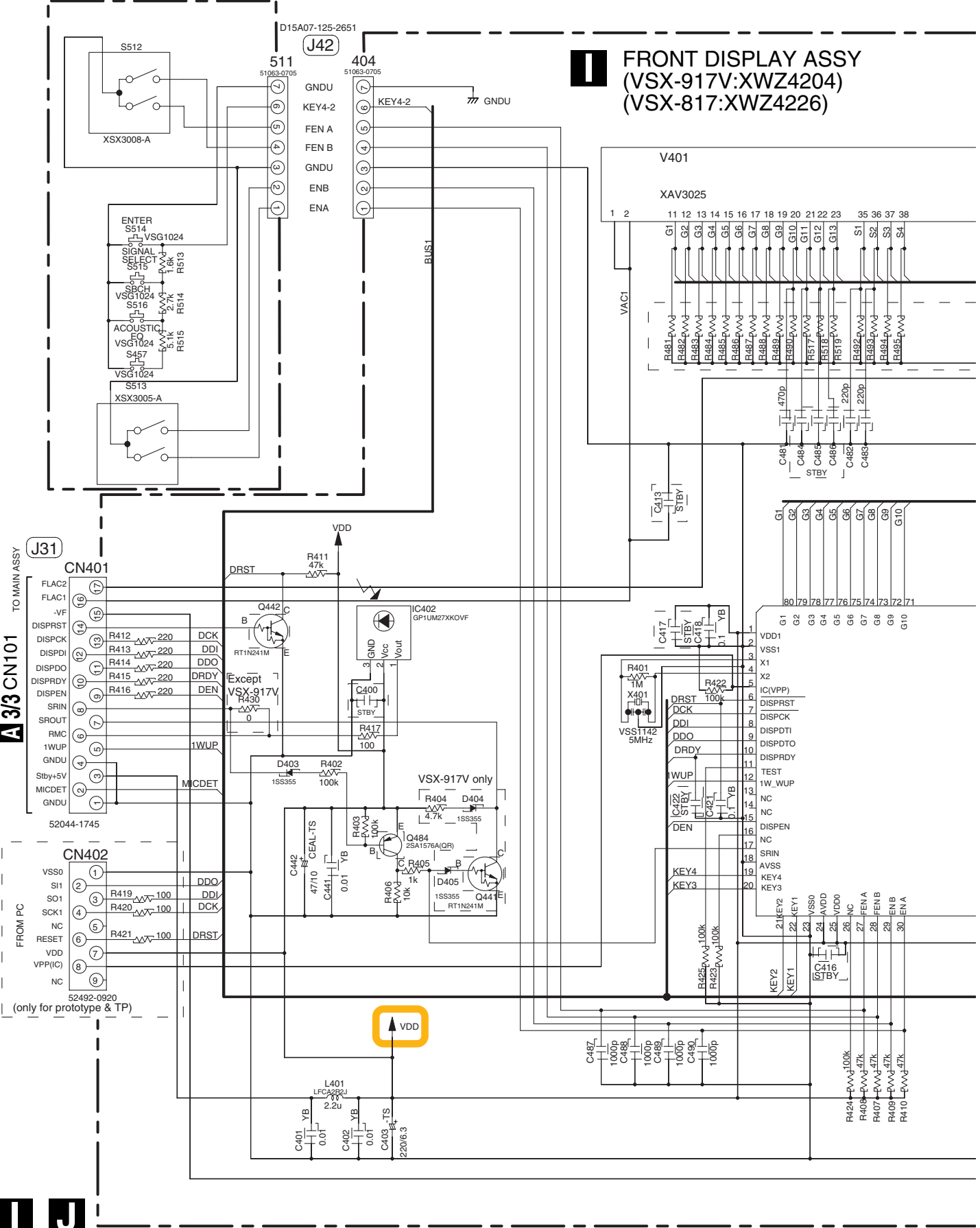

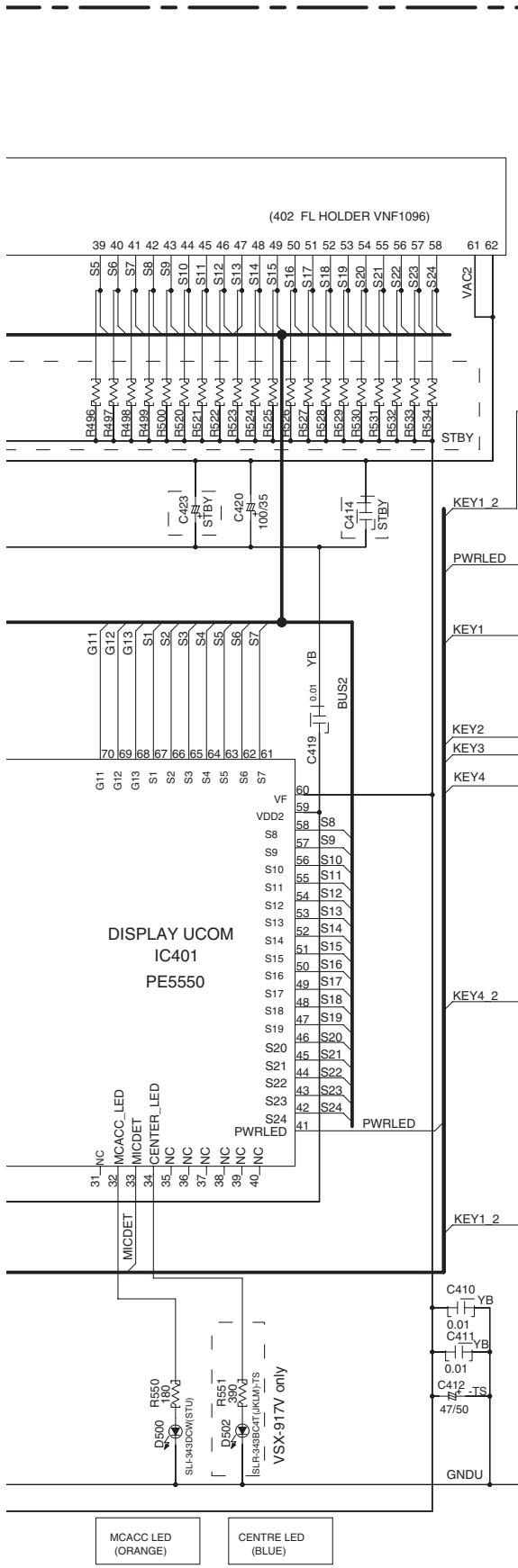

NOTE

1. RESISTORS
 Unit: k-kΩ, M-MΩ or Ω unless otherwise noted.
 Rated power: 1/16W unless otherwise noted.
 Tolerance: (J) ± 5% unless otherwise noted.

2. CAPACITORS
 Unit: p-pF or μF unless otherwise noted.
 Ratings: Capacity(μF)/Voltage(V) unless otherwise noted.
 Rated Voltage: 50V expect for electrolytic capacitors.

3. TACT SWITCHES
 Indicated in VSG1024

K POWER KEY ASSY
(VSX-917V: XWZ4254)
(VSX-817: XWZ4206)

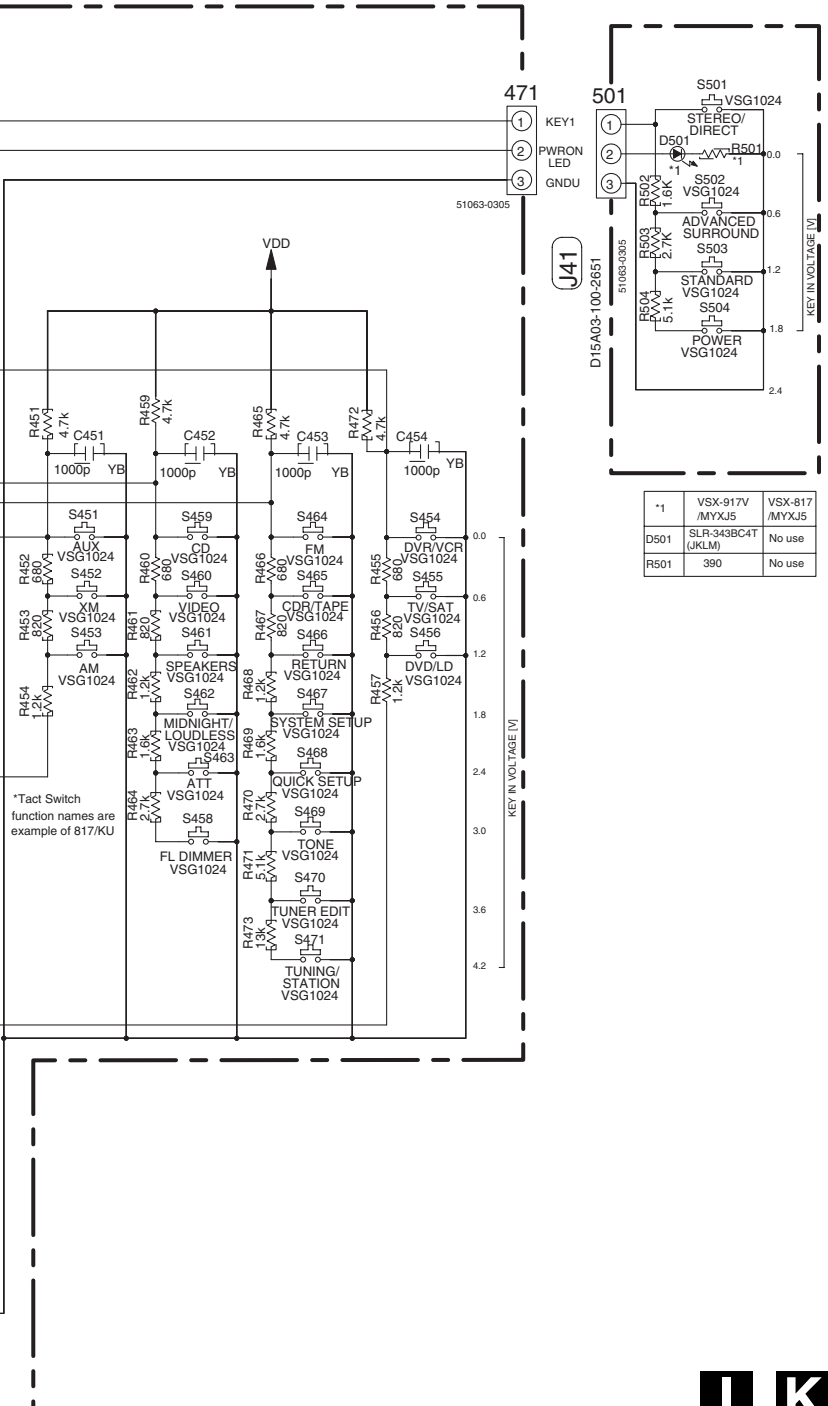

*1	VSX-917V /MYXJ5	VSX-817 /MYXJ5
D501	SLR-343BC4T (JKLM)	No use
R501	390	No use

MICACC LED (ORANGE)
 CENTRE LED (BLUE)

3.12 S.VIDEO, TRANS4 and REGULATOR ASSYS

M TRANS4 ASSY (XWZ4225)

CAUTION : FOR CONTINUED PROTECTION AGAINST RISK OF FIRE, REPLACE ONLY WITH SAME TYPE NO. AEK7008 MFD, BY LITTELFUSE INK. FOR IC357.

A 2/3 CN251

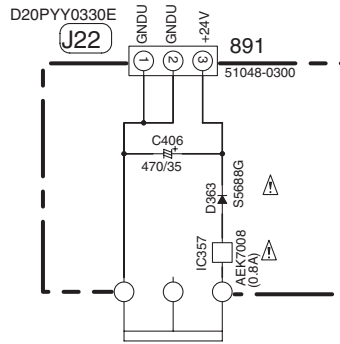

NOTE

1.RESISTORS

Unit: k-K Ω , M-M Ω or Ω unless otherwise noted.
Rated power: 1/16W unless otherwise noted.
Tolerance: (J) \pm 5% unless otherwise noted.

2.CAPACITORS

Unit: p-pF or μ F unless otherwise noted.
Ratings: Capacity(μ F)/Voltage(V) unless otherwise noted.
Rated Voltage: 50V expect for electrolytic capacitors.

- Y SIGNAL ROUTE (S-VIDEO)
- C SIGNAL ROUTE (S-VIDEO)

L S. VIDEO ASSY (VSX-917V:XWZ4228)

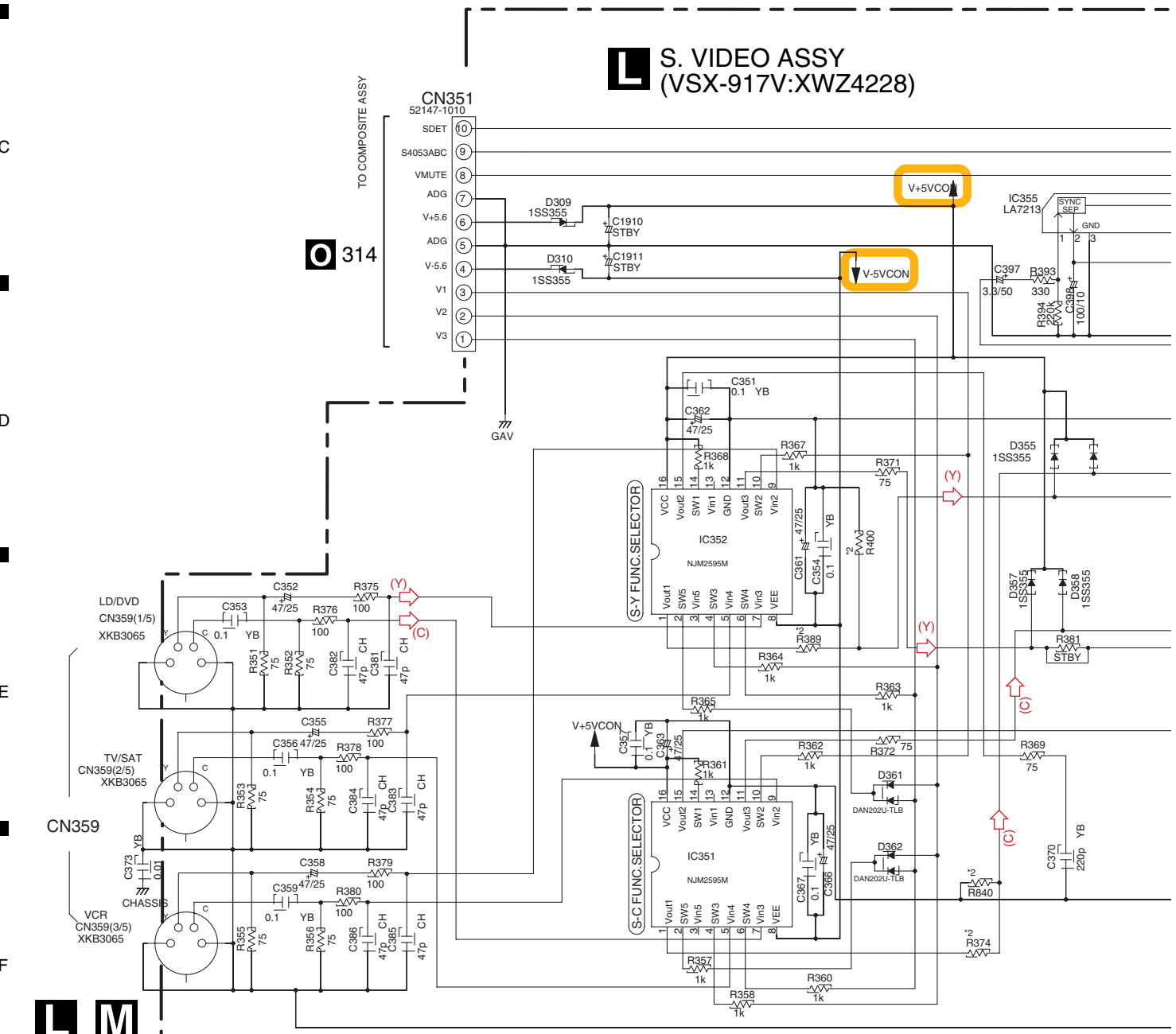

*1	VSX-917V /MYXJ5	VSX-817 /MYXJ5
IC809	NJM2389F	-
C809	O	-
C810	O	-
R809	O(1K)	-
R810	O(3K)	-
R820	O(0.15K)	-
D814	O	-
IC807	-	TA7805S
R802	-	O(220/2W)
R818	-	-
R819	-	O(0)
C817	-	O
C816	-	O
D810	-	O
D813	-	O
IC808	BA50BCOT	TA7805S
C818	O	O
C819	O	O
D810	O	O
W376	O	O
W378	O	O
W379	O	O
W380	O	O

C 2/2
810

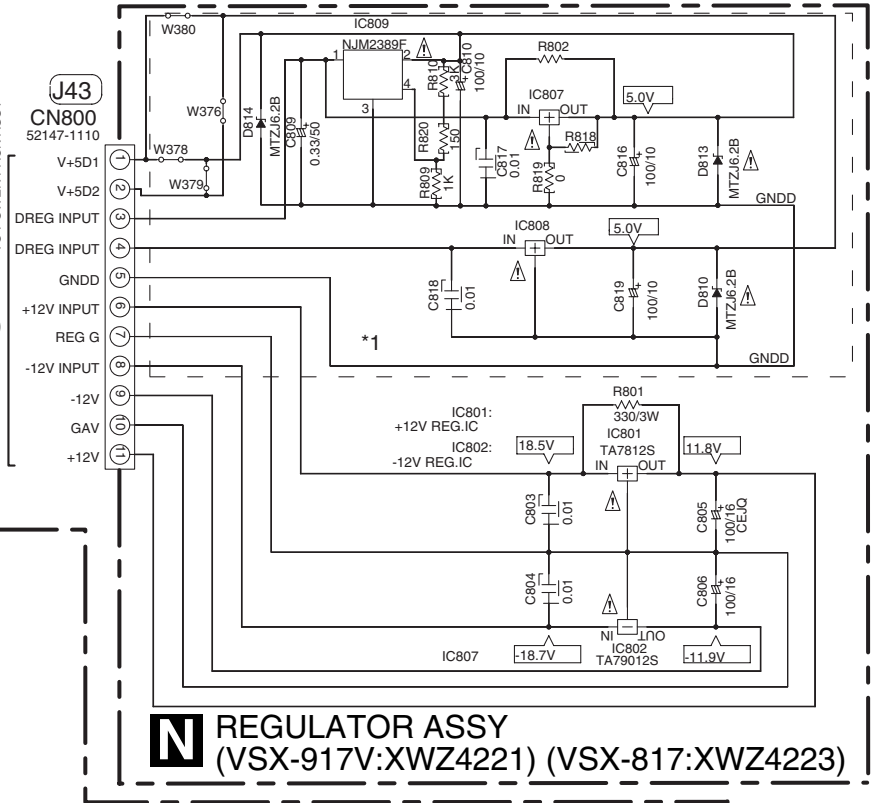

N REGULATOR ASSY
(VSX-917V: XWZ4221) (VSX-817: XWZ4223)

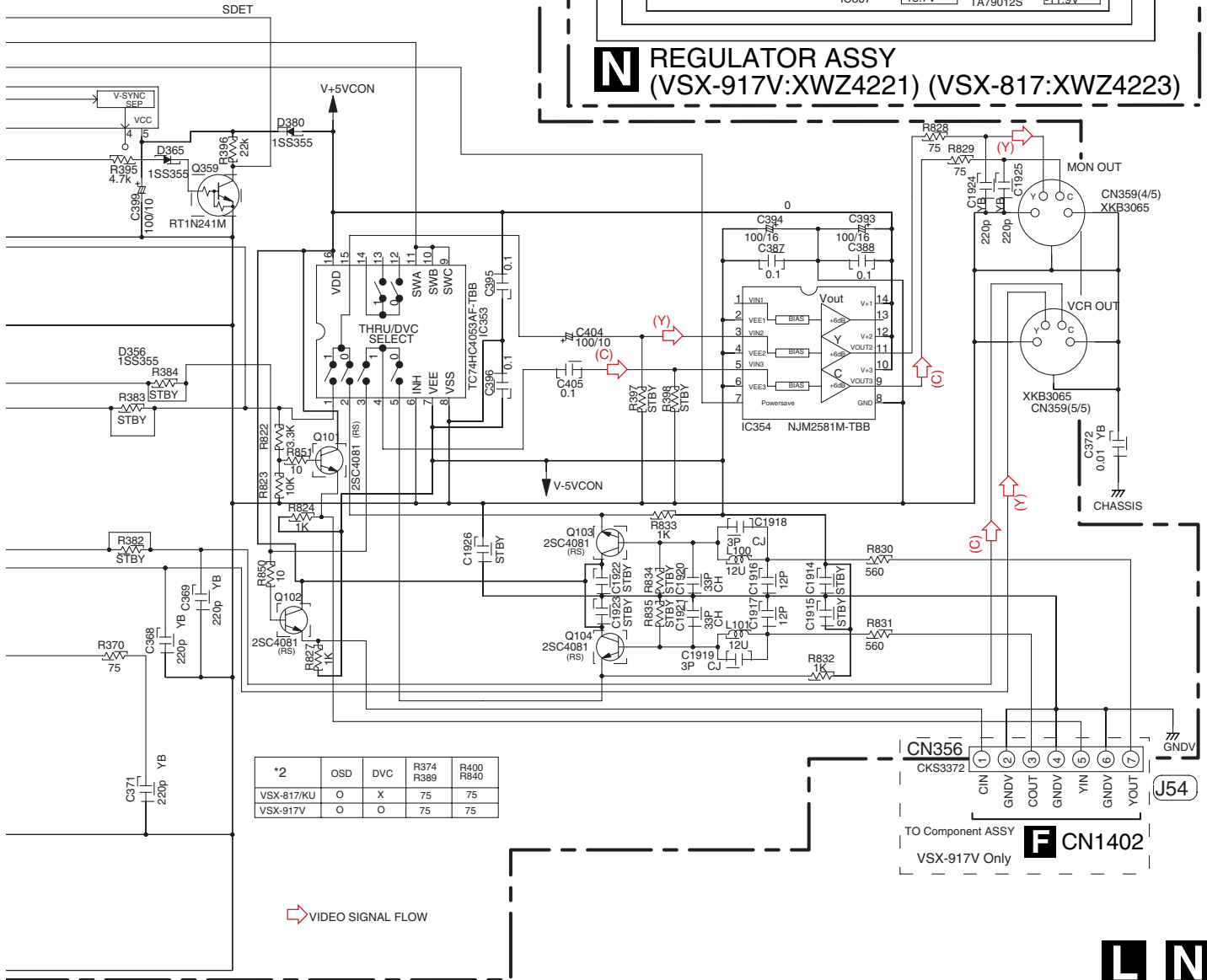

*2	OSD	DVC	R374 R389	R400 R840
VSX-817/KU	O	X	75	75
VSX-917V	O	O	75	75

VIDEO SIGNAL FLOW

3.13 COMP VIDEO and BOARD TO BOARD ASSYS

COMP VIDEO ASSY (VSX-917V:XWZ4267)

A
B
C
D
E
F

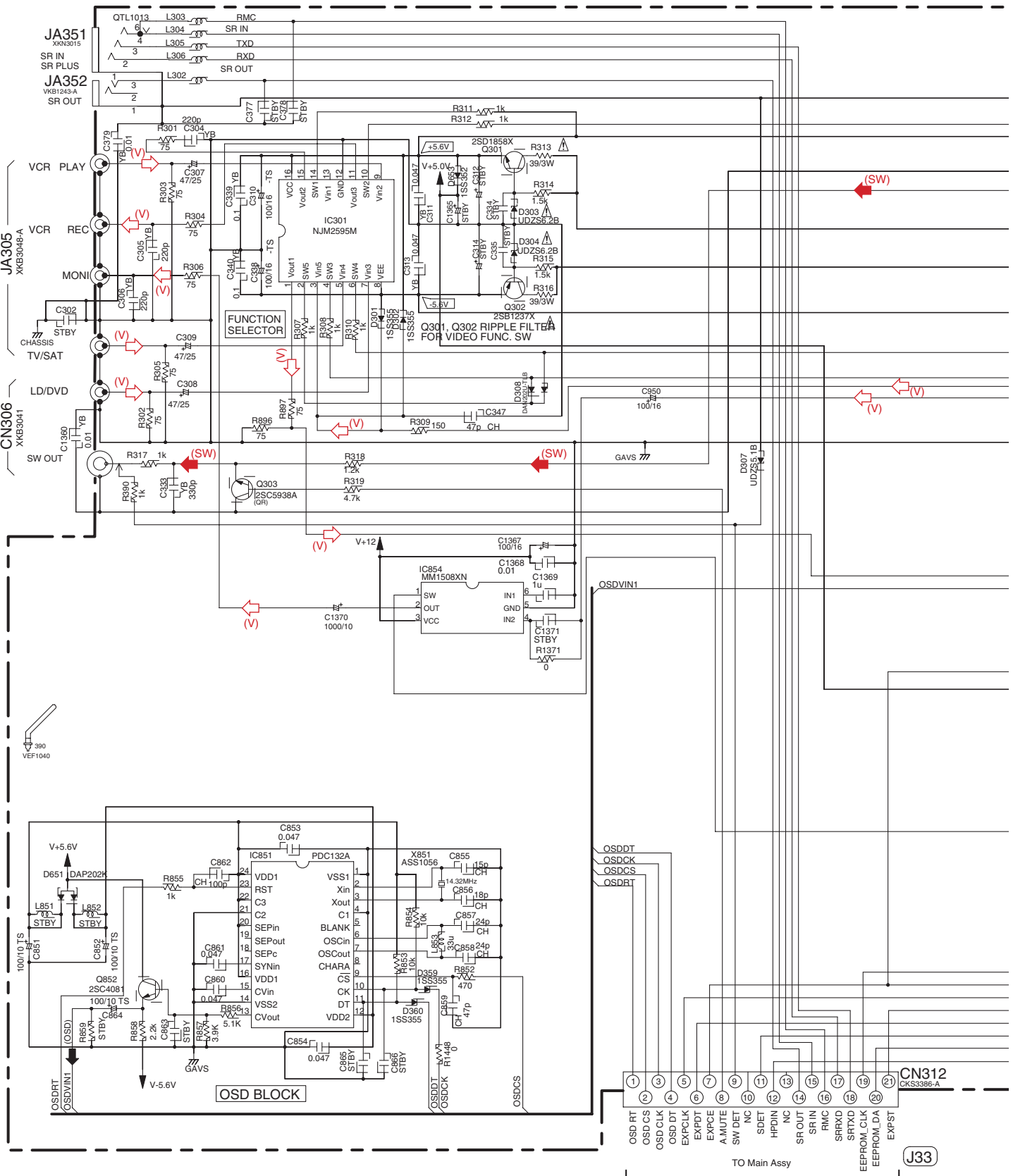

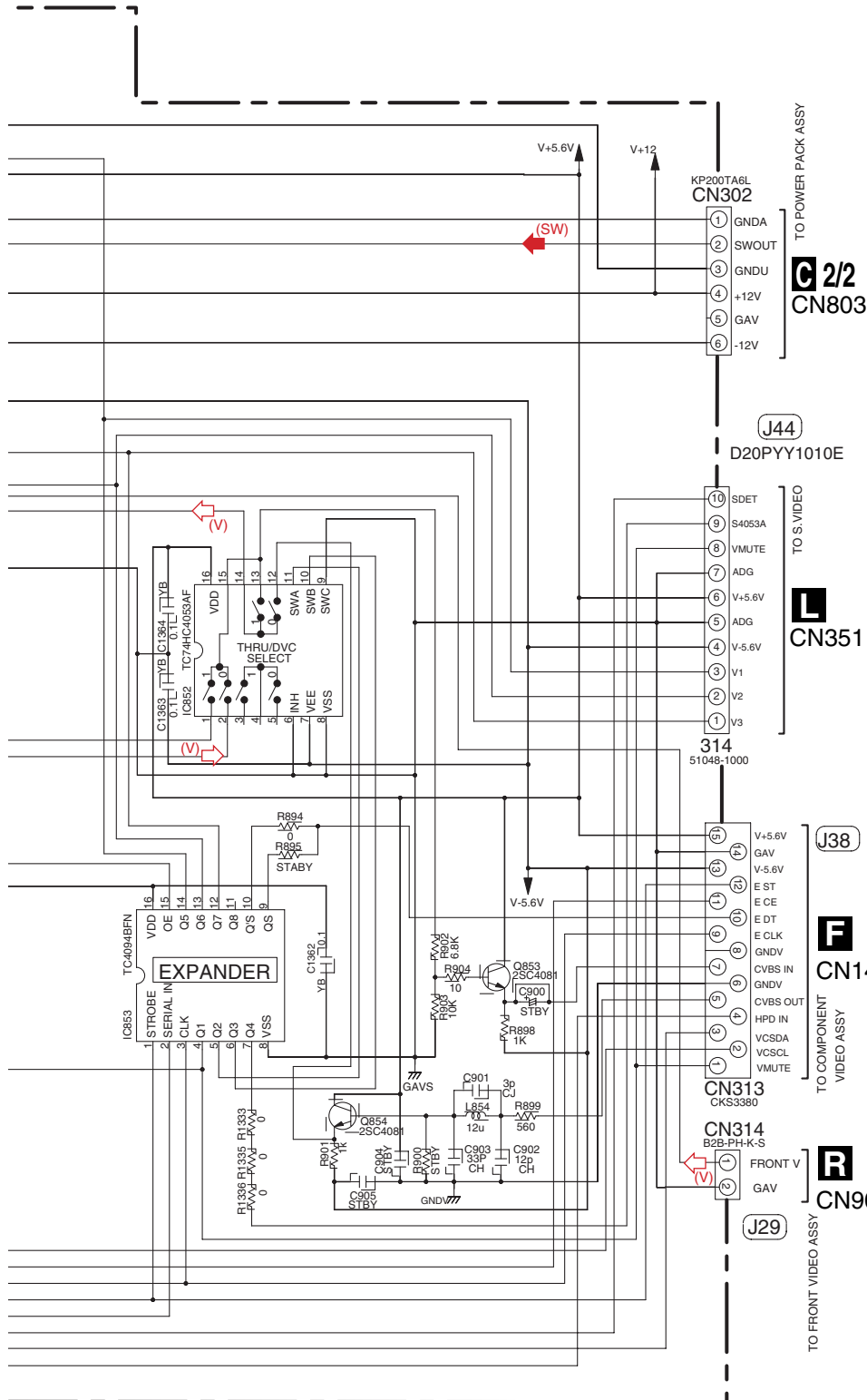

(V) : Video Signal Route
 (SW) : Audio Signal Route (SubWoofer ch)

P BOARD TO BOARD ASSY (VSX-917V: XWZ4268)

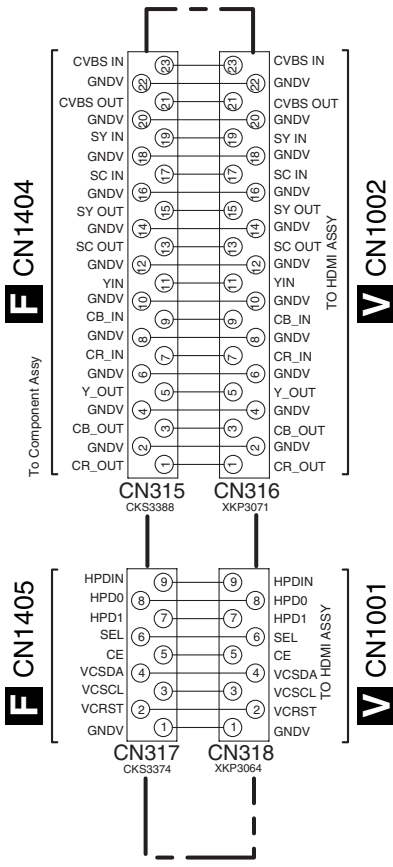

NOTE

1. RESISTORS
 Unit: k: kΩ, M: MΩ or Ω unless otherwise noted.
 Rated power: 1/16W unless otherwise noted.
 Tolerance: (J) ± 5% unless otherwise noted.

2. CAPACITORS
 Unit: p: pF or μF unless otherwise noted.
 Ratings: Capacity(μF)/Voltage(V) unless otherwise noted.
 Rated Voltage: 50V expect for electrolytic capacitors.

3.14 VIDEO, DIGITAL INPUT, FRONT VIDEO and PRIMARY ASSYS

VIDEO ASSY (VSX-817: XWZ4209)

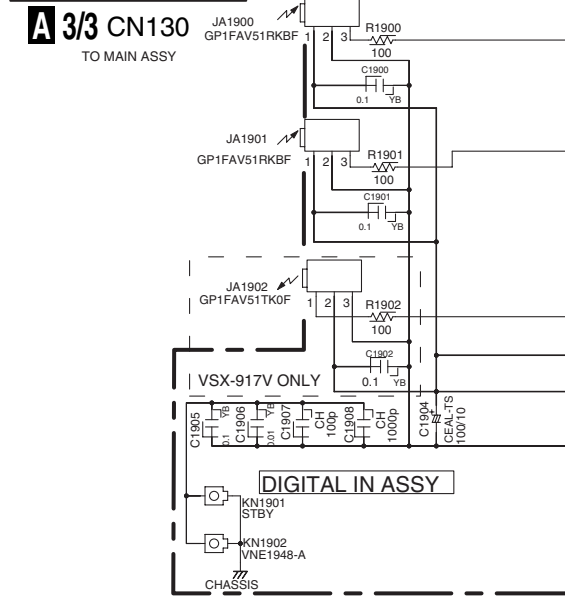
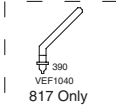
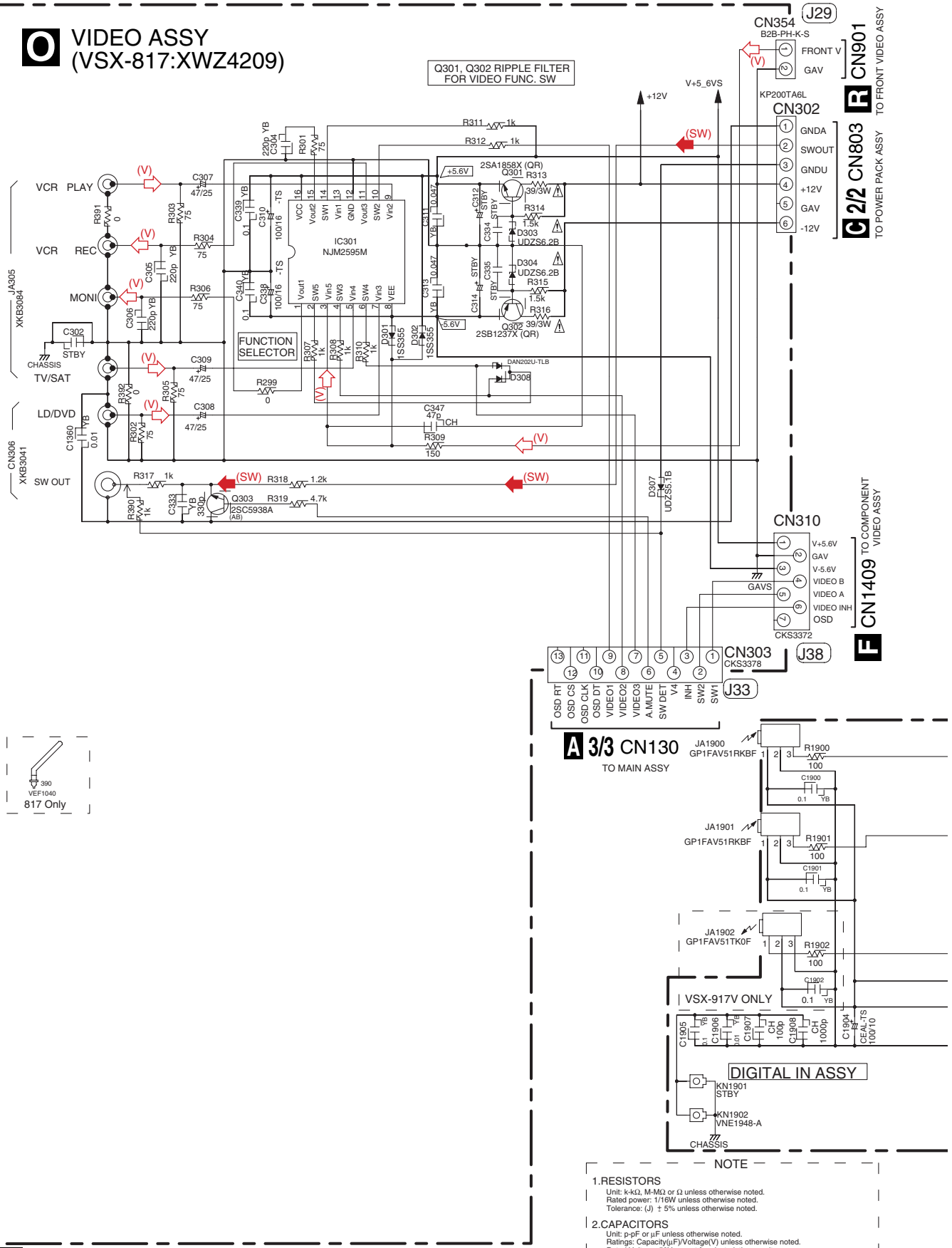

- NOTE**
- RESISTORS**
Unit: k-Ω, M-Ω or Ω unless otherwise noted.
Rated power: 1/16W unless otherwise noted.
Tolerance: (J) ± 5% unless otherwise noted.
 - CAPACITORS**
Unit: p-F or μF unless otherwise noted.
Ratings: Capacity(μF)/Voltage(V) unless otherwise noted.
Rated Voltage: 50V except for electrolytic capacitors.

S PRIMARY ASSY (XWZ4216)

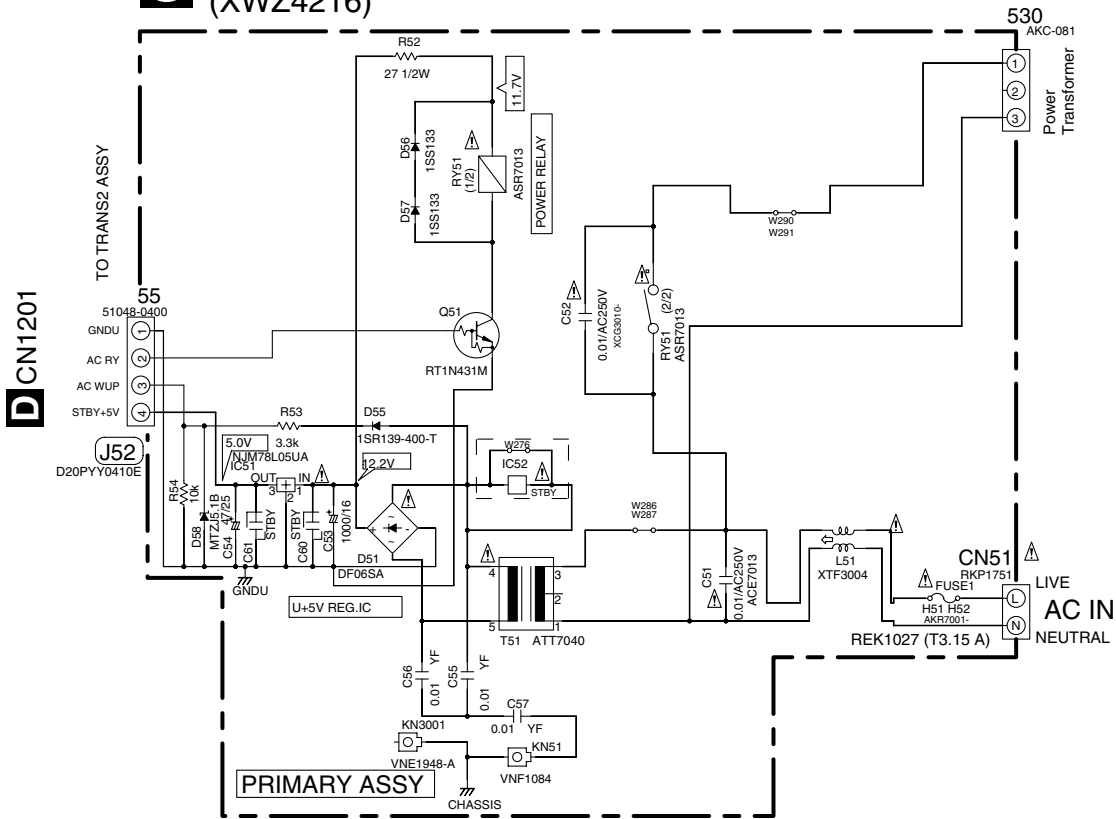

• NOTE FOR FUSE REPLACEMENT

CAUTION -FOR CONTINUED PROTECTION AGAINST RISK OF FIRE. REPLACE WITH SAME TYPE AND RATINGS OF FUSE.

R FRONT VIDEO ASSY (XWZ4214)

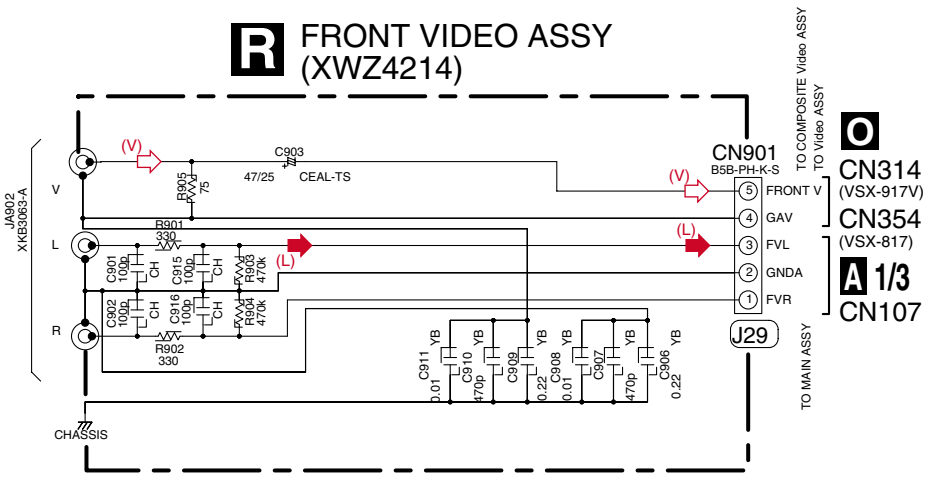

- (V) Video Signal Route
- (L) Audio Signal Route (L ch)
- (SW) Audio Signal Route (SubWoofer ch)

Q DIGITAL INPUT ASSY (VSX-917V:XWZ4213) (VSX-817:XWZ4212)

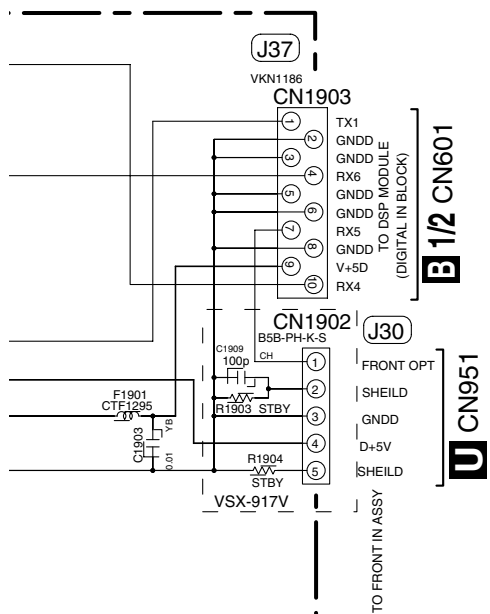

Q R S

3.15 FRONT IN ASSY

U FRONT IN ASSY (VSX-917V:XWK3314) (VSX-817:XWK3312)

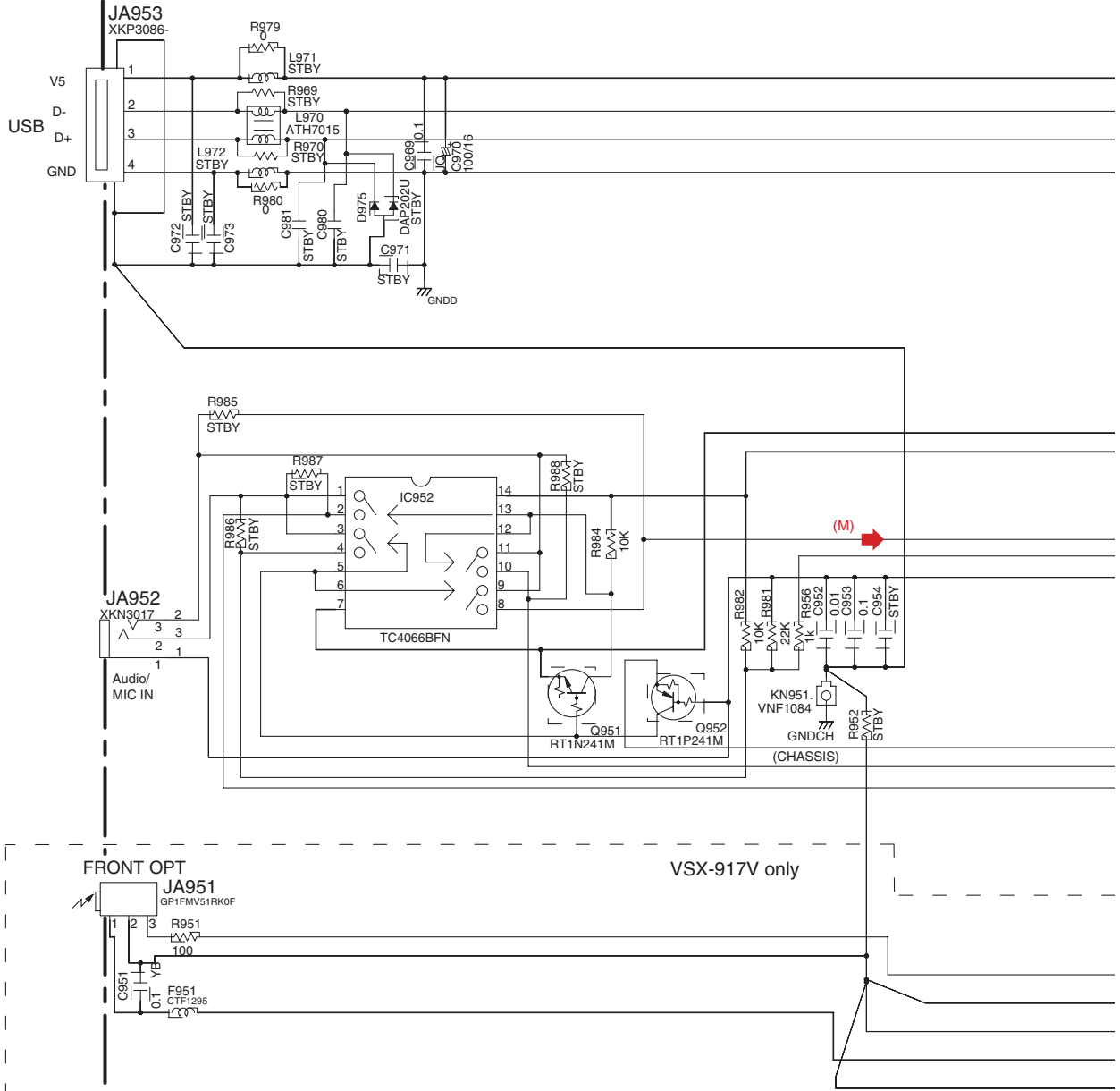

NOTE

1.RESISTORS
Unit: k- Ω , M-M Ω or Ω unless otherwise noted.
Rated power: 1/16W unless otherwise noted.
Tolerance: (J) \pm 5% unless otherwise noted.

2.CAPACITORS
Unit: p-pF or μ F unless otherwise noted.
Ratings: Capacity(μ F)/Voltage(V) unless otherwise noted.
Rated Voltage: 50V expect for electrolytic capacitors.

MODEL	ASSY NO	USB	MCACC	F.AUDIO IN	FRONT OPT
VSX-817/MYXJ5	XWK3312	○	○	○	X
VSX-917V/MYXJ5	XWK3314	○	○	○	○

(M) : Audio Signal Route (Mic)

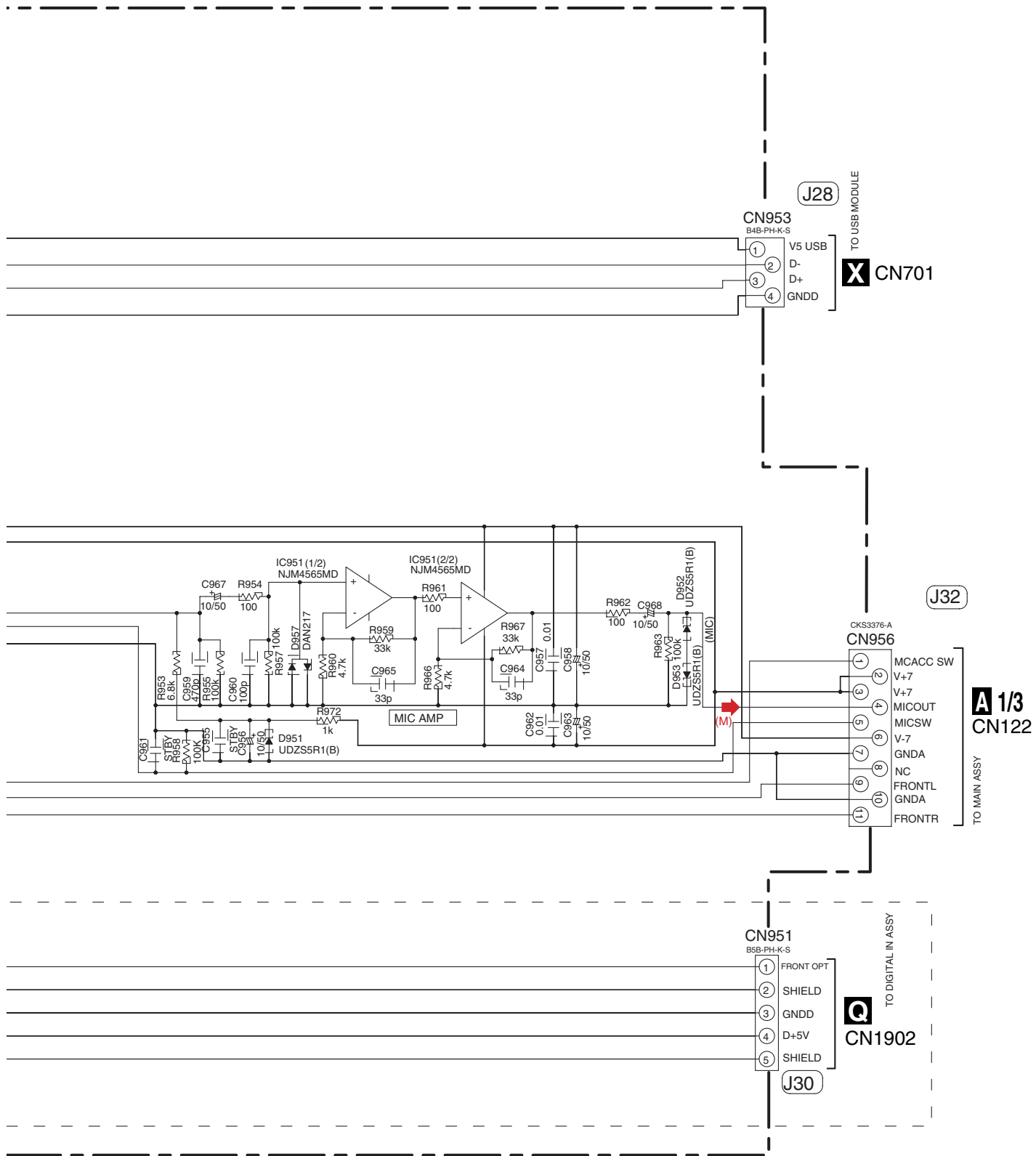

3.16 HDMI & DVC ASSY (VSX-917V ONLY)

HDMI&DVC ASSY (VSX-917V:AWQ7039)

A

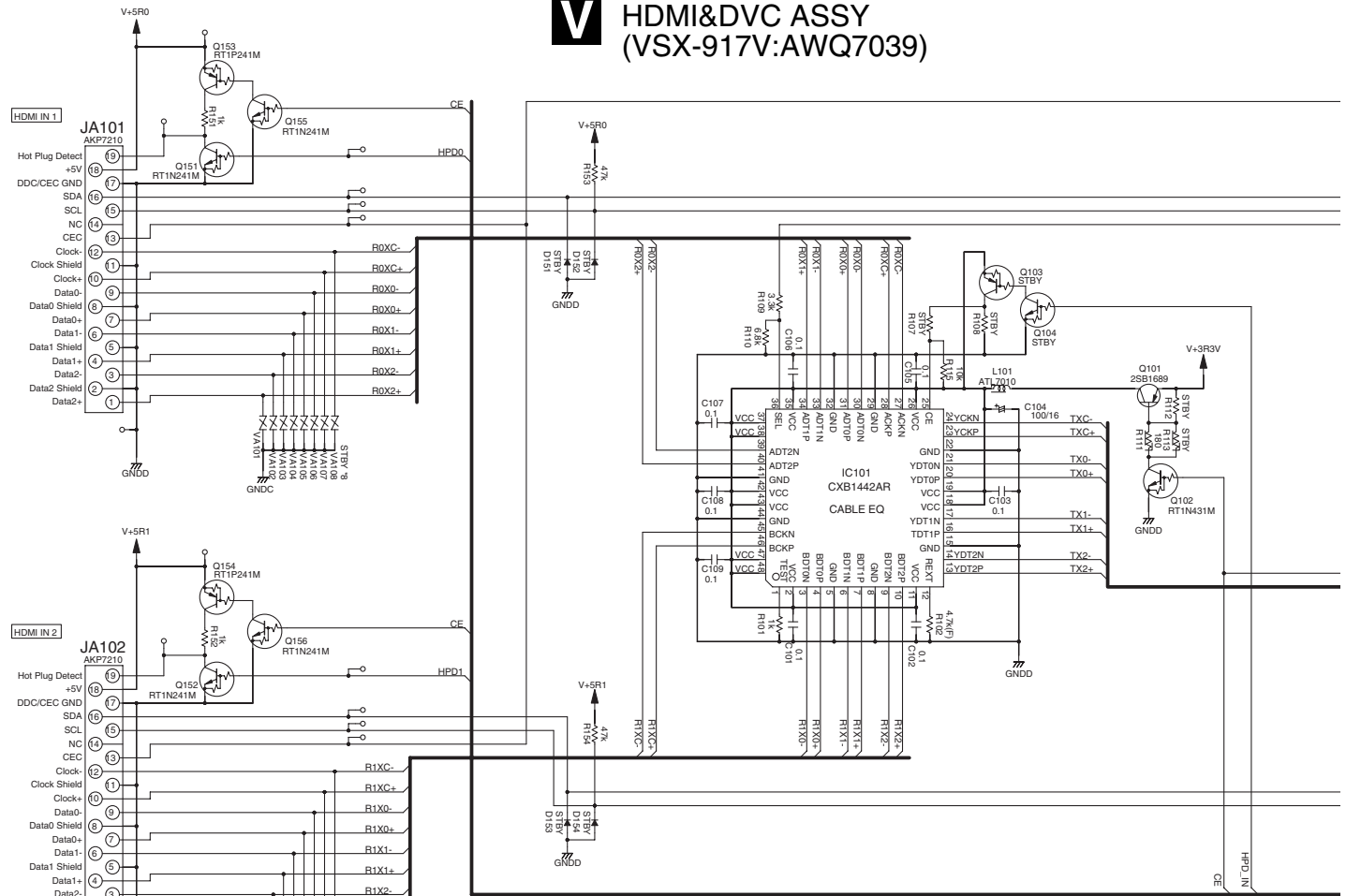

B

C

D

E

F

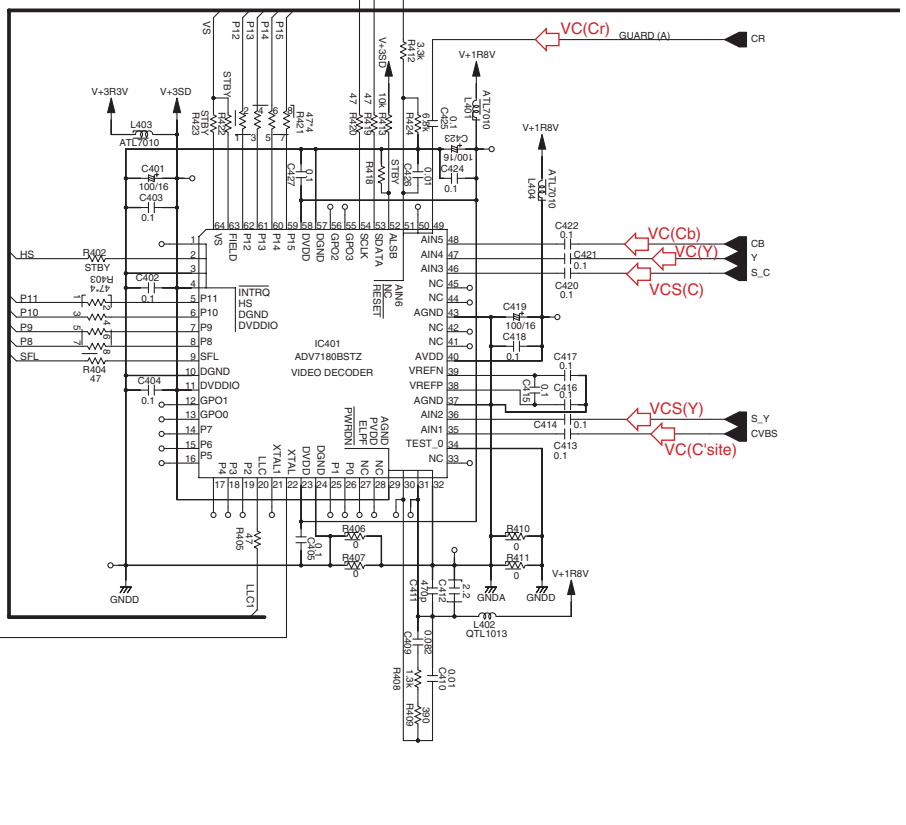

	:2125 Size
	RS1/10S-
	:1608 Size
	RS1/16S-
	:2125 Size
	CKSQ*-
	:1608 Size
	CCSR*-
	CKSR*-
	CEJQ- TS

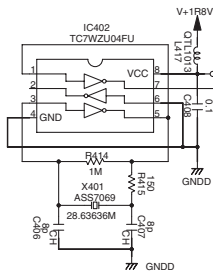

A
B
C
D
E
F

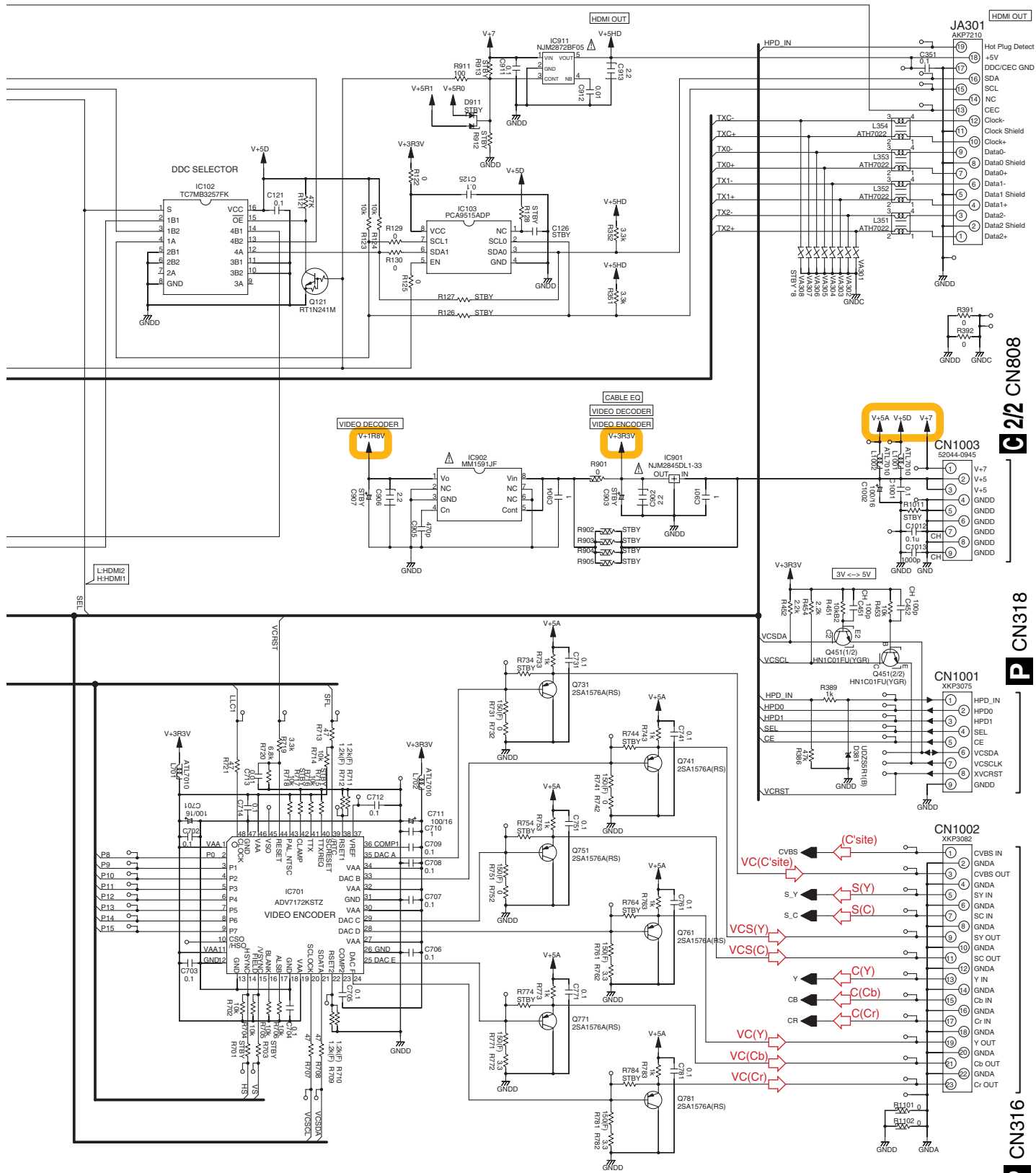

3.17 USB ASSY

X USB ASSY (AWX8704)

A

B

C

D

E

F

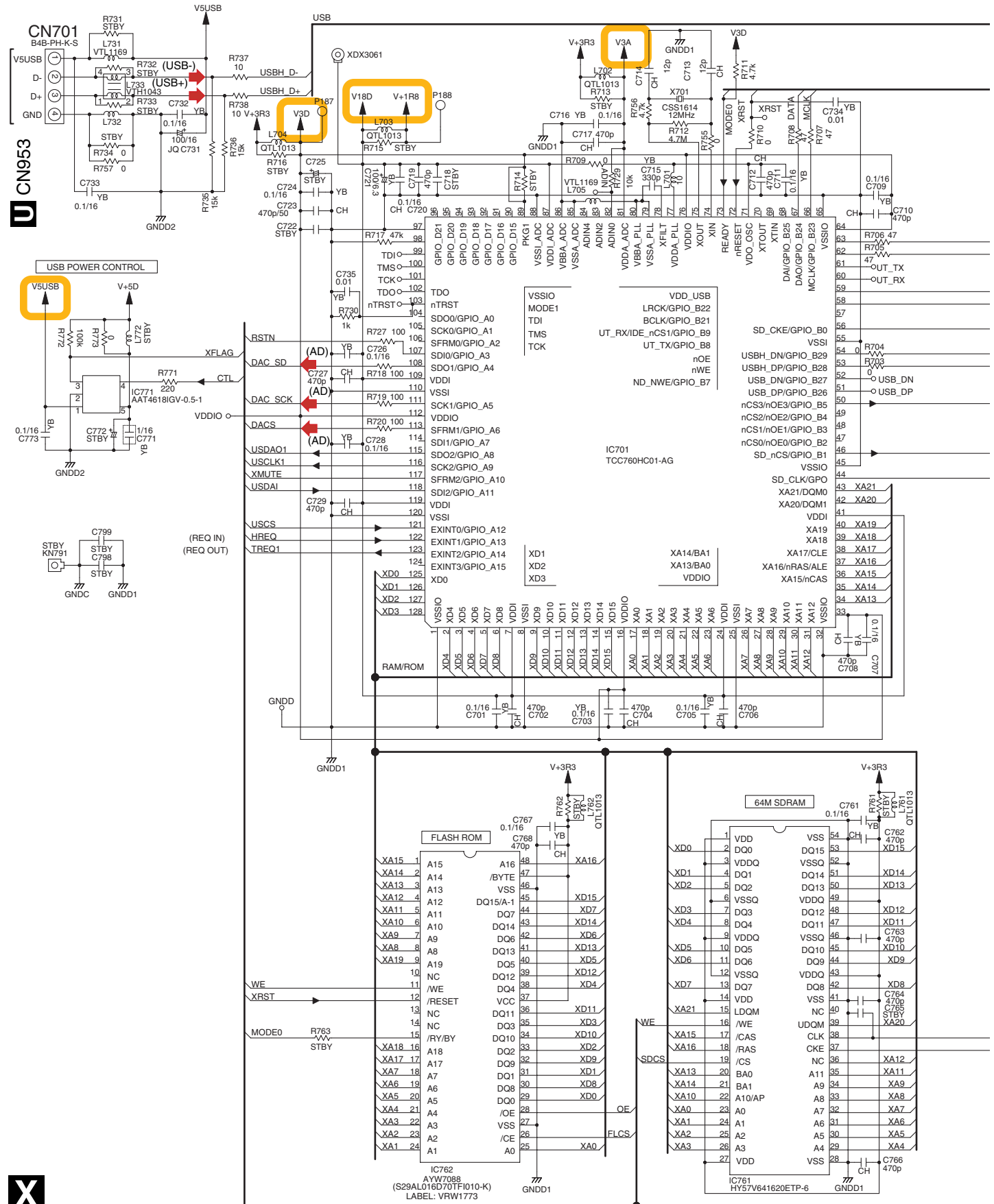

A
B
C
D
E
F

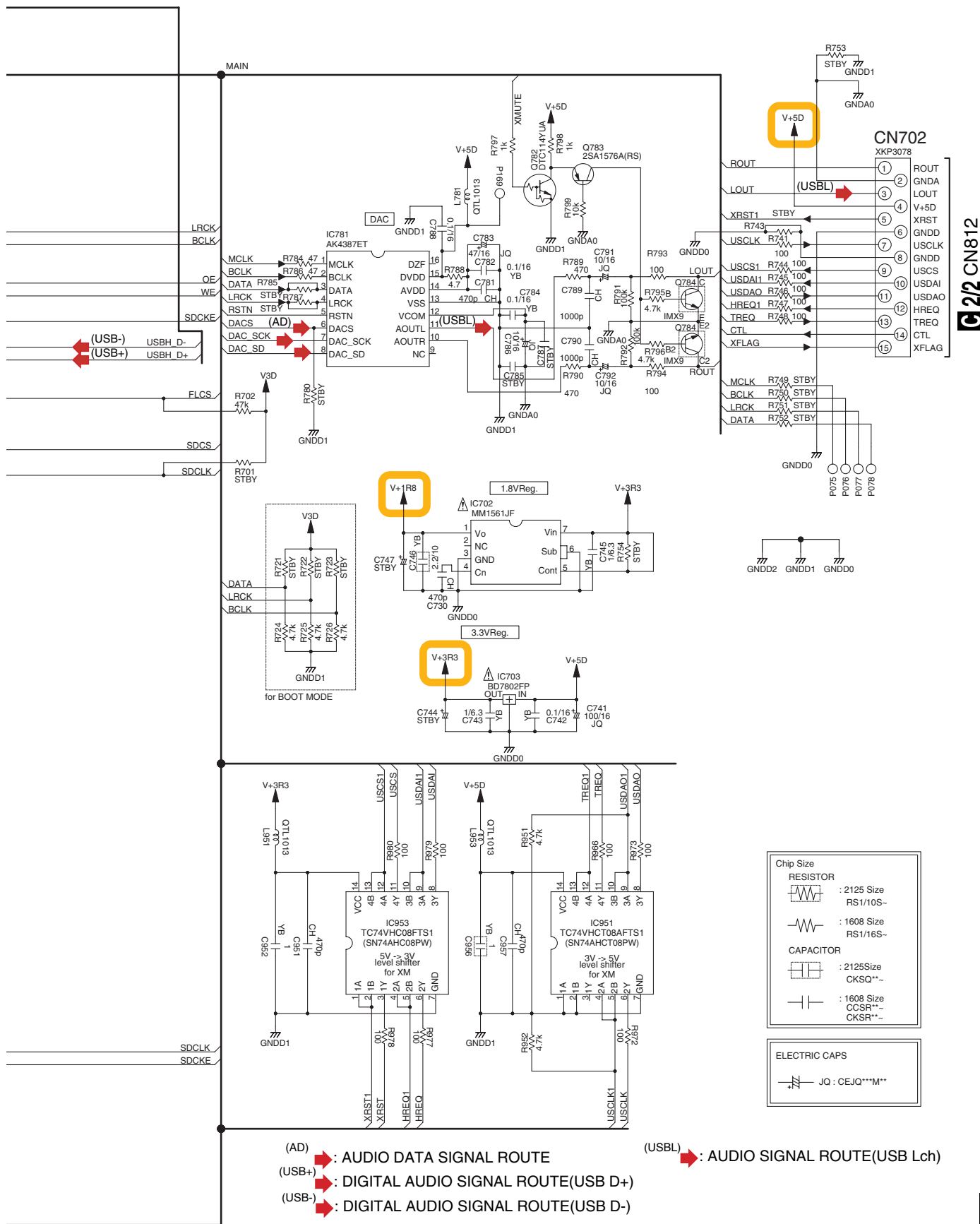

(AD) → : AUDIO DATA SIGNAL ROUTE
 (USB+) → : DIGITAL AUDIO SIGNAL ROUTE(USB D+)
 (USB-) → : DIGITAL AUDIO SIGNAL ROUTE(USB D-)
 (USBL) → : AUDIO SIGNAL ROUTE(USB Lch)

Chip Size	
RESISTOR	
	: 2125 Size
	: RS1/10S-
	: 1608 Size
	: RS1/16S-
CAPACITOR	
	: 2125Size
	: CKSQ**
	: 1608 Size
	: CCSR**
	: CKSR**









ELECTRIC CAPS	
	: CEJQ**M**

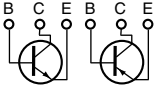

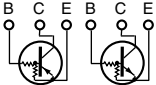
4. PCB CONNECTION DIAGRAM

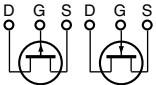
NOTE FOR PCB DIAGRAMS :

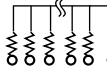
1. Part numbers in PCB diagrams match those in the schematic diagrams.
2. A comparison between the main parts of PCB and schematic diagrams is shown below.

Symbol In PCB Diagrams	Symbol In Schematic Diagrams	Part Name
		Transistor
		Transistor with resistor
		Field effect transistor
		Resistor array
		3-terminal regulator

3. The parts mounted on this PCB include all necessary parts for several destinations.
For further information for respective destinations, be sure to check with the schematic diagram.
4. View point of PCB diagrams.

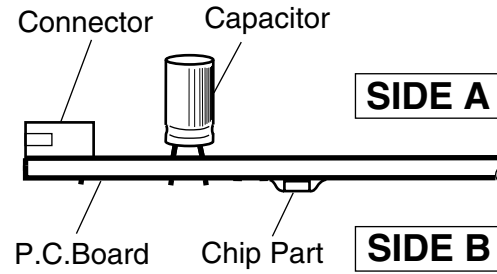

5 6 7 8

4.1 USB ASSY

SIDE A

X USB ASSY

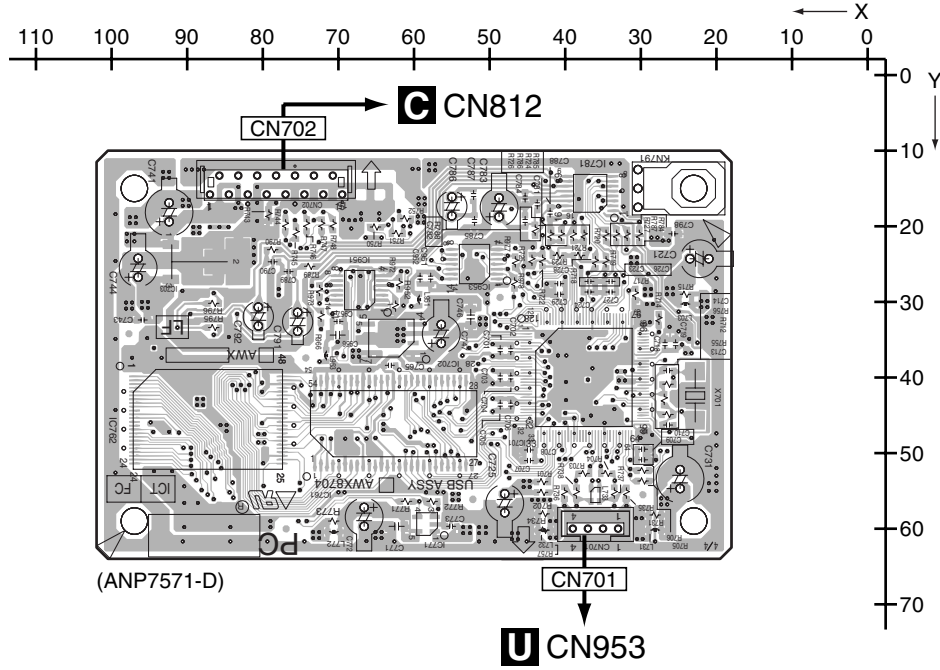

SIDE B

X USB ASSY

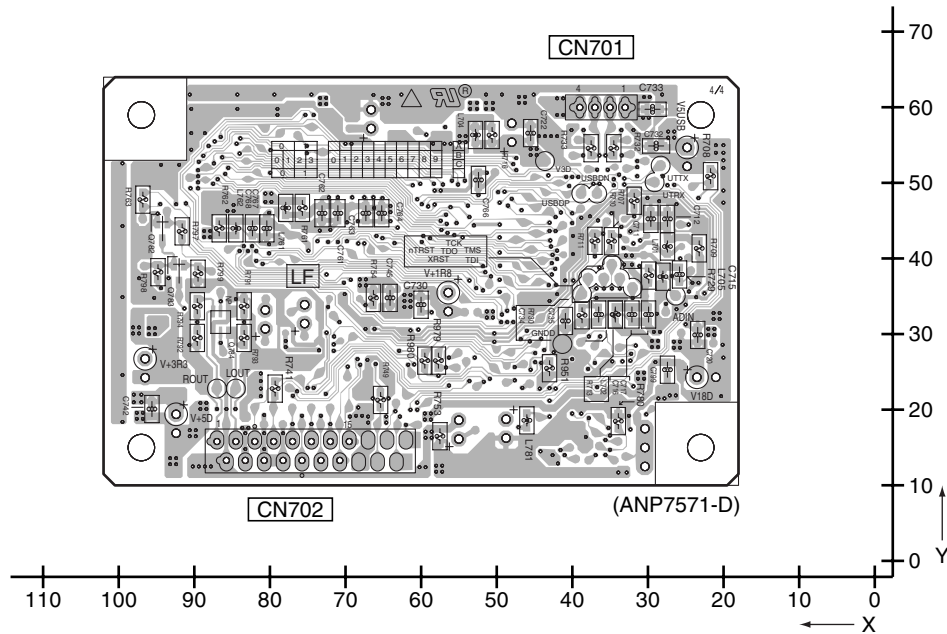

X

X

4.2 MAIN ASSY

SIDE A

A

B

C

D

E

F

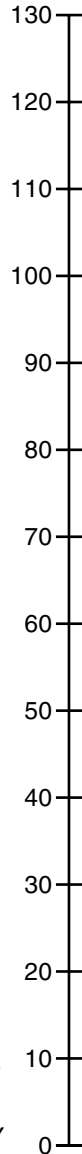

A MAIN ASSY

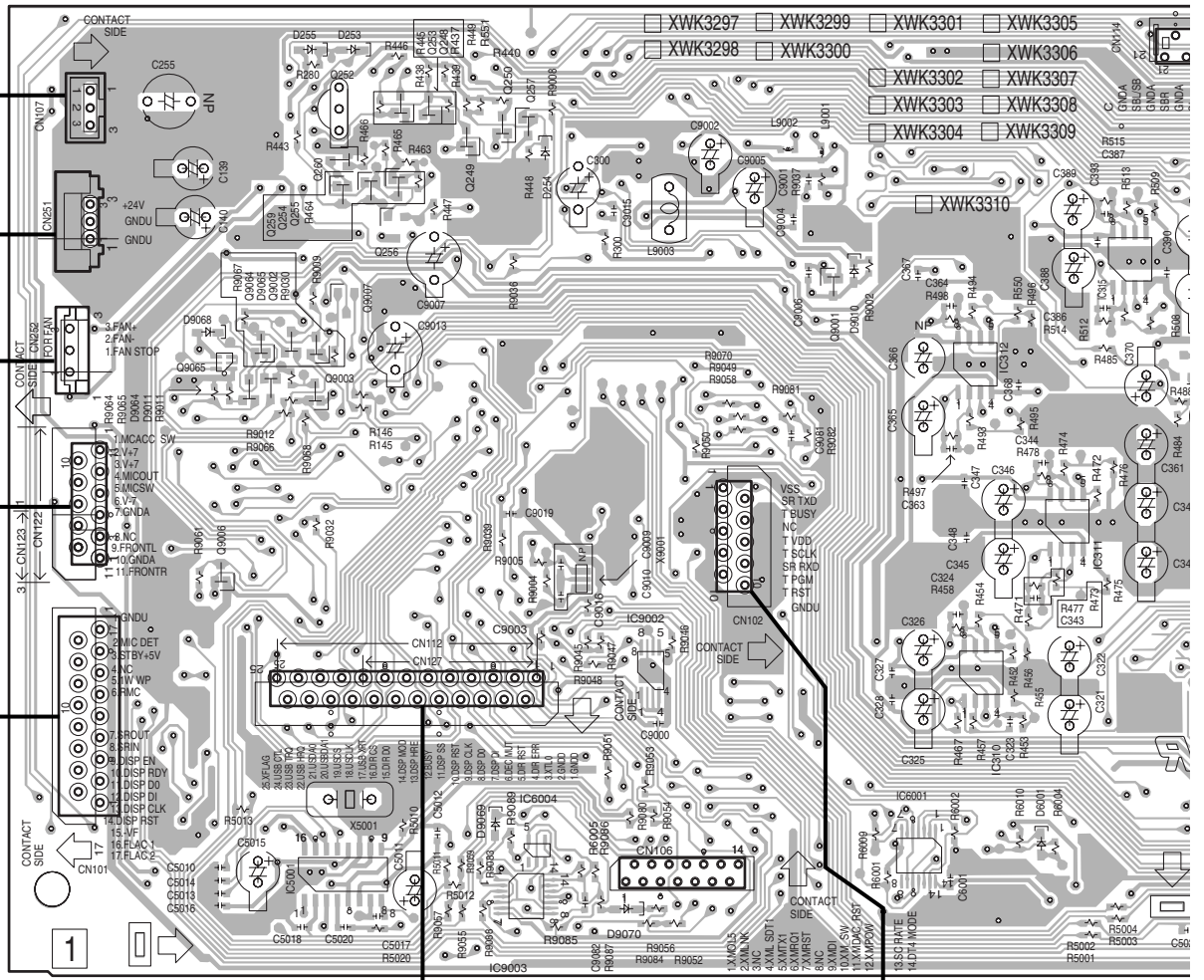

(XNP3116-B)

CN127
CN817
CN102
for FLASH

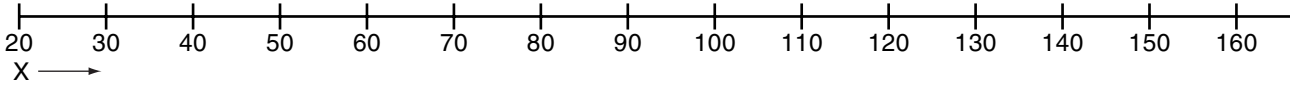

A

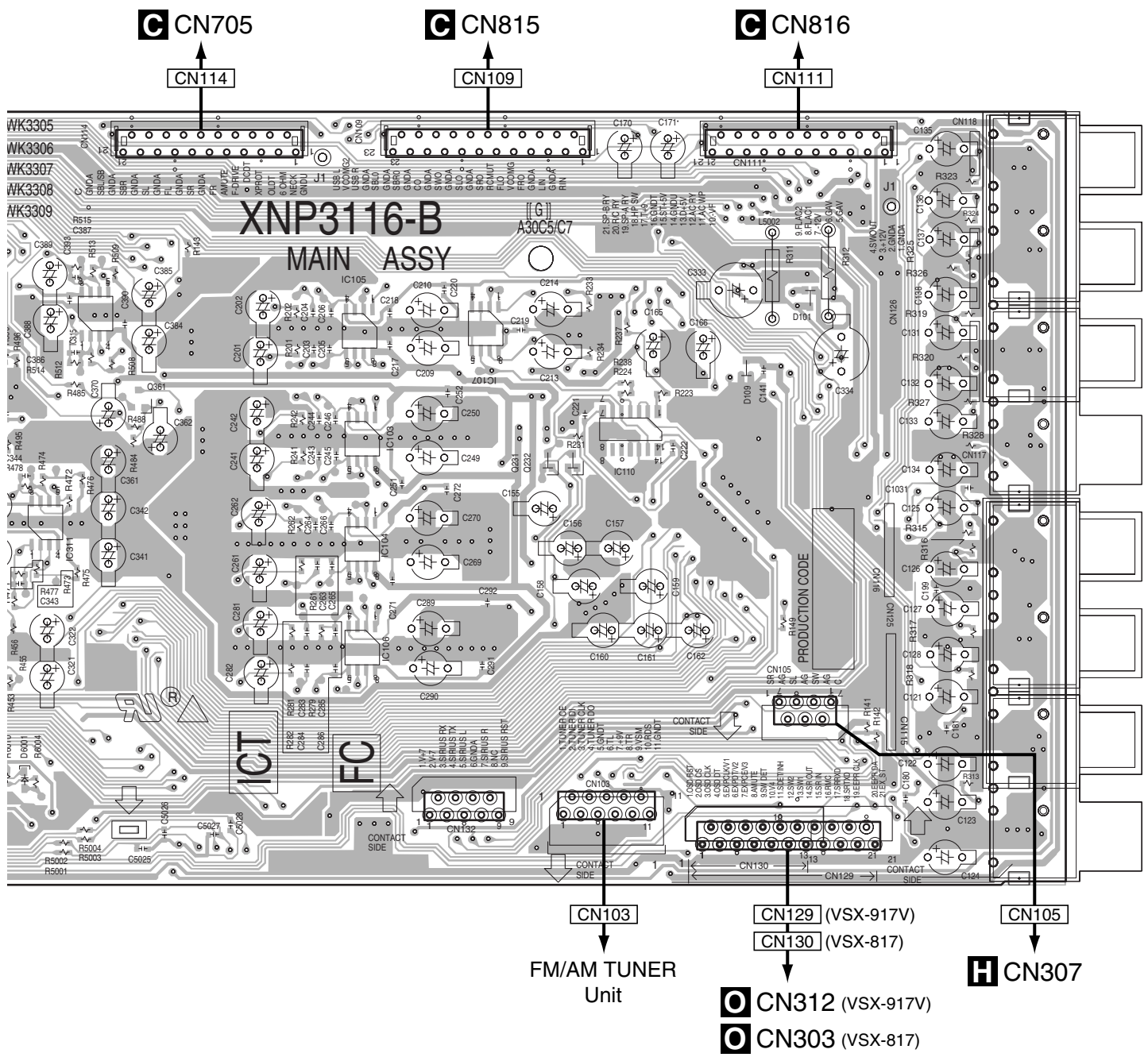

150 160 170 180 190 200 210 220 230 240 250 260 270 280 290 300

SIDE B

A

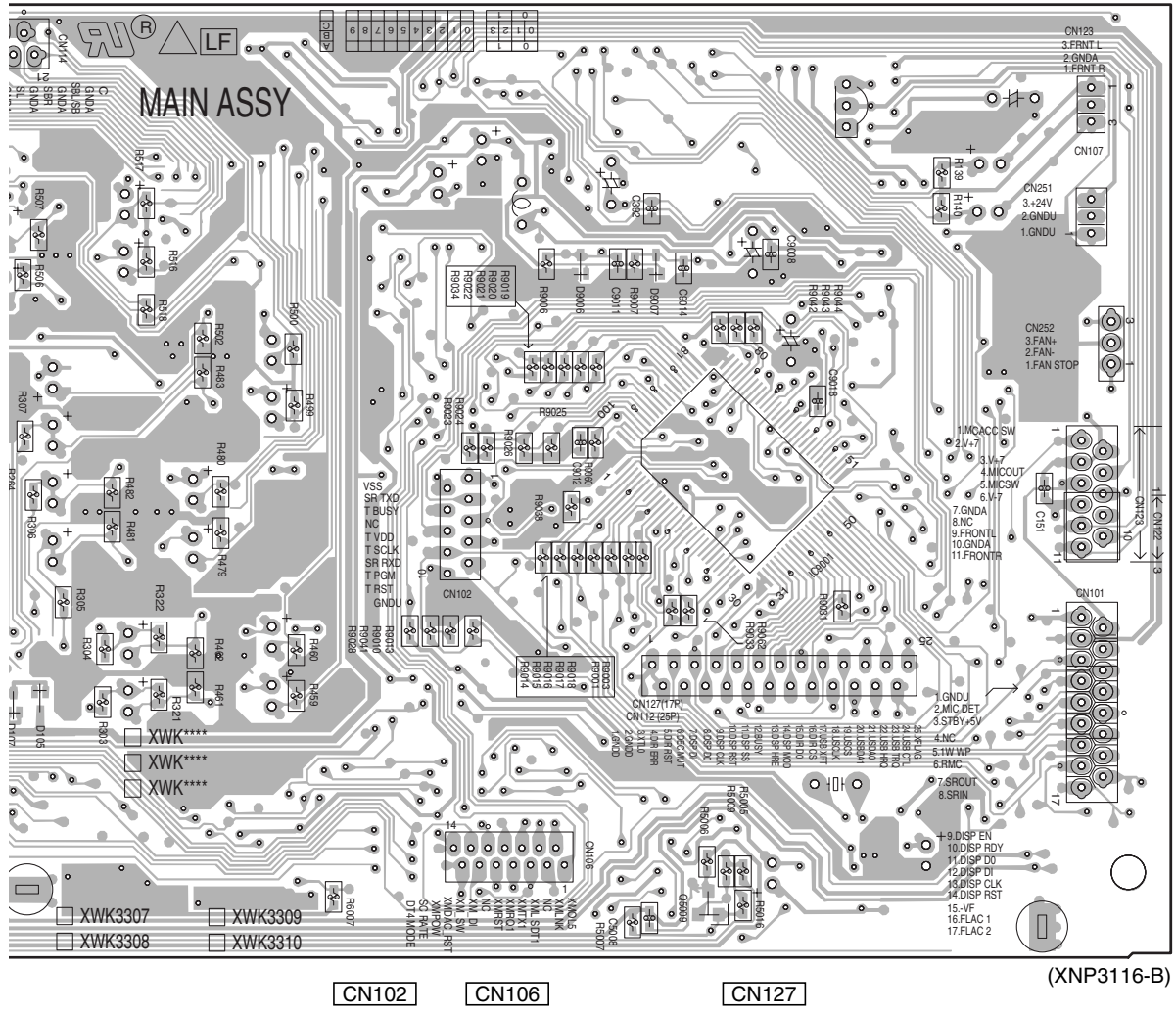

B

C

D

E

F

A

4.3 DSP ASSY

SIDE A

B DSP ASSY

SIDE A

A

Q CN1903

CN601

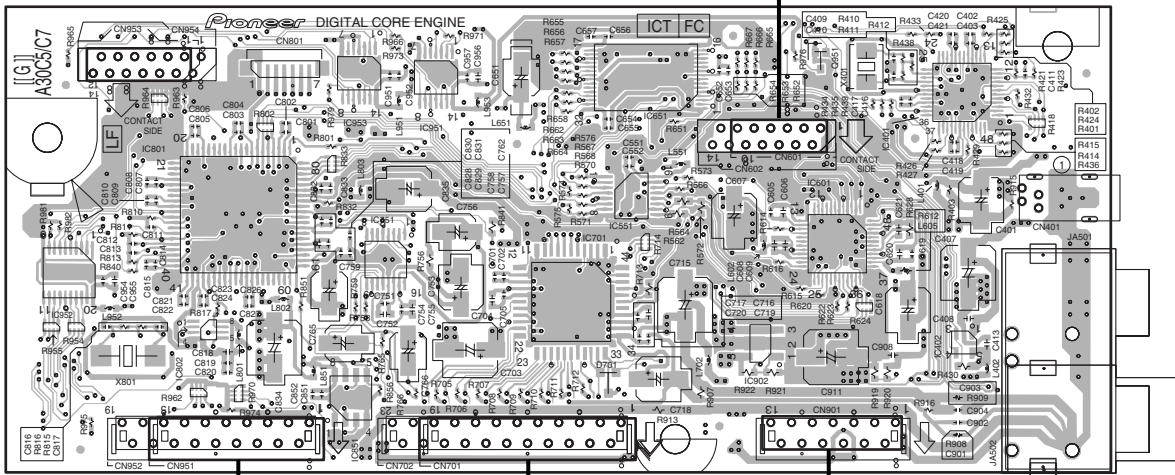

(ANP7594-A)

C CN807

C CN806

C CN805

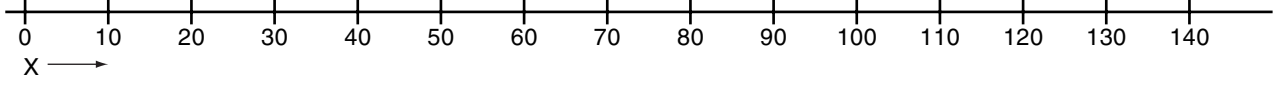

SIDE B

SIDE B

D

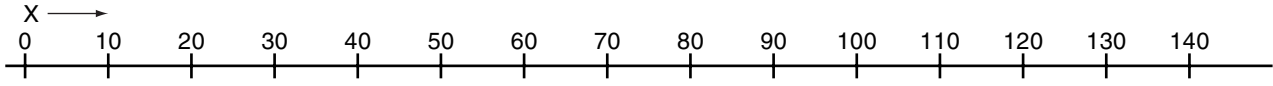

Y

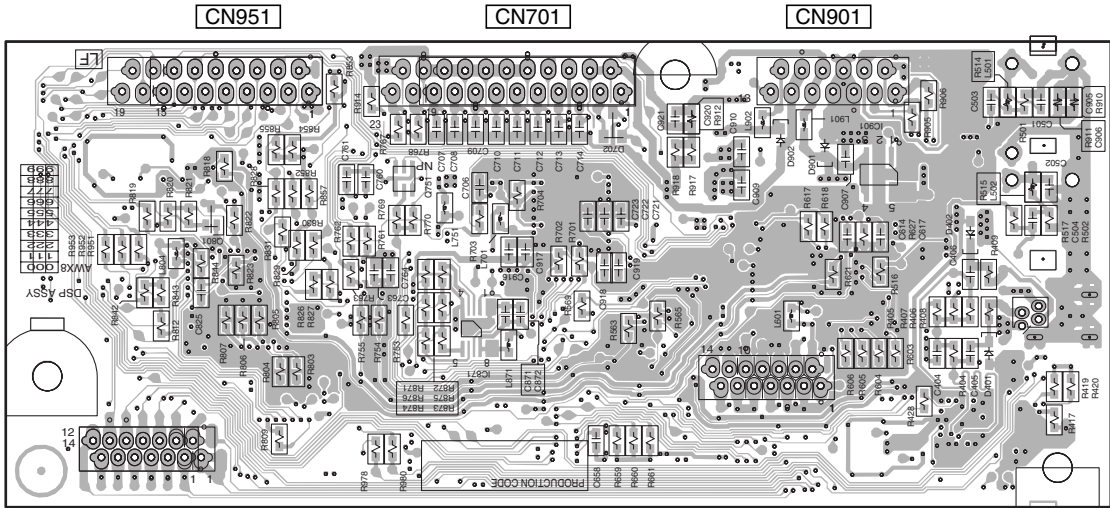

(ANP7594-A)

B DSP ASSY

4.4 TRANS2 and TRANS3 ASSYS

SIDE A

SIDE A

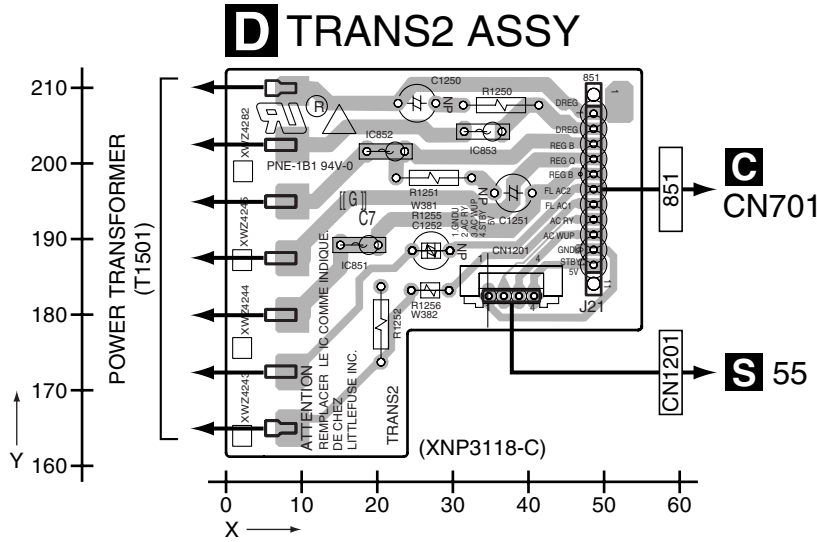

E TRANS3 ASSY

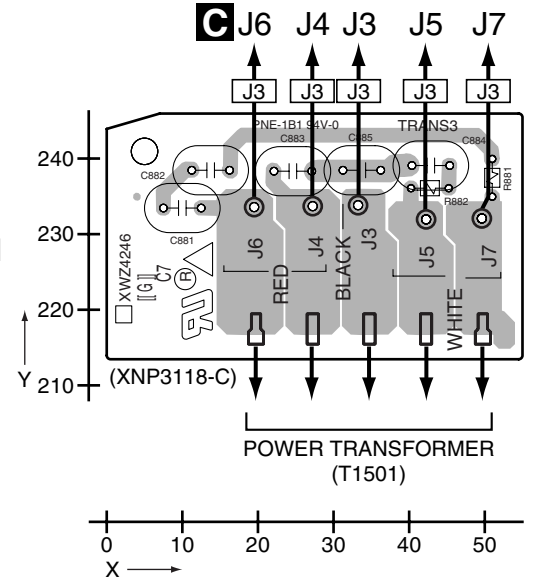

SIDE B

SIDE B

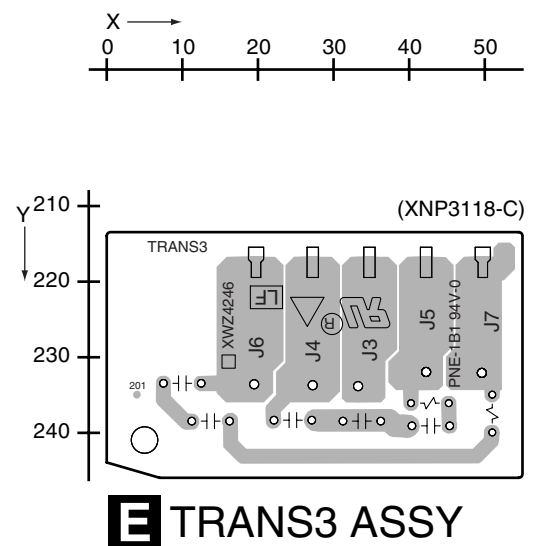
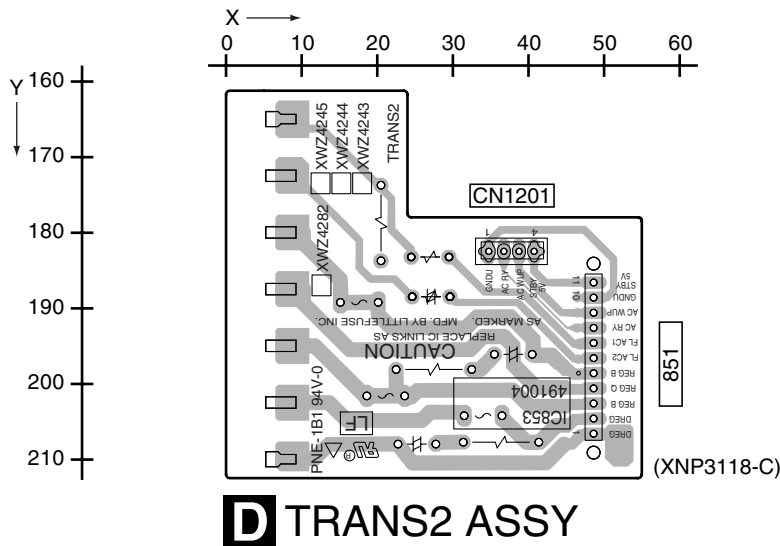

D E

4.5 POWER PACK ASSY

SIDE A

POWER PACK ASSY

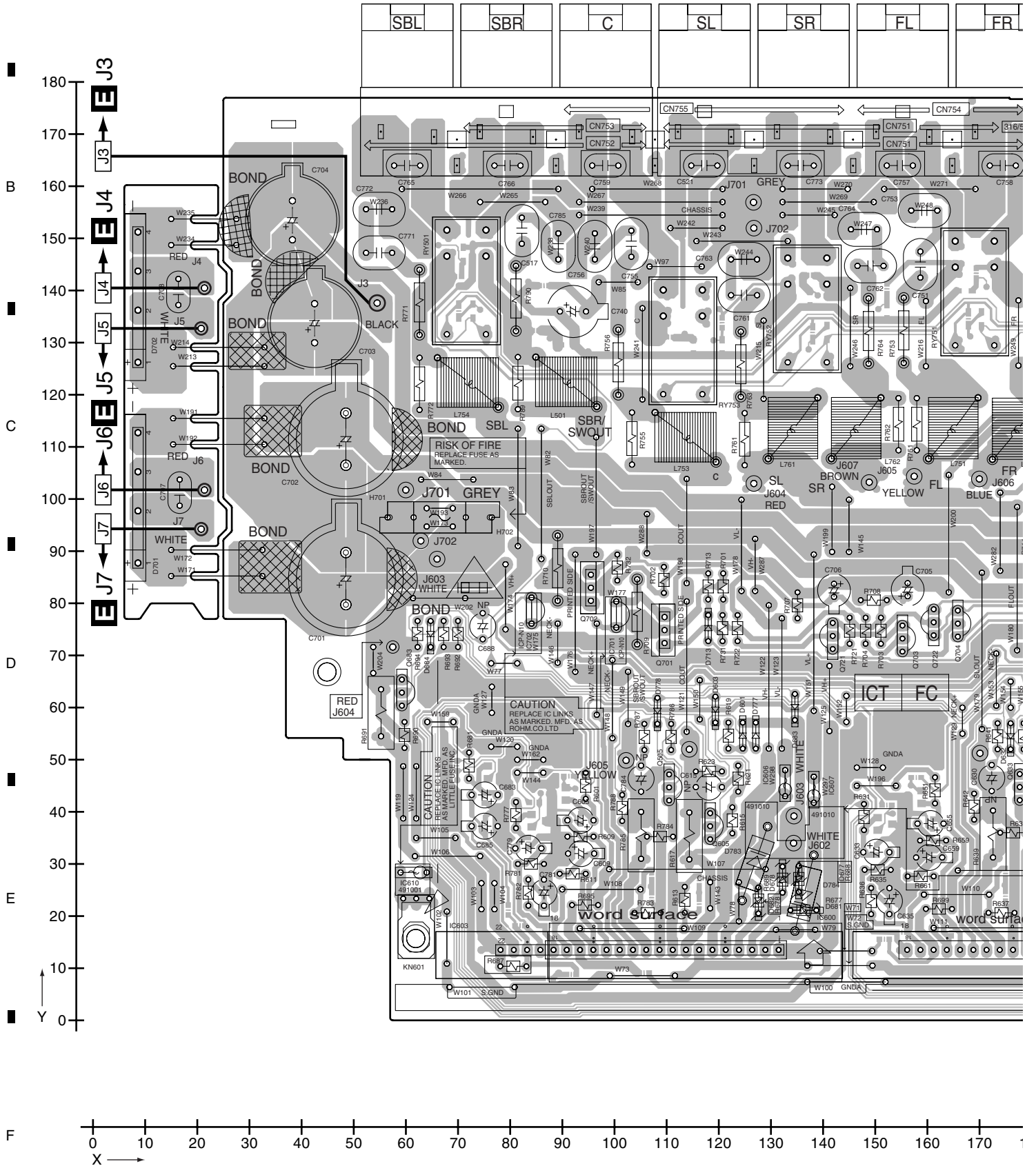

SIDE A

A

B

C

D

E

F

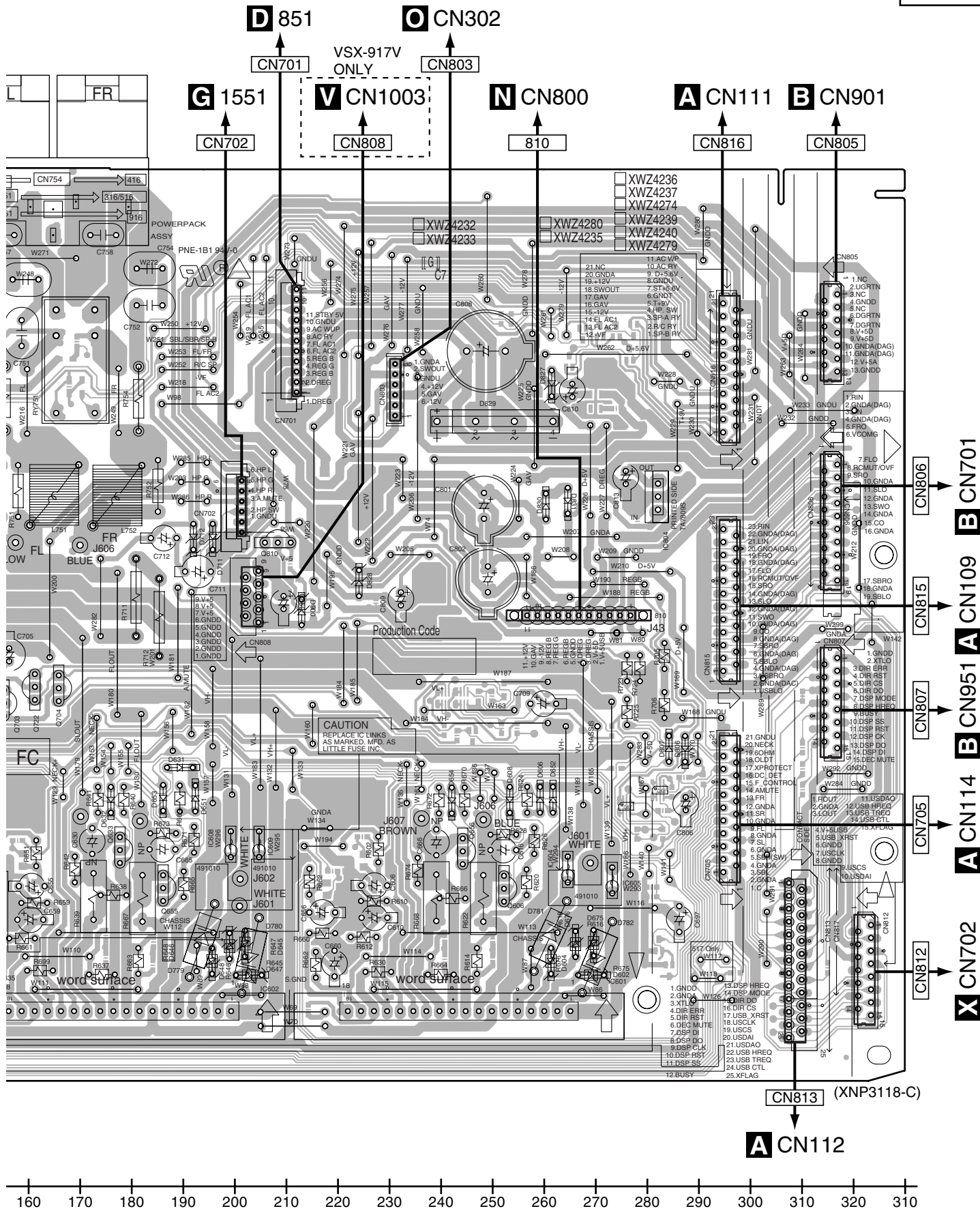

D 851 **O** CN302

G 1551 **V** CN1003 **N** CN800 **A** CN111 **B** CN901

CN702 CN808 810 CN816 CN805

X CN702 **A** CN114 **B** CN951 **A** CN109 **B** CN701

CN813 (XNP3118-C)

A CN112

160 170 180 190 200 210 220 230 240 250 260 270 280 290 300 310 310



SIDE B

POWER PACK ASSY

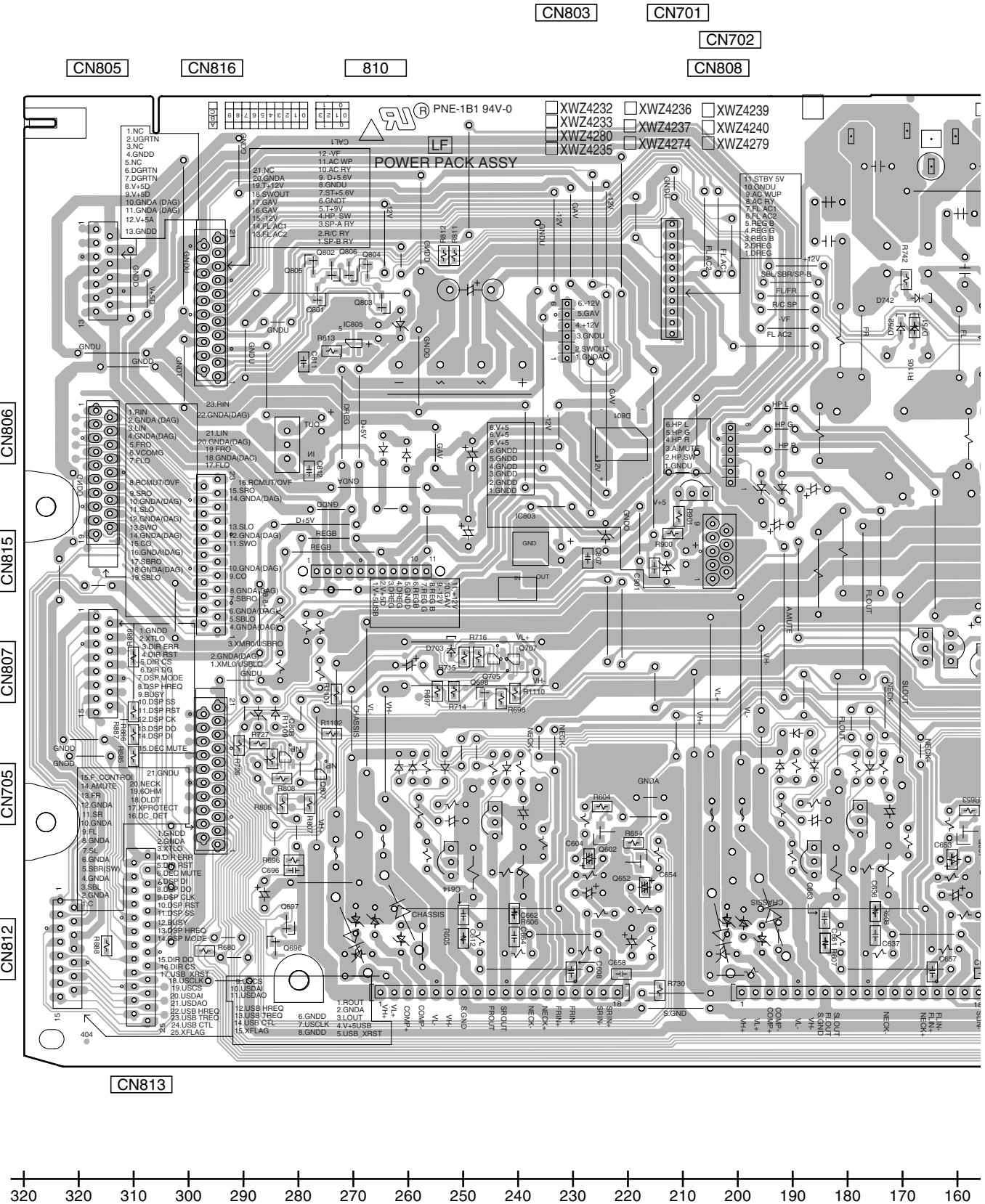

SIDE B

A

J3

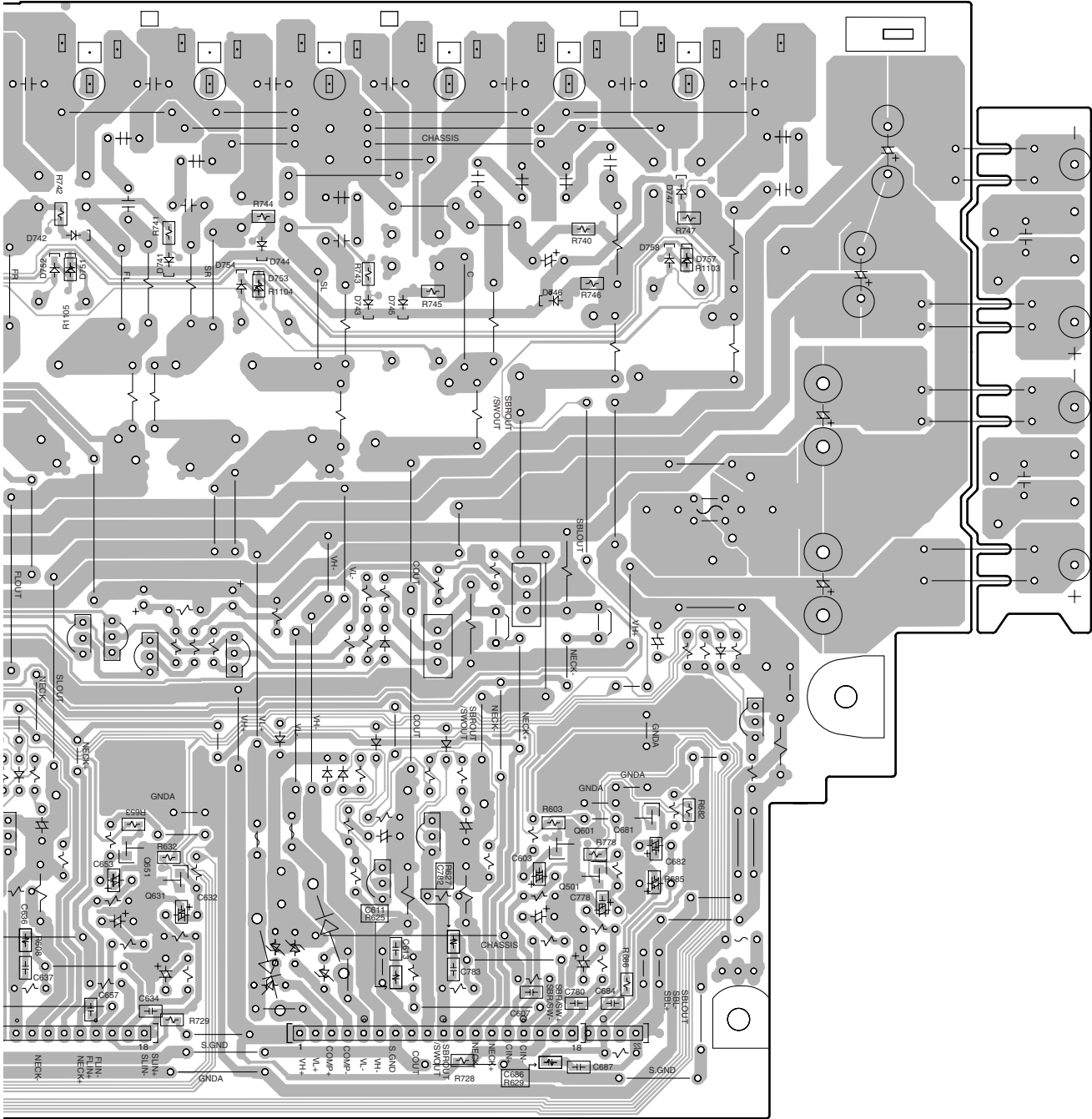

(XNP3118-C)

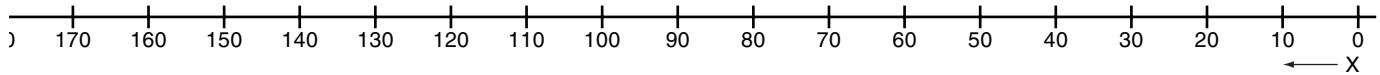
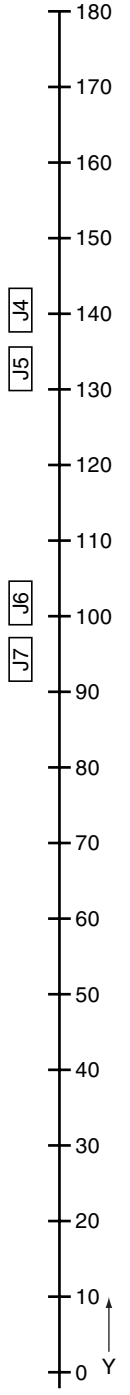

A
B
C
D
E
F



4.6 COMPONENT VIDEO ASSY

1 2 3 4

SIDE A

SIDE A

COMPONENT VIDEO ASSY

O CN313 (VSX-917V)
CN310 (VSX-817)

L CN356 **P** CN317

P CN315 VSX-917V ONLY

CN1406 (VSX-917V)
CN1409 (VSX-817)

CN1402

CN1405

CN1404

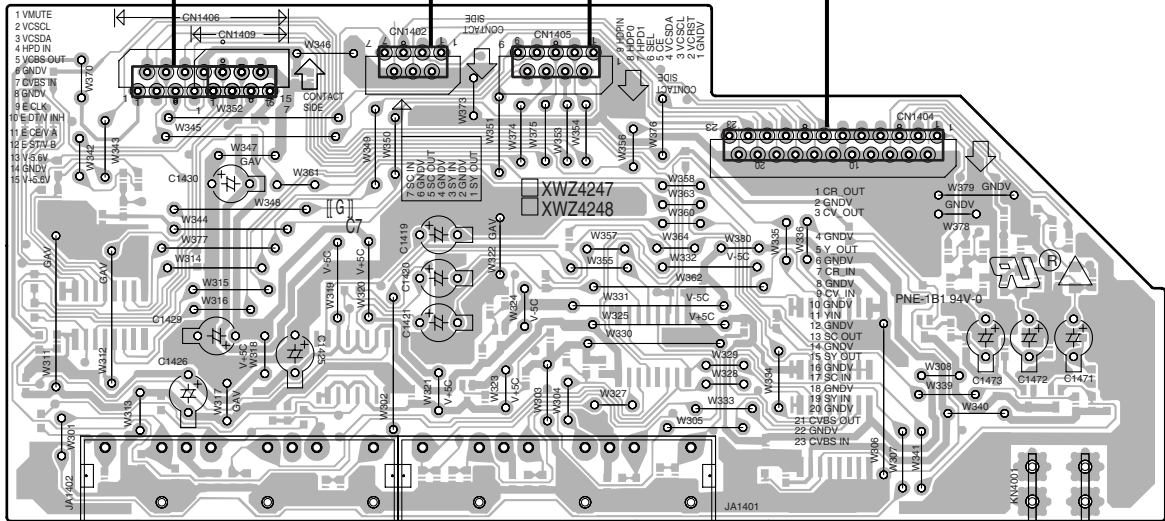

SIDE B

SIDE B

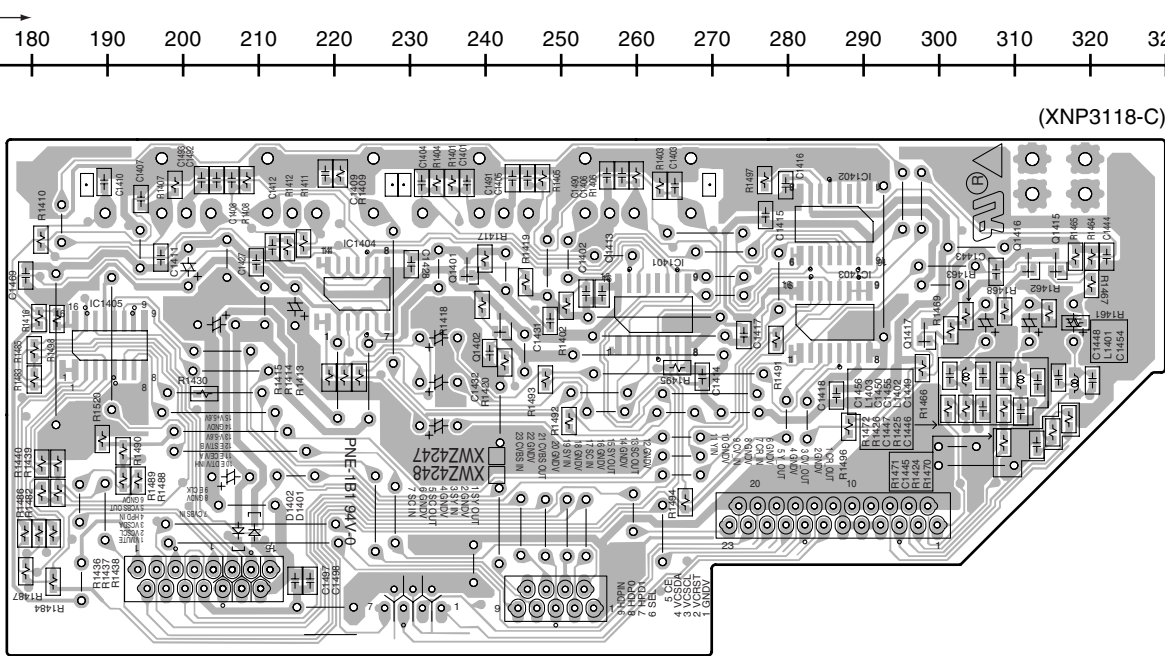

CN1406 (VSX-917V)
CN1409 (VSX-817)

CN1402

CN1405

CN1404

COMPONENT VIDEO ASSY

1 2 3 4

4.8 FRONT DISPLAY ASSY

SIDE A

FRONT DISPLAY ASSY

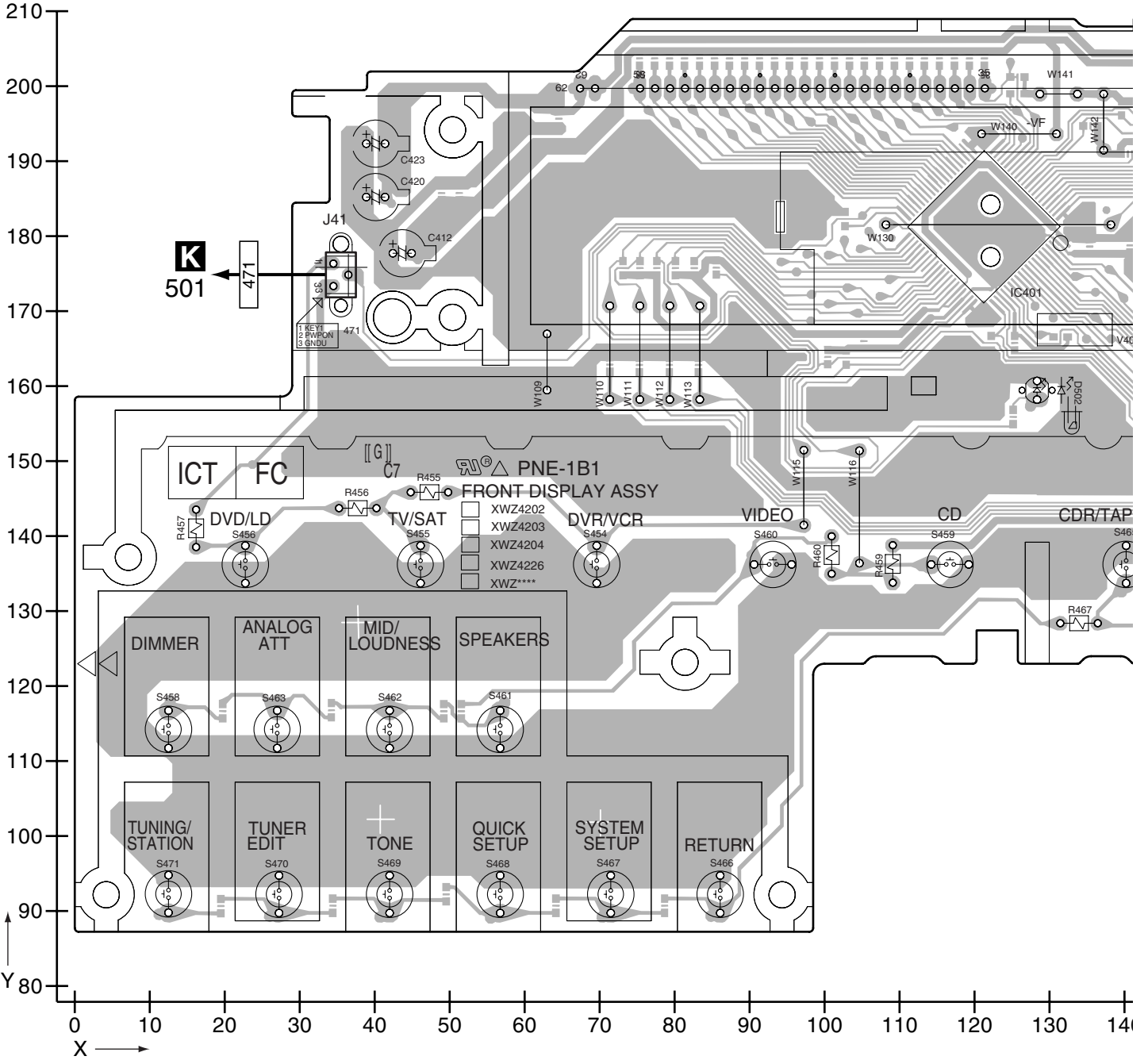

SIDE A

A

B

C

D

E

F

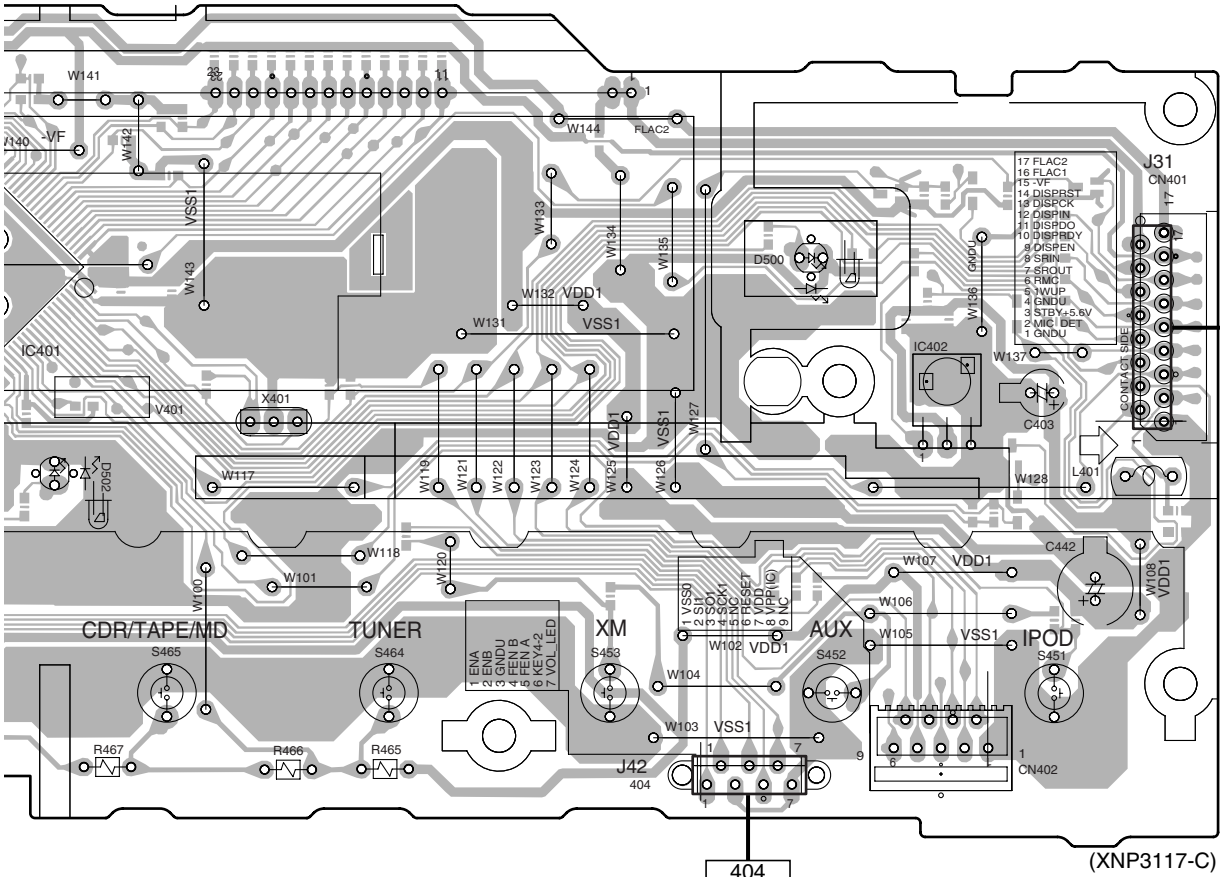

A CN101

404
J 511

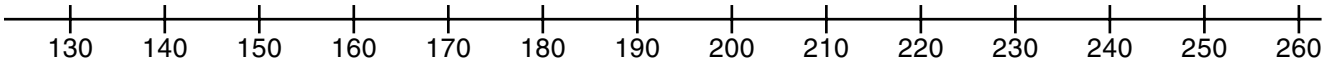

SIDE B

A

B

C

D

E

F

FRONT DISPLAY ASSY

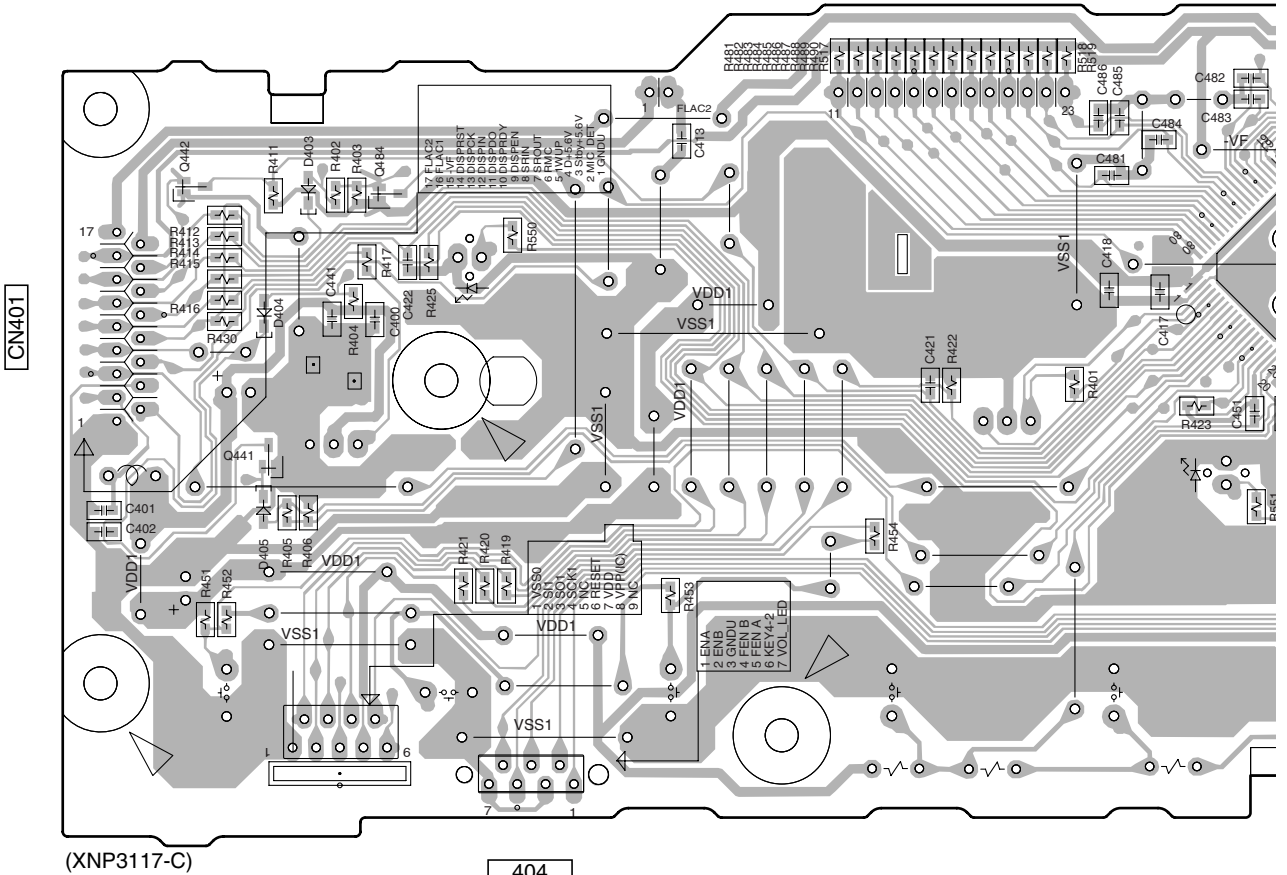

SIDE B

A

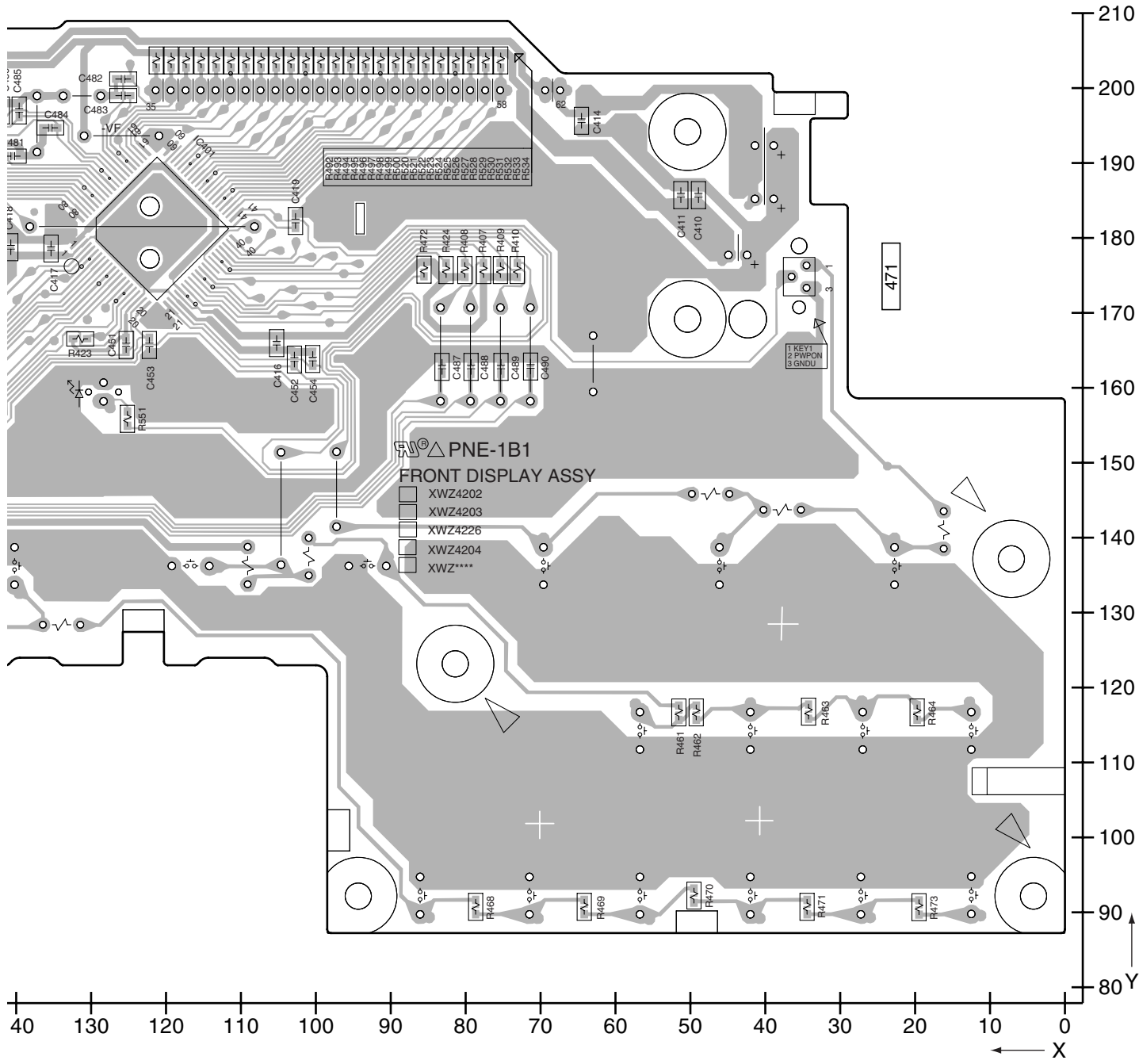

B

C

D

E

F

4.9 ROTARY ENCODER and POWER KEY ASSYS

SIDE A

SIDE A

J ROTARY ENCODER ASSY

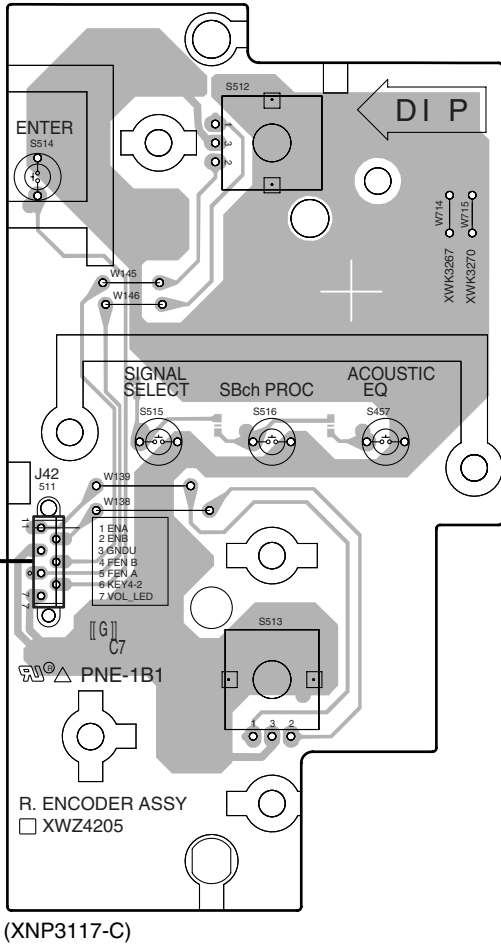

K POWER KEY ASSY

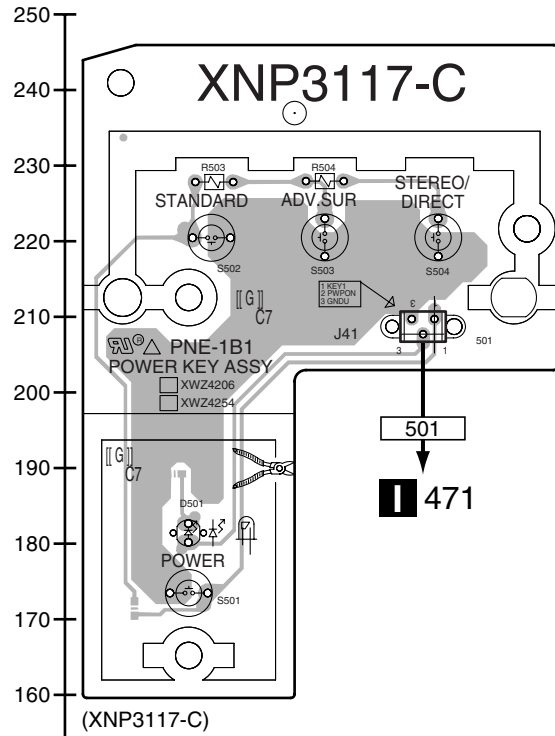

250
240
230
220
210
200
190
180
170
160
150
140
130
120
110

250 260 270 280 290 300 310 320
X →

250
240
230
220
210
200
190
180
170
160
150

0 10 20 30 40 50 60
X →

J K

SIDE B

SIDE B

A

K POWER KEY ASSY

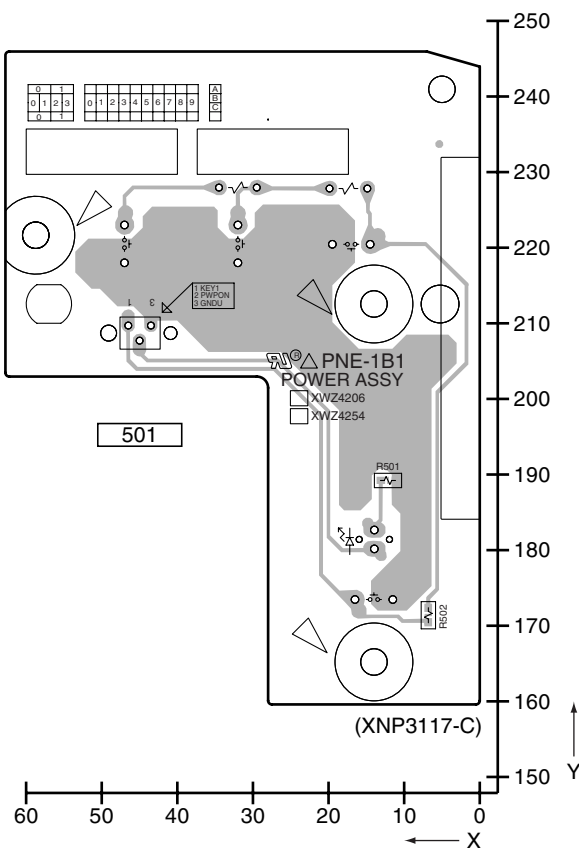

J ROTARY ENCODER ASSY

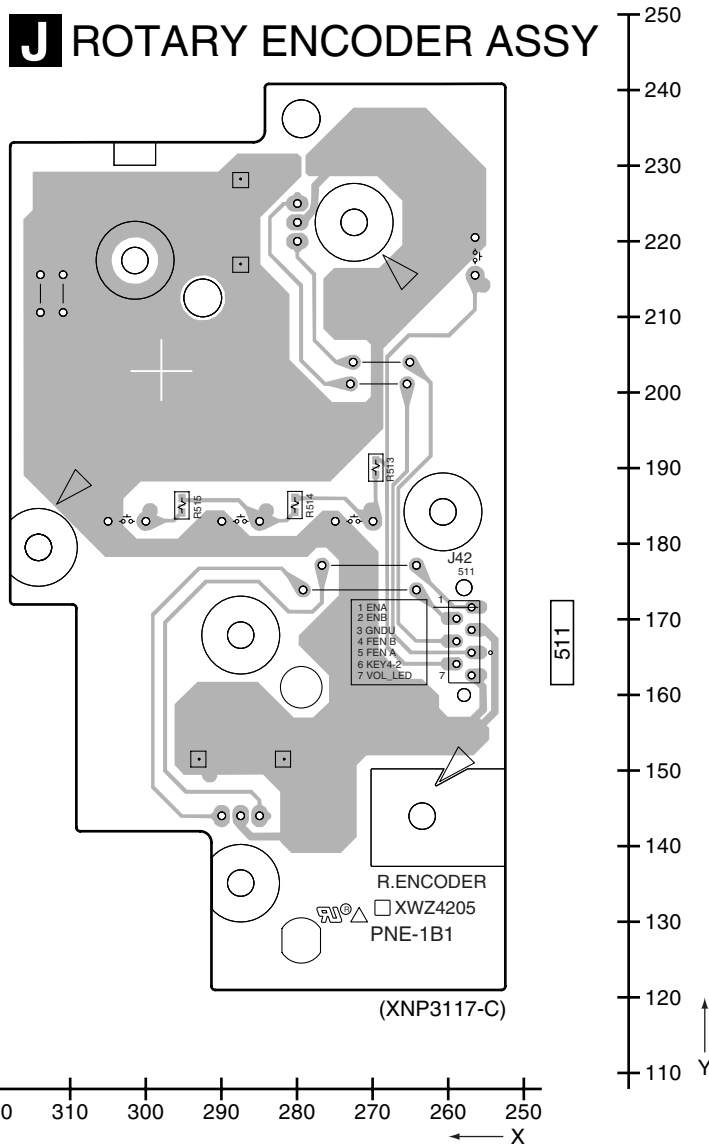

B

C

D

E

J K

4.10 S.VIDEO ASSY

1 2 3 4

A **SIDE A**

SIDE A

S.VIDEO ASSY

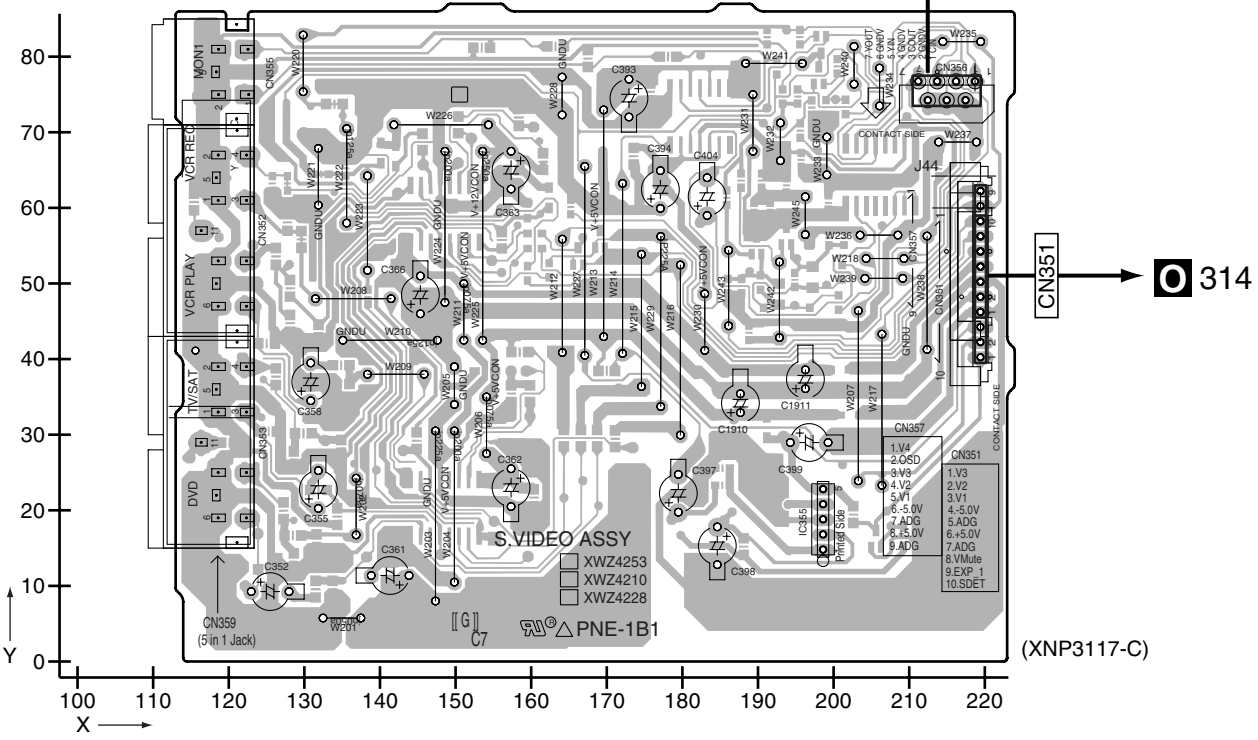

A **SIDE B**

SIDE B

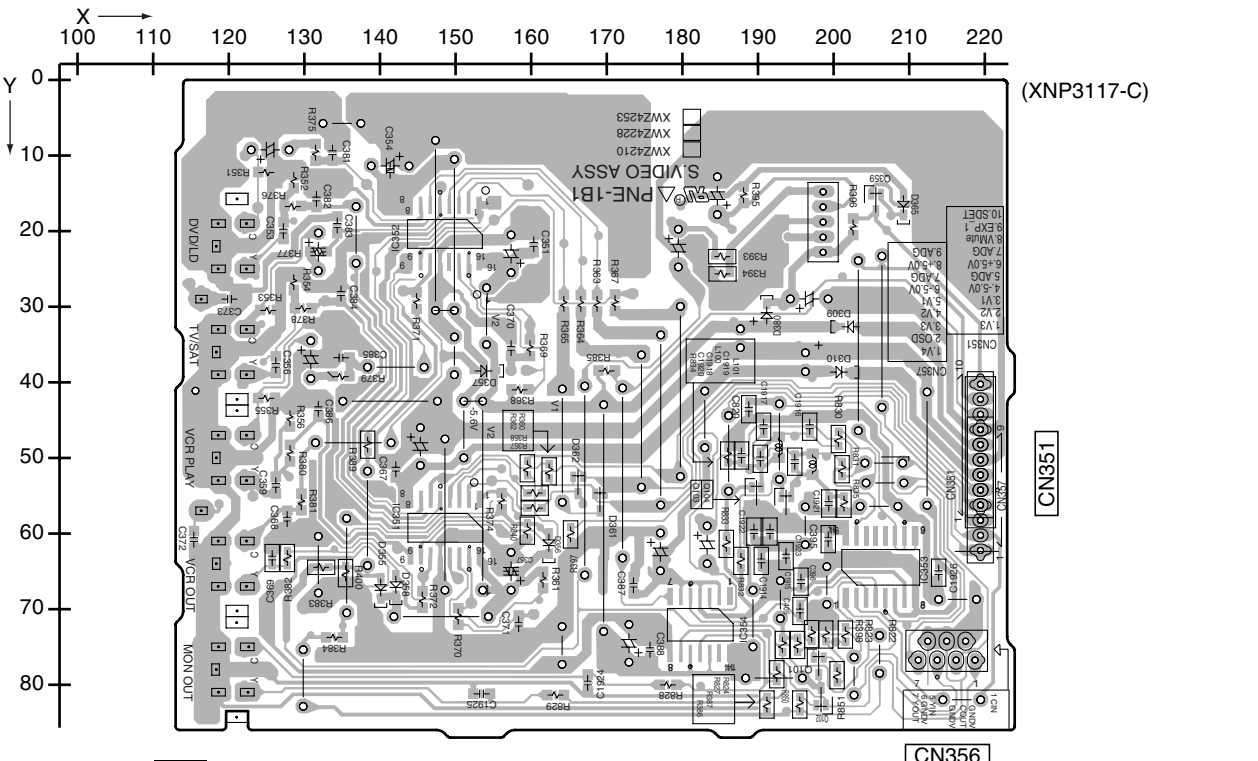

S.VIDEO ASSY

1 2 3 4

4.11 TRANS4 and REGULATOR ASSYS

SIDE A

SIDE A

M TRANS4 ASSY

N REGULATOR ASSY

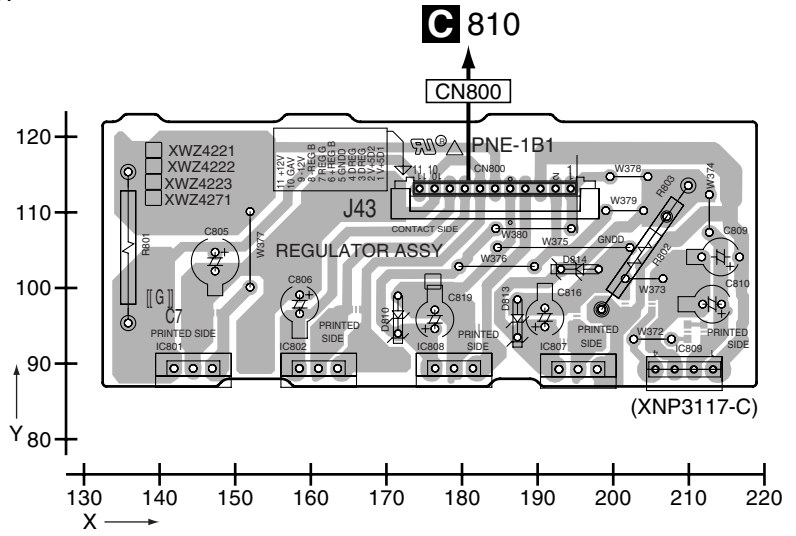
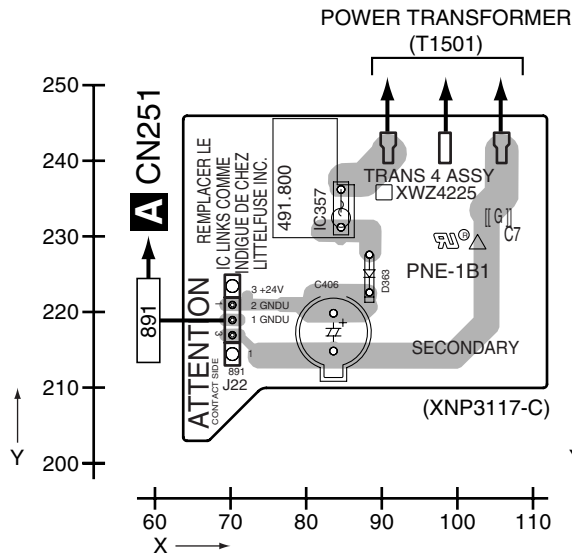

SIDE B

SIDE B

M TRANS4 ASSY

N REGULATOR ASSY

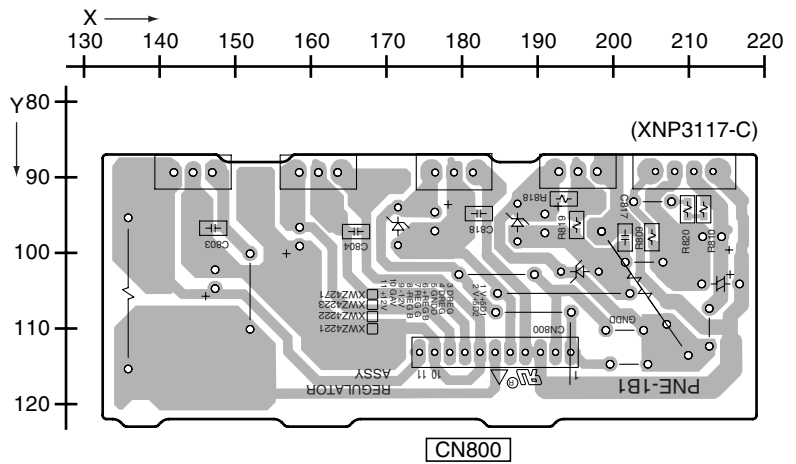
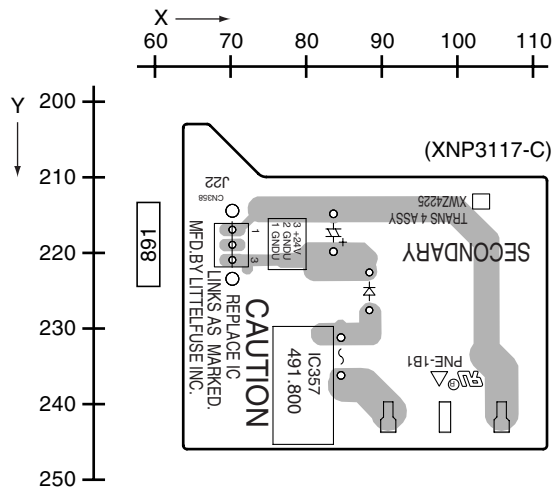

4.12 COMP VIDEO and BOARD TO BOARD ASSYS (VSX-917V ONLY)

SIDE A

COMP VIDEO ASSY

SIDE A

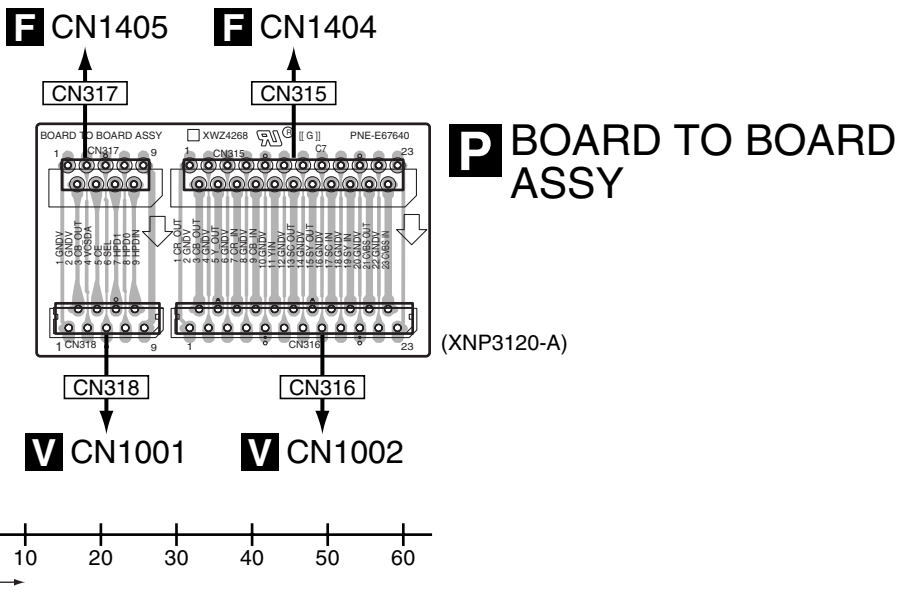
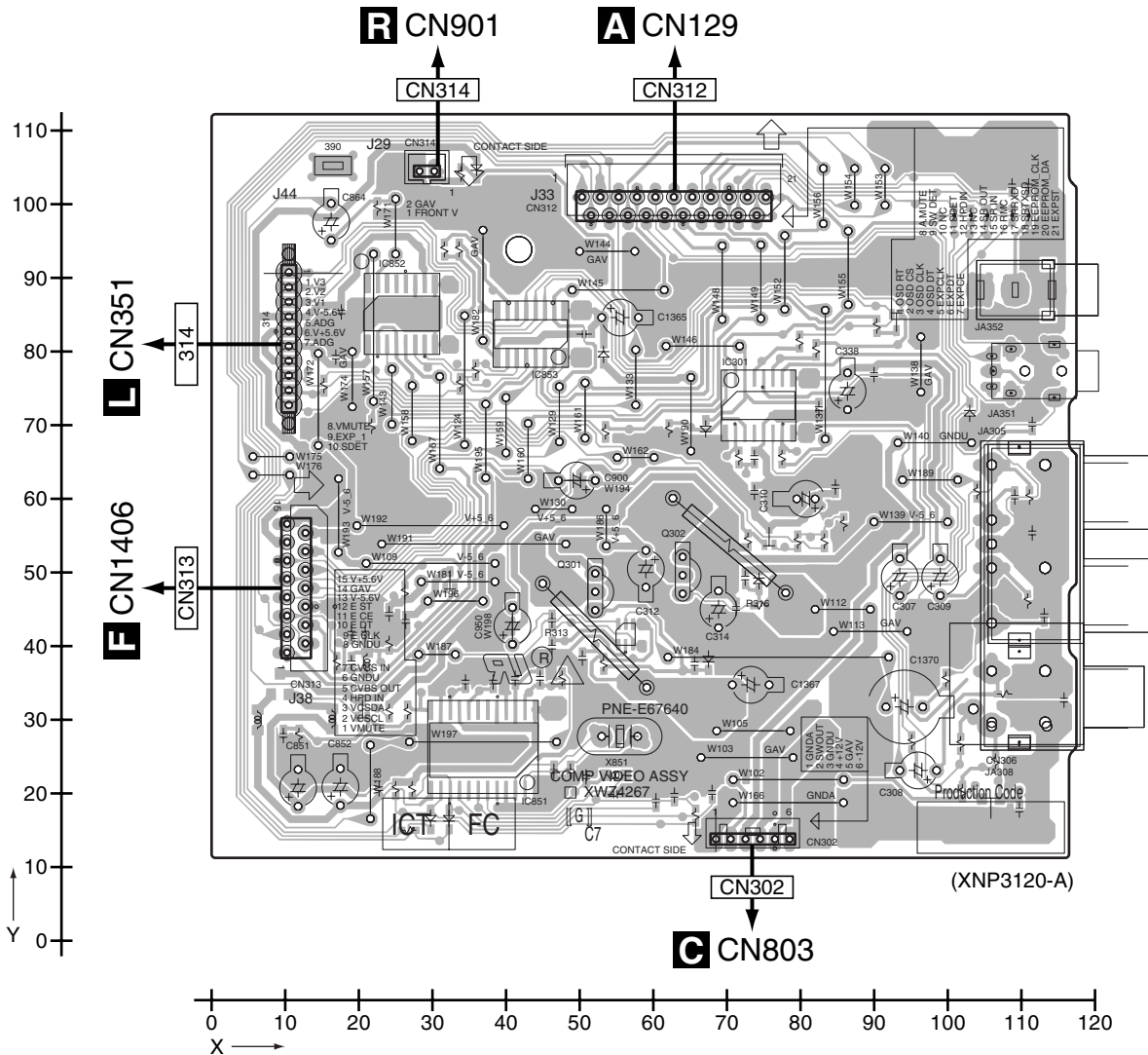

O P

SIDE B

SIDE B

COMP VIDEO ASSY

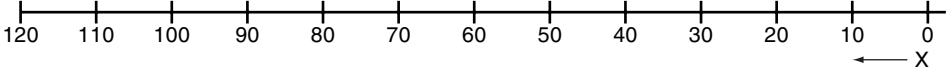
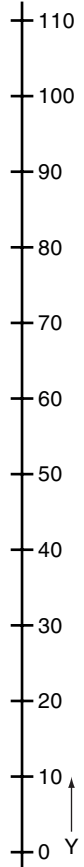
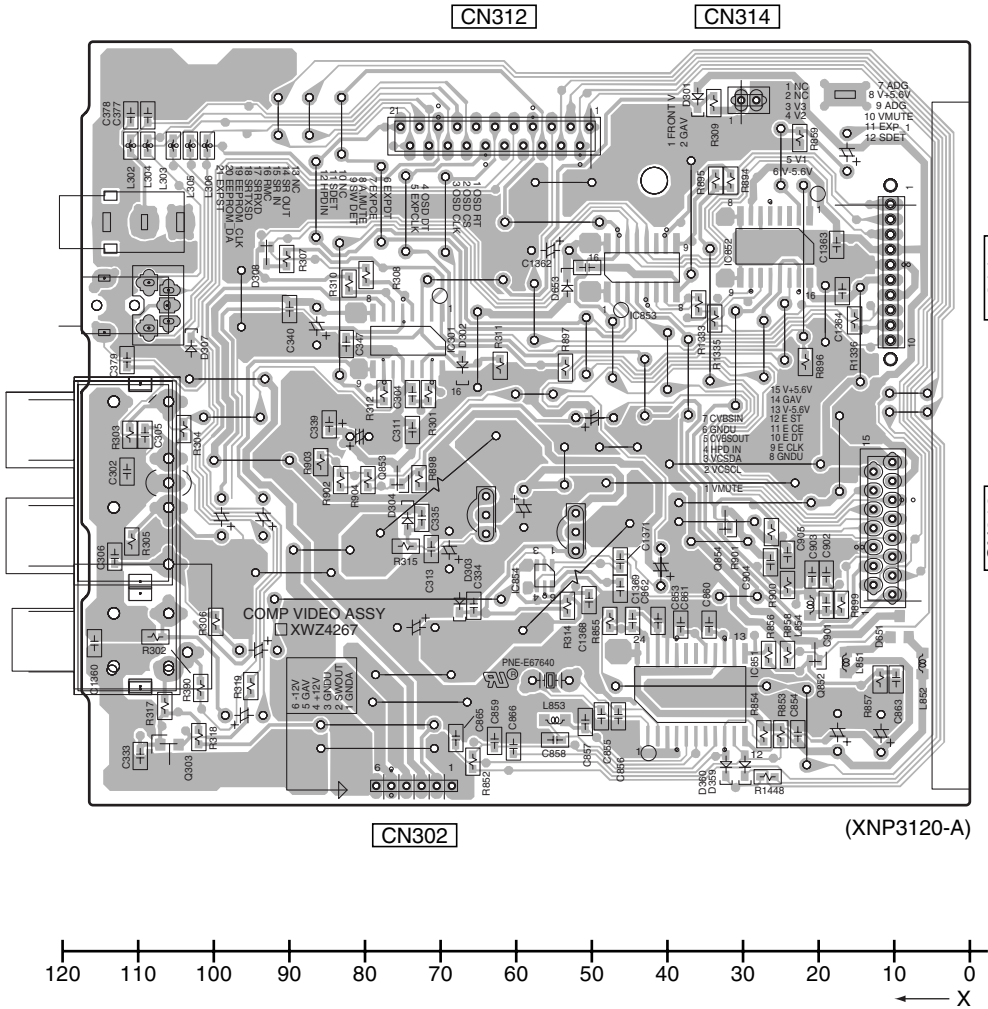

BOARD TO BOARD ASSY

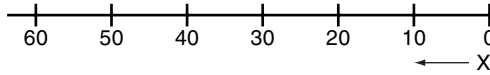
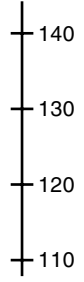
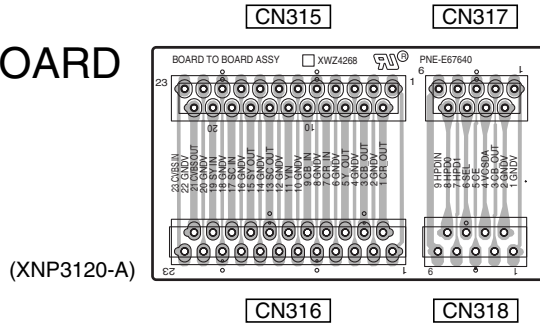

4.13 VIDEO ASSY (VSX-817 ONLY)

1 2 3 4

A **SIDE A**

SIDE A

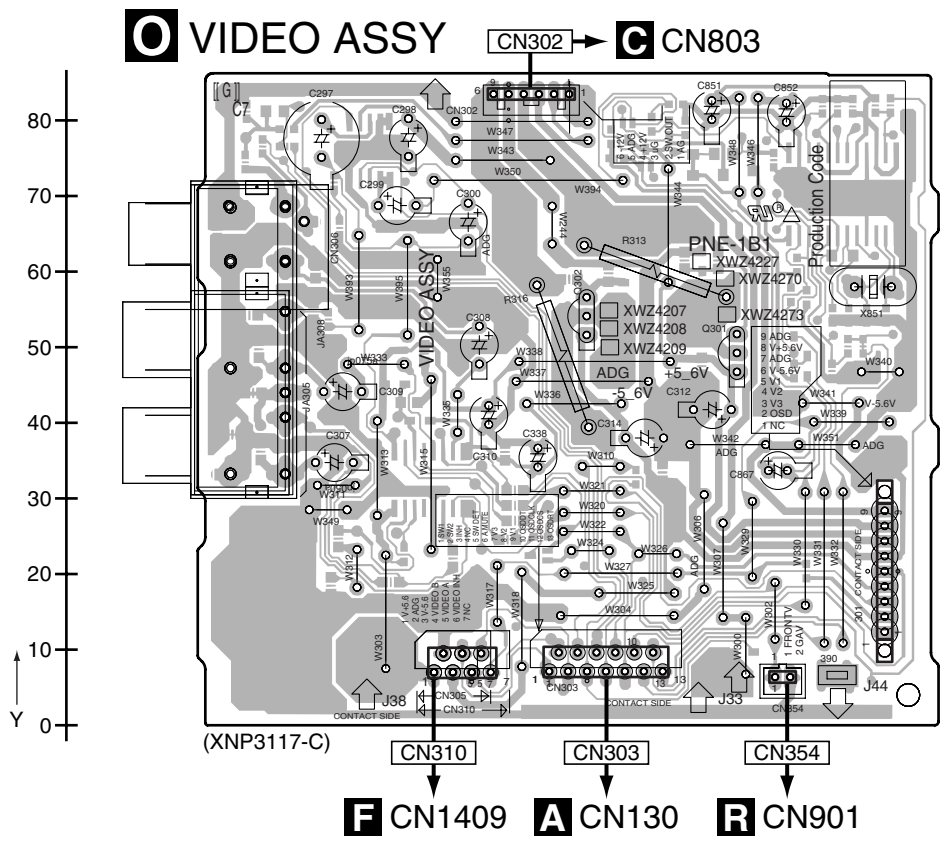

SIDE B

SIDE B

D

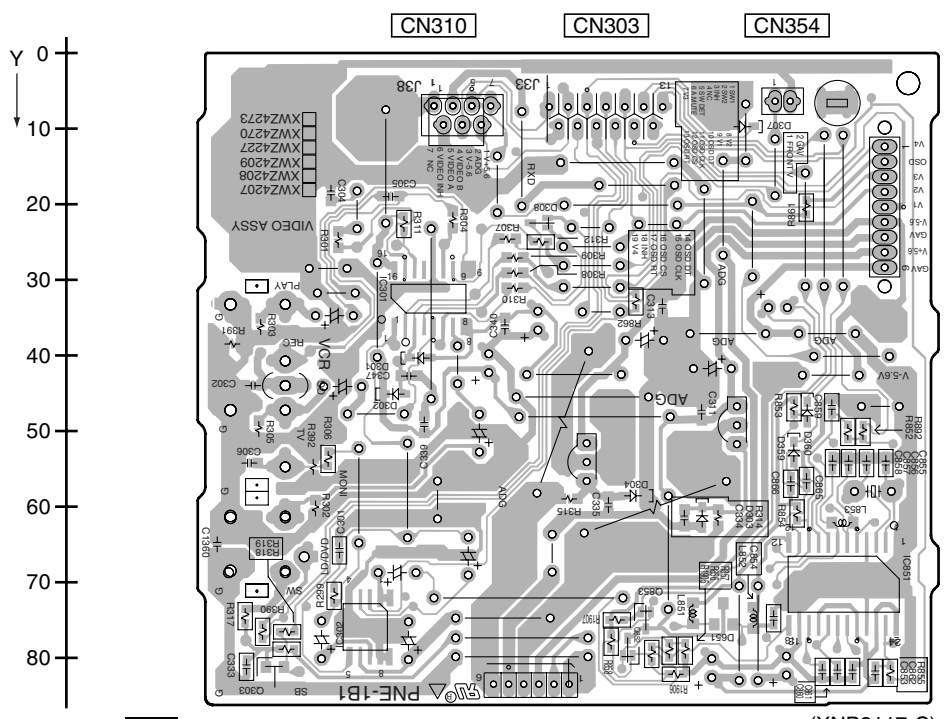

VIDEO ASSY

VSX-917V-K

1 2 3 4

4.14 DIGITAL INPUT and FRONT VIDEO ASSYS

SIDE A

SIDE A

Q DIGITAL INPUT ASSY

R FRONT VIDEO ASSY

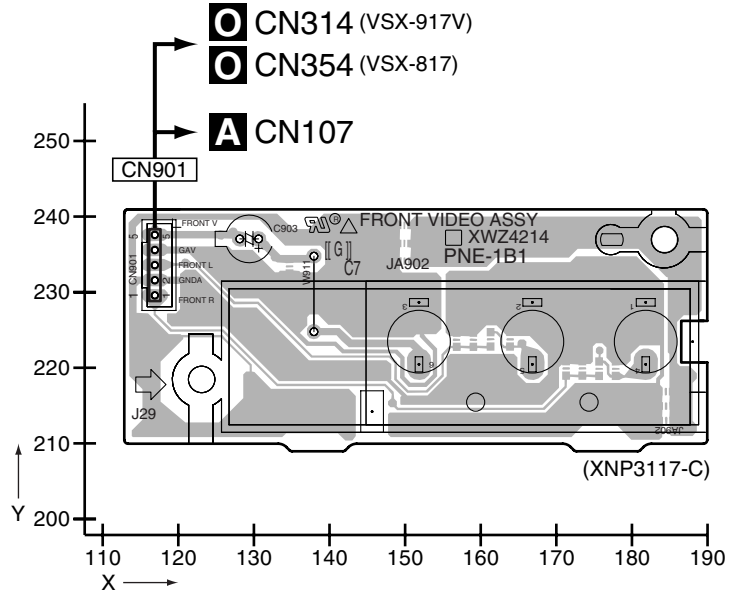
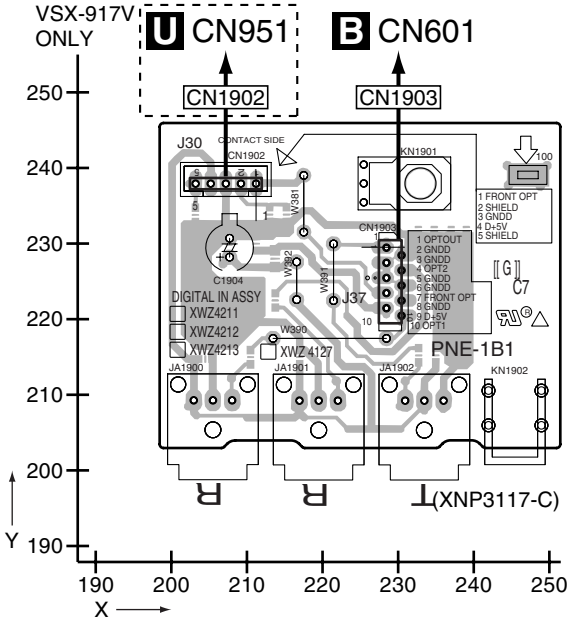

SIDE B

SIDE B

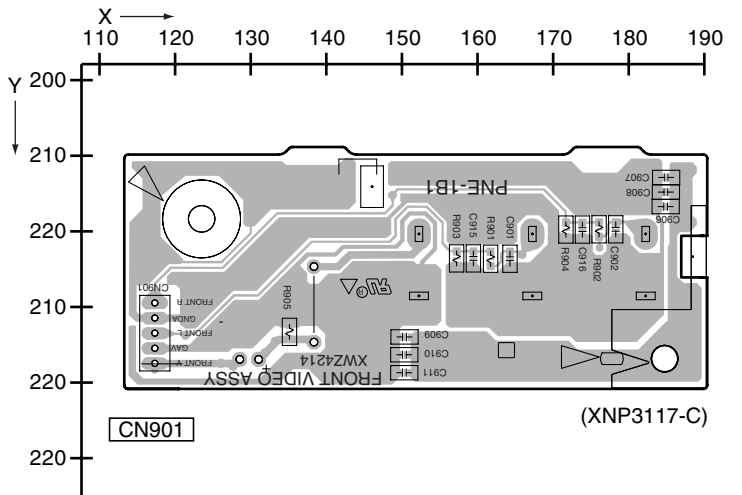
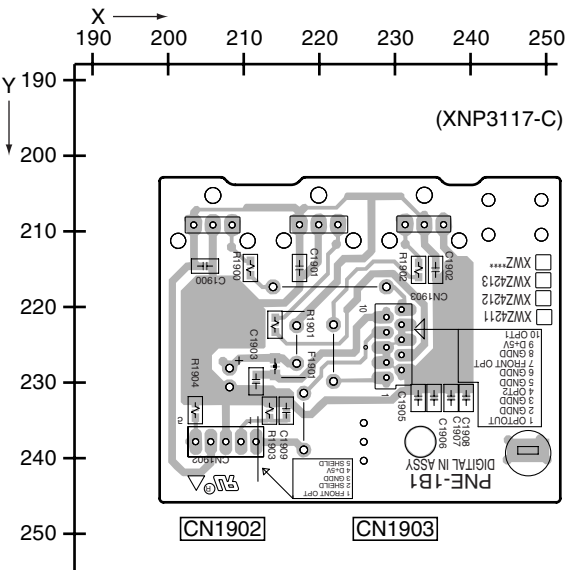

Q DIGITAL INPUT ASSY

R FRONT VIDEO ASSY

Q R

4.15 PRIMARY ASSY

SIDE A

SIDE A

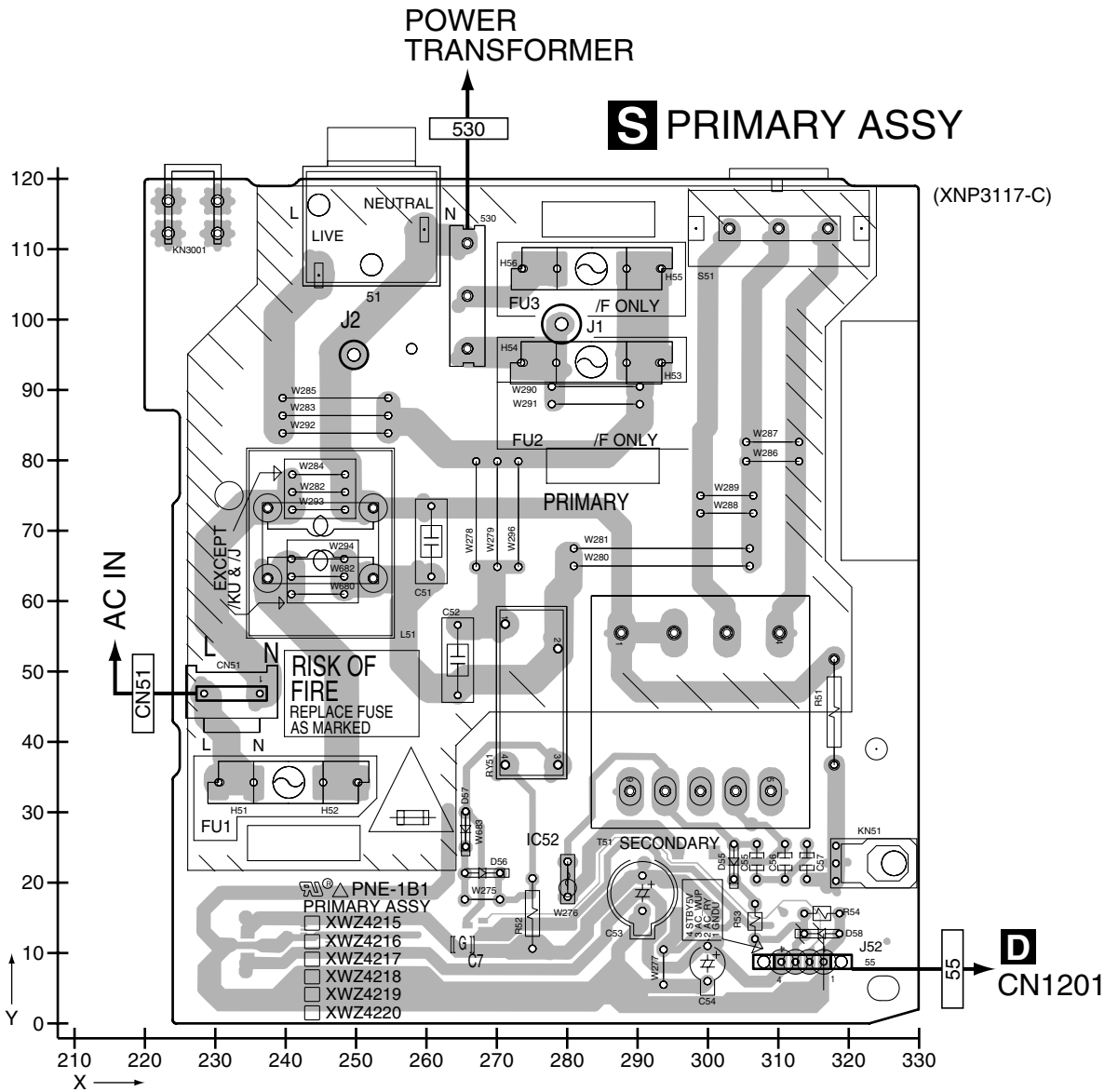

- SW PNE-1B1
- PRIMARY ASSY
- XWZ4215
- XWZ4216
- XWZ4217
- XWZ4218
- XWZ4219
- XWZ4220

S

SIDE B

SIDE B

A

B

C

D

E

F

S PRIMARY ASSY

530

(XNP3117-C)

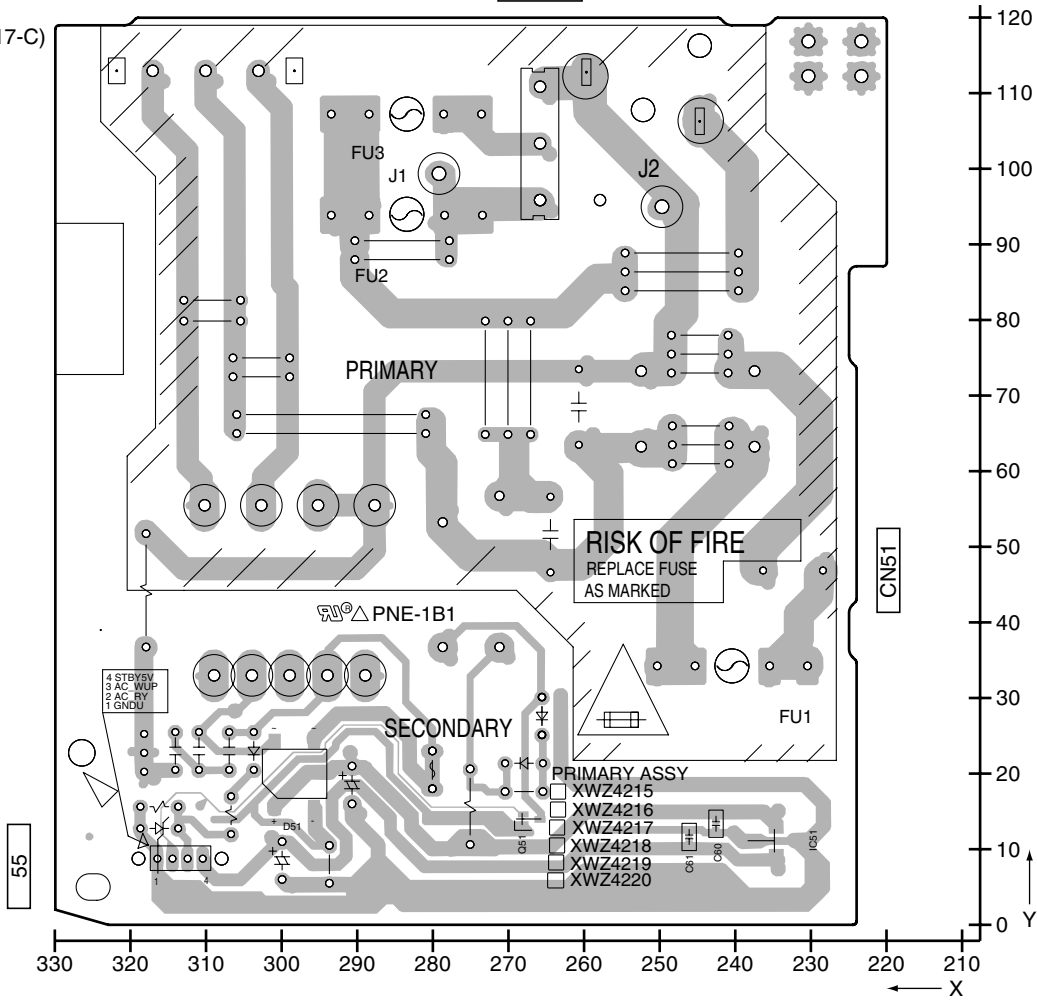

4.16 FRONT IN ASSY

1

2

3

4

A **SIDE A**

SIDE B

U FRONT IN ASSY

U FRONT IN ASSY

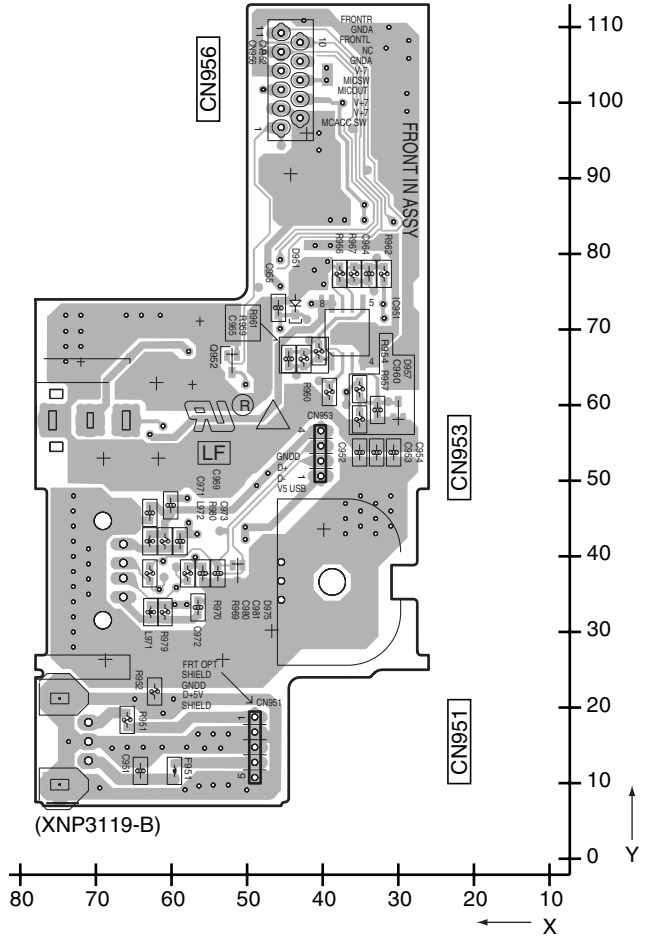
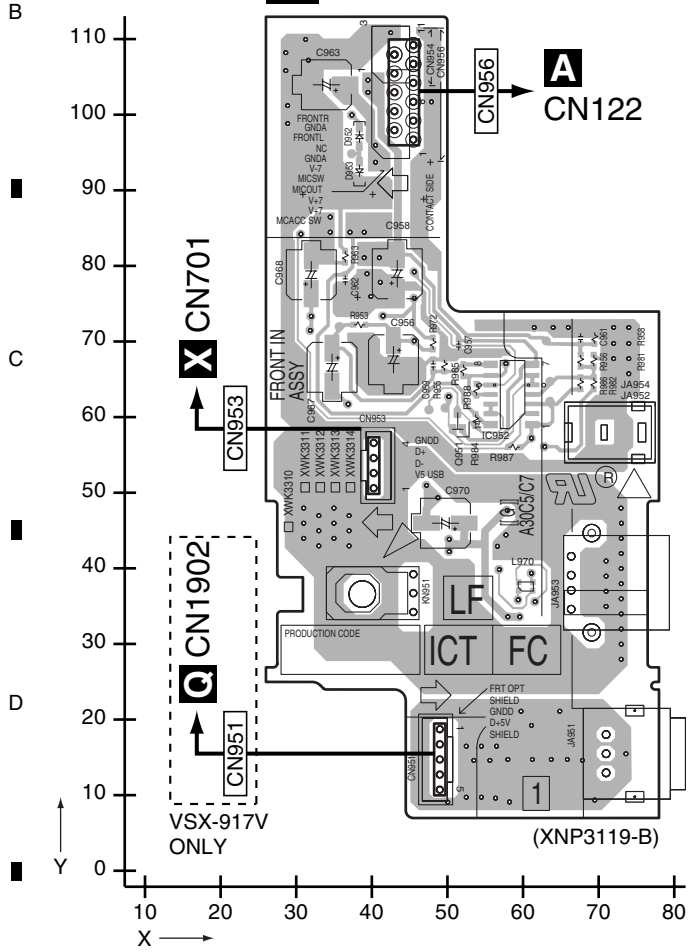

E

F



1

2

3

4

4.17 HDMI&DVC ASSY (VSX-917V ONLY)

SIDE A

SIDE A

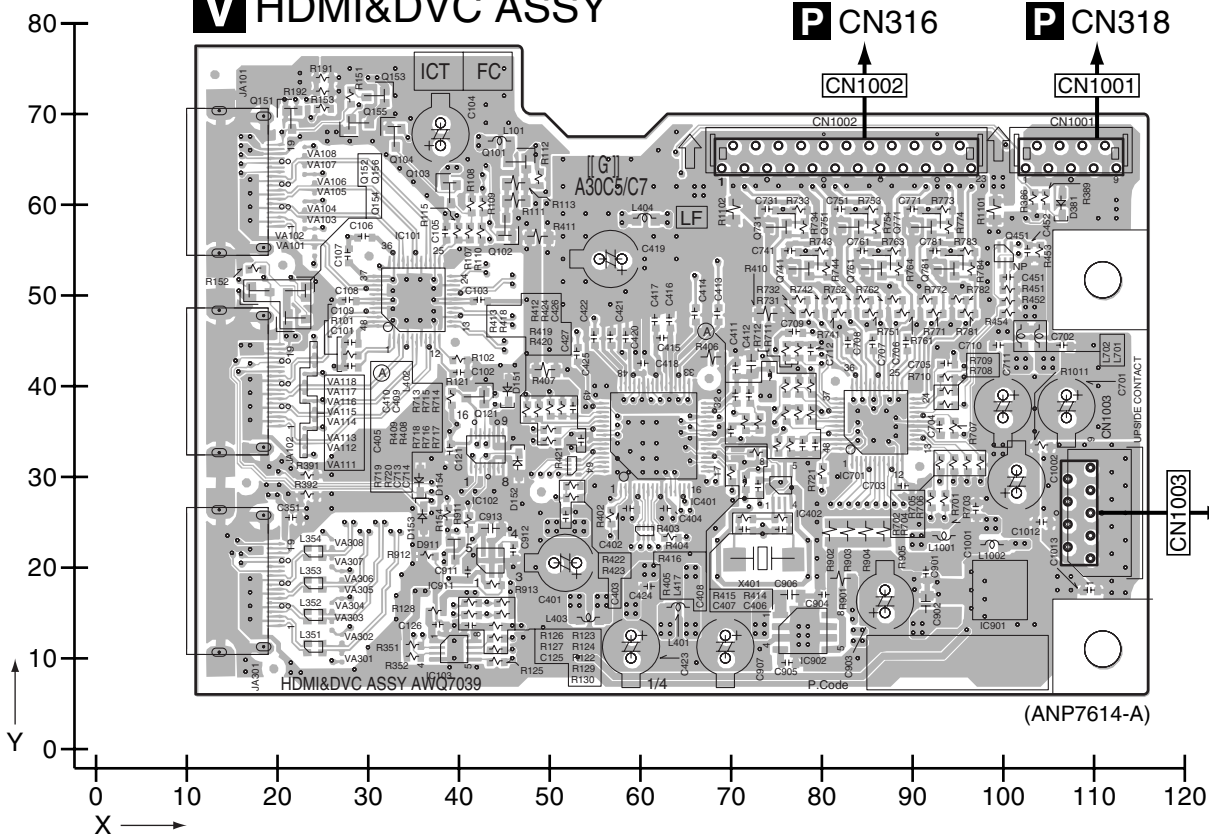

SIDE B

SIDE B

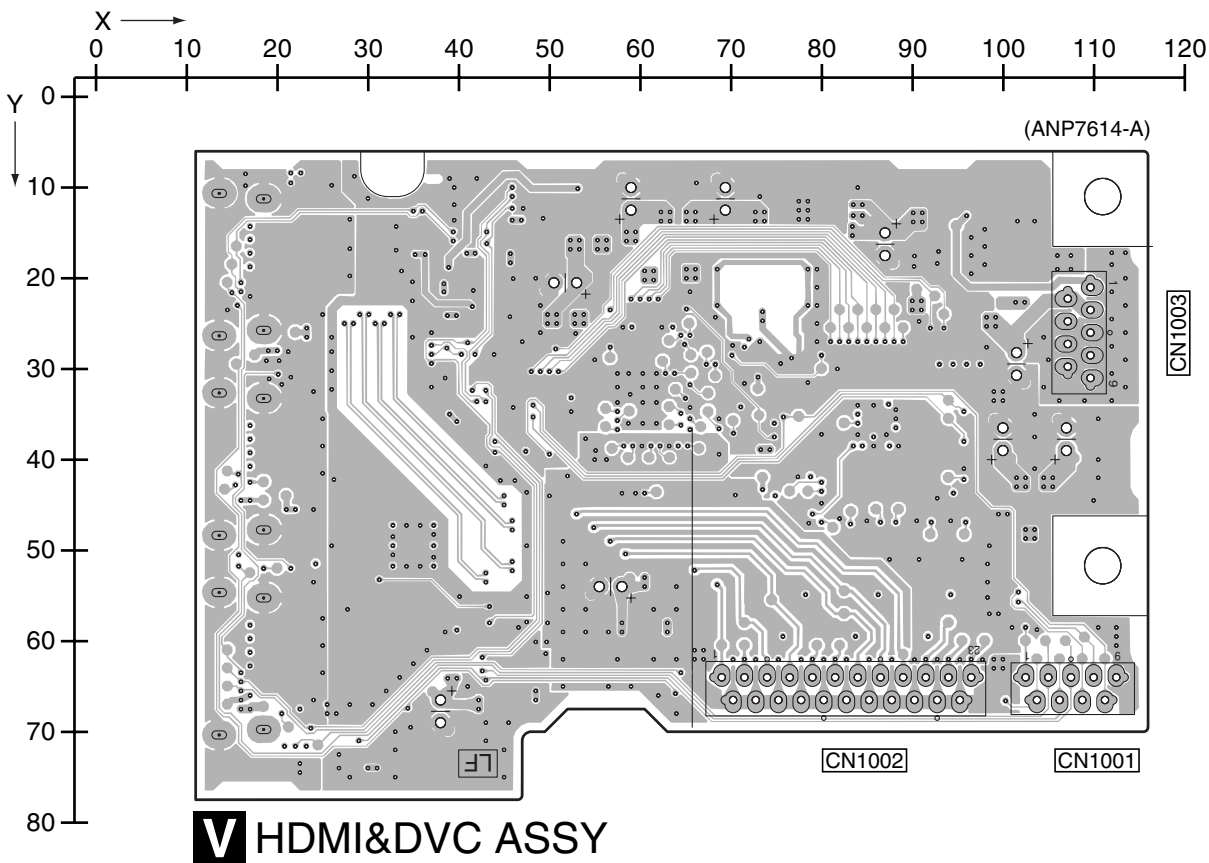

5. PCB PARTS LIST

NOTES: ● Parts marked by "NSP" are generally unavailable because they are not in our Master Spare Parts List.

● The Δ mark found on some component parts indicates the importance of the safety factor of the part. Therefore, when replacing, be sure to use parts of identical designation.

● When ordering resistors, first convert resistance values into code form as shown in the following examples.

Ex.1 When there are 2 effective digits (any digit apart from 0), such as 560 ohm and 47k ohm (tolerance is shown by J=5%, and K=10%).

560 Ω → 56 x 10¹ → 561 RD1/4PU 5 6 7 J
 47k Ω → 47 x 10³ → 473 RD1/4PU 4 7 3 J
 0.5 Ω → R50 RN2H R 5 0 K
 1 Ω → 1R0 RS1P 7 R 0 K

Ex.2 When there are 3 effective digits (such as in high precision metal film resistors).

5.62k Ω → 562 x 10¹ → 5621 RN1/4PC 5 6 2 1 F

● Meaning of the figures and others in the parentheses in the parts list.

Example IC 301 is on the point (face A, 91 of x-axis, and 111 of y-axis) of the corresponding PC board.

IC 301 (A, 91, 111) IC NJM2068V

LIST OF ASSEMBLIES

Mark	Symbol and Description	VSX-917V /MYXJ5	VSX-817 /MYXJ5
NSP	1..MAIN ASSY	XWK3308	XWK3304
	1..DSP ASSY	AWX8810	AWX8810
	1..AMP ASSY	XWK3294	XWK3290
	2..POWER PACK ASSY	XWZ4240	XWZ4236
	2..TRANS2 ASSY	XWZ4282	XWZ4245
	2..TRANS3 ASSY	XWZ4246	XWZ4246
	2..COMPONENT VIDEO ASSY	XWZ4248	XWZ4247
	2..5.1CH INPUT ASSY	XWZ4249	XWZ4249
	2..BIND ASSY	XWZ4252	XWZ4252
	2..HEAD PHONE ASSY	XWZ4265	XWZ4265
NSP	1..COMPLEX ASSY	XWK3280	XWK3275
	2..FRONT DISPLAY ASSY	XWZ4204	XWZ4226
	2..ROTARY ENCODER ASSY	XWZ4205	XWZ4205
	2..VIDEO ASSY	Not used	XWZ4209
	2..S. VIDEO ASSY	XWZ4228	Not used
	2..DIGITAL INPUT ASSY	XWZ4213	XWZ4212
	2..FRONT VIDEO ASSY	XWZ4214	XWZ4214
	2..PRIMARY ASSY	XWZ4216	XWZ4216
	2..REGULATOR ASSY	XWZ4221	XWZ4223
	2..TRANS4 ASSY	XWZ4225	XWZ4225
2..POWER KEY ASSY	XWZ4254	XWZ4206	
NSP	1..FRONT IN ASSY	XWK3314	XWK3312
	1..COMPOSITE VIDEO ASSY	XWK3315	Not used
	2..COMP VIDEO ASSY	XWZ4267	Not used
	2..BOARD TO BOARD ASSY	XWZ4268	Not used
	1..HDMI&DVC ASSY	AWQ7039	Not used
NSP	1..USB ASSY	AWX8704	AWX8704
	1..FM/AM TUNER UNIT	AXX7170	AXX7170

■ CONTRAST OF PCB ASSEMBLIES

A MAIN ASSY

XWK3304 and XWK3308 are constructed the same except for the following:

Mark	Symbol and Description	XWK3308	XWK3304
	IC6001	TC74VHCT125AFTS1	Not used
	IC9001	PEG375B8	PEG377A
	D6001	1SS355	Not used
	CN129 CONNECTOR	CKS3386	Not used
	CN130 CONNECTOR	Not used	CKS3378
	R6001, R6002	RS1/16S104J	Not used
	R6004, R6009	RS1/16S101J	Not used
	R6007	RS1/16S102J	Not used
	R6010	RS1/16S182J	Not used
	R9025	RS1/16S183J	RS1/16S152J
	R9045, R9046	RS1/16S101J	RS1/16S471J
	R9048	RS1/16S472J	RS1/16S103J
	R9068	Not used	RS1/16S0R0J
	C6001	CKSRYB104K16	Not used

C POWER PACK ASSY

XWZ4236 and XWZ4240 are constructed the same except for the following:

Mark	Symbol and Description	XWZ4240	XWZ4236
⚠	IC803	BA05FP	NJM78M05DL1A
	Q810	2SD1858X	Not used
	D900	MTZJ7R5(B)	Not used
	CN808 CONNECTOR	CKS3374	Not used
	R900	RS1/16S102J	Not used
	R901	RS1/16S100J	Not used
	C850	CEAT101M10	Not used
	C901	CKSRYB104K16	Not used

D TRANS2 ASSY

XWZ4245 and XWZ4282 are constructed the same except for the following:

Mark	Symbol and Description	XWZ4282	XWZ4245
⚠	R1225	RD1/4PU3R3J	Not used

I FRONT DISPLAY ASSY

XWZ4226 and XWZ4204 are constructed the same except for the following:

Mark	Symbol and Description	XWZ4204	XWZ4226
	Q441	RT1N241M	Not used
	D404, D405	1SS355	Not used
	D502	SLR343BC4T	Not used
	R404	RS1/16S472J	Not used
	R430	Not used	RS1/16S0R0J
	R551	RS1/16S391J	Not used

K POWER KEY ASSY

XWZ4206 and XWZ4254 are constructed the same except for the following:

Mark	Symbol and Description	XWZ4254	XWZ4206
	D501	SLR343BC4T	Not used
	R501	RS1/16S391J	Not used

N REGULATOR ASSY

XWZ4223 and XWZ4221 are constructed the same except for the following:

Mark	Symbol and Description	XWZ4221	XWZ4223
⚠	IC807	Not used	TA7805S
⚠	IC808	BA50BC0T	TA7805S
⚠	IC809	NJM2389F	Not used
	D813	Not used	MTZJ6R2
	D814	MTZJ6R2	Not used
	R802	Not used	RS2LMF221J
	R809	RS1/16S102J	Not used
	R810	RS1/16S302J	Not used
	R819	Not used	RS1/16S0R0J
	R820	RS1/16S151J	Not used
	C809	CEATR33M50	Not used
	C810	CEAT101M10	Not used
	C816	Not used	CEAT101M10
	C817	Not used	CKSRYB103K25

Q DIGITAL INPUT ASSY

XWZ4212 and XWZ4213 are constructed the same except for the following:

Mark	Symbol and Description	XWZ4213	XWZ4212
	CN1902 CONNECTOR POST	B5B-PH	Not used
	JA1902 OPT. LINK IN	GP1FAV51TK0F	Not used
	R1902	RS1/16S101J	Not used
	C1902	CKSRYB104K25	Not used
	C1909	CCSRCH101J50	Not used

U FRONT IN ASSY

XWK3312 and XWK3314 are constructed the same except for the following:

Mark	Symbol and Description	XWK3314	XWK3312
	F951 INDUCTOR	CTF1295	Not used
	CN951 KR CONNECTOR	B5B-PH-K-S	Not used
	JA951 OPT. LINK IN	GP1FMV51RK0F	Not used
	R951	RS1/16S101J	Not used
	C915	CKSRYB104K50	Not used

PCB PARTS LIST FOR VSX-917V/MYXJ5 UNLESS OTHERWISE NOTED

Mark No.	Description	Part No.	Mark No.	Description	Part No.
AMP ASSY					
			IC 107 (A,216,88)	DUAL OP-AMP	NJM4565MD
MISCELLANEOUS					
J 6	BOARD IN WIRE	DB230ND0	IC 108 (B,255,64)	8CH E-VOL	R2S15205FP(P)
J 606	BOARD IN WIRE	DB621ND0	IC 110 (A,237,73)	IC	TC4066BFN
J 607	BOARD IN WIRE	DB118ND0	IC 310 (A,142,42)	DUAL OP-AMP	NJM4565MD
			IC 311 (A,152,60)	DUAL OP-AMP	NJM4565MD
			IC 312 (A,142,78)	DUAL OP-AMP	NJM4565MD
COMPLEX ASSY					
MISCELLANEOUS					
J 41	JUMPER WIRE	D15A03-100-2651	IC 315 (A,160,90)	DUAL OP-AMP	NJM4565MD
J 42	JUMPER WIRE	D15A07-125-2651	IC 5001(A,69,19)	RDS DECODER IC	LC72725KM
			IC 6001(A,135,21)	IC	TC74VHCT125AFTS1
			IC 9001(B,82,64)	CPU	PEG375B8
			IC 9002(A,104,42)	EEPROM	BR24L16FV-W
			Q 231 (A,225,69)	DIGITAL TR(SC-70)	RT1P241M
			Q 232 (A,229,69)	TRANSISTOR	RT1N241M
			Q 248 (A,79,108)	TRANSISTOR	2SC4081
			Q 249 (A,83,104)	TRANSISTOR	RT1N241M
			Q 250 (A,87,105)	TRANSISTOR	2SC4081
MAIN ASSY					
MISCELLANEOUS					
IC 103 (A,198,72)	DUAL OP-AMP	NJM4565MD	Q 252 (A,68,105)	TRANSISTOR	2SD1858X
IC 104 (A,198,56)	DUAL OP-AMP	NJM4565MD	Q 253 (A,75,108)	TRANSISTOR	RT1N241M
IC 105 (A,198,87)	DUAL OP-AMP	NJM4565MD			
IC 106 (A,198,41)	DUAL OP-AMP	NJM4565MD			

5			6			7			8		
Mark No.	Description	Part No.	Mark No.	Description	Part No.	Mark No.	Description	Part No.	Mark No.	Description	Part No.
Q 254	(A,72,98) DIGITAL TR(SC-70)	RT1P241M	R 102	(B,293,12)	RS1/16S331J						
Q 255	(A,75,98) TRANSISTOR	2SC4081	R 103	(B,283,62)	RS1/16S222J						
Q 257	(A,90,105) TRANSISTOR	2SA1576A	R 104	(B,283,52)	RS1/16S222J						
			R 105	(B,283,48)	RS1/16S331J						A
Q 259	(A,69,97) DIGITAL TR(SC-70)	RT1P241M									
Q 260	(A,68,101) TRANSISTOR	2SC4081	R 106	(B,293,40)	RS1/16S331J						
Q 361	(A,166,78) TRANSISTOR	2SC5938A	R 107	(B,283,88)	RS1/16S331J						
Q 9001	(A,125,87) DIGITAL TR(SC-70)	RT1N431M	R 108	(B,293,81)	RS1/16S331J						
Q 9002	(A,66,80) DIGITAL TR(SC-70)	RT1P241M	R 109	(B,283,75)	RS1/16S331J						
			R 110	(B,293,68)	RS1/16S331J						
Q 9003	(A,65,75) DIGITAL TR(SC-70)	RT1P241M									
Q 9007	(A,69,85) TRANSISTOR	DTC143TK	R 111	(B,283,112)	RS1/16S222J						
Q 9064	(A,59,80) DIGITAL TR(SC-70)	RT1P241M	R 112	(B,283,106)	RS1/16S222J						
Q 9065	(A,55,78) TRANSISTOR	UMD2N	R 113	(B,283,101)	RS1/16S331J						
D 103	(B,173,35) DIODE	DAN217U	R 114	(B,293,96)	RS1/16S331J						
			R 129	(B,283,34)	RS1/16S331J						B
D 105	(B,163,37) DIODE	DAN217U									
D 107	(B,166,37) DIODE	DAN217U	R 130	(B,283,25)	RS1/16S331J						
D 253	(A,70,114) DIODE	UDZS13(B)	R 145	(A,71,73)	RS1/16S102J						
D 254	(A,92,102) DIODE	UDZS5R1(B)	R 146	(A,71,74)	RS1/16S102J						
D 255	(A,65,114) DIODE	UDZS13(B)	R 147	(B,233,67)	RS1/16S472J						
			R 148	(B,228,62)	RS1/16S472J						
D 311	(B,259,93) DIODE	1SS355									
D 312	(B,268,93) DIODE	1SS355	R 149	(A,259,45)	RS1/16S104J						
D 331	(B,260,87) DIODE	UDZS6R8(B)	R 180	(B,278,97)	RS1/16S0R0J						
D 332	(B,263,87) DIODE	UDZS6R8(B)	R 181	(B,273,78)	RS1/16S0R0J						
D 6001	(A,149,22) DIODE	1SS355	R 182	(B,275,75)	RS1/16S0R0J						
			R 183	(B,276,67)	RS1/16S0R0J						
D 9006	(B,99,89) DIODE	DAN217U									
D 9007	(B,91,89) DIODE	DAN217U	R 201	(A,189,85)	RS1/16S473J						C
D 9010	(A,128,88) DIODE	1SS355	R 202	(A,189,90)	RS1/16S473J						
D 9011	(A,60,75) DIODE	DAN202U	R 205	(B,189,85)	RS1/16S392J						
D 9064	(A,58,75) DIODE	DAP202U	R 206	(B,189,91)	RS1/16S392J						
			R 207	(B,191,85)	RS1/16S392J						
D 9065	(A,63,80) DIODE	DAP202U									
D 9068	(A,53,81) DIODE	1SS355	R 208	(B,191,91)	RS1/16S392J						
L 101	(B,260,98) CHIP SOLID INDUCTOR	QTL1013	R 209	(B,198,85)	RS1/16S392J						
L 102	(B,265,97) CHIP SOLID INDUCTOR	QTL1013	R 210	(B,198,91)	RS1/16S392J						
L 5002	(A,257,104) CHIP SOLID INDUCTOR	QTL1013	R 211	(B,200,85)	RS1/16S332J						
			R 212	(B,200,91)	RS1/16S332J						
L 9001	(A,124,102) CHIP SOLID INDUCTOR	ATL7002									
L 9002	(A,120,103) CHIP SOLID INDUCTOR	ATL7002	R 221	(B,220,84)	RS1/16S472J						
L 9003	(A,106,98) RADIAL INDUCTOR	LFCA2R2J	R 222	(B,219,91)	RS1/16S472J						D
X 5001	(A,67,27) CRYSTAL RESONATOR (4.332 MHz)	ASS7004	R 223	(A,242,78)	RS1/16S472J						
X 9001	(A,96,53) CERAMIC RESONATOR (15.7 MHz)	XSS3004	R 224	(A,236,78)	RS1/16S472J						
			R 225	(B,225,84)	RS1/16S392J						
CN101	(A,41,27) CONNECTOR	CKS3382	R 226	(B,225,91)	RS1/16S392J						
CN102	(A,113,63) CONNECTOR	52045-1045	R 231	(A,229,72)	RS1/16S104J						
CN103	(A,227,17) 11P CONNECTOR	52044-1145	R 233	(A,231,91)	RS1/16S474J						
CN105	(A,266,34) CONNECTOR	CKS3372	R 234	(A,231,84)	RS1/16S474J						
CN107	(A,39,109) CONNECTOR POST	B3B-PH	R 237	(A,237,88)	RS1/16S122J						
CN109	(A,230,113) 23P SOCKET	XKP3055	R 238	(A,236,80)	RS1/16S122J						
CN111	(A,274,113) 21P SOCKET	XKP3091	R 241	(A,190,69)	RS1/16S473J						
CN112	(A,91,41) CONNECTOR	CKS3390	R 242	(A,190,74)	RS1/16S473J						E
CN114	(A,189,113) 21P SOCKET	XKP3091	R 245	(B,188,69)	RS1/16S332J						
CN122	(A,41,55) CONNECTOR	CKS3376	R 246	(B,188,75)	RS1/16S332J						
CN129	(A,247,13) CONNECTOR	CKS3386	R 247	(B,190,69)	RS1/16S332J						
CN141	8P PIN JACK	XKB3064	R 248	(B,190,75)	RS1/16S332J						
CN142	8P PIN JACK	XKB3067	R 249	(B,197,69)	RS1/16S332J						
CN251	(A,39,92) 3P JUMPER CONNECTOR	52147-0310	R 250	(B,197,75)	RS1/16S332J						
CN252	(A,37,77) 3P TOP POST	B3B-EH	R 251	(B,199,69)	RS1/16S182J						
101	PCB BINDER	VEF1040	R 252	(B,199,75)	RS1/16S182J						
102	PCB BINDER	VEF1040	R 261	(A,189,53)	RS1/16S473J						
			R 262	(A,189,59)	RS1/16S473J						
			R 264	(B,186,60)	RS1/16S392J						F
			R 265	(B,188,53)	RS1/16S332J						
			R 266	(B,188,60)	RS1/16S472J						
RESISTORS											
R 101	(B,282,19)	RS1/16S331J									

1

2

3

4

Mark No. Description**Part No.****Mark No. Description****Part No.**

R 267 (B,190,53)
 R 268 (B,190,60)
 R 269 (B,197,53)
 R 270 (B,197,60)

RS1/16S332J
 RS1/16S123J
 RS1/16S332J
 RS1/16S122J

R 512 (A,159,83)
 R 513 (A,159,96)
 R 514 (A,157,83)
 R 515 (A,157,97)

RS1/16S362J
 RS1/16S362J
 RS1/16S153J
 RS1/16S153J

A

R 271 (B,199,53)
 R 272 (B,199,60)
 R 274 (B,202,60)
 R 281 (A,188,44)
 R 282 (A,188,38)

RS1/16S182J
 RS1/16S272J
 RS1/16S271J
 RS1/16S473J
 RS1/16S473J

R 516 (B,150,89)
 R 517 (B,150,96)
 R 551 (A,85,108)
 R 5010(A,76,24)
 R 5011(A,81,20)

RS1/16S103J
 RS1/16S103J
 RS1/16S822J
 RS1/16S473J
 RS1/16S473J

R 285 (B,188,45)
 R 286 (B,188,38)
 R 287 (B,191,45)
 R 288 (B,191,38)
 R 289 (B,197,45)

RS1/16S332J
 RS1/16S332J
 RS1/16S332J
 RS1/16S332J
 RS1/16S332J

R 5012(A,82,18)
 R 5013(A,57,26)
 R 6001(A,132,18)
 R 6002(A,139,24)
 R 6004(A,151,22)

RS1/16S102J
 RS1/16S102J
 RS1/16S104J
 RS1/16S104J
 RS1/16S101J

B

R 290 (B,197,38)
 R 291 (B,200,45)
 R 292 (B,199,39)
 R 303 (B,156,37)
 R 304 (B,155,43)

RS1/16S332J
 RS1/16S182J
 RS1/16S182J
 RS1/16S101J
 RS1/16S101J

R 6007(B,128,14)
 R 6009(A,130,23)
 R 6010(A,147,23)
 R 9001(B,94,54)
 R 9002(A,129,89)

RS1/16S102J
 RS1/16S101J
 RS1/16S182J
 RS1/16S0R0J
 RS1/16S473J

R 305 (B,160,49)
 R 306 (B,164,61)
 R 307 (B,165,68)
 R 308 (B,171,72)
 R 311 (A,258,102)

RS1/16S101J
 RS1/16S101J
 RS1/16S101J
 RS1/16S101J
 RS1LMF101J

R 9003(B,92,54)
 R 9006(B,103,89)
 R 9007(B,93,89)
 R 9008(A,93,107)
 R 9009(A,65,85)

RS1/16S0R0J
 RS1/16S474J
 RS1/16S474J
 RS1/16S221J
 RS1/16S473J

C

R 312 (A,266,102)
 R 437 (A,81,108)
 R 438 (A,79,112)
 R 439 (A,80,112)
 R 440 (A,87,108)

METAL OXIDE RESISTOR

RS1LMF101J
 RS1/16S103J
 RS1/16S103J
 RS1/16S103J
 RS1/16S103J

R 9010(B,115,45)
 R 9011(A,63,76)
 R 9012(A,63,73)
 R 9013(B,112,45)
 R 9014(B,104,54)

RS1/16S512J
 RS1/16S102J
 RS1/16S0R0J
 RS1/16S471J
 RS1/16S471J

R 443 (A,63,104)
 R 445 (A,73,107)
 R 448 (A,90,102)
 R 449 (A,83,108)
 R 453 (A,147,36)

RS1/16S471J
 RS1/16S223J
 RS1/16S104J
 RS1/16S822J
 RS1/16S362J

R 9015(B,102,54)
 R 9016(B,100,54)
 R 9017(B,98,54)
 R 9018(B,96,54)
 R 9019(B,98,76)

RS1/16S471J
 RS1/16S471J
 RS1/16S471J
 RS1/16S471J
 RS1/16S471J

D

R 454 (A,142,48)
 R 457 (A,141,36)
 R 458 (A,140,47)
 R 459 (B,133,38)
 R 460 (B,133,43)

RS1/16S362J
 RS1/16S153J
 RS1/16S153J
 RS1/16S103J
 RS1/16S103J

R 9020(B,99,76)
 R 9021(B,101,76)
 R 9022(B,103,76)
 R 9023(B,112,67)
 R 9024(B,110,67)

RS1/16S471J
 RS1/16S471J
 RS1/16S471J
 RS1/16S103J
 RS1/16S103J

R 463 (A,76,101)
 R 464 (A,77,99)
 R 465 (A,74,102)
 R 466 (A,71,101)
 R 473 (A,151,53)

RS1/16S223J
 RS1/16S223J
 RS1/16S223J
 RS1/16S223J
 RS1/16S362J

R 9025(B,103,67)
 R 9028(B,119,45)
 R 9030(A,68,79)
 R 9031(B,69,48)
 R 9032(A,66,59)

RS1/16S183J
 RS1/16S104J
 RS1/16S470J
 RS1/16S104J
 RS1/16S104J

E

R 474 (A,152,66)
 R 477 (A,149,52)
 R 478 (A,150,65)
 R 479 (B,142,57)
 R 480 (B,142,62)

RS1/16S362J
 RS1/16S153J
 RS1/16S153J
 RS1/16S103J
 RS1/16S103J

R 9033(B,89,48)
 R 9036(A,88,89)
 R 9037(A,124,99)
 R 9039(A,87,57)
 R 9041(B,117,45)

RS1/16S104J
 RS1/16S221J
 RS1/16S104J
 RS1/16S104J
 RS1/16S104J

R 484 (A,165,71)
 R 485 (A,157,80)
 R 493 (A,141,71)
 R 494 (A,141,84)
 R 497 (A,139,69)

RS1/16S104J
 RS1/16S472J
 RS1/16S362J
 RS1/16S362J
 RS1/16S153J

R 9042(B,83,81)
 R 9043(B,81,81)
 R 9044(B,79,81)
 R 9045(A,97,46)
 R 9046(A,107,46)

RS1/16S103J
 RS1/16S103J
 RS1/16S103J
 RS1/16S101J
 RS1/16S101J

F

R 498 (A,139,83)
 R 499 (B,133,72)
 R 500 (B,133,79)
 R 502 (B,144,80)
 R 504 (B,171,86)

RS1/16S153J
 RS1/16S103J
 RS1/16S103J
 RS1/16S204J
 RS1/16S222J

R 9047(A,98,46)
 R 9048(A,98,43)
 R 9060(B,98,68)
 R 9062(B,87,48)
 R 9064(A,54,74)

RS1/16S103J
 RS1/16S472J
 RS1/16S473J
 RS1/16S471J
 RS1/16S103J

R 505 (B,170,92)

RS1/16S222J

R 9065(A,56,74)

RS1/16S103J

1

2

3

4

5		6		7		8	
Mark No.	Description	Part No.	Mark No.	Description	Part No.		
R 9066	(A,62,72)	RS1/16S103J					
R 9067	(A,57,83)	RS1/16S103J	C 165	(A,240,86)	CEAT1R0M50		
R 9081	(A,120,72)	RS1/16S221J	C 166	(A,248,86)	CEAT1R0M50		
R 9082	(A,122,69)	RS1/16S274J	C 170	(A,236,115)	CEAT100M50		A
			C 171	(A,242,115)	CEAT100M50		
			C 179	(B,294,76)	CKSRYP103K50		
CAPACITORS							
C 101	(B,293,18)	CCSRCH101J50	C 180	(A,277,19)	CKSRYP103K50		
C 102	(B,295,12)	CCSRCH101J50	C 181	(A,283,30)	CCSRCH101J50		
C 103	(B,295,56)	CCSRCH101J50	C 182	(B,285,28)	CCSRCH101J50		
C 104	(B,296,51)	CCSRCH101J50	C 183	(B,287,14)	CCSRCH101J50		
C 105	(B,293,45)	CCSRCH101J50	C 184	(B,285,14)	CCSRCH101J50		
C 106	(B,296,40)	CCSRCH101J50	C 185	(B,283,44)	CCSRCH101J50		
C 107	(B,293,86)	CCSRCH101J50	C 186	(B,288,42)	CCSRCH101J50		
C 108	(B,296,81)	CCSRCH101J50	C 187	(B,283,84)	CCSRCH101J50		
C 109	(B,293,72)	CCSRCH101J50	C 188	(B,285,83)	CCSRCH101J50		B
C 110	(B,296,68)	CCSRCH101J50	C 189	(B,283,71)	CCSRCH101J50		
C 111	(B,296,111)	CCSRCH101J50	C 190	(B,287,70)	CCSRCH101J50		
C 112	(B,297,107)	CCSRCH101J50	C 191	(B,283,97)	CCSRCH101J50		
C 113	(B,293,100)	CCSRCH101J50	C 192	(B,285,96)	CCSRCH101J50		
C 114	(B,296,96)	CCSRCH101J50	C 197	(B,292,29)	CCSRCH101J50		
C 115	(B,262,98)	CKSRYP103K50	C 198	(B,294,25)	CCSRCH101J50		
C 116	(B,267,97)	CKSRYP103K50	C 199	(A,281,50)	CKSRYP103K50		
C 117	(B,283,116)	CCSRCH220J50	C 201	(A,183,85)	CEAT2R2M50		
C 118	(B,285,109)	CCSRCH220J50	C 202	(A,184,92)	CEAT2R2M50		
C 121	(A,280,34)	CEAT100M50	C 205	(A,193,85)	CCSRCH331J50		
C 122	(A,280,25)	CEAT100M50	C 206	(A,194,90)	CCSRCH331J50		C
C 123	(A,280,19)	CEAT100M50	C 207	(B,193,85)	CCSRCH331J50		
C 124	(A,280,11)	CEAT100M50	C 208	(B,193,91)	CCSRCH331J50		
C 125	(A,280,62)	CEAT100M50	C 213	(A,223,84)	CEAT100M50		
C 126	(A,280,53)	CEAT100M50	C 214	(A,223,90)	CEAT100M50		
C 127	(A,280,47)	CEAT100M50	C 217	(A,202,85)	CKSRYP103K50		
C 128	(A,280,40)	CEAT100M50	C 218	(A,202,90)	CKSRYP103K50		
C 131	(A,280,87)	CEAT100M50	C 219	(A,221,87)	CKSRYP104K16		
C 132	(A,280,80)	CEAT100M50	C 220	(A,210,93)	CKSRYP104K16		
C 133	(A,280,74)	CEAT100M50	C 221	(A,230,75)	CKSRYP103K50		
C 134	(A,280,67)	CEAT100M50	C 222	(A,243,70)	CKSRYP103K50		
C 135	(A,280,114)	CEAT100M50	C 241	(A,183,70)	CEAT2R2M50		D
C 136	(A,280,106)	CEAT100M50	C 242	(A,183,77)	CEAT2R2M50		
C 137	(A,280,101)	CEAT100M50	C 245	(A,194,69)	CCSRCH331J50		
C 138	(A,280,93)	CEAT100M50	C 246	(A,194,74)	CCSRCH331J50		
C 139	(A,53,100)	CEAT100M50	C 247	(B,193,69)	CCSRCH331J50		
C 140	(A,53,95)	CEAT100M50	C 248	(B,193,75)	CCSRCH331J50		
C 141	(A,256,82)	CKSRYP104K50	C 249	(A,205,69)	CEAT100M50		
C 145	(B,256,81)	CCSRCH101J50	C 250	(A,205,75)	CEAT100M50		
C 146	(B,258,81)	CCSRCH101J50	C 251	(A,204,65)	CKSRYP103K50		
C 147	(B,253,81)	CKSRYP103K50	C 252	(A,211,78)	CKSRYP103K50		
C 148	(B,238,67)	CKSRYP223K25	C 261	(A,183,54)	CEAT2R2M50		E
C 149	(B,235,67)	CKSRYP473K25	C 262	(A,183,62)	CEAT2R2M50		
C 150	(B,231,67)	CKSQYB154K16	C 264	(A,191,59)	CCSRCH331J50		
C 151	(B,45,62)	CKSRYP103K50	C 265	(A,194,53)	CCSRCH331J50		
C 152	(B,230,62)	CKSRYP223K25	C 266	(A,194,59)	CCSRCH221J50		
C 153	(B,234,62)	CKSRYP473K25	C 267	(B,193,53)	CCSRCH331J50		
C 154	(B,232,62)	CKSQYB154K16	C 268	(B,193,60)	CCSRCH101J50		
C 155	(A,226,62)	CEAT101M10	C 269	(A,205,54)	CEAT100M50		
C 156	(A,229,56)	CEAT101M10	C 270	(A,205,60)	CEAT100M50		
C 157	(A,236,56)	CEAT101M10	C 271	(A,203,51)	CKSRYP103K50		
C 158	(A,232,50)	CEAT101M10	C 272	(A,210,64)	CKSRYP103K50		F
C 159	(A,241,50)	CEAT101M10	C 281	(A,183,46)	CEAT2R2M50		
C 160	(A,234,44)	CEAT101M10	C 282	(A,184,39)	CEAT2R2M50		
C 161	(A,241,44)	CEAT101M10	C 285	(A,194,44)	CCSRCH331J50		
C 162	(A,248,44)	CEAT101M10	C 286	(A,194,38)	CCSRCH331J50		

Mark No. Description**Part No.****Mark No. Description****Part No.**

C 287 (B,193,45) CCSRCH331J50
 C 288 (B,193,38) CCSRCH331J50
 C 289 (A,205,44) CEAT100M50
 C 290 (A,206,38) CEAT100M50
 C 291 (A,216,39) CKSRYB103K50

C 292 (A,216,48) CKSRYB103K50
 C 323 (A,146,36) CCSRCH101J50
 C 324 (A,140,49) CCSRCH101J50
 C 325 (A,136,39) ELECT. CAPACITOR CEAT220M50
 C 326 (A,136,46) ELECT. CAPACITOR CEAT220M50

C 327 (A,132,42) CKSRYB103K50
 C 328 (A,132,39) CKSRYB103K50
 C 333 (A,255,93) CEAT101M10
 C 334 (A,268,81) CEAT101M10
 C 343 (A,149,51) CCSRCH101J50

C 344 (A,150,66) CCSRCH101J50
 C 345 (A,145,56) ELECT. CAPACITOR CEAT220M50
 C 346 (A,145,63) ELECT. CAPACITOR CEAT220M50
 C 347 (A,140,64) CKSRYB103K50
 C 348 (A,141,58) CKSRYB103K50

C 362 (A,169,70) CEAT100M50
 C 363 (A,139,68) CCSRCH101J50
 C 364 (A,139,84) CKSRYB472K50
 C 365 (A,136,73) ELECT. CAPACITOR CEAT220M50
 C 366 (A,136,80) ELECT. CAPACITOR CEANP4R7M50

C 367 (A,135,88) CKSRYB103K50
 C 368 (A,147,75) CKSRYB103K50
 C 370 (A,161,74) CEAT4R7M50
 C 386 (A,157,84) CCSRCH101J50
 C 387 (A,157,95) CCSRCH101J50

C 388 (A,153,90) ELECT. CAPACITOR CEAT220M50
 C 389 (A,153,97) ELECT. CAPACITOR CEAT220M50
 C 390 (A,164,88) CKSRYB103K50
 C 392 (B,91,95) CKSRYB102K50
 C 393 (A,156,92) CKSRYB103K50

C 1031(A,286,65) CCSRCH220J50
 C 1041(B,287,55) CCSRCH220J50
 C 5001(B,230,10) CKSRYB102K50
 C 5002(B,232,10) CKSRYB103K50
 C 5003(B,234,10) CKSRYB105K10

C 5011(A,77,16) CEJQ100M50
 C 5013(A,54,17) CCSRCH270J50
 C 5014(A,54,18) CCSRCH270J50
 C 5015(A,59,20) CEJQ470M16
 C 5016(A,54,15) CKSRYB103K50

C 5017(A,73,14) CCSRCH561J50
 C 5020(A,69,13) CKSRYB472K50
 C 5025(A,166,12) CKSRYB102K50
 C 5026(A,170,14) CKSRYB102K50
 C 5027(A,177,14) CKSRYB102K50

C 5028(A,179,16) CCSRCH220J50
 C 6001(A,139,18) CKSRYB104K16
 C 9004(A,121,94) CKSRYB103K50
 C 9005(A,116,99) CEJQ2R2M50
 C 9006(A,122,88) CKSRYB105K10

C 9007(A,79,92) ELECT. CAPACITOR CEAT331M6R3
 C 9008(B,77,90) CKSRYB103K50
 C 9011(B,95,89) CKSRYB473K16
 C 9014(B,87,88) CKSRYB473K16
 C 9015(A,100,95) CKSRYB102K50

C 9018(B,72,72) CKSRYB104K50
 C 9081(A,120,69) CKSRYB103K50
 C 9082(A,97,16) CKSRYB104K16

B DSP ASSY **MISCELLANEOUS**

IC 601 (A,109,36) DA I/F TRANSCEIVER AK4114VQ
 IC 701 (A,77,29) CODEC IC AK4628AVQ
 IC 801 (A,37,39) DSP IC DSPC56371AF180
 IC 802 (A,33,26) IC TC7WU04FU
 IC 851 (A,50,17) FLASH ROM IC PDC151A8

IC 871 (B,65,43) IC TC7WH125FU
 ⚠ IC 901 (B,114,24) REGURATOR IC PQ1LAX95MSPQ
 ⚠ IC 902 (A,99,24) REGURATOR IC PQ1LAX95MSPQ
 IC 952 (A,16,32) IC TC74VHCT541AFTS1
 Q 801 (B,33,29) TRANSISTOR RT1N241M

D 701 (A,81,19) DIODE MA152WA
 D 702 (B,82,18) DIODE MA152WK
 D 901 (B,107,21) DIODE UDZS5R6(B)
 D 902 (B,102,20) DIODE UDZS5R6(B)
 L 601 (B,103,41) CHIP SOLID INDUCTOR QTL1013

L 602 (A,100,36) CHIP SOLID INDUCTOR QTL1013
 L 701 (B,68,30) CHIP SOLID INDUCTOR QTL1013
 L 702 (A,93,22) CHIP SOLID INDUCTOR QTL1013
 L 801 (A,37,25) CHIP SOLID INDUCTOR QTL1013
 L 802 (A,42,29) CHIP SOLID INDUCTOR ATL7002

L 803 (A,51,42) CHIP SOLID INDUCTOR ATL7002
 L 804 (B,29,34) CHIP SOLID INDUCTOR QTL1013
 L 851 (A,46,21) CHIP SOLID INDUCTOR QTL1013
 L 871 (B,69,45) CHIP SOLID INDUCTOR QTL1013
 L 901 (B,105,18) CHIP SOLID INDUCTOR ATL7002

L 902 (B,100,18) CHIP SOLID INDUCTOR ATL7002
 L 952 (A,21,28) CHIP SOLID INDUCTOR QTL1013
 JA501 (A,142,22) JACK AKB7131
 X 801 (A,23,22) CRYSTAL RESONATOR XSS3003
 (24.576MHz)
 CN601 (A,107,50) 10P CONNECTOR VKN1241

CN701 (A,83,14) 19P SOCKET XKP3080
 CN901 (A,116,14) 13P SOCKET XKP3077
 CN951 (A,45,14) 15P SOCKET XKP3078

RESISTORS

R 403 (A,122,42) RS1/16SS0R0J
 R 501 (B,131,16) RS1/16S750J
 R 502 (B,134,30) RS1/16S750J
 R 516 (B,114,36) RS1/16S100J
 R 517 (B,130,30) RS1/16S100J

R 572 (A,92,40) RS1/16S0R0J
 R 573 (A,91,44) RS1/16SS0R0J
 R 574 (A,76,42) RS1/16SS0R0J
 R 575 (A,76,40) RS1/16SS0R0J
 R 576 (A,78,44) RS1/16SS0R0J

R 604 (B,114,46) RS1/16S104J
 R 605 (B,112,46) RS1/16S104J
 R 606 (B,110,46) RS1/16S104J
 R 612 (A,117,33) RS1/16S0R0J
 R 614 (A,102,38) RS1/16SS101J

R 615 (A,104,30) RS1/16SS470J
 R 616 (A,102,34) RS1/16SS101J

5		6		7		8	
Mark No.	Description	Part No.	Mark No.	Description	Part No.	Mark No.	Description
R 617	(B,105,31)	RS1/16S101J	R 874	(B,59,44)	RS1/16S470J		
R 618	(B,107,31)	RS1/16S101J	R 905	(B,118,17)	RS1/16S104J		
R 620	(A,106,30)	RS1/16SS470J	R 906	(B,120,15)	RS1/16S104J		
R 621	(B,108,36)	RS1/16S220J	R 908	(A,123,13)	RS1/16SS0R0J		
R 624	(A,112,28) RESISTOR ARRAY	RAB4CQ101J	R 919	(A,113,20)	RS1/16S1202F		
R 627	(B,112,32)	RS1/16S103J	R 920	(A,115,20)	RS1/16S2002F		
R 628	(A,117,38)	RS1/16S1802F	R 921	(A,101,20)	RS1/16S1202F		
R 665	(A,99,58)	RS1/16SS0R0J	R 922	(A,98,20) CHIP RESISTOR	RS1/16S1000F		
R 666	(A,98,58)	RS1/16SS0R0J	R 951	(B,25,33)	RS1/16S101J		
R 667	(A,97,58)	RS1/16SS0R0J	R 952	(B,23,33)	RS1/16S101J		
R 701	(B,78,35)	RS1/16S470J	R 953	(B,21,33)	RS1/16S101J		
R 702	(B,75,35)	RS1/16S101J	R 954	(A,17,26) RESISTOR ARRAY	RAB4CQ101J		
R 704	(B,70,27)	RS1/16S4R7J	R 955	(A,14,26) RESISTOR ARRAY	RAB4CQ101J		
R 705	(A,60,18)	RS1/16SS101J	R 962	(A,32,18) RESISTOR ARRAY	RAB4CQ104J		
R 706	(A,63,18)	RS1/16SS101J	R 970	(A,37,18) RESISTOR ARRAY	RAB4CQ104J		
R 707	(A,65,18)	RS1/16SS101J	R 981	(A,14,38)	RS1/16SS0R0J		
R 708	(A,68,18)	RS1/16SS101J	R 982	(A,15,38)	RS1/16SS0R0J		
R 709	(A,70,18)	RS1/16SS101J					
R 710	(A,73,18)	RS1/16SS101J	CAPACITORS				
R 711	(A,75,18)	RS1/16SS101J	C 503	(B,127,16)	CKSRYB103K50		
R 712	(A,78,18)	RS1/16SS101J	C 504	(B,132,30)	CKSRYB103K50		
R 713	(A,86,30)	RS1/16S470J	C 606	(A,102,40)	CKSRYB104K16		
R 714	(A,85,36) RESISTOR ARRAY	RAB4CQ101J	C 607	(A,96,39)	CEVW470M6R3		
R 801	(A,48,48)	RS1/16SS470J	C 608	(A,101,36)	CCSRCH471J50		
R 802	(A,40,50) RESISTOR ARRAY	RAB4CQ101J	C 609	(A,102,36)	CKSRYB104K16		
R 803	(B,44,48)	RS1/16S103J	C 614	(B,110,32)	CKSRYB104K16		
R 804	(B,42,48)	RS1/16S103J	C 617	(B,114,32)	CKSRYB102K50		
R 805	(B,39,42)	RS1/16S103J	C 618	(A,117,28)	CEVW470M6R3		
R 806	(B,37,42)	RS1/16S103J	C 619	(A,118,35)	CKSSYB104K10		
R 807	(B,35,42)	RS1/16S473J	C 620	(A,116,35)	CCSRCH471J50		
R 810	(A,26,39)	RS1/16SS473J	C 621	(A,116,38)	CKSRYB474K10		
R 811	(A,24,37)	RS1/16SS472J	C 701	(A,67,32)	CKSSYB103K16		
R 812	(B,27,43)	RS1/16S101J	C 703	(A,64,23)	CEVW101M16		
R 813	(A,24,34)	RS1/16SS103J	C 704	(A,67,29)	CKSRYB104K16		
R 815	(A,25,26)	RS1/16SS105J	C 705	(A,68,30)	CCSSCH101J50		
R 816	(A,23,26)	RS1/16SS471J	C 706	(B,66,26)	CKSRYB104K16		
R 817	(A,34,28)	RS1/16SS101J	C 707	(B,60,19)	CKSRYB471K50		
R 818	(B,35,23)	RS1/16S220J	C 708	(B,63,19)	CKSRYB471K50		
R 819	(B,26,29)	RS1/16S101J	C 709	(B,65,19)	CKSRYB471K50		
R 821	(B,31,29)	RS1/16S0R0J	C 710	(B,68,19)	CKSRYB471K50		
R 822	(B,36,30)	RS1/16S103J	C 711	(B,70,19)	CKSRYB471K50		
R 823	(B,36,36)	RS1/16S473J	C 712	(B,73,19)	CKSRYB471K50		
R 827	(B,48,38)	RS1/16S470J	C 713	(B,75,19)	CKSRYB471K50		
R 828	(B,41,27)	RS1/16S470J	C 714	(B,78,19)	CKSRYB471K50		
R 829	(B,44,33)	RS1/16S470J	C 715	(A,90,29)	CEVW101M16		
R 830	(B,46,33)	RS1/16S470J	C 716	(A,86,27)	CKSRYB104K16		
R 831	(B,42,31)	RS1/16S470J	C 717	(A,85,27)	CKSSYB471K50		
R 832	(A,47,41)	RS1/16SS470J	C 718	(A,87,20)	CEVW470M6R3		
R 833	(A,48,45) RESISTOR ARRAY	RAB4CQ470J	C 720	(A,85,24)	CKSSYB104K10		
R 840	(A,24,33)	RS1/16SS101J	C 763	(B,53,36)	CKSRYB471K50		
R 841	(A,67,38)	RS1/16S473J	C 764	(B,55,36)	CKSRYB104K16		
R 851	(A,44,28)	RS1/16SS470J	C 802	(A,42,50)	CKSSYB104K10		
R 852	(B,43,27)	RS1/16S222J	C 803	(A,37,49)	CKSSYB471K50		
R 853	(B,48,14)	RS1/16S103J	C 804	(A,37,50)	CKSSYB104K10		
R 855	(B,41,21)	RS1/16S103J	C 806	(A,31,50)	CKSSYB104K10		
R 856	(A,54,18)	RS1/16SS103J	C 808	(A,26,43)	CKSSYB104K10		
R 857	(B,45,27)	RS1/16S103J	C 809	(A,27,41)	CKSSYB471K50		
R 871	(B,59,36)	RS1/16S470J	C 810	(A,26,41)	CKSSYB104K10		
R 872	(B,61,36)	RS1/16S470J	C 814	(A,27,33)	CKSSYB471K50		
R 873	(B,61,44)	RS1/16S470J	C 815	(A,25,33)	CKSSYB104K10		

Mark No.	Description	Part No.	Mark No.	Description	Part No.
C 816	(A,21,26)	CCSSCH5R0C50	Q 683	(A,59,65) TRANSISTOR	2SC2240
C 817	(A,27,26)	CCSSCH5R0C50	Q 696	(B,284,22) TRANSISTOR	2SC4081
C 818	(A,35,23)	CCSRCH471J50			
A C 819	(A,35,22)	CKSSYB104K10	Q 697	(B,282,26) TRANSISTOR	2SC4081
			Q 698	(B,246,67) TRANSISTOR	RT1N241M
C 821	(A,30,30)	CKSSYB471K50	⚠ Q 701	(A,110,72) TRANSISTOR	2SC5511
C 822	(A,30,29)	CKSSYB104K10	⚠ Q 702	(A,96,86) TRANSISTOR	2SA2005
C 823	(A,32,30)	CKSSYB471K50	Q 703	(A,155,76) TRANSISTOR	2SA1145
C 824	(A,32,28)	CKSSYB104K10			
C 825	(B,32,39)	CKSRYB103K50	Q 704	(A,166,79) TRANSISTOR	2SC2240
			Q 705	(B,245,74) CHIP TRANSISTOR	RN4903
C 826	(A,38,29)	CKSSYB471K50	Q 707	(B,241,74) CHIP TRANSISTOR	RN4903
C 827	(A,38,28)	CKSSYB104K10	Q 721	(A,142,71) TRANSISTOR	2SA1145
C 829	(A,47,36)	CKSSYB104K10	Q 722	(A,161,74) TRANSISTOR	2SC2240
C 830	(A,47,39)	CKSSYB471K50			
C 831	(A,48,39)	CKSSYB104K10	Q 801	(B,277,141) DIGITAL TR(SC-70)	RT1P241M
			Q 802	(B,274,145) TRANSISTOR	RT1N241M
C 833	(A,48,43)	CKSSYB104K10	Q 803	(B,265,140) DIGITAL TR(SC-70)	RT1P241M
C 834	(A,41,23)	CEVW101M16	Q 804	(B,268,145) TRANSISTOR	RT1N241M
C 835	(A,57,42) CHIP ELECT.CAPACITOR	CEVW101M4	Q 805	(B,277,146) DIGITAL TR(SC-70)	RT1P241M
C 852	(A,45,18)	CKSSYB104K10			
C 872	(B,70,41)	CKSRYB104K16	Q 806	(B,271,145) TRANSISTOR	RT1N241M
			Q 807	(B,276,53) TRANSISTOR	RT3P22M
C 907	(B,110,23)	CKSRYB105K16	Q 808	(B,283,56) TRANSISTOR	RT3N22M
C 908	(A,115,22)	CKSRYB105K16	Q 810	(A,206,104) TRANSISTOR	2SD1858X
C 909	(B,97,26)	CKSRYB105K16	D 601	(A,125,57) DIODE	1SS133
C 910	(B,97,22)	CKSRYB105K16			
C 916	(B,69,34)	CKSRYB471K50	D 602	(A,272,21) ZENER DIODE	MTZJ15A
			D 603	(A,119,57) DIODE	1SS133
C 917	(B,71,34)	CKSRYB103K50	D 604	(A,261,21) ZENER DIODE	MTZJ15A
C 918	(B,81,36)	CKSRYB104K16	D 606	(A,259,57) DIODE	1SS133
C 919	(B,82,36)	CKSRYB471K50	D 608	(A,253,52) DIODE	1SS133
C 955	(A,22,31)	CKSRYB104K16			

C POWER PACK ASSY MISCELLANEOUS

⚠ IC 601	(A,265,14) POWER PACK 2CH	STK412-530	D 652	(A,262,57) DIODE	1SS133
⚠ IC 602	(A,199,14) POWER PACK 2CH	STK412-530	D 653	(A,186,52) DIODE	1SS133
⚠ IC 603	(A,132,14) POWER PACK 3CH	STK413-530	D 654	(A,242,52) DIODE	1SS133
⚠ IC 604	(A,265,43) PROTECTOR(10A)	AEK7022	D 681	(A,139,21) ZENER DIODE	MTZJ15A
⚠ IC 605	(A,273,41) PROTECTOR(10A)	AEK7022	D 682	(A,128,21) ZENER DIODE	MTZJ15A
⚠ IC 606	(A,133,48) PROTECTOR(10A)	AEK7022			
⚠ IC 607	(A,138,47) PROTECTOR(10A)	AEK7022	D 683	(A,135,58) DIODE	1SS133
⚠ IC 608	(A,199,48) PROTECTOR(10A)	AEK7022	D 684	(A,65,72) DIODE	1SS133
⚠ IC 609	(A,205,48) PROTECTOR(10A)	AEK7022	⚠ D 701	(A,9,88) DIODE	D5SBA20(B)
⚠ IC 610	(A,59,28) PROTECTOR(1A)	AEK7009	⚠ D 702	(A,9,126) DIODE	D5SBA20(B)
			D 703	(B,252,76) DIODE	1SS355
IC 701	(A,100,80) IC PROTECTOR	ICP-N10	D 711	(A,196,103) ZENER DIODE	MTZJ22D
IC 702	(A,84,81) IC PROTECTOR	ICP-N10	D 712	(A,192,103) DIODE	MTZJ6R8(B)
⚠ IC 803	(B,238,94) IC	BA05FP	D 713	(A,118,78) DIODE	1SS133
⚠ IC 804	(A,282,111) REGULATOR IC	TA7809S	D 741	(B,152,136) DIODE	1SS355
⚠ IC 805	(B,270,132) LDO REGULATOR(5V)	NJM2831F05	D 742	(B,167,140) DIODE	1SS355
Q 501	(B,86,38) TRANSISTOR	2SC5938A	D 743	(B,121,129) DIODE	1SS355
Q 505	(A,111,47) TRANSISTOR	2SC2240	D 744	(B,138,139) DIODE	1SS355
Q 601	(B,89,44) TRANSISTOR	2SC5938A	D 745	(B,115,129) DIODE	1SS355
Q 602	(B,224,43) TRANSISTOR	2SC5938A	D 746	(B,91,130) DIODE	1SS355
Q 605	(A,118,40) TRANSISTOR	2SC2240	D 747	(B,71,147) DIODE	1SS355
Q 606	(A,252,40) TRANSISTOR	2SC2240	D 751	(B,168,135) DIODE	1SS355
Q 631	(B,152,38) TRANSISTOR	2SC5938A	D 752	(B,170,135) DIODE	1SS355
Q 633	(A,178,47) TRANSISTOR	2SC2240	D 753	(B,138,132) DIODE	1SS355
Q 651	(B,158,43) TRANSISTOR	2SC5938A	D 754	(B,141,132) DIODE	1SS355
Q 652	(B,219,37) TRANSISTOR	2SC5938A	D 757	(B,70,136) DIODE	1SS355
Q 655	(A,186,40) TRANSISTOR	2SC2240	D 758	(B,73,136) DIODE	1SS355
Q 656	(A,244,47) TRANSISTOR	2SC2240	D 777	(A,127,57) DIODE	1SS133
Q 681	(B,77,48) TRANSISTOR	2SC5938A	D 778	(A,108,57) DIODE	1SS133

5		6		7		8	
Mark No.	Description	Part No.	Mark No.	Description	Part No.		
D 779	(A,196,34) DIODE	30PDA20-FC6	R 618	(A,266,29)	RD1/4PU562J		
D 780	(A,201,17) DIODE	30PDA20-FC6	R 619	(A,122,52)	RD1/4PU182J		
			R 620	(A,257,36)	RD1/4PU331J		
D 781	(A,264,35) DIODE	30PDA20-FC6					
D 782	(A,267,17) DIODE	30PDA20-FC6	R 621	(A,124,49)	RD1/4PU821J		A
D 783	(A,129,37) DIODE	30PDA20-FC6	△ R 622	(A,248,31) RESISTOR (0.22, 5W)	ACN7094		
D 784	(A,135,17) DIODE	30PDA20-FC6	R 623	(A,116,48)	RD1/4PU223J		
△ D 801	(B,221,113) BRIDGE DIODE	S1VB(A)60SD	R 624	(A,257,52)	RD1/4PU182J		
			R 625	(B,116,22)	RS1/16S0R0J		
D 806	(A,287,62) DIODE	MTZJ6R2(B)					
D 807	(A,284,67) DIODE	1SS133	R 626	(A,258,49)	RD1/4PU821J		
D 827	(A,262,133) DIODE	MTZJ6R2(B)	R 627	(B,107,28)	RS1/16S0R0J		
D 828	(A,224,99) DIODE	MTZJ6R2(B)	R 628	(A,250,48)	RD1/4PU223J		
△ D 829	(A,239,128) DIODE	D3SBA20(B)	R 629	(B,92,9)	RS1/16S0R0J		
			R 630	(A,230,21)	RD1/4PU102J		
D 900	(A,213,93) DIODE	MTZJ7R5(B)					
L 501	(A,97,118) COIL	ATH1004	R 631	(A,148,42)	RD1/4PU102J		B
L 751	(A,160,108) COIL	ATH1004	R 632	(B,152,41)	RS1/16S103J		
L 752	(A,173,108) COIL	ATH1004	R 635	(A,153,29)	RD1/4PU563J		
L 753	(A,120,107) COIL	ATH1004	R 636	(A,149,25)	RD1/4PU182J		
			R 637	(A,172,21)	RD1/4PU563J		
L 754	(A,78,118) COIL	ATH1004					
L 761	(A,130,108) COIL	ATH1004	R 638	(A,174,36)	RD1/4PU331J		
L 762	(A,142,108) COIL	ATH1004	△ R 639	(A,173,31) RESISTOR (0.22, 5W)	ACN7094		
J 43	JUMPER WIRE 11P	D2OPYY1120E	R 640	(A,179,57)	RD1/4PU182J		
KN601	(A,65,23) WRAPPING TERMINAL	VNF1084	R 641	(A,174,52)	RD1/4PU821J		
			R 642	(A,169,39)	RD1/4PU223J		
RY501	(A,75,132) RELAY	ASR7001					
RY751	(A,173,130) RELAY	ASR7001	R 647	(A,202,29)	RD1/4PU562J		
RY752	(A,141,126) RELAY	ASR7001	R 648	(A,199,29)	RD1/4PU562J		C
RY753	(A,117,120) RELAY	ASR7001	R 651	(A,162,47)	RD1/4PU102J		
CN701	(A,212,134) 11PJUMPER CONNECTOR	52147-1110	R 652	(A,215,36)	RD1/4PU102J		
			R 653	(B,158,47)	RS1/16S103J		
CN702	(A,201,106) 6PJUMPER CONNECTOR	52147-0610					
CN705	(A,295,40) 21P PLUG	XKM3011	R 654	(B,219,41)	RS1/16S103J		
CN751	SP TERMINAL 8-P(V0)	XKE3042	R 659	(A,159,35)	RD1/4PU563J		
CN752	SP TERMINAL 6-P(V0)	XKE3043	R 660	(A,220,29)	RD1/4PU563J		
CN803	(A,231,129) 6P PLUG	KM200TA6	R 661	(A,156,28)	RD1/4PU182J		
			R 662	(A,216,20)	RD1/4PU182J		
CN805	(A,317,153) 13P PLUG	XKP3066					
CN806	(A,317,120) 19P PLUG	XKP3069	R 663	(A,181,21)	RD1/4PU563J		
CN807	(A,317,82) 15P PLUG	XKP3067	R 664	(A,238,21)	RD1/4PU563J		
CN808	(A,205,89) CONNECTOR	CKS3374	R 665	(A,190,36)	RD1/4PU331J		D
CN812	(A,323,30) 15P PLUG	XKP3067	R 666	(A,240,35)	RD1/4PU331J		
			△ R 667	(A,182,31) RESISTOR (0.22, 5W)	ACN7094		
CN813	(A,308,38) CONNECTOR	CKS3390					
CN815	(A,295,79) 23P PLUG	XKM3006	△ R 668	(A,239,31) RESISTOR (0.22, 5W)	ACN7094		
CN816	(A,295,126) 21P PLUG	XKM3011	R 669	(A,189,52)	RD1/4PU182J		
810	(A,277,90) 11P CABLE HOLDER	51048-1100	R 670	(A,245,52)	RD1/4PU182J		
			R 671	(A,192,49)	RD1/4PU821J		
			R 672	(A,240,57)	RD1/4PU821J		
RESISTORS							
R 601	(A,95,48)	RD1/4PU102J					
R 602	(A,228,42)	RD1/4PU102J	R 673	(A,184,48)	RD1/4PU223J		
R 603	(B,91,47)	RS1/16S103J	R 674	(A,236,38)	RD1/4PU223J		
R 604	(B,225,47)	RS1/16S103J	R 681	(A,72,51)	RD1/4PU102J		
R 605	(B,250,23)	RS1/16S0R0J	R 682	(B,70,49)	RS1/16S103J		E
			R 685	(B,75,37)	RS1/16S563J		
R 606	(B,241,28)	RS1/16S0R0J					
R 607	(B,184,23)	RS1/16S0R0J	R 686	(B,80,21)	RS1/16S182J		
R 608	(B,175,28)	RS1/16S0R0J	R 687	(A,83,10)	RD1/4PU563J		
R 609	(A,91,35)	RD1/4PU563J	R 688	(A,135,30)	RD1/4PU562J		
R 610	(A,225,35)	RD1/4PU563J	R 689	(A,132,30)	RD1/4PU562J		
			R 690	(A,60,52)	RD1/4PU331J		
R 611	(A,90,28)	RD1/4PU182J					
R 612	(A,223,28)	RD1/4PU182J	△ R 691	(A,55,55) RESISTOR (0.22, 5W)	ACN7094		
R 613	(A,114,21)	RD1/4PU563J	R 692	(A,70,72)	RD1/4PU182J		
R 614	(A,247,21)	RD1/4PU563J	R 693	(A,67,77)	RD1/4PU821J		
R 615	(A,123,36)	RD1/4PU331J	R 694	(A,62,72)	RD1/4PU223J		
			R 695	(A,97,22)	RD1/4PU102J		F
R 616	(A,270,29)	RD1/4PU562J					
△ R 617	(A,114,31) RESISTOR (0.22, 5W)	ACN7094	R 696	(B,281,38)	RS1/16S103J		
			R 697	(B,255,68)	RS1/16S103J		

Mark No. Description**Part No.****Mark No. Description****Part No.**

R 698 (B,243,67)
R 699 (A,165,21)
R 701 (A,121,86)

RS1/16S333J
RD1/4PU102J
RD1/4PU682J

R 807 (B,278,48)
R 808 (B,283,52)
R 813 (B,274,130)

RS1/16S103J
RS1/16S102J
RS1/16S102J

A

R 702 (A,110,87)
R 703 (A,151,72)
R 704 (A,148,77)
R 705 (A,283,85)
R 706 (A,283,75)

RD1/4PU682J
RD1/4PU104J
RD1/4PU104J
RD1/4PU473J
RD1/4PU473J

R 885 (B,310,57)
R 886 (B,310,61)
R 887 (B,310,65)
R 888 (B,315,22)
R 900 (B,212,97)

RS1/16S221J
RS1/16S221J
RS1/16S221J
RS1/16S221J
RS1/16S102J

R 707 (A,135,77)
R 708 (A,147,81)
⚠ R 711 (A,181,86) METAL OXIDE RESISTOR
R 713 (A,118,86)
R 714 (B,252,68)

RD1/4PU124J
RD1/4PU124J
RS2LMF222J
RD1/4PU102J
RS1/16S102J

R 901 (B,211,100)
R 1101(B,273,68)
R 1102(B,274,61)
R 1109(B,285,56)
R 1110(B,241,68)

RS1/16S100J
RS1/16S0R0J
RS1/16S0R0J
RS1/16S0R0J
RS1/16S0R0J

B

R 715 (B,250,75)
R 716 (B,247,75)
R 721 (A,145,77)
R 722 (A,124,78)
R 723 (A,276,78)

RS1/16S103J
RS1/16S103J
RD1/4PU822J
RD1/4PU822J
RD1/4PU473J

CAPACITORS

C 517 (A,82,154) FILM CAPACITOR
C 521 (A,120,164) FILM CAPACITOR
C 603 (B,94,39)
C 604 (B,227,38)
C 605 (A,96,38)

CQ MBA224J50
CQ MBA123J50
CK SRYB331K50
CK SRYB331K50
CEAT4R7M50

R 724 (A,279,83)
R 725 (A,276,74)
R 726 (B,291,59)
R 727 (B,287,59)
R 728 (B,106,9)

RD1/4PU473J
RD1/4PU103J
RS1/16S103J
RS1/16S103J
RS1/16S123J

C 606 (A,230,38)
C 607 (B,95,20)
C 608 (B,230,17)
C 609 (A,91,32)
C 610 (A,225,32)

CEAT4R7M50
CCSRCH470J50
CCSRCH470J50
CEAT101M16
CEAT101M16

C

R 729 (B,152,16)
R 730 (B,214,14)
R 731 (A,121,73)
R 732 (A,101,89)
R 740 (B,87,141)

RS1/16S123J
RS1/16S123J
RD1/4PU220J
RD1/4PU220J
RS1/16S683J

C 613 (B,116,27)
C 614 (B,250,28)
C 615 (A,116,45)
C 616 (A,250,45)
C 630 (A,172,44)

CCSRCJ3R0C50
CCSRCJ3R0C50
CEANP2R2M50
CEANP2R2M50
CEANP2R2M50

R 741 (B,152,140)
R 742 (B,169,143)
R 743 (B,121,134)
R 744 (B,137,143)
R 745 (B,110,131)

RS1/16S333J
RS1/16S333J
RS1/16S333J
RS1/16S333J
RS1/16S333J

C 632 (B,150,33)
C 633 (A,148,32)
C 634 (B,155,17)
C 635 (A,153,25)
C 637 (B,175,24)

CK SRYB331K50
CEAT4R7M50
CCSRCH470J50
CEAT101M16
CCSRCJ3R0C50

R 746 (B,85,132)
R 747 (B,70,143)

RS1/16S333J
RS1/16S333J

C 653 (B,161,38)
C 654 (B,217,33)
C 655 (A,163,38)
C 656 (A,215,33)
C 657 (B,165,17)

CK SRYB331K50
CK SRYB331K50
CEAT4R7M50
CEAT4R7M50
CCSRCH470J50

D

⚠ R 751 (A,158,119) CARBON FILM RESISTOR
⚠ R 752 (A,185,120) CARBON FILM RESISTOR
⚠ R 753 (A,156,126) METAL OXIDE RESISTOR

RD1/4PUF101J
RD1/4PUF101J
RS1LMF4R7J

⚠ R 754 (A,181,126) METAL OXIDE RESISTOR
⚠ R 755 (A,103,117) CARBON FILM RESISTOR
⚠ R 756 (A,101,120) METAL OXIDE RESISTOR
⚠ R 761 (A,125,117) CARBON FILM RESISTOR
⚠ R 762 (A,155,119) CARBON FILM RESISTOR

RS1LMF4R7J
RD1/4PUF101J
RS1LMF4R7J
RD1/4PUF101J
RD1/4PUF101J

C 658 (B,221,17)
C 659 (A,158,31)
C 660 (A,219,25)
C 663 (B,184,27)
C 664 (B,241,24)

CCSRCH470J50
CEAT101M16
CEAT101M16
CCSRCJ3R0C50
CCSRCJ3R0C50

⚠ R 763 (A,124,132) METAL OXIDE RESISTOR
⚠ R 764 (A,149,139) METAL OXIDE RESISTOR
⚠ R 771 (A,63,144) METAL OXIDE RESISTOR
⚠ R 772 (A,63,127) CARBON FILM RESISTOR
R 777 (A,81,37)

RS1LMF4R7J
RS1LMF4R7J
RS1LMF4R7J
RD1/4PUF101J
RD1/4PU102J

C 665 (A,184,45)
C 666 (A,239,49)
C 682 (B,75,43)
C 683 (A,78,43)
C 684 (B,82,18)

CEANP2R2M50
CEANP2R2M50
CK SRYB331K50
CEAT4R7M50
CCSRCH470J50

E

R 778 (B,85,42)
R 781 (A,87,30)
R 782 (A,84,22)
R 783 (A,104,21)
R 784 (A,111,35)

RS1/16S103J
RD1/4PU563J
RD1/4PU182J
RD1/4PU563J
RD1/4PU331J

C 685 (A,78,37)
C 687 (B,87,8)
C 688 (A,75,78)
C 696 (B,281,36)
C 697 (A,286,34)

CEAT101M16
CCSRCJ3R0C50
CEANP2R2M50
CK SRYB102K50
CEAT221M6R3

⚠ R 785 (A,105,31) RESISTOR (0.22, 5W)
R 786 (A,111,57)
R 787 (A,106,57)
R 788 (A,102,38)
R 789 (A,82,127) CARBON FILM RESISTOR

ACN7094
RD1/4PU182J
RD1/4PU821J
RD1/4PU223J
RD1/4PUF101J

C 701 (A,49,80) E-CAP 5600/71
C 702 (A,49,107) E-CAP 5600/71
C 703 (A,43,130) ELECT.CAPACITOR
C 704 (A,38,150) ELECT.CAPACITOR
C 705 (A,156,81) ELECT. CAPACITOR

XCH3027
XCH3027
XCH3012
XCH3012
CEAT100M2A

F

⚠ R 790 (A,81,132) METAL OXIDE RESISTOR
R 806 (B,283,48)

RS1LMF4R7J
RS1/16S103J

Mark No.	Description	Part No.
C 706 (A,142,84)	ELECT. CAPACITOR	CEAT100M2A
C 709 (A,257,73)		CEAT1R0M50
C 711 (A,195,99)	ELECT. CAPACITOR	CEAT101M35
C 712 (A,189,105)		CEAT101M10
C 740 (A,90,136)		CEAT101M25
C 751 (A,159,143)	FILM CAPACITOR	CQMBA224J50
C 752 (A,181,150)	FILM CAPACITOR	CQMBA224J50
C 753 (A,157,155)	FILM CAPACITOR	CQMBA224J50
C 754 (A,181,158)	FILM CAPACITOR	CQMBA224J50
C 755 (A,103,147)	FILM CAPACITOR	CQMBA224J50
C 756 (A,96,151)	FILM CAPACITOR	CQMBA224J50
C 757 (A,157,164)	FILM CAPACITOR	CQMBA123J50
C 758 (A,177,164)	FILM CAPACITOR	CQMBA123J50
C 759 (A,101,164)	FILM CAPACITOR	CQMBA123J50
C 761 (A,122,139)	FILM CAPACITOR	CQMBA224J50
C 762 (A,152,145)	FILM CAPACITOR	CQMBA224J50
C 763 (A,122,146)	FILM CAPACITOR	CQMBA224J50
C 764 (A,150,152)	FILM CAPACITOR	CQMBA224J50
C 765 (A,63,164)	FILM CAPACITOR	CQMBA123J50
C 766 (A,82,164)	FILM CAPACITOR	CQMBA123J50
C 771 (A,52,147)	FILM CAPACITOR	CQMBA224J50
C 772 (A,52,156)	FILM CAPACITOR	CQMBA224J50
C 773 (A,138,164)	FILM CAPACITOR	CQMBA123J50
C 778 (B,84,34)		CKSRYB331K50
C 779 (A,81,33)		CEAT4R7M50
C 780 (B,88,18)		CCSRCH470J50
C 781 (A,87,27)		CEAT101M16
C 783 (B,107,24)		CCSRCJ3R0C50
C 784 (A,105,49)		CEANP2R2M50
C 785 (A,89,146)	FILM CAPACITOR	CQMBA224J50
C 801 (A,248,114)	ELECT. CAPACITOR	CEAT222M25
C 802 (A,249,100)	ELECT. CAPACITOR	CEAT222M25
C 806 (A,288,55)		CEAT1R0M50
C 807 (B,227,93)		CKSRYB103K25
C 808 (A,245,142)	ELECT. CAPACITOR	CEAT472M16
C 809 (A,232,95)		CEAT101M10
C 810 (A,266,133)		CEAT101M10
C 811 (B,279,128)		CKSRYB103K25
C 812 (B,278,109)		CKSRYB103K25
C 813 (A,276,118)		CEAT101M16
C 850 (A,210,94)		CEAT101M10
C 901 (B,215,91)		CKSRYB104K16

D TRANS2 ASSY

MISCELLANEOUS

△ IC 853 (A,32,204)	PROTECTOR(7A)	AEK7021
J 21	JUMPER WIRE 11P	D20PYY1130E
△ CN1201(A,35,183)	4P JUMPER CONNECTOR	52147-0410
△ 851 (A,49,207)	11P CABLE HOLDER	51048-1100

RESISTORS

R 1255(A,25,189)	RD1/4PU3R3J
------------------	-------------

E TRANS3 ASSY

RESISTORS

R 881 (A,51,235)	RD1/4PU4R7J
R 882 (A,40,236)	RD1/4PU4R7J

CAPACITORS

Mark No.	Description	Part No.
C 881 (A,13,234)	MYLAR FILM CAPACITOR	COMA333K2E
C 882 (A,16,239)	MYLAR FILM CAPACITOR	COMA333K2E
C 883 (A,27,238)	FILM CAPACITOR	COMBA333J50
C 884 (A,40,239)	FILM CAPACITOR	COMBA333J50

F COMPONENT VIDEO ASSY (vsx-917v) **MISCELLANEOUS**

IC 1401(B,262,201)	LOGIC IC	TC74HC4052AF
IC 1402(B,286,189)	LOGIC IC	TC74HC4052AF
IC 1403(B,286,202)	LOGIC IC	TC74HC4053AF
IC 1404(B,223,198)	VIDEO IC	NJM2581M
IC 1405(B,190,205)	LOGIC IC	TC4094BFN

Q 1415(B,316,194)	TRANSISTOR	2SC4081
Q 1416(B,312,194)	TRANSISTOR	2SC4081
Q 1417(B,298,203)	TRANSISTOR	2SC4081
D 1401(B,210,230)	DIODE	1SS355
D 1402(B,207,230)	DIODE	1SS355

L 1401(B,318,210)	CHIP COIL	LCYA120J2520
L 1402(B,311,210)	CHIP COIL	LCYA120J2520
L 1403(B,304,209)	CHIP COIL	LCYA120J2520
JA 1401(A,250,175)	6P RCA PINJACK	XKB3025
JA 1402(A,208,175)	6P RCA PINJACK	XKB3025

CN1402(A,234,240)	CONNECTOR	CKS3372
CN1404(A,300,229)	CONNECTOR	CKS3388
CN1405(A,254,240)	CONNECTOR	CKS3374
CN1406(A,194,235)	CONNECTOR	CKS3380

RESISTORS

R 1401(B,236,184)	RS1/16S750J
R 1402(B,251,200)	RS1/16S750J
R 1403(B,263,184)	RS1/16S750J
R 1404(B,234,184)	RS1/16S750J
R 1405(B,248,183)	RS1/16S750J

R 1406(B,260,183)	RS1/16S750J
R 1407(B,199,184)	RS1/16S750J
R 1408(B,209,183)	RS1/16S750J
R 1409(B,221,182)	RS1/16S750J
R 1410(B,181,191)	RS1/16S750J

R 1411(B,216,192)	RS1/16S750J
R 1412(B,214,192)	RS1/16S750J
R 1416(B,181,201)	RS1/16S102J
R 1424(B,315,217)	RS1/16S561J
R 1425(B,309,213)	RS1/16S561J

R 1426(B,304,213)	RS1/16S561J
R 1430(B,203,211)	RS1/16S473J
R 1439(B,184,221)	RS1/16S473J
R 1440(B,181,221)	RS1/16S473J
R 1461(B,318,202)	RS1/16S223J

R 1462(B,315,201)	RS1/16S223J
R 1463(B,304,201)	RS1/16S223J
R 1464(B,320,193)	RS1/16S102J
R 1465(B,318,193)	RS1/16S102J
R 1466(B,298,208)	RS1/16S102J

R 1467(B,320,197)	RS1/16S101J
R 1468(B,309,201)	RS1/16S101J
R 1469(B,302,203)	RS1/16S101J
R 1470(B,317,215)	RS1/16S0R0J
R 1471(B,309,218)	RS1/16S0R0J

R 1472(B,301,213)	RS1/16S0R0J
R 1485(B,180,206)	RS1/16S0R0J

Mark No. Description

R 1486(B,181,225)
R 1487(B,179,235)
R 1488(B,194,223)

Part No.

RS1/16S0R0J
RS1/16S0R0J
RS1/16S0R0J

Mark No. Description

R 1411(B,216,192)
R 1412(B,214,192)
R 1482(B,184,225)
R 1483(B,180,210)
R 1484(B,183,236)

Part No.

RS1/16S750J
RS1/16S750J
RS1/16S0R0J
RS1/16S0R0J
RS1/16S0R0J

R 1495(B,265,208)
R 1497(B,277,183)

RS1/16S750J
RS1/16S750J

R 1489(B,192,223)
R 1490(B,192,219)
R 1491(B,279,204)
R 1492(B,251,215)
R 1493(B,248,210)

RS1/16S0R0J
RS1/16S0R0J
RS1/16S0R0J
RS1/16S0R0J
RS1/16S0R0J

CAPACITORS

C 1413(B,256,198)
C 1414(B,269,209)
C 1415(B,277,188)
C 1416(B,280,184)
C 1417(B,274,204)

CKSRYB103K50
CKSRYB103K50
CKSRYB103K50
CKSRYB103K50
CKSRYB103K50

C 1418(B,287,212)
C 1419(A,231,216)
C 1420(A,231,210)
C 1421(A,231,204)
C 1425(A,215,202)

CKSRYB103K50
CEAT101M10
CEAT101M10
CEAT101M10
CEAT101M10

C 1426(A,201,197)
C 1427(B,210,194)
C 1428(B,230,194)
C 1445(B,313,218)
C 1446(B,311,214)

CEAT101M10
CKSRYB104K50
CKSRYB104K50
CCSRCH120J50
CCSRCH120J50

C 1447(B,306,213)
C 1448(B,316,209)
C 1449(B,313,210)
C 1450(B,306,209)
C 1454(B,320,210)

CCSRCH120J50
CCSRCH330J50
CCSRCH330J50
CCSRCH330J50
CCSRCJ3R0C50

C 1455(B,309,209)
C 1456(B,302,209)
C 1469(B,179,196)
C 1471(A,318,205)
C 1472(A,312,205)

CCSRCJ3R0C50
CCSRCJ3R0C50
CKSRYB104K50
CEAT470M25
CEAT470M25

C 1473(A,306,205)
C 1490(B,256,183)
C 1491(B,244,183)
C 1492(B,205,183)
C 1493(B,203,183)

CEAT470M25
CKSRYB103K50
CKSRYB103K50
CKSRYB103K50
CKSRYB103K50

CAPACITORS

C 1413(B,256,198)
C 1414(B,269,209)
C 1415(B,277,188)
C 1416(B,280,184)
C 1419(A,231,216)

CKSRYB103K50
CKSRYB103K50
CKSRYB103K50
CKSRYB103K50
CEAT101M10

C 1420(A,231,210)
C 1421(A,231,204)
C 1425(A,215,202)
C 1426(A,201,197)
C 1427(B,210,194)

CEAT101M10
CEAT101M10
CEAT101M10
CEAT101M10
CKSRYB104K50

C 1428(B,230,194)
C 1490(B,256,183)
C 1491(B,244,183)
C 1492(B,205,183)
C 1493(B,203,183)

CKSRYB104K50
CKSRYB103K50
CKSRYB103K50
CKSRYB103K50
CKSRYB103K50

**G HEAD PHONE ASSY
MISCELLANEOUS**

Q 1551(B,78,211) TRANSISTOR 2SC5938A
Q 1552(B,102,219) TRANSISTOR 2SC5938A
J 47 JUMPER WIRE D20PY0640E
JA 1551(A,117,233) HEADPHONE JACK XKB3066
KN1551(A,69,231) WRAPPING TERMINAL VNF1084

1551(A,59,220) 6P CABLE HOLDER 51048-0600

RESISTORS

△ R 1551(A,84,202) METAL OXIDE RESISTOR RS2LMF331J
△ R 1552(A,78,203) METAL OXIDE RESISTOR RS2LMF331J
△ R 1553(A,108,221) METAL OXIDE RESISTOR RS1LMF151J
△ R 1554(A,93,216) METAL OXIDE RESISTOR RS1LMF151J
R 1555(B,100,216) RS1/16S472J

R 1556(B,81,210) RS1/16S472J
R 1557(B,87,228) RS1/16S102J

CAPACITORS

C 1551(B,94,226) CKSRYB223K50
C 1552(B,83,210) CKSRYB223K50
C 1553(B,110,224) CKSRYB103K50
C 1554(B,110,226) CCSRCH471J50
C 1555(B,110,229) CKSRYB104K16

C 1556(B,112,239) CKSRYB103K50
C 1557(B,109,239) CCSRCH471J50
C 1558(B,107,239) CKSRYB104K16
C 1561(A,69,205) ELECT. CAPACITOR CEANP470M50
C 1562(A,71,223) ELECT. CAPACITOR CEANP470M50

**F COMPONENT VIDEO ASSY (VSX-817)
MISCELLANEOUS**

IC 1401(B,262,201) LOGIC IC
IC 1402(B,286,189) LOGIC IC
IC 1404(B,223,198) VIDEO IC
D 1401(B,210,230) DIODE
D 1402(B,207,230) DIODE

TC74HC4052AF
TC74HC4052AF
NJM2581M
1SS355
1SS355

JA 1401(A,250,175) 6P RCA PINJACK
JA 1402(A,208,175) 6P RCA PINJACK
CN1409(A,204,235) CONNECTOR

XKB3025
XKB3025
CKS3372

RESISTORS

R 1401(B,236,184)
R 1402(B,251,200)
R 1403(B,263,184)
R 1404(B,234,184)
R 1405(B,248,183)

RS1/16S750J
RS1/16S750J
RS1/16S750J
RS1/16S750J
RS1/16S750J

R 1406(B,260,183)
R 1407(B,199,184)
R 1408(B,209,183)
R 1409(B,221,182)
R 1410(B,181,191)

RS1/16S750J
RS1/16S750J
RS1/16S750J
RS1/16S750J
RS1/16S750J

5
Mark No. Description Part No.

**H 5.1CH INPUT ASSY
 MISCELLANEOUS**

CN307 (A,125,219) 7P CONNECTOR 52044-0745
 CN309 (A,167,225) PIN JACK(4P) XKB3035

RESISTORS

R 1001(B,147,233) RS1/16S474J
 R 1002(B,150,226) RS1/16S474J
 R 1003(B,149,236) RS1/16S331J
 R 1004(B,150,228) RS1/16S331J
 R 1009(B,150,224) RS1/16S474J

 R 1010(B,151,212) RS1/16S474J
 R 1011(B,150,222) RS1/16S331J
 R 1012(B,150,214) RS1/16S331J

CAPACITORS

C 1001(B,151,233) CCSRCH101J50
 C 1002(B,151,230) CCSRCH101J50
 C 1003(B,143,233) CKSRYB221K50
 C 1004(B,147,230) CKSRYB221K50
 C 1009(A,146,236) CEAT4R7M50

 C 1010(A,146,228) CEAT4R7M50
 C 1012(B,159,226) CKSRYB103K50
 C 1013(B,151,219) CCSRCH101J50
 C 1014(B,151,216) CCSRCH101J50
 C 1015(B,147,224) CKSRYB221K50

 C 1016(B,147,216) CKSRYB221K50
 C 1021(A,146,214) CEAT4R7M50
 C 1022(A,146,221) CEAT4R7M50

**I FRONT DISPLAY ASSY
 MISCELLANEOUS**

IC 401 (B,121,181) DISPLAY U-COM PE5550A
 IC 402 (A,223,169) REMOTE RECEIVER UNIT GP1UM27XK0VF
 Q 441 (B,230,161) TRANSISTOR RT1N241M
 Q 442 (B,238,190) TRANSISTOR RT1N241M
 Q 484 (B,217,189) TRANSISTOR 2SA1576A

 D 403 (B,226,189) DIODE 1SS355
 D 404 (B,230,176) DIODE 1SS355
 D 405 (B,230,156) DIODE 1SS355
 D 500 (A,210,182) LED(ORANGE) SLI-343DCW(STU)
 D 502 (A,128,161) LED(BLUE) SLR343BC4T(JKLM)

 L 401 (A,242,159) RADIAL INDUCTOR LFCA2R2J
 V 401 (A,189,200) FL TUBE XAV3025
 S 451 (A,234,139) SWITCH VSG1024
 S 452 (A,213,136) SWITCH VSG1024
 S 453 (A,187,134) SWITCH VSG1024

 S 454 (A,70,134) SWITCH VSG1024
 S 455 (A,46,134) SWITCH VSG1024
 S 456 (A,23,134) SWITCH VSG1024
 S 458 (A,13,112) SWITCH VSG1024
 S 459 (A,114,136) SWITCH VSG1024

 S 460 (A,91,136) SWITCH VSG1024
 S 461 (A,57,112) SWITCH VSG1024
 S 462 (A,42,112) SWITCH VSG1024
 S 463 (A,27,112) SWITCH VSG1024
 S 464 (A,164,134) SWITCH VSG1024

 S 465 (A,140,134) SWITCH VSG1024
 S 466 (A,86,90) SWITCH VSG1024
 S 467 (A,72,90) SWITCH VSG1024

7
Mark No. Description Part No.

S 468 (A,57,90) SWITCH VSG1024
 S 469 (A,42,90) SWITCH VSG1024

 S 470 (A,27,90) SWITCH VSG1024
 S 471 (A,13,90) SWITCH VSG1024
 X 401 (A,149,165) CERAMIC RESONATOR VSS1142
 (5.00 MHz)
 CN401 (A,246,165) 17P CONNECTOR 52044-1745
 471 (A,35,176) CABLE HOLDER(3P) 51063-0305

 402 FL HOLDER(FE) VNF1096
 404 (A,197,127) CABLE HOLDER(7P) 51063-0705

RESISTORS

R 401 (B,144,169) RS1/16S105J
 R 402 (B,223,189) RS1/16S104J
 R 403 (B,220,189) RS1/16S104J
 R 404 (B,221,178) RS1/16S472J
 R 405 (B,228,155) RS1/16S102J

 R 406 (B,226,155) RS1/16S103J
 R 407 (B,78,176) RS1/16S473J
 R 408 (B,80,176) RS1/16S473J
 R 409 (B,75,176) RS1/16S473J
 R 410 (B,73,176) RS1/16S473J

 R 411 (B,229,189) RS1/16S473J
 R 412 (B,234,187) RS1/16S221J
 R 413 (B,234,184) RS1/16S221J
 R 414 (B,234,182) RS1/16S221J
 R 415 (B,234,180) RS1/16S221J

 R 416 (B,234,178) RS1/16S221J
 R 417 (B,219,182) RS1/16S101J
 R 422 (B,157,169) RS1/16S104J
 R 423 (B,131,167) RS1/16S104J
 R 424 (B,83,176) RS1/16S104J

 R 425 (B,213,182) RS1/16S104J
 R 451 (B,236,144) RS1/16S472J
 R 452 (B,234,144) RS1/16S681J
 R 453 (B,187,147) RS1/16S821J
 R 454 (B,166,153) RS1/16S122J

 R 455 (A,45,146) RD1/4PU681J
 R 456 (A,35,144) RD1/4PU821J
 R 457 (A,16,139) RD1/4PU122J
 R 459 (A,109,134) RD1/4PU472J
 R 460 (A,101,135) RD1/4PU681J

 R 461 (B,52,117) RS1/16S821J
 R 462 (B,49,117) RS1/16S122J
 R 463 (B,34,117) RS1/16S162J
 R 464 (B,20,117) RS1/16S272J
 R 465 (A,161,128) RD1/4PU472J

 R 466 (A,151,128) RD1/4PU681J
 R 467 (A,131,128) RD1/4PU821J
 R 468 (B,79,91) RS1/16S122J
 R 469 (B,64,91) RS1/16S162J
 R 470 (B,50,92) RS1/16S272J

 R 471 (B,34,91) RS1/16S512J
 R 472 (B,86,176) RS1/16S472J
 R 473 (B,19,91) RS1/16S133J
 R 550 (B,204,185) RS1/16S181J
 R 551 (B,125,156) RS1/16S391J

CAPACITORS

C 401 (B,247,155) CKSRYB103K50
 C 402 (B,247,153) CKSRYB103K50

Mark No. Description**Part No.****Mark No. Description****Part No.**

C 403 (A,234,168) CEAT221M6R3
 C 410 (B,49,186) CKSRYB103K50
 C 411 (B,51,186) CKSRYB103K50

Q 101 (B,198,78) TRANSISTOR 2SC4081
 Q 102 (B,198,82) TRANSISTOR 2SC4081
 Q 103 (B,190,55) TRANSISTOR 2SC4081
 Q 104 (B,194,56) TRANSISTOR 2SC4081
 Q 359 (B,206,16) TRANSISTOR RT1N241M

C 412 (A,42,178) CEAT470M50
 C 418 (B,141,179) CKSRYB104K16
 C 419 (B,103,182) CKSRYB103K50
 C 420 (A,39,185) ELECT. CAPACITOR CEAT101M35
 C 421 (B,160,169) CKSRYB104K16

D 309 (B,202,33) DIODE 1SS355
 D 310 (B,201,39) DIODE 1SS355
 D 355 (B,140,67) DIODE 1SS355
 D 356 (B,162,61) DIODE 1SS355
 D 357 (B,154,39) DIODE 1SS355

C 441 (B,223,176) CKSRYB103K50
 C 442 (A,239,146) CEAL470M10
 C 451 (B,125,166) CKSRYB102K50
 C 452 (B,103,164) CKSRYB102K50
 C 453 (B,122,166) CKSRYB102K50

D 358 (B,142,67) DIODE 1SS355
 D 361 (B,169,56) DIODE DAN202U
 D 362 (B,166,54) DIODE DAN202U
 D 365 (B,209,17) DIODE 1SS355
 D 380 (B,191,31) DIODE 1SS355

C 454 (B,100,164) CKSRYB102K50
 C 481 (B,140,191) CCSRCH471J50
 C 482 (B,126,201) CCSRCH221J50
 C 483 (B,126,199) CCSRCH221J50
 C 487 (B,83,163) CKSRYB102K50

L 100 (B,193,49) CHIP COIL LCYA120J2520
 L 101 (B,197,51) CHIP COIL LCYA120J2520
 CN351 (A,219,40) 10PJUMPER CONNECTOR 52147-1010
 CN356 (A,219,77) CONNECTOR CKS3372
 CN359 MINI DIN SOCKET XKB3065

C 488 (B,79,163) CKSRYB102K50
 C 489 (B,75,163) CKSRYB102K50
 C 490 (A,22,149) CKSRYB102K50

RESISTORS

R 351 (B,125,12) RS1/16S750J
 R 352 (B,129,13) RS1/16S750J
 R 353 (B,125,31) RS1/16S750J
 R 354 (B,129,27) RS1/16S750J
 R 355 (B,125,42) RS1/16S750J

R 356 (B,128,45) RS1/16S750J
 R 357 (B,161,57) RS1/16S102J
 R 358 (B,161,55) RS1/16S102J
 R 360 (B,162,52) RS1/16S102J
 R 361 (B,162,66) RS1/16S102J

R 362 (B,160,51) RS1/16S102J
 R 363 (B,169,30) RS1/16S102J
 R 364 (B,167,30) RS1/16S102J
 R 365 (B,164,30) RS1/16S102J
 R 367 (B,171,30) RS1/16S102J

R 368 (B,159,41) RS1/16S102J
 R 369 (B,160,36) RS1/16S750J
 R 370 (B,150,71) RS1/16S750J
 R 371 (B,145,29) RS1/16S750J
 R 372 (B,146,69) RS1/16S750J

R 374 (B,156,56) RS1/16S750J
 R 375 (B,132,10) RS1/16S101J
 R 376 (B,129,17) RS1/16S101J
 R 377 (B,132,23) RS1/16S101J
 R 378 (B,130,30) RS1/16S101J

R 379 (B,135,39) RS1/16S101J
 R 380 (B,128,49) RS1/16S101J
 R 389 (B,138,48) RS1/16S750J
 R 393 (B,185,23) RS1/16S331J
 R 394 (B,185,26) RS1/16S224J

R 395 (B,188,15) RS1/16S472J
 R 396 (B,203,20) RS1/16S223J
 R 400 (B,135,65) RS1/16S750J
 R 822 (B,202,73) RS1/16S332J
 R 823 (B,199,73) RS1/16S103J

R 824 (B,195,75) RS1/16S102J
 R 827 (B,193,75) RS1/16S102J
 R 828 (B,178,80) RS1/16S750J

J ROTARY ENCODER ASSY**MISCELLANEOUS**

S 457 (A,300,183) SWITCH VSG1024
 S 512 (A,288,223) ROTARY ENCODER (JOG) XSX3008
 S 513 (A,288,152) ROTARY ENCODER XSX3005
 S 514 (A,257,216) SWITCH VSG1024
 S 515 (A,270,183) SWITCH VSG1024

S 516 (A,285,183) SWITCH VSG1024
 511 (A,257,172) CABLE HOLDER(7P) 51063-0705

RESISTORS

R 513 (B,270,190) RS1/16S162J
 R 514 (B,280,185) RS1/16S272J
 R 515 (B,295,185) RS1/16S512J

K POWER KEY ASSY**MISCELLANEOUS**

D 501 (A,14,183) LED(BLUE) SLR343BC4T(JKLM)
 S 501 (A,12,174) SWITCH VSG1024
 S 502 (A,20,221) SWITCH VSG1024
 S 503 (A,32,218) SWITCH VSG1024
 S 504 (A,47,218) SWITCH VSG1024

501 (A,47,210) CABLE HOLDER(3P) 51063-0305

RESISTORS

R 501 (B,12,189) RS1/16S391J
 R 502 (B,7,171) RS1/16S162J
 R 503 (A,15,228) RD1/4PU272J
 R 504 (A,30,228) RD1/4PU512J

L S.VIDEO ASSY**MISCELLANEOUS**

IC 351 (B,149,59) VIDEO SW IC NJM2595M
 IC 352 (B,149,20) VIDEO SW IC NJM2595M
 IC 353 (B,206,64) LOGIC IC TC74HC4053AF
 IC 354 (B,182,72) VIDEO IC NJM2581M
 IC 355 (A,199,15) IC LA7213

5	6
Mark No. Description	Part No.
R 829 (B,163,81)	RS1/16S750J
R 830 (B,201,48)	RS1/16S561J
R 831 (B,201,52)	RS1/16S561J
R 832 (B,188,64)	RS1/16S102J
R 833 (B,186,61)	RS1/16S102J
R 840 (B,160,60)	RS1/16S750J
R 850 (B,196,83)	RS1/16S100J
R 851 (B,201,79)	RS1/16S100J
CAPACITORS	
C 351 (B,160,22)	CKSRYB104K25
C 352 (A,123,9)	CEAT470M25
C 353 (B,127,20)	CKSRYB104K25
C 354 (B,141,12)	CKSRYB104K25
C 355 (A,132,20)	CEAT470M25
C 356 (B,126,38)	CKSRYB104K25
C 357 (B,157,65)	CKSRYB104K25
C 358 (A,131,35)	CEAT470M25
C 359 (B,126,54)	CKSRYB104K25
C 361 (A,144,11)	CEAT470M25
C 362 (A,157,26)	CEAT470M25
C 363 (A,157,68)	CEAT470M25
C 366 (A,145,46)	CEAT470M25
C 367 (B,142,52)	CKSRYB104K25
C 368 (B,128,58)	CKSRYB221K50
C 369 (B,126,63)	CKSRYB221K50
C 370 (B,157,36)	CKSRYB221K50
C 371 (B,158,72)	CKSRYB221K50
C 372 (B,115,61)	CKSRYB103K50
C 373 (B,120,29)	CKSRYB103K50
C 381 (B,134,10)	CCSRCH470J50
C 382 (B,132,16)	CCSRCH470J50
C 383 (B,134,19)	CCSRCH470J50
C 384 (B,135,28)	CCSRCH470J50
C 385 (B,135,37)	CCSRCH470J50
C 386 (B,132,44)	CCSRCH470J50
C 387 (B,174,67)	CKSRYB104K25
C 388 (B,176,75)	CKSRYB104K25
C 393 (A,173,77)	CEAT101M16
C 394 (A,177,60)	CEAT101M16
C 395 (B,199,61)	CKSRYB104K25
C 396 (B,196,66)	CKSRYB104K25
C 397 (A,180,20)	CEAT3R3M50
C 398 (A,185,18)	CEAT101M10
C 399 (A,194,29)	CEAT101M10
C 404 (A,183,59)	CEAT101M10
C 405 (B,196,70)	CKSRYB104K25
C 1916(B,197,46)	CCSRCH120J50
C 1917(B,191,46)	CCSRCH120J50
C 1918(B,190,50)	CCSRCH120J50
C 1919(B,195,51)	CCSRCH120J50
C 1920(B,188,50)	CCSRCH330J50
C 1921(B,199,56)	CCSRCH330J50
C 1924(B,168,80)	CKSRYB221K50
C 1925(B,153,81)	CKSRYB221K50

M TRANS4 ASSY MISCELLANEOUS

△ IC 357 (A,85,236) PROTECTOR (800 mA) AEK7008

7	8
Mark No. Description	Part No.
D 363 (A,88,223) DIODE	S5688G
J 22 JUMPER WIRE	D20PYY0330E
891 (A,70,221) 3P CABLE HOLDER	51048-0300
CAPACITORS	
C 406 (A,84,220) ELECT. CAPACITOR	CEAT471M35

N REGULATOR ASSY MISCELLANEOUS

△ IC 801 (A,147,89) REGULATOR IC	TA7812S
△ IC 802 (A,164,89) REGULATOR IC	TA79012S
△ IC 808 (A,181,89) REGULATOR IC	BA50BC0T
△ IC 809 (A,213,89) REGULATOR IC	NJM2389F
D 810 (A,172,94) DIODE	MTZJ6R2(B)
D 814 (A,193,103) DIODE	MTZJ6R2(B)
CN800 (A,194,113) 11PJUMPER CONNECTOR	52147-1110

RESISTORS

R 801 (A,136,95) METAL OXIDE RESISTOR	RS3LMF331J
R 809 (B,205,98)	RS1/16S102J
R 810 (B,212,94)	RS1/16S302J
R 820 (B,210,94)	RS1/16S151J

CAPACITORS

C 803 (B,147,97)	CKSRYB103K25
C 804 (B,166,97)	CKSRYB103K25
C 805 (A,147,105)	CEJQ101M16
C 806 (A,159,99)	CEAT101M16
C 809 (A,217,104) ELECT. CAPACITOR	CEATR33M50
C 810 (A,214,98)	CEAT101M10
C 818 (B,182,95)	CKSRYB103K25
C 819 (A,176,95)	CEAT101M10

O COMP VIDEO ASSY (vsx-917V) MISCELLANEOUS

IC 301 (B,74,73) VIDEO SW IC	NJM2595M
IC 851 (B,37,26) CHARACTER GENERATOR	PDC132A
IC 852 (B,26,85) LOGIC IC	TC74HC4053AF
IC 853 (B,43,82) LOGIC IC	TC4094BFN
IC 854 (B,56,42) VIDEO SW IC	MM1508XN
△ Q 301 (A,52,50) TRANSISTOR	2SD1858X
△ Q 302 (A,64,52) TRANSISTOR	2SB1237X
Q 303 (B,106,18) TRANSISTOR	2SC5938A
Q 852 (B,21,32) TRANSISTOR	2SC4081
Q 853 (B,76,55) TRANSISTOR	2SC4081
Q 854 (B,32,49) TRANSISTOR	2SC4081
D 301 (B,36,105) DIODE	1SS355
D 302 (B,67,69) DIODE	1SS355
D 303 (B,68,38) DIODE	UDZS6R2(B)
D 304 (B,74,49) DIODE	UDZS6R2(B)
D 307 (B,103,72) DIODE	UDZS5R1(B)
D 308 (B,93,84) DIODE	DAN202U
D 359 (B,32,17) DIODE	1SS355
D 360 (B,30,17) DIODE	1SS355
D 651 (B,9,35) DIODE	DAP202K
D 653 (B,53,80) DIODE	1SS352
L 302 (B,111,99) CHIP SOLID INDUCTOR	QTL1013
L 303 (B,105,99) CHIP SOLID INDUCTOR	QTL1013
L 304 (B,109,99) CHIP SOLID INDUCTOR	QTL1013
L 305 (B,103,99) CHIP SOLID INDUCTOR	QTL1013

Mark No.	Description	Part No.	Mark No.	Description	Part No.
L 306 (B,101,99)	CHIP SOLID INDUCTOR	QTL1013	C 304 (B,74,66)		CKSRyb221K50
L 853 (B,55,23)	CHIP COIL	LCYA330J2520	C 305 (B,109,60)		CKSRyb221K50
L 854 (B,21,38)	CHIP COIL	LCTAW120J2520	C 306 (B,113,44)		CKSRyb221K50
J 44	JUMPER WIRE	D20PYY1010E	C 307 (A,94,47)		CEAT470M25
JA305 (A,119,54)	PIN JACK(4P)YELLOW	XKB3048	C 308 (A,99,23)		CEAT470M25
JA351 (A,118,77)	MINI JACK(4P) /W SW	XKN3015	C 309 (A,99,47)		CEAT470M25
JA352 (A,114,88)	JACK	VKB1243	C 310 (A,82,60)		CEAT101M16
X 851 (A,53,28)	CRYSTAL RESONATOR (14.31818 MHz)	ASS1056	C 311 (B,74,61)		CKSRyb473K25
CN302 (A,69,14)	6P SOCKET	KP200TA6L	C 313 (B,71,45)		CKSRyb473K25
CN306 (A,119,33)	2P PIN JACK	XKB3041	C 333 (B,110,18)		CKSRyb331K50
CN312 (A,75,101)	CONNECTOR	CKS3386	C 338 (A,86,72)		CEAT101M16
CN313 (A,10,57)	CONNECTOR	CKS3380	C 339 (B,85,62)		CKSRyb104K25
CN314 (A,30,105)	CONNECTOR POST	B2B-PH	C 340 (B,90,77)		CKSRyb104K25
314 (A,11,91)	10P CABLE HOLDER	51048-1000	C 347 (B,83,72)		CCSRCH470J50
390 (A,17,105)	PCB BINDER	VEF1040	C 379 (B,112,70)		CKSRyb103K50

RESISTORS

R 301 (B,72,66)		RS1/16S750J	C 851 (A,12,18)		CEAT101M10
R 302 (B,108,34)		RS1/16S750J	C 852 (A,18,18)		CEAT101M10
R 303 (B,111,60)		RS1/16S750J	C 853 (B,41,36)		CKSRyb473K25
R 304 (B,104,61)		RS1/16S750J	C 854 (B,23,21)		CKSRyb473K25
R 305 (B,111,46)		RS1/16S750J	C 855 (B,49,23)		CCSRCH150J50
R 306 (B,100,36)		RS1/16S750J	C 856 (B,47,23)		CCSRCH180J50
R 307 (B,90,84)		RS1/16S102J	C 857 (B,51,22)		CCSRCH240J50
R 308 (B,80,81)		RS1/16S102J	C 858 (B,55,20)		CCSRCH240J50
R 309 (B,34,104)		RS1/16S151J	C 859 (B,63,20)		CCSRCH470J50
R 310 (B,82,80)		RS1/16S102J	C 860 (B,35,35)		CKSRyb473K25
R 311 (B,62,69)		RS1/16S102J	C 861 (B,38,35)		CKSRyb473K25
R 312 (B,78,66)		RS1/16S102J	C 862 (B,45,36)		CCSRCH101J50
⚠ R 313 (A,59,34)	METAL OXIDE RESISTOR	RS3LMF390J	C 864 (A,16,95)		CEAT101M10
R 314 (B,53,38)		RS1/16S152J	C 901 (B,19,38)		CCSRJC3R0C50
R 315 (B,75,46)		RS1/16S152J	C 902 (B,19,42)		CCSRCH120J50
⚠ R 316 (A,78,47)	METAL OXIDE RESISTOR	RS3LMF390J	C 903 (B,21,42)		CCSRCH330J50
R 317 (B,107,24)		RS1/16S102J	C 950 (A,41,40)		CEAT101M16
R 318 (B,102,20)		RS1/16S122J	C 1360(B,116,33)		CKSRyb103K50
R 319 (B,95,27)		RS1/16S472J	C 1362(B,51,82)		CKSRyb104K25
R 390 (B,102,27)		RS1/16S102J	C 1363(B,18,85)		CKSRyb104K25
R 852 (B,66,17)		RS1/16S471J	C 1364(B,17,79)		CKSRyb104K25
R 853 (B,25,21)		RS1/16S103J	C 1367(A,71,35)		CEAT101M16
R 854 (B,27,21)		RS1/16S103J	C 1368(B,50,38)		CKSRyb103K50
R 855 (B,48,36)		RS1/16S102J	C 1369(B,46,40)		CKSRyb105K16
R 856 (B,27,31)		RS1/16S512J	C 1370(A,92,32)	ELECTR.CAPACITOR	CEAT102M10
R 857 (B,12,28)		RS1/16S392J			
R 858 (B,24,31)		RS1/16S222J			
R 894 (B,32,94)		RS1/16S0R0J			
R 896 (B,22,70)		RS1/16S750J			
R 897 (B,54,69)		RS1/16S750J			
R 898 (B,73,54)		RS1/16S102J			
R 899 (B,17,38)		RS1/16S561J			
R 901 (B,26,47)		RS1/16S102J			
R 902 (B,83,54)		RS1/16S682J			
R 903 (B,86,57)		RS1/16S103J			
R 904 (B,80,54)		RS1/16S100J			
R 1333(B,36,78)		RS1/16S0R0J			
R 1335(B,34,76)		RS1/16S0R0J			
R 1336(B,15,75)		RS1/16S0R0J			
R 1371		RS1/16S0R0J			
R 1448(B,27,15)		RS1/16S0R0J			

CAPACITORS

VIDEO ASSY (vsx-817)

MISCELLANEOUS

IC 301 (B,46,32)	VIDEO SW IC	NJM2595M
⚠ Q 301 (A,86,47)	TRANSISTOR	2SD1858X
⚠ Q 302 (A,66,52)	TRANSISTOR	2SB1237X
Q 303 (B,25,83)	TRANSISTOR	2SC5938A
D 301 (B,44,40)	DIODE	1SS355
D 302 (B,41,45)	DIODE	1SS355
D 303 (B,82,61)	DIODE	UDZS6R2(B)
D 304 (B,73,59)	DIODE	UDZS6R2(B)
D 307 (B,87,10)	DIODE	UDZS5R1(B)
D 308 (B,60,23)	DIODE	DAN202U
D 359 (B,94,53)	DIODE	1SS355
D 360 (B,96,48)	DIODE	1SS355
JA305 (A,14,44)	PIN JACK(4P)YELLOW	XKB3048
CN302 (A,64,84)	6P SOCKET	KP200TA6L
CN303 (A,62,7)	CONNECTOR	CKS3378
CN306 (A,14,65)	2P PIN JACK	XKB3041

5	6
Mark No. Description	Part No.
CN310 (A,46,7) CONNECTOR	CKS3372
CN354 (A,91,6) CONNECTOR POST	B2B-PH
390 (A,100,7) PCB BINDER	VEF1040
RESISTORS	
R 299 (B,33,72)	RS1/16S0R0J
R 301 (B,34,25)	RS1/16S750J
R 302 (B,31,60)	RS1/16S750J
R 303 (B,23,36)	RS1/16S750J
R 304 (B,49,22)	RS1/16S750J
R 305 (B,23,50)	RS1/16S750J
R 306 (B,32,54)	RS1/16S750J
R 307 (B,56,25)	RS1/16S102J
R 308 (B,57,29)	RS1/16S102J
R 309 (B,57,27)	RS1/16S151J
R 310 (B,57,31)	RS1/16S102J
R 311 (B,42,23)	RS1/16S102J
R 312 (B,60,25)	RS1/16S102J
△ R 313 (A,85,57) METAL OXIDE RESISTOR	RS3LMF390J
R 314 (B,84,61)	RS1/16S152J
R 315 (B,64,59)	RS1/16S152J
△ R 316 (A,67,39) METAL OXIDE RESISTOR	RS3LMF390J
R 317 (B,21,75)	RS1/16S102J
R 318 (B,27,79)	RS1/16S122J
R 319 (B,27,77)	RS1/16S472J
R 390 (B,24,77)	RS1/16S102J
R 391 (B,20,38)	RS1/16S0R0J
R 392 (B,30,55)	RS1/16S0R0J

CAPACITORS

C 304 (B,33,19)	CKSRYB221K50
C 305 (B,41,19)	CKSRYB221K50
C 306 (B,22,54)	CKSRYB221K50
C 307 (A,31,35)	CEAT470M25
C 308 (A,52,53)	CEAT470M25
C 309 (A,32,44)	CEAT470M25
C 310 (A,54,42)	CEAT101M16
C 311 (B,82,48)	CKSRYB473K25
C 313 (B,76,34)	CKSRYB473K25
C 333 (B,21,81)	CKSRYB331K50
C 338 (A,60,37)	CEAT101M16
C 339 (B,45,49)	CKSRYB104K25
C 340 (B,56,36)	CKSRYB104K25
C 347 (B,43,43)	CCSRCH470J50
C 1360(B,18,65)	CKSRYB103K50

P BOARD TO BOARD ASSY

MISCELLANEOUS

CN315 (A,59,139) CONNECTOR	CKS3388
CN316 (A,59,117) 23P PLUG	XKP3071
CN317 (A,26,139) CONNECTOR	CKS3374
CN318 (A,26,117) 9P PLUG	XKP3064

Q DIGITAL INPUT ASSY

MISCELLANEOUS

F 1901(B,214,228) INDUCTOR	CTF1295
JA1900(A,206,201) OPT. LINK IN	GP1FAV51RKBF
JA1901(A,220,201) OPT. LINK IN	GP1FAV51RKBF
JA1902(A,234,201) OPT. LINK IN	GP1FAV51TK0F
KN1902(A,249,206) SCREW PLATE	VNE1948

7	8
Mark No. Description	Part No.
CN1902(A,211,238) CONNECTOR POST	B5B-PH
CN1903(A,229,230) CONNECTOR	VKN1186

RESISTORS

R 1900(B,211,215)	RS1/16S101J
R 1901(B,214,223)	RS1/16S101J
R 1902(B,233,215)	RS1/16S101J

CAPACITORS

C 1900(B,205,215)	CKSRYB104K25
C 1901(B,217,215)	CKSRYB104K25
C 1902(B,235,215)	CKSRYB104K25
C 1903(B,211,230)	CKSRYB103K50
C 1904(A,208,228)	CEAL101M10
C 1905(B,233,232)	CKSRYB104K25
C 1906(B,235,232)	CKSRYB103K50
C 1907(B,237,232)	CCSRCH101J50
C 1908(B,239,232)	CKSRYB102K50
C 1909(B,215,234)	CCSRCH101J50

R FRONT VIDEO ASSY

MISCELLANEOUS

JA 902 (A,167,224) 3P PIN JACK	XKB3063
CN901 (A,117,230) CONNECTOR POST	B5B-PH

RESISTORS

R 901 (B,161,224)	RS1/16S331J
R 902 (B,176,220)	RS1/16S331J
R 903 (B,157,224)	RS1/16S474J
R 904 (B,171,220)	RS1/16S474J
R 905 (B,135,233)	RS1/16S750J

CAPACITORS

C 901 (B,164,224)	CCSRCH101J50
C 902 (B,178,220)	CCSRCH101J50
C 903 (A,131,237) ELECTR. CAPACITOR	CEAL470M25
C 906 (B,185,217)	CKSRYB224K16
C 907 (B,185,213)	CKSRYB471K50
C 908 (B,185,215)	CKSRYB103K25
C 909 (B,150,234)	CKSRYB224K16
C 910 (B,150,236)	CKSRYB471K50
C 911 (B,150,239)	CKSRYB103K25
C 915 (B,159,224)	CCSRCH101J50
C 916 (B,173,220)	CCSRCH101J50

S PRIMARY ASSY

MISCELLANEOUS

△ IC 51 (B,236,11) IC	NJM78L05UA
Q 51 (B,267,14) DIGITAL TR(SC-70)	RT1N431M
△ D 51 (B,298,20) BRIDGE DIODE	DF06SA
D 55 (A,304,21) DIODE	1SR139-400
D 56 (A,271,21) DIODE	1SS133
D 57 (A,266,25) DIODE	1SS133
D 58 (A,314,13) DIODE	MTZJ5R1(B)
L 51 (A,253,73) LINE FILTER	XTF3004
H 51 (A,231,34) FUSE CLIP	AKR7001
H 52 (A,250,34) FUSE CLIP	AKR7001
J 52 JUMPER WIRE	D20PYY0410E
KN51 (A,318,25) WRAPPING TERMINAL	VNF1084
KN3001(A,223,117) SCREW PLATE	VNE1948
△ RY51 (A,271,57) JOE LOWPOWER RELAY	ASR7013

Mark No. Description Part No.

⚠ T 51 (A,288,56) STANDBY TRANSFORMER ATT7040

⚠ CN51 (A,236,47) AC CODE SOCKET RKP1751
 55 (A,317,9) 4P CABLE HOLDER 51048-0400

RESISTORS

R 52 (A,275,11) RD1/2PM270J
 R 53 (A,307,12) RD1/4PU332J
 R 54 (A,319,16) RD1/4PU103J

CAPACITORS

⚠ C 51 (A,261,64) FILM CAPACITOR ACE7013
 ⚠ C 52 (A,265,57) SAFETY CAPACITOR XCG3010
 C 53 (A,291,21) ELECT. CAPACITOR CEAT102M16
 C 54 (A,300,11) CEAT470M25
 C 55 (A,307,21) CKPUYF103Z25

C 56 (A,311,21) CKPUYF103Z25
 C 57 (A,314,21) CKPUYF103Z25

Mark No. Description Part No.

C 951 (B,64,12) CKSRYB104K50
 C 952 (B,35,54) CKSRYB103K50
 C 953 (B,33,54) CKSRYB104K50
 C 956 (A,43,68) CHIP ELECT.CAPACITOR CEWW100M50
 C 957 (A,52,70) CKSRYB103K50

C 958 (A,43,79) CHIP ELECT.CAPACITOR CEWW100M50
 C 959 (A,48,67) CKSRYB471K50
 C 960 (B,33,59) CCSRCH101J50
 C 962 (A,37,78) CKSRYB103K50
 C 963 (A,34,104) CHIP ELECT.CAPACITOR CEWW100M50

C 964 (B,34,77) CCSRCH330J50
 C 965 (B,45,66) CCSRCH330J50
 C 967 (A,35,67) CHIP ELECT.CAPACITOR CEWW100M50
 C 968 (A,32,79) CHIP ELECT.CAPACITOR CEWW100M50
 C 969 (B,60,47) CKSRYB104K16

C 970 (A,50,46) CEWW101M16

U FRONT IN ASSY MISCELLANEOUS

IC 951 (B,37,70) DUAL OP-AMP NJM4565MD
 IC 952 (A,59,63) IC TC4066BFN
 Q 951 (A,51,60) TRANSISTOR RT1N241M
 Q 952 (B,52,66) DIGITAL TR(SC-70) RT1P241M
 D 951 (B,44,73) DIODE UDZS5R1(B)

D 952 (A,38,97) DIODE UDZS5R1(B)
 D 953 (A,38,93) DIODE UDZS5R1(B)
 D 957 (B,30,59) DIODE DAN217U
 L 970 (A,60,38) COIL ATH7015
 F 951 (B,60,12) INDUCTOR CTF1295

JA951 (A,80,16) OPTICAL IN MOD. GP1FMV51RK0F
 JA952 (A,78,58) STEREO MINI JACK XKN3017
 JA953 (A,79,38) USB CONNECTOR XKP3086
 KN951 (A,46,34) WRAPPING TERMINAL VNF1084
 CN951 (A,49,19) CONNECTOR POST B5B-PH

CN953 (A,40,51) CONNECTOR B4B-PH
 CN956 (A,46,97) CONNECTOR CKS3376

RESISTORS

R 951 (B,66,18) RS1/16S101J
 R 953 (A,38,72) RS1/16S682J
 R 954 (B,35,62) RS1/16S101J
 R 955 (A,50,67) RS1/16S104J
 R 956 (A,68,68) RS1/16S102J

R 957 (B,35,58) RS1/16S104J
 R 958 (A,70,71) RS1/16S104J
 R 959 (B,43,66) RS1/16S333J
 R 960 (B,39,62) RS1/16S472J
 R 961 (B,41,67) RS1/16S101J

R 962 (B,32,77) RS1/16S101J
 R 963 (A,37,81) RS1/16S104J
 R 966 (B,38,77) RS1/16S472J
 R 967 (B,36,77) RS1/16S333J
 R 972 (A,48,70) RS1/16S102J

R 979 (B,61,33) RS1/16S0R0J
 R 980 (B,61,42) RS1/16S0R0J
 R 981 (A,69,68) RS1/16S223J
 R 982 (A,69,65) RS1/16S103J
 R 984 (A,54,60) RS1/16S103J

CAPACITORS**V HDMI&DVC ASSY MISCELLANEOUS**

IC 101 (A,35,50) HDMI/DVI CABLE EQ CXB1442AR
 IC 102 (A,43,33) IC TC7MB3257FK
 IC 103 (A,40,11) I2C BUS REPEATER IC PCA9515ADP
 IC 401 (A,62,35) VIDEO DECODER IC ADV7180BSTZ
 IC 402 (A,76,29) LOGIC IC TC7WZU04FU

IC 701 (A,86,36) VIDEO ENCODER IC ADV7172KSTZ
 ⚠ IC 901 (A,99,18) REGULATOR IC NJM2845DL1-33
 ⚠ IC 902 (A,78,13) REGULATOR IC MM1591JF
 ⚠ IC 911 (A,44,21) REGULATOR IC NJM2872BF05
 Q 101 (A,46,65) CHIP TRANSISTOR 2SB1689

Q 102 (A,45,58) DIGITAL TR(SC-70) RT1N431M
 Q 121 (A,42,39) TRANSISTOR RT1N241M
 Q 151 (A,22,70) TRANSISTOR RT1N241M
 Q 152 (A,18,51) TRANSISTOR RT1N241M
 Q 153 (A,31,72) DIGITAL TR(SC-70) RT1P241M

Q 154 (A,22,48) DIGITAL TR(SC-70) RT1P241M
 Q 155 (A,29,69) TRANSISTOR RT1N241M
 Q 156 (A,22,51) TRANSISTOR RT1N241M
 Q 451 (A,100,55) CHIP TRANSISTOR HN1C01FU
 Q 731 (A,75,58) TRANSISTOR 2SA1576A

Q 741 (A,78,53) TRANSISTOR 2SA1576A
 Q 751 (A,83,58) TRANSISTOR 2SA1576A
 Q 761 (A,86,53) TRANSISTOR 2SA1576A
 Q 771 (A,91,58) TRANSISTOR 2SA1576A
 Q 781 (A,94,53) TRANSISTOR 2SA1576A

D 381 (A,106,60) DIODE UDZS5R1(B)
 L 101 (A,45,67) CHIP BEADS ATL7010
 ⚠ L 351 (A,24,11) COIL ATH7022
 ⚠ L 352 (A,24,15) COIL ATH7022
 ⚠ L 353 (A,24,18) COIL ATH7022

⚠ L 354 (A,24,22) COIL ATH7022
 L 401 (A,64,16) CHIP BEADS ATL7010
 L 402 (A,74,41) CHIP SOLID INDUCTOR QTL1013
 L 403 (A,54,15) CHIP BEADS ATL7010
 L 404 (A,61,59) CHIP BEADS ATL7010

L 417 (A,72,30) CHIP SOLID INDUCTOR QTL1013
 L 701 (A,104,46) CHIP BEADS ATL7010
 L 702 (A,102,46) CHIP BEADS ATL7010
 L 1001(A,94,24) CHIP BEADS ATL7010
 L 1002(A,99,23) CHIP BEADS ATL7010

Mark No. Description**Part No.****Mark No. Description****Part No.**

C 410 (A,71,39)
 C 411 (A,71,42)
 C 412 (A,72,43)
 C 413 (A,69,48)

CKSRYB103K50
 CKSRYB471K50
 CKSQYB225K10
 CKSRYB104K16

IC 762 (A,87,46) FLASH ROM
 IC 771 (A,58,59) LOAD SWITCHING
 IC 781 (A,37,16) AUDIO DAC
 IC 951 (A,67,28) IC
 IC 953 (A,52,25) IC
 IC 9762FLASH MEMORY IC

AYW7088
 AAT4618IGV-0.5-1
 AK4387ET
 TC74VHCT08AFTS1
 TC74VHC
 S29AL016D70TFI01008FTS1

C 414 (A,66,48)
 C 415 (A,62,45)
 C 416 (A,63,47)
 C 417 (A,62,47)
 C 418 (A,60,43)

CKSRYB104K16
 CKSRYB104K16
 CKSRYB104K16
 CKSRYB104K16
 CKSRYB104K16

Q 782 (B,94,44) CHIP TRANSISTOR
 Q 783 (B,92,38) TRANSISTOR
 Q 784 (B,87,32) TRANSISTOR
 L 701 (B,27,42) INDUCTOR
 L 702 (B,34,33) CHIP SOLID INDUCTOR

DTC114YUA
 2SA1576A
 IMX9
 LCTC100K1608
 QTL1013

C 419 (A,58,54)
 C 420 (A,58,45)
 C 421 (A,57,45)
 C 422 (A,55,45)
 C 423 (A,59,13)

CEJQ101M16
 CKSRYB104K16
 CKSRYB104K16
 CKSRYB104K16
 CEJQ101M16

L 703 (A,24,30) CHIP SOLID INDUCTOR
 L 704 (B,53,56) CHIP SOLID INDUCTOR
 L 705 (B,28,38) CHIP FERRITE BEADS
 L 731 (A,28,60) CHIP FERRITE BEADS
 L 733 (A,36,56) COIL

QTL1013
 QTL1013
 VTL1169
 VTL1169
 VTH1043

C 424 (A,61,18)
 C 425 (A,53,44)
 C 426 (A,53,38)
 C 427 (A,54,34)
 C 451 (A,101,52)

CKSRYB104K16
 CKSRYB104K16
 CKSRYB103K50
 CKSRYB104K16
 CCSRCH101J50

L 761 (B,78,47) CHIP SOLID INDUCTOR
 L 762 (B,85,44) CHIP SOLID INDUCTOR
 L 781 (B,46,19) CHIP SOLID INDUCTOR
 L 951 (A,59,30) CHIP SOLID INDUCTOR
 L 953 (A,72,37) CHIP SOLID INDUCTOR

QTL1013
 QTL1013
 QTL1013
 QTL1013
 QTL1013

C 452 (A,103,55)
 C 701 (A,107,39)
 C 702 (A,107,45)
 C 703 (A,89,29)
 C 704 (A,93,36)

CCSRCH101J50
 CEJQ101M16
 CKSRYB104K16
 CKSRYB104K16
 CKSRYB104K16

X 701 (A,23,42) CRYSTAL OSCILLATOR
 CN701 (A,33,60) CONNECTOR
 CN702 (A,87,16) 15P SOCKET

CSS1614
 B4B-PH
 XKP3078

C 705 (A,94,43)
 C 706 (A,89,45)
 C 707 (A,86,45)
 C 708 (A,83,45)
 C 709 (A,77,46)

CKSRYB104K16
 CKSRYB104K16
 CKSRYB104K16
 CKSRYB104K16
 CKSRYB104K16

RESISTORS

R 702 (A,43,55)
 R 703 (A,38,53)
 R 704 (A,35,53)
 R 705 (A,30,54)
 R 706 (A,30,52)

RS1/16S473J
 RS1/16S0R0J
 RS1/16S0R0J
 RS1/16S470J
 RS1/16S470J

C 710 (A,100,45)
 C 711 (A,100,39)
 C 712 (A,79,44)
 C 713 (A,78,34)
 C 714 (A,79,34)

CKSRYB105K16
 CEJQ101M16
 CKSRYB104K16
 CKSRYB103K50
 CKSRYB104K16

R 707 (B,32,48)
 R 708 (B,22,51)
 R 709 (B,23,41)
 R 710 (B,35,42)
 R 711 (B,37,42)

RS1/16S470J
 RS1/16S470J
 RS1/16S0R0J
 RS1/16S0R0J
 RS1/16S472J

C 731 (A,74,60)
 C 741 (A,77,55)
 C 751 (A,82,60)
 C 761 (A,85,55)
 C 771 (A,90,60)

CKSRYB104K16
 CKSRYB104K16
 CKSRYB104K16
 CKSRYB104K16
 CKSRYB104K16

R 712 (A,27,43)
 R 717 (A,31,29)
 R 718 (A,36,25)
 R 719 (A,35,25)
 R 720 (A,35,21)

RS1/16S475J
 RS1/16S473J
 RS1/16S101J
 RS1/16S101J
 RS1/16S101J

C 781 (A,93,55)
 C 901 (A,92,20)
 C 902 (A,92,16)
 C 904 (A,80,17)
 C 905 (A,76,10)

CKSRYB104K16
 CKSRYB105K16
 CKSQYB225K10
 CKSRYB105K16
 CKSRYB471K50

R 724 (A,39,21)
 R 725 (A,44,25)
 R 726 (A,42,21)
 R 727 (A,33,21)
 R 729 (B,30,38)

RS1/16S472J
 RS1/16S472J
 RS1/16S472J
 RS1/16S101J
 RS1/16S103J

C 906 (A,77,17)
 C 911 (A,41,20)
 C 912 (A,46,22)
 C 913 (A,44,24)
 C 1001(A,97,27)

CKSQYB225K10
 CKSRYB104K16
 CKSRYB103K50
 CKSQYB225K10
 CKSRYB104K16

R 730 (B,39,33)
 R 734 (A,43,58)
 R 735 (A,32,55)
 R 736 (A,40,55)
 R 737 (A,34,55)

RS1/16S102J
 RS1/16S0R0J
 RS1/16S153J
 RS1/16S153J
 RS1/16S100J

C 1002(A,102,28)
 C 1012(A,104,25)
 C 1013(A,110,18)

CEJQ101M16
 CKSRYB104K16
 CKSRYB102K50

R 738 (A,39,55)
 R 741 (B,79,23)
 R 744 (A,77,20)
 R 745 (A,76,21)
 R 746 (A,74,20)

RS1/16S100J
 RS1/16S101J
 RS1/16S101J
 RS1/16S101J
 RS1/16S101J

X USB ASSY

MISCELLANEOUS

IC 701 (A,37,40) USB MEDIA CONTROL IC
 ⚠ IC 702 (A,63,35) REGULATOR IC
 ⚠ IC 703 (A,87,25) REGULATOR IC
 IC 761 (A,63,46) SD-RAM(64M)

TCC760HC01-AG
 MM1561JF
 BD7802FP
 HY57V641620ETP-6

R 747 (A,72,20)
 R 748 (A,71,20)
 R 755 (A,26,45)
 R 756 (A,26,41)

RS1/16S101J
 RS1/16S101J
 RS1/16S0R0J
 RS1/16S472J

5		6		7		8	
Mark No.	Description	Part No.	Mark No.	Description	Part No.	Mark No.	Description
R 757	(A,43,60)	RS1/16S0R0J	C 734	(B,41,32)	CKSRYPB103K50		
R 771	(A,61,56)	RS1/16S221J	C 735	(B,37,33)	CKSRYPB103K50		
R 772	(A,58,56)	RS1/16S104J	C 741	(A,92,19)	CEJQ101M16		
R 773	(A,71,59)	RS1/16S0R0J	C 742	(B,96,20)	CKSRYPB104K16	A	
R 784	(A,30,21)	RS1/16S470J	C 743	(A,96,32)	CKSRYPB105K6R3		
R 786	(A,41,21)	RS1/16S470J	C 745	(B,64,35)	CKSRYPB105K6R3		
R 788	(A,44,21)	RS1/16S4R7J	C 746	(A,53,32)	CKSQYB225K10		
R 789	(A,74,25)	RS1/16S471J	C 761	(B,71,46)	CKSRYPB104K16		
R 790	(A,79,23)	RS1/16S471J	C 762	(B,73,46)	CCSRCH471J50		
R 791	(B,83,34)	RS1/16S104J	C 763	(B,67,46)	CCSRCH471J50		
R 792	(B,90,30)	RS1/16S104J	C 764	(B,65,46)	CCSRCH471J50		
R 793	(B,83,30)	RS1/16S101J	C 766	(B,52,50)	CCSRCH471J50		
R 794	(B,90,34)	RS1/16S101J	C 767	(B,80,44)	CKSRYPB104K16		
R 795	(A,87,33)	RS1/16S222J	C 768	(B,82,44)	CCSRCH471J50		
R 796	(A,87,30)	RS1/16S222J	C 771	(A,62,60)	CKSQYB105K16	B	
R 797	(B,92,44)	RS1/16S102J	C 773	(A,55,60)	CKSRYPB104K16		
R 798	(B,95,38)	RS1/16S102J	C 781	(A,44,17)	CCSRCH471J50		
R 799	(B,90,38)	RS1/16S103J	C 782	(A,45,19)	CKSRYPB104K16		
R 951	(B,43,26)	RS1/16S472J	C 783	(A,49,19)	CEJQ470M16		
R 952	(A,62,31)	RS1/16S472J	C 784	(A,45,16)	CKSRYPB104K16		
R 966	(A,72,32)	RS1/16S101J	C 786	(A,55,16)	CEJQ100M16		
R 972	(A,62,28)	RS1/16S101J	C 788	(A,42,18)	CKSRYPB104K16		
R 973	(A,73,29)	RS1/16S101J	C 789	(A,77,26)	CKSRYPB102K50		
R 977	(A,47,25)	RS1/16S101J	C 790	(A,79,25)	CKSRYPB102K50		
R 978	(A,47,28)	RS1/16S101J	C 791	(A,75,31)	CEJQ100M16		
R 979	(B,58,27)	RS1/16S101J	C 792	(A,81,31)	CEJQ100M16	C	
R 980	(B,60,27)	RS1/16S101J	C 951	(A,58,27)	CCSRCH471J50		
			C 952	(A,59,27)	CKSRYPB105K10		
			C 956	(A,70,34)	CKSQYB105K10		
			C 957	(A,70,33)	CCSRCH471J50		
CAPACITORS			FM/AM TUNER UNIT				
C 701	(A,49,36)	CKSRYPB104K16	FM/AM TUNER UNIT has no service part.				
C 702	(A,47,36)	CCSRCH471J50					
C 703	(A,49,40)	CKSRYPB104K16					
C 704	(A,47,40)	CCSRCH471J50					
C 705	(A,49,44)	CKSRYPB104K16					
C 706	(A,47,44)	CCSRCH471J50					
C 707	(A,45,51)	CKSRYPB104K16					
C 708	(A,45,50)	CCSRCH471J50					
C 709	(A,30,51)	CKSRYPB104K16					
C 710	(A,30,50)	CCSRCH471J50					
C 711	(B,30,45)	CKSRYPB104K16					
C 712	(B,27,45)	CCSRCH471J50					
C 713	(A,26,46)	CCSRCH120J50					
C 714	(A,26,39)	CCSRCH120J50					
C 715	(B,26,38)	CKSRYPB331K50					
C 716	(B,32,33)	CKSRYPB104K16					
C 717	(B,30,33)	CCSRCH471J50					
C 719	(A,25,36)	CCSRCH471J50					
C 720	(B,23,30)	CKSRYPB104K16					
C 721	(A,24,24)	CEJQ101M6R3					
C 723	(A,37,27)	CCSRCH471J50					
C 724	(A,37,29)	CKSRYPB104K16					
C 726	(A,34,27)	CKSRYPB104K16					
C 727	(A,34,29)	CCSRCH471J50					
C 728	(A,41,28)	CKSRYPB104K16					
C 729	(A,41,29)	CCSRCH471J50					
C 730	(B,60,34)	CCSRCH471J50					
C 731	(A,25,55)	CEJQ101M16					
C 732	(B,29,55)	CKSRYPB104K16					
C 733	(B,29,60)	CKSRYPB104K16					

6. ADJUSTMENT

There is no information to be shown in this chapter.

7. GENERAL INFORMATION

7.1 DIAGNOSIS

7.1.1 DSP TROUBLESHOOTING

■ Troubleshooting for all destination

- When a sound is not out in the multi-CH signal playback mode or surround mode with the digital signal input.
(SurroundBack is not output by setting.)
- Suppose CR to be poor contact and that is not damaged.
- This shows failure analysis of DSP Assy.

Step 0: Preliminary confirmation

Confirm the following items before checking

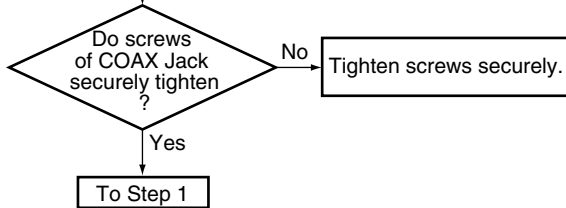

Step 1: MUTE pin

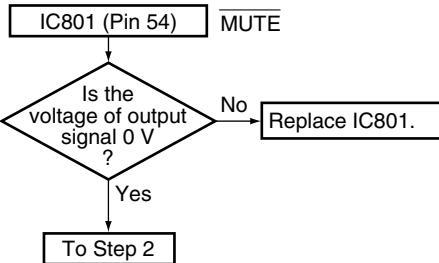

Step 2: BtoB connector

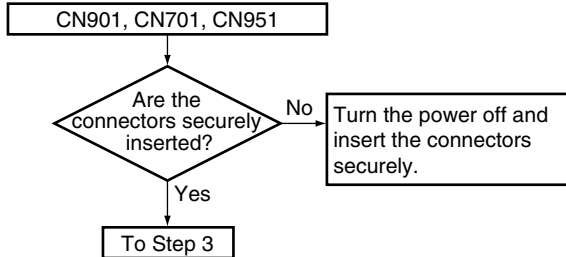

Step 3: Regulator IC

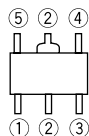
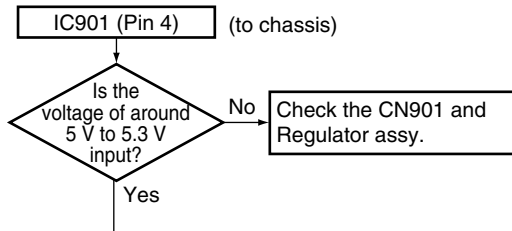

Part shape and Pin arrangement of IC901 and IC902

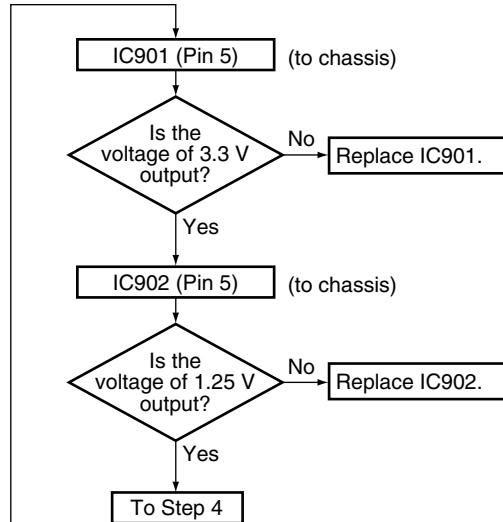

Step 4: 3 V to 5 V conversion

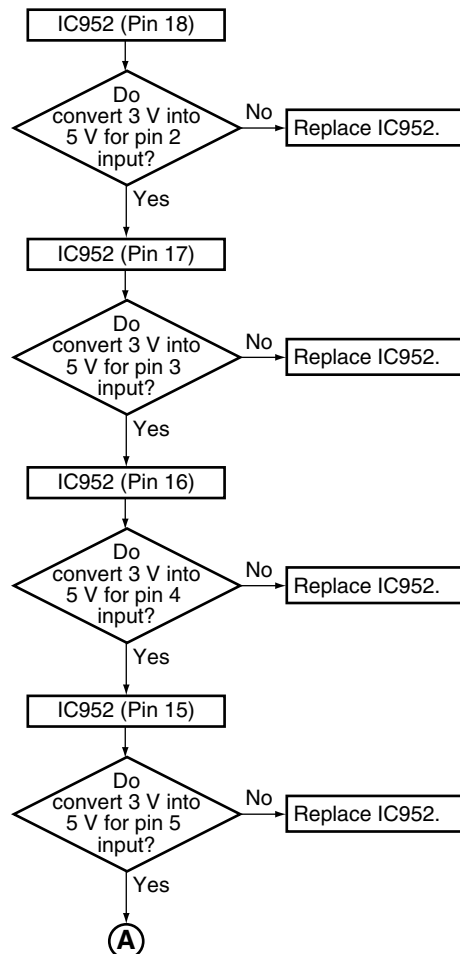

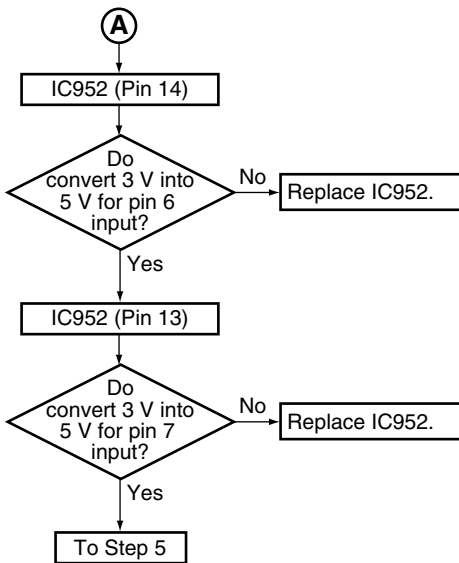

Step 5: X'tal

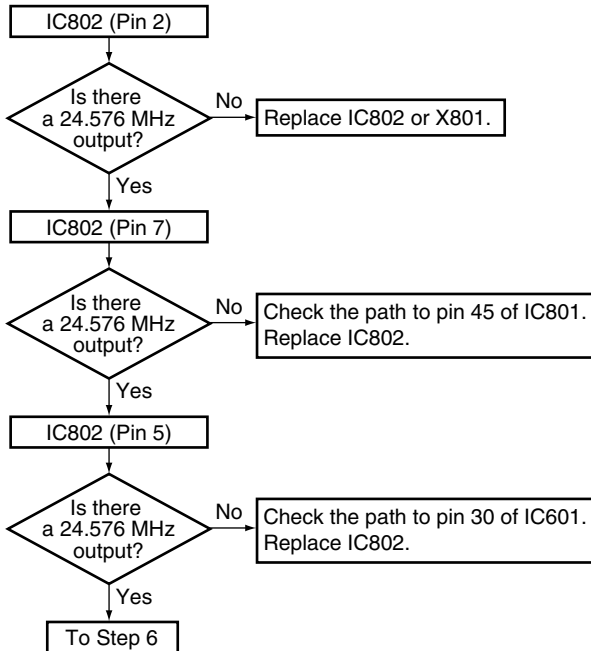

Step 6: DIR

Check that the SPDIF signal is output.
Check that changes by pulling out and inserting the digital input lines.

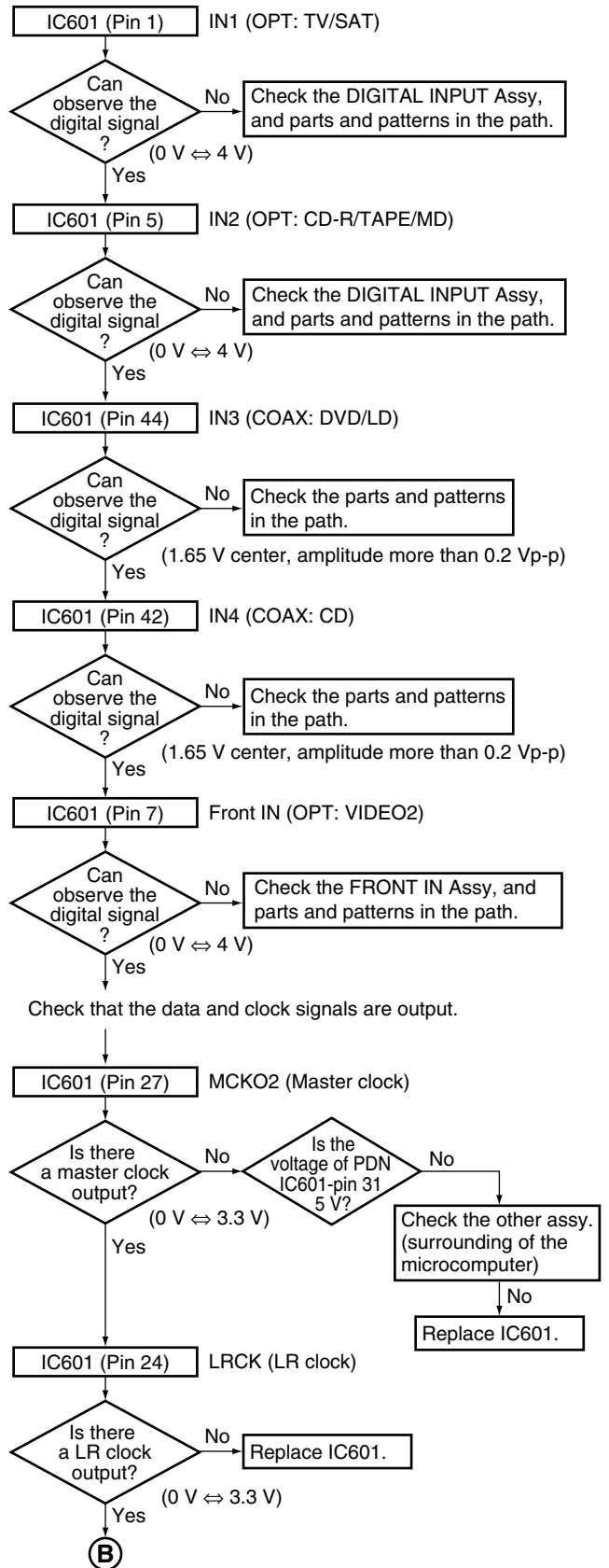



Step 7: DSP output (digital)

Digital output of each CH when inputting the digital signal with audio.

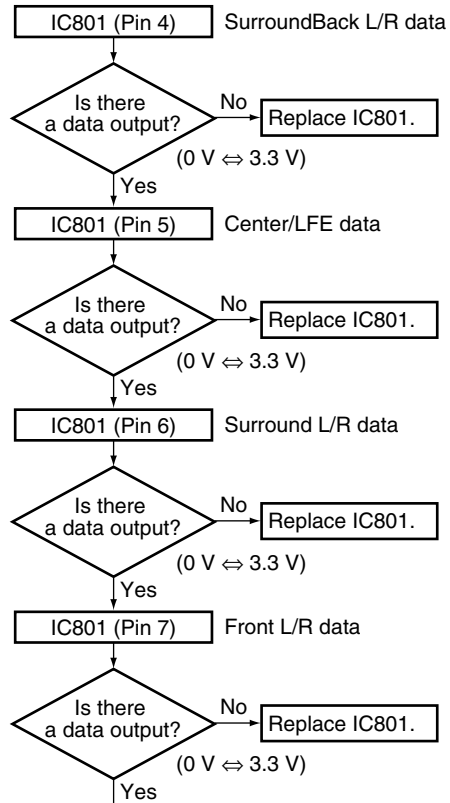

Digital output of each CH when inputting the digital signal (-∞ dB (no audio)).

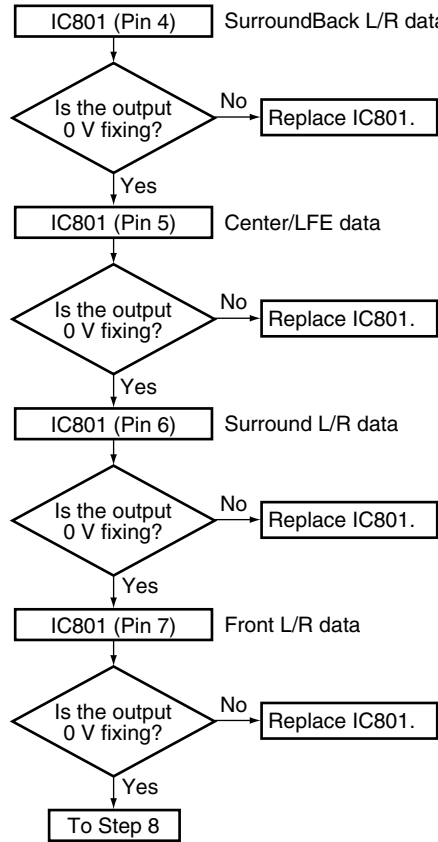

Step 8: Codec output (analog)

Analog output of each CH when inputting the digital signal with audio.

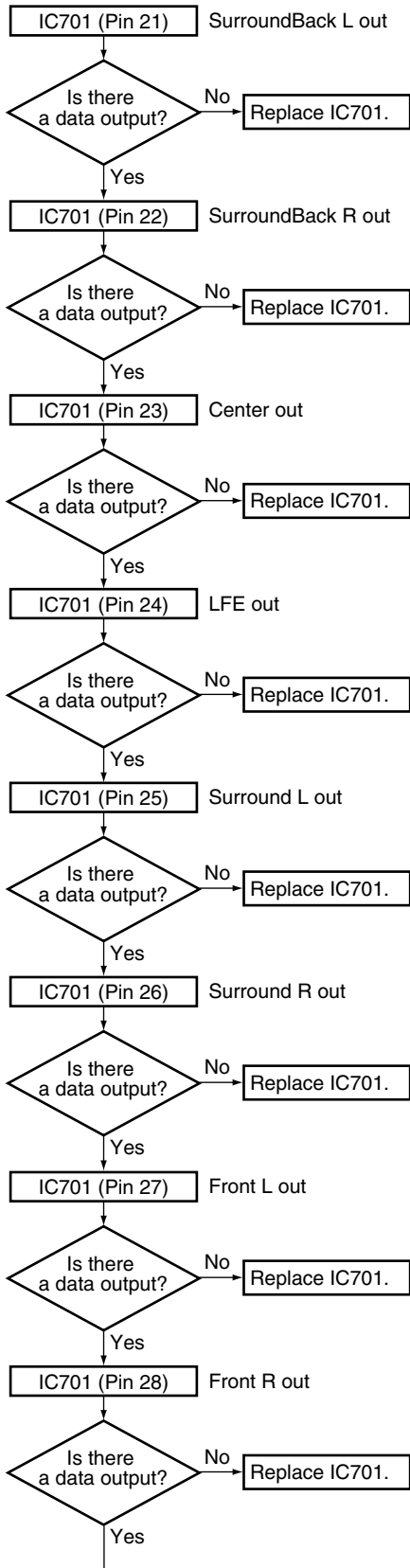

Analog output of each CH when inputting the digital signal (-∞ dB (no audio)).

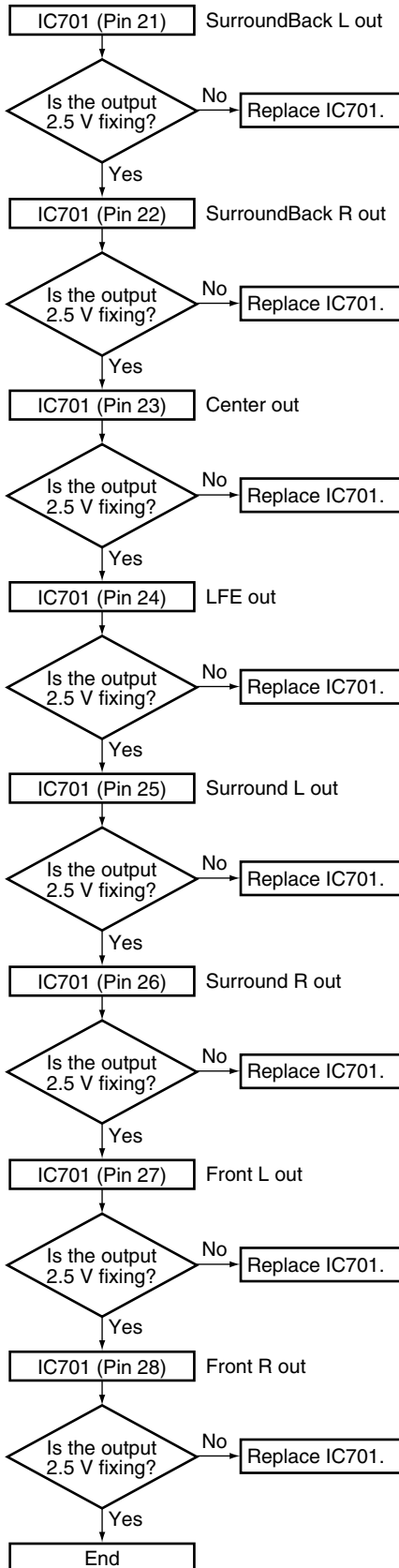

A
B
C
D
E
F

Troubleshooting in the MCACC mode

- When the MCACC mode is turned on (SurroundBack is not output by setting.)
- Suppose CR to be poor contact and that is not damaged.
- This shows failure analysis of DSP Assy.

Step 0: Preliminary confirmation

Confirm the following items before checking

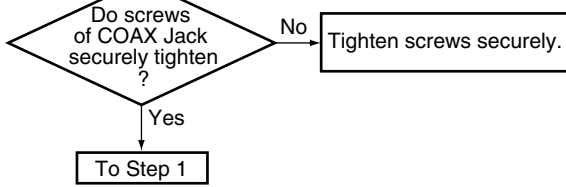

Step 1: MUTE pin

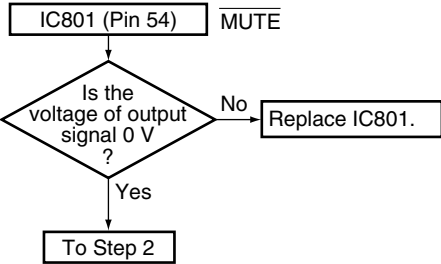

Step 2: BtoB connector

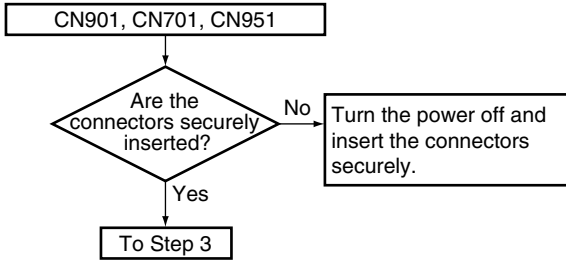

Step 3: Regulator IC

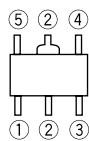
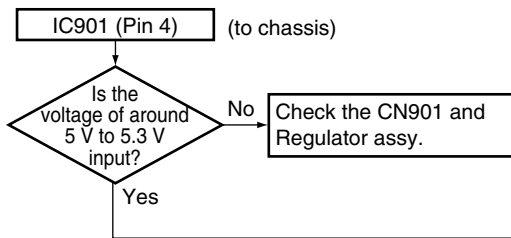

Part shape and Pin arrangement of IC901 and IC902

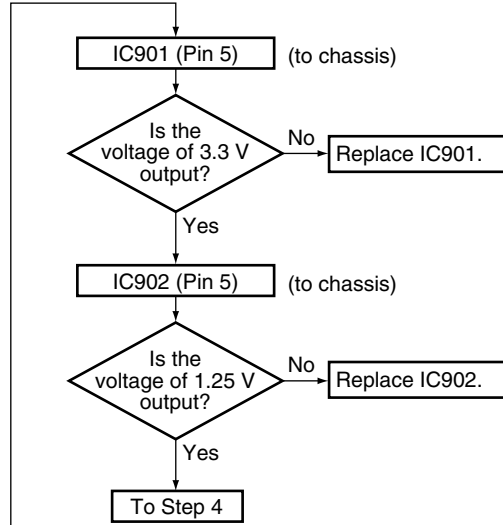

Step 4: 3 V to 5 V conversion

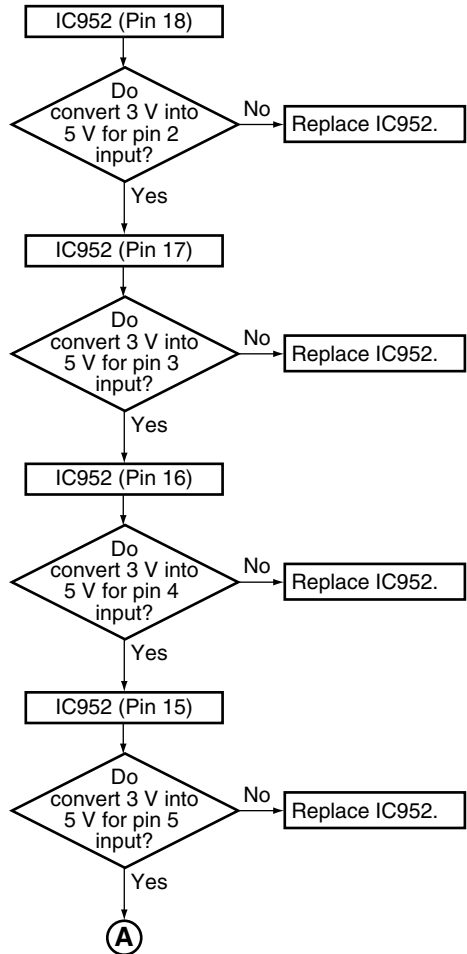

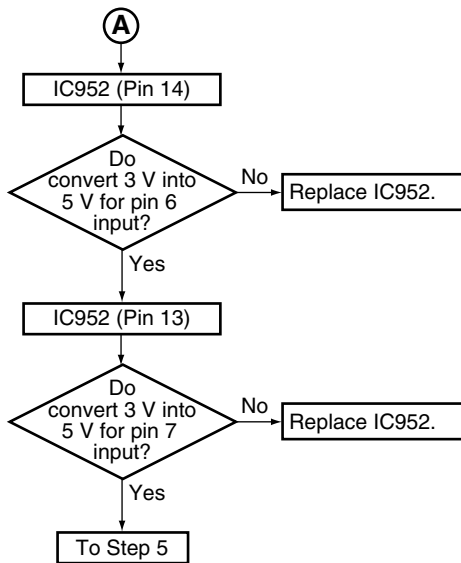

Step 5: X'tal

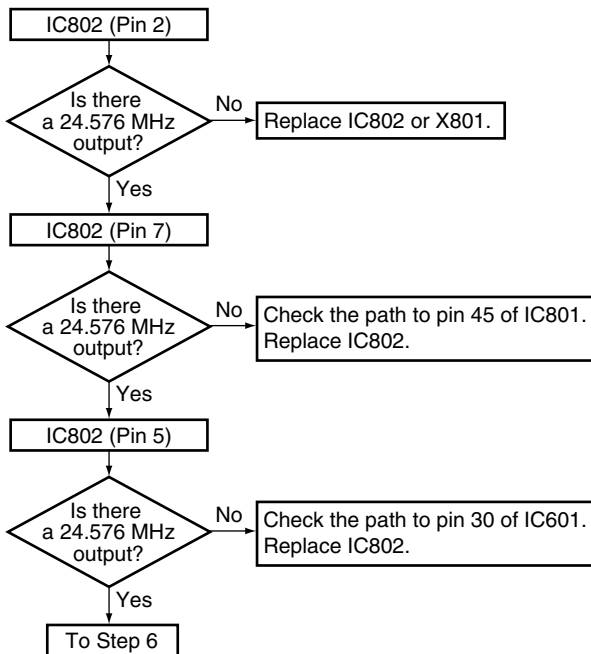

Step 6: ROM

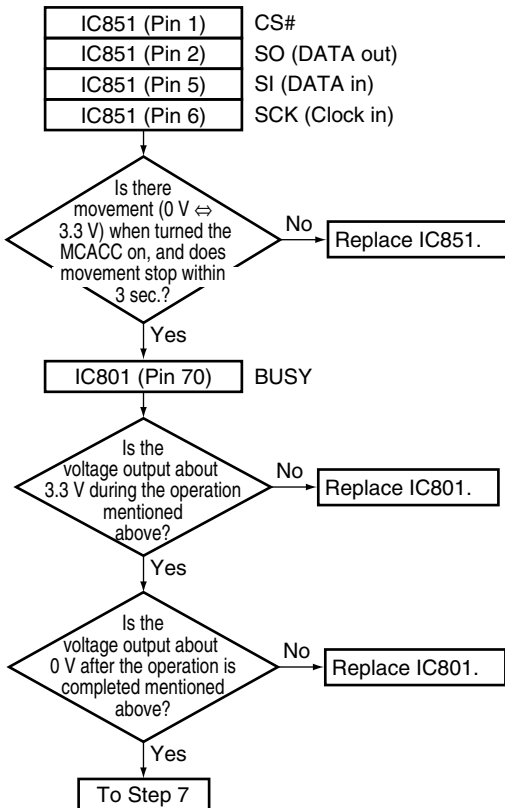

Step 7: DSP output (digital)

Digital output when indicated each CH.

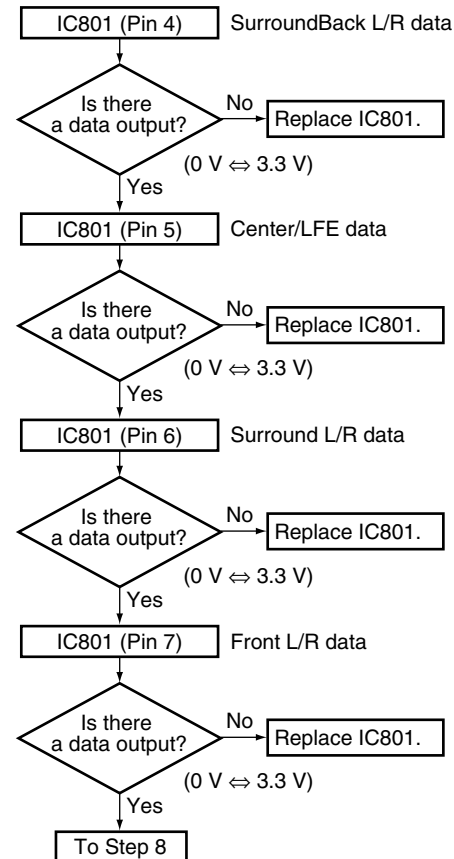

Step 8: CODEC output (analog)

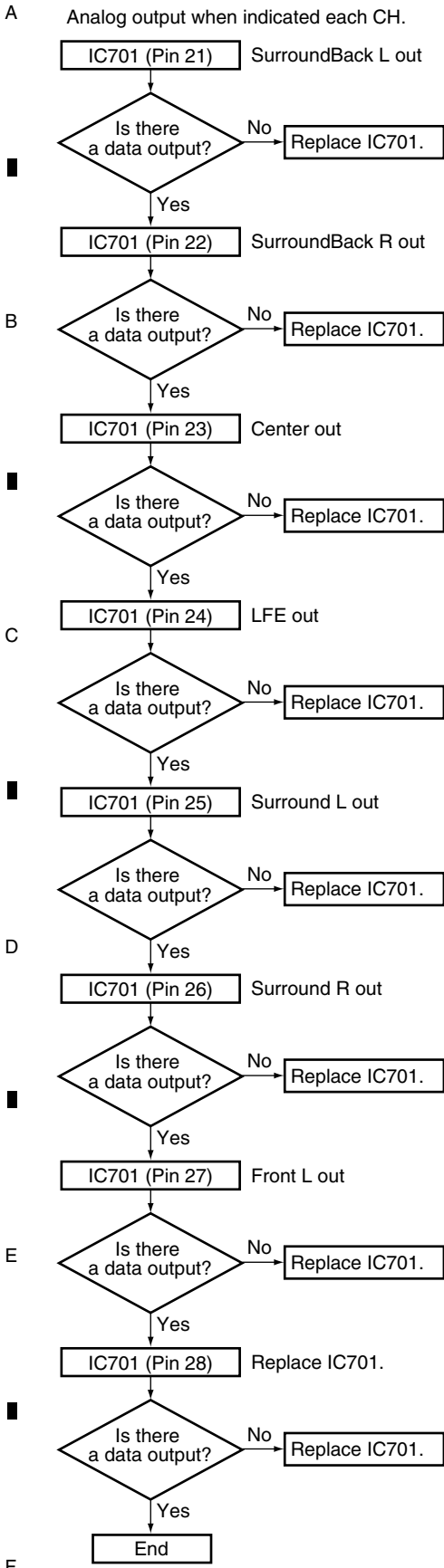

• DSP Block Diagram

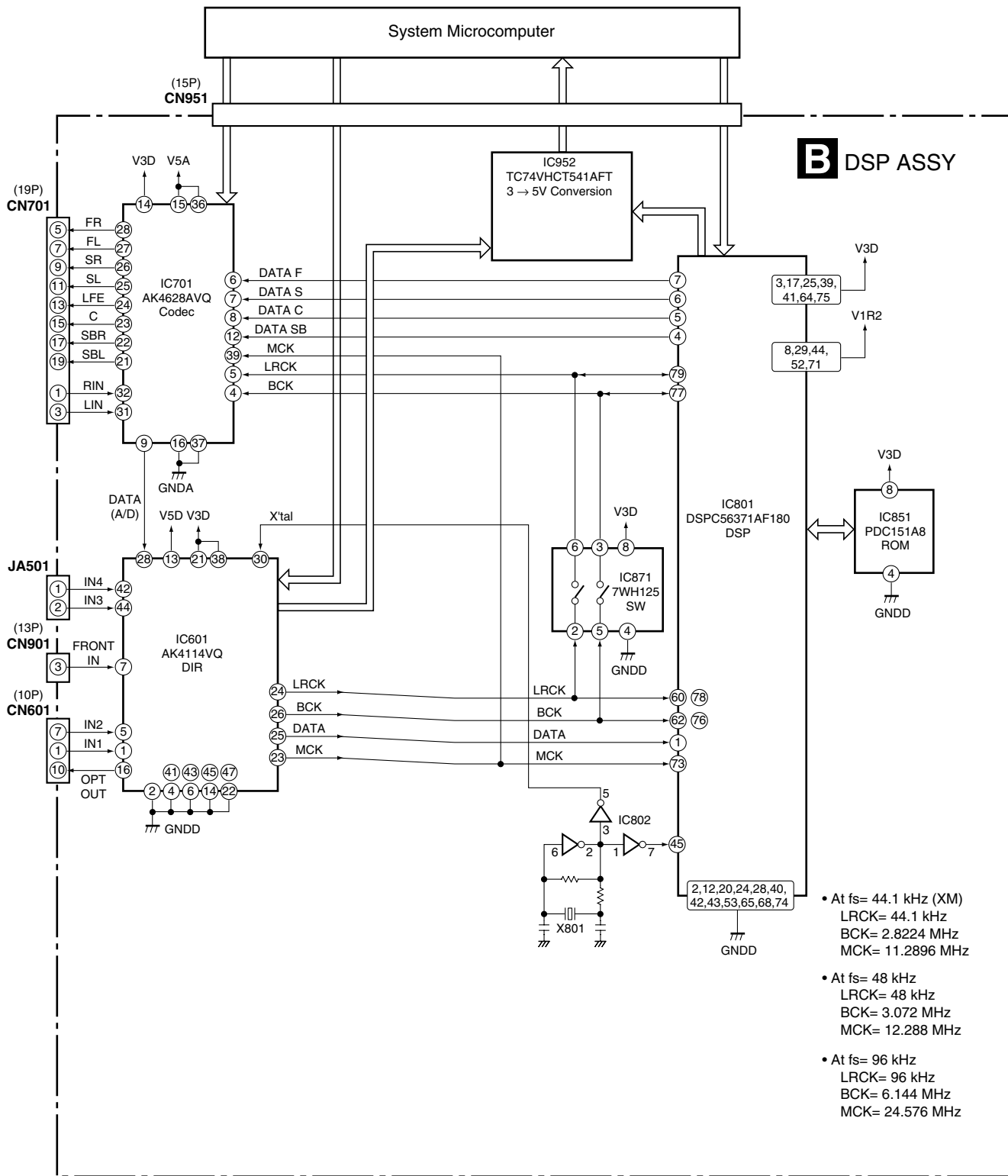

7.1.2 HDMI TROUBLESHOOTING (VSX-917V ONLY)

HDMI Simple Diagnosis

Please refer to the one point trouble shooting first before checking the flow chart on the next page.

HDMI

Symptom	Remedy
No picture or sound.	<ul style="list-style-type: none"> If the problem still persists when connecting your HDMI component directly to your monitor, please consult the component or monitor manual or contact the manufacturer for support.
No picture.	<ul style="list-style-type: none"> Depending in the output settings of the source component, it may be outputting a video format that can't be displayed. Change the output settings of the source, or connect using the component, S-video or composite jacks.
No sound, or sound suddenly ceases.	<ul style="list-style-type: none"> Since the HDMI audio signal is sent through this receiver to your TV, you need to make separate connections for audio if you want to hear your HDMI component through this system. If you've made separate connections for audio, make sure you have assigned the analog/digital jack(s) to the corresponding HDMI input for the component. Check the audio output settings of the source component.

Causes for no display or sound from the monitor

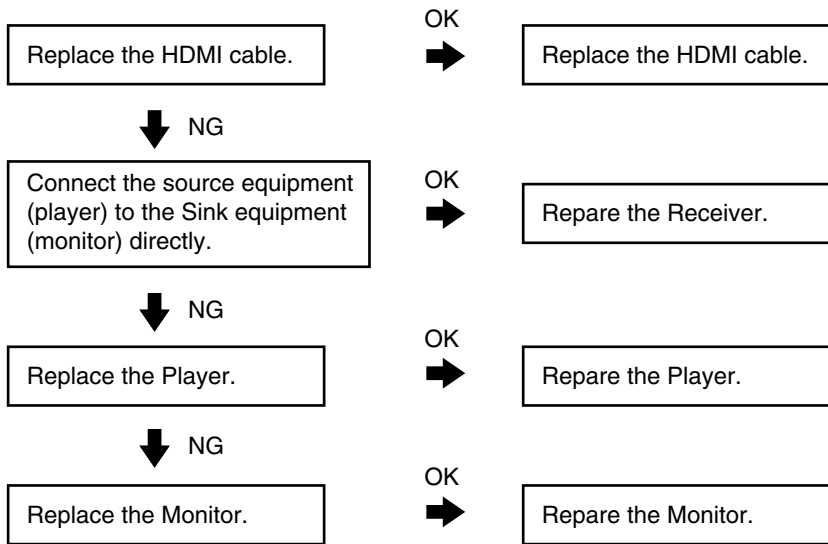

HDMI Troubleshooting

- The parts marked like **V+5** in the following chart are located in "HDMI & DVC Assy Check Points".

Common section

Step 1-1: Connections

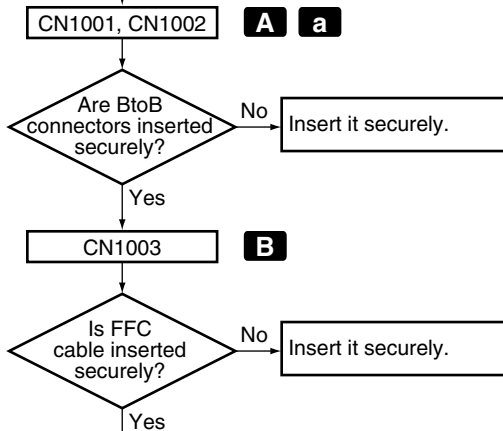

Step 1-2: Power supply

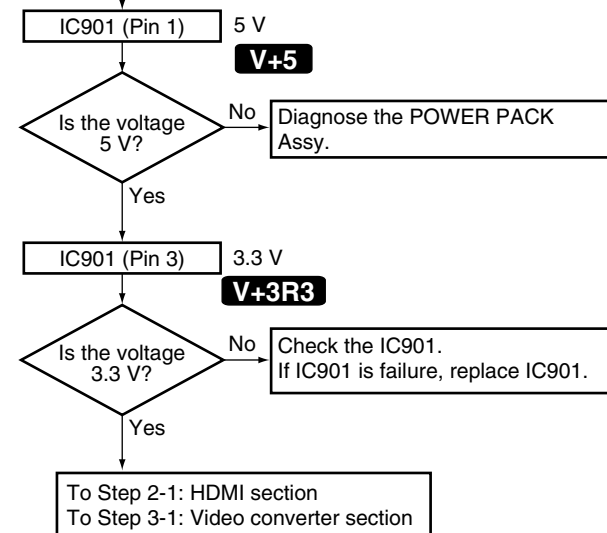

HDMI section

Step 2-1: CE

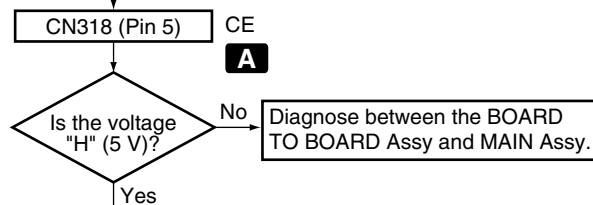

Step 2-2: Power supply

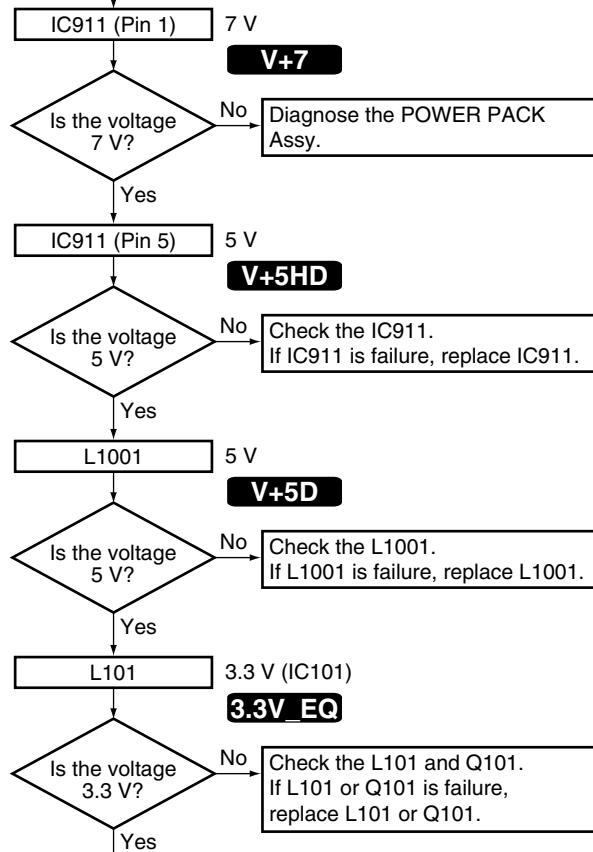

Step 2-3: SEL

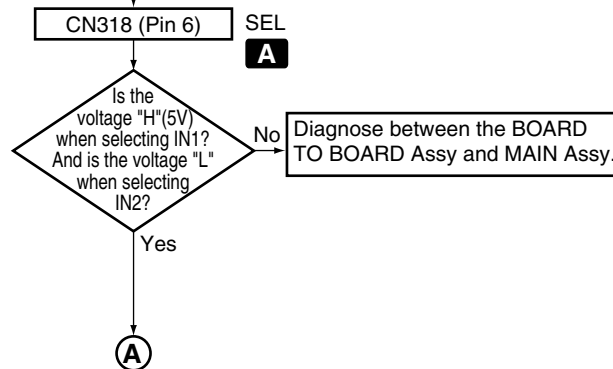

A
B
C
D
E
F

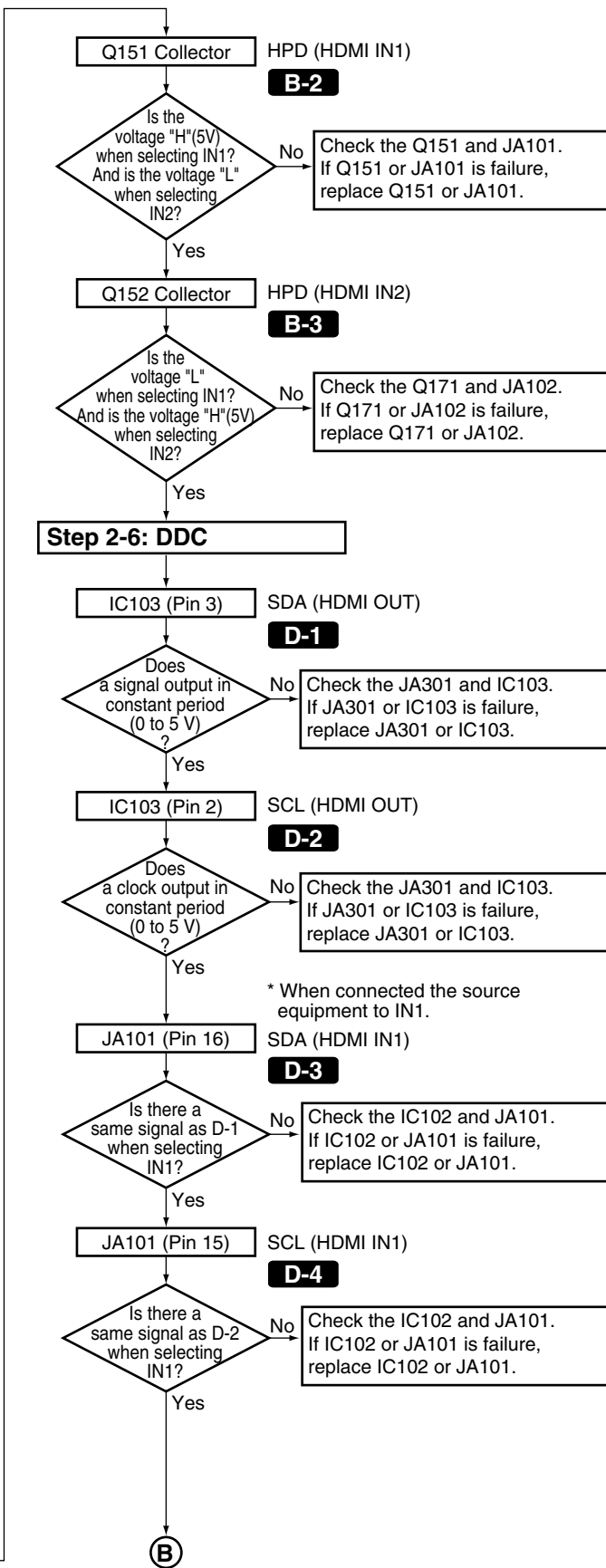
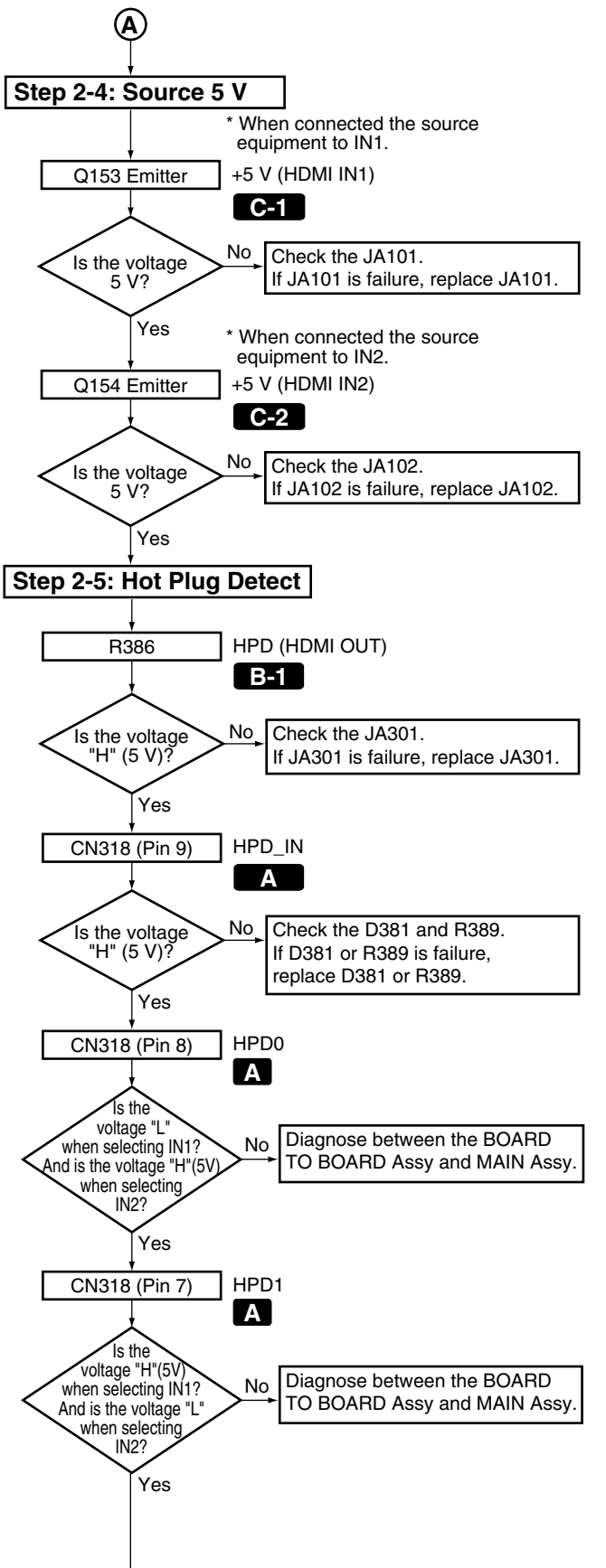

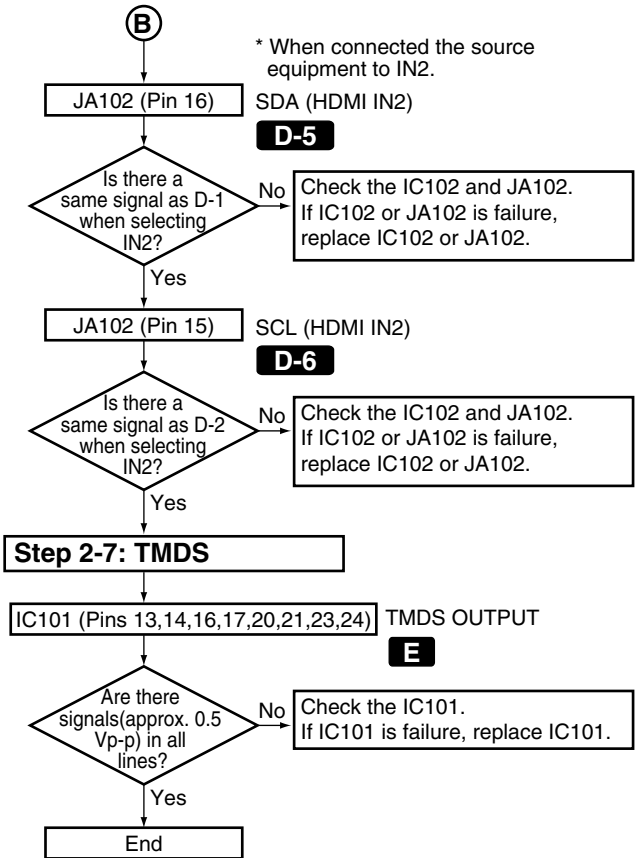

[Video converter]

Step 3-1: Power Supply

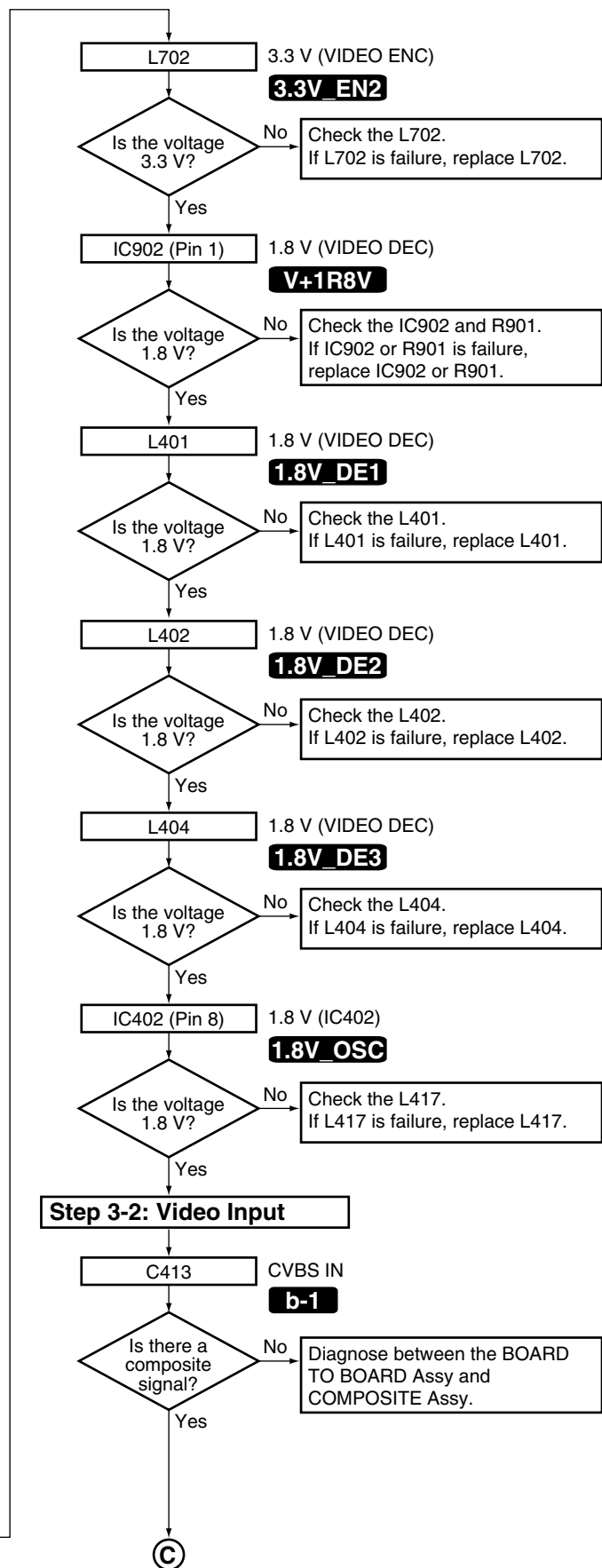
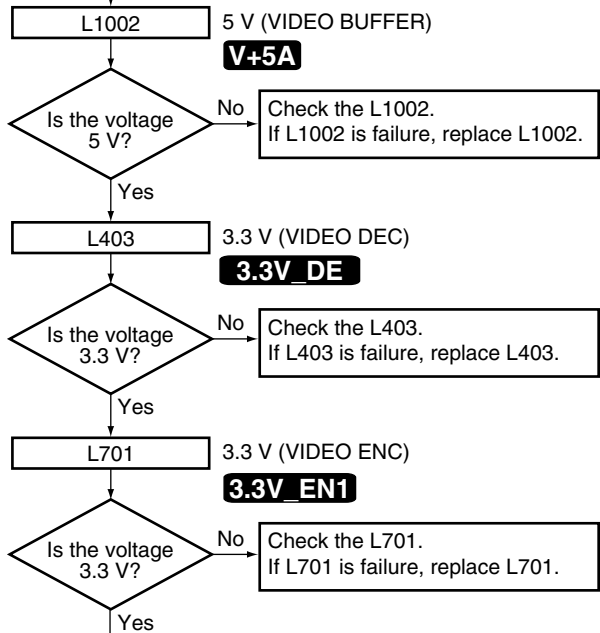

A
B
C
D
E
F

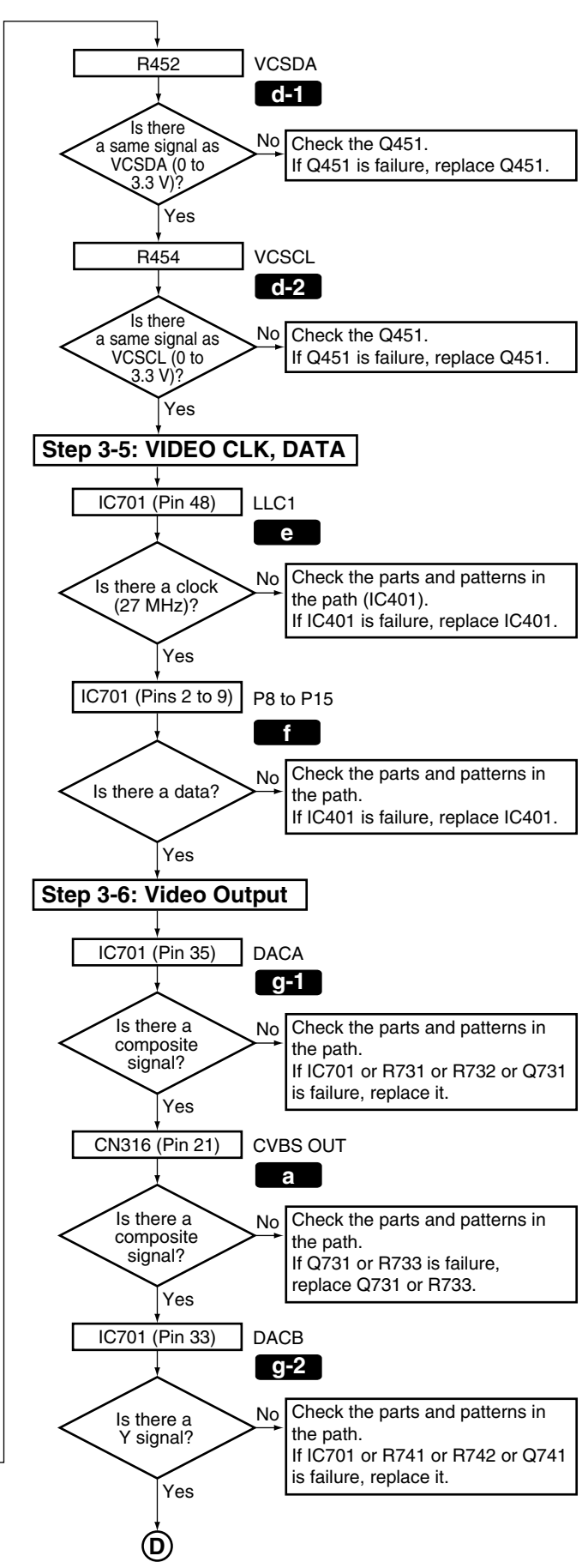
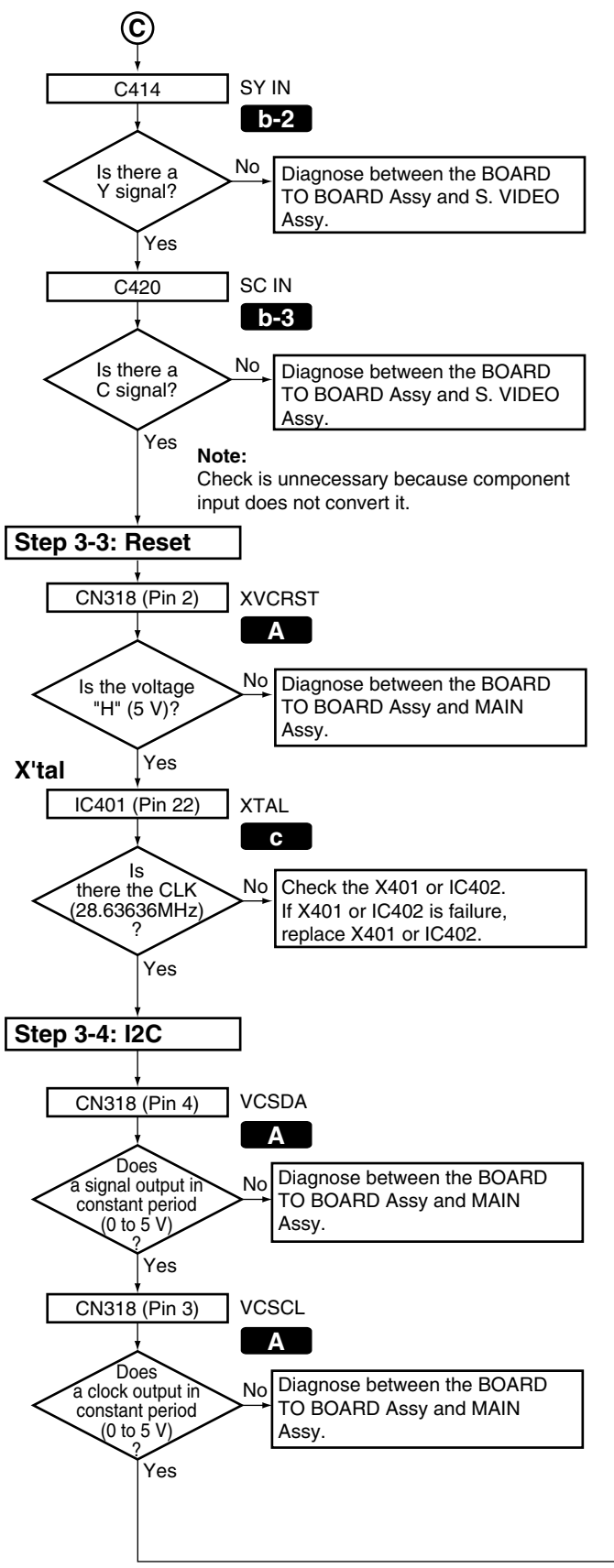

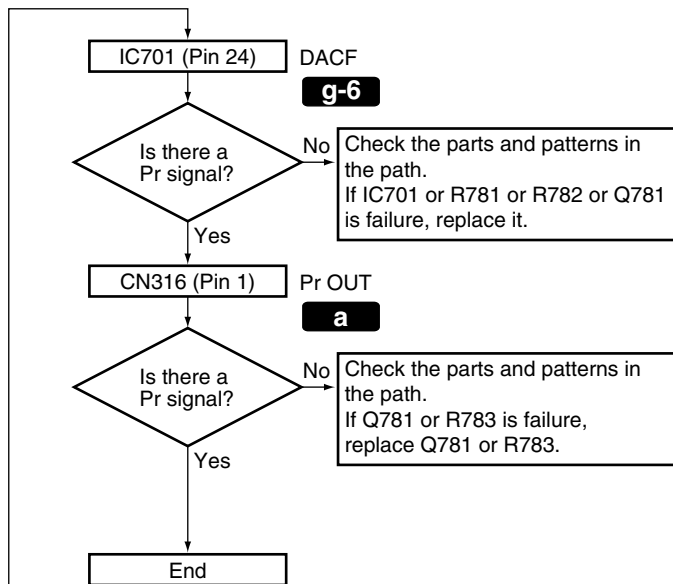
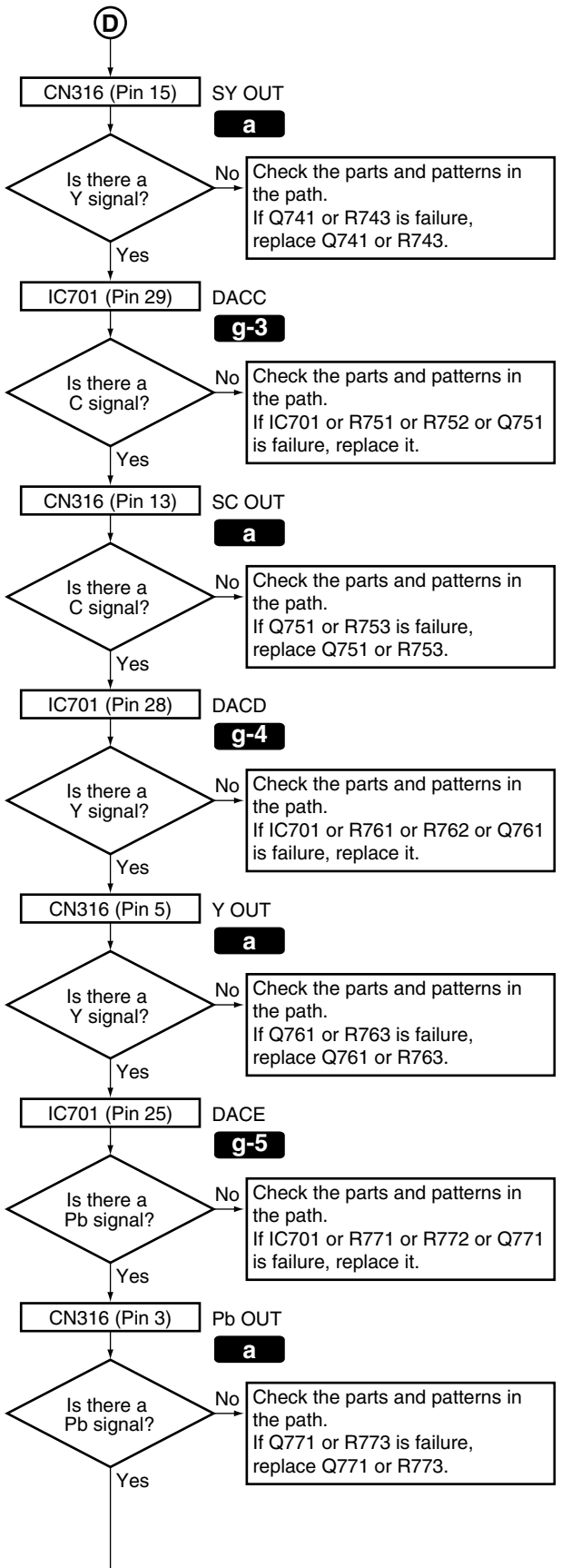

A
B
C
D
E
F

HDMI & DVC Assy Check Points

A



V HDMI&DVC ASSY

P BOARD TO BOARD ASSY

V HDMI&DVC ASSY **SIDE A**

C

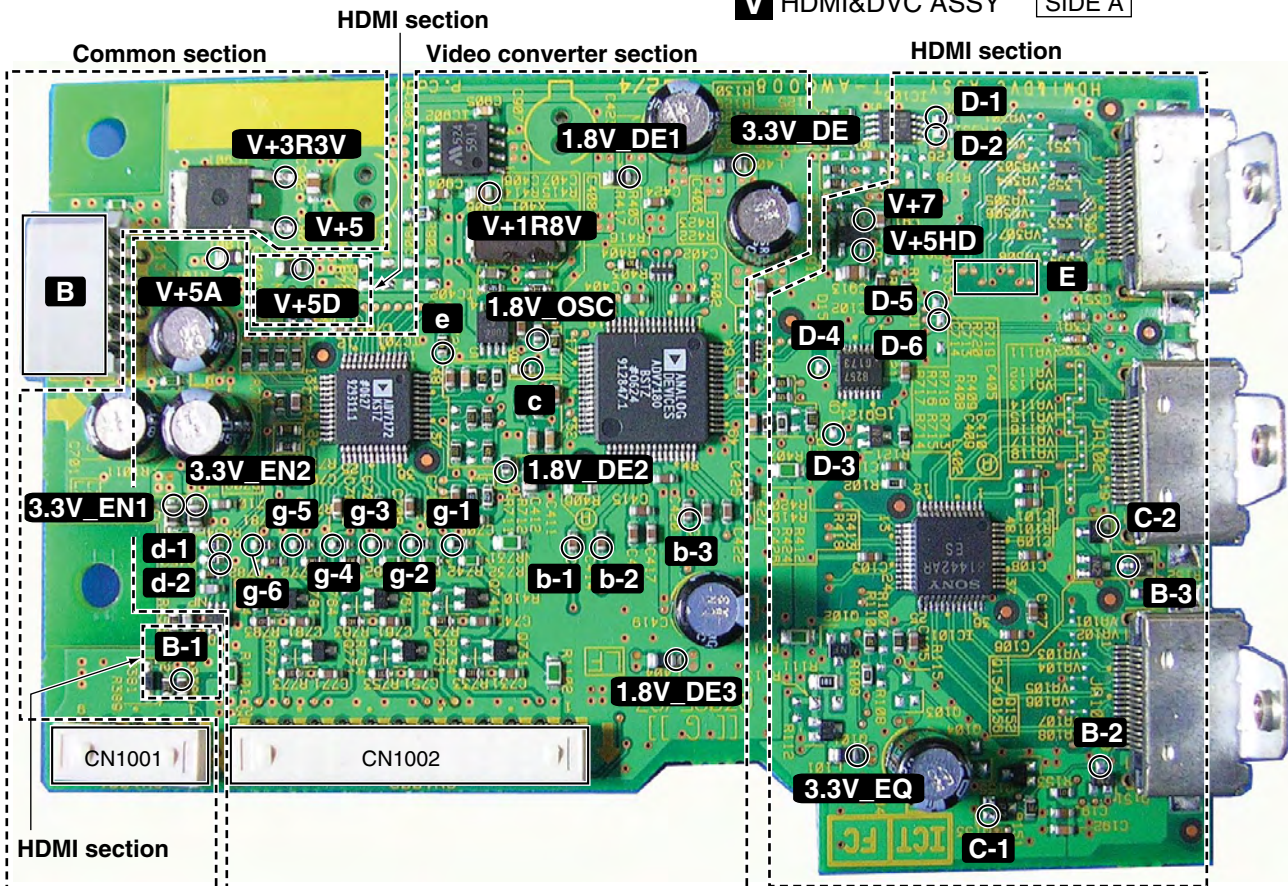

D

E

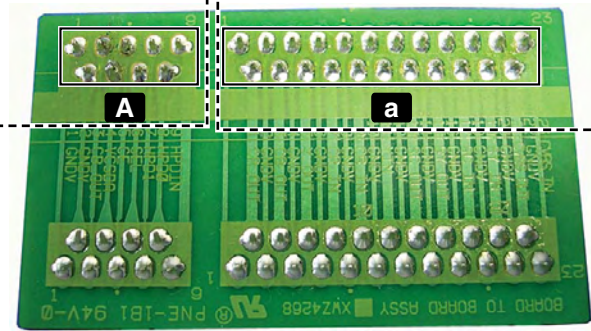

P BOARD TO BOARD ASSY **SIDE B**

Block Diagram of the HDMI & DVC Assy

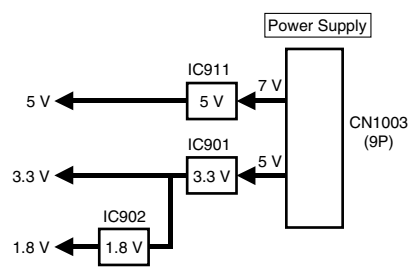
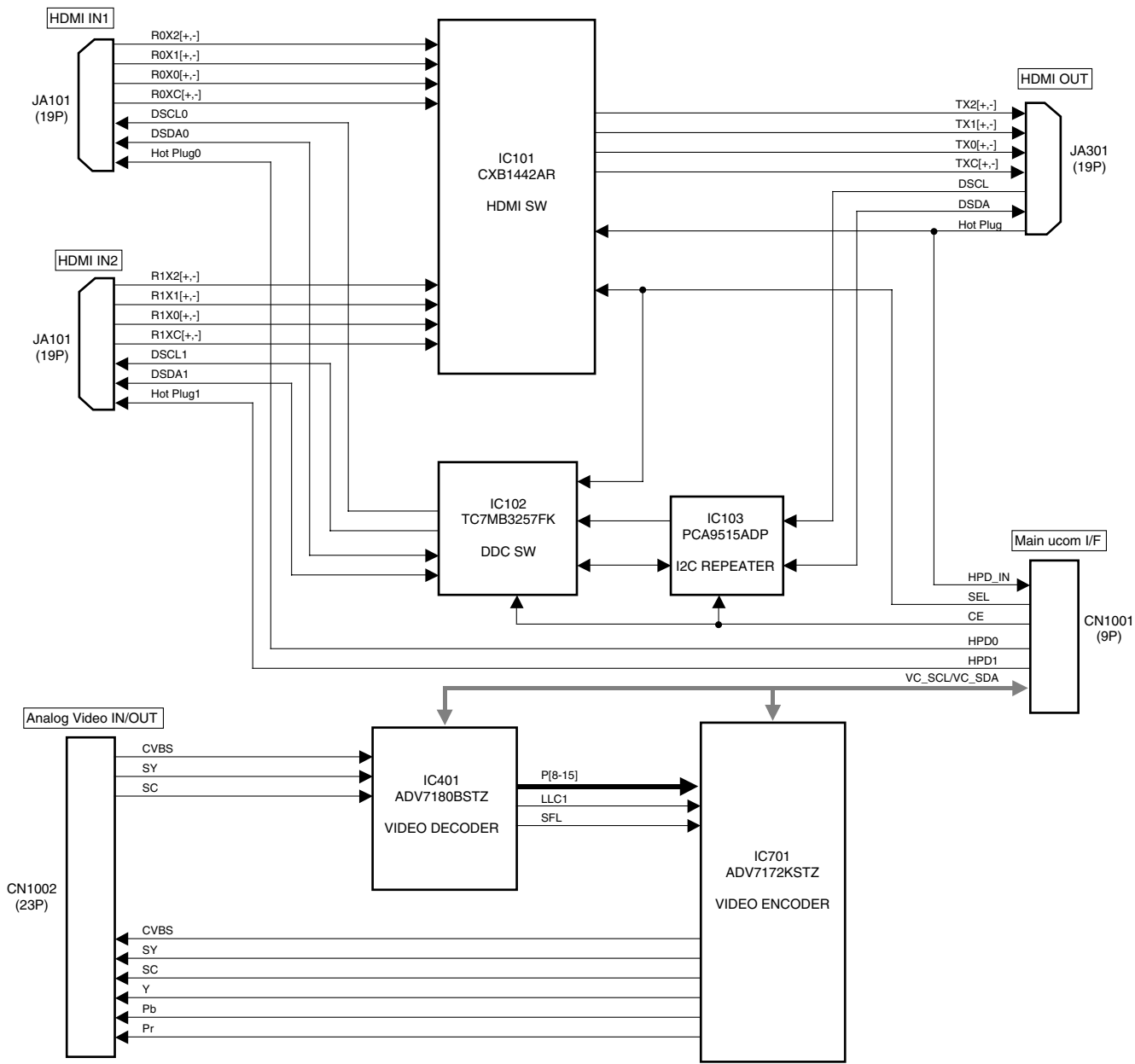

7.1.3 DISASSEMBLY

Note: Even if the unit shown in the photos and illustrations in this manual may differ from your product, the procedures described here are common.

Diagnosis of the Unit

Caution:
Heatsink section in work becomes hot, and be careful with it.

- ① Remove the bonnet by removing the six screws.
- ② Remove the two screws.
- ③ Remove the four screws.
- ④ Remove the push rivet.
- ⑤ Release the three binders.
- ⑥ Remove the BIND Assy by removing the one screw.

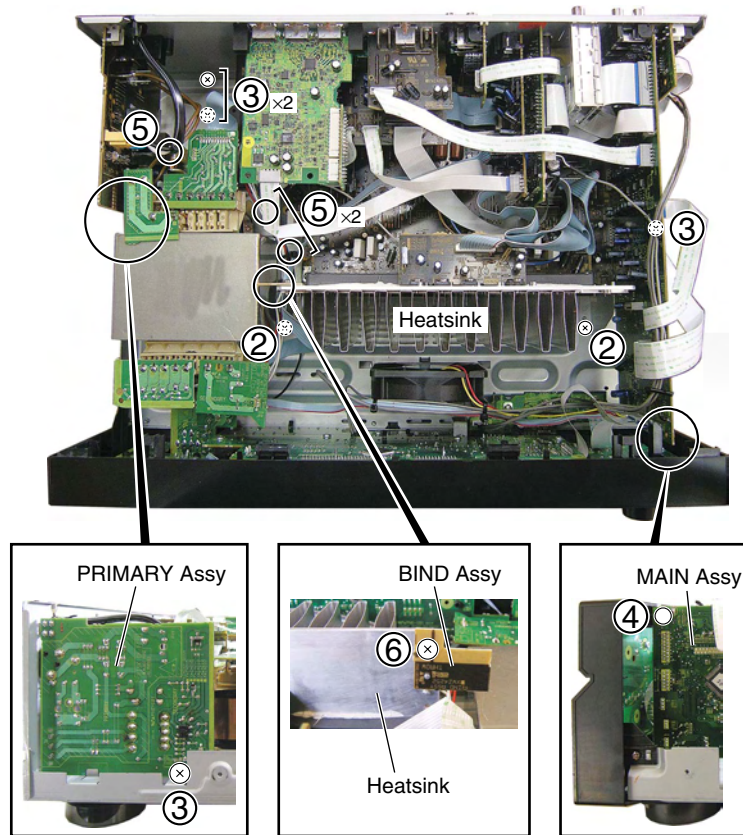

- ⑦ Remove the one screw.

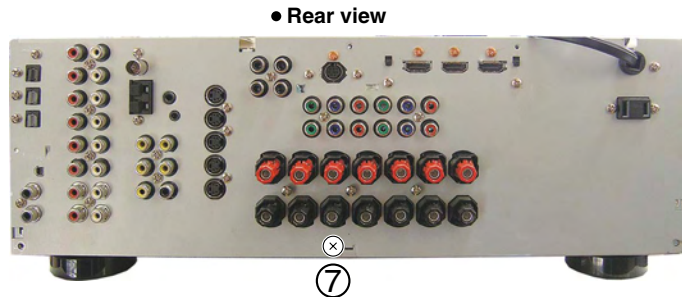

⑧ Arrange the unit as shown in the photo below.

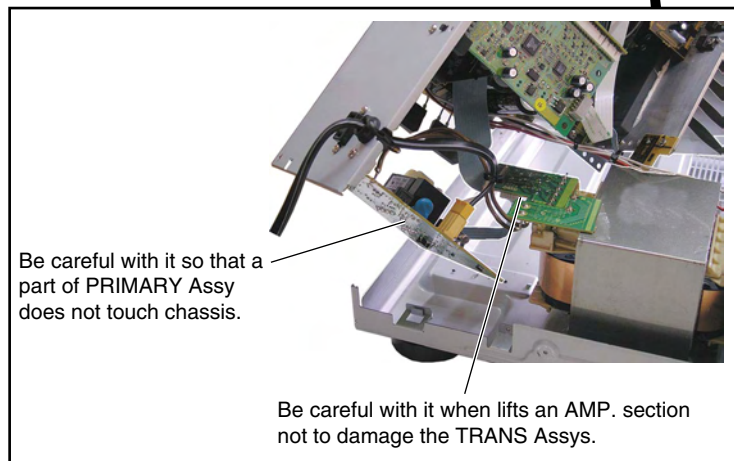
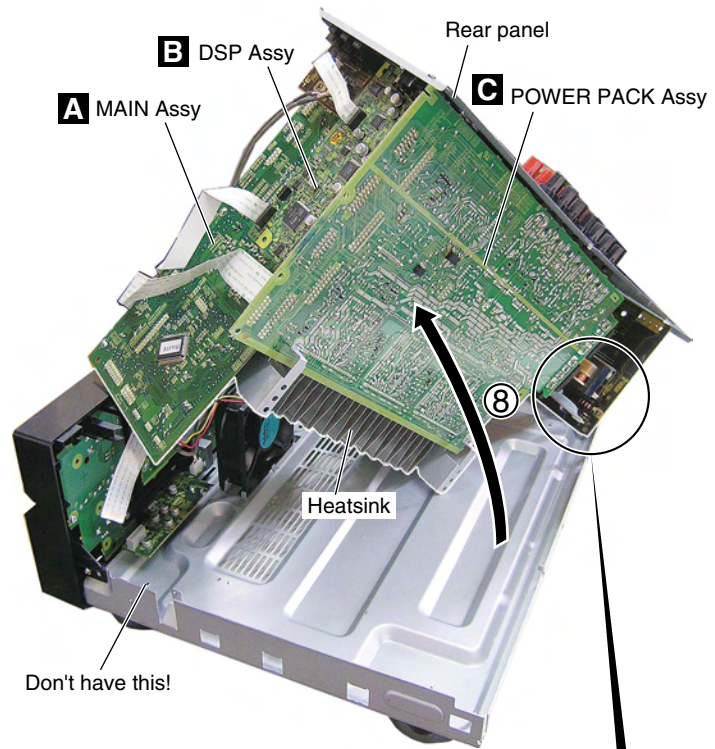

Caution:

During diagnosis, be sure NOT to remove the three screws marked Ⓐ in the above photo. There is the case that a product does not work normally when removes these screws.

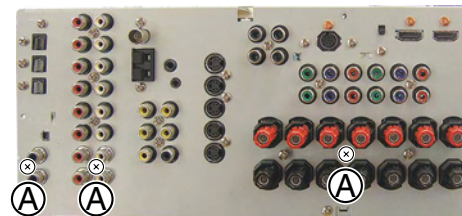

Front Panel Section

A

- ① Remove the five screws.
- ② Remove the two screws.
- ③ Unhook the two hooks.

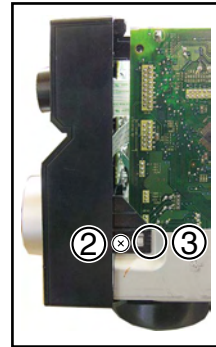
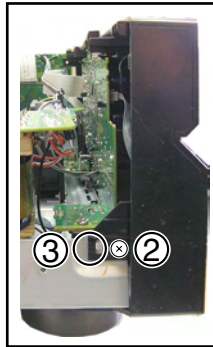

B



C

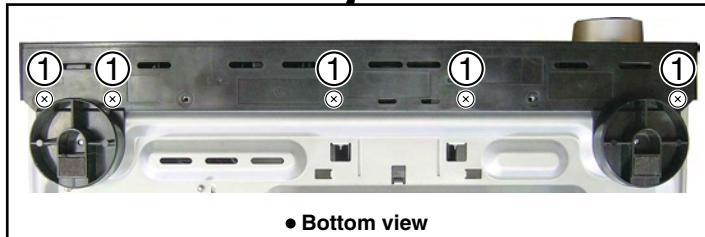

D



- ④ Remove the front panel section.

E

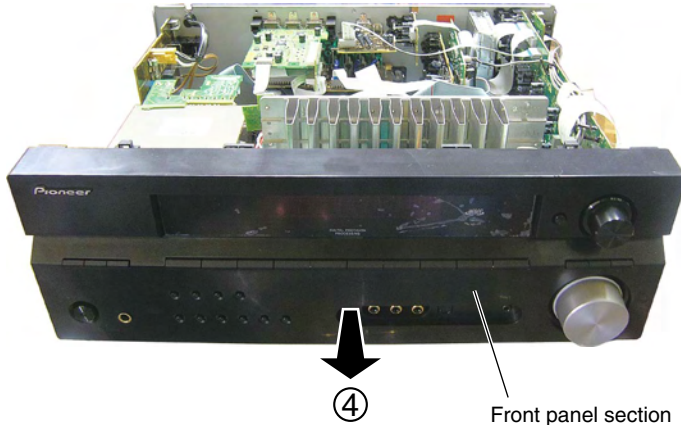

F

PCB Location

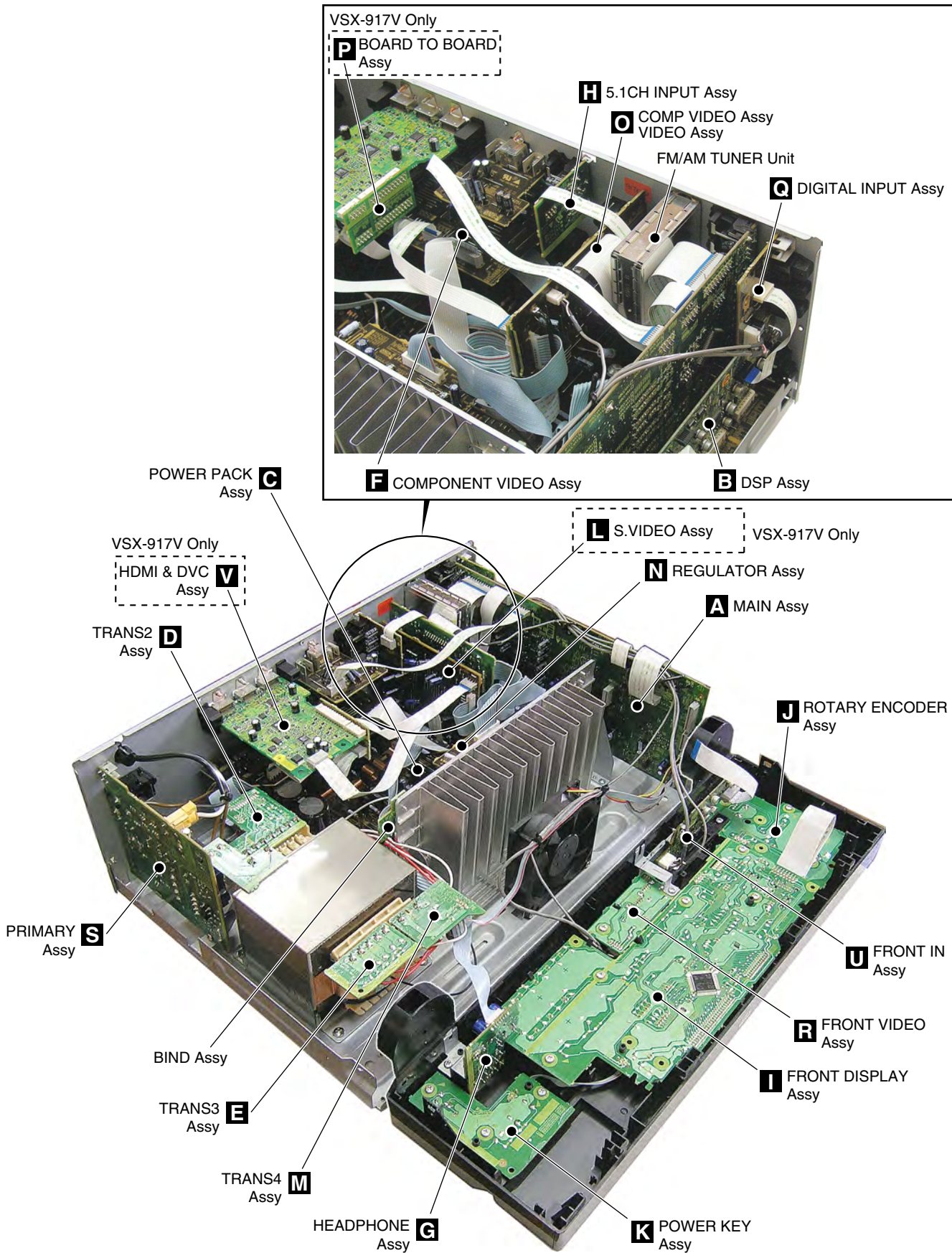

7.2 PARTS

7.2.1 IC

The information shown in the list is basic information and may not correspond exactly to that shown in the schematic diagrams.

List of IC

PEG375B8, PQ1LAX95MSPQ, PDC151A8, F2621E-01

PEG375B8 (MAIN ASSY : IC9001)

System Control MCU

Pin Arrangement (Top View)

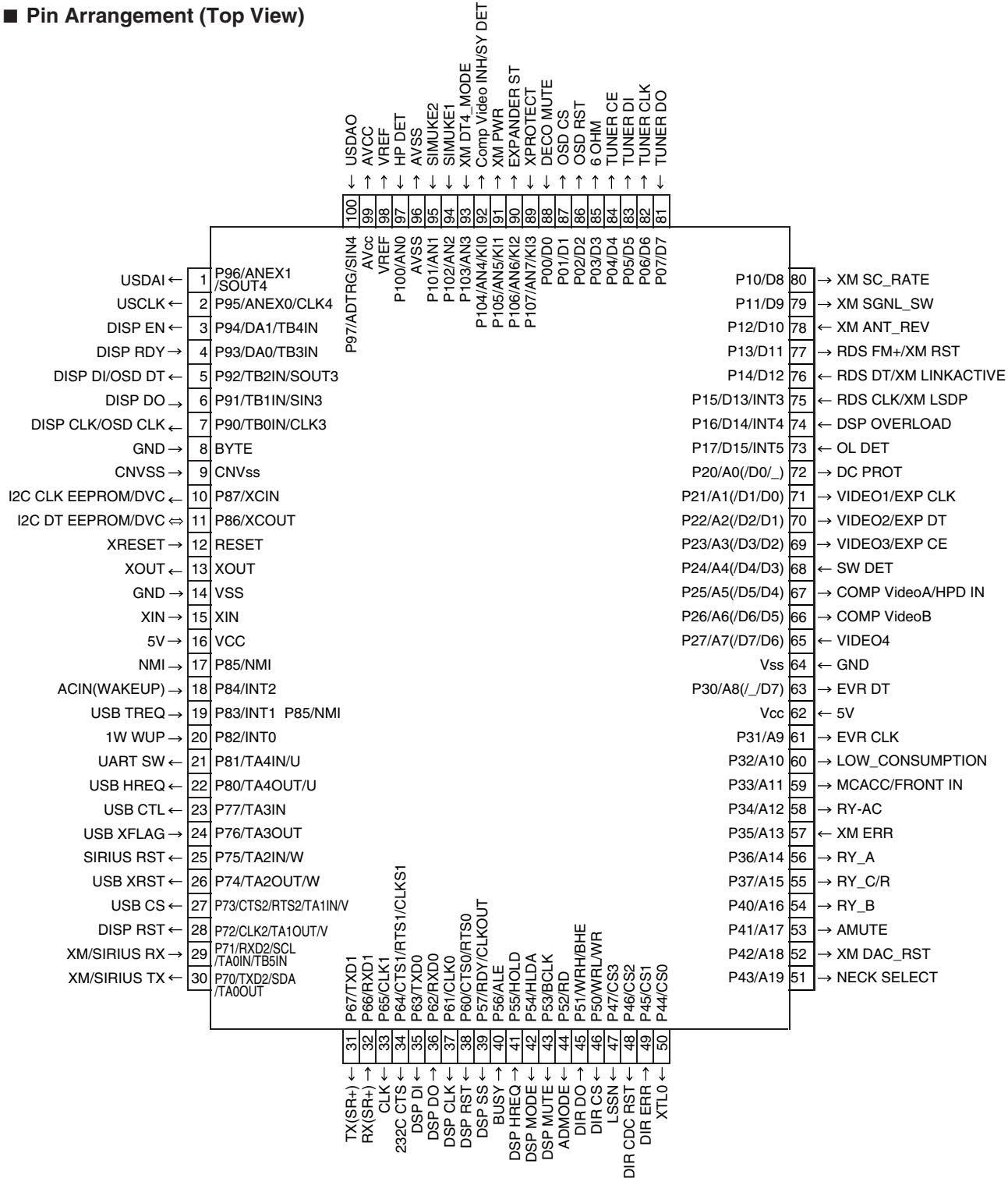

• Pin Function

No.	Port	Pin Name	I/O	Pin Function
1	P96/ANEX1/SOUT4	USDAI	O	Data out to USB
2	P95/ANEX0/CLK4	USCLK	O	Clock signal from USB
3	P94/DA1/TB4IN	DISP EN	O	Enable signal to display u-com
4	P93/DA0/TB3IN	DISP RDY	I	Ready signal from display u-com
5	P92/TB2IN/SOUT3	DISP DI/OSD DT	O	Data out to display u-com
6	P91/TB1IN/SIN3	DISP DO	I	Data in from display u-com
7	P90/TB0IN/CLK3	DISP CLK/OSD CLK	O	Clock signal to display u-com
8	BYTE	GND	I	Ground
9	CNVss	CNVSS	I	Terminate to GND with resistor
10	P87/XCIN	I2C CK EEPROM/DVC	O	I2C bus for EEPROM, DVC
11	P86/XCOUT	I2C DT EEPROM/DVC	I/O	I2C bus for EEPROM, DVC
12	RESET	XRESET	I	Reset signal input
13	XOUT	XOUT	O	X'tal output
14	VSS	GND	I	Ground
15	XIN	XIN	I	X'tal input
16	VCC	5V	I	Power supply
17	P85/NMI	NMI	I	Pull-up to +5 V with resistor
18	P84/INT2	ACIN(WAKEUP)	I	AC pulse in
19	P83/INT1 P85/NMI	USB TREQ	I	Request from TCC760 to main u-com
20	P82/INT0	1W WUP	I	Wake up signal from display u-com (pull-down)
21	P81/TA4IN/U	UART SW	O	XM/SIRIUS UART BUS SWITCH control
22	P80/TA4OUT/U	USB HREQ	O	Request from main u-com to TCC760
23	P77/TA3IN	USB CTL	O	From main u-com to USB power switch IC
24	P76/TA3OUT	USB XFLAG	I	From USB power switch IC to main u-com
25	P75/TA2IN/W	SIRIUS RST	O	Reset signal to SIRIUS
26	P74/TA2OUT/W	USB XRST	O	Reset signal to USB (pull-down)
27	P73/CTS2/RTS2/TA1IN/V	USB CS	O	From main u-com to TCC760
28	P72/CLK2/TA1OUT/V	DISP RST	O	Reset signal to display u-com
29	P71/RXD2/SCL/TA0IN/TB5IN	XM/SIRIUS RX	I	
30	P70/TXD2/SDA/TA0OUT	XM SIRIUS TX	O	Pull-up
31	P67/TXD1	TX (SR+)	O	SR+ communication
32	P66/RxD1	RX (SR+)	I	SR+ communication
33	P65/CLK1	CLK	O	It is necessary when writing for JIG
34	P64/CTS1/RTS1/CLKS1	232C CTS	O	For rewriting 232C (Admit communication)
35	P63/TXD0	DSP DI	O	Data output signal for communication with DSP and DIR
36	P62/RxD0	DSP DO	I	Data input signal for communication with DSP
37	P61/CLK0	DSP CLK	O	Clock signal for communication with DSP and DIR
38	P60/CTS0/RTS0	DSP RST	O	Reset signal for DSP
39	P57/RDY/CLKOUT	DSP SS	O	Strobe select signal to DSP
40	P56/ALE	BUSY	I	Use it in MCACC
41	P55/HOLD	DSP HREQ	I	DSP error detect signal
42	P54/HLDA	DSP MODE	O	Mode select of DSP (ROM/RAM)
43	P53/BCLK	DSP MUTE	O	DSP ASSY mute
44	P52/RD	ADMODE	O	DSP ASSY
45	P51/WRH/BHE	DIR DO	I	Data input signal for communication with DIR/DAC
46	P50/WRL/WR	DIR CS	O	Chip select signal for communication with DIR/DAC
47	P47/CS3	LSSN	O	DSP ASSY
48	P46/CS2	DIR CDC RST	O	Reset signal for DIR CODEC
49	P45/CS1	DIR ERR	I	lock/unlock signal
50	P44/CS0	XTL0	O	DIR X'tal change

• Pin Function

No.	Port	Pin Name	I/O	Pin Function
51	P43/A19	NECK SELECT	O	For 8ohm spk impedance: *H at Adv , Sandard, 5.1Multich, speaker A+B (7ch model). For 6 ohm spk impedance: L
52	P42/A18	XM DAC_RST	O	
53	P41/A17	AMUTE	O	System mute
54	P40/A16	RY_B	O	Speaker B relay-on / OFF at 916, 816 and 516. This RY_B is used for SW relay at 316.
55	P37/A15	RY_C/R	O	Rear one / center relay-on / OFF
56	P36/A14	RY_A	O	Speaker A relay-on / OFF
57	P35/A13	XM_ERR	I	
58	P34/A12	RY-AC	O	AC relay on/off
59	P33/A11	MCACC/FRONT IN	O	For analog switching control
60	P32/A10	LOW_CONSUMPTION	O	When 1 minutes passed after power off and then go into stop mode and port L, else H.
61	P31/A9	EVR CLK	O	Clock signal for Function and E-volume
62	Vcc	5V	I	
63	P30/A8/_/D7	EVR DT	O	Data signal for Function and E-volume
64	Vss	GND	I	
65	P27/A7(/D7/D6)	VIDEO4	O	917: SYNC DETECT , others: COMONENT VIDEO INH
66	P26/A6(/D6/D5)	COMP VideoB	O	Component terminal control
67	P25/A5(/D5/D4)	COMP VideoA/HPDIN	O	917: HDMI HOT PLUG DETECT, others: COMPONENT VIDEO A
68	P24/A4(/D4/D3)	SW DET	I	"H": SW YES, "L": SW NO
69	P23/A3(/D3/D2)	VIDEO3/EXP CE	O	917: EXPANDER CE , others: VIDEO3
70	P22/A2(/D2/D1)	VIDEO2/EXP DT	O	917: EXPANDER DATA ,others: VIDEO2
71	P21/A1(/D1/D0)	VIDEO1/EXP CLK	O	917: EXPANDER CLK , others: VIDEO1
72	P20/A0(/D0/_)	DC PROT	I	Amplifier DC detection. H:Normal, L:Abnormal
73	P17/D15/INT5	OL DET	I	Amplifier overload detection. H:Normal, L:Abnormal
74	P16/D14/INT4	DSP OVERLOAD	I	ANALOG OVER LOAD detect (H : detect)
75	P15/D13/INT3	RDS CLK/XM LSDP	I	RDS clock in signal
76	P14/D12	RDS DT/XM LINKACTIVE	I	RDS data in signal
77	P13/D11	RDS FM+/XM RST	O	RDS power supply. FM: Low, AM:High
78	P12/D10	XM ANT_REV	I	
79	P11/D9	XM SGNL_SW	O	
80	P10/D8	XM SC_RATE	O	
81	P07/D7	TUNER DO	I	Data input signal for tuner control
82	P06/D6	TUNER CLK	O	Clock signal for tuner control
83	P05/D5	TUNER DI	O	Data output signal for tuner control
84	P04/D4	TUNER CE	O	Chip select signal for tuner control
85	P03/D3	6 OHM	O	If stop mode, port L, else according to setting (J model No connect)
86	P02/D2	OSD RST	O	
87	P01/D1	OSD CS	O	
88	P00/D0	DECO MUTE	I	1st DSP detect port
89	P107/AN7/KI3	XPROTECT	I	Power supply abnormal condition detection. H: Normal, L: Abnormal.
90	P106/AN6/KI2	EXPANDER ST	O	Master volume ATT control (-15dB or less : L)
91	P105/AN5/KI1	XM PWR	O	
92	P104/AN4/KI0	Comp Video INH/SY DET	I/O	917: SYNC DETECT , others: COMONENT VIDEO INH
93	P103/AN3	XM DT4_MODE	I	
94	P102/AN2	SIMUKE1	I	Input 1 to switch region
95	P101/AN1	SIMUKE2	I	Input 2 to switch region
96	AVSS	AVSS	I	connects with VCC.
97	P100/AN0	HP DET	I	HP detection H:detected.
98	VREF	VREF	I	connects with VCC.
99	AVcc	AVCC	I	connects with VCC.
100	P97/ADTRG/SIN4	USDAO	I	data input from USB

■ PQ1LAX95MSPQ (DSP ASSY : IC901, IC902)

• REGURATOR IC

● Block diagram

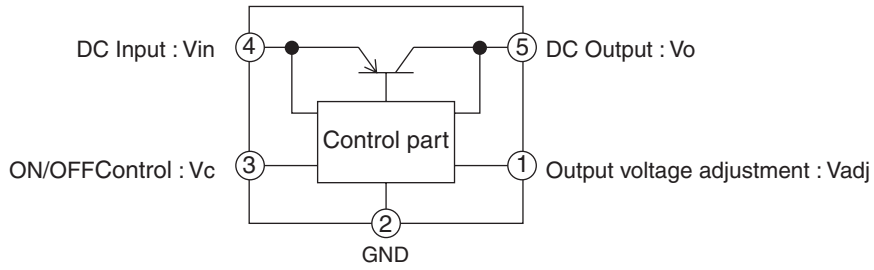

A
B
C
D
E
F

PDC151A8 (DSP ASSY : IC851)

• FLASH ROM

• Pin Arrangement (Top view)

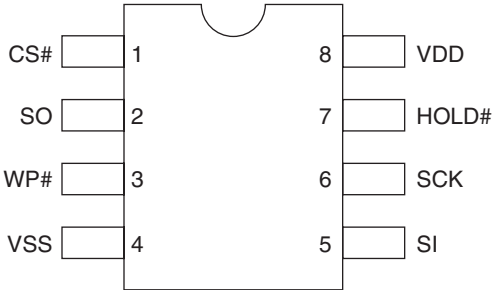

• Block Diagram

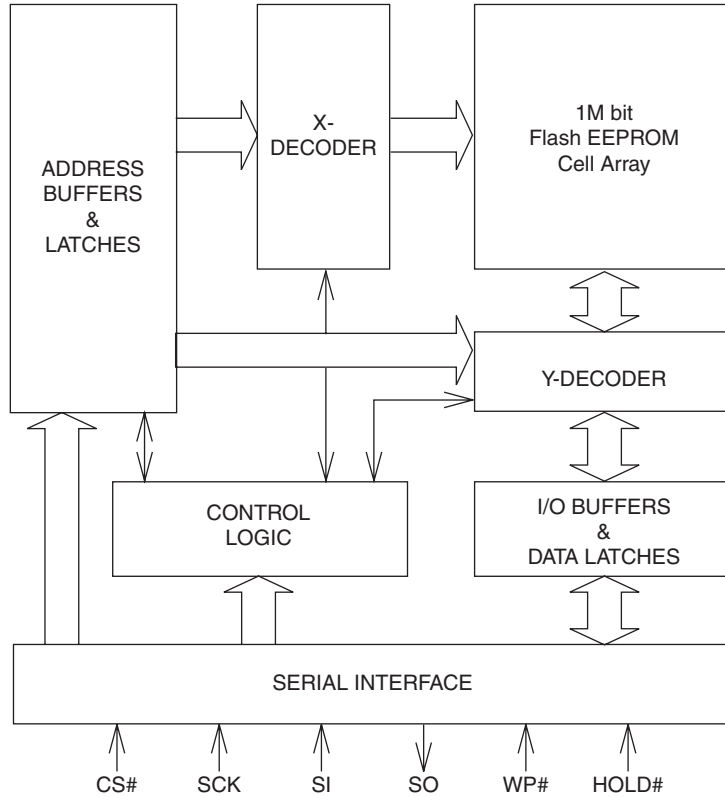

• Pin Description

Symbol	Pin Description	Function
SCK	Serial clock	To control the timing of serial data input and output. To latch input data and addresses synchronously at the rising edge of SCK, and read out Output data synchronously at the falling edge.
SI	Serial data input	To input data or addresses serially from MSB to LSB (Least Significant Bit).
SO	Serial data input	To output data serially from MSB to LSB.
CS#	Chip select	To activate the device when this pin is LOW. To deselect and put the device to standby mode when this pin is HIGH.
WP#	Write-protect	To write-protect the Block Protect bits (BP0, BP1) and the Status Register Write Protect bit (SRWP) of the Status Register in co-operation with the Status Register Write Protect bit (SRWP).
HOLD#	Hold	To pause any serial communications with the device without deselecting the device.
VDD	Power supply	To provide from 2.7V to 3.6V supply
VSS	Ground	

7.3 EXPLANATION

7.3.1 DETECTION CIRCUIT

1. DC Derection Circuit Diagram : Example of VSX-917V/KUXJ/CA

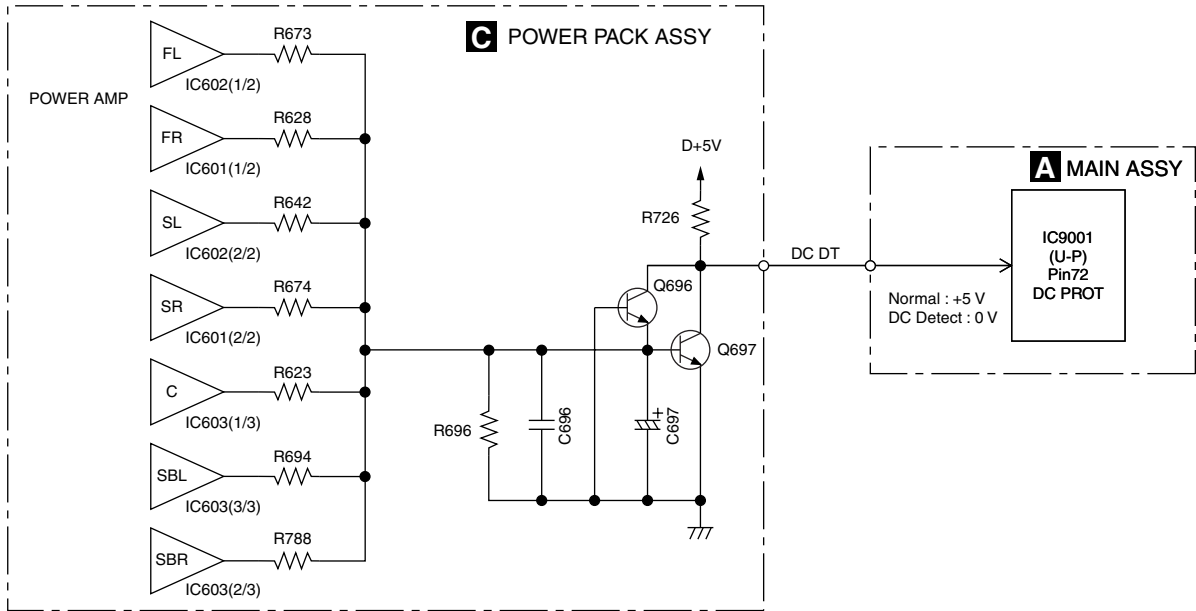

2. Overload Detection Circuit Diagram: Example of VSX-917V/KUXJ/CA FRONT Channel

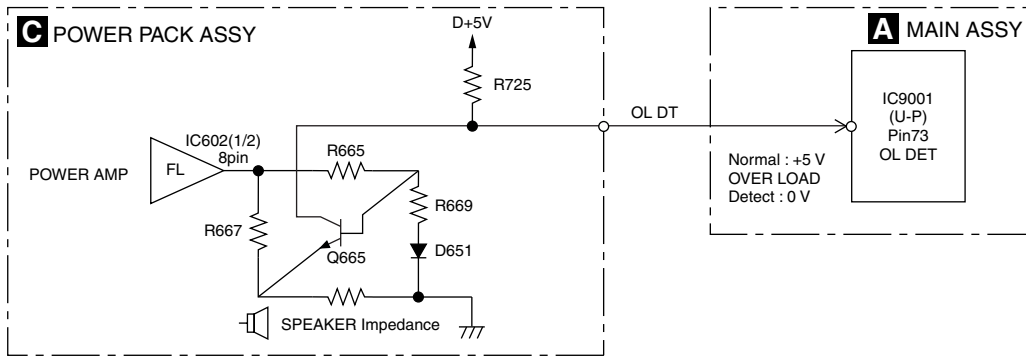

3. Fan Stop Protection Circuit Diagram

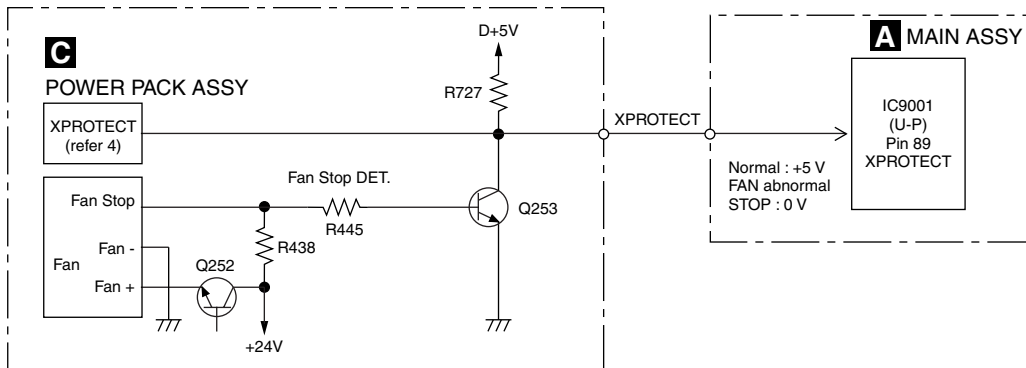

4. XPROTECT Detection Circuit Diagram

A When below 6 kind of voltage supply become to be short circuit to GND, XPROTECT circuit work and U-P input port voltage change from +5 V to 0 V. The U-P detect this condition as ERROR.

- Voltage supply to POWER AMP IC (V neck+)
- Voltage supply to POWER AMP IC (V neck-)
- Voltage supply to POWER AMP IC (VL+)
- Voltage supply to POWER AMP IC (VL-)
- Voltage supply to +12 V REGULATOR IC
- Voltage supply to -12 V REGULATOR IC

B

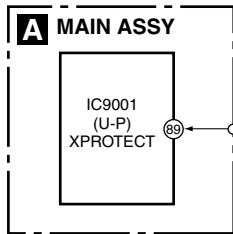

C

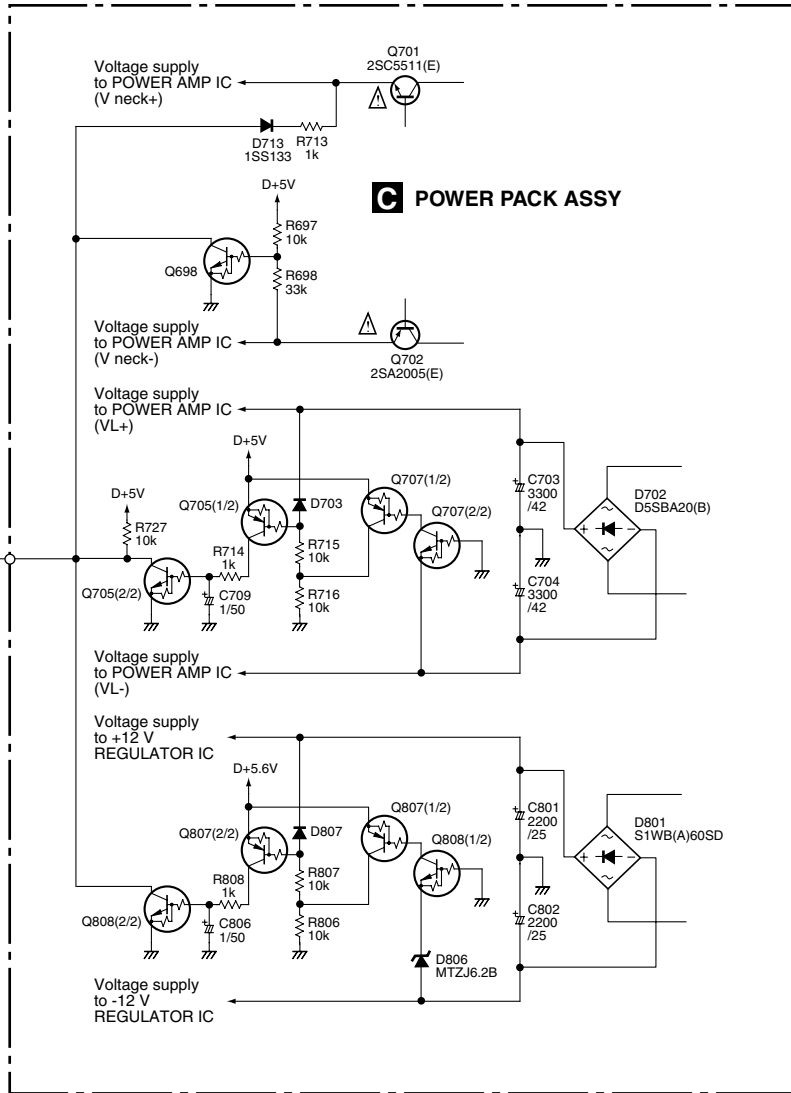

D

E

F

1. DC-abnormality detection

DC detection is only enabled 2 seconds after power-on.
 If there is a fault in the power amplifier or a high-level signal lower than 5 Hz is input, the DC_DET port becomes "L".
 If the "L" is detected, the microprocessor will perform as following flow chart.

In the case of simultaneous detection with the overload protection circuit, DC-abnormality detection is performed preferentially to overload detection.

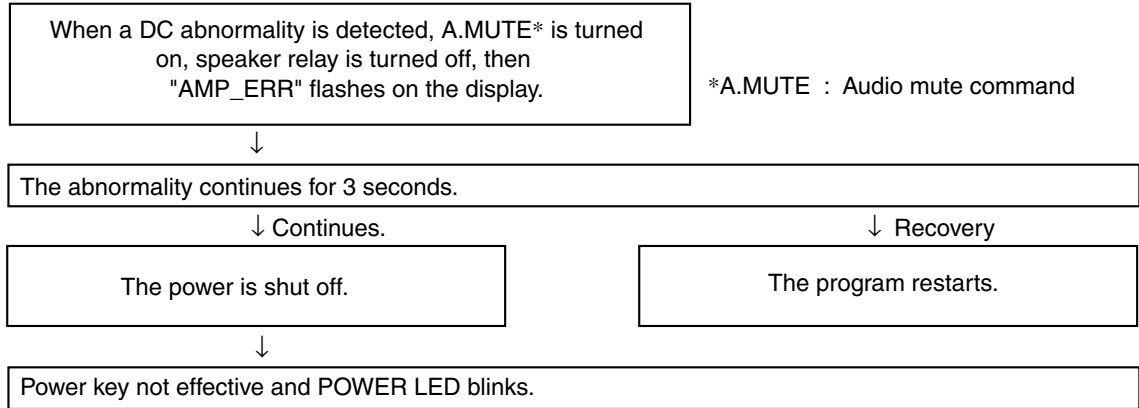

*A.MUTE : Audio mute command

However, when the following keys are pushed so that the key input of a line and the service can be carried out, power can be on.

- ① TESTMODE ON (A55F+A55F)
- ② When power off, push FRONT ENTER key + AUTO SURR/DIRECT key continuously 2sec. (②: When a DC abnormality is detected and the power is shut off.)

Any other key input from front panel or remote control will not be detected.

2. Overload detection

If the speaker terminals are short-circuited or low-load driving is detected, the OL_DET port becomes "L".
 If the "L" is detected, the microprocessor will perform as following flow chart.

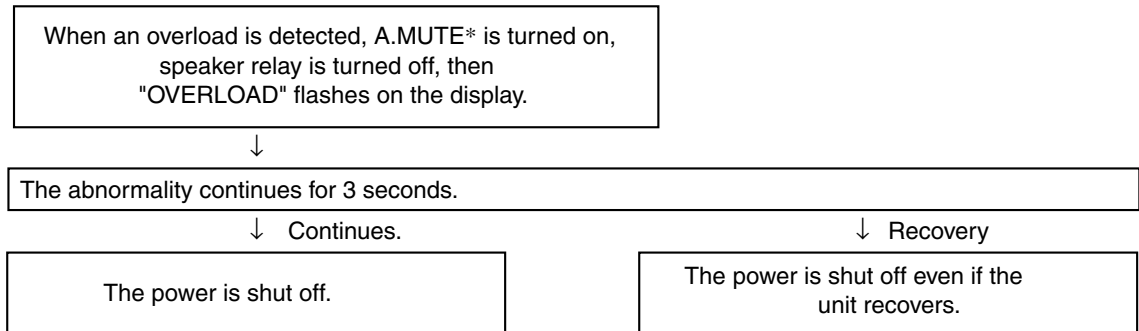

3. XPROTECT detection

XPROTECT is started to be monitored 200msec after power on.

XPROTECT port is checked every 20msec.

If Low level (ERROR) is recognized during consecutive 9 times, micon judge it as XPROTECT ERROR.

It processes more preferentially than DC abnormal detection and overload detection.

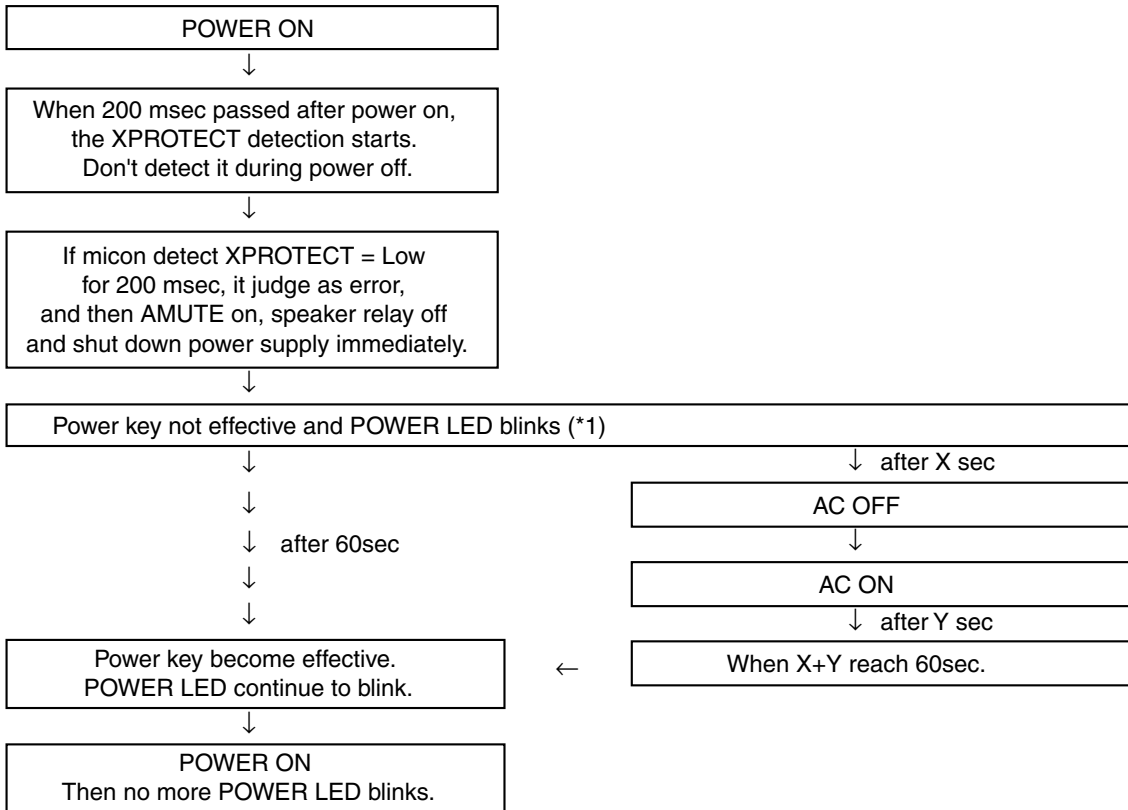

(*1) However, when the following keys are pushed so that the key input of a line and the service can be carried out, power can be on.

① TESTMODE ON (A55F+A55F)

② When power off, push FRONT ENTER key + AUTO SURR/DIRECT key continuously 2sec.

(Effective, only when power-off is carried out by DC detection / XPROTECT detection)

Any other key input from front panel or remote control will not be detected.

4. Fan stop detection operation flow in the XPROTECT detection

If the fan is forcibly stopped or become out of order, the 'XPROTECT' port becomes "L". Then an abnormality of fan is detected.

- Detection routine and recovery is same as "3. XPROTECT detection".

7.3.3 AMPLIFIER FAILURE DIAGNOSIS FLOW CHART

■ Amplifier failure diagnosis flow chart

When DC detection is activated ("AMP_ERR" flashes on the display), failure (damage) of the power amplifier section is considered.

Caution:

When releasing the lock state of power key before repair, please be careful because there is the possibility that more damages will occur when turning on the power once again!

• According to a symptom, perform the following confirmation beforehand.

1) Are there any Fuses and IC protectors open?

↓

2) After turn on the power, confirm that the supply voltage of the point that can be measured is appropriate. (Particularly the supply voltage of the power Tr and drive step)

↓

3) Whether the voltage of pin2 and pin5 of IC601, IC602 or IC603 is equal to (VL-0.7V). If not (eg, equal to VH), then change the corresponding power pack IC601, IC602 or IC603.

↓

4) Furthermore, check the output DC voltage of each channel of power pack IC601, IC602 and IC603 to limit the failure channel and identify the defect power pack.

↓

• After identify the failure channel, check that each part is not damaged (resistor, diode... etc. value / open / short)

8. PANEL FACILITIES

Front panel (VSX-917V)

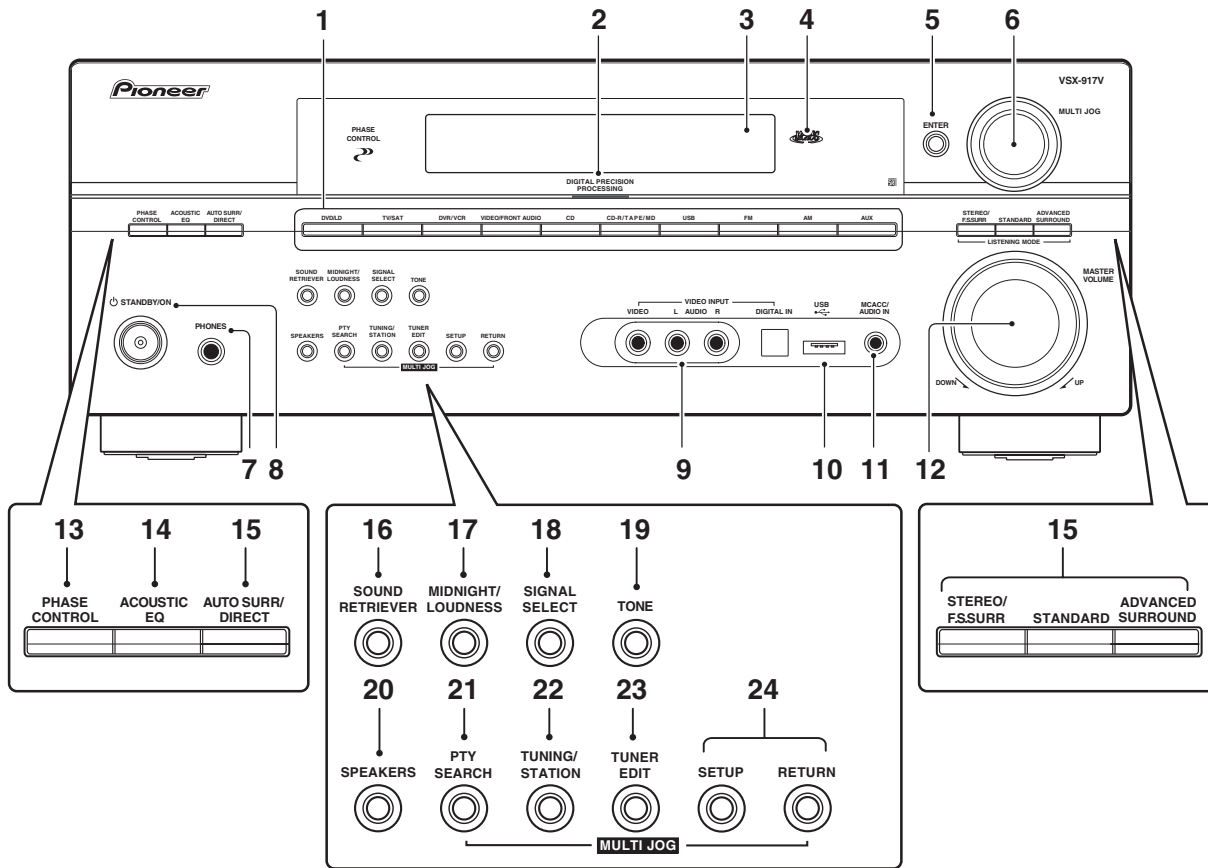

1 Input select buttons

Press to select an input source.

2 Digital Precision Processing indicator

Lights to indicate digital processing.

3 Character display

See Display.

4 MCACC indicator

Lights when Acoustic Calibration EQ is on (Acoustic Calibration EQ is automatically set to **ALL CH ADJUST** after the Auto MCACC Setup or EQ Auto Setup).

5 ENTER

6 MULTI JOG dial

Use the **MULTI JOG** dial to select various settings and menu options.

7 PHONES jack

Use to connect headphones (when connected, there is no sound output from the speakers).

8 \odot STANDBY/ON

Switches the receiver between on and standby.

9 VIDEO INPUT

See Connecting to the front panel video terminal.

10 USB terminal

See Using the USB interface.

11 MCACC/AUDIO IN jack

Use to connect a microphone when performing Auto MCACC setup, or connect an auxiliary component using a stereo mini-jack cable.

12 MASTER VOLUME dial

13 PHASE CONTROL

Press to switch on/off Phase Control.

14 ACOUSTIC EQ

Press to select an Acoustic Calibration EQ setting.

15 LISTENING MODE buttons

AUTO SURR/DIRECT

Selects Auto Surround (Auto playback) or Stream Direct playback.

STEREO/F.S.SURR - Switches between stereo playback and Front Stage Surround Advance modes.

STANDARD - Press for Standard decoding and to switch between the various Pro Logic IIx and Neo:6 options.

ADVANCED SURR - Use to switch between the surround modes.

16 SOUND RETRIEVER

Press to restore CD quality sound to compressed audio sources.

17 MIDNIGHT/LOUDNESS

Switches between Midnight and Loudness listening.

18 SIGNAL SELECT

Use to select an input signal.

19 TONE

Press this button to access the bass and treble controls, which you can then adjust with the **MULTI JOG** dial.

20 SPEAKERS

Use to change the speaker system and the impedance setting.

21 PTY SEARCH

Use this button to search for RDS program types.

22 TUNING/STATION

Selects the frequency and station presets when using the tuner.

23 TUNER EDIT

Press to memorize and name a station for recall.

24 System Setup menu controls

SETUP - Use with the **MULTI JOG** dial to access the System Setup menu.

RETURN - Press to confirm and exit the current menu.

Rear panel (VSX-917V)

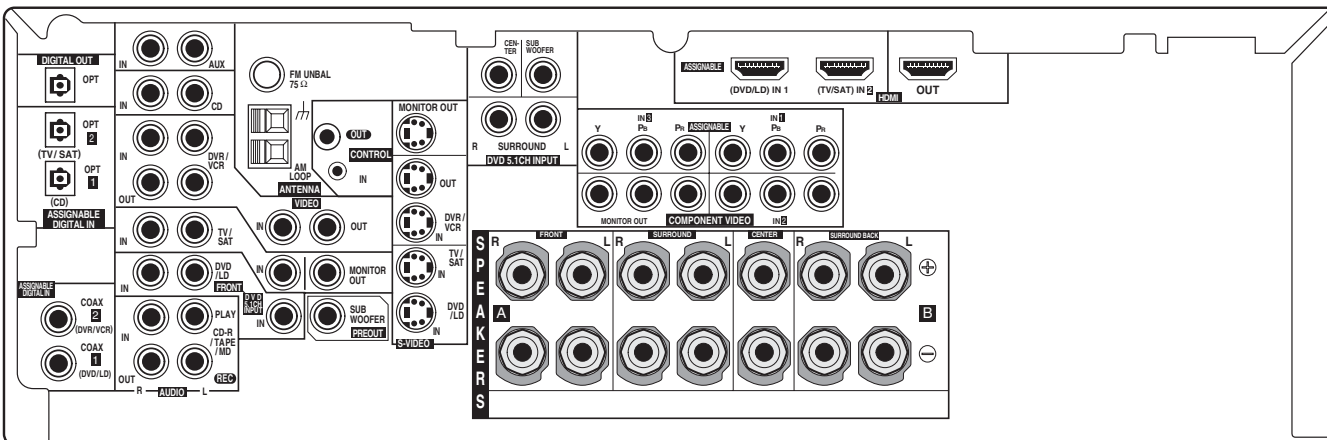

Rear panel (VSX-817)

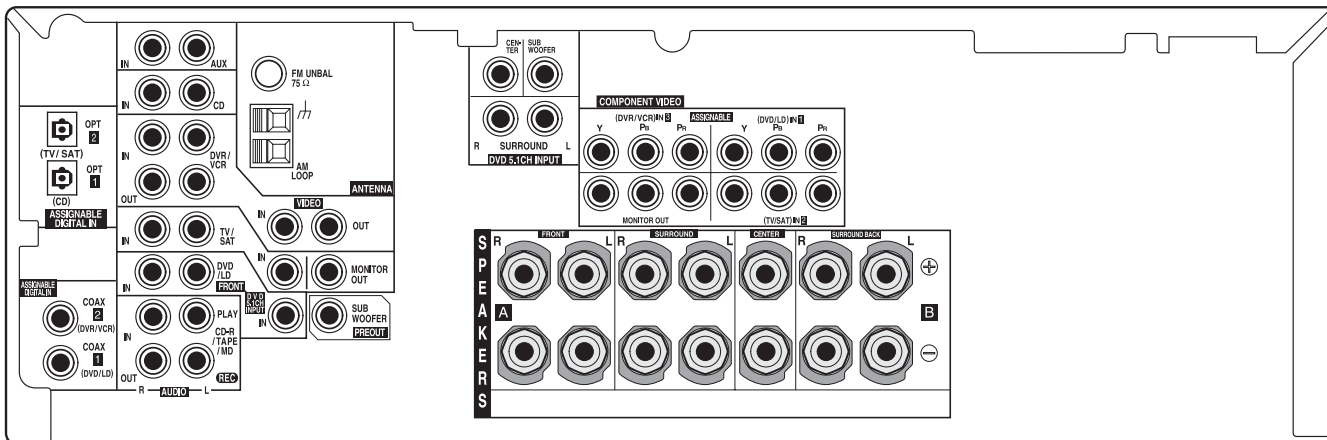

Display (VSX-917V)

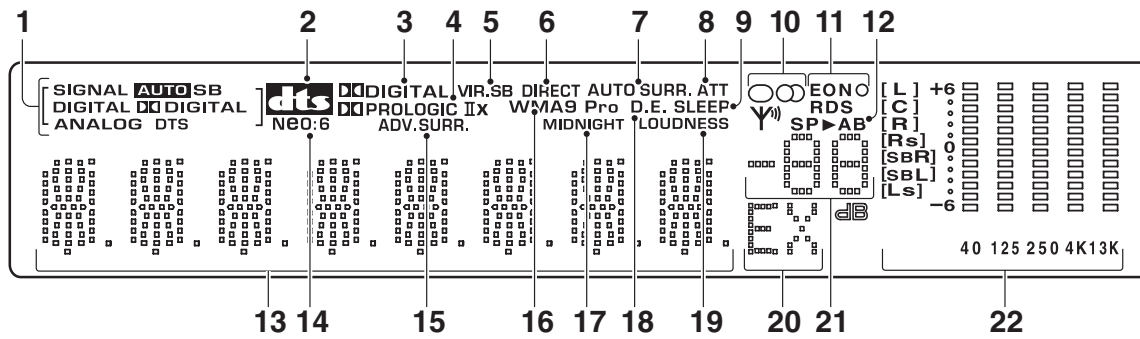

1 SIGNAL indicators

Lights to indicate the type of input signal:

AUTO - Lights when **AUTO** signal select is on.

SB - Depending on the source, this lights when a signal with surround back channel encoding is detected.

DIGITAL - Lights when a digital audio signal is detected.

DIGITAL - Lights when a Dolby Digital encoded signal is detected.

ANALOG - Lights when an analog signal is detected.

DTS - Lights when a source with DTS encoded audio signals is detected.

2 **dts**

Lights to indicate decoding of a DTS multichannel signal.

3 **DIGITAL**

Lights to indicate decoding of a Dolby Digital multichannel signal.

4 **PRO LOGIC IIx**

PRO LOGIC II lights to indicate Pro Logic II decoding. **PRO LOGIC IIx** lights to indicate Pro Logic IIx decoding (see Listening in surround sound).

5 **VIR.SB**

Lights during Virtual surround back processing.

6 **DIRECT**

Lights when source Stream Direct playback is in use. Direct playback bypasses the tone controls for the most accurate reproduction of a source.

7 **AUTO SURR.**

Lights when Auto Surround (see Auto playback) is on.

8 **ATT**

Lights when **ANALOG ATT** is used to attenuate (reduce) the level of the analog input signal.

9 **SLEEP**

Lights when the sleep mode is active (see Remote control below).

10 Tuner indicators

○ - Lights when the mono mode is set using the **MPX** button.

⊕ - Lights when a stereo FM broadcast is being received in auto stereo mode.

Ψ - Lights when a broadcast is being received.

11 EON/RDS indicators

EON - Lights when the EON mode is set, and flashes during an EON broadcast. The ○ indicator lights when the current station carries the EON service.

RDS - Lights when an RDS broadcast is received.

12 Speaker indicators

Lights to indicate the current speaker system, **A** and/or **B**.

13 Character display

14 Neo:6

Lights to indicate Neo:6 processing.

15 **ADV.SURR. (Advanced Surround)**

Lights when one of the Advanced Surround modes has been selected.

16 **WMA9 Pro**

Lights to indicate decoding of a WMA9 Pro signal.

17 **MIDNIGHT**

Lights during Midnight listening.

18 **D.E.**

Lights when Dialog Enhancement is switched on.

19 **LOUDNESS**

Lights during Loudness listening.

20 **EX**

Lights when a Dolby Digital Surround EX encoded signal is detected.

21 **Master volume level**

Shows the overall volume level.

22 **MCACC channel EQ/Sound Retriever indicators**

These indicators show the EQ balance for each channel in Checking your Acoustic Calibration EQ settings. Also, **L** and **R** light when the Sound Retriever is active.

Remote control (VSX-917V)

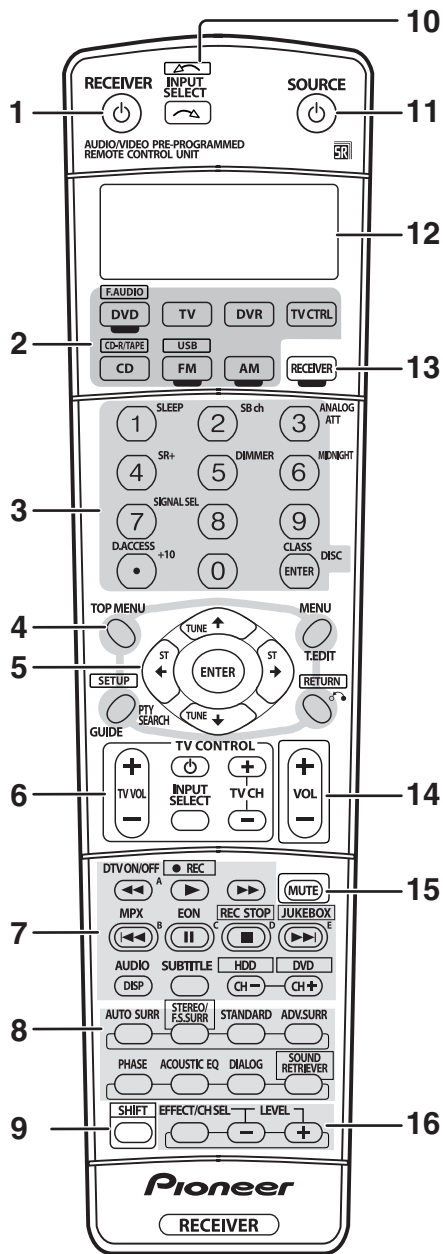

1 RECEIVER

This switches between standby and on for this receiver.

2 MULTI CONTROL buttons

Press to select control of other components

3 Number buttons and other receiver/component controls

Use the number buttons to directly select a radio frequency or the tracks on a CD, DVD, etc.

DISC (ENTER) can be used to enter commands for TV or DTV, and can also be used to select a disc in a multi-CD player.

The following are accessed by pressing the **RECEIVER** button first:

SLEEP - Press to change the amount of time before the receiver switches into standby (**90 min - 60 min - 30 min - Off**). You can check the remaining sleep time at any time by pressing **SLEEP** once.

SB ch - Selects the surround back channel mode or virtual surround back mode.

ANALOG ATT - Attenuates (lowers) the level of an analog input signal to prevent distortion.

SR + - Switches the SR+ mode on/off.

DIMMER - Dims or brightens the display.

MIDNIGHT - Use Midnight when listening to movie soundtracks at low volume. Use Loudness to boost the bass and treble at low volume.

SIGNAL SEL - Use to select an input signal.

D.ACCESS - After pressing, you can access a radio station directly using the number buttons.

CLASS - Switches between the three banks (classes) of radio station presets.

4 Tuner/component control buttons/SETUP

The following button controls (except **SETUP**) can be accessed after you have selected the corresponding **MULTI CONTROL** button (**DVD, FM, AM, TV, etc.**).

TOP MENU - Displays the disc "top" menu of a DVD.

MENU - Displays the disc menu of DVD-Video discs. It also displays TV and DTV menus.

T.EDIT - Press to memorize and name a station for recall.

SETUP (Press **RECEIVER** first to access) - Use to access the System Setup menu.

PTY SEARCH - Use this button to search for RDS program types.

GUIDE - Displays the guides on a digital TV.

RETURN - Press to confirm and exit the current menu (also use to return to the previous menu with DVDs or to select closed captioning with DTV).

5 ◀▶↕ (TUNE/ST +/-) /ENTER

Use the arrow buttons when setting up your surround sound system. Also used to control DVD menus/options and for deck 1 of a double cassette deck player. Use the **TUNE** ↓/↑ buttons to find radio frequencies and use **ST** ◀/▶ to find preset stations.

6 TV CONTROL buttons

These buttons are dedicated to control the TV assigned to the **TV CTRL** button. Thus if you only have one TV to hook up to this system assign it to the **TV CTRL MULTI CONTROL** button. If you have two TVs, assign the main TV to the **TV CTRL** button.

TV ⏻ - Use to turn on/off the TV power.

TV VOL +/- - Use to adjust the TV volume.

INPUT SELECT - Use to select the TV input signal.

TV CH +/- - Use to select channels.

7 Component control buttons

The main buttons (▶, ■, etc.) are used to control a component after you have selected it using the **MULTI CONTROL** buttons.

The controls above these buttons can be accessed after you have selected the corresponding **MULTI CONTROL** button (for example **DVD**, **DVR** or **TV** (when connected to a DTV)).

DTV ON/OFF - Switches a digital TV on/off.

MPX - Switches between stereo and mono reception of FM broadcasts. If the signal is weak then switching to mono will improve the sound quality.

EON - Use to search for programs that are broadcasting traffic or news information.

AUDIO - Changes the audio language or channel on DVD discs.

DISP - Switches between named station presets and radio frequencies.

SUBTITLE - Displays/changes the subtitles included in multilingual DVD-Video discs.

CH +/- - Use to select channels when using a TV, VCR, DVR, etc.

The following DVR controls can be accessed by pressing **SHIFT**:

● **REC** - Starts recording.

REC STOP - Stops recording.

JUKEBOX - Switches to the Jukebox feature.

HDD/DVD - These buttons switch between the hard disk and DVD controls for DVD/HDD recorders.

8 RECEIVER CONTROL buttons

AUTO SURR - Selects Auto Surround (Auto playback) or Stream Direct playback.

STEREO/F.S.SURR - Switches between stereo playback and Front Stage Surround Advance modes.

STANDARD - Press for Standard decoding and to switch between the various Pro Logic IIx and Neo:6 options.

ADV.SURR. - Use to switch between the various surround modes.

PHASE - Press to switch on/off Phase Control.

ACOUSTIC EQ - Press to select an Acoustic Calibration EQ setting.

DIALOG - Use to make dialog stand out when watching TV or a movie.

SOUND RETRIEVER - Press to restore CD quality sound to compressed audio sources.

9 SHIFT

Press to access the DVR controls (above the component control buttons) as well as some receiver controls.

10 INPUT SELECT

Use to select the input source (use **SHIFT** for **INPUT SELECT** ).

11 ⏻ SOURCE

Press to turn on/off other components connected to the receiver.

12 Character display (LCD)

This display shows information when transmitting control signals.

The following commands are shown when you're setting the remote to control other components (see Controlling the rest of your system):

SETUP - Indicates the setup mode, from which you choose the options below.

PRESET - See Selecting preset codes directly.

DIRECT F - See Direct function.

ERASE - See Erasing one of the remote control button settings.

RESET - See Erasing all of the remote control presets.

READ ID - See Confirming preset codes.

13 RECEIVER

Switches the remote to control the receiver (used to select the green commands above the number buttons (**DIMMER**, etc)). Also use this button to set up surround sound.

14 VOL +/-

Use to set the listening volume.

15 MUTE

Mutes the sound or restores the sound if it has been muted (adjusting the volume also restores the sound).

16 EFFECT/CH SEL

Press repeatedly to select a channel, then use +/- to adjust the level (see Tip). Also adjusts the level of the Advanced Surround effects, Dolby Pro Logic IIx Music, and Neo:6 Music parameters. You can then use the +/- buttons to make these adjustments.

Using this receiver with a Pioneer plasma display

If you have a Pioneer plasma display², you can use an SR+ cable to connect it to this unit and take advantage of various convenient features, such as automatic video input switching of the plasma display when the input is changed.

SERVICE PARTS

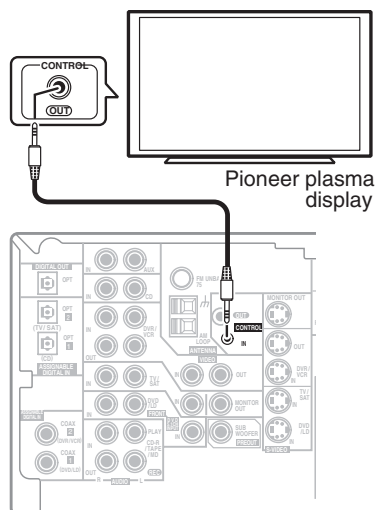
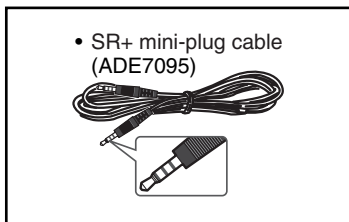

This receiver

- Use a 3-ringed miniplug SR+ cable¹ to connect the CONTROL IN jack of this receiver with the CONTROL OUT of your plasma display.

Before you can use the extra SR+ features, you need to make a few settings in the receiver. See SR+ Setup for Pioneer plasma displays for detailed instructions.

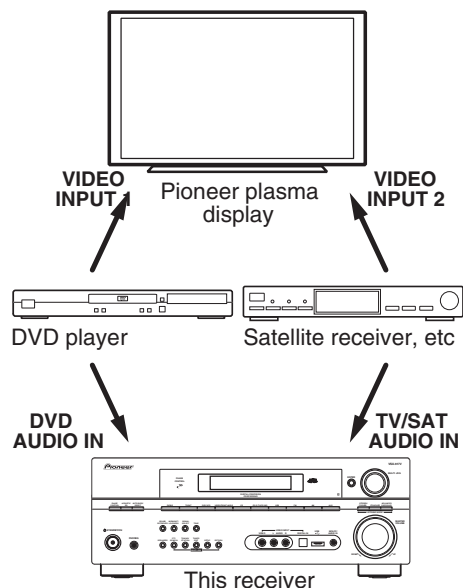

To make the most of the SR+ features, you should connect your source components (DVD player, etc.) in a slightly different way to that described in this chapter. For each component, connect the video output directly to the plasma display, and just connect the audio (analog and/or digital) to this receiver.

Note

¹ The 3-ringed SR+ cable from Pioneer is commercially available under the part number ADE7095. Contact the Pioneer Customer Support division for more information on obtaining an SR+ cable (you can also use a commercially available 3-ringed mini phone plug for the connection).

If you connect to a Pioneer plasma display using an SR+ cable, you will need to point the remote control at the plasma display remote sensor to control the receiver. In this case, you won't be able to control the receiver using the remote control if you switch the plasma display off.

² The automatic volume muting feature is enabled separately; see SR+ Setup for Pioneer plasma displays.

Using the SR+ mode with a Pioneer plasma display

When connected using an SR+ cable, a number of features become available to make using this receiver with your Pioneer plasma display even easier. These features include:

- On-screen volume display.
- On-screen display of listening mode.
- Automatic video input switching on the plasma display.
- Automatic volume muting on the plasma display.¹

See also SR+ Setup for Pioneer plasma displays for more on setting up the receiver.

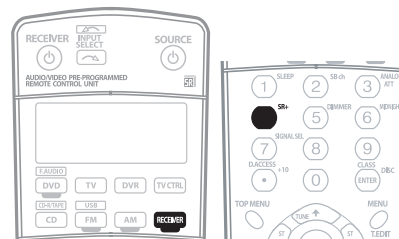

- 1 Make sure that the plasma display and this receiver are switched on and that they are connected with the SR+ cable.

See Using this receiver with a Pioneer plasma display above for more on this.

- 2 To switch SR+ mode on/off, press RECEIVER, then the SR+ button.

The front panel display shows SR+ ON or OFF.

CLEANING



A

Before shipping out the product, be sure to clean the following positions by using the prescribed cleaning tools:

Position to be cleaned	Cleaning tools
Fans	Cleaning paper : GED-008

B

C

D

E

F