

# Pioneer

## Service Manual

ORDER NO.  
**RRV4079**

**AUDIO/VIDEO MULTI-CHANNEL RECEIVER**

# VSX-31

# VSX-30

# VSX-925-K

**THIS MANUAL IS APPLICABLE TO THE FOLLOWING MODEL(S) AND TYPE(S).**

Model	Type	Power Requirement	Remarks
VSX-31	UXCNCB	AC 120 V	
VSX-30	UXCNCB	AC 120 V	
VSX-925-K	CUXCN	AC 120 V	

**This service manual should be used together with the following manual(s).**

Model No.	Order No.	Remarks
VSX-1020-K/UXCNCB	RRV4045	

**For SPECIFICATIONS and PANEL FACILITIES, refer to the operating instructions.**

**PIONEER CORPORATION** 1-1, Shin-ogura, Saiwai-ku, Kawasaki-shi, Kanagawa 212-0031, Japan  
**PIONEER ELECTRONICS (USA) INC.** P.O. Box 1760, Long Beach, CA 90801-1760, U.S.A.  
**PIONEER EUROPE NV** Haven 1087, Keetberglaan 1, 9120 Melsele, Belgium  
**PIONEER ELECTRONICS ASIACENTRE PTE. LTD.** 253 Alexandra Road, #04-01, Singapore 159936

©PIONEER CORPORATION 2010

K-ZZZ MAY 2010 Printed in Japan

# 1. CONTRAST OF MISCELLANEOUS PARTS

NOTES: ● Parts marked by "NSP" are generally unavailable because they are not in our Master Spare Parts List.

- The  $\Delta$  mark found on some component parts indicates the importance of the safety factor of the part. Therefore, when replacing, be sure to use parts of identical designation.
- Screws adjacent to  $\nabla$  mark on product are used for disassembly.
- For the applying amount of lubricants or glue, follow the instructions in this manual. (In the case of no amount instructions, apply as you think it appropriate.)
- Nos. indicate the pages and Nos. in the service manual for the base model.

● When ordering resistors, first convert resistance values into code form as shown in the following examples.  
 Ex.1 When there are 2 effective digits (any digit apart from 0), such as 560 ohm and 47k ohm (tolerance is shown by J=5%, and K=10%).

560Ω	→	56 x 10 <sup>1</sup>	→	561	.....	RD1/4PU	5	6	1	J
47kΩ	→	47 x 10 <sup>3</sup>	→	473	.....	RD1/4PU	4	7	3	J
0.5Ω	→	R50	.....			RN2HR	5	0		K
1Ω	→	1R0	.....			RS1P	1	R	0	K

Ex.2 When there are 3 effective digits (such as in high precision metal film resistors).

5.62kΩ	→	562 x 10 <sup>1</sup>	→	5621	.....	RN1/4PC	5	6	2	1	F
--------	---	-----------------------	---	------	-------	---------	---	---	---	---	---

## CONTRAST TABLE

VSX-1020-K/UXCNCB, VSX-31/UXCNCB, VSX-30/UXCNCB and VSX-925-K/CUXCN are constructed the same except for the following:

Mark	No.	Symbol and Description	VSX-1020-K /UXCNCB	VSX-31 /UXCNCB	VSX-30 /UXCNCB	VSX-925-K /CUXCN	Remarks
<b>PCB ASSEMBLIES</b>							
NSP	P58-1	1..MAIN ASSY	7025HK0918010-IL	7025HK0918060-IL	7025HK0918060-IL	7025HK0918010-IL	No. 83
		2..MAIN ASSY	7028069211010-IL	7028069211060-IL	7028069211060-IL	7028069211010-IL	
NSP	P58-6 P58-8 P58-9	1..FRONT ASSY	7025HK0918011-IL	7025HK0918061-IL	7025HK0917071-IL	7025HK0917015-IL	
		2..DISPLAY ASSY	7028069221010-IL	7028069221060-IL	70280692210B0-IL	70280692210D0-IL	
		2..USB MTG ASSY	7028069223010-IL	7028069223010-IL	Not used	Not used	
		2..HDMI MTG ASSY	7028069224010-IL	7028069224010-IL	Not used	Not used	
NSP	P58-12 P58-13 P58-14 P58-16 P58-17	1..INPUT ASSY	7025HK0918013-IL	7025HK0918062-IL	7025HK0917072-IL	7025HK0917013-IL	
		2..AUDIO ASSY	7028069241010-IL	7028069241010-IL	7028069241020-IL	7028069241020-IL	
		2..COMPONENT ASSY	7028069242010-IL	7028069242030-IL	7028069242030-IL	7028069242010-IL	
		2..COMPOSITE ASSY	7028069243010-IL	7028069243010-IL	7028069243020-IL	7028069243020-IL	
		2..F-VIDEO ASSY	7028069245010-IL	7028069245010-IL	7028069248020-IL	7028069248020-IL	
		2..MIC ASSY	7028069246010-IL	7028069246010-IL	7028069247020-IL	7028069247020-IL	
		2..USB ASSY	Not used	Not used	7028069245020-IL	7028069245020-IL	
NSP	P58-18	1..F-HDMI ASSY	7025HK0918014-IL	7025HK0918014-IL	Not used	Not used	
		2..F-HDMI ASSY	7028069251010-IL	7028069251010-IL	Not used	Not used	
NSP	P58-19	1..D-MAIN ASSY	7025HK0918015-IL	7025HK0918015-IL	7025HK0917014-IL	7025HK0917014-IL	
		2..D-MAIN ASSY	7028069261010-IL	7028069261010-IL	7028069261020-IL	7028069261020-IL	
<b>PACKING SECTION</b>							
NSP	P55-7 P55-10 P55-14	Operating Instructions (En, Es)	5707000003280-IL	5707000003270-IL	5707000003270-IL	Not used	
		Operating Instructions (En, Frca)	Not used	Not used	Not used	5707000003320-IL	
		Box, Gift	6007211670010-IL	6007211670060-IL	6007211660070-IL	6007211660010-IL	
		Label Getter 1020U	5507000004560-IL	Not used	Not used	5507000004560-IL	
NSP	$\Delta$	Power Cord	Not used	L068125130010-IL	L068125130010-IL	Not used	
		Warranty Card	Not used	ARY7007	ARY7007	Not used	
<b>EXTERIOR SECTION</b>							
NSP	$\Delta$	P58-26 Cord Assy	L068125101710-IL	Not used	Not used	L068125101710-IL	
		P58-27 Cable, HDMI	L304201190020-IL	L304201190020-IL	Not used	Not used	
		P58-30 Pioneer Badge	XAM3006	PAM1791	PAM1791	XAM3006	
		P58-33 Sheet	1217211162000-IL	1217211162010-IL	1217211152030-IL	1217211152010-IL	
		P58-36 Panel Front	3067214871000-IL	3067214871020-IL	3067214861020-IL	3067214861030-IL	
		P58-38 Chassis Back	3207213476000-IL	3207213476400-IL	3207213466500-IL	3207213466000-IL	
NSP	$\Delta$	P58-40 Foot	4007210391000-IL	4000210391000-IL	4000210391000-IL	4000210391000-IL	
		P58-53 Cover	4317215111000-IL	4317215111010-IL	4317215111010-IL	4317215111020-IL	
		P58-57 Stopper	4380040162010-IL	Not used	Not used	4380040162010-IL	

Mark	No.	Symbol and Description	VSX-1020-K /UJCNCB	VSX-31 /UJCNCB	VSX-30 /UJCNCB	VSX-925-K /CUXCN	Remarks
⚠	P58-58	Window Display	5077212953100-IL	5077212953110-IL	5077212953110-IL	5077212953100-IL	
		Socket,Power AC	Not used	G430040560020-IL	G430040560020-IL	Not used	No. 84
		CN,Wire	Not used	L000211020070-IL	L000211020070-IL	Not used	No. 85
		Screw, Tap Tite	Not used	B020030083F10-IL	B020030083F10-IL	Not used	No. 86

Notes : The numbers in the remarks column correspond to the numbers on the "EXPLODED VIEWS".

For PCB ASSEMBLIES, Refer to "2. SCHEMATIC DIAGRAM", "3. PCB CONNECTION DIAGRAM" and "4. PCB PARTS LIST".

## EXPLODED VIEWS EXTERIOR SECTION

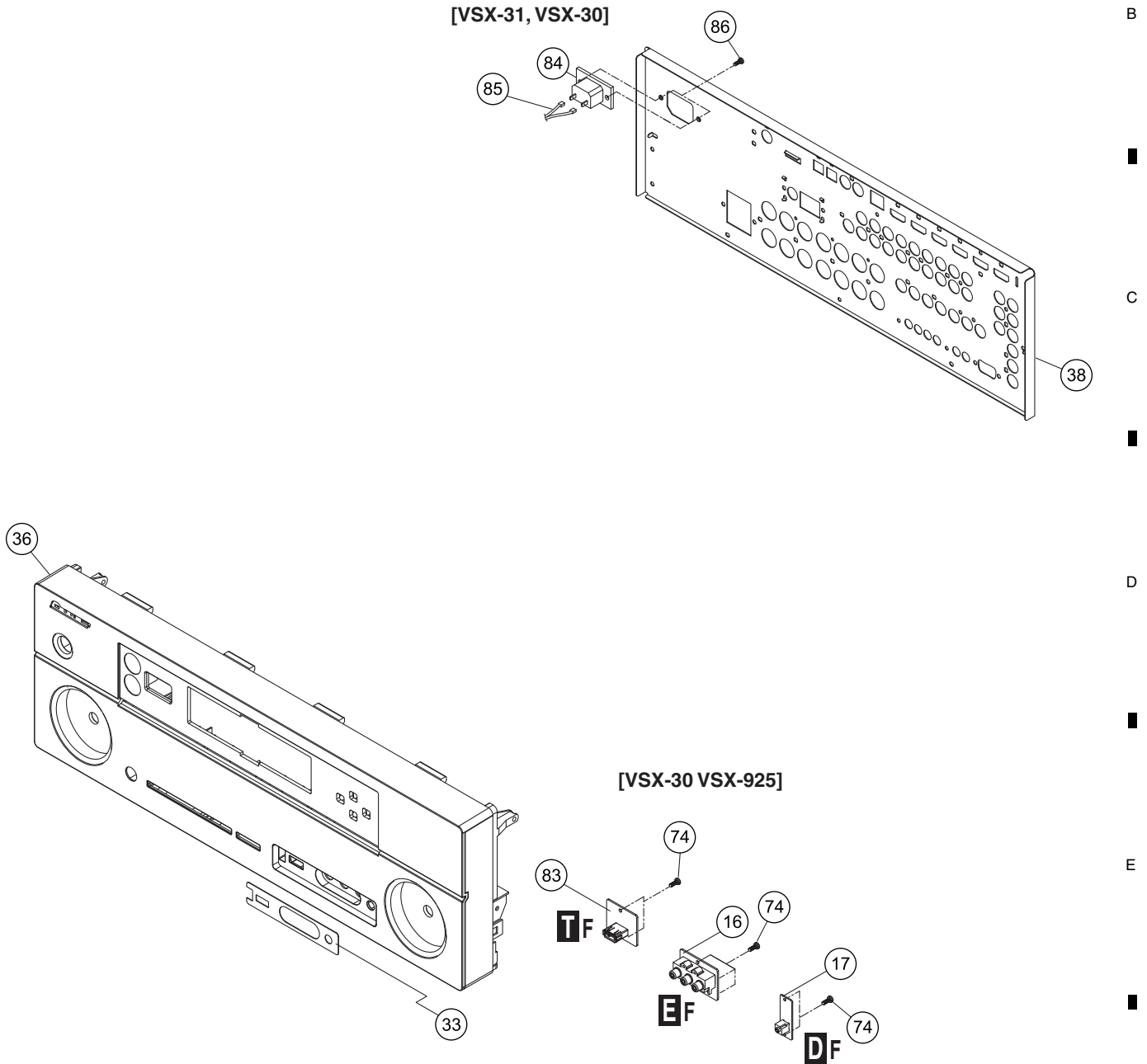

# 2. SCHEMATIC DIAGRAM

## 2.1 AUDIO ASSY

**AF** AUDIO ASSY  
(7028069241020-IL:VSX-30/UXCNCB,  
VSX-925-K/CUXCN)

**P** CN7602

**O** JP4001

A  
B  
C  
D  
E  
F

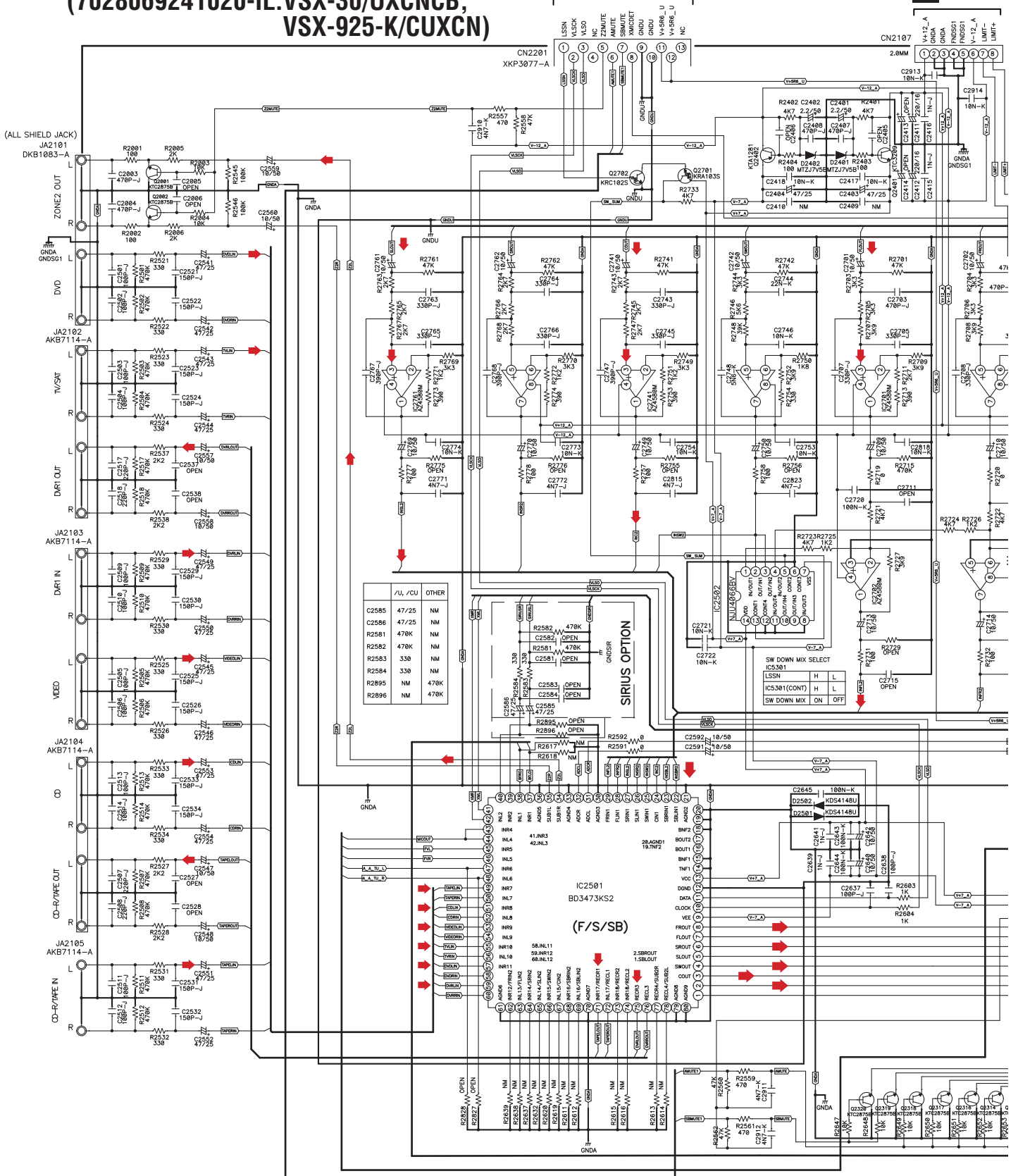



# 2.2 COMPONENT ASSY

## B F COMPONENT ASSY (7028069242030-IL:VSX-31/UXCNCB VSX-30/UXCNCB)

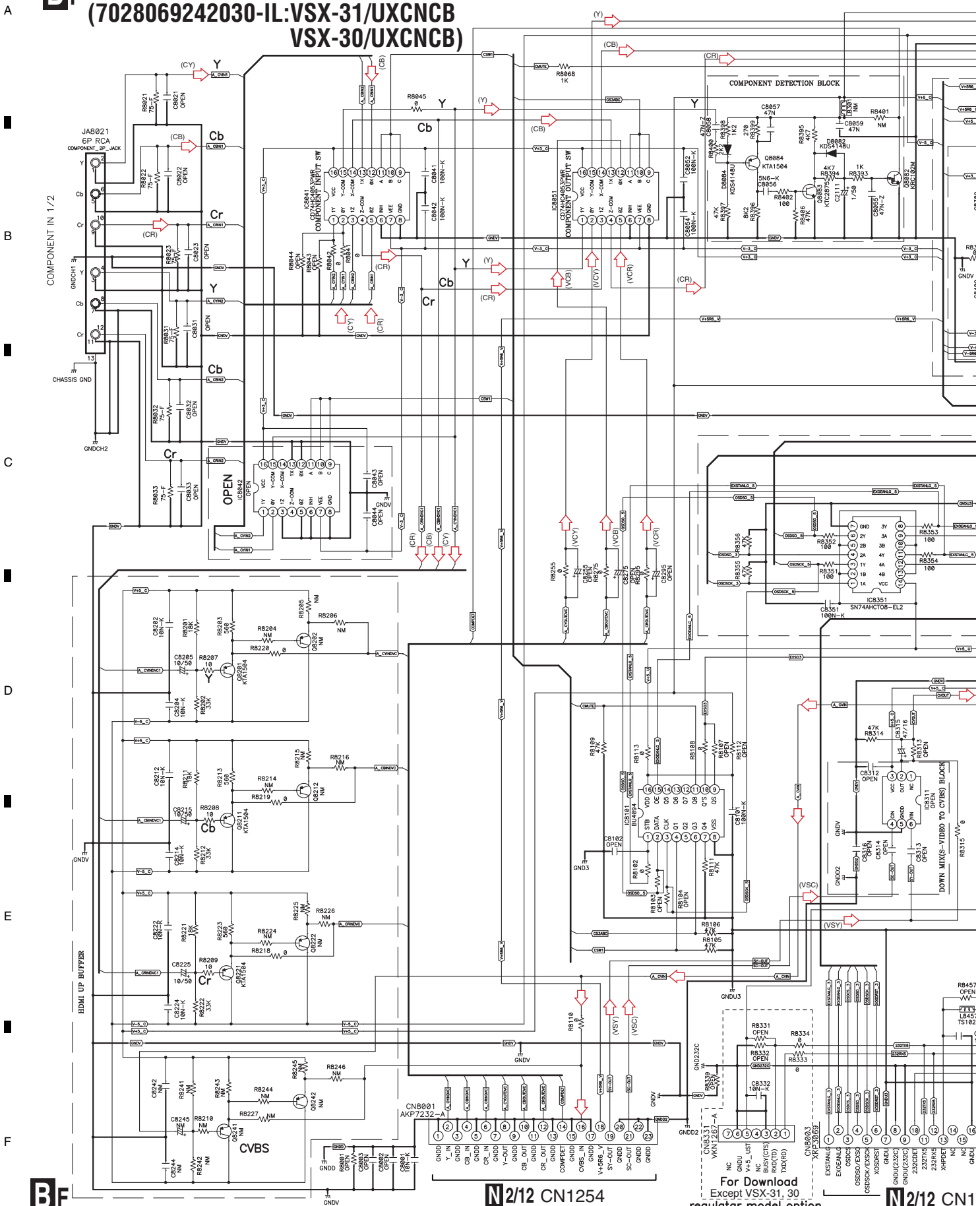

N/212 CN1254

For Download  
Except VSX-31, 30  
regulator model option

N/212 CN1

VSX-31





A  
B  
C  
D  
E  
F

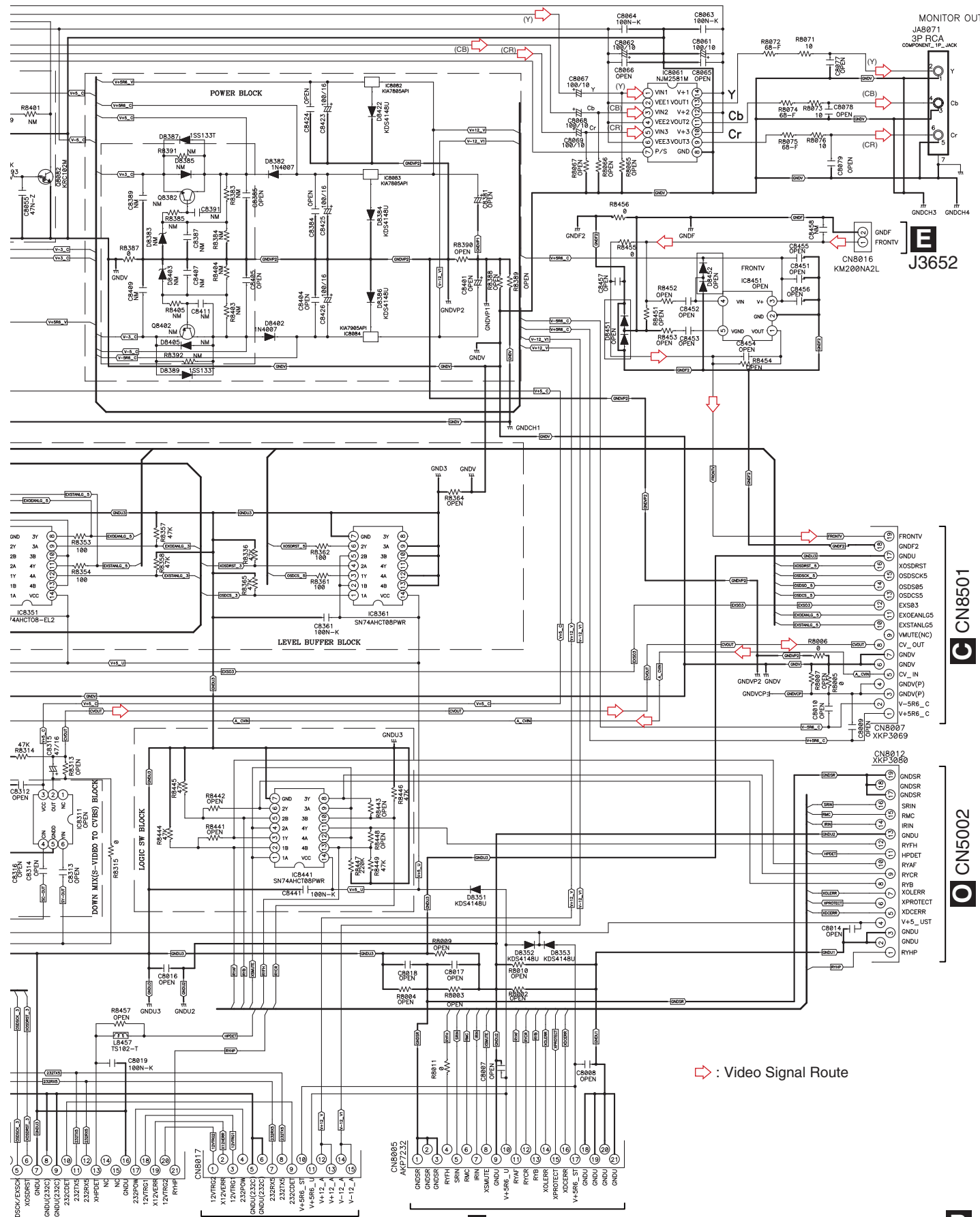

MONITOR OUT  
JA8071  
3P RCA  
COMPONENT\_IP\_JACK

J3652  
CN8016  
KM200NA2L

CN8501

CN5002

Video Signal Route

2/12 CN1252

CP6

2/12 CN1250

VSX-31

BF

# 2.3 COMPOSITE ASSY

## CF COMPOSITE ASSY (7028069243020-IL)

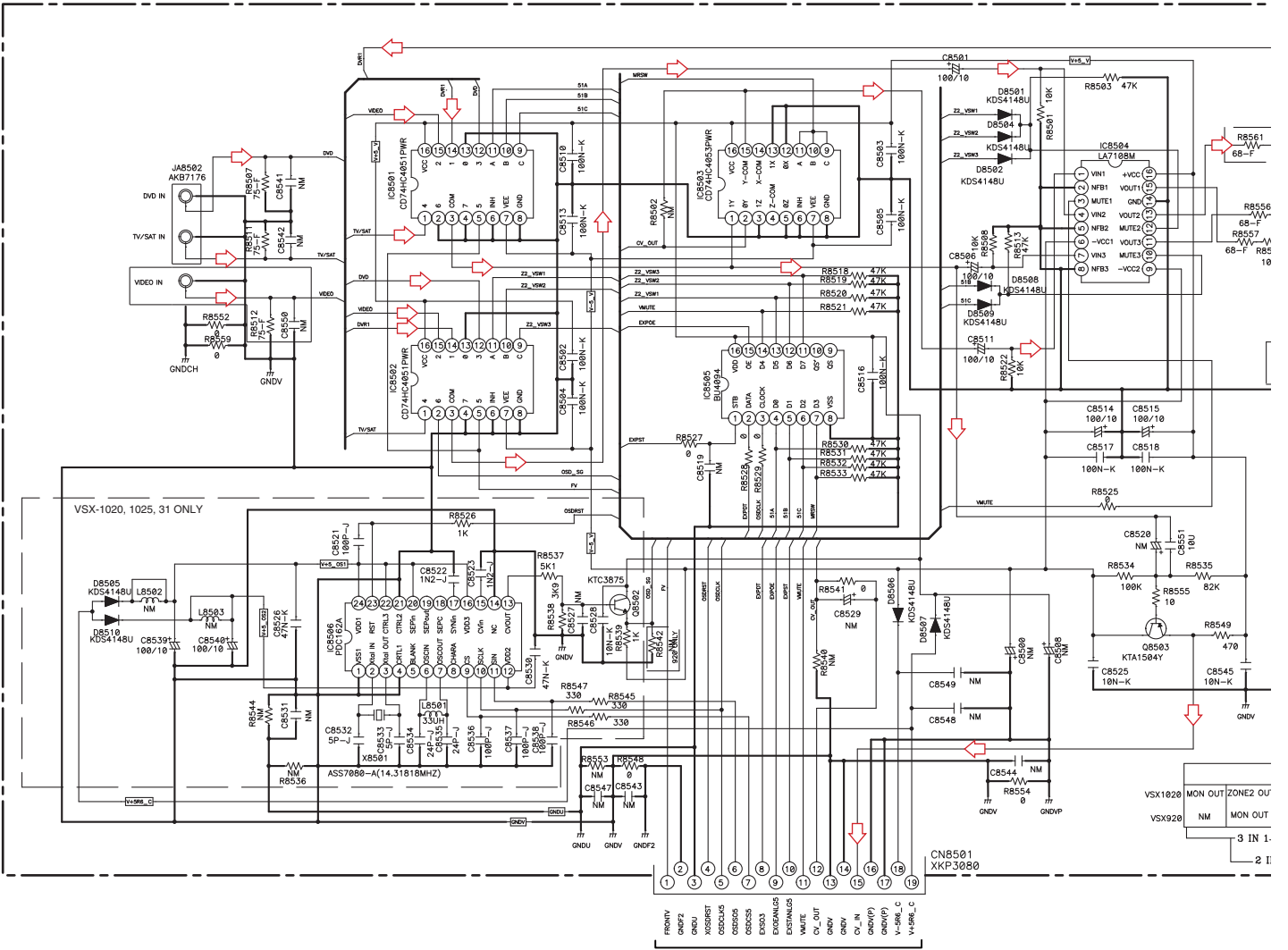

**B** CN8007





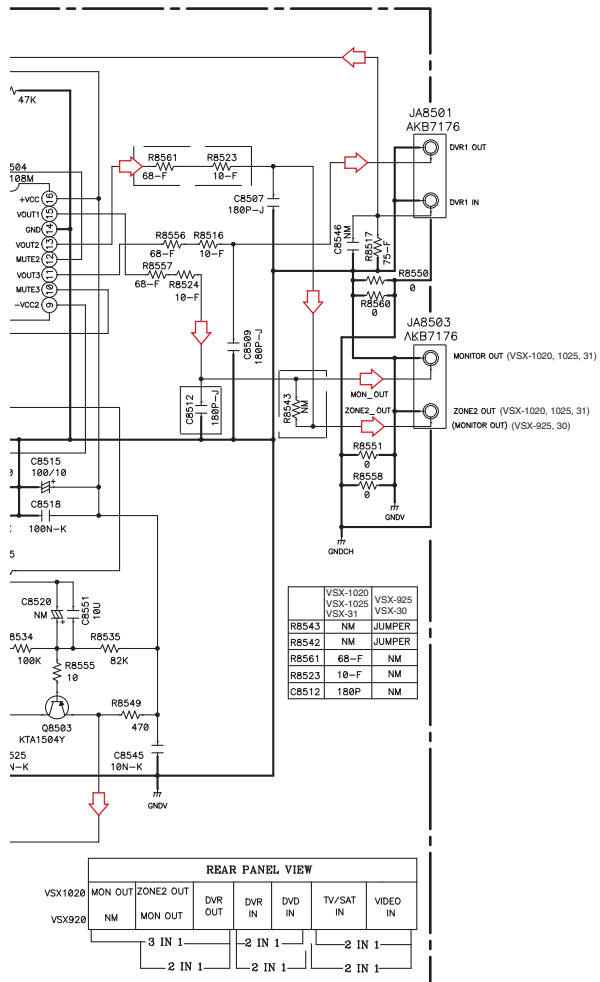

# 2.4 DISPLAY ASSY

## KF DISPLAY ASSY (7028069221060-IL:VSX-31/UXCNCB) (70280692210B0-IL:VSX-30/UXCNCB)(70280692210D0-IL:VSX-925-K/CUXCN)

FLT3001  
HNA-16MM62T  
HNA-16MM62T(SAMSUNG)  
OR AAV7115(FUTABA)

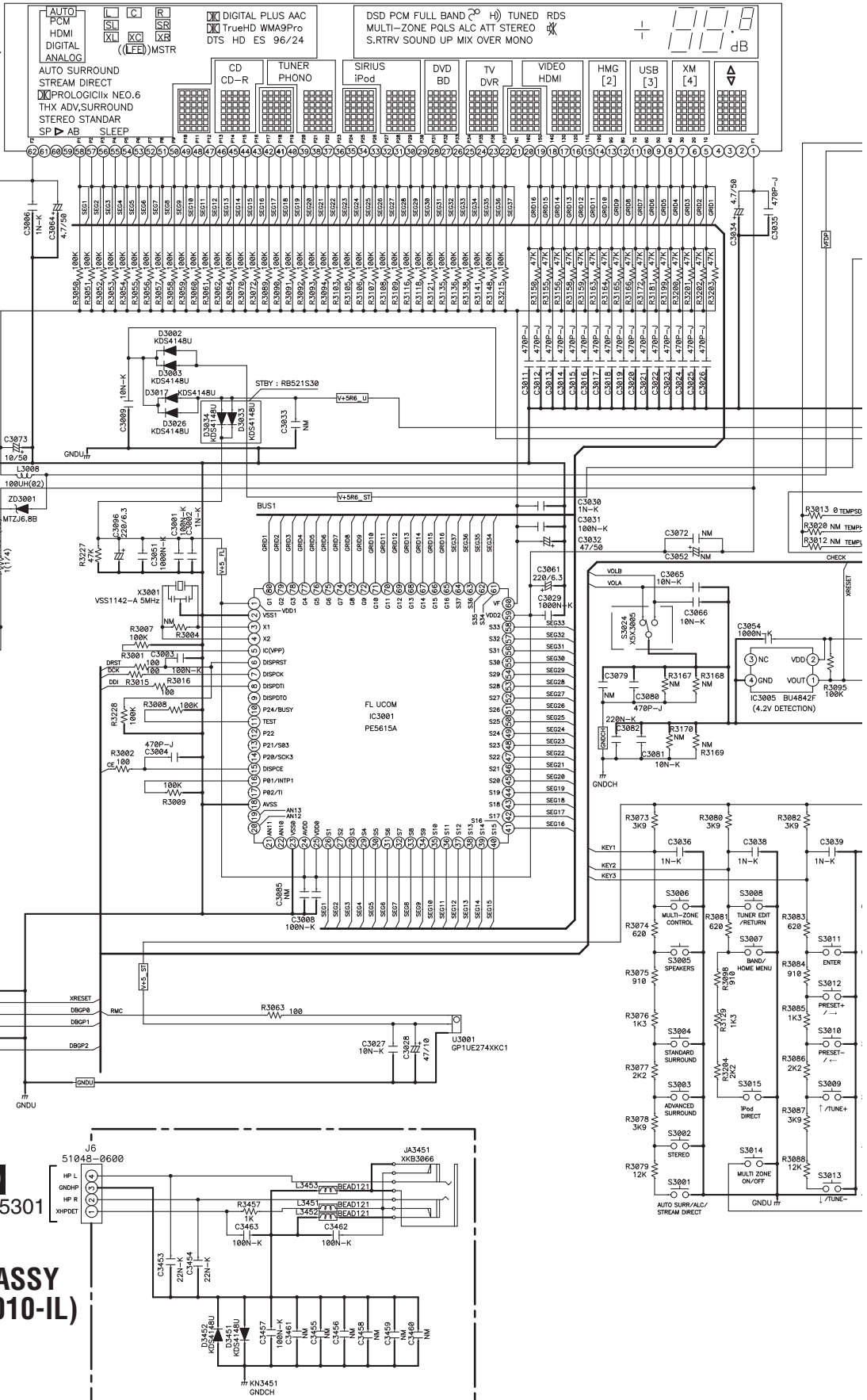

### MODEL DISCRIMINATION

NAME	R No.					
MODEL / AREA	R3021	R3022	R3025	R3026	R3027	R3028
VSX-925 / CUXCN	0.47(1)	0.47(1)	1(1/4)	1(1/4)	NM	NM
VSX-30 / UXCNCB	0.47(1)	0.47(1)	1(1/4)	1(1/4)	NM	NM
VSX-31 / UXCNCB	0.47(1)	0.47(1)	1(1/4)	1(1/4)	NM	NM

FOR DEBUG & D.L.



## L HEADPHONE ASSY (7028069225010-IL)



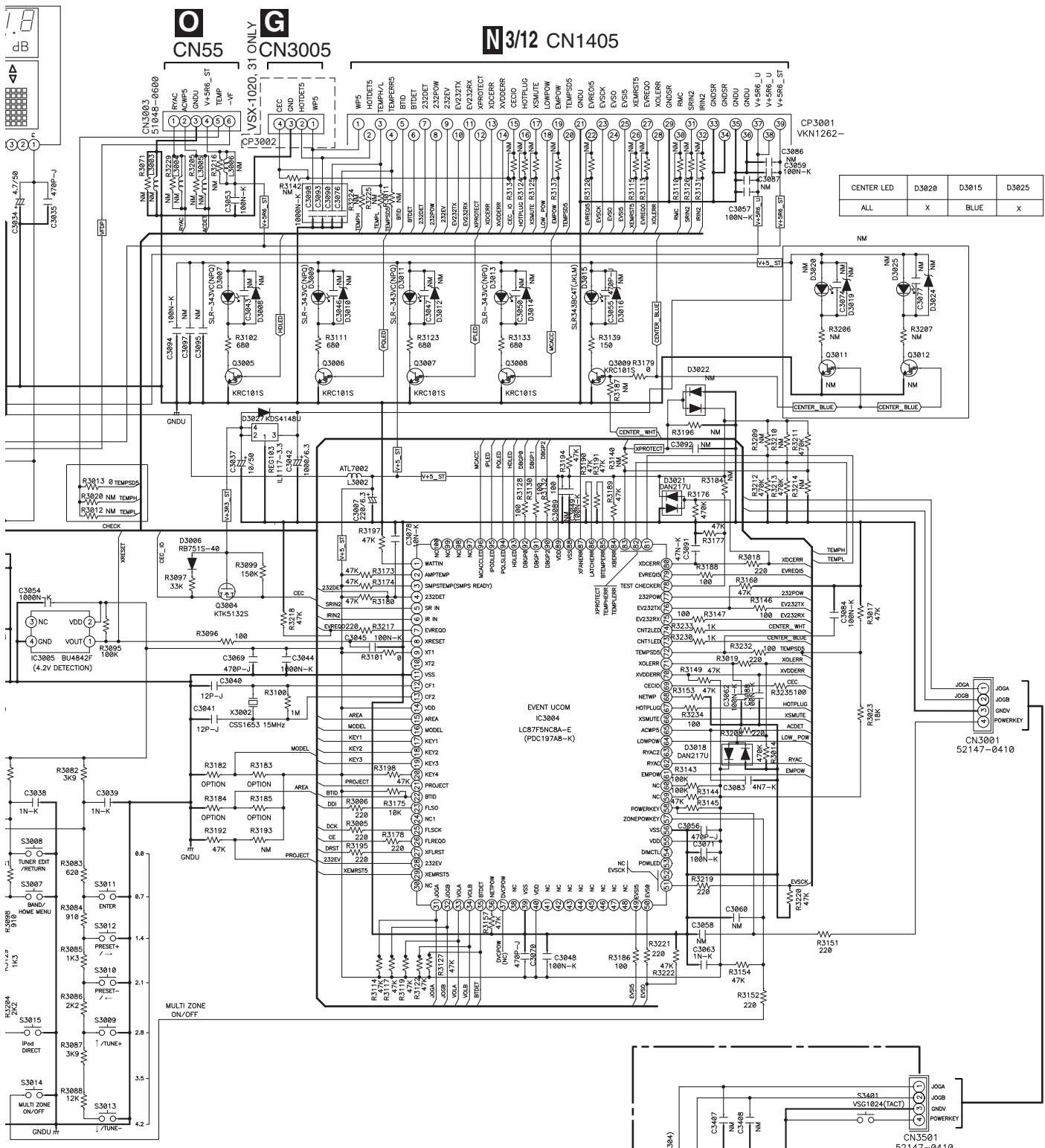

CENTER LED	D3020	D3015	D3025
ALL	X	BLUE	X

MODEL DISCRIMINATION

NAME	PROJECT	MODEL	AREA
MODEL /AREA	R3192 R3193	R3182 R3183	R3164 R3185
VSX-025 /UXCXC	47k NM	22k 33k	47k NM
VSX-30 /UXCNCB	47k NM	10k 39k	47k NM
VSX-31 /UXCNCB	47k NM	39k 10k	47k NM

**M** POWER SW ASSY  
(7028069222010-IL)



# 2.5 D-MAIN ASSY (5/12)

1

2

3

4

A

B

C

D

E

F

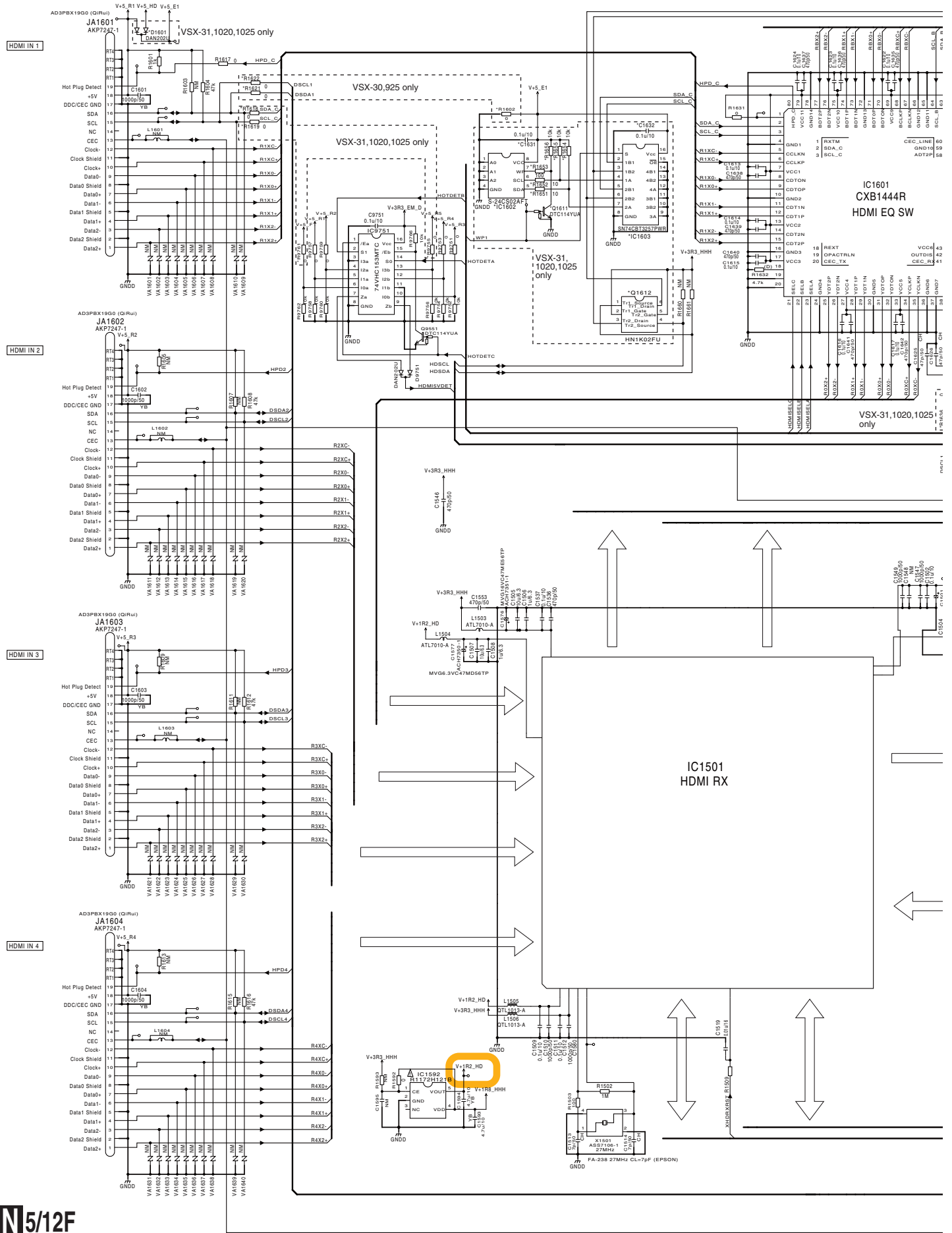

1

2

3

4

**N5/12F D-MAIN ASSY  
(7028069261020-IL:  
VSX-30/UXCNCB,  
VSX-925-K/CUXCN)**

• HDMI PART (1/2)

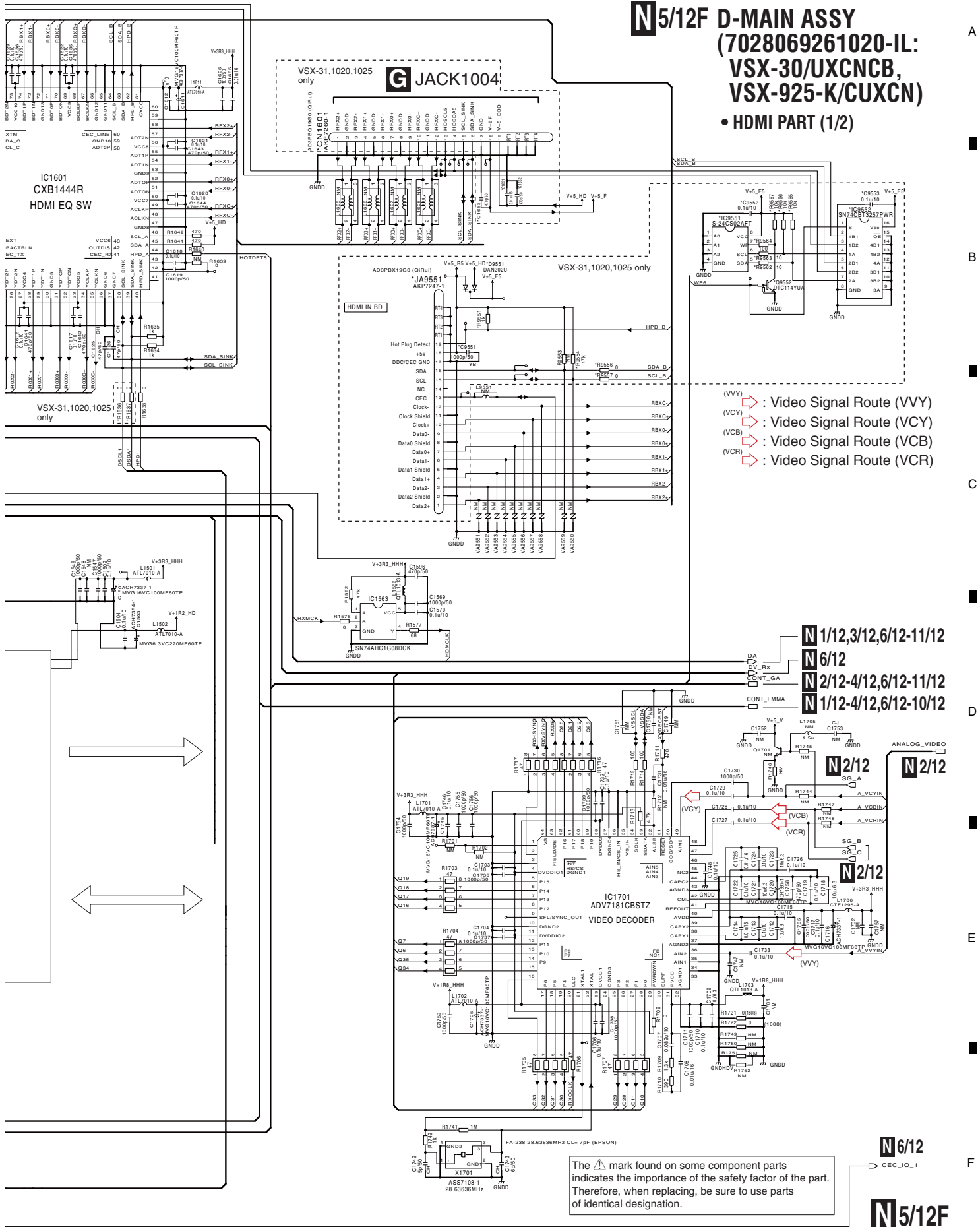

- (VVY) Video Signal Route (VVY)
- (VCY) Video Signal Route (VCY)
- (VCB) Video Signal Route (VCB)
- (VCR) Video Signal Route (VCR)

- N 1/12,3/12,6/12-11/12
- N 6/12
- N 2/12-4/12,6/12-11/12
- N 1/12-4/12,6/12-10/12

- N 2/12
- N 2/12

- N 2/12

- N 6/12

The  $\Delta$  mark found on some component parts indicates the importance of the safety factor of the part. Therefore, when replacing, be sure to use parts of identical designation.

**N5/12F**

# 2.6 D-MAIN ASSY (7/12)

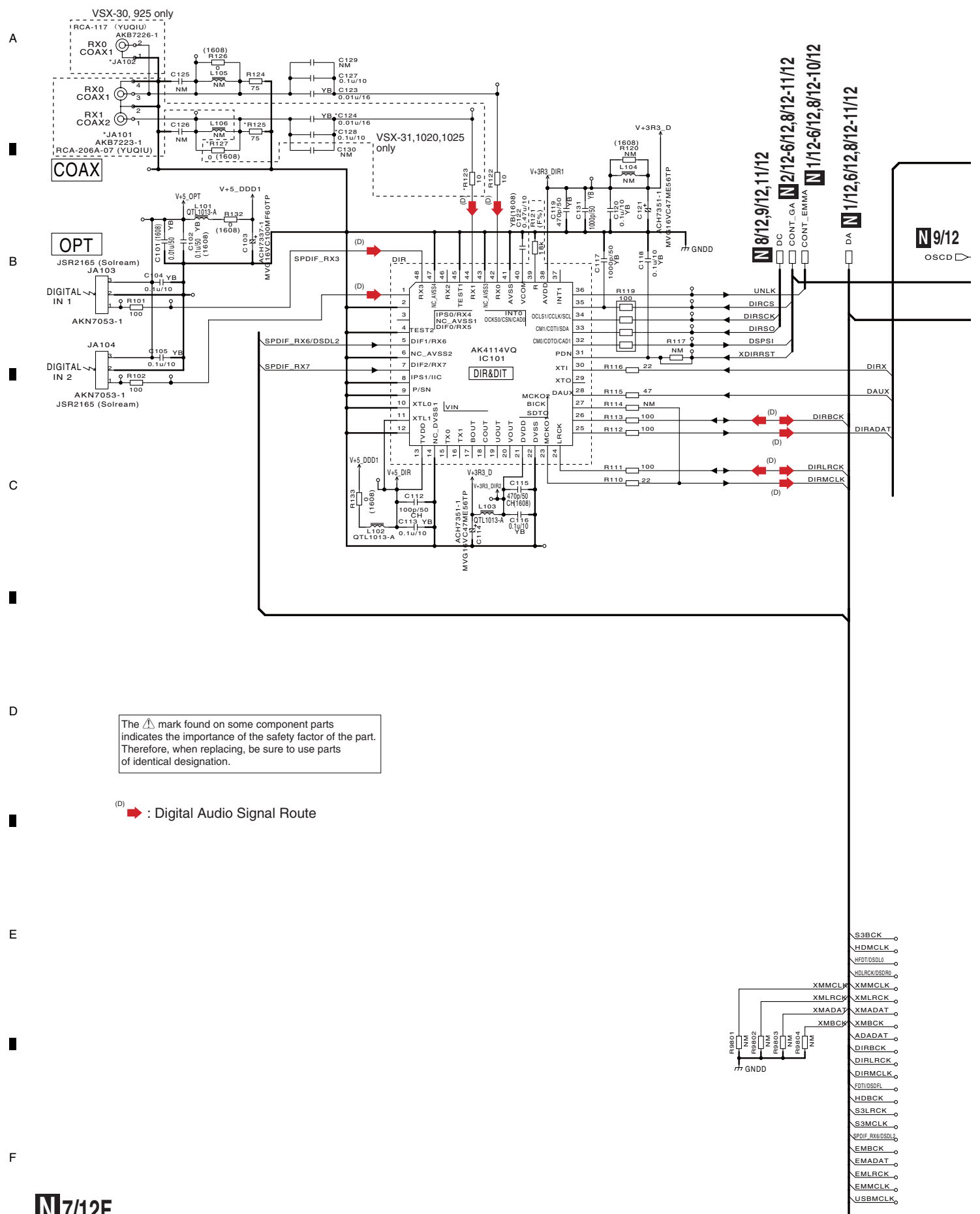

The  $\Delta$  mark found on some component parts indicates the importance of the safety factor of the part. Therefore, when replacing, be sure to use parts of identical designation.

(D)  $\rightarrow$  : Digital Audio Signal Route

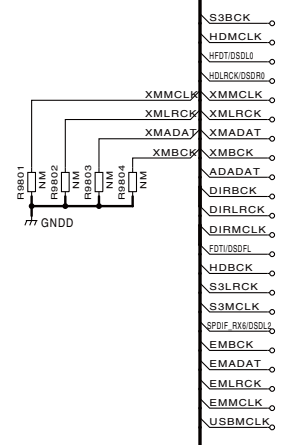



# N7/12F D-MAIN ASSY

(7028069261020-IL:VSX-30/UXCNB,  
VSX-925-K/CUXCN)

• DSP PART (1/5)

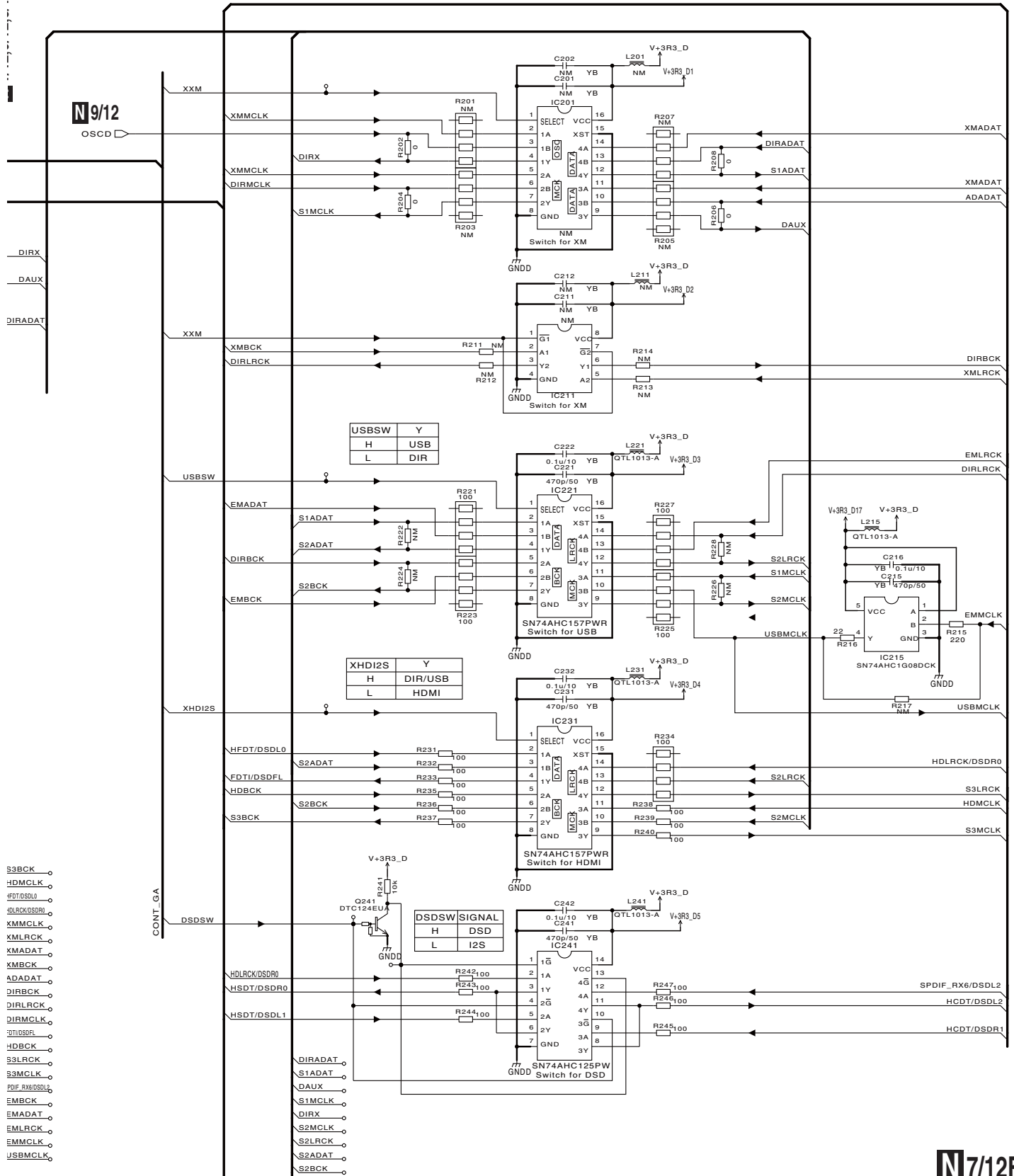

USBSW	Y
H	USB
L	DIR

XHDI2S	Y
H	DIR/USB
L	HDMI

DSDSW	SIGNAL
H	DSD
L	I2S



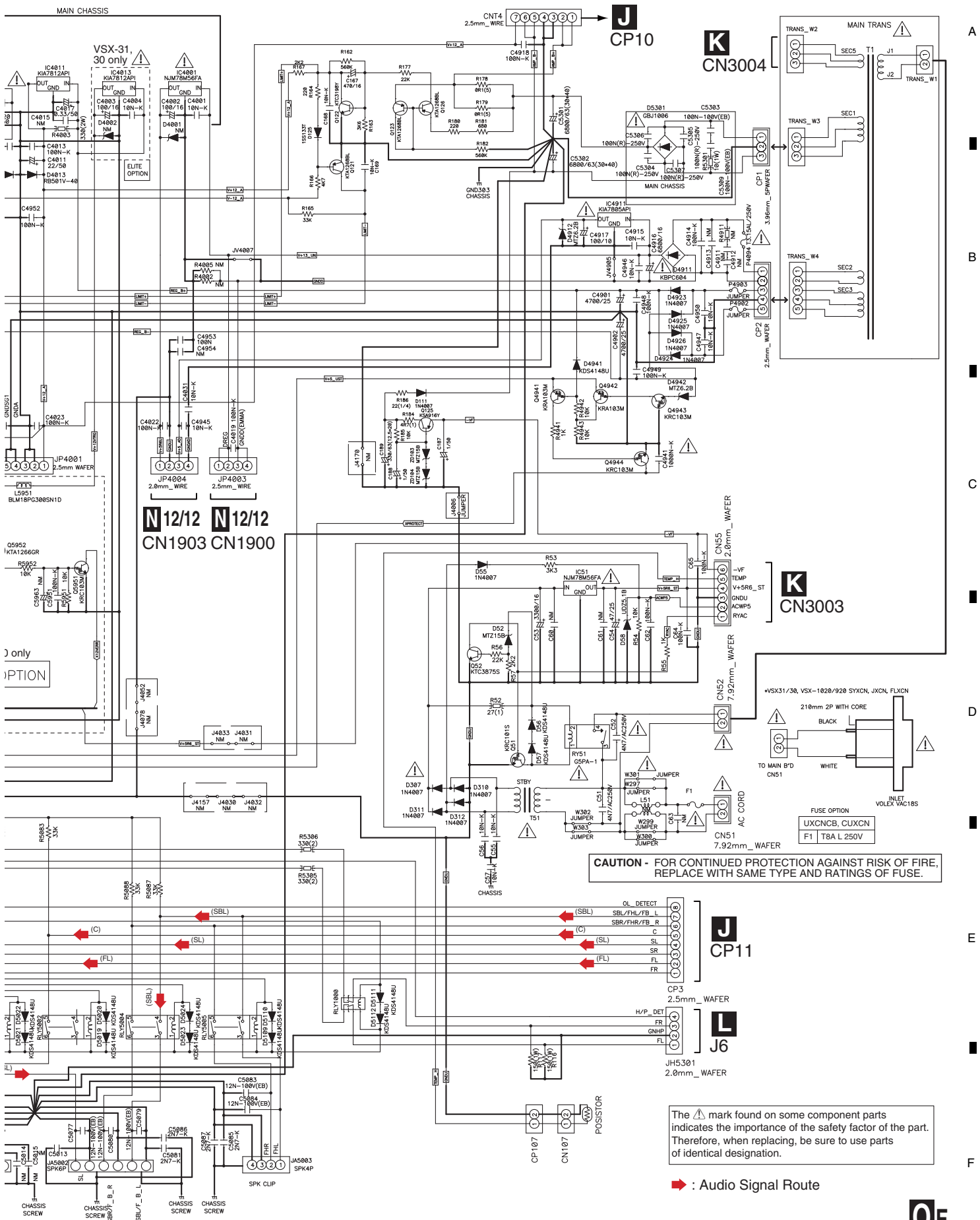

The  $\Delta$  mark found on some component parts indicates the importance of the safety factor of the part. Therefore, when replacing, be sure to use parts of identical designation.

➔ : Audio Signal Route





# 4. PCB PARTS LIST

**Mark No. Description Part No.**

**Mark No. Description Part No.**

**A F AUDIO ASSY (VSX-30, VSX-925)**  
**SEMICONDUCTORS**

IC 2501	BD3473KS2
IC 2502	J040406600010-IL
IC 2701,2702,2741,2761	J121458000020-IL
IC 2781,2821	J121458000020-IL
Q 2001,2002,2312-2320	INC2001AC1
Q 2401,2681	J5023209Y0010-IL
Q 2402	J5001281Y0010-IL
Q 2701	J520103S00210-IL
Q 2702	J522101411210-IL
D 2401,2402	UDZS7R5(B)
D 2501,2502,2603-2616	K005041480030-IL
D 2681	UDZS10(B)

**MISCELLANEOUS**

JA 8501-8503 TER,RCA 2PIN	G601206A0100Y-IL
CN 8501 CN,WAFER	L109012521910-IL

**D F MIC ASSY (VSX-30, VSX-925)**  
**SEMICONDUCTORS**

IC 3652	NJM2068M
D 3659,3670,3671	UDZS5R1(B)

**MISCELLANEOUS**

JA 3654 JACK,D3.5	G401PJ354H40Y-IL
-------------------	------------------

**E F F-VIDEO ASSY (VSX-30, VSX-925)**  
**SEMICONDUCTORS**

D 3656,3657	K005041480030-IL
-------------	------------------

**MISCELLANEOUS**

L 3651 RESISTOR	RS1/10SR0R0J
JA 3651 TER,RCA 3PIN	G60603W0192GD-IL

**CAPACITORS**

C 3656-3658	RS1/10SR0R0J
-------------	--------------

**MISCELLANEOUS**

JA 2101-2103 TER,RCA 6PIN	G603603A0500Y-IL
JA 2107 TER,RCA 1PIN	G600107A0000Y-IL
CN2102 CN,WAFER	L109012522310-IL
CN2106 CN,WAFER	L109012521710-IL
CN2201 CN,WAFER	L109012521310-IL

**K F DISPLAY ASSY (VSX-31)**  
**SEMICONDUCTORS**

IC 3001	PE5615A
IC 3004	8952102000030-IL
IC 3005	BU4842F
IC 9103	J126111700041-IL
Q 3004	J544513200010-IL
Q 3005-3009	J522104311210-IL
D 3002,3003,3017,3026	K005041480030-IL
D 3006	K125751400010-IL
D 3007,3009,3011,3013	SLR-343VC(NPQ)
D 3015	SLR343BC4T(JKLM)
D 3018,3021	K005021700200-IL
D 3027,3033,3034	K005041480030-IL
D 9001 (ZD3001)	MTZJ6R8(B)

**B F COMPONENT ASSY (VSX-31, VSX-30)**  
**SEMICONDUCTORS**

IC 8041,8051	CD74HC4053PW
IC 8061	NJM2581M
IC 8082,8083	KIA7805API
IC 8084	J126790500070-IL
IC 8101	BU4094BCFV
IC 8351,8361,8441	SN74AHCT08PW
Q 8082	J522101411210-IL
Q 8083	INC2001AC1
Q 8084,8201,8211,8221	J520015301210-IL
D 8082,8084,8351-8354	K005041480030-IL
D 8382,8402	K000400700010-IL
D 8386,8422	K005041480030-IL
D 8387,8389	1SS133

**MISCELLANEOUS**

H 3001 FL HOLDER	4320211016000-IL
V 3001 (FLT3001) DISPLAY,FLT	K530166000010-IL
S 3001-3015 SWITCH	G180501000010-IL
S 3024 SW,ENCODER	G121123040011-IL
X 3001 RESONATOR,CERAMIC (5 MHz)	E830500000020-IL
X 3002 CRYSTAL (15 MHz)	E80015R000020-IL
U 3001 MODULE,REMOCON	E940349003810-IL

**MISCELLANEOUS**

JA 8021 TER,RCA 6PIN	G603603A0260Y-IL
JA 8071 TER,RCA 3PIN	G606303A0800Y-IL
CN8001 CN,WAFER	L109012512310-IL
CN8003,8005 CN,WAFER	L109012512110-IL
CN8007 CN,WAFER	L109012511910-IL
CN8012 CN,WAFER	L109012521910-IL
CN8017 CN,WAFER	L109012521510-IL

**RESISTORS**

R 3021,3022	C060R47065050-IL
R 3025,3026	C060001063050-IL

**C F COMPOSITE ASSY (VSX-30, VSX-925)**  
**SEMICONDUCTORS**

IC 8501,8502	CD74HC4051PW
IC 8503	CD74HC4053PW
IC 8504	J171710800010-IL
IC 8505	BU4094BCF
Q 8503	J520015301210-IL
D 8501,8502,8504	K005041480030-IL
D 8506-8509	K005041480030-IL

**CAPACITORS**

C 3042	D040102081070-IL
--------	------------------

**K F DISPLAY ASSY (VSX-30)**  
**SEMICONDUCTORS**



Mark	No.	Description	Part No.
	IC	3001	PE5615A
	IC	3004	8952102000030-IL
	IC	3005	BU4842F
	IC	9103	J126111700041-IL
	Q	3004	J544513200010-IL
	Q	3005-3009	J522104311210-IL
	D	3002,3003,3017,3026	K005041480030-IL
	D	3006	K125751400010-IL
	D	3007,3009,3011,3013	SLR-343VC(NPQ)
	D	3015	SLR343BC4T(JKLM)
	D	3018,3021	K005021700200-IL
	D	3027,3033,3034	K005041480030-IL
	D	9001 (ZD3001)	MTZJ6R8(B)

**MISCELLANEOUS**

H	3001	FL HOLDER	4320211016000-IL
V	3001 (FLT3001)	DISPLAY,FLT	K530166000010-IL
S	3001-3015	SWITCH	G180501000010-IL
S	3024	SW,ENCODER	G121123040011-IL
X	3001	RESONATOR,CERAMIC (5 MHz)	E830500000020-IL
X	3002	CRYSTAL (15 MHz)	E80015R000020-IL
U	3001	MODULE,REMOCON	E940349003810-IL

**RESISTORS**

R	3021,3022	C060R47065050-IL
R	3025,3026	C060001063050-IL

**CAPACITORS**

C	3042	D040102081070-IL
---	------	------------------

**K F DISPLAY ASSY (vsx-925)****SEMICONDUCTORS**

	IC	3001	PE5615A
	IC	3004	8952102000030-IL
	IC	3005	BU4842F
	IC	9103	J126111700041-IL
	Q	3004	J544513200010-IL
	Q	3005-3009	J522104311210-IL
	D	3002,3003,3017,3026	K005041480030-IL
	D	3006	K125751400010-IL
	D	3007,3009,3011,3013	SLR-343VC(NPQ)
	D	3015	SLR343BC4T(JKLM)
	D	3018,3021	K005021700200-IL
	D	3027,3033,3034	K005041480030-IL
	D	9001 (ZD3001)	MTZJ6R8(B)

**MISCELLANEOUS**

H	3001	FL HOLDER	4320211016000-IL
V	3001 (FLT3001)	DISPLAY,FLT	K530166000010-IL
S	3001-3015	SWITCH	G180501000010-IL
S	3024	SW,ENCODER	G121123040011-IL
X	3001	RESONATOR,CERAMIC (5 MHz)	E830500000020-IL
X	3002	CRYSTAL (15 MHz)	E80015R000020-IL
U	3001	MODULE,REMOCON	E940349003810-IL

**RESISTORS**

R	3021,3022	C060R47065050-IL
R	3025,3026	C060001063050-IL

**CAPACITORS**

C	3042	D040102081070-IL
---	------	------------------

Mark	No.	Description	Part No.
		<b>N F D-MAIN ASSY (vsx-30, vsx-925)</b>	
		<b>SEMICONDUCTORS</b>	
	IC	101	AK4114VQ
	IC	215,900,1081,1306	SN74AHC1G08DCK
	IC	221,231,9004	J040741570070-IL
	IC	241	J040741250170-IL
	IC	251	K4S641632N-LC60
	IC	261	8952102000020-IL
	IC	271	SN74AHC1G32DCK
	IC	281,291	J040745730230-IL
	IC	301	DSPA56720AG
	IC	361	SN74AHC04PW
	IC	363	J040741260070-IL
	IC	364,1813	J040741080060-IL
	IC	391,1407	SN74AHC08PW
	IC	452,1801-1803,1805	SN74LVC541APW
	IC	501	AK5358AET
	⚠	IC 581	NJM2885DL1-33
	⚠	IC 582	RP131H101D
	IC	602,652,702,752	WM8728SEDS
	IC	800	UPD61283F1-407LU2A
	IC	801,802	NJM12904V
	IC	803,1302	J040740400320-IL
	IC	1000,1001	K4H561638J-LCB3
	IC	1050	8952102000011-IL
	⚠	IC 1100,1101	S-1170B33UC-OTS
	⚠	IC 1102	S-1170B25UC-OTK
	⚠	IC 1104	MM1701WH
	IC	1250,9001,9401	J046255100010-IL
	IC	1251	J040740400310-IL
	IC	1300	PE7008A
	IC	1301	341S2164
	⚠	IC 1303	S-1132B25-U5
	IC	1305	BU4094BCFV
	IC	1401	J040741260060-IL
	IC	1406	SN74AHCT125PW
	IC	1408	SN74AHCT08PW
	IC	1501	SI19233ACTU
	IC	1563,9402	SN74AHC1G08DCK
	⚠	IC 1592	R1172H121B
	IC	1601	CXB1444R
	IC	1701	ADV7181CBSTZ
	IC	1800	ABT1015
	IC	1804,1806	SN74LVC1G125DCK
	IC	1807-1811	J040745410070-IL
	⚠	IC 1900	TPS54350PWP
	⚠	IC 1930	LTC3850EGN
	IC	9000	SI19134CTU
	IC	9451	LAN9211-ABZJ
	IC	9751	J040741530050-IL
	Q	241,552,9701	J522012400010-IL
	Q	551	RTQ025P02
	Q	800,801,1150,1154	2SA1576A
	Q	1151,1155,1157,1998	2SC4081
	Q	1156,1200-1204,1405	2SA1576A
	Q	1300,1401-1403,9703	J520012400010-IL
	Q	1400	J522011400010-IL
	Q	1407-1409,1999,9702	UMD2N

Mark	No.	Description	Part No.
	Q	1900	RTQ045N03
	Q	1930,1931	SP8K1
	Q	9000	UMB1N
A	Q	9001,9551	J522011400020-IL
	D	484	DAN217U
	D	501,1998	DAP202U
	D	502,1402,9751	DAN202U
	D	551,1997	1SS355
	D	582	1SR154-400
	D	1200	RR264M-400
	D	1400	RB501V-40
	D	1930,1931	RB160VA-40
	D	1999	UDZS5R6(B)
B	D	9000	UDZS5R1(B)

Mark	No.	Description	Part No.
	Q	3001	J520015301210-IL
	Q	3002,3011,5020	J522102411210-IL
	Q	3010,5017,5019,5022	J520103S00210-IL
	Q	4941,4942	J6010103M0010-IL
	Q	4943,4944,5902,5951	J6030103M0010-IL
	Q	5018,5021,5508-5511	J5220232S0010-IL
	Q	5505-5507	J520103S00210-IL
	Q	5952,5953,5956,5959	J5001266G0050-IL
	Q	5954,5955	J6030103M0010-IL
	D	52,9103(ZD103),9104(ZD104)	MTZJ15(B)
	D	55,111,307	K000400700010-IL
	D	56,57,3001,3004	K005041480030-IL
	D	58	UDZS5R1(B)
	D	125	1SS133
	D	310-312,4923-4926	K000400700010-IL
	D	3005,3030,4941	K005041480030-IL
	D	4012,4013	RB501V-40
	D	4911	K047604000020-IL
	D	4912,4942	MTZJ6R2(B)
	D	5019-5024,5107-5113	K005041480030-IL
	D	5301	K047100600010-IL
	D	5901,5902,5905,5907	K005041480030-IL
	D	5908	K005041480030-IL

### MISCELLANEOUS

L	1901	COIL,INDUCTOR	D310104503300-IL
L	1931	COIL,INDUCTOR	D310603001500-IL
L	1932	COIL,INDUCTOR	D310603003900-IL
JA	102	TER,RCA 1PIN	G60011703000Y-IL
JA	103,104	MODULE	E100216500010-IL
JA	481	JACK,DIN	G403515397000-IL
JA	1601-1604,9000	CN.WAFER	L109100190050-IL
JA	9401	CONNECTOR	CKS5712
JA	9451	JACK,MODULAR	G4060RJ450120-IL
C	KN481	BRACKET	4010210196100-IL

X	361	OSCILATOR,CERA CHIP (22.5792 MHz)	E85522R579210-IL
X	362	OSCILATOR,CERA CHIP (24.576 MHz)	E85524R576050-IL
X	801,1501	CRYSTAL CHIP (27 MHz)	E80527R000050-IL
X	1250	CRYSTAL CHIP (48 MHz)	E80548R000060-IL
X	1300	CRYSTAL CHIP (36.864 MHz)	E80536R864060-IL

X	1701	CRYSTAL CHIP (28.63636 MHz)	E80528R636360-IL
X	9451	CRYSTAL CHIP (25 MHz)	E80525R000050-IL
CN	482	CN,WAFER	L109012521910-IL
CN	501,1254	CN,WAFER	L109012522310-IL
CN	1250,1252	CN,WAFER	L109012522110-IL

CN	1401	CN,WAFER	L109012521310-IL
----	------	----------	------------------

### CAPACITORS

C	333	D050221081250-IL
C	505,1203,1801,1824	D011106572200-IL
C	1411	D040222082020-IL
C	1826,9001,9406	D011106572200-IL
C	1900	D050101085210-IL

C	1903,1904,1931,1932	D011106574300-IL
C	1939,1943	D011476572310-IL
C	9035-9042	D010R40137100-IL
C	9472	D050101083200-IL

## OF MAIN ASSY (VSX-31, VSX-30)

### SEMICONDUCTORS

IC	51,4001	NJM78M56FA
IC	4011,4013	KIA7812API
IC	4012	KIA7912PI
IC	4911	KIA7805API
IC	5772	J046323200020-IL

Q	51	J522104311210-IL
Q	52,4932	J522038750210-IL
Q	121,123,126	J5001268B0050-IL
Q	122,5501-5504	J5023198Y0000-IL
Q	125	J5000916Y0050-IL

### MISCELLANEOUS

L	4841,4853,4854	FERRITE BEAD	D340160831210-IL
L	4861	FERRITE BEAD	D340160861020-IL
L	4862	FERRITE BEAD	D340160862410-IL
L	5901	FERRITE BEAD	D340160831210-IL
L	5951	COIL,BEAD	D340160833000-IL

JA	4841,4851,4861,4871	JACK,D3.5	G401PJ3080100-IL
JA	5001	TER,BOARD SCREW 8P	G614108V1010M-IL
JA	5002	TER,BOARD SCREW 4P	G612405E0200Y-IL
JA	5003	TER,BOARD SCREW 2P	G611201A0200Y-IL
JA	5004	TER,BOARD PUSH 4P	G594408SA030Y-IL

JA	5807,5808	JACK,D3.5	G401PJ3080100-IL
JA	5809	CN.WAFER INTERFACE	L103090090040-IL
RY	51	RELAY	G680060102020-IL
RY	1000	RELAY	G680240202030-IL
RY	5001-5005	RELAY	G680120503020-IL

T	51	POWER TRANS	8200280150620-IL
CN	5002	CN,WAFER	L109012511910-IL
CN	9006 (CP6)	CN,WAFER	L109012511510-IL
FU	1 (F1)	FUSE GLASS TUBE 20MM	N751508001160-IL
FU	4094 (P4094)	FUSE GLASS TUBE 20MM	N751503151160-IL

### RESISTORS

R	52	C060027065050-IL
R	116,117	C060015165050-IL
R	178,179	C141R10069010-IL
R	184	C0604R7065050-IL
R	186	C060022063050-IL

R	4003	C060033166520-IL
R	5301	C060010065050-IL
R	5305,5306	C060033166050-IL
R	9005	RS1/4SAORJ
Other Resistors		RD1/4PU###J

### CAPACITORS

C	51,52	D00847208H010-IL
C	53	D040332083010-IL
C	189	D040331088230-IL

<u>Mark</u>	<u>No.</u>	<u>Description</u>	<u>Part No.</u>
C	4901,4902		D040472084020-IL
C	4916		D040682083240-IL
C	4953		D005104597531-IL
C	5073-5075,5077-5080		D02012306C060-IL
C	5083,5084		D02012306C060-IL
C	5301,5302		D040682088010-IL
C	5303,5309		D02010406C060-IL
C	5304-5307		D02010407H080-IL

## **T** F USB ASSY (VSX-30, VSX-925)

### SEMICONDUCTORS

D 3603,3672 RS1/8SQ0R0J

### MISCELLANEOUS

L 3601-3604 RESISTOR RS1/10SR0R0J  
JA 3601 CN,PLUG CONTACT G480040101410-IL

### CAPACITORS

C 3606 RS1/10SR0R0J