

Service Manual

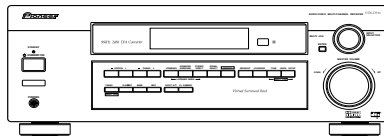

VSX-D511-K

ORDER NO.
RRV2599

AUDIO/VIDEO MULTI-CHANNEL RECEIVER

VSX-D511-K

VSX-D511-S

THIS MANUAL IS APPLICABLE TO THE FOLLOWING MODEL(S) AND TYPE(S).

Model	Type	Power Requirement	Remarks
VSX-D511-K	MVXJI	AC230V	
VSX-D511-S	MYXJIEW	AC220-230V	
VSX-D511-K	MYXJIEW	AC220-230V	
VSX-D511-K	MYXJIGR	AC220-230V	



For details, refer to "Important symbols for good services" on the next page.

SAFTY INFORMATION



This service manual is intended for qualified service technicians; it is not meant for the casual do-it-yourselfer. Qualified technicians have the necessary test equipment and tools, and have been trained to properly and safely repair complex products such as those covered by this manual.

Improperly performed repairs can adversely affect the safety and reliability of the product and may void the warranty. If you are not qualified to perform the repair of this product properly and safely, you should not risk trying to do so and refer the repair to a qualified service technician.



WARNING

This product contains lead in solder and certain electrical parts contain chemicals which are known to the state of California to cause cancer, birth defects or other reproductive harm.

Health & Safety Code Section 25249.6 – Proposition 65



NOTICE

(FOR CANADIAN MODEL ONLY)

Fuse symbols  (fast operating fuse) and/or  (slow operating fuse) on PCB indicate that replacement parts must be of identical designation.

REMARQUE

(POUR MODÈLE CANADIEN SEULEMENT)

Les symboles de fusible  (fusible de type rapide) et/ou  (fusible de type lent) sur CCI indiquent que les pièces de remplacement doivent avoir la même désignation.

(FOR USA MODEL ONLY)

1. SAFETY PRECAUTIONS

The following check should be performed for the continued protection of the customer and service technician.

LEAKAGE CURRENT CHECK

Measure leakage current to a known earth ground (water pipe, conduit, etc.) by connecting a leakage current tester such as Simpson Model 229-2 or equivalent between the earth ground and all exposed metal parts of the appliance (input/output terminals, screwheads, metal overlays, control shaft, etc.). Plug the AC line cord of the appliance directly into a 120V AC 60 Hz outlet and turn the AC power switch on. Any current measured must not exceed 0.5 mA.

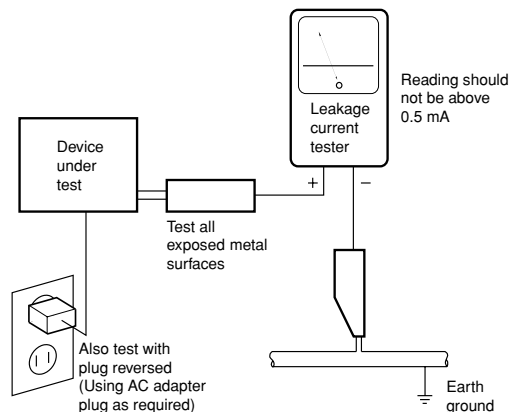

AC Leakage Test

ANY MEASUREMENTS NOT WITHIN THE LIMITS OUTLINED ABOVE ARE INDICATIVE OF A POTENTIAL SHOCK HAZARD AND MUST BE CORRECTED BEFORE RETURNING THE APPLIANCE TO THE CUSTOMER.

2. PRODUCT SAFETY NOTICE

Many electrical and mechanical parts in the appliance have special safety related characteristics. These are often not evident from visual inspection nor the protection afforded by them necessarily can be obtained by using replacement components rated for voltage, wattage, etc. Replacement parts which have these special safety characteristics are identified in this Service Manual.

Electrical components having such features are identified by marking with a Δ on the schematics and on the parts list in this Service Manual.

The use of a substitute replacement component which does not have the same safety characteristics as the PIONEER recommended replacement one, shown in the parts list in this Service Manual, may create shock, fire, or other hazards.

Product Safety is continuously under review and new instructions are issued from time to time. For the latest information, always consult the current PIONEER Service Manual. A subscription to, or additional copies of, PIONEER Service Manual may be obtained at a nominal charge from PIONEER.

[Important symbols for good services]

In this manual, the symbols shown below indicate that adjustments, settings or cleaning should be made securely. When you find the procedures bearing any of the symbols, be sure to fulfill them:

1. Product safety

You should conform to the regulations governing the product (safety, radio and noise, and other regulations), and should keep the safety during servicing by following the safety instructions described in this manual.

2. Adjustments

To keep the original performances of the product, optimum adjustments or specification confirmation is indispensable. In accordance with the procedures or instructions described in this manual, adjustments should be performed.

3. Cleaning

For optical pickups, tape-deck heads, lenses and mirrors used in projection monitors, and other parts requiring cleaning, proper cleaning should be performed to restore their performances.

4. Shipping mode and shipping screws

To protect the product from damages or failures that may be caused during transit, the shipping mode should be set or the shipping screws should be installed before shipping out in accordance with this manual, if necessary.

5. Lubricants, glues, and replacement parts

Appropriately applying grease or glue can maintain the product performances. But improper lubrication or applying glue may lead to failures or troubles in the product. By following the instructions in this manual, be sure to apply the prescribed grease or glue to proper portions by the appropriate amount. For replacement parts or tools, the prescribed ones should be used.

CONTENTS

	SAFTY INFORMATION2
A	1. SPECIFICATIONS5
	2. EXPLODED VIEWS AND PARTS LIST6
	2.1 PACKING6
	2.2 EXTERIOR SECTION8
	2.3 FRONT PANEL SECTION	10
	3. BLOCK DIAGRAM AND SCHEMATIC DIAGRAM	12
	3.1 BLOCK DIAGRAM	12
	3.2 OVERALL WIRING CONNECTION DIAGRAM	14
	3.3 D.D & INPUT(1/4) ASSY.	16
	3.4 D.D & INPUT(2/4) ASSY.	18
B	3.5 D.D & INPUT(3/4) ASSY.	20
	3.6 D.D & INPUT(4/4) ASSY.	22
	3.7 AMP & PRIMARY(1/2), TRANS2 and TRANS3 ASSYS	24
	3.8 AMP & PRIM.(2/2), REG., HASHIGETA, B TO B and MECH SW ASSYS	26
	3.9 VIDEO, 6CH IN and S.VIDEO ASSYS.	28
	3.10 FRONT, R.ENCODER and POWER SW ASSYS	30
	3.11 DIGITAL IN, H.P. and KAWA ASSYS	32
	3.12 FM/AM TUNER MODULE	34
	4. PCB CONNECTION DIAGRAM	36
	4.1 TRANS1, TRANS2 and TRANS3 ASSYS	37
C	4.2 D.D & INPUT ASSY	38
	4.3 AMP INPUT, AMP & PRIMARY and MECHA SW ASSYS.	42
	4.4 FRONT, POWER SW, H.P. and R.ENCODER ASSYS	44
	4.5 REGULATOR, HASHIGETA and KAWA ASSYS.	48
	4.6 DIGITAL IN, 6CH IN, VIDEO and BOARRO TO BOARD ASSYS	50
	4.7 FM/AM TUNER MODULE	52
	5. PCB PARTS LIST	53
	6. ADJUSTMENT	58
	7. GENERAL INFORMATION.	59
	7.1 DISASSEMBLY and DIAGNOSI	59
	7.1.1 DISASSEMBLY and PCB LOCATION	59
	7.1.2 U-COM BLOCKDIAGRAM.	60
	7.1.3 PROTECTION CIRCUIT.	61
	7.1.4 POWER ON SEQUENCE	62
	7.1.5 POWER OFF SEQUENCE	63
	7.2 PARTS	64
	7.2.1 IC	64
	7.2.2 DISPLAY	73
	8. PANEL FACILITIES	75

1. SPECIFICATIONS

Amplifier Section

Continuous Power Output (STEREO mode)

Front 80 W per channel
(DIN 1kHz, THD 1.0 %, 8 Ω)

Continuous Power Output

Front 80 W per channel
(1kHz, THD 1.0 %, 8 Ω)

Center 80 W (1kHz, THD 1.0 %, 8 Ω)

Surround 80 W per channel (1kHz, THD 1.0 %, 8 Ω)

Above specifications are applicable when the power supply is 230V.

Input (Sensitivity/Impedance)

CD, VCR/DVR, CD-R/TAPE/MD, DVD/LD, TV/SAT ... 200 mV/47 kΩ

Frequency Response

CD, VCR/DVR, CD-R/TAPE/MD, DVD/LD, TV/SAT
..... 5 Hz to 100,000 Hz ± 3 dB

Output (Level/Impedance)

VCR/DVR REC, CD-R/TAPE/MD REC 200 mV/2.2 kΩ

Tone Control

BASS ± 6 dB (100 Hz)

TREBLE ± 6 dB (10 kHz)

LOUDNESS +9 dB/+9 dB (100 Hz/10 kHz)

Signal-to-Noise Ratio [DIN (Continuous rated power output/50 mW)]

CD, VCR/DVR, CD-R/TAPE/MD, DVD/LD, TV/SAT 88/64 dB

Video Section

Input (Sensitivity/Impedance)

VCR/DVR, DVD/LD, TV/SAT 1 V_{p-p}/75 Ω

Output (Level/Impedance)

VCR/DVR 1 V_{p-p}/75 Ω

Frequency Response

VCR/DVR, DVD/LD, TV/SAT \leftrightarrow MONITOR 5 Hz to 7 MHz ± 3 dB

Signal-to-Noise Ratio 55 dB

Cross Talk 55 dB

Manufactured under license from Dolby Laboratories.
"Dolby", "Pro Logic II" and the double D symbol Σ are
trademarks of Dolby Laboratories.

"DTS", "ES" and "DTS Digital Surround" are trademarks
of Digital Theater Systems, Inc.

FM Tuner Section

Frequency Range 87.5 MHz to 108 MHz

Usable Sensitivity Mono: 13.2 dBf, IHF (1.3 μ V/ 75 Ω)

50 dB Quieting Sensitivity Mono: 20.2 dB
Stereo: 38.6 dBf

Signal-to-Noise Ratio Mono: 73 dB (at 85 dBf)
Stereo: 70 dB (at 85 dBf)

Signal-to-Noise Ratio (DIN) Mono: 62 dB
Stereo: 58 dB

Distortion Stereo: 0.5 % (1 kHz)

Alternate Channel Selectivity 60 dB (400 kHz)

Stereo Separation 40 dB (1 kHz)

Frequency Response 30 Hz to 15 kHz (± 1 dB)

Antenna Input (DIN) 75 Ω unbalanced

AM Tuner Section

Frequency Range 531 kHz to 1,602 kHz

Sensitivity (IHF, Loop antenna) 350 μ V/m

Selectivity 25 dB

Signal-to-Noise Ratio 50 dB

Antenna Loop antenna

Miscellaneous

Power Requirements

UK model AC 230 V, 50/60Hz

European model AC 220-230 V, 50/60 Hz

Power Consumption

..... 220W

In Standby 1 W

Dimensions 420 (W) x 158 (H) x 393 (D) mm

Weight (without package)

..... 9.0 kg

Furnished Parts

AM loop antenna 1

FM wire antenna 1

Dry cell batteries (AA size IEC R6P) 2

Remote control 1

Operating instructions 1



Note

Specifications and the design are subject to possible modifications
without notice, due to improvements.

Accessories

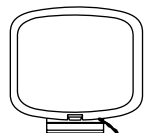

AM loop antenna
(ATB7009)

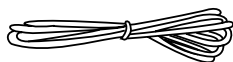

FM wire antenna
(ADH7005)

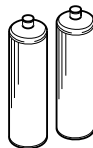

AA size IEC R6P
Dry cell batteries (x2)

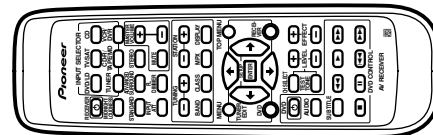

Remote control unit
(XXD3039)

2. EXPLODED VIEWS AND PARTS LIST

- NOTES:
- Parts marked by "NSP" are generally unavailable because they are not in our Master Spare Parts List.
 - The \triangle mark found on some component parts indicates the importance of the safety factor of the part. Therefore, when replacing, be sure to use parts of identical designation.
 - Screws adjacent to \blacktriangledown mark on product are used for disassembly.
 - For the applying amount of lubricants or glue, follow the instructions in this manual.
(In the case of no amount instructions, apply as you think it appropriate.)

2.1 PACKING

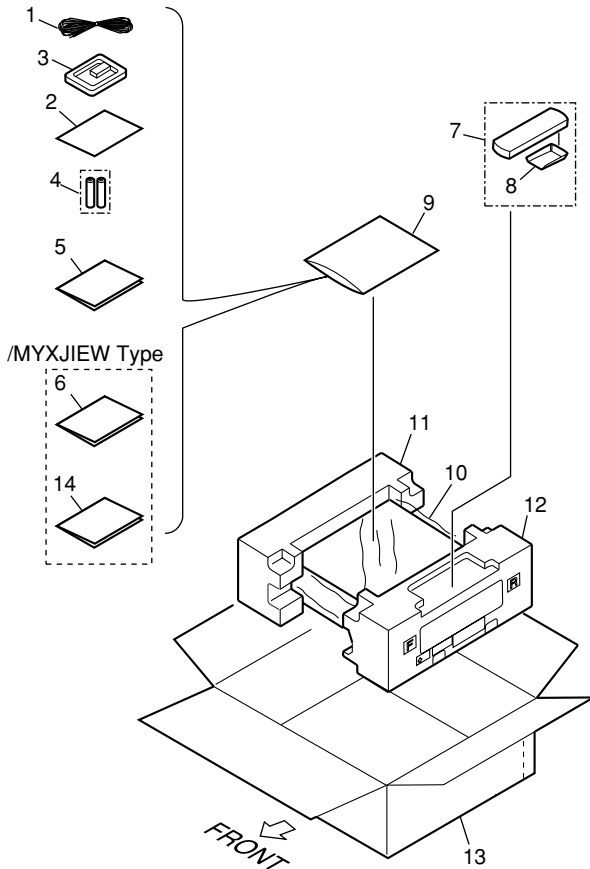

PACKING parts List

<u>Mark No.</u>	<u>Description</u>	<u>Part No.</u>	<u>Mark No.</u>	<u>Description</u>	<u>Part No.</u>
1	FM wire antenna	ADH7005	8	Battery Cover	AZA7378
NSP 2	Warranty Card	ARY7022	NSP 9	Polyethylene Bag	Z21-038
3	AM loop antenna	ATB7009	10	Packing Sheet	AHG7069
NSP 4	Dry cell batteries (AA/R6P)	VEM-013	11	Left Pad R5	XHA3032
5	Operating instructions (English/German)	XRE3057	12	Right Pad R5	XHA3033
6	Operating instructions	See Contrast table(2)	13	Packing Case	See Contrast table(2)
7	Remote Control Unit	XXD3039	14	Operating instructions	See Contrast table(2)

(2) CONTRAST TABLE

VSX-D511-K/MVXJI, /MYXJIEW, /MYXJIGR and VSX-D511-S/MYXJIEW are constructed the same except for the following :

Mark	NO	Symbol and Description	VSX-D511-K/ MVXJI	VSX-D511-S/ MYXJIEW	VSX-D511-K/ MYXJIEW	VSX-D511-K/ MYXJIGR
	6	Operating Instructions (French,Italian)	Not used	XRC3056	XRC3056	Not used
	13	Packing Case	XHD3204	XHD3205	XHD3204	XHD3204
	14	Operating Instructions (Spanish,Dutch)	Not used	XRC3070	XRC3070	Not used

2.2 EXTERIOR SECTION

A

B

C

D

E

F

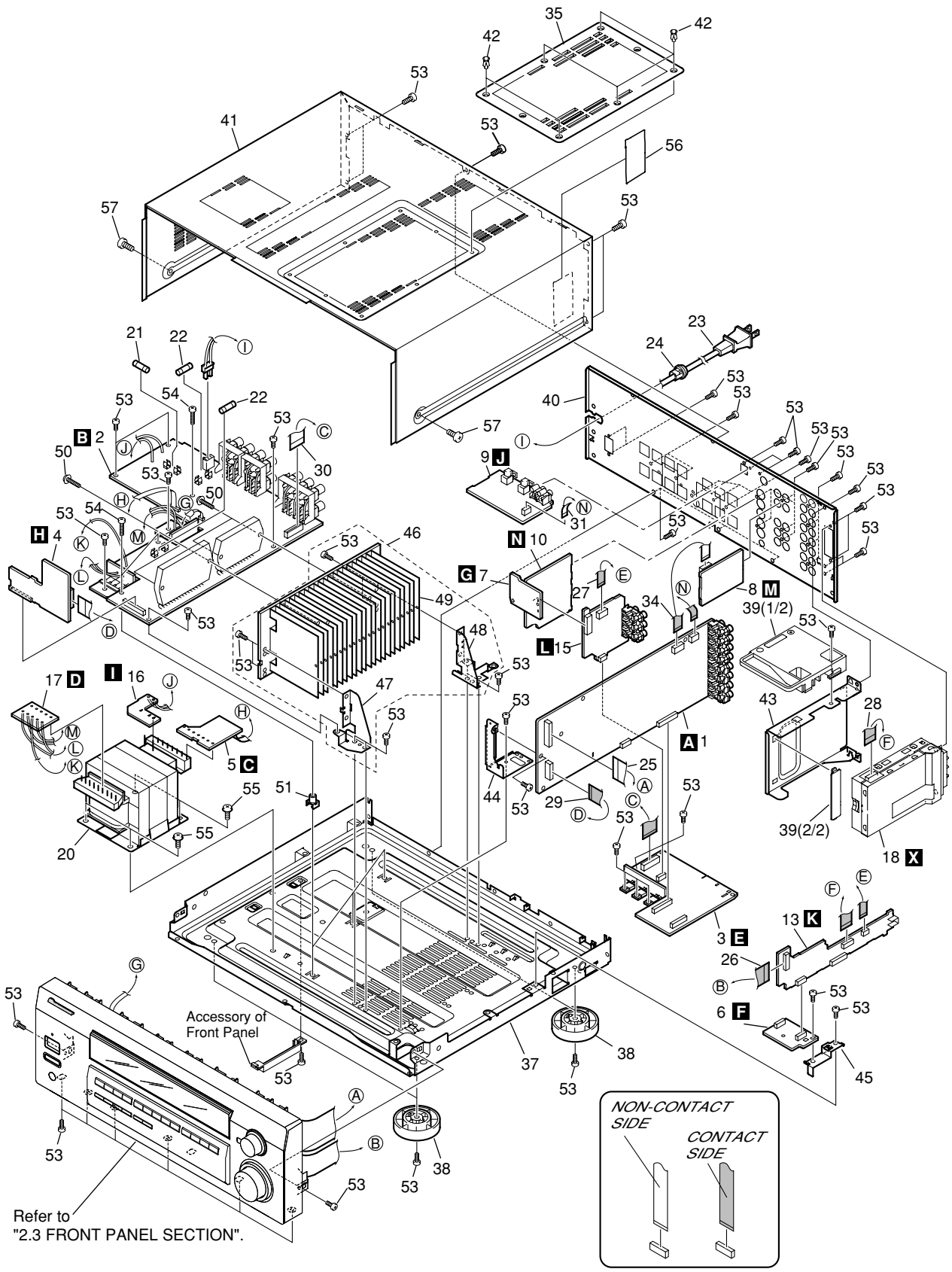

EXTERIOR SECTION parts List

Mark No.	Description	Part No.	Mark No.	Description	Part No.
1	D.D & INPUT ASSY	XWX3044		DD CN106 - AMP INPUT CN254	
2	AMP ASSY	XWZ3533	30	23P F•F•C/30V (J36)	XDD3102
3	REGULATOR ASSY	XWZ3544		AMP CN53 - REGULATOR CN801	
4	AMP INPUT ASSY	XWZ3547			
5	TRANS2 ASSY	XWZ3555	31	7P F•F•C/30V (J37)	XDD3103
				DD CN9101 - DIGITAL IN CN1901	
6	HASHIGETA ASSY	XWZ3566	32	
7	BOARD TO BOARD ASSY	XWZ3527	33	
8	6CH IN ASSY	XWZ3507	34	9P F•F•C/30V (J48)	XDD3106
9	DIGITAL IN ASSY	XWZ3518		DD CN104 - 6CH IN CN307	
10	S. VIDEO ASSY	XWZ3521	35	Top Cover	See Contrast table(2)
11		36	
12		NSP 37	Under Base 409	ANA7094
13	KAWA ASSY	XWZ3529	38	Insulator	PNW2766
14		39	FFC Cover R5	XMR3047
15	VIDEO ASSY	XWZ3490	40	Rear Panel	XNC3143
NSP 16	TRANS1 ASSY	XWZ3552	41	Bonnet D510	See Contrast table(2)
NSP 17	TRANS3 ASSY	XWZ3560	42	Push Rivet	See Contrast table(2)
18	FM/AM TUNER MODULE	AXQ7232	43	Tuner Shield R5	XNG3072
19		44	PCB Angle R5	XNG3073
⚠ 20	Power Transformer (T1)	ATS7259	45	Reg Support R5	XNG3074
21		NSP 46	Heat Sink Assy 0.8	ANH7118
⚠ 22	Fuse (FU1:T2.5A)	REK1026	47	Heat Sink Angle F	ANG7251
⚠ 23	Power Cord	See Contrasttable(2)	48	Heat Sink Angle R	ANG7252
24	Cord Stopper	CM-22B	NSP 49	Heat Sink 0.8	ANH7110
25	28P F•F•C/30V (J31)	XDD3097	50	Screw 3x23	ABA7043
	DD CN102 - FRONT CN402				
26	17P F•F•C/30V (J32)	XDD3098	51	PCB Mold	AMR2533
	KAWA CN5001 - FRONT CN401		52	Screw	See Contrast table(2)
27	7P F•F•C/30V (J33)	XDD3099	53	Screw	BBZ30P080FMC
	KAWA CN5004 - VIDEO CN503		54	Screw	BBZ30P200FMC
28	13P F•F•C/30V (J34)	XDD3100	55	Screw	FBT40P080FZK
	KAWA CN5005 - FM/AM TUNER CN201				
29	19P F•F•C/30V (J35)	XDD3101	56	Tuner Sheet	XEC3031
			57	Screw	See Contrast table(2)

(2) CONTRAST TABLE

VSX-D511-K/MVXJI, /MYXJIEW, /MYXJIGR and VSX-D511-S/MYXJIEW are constructed the same except for the following :

Mark	NO	Symbol and Description	VSX-D511-K/ MVXJI	VSX-D511-S/ MYXJIEW	VSX-D511-K/ MYXJIEW	VSX-D511-K/ MYXJIGR
⚠	23	AC Power Cord	VDG1076	VDG1077	VDG1077	VDG1077
	35	Top Cover	XME3004	XME3006	XME3004	XME3004
	41	Bonnet	XZN3111	XZN3122	XZN3111	XZN3111
	42	Push Rivet	AEC7025	XEC3026	AEC7025	AEC7025
	57	Screw	FBT40P080FZK	FBT40P080FNI	FBT40P080FZK	FBT40P080FZK

2.3 FRONT PANEL SECTION

A

B

C

D

E

F

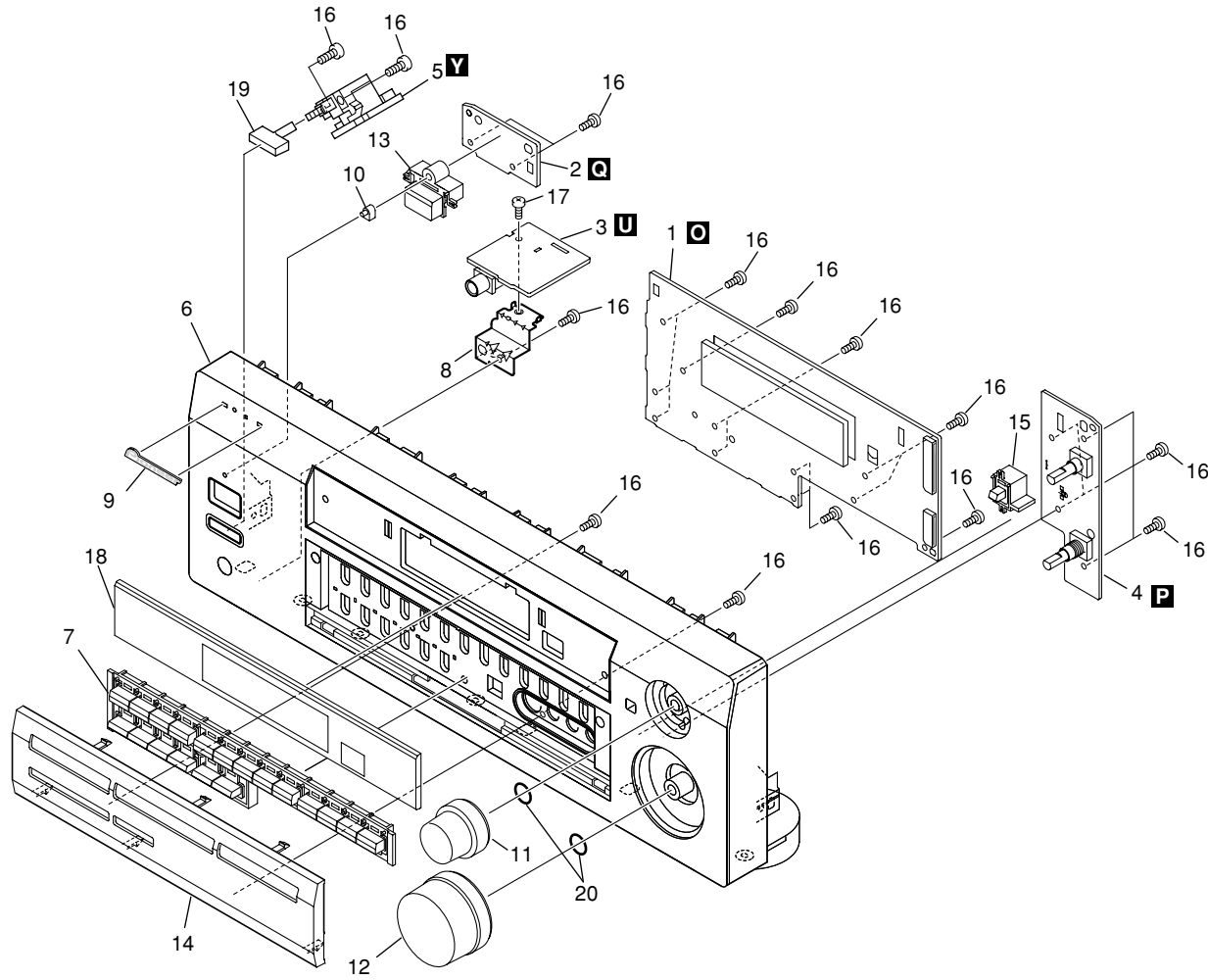

FRONT PANEL SECTION parts List

<u>Mark No.</u>	<u>Description</u>	<u>Part No.</u>	<u>Mark No.</u>	<u>Description</u>	<u>Part No.</u>
1	FRONT ASSY	XWZ3493	11	Select Knob	See Contrast table(2)
2	POWER SW ASSY	XWZ3510	12	Volume Knob	See Contrast table(2)
3	H.P. ASSY	XWZ3513	13	Power Button	See Contrast table(2)
4	R. ENCODER ASSY	XWZ3511	14	Sub Panel	See Contrast table(2)
5	MECH SW ASSY	XWZ3514	15	Jog Button	See Contrast table(2)
6	Front Panel	See Contrast table(2)	16	Screw	PPZ30P080FMC
7	Sub Button	See Contrast table(2)	17	Screw	BBZ30P080FMC
8	Earth Plate R5 HP	XNG3066	18	D Panel R5 W	XAK3320
9	Pioneer Badge	See Contrast table(2)	19	Power Button M	See Contrast table(2)
10	Led Lens 1.6	XAK3308	20	C Ring DIA8.1	XBH3016

(2) CONTRAST TABLE

VSX-D511-K/MVXJI, /MYXJIEW, /MYXJIGR and VSX-D511-S/MYXJIEW are constructed the same except for the following :

Mark	NO	Symbol and Description	VSX-D511-K/ MVXJI	VSX-D511-S/ MYXJIEW	VSX-D511-K/ MYXJIEW	VSX-D511-K/ MYXJIGR
	6	Front Panel	XMB3065	XMB3076	XMB3065	XMB3065
	7	Sub Button	XAD3125	XAD3133	XAD3125	XAD3125
	9	Pioneer Badge	XAM3006	VAM1129	XAM3006	XAM3006
	11	Select Knob	XAB3023	XAB3024	XAB3023	XAB3023
	12	Volume Knob	XAB3025	XAB3026	XAB3025	XAB3025
	13	Power Button	XAD3123	XAD3129	XAD3123	XAD3123
	14	Sub Panel	XAK3273	XAK3299	XAK3273	XAK3273
	15	Jog Button	XAD3124	XAD3131	XAD3124	XAD3124
	19	Power Button M	XAD3127	XAD3137	XAD3127	XAD3127

3. BLOCK DIAGRAM AND SCHEMATIC DIAGRAM

3.1 BLOCK DIAGRAM

A

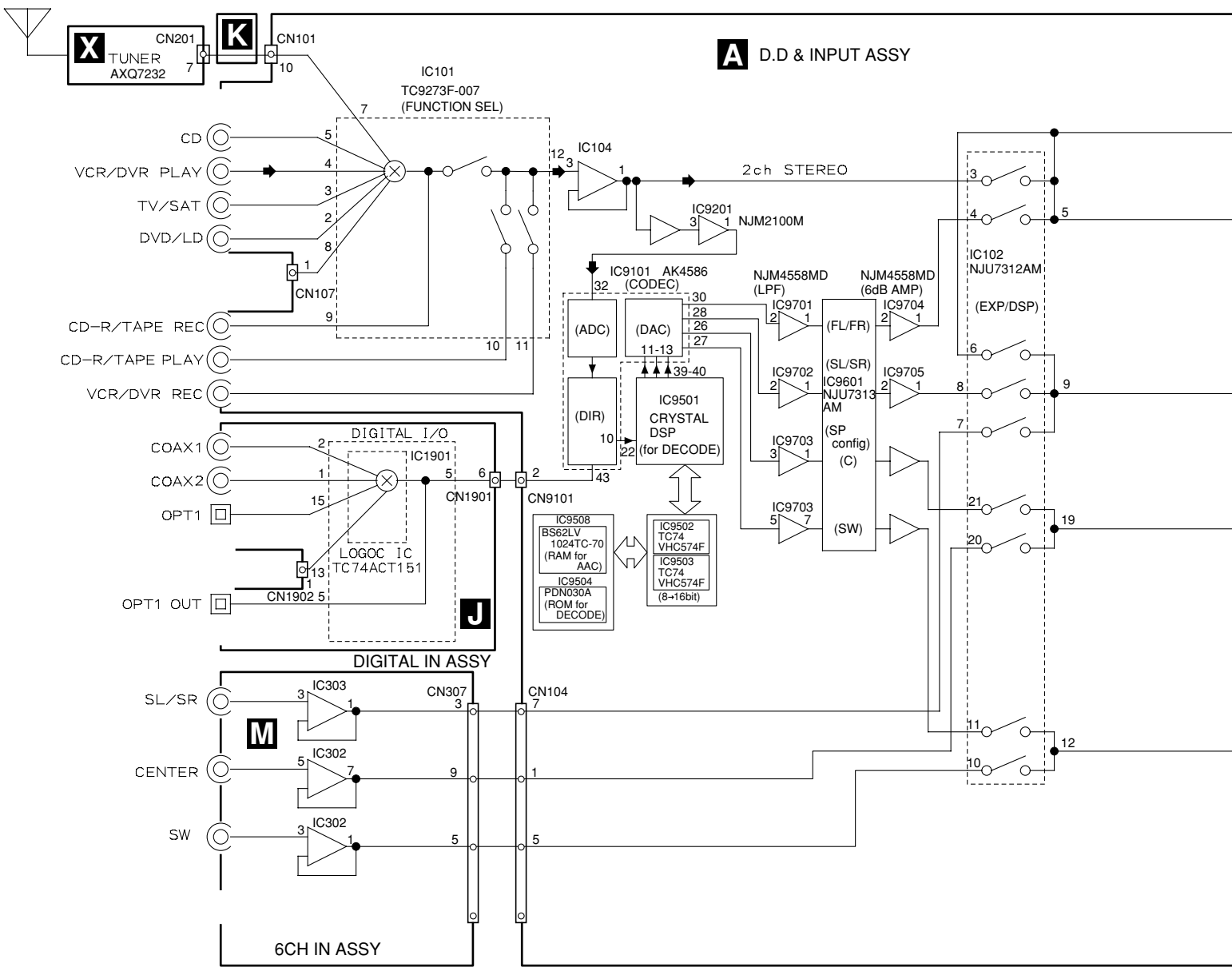

B

C

D

E

F

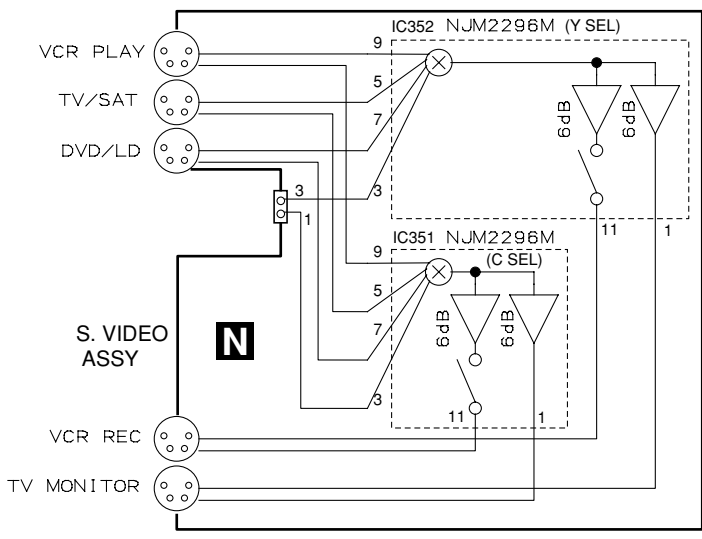

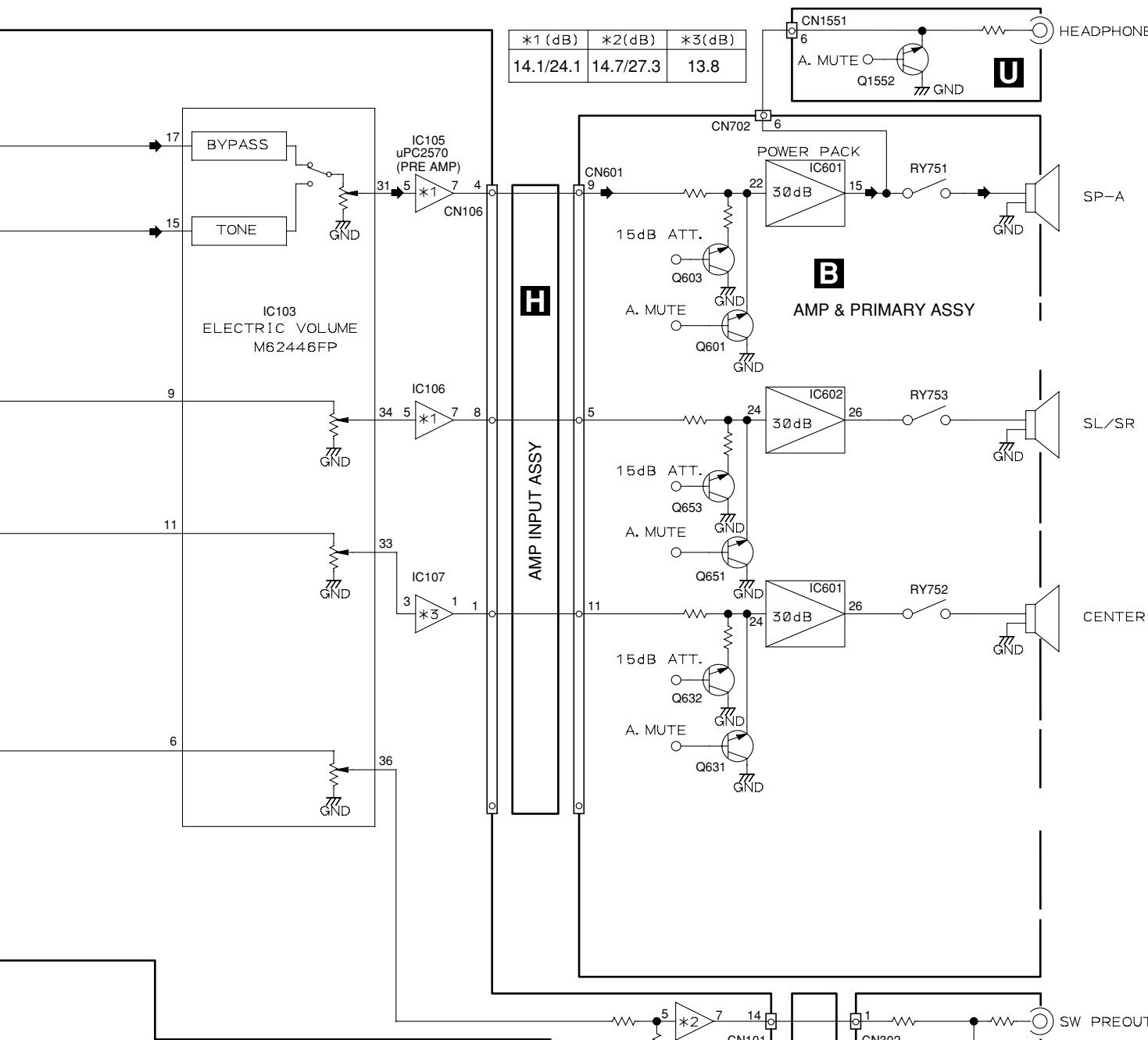

*1 (dB)	*2(dB)	*3(dB)
14.1/24.1	14.7/27.3	13.8

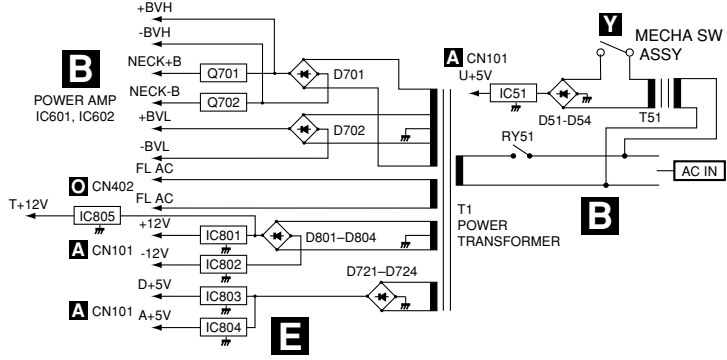
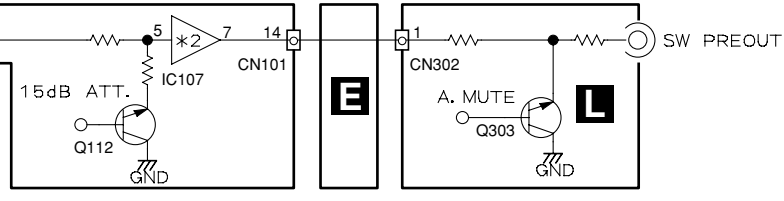
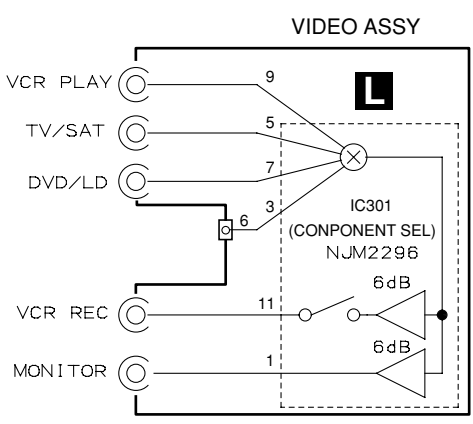

3.2 OVERALL WIRING CONNECTION DIAGRAM

A

B

C

D

E

F

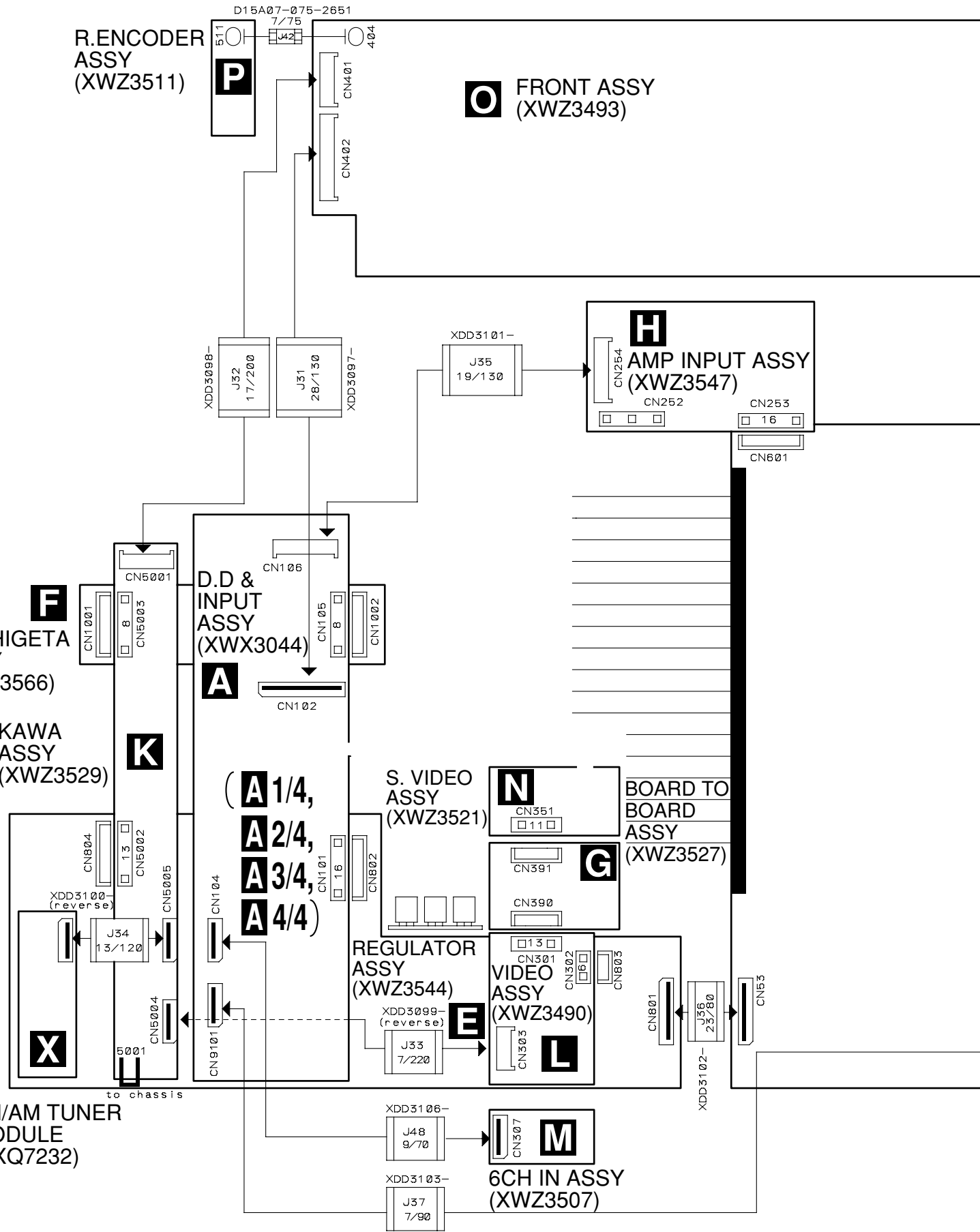

Note : When ordering service parts, be sure to refer to "EXPLODED VIEWS and PARTS LIST" or "PCB PARTS LIST".

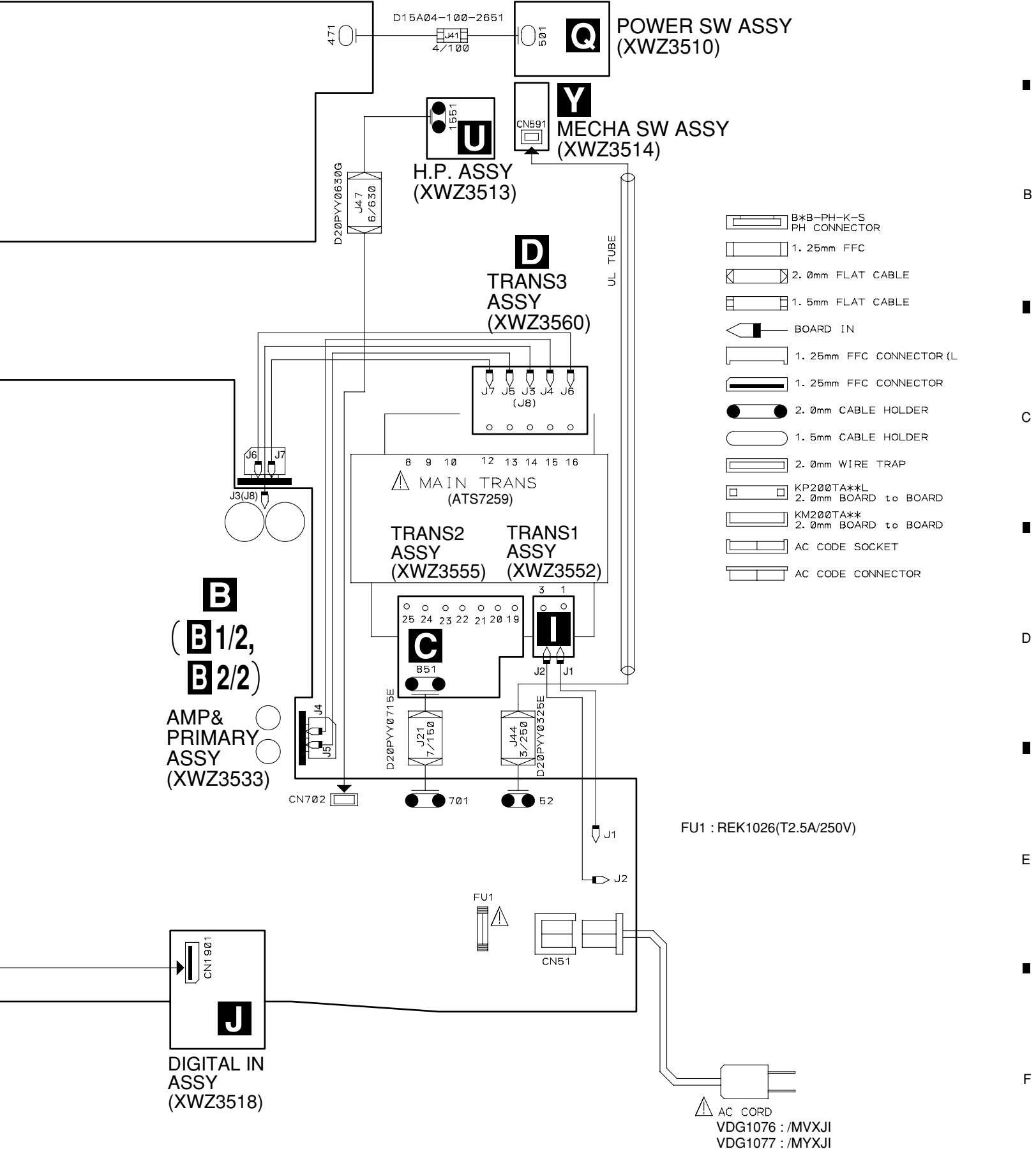

3.3 D.D & INPUT(1/4) ASSY

A 1/4 D.D & INPUT ASSY (XWX3044)

TO CODEC & PRE AMP BLOCK

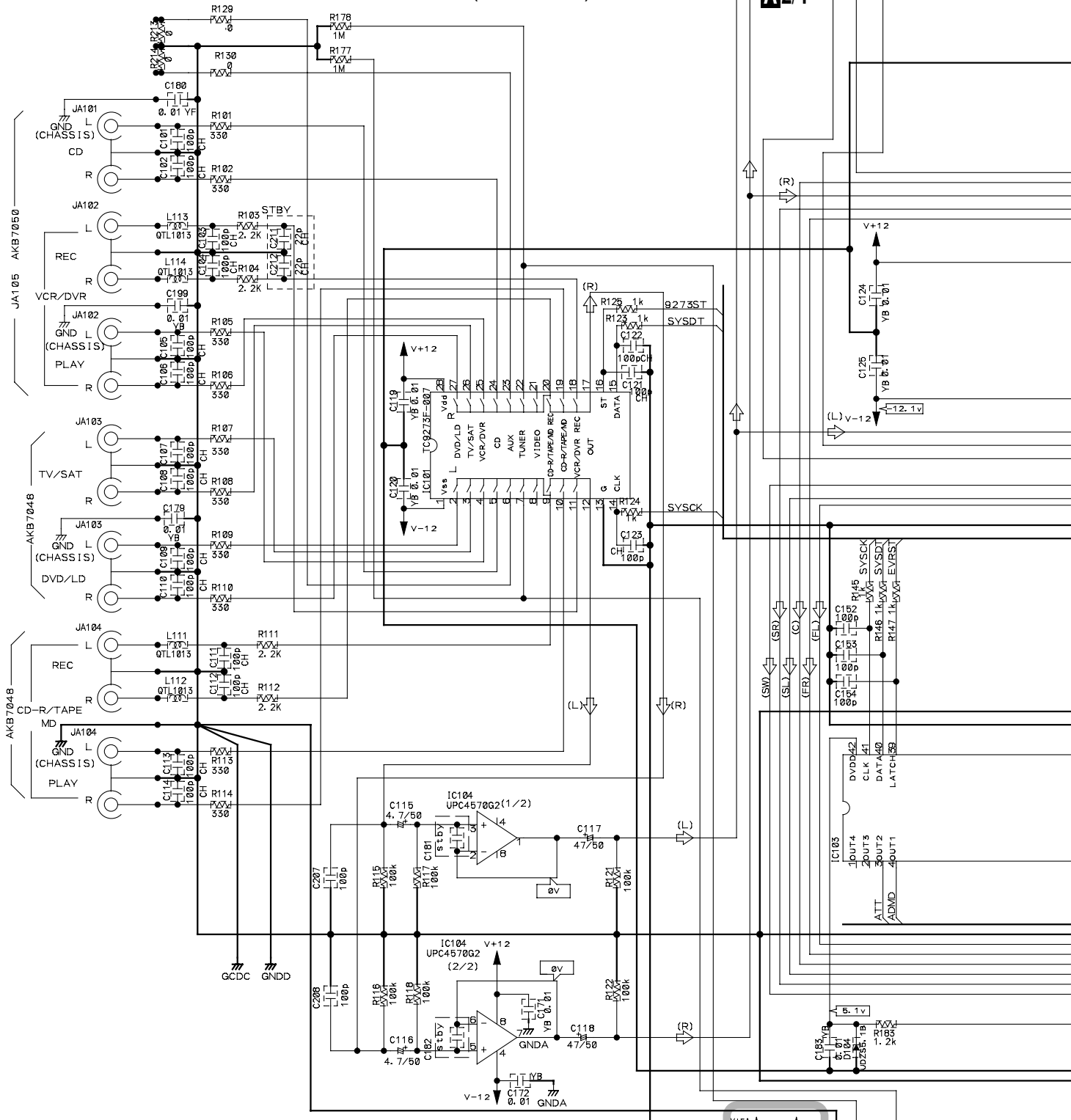

NOTES: NO INDICATED PARTS IS...
 RESISTOR: RS1/16S***J-T, RS1/10S***J-T
 CEMICAL CAPASITOR: CEAT***M**T, -TS
 CERAMIC CAPASITOR: CCSRCH***50-T
 CKSRYB***50-T
 (SQ): CKSQ, CCSQ

↻ : AUDIO SIGNAL FLOW

TO REG. ASSY

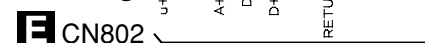

A 1/4

VSX-D511-K

3.4 D.D & INPUT(2/4) ASSY

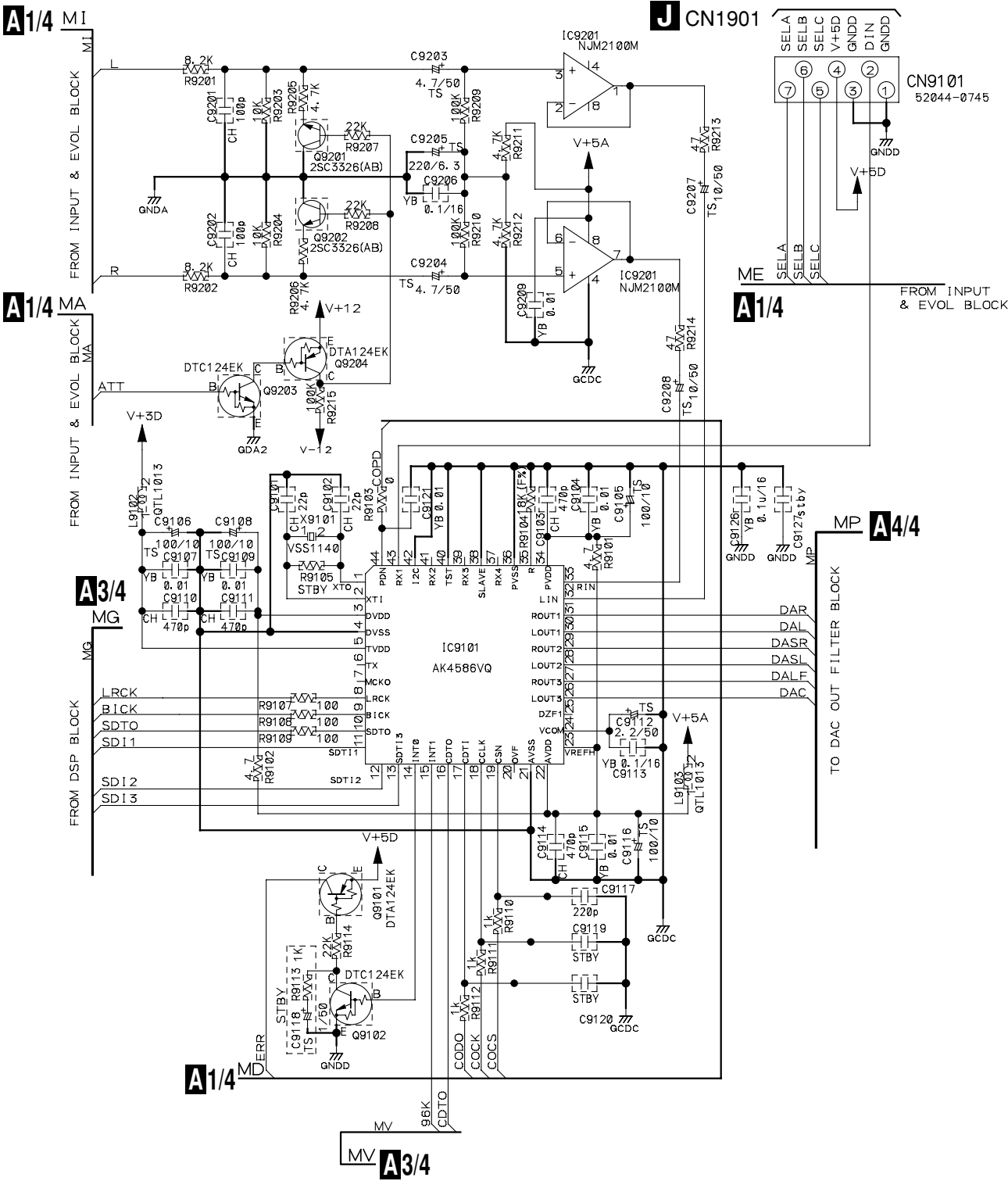

A 2/4 D.D & INPUT ASSY (XWX3044)

A 2/4

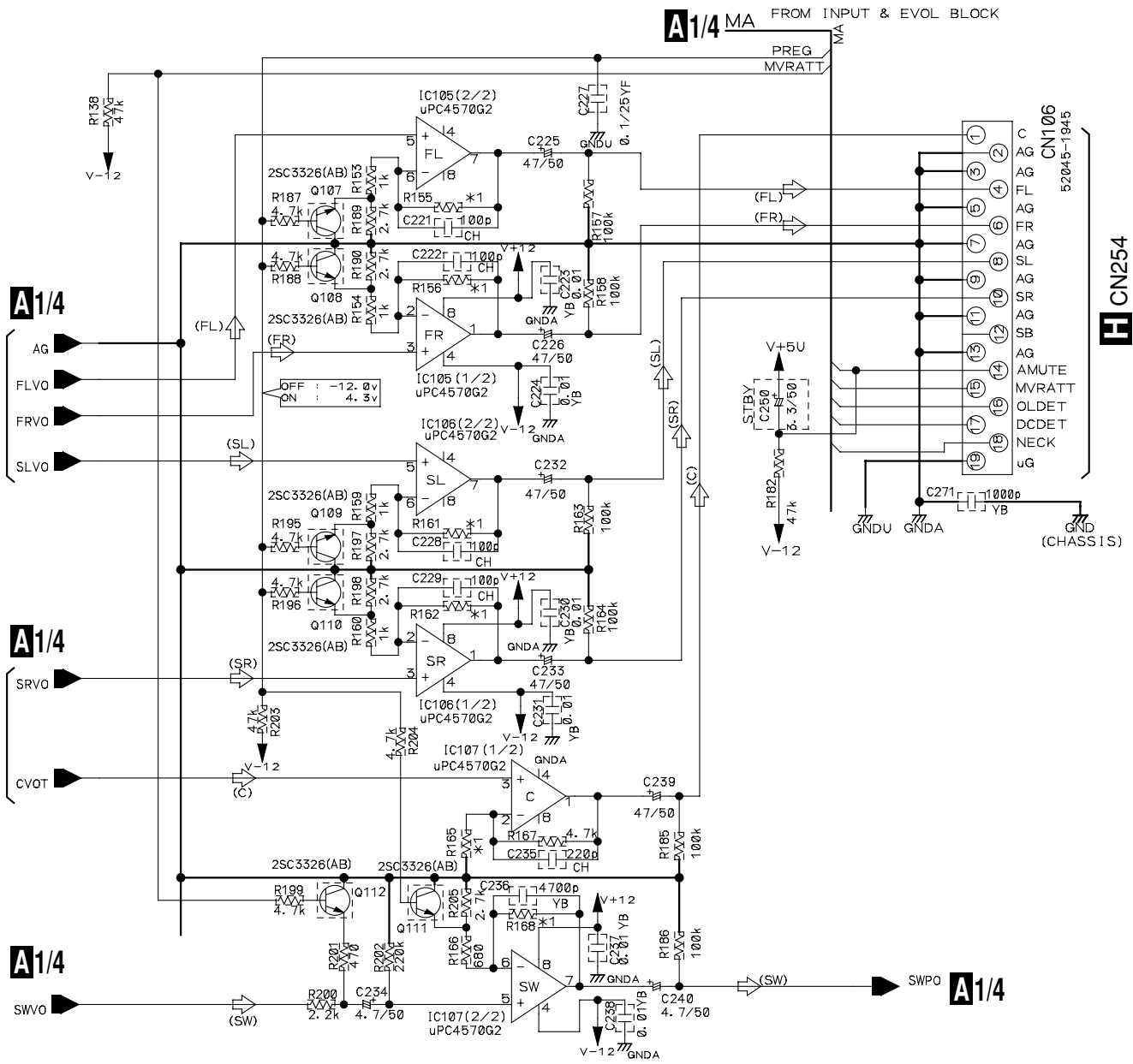

*1	FRONT, SURROUND		SW		CENTER, SB	
	R155 R156 R161 R162 (Ω)	GAIN (dB)	R168 (Ω)	GAIN (dB)	R165 (Ω)	GAIN (dB)
	15k	14. 1/24. 1	15k	14. 7/27. 3	1. 2k	13. 8

3.5 D.D & INPUT(3/4) ASSY

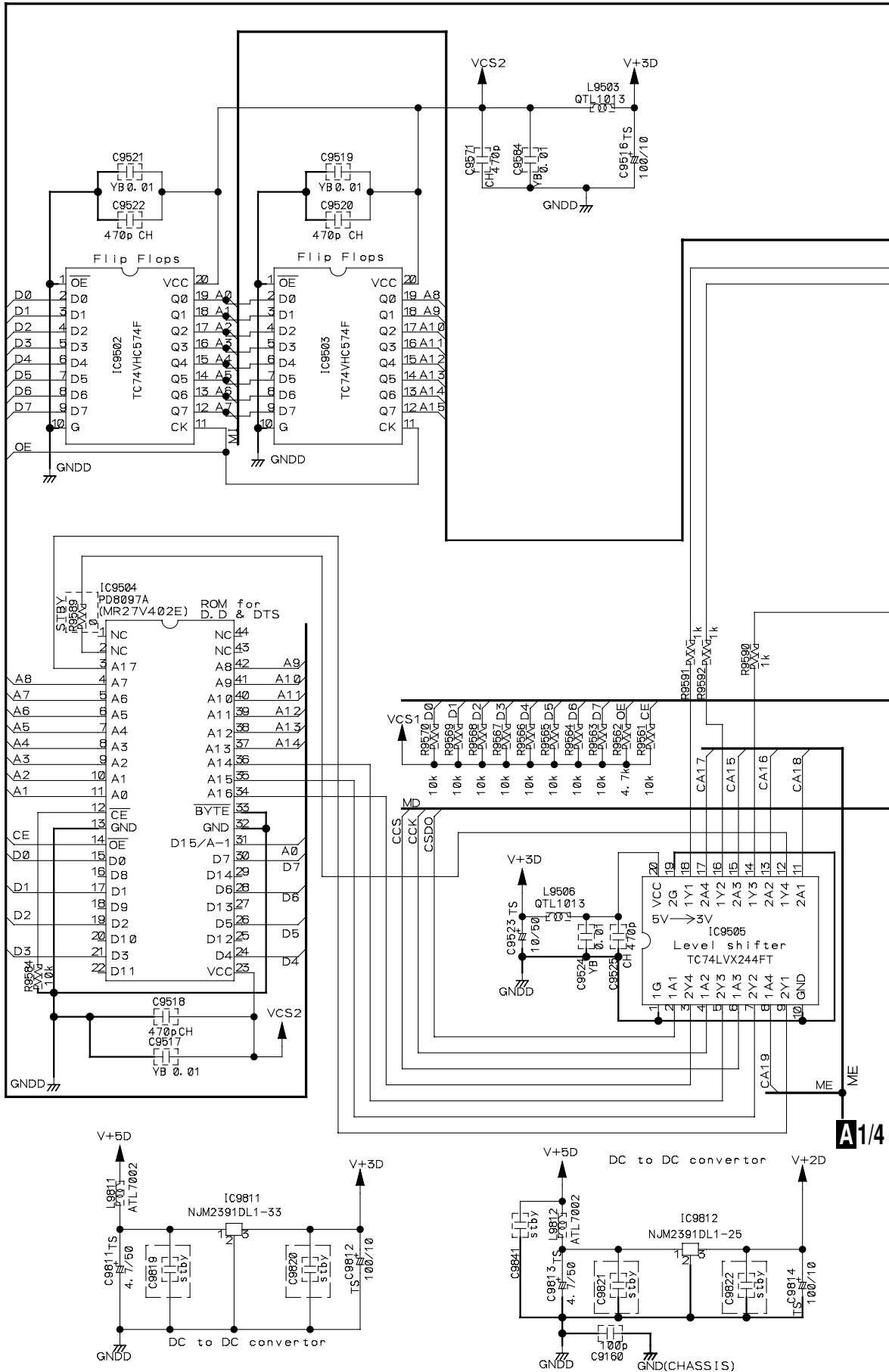

A/3/4

VSX-D511-K

Main DSP 1 decodes D.D and DTS signals.

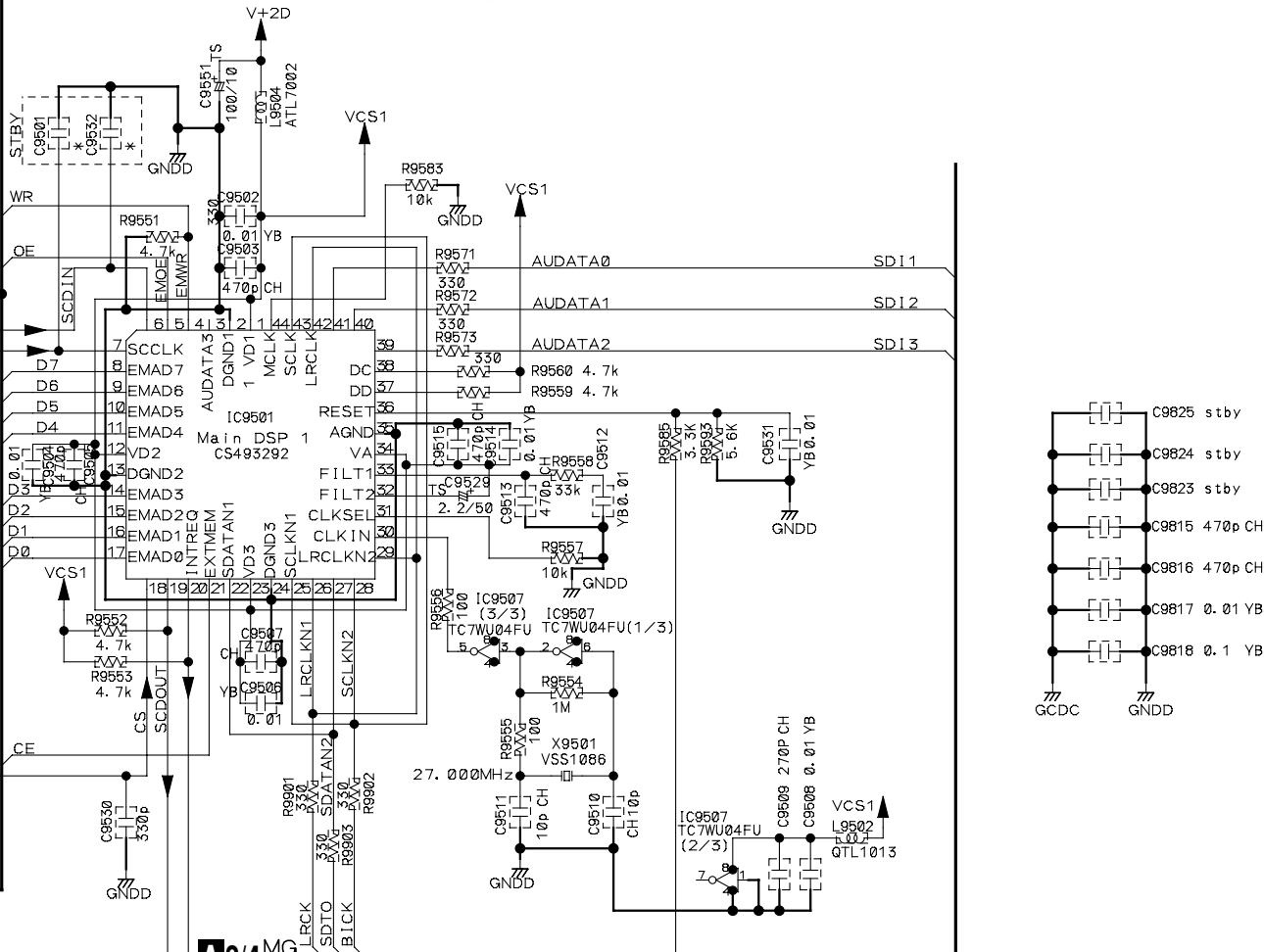

A2/4 MG

TO CODEC & PRE AMP BLOCK

A1/4 MD

A3/4 D.D & INPUT ASSY (XWX3044)

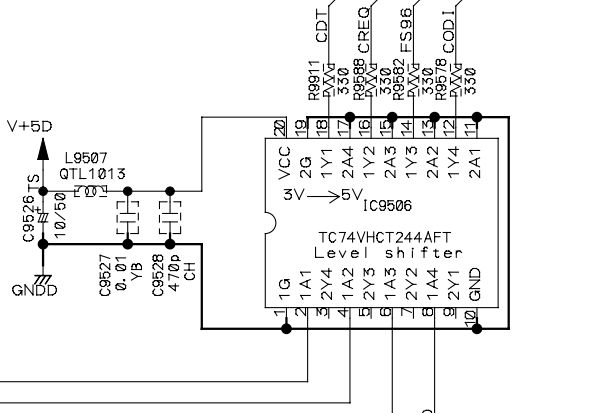

A2/4 MV

TO CODEC & PRE AMP BLOCK

A3/4

3.6 D.D & INPUT(4/4) ASSY

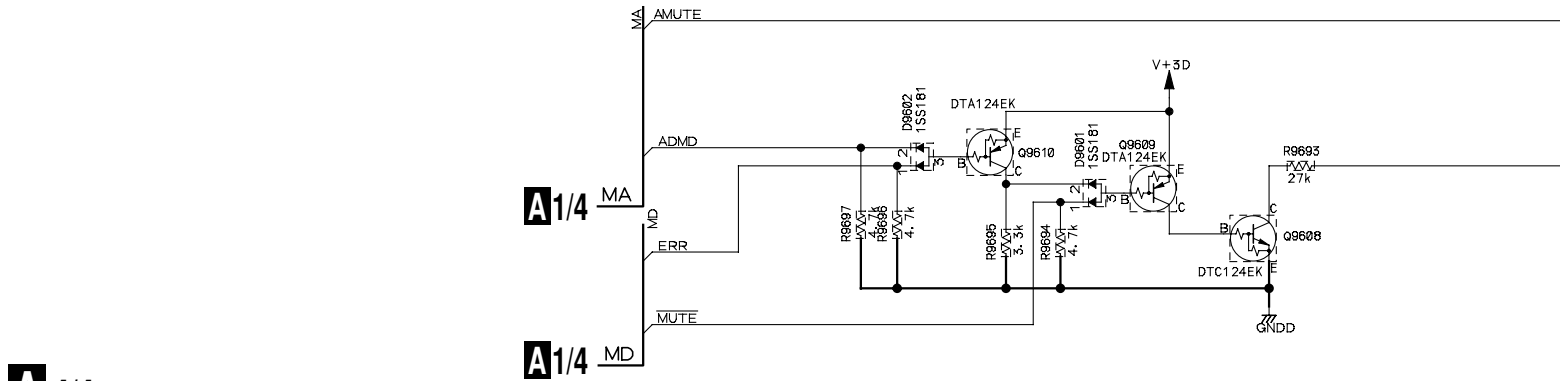
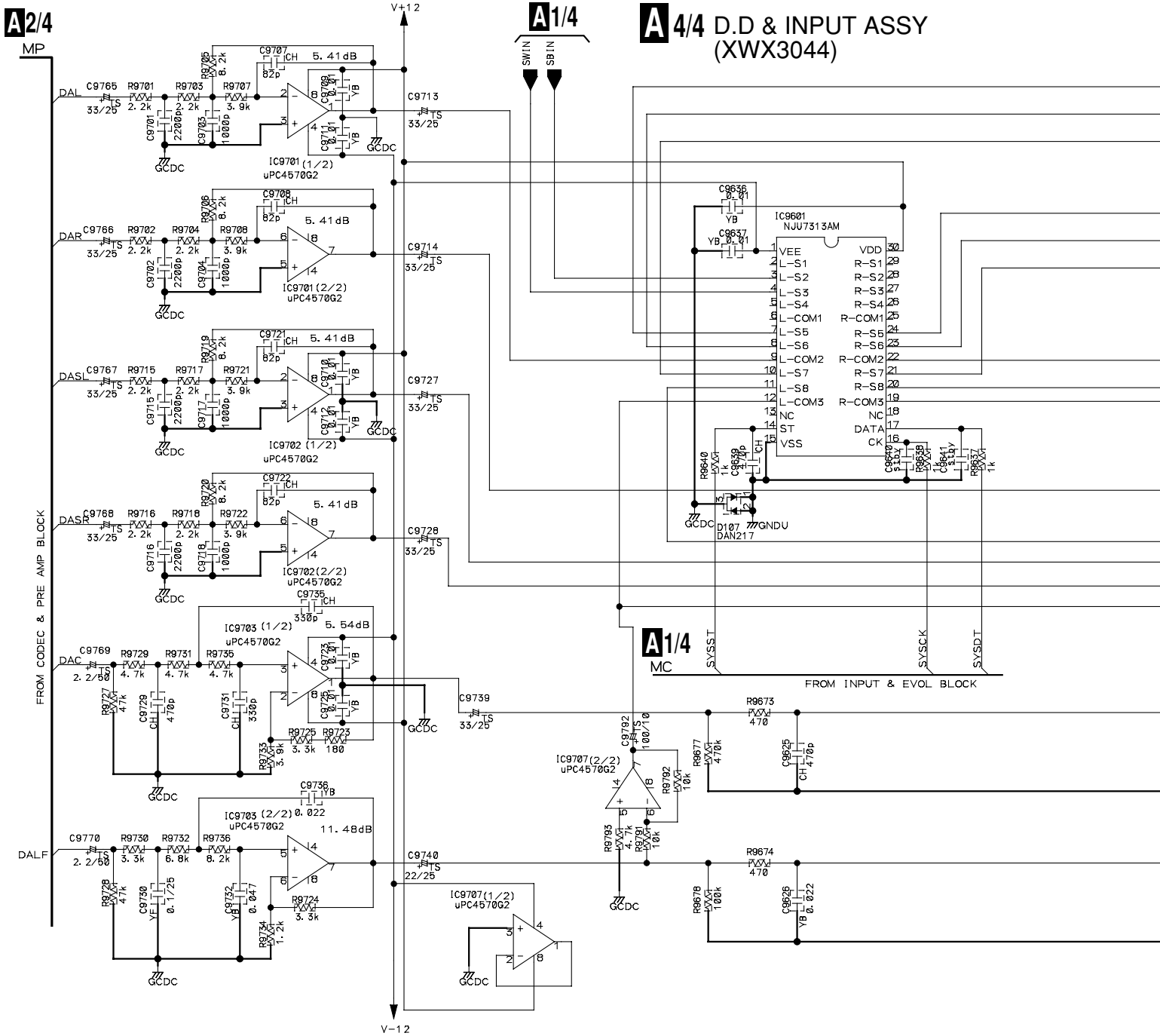

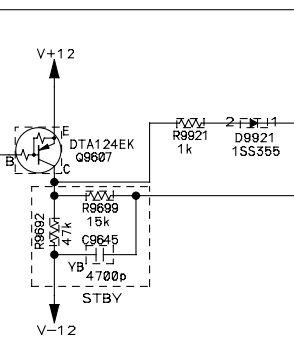
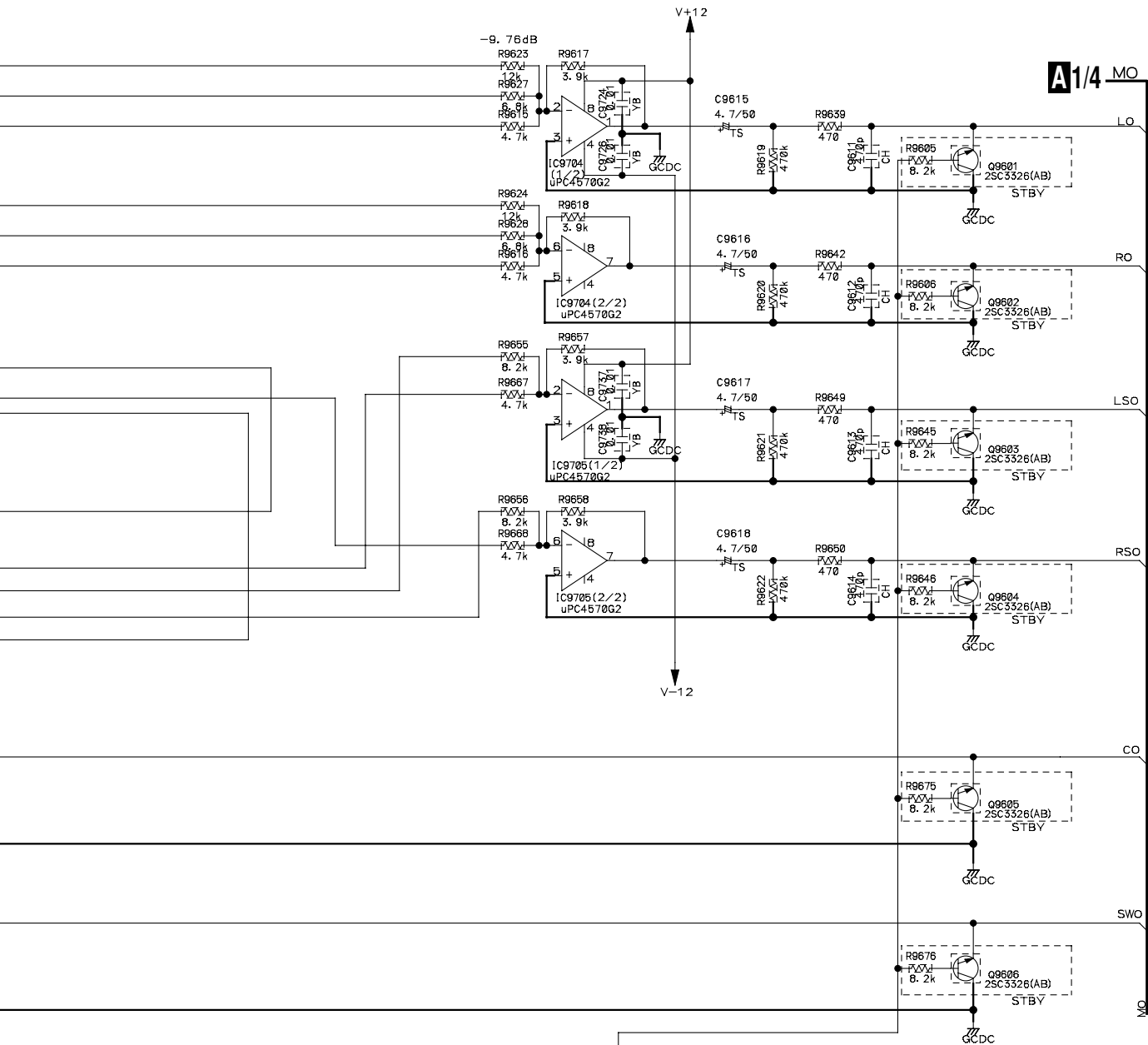

A1/4 MO

TO INPUT & EVOL BLOCK

3.7 AMP & PRIMARY(1/2), TRANS2 and TRANS3 ASSYS

A
B
C
D
E
F

B 1/2 AMP&PRIMARY ASSY (XWZ3533)

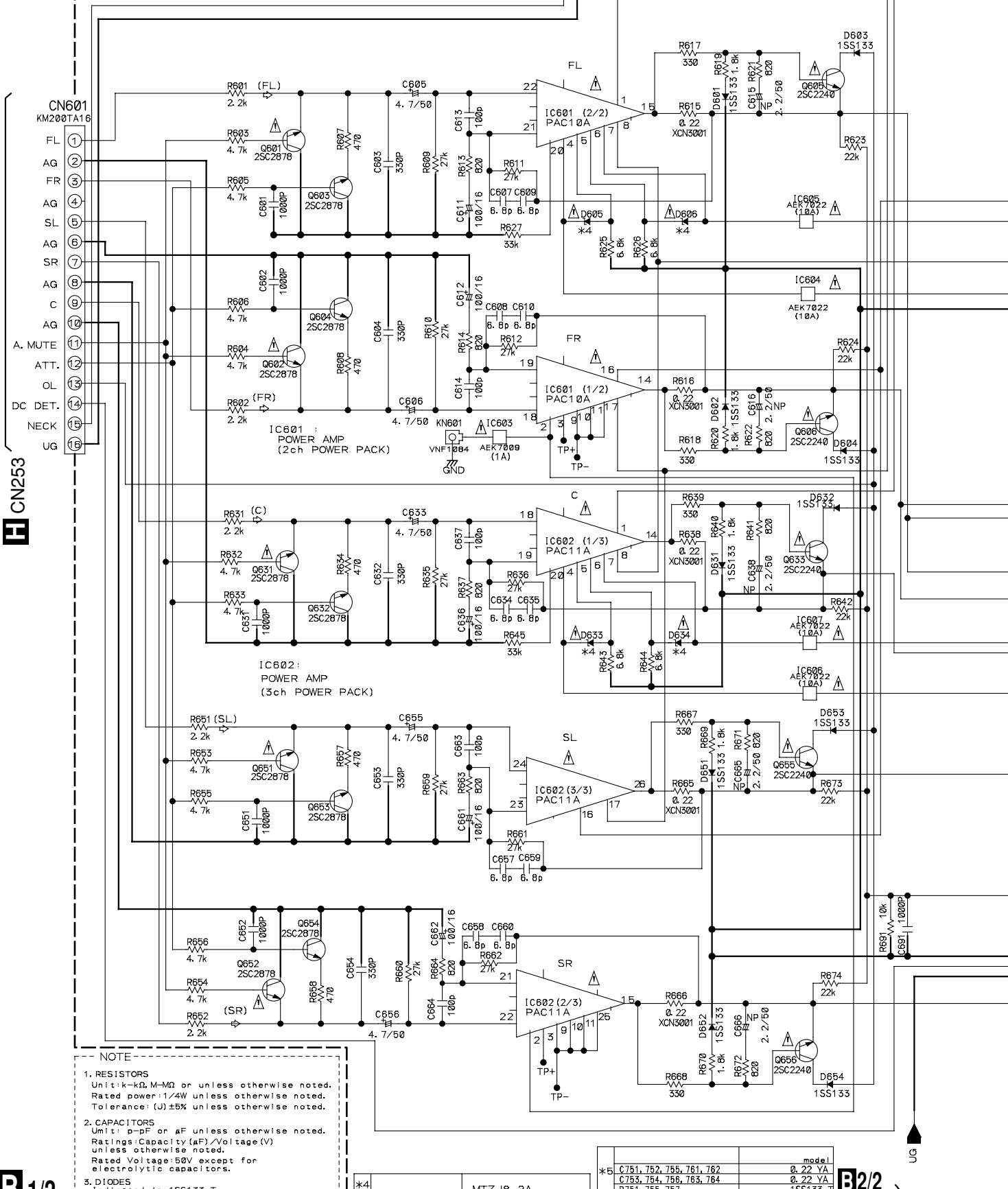

NOTE

- RESISTORS**
Unit: k-Ω, M-Ω or #F unless otherwise noted.
Rated power: 1/4W unless otherwise noted.
Tolerance: (J) ±5% unless otherwise noted.
- CAPACITORS**
Unit: p-pF or #F unless otherwise noted.
Ratings: Capacity (μF)/Voltage (V) unless otherwise noted.
Rated Voltage: 50V except for electrolytic capacitors.
- DIODES**
Indicated in 1S5133-T

*5		model
C751, 752, 755, 761, 762		0.22 YA
C753, 754, 756, 763, 764		0.22 YA
D751, 755, 757		1S5133-T

*4 MTZJB. 2A

B 1/2

B 2/2

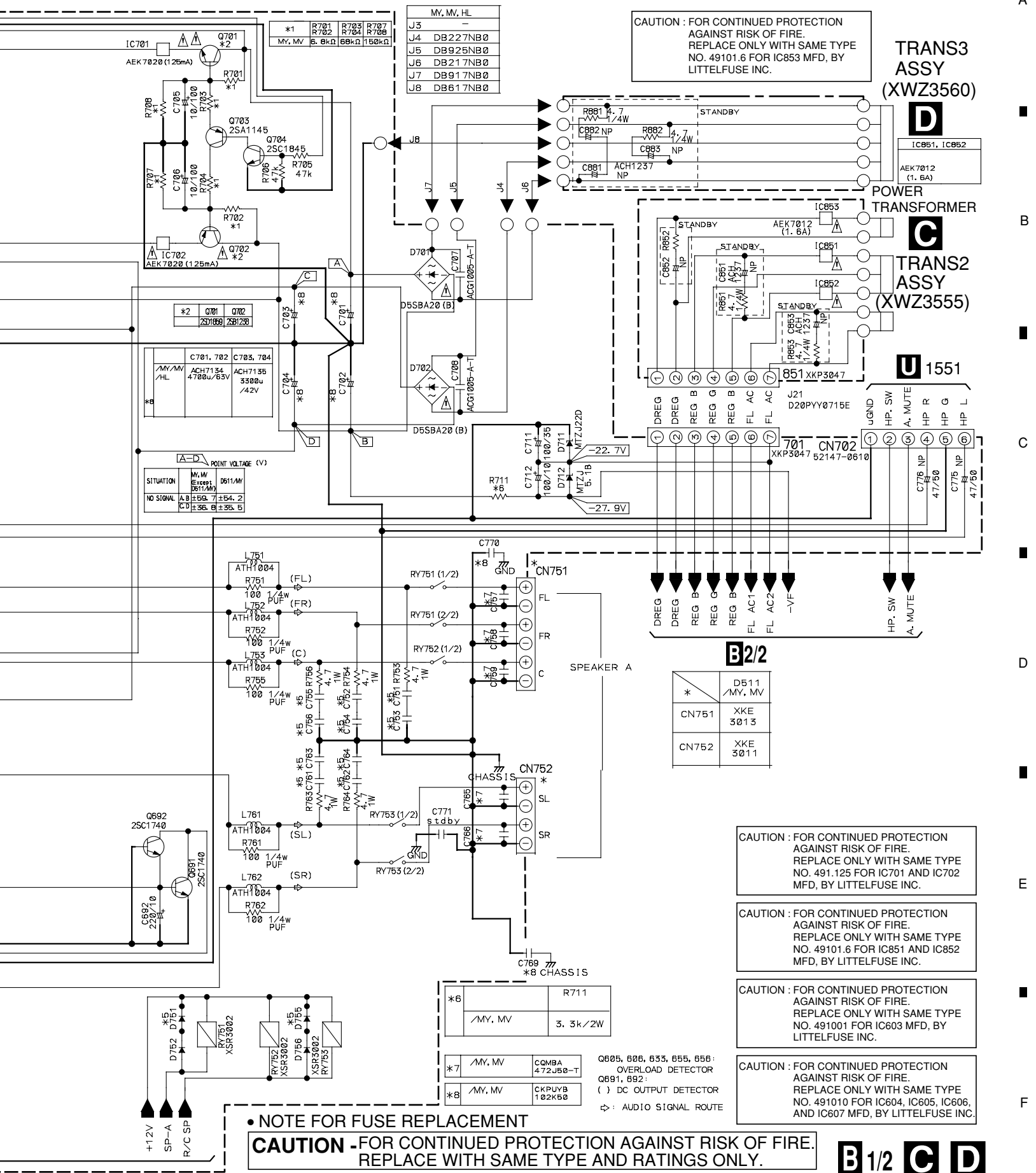

MY, MV, HL	
J3	DB227NB0
J4	DB925NB0
J6	DB217NB0
J7	DB917NB0
J8	DB617NB0

CAUTION : FOR CONTINUED PROTECTION AGAINST RISK OF FIRE. REPLACE ONLY WITH SAME TYPE NO. 49101.6 FOR IC853 MFD, BY LITTELFUSE INC.

TRANS3 ASSY (XWZ3560)

D

IC851, IC852
AEK7012 (1.6A)

POWER TRANSFORMER

C

TRANS2 ASSY (XWZ3555)

U 1551

*2	Q701	Q702
	2S1199	2S1238

C701, 702	C705, 704
ACH7134	ACH7155
4700u/65V	3300u
	/42V

A-D POINT VOLTAGE (V)			
SITUATION	M, MV	EX	D511/M
NO SIGNAL	A	B	±50.7 ±54.2
	C	D	±36.8 ±35.5

B2/2

*	D511
	/MY, MV
CN751	XKE 3013
CN752	XKE 3011

CAUTION : FOR CONTINUED PROTECTION AGAINST RISK OF FIRE. REPLACE ONLY WITH SAME TYPE NO. 491.125 FOR IC701 AND IC702 MFD, BY LITTELFUSE INC.

CAUTION : FOR CONTINUED PROTECTION AGAINST RISK OF FIRE. REPLACE ONLY WITH SAME TYPE NO. 49101.6 FOR IC851 AND IC852 MFD, BY LITTELFUSE INC.

CAUTION : FOR CONTINUED PROTECTION AGAINST RISK OF FIRE. REPLACE ONLY WITH SAME TYPE NO. 491001 FOR IC603 MFD, BY LITTELFUSE INC.

CAUTION : FOR CONTINUED PROTECTION AGAINST RISK OF FIRE. REPLACE ONLY WITH SAME TYPE NO. 491010 FOR IC604, IC605, IC606, AND IC607 MFD, BY LITTELFUSE INC.

• NOTE FOR FUSE REPLACEMENT

CAUTION - FOR CONTINUED PROTECTION AGAINST RISK OF FIRE. REPLACE WITH SAME TYPE AND RATINGS ONLY.

*6	R711
	/MY, MV
	3.3k/2W

*7	/MY, MV	CQMB
		472J50-T
*8	/MY, MV	CKPVB
		102K50

O605, 606, 635, 655, 656 :
OVERLOAD DETECTOR
O691, 692 :
() DC OUTPUT DETECTOR
⇨ : AUDIO SIGNAL ROUTE

B 1/2 C D

3.8 AMP & PRIM.(2/2), REG., HASHIGETA, B TO B and MECH SW ASSYS

HASHIGETA ASSY (XWZ3566)

F

G

BOARD TO BOARD ASSY (XWZ3527)

N CN351

K CN5003

A1/4 CN105



CN390 KM200TA13

L CN301

K CN804 KM200TA13

IC804: AD+5V REG. IC

IC804: NJM78M05FA

- ① AC WUP
- ② AC RY
- ③ FL AC1
- ④ FL AC2
- ⑤ -VF
- ⑥ SP-A RY
- ⑦ R/C RY
- ⑧ SP-B RY
- ⑨ HP. SW
- ⑩ TR
- ⑪ TG
- ⑫ TL
- ⑬ T+12V

A1/4 CN101

- ① U+5V
- ② UG
- ③ AD+5V
- ④ DAG
- ⑤ D+5V
- ⑥ DG
- ⑦ RETURN
- ⑧ TR
- ⑨ TG
- ⑩ TL
- ⑪ -12V
- ⑫ ADG
- ⑬ +12V
- ⑭ SWOUT
- ⑮ AG
- ⑯ AG

L CN802 KM200TA16

CN803 KM200TA6

- ① SWOUT
- ② AG
- ③ UG
- ④ +12V
- ⑤ ADG
- ⑥ -12V

E REGULATOR ASSY (XWZ3544)

IC803: D+5V REG. IC

IC803: NJM78M05FA

R801 stdby

IC801: +12V REG. IC

IC802: -12V REG. IC

IC805: T. +12V REG. IC

B2/2 AMP & PRIMARY ASSY (XWZ3533)

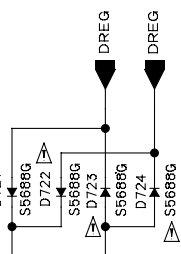

- ① DREG
- ② DREG
- ③ REG B
- ④ REG G
- ⑤ REG B
- ⑥ FL AC1
- ⑦ FL AC2
- ⑧ -VF
- ⑨ AC WUP
- ⑩ AC RY
- ⑪ U+5V
- ⑫ UG
- ⑬ SP-A RY
- ⑭ +12V
- ⑮ SP-B RY
- ⑯ HP. SW
- ⑰ R/C RY

B1/2 CN53 52045-2345

B2/2 E F G

CN801 52045-2345

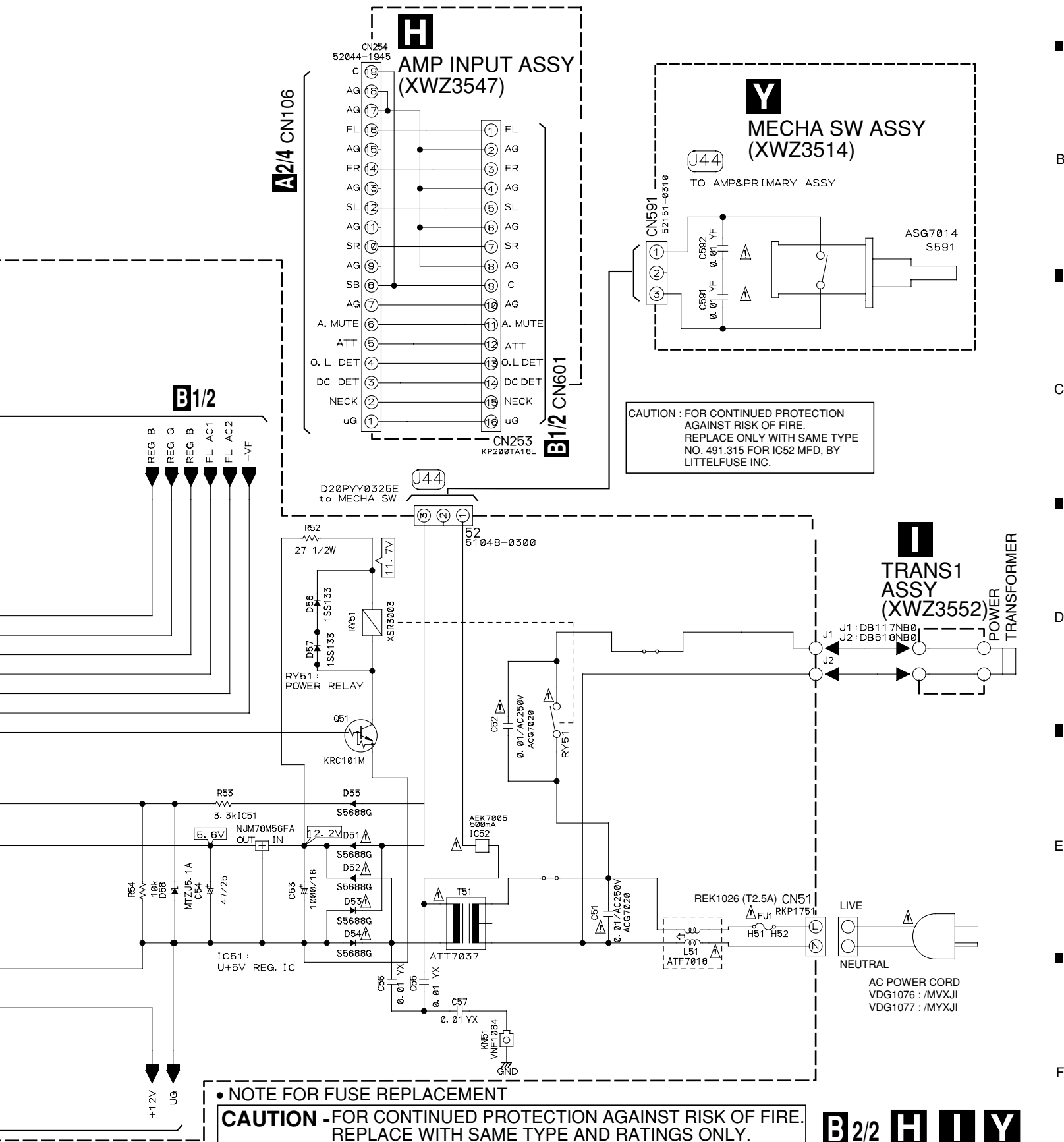

3.9 VIDEO, 6CH IN and S.VIDEO ASSYS

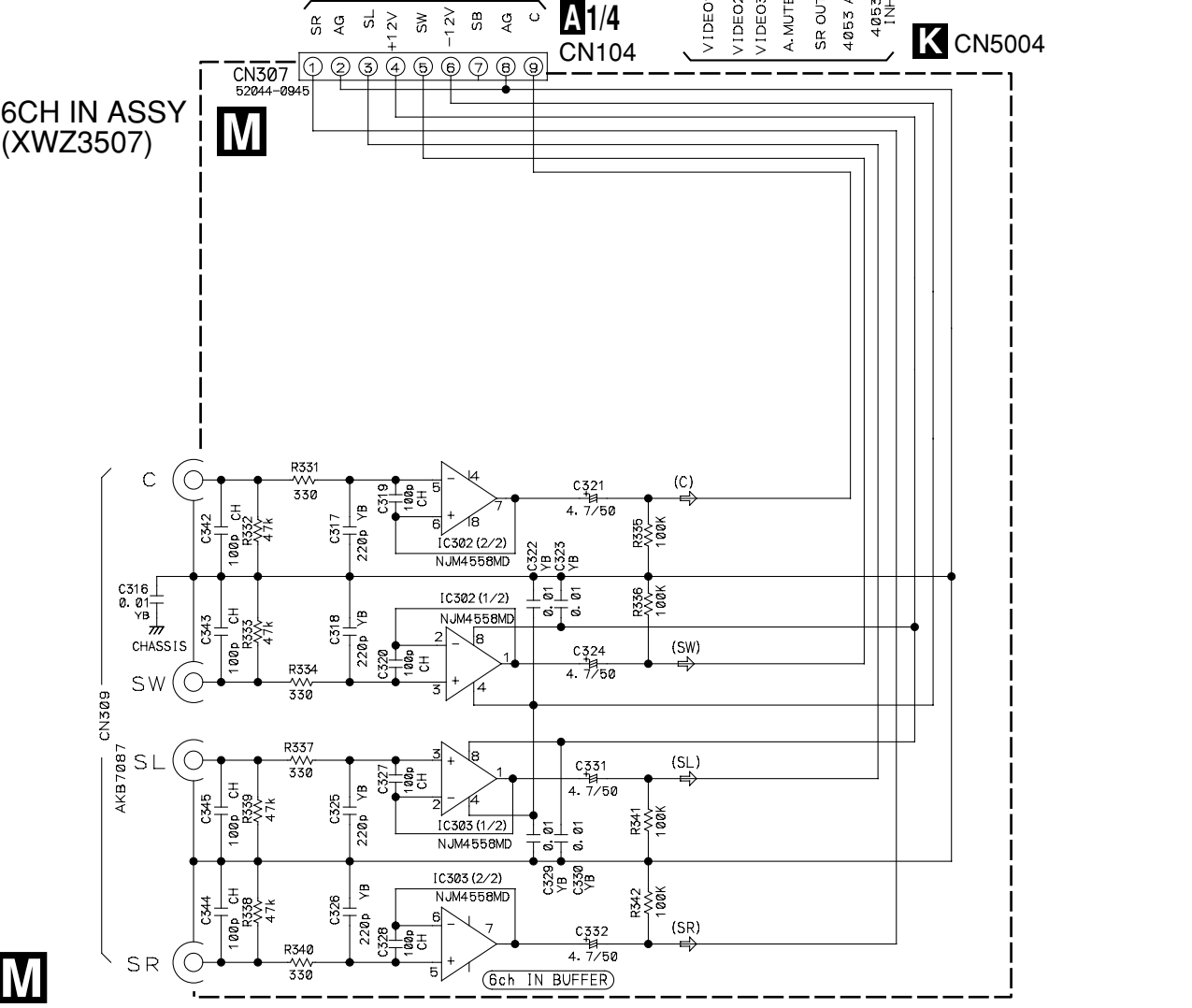
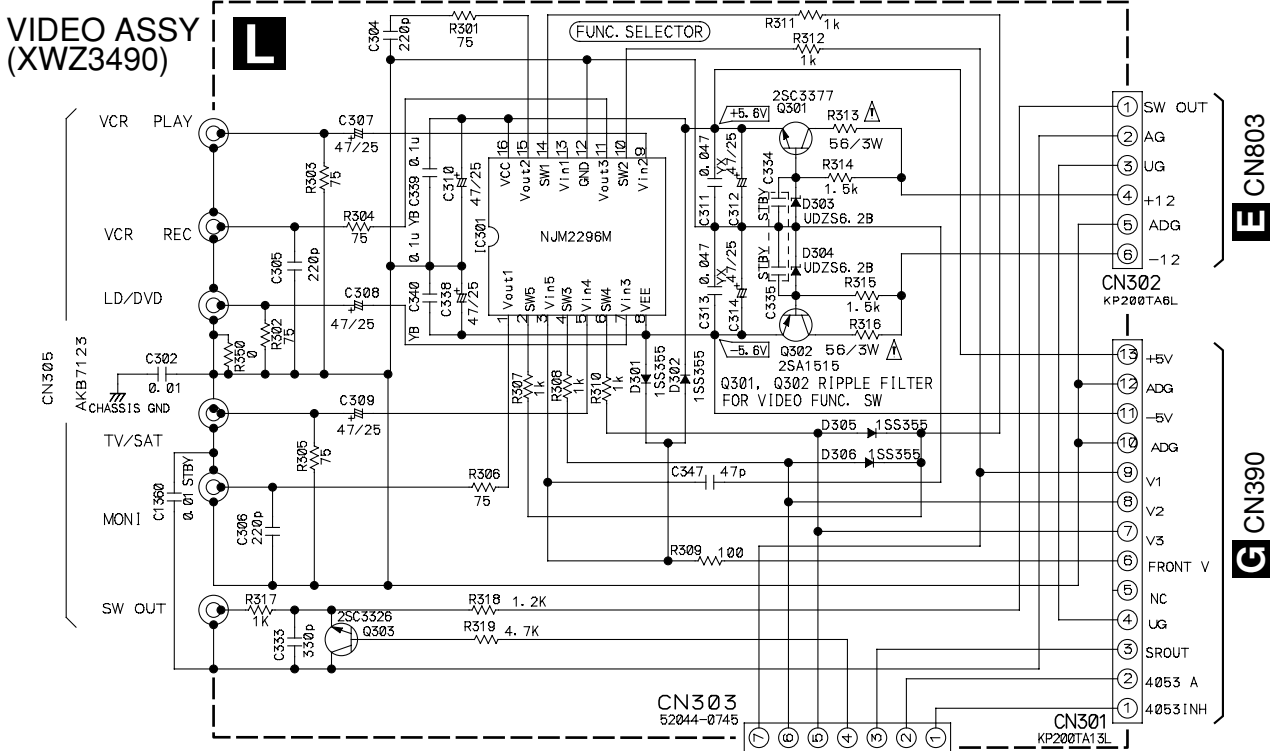

NOTE

- RESISTORS
Unit: k- Ω , M- Ω or Ω unless otherwise noted.
Rated power: 1/10W unless otherwise noted.
Tolerance: (J) \pm 5% unless otherwise noted.
- CAPACITORS
Unit: p-pF or μ F unless otherwise noted.
Ratings: Capacity(μ F)/Voltage (V) unless otherwise noted.
Rated Voltage: 50V except for electrolytic capacitors.
- DIODES
Indicated in 1SS355-TRB

NJM2296D control port status

SW1	SW2	SW3	SW4	SW5	Vout1	Vout2	Vout3	
1	0	(1)	0	1	Vin2	Vin2	mute	VIN 2. VCR
1	1	(1)	0	1	Vin3	Vin3	Vin3	VIN 3. DVD/LD
1	1	0	1	1	Vin4	Vin4	Vin4	VIN 4. TV/SAT
1	1	1	1	1	Vin5	Vin5	Vin5	VIN 5. FRONT
0	0	(0)	(0)	0	mute	mute	mute	Vout1. MON out
								Vout2. MR out
								Vout3. VCR out

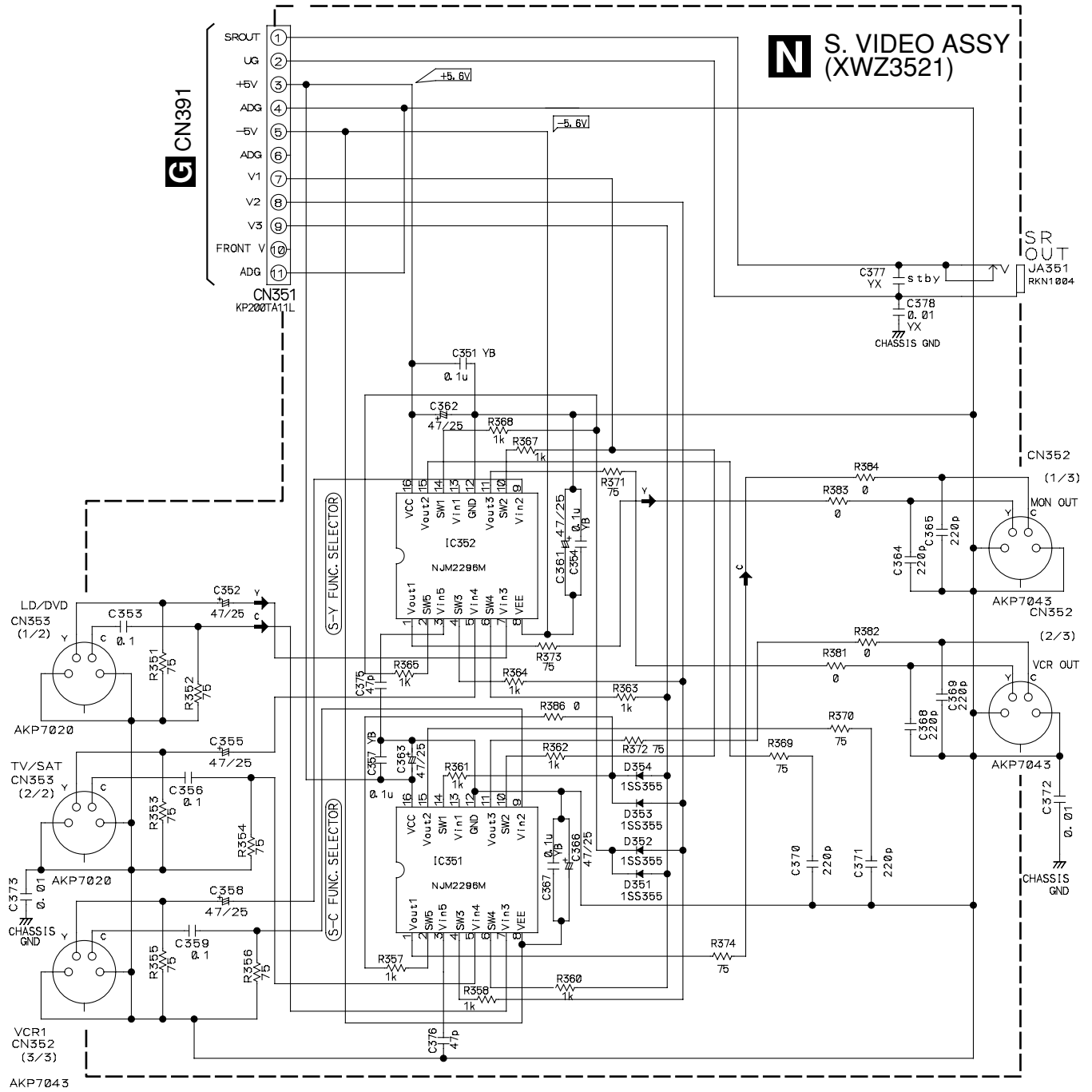

→ VIDEO SIGNAL FLOW
⇨ AUDIO SIGNAL FLOW



3.10 FRONT, R.ENCODER and POWER SW ASSYS

A
B
C
D
E
F

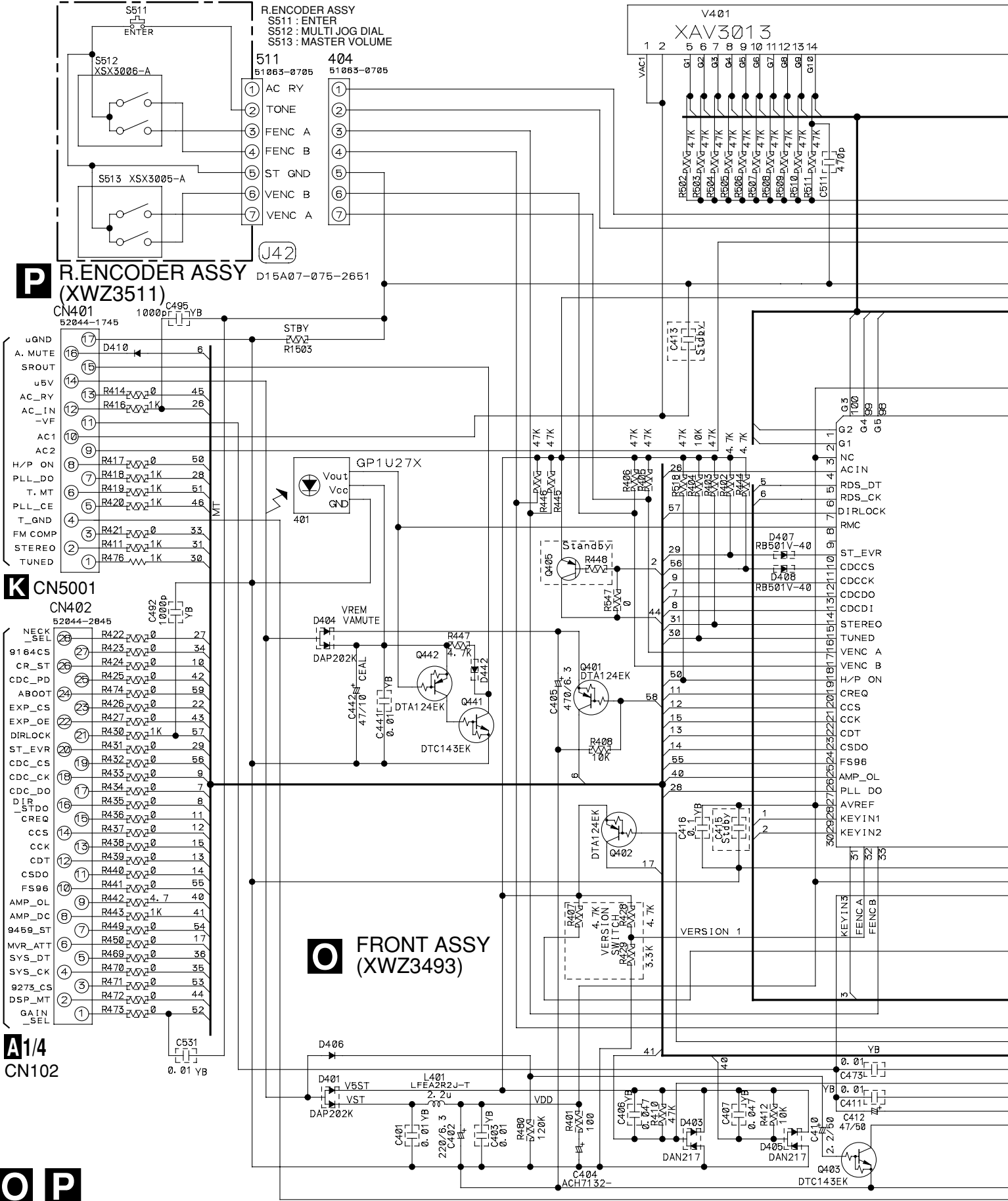

(402 FL HOLDER VNF1096-)

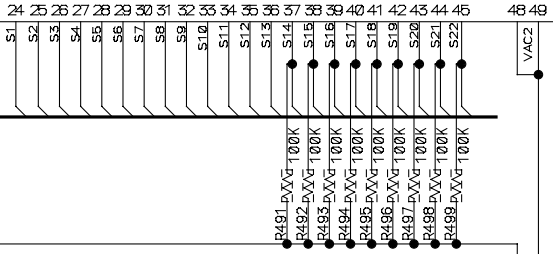

- NOTE**
- RESISTORS**
Unit: k- Ω , M-M Ω or Ω unless otherwise noted.
Rated power: 1/10W unless otherwise noted.
Tolerance: (J) $\pm 5\%$ unless otherwise noted.
 - CAPACITORS**
Unit: p-pF or μ F unless otherwise noted.
Ratings: Capacity (μ F)/Voltage (V) unless otherwise noted.
Rated Voltage: 50V except for electrolytic capacitors.
JA: CEJA
 - DIODES**
Indicated in 1SS355-TBR.
 - TACT SWITCHES**
Indicated in ASG1051.

POWER SW ASSY (XWZ3510)

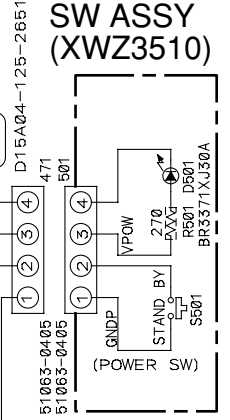

POWER SW ASSY
S501 : POWER STANDBY/ON

- FRONT ASSY**
- S451 : SIGNAL SELECT
 - S452 : MONITOR
 - S453 : MIDNIGHT
 - S454 : LOUDNESS
 - S455 : TONE
 - S456 : SETUP
 - S457 : ADVANCED SURR
 - S458 : DIRECT
 - S459 : EON MODE
 - S460 : PTY SEARCH
 - S461 : MPX
 - S462 : BAND
 - S463 : STANDARD
 - S464 : TUNING(+)
 - S465 : TUNING(-)
 - S466 : STATION(+)
 - S467 : STATION(-)
 - S468 : MULTI JOG (TUNER EDIT)
 - S476 : CLASS

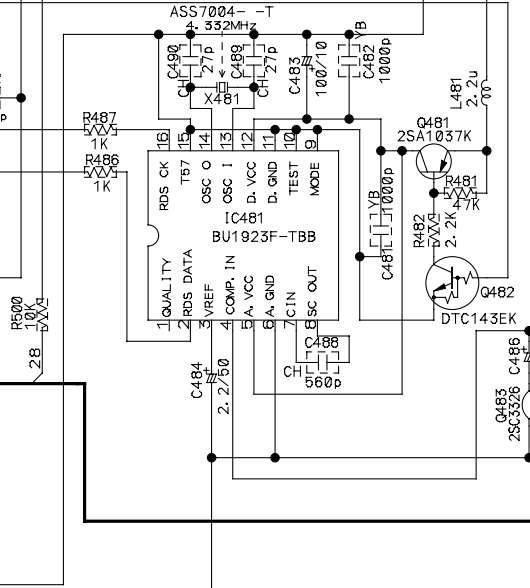
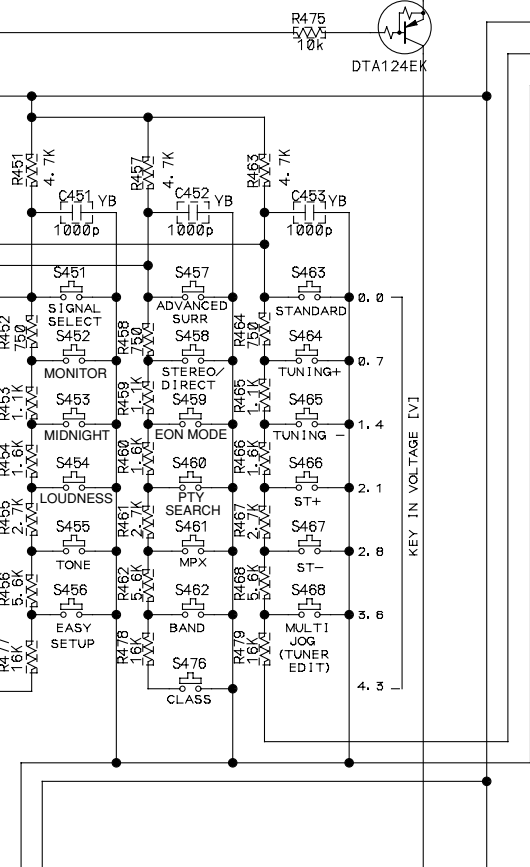
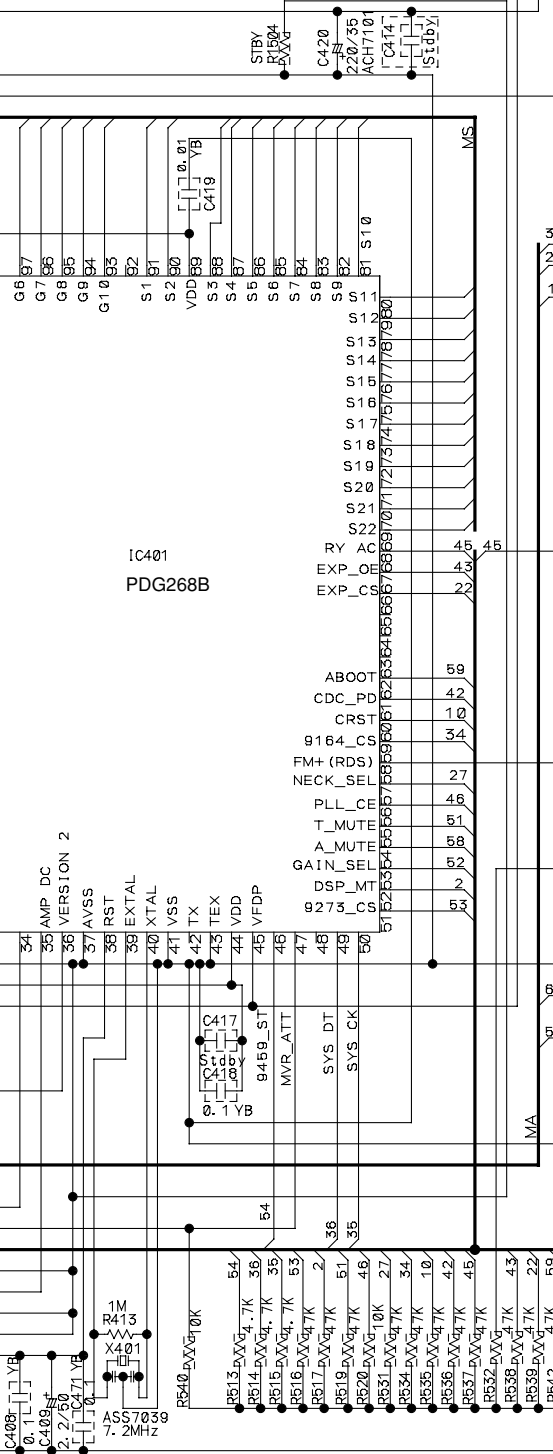

VSX-D511-K

3.11 DIGITAL IN, H.P. and KAWA ASSYS

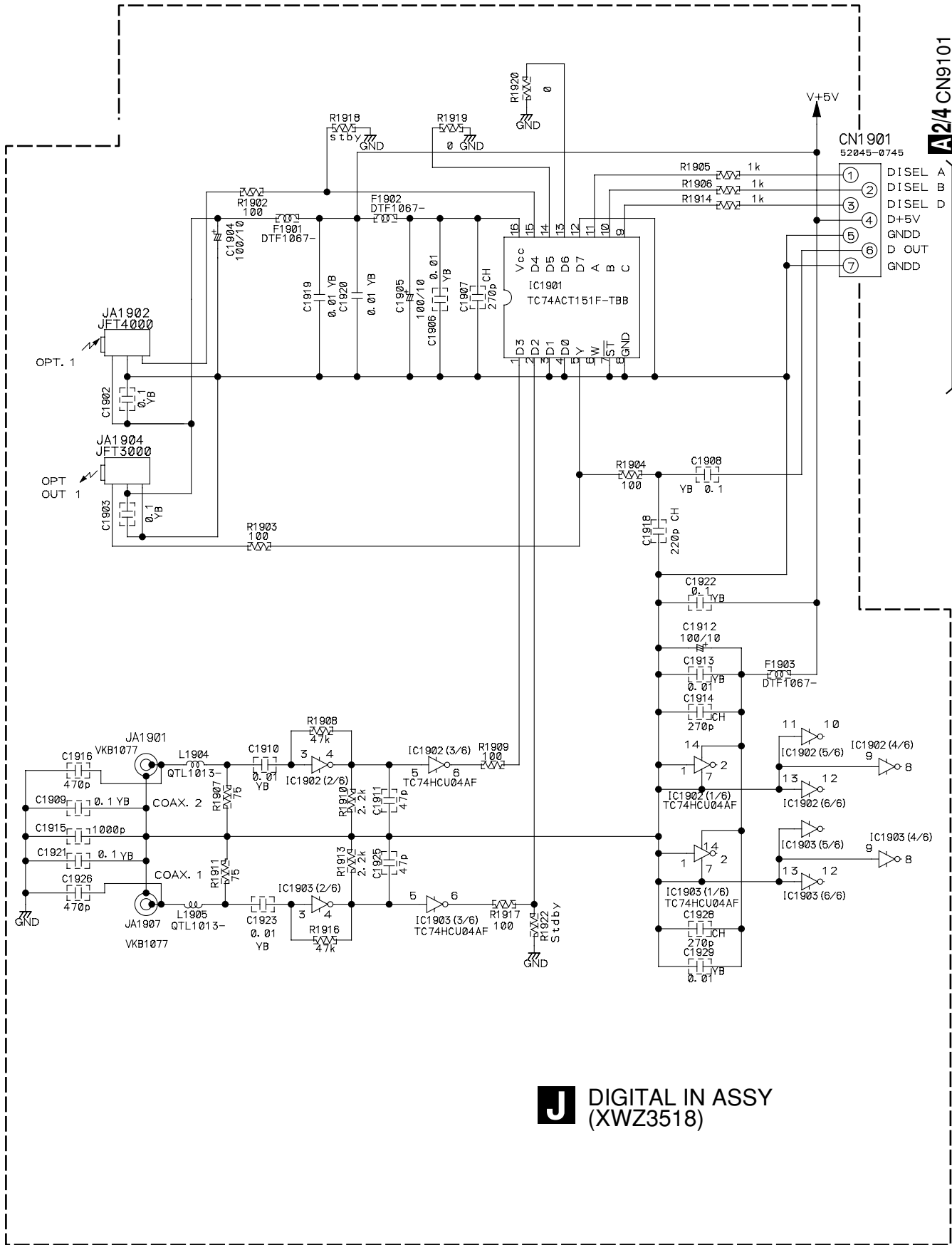

J DIGITAL IN ASSY (XWZ3518)

3.12 FM/AM TUNER MODULE

X FM/AM TUNER MODULE (AXQ7232)

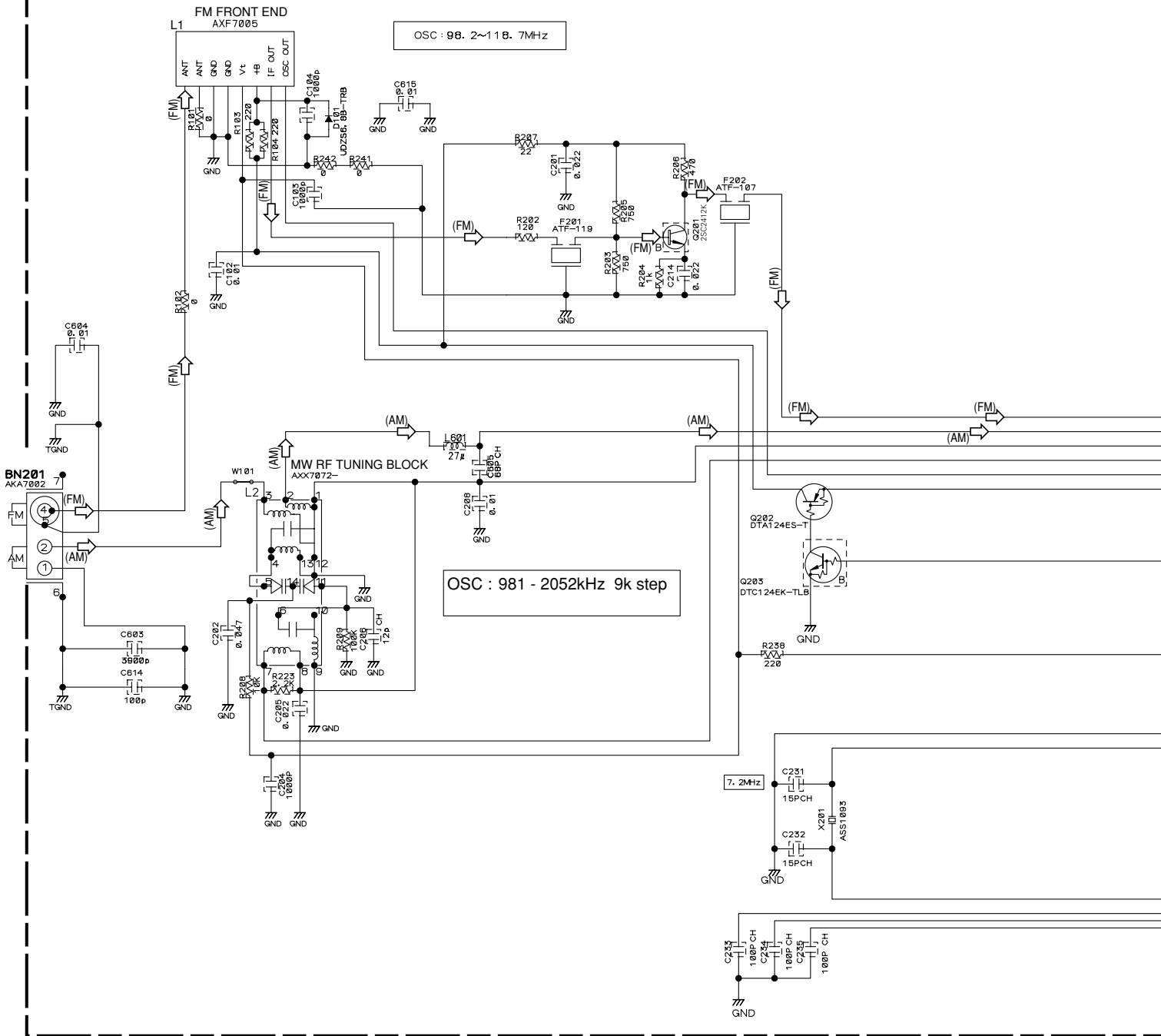

Notes

1. RESISTORS

Indicated in Ω, 1/16W±5% Tolerance unless otherwise noted K:KΩ, M:MΩ.



2. CAPACITORS

Indicated in Capacity (μF)/VOLTAGE (V) unless otherwise noted P:PF.

3. DIODES

No mark diode is 1S5133.

 : The power supply is shown with the marked box.



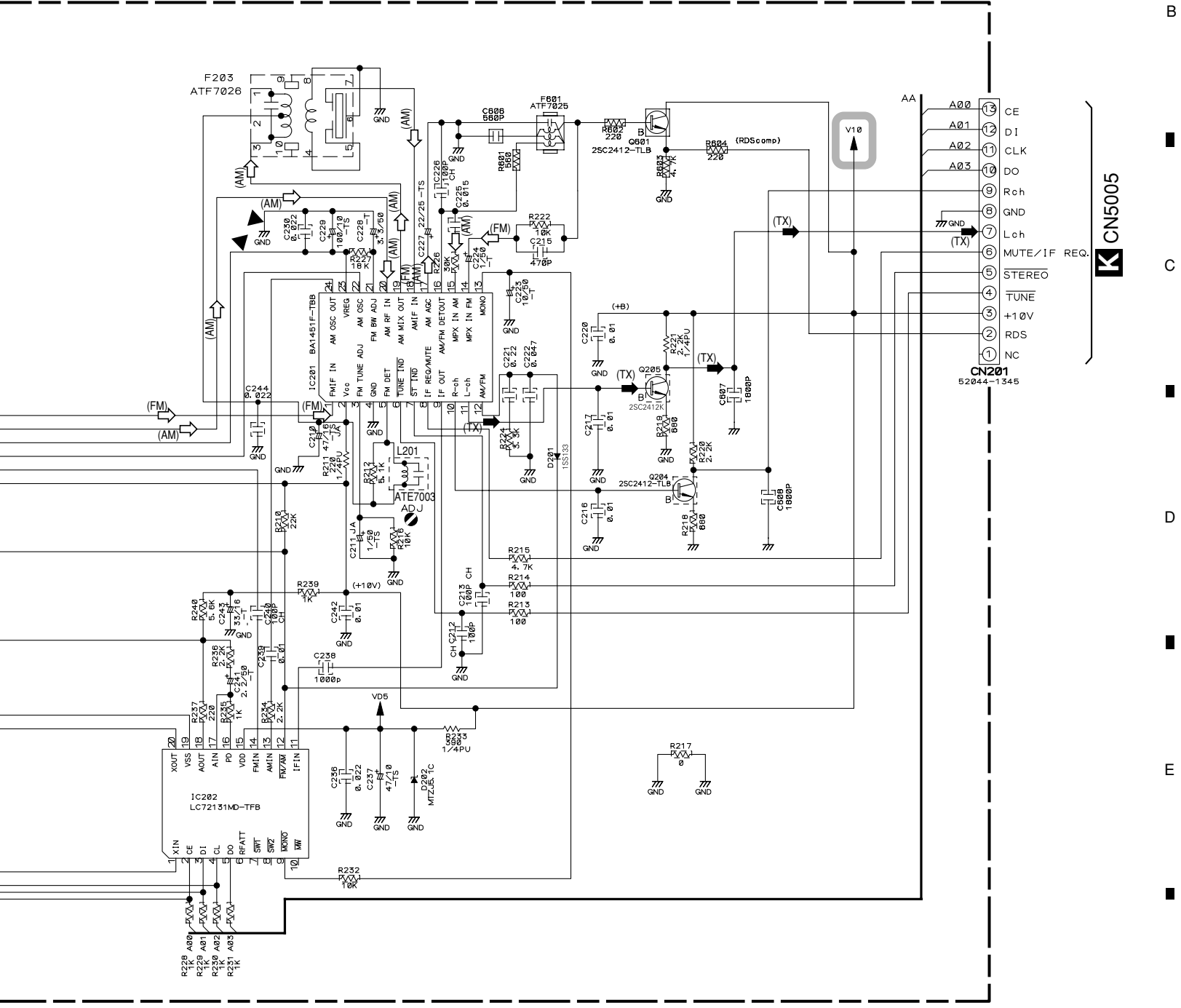



(TX)  : AUDIO SIGNAL ROUTE (TUNER)
(AM)  : AM SIGNAL ROUTE
(FM)  : FM SIGNAL ROUTE

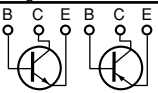

4. PCB CONNECTION DIAGRAM

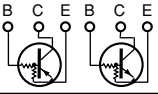
NOTE FOR PCB DIAGRAMS :

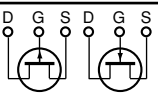
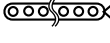
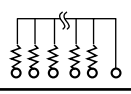
1. Part numbers in PCB diagrams match those in the schematic diagrams.
2. A comparison between the main parts of PCB and schematic diagrams is shown below.

Symbol In PCB Diagrams	Symbol In Schematic Diagrams	Part Name
		Transistor
		Transistor with resistor
		Field effect transistor
		Resistor array
		3-terminal regulator

3. The parts mounted on this PCB include all necessary parts for several destinations.
For further information for respective destinations, be sure to check with the schematic diagram.
4. View point of PCB diagrams.

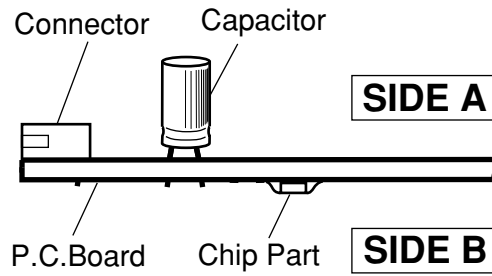

4.1 TRANS1, TRANS2 and TRANS3 ASSYS

SIDE A

SIDE A

D TRANS3 ASSY

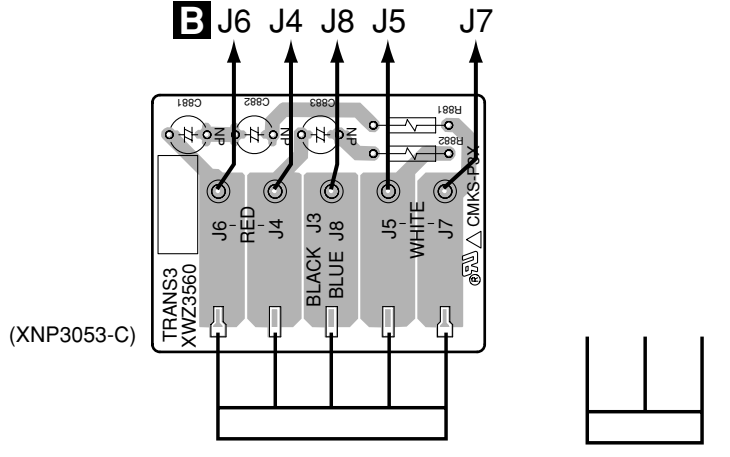

POWER TRANSFORMER

B J6 J4 J8 J5 J7

C TRANS2 ASSY

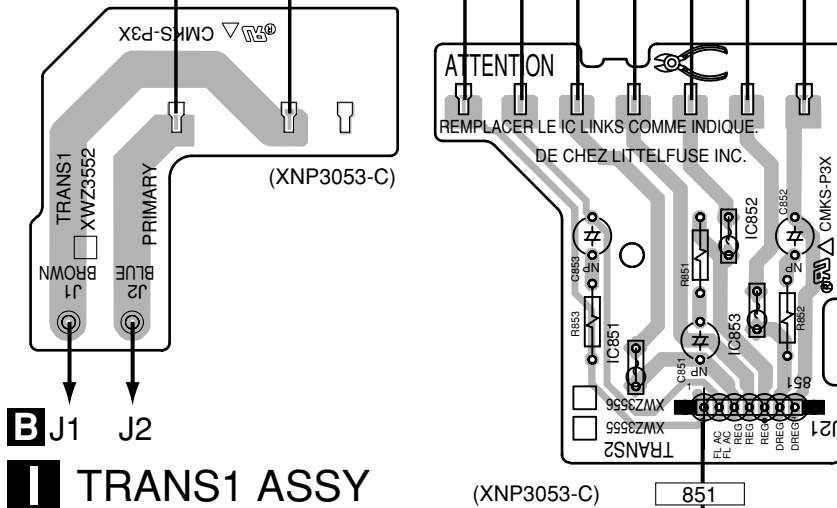

ATTENTION
REPLACER LE IC LINKS COMME INDIQUE.
DE CHEZ LITTELFUSE INC.

B J1 J2
I TRANS1 ASSY

B 701

C D I

C D I

SIDE B

A D.D & INPUT ASSY

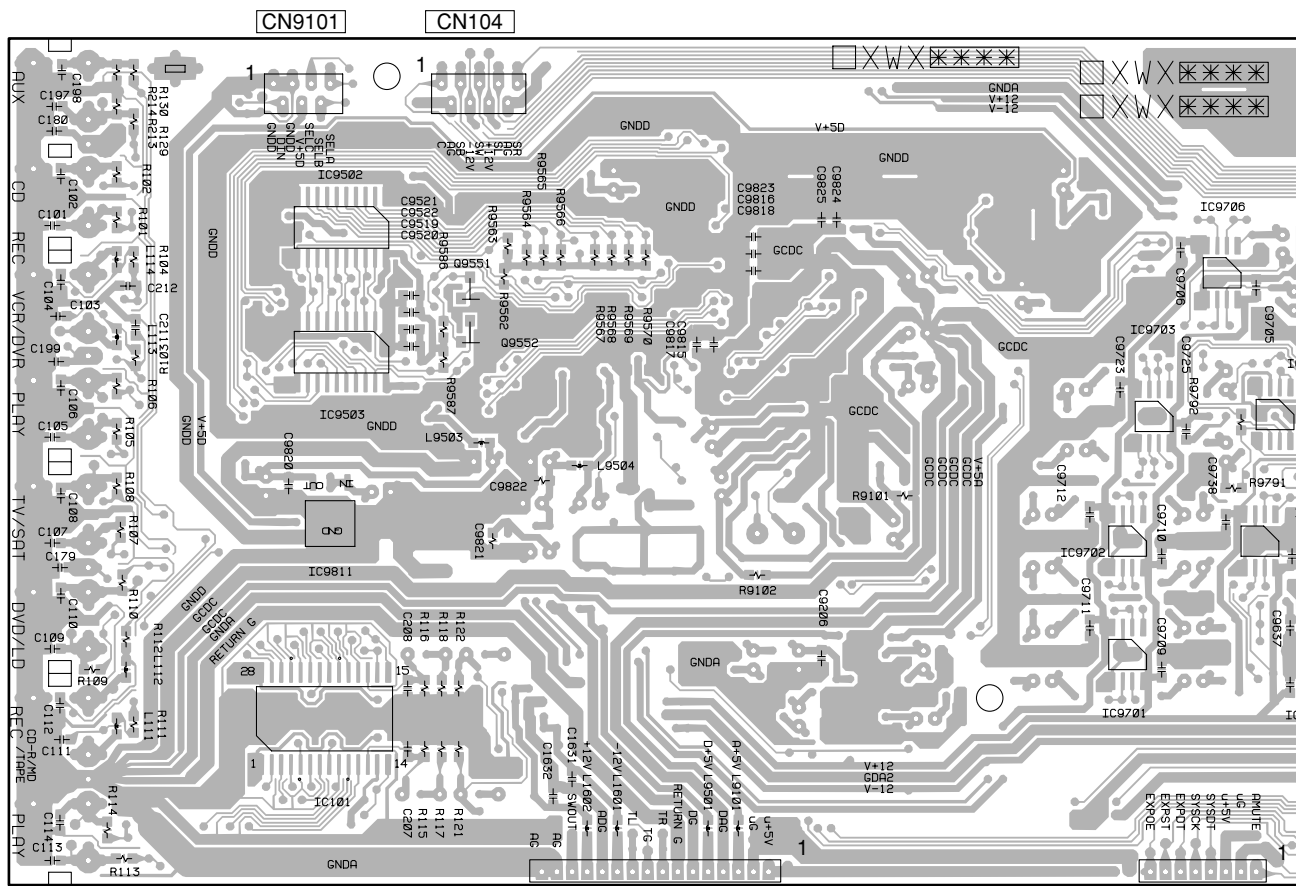

- IC9502
- IC9503
- IC9811
- IC101
- Q9551
- Q9552
- CN101
- CN9101
- CN104
- CN105
- IC9700
- IC9703
- IC9705
- IC9706
- IC9707
- IC9708
- IC9709
- IC9710
- IC9711
- IC9712
- IC9723
- IC9725
- IC9726
- IC9728
- IC9729
- IC9730
- IC9731
- IC9732
- IC9733
- IC9734
- IC9735
- IC9736
- IC9737
- IC9738
- IC9739
- IC9740
- IC9741
- IC9742
- IC9743
- IC9744
- IC9745
- IC9746
- IC9747
- IC9748
- IC9749
- IC9750
- IC9751
- IC9752
- IC9753
- IC9754
- IC9755
- IC9756
- IC9757
- IC9758
- IC9759
- IC9760
- IC9761
- IC9762
- IC9763
- IC9764
- IC9765
- IC9766
- IC9767
- IC9768
- IC9769
- IC9770
- IC9771
- IC9772
- IC9773
- IC9774
- IC9775
- IC9776
- IC9777
- IC9778
- IC9779
- IC9780
- IC9781
- IC9782
- IC9783
- IC9784
- IC9785
- IC9786
- IC9787
- IC9788
- IC9789
- IC9790
- IC9791
- IC9792
- IC9793
- IC9794
- IC9795
- IC9796
- IC9797
- IC9798
- IC9799
- IC9800

A

SIDE B

A
B
C
D
E
F

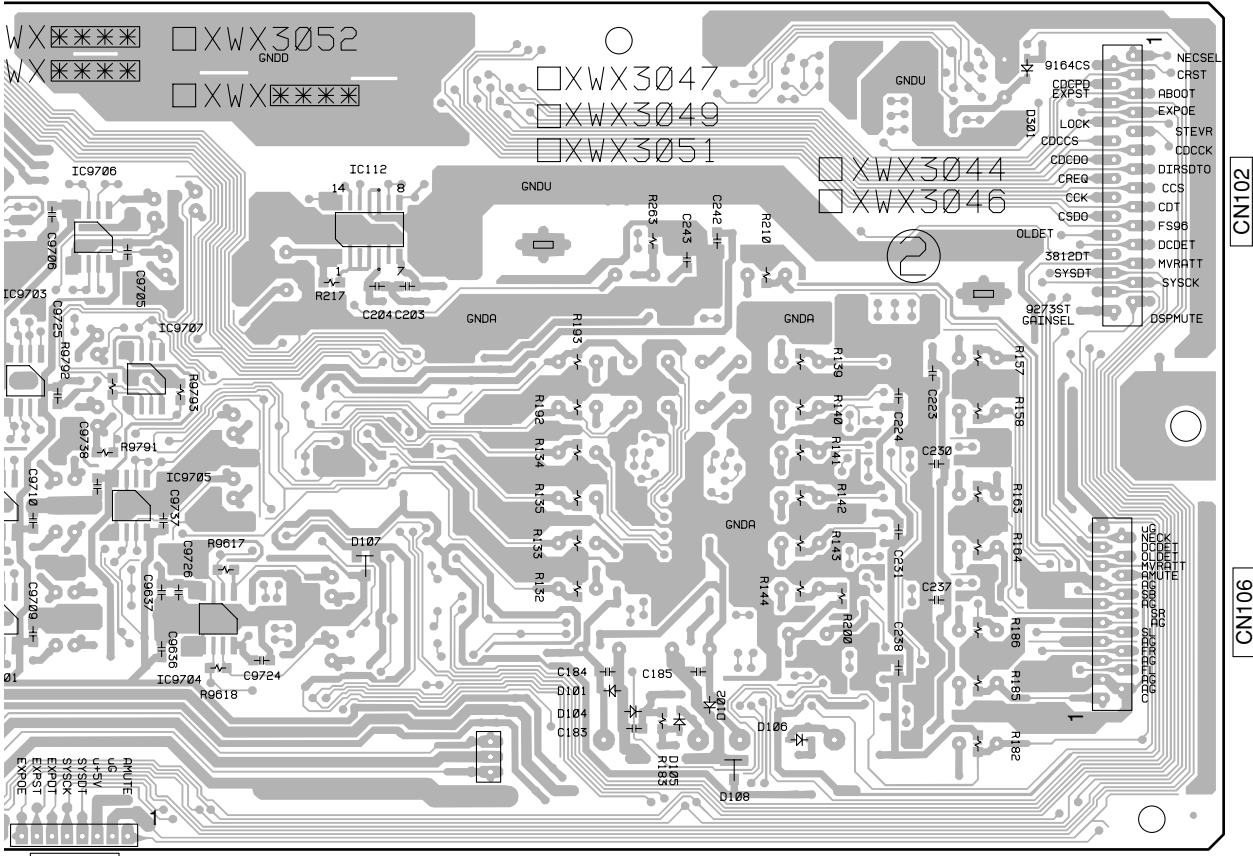

CN105		IC9705	IC112
39703	IC9707		
02	IC9705		
	IC9704		

(XNP3056-C)

4.3 AMP INPUT, AMP & PRIMARY and MECHA SW ASSYS

SIDE A

Y MECHA SW ASSY

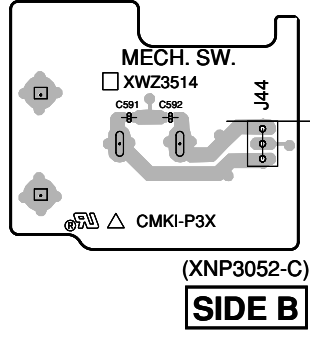
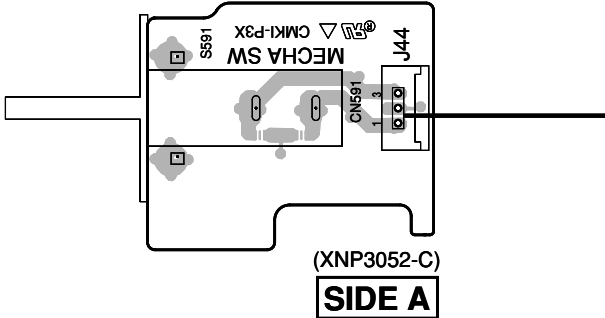
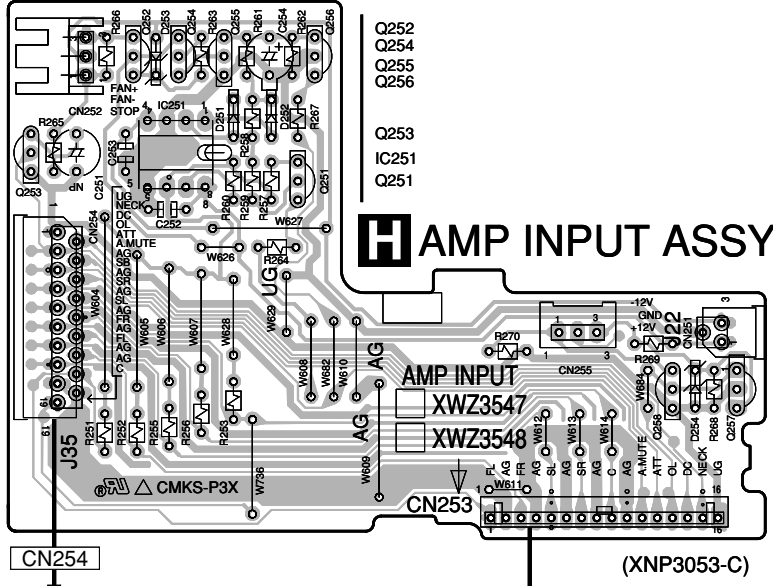

A CN106

B AMP&PRIMARY ASSY

- Q704
- Q702
- IC702
- Q703

- Q701
- IC701

- Q655

- Q697
- Q696
- Q681
- Q682
- Q652
- Q654
- Q633
- Q656
- Q683
- Q606
- Q605

- IC607
- IC606
- Q601
- Q603
- Q651
- Q631
- IC605
- Q653
- Q632
- IC604

- IC602
- IC601
- IC603

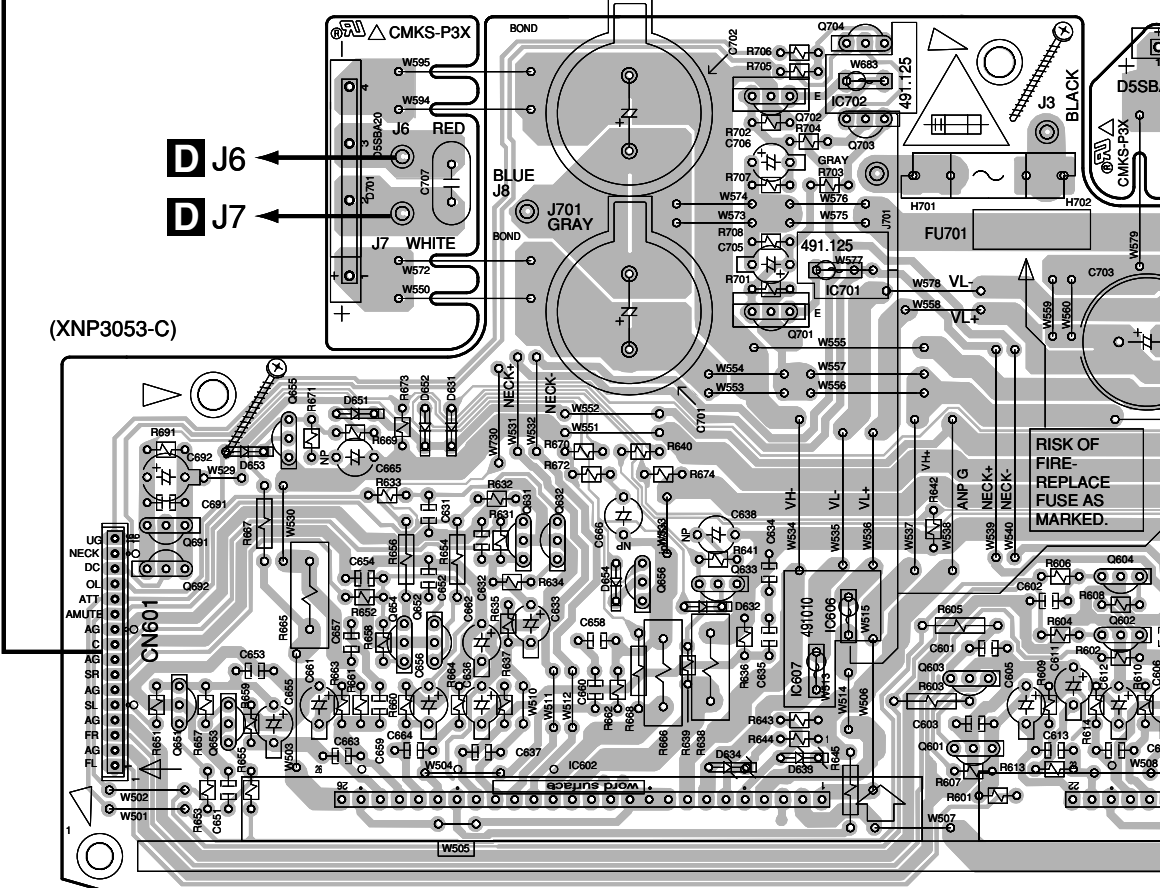

B H Y

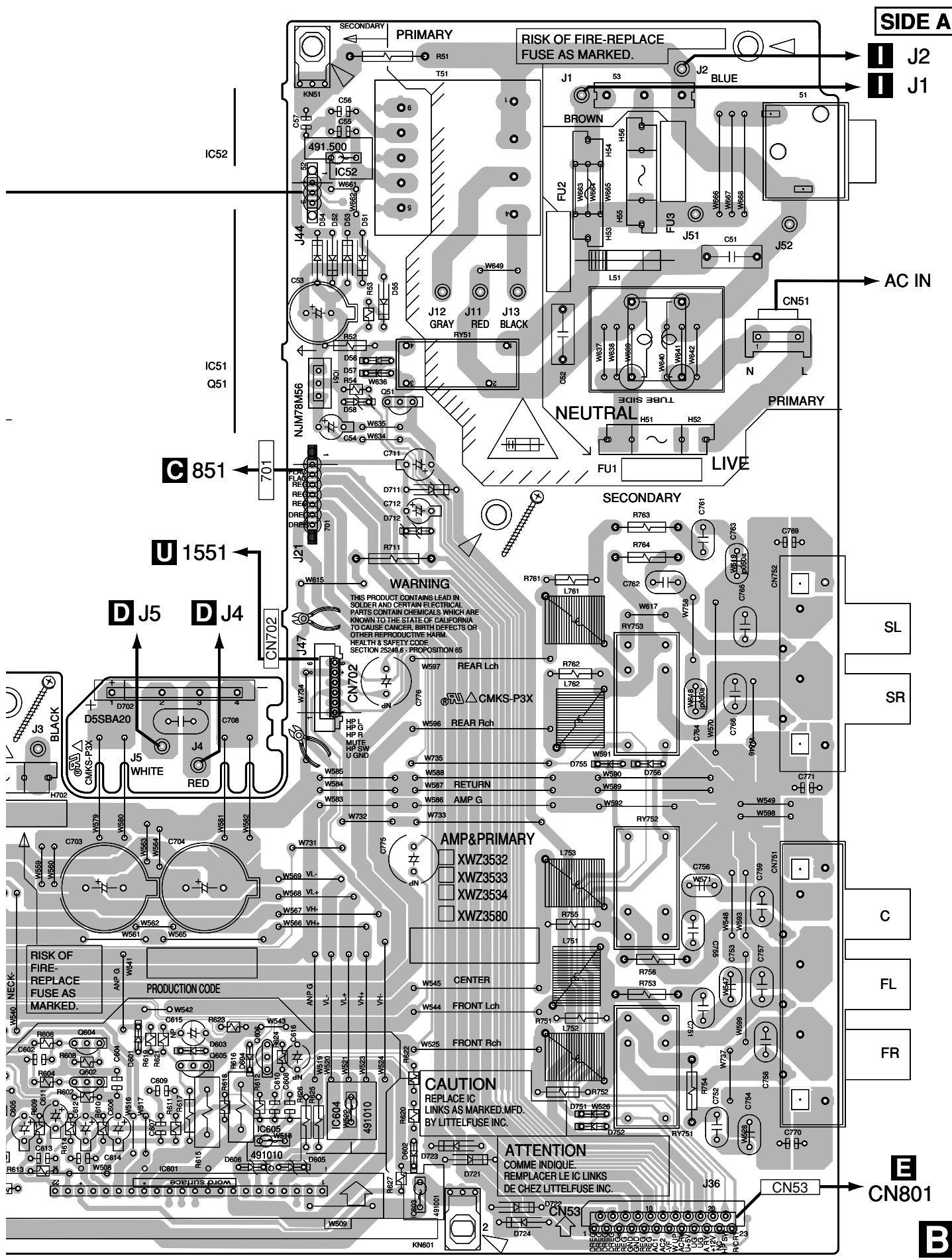

SIDE A

J2
J1

AC IN

C 851

U 1551

D J5 **D** J4

WARNING
 THIS PRODUCT CONTAINS LEAD IN SOLDER AND CERTAIN ELECTRICAL PARTS CONTAIN CHEMICALS WHICH ARE KNOWN TO THE STATE OF CALIFORNIA TO CAUSE CANCER, BIRTH DEFECTS OR OTHER REPRODUCTIVE HARM.
 HEALTH & SAFETY CODE SECTION 25246.6, PROPOSITION 65

AMP&PRIMARY
 XWZ3532
 XWZ3533
 XWZ3534
 XWZ3580

RISK OF FIRE-REPLACE FUSE AS MARKED.

PRODUCTION CODE

CAUTION
 REPLACE IC LINKS AS MARKED.MFD. BY LITTELFUSE INC.

ATTENTION
 COMME INDIQUE.
 REMPLACER LE IC LINKS DE CHEZ LITTELFUSE INC.

E CN801

B

4.4 FRONT, POWER SW, H.P. and R.ENCODER ASSYS

SIDE A

O FRONT ASSY

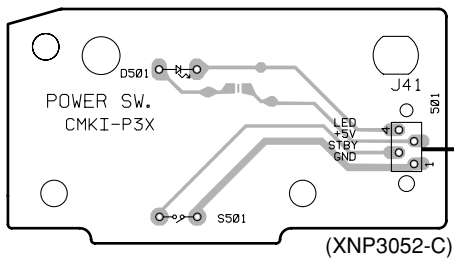
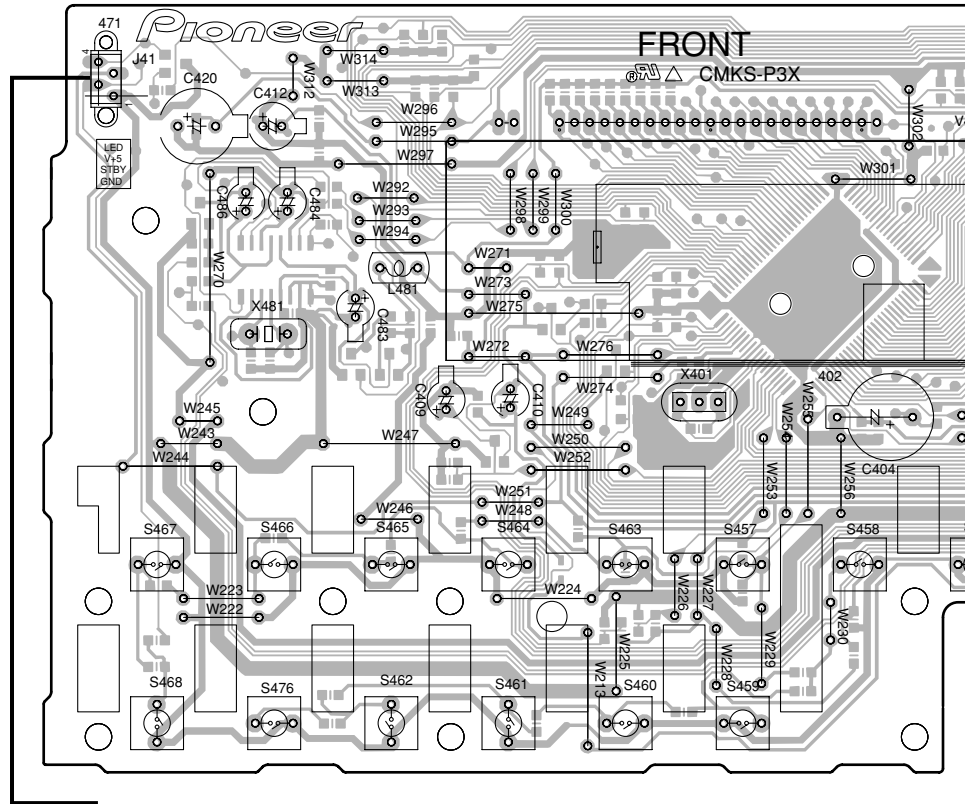

Q POWER SW ASSY

B CN702

U H.P ASSY

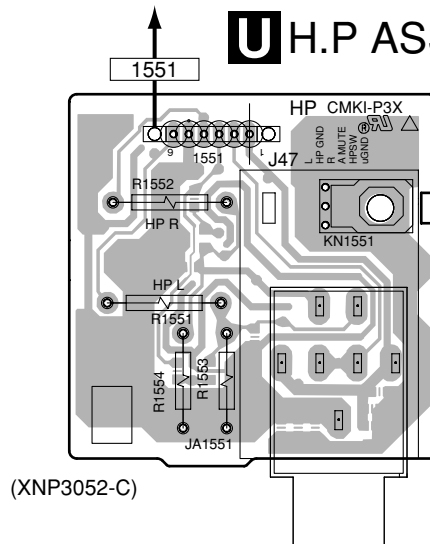

O Q U

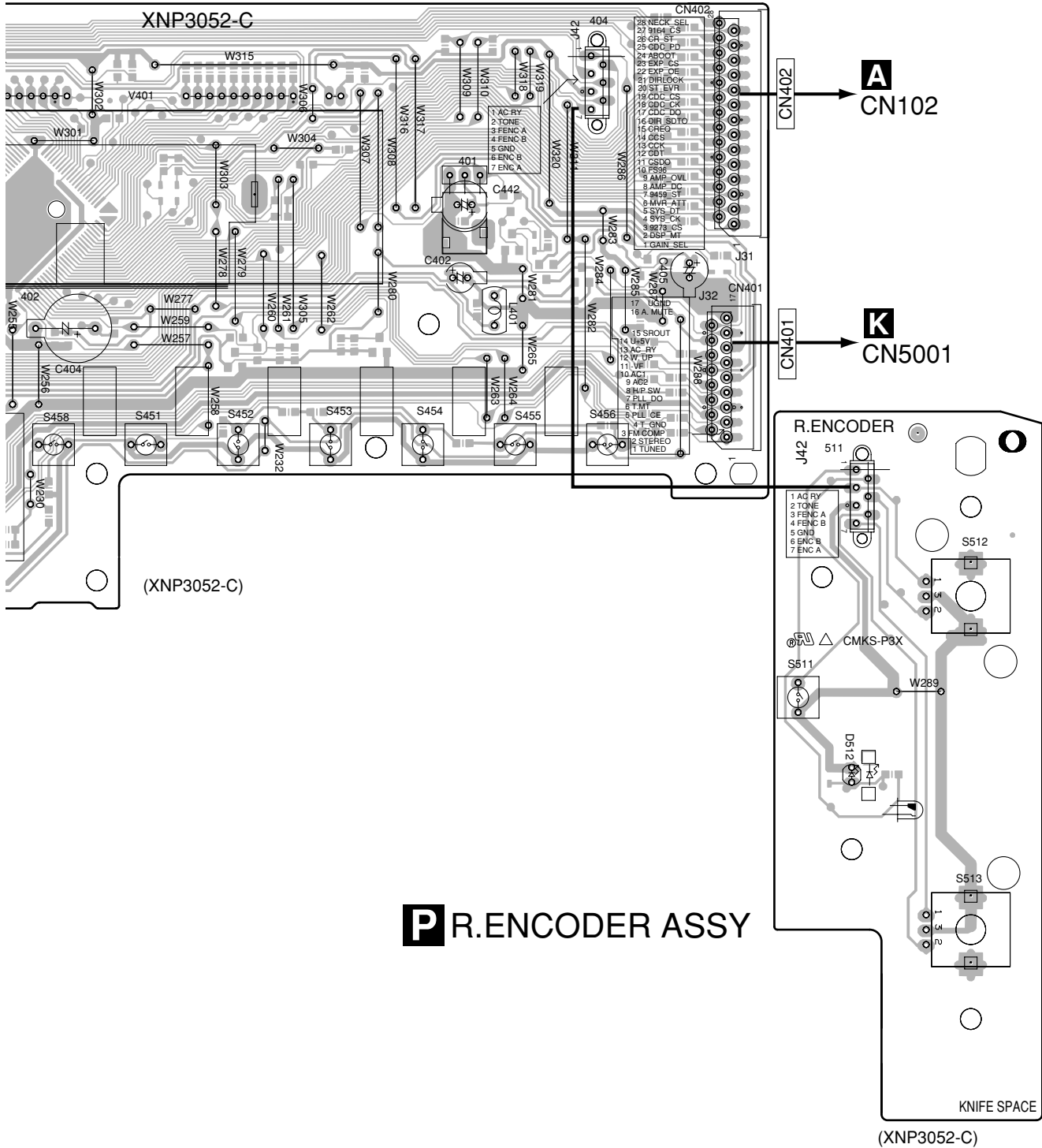

P R.ENCODER ASSY

SIDE B

FRONT ASSY

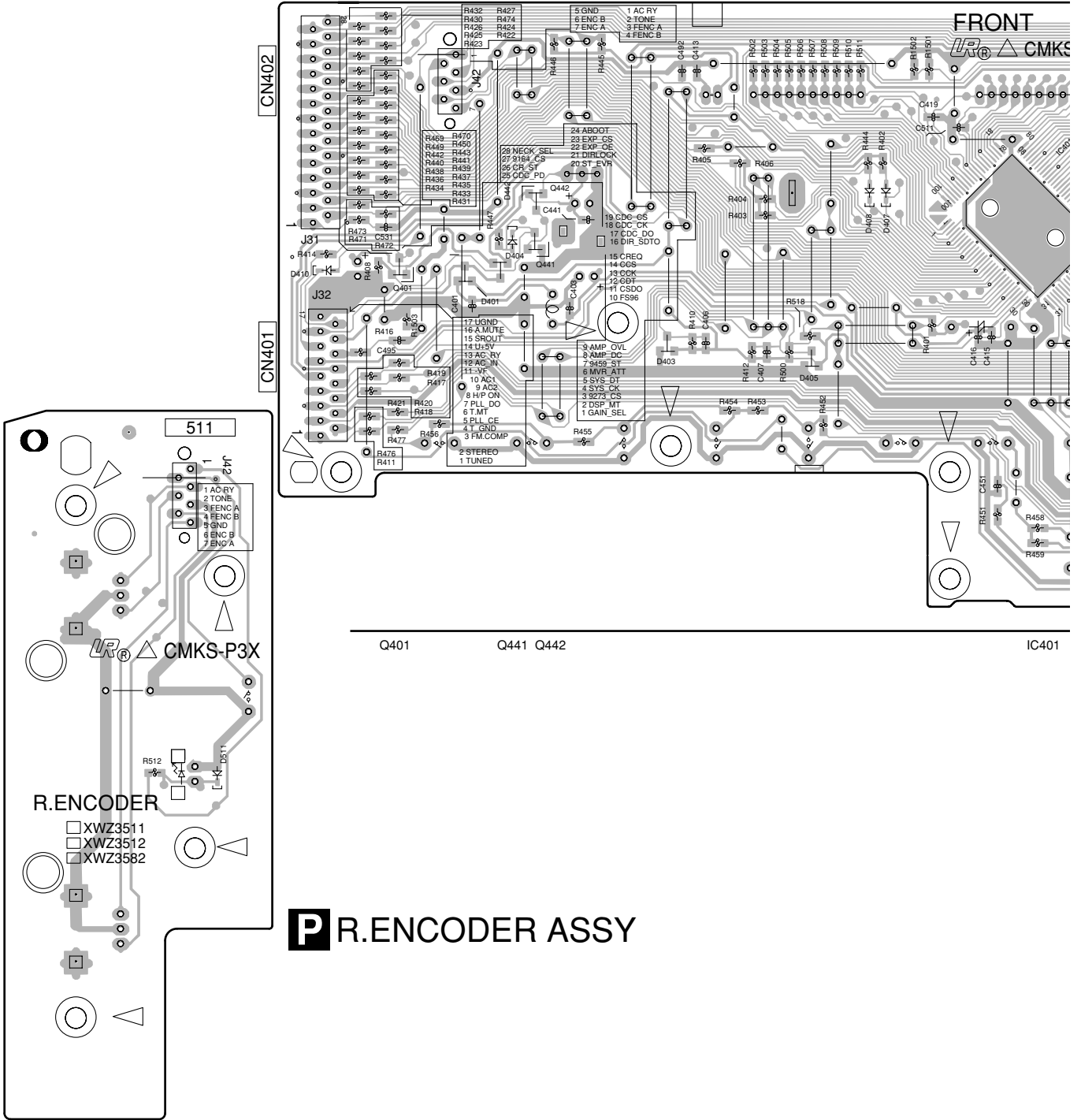

R.ENCODER ASSY

OP

VSX-D511-K

SIDE B

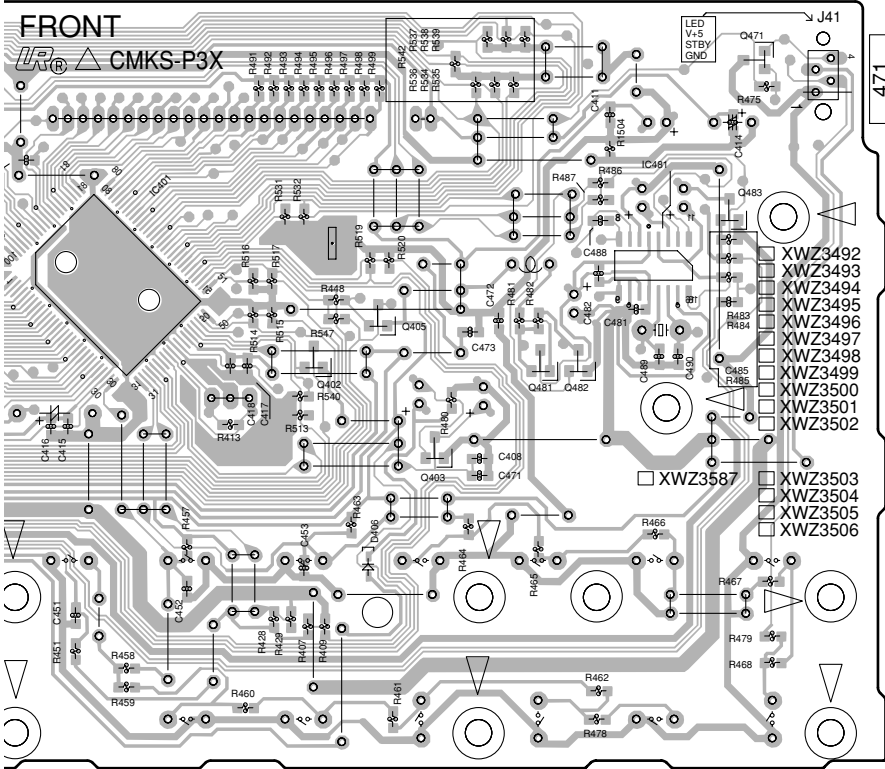

(XNP3052-C)

IC401 Q402 Q405 Q403 Q481 Q482 IC481 Q483 Q471

U H.P ASSY

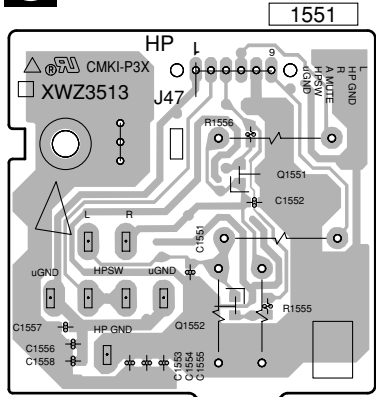

(XNP3052-C)

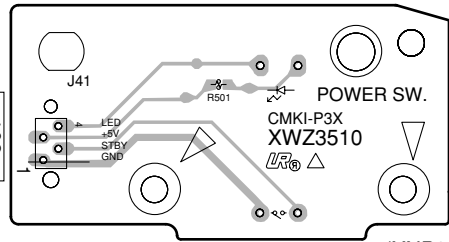

(XNP3052-C)

Q POWER SW ASSY

4.5 REGULATOR, HASHIGETA and KAWA ASSYS

SIDE A

S

F HASHIGETA ASSY

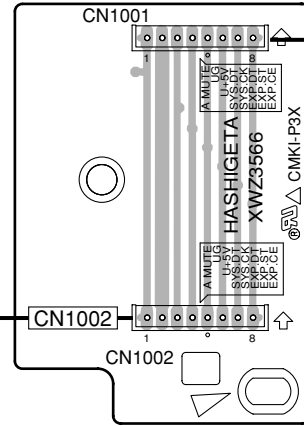

A CN105

E REGULATOR ASSY

(XNP3053-C)

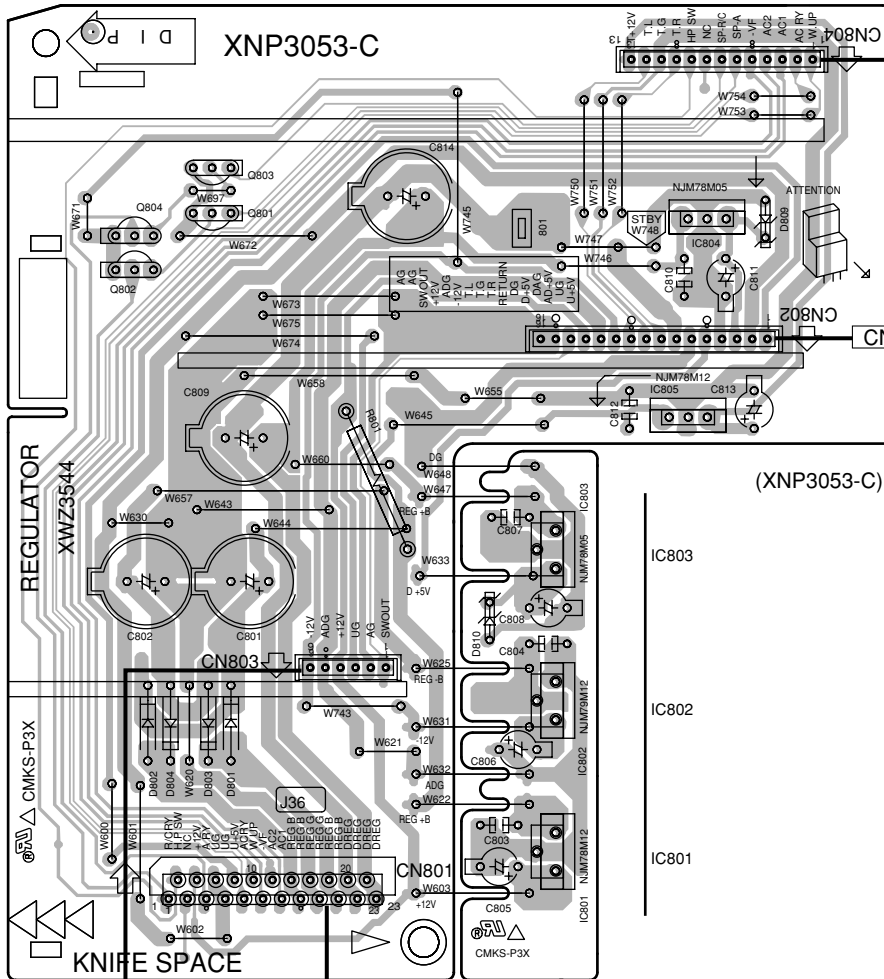

Q805
Q803
Q806
Q801
IC804
Q804
Q802

A CN101

IC805

(XNP3053-C)

IC803

IC802

IC801

Q5001

L CN302

B CN53

E F

SIDE A

SIDE B

KAWA ASSY

KAWA ASSY

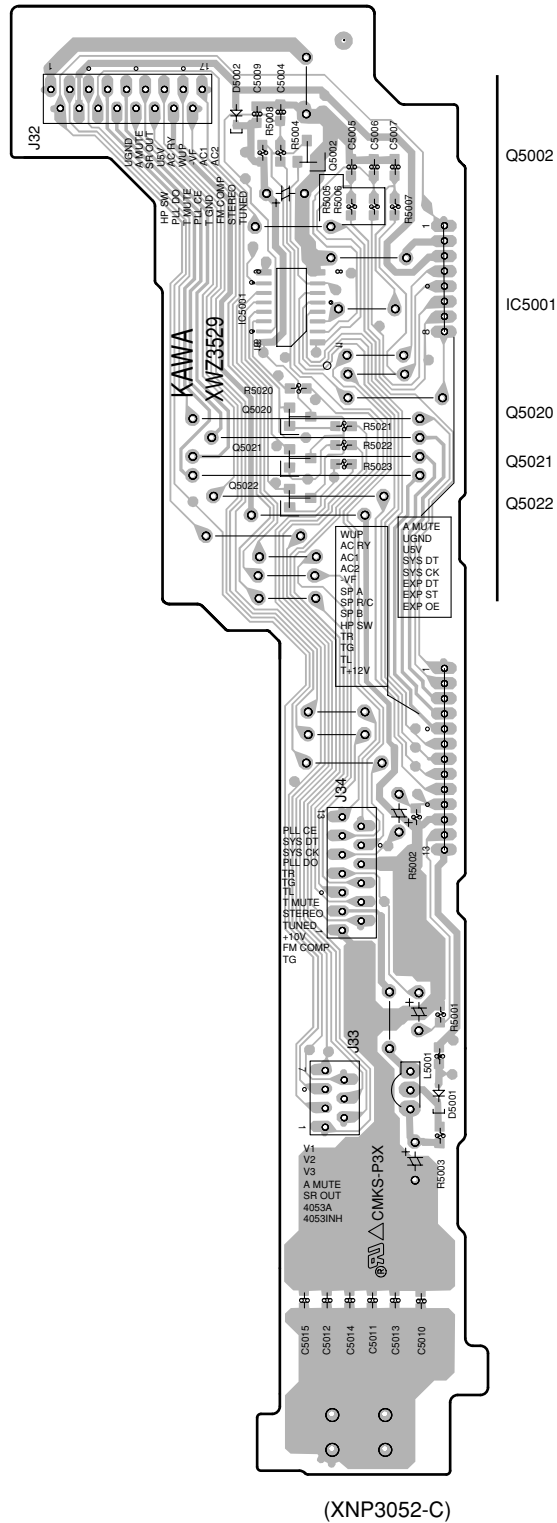
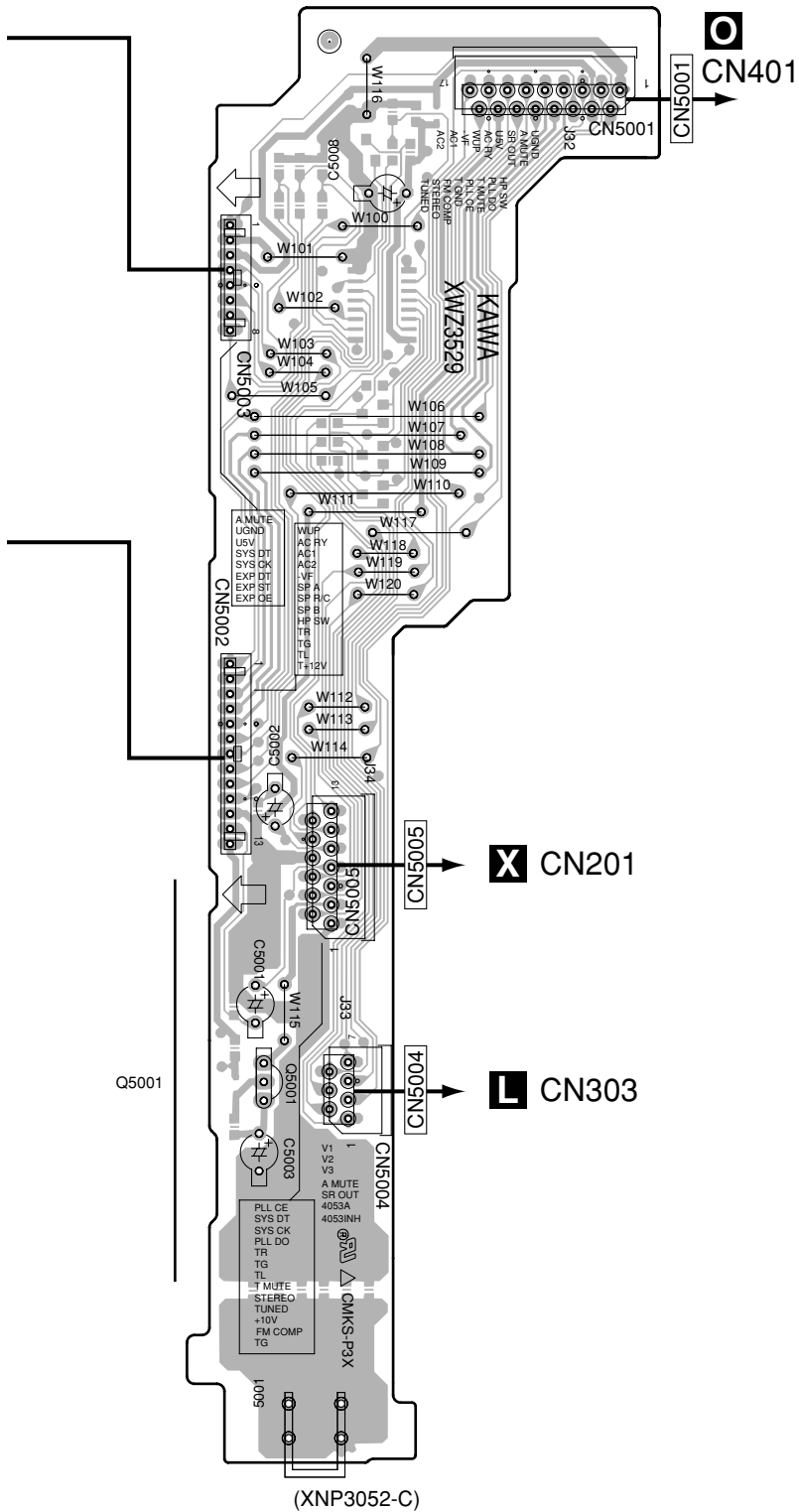

(XNP3052-C)

(XNP3052-C)



4.6 DIGITAL IN, 6CH IN, VIDEO and BOARRO TO BOARD ASSYS

SIDE A

J DIGITAL IN ASSY

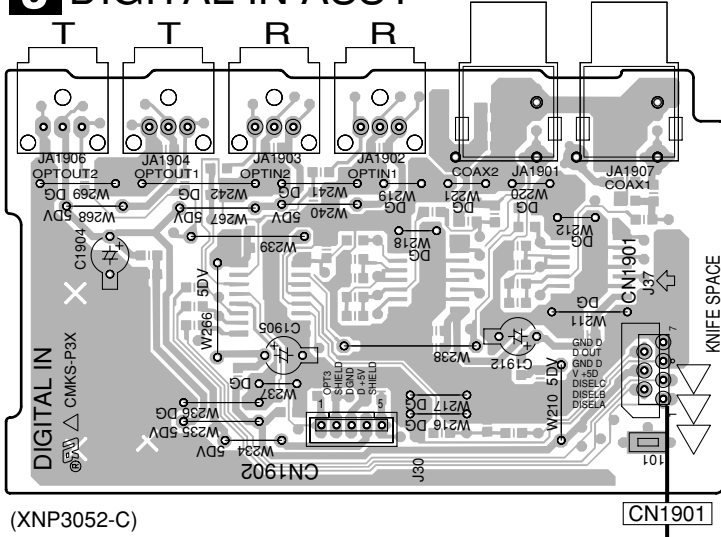

A CN9101

M 6CH IN ASSY

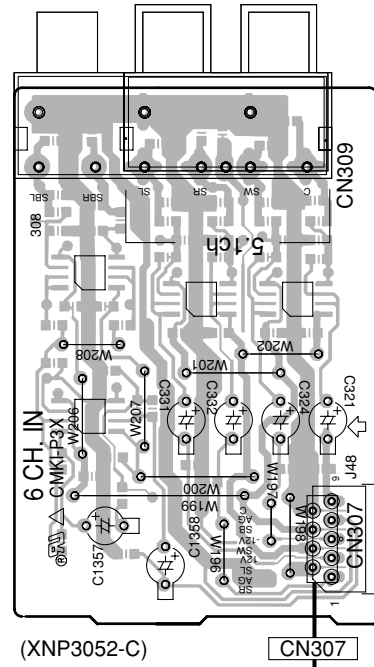

A CN104

L VIDEO ASSY

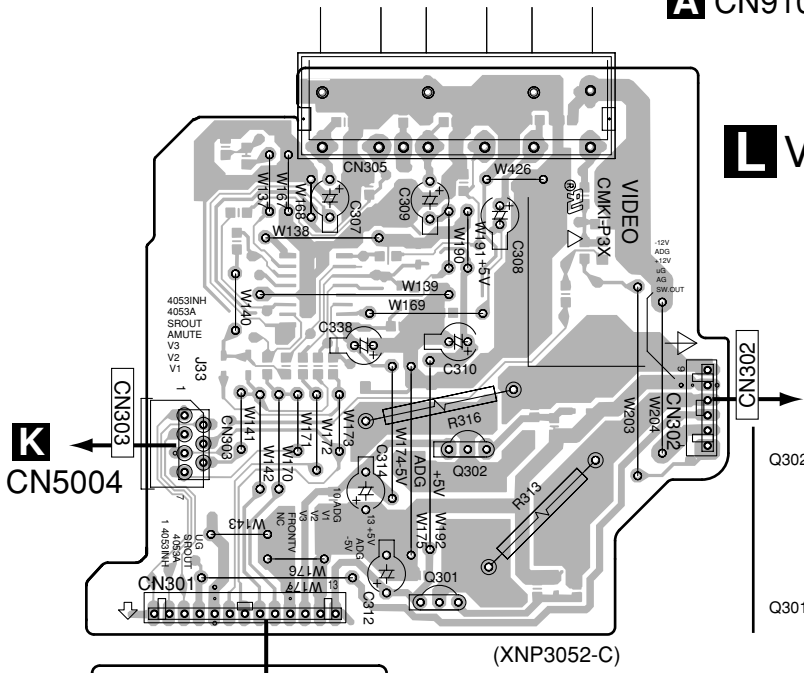

E CN803

G BOARD TO BOARD ASSY

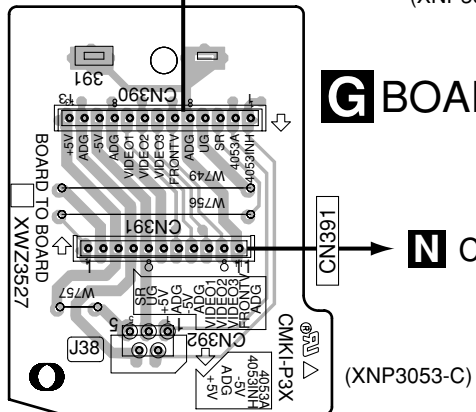

N CN351

G J L M

SIDE B

M 6CH IN ASSY

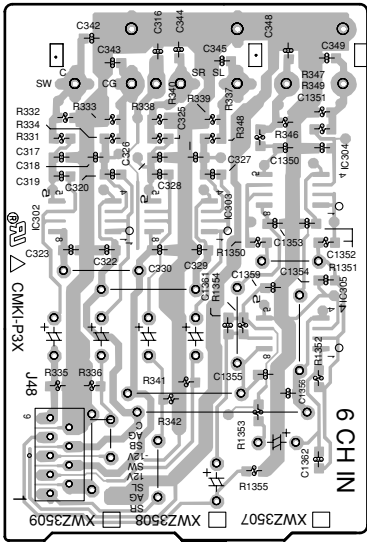

CN307 (XNP3052-C)

J DIGITAL IN ASSY

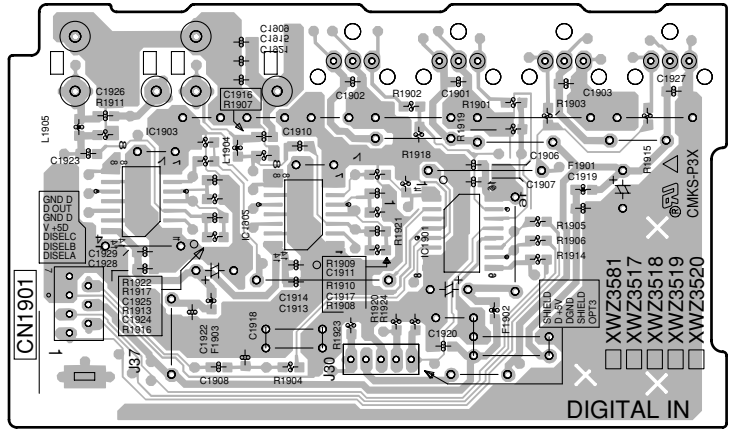

IC1903 IC1902 IC1901 (XNP3052-C)

L VIDEO ASSY

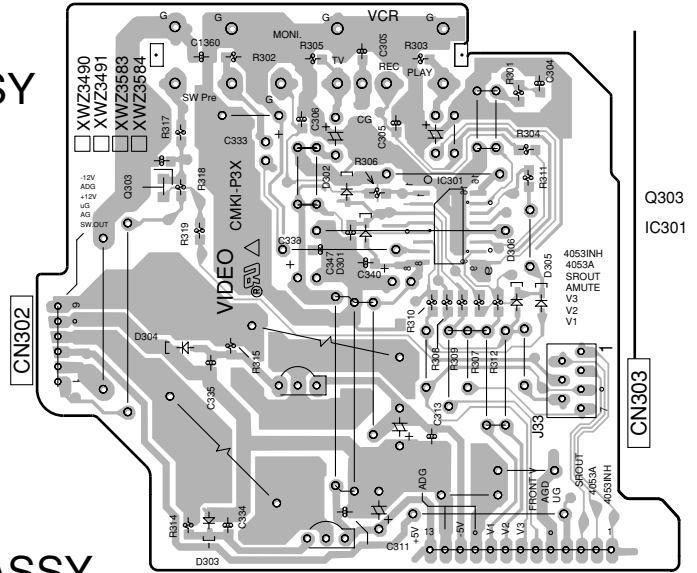

(XNP3052-C)

G BOARD TO BOARD ASSY

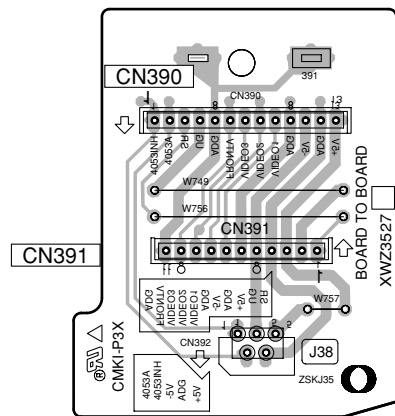

(XNP3053-C)

G J L M

4.7 FM/AM TUNER MODULE

SIDE B

SIDE A

X FM/AM TUNER MODULE

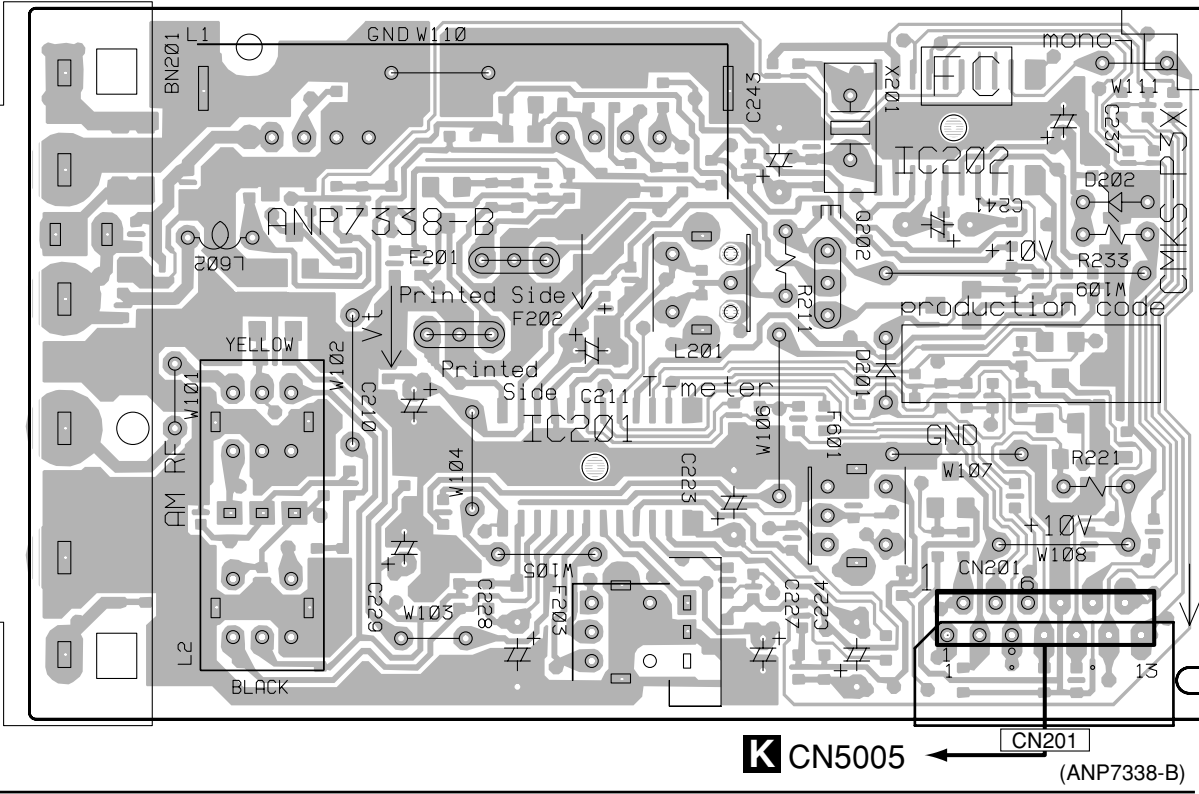

X FM/AM TUNER MODULE

SIDE B

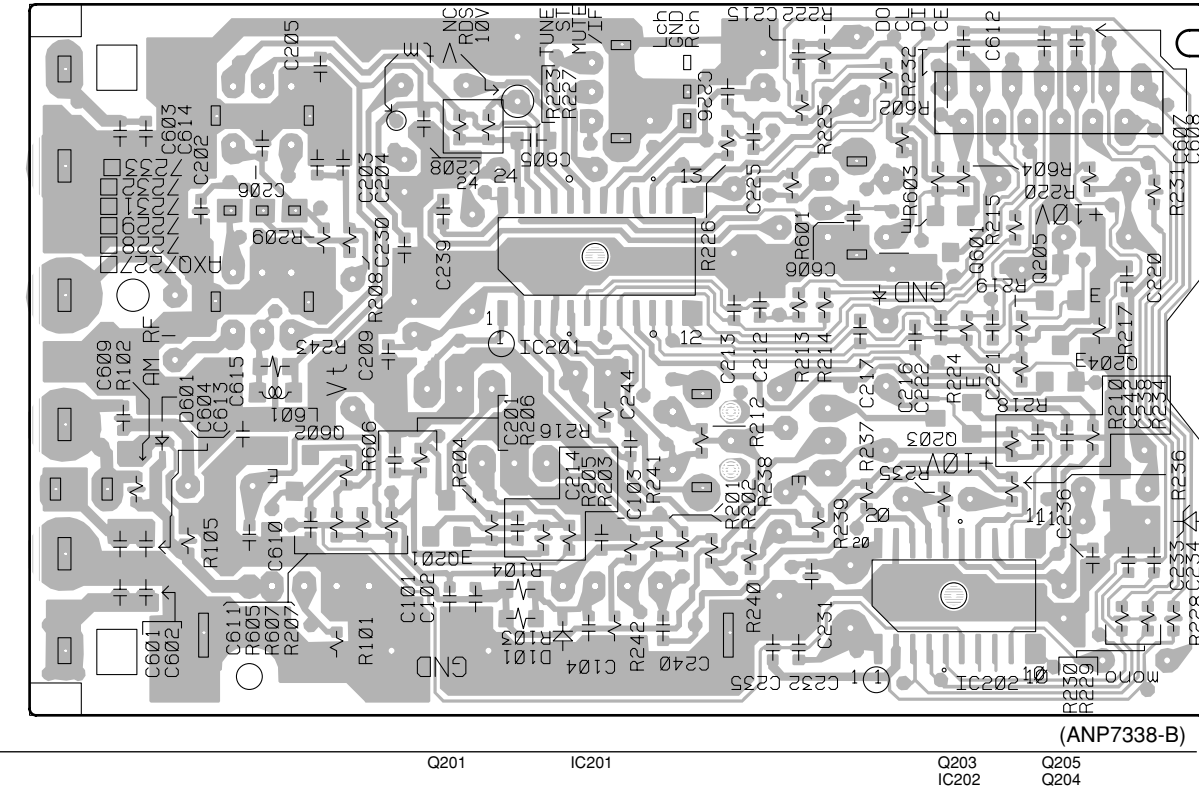

5. PCB PARTS LIST

NOTES: ● Parts marked by "NSP" are generally unavailable because they are not in our Master Spare Parts List.

● The Δ mark found on some component parts indicates the importance of the safety factor of the part. Therefore, when replacing, be sure to use parts of identical designation.

● When ordering resistors, first convert resistance values into code form as shown in the following examples.

Ex.1 When there are 2 effective digits (any digit apart from 0), such as 560 ohm and 47k ohm (tolerance is shown by J=5%, and K=10%).

560 Ω \rightarrow 56×10^1 \rightarrow 561 RD1/4PU 5 6 7 J

47k Ω \rightarrow 47×10^3 \rightarrow 473 RD1/4PU 4 7 3 J

0.5 Ω \rightarrow R50 RN2H R 5 0 K

1 Ω \rightarrow 1R0 RS1P 1 R 0 K

Ex.2 When there are 3 effective digits (such as in high precision metal film resistors).

5.62k Ω \rightarrow 562×10^1 \rightarrow 5621 RN1/4PC 5 6 2 1 F

Mark No. Description Part No.

LIST OF ASSEMBLIES

Mark No.	Description	Part No.
	1..D.D & INPUT ASSY	XWX3044
NSP	1..AMP & PS ASSY	XWK3053
	2..AMP & PRIMARY ASSY	XWZ3533
	2..REGULATOR ASSY	XWZ3544
	2..AMP INPUT ASSY	XWZ3547
NSP	2..TRANS1 ASSY	XWZ3552
	2..TRANS2 ASSY	XWZ3555
NSP	2..TRANS3 ASSY	XWZ3560
	2..HASHIGETA ASSY	XWZ3566
	2..BOARD TO BOARD ASSY	XWZ3527
NSP	1..COMPLEX ASSY	XWK3038
	2..FRONT ASSY	XWZ3493
	2..6CH IN ASSY	XWZ3507
	2..POWER SW ASSY	XWZ3510
	2..H.P. ASSY	XWZ3513
	2..DIGITAL IN ASSY	XWZ3518
	2..S. VIDEO ASSY	XWZ3521
	2..KAWA ASSY	XWZ3529
	2..R. ENCODER ASSY	XWZ3511
	2..VIDEO ASSY	XWZ3490
	2..MECHA SW ASSY	XWZ3514
	1..FM/AM TUNER MODULE	AXQ7232

Mark No. Description Part No.

COMPLEX ASSY

OTHERS

J 41 (JUMPER WIRED)	D15A04-100-2651
J 42 (JUMPER WIRED)	D15A07-075-2651
J 47 (JUMPER WIRED)	D20PYY0630E

AMP & PS ASSY

OTHERS

J 701 (AWG14 BOARD IN)	DB812NBO
J 21 (JUMPER WIRED)	D20PYY0715E

A D.D & INPUT ASSY

SEMICONDUCTORS

IC9101	AK4586VQ
IC301	BU4094BCF
IC9501	CS493292
IC103	M62446FP
IC9201	NJM2100M
IC9812	NJM2391DL1-25
IC9811	NJM2391DL1-33

Mark No. Description Part No.

IC102	NJU7312AM
IC9601	NJU7313AM
IC9504	PD8097A
IC9505	TC74LVX244FT
IC9502, IC9503	TC74VHC574F
IC9506	TC74VHCT244AFT
IC9507	TC7WU04FU
IC101	TC9273F-007
IC104-IC107, IC9701-IC9705, IC9707	UPC4570G2
Q107-Q112, Q9201, Q9202	2SC3326
Q9101, Q9204, Q9607, Q9609, Q9610	DTA124EK
Q9102, Q9203, Q9608	DTC124EK
D9601, D9602	1SS181
D105, D106, D301, D9921	1SS355
D107, D108	DAN217
D201, D202	RB501V-40
D104	UDZS5.1B
D101, D102	UDZS6.8B

COILS AND FILTERS

L9101, L9501, L9504, L9811, L9812	ATL7002
L111-L114, L1601, L1602	QTL1013
L9102, L9103, L9502, L9503	QTL1013
L9506, L9507	QTL1013

CAPACITORS

C9510, C9511	CCSRCH100D50
C101-C114, C121-C123	CCSRCH101J50
C126-C128, C152-C154	CCSRCH101J50
C207, C208, C221, C222	CCSRCH101J50
C228, C229, C9160, C9201, C9202	CCSRCH101J50
C9101, C9102	CCSRCH220J50
C235, C9117	CCSRCH221J50
C9509	CCSRCH271J50
C9530, C9731, C9735	CCSRCH331J50
C9103, C9110, C9111, C9114, C9503	CCSRCH471J50
C9505, C9507, C9513, C9515, C9518	CCSRCH471J50
C9520, C9522, C9525, C9528, C9571	CCSRCH471J50
C9611-C9614, C9625, C9639, C9729	CCSRCH471J50
C9815, C9816	CCSRCH471J50
C9707, C9708, C9721, C9722	CCSRCH820J50
C130-C137, C146-C151, C305	CEAT100M50
C9207, C9208, C9523, C9526	CEAT100M50
C9105, C9106, C9108, C9116, C9516	CEAT101M10
C9551, C9792, C9812, C9814	CEAT101M10
C9740	CEAT220M25
C9205	CEAT221M6R3
C9112, C9529, C9769, C9770	CEAT2R2M50

Mark No.	Description	Part No.
C9713, C9714, C9727, C9728, C9739		CEAT330M25
C9765-C9768		CEAT330M25
C144, C145		CEAT3R3M50
C117, C118, C225, C226		CEAT470M50
C232, C233, C239		CEAT470M50
C155, C156		CEAT471M10
C115, C116, C234, C240		CEAT4R7M50
C9203, C9204, C9615-C9618, C9811		CEAT4R7M50
C9813		CEAT4R7M50
C271, C9703, C9704, C9717, C9718		CKSRYB102K50
C119, C120, C124, C125, C138		CKSRYB103K50
C141, C171, C172, C179, C180		CKSRYB103K50
C183, C199, C223, C224		CKSRYB103K50
C230, C231, C237, C238, C304		CKSRYB103K50
C9104, C9107, C9109, C9121, C9209		CKSRYB103K50
C9502, C9504, C9506, C9508, C9512		CKSRYB103K50
C9514, C9517, C9519, C9521, C9524		CKSRYB103K50
C9527, C9531, C9584, C9636, C9637		CKSRYB103K50
C9709-C9712, C9723-C9726		CKSRYB103K50
C9737, C9738, C9817		CKSRYB103K50
C140, C143, C1631, C1632		CKSRYB104K16
C173, C174, C9113, C9115, C9126		CKSRYB104K16
C9206, C9818		CKSRYB104K16
C9701, C9702, C9715, C9716		CKSRYB222K50
C9736		CKSRYB223K25
C139, C142, C9626		CKSRYB223K50
C236		CKSRYB472K50
C184, C185, C9732		CKSRYB473K25
C227, C9730		CKSRYF104Z25

RESISTORS

R9104	RS1/16S1802F
⚠ R174, R175	RS1LMF101J
OtherResistors	RS1/16S###J

OTHERS

CN9101 7P FFC CONNECTOR	52044-0745
CN104 9P FFC CONNECTOR	52044-0945
CN106 19P FFC CONNECTOR	52045-1945
CN102 28P FFC CONNECTOR	52045-2845
JA103, JA104 4P PIN JACK	AKB7048
JA105 6P PIN JACK	AKB7050
CN101 16P SOCKET	KP200TA16L
CN105 8P SOCKET	KP200TA8L
X9501 (CRYSTAL RES. 27.0MHz)	VSS1086
X9101 (CRYSTAL RES. 12.3MHz)	VSS1140

B AMP & PRIMARY ASSY

SEMICONDUCTORS

⚠ IC603(1A)	AEK7009
⚠ IC701, IC702(125mA)	AEK7020
⚠ IC604-IC607(10A)	AEK7022
⚠ IC52(500mA)	AEK7005
IC51	NJM78M56FA

⚠ IC601	PAC010A
⚠ IC602	PAC011A
Q703	2SA1145
Q702	2SB1238X
Q691, Q692	2SC1740S
Q704	2SC1845

Mark No.	Description	Part No.
Q605, Q606, Q633, Q655, Q656		2SC2240
Q601-Q604, Q631, Q632		2SC2878
Q651-Q654		2SC2878
Q701		2SD1859X
Q51		KRC101M
D56, D601-D604, D631, D632		1SS133
D57, D651-D654, D752, D756		1SS133
D751, D755		1SS133
⚠ D701, D702		D5SBA20(B)
D605, D606, D633, D634		MTZJ8.2A
D711		MTZJ22D
D58		MTZJ5.1A
D712		MTZJ5.1B
⚠ D51-D55, D721-D724		S5688G

COILS AND FILTERS

⚠ L51 (0.3mH/270v)	ATF7018
L751-L753, L761, L762(0.7uH)	ATH1004

SWITCHES AND RELAYS

RY751-RY753	XSR3002
⚠ RY51	XSR3003

CAPACITORS

C707, C708(0.01/150)	ACG1005
⚠ C51, C52(0.01/250v)	ACG7020
C703, C704(3300/42)	ACH7135
C701, C702(4700/63)	ACH7134
C607-C610, C634, C635	CCPUCH6R8K50
C657-C660	CCPUCH6R8K50
C615, C616, C638, C665, C666	CEANP2R2M50
C775, C776	CEANP470M50
C705, C706	CEAT100M2A
C712	CEAT101M10
C611, C612, C636, C661, C662	CEAT101M16
C711	CEAT101M35
C53	CEAT102M16
C692	CEAT221M10
C54	CEAT470M25
C605, C606, C633, C655, C656	CEAT4R7M50
C751-C756, C761-C764	CFTYA224J50
C613, C614, C637, C663, C664	CKPUYB101K50
C601, C602, C631, C651, C652	CKPUYB102K50
C691, C769, C770	CKPUYB102K50
C603, C604, C632, C653, C654	CKPUYB331K50
C55-C57	CKPUYF103Z25
C757-C759, C765, C766	CQ MBA472J50

RESISTORS

⚠ R52	RD1/2PM270J
⚠ R751, R752, R755, R761, R762	RD1/4PUF101J
⚠ R753, R754, R756, R763, R764	RS1LMF4R7J
⚠ R711	RS2LMF332J
⚠ R615, R616, R638, R665, R666(0.22)	XCN3001
OtherResistors	RD1/4PU###J

OTHERS

CN53(23P FFC CONNECTOR)	52045-2345
CN702(6P CONNECTOR)	52147-0610
52 3P CABLE HOLDER	51048-0300
H53, H54, H701, H702(FUSE CLIP)	AKR7001
⚠ T51(SUB TRANS FORMER)	ATT7037
CN601(16P PLUG)	KM200TA16

Mark No.	Description	Part No.
	CN51(AC INLET)	RKP1751
	KN51,KN601 (EARTH METAL FITTING)	VNF1084
	CN752(4P SPEAKER TERMINAL)	XKE3011
	CN751(6P SPEAKER TERMINAL)	XKE3013
	701 7P CABLE HOLDER	XKP3047
	J21 20P JUMPER WIRE	D20PYY0715E
	J6 JUMPER WIRE	DB215NB0

C TRANS 2 ASSY SEMICONDUCTORS

⚠ IC851-IC853(1.6/125) AEK7012

OTHERS

851 XKP3047

D TRANS 3 ASSY

TRANS3 ASSY has no service part.

E REGULATOR ASSY SEMICONDUCTORS

IC803, IC804 NJM78M05FA
IC801, IC805 NJM78M12FA
IC802 NJM79M12FA
Q801, Q803 KRA103M
Q802, Q804 KRC102M

D809, D810 MTZJ6.2A
⚠ D801-D804 S5688G

CAPACITORS

C808, C811 CEAT101M10
C805, C806, C813 CEAT101M16
C801, C802 CEAT222M25
C809 CEAT332M16
C803, C804, C807, C810, C812 CKPUYF103Z25

OTHERS

CN801(23P CONNECTOR) 52045-2345
CN804 (13P PLUG) KM200TA13
CN802 (16P PLUG) KM200TA16
CN803 (6P PLUG) KM200TA6

F HASHICETA ASSY

OTHERS

CN1001, CN1002(8P PLUG) KM200TA8

G BOARD TO BOARD ASSY

OTHERS

CN391 (11P PLUG) KM200TA11
CN390 (13P PLUG) KM200TA13

H AMP INPUT ASSY

OTHERS

CN254 (19P FFC SOCKET) 52044-1945
CN253 (16P SOCKET) KP200TA16L

I TRANS1 ASSY

TRANS1 ASSY has no service part.

J DIGITAL IN ASSY SEMICONDUCTORS

Mark No.	Description	Part No.
	IC1901	TC74ACT151F
	IC1902, IC1903	TC74HCU04AF

COILS AND FILTERS

F1901-F1903(BK2125HS601) DTF1067
L1904, L1905 QTL1013

CAPACITORS

C1918 CCSRCH221J50
C1907, C1914, C1928 CCSRCH271J50
C1925 CCSRCH470J50
C1916, C1926 CCSRCH471J50
C1904, C1905, C1912 CEAT101M10

C1915 CKSRYB102K50
C1906, C1919, C1920, C1923, C1929 CKSRYB103K50
C1910, C1913 CKSRYB103K50
C1902, C1908, C1909, C1921, C1922 CKSRYB104K25
C1903 CKSRYB104K25

RESISTORS

OtherResistors RS1/16S###J

OTHERS

CN1901(7P FFC CONNECTOR) 52045-0745
JA1902 (OPTICAL LINK IN) JFJ4000-010020
JA1904 (OPTICAL OUT) JFJ3000-010020
JA1901,JA1907(1P PIN JACK) VKB1077

K KAWA ASSY SEMICONDUCTORS

IC5001 BU4094BCF
Q5001 2SC1740S
Q5020-Q5022 DTC114TK
Q5002 DTC143EK
D5001, D5002 1SS355

COILS AND FILTERS

L5001 QTL1013

CAPACITORS

C5004-C5007 CCSRCH101J50
C5012 CCSRCH471J50
C5001, C5002 CEAT100M50
C5003 CEAT101M16
C5009 CKSRYB103K50

C5011 CKSRYB104K16
C5010 CKSRYF105Z10

RESISTORS

All Resistors RS1/16S###J

OTHERS

CN5004 (7P FFC CONNECTOR) 52044-0745
CN5005 (13P FFC CONNECTOR) 52044-1345
CN5001 (17P FFC CONNECTOR) 52044-1745
CN5002 (13P SOCKET) KP200TA13L
CN5003 (8P SOCKET) KP200TA8L

5001 (SCREW TERMINAL) VNE1948

L VIDEO ASSY SEMICONDUCTORS

IC301 NJM2296M
Q302 2SA1515
Q303 2SC3326
Q301 2SC3377

Mark No. Description Part No.

D301, D302, D305, D306

1SS355

D303, D304

UDZS6.2B

CAPACITORSC347
C307-C310, C312, C314, C338
C1360, C302
C339, C340
C304-C306CCSRCH470J50
CEAT470M25
CKSRYB103K50
CKSRYB104K25
CKSRYB221K50C333
C311, C313CKSRYB331K50
CKSRYB473K25**RESISTORS**⚠ R313, R316
OtherResistorsRS3LMF560J
RS1/16S###J**OTHERS**CN303 (7P CONNECTOR)
CN305 (6P PIN JACK)
CN301 (13P SOCKET)
CN302 (6P SOCKET)52044-0745
AKB7123
KP200TA13L
KP200TA6L**M 6CH IN ASSY
SEMICONDUCTORS**

IC302, IC303

NJM4558MD

CAPACITORSC319, C320, C327, C328
C342-C345
C321, C324, C331, C332
C316, C322, C323, C329, C330
C317, C318, C325, C326CCSRCH101J50
CCSRCH101J50
CEAT4R7M50
CKSRYB103K50
CKSRYB221K50**RESISTORS**

All Resistors

RS1/16S###J

OTHERSCN307 (9P CONNECTOR)
CN309 (6P PIN JACK)52044-0945
AKB7087**N S.VIDEO ASSY
SEMICONDUCTORS**IC351, IC352
D351-D354NJM2296M
1SS355**CAPACITORS**C375, C376
C352, C355, C358, C361-C363
C366
C372, C373, C378
C351, C353, C354, C356, C357CCSRCH470J50
CEAT470M25
CEAT470M25
CKSRYB103K50
CKSRYB104K25C359, C367
C364, C365, C368-C371CKSRYB104K25
CKSRYB221K50**RESISTORS**

All Resistors

RS1/16S###J

OTHERSCN353 (4Px2 MINI DIN SOCKET)
CN352 (4Px3 MINI DIN SOCKET)
CN351 (11P SOCKET)
JA351 (REMOTE JACK)AKP7020
AKP7043
KP200TA11L
RKN1004**O FRONT ASSY
SEMICONDUCTORS****Mark No. Description Part No.**

IC401

PDG268B

IC481

BU1923F

Q401, Q402, Q442, Q471

DTA124EK

Q403, Q441, Q482

DTC143EK

Q481

2SA1037K

Q483

2SC3326

D406, D410, D442

1SS355

D403, D405

DAN217

D401, D404

DAP202K

D407, D408

RB501V-40

COILS AND FILTERS

L401, L481

LFEA2R2J

SWITCHES AND RELAYS

S451-S468, S476

ASG1051

CAPACITORS

C420 (220mF/35V)

ACH7101

C404 (0.047F/5.5V)

ACH7132

C511

CCSRCH471J50

C488

CCSRCH561J50

C489, C490

CCSRCH270J50

C442

CEAL470M10

C402

CEAT221M6R3

C483

CEAT101M10

C486

CEAT1R0M50

C409, C410, C484

CEAT2R2M50

C412

CEAT470M50

C405

CEAT471M6R3

C451-C453, C472, C492, C495

CKSRYB102K50

C481, C482

CKSRYB102K50

C401, C403, C411, C419, C441

CKSRYB103K50

C531

CKSRYB103K50

C408, C416, C418, C471

CKSRYB104K16

C485

CKSRYB472K50

C406, C407

CKSRYB473K16

RESISTORS

All Resistors

RS1/16S###J

OTHERS

471 (4P CABLE HOLDER)

51063-0405

404 (7P CABLE HOLDER)

51063-0705

CN401 (17P FFC CONNCTOR)

52044-1745

CN402 (28P FFC CONNCTOR)

52044-2845

V401 (FL TUBE)

XAV3013

401 (REMOTE CONTROL UNIT)

GP1U27X

J41 (4P JUMPER WIRE)

D15A04-100-2651

J42 (7P JUMPER WIRE)

D15A07-075-2651

X401 CERAMIC RESO.(7.2MHz)

ASS7039

X481 CERAMIC RESO.(4.3MHz)

ASS7004

**P R.ENCODER ASSY
SWITCHES AND RELAYS**

S511

ASG1051

S513 (ROTARY ENCODER)

XSX3005

S512 (ROTARY ENCODER)

XSX3006

OTHERS

511 (7P CABLE HOLDER)

51063-0705

**Q POWER SW ASSY
SEMICONDUCTORS**

Mark No.	Description	Part No.
D501		BR3371XJ30A
SWITCHES AND RELAYS		
S501		ASG1051

RESISTORS

All Resistors	RS1/16S###J
---------------	-------------

OTHERS

501(CABLEB HOLDER 4P)	51063-0405
-----------------------	------------

**H.P. ASSY
SEMICONDUCTORS**

Q1551, Q1552	2SC3326
--------------	---------

CAPACITORS

C1554, C1557	CCSRCH471J50
C1553, C1556	CKSRYB103K50
C1555, C1558	CKSRYB104K16
C1551, C1552	CKSRYB223K50

RESISTORS

⚠ R1553, R1554	RS1LMF471J
⚠ R1551, R1552	RS2LMF331J
Other Resistors	RS1/16S###J

OTHERS

1551 (6P CABLE HOLDER)	51048-0600
JA1551 (HEADPHONE JACK)	RKB1014
KN1551 (EARTH METAL FITTING)	VNF1084
J47	D20PYY0630E

**FM/AM TUNER MODULE
SEMICONDUCTORS**

IC201	BA1451F
IC202	LC72131MD
Q201, Q204, Q205	2SC2412K
Q202	DTA124ES
Q203	DTC124EK

D201	1SS133
D202	MTZJ5.1C

COILS AND FILTERS

L201 (FM DETECTOR COIL)	ATE7003
F202 (CERAMIC FILTER)	ATF-107
F201 (CERAMIC FILTER)	ATF-119
F203 (AM CERAMIC FILTER)	ATF7026
F601 (ANTIBIRDIE FILTER)	ATF7025

L601 (TIP COIL)	LCTA270J2520
L602 (INDUCTER)	LAU2R2J

CAPACITORS

C206	CCSRCH120J50
C212, C213, C226, C233-C235	CCSRCH101J50
C240	CCSRCH101J50
C231, C232, C614	CCSRCH150J50
C223	CEAT100M50

C229	CEAT101M10
C224	CEAT1R0M50
C227	CEAT220M25
C241	CEAT2R2M50
C243	CEAT330M16

C228	CEAT3R3M50
C237	CEAT470M10

Mark No.	Description	Part No.
C211		CEJQ1R0M50
C210		CEJQ470M16
C103, C104, C204, C238, C609		CKSRYB102K50
C102, C208, C216, C220, C615		CKSRYB103K50
C217, C239, C242, C604, C610		CKSRYB103K50
C225		CKSRYB153K50
C201, C205, C214, C230, C611		CKSRYB223K50
C244, C236		CKSRYB223K50

C221	CKSRYB224K10
C202, C222	CKSRYB473K16
C215	CKSRYB471K50
C605	CCSQCH680J50
C606	CKSRYB561K50

C607, C608	CKSRYB182K50
------------	--------------

RESISTORS

R211	RD1/4PU221J
R221	RD1/4PU222J
R233	RD1/4PU391J
R243	RS1/10S0R0J
R103	RS1/10S221J

R104	RS1/10S221J
Other Resistors	RS1/16S###J

OTHERS

CN201 (13P SOCKET)	52044-1345
BN201 (2P ANTENNA TERM.)	AKA7002
(SHIELD CASE T)	ANK7072
(SHIELD CASE B)	ANK7073
X201 (CRYSTAR RES.(7.2MHz))	ASS1093

FM FRONT END	AXF7005
AM RF TUNING BLOCK	AXX7072

**MECHA SW ASSY
CAPACITORS**

C591, C592	CKSRYB103K50
------------	--------------

SWITCHES AND RELAYS

S591	ASG7014
------	---------

OTHERS

CN591(3P JUMPER CONNCTOR)	52151-0310
---------------------------	------------

6. ADJUSTMENT



Notice) Even if it removes TUNER, other functions operate.

■ AM Tuner Section

- There is no adjustment in the AM tuner.

■ FM Tuner Section

- Set the mode selector to FM BAND.
- Connect the wiring as shown in Fig. 1.

Step No.	Adjustment Title	ANT. Input level and signal condition			Adjustment	
		Frequency (MHz)	Modulation	Input Level (dB μ V)	Adjust point	Contents
1	T-METER Adjustment	98	OFF	80	L201	Adjust L201 so that the DC voltage between Pin 21 and Pin 23 of IC201 (Test point V _{tm}) gets within 0 \pm 50mV.

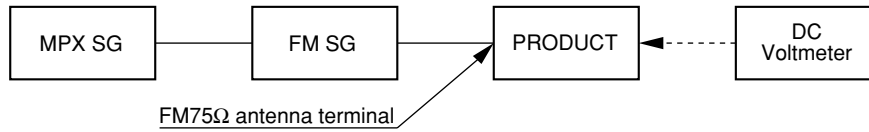

Fig.1 Adjustment Wiring Diagram

U FM/AM TUNER MODULE

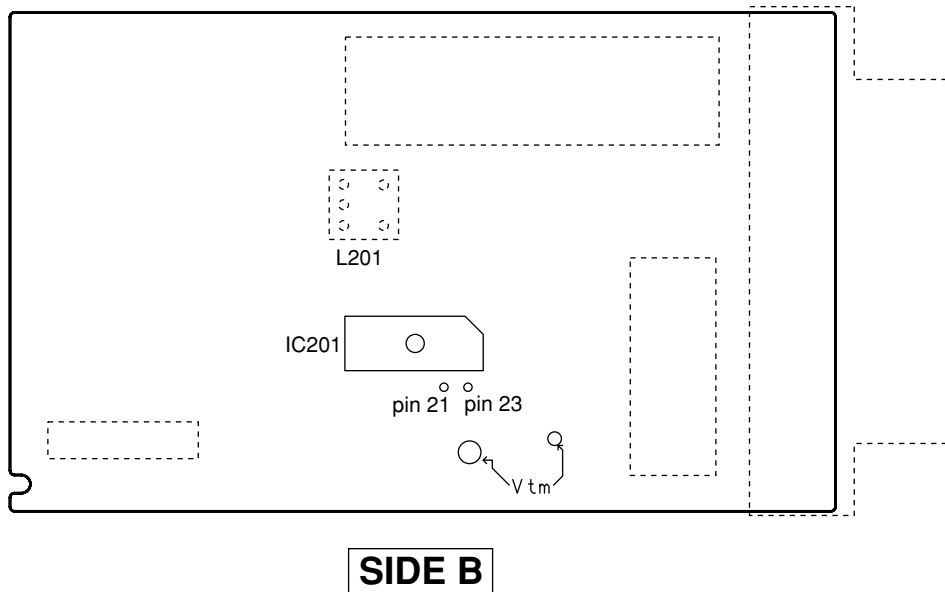

Fig.2 Adjustment Point

7. GENERAL INFORMATION

7.1 DISASSEMBLY and DIAGNOSI

7.1.1 DISASSEMBLY and PCB LOCATION

■ Diagnosis

① Remove the Bonnet (seven screws).

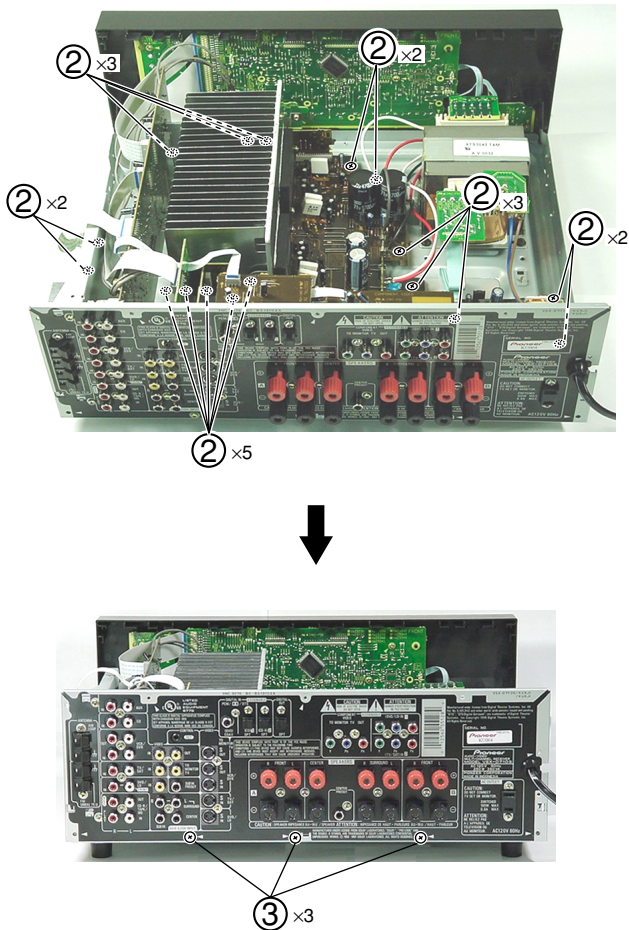

Note : This photograph shows other models. However, the work method is the same.

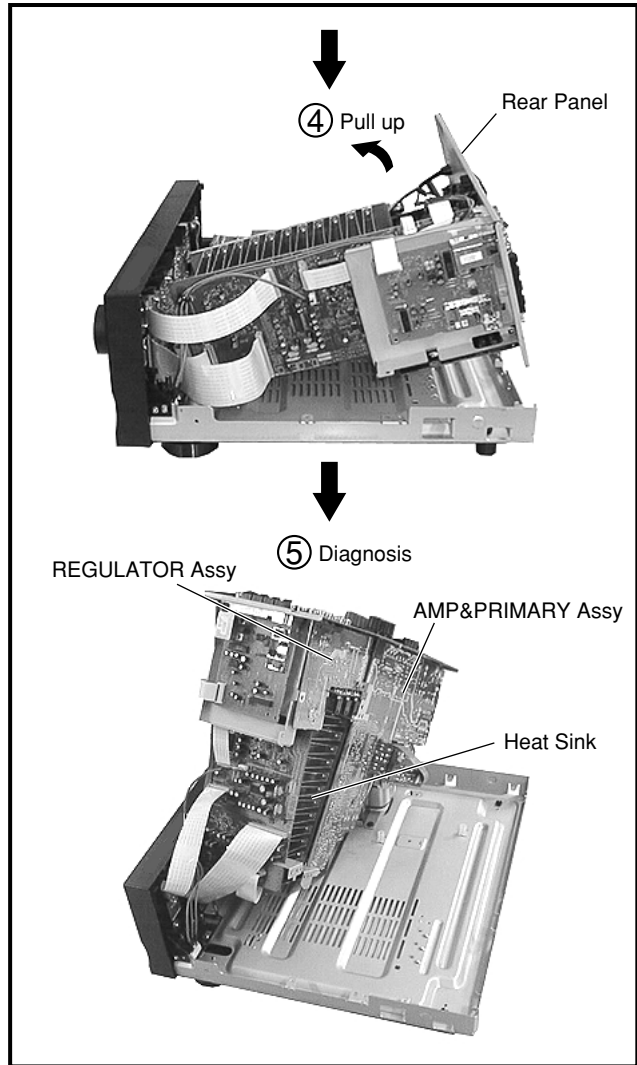

Note : If a speaker and the screw of a rear panel are removed, a set will stop moving. Even if it removes TUNER Unit, it is uninfluential in operation of those other than TUNER Unit.

■ PCB Location

NOTE : This photograph is VSX-D711

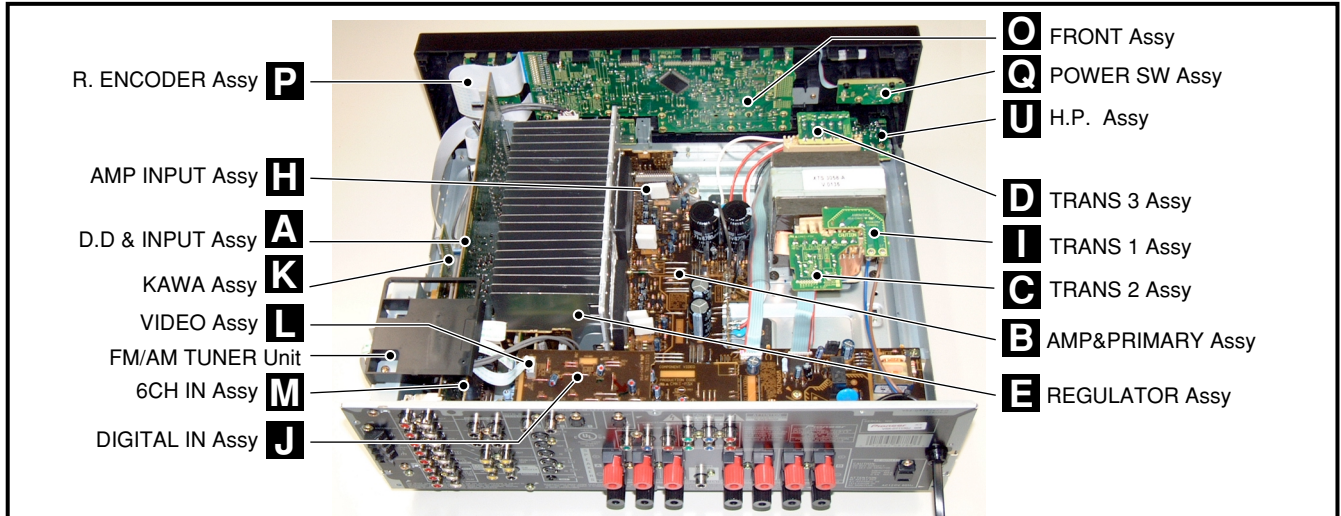

7.1.2 U-COM BLOCKDIAGRAM

A
B
C
D
E
F

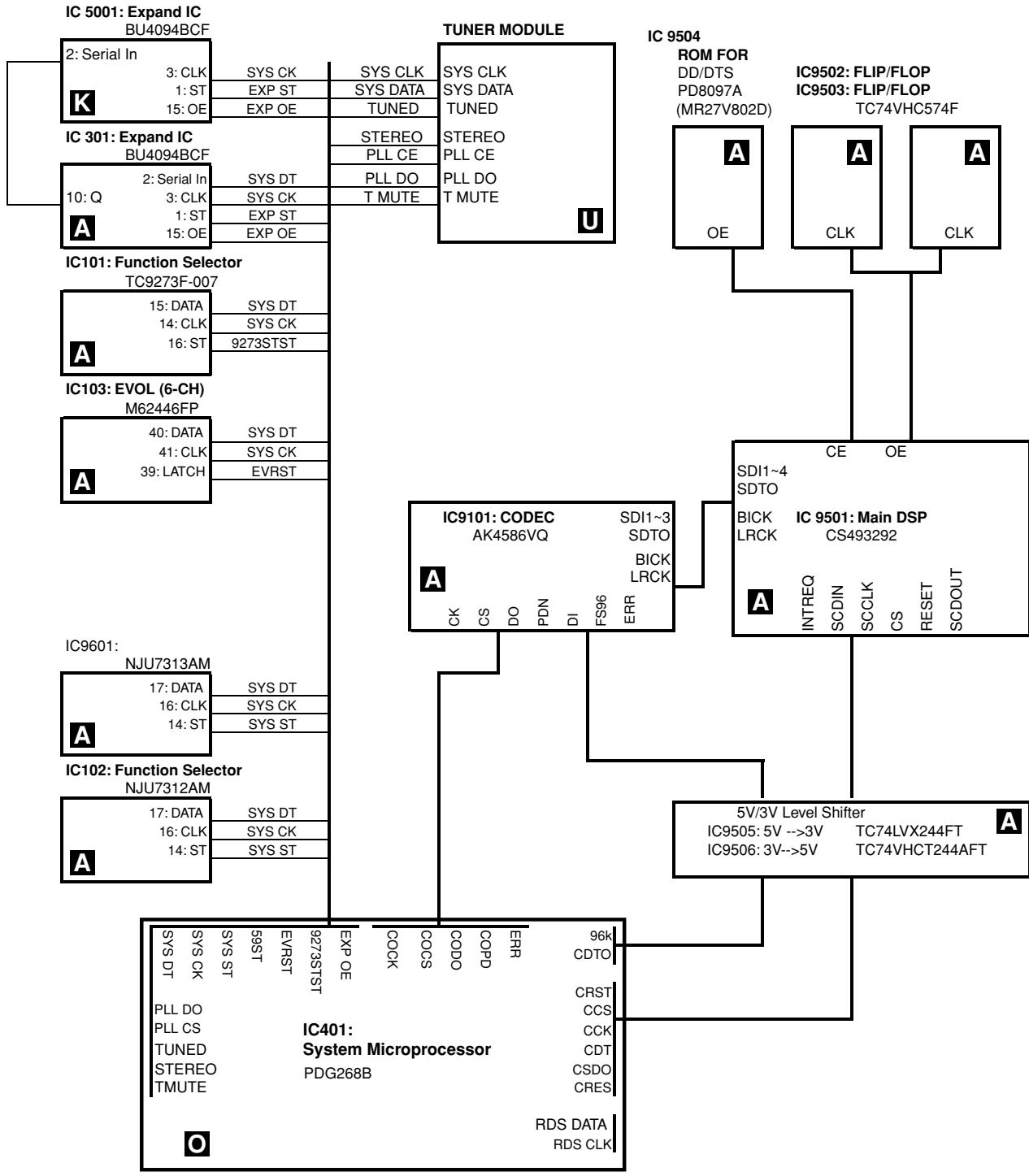

7.1.3 PROTECTION CIRCUIT

1. DC abnormal detection

It processes more preferentially than overload detection.

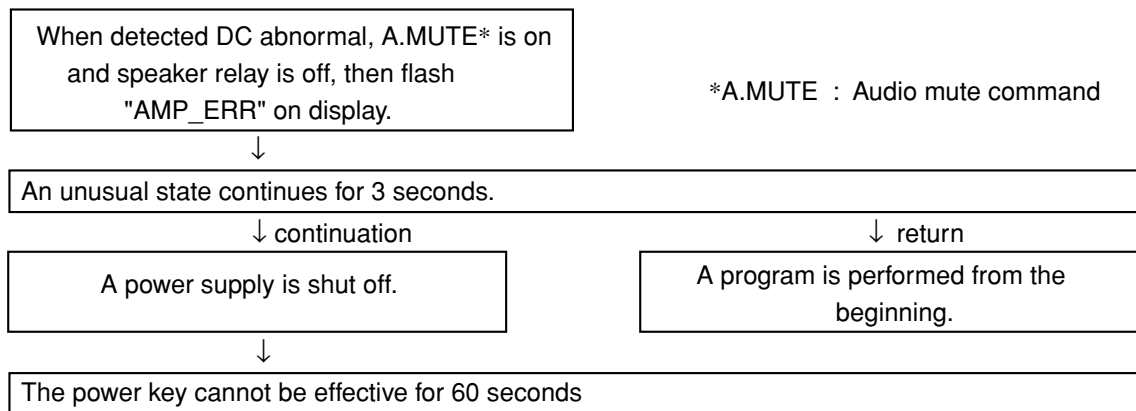

If the AC plug is pulled off within 60 sec, and then it is plugged in again, the unit will be reset for 60 sec.

2. Overload detection

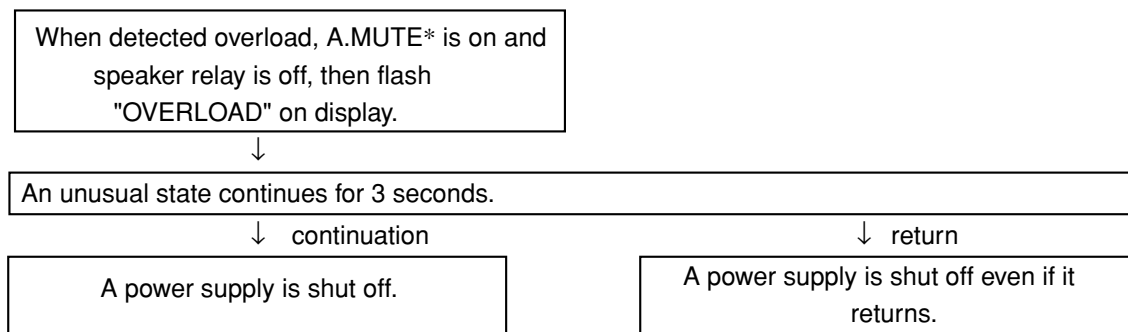

7.1.4 POWER ON SEQUENCE

POWER ON SEQUENCE

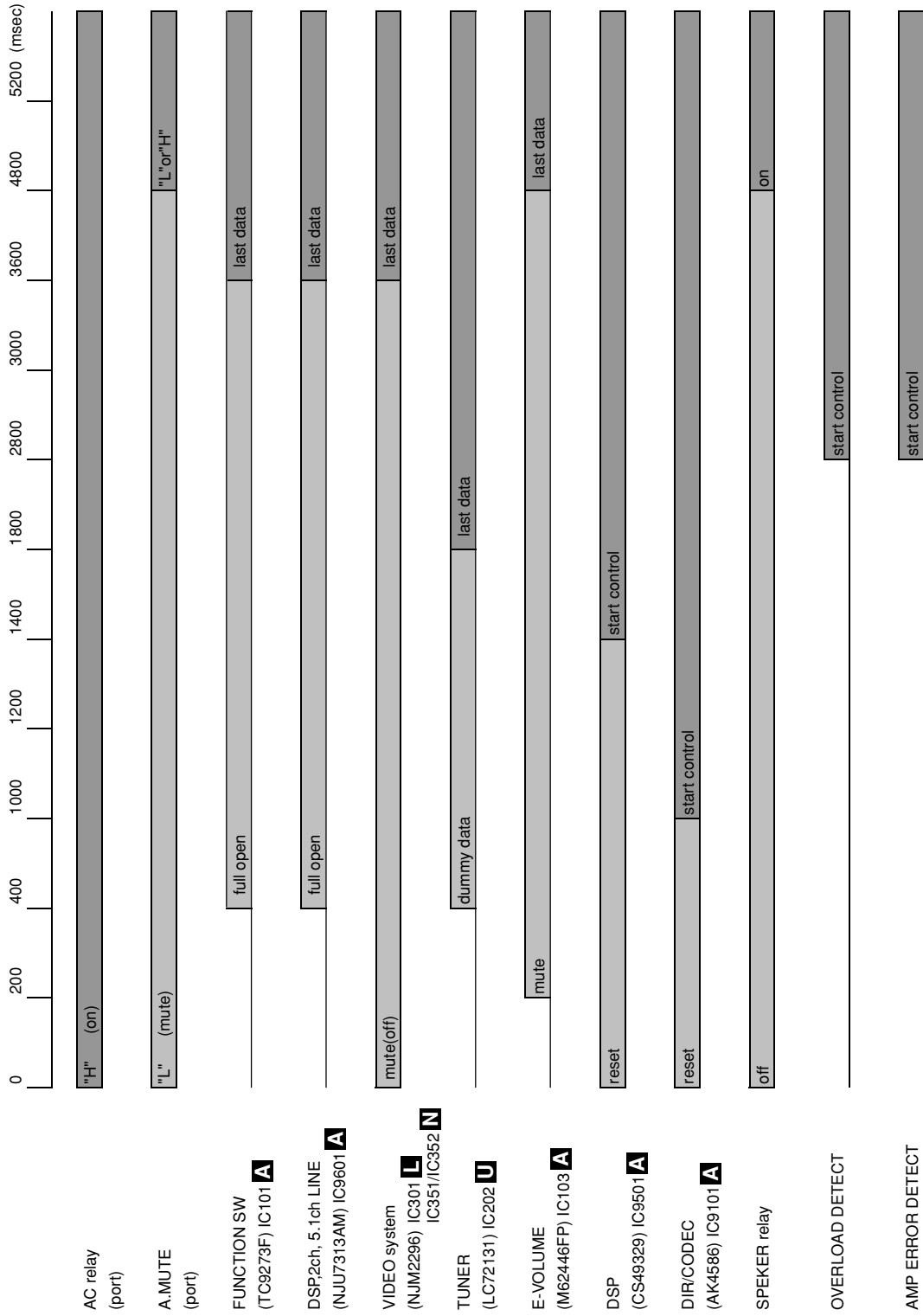

7.1.5 POWER OFF SEQUENCE

■ POWER OFF SEQUENCE

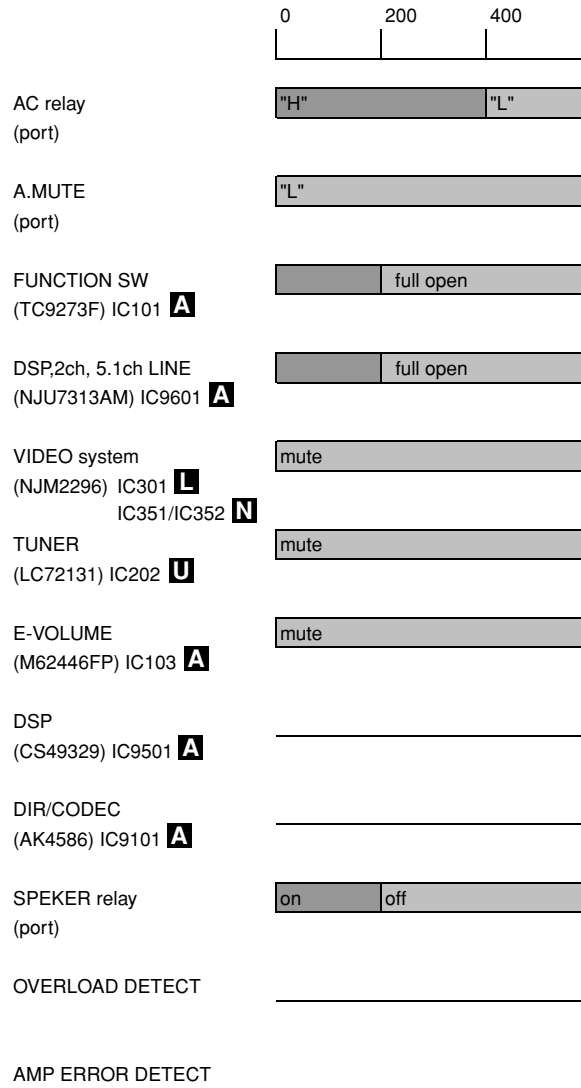

7.2 PARTS

7.2.1 IC

The information shown in the list is basic information and may not correspond exactly to that shown in the schematic diagrams.

List of IC

PDG268B, AK4586VQ, BD3812F, NJU7312AM, PD8097A, AK4382

PDG268B (FRONT ASSY : IC401)

System Control MCU

Pin Arrangement (Top View)

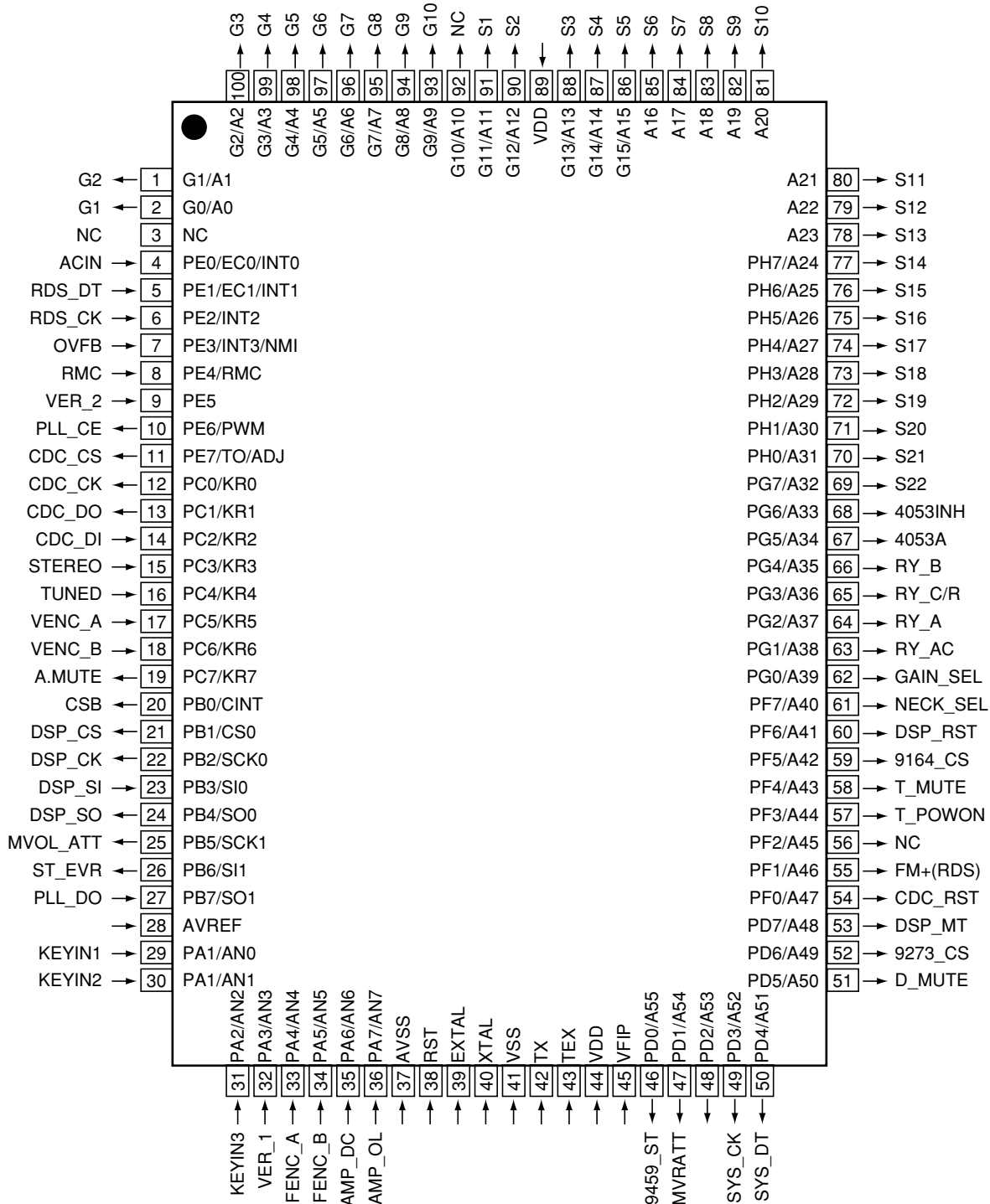

• Pin Function

No.	Pin Name	I/O	Pin Function	Active
1	G2	O	Grid output 2	H
2	G1	O	Grid output 1	H
3	NC	–	Connect to Vdd	
4	ACIN	I	Input AC pulse	
5	RDS_DT	I	Serial control DATA signal of RDS communication	
6	RDS_CK	I	Serial control CLOCK signal of RDS communication (Use external interrupt)	
7	DIRLOCK	I	ERR/OVER input from CODEC	
8	RMC	I	Remote control signal input (no-carrier signal)	
9	VER_2	I	Destination switch 2	
10	ST_EVR	O	Strobe of communication for E-volume	H
11	CDC_CS	O	Chip select for CODEC	
12	CDC_CK	O	Control clock for CODEC & TC9164	
13	CDC_DO	O	Control data for CODEC & TC9164	
14	CDC DI	I	Data input from DIR	
15	STEREO	I	Signal to switch Stereo / Monoral	
16	TUNED	I	Condition of TUNED	
17	VENC_A	I	Input from rotary encoder of E-volume (A)	
18	VENC_B	I	Input from rotary encoder of E-volume (B)	
19	HP ON	I	Headphone detect	L
20	CREQ	I	Request for DSP	L
21	CCS	O	Chip select for DSP	L
22	CCK	O	Clock signal for DSP	H
23	CDT	I	DATA input signal for DSP	
24	CSDO	O	DATA output signal for DSP	H
25	FS 96	I	96 k	H
26	AMP_OL	I	Detect overload of protection circuit (L: overload)	H
27	PLL_DO	I	Data input signal for communication with LC72131 (Tuner)	
28	AVref	–	Connect to Vdd	
29	KEYIN1	I	Key input A/D conversion port 1	
30	KEYIN2	I	Key input A/D conversion port 2	
31	KEYIN3	I	Key input A/D conversion port 3	
32	VER_1	I	Input 1 to switch region (A/D input)	
33	FENC_A	I	FUNC Rotary encoder signal input (A)	
34	FENC_B	I	FUNC Rotary encoder signal input (B)	
35	AMP_DC	I	Detect trouble DC of protection circuit (L : Trouble)	L
36	VER_2	I	Input 2 to switch region (A/D input)	L
37	AVSS	–	Connect to Vss	
38	RST	–	Reset	
39	EXTAL	–	Connect to the oscillator (7.2MHz)	
40	XTAL	–		
41	VSS	–	Connect to Vss	
42	TX	–	NC	
43	TEX	–	Connect to Vss	
44	VDD	–	+5V	
45	VFDP	–	-30V	
46	9459_ST	O	Strobe for E-volume (TC9459) of SB	
47	MVRATT	O	ATT control of master volume for E-volume (less than -15dB : L)	H
48				H
49	SYS_DT	O	Data signal for communication with M62446, TC9163, TC9164 and PLL	H
50	SYS_CK	O	Clock signal for communication with M62446, TC9163, TC9164 and PLL	H

• Pin Function

No.	Pin Name	I/O	Pin Function	Active
51	9273_CS	O	Chip select for TC9273	H
52	DSP_MT	O	DSP Mute (ASSY mute)	H
53	GAIN_SEL	O	Gain select (5.1ch and Stereo of analog input : H)	H
54	AMUTE	O	Audio mute	H
55	T_MUTE	O	Tuner mute	H
56	PLL_CE	O	Chip select for communication to LC72131 (Tuner)	
57	NECK_SEL	O	5.1ch, surround mode and A+B Stereo : H / Stereo : L	H
58	FM+(RDS)	O	Tr switch ON/OFF for power supply of RDS decoder (L : AM, power OFF , H : Other)	H
59	9164_CS	O	TC9163, TC9164 Chip select	
60	CRST	O	Reset for DSP	
61	CDC_PD	O	Power down for CODEC	
62	ABOT	O	Abort for DSP	H
63	RY_AC	O	AC relay ON/OFF	H
64	RY_A	O	Speaker A relay ON/OFF	H
65	RY_C/R	O	Rear/Center Speaker relay ON/OFF	H
66	EXP_CS	O	Chip select for expand IC	H
67	EXP_OE	O	Chip select for expand IC	H
68	RY_AC	O	AC relay ON/OFF control	H
69	S22	O	Segment output 22	H
70	S21		Segment output 21	
71	S20		Segment output 20	
72	S19		Segment output 19	
73	S18		Segment output 18	
74	S17		Segment output 17	
75	S16		Segment output 16	
76	S15		Segment output 15	
77	S14		Segment output 14	
78	S13		Segment output 13	
79	S12		Segment output 12	
80	S11		Segment output 11	
81	S10		Segment output 10	
82	S9		Segment output 9	
83	S8		Segment output 8	
84	S7		Segment output 7	
85	S6		Segment output 6	
86	S5		Segment output 5	
87	S4		Segment output 4	
88	S3		Segment output 3	
89	VDD	-	5V	
90	S2	O	Segment output 2	H
91	S1		Segment output 1	
92	Not used	O	Not used (Fixed Vfdp)	
93	G10	O	Grid output 10	H
94	G9		Grid output 9	
95	G8		Grid output 8	
96	G7		Grid output 7	
97	G6		Grid output 6	
98	G5		Grid output 5	
99	G4		Grid output 4	
100	G3		Grid output 3	

■ **AK4586VQ (DD & INPUT ASSY : IC9101)**

• 96kHz 24Bit 6-channel CODEC with DIR

■ **Pin Arrangement (Top View)**

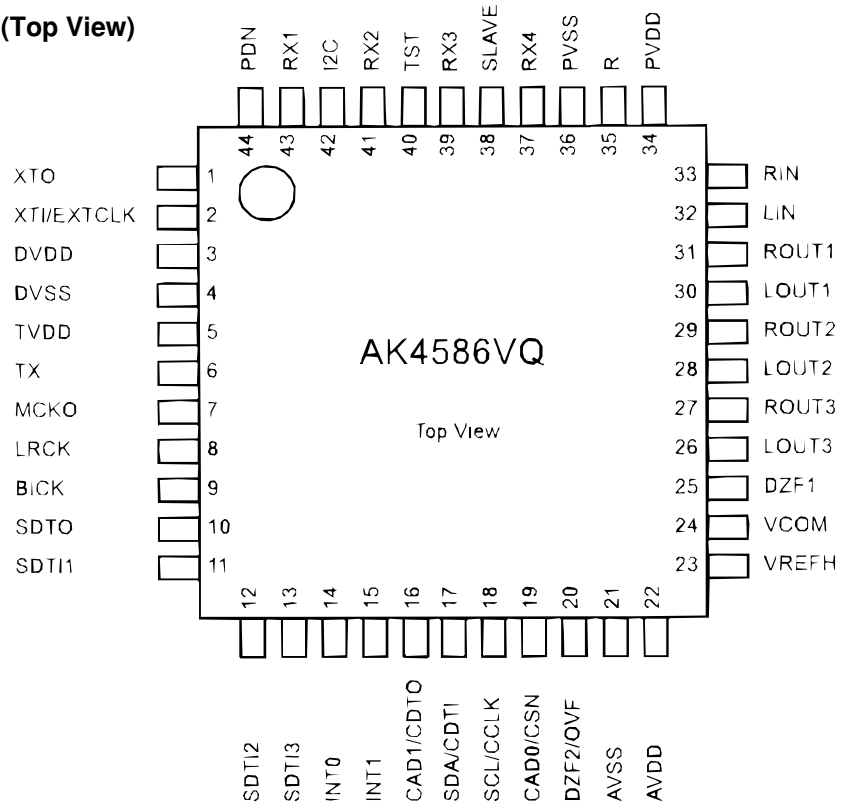

■ **Block Diagram**

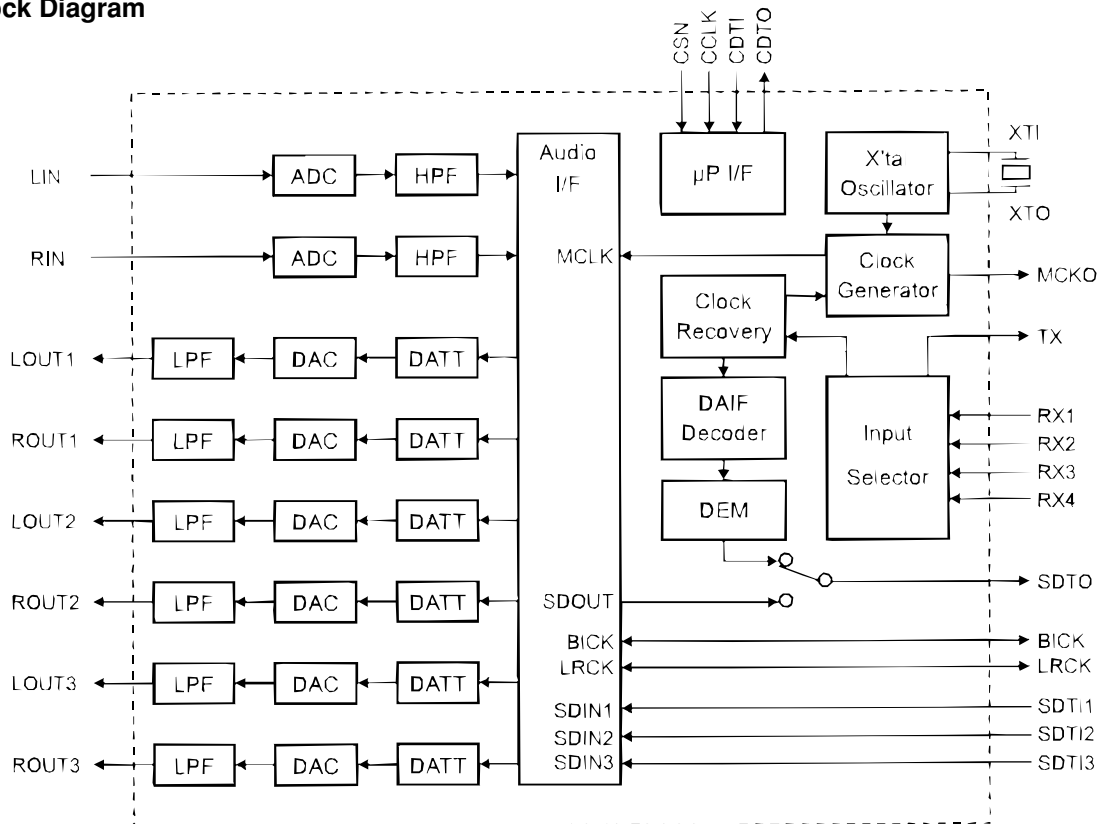

■ Pin / Function

PIN/FUNCTION

No.	Pin Name	I/O	Function
1	XTO	O	X'tal Output Pin
2	XTI	I	X'tal Input Pin
	EXTCLK	I	External Master Clock Input Pin
3	TVDD	-	Output Buffer Power Supply Pin, 2.7V~5.5V
4	DVSS	-	Digital Ground Pin, 0V
5	DVDD	-	Digital Power Supply Pin, 4.5V~5.5V
6	TX	O	Transmit channel (through data) Output Pin
7	MCKO	O	Master Clock Output Pin
8	LRCK	I/O	Input/Output Channel Clock Pin
9	BICK	I/O	Audio Serial Data Clock Pin
10	SDTO	O	Audio Serial Data Output Pin
11	SDTI1	I	DAC1 Audio Serial Data Input Pin
12	SDTI2	I	DAC2 Audio Serial Data Input Pin
13	SDTI3	I	DAC3 Audio Serial Data Input Pin
14	INT0	O	Interrupt 0 pin
15	INT1	O	Interrupt 1 pin
16	CDTO	O	Control Data Output Pin in 4-wire serial control mode
	CAD1	I	Chip Address 1 Pin in I ² C bus control mode
17	CDTI	I	Control Data Input Pin in 4-wire serial control mode
	SDA	I/O	Control Data Input/Output Pin in I ² C bus control mode
18	CCLK	I	Control Data Clock Pin in 4-wire serial control mode
	SCL	I	Control Data Clock Pin in I ² C bus control mode
19	CSN	I	Chip Select Pin in 4-wire serial control mode
	CAD0	I	Chip Address 0 Pin in I ² C bus control mode
20	DZF2	O	Zero Input Detect 2 Pin (Note 1) When the input data of the group 1 follow total 8192 LRCK cycles with "0" input data, this pin goes to "H".
	OVF	O	Analog Input Overflow Detect Pin (Note 2) This pin goes to "H" if the analog input of Lch or Rch is overflows.
21	AVSS	-	Analog Ground Pin, 0V
22	AVDD	-	Analog Power Supply Pin, 4.5V~5.5V

■ Pin / Function

No.	Pin Name	I/O	Function
23	VREFH	I	Positive Voltage Reference Input Pin, AVDD
24	VCOM	O	Common Voltage Output Pin, AVDD/2 Large external capacitor around 2.2 μ F is used to reduce power-supply noise.
25	DZF1	O	Zero Input Detect 1 Pin (Note 1) When the input data of the group 1 follow total 8192 LRCK cycles with "0" input data, this pin goes to "H".
26	LOUT3	O	DAC3 Lch Analog Output Pin
27	ROUT3	O	DAC3 Rch Analog Output Pin
28	LOUT2	O	DAC2 Lch Analog Output Pin
29	ROUT2	O	DAC2 Rch Analog Output Pin
30	LOUT1	O	DAC1 Lch Analog Output Pin
31	ROUT1	O	DAC1 Rch Analog Output Pin
32	LIN	I	Lch Analog Input Pin
33	RIN	I	Rch Analog Input Pin
34	PVDD	-	PLL Power Supply Pin, 4.5V~5.5V
35	R	-	External Resistor Pin 18k Ω +/-1% resistor to PVSS externally.
36	PVSS	-	PLL Ground Pin, 0V
37	RX4	I	Receiver Channel 4 Pin (Internal biased pin)
38	SLAVE	I	Slave Mode Pin "L": Master mode or Slave mode, "H": Slave mode
39	RX3	I	Receiver Channel 3 Pin (Internal biased pin)
40	TST	I	Test Pin This pin should be connected to DVSS.
41	RX2	I	Receiver Channel 2 Pin (Internal biased pin)
42	I2C	I	Control Mode Select Pin "L": 4-wire Serial, "H": I ² C Bus
43	RX1	I	Receiver Channel 1 Pin (Internal biased pin)
44	PDN	I	Power-Down & Reset Pin When "L", the AK4586 is powered-down, all output pins go to "L" and the control registers are reset to default state. If the state of CAD1-0 changes, then the AK4586 must be reset by PDN.

Notes:

1. The group 1 and 2 can be selected by DZFM2-0 bits.
2. This pin becomes OVF pin if OVFE bit is set to "1".
3. All input pins except internal biased pins should not be left floating.

BD3812F (D.D & INPUT ASSY : IC112)

• Audio Sound Processor

• Block Diagram

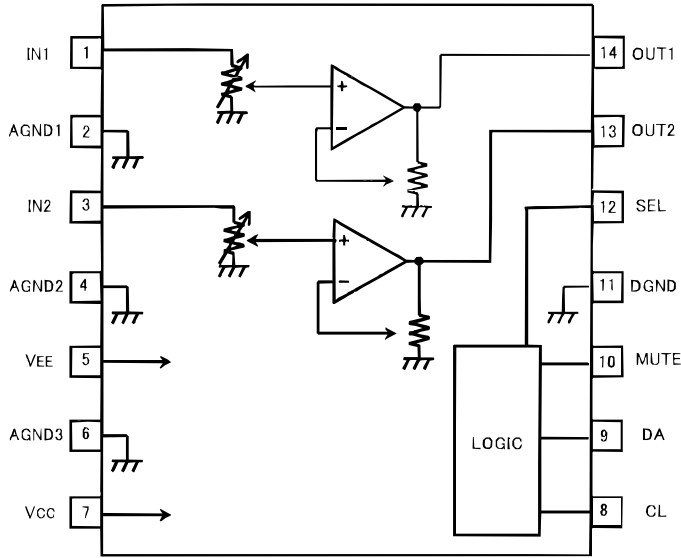

• Pin Function

No.	Pin Name	Function
1	IN1	1ch input terminal
2	AGND1	Analog ground terminal
3	IN2	2ch input terminal
4	AGND2	Analog ground terminal
5	Vee	(-) Power supply terminal
6	AGND3	Analog ground terminal
7	Vcc	(+) Power supply terminal
8	CL	Serial clock input terminal
9	DA	Serial data an latch input terminal
10	MUTE	Mute terminal
11	DGND	Ground terminal for comparator
12	SEL	Serial data select terminal
13	OUT2	2ch output terminal
14	OUT1	1ch output terminal

NJU7312AM (D.D & INPUT ASSY : IC102)

• Analog Switch Array

• Block Diagram

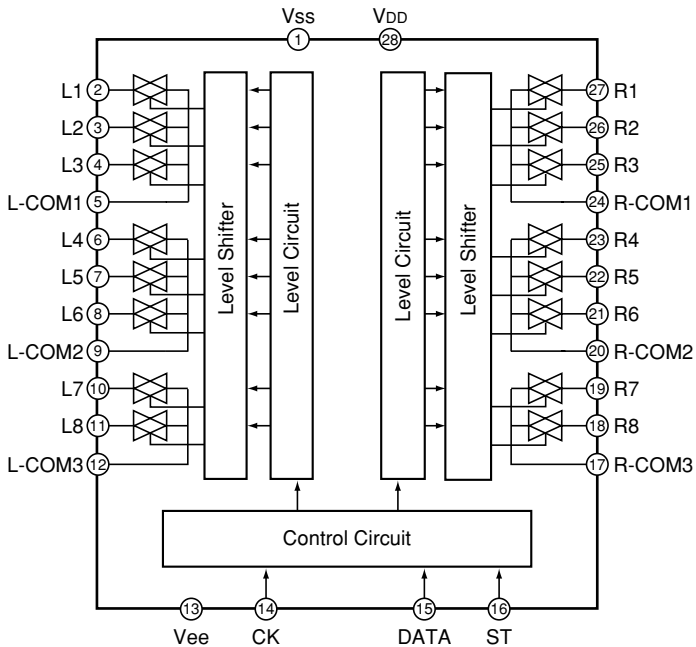

• Pin Function

No.	Pin Name	Function
1	VSS	Minus Power Supply
2, 27	L1,R1	Input and Output
3, 26	L2,R2	
4, 25	L3,R3	
5, 24	COM1	
6, 23	L4,R4	
7, 22	L5,R5	
8, 21	L6,R6	
9, 20	COM2	
10, 19	L7,R7	
21, 18	L8,R8	
26, 17	COM3	
13	GND	Digital Ground
14	CK	Clock Input
15	DATA	Data Input
16	ST	Strobe Input
28	VDD	Plus Power Supply

■ PD8097A (D.D & INPUT ASSY : IC9504)

• 4Mb P2ROM

■ Pin Arrangement (Top View)

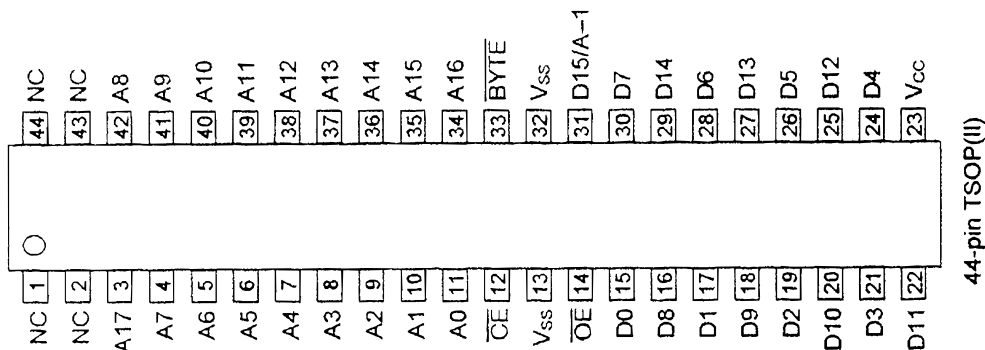

■ Block Diagram

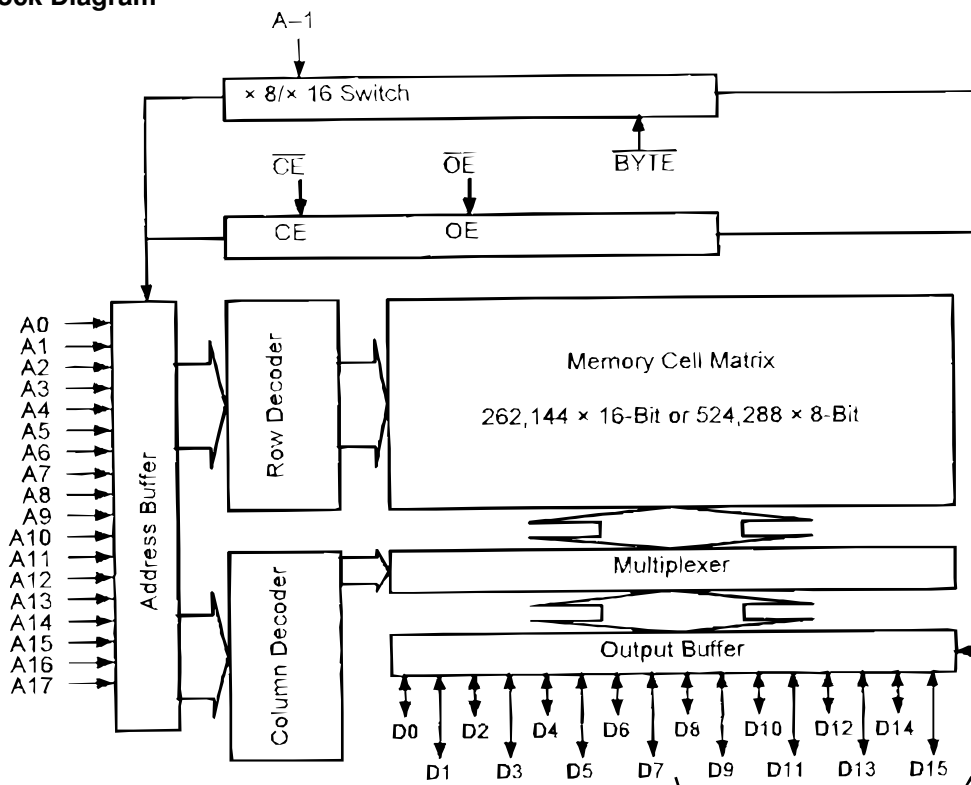

In 8-bit output mode, these pins are placed in a high-Z state and pin D15 functions as the A-1 address pin.

AK4382AVT (DD & INPUT ASSY : IC9102)

• D/A Converter IC

Block Diagram

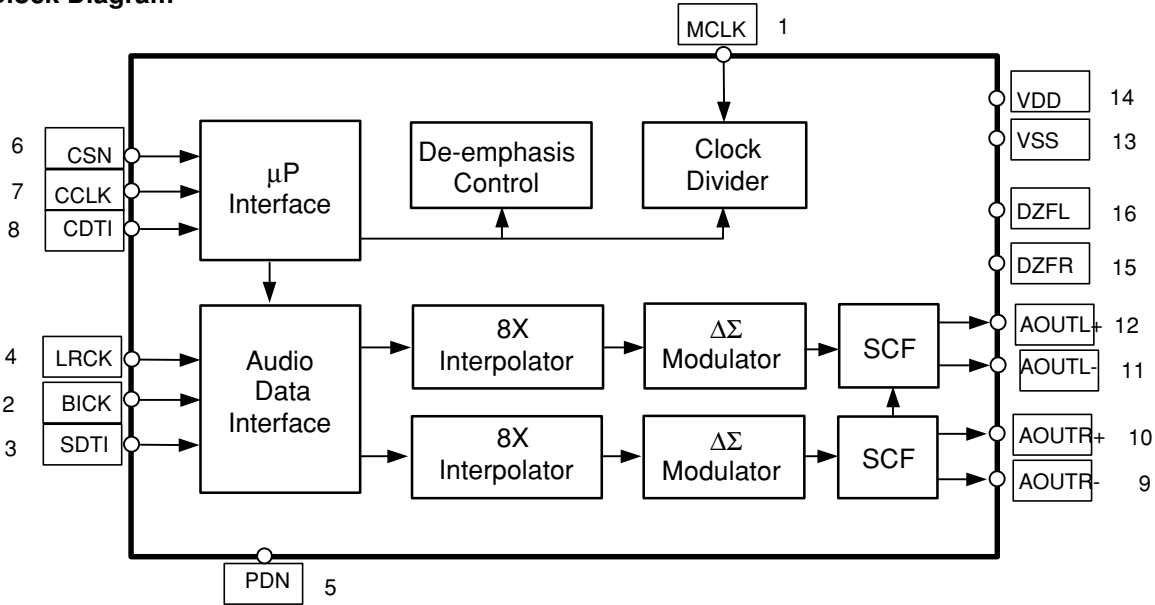

Pin Function

Pin / Function			
No.	Pin Name	I/O	Function
1	MCLK	I	Master Clock Input Pin An external TTL clock should be input on this pin.
2	BICK	I	Audio Serial Data Clock Pin
3	SDTI	I	Audio Serial Data Input Pin
4	LRCK	I	L/R Clock Pin
5	PDN	I	PowerDown Mode Pin When at $\bar{L}\hat{1}$, the AK4382 is in the power down mode and is held in reset. The AK4382 should always be reset upon power-up.
6	CSN	I	Chip Select Pin
7	CCLK	I	Control Data Input Pin
8	CDTI	I	Control Data Input Pin
9	AOUTR-	O	Rch Negative Analog Output Pin
10	AOUTR+	O	Rch Positive Analog Output Pin
11	AOUTL-	O	Lch Negative Analog Output Pin
12	AOUTL+	O	Lch Positive Analog Output Pin
13	VSS	-	Ground Pin
14	VDD	-	Power Supply Pin
15	DZFR	O	Rch Data Zero Input Detect Pin
16	DZFL	O	Lch Data Zero Input Detect Pin

Note: All input pins should not be left floating.

7.2.2 DISPLAY

■ XAV3013 (FRONT ASSY : V401)

• FL DISPLAY

• Pin Assignment

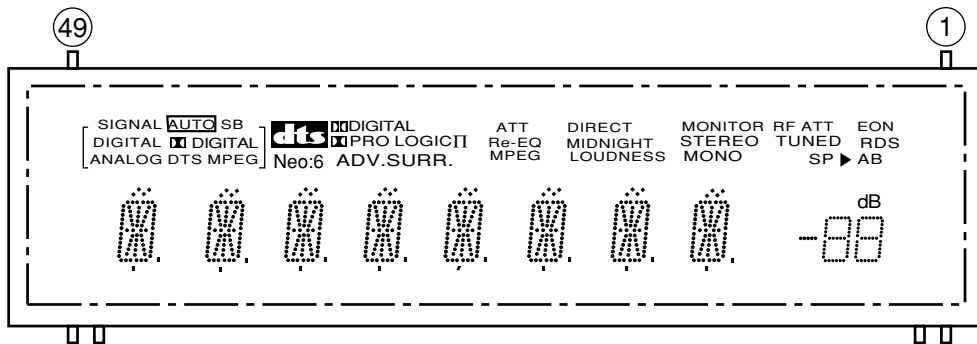

• Grid Assignment

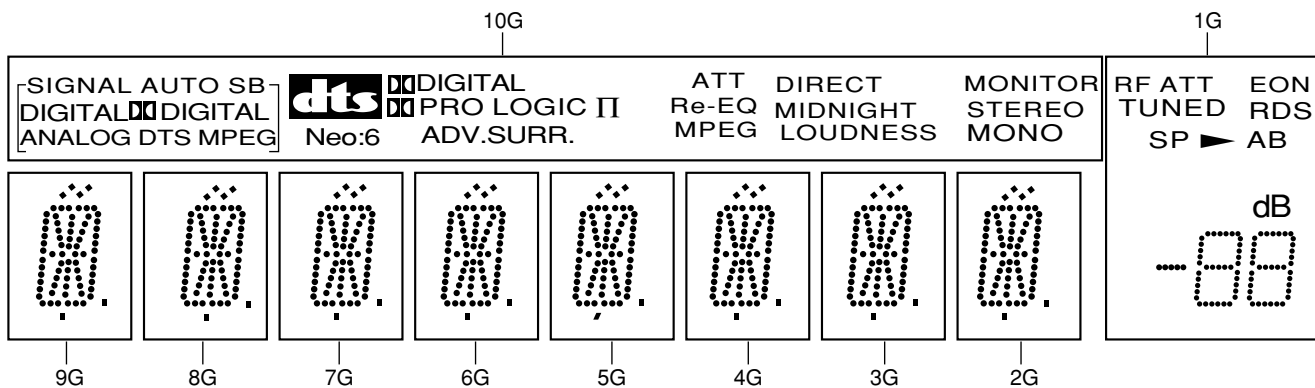

• Segment Designation

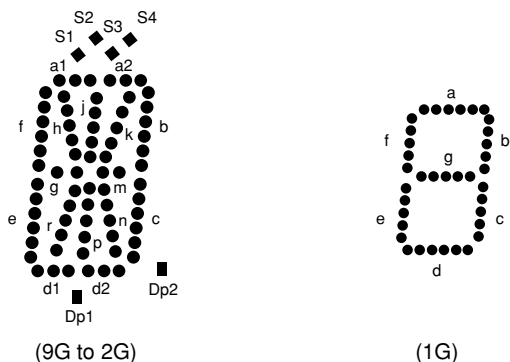

• Pin Connection

Pin No.	49	48	47	46	45	44	43	42	41	40	39	38	37	36	35	34	33	32	31	30	29	28	27	26	25
Connection	F2	F2	NP	NP	P22	P21	P20	P19	P18	P17	P16	P15	P14	P13	P12	P11	P10	P9	P8	P7	P6	P5	P4	P3	P2
Pin No.	24	23	22	21	20	19	18	17	16	15	14	13	12	11	10	9	8	7	6	5	4	3	2	1	
Connection	P1	NX	NX	NX	NX	NX	NX	NX	NX	NX	10G	9G	8G	7G	6G	5G	4G	3G	2G	1G	NP	NP	F1	F1	

- NOTE 1) F1, F2..... Filament
 2) NP..... No pin
 3) NX..... No extend pin
 4) DL..... Datum Line
 5) 1G to 10G..... Grid
 6) Field of vision is a minimum of 21.8° from the lower side.

• Anode Connection

	10G	9G	8G	7G	6G	5G	4G	3G	2G	1G
P1	S1	a1	a1	a1	a1	a1	a1	a1	a1	RFATT
P2	AUTO	a2	a2	a2	a2	a2	a2	a2	a2	EON
P3	SB	h	h	h	h	h	h	h	h	○
P4	DIGITAL	j	j	j	j	j	j	j	j	TUNED
P5	ANALOG	k	k	k	k	k	k	k	k	RDS
P6	DIGITAL (L)	b	b	b	b	b	b	b	b	S1
P7	DTS	f	f	f	f	f	f	f	f	A
P8	MPEG	m	m	m	m	m	m	m	m	B
P9	dtc	g	g	g	g	g	g	g	g	1a
P10	MPEG	c	c	c	c	c	c	c	c	1b
P11	DIGITAL (R)	e	e	e	e	e	e	e	e	1f
P12	PROLOGIC II	r	r	r	r	r	r	r	r	1g
P13	Neo:6	p	p	p	p	p	p	p	p	1c
P14	ATT	n	n	n	n	n	n	n	n	1e
P15	ADV.SURR.	d1	d1	d1	d1	d1	d1	d1	d1	1d
P16	Re-EQ	d2	d2	d2	d2	d2	d2	d2	d2	2a
P17	DIRECT	Dp2	Dp2	Dp2	Dp2	Dp2	Dp2	Dp2	Dp2	2b
P18	MIDNIGHT	Dp1	Dp1	Dp1	Dp1	Dp1	Dp1	Dp1	Dp1	2f
P19	LOUDNESS	S1	S1	S1	S1	S1	S1	S1	S1	2g
P20	MONITOR	S4	S4	S4	S4	S4	S4	S4	S4	2c
P21	STEREO	S2	S2	S2	S2	S2	S2	S2	S2	2e
P22	MONO	S3	S3	S3	S3	S3	S3	S3	S3	2d

8. PANEL FACILITIES

Front panel

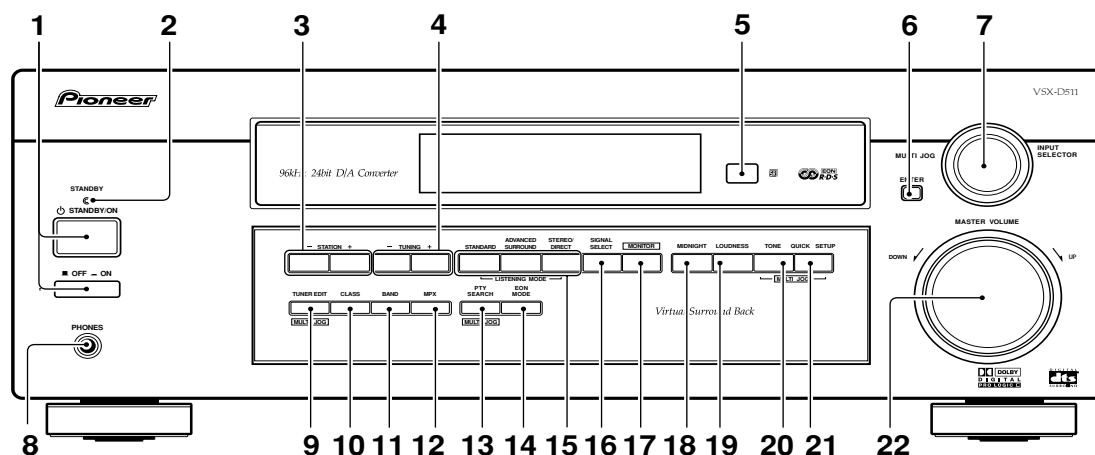

1 **STANDBY/ON**

Switches the receiver between on and standby.

2 **STANDBY indicator**

Lights when the receiver is in standby mode.

3 **STATION (+/-) buttons**

Selects station presets when using the tuner.

4 **TUNING (+/-) buttons**

Selects the frequency when using the tuner.

5 **Remote sensor**

Receives the signals from the remote control.

6 **ENTER**

7 **MULTI JOG/INPUT SELECTOR dial**

The MULTI JOG/INPUT SELECTOR dial performs a number of tasks.

Use it to select options after pressing **TONE CONTROL**, **QUICK SETUP** or **TUNER EDIT**.

8 **PHONES jack**

Use to connect headphones.

9 **TUNER EDIT**

Press to memorize and name a station for recall using the station (+/-) buttons.

10 **CLASS**

Switches between the three banks (classes) of station presets.

11 **BAND**

Switches between AM and FM radio bands.

12 **MPX**

Press the MPX button to receive a radio broadcast in mono.

13 **PTY SEARCH**

Use to search for different program types in RDS mode.

14 **EON MODE**

Use to search for different programs that are transmitting traffic or news information (this search method is called EON).

15 **LISTENING MODE buttons**

STANDARD

Press for Standard decoding and to switch between the various Pro Logic II options.

ADVANCED SURROUND

Use to switch between the various surround modes.

STEREO/DIRECT

Switches direct playback on or off. Direct playback bypasses the tone controls and channel levels for the most accurate reproduction of a source.

16 **SIGNAL SELECT**

Use to select between an analog or digital signal.

17 **MONITOR**

Press to switch tape monitoring on/off.

18 **MIDNIGHT**

Use when listening to movie soundtracks at low volumes.

19 **LOUDNESS**

Use to boost the bass and treble at low volumes.

20 **TONE**

Press this button to access the bass and treble controls, which you can then adjust with the MULTI JOG/INPUT SELECTOR dial.

21 **QUICK SETUP**

22 **MASTER VOLUME**

When the headphones are connected, there is no sound output from the speakers.

Display

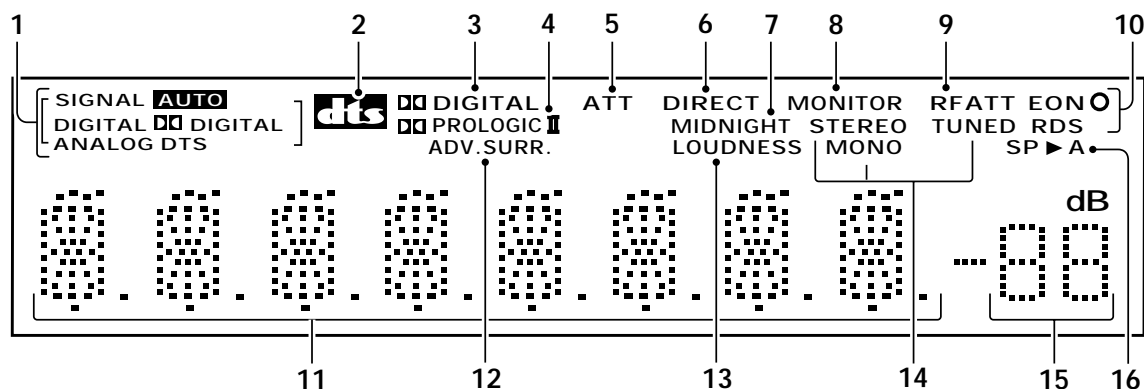

1 SIGNAL SELECT indicators

Lights to indicate the type of input signal assigned for the current component:

AUTO

Lights when AUTO signal select is on

SB

Depending on the source, this lights when a signal with surround back channel encoding is detected.

DIGITAL

Lights when a digital audio signal is detected.

DIGITAL

Lights when a Dolby Digital encoded signal is detected.

ANALOG

Lights when an analog signal is detected.

DTS

Lights when a source with DTS encoded audio signals is detected.

2 DTS

When the Standard mode of the receiver is on, this lights to indicate decoding of a DTS signal.

3 DIGITAL

When the Standard mode of the receiver is on, this lights to indicate decoding of a Dolby Digital signal.

4 PRO LOGIC II

When the Standard mode of the receiver is on, this lights to indicate Pro Logic II decoding.

5 ATT

Lights when INPUT ATT is used to attenuate (reduce) the level of the analog input signal.

6 DIRECT

Lights when source direct playback is in use. This function bypasses all tone, balance, Advanced surround, and Dolby Surround effects.

7 MIDNIGHT

Lights during Midnight listening.

8 MONITOR

Lights when MONITOR is selected

9 RF ATT

Lights when the RF ATT is on .

10 EON and ○

The ○ indicator lights to inform you that the currently tuned station carries the EON data service. When the EON mode is set, the EON indicator lights, but during actual reception of an EON broadcast the EON indicator will flash.

RDS: Lights when an RDS broadcast is received.

11 Character display

12 ADV. SURR (Advanced Surround)

Lights when one of the Advanced Surround modes has been selected.

13 LOUDNESS

Lights when LOUDNESS has been selected.

14 TUNER indicators

STEREO:

Lights when a stereo FM broadcast is being received in auto stereo mode.

MONO:

Lights when the mono mode is set using the MPX button.

TUNED:

Lights when a broadcast is being received.

15 Master volume level

Shows the overall volume level. ---dB indicates the minimum level, and -0 dB indicates the maximum level.

Depending on your level settings for each channel, the maximum level can range between -10 dB and -0 dB.

16 Speaker indicator

Shows if the speaker system is on or not.

SP ►A means speakers are switched on. SP ► means the head phones are connected.

Remote control

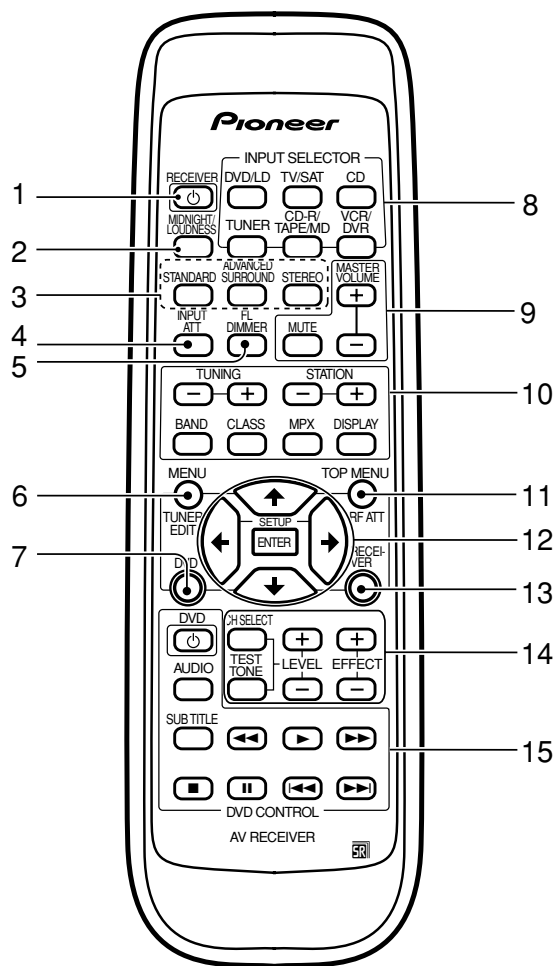

1 RECEIVER

Switches the receiver between on and standby.

2 MIDNIGHT/LOUDNESS

Use to switch to Midnight or Loudness listening.

3 LISTENING MODE buttons

STANDARD

Press for Standard decoding and to switch between the various Pro Logic II options.

ADVANCED SURROUND

Use to switch between the various surround modes.

STEREO/DIRECT

Switches direct playback on or off. Direct playback bypasses the tone controls and channel levels for the most accurate reproduction of a source.

4 INPUT ATT

Use to attenuate (lower) the level of an analog input signal to prevent distortion.

5 FL DIMMER

Use this button to make the fluorescent display (FL) dimmer or brighter.

6 MENU (DVD control)

Use to access different menus associated with your DVD player. TUNER EDIT (Receiver control) (pages 35–36)

Press to memorize and name a station for recall using the STATION (+/-) buttons.

7 DVD

Use to switch over to the DVD controls on the remote control.

The DVD controls on the remote control (**TOP MENU**, **MENU**, and **ENTER/SETUP** buttons) can only be used for DVD control after pressing **DVD** on the remote. See the next page for more on the separate **DVD CONTROL** buttons.

8 INPUT SELECTOR buttons

Use to select the input source.

9 Volume buttons

Use **MASTER VOLUME +/-** to set the overall listening volume.

Use **MUTE** to mute the sound or restore the sound if it has been muted.

10 Tuner controls

The **TUNING +/-** buttons can be used to find radio frequencies.

The **STATION +/-** buttons can be used to select preset radio stations.

BAND

Use to switch between the AM and FM bands when the tuner is selected.

CLASS

Use to switch between the three banks (classes) of station presets.

MPX

Use to switch between auto stereo and mono reception of FM broadcasts. If the signal is weak then switching to mono will improve the sound quality.

DISPLAY

Use to switch the display between the station preset name and the frequency.

11 TOP MENU

Displays the disc 'top' menu of a DVD.

RF ATT (Receiver control)

Use to lower the input level of a radio signal that is too powerful or contain interference thus causing the receiver to distort.

12 and ENTER/SETUP buttons

Use these arrow buttons when setting up your surround sound system. These buttons are also used to control DVD menus/options.

12 ⇐ ⇨ ↑ ↓ and ENTER/SETUP buttons

Use these arrow buttons when setting up your surround sound system.
These buttons are also used to control DVD menus/options.

13 RECEIVER

Use to switch to the receiver controls on the remote control.
Also used when setting up the surround sound for the receiver.

14 CHANNEL SELECT

Use to select a channel when setting up the surround sound of the receiver.

TEST TONE

Use to sound the test tones when setting up the surround sound of the receiver.

LEVEL +/-

Use to set up the levels of the surround sound of the receiver.

EFFECT +/-

Use to add or subtract the amount of effect in different sound modes or advanced listening modes.

15 DVD CONTROL buttons

You can use these buttons to control a Pioneer DVD player connected to your system.

Button	What it does
DVD	Turns DVD power on/off.
AUDIO	Changes the audio language or channel.
SUBTITLE	Displays/changes the subtitles included in multilingual DVD-Video discs.
◀◀	Press to start fast reverse scanning.
▶▶	Starts playback.
▶▶▶	Press to start fast forward scanning.
■	Stops playback.
	Pauses a disc that's playing, or restarts a paused disc.
◀◀◀	Skips to the start of the current track or chapter, then to previous tracks/chapters.
▶▶▶	Skips to the next track or chapter.

Rear Panel

