

Service Manual

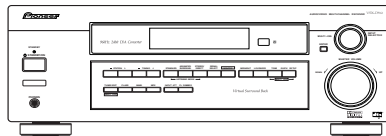

VSX-D512-K

ORDER NO.
RRV2743

AUDIO/VIDEO MULTI-CHANNEL RECEIVER

VSX-D512-K

VSX-D512-S

THIS MANUAL IS APPLICABLE TO THE FOLLOWING MODEL(S) AND TYPE(S).

Model	Type	Power Requirement	Remarks
VSX-D512-K	MYXJIEW	AC220-230V	
VSX-D512-S	MVJI	AC230V	
VSX-D512-S	MYXJIEW	AC220-230V	
VSX-D512-S	MYXJIFG	AC220-230V	



For details, refer to "Important symbols for good services" .

SAFETY INFORMATION



This service manual is intended for qualified service technicians ; it is not meant for the casual do-it-yourselfer. Qualified technicians have the necessary test equipment and tools, and have been trained to properly and safely repair complex products such as those covered by this manual.

Improperly performed repairs can adversely affect the safety and reliability of the product and may void the warranty. If you are not qualified to perform the repair of this product properly and safely, you should not risk trying to do so and refer the repair to a qualified service technician.



WARNING

This product contains lead in solder and certain electrical parts contain chemicals which are known to the state of California to cause cancer, birth defects or other reproductive harm.

Health & Safety Code Section 25249.6 – Proposition 65



NOTICE

(FOR CANADIAN MODEL ONLY)

Fuse symbols  (fast operating fuse) and/or  (slow operating fuse) on PCB indicate that replacement parts must be of identical designation.

REMARQUE

(POUR MODÈLE CANADIEN SEULEMENT)

Les symboles de fusible  (fusible de type rapide) et/ou  (fusible de type lent) sur CCI indiquent que les pièces de remplacement doivent avoir la même désignation.

(FOR USA MODEL ONLY)

1. SAFETY PRECAUTIONS

The following check should be performed for the continued protection of the customer and service technician.

LEAKAGE CURRENT CHECK

Measure leakage current to a known earth ground (water pipe, conduit, etc.) by connecting a leakage current tester such as Simpson Model 229-2 or equivalent between the earth ground and all exposed metal parts of the appliance (input/output terminals, screwheads, metal overlays, control shaft, etc.). Plug the AC line cord of the appliance directly into a 120V AC 60Hz outlet and turn the AC power switch on. Any current measured must not exceed 0.5mA.

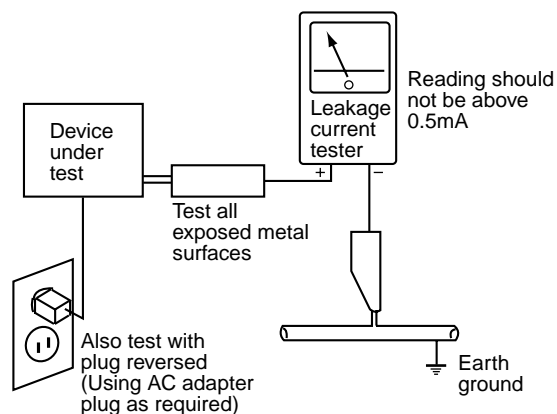

AC Leakage Test

ANY MEASUREMENTS NOT WITHIN THE LIMITS OUTLINED ABOVE ARE INDICATIVE OF A POTENTIAL SHOCK HAZARD AND MUST BE CORRECTED BEFORE RETURNING THE APPLIANCE TO THE CUSTOMER.

2. PRODUCT SAFETY NOTICE

Many electrical and mechanical parts in the appliance have special safety related characteristics. These are often not evident from visual inspection nor the protection afforded by them necessarily can be obtained by using replacement components rated for voltage, wattage, etc. Replacement parts which have these special safety characteristics are identified in this Service Manual.

Electrical components having such features are identified by marking with a Δ on the schematics and on the parts list in this Service Manual.

The use of a substitute replacement component which does not have the same safety characteristics as the PIONEER recommended replacement one, shown in the parts list in this Service Manual, may create shock, fire, or other hazards.

Product Safety is continuously under review and new instructions are issued from time to time. For the latest information, always consult the current PIONEER Service Manual. A subscription to, or additional copies of, PIONEER Service Manual may be obtained at a nominal charge from PIONEER.

[Important symbols for good services]

In this manual, the symbols shown-below indicate that adjustments, settings or cleaning should be made securely. When you find the procedures bearing any of the symbols, be sure to fulfill them:

1. Product safety

You should conform to the regulations governing the product (safety, radio and noise, and other regulations), and should keep the safety during servicing by following the safety instructions described in this manual.

2. Adjustments

To keep the original performances of the product, optimum adjustments or specification confirmation is indispensable. In accordance with the procedures or instructions described in this manual, adjustments should be performed.

3. Cleaning

For optical pickups, tape-deck heads, lenses and mirrors used in projection monitors, and other parts requiring cleaning, proper cleaning should be performed to restore their performances.

4. Shipping mode and shipping screws

To protect the product from damages or failures that may be caused during transit, the shipping mode should be set or the shipping screws should be installed before shipping out in accordance with this manual, if necessary.

5. Lubricants, glues, and replacement parts

Appropriately applying grease or glue can maintain the product performances. But improper lubrication or applying glue may lead to failures or troubles in the product. By following the instructions in this manual, be sure to apply the prescribed grease or glue to proper portions by the appropriate amount. For replacement parts or tools, the prescribed ones should be used.

A

B

C

D

E

F

CONTENTS

	SAFETY INFORMATION	2
A	1. SPECIFICATIONS	5
	2. EXPLODED VIEWS AND PARTS LIST	6
	2.1 PACKING	6
	2.2 EXTERIOR SECTION.....	8
	2.3 FRONT PANEL SECTION	10
	3. BLOCK DIAGRAM AND SCHEMATIC DIAGRAM	12
	3.1 BLOCK DIAGRAM	12
	3.2 OVERALL WIRING CONNECTION DIAGRAM.....	14
	3.3 D.D & INPUT(1/4) ASSY	16
	3.4 D.D & INPUT(2/4) ASSY	18
	3.5 D.D & INPUT(3/4) ASSY	20
	3.6 D.D & INPUT(4/4) ASSY	22
B	3.7 AMP & PRIMARY(1/2), TRANS2 and TRANS3 ASSYS	24
	3.8 AMP & PRIM.(2/2), REG., HASHIGETA and MECH SW ASSYS	26
	3.9 VIDEO and 6CH IN ASSYS	28
	3.10 FRONT, R.ENCODER and POWER SW ASSYS	30
	3.11 DIGITAL IN, H.P. and KAWA ASSYS	32
	3.12 FM/AM TUNER MODULE	34
	4. PCB CONNECTION DIAGRAM	36
	4.1 TRANS1, TRANS2 and TRANS3 ASSYS	37
	4.2 D.D & INPUT ASSY	38
	4.3 AMP INPUT, AMP & PRIMARY and MECHA SW ASSYS.....	42
	4.4 FRONT, POWER SW, H.P. and R.ENCODER ASSYS	44
	4.5 REGULATOR, HASHIGETA and KAWA ASSYS.....	48
C	4.6 DIGITAL IN, 6CH IN and VIDEO ASSYS	50
	4.7 FM/AM TUNER MODULE	52
	5. PCB PARTS LIST	53
	6. ADJUSTMENT	58
	7. GENERAL INFORMATION	59
	7.1 DISASSEMBLY and DIAGNOSIS	59
	7.1.1 DISASSEMBLY and PCB LOCATION.....	59
	7.1.2 U-COM BLOCKDIAGRAM	60
	7.1.3 PROTECTION CIRCUIT	61
	7.1.4 POWER ON SEQUENCE	62
	7.1.5 POWER OFF SEQUENCE	63
	7.2 PARTS.....	64
D	7.2.1 IC	64
	7.2.2 DISPLAY	69
	8. PANEL FACILITIES	71

1. SPECIFICATIONS

Amplifier Section

Continuous Power Output (STEREO mode)

Front 80 W per channel
(DIN 1kHz, THD 1.0 %, 8 Ω)

Continuous Power Output

Front 80 W per channel
(1kHz, THD 1.0 %, 8 Ω)

Center 80 W (1kHz, THD 1.0 %, 8 Ω)

Surround 80 W per channel (1kHz, THD 1.0 %, 8 Ω)

• Above specifications are applicable when the power supply is 230V.

Input (Sensitivity/Impedance)

CD, VCR/DVR, CD-R/TAPE/MD, DVD/LD, TV/SAT ... 200 mV/47 kΩ

Frequency Response

CD, VCR/DVR, CD-R/TAPE/MD, DVD/LD, TV/SAT
..... 5 Hz to 100,000 Hz ± 3 dB

Output (Level/Impedance)

VCR/DVR REC, CD-R/TAPE/MD REC 200 mV/2.2 kΩ

Tone Control

BASS ± 6 dB (100 Hz)

TREBLE ± 6 dB (10 kHz)

LOUDNESS +9 dB/+9 dB (100 Hz/10 kHz)

Signal-to-Noise Ratio [DIN (Continuous rated power output/50 mW)]

CD, VCR/DVR, CD-R/TAPE/MD, DVD/LD, TV/SAT 88/64 dB

Video Section

Input (Sensitivity/Impedance)

VCR/DVR, DVD/LD, TV/SAT 1 Vp-p/75 Ω

Output (Level/Impedance)

VCR/DVR 1 Vp-p/75 Ω

Frequency Response

VCR/DVR, DVD/LD, TV/SAT \Leftrightarrow MONITOR 5 Hz to 7 MHz ± 3 dB

Signal-to-Noise Ratio 55 dB

Cross Talk 55 dB

Manufactured under license from Dolby Laboratories.

"Dolby", "Pro Logic II" and the double D symbol  are trademarks of Dolby Laboratories.

"DTS", "ES" and "DTS Digital Surround" are trademarks of Digital Theater Systems, Inc.

FM Tuner Section

Frequency Range 87.5 MHz to 108 MHz

Usable Sensitivity Mono: 13.2 dBf, IHF (1.3 μV/ 75 Ω)

50 dB Quieting Sensitivity Mono: 20.2 dB

Stereo: 38.6 dBf

Signal-to-Noise Ratio Mono: 73 dB (at 85 dBf)

Stereo: 70 dB (at 85 dBf)

Signal-to-Noise Ratio (DIN) Mono: 62 dB

Stereo: 58 dB

Distortion Stereo: 0.5 % (1 kHz)

Alternate Channel Selectivity 60 dB (400 kHz)

Stereo Separation 40 dB (1 kHz)

Frequency Response 30 Hz to 15 kHz (± 1 dB)

Antenna Input (DIN) 75 Ω unbalanced

AM Tuner Section

Frequency Range 531 kHz to 1,602 kHz

Sensitivity (IHF, Loop antenna) 350 μV/m

Selectivity 25 dB

Signal-to-Noise Ratio 50 dB

Antenna Loop antenna

Miscellaneous

Power Requirements

UK model AC 230 V, 50/60Hz

European model AC 220-230 V, 50/60 Hz

Power Consumption

..... 220W

In Standby 1 W

Dimensions 420 (W) x 158 (H) x 393 (D) mm

Weight (without package)

..... 9.0 kg

Furnished Parts

AM loop antenna 1

FM wire antenna 1

Dry cell batteries (AA size IEC R6P) 2

Remote control 1

Operating instructions 1



Note

Specifications and the design are subject to possible modifications without notice, due to improvements.

Accessories

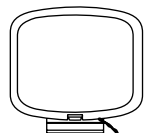

AM loop antenna
(ATB7009)

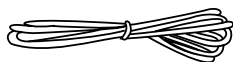

FM wire antenna
(ADH7030)

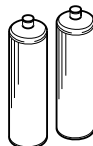

AA size IEC R6P
Dry cell batteries (x2)

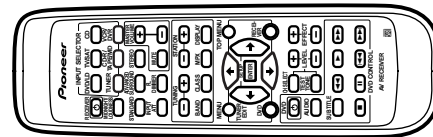

Remote control
(XXD3039)

2. EXPLODED VIEWS AND PARTS LIST

- NOTES:
- Parts marked by "NSP" are generally unavailable because they are not in our Master Spare Parts List.
 - The \triangle mark found on some component parts indicates the importance of the safety factor of the part. Therefore, when replacing, be sure to use parts of identical designation.
 - Screws adjacent to \blacktriangledown mark on product are used for disassembly.
 - For the applying amount of lubricants or glue, follow the instructions in this manual. (In the case of no amount instructions, apply as you think it appropriate.)

2.1 PACKING

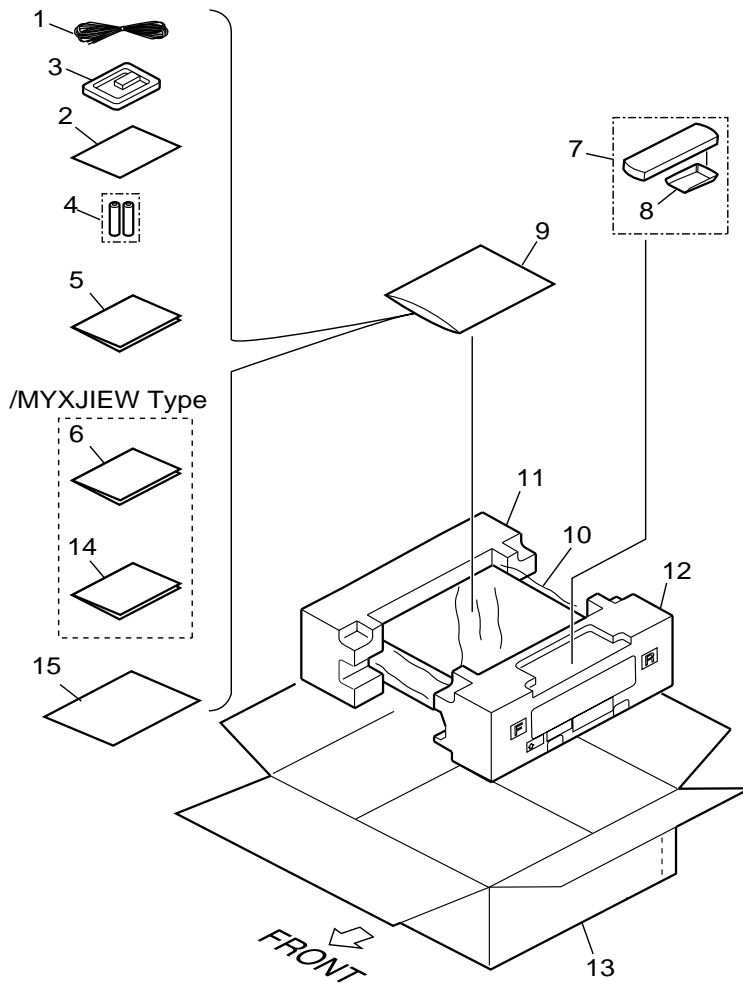

PACKING parts List

<u>Mark No.</u>	<u>Description</u>	<u>Part No.</u>	<u>Mark No.</u>	<u>Description</u>	<u>Part No.</u>
1	FM wire antenna	ADH7030	NSP 9	Literature Bag	AHG1180
NSP 2	Warranty Card	ARY7065	10	Packing Sheet	AHG7069
3	AM loop antenna	ATB7009			
NSP 4	Dry cell batteries (AA/R6P)	VEM1031	11	Left Pad R5	XHA3032
5	Operating instructions (English/Italian)	See Contrast table(2)	12	Right Pad R5	XHA3033
			13	Packing Case	See Contrast table(2)
			14	Operating instructions	See Contrast table(2)
6	Operating instructions	See Contrast table(2)	NSP 15	Accessory Board	XHB3008
7	Remote Control	XXD3039			
8	Battery Cover	AZA7378			

(2) CONTRAST TABLE

VSX-D512-S/MVXJI, /MYXJIEW, /MYXJIFG and VSX-D512-K/MYXJIEW are constructed the same except for the following :

Mark	NO	Symbol and Description	VSX-D512-K/ MYXJIEW	VSX-D512-S/ MVXJI	VSX-D512-S/ MYXJIEW	VSX-D512-S/ MYXJIFG
	5	Operating Instructions (English,Italian)	XRE3068	XRE3068	XRE3068	Not used
	6	Operating Instructions (French,German)	XRC3080	Not used	XRC3080	XRC3080
	13	Packing Case	XHD3328	XHD3329	XHD3329	XHD3329
	14	Operating Instructions (Spanish,Dutch)	XRC3079	Not used	XRC3079	Not used

2.2 EXTERIOR SECTION

A

B

C

D

E

F

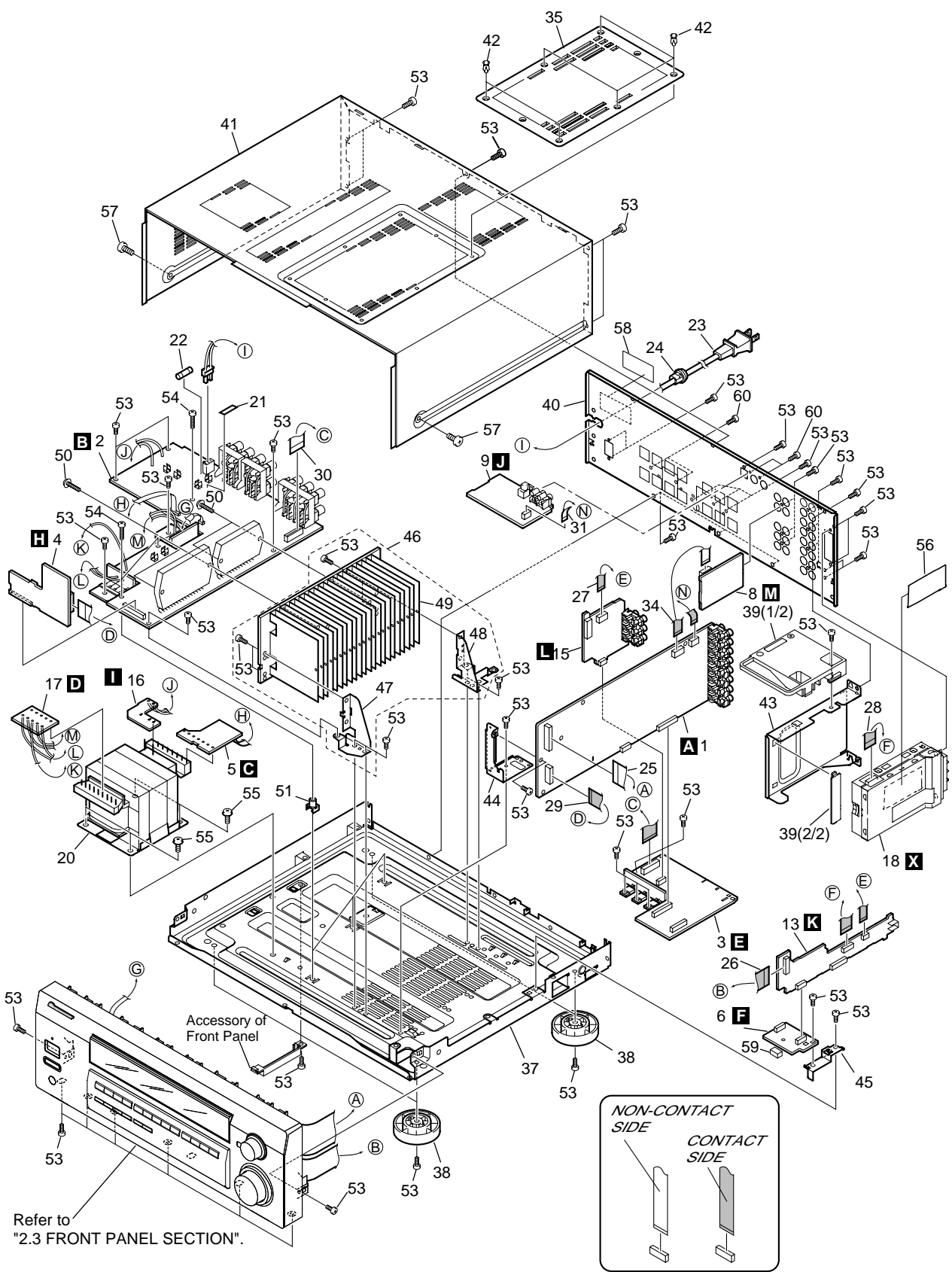

EXTERIOR SECTION parts List

Mark No.	Description	Part No.	Mark No.	Description	Part No.
1	D.D & INPUT ASSY	XWX3044		AMP CN53 - REGULATOR CN801	
2	AMP & PRIMAR ASSY	XWZ3533			
3	REGULATOR ASSY	XWZ3544	31	7P F•F•C/30V (J37)	XDD3103
4	AMP INPUT ASSY	XWZ3547		DD CN9101 - DIGITAL IN CN1901	
5	TRANS2 ASSY	XWZ3555	32	•••••	
			33	•••••	
6	HASHIGETA ASSY	XWZ3566	34	9P F•F•C/30V (J48)	XDD3106
7	•••••			DD CN104 - 6CH IN CN307	
8	6CH IN ASSY	XWZ3507	35	Top Cover	See Contrast table(2)
9	DIGITAL IN ASSY	XWZ3747			
10	•••••		36	•••••	
			NSP 37	Under Base 409	ANA7094
11	•••••		38	Insulator	PNW2766
12	•••••		39	FFC Cover R5	XMR3047
13	KAWA ASSY	XWZ3529	40	Rear Panel	XNC3191
14	•••••				
15	VIDEO ASSY	XWZ3490	41	Bonnet D510	See Contrast table(2)
			42	Push Rivet	See Contrast table(2)
NSP 16	TRANS1 ASSY	XWZ3552	43	Tuner Shield R5	XNG3072
NSP 17	TRANS3 ASSY	XWZ3560	44	PCB Angle R5	XNG3073
18	FM/AM TUNER MODULE	AXQ7232	45	Reg Support R5	XNG3074
19	•••••				
⚠ 20	Power Transformer (T1)	ATS7259	NSP 46	Heat Sink Assy 0.8	ANH7118
			47	Heat Sink Angle F	ANG7251
NSP 21	Fuse Card	AAX7277	48	Heat Sink Angle R	ANG7252
⚠ 22	Fuse (FU1:T2.5A)	REK1026	NSP 49	Heat Sink 0.8	ANH7110
⚠ 23	Power Cord	See Contrast table(2)	50	Screw 3x23	ABA7043
24	Cord Stopper	CM-22B			
25	28P F•F•C/30V (J31)	XDD3097	51	PCB Mold	AMR2533
	DD CN102 - FRONT CN402		52	•••••	
			53	Screw	BBZ30P080FMC
26	17P F•F•C/30V (J32)	XDD3098	54	Screw	BBZ30P200FMC
	KAWA CN5001 - FRONT CN401		55	Screw	FBT40P080FZK
27	7P F•F•C/30V (J33)	XDD3099			
	KAWA CN5004 - VIDEO CN503		56	Tuner Sheet	XEC3031
28	13P F•F•C/30V (J34)	XDD3100	57	Screw	See Contrast table(2)
	KAWA CN5005 - FM/AM TUNER CN201		NSP 58	N Label 512/MY	See Contrast table(2)
29	19P F•F•C/30V (J35)	XDD3101	59	Spacer R5(Rub)	XEB3029
	DD CN106 - AMP INPUT CN254		60	Screw	BBT30P100FCC
30	23P F•F•C/30V (J36)	XDD3102			

(2) CONTRAST TABLE

VSX-D512-S/MVXJI, /MYXJIEW, /MYXJIFG and VSX-D512-K/MYXJIEW are constructed the same except for the following :

Mark	NO	Symbol and Description	VSX-D512-K/ MYXJIEW	VSX-D512-S/ MVXJI	VSX-D512-S/ MYXJIEW	VSX-D512-S/ MYXJIFG
⚠	23	AC Power Cord	VDG1077	VDG1076	VDG1077	VDG1077
	35	Top Cover	XME3004	XME3006	XME3006	XME3006
	41	Bonnet	XZN3111	XZN3122	XZN3122	XZN3122
	42	Push Rivet	AEC7025	XEC3026	XEC3026	XEC3026
	57	Screw	FBT40P080FZK	FBT40P080FNI	FBT40P080FNI	FBT40P080FNI
NSP	58	N Label 512	Not used	XAL3150	XAL3150	XAL3150

2.3 FRONT PANEL SECTION

A

B

C

D

E

F

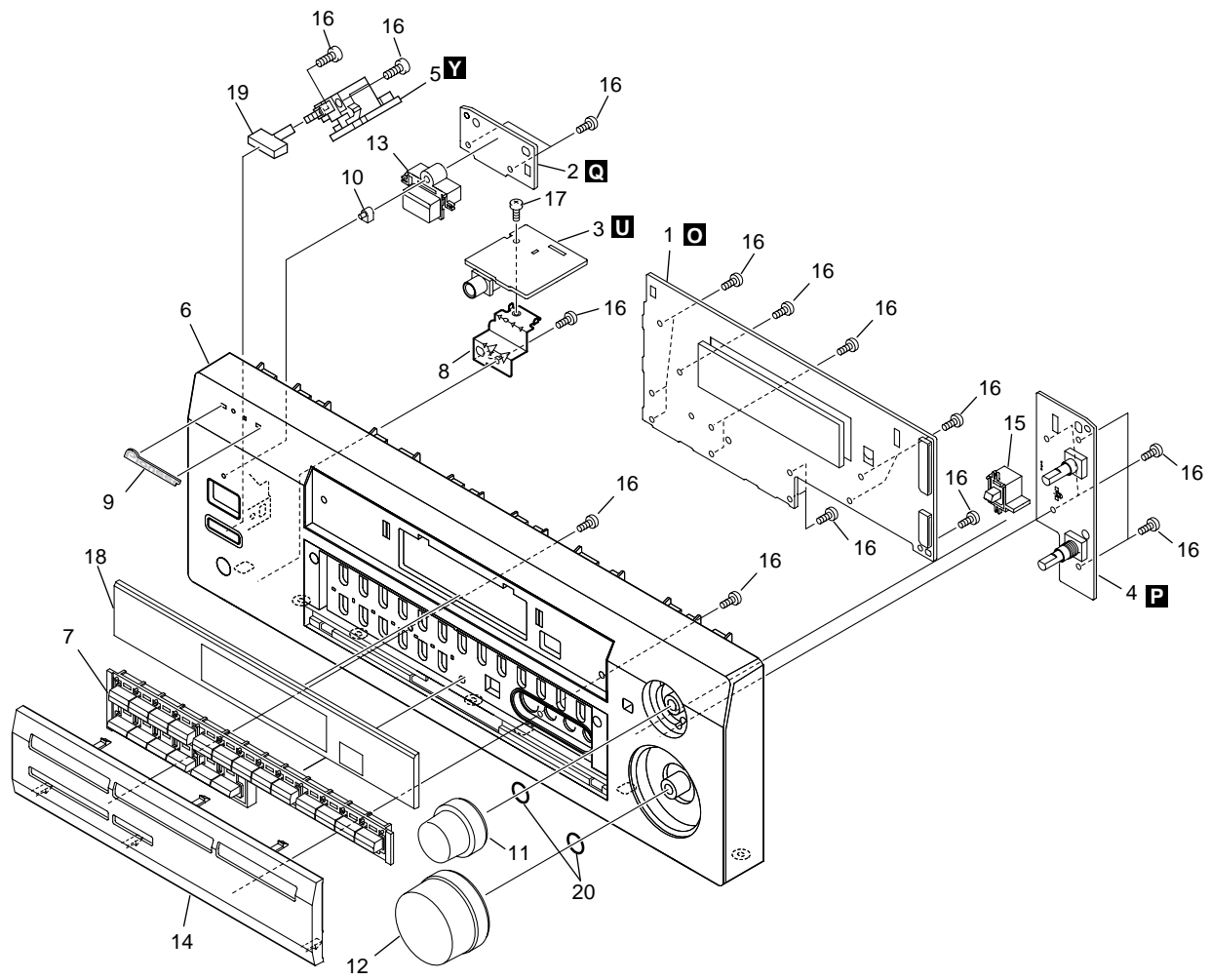

FRONT PANEL SECTION parts List

<u>Mark No.</u>	<u>Description</u>	<u>Part No.</u>	<u>Mark No.</u>	<u>Description</u>	<u>Part No.</u>
1	FRONT ASSY	XWZ3493	11	Select Knob	See Contrast table(2)
2	POWER SW ASSY	XWZ3510	12	Volume Knob	See Contrast table(2)
3	H.P. ASSY	XWZ3513	13	Power Button	See Contrast table(2)
4	R. ENCODER ASSY	XWZ3511	14	Sub Panel	See Contrast table(2)
5	MECH SW ASSY	XWZ3514	15	Jog Button	See Contrast table(2)
6	Front Panel	See Contrast table(2)	16	Screw	PPZ30P080FMC
7	Sub Button	See Contrast table(2)	17	Screw	BBZ30P080FMC
8	Earth Plate R5 HP	XNG3066	18	D Panel R5 W	XAK3320
9	Pioneer Badge	See Contrast table(2)	19	Power Button M	See Contrast table(2)
10	LED Lens 1.6	XAK3308	20	C Ring DIA8.1	XBH3016

(2) CONTRAST TABLE

VSX-D512-S/MVXJI, /MYXJIEW, /MYXJIFG and VSX-D512-K/MYXJIEW are constructed the same except for the following :

Mark	NO	Symbol and Description	VSX-D512-K/ MYXJIEW	VSX-D512-S/ MVXJI	VSX-D512-S/ MYXJIEW	VSX-D512-S/ MYXJIGR
	6	Front Panel	XMB3113	XMB3114	XMB3114	XMB3114
	7	Sub Button	XAD3125	XAD3133	XAD3133	XAD3133
	9	Pioneer Badge	XAM3006	VAM1129	VAM1129	VAM1129
	11	Select Knob	XAB3023	XAB3024	XAB3024	XAB3024
	12	Volume Knob	XAB3025	XAB3026	XAB3026	XAB3026
	13	Power Button	XAD3123	XAD3129	XAD3129	XAD3129
	14	Sub Panel	XAK3273	XAK3385	XAK3385	XAK3385
	15	Jog Button	XAD3124	XAD3131	XAD3131	XAD3131
	19	Power Button M	XAD3127	XAD3137	XAD3137	XAD3137

3. BLOCK DIAGRAM AND SCHEMATIC DIAGRAM

3.1 BLOCK DIAGRAM

A

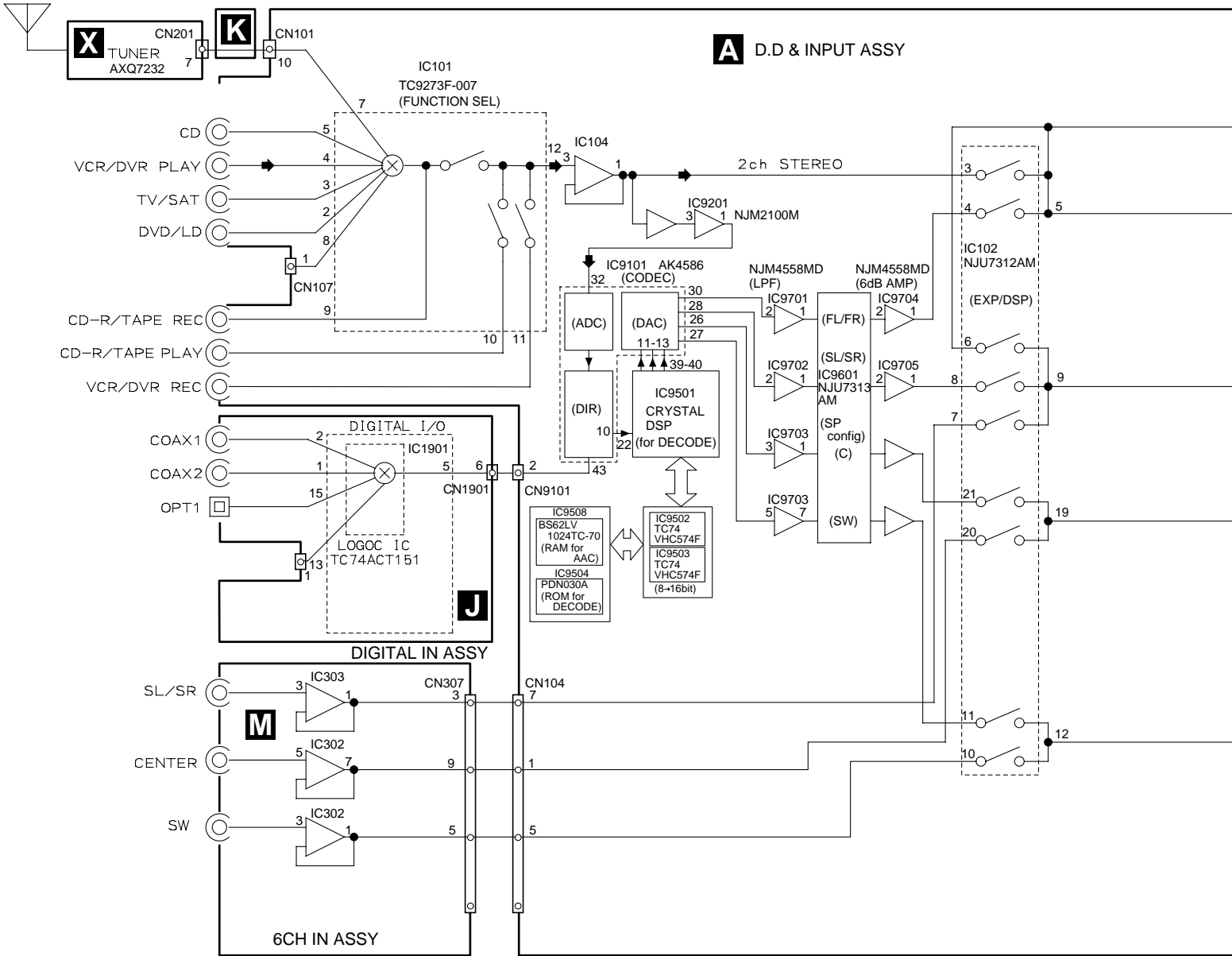

E

F

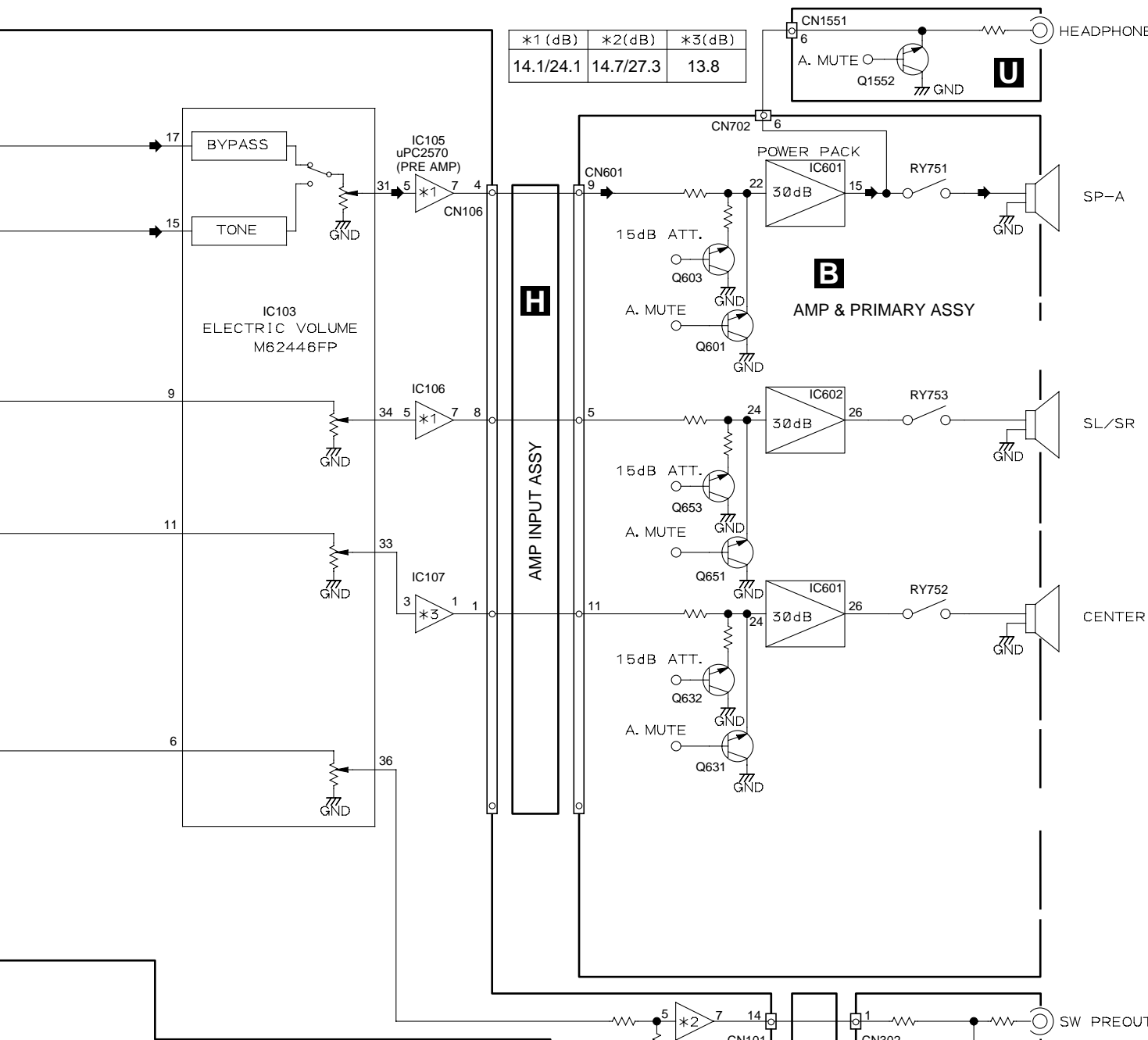

*1 (dB)	*2(dB)	*3(dB)
14.1/24.1	14.7/27.3	13.8

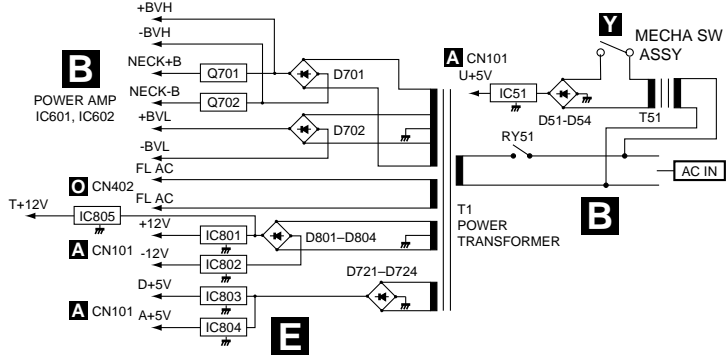
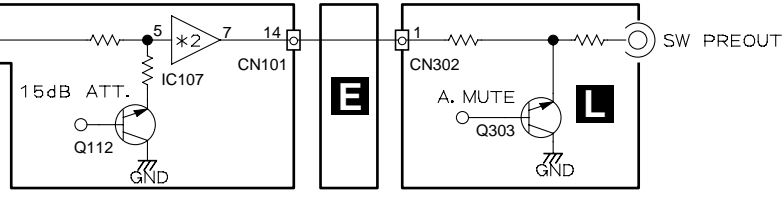
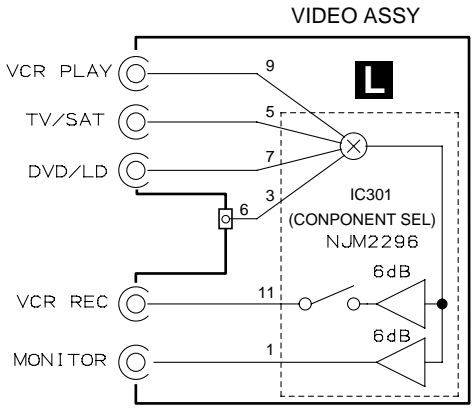

3.2 OVERALL WIRING CONNECTION DIAGRAM

A

B

C

D

E

F

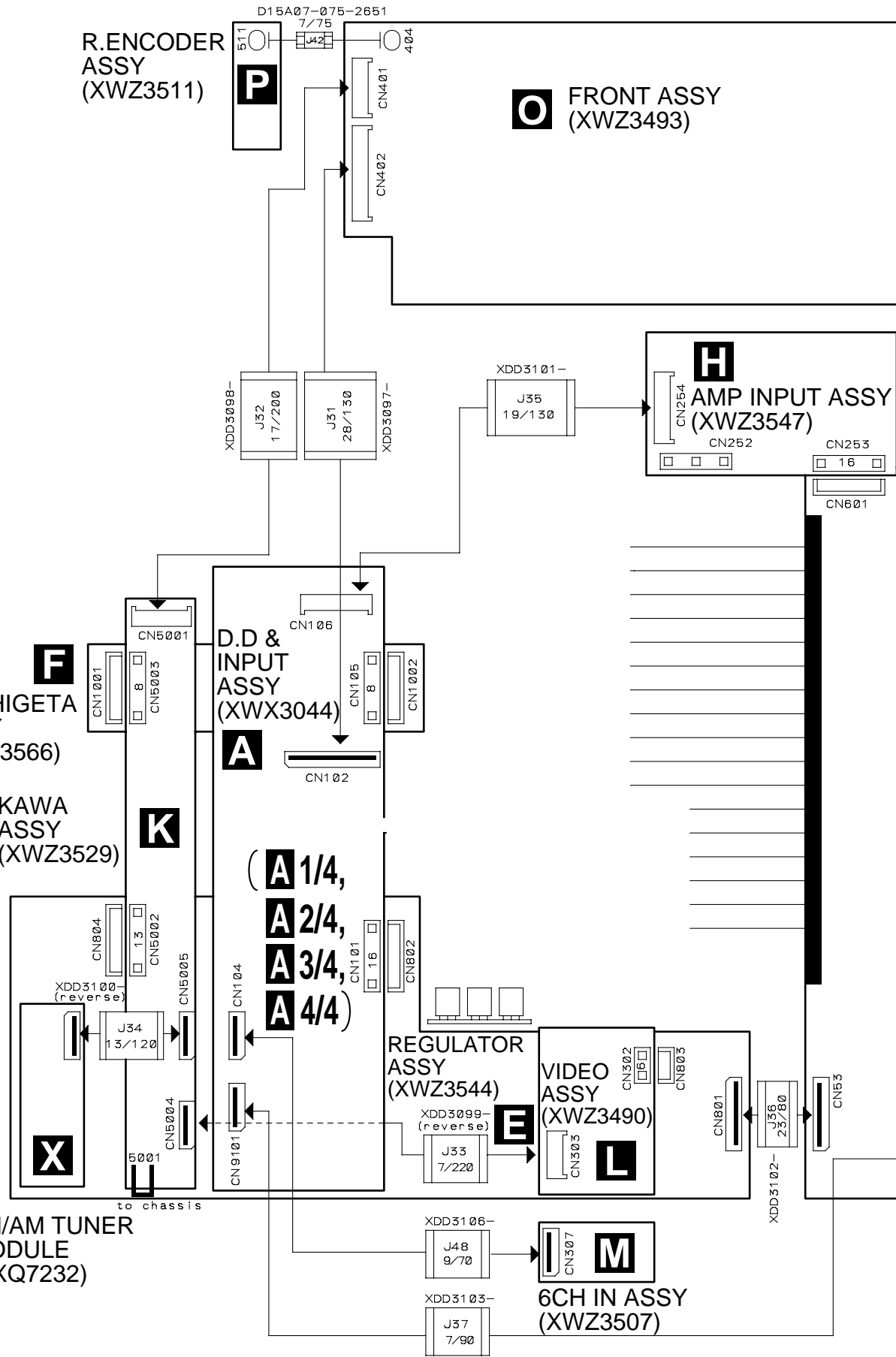

Note : When ordering service parts, be sure to refer to "EXPLODED VIEWS and PARTS LIST" or "PCB PARTS LIST".

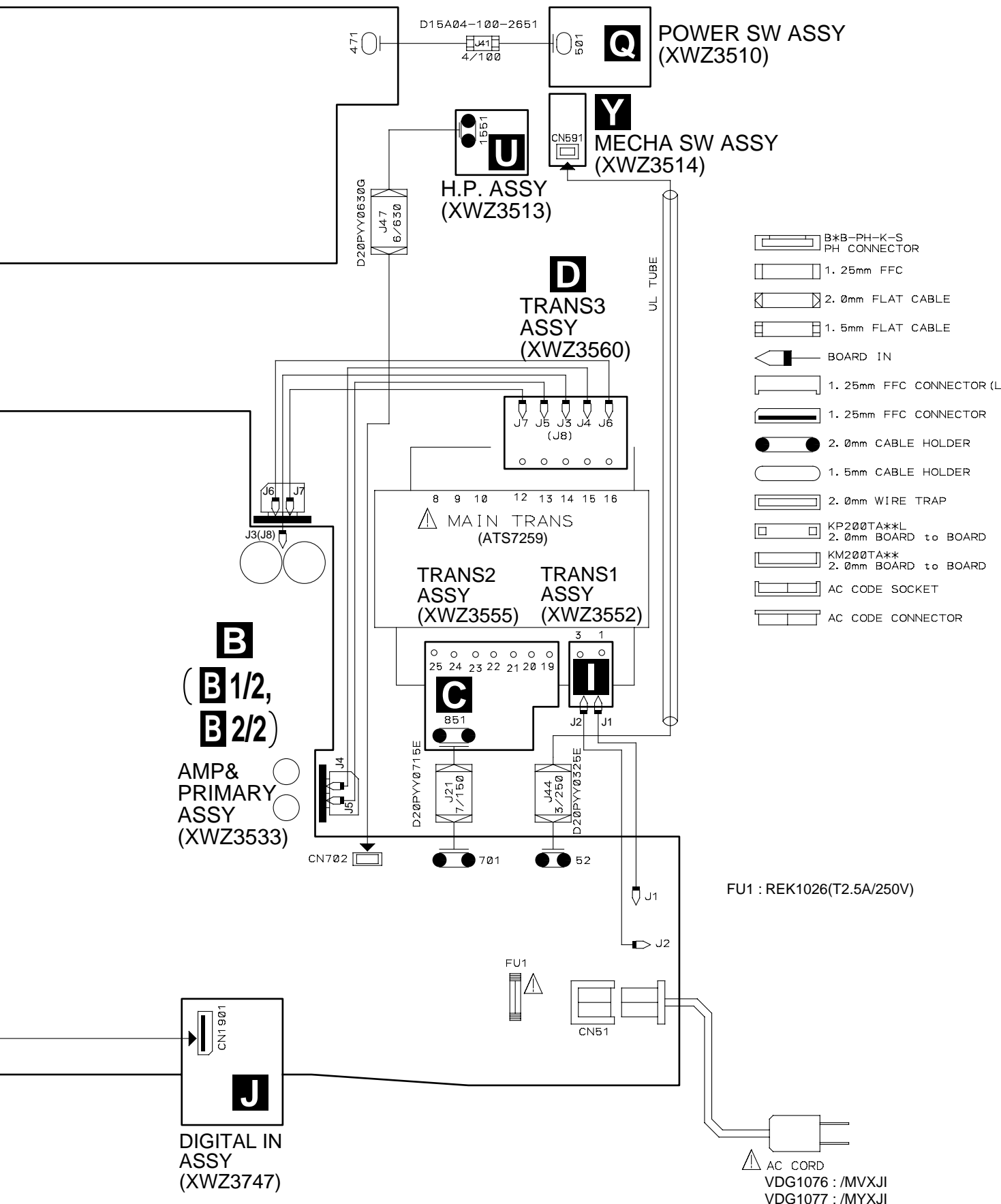

3.3 D.D & INPUT(1/4) ASSY

A 1/4 D.D & INPUT ASSY (XWX3044)

TO CODEC & PRE AMP BLOCK

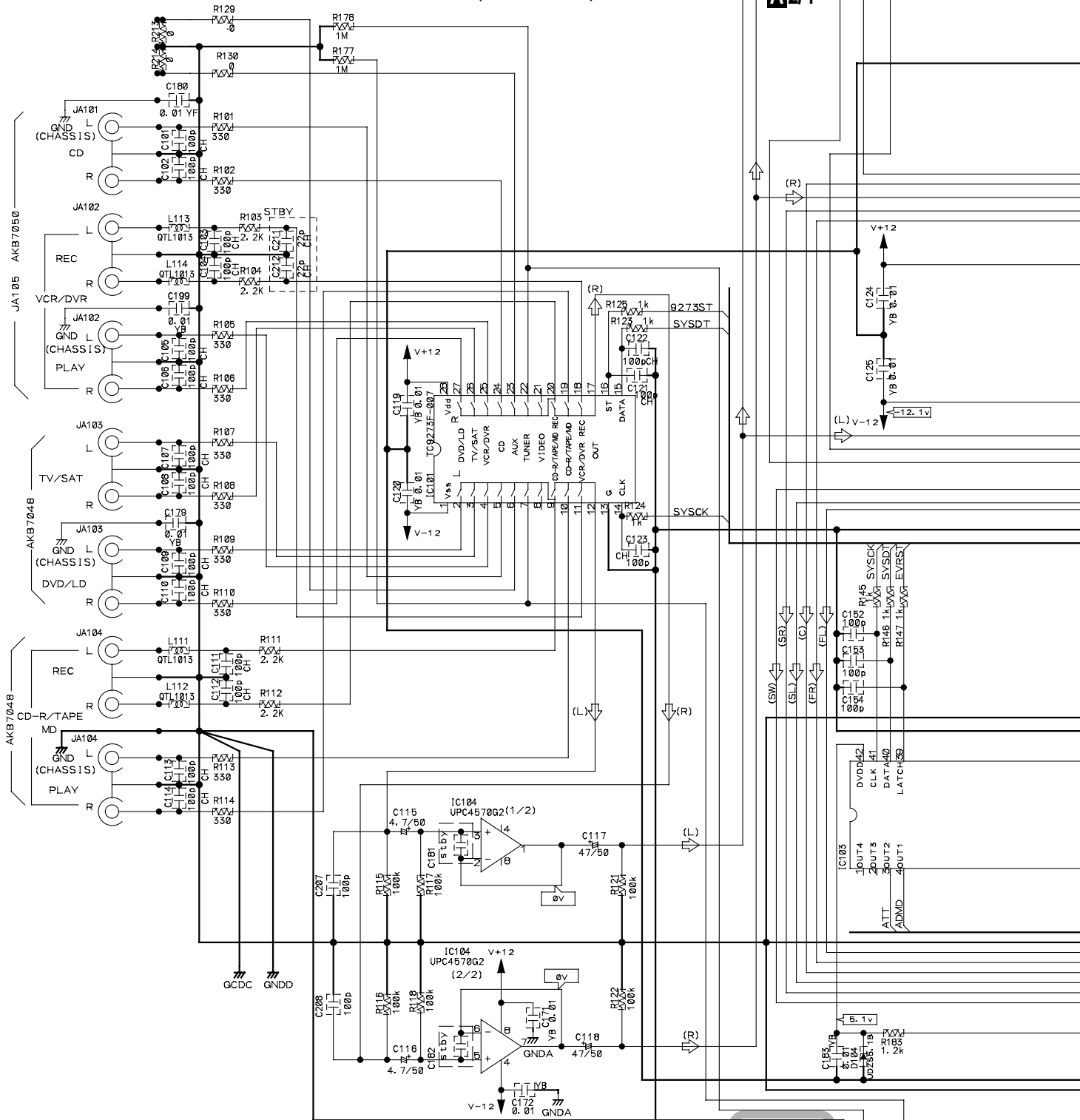

NOTES: NO INDICATED PARTS IS...
 RESISTOR: RS1/16S***J-T, RS1/10S***J-T
 CEMICAL CAPASITOR: CEAT***M**T, -TS
 CERAMIC CAPASITOR: CCSRCH***50-T
 CKSRYB***50-T
 (SQ): CKSQ, CCSQ

↻ : AUDIO SIGNAL FLOW

TO REG. ASSY

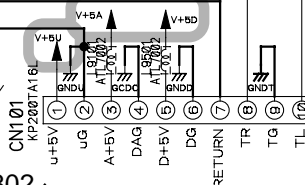

A 1/4

VSX-D512-K

E CN802

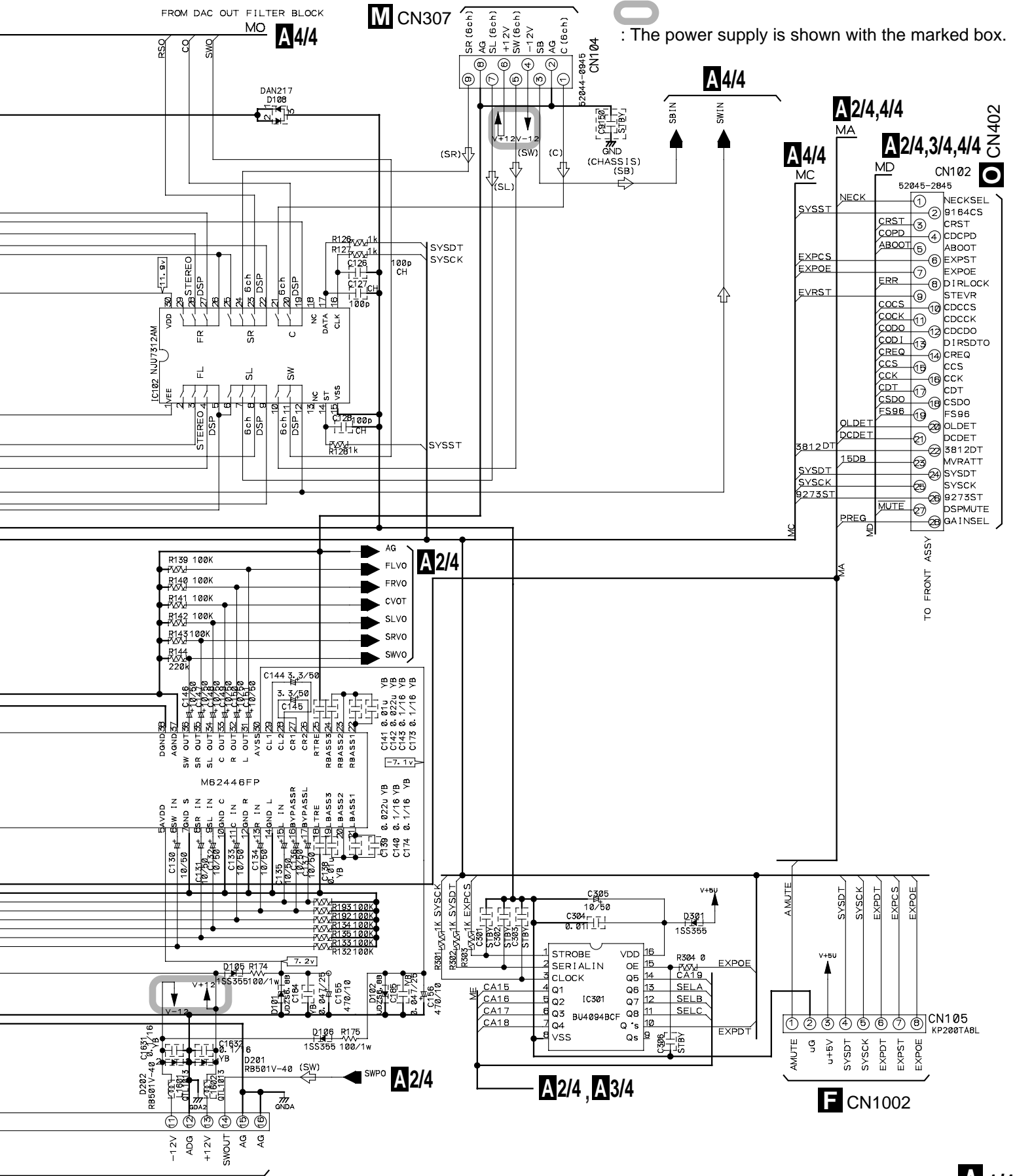

O : The power supply is shown with the marked box.

3.4 D.D & INPUT(2/4) ASSY

A

A1/4 MI

J CN1901

CN9101
52044-0745

B

A1/4 MA

A1/4

FROM INPUT & EVOL BLOCK

C

A3/4 MG

A4/4 MP

TO DAC OUT FILTER BLOCK

D

FROM DSP BLOCK
LRCK
BICK
SDTO
SDI1
SDI2
SDI3

A1/4 MDERR

A3/4 MV

E

F

A2/4 D.D & INPUT ASSY
(XWX3044)

A2/4

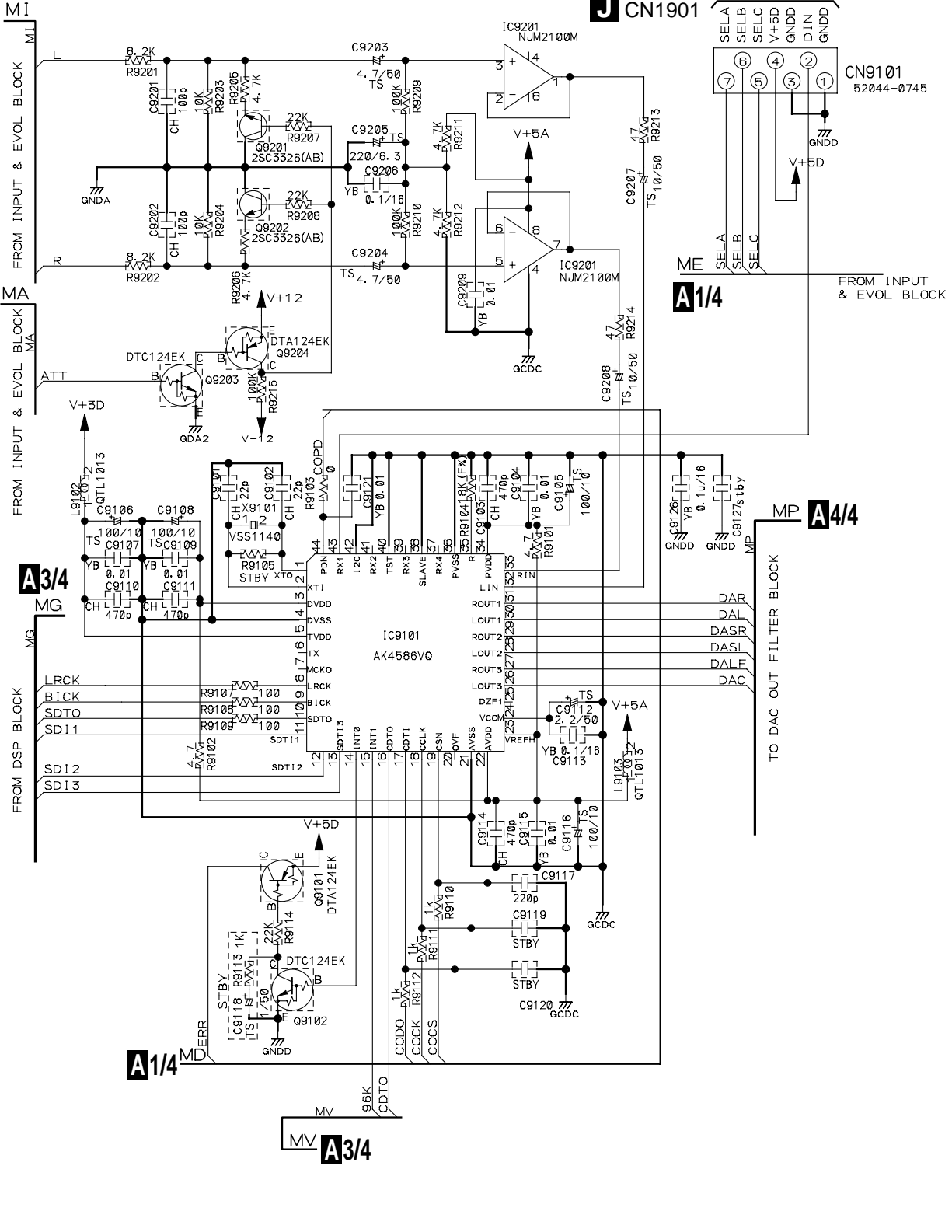

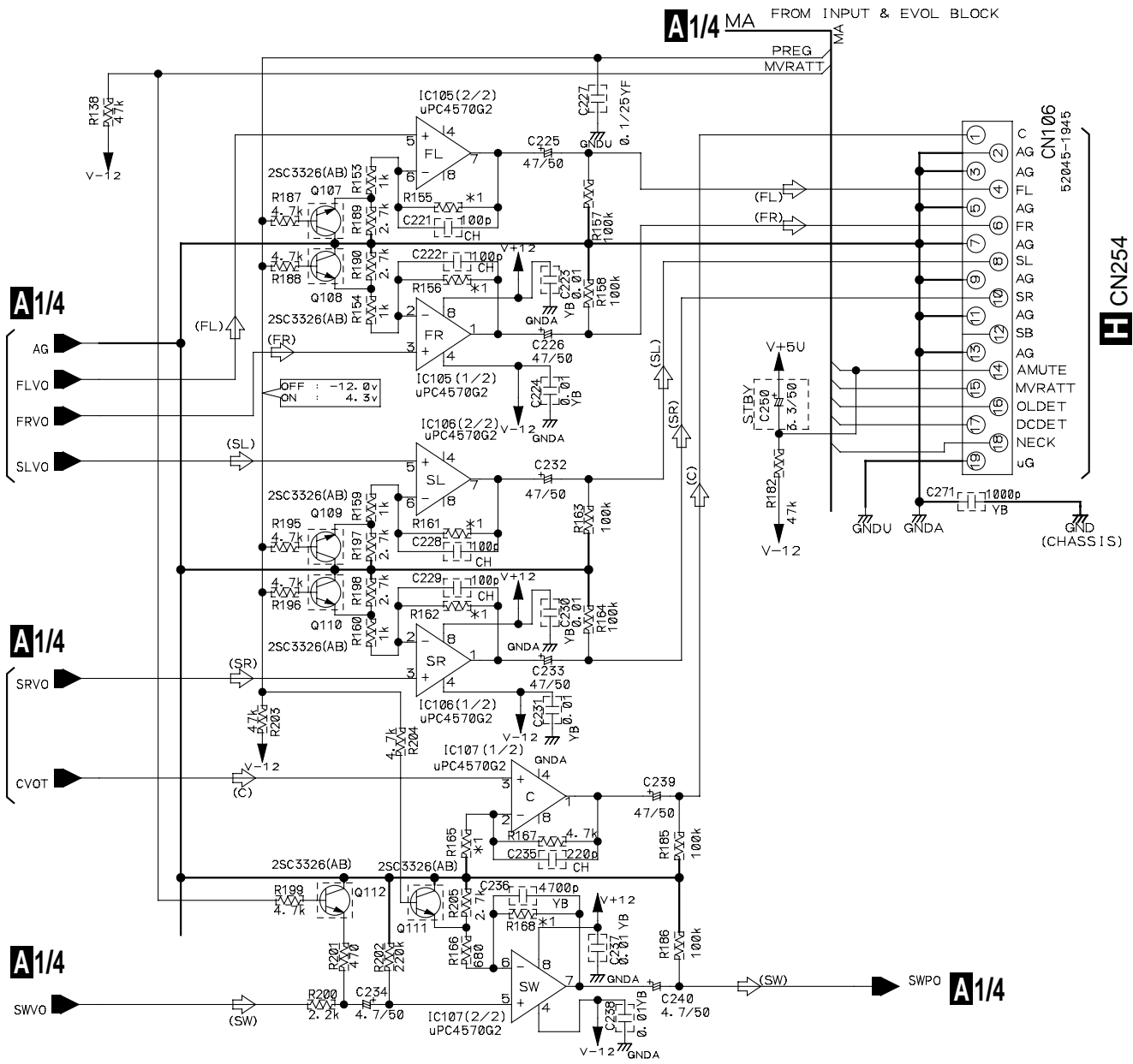

*1	FRONT, SURROUND		SW		CENTER, SB	
	R155 R156 R161 R162 (Ω)	GAIN (dB)	R168 (Ω)	GAIN (dB)	R165 (Ω)	GAIN (dB)
	15k	14. 1/24. 1	15k	14. 7/27. 3	1. 2k	13. 8

3.5 D.D & INPUT(3/4) ASSY

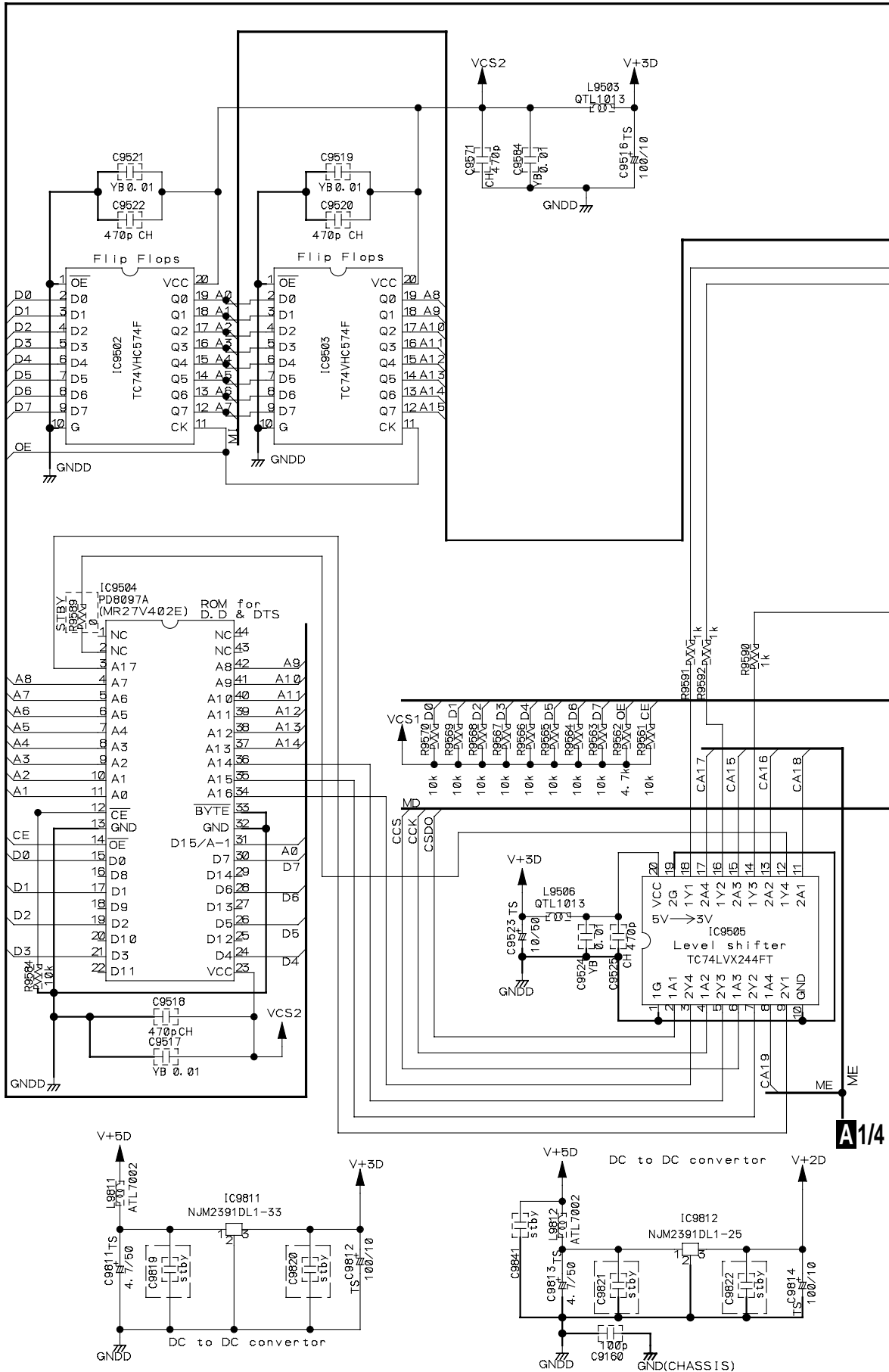

A 3/4

VSX-D512-K

Main DSP 1 decodes D.D and DTS signals.

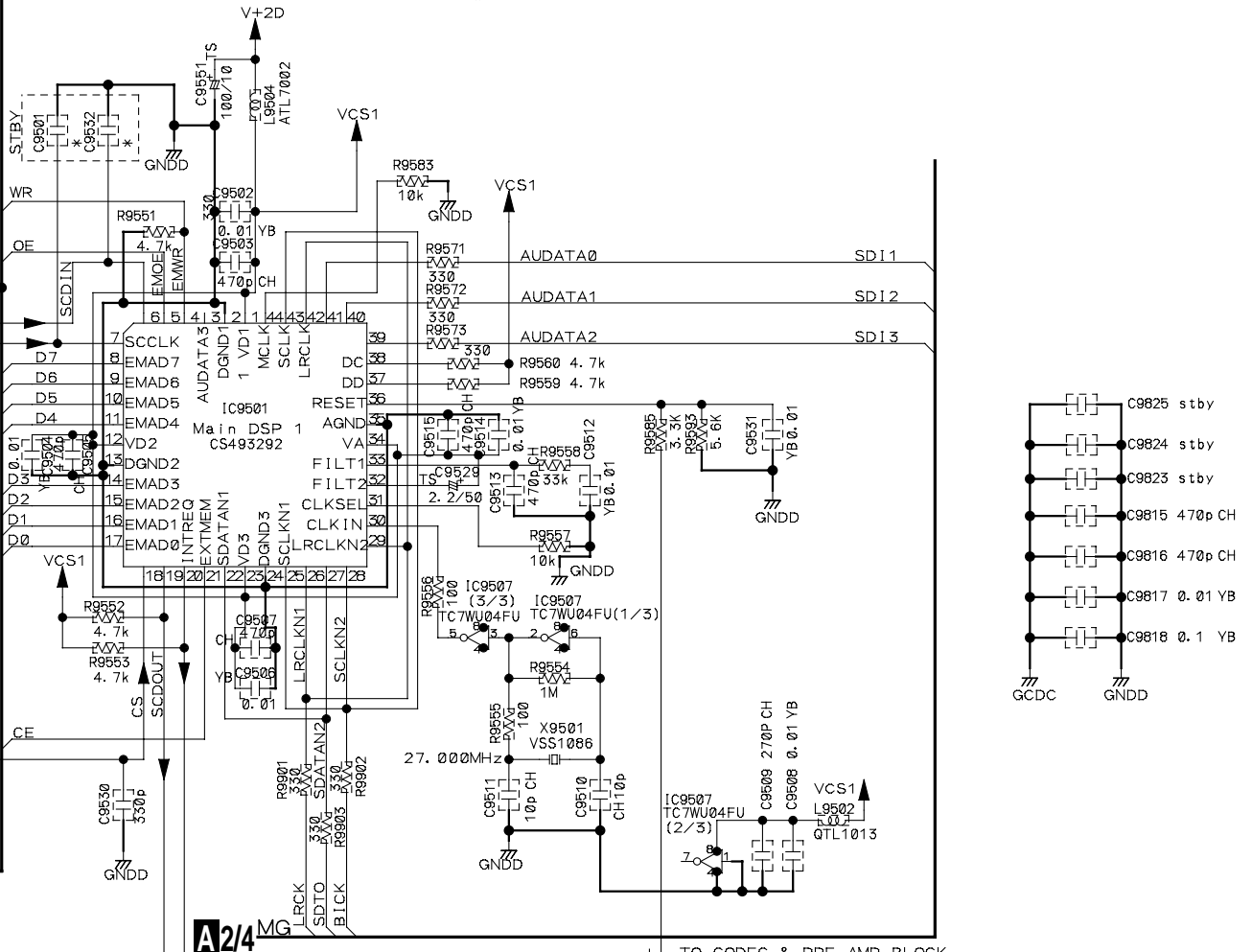

A2/4 MG

TO CODEC & PRE AMP BLOCK

A1/4 MD

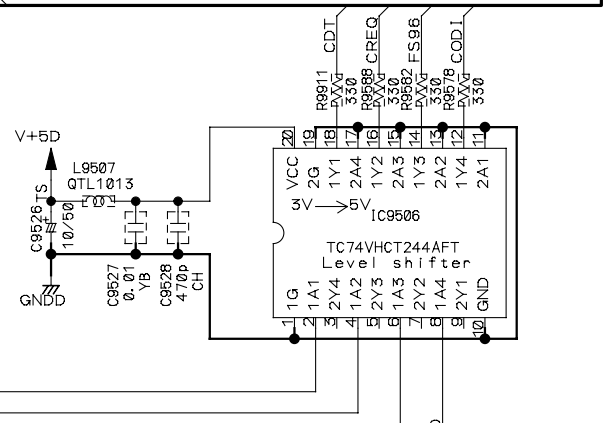

A 3/4 D.D & INPUT ASSY (XWX3044)

A2/4 MV

TO CODEC & PRE AMP BLOCK

A 3/4

3.6 D.D & INPUT(4/4) ASSY

A/4

A1/4

A/4 D.D & INPUT ASSY (XWX3044)

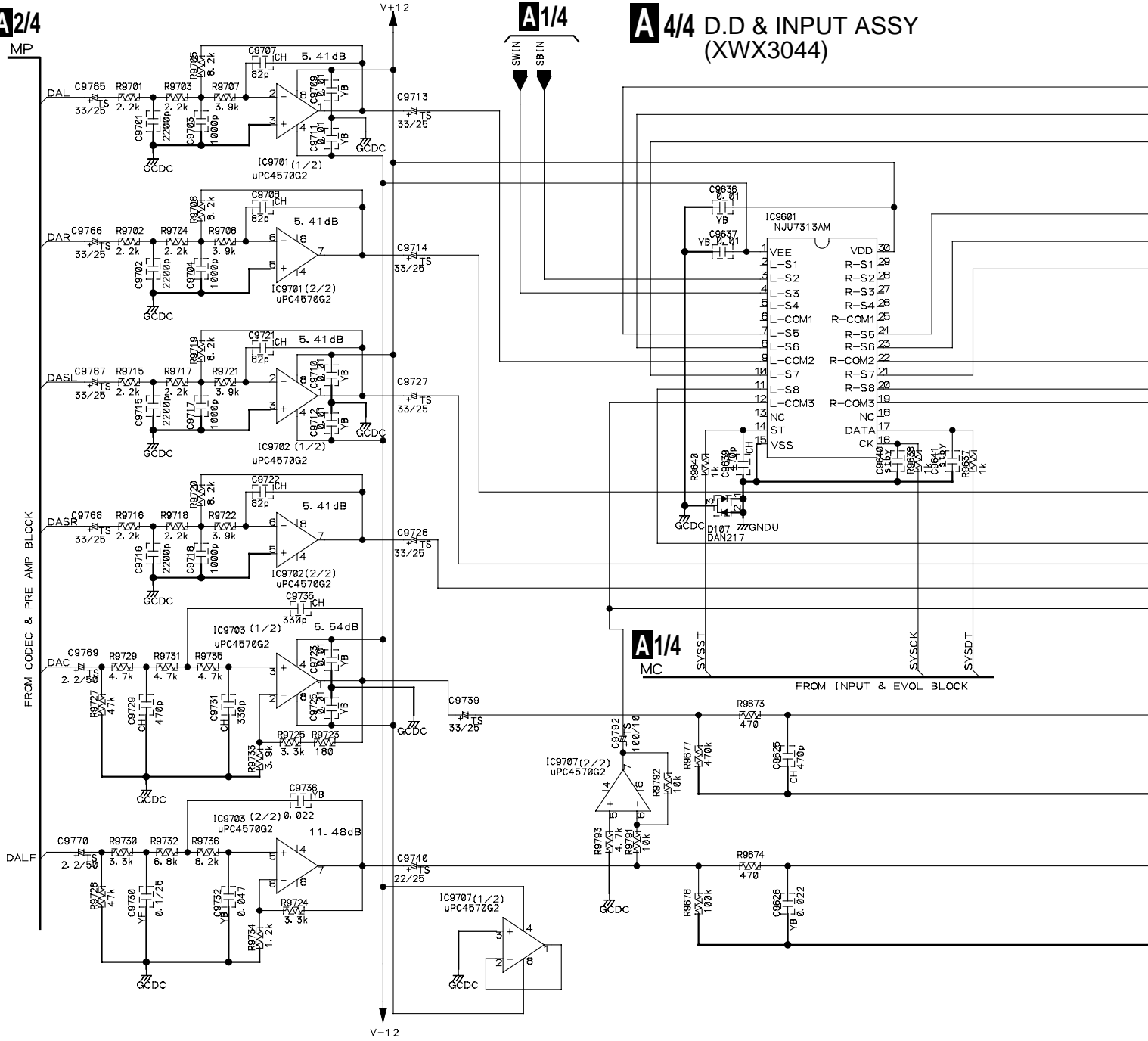

A1/4 MC

A1/4 MA

A1/4 MD

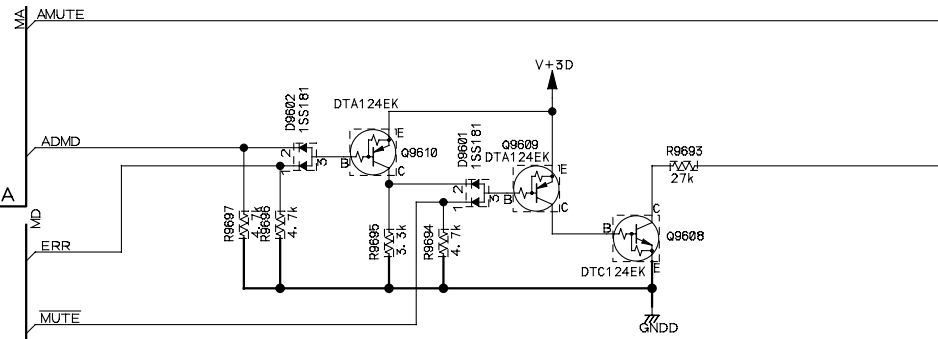

A/4

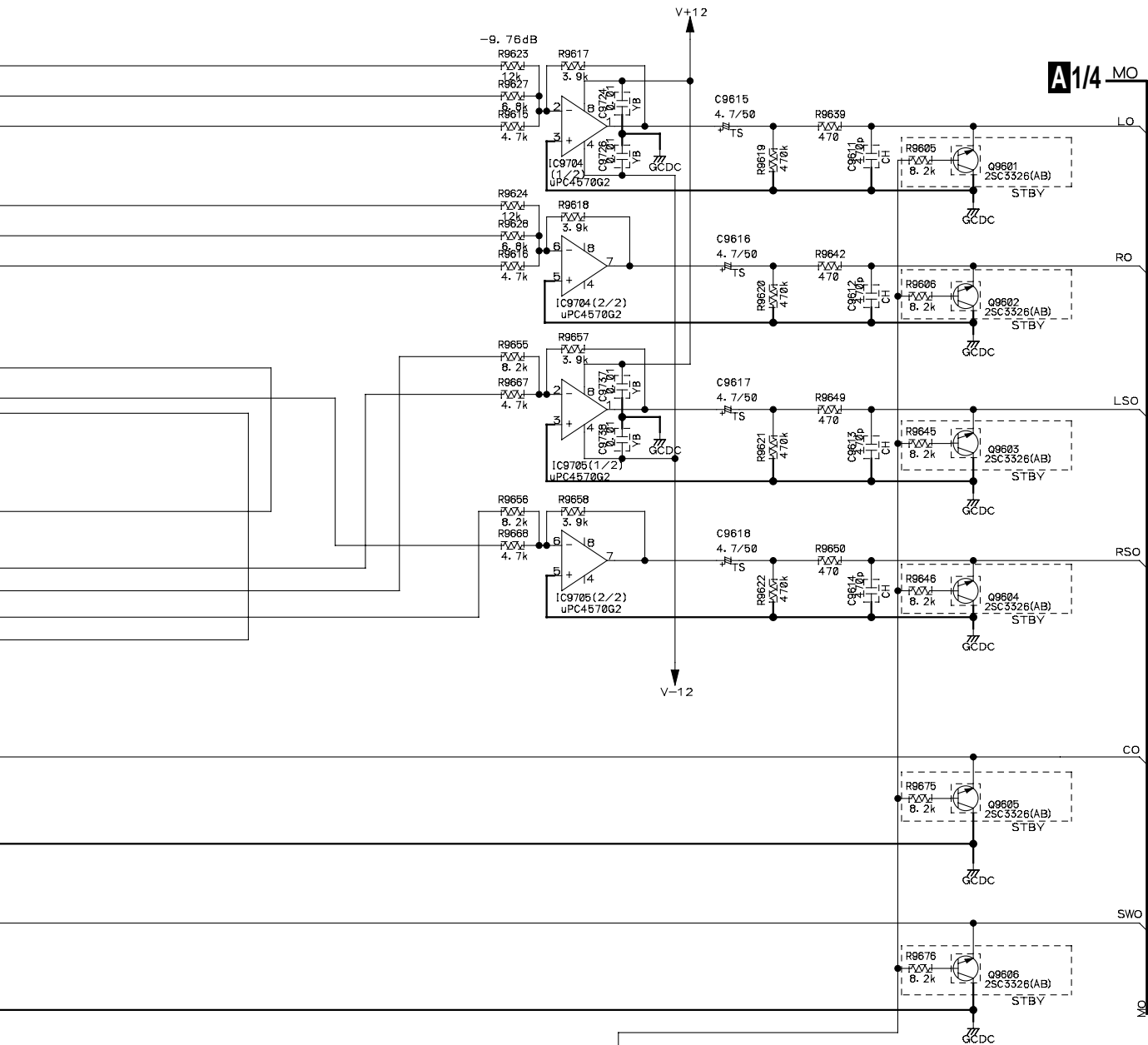

TO INPUT & EVOL BLOCK

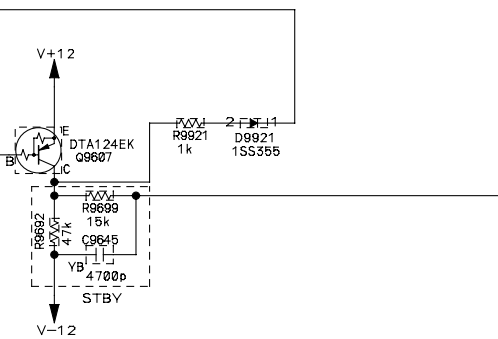

A1/4 MO

3.7 AMP & PRIMARY(1/2), TRANS2 and TRANS3 ASSYS

A
B
C
D
E
F

B 1/2 AMP&PRIMARY ASSY (XWZ3533)

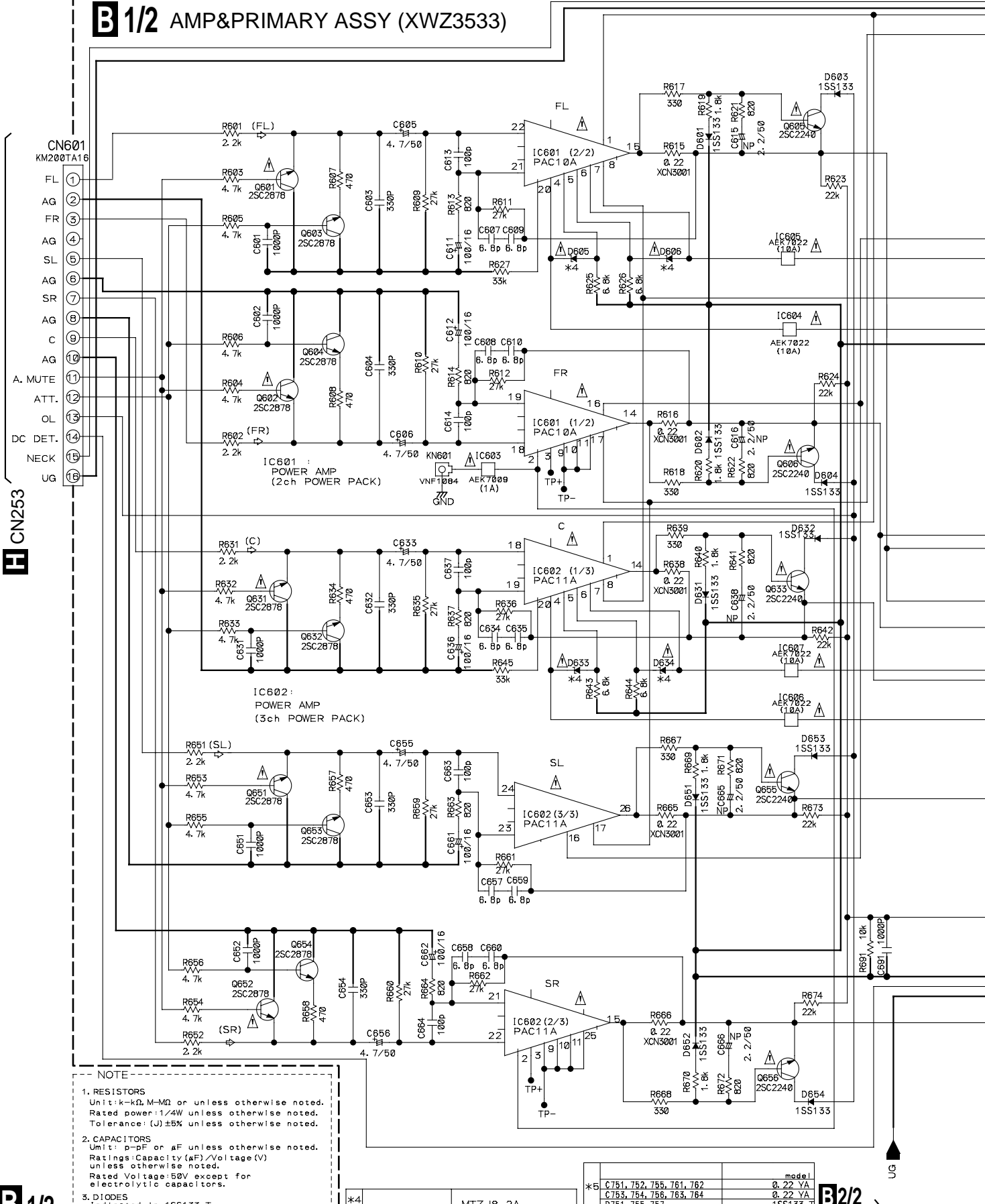

NOTE

- RESISTORS**
Unit: k- Ω , M- Ω or μ F unless otherwise noted.
Rated power: 1/4W unless otherwise noted.
Tolerance: (J) \pm 5% unless otherwise noted.
- CAPACITORS**
Unit: p-pF or μ F unless otherwise noted.
Ratings: Capacity (μ F)/Voltage (V) unless otherwise noted.
Rated Voltage: 50V except for electrolytic capacitors.
- DIODES**
Indicated in 1SS133-T

Part No.	Model
*5 C751, 752, 755, 761, 762	ϕ . 22 YA
C753, 754, 756, 763, 764	ϕ . 22 YA
D751, 755, 757	1SS133-T

B 1/2

B 2/2

VSX-D512-K

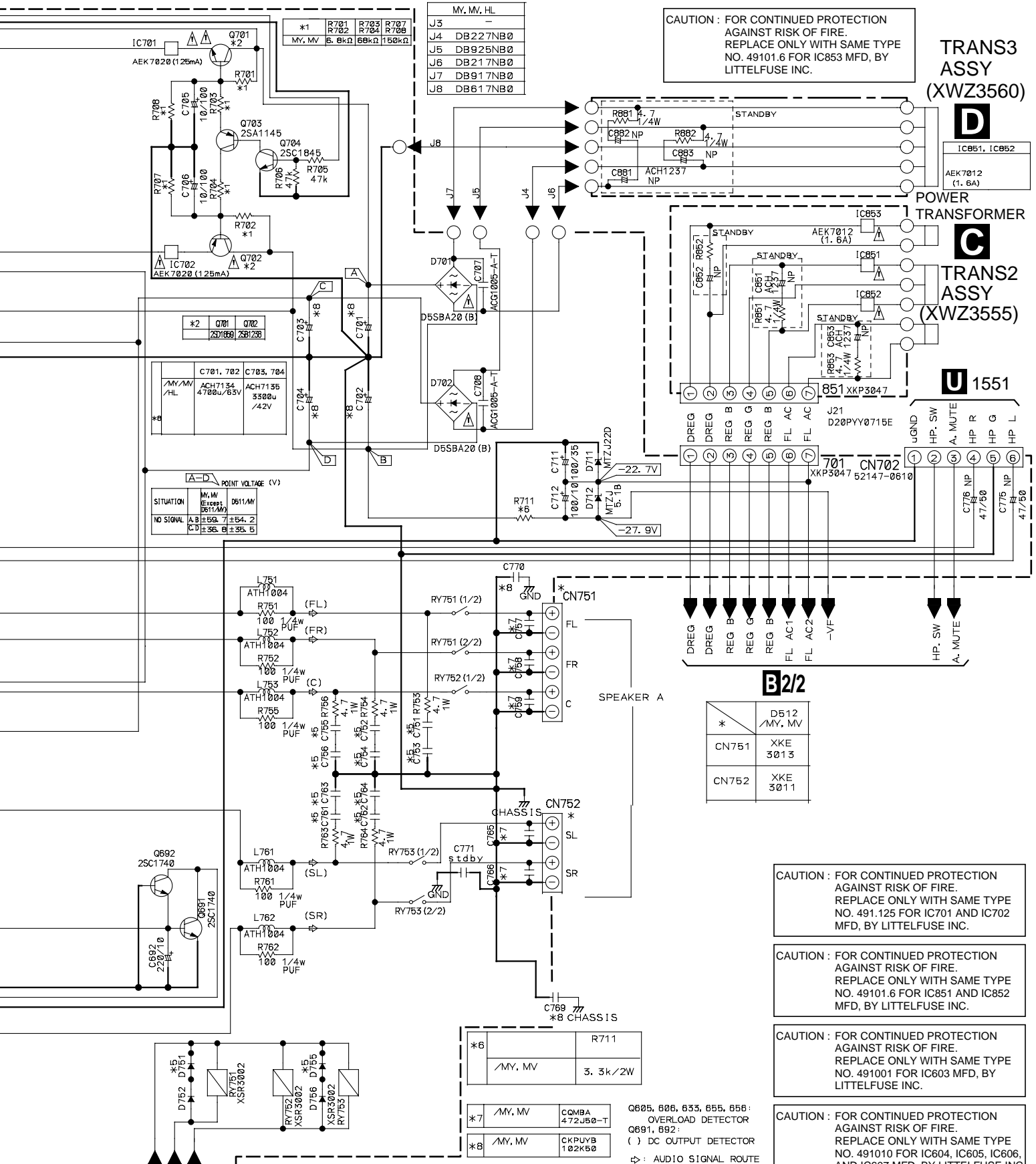

CAUTION : FOR CONTINUED PROTECTION AGAINST RISK OF FIRE. REPLACE ONLY WITH SAME TYPE NO. 49101.6 FOR IC853 MFD, BY LITTELFUSE INC.

TRANS3 ASSY (XWZ3560)

D

IC851, IC852 AEK7012 (1.6A)

POWER TRANSFORMER

C

TRANS2 ASSY (XWZ3555)

U 1551

A-D POINT VOLTAGE (V)

SITUATION	M/M	M/M	D511/M
NO SIGNAL	A	B	C/D
	±50.7 ±54.2	±36.8 ±35.5	

*	D512 /MY, MV
CN751	XKE 3013
CN752	XKE 3011

CAUTION : FOR CONTINUED PROTECTION AGAINST RISK OF FIRE. REPLACE ONLY WITH SAME TYPE NO. 491.125 FOR IC701 AND IC702 MFD, BY LITTELFUSE INC.

CAUTION : FOR CONTINUED PROTECTION AGAINST RISK OF FIRE. REPLACE ONLY WITH SAME TYPE NO. 49101.6 FOR IC851 AND IC852 MFD, BY LITTELFUSE INC.

CAUTION : FOR CONTINUED PROTECTION AGAINST RISK OF FIRE. REPLACE ONLY WITH SAME TYPE NO. 491001 FOR IC603 MFD, BY LITTELFUSE INC.

CAUTION : FOR CONTINUED PROTECTION AGAINST RISK OF FIRE. REPLACE ONLY WITH SAME TYPE NO. 491010 FOR IC604, IC605, IC606, AND IC607 MFD, BY LITTELFUSE INC.

NOTE FOR FUSE REPLACEMENT

CAUTION -FOR CONTINUED PROTECTION AGAINST RISK OF FIRE. REPLACE WITH SAME TYPE AND RATINGS ONLY.

*6	/MY, MV	CMBA 472J50-T
*7	/MY, MV <td>CKPUYB 102K50</td>	CKPUYB 102K50

Q605, 606, 635, 655, 656 : OVERLOAD DETECTOR
Q691, 692 : () DC OUTPUT DETECTOR
▷ : AUDIO SIGNAL ROUTE

B 1/2 C D

3.8 AMP & PRIM.(2/2), REG., HASHIGETA and MECH SW ASSYS

HASHIGETA ASSY (XWZ3566)

F

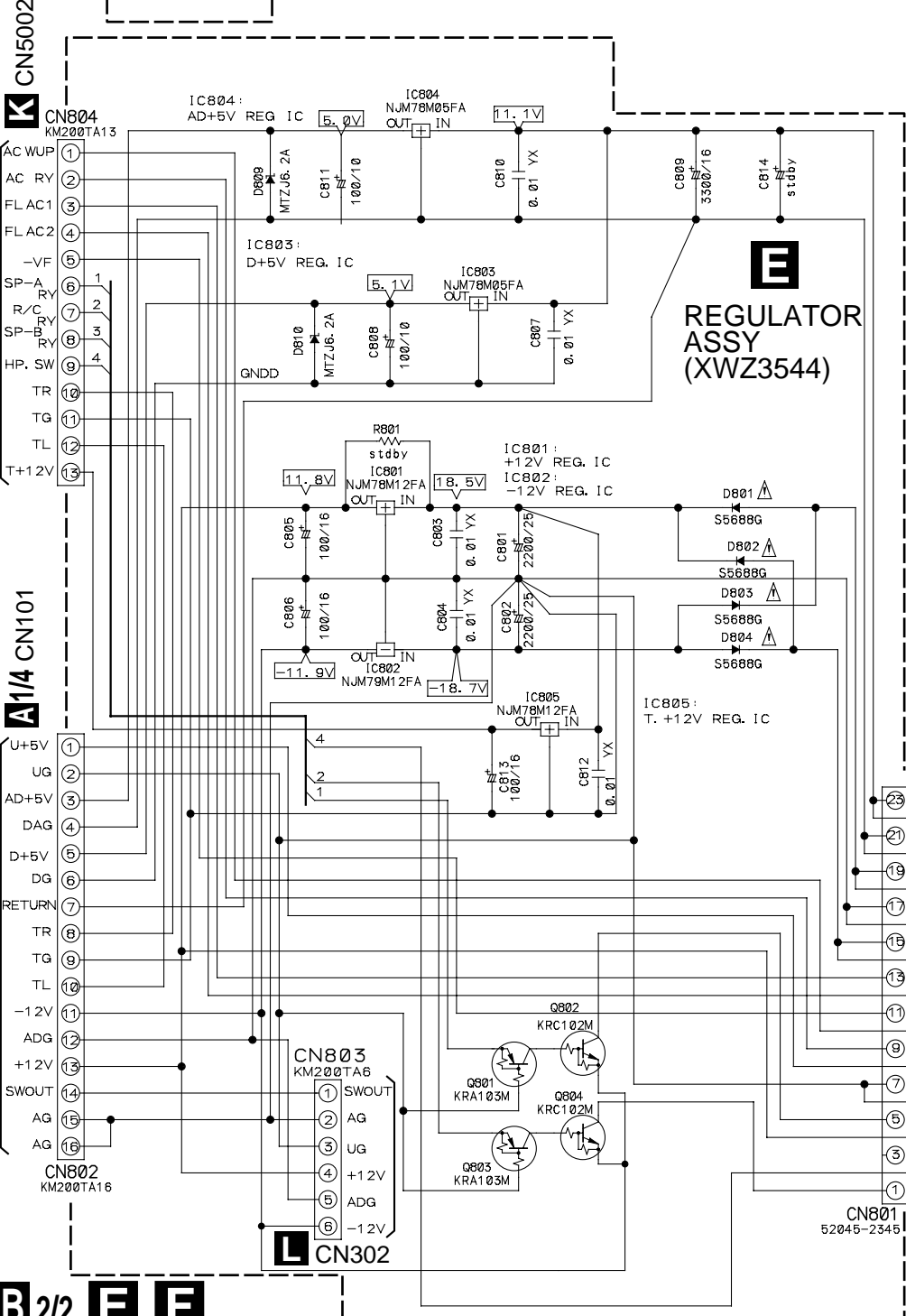
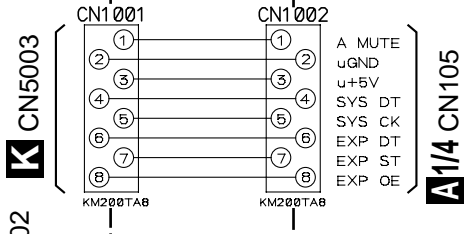

B 2/2 AMP & PRIMARY ASSY (XWZ3533)

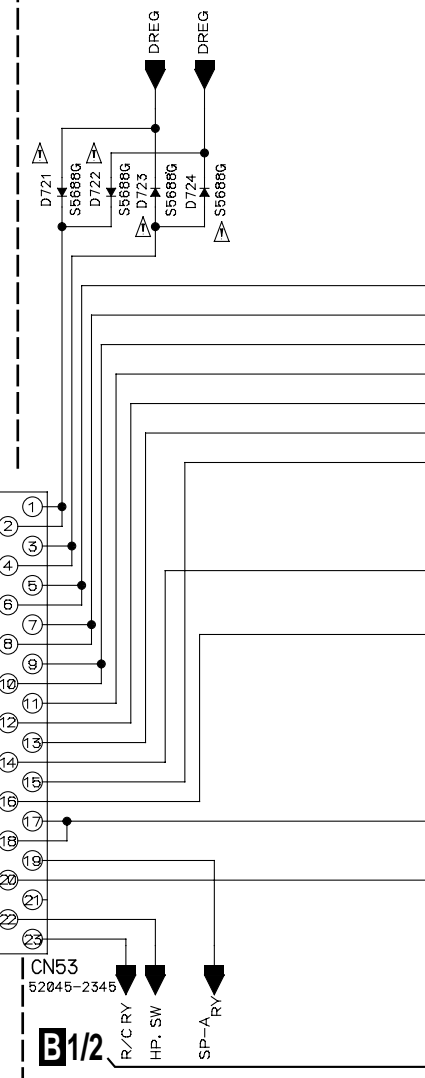

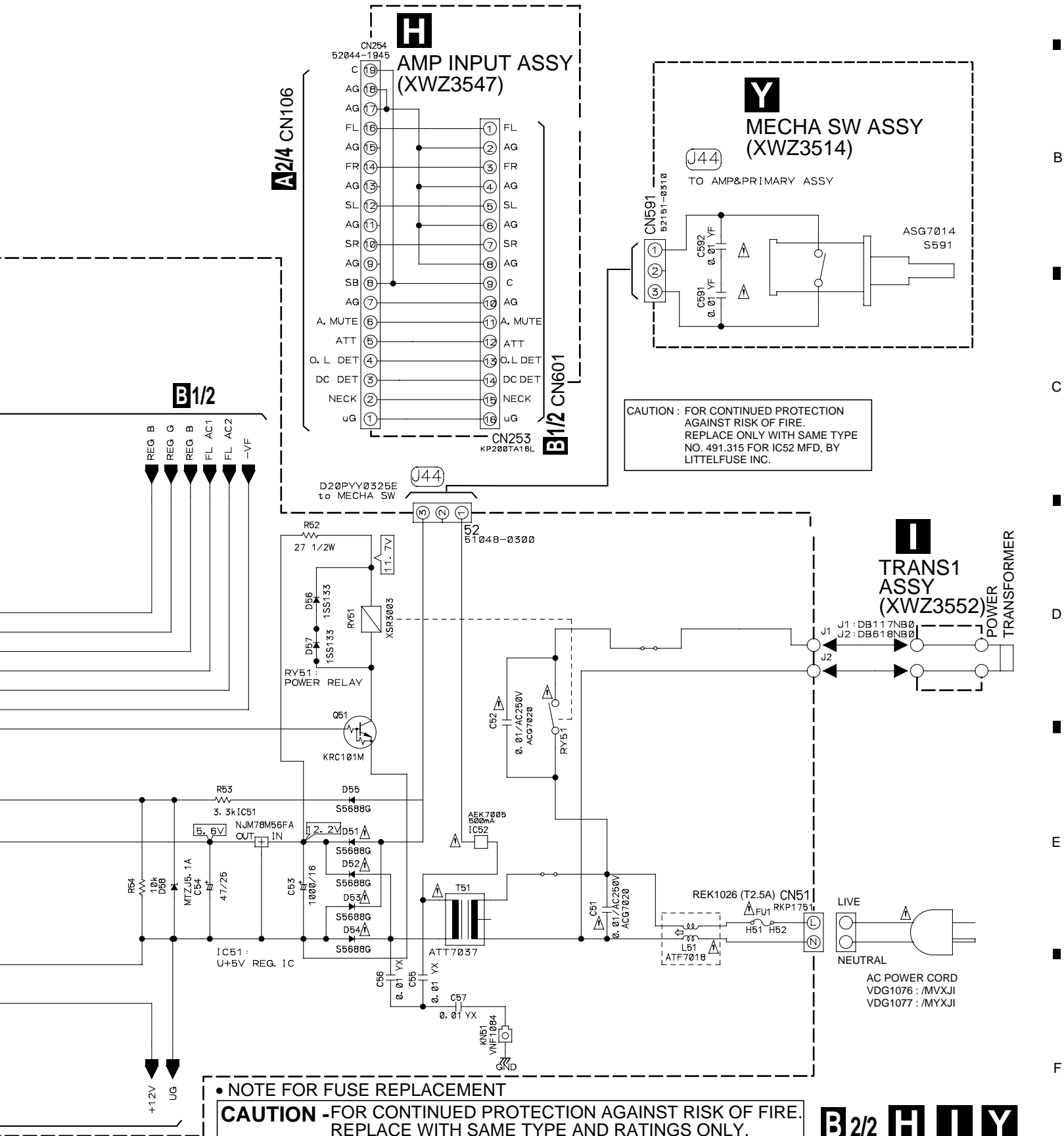

3.9 VIDEO and 6CH IN ASSYS

VIDEO ASSY (XWZ3490)

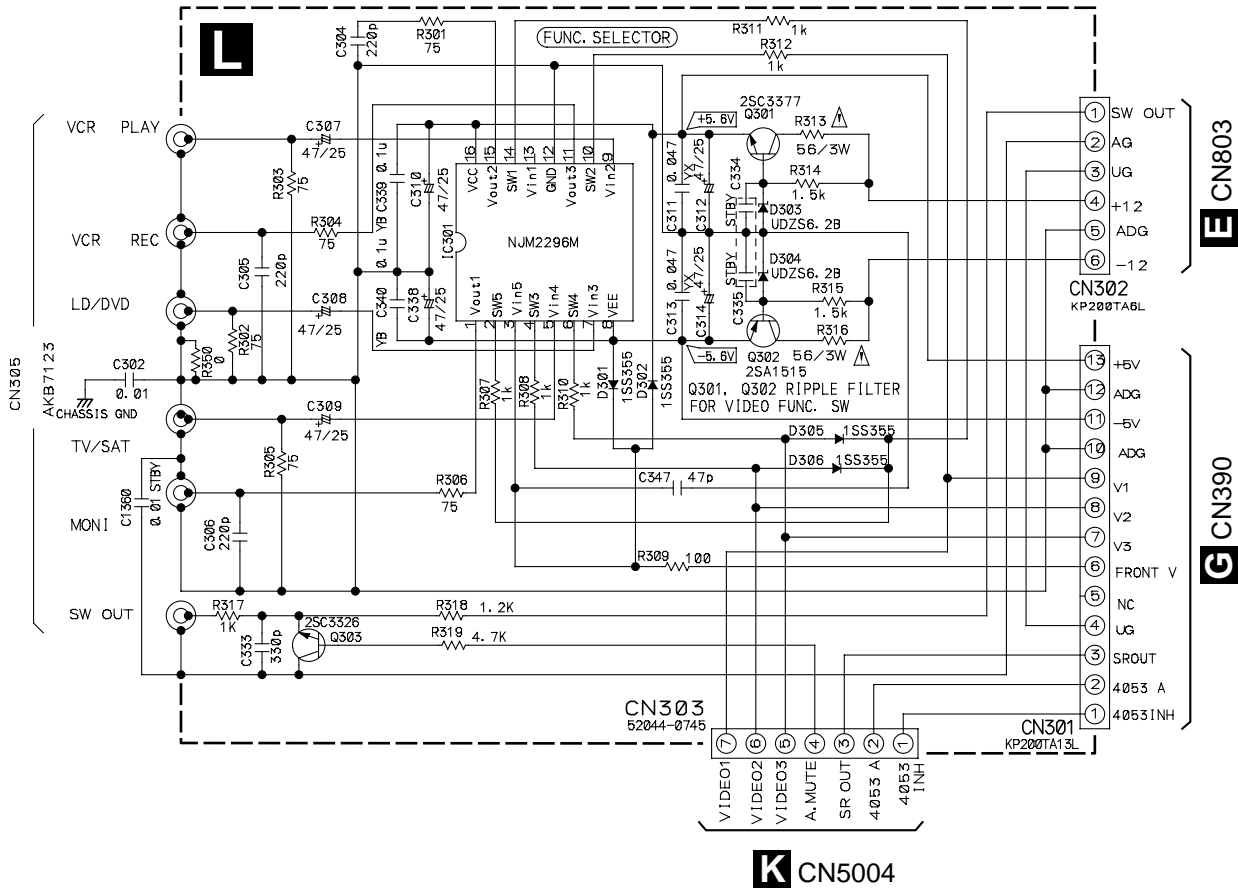

NJM2296D control port status

SW1	SW2	SW3	SW4	SW5	Vout1	Vout2	Vout3
1	0	(1)	0	1	Vin2	Vin2	mute
1	1	(1)	0	1	Vin3	Vin3	Vin3
1	1	0	1	1	Vin4	Vin4	Vin4
1	1	1	1	1	Vin5	Vin5	Vin5
0	0	(0)	(0)	0	mute	mute	mute

VIN 2. VCR
 VIN 3. DVD/LD
 VIN 4. TV/SAT
 VIN 5. FRONT
 Vout1. MON out
 Vout2.
 Vout3. VCR out

NOTE

1. RESISTORS
 Unit: k- Ω , M- Ω or Ω unless otherwise noted.
 Rated power: 1/10W unless otherwise noted.
 Tolerance: (J) \pm 5% unless otherwise noted.

2. CAPACITORS
 Unit: p-pF or μ F unless otherwise noted.
 Ratings: Capacity(μ F)/Voltage(V) unless otherwise noted.
 Rated Voltage: 50V except for electrolytic capacitors.

3. DIODES
 Indicated in 1SS355-TRB

- : AUDIO SIGNAL ROUTE
- (FL) : AUDIO SIGNAL ROUTE (Front L ch)
- (SL) : AUDIO SIGNAL ROUTE (Rear L ch)
- (SW) : AUDIO SIGNAL ROUTE (Sub Woofer)
- (C) : AUDIO SIGNAL ROUTE (Center)

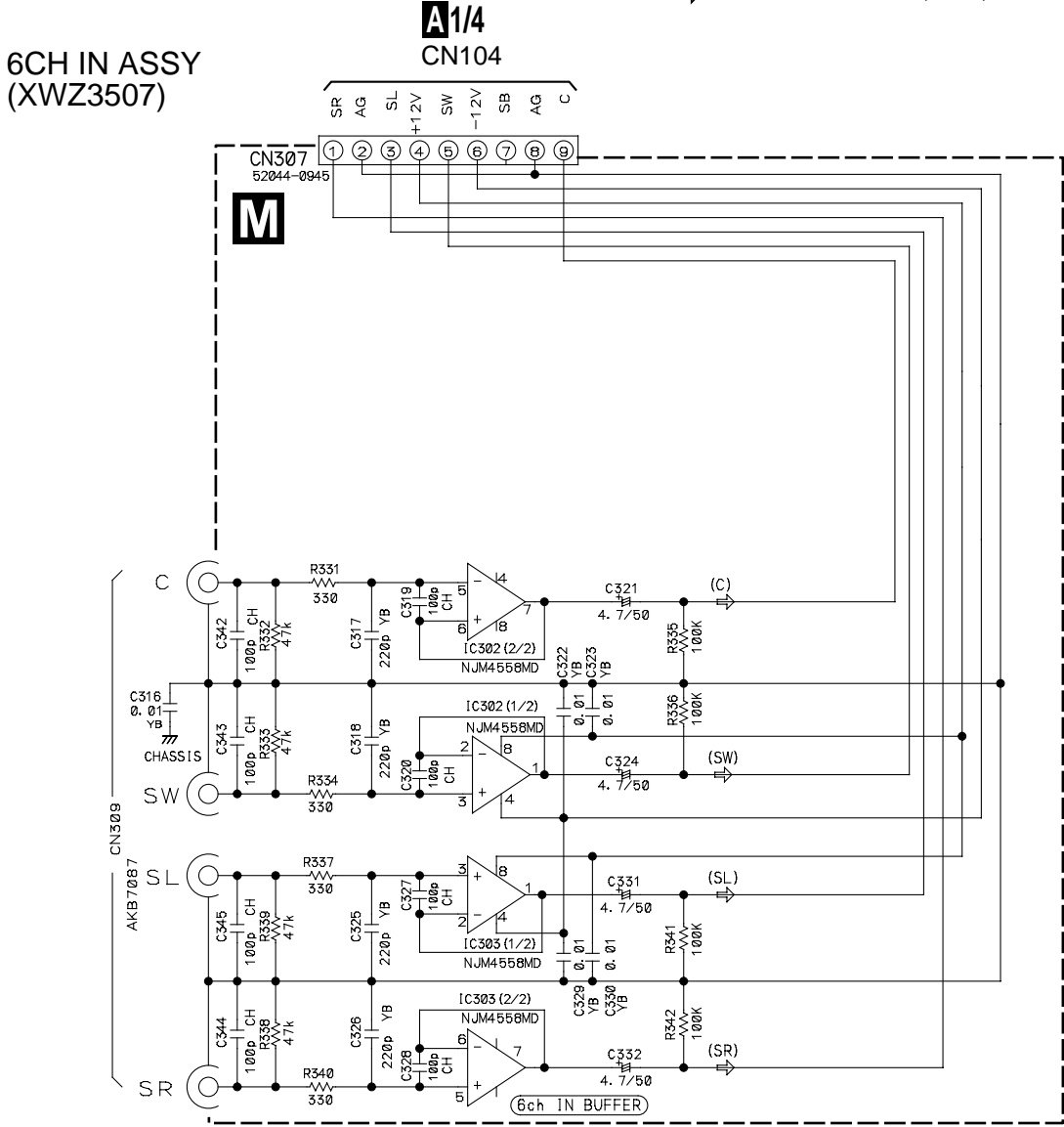

3.10 FRONT, R.ENCODER and POWER SW ASSYS

A
B
C
D
E
F

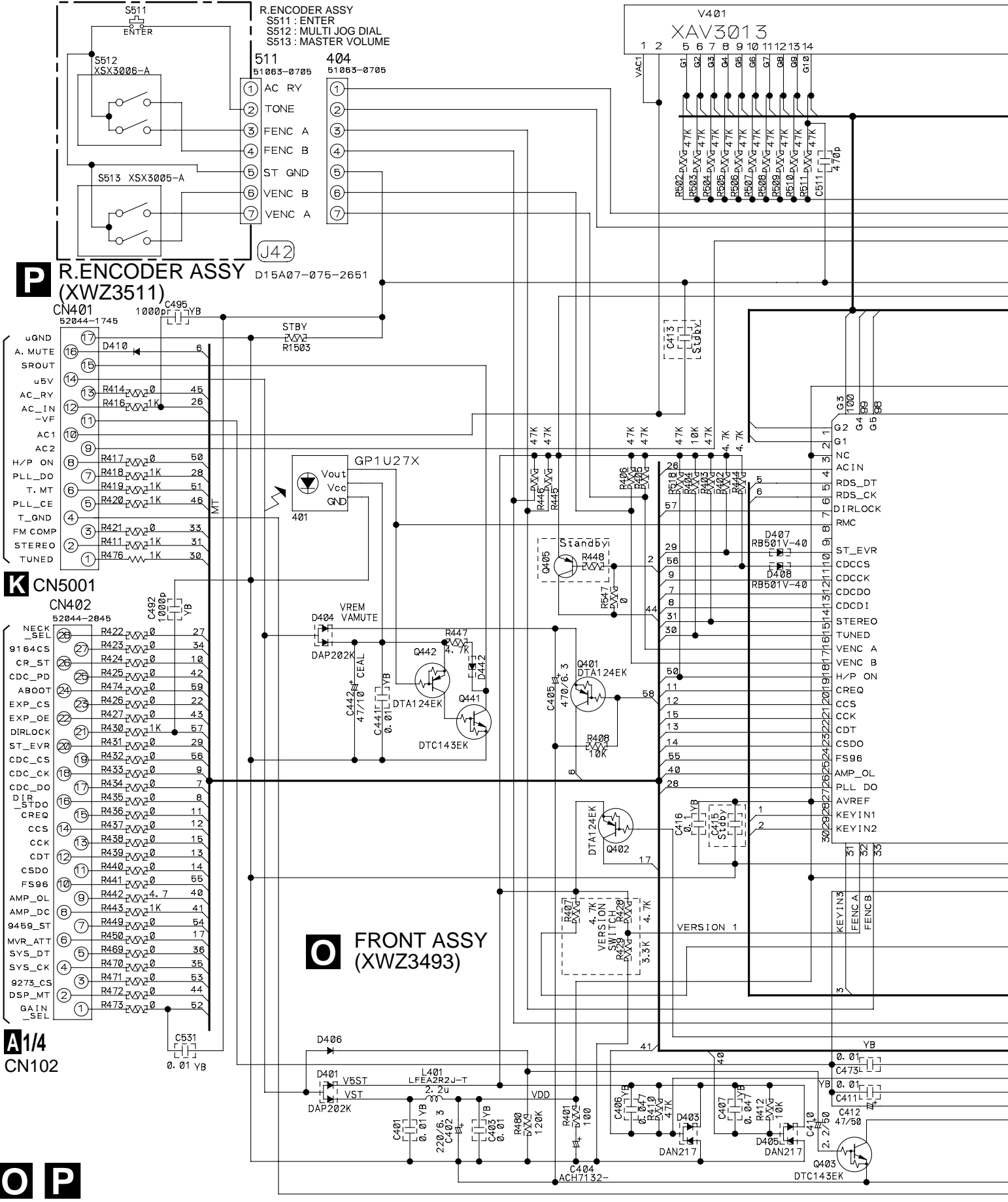

(402 FL HOLDER VNF1096-)

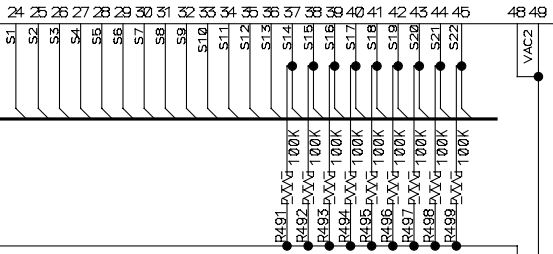

- NOTE**
- RESISTORS**
Unit: k- Ω , M-M Ω or Ω unless otherwise noted.
Rated power: 1/10W unless otherwise noted.
Tolerance: (J) \pm 5% unless otherwise noted.
 - CAPACITORS**
Unit: p-pF or μ F unless otherwise noted.
Ratings: Capacity (μ F)/Voltage (V) unless otherwise noted.
Rated Voltage: 50V except for electrolytic capacitors.
JA:CEJA
 - DIODES**
Indicated in 1SS355-TBR.
 - TACT SWITCHES**
Indicated in ASG1051.

POWER SW ASSY (XWZ3510)

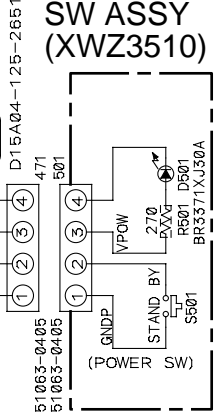

- POWER SW ASSY**
S501 : POWER STANDBY/ON
- FRONT ASSY**
S451 : SIGNAL SELECT
S452 : MONITOR
S453 : MIDNIGHT
S454 : LOUDNESS
S455 : TONE
S456 : SETUP
S457 : ADVANCED SURR
S458 : DIRECT
S459 : EON MODE
S460 : PTY SEARCH
S461 : MPX
S462 : BAND
S463 : STANDARD
S464 : TUNING(+)
S465 : TUNING(-)
S466 : STATION(+)
S467 : STATION(-)
S468 : MULTI JOG (TUNER EDIT)
S476 : CLASS

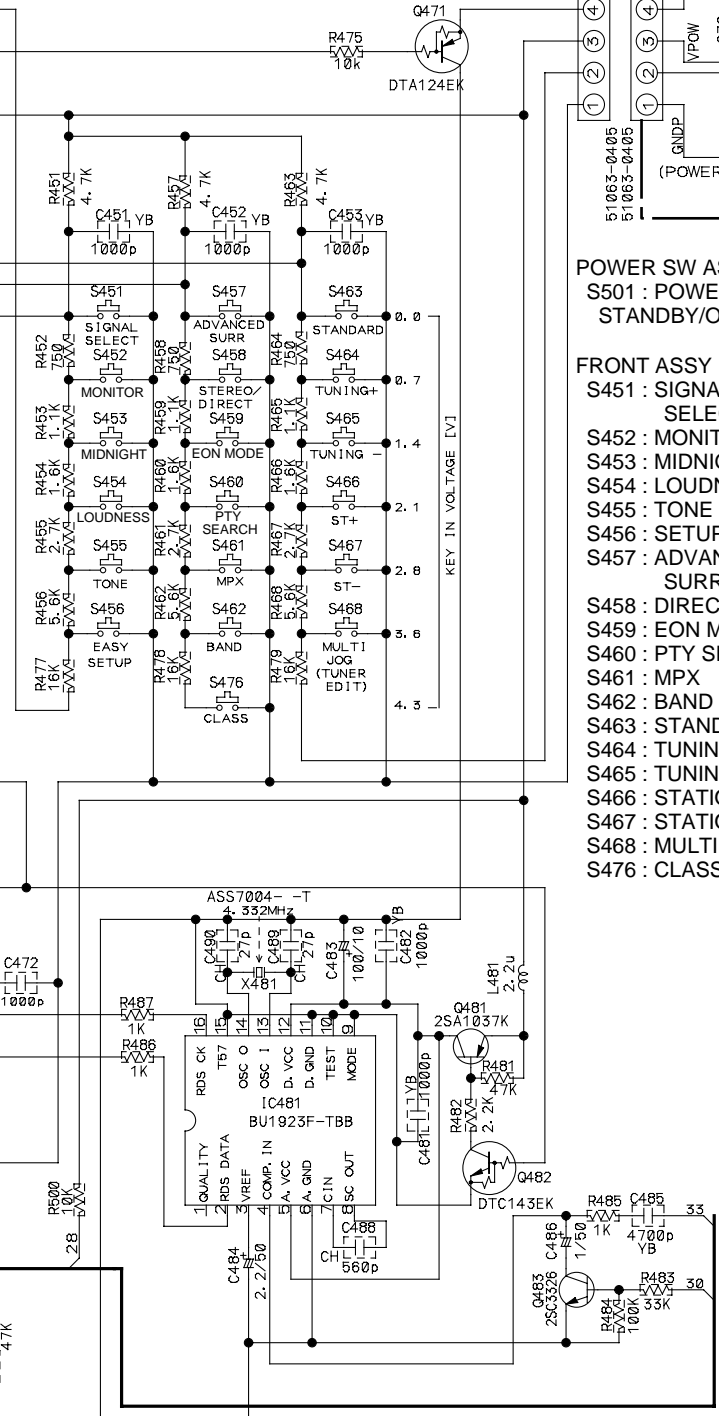
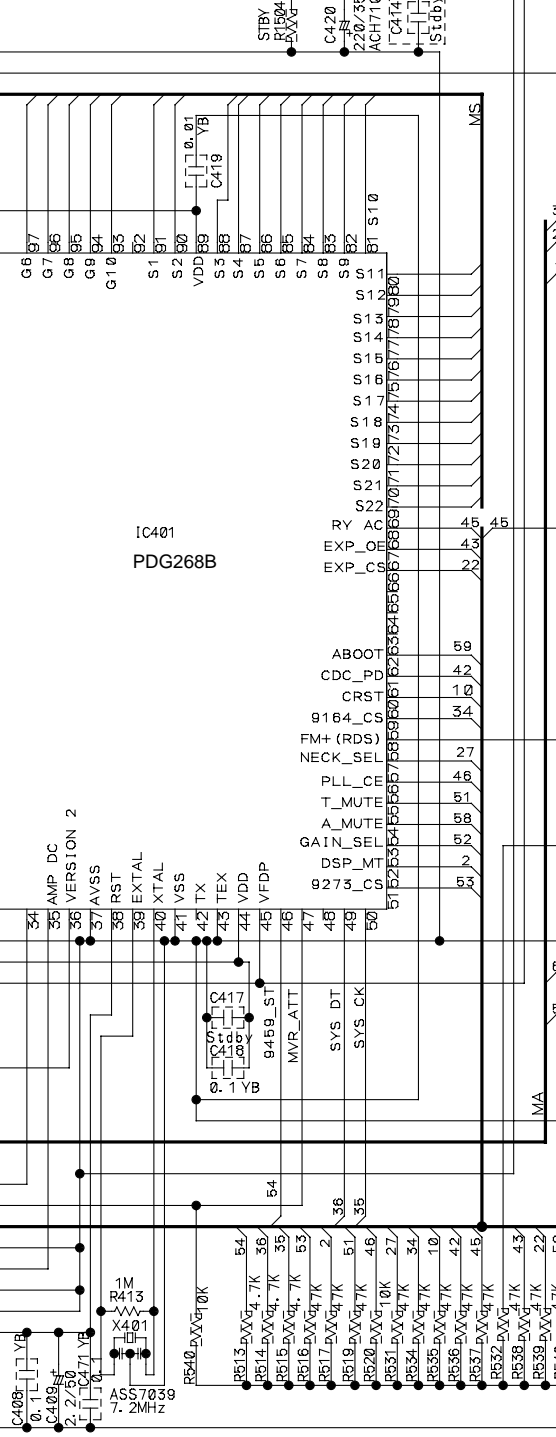

3.11 DIGITAL IN, H.P. and KAWA ASSYS

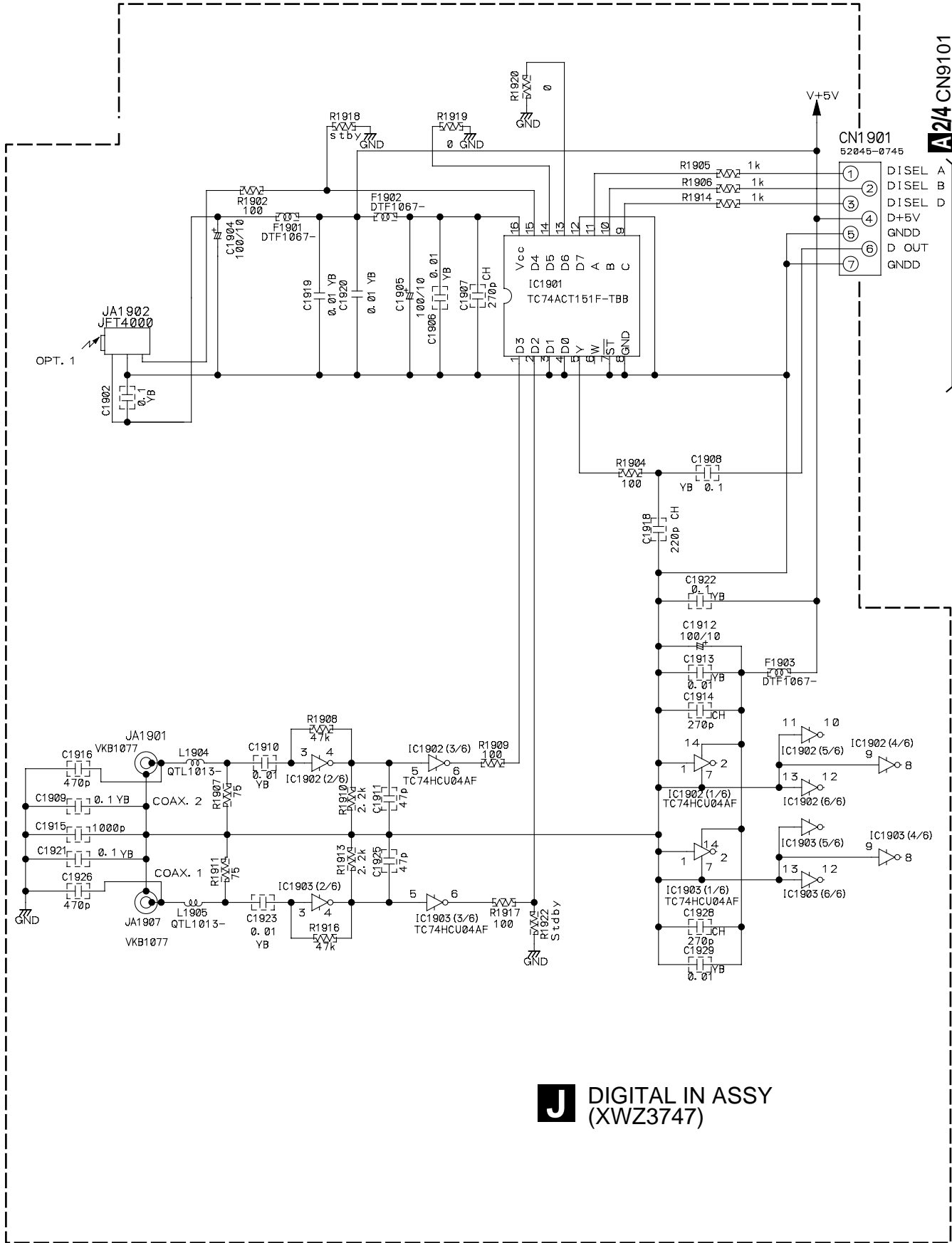

J DIGITAL IN ASSY (XWZ3747)

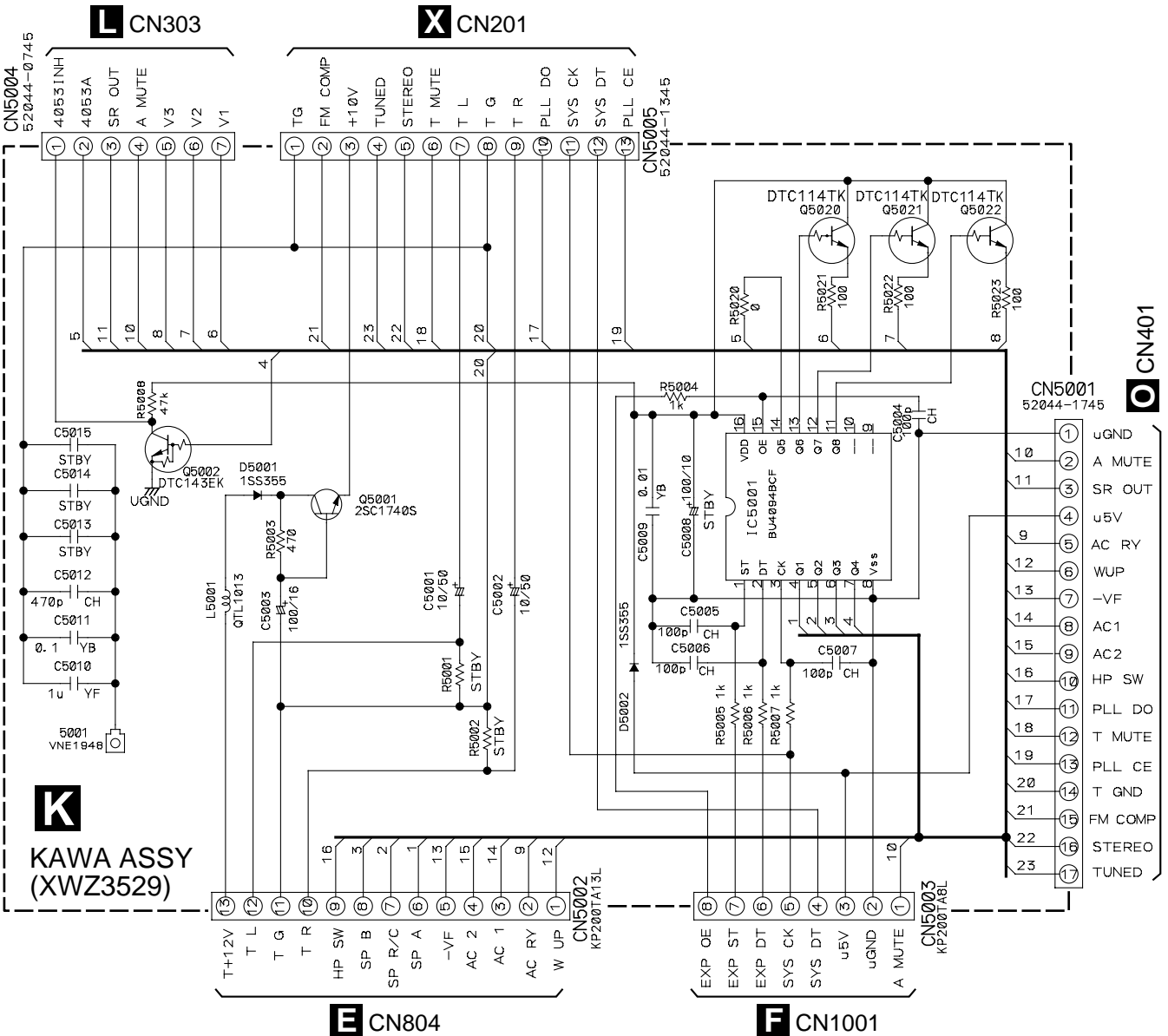
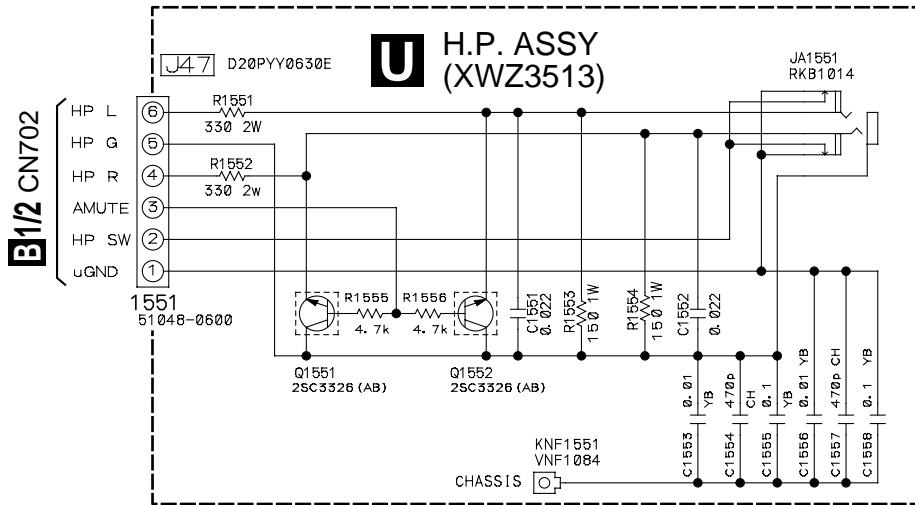

3.12 FM/AM TUNER MODULE

FM/AM TUNER MODULE (AXQ7232)

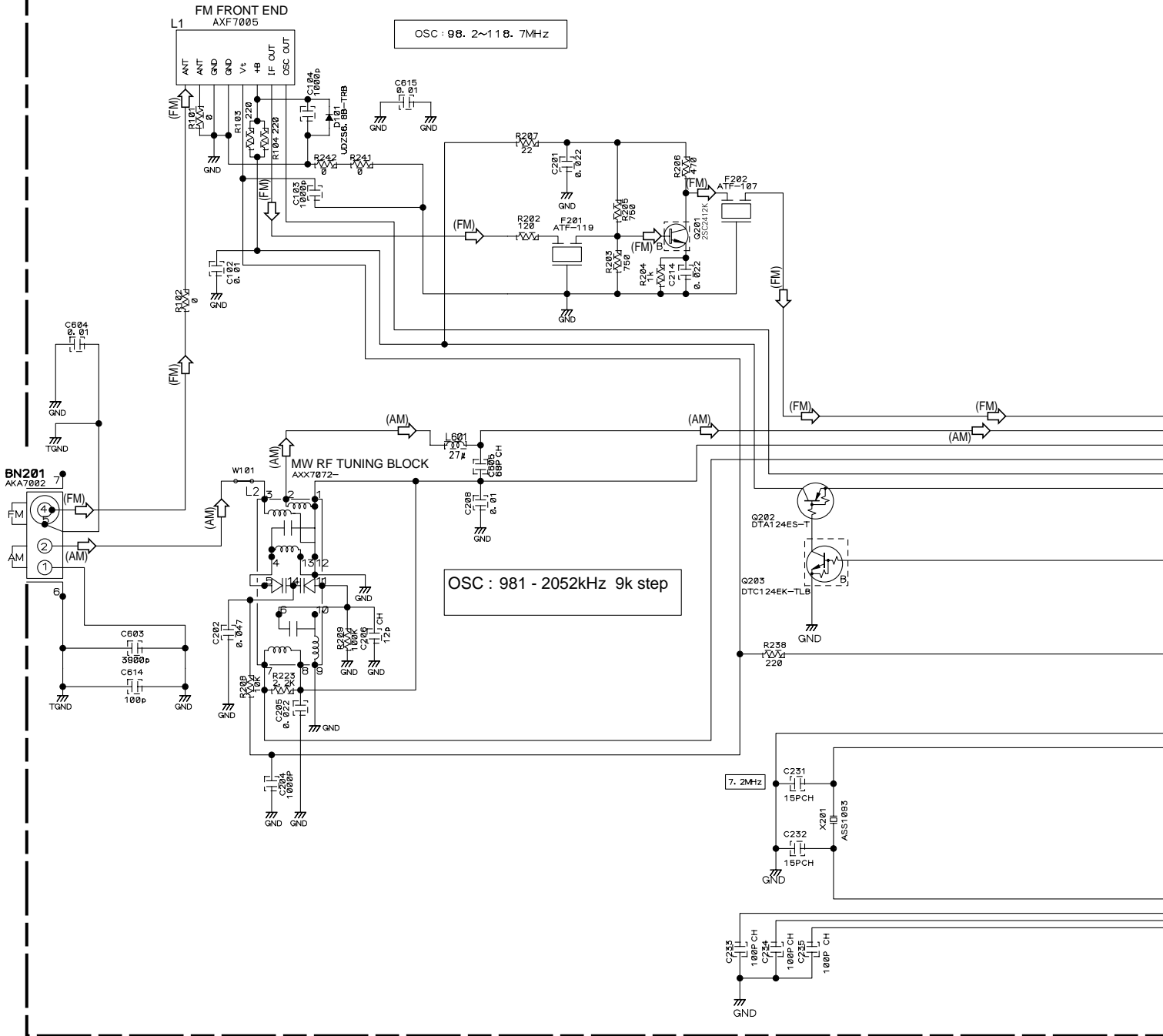

Notes

1. RESISTORS

Indicated in Ω, 1/16W±5% Tolerance unless otherwise noted K:KΩ, M:MΩ.



2. CAPACITORS

Indicated in Capacity (μF)/VOLTAGE (V) unless otherwise noted P:PF.

3. DIODES

No mark diode is 1S5133.

 : The power supply is shown with the marked box.



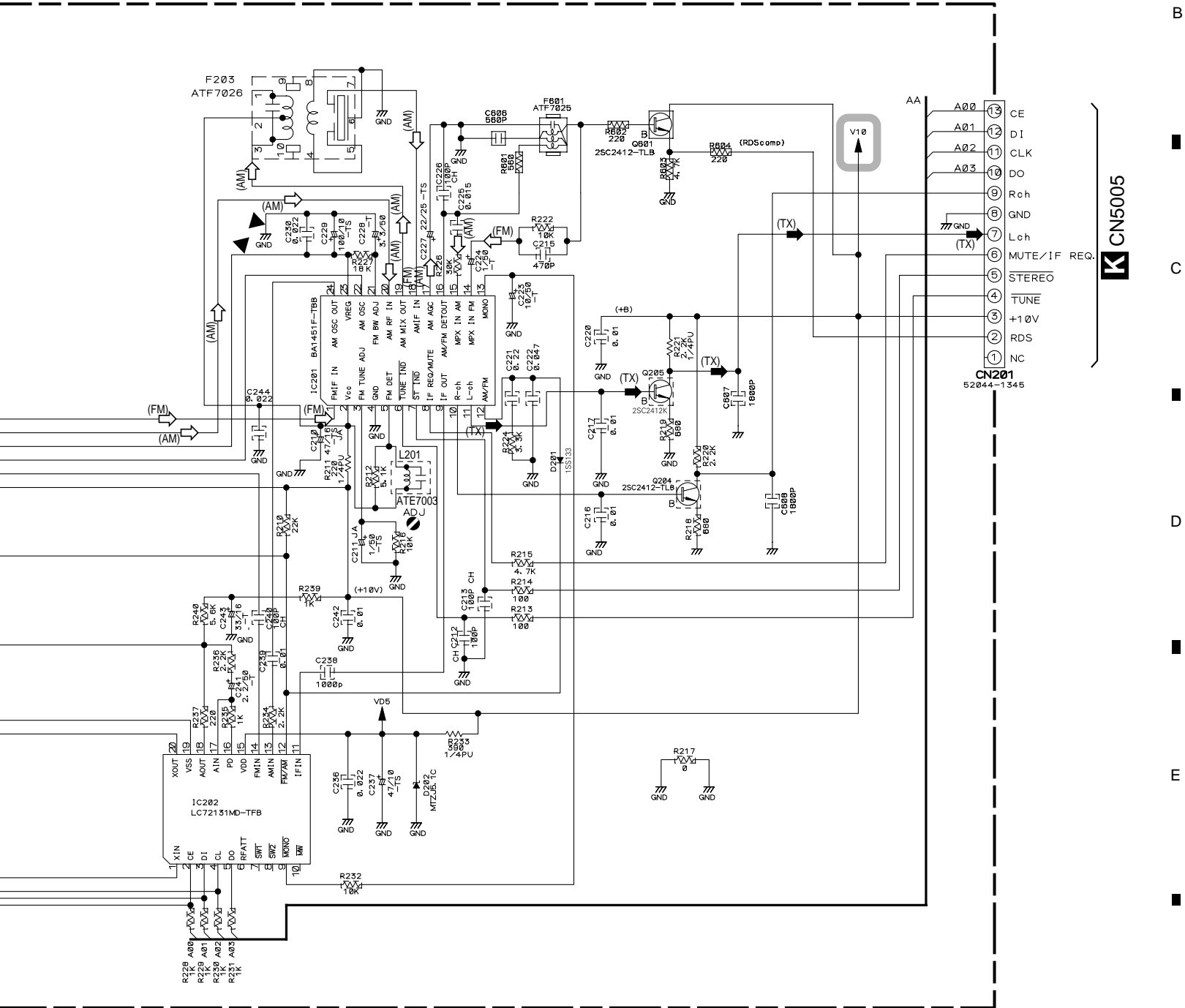





-  : AUDIO SIGNAL ROUTE (TUNER)
-  : AM SIGNAL ROUTE
-  : FM SIGNAL ROUTE

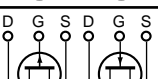

4. PCB CONNECTION DIAGRAM

NOTE FOR PCB DIAGRAMS :

- 1. Part numbers in PCB diagrams match those in the schematic diagrams.
- 2. A comparison between the main parts of PCB and schematic diagrams is shown below.

Symbol In PCB Diagrams	Symbol In Schematic Diagrams	Part Name
		Transistor
		Transistor with resistor
		Field effect transistor
		Resistor array
		3-terminal regulator

- 3. The parts mounted on this PCB include all necessary parts for several destinations.
For further information for respective destinations, be sure to check with the schematic diagram.
- 4. View point of PCB diagrams.

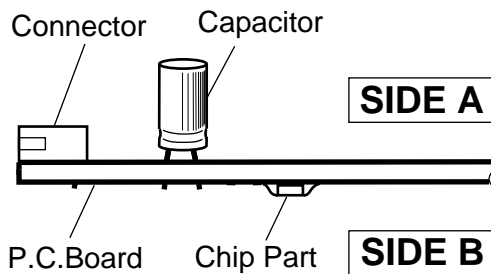

4.1 TRANS1, TRANS2 and TRANS3 ASSYS

SIDE A

SIDE A

D TRANS3 ASSY

B J6 J4 J8 J5 J7

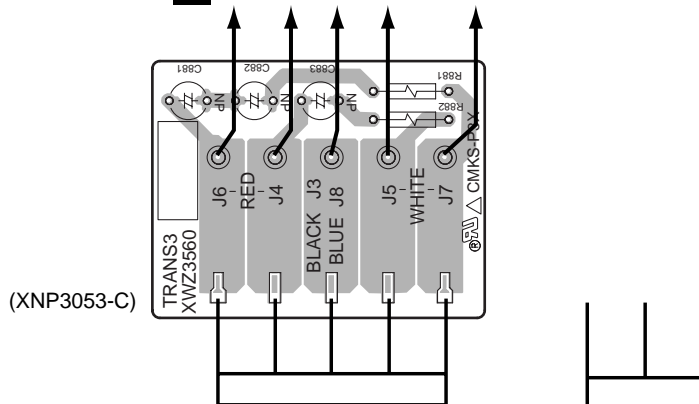

C TRANS2 ASSY

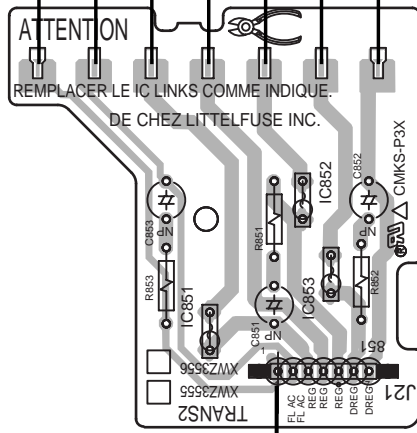

I TRANS1 ASSY

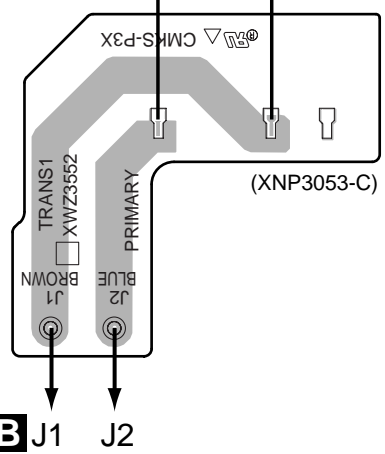

B 701

C D I

C D I

1 2 3 4

SIDE B

A D.D & INPUT ASSY

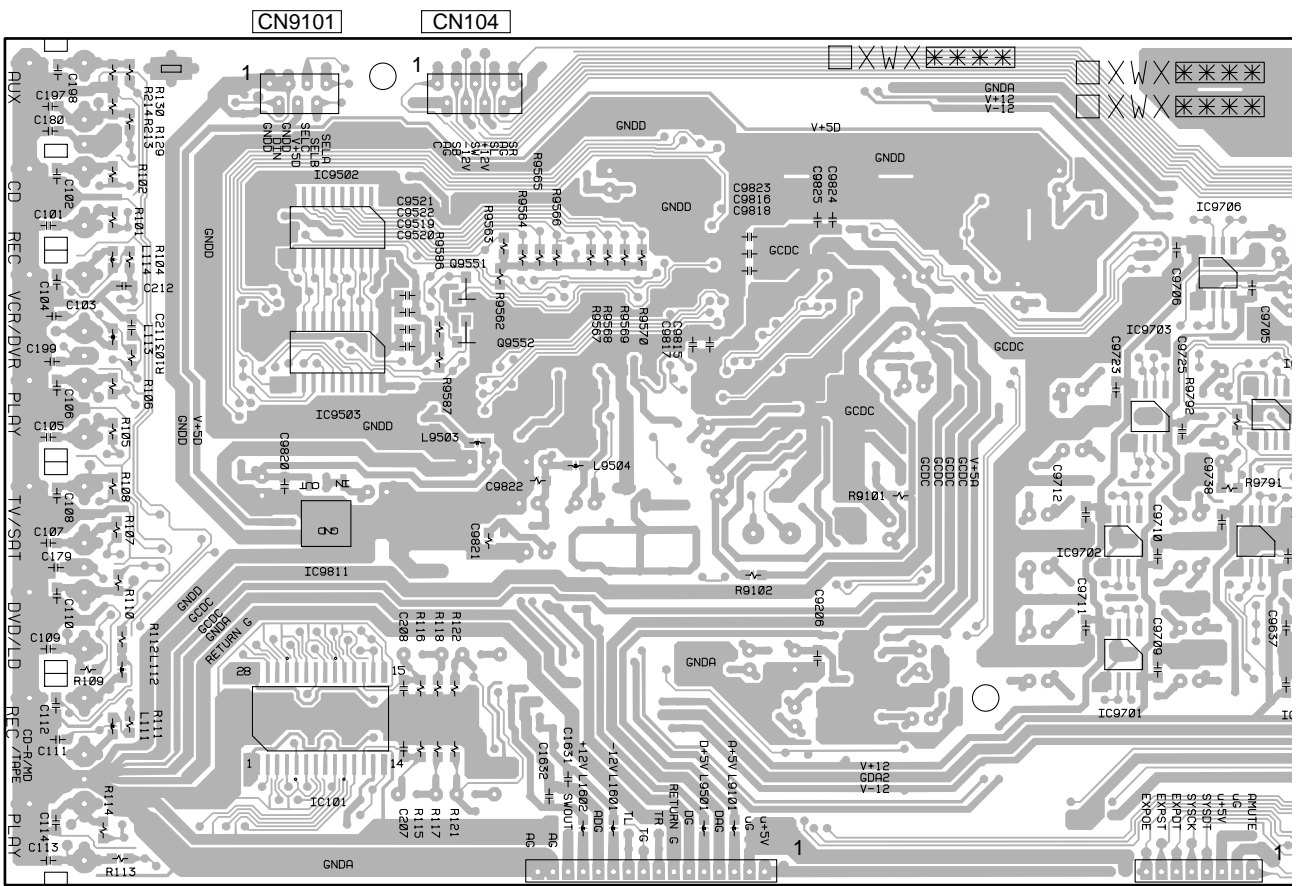

- | | | | | |
|--------|-------|-------|--------------|--------|
| IC9502 | Q9551 | Q9552 | CN101 | IC9705 |
| IC9503 | | | | IC9703 |
| IC9811 | | | | IC9702 |
| IC101 | | | | IC9705 |

A

1 2 3 4

SIDE B

A

B

C

D

E

F

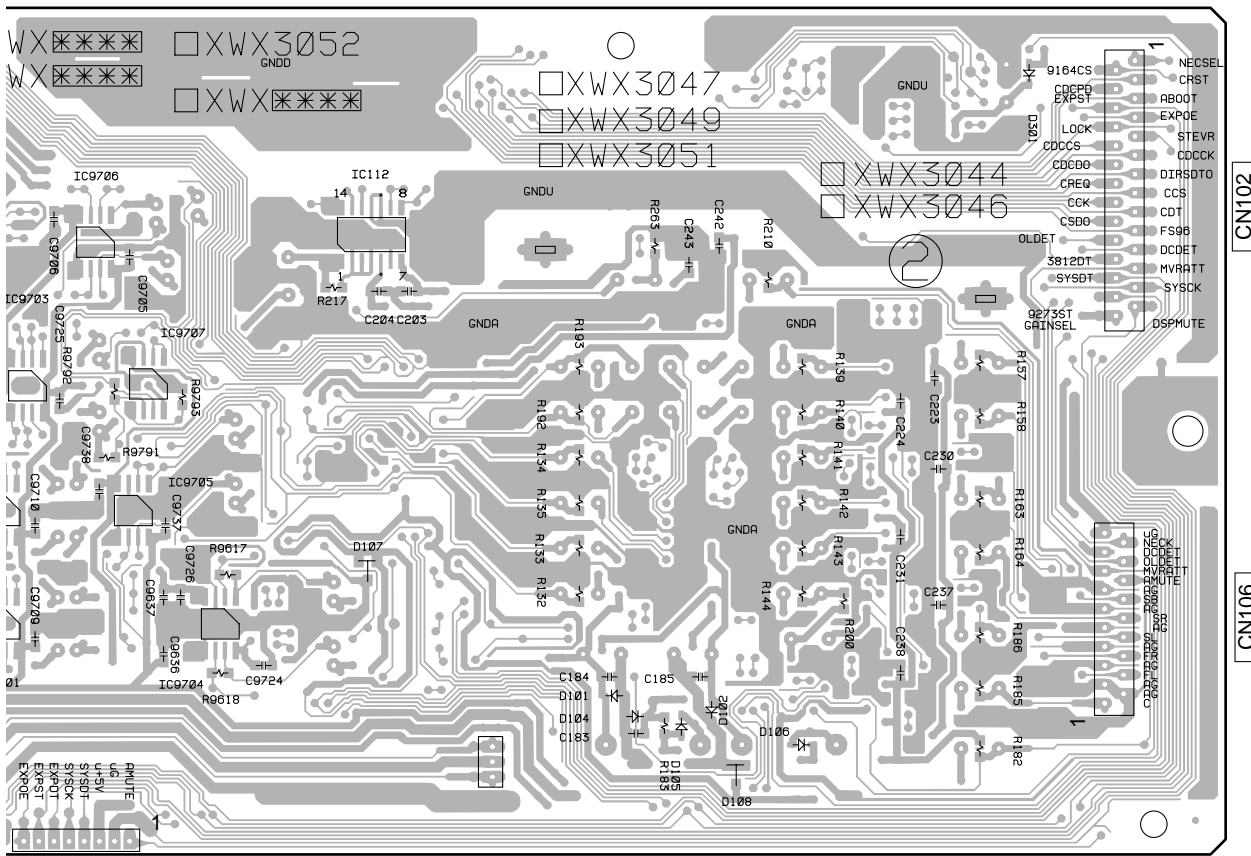

IC9705 IC112 (XNP3056-C)
 39703 IC9707
 02 IC9705
 IC9704

4.3 AMP INPUT, AMP & PRIMARY and MECHA SW ASSYS

SIDE A

Y MECHA SW ASSY

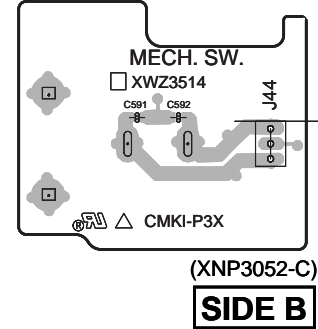
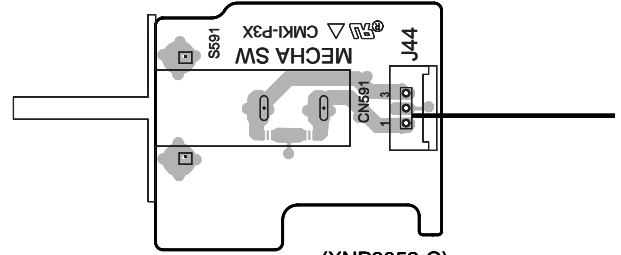
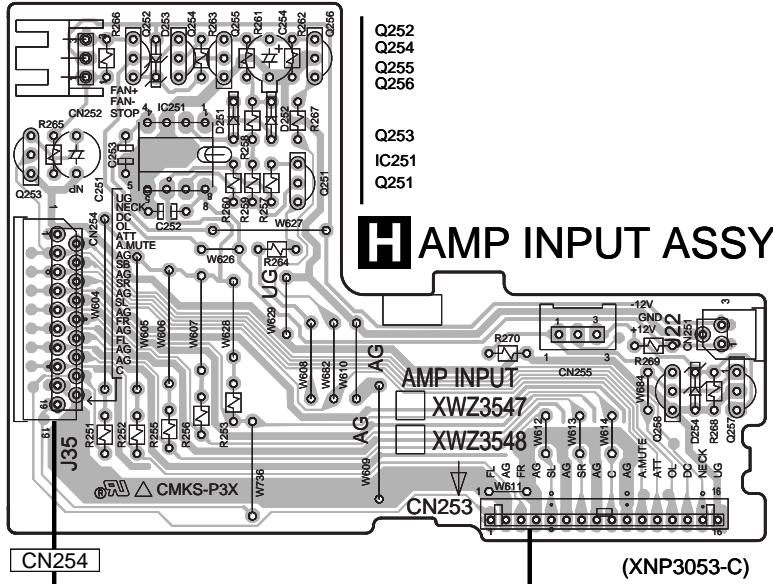

A CN106

B AMP&PRIMARY ASSY

- Q704
- Q702
- IC702
- Q703
- Q701
- IC701
- Q655
- Q697
- Q696
- Q681
- Q682
- Q652
- Q654
- Q633
- Q656
- Q683
- Q606
- Q605
- IC607
- IC606
- Q601
- Q603
- Q651
- Q631
- Q653
- Q632
- IC604
- IC602
- IC601
- IC603

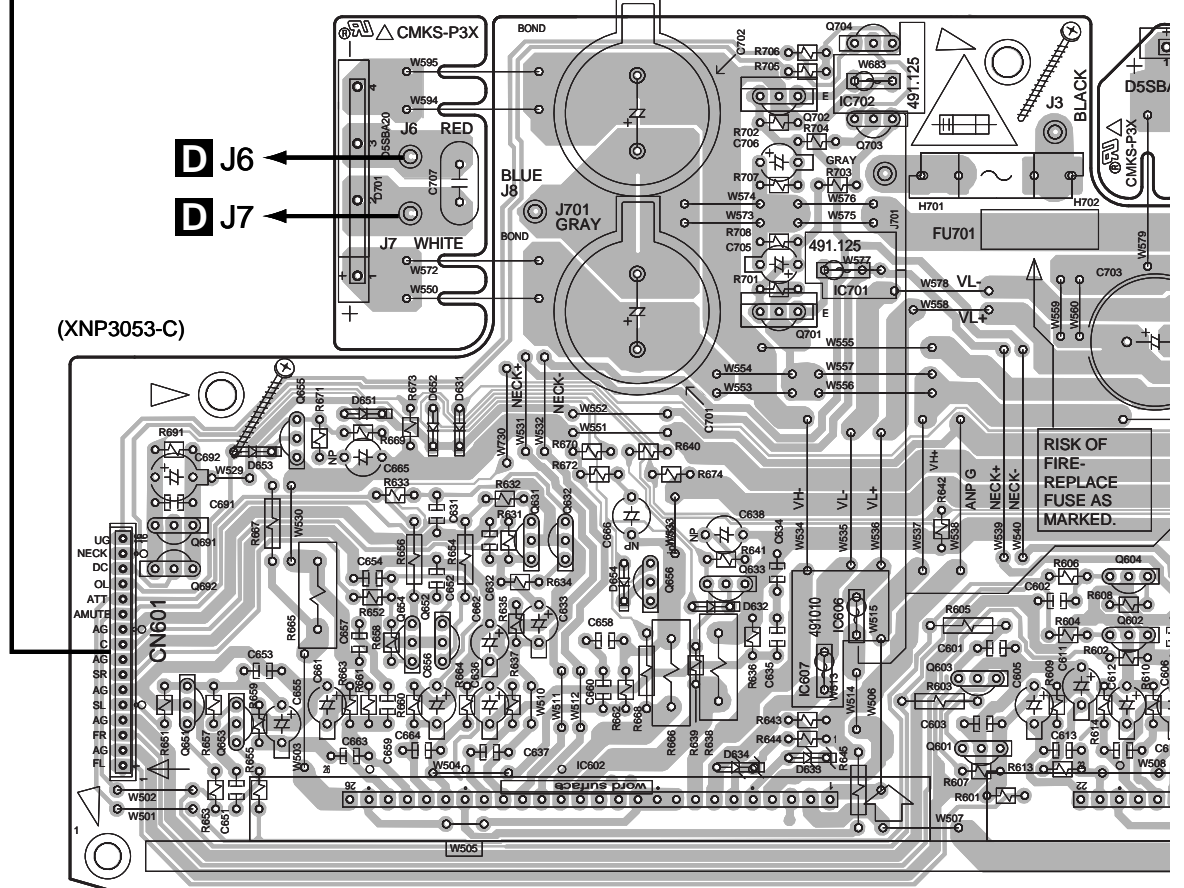

B H Y

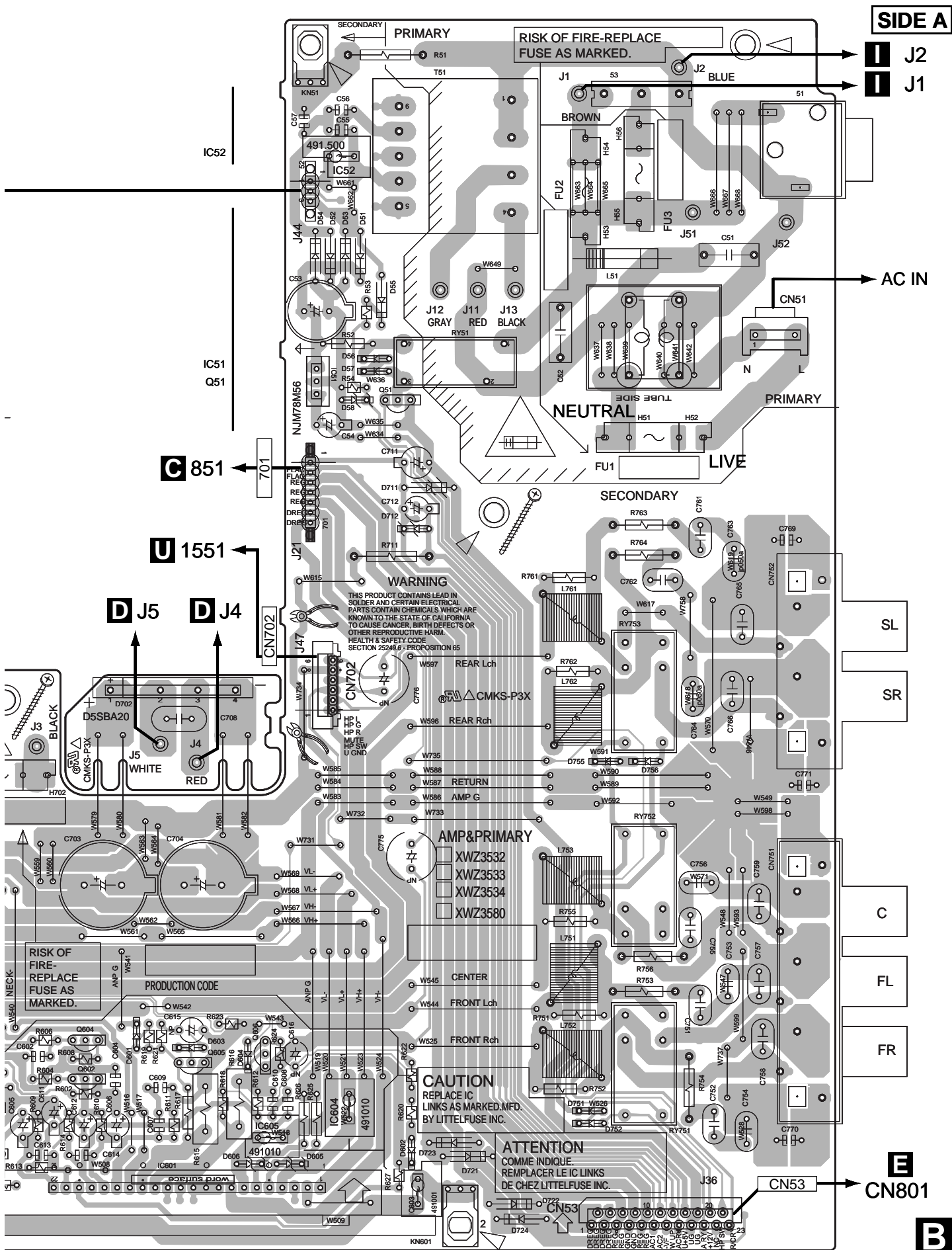

SIDE A

J2
J1

AC IN

C 851

U 1551

D J5 **D** J4

SL

SR

- AMP&PRIMARY**
- XWZ3532
 - XWZ3533
 - XWZ3534
 - XWZ3580

C

FL

FR

E
CN801

B

VSX-D512-K

4.4 FRONT, POWER SW, H.P. and R.ENCODER ASSYS

SIDE A

O FRONT ASSY

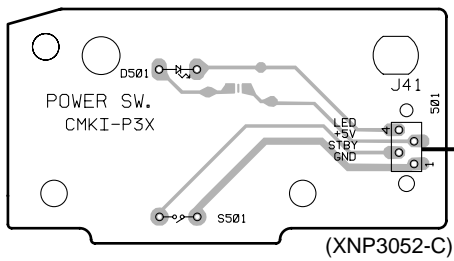
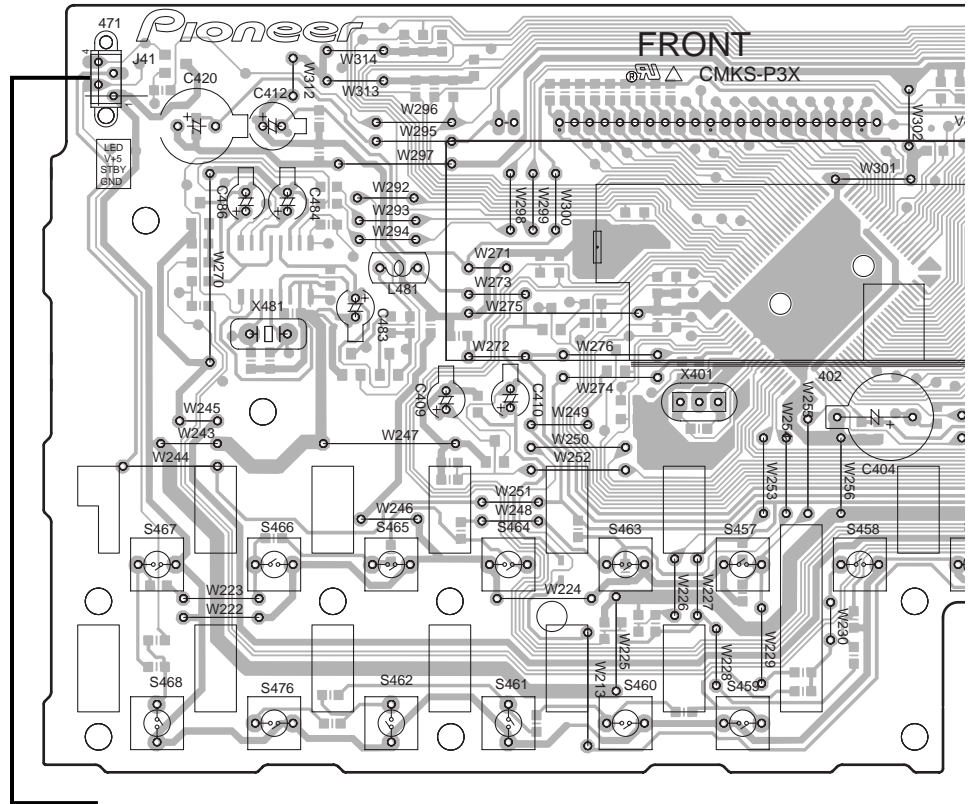

Q POWER SW ASSY

B CN702

U H.P ASSY

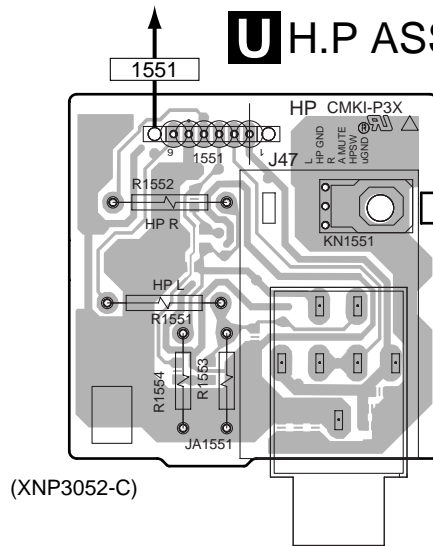

O Q U

SIDE A

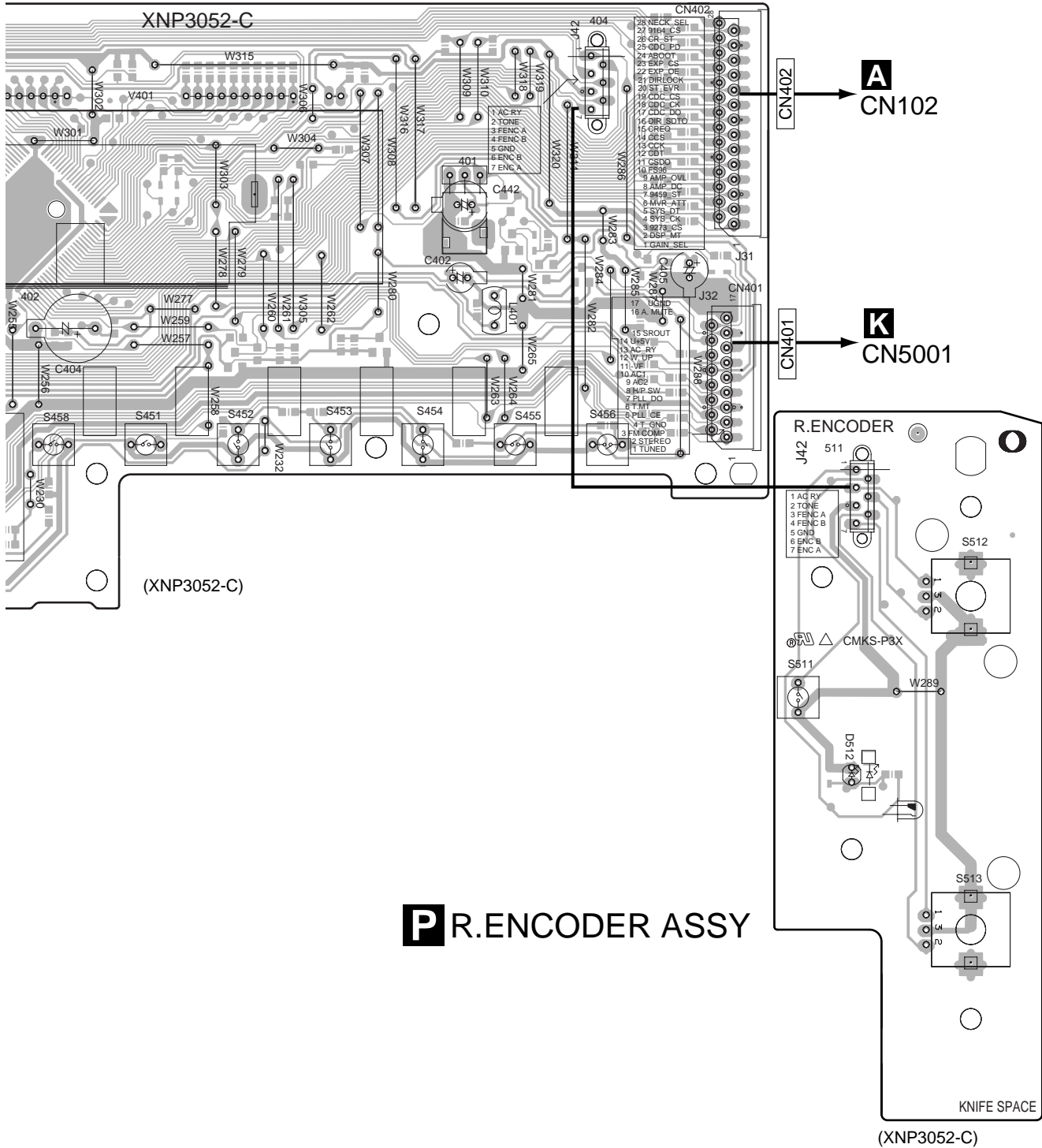

P R.ENCODER ASSY

OP

SIDE B

FRONT ASSY

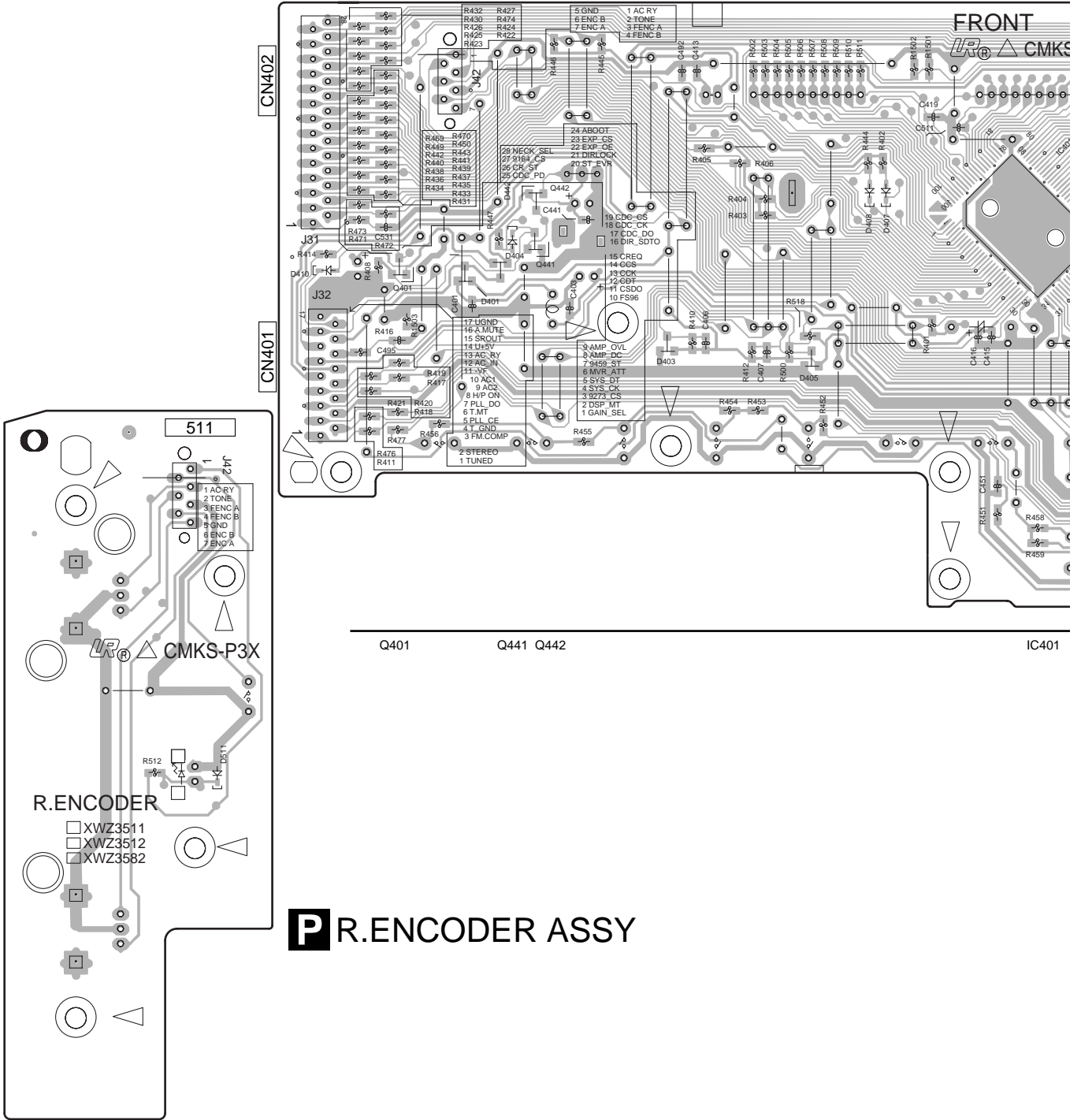

P R.ENCODER ASSY

(XNP3052-C)

OP

VSX-D512-K

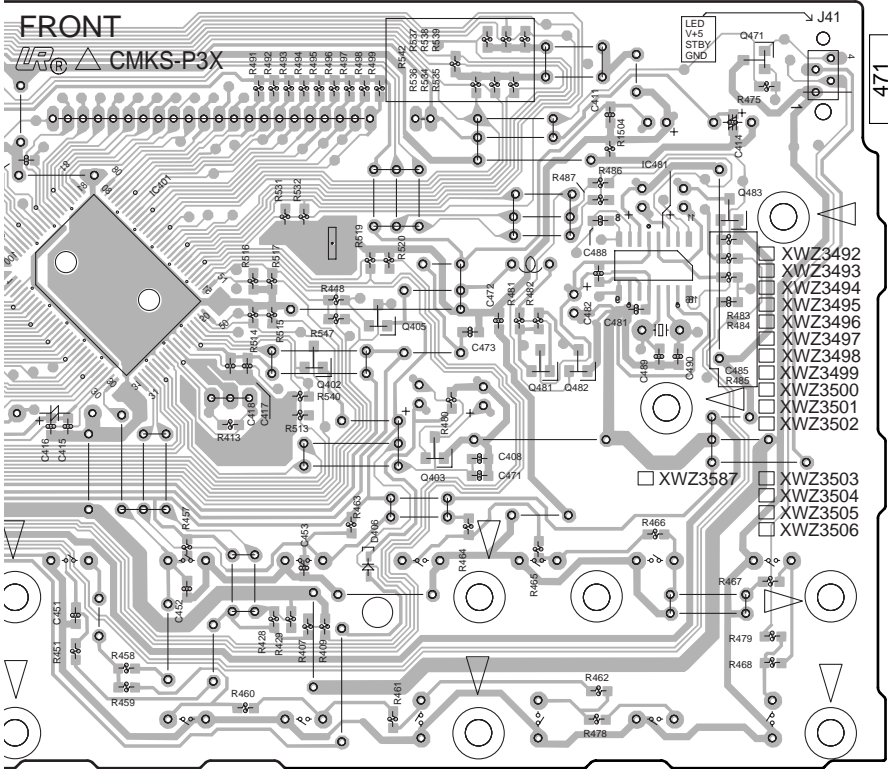

(XNP3052-C)

IC401 Q402 Q405 Q403 Q481 Q482 IC481 Q483 Q471

U H.P ASSY

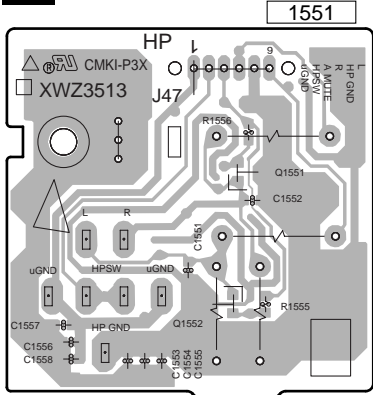

(XNP3052-C)

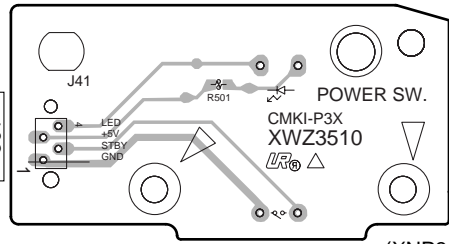

(XNP3052-C)

Q POWER SW ASSY

4.5 REGULATOR, HASHIGETA and KAWA ASSYS

SIDE A

S

F HASHIGETA ASSY

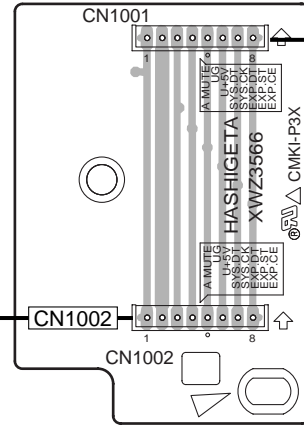

A CN105

E REGULATOR ASSY

(XNP3053-C)

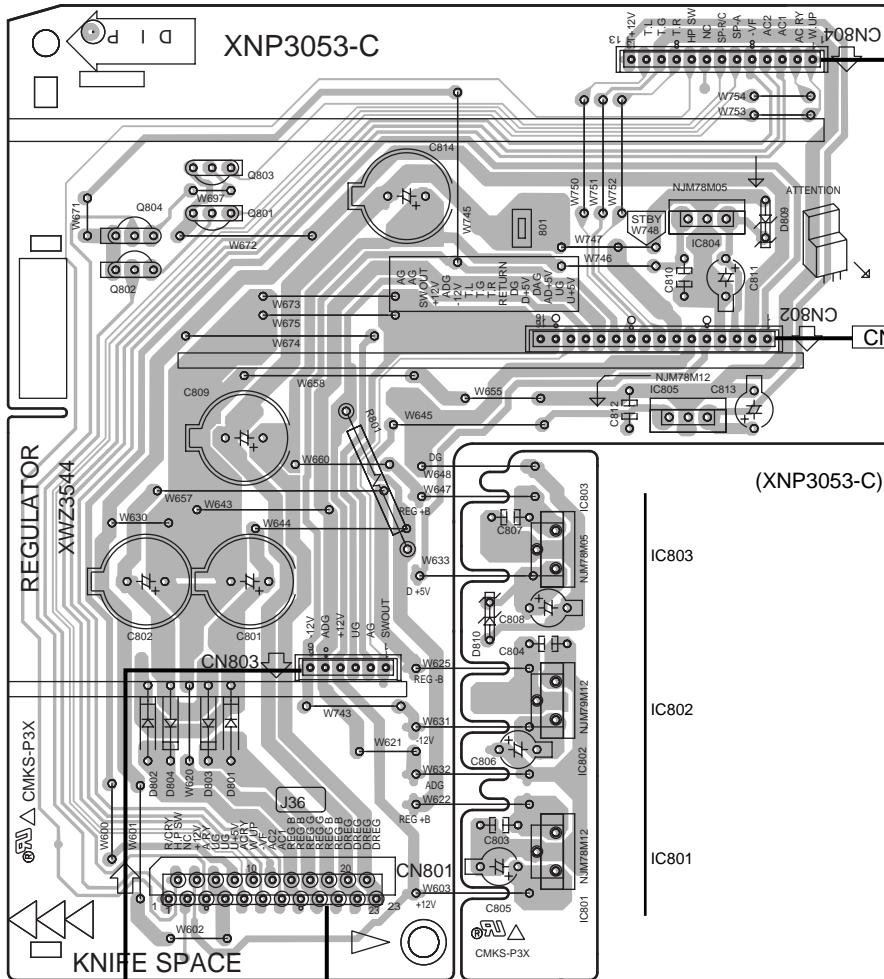

Q805
Q803
Q806
Q801
IC804
Q804
Q802

A CN101

IC805

(XNP3053-C)

IC803

IC802

IC801

Q5001

L CN302

B CN53

E F

SIDE A

SIDE B

K KAWA ASSY

K KAWA ASSY

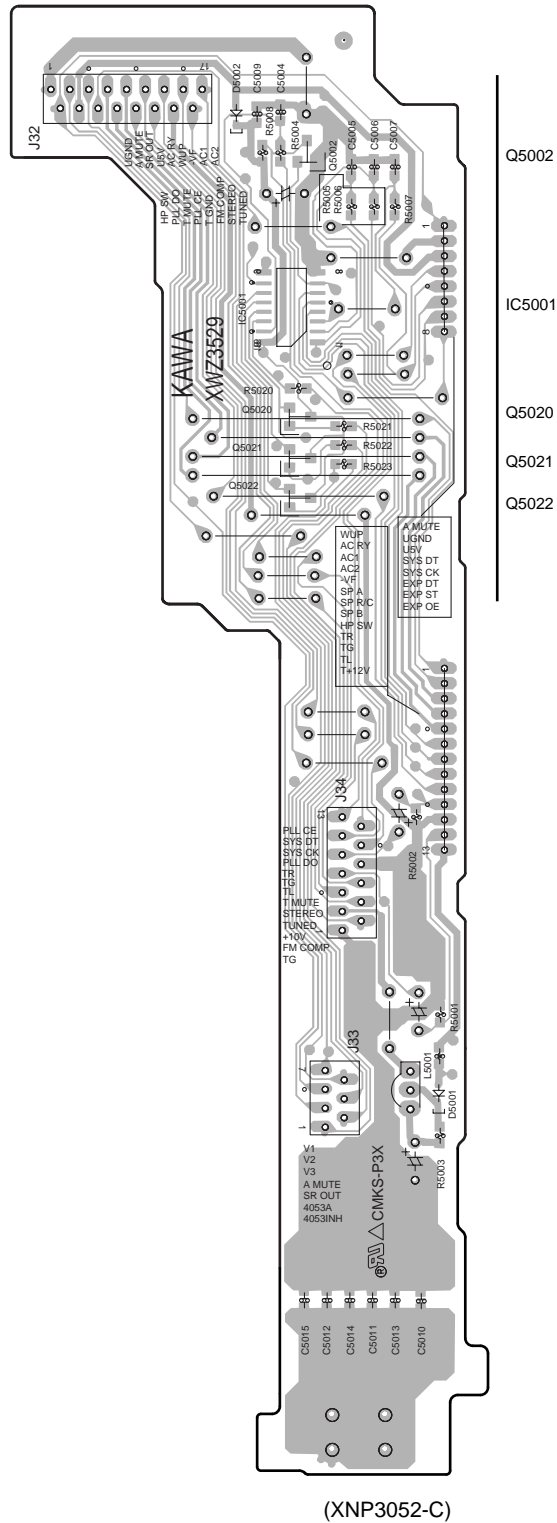
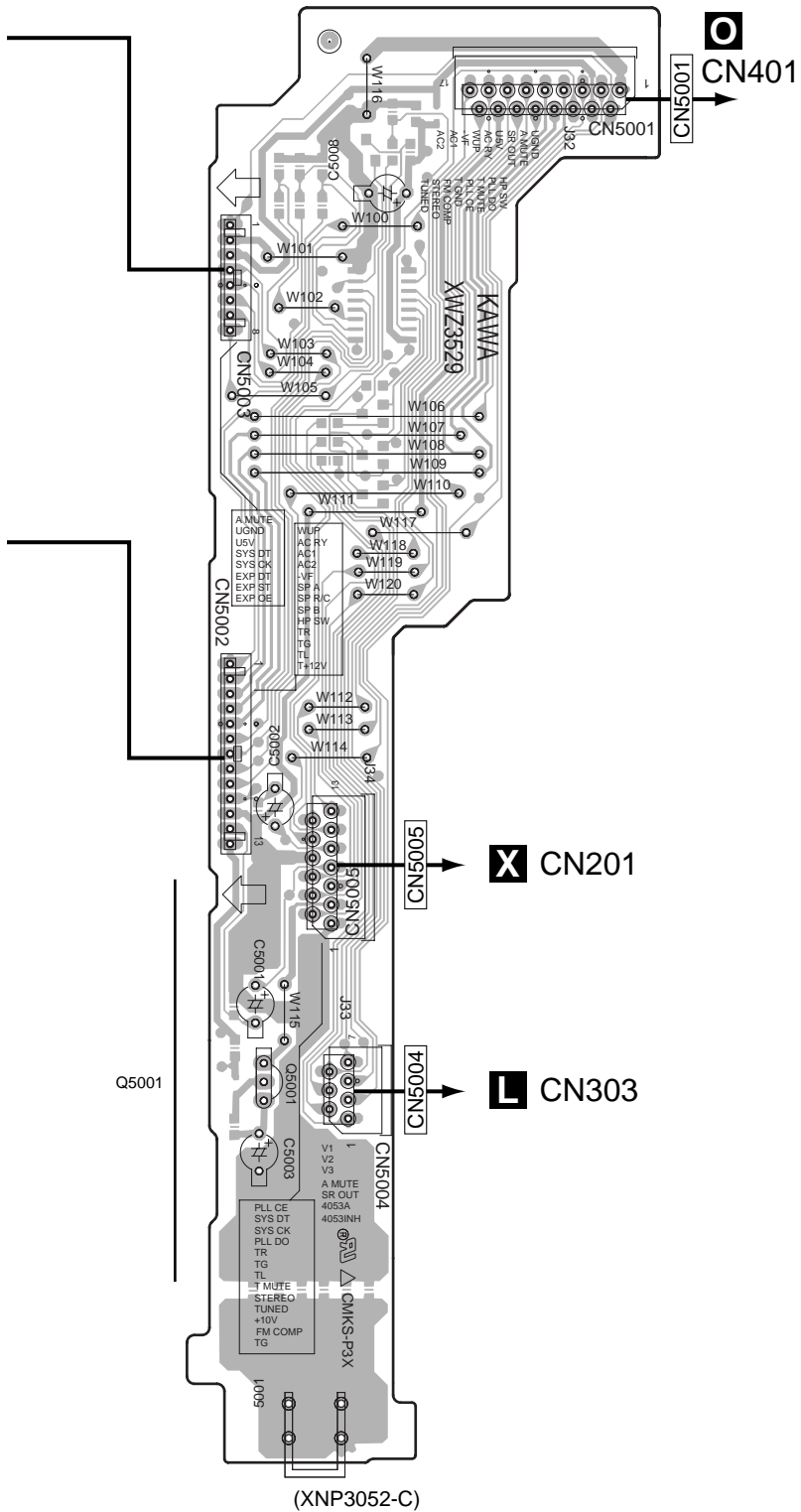

(XNP3052-C)

(XNP3052-C)

4.6 DIGITAL IN, 6CH IN and VIDEO ASSYS

SIDE A

J DIGITAL IN ASSY

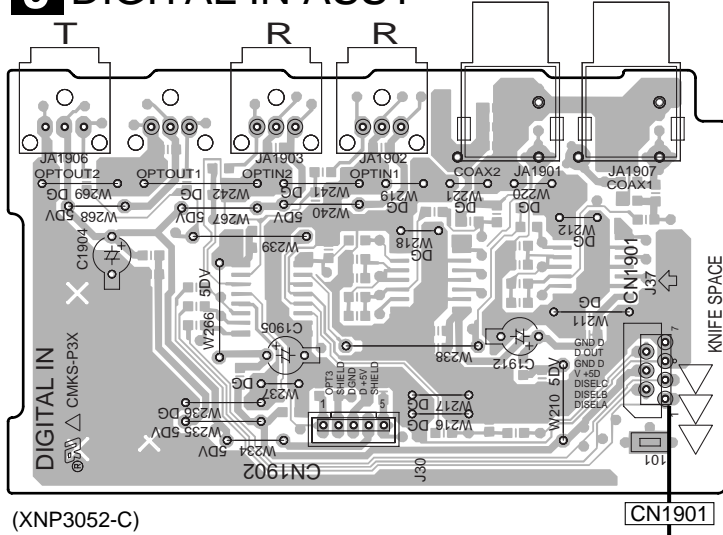

A CN9101

M 6CH IN ASSY

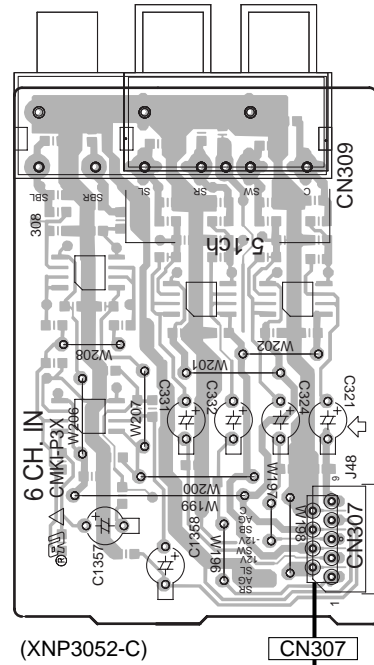

A CN104

L VIDEO ASSY

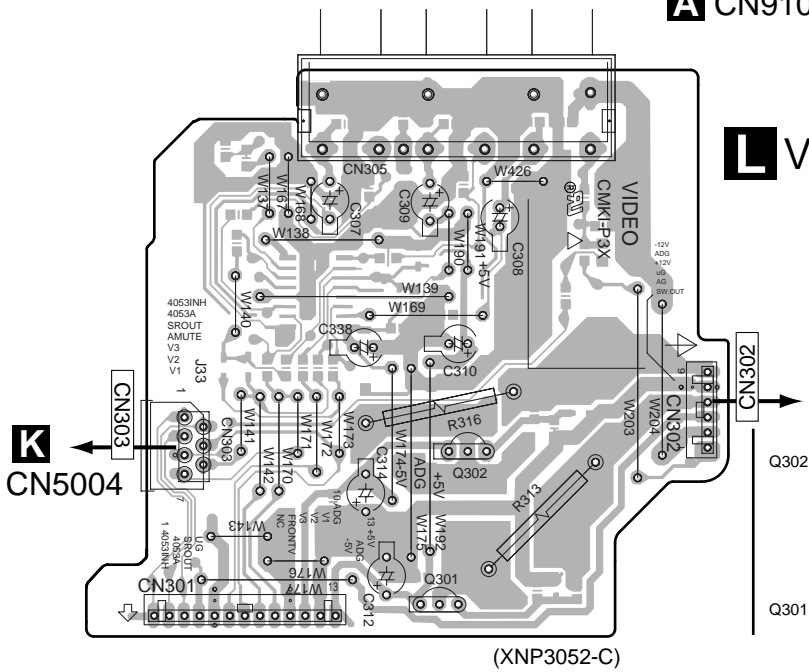

E CN803

J L M

SIDE B

M 6CH IN ASSY

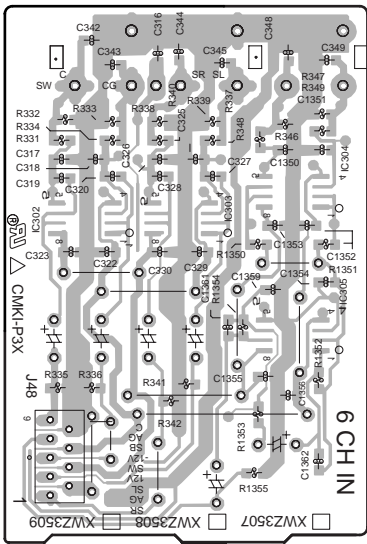

CN307 (XNP3052-C)

J DIGITAL IN ASSY

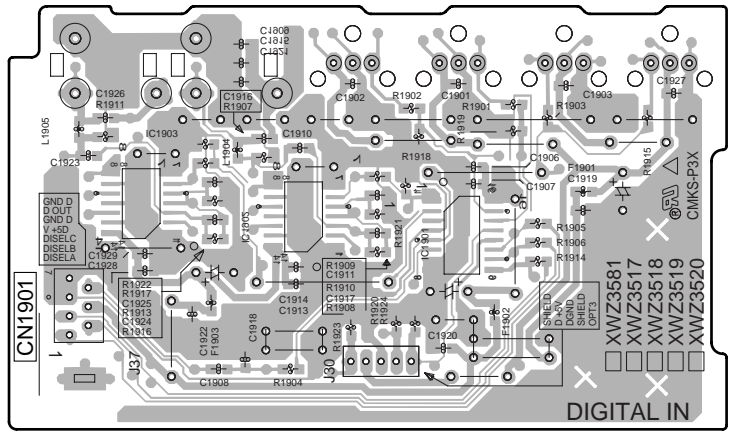

IC1903 IC1902 IC1901 (XNP3052-C)

L VIDEO ASSY

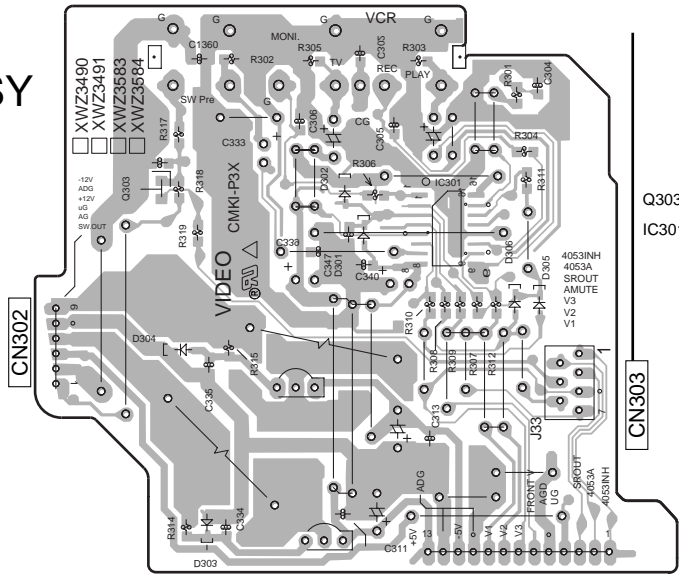

(XNP3052-C)

J L M

4.7 FM/AM TUNER MODULE

SIDE B

SIDE A

X FM/AM TUNER MODULE

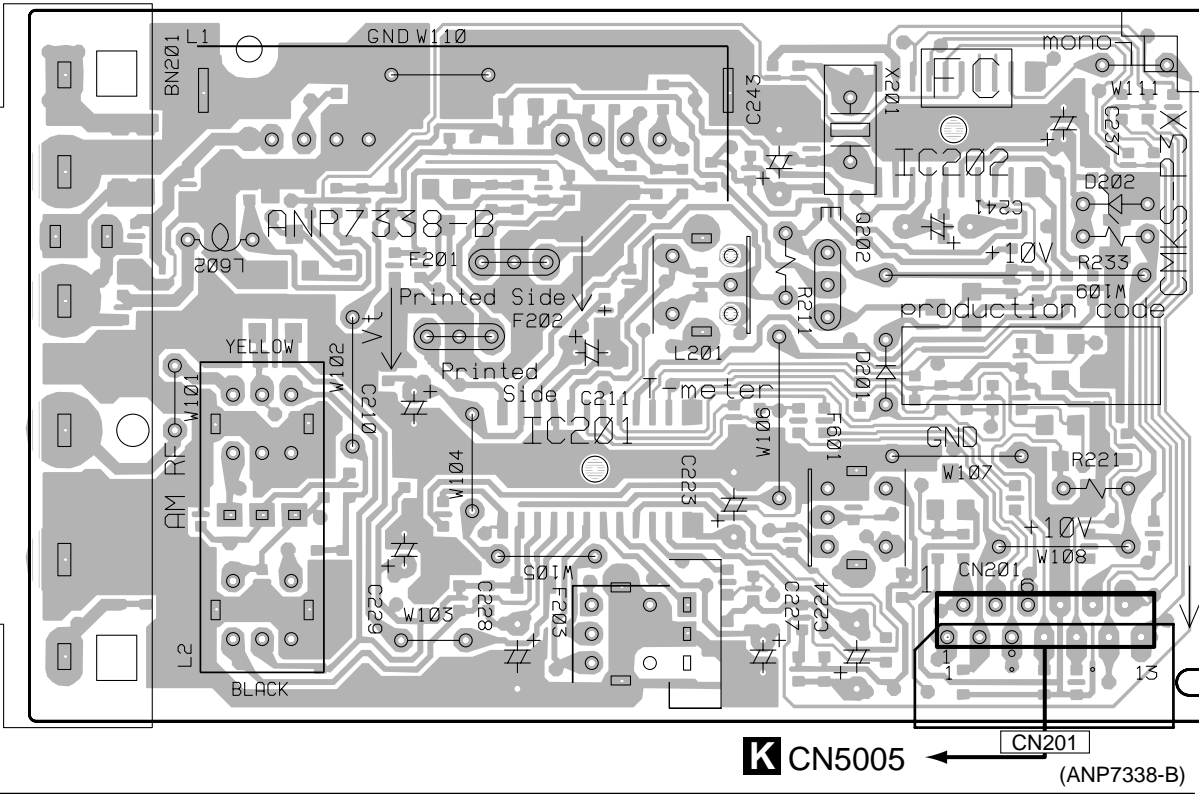

X FM/AM TUNER MODULE

SIDE B

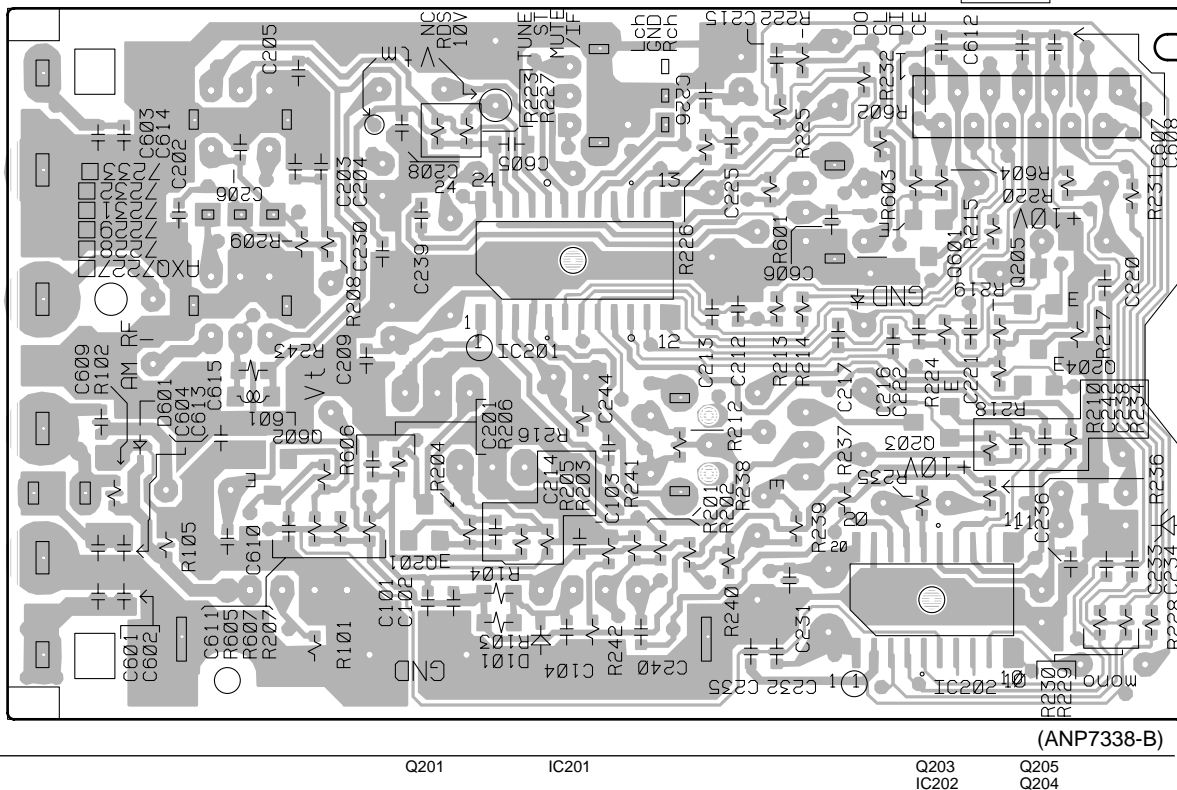

5. PCB PARTS LIST

NOTES: ● Parts marked by "NSP" are generally unavailable because they are not in our Master Spare Parts List.

● The Δ mark found on some component parts indicates the importance of the safety factor of the part. Therefore, when replacing, be sure to use parts of identical designation.

● When ordering resistors, first convert resistance values into code form as shown in the following examples.

Ex.1 When there are 2 effective digits (any digit apart from 0), such as 560 ohm and 47k ohm (tolerance is shown by J=5%, and K=10%).

560 Ω \rightarrow 56 x 10¹ \rightarrow 561 RD1/4PU $\overline{561}J$
 47k Ω \rightarrow 47 x 10³ \rightarrow 473 RD1/4PU $\overline{473}J$
 0.5 Ω \rightarrow R50 RN2H $\overline{R50}K$
 1 Ω \rightarrow 1R0 RS1P $\overline{1R0}K$

Ex.2 When there are 3 effective digits (such as in high precision metal film resistors).

5.62k Ω \rightarrow 562 x 10¹ \rightarrow 5621 RN1/4PC $\overline{5621}F$

Mark No. Description Part No.

LIST OF ASSEMBLIES

Mark No.	Description	Part No.
	1..D.D & INPUT ASSY	XWX3044
NSP	1..AMP & PS ASSY	XWK3113
	2..AMP & PRIMARY ASSY	XWZ3533
	2..REGULATOR ASSY	XWZ3544
	2..AMP INPUT ASSY	XWZ3547
NSP	2..TRANS1 ASSY	XWZ3552
	2..TRANS2 ASSY	XWZ3555
NSP	2..TRANS3 ASSY	XWZ3560
	2..HASHIGETA ASSY	XWZ3566
	2..HOLDER	XWZ3572
NSP	1..COMPLEX ASSY	XWK3107
	2..FRONT ASSY	XWZ3493
	2..6CH IN ASSY	XWZ3507
	2..POWER SW ASSY	XWZ3510
	2..H.P. ASSY	XWZ3513
	2..DIGITAL IN ASSY	XWZ3747
	2..KAWA ASSY	XWZ3529
	2..R. ENCODER ASSY	XWZ3511
	2..VIDEO ASSY	XWZ3490
	2..MECHA SW ASSY	XWZ3514
	1..FM/AM TUNER MODULE	AXQ7232

Mark No. Description Part No.

COMPLEX ASSY

OTHERS

J 41 (JUMPER WIRED)	D15A04-100-2651
J 42 (JUMPER WIRED)	D15A07-075-2651
J 47 (JUMPER WIRED)	D20PYY0630E

AMP & PS ASSY

OTHERS

J 701 (AWG14 BOARD IN)	DB812NBO
J 21 (JUMPER WIRED)	D20PYY0715E

A D.D & INPUT ASSY

SEMICONDUCTORS

IC9101	AK4586VQ
IC301	BU4094BCF
IC9501	CS493292
IC103	M62446FP
IC9201	NJM2100M
IC9812	NJM2391DL1-25
IC9811	NJM2391DL1-33
IC102	NJU7312AM

Mark No. Description Part No.

IC9601	NJU7313AM
IC9504	PD8097A
IC9505	TC74LVX244FT
IC9502, IC9503	TC74VHC574F
IC9506	TC74VHCT244AFT
IC9507	TC7WU04FU
IC101	TC9273F-007
IC104-IC107, IC9701-IC9705, IC9707	UPC4570G2
Q107-Q112, Q9201, Q9202	2SC3326
Q9101, Q9204, Q9607, Q9609, Q9610	DTA124EK
Q9102, Q9203, Q9608	DTC124EK
D9601, D9602	1SS181
D105, D106, D301, D9921	1SS355
D107, D108	DAN217
D201, D202	RB501V-40
D104	UDZS5.1B
D101, D102	UDZS6.8B

COILS AND FILTERS

L9101, L9501, L9504, L9811, L9812	ATL7002
L111-L114, L1601, L1602	QTL1013
L9102, L9103, L9502, L9503	QTL1013
L9506, L9507	QTL1013

CAPACITORS

C9510, C9511	CCSRCH100D50
C101-C114, C121-C123	CCSRCH101J50
C126-C128, C152-C154	CCSRCH101J50
C207, C208, C221, C222	CCSRCH101J50
C228, C229, C9160, C9201, C9202	CCSRCH101J50
C9101, C9102	CCSRCH220J50
C235, C9117	CCSRCH221J50
C9509	CCSRCH271J50
C9530, C9731, C9735	CCSRCH331J50
C9103, C9110, C9111, C9114, C9503	CCSRCH471J50
C9505, C9507, C9513, C9515, C9518	CCSRCH471J50
C9520, C9522, C9525, C9528, C9571	CCSRCH471J50
C9611-C9614, C9625, C9639, C9729	CCSRCH471J50
C9815, C9816	CCSRCH471J50
C9707, C9708, C9721, C9722	CCSRCH820J50
C130-C137, C146-C151, C305	CEAT100M50
C9207, C9208, C9523, C9526	CEAT100M50
C9105, C9106, C9108, C9116, C9516	CEAT101M10
C9551, C9792, C9812, C9814	CEAT101M10
C9740	CEAT220M25
C9205	CEAT221M6R3
C9112, C9529, C9769, C9770	CEAT2R2M50

Mark No.	Description	Part No.	Mark No.	Description	Part No.
A	C9713, C9714, C9727, C9728, C9739 C9765-C9768 C144, C145	CEAT330M25 CEAT330M25 CEAT3R3M50	Q601-Q604, Q631, Q632 Q651-Q654 Q701	2SC2878 2SC2878 2SD1859X	
	C117, C118, C225, C226 C232, C233, C239 C155, C156 C115, C116, C234, C240 C9203, C9204, C9615-C9618, C9811	CEAT470M50 CEAT470M50 CEAT471M10 CEAT4R7M50 CEAT4R7M50	Q51 D56, D601-D604, D631, D632 D57, D651-D654, D752, D756 D751, D755 ⚠ D701, D702	KRC101M 1SS133 1SS133 1SS133 D5SBA20(B)	
	C9813 C271, C9703, C9704, C9717, C9718 C119, C120, C124, C125, C138 C141, C171, C172, C179, C180 C183, C199, C223, C224	CEAT4R7M50 CKSRYB102K50 CKSRYB103K50 CKSRYB103K50 CKSRYB103K50	D605, D606, D633, D634 D711 D58 D712 ⚠ D51-D55, D721-D724	MTZJ8.2A MTZJ22D MTZJ5.1A MTZJ5.1B S5688G	
B	C230, C231, C237, C238, C304 C9104, C9107, C9109, C9121, C9209 C9502, C9504, C9506, C9508, C9512 C9514, C9517, C9519, C9521, C9524 C9527, C9531, C9584, C9636, C9637	CKSRYB103K50 CKSRYB103K50 CKSRYB103K50 CKSRYB103K50 CKSRYB103K50	COILS AND FILTERS ⚠ L51 (0.3mH/270V) L751-L753, L761, L762(0.7uH)	ATF7018 ATH1004	
	C9709-C9712, C9723-C9726 C9737, C9738, C9817 C140, C143, C1631, C1632 C173, C174, C9113, C9115, C9126 C9206, C9818	CKSRYB103K50 CKSRYB103K50 CKSRYB104K16 CKSRYB104K16 CKSRYB104K16	SWITCHES AND RELAYS RY751-RY753 ⚠ RY51	XSR3002 XSR3003	
C	C9701, C9702, C9715, C9716 C9736 C139, C142, C9626 C236 C184, C185, C9732 C227, C9730	CKSRYB222K50 CKSRYB223K25 CKSRYB223K50 CKSRYB472K50 CKSRYB473K25 CKSRYF104Z25	CAPACITORS C707, C708(0.01uF/150V) ⚠ C51, C52(0.01uF/250V) C703, C704(3300uF/42V) C701, C702(4700uF/63V) C607-C610, C634, C635 C657-C660 C615, C616, C638, C665, C666 C775, C776 C705, C706 C712 C611, C612, C636, C661, C662 C711 C53 C692 C54	ACG1005 ACG7020 ACH7135 ACH7134 CCPUCH6R8K50 CCPUCH6R8K50 CEANP2R2M50 CEANP470M50 CEAT100M2A CEAT101M10 CEAT101M16 CEAT101M35 CEAT102M16 CEAT221M10 CEAT470M25 CEAT4R7M50 CFTYA224J50 CKPUYB101K50 CKPUYB102K50 CKPUYB102K50 CKPUYB331K50 CKPUYF103Z25 CQMBA472J50	
	RESISTORS R9104 ⚠ R174, R175 Other Resistors	RS1/16S1802F RS1LMF101J RS1/16S###J			
D	OTHERS CN9101 7P FFC CONNECTOR CN104 9P FFC CONNECTOR CN106 19P FFC CONNECTOR CN102 28P FFC CONNECTOR JA103, JA104 4P PIN JACK JA105 6P PIN JACK CN101 16P SOCKET CN105 8P SOCKET X9501 (CRYSTAL RES. 27.0MHz) X9101 (CRYSTAL RES. 12.3MHz)	52044-0745 52044-0945 52045-1945 52045-2845 AKB7048 AKB7050 KP200TA16L KP200TA8L VSS1086 VSS1140			
E	B AMP & PRIMARY ASSY SEMICONDUCTORS ⚠ IC603(1A) ⚠ IC701, IC702(125mA) ⚠ IC604-IC607(10A) ⚠ IC52(500mA) IC51 ⚠ IC601 ⚠ IC602 Q703 Q702 Q691, Q692 Q704 Q605, Q606, Q633, Q655, Q656	AEK7009 AEK7020 AEK7022 AEK7005 NJM78M56FA PAC010A PAC011A 2SA1145 2SB1238X 2SC1740S 2SC1845 2SC2240	RESISTORS ⚠ R52 ⚠ R751, R752, R755, R761, R762 ⚠ R753, R754, R756, R763, R764 ⚠ R711 ⚠ R615, R616, R638, R665, R666(0.22) Other Resistors	RD1/2PM270J RD1/4PUF101J RS1LMF4R7J RS2LMF332J XCN3001 RD1/4PU###J	
F			OTHERS CN53(23P FFC CONNECTOR) CN702(6P CONNECTOR) 52 3P CABLE HOLDER H53, H54, H701, H702(FUSE CLIP) ⚠ T51(SUB TRANS FORMER) CN601(16P PLUG) CN51(AC INLET)	52045-2345 52147-0610 51048-0300 AKR7001 ATT7037 KM200TA16 RKP1751	

Mark No.	Description	Part No.
KN51,KN601	(EARTH METAL FITTING)	VNF1084
CN752(4P)	SPEAKER TERMINAL)	XKE3011
CN751(6P)	SPEAKER TERMINAL)	XKE3013
701	7P CABLE HOLDER	XKP3047
J21	20P JUMPER WIRE	D20PYY0715E
J6	JUMPER WIRE	DB215NB0

C TRANS 2 ASSY SEMICONDUCTORS

⚠ IC851-IC853(1.6A/125V) AEK7012

OTHERS

851 XKP3047

D TRANS 3 ASSY

TRANS3 ASSY has no service part.

E REGULATOR ASSY SEMICONDUCTORS

IC803, IC804 NJM78M05FA
IC801, IC805 NJM78M12FA
IC802 NJM79M12FA
Q801, Q803 KRA103M
Q802, Q804 KRC102M

D809, D810 MTZJ6.2A
⚠ D801-D804 S5688G

CAPACITORS

C808, C811 CEAT101M10
C805, C806, C813 CEAT101M16
C801, C802 CEAT222M25
C809 CEAT332M16
C803, C804, C807, C810, C812 CKPUYF103Z25

OTHERS

CN801(23P CONNECTOR) 52045-2345
CN804 (13P PLUG) KM200TA13
CN802 (16P PLUG) KM200TA16
CN803 (6P PLUG) KM200TA6

F HASHICETA ASSY

OTHERS

CN1001, CN1002(8P PLUG) KM200TA8

H AMP INPUT ASSY

OTHERS

CN254 (19P FFC SOCKET) 52044-1945
CN253 (16P SOCKET) KP200TA16L

I TRANS1 ASSY

TRANS1 ASSY has no service part.

J DIGITAL IN ASSY SEMICONDUCTORS

IC1901 TC74ACT151F
IC1902 TC74HCU04AF

COILS AND FILTERS

F1901-F1903(BK2125HS601) DTF1067
L1904, L1905 QTL1013

Mark No. Description Part No.

CAPACITORS

C1918 CCSRCH221J50
C1907, C1914, C1928 CCSRCH271J50
C1925 CCSRCH470J50
C1916, C1926 CCSRCH471J50
C1904, C1905, C1912 CEAT101M10

C1915 CKSRYB102K50
C1906, C1919, C1920, C1923, C1929 CKSRYB103K50
C1910, C1913 CKSRYB103K50
C1902, C1908, C1909, C1921, C1922 CKSRYB104K25
C1903 CKSRYB104K25

RESISTORS

Other Resistors RS1/16S###J

OTHERS

CN1901(7P FFC CONNECTOR) 52045-0745
JA1902 (OPTICAL LINK IN) JFJ4000-010020
1904 (Label) XAL3193
JA1901,JA1907(1P PIN JACK) VKB1077

K KAWA ASSY SEMICONDUCTORS

IC5001 BU4094BCF
Q5001 2SC1740S
Q5020-Q5022 DTC114TK
Q5002 DTC143EK
D5001, D5002 1SS355

COILS AND FILTERS

L5001 QTL1013

CAPACITORS

C5004-C5007 CCSRCH101J50
C5012 CCSRCH471J50
C5001, C5002 CEAT100M50
C5003 CEAT101M16
C5009 CKSRYB103K50

C5011 CKSRYB104K16
C5010 CKSRYF105Z10

RESISTORS

All Resistors RS1/16S###J

OTHERS

CN5004 (7P FFC CONNECTOR) 52044-0745
CN5005 (13P FFC CONNECTOR) 52044-1345
CN5001 (17P FFC CONNECTOR) 52044-1745
CN5002 (13P SOCKET) KP200TA13L
CN5003 (8P SOCKET) KP200TA8L

5001 (SCREW TERMINAL) VNE1948

L VIDEO ASSY SEMICONDUCTORS

IC301 NJM2296M
Q302 2SA1515
Q303 2SC3326
Q301 2SC3377
D301, D302, D305, D306 1SS355

D303, D304 UDZS6.2B

CAPACITORS

C347 CCSRCH470J50

Mark No. Description Part No.

C307-C310, C312, C314, C338
C1360, C302
C339, C340
C304-C306

CEAT470M25
CKSRYB103K50
CKSRYB104K25
CKSRYB221K50

C333
C311, C313

CKSRYB331K50
CKSRYB473K25

RESISTORS

⚠ R313, R316
Other Resistors

RS3LMF560J
RS1/16S###J

OTHERS

CN303 (7P CONNECTOR)
CN305 (6P PIN JACK)
CN301 (13P SOCKET)
CN302 (6P SOCKET)

52044-0745
AKB7123
KP200TA13L
KP200TA6L

**M 6CH IN ASSY
SEMICONDUCTORS**

IC302, IC303

NJM4558MD

CAPACITORS

C319, C320, C327, C328
C342-C345
C321, C324, C331, C332
C316, C322, C323, C329, C330
C317, C318, C325, C326

CCSRCH101J50
CCSRCH101J50
CEAT4R7M50
CKSRYB103K50
CKSRYB221K50

RESISTORS

All Resistors

RS1/16S###J

OTHERS

CN307 (9P CONNECTOR)
CN309 (6P PIN JACK)

52044-0945
AKB7087

**O FRONT ASSY
SEMICONDUCTORS**

IC401
IC481
Q401, Q402, Q442, Q471
Q403, Q441, Q482
Q481

PDG268B
BU1923F
DTA124EK
DTC143EK
2SA1037K

Q483
D406, D410, D442
D403, D405
D401, D404
D407, D408

2SC3326
1SS355
DAN217
DAP202K
RB501V-40

COILS AND FILTERS

L401, L481

LFEA2R2J

SWITCHES AND RELAYS

S451-S468, S476

ASG1051

CAPACITORS

C420 (220uF/35V)
C404 (0.047F/5.5V)
C511
C488
C489, C490

ACH7101
ACH7132
CCSRCH471J50
CCSRCH561J50
CCSRCH270J50

C442
C402
C483
C486

CEAL470M10
CEAT221M6R3
CEAT101M10
CEAT1R0M50

Mark No. Description Part No.

C409, C410, C484

CEAT2R2M50

C412
C405
C451-C453, C472, C492, C495
C481, C482
C401, C403, C411, C419, C441

CEAT470M50
CEAT471M6R3
CKSRYB102K50
CKSRYB102K50
CKSRYB103K50

C531
C408, C416, C418, C471
C485
C406, C407

CKSRYB103K50
CKSRYB104K16
CKSRYB472K50
CKSRYB473K16

RESISTORS

All Resistors

RS1/16S###J

OTHERS

471 (4P CABLE HOLDER)
404 (7P CABLE HOLDER)
CN401 (17P FFC CONNECTOR)
CN402 (28P FFC CONNECTOR)
V401 (FL TUBE)

51063-0405
51063-0705
52044-1745
52044-2845
XAV3013

401 (REMOTE CONTROL UNIT)
J41 (4P JUMPER WIRE)
J42 (7P JUMPER WIRE)
X401 CERAMIC RESO.(7.2MHz)
X481 CERAMIC RESO.(4.3MHz)

GP1U27X
D15A04-100-2651
D15A07-075-2651
ASS7039
ASS7004

**P R.ENCODER ASSY
SWITCHES AND RELAYS**

S511
S513 (ROTARY ENCODER)
S512 (ROTARY ENCODER)

ASG1051
XSX3005
XSX3006

OTHERS

511 (7P CABLE HOLDER)

51063-0705

**Q POWER SW ASSY
SEMICONDUCTORS**

D501

BR3371XJ30A

SWITCHES AND RELAYS

S501

ASG1051

RESISTORS

All Resistors

RS1/16S###J

OTHERS

501(CABLEB HOLDER 4P)

51063-0405

**U H.P. ASSY
SEMICONDUCTORS**

Q1551, Q1552

2SC3326

CAPACITORS

C1554, C1557
C1553, C1556
C1555, C1558
C1551, C1552

CCSRCH471J50
CKSRYB103K50
CKSRYB104K16
CKSRYB223K50

RESISTORS

⚠ R1553, R1554
⚠ R1551, R1552
Other Resistors

RS1LMF151J
RS2LMF331J
RS1/16S###J

<u>Mark No.</u>	<u>Description</u>	<u>Part No.</u>
<u>OTHERS</u>		
1551	(6P CABLE HOLDER)	51048-0600
JA1551	(HEADPHONE JACK)	RKB1014
KN1551	(EARTH METAL FITTING)	VNF1084
J47		D20PYY0630E

X FM/AM TUNER MODULE

SEMICONDUCTORS

IC201	BA1451F
IC202	LC72131MD
Q201, Q204, Q205	2SC2412K
Q202	DTA124ES
Q203	DTC124EK
D201	1SS133
D202	MTZJ5.1C

COILS AND FILTERS

L201 (FM DETECTOR COIL)	ATE7003
F202 (CERAMIC FILTER)	ATF-107
F201 (CERAMIC FILTER)	ATF-119
F203 (AM CERAMIC FILTER)	ATF7026
F601 (ANTIBIRDIE FILTER)	ATF7025
L601 (TIP COIL)	LCTA270J2520
L602 (INDUCTER)	LAU2R2J

CAPACITORS

C206	CCSRCH120J50
C212, C213, C226, C233-C235	CCSRCH101J50
C240	CCSRCH101J50
C231, C232, C614	CCSRCH150J50
C223	CEAT100M50
C229	CEAT101M10
C224	CEAT1R0M50
C227	CEAT220M25
C241	CEAT2R2M50
C243	CEAT330M16
C228	CEAT3R3M50
C237	CEAT470M10
C211	CEJQ1R0M50
C210	CEJQ470M16
C103, C104, C204, C238, C609	CKSRYB102K50
C102, C208, C216, C220, C615	CKSRYB103K50
C217, C239, C242, C604, C610	CKSRYB103K50
C225	CKSRYB153K50
C201, C205, C214, C230, C611	CKSRYB223K50
C244, C236	CKSRYB223K50
C221	CKSRYB224K10
C202, C222	CKSRYB473K16
C215	CKSRYB471K50
C605	CCSQCH680J50
C606	CKSRYB561K50
C607, C608	CKSRYB182K50

RESISTORS

R211	RD1/4PU221J
R221	RD1/4PU222J
R233	RD1/4PU391J
R243	RS1/10S0R0J
R103	RS1/10S221J
R104	RS1/10S221J
Other Resistors	RS1/16S###J

<u>Mark No.</u>	<u>Description</u>	<u>Part No.</u>
<u>OTHERS</u>		
CN201	(13P SOCKET)	52044-1345
BN201	(2P ANTENNA TERM.) (SHIELD CASE T)	AKA7002
	(SHIELD CASE B)	ANK7072
X201	(CRYSTAR RES.(7.2MHz))	ANK7073
		ASS1093
	FM FRONT END	AXF7005
	AM RF TUNING BLOCK	AXX7072

Y MECHA SW ASSY

CAPACITORS

C591, C592	CKSRYB103K50
------------	--------------

SWITCHES AND RELAYS

S591	ASG7014
------	---------

OTHERS

CN591(3P JUMPER CONNCTOR)	52151-0310
---------------------------	------------

6. ADJUSTMENT



■ AM Tuner Section

- There is no adjustment in the AM tuner.

■ FM Tuner Section

- Set the mode selector to FM BAND.
- Connect the wiring as shown in Fig. 1.

Step No.	Adjustment Title	ANT. Input level and signal condition			Adjustment	
		Frequency (MHz)	Modulation	Input Level (dB μ V)	Adjust point	Contents
1	T-METER Adjustment	98	OFF	80	L201	Adjust L201 so that the DC voltage between Pin 21 and Pin 23 of IC201 (Test point V _{tm}) gets within 0 ± 50 mV.

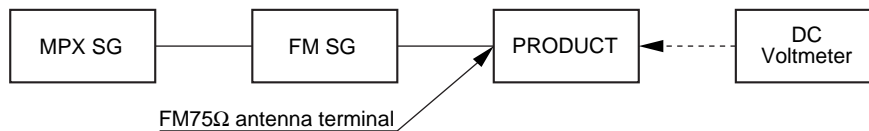

Fig.1 Adjustment Wiring Diagram

X FM/AM TUNER MODULE

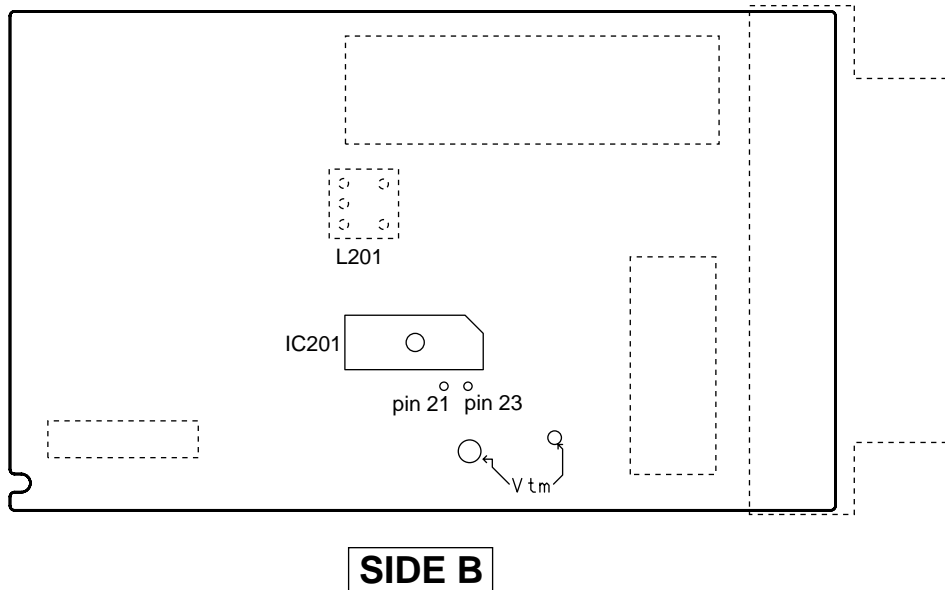

Fig.2 Adjustment Point

7. GENERAL INFORMATION

7.1 DISASSEMBLY and DIAGNOSIS

7.1.1 DISASSEMBLY and PCB LOCATION

Diagnosis

① Remove the top cover (seven screws).

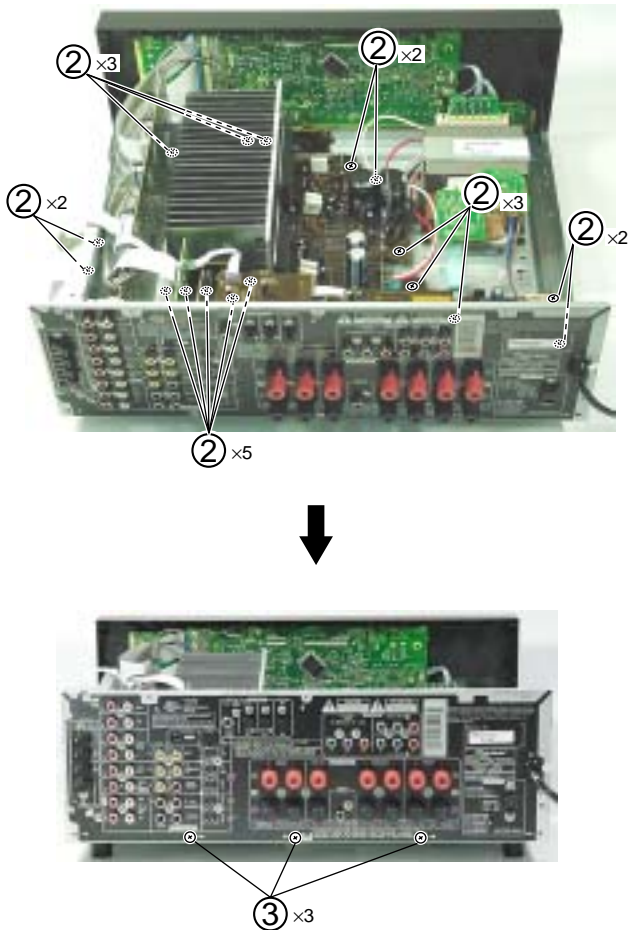

Note : This photograph may show a different model, however, the method for disassembly is the same.

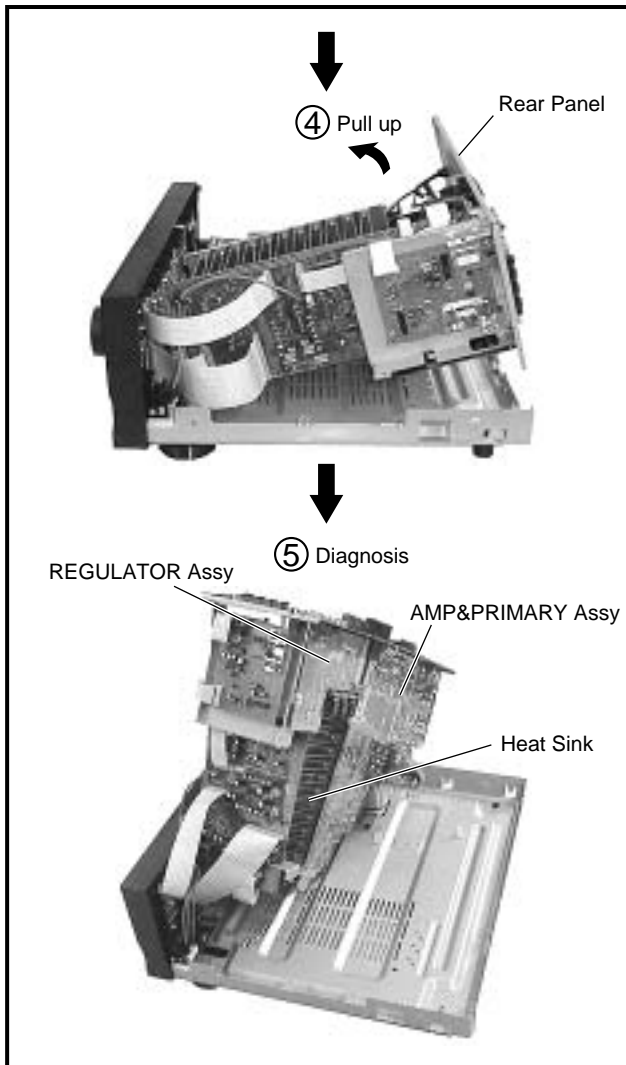

Note : If the speaker and the screw of the rear panel are removed, the unit will stop operating. Even if the FM/AM TUNER MODULE is disconnected, other functions can operate.

PCB Location

NOTE : This photograph is VSX-D711

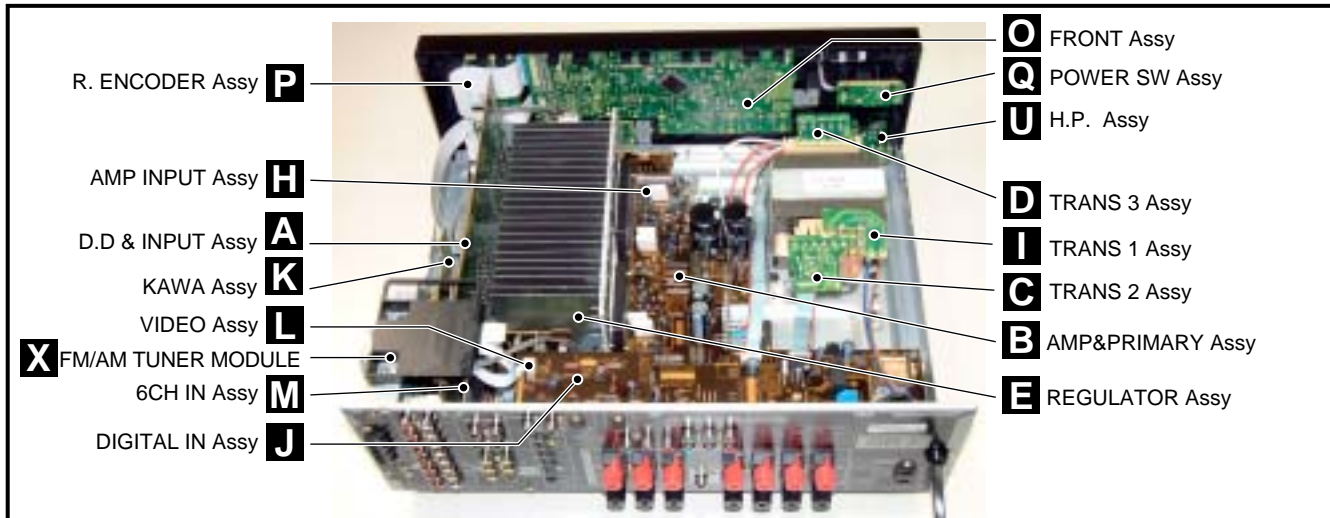

7.1.2 U-COM BLOCKDIAGRAM

A
B
C
D
E
F

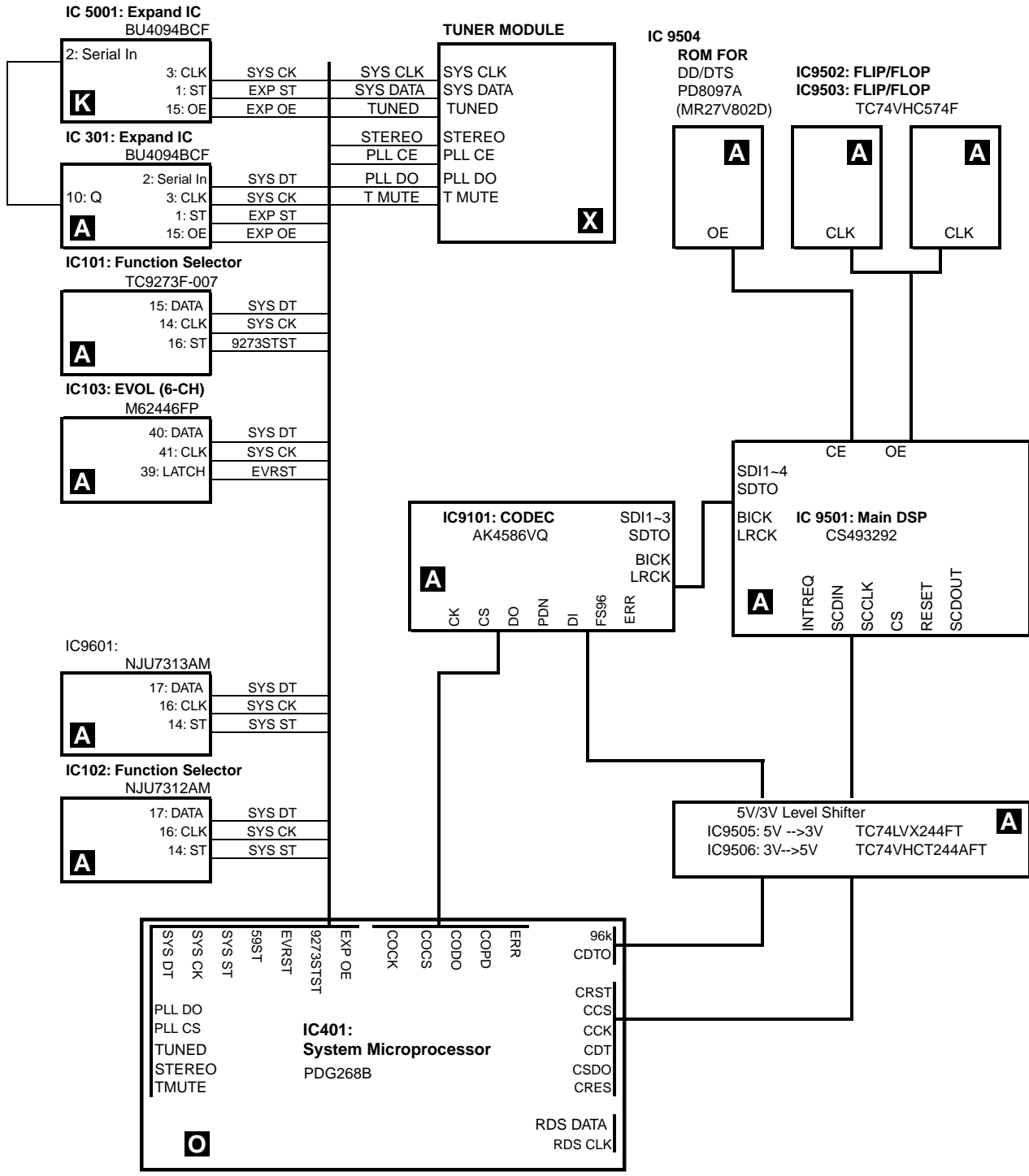

7.1.3 PROTECTION CIRCUIT

1. DC-abnormality detection

In the case of simultaneous detection with the overload protection circuit, DC-abnormality detection is performed preferentially to overload detection.

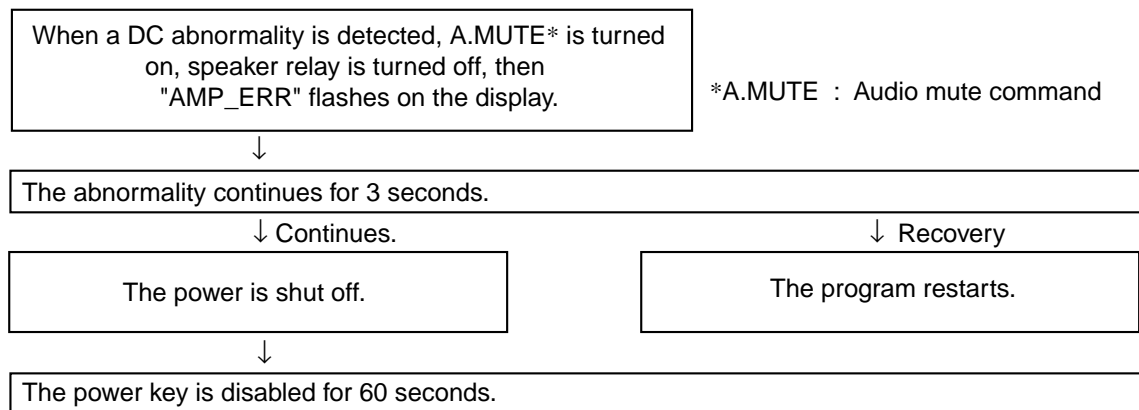

If the AC power cord is unplugged within 60 seconds after the power is shut off then plugged in again, the unit will be reset in 60 seconds.

2. Overload detection

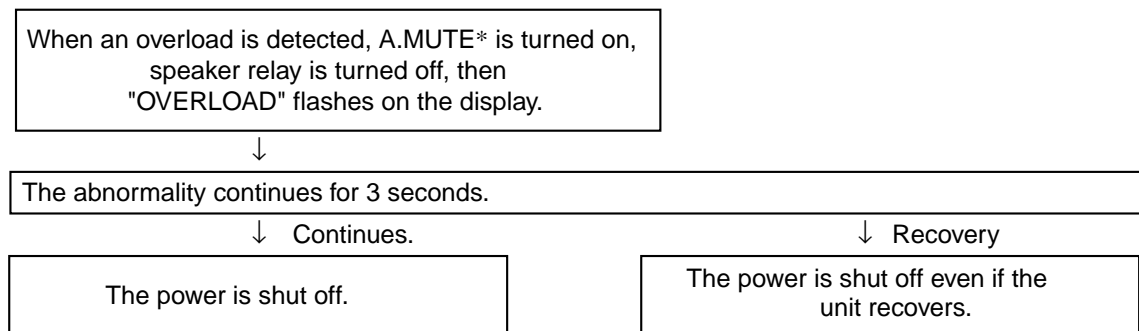

7.1.4 POWER ON SEQUENCE

POWER ON SEQUENCE

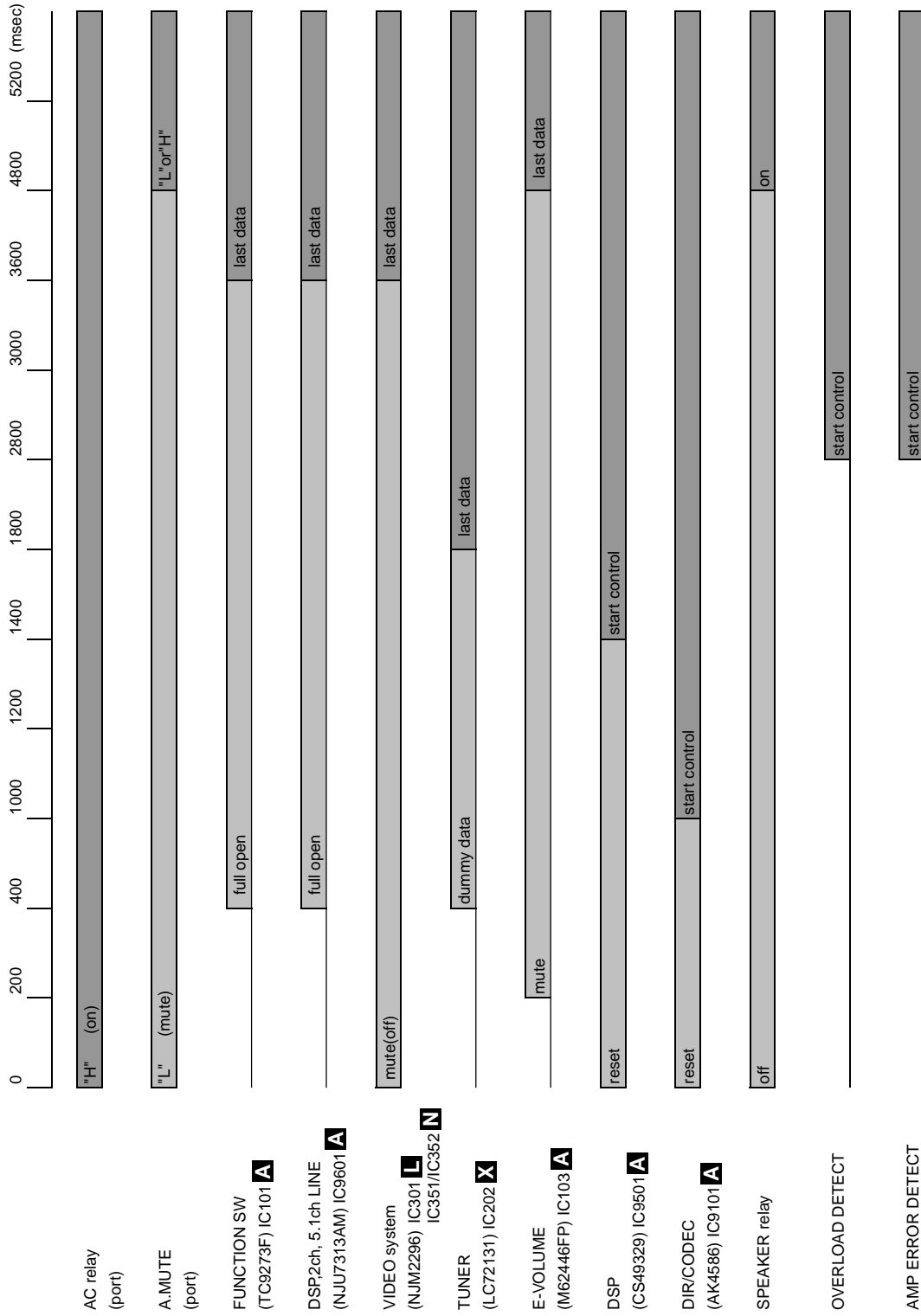

7.1.5 POWER OFF SEQUENCE

■ POWER OFF SEQUENCE

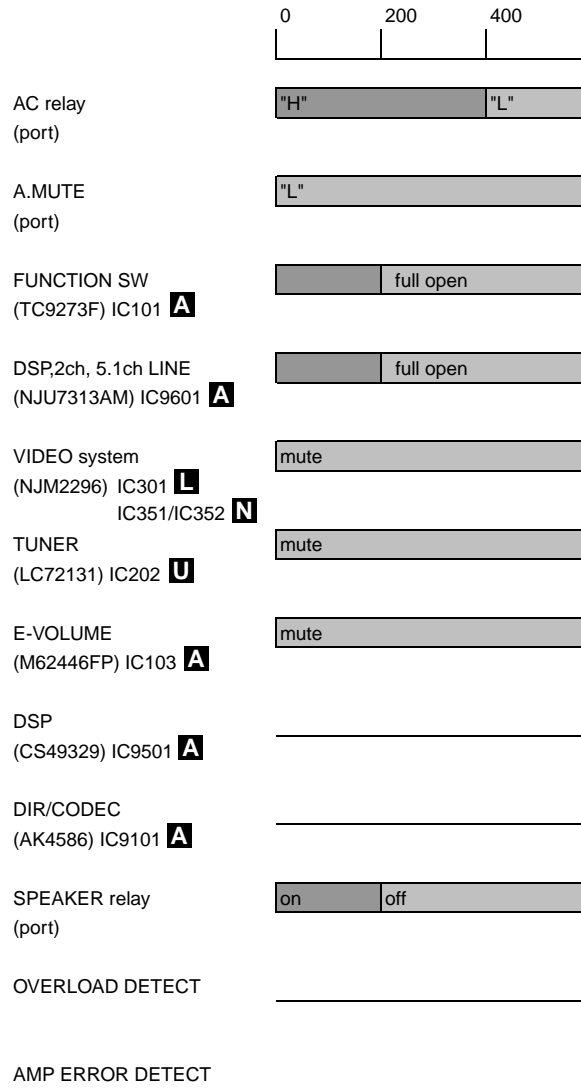

7.2 PARTS

7.2.1 IC

The information shown in the list is basic information and may not correspond exactly to that shown in the schematic diagrams.

List of IC

PDG268B, AK4586VQ, NJU7312AM, PD8097A

PDG268B (FRONT ASSY : IC401)

System Control MCU

Pin Arrangement (Top View)

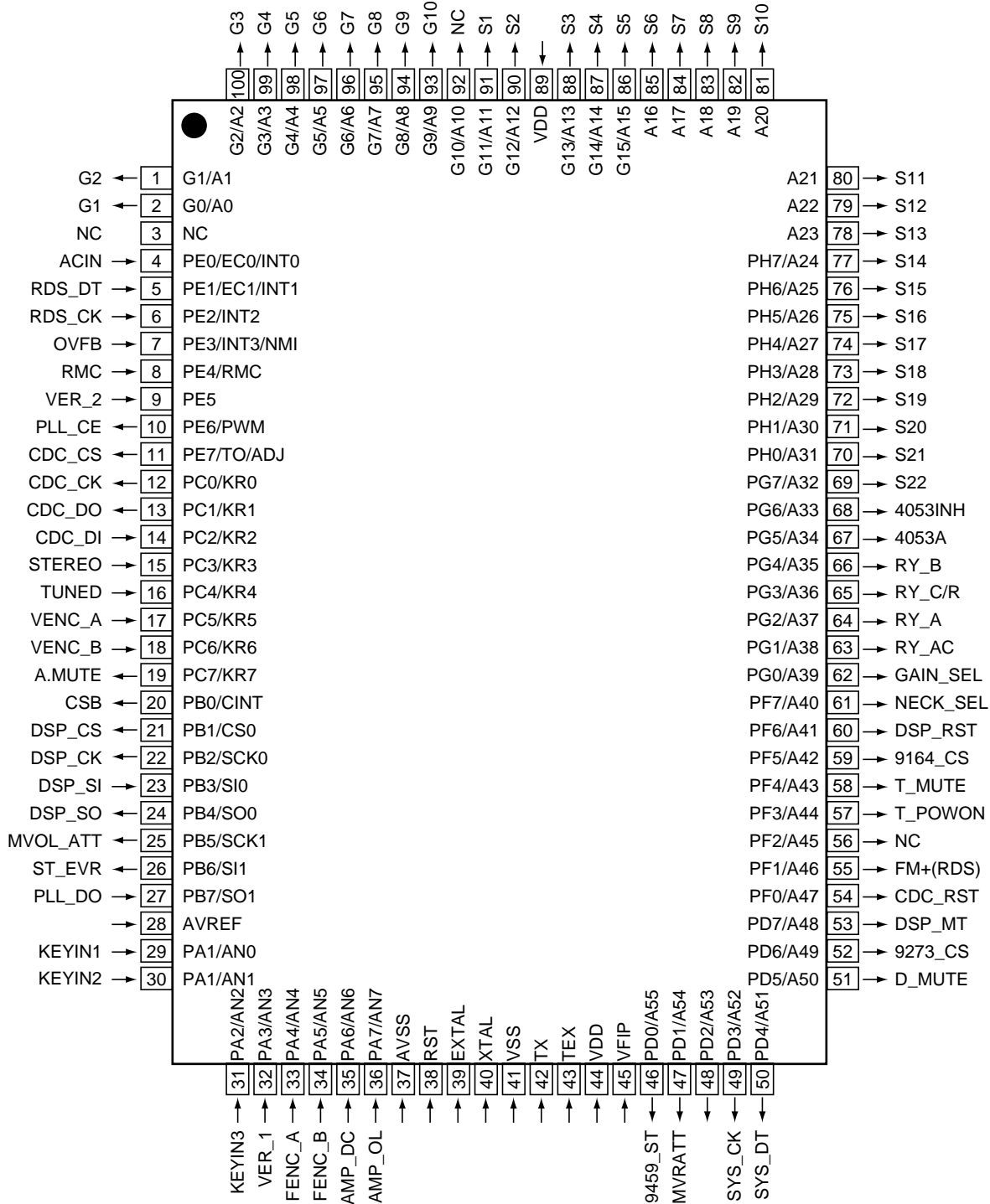

• Pin Function

No.	Pin Name	I/O	Pin Function	Active
1	G2	O	Grid output 2	H
2	G1	O	Grid output 1	H
3	NC	–	Connect to Vdd	
4	ACIN	I	Input AC pulse	
5	RDS_DT	I	Serial control DATA signal of RDS communication	
6	RDS_CK	I	Serial control CLOCK signal of RDS communication (Use external interrupt)	
7	DIRLOCK	I	ERR/OVER input from CODEC	
8	RMC	I	Remote control signal input (no-carrier signal)	
9	VER_2	I	Destination switch 2	
10	ST_EVR	O	Strobe of communication for E-volume	H
11	CDC_CS	O	Chip select for CODEC	
12	CDC_CK	O	Control clock for CODEC & TC9164	
13	CDC_DO	O	Control data for CODEC & TC9164	
14	CDC DI	I	Data input from DIR	
15	STEREO	I	Signal to switch Stereo / Monoral	
16	TUNED	I	Condition of TUNED	
17	VENC_A	I	Input from rotary encoder of E-volume (A)	
18	VENC_B	I	Input from rotary encoder of E-volume (B)	
19	HP ON	I	Headphone detect	L
20	CREQ	I	Request for DSP	L
21	CCS	O	Chip select for DSP	L
22	CCK	O	Clock signal for DSP	H
23	CDT	I	DATA input signal for DSP	
24	CSDO	O	DATA output signal for DSP	H
25	FS 96	I	96 k	H
26	AMP_OL	I	Detect overload of protection circuit (L: overload)	H
27	PLL_DO	I	Data input signal for communication with LC72131 (Tuner)	
28	AVref	–	Connect to Vdd	
29	KEYIN1	I	Key input A/D conversion port 1	
30	KEYIN2	I	Key input A/D conversion port 2	
31	KEYIN3	I	Key input A/D conversion port 3	
32	VER_1	I	Input 1 to switch region (A/D input)	
33	FENC_A	I	FUNC Rotary encoder signal input (A)	
34	FENC_B	I	FUNC Rotary encoder signal input (B)	
35	AMP_DC	I	Detect trouble DC of protection circuit (L : Trouble)	L
36	VER_2	I	Input 2 to switch region (A/D input)	L
37	AVSS	–	Connect to Vss	
38	RST	–	Reset	
39	EXTAL	–	Connect to the oscillator (7.2MHz)	
40	XTAL	–		
41	VSS	–	Connect to Vss	
42	TX	–	NC	
43	TEX	–	Connect to Vss	
44	VDD	–	+5V	
45	VFDP	–	-30V	
46	9459_ST	O	Strobe for E-volume (TC9459) of SB	
47	MVRATT	O	ATT control of master volume for E-volume (less than -15dB : L)	H
48				H
49	SYS_DT	O	Data signal for communication with M62446, TC9163, TC9164 and PLL	H
50	SYS_CK	O	Clock signal for communication with M62446, TC9163, TC9164 and PLL	H

• Pin Function

No.	Pin Name	I/O	Pin Function	Active
51	9273_CS	O	Chip select for TC9273	H
52	DSP_MT	O	DSP Mute (ASSY mute)	H
53	GAIN_SEL	O	Gain select (5.1ch and Stereo of analog input : H)	H
54	AMUTE	O	Audio mute	H
55	T_MUTE	O	Tuner mute	H
56	PLL_CE	O	Chip select for communication to LC72131 (Tuner)	
57	NECK_SEL	O	5.1ch, surround mode and A+B Stereo : H / Stereo : L	H
58	FM+(RDS)	O	Tr switch ON/OFF for power supply of RDS decoder (L : AM, power OFF , H : Other)	H
59	9164_ CS	O	TC9163, TC9164 Chip select	
60	CRST	O	Reset for DSP	
61	CDC_PD	O	Power down for CODEC	
62	ABOT	O	Abort for DSP	H
63	RY_AC	O	AC relay ON/OFF	H
64	RY_A	O	Speaker A relay ON/OFF	H
65	RY_C/R	O	Rear/Center Speaker relay ON/OFF	H
66	EXP CS	O	Chip select for expand IC	H
67	EXP OE	O	Chip select for expand IC	H
68	RY_AC	O	AC relay ON/OFF control	H
69	S22	O	Segment output 22	H
70	S21		Segment output 21	
71	S20		Segment output 20	
72	S19		Segment output 19	
73	S18		Segment output 18	
74	S17		Segment output 17	
75	S16		Segment output 16	
76	S15		Segment output 15	
77	S14		Segment output 14	
78	S13		Segment output 13	
79	S12		Segment output 12	
80	S11		Segment output 11	
81	S10		Segment output 10	
82	S9		Segment output 9	
83	S8		Segment output 8	
84	S7		Segment output 7	
85	S6		Segment output 6	
86	S5		Segment output 5	
87	S4		Segment output 4	
88	S3		Segment output 3	
89	VDD	-	5V	
90	S2	O	Segment output 2	H
91	S1		Segment output 1	
92	Not used	O	Not used (Fixed Vfdp)	
93	G10	O	Grid output 10	H
94	G9		Grid output 9	
95	G8		Grid output 8	
96	G7		Grid output 7	
97	G6		Grid output 6	
98	G5		Grid output 5	
99	G4		Grid output 4	
100	G3		Grid output 3	

BD3812F (D.D & INPUT ASSY : IC112)

• Audio Sound Processor

• Block Diagram

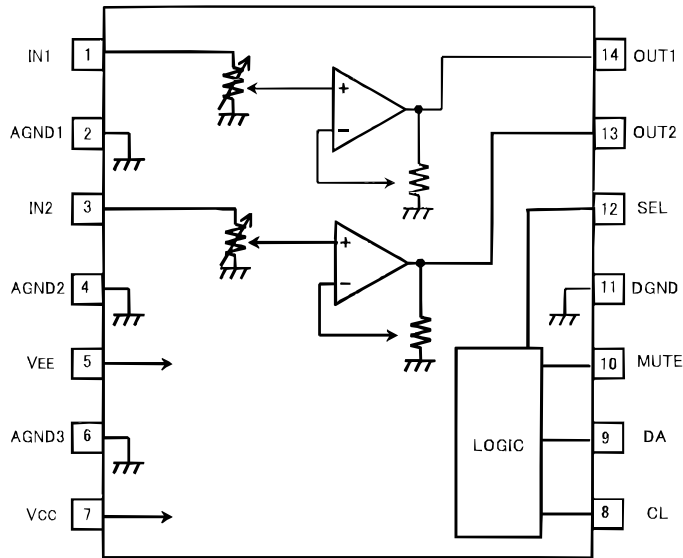

• Pin Function

No.	Pin Name	Function
1	IN1	1ch input terminal
2	AGND1	Analog ground terminal
3	IN2	2ch input terminal
4	AGND2	Analog ground terminal
5	Vee	(-) Power supply terminal
6	AGND3	Analog ground terminal
7	Vcc	(+) Power supply terminal
8	CL	Serial clock input terminal
9	DA	Serial data an latch input terminal
10	MUTE	Mute terminal
11	DGND	Ground terminal for comparator
12	SEL	Serial data select terminal
13	OUT2	2ch output terminal
14	OUT1	1ch output terminal

NJU7312AM (D.D & INPUT ASSY : IC102)

• Analog Switch Array

• Block Diagram

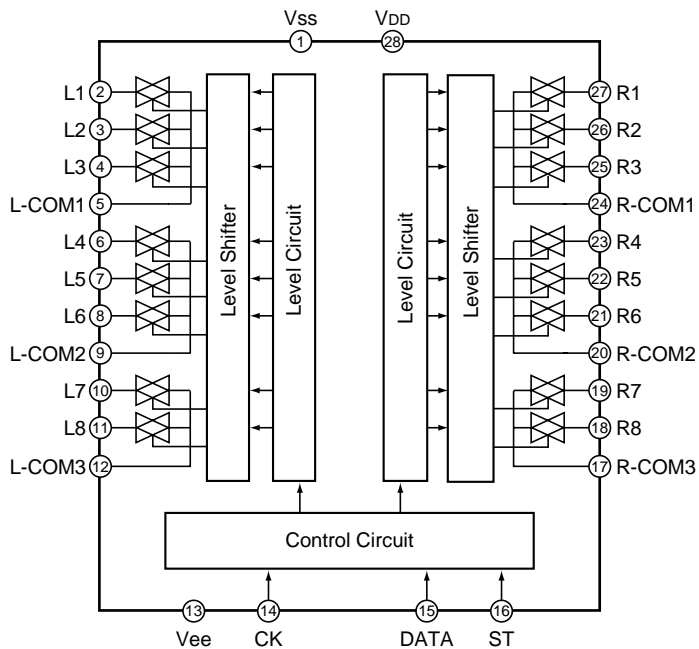

• Pin Function

No.	Pin Name	Function
1	VSS	Minus Power Supply
2, 27	L1,R1	Input and Output
3, 26	L2,R2	
4, 25	L3,R3	
5, 24	COM1	
6, 23	L4,R4	
7, 22	L5,R5	
8, 21	L6,R6	
9, 20	COM2	
10, 19	L7,R7	
21, 18	L8,R8	
26, 17	COM3	
13	GND	Digital Ground
14	CK	Clock Input
15	DATA	Data Input
16	ST	Strobe Input
28	VDD	Plus Power Supply

■ PD8097A (D.D & INPUT ASSY : IC9504)

• 4Mb P2ROM

■ Pin Arrangement (Top View)

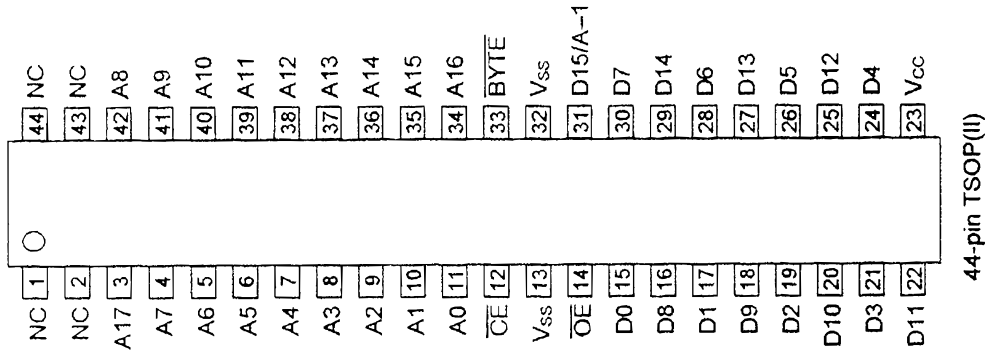

■ Block Diagram

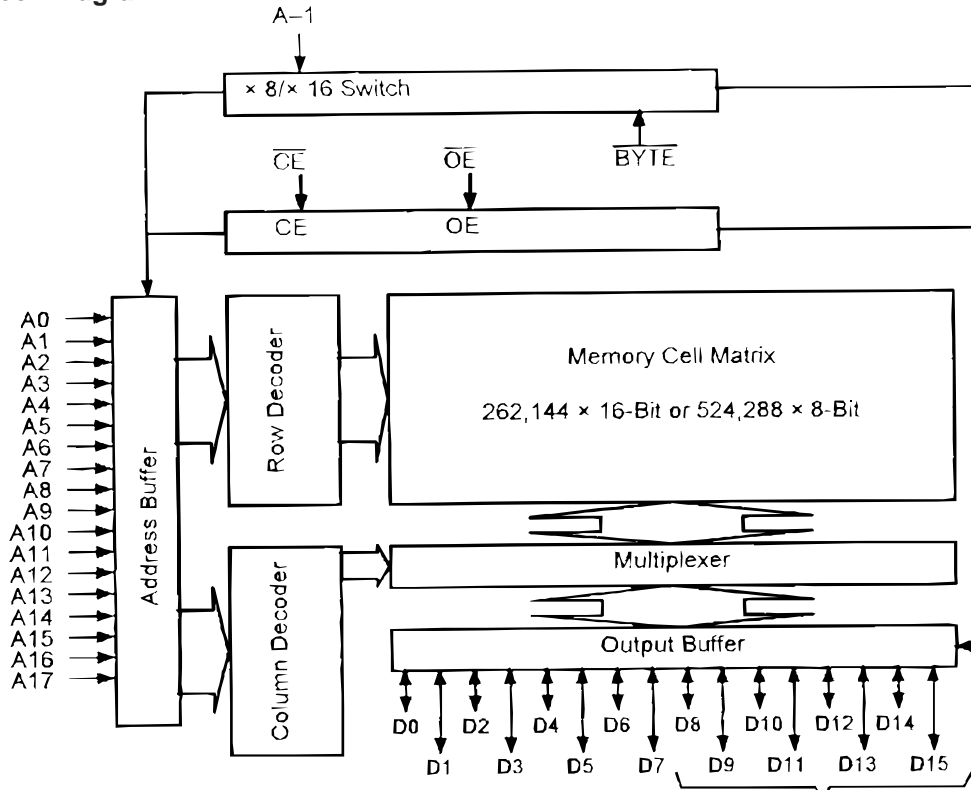

In 8-bit output mode, these pins are placed in a high-Z state and pin D15 functions as the A-1 address pin.

5

6

7

8

7.2.2 DISPLAY

■ XAV3013 (FRONT ASSY : V401)

• FL DISPLAY

• Pin Assignment

• Grid Assignment

• Segment Designation

VSX-D512-K

5

6

7

8

69

• Pin Connection

Pin No.	49	48	47	46	45	44	43	42	41	40	39	38	37	36	35	34	33	32	31	30	29	28	27	26	25
Connection	F2	F2	NP	NP	P22	P21	P20	P19	P18	P17	P16	P15	P14	P13	P12	P11	P10	P9	P8	P7	P6	P5	P4	P3	P2
Pin No.	24	23	22	21	20	19	18	17	16	15	14	13	12	11	10	9	8	7	6	5	4	3	2	1	
Connection	P1	NX	NX	NX	NX	NX	NX	NX	NX	NX	10G	9G	8G	7G	6G	5G	4G	3G	2G	1G	NP	NP	F1	F1	

- NOTE
- 1) F1, F2..... Filament
 - 2) NP..... No pin
 - 3) NX..... No extend pin
 - 4) DL..... Datum Line
 - 5) 1G to 10G..... Grid
 - 6) Field of vision is a minimum of 21.8° from the lower side.

• Anode Connection

	10G	9G	8G	7G	6G	5G	4G	3G	2G	1G
P1	S1	a1	a1	a1	a1	a1	a1	a1	a1	RFATT
P2	AUTO	a2	a2	a2	a2	a2	a2	a2	a2	EON
P3	SB	h	h	h	h	h	h	h	h	○
P4	DIGITAL	j	j	j	j	j	j	j	j	TUNED
P5	ANALOG	k	k	k	k	k	k	k	k	RDS
P6	DIGITAL (L)	b	b	b	b	b	b	b	b	S1
P7	DTS	f	f	f	f	f	f	f	f	A
P8	MPEG	m	m	m	m	m	m	m	m	B
P9	dts	g	g	g	g	g	g	g	g	1a
P10	MPEG	c	c	c	c	c	c	c	c	1b
P11	DIGITAL (R)	e	e	e	e	e	e	e	e	1f
P12	PROLOGIC II	r	r	r	r	r	r	r	r	1g
P13	Neo:6	p	p	p	p	p	p	p	p	1c
P14	ATT	n	n	n	n	n	n	n	n	1e
P15	ADV.SURR.	d1	d1	d1	d1	d1	d1	d1	d1	1d
P16	Re-EQ	d2	d2	d2	d2	d2	d2	d2	d2	2a
P17	DIRECT	Dp2	Dp2	Dp2	Dp2	Dp2	Dp2	Dp2	Dp2	2b
P18	MIDNIGHT	Dp1	Dp1	Dp1	Dp1	Dp1	Dp1	Dp1	Dp1	2f
P19	LOUDNESS	S1	S1	S1	S1	S1	S1	S1	S1	2g
P20	MONITOR	S4	S4	S4	S4	S4	S4	S4	S4	2c
P21	STEREO	S2	S2	S2	S2	S2	S2	S2	S2	2e
P22	MONO	S3	S3	S3	S3	S3	S3	S3	S3	2d

8. PANEL FACILITIES

Front panel

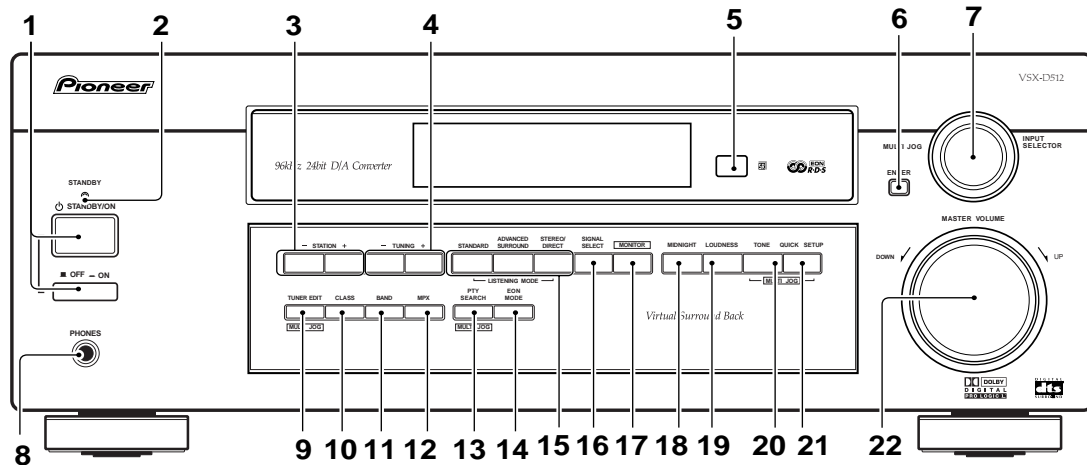

1 **STANDBY/ON-power** OFF ON buttons
STANDBY/ON Switches the receiver between on and standby. The power button switches the receiver off.

2 **STANDBY indicator**
Lights when the receiver is in standby mode.

3 **STATION (+/-) buttons**
Selects station presets when using the tuner.

4 **TUNING (+/-) buttons**
Selects the frequency when using the tuner.

5 **Remote sensor**
Receives the signals from the remote control.

6 **ENTER**

7 **MULTI JOG/INPUT SELECTOR dial**
The **MULTI JOG/INPUT SELECTOR** dial performs a number of tasks.
Use it to select options after pressing **TONE CONTROL**, **QUICK SETUP** or **TUNER EDIT**.

8 **PHONES jack**
Use to connect headphones.

9 **TUNER EDIT**
Press to memorize and name a station for recall using the station (+/-) buttons.

10 **CLASS**
Switches between the three banks (classes) of station presets.

11 **BAND**
Switches between AM and FM radio bands.

12 **MPX**
Press the MPX button to receive a radio broadcast in mono.



Note

When the headphones are connected, there is no sound output from the speakers.

13 **PTY SEARCH**
Use to search for different program types in RDS mode.

14 **EON MODE**
Use to search for different programs that are transmitting traffic or news information (this search method is called EON).

15 **LISTENING MODE buttons**
STANDARD
Press for Standard decoding and to switch between the various Pro Logic II options.
ADVANCED SURROUND
Use to switch between the various surround modes.
STEREO/DIRECT
Switches direct playback on or off. Direct playback bypasses the tone controls and channel levels for the most accurate reproduction of a source.

16 **SIGNAL SELECT**
Use to select between an analog or digital signal.

17 **MONITOR**
Press to switch tape monitoring on/off.

18 **MIDNIGHT**
Use when listening to movie soundtracks at low volumes.

19 **LOUDNESS**
Use to boost the bass and treble at low volumes.

20 **TONE**
Press this button to access the bass and treble controls, which you can then adjust with the **MULTI JOG/INPUT SELECTOR** dial.

21 **QUICK SETUP**
22 **MASTER VOLUME**

Display

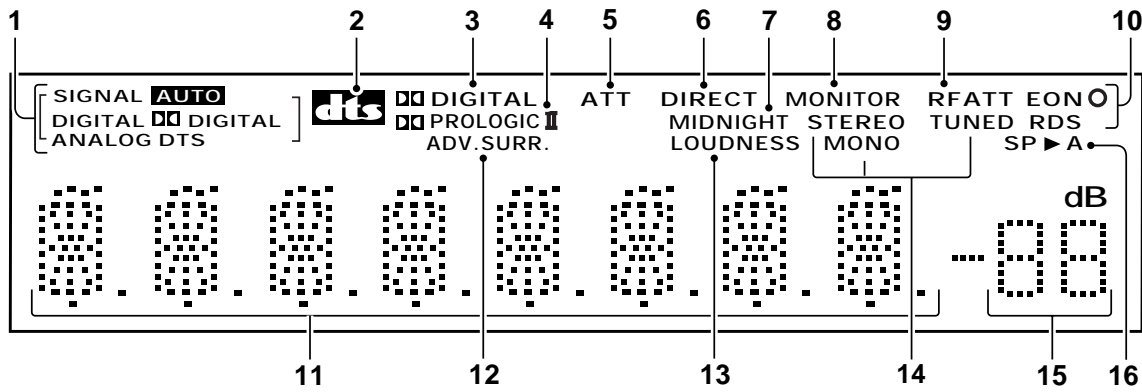

1 SIGNAL SELECT indicators

Lights to indicate the type of input signal assigned for the current component:

AUTO

Lights when AUTO signal select is on

SB

Depending on the source, this lights when a signal with surround back channel encoding is detected.

DIGITAL

Lights when a digital audio signal is detected.

DIGITAL

Lights when a Dolby Digital encoded signal is detected.

ANALOG

Lights when an analog signal is detected.

DTS

Lights when a source with DTS encoded audio signals is detected.

2 DTS

When the Standard mode of the receiver is on, this lights to indicate decoding of a DTS signal.

3 DIGITAL

When the Standard mode of the receiver is on, this lights to indicate decoding of a Dolby Digital signal.

4 PRO LOGIC II

When the Standard mode of the receiver is on, this lights to indicate Pro Logic II decoding.

5 ATT

Lights when INPUT ATT is used to attenuate (reduce) the level of the analog input signal.

6 DIRECT

Lights when source direct playback is in use. This function bypasses all tone, balance, Advanced surround, and Dolby Surround effects.

7 MIDNIGHT

Lights during Midnight listening.

8 MONITOR

Lights when MONITOR is selected

9 RF ATT

Lights when the RF ATT is on .

10 EON and

The \circ indicator lights to inform you that the currently tuned station carries the EON data service. When the EON mode is set, the EON indicator lights, but during actual reception of an EON broadcast the EON indicator will flash. RDS: Lights when an RDS broadcast is received.

11 Character display

12 ADV. SURR. (Advanced Surround)

Lights when one of the Advanced Surround modes has been selected.

13 LOUDNESS

Lights when LOUDNESS has been selected.

14 TUNER indicators

STEREO:

Lights when a stereo FM broadcast is being received in auto stereo mode.

MONO:

Lights when the mono mode is set using the MPX button.

TUNED:

Lights when a broadcast is being received.

15 Master volume level

Shows the overall volume level. ---dB indicates the minimum level, and -0 dB indicates the maximum level.



Note

Depending on your level settings for each channel, the maximum level can range between -10 dB and -0 dB.

16 Speaker indicator

Shows if the speaker system is on or not.

SP ►A means speakers are switched on. SP ► means the head phones are connected.

Remote control

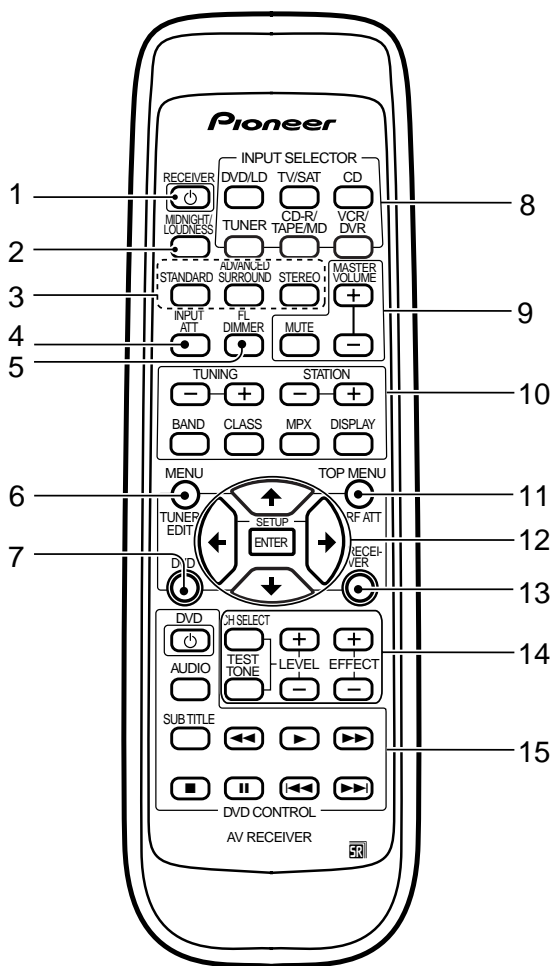

1 RECEIVER

Switches the receiver between on and standby.

2 MIDNIGHT/LOUDNESS

Use to switch to Midnight or Loudness listening.

3 LISTENING MODE buttons STANDARD

Press for Standard decoding and to switch between the various Pro Logic II options.

ADVANCED SURROUND

Use to switch between the various surround modes.

STEREO/DIRECT

Switches direct playback on or off. Direct playback bypasses the tone controls and channel levels for the most accurate reproduction of a source.

4 INPUT ATT

Use to attenuate (lower) the level of an analog input signal to prevent distortion.

5 FL DIMMER

Use this button to make the fluorescent display (FL) dimmer or brighter.

6 MENU (DVD control)

Use to access different menus associated with your DVD player. TUNER EDIT (Receiver control) (pages 35–36)

Press to memorize and name a station for recall using the STATION (+/-) buttons.

7 DVD

Use to switch over to the DVD controls on the remote control.



Note

The DVD controls on the remote control (**TOP MENU**, **MENU**, , , ,) and **ENTER/SETUP** buttons) can only be used for DVD control after pressing **DVD** on the remote. See the next page for more on the separate **DVD CONTROL** buttons.

8 INPUT SELECTOR buttons

Use to select the input source.

9 Volume buttons

Use **MASTER VOLUME +/-** to set the overall listening volume.

Use **MUTE** to mute the sound or restore the sound if it has been muted.

10 Tuner controls

The **TUNING +/-** buttons can be used to find radio frequencies.

The **STATION +/-** buttons can be used to select preset radio stations.

BAND

Use to switch between the AM and FM bands when the tuner is selected.

CLASS

Use to switch between the three banks (classes) of station presets.

MPX

Use to switch between auto stereo and mono reception of FM broadcasts. If the signal is weak then switching to mono will improve the sound quality.

DISPLAY

Use to switch the display between the station preset name and the frequency.

11 TOP MENU

Displays the disc 'top' menu of a DVD.

RF ATT (Receiver control)

Use to lower the input level of a radio signal that is too powerful or contain interference thus causing the receiver to distort.

12 , , , and ENTER/SETUP buttons

Use these arrow buttons when setting up your surround sound system. These buttons are also used to control DVD menus/options.

12 ⇐ ⇨ ↑ ↓ and ENTER/SETUP buttons

Use these arrow buttons when setting up your surround sound system.
These buttons are also used to control DVD menus/options.

13 RECEIVER

Use to switch to the receiver controls on the remote control.
Also used when setting up the surround sound for the receiver.

14 CHANNEL SELECT

Use to select a channel when setting up the surround sound of the receiver.

TEST TONE

Use to sound the test tones when setting up the surround sound of the receiver.

LEVEL +/-

Use to set up the levels of the surround sound of the receiver.

EFFECT +/-

Use to add or subtract the amount of effect in different sound modes or advanced listening modes.

15 DVD CONTROL buttons

You can use these buttons to control a Pioneer DVD player connected to your system.

Button	What it does
DVD	Turns DVD power on/off.
AUDIO	Changes the audio language or channel.
SUBTITLE	Displays/changes the subtitles included in multilingual DVD-Video discs.
⏮	Press to start fast reverse scanning.
▶	Starts playback.
⏭	Press to start fast forward scanning.
■	Stops playback.
⏸	Pauses a disc that's playing, or restarts a paused disc.
⏮	Skips to the start of the current track or chapter, then to previous tracks/chapters.
⏭	Skips to the next track or chapter.

Rear Panel

