

Pioneer

Service Manual

ORDER NO.
RRV2366

AUDIO/VIDEO MULTI-CHANNEL RECEIVER

VSX-D939TX

THIS MANUAL IS APPLICABLE TO THE FOLLOWING MODEL(S) AND TYPE(S).

Type	Model	Power Requirement	The voltage can be converted by the following method.
	VSX-D939TX		
HL	○	AC220-230V	AC240V, *
LB	○	AC110V	_____

* : Alter the wiring of the Power-supply block at the primary winding of Power-transformer referring to the "Line Voltage Selection" described in Service Manual.

● This service manual should be used together with the following manual(s):

Model No.	Order No.	Remarks
VSX-37TX/KU/CA	RRV2295	

CONTENTS

1. CONTRAST OF MISCELLANEOUS PARTS	2
2. PCB CONNECTION DIAGRAM	8
3. SCHEMATIC DIAGRAM	10
4. REMOTE CONTROL UNIT	25

1. CONTRAST OF MISCELLANEOUS PARTS

- NOTES: ● Parts marked by "NSP" are generally unavailable because they are not in our Master Spare Parts List.
 ● The Δ mark found on some component parts indicates the importance of the safety factor of the part. Therefore, when replacing, be sure to use parts of identical designation.
 ● Screws adjacent to \blacktriangledown mark on product are used for disassembly.
 ● Reference Nos. indicate the pages and Nos. in the service manual for the base model.
 ● When ordering resistors, first convert resistance values into code form as shown in the following examples.
 Ex.1 When there are 2 effective digits (any digit apart from 0), such as 560 ohm and 47k ohm (tolerance is shown by J=5%, and K=10%).

560 \rightarrow 56 x 10¹ \rightarrow 561 RD1/4PU $\boxed{5}\boxed{6}\boxed{1}\boxed{J}$
 47k \rightarrow 47 x 10³ \rightarrow 473 RD1/4PU $\boxed{4}\boxed{7}\boxed{3}\boxed{J}$
 0.5 \rightarrow R50 RN2H $\boxed{R}\boxed{5}\boxed{0}\boxed{K}$
 1 \rightarrow 1R0 RS1P $\boxed{1}\boxed{R}\boxed{0}\boxed{K}$

Ex.2 When there are 3 effective digits (such as in high precision metal film resistors).
 5.62k \rightarrow 562 x 10¹ \rightarrow 5621 RN1/4PC $\boxed{5}\boxed{6}\boxed{2}\boxed{1}\boxed{F}$

■ CONTRAST TABLE

VSX-D939TX/HL, LB and VSX-37TX/KU/CA are constructed the same except for the following :

Ref. No.	Mark	Symbol and Description	Part No.			Remarks
			VSX-37TX /KU/CA	VSX-D939TX /HL	VSX-D939TX /LB	
ASSEMBLIES						
P5- 5	NSP	MAIN ASSY	AWK7641	AWK7647	AWK7646	No. 1
P5-12		└ MAIN CONTROL ASSY	AWX7706	AWX7712	AWX7711	
		└ VIDEO ASSY	AWX7394	AWX7677	AWX7677	
P5- 2	NSP	COMPLEX ASSY	AWK7522	AWK7529	AWK7543	
P5- 3		└ EXTERNAL IN ASSY	AWX7398	AWX7413	AWX7413	
P5- 4		└ A- PINJACK ASSY	AWX7397	AWX7412	AWX7412	
P5- 9		└ CONNECTION ASSY	AWX7313	AWX7347	AWX7347	
		└ REGULATOR ASSY	AWX7310	AWX7832	AWX7832	
P5-10		└ TRANS 1 ASSY	AWX7316	AWX7316	Not used	
P5-10		└ TRANS 1/LB ASSY	Not used	Not used	AWX7447	
P5-11		└ TRANS 2-2 ASSY	AWX7366	AWX7518	AWX7518	
P5-15		└ PRIMARY ASSY	AWX7311	AWX7345	AWX7429	
P5-14	NSP	FRONT/VAMP ASSY	AWK7656	AWK7661	AWK7661	
P9- 2		└ VOLUME ASSY	AWX7367	Not used	Not used	
P9- 3		└ DISPLAY ASSY	AWX7698	AWX7703	AWX7703	
		└ ROTARY ENCODER ASSY	AWX7328	AWX7726	AWX7726	
P5- 6	NSP	POWER/CURRENT ASSY	AWK7651	AWK7655	AWK7654	
P5- 8		└ TRANS 2-1 ASSY	AWX7694	AWX7696	AWX7696	
		└ SP/PS ASSY	AWX7688	AWX7693	AWX7692	
PACKING SECTION						
P3- 2		FM Wire Antenna	ADH7007	ADH7010	ADH7011	
P3- 3		Operating Instructions (English)	ARB7231	ARB7235	ARB7235	
P3- 3		Operating Instructions (Chinese)	Not used	ARC7321	ARC7321	
P3- 4		Remote Control Unit	AXD7257	AXD7279	AXD7279	
P3- 9		Packing Case	AHD7881	AHD7889	AHD7889	
P3-12	NSP	Warranty Card	ARY1026	Not used	Not used	
EXTERIOR SECTION						
P5-20	Δ	AC Power Cord	ADG7028	VDG1063	ADG7023	
P5-21	Δ	Power Transformer (T1)	ATS7252	ATS7253	Not used	
P5-21	Δ	Power Transformer (T1) (AC110V)	Not used	Not used	ATS7255	
P5-22		FM/AM TUNER Unit	AXX7046	AXX7048	AXX7047	
P5-23	Δ	Fuse (FU1 : T4A)	VEK1029	AEK-514	Not used	
P5-23	Δ	Fuse (FU1 : 10A)	VEK1029	Not used	DEK1045	
P5-24	Δ	Fuse (FU4 : T2A)	REK1079	AEK-511	AEK-511	
P5-25	Δ	Fuse (FU5 : T2A)	REK1079	AEK-511	AEK-511	

Ref. No.	Mark	Symbol and Description	Part No.			Remarks
			VSX-37TX /KU/CA	VSX-D939TX /HL	VSX-D939TX /LB	
P5-26		AC Cord Spacer	ANG1153	ANG7281	Not used	
P5-26		Cord Stopper	Not used	CM-22B	CM-22C	
P5-27		Bonnet Case	AZN7789	AZN7861	AZN7865	
P5-54		Rear Panel	ANC7944	ANC7954	ANC7955	
P5-58		Side Escutcheon L	AAK7633	AAK7662	AAK7662	
P5-59		Side Escutcheon R	AAK7634	AAK7663	AAK7663	
	△	AC Socket 3P Sheet	Not used	AKP-502	Not used	No. 2
		Fuse Holder	Not used	AED7035	AED7035	No. 3
	△	Fuse (T5A)	Not used	VKR1003	Not used	No. 4
		Fuse (T5A)	Not used	PEK1003	Not used	No. 5
	△	Fan Motor	Not used	AXM7012	Not used	No. 6
		Acetate Tape	Not used	AEH7013	AEH7013	No. 7
		Washer	Not used	WA42N100W050	WA42N100W050	No. 8
HEAT SINK SECTION						
P7- 9	NSP	Heat Sink	ANH7103	ANH7103	ANH7102	
P7- 12	NSP	Power Supply Plate	ANG7280	ANG7240	ANG7240	
	△	Thermistor	Not used	AEX7004	Not used	No. 9
FRONT PANEL SECTION						
P9- 4		Door Hinge L	AMR7252	AMR7325	AMR7325	
P9- 5		Door Hinge R	AMR7253	AMR7326	AMR7326	
P9- 7		Door Panel	AMB7722	ANB7239	ANB7239	
P9- 9		Door Plate	AAH7024	Not used	Not used	
P9-10		Door Sheet	AAK7789	AAH7069	AAH7069	
P9-11		Display Panel	AAK7625	AAK7792	AAK7792	
P9-12		Function Lens 27	AAK7628	Not used	Not used	
P9-13		Power Button	AAD7440	AAD7485	AAD7485	
P9-14		MR Button	AAD7514	Not used	Not used	
P9-18		Lead Card 08P (J19)	ADD7168	Not used	Not used	
P9-20		Damper Assy	AXA7078	AXA7076	AXA7076	
P9-21		Sub Panel	AMB7622	ANB7207	ANB7207	
P9-22		Volume Ring	AAK7623	AAH7016	AAH7016	
P9-24		Door Cusion	AEB7152	AEB7153	AEB7153	
P9-25		Front Panel	AMB7717	ANB7238	ANB7238	
P9-27		Name Plate	PAN1376	PAN1377	PAN1377	
P9-29		FL Sheet	AAK7627	AAK7805	AAK7805	
P9-30		Volume Knob (MASTER)	AAB7194	AAB7210	AAB7210	
P9-31		Rotary Knob (INPUT SELECTOR)	AAB7221	AAB7209	AAB7209	
P9-38		Panel Base	AMB7570	AMB7572	AMB7572	
		POWER Button MG	Not used	AAD7491	AAD7491	No. 10
		Earth Spring	Not used	ABH7172	AAD7172	No. 11

Notes : ●The numbers in the remarks column correspond to the numbers on the “EXPLODED VIEWS”.

- For PCB ASSEMBLIES, Refer to “CONTRAST OF PCB ASSEMBLIES”, “2. PCB CONNECTION DIAGRAM” and “3. SCHEMATIC DIAGRAM”.

VSX-D939TX

■ EXPLODED VIEWS ● EXTERIOR SECTION

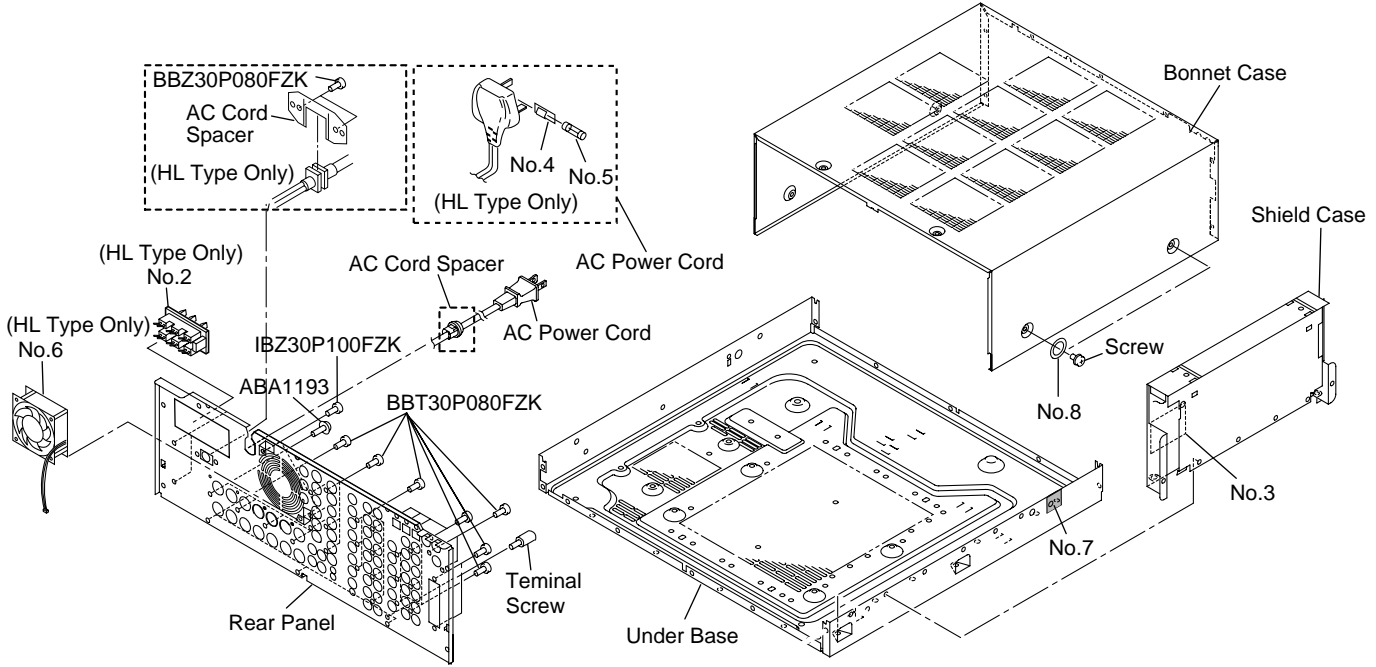

● FRONT PANEL and HEAT SINK SECTIONS

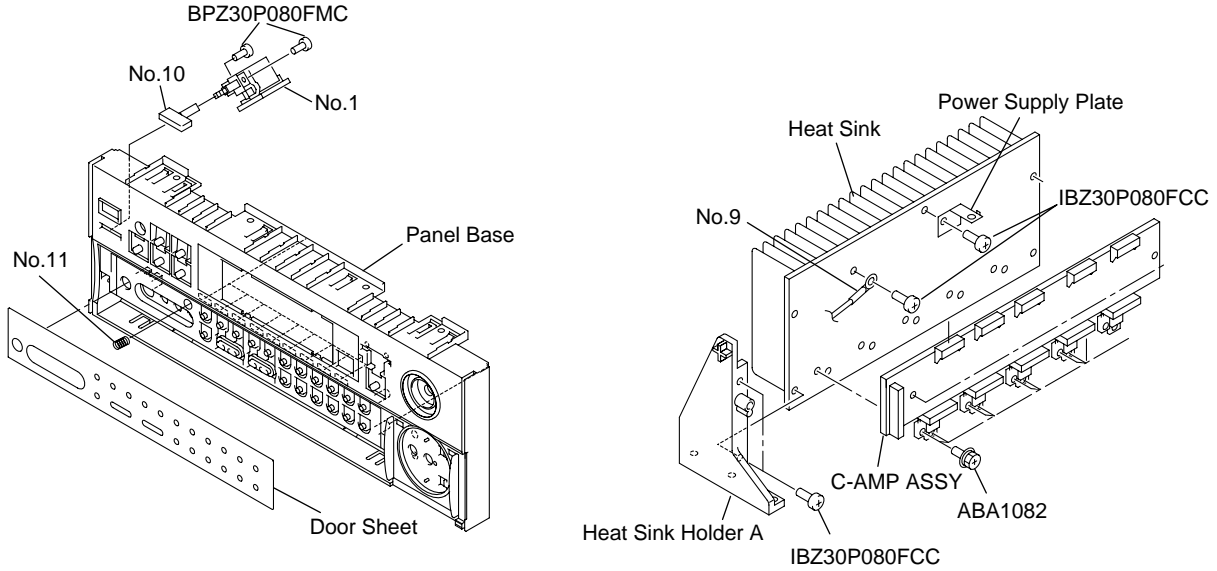

■ CONTRAST OF PCB ASSEMBLIES

BF A-PINJACK ASSY

AWX7412 and AWX7397 are constructed the same except for the following :

Mark	Symbol and Description	Part No.		Remarks
		AWX7397	AWX7412	
	C1001-C1006,C1009,C1010,C1013,C1014 C1007,C1008,C1011,C1012,C1015- C1018 R1017, R1018	Not used Not used Not used	CCCSL271J50 CCCSL101J50 RD1/4PU101J	

AF EXTERNAL IN ASSY

AWX7413 and AWX7398 are constructed the same except for the following :

Mark	Symbol and Description	Part No.		Remarks
		AWX7398	AWX7413	
	C1101- C1106	Not used	CCCSL271J50	

CF CONNECTION ASSY

AWX7347 and AWX7313 are constructed the same except for the following :

Mark	Symbol and Description	Part No.		Remarks
		AWX7313	AWX7347	
	C1301- C1306 C1353, C1354 C1355, C1356 C1365, C1366 L1351- L1354 R1353, R1354	Not used Not used Not used CEAT101M16 Not used RD1/4PU331J	CCCSL680J50 CCCSL181J50 CKCYB331K50 CEAT101M25 LAU181J RD1/4PU122J	

DF MAIN CONTROL ASSY

AWX7712, AWX7711 and AWX7706 are constructed the same except for the following :

Mark	Symbol and Description	Part No.			Remarks
		AWX7706	AWX7712	AWX7711	
	IC102 IC109 IC110 IC115 IC901 Q113, Q114 D201, D202 D251, D252 D253 C101- C106, C183- C188 C113, C114 C131, C132, C253, C254 C141, C142, C145- C150 C143, C144 C252 C155, C156, C165, C166 C175, C176 C960, C961 R109 R110 R129, R130 R135, R136, R923, R926, R928 R131, R132 R133, R134, R141- R144 R934- R936, R986, R987 R207- R211, R252, R253 R145, R146 R254 R251 R255 R325- R330, R333, R334 R370, R996 R924, R925, R927 R923, R926 JA931	BU4052BCF NJM4558MD M62429FP Not used PD5589A 2SC2878 UDZS5.1B Not used Not used Not used Not used Not used Not used CEAT100M50 CKSQYB103K50 Not used Not used Not used CCSQCH101J50 RD1/2VM391J RS1/10S472J RS1/10S104J RS1/10S103J RS1/10S471J RS1/10S102J RS1/10S102J Not used RS1/10S473J Not used Not used Not used RS1/10S0R0J Not used Not used Not used Not used VKB1060	Not used Not used Not used NJM4558LD PD5596A Not used Not used 1SS355 UDZS5.1B CCSQCH221J50 CCSQCH331J50 CKSQYB103K50 Not used Not used CEAT470M16 CCSQCH101J50 CCSQCH101J50 Not used Not used Not used Not used Not used RS1/10S104J Not used RS1/10S102J RS1/10S474J RS1/10S393J Not used RS1/10S0R0J RS1/10S103J Not used Not used	Not used Not used Not used Not used PD5596A Not used Not used Not used Not used CCSQCH221J50 CCSQCH331J50 Not used Not used Not used CCSQCH101J50 CCSQCH101J50 Not used Not used Not used Not used Not used Not used Not used Not used Not used Not used Not used RS1/10S103J Not used	

JF TRANS 2-1 ASSY

AWX7696 and AWX7694 are constructed the same except for the following :

Mark	Symbol and Description	Part No.		Remarks
		AWX7694	AWX7696	
△	C4501, C4503, C4511 (1μF/100V) D4513 Q4503- Q4505	ACH1237 Not used Not used	Not used MTZJ16B DTA143ES	
△	R4501, R4503, R4511	RFA1/4PS100J	Not used	

LF SP / PS ASSY

AWX7693, AWX7692 and AWX7688 are constructed the same except for the following :

Mark	Symbol and Description	Part No.			Remarks
		AWX7688	AWX7693	AWX7692	
△	IC3001 Q3005 Q3501 Q3502- Q3505 Q3506	Not used Not used Not used Not used Not used	AEK7007 DTA124ES 2SC4793 DTC124ES 2SA992	Not used DTA124ES Not used Not used Not used	
△	D3052, D3054, D3056, D3058, D3060 D3503, D3504, D3509 D3501, D3502 D3505 D3507	Not used Not used Not used Not used Not used	1SS133 1SS133 S5688G MTZJ16B MTZJ5.1B	1SS133 Not used Not used Not used Not used	
	D3508 C3101- C3105 C3106- C3110 C3501 C3502	Not used CFTYA104J50 Not used Not used Not used	MTZJ11B CFTYA224J50 CFTYA224J50 CEAT471M35 CEAT1R0M50	Not used CFTYA224J50 CFTYA224J50 Not used Not used	
	C3503 C3504 C3505 C3506 R3133, R3134	Not used Not used Not used Not used Not used	CKCYF103Z50 CEAT471M25 CEAT101M16 CCCCH680J50 RS1LMF471J	Not used Not used Not used Not used RS1LMF471J	
	R3501 R3502, R3506, R3507 R3503 R3504 R3505	Not used Not used Not used Not used Not used	RD1/4PU820J RD1/4PU473J RD1/4PU102J RD1/4PU104J RD1/4PU682J	Not used Not used Not used Not used Not used	
NSP NSP	R3508 Y0006 Y0007 CN3002 CN3101 CN3102	Not used ADX7352 ADX7353 Not used AKE7058 AKE7060	RD1/4PU103J Not used Not used KM250MA3 AKE7059 AKE7061	Not used Not used Not used Not used AKE7059 AKE7061	

MF REGULATOR ASSY

AWX7832 and AWX7310 are constructed the same except for the following :

Mark	Symbol and Description	Part No.		Remarks
		AWX7310	AWX7832	
	IC5001, C5002 R5004, R5005	NJM78M15FA Not used	NJM7815FA RS2LMF2R7J	

OF TRANS 2-2 ASSY

AWX7518 and AWX7366 are constructed the same except for the following :

Mark	Symbol and Description	Part No.		Remarks
		AWX7366	AWX7518	
△	C5501	Not used	CEANPR47M50	
△	C5502	Not used	ACH1237 (1μF/100V)	
△	R5501	Not used	RFA1/4PS100J	
	R5502	Not used	RD1/4PU104J	

SF DISPLAY ASSY

AWX7703 and AWX7698 are constructed the same except for the following :

Mark	Symbol and Description	Part No.		Remarks
		AWX7698	AWX7703	
	IC7051	TC7W53FU	Not used	
	IC7071	M66311FP	Not used	
	Q7002, Q7054	DTC124EK	Not used	
	Q7053	FMA1A	Not used	
	D7002	SLR-343VR	Not used	
	D7054- D7057	1SS355	Not used	
	D7071- D7079	SLR-343VR	Not used	
	S7019, S7020	VSG1009	Not used	
	C7011, C7073, C7074	CKSQYB102K50	Not used	
	C7053	CKSQYB153K50	Not used	
	C7071	CEAL101M6R3	Not used	
	C7072	CKSQYB473K50	Not used	
	R7038, R7071- R7079	RS1/10S271J	Not used	
	R7056	RS1/10S223J	Not used	
	R7057, S7061	RS1/10S103J	Not used	
	R7058	RS1/10S392J	Not used	
	R7062	RS1/10S0R0J	Not used	
	R7080- R7083	RS1/10S102J	Not used	
	R7092	RS1/10S473J	Not used	
	0505	VEF1040	Not used	
	CN7003	52045-0845	Not used	

TF ROTARY ENCODER ASSY

AWX7726 and AWX7328 are constructed the same except for the following :

Mark	Symbol and Description	Part No.		Remarks
		AWX7328	AWX7726	
	C7103, C7104	Not used	CKSQYB103K50	
	R7103, C7104	Not used	RS1/10S103J	
	S7101	Not used	ASX7004	

VSX-D939TX

PF VIDEO ASSY

AWX7677 and AWX7394 are constructed the same except for the following :

Mark	Symbol and Description	Part No.		Remarks
		AWX7394	AWX7677	
	IC731 D731 C732, C733, C736 C791 R717 R732- R735 CN701 CN702 JA705	NJM2279M 1SS355 CKSQYB473K50 CKSQYB103K RS1/10S101J RS1/10S102J 52045-2645 52045-2145 AKN7014	Not used Not used Not used Not used RS1/10S0R0J Not used HLEM26S-1 HLEM21S-1 Not used	

VF PRIMARY ASSY

AWX7345, AWX7429 and AWX7311 are constructed the same except for the following:

Mark	Symbol and Description	Part No.			Remarks
		AWX7311	AWX7345	AWX7429	
	C6002, C6003 C6006 R6001 R6002 L6003, L6004 J6000 T6001 RY6001 Y6003 AWG18 BOARD IN Y6004 AWG18 BOARD IN Y6005 AWG18 BOARD IN 6004 6001	ACG7020 CEAT470M25 RCN1080 Not used Not used Not used ATT7043 ASR7022 Not used Not used Not used AKP1053 Not used	ACE7014 CEAT221M25 Not used RD1/4PU1R0J ATX1012 D20PYY0335E ATT7040 ASR1044 ADX7321 ADX7320 ADX7319 Not used 51048-0300	ACG7020 CEAT470M25 Not used Not used Not used D20PYY0335E ATT7041 ASR1022 Not used Not used Not used AKP1053 51048-0300	

NF TRANS 1/LB ASSY

TRANS 1/LB Assy has no service parts.

■ PCB PARTS LIST

Mark	No.	Description	Part No.	Mark	No.	Description	Part No.
------	-----	-------------	----------	------	-----	-------------	----------

VA P-SW ASSY (AWX7330)

SWITCHES AND RELAYS

S6801 ASG1035

CAPACITORS

C6801, C6802 CGCYX103K25

OTHERS

CN6801 3P JUMPER CONNECTOR 52151-0310

2. PCB CONNECTION DIAGRAM

2.1 P-SW ASSY

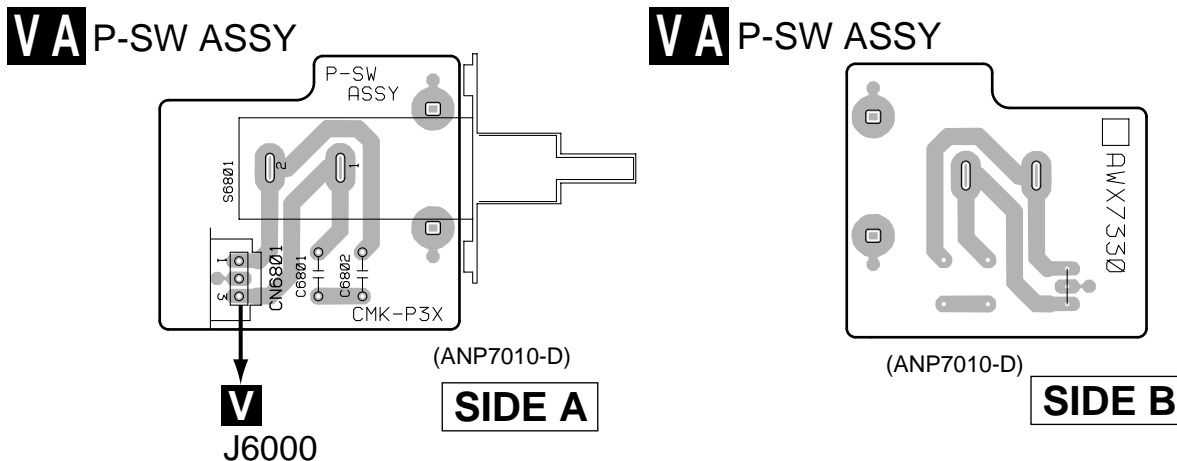

2.2 TRANS 1/LB ASSY

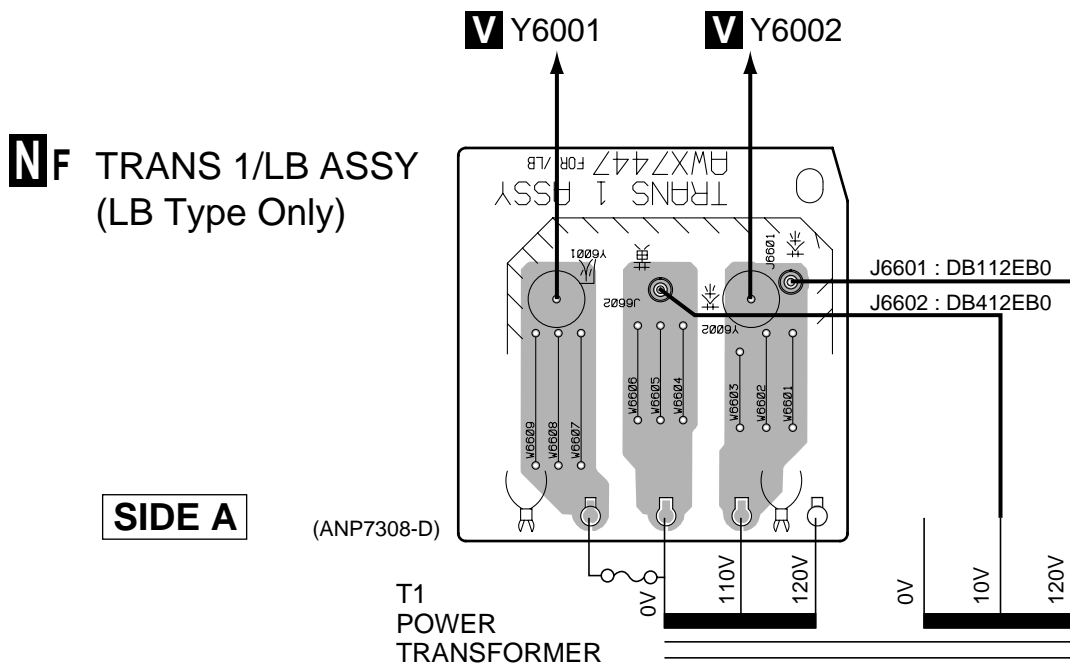

3. SCHEMATIC DIAGRAM

3.1 EXTRA IN, A-PINJACK and CONNECTION ASSYS

A F
EXTRA IN ASSY
(AWX7413)

JA1101-JA1103
(AKB7095)

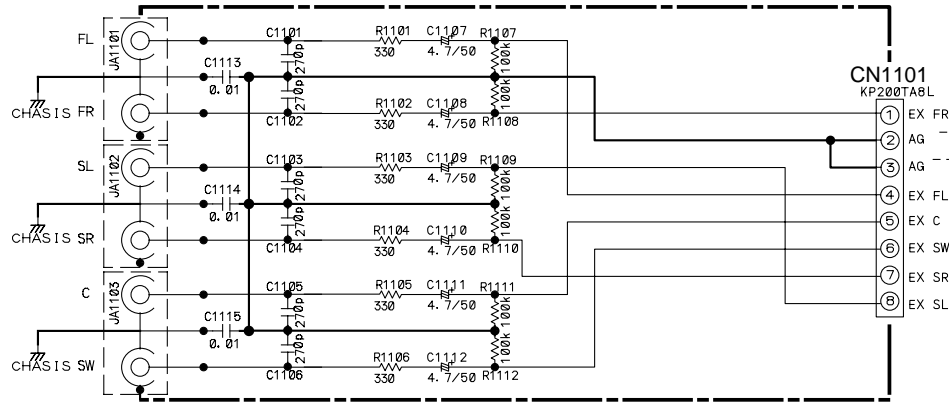

B F
A-PINJACK ASSY
(AWX7412)

JN1016: AKB7120

JN1015: AKB7048

JA1011-JA1013 :
AKB7048

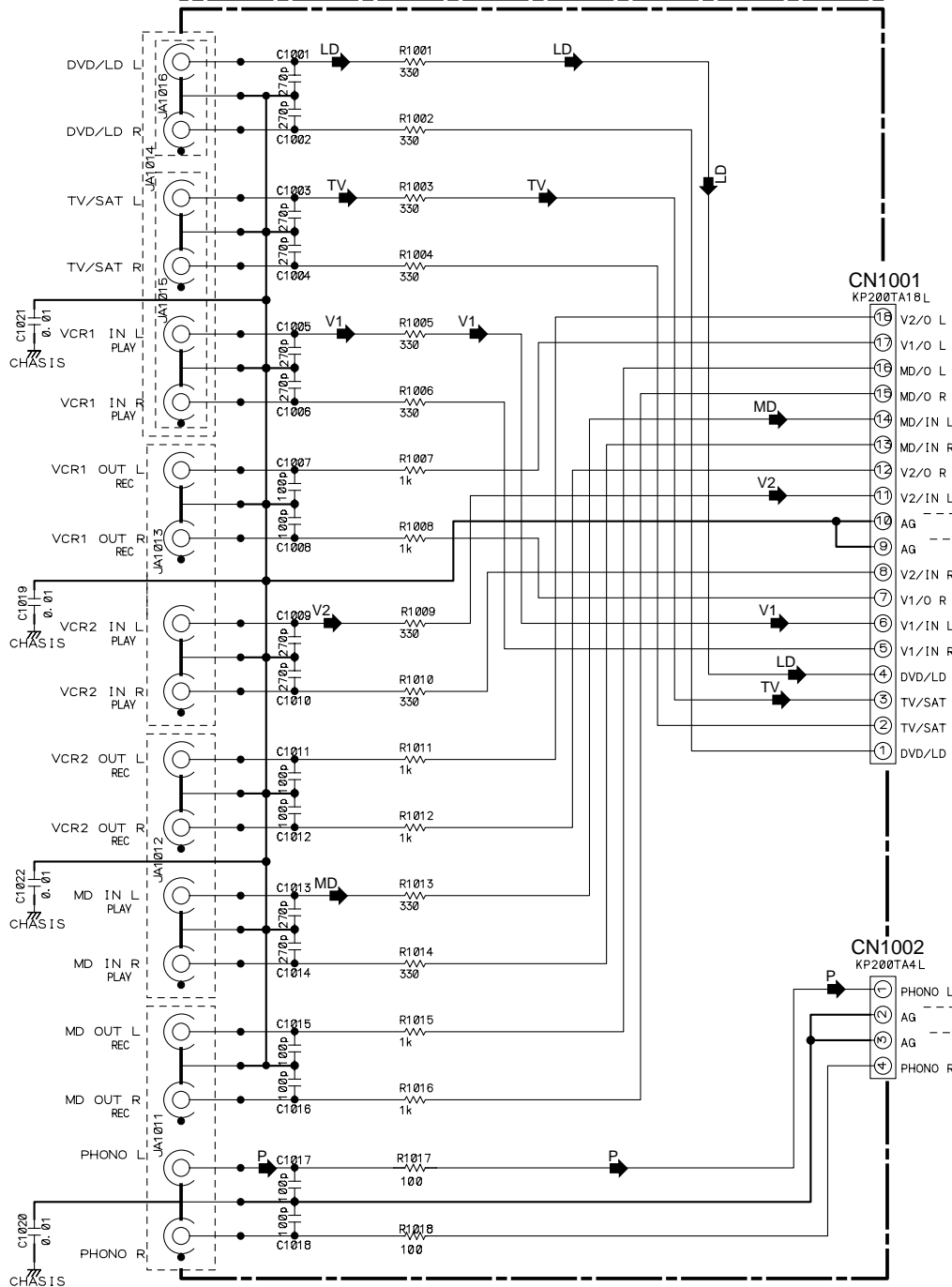

Note : When ordering service parts, be sure to refer to "EXPLODED VIEWS and PARTS LIST" or "PCB PARTS LIST"

CF CONNECTION ASSY (AWX7347)

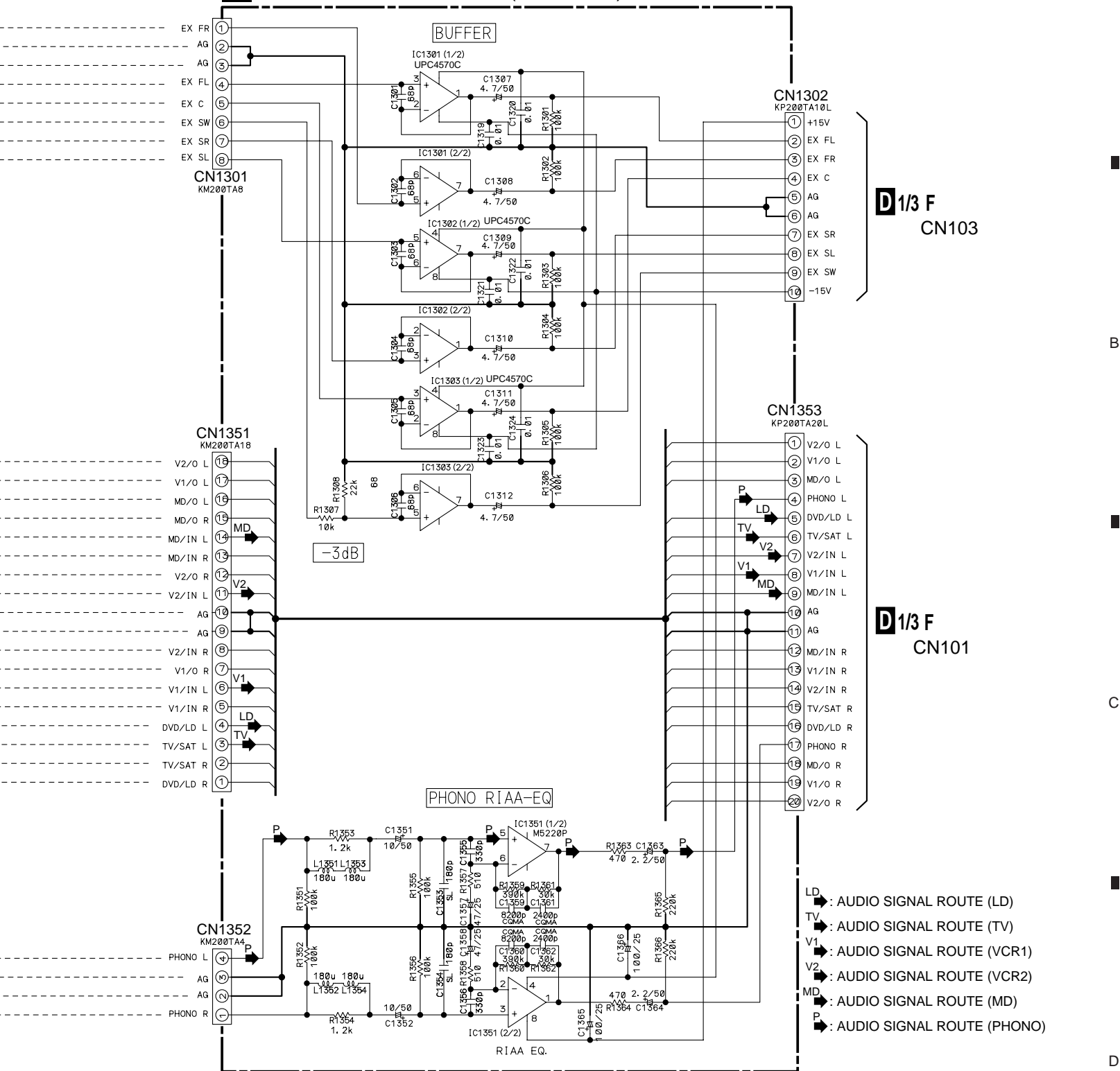

D 1/3 F
CN103

D 1/3 F
CN101

- LD : AUDIO SIGNAL ROUTE (LD)
- TV : AUDIO SIGNAL ROUTE (TV)
- V1 : AUDIO SIGNAL ROUTE (VCR1)
- V2 : AUDIO SIGNAL ROUTE (VCR2)
- MD : AUDIO SIGNAL ROUTE (MD)
- P : AUDIO SIGNAL ROUTE (PHONO)

3.2 MAIN CONTROL ASSY (1/3)

The power supply is shown with the marked box.

A

B

C

D

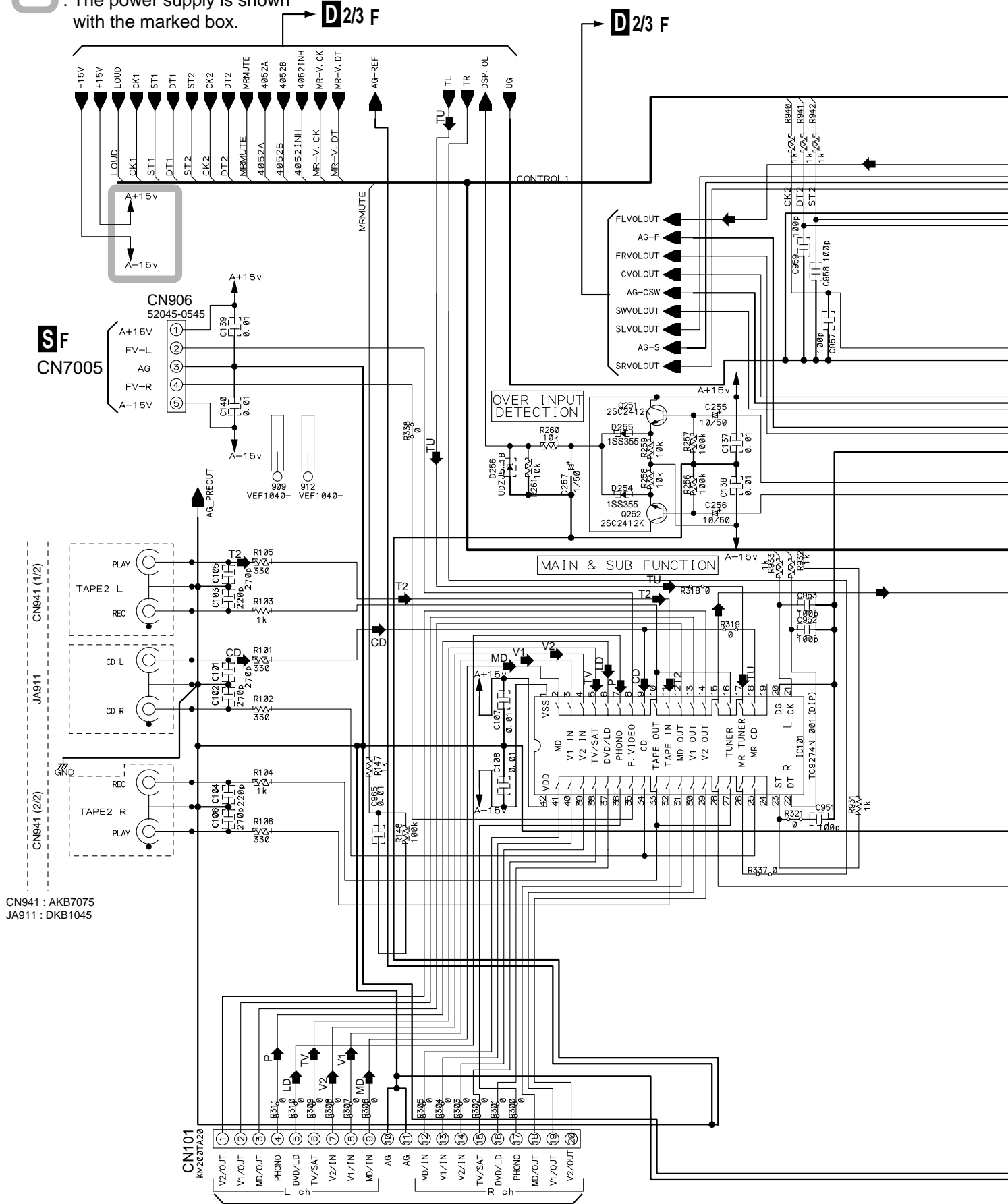

D 1/3 F MAIN CONTROL ASSY
 (HL : AWX7712)
 (LB : AWX7711)

- ▶ : AUDIO SIGNAL ROUTE
- LD ▶ : AUDIO SIGNAL ROUTE (LD)
- TV ▶ : AUDIO SIGNAL ROUTE (TV)
- V1 ▶ : AUDIO SIGNAL ROUTE (VCR1)
- V2 ▶ : AUDIO SIGNAL ROUTE (VCR2)
- MD ▶ : AUDIO SIGNAL ROUTE (MD)
- P ▶ : AUDIO SIGNAL ROUTE (PHONO)
- TU ▶ : AUDIO SIGNAL ROUTE (TUNER)
- CD ▶ : AUDIO SIGNAL ROUTE (CD)
- T2 ▶ : AUDIO SIGNAL ROUTE (TAPE2)

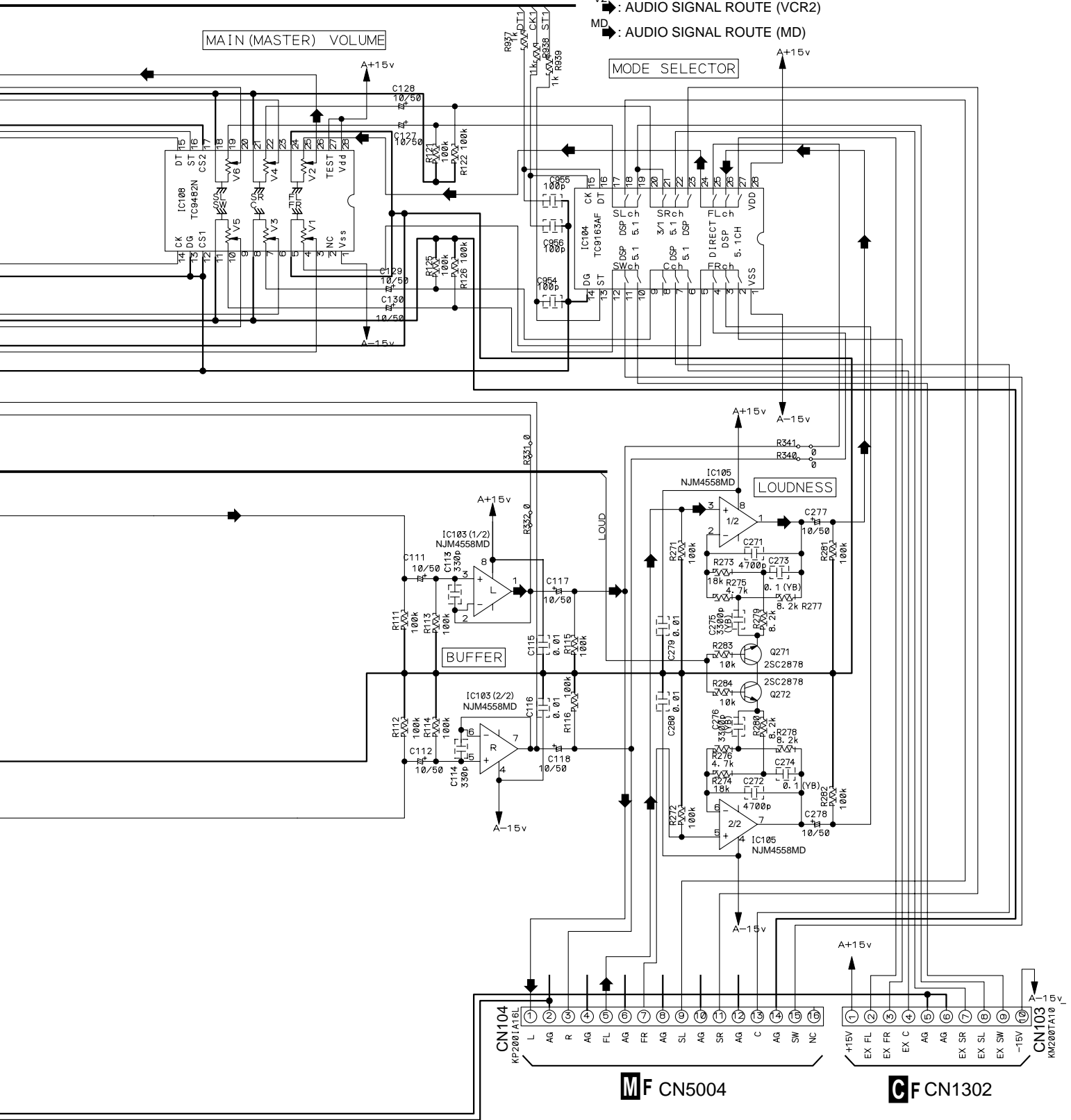

MF CN5004

CF CN1302

3.3 MAIN CONTROL ASSY (2/3)

D 2/3 F MAIN CONTROL ASSY
(HL : AWX7712)
(LB : AWX7711)

D 1/3 F

D 3/3 F

A

B

C

D

D 1/3 F

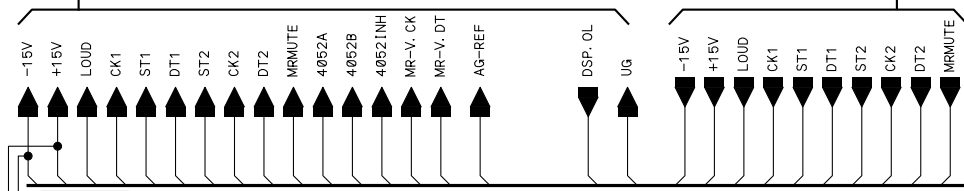

PREAMP SECTION

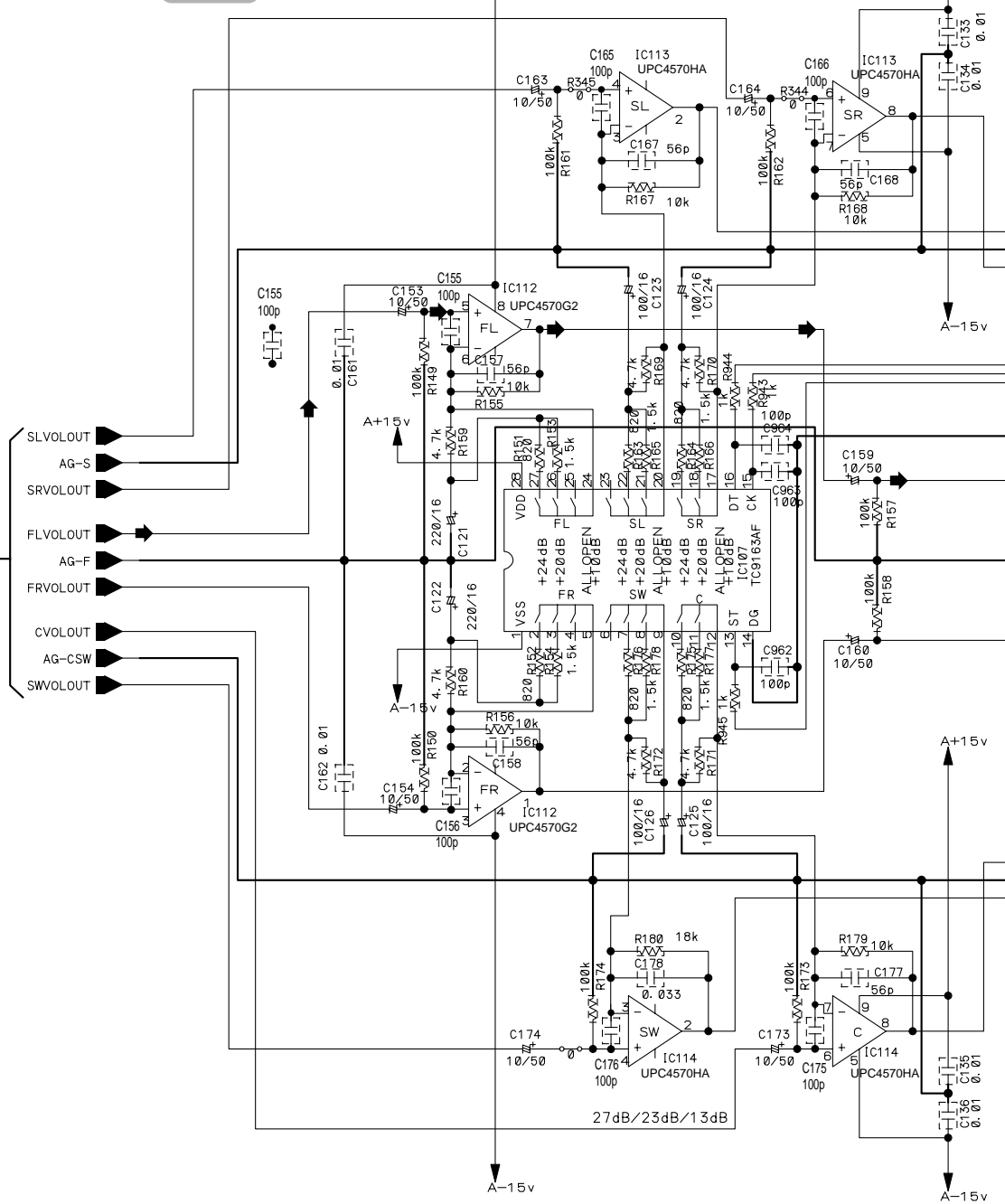

 : The power supply is shown with the marked box.

 : AUDIO SIGNAL ROUTE

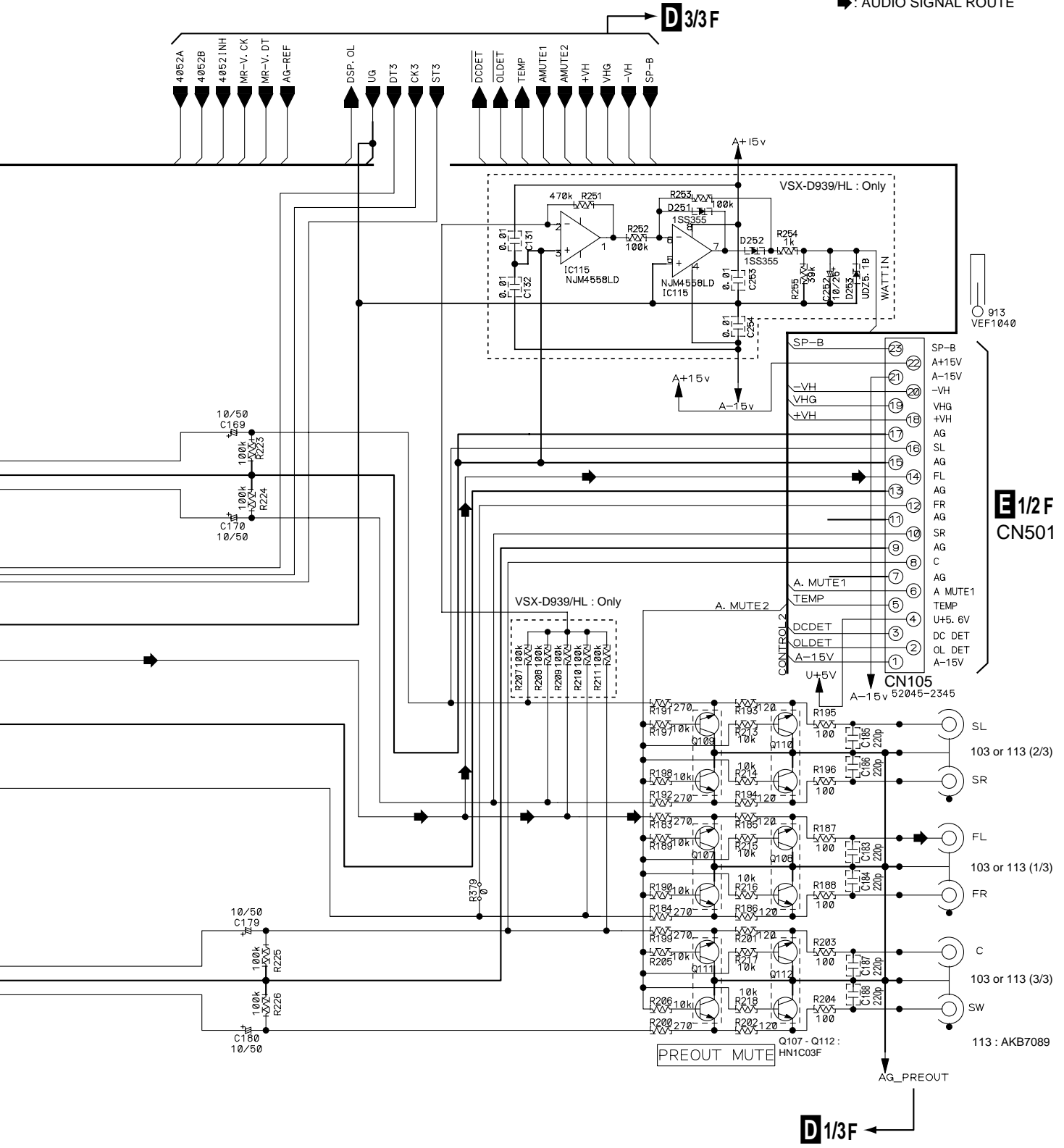



 1/2F
CN501

 1/3F

 2/3F

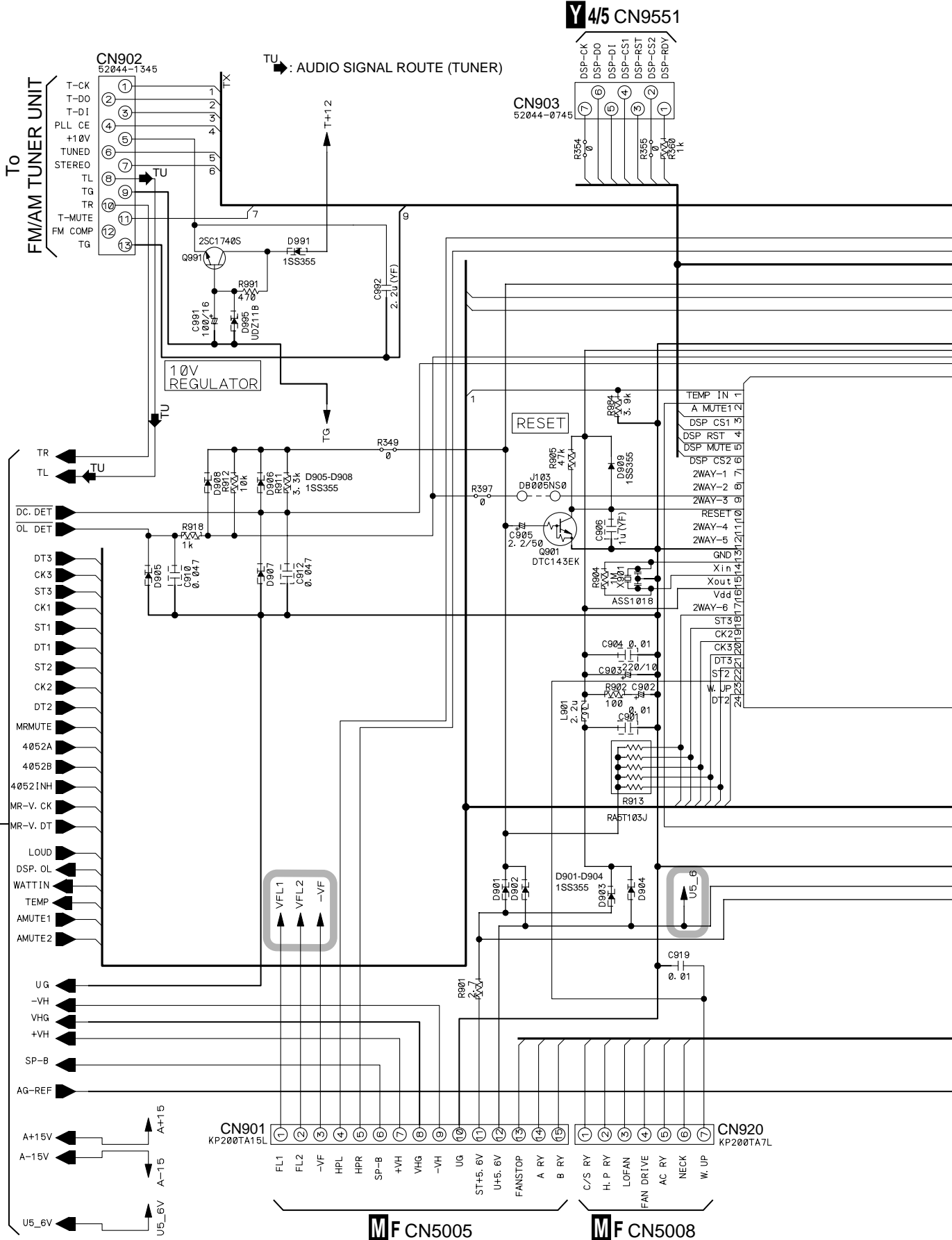
3.4 MAIN CONTROL ASSY (3/3)



 : The power supply is shown with the marked box.

D3/3 F
MAIN CONTROL ASSY
(HL : AWX7712)
(LB : AWX7711)

SF CN7001

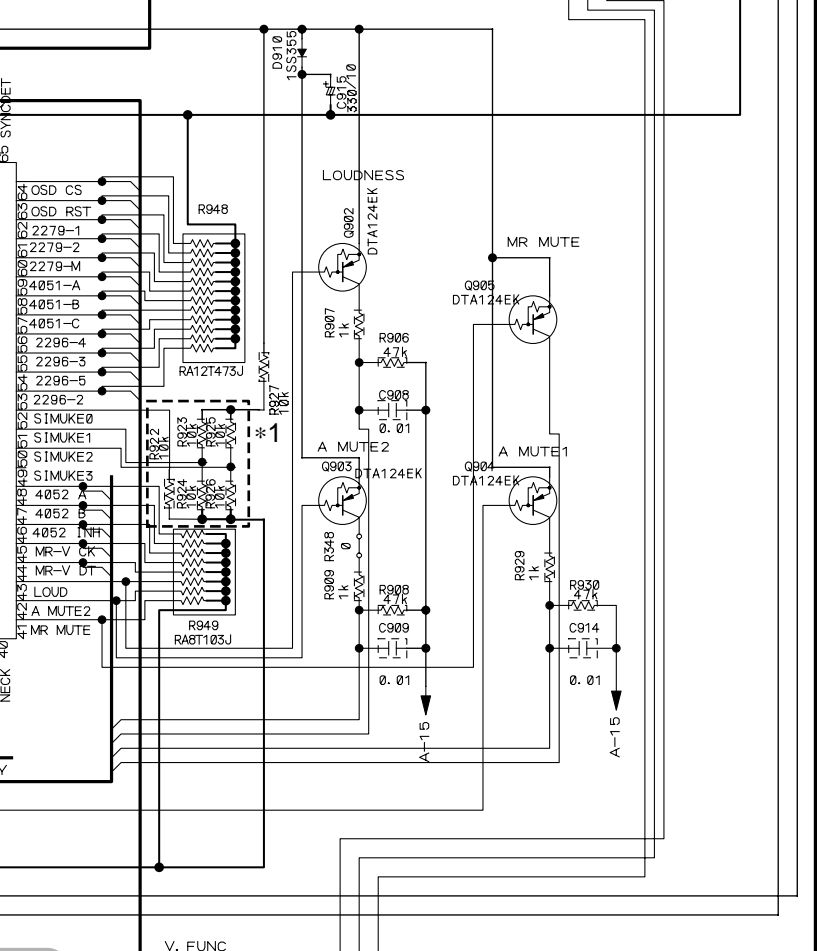
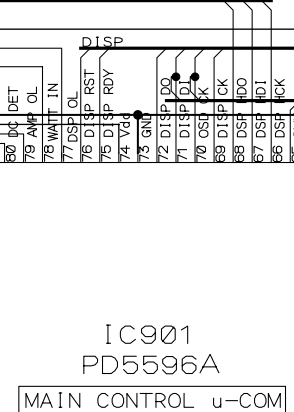
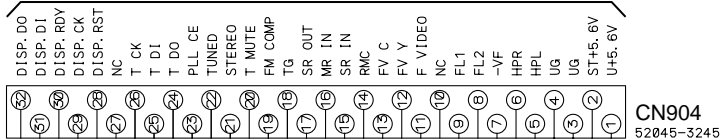

- *1
- R923 : VSX-D939TX/LB ONLY
- R924 : VSX-D939TX/HL ONLY
- R925 : VSX-D939TX/HL ONLY
- R926 : VSX-D939TX/LB ONLY
- R927 : VSX-D939TX/HL ONLY

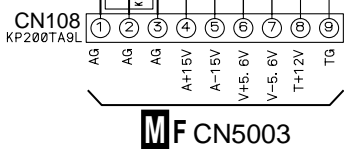

MF CN5003

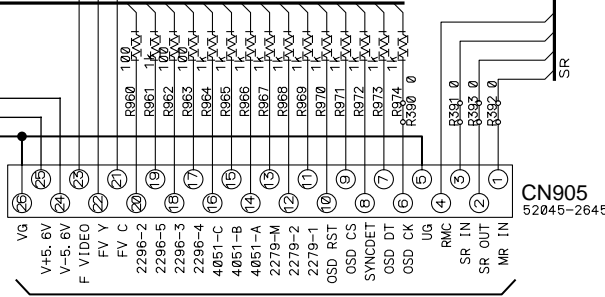

PF CN701

3.5 TRANS 2-1, DIODE and SP/PS ASSYS

CAUTION : FOR CONTINUED PROTECTION AGAINST RISK OF FIRE.
REPLACE ONLY WITH SAME TYPE NO. 49102.5 MFD, BY
LITTELFUSE INC. FOR IC4501, IC4502 (AEK7014).

Y1 : ADX7284- (BLK) Y5 : ADX7288- (BLU)
Y2 : ADX7285- (BWN) Y6 : ADX7289- (RED)
Y3 : ADX7286- (GRV) Y7 : ADX7290- (BLU)
Y4 : ADX7287- (RED) Y14 : ADX7297- (BLK)

RECTIFIER FOR POWER AMP "VL"

JF
TRANS 2-1 ASSY
(AWX7696)

K DIODE ASSY
(AWX7697)

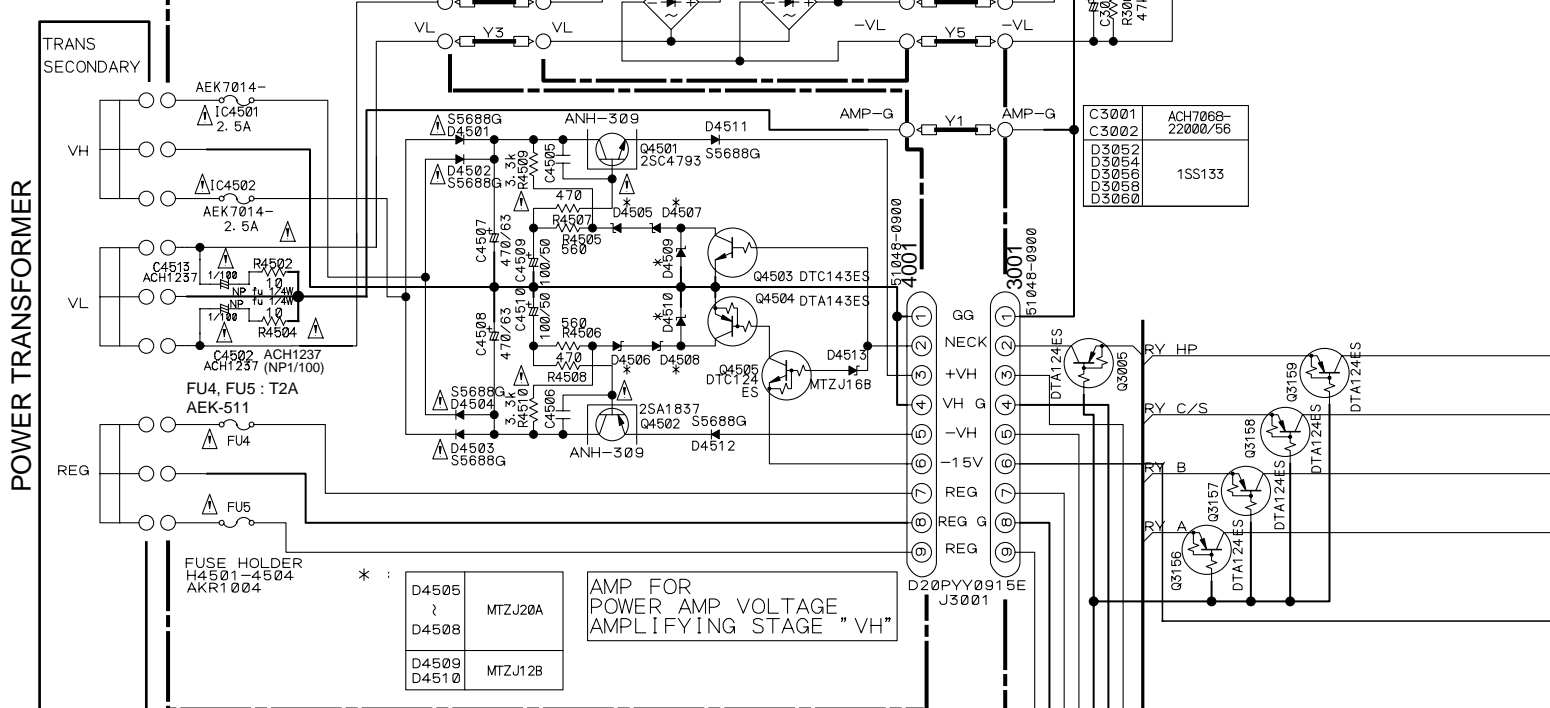

• NOTE FOR FUSE REPLACEMENT

CAUTION -FOR CONTINUED PROTECTION AGAINST RISK OF FIRE.
REPLACE WITH SAME TYPE AND RATINGS ONLY.

CAUTION : FOR CONTINUED PROTECTION AGAINST RISK OF FIRE.
REPLACE ONLY WITH SAME TYPE NO. 491.750 MFD, BY
LITTELFUSE INC. FOR IC4501, IC4502 (AEK7014).

Vf
CN6003

CN3001
KM200TA4

CN3002
KM250MA3

COOLING FAN FAN CONTROL
(NORMAL : 0V/STOP : +27V)

For VSX-D939TX/HL : Only



HA - HE

- Y8 : ADX7291- (BLK)
- Y9 : ADX7292- (WHT)
- Y10 : ADX7293- (ORG)
- Y11 : ADX7294- (VLT)
- Y12 : ADX7295- (YEL)
- Y13 : ADX7296- (GRN)
- Y17 : ADX7298- (BLK)

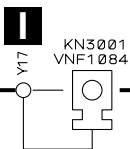

LF SP/PS ASSY
(HL:AWX7693)
(LB:AWX7692)

AMP G Y8 AMP G

SPEAKER RELAY

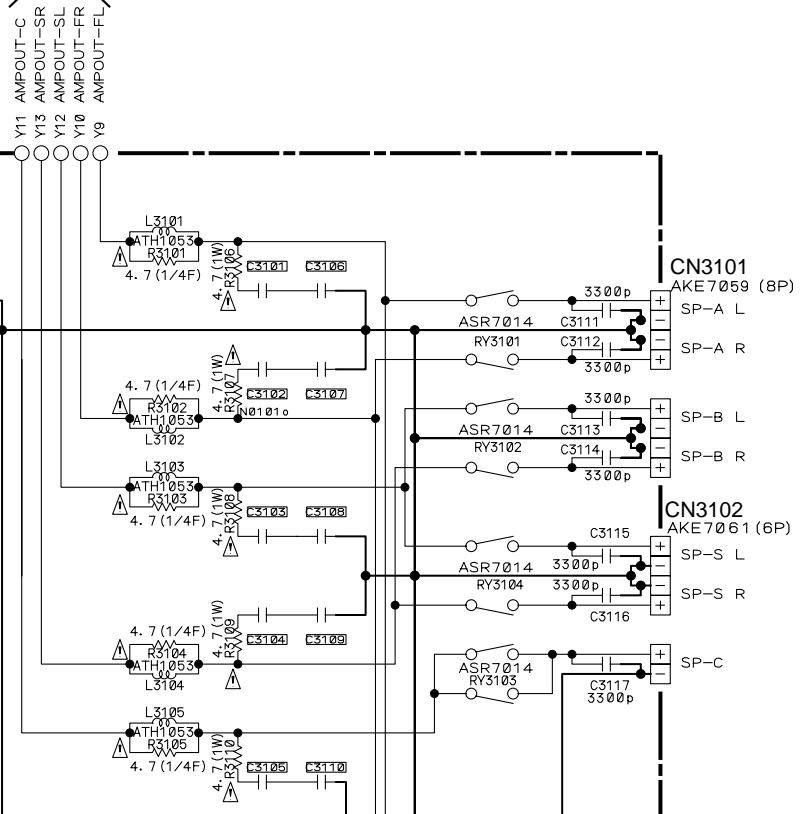
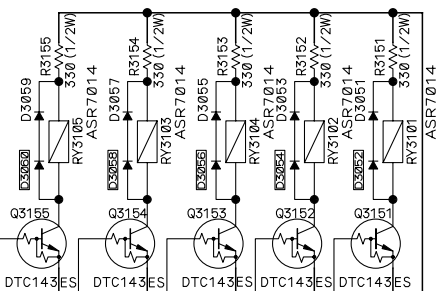

C3101	C3105	CFTYA224J50
C3106	C3110	CFTYA224J50

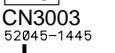
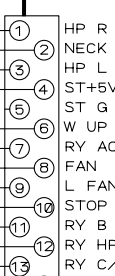
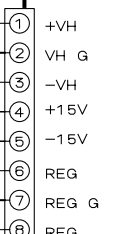
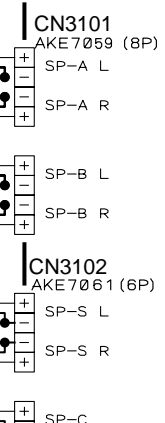

M CN5001

M CN5002



3.6 REGULATOR, TRANS 1 and TRANS 2-2 ASSYS

M REGULATOR ASSY (AWX7832)

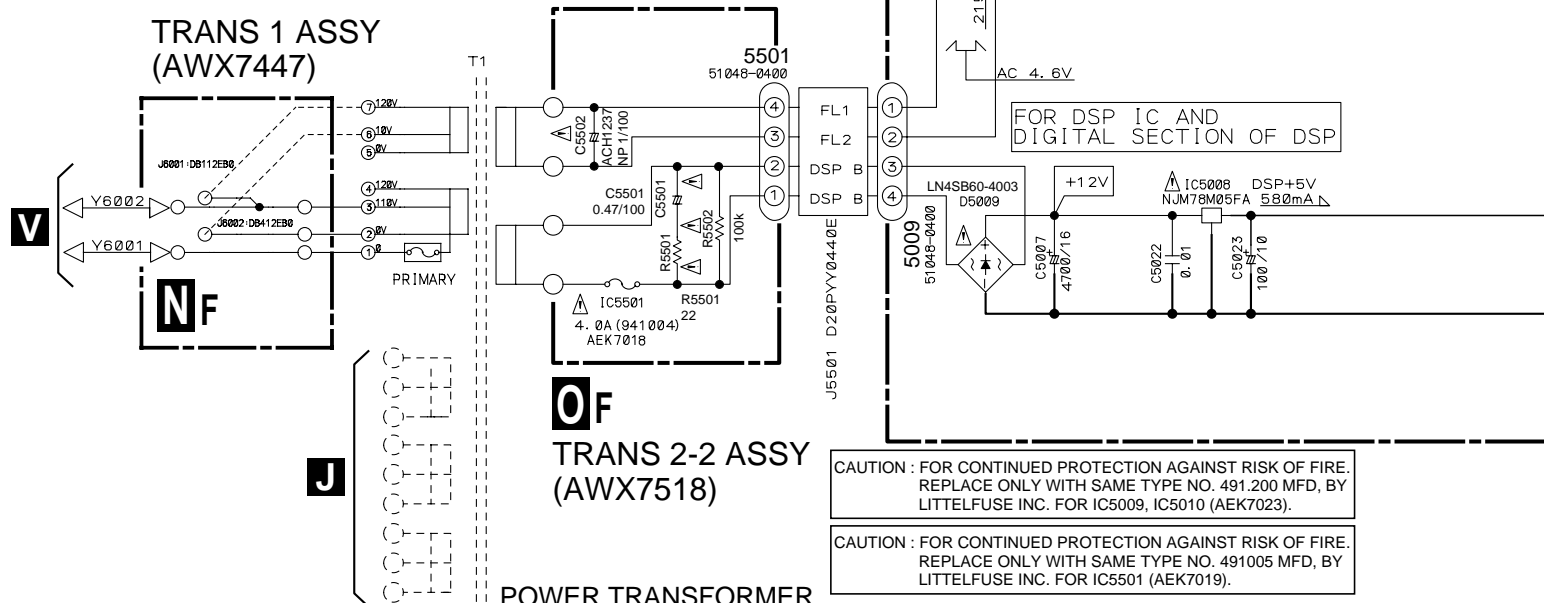
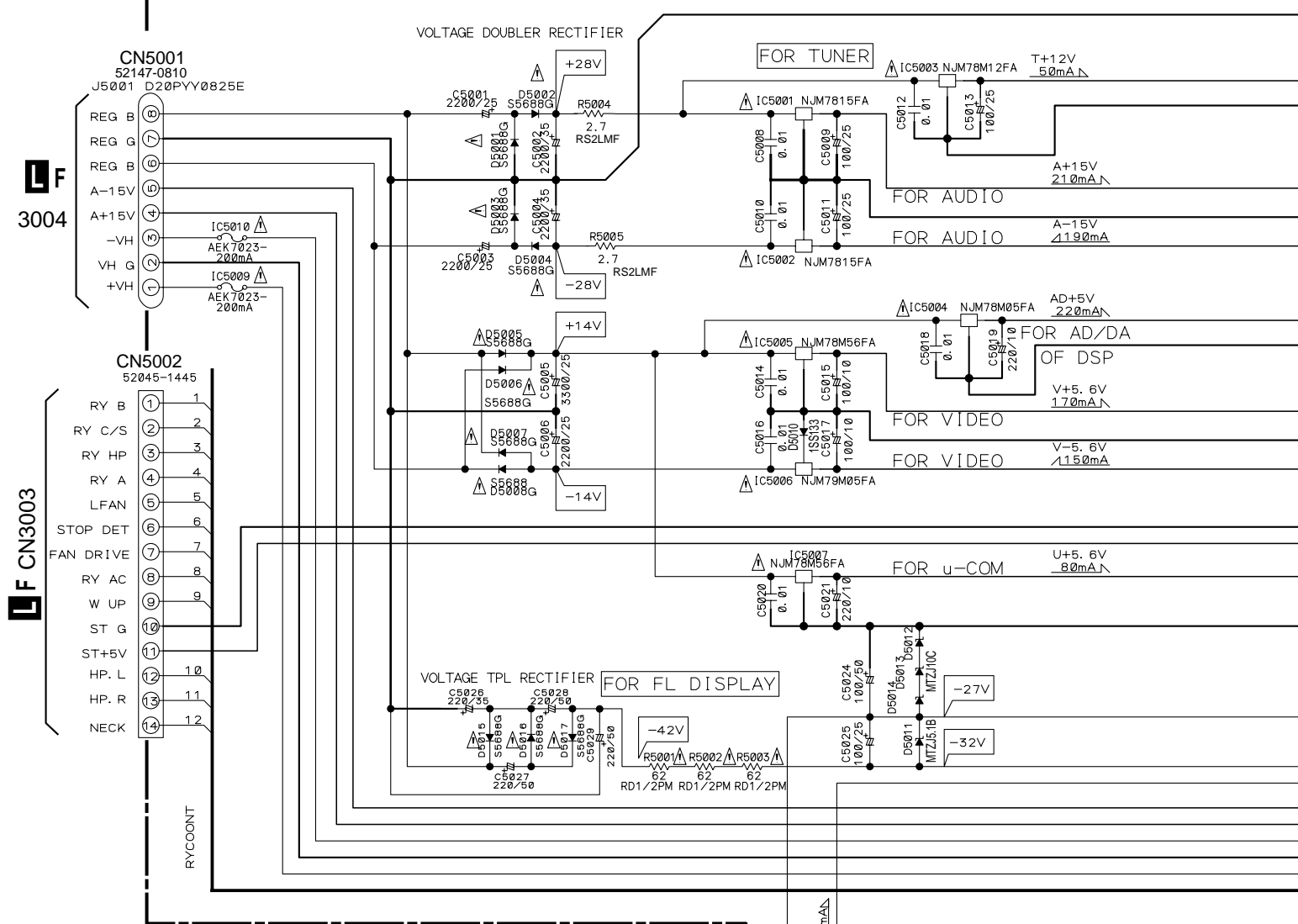

➔: AUDIO SIGNAL ROUTE

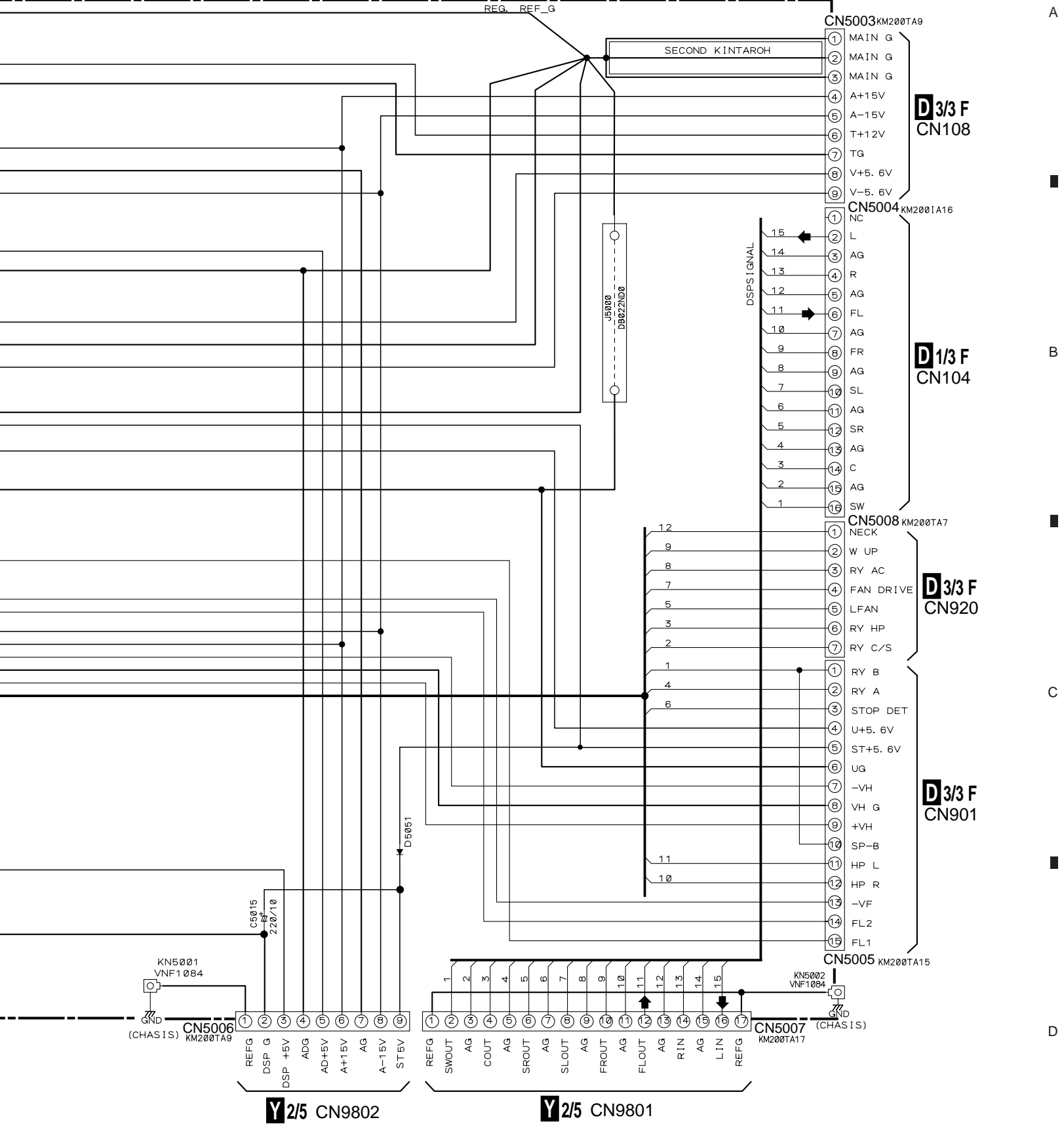

A
B
C
D

Y2/5 CN9802

Y2/5 CN9801



3.7 VIDEO, PRIMARY and P-SW ASSYS

PF VIDEO ASSY (AWX7677)

TRUTH TABLE OF IC751 (BU4053BCF)

CONDITION	A	B	C	INH	X OUT	Y OUT
S NOT USED	0	0	0	0	1X	1Y
S USED	1	1	0	0	0X	0Y

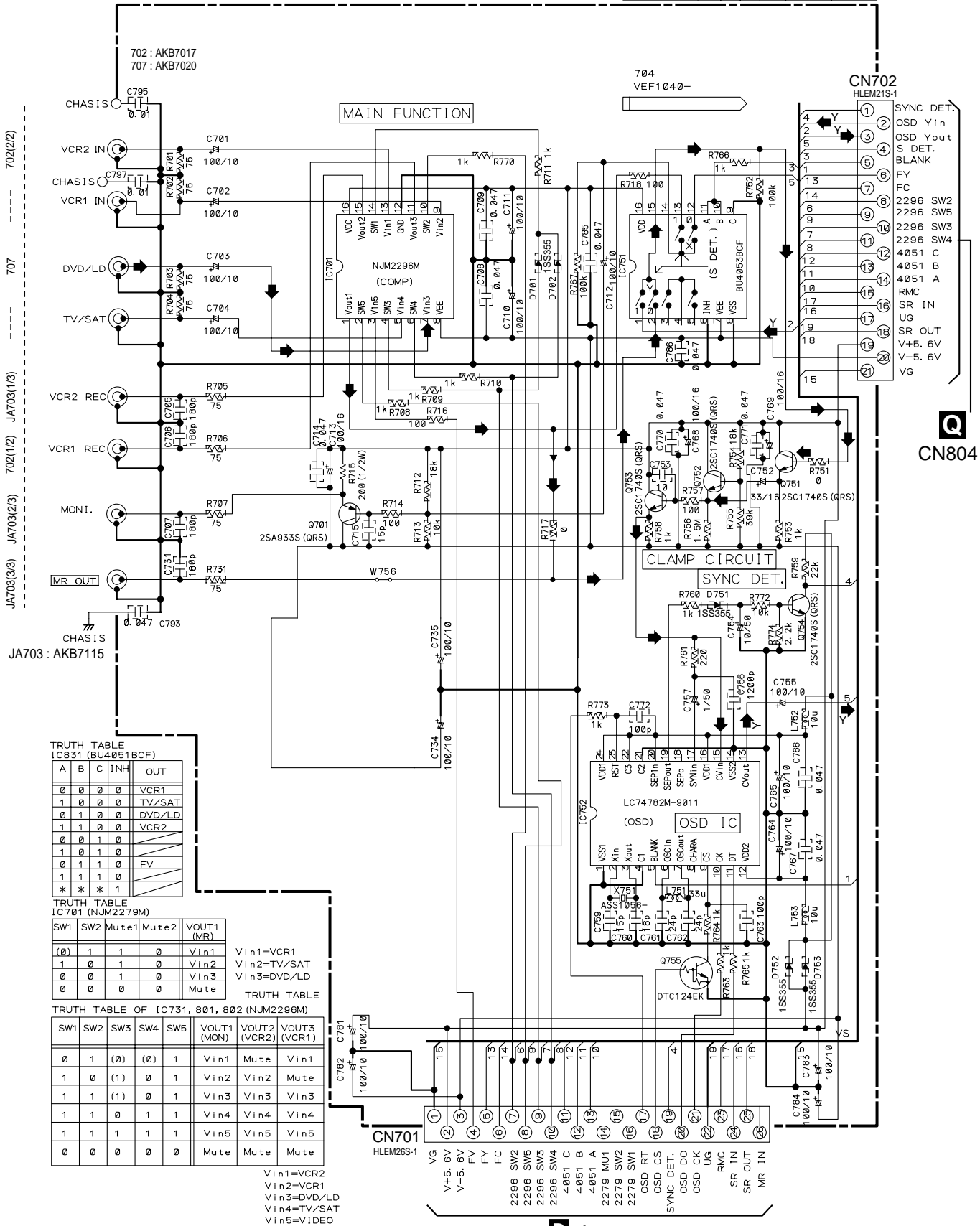

TRUTH TABLE IC831 (BU4051BCF)

A	B	C	INH	OUT
0	0	0	0	VCR1
1	0	0	0	TV/SAT
0	1	0	0	DVD/LD
1	1	0	0	VCR2
0	0	1	0	FV
1	0	1	0	FV
0	1	1	0	FV
1	1	1	0	FV
*	*	*	1	

TRUTH TABLE IC701 (NJM2279M)

SW1	SW2	Mute1	Mute2	VOUT1 (MR)
0	1	1	0	Vin1
1	0	1	0	Vin2
0	0	1	0	Vin3
0	0	0	1	Mute

TRUTH TABLE IC731, 801, 802 (NJM2296M)

SW1	SW2	SW3	SW4	SW5	VOUT1 (MON)	VOUT2 (VCR2)	VOUT3 (VCR1)
0	1	(0)	(0)	1	Vin1	Mute	Vin1
1	0	(1)	0	1	Vin2	Mute	Vin2
1	1	(1)	0	1	Vin3	Mute	Vin3
1	1	0	1	1	Vin4	Mute	Vin4
1	1	1	1	1	Vin5	Mute	Vin5
0	0	0	0	0	Mute	Mute	Mute

Vin1=VCR2
 Vin2=VCR1
 Vin3=DVD/LD
 Vin4=TV/SAT
 Vin5=VIDEO

D3/3 F CN905

VA P-SW ASSY (AWX7330)
VF PRIMARY ASSY
 (HL : AWX7345)
 (LB : AWX7429)

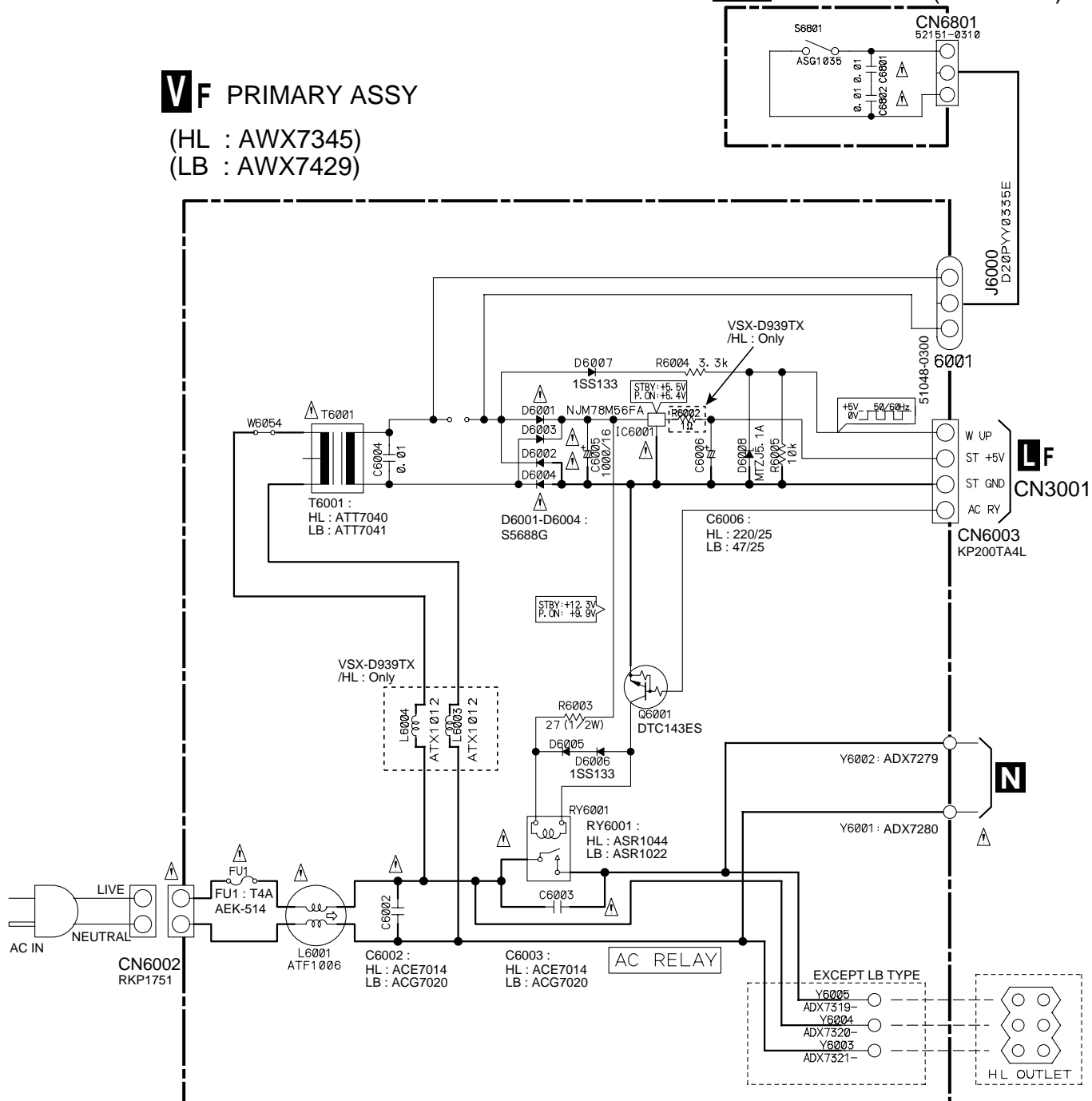

• NOTE FOR FUSE REPLACEMENT
CAUTION -FOR CONTINUED PROTECTION AGAINST RISK OF FIRE.
 REPLACE WITH SAME RY TYPE AND RATINGS ONLY.

3.8 ROTARY ENCODER ASSY

TF ROTARY ENCODER ASSY (AWX7726)

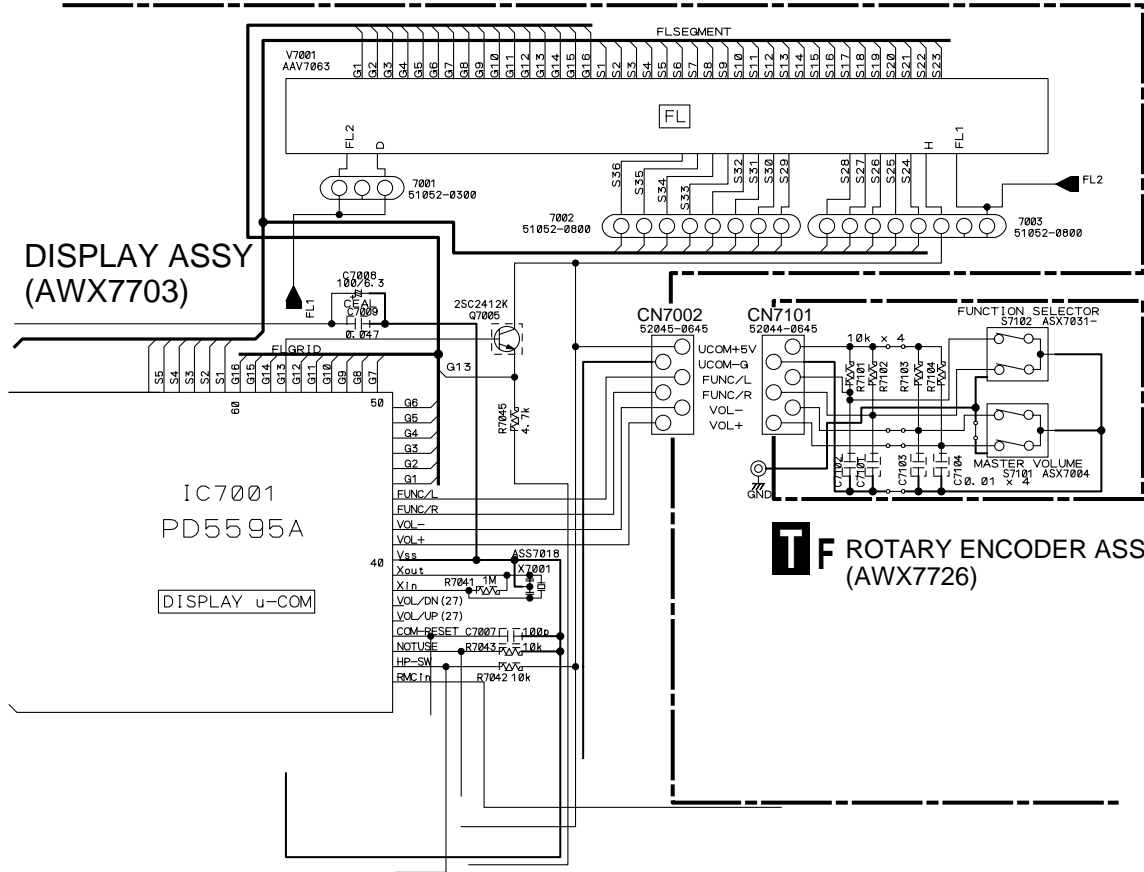
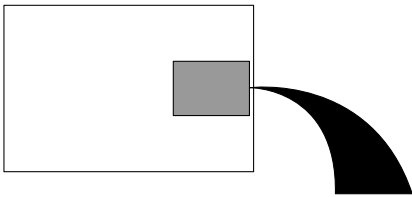

TF ROTARY ENCODER ASSY (AWX7726)

4. REMOTE CONTROL UNIT [AXD7279]

4.1 CONTRAST OF MISCELLANEOUS PARTS

- NOTES :
- Parts marked by “NSP” are generally unavailable because they are not in our Master Spare Parts List.
 - The \triangle mark found on some component parts indicates the importance of the safety factor of the part. Therefore, when replacing, be sure to use parts of identical designation.
 - Screw adjacent to ∇ mark on the product are used for disassembly.
 - Reference Nos. indicate the pages and Nos. in the service manual for the base model.

■ CONTRAST OF REMOTE CONTROL UNIT

AXD7279 and AXD7257 are constructed the same except for the following:

Ref. No.	Mark	Symbol and Description	Part No.		Remarks
			AXD7257	AXD7279	
P104-2		Name Plate B	AZA7381	AZA7386	(AZA7399:Goid)
P104-3		Rubber Sheet	AZA7382	AZA7390	
P104-8		Battery Cover	AZA7841	AZA7791	
P104-10		Case B	AZN7781	AZN7793	
P104-13		Knob	AZA7398	AZA7399	
P104-15		Caee A Assy	AZA7846	AZA7850	

■ REMOTE PCB MODEL SWITCH

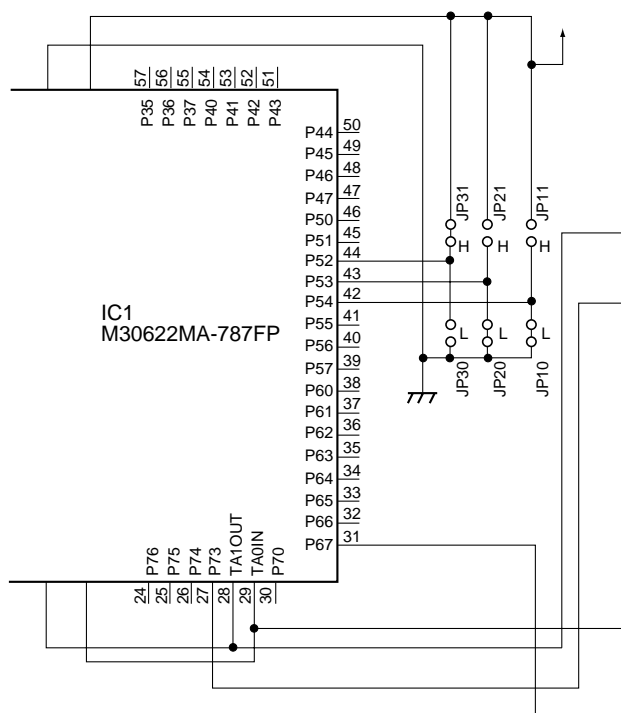

MODEL SWITCH

Model	JP10	JP11	JP20	JP21	JP30	JP31
AXD7257, AXD7278	-	○	-	○	-	○
AXD7258, AXD7279	-	○	-	○	○	-
AXD7259	-	○	○	-	-	○
AXD7266	-	○	○	-	○	-
AXD7273	○	-	-	○	-	○
AXD7275	○	-	-	○	○	-

Service Manual

Pioneer

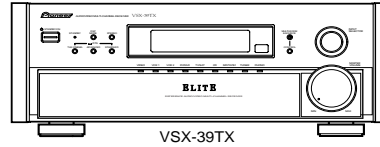

ORDER NO.
RRV2295

AUDIO/VIDEO MULTI-CHANNEL RECEIVER

VSX-39TX

VSX-37TX

VSX-36TX

VSX-D909S

THIS MANUAL IS APPLICABLE TO THE FOLLOWING MODEL(S) AND TYPE(S).

Type	Model				Power Requirement	Remarks
	VSX-39TX	VSX-37TX	VSX-36TX	VSX-D909S		
KU/CA	○	○	○	○	AC120V	

CONTENTS

1. SAFETY INFORMATION	2	7. GENERAL INFORMATION	89
2. EXPLODED VIEWS AND PARTS LIST	3	7.1 DISASSEMBLY	89
3. BLOCK DIAGRAM AND SCHEMATIC DIAGRAM	10	7.2 PARTS	91
4. PCB CONNECTION DIAGRAM	52	7.2.1 IC	91
5. PCB PARTS LIST	74	7.2.2 DISPLAY	95
6. ADJUSTMENT	88	7.3 REMOTE CONTROL UNIT	98
		8. PANEL FACILITIES AND SPECIFICATIONS	109

PIONEER ELECTRONIC CORPORATION 4-1, Meguro 1-chome, Meguro-ku, Tokyo 153-8654, Japan
PIONEER ELECTRONICS SERVICE, INC. P.O. Box 1760, Long Beach, CA 90801-1760, U.S.A.
PIONEER EUROPE N V Haven 1087, Keetberglaan 1, 9120 Melsele, Belgium
PIONEER ELECTRONICS ASIACENTRE PTE. LTD. 253 Alexandra Road, #04-01, Singapore 159936
 © PIONEER ELECTRONIC CORPORATION 2000

1. SAFETY INFORMATION

This service manual is intended for qualified service technicians ; it is not meant for the casual do-it-yourselfer. Qualified technicians have the necessary test equipment and tools, and have been trained to properly and safely repair complex products such as those covered by this manual. Improperly performed repairs can adversely affect the safety and reliability of the product and may void the warranty. If you are not qualified to perform the repair of this product properly and safely, you should not risk trying to do so and refer the repair to a qualified service technician.



WARNING

This product contains lead in solder and certain electrical parts contain chemicals which are known to the state of California to cause cancer, birth defects or other reproductive harm.

Health & Safety Code Section 25249.6 – Proposition 65



NOTICE

(FOR CANADIAN MODEL ONLY)

Fuse symbols  (fast operating fuse) and/or  (slow operating fuse) on PCB indicate that replacement parts must be of identical designation.

REMARQUE

(POUR MODÈLE CANADIEN SEULEMENT)

Les symboles de fusible  (fusible de type rapide) et/ou  (fusible de type lent) sur CCI indiquent que les pièces de remplacement doivent avoir la même désignation.

(FOR USA MODEL ONLY)

1. SAFETY PRECAUTIONS

The following check should be performed for the continued protection of the customer and service technician.

LEAKAGE CURRENT CHECK

Measure leakage current to a known earth ground (water pipe, conduit, etc.) by connecting a leakage current tester such as Simpson Model 229-2 or equivalent between the earth ground and all exposed metal parts of the appliance (input/output terminals, screwheads, metal overlays, control shaft, etc.). Plug the AC line cord of the appliance directly into a 120V AC 60Hz outlet and turn the AC power switch on. Any current measured must not exceed 0.5mA.

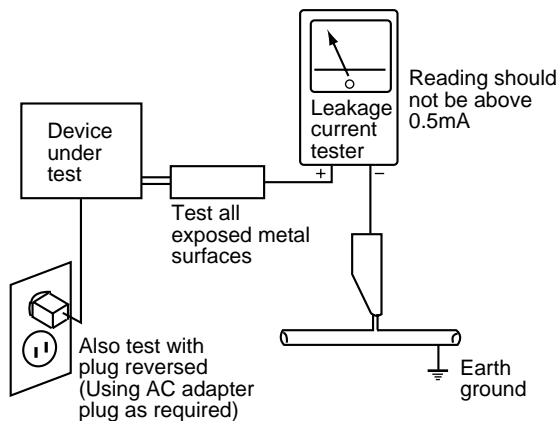

AC Leakage Test

ANY MEASUREMENTS NOT WITHIN THE LIMITS OUTLINED ABOVE ARE INDICATIVE OF A POTENTIAL SHOCK HAZARD AND MUST BE CORRECTED BEFORE RETURNING THE APPLIANCE TO THE CUSTOMER.

2. PRODUCT SAFETY NOTICE

Many electrical and mechanical parts in the appliance have special safety related characteristics. These are often not evident from visual inspection nor the protection afforded by them necessarily can be obtained by using replacement components rated for voltage, wattage, etc. Replacement parts which have these special safety characteristics are identified in this Service Manual.

Electrical components having such features are identified by marking with a Δ on the schematics and on the parts list in this Service Manual.

The use of a substitute replacement component which does not have the same safety characteristics as the PIONEER recommended replacement one, shown in the parts list in this Service Manual, may create shock, fire, or other hazards.

Product Safety is continuously under review and new instructions are issued from time to time. For the latest information, always consult the current PIONEER Service Manual. A subscription to, or additional copies of, PIONEER Service Manual may be obtained at a nominal charge from PIONEER.

2. EXPLODED VIEWS AND PARTS LIST

- NOTES: ● Parts marked by "NSP" are generally unavailable because they are not in our Master Spare Parts List.
 ● The Δ mark found on some component parts indicates the importance of the safety factor of the part. Therefore, when replacing, be sure to use parts of identical designation.
 ● Screws adjacent to ▼ mark on the product are used for disassembly.

2.1 PACKING

● VSX-39TX

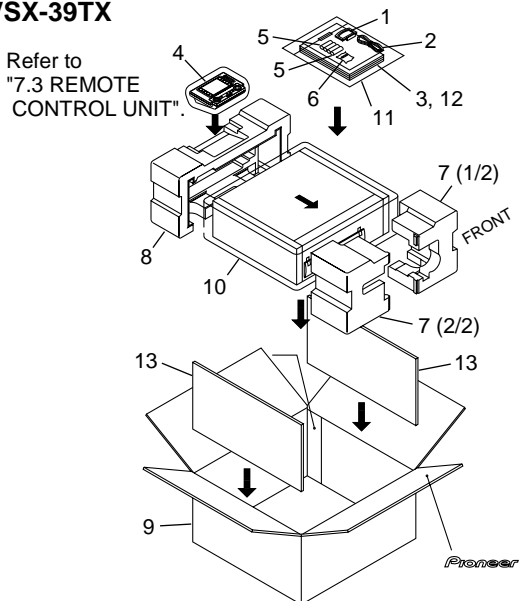

● Other Models

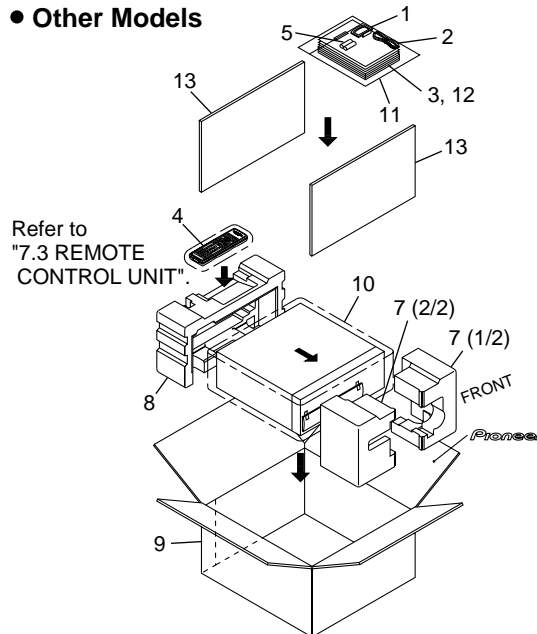

(1) PACKING PARTS LIST

Mark	No.	Description	Part No.	Mark	No.	Description	Part No.
	1	AM Loop Antenna	ATB7009		8	Rear Pad	See Contrast table (2)
	2	FM Wire Antenna	ADH7007		9	Packing Case	See Contrast table (2)
	3	Operating Instructions (English)	See Contrast table (2)		10	Packing Sheet	RHC1023
	4	Remote Control Unit	See Contrast table (2)	NSP	11	Polyethylene Bag (0.03×230×340)	Z21-038
NSP	5	Alkaline Dry Cell Battery (LR6, AA)	VEM1021	NSP	12	Warranty Card	See Contrast table (2)
	6	Cushion for Remote (for Remote Control Unit)	See Contrast table (2)		13	Spacer	See Contrast table (2)
	7	Front Pad	See Contrast table (2)				

(2) CONTRAST TABLE

VSX-39TX, VSX-37TX, VSX-36TX and VSX-D909S are constructed the same except for the following :

Mark	No.	Symbol and Description	Part No.				Remarks
			VSX-39TX	VSX-37TX	VSX-36TX	VSX-D909S	
	3	Operating Instructions (English)	ARB7230	ARB7231	ARB7231	ARB7232	
	4	Remote Control Unit (39)	AXD7254	Not used	Not used	Not used	
	4	Remote Control Unit (36)	Not used	AXD7257	AXD7257	Not used	
	4	Remote Control Unit (909S)	Not used	Not used	Not used	AXD7278	
	6	Cushion for Remote	AXG7080	Not used	Not used	Not used	
	7	Front Pad 29	AHA7255	Not used	Not used	Not used	
	7	Front Pad 26	Not used	AHA7253	AHA7253	AHA7253	
	8	Rear Pad 29	AHA7256	Not used	Not used	Not used	
	8	Rear Pad 26	Not used	AHA7254	AHA7254	AHA7254	
	9	Packing Case 39TX	AHD7882	Not used	Not used	Not used	
	9	Packing Case 37TX	Not used	AHD7881	Not used	Not used	
	9	Packing Case 36TX	Not used	Not used	AHD7880	Not used	
	9	Packing Case 909S	Not used	Not used	Not used	AHD7883	
NSP	12	Warranty Card EL	ARY1026	ARY1026	ARY1026	Not used	
NSP	12	Warranty Card PA	Not used	Not used	Not used	ARY7045	
	13	Spacer 29	AHB7033	Not used	Not used	Not used	
	13	Spacer 26	Not used	AHB7032	AHB7032	AHB7032	

(1) EXTERIOR PARTS LIST

Mark	No.	Description	Part No.	Mark	No.	Description	Part No.
NSP	1	EXTRA-5.1 Assy	See Contrast table (2)		46	COMPONENT Assy	AWX7635
NSP	2	EXTERNAL IN Assy	See Contrast table (2)		47	TRIM Assy	AWX7655
NSP	3	A-PINJACK Assy	See Contrast table (2)	NSP	48	Panel Stay	See Contrast table (2)
	4	CONNECTION Assy	AWX7313		49	PC Support	VEC1549
	5	MAIN CONTROL Assy	See Contrast table (2)	NSP	50	PCB Holder	AEC7057
	6	TRANS 2-1 ASSY	See Contrast table (2)	NSP	51	PCB Holder	PNW2100
	7	DIODE Assy	See Contrast table (2)	NSP	52	PCB Mould	AMR1525
	8	SP/PS Assy	See Contrast table (2)		53	PCB Spacer	AEC1372
	9	REGULATOR Assy	AWX7310		54	Rear Panel	See Contrast table (2)
	10	TRANS 1 Assy	AWX7316		55	Shield Case	See Contrast table (2)
	11	TRANS 2-2 Assy	AWX7366		56	Side Board 29 L	See Contrast table (2)
	12	VIDEO Assy	See Contrast table (2)		57	Side Board 29 R	See Contrast table (2)
	13	S-VIDEO Assy	See Contrast table (2)		58	Side Escutcheon L	See Contrast table (2)
	14	VOLUME Assy	See Contrast table (2)		59	Side Escutcheon R	See Contrast table (2)
	15	PRIMARY Assy	AWX7311		60	Side Sash L 29	See Contrast table (2)
	16	RF/DIGITAL IN Assy	See Contrast table (2)		61	Side Sash R 29	See Contrast table (2)
NSP	17	OPT OUT Assy	AWX7643		62	Stud Cover	AEC7105
	18	DSP Assy	See Contrast table (2)		63	Terminal Screw	AKE-031
	19	V-AMP Assy	See Contrast table (2)	NSP	64	Under Base 29	See Contrast table (2)
△	20	AC Power Cord	See Contrast table (2)	NSP	65	Binder (BK-1)	ZCA-BK1
△	21	Power Transformer (T1)	ATS7252		66	Screw	BBT30P080FCC
	22	FM/AM TUNER Unit	AXX7046		67	Screw	BBZ30P080FZK
△	23	Fuse (FU1 : 10A)	VEK1029		68	Screw	ABA1193
△	24	Fuse (FU4 : 2.5A)	REK1079		69	Screw	IBZ30P080FCC
△	25	Fuse (FU5 : 2.5A)	REK1079		70	Screw	BBZ30P180FMC
	26	AC Cord Spacer	See Contrast table (2)		71	Screw	ABA1053
	27	Bonnet Case	See Contrast table (2)		72	Screw	BBT30P040FZK
	28	2P Shield with Housing (J24)	ADX7250		73	Screw	FBT40P080FZK
	29	Lead Card 07P (J13)	ADD7161		74	Wood Collar	See Contrast table (2)
	30	Lead Card 13P AD (J22)	ADD7250		75	Screw	See Contrast table (2)
	31	Lead Card 13P AD (J16)	ADD7169		76	Lead Card 06P (J27)	ADD7248
	32	Lead Card 14P (J17)	ADD7165		77	Lead Card 13P (J26)	ADD7251
	33	Lead Card 21P (J18)	ADD7164		78	Lead Card 04P (J29)	ADD7247
	34	Lead Card 23P BD SLD (J12)	ADD7160		79	Lead Card 09P (J28)	ADD7249
	35	Lead Card 26P (J15)	ADD7163		80	Cushion C	PNM1059
	36	Lead Card 28P (J23)	ADD7171		81	Screw	IBZ30P100FCC
	37	Assy Holder	See Contrast table (2)		82	Spacer	See Contrast table (2)
	38	Assy Holder B	AMR7267		83	Remo-con. Cushion	AEB7167
	39	Card Spacer	AEC7133		84	Spacer	AEB7180
	40	Card Spacer	DEC1772		85	S. Cushion	See Contrast table (2)
	41	2CH I/O PJ Assy	AWX7634		86	Sheet	See Contrast table (2)
	42	Cushion 55	PNM1316		87	Locking Card Spacer	VEC1596
NSP	43	Frame	See Contrast table (2)				
	44	Insulator	PNW2766				
	45	Locking Card Spacer	DEC1908				

VSX-39TX, VSX-37TX, VSX-36TX, VSX-D909S

(2) CONTRAST TABLE

VSX-39TX, VSX-37TX, VSX-36TX and VSX-D909S are constructed the same except for the following :

Mark	No.	Symbol and Description	Part No.				Remarks
			VSX-39TX	VSX-37TX	VSX-36TX	VSX-D909S	
NSP	1	EXTRA-5.1 Assy	AWX7314	Not used	Not used	Not used	
NSP	2	EXTERNAL IN Assy	Not used	AWX7398	AWX7398	AWX7398	
NSP	3	A-PINJACK Assy	AWX7312	AWX7397	AWX7397	AWX7397	
	5	MAIN CONTROL Assy	AWX7705	AWX7706	AWX7707	AWX7708	
	6	TRANS 2-1 Assy	AWX7659	AWX7694	AWX7695	AWX7695	
	7	DIODE Assy	AWX7660	AWX7697	AWX7697	AWX7697	
	8	SP/PS Assy	AWX7658	AWX7688	AWX7689	AWX7689	
	12	VIDEO Assy	AWX7307	AWX7394	AWX7394	AWX7394	
	13	S-VIDEO Assy	AWX7678	AWX7679	AWX7679	AWX7679	
	14	VOLUME Assy	AWX7367	AWX7367	Not used	Not used	
	16	RF / DIGITAL IN Assy	AWX7637	AWX7638	AWX7642	AWX7642	
	18	DSP Assy	AWX7632	AWX7632	AWX7633	AWX7633	
	19	V-AMP Assy	AWX7729	AWX7309	AWX7309	AWX7409	
△	20	AC Power Cord	ADG7028	ADG7028	ADG7024	ADG7024	
	26	AC Cord Spacer	ANG1153	ANG1153	Not used	Not used	
	26	Cord Stopper	Not used	Not used	CM-22C	CM-22C	
	27	Bonnet Case 29	AZN7790	Not used	Not used	Not used	
	27	Bonnet Case 26	Not used	AZN7789	AZN7789	AZN7789	
	37	Assy Holder	ANG7322	ANG7321	ANG7321	ANG7321	
	41	2CH I/O P J Assy	AWX7634	AWX7646	AWX7646	AWX7646	
NSP	43	Frame 29	ANG7243	Not used	Not used	Not used	
NSP	43	Frame 26	Not used	ANG7238	ANG7238	ANG7238	
	46	COMPONENT Assy	AWX7635	AWX7636	AWX7636	AWX7636	
NSP	48	Panel Stay 29	AND7032	Not used	Not used	Not used	
NSP	48	Panel Stay 26	Not used	AND7031	AND7031	AND7031	
	54	Rear Panel 39	ANC7945	Not used	Not used	Not used	
	54	Rear Panel 37	Not used	ANC7944	Not used	Not used	
	54	Rear Panel 36	Not used	Not used	ANC7943	Not used	
	54	Rear Panel D909S	Not used	Not used	Not used	ANC7946	
	55	Shield Case 39	ANK7079	Not used	Not used	Not used	
	55	Shield Case 36	Not used	ANK7078	ANK7054	ANK7054	
	56	Side Board 29 L	AMS7013	Not used	Not used	Not used	
	57	Side Board 29 R	AMS7014	Not used	Not used	Not used	
	58	Side Escutcheon L 29	AAK7635	Not used	Not used	Not used	
	58	Side Escutcheon L 26	Not used	AAK7633	AAK7633	AAK7633	
	59	Side Escutcheon R 29	AAK7636	Not used	Not used	Not used	
	59	Side Escutcheon R 26	Not used	AAK7634	AAK7634	AAK7634	
	60	Side Sash L 29	AAH7019	Not used	Not used	Not used	
	61	Side Sash R 29	AAH7020	Not used	Not used	Not used	
NSP	64	Under Base 29	ANA7091	Not used	Not used	Not used	
NSP	64	Under Base 26	Not used	ANA7089	ANA7089	ANA7089	
	74	Wood Collar	AEC1165	Not used	Not used	Not used	
	75	Screw	ABA1086	Not used	Not used	Not used	
	82	Spacer	AEB7179	Not used	Not used	Not used	
	85	S. Cushion	AEB7178	Not used	Not used	Not used	
	86	Sheet	AED7035	Not used	Not used	Not used	

2.3 HEAT SINK SECTION

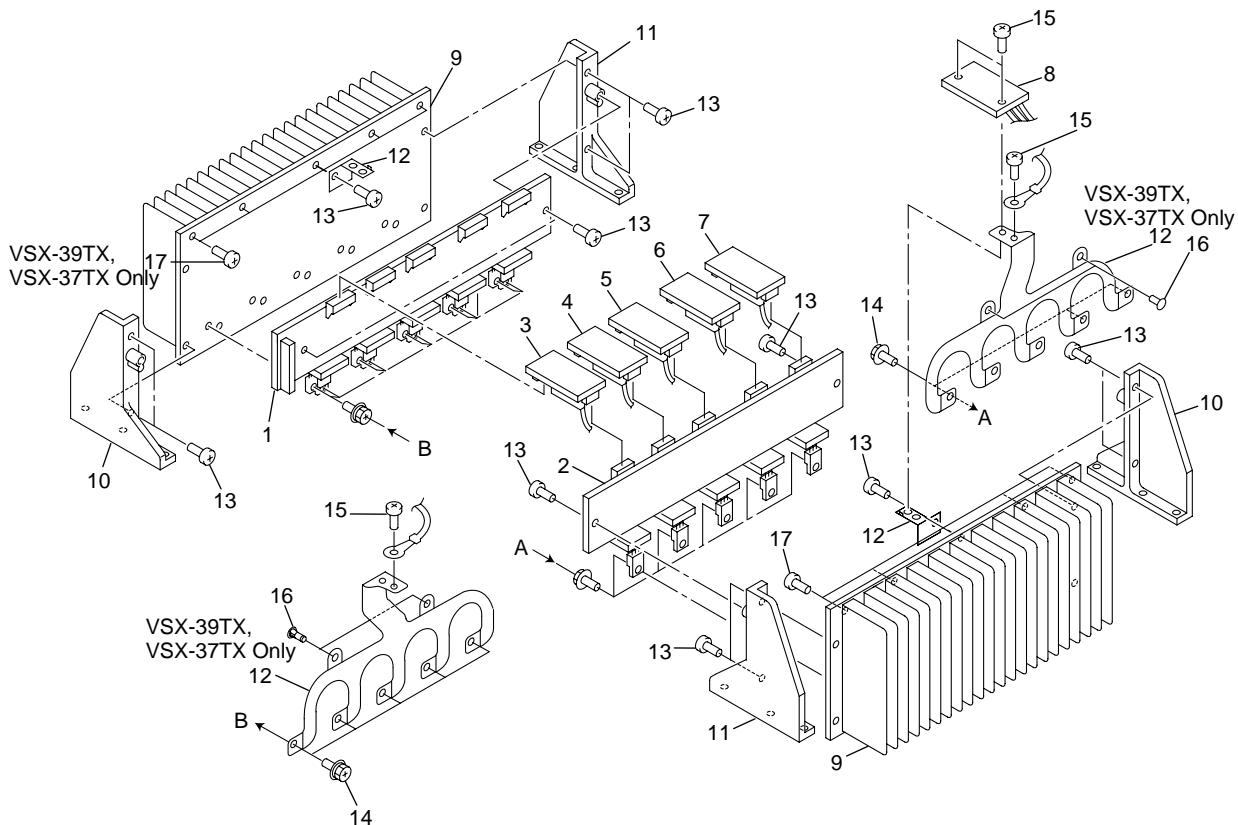

(1) HEAT SINK SECTION PARTS LIST

Mark	No.	Description	Part No.	Mark	No.	Description	Part No.
	1	C-AMP N Assy	AWX7681		11	Heat Sink Holder B	AMR7256
NSP	2	C-AMP-P Assy	AWX7680	NSP	12	Power Supply Plate	See Contrast table (2)
NSP	3	OUTPUT-SL Assy	AWX7685		13	Screw	See Contrast table (2)
NSP	4	OUTPUT-FL Assy	AWX7682		14	Screw	ABA1082
	5	OUTPUT-C Assy	AWX7684		15	Screw	IBZ30P080FCC
NSP	6	OUTPUT-FR Assy	AWX7683		16	Card Spacer	See Contrast table (2)
NSP	7	OUTPUT-SR Assy	AWX7686		17	Screw	See Contrast table (2)
	8	VL-TERMINAL Assy	AWX7657				
NSP	9	Heat Sink	See Contrast table (2)				
	10	Heat Sink Holder A	AMR7255				

(2) CONTRAST TABLE

VSX-39TX, VSX-37TX, VSX-36TX and VSX-D909S are constructed the same except for the following :

Mark	No.	Symbol and Description	Part No.				Remarks
			VSX-39TX	VSX-37TX	VSX-36TX	VSX-D909S	
NSP	9	Heat Sink D10	ANH7103	ANH7103	Not used	Not used	
NSP	9	Heat Sink 26	Not used	Not used	ANH7102	ANH7102	
NSP	12	Power Supply Plate	ANG7280	ANG7280	ANG7240	ANG7240	
	13	Screw	IBZ30P080FCC	IBZ30P080FCC	BBZ30P080FZK	BBZ30P080FZK	
NSP	16	Card Spacer	DNK2769	DNK2769	Not used	Not used	
	17	Screw	BBZ40P080FCC	BBZ40P080FCC	Not used	Not used	

2.4 FRONT PANEL SECTION

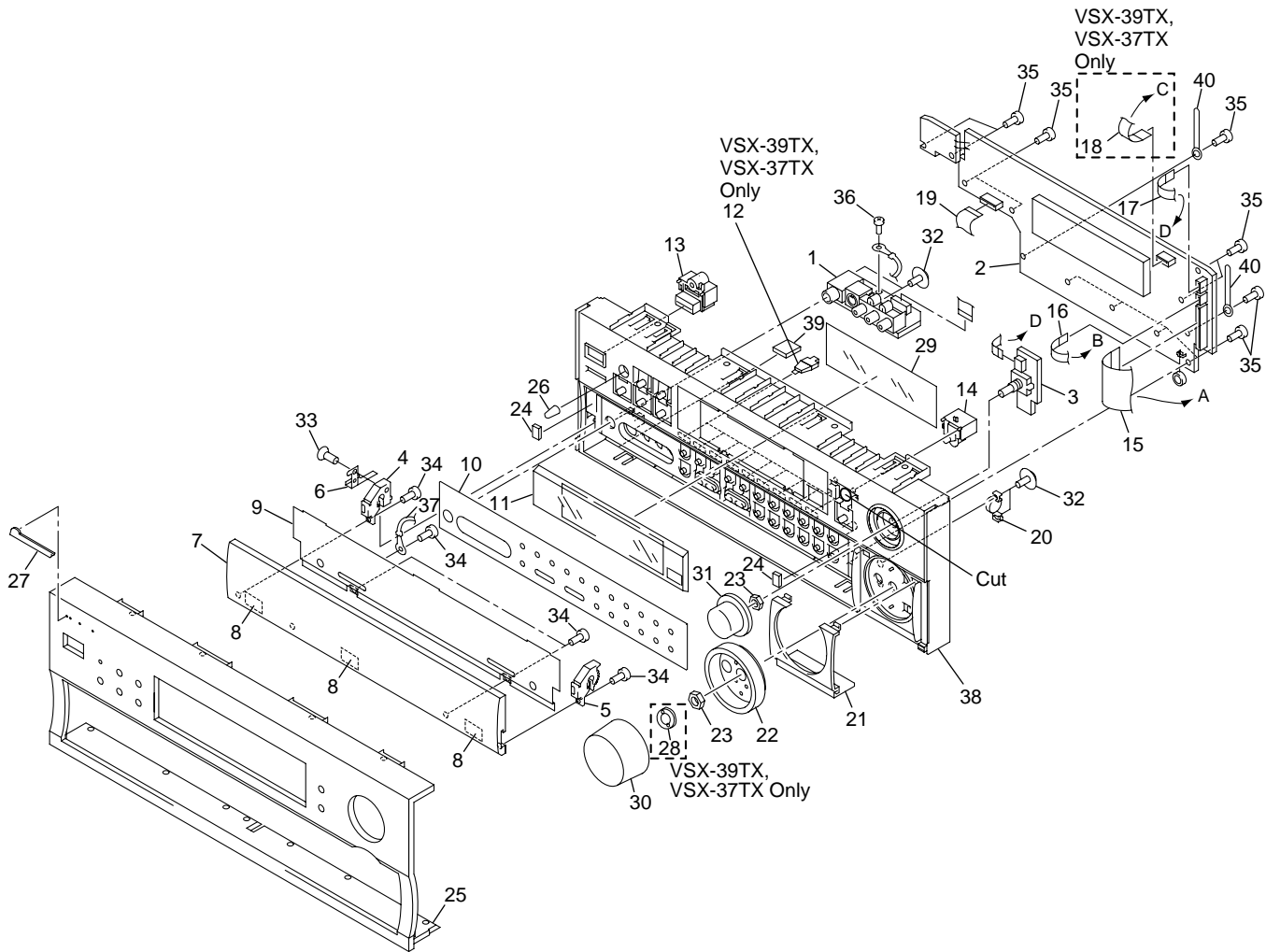

VSX-39TX, VSX-37TX, VSX-36TX, VSX-D909S

(1) FRONT PANEL SECTION PARTS LIST

Mark	No.	Description	Part No.	Mark	No.	Description	Part No.
NSP	1	H. PHONE/F. VIDEO Assy	AWX7342	21	Sub Panel	See Contrast table (2)	
	2	DISPLAY Assy	See Contrast table (2)	22	Volume Ring	See Contrast table (2)	
	3	ROTARY ENCODER Assy	See Contrast table (2)	23	Nut	NK90FUC	
	4	Door Hinge 26 L	AMR7252	24	Door Cushion B	AEB7152	
	5	Door Hinge 26 R	AMR7253	25	Front Panel	See Contrast table (2)	
NSP	6	Magnet Angle	ANG7241	26	LED Lens	PNW2019	
NSP	7	Door Panel	See Contrast table (2)	27	Name Plate B	PAN1376	
NSP	8	Spacer	VEC-244	28	Ring Spacer D5	See Contrast table (2)	
NSP	9	Door Plate 26	AAH7024	29	FL Sheet 26	AAK7627	
	10	Door Sheet	See Contrast table (2)	30	Volume Knob (MASTER VOLUME)	See Contrast table (2)	
	11	Display Panel 26	AAK7625	31	Rotary Knob (INPUT SELECTOR)	See Contrast table (2)	
	12	Function Lens 27	See Contrast table (2)	32	Screw	ABA7053	
	13	Power Button (STANDBY/ON)	AAD7440	33	Screw	PBA1096	
	14	MR Button (MULTIROOM)	AAD7514	34	Screw	BPZ30P060FMC	
	15	Lead Card 32P (J11)	ADD7159				
	16	Lead Card 05P (J14)	ADD7254	35	Screw	BPZ30P080FMC	
	17	Lead Card 06P (J20)	ADD7167	36	Screw	BBZ30P080FZK	
	18	Lead Card 08P (J19)	See Contrast table (2)	NSP 37	Cord with Plug	ADH7020	
	19	Lead Card 12P (J21)	ADD7166	38	Panel Base	See Contrast table (2)	
	20	Damper Assy (60)	AXA7078	39	Magnet	AMF7002	
				40	Cord Clamper	RNH-184	

(2) CONTRAST TABLE

VSX-39TX, VSX-37TX, VSX-36TX and VSX-D909S are constructed the same except for the following :

Mark	No.	Symbol and Description	Part No.				Remaks
			VSX-39TX	VSX-37TX	VSX-36TX	VSX-D909S	
NSP	1	H.PHONE/F.VIDEO Assy	AWX7342	AWX7342	AWX7528	AWX7528	
	2	DISPLAY Assy	AWX7698	AWX7698	AWX7699	AWX7700	
	3	ROTARY ENCODER Assy	AWX7328	AWX7328	AWX7726	AWX7726	
	7	Door Panel 39	AMB7722	AMB7718	AMB7718	Not used	
	7	Door Panel 98SD	Not used	Not used	Not used	AMB7624	
	10	Door Sheet 39	AAK7789	AAK7789	AAK7789	Not used	
	10	Door Sheet D909S	Not used	Not used	Not used	AAK7790	
	12	Function Lens 27	AAK7628	AAK7628	Not used	Not used	
	18	Lead Card 08P (J19)	ADD7168	ADD7168	Not used	Not used	
	21	Sub Panel 29	AMB7622	AMB7622	Not used	Not used	
	21	Sub Panel 26	Not used	Not used	AMB7575	Not used	
	21	Sub Panel 908	Not used	Not used	Not used	AMB7617	
	22	Volume Ring D10	AAH7016	Not used	Not used	Not used	
	22	Volume Ring 26	Not used	AAK7623	AAK7623	AAK7623	
	25	Front Panel 39	AMB7718	Not used	Not used	Not used	
	25	Front Panel 37	Not used	AMB7717	Not used	Not used	
	25	Front Panel 36	Not used	Not used	AMB7716	Not used	
	25	Front Panel D909S	Not used	Not used	Not used	AMB771	
	28	Ring Spacer D5	AWL7038	AWL7038	Not used	Not used	
	30	Volume Knob 27	AAB7194	AAB7194	Not used	Not used	
	30	Volume Knob 26	Not used	Not used	AAB7193	AAB7193	
31	Rotary Knob 29	AAB7221	AAB7221	Not used	Not used		
31	Rotary Knob 26	Not used	Not used	AAB7196	AAB7196		
38	Panel Base 27	AMB7570	AMB7570	Not used	Not used		
38	Panel Base 26	Not used	Not used	AMB7569	AMB7569		

3. BLOCK DIAGRAM AND SCHEMATIC DIAGRAM

3.1 BLOCK DIAGRAM

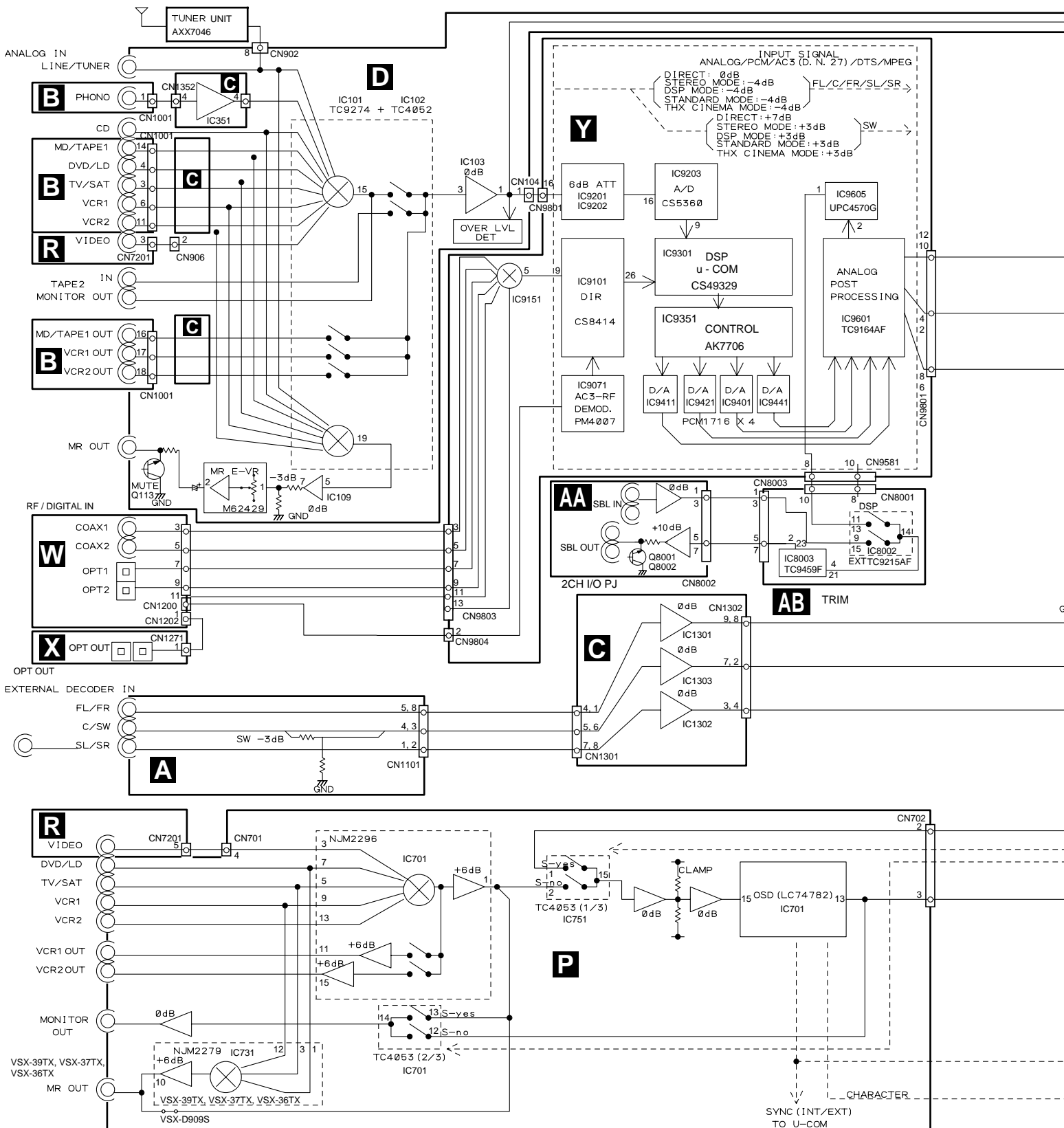

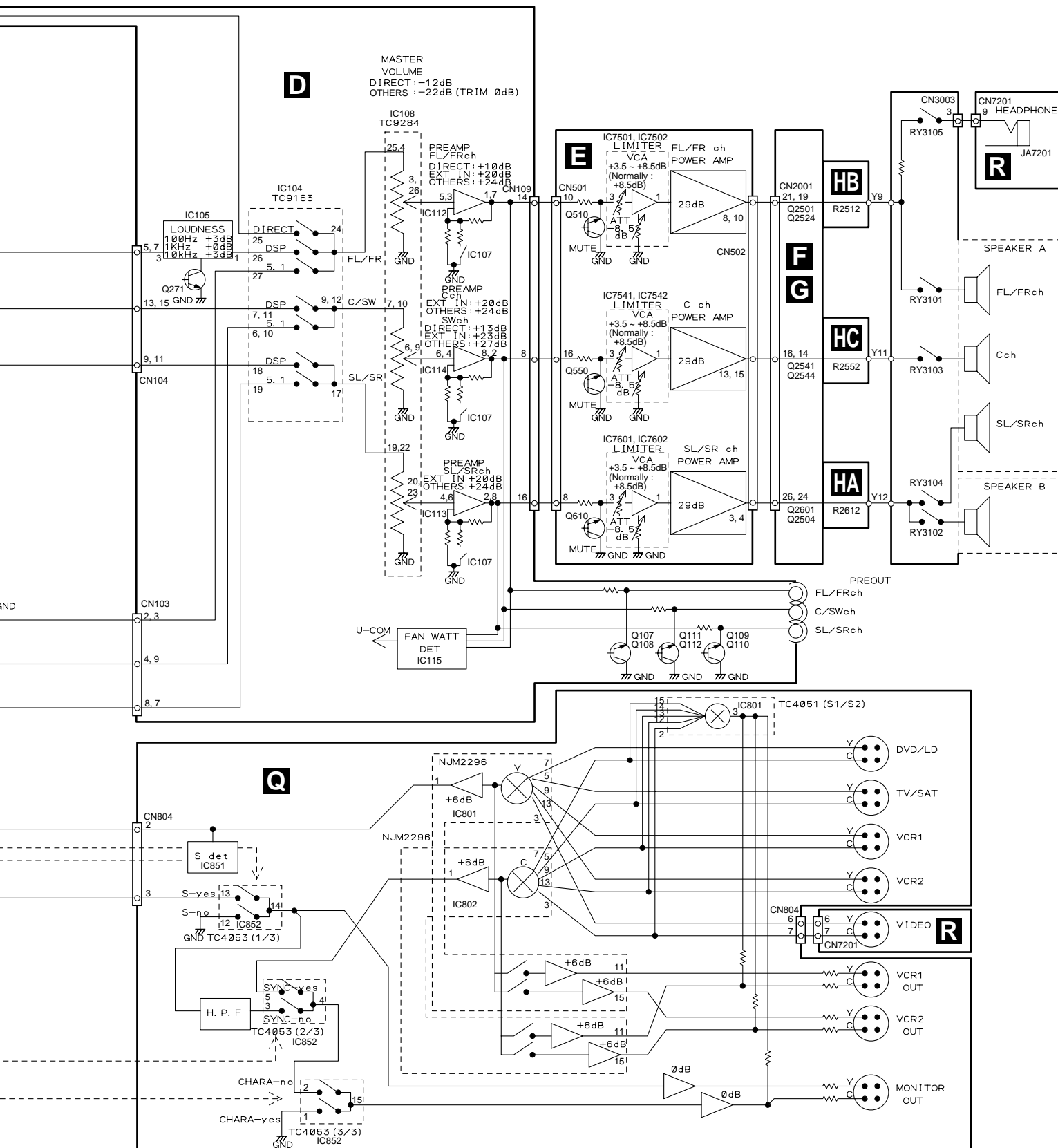

3.2 OVERALL WIRING CONNECTION DIAGRAM

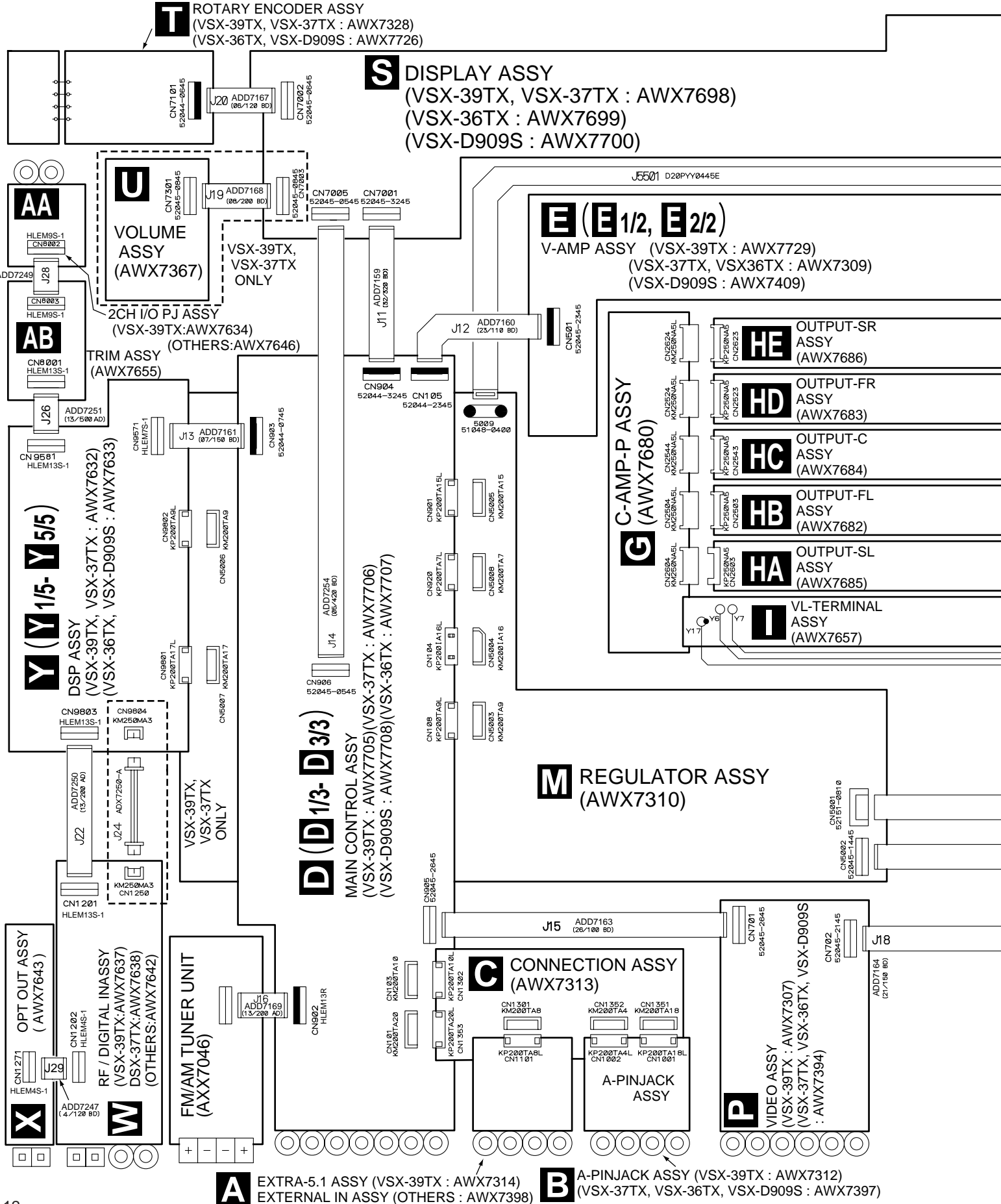

VSX-39TX, VSX-37TX, VSX-36TX, VSX-D909S

Note : When ordering service parts, be sure to refer to "EXPLODED VIEWS and PARTS LIST" or "PCB PARTS LIST".

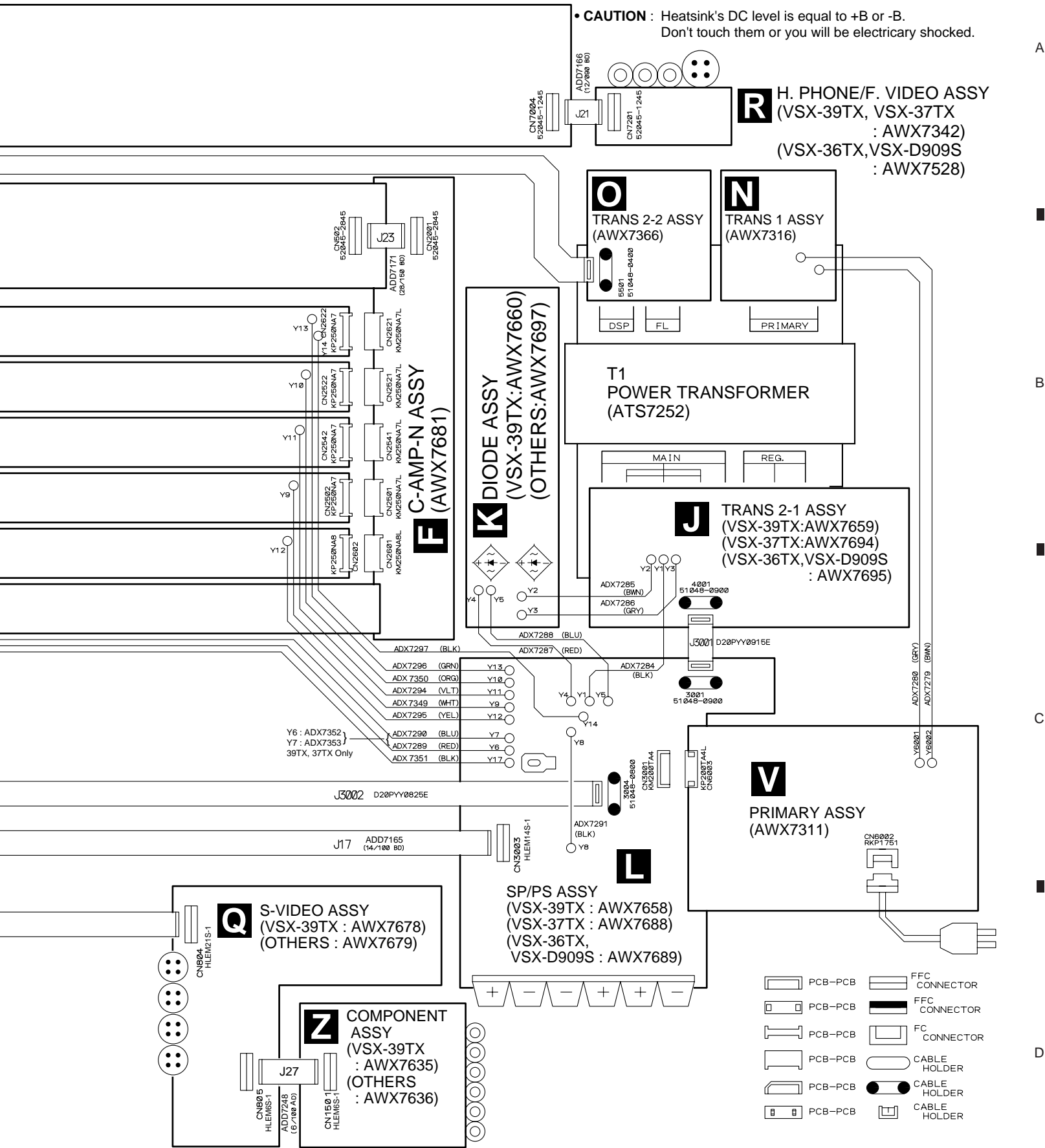

3.3 EXTRA-5.1 (EXTERNAL IN), A-PINJACK and CONNECTION ASSYS

A
EXTRA-5.1 ASSY
 (VSX-39TX : AWX7314)
EXTERNAL IN ASSY
 (OTHERS : AWX7398)

JA1101-JA1103 ;
 VSX-39TX : AKB7121
 OTHERS : AKB7095

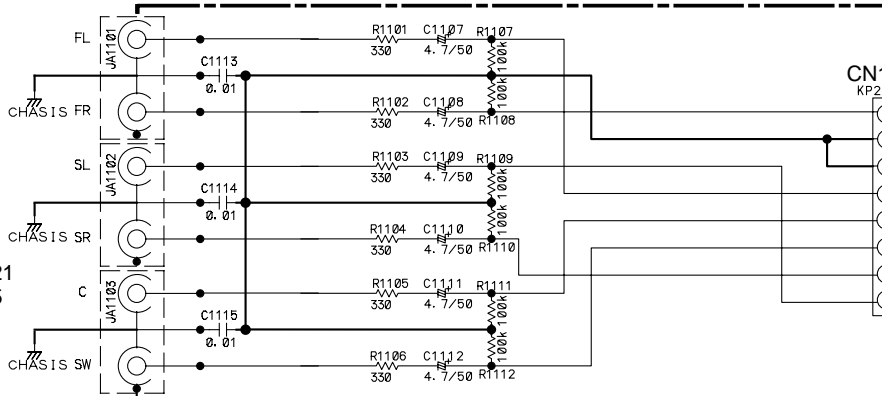

B
A-PINJACK ASSY
 (VSX-39TX : AWX7312)
 (VSX-37TX, VSX-36TX,
 VSX-D909S : AWX7397)

JN1014: AKB7119
 (VSX-39TX ONLY)

JA1015: AKB7048
 JA1016: AKB7120
 (VSX-37TX, VSX-36TX,
 VSX-D909S ONLY)

JA1011-JA1013 ;
 VSX-39TX : AKB7108
 OTHERS : AKB7048

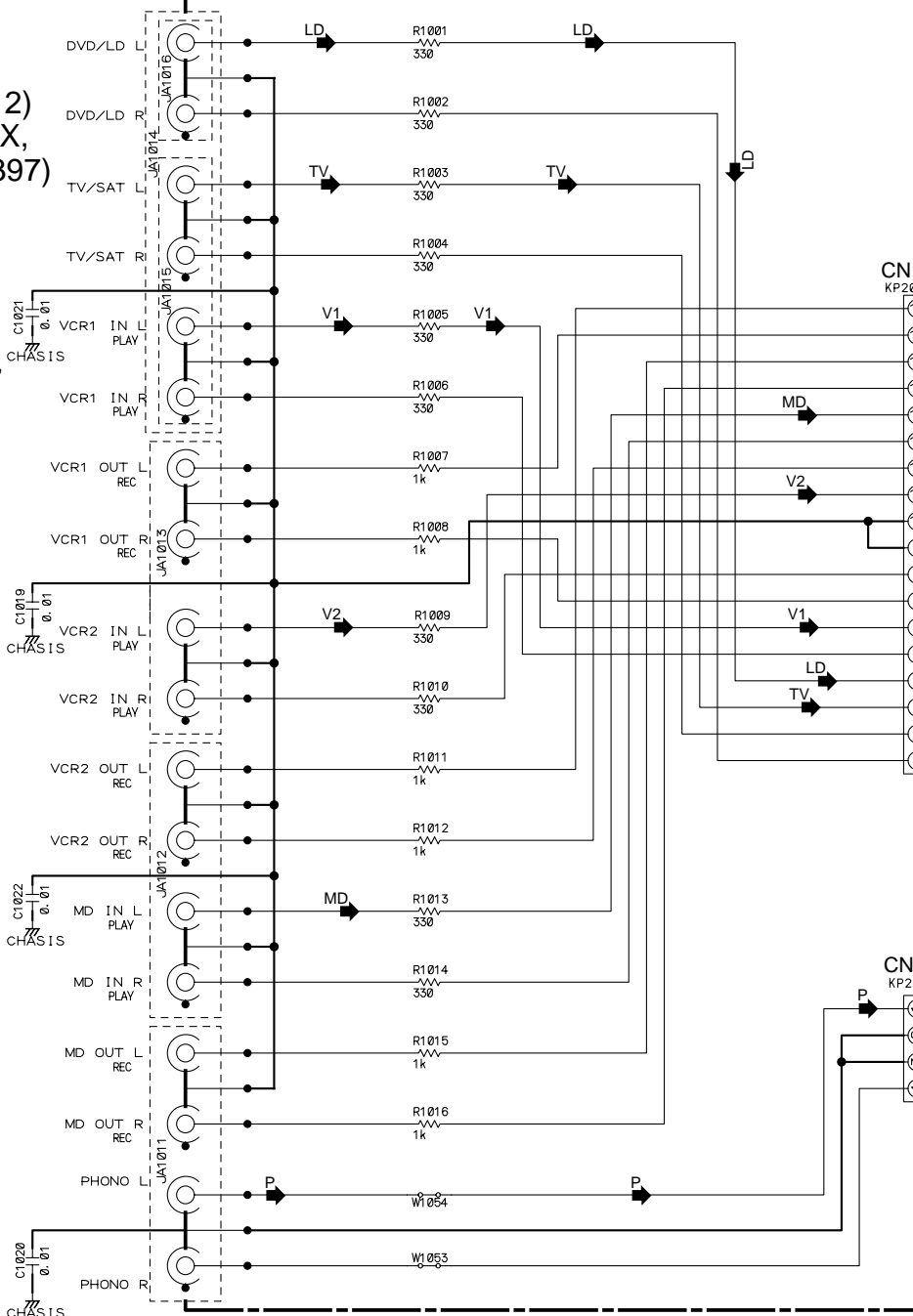

C CONNECTION ASSY (AWX7313)

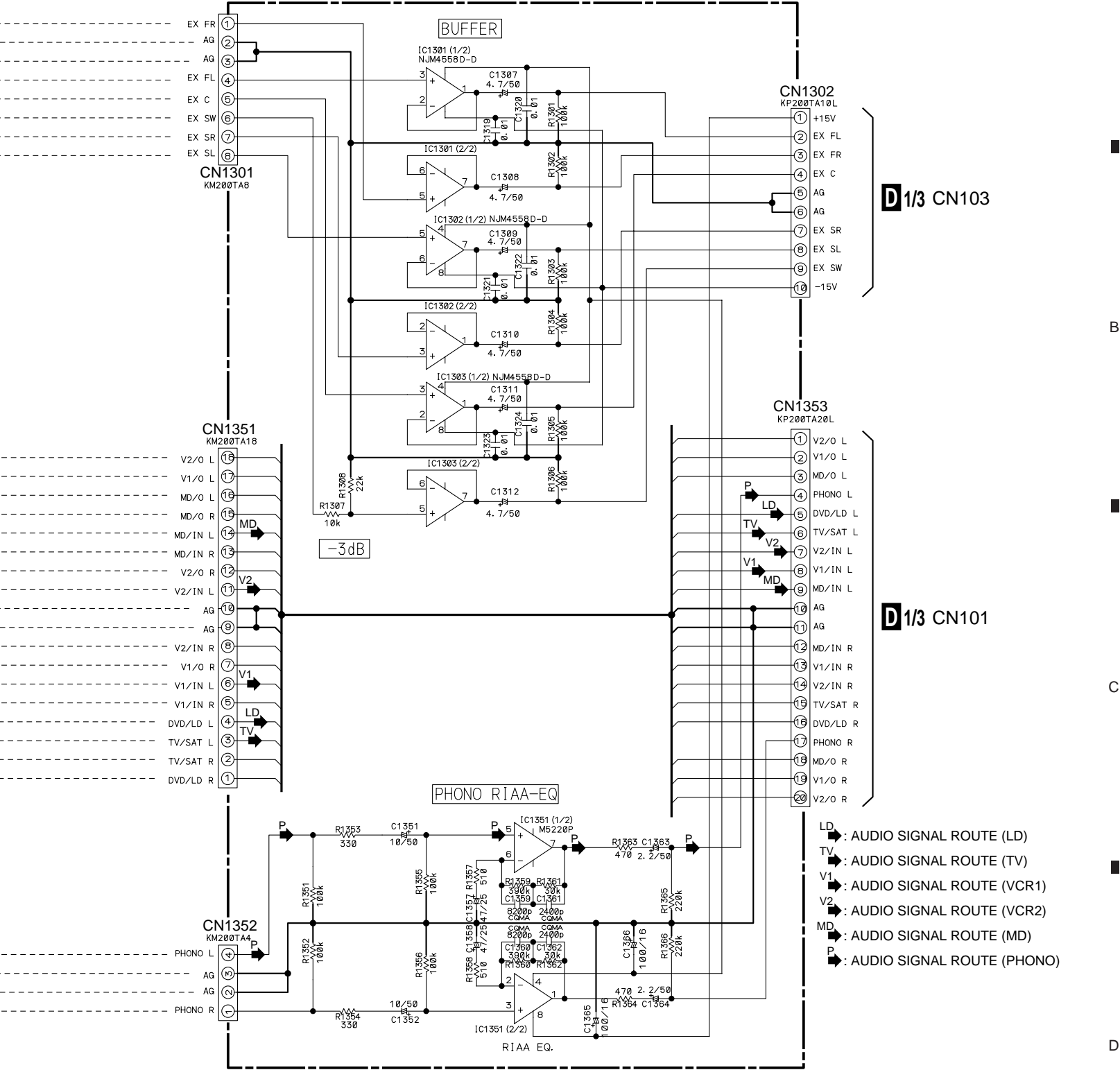

D 1/3 CN103

D 1/3 CN101

- LD : AUDIO SIGNAL ROUTE (LD)
- TV : AUDIO SIGNAL ROUTE (TV)
- V1 : AUDIO SIGNAL ROUTE (VCR1)
- V2 : AUDIO SIGNAL ROUTE (VCR2)
- MD : AUDIO SIGNAL ROUTE (MD)
- P : AUDIO SIGNAL ROUTE (PHONO)



VSX-39TX, VSX-37TX, VSX-36TX, VSX-D909S

3.4 MAIN CONTROL ASSY (1/3)

S : The power supply is shown with the marked box.

A

B

C

D

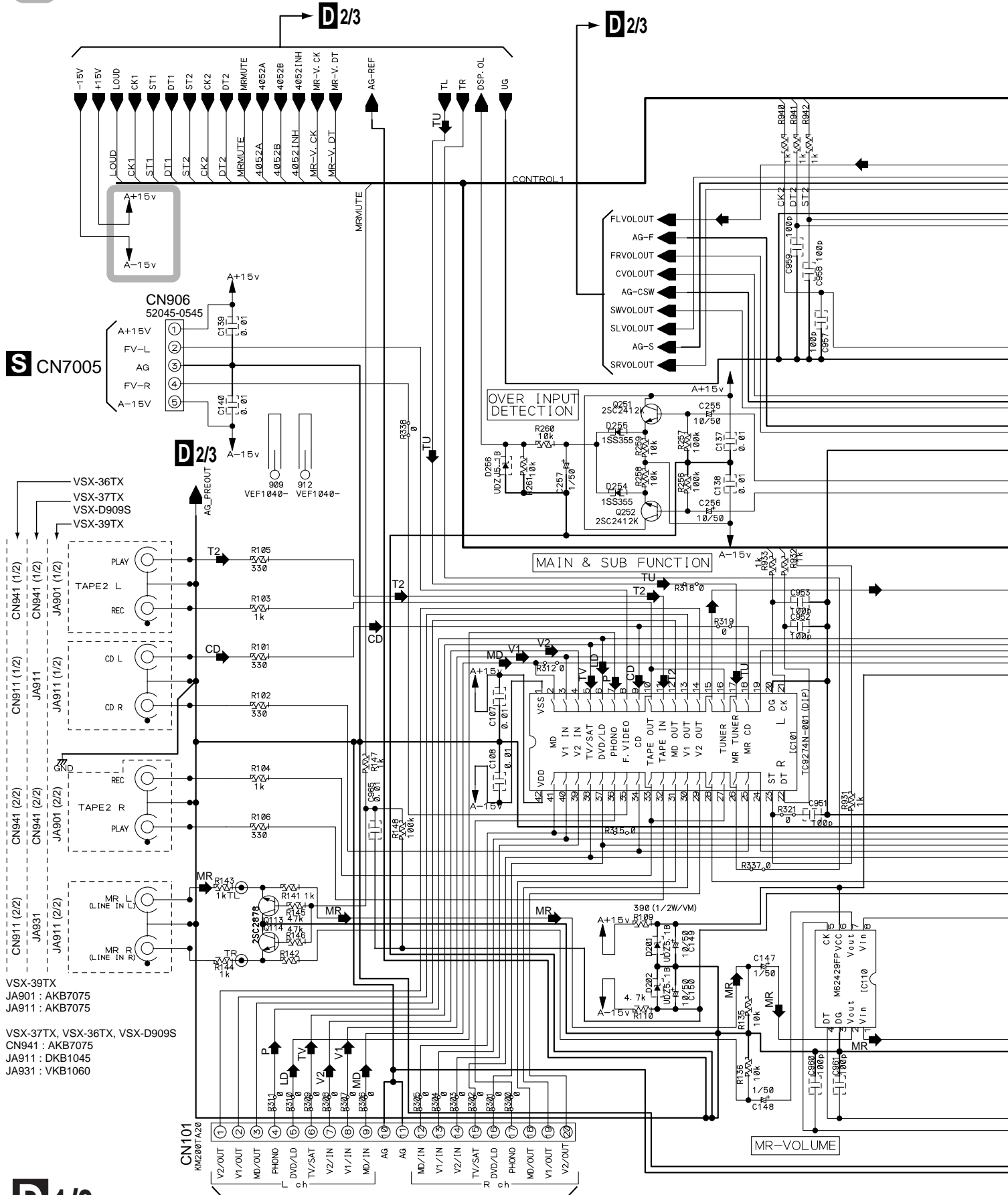

VSX-39TX
JA901 : AKB7075
JA911 : AKB7075

VSX-37TX, VSX-36TX, VSX-D909S
CN941 : AKB7075
JA911 : DKB1045
JA931 : VKB1060

D1/3

MAIN CONTROL ASSY

(VSX-39TX : AWX7705)

(VSX-37TX : AWX7706)(VSX-D909S : AWX7708)

(VSX-36TX : AWX7707)

- ▶ : AUDIO SIGNAL ROUTE
- LD ▶ : AUDIO SIGNAL ROUTE (LD)
- TV ▶ : AUDIO SIGNAL ROUTE (TV)
- V1 ▶ : AUDIO SIGNAL ROUTE (VCR1)
- V2 ▶ : AUDIO SIGNAL ROUTE (VCR2)
- MD ▶ : AUDIO SIGNAL ROUTE (MD)
- P ▶ : AUDIO SIGNAL ROUTE (PHONO)
- TU ▶ : AUDIO SIGNAL ROUTE (TUNER)
- CD ▶ : AUDIO SIGNAL ROUTE (CD)
- T2 ▶ : AUDIO SIGNAL ROUTE (TAPE2)
- MR ▶ : AUDIO SIGNAL ROUTE (MR)

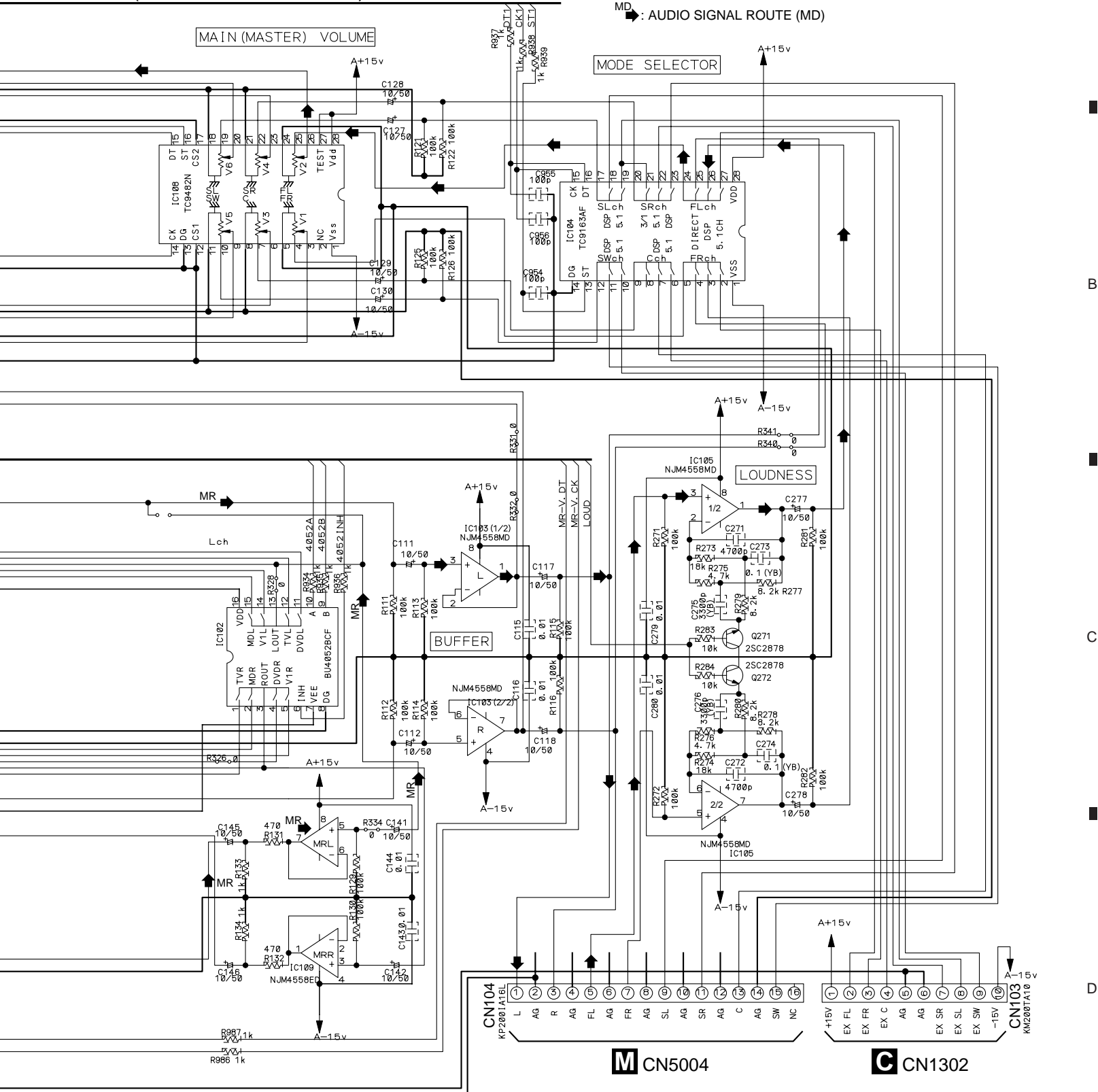



M CN5004

C CN1302

3.5 MAIN CONTROL ASSY (2/3)

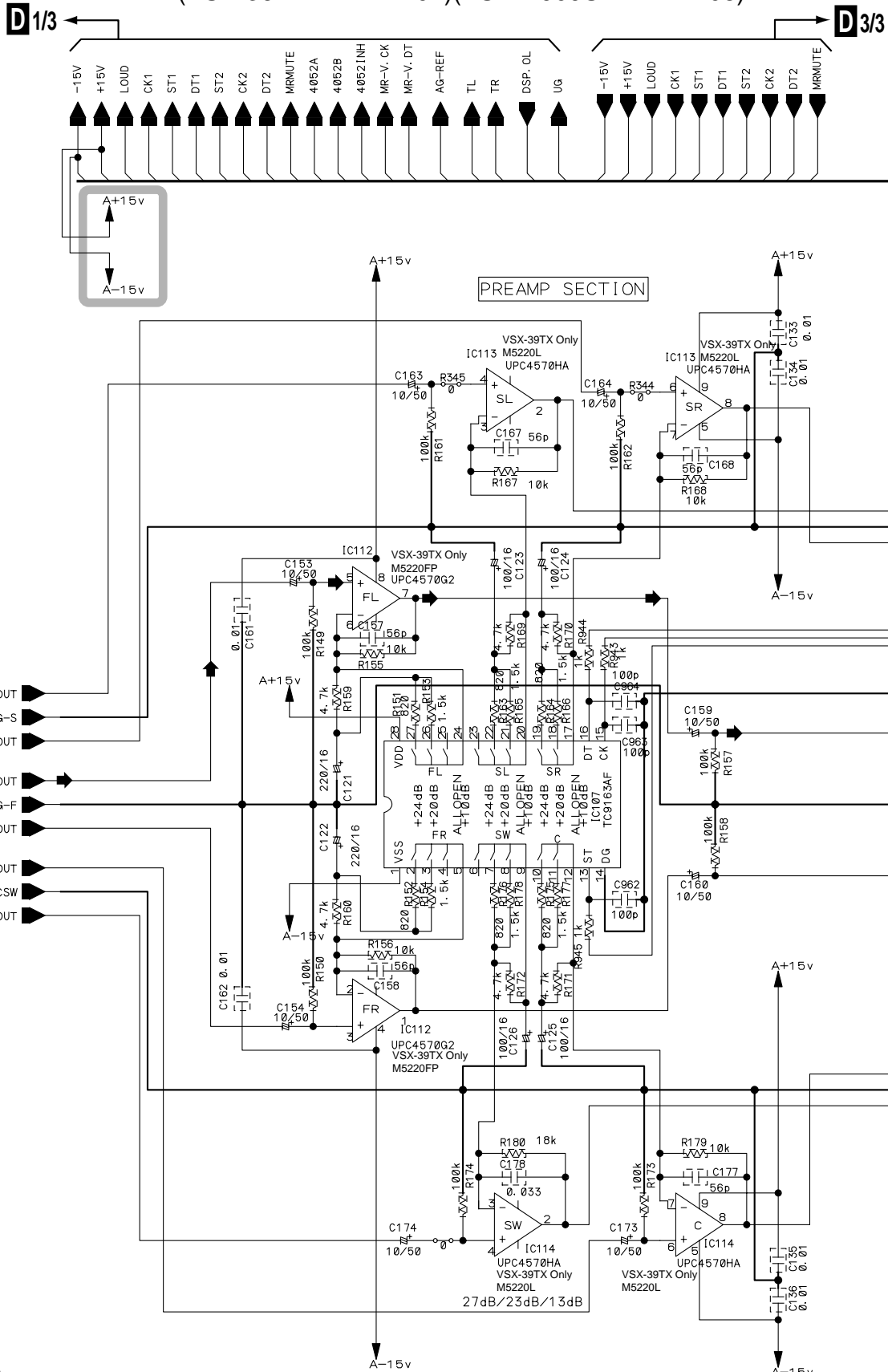
D 2/3 MAIN CONTROL ASSY
 (VSX-39TX : AWX7705)(VSX-37TX : AWX7706)
 (VSX-36TX : AWX7707)(VSX-D909S : AWX7708)



 : The power supply is shown with the marked box.

 : AUDIO SIGNAL ROUTE

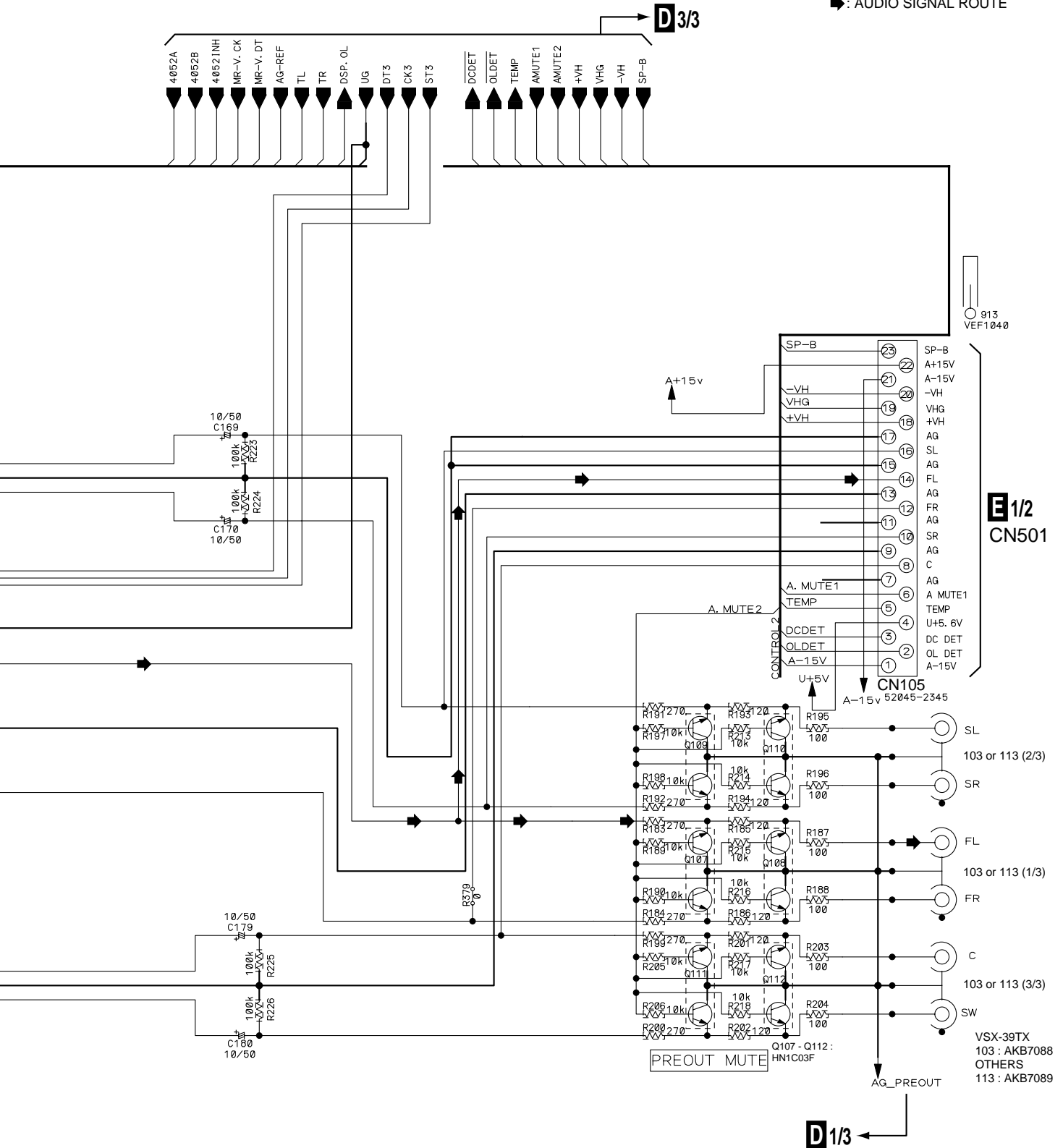

E1/2
CN501

D1/3

3.6 MAIN CONTROL ASSY (3/3)

A

B

C

D

D 2/3

Y 4/5 CN9551

M CN5005

M CN5008

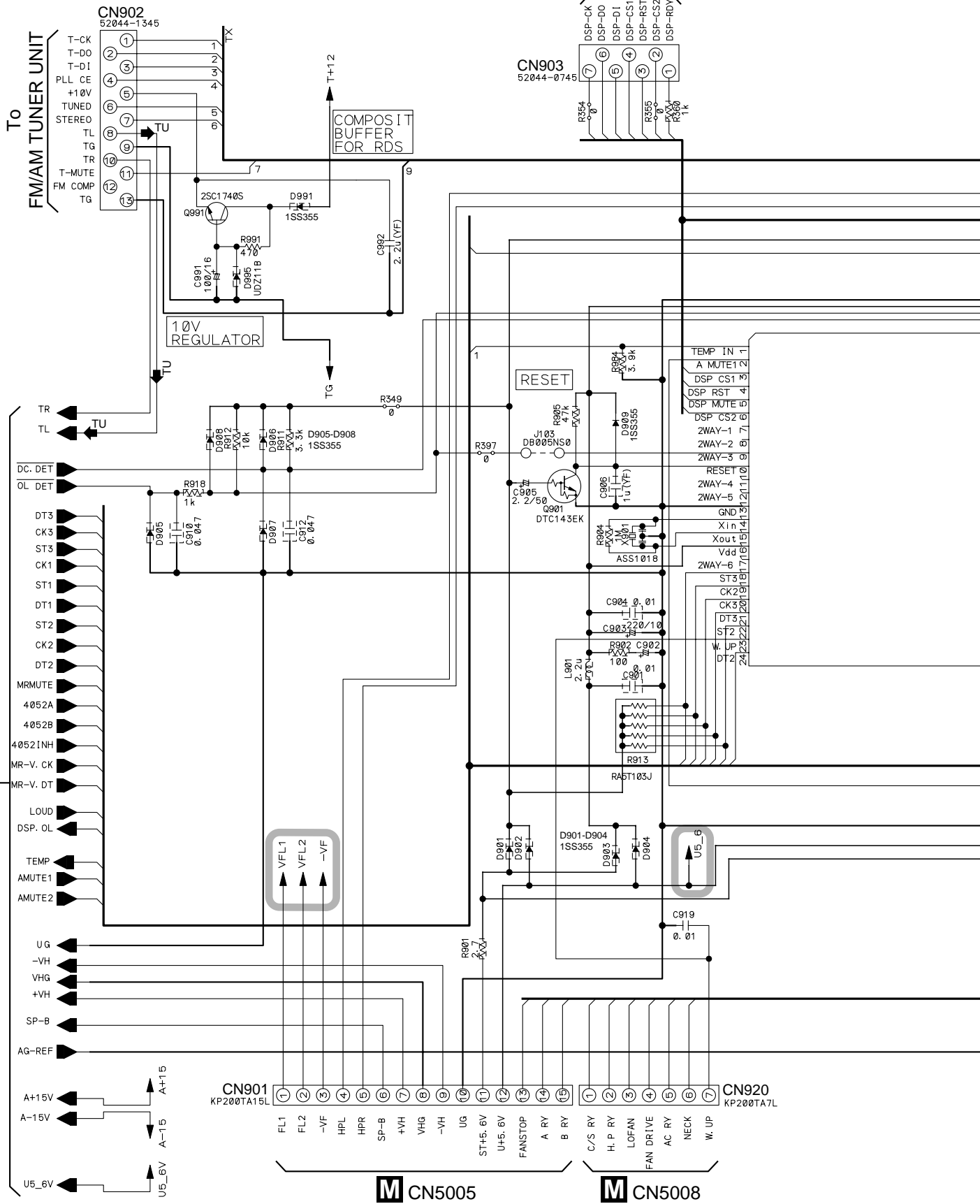

VSX-39TX, VSX-37TX, VSX-36TX, VSX-D909S

O : The power supply is shown with the marked box.

TU : AUDIO SIGNAL ROUTE (TUNER)

D 3/3

MAIN CONTROL ASSY
 (VSX-39TX : AWX7705)
 (VSX-37TX : AWX7706)
 (VSX-36TX : AWX7707)
 (VSX-D909S : AWX7708)

S CN7001

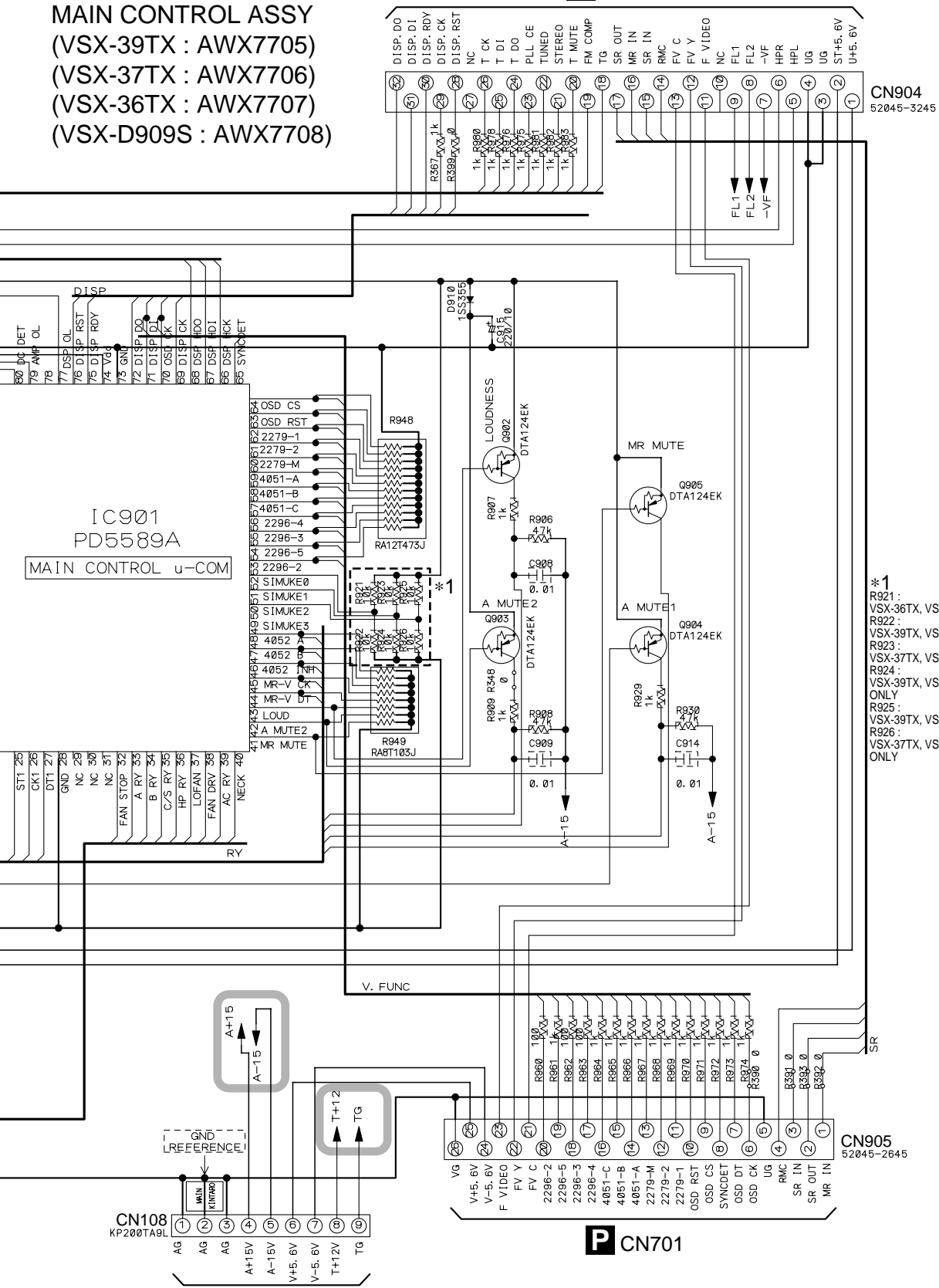

- *1
 R921 : VSX-36TX, VSX-D909S ONLY
 R922 : VSX-39TX, VSX-37TX ONLY
 R923 : VSX-37TX, VSX-D909S ONLY
 R924 : VSX-39TX, VSX-36TX ONLY
 R925 : VSX-39TX, VSX-D909S ONLY
 R926 : VSX-37TX, VSX-36TX ONLY

P CN701

M CN5003

D 3/3

3.7 V-AMP ASSY (1/2)

E 1/2 V-AMP ASSY

(VSX-39TX : AWX7729)(VSX-37TX, VSX-36TX : AWX7309)
 (VSX-D909S : AWX7409)

A

B

C

D

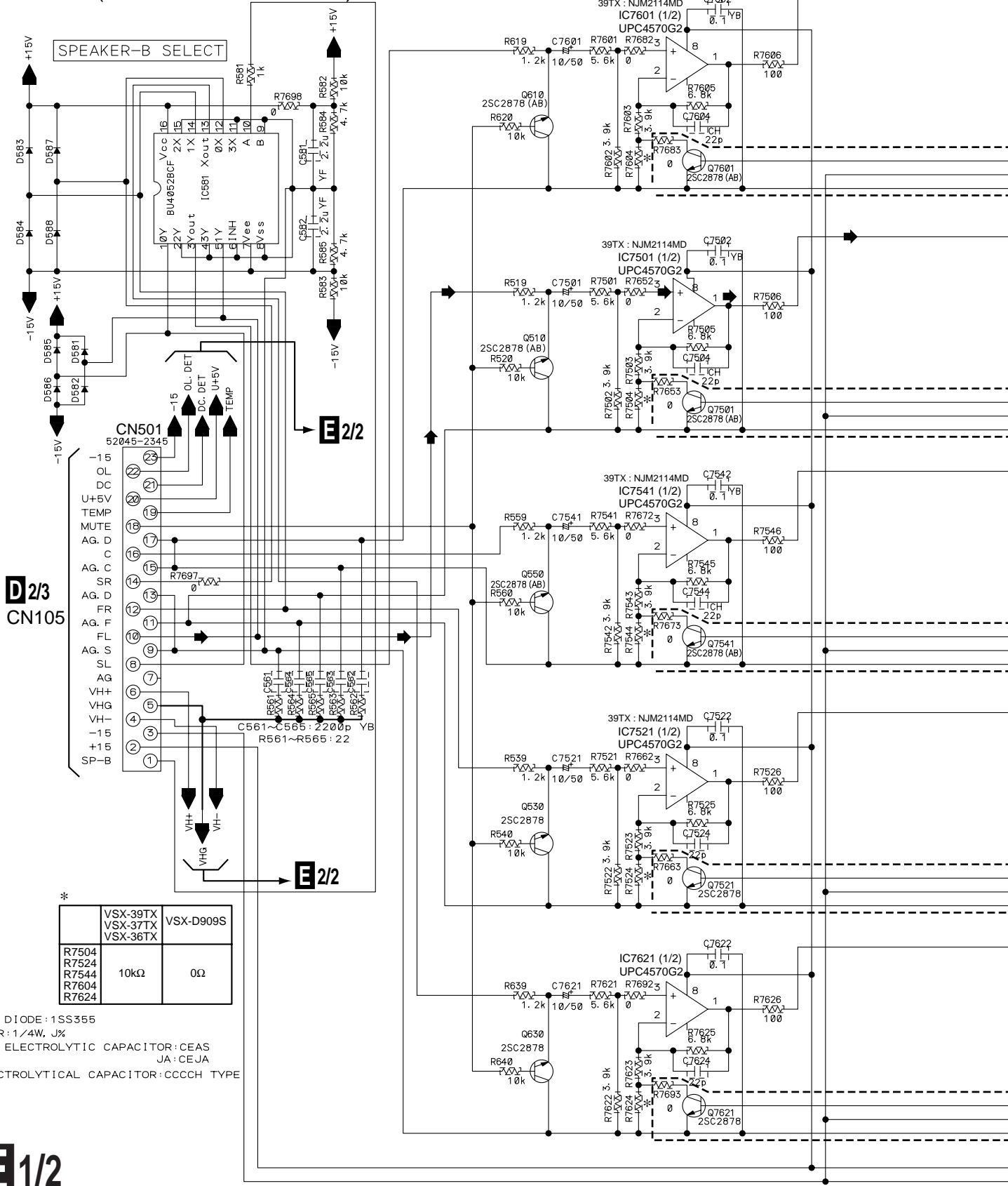

D 2/3
CN105

*

	VSX-39TX VSX-37TX VSX-36TX	VSX-D909S
R7504	10kΩ	0Ω
R7524	10kΩ	0Ω
R7544	10kΩ	0Ω
R7604	10kΩ	0Ω
R7624	10kΩ	0Ω

- NO MARK DIODE:1SS355
- RESISTOR:1/4W, JX
- NO MARK ELECTROLYTIC CAPACITOR:CEAS
JA:CEJA
- NON ELECTROLYTICAL CAPACITOR:CCCCH TYPE

VSX-39TX, VSX-37TX, VSX-36TX, VSX-D909S

MAIN CHANNEL LIMITER

VSX-39TX, VSX-37TX, VSX-36TX ONLY

➔ : AUDIO SIGNAL ROUTE

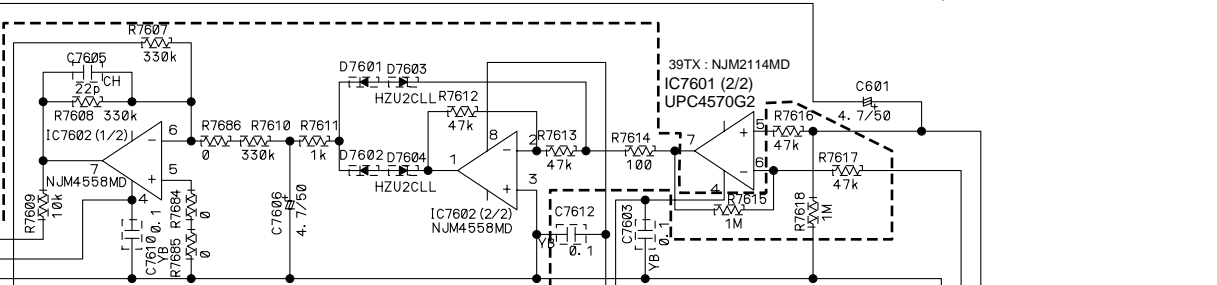

VSX-39TX, VSX-37TX, VSX-36TX ONLY

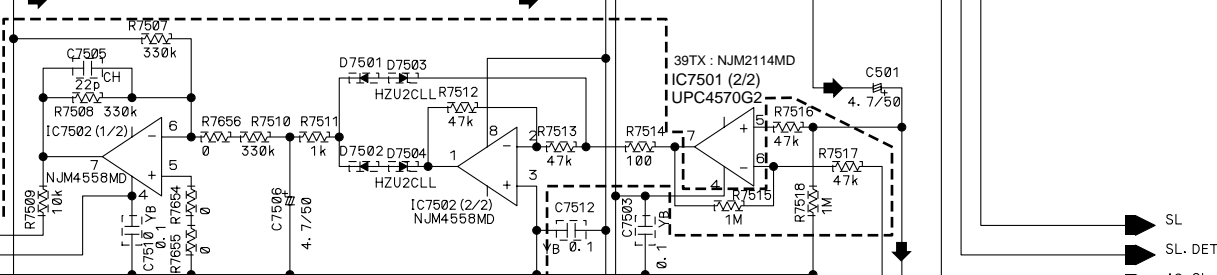

VSX-39TX, VSX-37TX, VSX-36TX ONLY

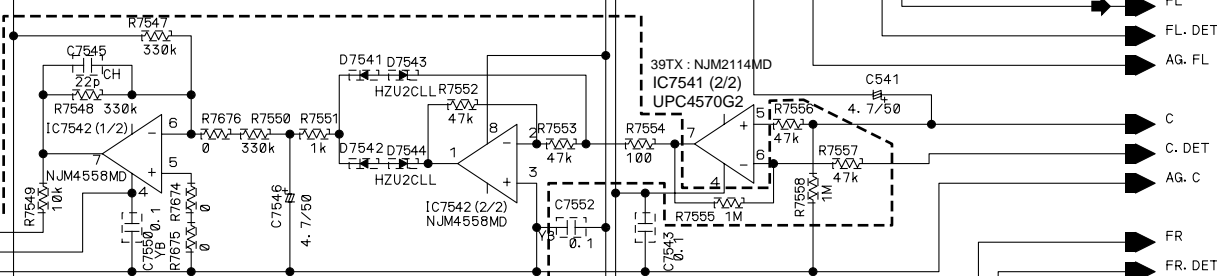

VSX-39TX, VSX-37TX, VSX-36TX ONLY

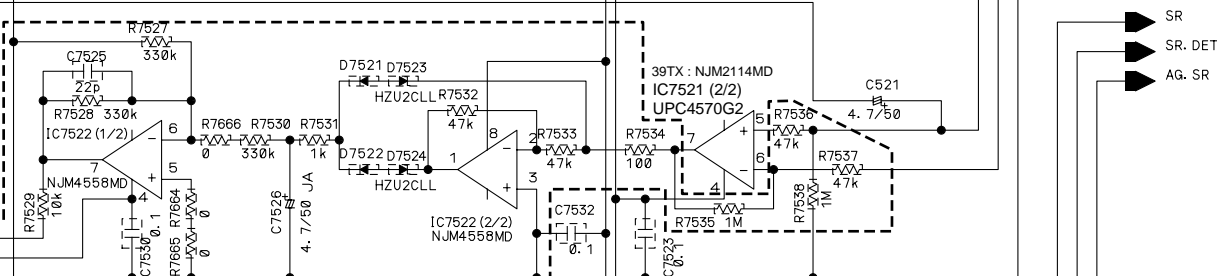

VSX-39TX, VSX-37TX, VSX-36TX ONLY

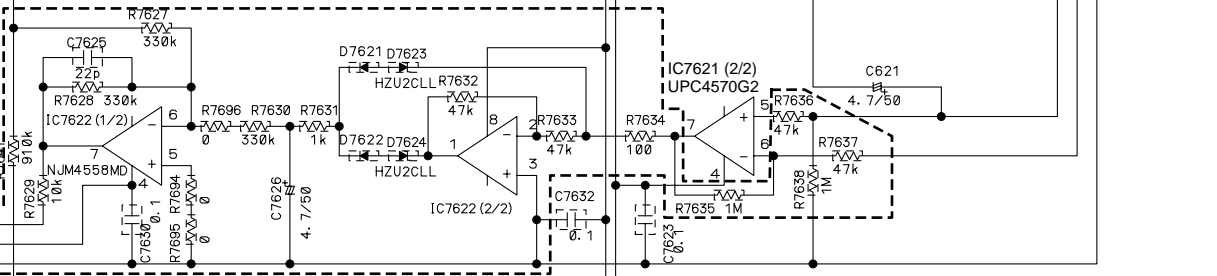

2/2

3.8 V-AMP ASSY (2/2)

A

B

C

D

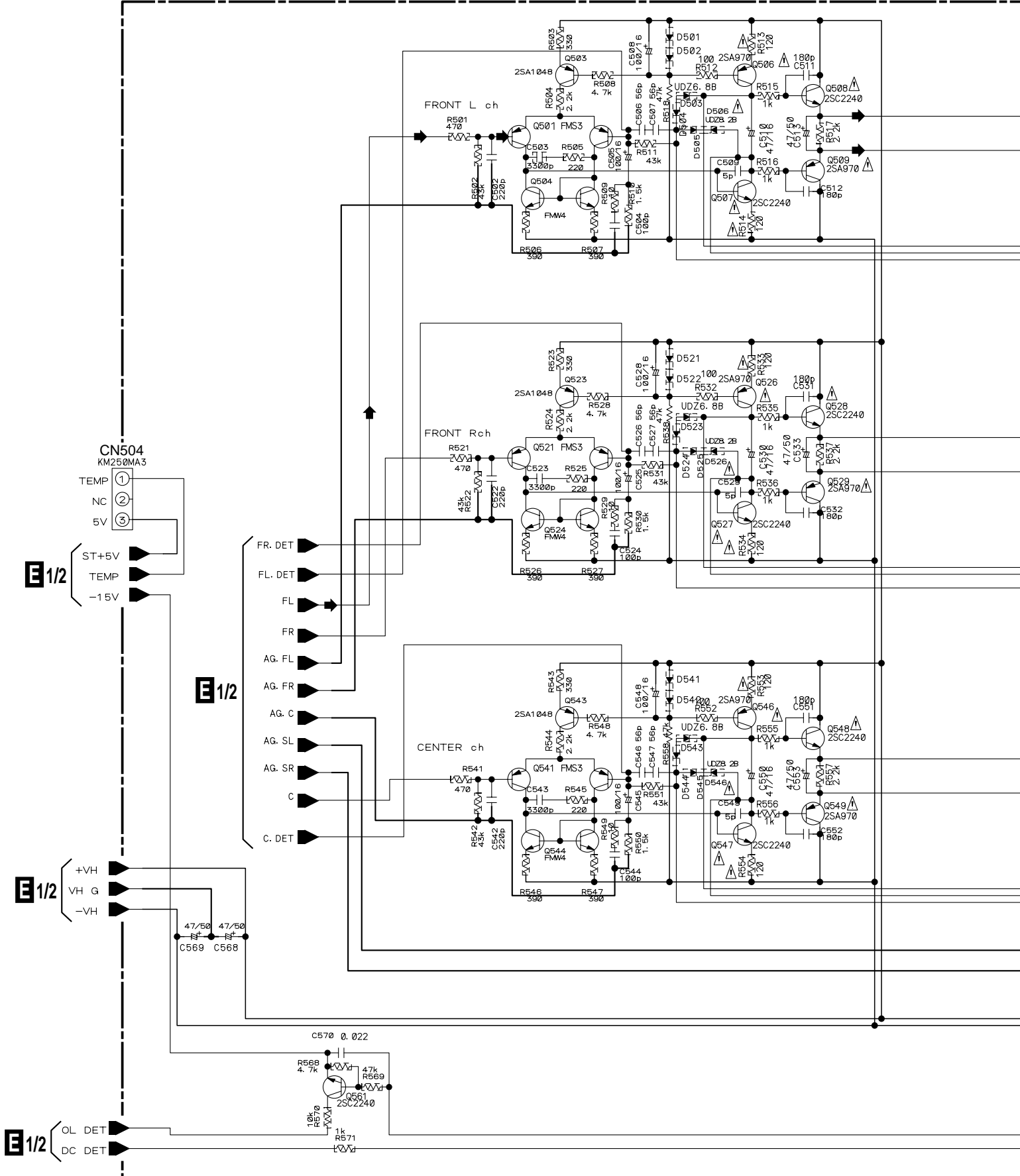

24 **E 2/2**

VSX-39TX, VSX-37TX, VSX-36TX, VSX-D909S

E 2/2 V-AMP ASSY

(VSX-39TX : AWX7729)(VSX-37TX, VSX-36TX : AWX7309)
(VSX-D909S : AWX7409)

POWER AMP VOLTAGE AMPLIFYING STAGE

➔ : AUDIO SIGNAL ROUTE

- NO MARK DIODE:1SS355
- RESISTOR:1/4W, J%
- NO MARK ELECTROLYTIC CAPACITOR:CEAS
JA:CEJA
- NON ELECTROLYTICAL CAPACITOR:CCCCH TYPE

CN502
52045-2845

- 1 B1+
- 2 B1-
- 3 G-
- 4 NFB
- 5 G+
- 6 B1+
- 7 B1-
- 8 G-
- 9 NFB
- 10 G+
- 11 B+
- 12 B-
- 13 G-
- 14 NFB
- 15 G+
- 16 B1+
- 17 B1-
- 18 G-
- 19 NFB
- 20 G+
- 21 B+
- 22 B-
- 23 G-
- 24 NFB
- 25 G+
- 26 OL DET
- 27 AMP G
- 28 DC DET

E 1/2

E 1/2

F
CN2001

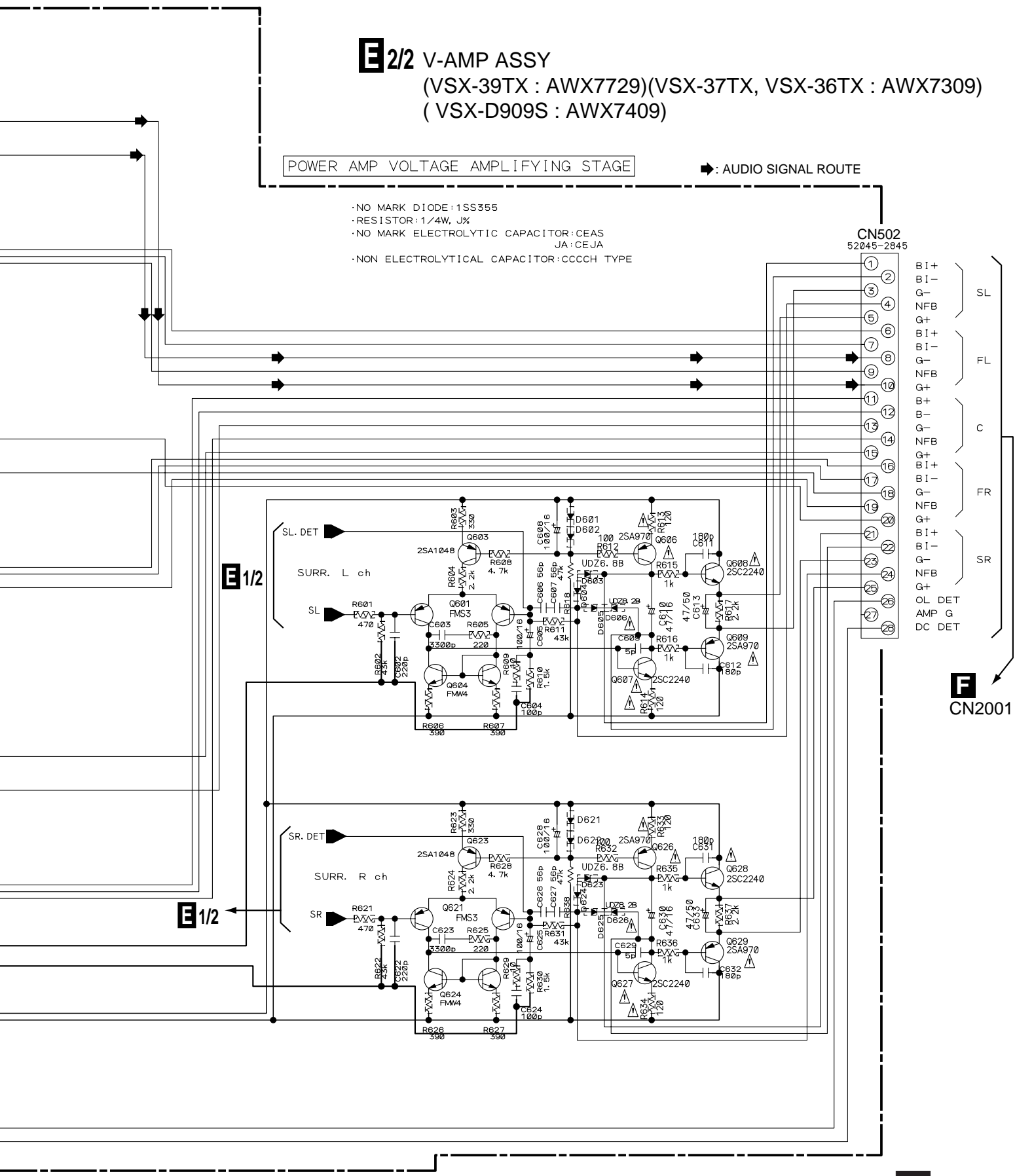

3.9 C-AMP-N, C-AMP-P, OUTPUT-SL, OUTPUT-FL, OUTPUT-C, OUTPUT-FR, OUTPUT-SR and VL-TERMINAL ASSYS

F
C-AMP-N ASSY
(AWX7681)

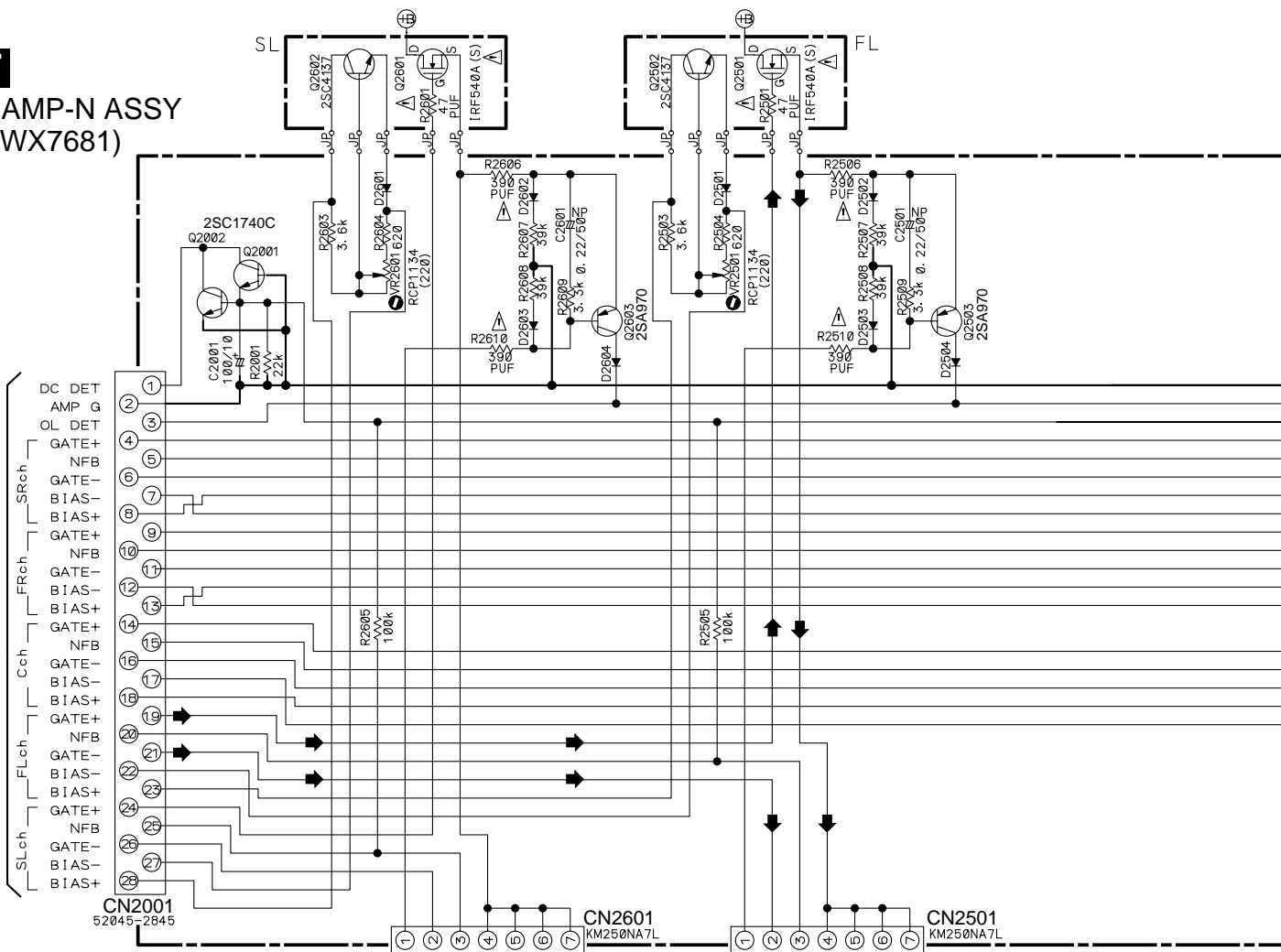

E 2/2
CN502

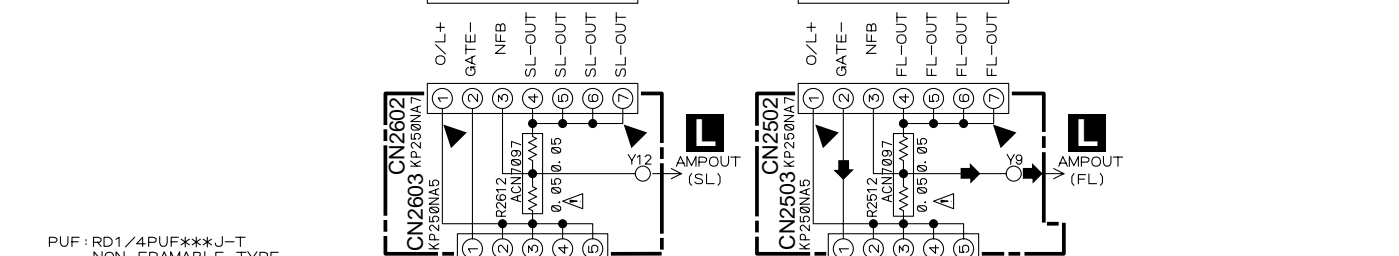

PUF: RD1/4PUF***J-T
NON FRAMABLE TYPE
DIODES WITHOUT INDICATION: 1S133

G
C-AMP-P ASSY
(AWX7680)

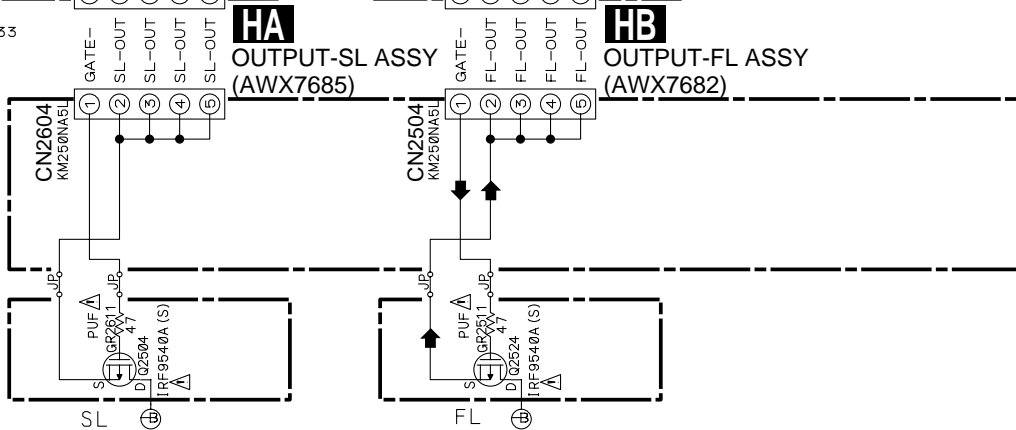

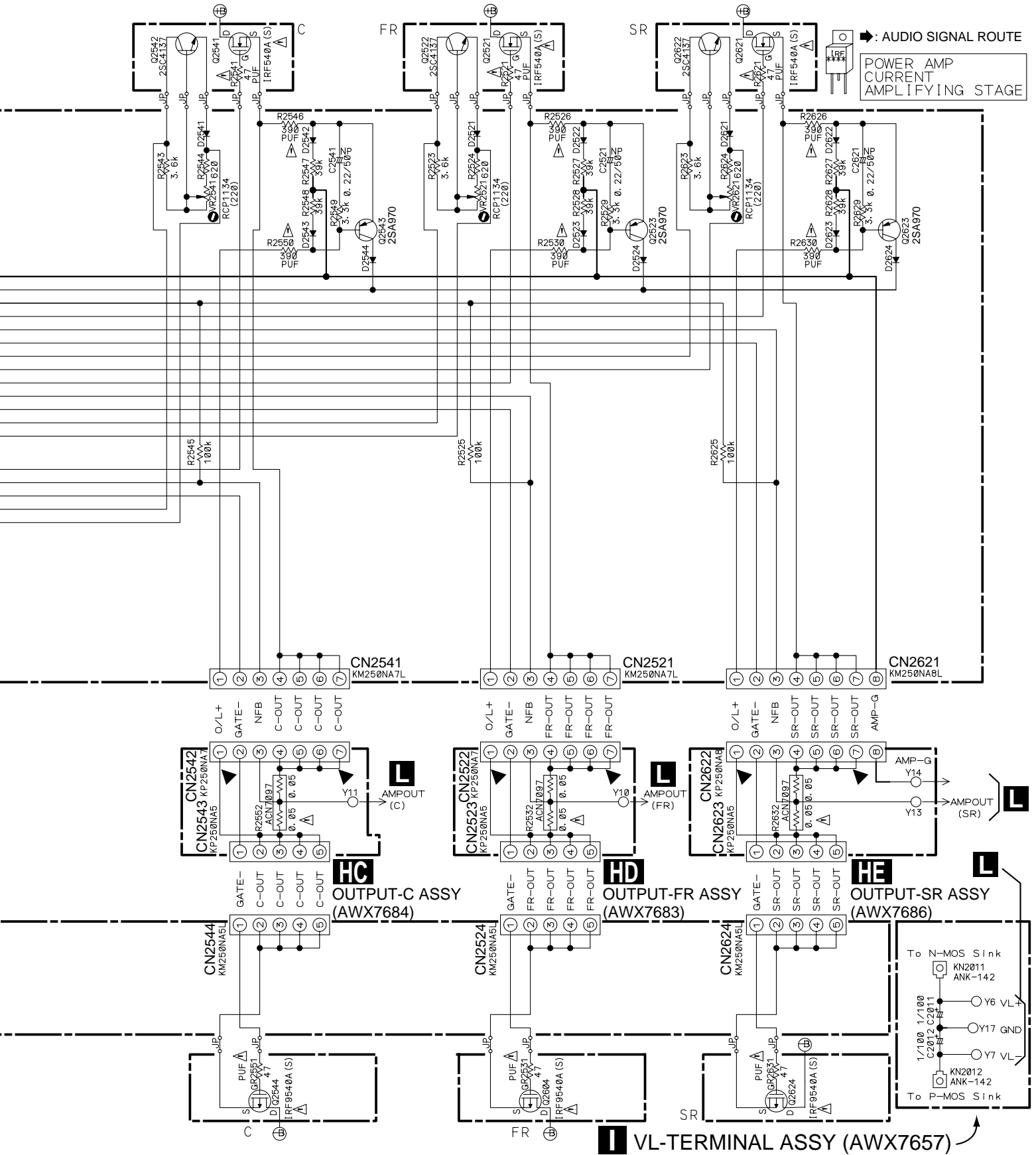

3.10 TRANS 2-1, DIODE and SP/PS ASSYS

- Y1 : ADX7284- (BLK)
- Y2 : ADX7285- (BWN)
- Y3 : ADX7286- (GRY)
- Y4 : ADX7287- (RED)
- Y5 : ADX7288- (BLU)
- Y6 : ADX7352- (RED) (VSX-39TX, 37TX) (Other)
- Y7 : ADX7353- (BLU) (VSX-39TX, 37TX) (Other)
- Y14 : ADX7297- (BLK)

A

B

C

D

TRANS 2-1 ASSY
 (VSX-39TX : AWX7659)
 (VSX-37TX : AWX7694)
 (VSX-36TX, VSX-D909S : AWX7695)

RECTIFIER FOR POWER AMP "VL"

DIODE ASSY
 (VSX-39TX:AWX7660) (OTHERS:AWX7697)

	VSX-39TX	VSX-36TX VSX-D909S
C3001	ACH7147	ACH7130
C3002	22000/56	22000/50
C3001	ACH7068	
C3002	22000/56	

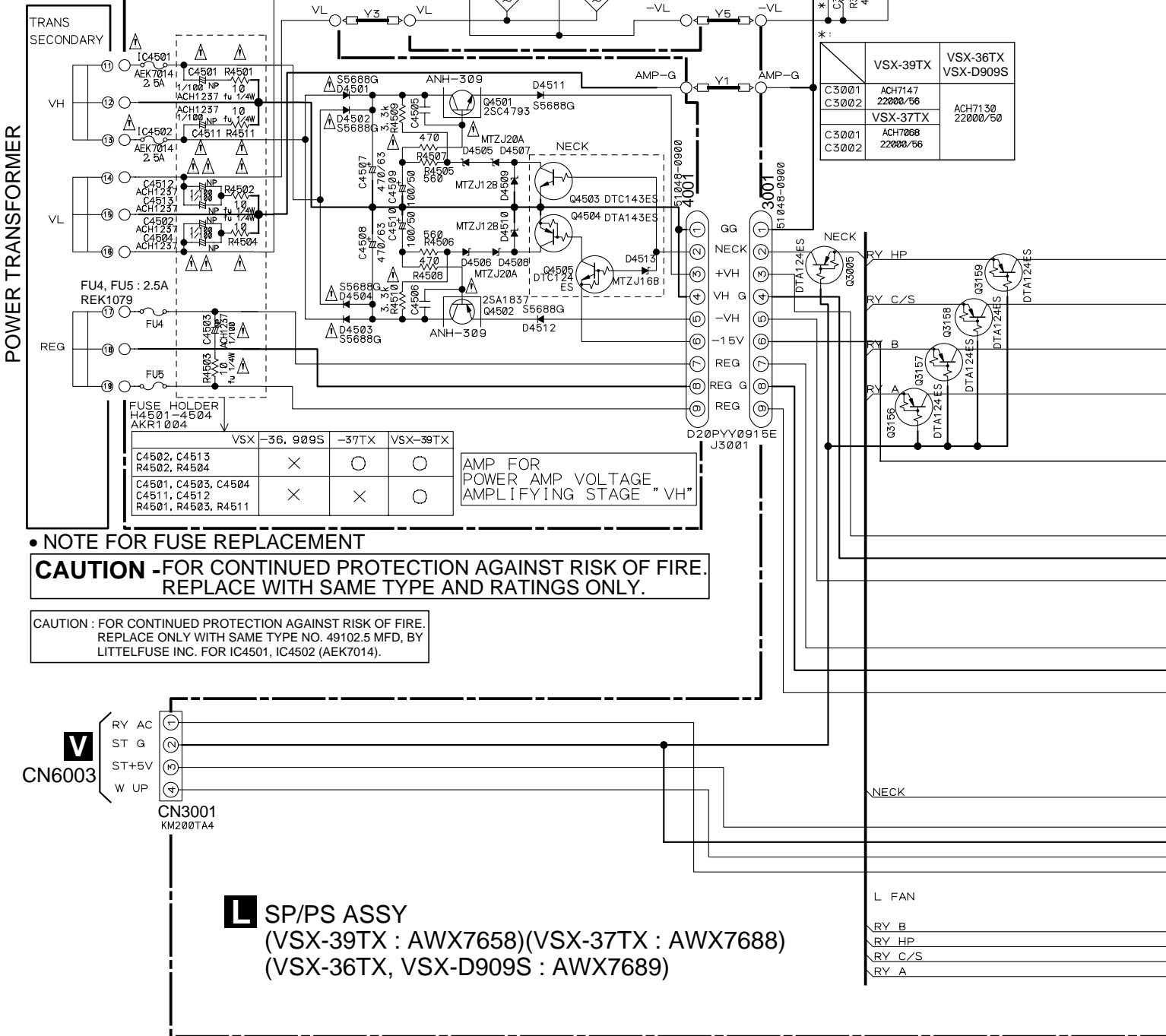

	VSX	-36, 909S	-37TX	VSX-39TX
C4502, C4513		×	○	○
R4502, R4504		×	○	○
C4501, C4503, C4504		×	×	○
C4511, C4512		×	×	○
R4501, R4503, R4511		×	×	○

AMP FOR POWER AMP VOLTAGE AMPLIFYING STAGE "VH"

NOTE FOR FUSE REPLACEMENT
CAUTION -FOR CONTINUED PROTECTION AGAINST RISK OF FIRE. REPLACE WITH SAME TYPE AND RATINGS ONLY.

CAUTION : FOR CONTINUED PROTECTION AGAINST RISK OF FIRE. REPLACE ONLY WITH SAME TYPE NO. 49102.5 MFD, BY LITTELFUSE INC. FOR IC4501, IC4502 (AEK7014).

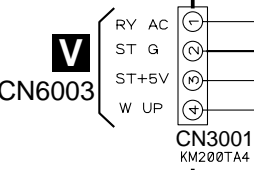

SP/PS ASSY
 (VSX-39TX : AWX7658)(VSX-37TX : AWX7688)
 (VSX-36TX, VSX-D909S : AWX7689)

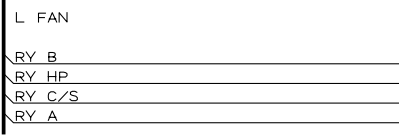

HA - HE

- Y8 : ADX7291 - (BLK)
- Y9 : ADX7292 - (WHT)
- Y10 : ADX7293 - (ORG)
- Y11 : ADX7294 - (VLT)
- Y12 : ADX7295 - (YEL)
- Y13 : ADX7296 - (GRN)
- Y17 : ADX7298 - (BLK)

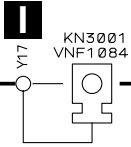

SPEAKER RELAY

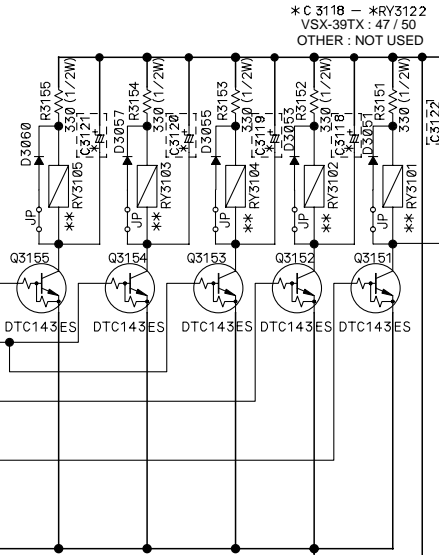

*C 3118 - **RY3122
VSX-39TX : 47 / 50
OTHER : NOT USED

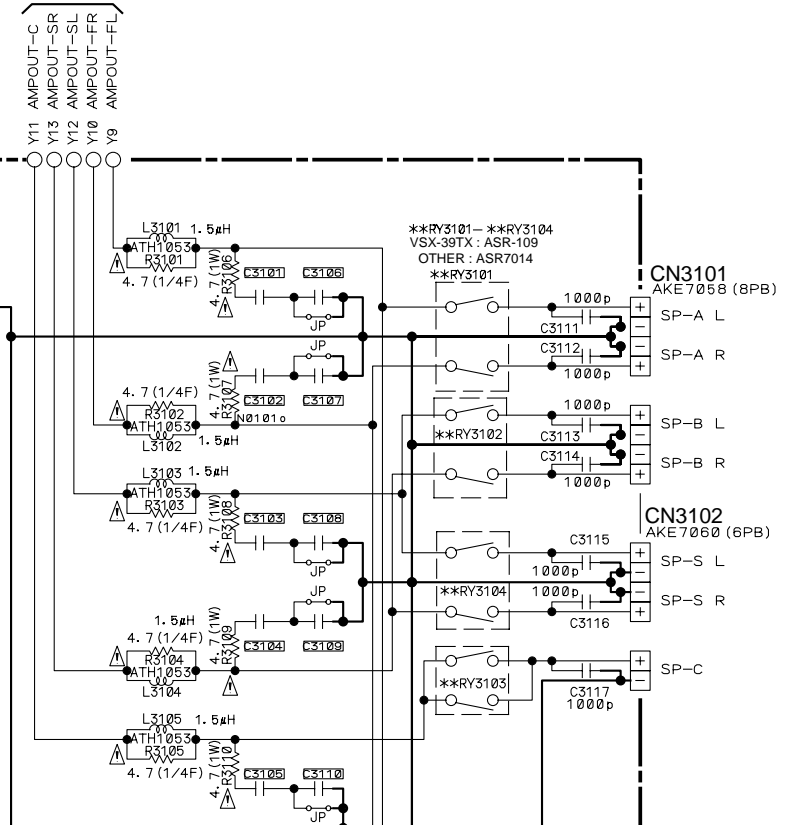

	VSX-36TX VSX-D909S	VSX-39TX VSX-37TX
C3101 C3105	CFTYA104J50	CFTYA104J50
C3106 C3110	JP	JP

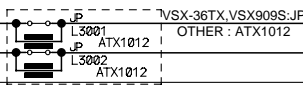

M CN5001

- 8 +VH
- 7 VH G
- 6 -VH
- 5 +15V
- 4 -15V
- 3 REG
- 2 REG G
- 1 REG

3004
51048-0800

- 1 HP R
- 2 NECK
- 3 HP L
- 4 ST+5V
- 5 ST G
- 6 W UP
- 7 RY AC
- 8 FAN
- 9 L FAN
- 10 STOP
- 11 RY B
- 12 RY HP
- 13 RY C/S
- 14 RY A

M CN5002

CN3003
52045-1445



3.11 REGULATOR, TRANS 1 and TRANS 2-2 ASSYS

M REGULATOR ASSY (AWX7310)

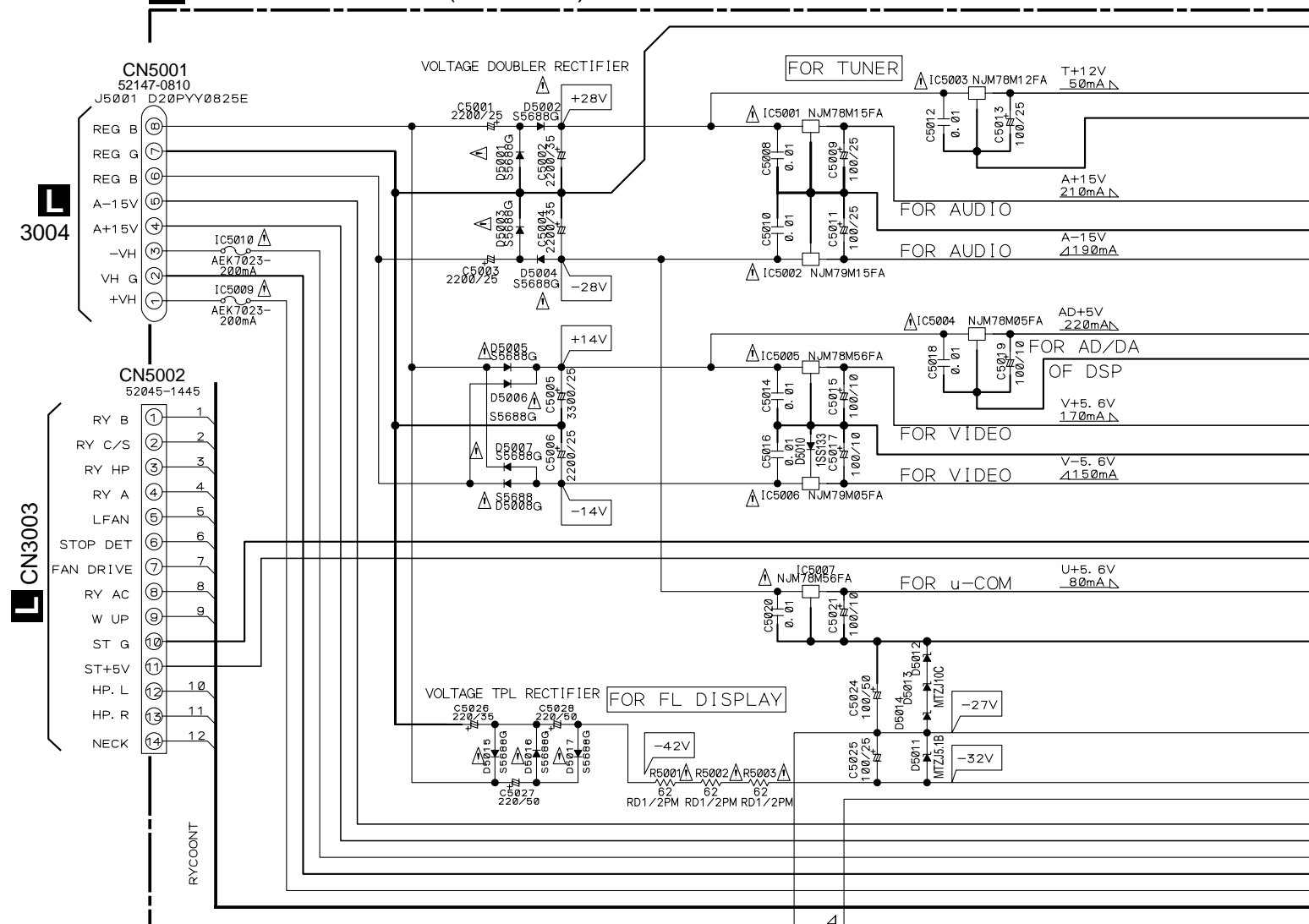

N TRANS 1 ASSY (AWX7316)

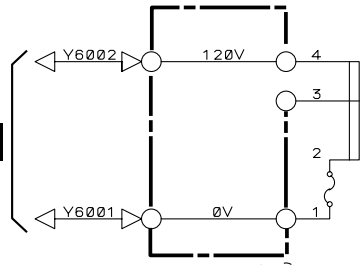

O TRANS 2-2 ASSY (AWX7366)

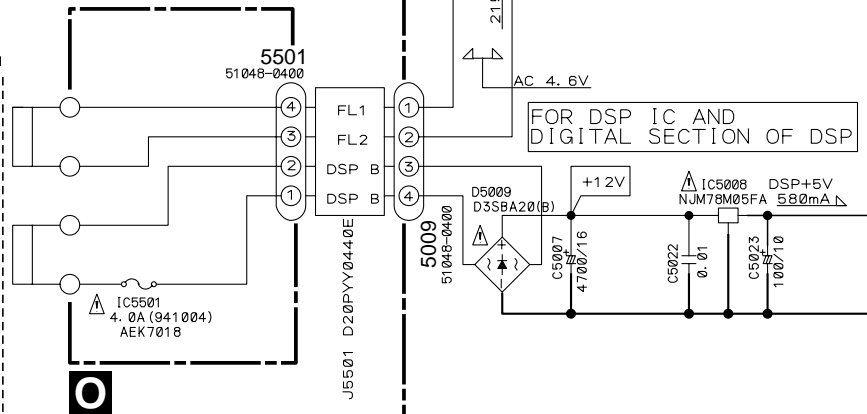

POWER TRANSFORMER

CAUTION : FOR CONTINUED PROTECTION AGAINST RISK OF FIRE. REPLACE ONLY WITH SAME TYPE NO. 491.200 MFD, BY LITTELFUSE INC. FOR IC5009, IC5010 (AEK7023).

CAUTION : FOR CONTINUED PROTECTION AGAINST RISK OF FIRE. REPLACE ONLY WITH SAME TYPE NO. 491004 MFD, BY LITTELFUSE INC. FOR IC5501 (AEK7018).

➔ : AUDIO SIGNAL ROUTE

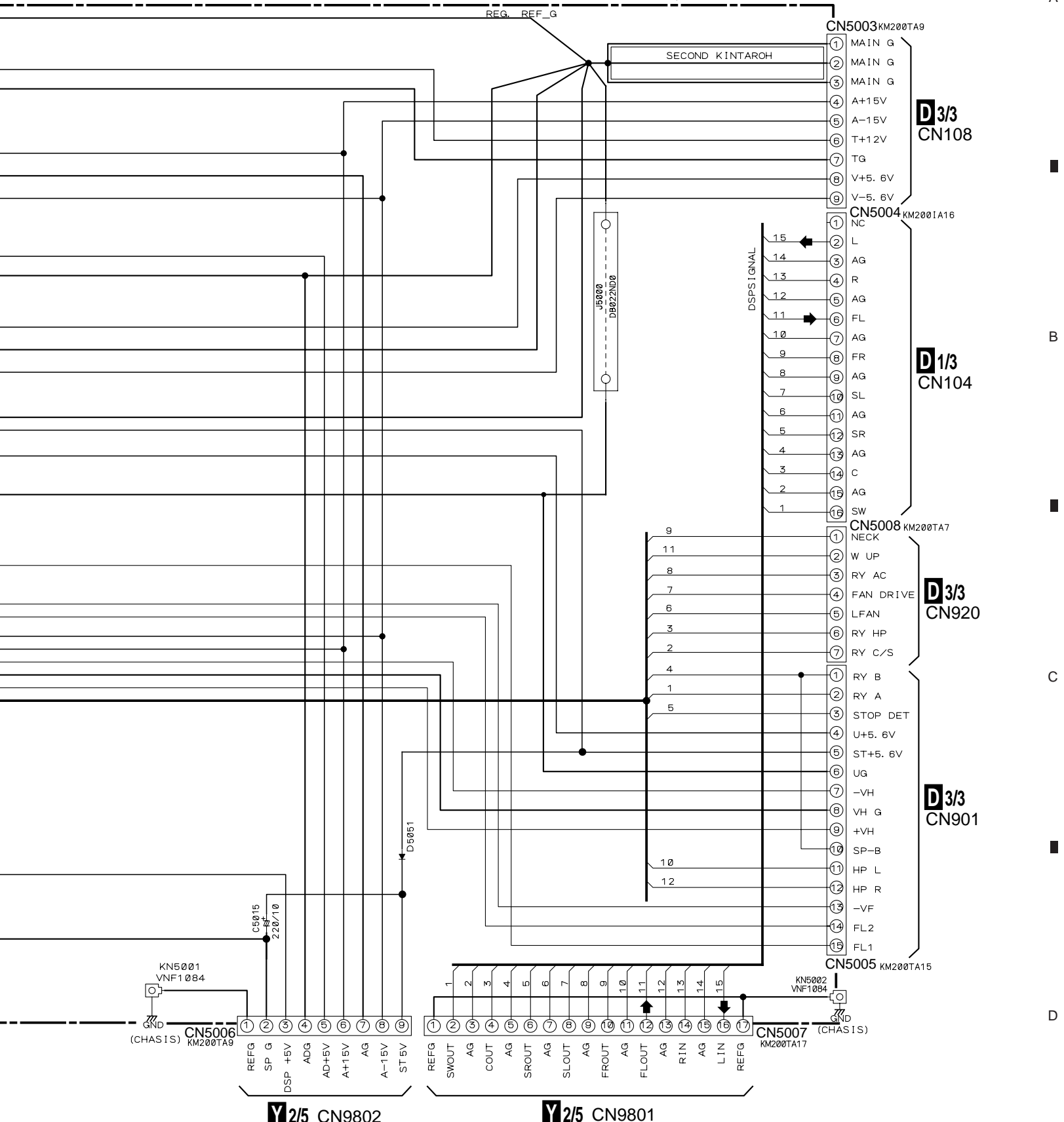

Y 2/5 CN9802

Y 2/5 CN9801



3.12 VIDEO and S-VIDEO ASSYS

P VIDEO ASSY
 (VSX-39TX : AWX7307)
 (VSX-37TX, VSX-36TX, VSX-D909S : AWX7394)

TRUTH TABLE OF IC751 (BU4053BCF)

CONDITION	A	B	C	INH	X OUT	Y OUT
S NOT USED	0	0	0	0	1X	1Y
S USED	1	1	1	0	0X	0Y

A

B

C

D

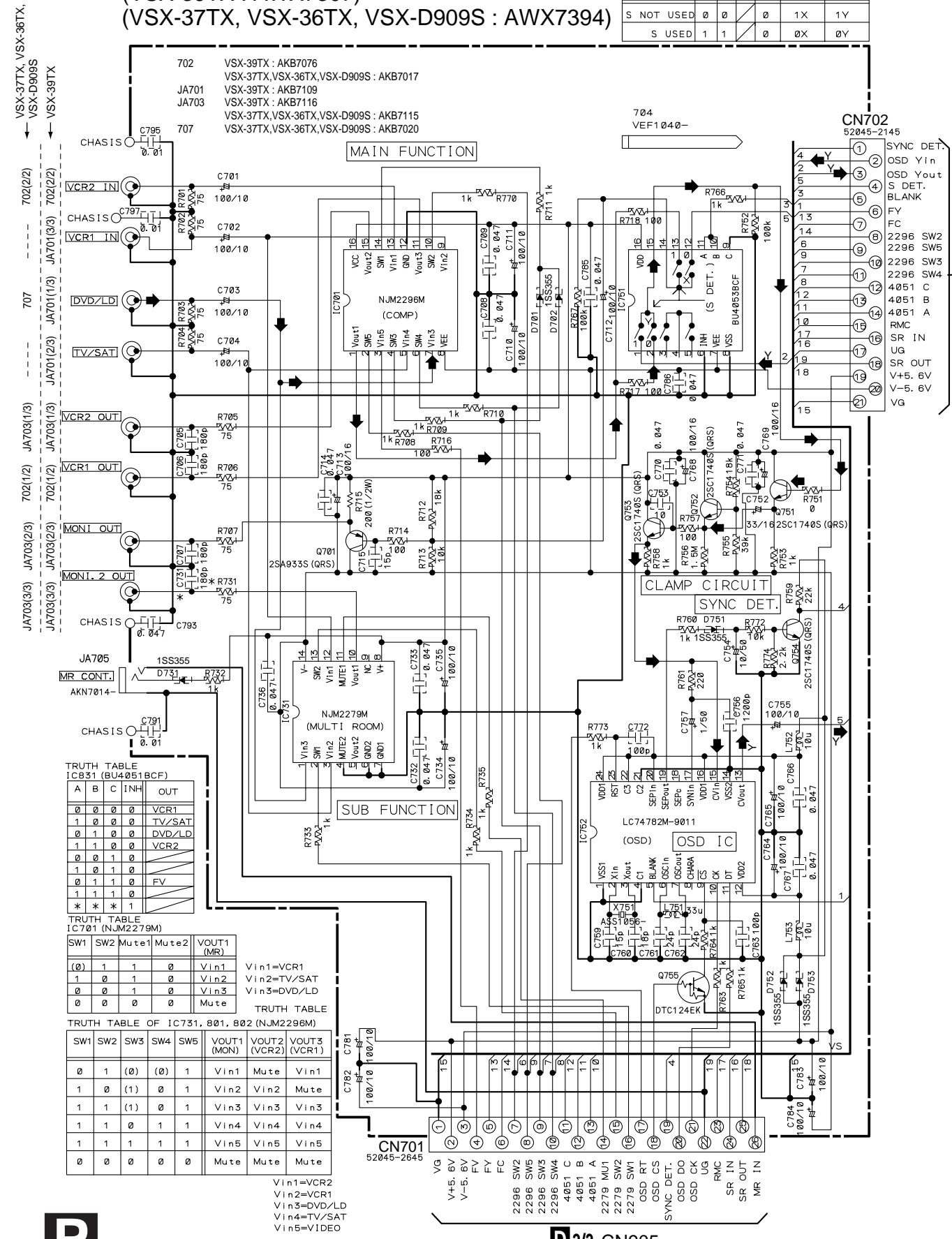

TRUTH TABLE IC751 (BU4051BCF)

A	B	C	INH	OUT
0	0	0	0	VCR1
1	0	0	0	TV/SAT
0	1	0	0	DVD/LD
0	1	1	0	VCR2
0	0	1	0	
1	0	1	0	
0	1	1	0	FV
1	1	1	0	
* * *	* * *	* * *	1	

TRUTH TABLE IC701 (NJM2279M)

SW1	SW2	Mute1	Mute2	VOUT1 (MR)
(0)	1	1	0	Vin1
1	0	1	0	Vin2
0	0	1	0	Vin3
0	0	0	0	Mute

TRUTH TABLE OF IC731, 801, 802 (NJM2296M)

SW1	SW2	SW3	SW4	SW5	VOUT1 (MON)	VOUT2 (VCR2)	VOUT3 (VCR1)
0	1	(0)	(0)	1	Vin1	Mute	Vin1
1	0	(1)	0	1	Vin2	Vin2	Mute
1	1	(1)	0	1	Vin3	Vin3	Vin3
1	1	0	1	1	Vin4	Vin4	Vin4
1	1	1	1	1	Vin5	Vin5	Vin5
0	0	0	0	0	Mute	Mute	Mute

Vin1=VCR2
 Vin2=VCR1
 Vin3=DVD/LD
 Vin4=TV/SAT
 Vin5=VIDEO



Q S-VIDEO ASSY
 (VSX-39TX : AWX7678)
 (OTHERS : AWX7679)

- ▶ : AUDIO SIGNAL ROUTE
- Y : Y SIGNAL ROUTE
- C : C SIGNAL ROUTE

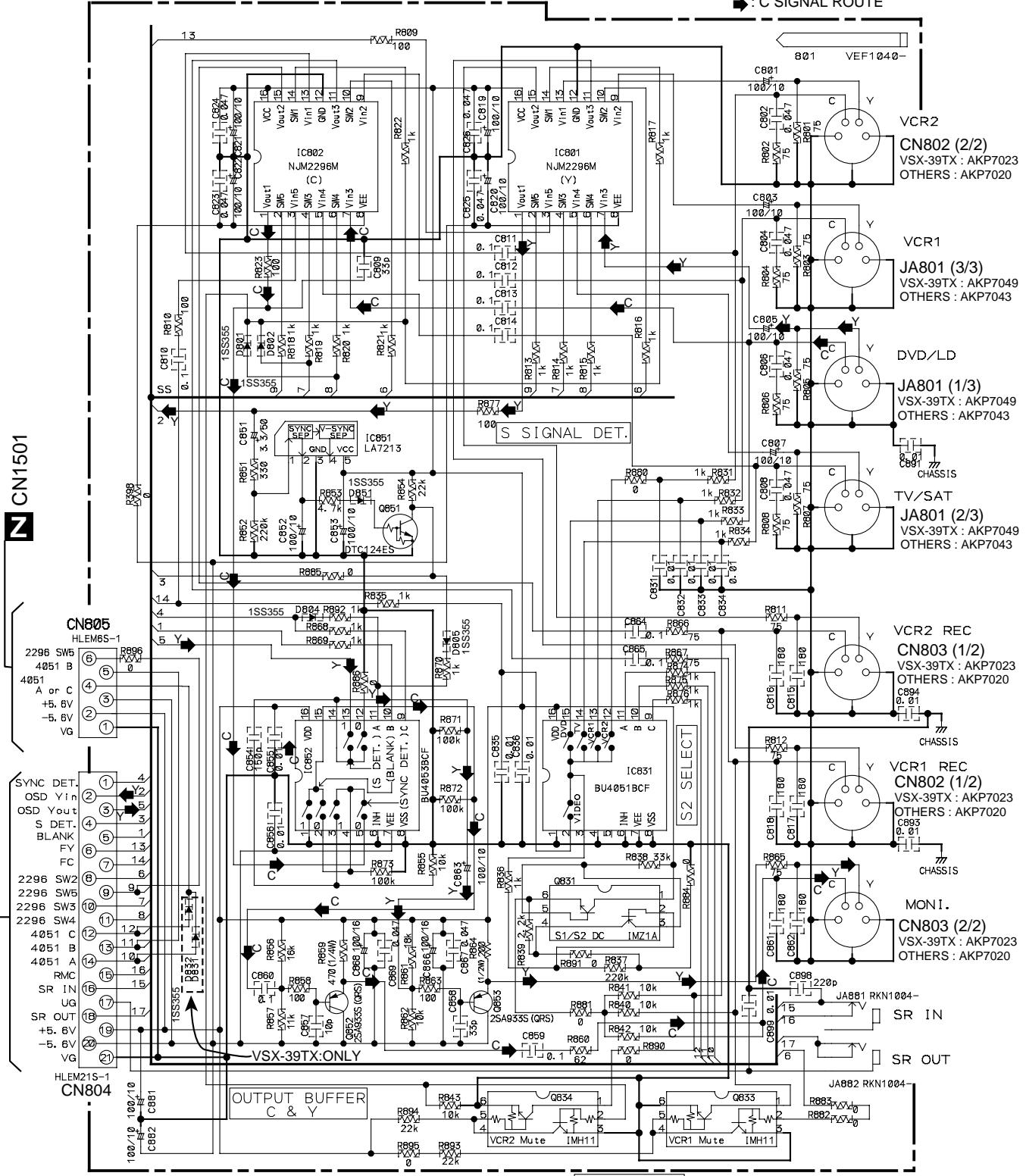

FOR ISOLATOR (0 OHM)

- R771 R887
- R775 R888
- R776 R889
- R777
- R778

C REC MUTE



VSX-39TX, VSX-37TX, VSX-36TX, VSX-D909S

3.13 H. PHONE/F. VIDEO, DISPLAY, ROTARY ENCODER and VOLUME ASSYS

R H. PHONE/F. VIDEO ASSY
(VSX-39TX, VSX-37TX : AWX7342)
(OTHERS : AWX7528)

S DISPLAY ASSY
(VSX-39TX, VSX-37TX : AWX7698)
(VSX-36TX : AWX7699)
(VSX-D909S : AWX7700)

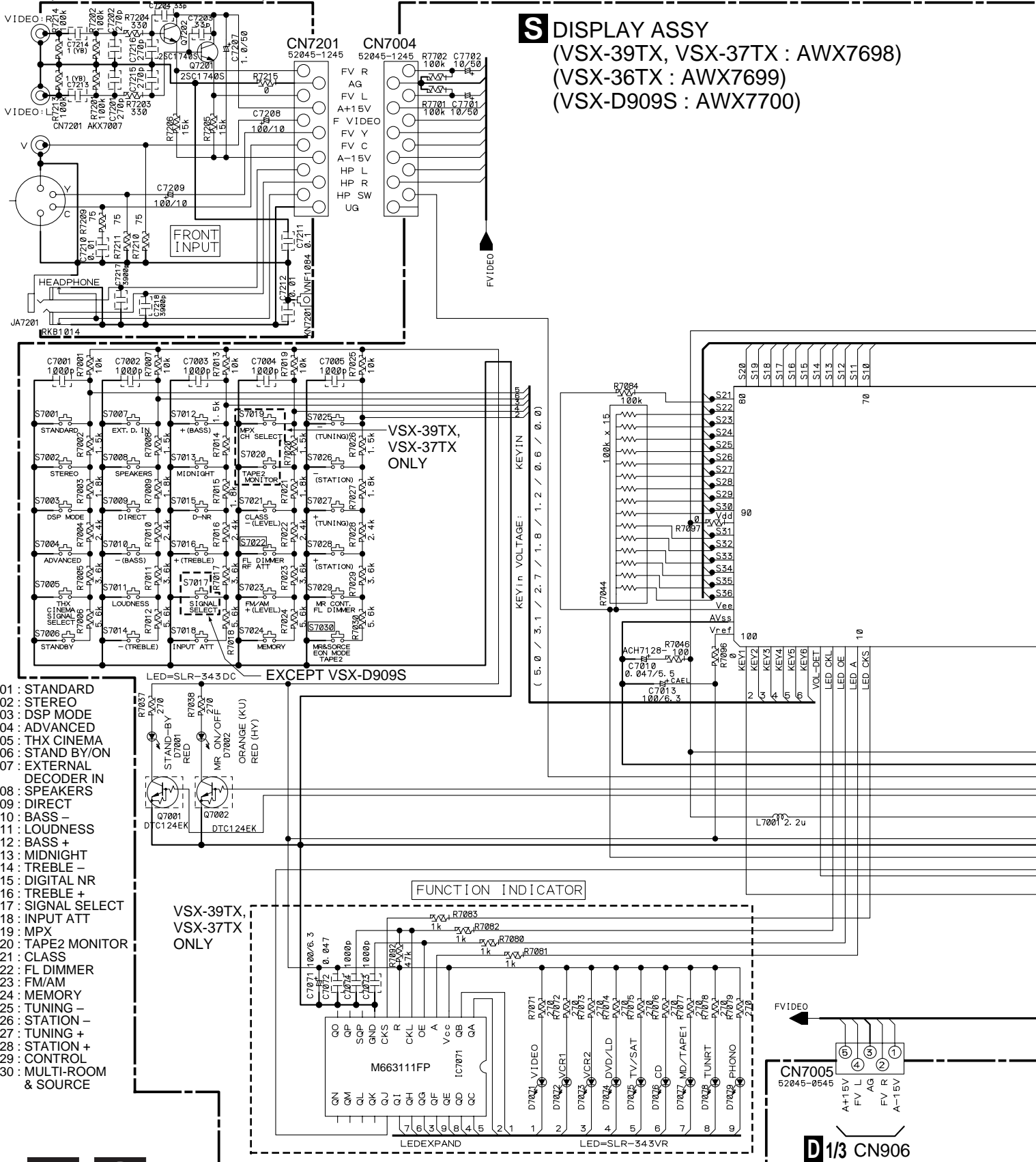

A

B

C

D

- S7001 : STANDARD
- S7002 : STEREO
- S7003 : DSP MODE
- S7004 : ADVANCED
- S7005 : THX CINEMA
- S7006 : STAND BY/ON
- S7007 : EXTERNAL
DECODER IN
- S7008 : SPEAKERS
- S7009 : DIRECT
- S7010 : BASS -
- S7011 : LOUDNESS
- S7012 : BASS +
- S7013 : MIDNIGHT
- S7014 : TREBLE -
- S7015 : DIGITAL NR
- S7016 : TREBLE +
- S7017 : SIGNAL SELECT
- S7018 : INPUT ATT
- S7019 : MPX
- S7020 : TAPE2 MONITOR
- S7021 : CLASS
- S7022 : FL DIMMER
- S7023 : FM/AM
- S7024 : MEMORY
- S7025 : TUNING -
- S7026 : STATION -
- S7027 : TUNING +
- S7028 : STATION +
- S7029 : CONTROL
- S7030 : MULTI-ROOM
& SOURCE



D 1/3 CN906

T ROTARY ENCODER ASSY
(VSX-39TX, VSX-37TX : AWX7328)
(VSX-26TX, VSX-D909S : AWX7405)

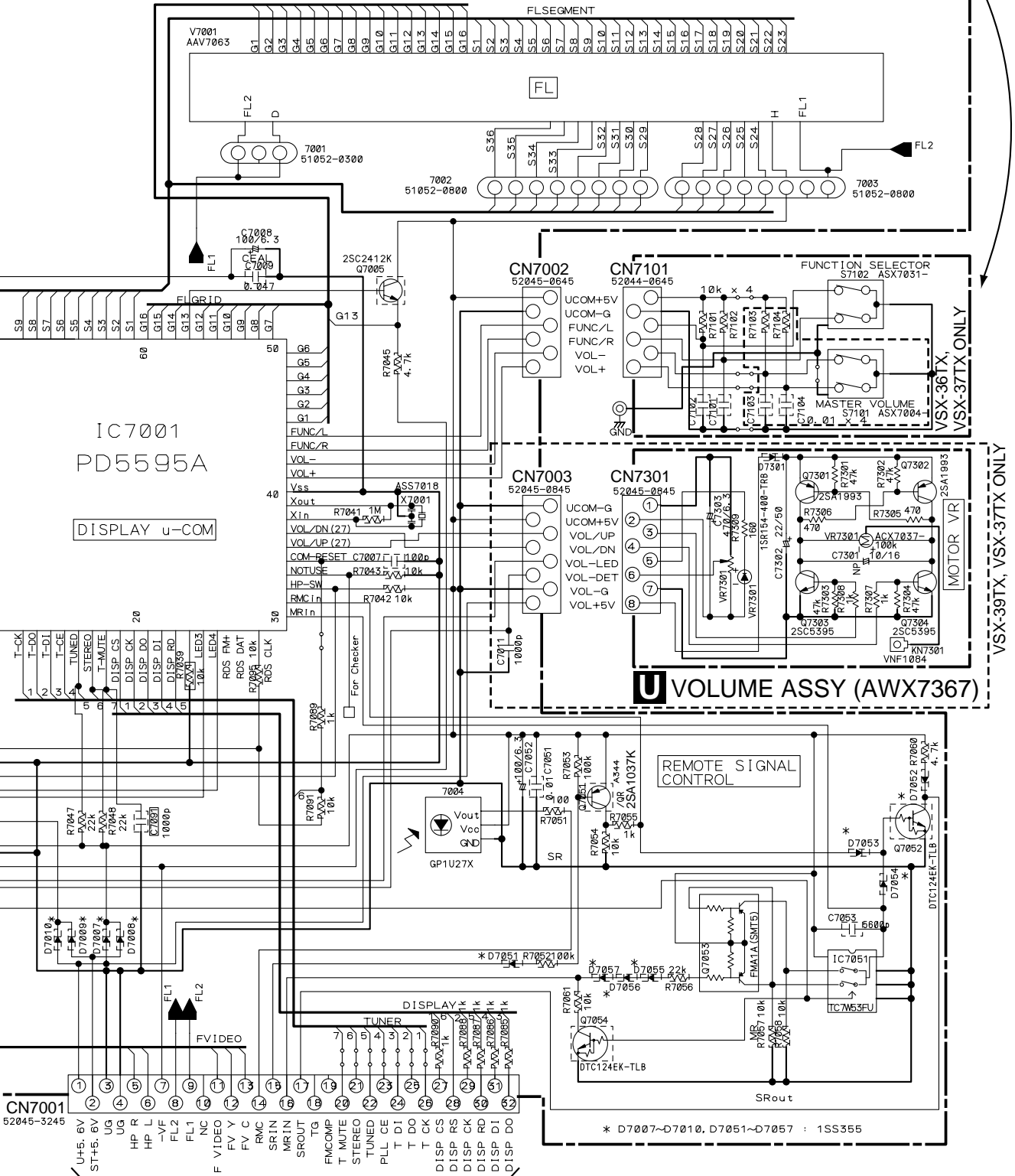

D3/3 CN904



3.14 PRIMARY ASSY

V PRIMARY ASSY (AWX7311)

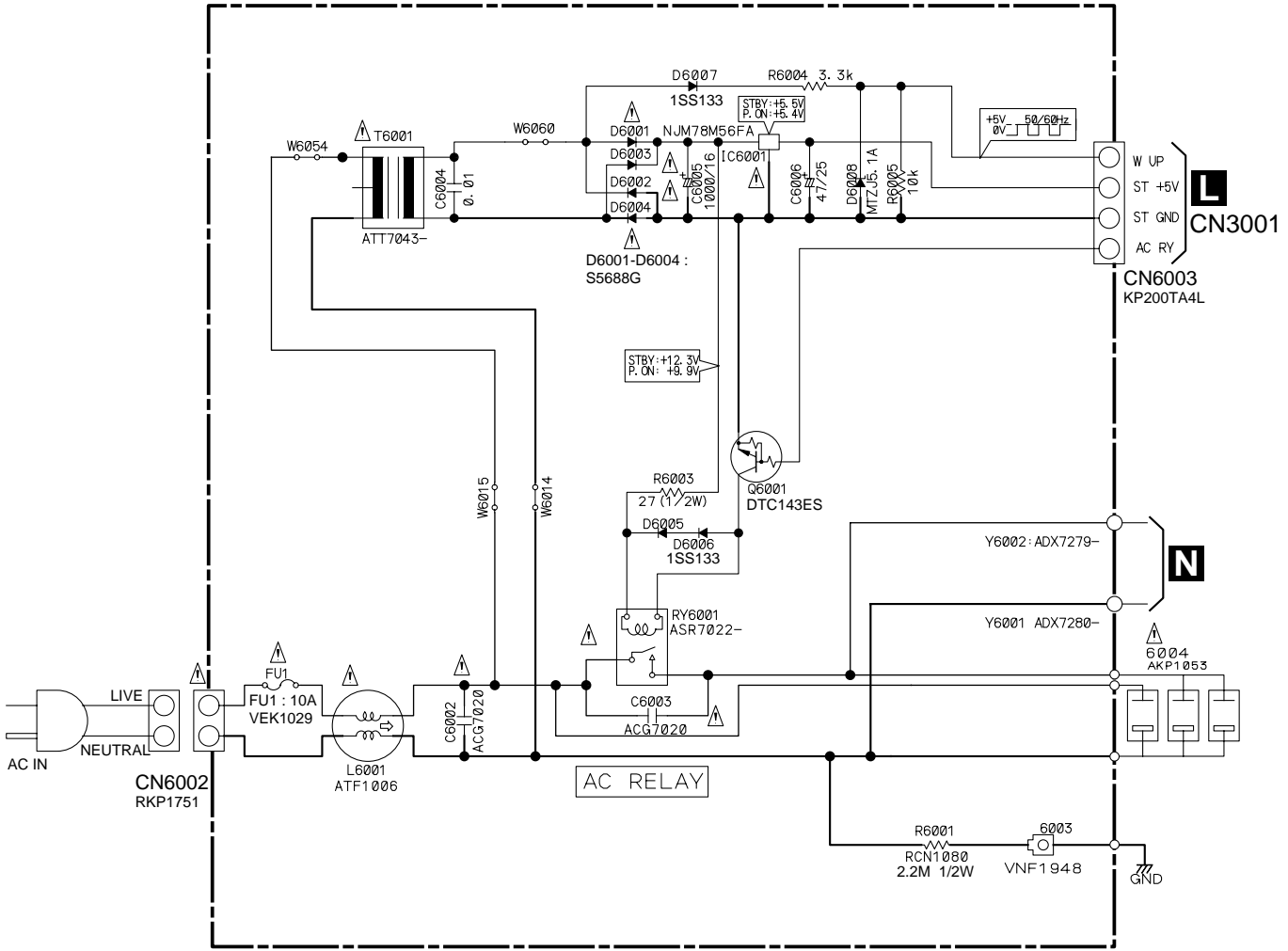

• NOTE FOR FUSE REPLACEMENT

**CAUTION -FOR CONTINUED PROTECTION AGAINST RISK OF FIRE.
REPLACE WITH SAME TYPE AND RATINGS ONLY.**

3.15 RF/DIGITAL INPUT and OPT OUT ASSYS

W RF / DIGITAL INPUT ASSY
 (VSX-39TX : AWX7637) (VSX-37TX : AWX7638)
 (VSX-36TX, VSX-D909S : AWX7642)

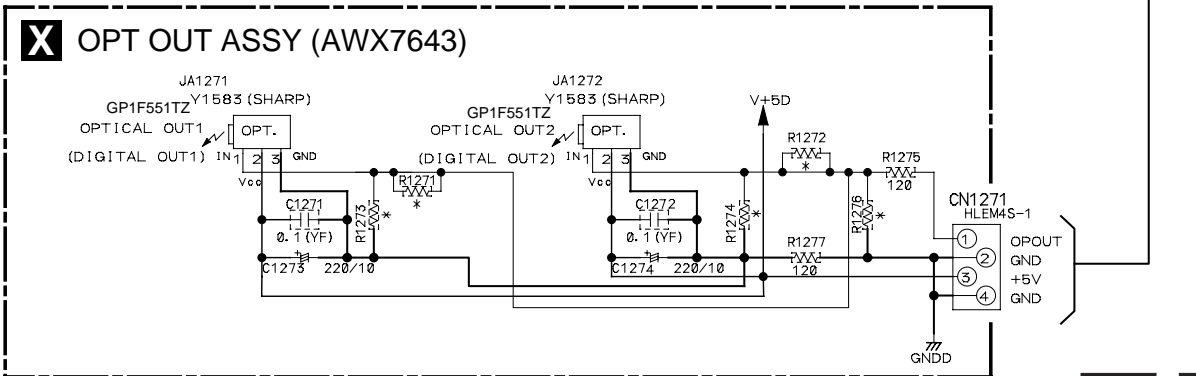
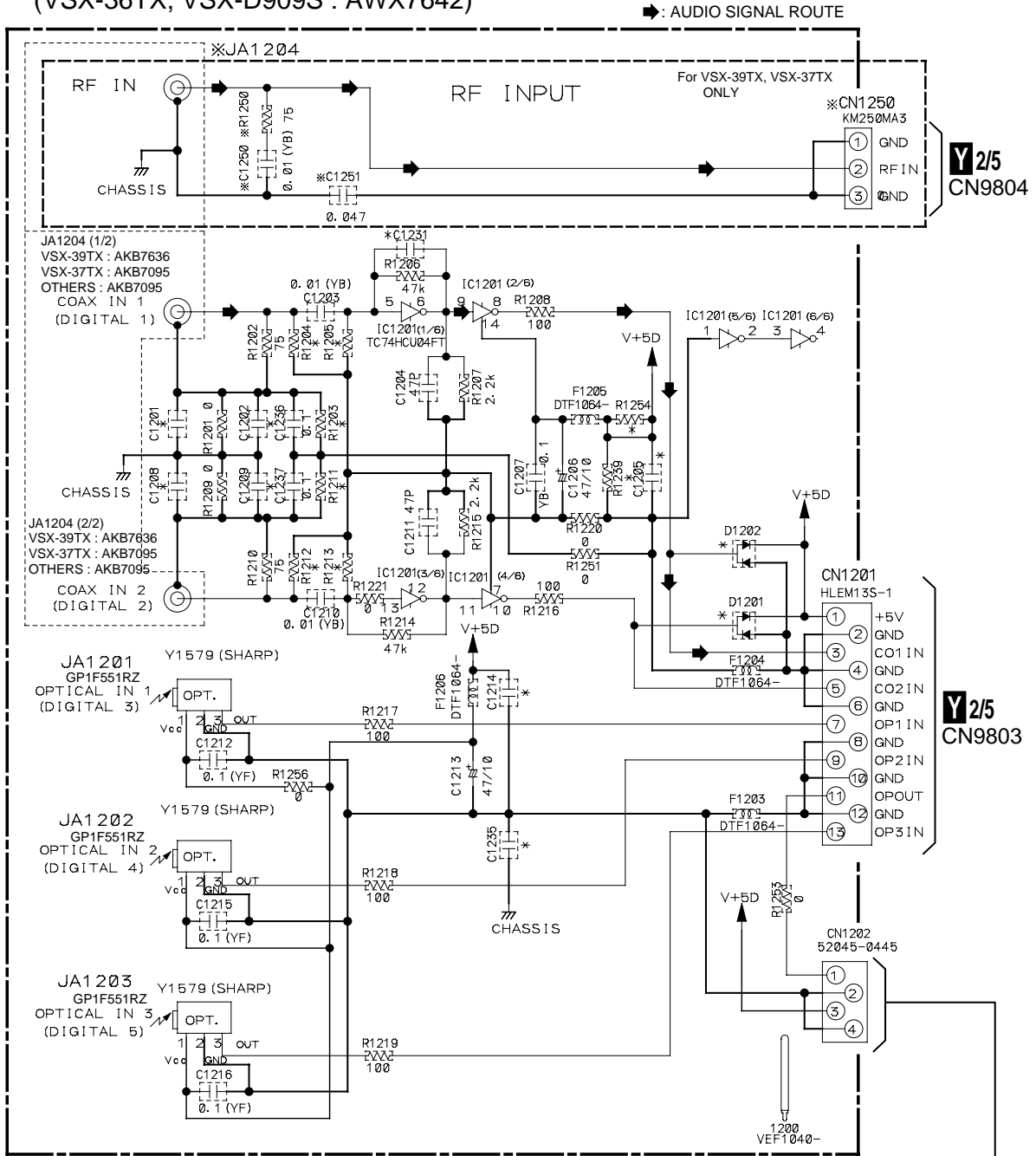

3.16 DSP ASSY (1/5)

Y 1/5 DSP ASSY
 (VSX-39TX, VSX-37TX : AWX7632)
 (VSX-36TX, VSX-D909S : AWX7633)

RF AMP

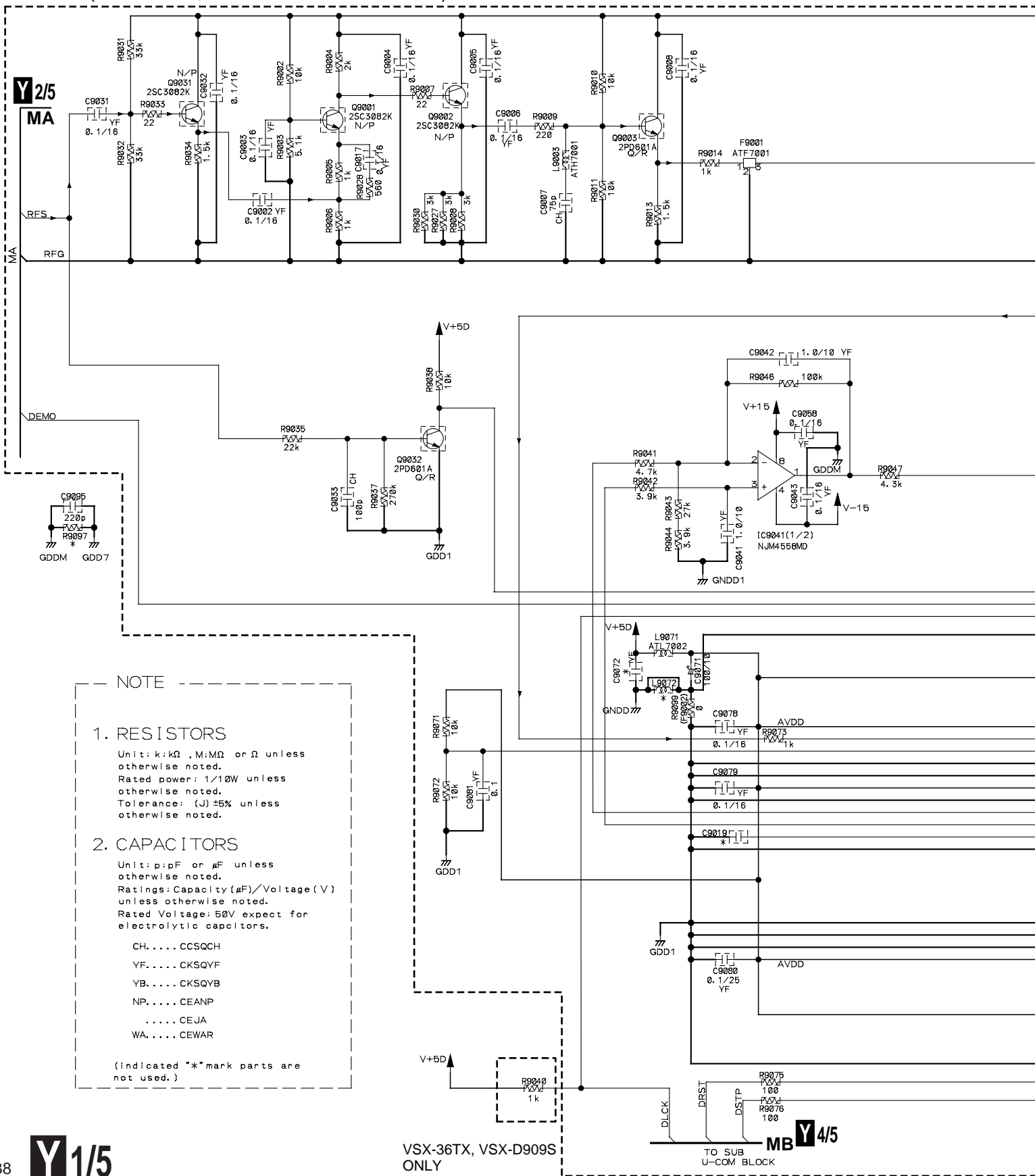

NOTE

1. RESISTORS
 Unit: k:kΩ, M:MΩ or Ω unless otherwise noted.
 Rated power: 1/10W unless otherwise noted.
 Tolerance: (J) ±5% unless otherwise noted.

2. CAPACITORS
 Unit: p:pF or μ:μF unless otherwise noted.
 Ratings: Capacity (μF)/Voltage (V) unless otherwise noted.
 Rated Voltage: 50V expect for electrolytic capacitors.

CH....CCSQCH
 YF....CKSQYF
 YB....CKSQYB
 NP....CEANP
CEJA
 WA....CEWAR

(indicated "*" mark parts are not used.)

VSX-36TX, VSX-D909S ONLY

TO SUB U-COM BLOCK **MB Y 4/5**

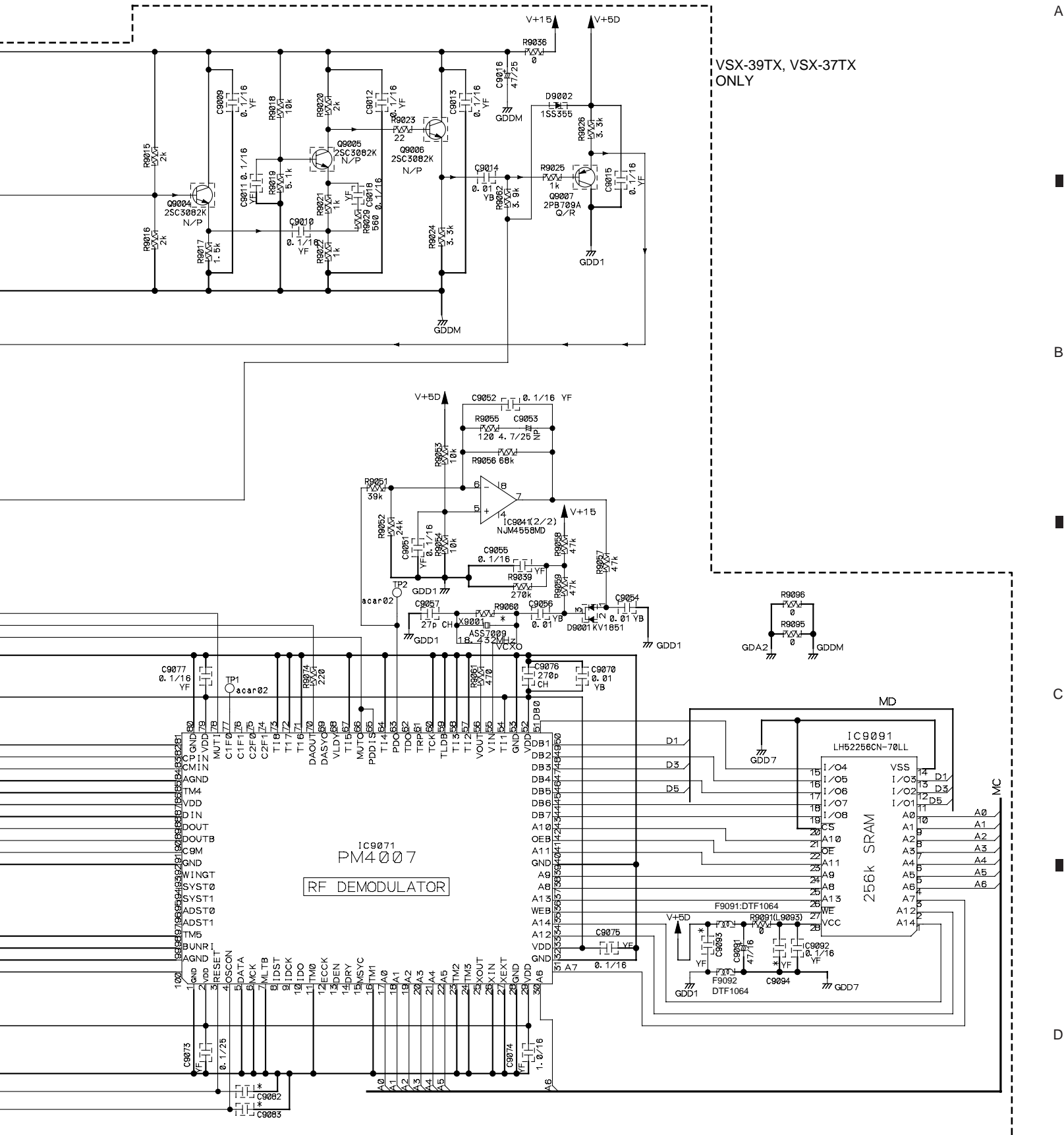

VSX-39TX, VSX-37TX ONLY

IC9071
PM4007
RF DEMODULATOR

MD

256k SRAM

MC

3.17 DSP ASSY (2/5)

A

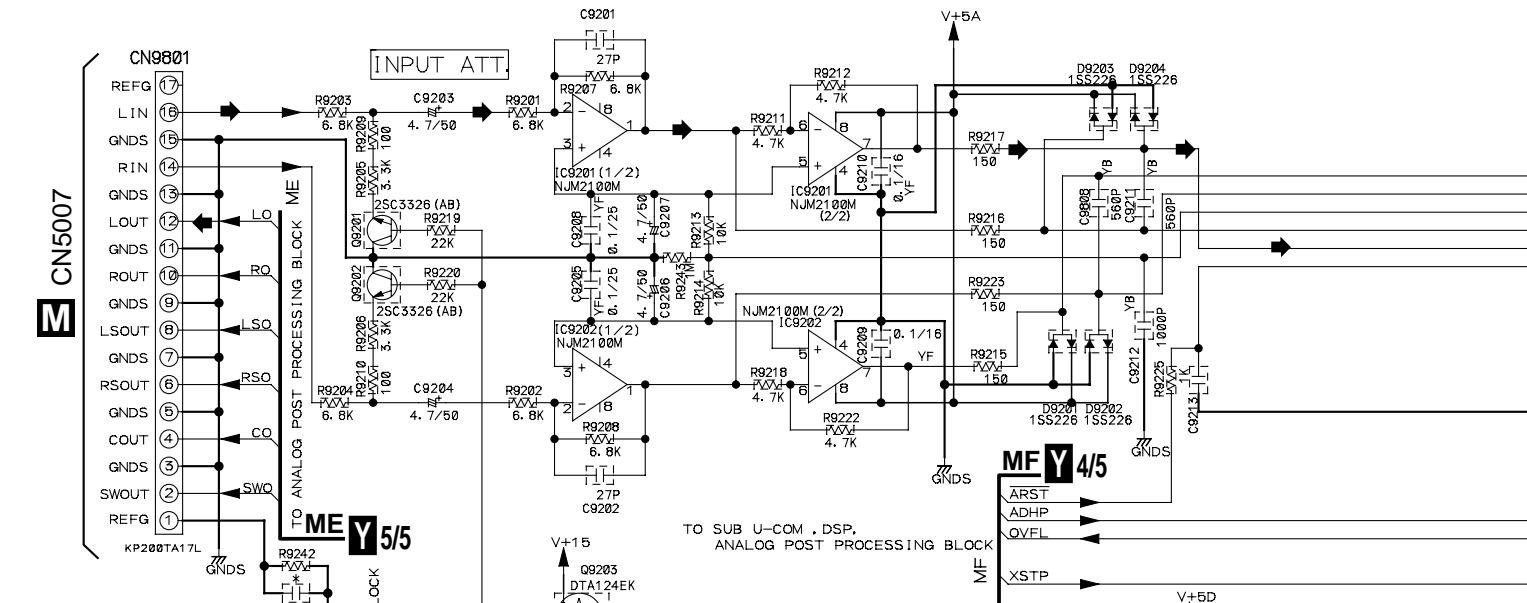

B

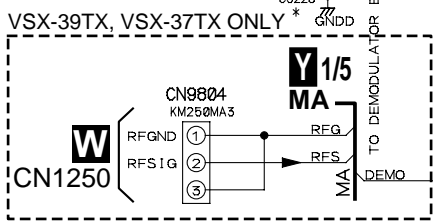

C

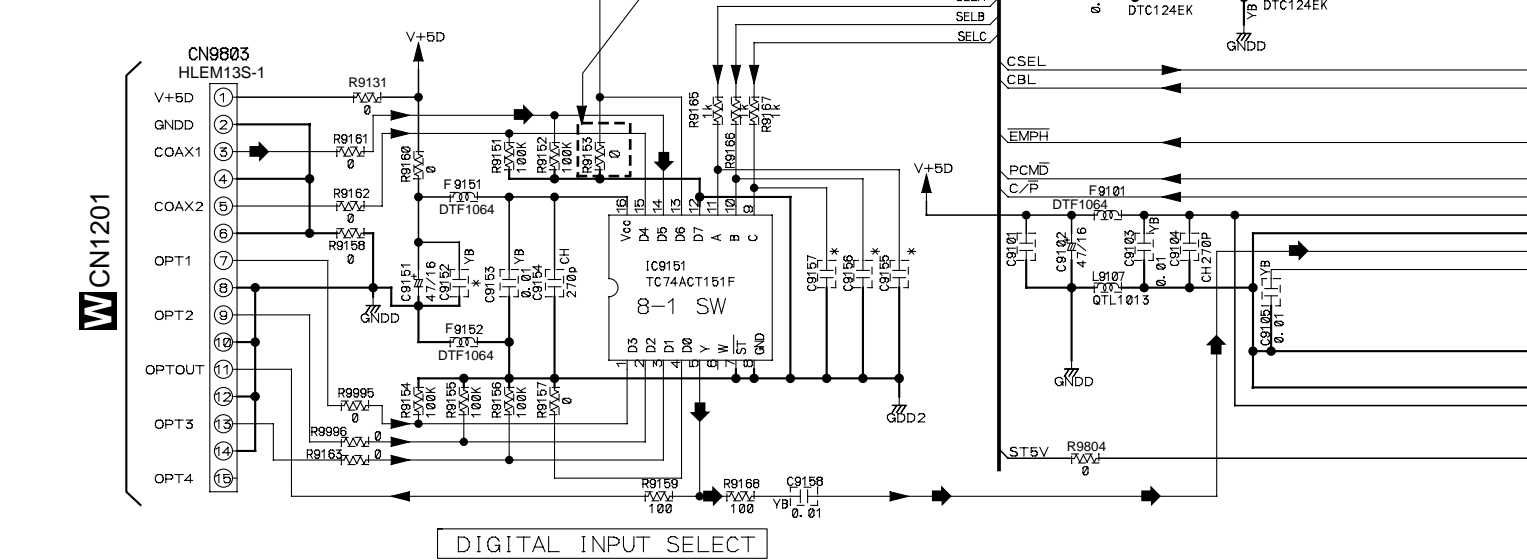

Y2/5 DSP ASSY
 (VSX-39TX, VSX-37TX : AWX7632)
 (VSX-36TX, VSX-D909S : AWX7633)

: The power supply is shown with the marked box.

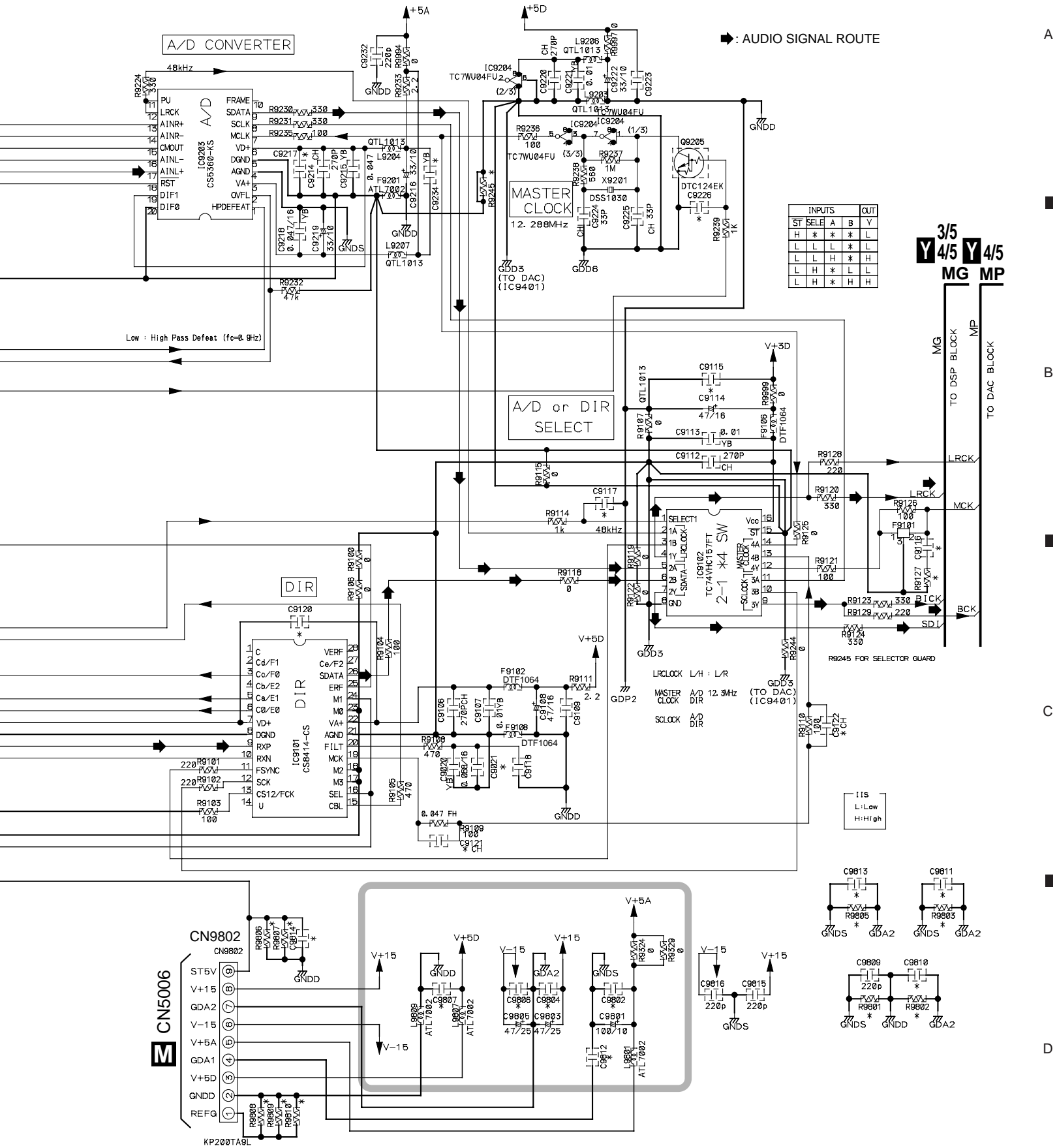

3.18 DSP ASSY (3/5)

Y 3/5 DSP ASSY
 (VSX-39TX, VSX-37TX : AWX7632)
 (VSX-36TX, VSX-D909S : AWX7633)

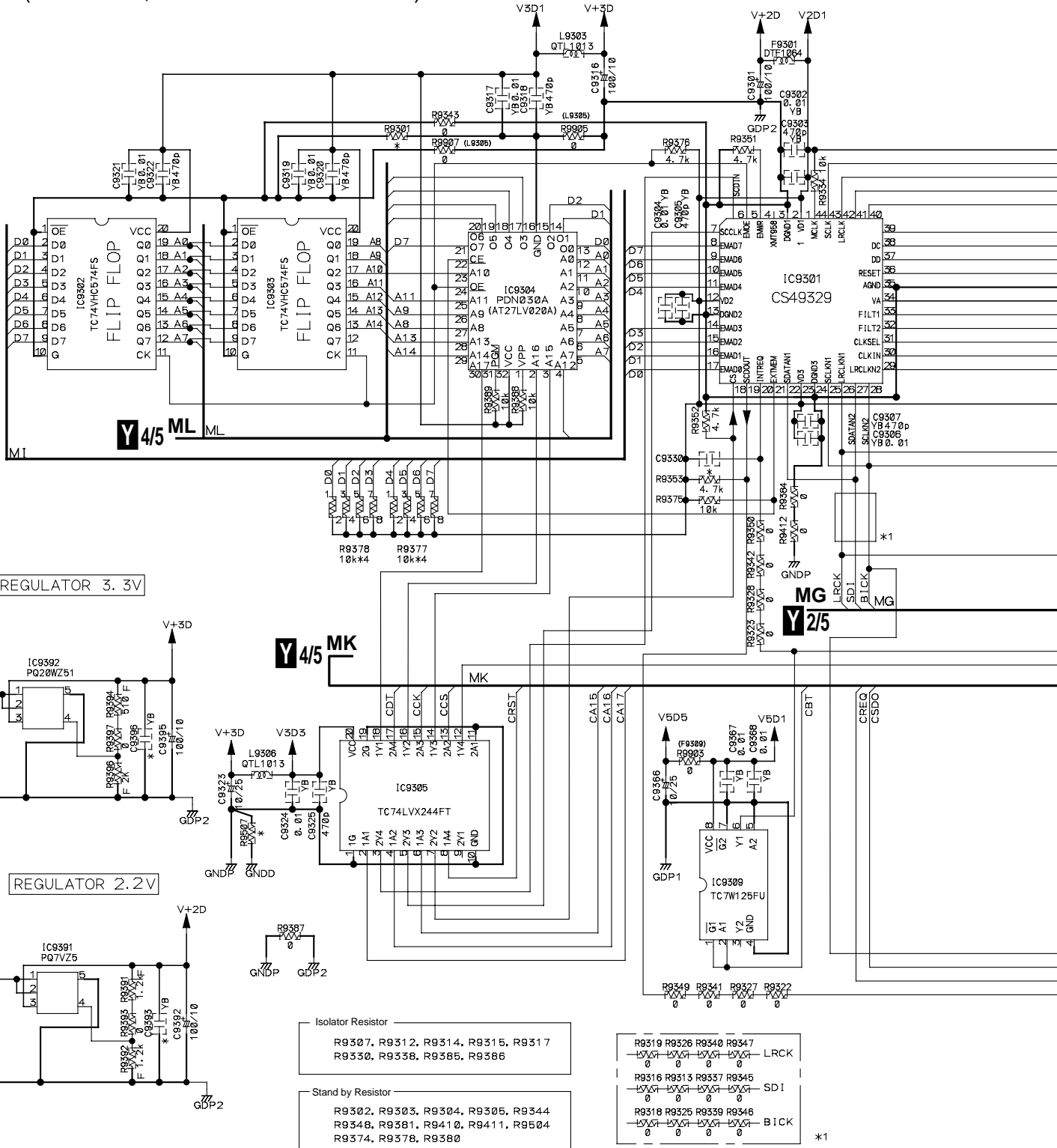

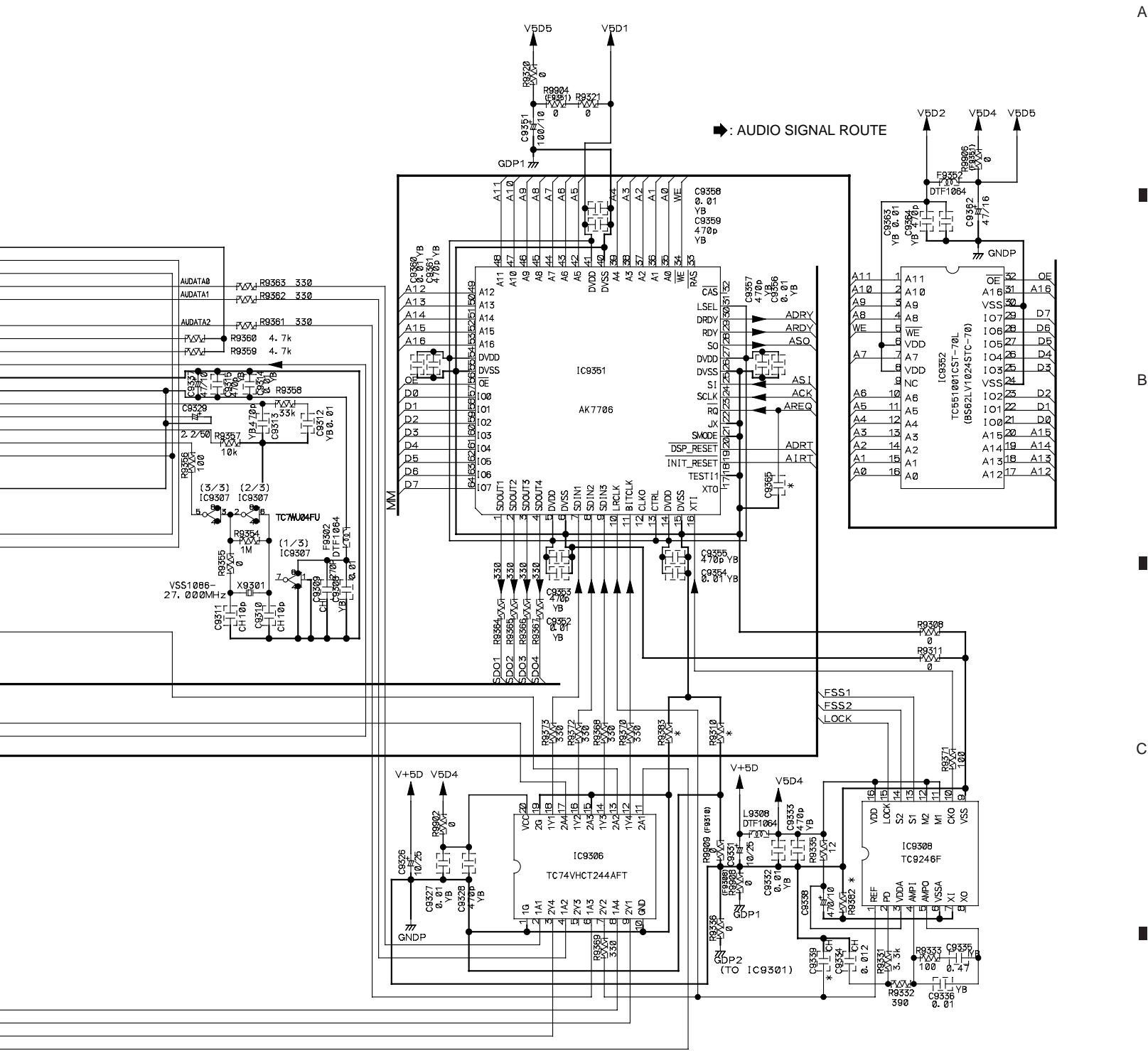

VSX-39TX, VSX-37TX, VSX-36TX, VSX-D909S

3.19 DSP ASSY (4/5)

Y 4/5 DSP ASSY
 (VSX-39TX, VSX-37TX : AWX7272)
 (VSX-36TX, VSX-D909S : AWX7633)

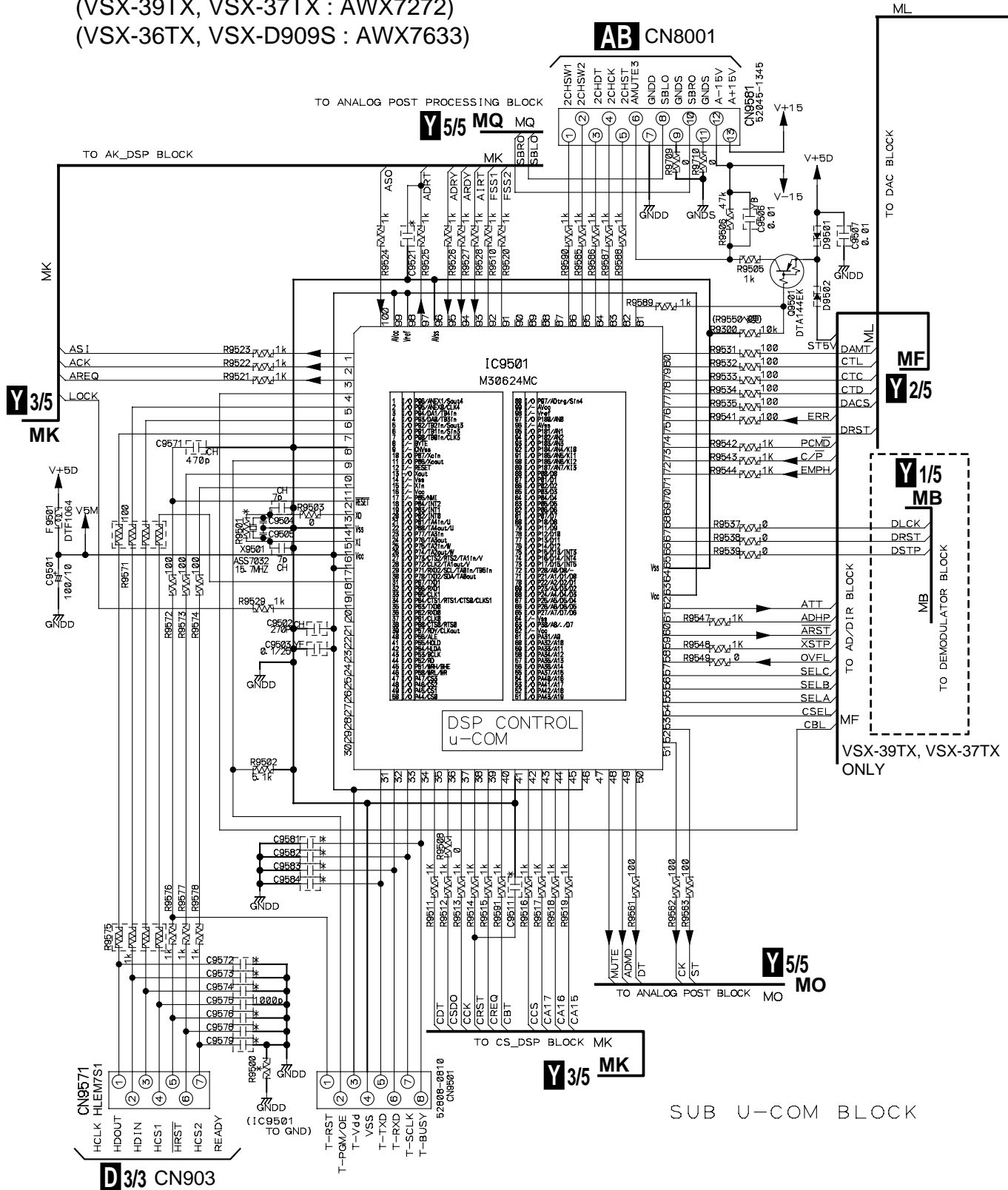

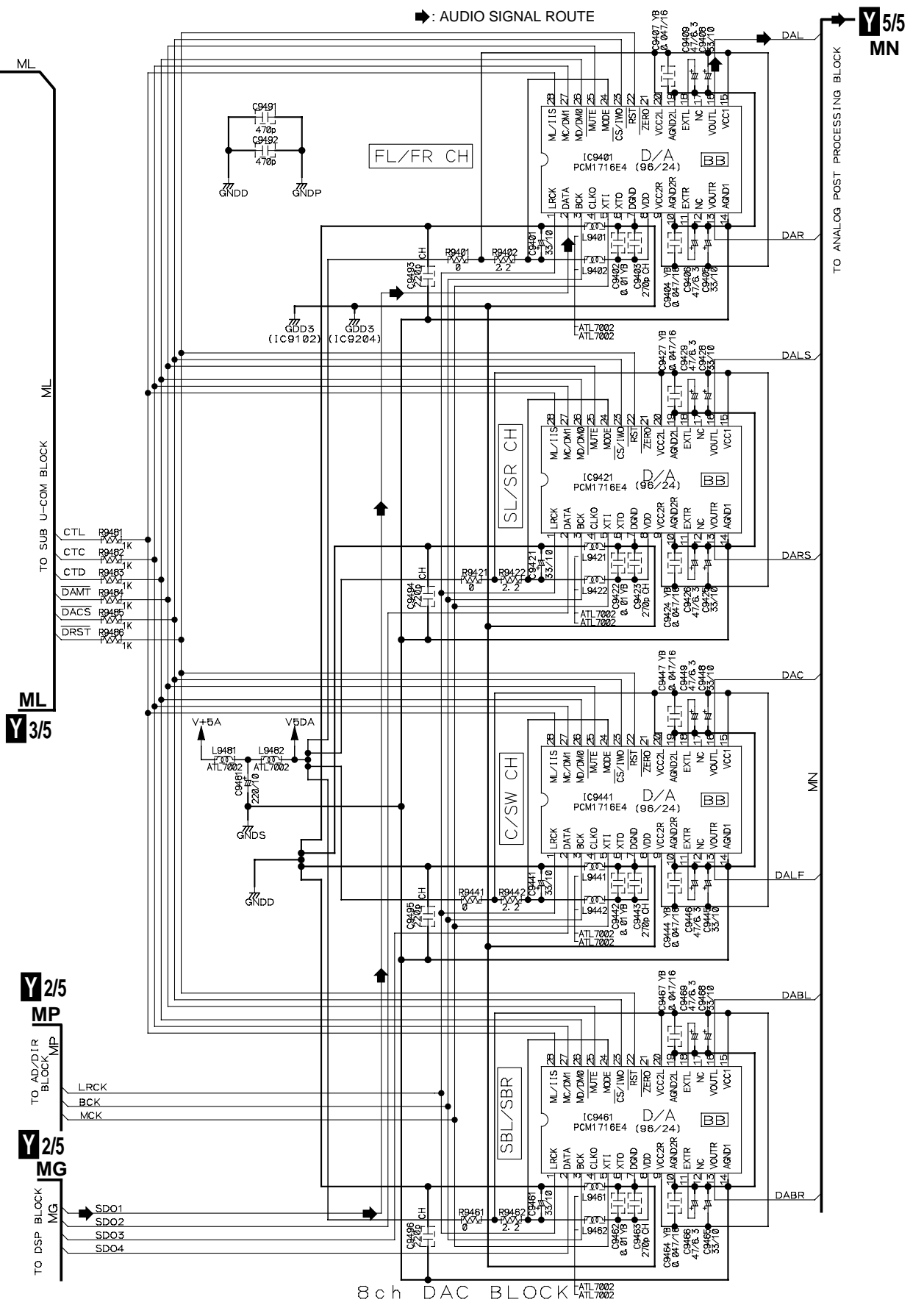

A

B

C

D

3.20 DSP ASSY (5/5)

Y 5/5
DSP ASSY
 (VSX-39TX, VSX-37TX : AWX7632)
 (VSX-36TX, VSX-D909S : AWX7633)

A

B

C

D

Y 4/5
MN

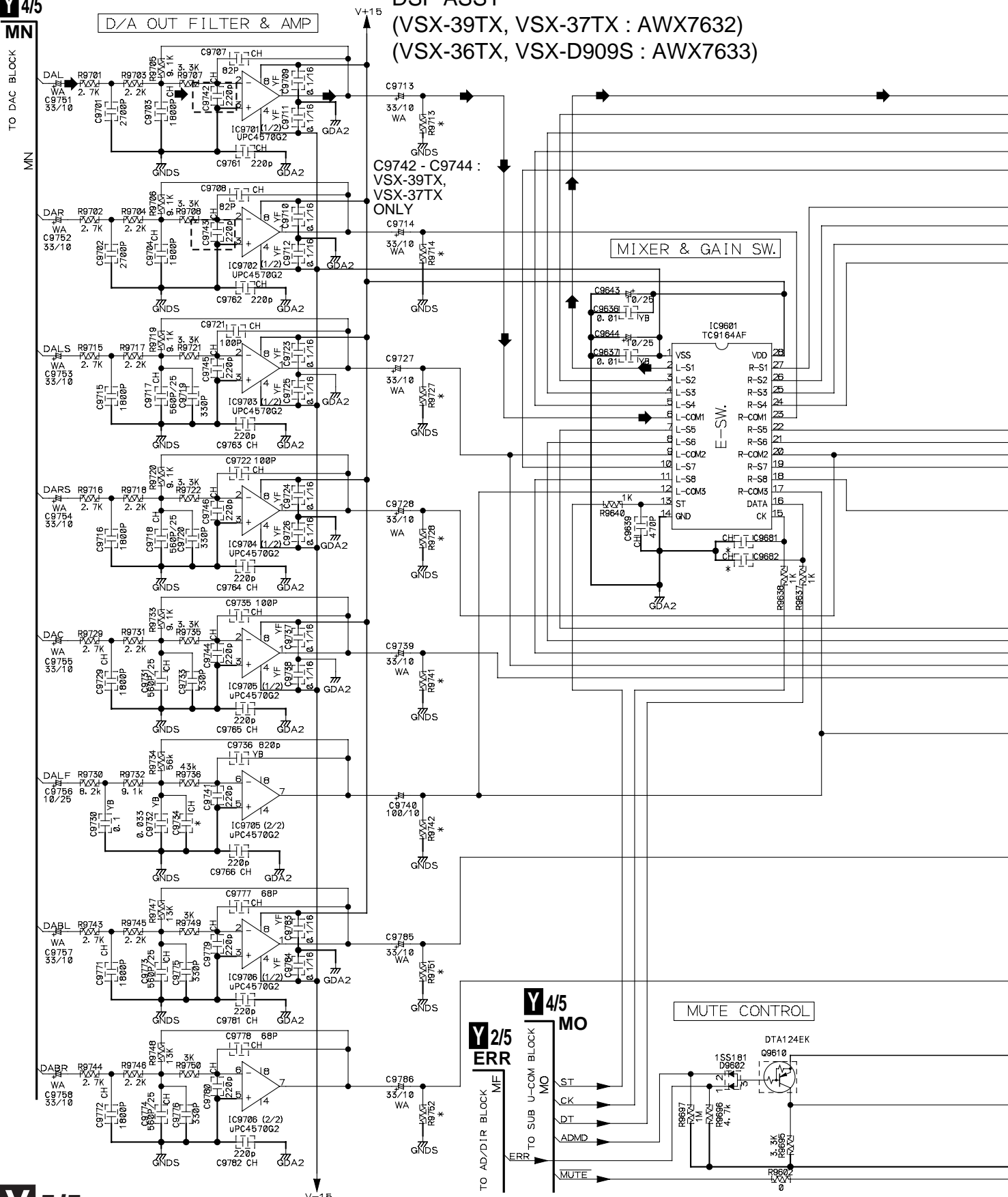

VSX-39TX, VSX-37TX, VSX-36TX, VSX-D909S

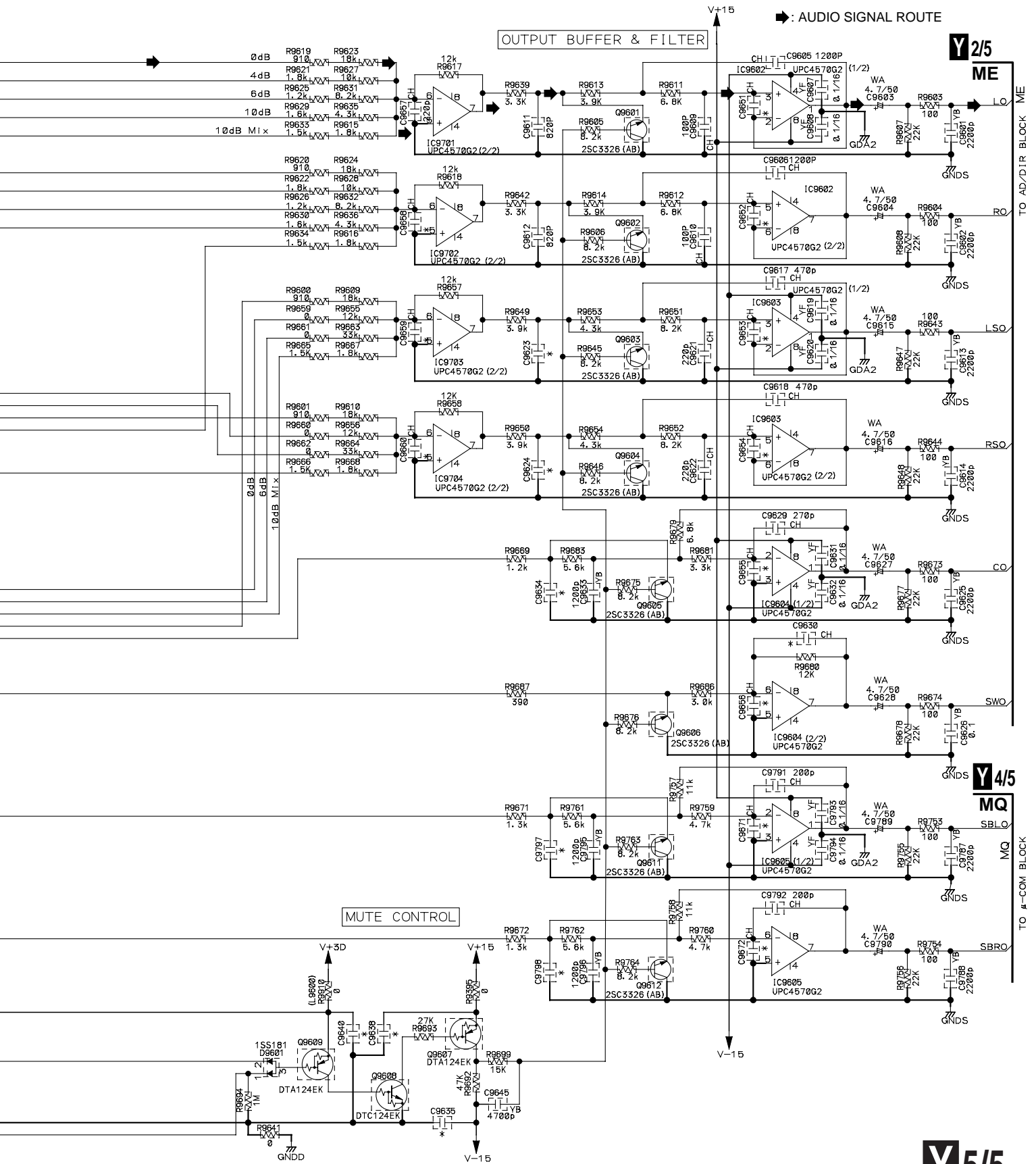

3.21 2CH I/O PJ and TRIM ASSYS

A

B

C

D

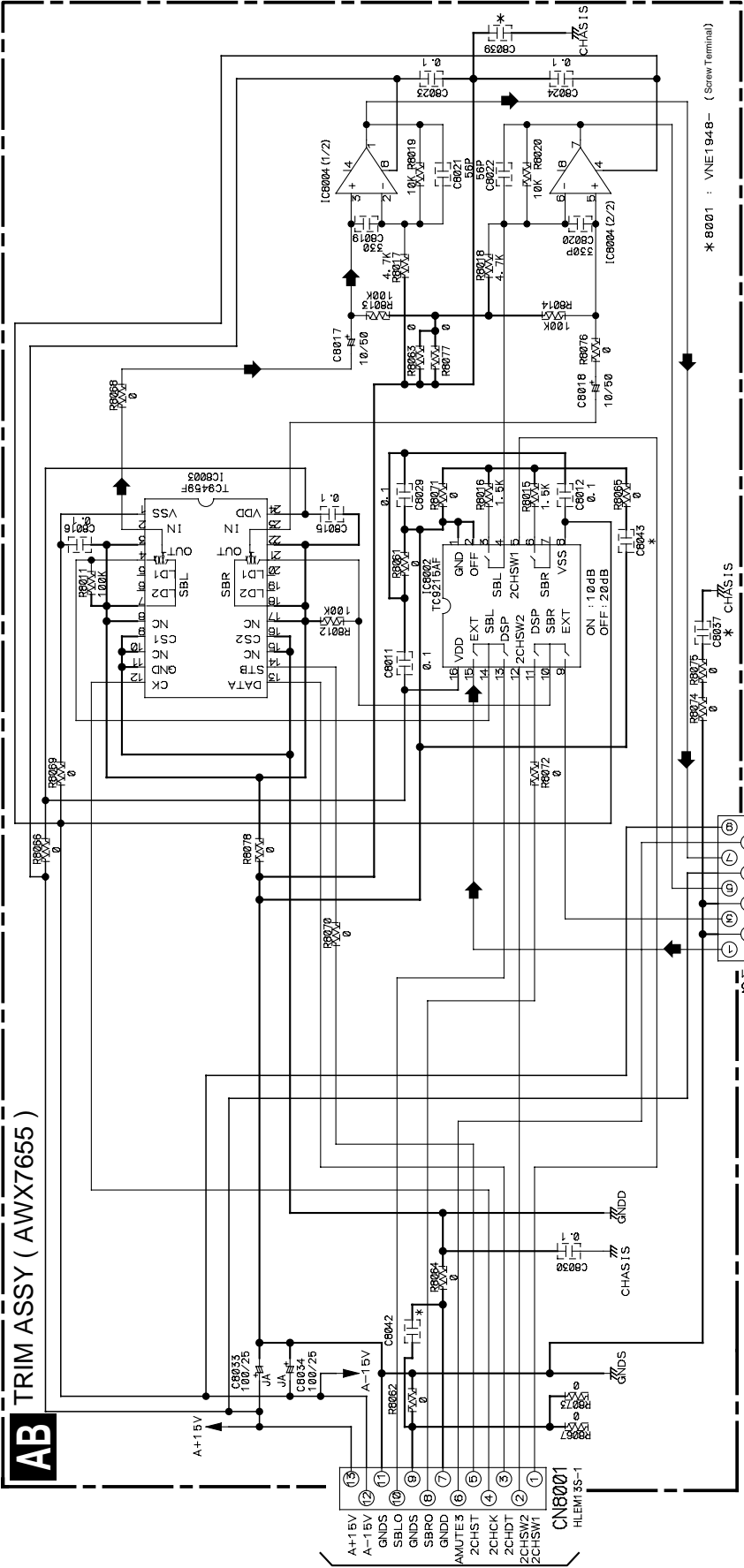

➡ : AUDIO SIGNAL ROUTE

CN8004 (2/2)
VSX-39TX : AKP7129
OTHERS : AKP7087

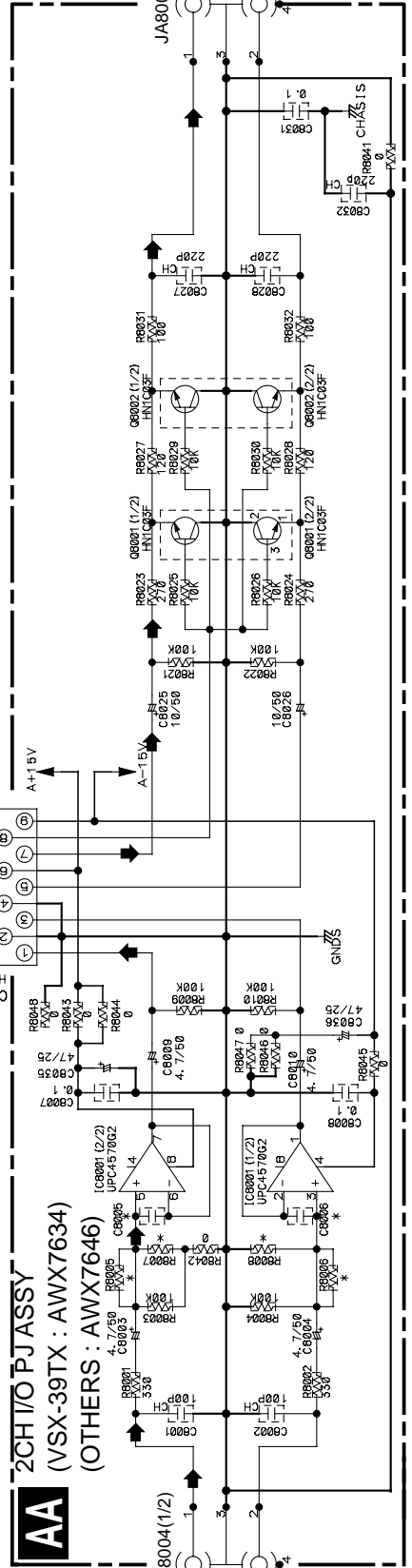

CN8004 (1/2)
VSX-39TX : AKP7129
OTHERS : AKP7087

AB TRIM ASSY (AWX7655)

AA 2CH I/O PJ ASSY
(VSX-39TX : AWX7634)
(OTHERS : AWX7646)

Y4/5 CN9581

3.22 COMPONENT ASSY

Z COMPONENT ASSY
 (VSX-39TX : AWX7635)
 (VSX-37TX, VSX-36TX, VSX-D909S : AWX7636)

Table of truth value

	①	②	③	④	⑤	To ①・⑤
FUNC	4051 AorC →4053 ABC	4051 B	①EX OR ②	2296 SW5	⑤NAND④ →4053 INH	4053 X, Y, Z OUT
DVD/LD	L	H	H	H	L	0
TV/SAT	H	L	H	H	L	1
VCR1	L	L	L	H	H	x
VCR2	H	H	L	H	H	x
VIDEO	H	H	L	H	H	x
Aud io	*	*	*	L	H	x

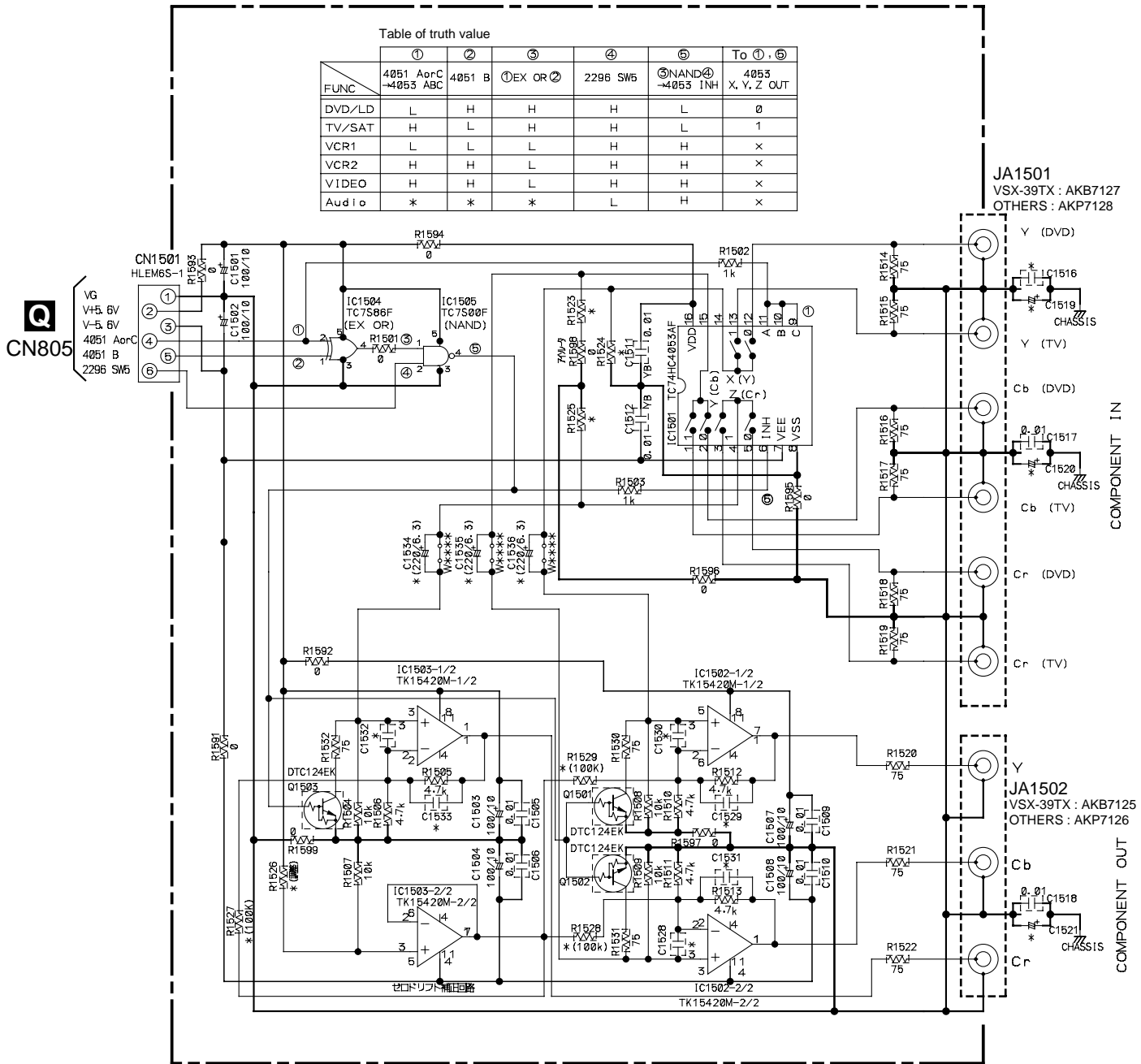

JA1501
 VSX-39TX : AKB7127
 OTHERS : AKP7128

JA1502
 VSX-39TX : AKB7125
 OTHERS : AKP7126

Q CN805

- ① VG
- ② V+5. 6V
- ③ V-5. 6V
- ④ 4051 AorC
- ⑤ 4051 B
- ⑥ 2296 SW5







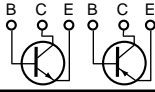

COMPONENT IN

COMPONENT OUT

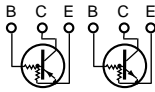
4. PCB CONNECTION DIAGRAM

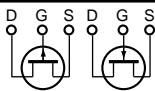
NOTE FOR PCB DIAGRAMS :

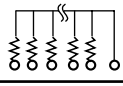
1. Part numbers in PCB diagrams match those in the schematic diagrams.
2. A comparison between the main parts of PCB and schematic diagrams is shown below.

Symbol In PCB Diagrams	Symbol In Schematic Diagrams	Part Name
		Transistor
		Transistor with resistor
		Field effect transistor
		Resistor array
		3-terminal regulator

3. The parts mounted on this PCB include all necessary parts for several destinations.
For further information for respective destinations, be sure to check with the schematic diagram.
4. View point of PCB diagrams.

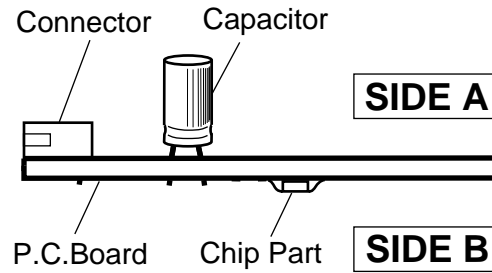

4.1 EXTRA-5.1 (EXTERNAL IN), A-PINJACK and CONNECTION ASSYS

B A-PINJACK ASSY

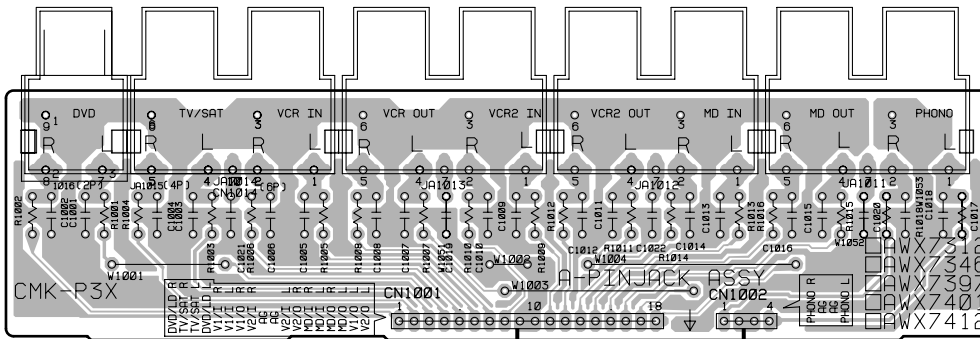

C CONNECTION ASSY

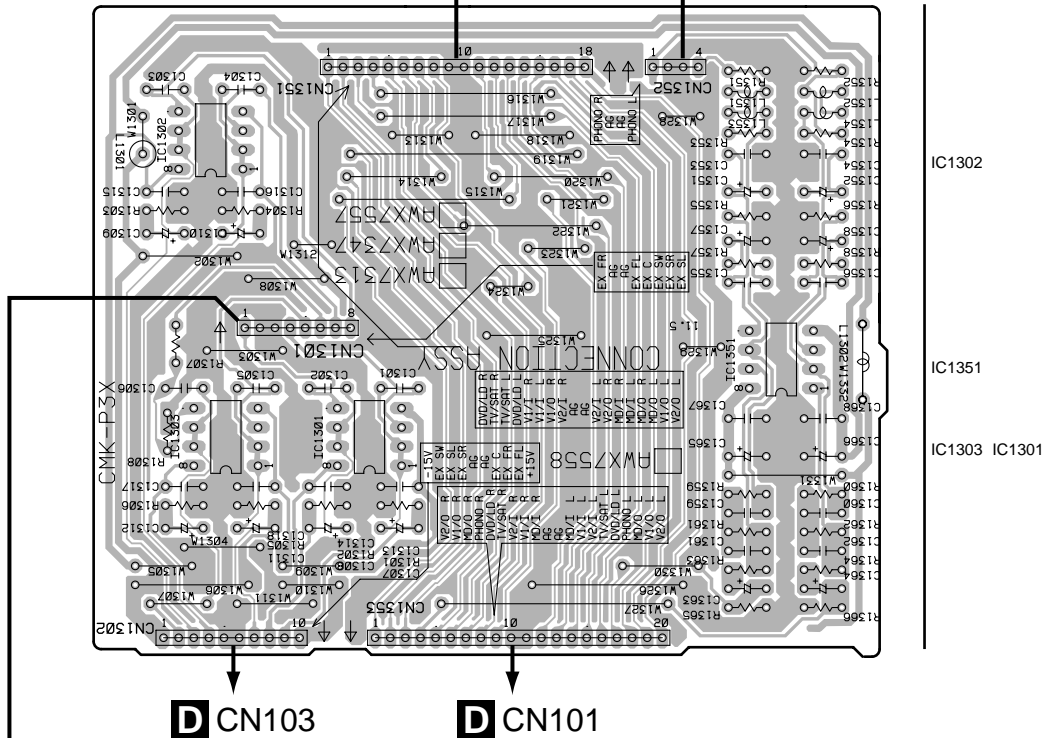

A EXTRA-5.1 (EXTERNAL IN) ASSY

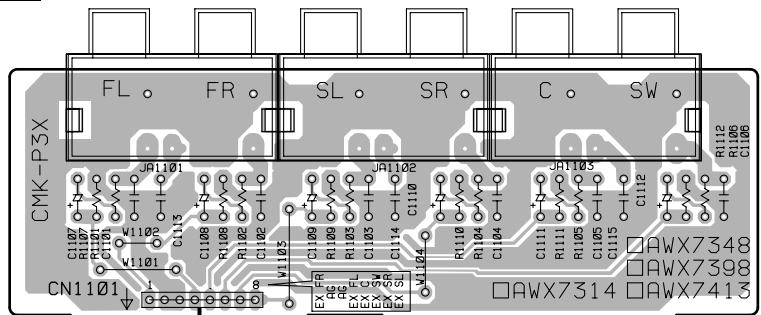

SIDE A

A B C

4.2 MAIN CONTROL ASSY

D MAIN CONTROL ASSY

G CN1302 **S** CN7005 **P** CN701 To FM/AM TUNER UNIT

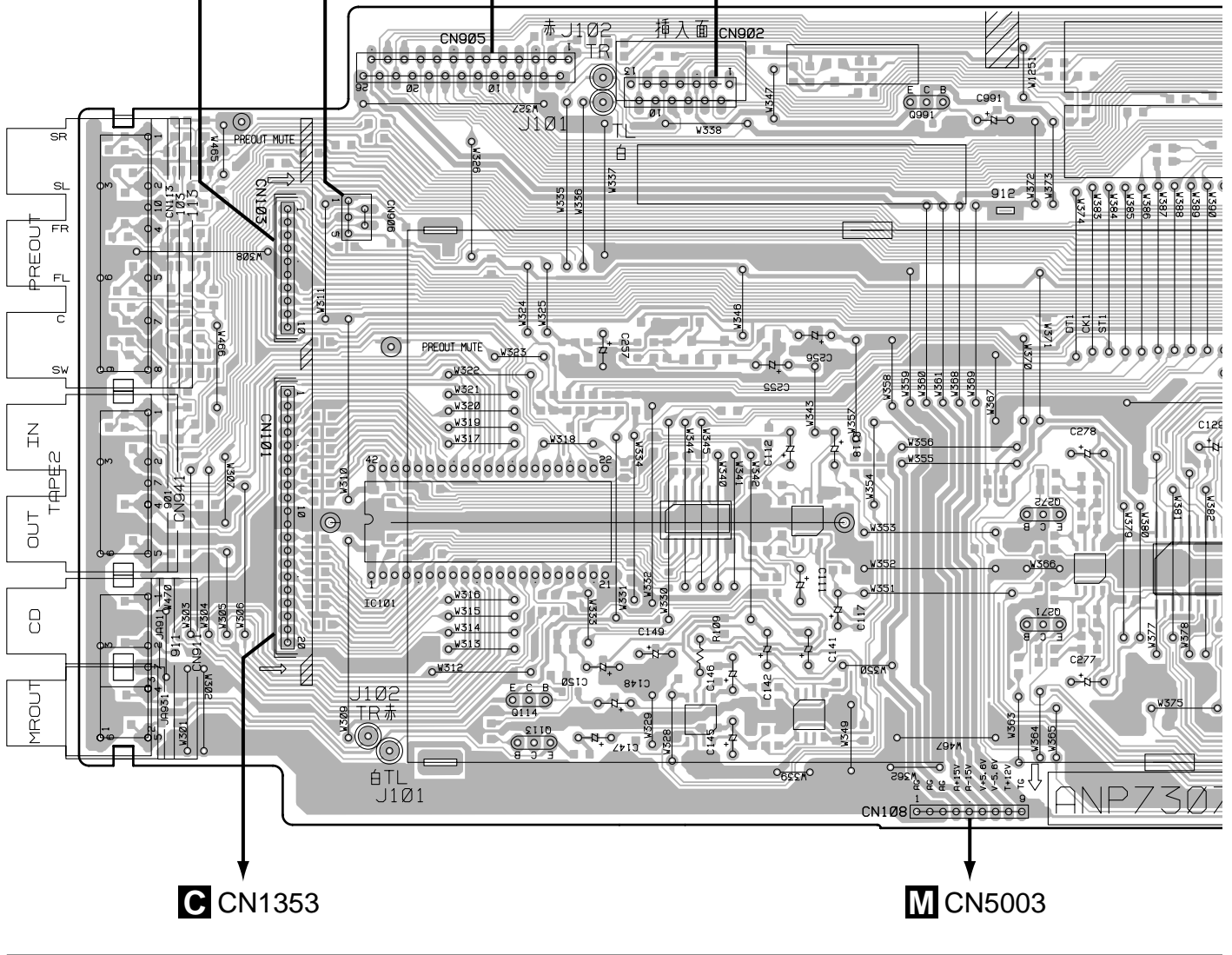

IC101 Q991 Q272
 Q114 Q271
 Q113

SIDE A

SIDE A

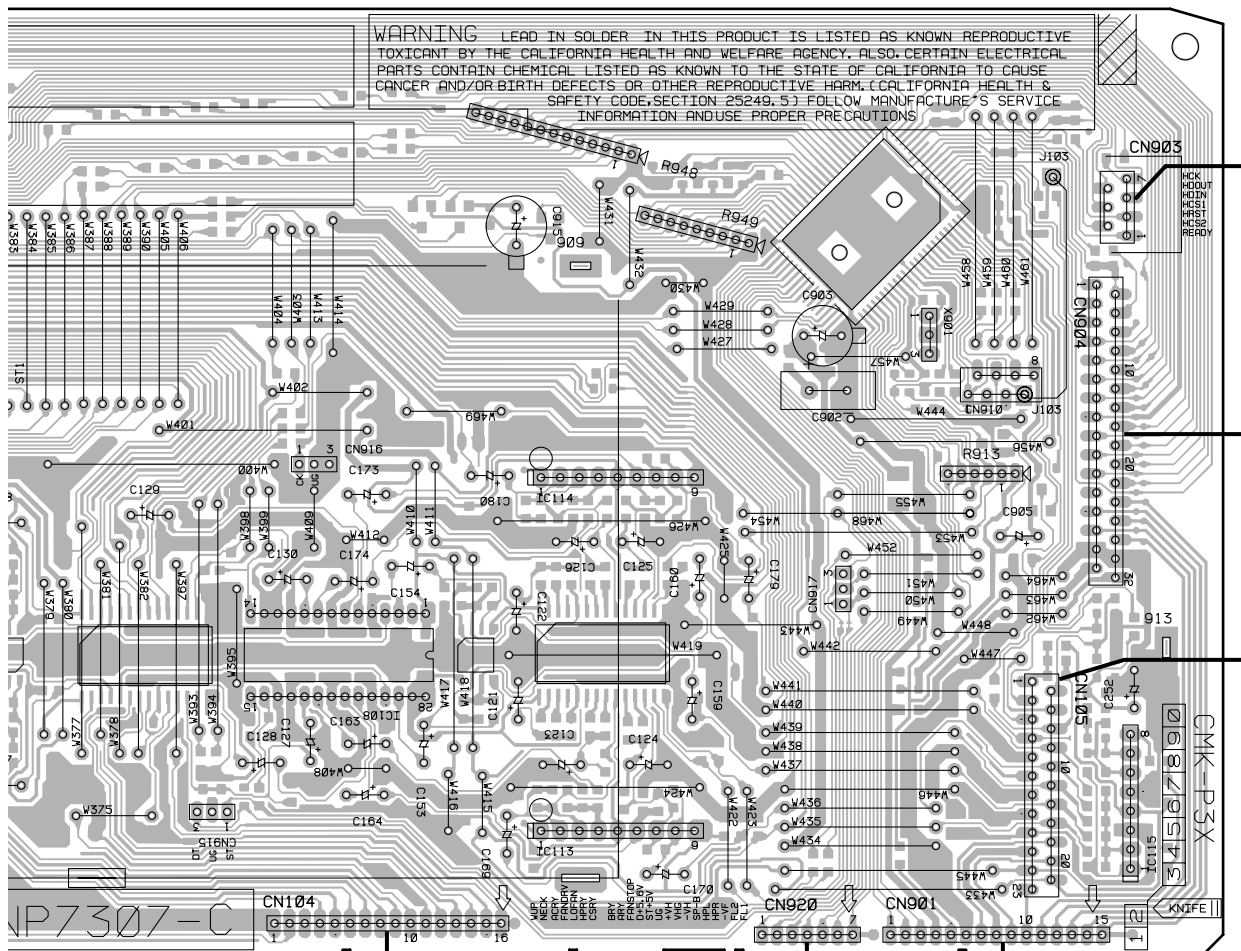

Y
CN9571

S
CN7001

E
CN501

M CN5004

M CN5008

M CN5005

IC108

IC114
IC113

IC115

D

D MAIN CONTROL ASSY

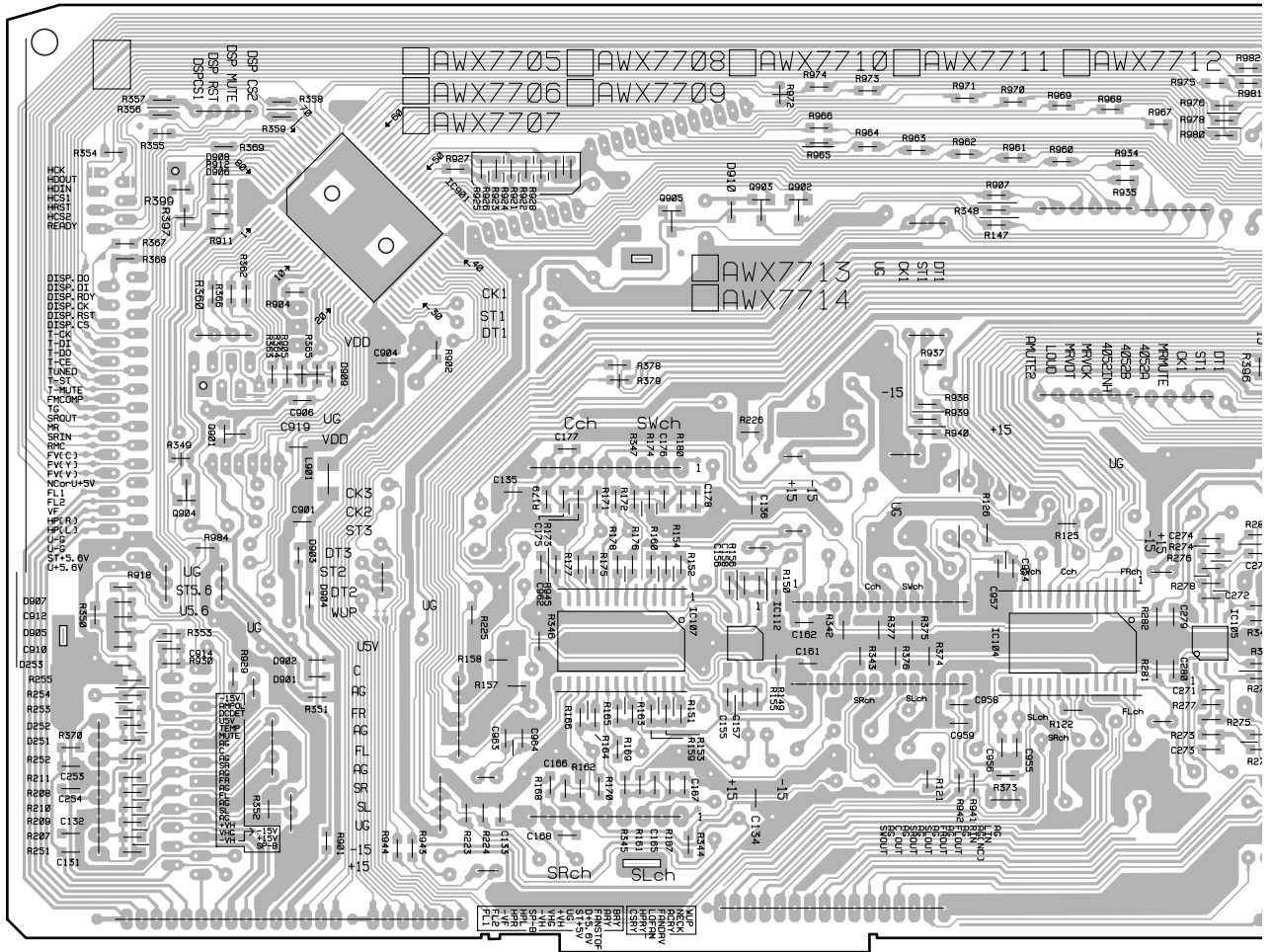

Q904 Q901 IC901 Q905 Q903 Q902 IC104 IC105
 IC107 IC112

SIDE B

SIDE B

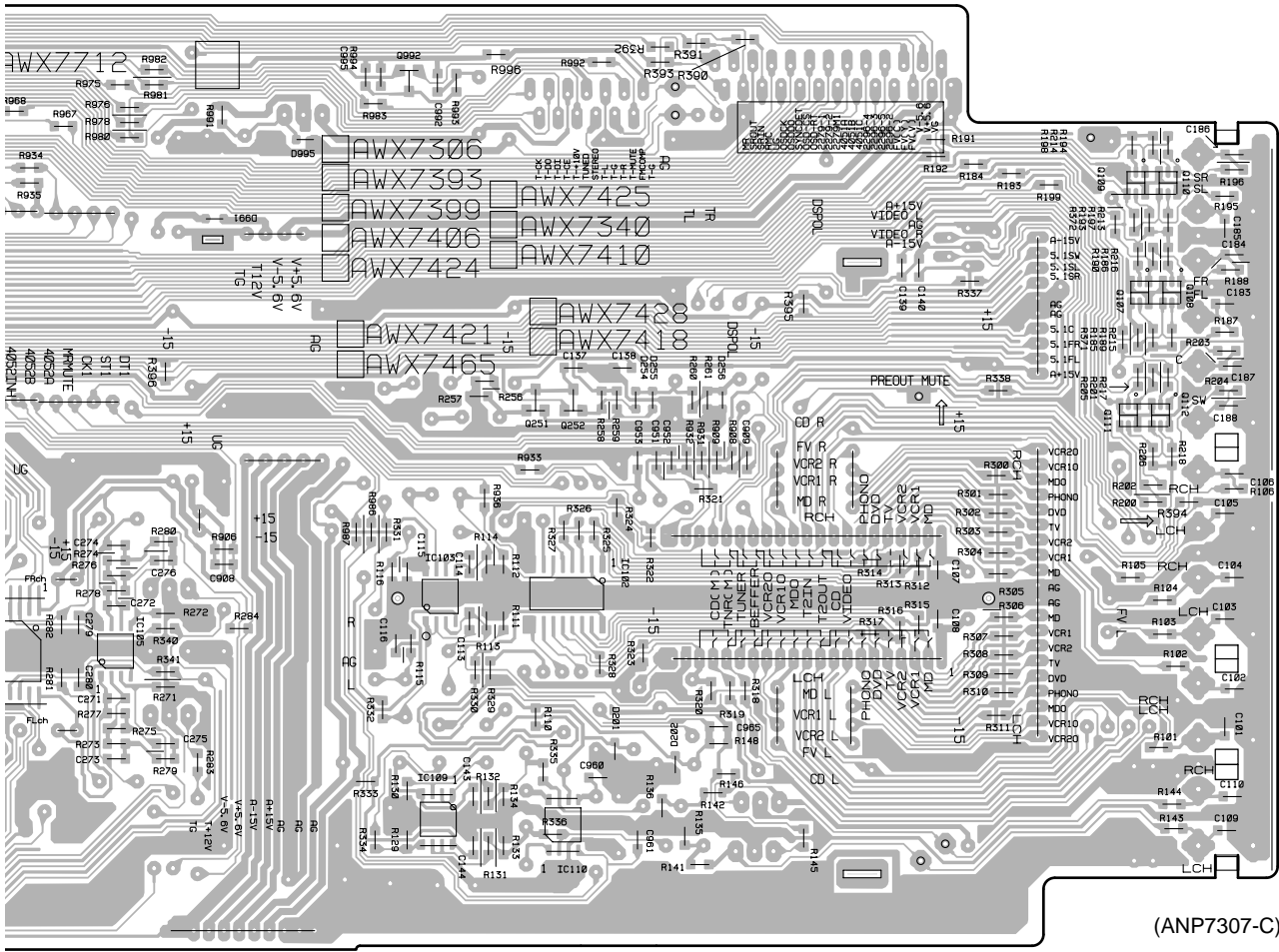

(ANP7307-C)

IC105

Q902

Q251 Q252

Q109 Q110

IC103

IC102

Q107 Q108

IC109

IC110

Q111 Q112

VSX-39TX, VSX-37TX, VSX-36TX, VSX-D909S

4.3 V-AMP ASSY

V-AMP ASSY

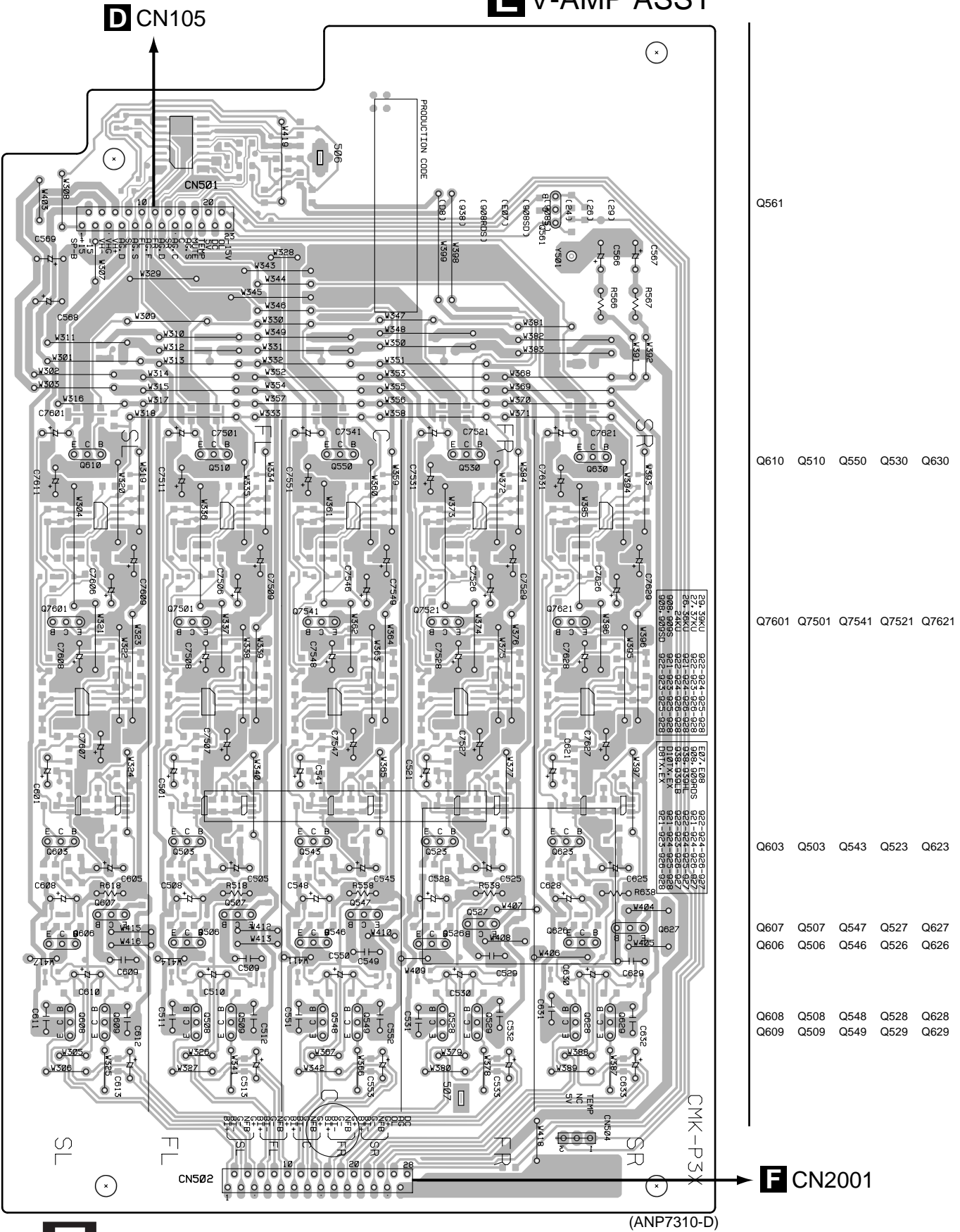

E V-AMP ASSY

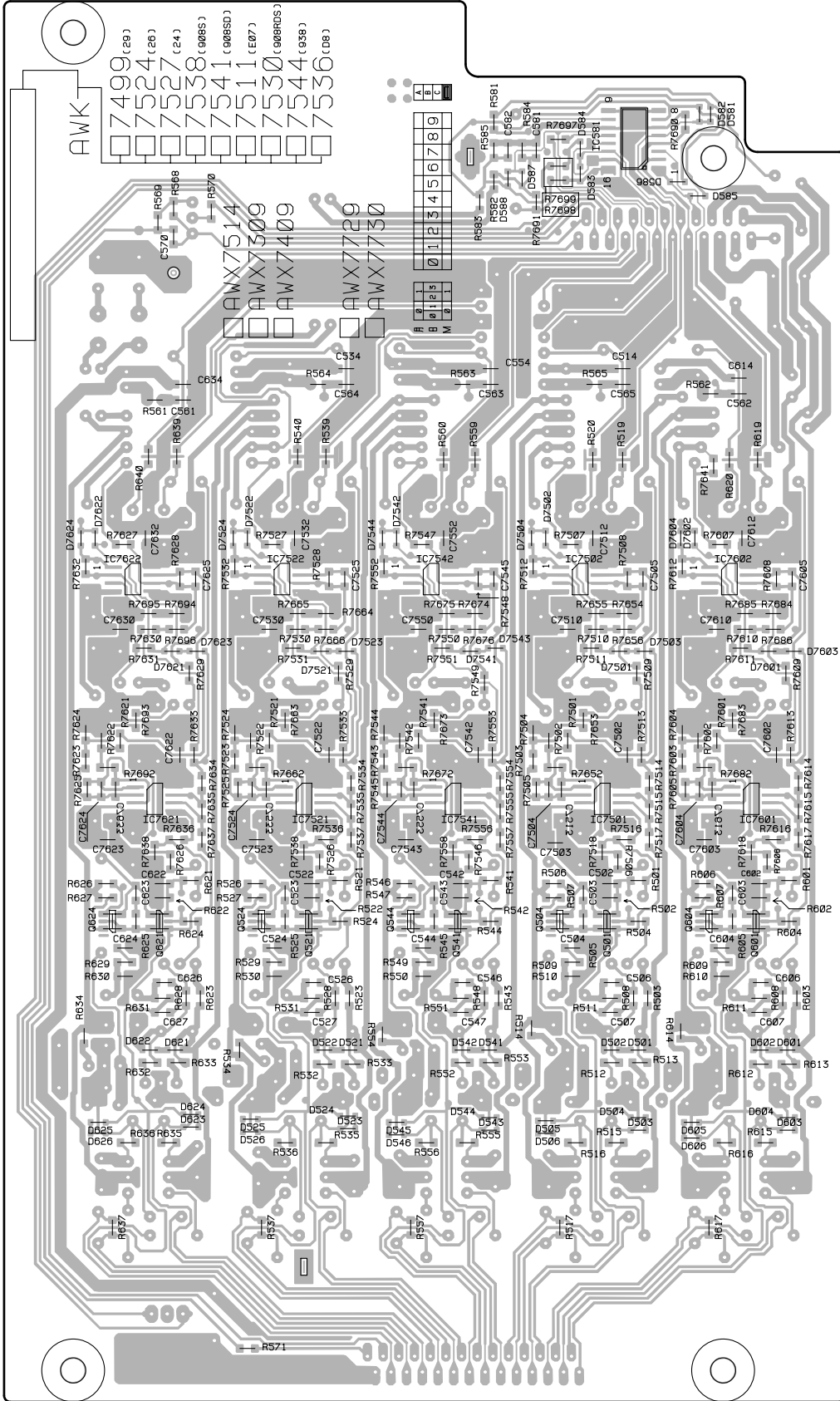

IC581

IC7622 IC7522 IC7542 IC7502 IC7602

IC7621 IC7521 IC7541 IC7501 IC7601

Q624 Q524 Q544 Q504 Q604
Q621 Q521 Q541 Q501 Q601

(ANP7310-F)

SIDE B



4.4 C-AMP-N, C-AMP-P, OUTPUT-SL, OUTPUT-FL, OUTPUT-C, OUTPUT-FR, OUTPUT-SR and VL-TERMINAL ASSYS

A

G C-AMP-P ASSY

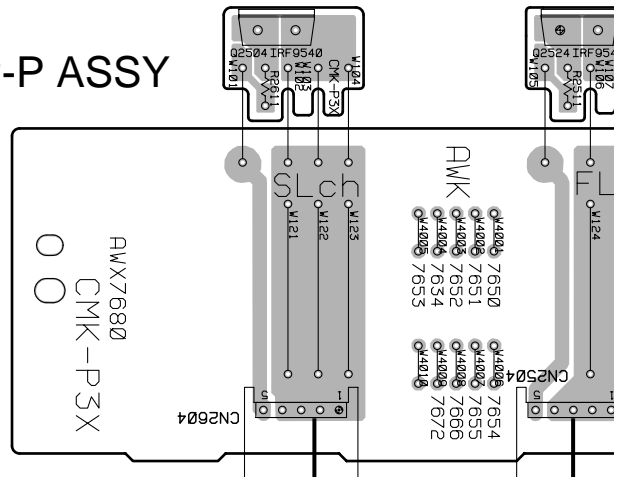

B

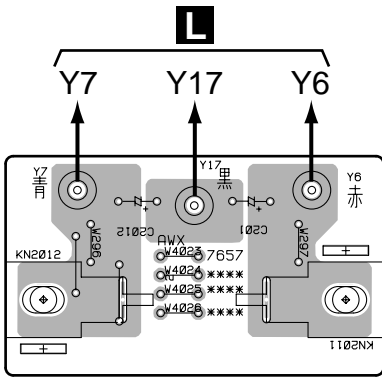

I VL-TERMINAL ASSY

HA OUTPUT-SL ASSY

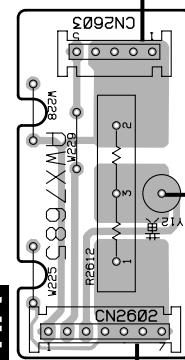

HB OUTPUT-FL ASSY

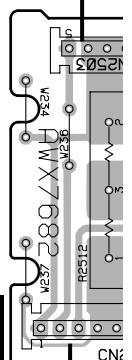

C

F C-AMP-N ASSY

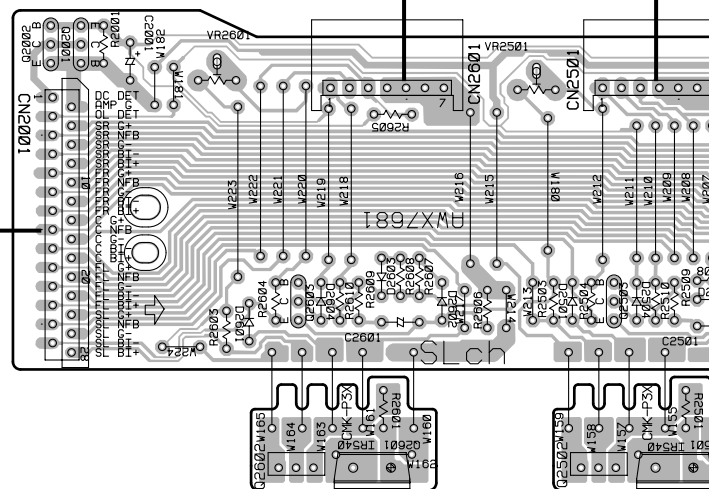

E CN502 205N

D

Q2002	Q2001	VR2601	Q2603	VR2501	Q2503
			Q2602		Q2502

SIDE A

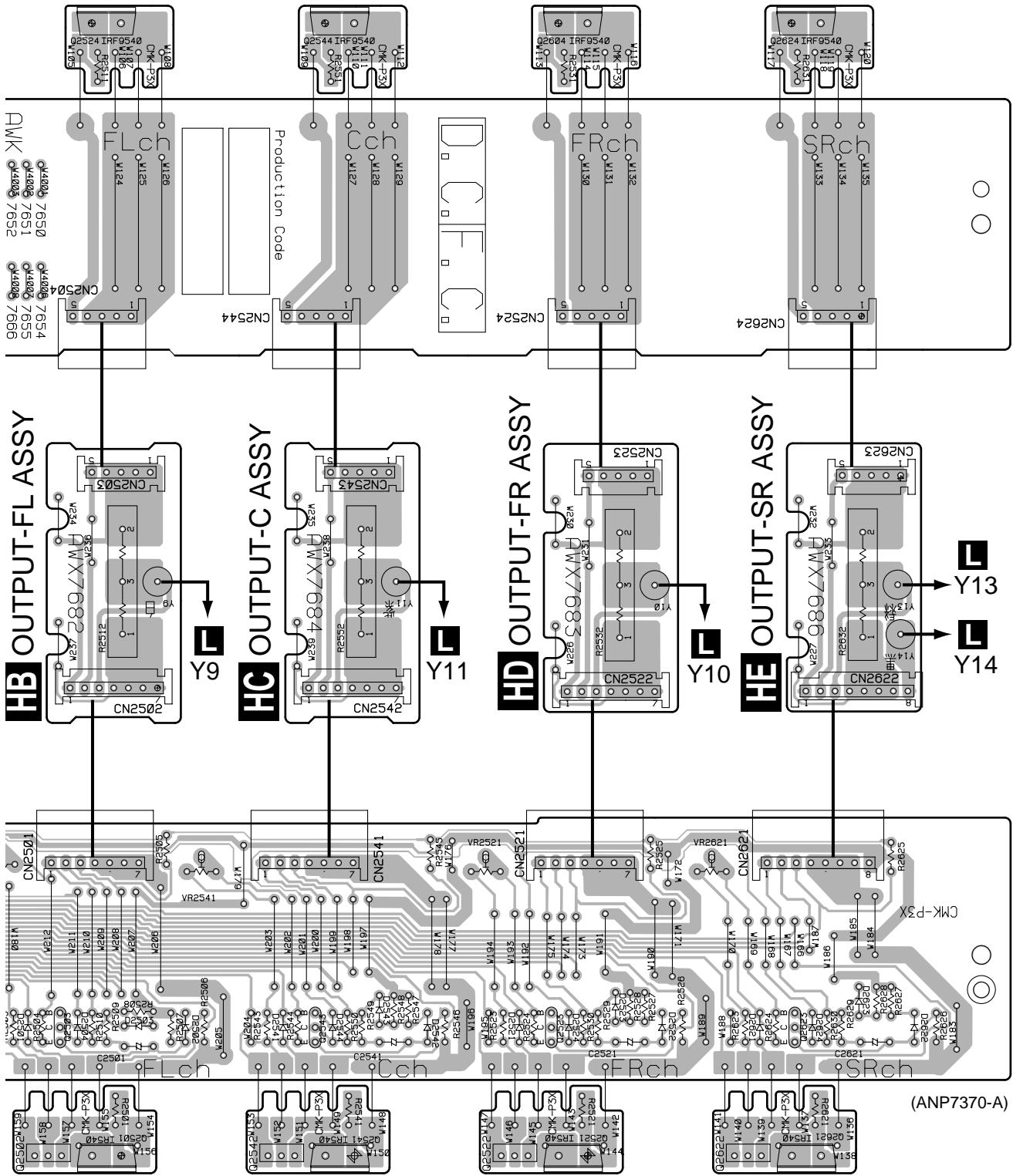

:501	VR2541	VR2521	VR2621
Q2503	Q2543	Q2523	Q2623
Q2502	Q2542	Q2522	Q2622



4.5 TRANS 2-1, DIODE, TRANS 1 and TRANS 2-2 ASSYS

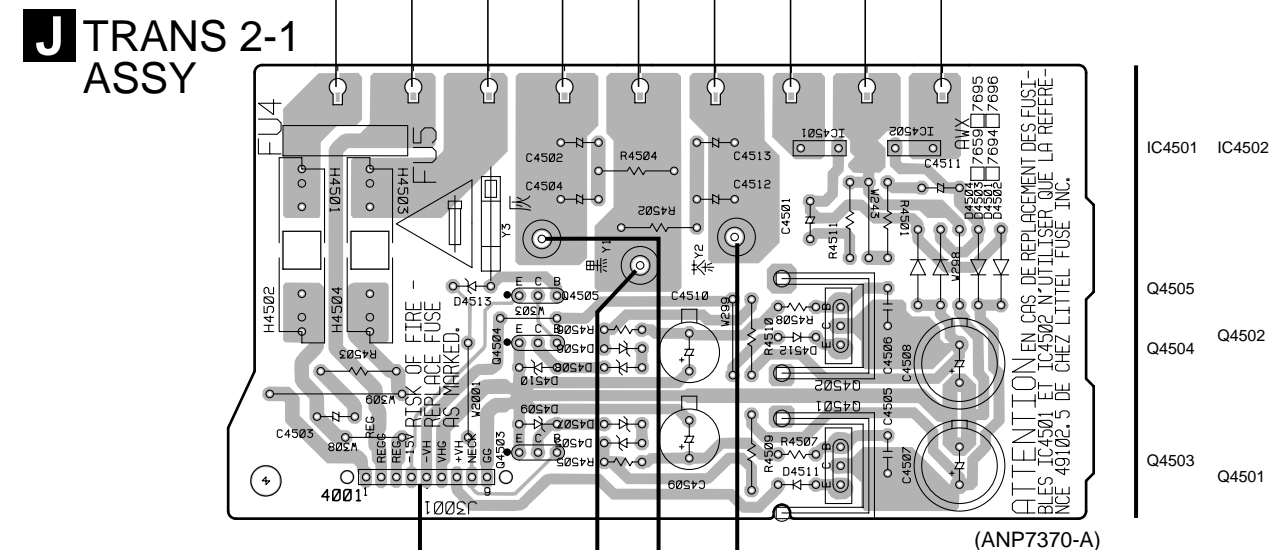
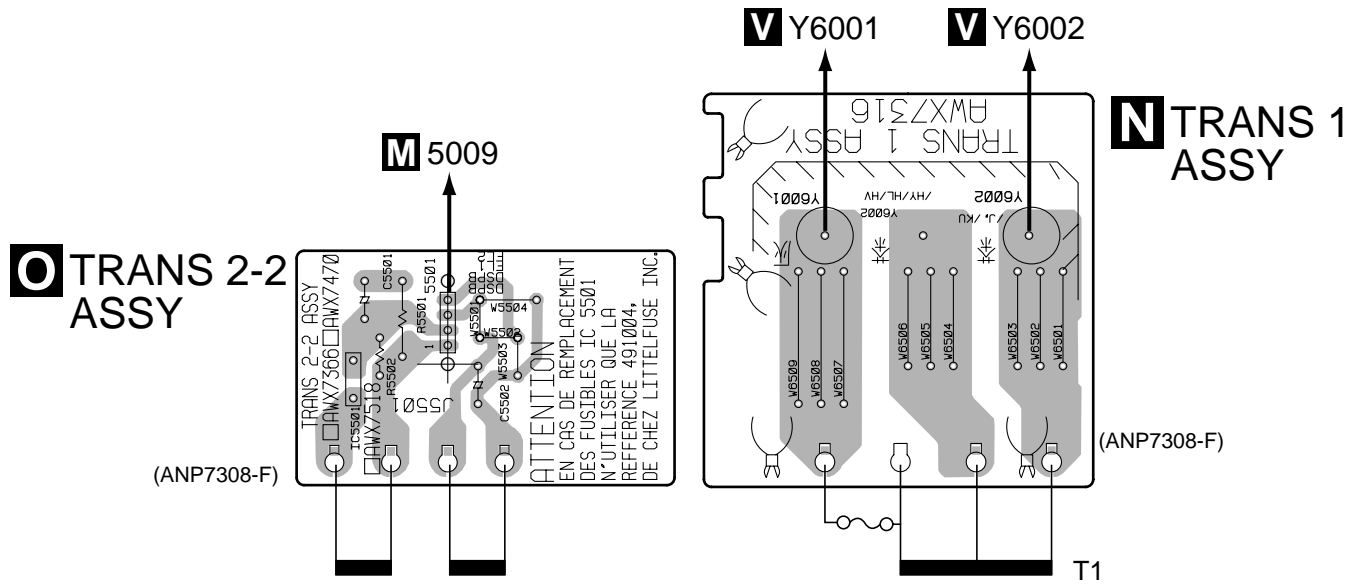

4.6 SP/PS ASSY

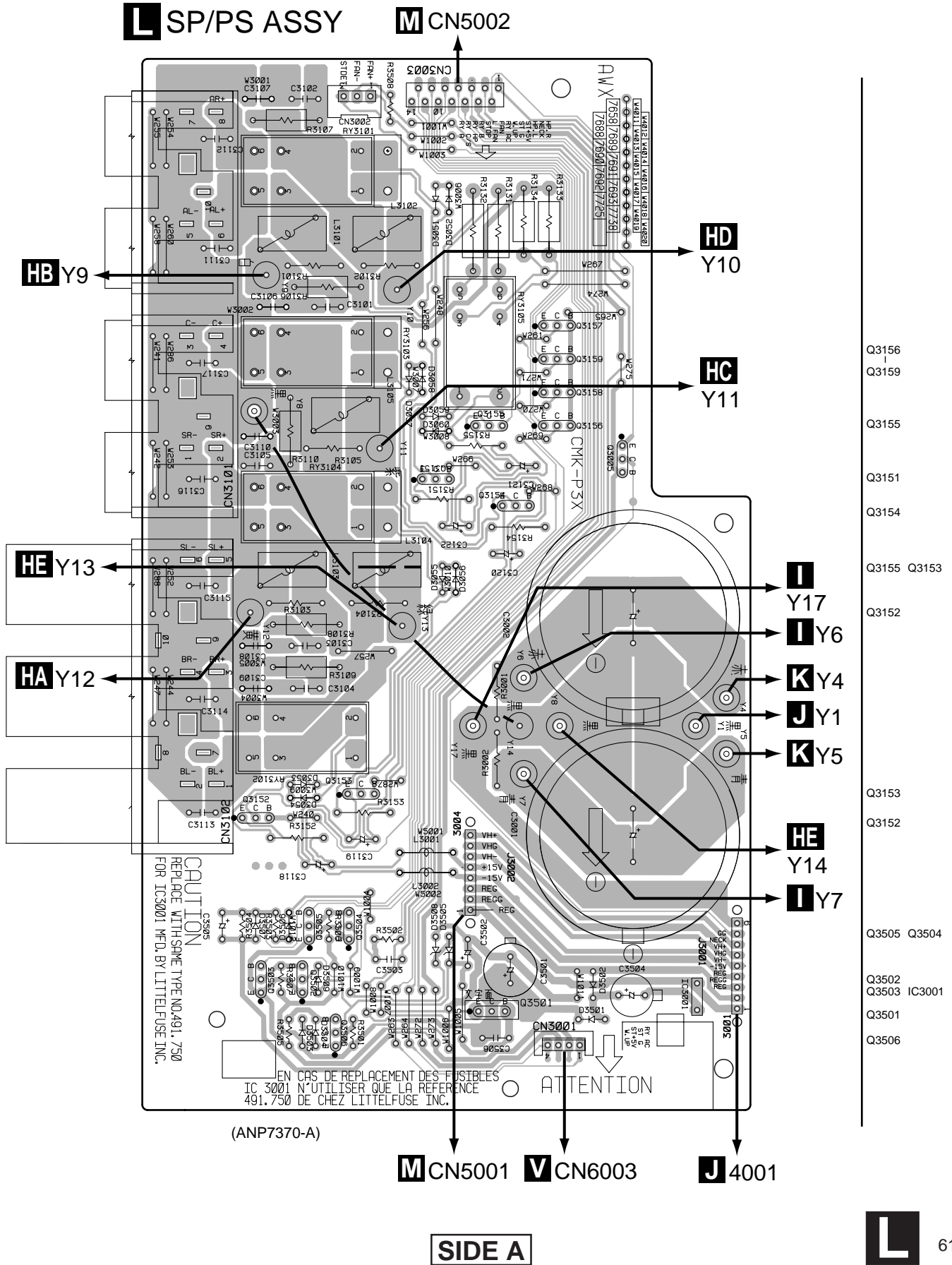

A
 B
 C
 D

1

2

3

4

1

2

3

4

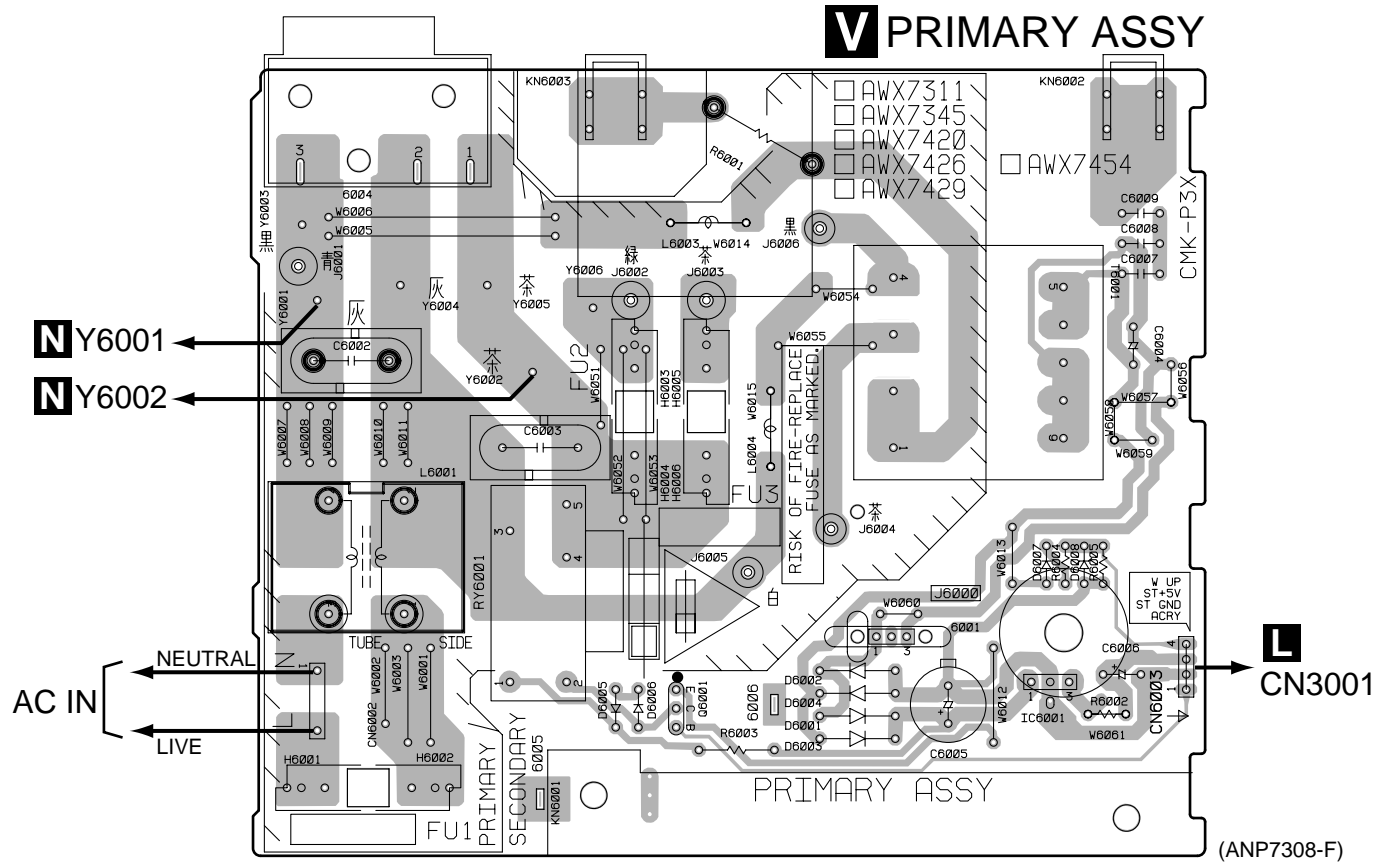
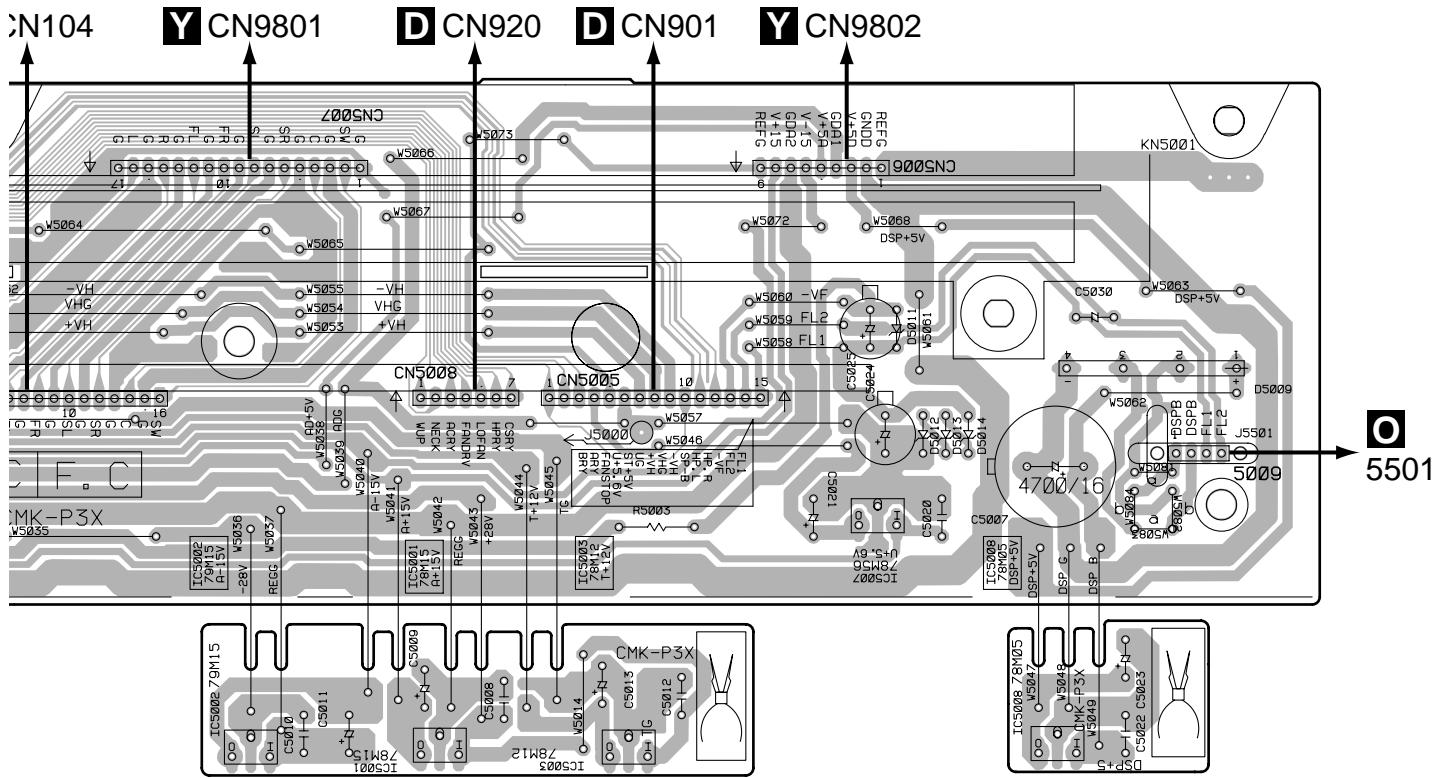

4.8 VIDEO ASSY

P VIDEO ASSY

A

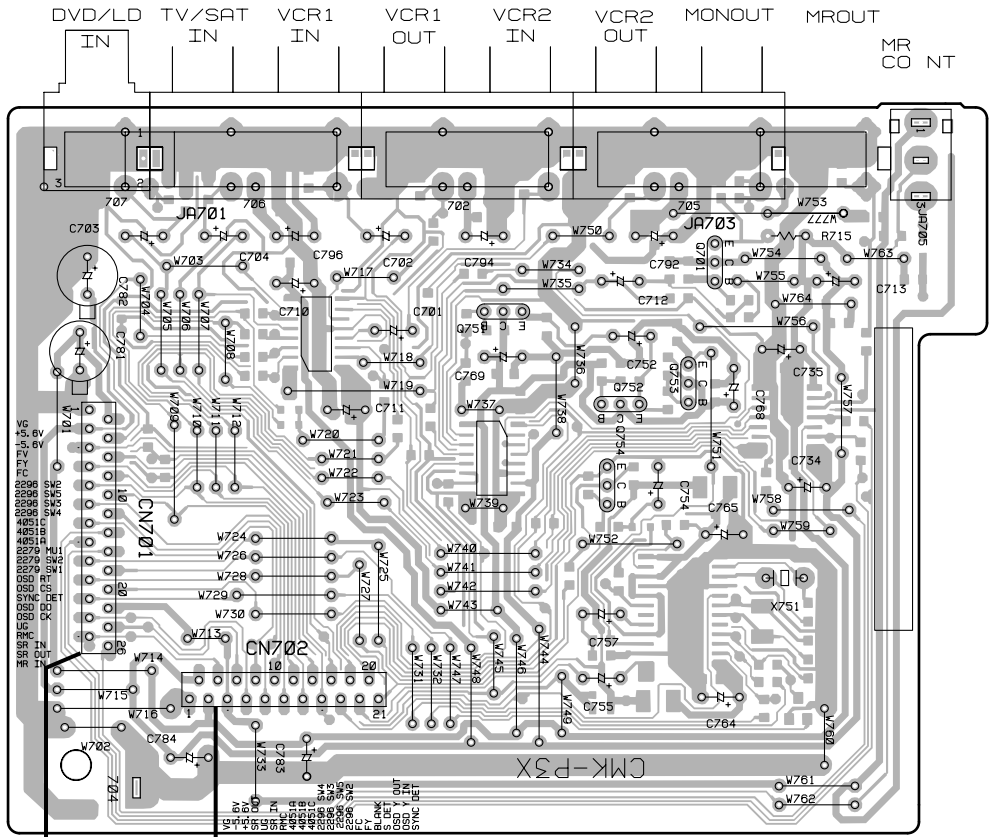

Q701
 Q751
 Q753
 Q752
 Q754

B

D CN905 **Q** CN804

P VIDEO ASSY

C

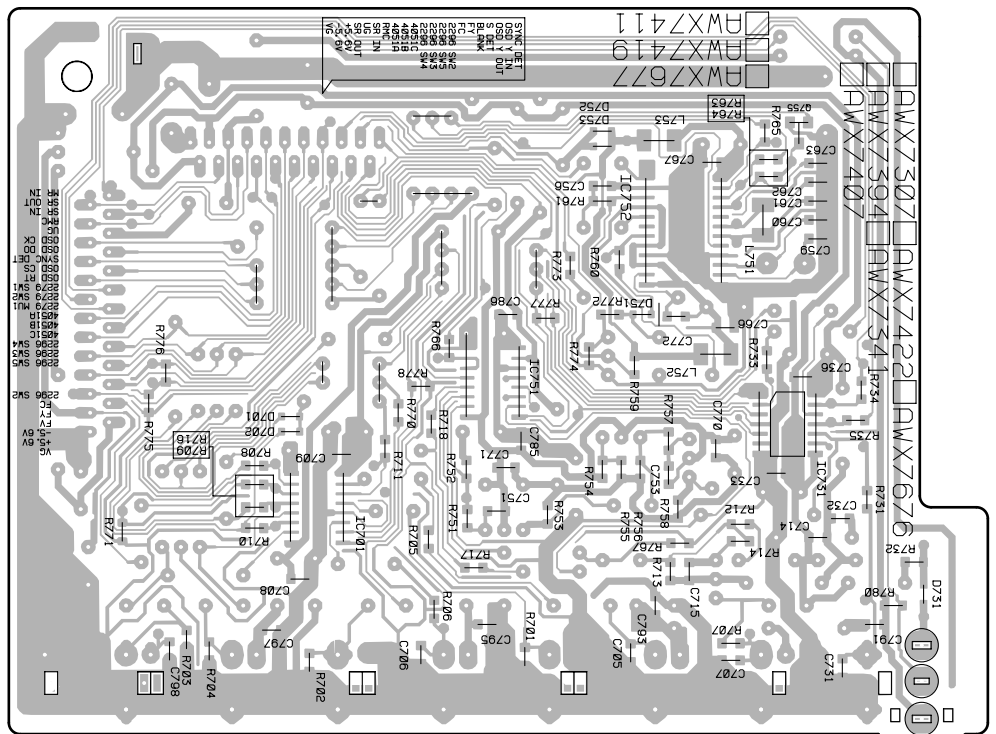

Q755
 IC752
 IC751
 IC731
 IC701

D

SIDE B

(ANP7307-C)



4.9 S-VIDEO ASSY

Q S-VIDEO ASSY

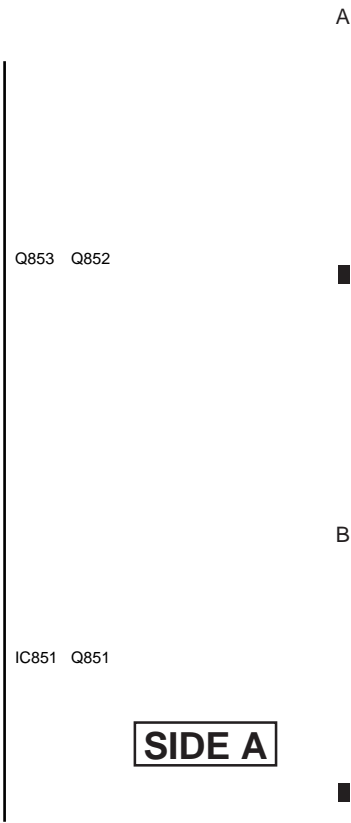
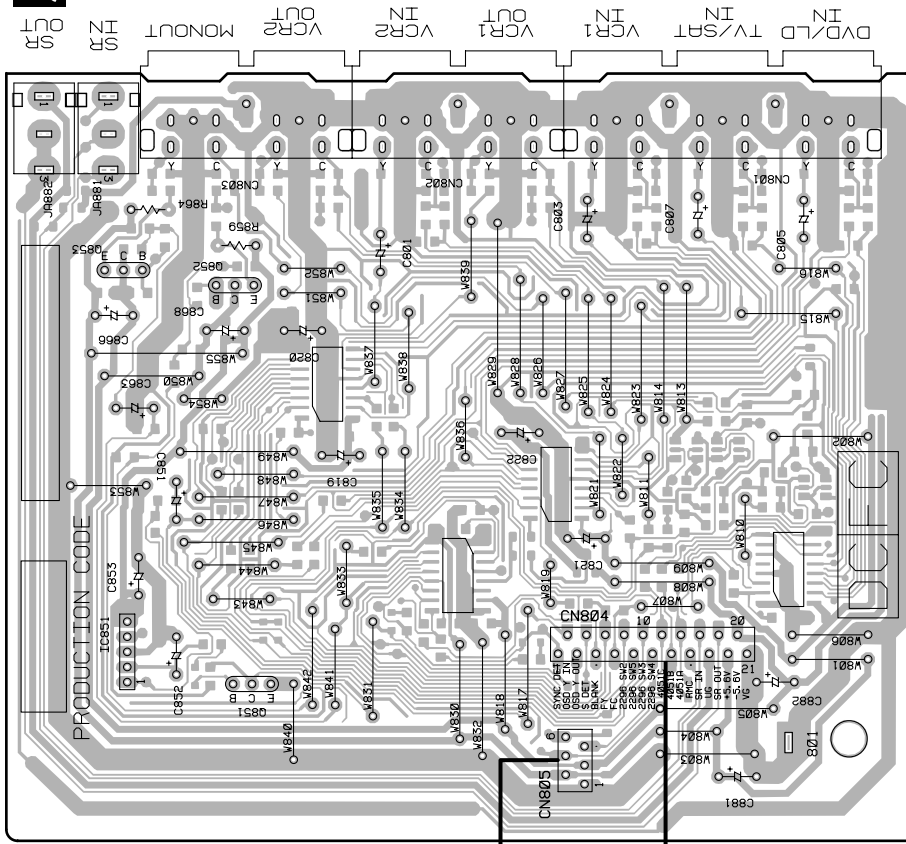

Z CN1501 **P** CN702

Q S-VIDEO ASSY

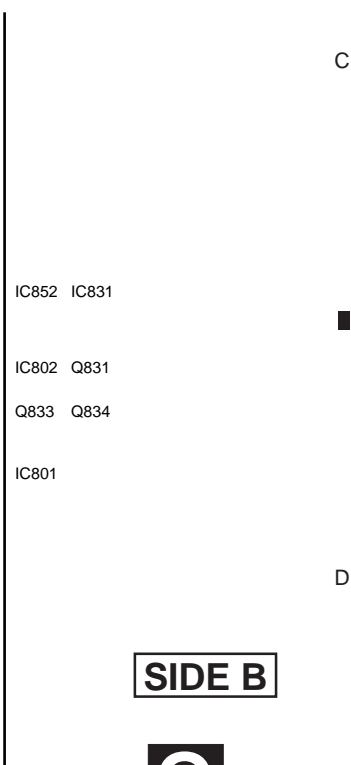
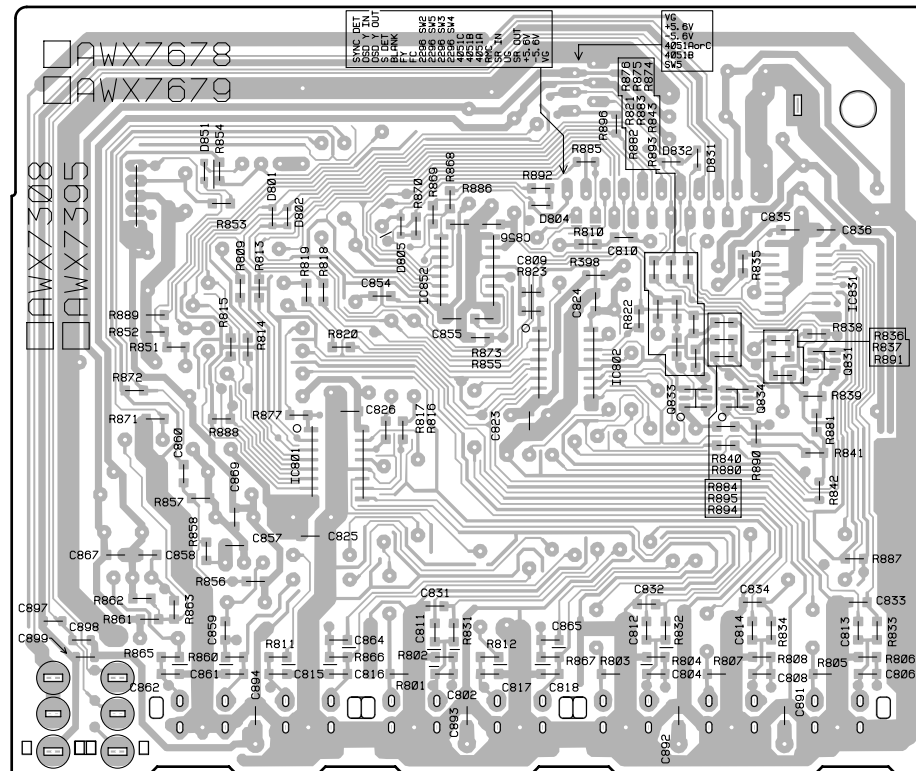

Q

(ANP7307-C)

4.10 H. PHONE/F. VIDEO, DISPLAY, ROTARY ENCODER and VOLUME ASSYS

A

U VOLUME ASSY

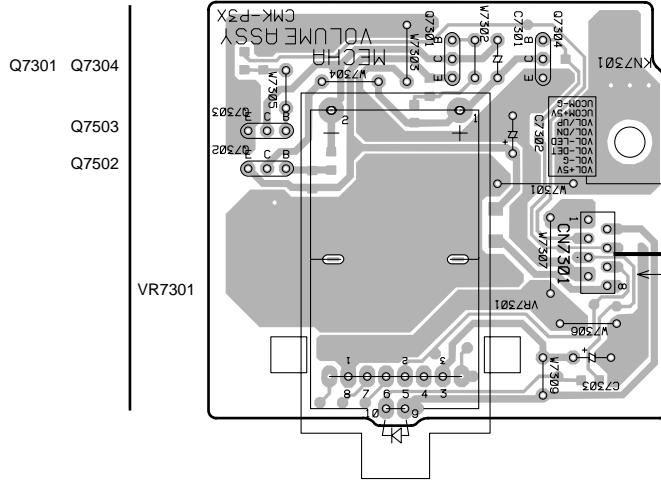

B

S DISPLAY ASSY

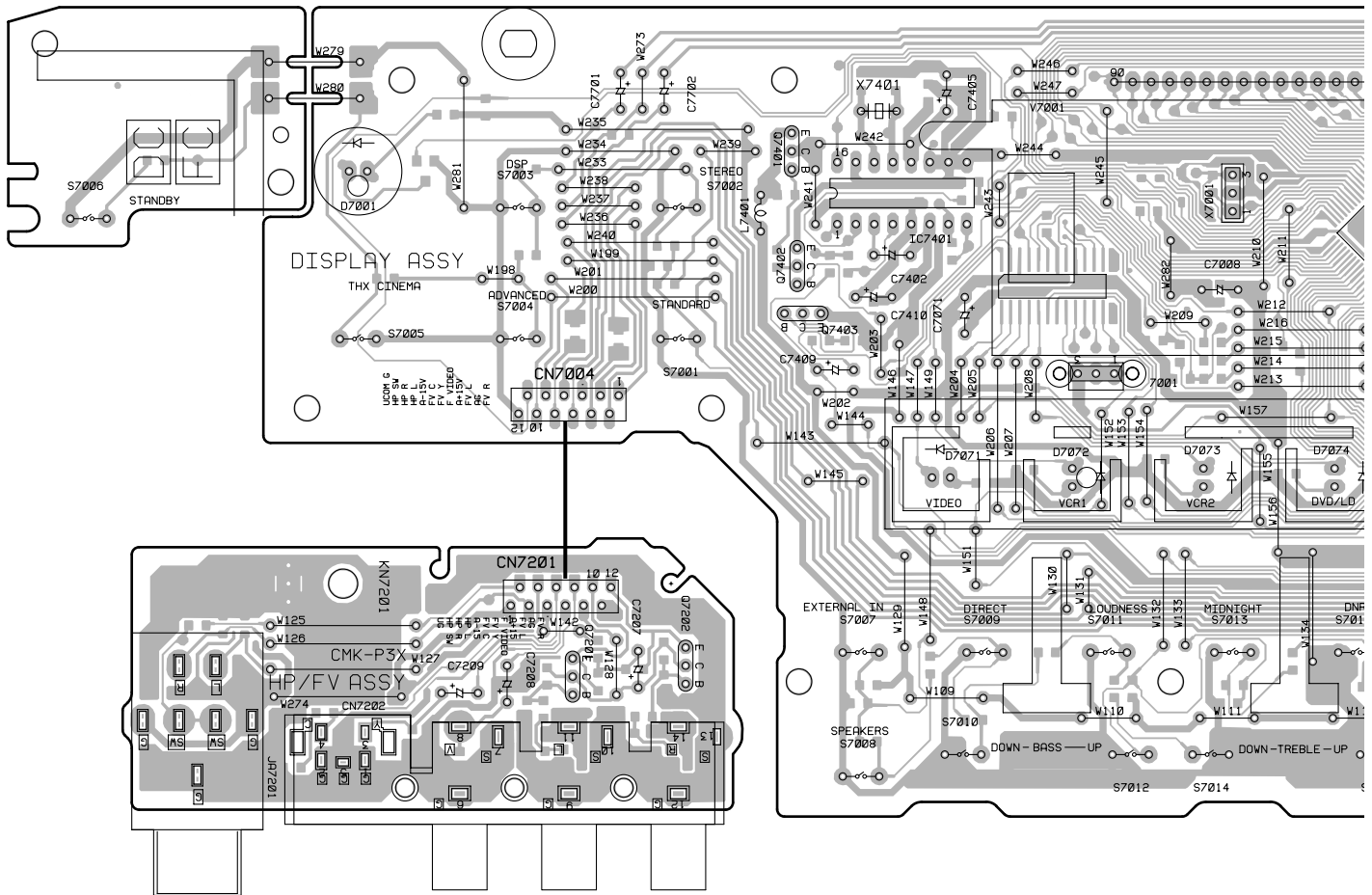

C

D

R H. PHONE/F. VIDEO ASSY

Q7201 Q7202

Q7401 IC7401
 Q7403

T ROTARY ENCODER ASSY

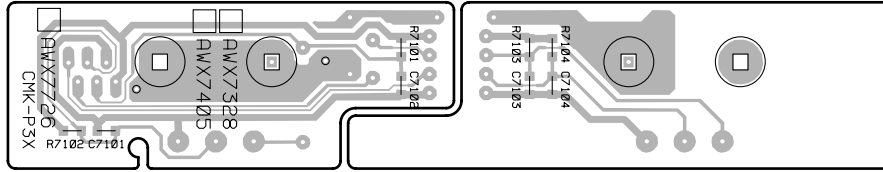

S DISPLAY ASSY

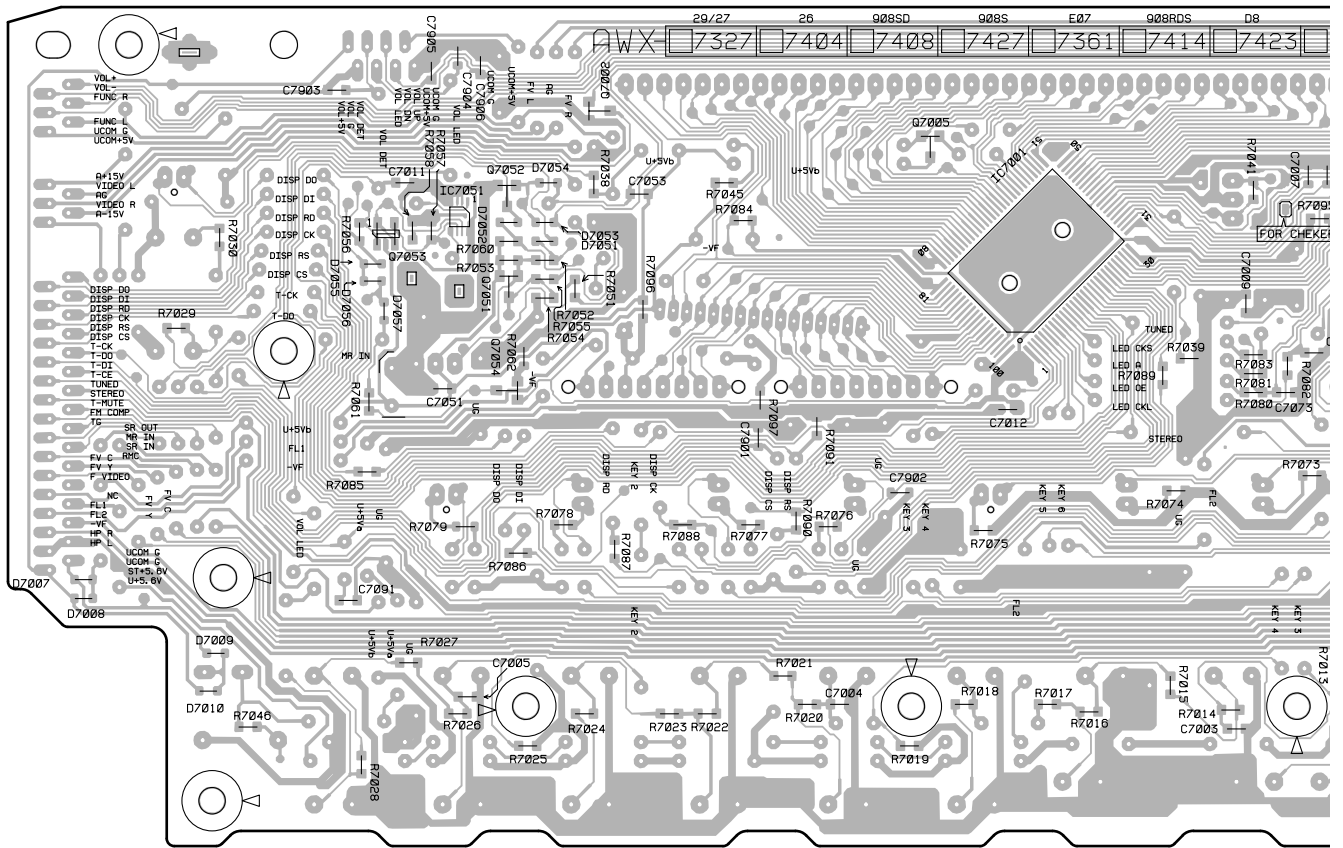

Q7053 Q7052 Q7002 Q7005 IC7001
 IC7051
 Q7051 Q7054

U VOLUME ASSY

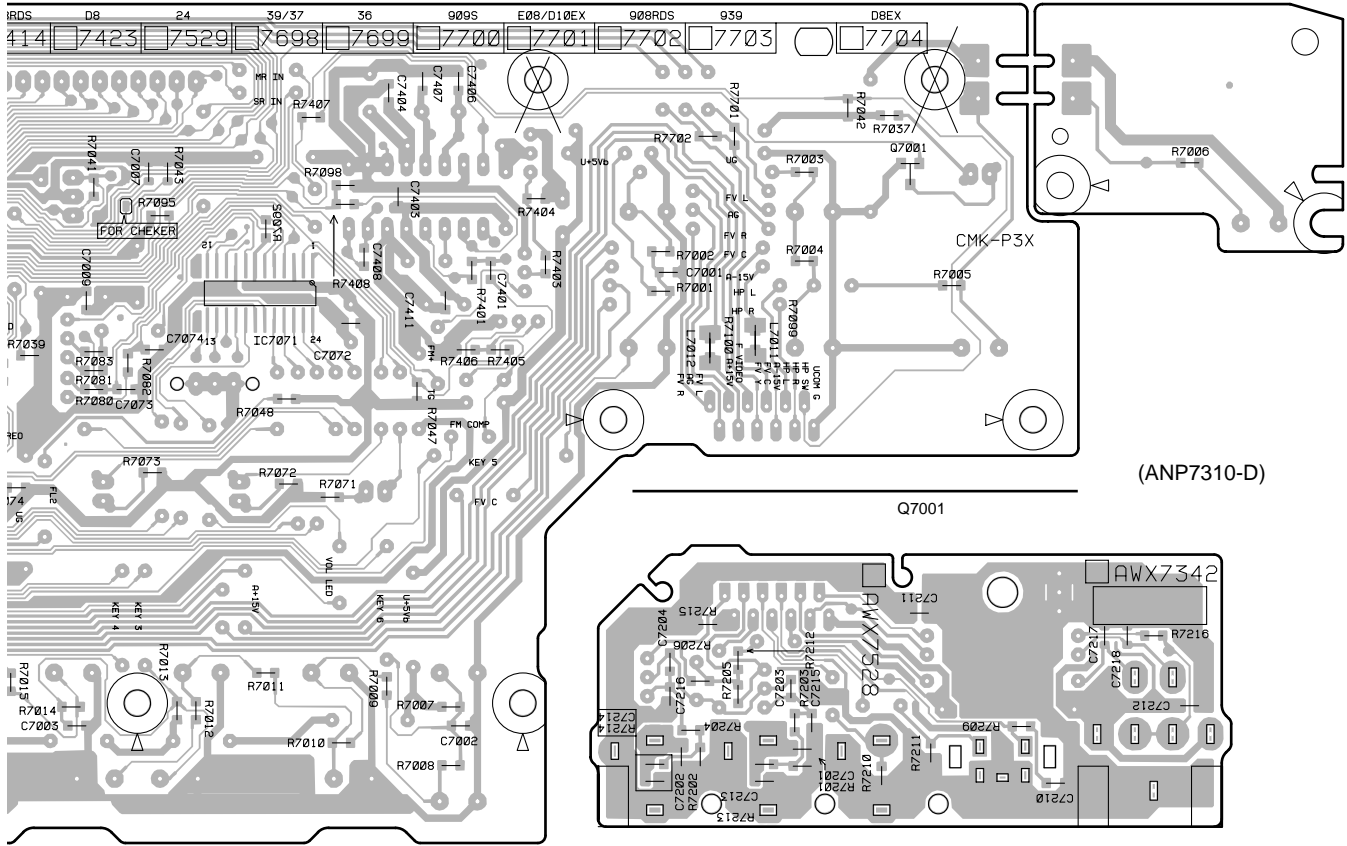
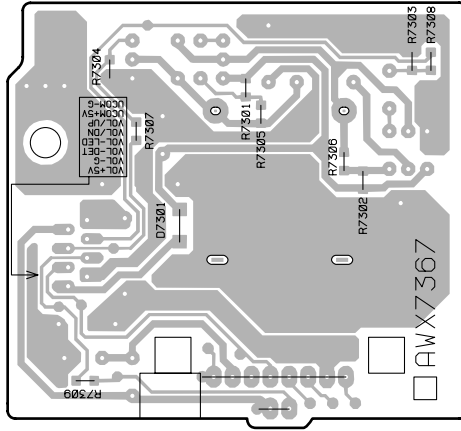

R H. PHONE/F. VIDEO ASSY

IC7071

SIDE B

R S U

VSX-39TX, VSX-37TX, VSX-36TX, VSX-D909S

4.11 DSP ASSY

A

B

C

D

- Q9001-Q9003
- IC9151 Q9032
- Q9004-Q9007
- Q9101-Q9104
- IC9071 IC9091
- IC9101
- Q9202-Q9204
- IC9501 IC9102
- IC9204
- Q9201
- IC9203
- IC9103
- IC9309
- IC9308
- IC9351
- IC9401
- IC9601
- IC9321
- Q9602
- IC9352
- IC9306
- IC9305 IC9421
- IC9307
- Q9603
- IC9301
- IC9441
- Q9610 Q9604
- Q9609 Q9605
- Q9608
- IC9304
- Q9607 Q9606
- IC9461
- Q9500
- Q9611
- Q9612

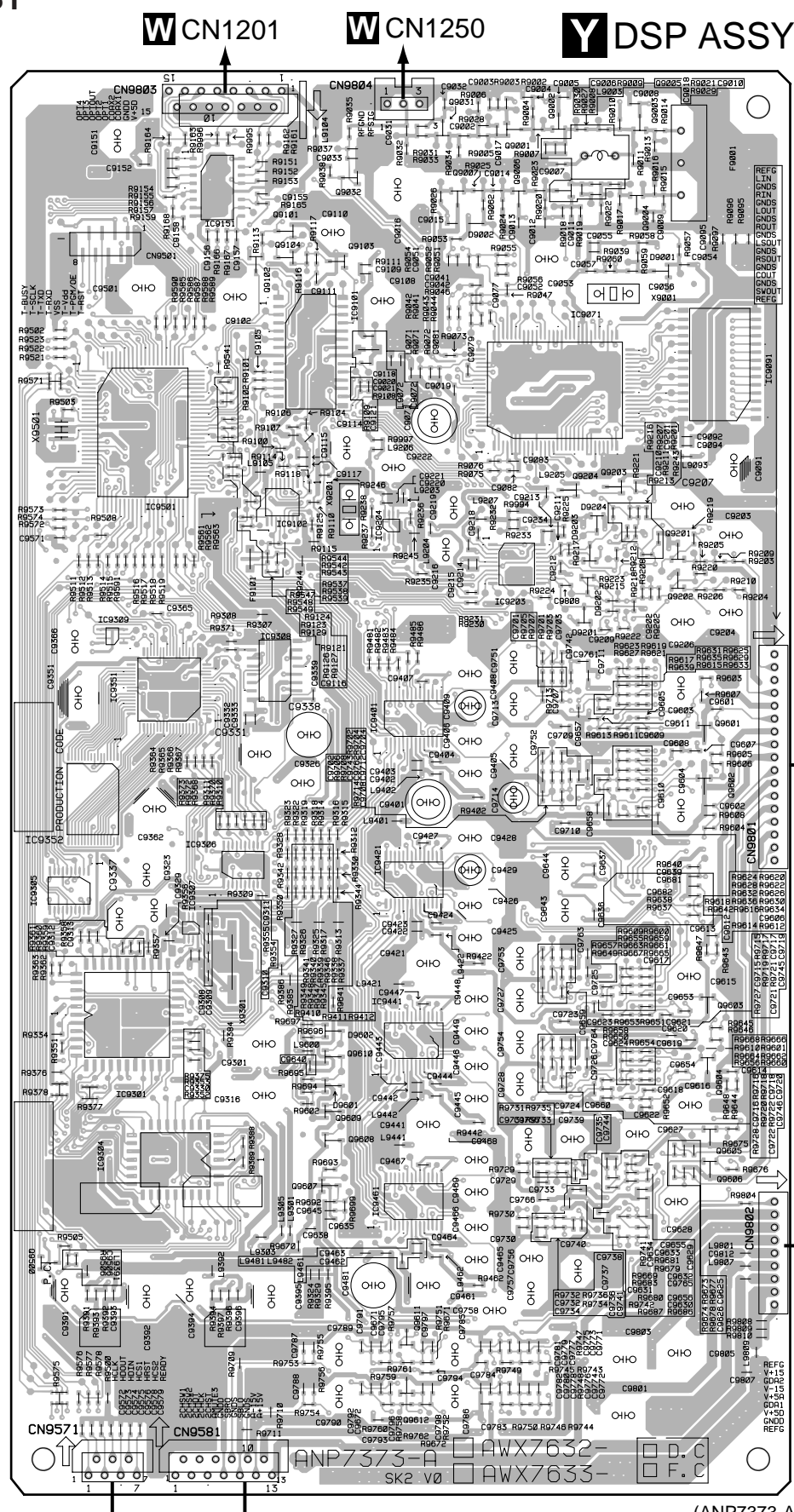

W CN1201

W CN1250

Y DSP ASSY

M CN5007

M CN5006

D CN903 **AB** CN8001

SIDE A

(ANP7373-A)



Y DSP ASSY

- IC9041
- IC9201
- Q9205
- IC9202
- IC9701
- IC9602
- IC9702
- IC9601
- IC9703
- IC9603
- IC9704
- IC9604
- IC9705
- IC9303
- IC9302
- IC9392
- IC9391
- IC9706
- IC9605

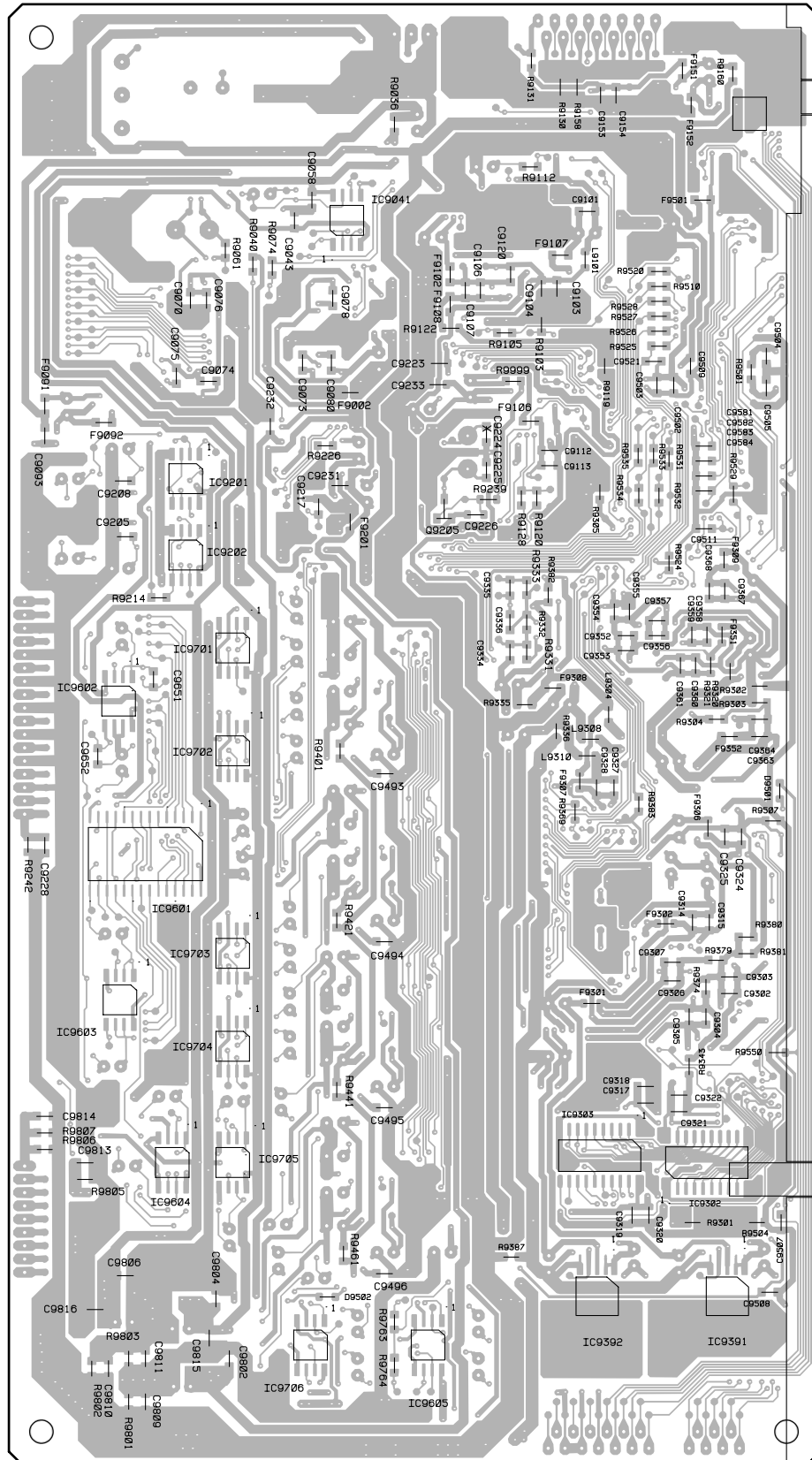

(ANP7373-A)

SIDE B



4.12 RF/DIGITAL IN, OPT OUT and COMPONENT ASSYS

X OPT OUT ASSY

SIDE A

W RF / DIGITAL IN ASSY

W CN1202

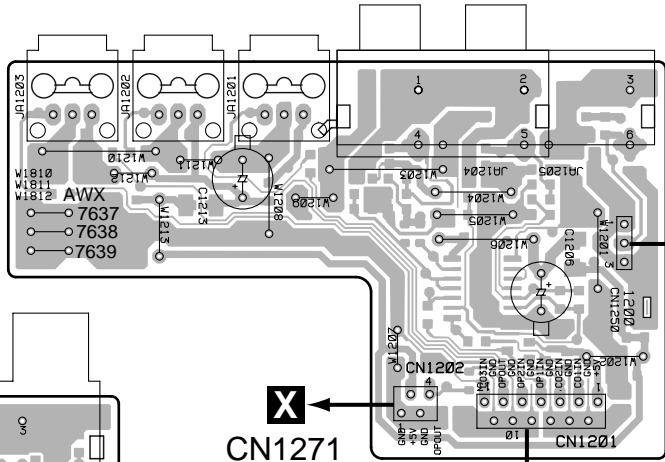
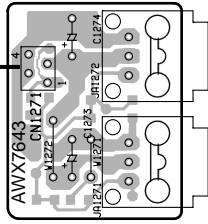

Y CN9804

X CN1271

(ANP7371-A)

Y CN9803

SIDE B

Z COMPONENT ASSY

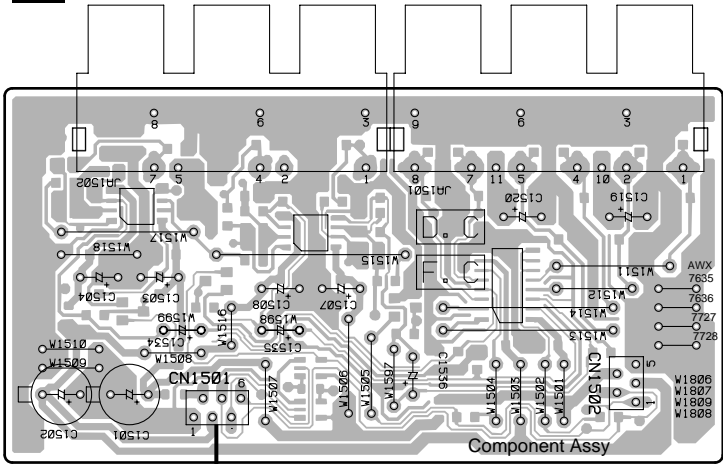

Q CN805

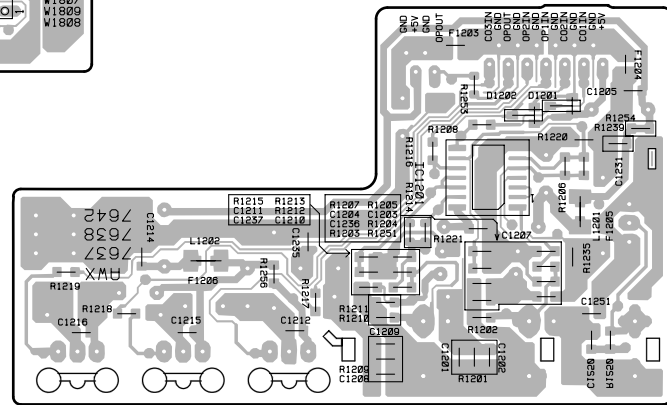

Z COMPONENT ASSY

W RF / DIGITAL IN ASSY

(ANP7371-A)

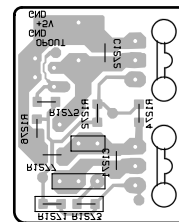
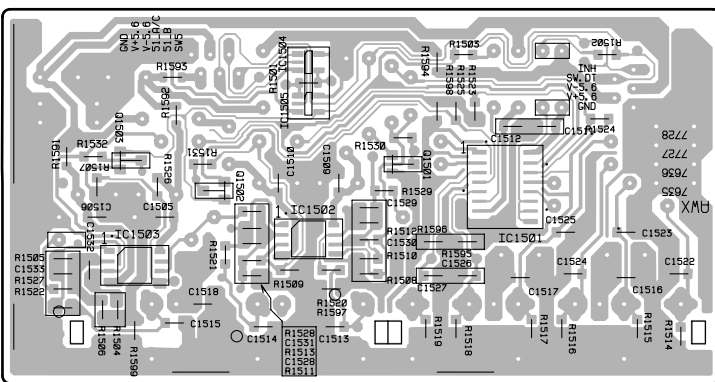

X OPT OUT ASSY

IC1503 Q1503 Q1502 IC1502 IC1504, IC1504 Q1501 IC1501



4.13 2CH I/O PJ and TRIM ASSYS

AB TRIM ASSY

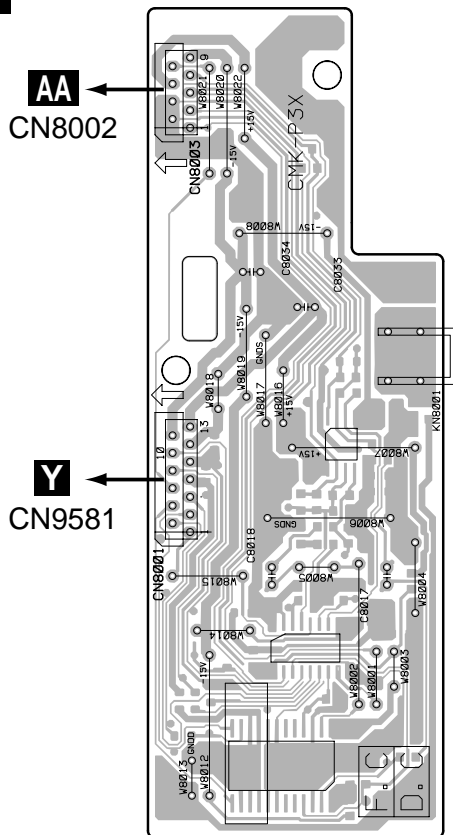

AA 2CH - I/O PJ ASSY

SIDE A

AB CN8003

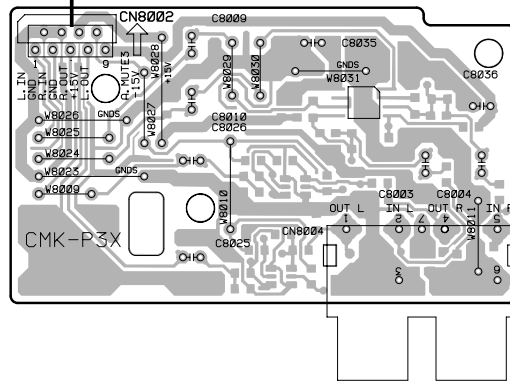

(ANP7372-A)

SIDE B

AB TRIM ASSY

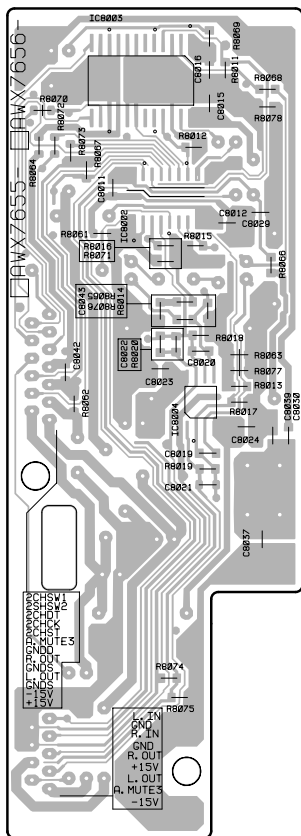

AA 2CH -I/O PJ ASSY

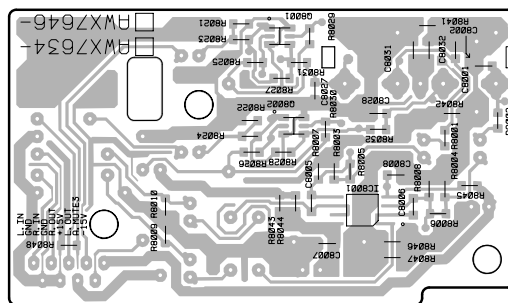

(ANP7372-A)

5. PCB PARTS LIST

NOTES: ● The Δ mark found on some component parts indicates the importance of the safety factor of the part. Therefore, when replacing, be sure to use parts of identical designation.

● When ordering resistors, first convert resistance values into code form as shown in the following examples.

Ex.1 When there are 2 effective digits (any digit apart from 0), such as 560 ohm and 47k ohm (tolerance is shown by J=5%, and K=10%).

560 Ω \rightarrow 56×10^1 \rightarrow 561 RD1/4PU $\begin{matrix} \boxed{5} & \boxed{6} & \boxed{1} \\ \boxed{J} \end{matrix}$
 47k Ω \rightarrow 47×10^3 \rightarrow 473 RD1/4PU $\begin{matrix} \boxed{4} & \boxed{7} & \boxed{3} \\ \boxed{J} \end{matrix}$
 0.5 Ω \rightarrow R50 RN2H $\begin{matrix} \boxed{R} & \boxed{5} & \boxed{0} \\ \boxed{K} \end{matrix}$
 1 Ω \rightarrow 1R0 RS1P $\begin{matrix} \boxed{1} & \boxed{R} & \boxed{0} \\ \boxed{K} \end{matrix}$

Ex.2 When there are 3 effective digits (such as in high precision metal film resistors).

5.62k Ω \rightarrow 562×10^1 \rightarrow 5621 RN1/4PC $\begin{matrix} \boxed{5} & \boxed{6} & \boxed{2} & \boxed{1} \\ \boxed{F} \end{matrix}$

■ LIST OF WHOLE PCB ASSEMBLIES

Mark	Symbol and Description	Part No.				Remarks
		VSX-39TX	VSX-37TX	VSX-36TX	VSX-D909S	
NSP	MAIN ASSY	AWK7640	AWK7641	AWK7642	AWK7643	
	└ MAIN CONTROL ASSY	AWX7705	AWX7706	AWX7707	AWX7708	
	└ VIDEO ASSY	AWX7307	AWX7394	AWX7394	AWX7394	
	└ S-VIDEO ASSY	AWX7678	AWX7679	AWX7679	AWX7679	
NSP	COMPLEX ASSY	AWK7497	AWK7522	AWK7522	AWK7522	
	└ REGULATOR ASSY	AWX7310	AWX7310	AWX7310	AWX7310	
	└ PRIMARY ASSY	AWX7311	AWX7311	AWX7311	AWX7311	
NSP	└ A-PINJACK ASSY	AWX7312	AWX7397	AWX7397	AWX7397	
	└ CONNECTION ASSY	AWX7313	AWX7313	AWX7313	AWX7313	
NSP	└ EXTRA-5.1 ASSY	AWX7314	Not used	Not used	Not used	
	└ EXTERNAL IN ASSY	Not used	AWX7398	AWX7398	AWX7398	
NSP	└ TRANS 2-2 ASSY	AWX7366	AWX7366	AWX7366	AWX7366	
	└ TRANS 1 ASSY	AWX7316	AWX7316	AWX7316	AWX7316	
NSP	COMPLEX 2 ASSY	AWK7626	AWK7627	AWK7628	AWK7628	
	└ COMPONENT ASSY	AWX7635	AWX7636	AWX7636	AWX7636	
	└ RF / DIGITAL IN ASSY	AWX7637	AWX7638	AWX7642	AWX7642	
NSP	└ OPT OUT ASSY	AWX7643	AWX7643	AWX7643	AWX7643	
NSP	2CH I/O ASSY	AWK7636	AWX7637	AWX7637	AWX7637	
	└ 2CH I/O PJ ASSY	AWX7634	AWX7646	AWX7646	AWX7646	
	└ TRIM ASSY	AWX7655	AWX7655	AWX7655	AWX7655	
NSP	FRONT/VAMP ASSY	AWK7667	AWK7656	AWK7657	AWK7658	
	└ V-AMP ASSY	AWX7729	AWX7309	AWX7309	AWX7409	
	└ DISPLAY ASSY	AWX7698	AWX7698	AWX7699	AWX7700	
NSP	└ ROTARY ENCODER ASSY	AWX7328	AWX7328	AWX7726	AWX7726	
	└ H. PHONE/F. VIDEO ASSY	AWX7342	AWX7342	AWX7528	AWX7528	
	└ VOLUME ASSY	AWX7367	AWX7367	Not used	Not used	
NSP	POWER/CURRENT ASSY	AWK7650	AWK7651	AWK7652	AWK7652	
NSP	└ C-AMP-P ASSY	AWX7680	AWX7680	AWX7680	AWX7680	
	└ C-AMP-N ASSY	AWX7681	AWX7681	AWX7681	AWX7681	
NSP	└ OUTPUT-FL ASSY	AWX7682	AWX7682	AWX7682	AWX7682	
NSP	└ OUTPUT-FR ASSY	AWX7683	AWX7683	AWX7683	AWX7683	
NSP	└ OUTPUT-C ASSY	AWX7684	AWX7684	AWX7684	AWX7684	
NSP	└ OUTPUT-SL ASSY	AWX7685	AWX7685	AWX7685	AWX7685	
NSP	└ OUTPUT-SR ASSY	AWX7686	AWX7686	AWX7686	AWX7686	
NSP	└ VL-TERMINAL ASSY	AWX7657	AWX7657	AWX7657	AWX7657	
	└ TRANS 2-1 ASSY	AWX7659	AWX7694	AWX7695	AWX7695	
NSP	└ DIODE ASSY	AWX7660	AWX7697	AWX7697	AWX7697	
	└ SP/PS ASSY	AWX7658	AWX7688	AWX7689	AWX7689	
NSP	DSP ASSY	AWX7632	AWX7632	AWX7633	AWX7633	

■ CONTRAST OF PCB ASSEMBLIES

D MAIN CONTROL ASSY

AWX7705, AWX7706, AWX7707 and AWX7708 are constructed the same except for the following :

Mark	Symbol and Description	Part No.				Remarks
		AWX7705	AWX7706	AWX7707	AWX7708	
	IC112	M5220FP	UPC4570G2	UPC4570G2	UPC4570G2	
	IC113	M5220L	UPC4570HA	UPC4570HA	UPC4570HA	
	IC114	M5220L	UPC4570HA	UPC4570HA	UPC4570HA	
	R921	Not used	Not used	RS1/10S103J	RS1/10S103J	
	R922	RS1/10S103J	RS1/10S103J	Not used	Not used	
	R923	Not used	RS1/10S103J	Not used	RS1/10S103J	
	R924	RS1/10S103J	Not used	RS1/10S103J	Not used	
	R925	RS1/10S103J	Not used	Not used	RS1/10S103J	
	R926	Not used	RS1/10S103J	RS1/10S103J	Not used	
	CN902 13P CONNECTOR	HLEM13R	HLEM13R	HLEM13R	HLEM13S	
	CN941 4P PIN JACK	Not used	AKB7015	AKB7015	AKB7015	
	JA911 2P PIN JACK	Not used	DKB1045	DKB1045	DKB1045	
	JA931 2P PIN JACK	Not used	VKB1060	VKB1060	VKB1060	
	103 6P PIN JACK	AKB7088	Not used	Not used	Not used	
	113 6P PIN JACK	Not used	AKB7089	AKB7089	AKB7089	
	JA901, JA911 4P PIN JACK	AKB7075	Not used	Not used	Not used	

E V-AMP ASSY

AWX7729, AWX7309 and AWX7409 are constructed the same except for the following :

Mark	Symbol and Description	Part No.			Remarks
		AWX7729	AWX7309	AWX7409	
	IC7501, IC7521, IC7541, IC7601, IC7621	NJM2114MD	UPC4570G2	UPC4570G2	
	IC7502, IC7522, IC7542, IC7602, IC7622	NJM4558MD	NJM4558MD	Not used	
	Q7501, Q7521, Q7541, Q7601, Q7621	2SC2878	2SC2878	Not used	
	D7501, D7502, D7521, D7522, D7541, D7542	1SS355	1SS355	Not used	
	D7601, D7602, D7621, D7622	1SS355	1SS355	Not used	
	D7503, D7504, D7523, D7524, D7543, D7544	HZU2CLL	HZU2CLL	Not used	
	D7603, D7604, D7623, D7624	HZU2CLL	HZU2CLL	Not used	
	C7505, C7525, C7545, C7605, C7625	CCSQCH220J50	CCSQCH220J50	Not used	
	C7506, C7526, C7546, C7606, C7626	CEAT4R7M50	CEAT4R7M50	Not used	
	C7510, C7530, C7550, C7610, C7630	CKSQYB104K25	CKSQYB104K25	Not used	
	R7504, R7524, R7544, R7604, R7624	RS1/10S103J	RS1/10S103J	RS1/10S0R0J	
	R7509, R7529, R7549, R7609, R7629	RS1/10S103J	RS1/10S103J	Not used	
	R7507, R7508, R7510, R7527, R7528, R7530	RS1/10S334J	RS1/10S334J	Not used	
	R7547, R7548, R7550, R7607, R7608, R7610	RS1/10S334J	RS1/10S334J	Not used	
	R7627, R7628, R7630	RS1/10S334J	RS1/10S334J	Not used	
	R7511, R7531, R7551, R7611, R7631	RS1/10S102J	RS1/10S102J	Not used	
	R7512, R7513, R7516, R7517, R7532, R7533	RS1/10S473J	RS1/10S473J	Not used	
	R7536, R7537, R7552, R7553, R7556, R7557	RS1/10S473J	RS1/10S473J	Not used	
	R7612, R7613, R7616, R7617, R7632, R7633	RS1/10S473J	RS1/10S473J	Not used	
	R7636, R7637	RS1/10S473J	RS1/10S473J	Not used	
	R7514, R7534, R7554, R7614, R7634	RS1/10S101J	RS1/10S101J	Not used	
	R7515, R7518, R7535, R7538, R7555, R7558	RS1/10S105J	RS1/10S105J	Not used	
	R7615, R7618, R7635, R7638	RS1/10S105J	RS1/10S105J	Not used	
	R7641	RS1/10S914J	RS1/10S914J	Not used	
	R7653 - R7656, R7663 - R7666, R7673 - R7676	RS1/10S0R0J	RS1/10S0R0J	Not used	
	R7683 - R7686, R7693 - R7696	RS1/10S0R0J	RS1/10S0R0J	Not used	

VSX-39TX, VSX-37TX, VSX-36TX, VSX-D909S

B A-PINJACK ASSY

AWX7312 and AWX7397 are constructed the same except for the following :

Mark	Symbol and Description	Part No.		Remarks
		AWX7312	AWX7397	
	CN1014 6P PIN JACK JA1011 - JA1013 4P PIN JACK JA1015 4P PIN JACK 1016 2P PIN JACK	AKB7119 AKB7108 Not used Not used	Not used AKB7048 AKB7048 AKB7120	

P VIDEO ASSY

AWX7307 and AWX7394 are constructed the same except for the following :

Mark	Symbol and Description	Part No.		Remarks
		AWX7307	AWX7394	
	JA701 3P PIN JACK JA703 3P PIN JACK 702 2P PIN JACK 707 1P PIN JACK 2P PIN JACK	AKB7109 AKB7116 AKB7076 Not used Not used	Not used AKB7115 Not used AKB7020 AKB7017	

Q S-VIDEO ASSY

AWX7678 and AWX7679 are constructed the same except for the following :

Mark	Symbol and Description	Part No.		Remarks
		AWX7678	AWX7679	
	CN801 4P MINI DIN SOCKET CN802, CN803 4P MINI DIN SOCKET JA801 4P MINI DIN SOCKET	Not used AKP7023 AKP7049	AKP7043 AKP7020 Not used	

S DISPLAY ASSY

AWX7698, AWX7699 and AWX7700 are constructed the same except for the following :

Mark	Symbol and Description	Part No.			Remarks
		AWX7698	AWX7699	AWX7700	
	IC7071 Q7002, Q7054 D7002 D7071 - D7079 S7019, S7020	M66311FP DTC124EK SLR-343DC(NPQ) SLR-343VR(MNP) VSG1009	Not used DTC124EK SLR-343DC(NPQ) Not used VSG1009	Not used Not used Not used Not used Not used	
	C7011, C7073, C7074 C7071 C7072 L7011, L7012 R7038	CKSQYB102K50 CEAL101M6R3 CKSQYB473K50 Not used RS1/10S271J	Not used Not used Not used Not used RS1/10S271J	Not used Not used Not used LCTA330J3225 Not used	
	R7042 R7061 R7071 - R7079 R7080 - R7083 R7092	RS1/10S103J RS1/10S103J RS1/10S271J RS1/10S102J RS1/10S473J	RS1/10S223J RS1/10S103J Not used Not used Not used	RS1/10S223J Not used Not used Not used Not used	
	R7099, R7100 CN7003 8P FFC CONNECTOR 505	RS1/10S0R0J 52045-0845 VEF1040	RS1/10S0R0J Not used Not used	Not used Not used Not used	

T ROTARY ENCODER ASSY

AWX7328 and AWX7726 are constructed the same except for the following :

Mark	Symbol and Description	Part No.		Remarks
		AWX7328	AWX7726	
	S7101 C7103, C7104 R7103, R7104	Not used Not used Not used	ASX7004 CKSQYB103K50 RS1/10S103J	

Y DSP ASSY

AWX7632 and AWX7633 are constructed the same except for the following :

Mark	Symbol and Description	Part No.		Remarks
		AWX7632	AWX7633	
	IC9041	NJM4558MD	Not used	
	IC9071	PM4007A	Not used	
	IC9091	LH52256CN-70LL	Not used	
	Q9001, Q9002, Q9004 - Q9006, Q9031	2SC3082K (NP)	Not used	
	Q9003, Q9032	2PD601A (QR)	Not used	
	Q9007	2PB709A (QR)	Not used	
	D9001	KV1851	Not used	
	D9002	1SS355	Not used	
	F9001	ATF7001	Not used	
	L9003	ATH7001	Not used	
	L9071	ATL7002	Not used	
	F9091, F9092	DTF1064	Not used	
	C9002 - C9006, C9008 - C9013, C9015, C9017	CKSRYF104Z16	Not used	
	C9018, C9031, C9032, C9051, C9052	CKSRYF104Z16	Not used	
	C9055, C9077, C9079, C9081, C9092	CKSRYF104Z16	Not used	
	C9043, C9058, C9073 - C9075, C9078, C9080	CKSQYF104Z25	Not used	
	C9007	CCSRCH750J50	Not used	
	C9014, C9054, C9056, C9070	CKSRYB103K50	Not used	
	C9016	CEJA470M25	Not used	
	C9033	CCSRCH101J50	Not used	
	C9041, C9042	CKSRYF105Z10	Not used	
	C9053	CEJQNP4R7M25	Not used	
	C9057	CCSRCH270J50	Not used	
	C9071	CEJQ101M10	Not used	
	C9076	CCSQCH271J50	Not used	
	C9091	CEJA470M16	Not used	
	C9095	CCSRCH221J50	Not used	
	R9002, R9010, R9011, R9018, R9038, R9053	RS1/16S103J	Not used	
	R9054, R9071, R9072	RS1/16S103J	Not used	
	R9003, R9019	RS1/16S512J	Not used	
	R9004, R9015, R9016, R9020	RS1/16S202J	Not used	
	R9005, R9006, R9014, R9021, R9022, R9025	RS1/16S102J	Not used	
	R9073	RS1/16S102J	Not used	
	R9007, R9023, R9033	RS1/16S220J	Not used	
	R9008, R9027, R9030	RS1/16S302J	Not used	
	R9009, R9074	RS1/16S221J	Not used	
	R9013, R9017, R9034	RS1/16S152J	Not used	
	R9024, R9026	RS1/16S332J	Not used	
	R9028, R9029	RS1/16S561J	Not used	
	R9031, R9032	RS1/16S333J	Not used	
	R9035	RS1/16S223J	Not used	
	R9036, R9091, R9095, R9096	RS1/16S0R0J	Not used	
	R9037, R9039	RS1/16S274J	Not used	
	R9041	RS1/16S472J	Not used	
	R9042, R9044, R9062	RS1/16S392J	Not used	
	R9043	RS1/16S273J	Not used	
	R9046	RS1/16S104J	Not used	
	R9047	RS1/16S432J	Not used	
	R9051	RS1/16S393J	Not used	
	R9052	RS1/16S243J	Not used	
	R9055	RS1/16S121J	Not used	
	R9056	RS1/16S683J	Not used	
	R9057 - R9059	RS1/16S473J	Not used	
	R9061	RS1/16S471J	Not used	
	R9075, R9076	RS1/16S101J	Not used	

VSX-39TX, VSX-37TX, VSX-36TX, VSX-D909S

Y DSP ASSY

Mark	Symbol and Description	Part No.		Remarks
		AWX7632	AWX7633	
	CN9804 3P PLUG X9001 CRYSTAL RESONATOR (18.432MHz)	KM250MA3 ASS7009	Not used Not used	

K DIODE ASSY

AWX7660 and AWX7697 are constructed the same except for the following :

Mark	Symbol and Description	Part No.		Remarks
		AWX7660	AWX7697	
	D3001, D3002	LN6SB60-4003	D5SBA20(B)	

W RF/DIGITAL IN ASSY

AWX7637, AWX7638 and AWX7642 are constructed the same except for the following :

Mark	Symbol and Description	Part No.			Remarks
		AWX7637	AWX7638	AWX7642	
	JA1204 2P PIN JACK 1200	AKB7092 VEF1040	AKB7091 VEF1040	AKB7095 Not used	

Z COMPONENT ASSY

AWX7635 and AWX7636 are constructed the same except for the following :

Mark	Symbol and Description	Part No.		Remarks
		AWX7635	AWX7636	
	JA1501 3P PIN JACK JA1502 3P PIN JACK	AKB7127 AKB7125	AKB7128 AKB7126	

J TRANS 2-1 ASSY

AWX7659, AWX7694 and AWX7695 are constructed the same except for the following :

Mark	Symbol and Description	Part No.			Remarks
		AWX7659	AWX7694	AWX7695	
	C4501, C4503, C4504 C4502 C4509, C4510 C4511, C4512 C4513 D4513 Q4503 Q4504 Q4505 R4501, R4503, R4511 R4502, R4504	ACH1237-A ACH1237-A CECA101M50 ACH1237-A ACH1237-A Not used Not used Not used Not used RFA1/4PS100J RFA1/4PS100J	Not used ACH1237-A CEAT101M50 Not used ACH1237-A Not used Not used Not used Not used Not used RFA1/4PS100J	Not used Not used CEAT101M50 Not used Not used MTZJ16B DTC143ES DTA143ES DTC124ES Not used Not used	

R H. PHONE / F. VIDEO ASSY

Although AWX7343 and AWX7528 are different in part number, they consist of the same components.

AA 2CH I/O PJ ASSY

AWX7634 and AWX7646 are constructed the same except for the following :

Mark	Symbol and Description	Part No.		Remarks
		AWX7634	AWX7646	
	CN8004	AKB7129	AKB7087	

L SP / PS ASSY

AWX7658, AWX7688 and AWX7689 are constructed the same except for the following :

Mark	Symbol and Description	Part No.			Remarks
		AWX7658	AWX7688	AWX7689	
	C3001, C3002 C3119 - C3122 L3001, L3002 Q3005 RY3101, RY3103, RY3104	ACH7147 CEAT470M50 ATX1012 Not used ASR-109	ACH7068 Not used ATX1012 Not used ASR7014	ACH7130 Not used Not used DTA124ES ASR7014	

PCB PARTS LIST FOR VSX-39TX/KU/CA

Mark	No.	Description	Part No.	Mark	No.	Description	Part No.
A		EXTRA-5.1 ASSY		B		A-PINJACK ASSY	
		CAPACITORS				CAPACITORS	
		C1107-C1112	CEAT4R7M50			C1019-C1022	CKCYF103Z50
		C1113-C1115	CKCYF103Z50				
		RESISTORS				RESISTORS	
		All Resistors	RD1/4PU□□□J			All Resistors	RD1/4PU□□□J
		OTHERS				OTHERS	
		JA1101-JA1103 2P PIN JACK	AKB7121			JA1011-JA1013 4P PIN JACK	AKB7108
		CN1101 8P SOCKET	KP200TA8L			CN1014 6P PIN JACK	AKB7119
						CN1001 18P SOCKET	KP200TA18L
						CN1002 4P SOCKET	KP200TA4L
A		EXTERNAL IN ASSY		C		CONNECTION ASSY	
		CAPACITORS				SEMICONDUCTORS	
		C1107-C1112	CEAT4R7M50			IC1351	M5220P
		C1113-C1115	CKCYF103Z50			IC1301-IC1303	NJM4558D-D
		RESISTORS				CAPACITORS	
		All Resistors	RD1/4PU□□□J			C1351,C1352	CEAT100M50
		OTHERS				C1365,C1366	CEAT101M16
		JA1101-JA1103	AKB7121			C1363,C1364	CEAT2R2M50
		CN1101 8P SOCKET	KP200TA8L				

VSX-39TX, VSX-37TX, VSX-36TX, VSX-D909S

Mark	No.	Description	Part No.
	C1357,C1358		CEAT470M25
	C1307-C1312		CEAT4R7M50
	C1313-C1318		CKCYF103Z50
	C1361,C1362		CQMA242J50
	C1359,C1360		CQMBA822J50

RESISTORS

All Resistors RD1/4PU□□□□J

OTHERS

CN1351	18P PLUG	KM200TA18
CN1352	4P PLUG	KM200TA4
CN1301	8P PLUG	KM200TA8
CN1302	10P SOCKET	KP200TA10L
CN1353	20P SOCKET	KP200TA20L

D MAIN CONTROL ASSY

SEMICONDUCTORS

IC102	BU4052BCF
IC110	M62429FP
IC103,IC105,IC109	NJM4558MD
IC901	PD5589A
IC104,IC107	TC9163AF
IC101	TC9274N-001
IC108	TC9482N
IC112	M5220FP
IC113,IC114	M5220L
Q991	2SC1740S
Q251,Q252	2SC2412K
Q113,Q114,Q271,Q272	2SC2878
Q902-Q905	DTA124EK
Q901	DTC143EK
Q107-Q112	HN1C03F
D254,D255,D901-D910,D991	1SS355
D995	UDZ11B
D201,D202,D256	UDZS5.1B

COIL

L901	CHIP COIL	LCTA2R2J3225
------	-----------	--------------

CAPACITORS

C902	ACH7058
C951-C964	CCSQCH101J50
C157,C158,C167,C168,C177	CCSQCH560J50
C111,C112,C117,C118	CEAT100M50
C127-C130,C141,C142	CEAT100M50
C145,C146,C149,C150	CEAT100M50
C153,C154,C159,C160	CEAT100M50
C163,C164,C169,C170	CEAT100M50
C173,C174,C179,C180	CEAT100M50
C255,C256,C277,C278	CEAT100M50
C123-C126,C991	CEAT101M16
C147,C148,C257	CEAT1R0M50
C903	CEAT221M10
C121,C122	CEAT221M16
C905	CEAT2R2M50
C915	CEAT331M10
C107,C108,C115,C116	CKSQYB103K50
C133-C140,C143,C144	CKSQYB103K50
C161,C162,C279,C280,C901	CKSQYB103K50
C904,C908,C909,C914,C919	CKSQYB103K50

Mark	No.	Description	Part No.
	C965		CKSQYB103K50
	C273,C274		CKSQYB104K25
	C275,C276		CKSQYB332K50
	C178		CKSQYB333K50
	C271,C272		CKSQYB472K50
	C910,C912		CKSQYB473K50
	C906		CKSQYF105Z16
	C992		CKSQYF225Z16

RESISTORS

R948	RA12T473J
R913	RA5T103J
R949	RA8T103J
R109	RD1/2VM391J
Other Resistors	RS1/10S□□□□J

OTHERS

X901	CERAMIC RESONATOR (4.19MHz)	ASS1018
CN903	7P FFC CONNECTOR	HLEM7R-1
CN902	13P FFC CONNECTOR	HLEM13R-1
CN906	5P FFC CONNECTOR	HLEM5S-1
CN105	23P FFC CONNECTOR	HLEM23S-1
CN905	26P FFC CONNECTOR	HLEM26S-1
CN904	32P FFC CONNECTOR	HLEM32S-1
CN901,CN911	4P PIN JACK	AKB7075
103	6P PIN JACK	AKB7088
CN103	10P PLUG	KM200TA10
CN101	20P PLUG	KM200TA20
CN104	16P SOCKET	KP200IA16L
CN901	15P SOCKET	KP200TA15L
CN920	7P SOCKET	KP200TA7L
CN108	9P SOCKET	KP200TA9L
909,912,913	PCB BINDER	VEF1040

E V-AMP ASSY

SEMICONDUCTORS

IC581	BU4052BCF
IC7502,IC7522,IC7542,IC7602,IC7622	NJM4558MD
IC7501,IC7521,IC7541,IC7601,IC7621	NJM2114MD
Q503,Q523,Q543,Q603,Q623	2SA1048
△ Q506,Q509,Q526,Q529,Q546	2SA970
△ Q549,Q606,Q609,Q626,Q629	2SA970
△ Q507,Q508,Q527,Q528	2SC2240
△ Q547,Q548,Q607,Q608	2SC2240
△ Q561	2SC2240
△ Q627,Q628	2SC2240
Q510,Q530,Q550,Q610,Q630	2SC2878
Q7501,Q7521,Q7541,Q7601,Q7621	2SC2878
Q501,Q521,Q541,Q601,Q621	FMS3
Q504,Q524,Q544,Q604,Q624	FMW4
D501,D502,D504,D505	1SS355
D521,D522,D524,D525	1SS355
D541,D542,D544,D545	1SS355
D581-D588,D601,D602	1SS355
D604,D605,D621,D622	1SS355
D624,D625,D7501,D7502	1SS355
D7521,D7522,D7541,D7542	1SS355
D7601,D7602,D7621,D7622	1SS355
D7503,D7504,D7523,D7524	HZU2CLL

Mark	No.	Description	Part No.
		D7543,D7544,D7603,D7604	HZU2CLL
		D7623,D7624	HZU2CLL
△		D503,D523,D543,D603,D623	UDZS6.8B
		D506,D526,D546,D606,D626	UDZS8.2B

CAPACITORS

C511,C512,C531,C532	CCCSL181K2H
C551,C552,C611,C612	CCCSL181K2H
C631,C632	CCCSL181K2H
C509,C529,C549,C609,C629	CCCSL5R0C2H
C504,C524,C544,C604,C624	CCSQCH101J50

C7504,C7505,C7524,C7525	CCSQCH220J50
C7544,C7545,C7604,C7605	CCSQCH220J50
C7624,C7625	CCSQCH220J50
C502,C522,C542,C602,C622	CCSQCH221J50
C506,C507,C526,C527	CCSQSL560J50

C546,C547,C606,C607	CCSQSL560J50
C626,C627	CCSQSL560J50
C7501,C7521,C7541,C7601,C7621	CEAT100M50
C505,C508,C525,C528,C545	CEAT101M16
C548,C605,C608,C625,C628	CEAT101M16

C510,C530,C550,C610,C630	CEAT470M16
C513,C533,C553,C568,C569	CEAT470M50
C613,C633	CEAT470M50
C501,C521,C541,C601,C621	CEAT4R7M50
C7506,C7526,C7546,C7606,C7626	CEAT4R7M50

C7502,C7503,C7510,C7512	CKSQYB104K25
C7522,C7523,C7530,C7532	CKSQYB104K25
C7542,C7543,C7550,C7552	CKSQYB104K25
C7602,C7603,C7610,C7612	CKSQYB104K25
C7622,C7623,C7630,C7632	CKSQYB104K25

C561-C565	CKSQYB222K50
C503,C523,C543,C603,C623	CKSQYB332K50
C570	CKSQYF223Z50
C581,C582	CKSQYF225Z16

RESISTORS

R518,R538,R558,R618,R638	RD1/4MUF473J
△ R513,R514,R533,R534	RS1/10S121J
△ R553,R554,R613,R614	RS1/10S121J
△ R633,R634	RS1/10S121J
Other Resistors	RS1/10S□□□J

OTHERS

CN501	23P FFC CONNECTOR	52045-2345
CN502	28P FFC CONNECTOR	52045-2845
CN504	3P PLUG	KM250MA3
506	PCB BINDER	VEF1040

F C-AMP-N ASSY

SEMICONDUCTORS

Q2503,Q2523,Q2543,Q2603,Q2623	2SA970
Q2001,Q2002	2SC1740S
Q2502,Q2522,Q2542,Q2602,Q2622	2SC4137
△ Q2501,Q2521,Q2541,Q2601,Q2621	IRF540A
D2501-D2504,D2521-D2524	1SS133

D2541-D2544,D2601-D2604	1SS133
D2621-D2624	1SS133

CAPACITORS

C2501,C2521,C2541,C2601,C2621	CEANPR22M50
C2001	CEAT101M10

Mark	No.	Description	Part No.
RESISTORS			
△		R2506,R2510,R2526,R2530,R2546	RD1/4PUF391J
△		R2550,R2606,R2610,R2626,R2630	RD1/4PUF391J
△		R2501,R2521,R2541,R2601,R2621	RD1/4PUF470J
		VR2501,VR2521,VR2541,VR2601	RCP1134
		(22Ω)	

VR2621 (22Ω)	RCP1134
Other Resistors	RD1/4PU□□□J

OTHERS

CN2001	28P FFC CONNECTOR	HLEM28S-1
CN2501,CN2521,CN2541,CN2601	7P PLUG	KM250NA7L
CN2621	8P PLUG	KM250NA8L

G C-AMP-P ASSY

SEMICONDUCTORS

△ Q2504,Q2524,Q2544,Q2604,Q2624	IRF9540A
---------------------------------	----------

RESISTORS

△ R2511,R2531,R2551,R2611,R2631	RD1/4PUF470J
---------------------------------	--------------

OTHERS

CN2504,CN2524,CN2544,CN2604	5P PLUG	KM250NA5L
CN2624	5P PLUG	KM250NA5L

HA OUTPUT-SL ASSY

RESISTOR

△ R2612 (0.05Ω/5W)	ACN7097
--------------------	---------

OTHERS

CN2603	5P SOCKET	KP250NA5
CN2602	7P SOCKET	KP250NA7

HB OUTPUT-FL ASSY

RESISTOR

△ R2512 (0.05Ω/5W)	ACN7097
--------------------	---------

OTHERS

CN2503	5P SOCKET	KP250NA5
CN2502	7P SOCKET	KP250NA7

HC OUTPUT-C ASSY

RESISTOR

△ R2552 (0.05Ω/5W)	ACN7097
--------------------	---------

OTHERS

CN2543	5P SOCKET	KP250NA5
CN2542	7P SOCKET	KP250NA7

VSX-39TX, VSX-37TX, VSX-36TX, VSX-D909S

Mark No. Description Part No.

HD OUTPUT-FR ASSY

RESISTOR

△ R2532 (0.05Ω/5W) ACN7097

OTHERS

CN2523 5P SOCKET KP250NA5
CN2522 7P SOCKET KP250NA7

HE OUTPUT-SR ASSY

RESISTOR

△ R2632 (0.05Ω/5W) ACN7097

OTHERS

CN2623 5P SOCKET KP250NA5
CN2622 8P SOCKET KP250NA8

I VL-TERMINAL ASSY

CAPACITORS

C2011,C2012 CEAT470M63

OTHERS

KN2011,KN2012 GROUND PLATE ANK-142

J TRANS 2-1 ASSY

SEMICONDUCTORS

△ IC4501,IC4502 (2.5A) AEK7014
△ Q4502 2SA1837
△ Q4501 2SC4793
D4509,D4510 MTZJ12B
D4505-D4508 MTZJ20A

△ D4501-D4504 S5688G
D4511,D4512 S5688G

CAPACITORS

C4501-C4504,C4511-C4513 ACH1237
C4509,C4510 CECA101M50
C4507,C4508 CEAT471M63

RESISTORS

△ R4509,R4510 RD1/4PMF332J
R4501-R4504,R4511 RFA1/4PS100J
Other Resistors RD1/4PU□□□J

OTHERS

4001 9P CABLE HOLDER 51048-0900
H4501-H4504 FUSE CLIP AKR1004
4501,4502 HEAT SINK ANH-309
4503,4504 SCREW BPZ30P080FZK

Mark No. Description Part No.

K DIODE ASSY

SEMICONDUCTORS

△ D3001,D3002 LN6SB60-4003

L SP/PS ASSY

SEMICONDUCTORS

Q3156-Q3159 DTA124ES
Q3151-Q3155 DTC143ES
D3051,D3053,D3055,D3057,D3059 1SS133

COILS AND FILTERS

L3101-L3105 AF CHOKE COIL ATH1053
L3001,L3002 CHIP BEAD ATX1012

RELAYS

RY3101,RY3103,RY3104 ASR-109
RY3102,RY3105 ASR7014

CAPACITORS

C3001,C3002 (22000μF/56V) ACH7147
C3118-C3122 CEAT470M50
C3101-C3105 CFTYA104J50
C3111-C3117 CQHA102J2A

RESISTORS

R3151-R3155 RD1/2PM331J
△ R3101-R3105 RD1/4PMF4R7J
R3001,R3002 RD1/4PMF473J
△ R3106-R3110 RS1LMF4R7J
△ R3131,R3132 RS2LMF331J

Other Resistors

RD1/4PM□□□J

OTHERS

3004 8P CABLE HOLDER 51048-0800
3001 9P CABLE HOLDER 51048-0900
CN3003 14P FFC CONNECTOR HLEM14S-1
CN3101 8P SPEAKER TERMINAL AKE7058
CN3102 6P SPEAKER TERMINAL AKE7060

J3002 JUMPER WIRE 8P D20PYY0825E
J3001 JUMPER WIRE 9P D20PYY0915E
CN3001 4P PLUG KM200TA4

M REGULATOR ASSY

SEMICONDUCTORS

△ IC5009,IC5010 (200mA) AEK7023
△ IC5004,IC5008 NJM78M05FA
△ IC5003 NJM78M12FA
△ IC5001 NJM78M15FA
△ IC5005,IC5007 NJM78M56FA

△ IC5006 NJM79M05FA
△ IC5002 NJM79M15FA
D5010,D5051 1SS133
△ D5009 D3SBA20(B)
D5012-D5014 MTZJ10C

D5011 MTZJ5.1B
△ D5001-D5008,D5015-D5017 S5688G

VSX-39TX, VSX-37TX, VSX-36TX, VSX-D909S

Mark No.	Description	Part No.
CAPACITORS		
C5015,C5017,C5019,C5021,C5023		CEAT101M10
C5009,C5011,C5013,C5025		CEAT101M25
C5024		CEAT101M50
C5051		CEAT221M10
C5026		CEAT221M35
C5027,C5028		CEAT221M50
C5001,C5003,C5006		CEAT222M25
C5002,C5004		CEAT222M35
C5005		CEAT332M25
C5007		CEAT472M16
C5008,C5010,C5012,C5014,C5016		CKCYF103Z50
C5018,C5020,C5022		CKCYF103Z50

Mark No.	Description	Part No.
RESISTORS		
R5001-R5003		RD1/2PM620J

Mark No.	Description	Part No.
OTHERS		
5009	4P CABLE HOLDER	51048-0400
CN5002	14P FFC CONNECTOR	52045-1445
CN5001	8P JUMPER CONNECTOR	52147-0810
J5000	BOARD IN WIRE	DB022ND0
CN5004	16P PLUG	KM200IA16
CN5005	15P PLUG	KM200TA15
CN5007	17P PLUG	KM200TA17
CN5008	7P PLUG	KM200TA7
CN5003,CN5006	9P PLUG	KM200TA9
KN5001,KN5002	EARTH METAL FITTING	VNF1084

N TRANS 1 ASSY
TRANS 1 Assy has no service parts.

O TRANS 2-2 ASSY **SEMICONDUCTOR**

△	IC5501 (4A)	AEK7018
OTHERS		
5501	4P CABLE HOLDER	51048-0400

P VIDEO ASSY **SEMICONDUCTORS**

IC751	BU4053BCF
IC752	LC74782M-9011
IC731	NJM2279M
IC701	NJM2296M
Q701	2SA933S
Q751-Q754	2SC1740S
Q755	DTC124EK
D701,D702,D731,D751-D753	1SS355

Mark No.	Description	Part No.
COILS		
L752,L753	CHIP COIL	LCTA100J3225
L751	CHIP COIL	LCTA330J3225

Mark No.	Description	Part No.
CAPACITORS		
C753		CCSQCH100D50
C763,C772		CCSQCH101J50
C715,C759		CCSQCH150J50
C760		CCSQCH180J50
C705-C707,C731		CCSQCH181J50
C761,C762		CCSQCH240J50
C754		CEAT100M50
C701-C704,C710-C712		CEAT101M10
C734,C735,C755,C764,C765		CEAT101M10
C781-C784		CEAT101M10
C713,C768,C769		CEAT101M16
C757		CEAT1R0M50
C752		CEAT330M16
C791,C795,C797		CKSQYB103K50
C756		CKSQYB122K50
C708,C709,C714,C732,C733		CKSQYB473K50
C736,C766,C767,C770,C771		CKSQYB473K50
C785,C786,C793		CKSQYB473K50

Mark No.	Description	Part No.
RESISTORS		
R715		RD1/2VM201J
Other Resistors		RS1/10S□□□□

Mark No.	Description	Part No.
OTHERS		
X751	CRYSTAL RESONATOR (14.31818MHz)	ASS1056
CN702	21P FFC CONNECTOR	52045-2145
CN701	26P FFC CONNECTOR	52045-2645
702	2P PIN JACK	AKB7076
JA701	3P PIN JACK	AKB7109
JA703	3P PIN AJCK	AKB7116
JA705	MULTI HOME JACK	AKN7014
704	PCB BINDER	VEF1040

Q S-VIDEO ASSY **SEMICONDUCTORS**

IC831	BU4051BCF
IC852	BU4053BCF
IC851	LA7213
IC801,IC802	NJM2296M
Q852,Q853	2SA933S
Q851	DTC124ES
Q833,Q834	IMH11
Q831	IMZ1A
D801,D802,D804,D805,D831	1SS355
D832,D851	1SS355

Mark No.	Description	Part No.
CAPACITORS		
C857		CCSQCH100D50
C854		CCSQCH151J50
C815-C818,C861,C862		CCSQCH181J50
C898		CCSQCH221J50
C809,C858		CCSQCH330J50
C801,C803,C805,C807		CEAT101M10
C819-C822,C852,C853,C863		CEAT101M10
C881,C882		CEAT101M10
C866,C868		CEAT101M16
C851		CEAT3R3M50
C831-C836,C855,C856,C891		CKSQYB103K50

VSX-39TX, VSX-37TX, VSX-36TX, VSX-D909S

Mark	No.	Description	Part No.
	C893,C894,C899		CKSQYB103K50
	C810-C814,C859,C860		CKSQYB104K25
	C864,C865		CKSQYB104K25
	C802,C804,C806,C808		CKSQYB473K50
	C823-C826,C867,C869		CKSQYB473K50

RESISTORS

R864	RD1/2VM201J
R859	RD1/4VM471J
Other Resistors	RS1/10S□□□J

OTHERS

CN804	21P FFC CONNECTOR	HLEM21S-1
CN802,CN803		AKP7023
	4P MINI DIN SOCKET	
CN805	6P FFC CONNECTOR	HLEM6S-1
JA801	4P MINI DIN SOCKET	AKP7049
JA881,JA882		RKN1004
	REMOTE CONTROL JACK	
801	PCB BINDER	VEF1040

R H. PHONE/F. VIDEO ASSY

SEMICONDUCTORS

Q7201,Q7202	2SC1740S
-------------	----------

CAPACITORS

C7201,C7202,C7215,C7216	CCSQCH271J50
C7203,C7204	CCSQCH330J50
C7208,C7209	CEAT101M10
C7207	CEAT470M35
C7210,C7212	CKSQYB103K50
C7211	CKSQYB104K25
C7213,C7214	CKSQYB105K10
C7217,C7218	CKSQYB392K50

RESISTORS

All Resistors	RS1/10S□□□J
---------------	-------------

OTHERS

CN7201	12P FFC CONNECTOR	52045-1245
CN7202	FRONT PIN JACK 4P	AKX7007
JA7201	HEADPHONE JACK	RKB1014
KN7201	EARTH METAL FITTING	VNF1084

S DISPLAY ASSY

SEMICONDUCTORS

IC7071	M66311FP
IC7001	PD5595A
IC7051	TC7W53FU
Q7051	2SA1037K
Q7005	2SC2412K
Q7001,Q7002,Q7052,Q7054	DTC124EK
Q7053	FMA1A
D7007-D7010,D7051-D7057	1SS355
D7002	SLR-343DC(NPQ)
D7001,D7071-D7079	SLR-343VR(MNP)

COIL

L7001	LFA2R2J
L7011,L7012	LCTA330J3225

Mark	No.	Description	Part No.
		SWITCHES	
	S7001-S7030		VSG1009

CAPACITORS

C7010 (0.047μF/5.5V)	ACH7132
C7007	CCSQCH101J50
C7008,C7013,C7071	CEAL101M6R3
C7701,C7702	CEAT100M50
C7052	CEAT101M6R3

C7001-C7005,C7011,C7073,C7074	CKSQYB102K50
C7091	CKSQYB102K50
C7051	CKSQYB103K50
C7009,C7072	CKSQYB473K50
C7053	CKSQYB153K50

RESISTORS

R7044	RA15T104J
Other Resistors	RS1/10S□□□J

OTHERS

X7001	CERAMIC RESONATOR (7.2MHz)	ASS7018
7001	3P CABLE HOLDER	51052-0300
7002,7003	8P CABLE HOLDER	51052-0800
CN7005	5P FFC CONNECTOR	52045-0545
CN7002	6P FFC CONNECTOR	52045-0645
CN7003	8P FFC CONNECTOR	52045-0845
CN7004	12P FFC CONNECTOR	52045-1245
CN7001	32P FFC CONNECTOR	52045-3245
V7001	FL TUBE	AAV7063
505	PCB BINDER	VEF1040

T ROTARY ENCODER ASSY

SWITCH

S7102	ASX7031
-------	---------

CAPACITORS

C7101,C7102	CKSQYB103K50
-------------	--------------

RESISTORS

All Resistors	RS1/10S□□□J
---------------	-------------

OTHERS

CN7101	6P FFC CONNECTOR	52044-0645
--------	------------------	------------

U VOLUME ASSY

SEMICONDUCTORS

Q7301,Q7302	2SA1993
Q7303,Q7304	2SC5395
D7301	1SR154-400

CAPACITORS

C7301	CEANP100M16
C7302	CEAT220M50
C7303	CEAT471M6R3

VSX-39TX, VSX-37TX, VSX-36TX, VSX-D909S

Mark	No.	Description	Part No.
RESISTORS			
	VR7301	(VARIABLE WITH MOTOR) Other Resistors	ACX7037 RS1/10S□□□□J

OTHERS			
	CN7301	8P FFC CONNECTOR	52045-0845
	KN7301	EARTH METAL FITTING	VNF1084

V PRIMARY ASSY

SEMICONDUCTORS			
△	IC6001 Q6001 D6005-D6007 D6008		NJM78M56FA DTC143ES 1SS133 MTZJ5.1A
△	D6001-D6004		S5688G

COIL			
△	L6001	LINE FILTER	ATF1006

TRANSFORMER			
△	T6001	STANDBY TRANS.	ATT7043

RELAY			
△	RY6001	POWER RELAY	ASR7022

CAPACITORS			
△	C6002,C6003 (10000pF/AC250V) C6005 C6006 C6004		ACG7020 CEAT102M16 CEAT470M25 CKCYF103Z50

RESISTORS			
	R6001 (2.2MΩ, 1/2W) R6003 Other Resistors		RCN1080 RD1/2PM270J RD1/4PU□□□□J

OTHERS			
△	6004	3P AC OUTLET	AKP1053
	H6001,H6002	FUSE CLIP	AKR1004
	CN6003	4P SOCKET	KP200TA4L
△	CN6002	AC CORD SOCKET	RKP1751
	6005	PCB BINDER	VEF1040
	6002,6003	SCREW TERMINAL	VNE1948

W RF/DIGITAL IN ASSY

SEMICONDUCTORS			
	IC1201		TC74HCU04AF

COILS AND FILTERS			
	F1203-F1206	CHIP BEAD	DTF1064

CAPACITORS			
	C1204,C1211 C1206,C1213 C1203,C1210,C1250 C1207,C1212,C1215,C1216 C1236,C1237		CCSQCH470J50 CEAT470M10 CKSQYB103K50 CKSQYF104Z25 CKSQYF104Z25
	C1251		CKSQYF473Z25

Mark	No.	Description	Part No.
RESISTORS			
		All Resistors	RS1/10S□□□□J

OTHERS			
	CN1201	13P FFC CONNECTOR	HLEM13S-1
	CN1202	4P FFC CONNECTOR	HLEM4S-1
	JA1204	3P PIN JACK	AKB7092
	JA1201,JA1202,JA1203	OPTICAL RECEIVE MOD.	GP1FA551RZ
	CN1250	3P PLUG 1200 PCB BINDER	KM250MA3 VEF1040

X OPT OUT ASSY

CAPACITORS			
	C1271,C1272 C1273,C1274		CKSQYF104Z50 CEAT221M10

RESISTORS			
		All Resistors	RS1/10S□□□□J

OTHERS			
	CN1271	4P FFC CONNECTOR	HLEM4S-1
	JA1271,JA1272	OPTICAL LINK MOD.	GP1FA551TZ

Y DSP ASSY

SEMICONDUCTORS			
	IC9351 IC9301 IC9203 IC9101 IC9201,IC9202		AK7706VT CS493292 CS5360-KS CS8414-CS NJM2100M
	IC9041 IC9401,IC9421,IC9441,IC9461 IC9501 IC9304 IC9071		NJM4558MD PCM1716E4 PD5590A PDN030A PM4007A
	IC9391 IC9392 IC9091 IC9305 IC9352		PQ7VZ5 PQ20WZ51 LH52256CN-70LL TC74LVX244FT TC551001CST-70L
	IC9151 IC9102 IC9302,IC9303 IC9306 IC9309		TC74ACT151F TC74VHC157FT TC74VHC574F TC74VHCT244AFT TC7W125FU
	IC9204,IC9307 IC9601 IC9308 IC9602-IC9705,IC9701-IC9706 Q9007		TC7WU04FU TC9164AF TC9246F UPC4570G2 2PB709A
	Q9003,Q9032 Q9001,Q9002,Q9004-Q9006,Q9031 Q9201,Q9202,Q9601-Q9606 Q9611,Q9612 Q9102,Q9104,Q9203,Q9607		2PD601A 2SC3082K 2SC3326 2SC3326 DTA124EK
	Q9609,Q9610 Q9101,Q9103,Q9204,Q9205,Q9608		DTA124EK DTC124EK

Mark	No.	Description	Part No.
	R9158,R9160,R9320,R9321,R9336 R9343,R9387,R9401,R9421,R9441 R9461,R9902-R9904,R9906 R9908,R9909,R9999 R9103,R9333,R9531-R9535		RS1/10S0R0J RS1/10S0R0J RS1/10S0R0J RS1/10S0R0J RS1/10S101J
	R9226,R9239,R9510,R9520 R9524-R9529 R9214,R9550 R9335 R9074,R9128		RS1/10S102J RS1/10S102J RS1/10S103J RS1/10S120J RS1/10S221J
	R9120,R9369 R9331 R9332 R9061,R9105 R9112		RS1/10S331J RS1/10S332J RS1/10S391J RS1/10S471J RS1/10S561J
	R9763,R9764 R9391,R9392 R9396 Other Resistors		RS1/10S822J RS1/16S1201F RS1/16S2001F RS1/16S□□□J

OTHERS

X9001	CRYSTAL RESONATOR (18.432MHz)	ASS7009
X9501	CRYSTAL RESONATOR (20MHz)	ASS7032
X9201	CRYSTAL RESONATOR (12.288MHz)	DSS1030
X9301	CHIP RESONATOR (27.0MHz)	VSS1086
CN9571 CN9581,CN9803	7P FFC CONNECTOR 13P FFC CONNECTOR	HLEM7S-1 HLEM13S-1
CN9804	3P PLUG	KM250MA3
CN9801	17P SOCKET	KP200TA17L
CN9802	9P SOCKET	KP200TA9L
CN9501	8P FFC CONNECTOR	VKN1598

**Z COMPONENT ASSY
SEMICONDUCTORS**

IC1501 IC1502,IC1503 IC1504 IC1505 Q1501-Q1503	TC74HC4053AF TK15420M TC7S86F TC7S00F DTC124EK
--	--

CAPACITORS

C1505,C1506,C1509-C1512 C1516-C1518 C1501-C1504,C1507,C1508	CKSQYB103K50 CKSQYB103K50 CEAT101M10
---	--

RESISTORS

All Resistors	RS1/10S□□□J
---------------	-------------

OTHERS

CN1501	6P FFC CONNECTOR	HLEM6S-1
JA1502	3P PIN JACK	AKB7125
JA1501	6P PIN JACK	AKB7127

Mark	No.	Description	Part No.
AA		2CH I/O PJ ASSY	
		SEMICONDUCTORS	
	IC8001 Q8001,Q8002		UPC4570G2 HN1C03F
		CAPACITORS	
	C8001,C8002 C8027,C8028,C8032 C8007,C8008,C8031 C8025,C8026 C8003,C8004,C8009,C8010		CCSQCH101J50 CCSQCH221J50 CKSQYF104Z25 CEAL100M50 CEAL4R7M50
	C8035,C8036		CEJA470M25
		RESISTORS	
	All Resistors		RS1/10S□□□J
		OTHERS	
	CN8002 9P FFC CONNECTOR JA8004 4P PIN JACK		HLEM9S-1 AKB7129

**AB TRIM ASSY
SEMICONDUCTORS**

IC8002 IC8003 IC8004	TC9215AF TC9459F UPC4570G2
----------------------------	----------------------------------

CAPACITORS

C8019,C8020 C8021,C8022 C8011,C8012,C8015,C8016,C8023 C8024,C8039 C8017,C8018	CCSQCH331J50 CCSQCH560J50 CKSQYF104Z25 CKSQYF104Z25 CEAL100M50
C8033,C8034	CEJA470M25

RESISTORS

All Resistors	RS1/10S□□□J
---------------	-------------

OTHERS

CN8001 13P FFC CONNECTOR CN8003 9P FFC CONNECTOR 8001 SCREW TERMINAL	HLEM13S-1 HLEM9S-1 VNE1948
--	----------------------------------

6. ADJUSTMENT

6.1 IDLE CURRENT ADJUSTMENT

- **CAUTION** : Heatsink's DC level is equal to +B or -B.
Don't touch them or you will be electricary shocked.

1. Decrease the level of the Adjustment Variable resistors (VR) for the channel to be adjusted. (Turn counterclockwise.)
2. Set the power switch to ON.
3. Connect the DC voltmeter as shown below and adjust VRs in step No. order so that voltages become $16\text{mV}^{+4\text{mV}}_{-0\text{mV}}$.
4. Ages for seven minutes.
5. Readjust in step No. order so that the voltages become $11.5\text{mV} \pm 1\text{mV}$ (10.5 to 12.5mV). Adjustment is completed.

Step No.	Adjustment VR	Adjustment ch
1	VR2601	SL ch
2	VR2501	FL ch
3	VR2541	C ch
4	VR2521	FR ch
5	VR2621	SR ch

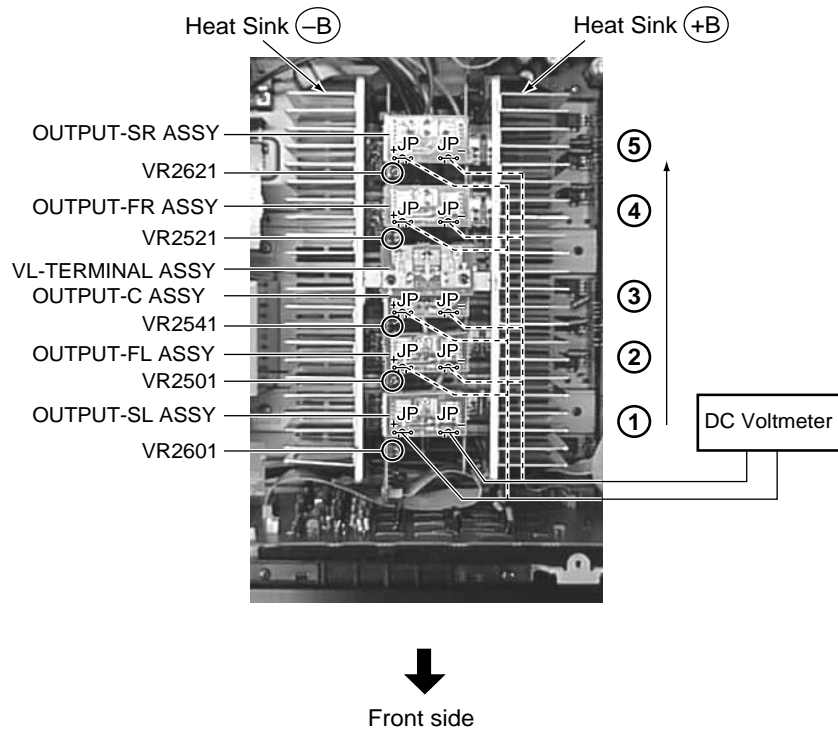

7. GENERAL INFORMATION

7.1 DISASSEMBLY

■ Bonnet

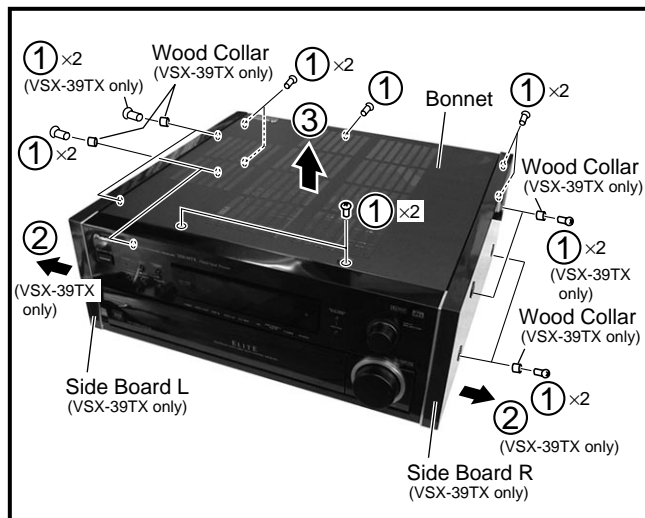

■ Front Panel Section

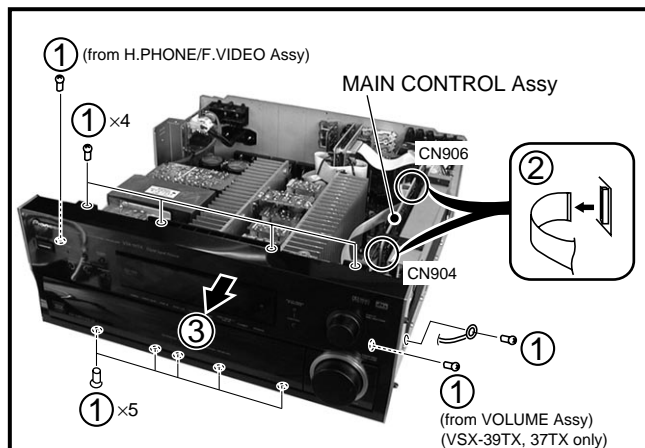

• PCB Location (Front Panel Section)

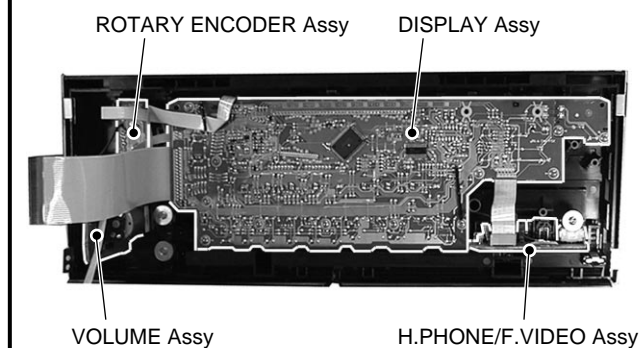

■ Heat Sink Section

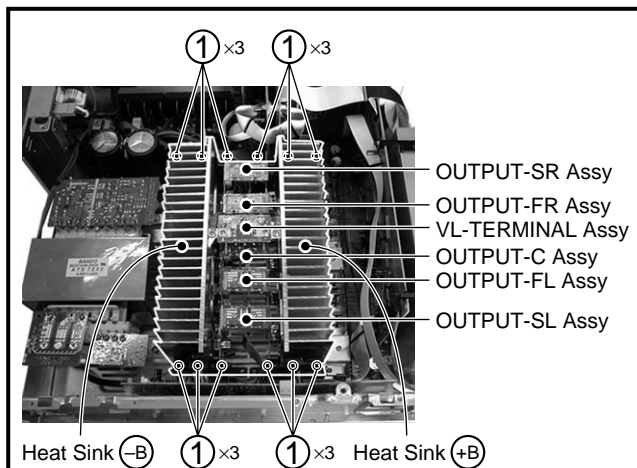

• **CAUTION** : Heatsink's DC level is equal to +B or - B. Don't touch them or you will be electrically shocked.

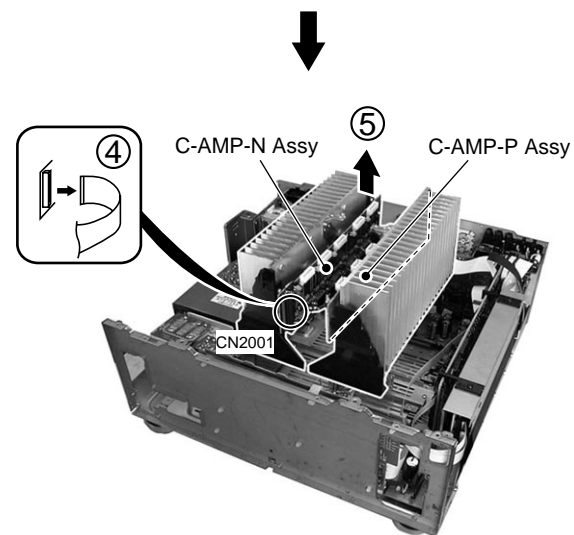
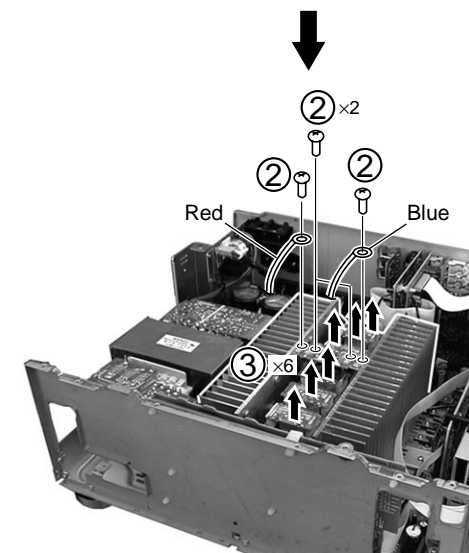

■ DIODE and REGULATOR Assemblies

• DIODE Assy

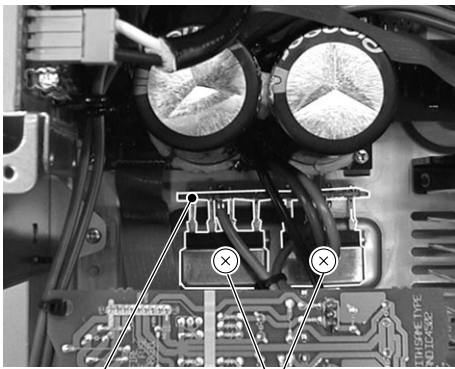

DIODE Assy

① x2

Replace the diode.



• REGULATOR Assy

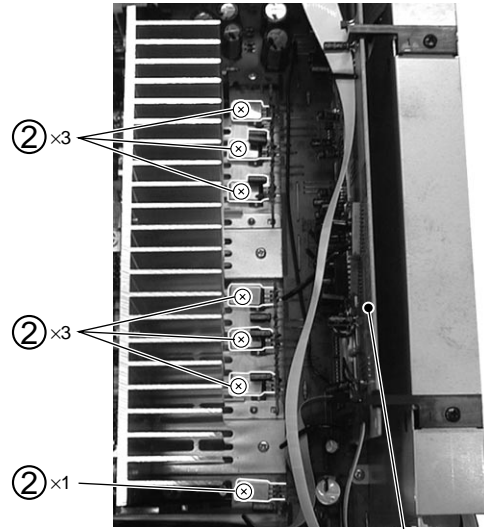

REGULATOR Assy

Replace the Regulator IC.

• PCB Location

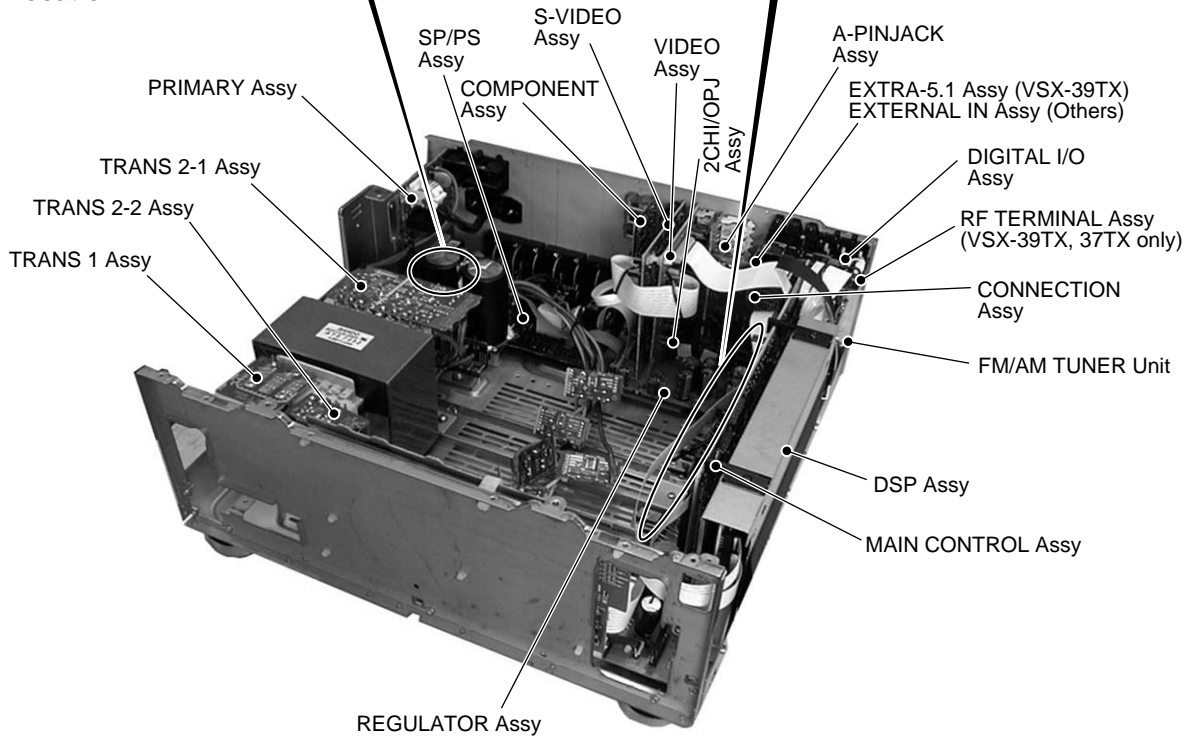

7.2 PARTS

7.2.1 IC

• The information shown in the list is basic information and may not correspond exactly to that shown in the schematic diagrams.

•List of IC

PD5595A, PD5589A

■ PD5595A (DISPLAY ASSY : IC7001)

• Display Control IC

• Pin Assignment (Top View)

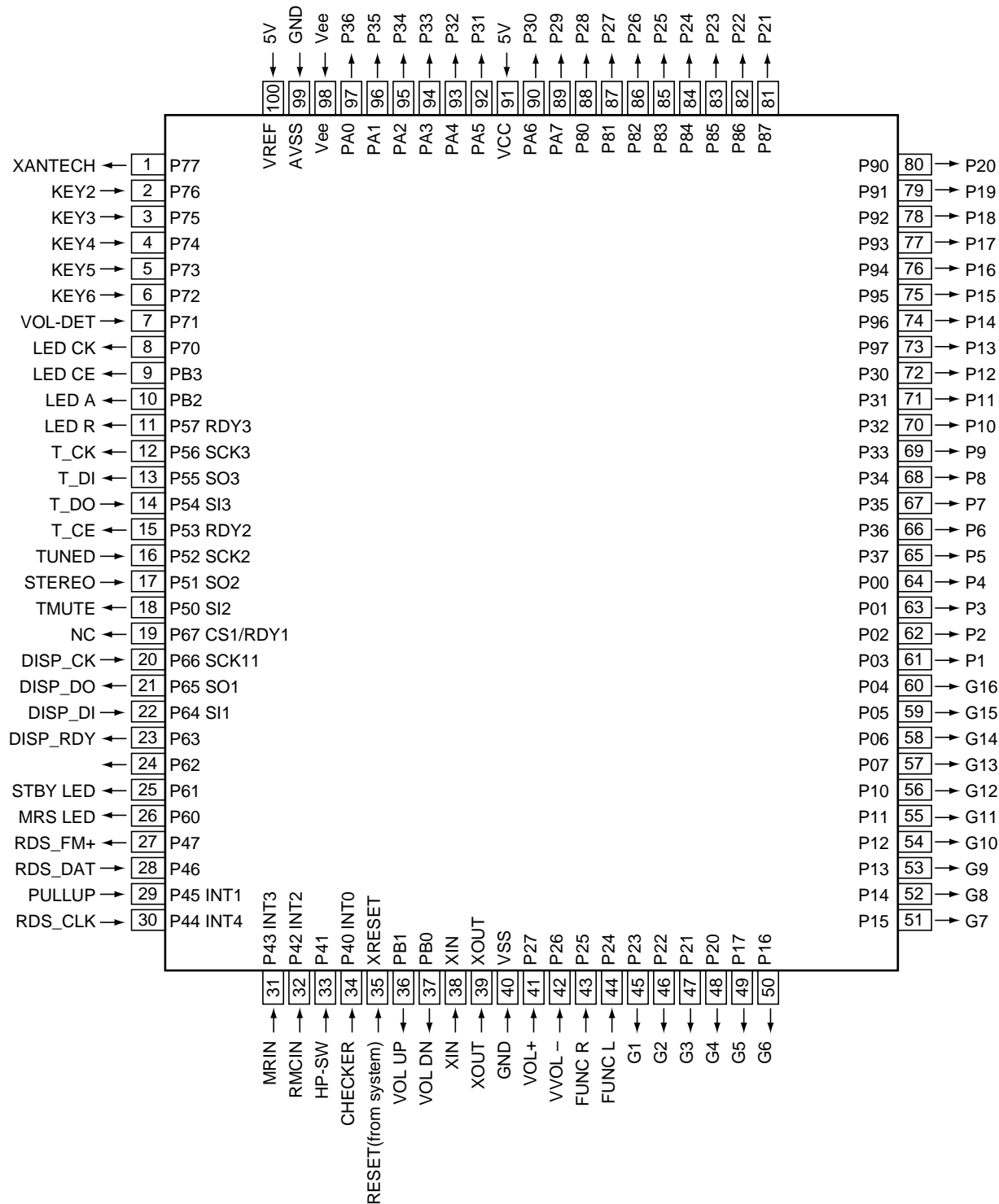

VSX-39TX, VSX-37TX, VSX-36TX, VSX-D909S

● Pin Function

No.	Pin Name	I/O	Function	No.	Pin Name	I/O	Function
1	XANTECH	O	XANTECH ON/OFF	51	G7	O	Grid output 7
2	KEY 2	I	Key scan input 2	52	G8	O	Grid output 8
3	KEY 3	I	Key scan input 3	53	G9	O	Grid output 9
4	KEY 4	I	Key scan input 4	54	G10	O	Grid output 10
5	KEY 5	I	Key scan input 5	55	G11	O	Grid output 11
6	KEY 6	I	Key scan input 6	56	G12	O	Grid output 12
7	VOL-DET	I	Detection of volume position	57	G13	O	Grid output 13
8	LED CKL	O	Clock for IC7071 M66311	58	G14	O	Grid output 14
9	LED OE	O	Output enable for IC7071 M66311	59	G15	O	Grid output 15
10	LED A	O	Data for IC7071 M66311	60	G16	O	Grid output 16
11	LED R	O	Reset for IC7071 M66311	61	S1	O	Segment output 1
12	T-CK	O	Clock for tuner module	62	S2	O	Segment output 2
13	T-DI	O	Data for tuner module	63	S3	O	Segment output 3
14	T-DO	I	Data from tuner module	64	S4	O	Segment output 4
15	T-CE	O	Chip enable for tuner module	65	S5	O	Segment output 5
16	TUNED	I	Tuned data from tuner module	66	S6	O	Segment output 6
17	STEREO	I	Stereo tuned data from tuner module	67	S7	O	Segment output 7
18	T-MUTE	O	Tuner mute ON/OFF	68	S8	O	Segment output 8
19	NC	O	Open	69	S9	O	Segment output 9
20	DISP CK	I	Clock from IC901 MAIN U-COM	70	S10	O	Segment output 10
21	DISP DO	O	Data for IC901 MAIN U-COM	71	S11	O	Segment output 11
22	DISP DI	I	Data from IC901 MAIN U-COM	72	S12	O	Segment output 12
23	DISP RDY	O	Data request for IC901 MAIN U-COM	73	S13	O	Segment output 13
24	NC	-	Open	74	S14	O	Segment output 14
25	STBY LED	O	Standby LED	75	S15	O	Segment output 15
26	MRS LED	O	Sub room LED (MR&S model), EON LED (RDS model)	76	S16	O	Segment output 16
27	RDS FM+	-	VDD for IC7401 BU1923 (RDS model only)	77	S17	O	Segment output 17
28	RDS DAT	O	Data for IC7401 BU1923 (RDS model only)	78	S18	O	Segment output 18
29	NC	I	(pull-up)	79	S19	O	Segment output 19
30	RDS CLK	I	Clock for IC7401 BU1923 (RDS model only)	80	S20	O	Segment output 20
31	MR IN	I	Sub room remote control (MR&S, MR model only)	81	S21	O	Segment output 21
32	RMC IN	I	Remote control	82	S22	O	Segment output 22
33	HP-SW	I	Headphone connect detect	83	S23	O	Segment output 23
34	NC	I	For unit check test mode detection	84	S24	O	Segment output 24
35	RESET	I	Reset	85	S25	O	Segment output 25
36	VOL/UP	O	Control for VOIL UP	86	S26	O	Segment output 26
37	VOL/DN	O	Control for VOL DOWN	87	S27	O	Segment output 27
38	XIN	-	Connect a 7.2MHz oscillator	88	S28	O	Segment output 28
39	XOUT	-		89	S29	O	Segment output 29
40	VSS	-	GND	90	S30	O	Segment output 30
41	VOL+	I	Rotary encoder signal +	91	VCC	-	Power supply +5V
42	VOL-	I	Rotary encoder signal -	92	S31	O	Segment output 31
43	FUNC/R	I	Rotary encoder signal R	93	S32	O	Segment output 32
44	FUNC/L	I	Rotary encoder signal L	94	S33	O	Segment output 33
45	G1	O	Grid output 1	95	S34	O	Segment output 34
46	G2	O	Grid output 2	96	S35	O	Segment output 35
47	G3	O	Grid output 3	97	S36	O	Segment output 36
48	G4	O	Grid output 4	98	VEE	-	Power supply 5V
49	G5	O	Grid output 5	99	AVSS	-	GND
50	G6	O	Grid output 6	100	VREF	-	Reference voltage 5V

VSX-39TX, VSX-37TX, VSX-36TX, VSX-D909S

● Pin Function

No.	Pin Name	I/O	Function	No.	Pin Name	I/O	Function
1	TEMP IN	I/O	O/open (KU,J,SD), I/Fan temperature A/D input (other)	41	MR MUTE	O	Audio mute ON/OFF for sub room (MR&S, MR model only)
2	A MUTE	O	Audio mute ON/OFF	42	A MUTE2	O	Audio preout mute ON/OFF
3	DSP CS1	O	Chip select for IC9501 DSP U-COM	43	LOUD	O	Loudness ON/OFF
4	DSP RST	O	Reset for IC9501 DSP U-COM	44	MR-V DT	O	Data for IC110 M62429FP control (MR&S model only)
5	DSP MUTE	I	Mute request from IC9501 DSP U-COM	45	MR-V CK	O	Clock for IC110 M62429FP control (MR&S model only)
6	DSP CS2	I	Chip select from IC9501 DSP U-COM	46	4052 INH	O	Inhibit for IC102 BU4052BCF control (MR&S model only)
7	NC	O	Open	47	4052 B	O	Control for IC102 BU4052BCF (MR&S model only)
8	NC	O	Open	48	4052 A		
9	AMPOL	I	Amp Overload detect	49	SIMUKE 3	I	SIMUKE (pull-up or down)
10	RESET	I	Reset	50	SIMUKE 2		
11	NC	O	Open	51	SIMUKE 1		
12	NC	O	Open	52	SIMUKE 0		
13	GND	-	GND	53	2296-2	O	Control for IC701, 801, 802 NJM2296M
14	XIN	I	Connect a 4.19MHz oscillator	54	2296-5		
15	XOUT	O		55	2296-3		
16	VDD	-	Power supply +5V	56	2296-4		
17	NC	O	Open	57	4051-C	O	Control for IC831 BU4051BCF
18	ST3	O	Strobe for IC107 TC9163F control	58	4051-B		
19	CK2	O	Clock for IC108 TC9482N control	59	4051-A		
20	CK3	O	Clock for IC107 TC9163F control	60	2279-M	O	Control for IC731 NJM2279M (MR&S model only)
21	DT3	O	Data for IC107 TC9163F control	61	2279-2		
22	ST2	O	Strobe for IC108 TC9482N control	62	2279-1		
23	W.UP	I	AC pulse input	63	OSD RST	O	Reset for IC752 LC74782M-9011
24	DT2	O	Data for IC108 TC9482N control	64	OSD CS	O	Chip select for IC752 LC74782M-9011
25	CK1	O	Clock for IC101 TC9274N and IC104 TC9163F control	65	SYNC DET	I	Detection of synchronizing signal
26	ST1	O	Strobe for IC101 TC9274N and IC104 TC9163F control	66	DSP HCK	O	Clock for IC9501 DSP U-COM
27	DT1	O	Data for IC101 TC9274N and IC104 TC9163F control	67	DSP HDI	O	Data for IC9501 DSP U-COM
28	GND	-	GND	68	DSP HDO	I	Data from IC9501 DSP U-COM
29	NC	O	Open	69	DISP CK	O	Clock for IC7001 DISP U-COM
30	NC	O	Open	70	OSD CK	O	Clock for IC752 LC74782M-9011
31	NC	O	Open	71	DISP DI	O	Data for IC7001 DISP U-COM
32	FAN STOP	I/O	O/Open (KU,J,SD), I/Fan stop detector (other)	72	DISP DO	I	Data from IC7001 DISP U-COM
33	A RY	O	SP A relay ON/OFF	73	GND	-	GND
34	B RY	O	SP B relay ON/OFF	74	VDD	-	Power supply +5V
35	C/S RY	O	SP C/S relay ON/OFF	75	DISP RDY	I	Data request from IC7001 DISP U-COM
36	HP RY	O	Headphone relay ON/OFF	76	DISP RST	O	Reset for IC7001 DISP U-COM
37	FAN LOW	O	Open (KU,J,SD), Fan low (other)	77	DSP OL	I	DSP overload detect, A/D input
38	FAN DRIVE	O	Open (KU,J,SD), Fan drive (other)	78	WATT IN	I/O	O/Open (KU,J,SD), I/Fan wattage input, A/D input (other)
39	AC RY	O	AC relay ON/OFF	79	AMP OL	I	Amp overload detect, A/D input
40	NECK	O	Neck ON/OFF (24,26,908,938 only)	80	DC DET	I	Detection of amp power error, A/D input

7.2.2 DISPLAY

■ AAV7063 (DISPLAY ASSY :V7001)

- FL Indicator Tube

• Pin Assignment

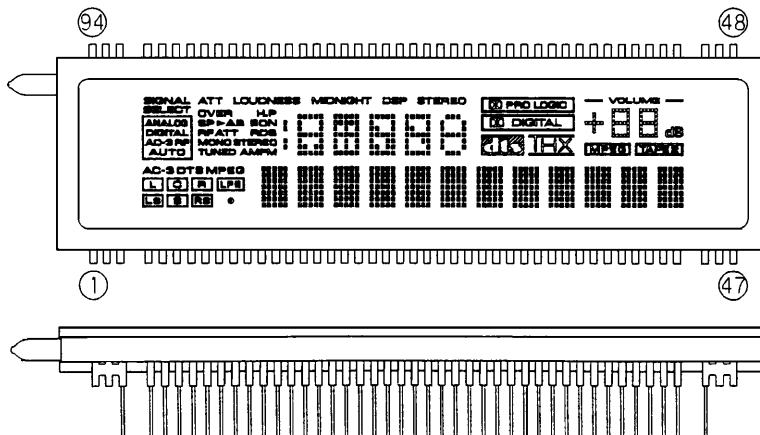

• Grid Assignment

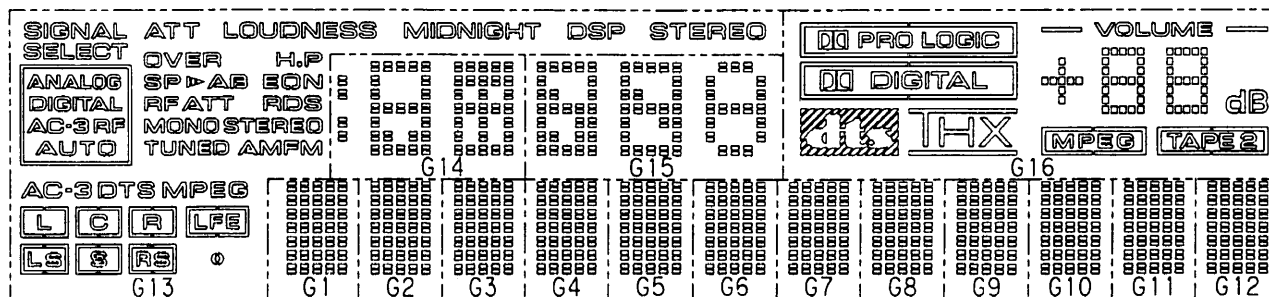

G1~G12				G14				G15																											
S1	S2	S3	S4	S5	S6	S7	S8	S9	S10	S11	S12	S13	S14	S15	S16	S17	S18	S19	S20	S21	S22	S23	S24	S25	S26	S27	S28	S29	S30	S31	S32	S33	S34	S35	S36
S6	S7	S8	S9	S10	S11	S12	S13	S14	S15	S16	S17	S18	S19	S20	S21	S22	S23	S24	S25	S26	S27	S28	S29	S30	S31	S32	S33	S34	S35	S36	S37	S38	S39	S40	S41
S16	S17	S18	S19	S20	S21	S22	S23	S24	S25	S26	S27	S28	S29	S30	S31	S32	S33	S34	S35	S36	S37	S38	S39	S40	S41	S42	S43	S44	S45	S46	S47	S48	S49	S50	S51
S21	S22	S23	S24	S25	S26	S27	S28	S29	S30	S31	S32	S33	S34	S35	S36	S37	S38	S39	S40	S41	S42	S43	S44	S45	S46	S47	S48	S49	S50	S51	S52	S53	S54	S55	S56
S31	S32	S33	S34	S35	S36	S37	S38	S39	S40	S41	S42	S43	S44	S45	S46	S47	S48	S49	S50	S51	S52	S53	S54	S55	S56	S57	S58	S59	S60	S61	S62	S63	S64	S65	S66

G16			
S18	S18	S17	S17
S18	S13	S13	S13
S18	S13	S14	S14
S18	S13	S14	S15
S18	S13	S14	S15
S17	S7	S8	S8

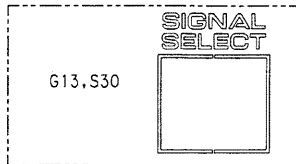
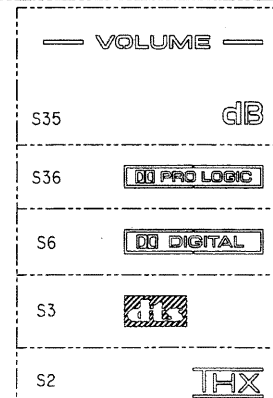

VSX-39TX, VSX-37TX, VSX-36TX, VSX-D909S

● Anode and Grid Connection

	G1~G12	G13	G14	G15	G16		G1~G12	G13	G14	G15	G16		G1~G12	G13	G14	G15	G16
S1	S1		S1	S1		S13	S13	DTS	S13	S13	S13	S25	S25	H.P	S25	S25	S25
S2	S2	FM	S2	S2	S2	S14	S14	AC-3 (DTS)	S14	S14	S14	S26	S26	AUTO	S26	S26	S26
S3	S3	AM	S3	S3	S3	S15	S15	RFATT	S15	S15	S15	S27	S27	AC-3RF	S27	S27	S27
S4	S4	MPEG	S4	S4	TAPE2	S16	S16	EON	S16	S16	S16	S28	S28	DIGITAL	S28	S28	S28
S5	S5	LFE	S5	S5	MPEG	S17	S17	(▷)A(B)	S17	S17	S17	S29	S29	ANALOG	S29	S29	S29
S6	S6	STEREO	S6	S6	S6	S18	S18	(▷)A(B)	S18	S18	S18	S30	S30	S30	S30	S30	S30
S7	S7	TUNED	S7	S7	S7	S19	S19	Ⓢ	S19	S19	S19	S31	S31	ATT	S31	S31	S31
S8	S8	MONO	S8	S8	S8	S20	S20	LS	S20	S20	S20	S32	S32	LOUDNESS	S32	S32	S32
S9	S9	R	S9	S9	S9	S21	S21	S	S21	S21	S21	S33	S33	MIDNIGHT	S33	S33	S33
S10	S10	C	S10	S10	S10	S22	S22	RS	S22	S22	S22	S34	S34	DSP	S34	S34	S34
S11	S11	L	S11	S11	S11	S23	S23	SPD▷	S23	S23	S23	S35	S35	(DSP) STEREO	S35	S35	S35
S12	S12	RDS	S12	S12	S12	S24	S24	OVER	S24	S24	S24	S36			S36	S36	S36

Pin No.	1	2	3	4	5	6	7	8	9	10	11	12	13	14	15	16	17	18	19	20	21	22	23	24
Assignment	NL	NL	F1	NP	D	IC	NL	NL	NL	NL	NL	NL	NL	NL	NL	NL	NL	NL	NL	NL	NL	NL	NL	NL

Pin No.	25	26	27	28	29	30	31	32	33	34	35	36	37	38	39	40	41	42	43	44	45	46	47
Assignment	NL	NL	S36	S35	S34	S33	S32	S31	S30	S29	NL	NL	NL	S28	S27	S26	S25	S24	H	NP	F2	NL	NL

Pin No.	48	49	50	51	52	53	54	55	56	57	58	59	60	61	62	63	64	65	66	67	68	69	70	71
Assignment	NL	NL	NL	NP	S23	S22	S21	S20	S19	S18	S17	S16	S15	S14	S13	S12	S11	S10	S9	S8	S7	S6	S5	S4

Pin No.	72	73	74	75	76	77	78	79	80	81	82	83	84	85	86	87	88	89	90	91	92	93	94
Assignment	S3	S2	S1	G16	G15	G14	G13	G12	G11	G10	G9	G8	G7	G6	G5	G4	G3	G2	G1	NP	NL	NL	NL

F1, F2 : Filament G1 to G16 : Grid S1 to S36 : Anode D : External connect to F1 NP: No Pin NL : Lead
 H : Power supply grid usually (ec level = Apply Typ 35.0 VDC) IC : Internal connection

7.3 REMOTE CONTROL UNIT

7.3.1 AXD7254 (for VSX-39TX)

7.3.1.1 EXPLODED VIEWS AND PARTS LIST

- NOTES:
- Parts marked by "NSP" are generally unavailable because they are not in our Master Spare Parts List.
 - The Δ mark found on some component parts indicates the importance of the safety factor of the part. Therefore, when replacing, be sure to use parts of identical designation.
 - Screws adjacent to \blacktriangledown mark on the product are used for disassembly.

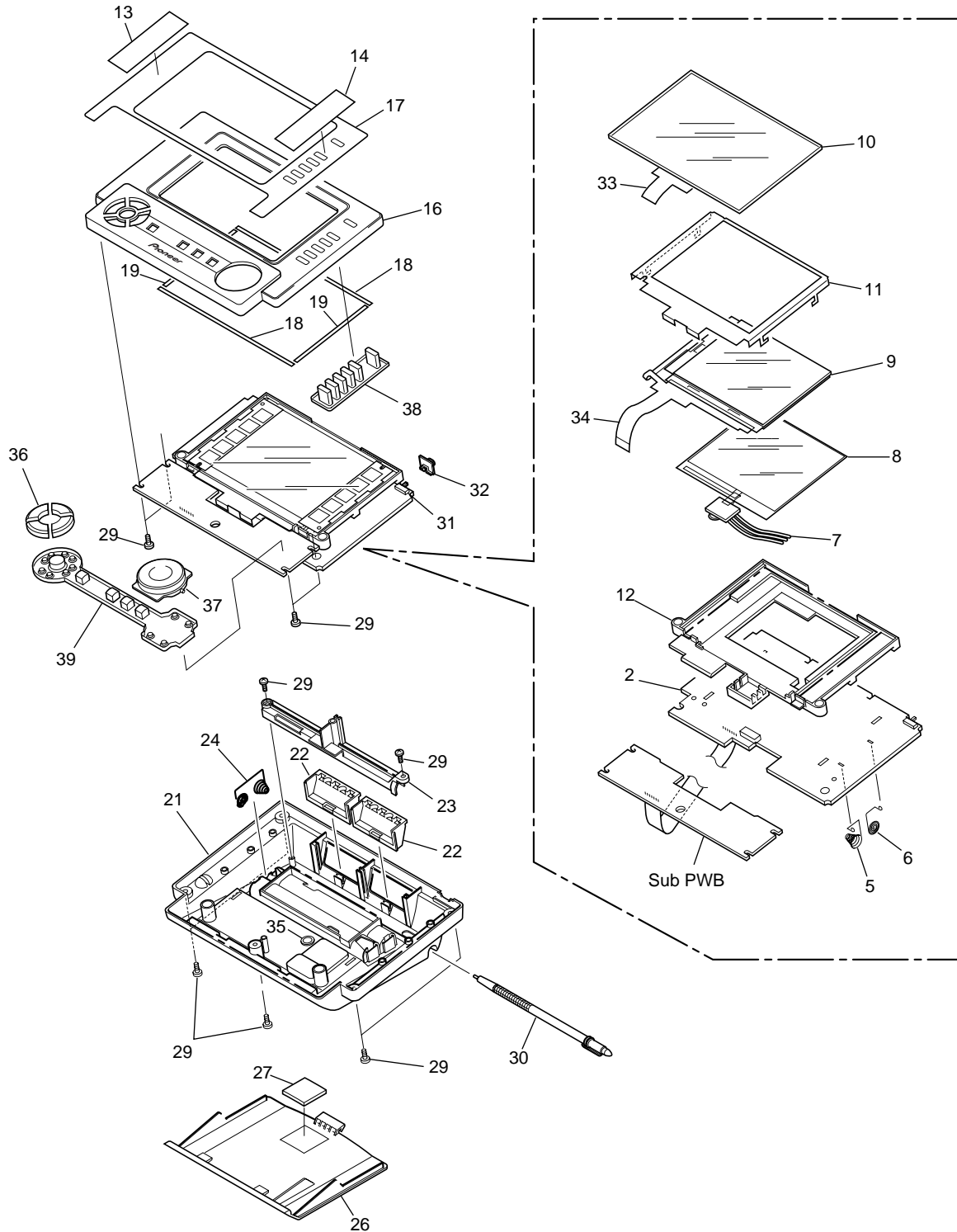

● PARTS LIST

Mark	No.	Description	Part No.
	1	•••••	
	2	PCB Assy	AZC7298
	3	•••••	
	4	•••••	
	5	Terminal A	411RRC15801R
	6	Terminal B	411RRC15901R
	7	Jumper Cable	E-AA1446-001
	8	EL Module	AZC7294
	9	LCD Module	AZC7295
	10	Touch Panel	NTX01005701R
	11	Frame	501RRC01901R
	12	LCD Holder	AZN7787
	13	Seal A	AZA7367
	14	Seal B	AZA7368
	15	•••••	
	16	Case A	AZN7840
	17	Name Plate	AZA7393
	18	Cushion A	701RRC04801R
	19	Cushion B	701RRC04901R
	20	•••••	
	21	Case B	AZN7784
	22	Filter	AZA7343
	23	Pen Holder	AZN7786
	24	Terminal	413RRC11201R
	25	•••••	
	26	Battery Cover	AZN7785
	27	Cushion C	701RRC03501R
	28	•••••	
	29	Screw	AZB7144
	30	Touch Pen	E-AA1445-001
	31	Slide Switch	JSB1220-0111
	32	Slide Knob	AZA7347
	33	FPC Connector	CFP5519-0101
	34	FPC Connector	E-CP0535-008
	35	MT Switch	JPM1030-0801
	36	Key Top A	AZA7345
	37	Key Top B	AZA7346
	38	Rubber Sheet A	AZA7348
	39	Rubber Sheet B	AZA7349

7.3.1.2 SCHEMATIC DIAGRAM

A

B

C

D

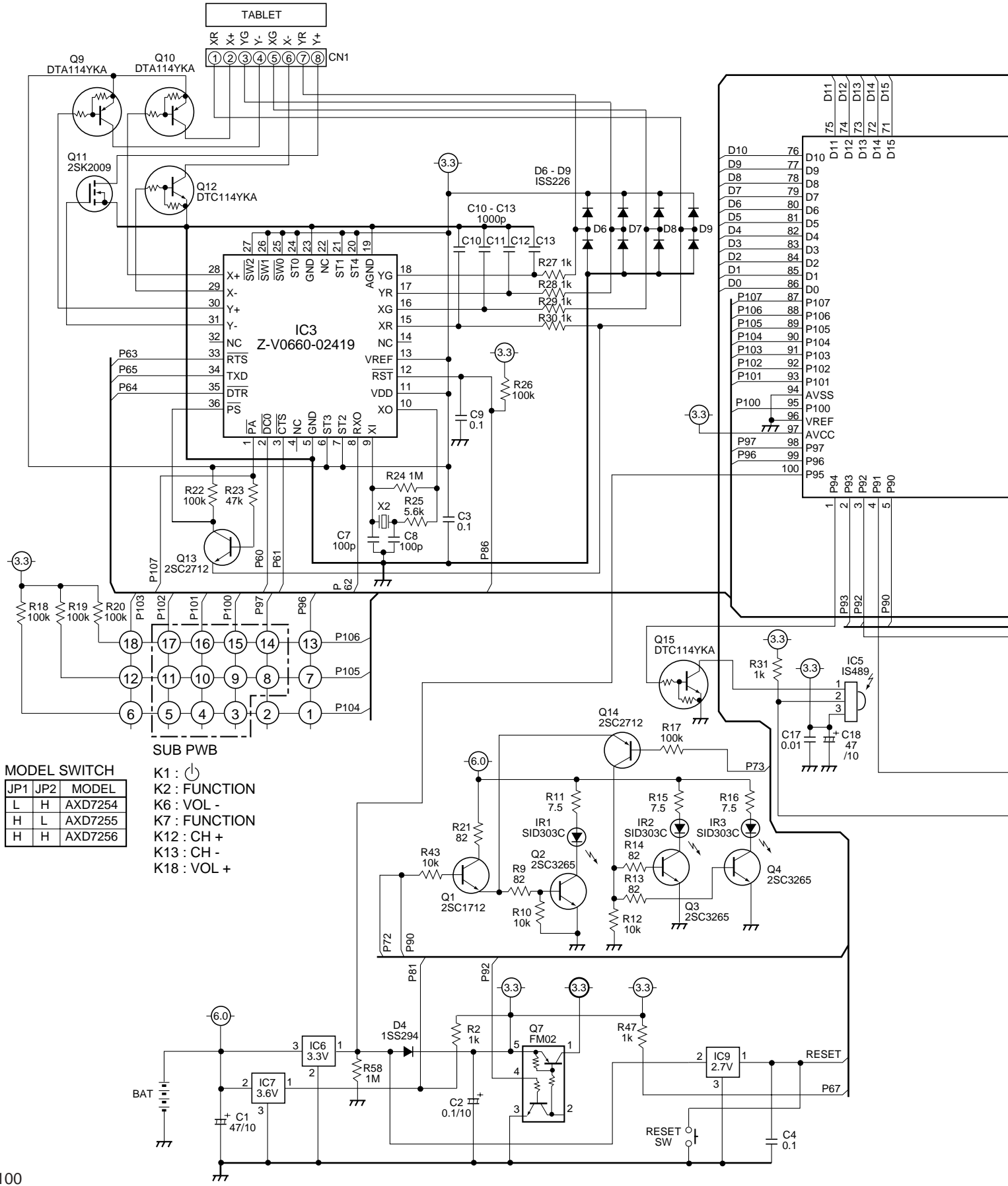

MODEL SWITCH

JP1	JP2	MODEL
L	H	AXD7254
H	L	AXD7255
H	H	AXD7256

- SUB PWB**
- K1 : (power)
 - K2 : FUNCTION
 - K6 : VOL -
 - K7 : FUNCTION
 - K12 : CH +
 - K13 : CH -
 - K18 : VOL +

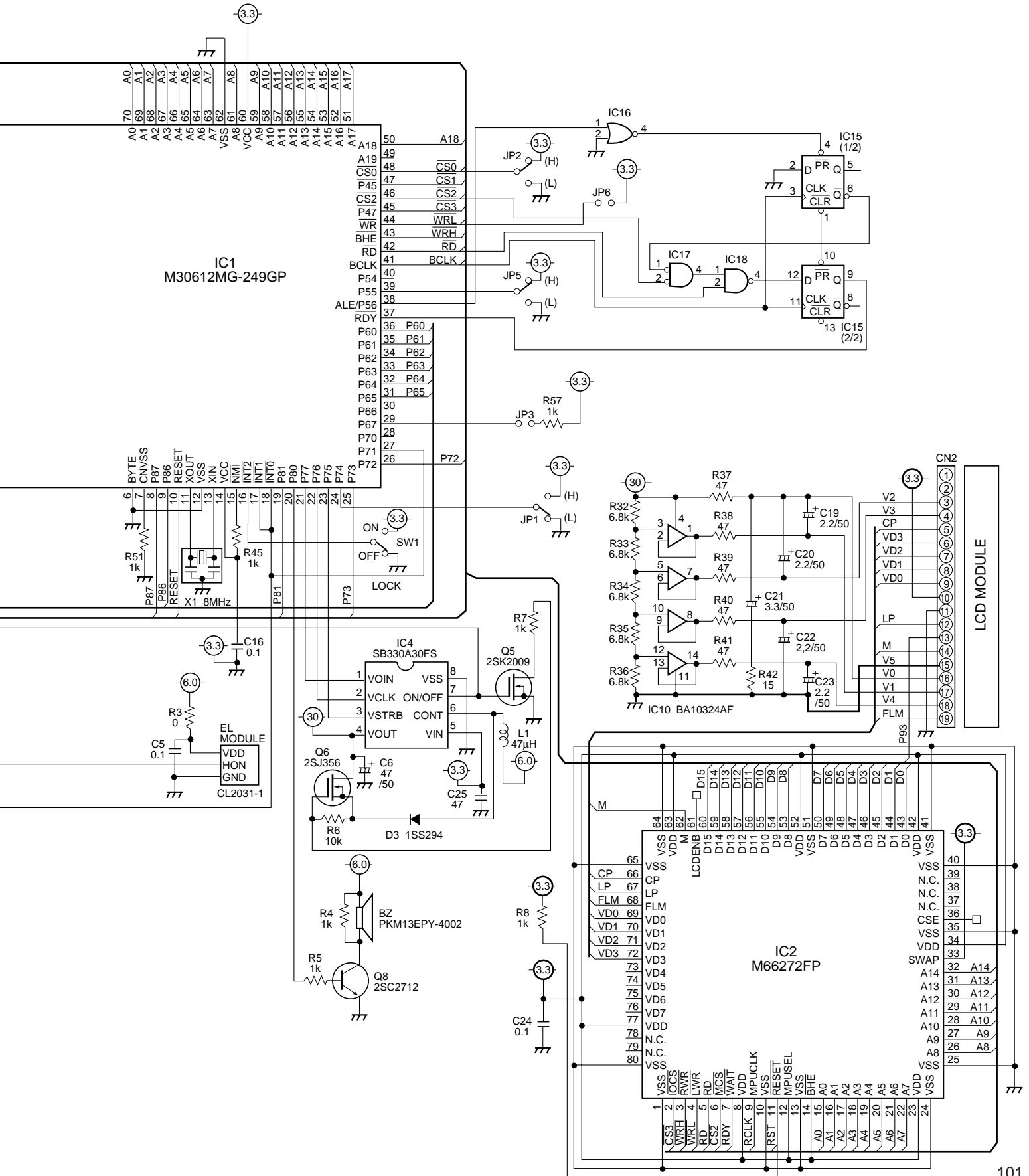

A
B
C
D

7.3.1.3 PCB DIAGRAM

A

B

C

D

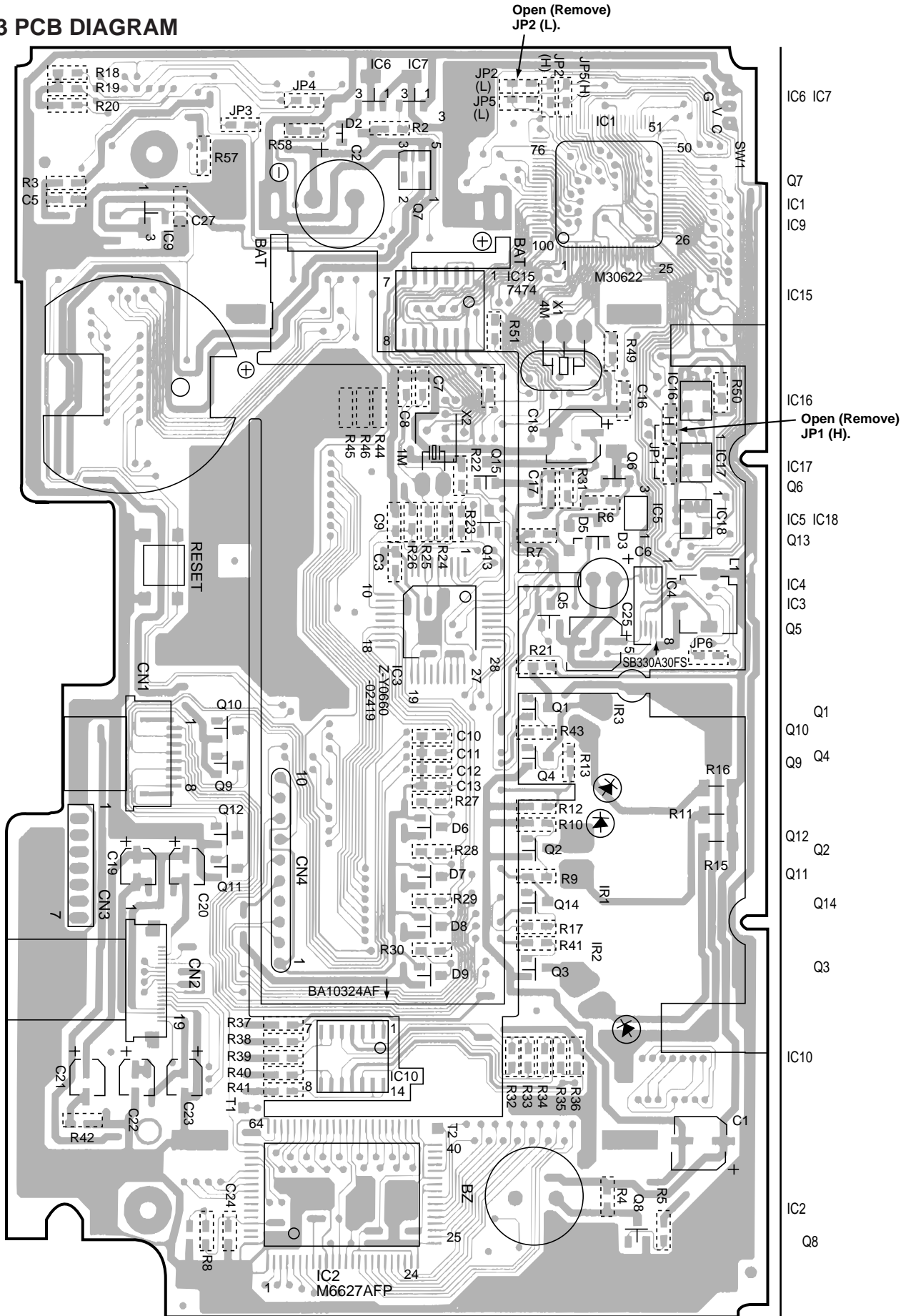

- IC6 IC7
- Q7
- IC1
- IC9
- IC15
- IC16
- Open (Remove) JP1 (H).
- IC17
- Q6
- IC5 IC18
- Q13
- IC4
- IC3
- Q5
- Q1
- Q10
- Q4
- Q9
- Q2
- Q11
- Q14
- Q3
- IC10
- IC2
- Q8

SIDE A

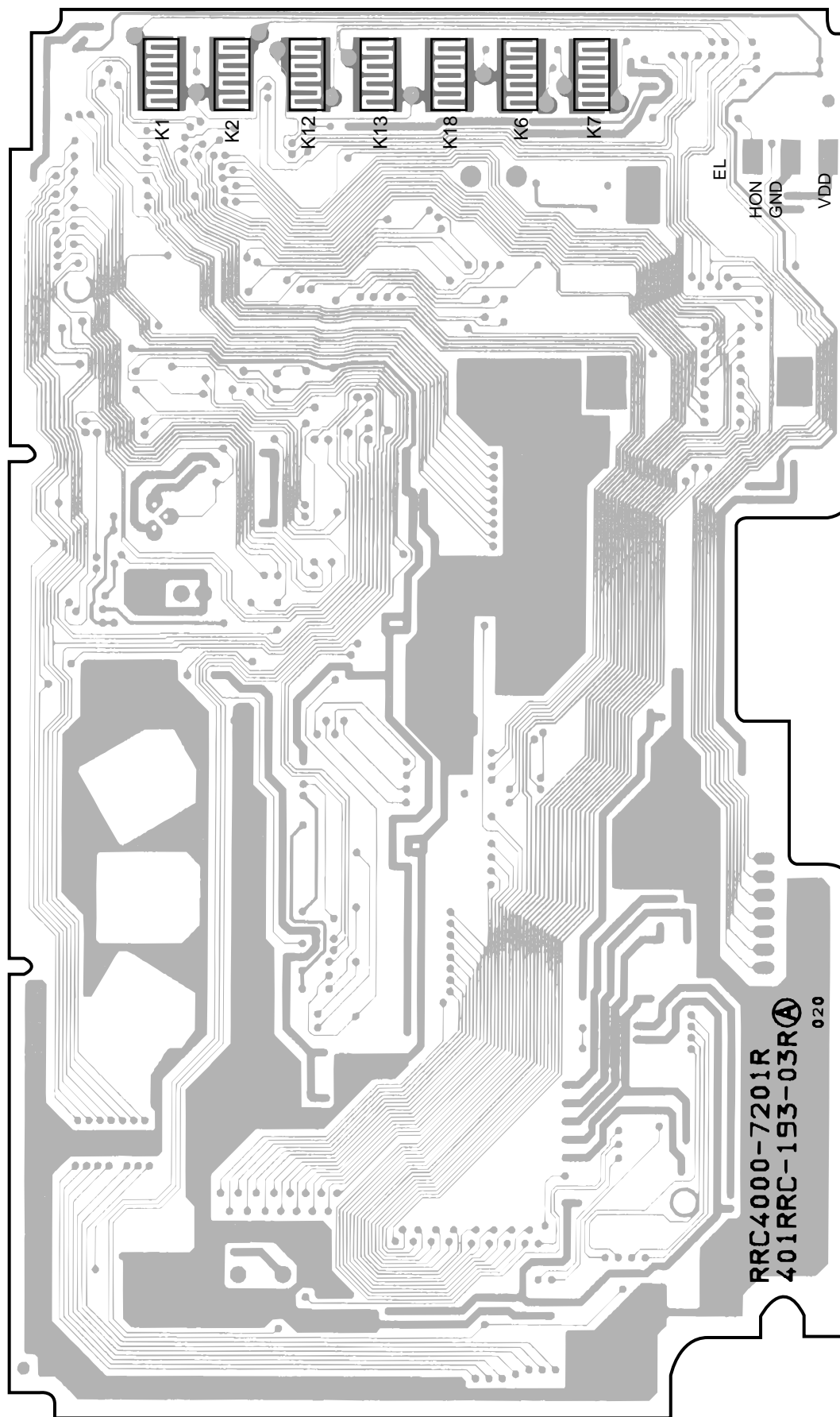

SIDE B

7.3.2 AXD7257 (Remote Control 37) and AXD7278 (Remote Control 909S)

7.3.2.1 EXPLODED VIEWS AND PARTS LIST

- NOTES:
- Parts marked by "NSP" are generally unavailable because they are not in our Master Spare Parts List.
 - The Δ mark found on some component parts indicates the importance of the safety factor of the part. Therefore, when replacing, be sure to use parts of identical designation.
 - Screws adjacent to \blacktriangledown mark on the product are used for disassembly.

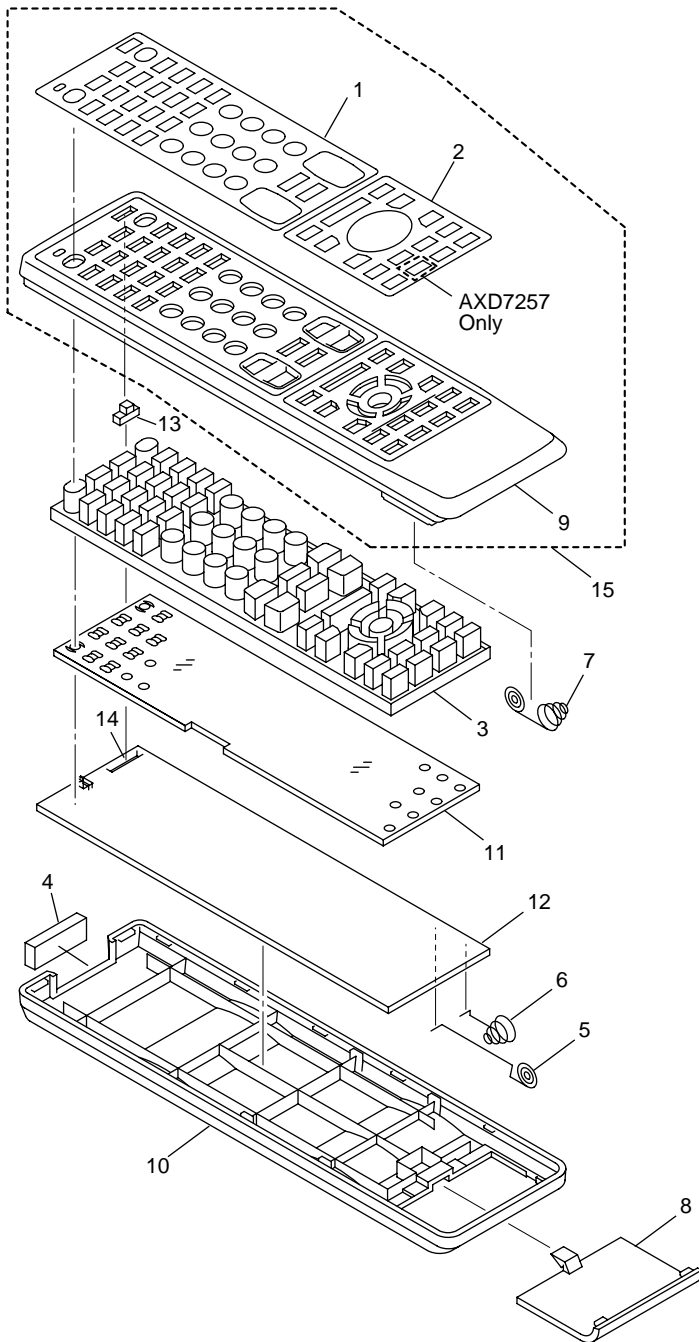

● PARTS LIST

Mark	No.	Description	Part No.
	1	Name Plate A	AZA7380
	2	Name Plate B (AXD7257)	AZA7381
	2	Name Plate B (AXD7278)	AZA7386
	3	Rubber Sheet (AXD7257)	AZA7382
	3	Rubber Sheet (AXD7278)	AZA7387
	4	Filter	AZA7340
	5	Terminal A (+)	AZB7141
	6	Terminal B (-)	AZB7142
	7	Spring	AZB7143
	8	Battery Cover	AZN7841
	9	Case (A)	AZN7832
	10	Case (B)	AZN7781
NSP	11	Illumi Plate	AZN7782
	12	PCB	AZW7260
	13	Knob	AZA7398
	14	Slide Switch	AZS7036
	15	Case A assy : 7257	AZN7846
	15	Case A assy : 7278	AZN7847

7.3.2.2 PCB DIAGRAM

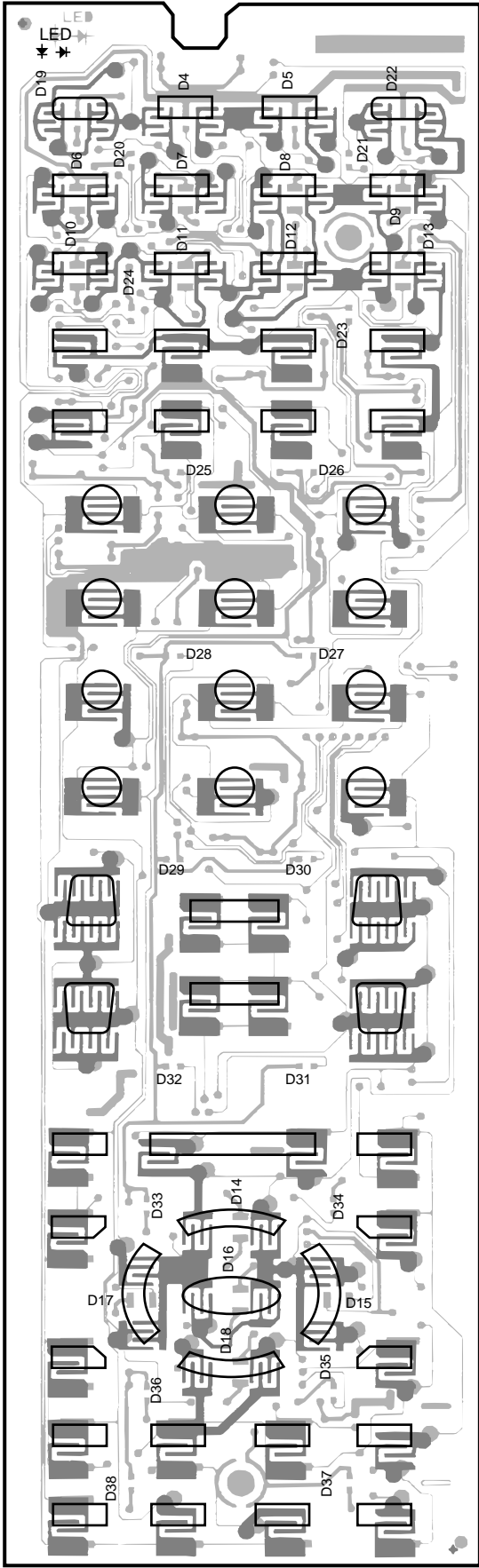

SIDE A

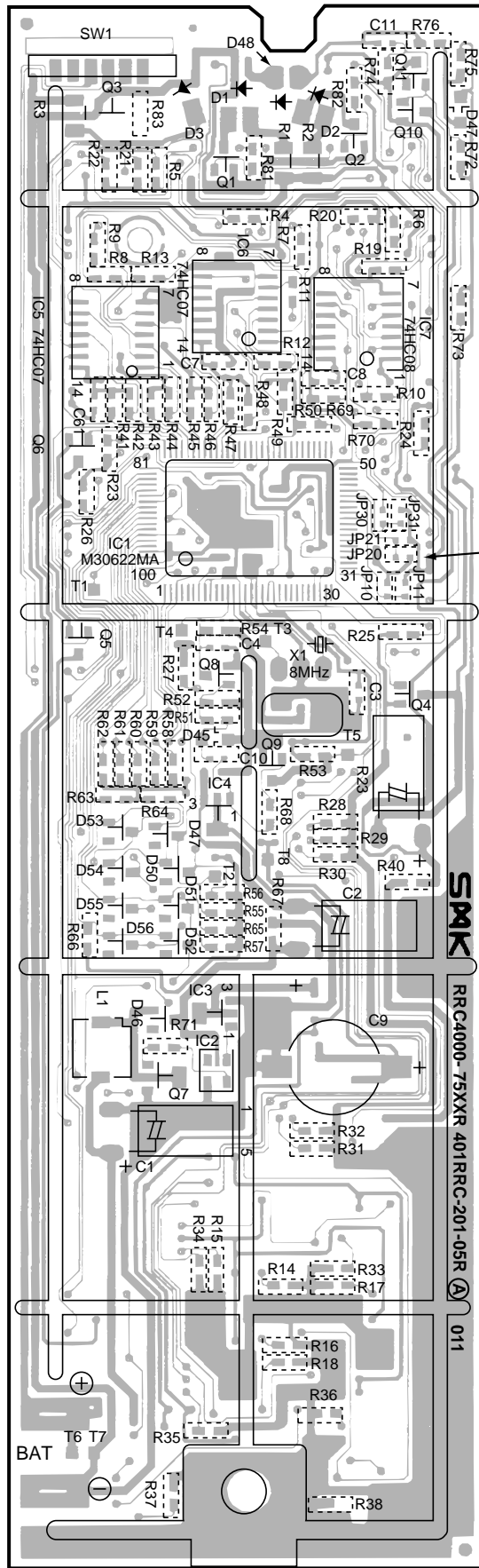

SIDE B

A
B
C
D

7.3.2.3 SCHEMATIC DIAGRAM

A

B

C

D

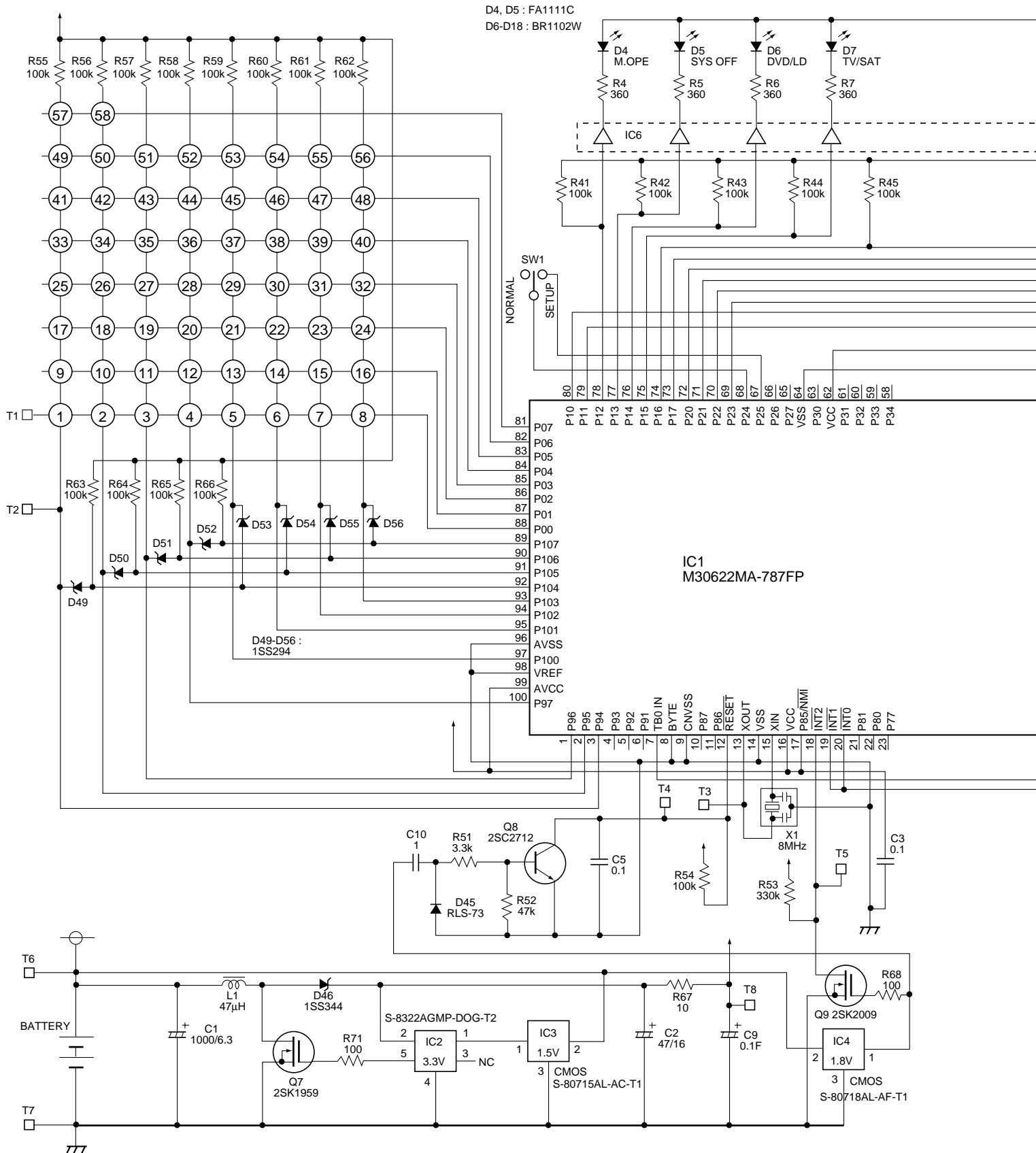

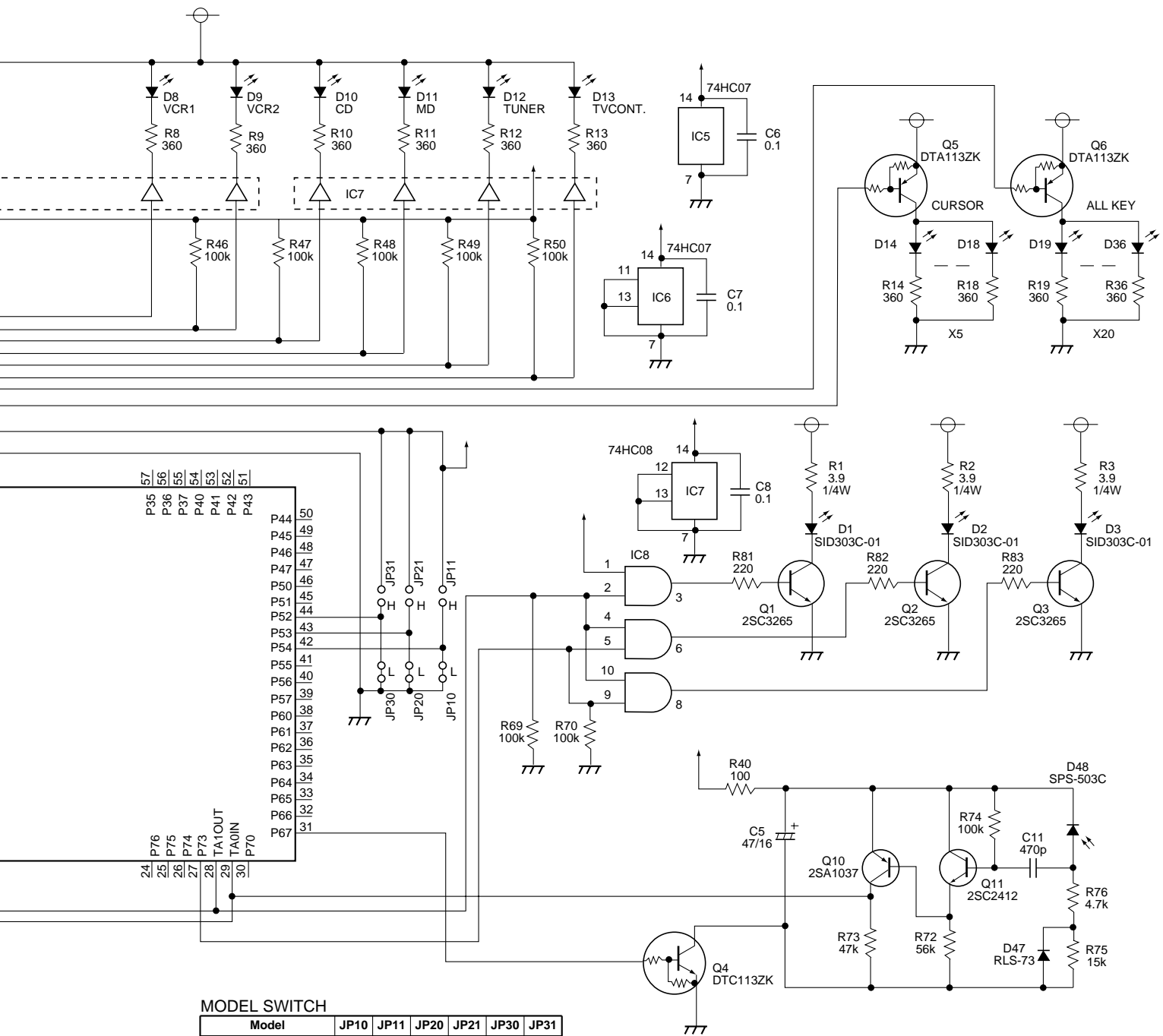

MODEL SWITCH

Model	JP10	JP11	JP20	JP21	JP30	JP31
AXD7257, AXD7278	-	○	-	○	-	○
AXD7258, AXD7279	-	○	-	○	○	-
AXD7259	-	○	○	-	-	○
AXD7266	-	○	○	-	○	-
AXD7273	○	-	-	○	○	-
AXD7275	○	-	-	○	○	-

7.3.2.4 PCB PARTS LIST

NOTES: ● The Δ mark found on some component parts indicates the importance of the safety factor of the part. Therefore, when replacing, be sure to use parts of identical designation.

● When ordering resistors, first convert resistance values into code form as shown in the following examples.

Ex.1 When there are 2 effective digits (any digit apart from 0), such as 560 ohm and 47k ohm (tolerance is shown by J=5%, and K=10%).

560 Ω	→	56×10^1	→	561	RD1/4PU	5	6	1	J
47k Ω	→	47×10^3	→	473	RD1/4PU	4	7	3	J
0.5 Ω	→	R50			RN2H	R	5	0	K
1 Ω	→	1R0			RS1P	1	R	0	K

Ex.2 When there are 3 effective digits (such as in high precision metal film resistors).

5.62k Ω	→	562×10^1	→	5621	RN1/4PC	5	6	2	1	F
----------------	---	-------------------	---	------	-------	---------	---	---	---	---	---

Mark	No.	Description	Part No.
	IC1		M30622MA-787FP
	IC2		S-8322AGMP-DOG-T2
	IC3		S-80715AL-AC-T1
	IC4		S-80718AL-AF-T1
	IC5,IC6		74HC07
	IC7		74HC08
	Q1-Q3		2SC3265
	Q4		DTC113ZK
	Q5,Q6		DTA113ZK
	Q7		2SK1959
	Q8		2SC2712
	Q9		2SK2009
	Q10		2SA1037
	Q11		2SC2412
	D1-D3		SID303C-01
	D6-D18		BR1102W
	D23-D36		CL190TD-CD
	D45,D47		RLS-73
	D46		1SS344
	D48		SPS-503C
	D49-D56		1SS294

8. PANEL FACILITIES AND SPECIFICATIONS

8.1 PANEL FACILITIES

■ Front Section (VSX-39TX, VSX-37TX, VSX-36TX)

All the controls on the front panel are explained and/or referenced here. To open the front panel push gently on the lower third of the panel.

VSX-39TX

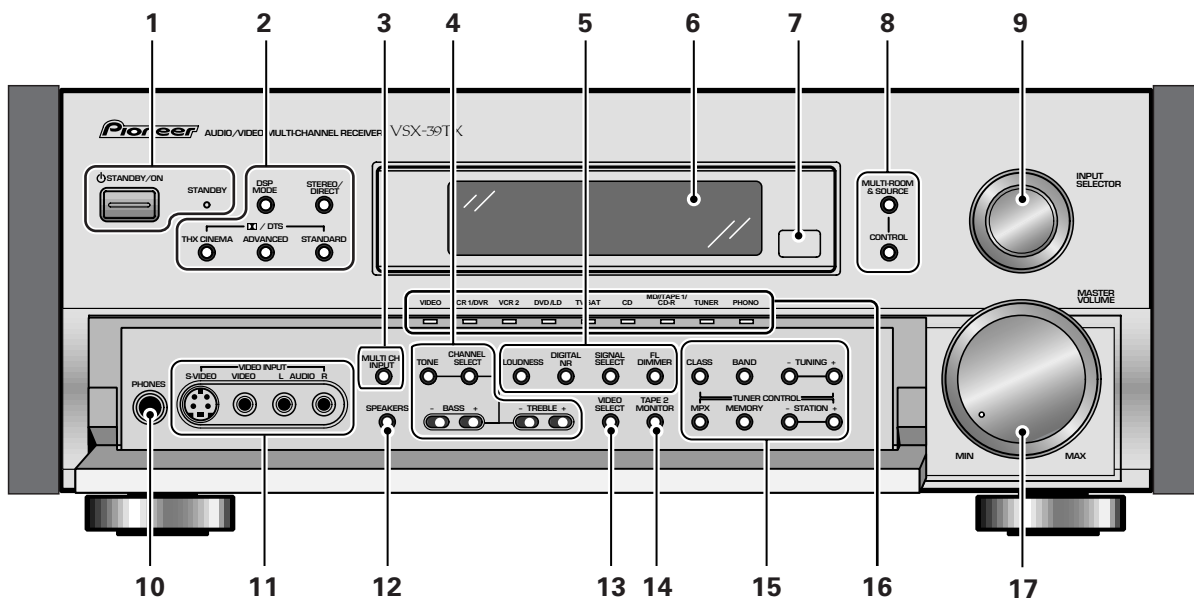

VSX-37TX
VSX-36TX

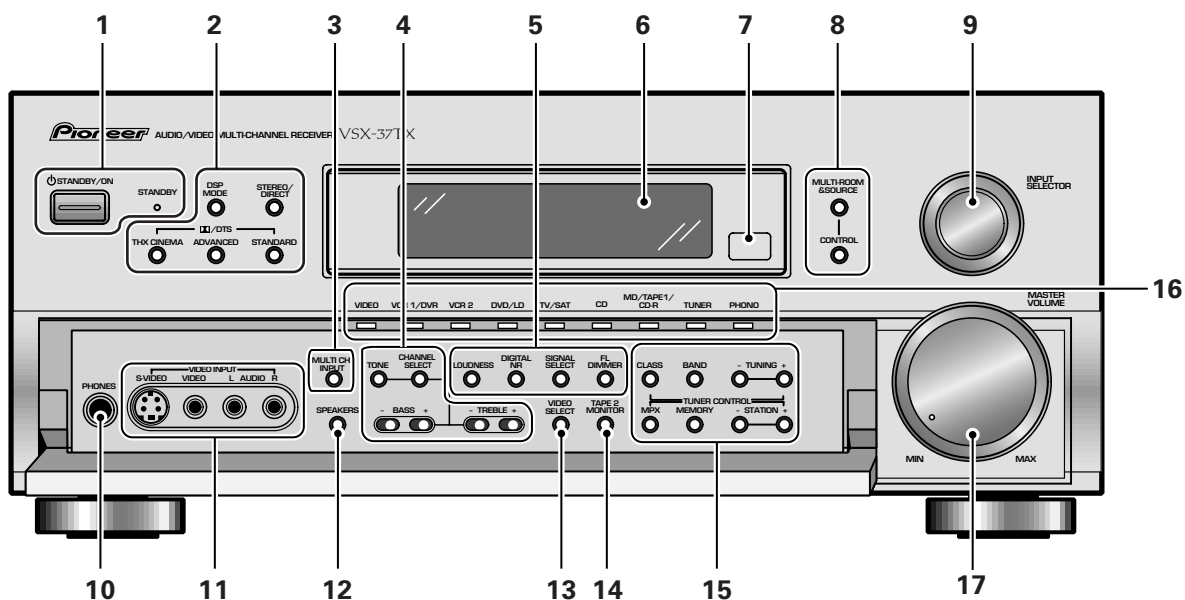

■ Front Section (VSX-D909S)

VSX-D909S

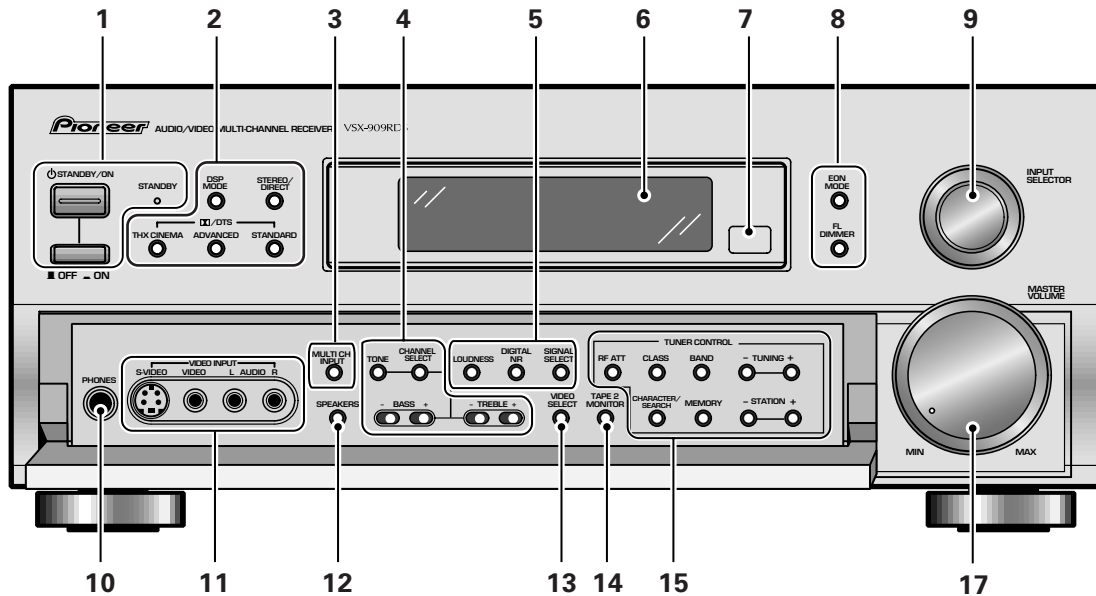

1 **STANDBY/ON button**

Press to switch the receiver ON or into STANDBY mode.

STANDBY indicator

Lights when the receiver is in STANDBY mode. (Please note that this receiver consumes a small amount of power [1.0 W] in the standby mode.)

2 **DSP MODE button**

Press repeatedly to select a DSP sound mode. (HALL 1, HALL 2, JAZZ, DANCE, THEATER 1, or THEATER 2, 5/7 CH STEREO). Use these modes to produce surround sound from standard (two channel) stereo sources and create different listening environments.

STEREO/DIRECT button

Switches the receiver into STEREO mode if it was in a different sound mode (like DSP mode) or toggles between DIRECT and STEREO mode. For more on STEREO mode .

DIRECT playback bypasses the tone controls, DIGITAL NR, LOUDNESS, MIDNIGHT and channel level for the most accurate reproduction of a program source.

THX CINEMA / DTS buttons

THX CINEMA – Cycles through the THX CINEMA, THX SURROUND EX or THX AUTO sound modes. If you have THX-certified speaker setup or want to re-create a THX-style sound environment. It is also appropriate for Dolby Digital, Dolby Pro Logic, DTS sources. Those with surround back speakers can use all three THX modes, those without can only use the THX CINEMA mode.

ADVANCED – Use to select one of the four Advanced Theater modes. Use to create certain types of sound environments when listening to Dolby Digital, Dolby Pro Logic, DTS sources.

STANDARD – Use for pure decoding of multi channel sources, especially Dolby Digital, Dolby Pro Logic, DTS sources. Each press toggles between STANDARD and STANDARD 7.1 mode (for use with SURROUND BACK speakers) and STANDARD auto (the receiver chooses the appropriate STANDARD mode). Those with surround back speakers can use all three STANDARD modes, those without can only use the STANDARD mode.

3 **MULTI CH INPUT**

Use to hook up an external component that can decode other types of signals and input them into the VSX-39TX.

4 **TONE control buttons**

TONE button

This button has two functions. Firstly, it switches between TONE ON and TONE BYPASS, which bypasses the tone circuitry. Secondly, you need to press the button before using the CHANNEL SELECT buttons to adjust the BASS & TREBLE (cannot be used in THX or MULTI CH IN modes).

CHANNEL SELECT button

Switches the tone adjust controls between the FRONT, CENTER, SURROUND and SURROUND BACK speakers. You can then use the BASS and TREBLE controls to adjust the sound.

BASS (-/+) button

Use to adjust low frequencies.

TREBLE (-/+) button

Use to adjust the high frequencies.

5 **LOUDNESS button**

Switches the LOUDNESS mode on or off (cannot be used in THX or MULTI CH IN modes).

DIGITAL NR button

Switches the DIGITAL NR on or off (cannot be used in THX or MULTI CH IN modes).



SIGNAL SELECT button

Use to select the type of signal being input into the receiver. Press SIGNAL SELECT repeatedly to select one of the following:

ANALOG – To select an analog signal.

DIGITAL – To select an optical or coaxial digital signal.

AC-3 RF – To select an  RF signal.

AUTO – This is the default. If there are analog, digital and  RF signals input, the receiver automatically selects the  RF signal. If there are analog and digital signals input the digital will be selected.

FL DIMMER button

Use to adjust the brightness of the main display.

6 Display

7 Remote sensor

Point the remote control toward the remote sensor to operate the receiver .

8 MULTI-ROOM & SOURCE button

Press to use the multi room feature (requires an optional PIONEER Multi-Room Remote Sensor Unit MR-100 or another IR receiver).

CONTROL button : Used together with the INPUT SELECTOR to select the function or use with the MASTER VOLUME to select the volume of the MULTI ROOM system.

9 INPUT SELECTOR dial

Turn to select a source component. (You can also use to select a function in the MULTI-ROOM & SOURCE mode). The source indicators show the current component:

DVD/LD – DVD player or Laser Disc player.

TV/SAT– TV or satellite tuner.

CD – Compact Disc player.

MD/TAPE1/CD-R – Tape deck, Mini Disc recorder or CD recorder connected to MD/TAPE 1/CD-R inputs/outputs.

TUNER – The receiver's built-in tuner.

PHONO – Turntable.

VIDEO – Video camera (etc.) connected to the VIDEO INPUT on the front panel.

VCR1/DVR – Video cassette recorder connected to VCR1/DVR inputs.

VCR 2 – Video cassette recorder or other component connected to VCR 2 inputs.

10 PHONES jack

Connect headphones for private listening (no sound will be heard through the speakers)

11 VIDEO INPUT jacks

S-VIDEO : Video input for connecting a video camera (etc.), that has an S-Video out.

VIDEO / AUDIO (L/R) : Video input for connecting a video camera, etc. that has standard video/audio outputs.

12 SPEAKERS (A/B) button

Use to select the speaker system. A is the primary setting. It plays all speakers hooked up to the A system. A & B setting only plays the front speakers of both the A & B systems and the subwoofer. Multi channel sources will be down-mixed to these Speakers so no sound will be lost. B setting only plays the front speakers connected to the B system and multi channel sources will be down-mixed to these two speakers. The button cycles through the speaker systems as follows: A⇒B⇒A&B⇒off.

13 VIDEO SELECT button

Switches the receiver between the various types of video input.

14 TAPE 2 MONITOR button

Selects the tape deck (MD recorder, etc.) connected to the TAPE 2 MONITOR inputs/outputs. Allows monitoring of a recording as it's being made.

15 TUNER CONTROL buttons

CLASS – Press repeatedly to switch the preset station classes.

BAND – Press to select the AM or FM band.

TUNING -/+ – Use to manually tune to radio stations.

MPX – Press to switch between auto stereo and MONO reception of FM broadcasts. When the broadcast signal is weak, selecting MONO will improve the sound quality.

MEMORY – Press to start the memorization of a preset station.

STATION -/+ – Use to choose programmed radio stations.

16 Source indicators

Shows the source currently selected.

17 MASTER VOLUME

Adjusts the overall receiver volume.

■ Display

All the display information is explained and /or referenced here.

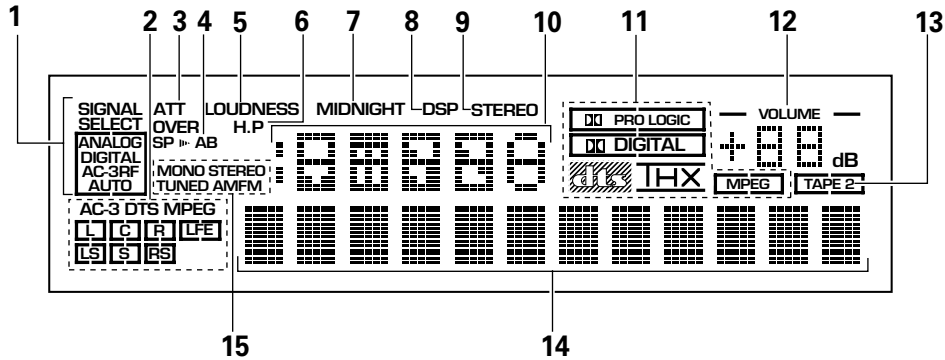

1 SIGNAL SELECT indicators

Light to indicate the input signal you selected.

ANALOG : Lights when analog signals are assigned.

DIGITAL : Lights when digital audio signals are selected.

AC-3 RF : Lights when AC-3 RF signals are assigned.

AUTO : Lights when the receiver is set to select the input signal automatically.

2 Program Format indicators

AC-3 : Lights when a source with Dolby Digital signals is played.

DTS : Lights when a source with DTS audio signals is played.

For Dolby Digital or DTS sources : These indicators change according to which channels are active in the source. When all three LS (left surround), S (surround) and RS (right surround) light at the same time it means a source with Surround EX or DTS-ES flag is being used.

L – Left front channel.

C – Center channel.

R – Right front channel.

LS – Left surround channel.

S – Surround channel (mono).

RS – Right surround channel.

LFE – Low Frequency Effects channel.

3 Analog level indicators

OVER – When the source signal is analog, this lights if the signal is in danger of distorting. Press INPUT ATT on the front panel to lower the signal level.

ATT – Lights when INPUT ATT is used to reduce the level of the analog source signal.

4 Speaker indicators

Light to indicate the current speaker system, A and/or B.

5 LOUDNESS indicator

Lights when the LOUDNESS mode is on.

6 H.P (headphones)

Lights when headphones are connected to the PHONES jack (speakers systems A and B both turn off automatically).

7 MIDNIGHT indicator

Lights when the MIDNIGHT LISTENING mode is on.

8 DSP indicator

Light when a DSP or Advanced Theater modes are selected.



9 STEREO indicator



Lights when a STEREO modes are selected.

10 Radio Frequency/Function indicator

Displays the function or the frequency of the current radio station.

11 / dts mode indicators

 DIGITAL : When the /dts mode on the receiver is on, this indicator lights to indicate playback of a Dolby Digital signal. However,  PRO LOGIC lights during 2 channel playback of Dolby Digital.

 PRO LOGIC : When the /dts mode on the receiver is on, this indicator lights during 2 channel playback.

DTS : When the /dts mode on the receiver is on, this indicator lights to indicate playback of a DTS signal.

THX: Lights when the HOME THX CINEMA mode is selected.

12 MASTER VOLUME indication

Displays current volume level.

13 TAPE 2 indicator

Lights when the TAPE 2 monitor is on.

14 Character display

Shows current mode, status, etc.

15 TUNER indicators

MONO : Lights when the tuner is set to receive FM broadcasts and when selected MPX mode.

STEREO : Lights when a FM stereo broadcast is received in the auto stereo mode.

TUNED : Lights when a broadcast is received.

AM/FM : Light to indicate the current band (FM or AM).

Remote Control Unit (VSX-39TX)

These pages describe the buttons on the remote control used to operate the receiver. Since the screen on this LCD remote control changes when you select a different function, explanations of buttons for controlling other components/functions can be found in the sections for those components/functions.

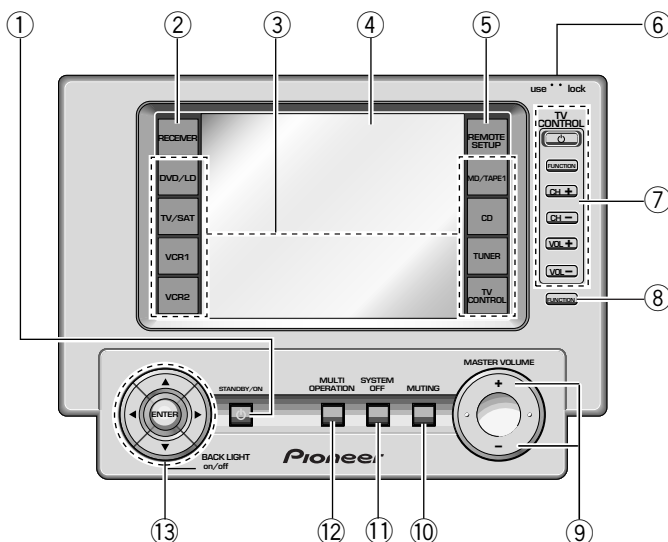

To turn on the remote control touch it anywhere on the screen.

① **STANDBY/ON button**

Press to turn power of the receiver on or to STANDBY (off).

② **RECEIVER button**

Press to switch the remote control into receiver mode or to get receiver screens.

③ **Function buttons**

These buttons are the basic controls that switch the mode of the receiver and allow you to control your other components.

DVD/LD: Press to switch the remote control into DVD/LD mode.

TV/SAT: Press to switch the remote control into TV/SAT (satellite tuner) mode.

VCR 1: Press to switch the remote control into VCR 1 mode.

VCR 2: Press to switch the remote control into VCR 2 mode.

MD/TAPE 1: Press to switch the remote control into MD/TAPE 1 mode.

CD: Press to switch the remote control into CD mode.

TUNER: Press to switch the remote control into TUNER mode.

TV CONTROL: Press so that the remote control can operate the TV CONTROL commands.

④ **REMOTE CONTROL screen**

⑤ **REMOTE SETUP button.**

Use to customize the remote control functions and the remote control itself. (See "Setting Up Remote Control of Other Components" starting on)

⑥ **LOCK switch**

Use to lock the remote control so it doesn't turn on by accident. For normal use keep it set in USE.

⑦ **TV CONTROL buttons**

The following buttons are used to control the TV only and can be used once they are preset to control your TV.

STANDBY/ON : Press to turn the power of the TV on/off.

FUNCTION : Press TV FUNC to select the TV for remote control operation.

CH +/- : Use these buttons to change the channel of the TV.

VOL +/- : Press to control the volume of the TV.

⑧ **FUNCTION button**

Press to select a source. The button will cycle through all the possible sources.

⑨ **MASTER VOLUME button**

Use to raise or lower the volume of the receiver.

⑩ **MUTING button**

Press to mute or restore the volume.

⑪ **SYSTEM OFF button**

This button turns off components in two ways. First, when pressed it will turn off all PIONEER components. Secondly, any component that has programmed into the SYSTEM OFF settings will be turned off.

For example : If you programmed power off in the SYSTEM OFF settings for your TV and VCR, pressing the SYSTEM OFF button will turn off these components even if they are not PIONEER products.

⑫ **MULTI OPERATION button**

Use this button to start the MULTI OPERATION mode. for how to program and use the MULTI OPERATION mode.

⑬ **▲/▼(BACK LIGHT on/off)/◀/▶/ENTER buttons**

These buttons can be used for a variety of operations. In the SYSTEM SETUP menu, the ▲/▼ buttons can be used to adjust CHANNEL DELAY or CHANNEL LEVEL.

The ▲/▼ buttons, pressed simultaneously, can be used to lock or unlock a setting.

These buttons are also used to control the DVD menu for the DVD remote control screen. If the remote control is in the REMOTE SETUP mode you can use the ▼ button to adjust the BACKLIGHT.

Basic Receiver LCD Screens

Receiver MAIN Screen

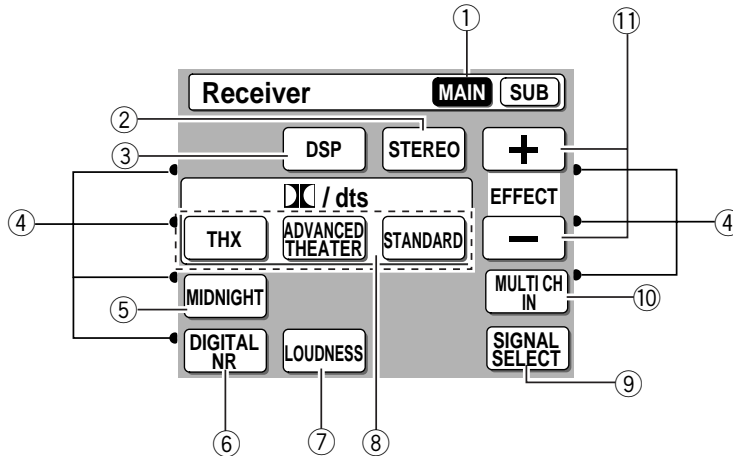

① **Receiver MAIN button**

Press this button to select the main receiver screen (above) when the remote control is on the sub receiver screen.

② **STEREO button**

Switches the receiver into STEREO mode if it was in a different sound mode (like ADVANCED THEATER or THX CINEMA) or toggles between DIRECT and STEREO mode.

③ **DSP button**

Press repeatedly to select a DSP sound mode.

④ **DIRECT FUNCTION on/off indicator**

These dots indicate whether the DIRECT FUNCTION is on or off for the function (DVD/LD, CD, etc.) they point to.

⑤ **MIDNIGHT button**

Switches the MIDNIGHT LISTENING mode on or off (for all modes except THX and MULTI CH IN).

⑥ **DIGITAL NR button**

Switches the DIGITAL NR on or off (for all modes except THX and MULTI CH IN).

⑦ **LOUDNESS button**

Switches the LOUDNESS mode on or off (for all modes except THX and MULTI CH IN).

⑧ **Dolby Digital/dts buttons**

Press these buttons to put the receiver in the selected surround sound mode. For more information on the modes.



⑨ **SIGNAL SELECT button**

Press SIGNAL SELECT repeatedly to select one of the following:

ANALOG : To select an analog signal.

DIGITAL : To select a digital signal (DVD/LD, TV/SAT, CD, MD/TAPE 1, VCR 1, VCR 2).

AC-3 RF : To select an  RF signal (DVD/LD, TV/SAT, VCR 1, VCR 2).

AUTO : This is the default. If there are analog, digital and  RF signals input, the receiver automatically selects the  RF signal. If there are analog and digital signals input the digital will be selected.

⑩ **MULTI CH IN button**

Use to hook up an external component that can decode other types of signals and input them into the VSX-39TX.

⑪ **EFFECT +/- button**

Use these buttons to increase or decrease the amount of effect applied in a DSP or Advanced Theater mode. When the amount of effect is increased in a DSP/Advanced Theater mode the characteristics of that mode become stronger and more noticeable. The scale ranges from 10-90 with 70 as the default setting. First turn on the DSP/Advanced Theater mode you want (by pressing the DSP/Advanced Theater button until you get the mode) and then increase or decrease the amount of effect.

Receiver SUB Screen

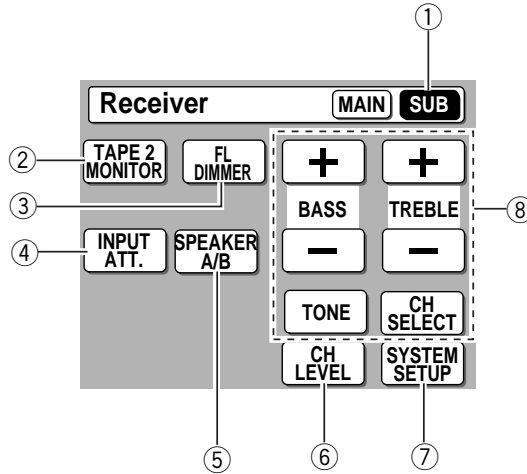

① Receiver MAIN button

Press this button to select the main receiver screen (above) when the remote control is on the sub receiver screen.

② STEREO button

Switches the receiver into STEREO mode if it was in a different sound mode (like ADVANCED THEATER or THX CINEMA) or toggles between DIRECT and STEREO mode.

③ DSP button

Press repeatedly to select a DSP sound mode.

④ DIRECT FUNCTION on/off indicator

These dots indicate whether the DIRECT FUNCTION is on or off for the function (DVD/LD, CD, etc.) they point to.

⑤ MIDNIGHT button

Switches the MIDNIGHT LISTENING mode on or off (for all modes except THX and MULTI CH IN).

⑥ DIGITAL NR button

Switches the DIGITAL NR on or off (for all modes except THX and MULTI CH IN).

⑦ LOUDNESS button

Switches the LOUDNESS mode on or off (for all modes except THX and MULTI CH IN).

⑧ DDD/dts buttons

Press these buttons to put the receiver in the selected surround sound mode. For more information on the modes .

⑨ SIGNAL SELECT button

Press SIGNAL SELECT repeatedly to select one of the following:

ANALOG : To select an analog signal.

DIGITAL : To select a digital signal (DVD/LD, TV/ SAT, CD, MD/TAPE 1, VCR 1, VCR 2).

AC-3 RF : To select an DDD RF signal (DVD/LD, TV/ SAT, VCR 1, VCR 2).

AUTO : This is the default. If there are analog, digital and DDD RF signals input, the receiver automatically selects the DDD RF signal. If there are analog and digital signals input the digital will be selected.

⑩ MULTI CH IN button

Use to hook up an external component that can decode other types of signals and input them into the VSX-39TX.

⑪ EFFECT +/- button

Use these buttons to increase or decrease the amount of effect applied in a DSP or Advanced Theater mode. When the amount of effect is increased in a DSP/Advanced Theater mode the characteristics of that mode become stronger and more noticeable. The scale ranges from 10-90 with 70 as the default setting. First turn on the DSP/Advanced Theater mode you want (by pressing the DSP/Advanced Theater button until you get the mode) and then increase or decrease the amount of effect.

Remote Control Unit (VSX-37TX/VSX-36TX/VSX-D909S)

These pages describe the buttons on the remote control used to operate the receiver.

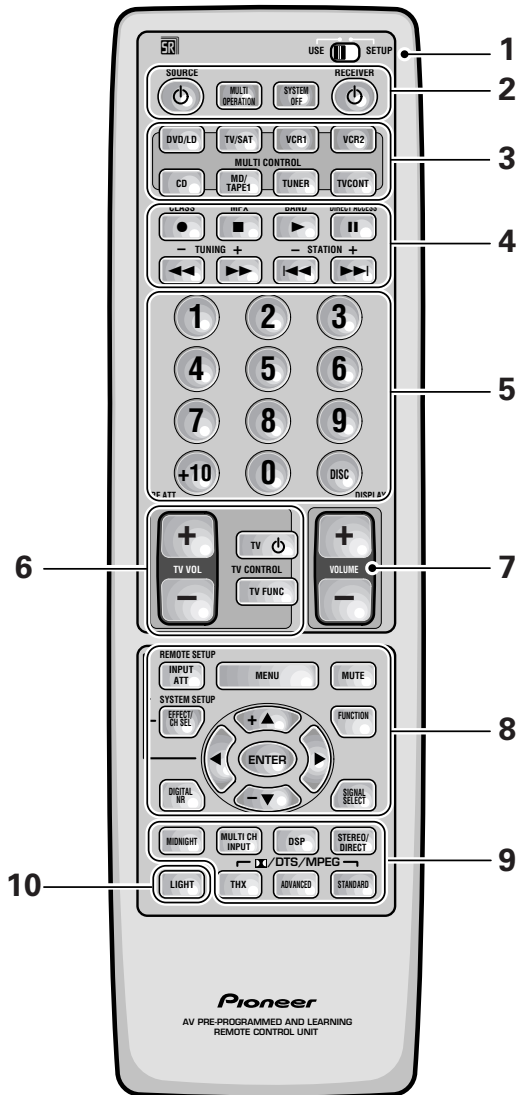

1 USE/SETUP slide switch

Use to put the remote into receiver SETUP, or receiver USE mode.

2 SOURCE button

Use to turn on the power of your other components after you have recalled or taught the signals to this remote control.

MULTI OPERATION button

Use this button to start the MULTI OPERATION mode. for how to program and use the MULTI OPERATION mode.

SYSTEM OFF button

This button turns off components in two ways. First, when pressed it will turn off all PIONEER components. Secondly, any component that has programmed into the SYSTEM OFF settings will also be turned off .

For example : If you programmed power on for your TV and VCR, pressing the SYSTEM OFF button will turn off these components even if they are not PIONEER products.

RECEIVER button

Press to turn power of the receiver on or to STANDBY (off).

3 MULTI CONTROL buttons

Use these to select a source and the corresponding remote operation mode.

For example, pressing TUNER selects the built in tuner and sets the remote operation to the tuner functions.

4 Component Control buttons

Use to control specific components, like a CD player or DVD player, after you have programmed the remote control to do these operations and the remote is put in that operation mode.

5 Number buttons

These buttons can perform a variety of different functions depending on the remote operation mode. They are most useful for CD and tuner operations.

6 TV CONTROL buttons

The following buttons are used to control the TV only and can be used no matter what function the remote control is set to.

TV SOURCE button – Press to turn the power of the TV on/off.

TV FUNC button – Press TV FUNC to select the TV for remote control operation.

TV VOL +/- button – Use to adjust the TV volume.

7 MASTER VOLUME buttons

Use to raise or lower the volume of the receiver.

8 INPUT ATT button (when USE mode is selected)

Use to lower the input level of an analog signal that is too powerful, thus causing the sound to distort (the OVERLOAD indicator will light).

REMOTE SETUP button (when SETUP mode is selected)

Use to customize the remote control functions and the remote control itself. (See "Setting Up the Remote Control to Control Other Components" starting on , "Multi Operation" starting on)

MENU button

Use to get the various menus for your TV or DTV.

MUTING button

Press to mute or restore the volume.

EFFECT/CH SEL (when USE mode is selected) button

EFFECT – Use these buttons to increase or decrease the amount of effect applied in a DSP or Advanced Theater mode. When the amount of effect is increased in a DSP/Advanced Theater mode the characteristics of that mode become stronger and more noticeable. The scale ranges from 10-90 with 70 as the default setting. First turn on the DSP/Advanced Theater you want (by pressing the DSP/Advanced Theater button until you get the mode) and then increase or decrease the amount of effect.

CH SEL – You may want to adjust the channels when listening to some sound sources. Use this button to select the channel you want to adjust.

SYSTEM SET UP button (when SETUP mode is selected)

Use to set up the speaker and sound systems. For more information see "Setting up for Surround Sound" starting on .

FUNCTION button

Press to select a source. The button will cycle through all the possible sources.

▲(+)/▼(-)/◀/▶/ENTER buttons

Use to operate the on-screen menu on your TV screen and enter commands when setting up surround sound, speakers levels & settings, and other set up features . Specific use of these buttons is described in conjunction with the operations they perform. For more information see each individual section.

DIGITAL NR button

Press to switch Digital NR on or off.

SIGNAL SELECT button

Press SIGNAL SELECT repeatedly to select one of the following:

ANALOG – Analog signal.

DIGITAL – Digital signal (DVD/LD, TV/SAT, CD, MD/TAPE 1/CD-R, VCR 1/DVR, VCR 2).

AC-3 RF (VSX-37TX only) –  RF signal (DVD/LD, TV/SAT, VCR 1, VCR 2).

AUTO – This is the default. If there are both analog, digital,  RF input signals, the receiver automatically selects the best possible signal.

9 MIDNIGHT button

Switches the MIDNIGHT mode on or off.

MULTI CH INPUT button

Press to switch to MULTI CH IN mode.

DSP button

Press repeatedly to select a DSP sound mode.

STEREO/DIRECT button

Switches the receiver into STEREO mode if it was in a different sound mode (like ADVANCED THEATER) or toggles between DIRECT and STEREO mode. For more on STEREO mode .

DIRECT playback bypasses the tone controls and channel level for the most accurate reproduction of a program source.

LIGHT button

Press to light the remote control buttons.

/DTS buttons

Press these buttons to put the receiver in the selected sound mode. For more information on the sound modes.

8.2 SPECIFICATIONS

VSX-39TX :

Continuous average power output of 120 watts* per channel, min., at 6 ohms, from 20 Hz to 20,000 Hz with no more than 0.09% total harmonic distortion (front).**

Audio Section

Continuous Power Output

Front 120 W + 120 W (20 Hz-20 kHz, 0.09 %, 6 Ω)
 Center 120 W (20 Hz-20 kHz, 0.09 %, 6 Ω)
 Rear 120 W + 120 W (20 Hz-20 kHz, 0.09 %, 6 Ω)

Input (Sensitivity/Impedance)

PHONO MM 4.7 mV/47 kΩ
 VCR 1/DVR, VCR 2, DVD/LD, TV/SAT, VIDEO, CD
 MD/TAPE 1/CD-R, TAPE 2 335 mV/47 kΩ

Phono Overload level (T.H.D.0.1 %, 1kHz)

PHONO MM 120 mV

Frequency Response

PHONO MM 20 Hz to 20,000 Hz ± 0.3 dB
 VCR 1/DVR, VCR 2, DVD/LD, TV/SAT, VIDEO, CD
 MD/TAPE 1/CD-R, TAPE 2 5 Hz to 100,000 Hz dB

Output (Level/Impedance)

VCR 1/DVR REC, VCR 2 REC, MD/TAPE 1/CD-R REC
 TAPE 2 REC 335 mV/2.2 kΩ

Tone Control

BASS ± 6 dB (100 Hz)
 TREBLE ± 6 dB (10 kHz)
 LOUDNESS +10 dB (100 Hz/10 kHz)

Signal-to-Noise Ratio (IHF, short circuited, A network)

PHONO MM 80 dB
 VCR 1/DVR, VCR 2, DVD/LD, TV/SAT, VIDEO, CD
 MD/TAPE 1, TAPE 2 101 dB
 MULTI CHANNEL IN 105 dB(Channel Level:Bypass)

Signal-to-Noise Ratio [EIA, at 1 W (1 kHz)]

PHONO MM 80 dB
 VCR 1/DVR, VCR 2, DVD/LD, TV/SAT, VIDEO, CD
 MD/TAPE 1/CD-R, TAPE 2 83 dB

* Measured pursuant to the Federal Trade Commission's Trade Regulation rule on Power Output Claims for Amplifiers.

** Measured by Audio Spectrum Analyzer.

Maintenance of External Surfaces

- Use a polishing cloth or dry cloth to wipe off dust and dirt.
- When the surfaces are dirty, wipe with a soft cloth dipped in some neutral cleanser diluted five or six times with water, and wrung out well, and then wipe again with a dry cloth. Do not use furniture wax or cleaners.
- Never use thinners, benzine, insecticide sprays or other chemicals on or near this unit, since these will corrode the surfaces.

Video Section

Input (Sensitivity) 1 Vp-p/75 Ω
 Output (Level/Impedance) 1 Vp-p/75 Ω
 Signal-to-Noise Ratio 65 dB
 Frequency Response 5 Hz to 10 MHz dB

Component Video Section

Input (Sensitivity) 1 Vp-p/75 Ω
 Output (Level/Impedance) 1 Vp-p/75 Ω
 Signal-to-Noise Ratio 65 dB

FM Tuner Section

Frequency Range 87.5 MHz to 108 MHz
 Usable Sensitivity Mono: 13.2 dBf, IHF (1.3 μV/75 Ω)
 50 dB Quieting Sensitivity Mono: 20.2 dBf
 Stereo: 38.6 dBf
 Signal-to-Noise Ratio Mono: 73 dB (at 85 dBf)
 Stereo: 70 dB (at 85 dBf)
 Distortion Stereo: 0.5 % (1 kHz)
 Alternate Channel Selectivity 60 dB (400 kHz)
 Stereo Separation 40 dB (1 kHz)
 Frequency Response 30 Hz to 15 kHz (± 1) dB
 Antenna Input 75 Ω unbalanced

AM Tuner Section

Frequency Range 530 kHz to 1,700 kHz
 Sensitivity (IHF, Loop antenna) 350 μV/m
 Selectivity 25 dB
 Signal-to-Noise Ratio 50 dB
 Antenna Loop antenna

Miscellaneous

Power Requirements AC 120 V, 60 Hz
 Power Consumption 460 W, 630 VA
 Power Consumption in Standby mode 1.0 W
 AC Outlet
 SWITCHED (x2) Total 100 W (0.8 A) MAX
 UNSWITCHED 100 W (0.8 A) MAX
 Dimensions 457 (W) × 174 (H) × 470 (D) mm
 (17-15/16 (W) × 6-13/16 (H) × 18-1/2 (D) in.)
 Weight (without package) 17.2 kg (37 lb 15 oz)

Furnished Parts

FM wire Antenna 1
 AM Loop Antenna 1
 "AA" IEC LR6 batteries 4
 Remote Control Unit 1
 Touch Pen 1
 Cushion for Remote 4
 Operating Instructions 1

NOTE:

Specifications and the design are subject to possible modifications without notice, due to improvements.

Amplifier Section

VSX-37TX :

Continuous average power output of 120 watts* per channel, min., at 6 ohms, from 20 Hz to 20,000 Hz with no more than 0.09% total harmonic distortion (front).**

VSX-36TX:

Continuous average power output of 100 watts* per channel, min., at 8 ohms, from 20 Hz to 20,000 Hz with no more than 0.09% total harmonic distortion (front).**

VSX-37TX :

Continuous Power Output

Front 120 W + 120 W (20 Hz-20 kHz, 0.09 %, 6 Ω)
Center 120 W (20 Hz-20 kHz, 0.09 %, 6 Ω)
Rear 120 W + 120 W (20 Hz-20 kHz, 0.09 %, 6 Ω)

VSX-36TX :

Continuous Power Output

Front 100 W + 100 W (20 Hz-20 kHz, 0.09 %, 8 Ω)
Center 100 W (20 Hz-20 kHz, 0.09 %, 8 Ω)
Rear 100 W + 100 W (20 Hz-20 kHz, 0.09 %, 8 Ω)

Audio Section

Input (Sensitivity/Impedance)

PHONO MM 4.7 mV/47 kΩ
VCR 1/DVR, VCR 2, DVD/LD, TV/SAT, VIDEO, CD
MD/TAPE 1/CD-R, TAPE 2 335 mV/47 kΩ

Phono Overload level (T.H.D.0.1 %, 1kHz)

PHONO MM 120 mV

Frequency Response

PHONO MM 20 Hz to 20,000 Hz ± 0.3 dB
VCR 1/DVR, VCR 2, DVD/LD, TV/SAT, VIDEO, CD
MD/TAPE 1/CD-R, TAPE 2 5 Hz to 100,000 Hz dB

Output (Level/Impedance)

VCR 1/DVR REC, VCR 2 REC, MD/TAPE 1/CD-R REC
TAPE 2 REC 335 mV/2.2 kΩ

Tone Control

BASS ± 6 dB (100 Hz)
TREBLE ± 6 dB (10 kHz)
LOUDNESS +10 dB (100 Hz/10 kHz)

Signal-to-Noise Ratio (IHF, short circuited, A network)

PHONO MM 80 dB
VCR 1/DVR, VCR 2, DVD/LD, TV/SAT, VIDEO, CD
MD/TAPE 1CD-R, TAPE 2 101 dB
MULTI CHANNEL IN 105 dB(Channel Level:Bypass)

Signal-to-Noise Ratio [EIA, at 1 W (1 kHz)]

PHONO MM 80 dB
VCR 1/DVR, VCR 2, DVD/LD, TV/SAT, VIDEO, CD
MD/TAPE 1/CD-R, TAPE 2 83 dB

* Measured pursuant to the Federal Trade Commission's Trade Regulation rule on Power Output Claims for Amplifiers.

** Measured by Audio Spectrum Analyzer.

Video Section

Input (Sensitivity) 1 Vp-p/75 Ω
Output (Level/Impedance) 1 Vp-p/75 Ω
Signal-to-Noise Ratio 65 dB
Frequency Response 5 Hz to 10 MHz dB

Component Video Section

Input (Sensitivity) 1 Vp-p/75 Ω
Output (Level/Impedance) 1 Vp-p/75 Ω
Signal-to-Noise Ratio 65 dB

FM Tuner Section

Frequency Range 87.5 MHz to 108 MHz
Usable Sensitivity Mono: 13.2 dBf, IHF (1.3 μV/75 Ω)
50 dB Quieting Sensitivity Mono: 20.2 dBf
Stereo: 38.6 dBf
Signal-to-Noise Ratio Mono: 73 dB (at 85 dBf)
Stereo: 70 dB (at 85 dBf)

Distortion Stereo: 0.5 % (1 kHz)
Alternate Channel Selectivity 60 dB (400 kHz)
Stereo Separation 40 dB (1 kHz)
Frequency Response 30 Hz to 15 kHz (± 1) dB
Antenna Input 75 Ω unbalanced

AM Tuner Section

Frequency Range 530 kHz to 1,700 kHz
Sensitivity (IHF, Loop antenna) 350 μV/m
Selectivity 25 dB
Signal-to-Noise Ratio 50 dB
Antenna Loop antenna

Miscellaneous

Power Requirements AC 120 V, 60 Hz

VSX-37TX :

Power Consumption 460 W, 630 VA
Power Consumption in Standby mode 1.0 W
AC Outlet
SWITCHED (x2) Total 100 W (0.8 A) MAX
UNSWITCHED 100 W (0.8 A) MAX
Dimensions 420 (W) × 173 (H) × 470 (D) mm
(16-9/16 (W) × 6-13/16 (H) × 18-1/2 (D) in.)
Weight (without package) 15.2 kg (33 lb 9 oz)

VSX-36TX :

Power Consumption 400 W, 550 VA
Power Consumption in Standby mode 1.0 W
AC Outlet
SWITCHED (x2) Total 100 W (0.8 A) MAX
UNSWITCHED 100 W (0.8 A) MAX
Dimensions 420 (W) × 173 (H) × 470 (D) mm
(16-9/16 (W) × 6-13/16 (H) × 18-1/2 (D) in.)
Weight (without package) 14.4 kg (31 lb 13 oz)

Furnished Parts



FM wire Antenna 1
AM loop Antenna 1
"AA" IEC LR6 batteries 2
Remote Control Unit 1
Operating Instructions 1

NOTE:

Specifications and the design are subject to possible modifications without notice, due to improvements.

VSX-39TX, VSX-37TX, VSX-36TX, VSX-D909S

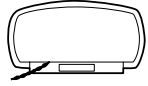
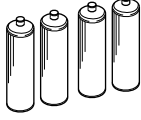
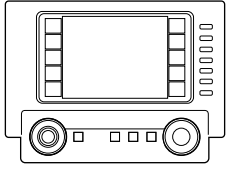
■ Accessories (VSX-39TX)

					
FM wire antenna (ADH7007)	AM loop antenna (ATB7009)	“AA” IEC LR6 batteries x 4	Remote control unit (Remocon39 : AXD7254)	Touch pen (E-AA1445-001)	Cushion for Remote x 4 (AXG7080)

■ Accessories (VSX-37TX/VSX-36TX/VSX-D909S)

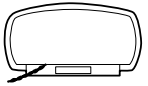
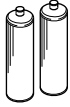
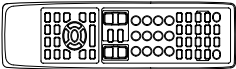
			
FM wire antenna (ADH7007)	AM loop antenna (ATB7009)	“AA” IEC LR6 batteries x 2	Remote control unit (Remocon37 : AXD7257) VSX-37TX/VSX-36TX (Remocon909S : AXD7278) VSX-D909S