

# Service Manual

Pioneer

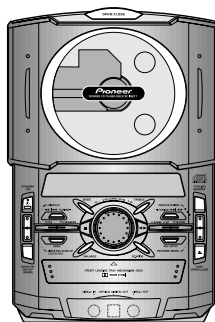

ORDER NO.  
RRV2148

## CD TUNER DECK XC-IS21T

THIS MANUAL IS APPLICABLE TO THE FOLLOWING MODEL(S) AND TYPE(S).

Type	Model	Power Requirement	Remarks
	XC-IS21T		
ZUCXJ	O	DC power supply from other system	

● This product is a system(s) component.

This product does not function properly when independent; to avoid malfunctions, be sure to connect it to the prescribed system component(s), otherwise damage may result.

Component	System	Service Manual	Remarks
	IS-21T		
CD TUNER DECK	XC-IS21T	RRV2148	This service manual
STEREO POWER AMPLIFIER	M-IS21	RRV2143	
SPEAKER SYSTEM	S-IS21	RRV2141	

## CONTENTS

1. SAFETY INFORMATION .....	2	7.1 DIAGNOSIS .....	57
2. EXPLODED VIEWS AND PARTS LIST .....	3	7.1.1 SEQUENCE AFTER THE POWER ON ...	57
3. BLOCK DIAGRAM AND SCHEMATIC DIAGRAM	16	7.1.2 SINGLE OPERATION METHOD .....	58
4. PCB CONNECTION DIAGRAM .....	34	7.1.3 DISASSEMBLY .....	60
5. PCB PARTS LIST .....	46	7.1.4 PCB LOCATION .....	64
6. ADJUSTMENT .....	51	7.2 PARTS .....	65
7. GENERAL INFORMATION .....	57	7.2.1 IC .....	65
		8. PANEL FACILITIES AND SPECIFICATIONS .....	70

# 1. SAFETY INFORMATION

This service manual is intended for qualified service technicians; it is not meant for the casual do-it-yourselfer. Qualified technicians have the necessary test equipment and tools, and have been trained to properly and safely repair complex products such as those covered by this manual. Improperly performed repairs can adversely affect the safety and reliability of the product and may void the warranty. If you are not qualified to perform the repair of this product properly and safely, you should not risk trying to do so and refer the repair to a qualified service technician.

**WARNING**

This product contains lead in solder and certain electrical parts contain chemicals which are known to the state of California to cause cancer, birth defects or other reproductive harm.

Health & Safety Code Section 25249.6 – Proposition 65

— IMPORTANT —  
THIS PIONEER APPARATUS CONTAINS  
LASER OF CLASS 1.  
SERVICING OPERATION OF THE APPARATUS  
SHOULD BE DONE BY A SPECIALLY  
INSTRUTED PERSON.

— LASER DIODE CHARACTERISTICS —  
MAXIMUM OUTPUT POWER: 5 mw  
WAVELENGTH: 780-785 nm

## 2. EXPLODED VIEWS AND PARTS LIST

- NOTES:
- Parts marked by "NSP" are generally unavailable because they are not in our Master Spare Parts List.
  - The  $\Delta$  mark found on some component parts indicates the importance of the safety factor of the part. Therefore, when replacing, be sure to use parts of identical designation.
  - Screws adjacent to  $\blacktriangledown$  mark on the product are used for disassembly.

### 2.1 PACKING

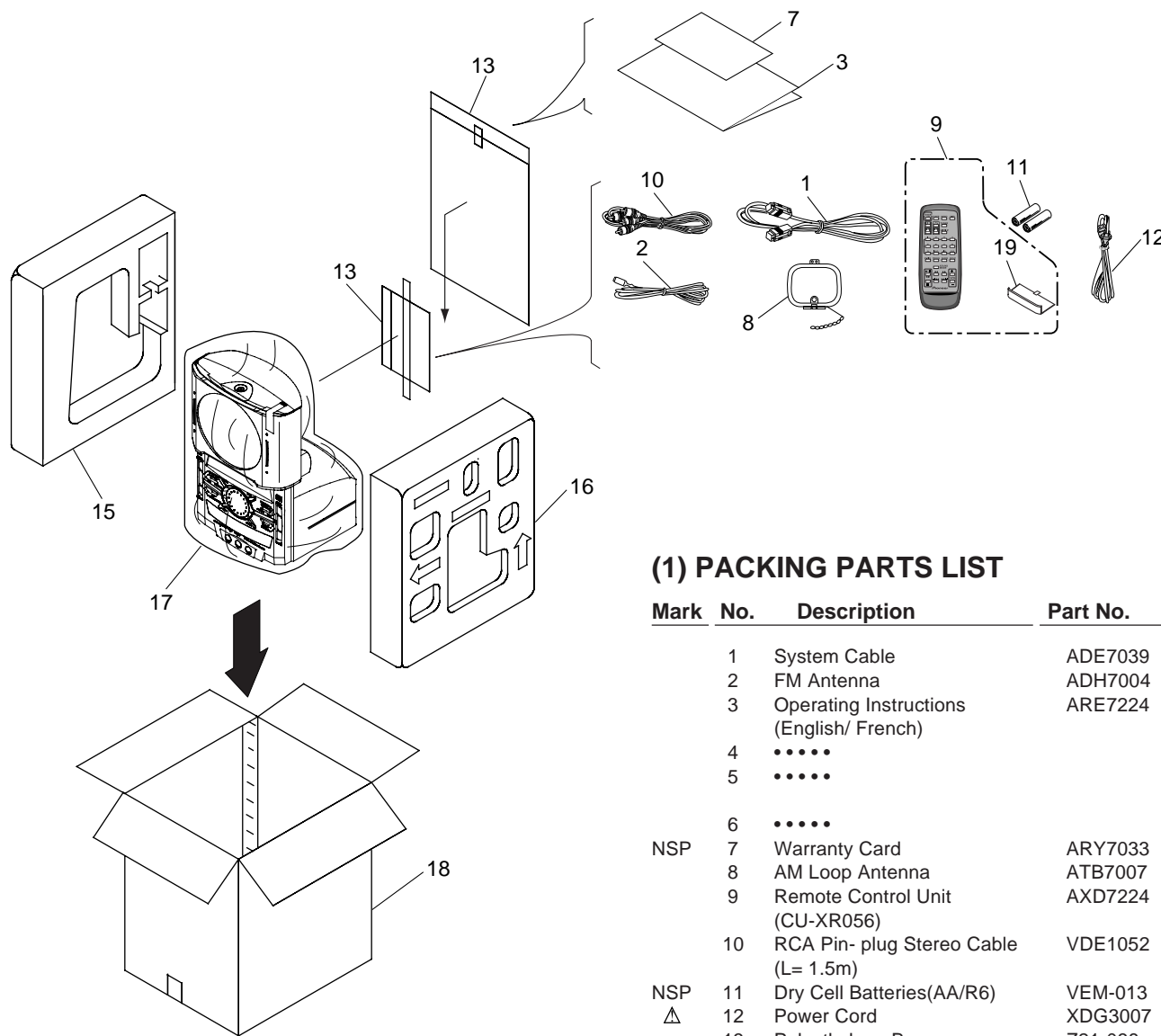

#### (1) PACKING PARTS LIST

Mark	No.	Description	Part No.
	1	System Cable	ADE7039
	2	FM Antenna	ADH7004
	3	Operating Instructions (English/ French)	ARE7224
	4	.....	
	5	.....	
	6	.....	
NSP	7	Warranty Card	ARY7033
	8	AM Loop Antenna	ATB7007
	9	Remote Control Unit (CU-XR056)	AXD7224
	10	RCA Pin- plug Stereo Cable (L= 1.5m)	VDE1052
NSP	11	Dry Cell Batteries(AA/R6)	VEM-013
$\Delta$	12	Power Cord	XDG3007
	13	Polyethylene Bag (0.03 x 230 x 340)	Z21-038
	14	.....	
	15	Side Pad ML	AHA7240
	16	Side Pad MR	AHA7241
	17	Packing Sheet	AHG7053
	18	Packing Case	AHD7751
	19	Battery Cover	AZA7331

2.2 EXTERIOR (1/2)

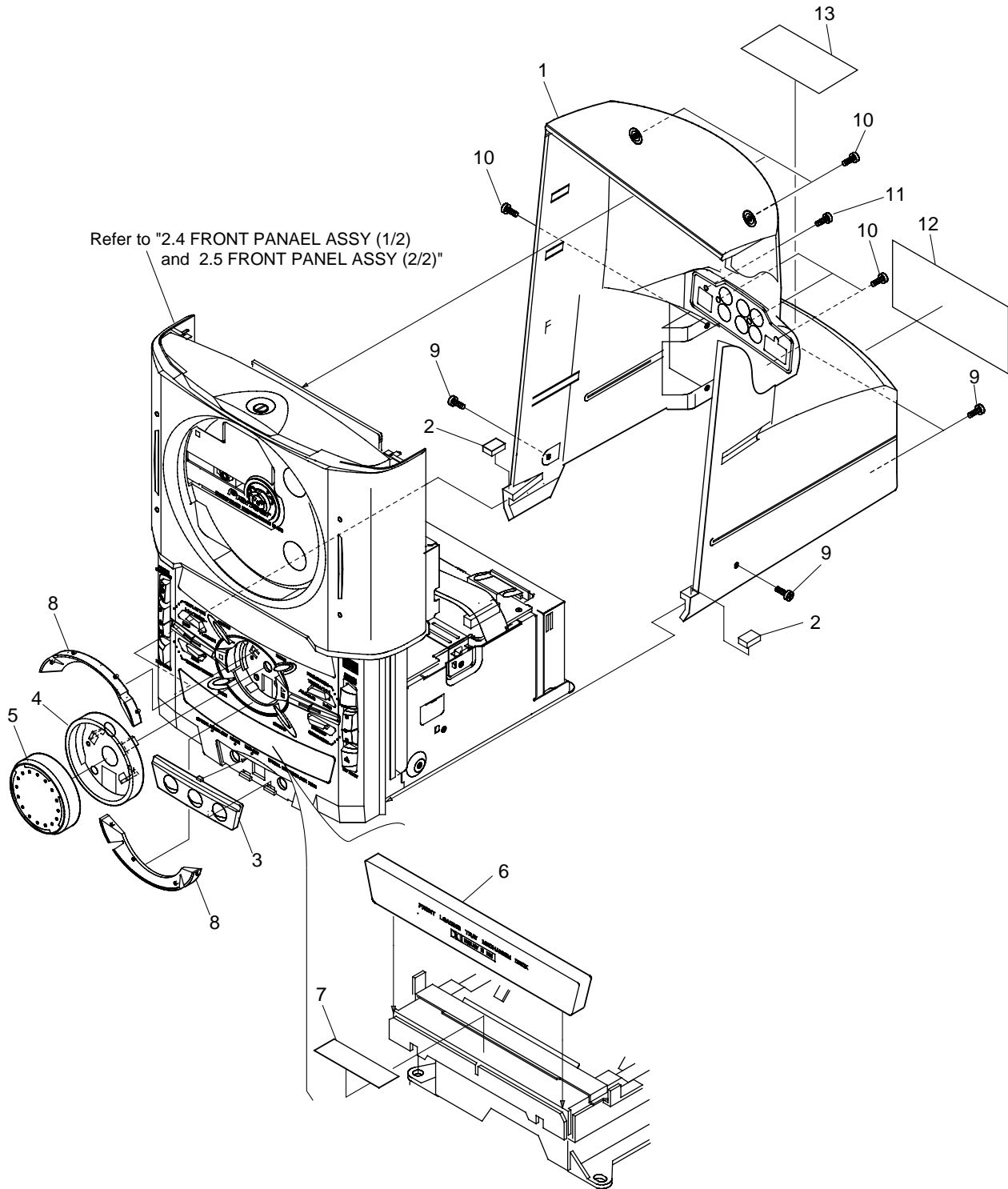

**(1) EXTERIOR (1/2) PARTS LIST**

<b>Mark</b>	<b>No.</b>	<b>Description</b>	<b>Parts No.</b>
	1	Rear Cover	AMC7029
	2	Cussion Rubber	AEB7154
	3	Jack Door	AAN7188
	4	Jog Lens	AAK7651
	5	Jog Knob	AAA7005
	6	Tray Cap	AAK7622
NSP	7	Tray Seal	RRW1162
	8	Jog Escutcheon	AAK7620
	9	Screw	BBZ30P080FMC
	10	Screw	VPZ30P100FMC
	11	Screw	BMZ30P060FZK
NSP	12	Name Label	AAL7231
	13	Label M	ARW7065

2.3 EXTERIOR (2/2)

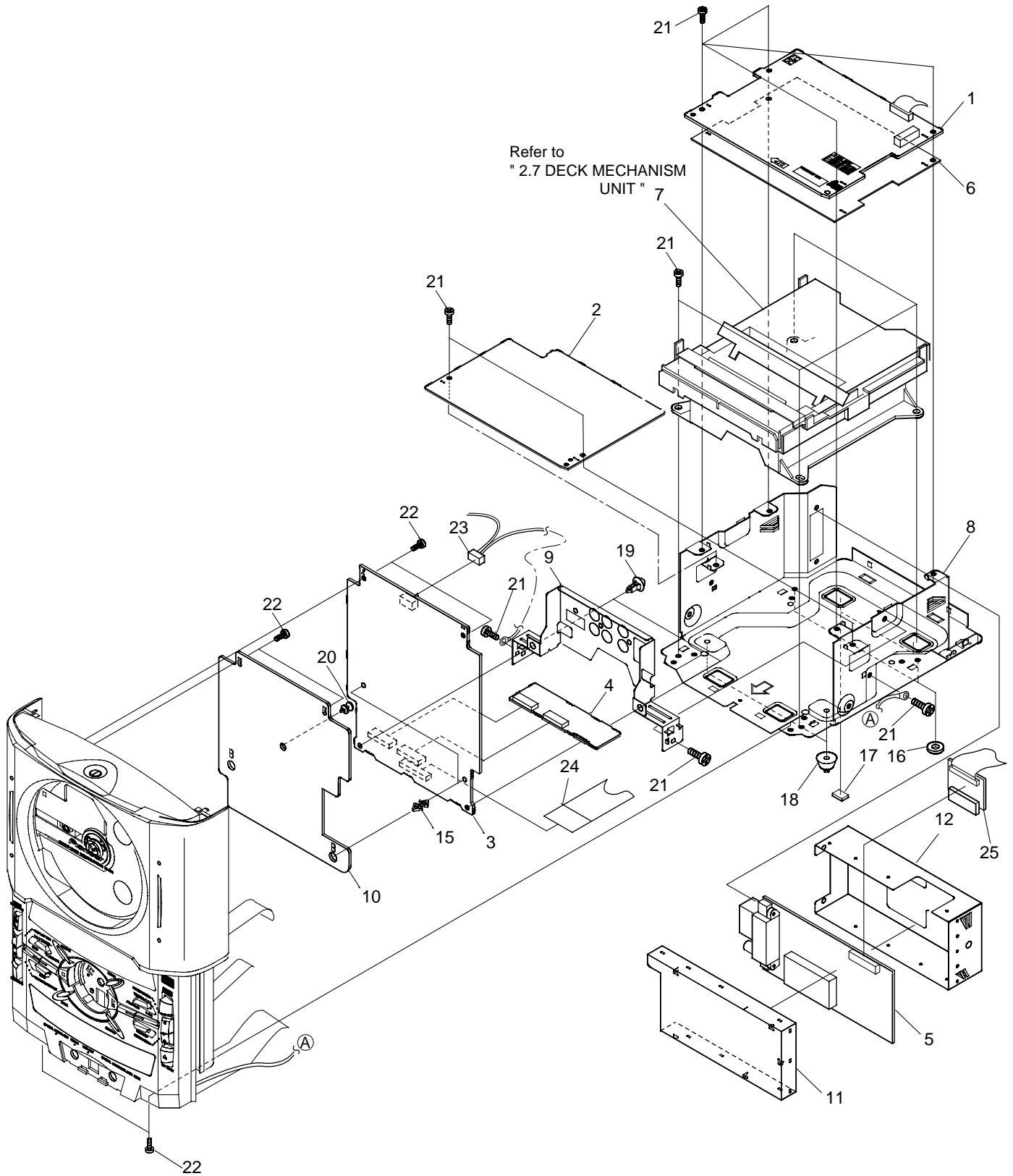

## ● EXTERIOR (2/2) PARTS LIST

Mark	No.	Description	Parts No.
	1	U- COM ASSY	AWU7327
	2	DECK ASSY	AWU7334
	3	AF ASSY	AWU7298
	4	R- TERMINAL ASSY	AWU7315
	5	FM/AM TUNER MODULE	AXQ7065
	6	Deck Shield	AEC7209
	7	DECK MECHANISM UNIT	AXA7075
NSP	8	Chassis M	ANA7087
	9	Rear Panel	ANC7735
NSP	10	Shield Plate	ANK7059
	11	Shield Case T	ANK7050
	12	Shield Case B	ANK7051
	13	•••••	
	14	•••••	
	15	PC Support	DEC1932
NSP	16	Spacer	AEB7092
	17	Rubber Sheet	AEB1111
	18	Leg Assy IS	AEC7202
	19	Locking Card Spacer	VEC1596
NSP	20	PCB Spacer (3 x 6)	AEC7156
	21	Screw	BBZ30P080FMC
	22	Screw	VPZ30P080FZK
	23	Connector Assy 3p	ADX7252
	24	23P F.F.C /30V	ADD7150
NSP	25	TX CONNECT ASSY	AWU7323

2.4 FRONT PANEL ASSY (1/2)

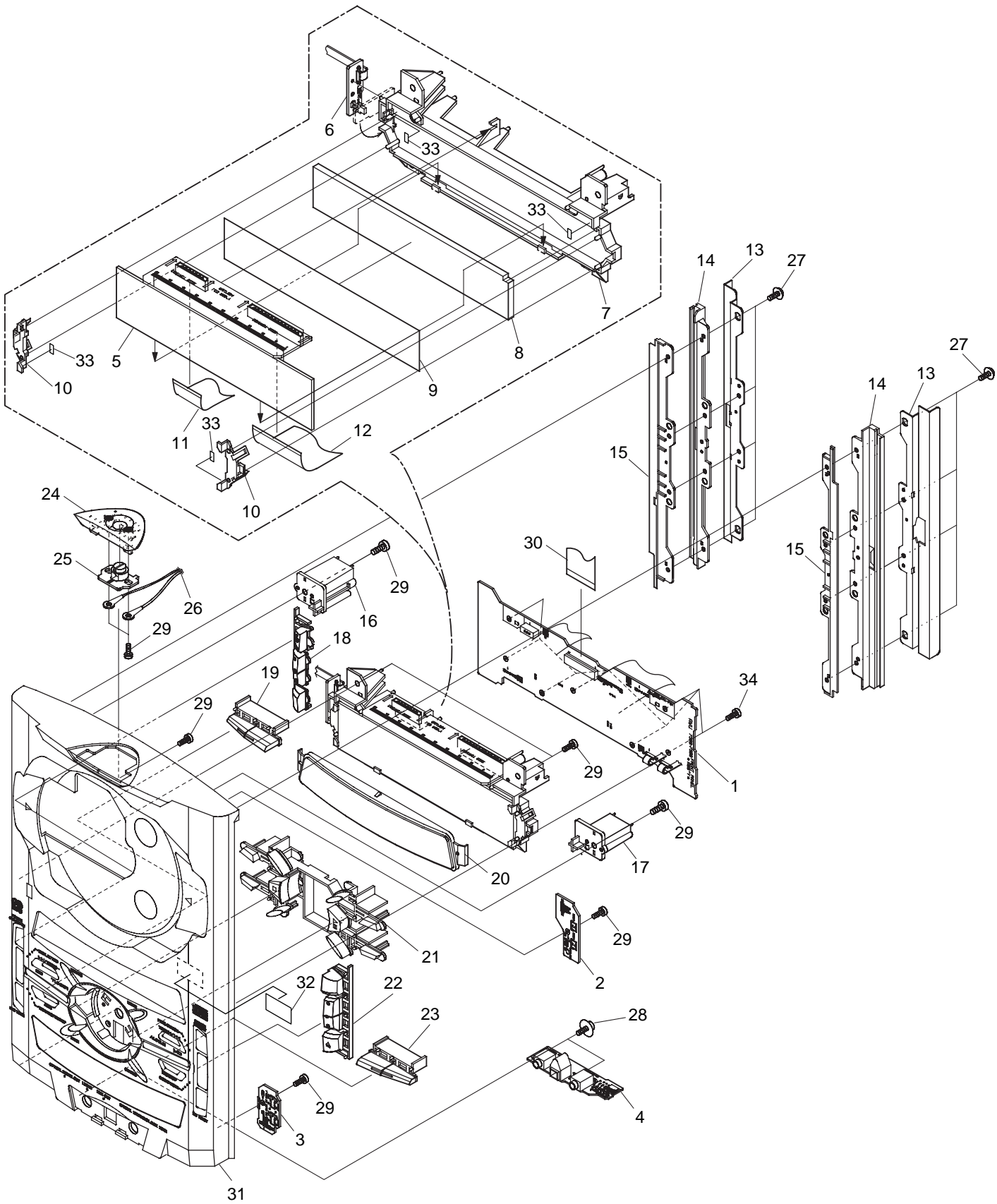



## ● FRONT PANEL ASSY (1/2) PARTS LIST

Mark	No.	Description	Parts No.
	1	FRONT PANEL ASSY	AWU7308
NSP	2	CD CLOSE SW ASSY	AWU7320
NSP	3	CD OPEN SW ASSY	AWU7319
	4	F- TERMINAL ASSY	AWU7311
NSP	5	LCD ASSY (TC)	AWU7354
NSP	6	LIGHT- L ASSY	AWU7321
	7	Lens Holder M	AMR7247
	8	Lens M	AAK7615
	9	Diffusion Sheet	AAK7666
	10	Reflector	AMR7248
	11	15P F.F.C/ 30V	ADD7147
	12	29P F.F.C/ 30V	ADD7148
	13	Frame	ANG7235
	14	Rail	AMR7239
	15	Blind	AMR7261
	16	PCB Holder L	AMR7262
	17	PCB Holder R	AMR7263
	18	Plating Button Assy	AXG7089
	19	Fuction Button B	AAD7511
	20	Window	AAK7621
	21	Complex Button	AAD7509
	22	Plating Button A	AAD7567
	23	Function Button A	AAD7510
	24	O/C Button	AAD7506
	25	Key O/C	AAD7526
	26	Connector 3p	ADX7252
	27	Screw	IPZ30P100FMC
	28	Screw	ABA1005
	29	Screw	VPZ30P080FZK
	30	17P F.F.C/ 30V	ADD7145
	31	Front Panel M	AMB7565
	32	PU Caution Label	ARW7059
	33	Spacer	AEC7216
	34	Screw	VPZ30P100FMC

2.5 FRONT PANEL ASSY (2/2)

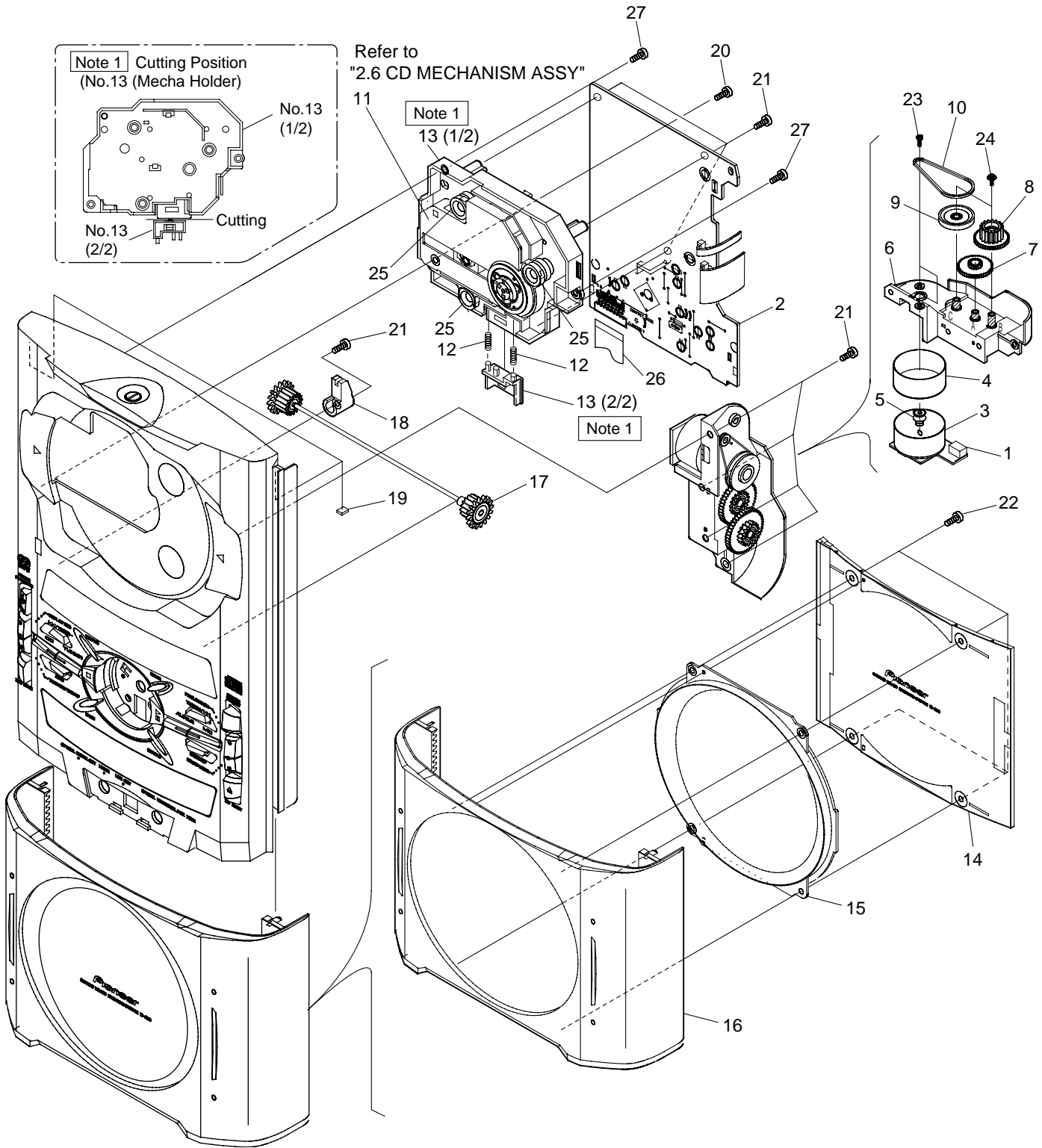

## ● FRONT PANEL ASSY (2/2) PARTS LIST

Mark	No.	Description	Parts No.
	1	CD MOTOR ASSY	AWU7318
	2	CD ASSY	AWU7305
	3	Slider Motor	VXM1033
NSP	4	Motor Shield	ANK7067
	5	Motor Pulley	PNW1634
	6	Gear Holder	AMR7240
	7	Gear A	ANW7063
	8	Gear B	AMR7260
	9	Gear Pulley A	ANW7066
	10	Belt	AEB7171
	11	CD MECHANISM ASSY	KSM-620AAA
	12	Float Spring	ABH7170
	13	Mechanism Holder	AMR7242
	14	CD Door Window	AAK7618
	15	CD Door Escutcheon	AAK7619
	16	CD Door	AAN7189
	17	Shaft Assy	AXG7078
	18	Shaft Holder	AMR7237
	19	Cussion Rubber	AEB7154
	20	Screw	BBZ30P080FMC
	21	Screw	VPZ30P080FZK
	22	Screw	ABA7054
	23	Screw	PMZ26P040FMC
	24	Screw	IPZ20P080FMC
	25	Float Rubber	AEB7129
	26	17P F.F.C/ 30V	ADD7146
	27	Screw	VPZ30P100FMC

2.6 CD MECHANISM ASSY

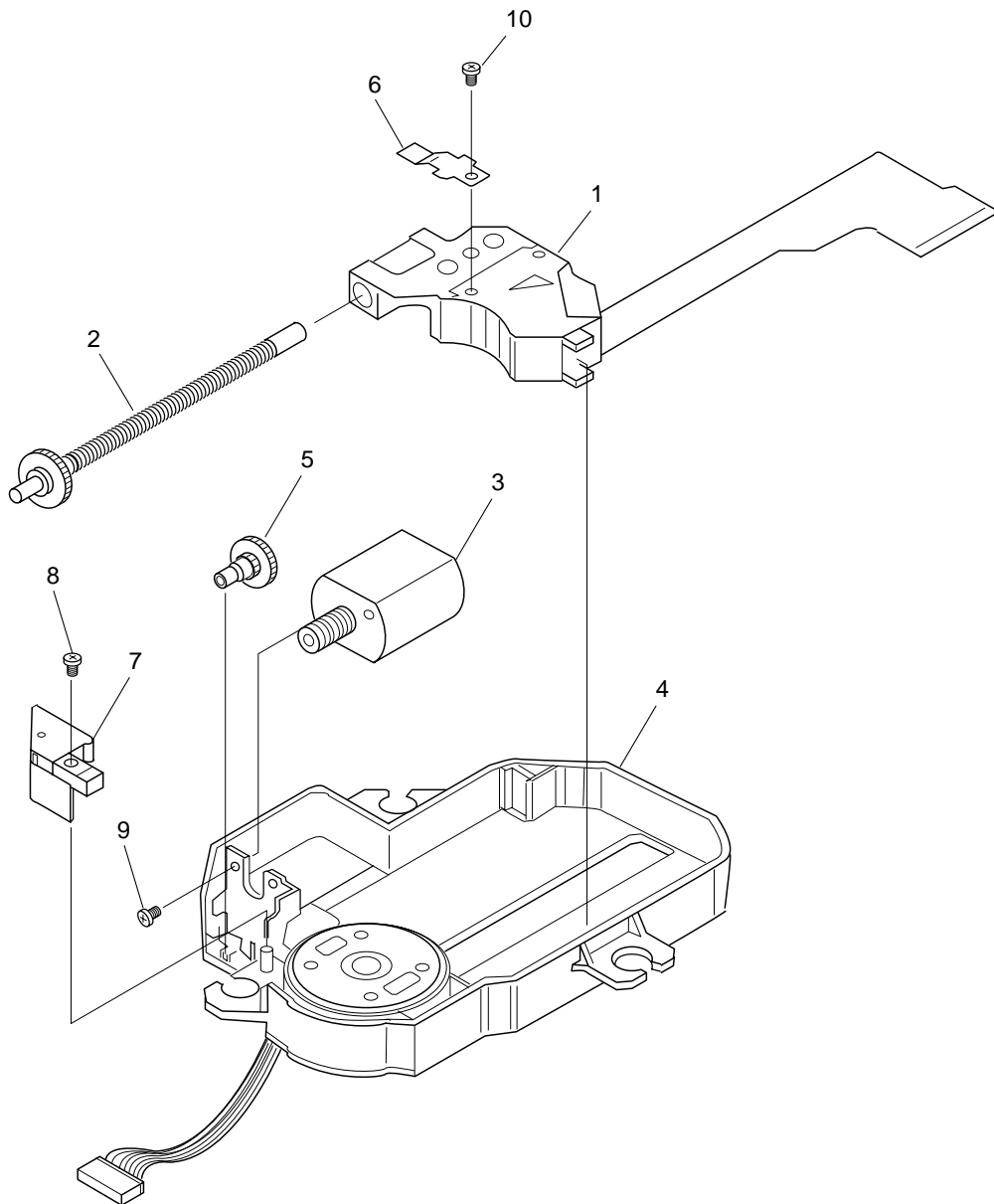

● CD MECHANISM ASSY PARTS LIST

Mark No.	Description	Parts No.
1	KSS-620A(RP)	8-820-063-(03)
2	Sled Screw Assy	X-2646-389-(1)
3	Sled Motor Assy	A-4912-199-(A)
4	MD Assy	X-2646-482-(1)
5	Geer BN	2-627-751-(02)
6	Rack Spring	2-646-912-(01)
7	Holder	2-646-913-(01)
8	Tapping Screw	2-646-352-01
9	Precision Screw	2-627-668-01
10	Tapping Screw	2-646-358-11

## 2.7 DECK MECHANISM UNIT (1/2)

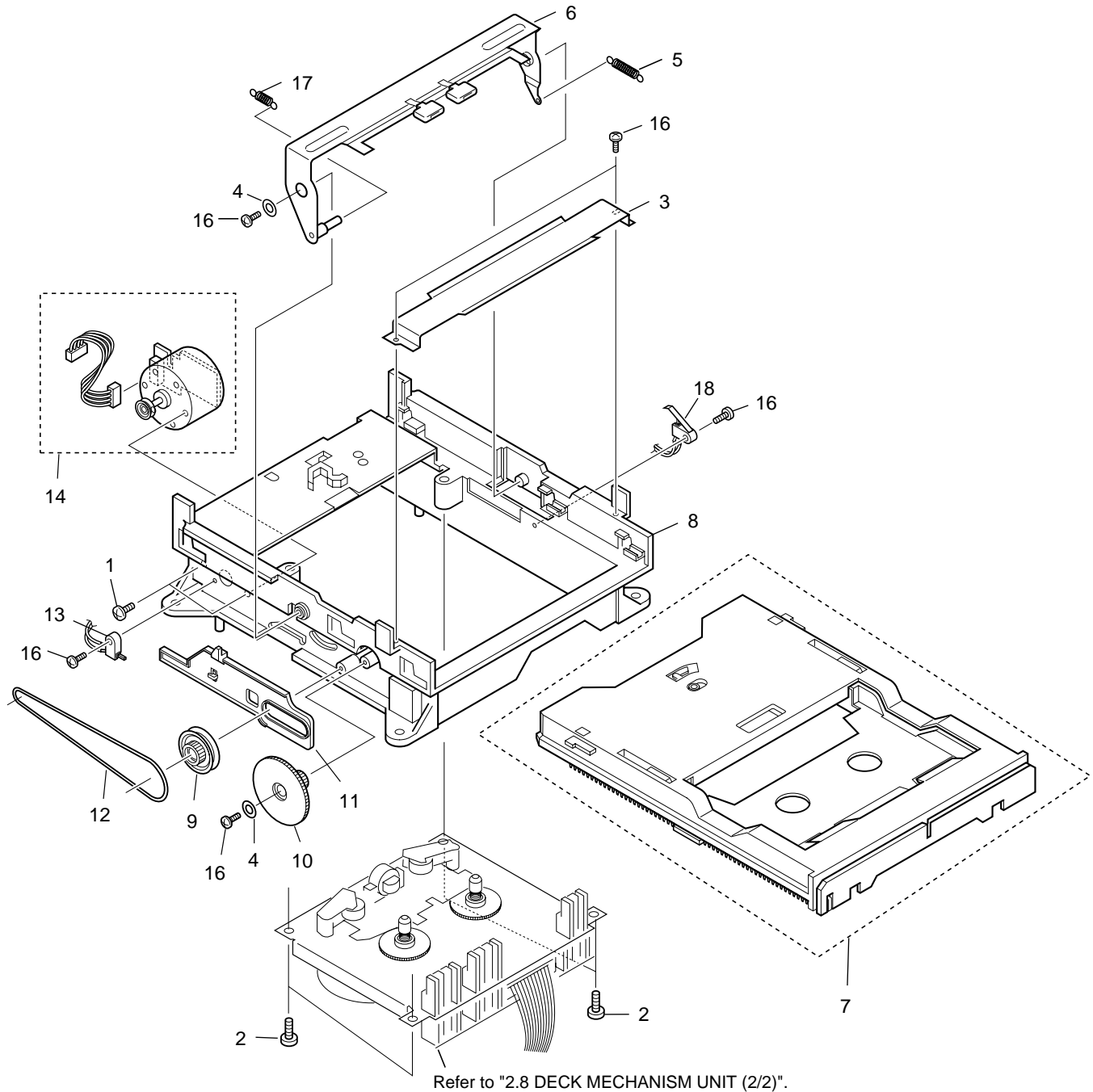

### ● DECK MECHANISM UNIT (1/2) PARTS LIST

Mark No.	Description	Parts No.	Mark No.	Description	Parts No.
1	Screw	FG114-14	11	Slider	FD57E-11
2	Screw	UG12H-15	12	LDG Belt	FF19L-12
3	Front BKT	FC64K-11	13	Switch	UE15S-14
4	Washer	MJ112-22	14	MTR Reel BLK	F564-313
5	SP Return	FK34N-11	15	•••••	
6	Plate Hold BLK	F573-258	16	Screw	UG12H-28
7	Holder CST BLK	F527-078	17	SP Clamper	FK34M-11
8	LDG Base	FD56R-12	18	Switch	UE18P-21
9	Pulley	FD56T-11			
10	LDG Gear	FD56U-11			

## 2.8 DECK MECHANISM UNIT (2/2)

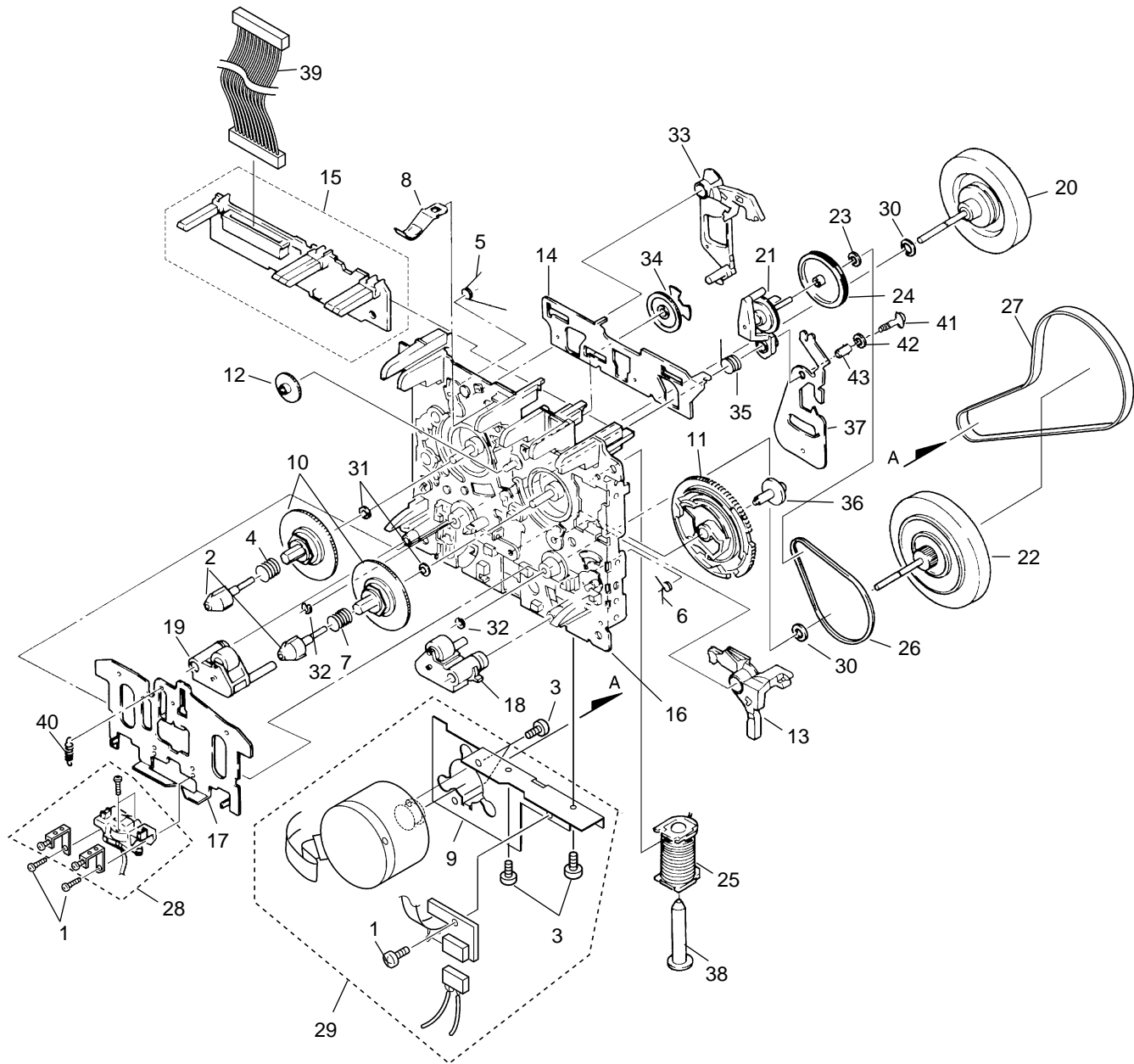

## ● DECK MECHANISM UNIT (2/2) PARTS

### LIST

Mark	No.	Description	Parts No.
	1	Screw	KG194-36
	2	Reel Feather	FD57D-13
	3	Screw	UG11S-14
	4	SP Reel(L)	FK32U-12
	5	SP Brake	FK33B-13
	6	SP Arm Play	FK33P-11
	7	SP Reel(R)	FK32V-12
	8	Spring Cassette	FC65M-11
	9	BKT MTR	FC64M-12
	10	Reel Base	FD52W-12
	11	Cam Gear	FD52Y-23
	12	Play Gear (A)	FD53K-12
	13	Arm Play	FD53D-19
	14	Plate Slide	FC61L-19
	15	PCB Control BLK	F567-617
	16	Chassis base BLK	F612-231
	17	Head Base	FC61K-32
	18	Roller Pinch BLK R	F514-129
	19	Roller Pinch BLK L	F514-130
	20	Assy F/W	FR24S-21
	21	Clutch Assy BLK	F522-037
	22	Clutch Assy BLK	F522-048
	23	Washer	FJ111-13
	24	F/R Pulley	FD53F-15
	25	Solenoid BLK	F765-279
	26	F/R Belt	FF18W-12
	27	Belt Main	FF19H-11
	28	Plate HD BLK	F513-824
	29	MTR MAIN BLK	F525-321
	30	Washer	FJ111-30
	31	Washer	FJ111-35
	32	Washer	UJ16F-11
	33	Lever Brake	FD53P-17
	34	FF Gear(A)	FD53L-12
	35	Cam SP	FK32S-14
	36	Screw	UJ14A-12
	37	Lever F/R	FC62G-14
	38	Plunger	FL41S-21
	39	Mecha-Cable	WH65N-11
	40	Spring HB	FK32T- 31
	41	Screw	UG15V-13
	42	Washer	MJ112- 22
	43	Spacer	UJ15V- 13

# 3. BLOCK DIAGRAM AND SCHEMATIC DIAGRAM

## 3.1 BLOCK DIAGRAM

A

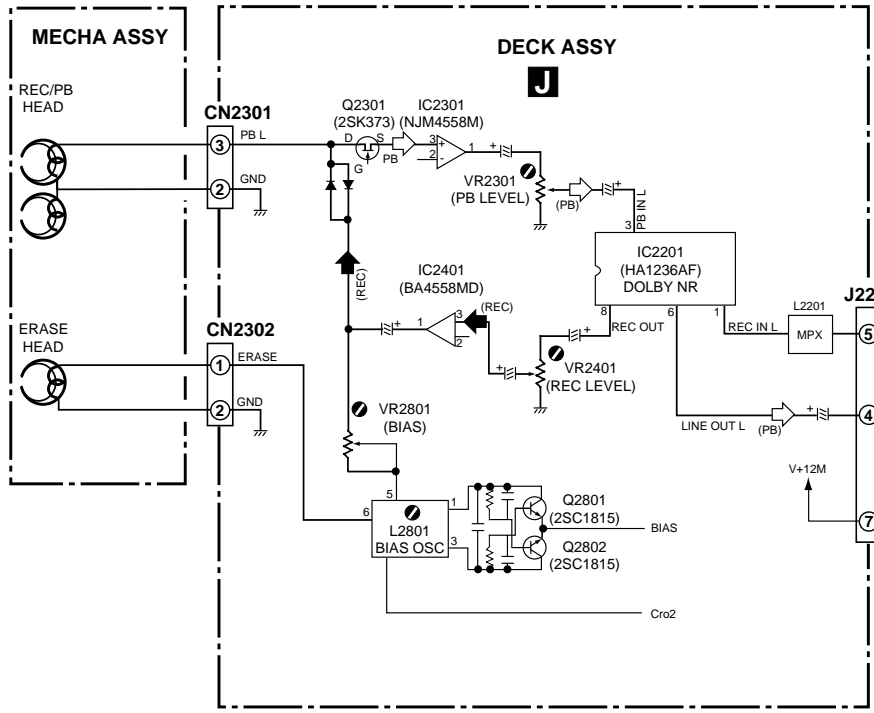

B

C

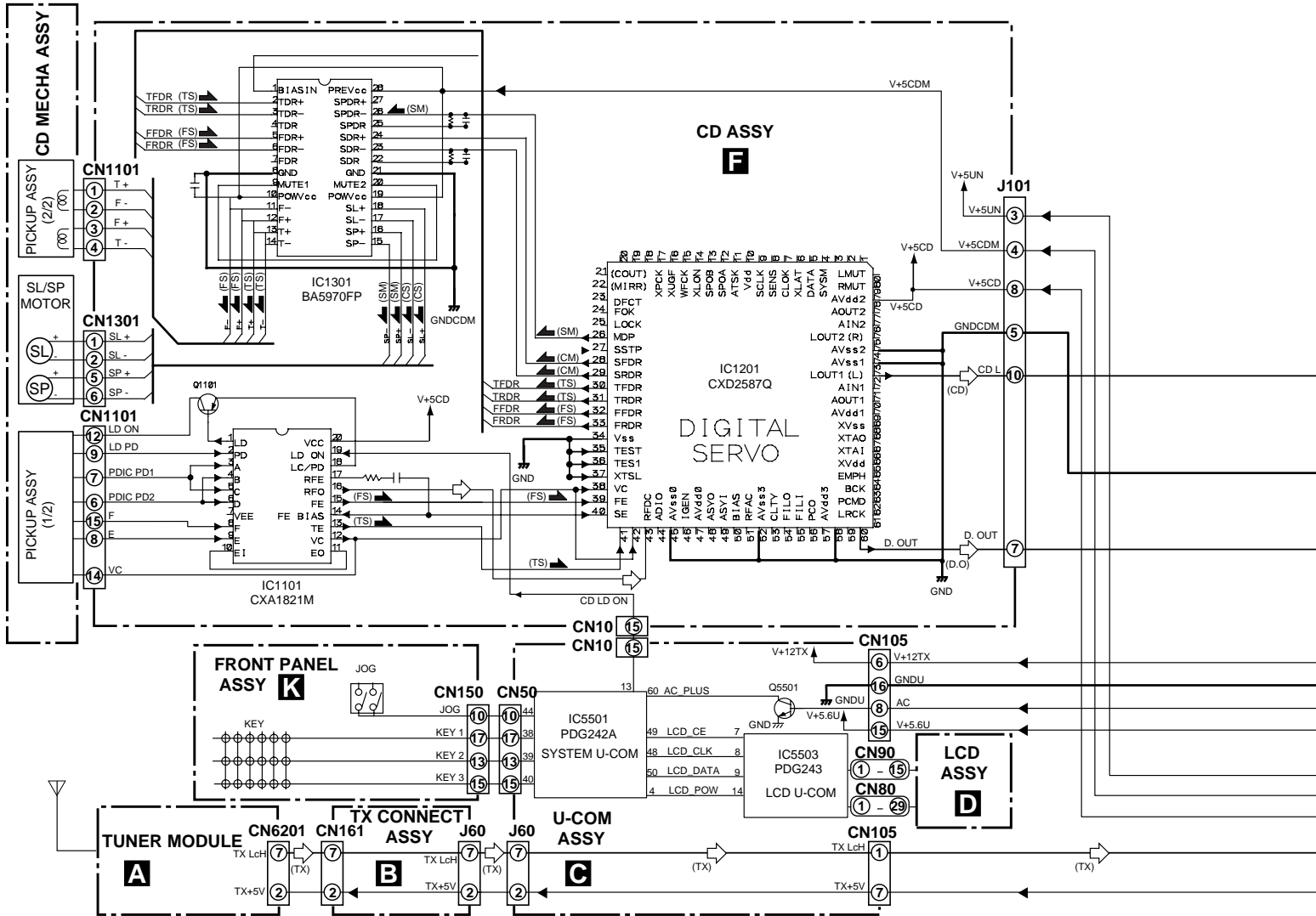

D



SIGNAL ROUTE

- (CD) : CD AUDIO SIGNAL
- (L1) : LINE 1 SIGNAL
- (PB) : DECK PB SIGNAL
- (L2) : LINE 2 SIGNAL
- (MO) : MAIN OUT SIGNAL
- (D.O) : OPTICAL OUT SIGNAL
- (TX) : TUNER AUDIO SIGNAL
- (LO1) : LINE OUT 1 SIGNAL
- (LO2) : LINE OUT 2 SIGNAL
- (LO) : LINE OUT SIGNAL
- (REC) : RECORDING SIGNAL
- (FS) : FOCUS SERVO LOOP LINE
- (TS) : TRACKING SERVO LOOP LINE
- (SM) : SPINDLE MOTOR ROUTE
- (CM) : CARRIAGE MOTOR ROUTE
- (LM) : LOADING MOTOR ROUTE

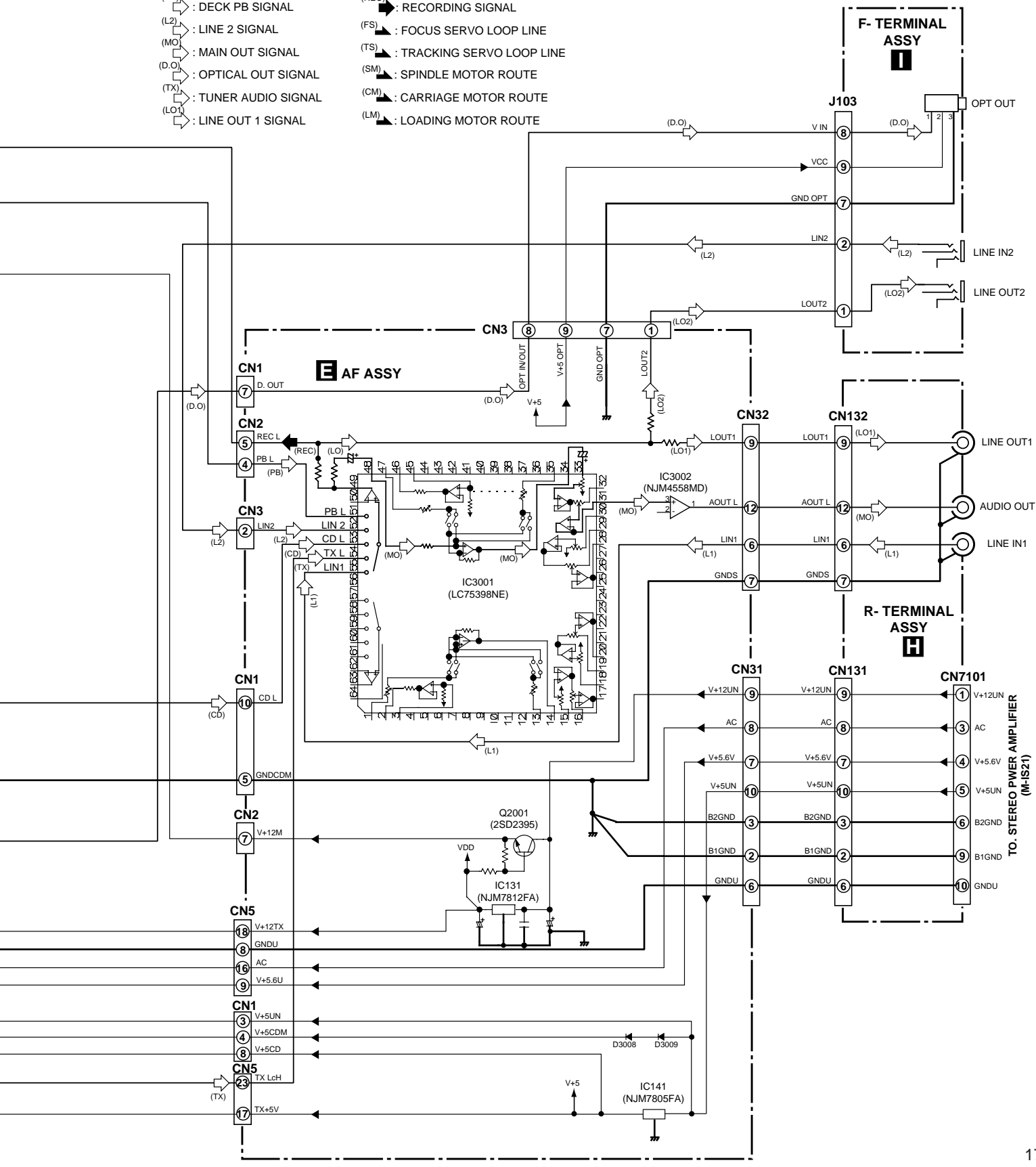

A

B

C

D

3.2 OVERALL CONNECTION DIAGRAM

A

B

C

D

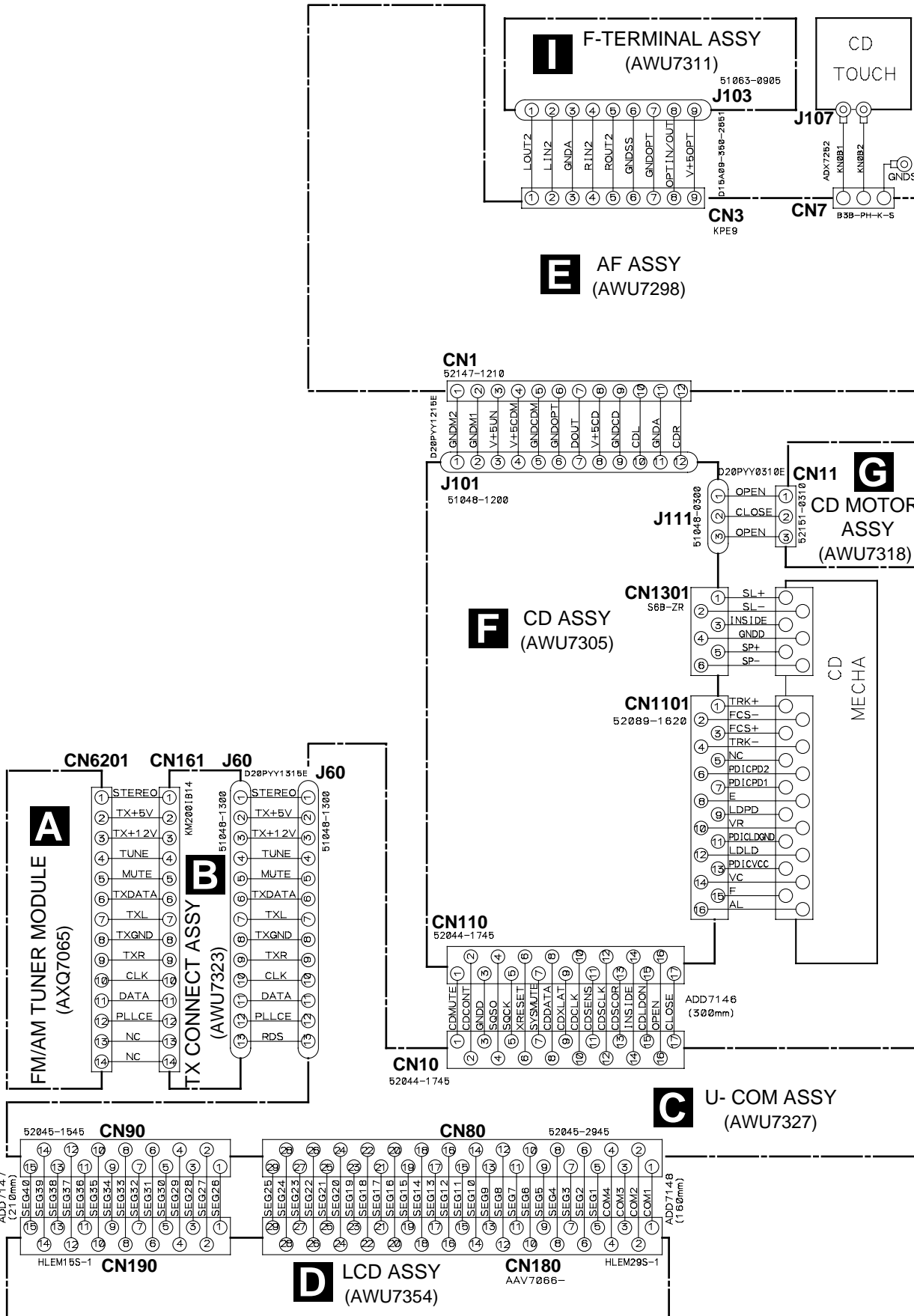

Note : When ordering service parts, be sure to refer to "EXPLODED VIEWS and PARTS LIST" or "PCB PARTS LIST".

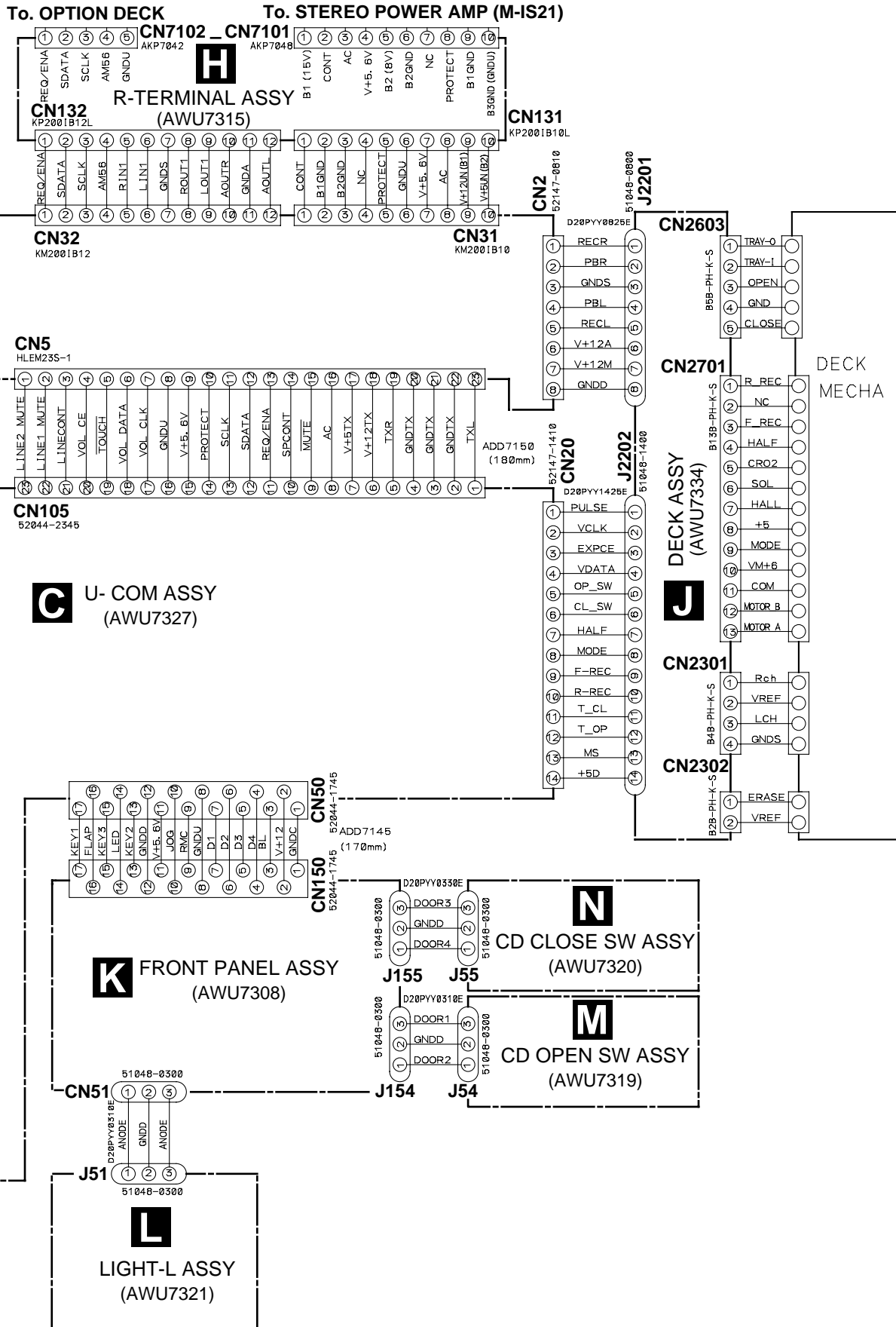

A

B

C

D

### 3.3 FM/AM TUNER MODULE and TX CONNECT ASSYS

A

B

C

D

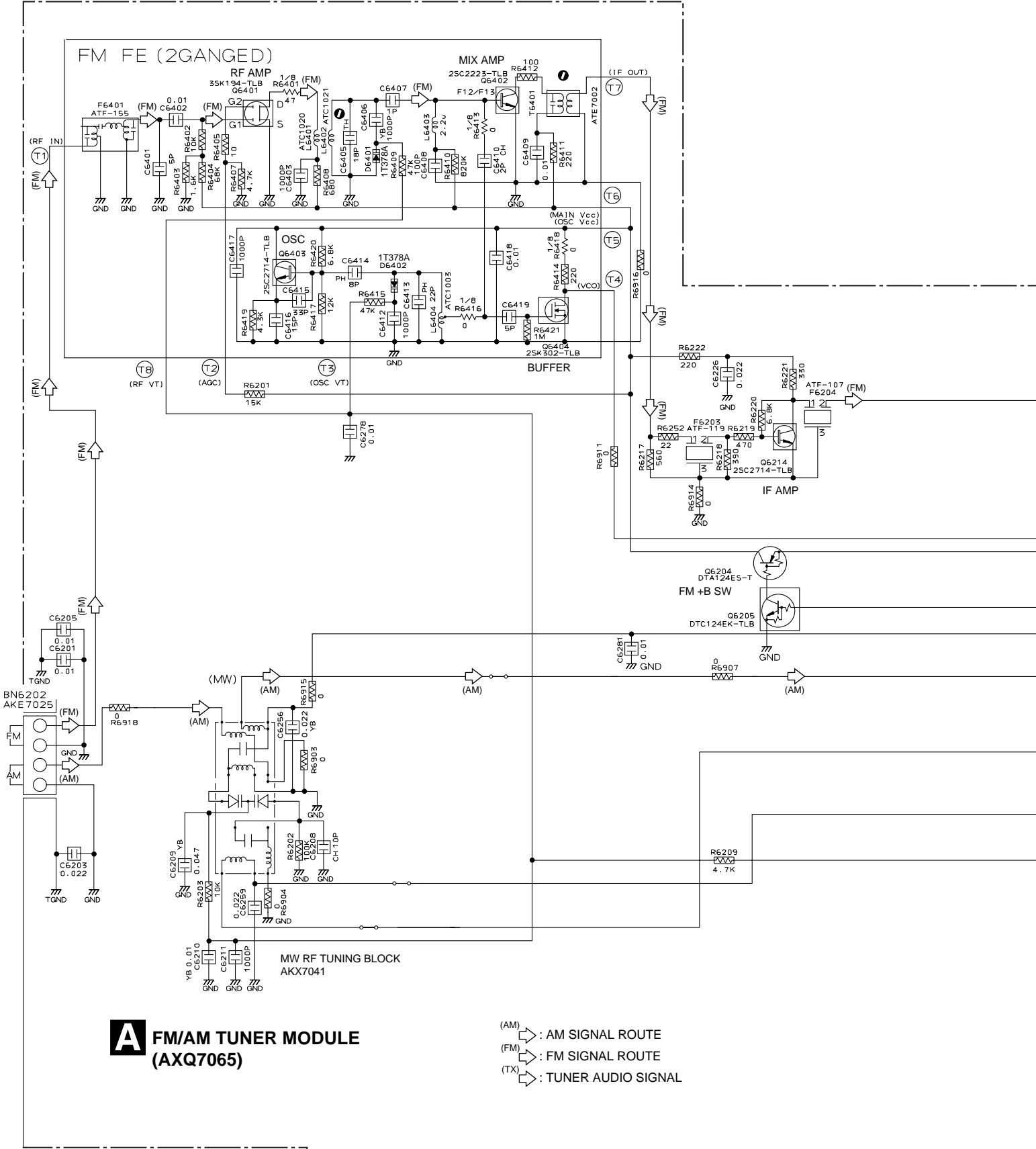

**FM/AM TUNER MODULE (AXQ7065)**

- (AM) : AM SIGNAL ROUTE
- (FM) : FM SIGNAL ROUTE
- (TX) : TUNER AUDIO SIGNAL

### Notes

#### 1. RESISTORS

Indicated in  $\Omega$ , 1/10W $\pm$ 5% Tolerance unless otherwise noted K:K $\Omega$ , M:M $\Omega$ .

#### 2. CAPACITORS

Indicated in Capacity ( $\mu$ F)/VOLTAGE (V) unless otherwise noted P:PF.

#### 3. DIODES

No mark diode is 1SS254.

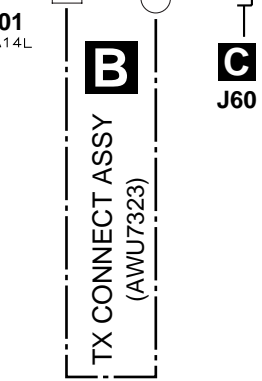
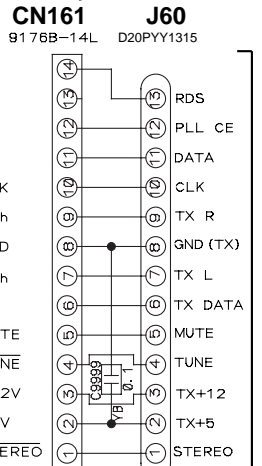
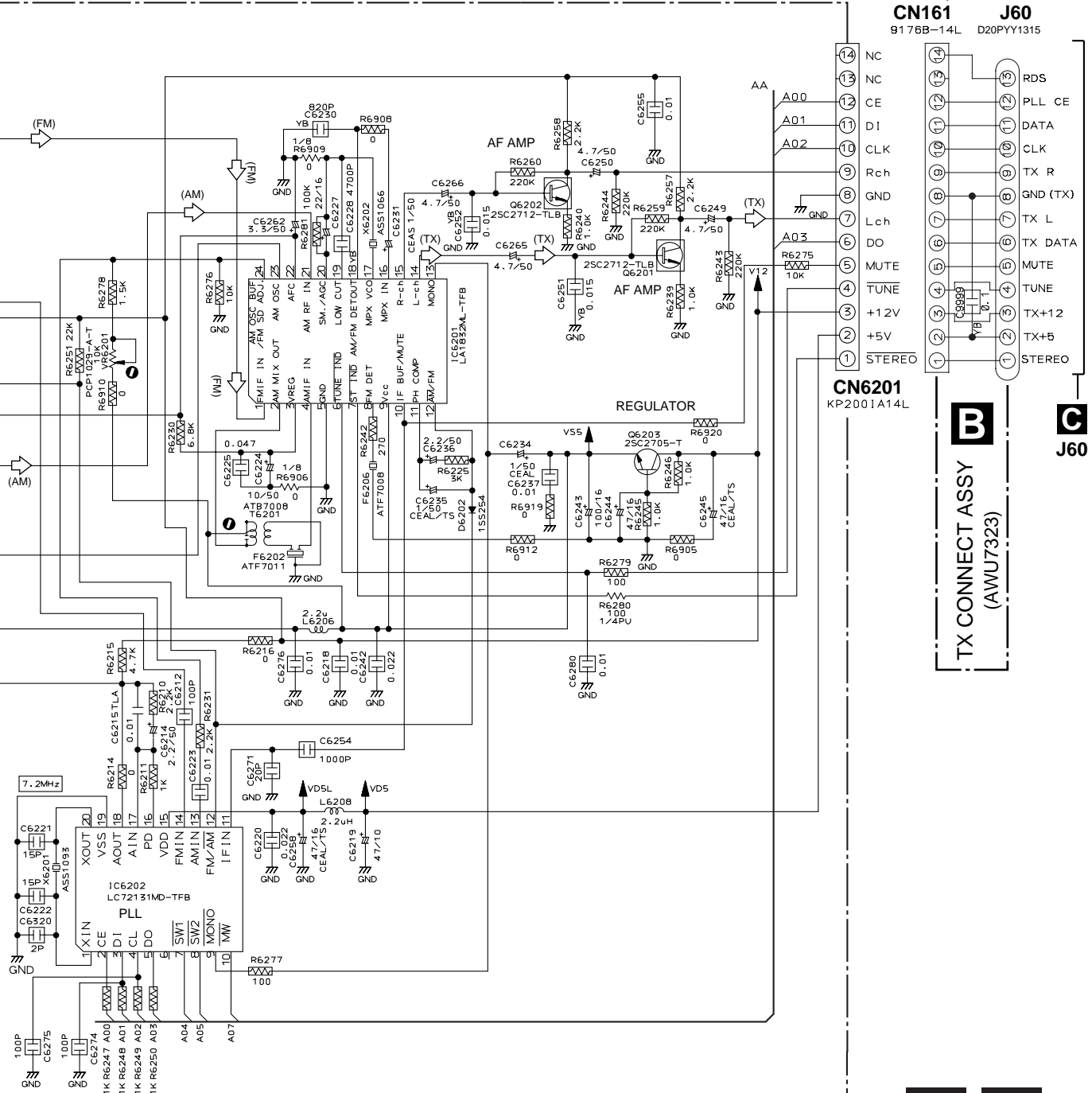

3.4 U-COM and LCD ASSYS

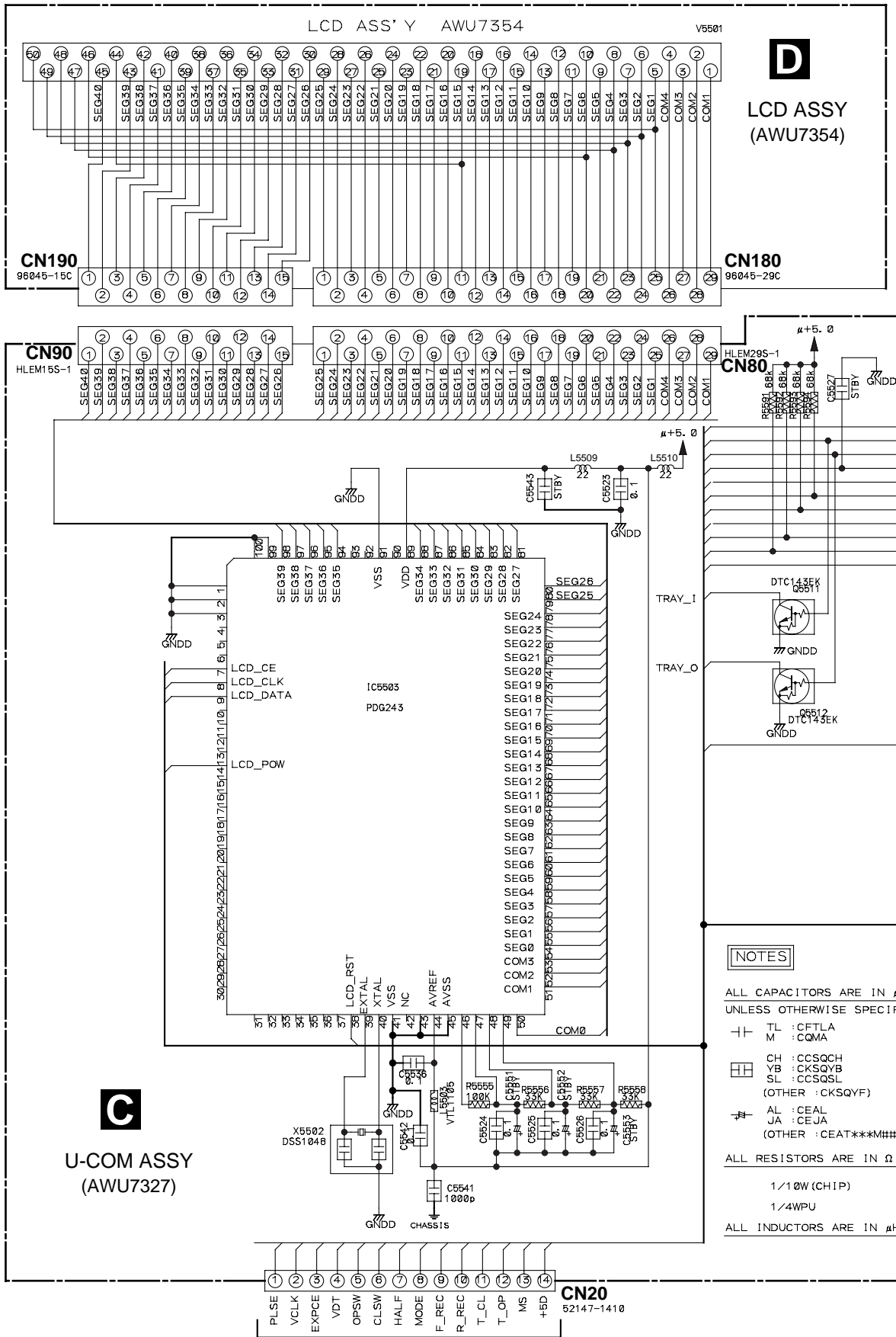

**K** CN150

**CN50**  
HELM175-1

**B** J60

**J60**  
D20PWV1 305E

**CN105**  
HELM23R-1

**E** CN5

**F** CN110

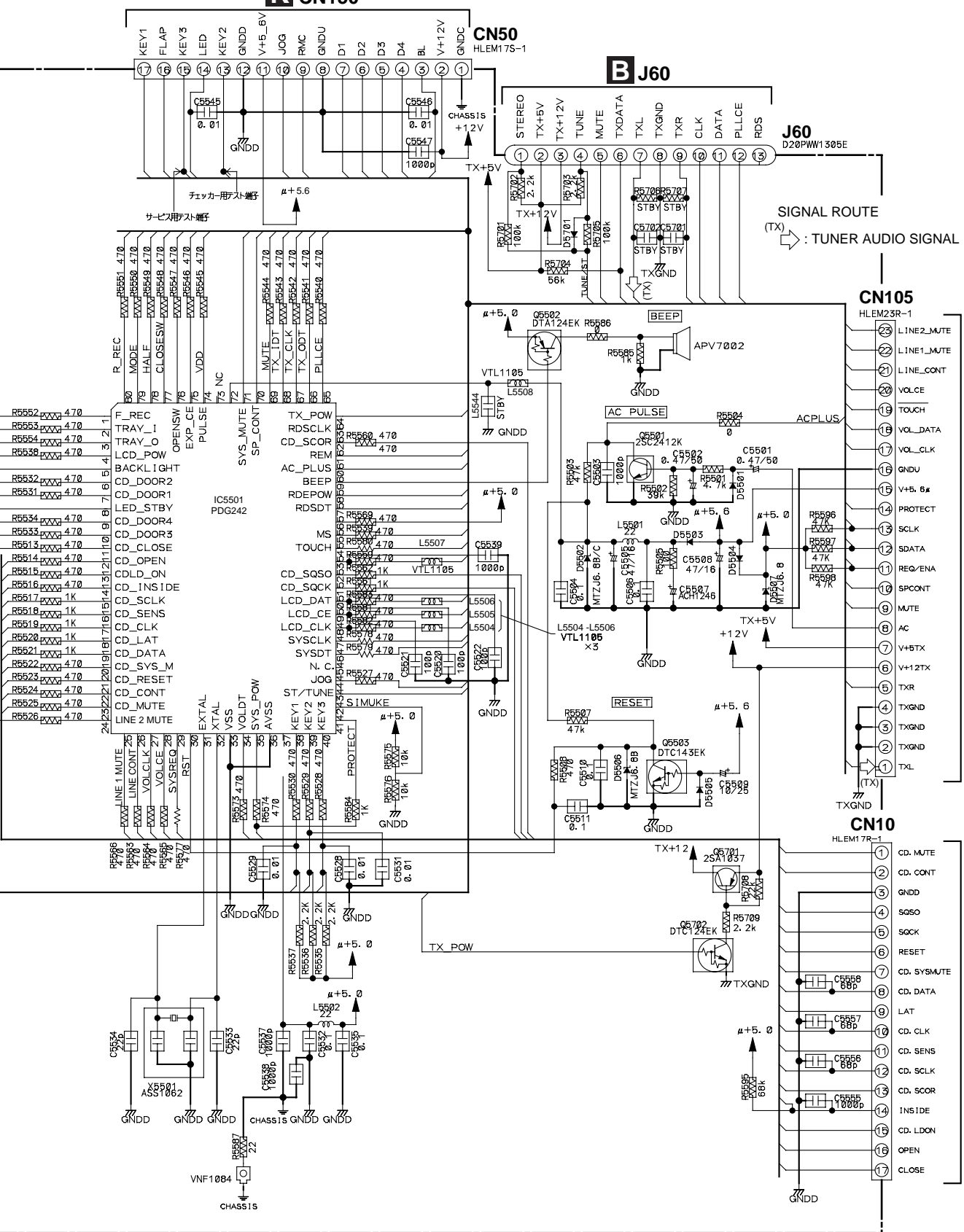

# XC-IS21T

## 3.5 AF ASSY

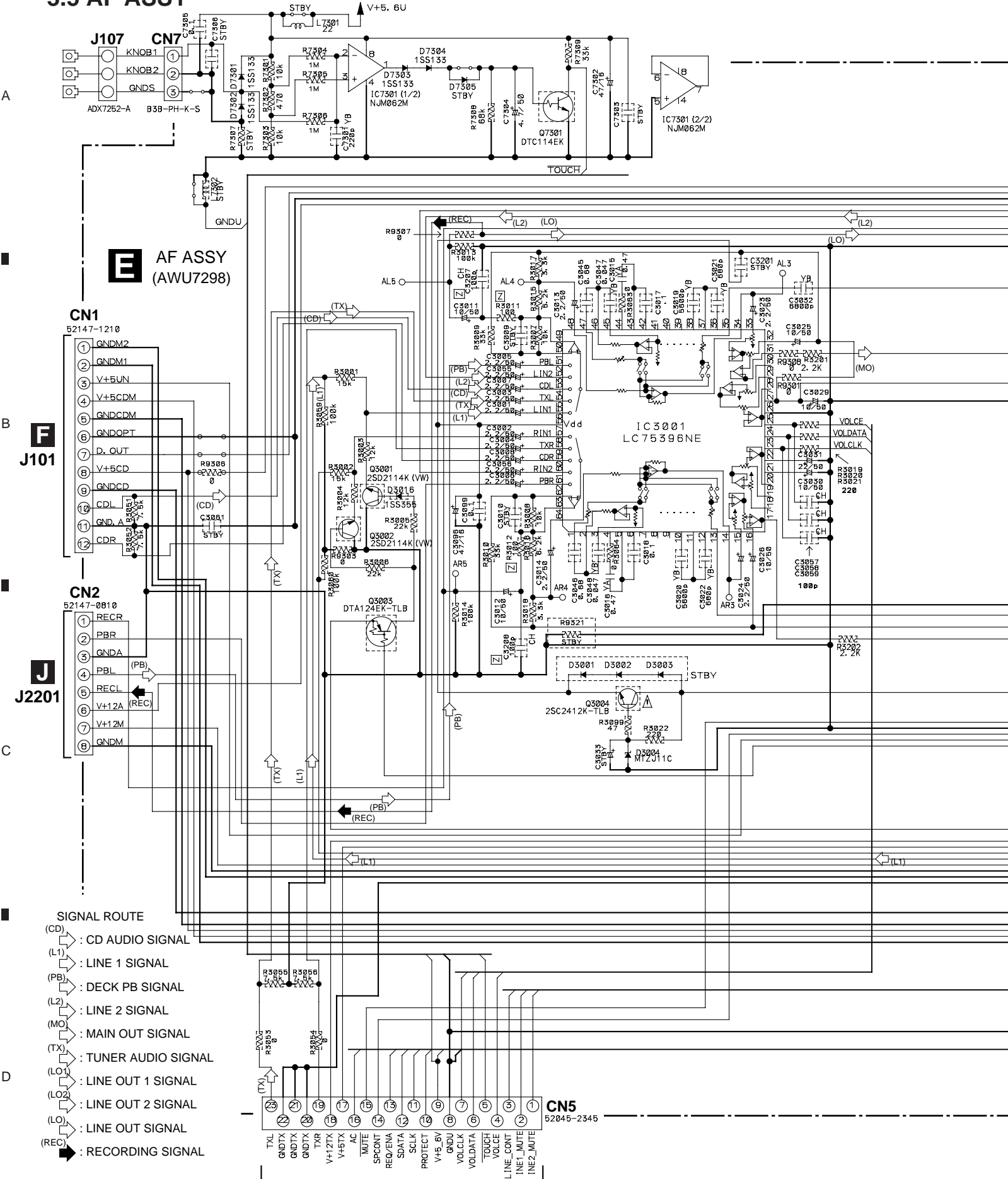

**E** AF ASSY (AWU7298)

**F** J101

**J** J2201

- SIGNAL ROUTE**
- (CD) : CD AUDIO SIGNAL
  - (L1) : LINE 1 SIGNAL
  - (PB) : DECK PB SIGNAL
  - (L2) : LINE 2 SIGNAL
  - (MO) : MAIN OUT SIGNAL
  - (TX) : TUNER AUDIO SIGNAL
  - (LO1) : LINE OUT 1 SIGNAL
  - (LO2) : LINE OUT 2 SIGNAL
  - (LO) : LINE OUT SIGNAL
  - (REC) : RECORDING SIGNAL

**C** CN105



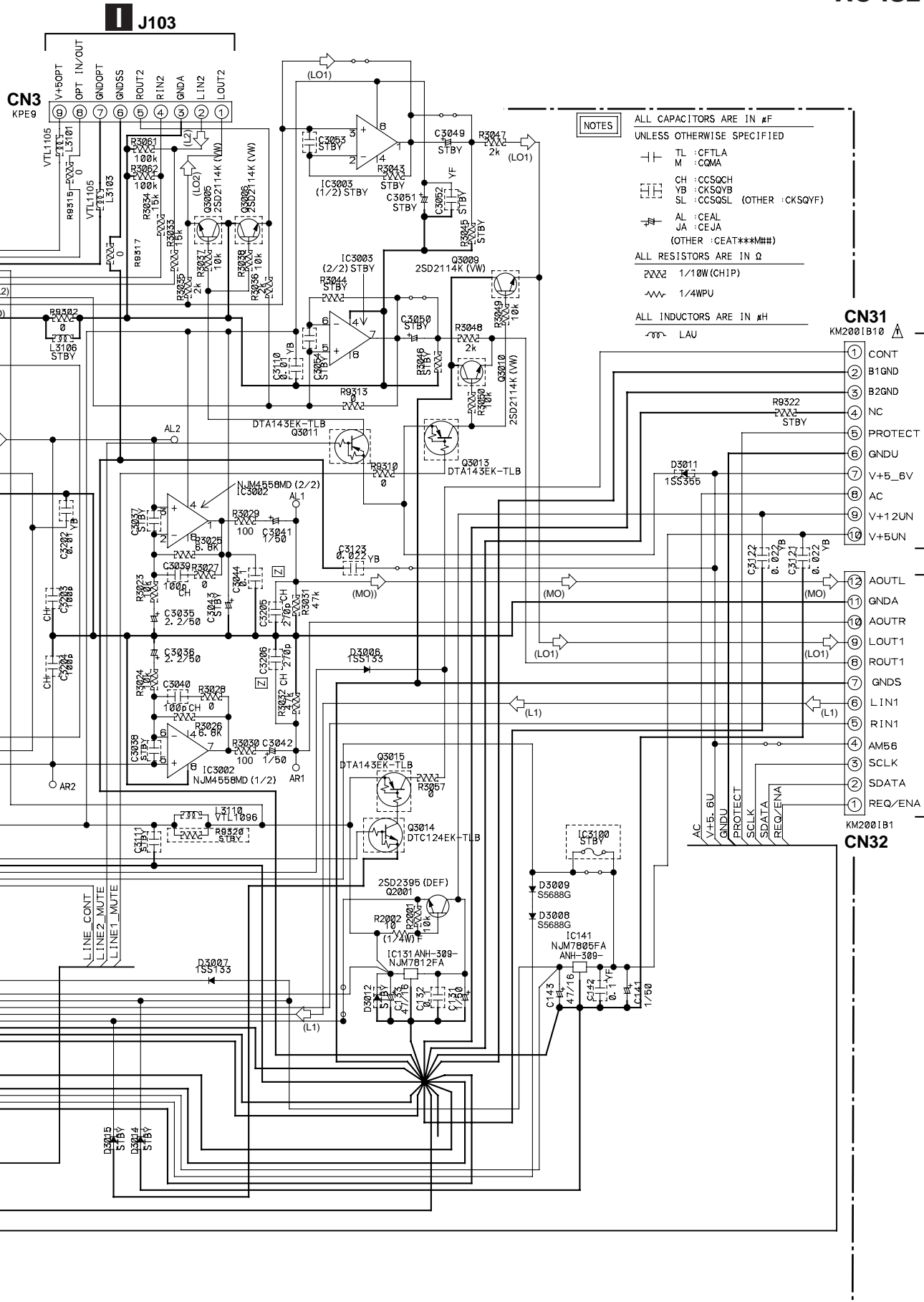

**NOTES**

ALL CAPACITORS ARE IN  $\mu$ F  
UNLESS OTHERWISE SPECIFIED

TL : CFTLA  
M : COMA

CH : CCSQCH  
YB : CKSQYB  
SL : CCSQSL (OTHER : CKSQVF)

AL : CEAL  
JA : CEJA  
(OTHER : CEAT\*\*KMH#)

ALL RESISTORS ARE IN  $\Omega$

1/10W (CHIP)

1/4WPU

ALL INDUCTORS ARE IN  $\mu$ H

LAU

- CN31**  
KM2001B10
- 1 CONT
  - 2 B1GND
  - 3 B2GND
  - 4 NC
  - 5 PROTECT
  - 6 GNDU
  - 7 V+5\_VB
  - 8 V+12UN
  - 9 V+5UN
- CN131**
- 13 AOUTL
  - 14 GND4
  - 15 AOUTR
  - 16 LOU1
  - 17 ROUT1
  - 18 GND5
  - 19 LIN1
  - 20 RIN1
  - 21 AM56
  - 22 SCLK
  - 23 SDATA
  - 24 REQ/ENA
- CN32**  
KM2001B1
- AC
  - V+5\_VB
  - GNDU
  - PROTECT
  - SCLK
  - SDATA
  - REQ/ENA

A

B

C

D

3.6 CD and CD MOTOR ASSYS

NOTES

ALL CAPACITORS ARE IN  $\mu$ F  
UNLESS OTHERWISE SPECIFIED

- TL : CFTLA
- M : CQMA
- CH : CCSQCH
- YB : CKSQYB
- SL : CCSQSL
- (OTHER : CKSQYF)
- AL : CEAL
- JA : CEJA
- (OTHER : CEAT\*\*\*M#H#)

ALL RESISTORS ARE IN  $\Omega$

- $\square$  1/10W (CHIP)
- $\sim$  1/4WPU
- ALL INDUCTORS ARE IN  $\mu$ H
- LAU

**F** CD ASSY  
(AWU7305)

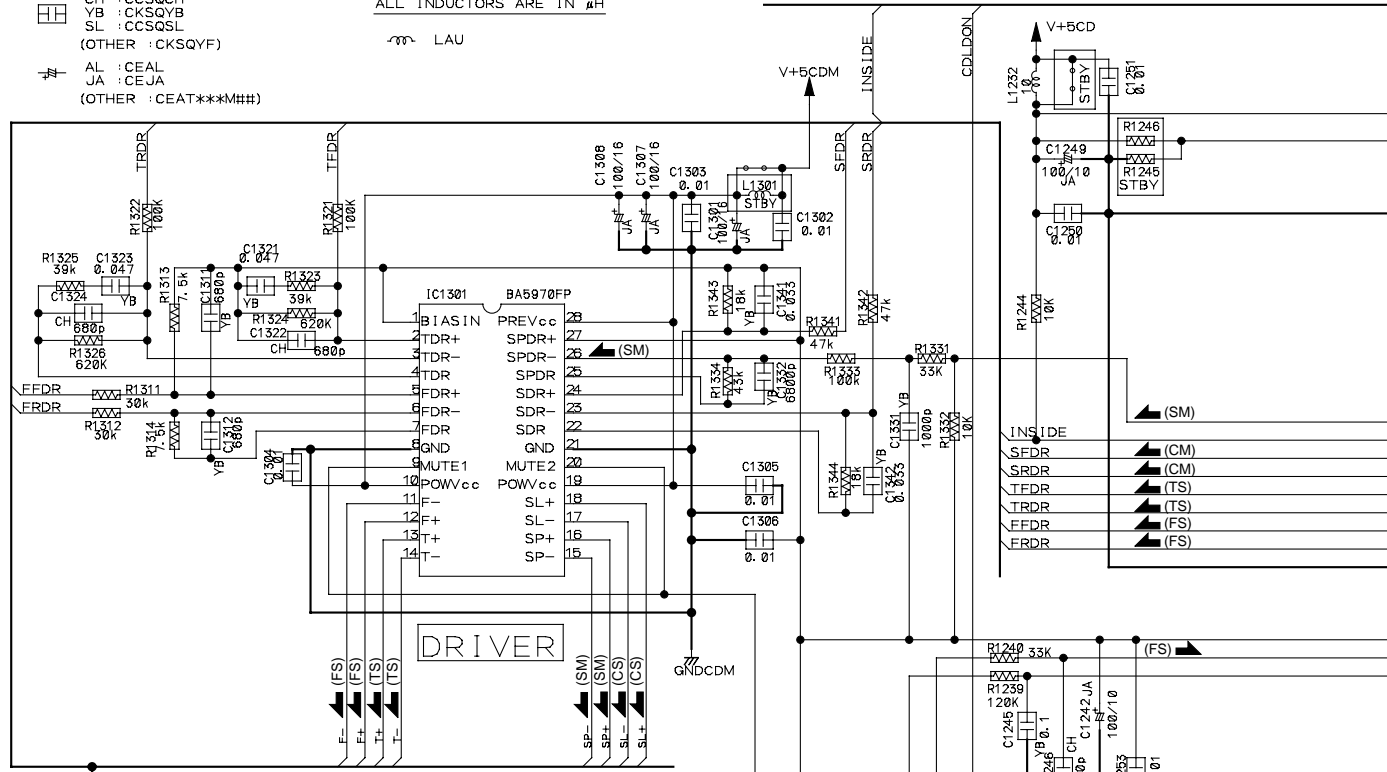

Note: The encircled numbers denote measuring point in the schematic diagram.

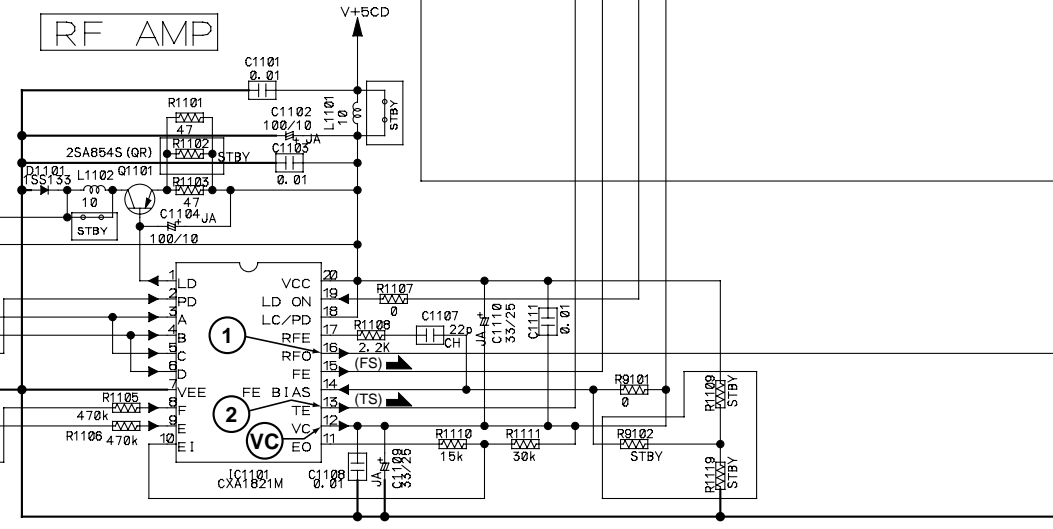
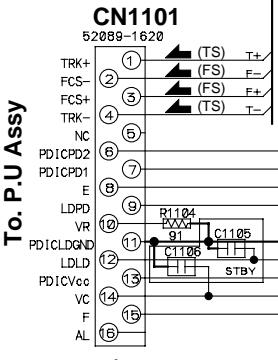
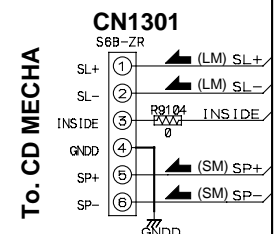
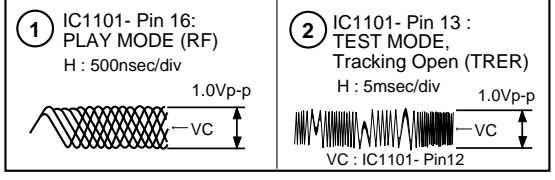

SIGNAL ROUTE

- $\square$  : CD AUDIO SIGNAL ROUTE (SM) : SPINDLE MOTOR ROUTE
- (FS) : FOCUS SERVO LOOP LINE (CM) : CARRIAGE MOTOR ROUTE
- (TS) : TRACKING SERVO LOOP LINE (LM) : LOADING MOTOR ROUTE



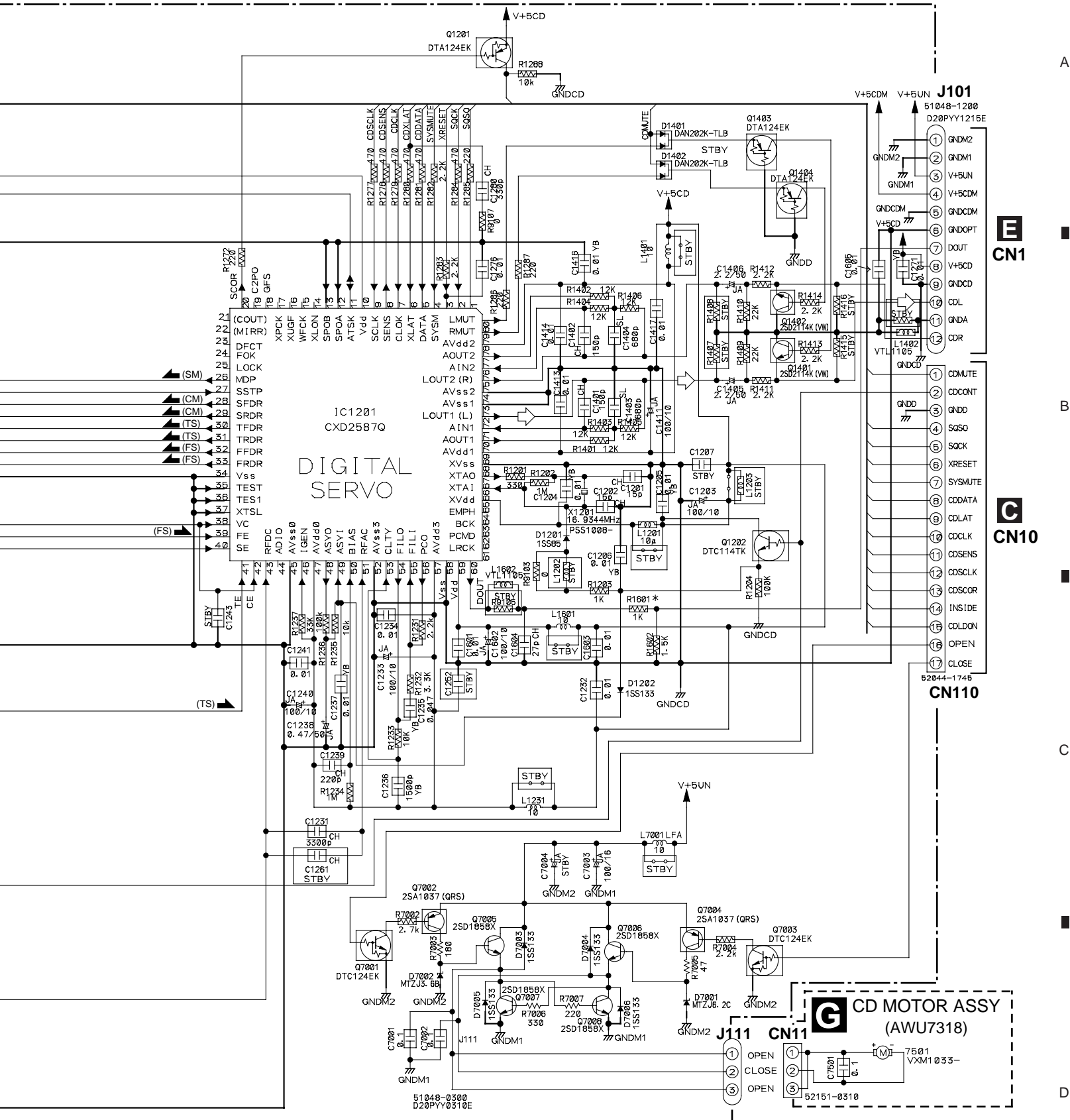

A

B

C

D

**E** CN1

**C** CN10

**G** CN11



### 3.7 R-TERMINAL and F-TERMINAL ASSYS

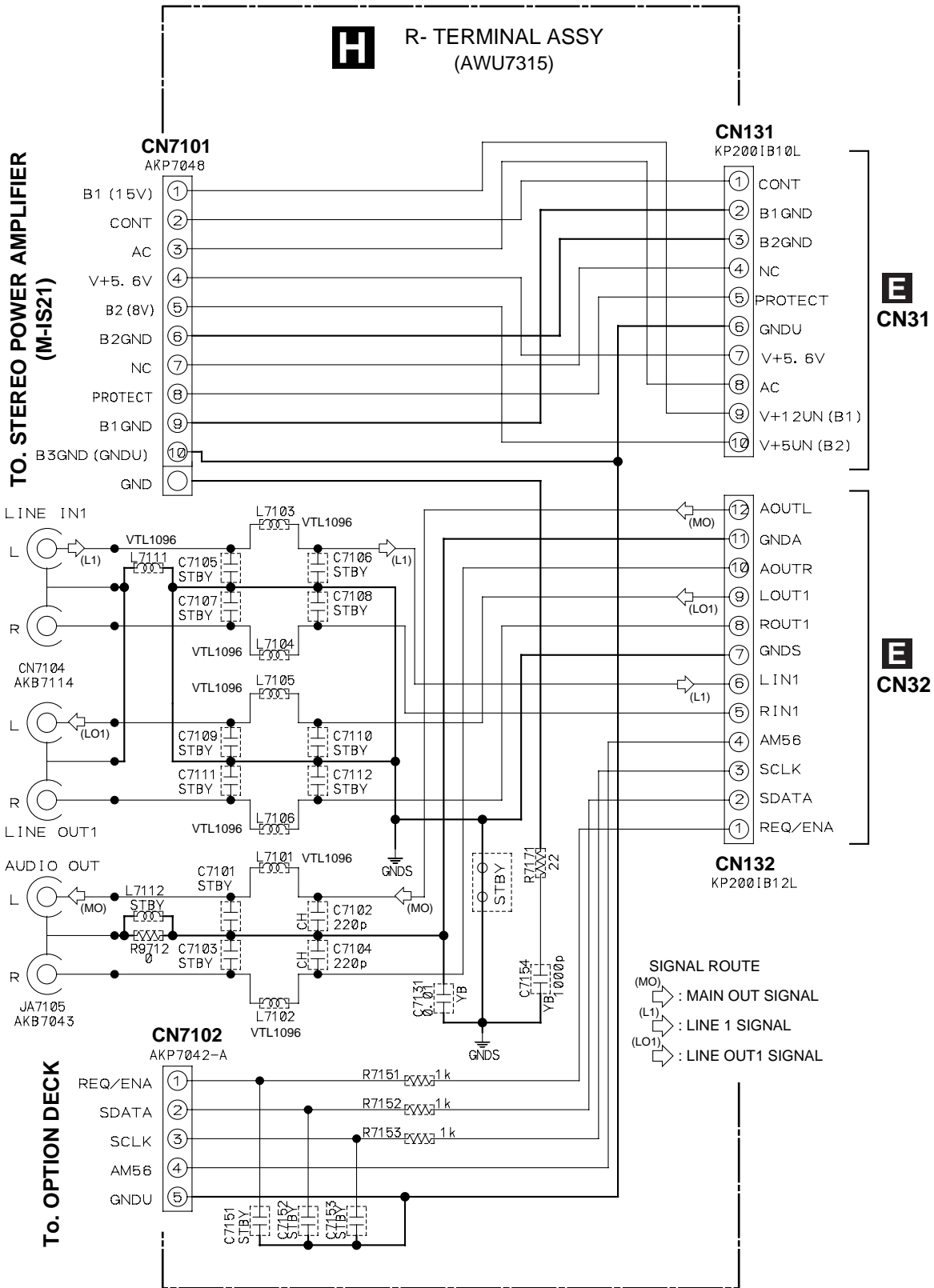

NOTES

ALL RESISTORS ARE IN  $\Omega$  ALL CAPACITORS ARE IN  $\mu F$   
 UNLESS OTHERWISE SPECIFIED

1/10W (CHIP)  
 1/4WPU  
 ALL INDUCTORS ARE IN  $\mu H$

LAU

TL : CFTLA  
 M : CQMA

CH : CCSQCH  
 YB : CKSQYB  
 SL : CCSQSL  
 (OTHER : CKSQYF)

AL : CEAL  
 JA : CEJA  
 (OTHER : CEAT\*\*\*M##)

F- TERMINAL ASSY (AWU7311)

SIGNAL ROUTE  
 : LINE2 SIGNAL  
 : LINE OUT2 SIGNA

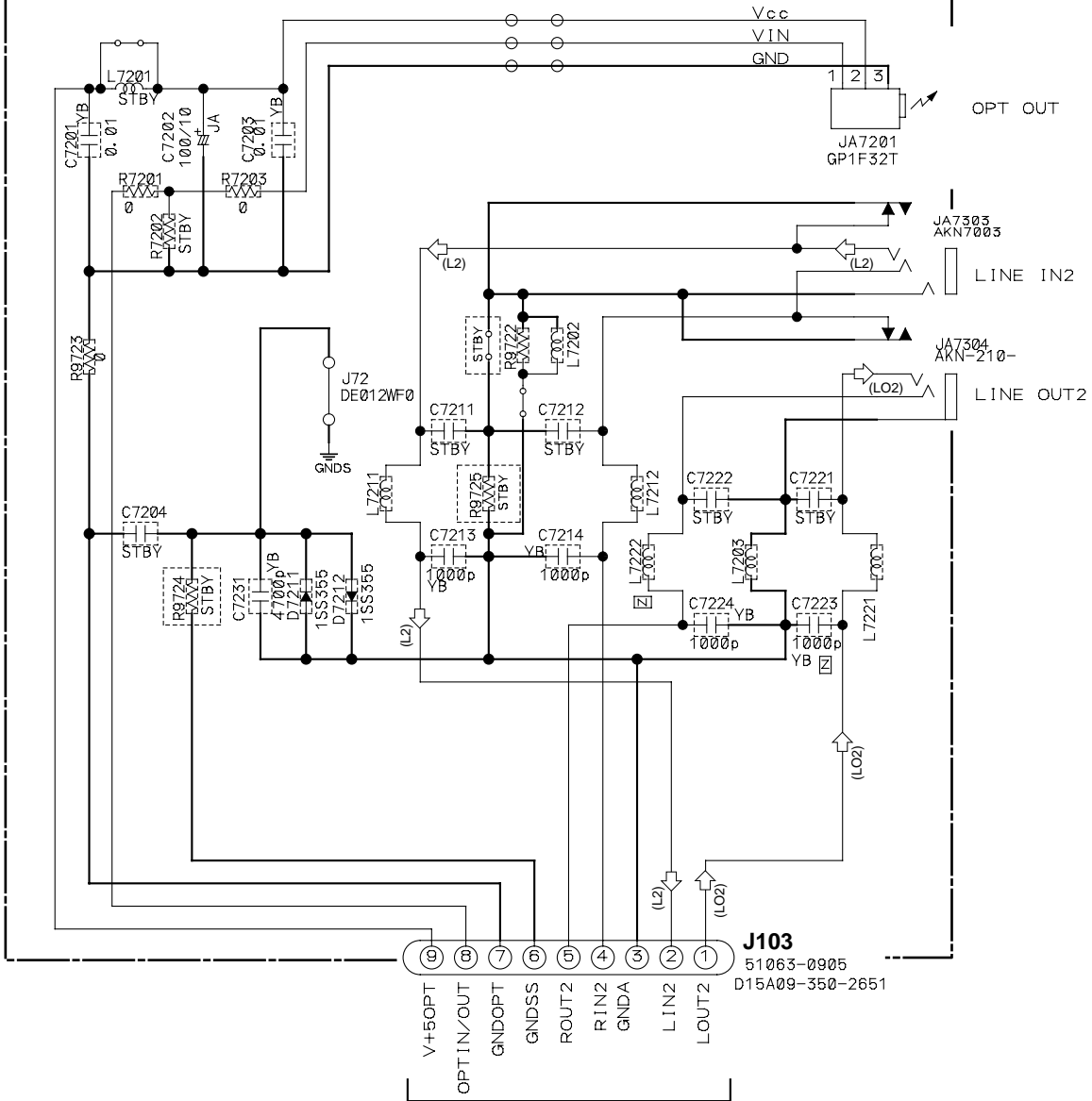

■ CN3



3.8 DECK ASSY

A

B

C

D

**J** DECK ASSY (AWU7334)

PB AMP

NOTES

- ALL CAPACITORS ARE IN  $\mu F$  UNLESS OTHERWISE SPECIFIED
- TL : CFTLA
  - M : CGMA
  - CH : CCSQCH
  - YB : CKSQYB
  - SL : CCSQSL
  - (OTHER : CKSQYF)
  - AL : CEAL
  - JA : CEJA
  - (OTHER : CEAT\*\*\*M###)
- ALL RESISTORS ARE IN  $\Omega$
- $\square$  1/10W (CHIP)
  - $\sim$  1/4WPU
  - ALL INDUCTORS ARE IN  $\mu H$
  - $\sim$  LAU

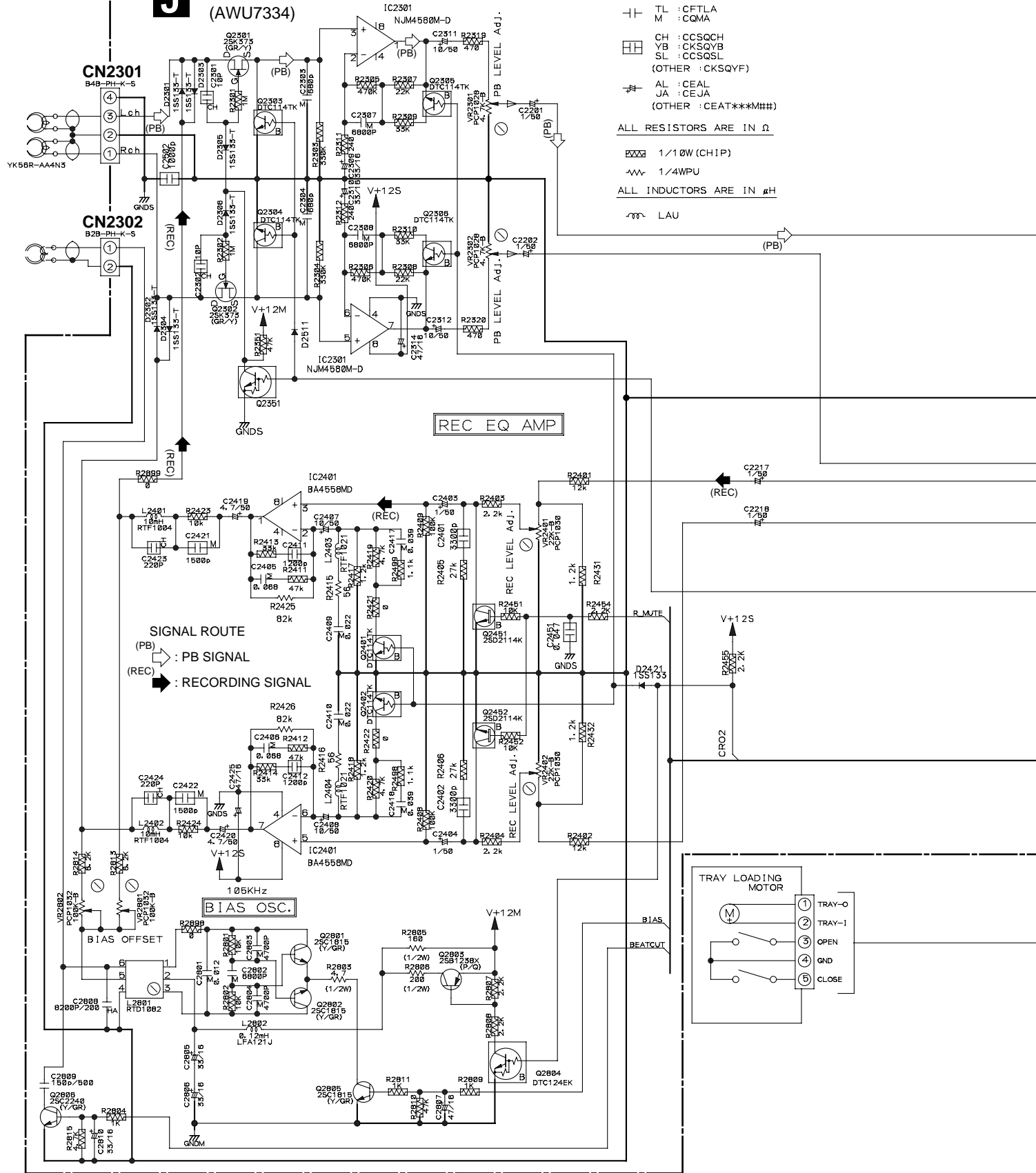

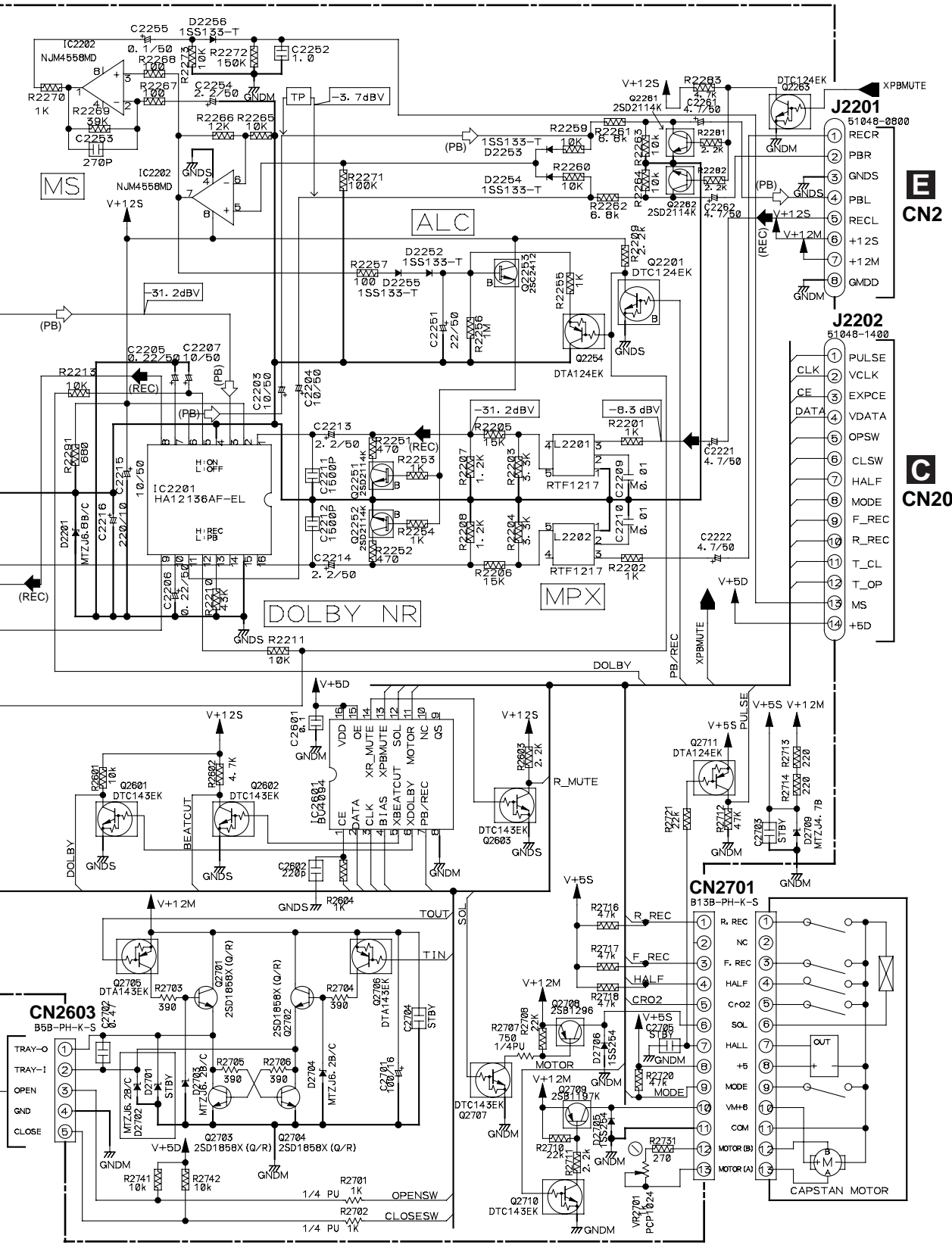

A  
E  
CN2  
B  
C  
CN20  
C  
CN2701  
D

### 3.9 FRONT PANEL, LIGHT-L, CD OPEN SW and CD CLOSE SW ASSYS

A

B

C

D

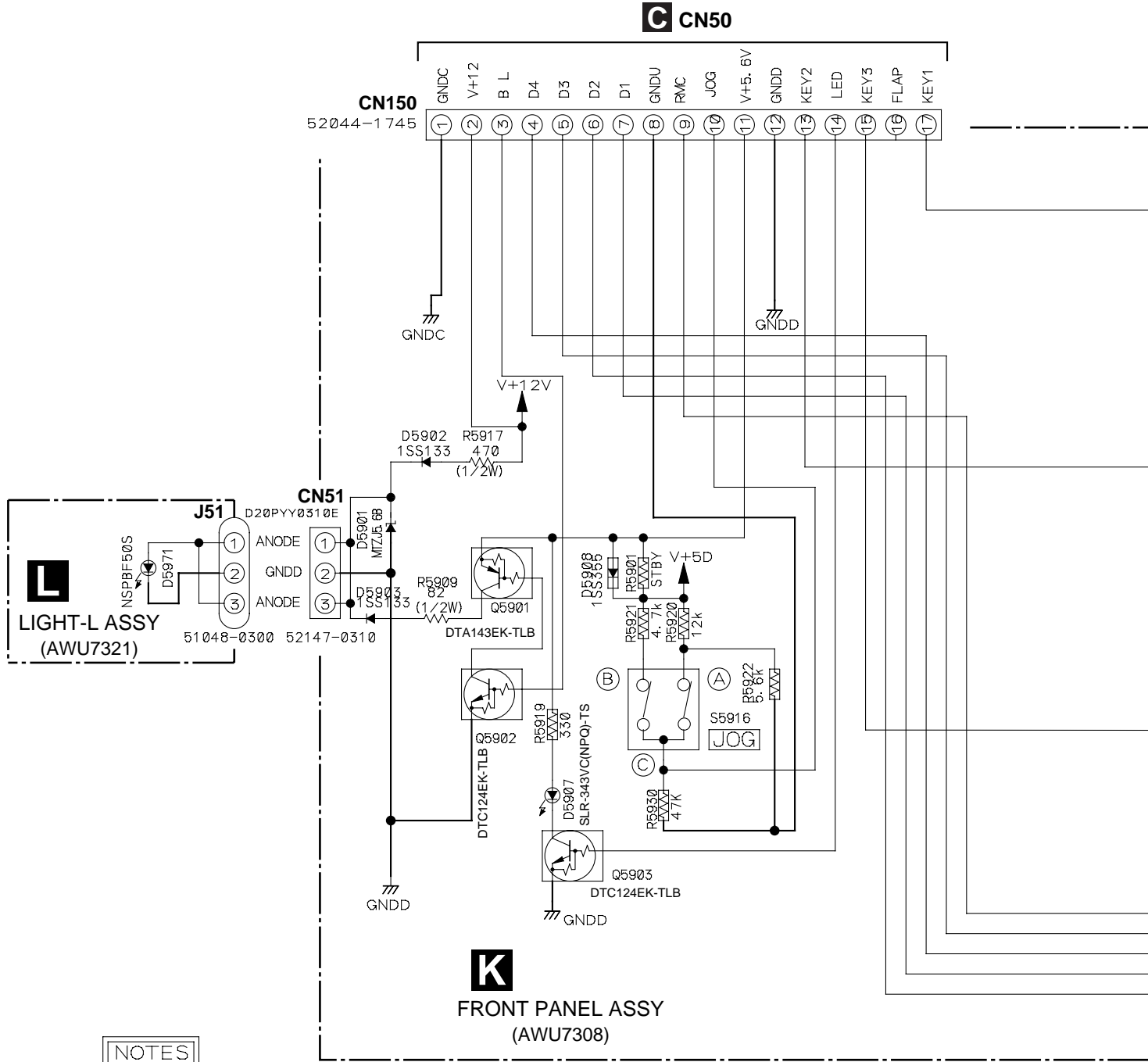

NOTES

ALL CAPACITORS ARE IN  $\mu\text{F}$   
UNLESS OTHERWISE SPECIFIED

TL : CFTLA  
M : CQMA

CH : CCSQCH  
YB : CKSQYB  
SL : CCSQSL  
(OTHER : CKSQYF)

AL : CEAL  
JA : CEJA  
(OTHER : CEAT\*\*M##)

ALL RESISTORS ARE IN  $\Omega$

1/10W (CHIP)  
1/4WPU

ALL INDUCTORS ARE IN  $\mu\text{H}$

LAU



FRONT PANEL ASSY (SW name)



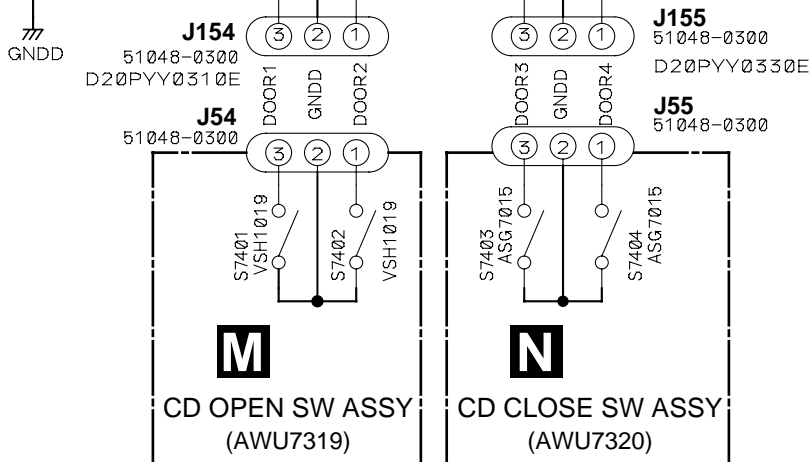
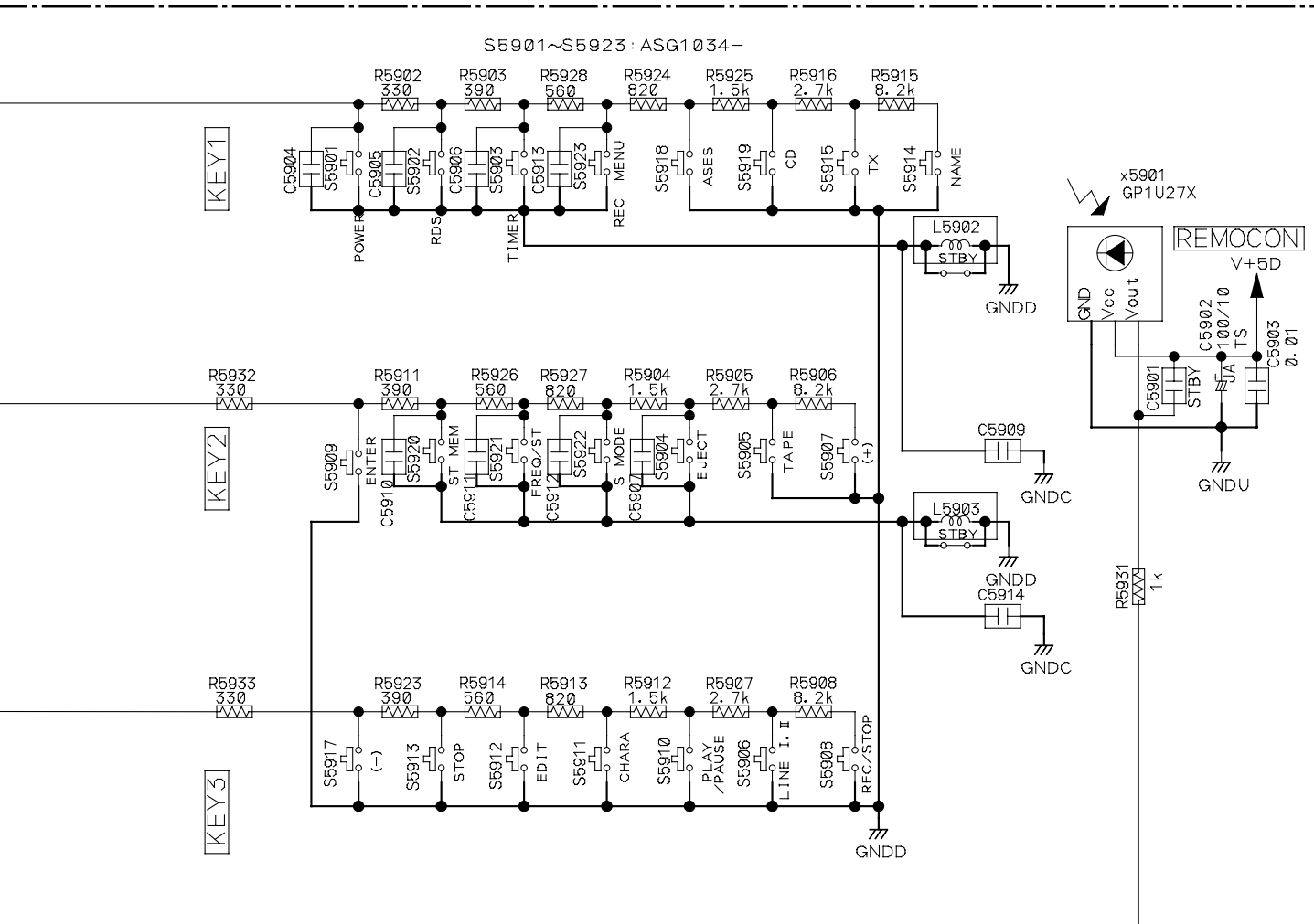





- S5901: POWER (STANDBY/ON)
- S5902: DISPLAY/RDS
- S5903: TIMER REC/WAKE UP
- S5904: TAPE/OPEN/CLOSE
- S5905: TAPE
- S5906: LINE1, 2
- S5907: ◀◀/TUNING+
- S5908: REC/STOP
- S5909: TREBLE
- S5910: PLAY/PAUSE
- S5911: ST.WIDE
- S5912: BASS
- S5913: STOP
- S5914: BALANCE
- S5915: TUNER
- S5916: VOLUME/JOG
- S5917: ▶▶/TUNING-
- S5918: BALANCE
- S5919: CD
- S5920: STATION MEMORY
- S5921: FREQ/STATION
- S5922: REVERSE
- S5923: DOLBY NR ON/OFF

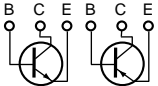

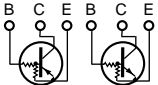
## 4. PCB CONNECTION DIAGRAM

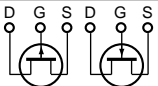
### NOTE FOR PCB DIAGRAMS :

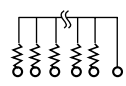
1. Part numbers in PCB diagrams match those in the schematic diagrams.
2. A comparison between the main parts of PCB and schematic diagrams is shown below.

Symbol In PCB Diagrams	Symbol In Schematic Diagrams	Part Name
		Transistor
		Transistor with resistor
		Field effect transistor
		Resistor array
		3-terminal regulator

3. The parts mounted on this PCB include all necessary parts for several destinations.  
For further information for respective destinations, be sure to check with the schematic diagram.
4. View point of PCB diagrams.

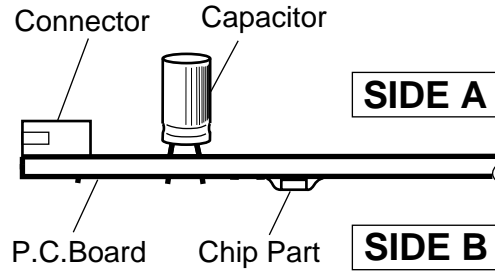

### 4.1 FM/AM TUNER MODULE and TX CONNECT ASSY

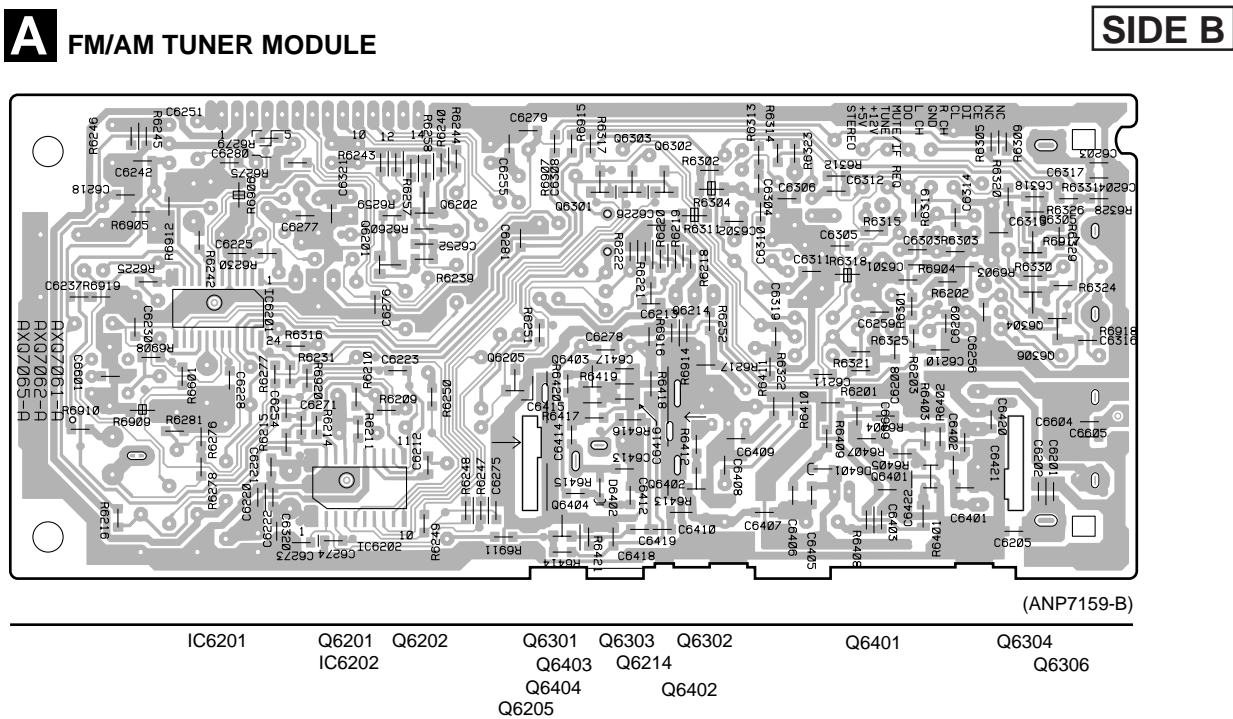
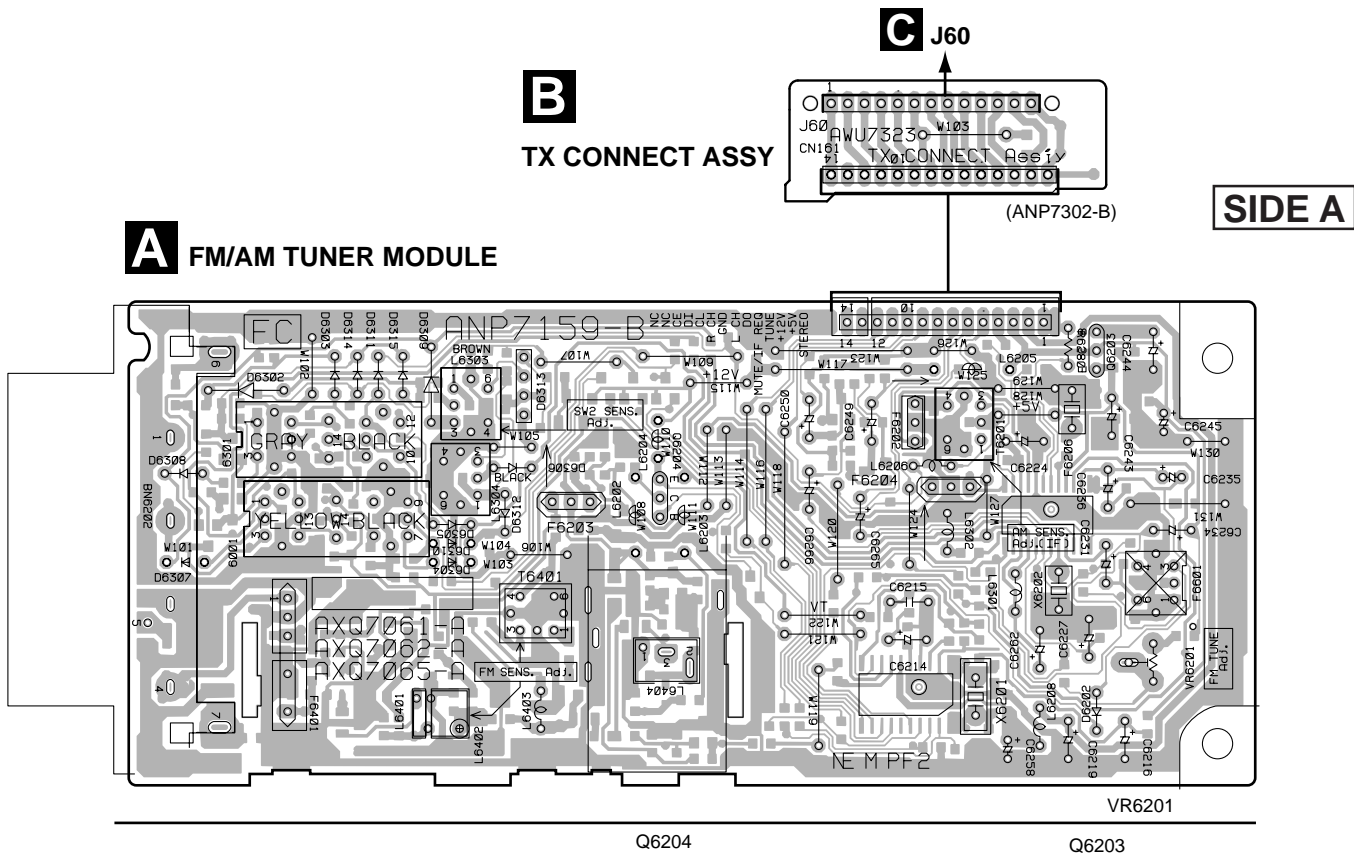

### 4.2 U-COM and LCD ASSYS

#### D LCD ASSY

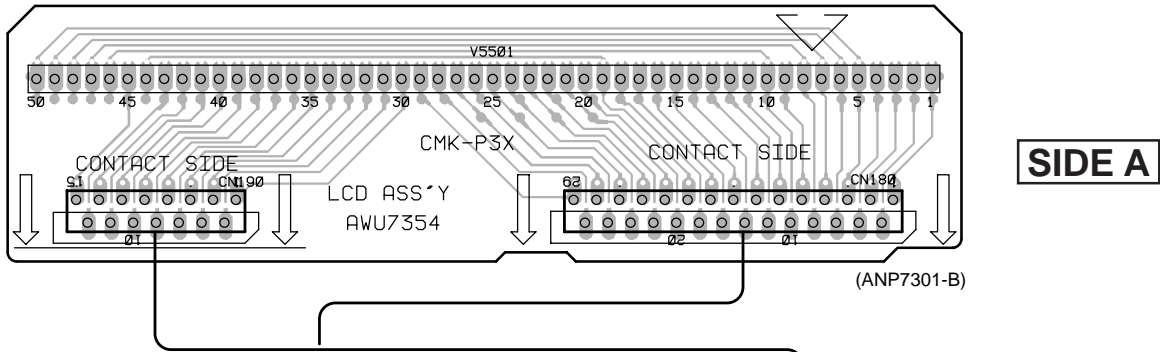

#### C U-COM ASSY

#### K CN150

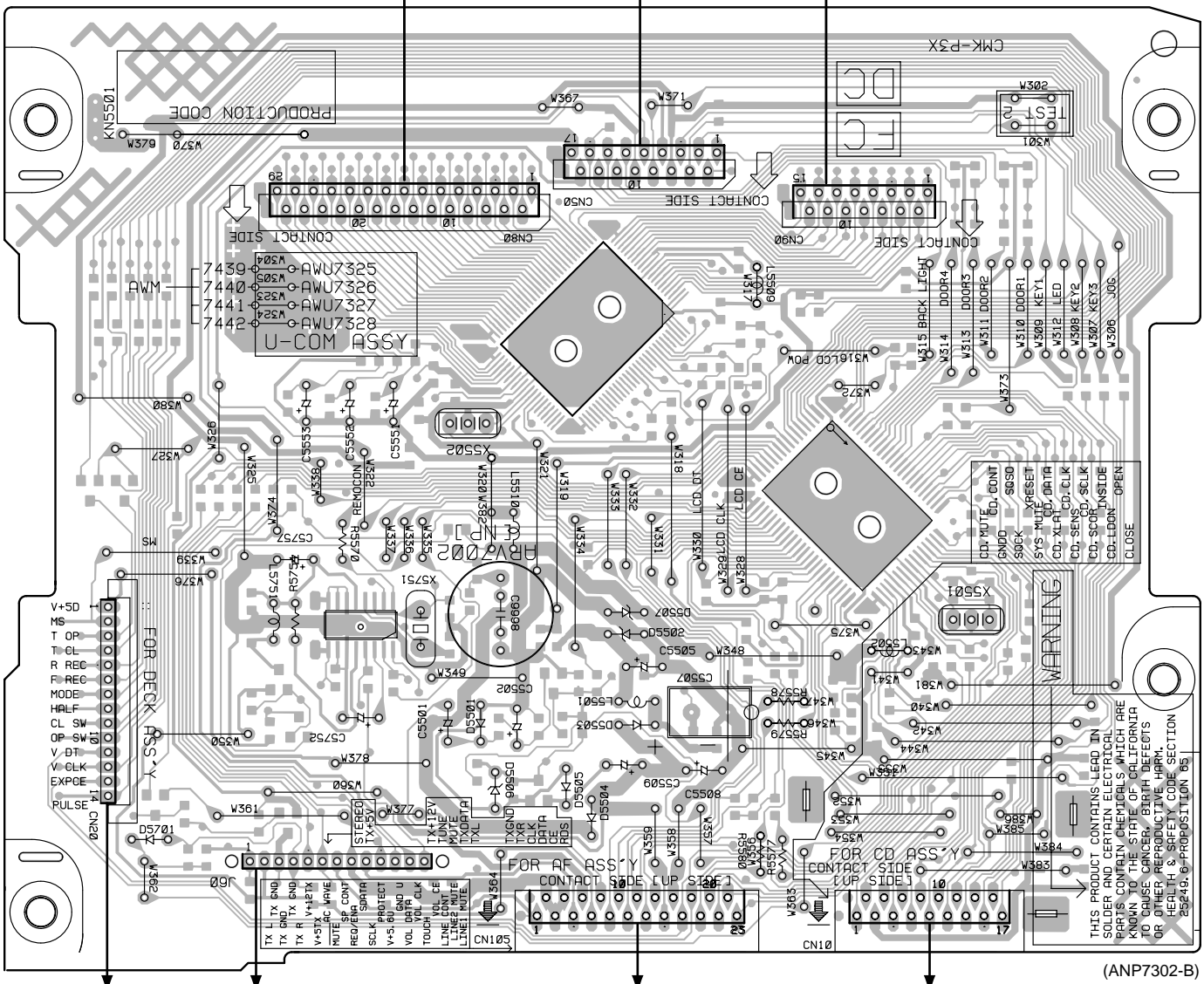

**J** J2202

**B** J60

**E** CN5

**F** CN110

(ANP7302-B)

**WARNING**  
THIS PRODUCT CONTAINS LEAD IN SOLDER AND CERTAIN ELECTRICAL PARTS CONTAIN CHEMICALS WHICH ARE KNOWN TO THE STATE OF CALIFORNIA OR OTHER REPRODUCTIVE HARM OR HEALTH & SAFETY CODE SECTION 25249.6-PROPOSITION 65

SIDE B

C U-COM ASSY

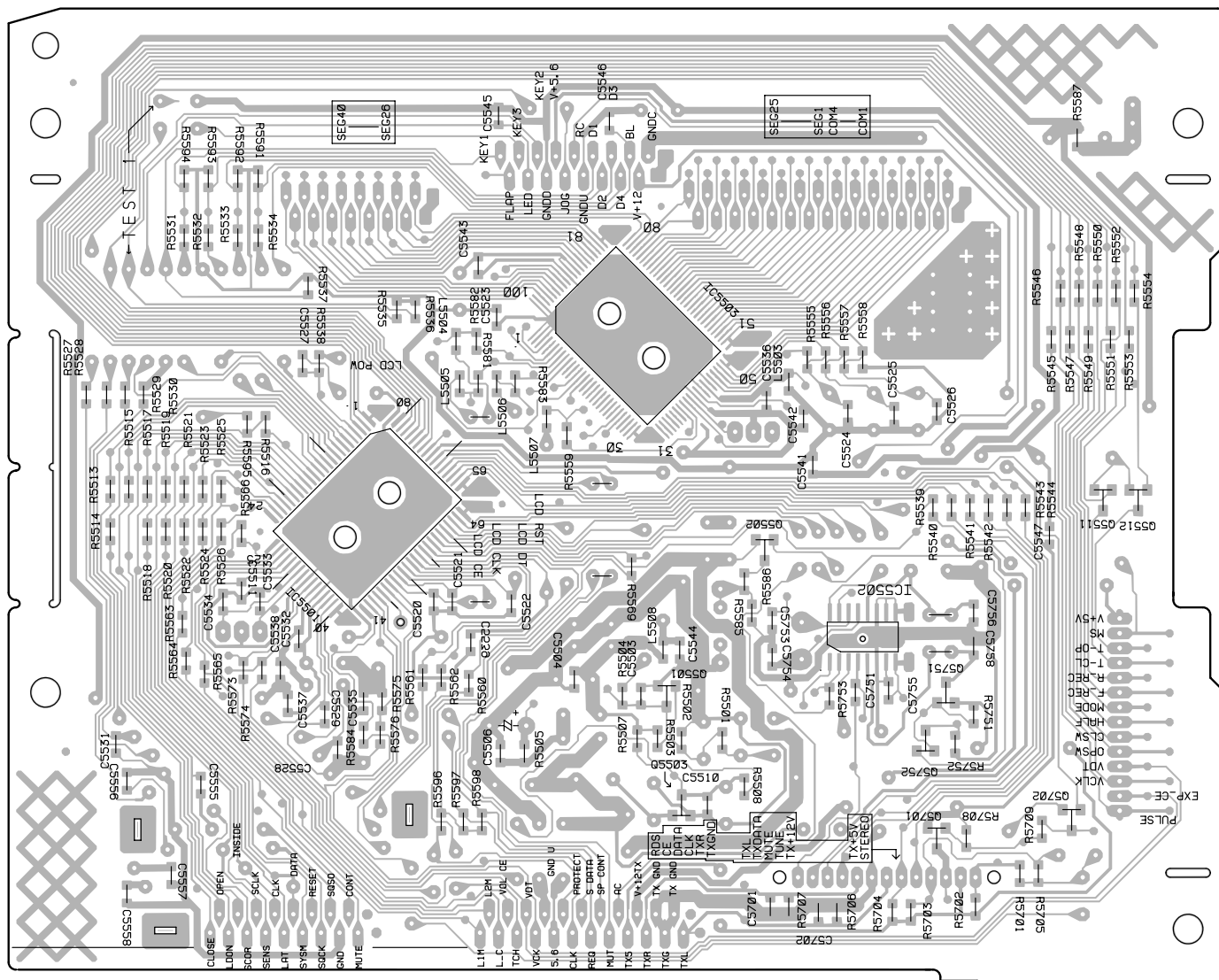

(ANP7302-B)

IC5501 IC5503 IC5502 Q5731 Q5511 Q5512  
 Q5501 Q5502 Q5752 Q5702  
 Q5503 Q5701



4.3 AF, F-TERMINAL and R-TERMINAL ASSYS

A

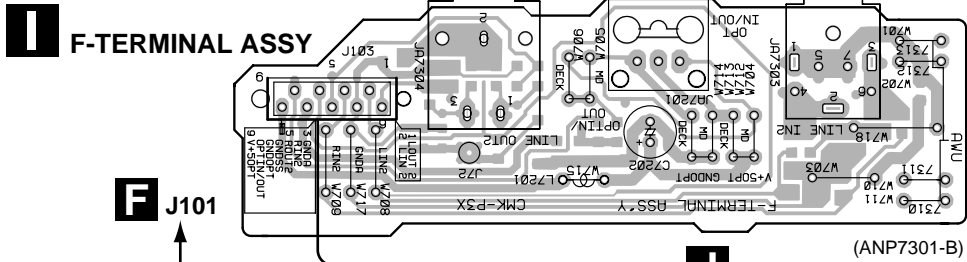

B



C



D

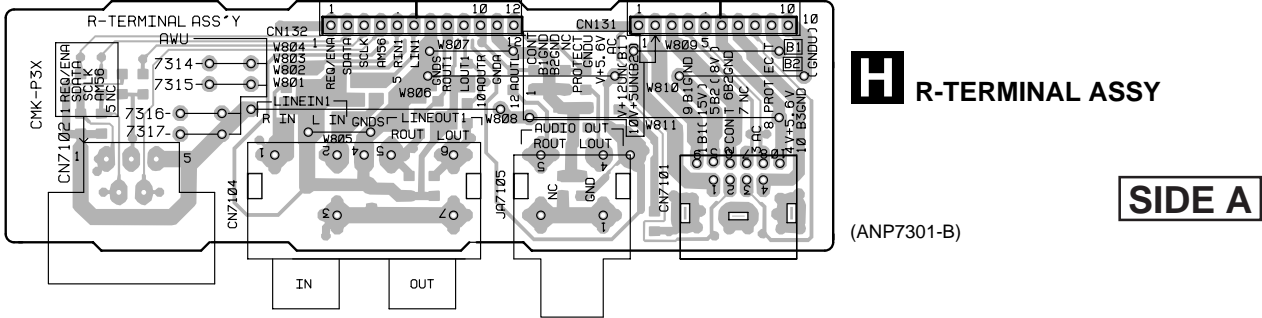

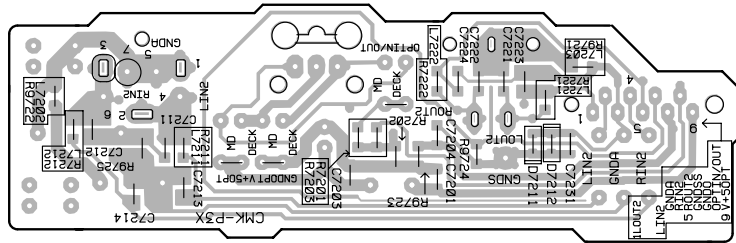

**F-TERMINAL ASSY**

(ANP7301-B)

**AF ASSY**

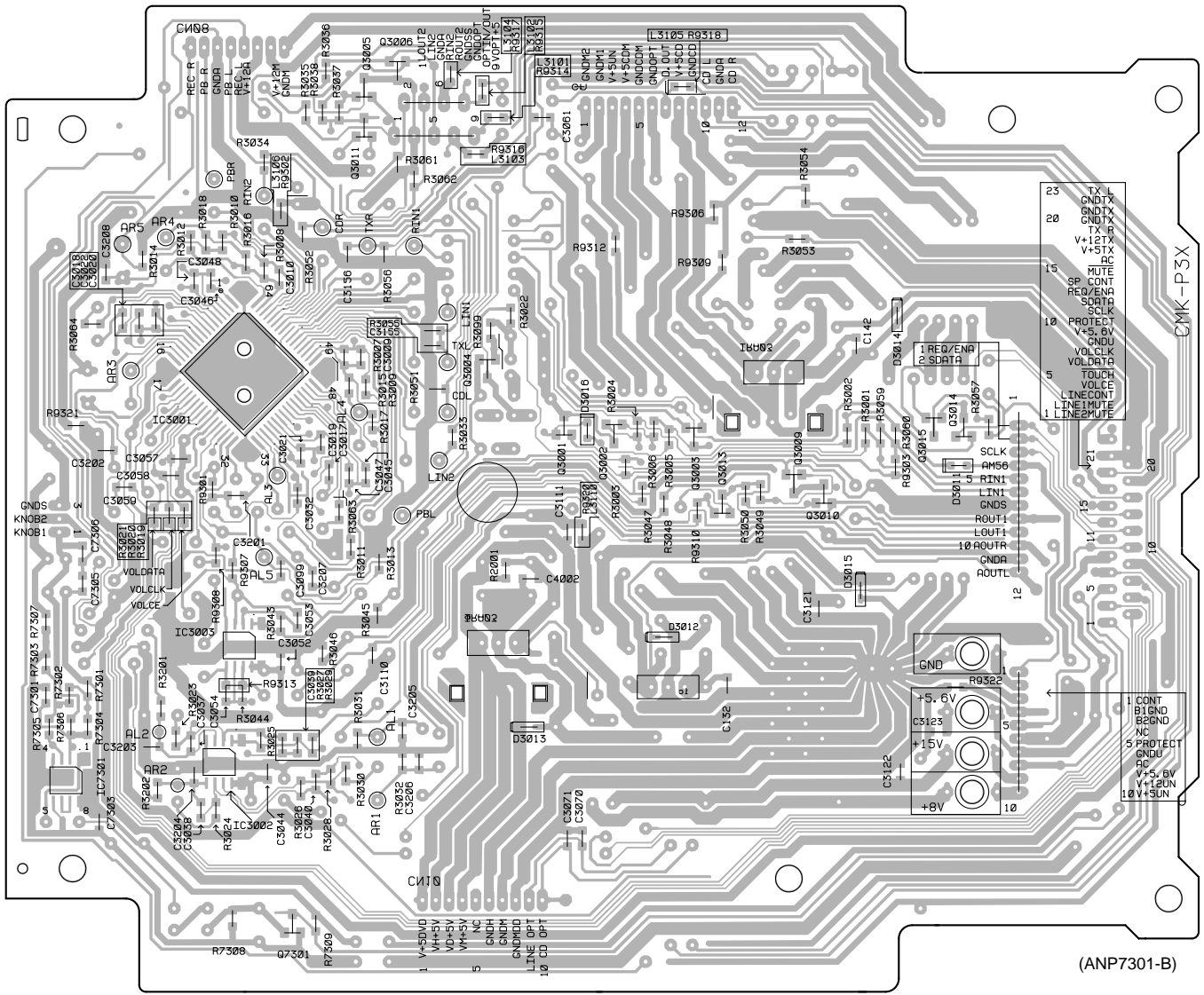

(ANP7301-B)

IC7301 IC3002 Q3005 Q3006 Q3004 Q3009 Q3015 Q3014  
Q3011 Q3001 Q3002 Q3003 Q3013 Q3010

**R-TERMINAL ASSY**

**SIDE B**

(ANP7301-B)

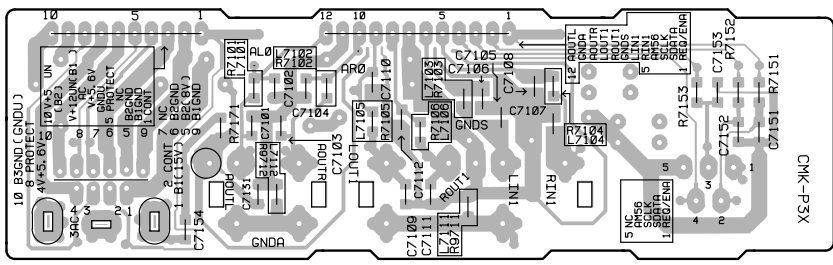





SIDE B

CD ASSY

Q1403 Q1404 Q1402 Q1401  
IC1201 Q1202

IC1301

Q7004  
Q7002 Q7003  
Q7001

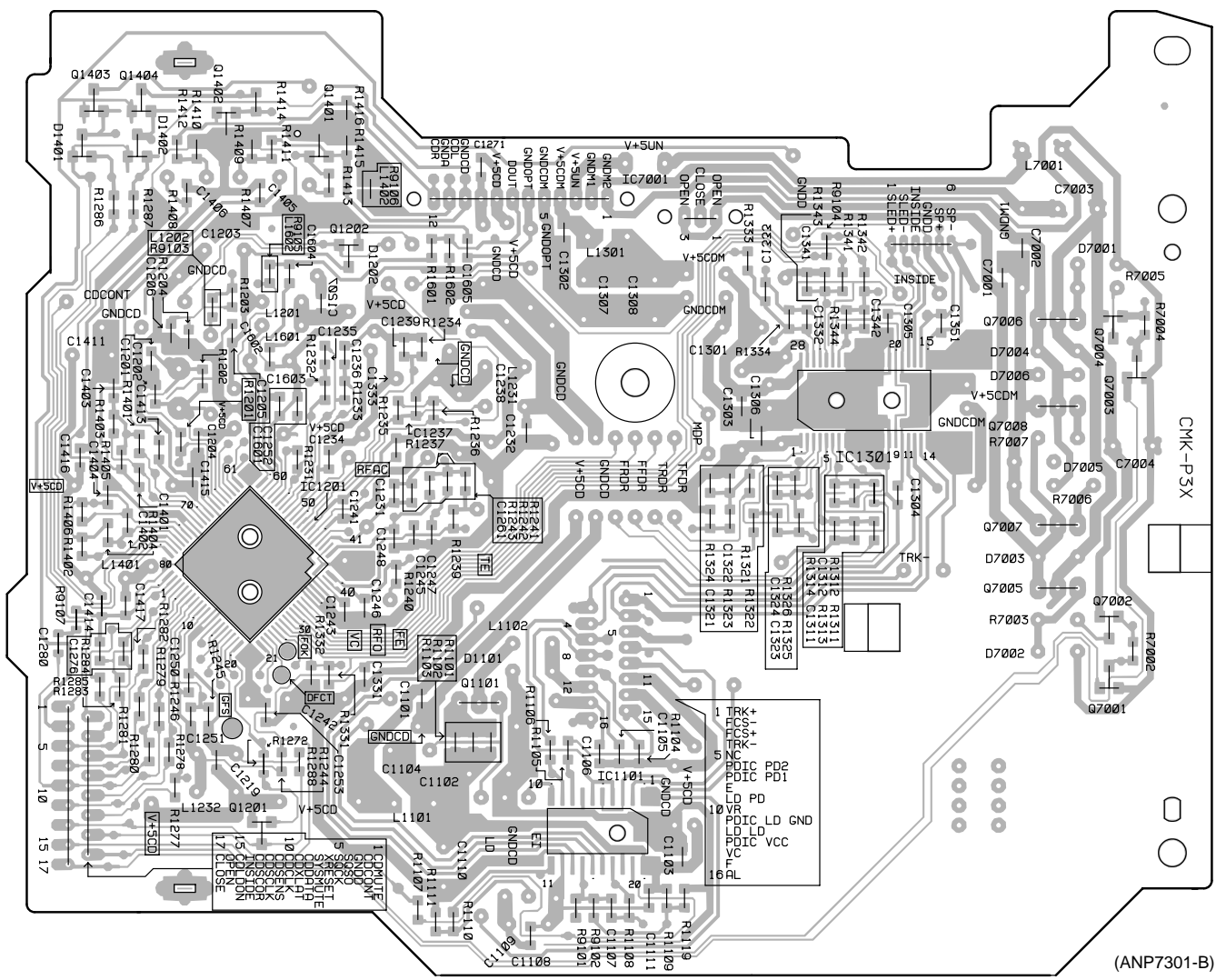

(ANP7301-B)



4.5 DECK ASSY

J DECK ASSY

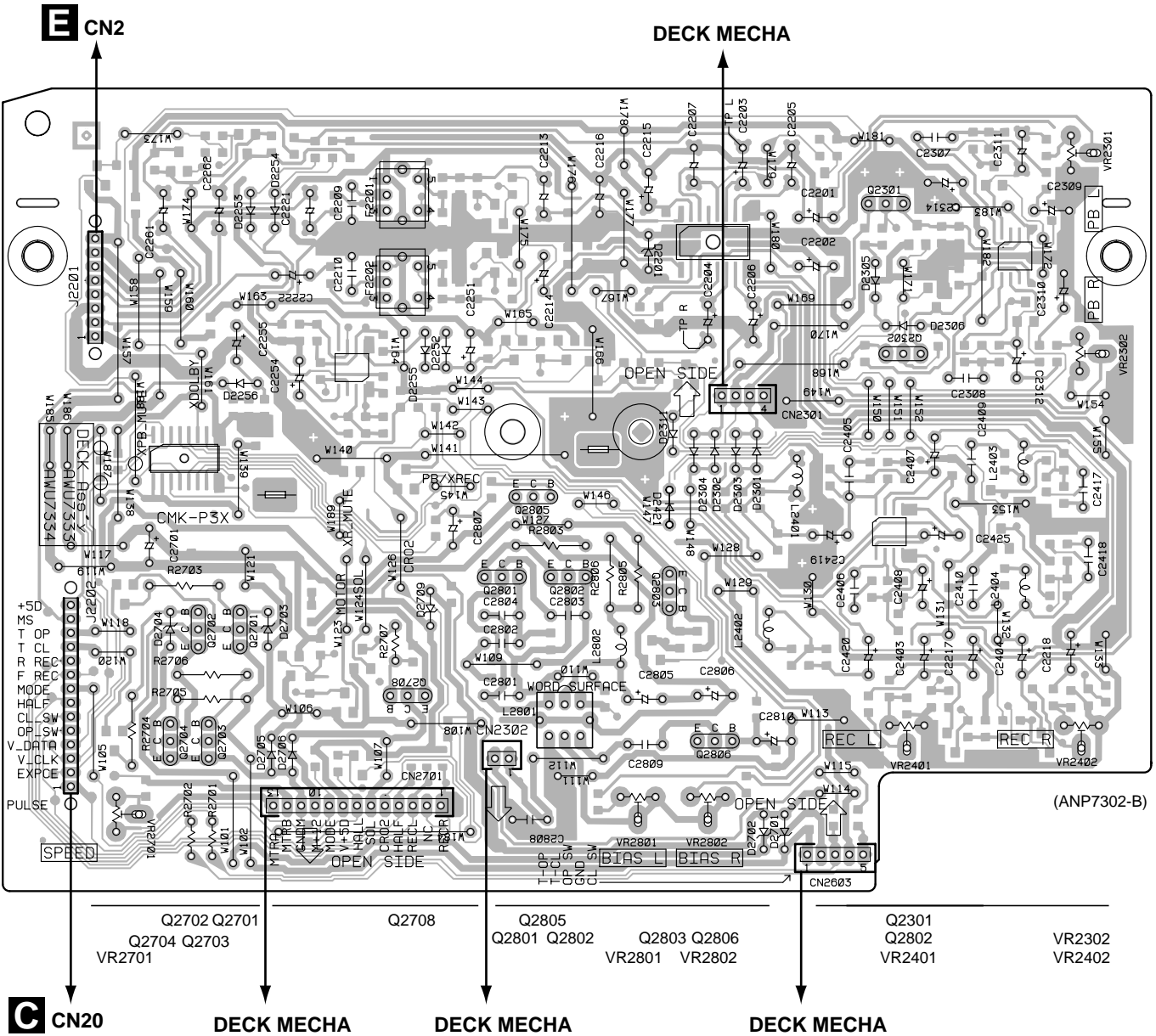

SIDE A

**J** DECK ASSY

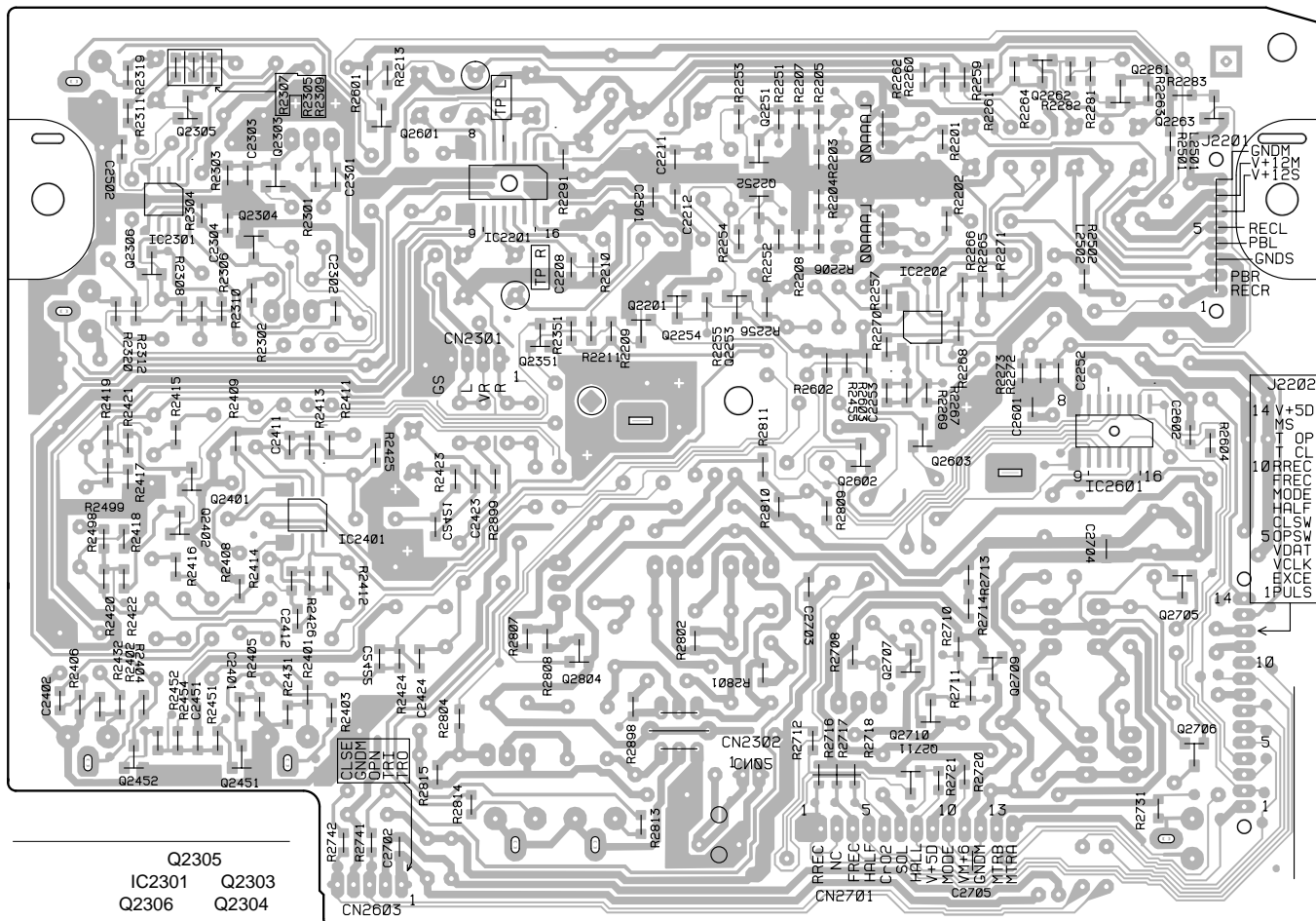

- Q2305
- IC2301 Q2303
- Q2306 Q2304
- Q2401
- Q2402
- Q2452 Q2451
- IC2401

- IC2201 Q2254 Q2253 Q2251
- Q2351 Q2201 Q2252
- Q2602 Q2603
- Q2707 Q2709
- Q2711 Q2710
- IC2202 Q2262 Q2261 Q2263
- IC2601
- Q2705
- Q2706

**SIDE B**

### 4.6 FRONT PANEL, LIGHT-L, CD CLOSE SW and CD OPEN SW ASSYS

#### **K** FRONT PANEL ASSY

#### **M** CD OPEN SW ASSY

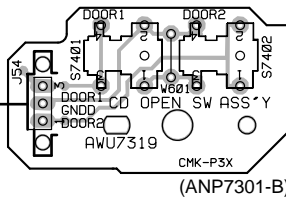

#### **N** CD CLOSE SW ASSY

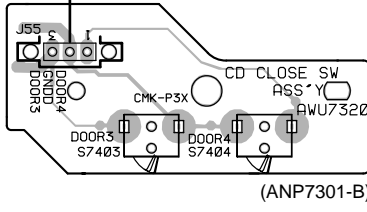

#### **L** LIGHT-L ASSY

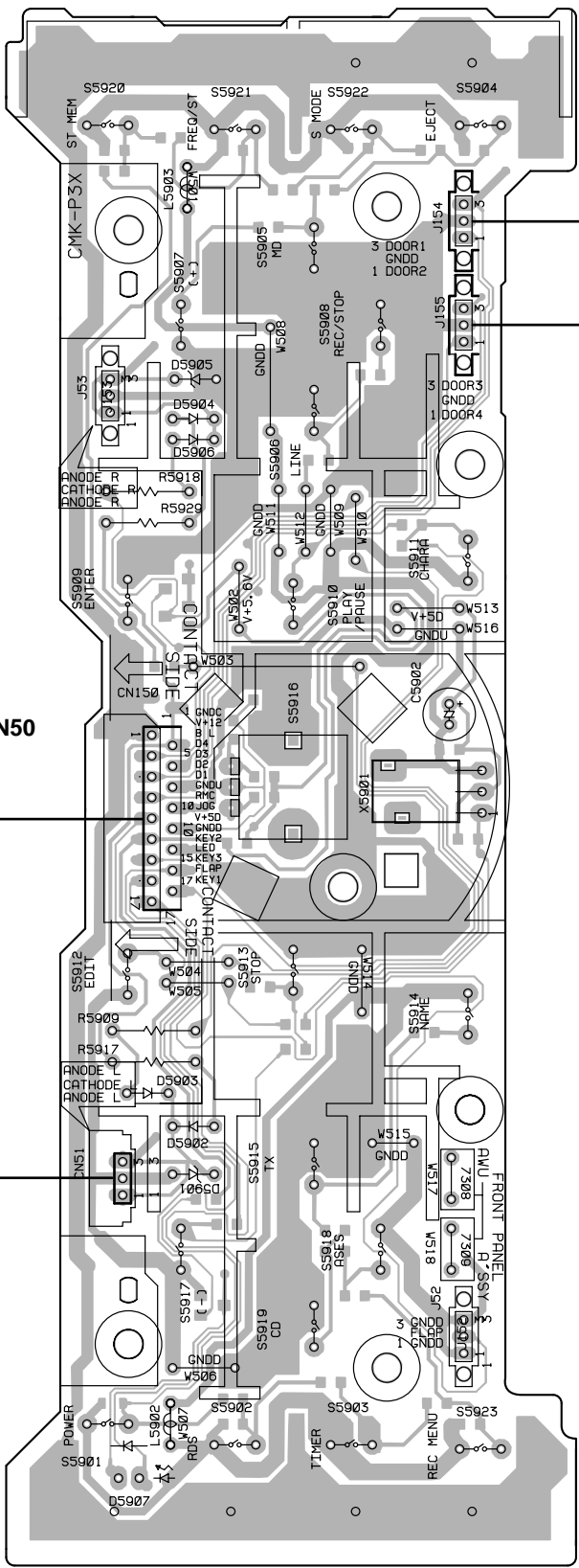
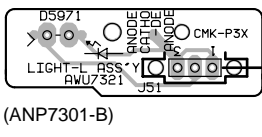

**SIDE A**

(ANP7301-B)

#### **C** CN50

A

B

C

D

**K** FRONT PANEL ASSY

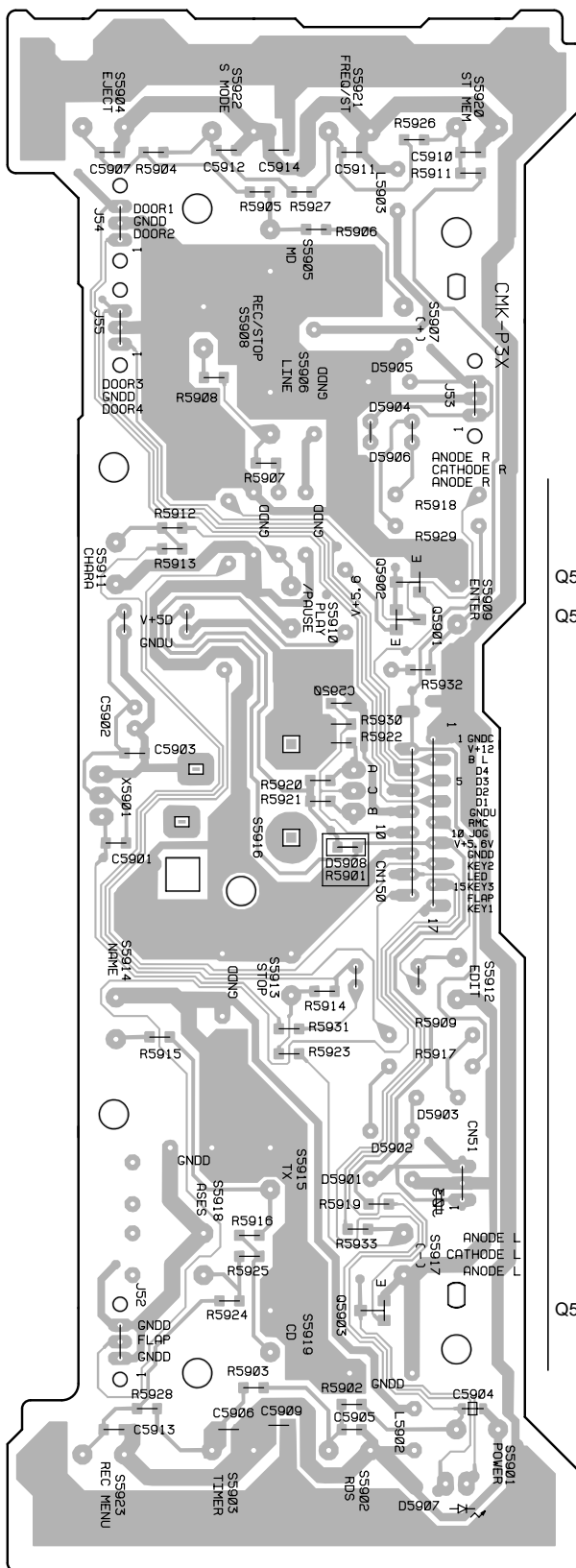

Q5902  
Q5901

Q5903

(ANP7301-B)

**SIDE B**

A  
B  
C  
D



# 5. PCB PARTS LIST

NOTES: ●Parts marked by "NSP" are generally unavailable because they are not in our Master Spare Parts List.

●The Δ mark found on some component parts indicates the importance of the safety factor of the part. Therefore, when replacing, be sure to use parts of identical designation.

●When ordering resistors, first convert resistance values into code form as shown in the following examples.

Ex.1 When there are 2 effective digits (any digit apart from 0), such as 560 ohm and 47k ohm (tolerance is shown by J=5%, and K=10%).

560 Ω	→	56 × 10 <sup>1</sup>	→	561	.....	RD1/4PU	<table border="1"><tr><td>5</td><td>6</td><td>1</td></tr></table>	5	6	1	J
5	6	1									
47k Ω	→	47 × 10 <sup>3</sup>	→	473	.....	RD1/4PU	<table border="1"><tr><td>4</td><td>7</td><td>3</td></tr></table>	4	7	3	J
4	7	3									
0.5 Ω	→	R50	.....			RN2H	<table border="1"><tr><td>R</td><td>5</td><td>0</td></tr></table>	R	5	0	K
R	5	0									
1 Ω	→	1R0	.....			RS1P	<table border="1"><tr><td>1</td><td>R</td><td>0</td></tr></table>	1	R	0	K
1	R	0									

Ex.2 When there are 3 effective digits (such as in high precision metal film resistors).

5.62k Ω	→	562 × 10 <sup>1</sup>	→	5621	.....	RN1/4PC	<table border="1"><tr><td>5</td><td>6</td><td>2</td><td>1</td></tr></table>	5	6	2	1	F
5	6	2	1									

Mark	No.	Description	Part No.	Mark	No.	Description	Part No.
------	-----	-------------	----------	------	-----	-------------	----------

## LIST OF ASSEMBLIES

		FM/AM TUNER MODULE	AXQ7065
NSP		COMPLEX ASSY	AWM7433
		├ AF ASSY	AWU7298
		├ CD ASSY	AWU7305
		├ FRONT PANEL ASSY	AWU7308
		├ F-TERMINAL ASSY	AWU7311
		├ R-TERMINAL ASSY	AWU7315
		├ CD MOTOR ASSY	AWU7318
NSP		├ CD OPEN SW ASSY	AWU7319
NSP		├ CD CLOSE SW ASSY	AWU7320
NSP		├ LIGHT-L ASSY	AWU7321
NSP		├ LCD ASSY	AWU7354
NSP		DECK-COMP ASSY	AWM7441
NSP		├ TX CONNECT ASSY	AWU7323
		├ U-COM ASSY	AWU7327
		├ DECK ASSY	AWU7334

## **A** FM/AM TUNER MODULE SEMICONDUCTORS

	IC6201	LA1832ML
	IC6202	LC72131MD
	Q6402	2SC2223
	Q6203	2SC2705
	Q6201, Q6202	2SC2712
	Q6214, Q6403	2SC2714
	Q6404	2SK302
	Q6401	3SK194
	Q6204	DTA124ES
	Q6205	DTC124EK
	D6202	1SS254
	D6401, D6402	1T378A

## COILS AND FILTERS

	L6404	ATC1003
	L6401	ATC1020
	L6402	ATC1021
	F6204	ATF-107
	F6203	ATF-119
	F6401	ATF-155
	F6206	ATF7008
	F6202	ATF7011
	L6206, L6208, L6403	LAU2R2J

## TRANSFORMERS

	T6201	ATB7008
	T6401	ATE7002

## CAPACITORS

	C6208	CCSQCH100D50
	C6212, C6274, C6275, C6408	CCSQCH101J50
	C6412	CCSQCH102J50
	C6221, C6222, C6416	CCSQCH150J50
	C6271	CCSQCH200J50
	C6415	CCSQCH330J50
	C6406	CCSQCH331J50
	C6401, C6419	CCSQCH5R0C50
	C6407	CCSQCK1R0C50
	C6410	CCSQCK2R0C50
	C6413	CCSQRH180J50
	C6414	CCSQRH8R0D50
	C6405	CCSQTH150J50
	C6234, C6235	CEAL1R0M50
	C6245	CEAL470M16
	C6224	CEAT100M50
	C6243	CEAT101M16
	C6231	CEAT1R0M50
	C6227	CEAT220M25
	C6214, C6236	CEAT2R2M50
	C6262	CEAT3R3M50
	C6219	CEAT470M10
	C6244	CEAT470M16
	C6249, C6250, C6265, C6266	CEAT4R7M50
	C6258	CEJA470M16
	C6215	CFTLA103J50
	C6211, C6254, C6403, C6417	CKSQYB102K50
	C6201, C6205, C6210, C6237, C6276	CKSQYB103K50
	C6278, C6280, C6281, C6402, C6409	CKSQYB103K50
	C6418	CKSQYB103K50
	C6251, C6252	CKSQYB153K50
	C6203, C6259	CKSQYB223K50
	C6228	CKSQYB472K50
	C6209	CKSQYB473K50
	C6230	CKSQYB821K50
	C6218, C6223, C6255	CKSQYF103Z50
	C6220, C6226, C6242, C6256	CKSQYF223Z50
	C6225	CKSQYF473Z50

Mark	No.	Description	Part No.
<b>RESISTORS</b>			
	R6280		RD1/4PU101J
	R6413, R6416, R6418, R6906, R6909		RS1/8S0R0J
	R6401		RS1/8S470J
	VR6201 (10kΩ)		PCP1029
	Other Resistors		RS1/10S□□□ J

<b>OTHERS</b>			
	BN6202 (4P ANTENA TERMINAL)		AKE7051
	X6202 (456 kHz)		ASS1066
	X6201 (7.2000 MHz)		ASS1093
	CN6201 (14P SOCKET)		KP200IA14L

**E AF ASSY**  
**SEMICONDUCTORS**

IC3001	LC75396NE
IC7301	NJM062M
IC3002	NJM4558MD
IC141	NJM7805FA
IC131	NJM7812FA
Q3004	2SC2412K
Q3001, Q3002, Q3005, Q3006	2SD2114K
Q3009, Q3010	2SD2114K
Q2001	2SD2395
Q3003	DTA124EK
Q3011, Q3013, Q3015	DTA143EK
Q7301	DTC114EK
Q3014	DTC124EK
D3006, D3007, D7301–D7304	1SS133
D3011, D3016	1SS355
D3004	MTZJ11C
D3008, D3009	S5688G

<b>COILS AND FILTERS</b>	
L7301	LAU220J
L3110	VTL1096
L3101, L3103	VTL1105

<b>CAPACITORS</b>	
C3039, C3040, C3057–C3059	CCSQCH101J50
C3203, C3204, C3207, C3208	CCSQCH101J50
C3205, C3206	CCSQCH271J50
C3011, C3012, C3025, C3026	CEAT100M50
C3029, C3030	CEAT100M50
C131, C141, C3041, C3042	CEAT1R0M50
C3031	CEAT220M50
C3001–C3008, C3013, C3014	CEAT2R2M50
C3023, C3024, C3035, C3036	CEAT2R2M50
C3055, C3056	CEAT2R2M50
C133, C143, C3096, C7302	CEAT470M16
C7304	CEJA4R7M50
C3015, C3016	CFTYA474J50
C3110, C3202	CKSQYB103K50
C7301	CKSQYB221K50
C3121–C3123	CKSQYB223K50
C3047, C3048	CKSQYB473K50
C3019, C3020	CKSQYB562K50
C3021, C3022	CKSQYB681K50
C3032	CKSQYB682K50

Mark	No.	Description	Part No.
	C132, C142, C3017, C3018, C3044		CKSQYF104Z50
	C3099, C7305		CKSQYF104Z50
	C3045, C3046		CKSQYF684Z16

<b>RESISTORS</b>			
	R2002		RD1/4PMF100J
	Other Resistors		RS1/10S□□□ J

<b>OTHERS</b>			
CN5 (23P FFC CONNECTOR)			52045-2345
CN2 (8P JUMPER CONNECTOR)			52147-0810
CN1 (12P JUMPER CONNECTOR)			52147-1210
CN7 (3P CONNECTOR)			B3B-PH-K-S
CN31 (10P PLUG)			KM200IB10
CN32 (12P PLUG)			KM200IB12
CN3 (9P JUMPER CONNECTOR)			KPE9

**F CD ASSY**  
**SEMICONDUCTORS**

IC1301	BA5970FP
IC1101	CXA1821M
IC1201	CXD2587Q
Q7002, Q7004	2SA1037K
Q1101	2SA854S
Q7005–Q7008	2SD1858X
Q1401, Q1402	2SD2114K
Q1201, Q1403, Q1404	DTA124EK
Q1202	DTC114TK
Q7001, Q7003	DTC124EK
D1101, D1202, D7003–D7006	1SS133
D1201	1SS85
D1401, D1402	DAN202K
D7002	MTZJ3.6B
D7001	MTZJ6.2C

<b>COILS AND FILTERS</b>	
L1101, L1102, L1201, L1231, L1232	LAU100J
L1401, L1601	LAU100J
L7001	LFA100J
L1402, L1602	VTL1105

<b>CAPACITORS</b>	
C1201, C1202	CCSQCH150J50
C1401, C1402	CCSQCH151J50
C1107	CCSQCH220J50
C1239, C1246, C1247	CCSQCH221J50
C1604	CCSQCH270J50
C1280	CCSQCH331J50
C1322, C1324	CCSQCH681J50
C1403, C1404	CCSLSL681J50
C1102, C1104, C1203, C1233, C1240	CEJA101M10
C1242, C1249, C1411, C1602	CEJA101M10
C1301, C1307, C1308, C7003	CEJA101M16
C1405, C1406	CEJA2R2M50
C1109, C1110	CEJA330M25
C1238	CEJAR47M50
C1331	CKSQYB102K50

# XC-IS21T

Mark	No.	Description	Part No.
	C1204–C1206, C1237, C1253, C1271 C1416, C1605 C1245 C1236 C1231		CKSQYB103K50 CKSQYB103K50 CKSQYB104K25 CKSQYB152K50 CKSQYB332K50
	C1341, C1342 C1235, C1321, C1323 C1311, C1312 C1332 C1101, C1103, C1108, C1111, C1232		CKSQYB333K50 CKSQYB473K50 CKSQYB681K50 CKSQYB682K50 CKSQYF103Z50
	C1234, C1241, C1250, C1251, C1276 C1302–C1306, C1413, C1414, C1417 C1601, C1603 C7001, C7002		CKSQYF103Z50 CKSQYF103Z50 CKSQYF103Z50 CKSQYF104Z50

## RESISTORS

R7003	RD1/4PU181J
R7007	RD1/4PU221J
R7006	RD1/4PU331J
R7005	RD1/4PU470J
Other Resistors	RS1/10S□□□ J

## OTHERS

111 (3P CABLE HOLDER)	51048-0300
101 (12P CABLE HOLDER)	51048-1200
CN110 (17P FFC CONNECTOR)	52044-1745
CN1101 (16P FFC CONNECTOR)	52089-1620
J111 (3P FLAT CABLE)	D20PYY0310E
J101 (12P FLAT CABLE)	D20PYY1215E
CN1301 (6P CONNECTOR)	S6B-ZR
1001, 1002 (PCB BINDER)	VEF1040
X1201 (16.9344MHz)	PSS1008

## **K** FRONT PANEL ASSY

### SEMICONDUCTORS

Q5901	DTA143EK
Q5902, Q5903	DTC124EK
D5902, D5903	1SS133
D5908	1SS355
D5901	MTZJ5.6B

D5907	SLR-343VC
-------	-----------

### SWITCHES AND RELAYS

S5916	ASX7026
S5901–S5915, S5917–S5923	XSG3001

### CAPACITORS

C5902	CEJA101M10
C5903	CKSQYF103Z50

### RESISTORS

R5917	RD1/2PM471J
R5909	RD1/2PM820J
Other Resistors	RS1/10S□□□ J

### OTHERS

154, 155 (3P CABLE HOLDER)	51048-0300
CN150 (17P FFC CONNECTOR)	52044-1745
CN51 (3P JUMPER CONNECTOR)	52147-0310
J54 (3P FLAT CABLE)	D20PYY0310E
J55 (3P FLAT CABLE)	D20PYY0330E

5901 (REMOTE RECEIVER UNIT)	GP1U27X
-----------------------------	---------

Mark	No.	Description	Part No.
<b>I</b>		<b>F-TERMINAL ASSY</b>	
		<b>SEMICONDUCTORS</b>	
		D7211, D7212	1SS355

### COILS AND FILTERS

L7202, L7203, L7211, L7212 L7221, L7222	VTL1096 VTL1096
--	--------------------

### CAPACITORS

C7202	CEJA101M10
C7213, C7214, C7223, C7224	CKSQYB102K50
C7201, C7203	CKSQYB103K50
C7231	CKSQYB472K50

### RESISTORS

Other Resistors	RS1/10S□□□ J
-----------------	--------------

### OTHERS

103 (9P CABLE HOLDER)	51063-0905
7304 (MINE JACK)	AKN-210
7303 (MINI JACK)	AKN7003
J103 (JUMPER WIRE)	D15A09-350-2651
JA7201 (OPTICAL LINK OUT)	GP1F32T

## **H** R-TERMINAL ASSY

### COILS AND FILTERS

L7101–L7106, L7111	VTL1096
--------------------	---------

### CAPACITORS

C7102, C7104	CCSQCH221J50
C7154	CKSQYB102K50
C7131	CKSQYB103K50

### RESISTORS

Other Resistors	RS1/10S□□□ J
-----------------	--------------

### OTHERS

JA7105 (2P PIN JACK)	AKB7043
CN7104 (4P PIN JACK)	AKB7114
CN7102 (5P SOCKET)	AKP7042
CN7101 (10P SOCKET)	AKP7048
CN131 (10P SOCKET)	KP200IB10L

CN132 (12P SOCKET)	KP200IB12L
--------------------	------------

## **G** CD MOTOR ASSY

### CAPACITORS

C7501	CKSQYF104Z50
-------	--------------

### OTHERS

CN11 (3P JUMPER CONNECTOR)	52151-0310
----------------------------	------------

## **M** CD OPEN SW ASSY

### SWITCHES AND RELAYS

S7401, S7402	VSH1019
--------------	---------

### OTHERS

54 (3P CABLE HOLDER)	51048-0300
----------------------	------------



Mark	No.	Description	Part No.
<b>N</b>		<b>CD CLOSE SW ASSY</b>	
		<b>SWITCHES AND RELAYS</b>	
		S7403, S7404	ASG7015

**OTHERS**

55	(3P CABLE HOLDER)	51048-0300
----	-------------------	------------

**L LIGHT-L ASSY**  
**SEMICONDUCTORS**

D5971		NSPBF50S-8451
-------	--	---------------

**OTHERS**

51	(3P CABLE HOLDER)	51048-0300
J51	(3P CABLE HOLDER)	D20PYY0310E

**D LCD ASSY**

**OTHERS**

CN190	(15P FFC CONNECTOR)	52045-1545
CN180	(29P FFC CONNECTOR)	52045-2945
V5501	(LCD DISPLAY)	AAV7066

**B TX CONNECT ASSY**

**CAPACITORS**

C9999		CKSQYB104K25
-------	--	--------------

**OTHERS**

160	(13P CABLE HOLDER)	51048-1300
CN161	(14P CONNECTOR)	9176B-14L

**C U-COM ASSY**  
**SEMICONDUCTORS**

IC5501		PDG242B
IC5503		PDG243A
Q5701		2SA1037K
Q5501		2SC2412K
Q5502		DTA124EK
Q5702		DTC124EK
Q5503, Q5511, Q5512		DTC143EK
D5501, D5503-D5505, D5701		1SS133
D5502, D5506, D5507		MTZJ6.8B

**COILS AND FILTERS**

L5501, L5502, L5509, L5510	LAU220J
L5503-L5508	VTL1105

**CAPACITORS**

C5507 (0.047F/5.5V)	ACH1246
C5520-C5522	CCSQCH101J50
C5533, C5534	CCSQCH220J50
C5556-C5558	CCSQCH680J50
C5509	CEAT100M50
C5502	CEAT1R0M50
C5505, C5508	CEAT470M16
C5501	CEATR47M50
C5503, C5537-C5539, C5541, C5547	CKSQYB102K50
C5555	CKSQYB102K50

Mark	No.	Description	Part No.
		C5528, C5529, C5531, C5545, C5546	CKSQYB103K50
		C5524-C5526	CKSQYB104K25
		C5504, C5506, C5510, C5511, C5523	CKSQYF104Z50
		C5532, C5535, C5536, C5542	CKSQYF104Z50

**RESISTORS**

R5577-R5580	RD1/4PU471J
Other Resistors	RS1/10S□□□ J

**OTHERS**

60	(13P CABLE HOLDER)	51048-1300
CN10	(17P FFC CONNECTOR)	52044-1745
CN105	(23P FFC CONNECTOR)	52044-2345
CN90	(15P FFC CONNECTOR)	52045-1545
CN50	(17P FFC CONNECTOR)	52045-1745

X5501	(12MHz)	ASS1062
X5502	(10MHz)	DSS1048
CN80	(29P FFC CONNECTOR)	52045-2945
CN20	(14P JUMPER CONNECTOR) (BUZZER)	52147-1410 APV7002

J60	(13P FLAT CABLE)	D20PYY1315E
10, 20	(PCB BINDER)	VEF1040
KN5501	(EARTH METAL FITTING)	VNF1084

**J DECK ASSY**

**SEMICONDUCTORS**

IC2601	BU4094BCF
IC2201	HA12136AF
IC2202, IC2301, IC2401	NJM4558MD
Q2709	2SB1197K
Q2803	2SB1238X

Q2708	2SB1296
Q2801, Q2802, Q2805	2SC1815
Q2806	2SC2240
Q2253	2SC2412K
Q2701-Q2704	2SD1858X

Q2251, Q2252, Q2261, Q2262	2SD2114K
Q2451, Q2452	2SD2114K
Q2301, Q2302	2SK373
Q2254, Q2711	DTA124EK
Q2705, Q2706	DTA143EK

Q2303-Q2306, Q2401, Q2402	DTC114TK
Q2201, Q2263, Q2351, Q2804	DTC124EK
Q2601-Q2603, Q2707, Q2710	DTC143EK
D2252-D2256, D2301-D2306, D2311	1SS133
D2421, D2705, D2706	1SS133

D2709	MTZJ4.7B
D2201, D2703, D2704	MTZJ6.2B

**COILS AND FILTERS**

L2802	LFA121J
L2801	RTD1082
L2401, L2402	RTF1004
L2403, L2404	RTF1021
F2201, F2202	RTF1217

L2501, L2502	VTL1096
--------------	---------

# XC-IS21T

Mark No.	Description	Part No.
----------	-------------	----------

## CAPACITORS

C2809		CCCSL151K2H
C2301, C2302		CCSQCH100D50
C2423, C2424		CCSQCH221J50
C2253		CCSQCH271J50
C2303, C2304		CCSQCH681J50
C2203, C2204, C2207, C2215		CEAT100M50
C2311, C2312, C2407, C2408		CEAT100M50
C2701		CEAT101M16
C2201, C2202, C2217, C2218, C2255		CEAT1R0M50
C2403, C2404		CEAT1R0M50
C2251		CEAT220M50
C2216		CEAT221M10
C2213, C2214, C2254		CEAT2R2M50
C2309, C2310, C2805, C2806, C2810		CEAT330M16
C2314, C2425, C2807		CEAT470M16
C2221, C2222, C2261, C2262		CEAT4R7M50
C2419, C2420		CEAT4R7M50
C2205, C2206		CEATR22M50
C2501, C2502		CKSQYB102K50
C2601		CKSQYB104K25
C2252		CKSQYB105K10
C2411, C2412		CKSQYB122K50
C2211, C2212, C2421, C2422		CKSQYB152K50
C2602		CKSQYB221K50
C2401, C2402		CKSQYB332K50
C2451		CKSQYB473K50
C2702		CKSQYB474K16
C2808		CQHA822J2A
C2209, C2210		CQMA103J50
C2801		CQMA123J50
C2409, C2410		CQMA223J50
C2803, C2804		CQMA332J50
C2417, C2418		CQMA393J50
C2307, C2308, C2802		CQMA682J50
C2405, C2406		CQMA683J50

## RESISTORS

R2805		RD1/2PM161J
R2806		RD1/2PM201J
R2703-R2706		RD1/2PM391J
R2803		RD1/2PM4R7J
R2701, R2702		RD1/4PU102J
R2707		RD1/4PU751J
VR2701	(1k $\Omega$ )	PCP1024
VR2301, VR2302	(4.7k $\Omega$ )	PCP1028
VR2401, VR2402	(22k $\Omega$ )	PCP1030
VR2801, VR2802	(100k $\Omega$ )	PCP1032
Other Resistors		RS1/10S□□□ J

## OTHERS

102	(8P CABLE HOLDER)	51048-0800
CN2701	(13P CONNECTOR)	B13B-PH-K-S
CN2302	(2P CONNECTOR)	B2B-PH-K-S
CN2301	(4P CONNECTOR)	B4B-PH-K-S
CN2603	(5P CONNECTOR)	B5B-PH-K-S
J2201	(8P FLAT CABLE)	D20PYY0825E
J2202	(14P FLAT CABLE) (BINDER)	D20PYY1425E VEF1040

## 6. ADJUSTMENT

For adjustment, use the stereo power amplifier (M-IS21).

### 6.1 DECK SECTION

#### 6.1.1 Adjustment Condition

- (1) The ground at the time of adjustment shall be W166.  
(Refer to Fig. 6-3).
- (2) Clean the heads and demagnetize them using a head eraser.
- (3) Set the measurement level to 0 dBV = 1 Vrms.
- (4) Use the specified tape for adjustment. Use the labeled (A) side of the test tape.
  - NCT-111 : For Tape Speed adjustment
  - STD-331E : For Playback adjustment
  - STD-632 : Normal blank tape
- \* As the reference recording level is 250 nwb/m for STD-331E, the recording level will be higher by 4 dB for STD-331B (160nwb/m). When adjusting, pay carefull attention to the type of tape used.
- (5) Provide yourself with the following measuring devides:
  - AC millivoltmeter
  - Low-frequency oscillator
  - Attenuator
  - Oscilloscope
- (6) Adjust both right and left channels unless otherwise specified.
- (7) Turn the DOLBY NR switch off unless otherwise specified.
- (8) Warm up the unit for several minutes before adjustment. In particular, be sure to warm up the unit in the REC/PLAY mode for 3 to 5 minutes before starting recording/playback frequency characteristics adjustment.
- (9) Always follow the indicated adjustment order.  
Otherwise, a complete adjustment may not be achieved.

#### ■ List of Adjustments

- Playback Section
  - (1) Tape Speed Confirmation
  - (2) Head Azimuth Adjustment
  - (3) Playback Level Adjustment
- Recording Section
  - (1) Recording Bias Adjustment
  - (2) Recording Level Adjustment

PLAY BACK

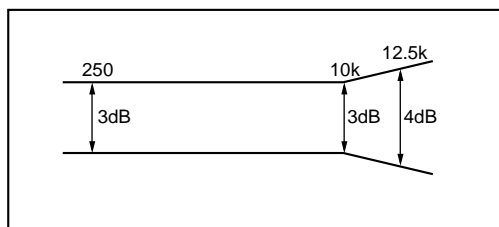

RECORDING

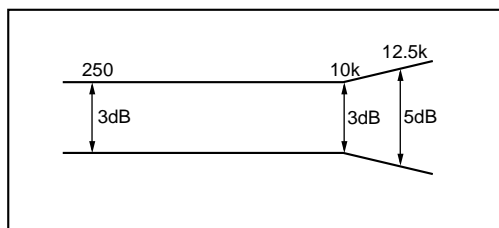

Fig. 6-1 Frequency Characteristics

Dolby noise reduction manufactured under license from Dolby Laboratories Licensing Corporation.  
"DOLBY" and the double-D symbol are trademarks of Dolby Laboratories Licensing Corporation.

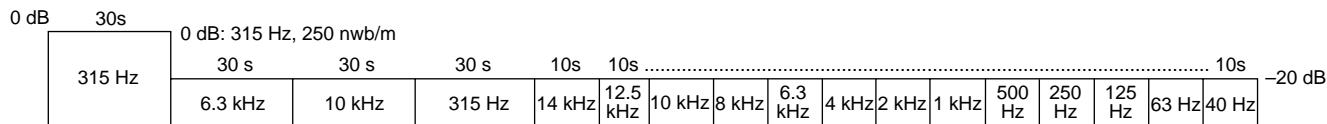

Fig. 6-2 Test Tape STD-331E

## 6.1.2 Playback Section

### (1) Tape Speed Confirmation

No.	Mode	Input Signal/Test Tape	Adjustment Points	Measurement Points	Adjustment Value	Remarks
1	PLAY	NCT-111 (3 kHz)	VR2701 (DECK ASSY) (Refer to Fig. 6-3)	TP R (C2204) (DECK ASSY)	3000 Hz $\begin{matrix} +10 \\ -10 \end{matrix}$ Hz	FWD adjustment REV Confirmation (3000 Hz $\begin{matrix} +60 \\ -60 \end{matrix}$ Hz)

### (2) Head Azimuth Adjustment

- This unit is equipped with auto tape selector.
- Do not switch between forward and reverse operation with the screwdriver inserted.

No.	Mode	Input Signal/Test Tape	Adjustment Points	Measurement Points	Adjustment Value	Remarks
1	PLAY	STD-331E test tape (Playback: 10 kHz, -20 dB)	Head azimuth adjustment Screw (Refer to Fig. 6-3)	TP L (C2203) TP R (C2204) (DECK ASSY)	Max. Playback signal level	After adjustment, apply silicon bond to the head azimuth adjustment screw.

### (3) Playback Level Adjustment

- Since this adjustment determines playback DolbyNR level, Perform it carefully.

No.	Mode	Input Signal/Test Tape	Adjustment Points		Measurement Points	Adjustment Value	Remarks
1	PLAY	STD-331E test tape (Playback: 315 Hz, 0 dB)	L ch	VR2301	TP L (C2203) TP R (C2204) (DECK ASSY)	-3.7 dBV	
			R ch	VR2302			

## 6.1.3 Recording Section

### (1) Recording Bias Adjustment

- After the adjustment, caution should be exercised so as not to become under bias by checking the distortion rate.

No.	Mode	Input Signal/Test Tape	Adjustment Points		Measurement Points	Adjustment Value	Remarks
1	REC/ PAUSE	Input a 315Hz signal to the LINE - IN terminal. *	Input signal level		TP L (C2203) TP R (C2204) (DECK ASSY)	-23.7 dBV	Repeat adjustment until playback level of the 10kHz signal is within 0.5dBV $\pm$ 0.5dB from that of the 315Hz signal.
2	REC $\rightarrow$ PLAY	Load the STD-632 test tape and record/playback the 315Hz and 10kHz signals. (see the Note below)	L ch	VR2801			
			R ch	VR2802			

Note: Set the 10kHz input signal level to the same value as the 315Hz input signal level of step 1.

### (2) Recording Level Adjustment

No.	Mode	Input Signal/Test Tape	Adjustment Points		Measurement Points	Adjustment Value	Remarks
1	REC/ PAUSE	Input a 315Hz signal to the LINE- IN terminal. *	Input signal level		TP L (C2203) TP R (C2204) (DECK ASSY)	-7.7 dBV	Repeat recording, playback and adjustment until playback level of the 315Hz signal becomes -7.7dBV $\pm$ 0.5dB.
2	REC $\rightarrow$ PLAY	STD-632 test tape and record/ playback the 315Hz signal.	L ch	VR2401			
			R ch	VR2402			

● DECK ASSY **J**

SIDE A

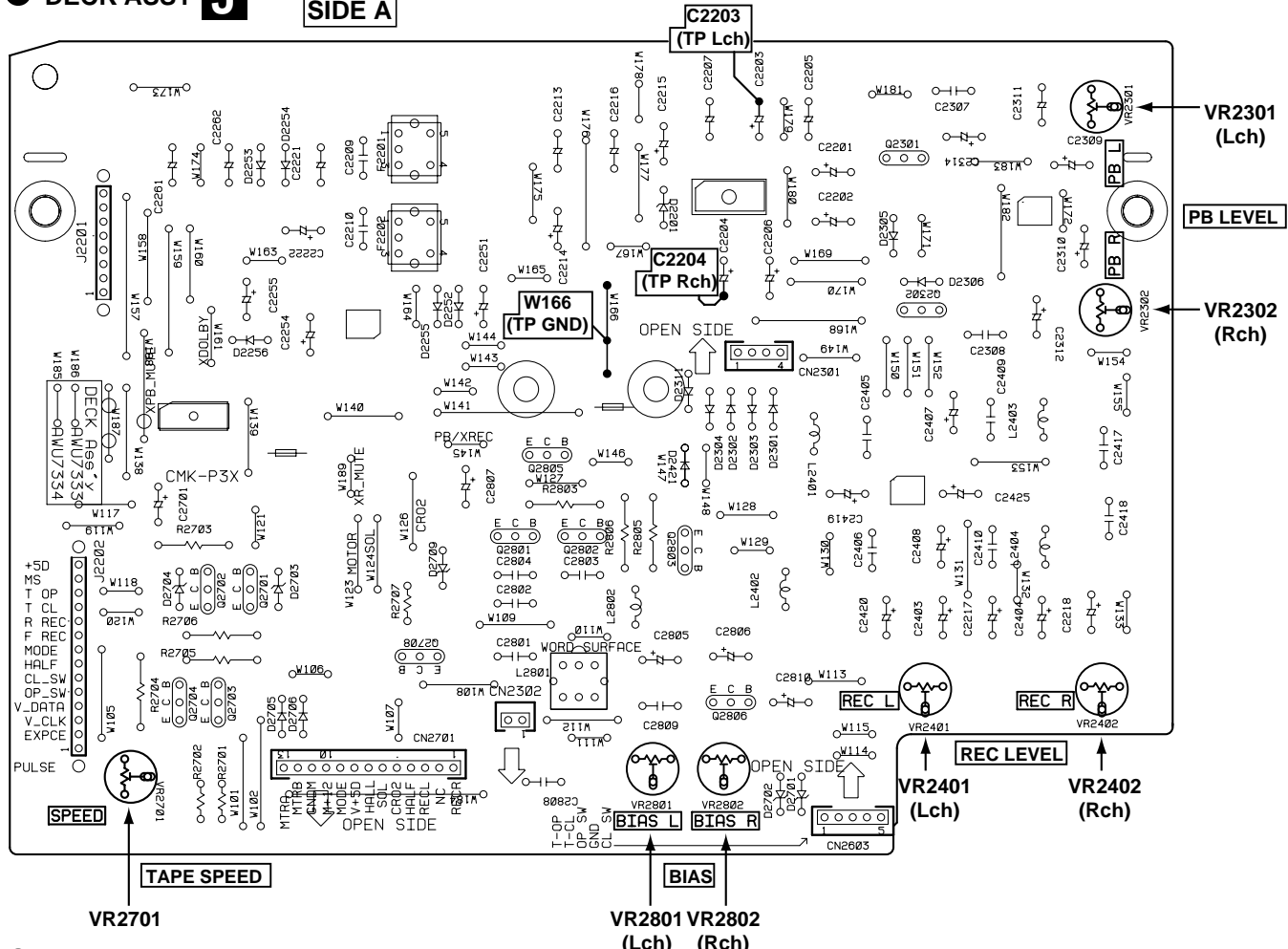

● MECHANISM UNIT

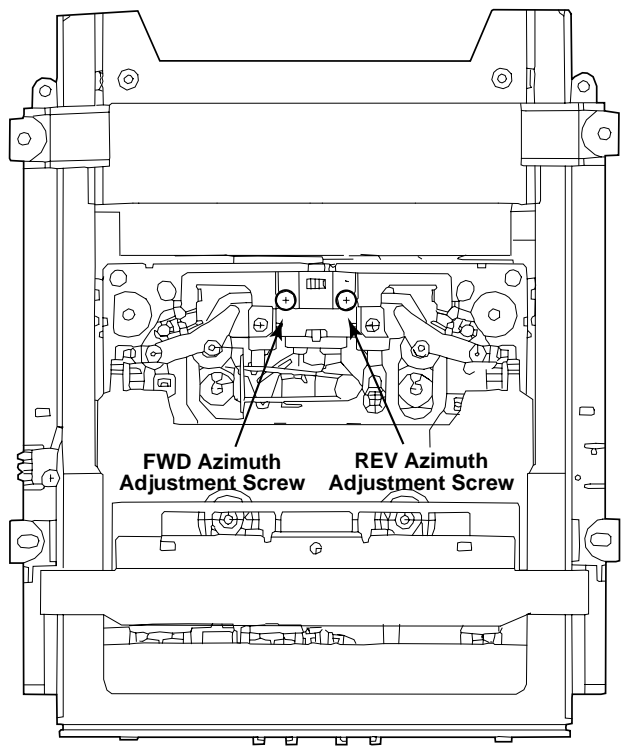

Fig. 6-3 Adjustment and Measurement Points

6.2 CD SECTION

Note : There is no information to be shown in this CD adjustment.

6.2.1 HOW TO START / CANCEL TEST MODE

**TEST MODE : ON**

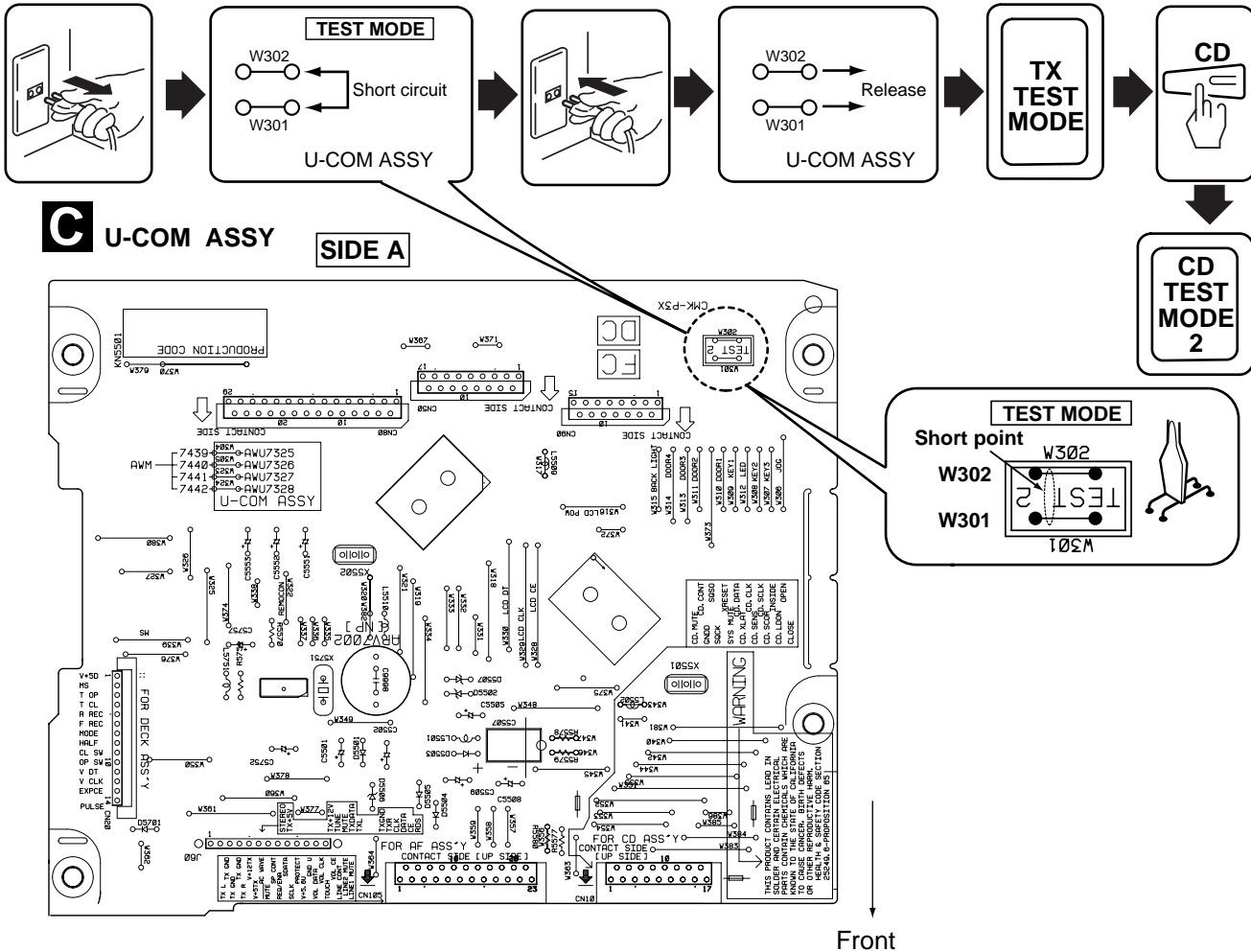
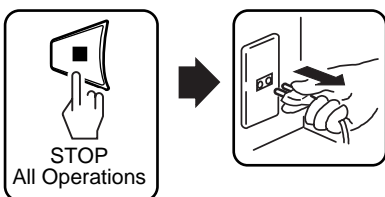
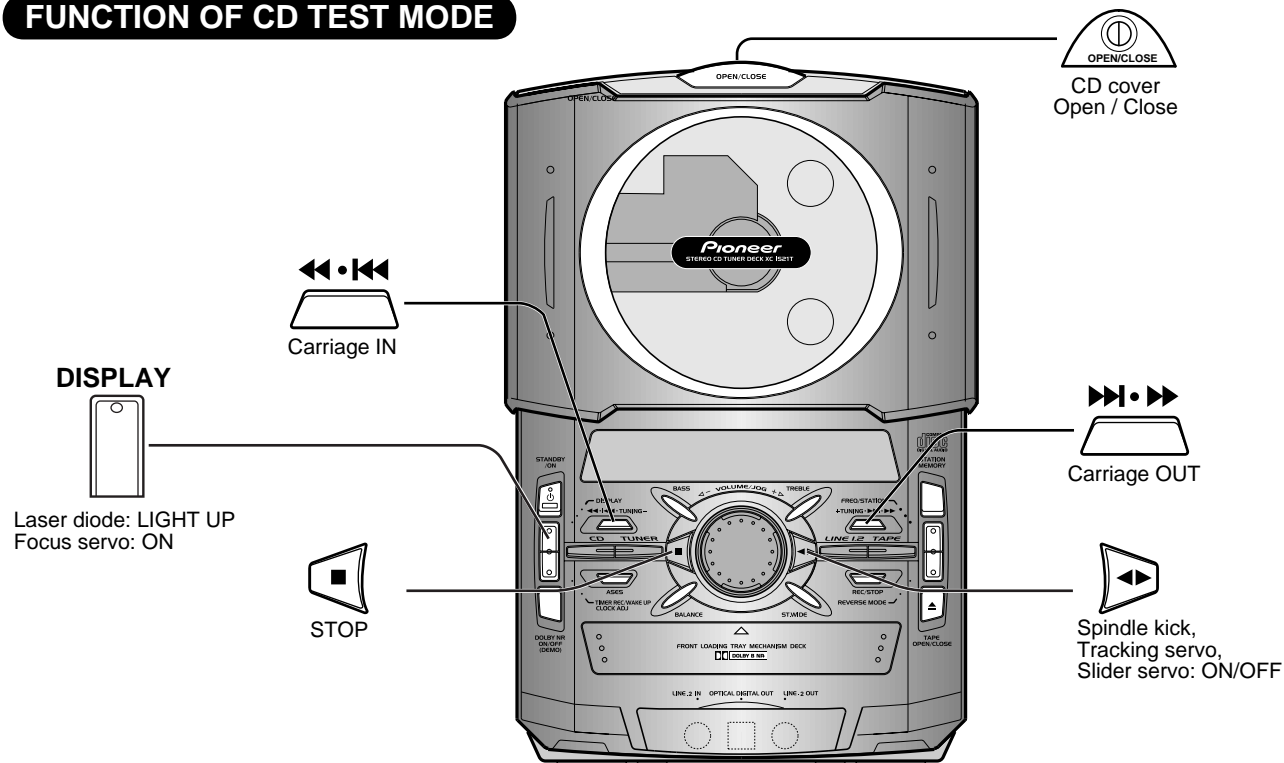

Fig. 6-4

**TEST MODE : STOP → CANCEL**



**FUNCTION OF CD TEST MODE**



**TEST MODE : PLAY**

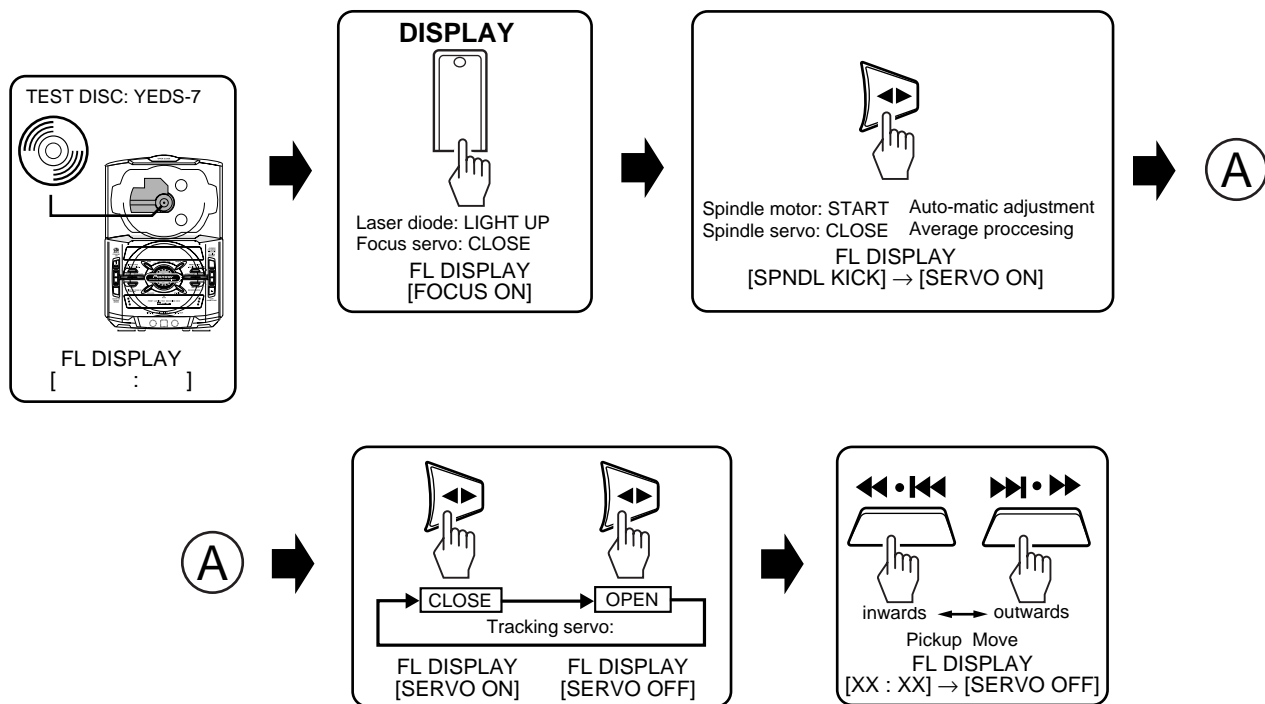

### 6.3 TUNER SECTION

#### 6.3.1 FM TUNER SECTION

- Set the mode selector to FM BAND.
- Connect the wiring as shown in Fig. 6-5.

Step No.	Adjustment Title	FM SG (1kHz, ±75kHz dev.)		Reception Frequency Display	Adjustment Location	Specifications
		Frequency (MHz)	Level (dBμV)			
1	Front End Sensitivity	98	0 – 30	98MHz	L6402 T6401	Adjust so that the DC voltage between the IC6201-Pin 20 and GND becomes at maximum level.
2	TUNED IND. Lighting Level	98	18 ± 2	98 MHz	VR6201	Adjust so that the indicator of TUNED IND. starts to light up.

Note: Before adjusting, make sure there is no gap between L6101 and L6102 . If there is a gap between them, bring them into contact with each other first, and then make adjustments.

#### 6.3.2 AM TUNER SECTION

- Set the mode selector to AM BAND.
- Connect the wiring as shown in Fig. 6-5

Step No.	Adjustment Title	AM SG (400Hz, 30% Mod.)		Reception Frequency Display	Adjustment Location	Specifications
		Frequency (kHz)	Level (dBμV/m)			
1	Front End Sensitivity	999*1	35 – 45	999 kHz*1	T6201	Adjust so that the DC voltage between the IC6201-Pin 20 and GND becomes at maximum level.

\*1: For the area using 10 kHz step, frequencies should be 1000 kHz.

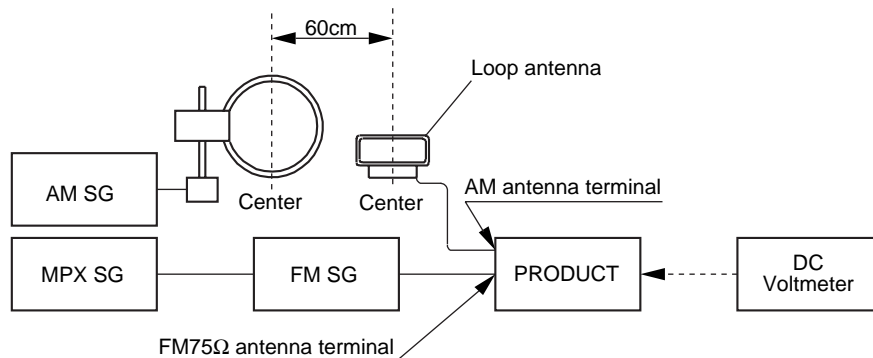

Fig. 6-5 AM and FM Adjustment Wiring Diagram

#### FM/AM TUNER MODULE

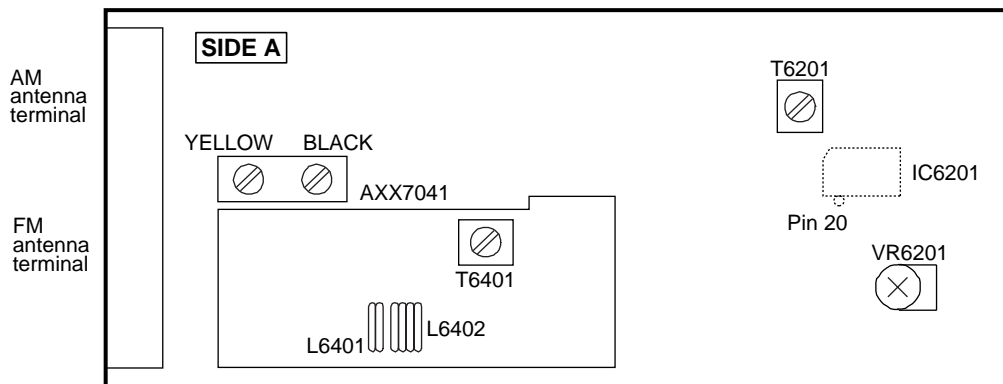

Fig. 6-6 Adjustment Point



# 7. GENERAL INFORMATION

## 7.1 DIAGNOSIS

### 7.1.1 SEQUENCE AFTER THE POWER ON

Note 1 : IC No. or P\*\* without name indicate the pin No. of microcomputer.

Note ;

\*1 : System bus communication  
P29 SYSCCLK  
P46 SYSDATA  
P47 SYSREQ

\*2 : Starts the LCD communication  
P48 LCDCLK  
P49 LCDCE  
P50 LCDDATA

\*3 : Transfer the Function, Volume, BASS and TREBLE data to the volume IC.  
P27 VOLCE  
P28 VOLDATA  
P34 VOLCLK

\*4 : Initial setting of CD decoder IC  
P17 CDCLK  
P18 CDLAT  
P19 CDDATA

\*5 : Initialize the TUNER PLL IC  
P65 TXCE  
P66 TXODAT  
P67 TXCLK  
P68 TXIDAT

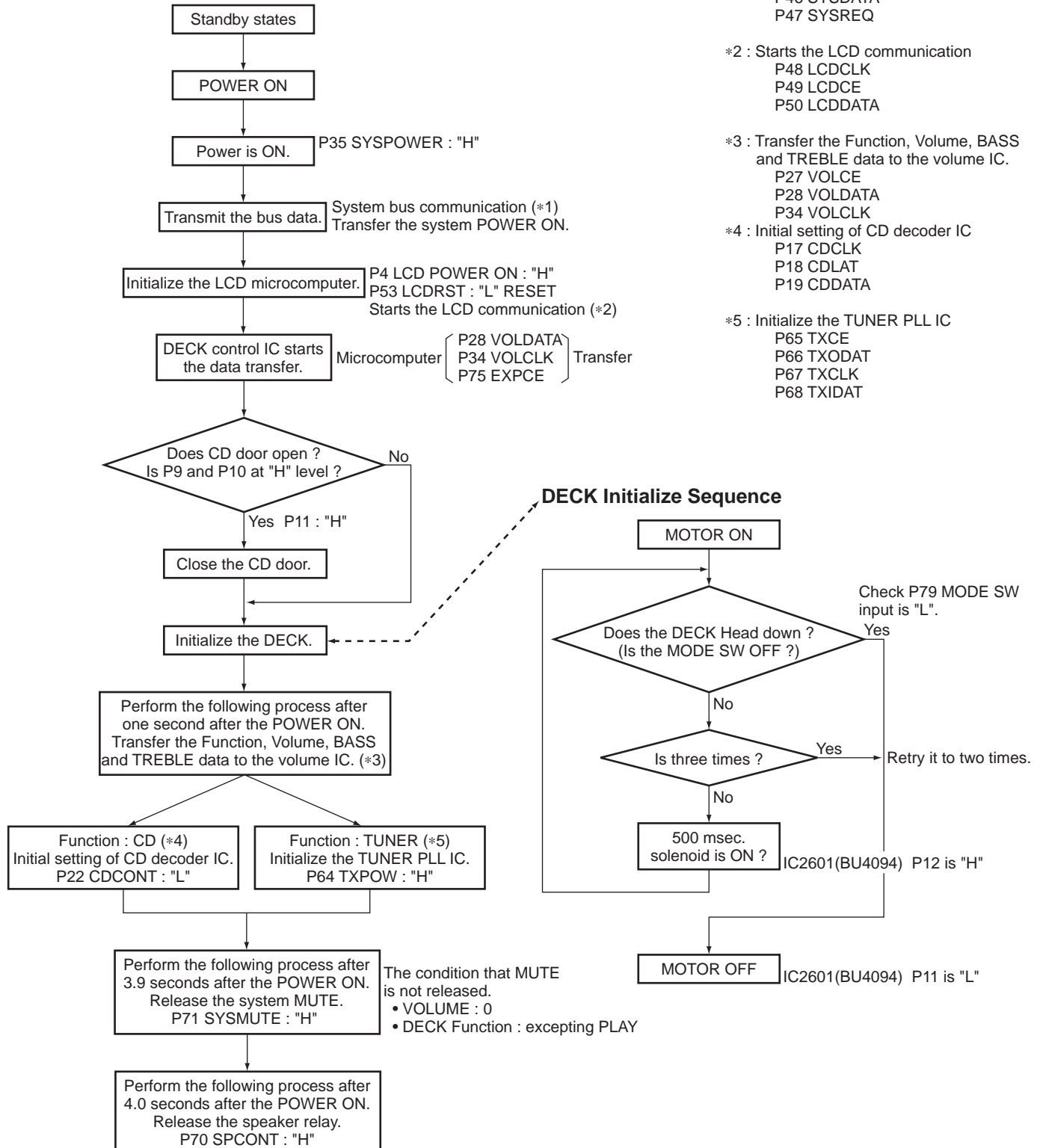

## 7.1.2 SINGLE OPERATION METHOD

### ■ Jigs and Measuring instruments

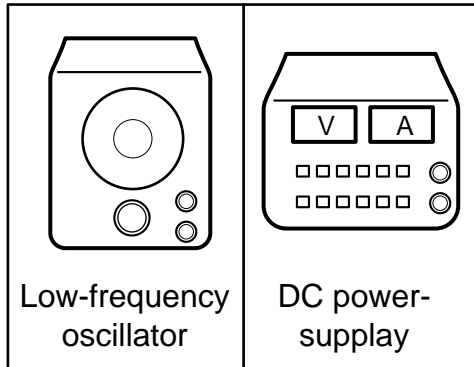

### ■ Single operation method and frequency oscillator inputlevel.

1. Connect part ① of the AF ASSY [W420(+8V), W421 (+15V), W422 (+5.6V), W423(GND)] and DC power-supply. (Refer to Fig. 7-1.)

Connect point ①	DC power-supply	
	Voltage (V)	Remarks
AF ASSY, W420 (+8v)	+8V	
AF ASSY, W421 (+15v)	+15V	
AF ASSY, W422 (+5.6v)	+5.6V	
AF ASSY, W423 (GND)	GND	

2. Connect part ② of the U-COM ASSY [CN105 pin8 (AC), AF ASSY[W423 (GND)]] and frequency oscillator. (Refer to Fig. 7-1 and 7-2.)

Connect point ②	Low-frequency oscillator			
	frequency	level	Gnd	Remarks
U-COM ASSY, CN105 pin8 (AC)	50 or 60 Hz	Approx.2.0 Vrms	———	Note.
AF ASSY, W423 (GND)	———	———	osc GND	

Note: Set up the low-frequency oscillator level with in the limits of product moves.

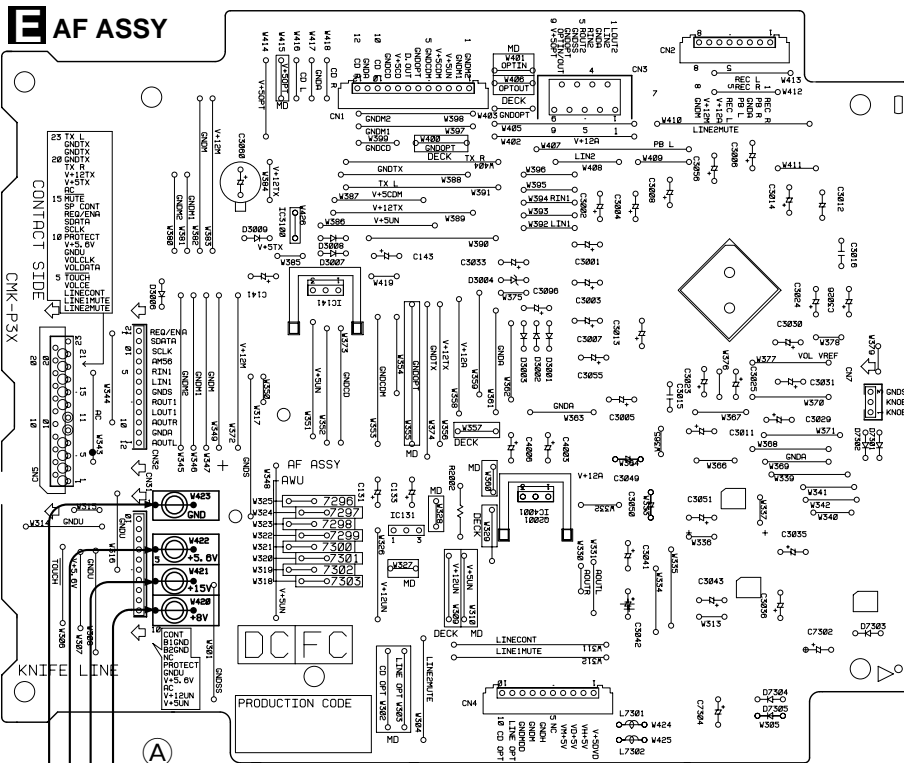

- W420.....+8V
- W421.....+15V
- W422.....+5.6V
- W423.....GND

Fig. 7-1

**SIDE A**

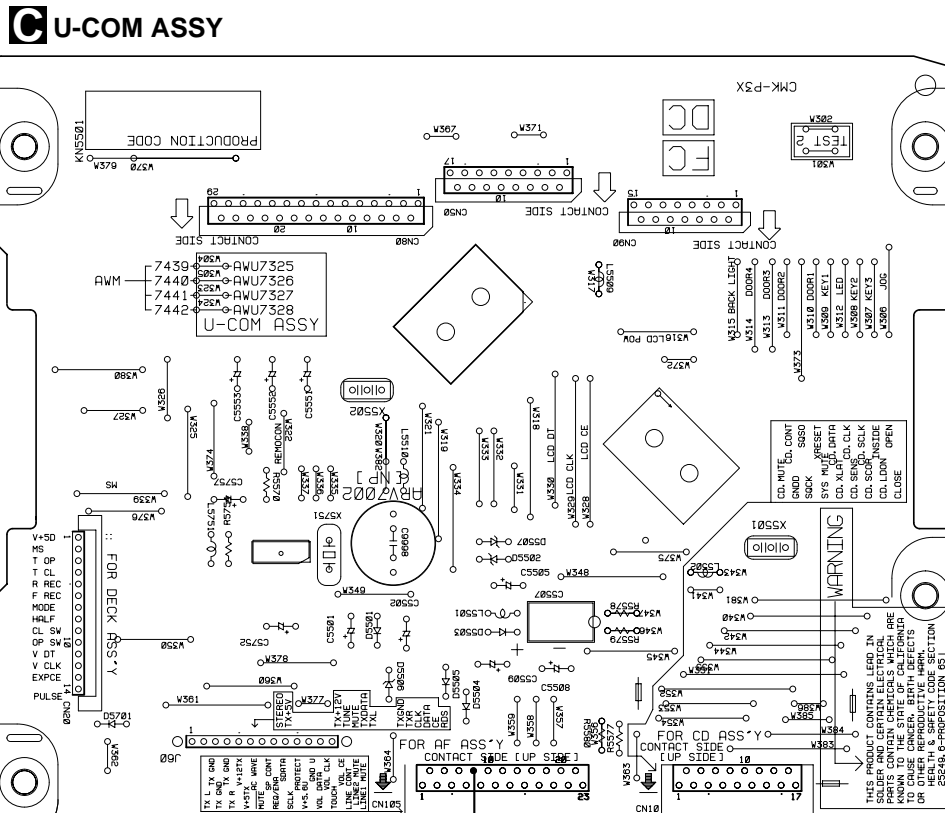

- Frequency: 50 or 60Hz
- Level: Approx. 2Vrms
- GND
- OSC
- CN105 pin8 (AC)

Fig. 7-2

**SIDE A**

7.1.3 DISASSEMBLY

**1** Front Panel Assy

Note : Flexible cables are not removed in the case of the adjustment, but remove the Flexible cables to apply in the case of the exchange or repair.

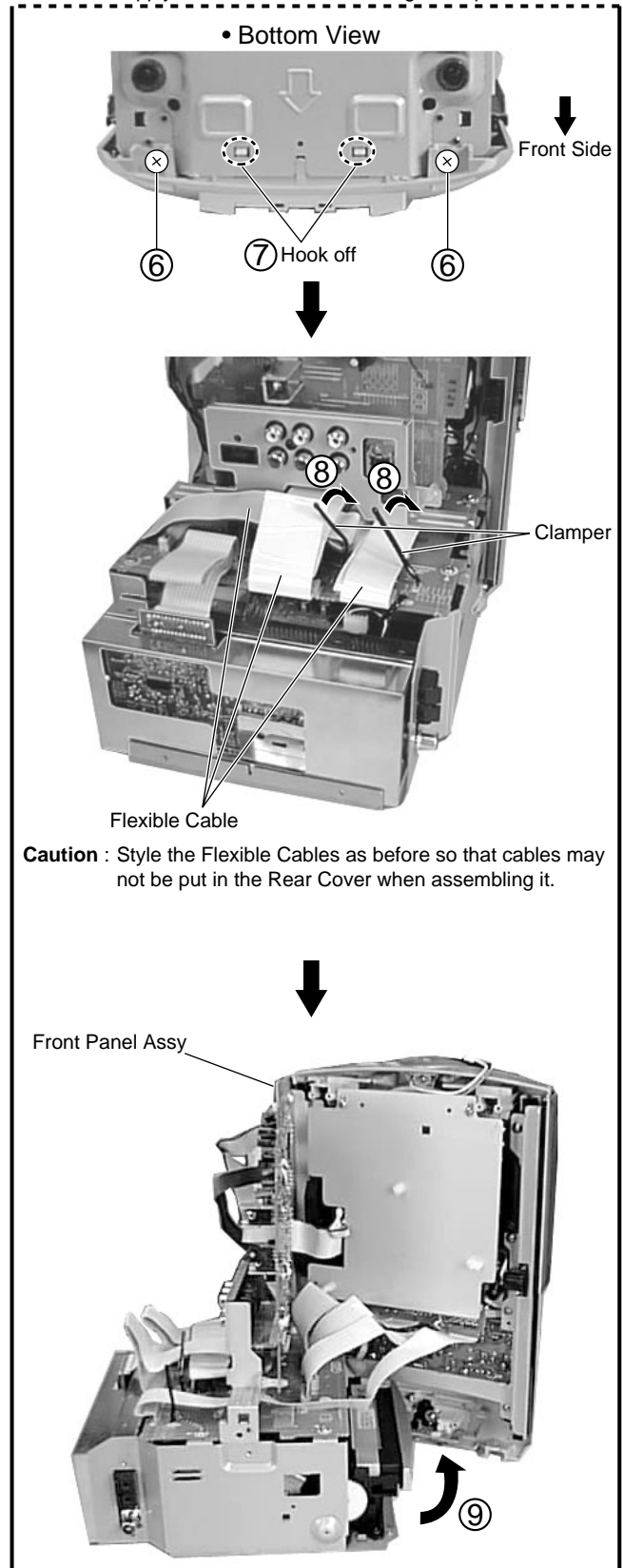
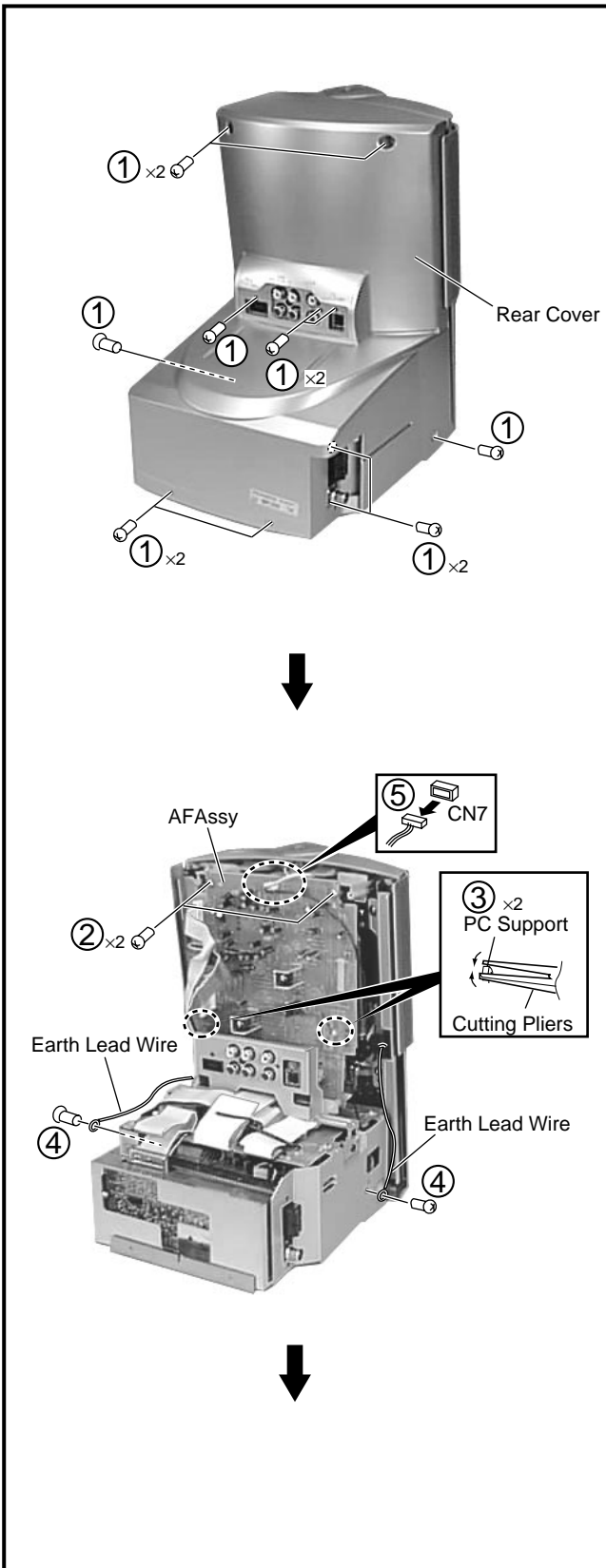

**2** CD Mechanism Assy

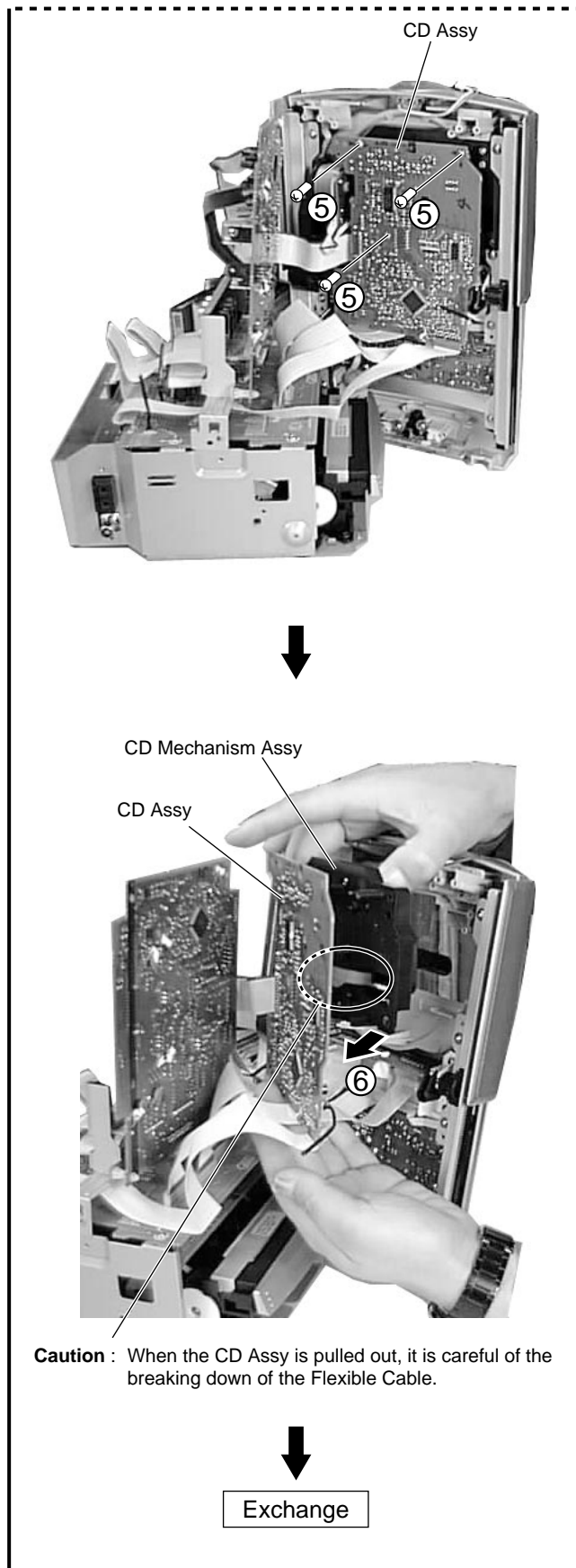
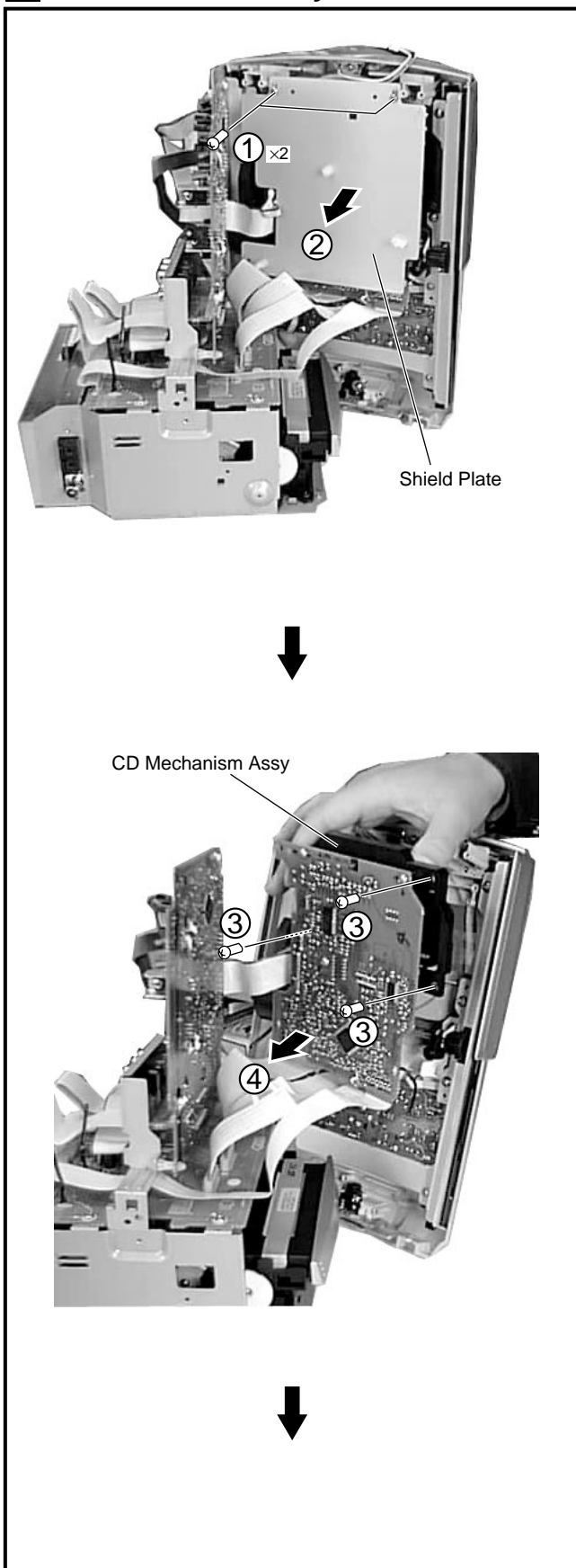

### 3 CD Door Drive Block

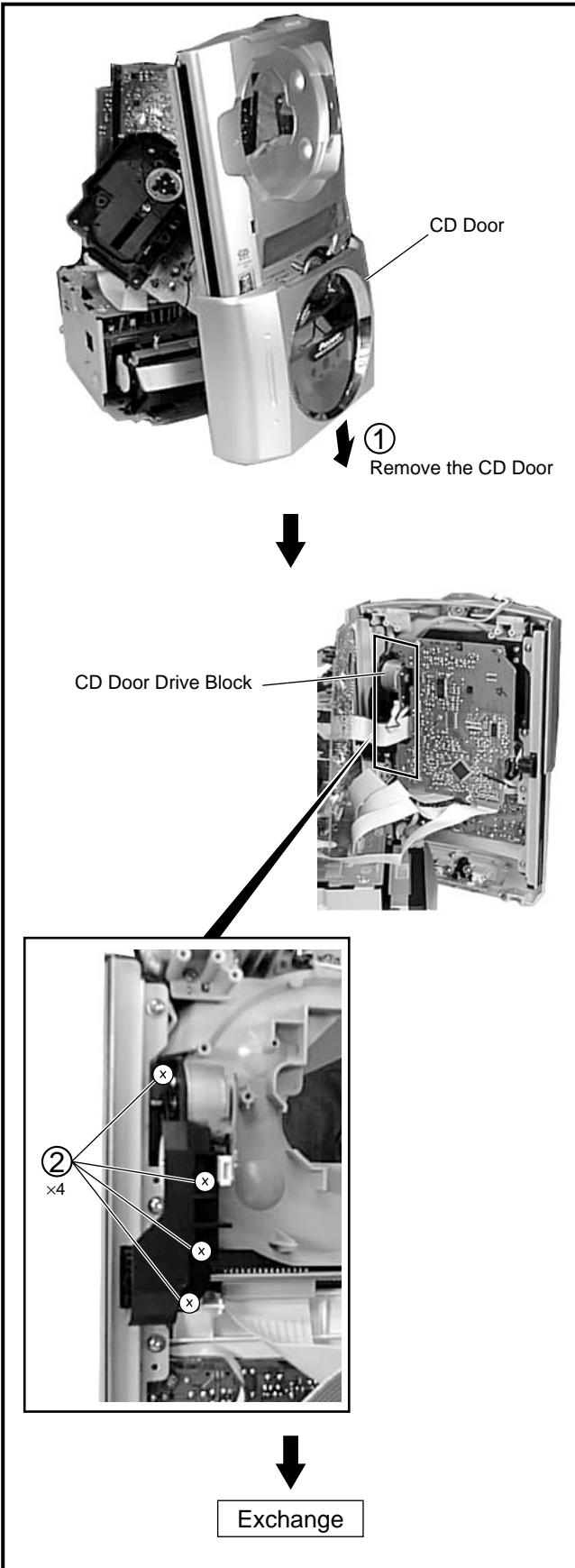

### 4 Deck Mechanism Unit

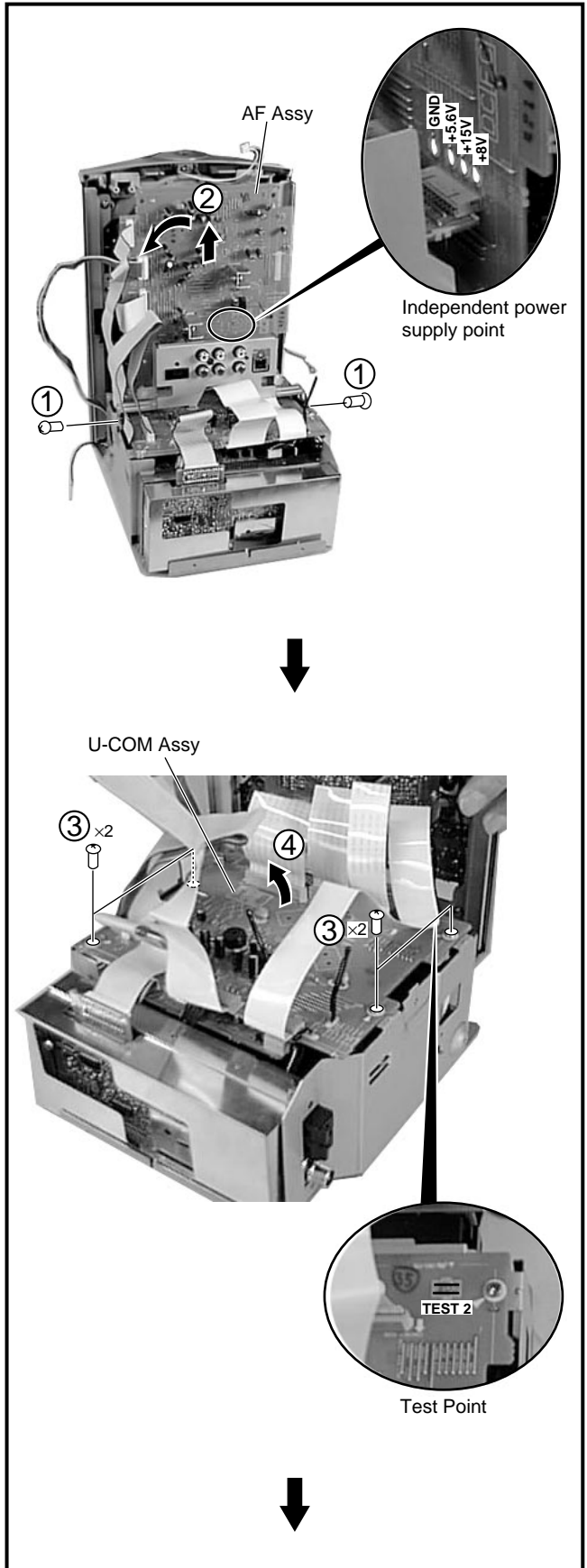

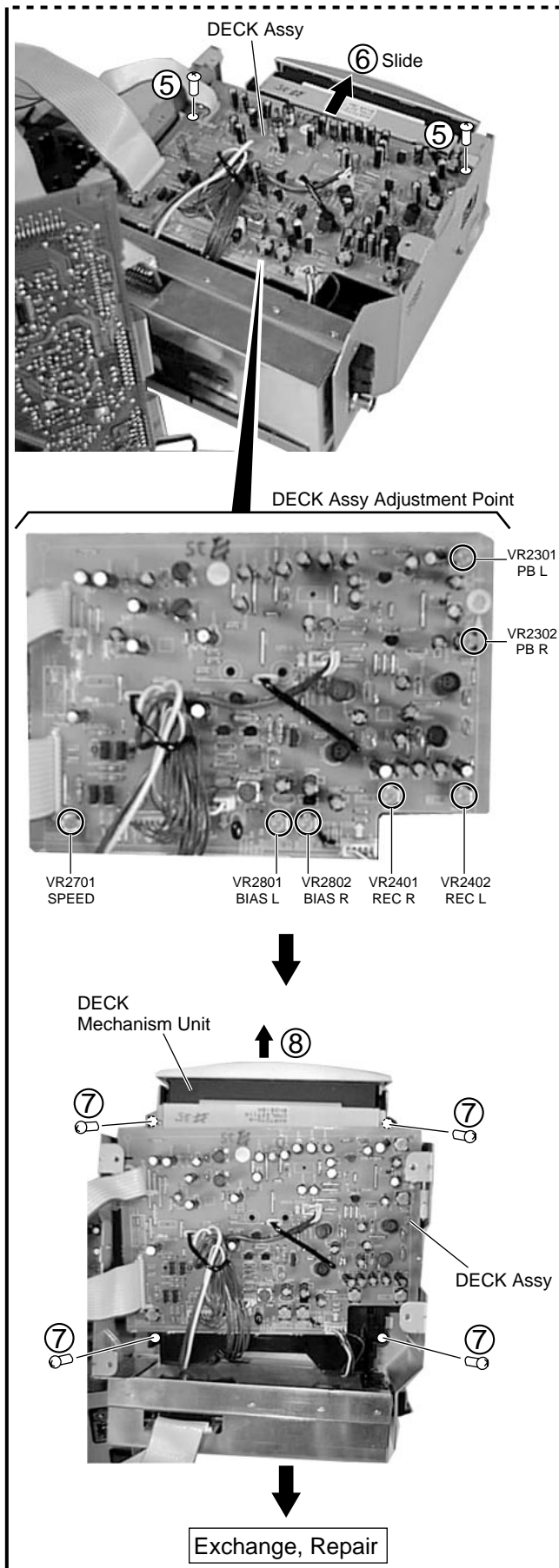

Note

① CD Door OPEN/CLOSE

When a connector CN7 of AF Assy is removed for the touch sensor system, sensor does not work and CD Door can't open and close. CD Door can open when the land of CN7 at the foil side is short-circuited with the finger.

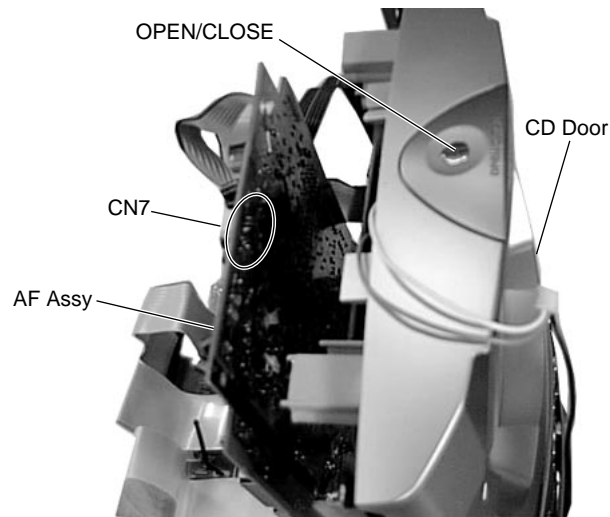

② FM/AM TUNER Module for European model

Shield Case is being soldered in the European model. Remove solder in the case such as exchange.

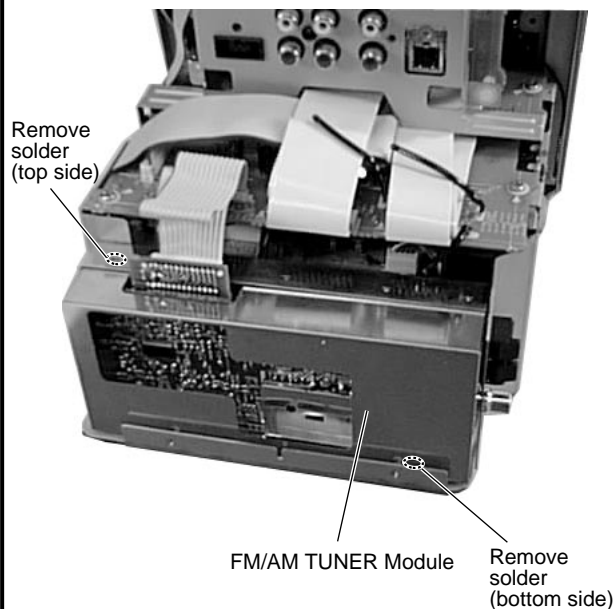

7.1.4 PCB LOCATION

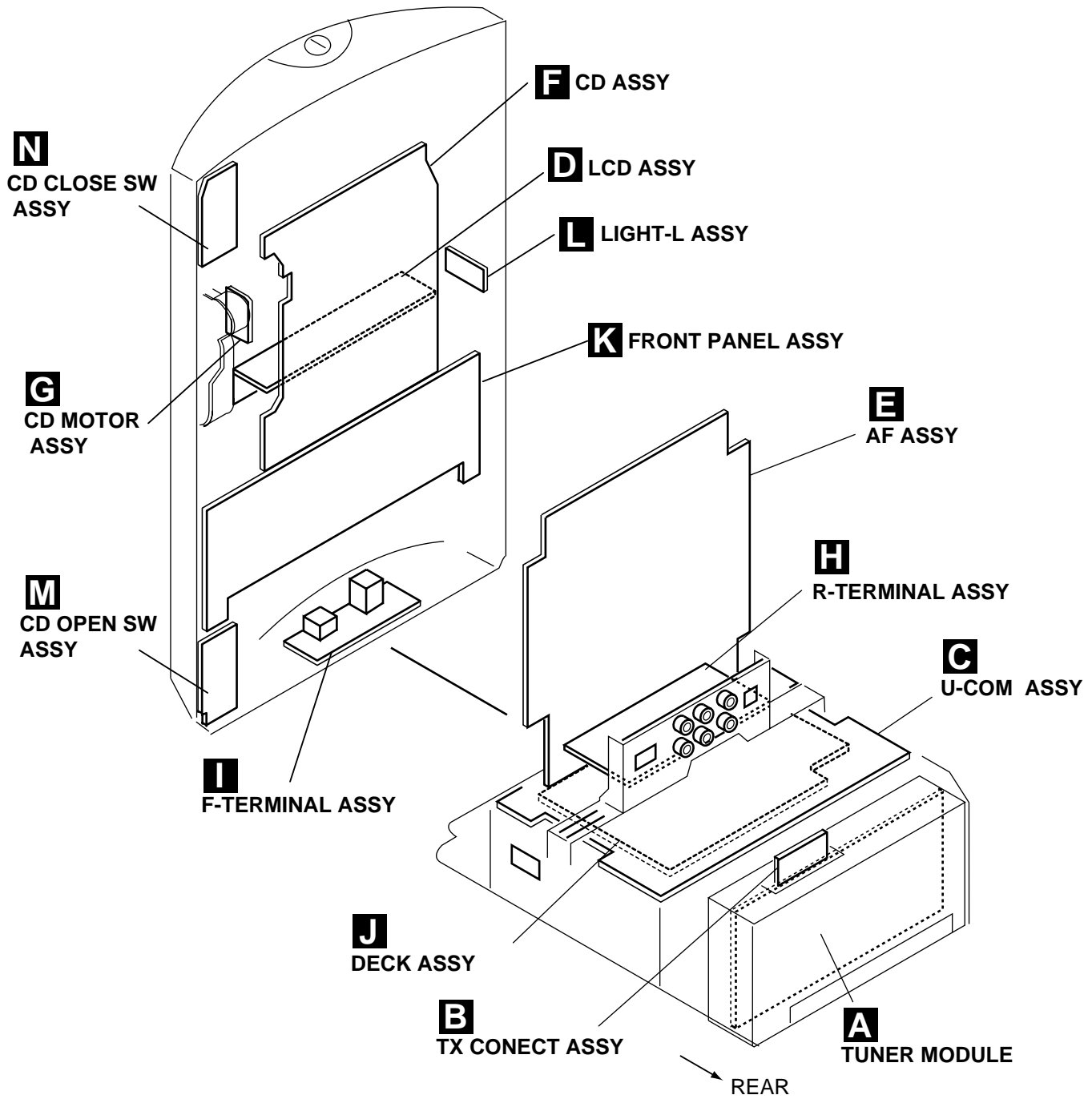



## 7.2 PARTS

### 7.2.1 IC

• The information shown in the list is basic information and may not correspond exactly to that shown in the schematic diagrams.

#### ■ CXA1821M (CD ASSY : IC1101)

• RF AMP. IC

●Block Diagram

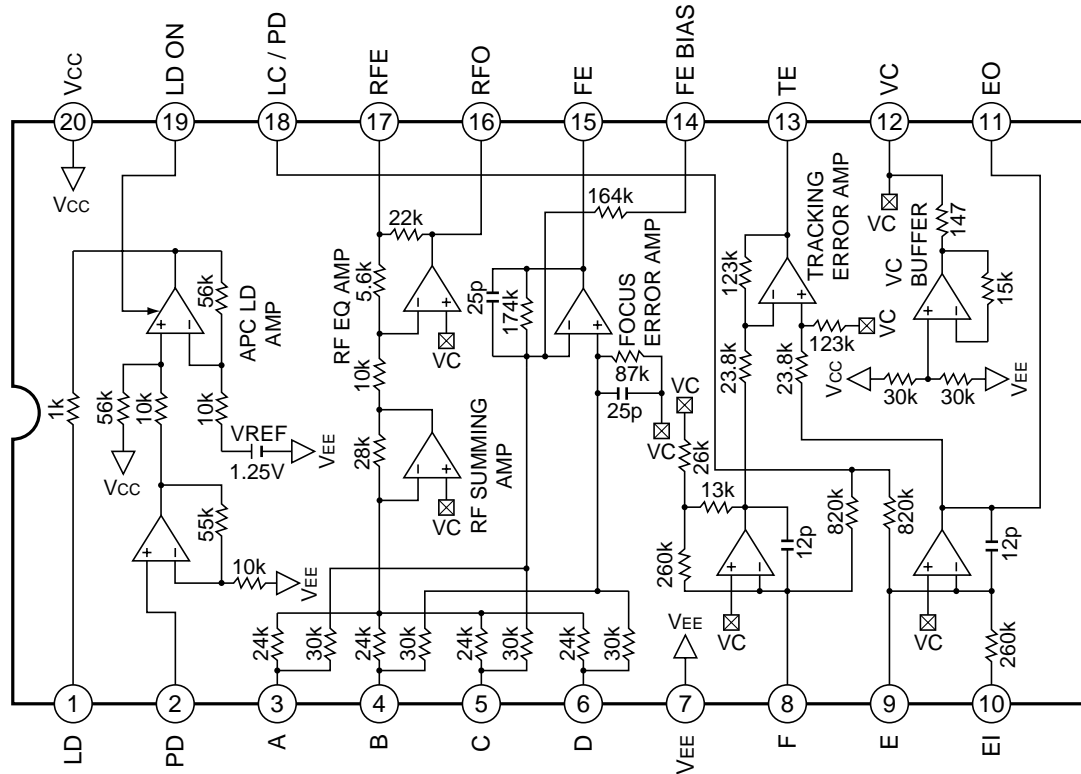

●Pin Function

No.	Pin Name	I/O	Function	No.	Pin Name	I/O	Function
1	LD	O	APC amplifier output	11	EO	-	Gain adjust the signal which was input from pin 9.
2	PD	I	APC amplifier input	12	VC	O	DC voltage output of (VCC+VEE)/2
3	A	I	RF amplifier and FE amplifier input	13	TE	O	Tracking error amplifier output F-E signal is output.
4	B			14	FE BIAS	I	Pin for focus bias adjustment
5	C			15	FE	O	Focus error amplifier output
6	D			16	RFO	O	RF amplifier output
7	VEE	-	Ground pin	17	RFE	-	Pin for RF amplifier equalization
8	F	I	Tracking error amplifier input.	18	LC/PD	I	Bias pin VCC : LC , OPEN : PDIC
9	E			19	LD ON	I	ON/OFF switching pin of APC amplifier VCC : ON, VEE : OFF
10	EI	-	Gain adjust the signal which was input from pin 9.	20	VCC	-	Power supply pin

## ■ CXD2587Q (CD ASSY : IC1201)

• SERVO IC

### ●Block Diagram

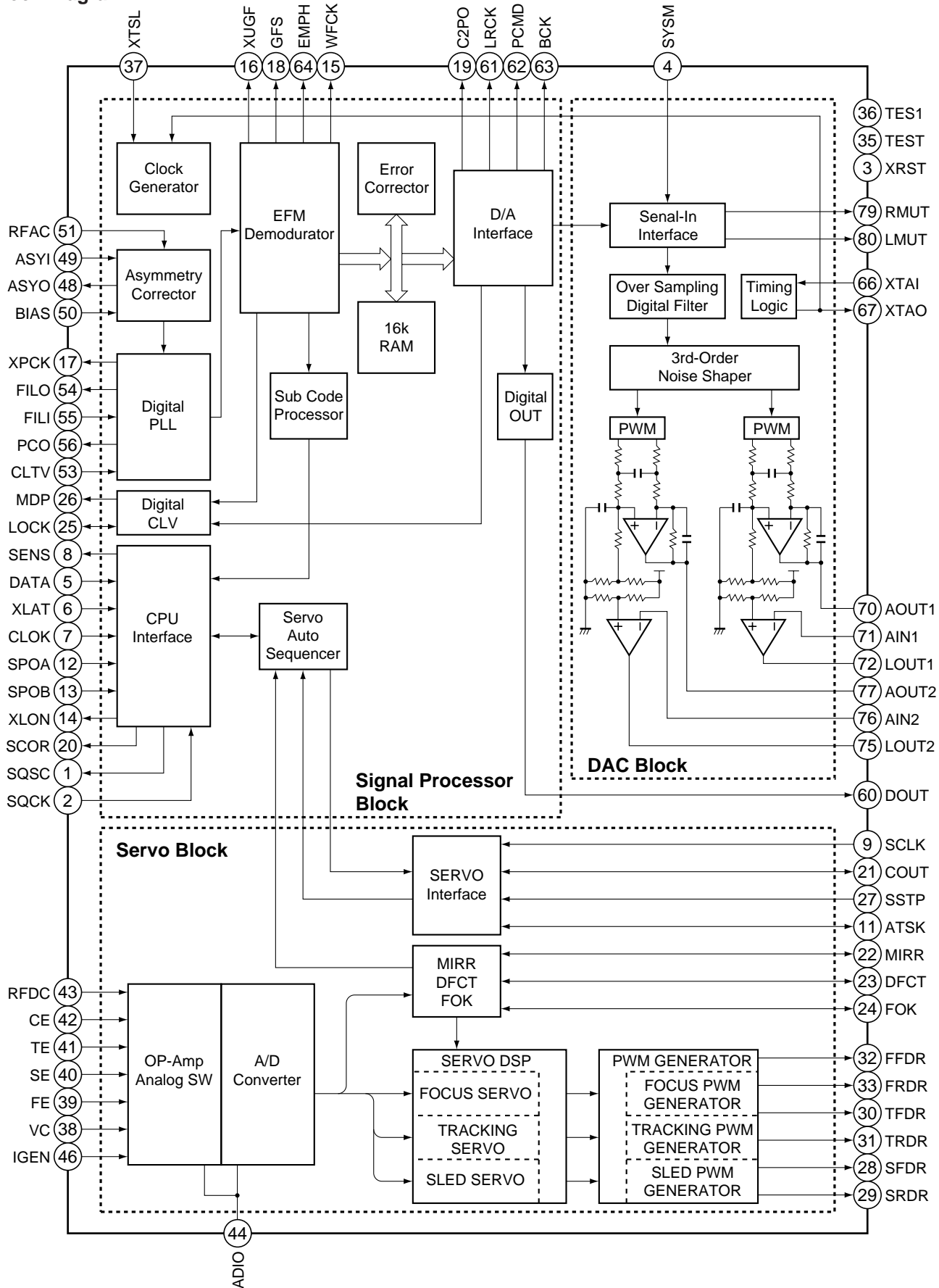

## ●Pin Function

iNo.	Pin Name	I/O	Function	No.	Pin Name	I/O	Function
1	SQSO	O	SubQ 80-bit, PCM peak and level data output CD TEXT data output	41	TE	I	Tracking error input
2	SQCK	I	Clock input for SQSO readout	42	CE	I	Center servo analog input
3	XRST	I	System reset Reset when "L"	43	RFDC	I	RF signal input
4	YSM	I	Mute input Mute when "H"	44	ADIO	O	OP amplifier output
5	DATA	I	Serial data input from CPU	45	AVss0	-	Analog GND
6	XLAT	I	Latch input from CPU Serial data is latched at the falling edge.	46	IGEN	I	Constant current input for OP amplifier
7	CLOK	I	Serial data transfer clock input from CPU	47	AVdd0	-	Analog power supply
8	SENS	O	SENS output to CPU	48	ASYO	O	EFM full-swing output ("L"=VSS, "H"=VDD)
9	SCLK	I	Clock input for SENS serial-data readout	49	ASYI	I	Asymmetry compare voltage input
10	Vdd	-	Digital power supply	50	BIAS	I	Constant current input of the asymmetry circuit
11	ATSK	I/O	Input and output for anti-shock	51	RFAC	I	EFM signal input
12	SPOA	I	Microcomputer extended interface (input A)	52	AVss3	-	Analog GND
13	SPOB	I	Microcomputer extended interface (input B)	53	CLTV	I	VCO control voltage input for master
14	XLON	O	Microcomputer extended interface (output)	54	FIL0	O	Filter output for master PLL (Slave=digital PLL)
15	WFCK	O	WFCK output	55	FIL1	I	Filter input for master PLL
16	XUGF	O	XUGF output MNT1 and RFCK output by switching the command.	56	PCO	O	Charge pump output for master PLL
17	XPLCK	O	XPLCK output MNT0 output by switching the command.	57	AVdd3	-	Analog power supply
18	GFS	O	GFS output MNT3 and XRAOF output by switching the command.	58	Vss	-	Digital GND
19	C2PO	O	C2PO output GTOP output by switching the command.	59	Vdd	-	Digital power supply
20	SCOR	O	Outputs "H" when either subcode sync. S0 or S1 is detected.	60	DOUT	O	DIGITAL OUT output
21	COUT	I/O	Input and output of track-number count signal	61	LRCK	O	D/A interface LR clock output f=Fs
22	MIRR	I/O	Mirror signal input and output	62	PCMD	O	D/A interface Serial data output (two's complement, MSB first)
23	DFCT	I/O	Defect signal input and output	63	BCK	O	D/A interface Bit clock output
24	FOK	I/O	Focus OK signal input and output	64	EMPH	O	Outputs "H" when the playback disc has emphasis, and "L" when there is no emphasis.
25	LOCK	I/O	GFS is sampled at 460Hz; when GFS is "H", this pin outputs "H". If GFS is "L" eight consecutive samples, this pin outputs "L". Input when LKIN="H".	65	XVdd	-	Power supply for master clock
26	MDP	O	Servo control output of spindle motor	66	XTAI	I	Crystal oscillation circuit input Input the external master clock via this pin.
27	SSTP	I	Detection signal input of disc innermost	67	XTAO	O	Crystal oscillation circuit output
28	SFDR	O	Sled drive output	68	XVss	-	GND for master clock
29	SRDR	O		69	AVdd1	-	Analog power supply
30	TFDR	O	Tracking drive output	70	AOUT1	O	L ch analog output
31	TRDR	O		71	AIN1	I	L ch OP amp. input
32	FFDR	O	Focus drive output	72	LOUT1	O	L ch LINE output
33	FRDR	O		73	AVss1	-	Analog GND
34	Vss	-	Digital GND	74	AVss2	-	Analog GND
35	TEST	I	TEST pin : normally GND	75	LOUT2	O	R ch LINE output
36	TEST	I		76	AIN2	I	R ch OP amp. input
37	XTSL	I	Crystal selector input "L":16.9344MHz, "H":33.8688MHz	77	AOUT2	O	R ch analog output
38	VC	I	Center voltage input	78	AVdd2	-	Analog power supply
39	FE	I	Focus error signal input	79	RMUT	O	R ch zero detection flag
40	SE	I	Sled error signal input	80	LMUT	O	L ch zero detection flag

## Notes)

- PCMD is an MSB first, two's complement output.
- GTOP is used to monitor the frame sync protection status. (High:sync protection window released)
- XUGF is the negative pulse for the frame sync derived from the EFM signal. It is the signal before sync protection.
- XPLCK is the inverse of the EFM PLL clock. The PLL is designed so that the falling edge of XPLCK and the EFM signal transition point coincide.
- GFS goes high when the frame sync and the insertion protection timing match.
- RFCK is derived with the crystal accuracy. This signal has a cycle of 136μs.
- C2PO represents the data error status.
- XRAOF is generated when the 16K RAM exceeds the ±4F jitter margin.

## ■ PDG242 (U-COM ASSY : IC5501)

### • System Control IC

#### ●Pin Function

No.	Name	I/O	Description
1	TCRECF	I	Mecha RECF SW
2	TCTIN	O	TAPE Tray load in
3	TCTOUT	O	TAPE Tray load out
4	LCD POWER	O	LCD ON/OFF
5	LIGHT	O	LCD Buck light control
6	CDDSW1	I	CD Door detection Input 1
7	CDDSW2	I	CD Door detection Input 2
8	STBYLED	O	Standby LED control
9	CDDSW3	I	CD Door detection Input 3
10	CDDSW4	I	CD Door detection Input 4
11	CDCOLSE	O	CD Door close drive output
12	CDOPEN	O	CD Door open drive output
13	CD LDON	I	CD laser diode control output
14	CDINSID	I	CD inside SW input
15	CDSCLK	O	CD automatic adjustment input clock
16	CDSSENS	I	CD LSI replay (GFS, FOK)
17	CDCLK	O	CD LSI clock
18	CDLAT	O	CD LSI latch
19	CDDATA	O	CD LSI data
20	CDSYSM	O	CD decoder mute control
21	CDRESET	O	CD LSI reset
22	CDCONT	O	CD LSI power control
23	CDMUTE	O	CD mute control
24	LINE2 MUTE	O	Line2 mute control
25	LINE1 MUTE	O	Line1 mute control
26	LINE CONT	O	Line ATT control
27	VOLCE	O	E-Volume LSI chip enabled
28	VOLDATA	O	E-Volume LSI data
29	SCLK	O	System bus clock
30	RST	-	Reset
31	EXTAL	-	Oscillator pulses
32	XTAL	-	( 12MHz)
33	Vss	-	GNDD
34	VOLCLK	O	E-Volume LSI clock
35	SYSPOW	O	System power control
36	AVSS	-	GNDD
37	AVREF	-	+5V
38	KEY1	O	Key input
39	KEY2	O	Key input
40	KEY3	O	Key input

No.	Name	I/O	Description
41	PROTECT	O	Protect detection input
42	SIMUKE	O	Model type select input
43	ST/TUNE	O	TX STREO/TUNED input
44	JOGIN	O	Multi JOG input
45	-	-	-
46	SDATA	I/O	Systembus data
47	SREQ	I/O	Systembus request
48	LCDCLK	O	LCD micro computer clock
49	LCDCE	O	LCD micro computer CE
50	LCDDAT	O	LCD micro computer data
51	CDSQCK	O	CD SUBQ clock
52	CDSQSO	I	CD SUBQ data input
53	LCDRST	O	LCD micro computer reset control
54	TOUCH	I	Touch sencer input
55	MS	I	MS Signal input
56	-	-	-
57	RDSDATA	I	RDS data input
58	PDSPOW	O	RDS power control
59	BEEP	O	beep control
60	ACPULS	I	AC puls input
61	REMIN	I	Remote control input
62	CDSCOR	I	CD SUBQ level input
63	RDSSCLK	I	RDS clock input
64	TXPOW	O	TX poer control
65	TXCE	O	TX LSI chip enabled
66	TXODAT	O	TX LSI data output
67	TXCLK	O	TX LSI clock
68	TXIDAT	I	TX LSI data input
69	TXMUTE	O	TX mute control
70	SPCONT	O	Speaker relay control
71	SYSMUTE	O	System mute control
72	VDD	-	+5.0V
73	NC	-	-
74	TCSENS	I	Reel pulse
75	EXPCE	O	EXPIC for CE control
76	TCOPEN	O	Tray open SW
77	TCCLOSE	O	Tray close SW
78	TCHALF	I	Mechanism HALF SW
79	TCMODE	I	Mechanism mode SW
80	TCRECR	I	Mechanism RECR SW



# 8. PANEL FACILITIES AND SPECIFICATIONS

## 8.1 PANEL FACILITIES

### ■ Front Panel

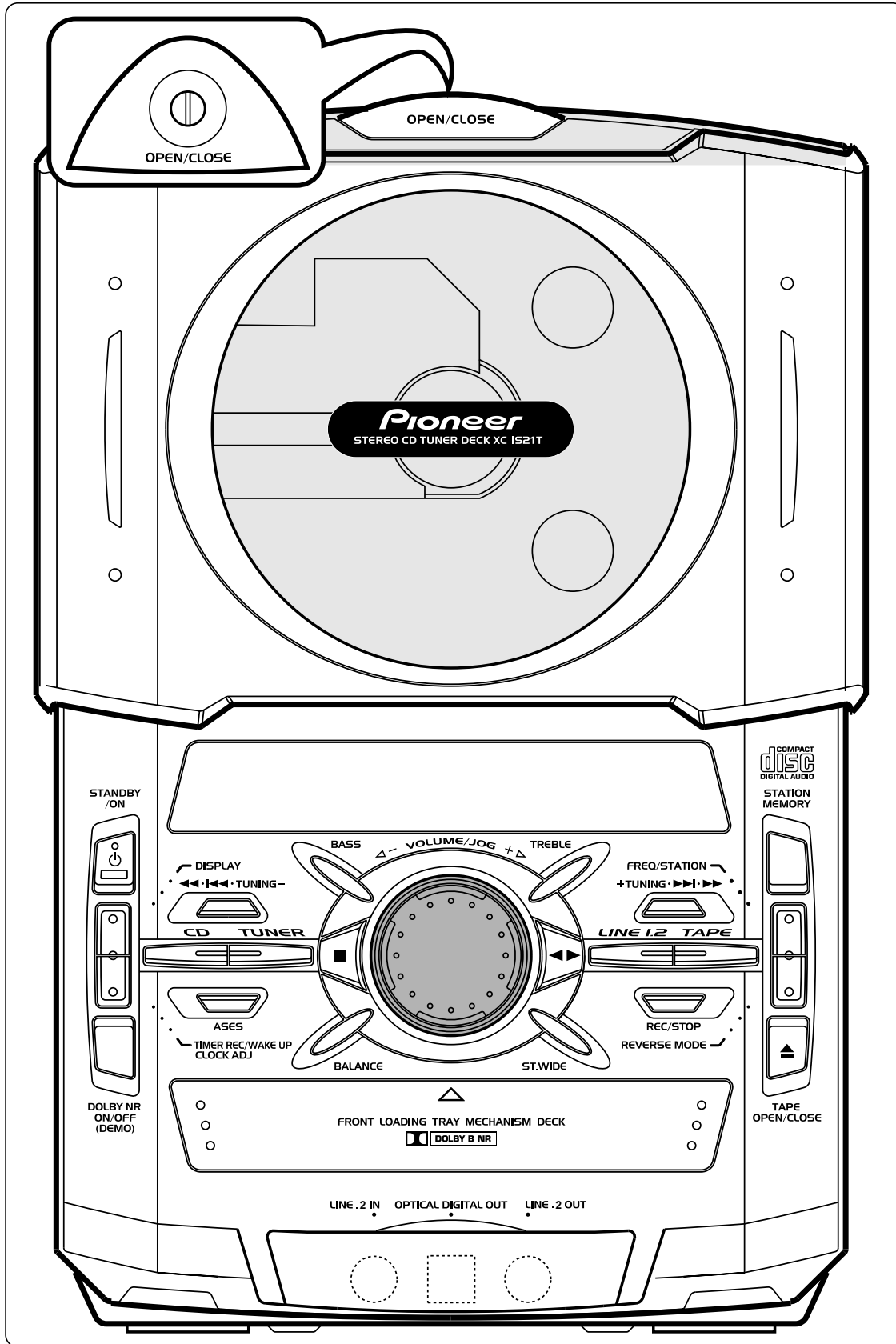

[CD Tuner Deck]

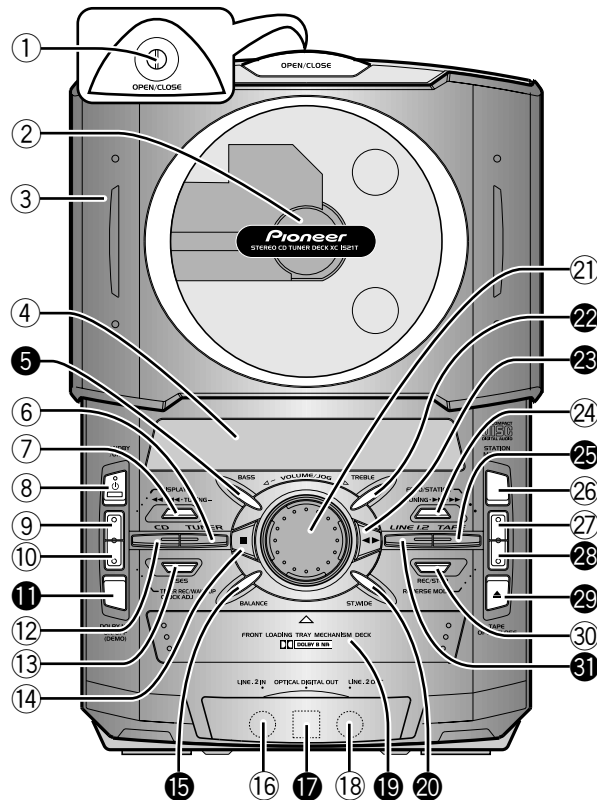

- |  |  |
|--|--|
| <p>① CD cover OPEN/CLOSE touch sensor</p> <p>② CD spindle</p> <p>③ CD slide cover</p> <p>④ Display window</p> <p>⑤ BASS button</p> <p>⑥ TUNER button</p> <p>⑦ ◀◀ •   ◀◀ • TUNING – button</p> <p>⑧ STANDBY/ON button and standby indicator</p> <p>⑨ DISPLAY button</p> <p>⑩ TIMER REC/WAKE UP/CLOCK ADJ button</p> <p>⑪ DOLBY* NR ON/OFF (DEMO) button</p> | <p>⑫ CD button</p> <p>⑬ ASES button</p> <p>⑭ Stop (■) button</p> <p>⑮ BALANCE button</p> <p>⑯ LINE 2 IN jack</p> <p>⑰ OPT (Optical) OUT jack</p> <p>⑱ LINE 2 OUT jack</p> <p>⑲ Cassette tray</p> <p>⑳ ST. (Stereo) WIDE button</p> <p>㉑ VOLUME/JOG dial</p> <p>㉒ TREBLE button</p> <p>㉓ Play/direction (◀▶) button</p> <p>㉔ TUNING + ◀▶▶▶ ▶▶▶▶ button</p> <p>㉕ TAPE button</p> <p>㉖ STATION MEMORY button</p> <p>㉗ FREQ (Frequency)/STATION button</p> <p>㉘ REVERSE MODE button</p> <p>㉙ TAPE OPEN/CLOSE (⏏) button</p> <p>㉚ REC/STOP button</p> <p>㉛ LINE 1, 2 button</p> |
|--|--|

This is the power switch.

**ON** : When set to the ON position, power is supplied and the unit becomes operational.

**STANDBY** : When set to the STANDBY position, the main power flow is cut and the unit is no longer fully operational. A minute flow of power feeds the unit to maintain operation readiness.

**Energy-Saving Design**

This product has been designed to reduce energy consumption when the unit is in the power off (standby) mode.

- Consult the Specifications for the power consumption in standby mode.

\*● Dolby noise reduction manufactured under license from Dolby Laboratories Licensing Corporation.

● “DOLBY” and the double-D symbol are trademarks of Dolby Laboratories Licensing Corporation.

## ■ Display

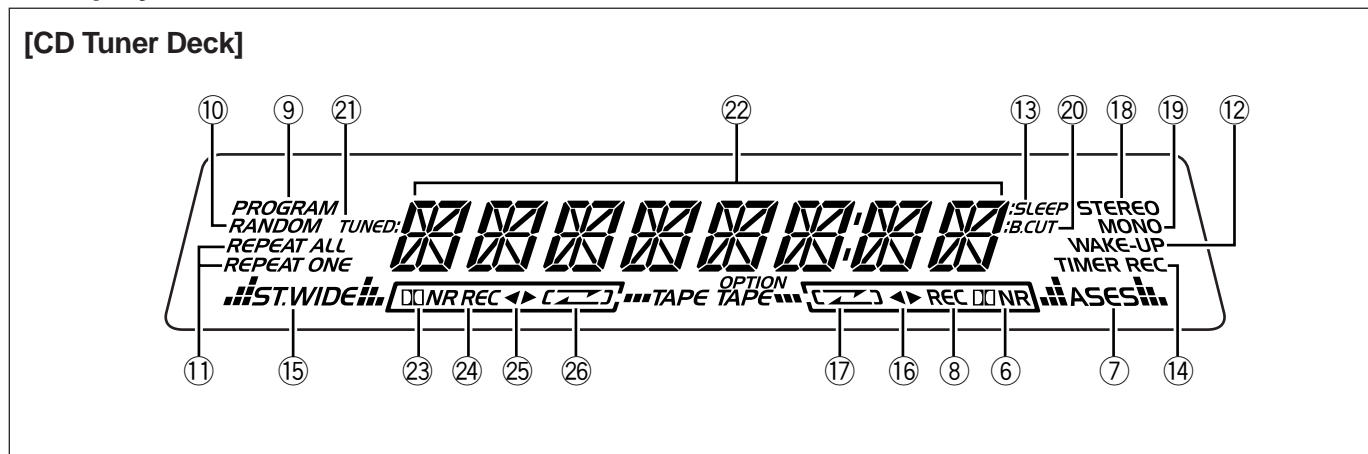

### Display window

- ⑥ Lights when Dolby NR on optional cassette deck is ON.
- ⑦ Lights when using A.S.E.S. (Auto Synchro Editing System).
- ⑧ Lights when optional cassette deck is set to recording mode.
- ⑨ Lights during program mode.
- ⑩ Lights during random playback.
- ⑪ Lights during repeat playback.
- ⑫ Lights when setting wake-up timer.
- ⑬ Lights during sleep timer operation.
- ⑭ Lights when setting timer recording.
- ⑮ Lights during stereo wide sound mode.
- ⑯ Lights to indicate tape direction of optional cassette deck.
- ⑰ Lights to indicate reverse mode of optional cassette deck.
- ⑱ Lights during FM stereo reception.
- ⑲ Lights when FM monaural reception is ON.
- ⑳ Lights when setting Beat Cut function.
- ㉑ Lights during radio broadcast reception.
- ㉒ Indicates frequency and major operation status.
- ㉓ Lights when Dolby NR is ON.
- ㉔ Lights when cassette deck is set to recording mode.
- ㉕ Lights to indicate tape direction of cassette deck.
- ㉖ Lights to indicate reverse mode of cassette deck.



## Remote Control Unit

### [CD Tuner Deck]

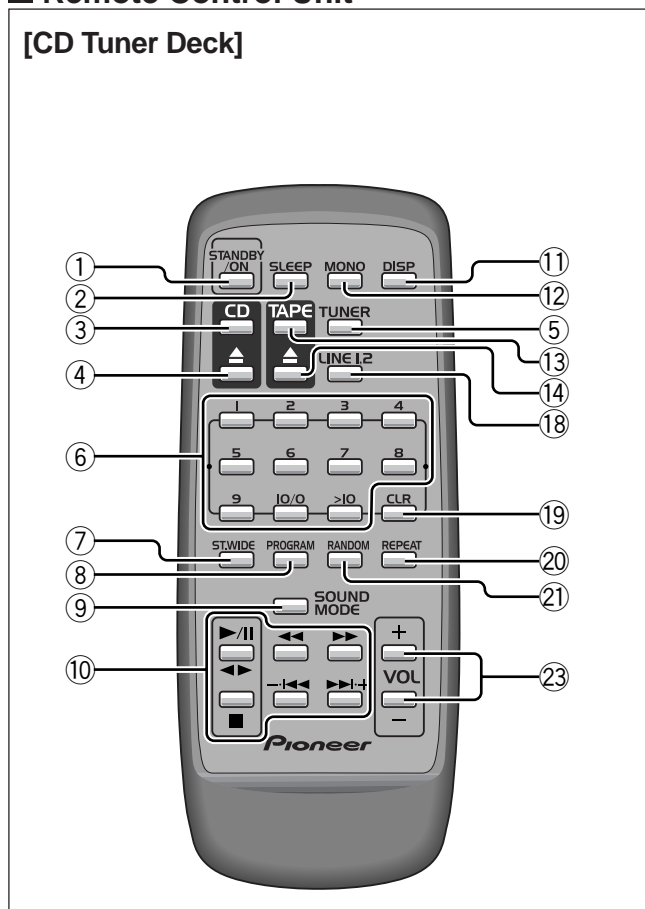

### ⑩ CD/MD/TAPE/TUNER operation buttons [CD/MD operation]

- ▶/|| : Play/pause button
- : Stop button
- ◀◀, ▶▶ : Manual search buttons
- ◀◀, ▶▶ : Track search buttons

### [TAPE operation]

- ◀▶ : Play button
- : Stop button
- ◀◀, ▶▶ : Fast forward, fast reverse buttons
- ◀◀, ▶▶ : Music search buttons

### [TUNER operation]

- ◀◀, ▶▶ : Frequency down, up buttons
- , + : Memory station no. decrement, increment buttons

### ⑪ DISP (display) button

### ⑫ MONO button

### ⑬ TAPE button

### ⑭ TAPE open/close (▲) button

### ⑮ LINE 1, 2 button

### ⑯ CLR (clear) button

### ⑰ REPEAT button

### ⑱ RANDOM button

### ⑳ VOL (volume) +, - button

Remote control buttons with the same name or mark as buttons on the front panel of the CD Tuner Deck control the same operations as the corresponding front panel buttons.

- ① **STANDBY/ON** button
- ② **SLEEP** button
- ③ **CD** button
- ④ **CD cover open/close (▲)** button
- ⑤ **TUNER** button
- ⑥ **Digit (1 – 9, 10/0, >10)** buttons
- ⑦ **ST. (stereo) WIDE** button
- ⑧ **PROGRAM** button
- ⑨ **SOUND MODE** button

## 8.2 SPECIFICATIONS

### ■ Amplifier Section

Continuous average power output of 55 watts\* per channel, min., at 6 ohms, from 60 Hz to 15,000 Hz with no more than 1.0 %\*\* total harmonic distortion.

\* Measured pursuant to the Federal Trade Commission's Trade Regulation rule on Power Output Claims for Amplifiers.

\*\* Measured by Audio Spectrum Analyzer.

### ■ FM Tuner Section

Frequency Range ..... 87.5 - 108MHz  
 Antenna ..... 75 Ω, unbalanced

### ■ AM Tuner Section

Frequency Range ..... 531 kHz - 1,602 kHz (9 kHz step);  
 530 kHz - 1,700 kHz (10 kHz step)  
 Antenna ..... Loop antenna

### ■ Compact Disc Player Section

Type ..... Compact disc digital audio system  
 Usable discs ..... Compact discs  
 Wow and Flutter ..... Limit of measurement  
 (0.001%) or less (EIAJ)

### ■ Cassette Deck Section

System ..... 4-track, 2-channel stereo  
 Heads ..... Recording/playback head x 1  
 Erasing head x 1  
 Motor ..... DC Servo motor x 1  
 Tape type ..... TYPE I (Normal), TYPE II (High/CrO<sub>2</sub>)

### ■ Miscellaneous (Stereo power amplifier : M-IS21)

Power Requirements ..... AC120 V, 60 Hz  
 Power Consumption ..... 120 W, 160 VA  
 Power Consumption in standby mode ..... 1 W  
 Dimensions:

CD Tuner Deck  
 ..... 205 (W) x 300 (H) x 237 (D) mm  
 8-1/16 (W) x 11-13/16 (H) x 9-5/16 (D) in.  
 Power Amplifier ..... 150 (W) x 300 (H) x 233 (D) mm  
 5-7/8 (W) x 11-13/16 (H) x 9-3/16 (D) in.

#### Weight:

CD Tuner Deck ..... 2.9 kg (6 lb 6 oz)  
 Power Amplifier ..... 4.0 kg (8 lb 13 oz)

### ■ Accessories

Operating Instructions ..... 2  
 Warranty Card ..... 1  
 FM antenna ..... 1  
 AM loop antenna ..... 1  
 Remote control unit ..... 1  
 Dry cell batteries (AA/R6) ..... 2  
 Power cord ..... 1  
 RCA pin-plug stereo cable ..... 1  
 System cable ..... 1

### ■ Accessories

Speaker cords ..... 2

#### NOTE:

*Specifications and design subject to possible modification without notice, due to improvements.*

## ■ Accessories

