

9.2 BOTTOM SECTION

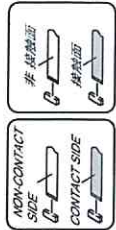
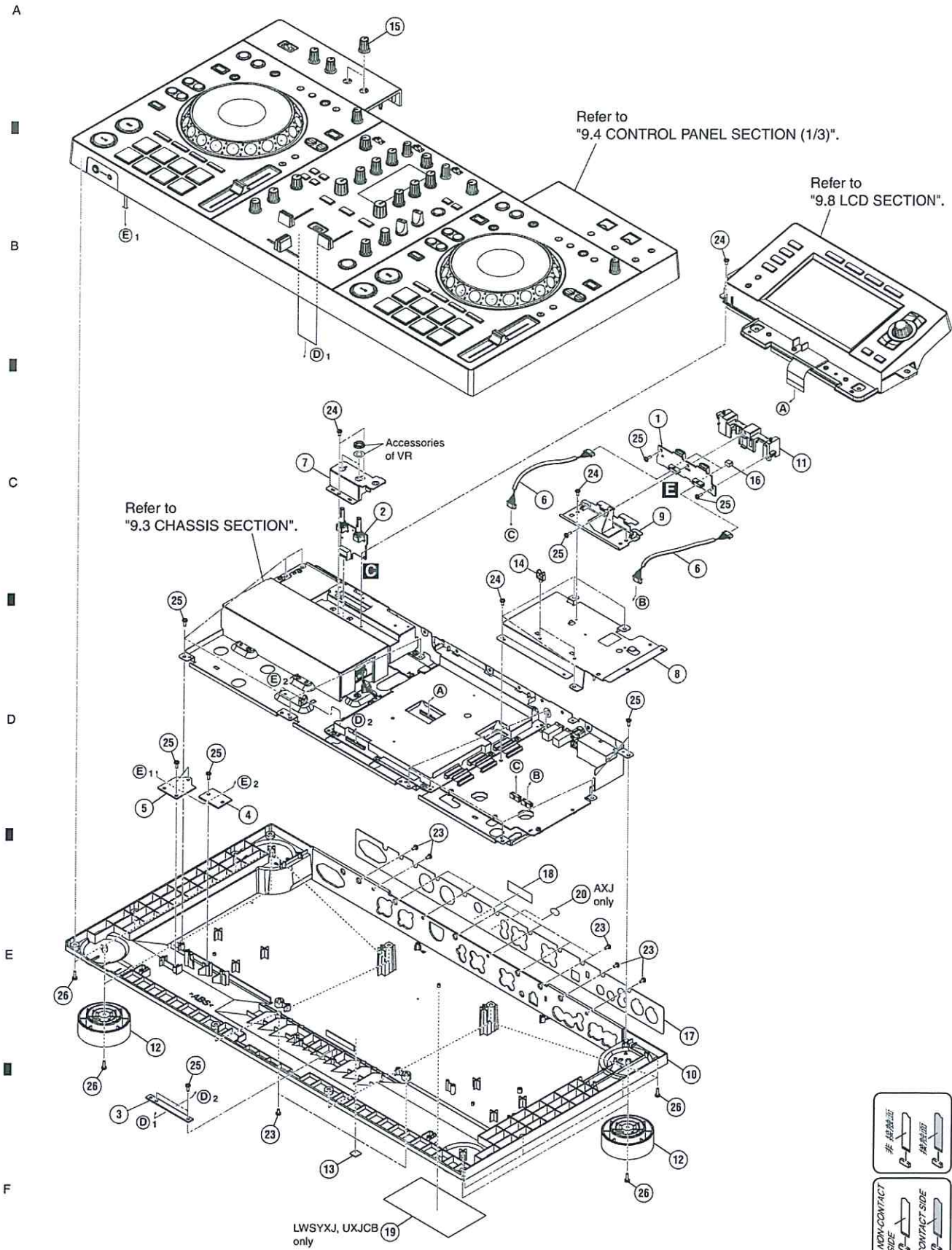

(1) BOTTOM SECTION PARTS LIST

<u>Mark No.</u>	<u>Description</u>	<u>Part No.</u>	<u>Mark No.</u>	<u>Description</u>	<u>Part No.</u>
1	USBA Assy	DWX4039			
2	MTRM Assy	DWX4052	16	Gasket/JOG	DEC3562
3	DKHD Assy	DWX4066	17	Rear Panel	See Contrast table (2)
4	HPHD Assy	DWX4067	NSP 18	Serial Label (UPC)	DRW2311
5	HMHD Assy	DWX4068	NSP 19	Label	See Contrast table (2)
			NSP 20	CCC S & E Label	See Contrast table (2)
6	Shielded Conn-Cable	DDA1080			
7	Stay	DNH3299	21	
8	Shield Case	DNH3303	22	
9	Stay	DNH3311	23	Screw	BBZ30P060FTB
⚠ 10	Chassis	DNK6704	24	Screw	BBZ30P060FTC
			25	Screw	BPZ30P080FNI
11	Base	DNK6708			
12	Insulator Assy	DXB2131	26	Screw	BPZ30P100FTB
13	Rubber Foot	VEB1349			
14	Holder	VEC1355			
15	Knob/LBK	DAA1284			

(2) CONTRAST TABLE

XDJ-RX2/LWSYXJ, UXJCB and AXJ are constructed the same except for the following:

Mark	No.	Symbol and Description	XDJ-RX2 /LWSYXJ	XDJ-RX2 /UXJCB	XDJ-RX2 /AXJ
	17	Rear Panel	DAH3158	DAH3158	DAH3195
NSP	19	Label	DRW2704	DRW2704	Not used
NSP	20	CCC S & E Label	Not used	Not used	DRW2310

9.3 CHASSIS SECTION

A

B

C

D

E

F

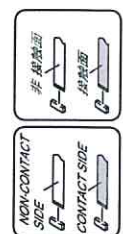
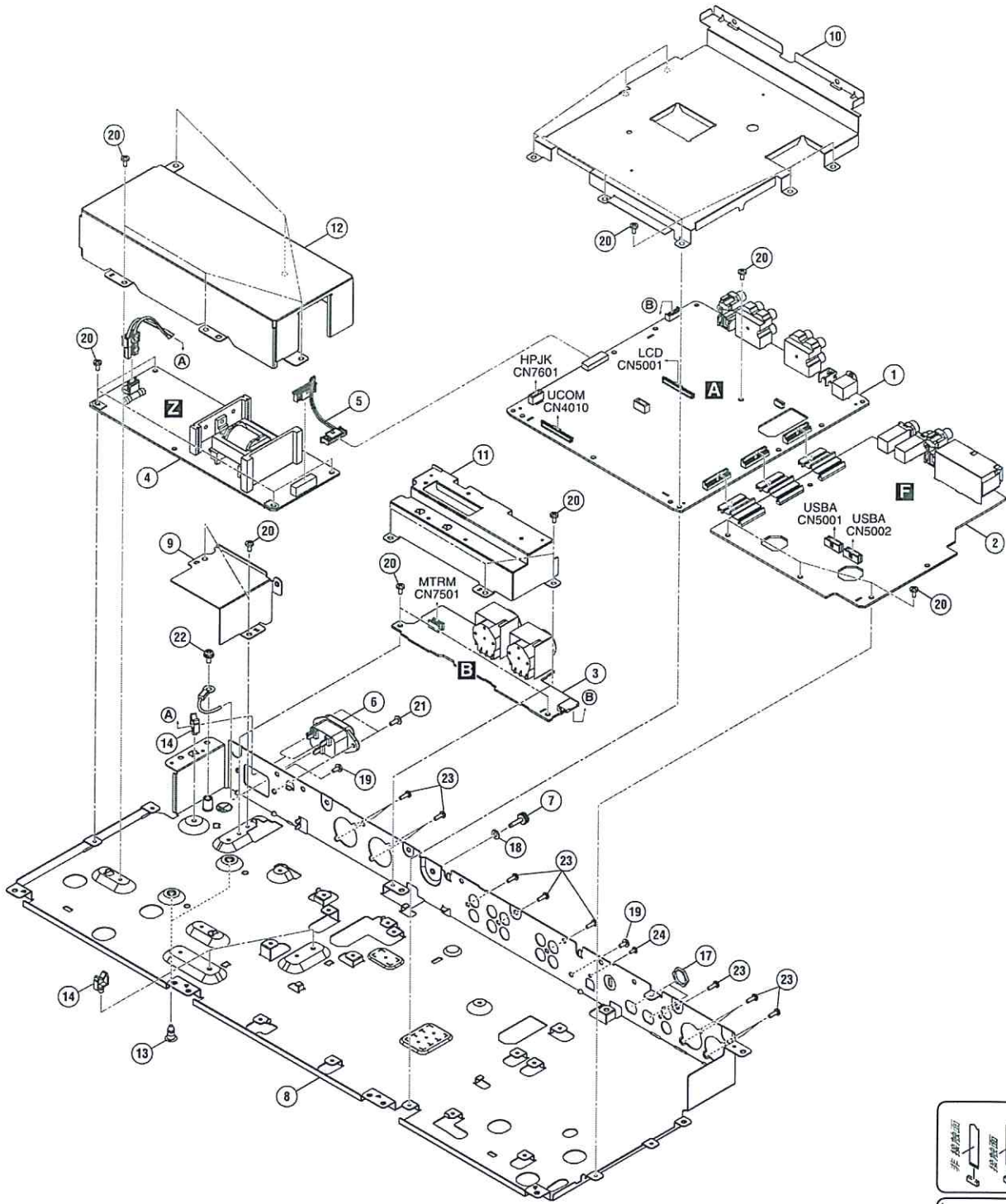

CHASSIS SECTION PARTS LIST

<u>Mark No.</u>	<u>Description</u>	<u>Part No.</u>	
1	MAIN Assy	DWX4035	
2	AOUT Assy	DWX4046	A
3	MCJK Assy	DWX4047	
⚠	4 SW POWER SUPPLY	DWR1548	
5	Crimp Connector	DDC1026	
⚠	6 AC Inlet	DKP3983	■
7	Earth Terminal	DKE1015	
8	Stay	DNH3298	
9	Shield Case	DNH3302	
10	Shield Case	DNH3304	
11	Shield Case	DNH3305	B
12	Shield Case	DNH3306	
NSP	13 PCB Holder	PNW1706	
14	Holder	VEC1355	
15		■
16		
17	Nut (M12)	NKX2FNI	
18	Spring Lock Washer	WS40FNI	
19	Screw	BBZ30P060FTB	
20	Screw	BBZ30P060FTC	C
21	Screw	IBZ30P080FTB	
22	Screw	PMH40P080FTC	
23	Screw	PPZ30P080FTB	
24	Screw (M3*5)	DBA1340	■
			D
			■
			E
			■
			F

9.4 CONTROL PANEL SECTION (1/3)

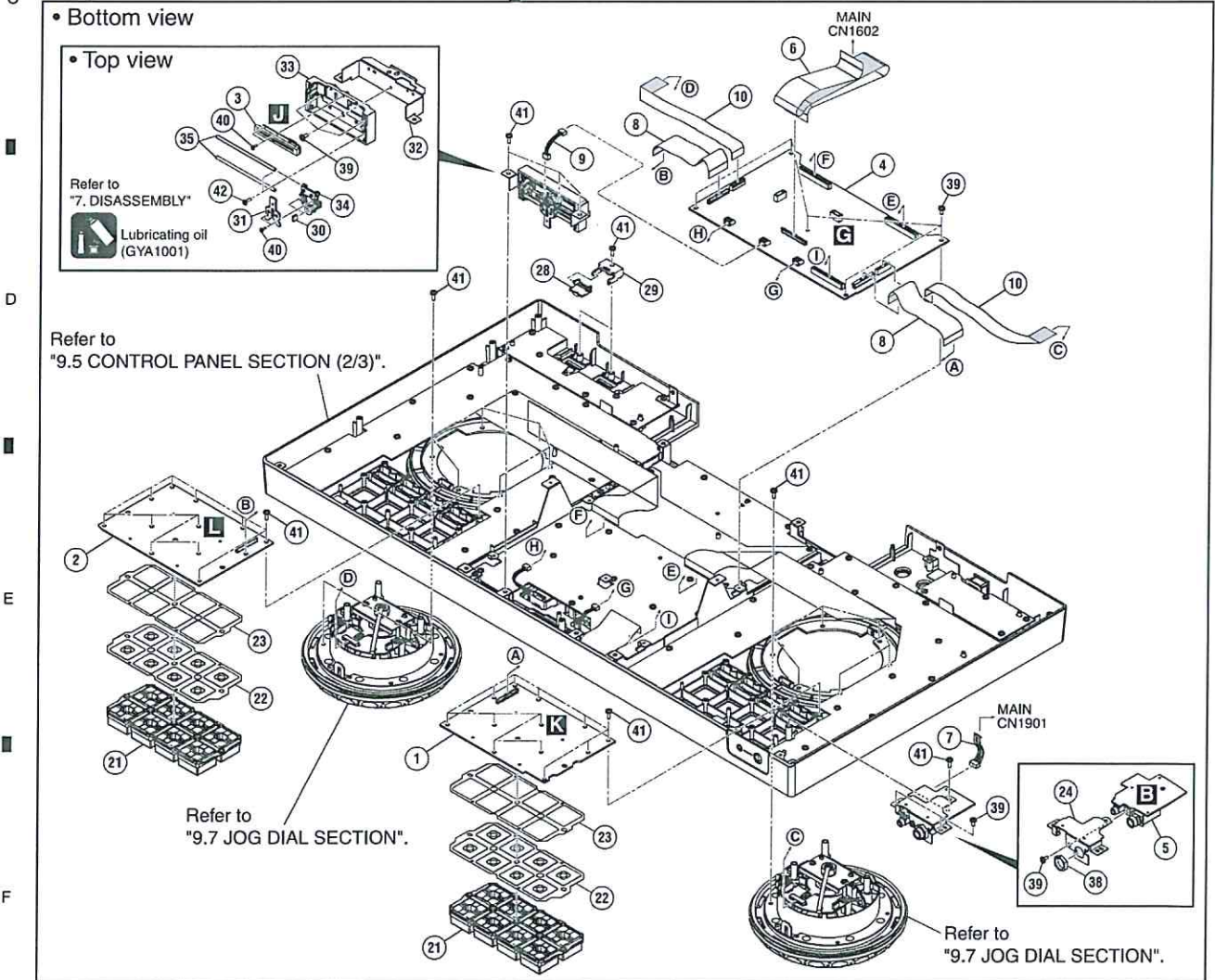
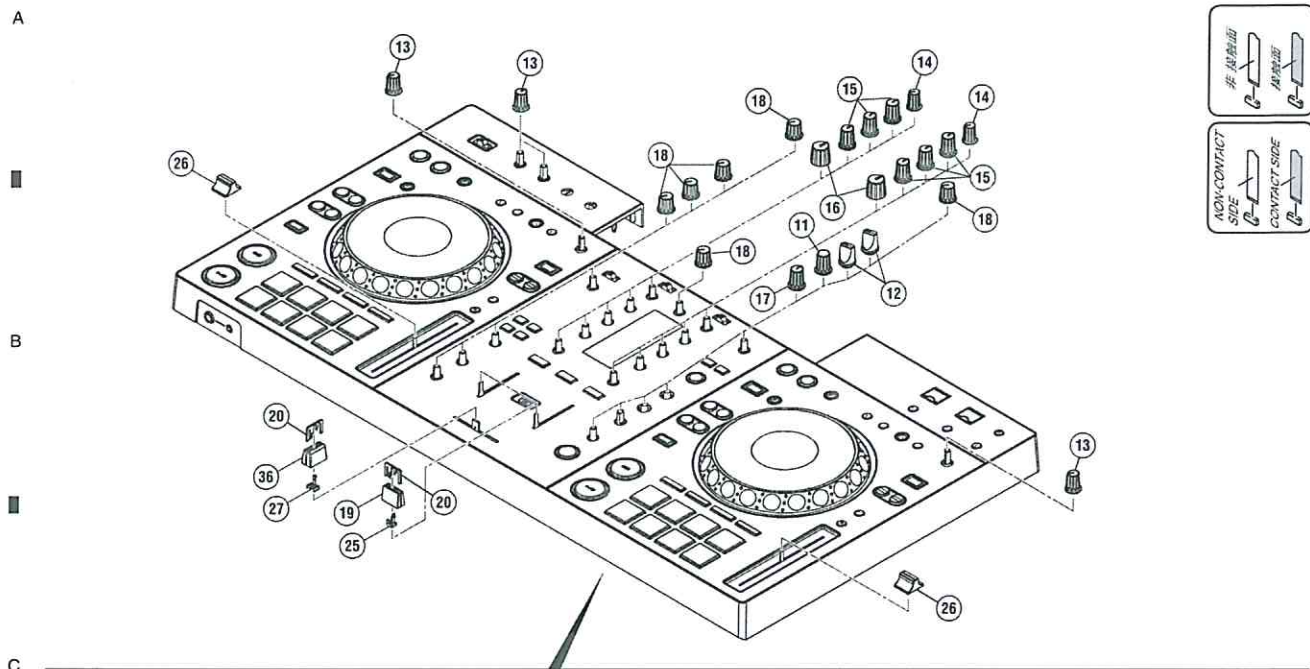

CONTROL PANEL SECTION (1/3) SECTION PARTS LIST

<u>Mark No.</u>	<u>Description</u>	<u>Part No.</u>	
1	PAD1 Assy	DWX4037	
2	PAD2 Assy	DWX4038	A
3	CRFD Assy	DWX4040	
4	UCOM Assy	DWX4045	
5	HPJK Assy	DWX4053	
6	FFC	DDD1812	
7	Connector Assy	PF04PP-D42	
8	FFC/50P	DDD1686	
9	Connector Assy	PF03PP-B05	
10	FFC	DDD1814	
11	Rotary SW Knob (C)	DAA1180	B
12	FX SEL Knob	DAA1213	
13	Knob/LBK	DAA1284	
14	Knob/CH	DAA1300	
15	Knob/RSW	DAA1305	
16	Knob/FRE	DAA1309	
17	Knob	DAA1368	
18	Knob	DAA1370	
19	Slider Knob 1	DAC2684	
20	Slider Knob 2	DAC2685	C
21	Button	DEB2057	
22	Sheet	DEC3739	
23	Spacer	DEC3740	
24	Stay/HP	DNH3182	
25	Slider Knob Stopper	DNK5888	
26	Knob/SLD	DNK5981	
27	Stopper	DNK6440	
28	Door	DNK6497	
29	Holder	DNK6710	D
NSP 30	Cushion	DEC3356	
31	Lever	DNH3211	
32	Stay	DNH3301	
33	Holder	DNK6425	
34	Slider	DNK6426	
35	Guide Bar	VLL1514	
36	Knob	DAC3238	
37	•••••		
38	Nut M12	DBN1018	E
39	Screw	BBZ30P060FTC	
40	Screw	BPZ20P050FTC	
41	Screw	BPZ30P080FNI	
42	Screw	CPZ26P080FTC	

9.5 CONTROL PANEL SECTION (2/3)

A • Bottom view

• Top view

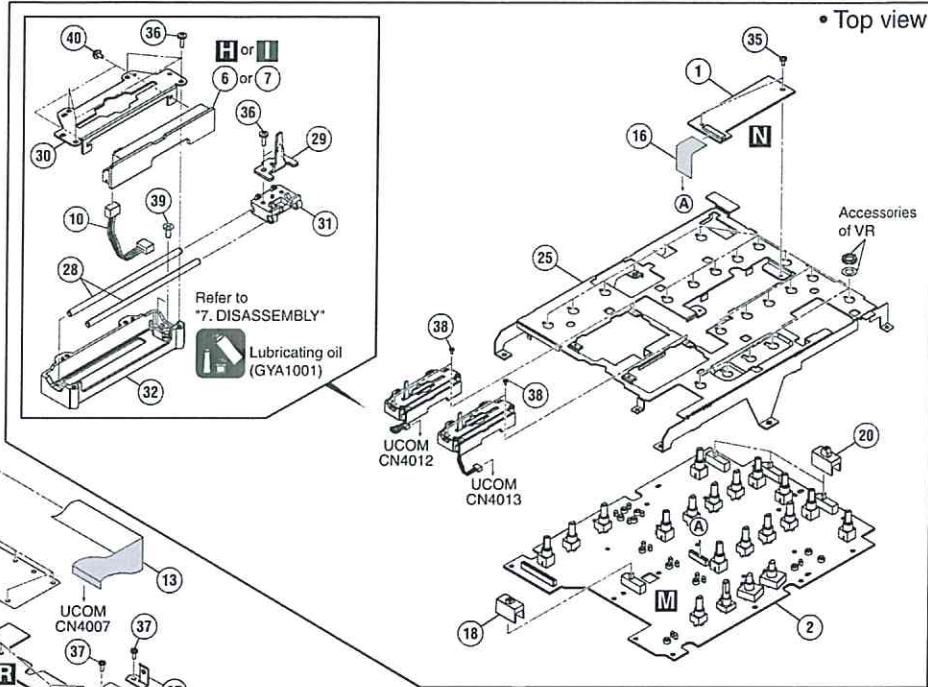

B

C

D

E

F

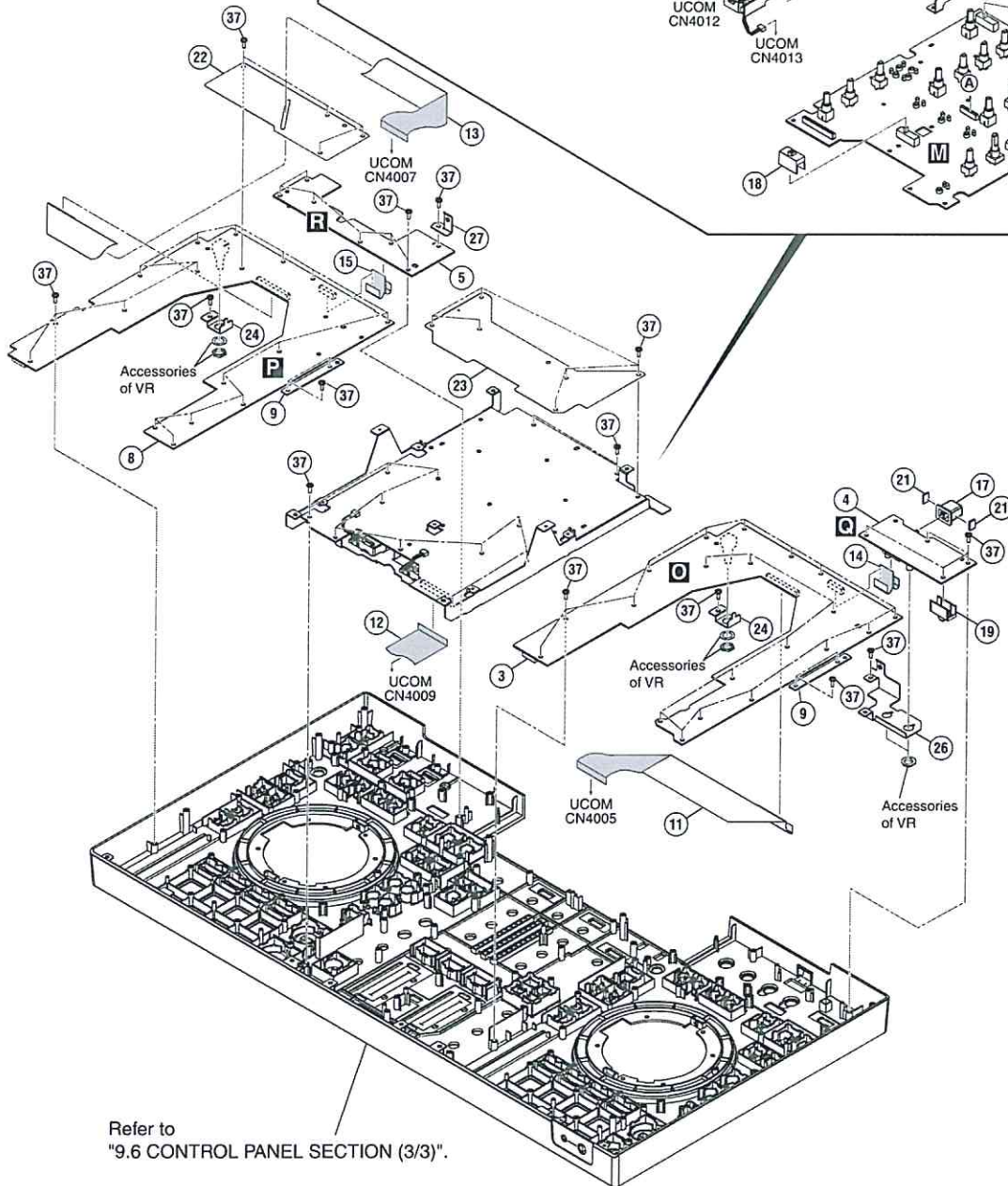

Refer to "9.6 CONTROL PANEL SECTION (3/3)".

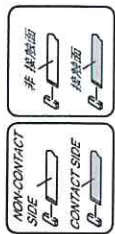

5 6 7 8

CONTROL PANEL SECTION (2/3) SECTION PARTS LIST

<u>Mark No.</u>	<u>Description</u>	<u>Part No.</u>	
1	LVMB Assy	DWX4048	
2	MXRB Assy	DWX4051	A
3	DCK1 Assy	DWX4054	
4	MEQB Assy	DWX4055	
5	RECB Assy	DWX4056	
6	CHF1 Assy	DWX4057	
7	CHF2 Assy	DWX4058	
8	DCK2 Assy	DWX4062	
9	DKHD Assy	DWX4066	
10	Connector Assy	PF03PP-B05	
11	FFC/39P	DDD1687	B
12	FFC	DDD1813	
13	FFC	DDD1745	
14	FFC/17P	DDD1684	
15	FFC/15P	DDD1660	
16	FFC/19P	DDD1689	
17	Power Knob	DAC2306	
18	Slide SW Cap (W)	DAC2401	
19	SW Cap	DAC2753	
20	Cap	DAC3136	C
21	Insulating Sheet	DEC3594	
22	Barrier	DEC3742	
23	Barrier	DEC3743	
24	VR Stay S	DNH2964	
25	Stay	DNH3297	
26	Stay	DNH3300	
27	Bracket	DNH3312	
NSP 28	Guide Shaft VK1	DLA1978	
29	Lever Plate	DNH2954	D
30	VR Stay	DNH2955	
31	Slider Base	DNK5851	
32	Shaft Holder	DNK5852	
33	•••••		
34	•••••		
35	Screw	BBZ30P060FTC	
36	Screw	BPZ20P060FTC	
37	Screw	BPZ30P080FNI	
38	Screw	BSZ20P040FTB	E
39	Screw	CPZ26P080FTC	
40	Screw	PMH20P040FTC	

5 6 7 8

CONTROL PANEL SECTION (3/3) SECTION PARTS LIST

<u>Mark No.</u>	<u>Description</u>	<u>Part No.</u>
1	1..XDJ-RX2 Panel Service Assy	DEA1076
△NSP 2	2..Control Panel	DNK6705
3	2..Slide Sheet 1C	DAH2404
NSP 4	2..Plate	DAH3151
NSP 5	2..Plate	DAH3152
NSP 6	2..Plate	DAH3153
NSP 7	2..Plate	DAH3154
NSP 8	2..Plate	DAH3155
NSP 9	2..Plate	DAH3157
NSP 10	2..DS Tape	DEH1091
NSP 11	2..DS Tape	DEH1093
12	2..Fader Packing	DEC3355
13	2..Packing	DEC3642
14	Gasket/JOG	DEC3562
15	Frame	DNH3296
16	Button/TMP	DAC2845
17	Button/PLY	DAC3018
18	Button/CAL	DAC3020
19	Button/DLT	DAC3021
20	Button/RVL	DAC3023
21	Button/SRC	DAC3028
22	Button/MT	DAC3029
23	Button/REL	DAC3030
24	Button/SYN	DAC3032
25	Button/TAP	DAC3038
26	Button/EF	DAC3040
27	Button/LOP	DAC3074
28	Button/BEF	DAC3075
29	Button/TSR	DAC3076
30	Button	DAC3285
31	Button	DAC3286
32	Button	DAC3287
33	Button	DAC3288
34	Screw	BPZ30P080FNI

A

B

C

D

E

F

9.7 JOG DIAL SECTION

A • Bottom view

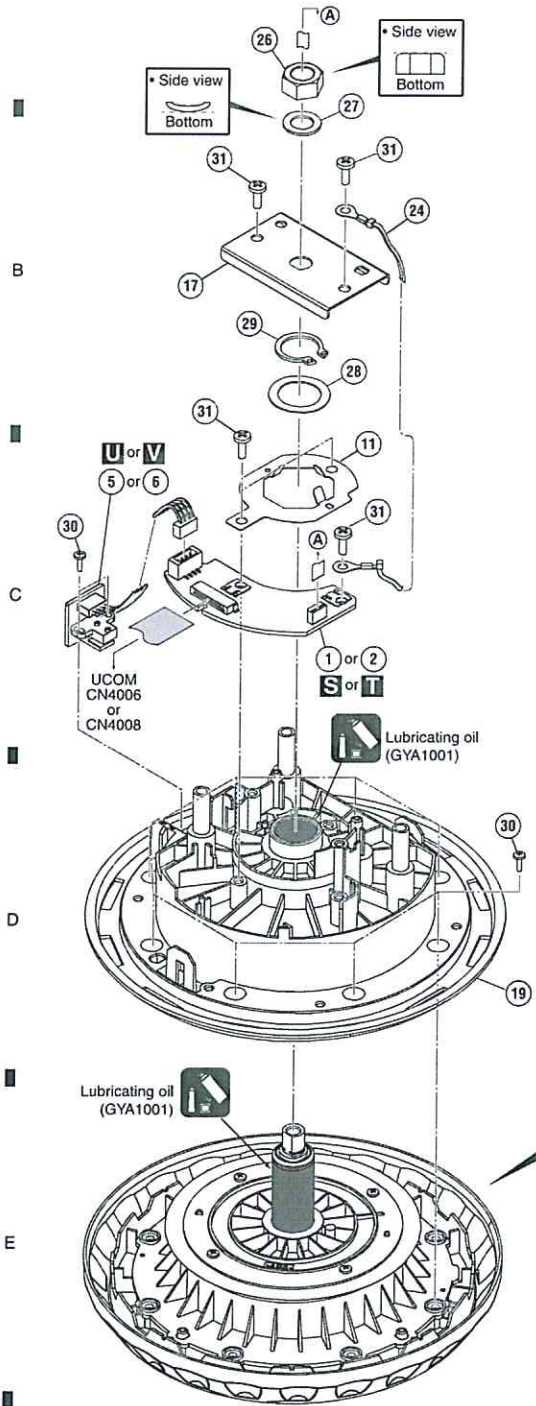

• Top view

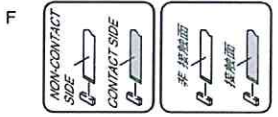
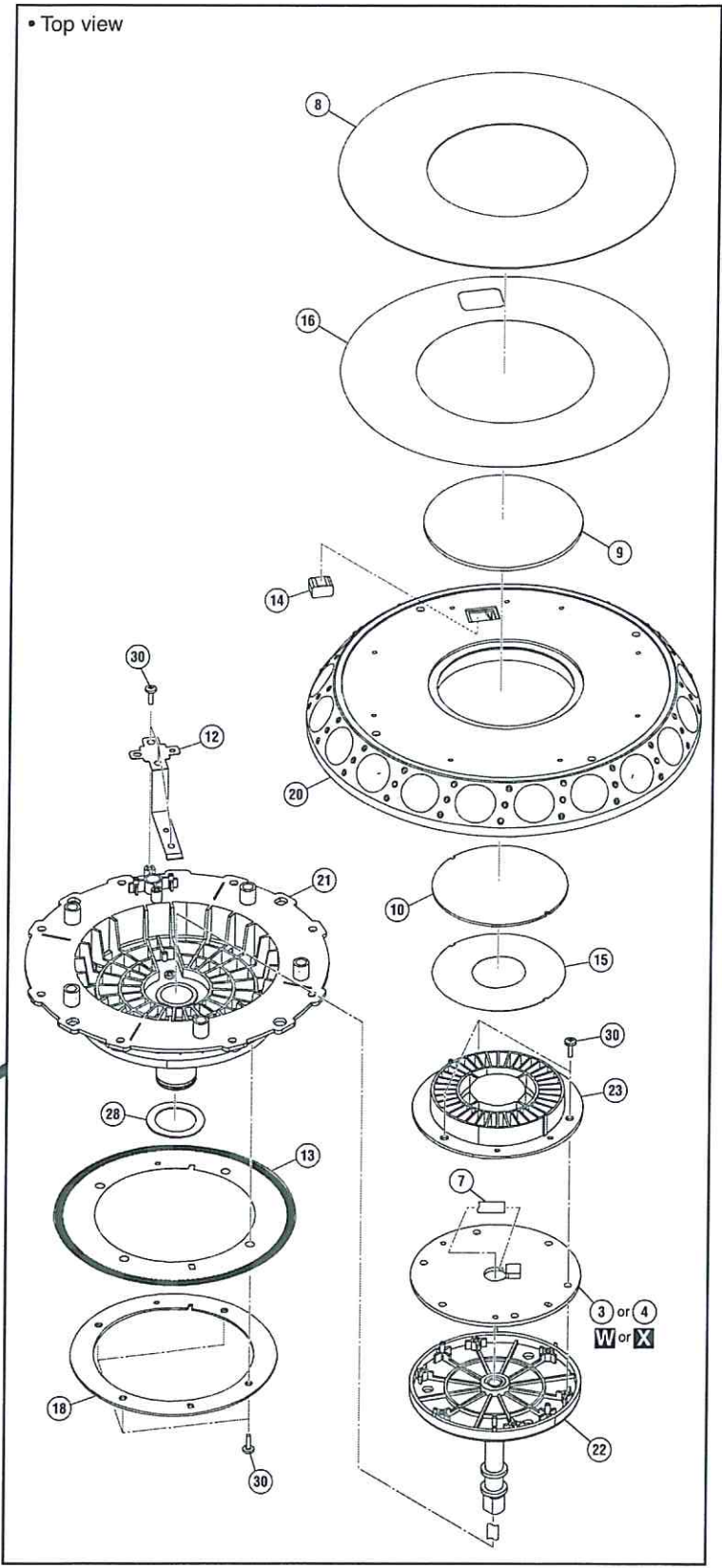

5 6 7 8

JOG DIAL SECTION PARTS LIST

<u>Mark No.</u>	<u>Description</u>	<u>Part No.</u>	
1	JOGT1 Assy	DWX4043	
2	JOGT2 Assy	DWX4044	A
3	JLED1 Assy	DWX4041	
4	JLED2 Assy	DWX4042	
5	JOG1 Assy	DWX4064	
6	JOG2 Assy	DWX4065	
7	FFC/6P	DDD1690	
8	Plate	DAH3167	
9	Window/JOG	DAH3003	
10	Window	DAH3004	
11	Leaf Spring/1	DBK1383	B
12	Leaf Spring/2	DBK1384	
13	Slit/JOG	DEC3515	
14	Gasket/JOG	DEC3562	
15	Diffuser/LED	DEC3575	
16	DS Tape/JOG	DEH1058	
17	Stay/LED	DNH3167	
18	Bracket/SLT	DNH3168	
19	Holder	DNK6741	
20	JOG Dial	DNK6709	C
21	JOG Dial/IN	DNK6373	
22	Holder/LED	DNK6374	
23	Spacer/LED	DNK6375	
24	Earth Lead Unit	DE005VC0	
25		
26	Nut	NA80FTC	
27	Spring Washer	WN80FTC	
28	Washer	WA154D225D050	
29	Washer	YC150FAC	D
30	Screw	BPZ20P060FTC	
31	Screw	BPZ30P080FNI	

9.8 LCD SECTION

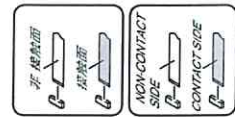
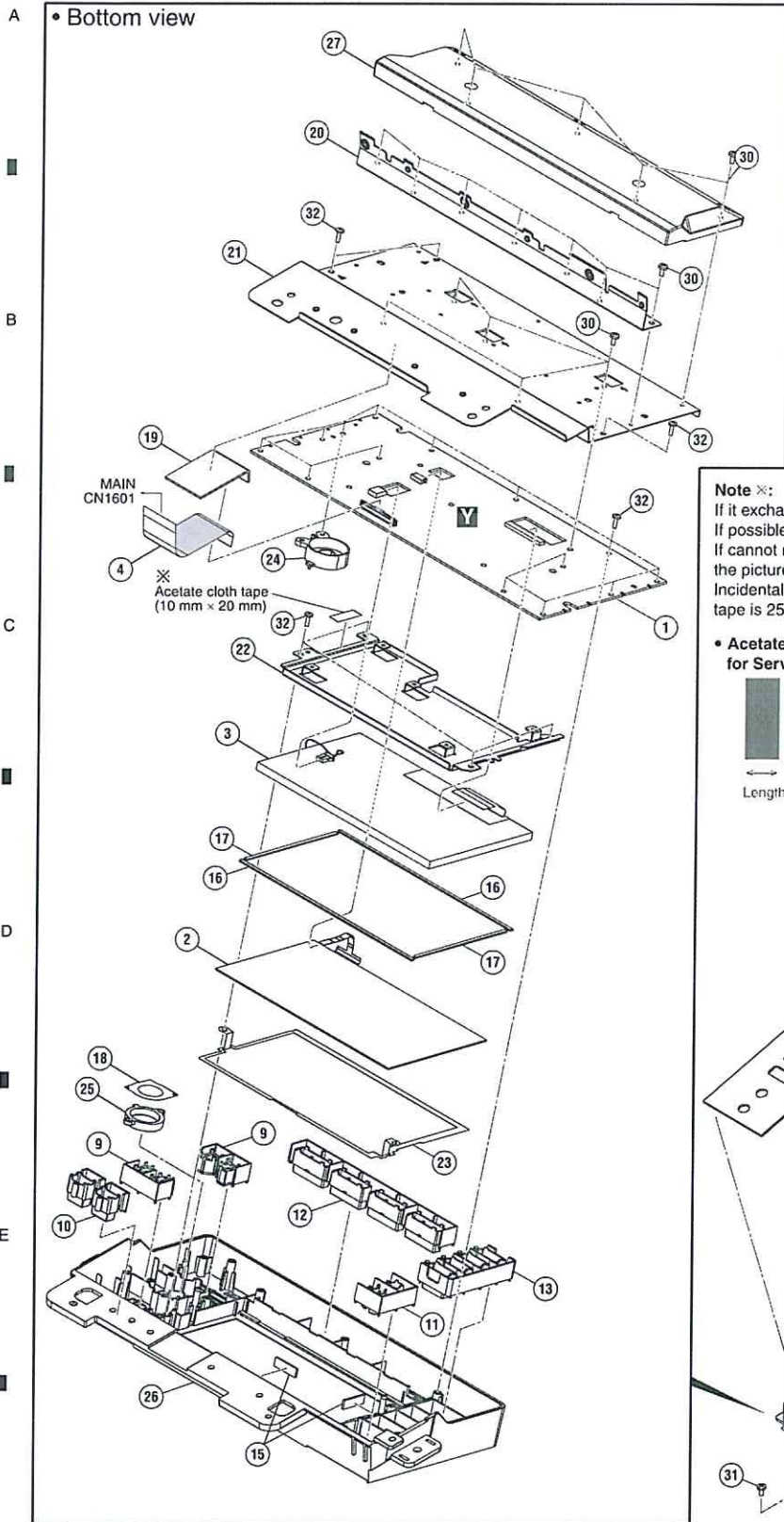

Note ※:
 If it exchanges the Stay (㊟), be sure to use Acetate cloth tape.
 If possible, reuse the original tape.
 If cannot reuse, paste Acetate cloth tape of service parts as shown in the picture.
 Incidentally, width of original tape is 10 mm, but width of service parts tape is 25 mm.

• Acetate cloth tape for Service

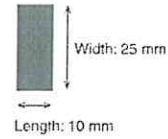

• Pasting position

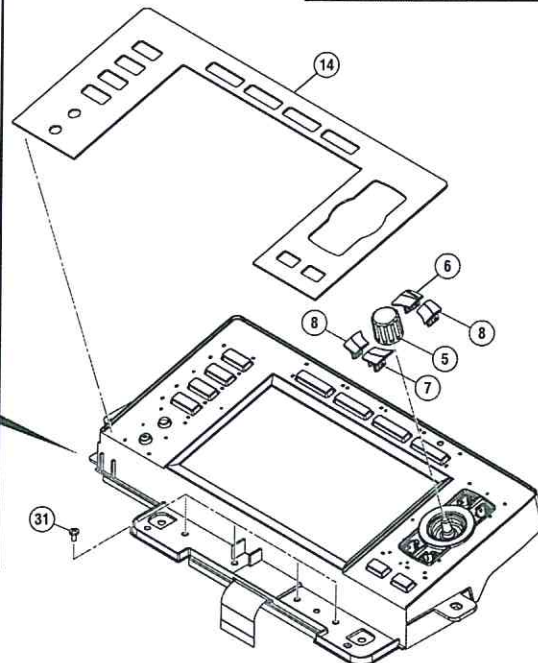
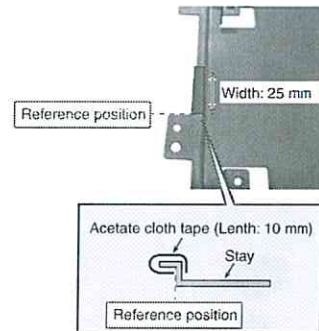

LCD SECTION PARTS LIST

<u>Mark No.</u>	<u>Description</u>	<u>Part No.</u>	
1	LCD Assy	DWX4036	
2	Touch Panel	DSX1130	A
3	TFT LCD	CWX4352	
4	FFC	DDD1811	
5	Dial Knob	DAA1246	
6	Button	DAC3113	
7	Button	DAC3117	
8	Button	DAC3118	
9	Button	DAC3289	
10	Button	DAC3290	
11	Button	DAC3291	B
12	Button	DAC3292	
13	Button	DAC3293	
14	Plate	DAH3156	
15	Packing/LCD	DEC3565	
16	Packing/L	DEC3568	
17	Packing/S	DEC3569	
18	Light-D Sheet	DEC3613	
19	Sheet	DEC3741	
20	Angle	DNH3307	C
21	Bracket	DNH3308	
22	Stay	DNH3309	
23	Plate	DNH3310	
24	Holder	DNK6467	
25	Lens	DNK6468	
⚠ 26	Panel	DNK6706	
27	Cover	DNK6707	
28	•••••		
29	•••••		
30	Screw	BBZ30P060FTB	D
31	Screw	BBZ30P060FTC	
32	Screw	BPZ26P080FTC	