

Service Manual

PIONEER®
The Art of Entertainment

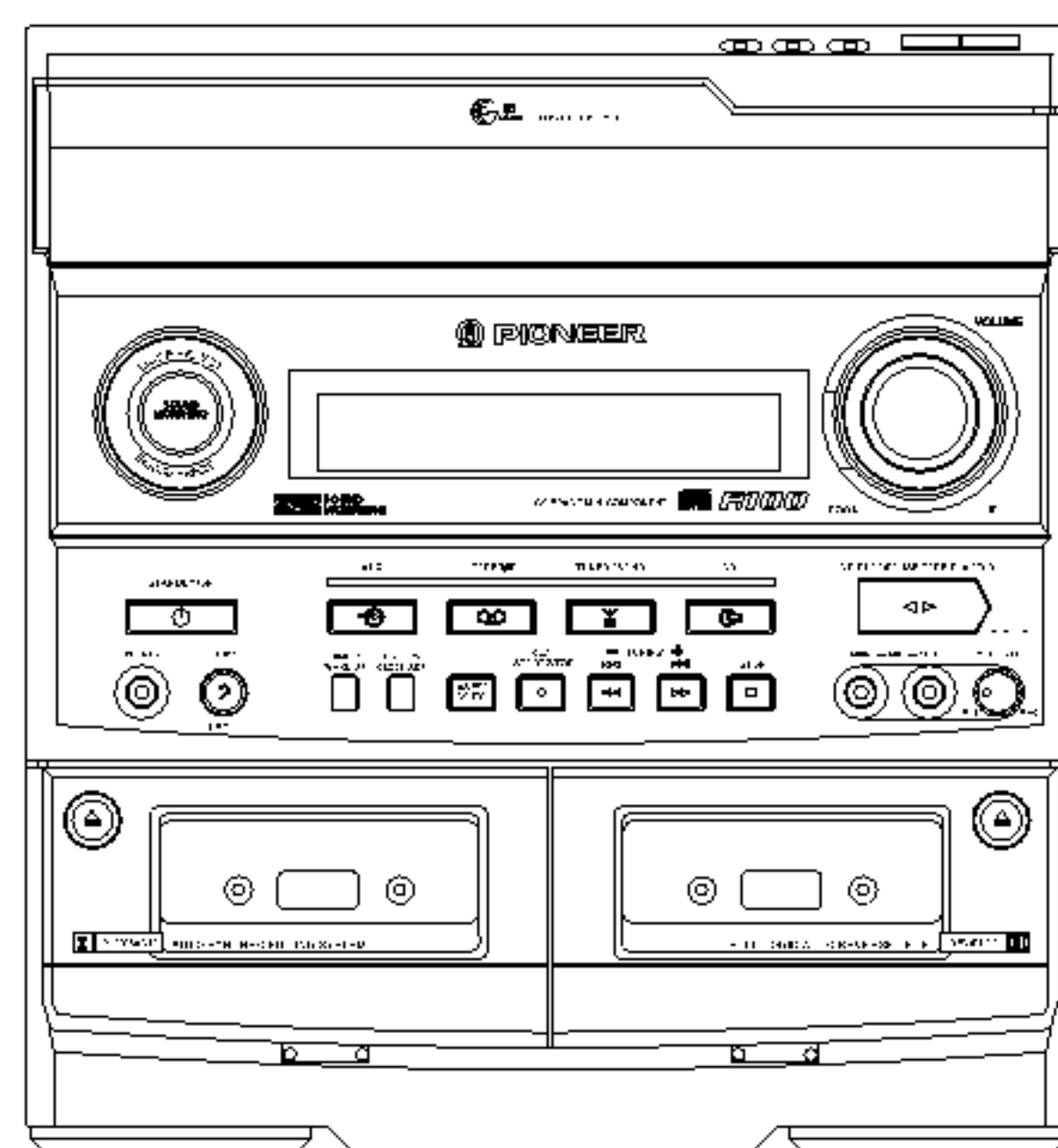

• XR-A100

ORDER NO.
RRV1865

STEREO CD CASSETTE DECK RECEIVER

XR-A200

XR-A100

THIS MANUAL IS APPLICABLE TO THE FOLLOWING MODEL(S) AND TYPE(S).

Type	Model		Power Requirement	The Voltage can be converted by the following method.
	XR-A200	XR-A100		
DDXJ	○	—	AC110-127V/220-230V/240V	With the voltage selector
DLXJ/NC	○	—	AC110-127V/220-230V/240V	With the voltage selector
DXJ/NC	○	—	AC110-127V/220-230V/240V	With the voltage selector
RDXJ	—	○	AC110-127V/220-240V	With the voltage selector
RLXJ/NC	—	○	AC110-127V/220-240V	With the voltage selector
RXJ/NC	—	○	AC110-127V/220-240V	With the voltage selector

CONTENTS

1. SAFETY INFORMATION	2	7. GENERAL INFORMATION	55
2. EXPLODED VIEWS AND PARTS LIST	3	7.1 PARTS	55
3. SCHEMATIC DIAGRAM	16	7.1.1 IC	55
4. PCB CONNECTION DIAGRAM	32	7.1.2 DISPLAY	57
5. PCB PARTS LIST	44	7.2 DIAGNOSIS	58
6. ADJUSTMENT	50	7.2.1 DISASSEMBLY	58
		7.2.2 TROUBLESHOOTING	60
		7.3 BLOCK DIAGRAM	64
		8. PANEL FACILITIES AND SPECIFICATIONS	65

PIONEER ELECTRONIC CORPORATION 4-1, Meguro 1-Chome, Meguro-ku, Tokyo 153, Japan
PIONEER ELECTRONICS SERVICE, INC. P.O. Box 1760, Long Beach, CA 90801-1760, U.S.A.
PIONEER ELECTRONIC (EUROPE) N.V. Haven 1087, Keetberglaan 1, 9120 Melsele, Belgium
PIONEER ELECTRONICS ASIACENTRE PTE. LTD. 501 Orchard Road, #10-00 Lane Crawford Place, Singapore 0923
 © PIONEER ELECTRONIC CORPORATION 1997

T - IZK OCT. 1997 Printed in Belgium

1. SAFETY INFORMATION

This service manual is intended for qualified service technicians ; it is not meant for the casual do-it-yourselfer. Qualified technicians have the necessary test equipment and tools, and have been trained to properly and safely repair complex products such as those covered by this manual.

Improperly performed repairs can adversely affect the safety and reliability of the product and may void the warranty. If you are not qualified to perform the repair of this product properly and safely, you should not risk trying to do so and refer the repair to a qualified service technician.

LABEL CHECK (For DLXJ/NC and RLXJ/NC types)

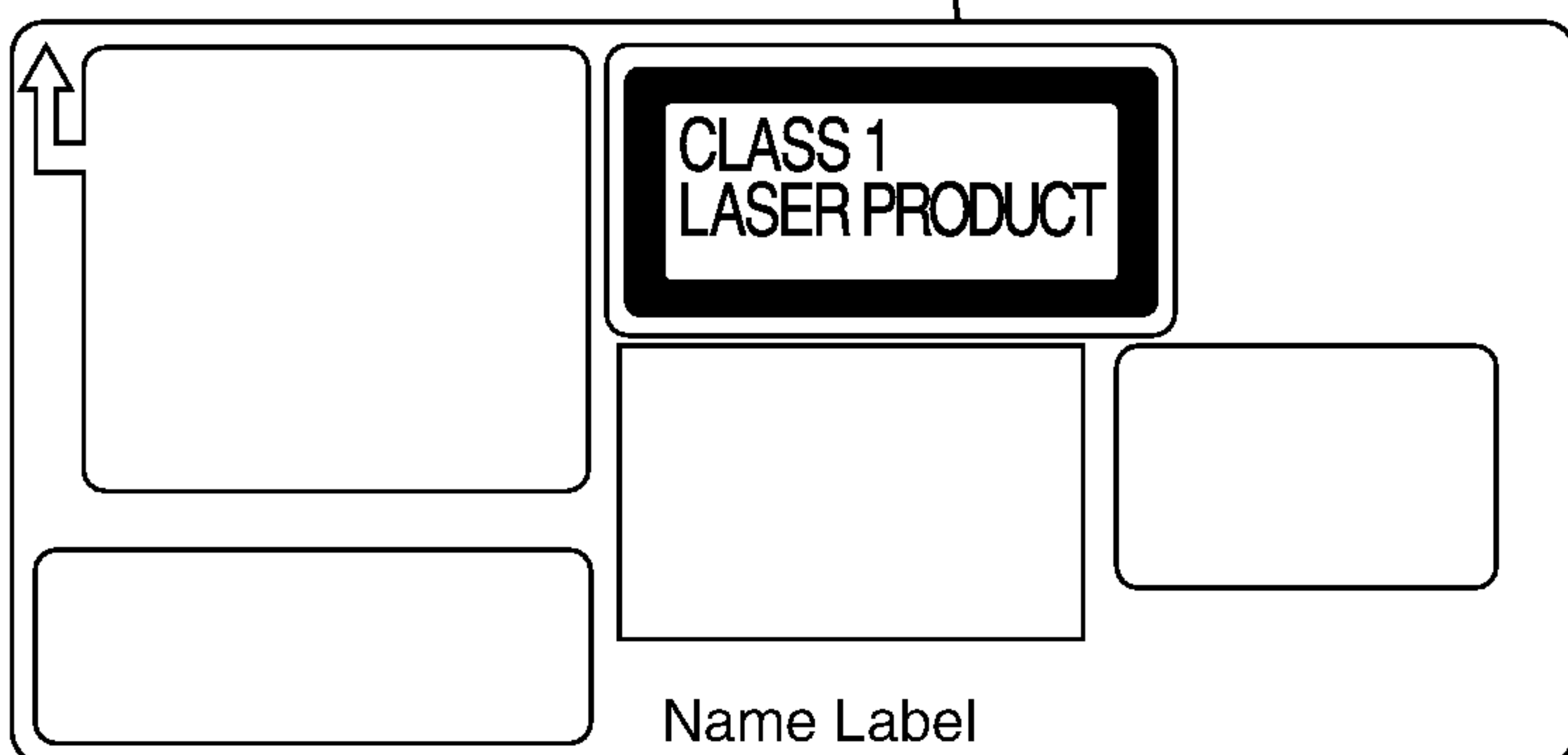
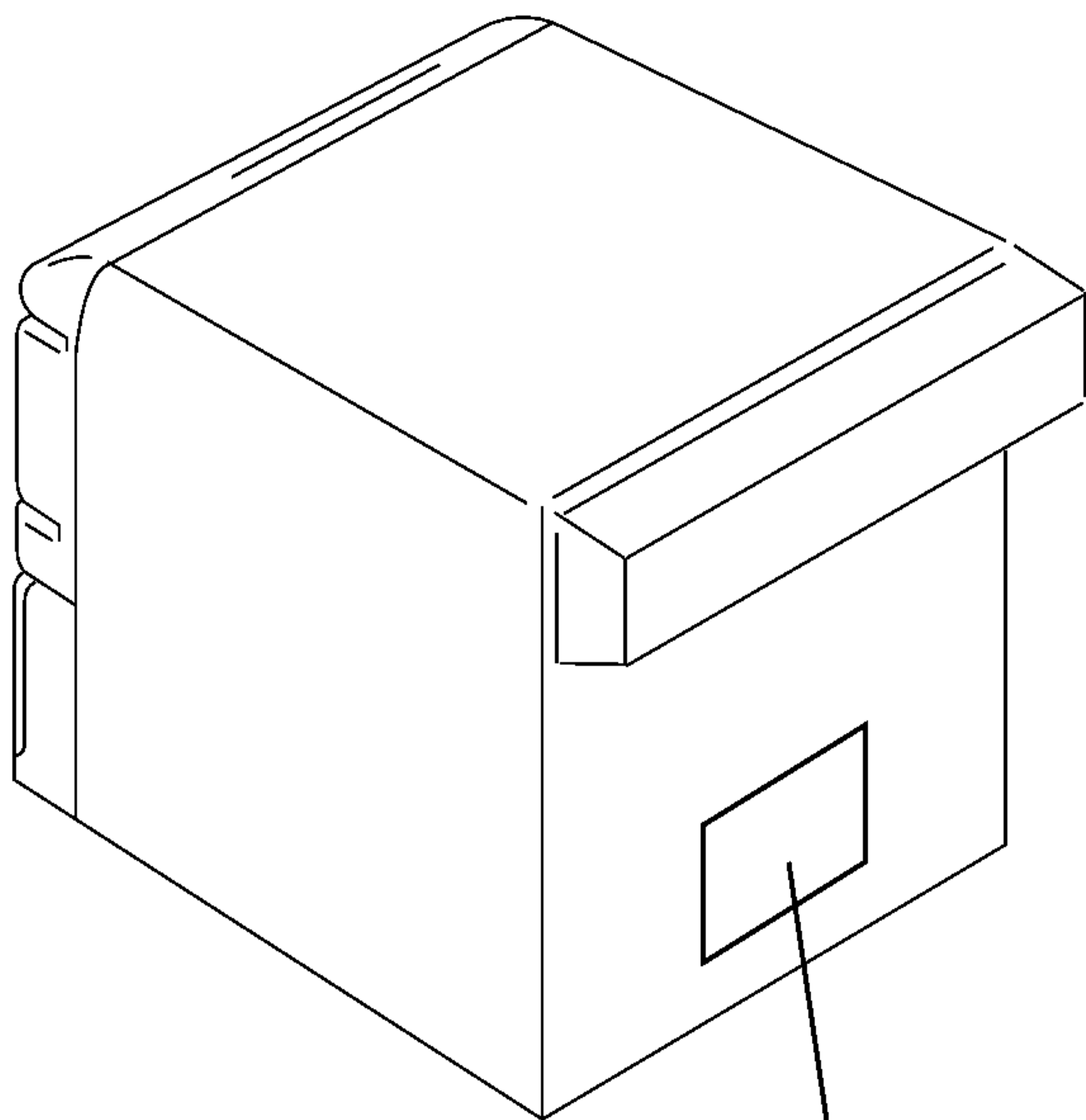

XAX3016 : DLXJ/NC Type
XAX3004 : RLXJ/NC Type

Additional Laser Caution

1. Laser Interlock Mechanism

The position of the switch (S8501) for detecting loading state is detected by the system microprocessor, and the design prevents laser diode oscillation when the switch (S8501) is pressed physically.

Thus, the interlock will no longer function if the switch (S8501) is released physically and deliberately.

The interlock also does not function in the test mode *. Laser diode oscillation will continue, if pin 62 of LA9240ML (IC8101) on the CD ASSY mounted on the \$M Loading Mechanism assembly is connected to GND, or else the terminals of Q8101 are shorted to each other (fault condition).

2. When the cover is opened, close viewing of the objective lens with the naked eye will cause exposure to a Class 1 laser beam.

* : Refer to page 54.

2. EXPLODED VIEWS AND PARTS LIST

- NOTES: ● Parts marked by "NSP" are generally unavailable because they are not in our Master Spare Parts List.
 ● The \triangle mark found on some component parts indicates the importance of the safety factor of the part. Therefore, when replacing, be sure to use parts of identical designation.
 ● Screws adjacent to \blacktriangledown mark on the product are used for disassembly.

2.1 PACKING

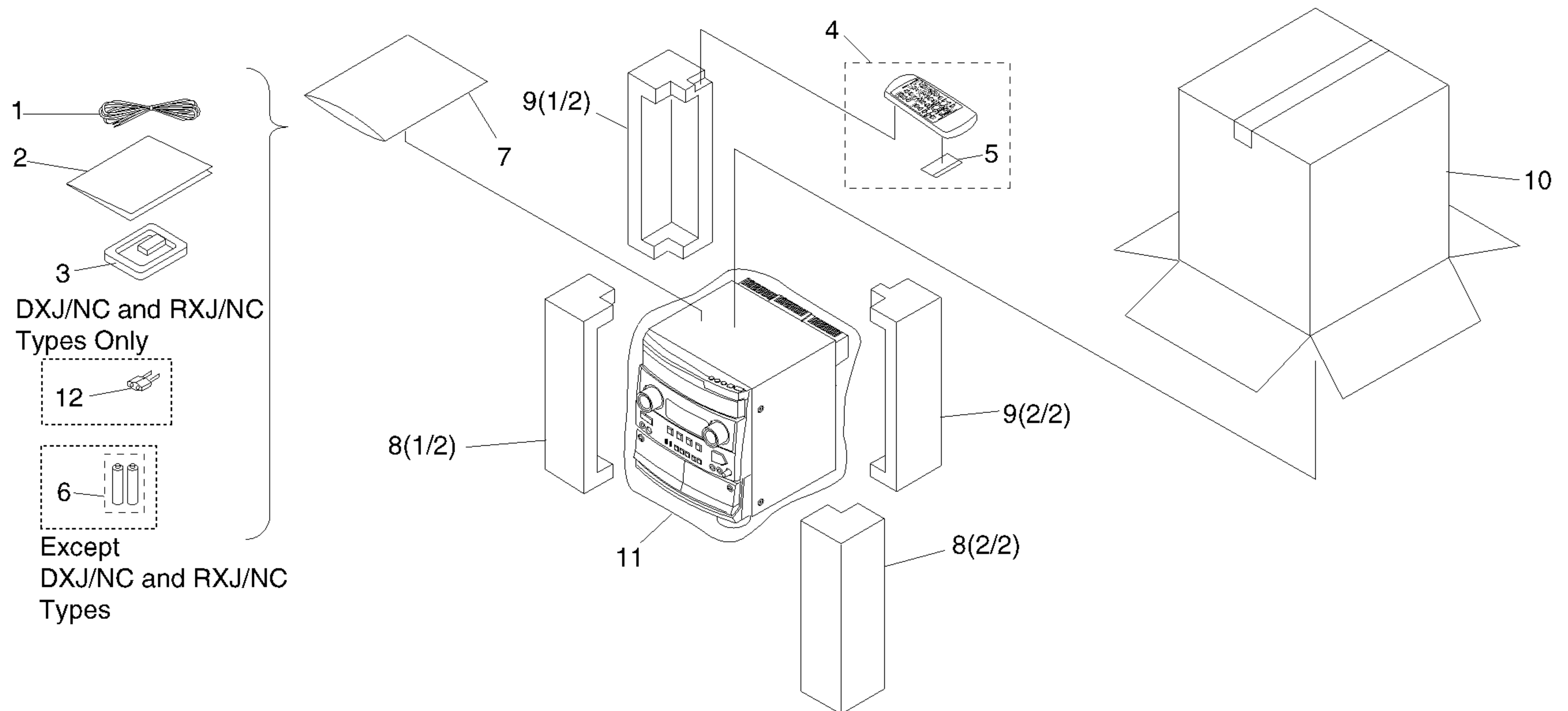

(1) PACKING PARTS LIST

Mark	No.	Description	Part No.	Mark	No.	Description	Part No.
	1	FM Antenna	ADH7004		9	R Protector	XHA3002
	2	Operating Instructions	See Contrast table (2)		10	Packing Case	See Contrast table (2)
	3	AM Loop Antenna	XTB3001		11	Packing Sheet	AHG7003
	4	Remote Control Unit (CU-XR039)	XZN3003	\triangle	12	Power-cord Plug Conversion Adapter	See Contrast table (2)
NSP	5	Battery Cover	AZA7204				
	6	Dry Cell Battery (R6P, AA)	See Contrast table (2)				
	7	Polyethylene Bag (0.03 × 230 × 340)	Z21-038				
	8	F Protector	XHA3001				

(2) CONTRAST TABLE

XR-A200/DDXJ, DLXJ/NC, DXJ/NC, XR-A100/RDXJ, RLXJ/NC and RXJ/NC are constructed the same except for the following :

Mark	No.	Symbol and Description	Part No.						Remarks
			XR-A200 /DDXJ	XR-A200 /DLXJ/NC	XR-A200 /DXJ/NC	XR-A100 /RDXJ	XR-A100 /RLXJ/NC	XR-A100 /RXJ/NC	
	2	Operating Instructions (English/Spanish/Portuguese)	Not used	Not used	XRE3003	Not used	Not used	XRE3003	
	2	Operating Instructions (English/Spanish/Chinese)	XRE3004	Not used	Not used	XRE3004	Not used	Not used	
	2	Operating Instructions (English/Russian/Chinese)	Not used	XRE3002	Not used	Not used	XRE3002	Not used	
NSP	6	Dry Cell Battery (R6P, AA)	VEM-013	VEM-013	Not used	VEM-013	VEM-013	Not used	
	10	Packing Case	XHD3016	XHD3014	XHD3014	XHD3006	XHD3004	XHD3004	
\triangle	12	Power-cord Plug Conversion Adapter	Not used	Not used	VKX1007	Not used	Not used	VKX1007	

(1) EXTERIOR (1/2) PARTS LIST

Mark	No.	Description	Part No.
NSP	1	20P F.F.C/30V	ADD7041
	2	CD \$M Loading Mechanism Assy	XXA3002
	3	Volume Knob	XAA3003
	4	Mic Knob	XAB3001
	5	S.C Knob	See Contrast table (2)
	6	Tray Cap	See Contrast table (2)
	7	Display Panel	See Contrast table (2)
	8	Bonnet Case	XZN3001
	9	Screw	BPZ30P100FZK
	10	S.C Button	See Contrast table (2)
	11	Screw	VBZ30P080FZK
	12	Disc Label	XAX3046

(2) CONTRAST TABLE

XR-A200/DDXJ, DLXJ/NC, DXJ/NC, XR-A100/RDXJ, RLXJ/NC and RXJ/NC are constructed the same except for the following :

Mark	No.	Symbol and Description	Part No.						Remarks
			XR-A200 /DDXJ	XR-A200 /DLXJ/NC	XR-A200 /DXJ/NC	XR-A100 /RDXJ	XR-A100 /RLXJ/NC	XR-A100 /RXJ/NC	
	5	S.C Knob	XAA3004	XAA3004	XAA3004	Not used	Not used	Not used	
	6	Tray Cap	XAK3009	XAK3009	XAK3009	XAK3008	XAK3008	XAK3008	
	7	Display Panel	XAK3004	XAK3004	XAK3004	XAK3003	XAK3003	XAK3003	
	10	S.C Button	Not used	Not used	Not used	XAD3003	XAD3003	XAD3003	

XR-A200, XR-A100

2.3 EXTERIOR (2/2)

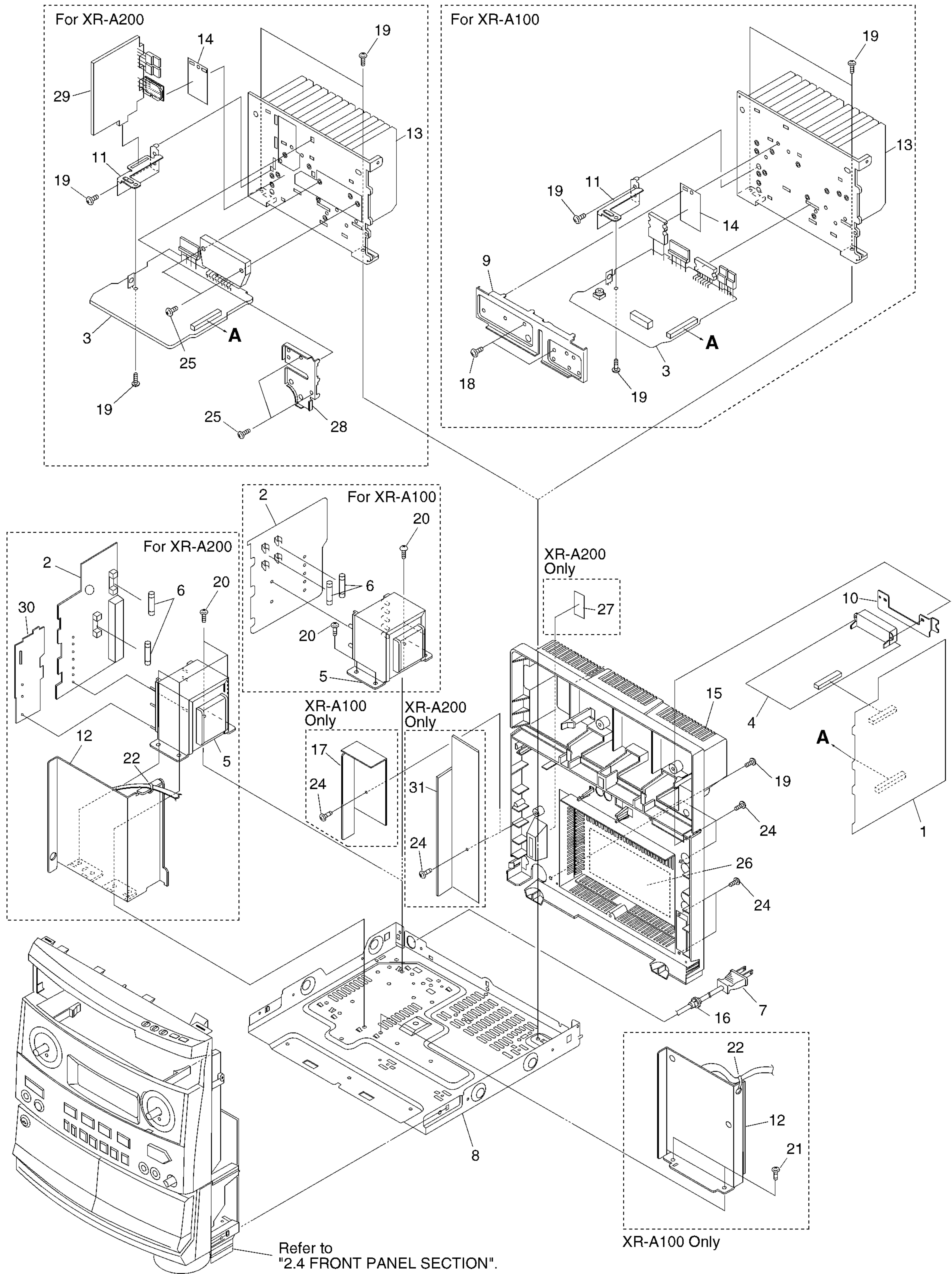

(1) EXTERIOR (2/2) PARTS LIST

Mark	No.	Description	Part No.	Mark	No.	Description	Part No.
	1	AF Assy	See Contrast table (2)		16	Strain Relief	CM-22B
	2	TRANS Assy	See Contrast table (2)		17	Barrier	See Contrast table (2)
	3	POWER Assy	See Contrast table (2)		18	Screw	BBZ30P120FMC
	4	FM/AM TUNER MODULE	AXQ7061		19	Screw	VBZ30P080FZK
△	5	T1 Power Transformer	See Contrast table (2)		20	Screw	ABA7031
△	6	FU1, FU2 Fuse	See Contrast table (2)		21	Screw	BCZ40P060FZK
△	7	AC Power Cord	See Contrast table (2)		22	Binder	ZCA-SKB90BK
NSP	8	Chassis	ANA7051		23	•••••	
	9	Bracket A	See Contrast table (2)		24	Screw	BPZ30P100FZK
	10	GND Plate	ANG7106		25	Screw	BBZ30P160FMC
	11	Bracket B	ANG7107	NSP	26	Name Label	See Contrast table (2)
	12	Shield Plate	See Contrast table (2)		27	Voltage Label	See Contrast table (2)
	13	Heat Sink	See Contrast table (2)		28	Bracket C	See Contrast table (2)
	14	Mica Sheet	AEE7015		29	POWER Assy 2	See Contrast table (2)
	15	Rear Cover	AMC7001		30	TRANS 2 Assy	See Contrast table (2)
					31	PVC Barrier	See Contrast table (2)

Note: The GND Plate (No.10) will tend to come off once it is removed, as the plate is fit with light pressure. If you have to remove the plate, secure it onto the Rear Cover with adhesive tape for reinstallation.

(2) CONTRAST TABLE

XR-A200/DDXJ, DLXJ/NC, DXJ/NC, XR-A100/RDXJ, RLXJ/NC and RXJ/NC are constructed the same except for the following :

Mark	No.	Symbol and Description	Part No.						Remarks
			XR-A200 /DDXJ	XR-A200 /DLXJ/NC	XR-A200 /DXJ/NC	XR-A100 /RDXJ	XR-A100 /RLXJ/NC	XR-A100 /RXJ/NC	
△	1	AF Assy	XWM3011	XWM3011	XWM3011	XWM3001	XWM3001	XWM3001	
	2	TRANS Assy	XWZ3021	XWZ3021	XWZ3021	AWZ8533	AWZ8533	AWZ8533	
	3	POWER Assy	XWZ3011	XWZ3011	XWZ3011	AWZ8534	AWZ8534	AWZ8534	
△	5	T1 Power Transformer (AC110-127V/220-230V/240V)	XTS3001	XTS3001	XTS3001	Not used	Not used	Not used	
△	5	T1 Power Transformer (AC110-127V/220-240V)	Not used	Not used	Not used	ATS7139	ATS7139	ATS7139	
△	6	FU1, FU2 Fuse (1.25A)	REK1023	REK1023	REK1023	Not used	Not used	Not used	
△	6	FU1, FU2 Fuse (1.0A)	Not used	Not used	Not used	REK1022	REK1022	REK1022	
△	7	AC Power Cord	ADG1157	PDG1058	PDG1058	ADG1157	PDG1058	PDG1058	
	9	Bracket A	Not used	Not used	Not used	ANG7100	ANG7100	ANG7100	
	12	Shield Plate	ANG7132	ANG7132	ANG7132	ANG7118	ANG7118	ANG7118	
	13	Heat Sink	ANH7063	ANH7063	ANH7063	ANH7059	ANH7059	ANH7059	
	17	Barrier	Not used	Not used	Not used	ANK7029	ANK7029	ANK7029	
NSP	26	Name Label	XAX3018	XAX3016	XAX3017	XAX3006	XAX3004	XAX3005	
	27	Voltage Label	AAX7391	AAX7391	AAX7391	Not used	Not used	Not used	
	28	Bracket C	ANG7127	ANG7127	ANG7127	Not used	Not used	Not used	
	29	POWER Assy 2	XWZ3012	XWZ3012	XWZ3012	Not used	Not used	Not used	
	30	TRANS 2 Assy	XWZ3022	XWZ3022	XWZ3022	Not used	Not used	Not used	
	31	PVC Barrier	AEC7074	AEC7074	AEC7074	Not used	Not used	Not used	

XR-A200, XR-A100

2.4 FRONT PANEL SECTION

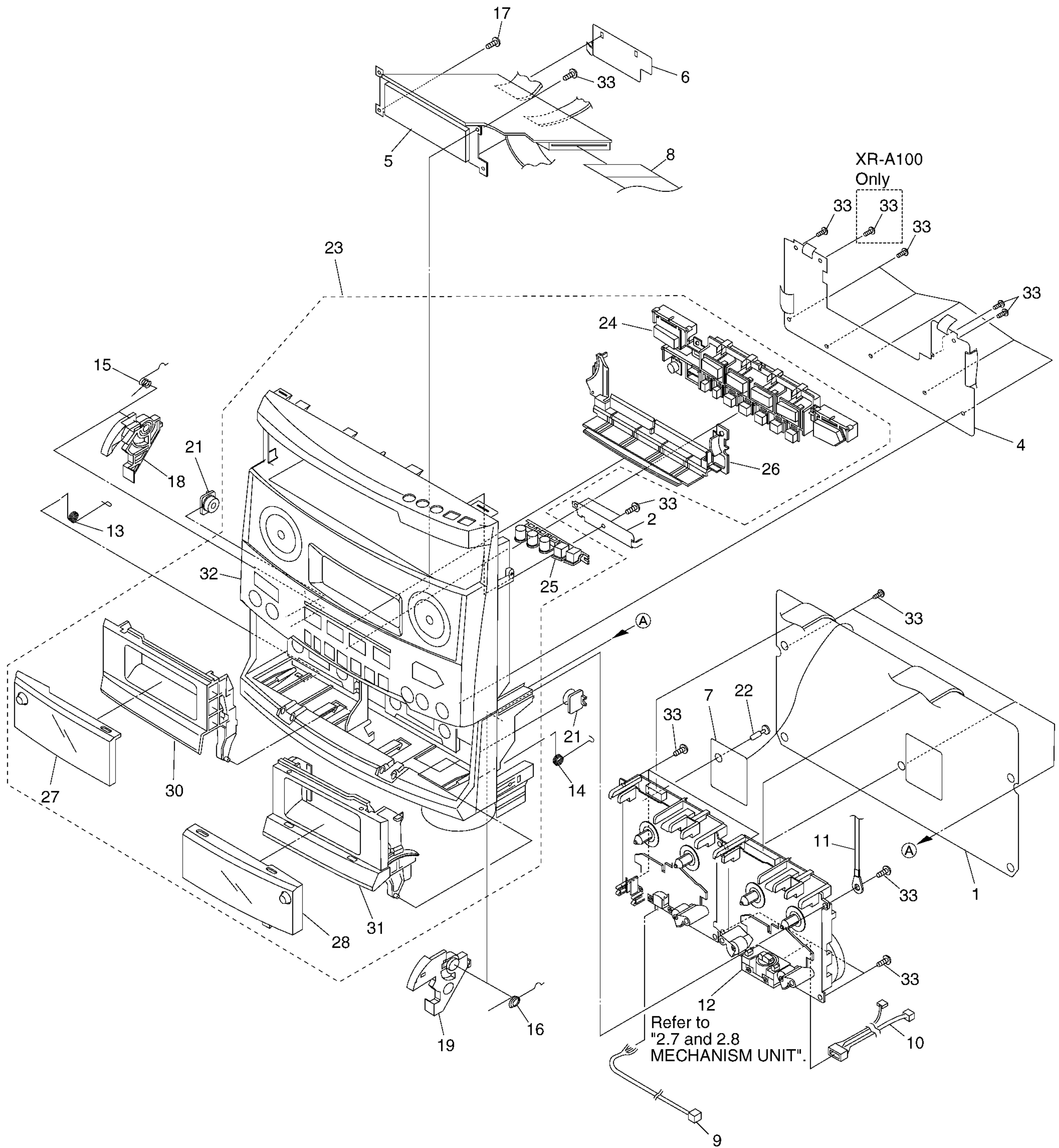

(1) FRONT PANEL SECTION PARTS LIST

Mark	No.	Description	Part No.	Mark	No.	Description	Part No.
	1	DECK Assy	XWZ3002		16	Latch Spring R	ABH7131
	2	CD SW Assy	XWZ3004		17	Screw	BPZ30P100FZK
	3	•••••			18	Latch Mold L	AMR7128
	4	DISPLAY Assy	See Contrast table (2)		19	Latch Mold R	AMR7129
	5	LCD Assy	See Contrast table (2)		20	•••••	
NSP	6	LAMP Assy	See Contrast table (2)		21	Damper Assy	AXA7052
	7	SHIELD Assy	XWZ3005		22	Push Rivet	AEC7071
	8	Flexible Cable 40P20	ADD7059	NSP	23	Front Panel Assy	See Contrast table (2)
	9	Connector Assy 3P	ADE7011		24	Function Button	XAD3001
	10	Connector Assy 5P	ADE7012		25	CD Button	XAD3002
NSP	11	Cord With Plug	DE015VE0		26	LT Conductor	XAK3001
	12	Mechanism Unit	XYM3001		27	Door Window L	XAK3014
	13	Door Spring L	ABH7128		28	Door Window R	XAK3015
	14	Door Spring R	ABH7129		29	•••••	
	15	Latch Spring L	ABH7130		30	Door Pocket L	XAN3001
					31	Door Pocket R	XAN3002
					32	Front Panel	See Contrast table (2)
					33	Screw	BPZ30P080FMC

(2) CONTRAST TABLE

XR-A200/DDXJ, DLXJ/NC, DXJ/NC, XR-A100/RDXJ, RLXJ/NC and RXJ/NC are constructed the same except for the following :

Mark	No.	Symbol and Description	Part No.						Remarks
			XR-A200 /DDXJ	XR-A200 /DLXJ/NC	XR-A200 /DXJ/NC	XR-A100 /RDXJ	XR-A100 /RLXJ/NC	XR-A100 /RXJ/NC	
	4	DISPLAY Assy	XWZ3023	XWZ3023	XWZ3023	XWZ3001	XWZ3001	XWZ3001	
	5	LCD Assy	XWZ3025	XWZ3025	XWZ3025	XWZ3006	XWZ3006	XWZ3006	
	6	LAMP Assy	XWZ3024	XWZ3024	XWZ3024	XWZ3008	XWZ3008	XWZ3008	
NSP	23	Front Panel Assy	XXG3003	XXG3003	XXG3003	XXG3002	XXG3002	XXG3002	
	32	Front Panel	XMB3003	XMB3003	XMB3003	XMB3002	XMB3002	XMB3002	

XR-A200, XR-A100

2.5 CD \$M LOADING MECHANISM ASSY

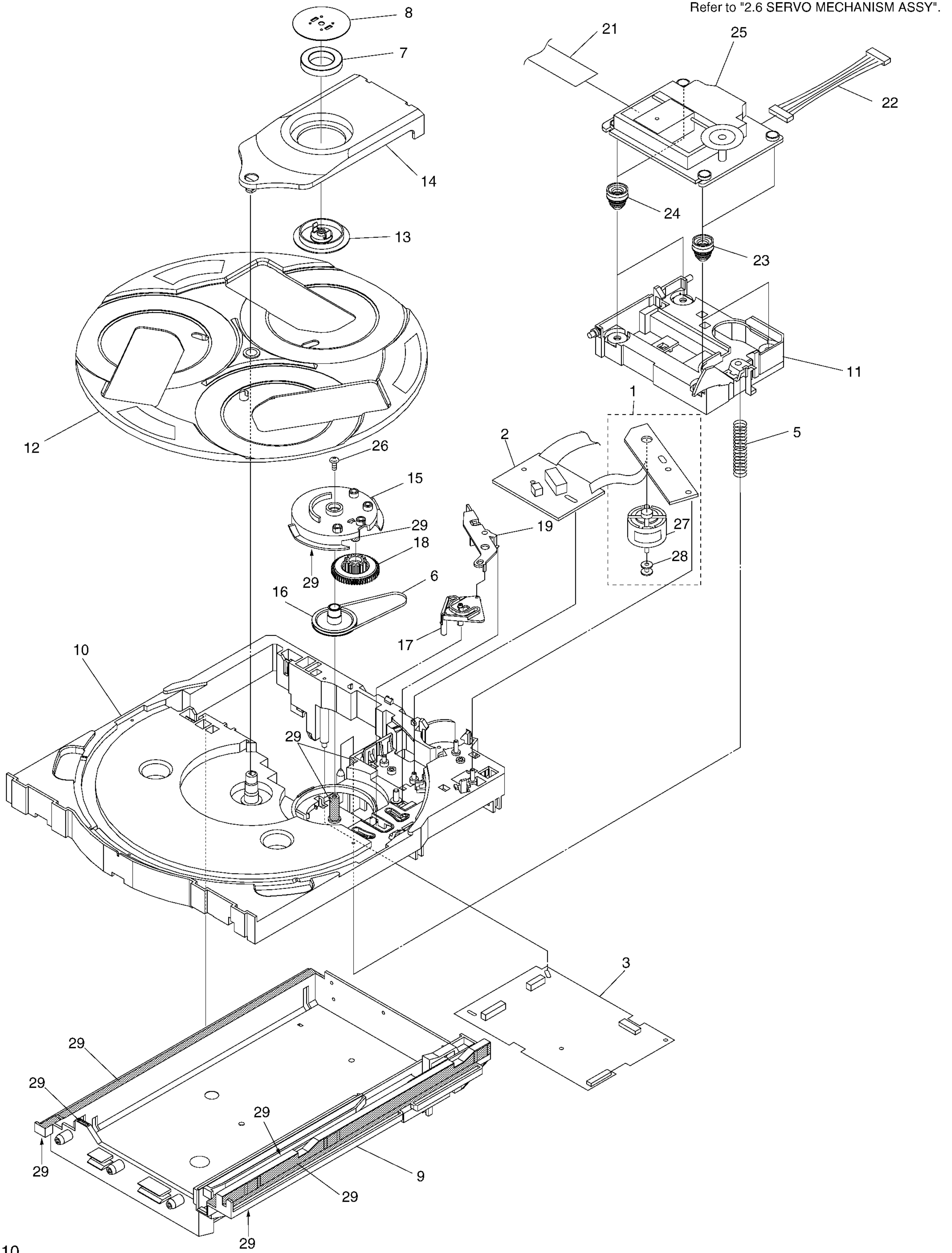

2.6 SERVO MECHANISM ASSY

● CD \$M LOADING MECHANISM ASSY PARTS LIST

Mark	No.	Description	Part No.
NSP	1	MOTOR Assy	AWZ8428
	2	SW Assy	AWZ8429
	3	CD Assy	AWZ8427
	4	•••••	
	5	Servo Spring	ABH7126
	6	Belt	AEB7072
	7	Clamp Magnet	AMF7001
	8	Yoke	ANB7067
	9	Mecha Base	ANW7087
	10	Loading Tray	ANW7088
	11	Servo Base	ANW7089
	12	Rotary Tray	ANW7113
	13	Clamper	ANW7091
	14	Clamper Holder	ANW7092
	15	Main Cam	ANW7093
	16	Gear Pully	ANW7094
	17	Lock Lever	ANW7095
	18	Planet Gear	ANW7096
	19	Actuator	ANW7097
	20	•••••	
	21	15P F.F.C/30V	ADD7038
	22	Connector Assy (6P)	ADE7010
	23	Float Rubber A	AEB7063
	24	Float Rubber B	AEB7066
	25	Servo Mechanism Assy	AXA7039
26	Screw	IPZ30P080FMC	
27	Carriage Motor	VXM1033	
28	Motor Pulley	PNW1634	
29	Ha Narl	GEM1016	

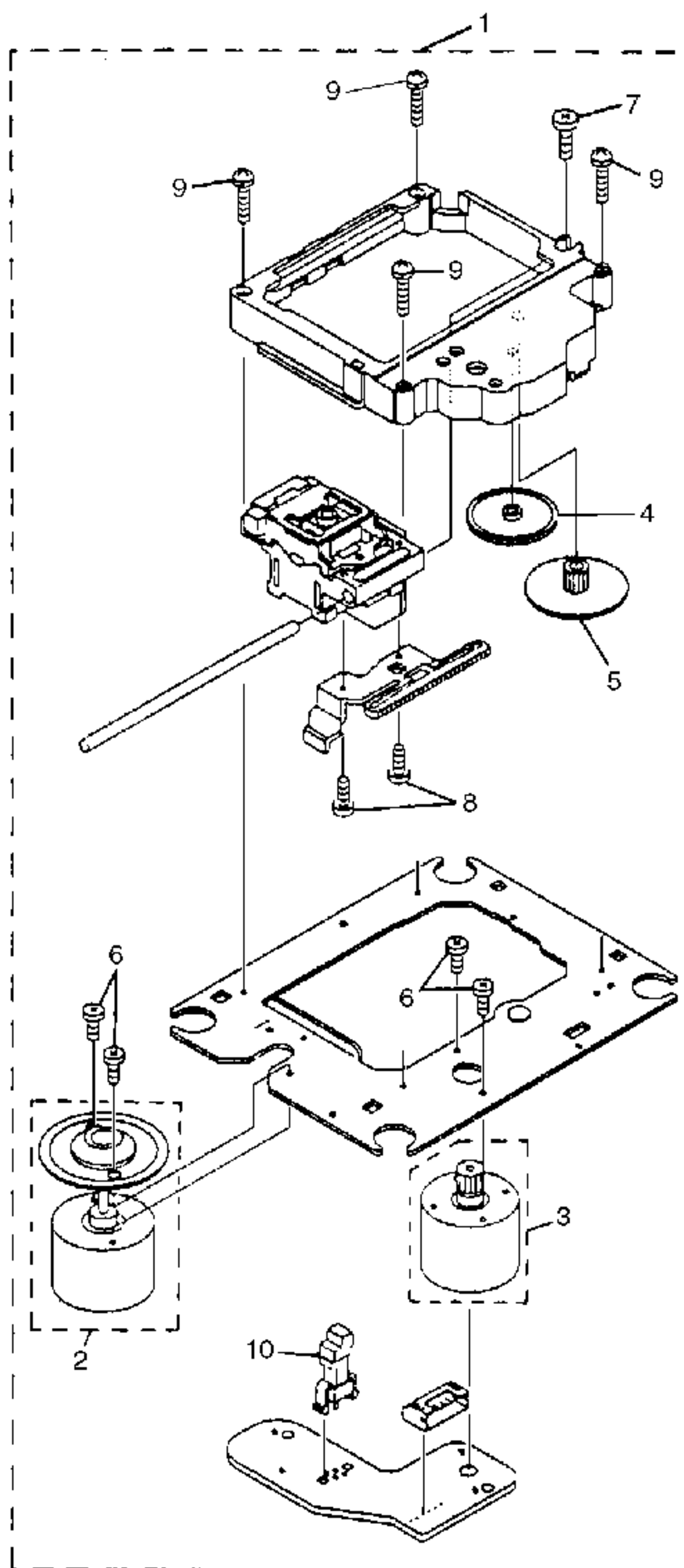

● SERVO MECHANISM ASSY PARTS LIST

Mark	No.	Description	Part No.
	1	Servo Mechanism	AXA7039
	2	SPINDLE MOTOR Assy	AEA7009
	3	SLEAD MOTOR Assy	AEA7010
	4	Gear A	AEA7013
	5	Gear B	AEA7014
	6	Screw	AEA7015
	7	Screw	AEA7016
	8	Screw	AEA7017
	9	Screw	AEA7018
	10	Leaf Switch	AEA7011

XR-A200, XR-A100

2.7 MECHANISM UNIT (FRONT SECTION)

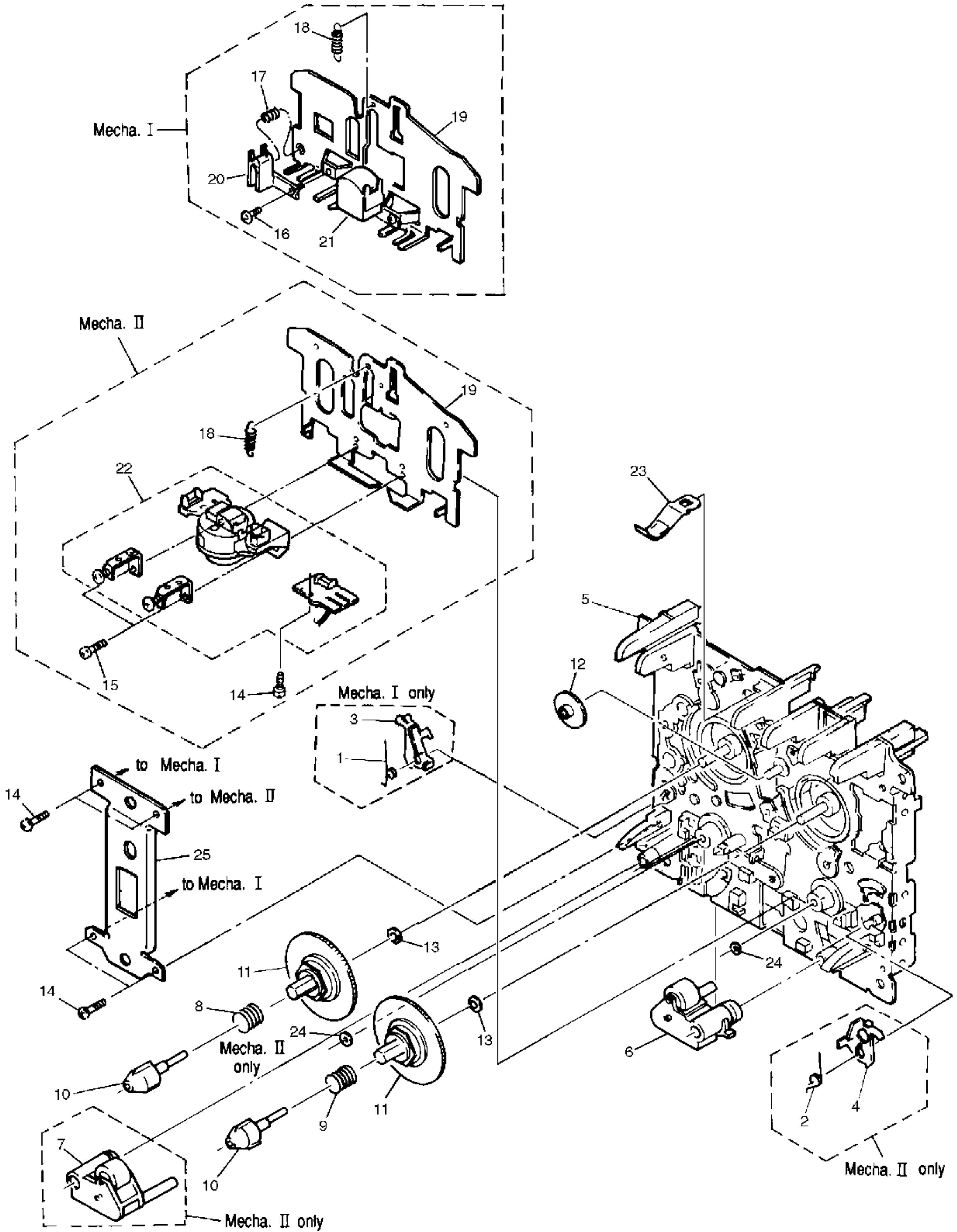

● MECHANISM UNIT (FRONT SECTION)
PARTS LIST

Mark	No.	Description	Part No.
	1	SP Interlock L (Mecha. I only)	RBH1385
	2	SP Interlock R (Mecha. II only)	RBH1386
	3	Arm Interlock L (Mecha. I only)	RNE1780
	4	Arm Interlock R (Mecha. II only)	RNE1781
	5	Chassis Base BLK (Mecha. I)	RXA1627
	5	Chassis Base BLK (Mecha. II)	RXA1626
	6	Roller Pinch BLK R (Mecha. I)	RXA1630
	6	Roller Pinch BLK R (Mecha. II)	RXA1628
	7	Roller Pinch BLK L (Mecha. II only)	RXA1629
	8	SP Reel (L)	RBH1388
	9	SP Reel (R)	RBH1389
	10	Reel Feather	RNK2072
	11	Reel Base	RNK2073
	12	Play Gear (A)	RNK2074
	13	Washer	WA41D065D025
	14	Screw	PCZ20P040FMC
	15	Screw	PMZ20P060FMC
	16	Screw M3 × 10	RBA1031
	17	Spring	RBH1076
	18	Spring HB	RBH1390
	19	Head Base (Mecha. I)	RNE1906
	19	Head Base (Mecha. II)	RNE1783
	20	Tape Guide (Mecha. I only)	RNK2077
	21	R/P Head (Mecha. I only)	XPB3001
	22	Plate HD BLK (Mecha. II only)	RXA1746
	23	SP Cassette	RNE1786
	24	Washer	WT15D040D050
	25	Mecha Bracket	RNE1907

2.8 MECHANISM UNIT (REAR SECTION)

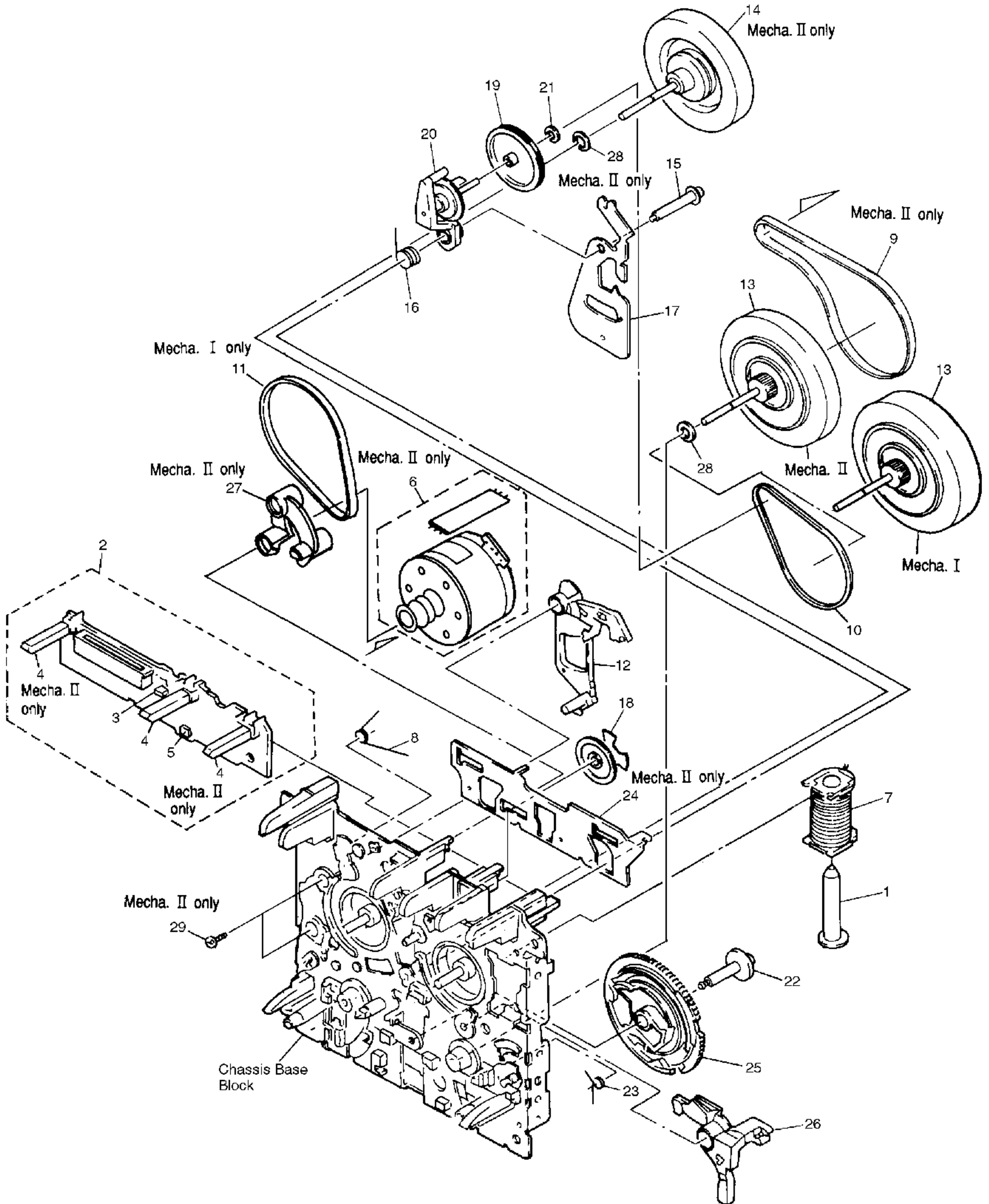

● MECHANISM UNIT (REAR SECTION)
PARTS LIST

Mark	No.	Description	Part No.
	1	Plunger	PLA1288
	2	PCB Control BLK (Mecha. I)	RXA1742
	2	PCB Control BLK (Mecha. II)	RXA1743
	3	Switch	RSG1018
	4	SPLF	RSN1023
	5	Photo-Transistor	SPI33534FG
	6	MTR Main BLK (Mecha. II only)	RXM1086
	7	Solenoid BLK	XXP3001
	8	SP Brake	RBH1387
	9	Main Belt (Mecha. II only)	REB1157
	10	F/R Belt	REB1254
	11	Joint Belt (Mecha. I only)	REB1307
	12	Lever Brake	RNK2071
	13	Clutch ASSY BLK (Mecha. I)	RXA1744
	13	Clutch ASSY BLK (Mecha. II)	RXA1745
	14	ASSY F/W (Mecha. II only)	RXA1769
	15	Screw 2-6 × 3.5	RBA1120
	16	Cam SP	RBH1393
	17	Lever F/R	RNE1782
	18	FF Gear (A)	RNK2075
	19	F/R Pulley	RNK2076
	20	Clutch ASSY BLK	RXA1632
	21	Washer	WA17D040D025
	22	Screw 2-9 × 3.5	RBA1121
	23	SP Arm Play (Mecha. I)	RBH1391
	23	SP Arm Play (Mecha. II)	RBH1392
	24	Plate Slide (Mecha. II only)	RNE1785
	25	Cam Gear	RNK2078
	26	Arm Play	RNK2079
	27	Motor Spacer (Mecha. II only)	RNK2244
	28	Washer	WA26D045D025
	29	Screw	PMA26P140FMC

3. SCHEMATIC DIAGRAM

3.1 OVERALL CONNECTION DIAGRAM

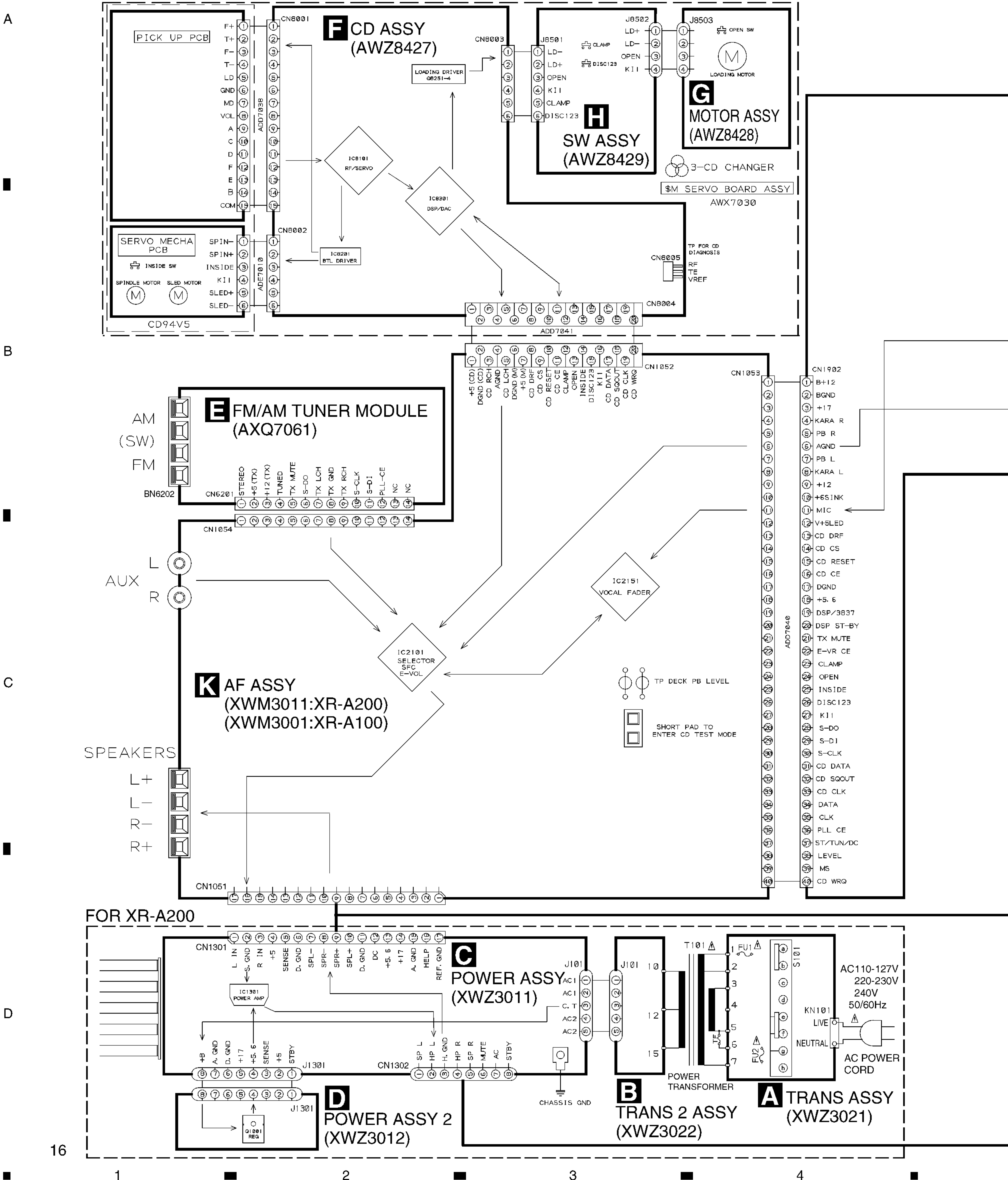

XR-A200, XR-A100

Note : When ordering service parts, be sure to refer to "EXPLODED VIEWS and PARTS LIST" or "PCB PARTS LIST".

N LAMP ASSY
(XWZ3024:XR-A200)
(XWZ3008:XR-A100)

O LCD ASSY
(XWZ3025:XR-A200)
(XWZ3006:XR-A100)

L CD SW ASSY
(XWZ3004)

M DISPLAY ASSY
(XWZ3023:XR-A200)
(XWZ3001:XR-A100)

I DECK ASSY
(XWZ3002)

J SHIELD ASSY
(XWZ3005)

FOR XR-A100

C POWER ASSY
(AWZ8534)

A TRANS ASSY(AWZ8533)

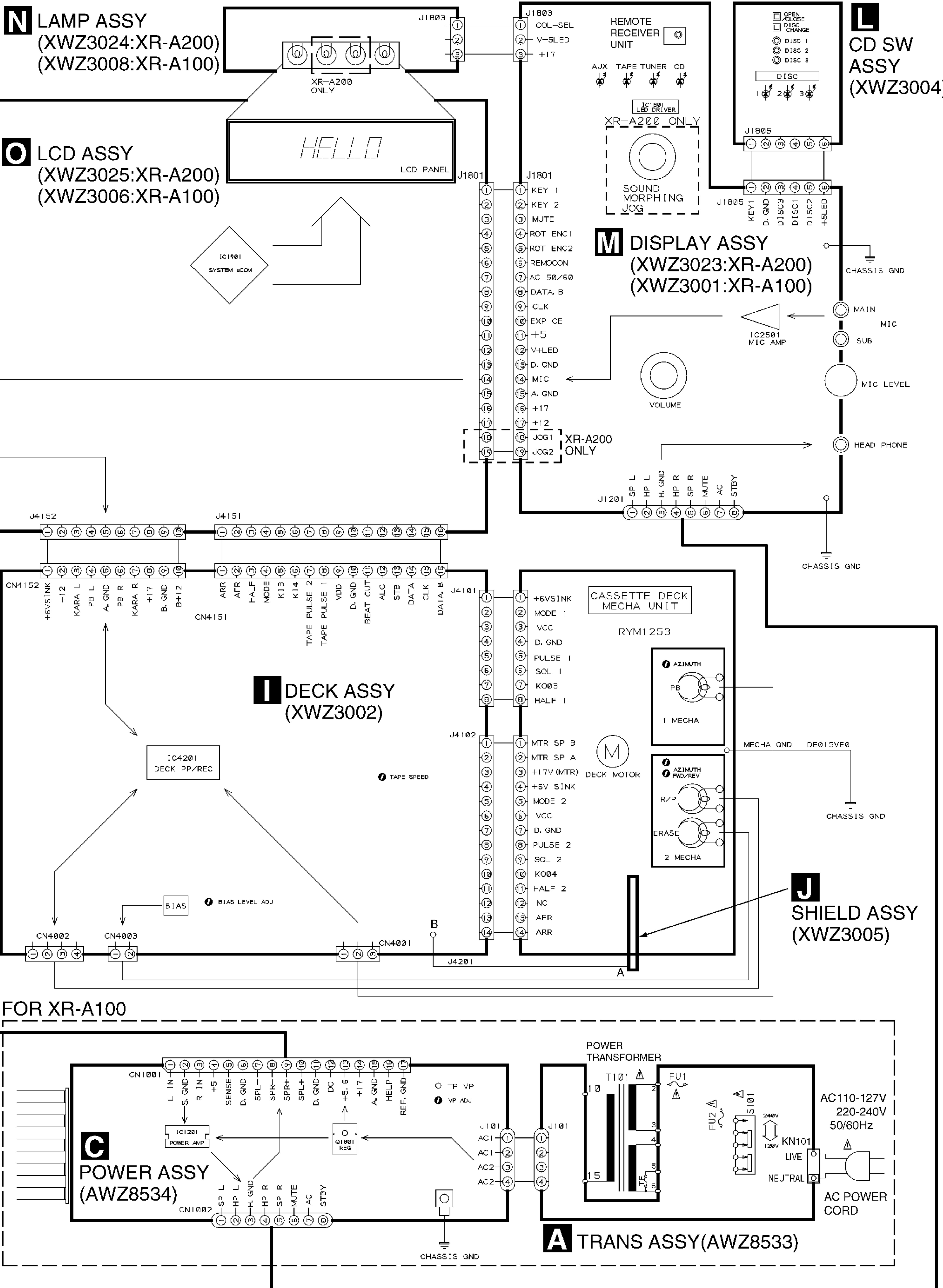

A

B

C

D

3.2 TRANS, TRANS 2, POWER ASSEMBLIES AND POWER ASSY 2 (XR-A200)

A

B

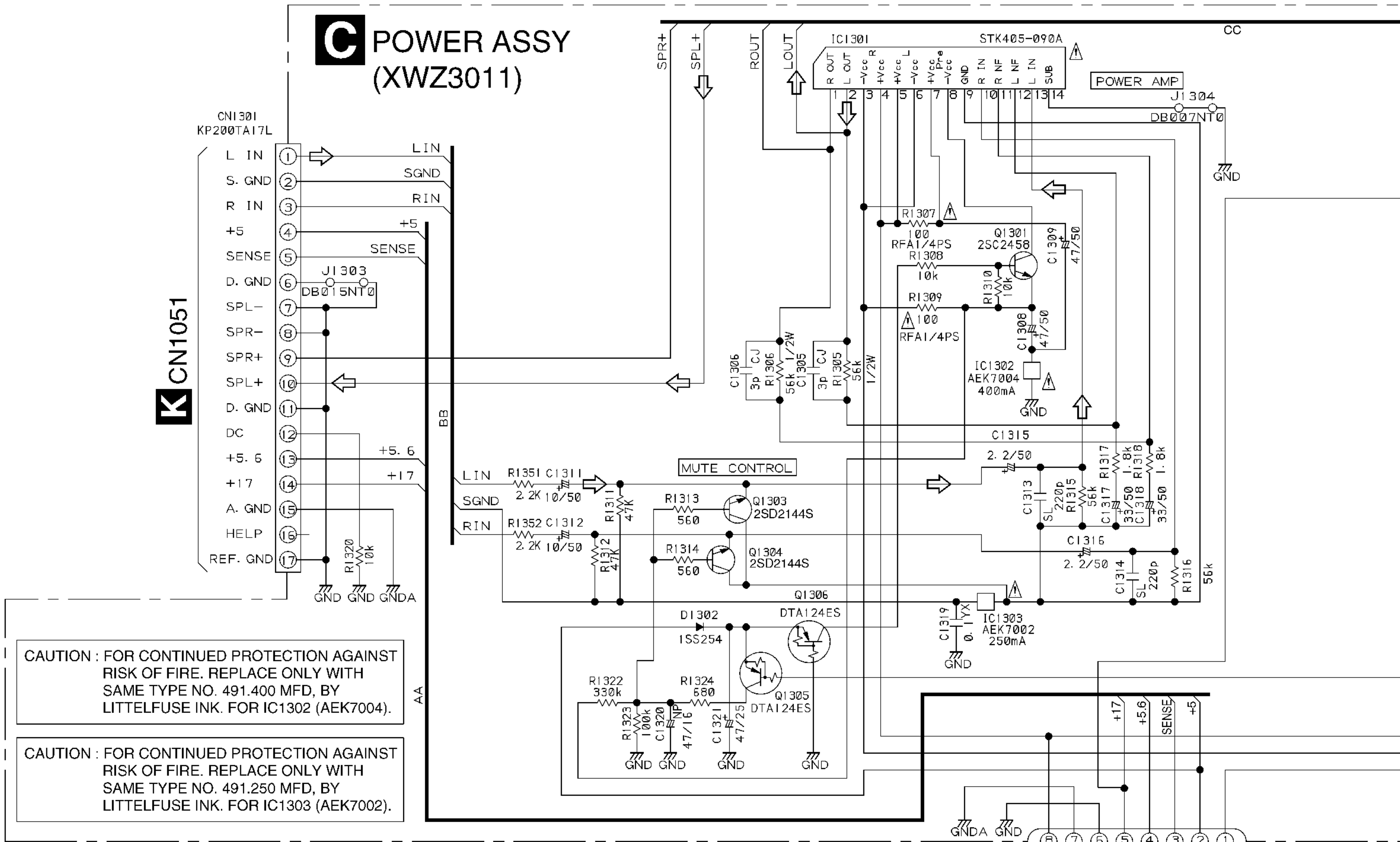

C

D

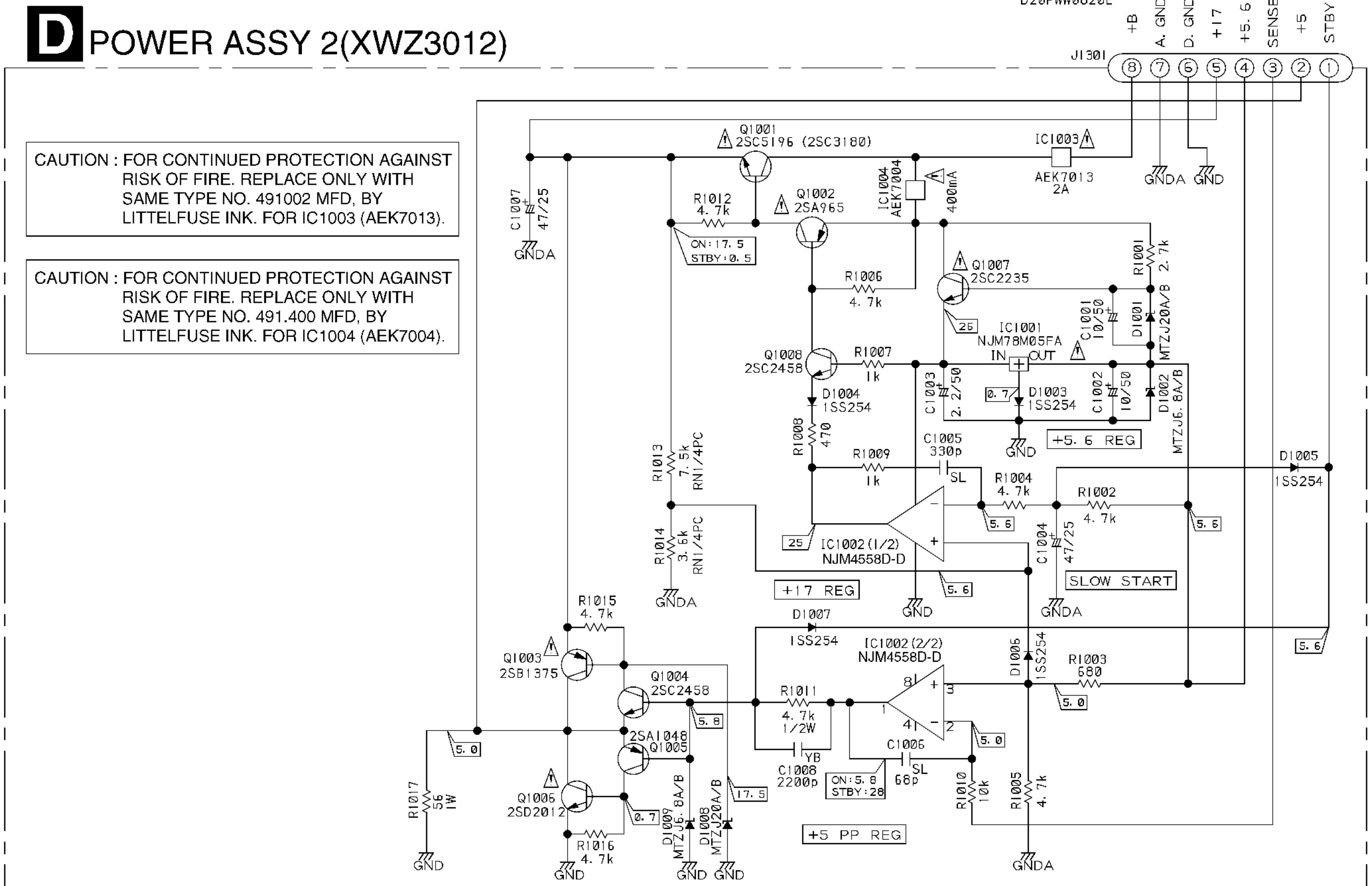

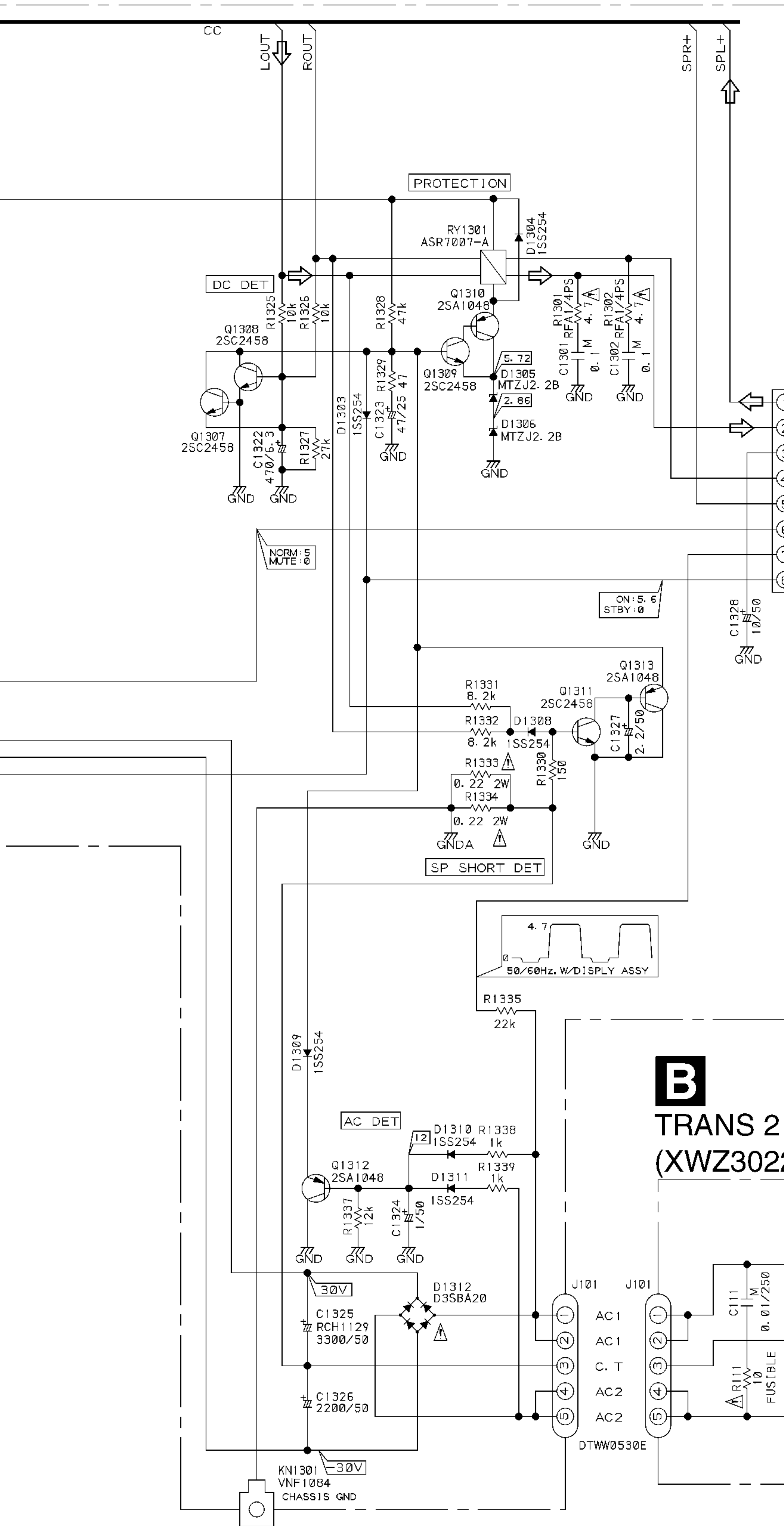

⇒ : AUDIO SIGNAL ROUTE

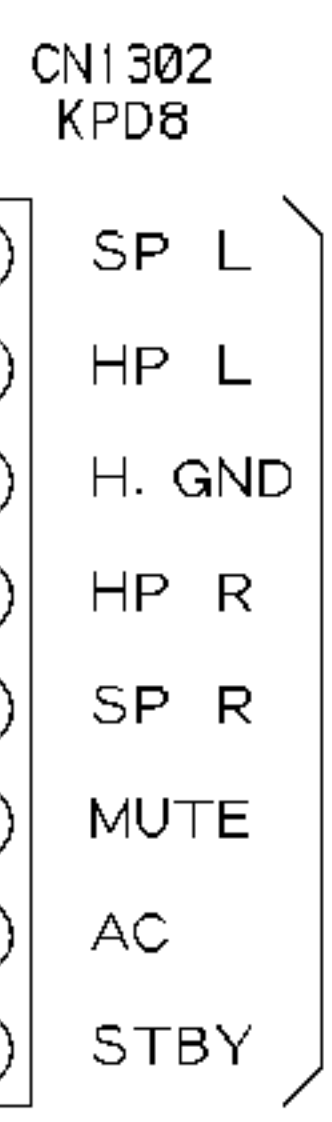

Notes:

- Resistors
Indicated in Ω, 1/4W, ±5% tolerance unless otherwise noted.
- Capacitors
Indicated in capacity (μF)/voltage (V) unless otherwise noted. Indication without voltage is 50V.
- Voltage
DC voltage (V) at no input signal.
- Others
The ⚠ mark found on some component parts indicates the importance of the safety factor of the parts. Therefore, when replacing, be sure to use parts of identical designation.

S101

110V-127V	c-d
	g-h
240V	b-c
	f-g
220V-230V	a-b
	e-f

B
TRANS 2 ASSY
(XWZ3022)

A
TRANS ASSY
(XWZ3021)

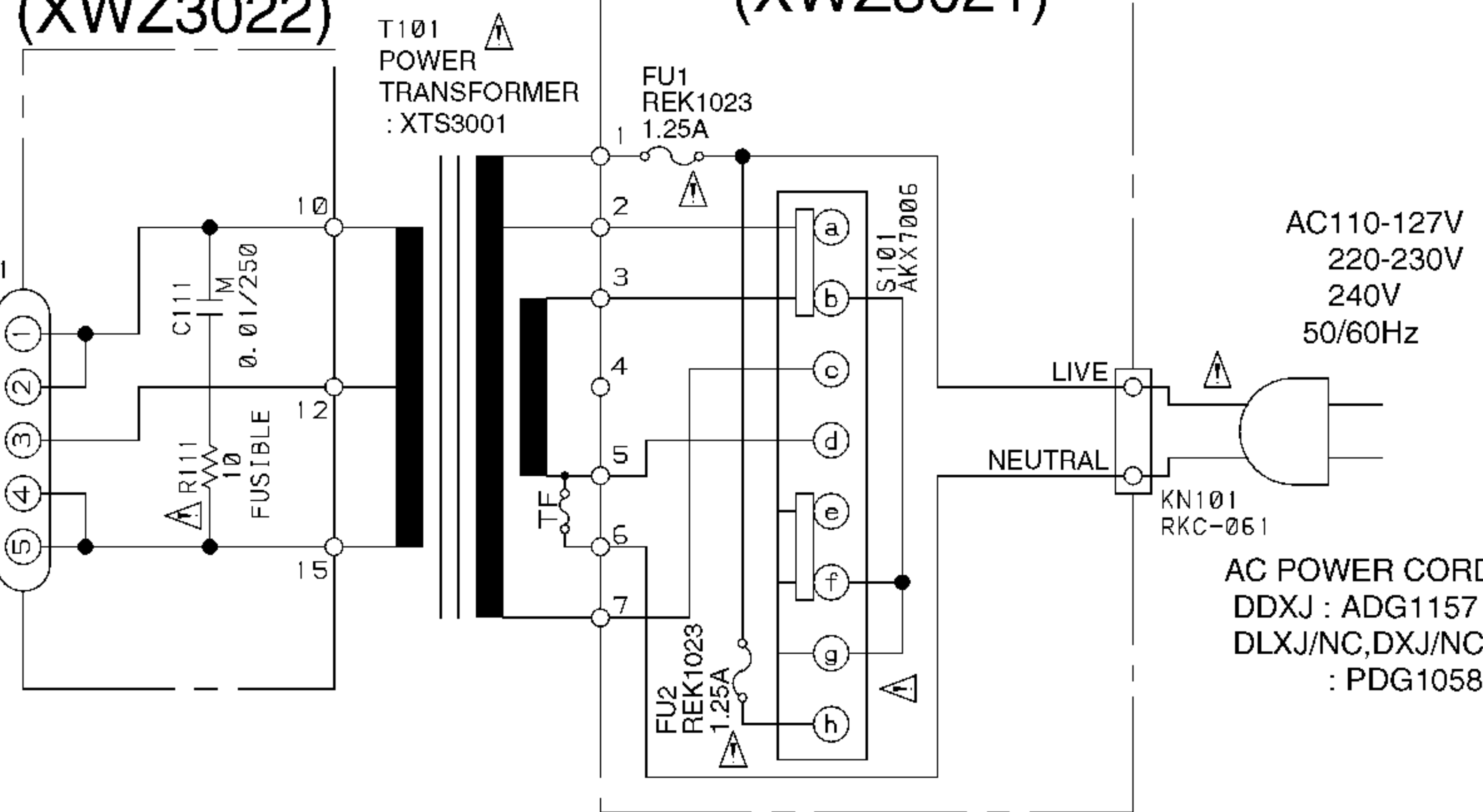

• NOTE FOR FUSE REPLACEMENT

CAUTION -FOR CONTINUED PROTECTION AGAINST RISK OF FIRE. REPLACE ONLY WITH SAME TYPE AND RATINGS ONLY.

3.3 TRANS AND POWER ASSEMBLIES (XR-A100)

C POWER ASSY(AWZ8534)

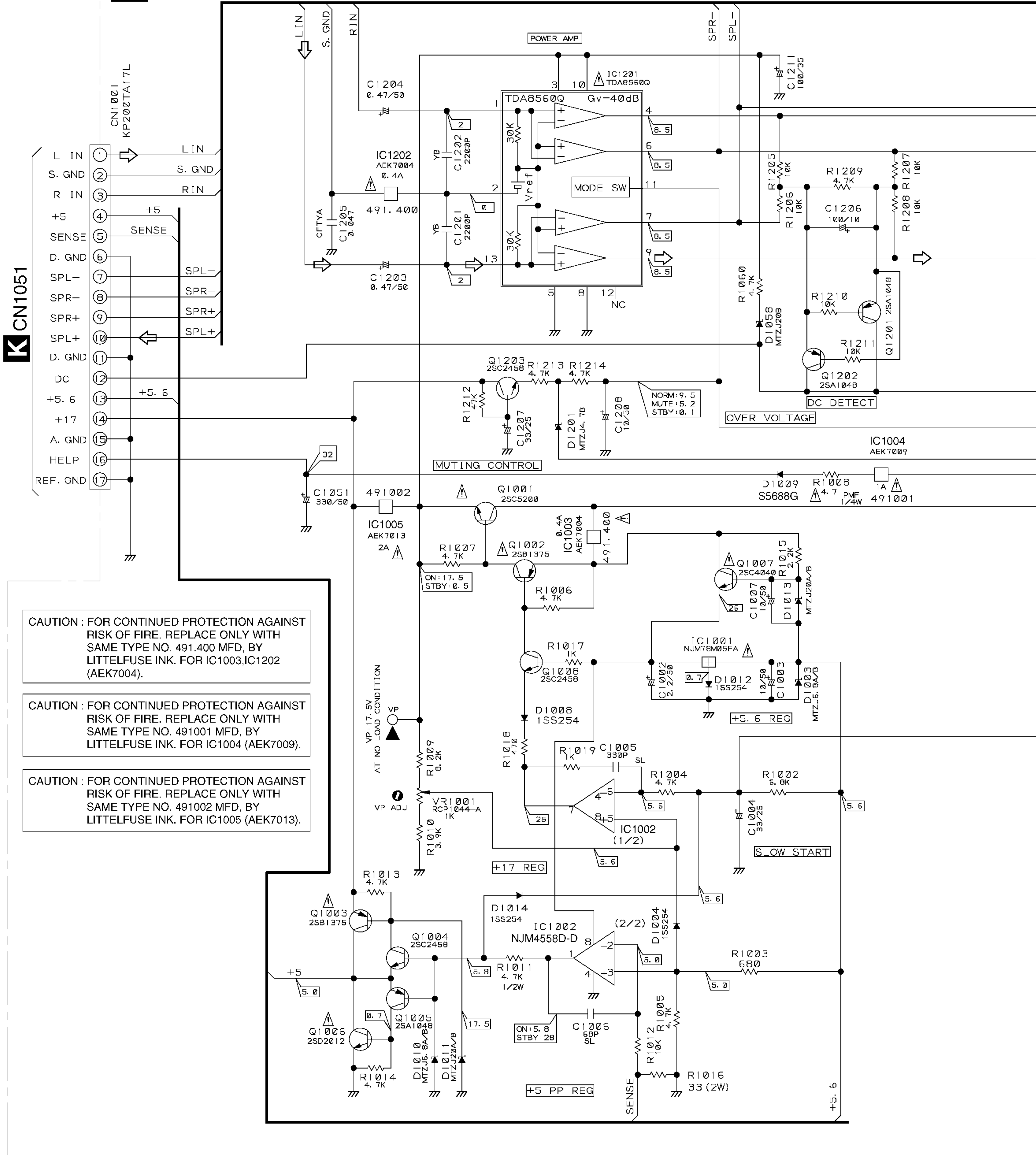

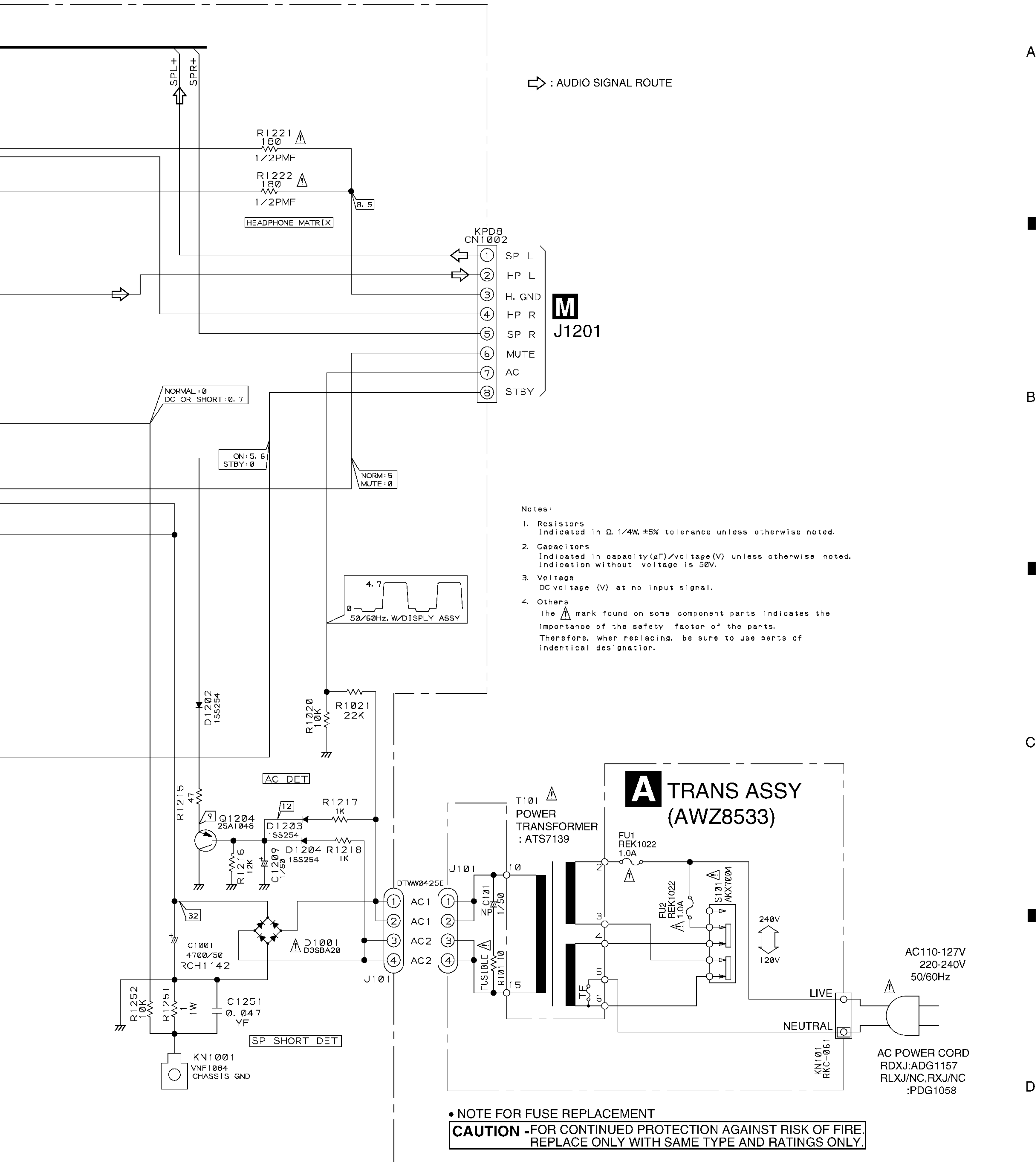

A

B

C

D

3.4 FM/AM TUNER MODULE

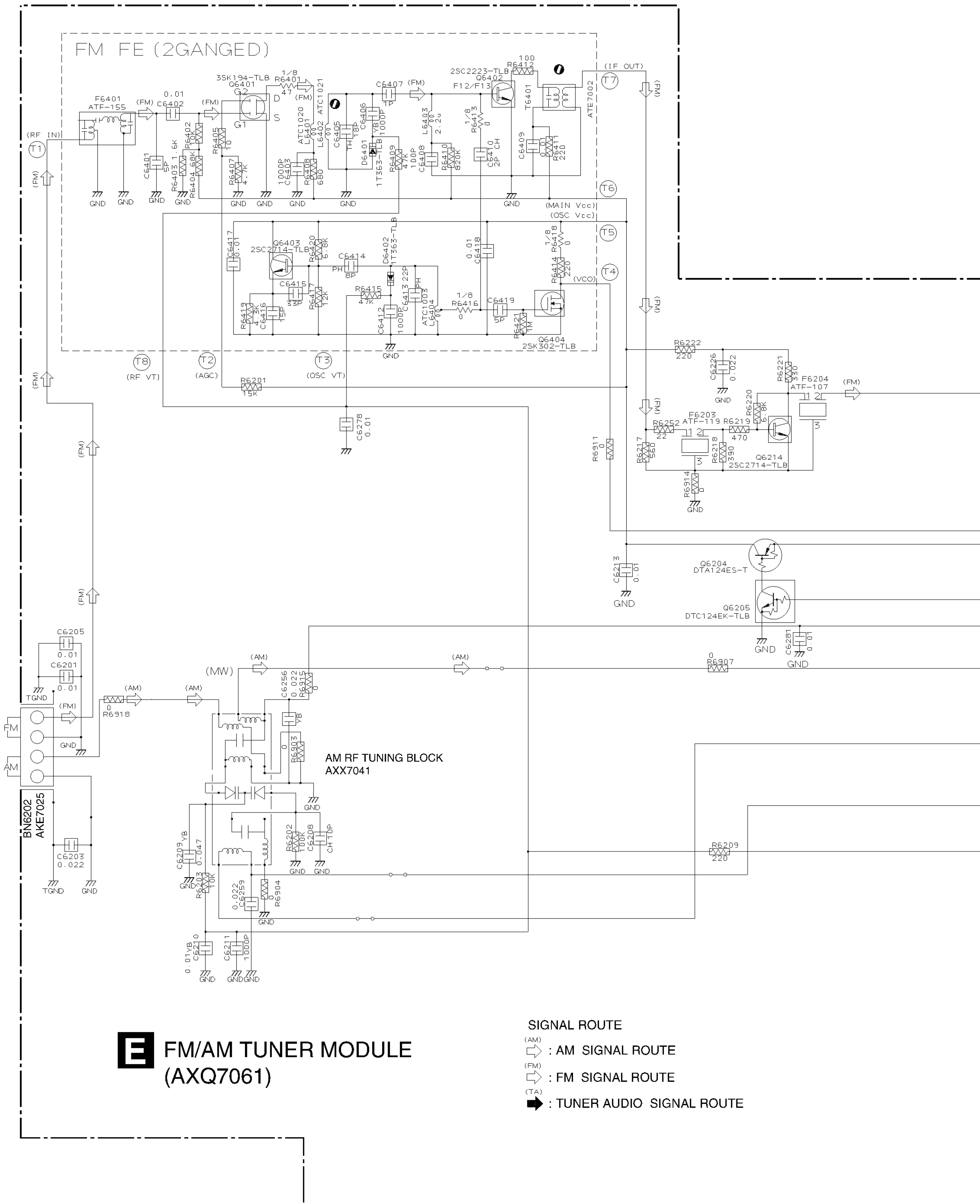

E FM/AM TUNER MODULE (AXQ7061)

- SIGNAL ROUTE
- (AM) : AM SIGNAL ROUTE
 - (FM) : FM SIGNAL ROUTE
 - (TA) : TUNER AUDIO SIGNAL ROUTE
 - ➡ : TUNER AUDIO SIGNAL ROUTE



Notes

1. RESISTORS

Indicated in Ω, 1/10W±5% Tolerance unless otherwise noted K;KΩ, M;MΩ.

2. CAPACITORS

Indicated in Capacity (μF)/VOLTAGE (V) unless otherwise noted P;PF.

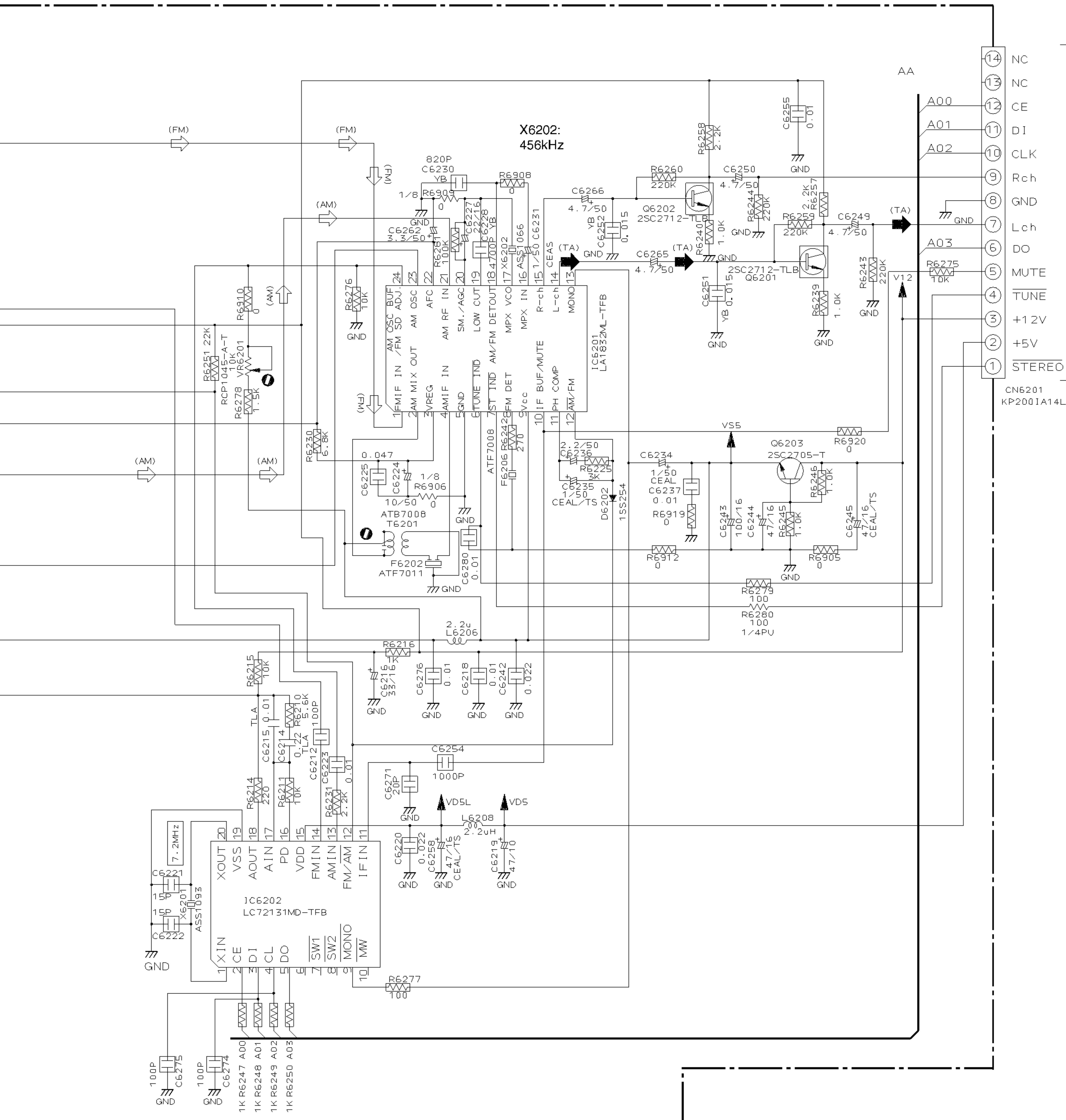

K CN1054



3.5 CD, MOTOR AND SW ASSEMBLIES

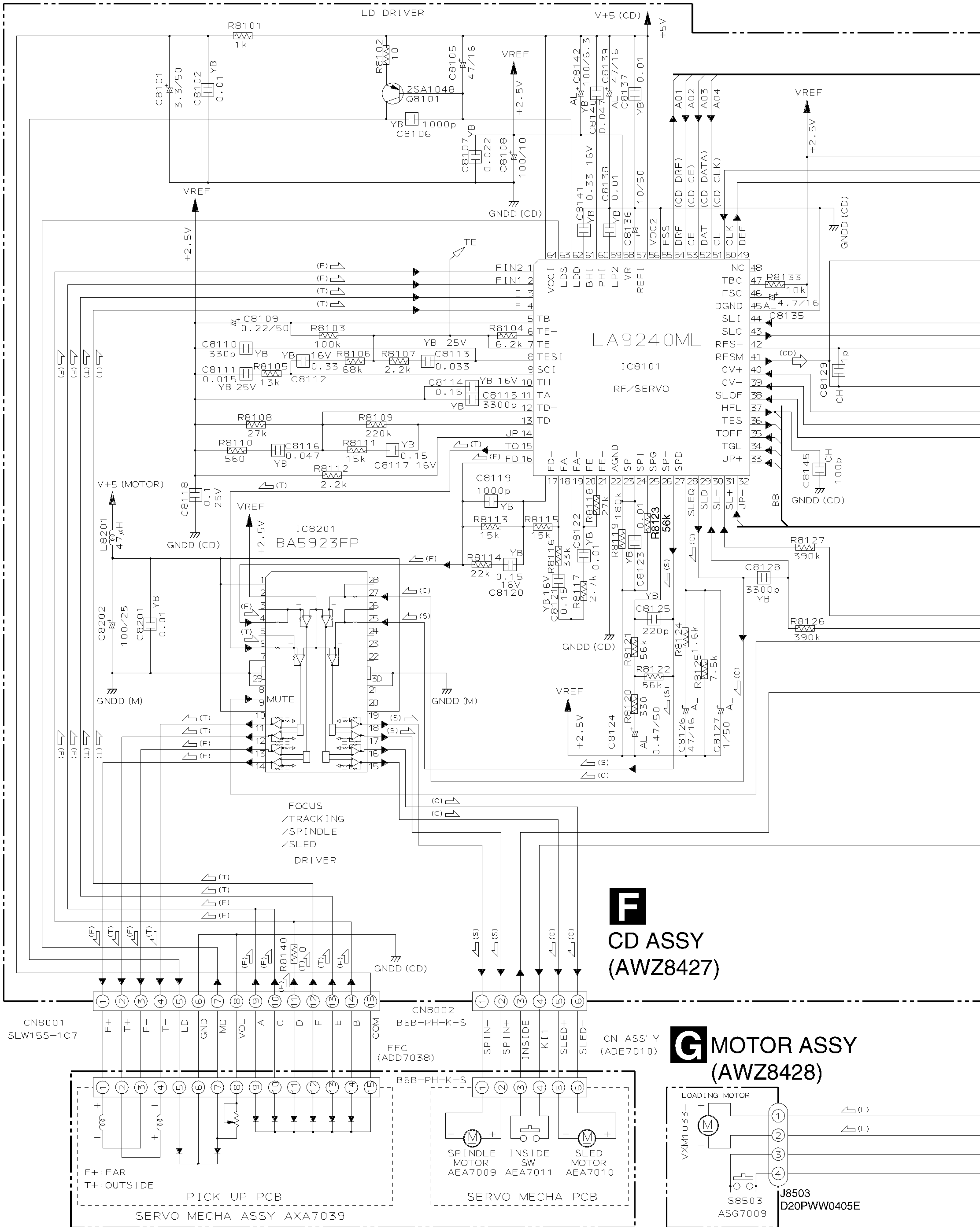

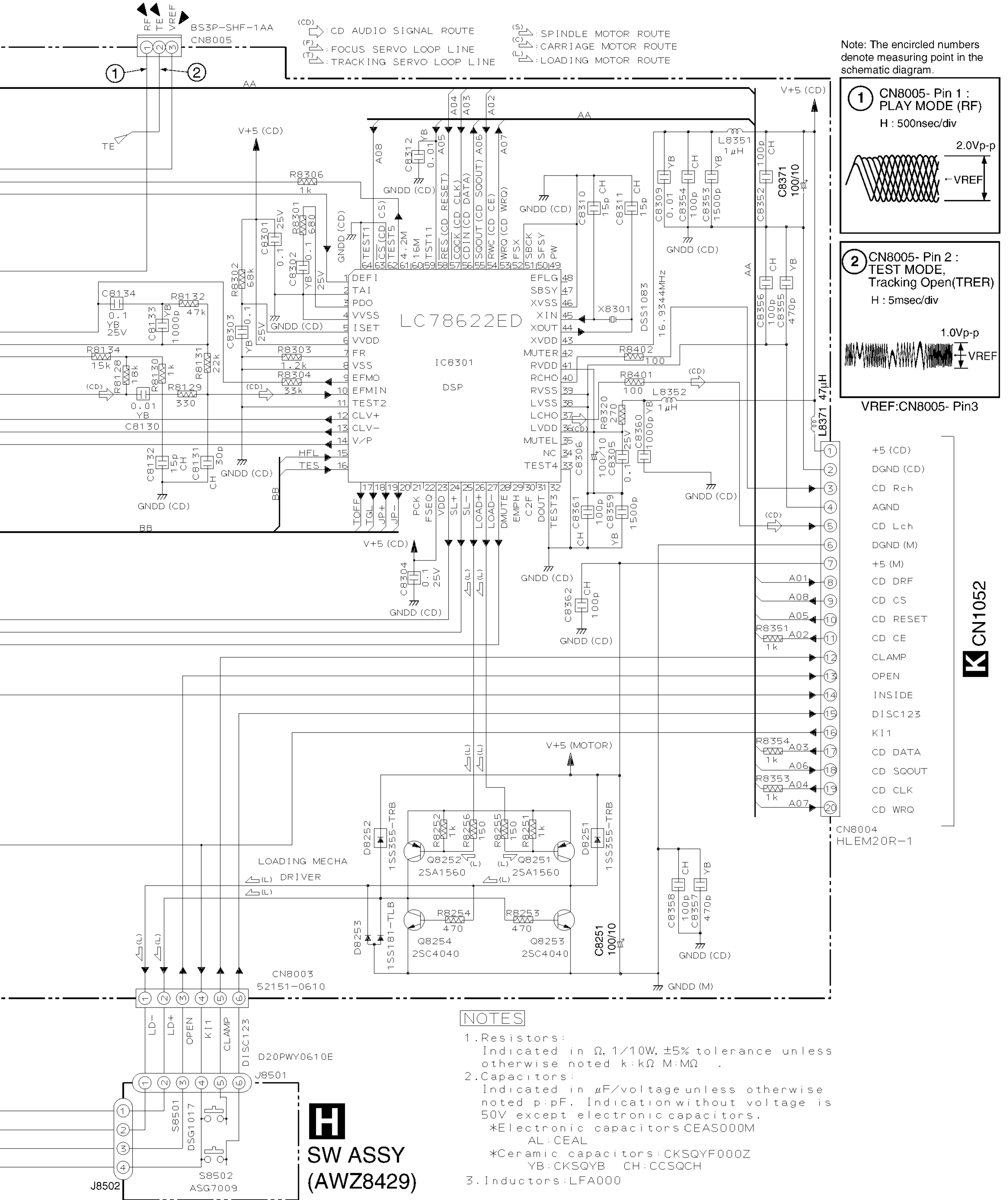

Note: The encircled numbers denote measuring point in the schematic diagram.

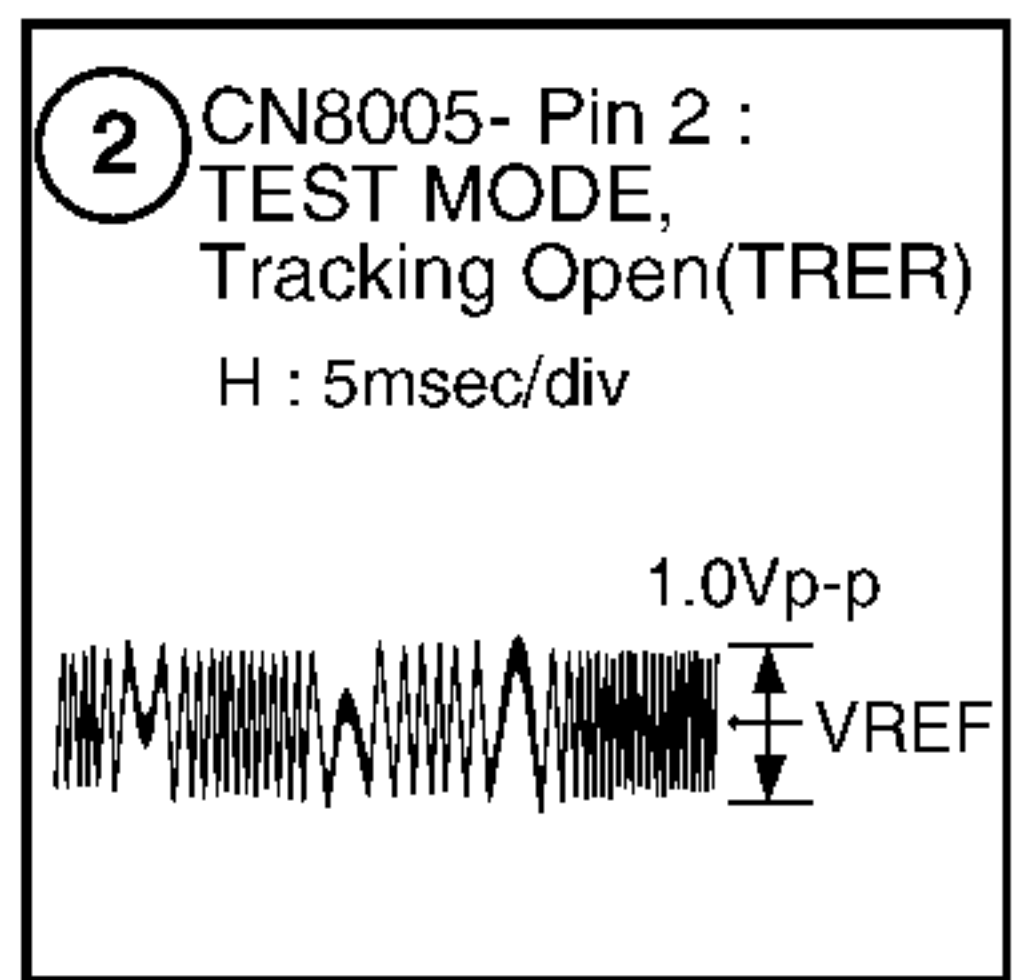
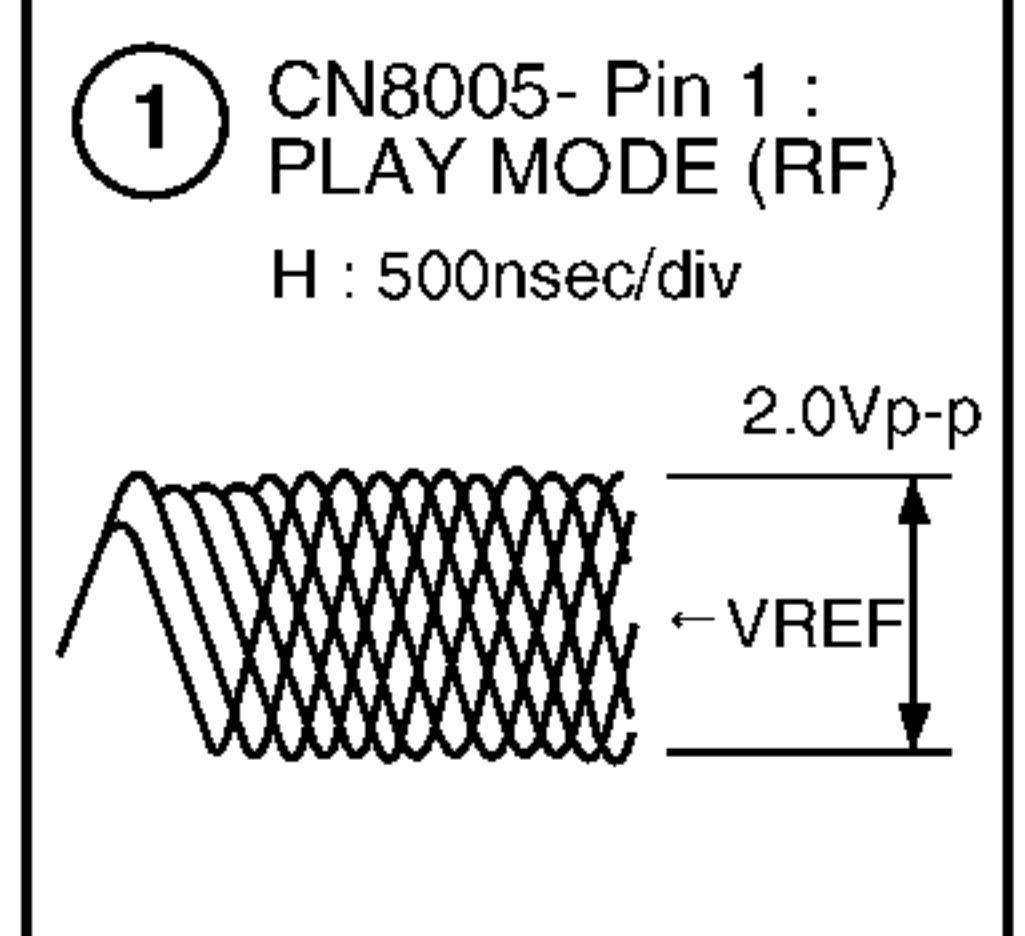

VREF:CN8005- Pin3

- 1 +5 (CD)
- 2 DGND (CD)
- 3 CD Rch
- 4 AGND
- 5 CD Lch
- 6 DGND (M)
- 7 +5 (M)
- 8 CD DRF
- 9 CD CS
- 10 CD RESET
- 11 CD CE
- 12 CLAMP
- 13 OPEN
- 14 INSIDE
- 15 DISC123
- 16 KI1
- 17 CD DATA
- 18 CD SQOUT
- 19 CD CLK
- 20 CD WRQ

K CN1052



XR-A200, XR-A100

3.6 DECK AND SHIELD ASSEMBLIES

NOTES

- Resistor:
Indicated in Ω , 1/4W, $\pm 5\%$ tolerance unless otherwise noted K:k Ω , M:M Ω .
- Capacitors:
Indicated in μF /voltage unless otherwise noted P:pF.
Indicated without voltage is 50V except electronic capacitors.
*Electronic capacitors: CEAS**M
*Ceramic capacitors: YB:CKCYB, SL:CCCSL
*Film capacitors: M:CQMA, PA:CQPA
- Diodes: ISS254

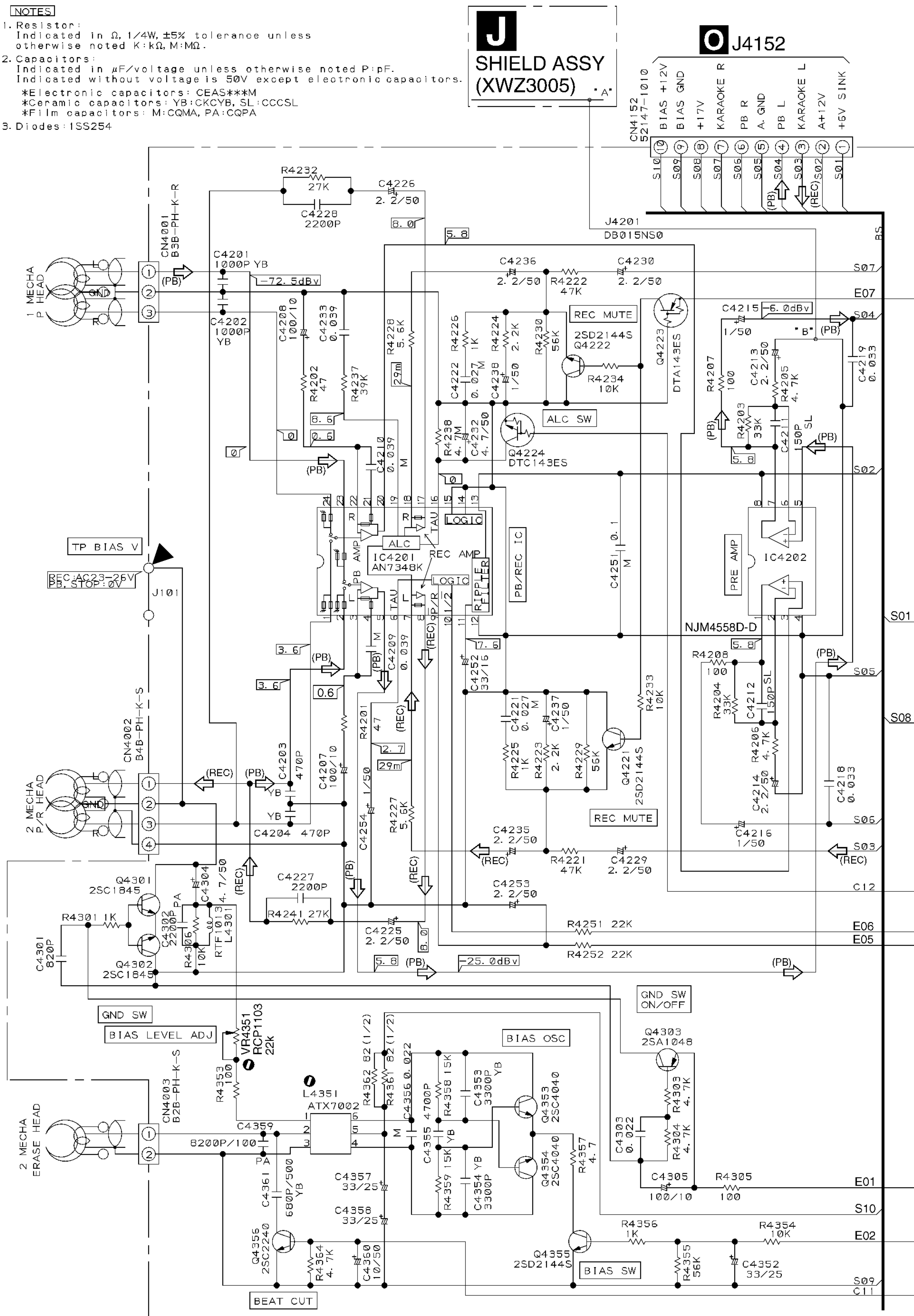

J4151

52147-1610
CN4151

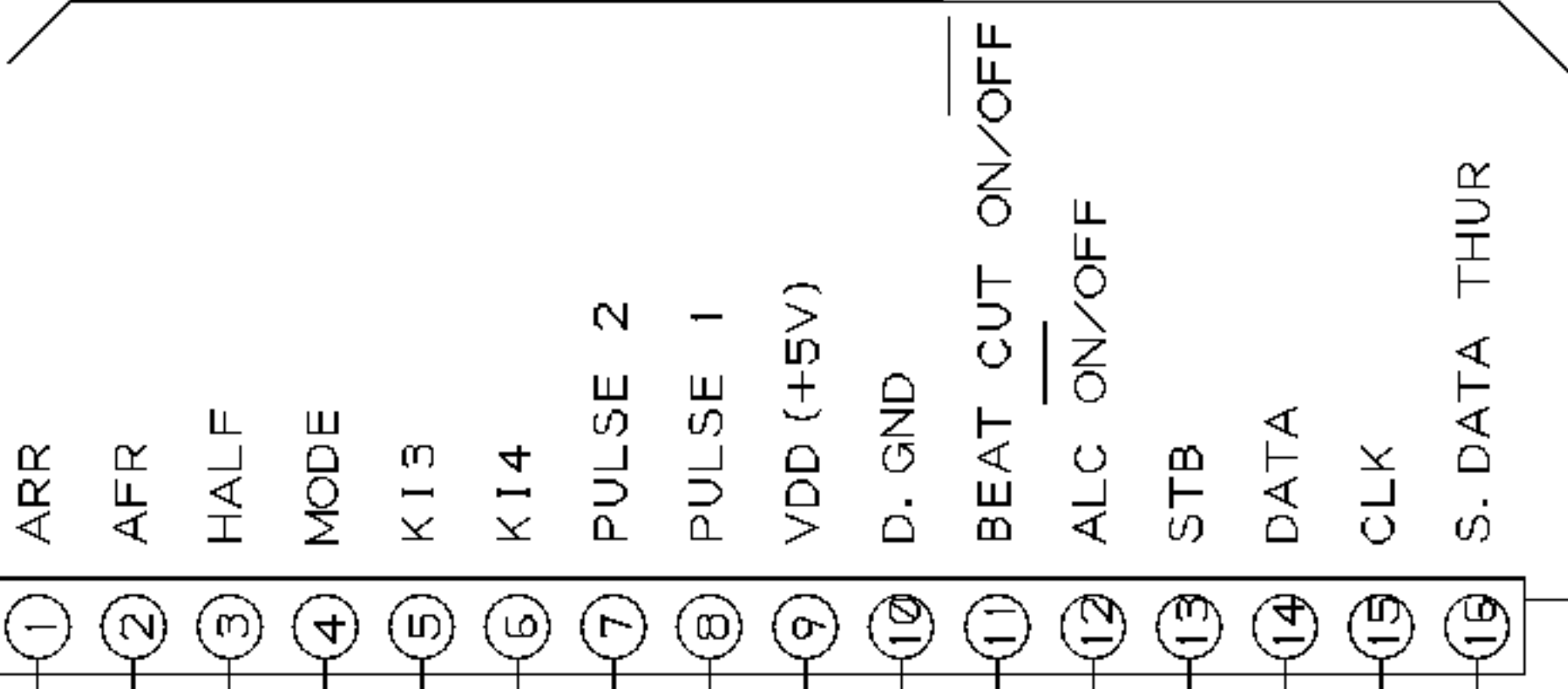

(PB) : DECK PB SIGNAL ROUTE
(REC) : DECK REC SIGNAL ROUTE

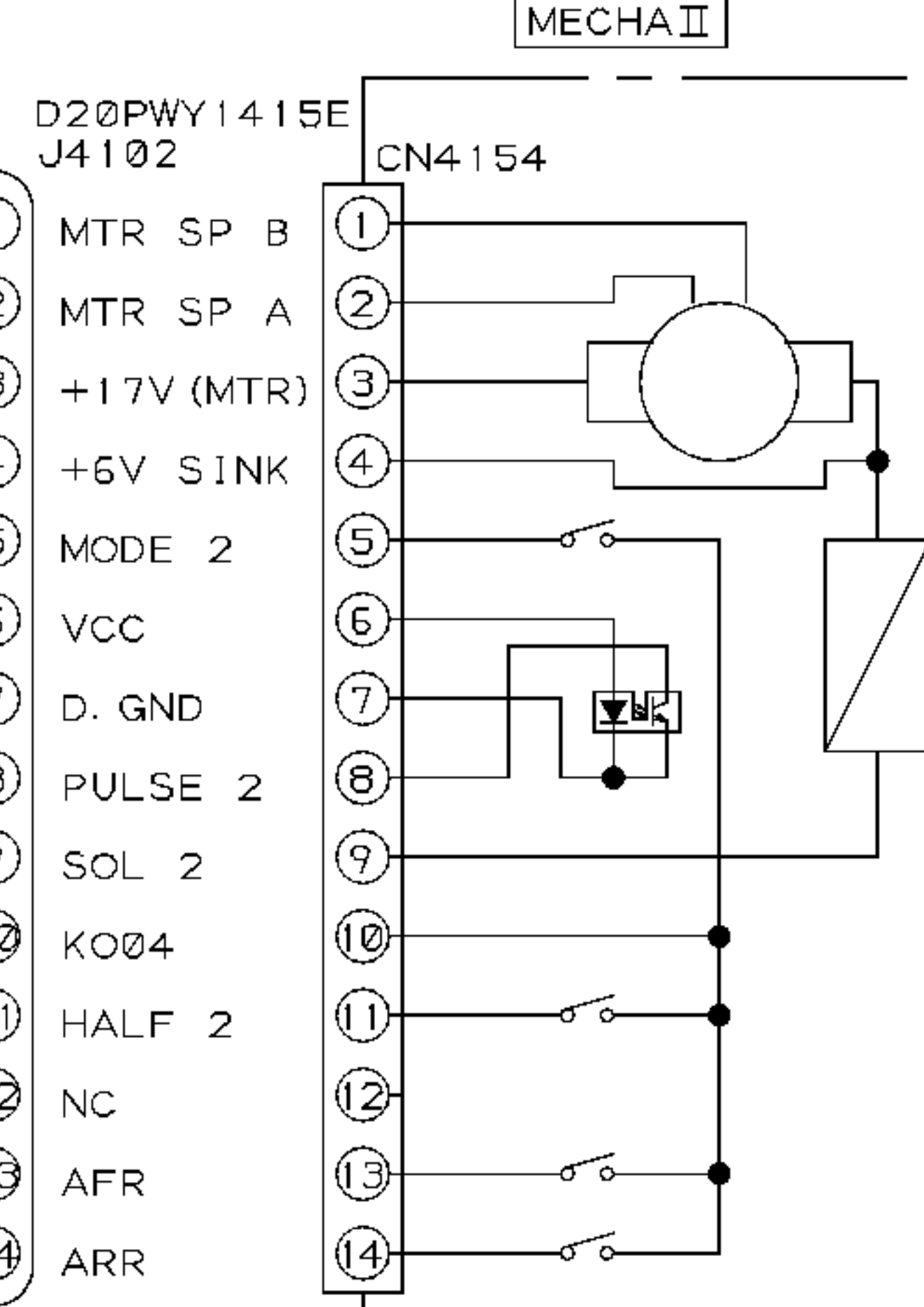
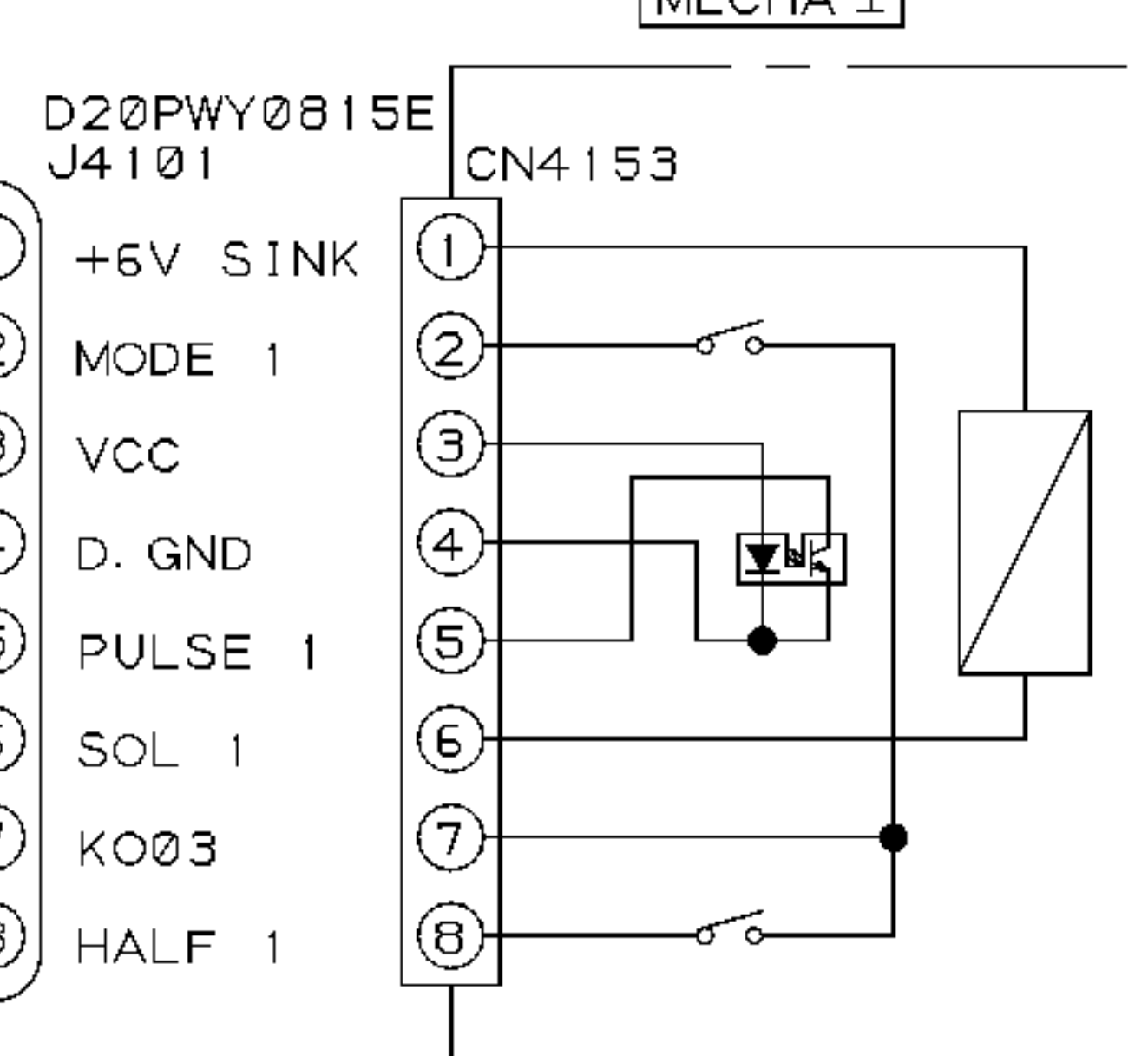
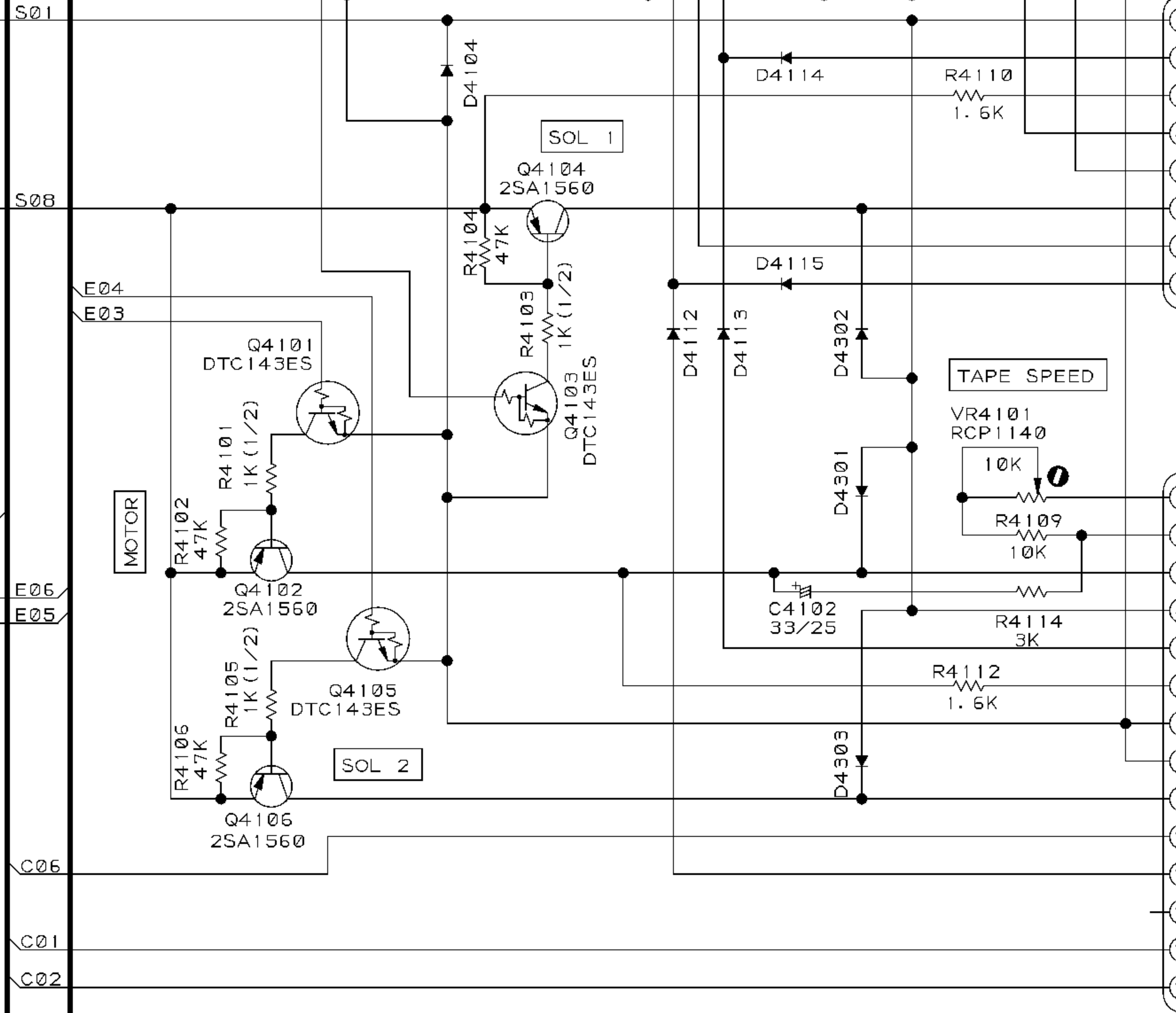
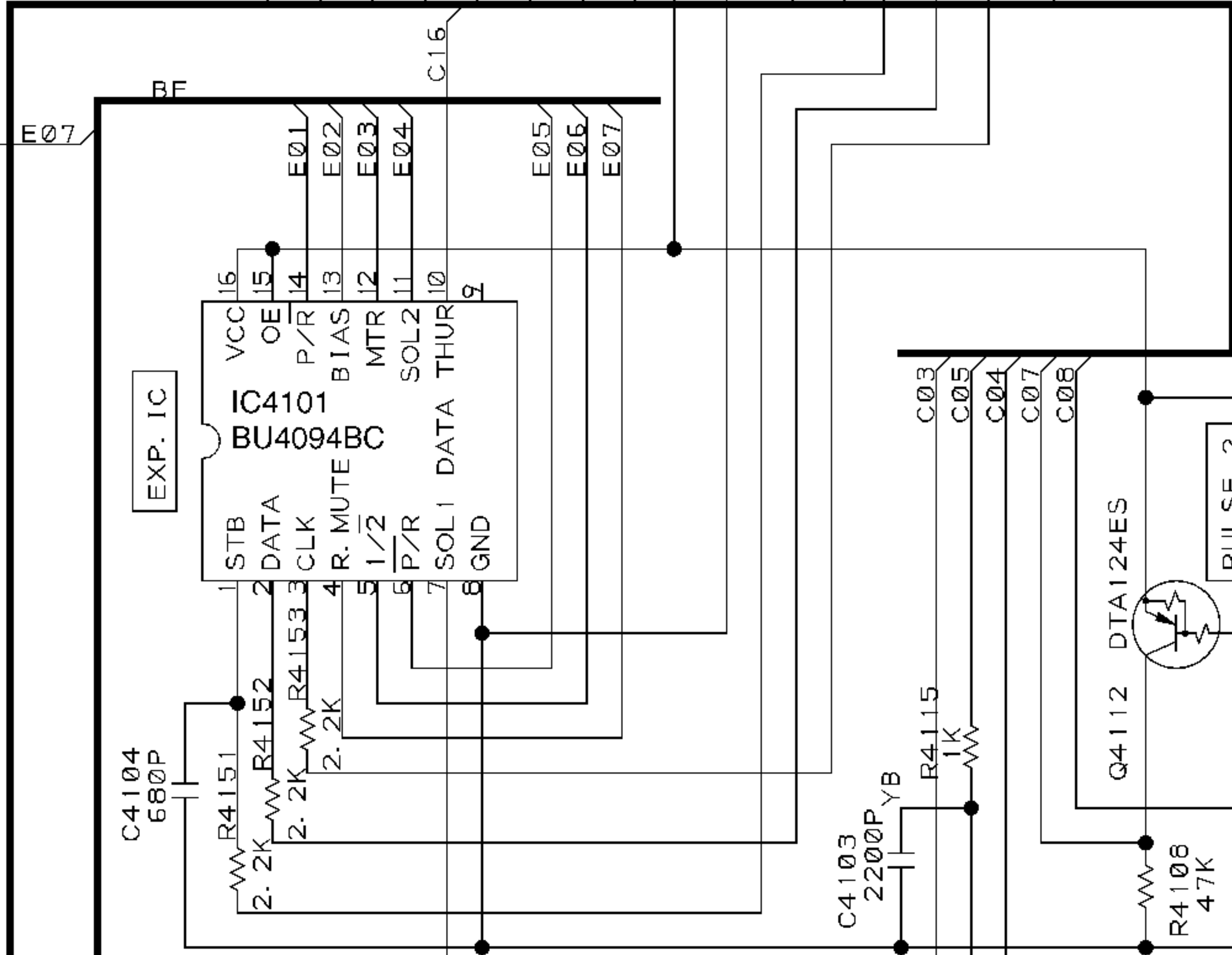

DECK ASSY(XWZ3002)

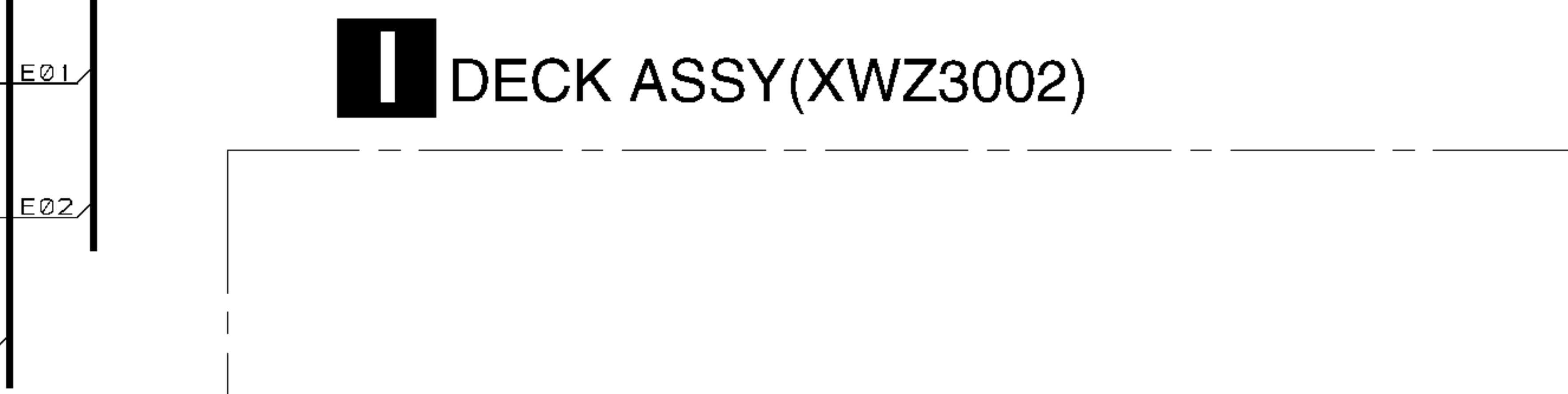

A

B

C

D



XR-A200, XR-A100

3.7 AF ASSY

A

B

C

D

F CN8004

K AF ASSY
(XWM3011 : XR-A200)
(XWM3001 : XR-A100)

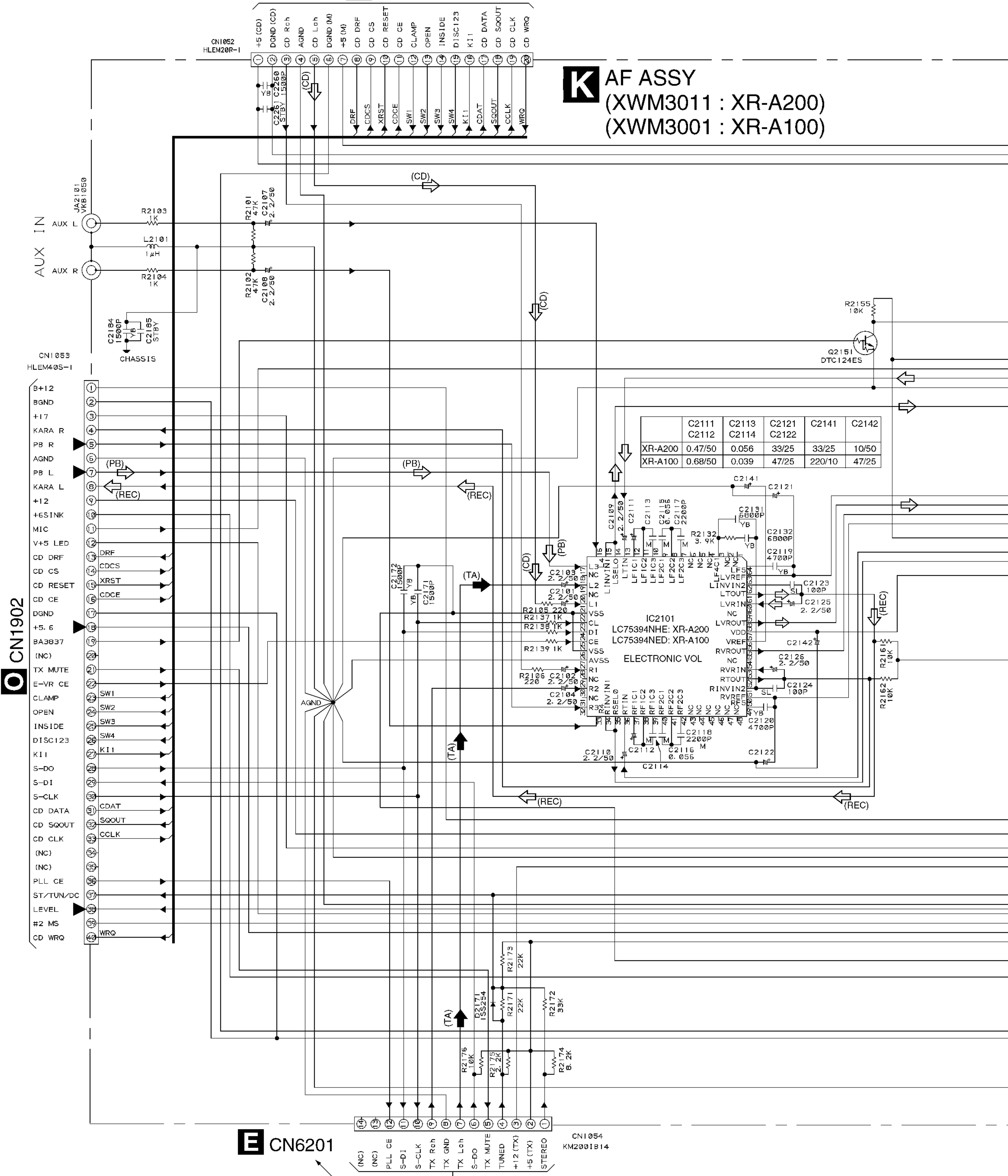

	C2111	C2113	C2121	C2141	C2142
XR-A200	0.47/50	0.056	33/25	33/25	10/50
XR-A100	0.68/50	0.039	47/25	220/10	47/25

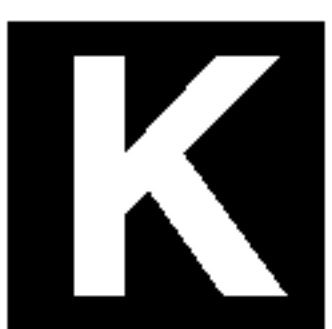

XR-A200, XR-A100

A

B

C

D

NOTES

- Resistors:
Indicated in Ω , $1/4W$, $\pm 5\%$ tolerance unless otherwise noted K:k Ω M:M Ω .
- Capacitors:
Indicated in μF /voltage unless otherwise noted P:pF. Indication without voltage is 50V except electronic capacitors.
*Electronic capacitors: CEAS000M
*Ceramic capacitors: CKCYF000Z
YB:CKCYB YX:CGCYX SL:CCCSL
*Film capacitors
M:CQMA
- Inductors: LAU000

- : AUDIO SIGNAL ROUTE
- : CD AUDIO SIGNAL ROUTE
- : TUNER AUDIO SIGNAL ROUTE
- : DECK PB SIGNAL ROUTE
- : DECK REC SIGNAL ROUTE

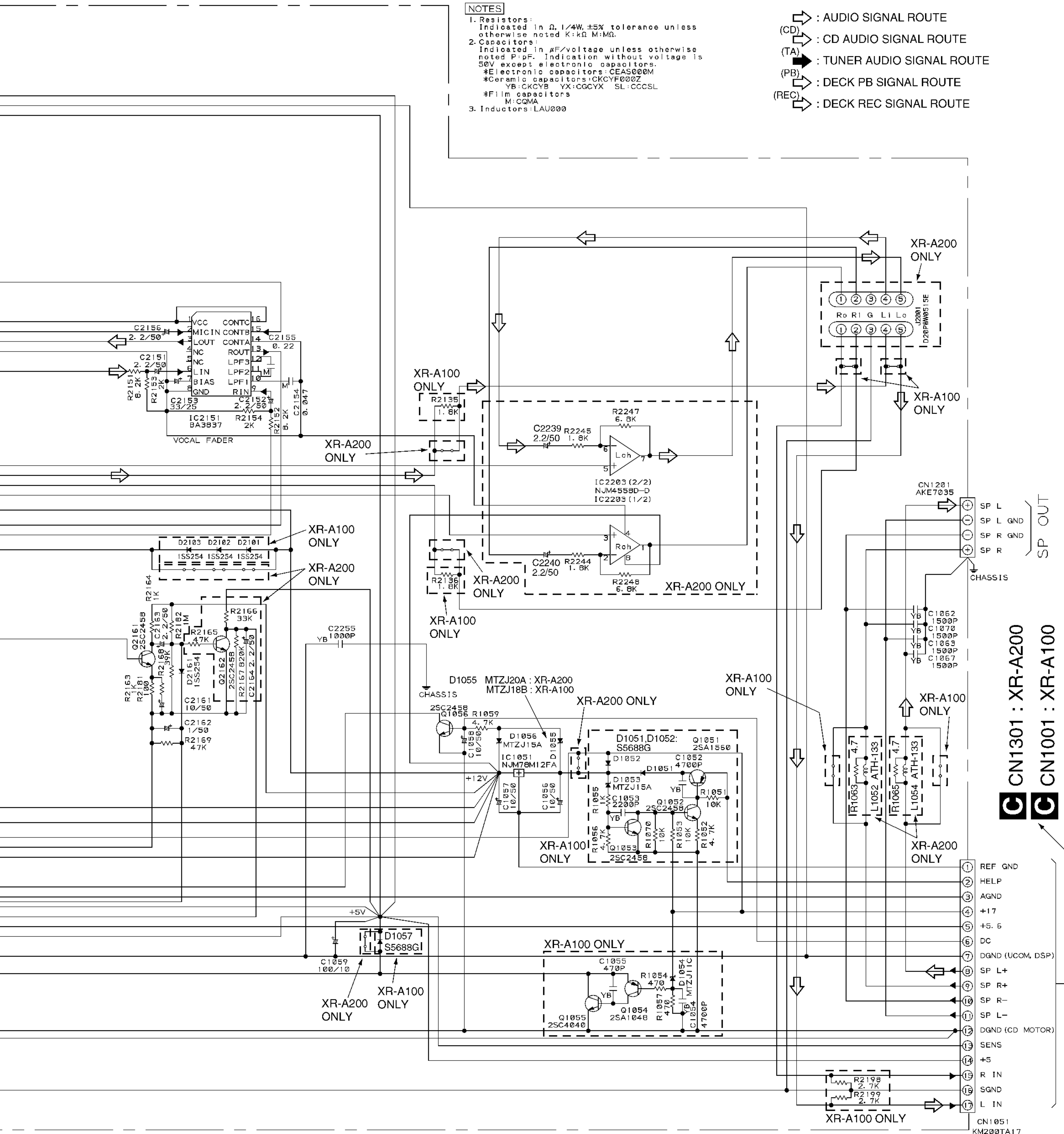

C CN1301 : XR-A200
C CN1001 : XR-A100

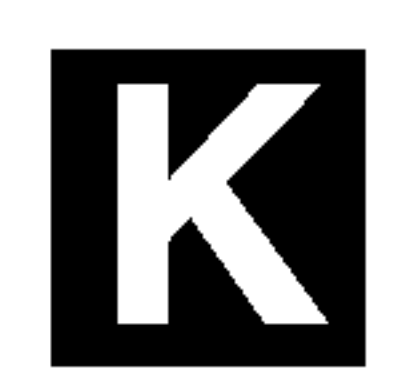

3.8 CD SW, DISPLAY, LAMP AND LCD ASSEMBLIES

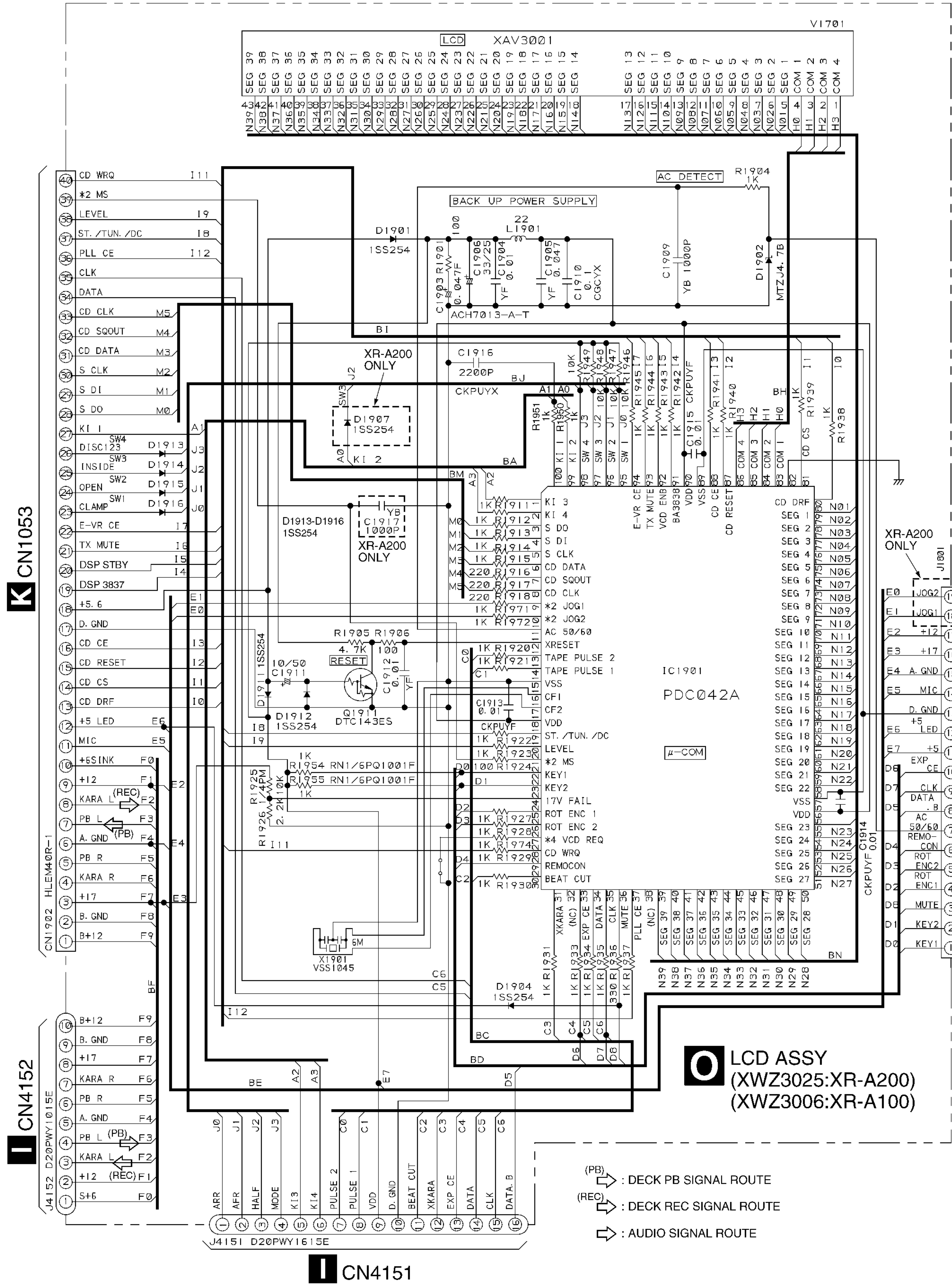

(PB) : DECK PB SIGNAL ROUTE
 (REC) : DECK REC SIGNAL ROUTE
 : AUDIO SIGNAL ROUTE

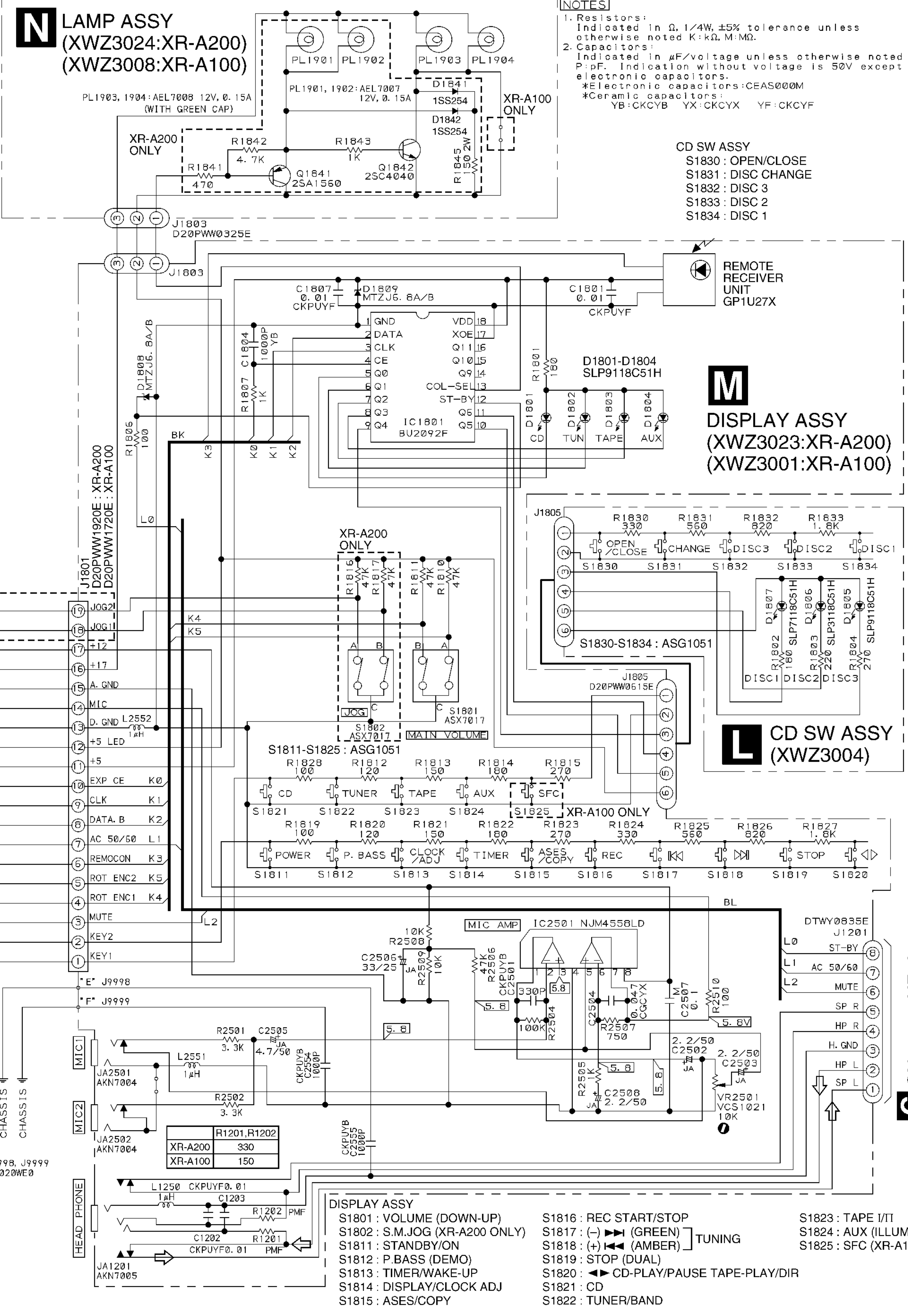





C CN1302 : XR-A200
C CN1002 : XR-A100

4. PCB CONNECTION DIAGRAM

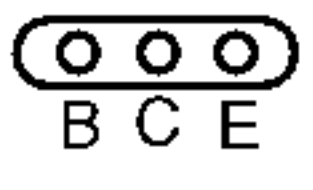
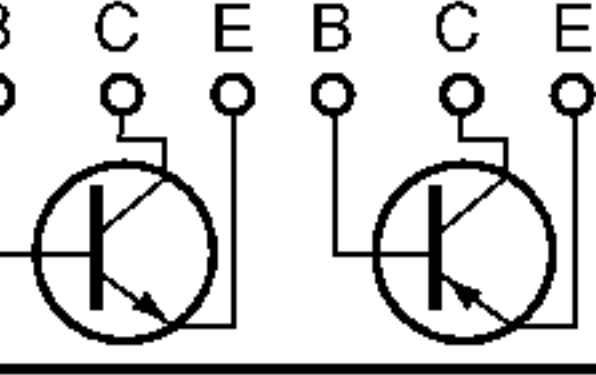
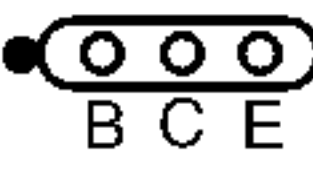
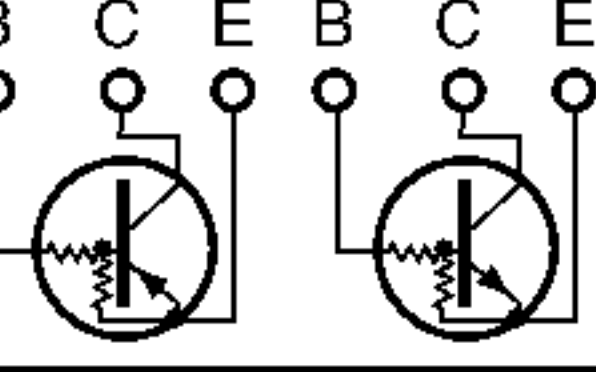
NOTE FOR PCB DIAGRAMS :

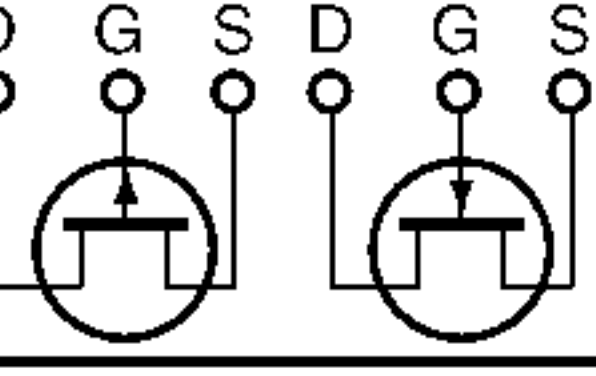
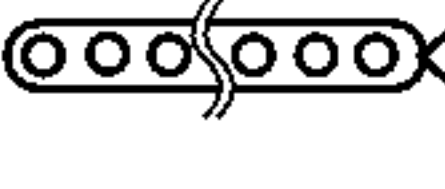
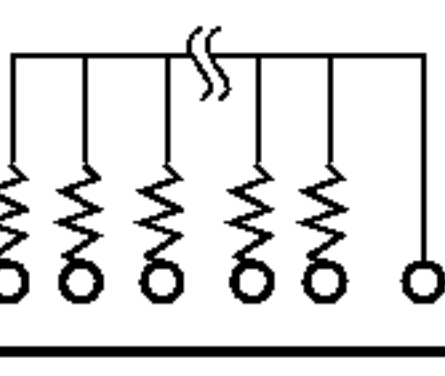
1. Part numbers in PCB diagrams match those in the schematic diagrams.
2. A comparison between the main parts of PCB and schematic diagrams is shown below.

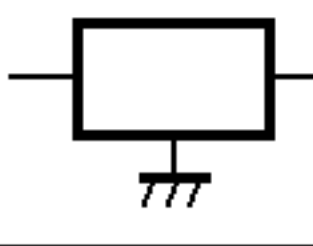
Symbol In PCB Diagrams	Symbol In Schematic Diagrams	Part Name
		Transistor
		Transistor with resistor
		Field effect transistor
		Resistor array
		3-terminal regulator

3. The parts mounted on this PCB include all necessary parts for several destinations.
For further information for respective destinations, be sure to check with the schematic diagram.
4. View point of PCB diagrams.

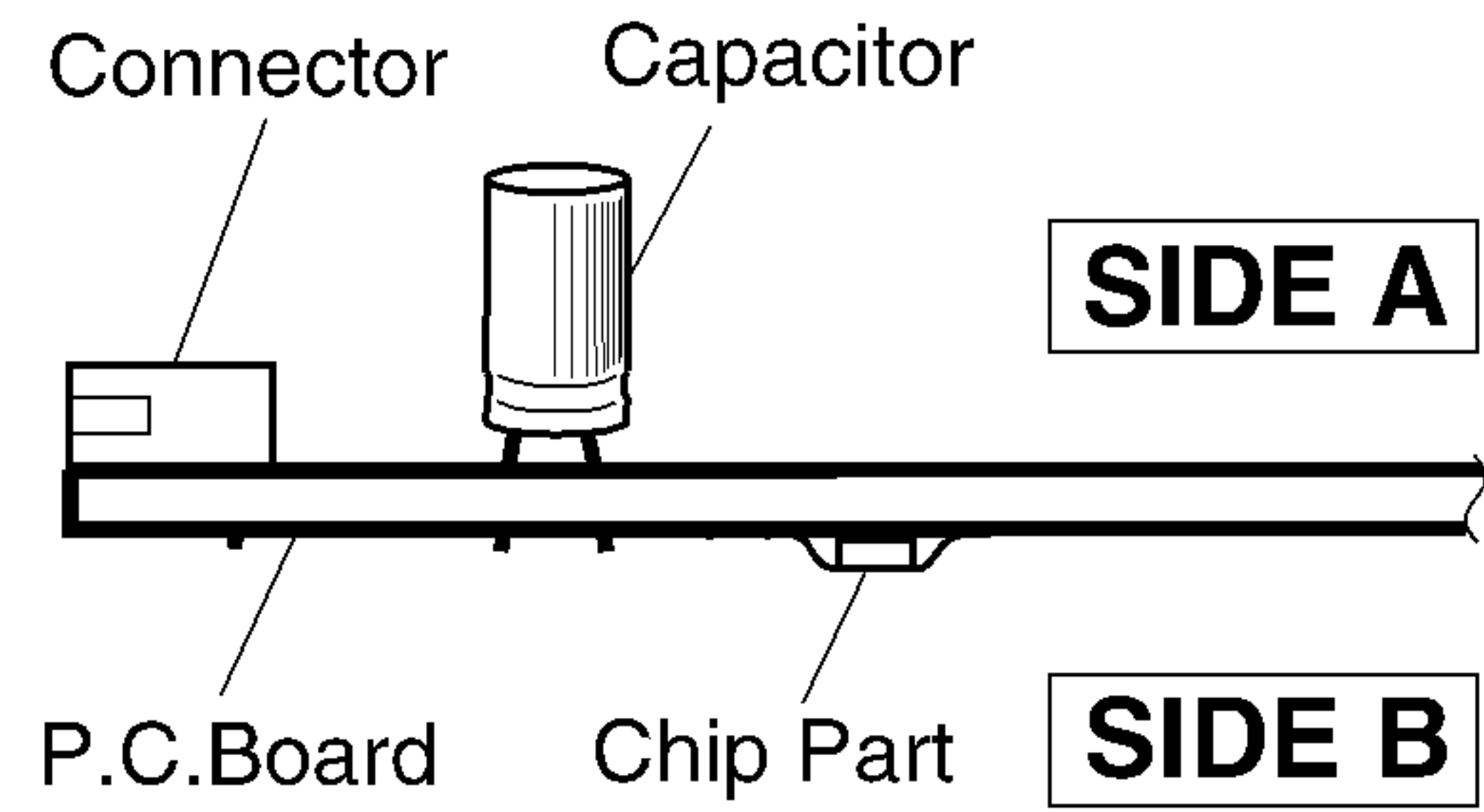

4.1 TRANS, TRANS 2, POWER ASSEMBLIES AND POWER ASSY 2 (XR-A200)

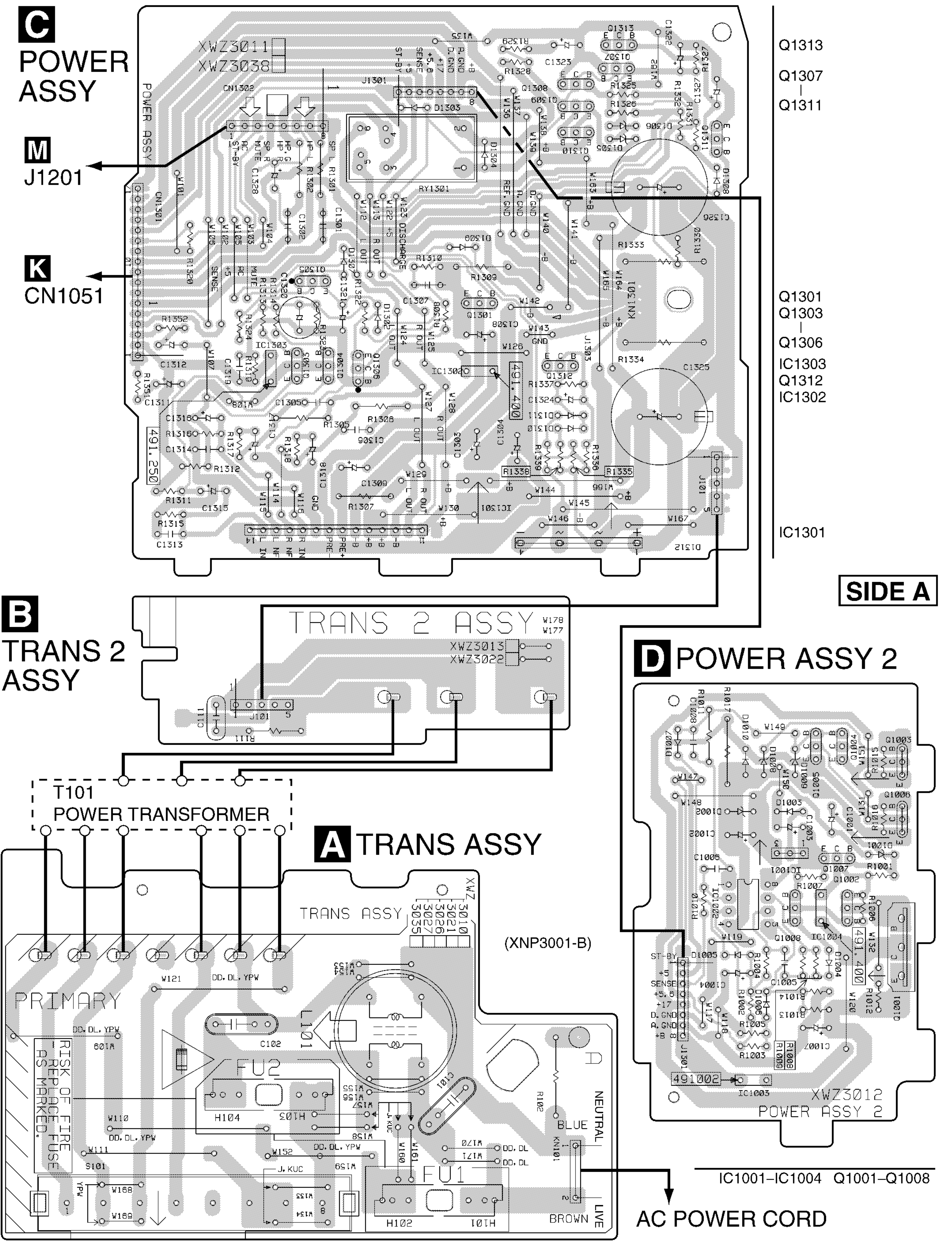

(XR-A200)

A B C D

4.2 TRANS AND POWER ASSEMBLIES (XR-A100)

A

C POWER ASSY

M
 J1201

K
 CN1051

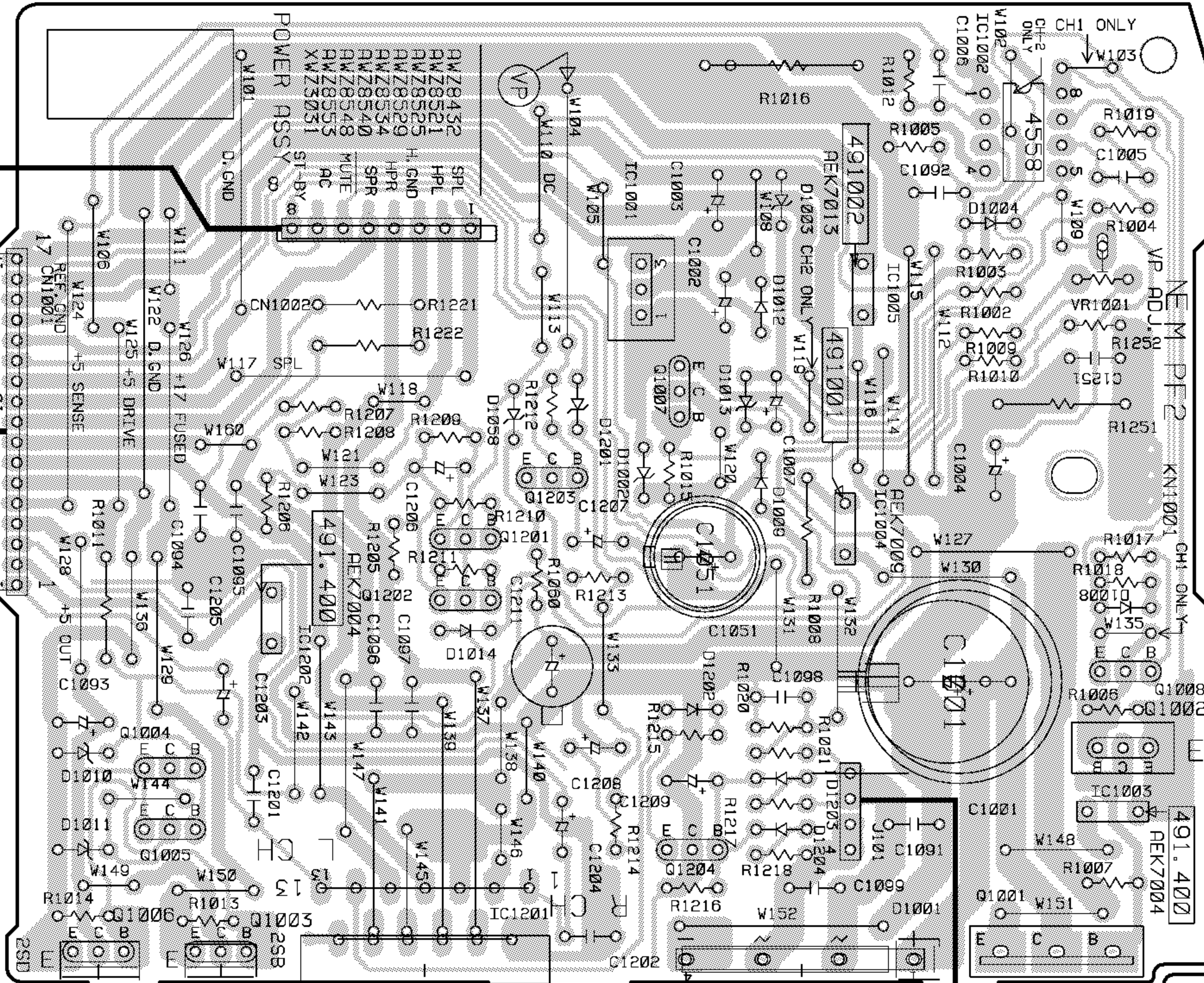

- IC1002
- VR1001
- IC1001
- IC1005
- Q1007
- IC1004
- Q1203
- Q1201
- IC1202
- Q1008
- Q1002
- IC1003
- Q1204
- Q1006
- Q1003
- IC1201
- Q1001

B

C

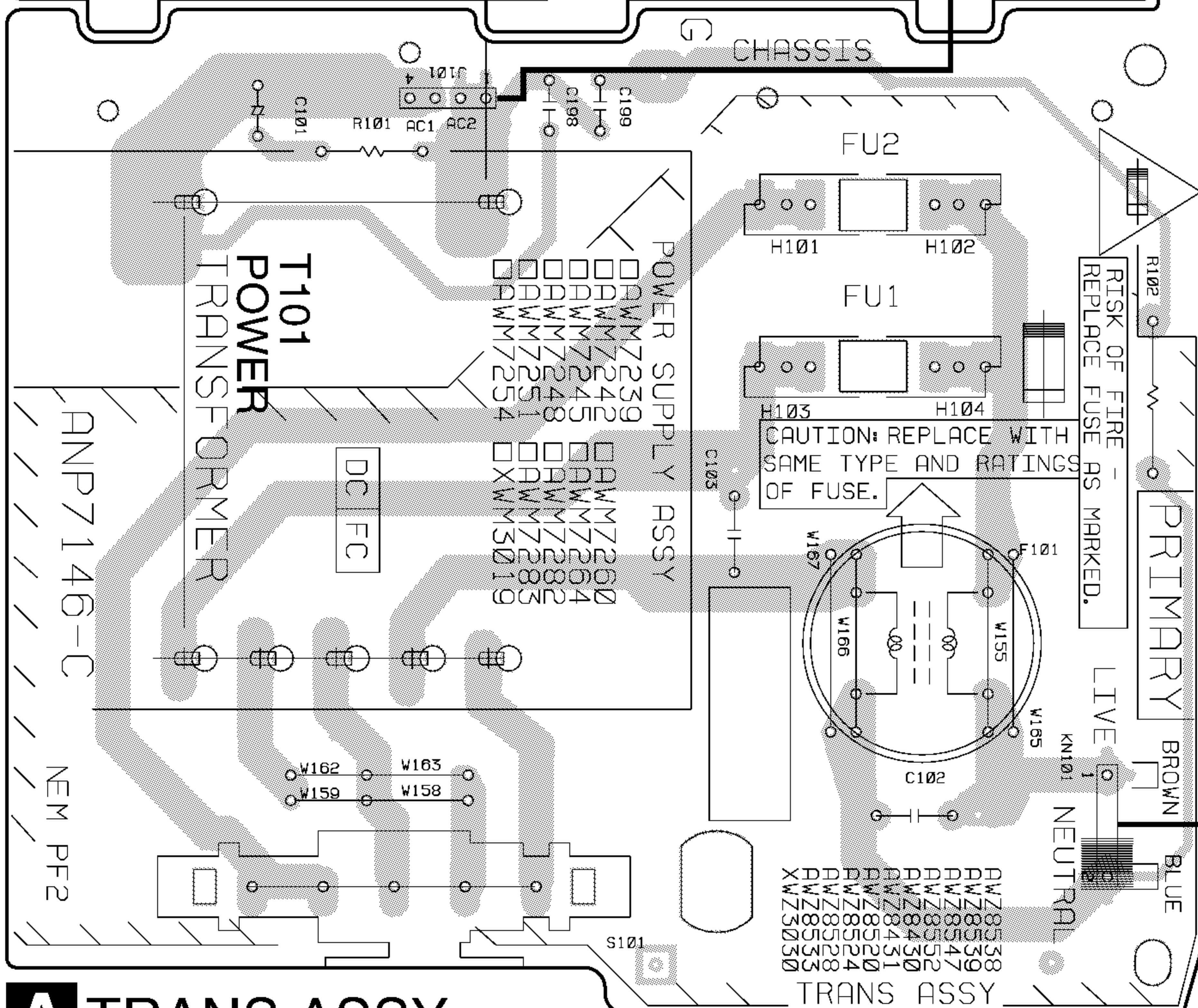

AC POWER CORD

A TRANS ASSY

(ANP7146-C)

SIDE A

4.3 FM/AM TUNER MODULE

E FM/AM TUNER MODULE

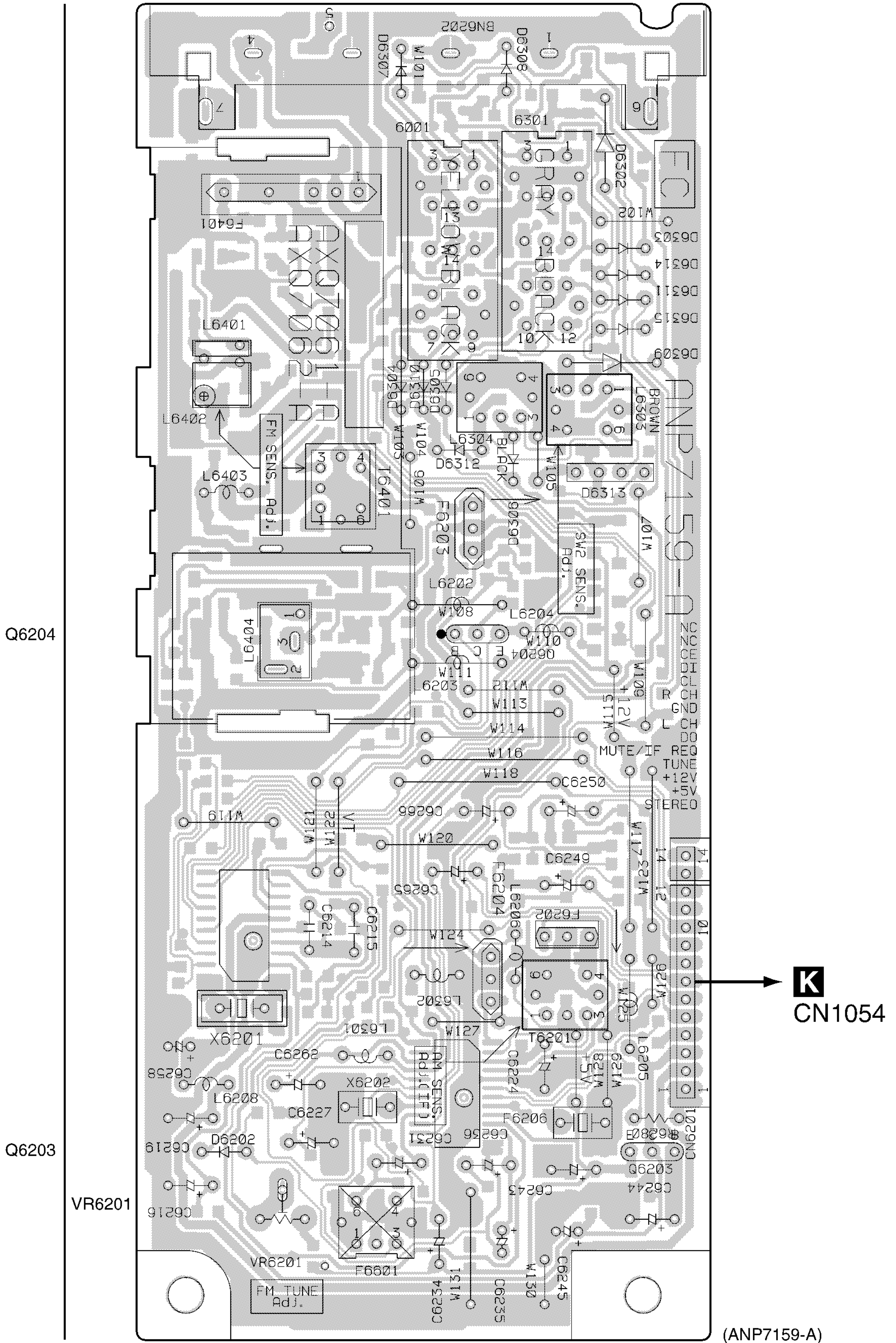

SIDE A



4.4 CD, MOTOR AND SW ASSEMBLIES

SIDE A

H SW ASSY

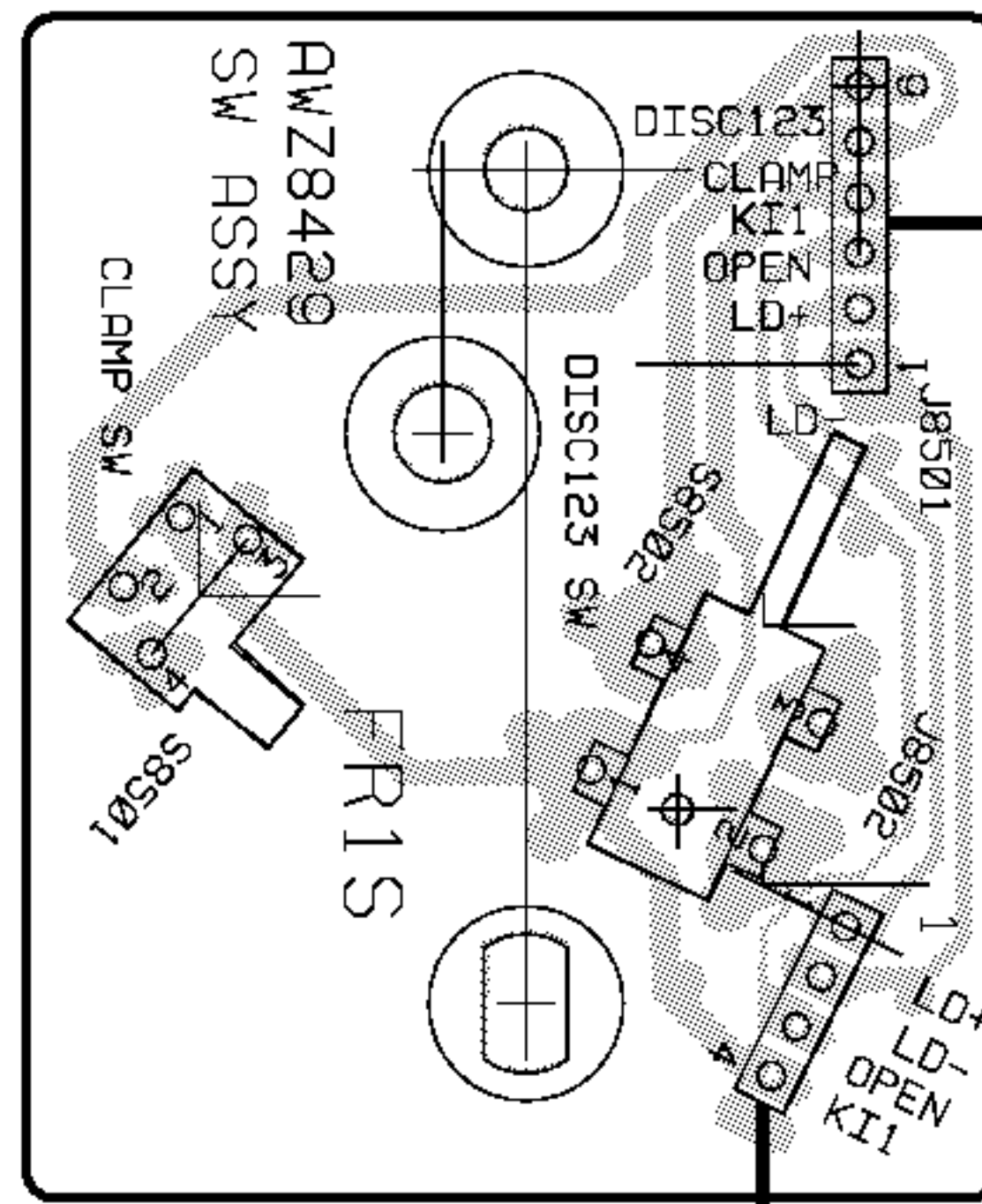

G MOTOR ASSY

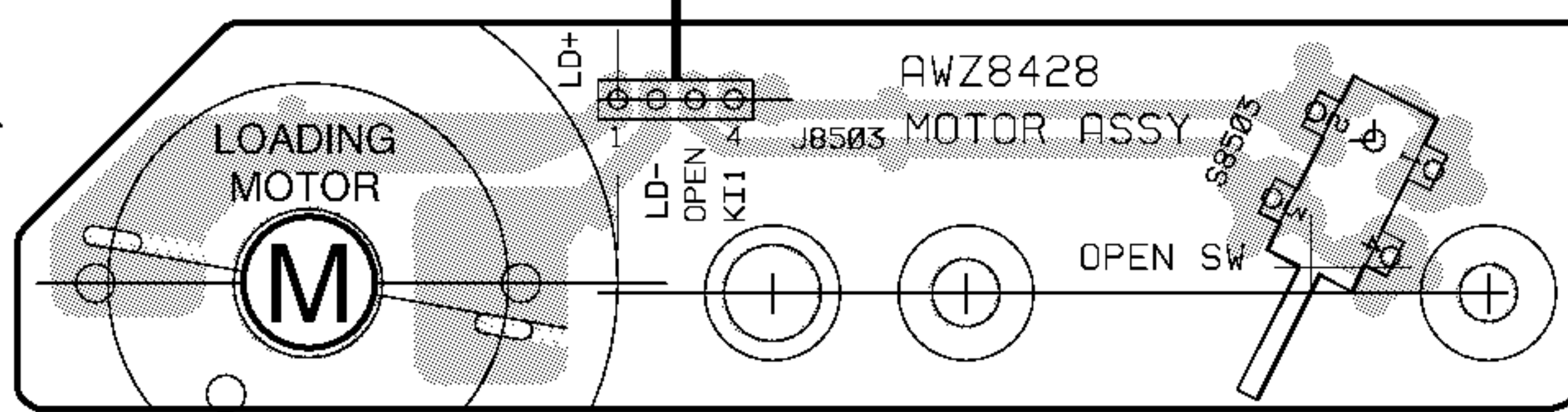

SERVO MECHANISM ASSY

PICKUP ASSY

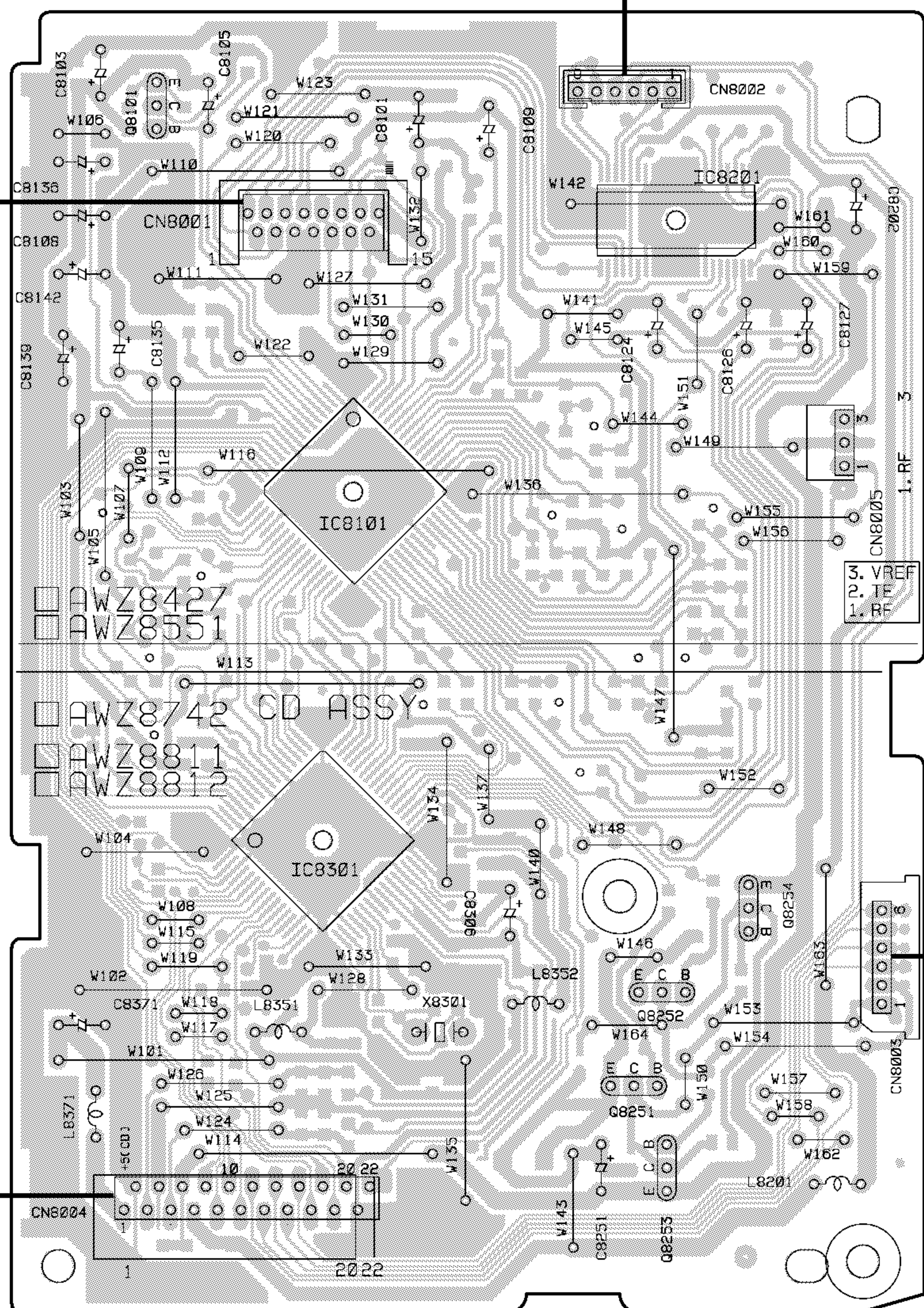

K CN1052

F CD ASSY

(ANP7144-D)

Q8101

Q8254

Q8252

Q8251

Q8253

F G H

H SW ASSY

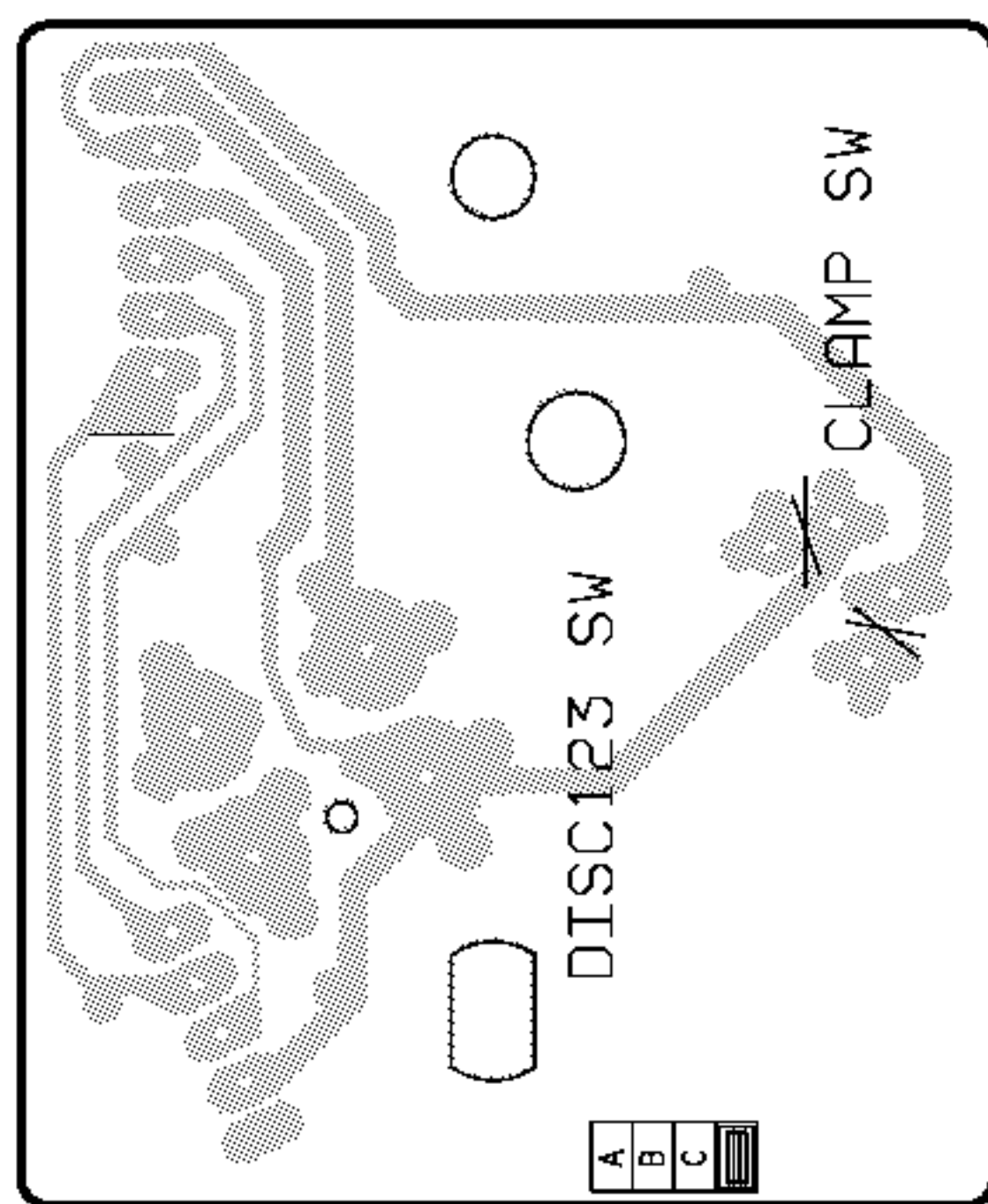

SIDE B

G MOTOR ASSY

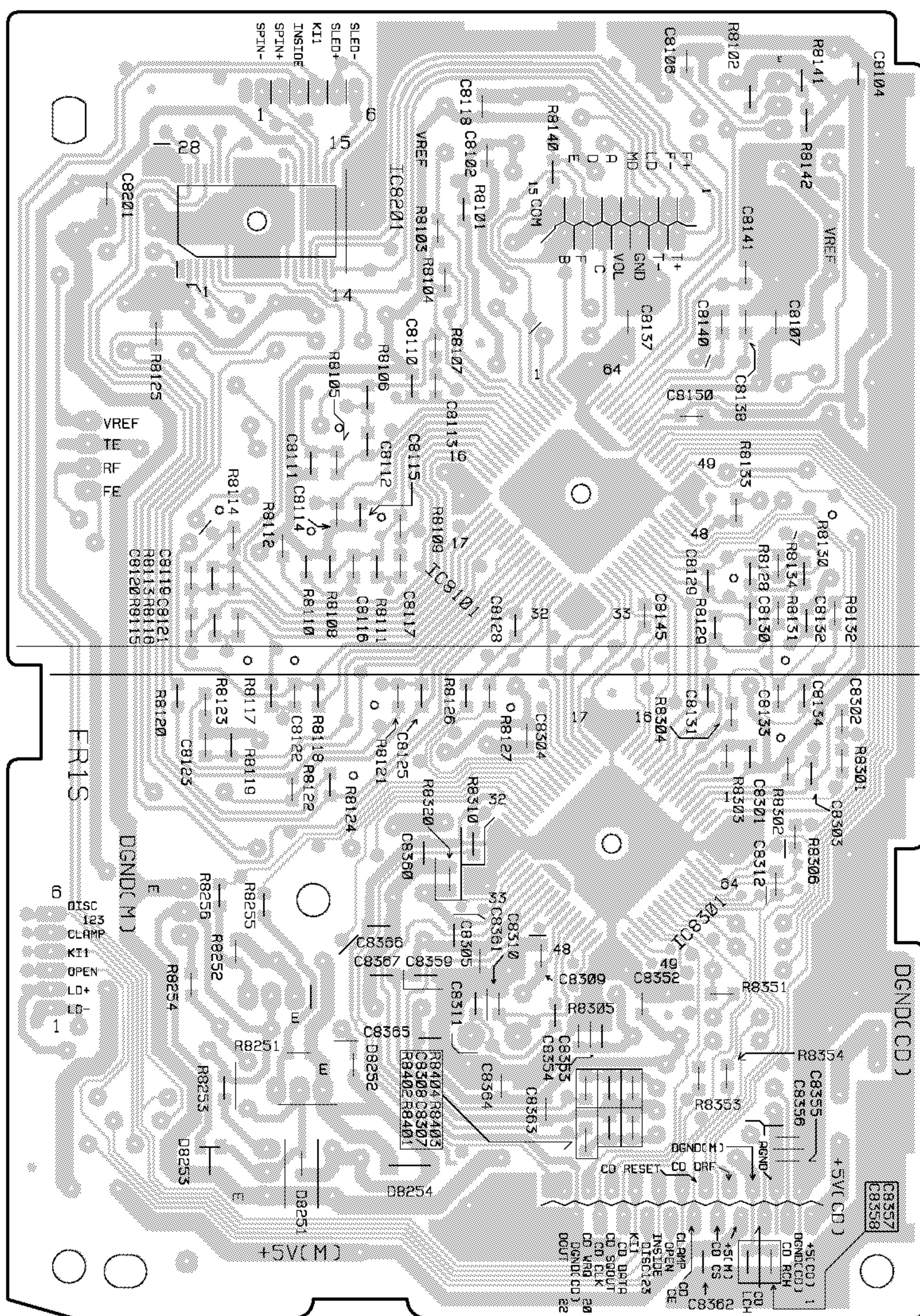
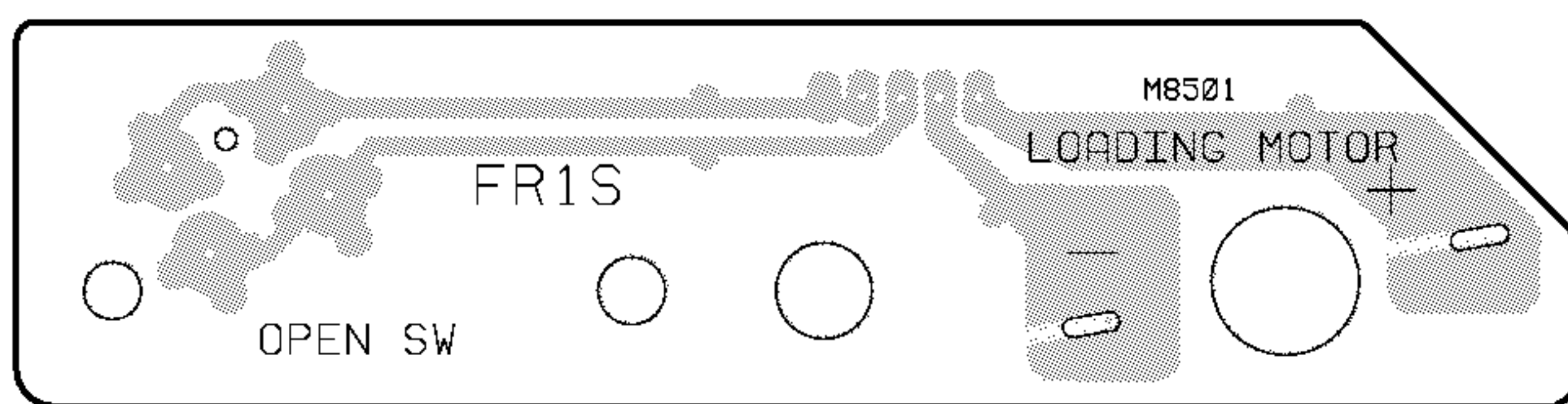

IC8201

IC8101

IC8301

F CD ASSY

(ANP7144-D)

4.6 AF ASSY

K AF ASSY

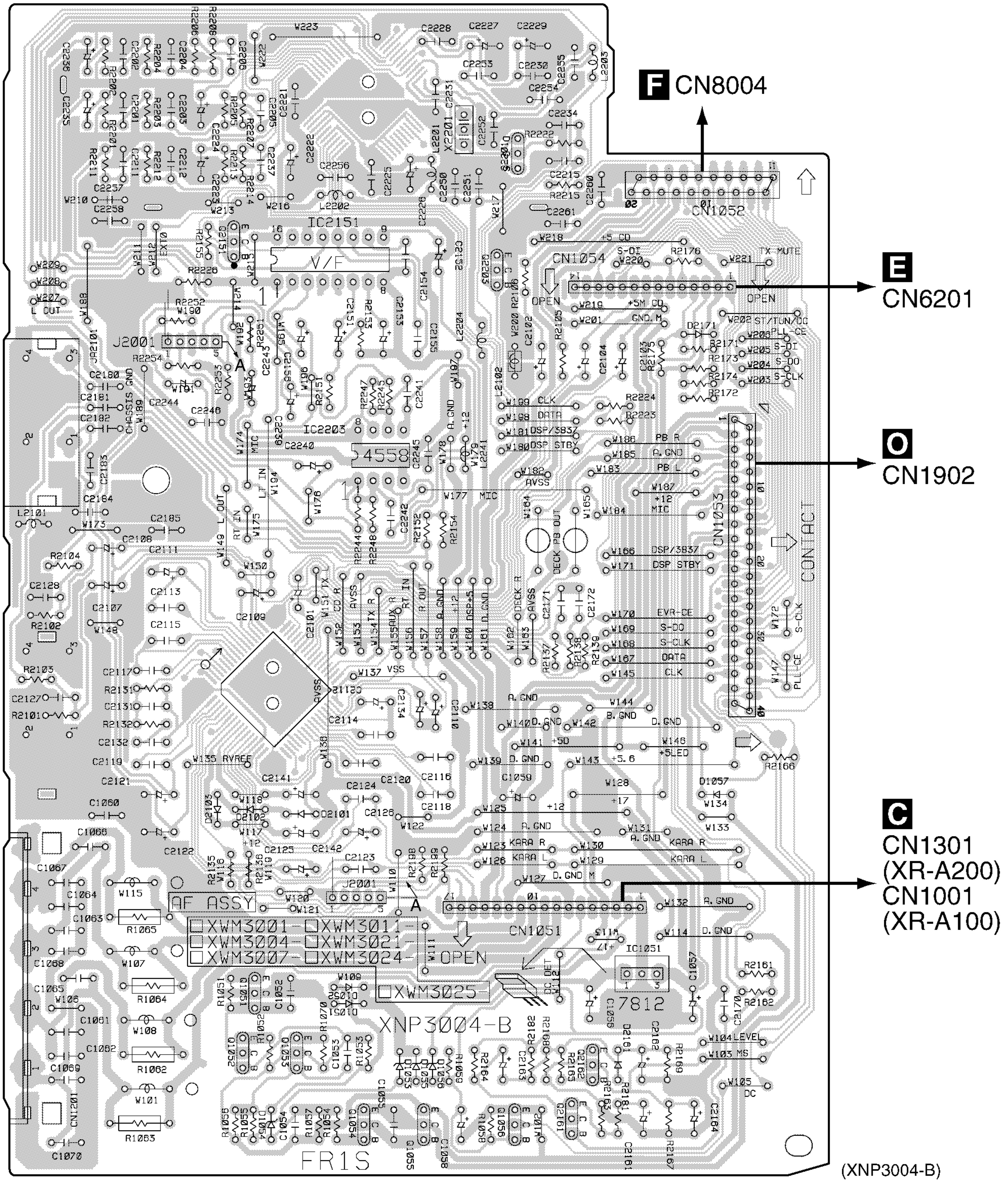

Q2151 IC2151 IC2203 Q2203 Q2201
 Q1051-Q1056 Q2161 Q2162 IC1051

SIDE A

4.7 CD SW, DISPLAY, LAMP AND LCD ASSEMBLIES

O LCD ASSY

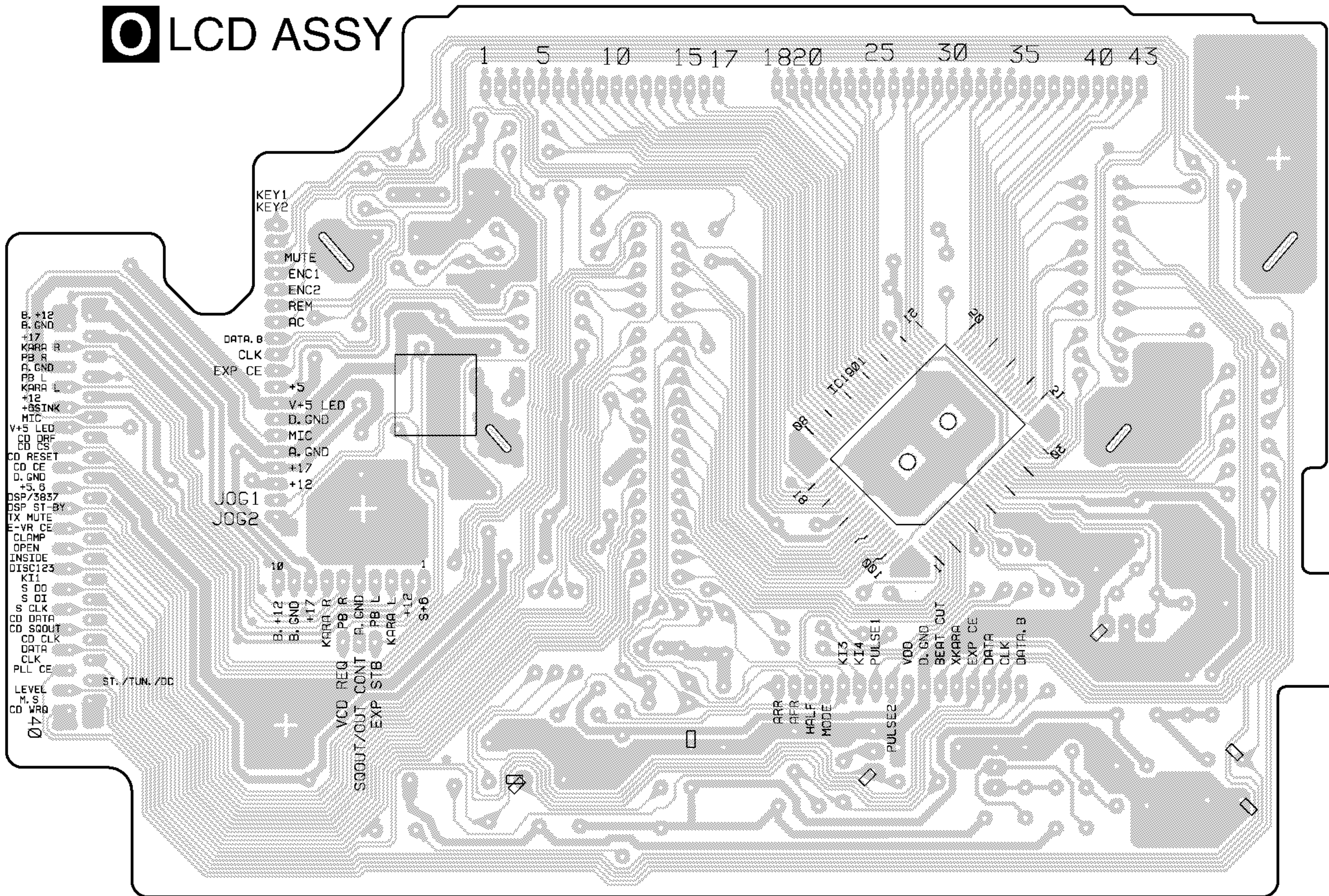

SIDE B

N LAMP ASSY

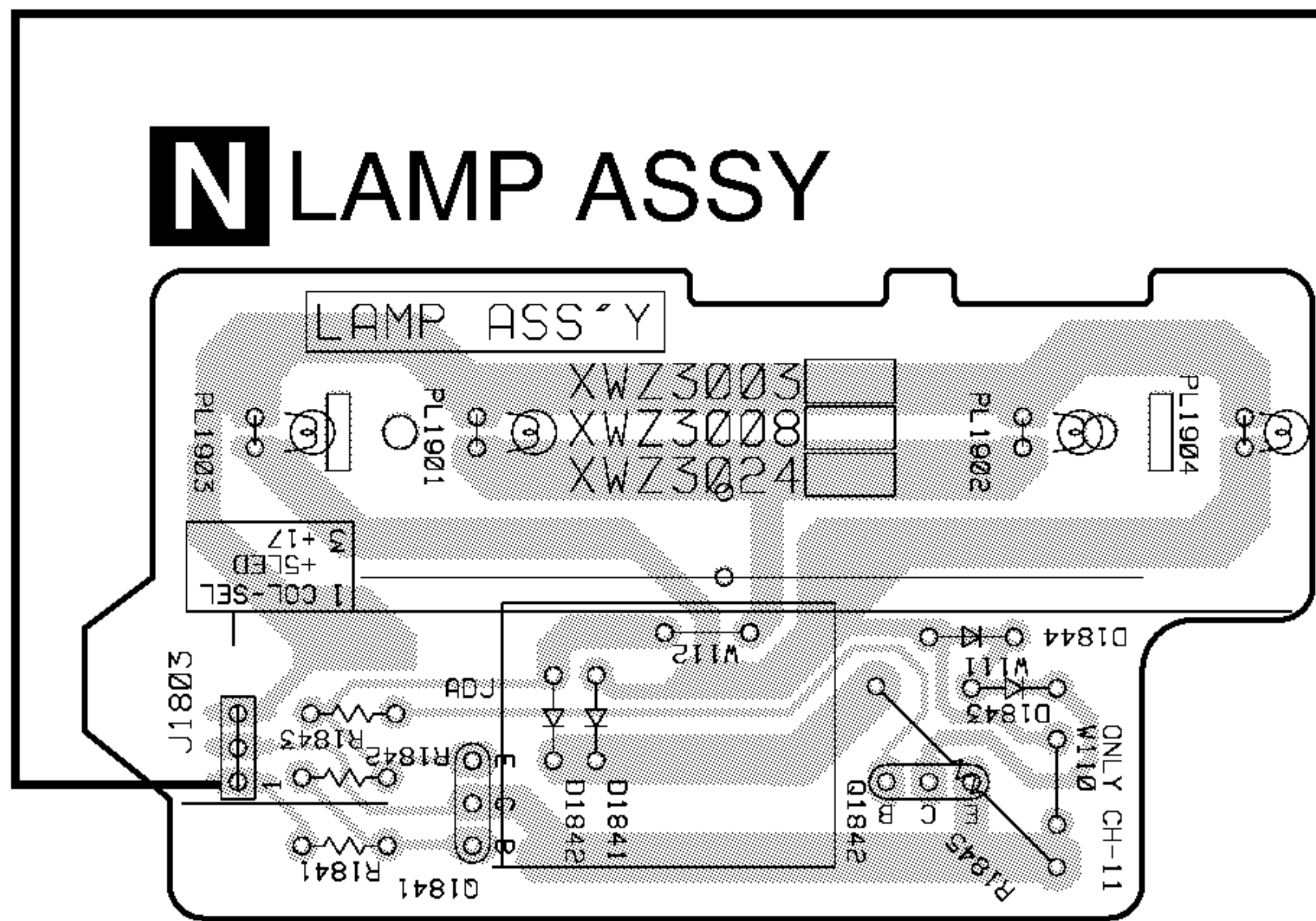

(XNP3002-B)

SIDE A

C CN1302 (XR-A200)
 CN1002 (XR-A100)

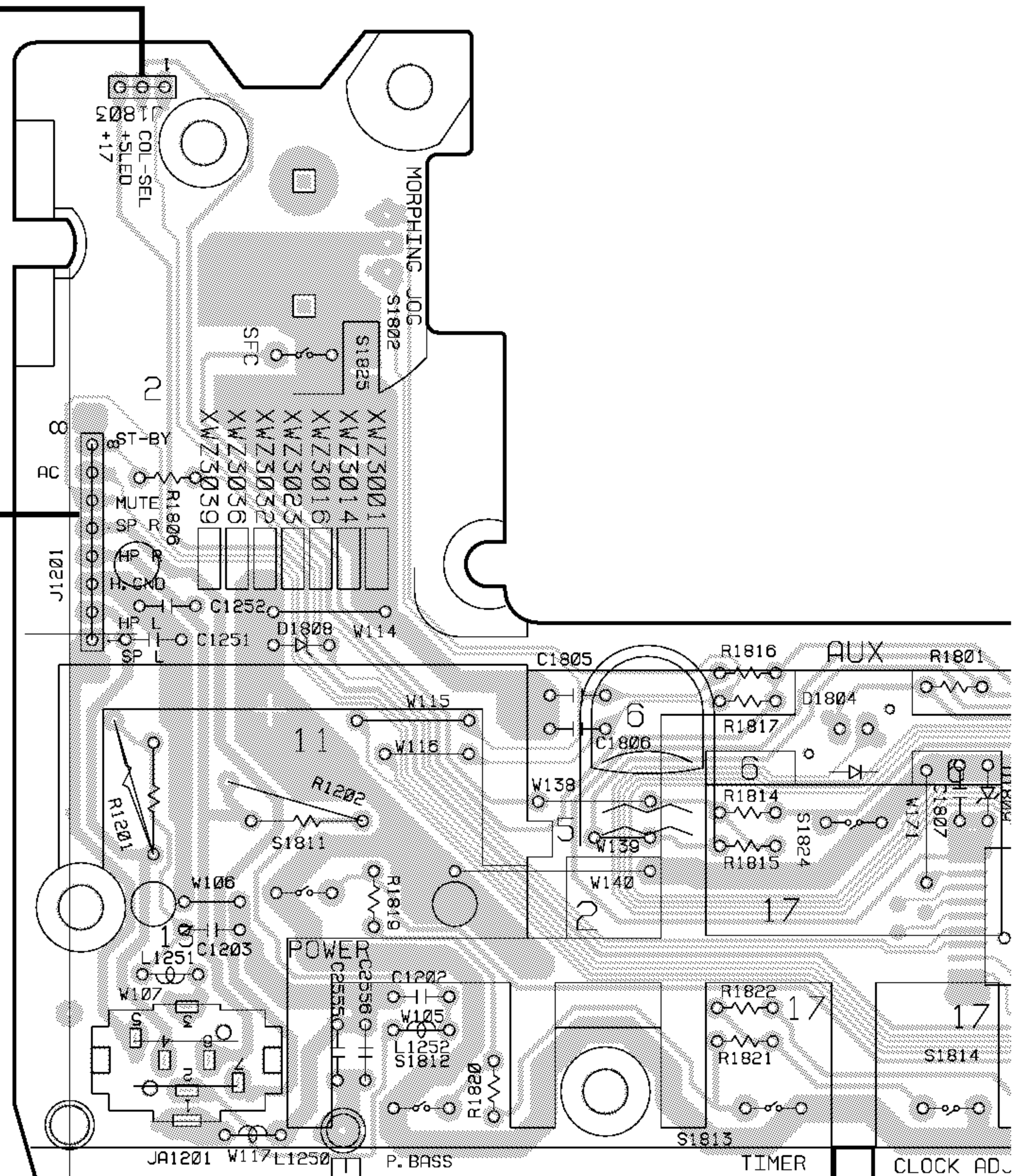

5. PCB PARTS LIST

NOTES: ●Parts marked by "NSP" are generally unavailable because they are not in our Master Spare Parts List.

●The \triangle mark found on some component parts indicates the importance of the safety factor of the part. Therefore, when replacing, be sure to use parts of identical designation.

●When ordering resistors, first convert resistance values into code form as shown in the following examples.

Ex.1 When there are 2 effective digits (any digit apart from 0), such as 560 ohm and 47k ohm (tolerance is shown by J=5%, and K=10%).

560 Ω \rightarrow 56×10^1 \rightarrow 561 RD1/4PU $\begin{matrix} 5 & 6 & 1 \\ \hline \end{matrix}$ J

47k Ω \rightarrow 47×10^3 \rightarrow 473 RD1/4PU $\begin{matrix} 4 & 7 & 3 \\ \hline \end{matrix}$ J

0.5 Ω \rightarrow R50 RN2H $\begin{matrix} R & 5 & 0 \\ \hline \end{matrix}$ K

1 Ω \rightarrow 1R0 RS1P $\begin{matrix} 1 & R & 0 \\ \hline \end{matrix}$ K

Ex.2 When there are 3 effective digits (such as in high precision metal film resistors).

5.62k Ω \rightarrow 562×10^1 \rightarrow 5621 RN1/4PC $\begin{matrix} 5 & 6 & 2 & 1 \\ \hline \end{matrix}$ F

LIST OF WHOLE PCB ASSEMBLIES

Mark	Symbol and Description	Part No.		Remarks
		XR-A200	XR-A100	
	FM AM TUNER MODULE	AXQ7061	AXQ7061	
	AF ASSY	XWM3011	XWM3001	
NSP	POWER SUPPLY ASSY	XWM3012	AWM7251	
	└POWER ASSY	XWZ3011	AWZ8534	
	└POWER ASSY 2	XWZ3012	Not used	
	└TRANS ASSY	XWZ3021	AWZ8533	
	└TRANS 2 ASSY	XWZ3022	Not used	
NSP	COMPLEX ASSY	XWM3013	XWM3002	
	└DECK ASSY	XWZ3002	XWZ3002	
	└CD SW ASSY	XWZ3004	XWZ3004	
NSP	└SHIELD ASSY	XWZ3005	XWZ3005	
	└DISPLAY ASSY	XWZ3023	XWZ3001	
	└LAMP ASSY	XWZ3024	XWZ3008	
	└LCD ASSY	XWZ3025	XWZ3006	
NSP	\$M SERVO BOARD ASSY	AWX7030	AWX7030	
	└CD ASSY	AWZ8427	AWZ8427	
	└MOTOR ASSY	AWZ8428	AWZ8428	
NSP	└SW ASSY	AWZ8429	AWZ8429	

Mark No. Description Part No.

A TRANS ASSY (XWZ3021)

SWITCH

S101 AKX7006

OTHERS

H101-H104 FUSE CLIP AKR7001
TERMINAL RKC-061

A TRANS ASSY (AWZ8533)

SWITCH

S101 AKX7004

CAPACITOR

C101 CEANP1R0M50

Mark No. Description Part No.

RESISTOR

R101 RF1/4PS100J

OTHERS

H101-H104 FUSE CLIP AKR1004
TERMINAL RKC-061

B TRANS 2 ASSY

CAPACITOR

C111 CQMA103K2E

RESISTOR

R111 RF1/4PS100J

Mark No. Description Part No.

C POWER ASSY (XWZ3011)

SEMICONDUCTORS

△	IC1303(250mA,125V)	AEK7002
△	IC1302(400mA,125V)	AEK7004
	IC1301	STK405-090A
	Q1310,Q1312,Q1313	2SA1048
	Q1301,Q1307-Q1309,Q1311	2SC2458
	Q1303,Q1304	2SD2144S
	Q1305,Q1306	DTA124ES
	D1302-D1304,D1308-D1311	1SS254
	D1312	D3SBA20
	D1305,D1306	MTZJ2.2B

RELAY

RY1301	ASR7007
--------	---------

CAPACITORS

C1305,C1306	CCCCJ3R0C50
C1313,C1314	CCCSL221J50
C1320	CEANP470M16
C1311,C1312,C1328	CEAT100M50
C1324	CEAT1R0M50
C1326	CEAT222M50
C1315,C1316,C1327	CEAT2R2M50
C1317,C1318	CEAT330M50
C1321,C1323	CEAT470M25
C1308,C1309	CEAT470M50
C1322	CEAT471M6R3
C1319	CGCYX104K25
C1301,C1302	CQMBA104J50
C1325(3300μF,50V)	RCH1129

RESISTORS

R1305,R1306	RD1/2PM563J
R1307,R1309	RFA1/4PS101J
R1301,R1302	RFA1/4PS4R7J
R1333,R1334	RS2LMFR22J
Other Resistors	RD1/4PU□□□J

OTHERS

CN1301 17P SOCKET	KP200TA17L
KN1301 EARTH METAL FITTING	VNF1084

C POWER ASSY (AWZ8534)

SEMICONDUCTORS

△	IC1003,IC1202 FUSE IC (400mA,125V)	AEK7004
△	IC1004 FUSE IC (1A,125V)	AEK7009
△	IC1005 FUSE IC (2A,125V)	AEK7013
	IC1002	NJM4558D-D
	IC1001	NJM78M05FA
	IC1201	TDA8560Q
	Q1005,Q1201,Q1202,Q1204	2SA1048
	Q1002,Q1003	2SB1375
	Q1004,Q1008,Q1203	2SC2458
	Q1007	2SC4040
	Q1001	2SC5200(P)
	Q1006	2SD2012
	D1004,D1008,D1012,D1014	1SS254
	D1202-D1204	1SS254

Mark No. Description Part No.

D1001	D3SBA20
D1011,D1013,D1058	MTZJ20A
D1201	MTZJ4.7B
D1003,D1010	MTZJ6.8A
D1009	S5688G

CAPACITORS

C1005	CCCSL331J50
C1006	CCCSL680J50
C1003,C1007,C1208	CEAS100M50
C1206	CEAS101M10
C1211	CEAS101M35
C1209	CEAS1R0M50
C1002	CEAS2R2M50
C1004,C1207	CEAS330M25
C1051	CEAS331M50
C1203,C1204	CEASR10M50
C1201,C1202	CKCYB222K50
C1205,C1251	CKCYF473Z50
C1001(4700μF,50V)	RCH1142

RESISTORS

R1011	RD1/2PM472J
R1221,R1222	RD1/2PMF181J
R1008	RD1/4PMF4R7J
R1251	RS1LMF1R0J
R1016	RS2LMF330J
VR1001(1kΩ)	RCP1044
Other Resistors	RD1/4PU□□□J

OTHERS

CN1001 17P SOCKET	KP200TA17L
KN1001 EARTH METAL FITTING	VNF1084

D POWER ASSY 2

SEMICONDUCTORS

△	IC1004(400mA,125V)	AEK7004
△	IC1003(2A,125V)	AEK7013
	IC1002	NJM4558D-D
	IC1001	NJM78M05FA
	Q1005	2SA1048
	Q1002	2SA965
	Q1003	2SB1375
	Q1007	2SC2235
	Q1004,Q1008	2SC2458
	Q1001	2SC5196(P)
	Q1006	2SD2012
	D1003-D1007	1SS254
	D1001,D1008	MTZJ20A
	D1002,D1009	MTZJ6.8A

CAPACITORS

C1005	CCCSL331J50
C1006	CCCSL680J50
C1001,C1002	CEAT100M50
C1003	CEAT2R2M50
C1004,C1007	CEAT470M25
C1008	CKCYB222K50

XR-A200, XR-A100

Mark No.	Description	Part No.
RESISTORS		
R1011		RD1/2PM472J
R1014		RN1/4PC3601F
R1013		RN1/4PC7501F
R1017		RS1LMF560J
	Other Resistors	RD1/4PU□□□J

F FM/AM TUNER MODULE

SEMICONDUCTORS

IC6201	LA1832ML
IC6202	LC72131MD
Q6402	2SC2223
Q6203	2SC2705
Q6201, Q6202	2SC2712
Q6214, Q6403	2SC2714
Q6404	2SK302
Q6401	3SK194
Q6204	DTA124ES
Q6205	DTC124EK
D6202	1SS254
D6401, D6402	1T363

COILS AND FILTERS

L6404	ATC1003
L6401	ATC1020
L6402	ATC1021
F6204	ATF-107
F6203	ATF-119
F6401	ATF-155
F6206	ATF7008
F6202	ATF7011
L6206, L6208, L6403	LAU2R2J

TRANSFORMERS

T6201	ATB7008
T6401	ATE7002

CAPACITORS

C6208	CCSQCH100D50
C6212, C6274, C6275, C6408	CCSQCH101J50
C6221, C6222, C6416	CCSQCH150J50
C6271	CCSQCH200J50
C6415	CCSQCH330J50
C6401, C6419	CCSQCH5R0C50
C6407	CCSQCK1R0C50
C6410	CCSQCK2R0C50
C6413	CCSQPH220J50
C6414	CCSQPH8R0D50
C6405	CCSQTH180J50
C6234, C6235	CEAL1R0M50
C6245	CEAL470M16
C6224	CEAS100M50
C6243	CEAS101M16
C6231	CEAS1R0M50
C6227	CEAS220M16
C6236	CEAS2R2M50
C6216	CEAS330M16
C6262	CEAS3R3M50

Mark No.	Description	Part No.
C6219		CEAS470M10
C6244		CEAS470M16
C6249, C6250, C6265, C6266		CEAS4R7M50
C6258		CEJA470M16
C6215		CFTLA103J50
C6214		CFTLA224J50
C6211, C6254, C6403, C6406, C6412		CKSQYB102K50
C6201, C6205, C6210, C6213, C6237		CKSQYB103K50
C6276, C6278, C6280, C6281, C6402		CKSQYB103K50
C6409, C6417, C6418		CKSQYB103K50
C6251, C6252		CKSQYB153K50
C6203, C6259		CKSQYB223K50
C6228		CKSQYB472K50
C6209		CKSQYB473K50
C6230		CKSQYB821K50
C6218, C6223, C6255		CKSQYF103Z50
C6220, C6226, C6242, C6256		CKSQYF223Z50
C6225		CKSQYF473Z50

RESISTORS

R6280	RD1/4PU101J
R6413, R6416, R6418, R6906, R6909	RS1/8S0R0J
R6401	RS1/8S470J
VR6201 (10kΩ)	RCP1045
Other Resistors	RS1/10S□□□J

OTHERS

BN6202		AKE7025
X6202	4P ANTENNA TERMINAL PLATE	ASS1066
X6201	CERAMIC RESONATOR (456kHz)	ASS1093
	CRYSTAL RESONATOR (7.2000MHz)	
CN6201	14P SOCKET	KP200IA14L
	AM RF TUNING BLOCK	AXX7041

F CD ASSY

SEMICONDUCTORS

IC8201	BA5923FP
IC8101	LA9240ML
IC8301	LC78622ED
Q8101	2SA1048
Q8251, Q8252	2SA1560
Q8253, Q8254	2SC4040
D8253	1SS181
D8251, D8252	1SS355

COILS

L8351, L8352	LFA1R0K
L8201, L8371	LFA470J

CAPACITORS

C8145, C8352, C8354, C8356, C8358	CCSQCH101J50
C8361, C8362	CCSQCH101J50
C8132, C8310, C8311	CCSQCH150J50
C8131	CCSQCH300J50
C8129	CCSQCK1R0C50
C8142	CEAL101M6R3
C8127	CEAL1R0M50
C8126, C8139	CEAL470M16
C8135	CEAL4R7M16
C8124	CEALR47M50

Mark	No.	Description	Part No.
	C8136		CEAS100M50
	C8108,C8251,C8306,C8371		CEAS101M10
	C8202		CEAS101M25
	C8101		CEAS3R3M50
	C8105		CEAS470M16
	C8109		CEASR22M50
	C8106,C8119,C8133,C8360		CKSQYB102K50
	C8102,C8122,C8123,C8130		CKSQYB103K50
	C8137,C8138,C8201,C8309,C8312		CKSQYB103K50
	C8134,C8302,C8303		CKSQYB104K25
	C8353,C8359		CKSQYB152K50
	C8111		CKSQYB153K25
	C8114,C8117,C8120,C8121		CKSQYB154K16
	C8125		CKSQYB221K50
	C8107		CKSQYB223K50
	C8110		CKSQYB331K50
	C8115,C8128		CKSQYB332K50
	C8113		CKSQYB333K25
	C8112,C8141		CKSQYB334K16
	C8355,C8357		CKSQYB471K50
	C8116,C8140		CKSQYB473K50
	C8118,C8301,C8304,C8305		CKSQYF104Z25

RESISTORS

All Resistors RS1/10S□□□J

OTHERS

CN8003	6PJUMPER CONNECTOR	52151-0610
CN8002	KR CONNECTOR	B6B-PH-K-S
CN8005	3P SIDE POST	BS3P-SHF-1AA
X8301	CERAMIC RESONATOR (16.9344MHz)	DSS1083
CN8004	FFC CONNECTOR 20P	HLEM20R-1
CN8001	1.0mm PITCH FFC CONNECTOR	SLW15S-1C7

G MOTOR ASSY

SWITCH

S8503 ASG7009

OTHERS

MOTOR PULLEY PNW1634
CARRIAGE MOTOR VXM1033

H SW ASSY

SWITCHES

S8502 ASG7009
S8501 DSG1017

OTHERS

J8501 D20PWY0610E
2mm PITCH JUMPER WIRE 6P

Mark	No.	Description	Part No.
------	-----	-------------	----------

I DECK ASSY

SEMICONDUCTORS

IC4201	AN7348K
IC4101	BU4094BC
IC4202	NJM4558D-D
Q4303	2SA1048
Q4102,Q4104,Q4106	2SA1560
Q4301,Q4302	2SC1845
Q4356	2SC2240
Q4353,Q4354	2SC4040
Q4221,Q4222,Q4355	2SD2144S
Q4111,Q4112	DTA124ES
Q4223	DTA143ES
Q4101,Q4103,Q4105,Q4224	DTC143ES
D4104,D4110-D4115,D4301-D4303	1SS254

COILS

L4351	ATX7002
L4301	RTF1013

CAPACITORS

C4211,C4212	CCCSL151J50
C4360	CEAT100M50
C4207,C4208,C4305	CEAT101M10
C4215,C4216,C4237,C4238,C4254	CEAT1R0M50
C4213,C4214,C4225,C4226	CEAT2R2M50
C4229,C4230,C4235,C4236,C4253	CEAT2R2M50
C4102,C4252,C4352,C4357,C4358	CEAT330M25
C4232,C4304	CEAT4R7M50
C4218,C4219	CGCYX333K25
C4201,C4202	CKCYB102K50
C4227,C4228	CKCYB152K50
C4103	CKCYB222K50
C4353,C4354	CKCYB332K50
C4203,C4204	CKCYB471K50
C4355	CKCYB472K50
C4361	CKCYB681K2H
C4104	CKCYB681K50
C4301	CKCYB821K50
C4303	CKCYF223Z50
C4251	CQMBA104J50
C4356	CQMBA223J50
C4221,C4222	CQMBA333J50
C4209,C4210,C4233	CQMBA393J50
C4302	CQPA222J2A
C4359	CQPA822J2A

RESISTORS

R4101,R4103,R4105	RD1/2PM102J
R4361,R4362	RD1/2PM820J
VR4351(22kΩ)	RCP1103
VR4101(10kΩ)	RCP1140
Other Resistors	RD1/4PU□□□J

OTHERS

CN4152	52147-1010
10P JUMPER CONNECTOR	
CN4151	52147-1610
16P JUMPER CONNECTOR	
CN4003	KR CONNECTOR B2B-PH-K-S
CN4001	KR CONNECTOR B3B-PH-K-R
CN4002	KR CONNECTOR B4B-PH-K-S

XR-A200, XR-A100

Mark	No.	Description	Part No.
------	-----	-------------	----------

J SHIELD ASSY

No service part

K AF ASSY (XWM3011)

SEMICONDUCTORS

IC2151	BA3837
IC2101	LC75394NHE
IC2203	NJM4558D-D
IC1051	NJM78M12FA
Q1056,Q2161,Q2162	2SC2458

Q2151	DTC124ES
D2161,D2171	1SS254
D1056	MTZJ15A
D1055	MTZJ20A

COILS

L1052,L1054	ATH-133
L2101	LAU1R0J

CAPACITORS

C2123,C2124	CCCSL101J50
C1056-C1058,C2142,C2161	CEAT100M50
C1059	CEAT101M10
C2162	CEAT1R0M50
C2101-C2104,C2107-C2110	CEAT2R2M50

C2125,C2126,C2151,C2152,C2156	CEAT2R2M50
C2163,C2164,C2239,C2240	CEAT2R2M50
C2121,C2122,C2141,C2153	CEAT330M25
C2111,C2112	CEATR47M50
C2255	CKCYB102K50

C1062,C1063,C1067,C1070	CKCYB152K50
C2171,C2172,C2184,C2260	CKCYB152K50
C2119,C2120	CKCYB472K50
C2131,C2132	CKCYB682K50
C2155	CQMA224J50

C2117,C2118	CQMBA222J50
C2154	CQMBA473J50
C2113-C2116	CQMBA563J50

RESISTORS

R1063,R1065	RD1/4PMF4R7J
Other Resistors	RD1/4PU□□□J

OTHERS

CN1201 4P SPEAKER TERMINAL	AKE7035
CN1052 FFC CONNECTOR 20P	HLEM20R-1
CN1053 FFC CONNECTOR 40P	HLEM40S-1
CN1054 14P PLUG	KM200IB14
CN1051 17P PLUG	KM200TA17

JA2101 2P PIN JACK	VKB1050
--------------------	---------

K AF ASSY (XWM3001)

SEMICONDUCTORS

IC2151	BA3837
IC2101	LC75394NED
IC1051	NJM78M12FA
Q1054	2SA1048
Q1051	2SA1560

Mark	No.	Description	Part No.
------	-----	-------------	----------

Q1052,Q1053,Q1056,Q2161	2SC2458
Q1055	2SC4040
Q2151	DTC124ES
D2101-D2103,D2161,D2171	1SS254
D1054	MTZJ11C

D1053,D1056	MTZJ15A
D1055	MTZJ18B
D1051,D1052,D1057	S5688G

COIL

L2101	LAU1R0J
-------	---------

CAPACITORS

C2123,C2124	CCCSL101J50
C2111,C2112	CEASR68M50
C1056-C1058,C2161	CEAT100M50
C1059	CEAT101M10
C2162	CEAT1R0M50

C2141	CEAT221M10
C2101-C2104,C2107-C2110	CEAT2R2M50
C2125,C2126,C2151,C2152,C2156	CEAT2R2M50
C2163	CEAT2R2M50
C2153	CEAT330M25

C2121,C2122,C2142	CEAT470M25
C2255	CKCYB102K50
C1062,C1063,C1067,C1070	CKCYB152K50
C2171,C2172,C2184,C2260	CKCYB152K50
C1053	CKCYB222K50

C1055	CKCYB471K50
C1052,C1054,C2119,C2120	CKCYB472K50
C2131,C2132	CKCYB682K50
C2155	CQMA224J50
C2117,C2118	CQMBA222J50

C2113,C2114	CQMBA393J50
C2154	CQMBA473J50
C2115,C2116	CQMBA563J50

RESISTORS

All Resistors	RD1/4PU□□□J
---------------	-------------

OTHERS

CN1201 4P SPEAKER TERMINAL	AKE7035
CN1052 FFC CONNECTOR 20P	HLEM20R-1
CN1053 FFC CONNECTOR 40P	HLEM40S-1
CN1054 14P PLUG	KM200IB14
CN1051 17P PLUG	KM200TA17

JA2101 2P PIN JACK	VKB1050
--------------------	---------

L CD SW ASSY

SEMICONDUCTORS

D1806	SLP3118C51H
D1807	SLP7118C51H
D1805	SLP9118C51H

SWITCHES

S1830-S1834	ASG1051
-------------	---------

RESISTORS

All Resistors	RD1/4PU□□□J
---------------	-------------

Mark No. Description Part No.

M DISPLAY ASSY

(1) CONTRAST TABLE

XWZ3023 and XWZ3001 are constructed the same except for the following:

Mark	Symbol and Description	Part No.		Remarks
		XWZ3023	XWZ3001	
	S1802 S1825 R1201, R1202 R1816, R1817	ASX7017 Not used RS1LMF331J RD1/4PU473J	Not used ASG1051 RD1/2PMF151J Not used	

(2) PARTS LIST FOR XWZ3023

SEMICONDUCTORS

IC1801	BU2092F
IC2501	NJM4558LD
D1808, D1809	MTZJ6.8A
D1801-D1804	SLP9118C51H

COILS

L1250, L2551, L2552	LAU1R0K
---------------------	---------

SWITCHES

S1811-S1824 S1801, S1802	ASG1051 ASX7017
-----------------------------	--------------------

CAPACITORS

C2502, C2503, C2508 C2506 C2505 C2504 C1804	CEJA2R2M50 CEJA330M25 CEJA4R7M50 CGCYX473K25 CKCYB102K50
C2554, C2555 C2501 C1202, C1203, C1801, C1807 C2507	CKPUYB102K50 CKPUYB331K50 CKPUYF103Z25 CQMBA104J50

RESISTORS

R1201, R1202 VR2501(10kΩ) Other Resistors	RS1LMF331J VCS1021 RD1/4PU□□□J
---	--------------------------------------

OTHERS

JA2501, JA2502 SR JACK JA1201 STEREO MINI JACK REMOTE RECEIVER UNIT	AKN7004 AKN7005 GP1U27X
---	-------------------------------

N LAMP ASSY

(1) CONTRAST TABLE

XWZ3024 and XWZ3008 are constructed the same except for the following:

Mark	Symbol and Description	Part No.		Remarks
		XWZ3024	XWZ3008	
	Q1841 Q1842 D1841, D1842 R1841 R1842	2SA1560 2SC4040 1SS254 RD1/4PU471J RD1/4PU472J	Not used Not used Not used Not used Not used	
	R1843 R1845 PL1901, PL1902 Sub Miniature Lamp (0.15A, 12V)	RD1/4PU102J RS2LMF151J AEL7007	Not used Not used Not used	

Mark No. Description Part No.

(2) PARTS LIST FOR XWZ3024

SEMICONDUCTORS

Q1841	2SA1560
Q1842	2SC4040
D1841, D1842	1SS254

RESISTORS

R1845 Other Resistors	RS2LMF151J RD1/4PU□□□J
--------------------------	---------------------------

OTHERS

PL1901, PL1902	SUB MINIATURE LAMP (0.15A, 12V)	AEL7007
PL1903, PL1904	SUB MINIATURE LAMP (0.15A, 12V)	AEL7008

O LCD ASSY

(1) CONTRAST TABLE

XWZ3025 and XWZ3006 are constructed the same except for the following:

Mark	Symbol and Description	Part No.		Remarks
		XWZ3025	XWZ3006	
	D1907 C1917	1SS254 CKCYB102K50	Not used Not used	

(2) PARTS LIST FOR XWZ3025

SEMICONDUCTORS

IC1901	PDC042A
Q1911	DTC143ES
D1901, D1904, D1907, D1911-D1916 D1902	1SS254 MTZJ4.7B

COIL

L1901	LAU220J
-------	---------

CAPACITORS

C1903(0.047F) C1911 C1906 C1910 C1909, C1917	ACH7013 CEAT100M50 CEAT330M25 CGCYX104K25 CKCYB102K50
C1904, C1912 C1905 C1913-C1915 C1916	CKCYF103Z50 CKCYF473Z50 CKPUYF103Z25 CKPUYX222M16

RESISTORS

R1925 R1954, R1955 Other Resistors	RD1/4PM103J RN1/4PC1001F RD1/4PU□□□J
--	--

OTHERS

CN1902	FFC CONNECTOR 40P	HLEM40R-1
X1901	CERAMIC RESONATOR (6.00MHz) LT FILTER	VSS1045 XAK3010
V1701	LCD DISPLAY	XAV3001

6. ADJUSTMENT

6.1 TUNER SECTION

■ FM Tuner Section

- Set the mode selector to FM BAND.
- Connect the wiring as shown in Fig. 1.

Step No.	Adjustment Title	FM SG (1kHz, ± 75kHz dev.)		Reception Frequency Display	Adjustment Location	Specifications
		Frequency (MHz)	Level (dB μ V)			
1	Front End Sensitivity	98	0-30	98MHz	L6402 T6401	Adjust so that the DC voltage between the IC6201-pin 20 and GND becomes at maximum level.
2	TUNED IND. Lighting Level	98	18 ± 2	98MHz	VR6201	Adjust so that the indicator of TUNED IND. starts to light up.

Note:
Before adjusting, make sure there is no gap between L6401 and L6402. If there is a gap between them, bring them into contact with each other first, and then make adjustments.

■ AM Tuner Section

- Set the mode selector to AM BAND.
- Connect the wiring as shown in Fig. 1.

Step No.	Adjustment Title	AM SG (400Hz, 30% Mod.)		Reception Frequency Display	Adjustment Location	Specifications
		Frequency (kHz)	Level (dB μ V/m)			
1	Front End Sensitivity	999 (*1)	35-45	999kHz (*1)	T6201	Adjust so that the DC voltage between the IC6201-pin 20 and GND becomes at maximum level.

Note (*1): For the area using 10kHz step, frequencies should be 1000kHz.

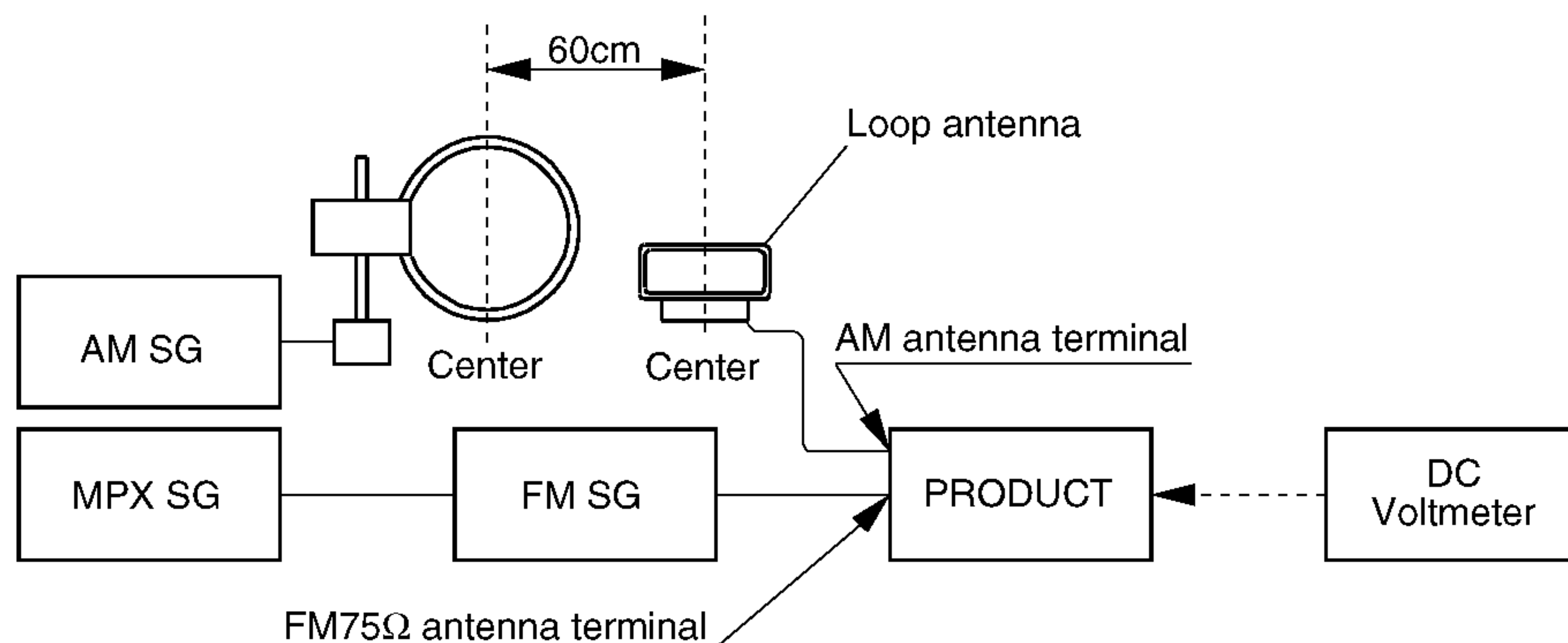

Fig. 1 AM and FM Adjustment Wiring Diagram

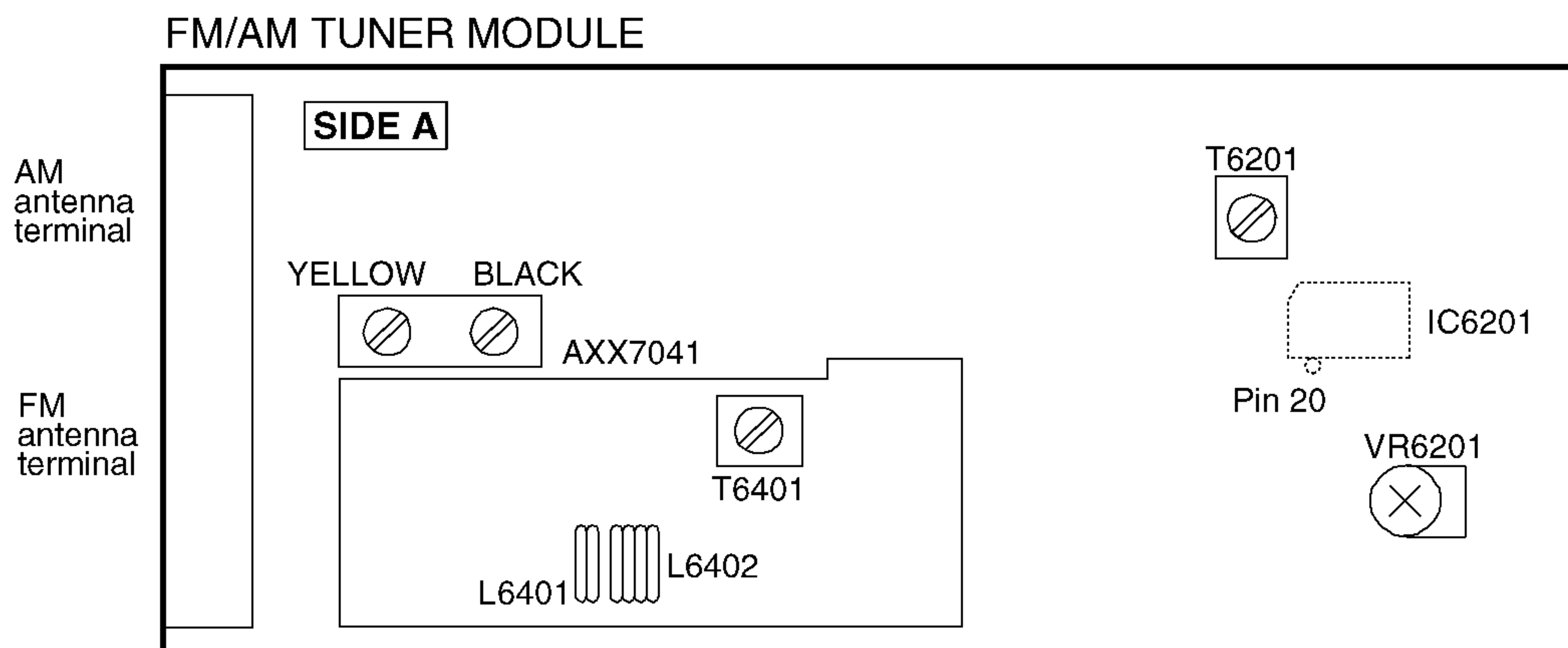

Fig. 2 Adjustment Point

6.2 CASSETTE DECK SECTION

- Adjustment points and test points are shown in Fig. 4 and Fig. 5.

■ Mechanical Adjustment

- Test tape: NCT-111 (3kHz, 30min).

1. Tape Speed Adjustment

No.	Mode	Test Tape	Adjusting Points	Measurement Points	Adjustment Procedure	Remarks
1	Deck I PLAY	NCT-111 (Playback : 3kHz)	VR4101 (DECK Assy)	PB OUT POINT (Rch) (AF Assy)	Press the PLAY SW and adjust so that the reading becomes 3000Hz ± 20Hz. Confirm that wow & flutter level is below 0.2% (in the reverse direction, confirm that the reading is within 3000Hz ± 60Hz).	

■ Electrical Adjustment

Check the following before starting.

- (1) Confirm that the tape speed adjustment has been completed.
- (2) Clean the heads and demagnetize them using a head eraser.
- (3) Set the measurement level to 0 dBV = 1 Vrms.
- (4) Use the specified tape for adjustment. Use the labeled (A) side of the test tape.
STD-331E : For playback check
STD-632 : Normal blank tape
- (5) Provide yourself with the following measuring devices:
 - AC voltmeter (Noisemeter : filter off)
 - AC millivoltmeter
 - Low-frequency oscillator
 - Attenuator
 - Oscilloscope
- (6) Adjust both right and left channels unless otherwise specified.

- (7) Warm up the unit for several minutes before adjustment.
In particular, be sure to warm up the unit in the REC/PLAY mode for 3 to 5 minutes before starting recording/playback frequency characteristics adjustment.
- (8) Always follow the indicated adjustment order.
Otherwise, a complete adjustment may not be achieved.

Playback Adjustment (Decks I and II)

- (1) Head Azimuth Adjustment

Recording Adjustment (Deck II)

- (1) Bias Oscillation Frequency Adjustment
- (2) Recording Bias Adjustment
- (3) ALC Operation Check

* As the reference recording level is 250nwb/m for STD-331E, the recording level will be higher by 4 dB for STD-331B (160nwb/m).
When adjusting, pay careful attention to the type of tape used.

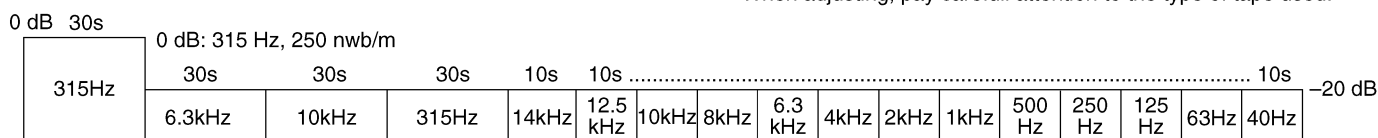

Fig. 3 STD-331E Test Tape

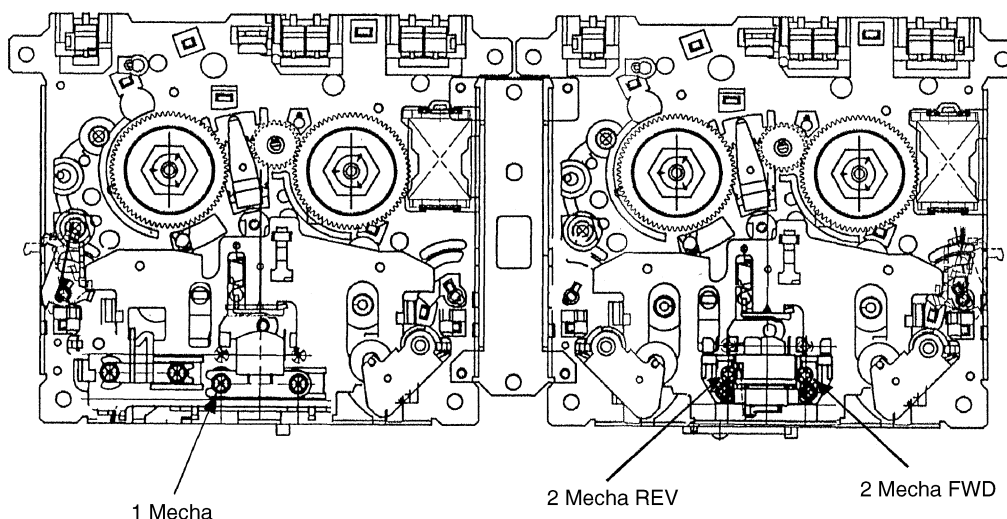

Fig. 4 Head Azimuth Adjustment Screw

XR-A200, XR-A100

■ Playback Adjustment

(1) Head Azimuth Adjustment

- Do not switch between forward and reverse operation with the screwdriver inserted.

Step	Mode	Input Signal/ Test Tape	Adjusting Points		Measurement Points	Adjustment Value	Remarks
1	PLAY	STD-331E test tape (Playback: 10kHz, -20dB)	Deck I	Head azimuth adjustment screw (Fig. 4)	DECK PB OUT (L, Rch) (AF Assy)	Max. playback signal level	After adjustment, apply silicon bond to the head azimuth adjustment screw.
			Deck II				

■ Recording Adjustment

(1) Bias Oscillation Frequency Adjustment

Step	Mode	Input Signal/ Test Tape	Adjusting Points		Measurement Points	Adjustment Value	Remarks
1	REC	Load the STD-632 test tape and set the recording mode.	Deck I	—————	—————	Oscillation frequency to be 105.0kHz ± 2kHz.	If the ASES/COPY button for four seconds while the power is in STAND BY mode, the frequency will decrease 2-3 kHz.
			DECK II	L4351 (DECK Assy)	Between (A) point in Fig. 5 and GND.		

(2) Recording Bias Adjustment

- Since this adjustment affects recording bias, prevent distortion from increasing due to underbias.

Step	Mode	Input Signal/Test Tape	Adjusting Points		Measurement Points	Adjustment Value	Remarks
1	REC → PLAY	Load the STD-632 test tape. Record the 315Hz and 10kHz signals at 25.2dBV input level and playback.	Deck I	—————	DECK PB OUT (L, Rch) (AF Assy)	Repeat adjustment until playback level of the 10kHz signal is within 0 ± 0.5dB from that of the 315Hz signal.	
			DECK II	VR4351 (DECK Assy)			
2	REC	Load the STD-632 test tape and record (No signal)	Deck II	VR4351 (DECK Assy)	TP BIAS V POINT (DECK Assy)	23V-26V	

(3) ALC Operation Check

Step	Mode	Input Signal/Test Tape	Adjusting Points		Measurement Points	Adjustment Value	Remarks
1	REC	Input a 315Hz signal to the AUX terminal and set the input selector to AUX.	Input signal level		DECK PB OUT (L, Rch) (AF Assy)	-8.2dBV	
2			Set to a level +10dB above the input level at step1.			-3.2 ± 2.5dBV	

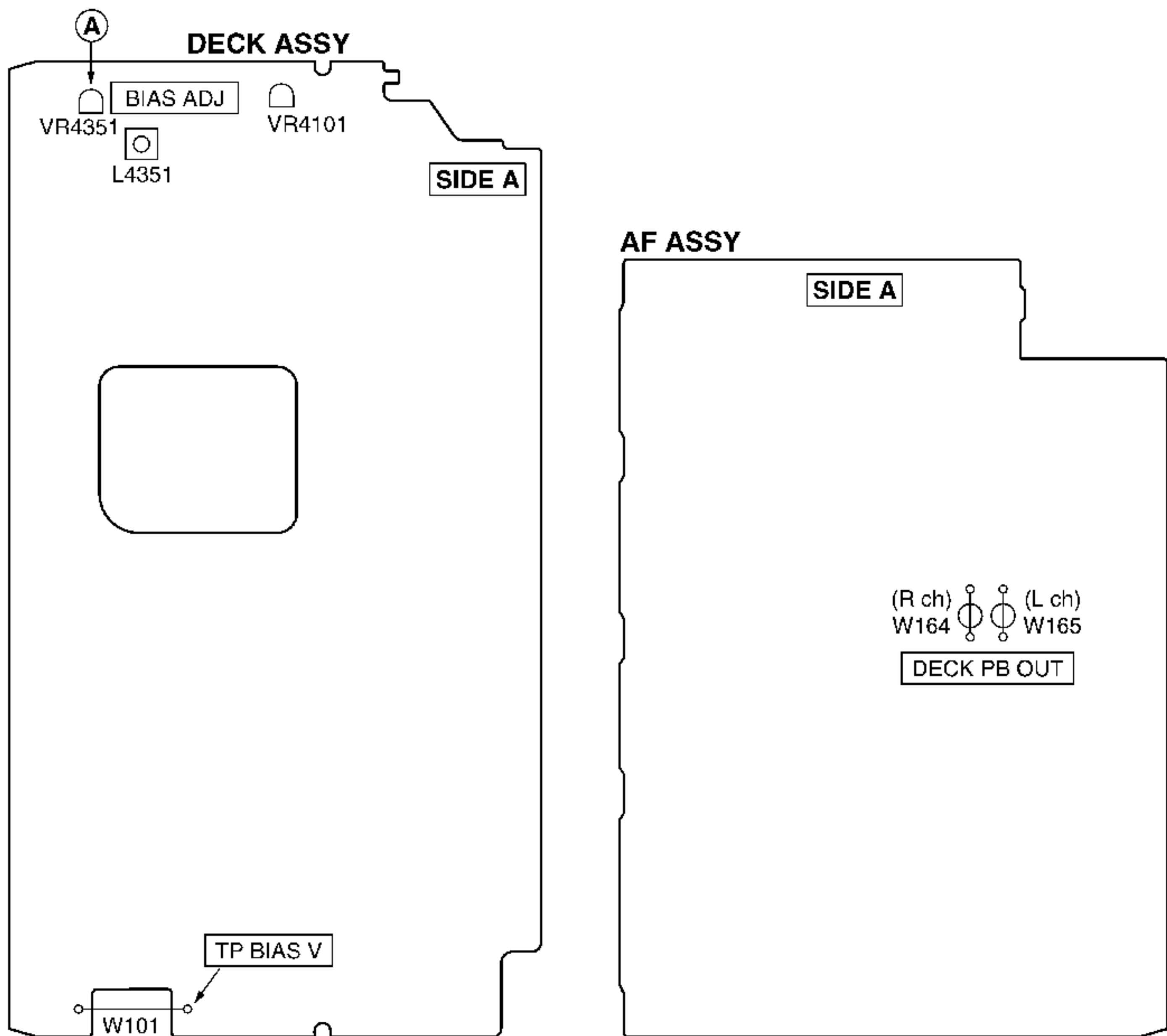

Fig. 5 Adjustment Points

6.3 POWER SECTION (XR-A100 Only)

■ Adjustment of Vp

Adjust VR1001 in the POWER Assy so that the voltage of Vp checking point W104 is $17.5 \pm 0.1V$.
Adjustment can be made when no load is applied while the power is turned ON and no signal is sent, as well as for the GND voltage or for the chassis.

Adjustment is required when the 5volte regulator, IC1001(NJM78M05FA) in the POWER Assy are replaced.

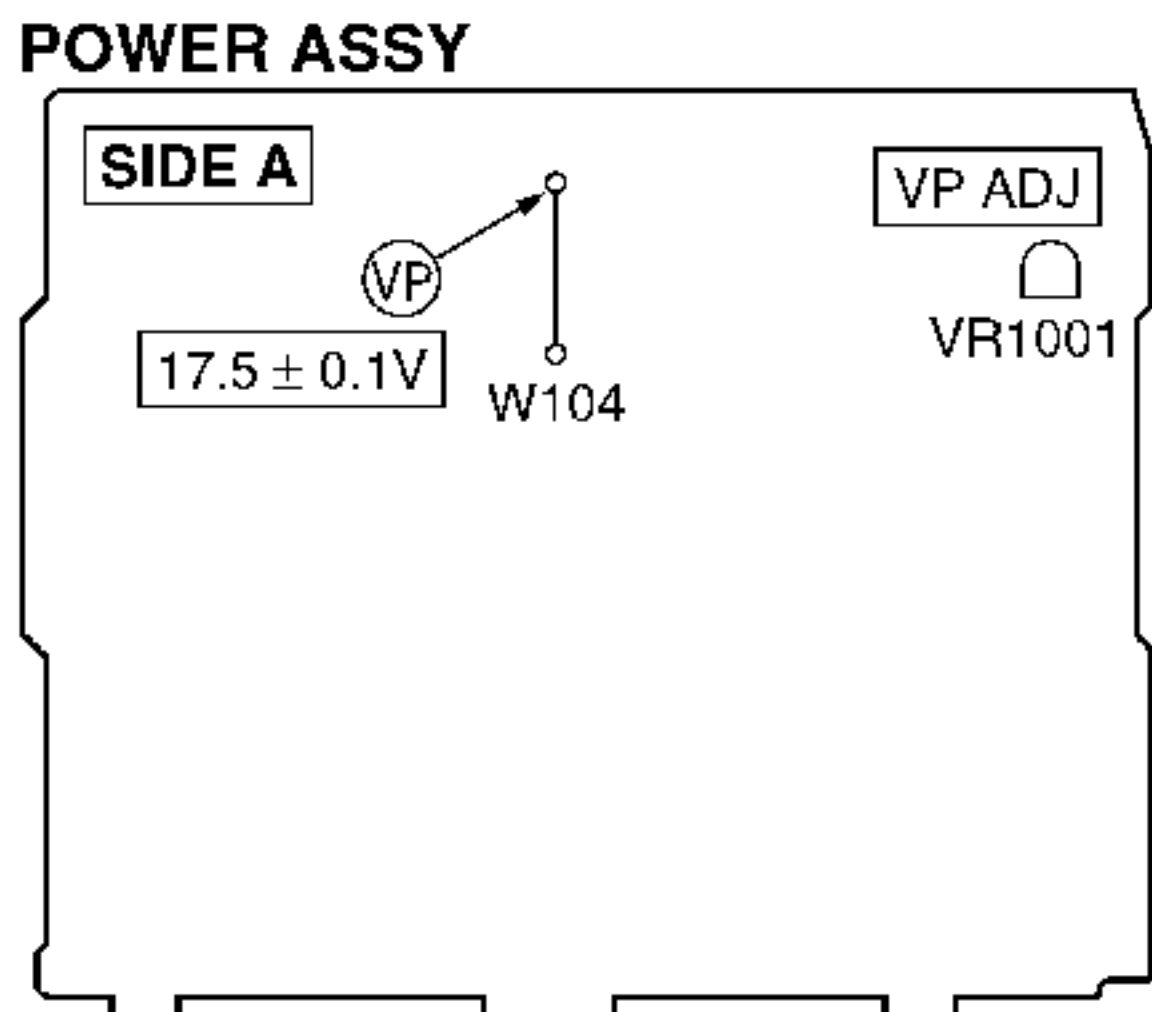

Fig. 6 Adjustment of Vp

6.4 TEST MODE

NOTE: There is no information to be shown in this CD adjustment.

■ How to Start/Cancel Test Mode

TEST MODE : ON

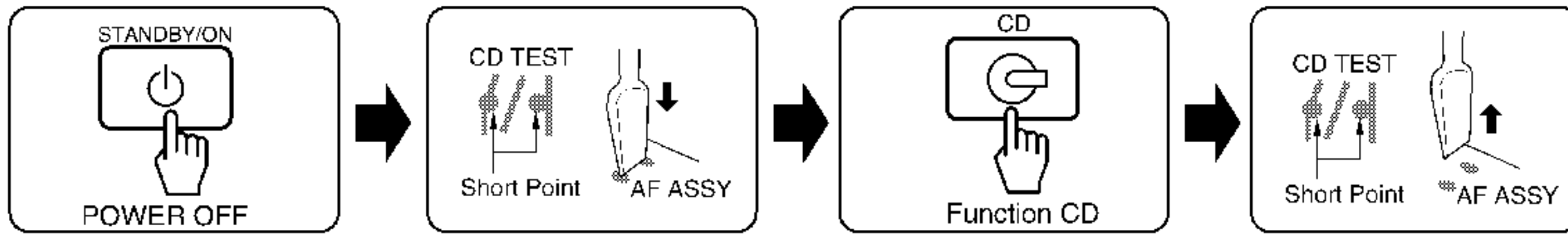

TEST MODE : PLAY

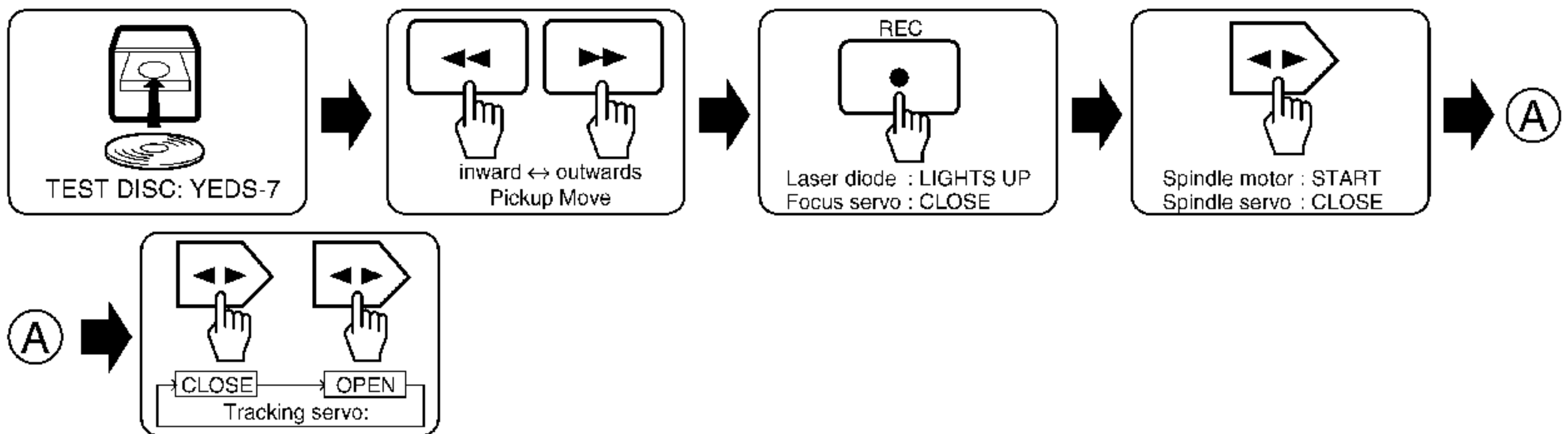

TEST MODE : STOP → CANCEL

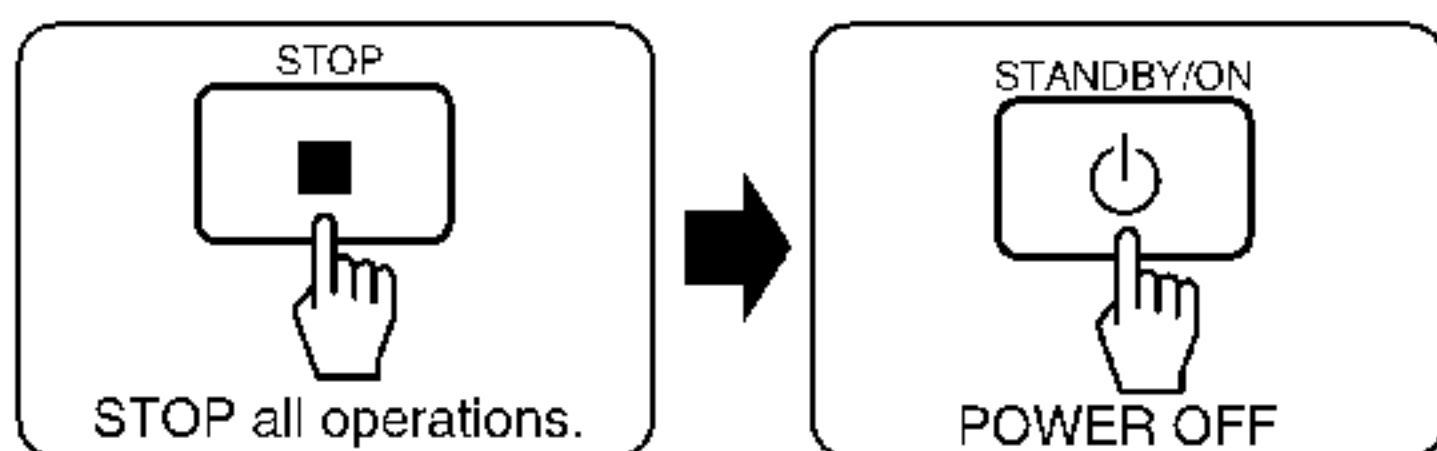

■ Test Point

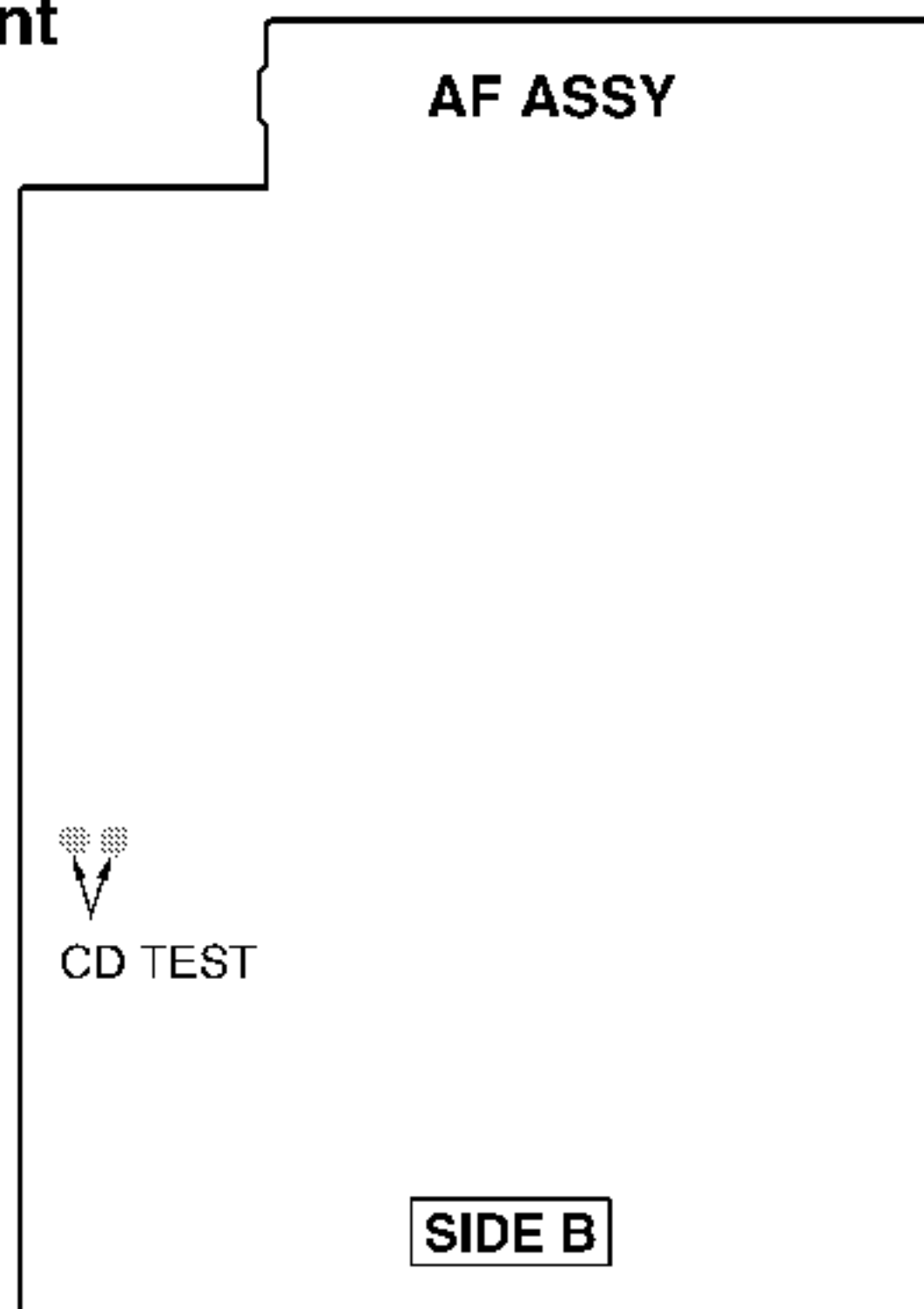

7. GENERAL INFORMATION

7.1 PARTS

7.1.1 IC

- The information shown in the list is basic information and may not correspond exactly to that shown in the schematic diagrams.

■ PDC042A (LCD ASSY : IC1901)

- System Control Microcomputer

●Pin Function

No.	Pin Name	I/O	Function	No.	Pin Name	I/O	Function
1	KI 3	O	Key scan output	36	MUTE	O	Power amp mute
2	KI 4			37	PLL CE	O	Tuner PLL enable
3	S DO	O	Serial data output (E- VR/TX)	38	N. C.	-	Not used
4	S DI	I	Serial data input (TX)	39	SEG39	O	LCD segment
5	S CLK	O	Serial clock (E- VR/TX)	40	SEG38		
6	CD DATA	O	Serial data output (CD)	41	SEG37		
7	CD SQOUT	I	Sub Q 80-bit input	42	SEG36		
8	CD CLK	O	Serial clock (CD)	43	SEG35		
9	JOG1 (A200) N. C. (A100)	I	Morphing jog pulse input 1 (A200) Not used (A100)	44	SEG34		
10	JOG2 (A200) N. C. (A100)	I	Morphing jog pulse input 2 (A200) Not used (A100)	45	SEG33		
11	AC50/60	I	AC pulse judgement	46	SEG32		
12	XRESET	I	"L" reset (microcomputer)	47	SEG31		
13	TAPE PULSE2	I	Tape 2 reel pulse signal	48	SEG30		
14	TAPE PULSE1	I	Tape 1 reel pulse signal	49	SEG29		
15	Vss	-	GND	50	SEG28		
16	CF1	I	Ceramic resonator (6MHz)	51	SEG27		
17	CF2			O	52		
18	VDD	-	V+5V	53	SEG25		
19	ST. /TUN. /DC.	I	A/D port for TX & DC level	54	SEG24		
20	LEVEL	I	A/D port for level meter	55	SEG23		
21	MS (A200) N. C. (A100)	I	A/D port for TAPE MS (A200) Not used (A100)	56	VDD	-	V+5V
22	KEY1	I	A/D port for key input	57	Vss	-	GND
23	KEY2			58	SEG22	O	LCD segment
24	17V FAIL	I	A/D port for voltage detection	59	SEG21		
25	ROT ENC1	I	Volume jog pulse 1	60	SEG20		
26	ROT ENC2	I	Volume jog pulse 2	61	SEG19		
27	N. C.	-	Not used	62	SEG18		
28	CD WRQ	I	Sub Q stand-by	63	SEG17		
29	REMOCON	I	Remote control signal input	64	SEG16		
30	BEAT CUT	O	Beat cut control	65	SEG15		
31	XKARA	O	ALC control	66	SEG14		
32	N. C.	-	Not used	67	SEG13		
33	EXP CE	O	(LED/DECK) enable for IC1801/4101	68	SEG12		
34	DATA	O	Serial output for expansion IC	69	SEG11		
35	CLK	O	Serial clock for expansion IC	70	SEG10		

XR-A200, XR-A100

No.	Pin Name	I/O	Function	No.	Pin Name	I/O	Function
71	SEG9	O	LCD segment	86	COM4	O	LCD common
72	SEG8			87	CD RESET	O	CD reset
73	SEG7			88	CD CE	O	CD enable
74	SEG6			89	Vss	-	GND
75	SEG5			90	VDD	-	V+5V
76	SEG4			91	BA3838	O	Vocal fader IC control
77	SEG3			92	N. C.	-	Not used
78	SEG2			93	TX MUTE	O	IF buffer ON/OFF
79	SEG1			94	E-VR CE	O	Pre-amp enable for VOL IC
80	CD DRF	I	Focus (RF- LEVEL) OK	95	SW1	I	Key scan input
81	CD CS	I	(CD-DSP chip select) (Built-in pull-down at DSP side)	96	SW2		
82	GND	-	GND	97	SW3		
83	COM1	O	LCD common	98	SW4		
84	COM2			O	Key scan output	99	KI2
85	COM3					100	KI1

7.1.2 DISPLAY

■ XAV3001 (LCD ASSY : V1701)

• LCD Display

● Pin Assignment

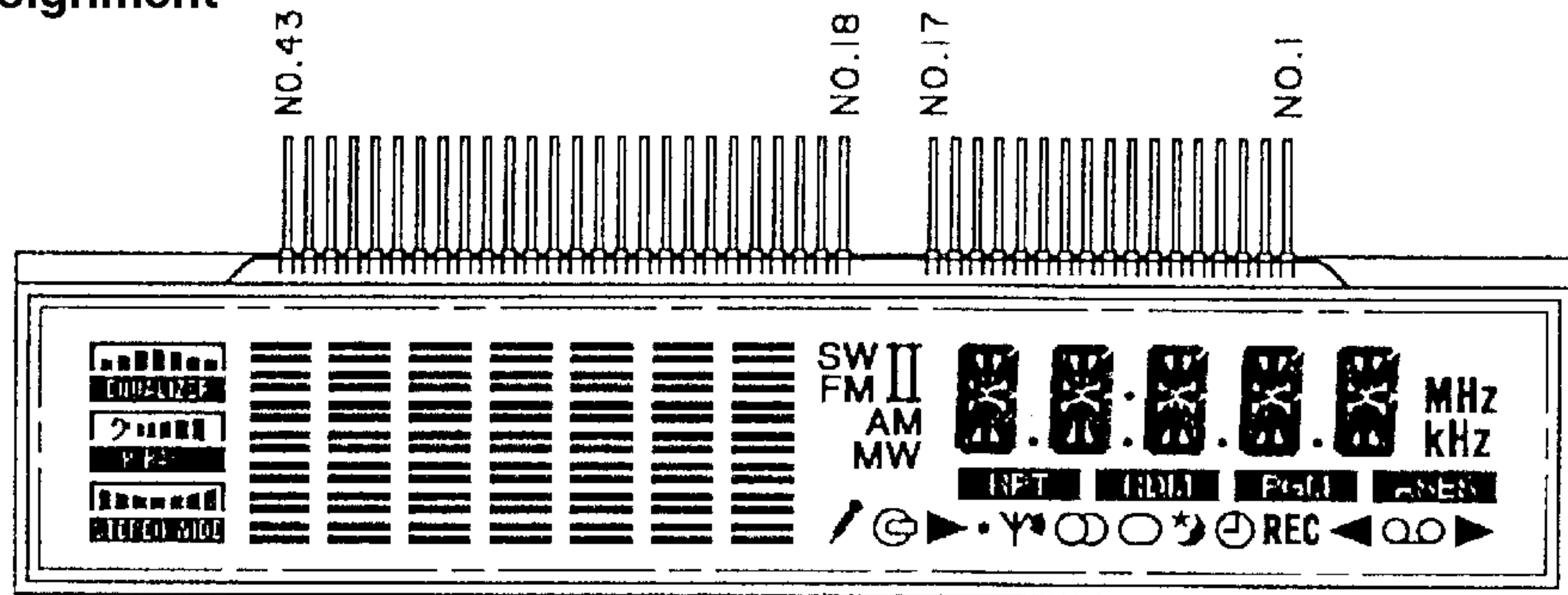

● Segment Assignment

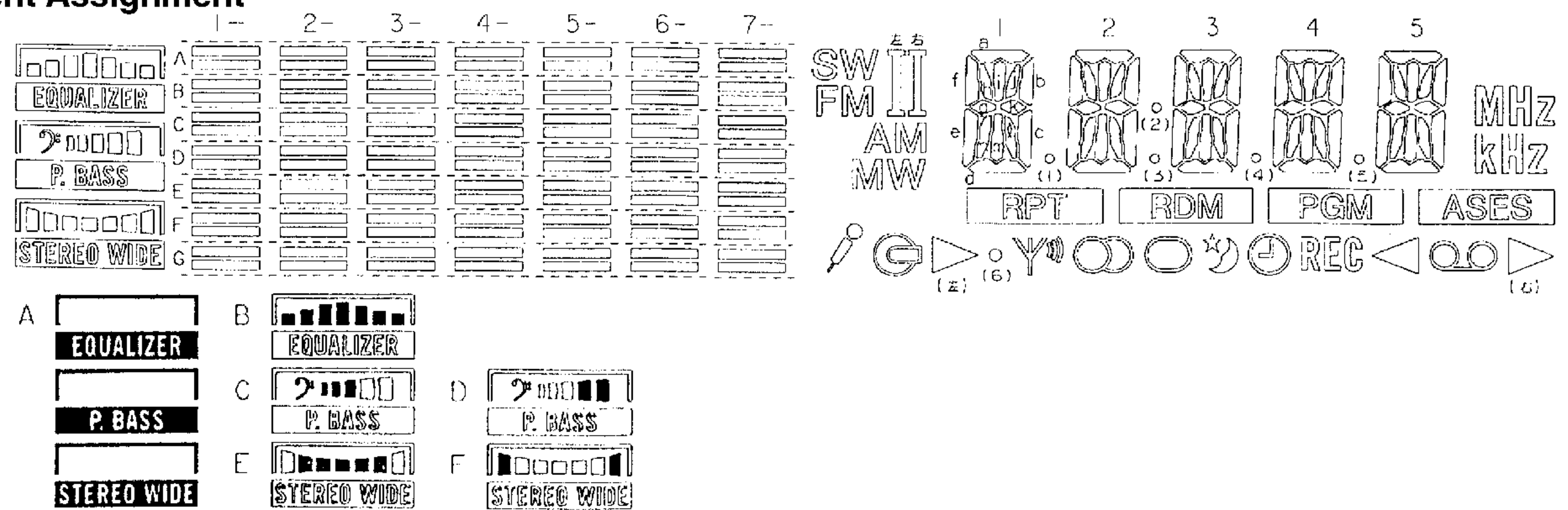

● Pin Connection

NO.	COM.1	COM.2	COM.3	COM.4	NO.	COM.1	COM.2	COM.3	COM.4
1				COM.4	18	☉	○(2)	○(3)	RDM
2			COM.3		19	2b	2k	2c	∞
3		COM.2			20	2j	2i	2m	2l
4	COM.1				21	2a	2h	2g	2n
5	MHz	KHz	ASES	▷(右)	22	○(1)	2f	2e	2d
6	5b	5k	5c	∞	23	1b	1k	1c	RPT
7	5j	5i	5m	5l	24	1j	1i	1m	1l
8	5a	5h	5g	5n	25	1a	1h	1g	1n
9	○(5)	5f	5e	5d	26		1f	1e	1d
10	4b	4k	4c	PGM	27	Ⅰ(右)	MW	▷(左)	○(6)
11	4j	4i	4m	4l	28	Ⅰ(左)	AM	⊗	⊕
12	4a	4h	4g	4n	29	SW	FM	⌘	○
13	○(4)	4f	4e	4d	30	7-A	7-B	7-C	7-D
14	3b	3k	3c	REC	31	6-A	6-B	6-C	6-D
15	3j	3i	3m	3l	32	5-A	5-B	5-C	5-D
16	3a	3h	3g	3n	33	4-A	4-B	4-C	4-D
17	⊖	3f	3e	3d	34	3-A	3-B	3-C	3-D
					35	2-A	2-B	2-C	2-D
					36	1-A	1-B	1-C	1-D
					37	F	4-G	4-F	4-E
					38	E	3-G	3-F	3-E
					39	B	1-G	1-F	1-E
					40	A	2-G	2-F	2-E
					41	C	7-G	7-F	7-E
					42	D	6-G	6-F	6-E
					43	△	5-G	5-F	5-E

7.2 DIAGNOSIS

7.2.1 DISASSEMBLY

■ CD \$M LOADING MECHANISM ASSY

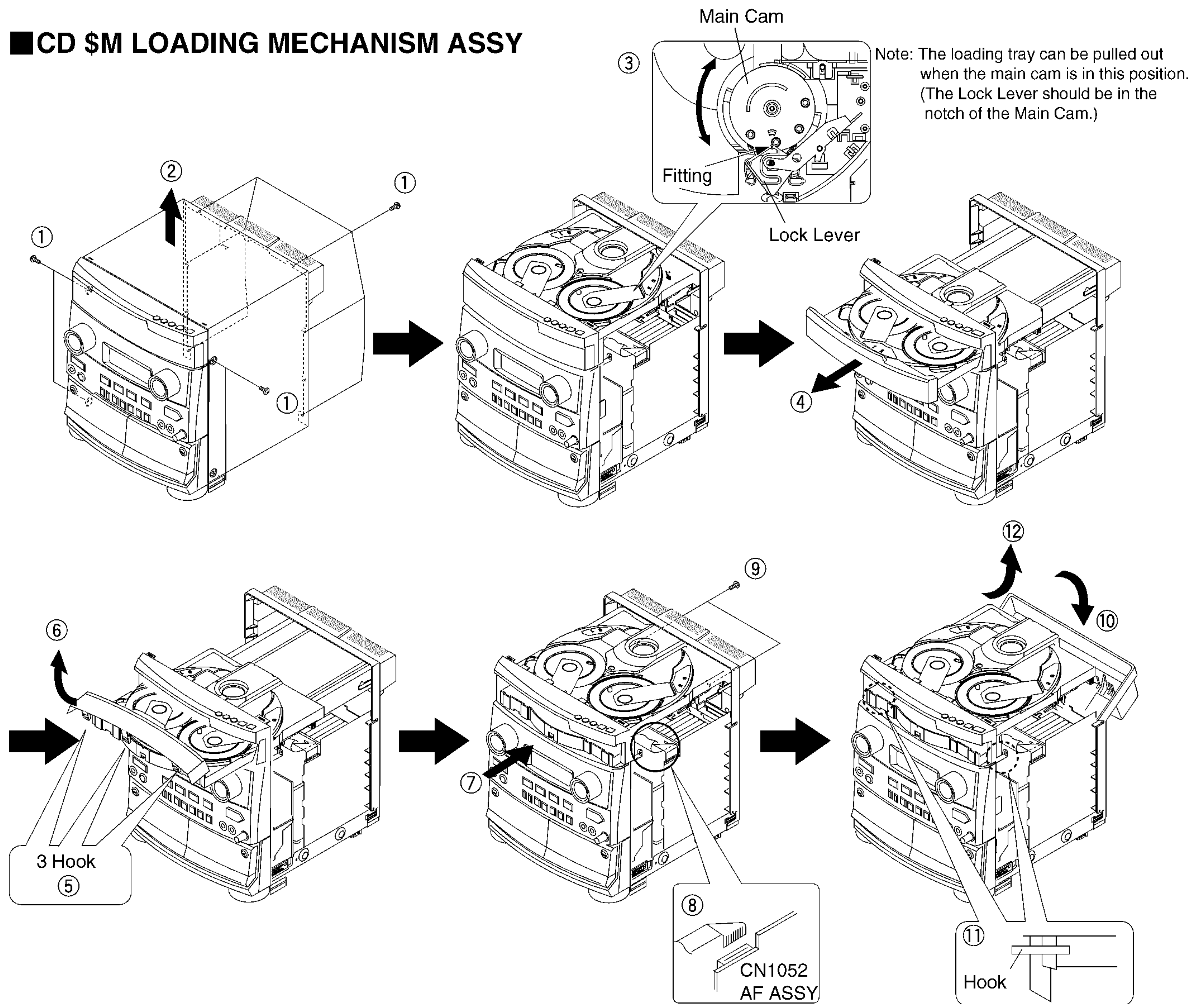

■ CD \$M LOADING MECHANISM ASSY ADDITIONAL TO JOB

● Mechanism Base (Bottom View)

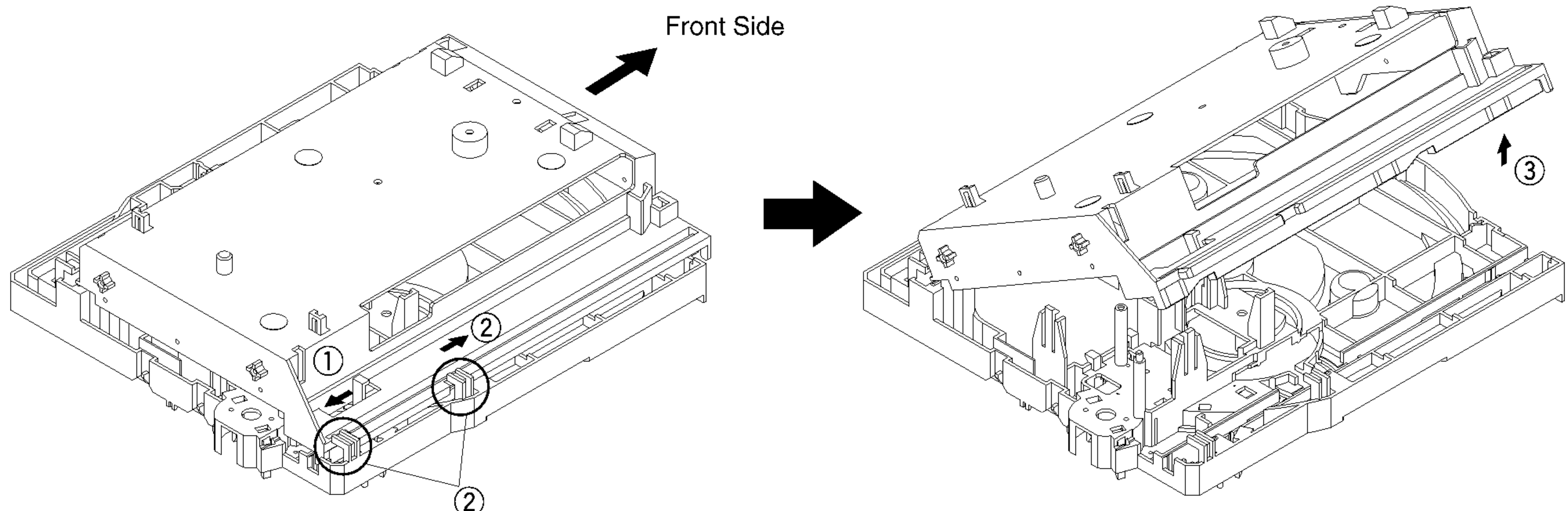

● Clamper Holder

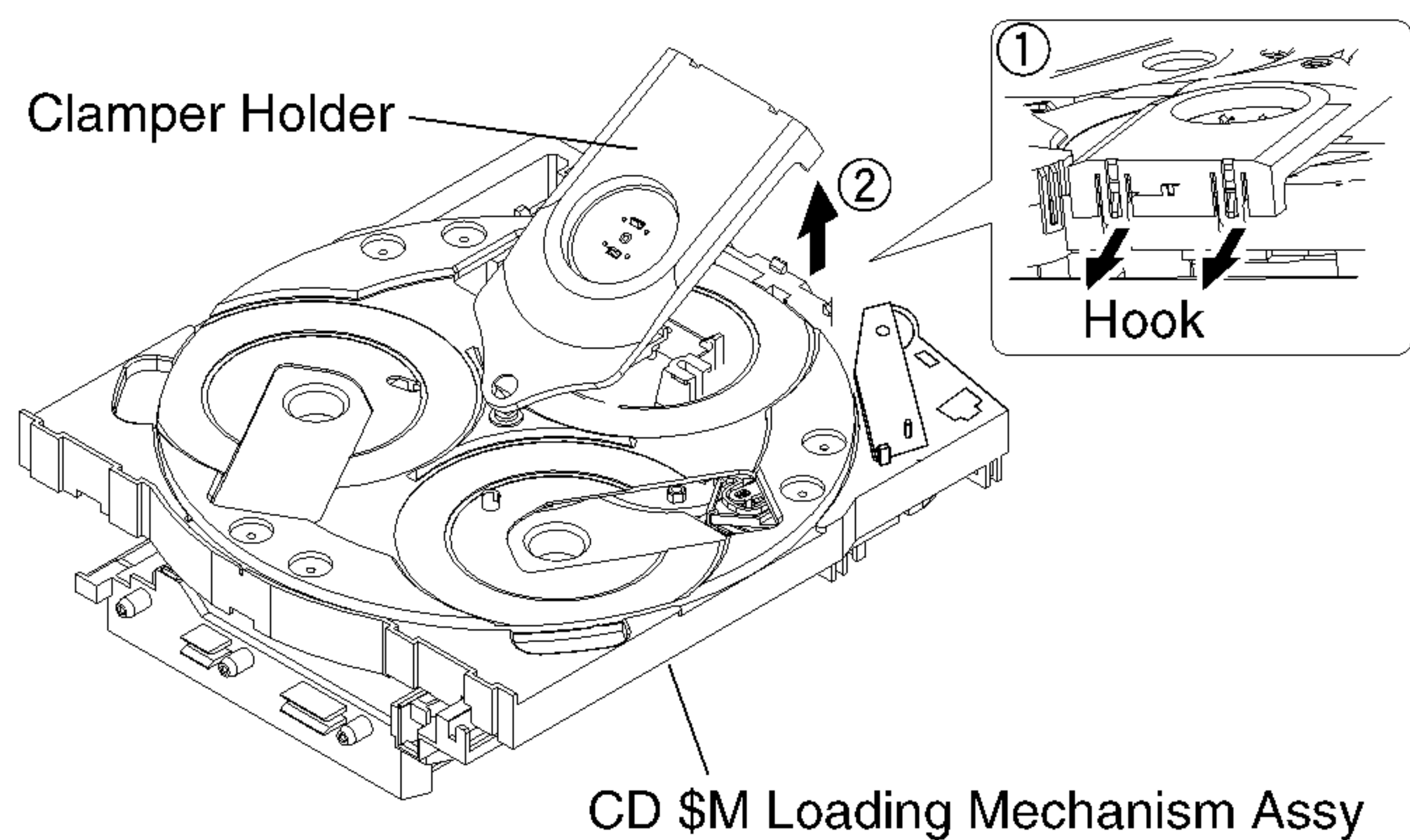

● Servo Base

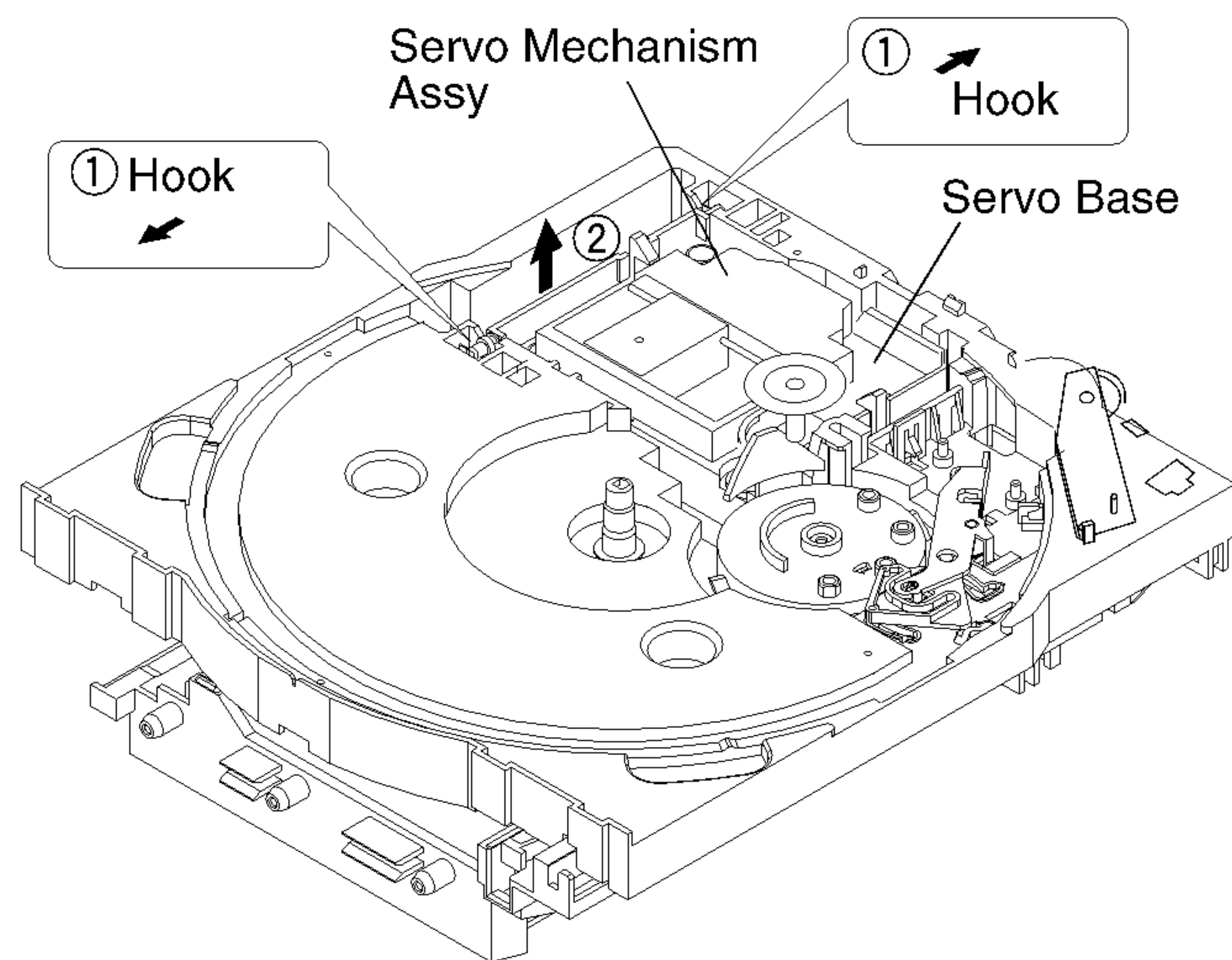

● Actuator

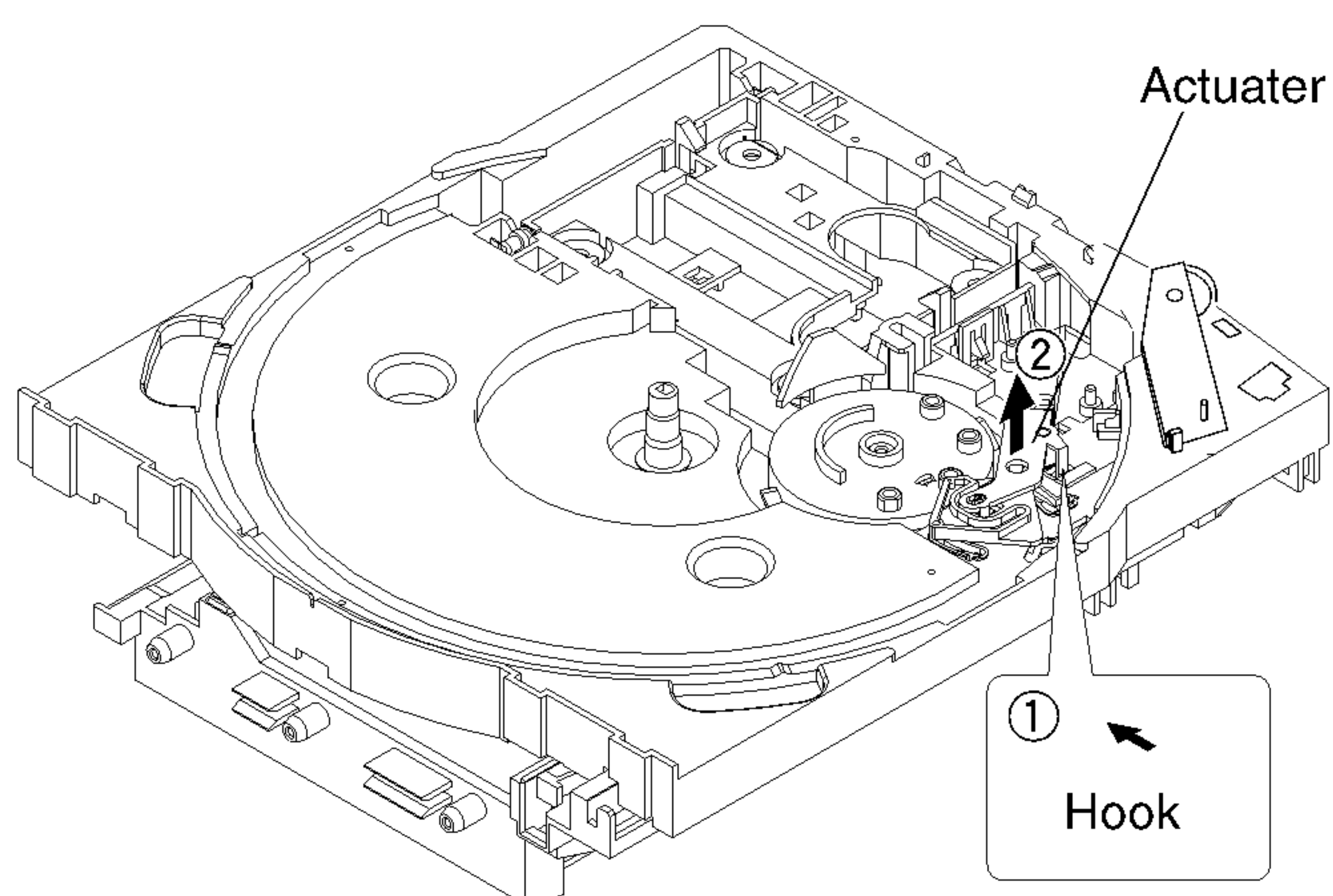

■ FITTING THE PULLEY INTO THE CARRIAGE MOTOR

For replacement of the carriage motor, fit the motor pulley by using the servicing pulley press-in station located on the loading tray, as shown in the figure on the right.

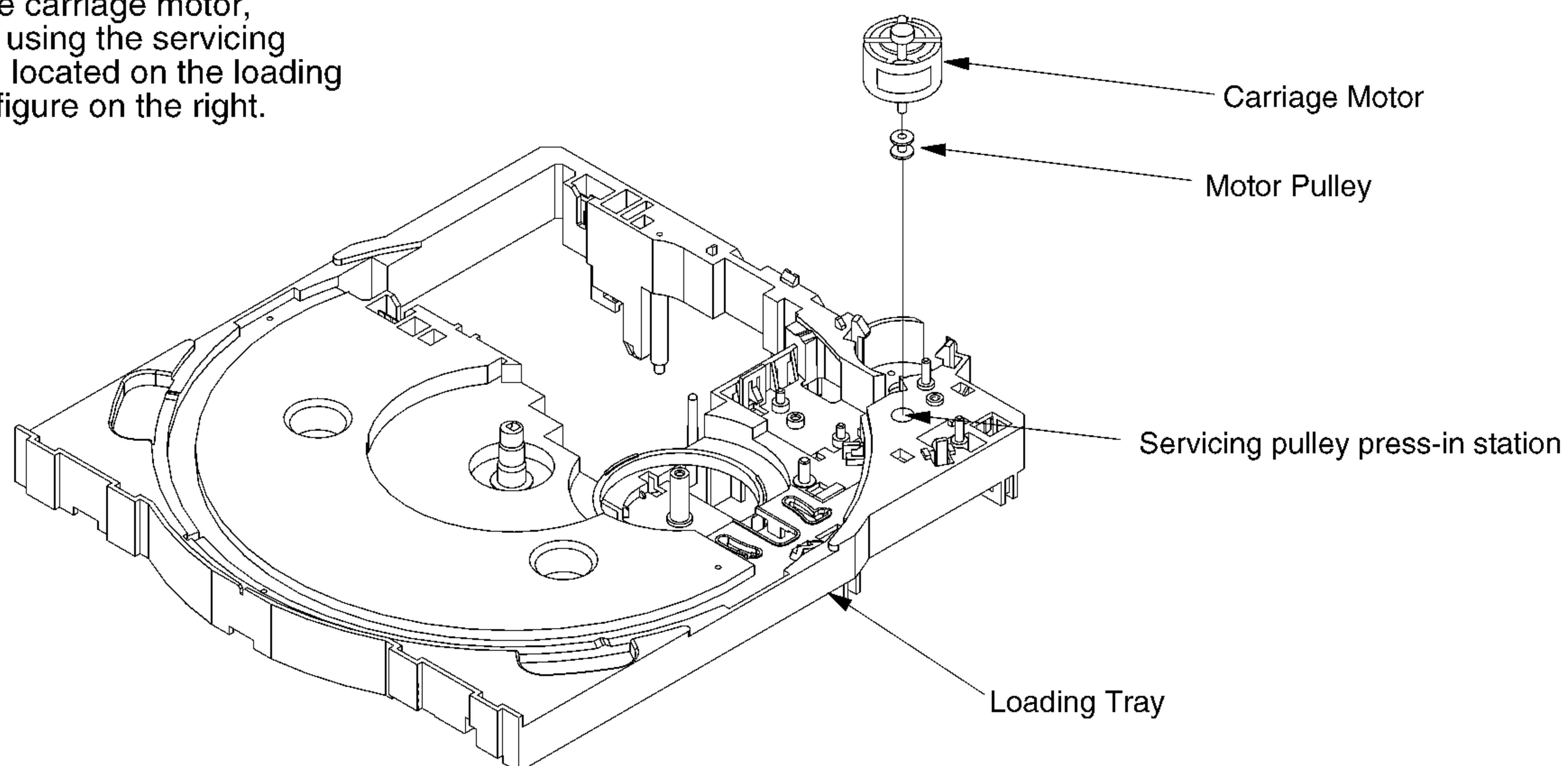

XR-A200, XR-A100

7.2.2 TROUBLESHOOTING

Note Do not short-circuit IC1003, IC1004 and IC1005 (ICP) for diagnosis. If the regulator is damaged by short circuit in ICP, the parts will be damaged to a wide extent of setting, making repair difficult.

List of Error Codes

An error code will be displayed in the LCD.

ERROR CODE	CAUSE	POINT TO BE CHECKED
E.1 : DC DET	DC appears in the SP terminal. Vp +17.5V is over 20V. Current passes toward the chassis.	Defective IC1302, IC1303 (XR-A200) or IC1201 (XR-A100) Improper operation of the regulator. → See “Adjustment of Vp cannot made”. Mica Sheet, 1Ω/1W (Power assy R1251) may be open. (XR-A100 only)
E.2 : Vp	Vp is below 6V or over 20V.	Regulator Adjustment of Vp (XR-A100 only) (Refer to page 53).
E.3 : DECK I E.4 : DECK II	Initialization could not be made.	Output of +17V and +6V SINK may be improper. Reel pulse may be improper. Deck mechanism lock (Lights up E.3 and E.4.)

The Power of The System Does Not Turn to ON. The Backlight Does Not Light Up.

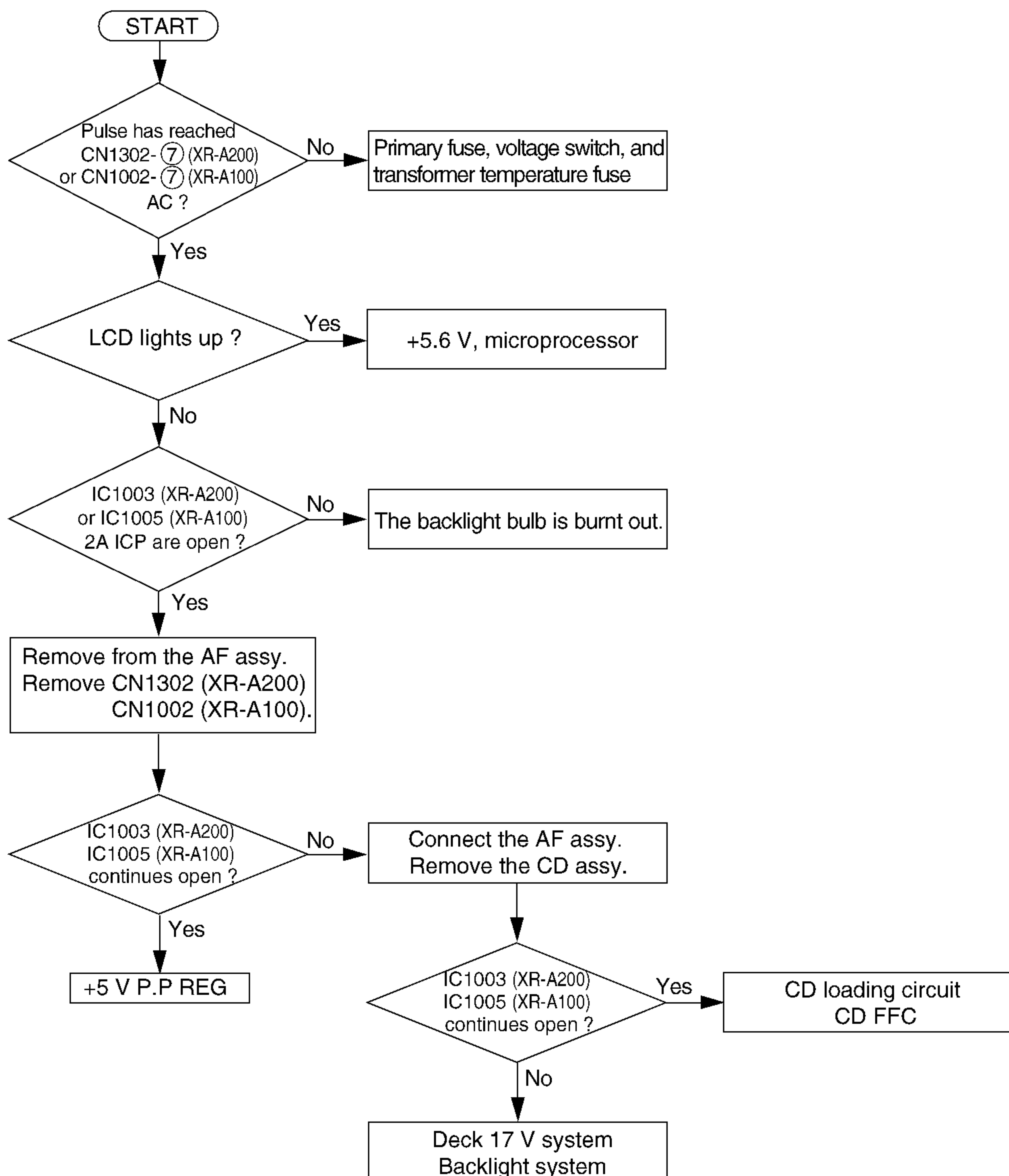

■ No Sound is Output.

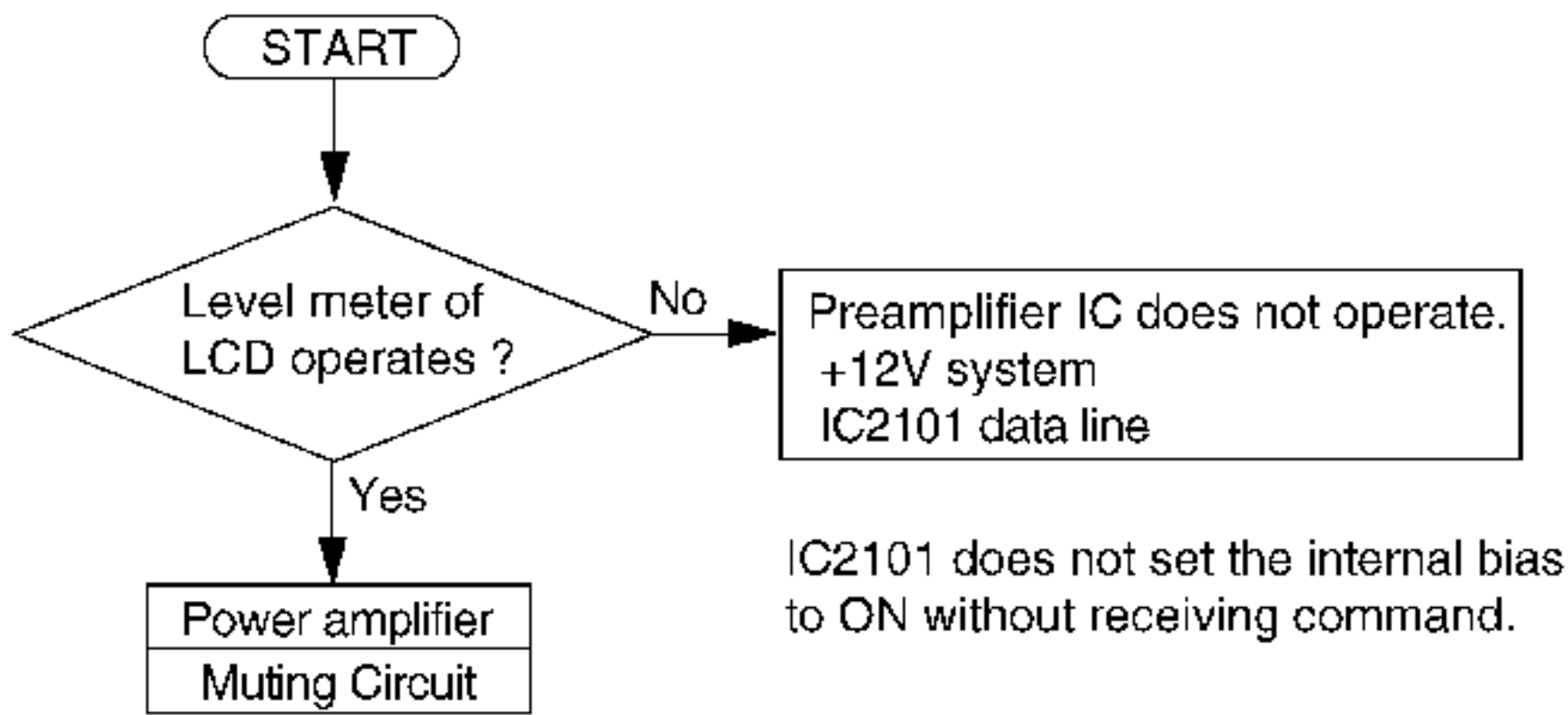

■ The System Does Not Playback CD.

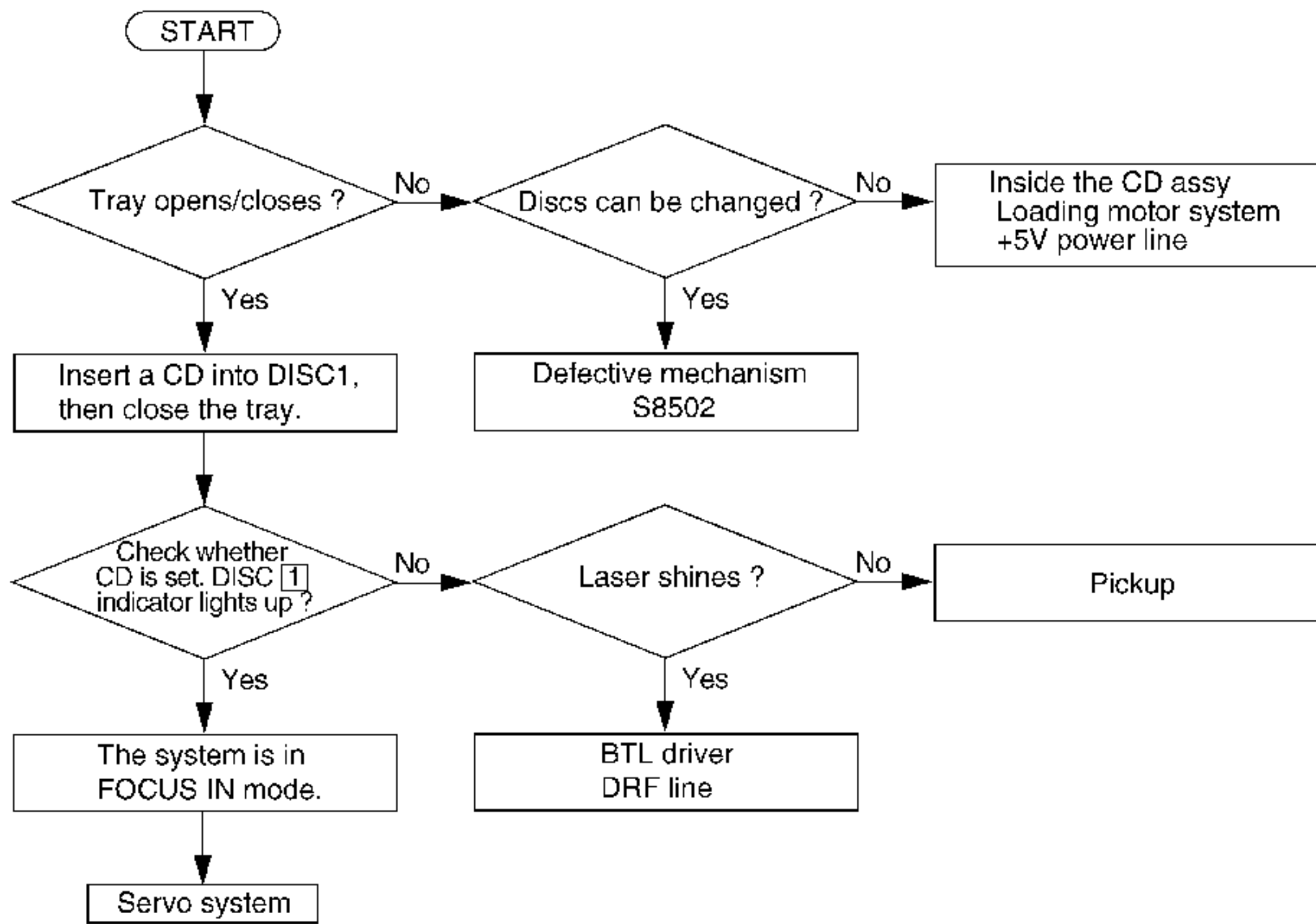

* CN8005 of the CD Assy shows RF OUT and a tracking error. Use them for diagnosis. No adjustment is required for the CD Assy. Disconnect the AC plug from the outlet and reset the microprocessor every time diagnosis is made. If the system microprocessor determines a malfunction in CD, no command will be sent to the CD Assy thereafter.

XR-A200, XR-A100

■ IC1004 (XR-A200) or IC1003 (XR-A100) (ICP of 400mA) is Broken.

- The +5.6V line is short-circuited. The 40-core FFC is not inserted straight.
- The 6.8V Zener diode of the +5.6V line is short-circuited.
 - D1003 in the Power assy
 - D1809 in the LED assy
- If the ICP is broken after disconnecting the Power assy from AF assy, IC1001 (78M05) or its surrounding parts may be malfunctioning.
- The ICP is also broken by short circuit of IC1002 (4558).
- The ICP is also broken by B-E short circuit of Q1001 (power TR, 2SC5196/5200).

The stereo set does not operate at all if the IC1004 (XR-A200) or IC1003 (XR-A100) is broken.

■ The Power of μ -COM Does Not Switch ON. Nothing is Displayed on The LCD.

- AC power is not supplied to the AC50/60Hz line of IC1901.
- Zener D1902 in the LCD assy is short-circuited because the headphone parallel jumper is inserted incorrectly (incorrect direction).
- Is +5.6V supplied?
- Is $\overline{\text{XRESET}}$ set to "H"? Is resetting completed?

■ IC1005 (ICP of 2A) is Broken, Although The Microprocessor is Operating. (XR-A100 Only)

- Does the ICP break after disconnecting from the AF Assy?

Yes → Inside the Power assy

No → Outside the Power assy

- Connect only the AF Assy. (Disconnect the headphone parallel jumper. CN1002)
If the ICP still breaks, AF Assy may have short-circuited, or a malfunction may have occurred in the front of +12V REG.
- Connect the 40-core FFC. Be sure that the flexible substrate is inserted correctly.
If the ICP still breaks, short circuit may have occurred in the complex (solenoid, motor, electrostatic Zener, LED assy, and +5.6 V line).
- Connect the CD assy.
If the ICP still breaks, short circuit may have occurred in the CD assy or the FFC of CD.

In such a case, the 5V PP REG is short-circuited. Check for short circuit in Q1003-1006 and D1011. (Because of the structure of the circuitry, short circuit is difficult to be detected by a tester. Replacing the circuitry as a whole will result in faster solution.)

NOTE If the headphone parallel jumper is removed, +17V voltage is supplied to μ -COM in standby mode. The power amplifier and all power sources will turn to ON. However, an IC that does not operate without serial data cannot be diagnosed.

■ Although Sound is Output, Discontinuance Occurs at Full Power. (XR-A100 Only)

- Vp is adjusted to high level. (The protective function for the power-amplifier ICs turns to ON.)
- Dedicated speakers for the system are not used. The protective circuit turns to ON during clipping if speakers with high inductance are used even though they have high impedance.
- IC1201 (TDA8560Q) is malfunctioning. → Replace the IC.
- LPF(C1201, C1202 [2200pF]) of IC1201, are not installed. If they are not installed, the system interferes with the preamplifier IC and causes oscillation, resulting in muted IC1201.
- Check for short circuit of the negative (-) terminals of L/R if the measuring instrument is connected to the SP terminal. If line noise from the measuring instrument is added, the power amplifier IC mutes and causes cracking noise.
- The power amplifier or +17V REG oscillates. Check Pin7 of IC1002 (4558) for major oscillation waveform appearing at the same time as with the cracking noise.

NOTE The power amplifier IC tends to cause discontinuance of sound with a slight oscillation or high-frequency noise.

Large Popping Noise is Output Only from The Headphone When Turning The Power to ON/OFF. (XR-A100 Only)

- The following headphone matrix resistors may be incorrect or disconnected.
R1221 and R1222 (POWER Assy)
R1201 and R1202 (DISPLAY Assy)
- H.GND of J1201 is disconnected.

The Following Symptoms Occur If IC1202 (0.4A) is Broken. (XR-A100 Only)

For SIG GND

- The top and bottom portions of waveforms () have different gain.

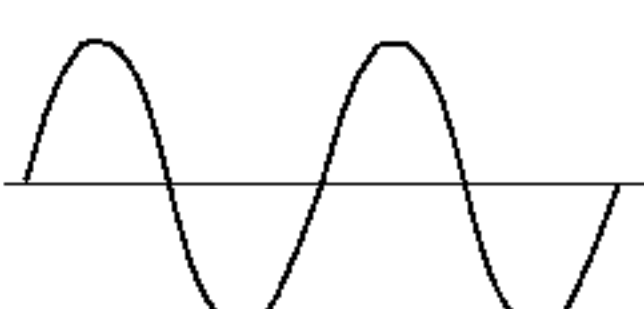
Proper waveforms () are obtained with load resistance.

- This ICP is broken when +B is supplied to the heat sink because micaite is not installed, or when IC1201 power amplifier ICs are malfunctioning.

If Mica Sheet for The Power Transformer is not Installed ?

- FOR XR-A100
 - +UNREG will be supplied to R1251 (1Ω,1W) of the POWER Assy, making the resistor open (or increasing the resistance value).
 - Current will be supplied to the rear part of IC1201 of the Power amplifier from the heat sink, resulting in incomplete functioning of the IC. At the worst, ICP, Zener diode, etc. will be destroyed.
 - Power transformer Q1001 will not be destroyed.
 - If a power source without breaker is used, the system stops demonstration mode 1 to 2 seconds after the power is turned ON, and forcedly enters standby mode. Error code E.2 (or E.1) lights up.
- FOR XR-A200
 - Set IC1003 to open.

NOTE Mica Sheet is placed higher than the heat-sink bracket. Thus, whether Mica Sheet is installed or not can be checked without removing the bracket.

Adjustment of Vp Cannot Be Made. Cannot Change from +17V.

- If +5.6V (for μ-COM) correctly output? → Correct the 5.6V system.
- Is 5.6V supplied to Pin 6 of IC1002 (4558)? This IC is Vref of +17V.
- Check the voltage of Pin7 of IC1002 (4558).
 - Cannot be changed from the Pin 8 side. → Short circuit in Q1001, Q1002, D1008, or Q1008
 - Cannot be changed from the Pin 4 side. → Q1001, Q1002, D1008, R1018, or Q1008 is open. Check whether UNREG voltage is supplied.

Otherwise, IC1002 is malfunctioning.

- Check for short circuit in D1014.
- IC1081 (LED driver in the LED Assy) is not functioning completely. Lift the ST-BY pin of CN1002 to adjust the IC.
- Check if R1251 (1W, 1W) is open. Chassis GND may be lifted. (XR-A100 only)
- If Vp is dislocated extremely, the microprocessor gives instruction to the system to enter standby mode. Error code E.2 lights up. If this is troublesome, leave ST-BY of CN1302 (XR-A200) or CN1002 (XR-A100) open so that +17V is maintained during standby mode.

NOTE Vp adjustment is completed in the Power assy. Therefore, it checking can be made by removing the headphone parallel jumper (the system will not enter standby mode) and AF Assy.

7.3 BLOCK DIAGRAM

• POWER SUPPLY MAP (For XR-A100)

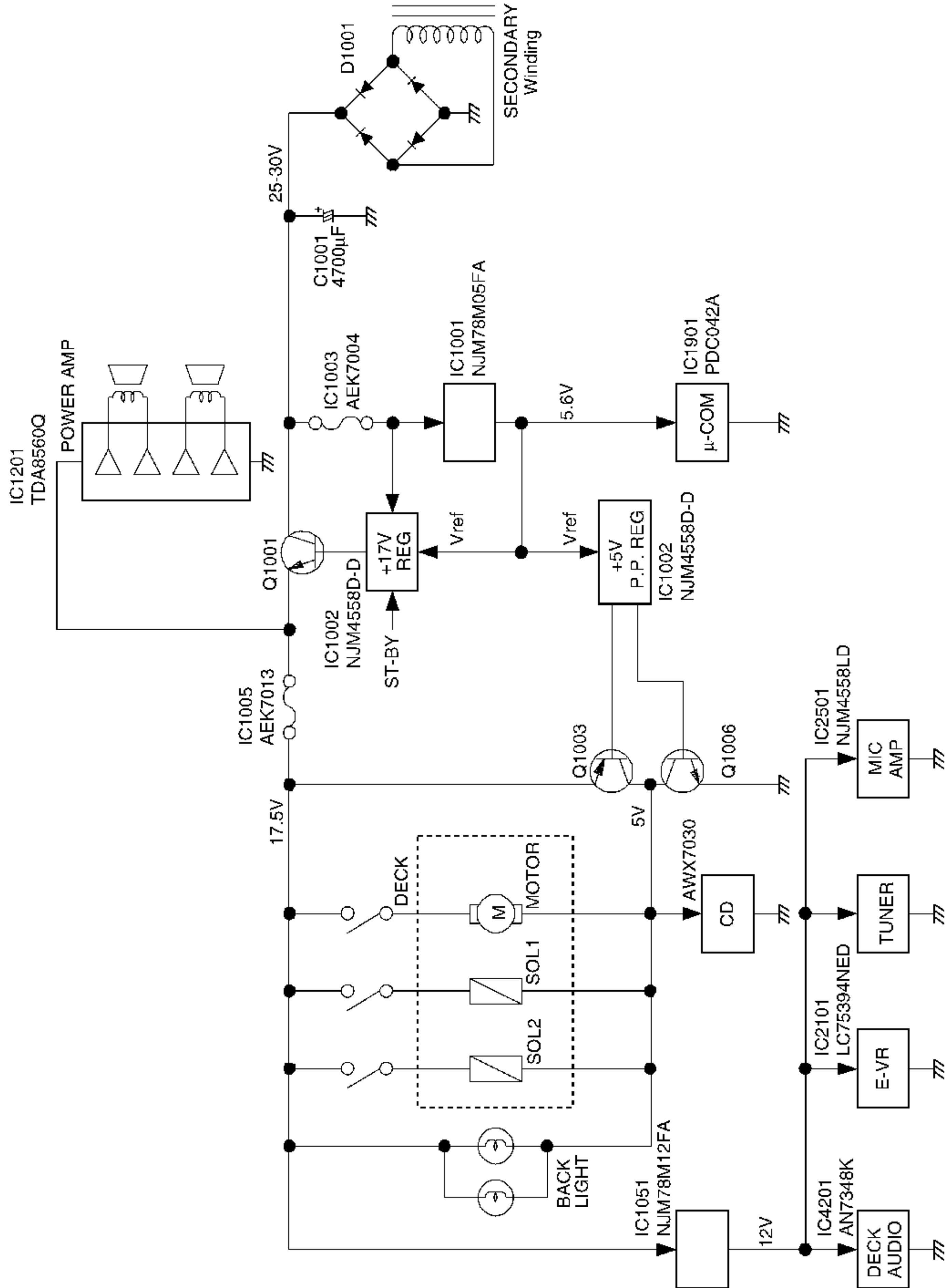

8. PANEL FACILITIES AND SPECIFICATIONS

■ PANEL FACILITIES

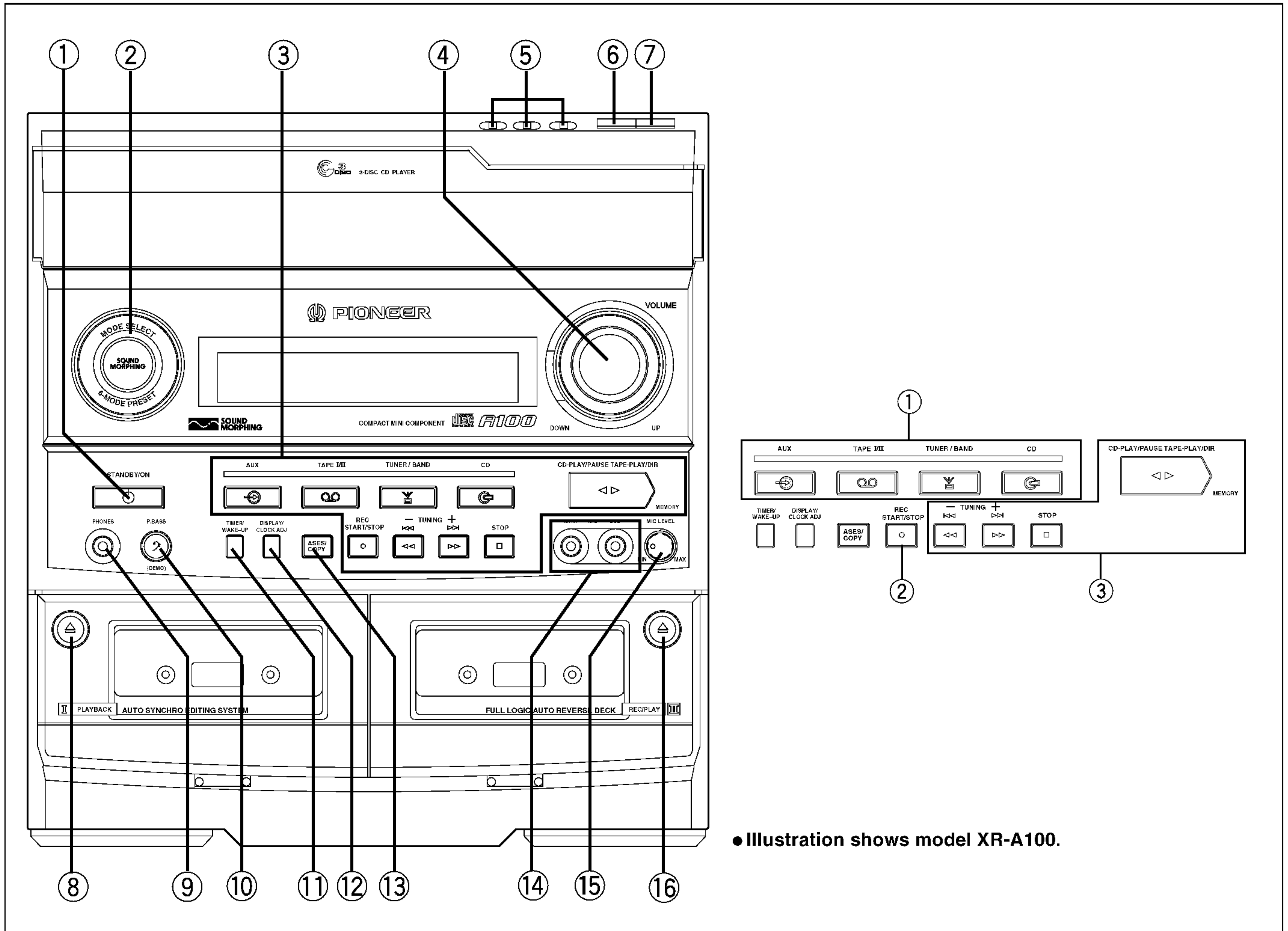

● Illustration shows model XR-A100.

- ① STANDBY/ON button
- ② SOUND MORPHING MODE button (XR-A100)
S.M. (SOUND MORPHING) JOG (XR-A200)
- ③ Function button section
- ④ VOLUME control
- ⑤ DISC select buttons (1 – 3)
- ⑥ DISC CHANGE button
- ⑦ CD OPEN/CLOSE button
- ⑧ DECK I EJECT (▲)
- ⑨ Headphones jack (PHONES)
- ⑩ P.BASS (DEMO) button
- ⑪ TIMER/WAKE-UP button
- ⑫ DISPLAY/CLOCK ADJ button
- ⑬ ASES/COPY button
- ⑭ MIC (MAIN, SUB) jacks
- ⑮ MIC LEVEL control
- ⑯ DECK II EJECT (▲)

Function button section

- ① FUNCTION buttons
 - ② REC START/STOP button
 - ③ Common operation buttons
- The roles of the buttons vary depending on the input functions.

During CD input:

- ▶▶ : Play/Pause
- : Stop
- ▶▶▶▶ : Fast forward/Track search
- ◀◀◀◀ : Fast reverse/Track search

During cassette deck input:

- ◀▶ : Play/Tape transport direction
- : Stop
- ▶▶ : Fast forward
- ◀◀ : Rewind
- ▶▶| : Music search + (XR-A200 only)
- |◀◀ : Music search - (XR-A200 only)

During tuner input:

- ◀▶ : Station memory
- : Frequency & Station down
- + : Frequency & Station up

XR-A200, XR-A100

Remote control unit

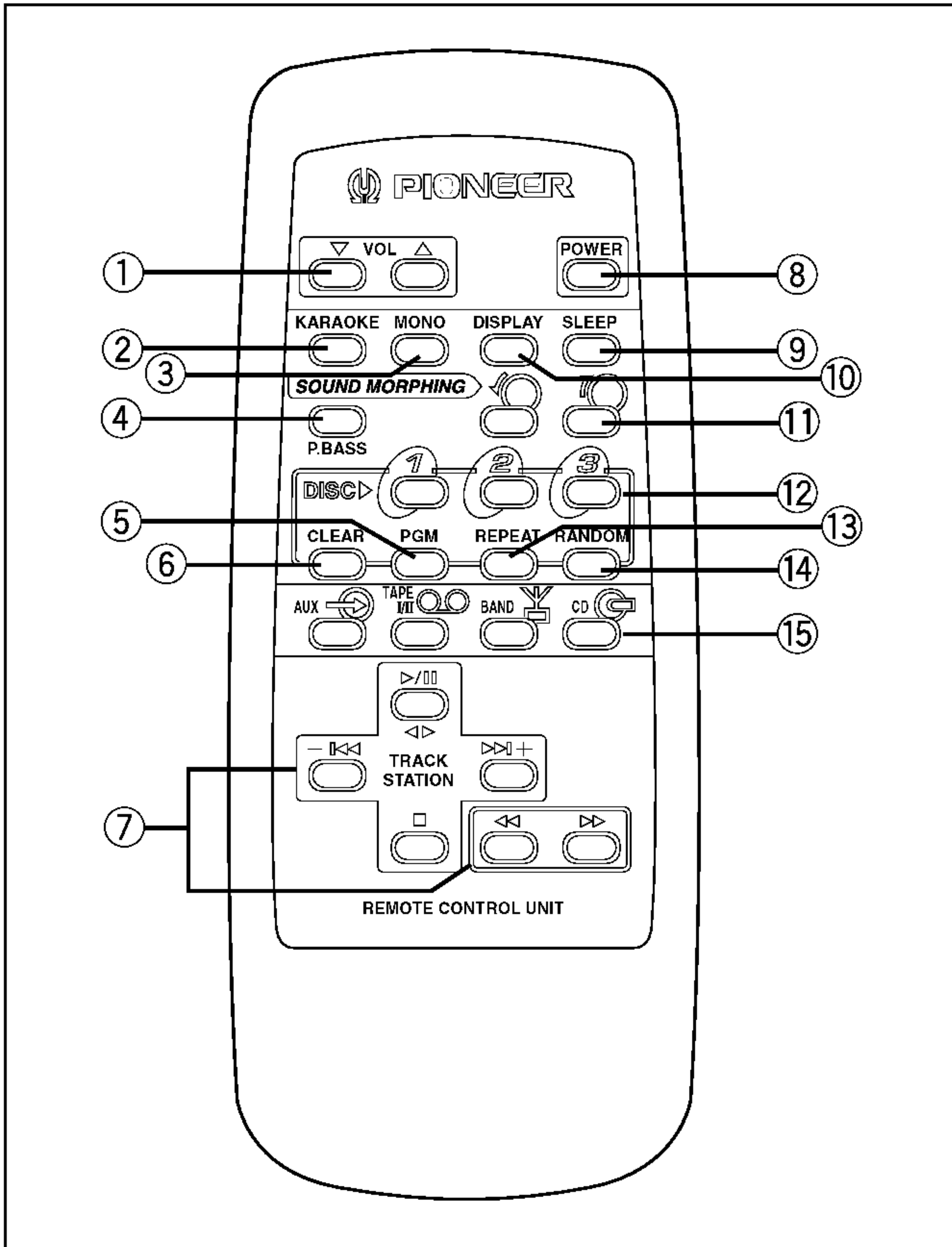

- ① VOLUME buttons
- ② KARAOKE button
- ③ MONO button
- ④ P.BASS button

⑤ PGM button

⑥ CLEAR button

⑦ Common operation buttons

The roles of the buttons vary depending on the input functions.

During CD input:

- ▶/|| : Play/Pause
- : Stop
- ▶▶ : Track search
- ◀◀ : Track search
- ▶▶▶ : Fast forward
- ◀◀◀ : Fast reverse

During cassette deck input:

- ◀▶ : Play/Tape transport direction
- : Stop
- ▶▶▶ : Music search + (XR-A200 only)
- ◀◀◀ : Music search - (XR-A200 only)
- ▶▶▶ : Fast forward
- ◀◀◀ : Rewind

During tuner input:

- ▶▶▶ : Station up
- ◀◀◀ : Station down
- ▶▶▶ : Frequency up
- ◀◀◀ : Frequency down

⑧ POWER button

⑨ SLEEP button

⑩ DISPLAY button

⑪ SOUND MORPHING buttons

⑫ DISC select buttons

⑬ REPEAT button

⑭ RANDOM button

⑮ FUNCTION buttons

■ SPECIFICATIONS

STEREO CD CASSETTE DECK RECEIVER

XR-A100, XR-A200

Amplifier Section

Continuous power output (RMS)

XR-A100	33 W + 33 W (1 kHz, T.H.D. 10 %, 4 Ω)
XR-A200	50 W + 50 W (1 kHz, T.H.D. 10 %, 6 Ω)

FM/AM Tuner Section

FM Tuner Section

Frequency Range	87.5 MHz to 108 MHz
Antenna Input	75 Ω unbalanced

AM Tuner Section

Frequency Range	
With 9 kHz step	531 kHz to 1,602 kHz
With 10 kHz step	530 kHz to 1,700 kHz
Antenna	Loop antenna

CD Section

Type	Compact disc digital audio system
Wow and Flutter	Limit of measurement (±0.001% W.PEAK) or less (EIAJ)

Cassette Deck Section

Systems	4-track, 2-channel stereo
Heads	Recording/playback head x 1 Playback head x 1 Erasing head x 1
Motor	DC servo motor x 1
Tape type	TYPE I (Normal) tape

Miscellaneous

Power Requirements

XR-A100	AC 110-127/220-240 V (switchable), 50/60 Hz
XR-A200	AC 110-127/220-230/240V (switchable), 50/60 Hz

Power Consumption

XR-A100	210 W
XR-A200	230 W

Dimensions

Weight (without package)

XR-A100	270 (W) x 300 (H) x 324 (D) mm
XR-A100	6.4 kg
XR-A200	6.9 kg

Accessories

Operating Instructions	1
Remote Control Unit	1
Dry Cell Batteries (AA/R6P)	2
FM Antenna	1
AM Loop Antenna	1

NOTE:

Specifications and design are subject to possible modifications without notice, due to improvements.

● ACCESSORIES

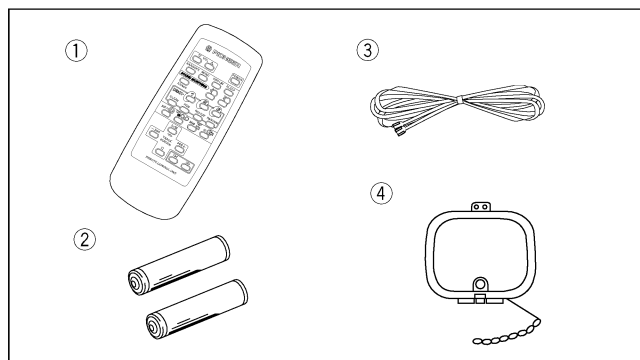

- ① Remote control unit x 1 : XZN3003 (CU-XR039)
- ② AA/R6P dry cell batteries x 2
- ③ FM antenna x 1 : ADH7004
- ④ AM loop antenna x 1 : XTB3001