

Pioneer

Service Manual

ORDER NO.
RRV1995

STEREO CD CASSETTE DECK RECEIVER

XR-A660SW XR-A660EE

● Refer to the service manual RRV2006 for XR-A660/DLXJ/NC.

THIS MANUAL IS APPLICABLE TO THE FOLLOWING MODEL(S) AND TYPE(S).

Type	Model		Power Requirement	The voltage can be converted by the following method.
	XR-A660SW	XR-A660EE		
DDXJ	○	—	AC110V-127V/220-230V/240V	With the voltage selector
MLWXJ/EE	—	○	AC220-230V	—

CONTENTS

1. CONTRAST OF MISCELLANEOUS PARTS	2
2. SCHEMATIC DIAGRAM	4
3. PCB CONNECTION DIAGRAM	10
4. ADJUSTMENT	11

PIONEER ELECTRONIC CORPORATION 4-1, Meguro 1-Chome, Meguro-ku, Tokyo 153-8654, Japan
PIONEER ELECTRONICS SERVICE, INC. P.O. Box 1760, Long Beach, CA 90801-1760, U.S.A.
PIONEER ELECTRONIC (EUROPE) N.V. Haven 1087, Keetberglaan 1, 9120 Melsele, Belgium
PIONEER ELECTRONICS ASIACENTRE PTE. LTD. 501 Orchard Road, #10-00 Wheelock Place, Singapore 238880
© PIONEER ELECTRONIC CORPORATION 1998

1. CONTRAST OF MISCELLANEOUS PARTS

NOTES: ●Parts marked by "NSP" and ⊗ can not be supplied.

- The Δ mark found on some component parts indicates the importance of the safety factor of the part. Therefore, when replacing, be sure to use parts of identical designation.
- Screws adjacent to ▼ mark on the product are used for disassembly.
- Reference Nos. indicate the pages and Nos. in the service manual for the base model.
- When ordering resistors, first convert resistance values into code form as shown in the following examples.

Ex.1 When there are 2 effective digits (any digit apart from 0), such as 560 ohm and 47k ohm (tolerance is shown by J=5%, and K=10%).

560 Ω	→	56 × 10 ¹	→	561	RD1/4PU	5	6	1	J
47k Ω	→	47 × 10 ³	→	473	RD1/4PU	4	7	3	J
0.5 Ω	→	R50			RN2H	R	5	0	K
1 Ω	→	1R0			RSIP	1	R	0	K

Ex.2 When there are 3 effective digits (such as in high precision metal film resistors).

5.62k Ω	→	562 × 10 ¹	→	5621	RN1/4PC	5	6	2	1	F
---------	---	-----------------------	---	------	-------	---------	---	---	---	---	---

■ CONTRAST TABLE

XR-A660SW/DDXJ, XR-A660EE/MLWXJ/EE and XR-A660/DLXJ/NC are constructed the same except for the following :

Ref. No.	Mark	Symbol and Description	Part No.			Remarks
			XR-A660 /DLXJ/NC	XR-A660SW /DDXJ	XR-A660EE /MLWXJ/EE	
ASSEMBLIES						
P7- 3	NSP ⊗	COMPLEX Assy	XWM3049	XWM3053	XWM3086	
P7- 29	⊗	├ PRIMARY Assy	XWZ3048	XWZ3048	XWZ3056	
P9- 1	⊗	├ SUB TRANS Assy	XWZ3049	XWZ3049	XWZ3155	
P7- 4	⊗	└ DISPLAY Assy	XWZ3085	XWZ3095	XWZ3096	
		FM/AM TUNER MODULE	AXQ7065	AXQ7062	AXQ7069	
PACKING SECTION						
P3- 1		FM Antenna	ADH7004	ADH7004	ADH7011	
P3- 2		Operating Instructions (English/ Chinese/ Russian)	XRE3009	Not used	Not used	
P3- 2		Operating Instructions (English/ Arabian/ Russian)	Not used	XRE3013	XRE3013	
P3- 10		Packing Case	XHD3032	XHD3042	XHD3043	
P3- 13	Δ	Power Cord	ADG1154	ADG1158	ADG1154	
		SW Antenna	Not used	ADH7006	Not used	
EXTERIOR(1/2) SECTION						
P5- 7	NSP	Display Panel	XAK3020	XAK3020	XAK3058	
		Getter	XAX3066	XAX3066	XAX3096	
EXTERIOR(2/2) SECTION						
P7- 5	Δ	T1 Power Tranceformer	XTS3015	XTS3015	XTS3016	
P7- 6	Δ	FU2, FU3 Fuse (T2A)	AEK1057	AEK1057	Not used	
P7- 7	Δ	FU1 Fuse (T2A)	Not used	Not used	AEK1057	
P7- 7	Δ	FU1 Fuse (T4A)	AEK1060	AEK1060	Not used	
P7- 15		Rear Panel	XNC3001	XNC3001	XNC3021	
P7- 25		Caution Label	PRW1018	Not used	Not used	
P7- 26	NSP	Name Label	Not used	XAL3005	Not used	
P7- 30	NSP	Fuse Card	AAX2357	AAX2357	Not used	
P7- 31		Fuse Card	Not used	Not used	AAX7026	
P7- 31	NSP	Fuse Card	AAX7099	AAX7099	Not used	

Note: ● For ASSEMBLIES, refer to "CONTRAST OF PCB ASSEMBLIES", "2. SCHEMATIC DIAGRAM" and "3. PCB CONNECTION DIAGRAM".

■ CONTRAST OF PCB ASSEMBLIES

GF PRIMARY ASSY

XWZ3056 and XWZ3048 are constructed the same except for the following :

Mark	Symbol and Description	Part No.		Remarks
		XWZ3048	XWZ3056	
	H3-H6 Fuse Clip S1	AKR7001 AKX7006	Not used Not used	

HF SUB TRANS ASSY

XWZ3155 and XWZ3049 are constructed the same except for the following :

Mark	Symbol and Description	Part No.		Remarks
		XWZ3049	XWZ3155	
	S2	AKX7004	Not used	

IF DISPLAY ASSY

XWZ3095, XWZ3096 and XWZ3085 are constructed the same except for the following :

Mark	Symbol and Description	Part No.			Remarks
		XWZ3085	XWZ3095	XWZ3096	
	C5501	Not used	Not used	CCSQCH220J50	
	C5502	Not used	Not used	CCSQCH270J50	
	C5815	Not used	Not used	CKSQYB103K50	
	D5594	Not used	1SS133	Not used	
	D5595	Not used	Not used	1SS133	
	R9996	RS1/10S0R0J	RS1/10S0R0J	RS1/10S561J	
	X5501 (6MHz)	RSS1050	RSS1050	ASS7015	

SIGNAL ROUTE

- (AM) AM SIGNAL ROUTE
- (FM) FM SIGNAL ROUTE
- (TA) TUNER AUDIO SIGNAL ROUTE

Notes

1. RESISTORS
Indicated in Ω, 1/10W±5% Tolerance unless otherwise noted K:KΩ, M:MΩ.
2. CAPACITORS
Indicated in Capacity (μF)/VOLTAGE (V) unless otherwise noted P:PF.
3. DIODES
No mark diode is 1SS254.

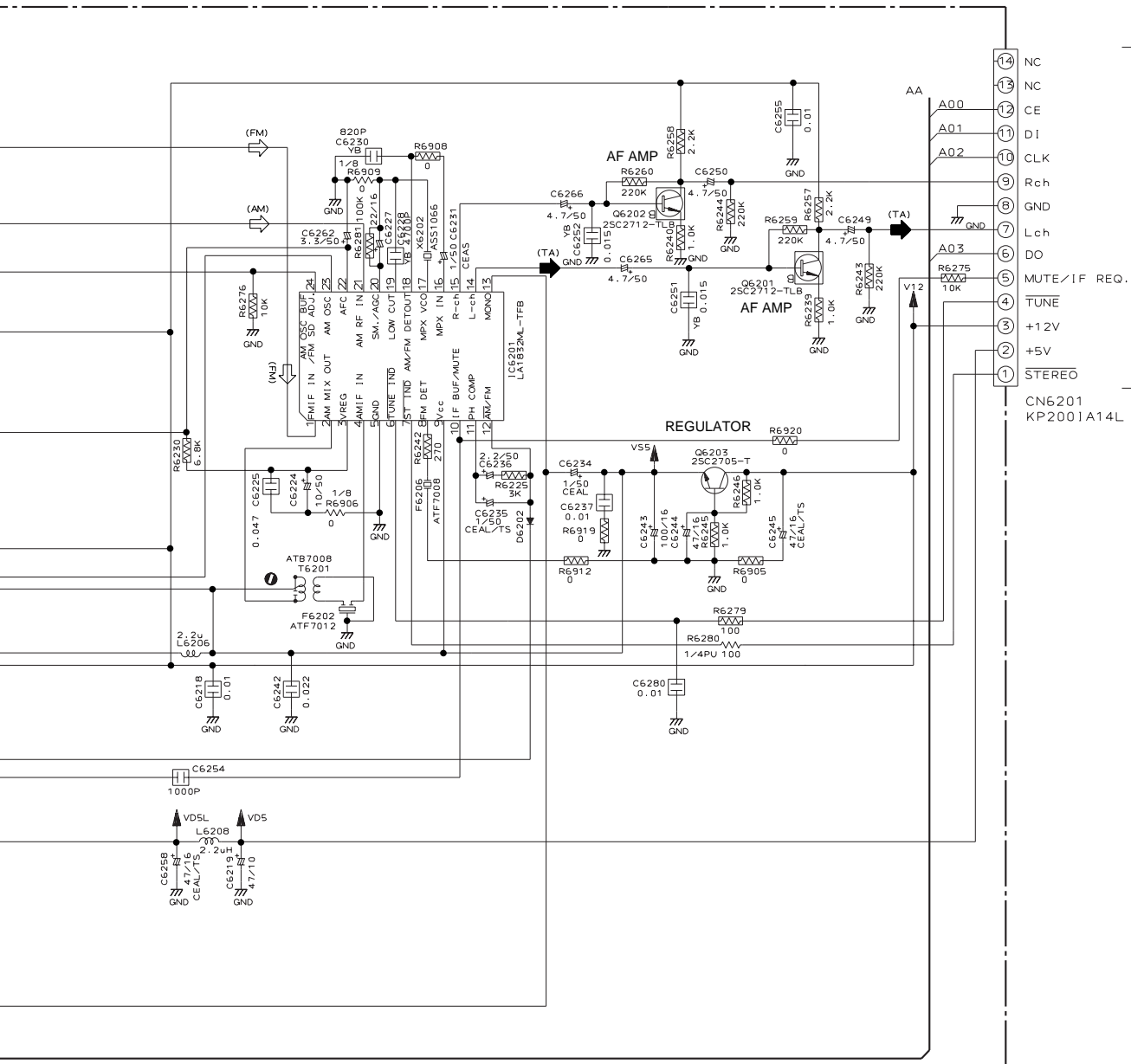

KN1054

- 14 NC
- 13 NC
- 12 CE
- 11 DI
- 10 CLK
- 9 Rch
- 8 GND
- 7 Lch
- 6 DO
- 5 MUTE/IF REQ.
- 4 TUNE
- 3 +12V
- 2 +5V
- 1 STEREO

CN6201
KP2001A14L

2.2 FM/AM TUNER MODULE (AXQ7069)

A

B

C

D

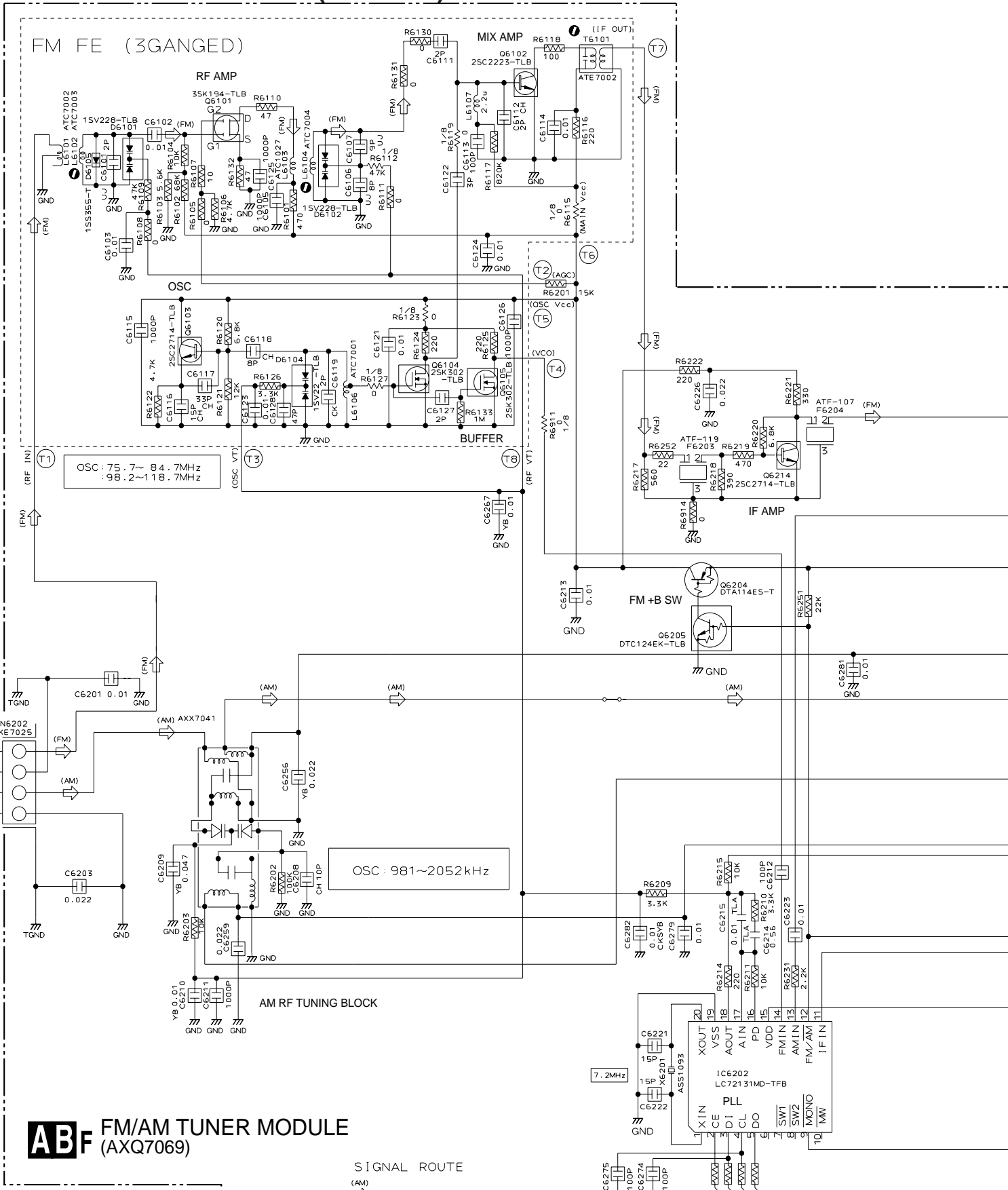

ABF FM/AM TUNER MODULE (AXQ7069)

SIGNAL ROUTE
 (AM) : AM SIGNAL ROUTE
 (FM) : FM SIGNAL ROUTE
 (TA) : TUNER AUDIO SIGNAL ROUTE



Notes

1. RESISTORS

Indicated in Ω , $1/10W \pm 5\%$ Tolerance unless otherwise noted K:K Ω , M:M Ω .

2. CAPACITORS

Indicated in Capacity (μF)/VOLTAGE (V) unless otherwise noted P:PF.

3. DIODES

No mark diode is 1SS254.

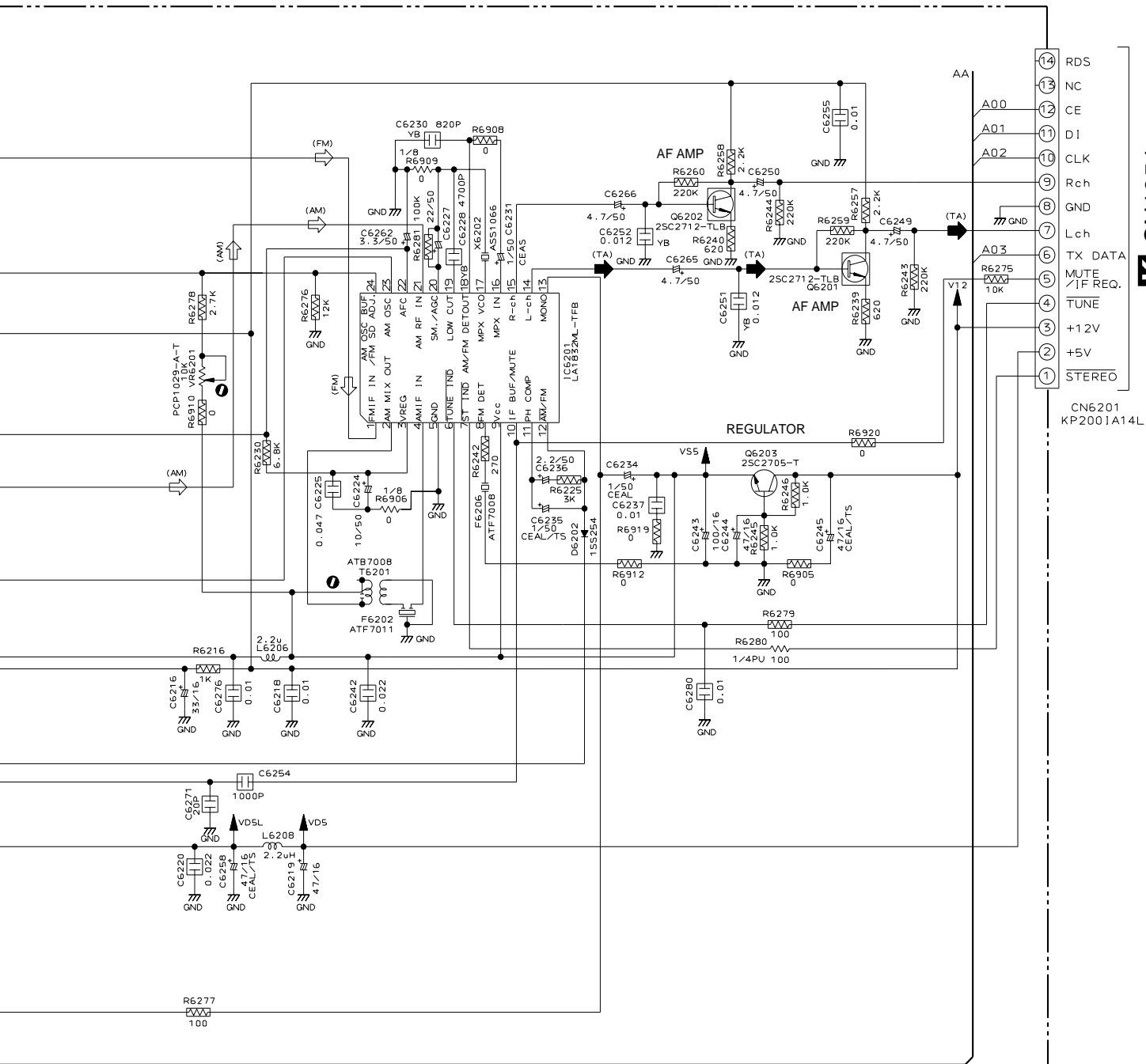

KN1054

- 14 RDS
- 13 NC
- 12 CE
- 11 DI
- 10 CLK
- 9 Rch
- 8 GND
- 7 Lch
- 6 TX DATA
- 5 MUTE /IF REQ.
- 4 TUNE
- 3 +12V
- 2 +5V
- 1 STEREO

CN6201
KP2001A14L

2.3 DISPLAY and CD SW LED ASSEMBLIES

DISPLAY ASSY (XR-A660SW: XWZ3095) (XR-A660EE : XWZ3096)

NOTES

ALL CAPACITORS ARE IN μF UNLESS OTHERWISE SPECIFIED

AL : CEAL JA : CEJA
HAQ : CEHAQ
(OTHER : CEAS**MHH#orCEAT***MHH#)

ALL RESISTORS ARE IN Ω

1/4W (CHIP)
1/4WPU

ALL INDUCTORS ARE IN μH

LAU

CH : CCSQCH
YB : CKSQYB
SL : CCSQSL
(OTHER : CKSQYF)

SWITCHES

DISPLAY ASSY

- | | |
|-----------------------|-------------------------|
| S5911 : DISPLAY | S5924 : REC/STOP |
| S5912 : TIMER | S5925 : FREQ/STATION |
| S5913 : ENTER | S5926 : DOLBY NR ON/OFF |
| S5914 : P. BASS | S5927 : ASES/COPY |
| S5915 : ZOOM SURROUND | S5928 : AUX |
| S5916 : BASS BLASTER | S5929 : TAPE I/II |
| S5917 : EQUALIZER | S5930 : TUNER/BAND |
| S5918 : PRESET | S5931 : CD |
| S5919 : STANDBY/ON | S5932 : DISC 1 SELECT |
| S5920 : TUNING - ◀◀◀◀ | S5933 : DISC 2 SELECT |
| S5921 : TUNING + ▶▶▶▶ | S5934 : DISC 3 SELECT |
| S5922 : STOP | S5935 : DISC CHANGE |
| S5923 : PLAY/PAUSE | S5936 : OPEN/CLOSE |

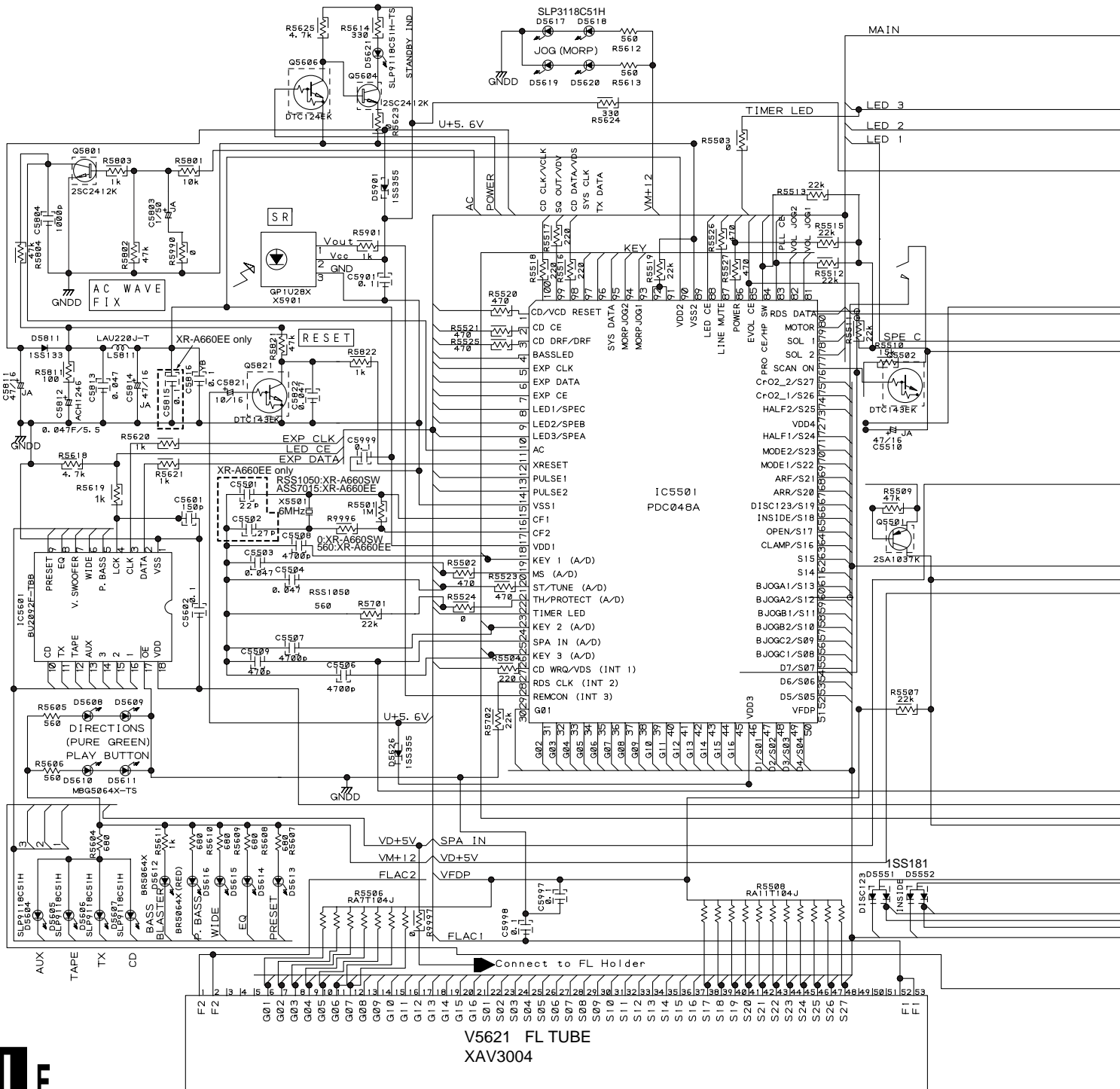

V5621 FL TUBE
XAV3004

CD SW LED ASSY
 S5937 : OPEN/CLOSE
 S5938 : DISC CHANGE
 S5939 : DISC 3 SELECT
 S5940 : DISC 2 SELECT
 S5941 : DISC 1 SELECT

CN5501
 52045-3845

E2/3 CN5101

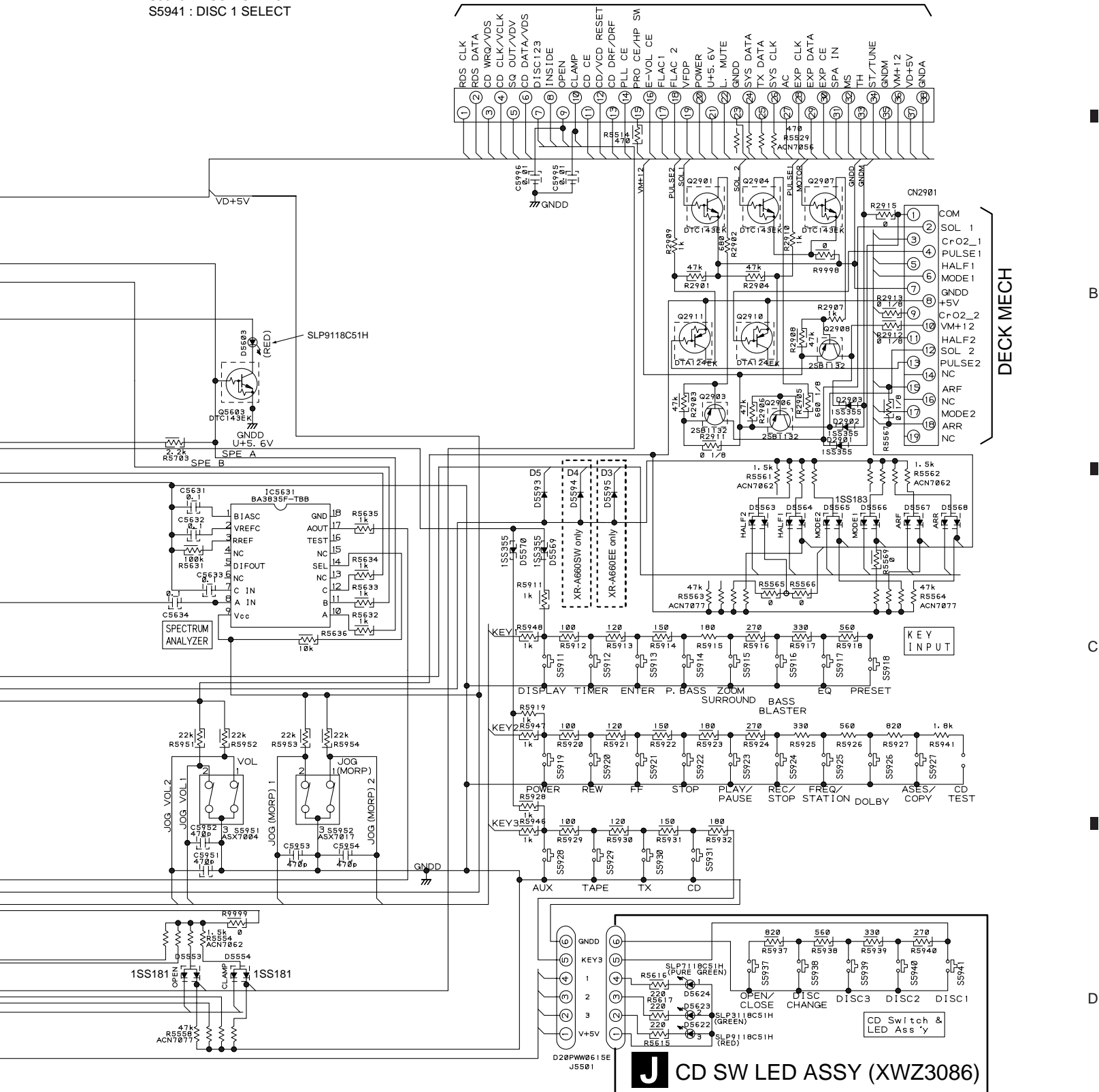

J CD SW LED ASSY (XWZ3086)



3. PCB CONNECTION DIAGRAM

3.1 FM/AM TUNER MODULE (AXQ7062)

● AXQ7062 is constructed the same PCB (ANP7159) as AXQ7065 , refer to the service manual RRV2006 for XR-A660.

3.2 FM/AM TUNER MODULE (AXQ7069)

K CN1054

AA **F** FM/AM TUNER MODULE

SIDE A

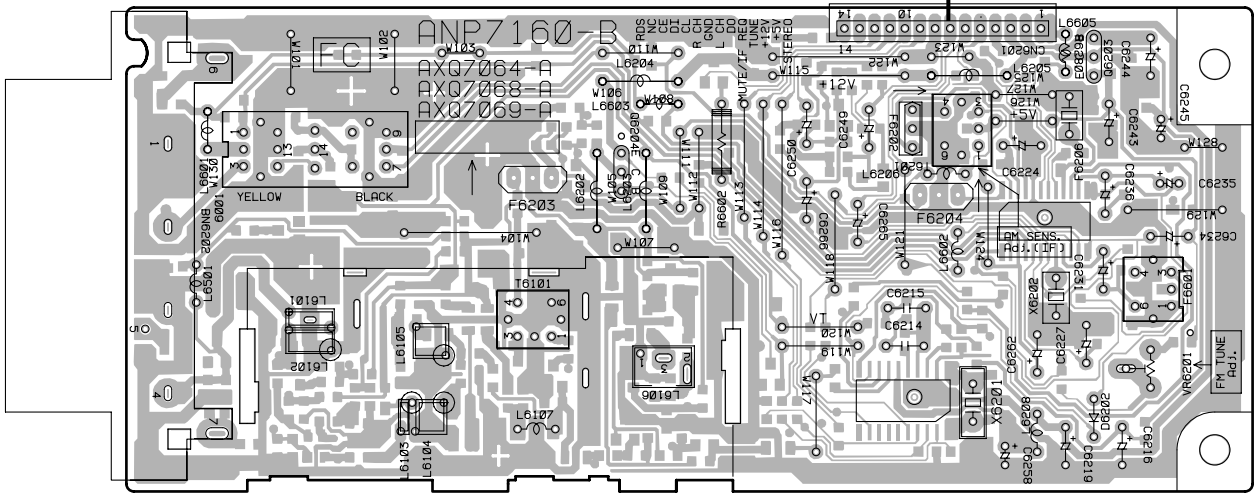

VR6201
 Q6204 Q6203
 (ANP7160-B)

AA **F** FM/AM TUNER MODULE

SIDE B

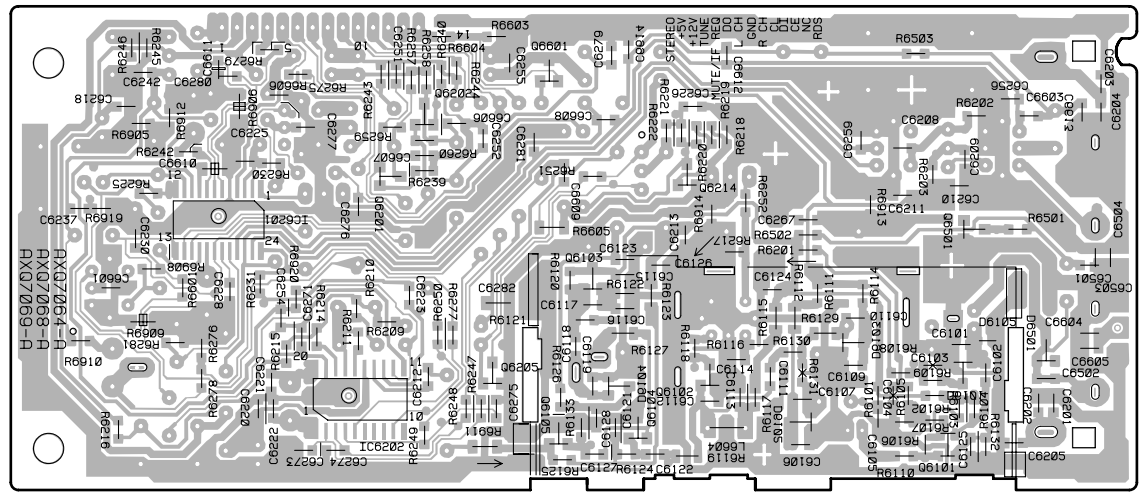

IC6201 Q6201 Q6202 Q6601 Q6214 Q6501
 IC6202 Q6205 Q6102 - Q6105 Q6101
 (ANP7160-B)

4. ADJUSTMENT

4.1 ADJUSTMENT FOR XR-A660SW

Note : Adjustment of XR-A660SW/DDXJ are the same as those of XR-A660/DLXJNC except for the following:

■ AM Tuner SW Section

- Set the mode selector to SW2.
- Connect the wiring as shown in Fig. 1.

Step No.	Adjustment Title	AM SG (400Hz, 30% Mod.)		Reception Frequency Display	Adjustment Location	Specifications
		Frequency (MHz)	Input Level (dBμV/EMF)			
1	AM Front End Sensitivity Adjustment	14	25-35	14MHz	L6303	Adjust so that the DC voltage between the IC6201-Pin 20 and GND becomes at maximum level.

Before adjustment, connect AM-ANT. and IEC-dummy ANT.. Signal input is through IEC-dummy ANT.. Connecting AM-ANT. follows Fig. 1.

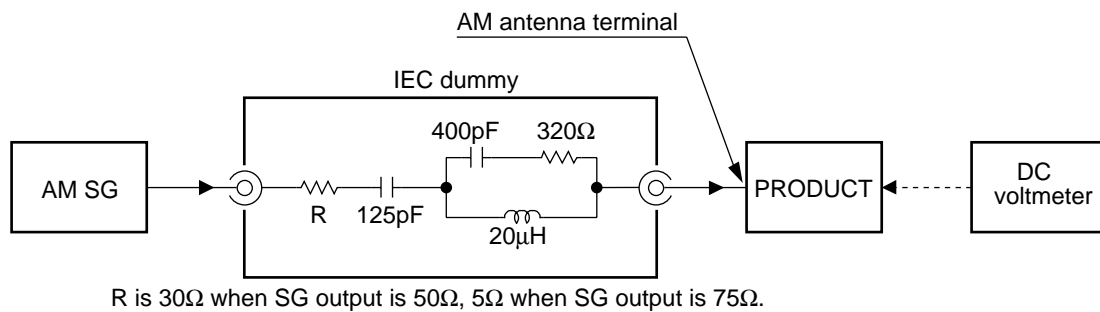

Fig. 1 SW adjustment wiring diagram

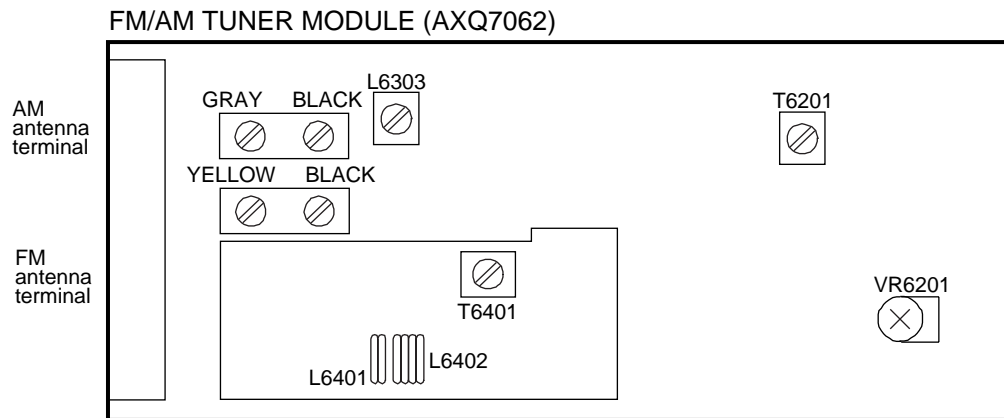

Fig. 2 Adjustment points

4.2 ADJUSTMENT FOR XR-A660EE

Note : Adjustment of XR-A660EE/MLWXJ/EE are the same as those of XR-A660/DLXJ/NC except for the following:

■ FM Tuner Section

- Set the mode selector to FM BAND.
- Connect the wiring as shown in Fig. 1.

Step No.	Adjustment Title	FM SG (1kHz, ±75kHz dev.)		Reception Frequency Display	Adjustment Location	Specifications
		Frequency (MHz)	Level (dBμV)			
1	Front End Sensitivity	70	0-30	70MHz	L6104 L6102 T6101	Adjust so that the DC voltage between the IC6201-Pin 20 and GND becomes at maximum level.
2	TUNED IND. Lighting Level	98	18±2	98MHz	VR6201	Adjust so that the indicator of TUNED IND. starts to light up.

Notes:

- Before adjusting, make sure there is no gap between L6101 and L6102 as well as between L6103 and L6104. If there is a gap between them, bring them into contact with each other first, and then make adjustments.

■ AM Tuner Section

- Set the mode selector to AM BAND.
- Connect the wiring as shown in Fig. 1.

Step No.	Adjustment Title	AM SG (400Hz, 30% Mod.)		Reception Frequency Display	Adjustment Location	Specifications
		Frequency (kHz)	Level (dBμV/m)			
1	Front End Sensitivity	999*1	35-45	999kHz*1	T6201	Adjust so that the DC voltage between the IC6201-Pin 20 and GND becomes at maximum level.

*1: For the area using 10kHz step, frequencies should be 1000kHz

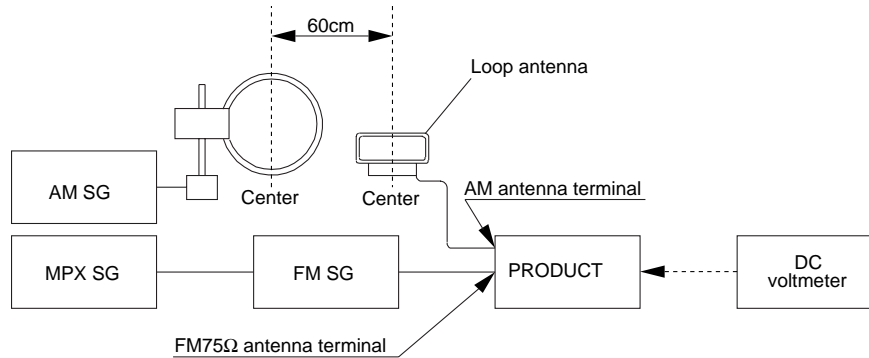

Fig. 1 AM and FM Adjustment Wiring Diagram

FM/AM TUNER MODULE (AXQ7069)

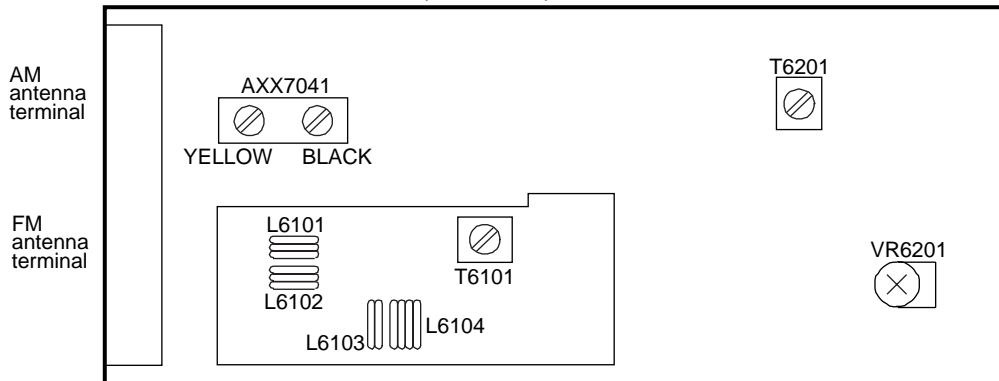

Fig. 2 Adjustment Points