

# Service Manual

ORDER NO.  
RRV2215

STEREO CD CASSETTE DECK RECEIVER

# XR-A670 XR-A370

THIS MANUAL IS APPLICABLE TO THE FOLLOWING MODEL(S) AND TYPE(S).

Type	Model		Power Requirement	The voltage can be converted by the following method.
	XR-A670	XR-A370		
DBDXJ	○	○	AC110-127V/220-230V/240V	With the voltage selector
DXJN/NC	○	○	AC110-127V/220-230V/240V	With the voltage selector
YPWXJ	○	○	AC240V	_____

● This service manual should be used together with the following manual(s):

Model No.	Order No.	Remarks
XR-A670/KUCXJ	RRV2188	

## CONTENTS

1. SAFETY INFORMATION .....	2
2. CONTRAST OF MISCELLANEOUS PARTS .....	3
3. SCHEMATIC DIAGRAM .....	6

# 1. SAFETY INFORMATION

## LABEL CHECK (for YPWXJ type)

— IMPORTANT —  
THIS PIONEER APPARATUS CONTAINS  
LASER OF CLASS 1.  
SERVICING OPERATION OF THE APPARATUS  
SHOULD BE DONE BY A SPECIALLY  
INSTRUCTED PERSON.

— LASER DIODE CHARACTERISTICS —  
MAXIMUM OUTPUT POWER: 5 mW  
WAVELENGTH: 780 - 785 nm

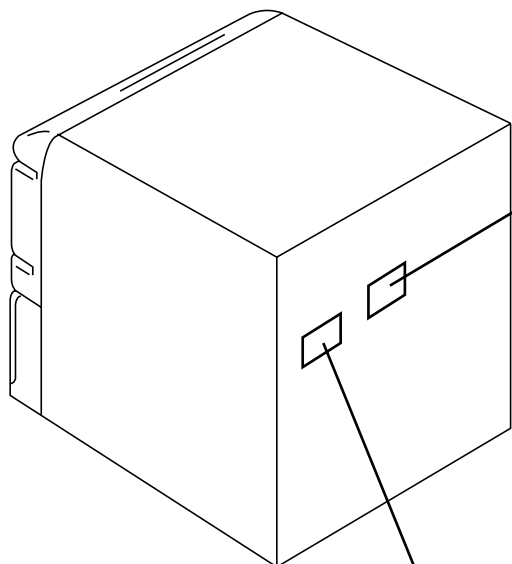

**CAUTION**  
INVISIBLE LASER  
RADIATION WHEN OPEN,  
AVOID EXPOSURE  
TO BEAM PRW1018

**CLASS 1  
LASER PRODUCT**

Printed on the Rear Panel

— Additional Laser Caution —

- 1. Laser Interlock Mechanism**  
The position of the switch (S9501) for detecting loading state is detected by the system microprocessor, and the design prevents laser diode oscillation when the switch (S9501) is pressed physically.  
Thus, the interlock will no longer function if the switch (S9501) is released physically and deliberately.  
The interlock also does not function in the test mode \*.  
Laser diode oscillation will continue, if pin 1 of CXA1821M (IC8101) on the CD ASSY mounted on the \$M Loading Mechanism assembly is connected to GND, or else the terminals of Q8101 are shorted to each other (fault condition).
- 2. When the cover is opened, close viewing of the objective lens with the naked eye will cause exposure to a Class 1 laser beam.**

\* : Refer to page 66 on the service manual RRV2188.

## 2. CONTRAST OF MISCELLANEOUS PARTS

- NOTES: ● Parts marked by "NSP" are generally unavailable because they are not in our Master Spare Parts List.  
 ● The  $\Delta$  mark found on some component parts indicates the importance of the safety factor of the part. Therefore, when replacing, be sure to use parts of identical designation.  
 ● Screws adjacent to  $\nabla$  mark on product are used for disassembly.  
 ● Reference Nos. indicate the pages and Nos. in the service manual for the base model.  
 ● When ordering resistors, first convert resistance values into code form as shown in the following examples.  
 Ex.1 When there are 2 effective digits (any digit apart from 0), such as 560 ohm and 47k ohm (tolerance is shown by J=5%, and K=10%).
- |     |   |                      |       |     |       |         |   |   |   |   |
|-----|---|----------------------|-------|-----|-------|---------|---|---|---|---|
| 560 | → | 56 x 10 <sup>1</sup> | →     | 561 | ..... | RD1/4PU | 5 | 6 | 1 | J |
| 47k | → | 47 x 10 <sup>3</sup> | →     | 473 | ..... | RD1/4PU | 4 | 7 | 3 | J |
| 0.5 | → | R50                  | ..... |     |       | RN2HR   | 5 | 0 |   | K |
| 1   | → | 1R0                  | ..... |     |       | RS1P    | 1 | R | 0 | K |
- Ex.2 When there are 3 effective digits (such as in high precision metal film resistors).
- |       |   |                       |   |      |       |         |   |   |   |   |   |
|-------|---|-----------------------|---|------|-------|---------|---|---|---|---|---|
| 5.62k | → | 562 x 10 <sup>1</sup> | → | 5621 | ..... | RN1/4PC | 5 | 6 | 2 | 1 | F |
|-------|---|-----------------------|---|------|-------|---------|---|---|---|---|---|

### ■ CONTRAST TABLE for XR-A670

XR-A670/DBDXJ, DXJN/NC, YPWXJ and XR-A670/KUCXJ are constructed the same except for the following :

Ref. No.	Mark	Symbol and Description	Part No.				Remarks
			XR-A670 /KUCXJ	XR-A670 /DBDXJ	XR-A670 /DXJN/NC	XR-A670 /YPWXJ	
<b>PCB ASSEMBLIES</b>							
P6-2		COMPLEX ASSY	XWM3113	XWM3111	XWM3111	XWM3112	
P6-3		└ PRIMARY ASSY	XWZ3224	XWZ3222	XWZ3222	XWZ3223	
P9-1		└ SUB TRANS ASSY	XWZ3227	XWZ3226	XWZ3226	XWZ3226	
		└ DISPLAY ASSY	XWZ3214	XWZ3212	XWZ3212	XWZ3212	
<b>PACKING SECTION</b>							
P4-1	$\Delta$	Power Cord	ADG7022	ADG1158	ADG1154	ADG1160	
P4-6	NSP	Dry Cell Battery (R6P, AA)	VEM-013	Not used	VEM-013	Not used	
P4-10		Packing Case	XHD3091	XHD3093	XHD3095	XHD3092	
P4-11	NSP	Warranty Card	ARY7033	Not used	Not used	ARY7027	
P4-13		Operating Instructions (English/French)	XRE3024	Not used	Not used	XRE3024	
P4-18	NSP	Polyethylene Bag	Not used	Not used	Not used	AHG7033	For Power Cord
		Operating Instructions (English/Chinese/Spanish)	Not used	XRE3025	Not used	Not used	
	$\Delta$	Operating Instructions (Thai)	Not used	Not used	XRC3017	Not used	
		Power-cord Plug Conversion Adapter	Not used	XKM3002	Not used	Not used	Accessories
<b>EXTERIOR SECTION</b>							
P6-7	$\Delta$	Power Transformer (AC120V)	XTS3032	Not used	Not used	Not used	
P6-7	$\Delta$	Power Transformer (AC110-127V/220-230V/240V)	Not used	XTS3031	XTS3031	XTS3031	
P6-8	$\Delta$	Fuse (FU1 : 6.3A)	REK1085	Not used	Not used	Not used	
P6-8	$\Delta$	Fuse (FU1 : T5A)	Not used	AEK1061	AEK1061	AEK1061	
P6-9	NSP	Fuse Caution Label	XAX3157	Not used	Not used	Not used	
P6-20		Rear Panel	XNC3040	XNC3042	XNC3042	XNC3041	
P6-35	NSP	Fuse Card	AAX2374	AAX7098	AAX7098	AAX7098	
P6-39		Cushion Leg B	XEB3009	XEB3009	Not used	XEB3009	
P6-43	NSP	Getter	XAX3143	XAX3145	XAX3145	XAX3144	
P6-44		Caution Label	Not used	Not used	Not used	PRW1018	
P6-45	$\Delta$	65 Label	ORW1069	Not used	Not used	Not used	
		Fuse (FU2, FU3 : T3.15A)	Not used	AEK1059	AEK1059	Not used	*1
		Fuse Card (For FU2, FU3)	Not used	AAX7493	AAX7493	Not used	*2
	NSP	Name Label	Not used	Not used	XAL3035	Not used	*3
<b>FRONT PANEL SECTION</b>							
P9-17		Display Panel	XAK3113	XAK3114	XAK3114	XAK3114	
P9-19		FL Cover	XAK3088	XAK3124	XAK3124	XAK3124	

Notes : For PCB ASSEMBLIES, Refer to "CONTRAST OF PCB ASSEMBLIES" and "3. SCHEMATIC DIAGRAM".

\*1 Refer to "3. SCHEMATIC DIAGRAM".

\*2 Stick Fuse Card on PRIMARY ASSY.

\*3 Stick Name Label on Rear Panel.

# XR-A670, XR-A370

## ■ CONTRAST TABLE for XR-A370

XR-A370/DBDXJ, DXJN/NC, YPWXJ and XR-A370/KUCXJ are constructed the same except for the following :

Ref. No.	Mark	Symbol and Description	Part No.				Remarks
			XR-A370 /KUCXJ	XR-A370 /DBDXJ	XR-A370 /DXJN/NC	XR-A370 /YPWXJ	
<b>PCB ASSEMBLIES</b>							
P6- 2		COMPLEX ASSY	XWM3108	XWM3106	XWM3106	XWM3107	
P6- 3		└ PRIMARY ASSY	XWZ3224	XWZ3222	XWZ3222	XWZ3223	
P9- 1		└ SUB TRANS ASSY	XWZ3227	XWZ3226	XWZ3226	XWZ3226	
		└ DISPLAY ASSY	XWZ3209	XWZ3207	XWZ3207	XWZ3207	
<b>PACKING SECTION</b>							
P4- 1	△	Power Cord	ADG7022	ADG1158	ADG1154	ADG1160	
P4- 6	NSP	Dry Cell Battery (R6P, AA)	VEM-013	Not used	VEM-013	Not used	
P4-10		Packing Case	XHD3082	XHD3086	XHD3087	XHD3084	
P4-11	NSP	Warranty Card	ARY7033	Not used	Not used	ARY7027	
P4-13		Operating Instructions (English/French)	XRE3024	Not used	Not used	XRE3024	
P4-18	NSP	Polyethylene Bag	Not used	Not used	Not used	AHG7033	For Power Cord
		Operating Instructions (English/Chinese/Spanish)	Not used	XRE3025	Not used	Not used	
		Operating Instructions (Thai)	Not used	Not used	XRC3017	Not used	
	△	Power-cord Plug Conversion Adapter	Not used	XKM3002	Not used	Not used	Accessories
<b>EXTERIOR SECTION</b>							
P6- 7	△	Power Transformer (AC120V)	XTS3017	Not used	Not used	Not used	
P6- 7	△	Power Transformer (AC110-127V/220-230V/240V)	Not used	XTS3015	XTS3015	XTS3015	
P6- 8	△	Fuse (FU1 : 5A)	REK1083	Not used	Not used	Not used	
P6- 8	△	Fuse (FU1 : T4A)	Not used	AEK1060	AEK1060	AEK1060	
P6- 9	NSP	Fuse Caution Label	XAX3122	Not used	Not used	Not used	
P6-20		Rear Panel	XNC3035	XNC3037	XNC3037	XNC3036	
P6-35	NSP	Fuse Card	AAX7097	Not used	Not used	Not used	
P6-39		Cushion Leg B	XEB3009	XEB3009	Not used	XEB3009	
P6-43	NSP	Getter	XAX3138	XAX3140	XAX3140	XAX3139	
P6-44		Caution Label	Not used	Not used	Not used	PRW1018	
P6-45		65 Label	ORW1069	Not used	Not used	Not used	
	△	Fuse (FU2, FU3 : T2A)	Not used	AEK1057	AEK1057	Not used	*1
	NSP	Name Label	Not used	Not used	XAL3030	Not used	*2
<b>FRONT PANEL SECTION</b>							
P9-17		Display Panel	XAK3108	XAK3109	XAK3109	XAK3012	
P9-19		FL Cover	XAK3088	XAK3124	XAK3124	XAK3124	
P9-24		POWER Button	XZN3085	XZN3086	XZN3086	XZN3086	
P9-30		Sub Panel	XZN3089	XZN3091	XZN3091	XZN3091	

Notes : For PCB ASSEMBLIES, Refer to "CONTRAST OF PCB ASSEMBLIES" and "3. SCHEMATIC DIAGRAM".

\*1 Refer to "3. SCHEMATIC DIAGRAM".

\*2 Stick Name Label on Rear Panel.

## ■ CONTRAST OF PCB ASSEMBLIES

### **H**F PRIMARY ASSY

XWZ3222, XWZ3223 and XWZ3224 are constructed the same except for the following :

Mark	Symbol and Description	Part No.			Remarks
		XWZ3224	XWZ3222	XWZ3223	
△	S1 VOLTAGE SELECTOR	Not used	XKX3001	Not used	
	H3-H6 FUSE CLIP	Not used	AKR7001	Not used	
NSP	Y4 JUMPER WIRE	Not used	XDX3009	XDX3009	
NSP	Y5 JUMPER WIRE	XDX3011	XDX3011	Not used	

### **I**F SUB TRANS ASSY

XWZ3226 and XWZ3227 are constructed the same except for the following :

Mark	Symbol and Description	Part No.		Remarks
		XWZ3227	XWZ3226	
	R1 (2.2MΩ/ 1/2)	RCN1080	Not used	
△	AN1 1P AC INLET	XKP3042	XKP3041	

### **J** DISPLAY ASSY

XWZ3212 and XWZ3214 are constructed the same except for the following :

Mark	Symbol and Description	Part No.		Remarks
		XWZ3214	XWZ3212	
	D5597	1SS355	Not used	

XWZ3207 and XWZ3209 are constructed the same except for the following :

Mark	Symbol and Description	Part No.		Remarks
		XWZ3209	XWZ3207	
	D5597	1SS355	Not used	

# 3. SCHEMATIC DIAGRAM

## 3.1 PRIMARY and SUB TRANS ASSYS

A

B

C

D

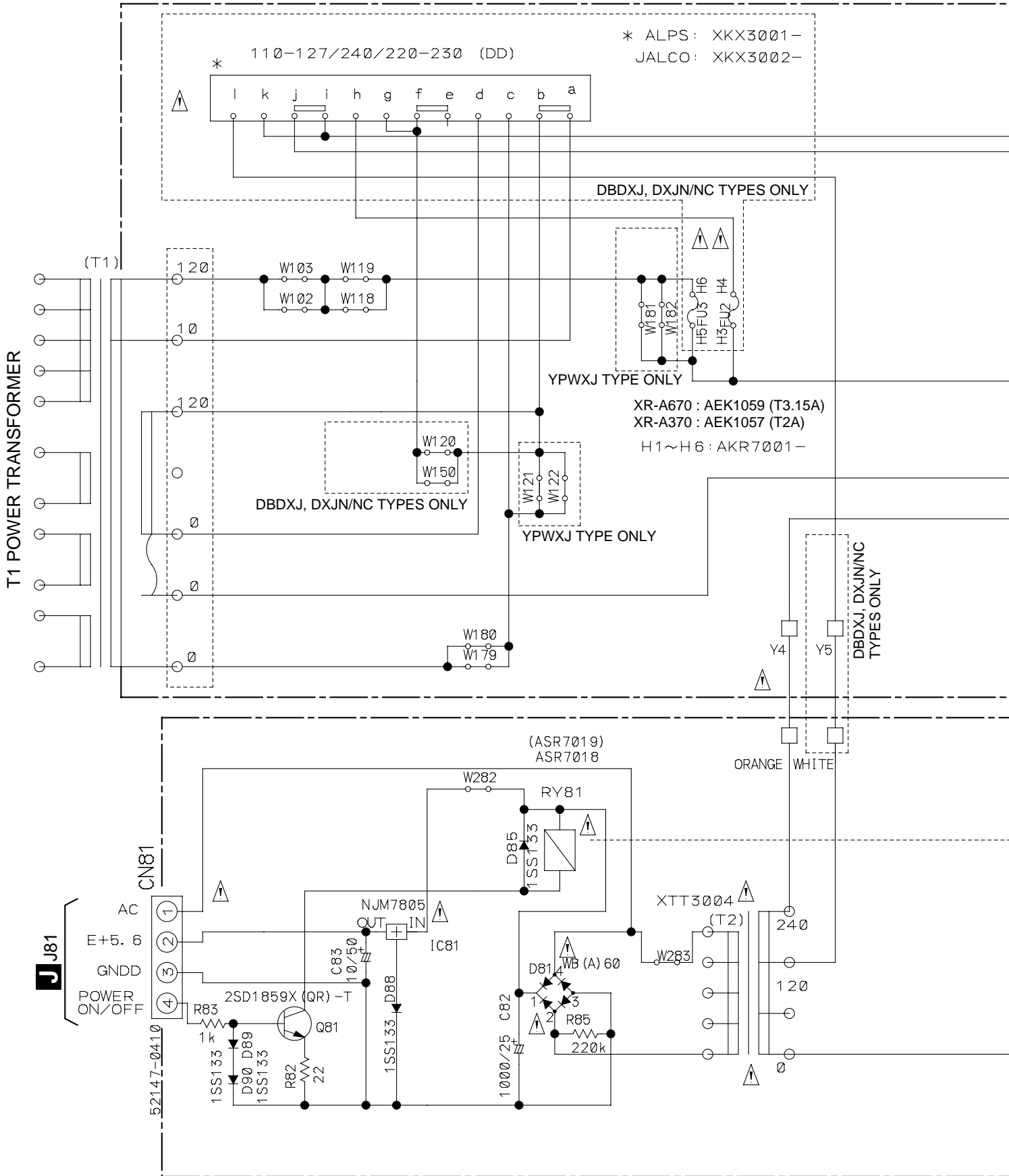

Note : When ordering service parts, be sure to refer to "EXPLODED VIEWS and PARTS LIST" or "PCB PARTS LIST"

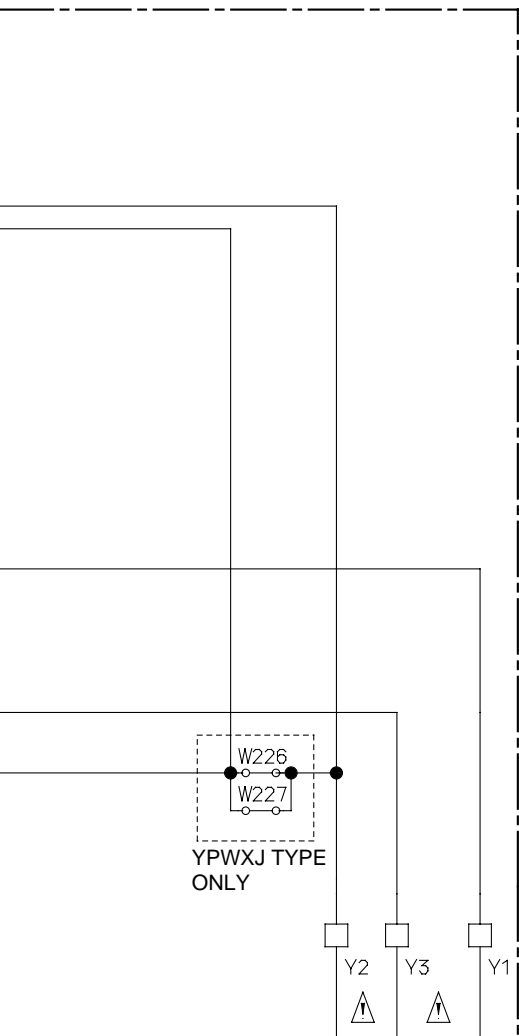

**PRIMARY ASSY**  
 (DBDXJ AND DXJN/NC TYPE : XWZ3222)  
 (YPWXJ TYPE : XWZ3223)

• NOTE FOR FUSE REPLACEMENT

**CAUTION** - FOR CONTINUED PROTECTION AGAINST RISK OF FIRE.  
 REPLACE WITH SAME TYPE AND RATINGS ONLY.

- Y3 BLUE XDX3007
- Y1 BROWN XDX3008
- Y4 ORANGE XDX3009
- Y2 GREY XDX3010
- Y5 WHITE XDX3011

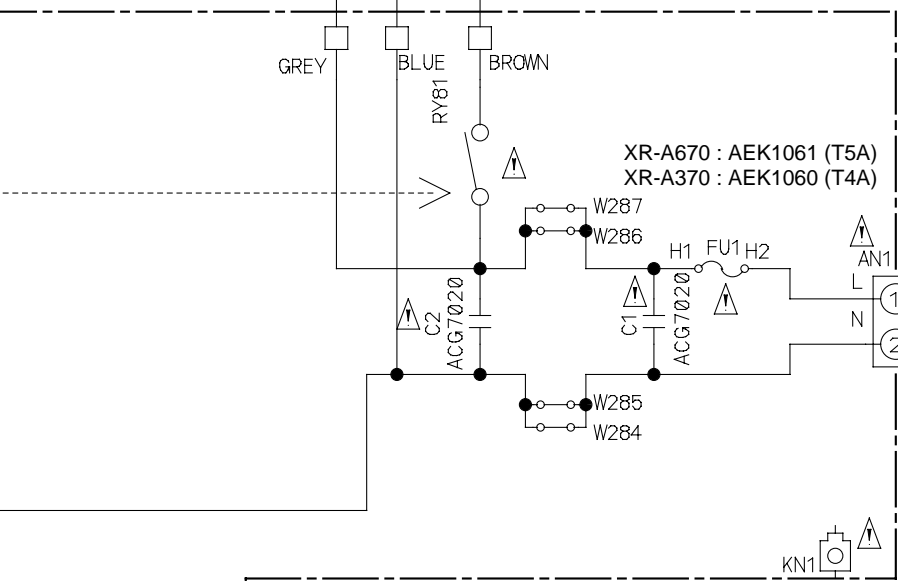

**SUB TRANS ASSY**  
 (XWZ3226)

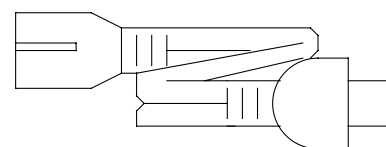

AC POWER CORD  
 DBDXJ TYPE : ADG1158  
 DXJN/NC TYPE : ADG1154  
 YPWXJ TYPE : ADG1160