

Service Manual

Pioneer

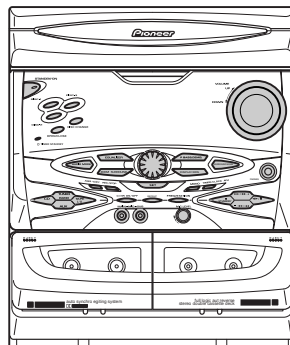

• XR-A6800

ORDER NO.
RRV2328

STEREO CD CASSETTE DECK RECEIVER

XR-A6800

XR-A4800

THIS MANUAL IS APPLICABLE TO THE FOLLOWING MODEL(S) AND TYPE(S).

Type	Model		Power Requirement	Remarks
	XR-A6800	XR-A4800		
MYXJ	○	○	AC220-230V	
NVXJ	-	○	AC230V	

CONTENTS

1. SAFETY INFORMATION	2	7. GENERAL INFORMATION	62
2. EXPLODED VIEWS AND PARTS LIST	3	7.1 DIAGNOSIS	62
3. BLOCK DIAGRAM AND SCHEMATIC DIAGRAM ...	16	7.1.1 DISASSEMBLY	62
4. PCB CONNECTION DIAGRAM	32	7.2 PARTS	65
5. PCB PARTS LIST	46	7.2.1 IC	65
6. ADJUSTMENT	53	7.2.2 DISPLAY	67
		8. PANEL FACILITIES AND SPECIFICATIONS	69

PIONEER CORPORATION 4-1, Meguro 1-chome, Meguro-ku, Tokyo 153-8654, Japan
PIONEER ELECTRONICS SERVICE, INC. P.O. Box 1760, Long Beach, CA 90801-1760, U.S.A.
PIONEER EUROPE NV Haven 1087, Keetberglaan 1, 9120 Melsele, Belgium
PIONEER ELECTRONICS ASIACENTRE PTE. LTD. 253 Alexandra Road, #04-01, Singapore 159936
 © PIONEER CORPORATION 2000

1. SAFETY INFORMATION

This service manual is intended for qualified service technicians ; it is not meant for the casual do-it-yourselfer. Qualified technicians have the necessary test equipment and tools, and have been trained to properly and safely repair complex products such as those covered by this manual. Improperly performed repairs can adversely affect the safety and reliability of the product and may void the warranty. If you are not qualified to perform the repair of this product properly and safely, you should not risk trying to do so and refer the repair to a qualified service technician.

— WARNING ! —

THE AEL (ACCESSIBLE EMISSION LEVEL) OF THE LASER POWER OUTPUT IS LESS THAN CLASS 1 BUT THE LASER COMPONENT IS CAPABLE OF EMITTING RADIATION EXCEEDING THE LIMIT FOR CLASS 1.
A SPECIALLY INSTRUCTED PERSON SHOULD DO SERVICING OPERATION OF THE APPARATUS.

— LASER DIODE CHARACTERISTICS —

MAXIMUM OUTPUT POWER: 5 mW
WAVELENGTH: 780 nm to 785 nm

LABEL CHECK (For MYXJ and NVXJ Types)

Printed on the Rear Panel

**CLASS 1
LASER PRODUCT**

MYXJ Type

VARO!
Avattaessa ja suojalukitus ohitetta-
essa olet alttiina näkymättömälle
lasersäteilylle. Älä katso säteeseen.
VARNING!
Osynlig laserstrålning när denna del
är öppnad och spärren är urkopplad.
Betrakta ej strålen. PRW1233

CAUTION
INVISIBLE LASER
RADIATION WHEN OPEN,
AVOID EXPOSURE
TO BEAM PRW1018

NVXJ Type

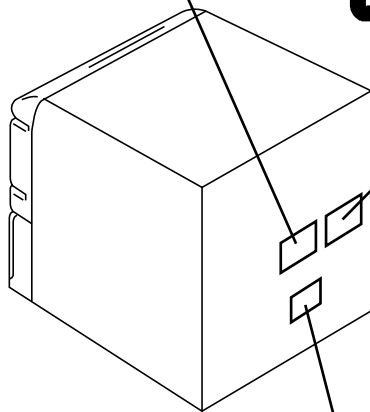

ADVARSEL
USYNLIG LASERSTRÅLING VED ÅBNING NÅR SIKKERHED SAF-
BRYDERE ER UDE AF FUNKTION.
UNDGÅ UDSÆTTELSE FOR STRÅLING
VORSICHT!
UNSIHTBARE LASER-STRÅHLUNG TRITTS AUS, WENN DECKEL
(ODER KLAPPE) GEÖFFNET IST! NICHT DEM STRAHL AUSSETZEN!
VRW1094

MYXJ Type

— Additional Laser Caution —

1. Laser Interlock Mechanism
The position of the switch (S9501) for detecting loading state is detected by the system microprocessor, and the design prevents laser diode oscillation when the switch (S9501) is pressed physically. Thus, the interlock will no longer function if the switch (S9501) is released physically and deliberately.
The interlock also does not function in the test mode *. Laser diode oscillation will continue, if pin 1 of CXA1821M (IC8101) on the CD ASSY mounted on the \$M Loading Mechanism assembly is connected to GND, or else the terminals of Q8101 are shorted to each other (fault condition).

2. When the cover is opened, close viewing of the objective lens with the naked eye will cause exposure to a Class 1 laser beam.

* : Refer to page 61.

2. EXPLODED VIEWS AND PARTS LIST

NOTES: ● Parts marked by "NSP" are generally unavailable because they are not in our Master Spare Parts List.
 ● The Δ mark found on some component parts indicates the importance of the safety factor of the part. Therefore, when replacing, be sure to use parts of identical designation.
 ● Screws adjacent to \blacktriangledown mark on the product are used for disassembly.

2.1 PACKING

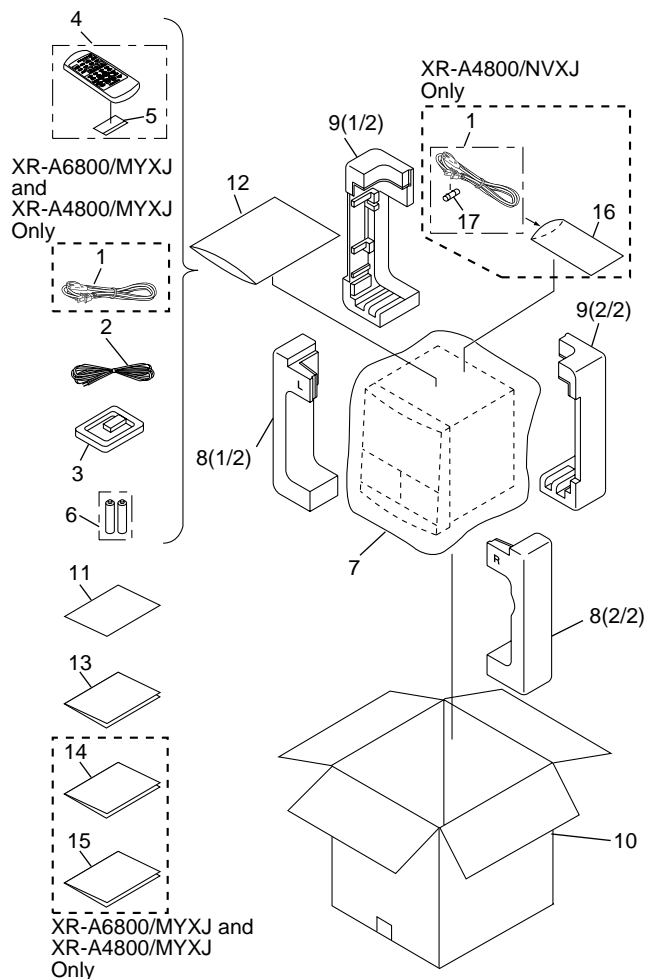

(1) PACKING PARTS LIST

Mark	No.	Description	Part No.
Δ	1	Power Cord	See Contrast table (2)
	2	FM Antenna	ADH7005
	3	AM Loop Antenna	XTB3001
	4	Remote Control Unit	XZN3106
	5	Battery Cover	XZN3103
NSP	6	Dry Cell Battery (R6P, AA)	VEM-013
	7	Packing Sheet	AHG7049
	8	Front Pad	XHA3018
	9	Rear Pad	XHA3019
	10	Packing Case	See Contrast table (2)
NSP	11	Warranty Card	ARY7022
	12	Polyethylene Bag (0.03 x 230 x 340)	Z21-038
	13	Operating Instructions (English/French)	XRE3030
	14	Operating Instructions (Italian/Dutch/German)	See Contrast table (2)
	15	Operating Instructions (Portuguese/Swedish/Spanish)	See Contrast table (2)
NSP	16	Polyethylene Bag	See Contrast table (2)
Δ	17	Fuse (T5A)	See Contrast table (2)

(2) CONTRAST TABLE

XR-A6800/MYXJ, XR-A4800/MYXJ and NVXJ are constructed the same except for the following :

Mark	No.	Symbol and Description	Part No.			Remarks
			XR-A6800/MYXJ	XR-A4800/MYXJ	XR-A4800/NVXJ	
Δ	1	Power Cord	ADG1154	ADG1154	ADG1156	
	10	Packing Case	XHD3143	XHD3142	XHD3142	
	14	Operating Instructions (Italian/Dutch/German)	XRC3020	XRC3020	Not used	
	15	Operating Instructions (Portuguese/Swedish/Spanish)	XRC3021	XRC3021	Not used	
NSP	16	Polyethylene Bag	Not used	Not used	AHG7033	
Δ	17	Fuse (T5A)	Not used	Not used	AEK7001	

2.2 EXTERIOR SECTION

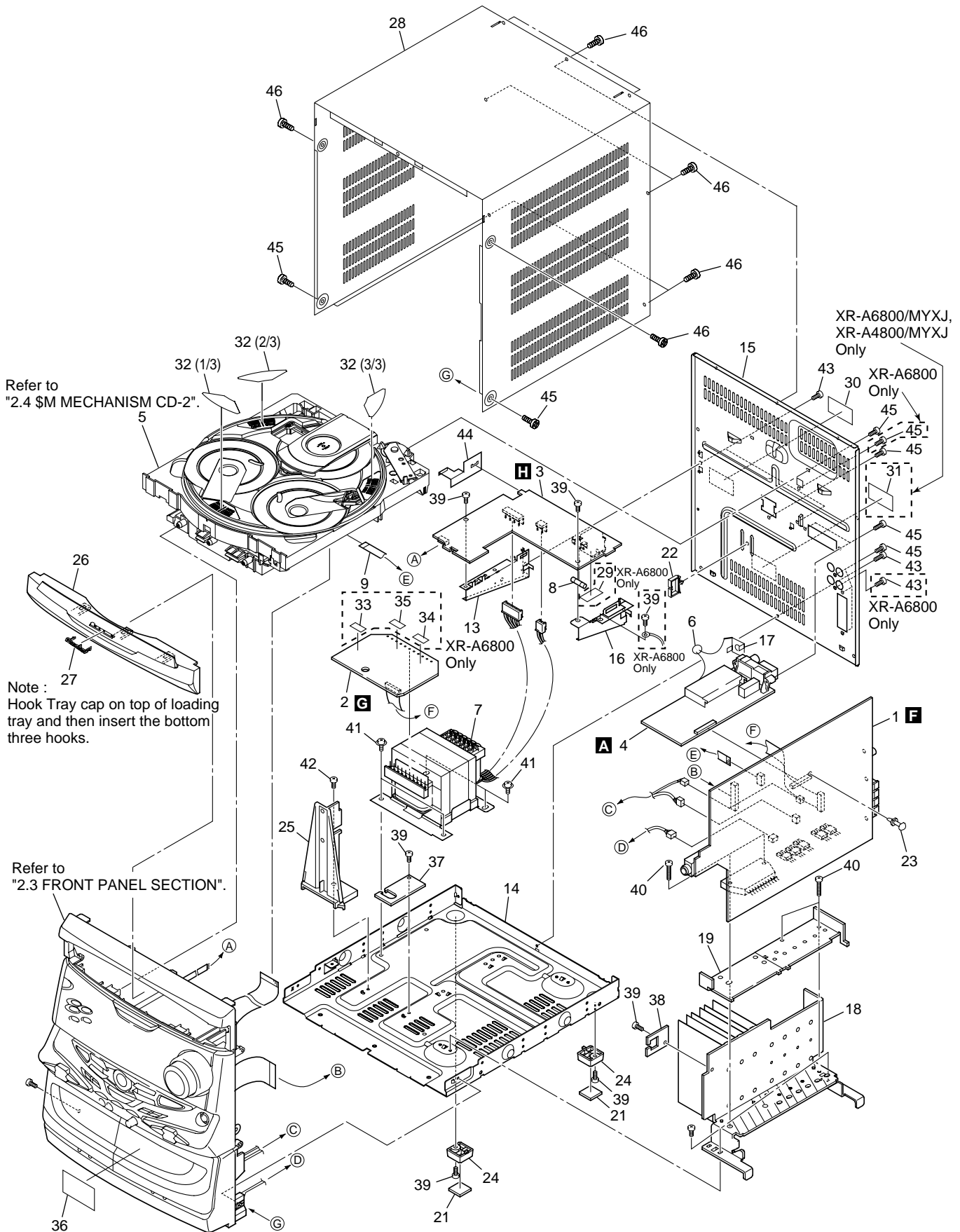

(1) EXTERIOR SECTION PARTS LIST

Mark	No.	Description	Part No.	Mark	No.	Description	Part No.
	1	AF Assy	See Contrast table (2)		26	Tray Cap Assy	XAK3156
	2	SECONDARY Assy	See Contrast table (2)		27	Pioneer Badge	XAM3001
	3	PRIMARY Assy	See Contrast table (2)		28	Bonnet Case	XZN3098
	4	FM/AM TUNER Module	AXQ7068	NSP	29	Fuse Card	See Contrast table (2)
NSP	5	\$M MECHANISM CD-2	See Contrast table (2)		30	Caution Label HE	See Contrast table (2)
△	6	Ceramic Capacitor (C1)	CKPUYB102K50		31	Caution Label	See Contrast table (2)
△	7	Power Transformer (T1)	See Contrast table (2)		32	Disc Label	XAX3127
△	8	Fuse (FU2)	See Contrast table (2)		33	ICP Label	See Contrast table (2)
	9	Flexible Cable (08P)	XDD3048		34	ICP Label	See Contrast table (2)
	10	•••••			35	ICP Label	See Contrast table (2)
	11	•••••		NSP	36	Getter	See Contrast table (2)
	12	•••••		NSP	37	DO NOT THROW Assy	•••••
	13	PCB Bracket	ANG7263	NSP	38	CABLE HOLDER Assy	•••••
NSP	14	Chassis	XNA3005		39	Screw	BBZ30P080FMC
	15	Rear Panel	See Contrast table (2)		40	Screw	BBZ30P180FMC
	16	PCB Bracket	XNG3006		41	Screw	ASZ40P060FMC
	17	Earth Plate	XNG3015		42	Screw	BPZ30P080FMC
	18	Heat Sink	See Contrast table (2)		43	Screw	VBZ30P080FZK
	19	Sub Heat Sink B	XNH3012		44	Barrier	XEC3013
	20	•••••			45	Screw	BPZ30P100FZK
	21	Cushion Leg A	XEB3008		46	Screw	VBT30P080FZK
	22	Wire Clip A	XEC3003				
	23	Card Spacer	XEC3008				
	24	Leg	XMR3012				
	25	SEC Holder A	See Contrast table (2)				

(2) CONTRAST TABLE

XR-A6800/MYXJ, XR-A4800/MYXJ and NVXJ are constructed the same except for the following :

Mark	No.	Symbol and Description	Part No.			Remarks
			XR-A6800/MYXJ	XR-A4800/MYXJ	XR-A4800/NVXJ	
NSP	1	AF Assy	XWZ3310	XWZ3297	XWZ3297	
	2	SECONDARY Assy	XWZ3304	XWZ3289	XWZ3289	
	3	PRIMARY Assy	XWZ3312	XWZ3299	XWZ3299	
	5	\$M MECHANISM CD-2	XXA3012	XXA3009	XXA3009	
△	7	Power Transformer (T1)	XTS3037	XTS3036	XTS3036	
△	8	Fuse (FU2)	AEK1061 (T5A)	AEK1060 (T4A)	AEK1060 (T4A)	
NSP	15	Rear Panel	XNC3058	XNC3053	XNC3053	
	18	Heat Sink	XNH3010	XNH3009	XNH3009	
	25	SEC Holder A	XMR3014	XMR3015	XMR3015	
	29	Fuse Card	AAX7098	Not used	Not used	
	30	Caution Label HE	PRW1233	PRW1233	PRW1018	
	31	Caution Label	VRW1094	VRW1094	Not used	
	33	ICP Label	XAX3121	Not used	Not used	
NSP	34	ICP Label	XAX3153	Not used	Not used	
	35	ICP Label	XAX3158	Not used	Not used	
	36	Getter	XAX3169	XAX3163	XAX3163	

2.3 FRONT PANEL SECTION

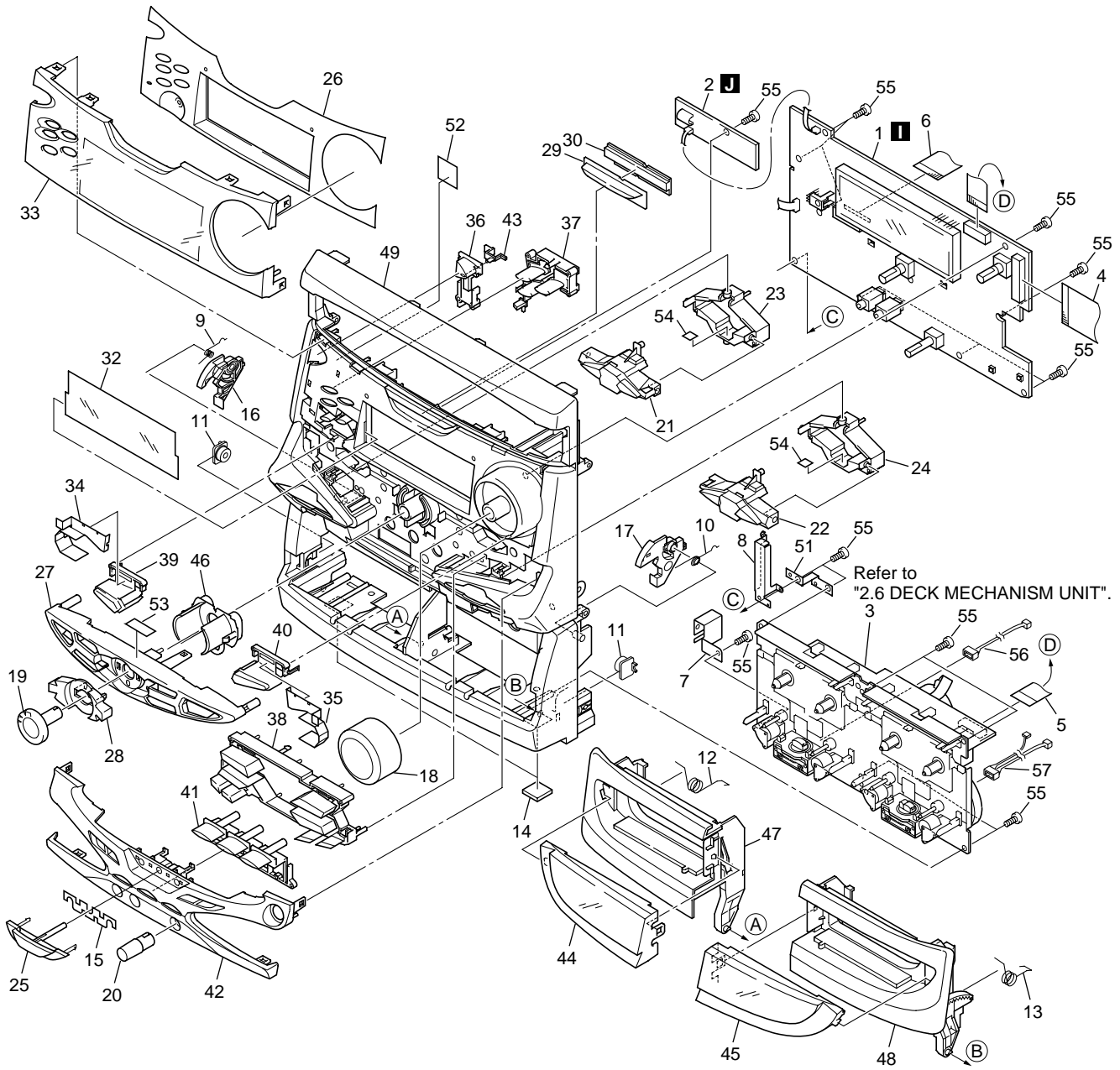

(1) FRONT PANEL SECTION PARTS LIST

Mark	No.	Description	Part No.	Mark	No.	Description	Part No.
	1	DISPLAY Assy	See Contrast table (2)	31	•••••		
	2	BLUE LED Assy	XWZ3292	32	FL Filter	XAK3162	
	3	Deck Mechanism Unit	XYM3012	33	FL Cover	XAK3163	
	4	Flexible Cable 27P	XDD3041	34	Cover Sheet L	XAK3184	
	5	Flexible Cable 15P	XDD3050	35	Cover Sheet R	XAK3185	
	6	Flexible Cable 19P	XDD3051	36	Power Button	See Contrast table (2)	
	7	GND Plate B	XNG3031	37	CD Button	XAD3045	
	8	GND Plate C	See Contrast table (2)	38	SC Button	XAD3046	
	9	Ratch Spring_L	ABH7130	39	SC Button L	XAD3047	
	10	Ratch Spring_R	ABH7131	40	SC Button R	XAD3048	
	11	Damper Assy	XXA3025	41	DOLBY Button	XAD3054	
	12	Door Spring_L	XBH3010	42	Sub Panel	See Contrast table (2)	
	13	Door Spring_R	XBH3011	43	ST Lens	XAK3151	
	14	Cushion Leg A	XEB3008	44	Deck Lens L	XAK3159	
	15	Cushion Spring	XEB3010	45	Deck Lens R	XAK3160	
	16	Ratch Mold_L	XMR3001	46	JOG Conductor	XAK3165	
	17	Ratch Mold_R	XMR3002	47	Deck Door_L	See Contrast table (2)	
	18	Volume Knob	XAA3013	48	Deck Door_R	See Contrast table (2)	
	19	JOG Knob	XAA3015	49	Front Panel	XMB3026	
	20	MIC Knob	XAB3007	50	•••••		
	21	FUNC Button L	See Contrast table (2)	51	GND Plate A	See Contrast table (2)	
	22	FUNC Button R	See Contrast table (2)	52	Spacer	XEB3012	
	23	FUNC Frame L	XAD3052	53	Spacer	XEB3013	
	24	FUNC Frame R	XAD3053	54	Spacer	XEB3011	
	25	CD ENT Button	XAD3055	55	Screw	BPZ30P080FMC	
	26	Display Panel	See Contrast table (2)	56	Connector Assy 3P	XDE3037	
	27	EQ Panel	See Contrast table (2)	57	Connector Assy 5P	XDE3038	
	28	JOG Lens	XAK3152				
	29	V Lens	XAK3153				
	30	LT Conductor	XAK3155				

(2) CONTRAST TABLE

XR-A6800/MYXJ, XR-A4800/MYXJ and NVXJ are constructed the same except for the following :

Mark	No.	Symbol and Description	Part No.			Remarks
			XR-A6800/MYXJ	XR-A4800/MYXJ	XR-A4800/NVXJ	
	1	DISPLAY Assy	XWZ3311	XWZ3298	XWZ3298	
	8	GND Plate C	XNG3047	Not used	Not used	
	21	FUNC Button L	XAD3050	XAD3076	XAD3076	
	22	FUNC Button R	XAD3051	XAD3077	XAD3077	
	26	Display Panel	XAK3130	XAK3125	XAK3125	
	27	EQ Panel	XAK3150	XAK3149	XAK3149	
	36	Power Button	XAD3044	XAD3043	XAD3043	
	42	Sub Panel	XAK3142	XAK3137	XAK3137	
	47	Deck Door_L	XAN3022	XAN3021	XAN3021	
	48	Deck Door_R	XAN3026	XAN3025	XAN3025	
	51	GND Plate A	Not used	XNG3030	XNG3030	

2.4 \$M MECHANISM CD-2

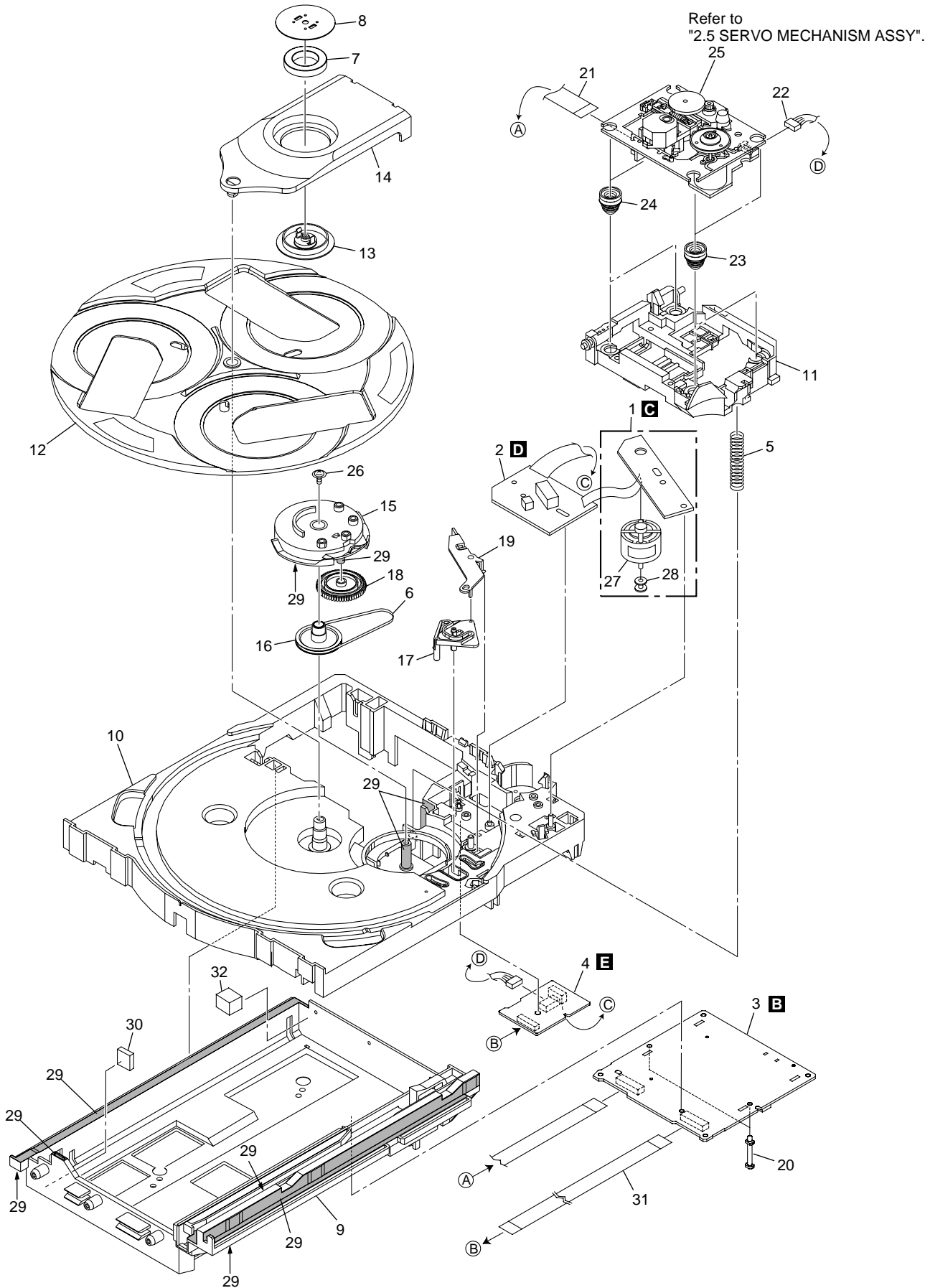

(1) \$M MECHANISM CD-2 PARTS LIST

Mark	No.	Description	Part No.	Mark	No.	Description	Part No.
	1	MOTOR Assy	XWZ3230		16	Gear Pulley	ANW7094
	2	SW Assy	XWZ3231		17	Lock Lever	ANW7095
	3	CD Assy	See Contrast table (2)		18	Planet Gear	ANW7096
	4	TRADE Assy	XWZ3232		19	Actuator	ANW7097
	5	Servo Spring	ABH7126		20	Mini Card Spacer	AEC7143
	6	Belt	AEB7072		21	16P 200 Flexible Cable/60V	XDD3036
	7	Clamp Magnet	AMF7001		22	Connector Assy (6P)	ADE7010
	8	Yoke	ANB7216		23	Float Rubber A	AEB7063
	9	Mecha Base	XNW3011		24	Float Rubber B	AEB7066
	10	Loading Tray	XNW3002		25	Servo Mechanism Assy	XXA3010
	11	Traverse Base	XNW3006		26	Screw	IPZ30P080FMC
	12	Rotary Tray	ANW7124		27	Carriage Motor	VXM1033
	13	Clamper	XNW3007		28	Motor Pulley	PNW1634
	14	Clamper Holder	XNW3004		29	Ha Narl	GEM1016
	15	Main Cam	ANW7093		30	Cushion Rubber	XEB3005
					31	11P 185 Flexible Cable/30V	XDD3037
					32	Cushion Rubber	XEB3007

(2) CONTRAST TABLE

\$M MECHANISM CD-2 (XXA3012) and (XXA3009) are constructed the same except for the following :

Mark	No.	Symbol and Description	Part No.		Remarks
			XXA3012 (XR-A6800)	XXA3009 (XR-A4800)	
	3	CD Assy	XWZ3233	XWZ3229	

2.5 SERVO MECHANISM ASSY

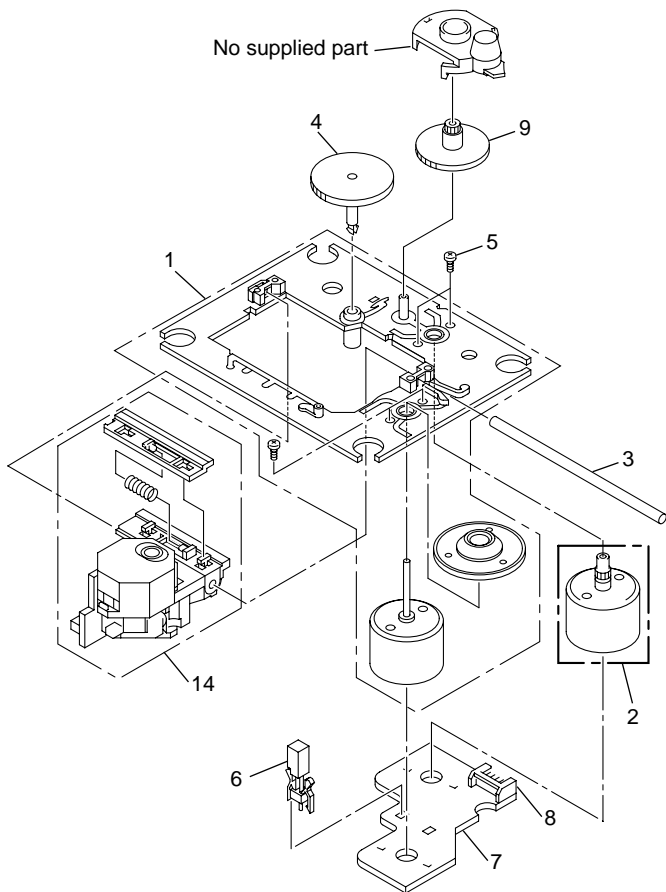

● SERVO MECHANISM ASSY PARTS LIST

Mark	No.	Description	Part No.
NSP	1	Motor Chassis Assy	•••••
	2	Motor Gear Assy	X-2625-769-(1)
	3	Sled Shaft	2-626-908-(01)
	4	Gear (A)(S)	2-625-188-(02)
NSP	5	Screw +P2*3	•••••
	6	Leaf Switch	1-572-085-(11)
	7	Motor(6p)(S)PCB	1-639-678-(12)
	8	Connector Pin 6p	1-564-722-(11)
	9	Gear(B)(RP)	2-627-003-(01)
	10	•••••	
	11	•••••	
	12	•••••	
	13	•••••	
	14	KSS-213C(Pick-up)	8-848-483-(05)

2.6 DECK MECHANISM UNIT

• DECK MECHANISM UNIT (1/2)

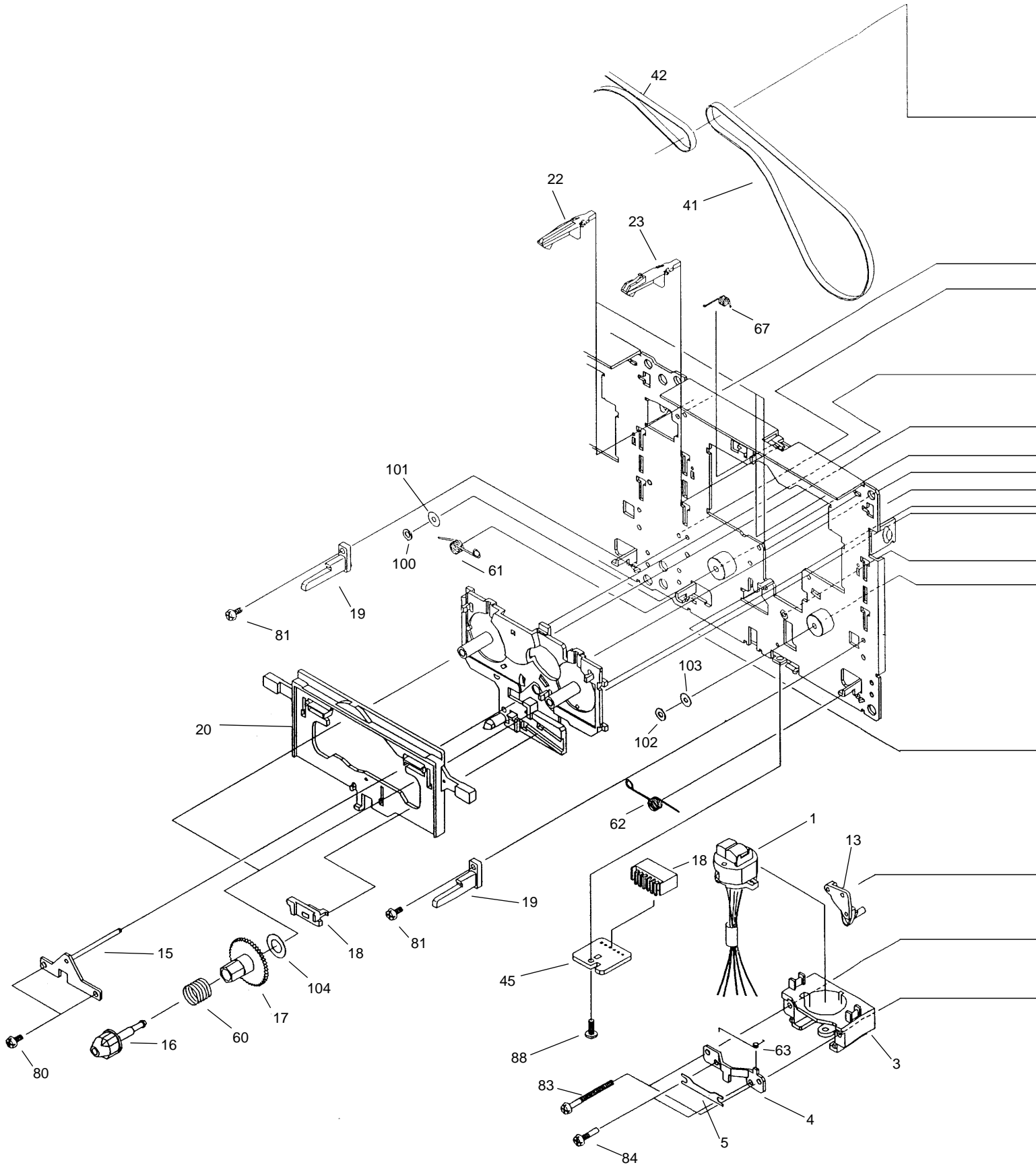

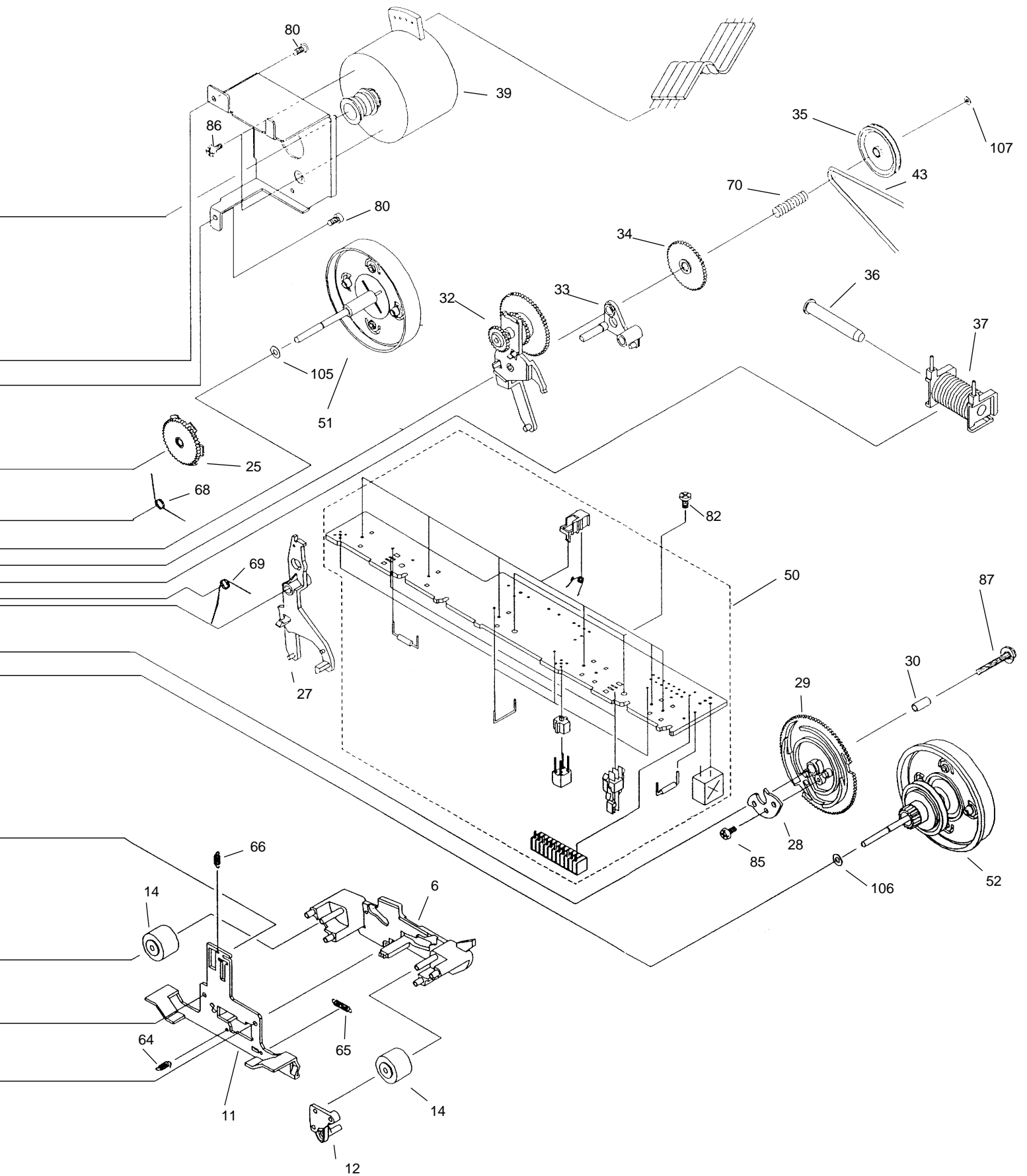

• DECK MECHANISM UNIT (2/2)

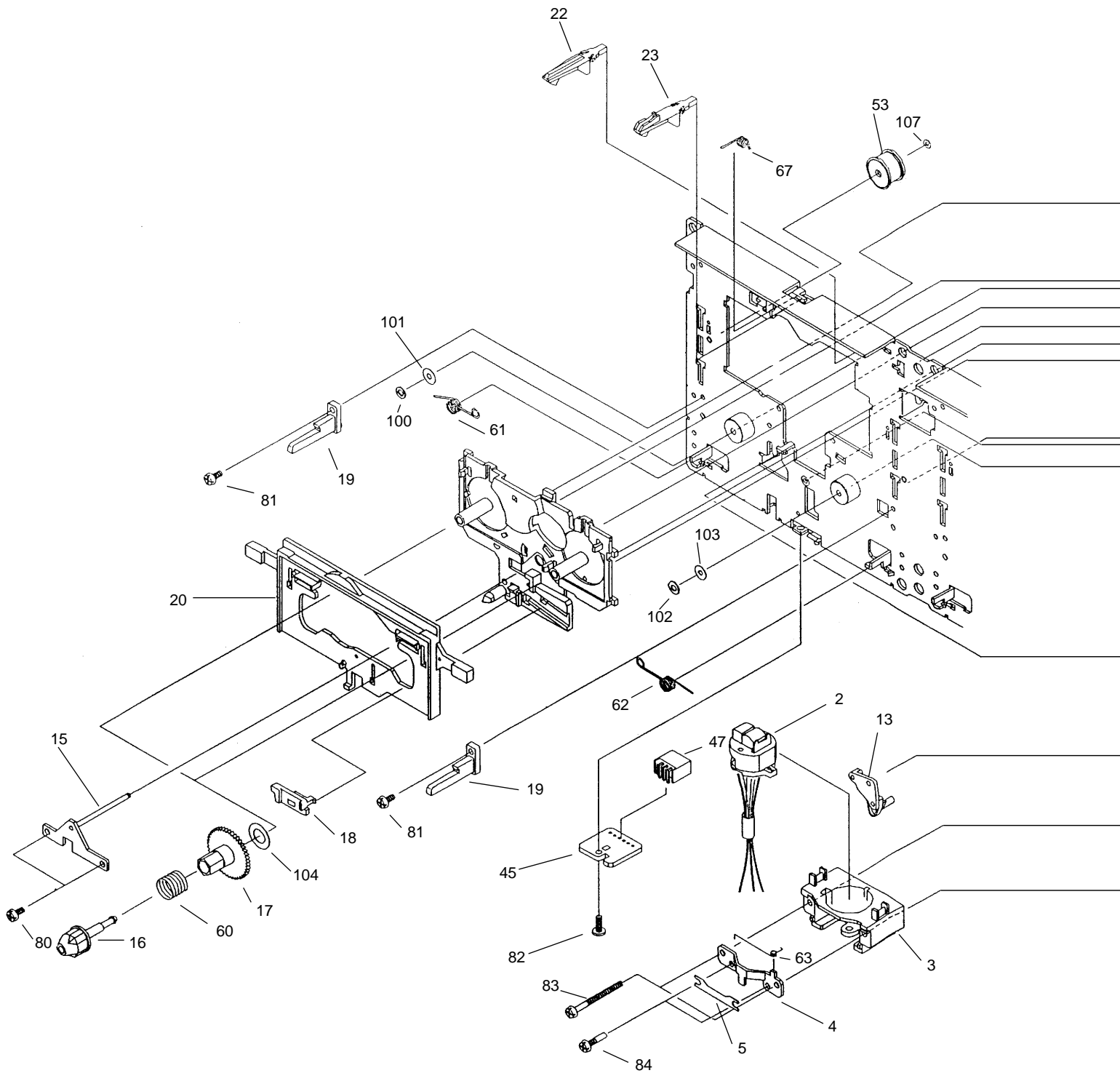

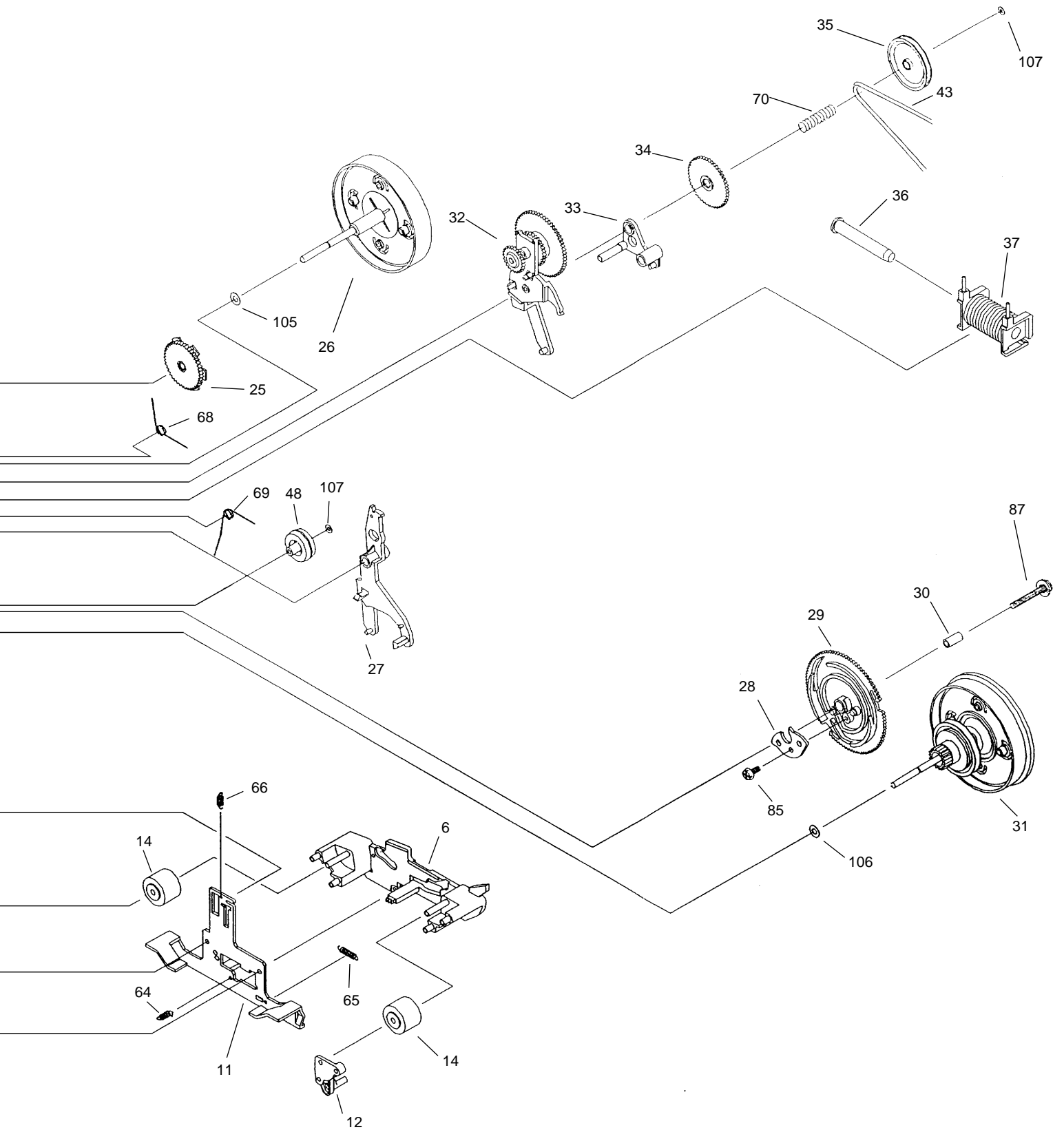

● DECK MECHANISM UNIT PARTS LIST

Mark	No.	Description	Part No.	Mark	No.	Description	Part No.
	1	Assy'y HD Holder	50-093-4373		60	Spring	01-081-4601
	2	Assy'y HD Holder	50-093-4104				
	3	Frame HD	50-219-3024		61	Spring	01-082-4652
	4	Plate AZ	50-119-4046		62	Spring	01-082-4651
	5	Spring AZ	50-160-4108		63	Spring	01-082-4650
					64	Spring	01-080-4649
	6	Lever HD	50-259-3342		65	Spring	01-080-4607
	11	Chassis HD	50-112-3045		66	Spring	01-080-4635
	12	Cap Pinch R	50-219-4033		67	Spring	01-082-4654
	13	Cap Pinch L	50-219-4034		68	Spring	01-082-4598
	14	Roller Pinch	50-027-41054		69	Spring	01-082-4597
	15	Ass'y Plate D	50-219-4311		70	Spring	01-081-4657
	16	Cap Reel	50-228-4020		80	Screw	GSE10A2003
	17	Gear Reel	50-222-4006				
	18	Lever ST	50-259-4041		81	Screw	GSE20A2005
	19	Guide C	50-219-4014		82	Screw	GSE10A2004
	20	Lever Brake	50-259-3251		83	Screw	GSD10A2018
					84	Screw	03-300-4056
					85	Screw	GSL10A1704
	22	Arm SW	50-239-4027				
	23	Arm CS	50-239-4026		86	Screw	GSP10A2603
	25	Ass'y Cover	50-093-4063		87	Screw	GSP11A2012
					88	Screw	GSE20A2004
	26	Ass'y Flywheel LA	50-093-3366				
	27	Arm Trigger	50-268-3016				
	28	Arm Cam	50-139-4292		100	Washer	GWN21X040040
	29	Gear Cam	50-221-3009				
	30	Coller	03-300-4455		101	Washer	GWM19X055035S
					102	Washer	GWM19S035035
	31	Ass'y Flywheel RA	50-093-3360		103	Washer	GWM17S050035S
	32	Ass'y Clutch	50-093-4069		104	Washer	GWM48X075010
	33	Arm UD A	50-239-4017		105	Washer	GWP23X040020
	34	Gear UD	50-222-4007				
	35	Pulley D	50-223-4254		106	Washer	GWP21X045020
					107	Washer	GWP12X030040S
	36	Plunger	03-300-4442				
	37	Ass'y Bobbin	50-093-4125				
	39	Ass'y Motor	50-093-4316				
	41	Belt BR	02-084-4205				
	42	Belt AR	02-084-4203				
	43	Belt FR	02-083-4188				
	45	PCB HD	50-070-4057				
	46	Housing	S5BPHKS				
	47	Housing	S3BPHKS				
	48	Pulley IDL	50-223-4023				
	50	Ass'y PCB	50-093-4363				
	51	Ass'y Flywheel L	50-093-3367				
	52	Ass'y Flywheel RB	50-093-3361				
	53	Pulley	33-229-4264				

3. BLOCK DIAGRAM AND SCHEMATIC DIAGRAM

3.1 BLOCK DIAGRAM and OVERALL WIRING DIAGRAM

A

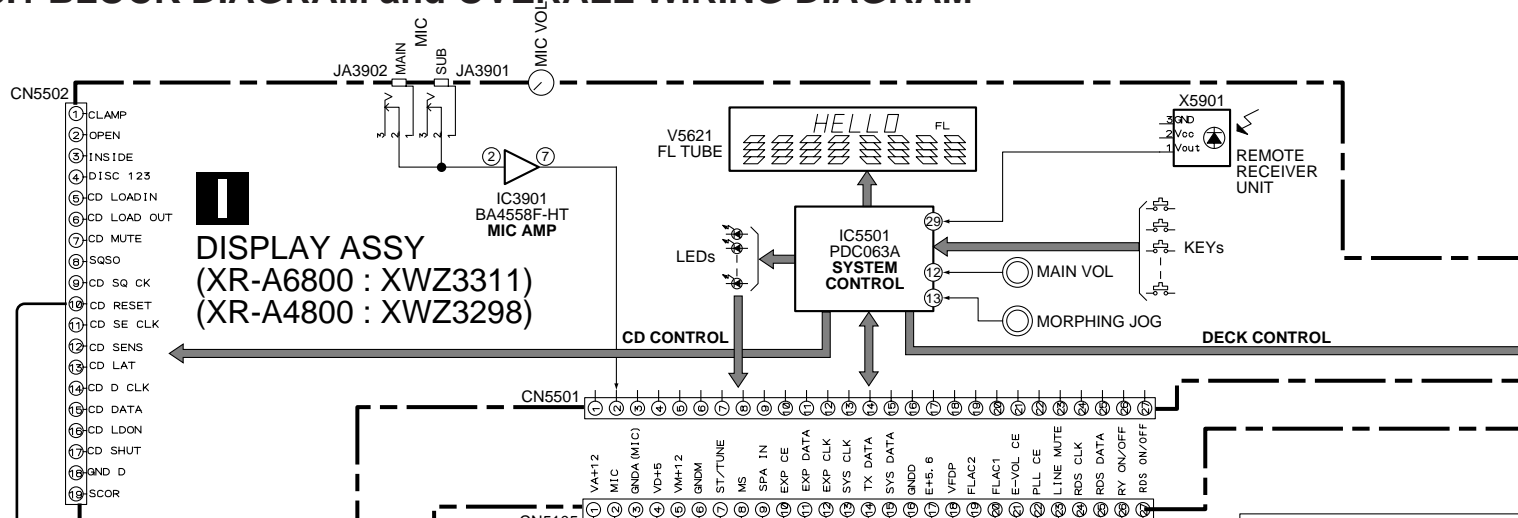

B

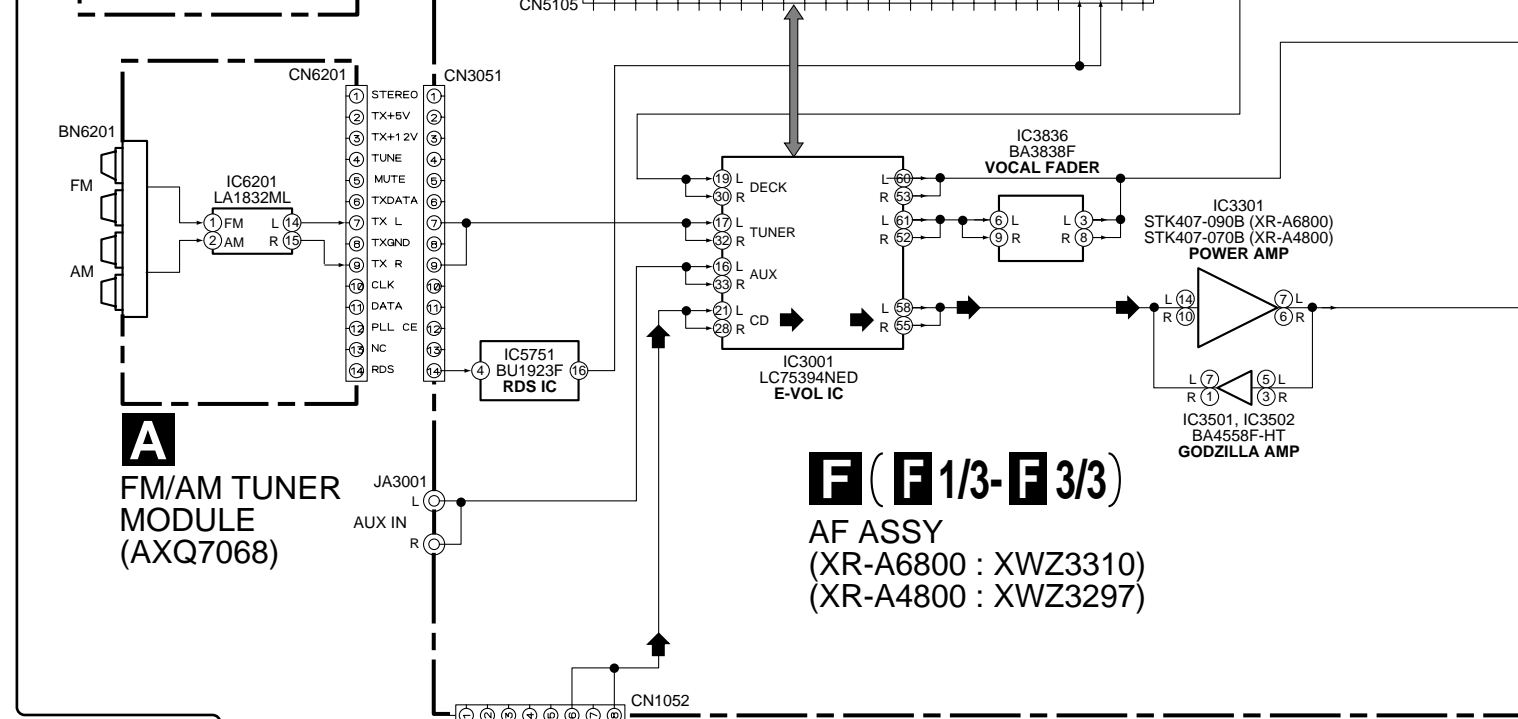

C

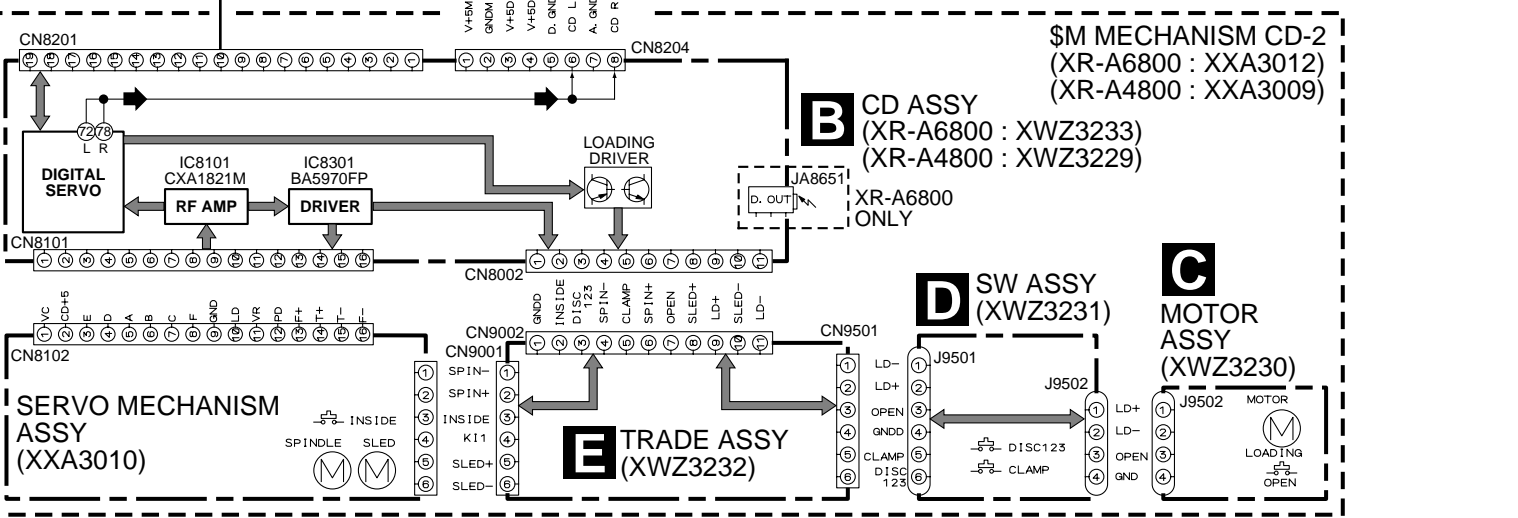

Note : When ordering service parts, be sure to refer to "EXPLODED VIEWS and PARTS LIST" or "PCB PARTS LIST".

J BLUE LED ASSY (XWZ3292)

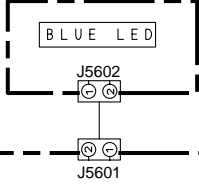

DECK MECHANISM UNIT (XYM3012)

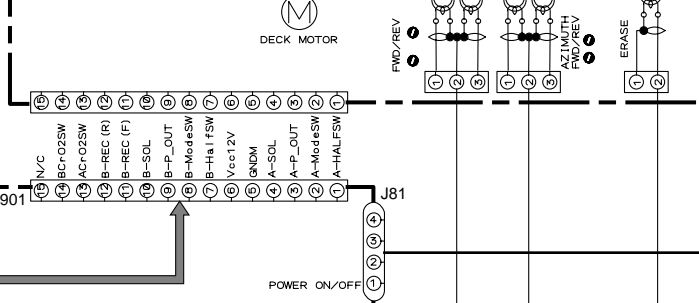

➔ : AUDIO SIGNAL ROUTE (CD)

XR-A6800 ONLY

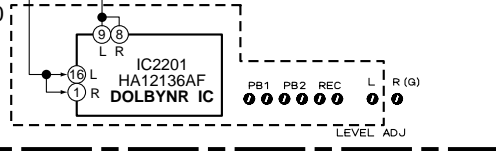

G SECONDARY ASSY (XR-A6800 : XWZ3304) (XR-A4800 : XWZ3289)

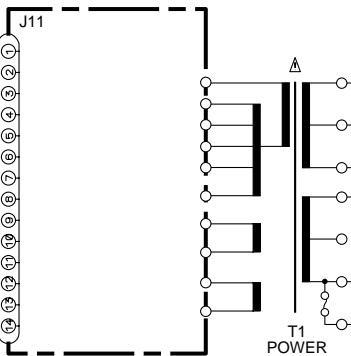

H PRIMARY ASSY (XR-A6800 : XWZ3312) (XR-A4800 : XWZ3299)

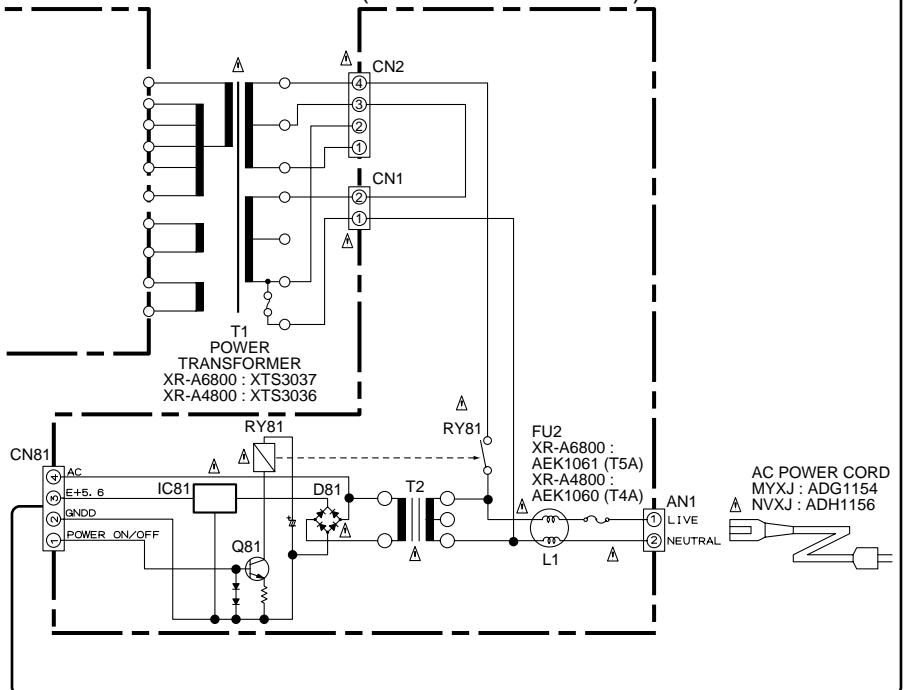

A
B
C
D

3.2 FM/AM TUNER MODULE

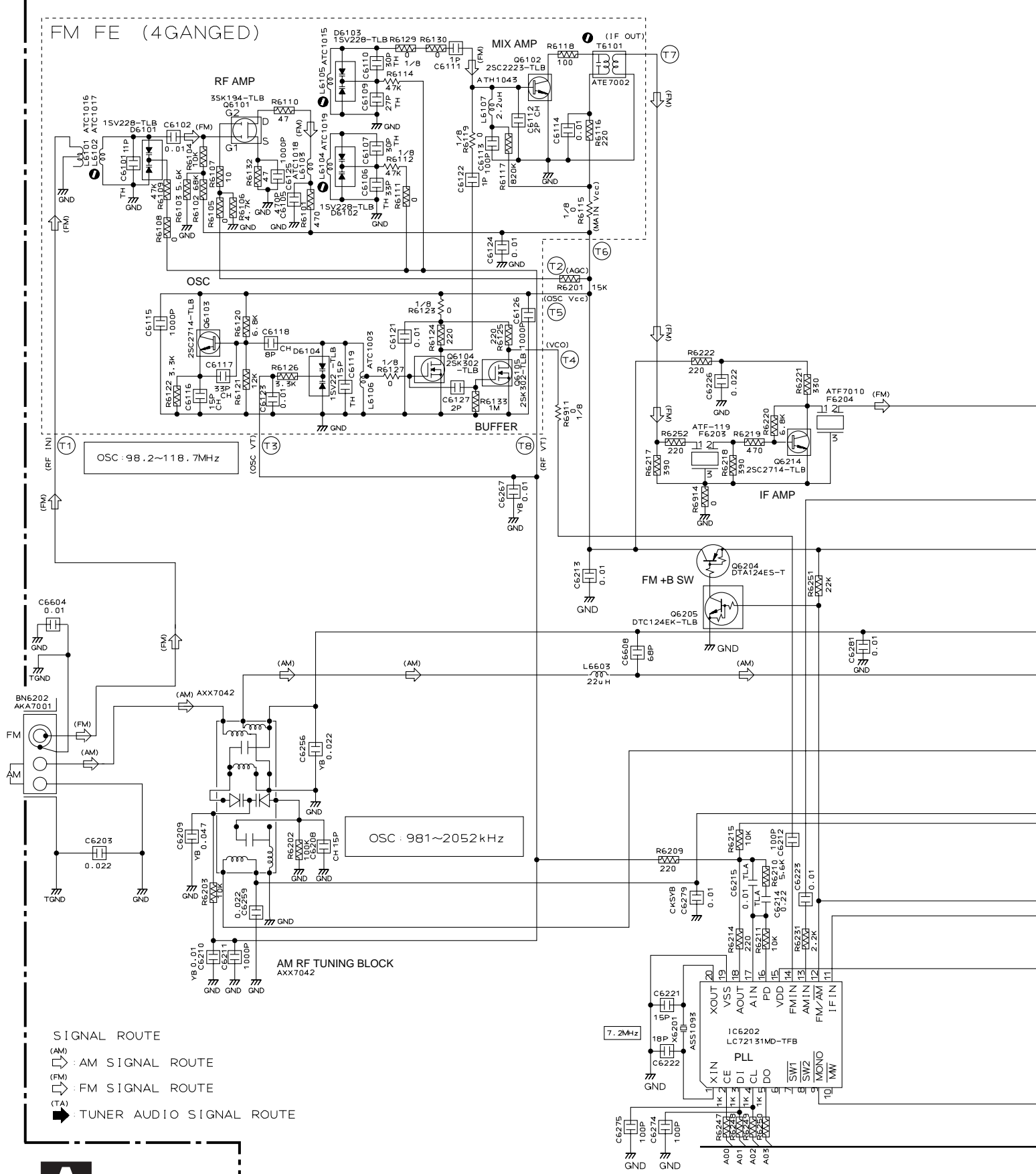

A FM/AM TUNER MODULE (AXQ7068)

O : The power supply is shown with the marked box.

Notes

1. RESISTORS

Indicated in Ω , 1/10W±5% Tolerance unless otherwise noted K:K Ω , M:M Ω .

2. CAPACITORS

Indicated in Capacity (μ F)/VOLTAGE (V) unless otherwise noted P:PF.

3. DIODES

No mark diode is 1SS254.

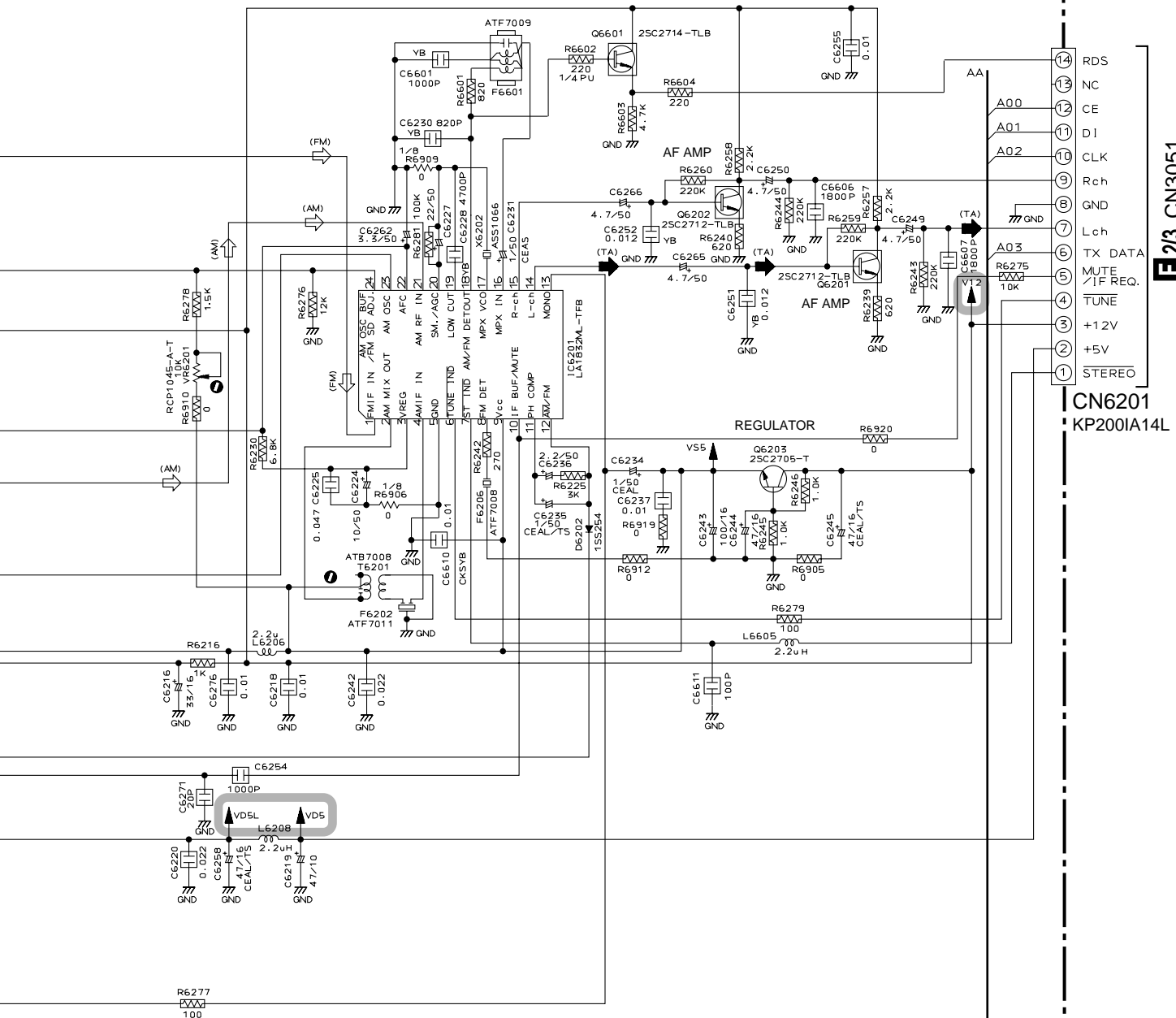

F 2/3 CN3051

CN6201
KP200IA14L

: The power supply is shown with the marked box.

- : CD AUDIO SIGNAL ROUTE
- : SPINDLE MOTOR ROUTE
- : FOCUS SERVO LOOP LINE
- : CARRIAGE MOTOR ROUTE
- : TRACKING SERVO LOOP LINE
- : LOADING MOTOR ROUTE

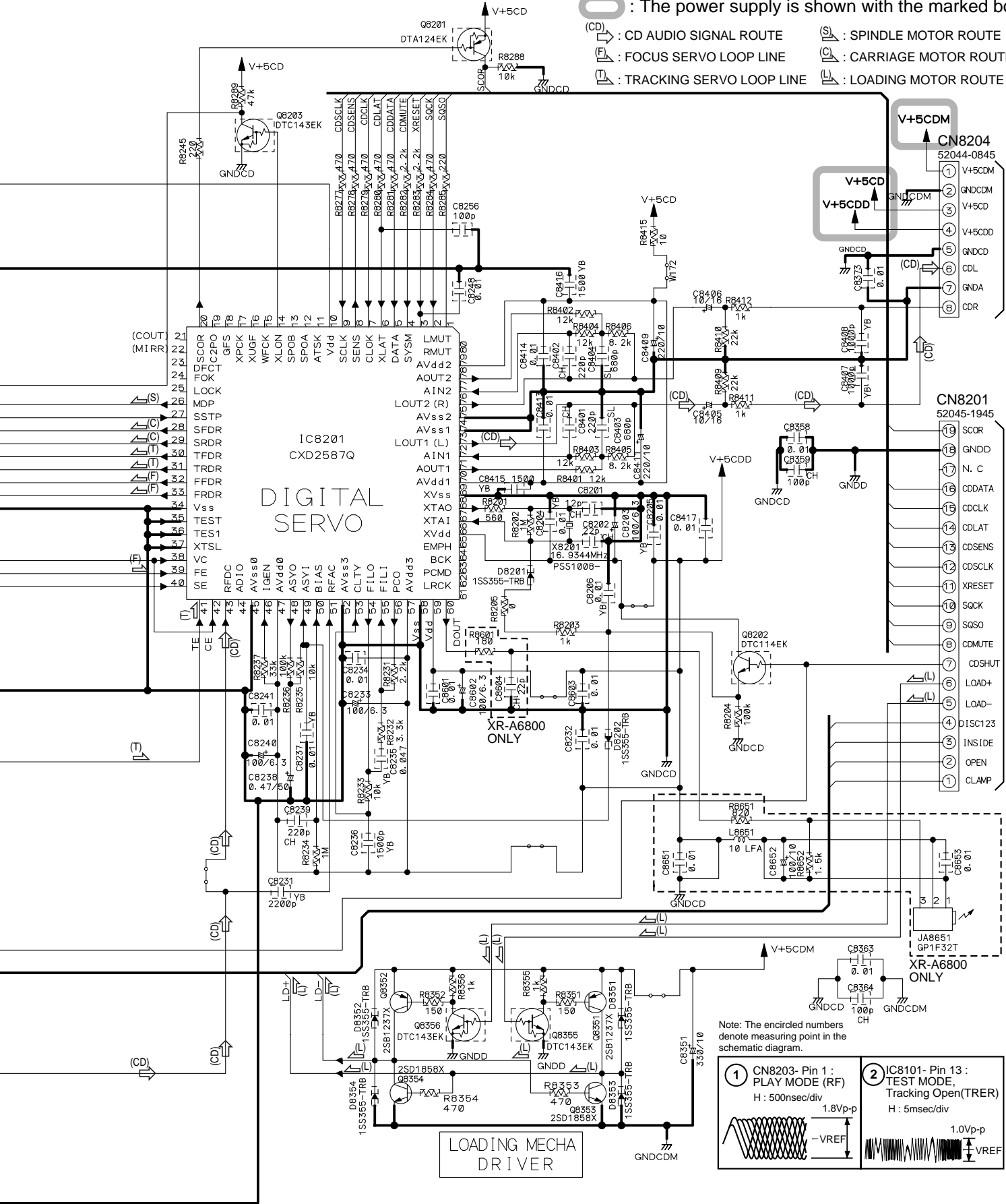

F 2/3 CN1052

I CN5502

Note: The circled numbers denote measuring point in the schematic diagram.

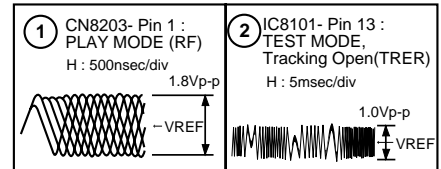

B

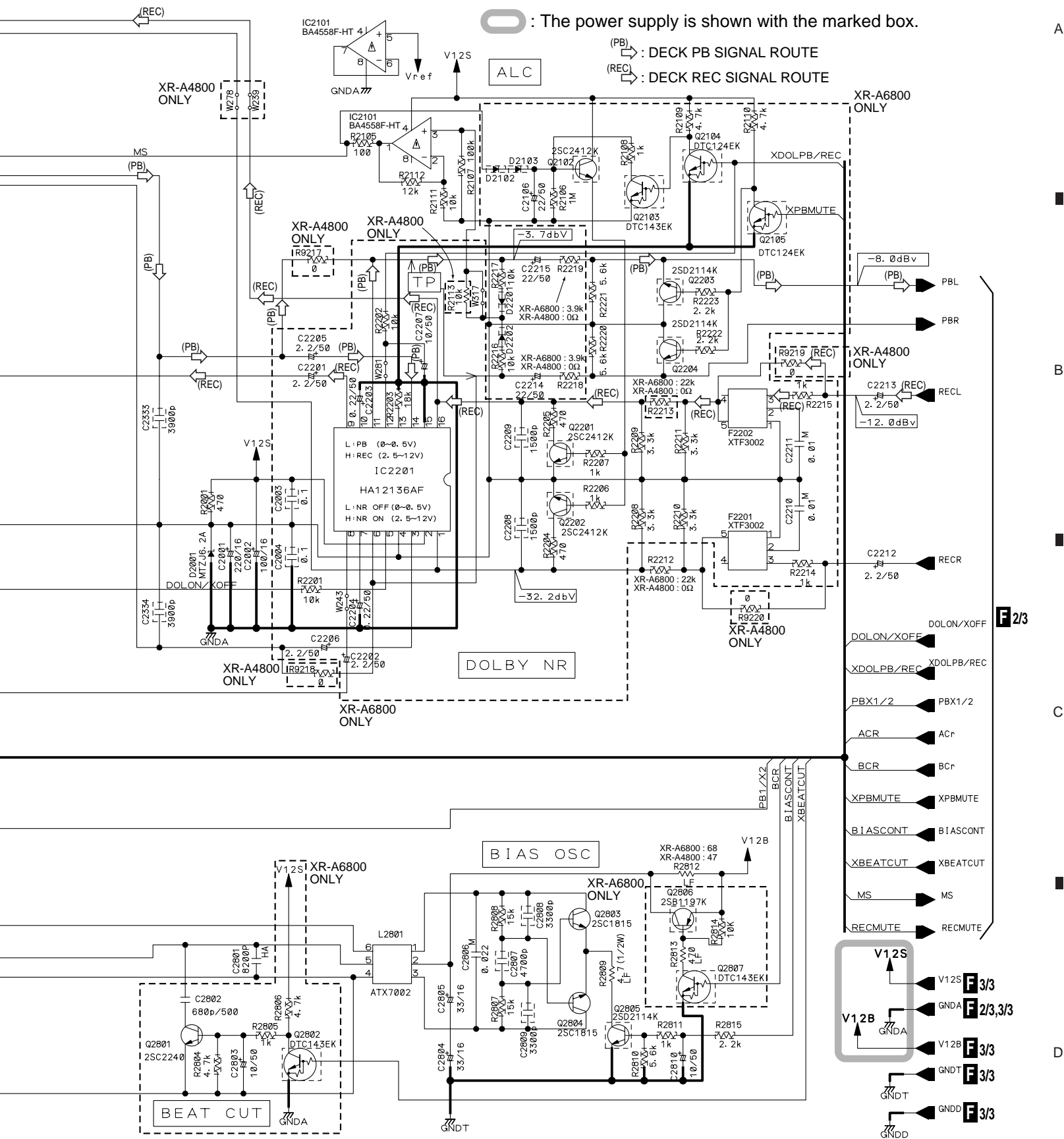

○ : The power supply is shown with the marked box.

(PB) : DECK PB SIGNAL ROUTE

(REC) : DECK REC SIGNAL ROUTE

A

B

C

D

F 2/3

F 1/3

3.5 AF ASSY (2/3)

F 2/3 AF ASSY
 (XR-A6800 : XWZ3310)
 (XR-A4800 : XWZ3297)

B CN8204

F 3/3

NOTES

- ALL CAPACITORS ARE IN #F
- UNLESS OTHERWISE SPECIFIED
- TL : CFTLA
- M : COMBA
- (OTHER : KCVF)
- CH : CCSRCH
- SL : CCSRSL
- (OTHER : CKSRYB)
- JA : CEJA
- AL : CEAL
- HAQ : CEHAQ
- (OTHER : CEAS###orCEAT###)
- ALL RESISTORS ARE IN Ω
- ∇ : 1/16W (CHIP)
- \sim : 1/4WPU
- ALL INDUCTORS ARE IN μ H
- LAU

CN1 052
 52045-0845

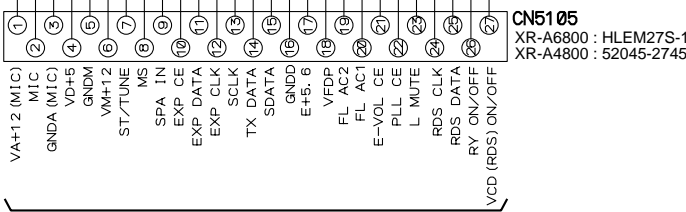
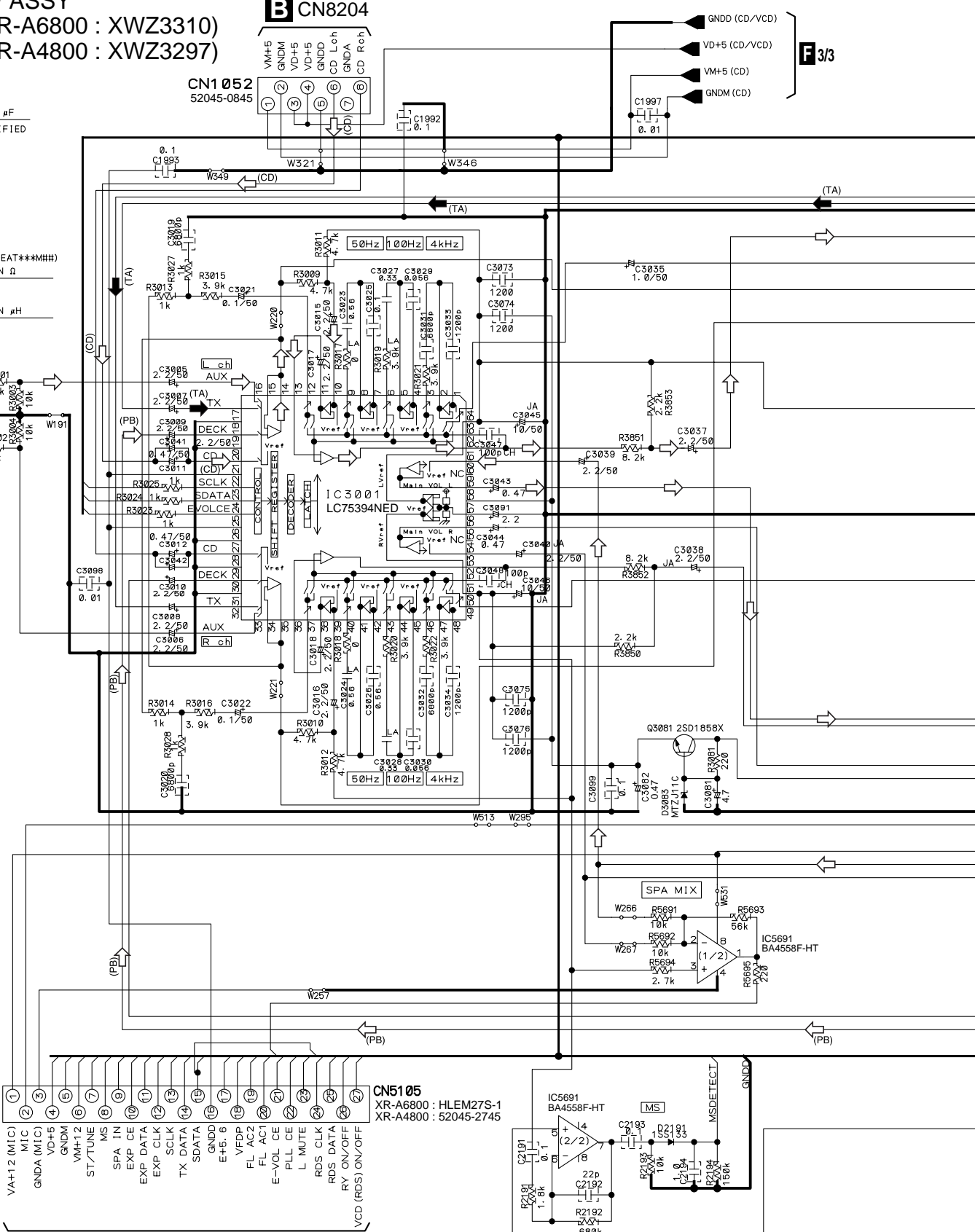
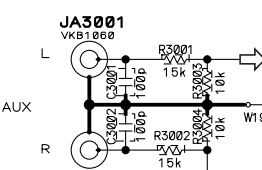

3.6 AF (3/3) and SECONDARY ASSYS

NOTES

- ALL CAPACITORS ARE IN #F
- UNLESS OTHERWISE SPECIFIED
 - TL : CFTLA
 - M : COMBA
- (OTHER : CKCYF)
- CH : CCSRPH
- YF : CKSRVF
- SL : CCSRSL
- (OTHER : CKSRVB)
- AL : CEAL NL : CEANL
- HAQ : CEHAQ
- (OTHER : CEAS+###orCEAT+###)
- ALL RESISTORS ARE IN Ω
- 1/16W (CHIP)
- 1/4WPU
- ALL INDUCTORS ARE IN #H
- LAU
- ALL NO MARK DIODES
- 1SS133

A

B

C

D

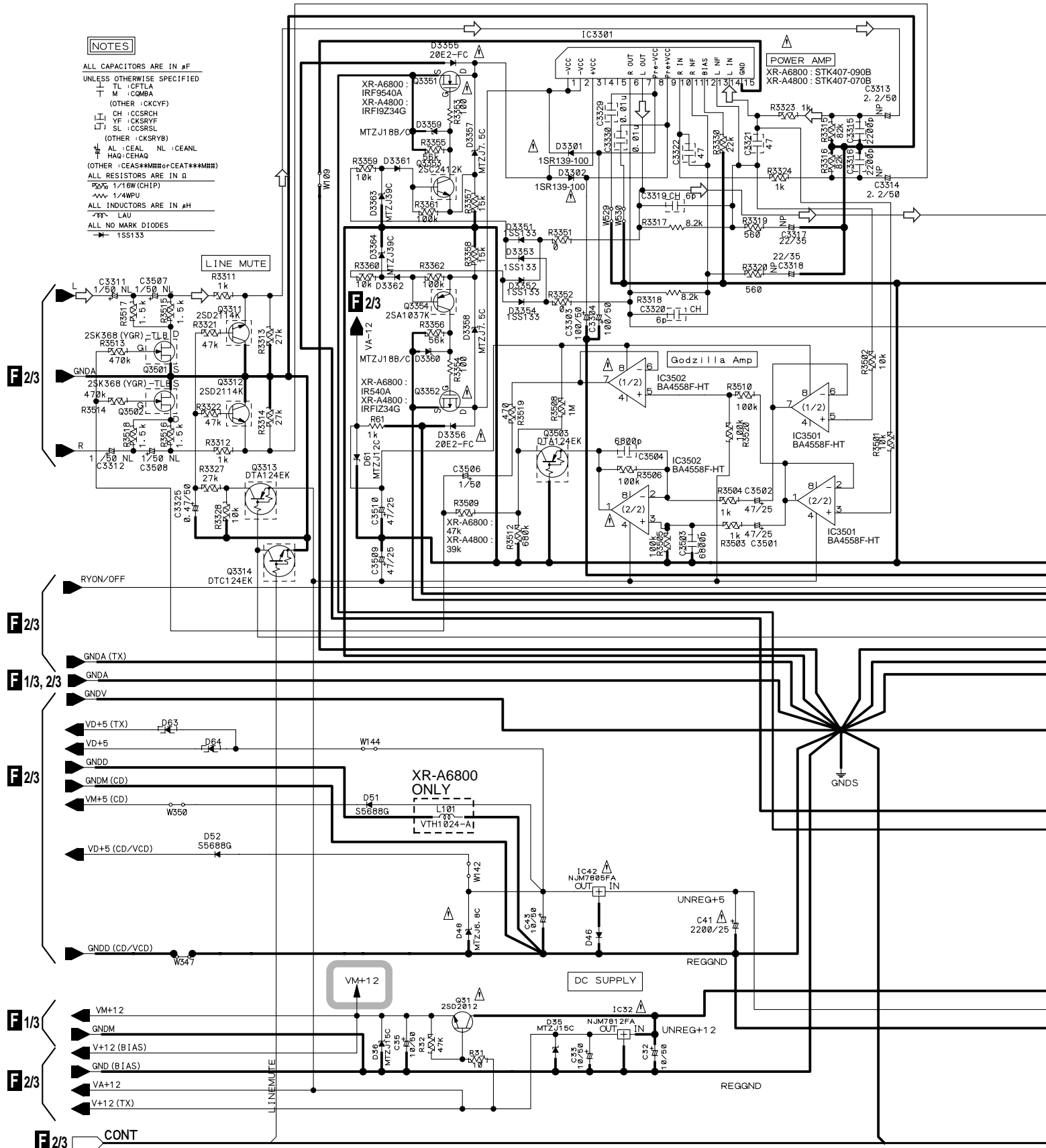

: The power supply is shown with the marked box.

3.7 PRIMARY ASSY

NOTES

ALL CAPACITORS ARE IN μF

UNLESS OTHERWISE SPECIFIED

TL : CFTLA

M : CQ MBA

(OTHER : CKCYF)

CH : CCSRCH

YF : CKSRYF

SL : CCSRSL

(OTHER : CKSRYB)

AL : CEAL

HAQ : CEHAQ

(OTHER : CEAS**M## or CEAT**M##)

ALL RESISTORS ARE IN Ω

1/16W (CHIP)

1/4WPU

ALL INDUCTORS ARE IN μH

LAU

NO MARK DIODE

1SS133

POWER TRANSFORMER
 XR-A6800 : XTS3037
 XR-A4800 : XTS3036

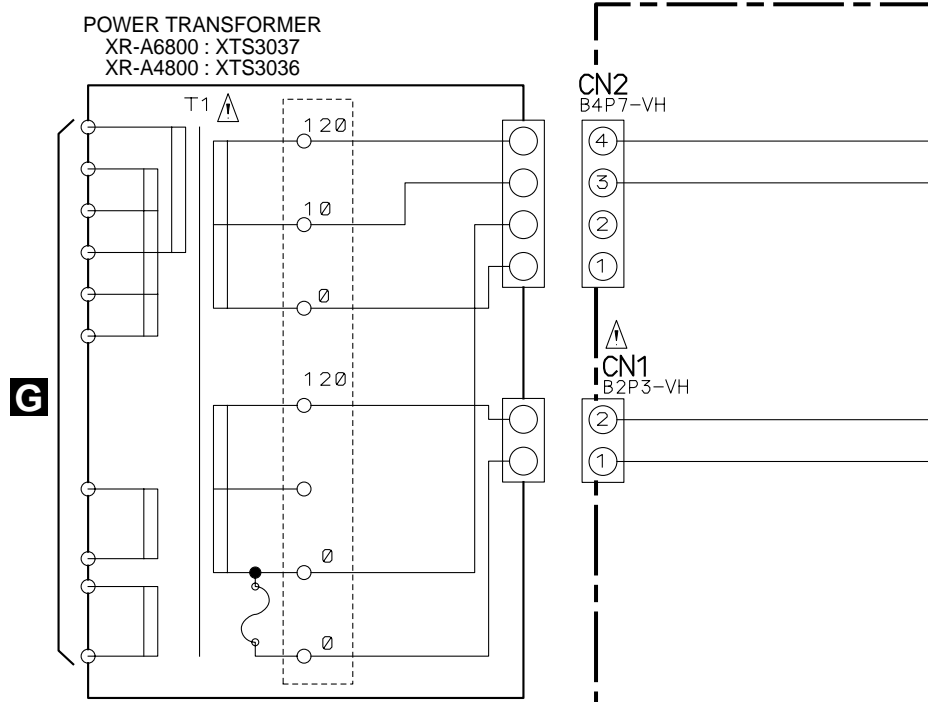

ASR7018

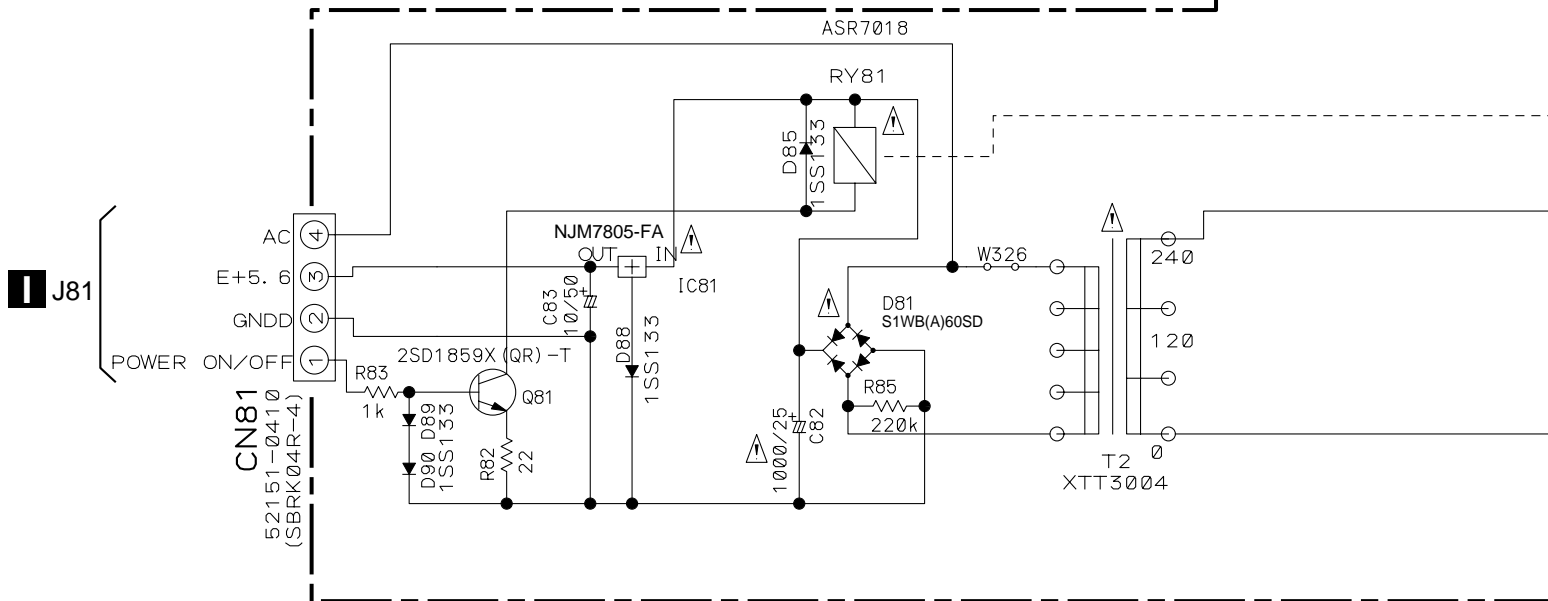

• NOTE FOR FUSE REPLACEMENT

CAUTION -FOR CONTINUED PROTECTION AGAINST RISK OF FIRE.
REPLACE WITH SAME TYPE AND RATINGS ONLY.



PRIMARY ASSY
(XR-A6800 : XWZ3312)
(XR-A4800 : XWZ3299)

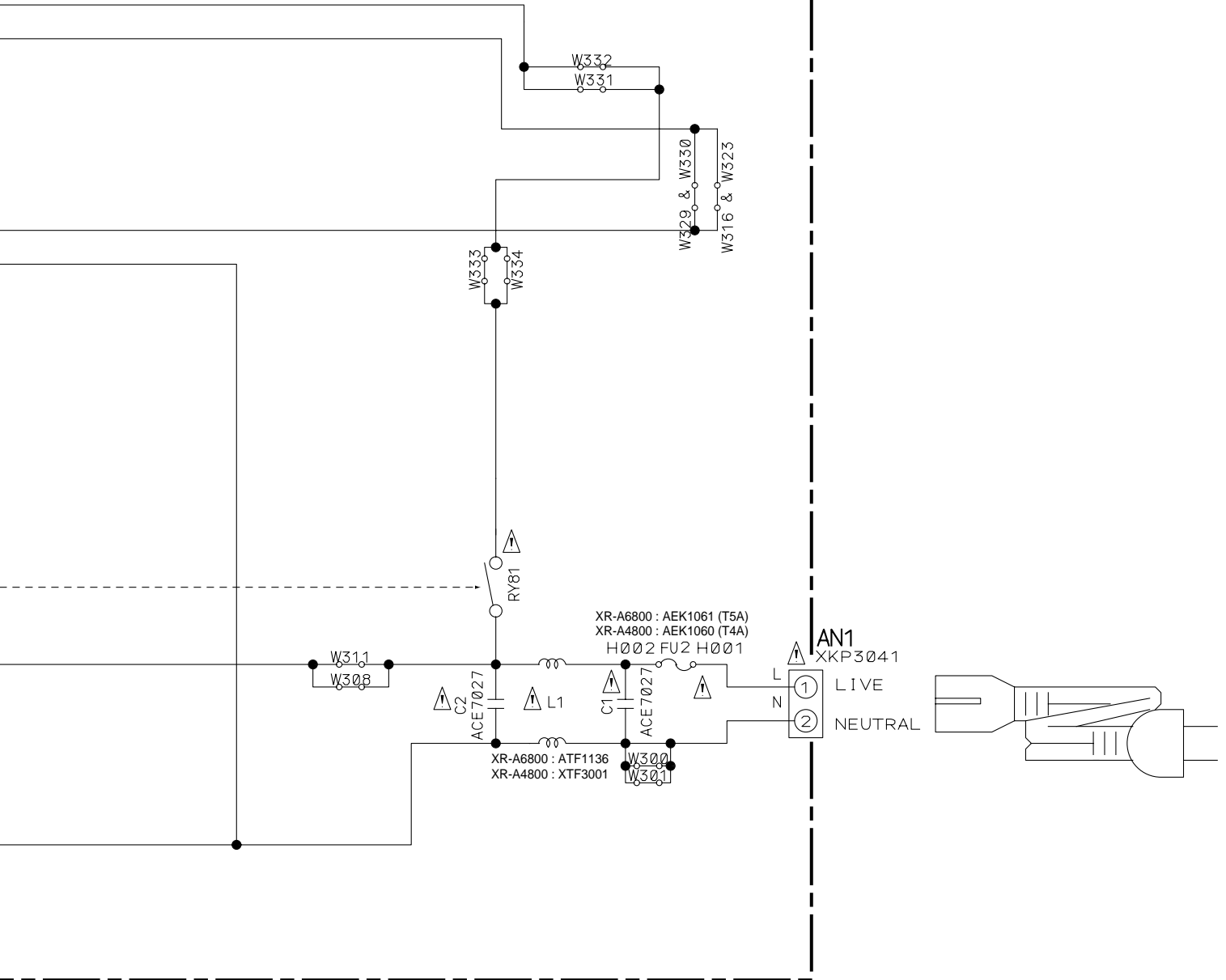

3.8 DISPLAY and BLUE LED ASSYS

DISPLAY ASSY (XR-A6800 : XWZ3311)
(XR-A4800 : XWZ3298)

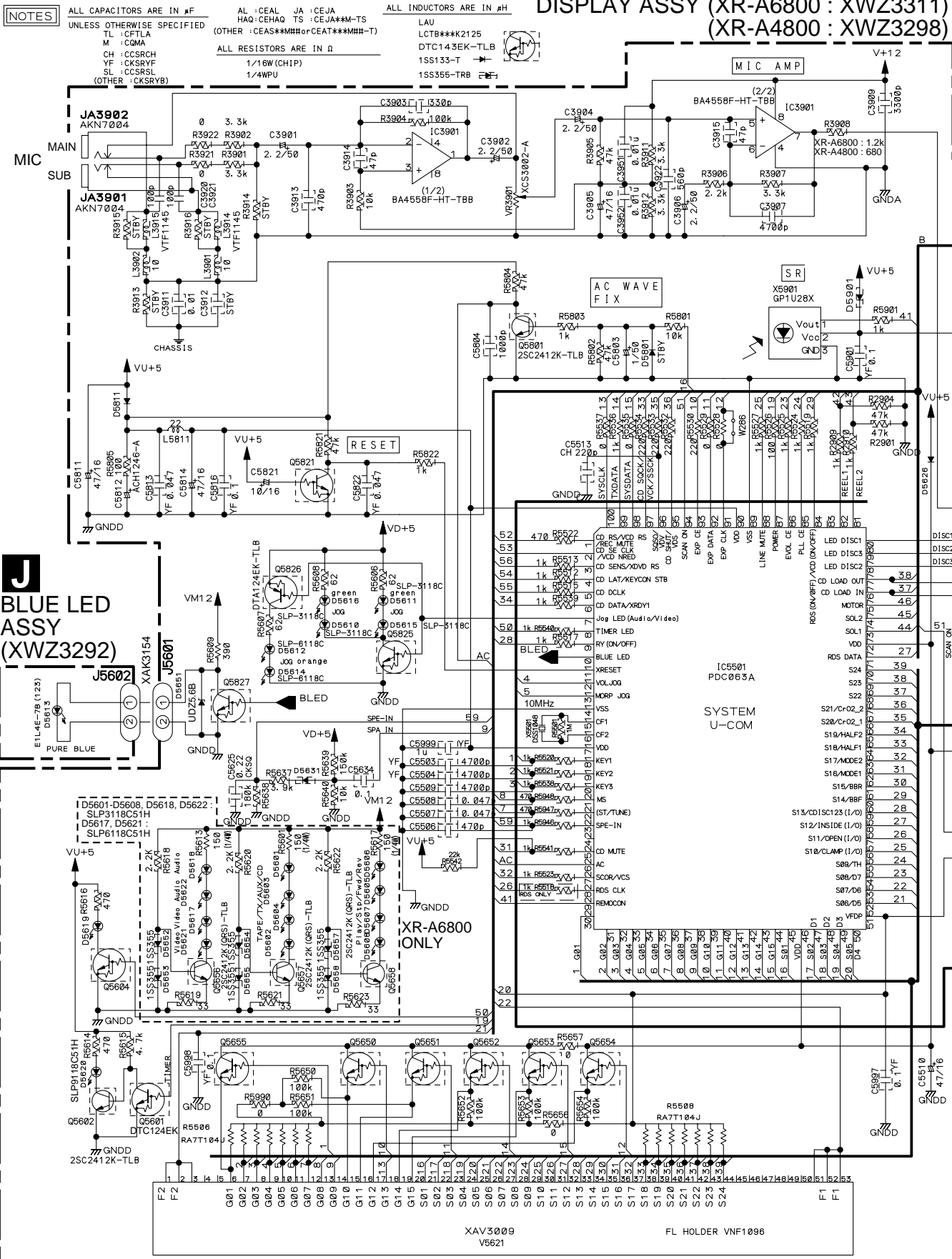

4. PCB CONNECTION DIAGRAM

NOTE FOR PCB DIAGRAMS :

1. Part numbers in PCB diagrams match those in the schematic diagrams.
2. A comparison between the main parts of PCB and schematic diagrams is shown below.
3. The parts mounted on this PCB include all necessary parts for several destinations.
 For further information for respective destinations, be sure to check with the schematic diagram.
4. View point of PCB diagrams.

Symbol In PCB Diagrams	Symbol In Schematic Diagrams	Part Name
		Transistor
		Transistor with resistor
		Field effect transistor
		Resistor array
		3-terminal regulator

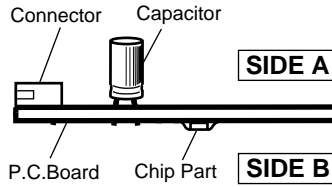

4.1 FM/AM TUNER MODULE

A FM/AM TUNER MODULE

F CN3051

SIDE A

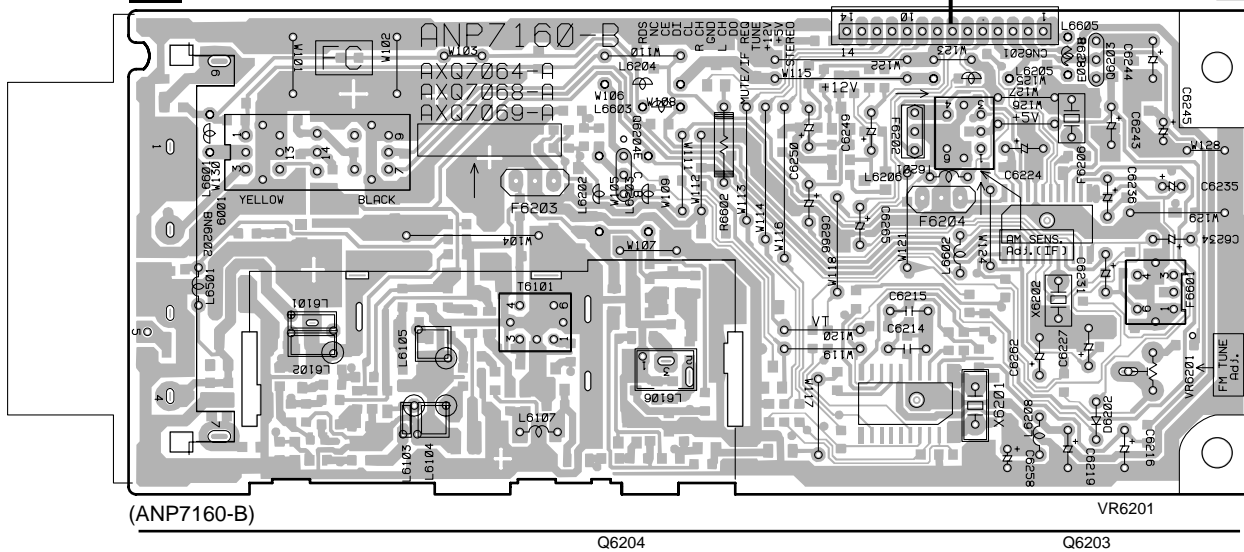

A FM/AM TUNER MODULE

SIDE B

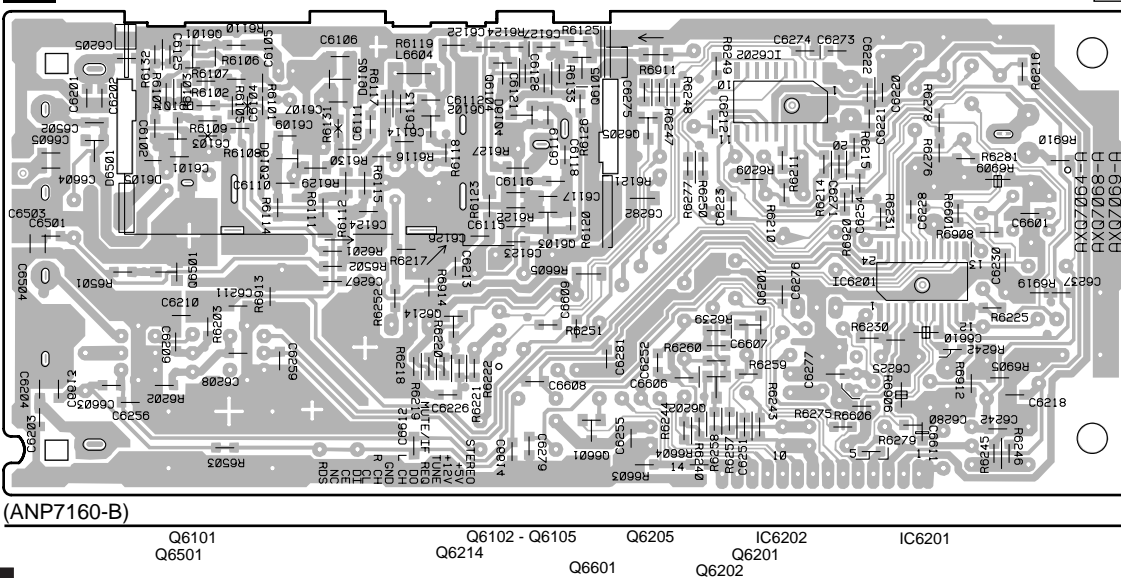

4.2 SECONDARY ASSY

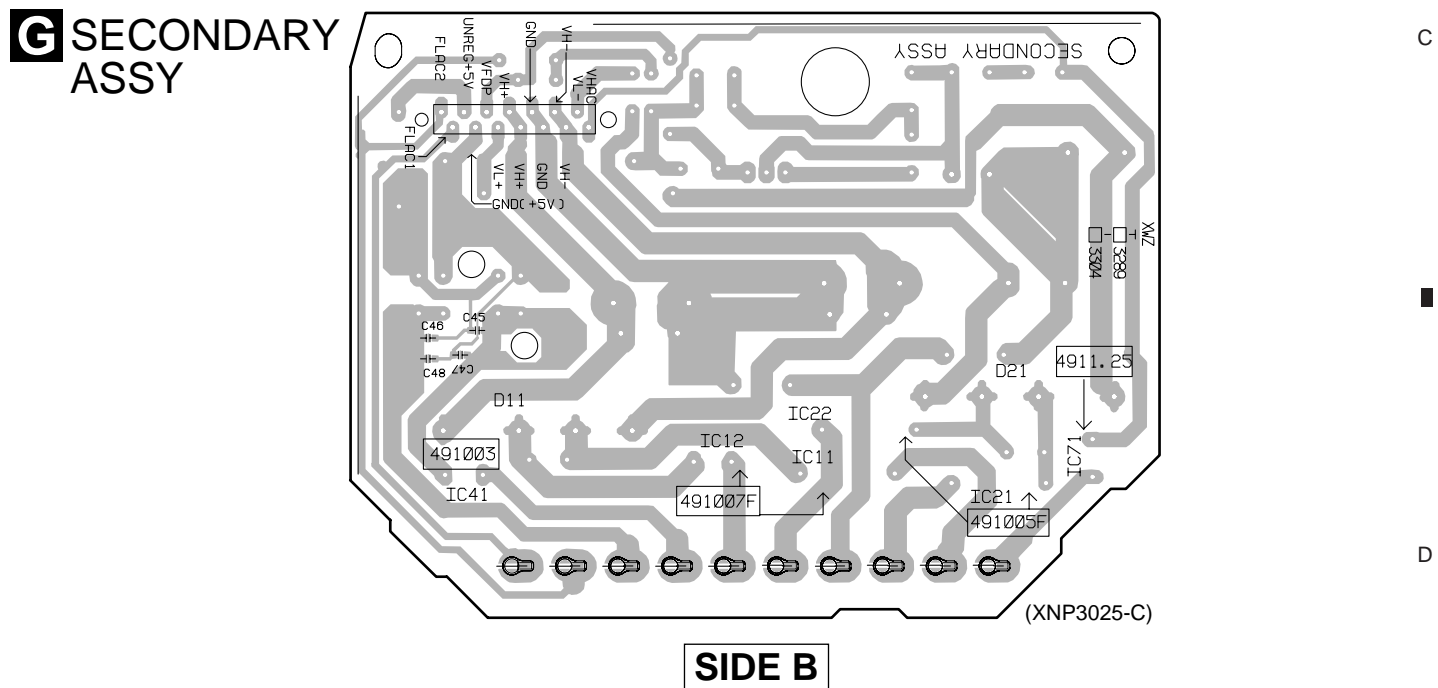
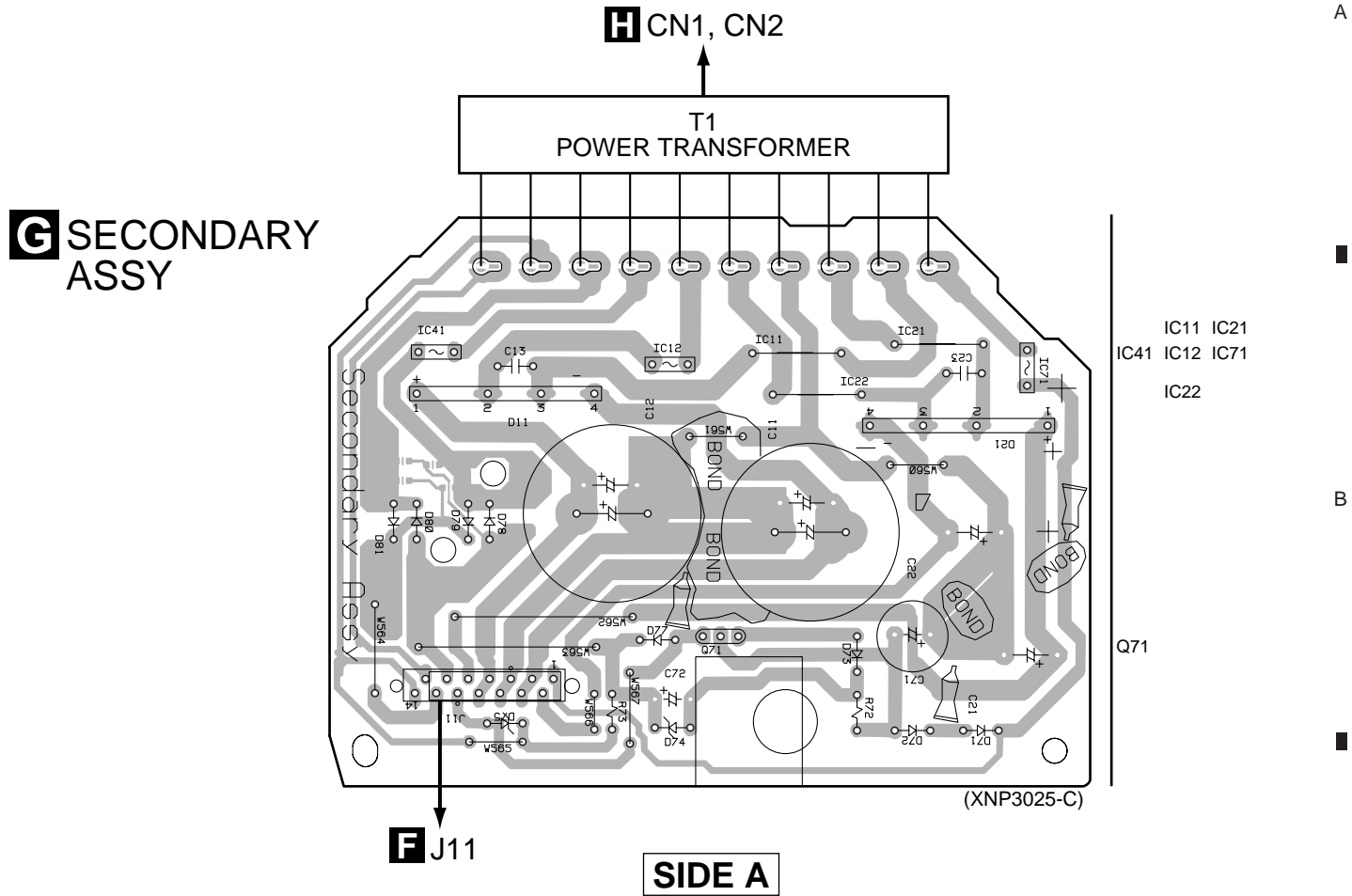

4.3 CD, MOTOR, SW and TRADE ASSYS

B CD ASSY

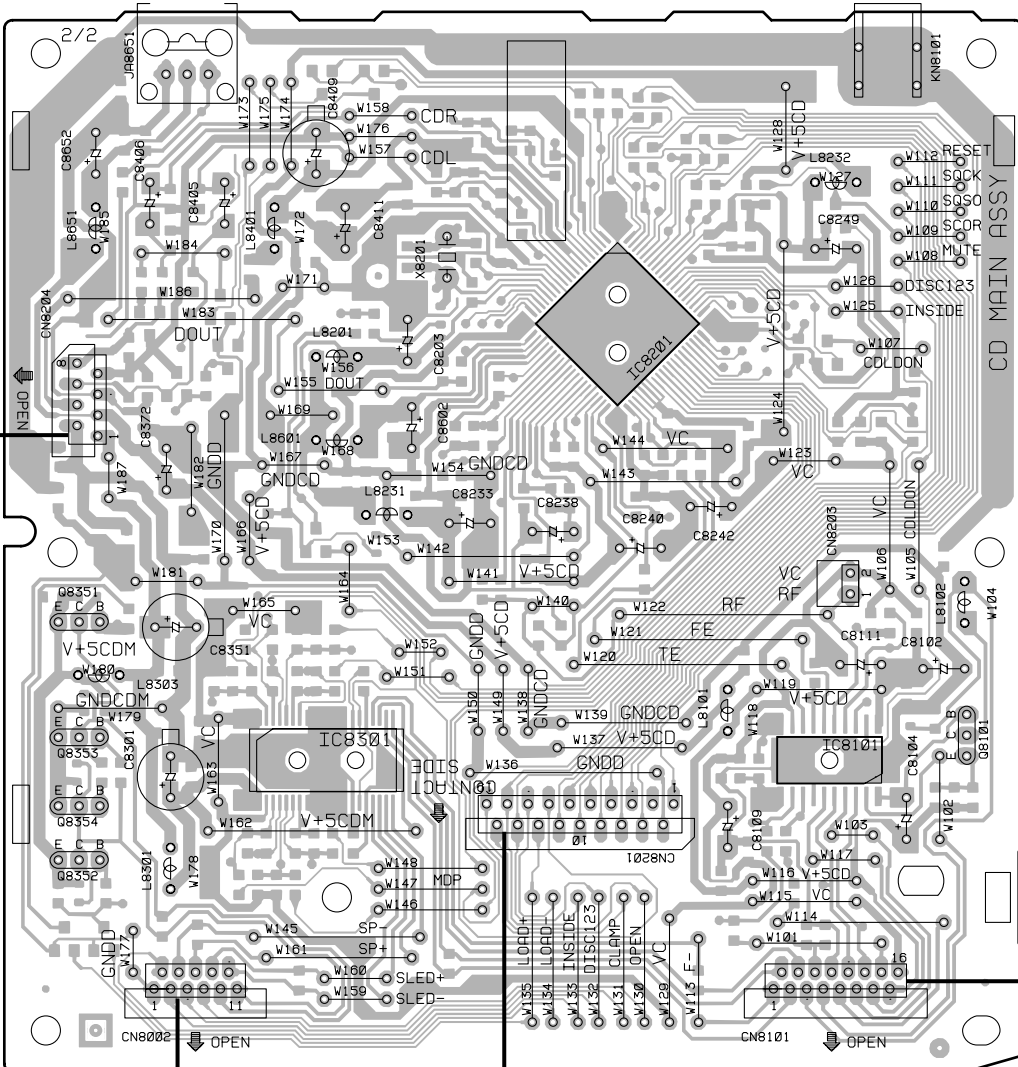

- IC8201
- Q8351
- Q8353
- Q8354
- Q8352
- Q8101
- IC8301
- IC8101
- IC8104

SERVO MECHANISM ASSY

F
CN1052

J
CN5501

D
SW ASSY

E
TRADE ASSY

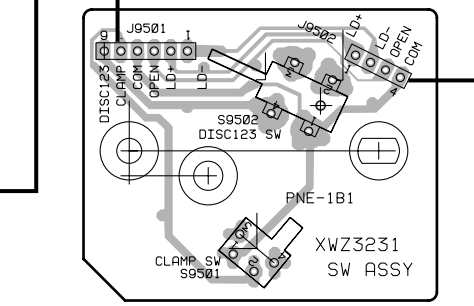
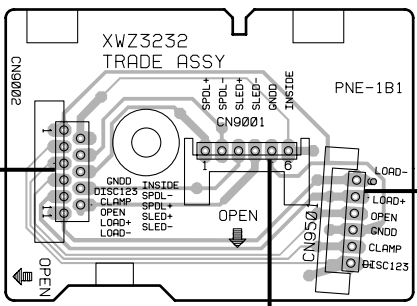

SERVO MECHANISM ASSY

SIDE A (XNP3023-B)

C
MOTOR ASSY

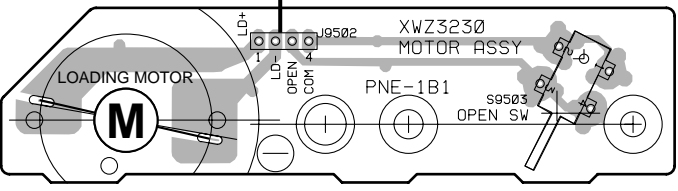

B CD ASSY

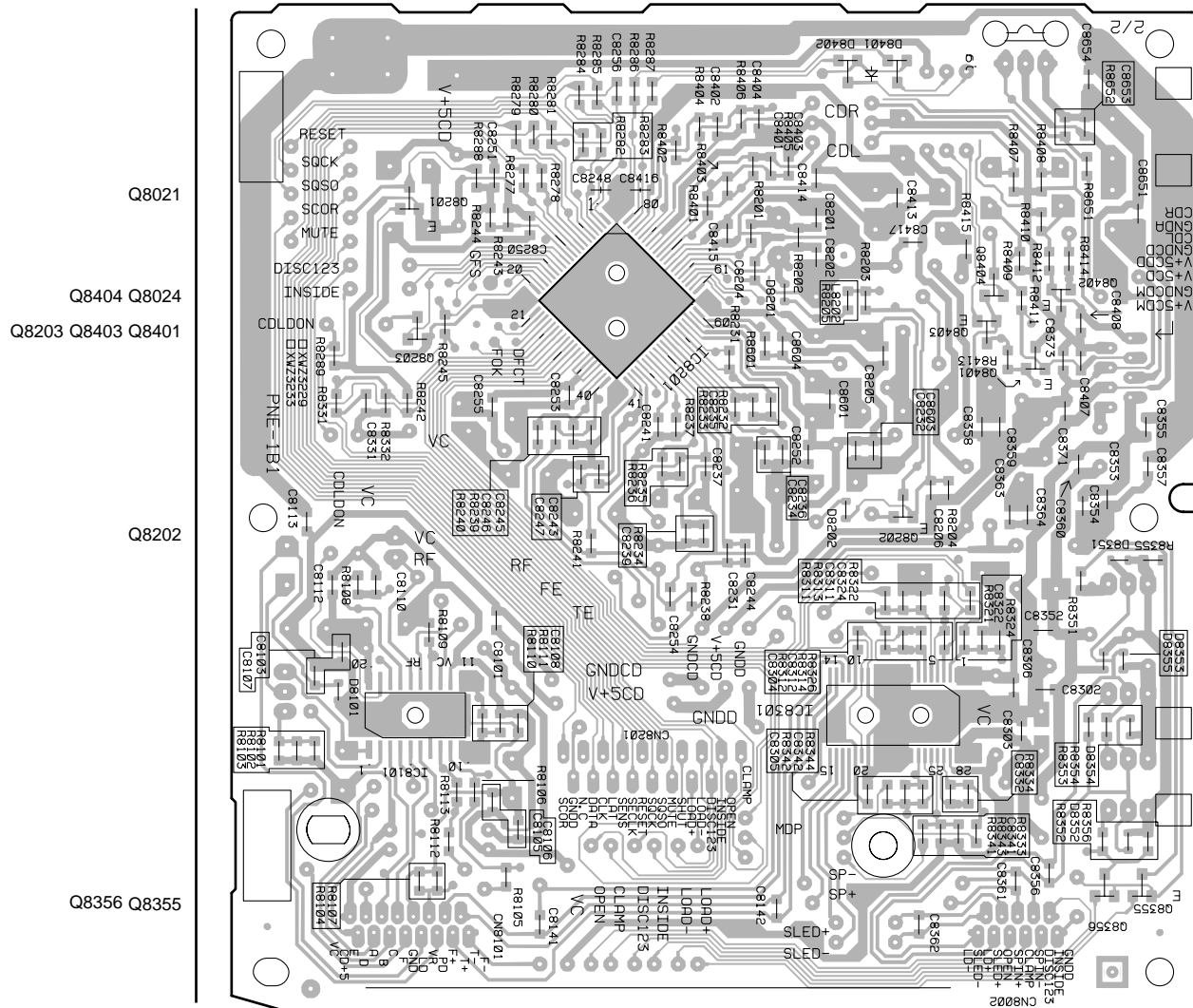

D SW ASSY

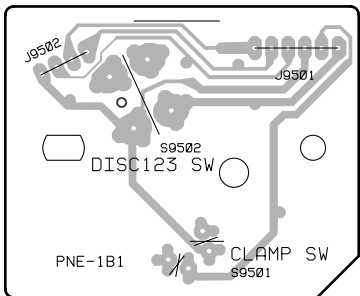

E TRADE ASSY

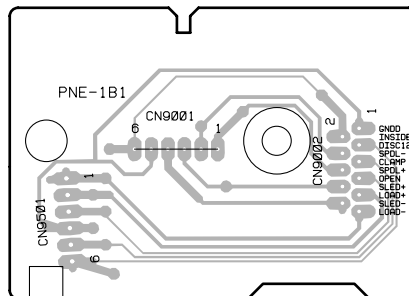

C MOTOR ASSY

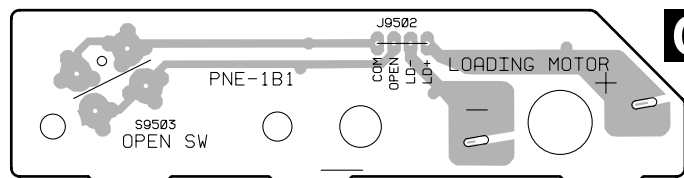

SIDE B (XNP3023-B)

4.4 AF ASSY

A

B

C

D

F AF ASSY

A CN6201

E

G J11

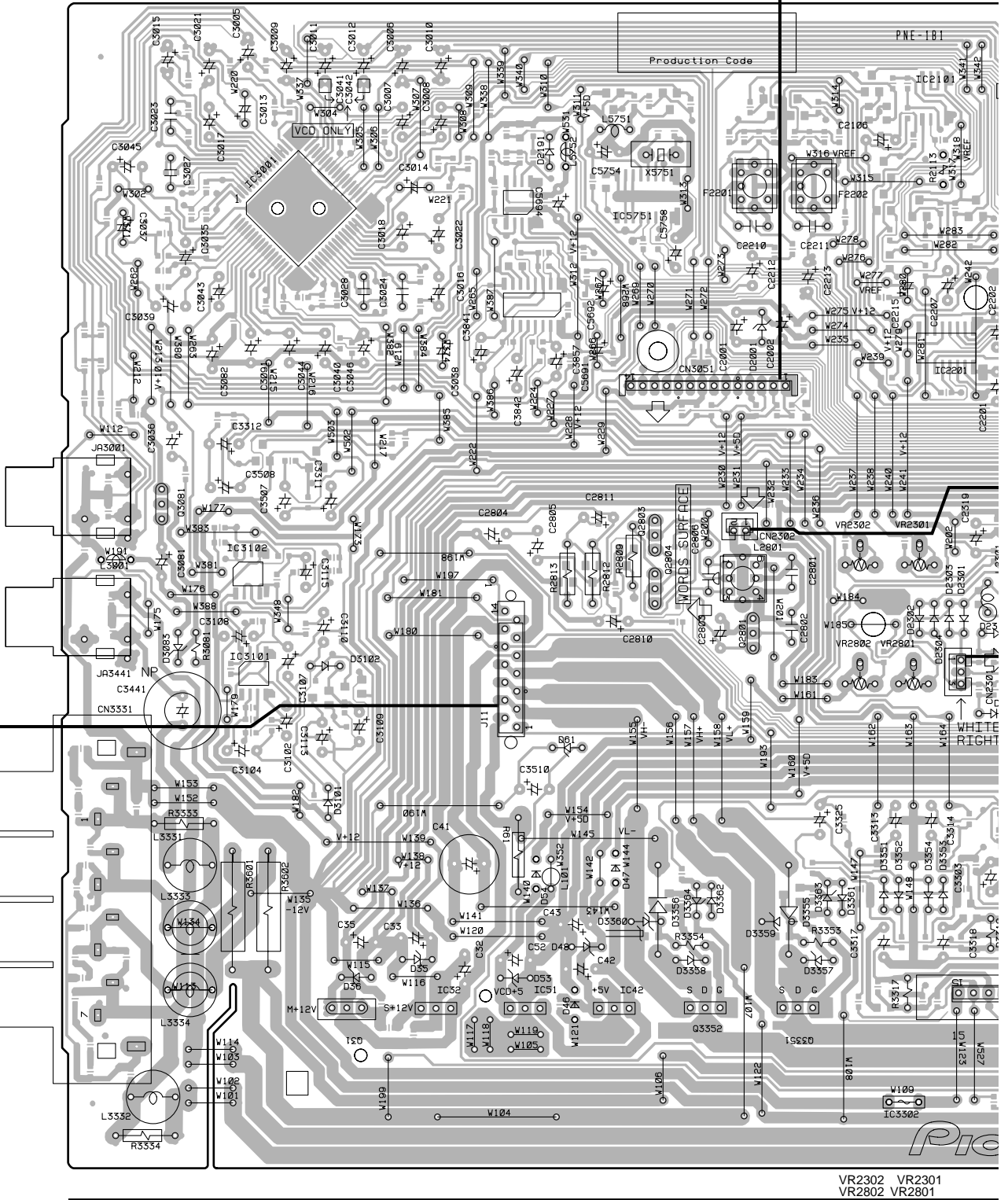

Q3081

Q2803

Q2801

VR2302 VR2301
VR2802 VR2801

Q31

IC32

IC51

Q2804

IC42

Q3352

Q3351

IC3302



B CN8204

I CN5501

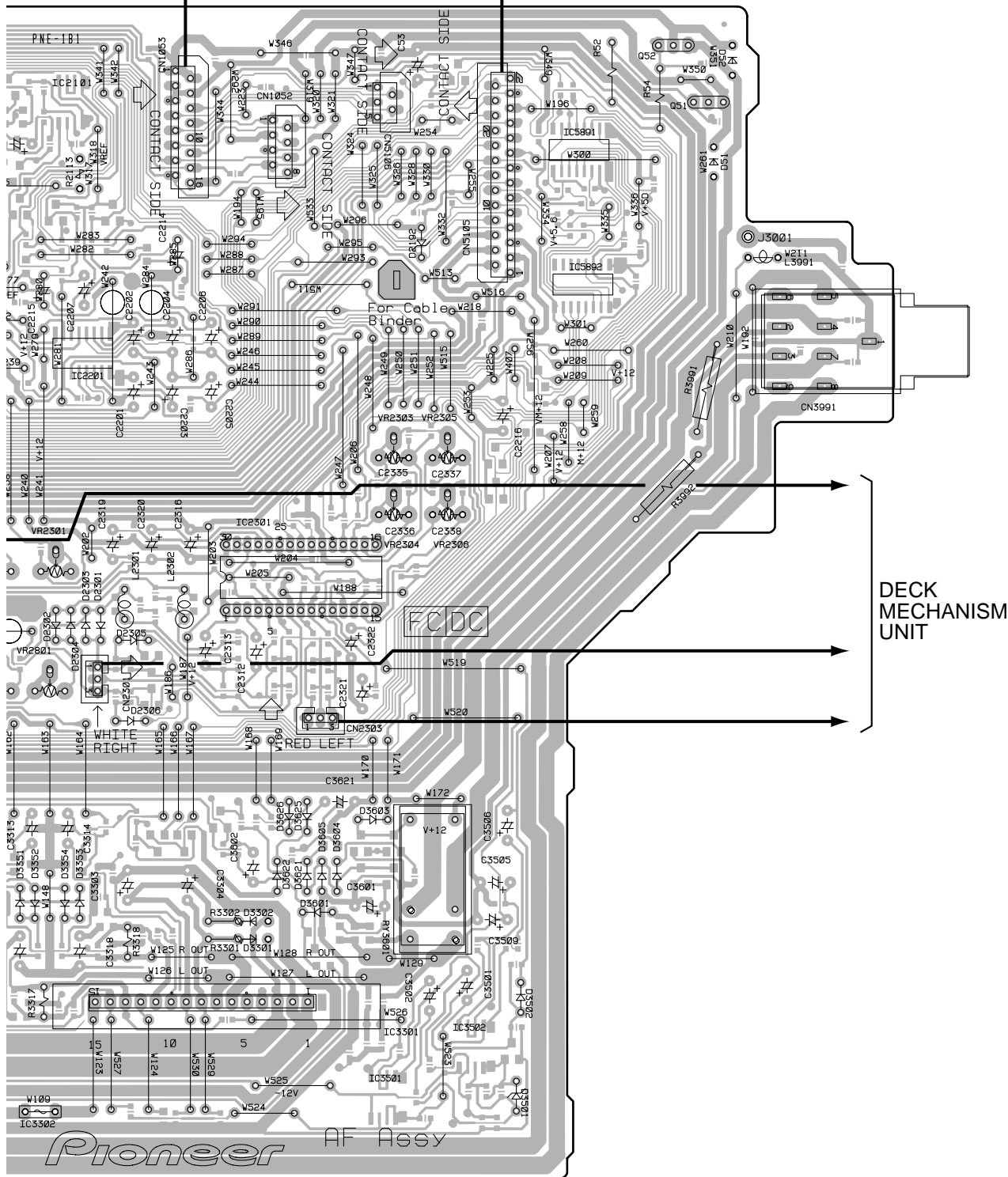

02 VR2301
02 VR2801

VR2303 VR2305
VR2304 VR2306

(XNP3025-C)

SIDE A

IC2301

Q52 Q51

IC3302

IC3301

F AF ASSY

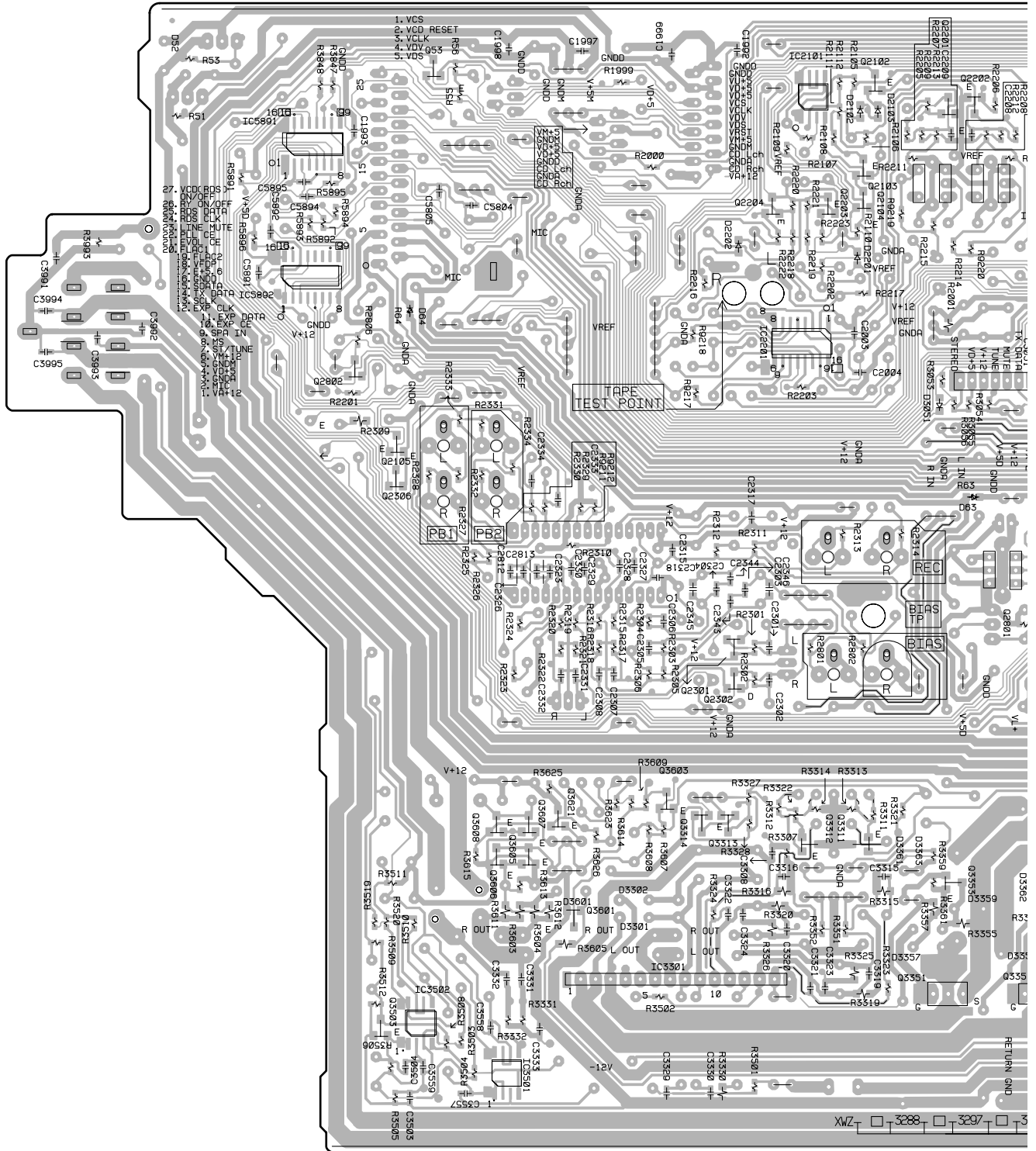

IC5891	Q53	IC2101	Q2102-Q2104	Q2202
IC5892	Q2802	Q2204	Q2203	
	Q2105	Q3603	Q3311	Q3353
	Q2306	Q3601	Q3312	Q3351
	Q3503	IC3501		
	IC3502	Q3602		
	IC3502	Q3603		
		IC3301		
		Q3314		
		Q3313		



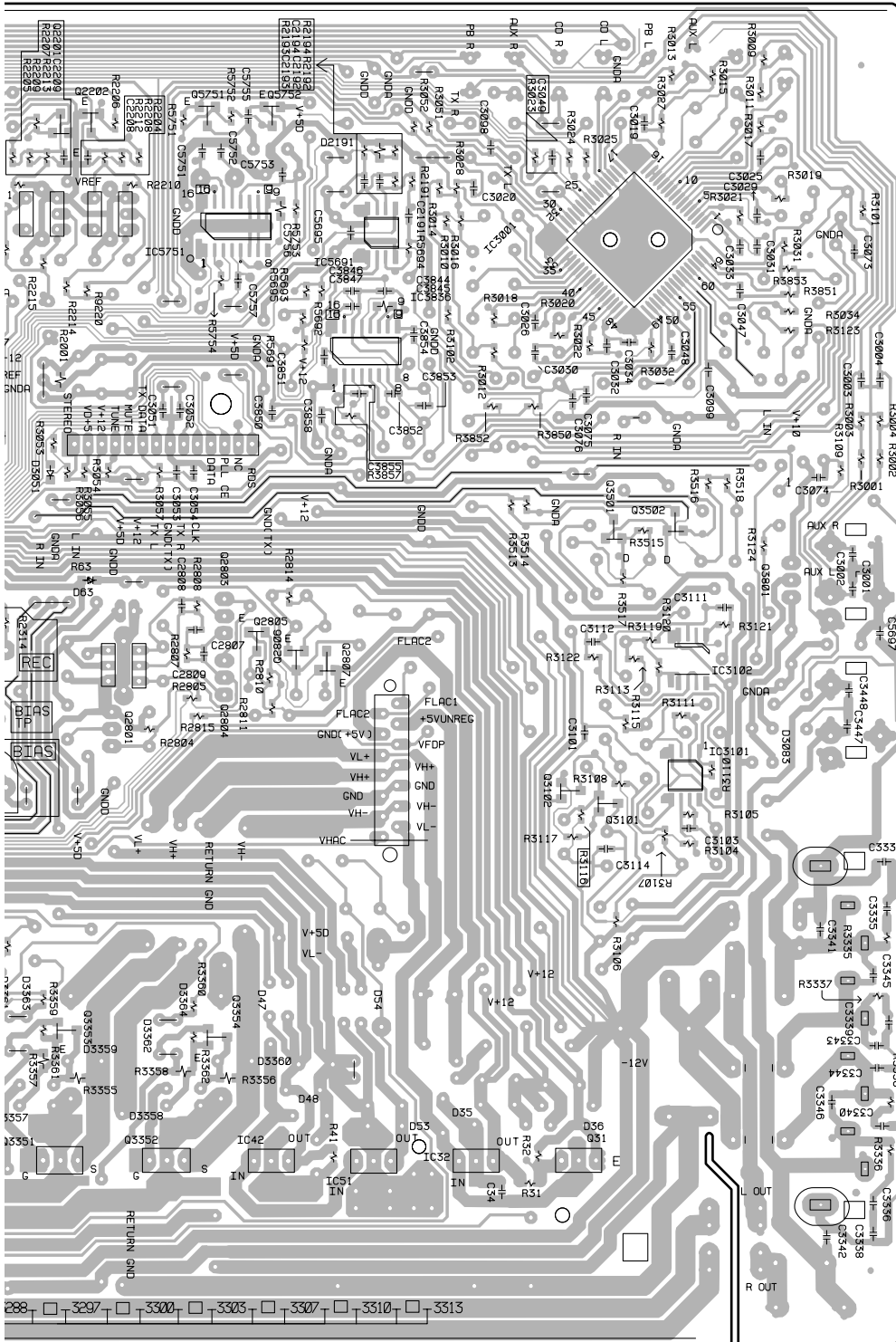

(XNP3025-C)

SIDE B

04	Q2202	Q5751	Q5752	IC3001
	Q3353	Q3354	Q2804-Q2807	Q3501
	Q3351	Q3352	IC42	Q3102
			IC51	Q3101
			IC32	IC3102
				IC3101



4.5 PRIMARY ASSY

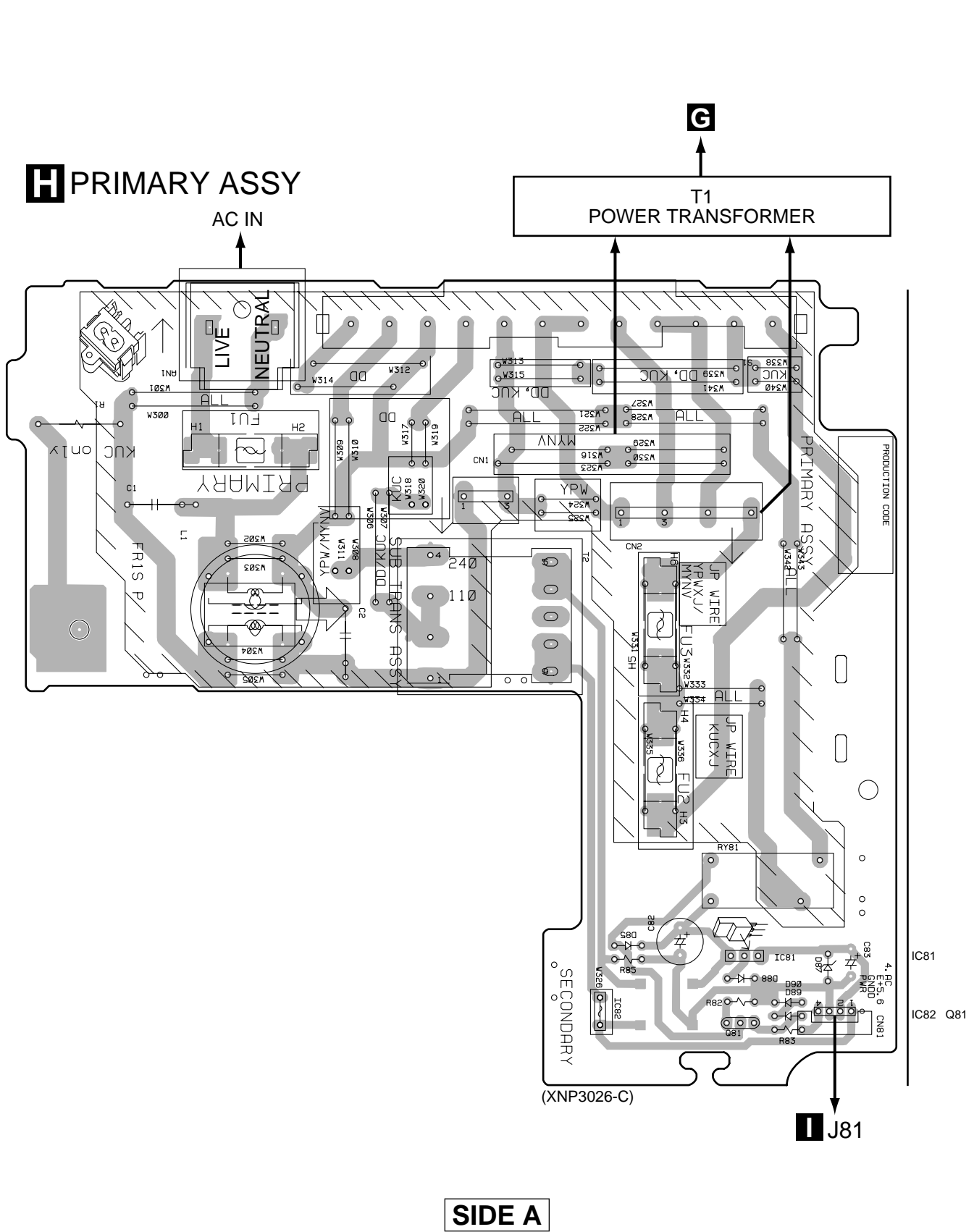

H PRIMARY ASSY

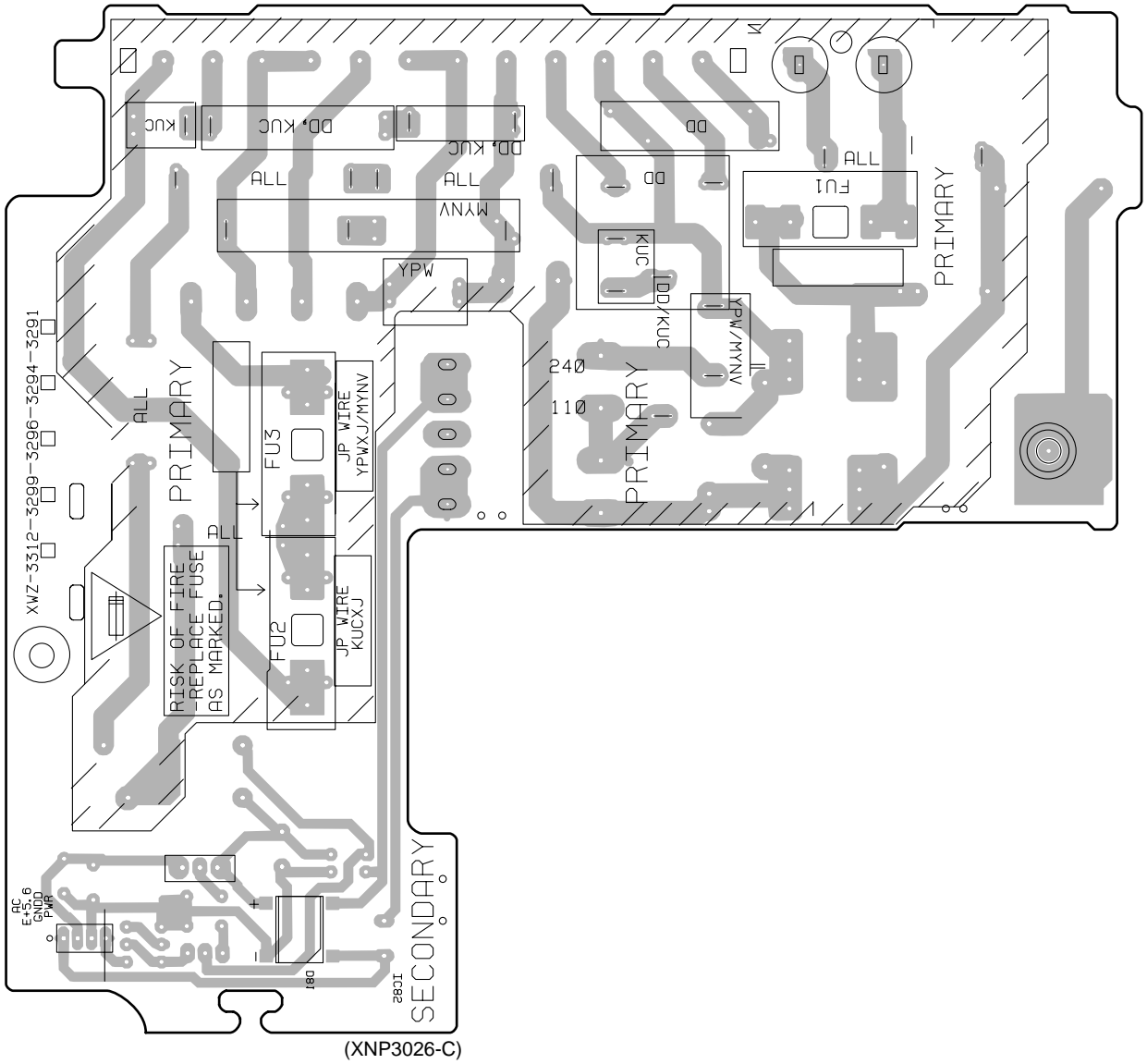

SIDE B



4.6 DISPLAY and BLUE LED ASSYS

J BLUE LED ASSY

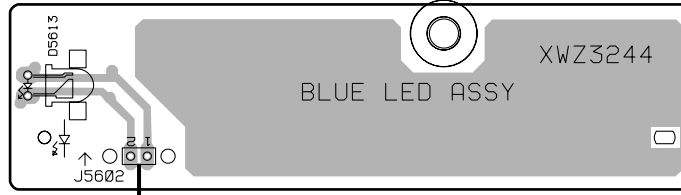

I DISPLAY ASSY

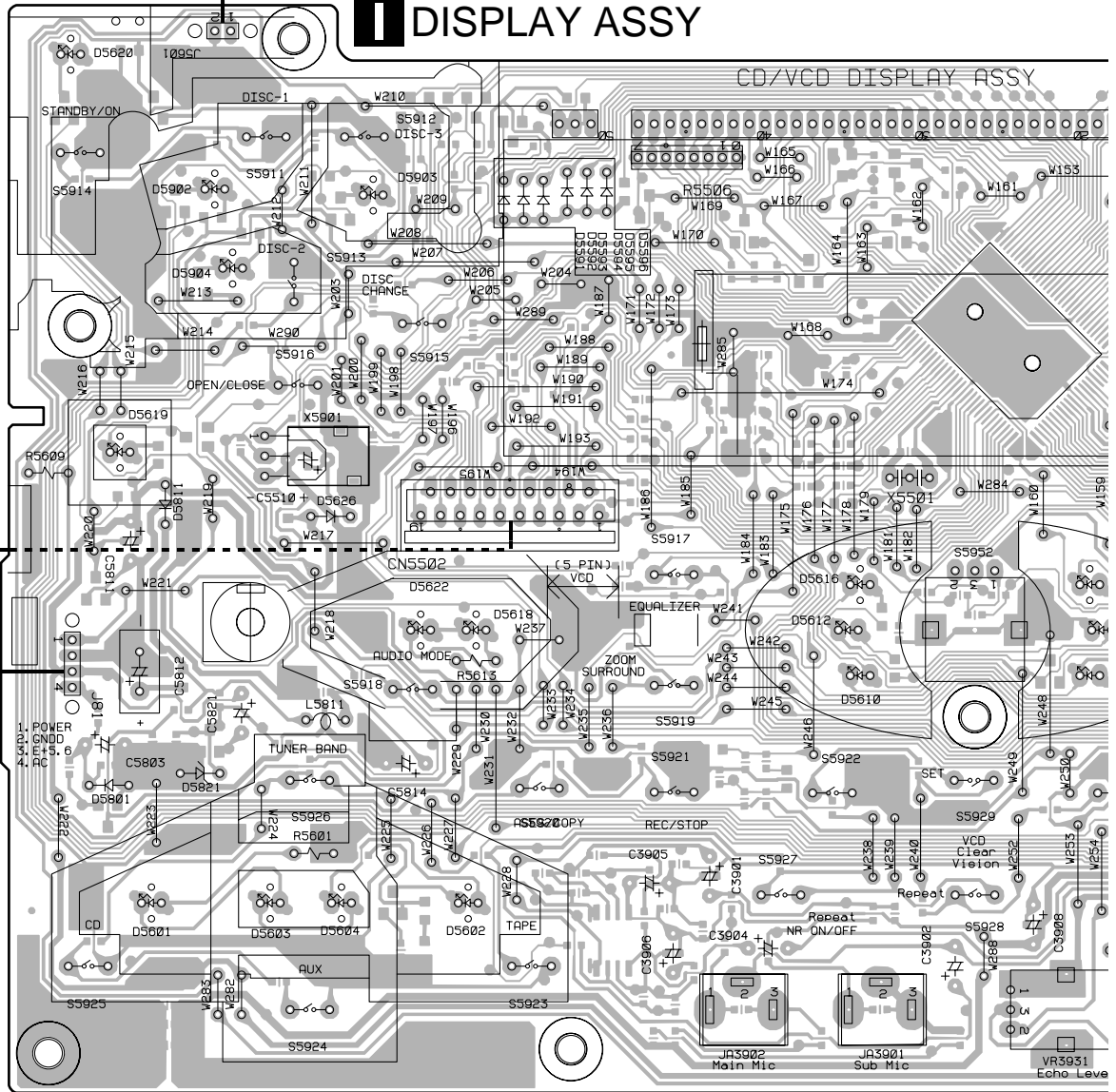

B
CN8201

H
CN81



A

B

C

D

DECK MECHANISM UNIT

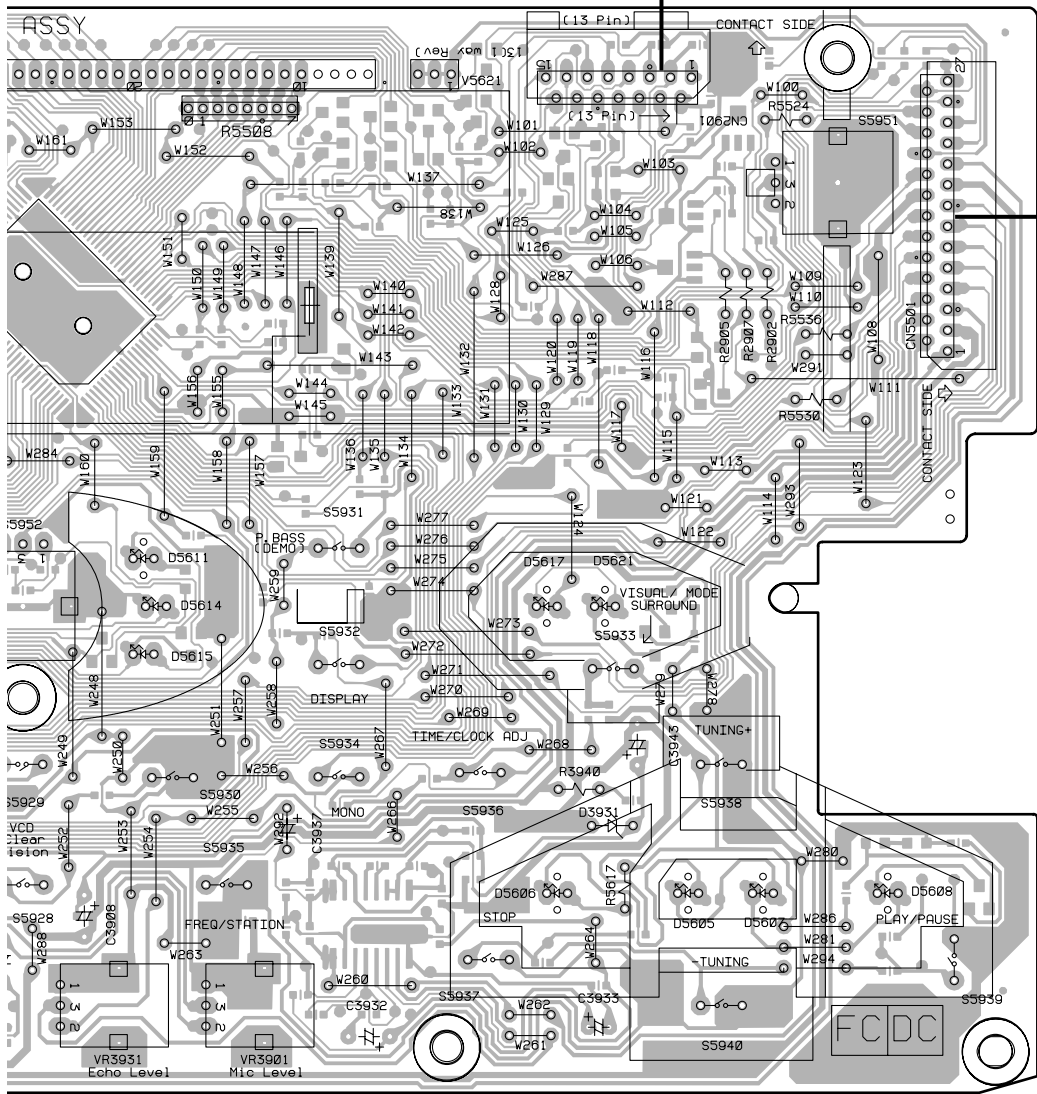

F CN5105

SIDE A

(XNP3026-C)

VR3931 VR3901

DISPLAY ASSY

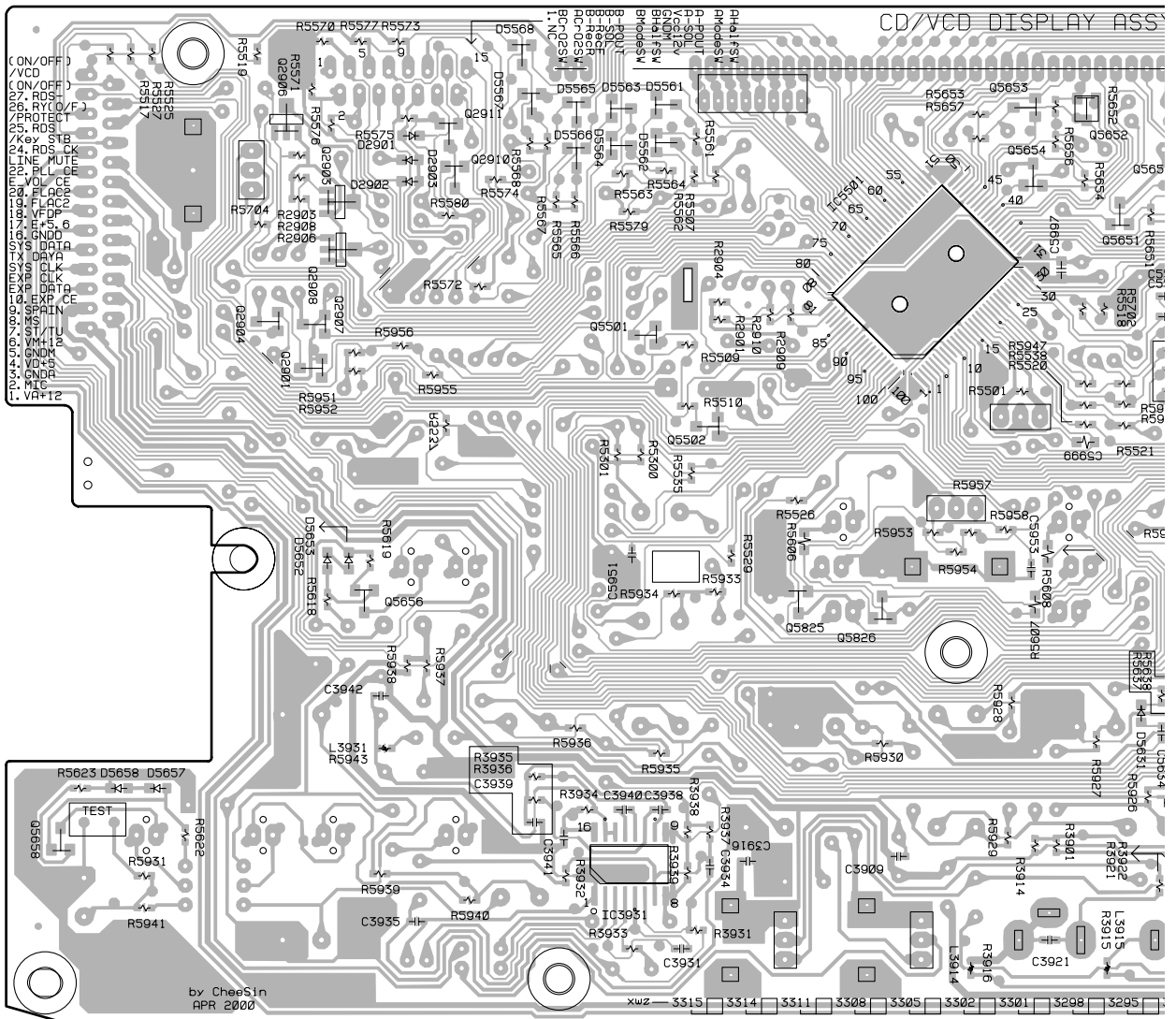

Q5658	Q2906	Q2911	IC5501	Q5650-Q5657
	Q2904	Q2910		
	Q2908	Q5501	Q5502	Q5825
	Q2907	IC3931	Q5826	
	Q5556			

J BLUE LED ASSY

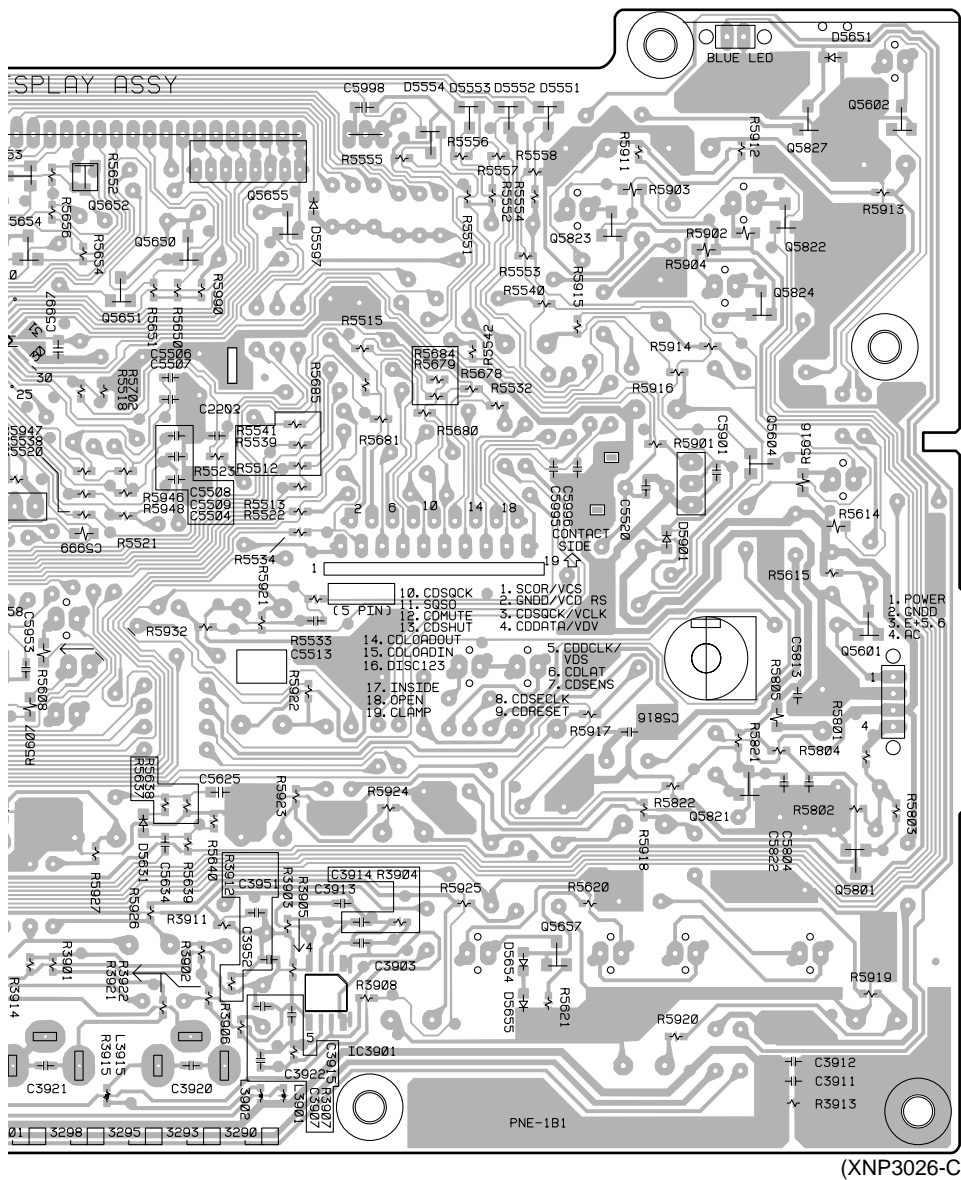
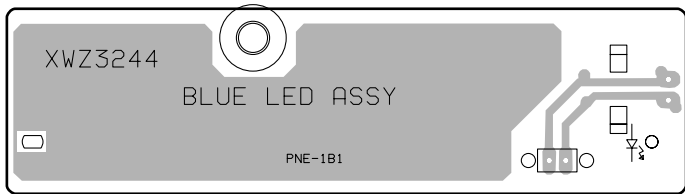

SIDE B

Q5650-Q5655

Q5823

Q5827

Q5602

IC3901

Q5657

Q5824

Q5601

Q5604

Q5801

Q5821



5. PCB PARTS LIST

NOTES: ●Parts marked by "NSP" are generally unavailable because they are not in our Master Spare Parts List.

●The Δ mark found on some component parts indicates the importance of the safety factor of the part.

Therefore, when replacing, be sure to use parts of identical designation.

●When ordering resistors, first convert resistance values into code form as shown in the following examples.

Ex.1 When there are 2 effective digits (any digit apart from 0), such as 560 ohm and 47k ohm (tolerance is shown by J=5%, and K=10%).

560 Ω → 56 × 10¹ → 561 RD1/4PU 5 6 1 J

47k Ω → 47 × 10³ → 473 RD1/4PU 4 7 3 J

0.5 Ω → R50 RN2H R 5 0 K

1 Ω → 1R0 RS1P 1 R 0 K

Ex.2 When there are 3 effective digits (such as in high precision metal film resistors).

5.62k Ω → 562 × 10¹ → 5621 RN1/4PC 5 6 2 1 F

■ LIST OF WHOLE PCB ASSEMBLIES

Mark	Symbol and Description	Part No.			Remarks
		XR-A6800/MYXJ	XR-A4800/MYXJ	XR-A4800/NVXJ	
	FM/ AM TUNER MODULE	AXQ7068	AXQ7068	AXQ7068	
NSP	\$M SERVO MECHANISM ASSY	XWX3008	XWX3007	XWX3007	
	└ CD ASSY	XWZ3233	XWZ3229	XWZ3229	
	└ MOTOR ASSY	XWZ3230	XWZ3230	XWZ3230	
	└ SW ASSY	XWZ3231	XWZ3231	XWZ3231	
	└ TRADE ASSY	XWZ3232	XWZ3232	XWZ3232	
	MAIN ASSY	XWM3163	XWM3152	XWM3152	
	└ AF ASSY	XWZ3310	XWZ3297	XWZ3297	
	└ SECONDARY ASSY	XWZ3304	XWZ3289	XWZ3289	
	COMPLEX ASSY	XWM3168	XWM3158	XWM3158	
	└ PRIMARY ASSY	XWZ3312	XWZ3299	XWZ3299	
	└ DISPLAY ASSY	XWZ3311	XWZ3298	XWZ3298	
	└ BLUE LED ASSY	XWZ3292	XWZ3292	XWZ3292	

B CD ASSY

XWZ3233 and XWZ3229 are constructed the same except for the following :

Mark	Symbol and Description	Part No.		Remarks
		XWZ3233	XWZ3229	
	L8651	LFA100J	Not used	
	C8604	CCSQCH220J50	Not used	
	C8651, C8653	CKSQYF103Z50	Not used	
	C8652	CEAT101M10	Not used	
	R8601	RS1/10S181J	Not used	
	R8651	RS1/10S821J	Not used	
	R8652	RS1/10S152J	Not used	
	JA8651 OPTICAL LINK OUT	GP1F32T	Not used	

G SECONDARY ASSY

XWZ3304 and XWZ3289 are constructed the same except for the following :

Mark	Symbol and Description	Part No.		Remarks
		XWZ3304	XWZ3289	
Δ	IC11	AEK7068 (10A)	AEK7047 (7A)	
Δ	IC12	AEK7022 (10A)	AEK7021 (7A)	
Δ	IC21, IC22	AEK7047 (7A)	AEK7046 (5A)	
Δ	C11, C12	XCH3001 (4700μF/71V)	ACH7071 (2200μF/63V)	

H PRIMARY ASSY

XWZ3312 and XWZ3299 are constructed the same except for the following :

Mark	Symbol and Description	Part No.		Remarks
		XWZ3312	XWZ3299	
△	L1 LINE FILTER	ATF1136	XTF3001	

I DISPLAY ASSY

XWZ3311 and XWZ3298 are constructed the same except for the following :

Mark	Symbol and Description	Part No.		Remarks
		XWZ3311	XWZ3298	
	Q5656-Q5658 D5561, D5562 D5593 D5601-D5608, D5618, D5622 D5617, D5621	2SC2412K 1SS181 1SS133 SLP3118C51H SLP6118C51H	Not used Not used Not used Not used Not used	
	D5652-D5655, D5657, D5658 R3908 R5561, R5562 R5570, R5571 R5601, R5613, R5617	1SS355 RS1/16S122J RS1/16S152J RS1/16S473J RD1/4PU151J	Not used RS1/16S681J Not used Not used Not used	
	R5618, R5620, R5622 R5619, R5621, R5623	RS1/16S222J RS1/16S330J	Not used Not used	

PCB PARTS LIST FOR XR-A6800/MYXJ UNLESS OTHERWISE NOTED

Mark	No.	Description	Part No.	Mark	No.	Description	Part No.
------	-----	-------------	----------	------	-----	-------------	----------

A FM/AM TUNER MODULE

SEMICONDUCTORS

IC6201	LA1832ML
IC6202	LC72131MD
Q6102	2SC2223
Q6203	2SC2705
Q6201, Q6202	2SC2712
Q6103, Q6214, Q6601	2SC2714
Q6104, Q6105	2SK302
Q6101	3SK194
Q6204	DTA124ES
Q6205	DTC124EK
D6202	1SS254
D6101-D6104	1SV228

COILS AND FILTERS

L6106	FM COIL	ATC1003
L6105	FM RF COIL	ATC1015
L6101	FM ANTENNA COIL	ATC1016
L6102	FM ANTENNA COIL	ATC1017
L6103	FM RF DRIVE COIL	ATC1018
L6104	FM RF TUNIG COIL	ATC1019
F6203	FM CERAMIC FILTER	ATF-119
F6206	FM CERAMIC DISCLI.	ATF7008
F6601	ANTI BIRDY FILTER	ATF7009
F6204	FM CERAMIC FILTER	ATF7010
F6202	AM CERAMIC FILTER	ATF7011
L6107	CHIP COIL	ATH1043
L6603		LAU220J
L6206, L6208, L6605		LAU2R2J

TRANSFORMERS

T6201	ATB7008
T6101	ATE7002

CAPACITORS

C6113, C6212, C6274, C6275, C6611	CCSQCH101J50
C6116, C6208, C6221	CCSQCH150J50
C6222	CCSQCH180J50
C6271	CCSQCH200J50
C6117	CCSQCH330J50
C6608	CCSQCH680J50
C6118	CCSQCH8R0D50
C6111, C6122	CCSQCK1R0C50
C6112, C6127	CCSQCK2R0C50
C6105	CCSQL471J50
C6101	CCSQTH110J50
C6119	CCSQTH150J50
C6109	CCSQTH270J50
C6107, C6110	CCSQTH300J50
C6106	CCSQTH330J50
C6234, C6235	CEAL1R0M50
C6245	CEAL470M16
C6224	CEAS100M50
C6243	CEAS101M16
C6231	CEAS1R0M50
C6227	CEAS220M16
C6236	CEAS2R2M50
C6216	CEAS330M16
C6262	CEAS3R3M50
C6219	CEAS470M10
C6244	CEAS470M16
C6249, C6250, C6265, C6266	CEAS4R7M50
C6258	CEJA470M16
C6215	CFTLA103J50
C6214	CFTLA224J50

XR-A6800, XR-A4800

Mark	No.	Description	Part No.
	C6115,C6125,C6126,C6211,C6254 C6601		CKSQYB102K50 CKSQYB102K50
	C6102,C6114,C6121,C6123,C6124 C6210,C6213,C6237,C6267,C6276 C6279,C6281,C6604		CKSQYB103K50 CKSQYB103K50 CKSQYB103K50
	C6251,C6252 C6606,C6607 C6203,C6259 C6228 C6209		CKSQYB123K50 CKSQYB182K50 CKSQYB223K50 CKSQYB472K50 CKSQYB473K50
	C6230 C6218,C6223,C6255 C6220,C6226,C6242,C6256 C6225 C6610		CKSQYB821K50 CKSQYF103Z50 CKSQYF223Z50 CKSQYF473Z50 CKSYB103K50

RESISTORS

R6602	RD1/4PU221J
R6115,R6119,R6123,R6127,R6129 R6906,R6909,R6911 R6112 VR6201 (10kΩ)	RS1/8S0R0J RS1/8S0R0J RS1/8S473J RCP1045
Other Resistors	RS1/10S□□□□J

OTHERS

BN6202	2P ANTENNA TERMINAL	AKA7001
X6202	CERAMIC RESONATOR (456kHz)	ASS1066
X6201	CRYSTAL RESONATOR (7.2000MHz)	ASS1093
CN6201	14P SOCKET	KP200IA14L

B CD ASSY

SEMICONDUCTORS

IC8301 IC8101 IC8201 Q8101 Q8351,Q8352	BA5970FP CXA1821M CXD2587Q 2SA854S 2SB1237X
Q8353,Q8354 Q8201 Q8202 Q8203,Q8355,Q8356 D8201,D8202,D8351-D8354	2SD1858X DTA124EK DTC114EK DTC143EK 1SS355

COILS

L8101,L8651 L8301	LFA100J LFA470J
----------------------	--------------------

CAPACITORS

C8256,C8359,C8364 C8201 C8110,C8202,C8604 C8239,C8246,C8247,C8401,C8402 C8322,C8324	CCSQCH101J50 CCSQCH120J50 CCSQCH220J50 CCSQCH221J50 CCSQCH681J50
C8403,C8404 C8405,C8406 C8102,C8104,C8652 C8203,C8233,C8240,C8242,C8249 C8602	CCSQSL681J50 CEAT100M50 CEAT101M10 CEAT101M6R3 CEAT101M6R3

Mark	No.	Description	Part No.
	C8301 C8409,C8411 C8109,C8111 C8351 C8238		CEAT102M6R3 CEAT221M10 CEAT330M25 CEAT331M10 CEATR47M50
	C8407,C8408 C8204-C8206,C8237,C8253,C8373 C8107,C8245 C8236,C8415,C8416 C8231,C8331		CKSQYB102K50 CKSQYB103K50 CKSQYB104K25 CKSQYB152K50 CKSQYB222K50
	C8341,C8342 C8235 C8311,C8312 C8332 C8101,C8103,C8106,C8108,C8112		CKSQYB333K50 CKSQYB473K50 CKSQYB681K50 CKSQYB822K50 CKSQYF103Z50
	C8232,C8234,C8241,C8248 C8250,C8251,C8302-C8306,C8358 C8363,C8413,C8414,C8417,C8601 C8603,C8651,C8653		CKSQYF103Z50 CKSQYF103Z50 CKSQYF103Z50 CKSQYF103Z50

RESISTORS

R8343,R8344 R8341,R8342 Other Resistors	RS1/10S1802F RS1/10S4702F RS1/10S□□□□J
---	--

OTHERS

X8201	CRYSTAL RESONATOR (16.9344MHz)	PSS1008
CN8204 CN8201 CN8203	8P FFC CONNECTOR 19P FFC CONNECTOR 2P TOP POST	52044-0845 52045-1945 B2P-SHF-1AA
JA8651 CN8002 CN8101	OPTICAL LINK OUT FFC CONNECTOR 11P FFC CONNECTOR 16P	GP1F32T SLW11R-1C7 SLW16R-1C7

C MOTOR ASSY

SWITCH

S9503	ASG7009
-------	---------

OTHERS

J9502	JUMPER WIRE 4P MOTOR PULLEY CARRIAGE MOTOR (LOADING)	D20PWW0405E PNW1634 VXM1033
-------	---	-----------------------------------

D SW ASSY

SWITCHES

S9502 S9501	ASG7009 DSG1017
----------------	--------------------

OTHERS

J9501	JUMPER WIRE 6P	D20PWY0610E
-------	----------------	-------------

E TRADE ASSY

OTHERS

CN9501 CN9001 CN9002	6P JUMPER CONNECTOR KR CONNECTOR FFC CONNECTOR 11P	52147-0610 S6B-PH-K-S SLW11R-1C7
----------------------------	--	--

Mark	No.	Description	Part No.	Mark	No.	Description	Part No.
F AF ASSY (XWZ3310)				CAPACITORS			
SEMICONDUCTORS							
		IC3836	BA3838F			C3345,C3346 (0.01μF)	ACG7021
△		IC2101,IC3101,IC3102,IC3501,IC3502	BA4558F-HT			C5756	CCSQCH561J50
		IC5691	BA4558F-HT			C2301,C2302	CCSRCH100D50
△		IC5751	BU1923F			C3001,C3002,C3047,C3048,C3858	CCSRCH101J50
		IC5891,IC5892	BU4094BCF			C2192	CCSRCH220J50
		IC2201	HA12136AF			C5751,C5752,C5755	CCSRCH270J50
		IC2301	HA12211NT			C5757	CCSRCH271J50
		IC3001	LC75394NED			C2327-C2330,C3321,C3322,C3852	CCSRCH470J50
△		IC42	NJM7805FA			C3854	CCSRCH470J50
△		IC32	NJM7812FA			C3994,C3995	CCSRCH681J50
		IC3301	STK407-090B			C3319,C3320	CCSRCH6R0D50
		Q3354,Q3601,Q3621,Q5751	2SA1037K			C3311,C3312,C3507,C3508	CEANL1R0M50
		Q2806	2SB1197K			C3317,C3318	CEANP220M35
		Q2803,Q2804	2SC1815			C3621	CEANP2R2M2A
		Q2801	2SC2240			C3313,C3314	CEANP2R2M50
		Q2102,Q2201,Q2202,Q3101,Q3102	2SC2412K			C3441	CEANP330M2A
		Q3353,Q3603,Q3605-Q3608	2SC2412K			C2207,C2803,C2810,C3045,C3115	CEAT100M50
		Q3081	2SD1858X			C32,C33,C35,C3602,C3842	CEAT100M50
△		Q31	2SD2012			C43,C5691,C5692,C5758	CEAT100M50
		Q2203,Q2204,Q2805,Q3311,Q3312	2SD2114K			C2002,C2316	CEAT101M16
		Q2301,Q2302,Q3501,Q3502	2SK368			C3303,C3304	CEAT101M50
		Q3313,Q3503	DTA124EK			C2312,C2313,C3035,C3036,C3110	CEAT1R0M50
		Q2104,Q2105,Q3314,Q5752	DTC124EK			C3506	CEAT1R0M50
		Q2103,Q2306,Q2802,Q2807	DTC143EK			C2106,C2214,C2215,C2321,C2322	CEAT220M50
△		Q3352	IRF540A			C2001,C3601	CEAT221M16
△		Q3351	IRF9540A	△		C41	CEAT222M25
△		D3301,D3302	1SR139-100			C2201,C2202,C2205,C2206	CEAT2R2M50
		D2191,D2301-D2306,D3101,D3102	1SS133			C2212,C2213,C2319,C2320	CEAT2R2M50
		D3351-D3354,D3361,D3362,D3601	1SS133			C3005-C3010,C3015-C3018,C3037	CEAT2R2M50
		D3603,D3604,D3621,D3622	1SS133			C3039,C3091,C3104	CEAT2R2M50
		D3625,D3626,D46	1SS133			C2804,C2805,C5754	CEAT330M16
		D2102,D2103,D2201,D2202,D3051	1SS355			C3107	CEAT3R3M50
		D63,D64	1SS355			C3841	CEAT470M16
△		D3355,D3356	20E2-FC			C3501,C3502,C3509,C3510	CEAT470M25
		D3083	MTZJ11C			C3081,C3108,C3109,C3857	CEAT4R7M50
		D61	MTZJ12C			C3021,C3022	CEATR10M50
		D35,D36	MTZJ15C			C2203,C2204	CEATR22M50
		D3359,D3360	MTZJ18B			C3011,C3012,C3043,C3044,C3082	CEATR47M50
		D3363,D3364	MTZJ39C			C3102,C3325	CEATR47M50
		D2001	MTZJ6.2A			C3046	CEJA100M50
		D48	MTZJ6.8C			C3038,C3040	CEJA2R2M50
		D3357,D3358	MTZJ7.5C			C3027,C3028	CFTLA334J50
		D51,D52	S5688G			C3023,C3024	CFTLA564J50
						C2802	CKCYB681K2H
						C2194	CKSQYB105K10
						C3845	CKSQYB224K16
						C3447,C3448,C3991,C5753,C5892	CKSRYB102K50
						C1997,C2315,C2317,C2318,C3053	CKSRYB103K50
						C3098,C3103,C3329,C3330	CKSRYB103K50
						C2003,C2004,C2191,C2193	CKSRYB104K16
						C3025,C3026,C3099,C3846,C3847	CKSRYB104K16
						C5891	CKSRYB104K16
						C3033,C3034,C3073-C3076	CKSRYB122K50
						C2208,C2209	CKSRYB152K50
						C3315,C3316	CKSRYB222K50
						C2323,C2326	CKSRYB223K50
						C2812,C2813	CKSRYB272K50
						C2808,C2809	CKSRYB332K50
						C2333,C2334	CKSRYB392K50
						C2807,C3051,C3052,C3851,C3853	CKSRYB472K50
COILS AND FILTERS							
		L3331-L3334 AF CHOKE COIL	ATH-133				
		L2801 OSC COIL	ATX7002				
		L2301,L2302	LTA822J				
		L101 FERRITE BEAD	VTH1024				
		F2201,F2202 MPX FILTER	XTF3002				
		L5751 AXIAL INDUCTOR	XTL3002				
RELAYS							
		RY3601	ASR7008				

XR-A6800, XR-A4800

Mark	No.	Description	Part No.
	C3855		CKSRYB472K50
	C3101,C3111,C3112,C3844,C3850		CKSRYB473K16
	C2303,C2304,C2343,C2344		CKSRYB561K50
	C3029,C3030		CKSRYB563K16
	C3019,C3020,C3031,C3032		CKSRYB682K50
	C3503,C3504		CKSRYB682K50
	C2307,C2308,C2331,C2332		CKSRYB821K50
	C3331-C3333,C3335-C3338		CKSRYF104Z50
	C2801		CQHA822J2A
	C2210,C2211		CQMBA103J50
	C2806		CQMBA223J50
RESISTORS			
	R2813		RD1/2LMF471J
	R2809		RD1/2LMF4R7J
	R2812		RD1/2LMF680J
	R3333,R3334		RD1/4LMF101J
	R3353,R3354		RD1/4PU101J
	R3081		RD1/4PU221J
	R3317,R3318		RD1/4PU823J
	R3605		RS1/10S103J
	R3357,R3358		RS1/10S153J
	R2309		RS1/10S222J
	R3330,R3611,R3612		RS1/10S223J
	R2001		RS1/10S471J
	R3319,R3320		RS1/10S561J
	R3355,R3356		RS1/10S563J
	R3315,R3316,R3603,R3604		RS1/10S823J
△	R61		RS1LMF821J
	R3991,R3992		RS2LMF331J
	R3601,R3602		RS3LMFR22J
	VR2303-VR2306 (10kΩ)		VCP1156
	VR2301,VR2302 (100kΩ)		VCP1162
	VR2801,VR2802 (220kΩ)		VCP1164
	Other Resistors		RS1/16S□□□□

OTHERS

	14P CABLE HOLDER	51063-1405
CN1052	8P FFC CONNECTOR	52045-0845
CN3331	4P SPEAKER TERMINAL	AKE7018
X5751	CRYSTAL RESONATOR (4.332MHz)	ASS7004
CN2302	KR CONNECTOR	B2B-PH-K-S
CN2303	KR CONNECTOR	B3B-PH-K-R
CN2301	KR CONNECTOR	B3B-PH-K-S
J11	JUMPER WIRE	D15A14-450-2651
CN5105	27P FFC CONNECTOR	HLEM27S-1
CN3051	14P PLUG	KM200IB14
	PCB BINDER	VEF1040
JA3001,JA3441	2P PIN JACK	VKB1060
JA3991	HEADPHONE JACK	XKN3004

F AF ASSY (XWZ3297)

SEMICONDUCTORS

△	IC3836	BA3838F
△	IC2101,IC3101,IC3102,IC3501,IC3502	BA4558F-HT
	IC5691	BA4558F-HT
△	IC5751	BU1923F
	IC5891	BU4094BCF

Mark	No.	Description	Part No.
	IC2301		HA12211NT
	IC3001		LC75394NED
△	IC42		NJM7805FA
△	IC32		NJM7812FA
△	IC3301		STK407-070B
	Q3354,Q3601,Q3621,Q5751		2SA1037K
	Q2803,Q2804		2SC1815
	Q3101,Q3102,Q3353,Q3603		2SC2412K
	Q3605-Q3608		2SC2412K
	Q3081		2SD1858X
△	Q31		2SD2012
	Q2805,Q3311,Q3312		2SD2114K
	Q2301,Q2302,Q3501,Q3502		2SK368
	Q3313,Q3503		DTA124EK
	Q3314,Q5752		DTC124EK
	Q2306		DTC143EK
△	Q3351		IRF19Z34G
△	Q3352		IRFIZ34G
△	D3301,D3302		1SR139-100
△	D2191		1SS133
	D2301-D2306		1SS133
△	D3101,D3102		1SS133
	D3351-D3354,D3361,D3362,D3601		1SS133
	D3603,D3604,D3621,D3622		1SS133
	D3625,D3626		1SS133
△	D46		1SS133
	D2201,D2202,D3051,D63,D64		1SS355
△	D3355,D3356		20E2-FC
	D3083		MTZJ11C
	D61		MTZJ12C
	D35,D36		MTZJ15C
	D3359,D3360		MTZJ18B
	D3363,D3364		MTZJ39C
	D2001		MTZJ6.2A
	D48		MTZJ6.8C
	D3357,D3358		MTZJ7.5C
	D51,D52		S5688G

COILS

L3331-L3334	AF CHOKE COIL	ATH-133
L2801	OSC COIL	ATX7002
L2301,L2302		LTA822J
L5751	AXIAL INDUCTOR	XTL3002

RELAYS

RY3601		ASR7008
--------	--	---------

CAPACITORS

C3345,C3346 (0.01μF)		ACG7021
C2335-C2338		CCCCH270J50
C5756		CCSQCH561J50
C2301,C2302		CCSRCH100D50
C3001,C3002,C3047,C3048,C3858		CCSRCH101J50
C2192		CCSRCH220J50
C5751,C5752,C5755		CCSRCH270J50
C5757		CCSRCH271J50
C2327-C2330,C3321,C3322,C3852		CCSRCH470J50
C3854		CCSRCH470J50
C3994,C3995		CCSRCH681J50
C3319,C3320		CCSRCH6R0D50
C3311,C3312,C3507,C3508		CEANL1R0M50
C3317,C3318		CEANP220M35
C3621		CEANP2R2M2A

Mark	No.	Description	Part No.
	C3313, C3314		CEANP2R2M50
	C2810, C3045, C3115, C32, C33		CEAT100M50
	C35, C3602, C3842, C43		CEAT100M50
	C5691, C5692, C5758		CEAT100M50
	C2002, C2316		CEAT101M16
	C3303, C3304		CEAT101M50
	C2312, C2313, C3035, C3036, C3110		CEAT1R0M50
	C3506		CEAT1R0M50
	C2214, C2215, C2321, C2322		CEAT220M50
	C2001, C3601		CEAT221M16
△	C41		CEAT222M25
	C2212, C2213, C2319, C2320		CEAT2R2M50
	C3005-C3010, C3015-C3018, C3037		CEAT2R2M50
	C3039, C3091, C3104		CEAT2R2M50
	C2804, C2805, C5754		CEAT330M16
	C3107		CEAT3R3M50
	C3841		CEAT470M16
	C3501, C3502, C3509, C3510		CEAT470M25
	C3081, C3108, C3109, C3857		CEAT4R7M50
	C3021, C3022		CEATR10M50
	C3011, C3012, C3043, C3044, C3082		CEATR47M50
	C3102, C3325		CEATR47M50
	C3046		CEJA100M50
	C3038, C3040		CEJA2R2M50
	C3027, C3028		CFTLA334J50
	C3023, C3024		CFTLA564J50
	C2194		CKSQYB105K10
	C3845		CKSQYB224K16
	C1997, C2315, C2317, C2318, C3053		CKSRYB103K50
	C3098, C3103, C3329, C3330, C5753		CKSRYB103K50
	C2191, C2193, C3025, C3026, C3099		CKSRYB104K16
	C3846, C3847, C5891		CKSRYB104K16
	C3033, C3034, C3073-C3076		CKSRYB122K50
	C3315, C3316		CKSRYB222K50
	C2323, C2326		CKSRYB223K50
	C2812, C2813		CKSRYB272K50
	C2808, C2809		CKSRYB332K50
	C2333, C2334		CKSRYB392K50
	C2807, C3051, C3052, C3853, C3855		CKSRYB472K50
	C3101, C3111, C3112, C3844, C3850		CKSRYB473K16
	C2303, C2304, C2343, C2344		CKSRYB561K50
	C3029, C3030		CKSRYB563K16
	C3019, C3020, C3031, C3032		CKSRYB682K50
	C3503, C3504		CKSRYB682K50
	C2307, C2308, C2331, C2332		CKSRYB821K50
	C3331-C3333, C3335-C3338		CKSRYF104Z50
	C2801		CQHA822J2A
	C2806		CQMA223J50

RESISTORS

R2812	RD1/2LMF470J
R2809	RD1/2LMF4R7J
R3333, R3334	RD1/4LMF101J
R3353, R3354	RD1/4PU101J
R2113	RD1/4PU103J
R3081	RD1/4PU221J
R3317, R3318	RD1/4PU823J
R3605	RS1/10S103J
R3357, R3358	RS1/10S153J
R2309	RS1/10S222J

Mark	No.	Description	Part No.
	R3330, R3611, R3612		RS1/10S223J
	R2001		RS1/10S471J
	R3319, R3320		RS1/10S561J
	R3355, R3356		RS1/10S563J
	R3315, R3316, R3603, R3604		RS1/10S823J
	R61		RS1LMF821J
△	R3991, R3992		RS2LMF331J
	R3601, R3602		RS3LMFR22J
	VR2802 (100kΩ)		VCP1162
	Other Resistors		RS1/16S□□□□

OTHERS

	14P CABLE HOLDER	51063-1405
CN1052	8P FFC CONNECTOR	52045-0845
CN5105	27P FFC CONNECTOR	52045-2745
CN3331	4P SPEAKER TERMINAL	AKE7018
X5751	CRYSTAL RESONATOR (4.332MHz)	ASS7004
CN2302	KR CONNECTOR	B2B-PH-K-S
CN2303	KR CONNECTOR	B3B-PH-K-R
CN2301	KR CONNECTOR	B3B-PH-K-S
J11	JUMPER WIRE	D15A14-450-2651
CN3051	14P PLUG	KM200IB14
	PCB BINDER	VEF1040
JA3001	2P PIN JACK	VKB1060
JA3991	HEADPHONE JACK	XKN3004

G SECONDARY ASSY

SEMICONDUCTORS

△	IC71 (1.25A)	AEK7010
△	IC41 (3A)	AEK7015
△	IC12 (10A)	AEK7022
△	IC21, IC22 (7A)	AEK7047
△	IC11 (10A)	AEK7068
	Q71	2SA965
	D73	1SS133
△	D11, D21	G5SBA20L
	D74	MTZJ33C
	D75	MTZJ8.2B
	D71, D72, D78-D81	S5688G

CAPACITORS

	C72	CEAT220M50
	C71	CEAT221M63
△	C21, C22	CEAT332M50
	C13	CQMA223K2E
△	C11, C12 (4700μF/71V)	XCH3001

RESISTORS

All Resistors	RD1/4PU□□□□
---------------	-------------

OTHERS

14P CABLE HOLDER	51063-1405
------------------	------------

H PRIMARY ASSY

SEMICONDUCTORS

△	IC81	NJM7805FA
	Q81	2SD1859X
	D85, D88-D90	1SS133
△	D81	S1WB(A)60SD

XR-A6800, XR-A4800

Mark	No.	Description	Part No.
COIL			
	L1	LINE FILTER	ATF1136
TRANSFORMERS			
△	T2		XTT3004
RELAY			
△	RY81		ASR7018
CAPACITORS			
△	C1,C2 (0.01μF)		ACE7027
	C83		CEAT100M50
△	C82		CEAT102M25
RESISTORS			
	All Resistors		RD1/4PU□□□□

OTHERS

	H1,H2	FUSE CLIP	AKR7001
△	CN1	2P VH CONNECTOR	B2P3-VH
△	CN2	4P VH CONNECTOR	B4P7-VH
△	AN1	1P AC INLET	XKP3041

I DISPLAY ASSY

SEMICONDUCTORS

IC3901	BA4558F-HT
IC5501	PDC063A
Q5501	2SA1037K
Q2903,Q2906,Q2908	2SB1132
Q5602,Q5656-Q5658,Q5801	2SC2412K
Q2910,Q2911,Q5826	DTA124EK
Q5601	DTC124EK
Q2901,Q2904,Q2907,Q5502,Q5604	DTC143EK
Q5650-Q5655,Q5821-Q5825,Q5827	DTC143EK
D5593-D5596,D5626,D5811	1SS133
D5551-D5554,D5561-D5568	1SS181
D2901-D2903,D5631,D5652-D5655	1SS355
D5657,D5658,D5901	1SS355
D5601-D5608,D5610,D5611	SLP3118C51H
D5615,D5616,D5618,D5622,D5904	SLP3118C51H
D5612,D5614,D5617,D5621	SLP6118C51H
D5902	SLP7118C51H
D5619,D5620,D5903	SLP9118C51H
D5651	UDZS5.6B

COILS

L3901,L3902	CHIP COIL	LCTB100K1608
L3914,L3915	CHIP SOLID INDUCTOR	VTL1145
L5811	AXIAL INDUCTOR	XTL3004

SWITCHES

S5911-S5921,S5923-S5929	XSG3001
S5931-S5940	XSG3001
S5951	XSX3003
S5952	XSX3004

CAPACITORS

C5812 (0.047F/5.5V)	ACH1246
C3920,C3921	CCSRCH101J50
C3903	CCSRCH331J50
C3914,C3915	CCSRCH470J50
C3913	CCSRCH471J50

Mark	No.	Description	Part No.
	C5821		CEAL100M16
	C5803		CEJA1ROM50
	C3901,C3902,C3904,C3906		CEJA2R2M50
	C3905,C5510,C5811,C5814		CEJA470M16
	C5997,C5998		CKSQYB104K25
	C5999		CKSQYB105K10
	C5625		CKSQYF224Z25
	C5804,C5951,C5953		CKSRYB102K50
	C3911,C3951,C3952,C5995,C5996		CKSRYB103K50
	C5816		CKSRYB104K16
	C5506		CKSRYB471K50
	C3907,C3909,C5503,C5504,C5509		CKSRYB472K50
	C5507,C5508		CKSRYB473K16
	C3922		CKSRYB561K50
	C5634,C5901		CKSRYF104Z50
	C5813,C5822		CKSRYF473Z50

RESISTORS

R5506,R5508	RA7T104J
R2905,R5524,R5536	RD1/4PU102J
R5601,R5613,R5617	RD1/4PU151J
R5530	RD1/4PU221J
R5609	RD1/4PU391J
R2902,R2907	RD1/4PU681J
R5805	RS1/10S101J
R5902-R5904	RS1/10S221J
R5614,R5616	RS1/10S471J
R5606-R5608	RS1/10S620J
VR3901 (10k-X1)	XCS3002
Other Resistors	RS1/16S□□□□

OTHERS

X5501	CERAMIC RESONATOR (10MHz)	DSS1048
	2P CABLE HOLDER	51048-0200
	4P CABLE HOLDER	51048-0400
CN5502	FFC CONNECTOR 19P	52492-1920
JA3901,JA3902	REMOTE CONTROL JACK	AKN7004
J5601	JUMPER WIRE 2P	D20PYY0210E
J81	JUMPER WIRE 4P	D20PYY0425E
X5901	REMOTE RECEIVER UNIT	GP1U28X
CN2901	FFC CONNECTOR 15P	HLEM15R-1
CN5501	FFC CONNECTOR 27P	HLEM27R-1
5621	FL HOLDER	VNF1096
V5621	FL TUBE	XAV3009

J BLUE LED ASSY

SEMICONDUCTOR

D5613	E1L4E-7B(123)
-------	---------------

OTHERS

2P CABLE HOLDER	51048-0200
LED HOLDER	XAK3154

6. ADJUSTMENT

6.1 TUNER SECTION

■ FM Tuner Section

- Set the mode selector to FM BAND.
- Connect the wiring as shown in Fig. 1.

Step No.	Adjustment Title	FM SG (1kHz, ± 75kHz dev.)		Reception Frequency Display	Adjustment Location	Specifications
		Frequency (MHz)	Level (dBμV)			
1	Front End Sensitivity	106	0 to 30	106MHz	L6104 L6105 L6102 T6101	Adjust so that the DC voltage between the IC6201 - pin 20 and GND becomes at maximum level.
2	Stereo Distortion	98 (ON STEREO)	80	98MHz	T6101	Minimize the distortion with 1/8 rotation of the core.
3	TUNED IND. Lighting Level	98	18 ± 2	98MHz	VR6201	Adjust so that the indicator of TUNED IND. starts to light up.

Note:

Before adjusting, make sure there is no gap between L6101 and L6102 as well as between L6103 and L6104. If there is a gap between them, bring them into contact with each other first, and then make adjustments.

■ AM Tuner Section

- Set the mode selector to AM BAND.
- Connect the wiring as shown in Fig. 1.

Step No.	Adjustment Title	AM SG (400Hz, 30% Mod.)		Reception Frequency Display	Adjustment Location	Specifications
		Frequency (kHz)	Level (dBμV/m)			
1	Front End Sensitivity	999 (*1)	35 to 45	999kHz (*1)	T6201	Adjust so that the DC voltage between the IC6201 - pin 20 and GND becomes at maximum level.

Note (*1) : For the area using 10kHz step, frequency should be 1000kHz.

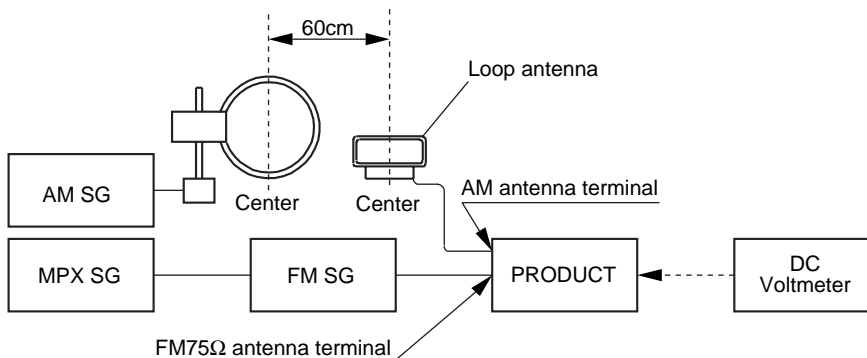

Fig.1 AM and FM Adjustment Wiring Diagram

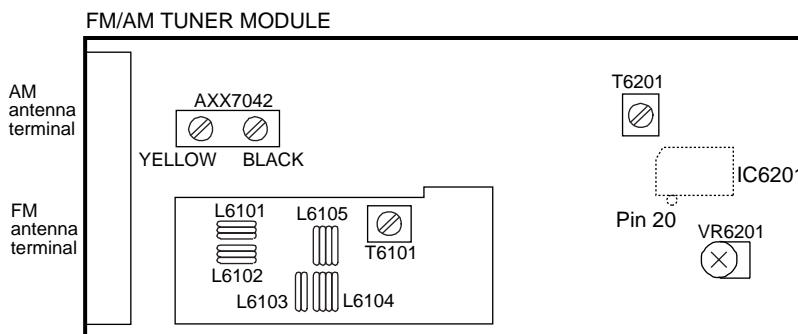

Fig.2 Adjustment Point

6.2 CASSETTE DECK SECTION

6.2.1 For XR-A6800

• Adjustment points and test points are shown in Fig.3, Fig.5 and Fig.7.

■ Mechanical Adjustment

• Test tape : NCT-111 (3kHz, 30min).

1. Tape Speed Adjustment

No.	Mode	Test Tape	Adjusting Points	Measurement Points	Adjustment Procedure	Remarks
1	Deck I PLAY	NCT-111 (Playback : 3kHz)	ADJ. VR on CASSETTE MECHA (Fig. 3)	TAPE TEST POINT (Rch) (AF Assy)	Press the PLAY SW and adjust so that the reading becomes $3000\text{Hz} \pm 20\text{Hz}$. Confirm that wow & flutter level is below 0.3% (in the reverse direction, confirm that the reading is within $3000\text{Hz} \pm 60\text{Hz}$).	

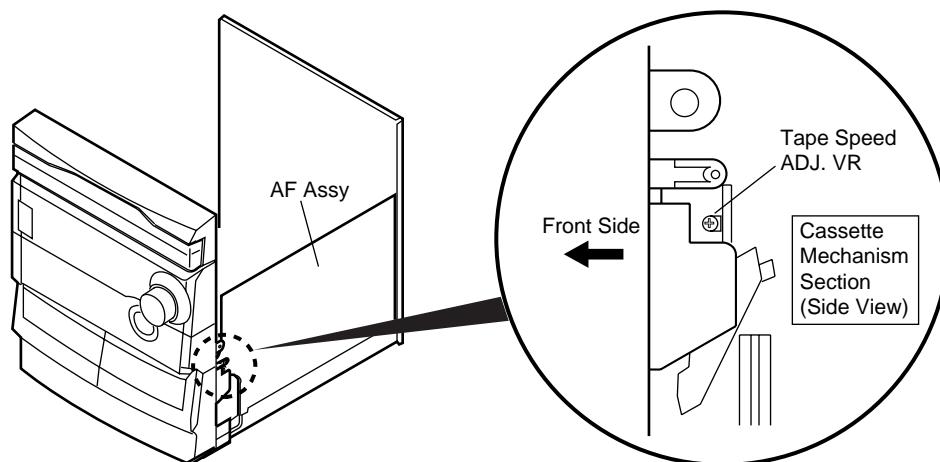

Fig.3 Tape Speed ADJ. Point

■ Electrical Adjustment

Check the following before starting.

- (1) Confirm that the tape speed adjustment has been completed.
- (2) Clean the heads and demagnetize them using a head eraser.
- (3) Set the measurement level to 0 dBV = 1 Vrms.
- (4) Use the specified tape for adjustment. Use the labeled (A) side of the test tape.
STD-331E : For playback check
STD-632 : Normal blank tape
- (5) Provide yourself with the following measuring devices:
 - AC millivoltmeter
 - Low-frequency oscillator
 - Attenuator
 - Oscilloscope
- (6) Adjust both right and left channels unless otherwise specified.
- (7) Turn the DOLBY NR switch off unless otherwise specified.
- (8) Warm up the unit for several minutes before adjustment.
In particular, be sure to warm up the unit in the REC/PLAY mode for 3 to 5 minutes before starting recording/playback frequency characteristics adjustment.
- (9) Always follow the indicated adjustment order.
Otherwise, a complete adjustment may not be achieved.

Playback Adjustment (Decks I and II)

- (1) Head Azimuth Adjustment
- (2) Playback Level Adjustment

Recording Adjustment (Deck I)

- (1) Bias Oscillation Frequency Adjustment
- (2) Recording Bias Adjustment
- (3) Recording Level Adjustment.
- (4) ALC Operation Check

* As the reference recording level is 250nwb/m for STD-331E, the recording level will be higher by 4 dB for STD-331B (160nwb/m). When adjusting, pay careful attention to the type of tape used.

*Dolby noise reduction manufactured under license from Dolby Laboratories Licensing Corporation.
"DOLBY" and the double-D symbol are trademarks of Dolby Laboratories Licensing Corporation.*

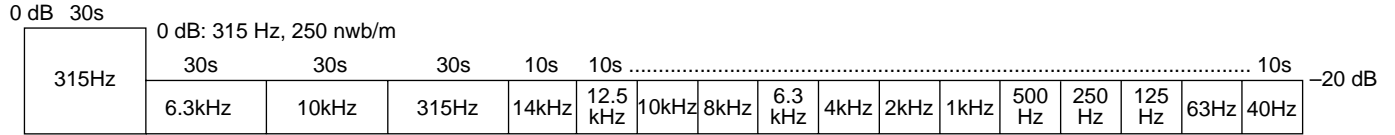

Fig.4 STD-331E Test Tape

■ Playback Adjustment

(1) Head Azimuth Adjustment

• Do not switch between forward and reverse operation with the screwdriver inserted.

Step	Mode	Input Signal/ Test Tape	Adjusting Points		Measurement Points	Adjustment Value	Remarks
1	PLAY	STD-331E test tape (Playback: 10kHz, -20dB)	Deck I	Head azimuth adjustment screw (Fig. 5)	TAPE TEST POINT (L, Rch) (AF Assy)	Max. playback signal level	After adjustment, apply silicon bond to the head azimuth adjustment screw.
			Deck II				

(2) Playback Level Adjustment

• Since this adjustment determines playback dolby NR level, perform it carefully.

Step	Mode	Input Signal/ Test Tape	Adjusting Points		Measurement Points	Adjustment Value	Remarks
1	PLAY	STD-331E test tape (Playback: 315Hz, 0dB)	Deck I	VR2303 (L ch) VR2304 (R ch)	TAPE TEST POINT (L, Rch) (AF Assy)	-3.7dBV	
			Deck II	VR2305 (L ch) VR2306 (R ch)			

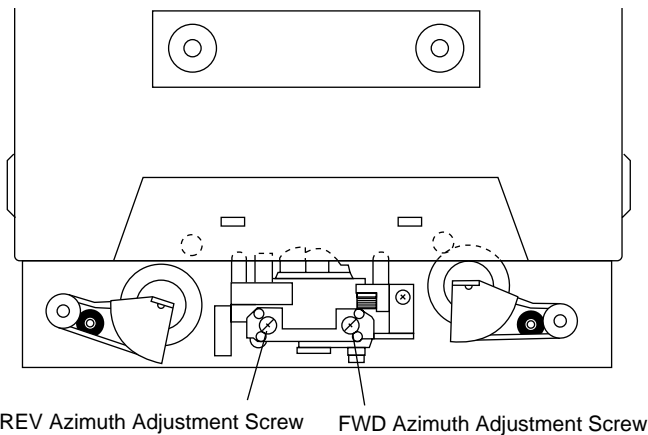
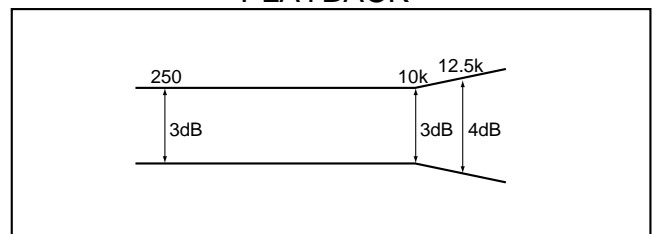

Fig. 5 Head Azimuth Adjustment Screw

PLAYBACK



RECORDING

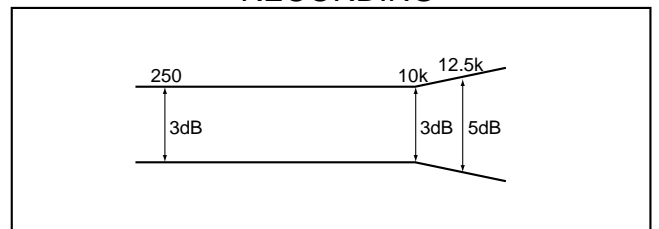

Fig. 6 Frequency Characteristics

■ Recording Adjustment

(1) Bias Oscillation Frequency Adjustment

Step	Mode	Input Signal/ Test Tape	Adjusting Points		Measurement Points	Adjustment Value	Remarks
1	REC	Load the STD-632 test tape and set the recording mode.	Deck II	_____	Between (A) point Fig. 7 and GND	Oscillation frequency to be 105.0kHz ± 2kHz.	If the REC/STOP button for four seconds while the power is in STANDBY mode, the frequency will decrease 2 to 3 kHz.
			Deck I	L2801 (AF Assy)			

(2) Recording Bias Adjustment

• Since this adjustment affects recording bias, prevent distortion from increasing due to underbias.

Step	Mode	Input Signal/Test Tape	Adjusting Points		Measurement Points	Adjustment Value	Remarks
1	REC	Input a 315 Hz signal to the AUX terminal and set the input selector to AUX.	Deck II	_____	TAPE TEST POINT (L, Rch) (AF Assy)	- 23.7 dBV	
			Deck I	Input signal level			
2	REC → PLAY	Load the STD-632 test tape and record/playback the 315Hz and 10kHz signals (see the Note below)	Deck II	_____	TAPE TEST POINT (L, Rch) (AF Assy)	Repeat adjustment until playback level of the 10kHz signal is within 0 ± 0.5 dB from that of the 315Hz signal.	
			Deck I	VR2801 (L ch) VR2802 (R ch)			

Note : Set the 10 kHz input signal level to the same value as the 315 Hz input signal level of step 1.

(3) Recording Level Adjustment

Step	Mode	Input Signal/Test Tape	Adjusting Points		Measurement Points	Adjustment Value	Remarks
1	REC	Input a 315 Hz signal to the AUX terminal and set the input selector to AUX.	Deck II	Input signal level	TAPE TEST POINT (L, Rch) (AF Assy)	- 7.7 dBV	
			Deck I				
2	REC → PLAY	Load the STD-632 test tape and record/playback the 315Hz signal.	Deck II	_____	TAPE TEST POINT (L, Rch) (AF Assy)	Repeat recording, playback and adjustment until playback level of the 315 Hz signal becomes - 7.7 dBV.	
			Deck I	VR2301 (L ch) VR2302 (R ch)			

(4) ALC Operation Check

Step	Mode	Input Signal/Test Tape	Adjusting Points		Measurement Points	Adjustment Value	Remarks
1	REC/ PAUSE	Input a 315 Hz signal to the AUX terminal and set the input selector to AUX.	Input signal level		TAPE TEST POINT (L, Rch) (AF Assy)	- 8.2 dBV	
2			Set to a level + 10dB above the input level at step 1.			Confirm that the reading is - 2.2 ± 2.5 dBV.	

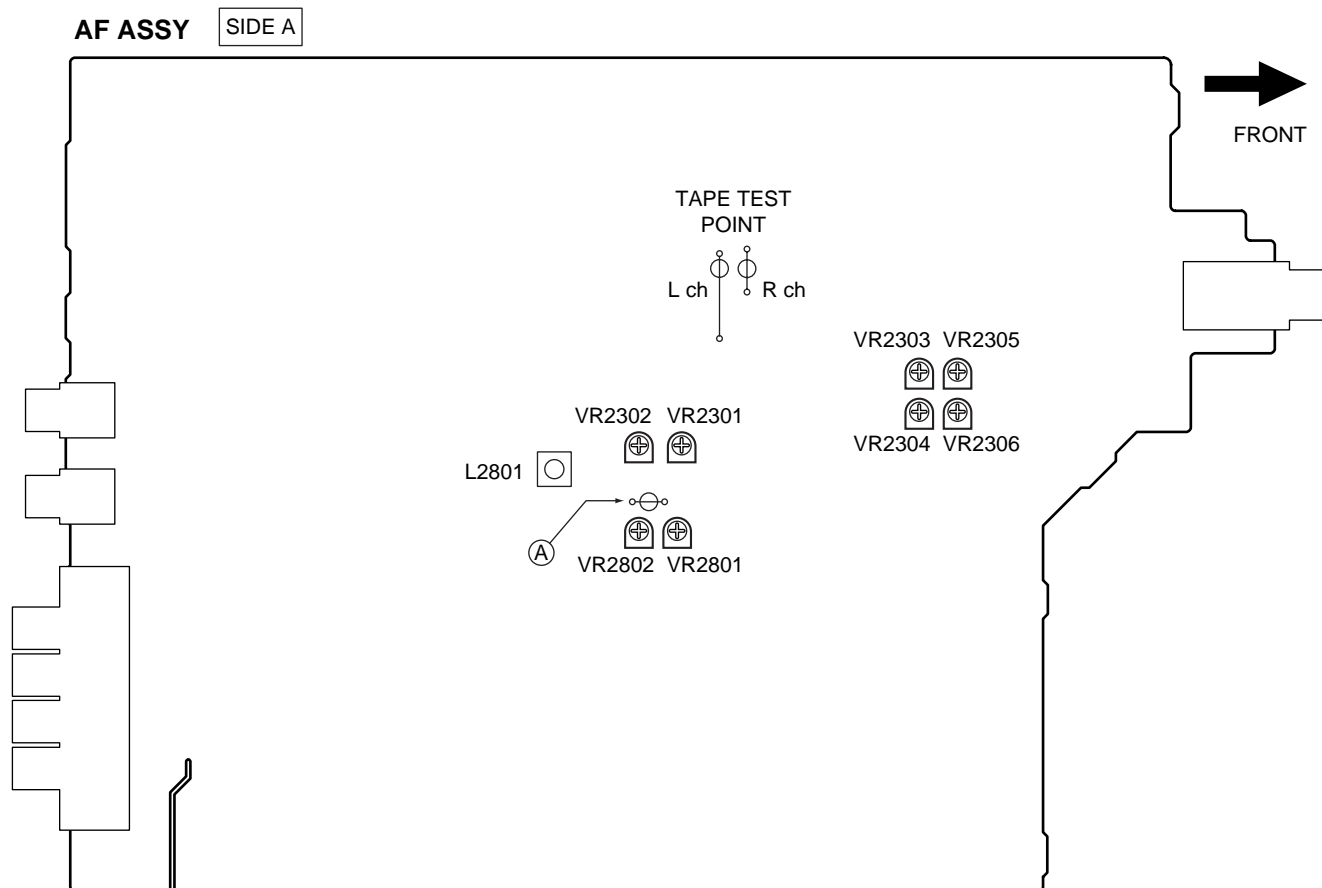

Fig.7 Adjustment and Measurement Points

6.2.2 For XR-A4800

• Adjustment points and test points are shown in Fig.8, Fig.10 and Fig.11.

■ Mechanical Adjustment

• Test tape : NCT-111 (3kHz, 30min).

1. Tape Speed Adjustment

No.	Mode	Test Tape	Adjusting Points	Measurement Points	Adjustment Procedure	Remarks
1	Deck I PLAY	NCT-111 (Playback : 3kHz)	ADJ. VR on CASSETTE MECHA (Fig. 8)	TAPE TEST POINT (Rch) (AF Assy)	Press the PLAY SW and adjust so that the reading becomes $3000\text{Hz} \pm 20\text{Hz}$. Confirm that wow & flutter level is below 0.3% (in the reverse direction, confirm that the reading is within $3000\text{Hz} \pm 60\text{Hz}$).	

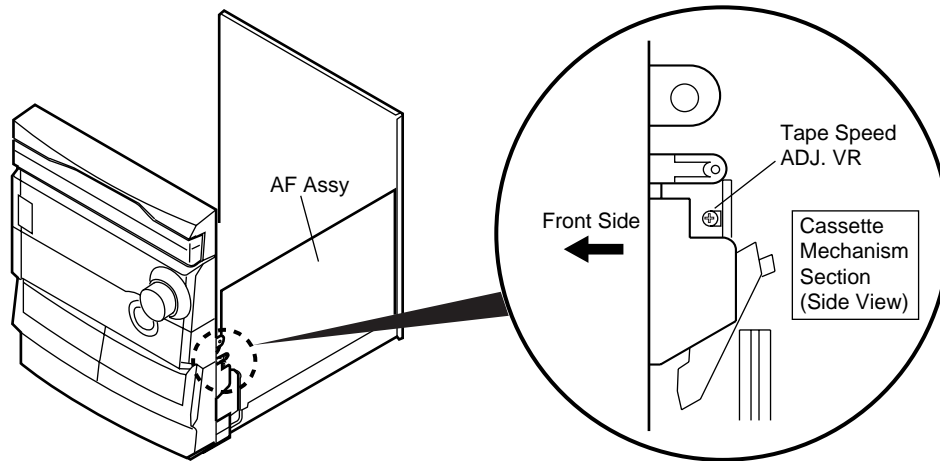

Fig.8 Tape Speed ADJ. Point

■ Electrical Adjustment

Check the following before starting.

- (1) Confirm that the tape speed adjustment has been completed.
- (2) Clean the heads and demagnetize them using a head eraser.
- (3) Set the measurement level to $0\text{ dBV} = 1\text{ Vrms}$.
- (4) Use the specified tape for adjustment. Use the labeled (A) side of the test tape.
STD-331E : For playback check
STD-632 : Normal blank tape
- (5) Provide yourself with the following measuring devices:
 - AC voltmeter (Noisemeter : filter off)
 - AC millivoltmeter
 - Low-frequency oscillator
 - Attenuator
 - Oscilloscope
- (6) Adjust both right and left channels unless otherwise specified.

- (7) Warm up the unit for several minutes before adjustment.
In particular, be sure to warm up the unit in the REC/PLAY mode for 3 to 5 minutes before starting recording/playback frequency characteristics adjustment.
- (8) Always follow the indicated adjustment order.
Otherwise, a complete adjustment may not be achieved.

Playback Adjustment (Decks I and II)

- (1) Head Azimuth Adjustment

Recording Adjustment (Deck I)

- (1) Bias Oscillation Frequency Adjustment
- (2) Recording Bias Adjustment

* As the reference recording level is 250nwb/m for STD-331E, the recording level will be higher by 4 dB for STD-331B (160nwb/m). When adjusting, pay careful attention to the type of tape used.

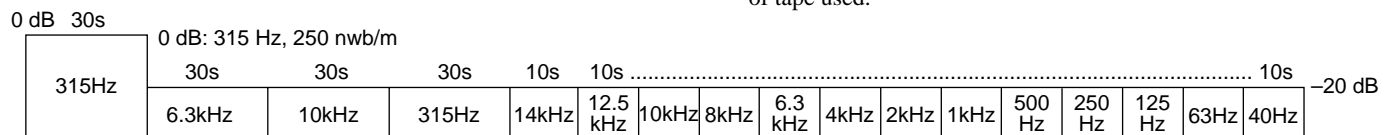
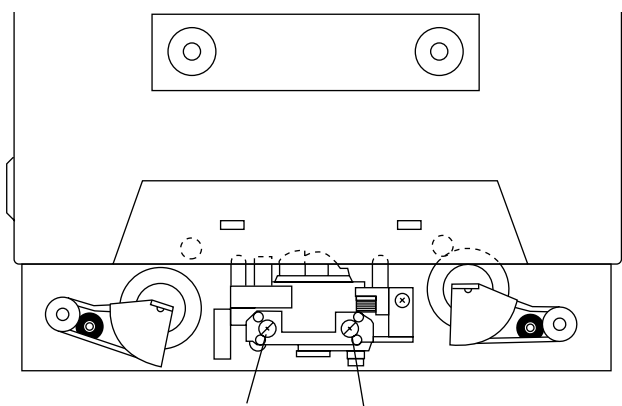

Fig.9 STD-331E Test Tape



REV Azimuth Adjustment Screw FWD Azimuth Adjustment Screw

Fig.10 Head Azimuth Adjustment Screw

■ Playback Adjustment

(1) Head Azimuth Adjustment

• Do not switch between forward and reverse operation with the screwdriver inserted.

Step	Mode	Input Signal/ Test Tape	Adjusting Points		Measurement Points	Adjustment Value	Remarks
1	PLAY	STD-331E test tape (Playback: 10kHz, -20dB)	Deck I	Head azimuth adjustment screw (Fig. 10)	TAPE TEST POINT (L, Rch) (AF Assy)	Max. playback signal level	After adjustment, apply silicon bond to the head azimuth adjustment screw.
		Deck II					

■ Recording Adjustment

(1) Bias Oscillation Frequency Adjustment

Step	Mode	Input Signal/ Test Tape	Adjusting Points		Measurement Points	Adjustment Value	Remarks
1	REC	Load the STD-632 test tape and set the recording mode.	Deck II	_____	_____	Oscillation frequency to be 105.0kHz ± 2kHz.	
			Deck I	L2801 (AF Assy)	Between ① point Fig. 11 and GND		

(2) Recording Bias Adjustment

• Since this adjustment affects recording bias, prevent distortion from increasing due to underbias.

Step	Mode	Input Signal/Test Tape	Adjusting Points		Measurement Points	Adjustment Value	Remarks
1	REC	Load the STD-632 test tape and record (No signal)	Deck I	VR2802 (AF Assy)	BIAS TP POINT (AF Assy)	24V to 27V	
2	REC → PLAY	Load the STD-632 test tape. Record the 315Hz and 10kHz signals at -25dBV input level (check ② point) and playback.	Deck II	_____	TAPE TEST POINT (L, Rch) (AF Assy)		Repeat adjustment until playback level of the 10kHz signal is within 0 ± 1.0dB from that of the 315Hz signal.
			Deck I	VR2802 (AF Assy)			

Note : No connecting to BIAS TP POINT at Step 2 REC → PLAY.

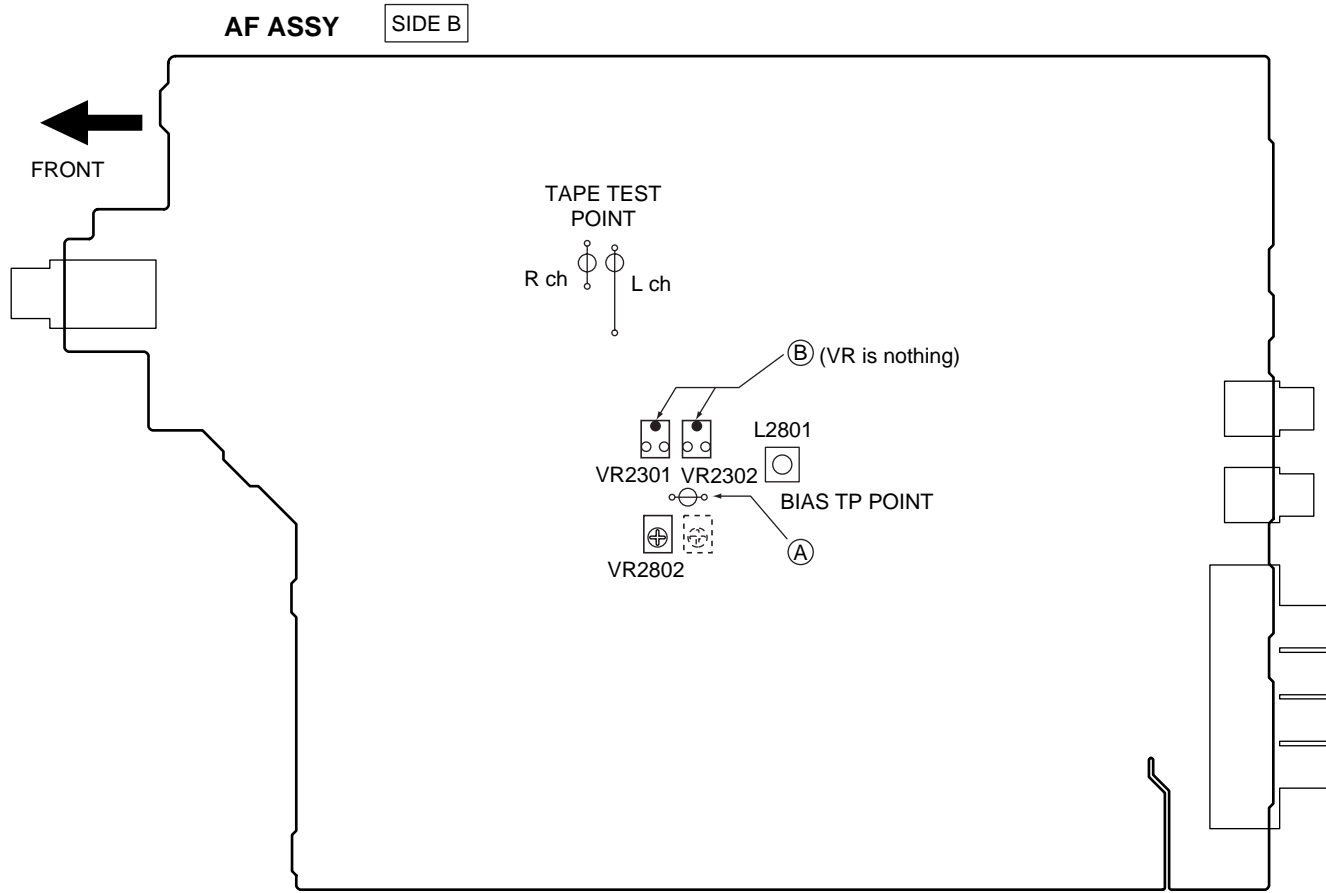

Fig.11 Adjustment and Measurement Points

6.3 TEST MODE

NOTE: There is no information to be shown in this CD adjustment.

■ How to Start/Cancel Test Mode

TEST MODE : ON

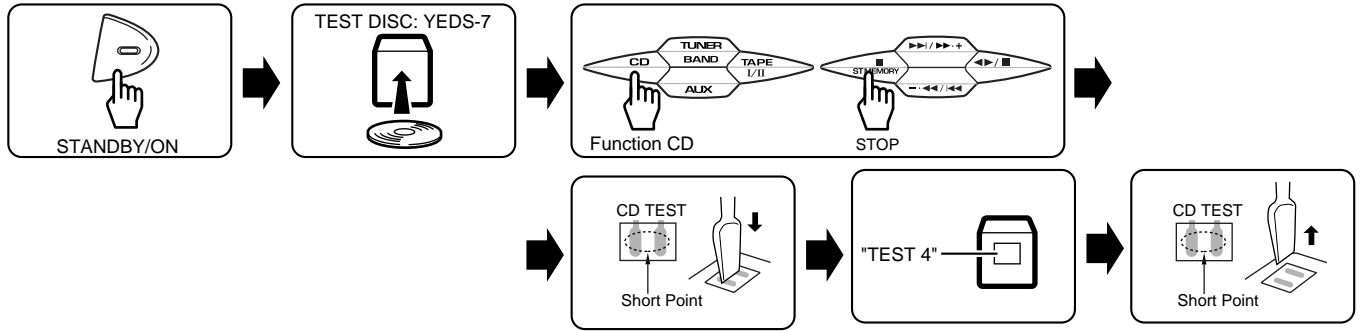

TEST MODE : PLAY

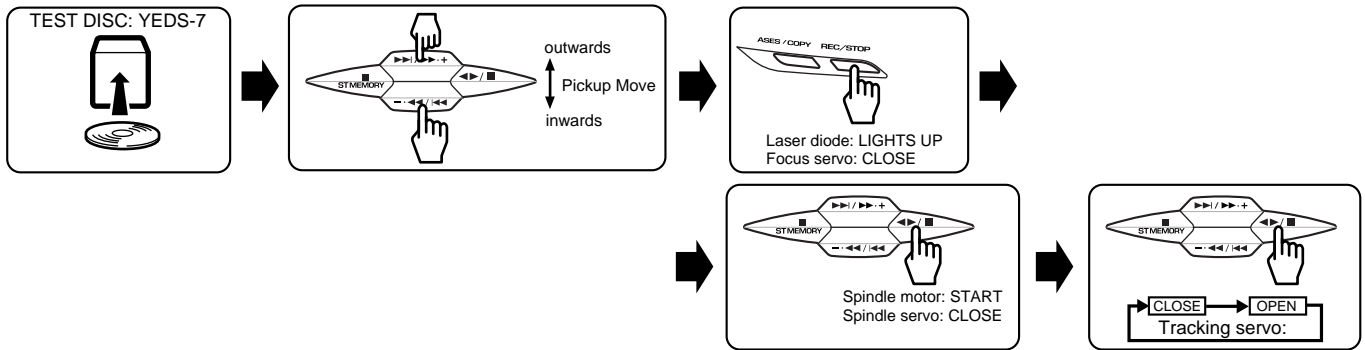

TEST MODE : STOP CANCEL

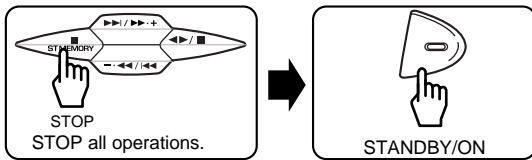

■ Test Point

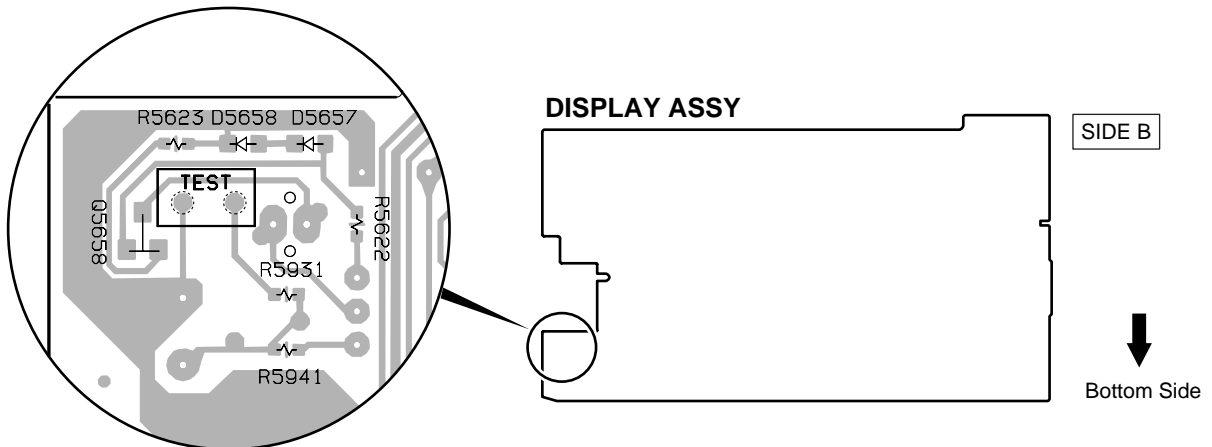

7. GENERAL INFORMATION

7.1 DIAGNOSIS

7.1.1 DISASSEMBLY

■ \$M MECHANISM CD-2

① Remove the Bonnet Case (Screws × 11)

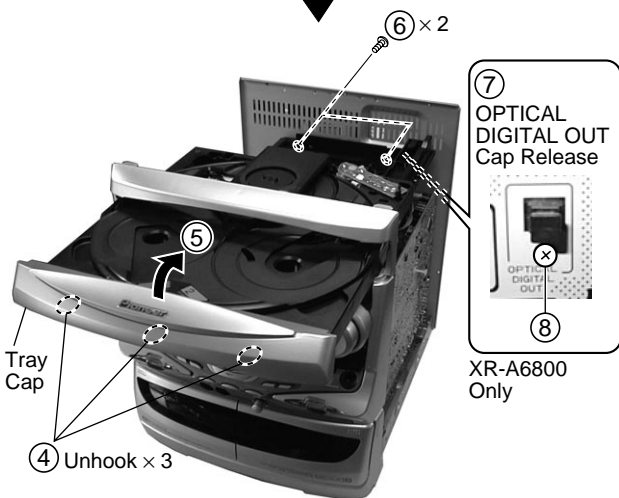
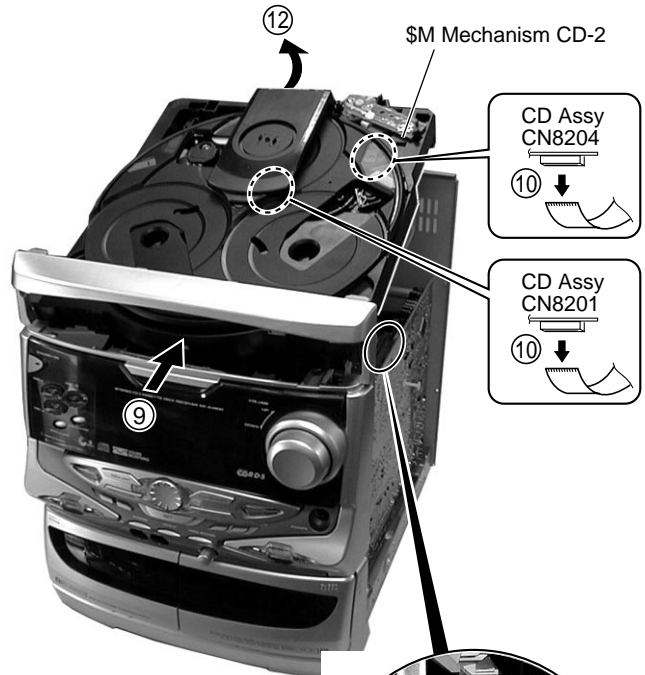
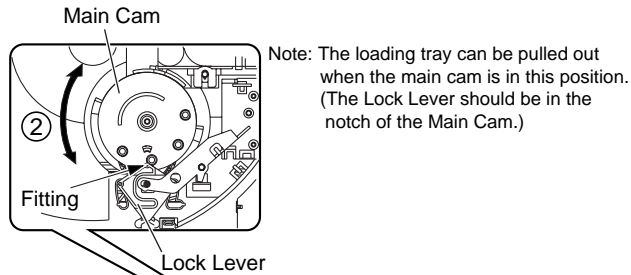

■ FRONT PANEL

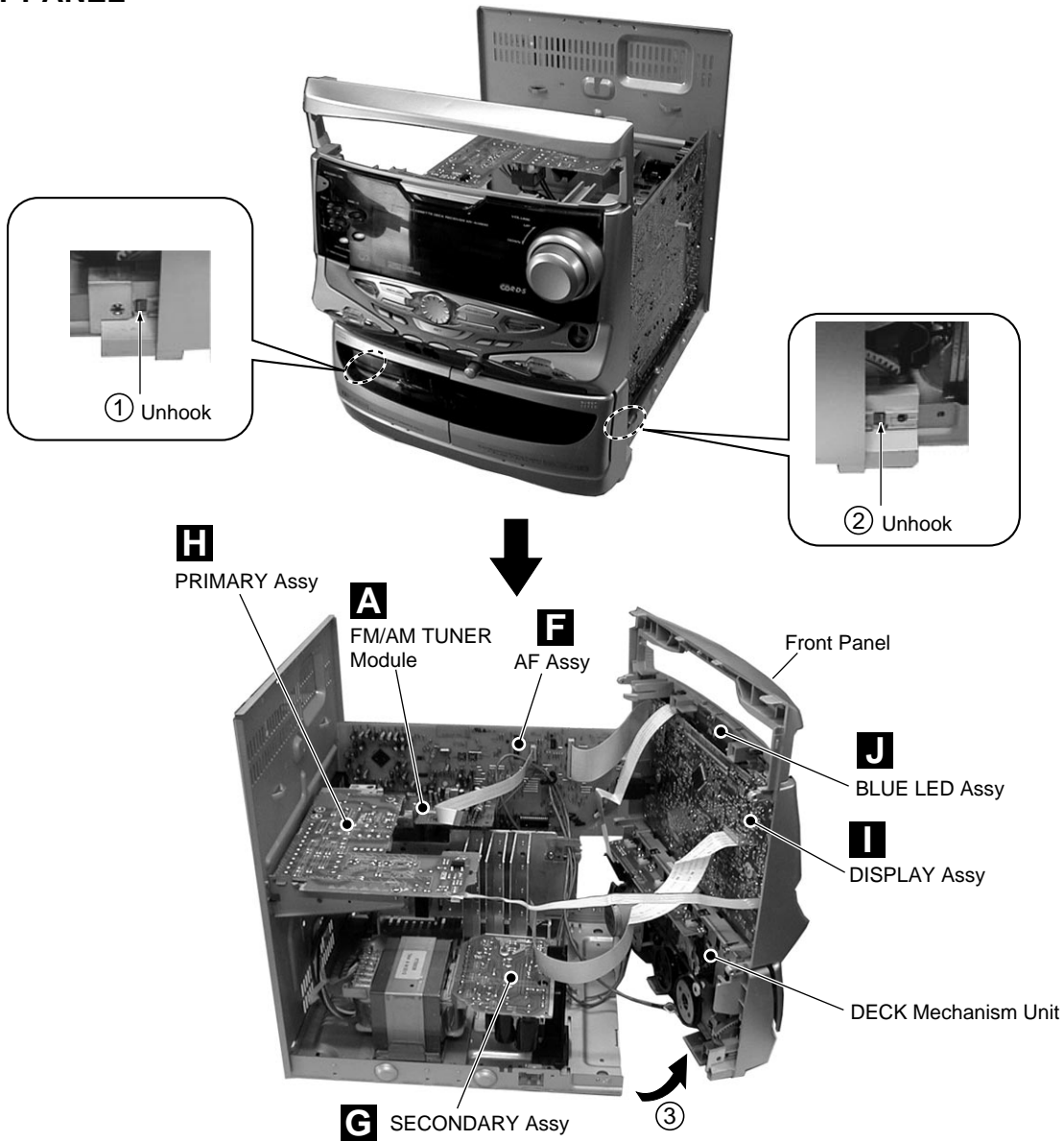

■ \$M MECHANISM CD-2 ADDITIONAL TO JOB

● Mechanism Base (Bottom View)

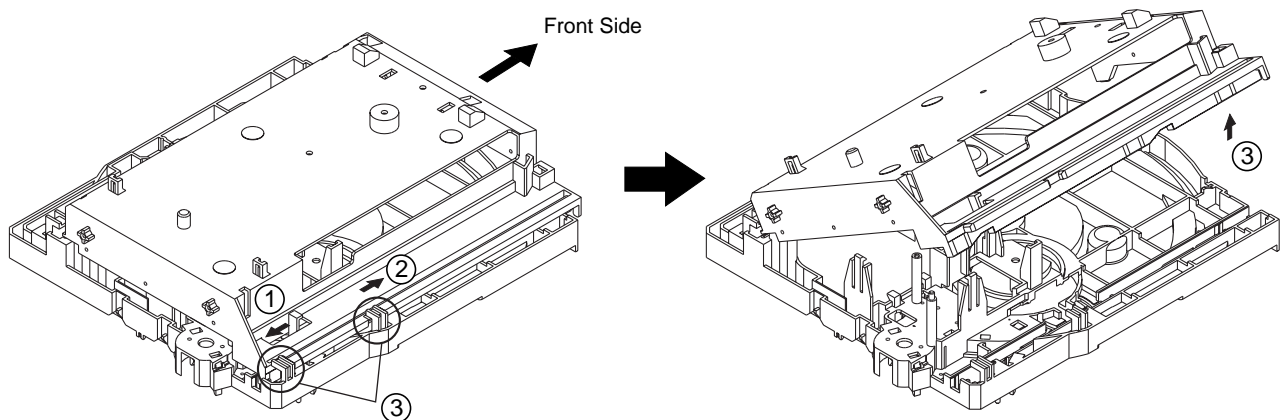

● Clamper Holder

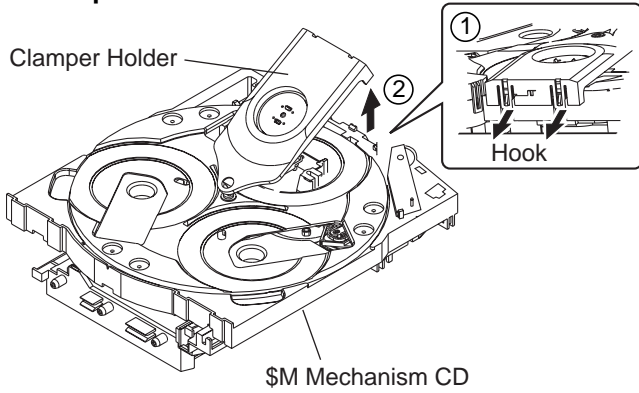

● Servo Base

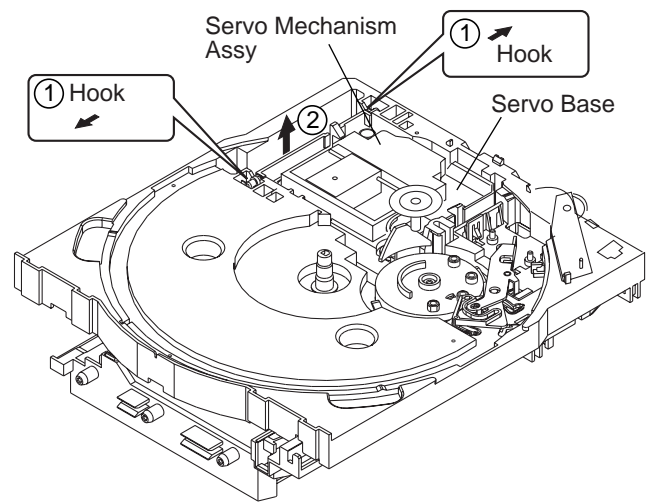

● Actuator

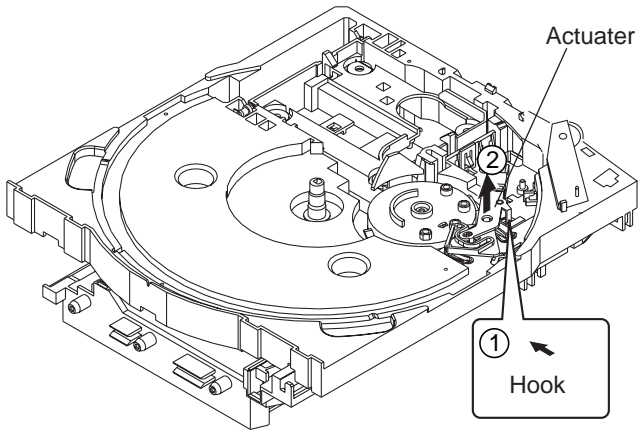

■ FITTING THE PULLEY INTO THE CARRIAGE MOTOR

For replacement of the carriage motor, fit the motor pulley by using the servicing pulley press-in station located on the loading tray, as shown in the figure on the right.

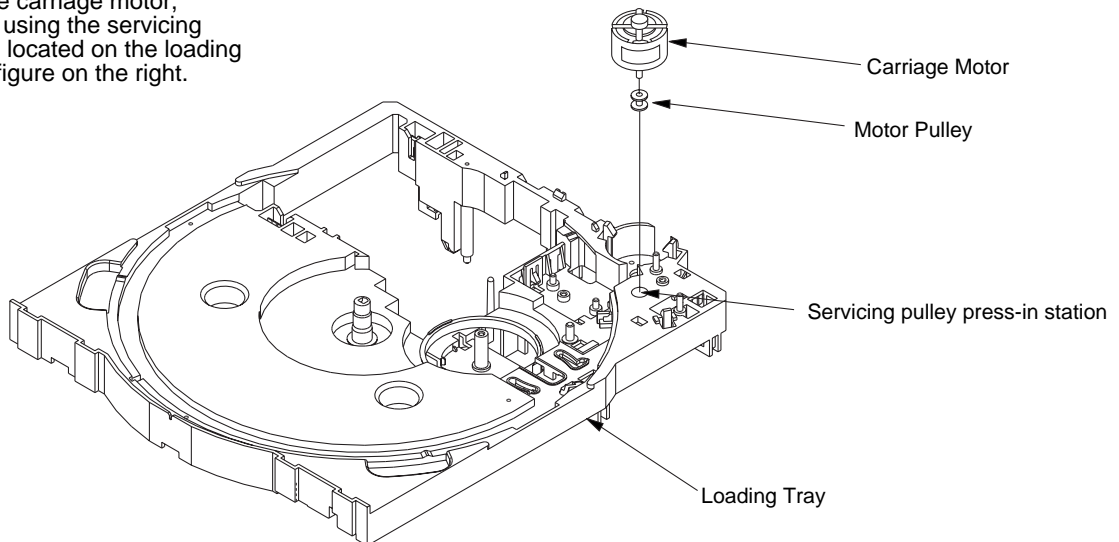

7.2 PARTS

7.2.1 IC

- The information shown in the list is basic information and may not correspond exactly to that shown in the schematic diagrams.

■ PDC063A (DISPLAY ASSY : IC5501)

- System Control Microcomputer IC

● Pin Function

No.	Pin Name	I/O	Function
1	CD RESET	O	Reset output for CD decoder
2	CD SE CLK	O	Clock output for CD decoder SENS data
3	CD SENS	I	CD SENS input
4	CD LAT	O	Latch output for CD decoder data
5	CD DCLK	O	Clock output for CD decoder data
6	CD DATA	O	CD decoder data output
7	A/V mode LED	O	Audio/Visual mode LED output
8	TIMER LED	O	TIMER LED output
9	RY ON/OFF	O	RELAY ON/OFF
10	BLUE LED	O	BLUE LED output
11	XRESET	I	CPU reset input
12	VOL JOG	I	Volume JOG input
13	MORF JOG	I	Sound morphing JOG input
14	VSS	–	Ground
15	CF1	I	
16	CF2	O	
17	VDD	–	Power supply
18	KEY1	I	Key input 1 (A/D)
19	KEY2		Key input 2 (A/D)
20	KEY3		Key input 3 (A/D)
21	MS	I	Deck MS input
22	ST/TUNE	I	Tuner STEREO/TUNE input
23	SPE-IN	I	Spectrum analyzer signal input
24	–	–	
25	CD MUTE	O	CD mute output (pull-up)
26	AC	I	AC pulse interrupt input
27	SCOR	I	CD SCOR interrupt input
28	RDS CLK	I	Tuner RDS clock interrupt input
29	REMOCON	I	Remote control interrupt input
30	G1	O	Grid output
31	G2		
32	G3		
33	G4		
34	G5		
35	G6		
36	G7		
37	G8		
38	G9		
39	G10		
40	G11		
41	G12		
42	G13		
43	G14		
44	G15		
45	S1	O	Segment 1 output
46	VDD	–	Power supply
47	S2/D5597	I/O	Segment 2 output/SW7 input
48	S3/D5598		Segment 3 output/SW6 input
49	S4/D5595		Segment 4 output/SW5 input
50	S5/D5594		Segment 5 output/SW4 input

XR-A6800, XR-A4800

No.	Pin Name	I/O	Function
51	VFDP	–	
52	S6/D5593	I/O	Segment 6 output/SW3 input
53	S7/D5592		Segment 7 output/SW2 input
54	S8/D5591		Segment 8 output/SW1 input
55	S9	O	Segment 9 output
56	S10/CLAMP	I/O	Segment 10 output/CD CLAMP SW input
57	S11/OPEN		Segment 11 output/CD OPEN SW input
58	S12/INSIDE		Segment 12 output/CD INSIDE SW input
59	S13/CDISC123		Segment 13 output/CD DISC 123 SW input
60	S14/ARF		Segment 14 output/DECK ARF SW input
61	S15/ARR		Segment 15 output/DECK ARR SW input
62	S16/MODE1		Segment 16 output/DECK MODE SW1 input
63	S17/MODE2		Segment 17 output/DECK MODE SW2 input
64	S18/HALF1		Segment 18 output/DECK HALF SW1 input
65	S19/HALF2		Segment 19 output/DECK HALF SW2 input
66	S20/CrO2_1		Segment 20 output/DECK CrO2 SW1 input
67	S21/CrO2_2	Segment 21 output/DECK CrO2 SW2 input	
68	S22	O	Segment 22 output
69	S23		Segment 23 output
70	S24		Segment 24 output
71	RDSDATA	I	Tuner RDS data input
72	VDD	–	Power supply
73	SOL2	O	DECK solenoid output 2
74	SOL1		DECK solenoid output 1
75	MOTOR	O	DECK motor output
76	CD LOAD IN	I	CD loading motor input (pull-down)
77	CD LOAD OUT	O	CD loading motor output (pull-down)
78	LED DISC3	O	DISC 3 LED output
79	LED DISC2		DISC 2 LED output
80	LED DISC1		DISC 1 LED output
81	REEL1	I	DECK reel pulse input 1
82	REEL2		DECK reel pulse input 2
83	–	–	
84	RDS MUTE	O	Mute output of Tuner RDS (pull-down)
85	PLL CE	O	Chip enable output of Tuner PLL
86	EVOL CE	O	Chip enable output of electronic volume IC
87	POWER	O	Power output
88	LINE MUTE	O	Line mute output
89	VSS	–	Ground
90	VDD	–	Power supply
91	EXP CLK	O	Clock output for EXP IC
92	EXP DATA	O	Data output for EXP IC
93	EXP CE	O	Chip enable output of EXP IC (BU4094BCF)
94	SCAN ON	O	Outputs for SW reading
95	CD SHUT	O	Crystal ON/OFF of the CD decoder
96	SQSO	I	CD subcode data input
97	CD SQCK	O	Clock output for CD subcode data
98	SYSDATA	O	Data output of the Tuner PLL data/electronic volume IC
99	TXDATA	I	Tuner data input
100	SYSCLK	O	Clock output of the Tuner PLL data/electronic volume IC

7.2.2 DISPLAY

■ XAV3009 (DISPLAY ASSY :V5621)

- FL Display
- Pin Assignment

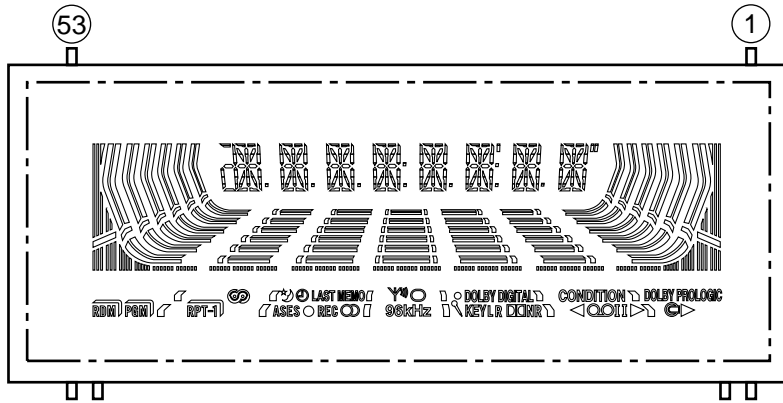

• Grid Assignment

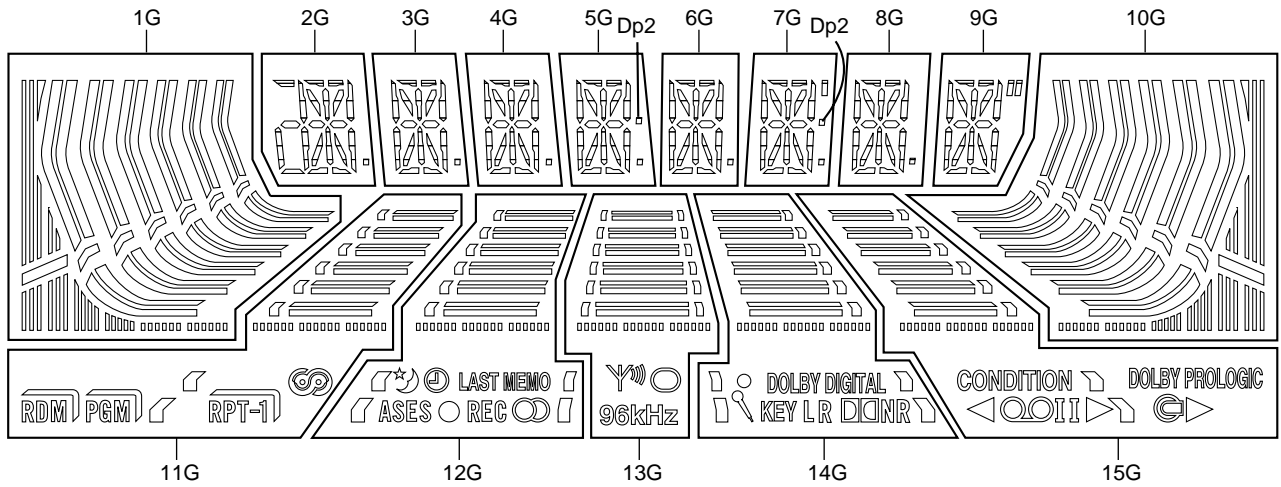

• Segment Designation

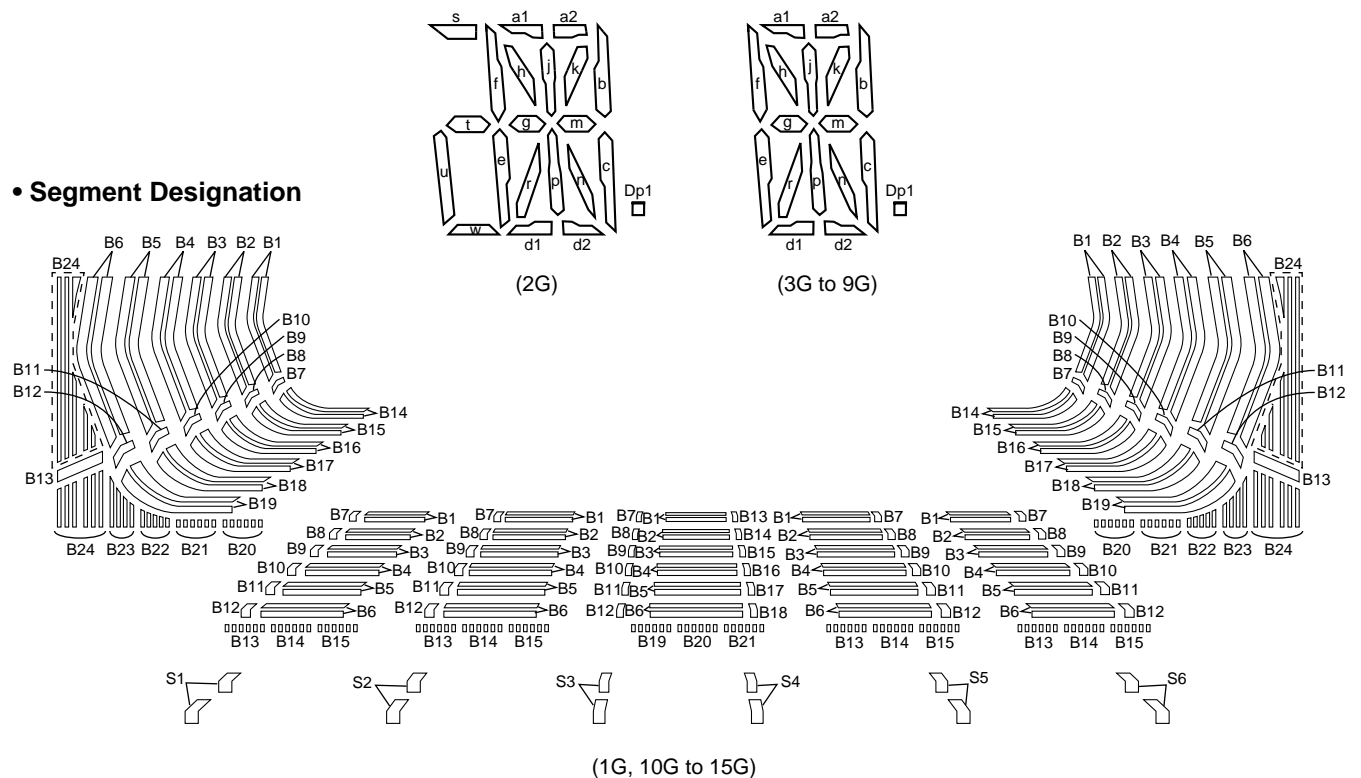

XR-A6800, XR-A4800

• Pin Connection

Pin No.	53	52	51	50	49	48	47	46	45	44	43	42	41	40	39	38	37	36	35	34	33	32	31	30	29	28	27
Connection	F2	F2	F2	NP	NP	1G	2G	3G	4G	5G	6G	7G	8G	9G	10G	11G	12G	13G	14G	15G	P1	P2	P3	P4	P5	P6	P7
Pin No.	26	25	24	23	22	21	20	19	18	17	16	15	14	13	12	11	10	9	8	7	6	5	4	3	2	1	
Connection	P8	P9	P10	P11	P12	P13	P14	P15	P16	P17	P18	P19	P20	P21	P22	P23	P24	NX	NX	NX	NX	NP	NP	F1	F1	F1	

- NOTE 1) F1, F2..... Filament
 2) NP..... No pin
 3) NX..... No extend pin
 4) DL..... Datum Line
 5) 1G to 15G..... Grid
 6) Field of vision is a minimum of 29° from the lower side.

• Anode Connection

	1G	2G	3G,4G	5G	6G	7G	8G	9G	10G	11G	12G	13G	14G	15G
P1	B24	—	—	—	—	—	—	—	B24	RDM	S2	96kHz	S4	▷ (RIGHT)
P2	B23	a1	a1	a1	a1	a1	a1	a1	B23		ASES			
P3	B22	a2	a2	a2	a2	a2	a2	a2	B22	PGM	○	○	KEY	S6
P4	B21	h	h	h	h	h	h	h	B21		REC	B21	L	▷ (LEFT)
P5	B19	j	j	j	j	j	j	j	B19	RPT	S3	B19	R	
P6	B17	k	k	k	k	k	k	k	B17			B17	DICNR	DOLBY PROLOGIC
P7	B15	b	b	b	b	b	b	b	B15	B15	B15	B15	B15	B15
P8	B14	f	f	f	f	f	f	f	B14	B14	B14	B14	B14	B14
P9	B13	g	g	g	g	g	g	g	B13	B13	B13	B13	B13	B13
P10	B6	m	m	m	m	m	m	m	B6	B6	B6	B6	B6	B6
P11	B11	c	c	c	c	c	c	c	B11	B11	B11	B11	B11	B11
P12	B10	e	e	e	e	e	e	e	B10	B10	B10	B10	B10	B10
P13	B4	r	r	r	r	r	r	r	B4	B4	B4	B4	B4	B4
P14	B9	p	p	p	p	p	p	p	B9	B9	B9	B9	B9	B9
P15	B8	n	n	n	n	n	n	n	B8	B8	B8	B8	B8	B8
P16	B2	d1	d1	d1	d1	d1	d1	d1	B2	B2	B2	B2	B2	B2
P17	B3	d2	d2	d2	d2	d2	d2	d2	B3	B3	B3	B3	B3	B3
P18	B12	dp1	dp1	dp1	dp1	dp1	dp1	—	B12	B12	B12	B12	B12	B12
P19	B18	—	—	dp2	—	dp2	—	—	B18	-1		B18	DOLBY DIGITAL	◁
P20	B20	—	—	—	—		—		B20	S1		B20	○	I
P21	B16	s	—	—	—	—	—	—	B16		LAST MEMO	B16	S5	CONDITION
P22	B5	t	—	—	—	—	—	—	B5	B5	B5	B5	B5	B5
P23	B1	u	—	—	—	—	—	—	B1	B1	B1	B1	B1	B1
P24	B7	w	—	—	—	—	—	—	B7	B7	B7	B7	B7	B7

8. PANEL FACILITIES AND SPECIFICATIONS

8.1 PANEL FACILITIES

■ Front Panel

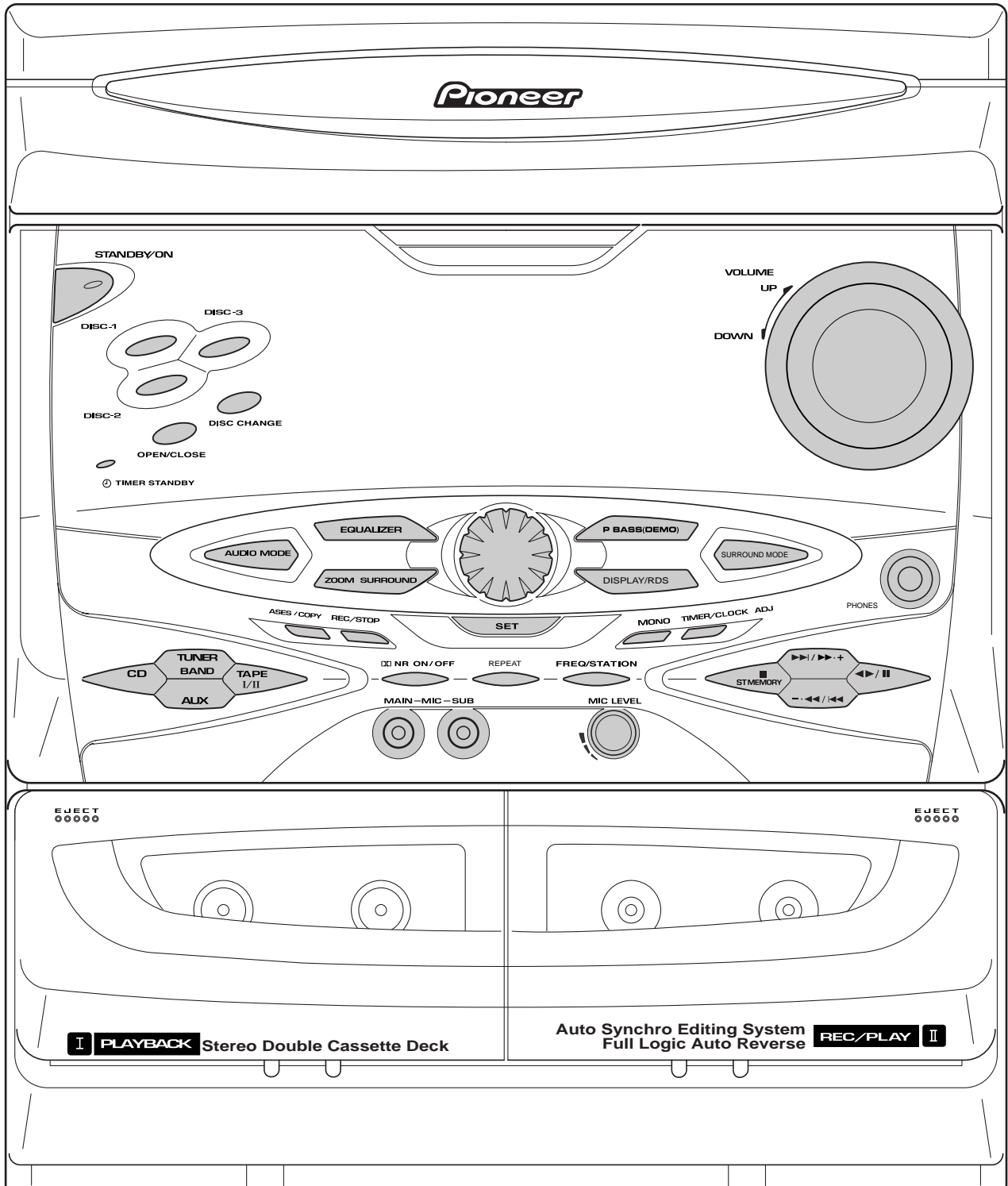

XR-A6800, XR-A4800

The illustration on this page shows the XR-A6800.
Not all features are available on the XR-A4800.

model: XR-A6800

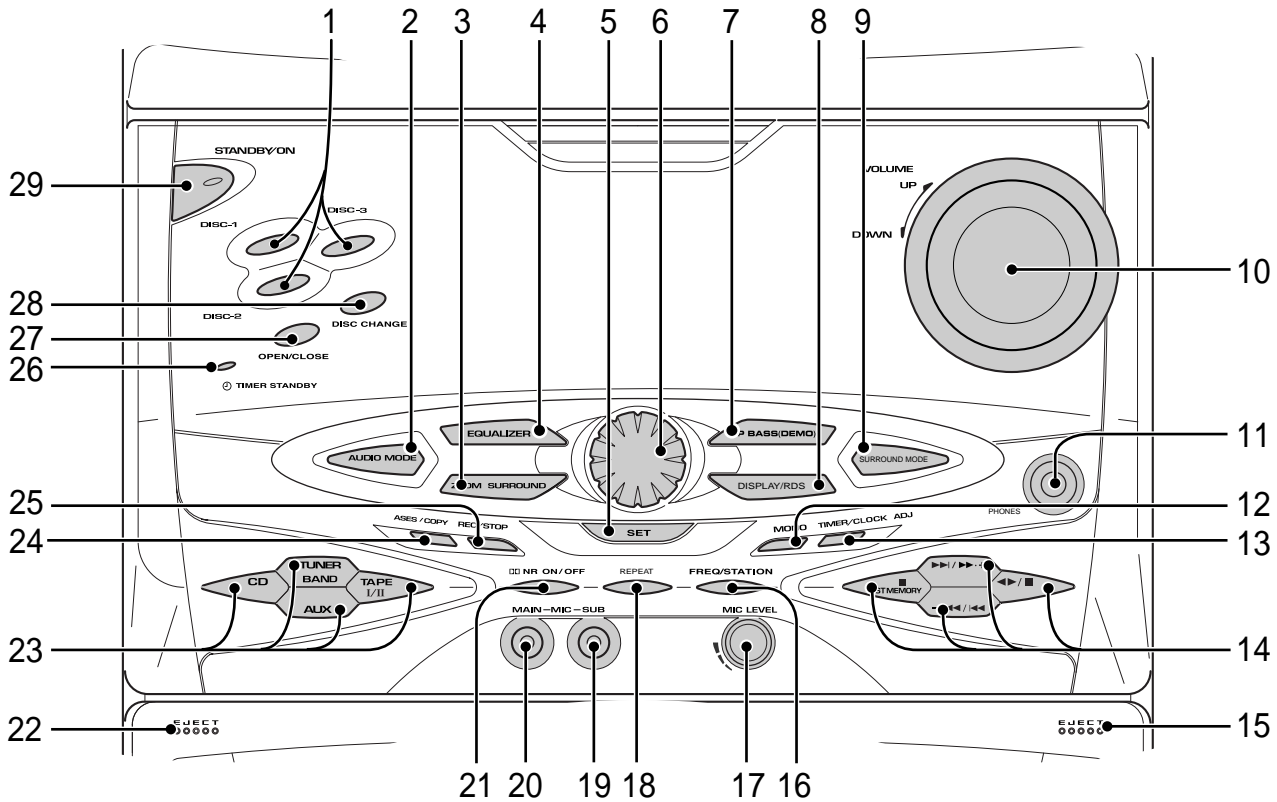

- 1 DISC-1/2/3
- 2 AUDIO MODE
- 3 ZOOM SURROUND
- 4 EQUALIZER
- 5 SET

Use to enter timer/clock settings, or user sound settings.

- 6 JOG dial
- 7 P.BASS (DEMO)
- 8 DISPLAY/RDS
- 9 SURROUND MODE

Use to morph between sound settings, and when setting the clock or timer.

- 10 VOLUME UP/DOWN
 - 11 PHONES jack (Headphones)
- Plug in a pair of headphones to this jack.

- 12 MONO
- 13 TIMER / CLOCK ADJ
- 14 Playback/tuning controls
- ST. MEMORY
- ▶▶/|▶▶.+.+
- .◀◀/|◀◀
- ◀◀/||

- 15 EJECT (tape II)
- Press to open the cassette door of deck II.

- 16 FREQ / STATION
- 17 MIC LEVEL
- 18 REPEAT
- 19 MIC SUB
- 20 MIC MAIN
- 21 XR-A6800 : ◻◻ NR* ON/OFF
- XR-A4800 : RANDOM

22 EJECT (tape I)

Press to open the cassette door of deck I.

23 Function select buttons

CD

TUNER BAND

AUX

TAPE I/II

24 ASES / COPY**25 REC / STOP****26 TIMER STANDBY indicator****27 OPEN/CLOSE****28 DISC CHANGE****29 STANDBY/ON and standby indicator**

Press to switch the unit between standby and on.
Indicator lights in standby.

* Manufactured under licence from Dolby Laboratories. "Dolby" and the double-D symbol are trademarks of Dolby Laboratories.

■ Display

The illustration on this page shows the XR-A6800.
Not all features are available on the XR-A4800.

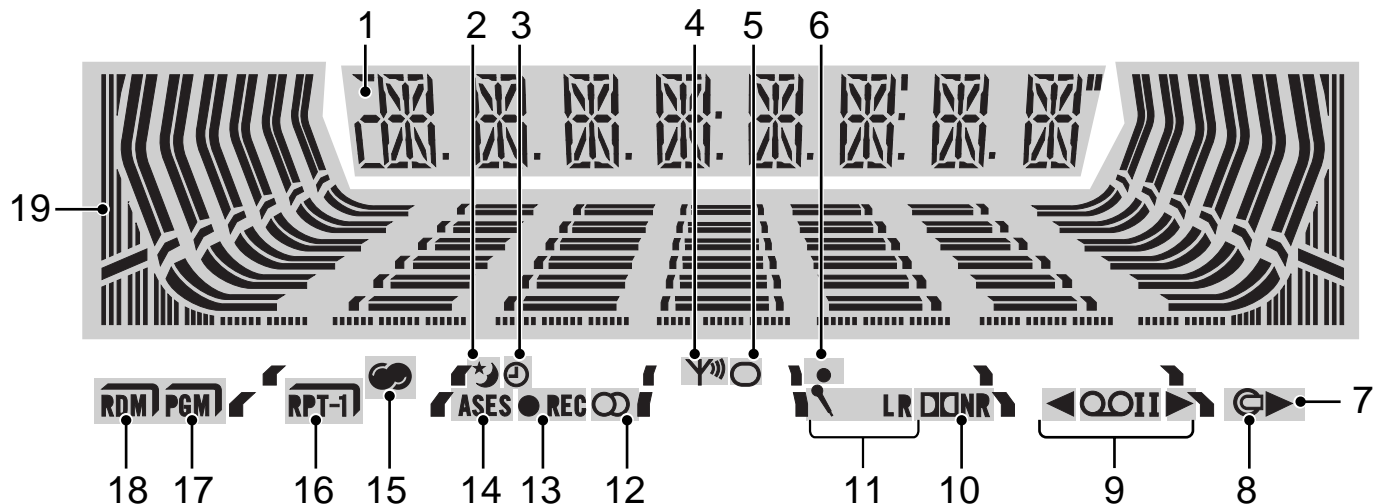

- | | |
|---|--|
| <p>1 Character display</p> <p>2 Lights when the sleep timer has been set.</p> <p>3 Lights when either the record timer or the wake up timer has been set.</p> <p>4 Lights when the tuner is receiving a broadcast.</p> <p>5 Lights when the tuner is set to mono FM mode.</p> <p>6 Lights when in beat cut 2 mode. (XR-A6800 model only)</p> <p>7 Lights when a CD is playing.</p> <p>8 Lights when the system is in CD mode.</p> <p>9 ◀ and ▶ – Indicates the current tape play/record direction.</p> <p>◻ I or II – Indicates the current tape deck, I or II.</p> | <p>10 Lights when Dolby Noise Reduction is switched on. (XR-A6800 model only)</p> <p>11 🎤 – Lights when in the karaoke mode.
L R – Indicates which channels of the karaoke track you're hearing.</p> <p>12 Lights when the tuner is receiving a stereo FM broadcast in auto stereo mode.</p> <p>13 Lights when recording to tape.</p> <p>14 Lights during automatic recording of a CD.</p> <p>15 Lights in RDS mode.</p> <p>16 Highlights during repeat play mode.</p> <p>17 Highlights during program playback mode.</p> <p>18 Highlights during random playback mode.</p> <p>19 Sound morphing / sound level display</p> |
|---|--|

Remote Control Unit



To learn about the function of a particular button, look up the name of the button in the following alphabetical list (buttons marked with symbols appear first).

- ⏻**
Press to switch the system on or into standby.
- (Stop)**
- ◀▶/|| (Play/pause/reverse)**
- ◀◀ (Reverse scan/fast rewind/radio tuning)**
- ▶▶ (Forward scan/fast forward/radio tuning)**
- ◀◀ (Reverse track skip/music search/preset station select)**
- ▶▶+ (Forward track skip/music search/preset station select)**
- >10**
Use to select numbers over 10 (press this button, then input the number using the other number buttons).
- 10/0**
Use as zero or 10 when entering numbers (for track numbers and station presets).
- 1-9**
Number buttons (for track numbers and station presets).
- A AUDIO/SURROUND**
- AUX**
- C CD**
- CLEAR**
Press to delete the most recently programmed track.
- D DISC-1/2/3**
- DISC CHANGE**
- DISPLAY**
- J JOG**
Use to morph between sound settings, and when setting the clock or timer.
- K KARAOKE**
- M MONO (SHIFT & 7)**
- MORPHING**
- MUTE**
- O OPEN/CLOSE**
- P PROGRAM**
- R RANDOM (SHIFT & 9)**
- REPEAT (SHIFT & 8)**
- S SHIFT**
Use to access secondary functions on the remote control.
- SLEEP**
- T TAPE I/II**
- TUNER/BAND**
- V VOLUME +/-**
Use to adjust the overall volume level.

8.2 SPECIFICATIONS

Amplifier section

Continuous Power Output

RMS (1 kHz, T.H.D. 10%, 6 Ω)	
XR-A6800	140 W + 140 W
XR-A4800	100 W + 100 W
DIN (1 kHz, T.H.D. 1%, 6 Ω)	
XR-A6800	85 W + 85 W
XR-A4800	65 W + 65 W

* Above specifications are for when power supply is 230 V.

Maximun Power

XR-A6800	220 W + 220 W
XR-A4800	146 W + 146 W

* Above specifications are for when power supply is 230 V.

CD section

Type	Compact disc digital audio system
Wow and Flutter	Limit of measurement (±0.001 % W.PEAK) or less (EIAJ)

Cassette deck section

Systems	4 track, 2-channel stereo
	Recording/playback head x 1
	Playback head x 1
	Erase head x 1
Motor	DC servo motor x 1
Tape types	
XR-A6800	TYPE I (Normal) tape
	TYPE II (HIGH/CrO ₂) tape
XR-A4800	TYPE I (Normal) tape

FM tuner section

Frequency Range	87.5 MHz to 108 MHz
Antenna input	75 Ω unbalanced

AM tuner section

Frequency Range	
With 9 kHz step	531 kHz to 1,602 kHz
With 10 kHz step	530 kHz to 1,700 kHz
Antenna input	Loop antenna

Miscellaneous



Power Requirements	AC 220-230 V, 50/60 Hz
	AC 230 V, 50/60 Hz (U.K. models)
Power Consumption	
XR-A6800	150 W
XR-A4800	120 W
Power Consumption in Standby mode	1 W
Dimensions	270 (W) x 320 (H) x 339 (D) mm
Weight (without package)	
XR-A6800	8.8 kg
XR-A4800	8.3 kg

Accessories

Operating instructions	1
Remote control unit	1
Power Cord	1
FM antenna	1
AM loop antenna	1
AA/R6P dry cell batteries	2
Speaker Cord — S-A6800 only	2

- Specifications and design subject to possible modification without notice, due to improvements.

Accessories

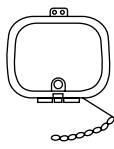
① Remote Control Unit × 1	② FM Antenna × 1 (MYXJ and NVXJ Types : ADH7005)	③ AM Loop Antenna × 1 (XTB3001)
		
	④ AA/R6P Dry Cell Batteries × 2 (VEM-013)	⑤ Power Cord × 1 (MYXJ Type : ADG1154) (NVXJ Type : ADG1156)
	