

Service Manual

PIONEER
The Art of Entertainment

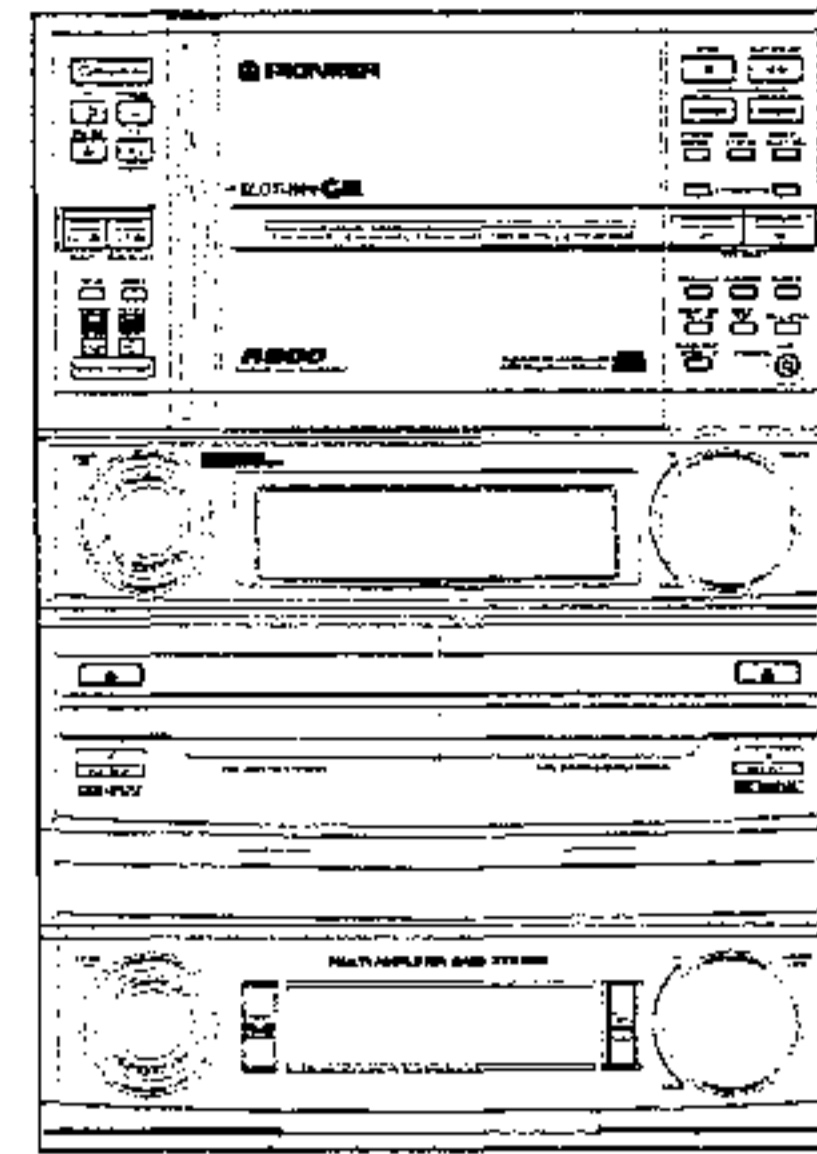

Illustration shows model XR-A800

ORDER NO.
ARP2972

STEREO FILE-TYPE CD CASSETTE DECK RECEIVER

XR-A800

XR-A700

THIS MANUAL IS APPLICABLE TO THE FOLLOWING MODEL(S) AND TYPE(S).

Type	Model		Power Requirement	The voltage can be converted by the following method
	XR-A800	XR-A700		
DDXJ	○	○	AC110-127V/220-230V/240V	With the voltage selector
DXJ/NC	○	○	AC110-127V/220-230V/240V	With the voltage selector
DLXJ/NC	○	○	AC110-120V/220-230V/240V	With the voltage selector

CONTENTS

1. SAFETY INFORMATION.....	2	7.1.1 IC	75
2. EXPLODED VIEWS AND PARTS LIST	4	7.1.2 DISPLAY	78
3. SCHEMATIC DIAGRAM	20	7.2 DIAGNOSIS	79
4. PCB CONNECTION DIAGRAM	41	7.2.1 DISASSEMBLY	79
5. PCB PARTS LIST	56	7.2.2 PCB LOCATIONS	81
6. ADJUSTMENT	65	7.3 BLOCK DIAGRAM	82
7. GENERAL INFORMATION	75	8. PANEL FACILITIES AND SPECIFICATIONS...	84
7.1 PARTS	75		

PIONEER ELECTRONIC CORPORATION 4-1, Meguro 1-Chome, Meguro-ku, Tokyo 153, Japan
PIONEER ELECTRONICS SERVICE, INC. P.O. Box 1760, Long Beach, CA 90801-1760, U.S.A.
PIONEER ELECTRONIC (EUROPE) N.V. Haven 1087, Keetberglaan 1, 9120 Melsele, Belgium
PIONEER ELECTRONICS ASIACENTRE PTE. LTD. 501 Orchard Road, #10-00 Lane Crawford Place, Singapore 0923
 © PIONEER ELECTRONIC CORPORATION 1997

1. SAFETY INFORMATION

This service manual is intended for qualified service technicians; it is not meant for the casual do-it-yourselfer. Qualified technicians have the necessary test equipment and tools, and have been trained to properly and safely repair complex products such as those covered by this manual.

Improperly performed repairs can adversely affect the safety and reliability of the product and may void the warranty. If you are not qualified to perform the repair of this product properly and safely, you should not risk trying to do so and refer the repair to a qualified service technician.

WARNING

Lead in solder used in this product is listed by the California Health and Welfare agency as a known reproductive toxicant which may cause birth defects or other reproductive harm (California Health & Safety Code, Section 25249.5).

When servicing or handling circuit boards and other components which contain lead in solder, avoid unprotected skin contact with the solder. Also, when soldering do not inhale any smoke or fumes produced.

NOTICE

(FOR CANADIAN MODEL ONLY)

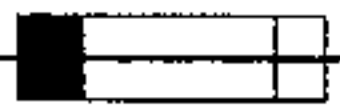
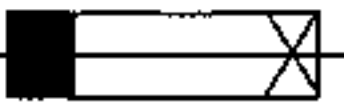
Fuse symbols  (fast operating fuse) and/or  (slow operating fuse) on PCB indicate that replacement parts must be of identical designation.

REMARQUE

(POUR MODÈLE CANADIEN SEULEMENT)

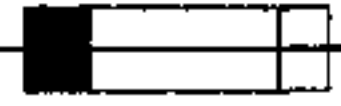
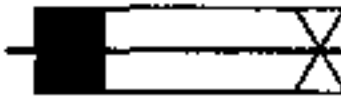
Les symboles de fusible  (fusible de type rapide) et/ou  (fusible de type lent) sur CCI indiquent que les pièces de remplacement doivent avoir la même désignation.

(FOR USA MODEL ONLY)

1. SAFETY PRECAUTIONS

The following check should be performed for the continued protection of the customer and service technician.

LEAKAGE CURRENT CHECK

Measure leakage current to a known earth ground (water pipe, conduit, etc.) by connecting a leakage current tester such as Simpson Model 229-2 or equivalent between the earth ground and all exposed metal parts of the appliance (input/output terminals, screwheads, metal overlays, control shaft, etc.). Plug the AC line cord of the appliance directly into a 120V AC 60 Hz outlet and turn the AC power switch on. Any current measured must not exceed 0.5 mA.

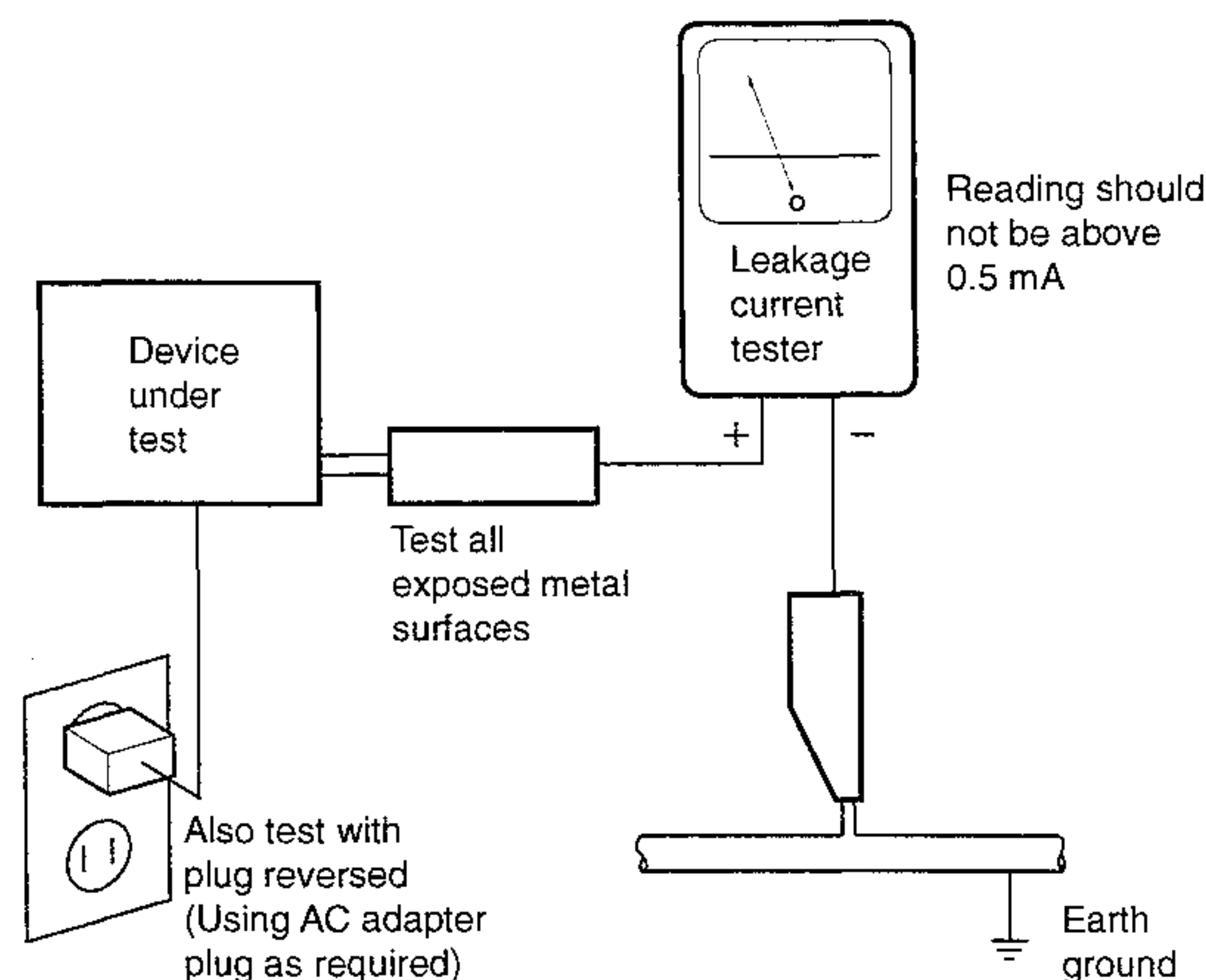

AC Leakage Test

ANY MEASUREMENTS NOT WITHIN THE LIMITS OUTLINED ABOVE ARE INDICATIVE OF A POTENTIAL SHOCK HAZARD AND MUST BE CORRECTED BEFORE RETURNING THE APPLIANCE TO THE CUSTOMER.

2. PRODUCT SAFETY NOTICE

Many electrical and mechanical parts in the appliance have special safety related characteristics. These are often not evident from visual inspection nor the protection afforded by them necessarily can be obtained by using replacement components rated for voltage, wattage, etc. Replacement parts which have these special safety characteristics are identified in this Service Manual.

Electrical components having such features are identified by marking with a ! on the schematics and on the parts list in this Service Manual.

The use of a substitute replacement component which does not have the same safety characteristics as the PIONEER recommended replacement one, shown in the parts list in this Service Manual, may create shock, fire, or other hazards.

Product Safety is continuously under review and new instructions are issued from time to time. For the latest information, always consult the current PIONEER Service Manual. A subscription to, or additional copies of, PIONEER Service Manual may be obtained at a nominal charge from PIONEER.

LABEL CHECK (for DLXJ/NC type)

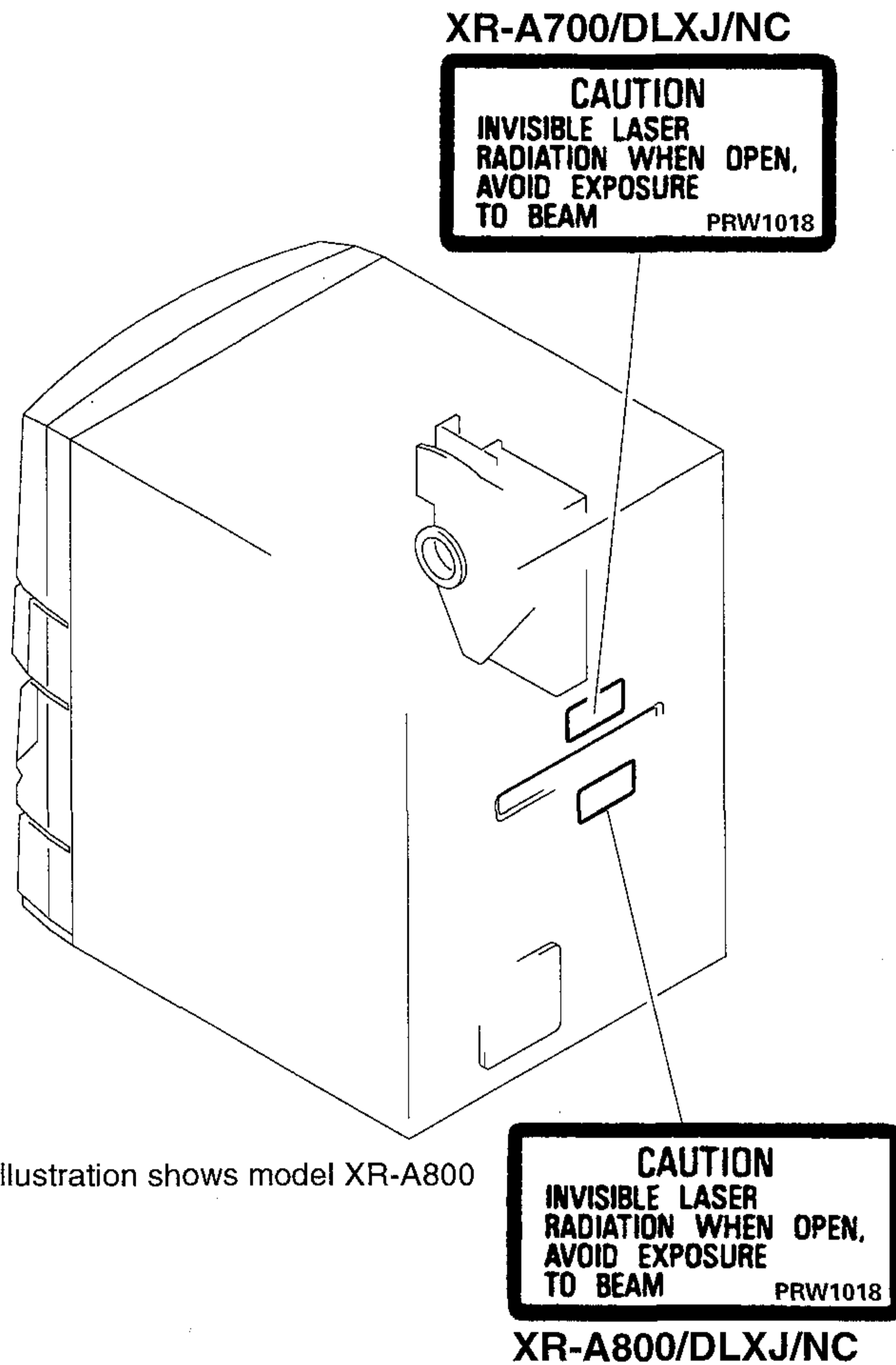

Additional Laser Caution

1. Laser Interlock Mechanism

The position of the switch (S651) for detecting loading state is detected by the system microprocessor, and the design prevents laser diode oscillation when the switch (S651) is not on CLMP terminal side (CLMP signal is OFF or high level.) Thus, the interlock will no longer function if the switch (S651) is deliberately set to CLMP terminal side. (low level)

The interlock also does not function in the test mode*. Laser diode oscillation will continue, if pin 1 of M51593FP (IC101) on the PRE-AMP BOARD ASSY mounted on the pickup assembly is connected to GND, or pin 19 is connected to low level (ON), or else the terminals of Q101 are shorted to each other (fault condition).

2. When the cover is opened, close viewing of the objective lens with the naked eye will cause exposure to a Class 1 laser beam.

*Refer to page 71.

2. EXPLODED VIEWS AND PARTS LIST

- NOTES: ● Parts marked by "NSP" are generally unavailable because they are not in our Master Spare Parts List.
 ● The Δ mark found on some component parts indicates the importance of the safety factor of the part. Therefore, when replacing, be sure to use parts of identical designation.
 ● Screws adjacent to ∇ mark on product are used for disassembly.

2.1 PACKING

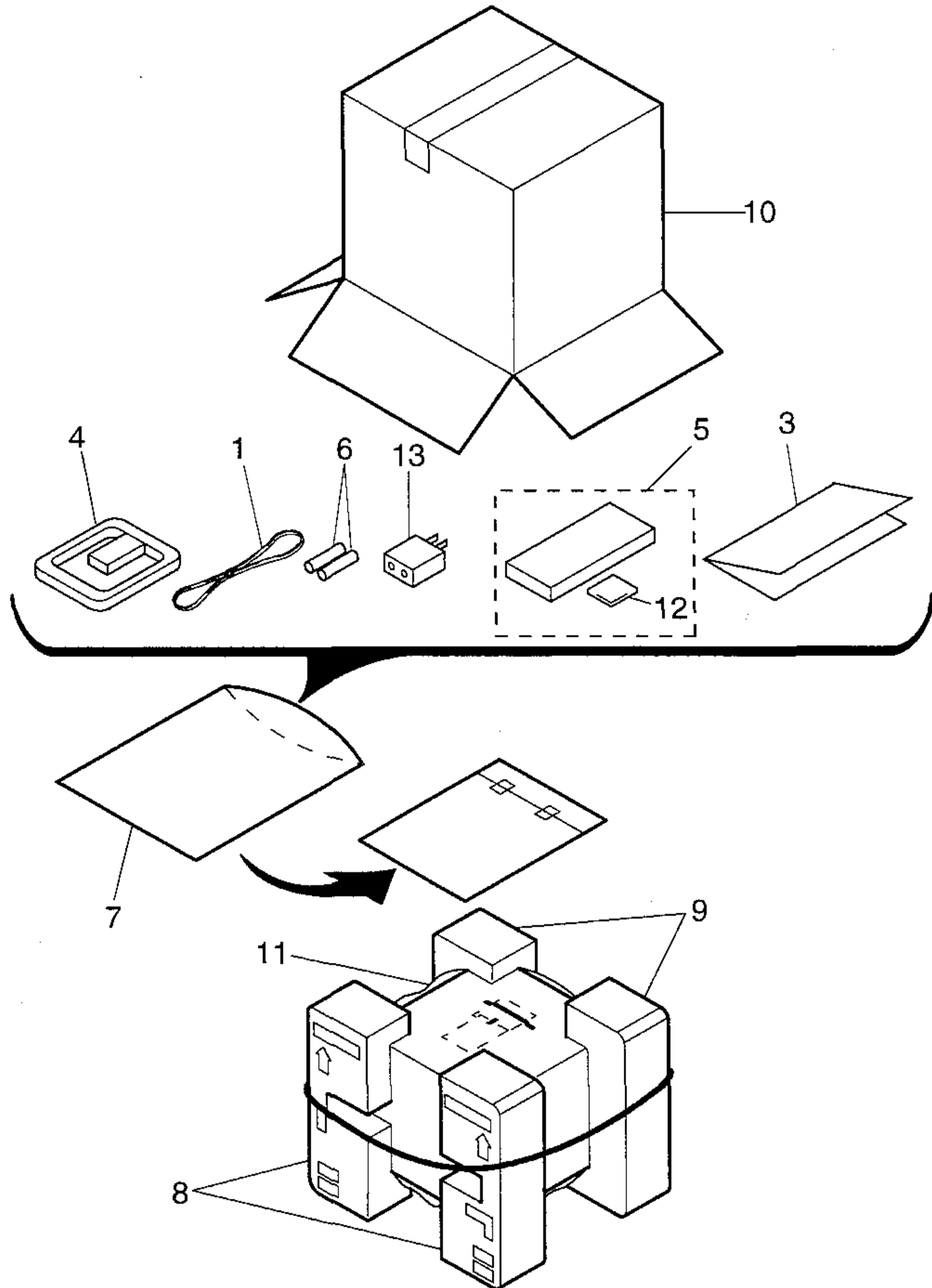

(1) PACKING PARTS LIST

Mark	No.	Description	Part No.
	1	FM Antenna	ADH7007
	2	
	3	Operating Instructions	See Contrast table (2)
	4	AM Loop Antenna	ATB7007
	5	Remote Control Unit	See Contrast table (2)
NSP	6	AA/R6P Dry Cell Batteries	VEM-013
NSP	7	Vinyl Bag	See Contrast table (2)
	8	Front Pad	See Contrast table (2)
	9	Rear Pad	See Contrast table (2)
	10	Packing Case	See Contrast table (2)
	11	Packing Sheet	AHG7049
	12	Battery Cover	AZA7281
	13	Power-cord Plug Conversion Adaptor	See Contrast table (2)

(2) CONTRAST TABLE

XR-A800/DDXJ, DXJ/NC, DLXJ/NC, XR-A700/DDXJ, DXJ/NC and DLXJ/NC types are constructed the same except for the following :

Mark	No.	Symbol and Description	Part No.						Remarks
			XR-A800			XR-A700			
			DDXJ	DXJ/NC	DLXJ/NC	DDXJ	DXJ/NC	DLXJ/NC	
	3	Operating Instructions (English/Spanish/Chinese)	ARE7145	Not used	Not used	ARE7145	Not used	Not used	
	3	Operating Instructions (English/Spanish/Portuguese)	Not used	ARE7151	Not used	Not used	ARE7151	Not used	
	3	Operating Instructions (English/Chinese)	Not used	Not used	ARE7150	Not used	Not used	ARE7150	
	5	Remote Control Unit (CU-XR045)	AXD7147	AXD7147	AXD7147	Not used	Not used	Not used	
	5	Remote Control Unit (CU-XR044)	Not used	Not used	Not used	AXD7146	AXD7146	AXD7146	
NSP	7	Vinyl Bag	AHG7037	AHG7037	AHG7037	AHG7038	AHG7038	AHG7038	
	8	Front pad	AHA7193	AHA7193	AHA7193	AHA7177	AHA7177	AHA7177	
	9	Rear pad	AHA7194	AHA7194	AHA7194	AHA7178	AHA7178	AHA7178	
	10	Packing Case	AHD7523	AHD7524	AHD7524	AHD7518	AHD7519	AHD7519	
	13	Power-cord Plug Conversion Adaptor	Not used	VKX1007	Not used	Not used	VKX1007	Not used	

2.2 FRONT PANEL SECTION

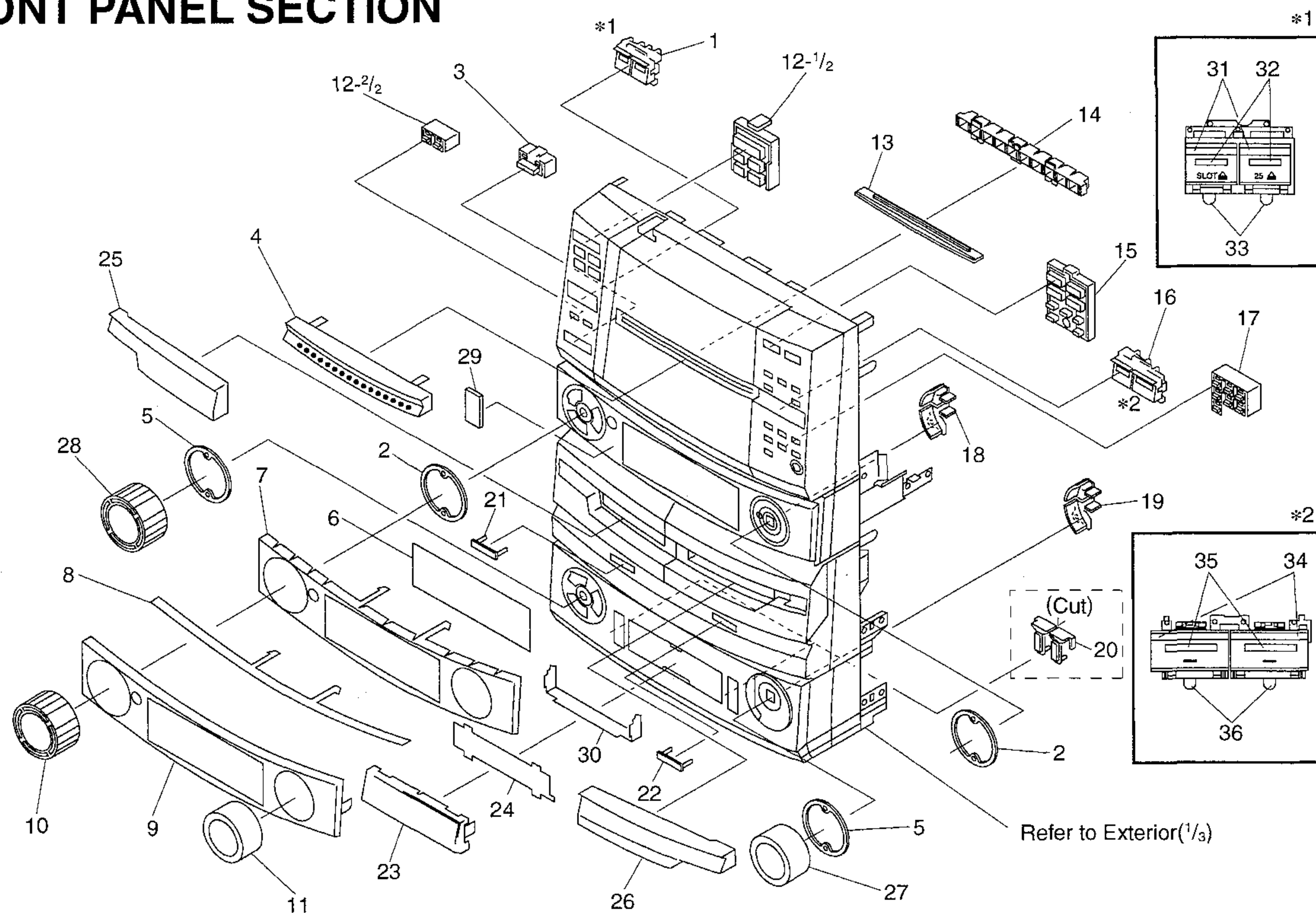

(1) FRONT PANEL SECTION PARTS LIST

Mark	No.	Description	Part No.	Mark	No.	Description	Part No.
NSP	1	Disc Button Assy L	AXG7054		20	Bass Button (P.BASS, BASS SYNTH)	See Contrast table (2)
	2	Knob Spacer	AAK7498		21	Azimuth Cover L	AAK7527
	3	SOUND Button	AAD7428		22	Azimuth Cover R	AAK7528
	4	25 Window	AAK7482		23	EQ Window	See Contrast table (2)
	5	Knob Spacer (BASS SYNTH)	See Contrast table (2)		24	EQ Filter	See Contrast table (2)
	6	FL Filter	AAK7485		25	Deck Door Lens L	AAK7459
	7	FL Cover A	AAK7519		26	Deck Door Lens R	AAK7460
	8	FL Cover B	AAK7530		27	Volume Knob (WOOFER LEVEL)	See Contrast table (2)
	9	FL Window	AAK7481		28	Jog knob Assy (P.BASS JOG)	See Contrast table (2)
	10	Jog knob Assy	AXG7051		29	FL Spacer	AEB7108
	11	Volume Knob	AAB7134		30	EQ Cover	See Contrast table (2)
	12	Power Button	AAD7427		31	Disc Button Cap L	AAK7487
	13	25 Lens	AAK7489		32	Disc Lens L	AAK7491
	14	LED Holder	AMR7196		33	Disc Button L	AAD7429
	15	Play Button	AAD7426		34	Disc Button Cap R	AAK7522
NSP	16	Disc Button Assy R	AXG7055	35	Disc Lens R	AAK7493	
	17	Program Button	AAD7425	36	Disc Button R	AAD7433	
	18	VOL. Ring	AAK7488				
	19	VOL. Ring (BASS SYNTH)	See Contrast table (2)				

(2) CONTRAST TABLE

XR-A800/DDXJ, DXJ/NC, DLXJ/NC, XR-A700/DDXJ, DXJ/NC and DLXJ/NC types are constructed the same except for the following :

Mark	No.	Symbol and Description	Part No.						Remarks
			XR-A800			XR-A700			
			DDXJ	DXJ/NC	DLXJ/NC	DDXJ	DXJ/NC	DLXJ/NC	
	5	Knob Spacer (BASS SYNTH)	AAK7498	AAK7498	AAK7498	Not used	Not used	Not used	
	19	VOL. Ring (BASS SYNTH)	AAK7488	AAK7488	AAK7488	Not used	Not used	Not used	
	20	Bass Button (P.BASS, BASS SYNTH)	AAD7424	AAD7424	AAD7424	Not used	Not used	Not used	
	23	EQ Window	AAK7483	AAK7483	AAK7483	Not used	Not used	Not used	
	24	EQ Filter	AAK7546	AAK7546	AAK7546	Not used	Not used	Not used	
	27	Volume Knob (WOOFER LEVEL)	AAB7134	AAB7134	AAB7134	Not used	Not used	Not used	
	28	Jog knob Assy (P.BASS JOG)	AXG7051	AXG7051	AXG7051	Not used	Not used	Not used	
	30	EQ Cover	AAK7547	AAK7547	AAK7547	Not used	Not used	Not used	

XR-A800, XR-A700

2.3 EXTERIOR (1/3) SECTION

*3

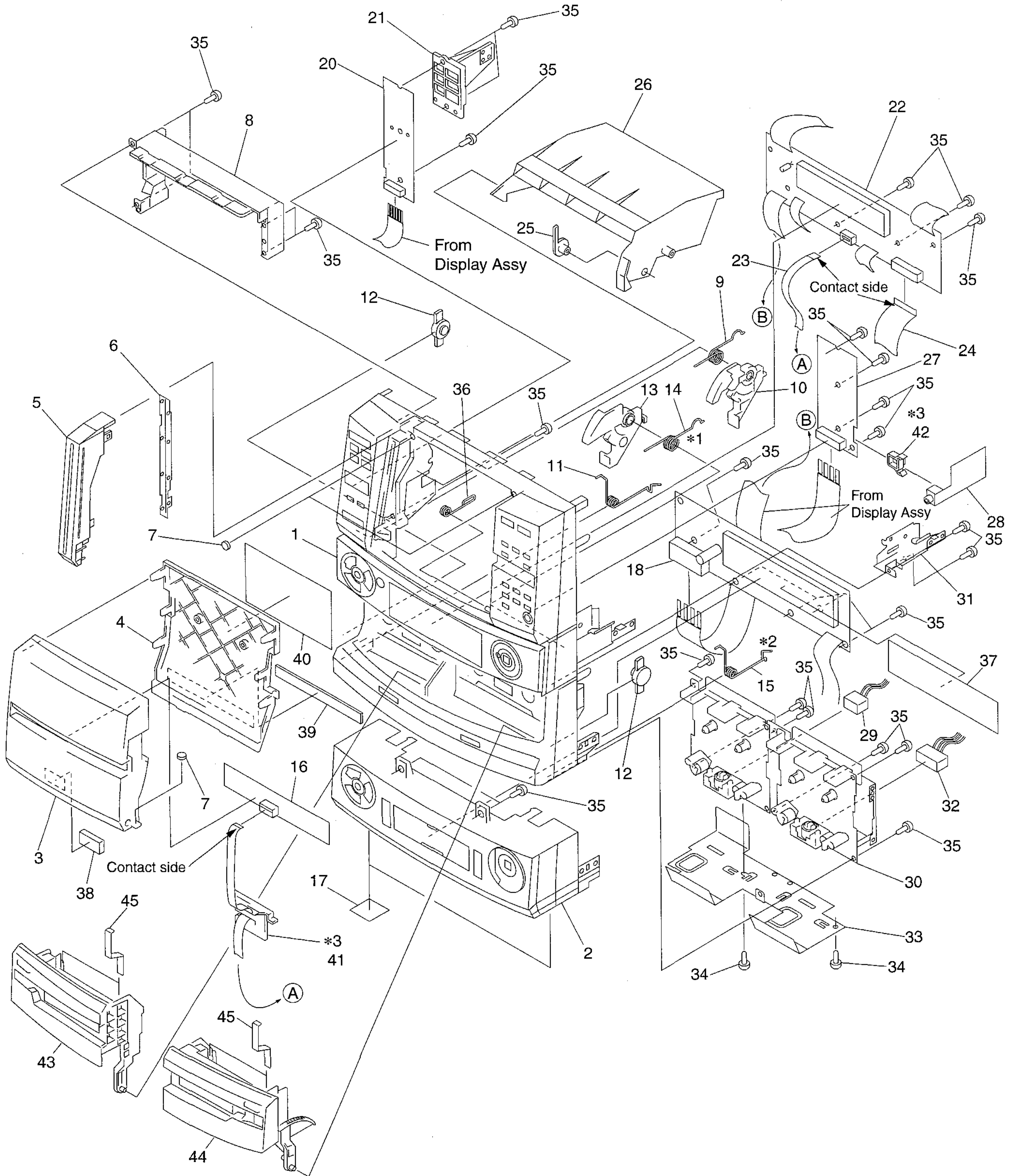
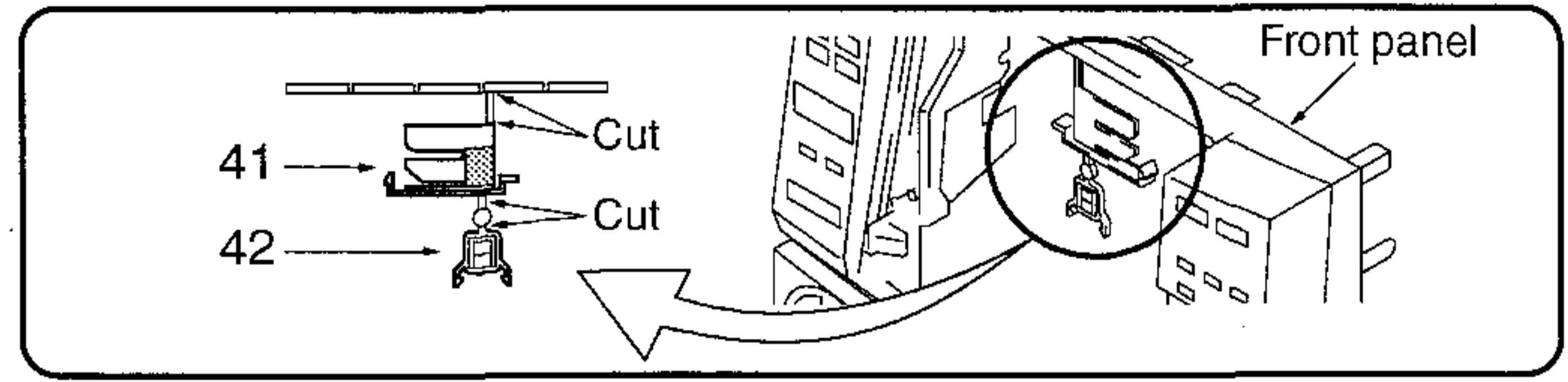

*1

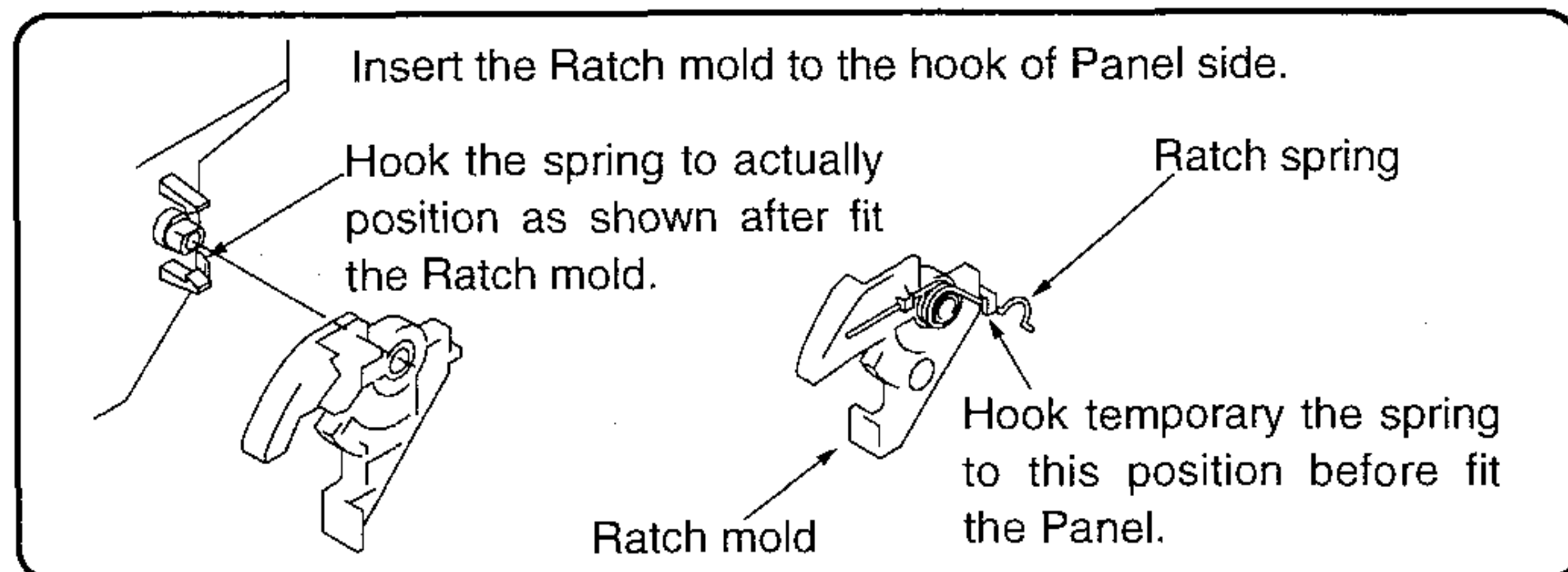

*2

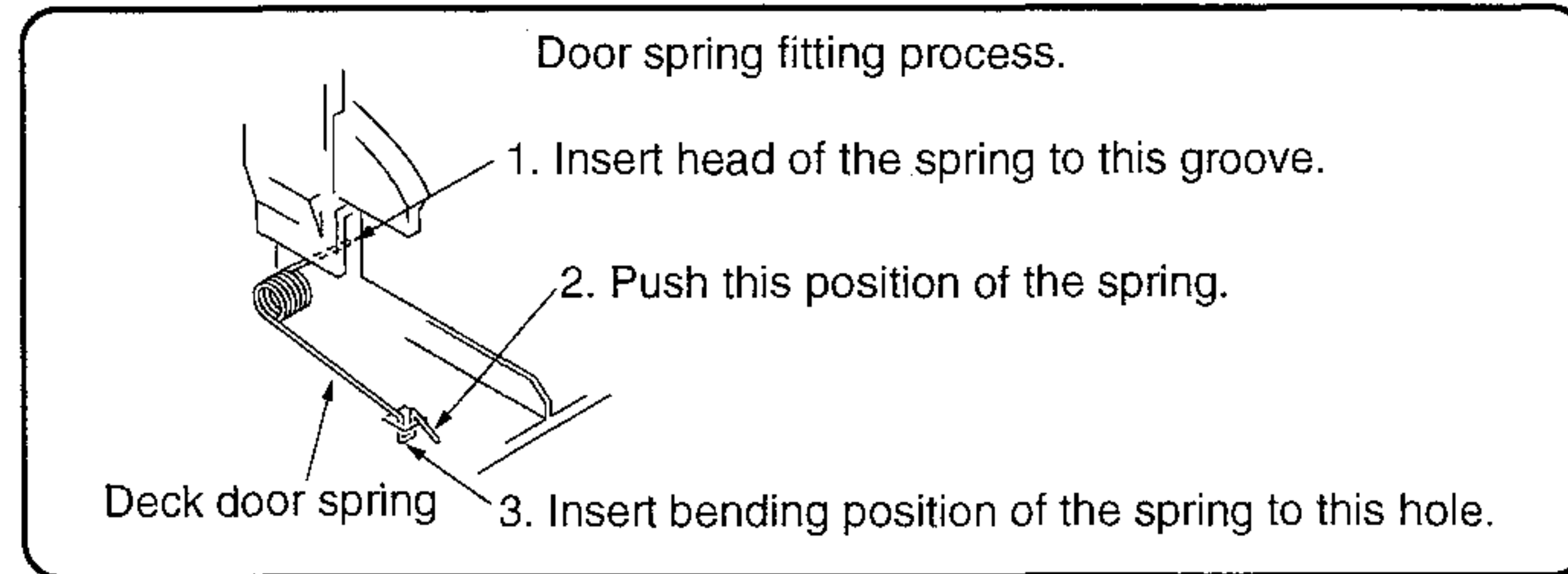

(1) EXTERIOR (1/3) SECTION PARTS LIST

Mark	No.	Description	Part No.	Mark	No.	Description	Part No.
	1	Front Panel A	See Contrast table (2)		26	Barrier (PLS)	AMR7135
	2	Front Panel B	See Contrast table (2)	NSP	27	RIGHT SW ASSY	AWZ8968
	3	CD Door (PLS)	See Contrast table (2)	NSP	28	HP ASSY	See Contrast table (2)
	4	CD Door Cover (PLS)	AAK7496		29	Connector Assy 3P	RKP1683
	5	Slot Cover	AAK7486		30	Mechanism Unit	AYM7002
	6	Slot Sheet	AWL7028		31	Earth Plate (MTL)	ANG7161
	7	Cushion Rubber	AEB7068		32	Connector Assy 5P	RKP1682
	8	Sub Panel (MTL)	ANG7164		33	Mecha. Shield	See Contrast table (2)
	9	Ratch Spring L	ABH7130		34	Screw	BCZ30P080FZK
	10	Ratch Mold L	AMR7128		35	Screw	BPZ30P080FMC
	11	Deck Door Spring L	ABH7155		36	CD Door Spring	ABH7157
	12	Damper Assy	AXA7057		37	EQ Sheet	See Contrast table (2)
	13	Ratch Mold R	AMR7129		38	FFC Spacer	AEB7104
	14	Ratch Spring R	ABH7131		39	Disc Rack Plate	AAK7251
	15	Deck Door Spring R	ABH7156		40	Caution Label	ARW7024
NSP	16	DOOR LED ASSY	AWZ8971		41	FFC Cover	AZA7279
	17	Rubber Sheet	AEB1111		42	Jack Holder	AZA7278
	18	SUB DISPLAY ASSY	See Contrast table (2)		43	Deck Door L	AAN7168
	19			44	Deck Door R	AAN7169
NSP	20	LEFT SW ASSY	AWZ8969		45	Spring	RBK1004
	21	PCB Mold	AMR7191				
	22	DISPLAY ASSY	See Contrast table (2)				
	23	7P F.F.C/30V	ADD7075				
	24	28P F.F.C/60V	ADD7076				
	25	Rink Holder (PLS)	AMR7142				

(2) CONTRAST TABLE

XR-A800/DDXJ, DXJ/NC, DLXJ/NC, XR-A700/DDXJ, DXJ/NC and DLXJ/NC types are constructed the same except for the following :

Mark	No.	Symbol and Description	Part No.						Remarks
			XR-A800			XR-A700			
			DDXJ	DXJ/NC	DLXJ/NC	DDXJ	DXJ/NC	DLXJ/NC	
	1	Front Panel A	AMB7482	AMB7482	AMB7482	AMB7465	AMB7465	AMB7465	
	2	Front Panel B	AMB7466	AMB7466	AMB7466	Not used	Not used	Not used	
	3	CD Door	AAK7502	AAK7502	AAK7502	AAK7495	AAK7495	AAK7495	
	18	SUB DISPLAY ASSY	AWP7017	AWP7017	AWP7017	Not used	Not used	Not used	
	22	DISPLAY ASSY	AWP7015	AWP7015	AWP7015	AWP7013	AWP7013	AWP7013	
NSP	28	HP ASSY	AWZ8967	AWZ8967	AWZ8967	AWZ8965	AWZ8965	AWZ8965	
	33	Mecha. Shield	ANK7036	ANK7036	ANK7036	Not used	Not used	Not used	
	37	EQ Sheet	AAK7548	AAK7548	AAK7548	Not used	Not used	Not used	

2.4 EXTERIOR (2/3) AND POWER AMP SECTION

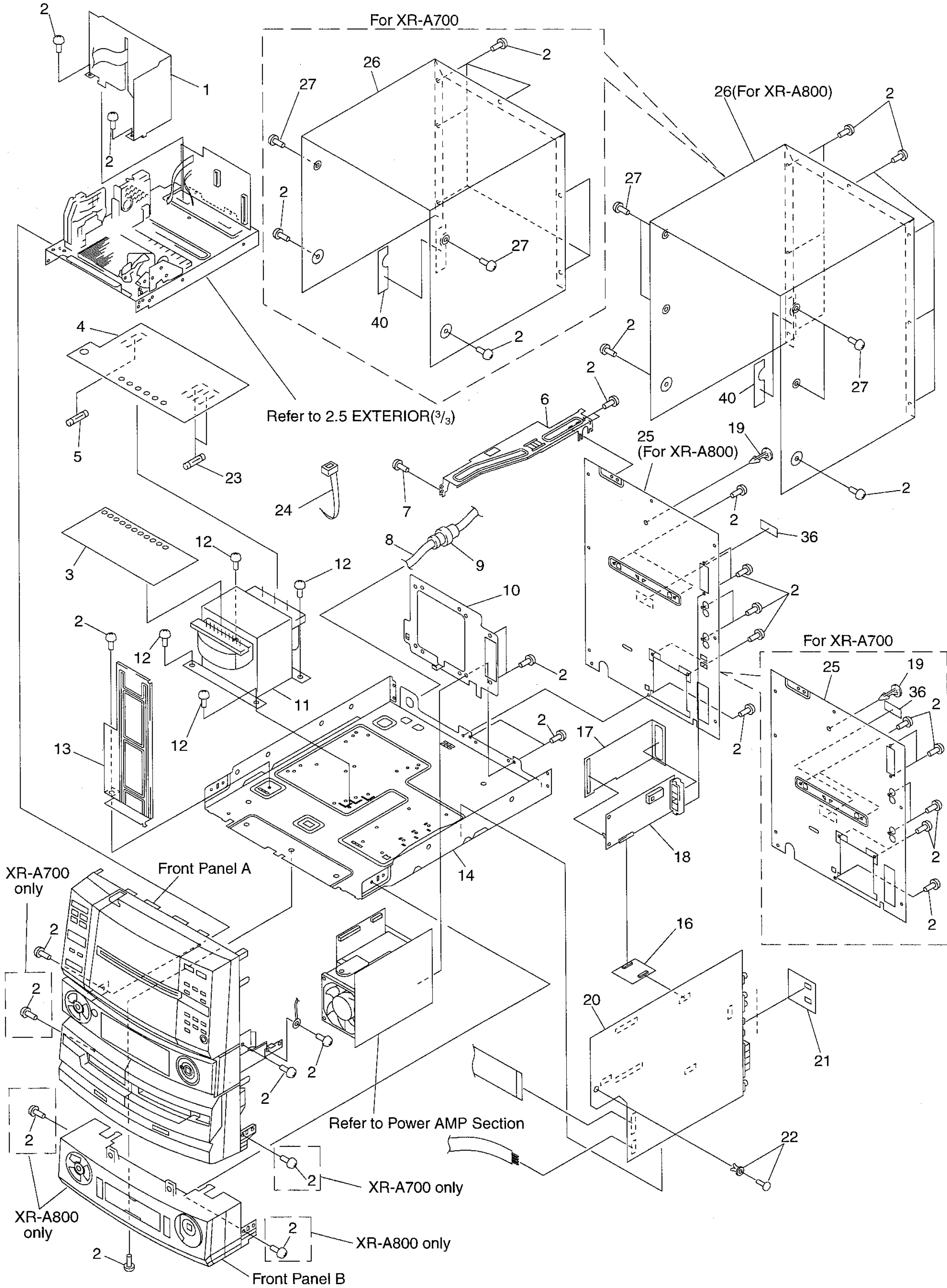

● POWER AMP SECTION

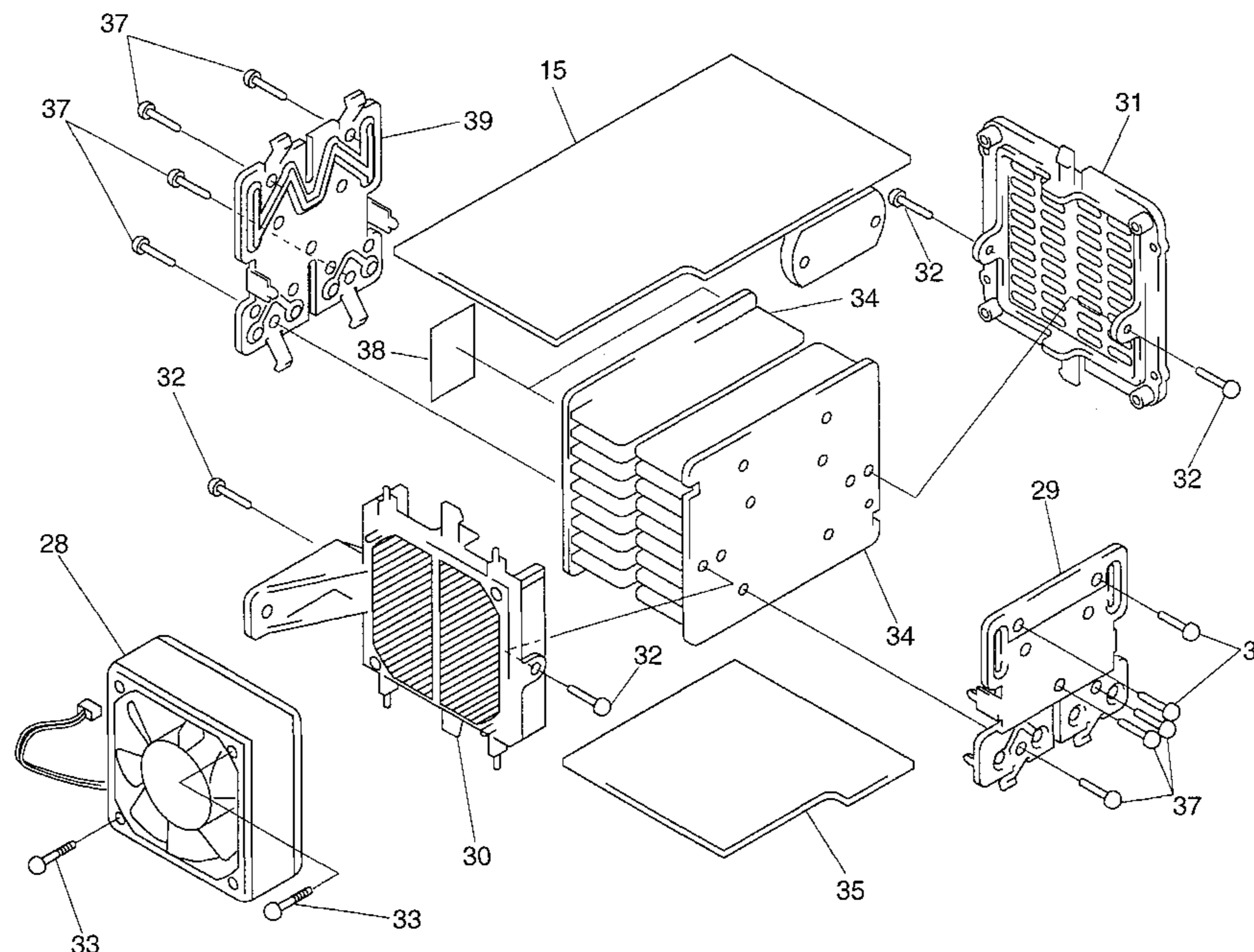

(1) EXTERIOR (2/3) AND POWER AMP SECTION PARTS LIST

Mark	No.	Description	Part No.	Mark	No.	Description	Part No.
	1	CD Cover (MTL)	ANG7165		21	Tweeter Cover	See Contrast table (2)
	2	Screw	BBZ30P080FZK		22	Push Rivet	AEC7069
NSP	3	SECONDARY ASSY	See Contrast table (2)	△	23	Fuse (T2A/250V, FU2, FU3)	AEK1057
NSP	4	PRIMARY ASSY	See Contrast table (2)		24	Binder	ZCA-SKB90BK
△	5	Fuse (T4A/250V, FU1)	AEK1060		25	Rear Panel	See Contrast table (2)
	6	Home Lock Stay (MTL)	AND7030		26	Bonnet Case	See Contrast table (2)
	7	Screw	BPZ30P120FZK		27	Screw	VPZ30P100FZK
△	8	AC Power Cord	See Contrast table (2)		28	DC Fan Motor	AXM7003
	9	Strain Relief	CM-22B		29	Power Pac Holder	ANG7109
	10	AF Hold Plate	ANG7160		30	Mold A	AMR7005
△	11	Power Transformer (T1)	See Contrast table (2)		31	Mold B	AMR7006
	12	Screw	BBZ40P080FZK		32	Screw	ABA1021
	13	Front Stay (MTL)	See Contrast table (2)		33	Screw	BPZ30P350FZK
NSP	14	Chassis (MTL)	ANA7034		34	Heat Sink	ANH7058
	15	AMP ASSY	See Contrast table (2)		35	POWER SUPPLY ASSY	See Contrast table (2)
NSP	16	TX CONNECT ASSY	AWZ8972		36	Caution Label	See Contrast table (2)
	17	TX Cover	AAK7501		37	Screw	BBZ30P180FMC
	18	FM/AM TUNER MODULE	AXQ7061		38	Mica Wafer	AEE7018
	19	Locking Card Spacer	VEC1596		39	Holder	ANG7009
	20	AF ASSY	See Contrast table (2)		40	Resistor Cover	AAK7558

(2) CONTRAST TABLE

XR-A800/DDXJ, DXJ/NC, DLXJ/NC, XR-A700/DDXJ, DXJ/NC and DLXJ/NC types are constructed the same except for the following :

Mark	No.	Symbol and Description	Part No.						Remarks
			XR-A800			XR-A700			
			DDXJ	DXJ/NC	DLXJ/NC	DDXJ	DXJ/NC	DLXJ/NC	
NSP	3	SECONDARY ASSY	AWZ8956	AWZ8956	AWZ8956	AWZ8953	AWZ8953	AWZ8953	
NSP	4	PRIMARY ASSY	AWZ8981	AWZ8981	AWZ8981	AWZ8977	AWZ8977	AWZ8977	
△	8	AC Power Cord	ADG1157	PDG1058	PDG1043	ADG1157	PDG1058	PDG1043	
△	11	Power Transformer (AC110-127V/220-230V/240V)	ATS7196	ATS7196	ATS7196	ATS7199	ATS7199	ATS7199	
	13	Front Stay	AND7029	AND7029	AND7029	AND7028	AND7028	AND7028	
	15	AMP ASSY	AWZ8944	AWZ8944	AWZ8944	AWZ8941	AWZ8941	AWZ8941	
	20	AF ASSY	AWZ8939	AWZ8939	AWZ8939	AWZ8937	AWZ8937	AWZ8937	
	21	Tweeter Cover	AAK7520	AAK7520	AAK7520	Not used	Not used	Not used	
	25	Rear Panel	ANC7604	ANC7612	ANC7613	ANC7603	ANC7606	ANC7607	
	26	Boonet Case	ANE7178	ANE7178	ANE7178	ANE7177	ANE7177	ANE7177	
	35	POWER SUPPLY ASSY	AWZ8950	AWZ8950	AWZ8950	AWZ8947	AWZ8947	AWZ8947	
	36	Caution Label	Not used	Not used	PRW1018	Not used	Not used	PRW1018	

2.5 EXTERIOR (3/3) SECTION

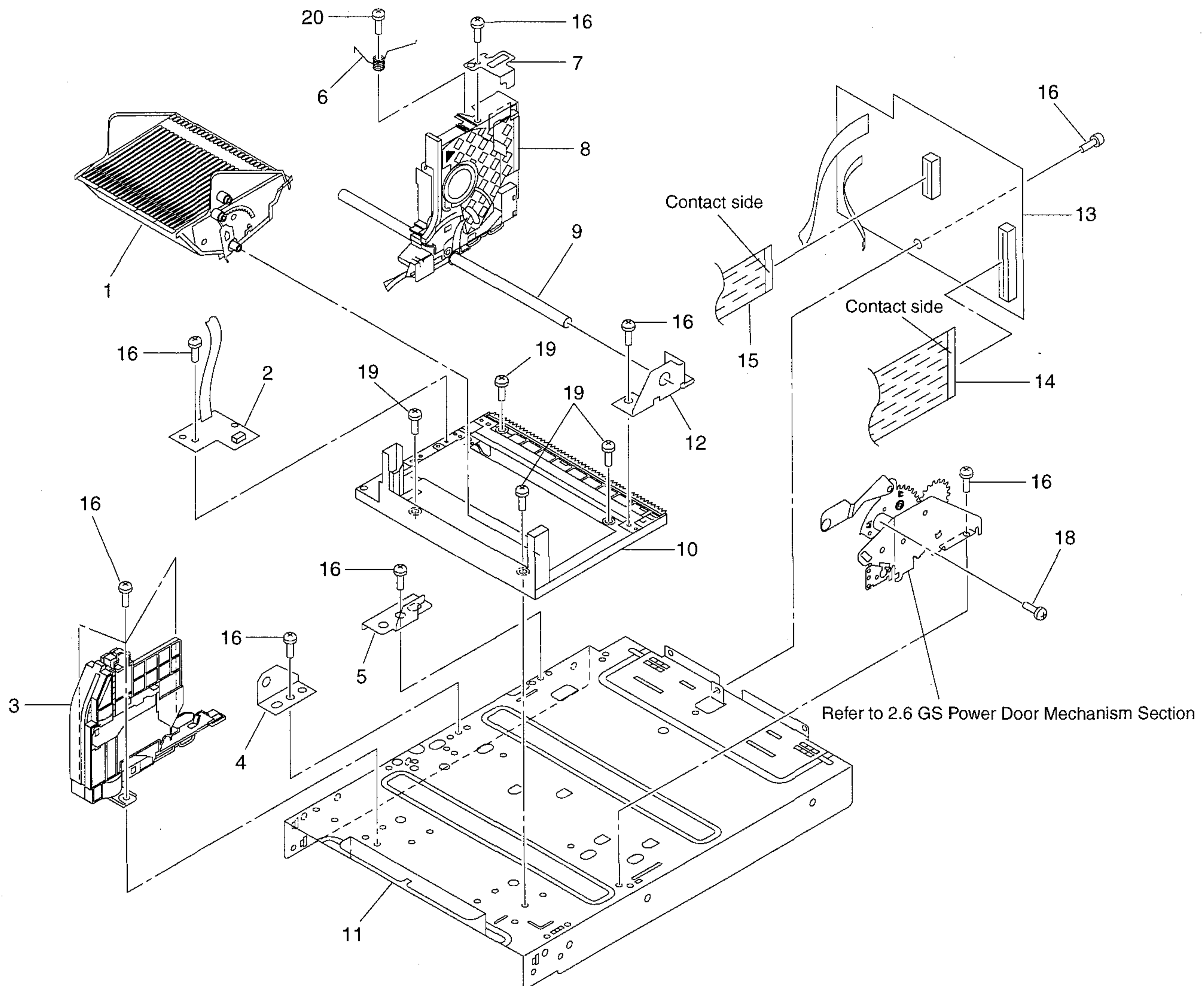

(1) EXTERIOR (3/3) SECTION PARTS LIST

Mark	No.	Description	Part No.	Mark	No.	Description	Part No.
	1	Disc Rack	ANW7069	11	Sub Chassis	ANA7057	
NSP	2	HOME SW ASSY	AWZ8975	12	Shaft Holder	ANB7021	
NSP	3	GS Slot-In Mechanism Assy	AXA7044	13	GM-CD ASSY	See Contrast table (2)	
	4	Shaft Holder GS	ANB7094	14	35P F.F.C/30V	ADD7050	
	5	Lock Angle 2 (MTL)	ANG7117	15	22P F.F.C/30V	ADD7016	
	6	Earth Spring	ABH7159	16	Screw	BBZ30P080FZK	
	7	Assist Angle 2	ANB7065	17		
NSP	8	GS Mechanism Assy	AXA7047	18	Screw	IPZ30P080FMC	
	9	Guide Shaft S	ALA7008	19	Screw C	PBA1106	
	10	Rack Base SP	ANW7118	20	Screw	IPZ20P080FMC	

(2) CONTRAST TABLE

XR-A800/DDXJ, DXJ/NC, DLXJ/NC, XR-A700/DDXJ, DXJ/NC and DLXJ/NC types are constructed the same except for the following :

Mark	No.	Symbol and Description	Part No.						Remarks
			XR-A800			XR-A700			
			DDXJ	DXJ/NC	DLXJ/NC	DDXJ	DXJ/NC	DLXJ/NC	
	13	GM-CD ASSY	AWZ8962	AWZ8962	AWZ8962	AWZ8959	AWZ8959	AWZ8959	

2.6 GS POWER DOOR MECHANISM SECTION

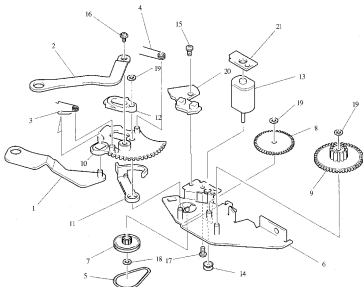

GS POWER DOOR MECHANISM SECTION PARTS LIST

Mark	No.	Description	Part No.	Mark	No.	Description	Part No.
	1	Link A (MTL)	ANG7103		11	SW Lever (ABS)	ANW7107
	2	Link B (MTL)	ANG7115		12	Push Plate (ABS)	ANW7108
	3	Door Spring	ABH7144	NSP	13	Motor	AXM7010
	4	Rack Spring	ABH7145		14	Motor Pulley (POM)	PNW1634
	5	Door Belt	AEB7067		15	Screw	BGZ20P060FMC
	6	Base Plate (SECC)	ANB7081		16	Screw	IPZ20P080FMC
	7	Gear Pulley (POM)	ANW7103		17	Screw	PMA20P030FMC
	8	Gear B (POM)	ANW7104		18	Washer	WT26D0600025
	9	Gear A (POM)	ANW7105		19	Washer	WT36D07200025
	10	Drive Gear (ABS/PC)	ANW7115	NSP	20	Door SW Assy	AWZ8970
				NSP	21	Door Motor Assy	AWZ8973

2.7 GS MECHANISM ASSY (1/2)

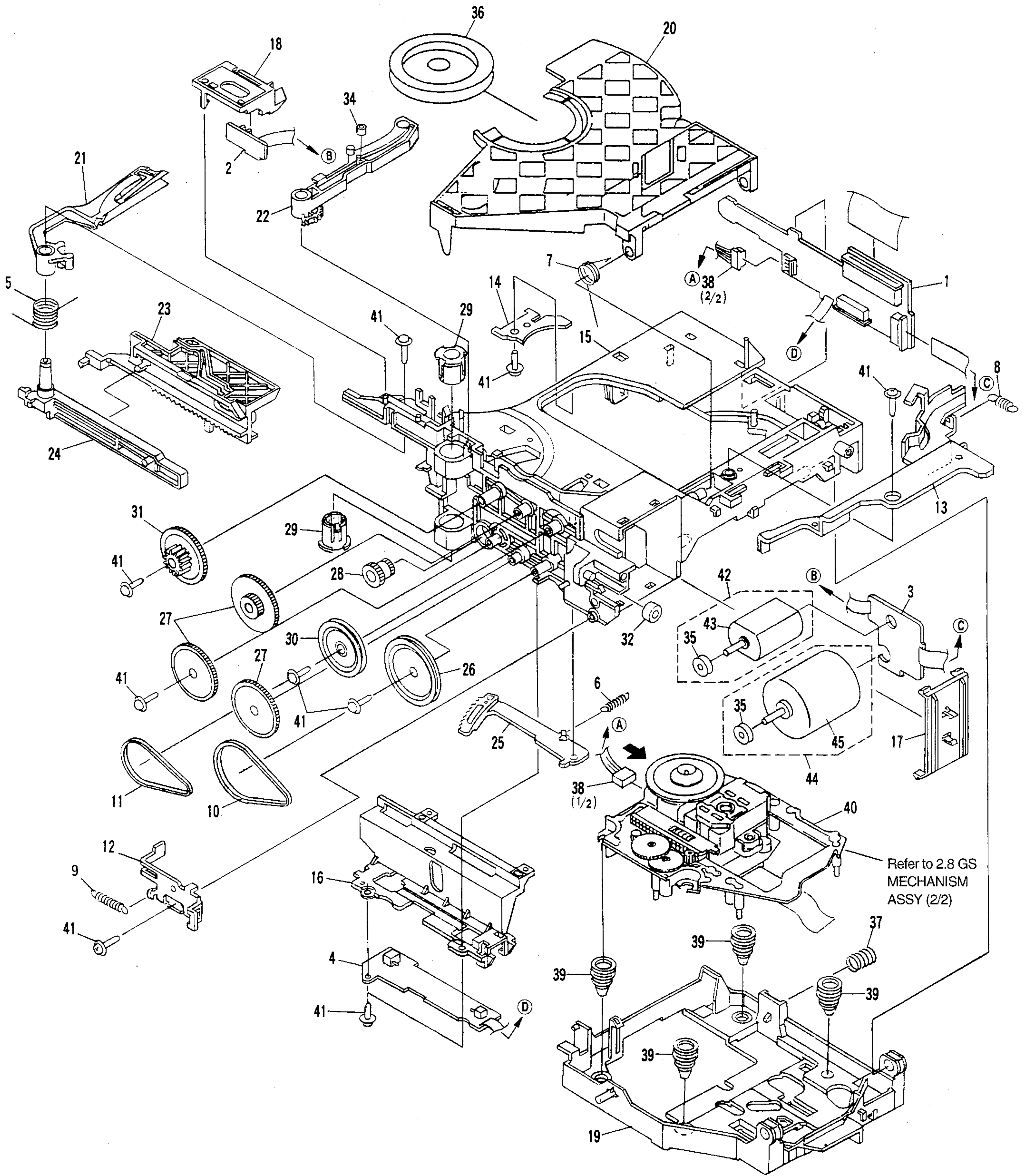

GS MECHANISM ASSY (1/2) PARTS LIST

Mark	No.	Description	Part No.	Mark	No.	Description	Part No.
NSP	1	MECHA PCB ASSY	AWZ8802				
NSP	2	SENSOR PCB ASSY	AWZ7836				
NSP	3	MOTOR PCB ASSY	AWZ7837				
NSP	4	SW PCB ASSY	AWZ7838				
	5	ARM A SPRING 2	ABH7124				
	6	GEAR PLATE SPRING	ABH7051				
	7	CLAMP SPRING	ABH7107				
	8	LOCK LEVER SPRING B	ABH7142				
	9	LOCK ANGLE SPRING 2	ABH7123				
	10	LOADING BELT	AEB7029				
	11	BELT	AEB7030				
NSP	12	LOCK ANGLE	ANB7027				
NSP	13	LOCK LEVER	ANB7038				
NSP	14	SERVO STOPPER S	ANB7047				
	15	LOADING BASE	ANW7086				
	16	CAM COVER	ANW7052				
	17	MOTOR HOLDER	ANW7053				
	18	SENSOR HOLDER	ANW7054				
	19	FLOAT BASE	ANW7080				
	20	CLAMPER HOLDER	ANW7117				
	21	ARM (A)	ANW7057				
	22	ARM (B)	ANW7058				
	23	DRIVE PLATE	ANW7059				
	24	ARM PLATE	ANW7060				
	25	GEAR PLATE	ANW7082				
					26	GEAR PULLEY (B)	ANW7062
					27	GEAR A	ANW7063
					28	DRIVE GEAR	ANW7064
					29	BEARING	ANW7065
					30	GEAR PULLEY A	ANW7066
					31	SELECT GEAR	ANW7067
					32	ROLLER	ANW7068
					33	
					34	ROLLER B	ANW7075
					35	MOTOR PULLEY	PNW1634
					36	CLAMPER	PNW2692
					37	FLOAT SPRING	ABH7049
					38	CONNECTOR ASSY (4P)	ADE7006
					39	FLOAT RUBBER	AEB7028
				NSP	40	SERVO MECHANISM ASSY GM	AXA7028
					41	SCREW	IPZ20P080FMC
					42	MOTOR ASSY (SELECT)	AEA7005
				NSP	43	MOTOR	PXM1002
					44	MOTOR ASSY	AEA7006
					45	LOADING MOTOR	VXM1034
						FROIL (for service)	GYA1001
						HA NARL (for service)	GEM1016

● How to install the disc table

- 1 Use nipper or other tool to cut the two sections marked (A) figure 1. Then remove the spacer.
- 2 While supporting the spindle motor shaft with the stopper, put spacer on top of the yoke M, and stick the disc table on top (takes about 9kg pressure). Take off the spacer.

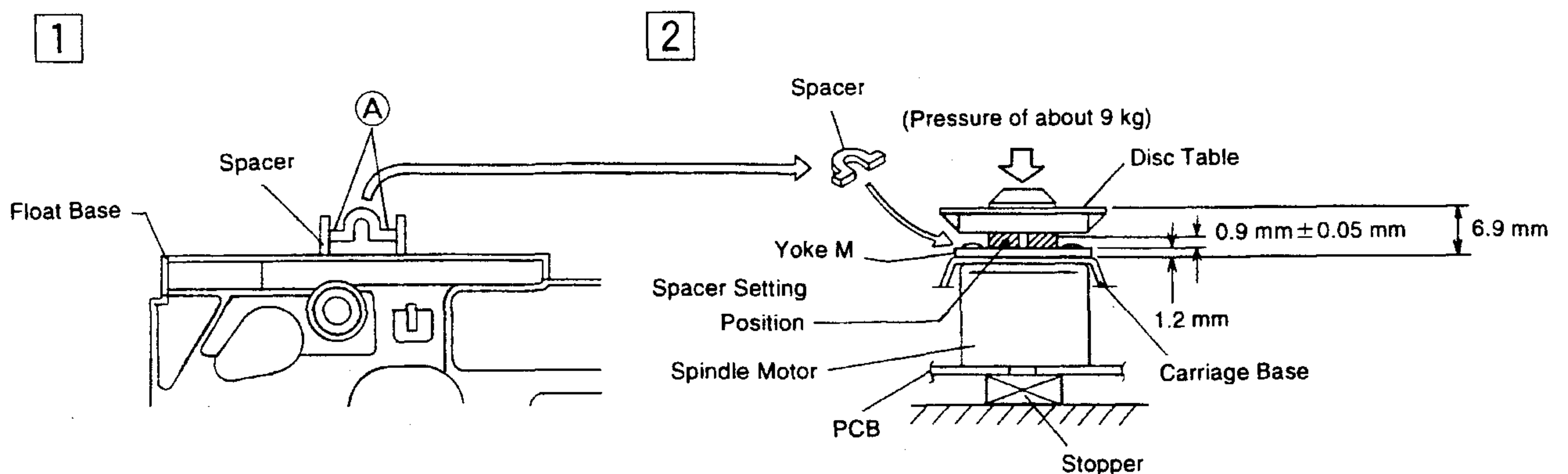

2.8 GS MECHANISM ASSY (2/2)

Servo Mechanism Assy GM

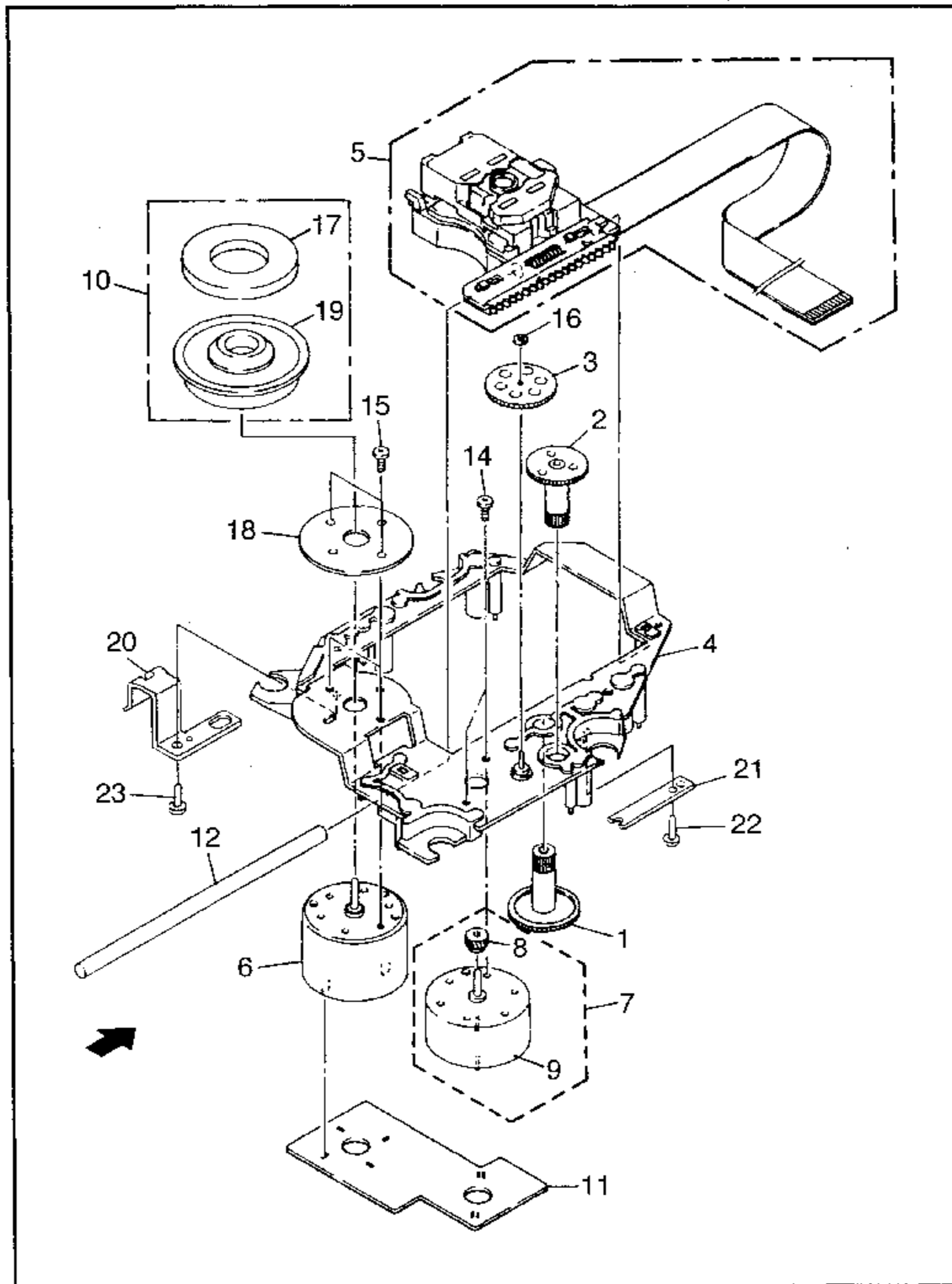

GS MECHANISM ASSY (2/2) PARTS LIST

Mark	No.	Description	Part No.	Mark	No.	Description	Part No.
	1	GEAR 1	PNW2052		11	MECHANISM BOARD ASSY	PWX1192
	2	GEAR 2	PNW2053		12	GUIDE BAR	PLA1094
	3	GEAR 3	PNW2054		13	
	4	CARRIAGE BASE	PNW2699		14	SCREW	JFZ17P025FZK
	5	PICKUP ASSY	AEA7004		15	SCREW	JFZ20P040FMC
	6	D.C. MOTOR ASSY (SPDL)	PEA1235		16	WASHER	WT12D032D025
	7	CARRIAGE DC MOTOR ASSY	PEA1246		17	CLAMP MAGNET	PMF1014
	8	PINION GEAR	PNW2055		18	YOKE M	PNB1312
NSP	9	CARRIAGE DC MOTOR/0.3W	PXM1027	NSP	19	DISC TABLE	PNW2410
	10	DISC TABLE ASSY	PEA1314	NSP	20	FLOAT ANGLE	ANB7020
					21	GEAR STOPPER	PNB1303
					22	SCREW	BPZ20P060FMC
					23	SCREW	BPZ26P100FMC

2.9 GS SLOT-IN MECHANISM ASSY

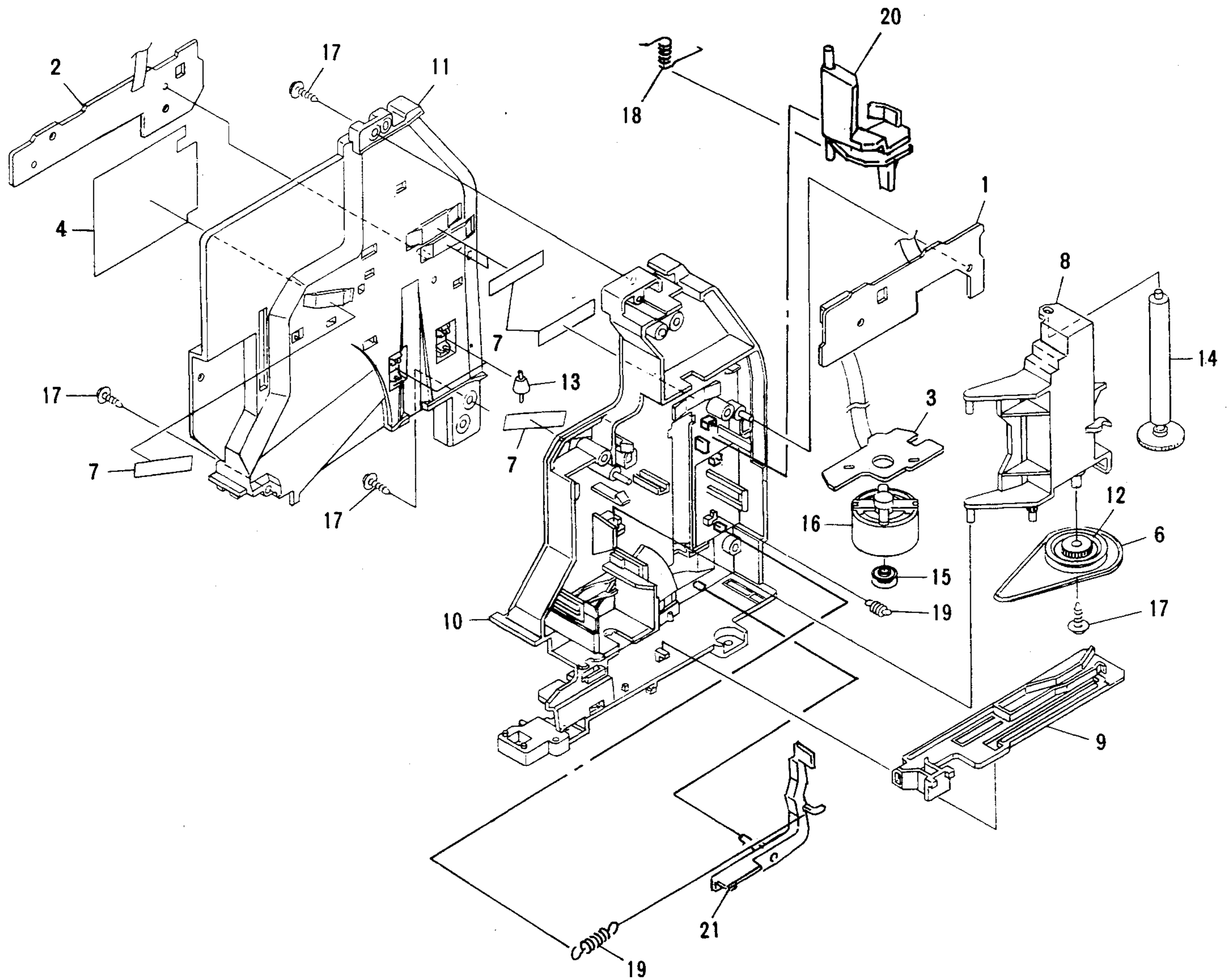

GS SLOT-IN MECHANISM ASSY PARTS LIST

Mark	No.	Description	Part No.	Mark	No.	Description	Part No.
NSP	1	Sensor Board Assy	AWZ8560	11	Case (S)	ANW7102	
NSP	2	LED Board Assy	AWZ8561	12	Gear Pulley A	ANW7066	
NSP	3	Motor Board Assy	AWZ8744	13	Guide Roller	ANW7076	
	4	Blind	AAK7219	14	Roller Assy	AXA7029	
	5		15	Motor Pulley	PNW1634	
	6	Belt	AEB7033	16	DC Motor/0.75W	PXM1010	
	7	Ecsaine	AED7004	17	Screw	IPZ20P080FMC	
	8	Gear Holder	ANW7110	18	Shutter Spring	ABH7136	
	9	Slide Plate	ANW7048	19	P.B Spring	ABH7137	
	10	Case (M)	ANW7101	20	Shutter	ANW7099	
				21	Lever	ANW7100	

2.10 MECHANISM UNIT

● Mechanism Unit I and II (1/2)

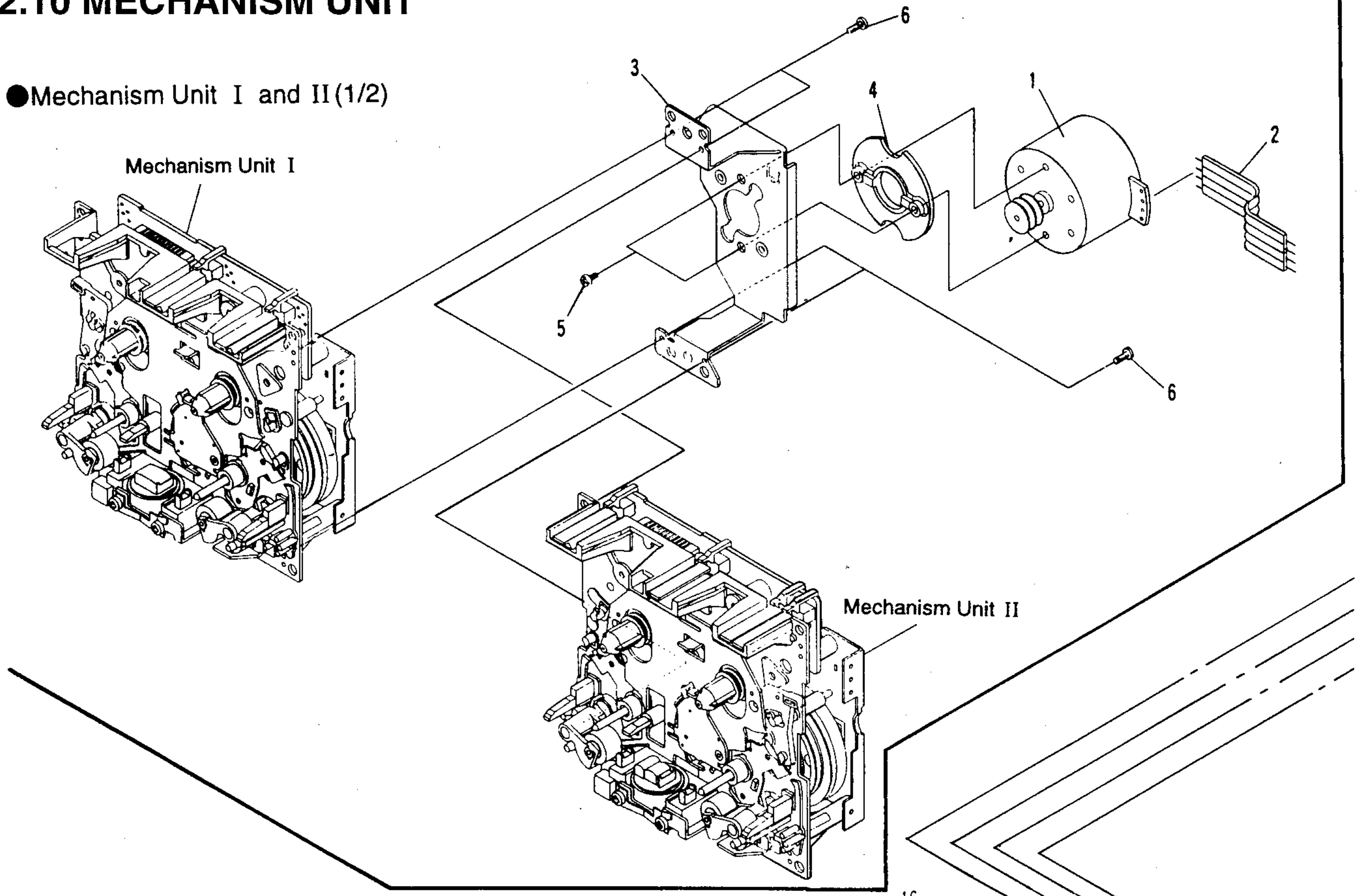

● Mechanism Unit I and II (2/2)

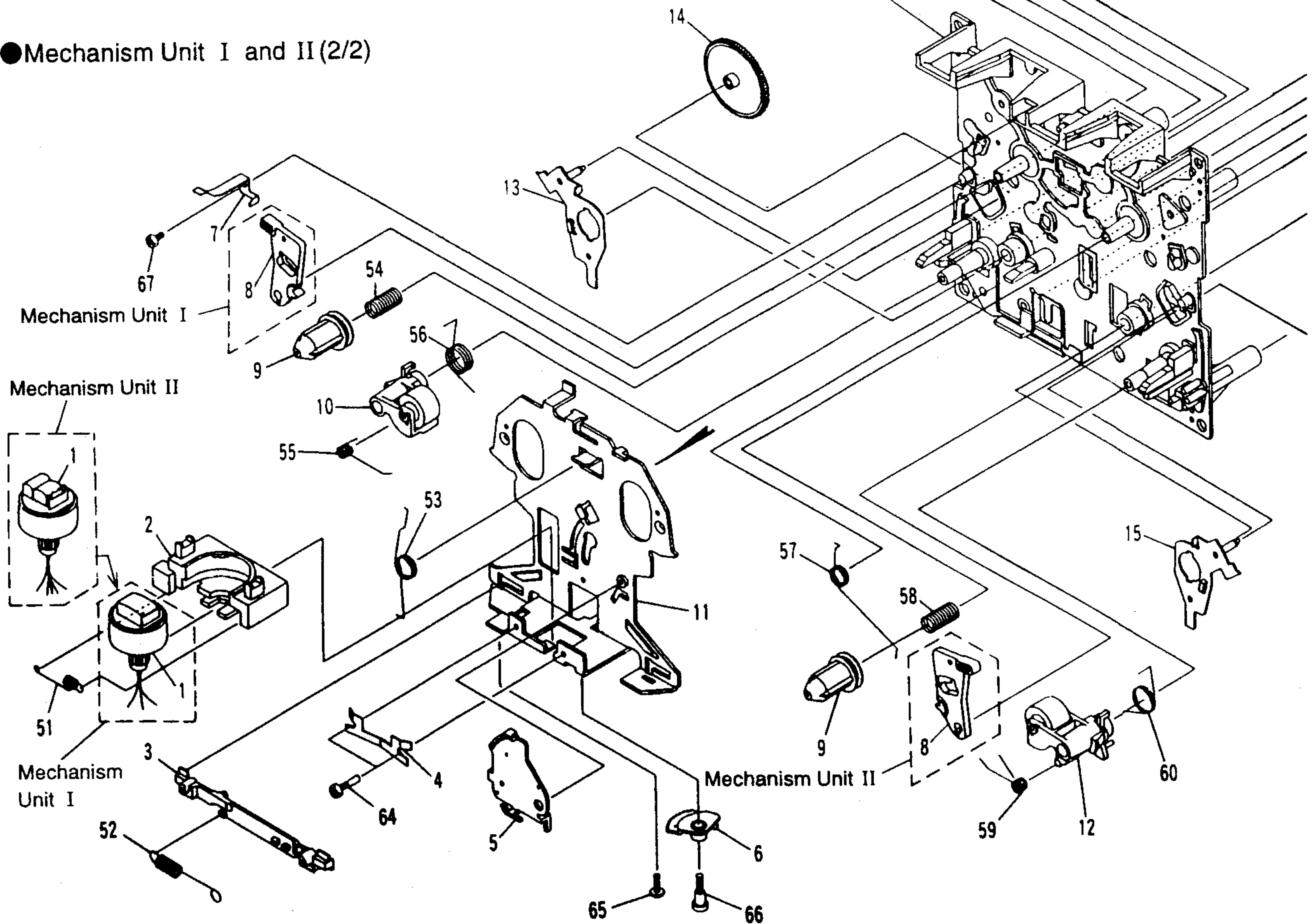

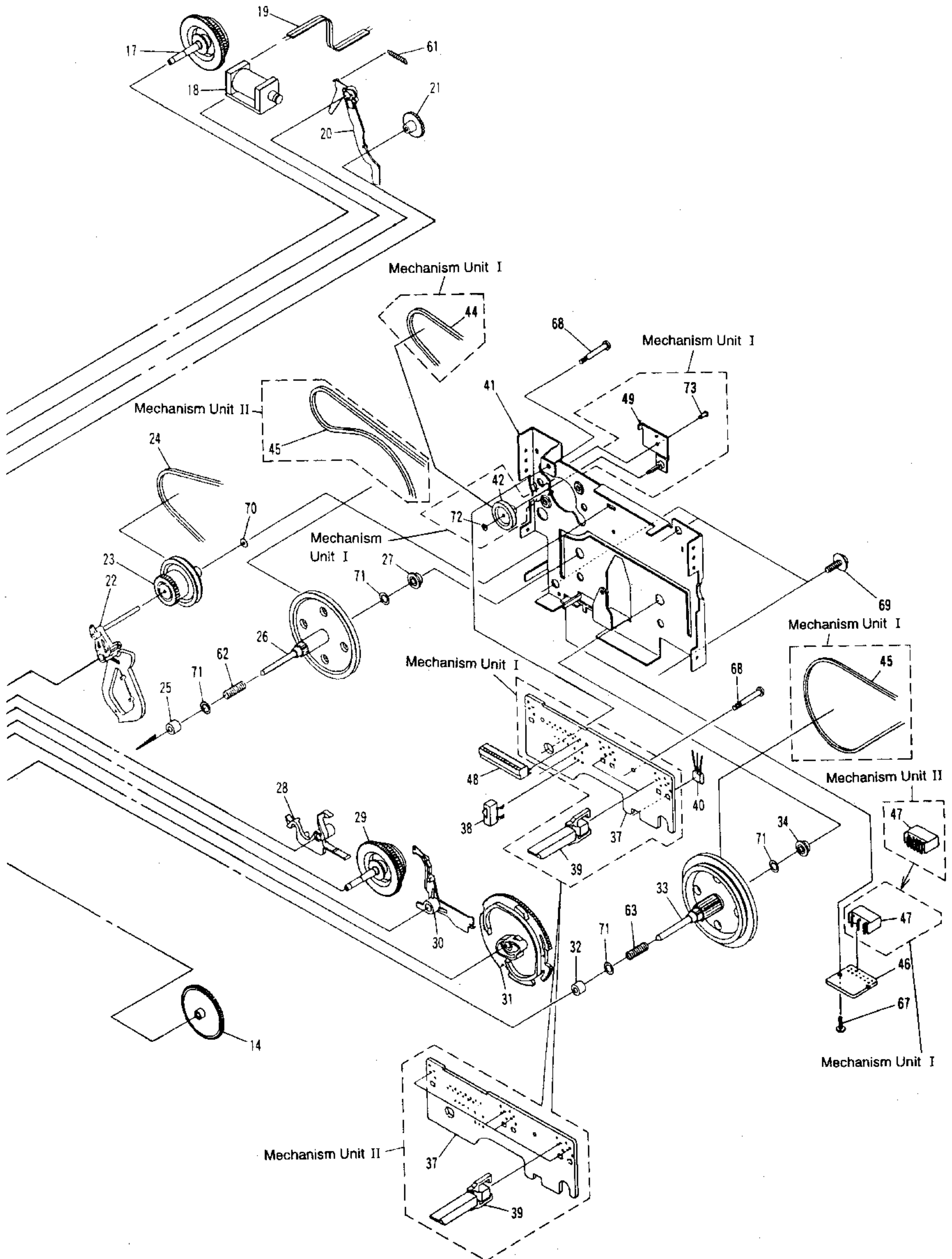

XR-A800, XR-A700

MECHANISM UNIT PARTS LIST

■ Mechanism unit I and II (1/2)

Mark	No.	Description	Part No.
NSP	1	ASSY MOTOR	RXM1080
	2	JUMPER WIRE	RDD1012
	3	BRACKET MOTOR	RNE1830
	4	SPACER	RNK1822
	5	SCREW	RBA1100
	6	SCREW	PCZ20P040FMC

■ Mechanism unit I and II (2/2)

Mark	No.	Description	Part No.
	1	ASSY HOLDER HEAD (*1)	RXA1400
	1	ASSY HOLDER HEAD (*2)	RXA1664
	2	FRAME HEAD	RNK1715
	3	LEVER HEAD	RNK1716
	4	SPRING AZIMUTH	RBK1006
	5	ASSY ARM ASSIST	RXA1401
	6	GEAR ARM HEAD	RNK1717
	7	SPRING CASSETTE	RBK1039
	8	EJECT LOCK	RNK1718
	9	CAP REEL	RNK1719
	10	ASSY PINCH ARM L	RXA1403
	11	CHASSIS HEAD	RNE1437
	12	ASSY PINCH ARM R	RXA1404
	13	ARM PLAY L	RNK1866
	14	GEAR PLAY	RNK1867
	15	ARM PLAY R	RNK1868
	16	CHASSIS OS	RXA1411
	17	ASSY SUB REEL L	RXA1407
	18	SOLENOID	RXP1020
	19	WIRE	RDC1006
	20	ARM RVS	RNK1721
	21	GEAR FF	RNK1723
	22	ASSY ARM FR	RXA1412
	23	ASSY PULLEY FR	RXA1413
	24	BELT FR	REB1292
	25	METAL	RNG1048
	26	ASSY FLYWHEEL L	RXA1690
	27	METAL	RNG1005
	28	ARM BRAKE	RNK1724
	29	ASSY SUB REEL R	RXA1408
	30	ARM TRIGER	RNK1722
	31	GEAR CAM	RNK1725
	32	METAL	RNG1049
	33	ASSY FLYWHEEL R	RXA1691
	34	METAL	RNG1004
	35	

Mark	No.	Description	Part No.
	36	
	37	P. C. BOARD	RNP1610
	38	SWITCH MODE	RSN1020
	39	SWITCH (LEAF)	RSN1019
	40	HALL IC	DN6851A
	41	BRACKET FW (*1)	RNE1854
	41	BRACKET FW (*2)	RNE1438
	42	PULLEY (*1 only)	RNK2132
	43	
	44	BELT FW (*1 only)	REB1291
	45	BELT MAIN (* 1)	REB1290
	45	BELT MAIN (* 2)	REB1289
	46	P. C. BOARD	RNP1348
	47	HOUSING (*1)	RKP1396
	47	HOUSING (*2)	RKP1397
	48	CONNECTOR (*1)	RKP1713
	48	CONNECTOR (*2)	RKP1714
	49	ASSY HOLDER (*1 only)	RXA1689
	50	
	51	SPRING	RBH1282
	52	SPRING	RBH1283
	53	SPRING	RBH1284
	54	SPRING	RBH1286
	55	SPRING	RBH1288
	56	SPRING	RBH1291
	57	SPRING	RBH1285
	58	SPRING	RBH1287
	59	SPRING	RBH1289
	60	SPRING	RBH1290
	61	SPRING	RBH1292
	62	FWP SP (SPRING)	RBH1061
	63	SPRING	RBH1325
	64	SCREW (For AZIMUTH)	RBA1023
	65	SCREW	RBA1027
	66	SCREW	RBA1030
	67	SCREW	PCZ20P040FMC
	68	SCREW	RBA1093
	69	SCREW	RBA1094
	70	WASHER	RBF1046
	71	WASHER	WA26D047D013
	72	WASHER (*1 only)	WT13D030D025
	73	SCREW (*1 only)	RBA1118

Note) *1: Mechanism Unit I
*2: Mechanism Unit II

3. SCHEMATIC DIAGRAM

3.1 OVERALL CONNECTION DIAGRAM

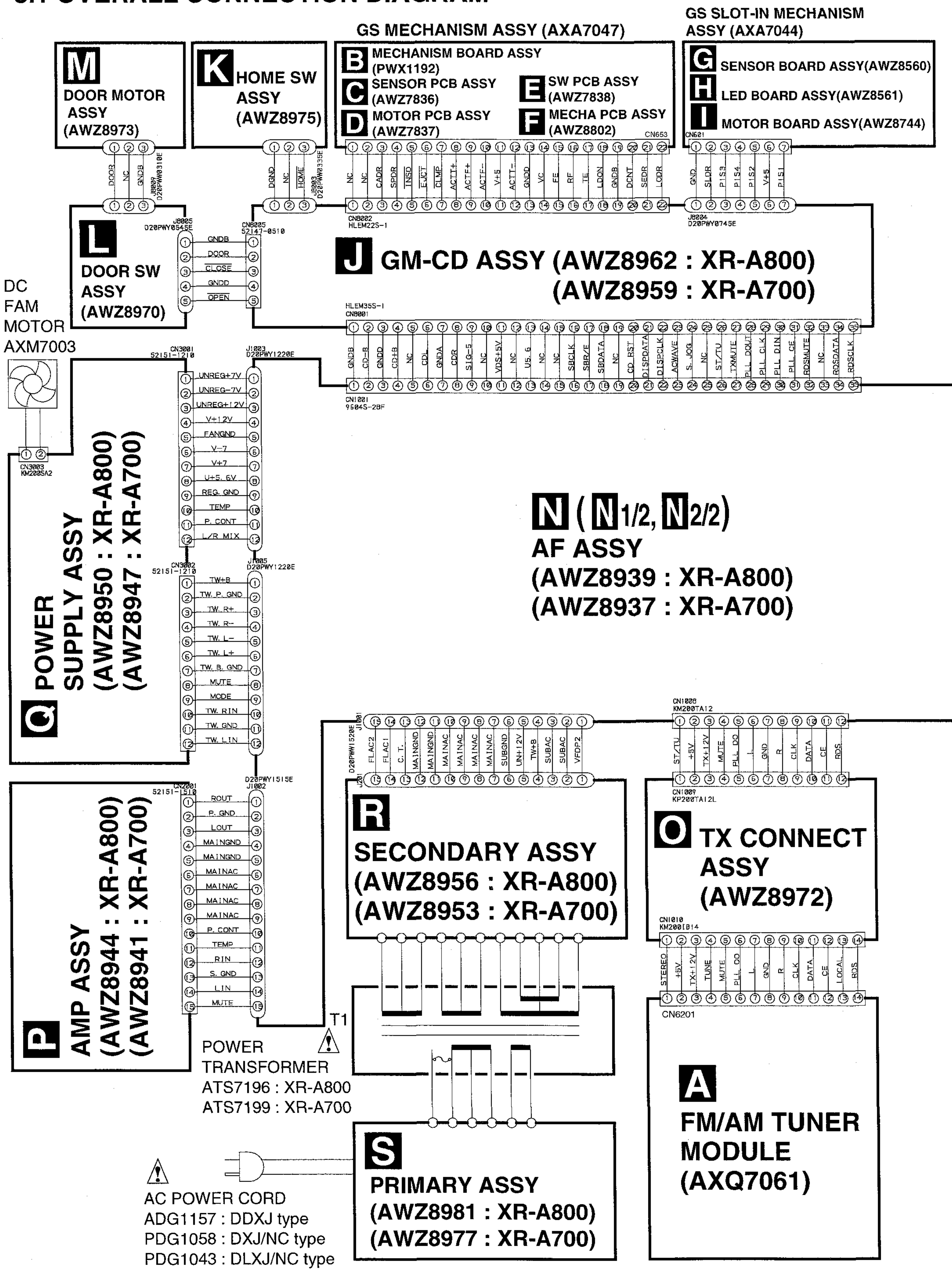

N (N1/2, N2/2)
AF ASSY
(AWZ8939 : XR-A800)
(AWZ8937 : XR-A700)

Note : When ordering service parts, be sure to refer to "EXPLODED VIEWS and PARTS LIST" or "PCB PARTS LIST"

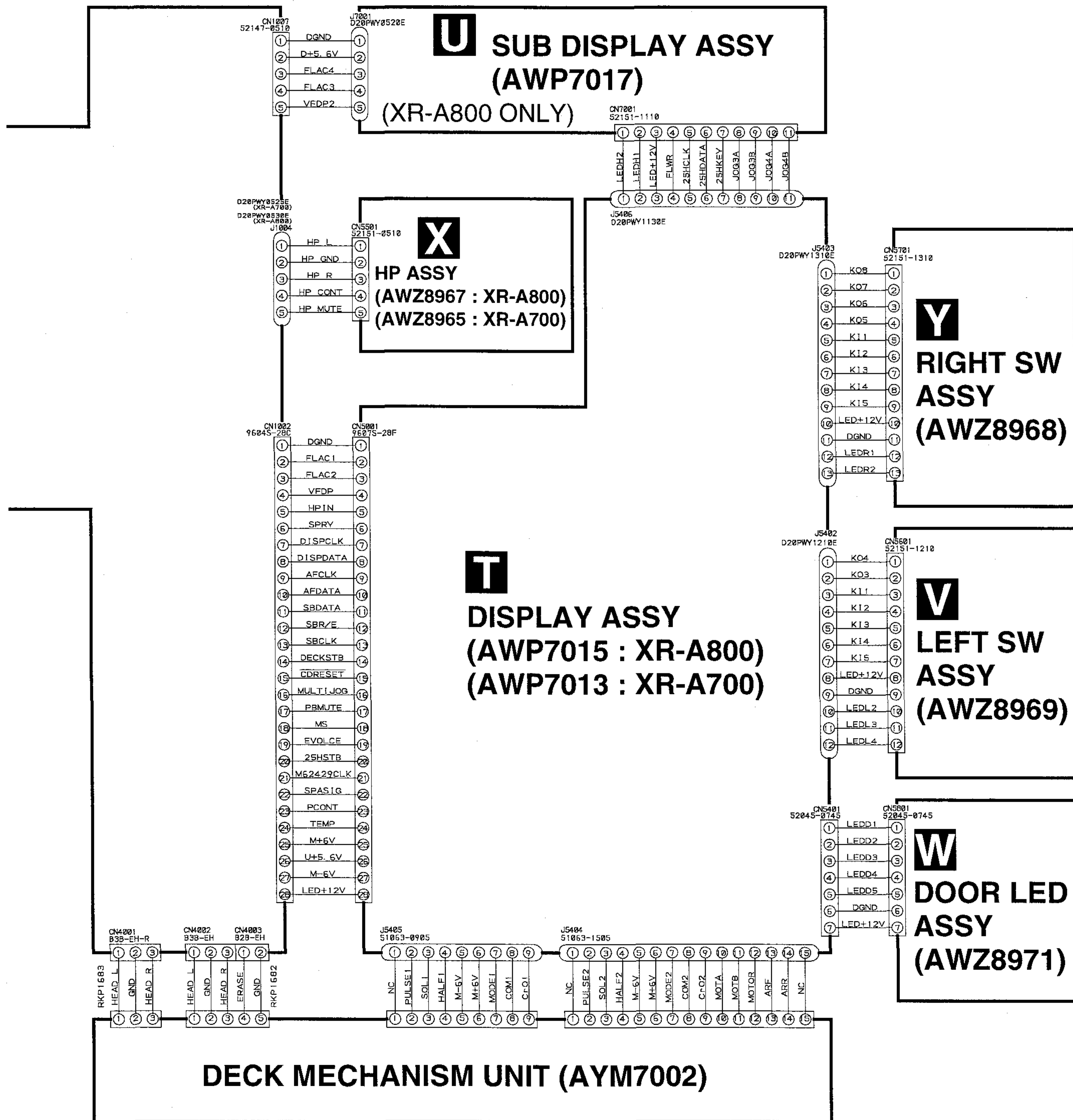

Notes

1. RESISTORS

Indicated in Ω , 1/10W \pm 5% Tolerance unless otherwise noted K:K Ω , M:M Ω .

2. CAPACITORS

Indicated in Capacity (μ F)/VOLTAGE (V) unless otherwise noted P:PF.

3. DIODES

No mark diode is 1SS254.

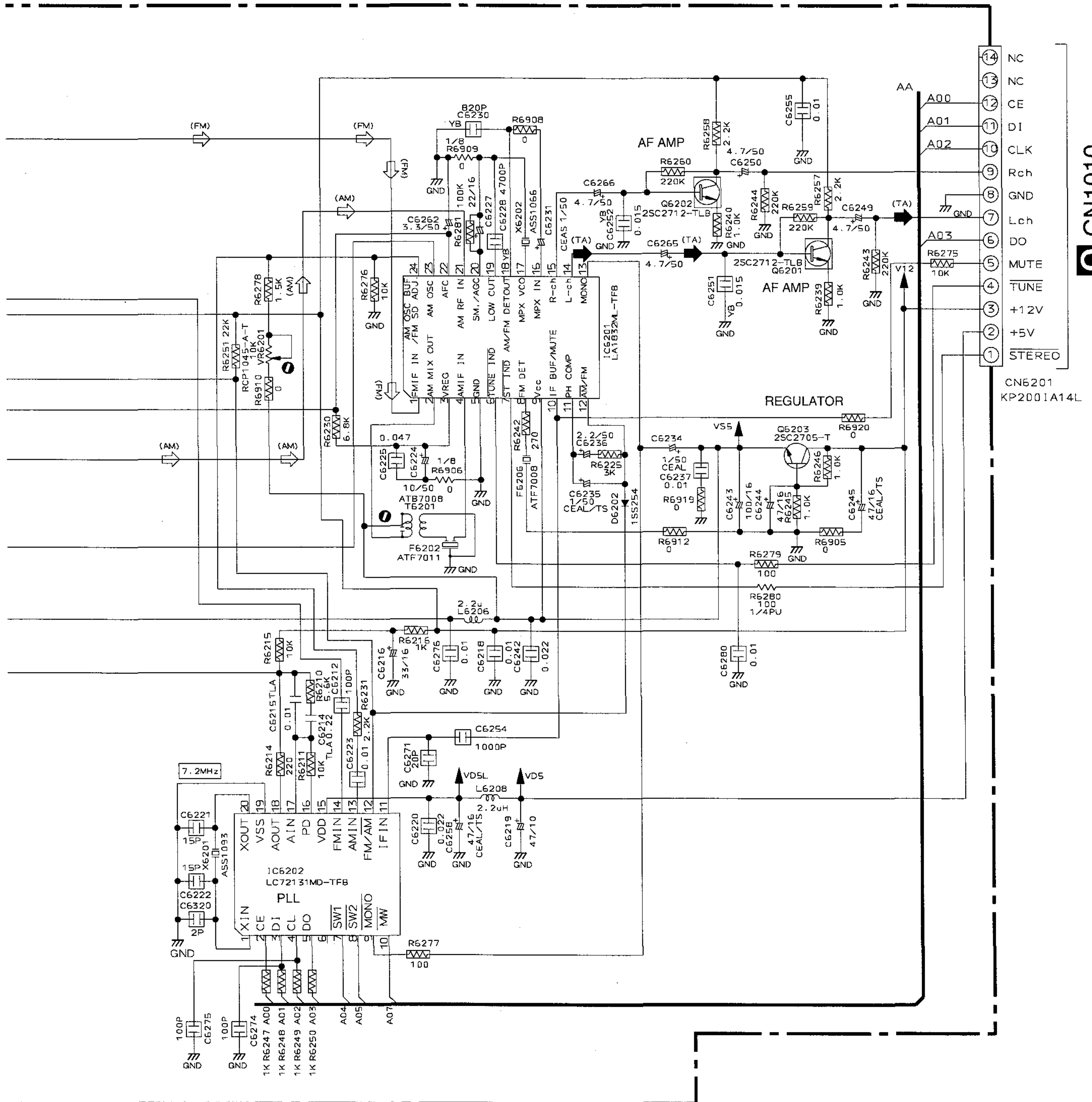

CN1010

3.3 GS MECHANISM ASSY AND GS SLOT-IN MECHANISM ASSY

GS MECHANISM ASSY (AXA7047)

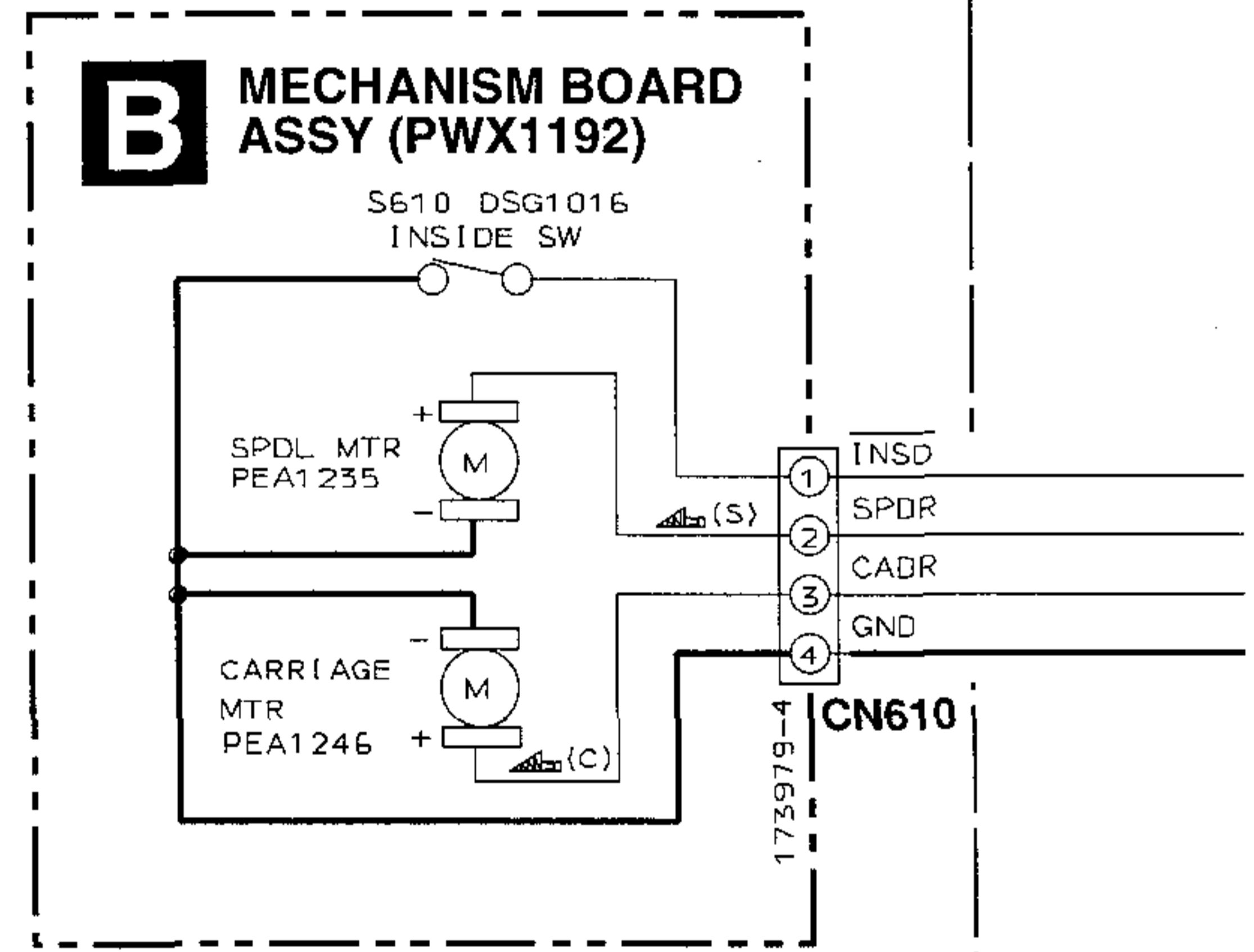
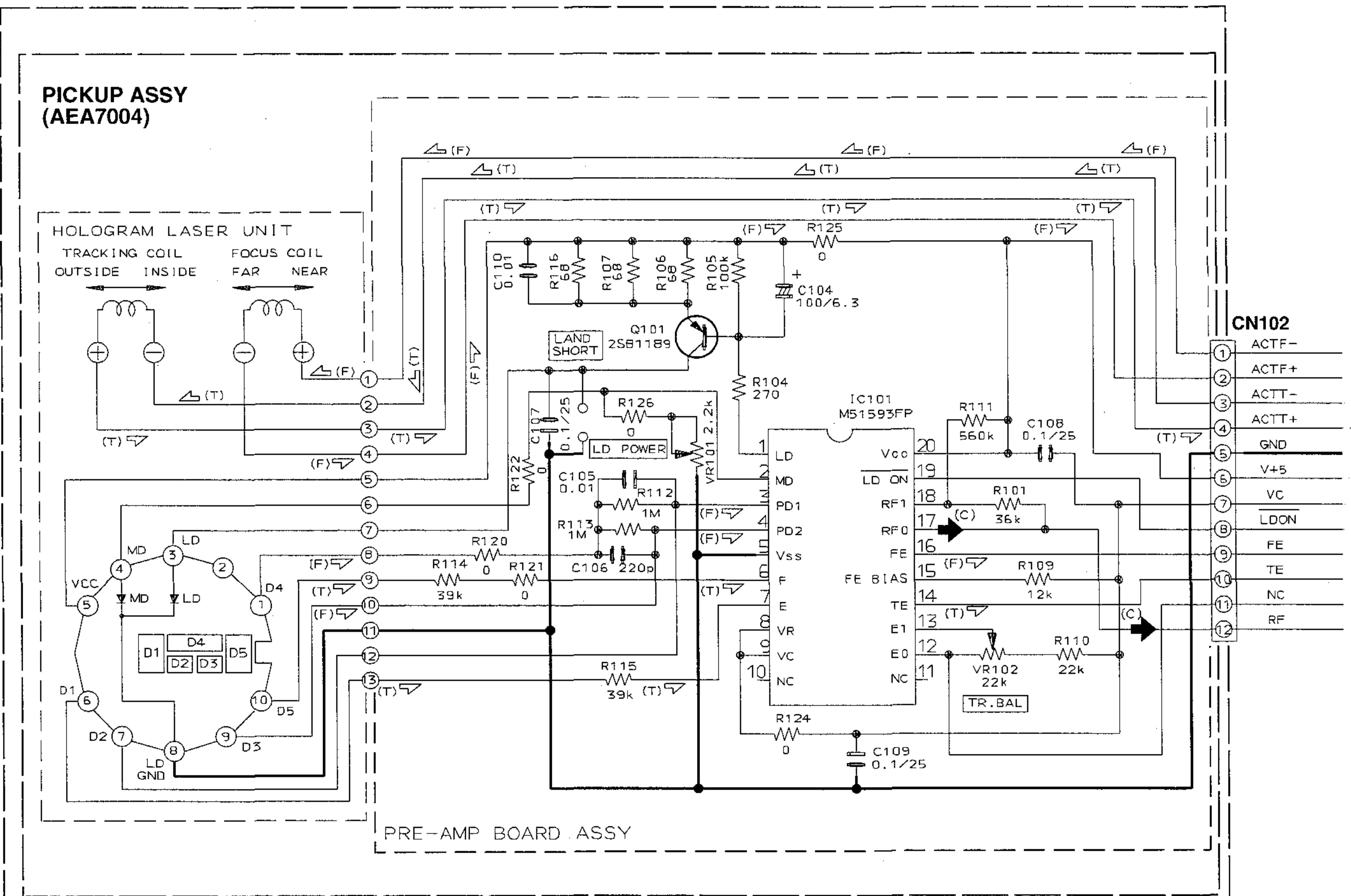

SERVO MECHANISM ASSY GM (AXA7028)

SIGNAL ROUTE

- (C) ➔ : CD AUDIO SIGNAL ROUTE
- (F) ➔ : FOCUS SERVO LOOP LINE
- (T) ➔ : TRACKING SERVO LOOP LINE
- (L) ➔ : LOADING MOTOR ROUTE
- (S) ➔ : SPINDLE MOTOR ROUTE
- (C) ➔ : CARRIAGE MOTOR ROUTE

Note : For the waveforms, refer to page 40.

SIGNAL ROUTE

- (C) and (C) : CD AUDIO SIGNAL
- (F) : FOCUS SERVO LOOP LINE
- (T) : TRACKING SERVO LOOP LINE
- (L) : LOADING MOTOR ROUTE
- (S) : SPINDLE MOTOR ROUTE
- (C) : CARRIAGE MOTOR ROUTE

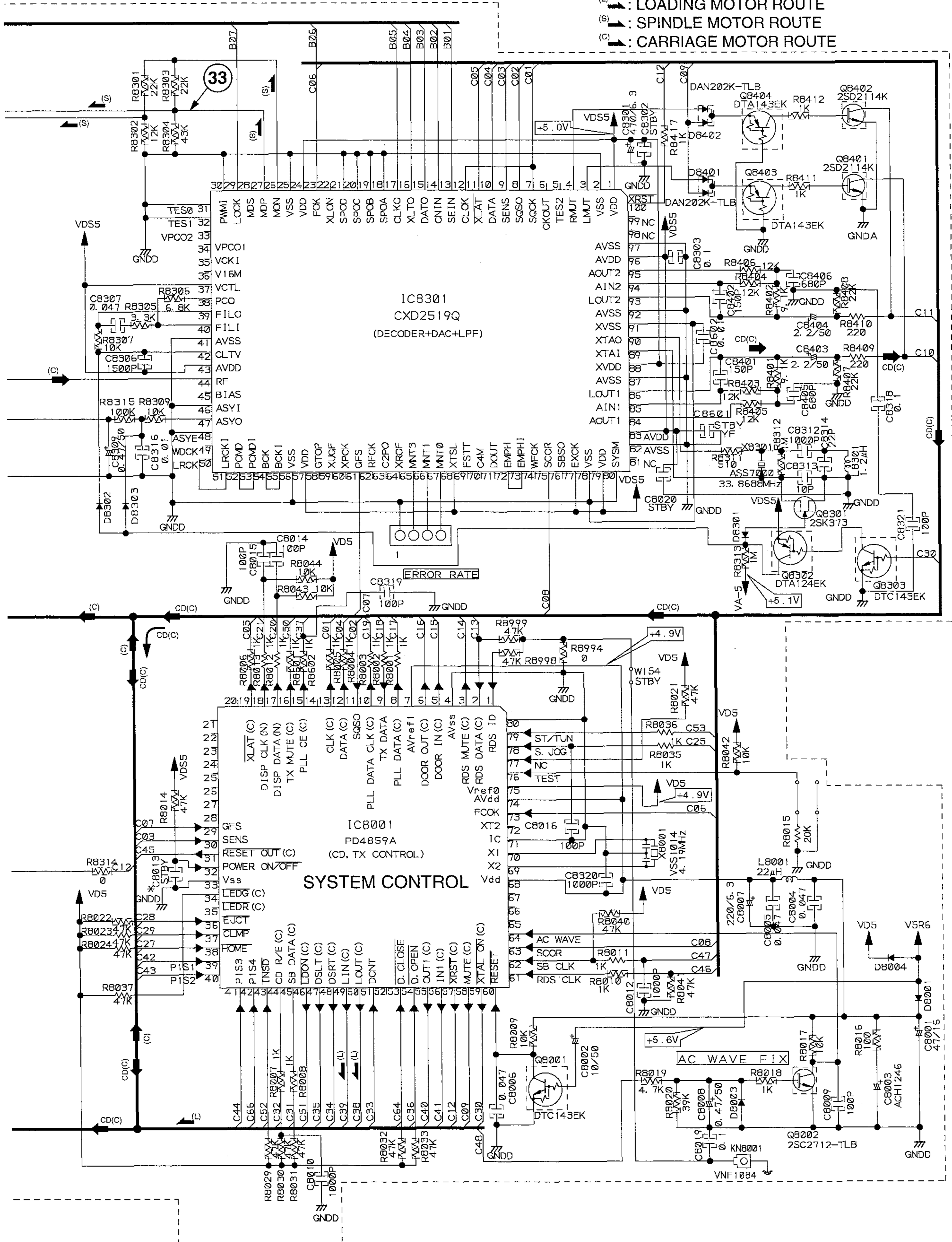

A

B

C

D



3.5 AF ASSY (1/2)

N AF ASSY (1/2)
(AWZ8939 : XR-A800)
(AWZ8937 : XR-A700)

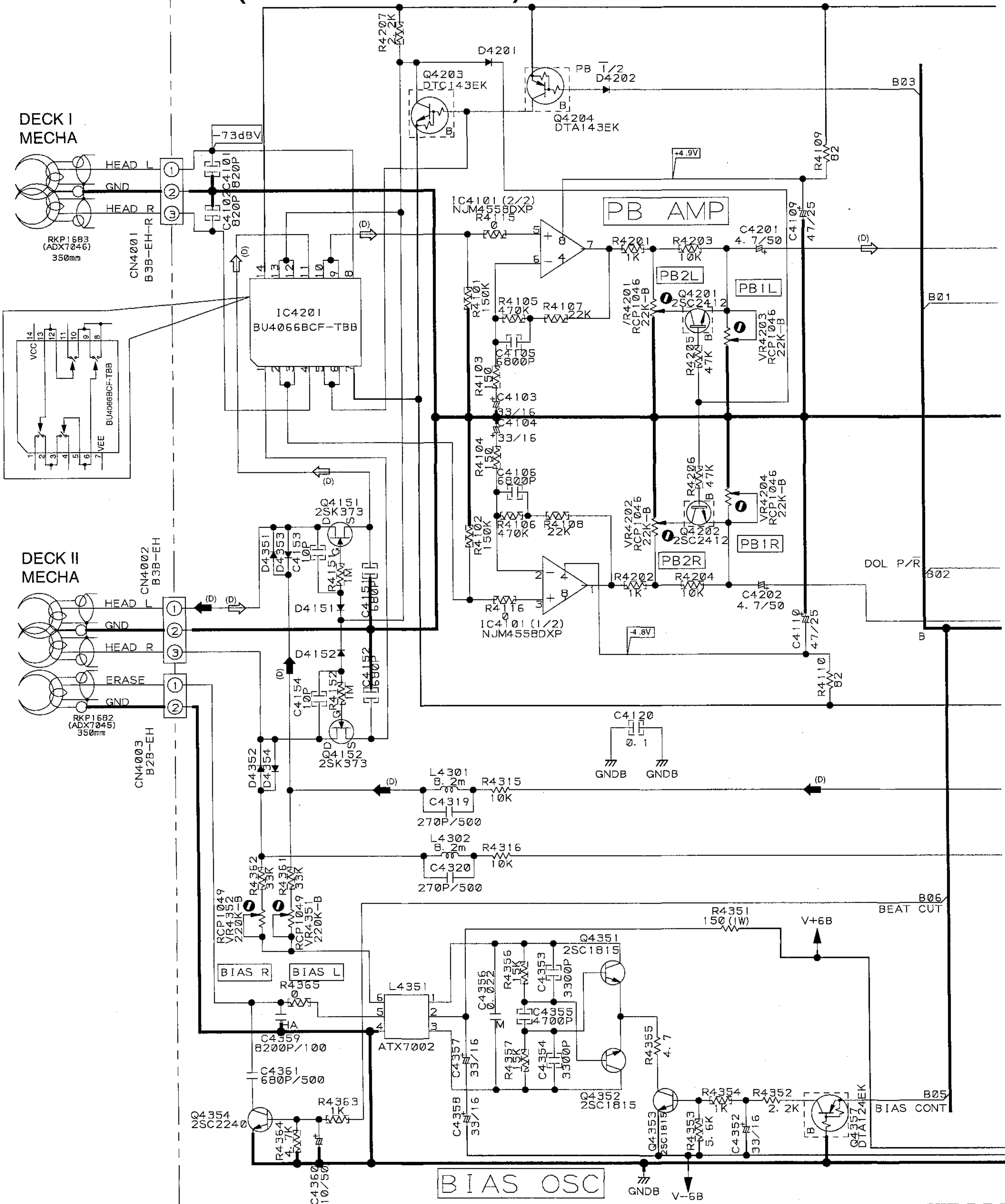

If the parts are not identified,
 the followings are used.
 * 1S5254-T

XR-A800, XR-A700

3.6 AF ASSY (2/2) AND TX CONNECT ASSY

J CN8001

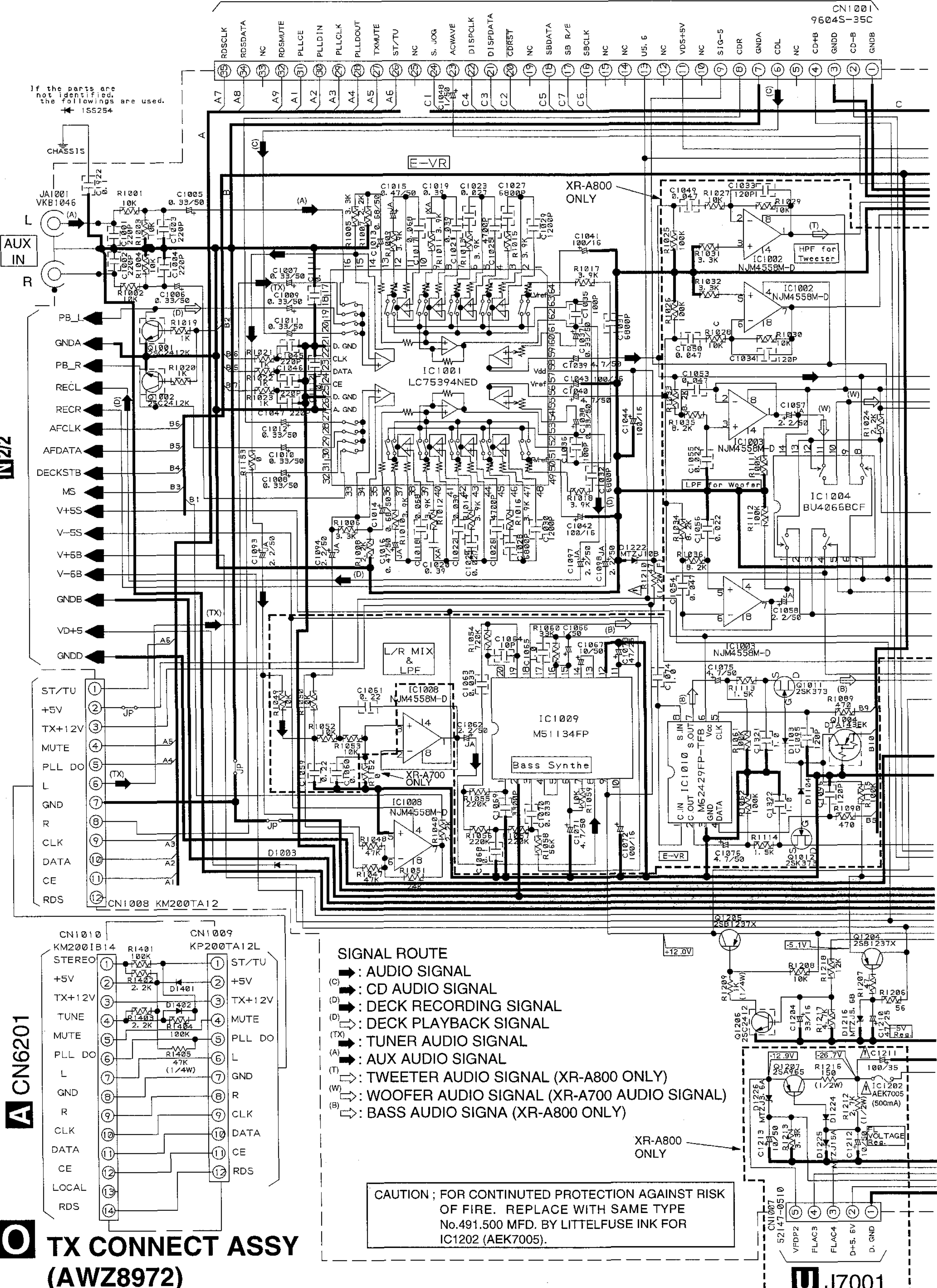

If the parts are not identified, the following are used.
 * 155254

N2/2

A CN6201

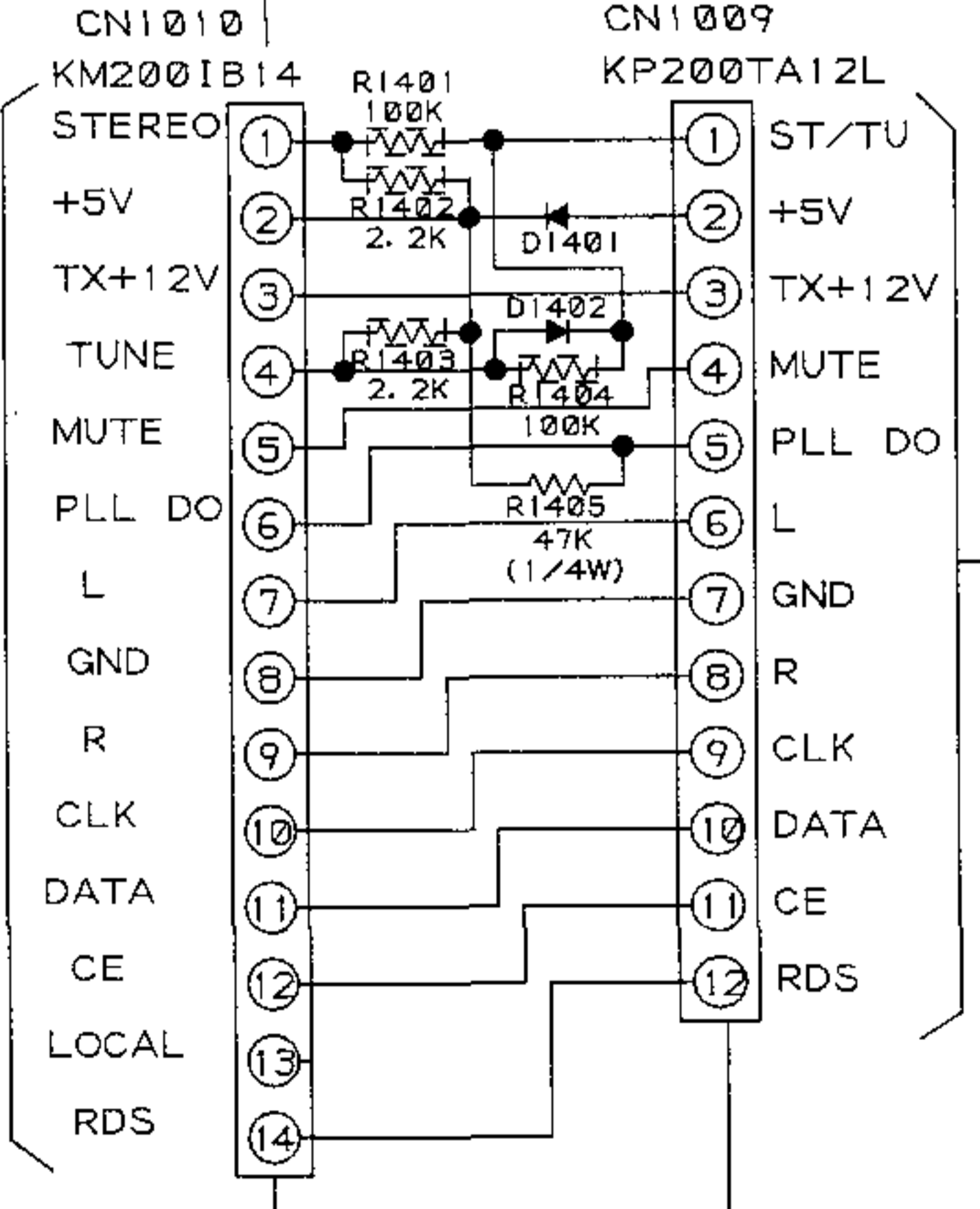

O TX CONNECT ASSY (AWZ8972)

SIGNAL ROUTE

- (C) → AUDIO SIGNAL
- (D) → CD AUDIO SIGNAL
- (E) → DECK RECORDING SIGNAL
- (F) → DECK PLAYBACK SIGNAL
- (TX) → TUNER AUDIO SIGNAL
- (A) → AUX AUDIO SIGNAL
- (T) → TWEETER AUDIO SIGNAL (XR-A800 ONLY)
- (W) → WOOFER AUDIO SIGNAL (XR-A700 AUDIO SIGNAL)
- (B) → BASS AUDIO SIGNAL (XR-A800 ONLY)

CAUTION ; FOR CONTINUED PROTECTION AGAINST RISK OF FIRE. REPLACE WITH SAME TYPE No.491.500 MFD. BY LITTELFUSE INK FOR IC1202 (AEK7005).

XR-A800 ONLY

U J7001

N AF ASSY (2/2)
 (AWZ8939 : XR-A800)
 (AWZ8937 : XR-A700)

T CN5001

CAUTION ; FOR CONTINUED PROTECTION AGAINST RISK OF FIRE. REPLACE WITH SAME TYPE No. 491250 MFD. BY LITTELFUSE INK FOR IC1203 (AEK7002).

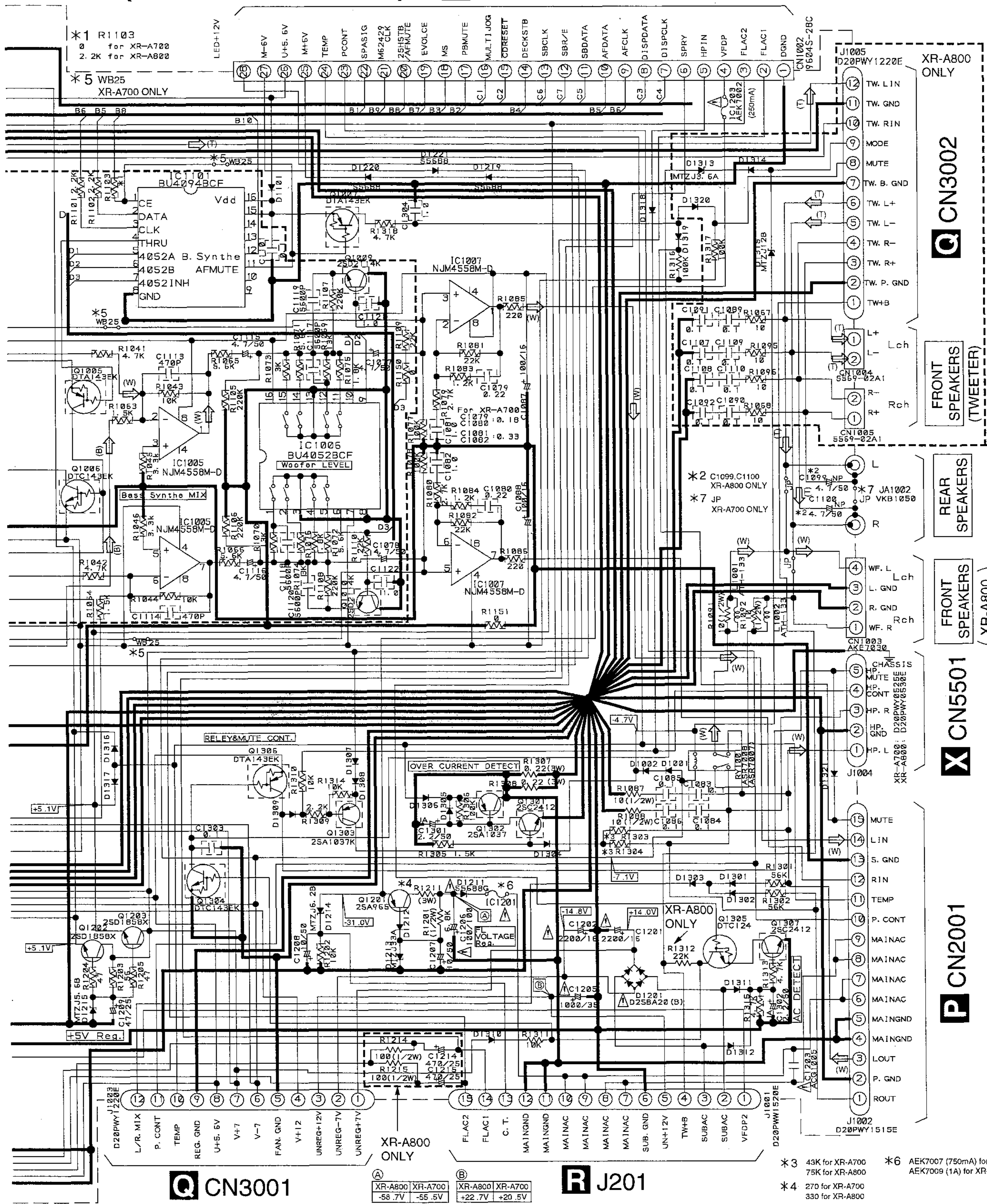

Q CN3001

	XR-A800	XR-A700
A	-58.7V	-55.5V
B	+22.7V	+20.5V

R J201

- *3 43K for XR-A700
75K for XR-A800
- *4 270 for XR-A700
330 for XR-A800
- *6 AEK7007 (750mA) for XR-A700
AEK7009 (1A) for XR-A800

CAUTION ; FOR CONTINUED PROTECTION AGAINST RISK OF FIRE. REPLACE WITH SAME TYPE No.491.750 MFD. BY LITTELFUSE INK FOR IC1201 (AEK7007 ; XR-A700).

CAUTION ; FOR CONTINUED PROTECTION AGAINST RISK OF FIRE. REPLACE WITH SAME TYPE No.491001 MFD. BY LITTELFUSE INK FOR IC1201 (AEK7009 ; XR-A800).

3.7 AMP ASSY, POWER SUPPLY ASSY, SECONDARY ASSY AND PRIMARY ASSY

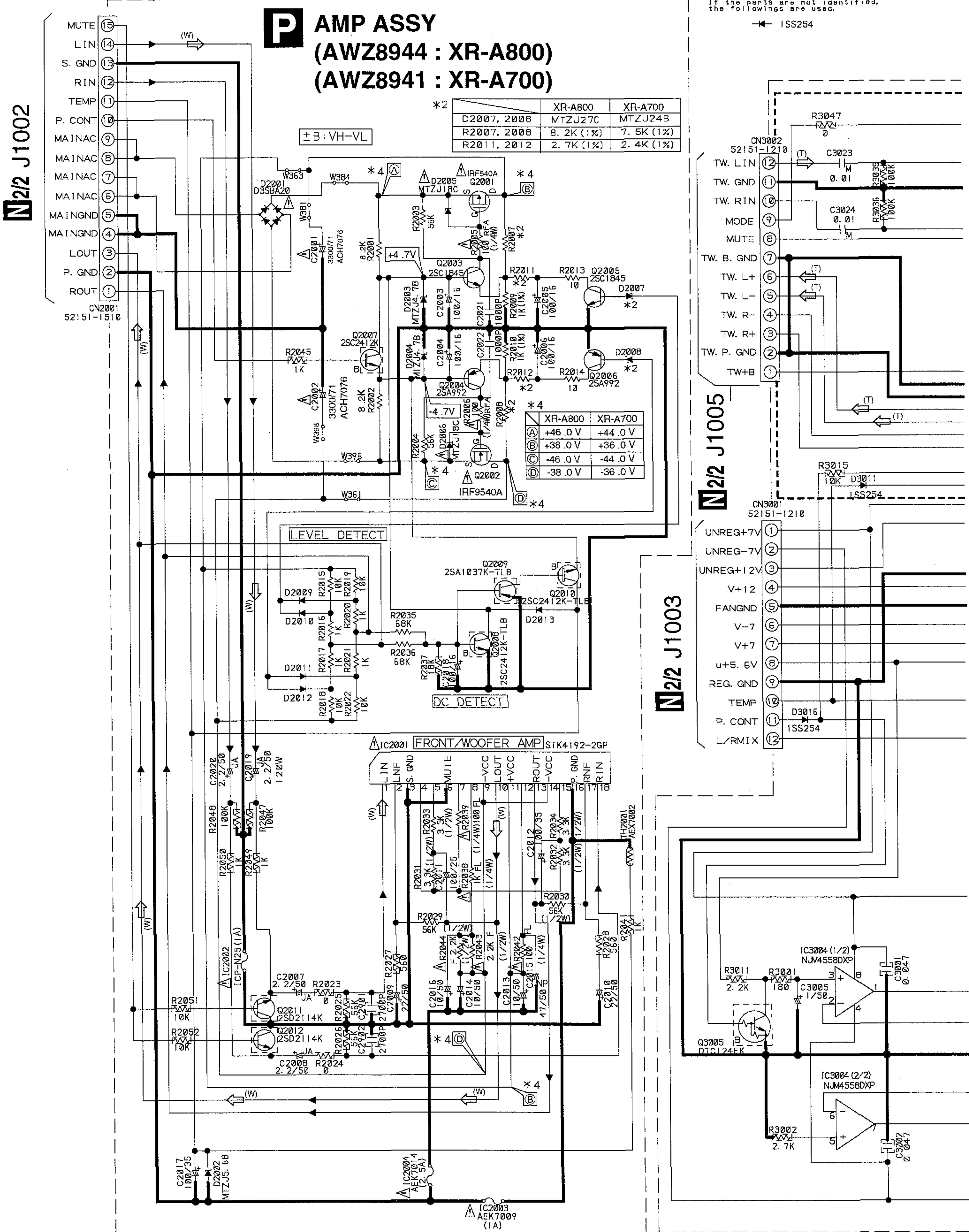

If the parts are not identified, the followings are used.
ISS254

CAUTION ; FOR CONTINUED PROTECTION AGAINST RISK OF FIRE. REPLACEMENT ONLY WITH SAME TYPE No. ICP-N25, MFD BY ROHM CO., LTD. FOR IC2002.

CAUTION ; FOR CONTINUED PROTECTION AGAINST RISK OF FIRE. REPLACE WITH SAME TYPE No. 49102.5 MFD. BY LITTELFUSE INK FOR IC2004 (AEK7014).

CAUTION ; FOR CONTINUED PROTECTION AGAINST RISK OF FIRE. REPLACE WITH SAME TYPE No. 491001 MFD. BY LITTELFUSE INK FOR IC2003 (AEK7009).



POWER SUPPLY ASSY (AWZ8950 : XR-A800) (AWZ8947 : XR-A700)

CAUTION : FOR CONTINUED PROTECTION AGAINST RISK OF FIRE. REPLACEMENT ONLY WITH SAME TYPE No. ICP-N25, MFD BY ROHM CO., LTD. FOR IC3005.

SIGNAL ROUTE
(W) : WOOFER AUDIO SIGNAL
(T) : TWEETER AUDIO SIGNAL

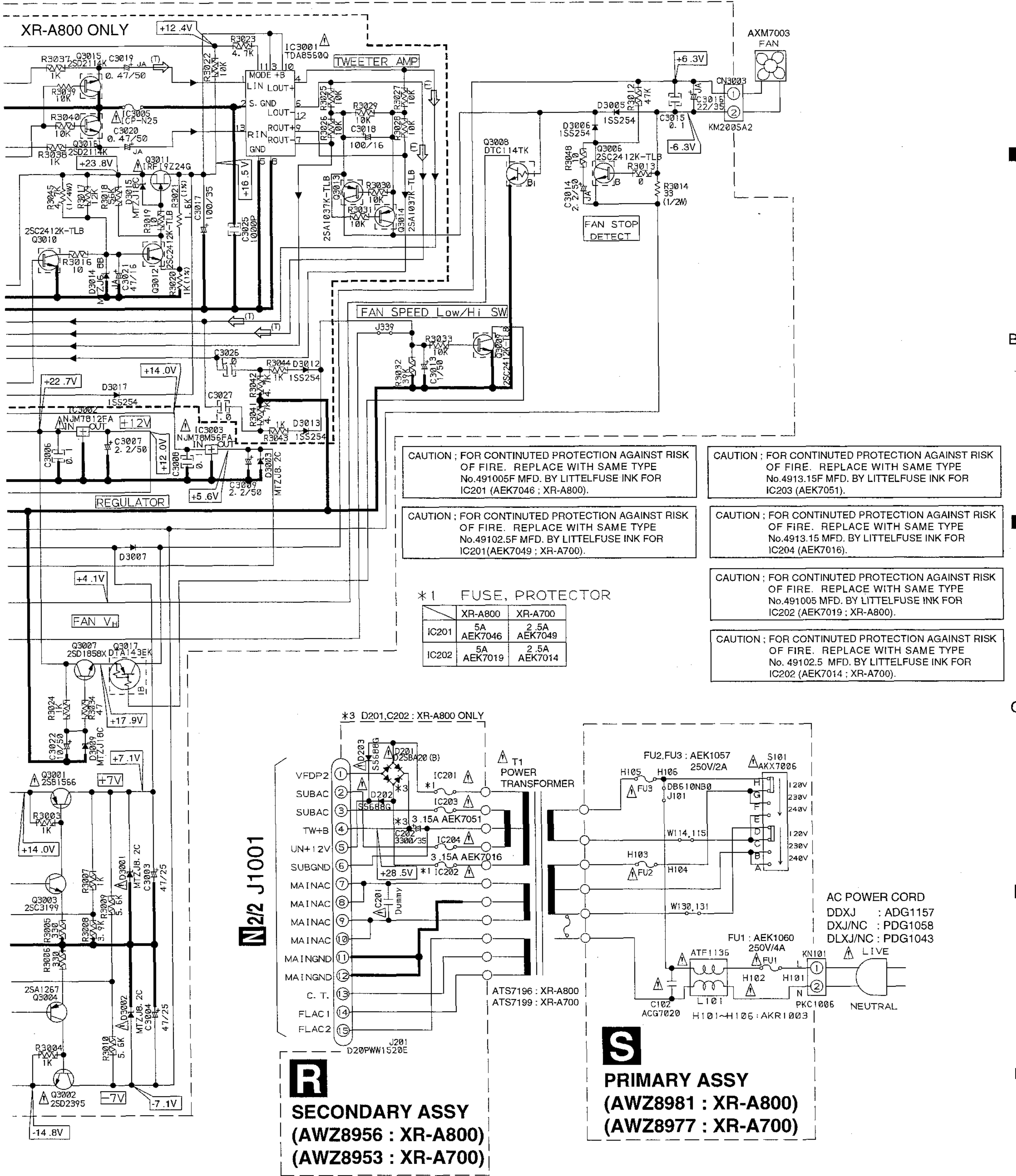

A

B

C

D

XR-A800, XR-A700

3.8 DISPLAY ASSY

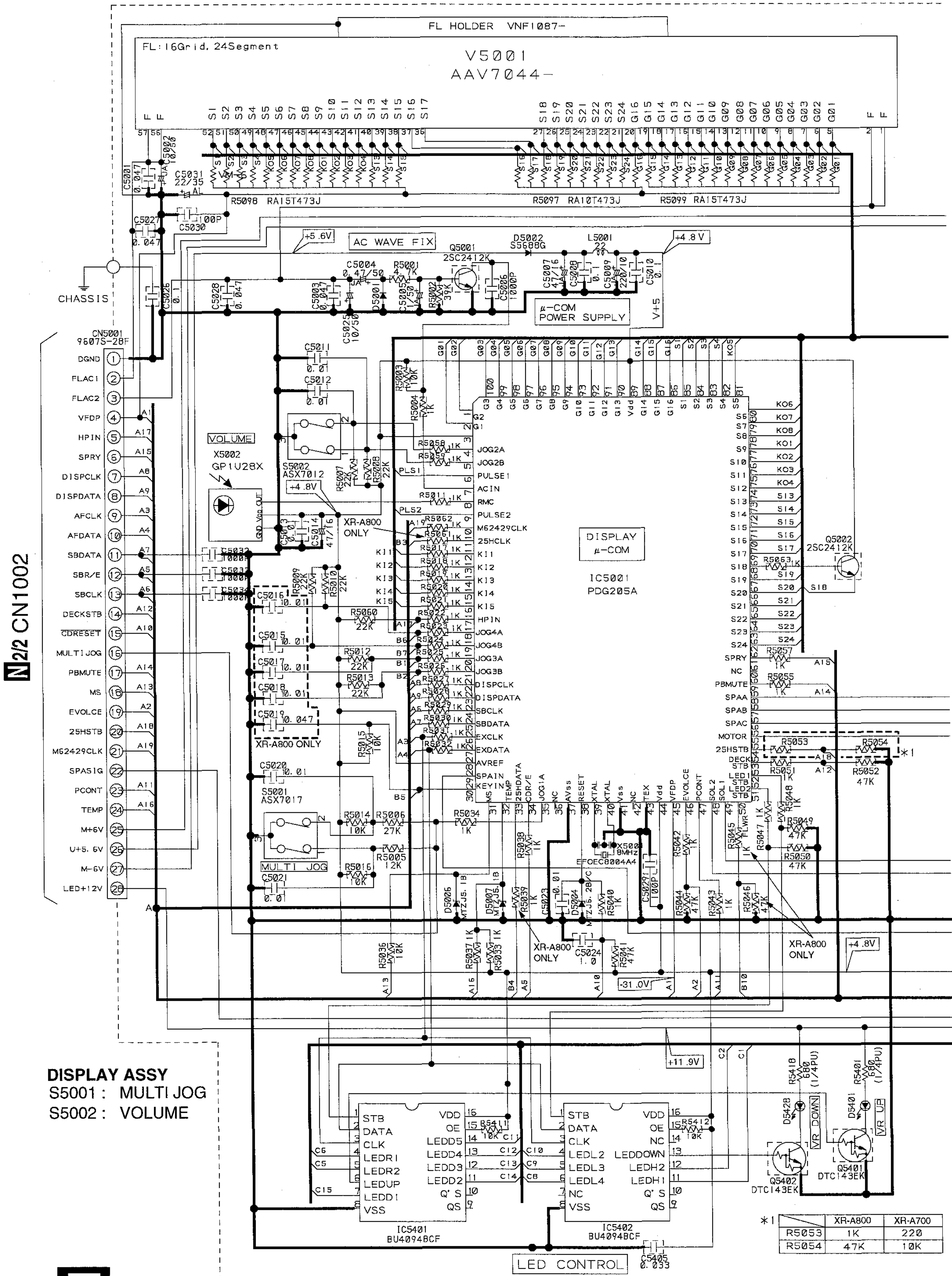

DISPLAY ASSY
S5001: MULTI JOG
S5002: VOLUME

	XR-A800	XR-A700
R5053	1K	220
R5054	47K	10K

If the parts are not identified, the followings are used.

← 1SS254

← SLP7118C51H-TS

T DISPLAY ASSY (AWP7015 : XR-A800) (AWP7013 : XR-A700)

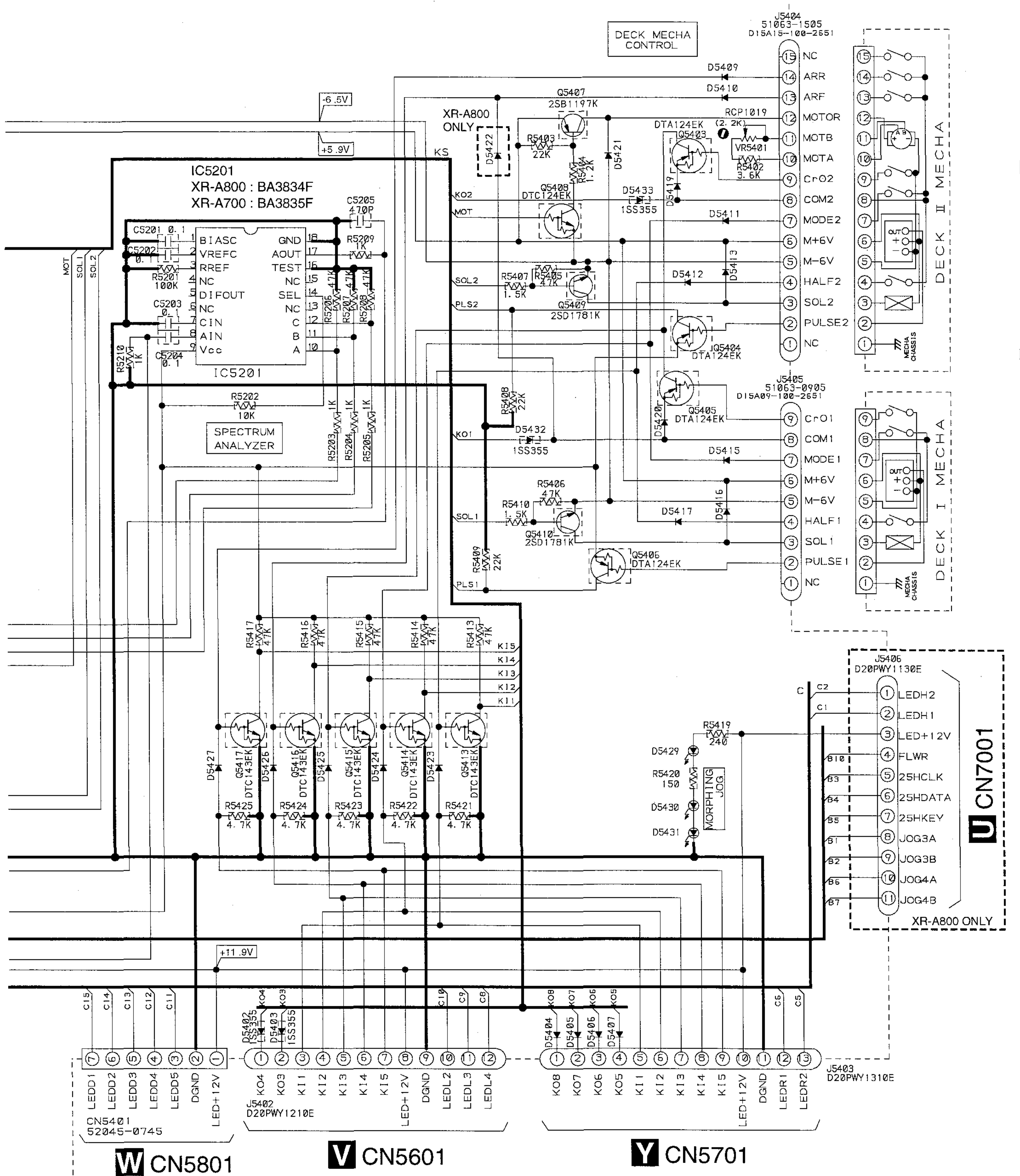

W CN5801

V CN5601

Y CN5701

U CN7001



3.9 SUB DISPLAY ASSY

U SUB DISPLAY ASSY (AWP7017 : XR-A800 ONLY)

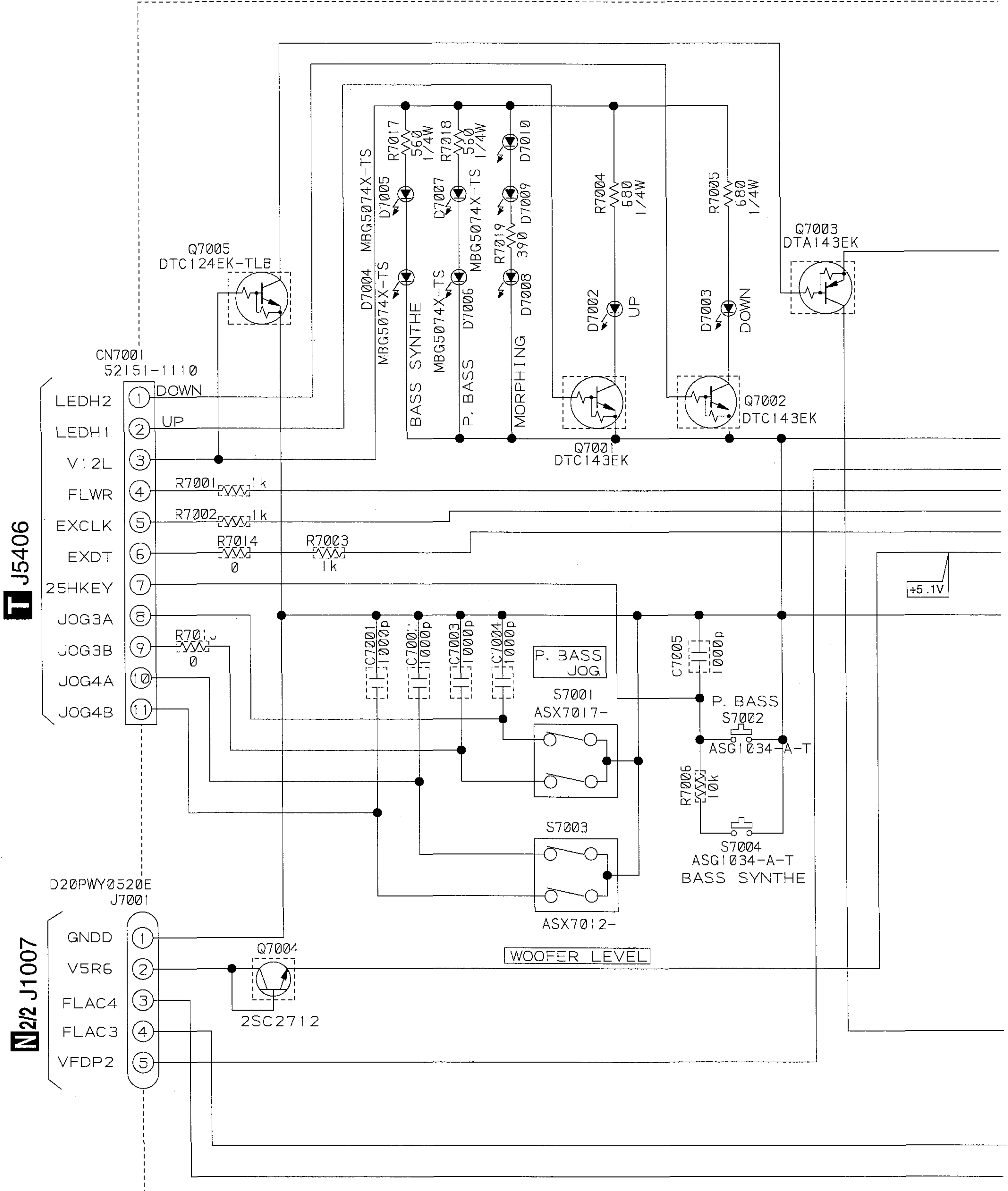

If the parts are not identified, the followings are used.

- SUB DISPLAY ASSY**
 S7001 : P.BASS JOG
 S7002 : P.BASS
 S7003 : WOOFER LEVEL
 S7004 : BASS SYNTH

SLP7118C51H-TS



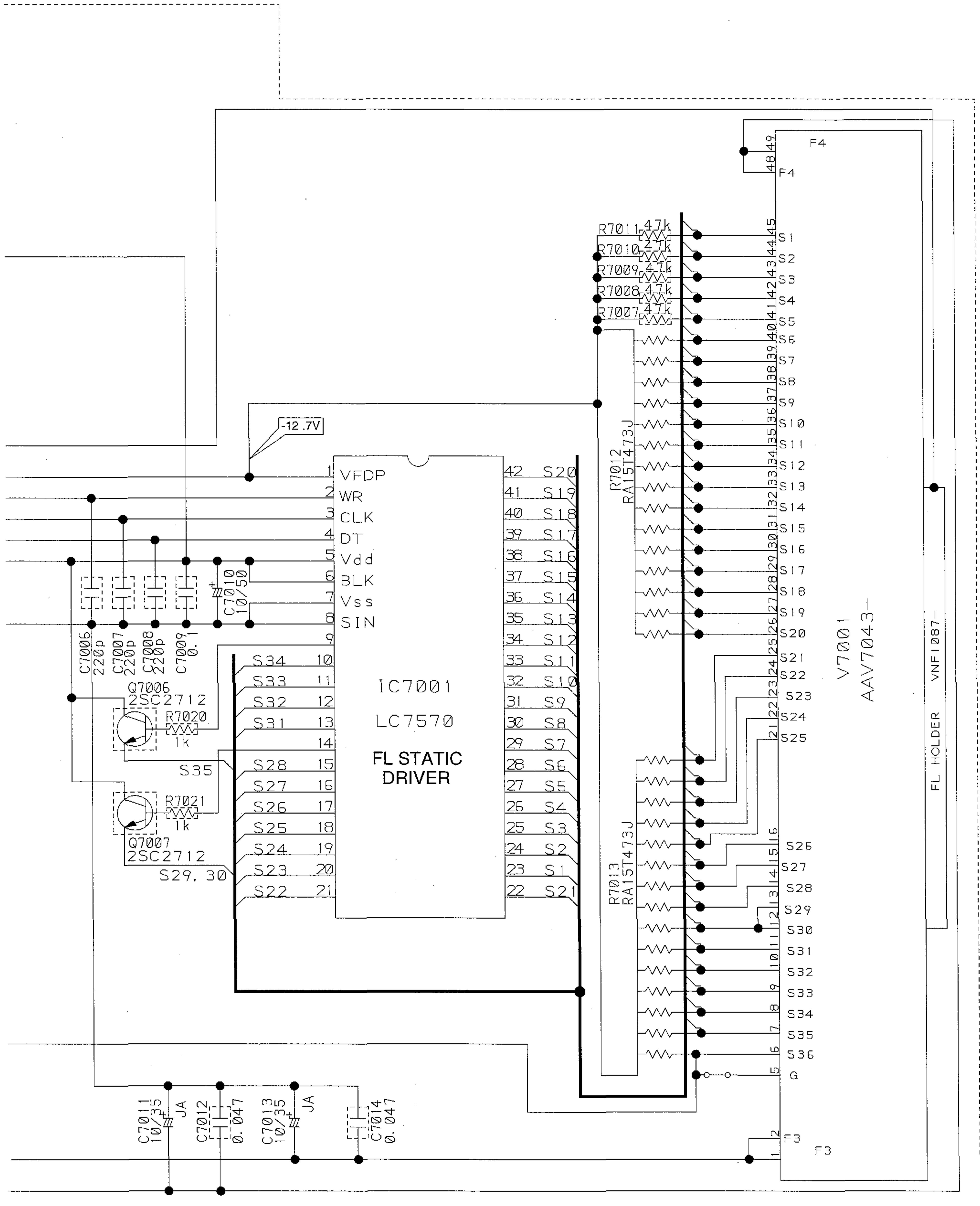

A
B
C
D



3.10 LEFT SW ASSY AND DOOR LED ASSY

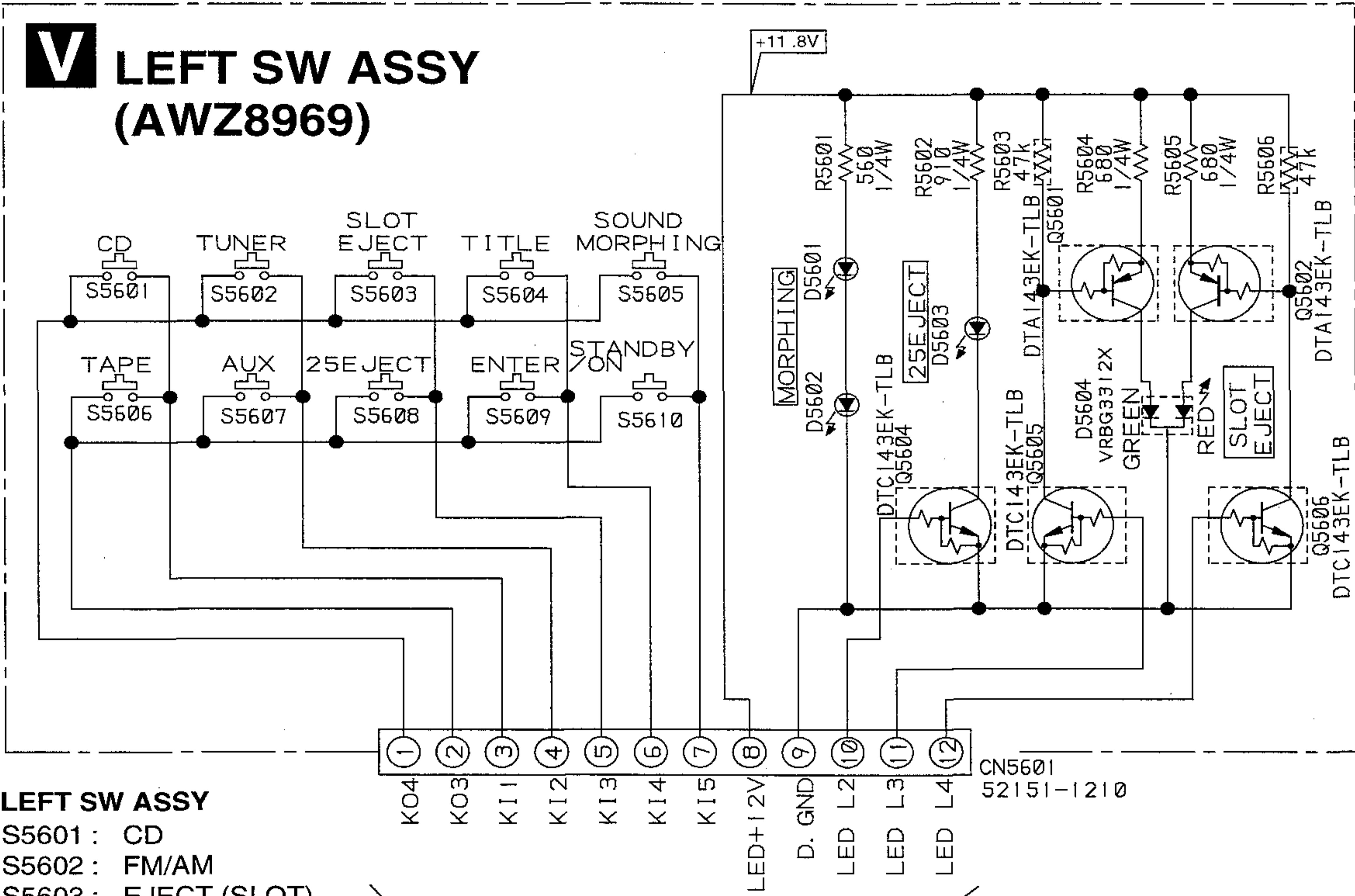

- LEFT SW ASSY**
- S5601 : CD
 - S5602 : FM/AM
 - S5603 : EJECT (SLOT)
 - S5604 : TITLE
 - S5605 : SOUND MORPHING
 - S5606 : TAPE I/II
 - S5607 : AUX (DEMO)
 - S5608 : OPEN/CLOSE (25)
 - S5609 : ENTER
 - S5610 : STANDBY/ON

T J5402

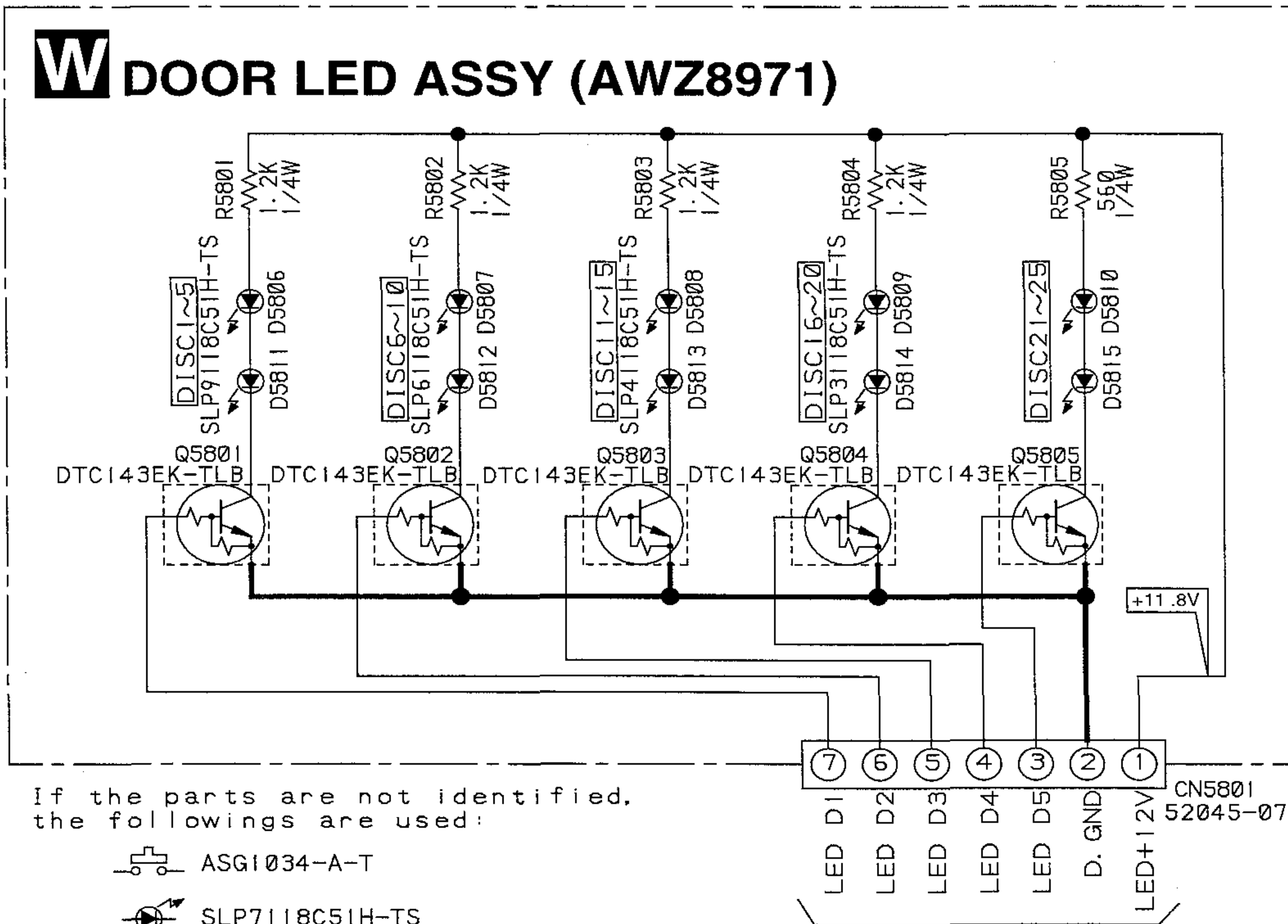

If the parts are not identified, the followings are used:

- ASG1034-A-T
- SLP7118C51H-TS

T J5401

3.11 HP ASSY AND RIGHT SW ASSY

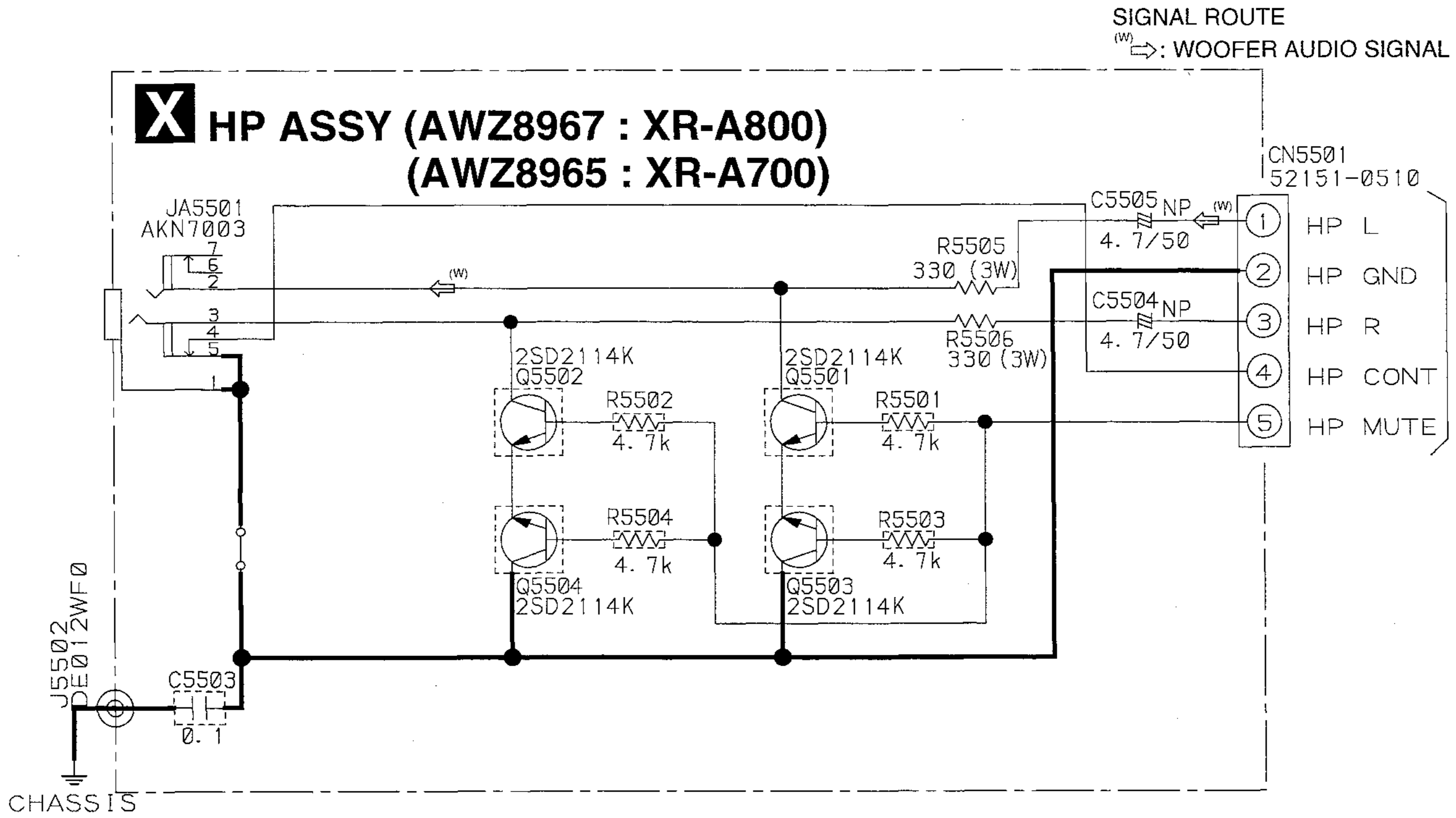

RIGHT SW ASSY

- S5701 : DOLBY NR ON/OFF
- S5702 : BEST A
- S5703 : STATION MEMORY
- S5704 : PROGRAM
- S5705 : TIMER REC/WAKE-UP
- S5706 : TUNING - / I <<<<
- S5707 : STOP
- S5708 : BEST B
- S5709 : FREQ/STATION
- S5710 : DISPLAY/CLOCK ADJ
- S5711 : TUNING + / >>>> I
- S5712 : DISC SELECT +
- S5713 : PLAY/PAUSE
- S5714 : DISC SELECT -
- S5715 : ASES/COPY
- S5716 : RANDOM
- S5717 : REPEAT
- S5718 : REC/STOP

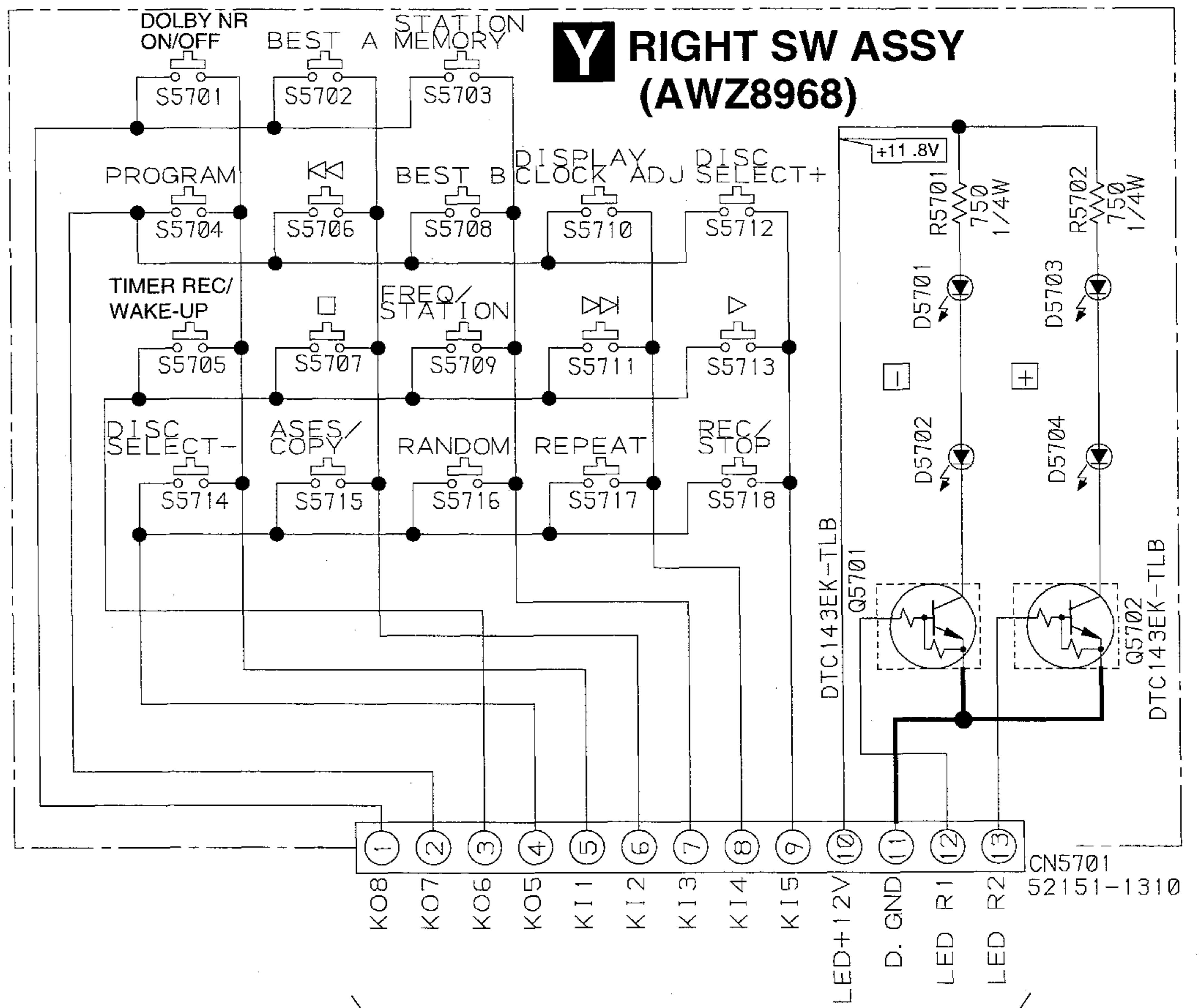

XR-A800, XR-A700

WAVEFORMS

Note : The encircled numbers denote measuring points in the schematic diagram.

*1 FOCUS-IN : Press the key without loading a disc.

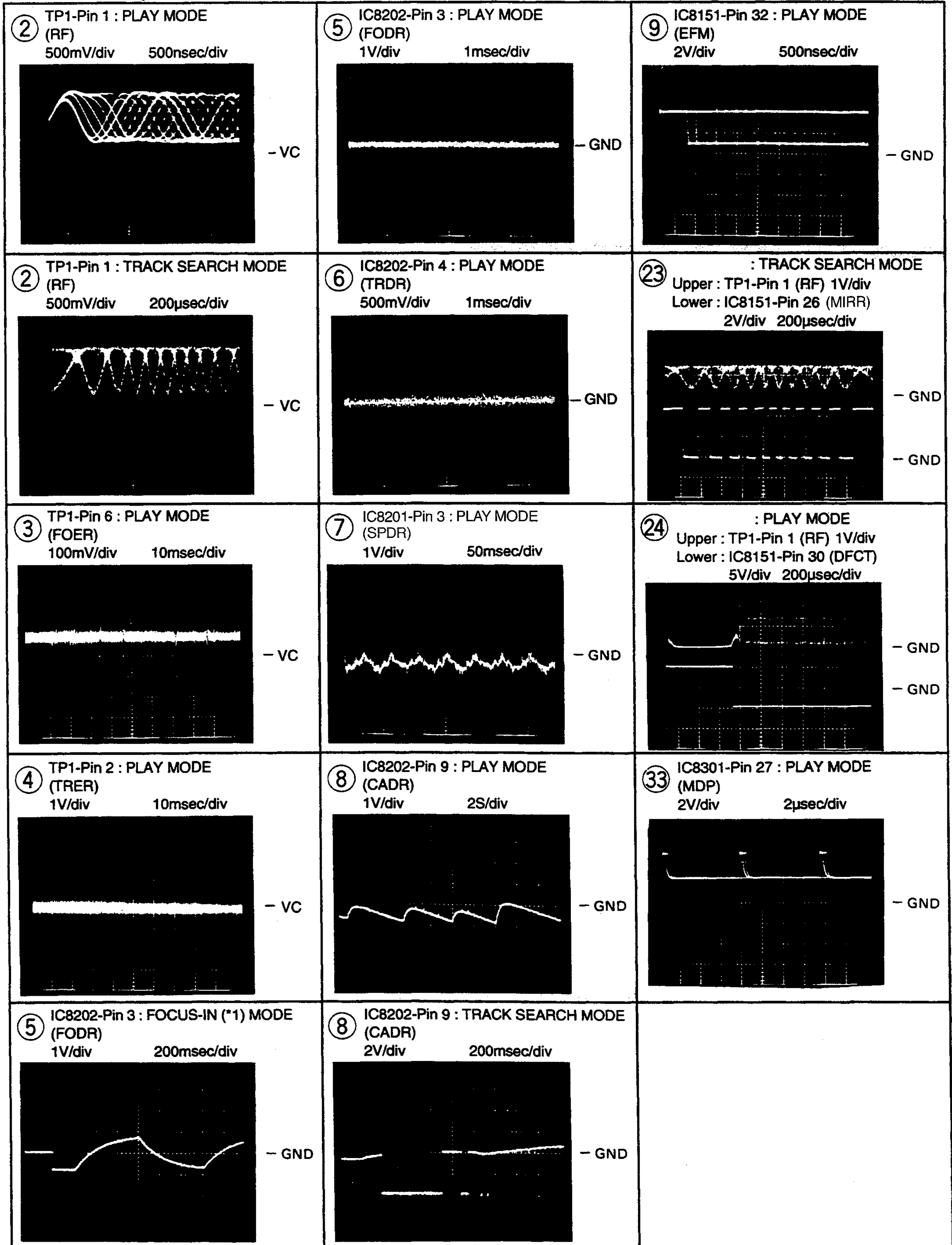

4.2 FM/AM TUNER MODULE

A

B

C

D

SIDE A

SIDE B

A FM/AM TUNER MODULE

A FM/AM TUNER MODULE

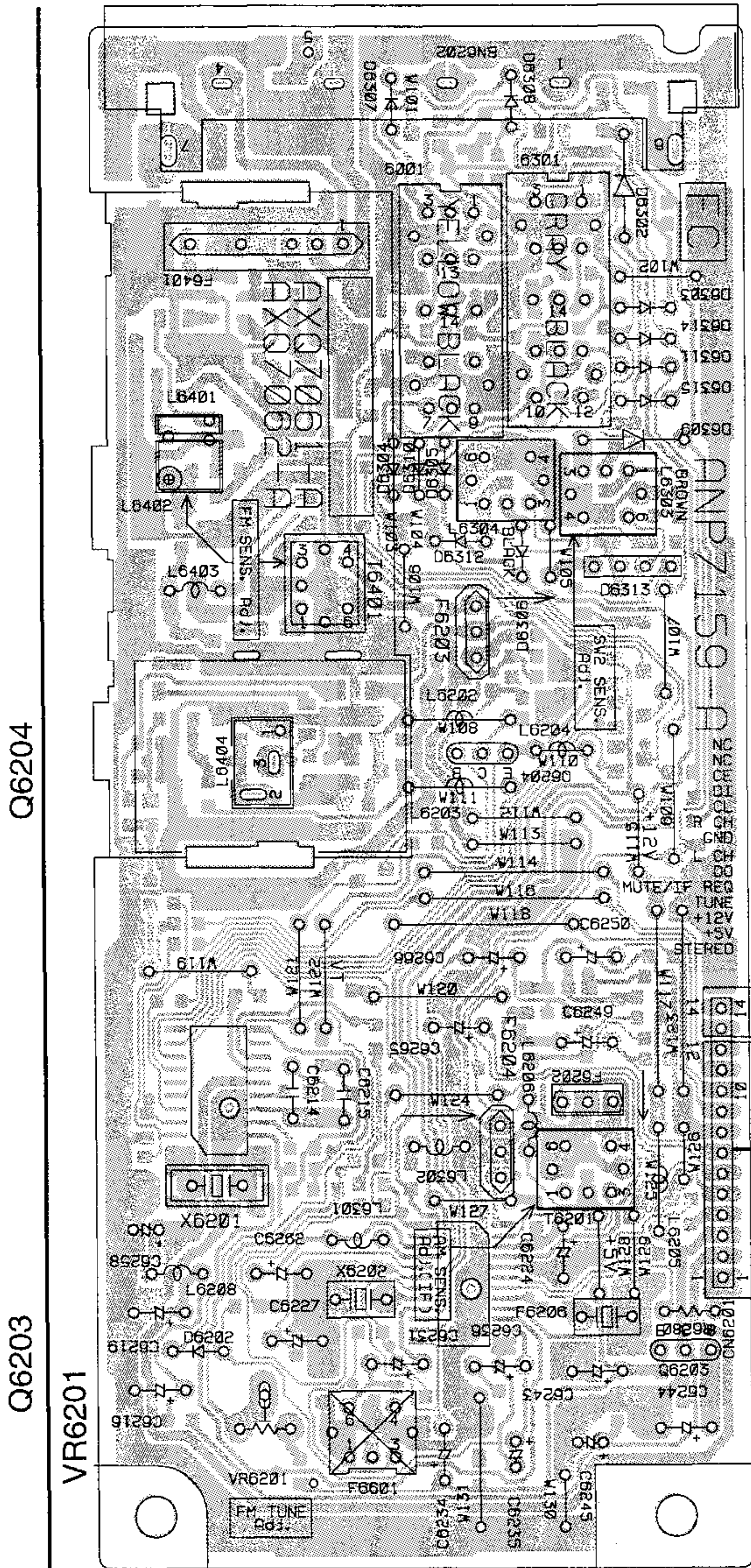

○ CN1010

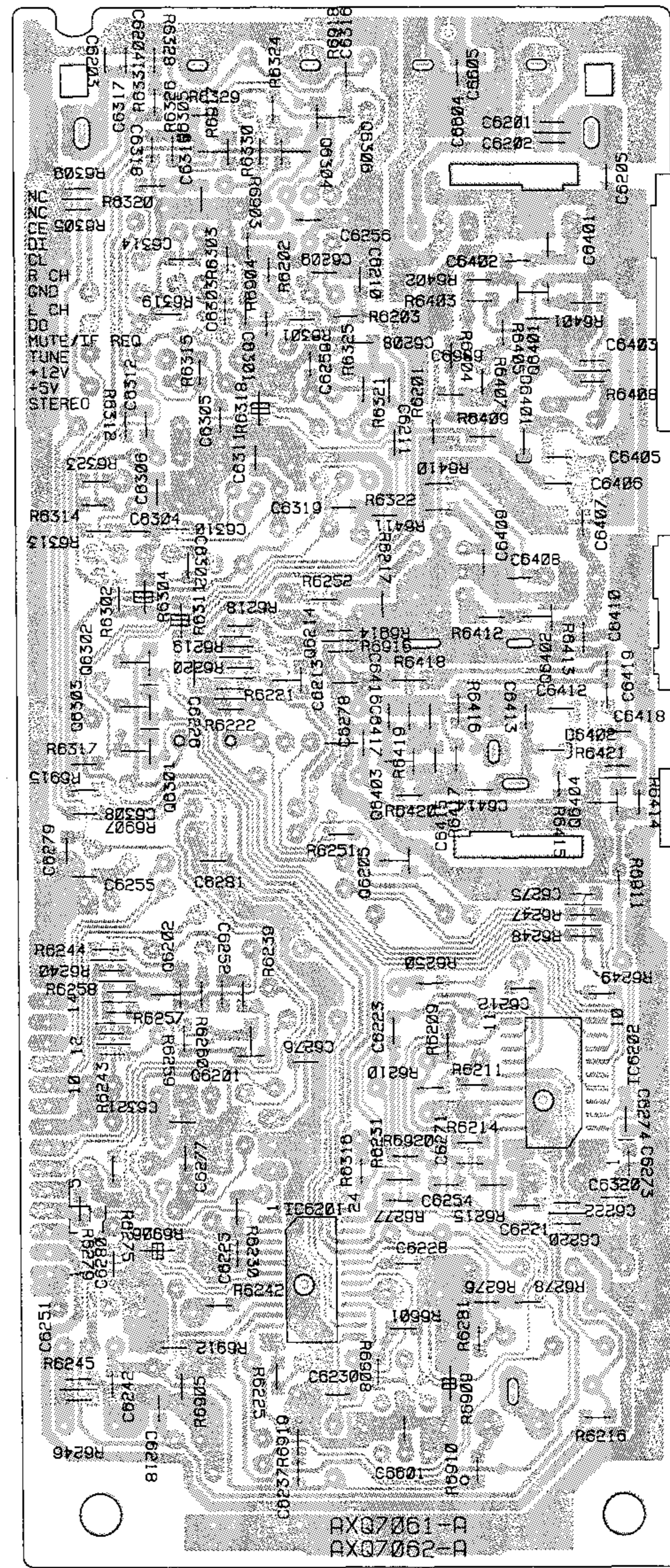

- IC6201
- Q6201
- Q6202
- IC6202
- Q6301
- Q6303
- Q6302
- Q6403
- Q6214
- Q6404
- Q6402
- Q6205
- Q6304
- Q6306

4.3 GS MECHANISM ASSY AND GS SLOT-IN MECHANISM ASSY

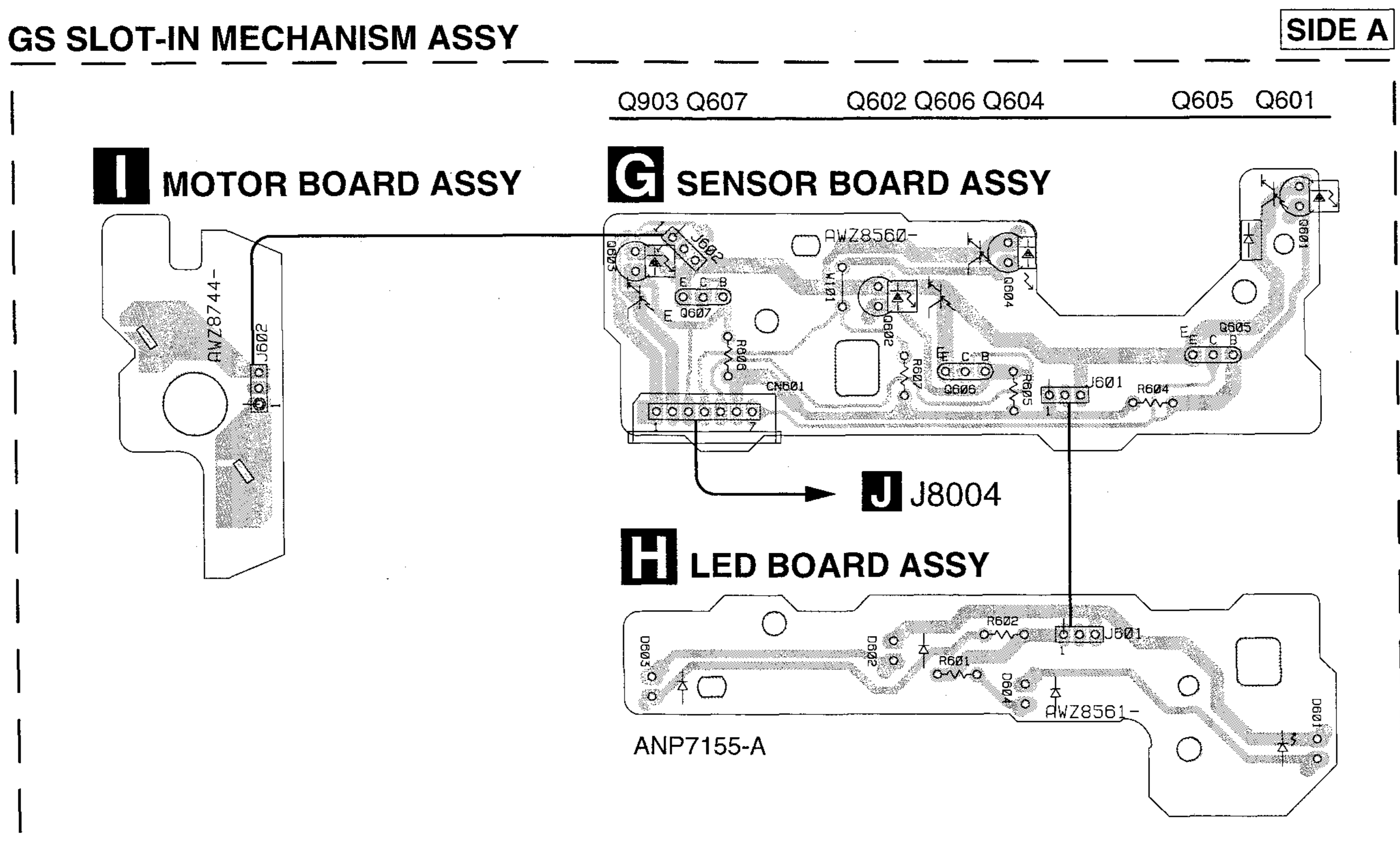
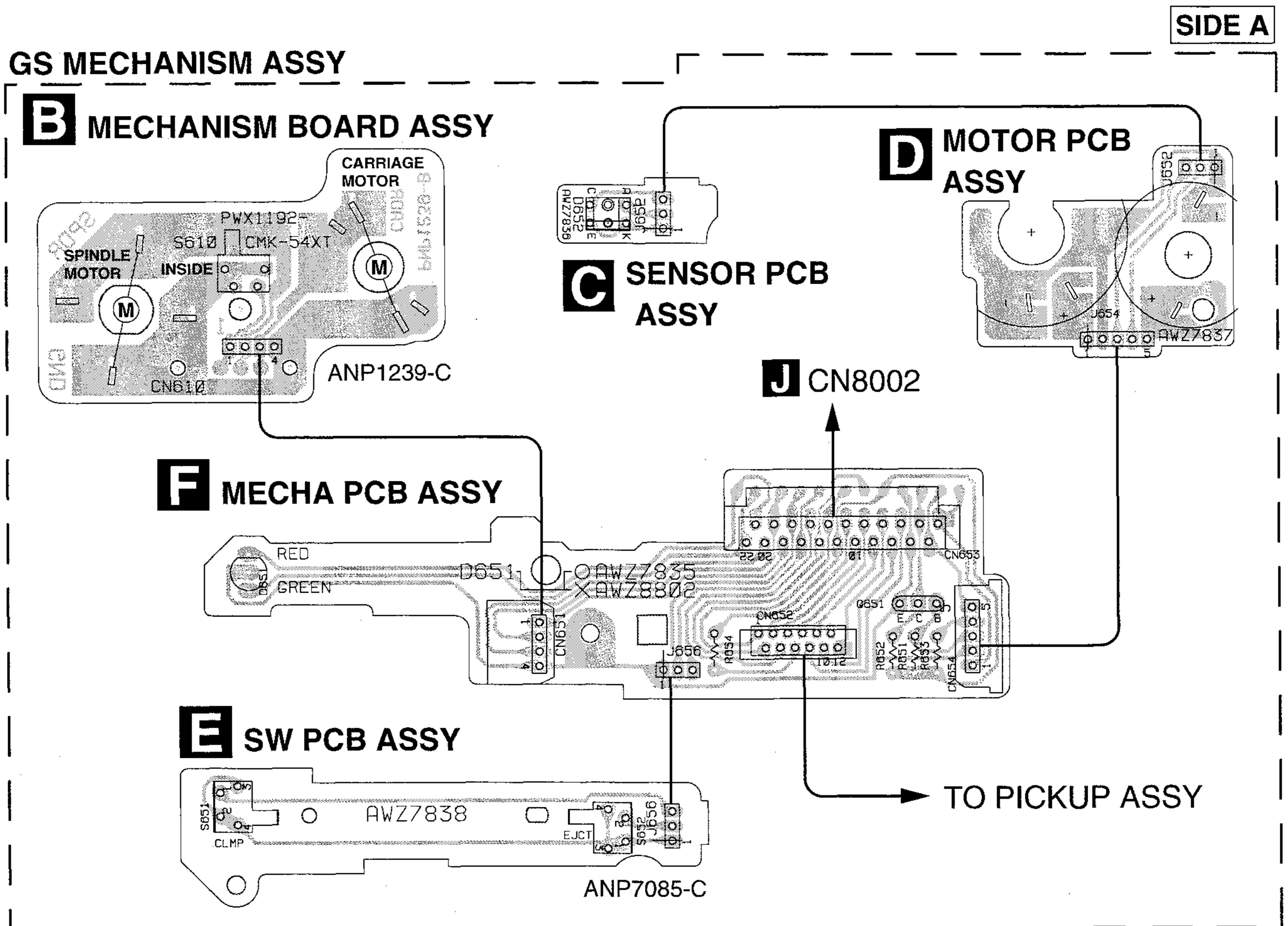

4.4 GM-CD ASSY, HOME SW ASSY, DOOR SW ASSY AND DOOR MOTOR ASSY

J GM-CD ASSY

F CN653

SIDE A

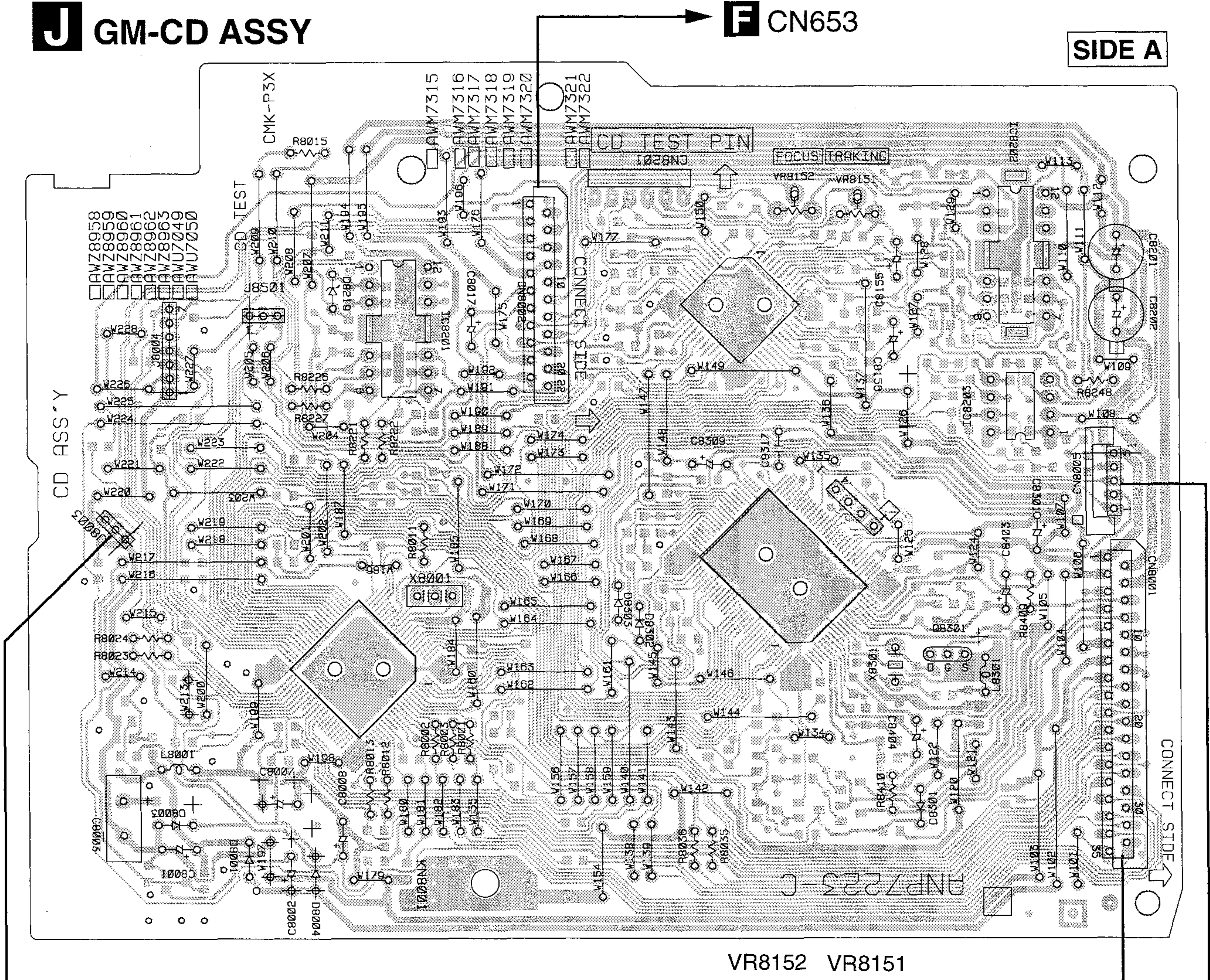

K HOME SW ASSY

N CN1001

L DOOR SW ASSY

M DOOR MOTOR ASSY

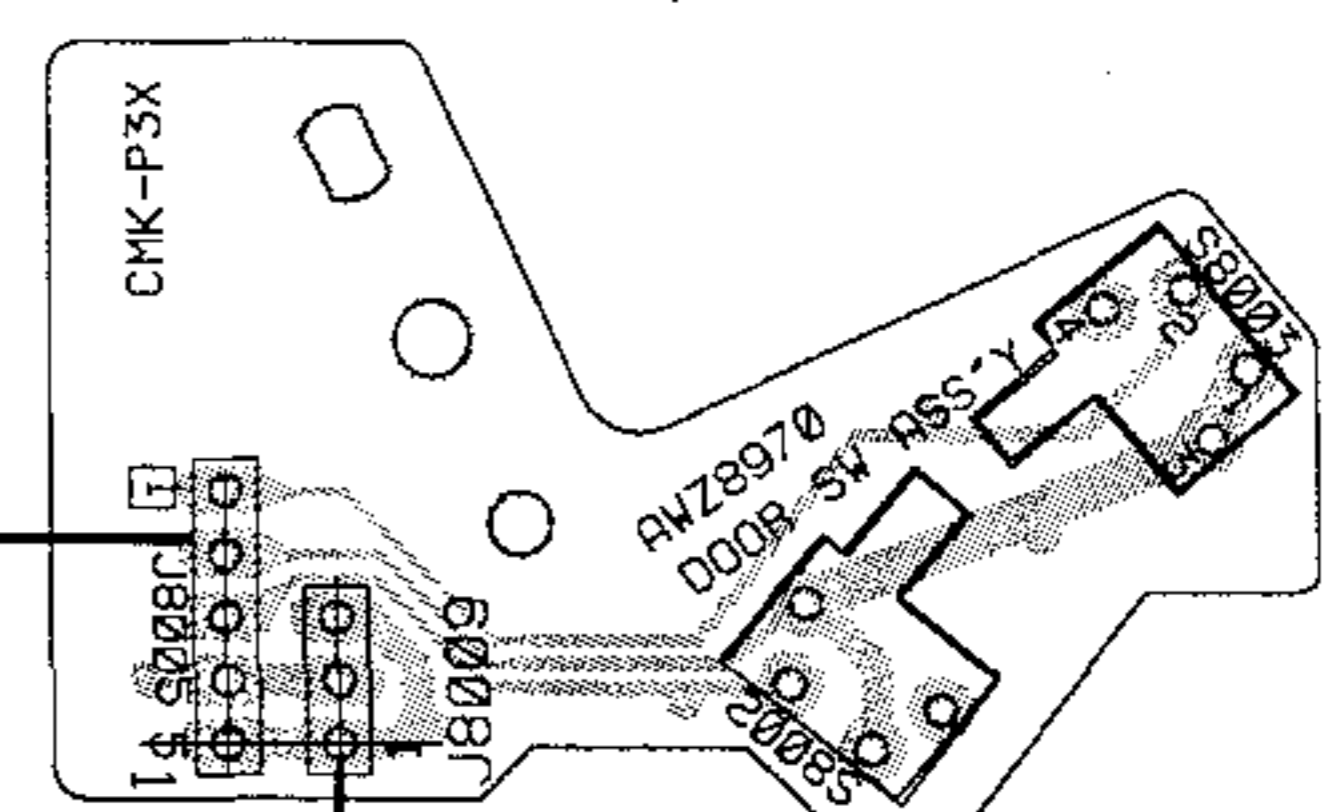
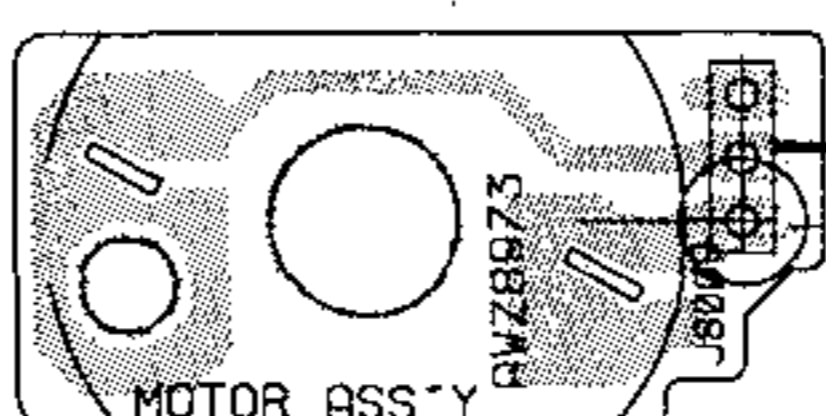
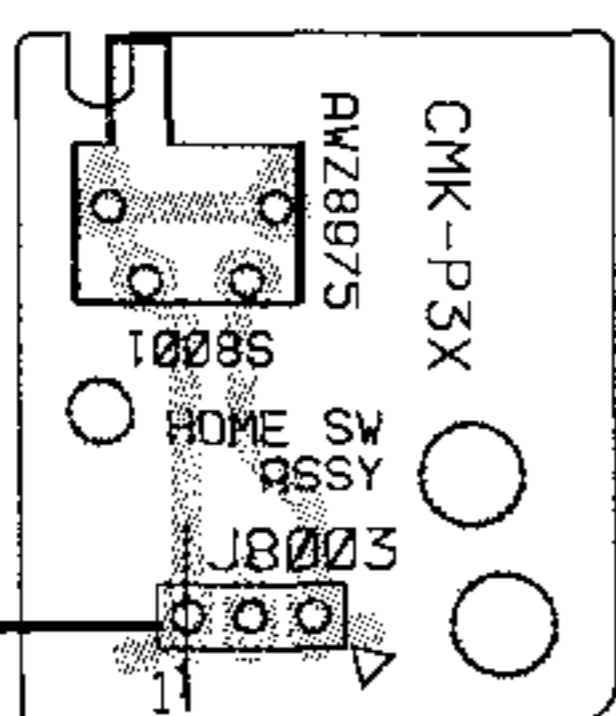

ANP7223-C

J GM-CD ASSY

SIDE B

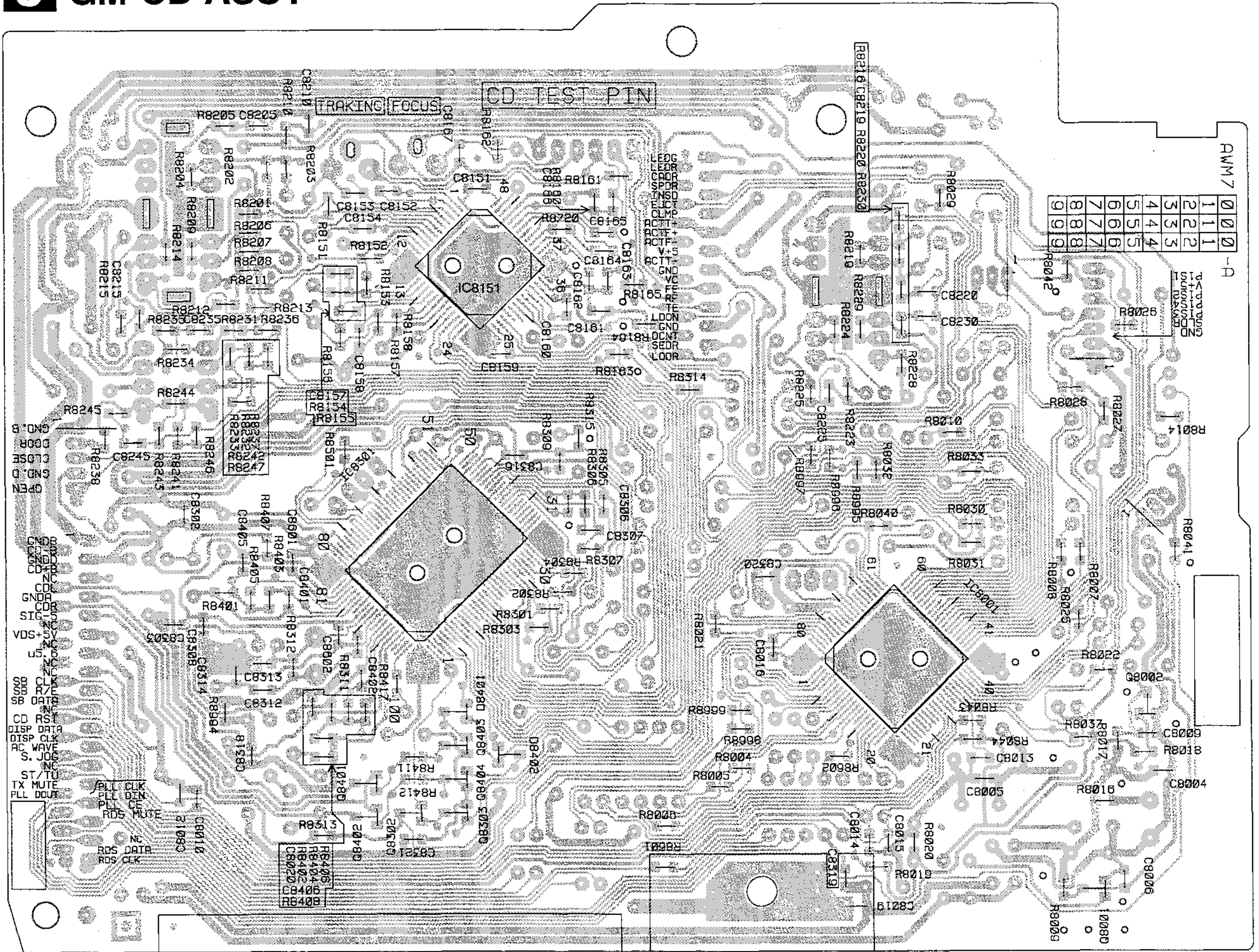

ANP7223-C

- IC8151
- IC8301
- Q8403
- Q8401
- Q8404
- Q8402
- Q8303
- Q8302
- IC8001
- Q8002
- Q8001

A

J CN8001

Q CN3002

B

C

Q CN3001

D

P CN2001

N

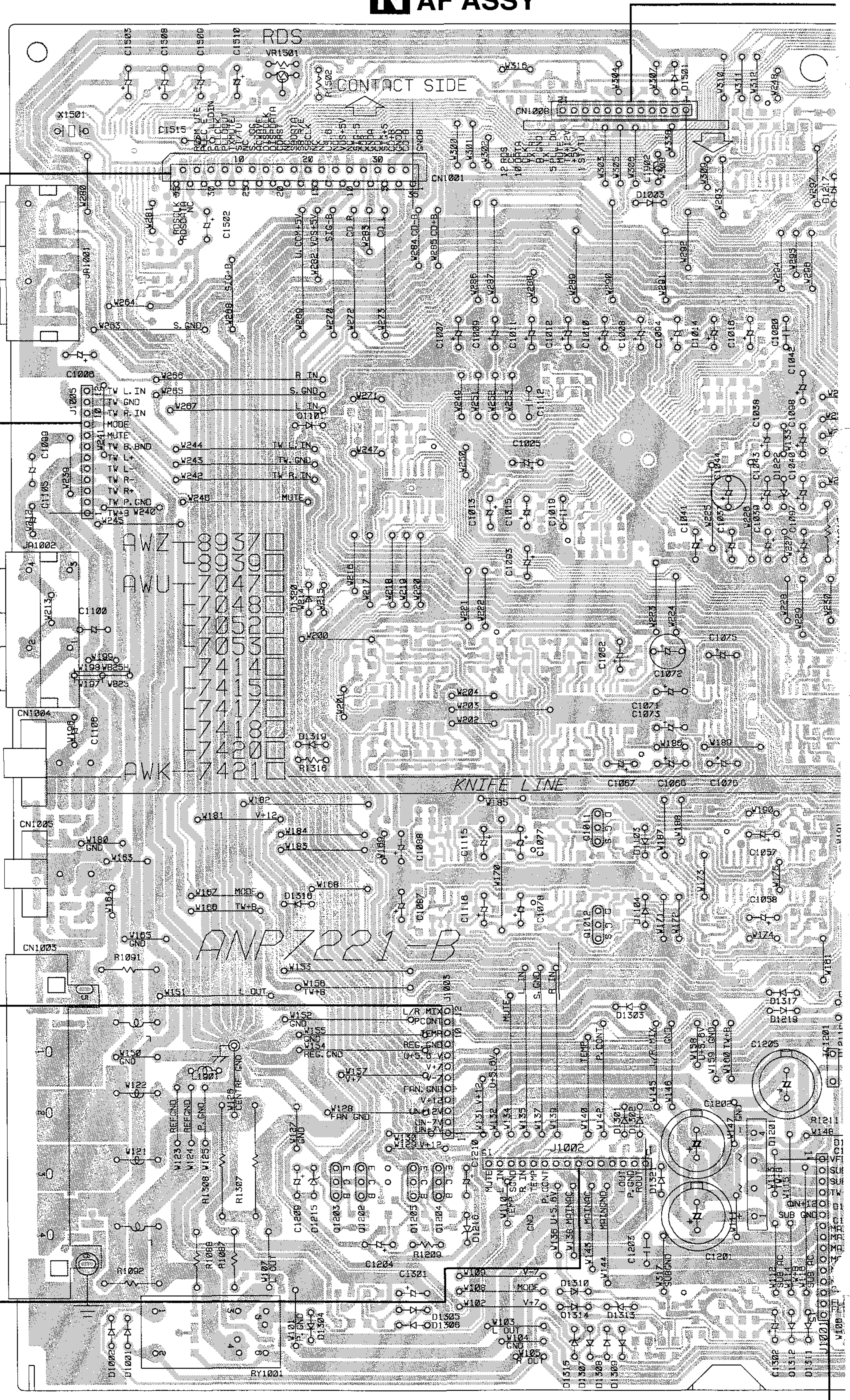

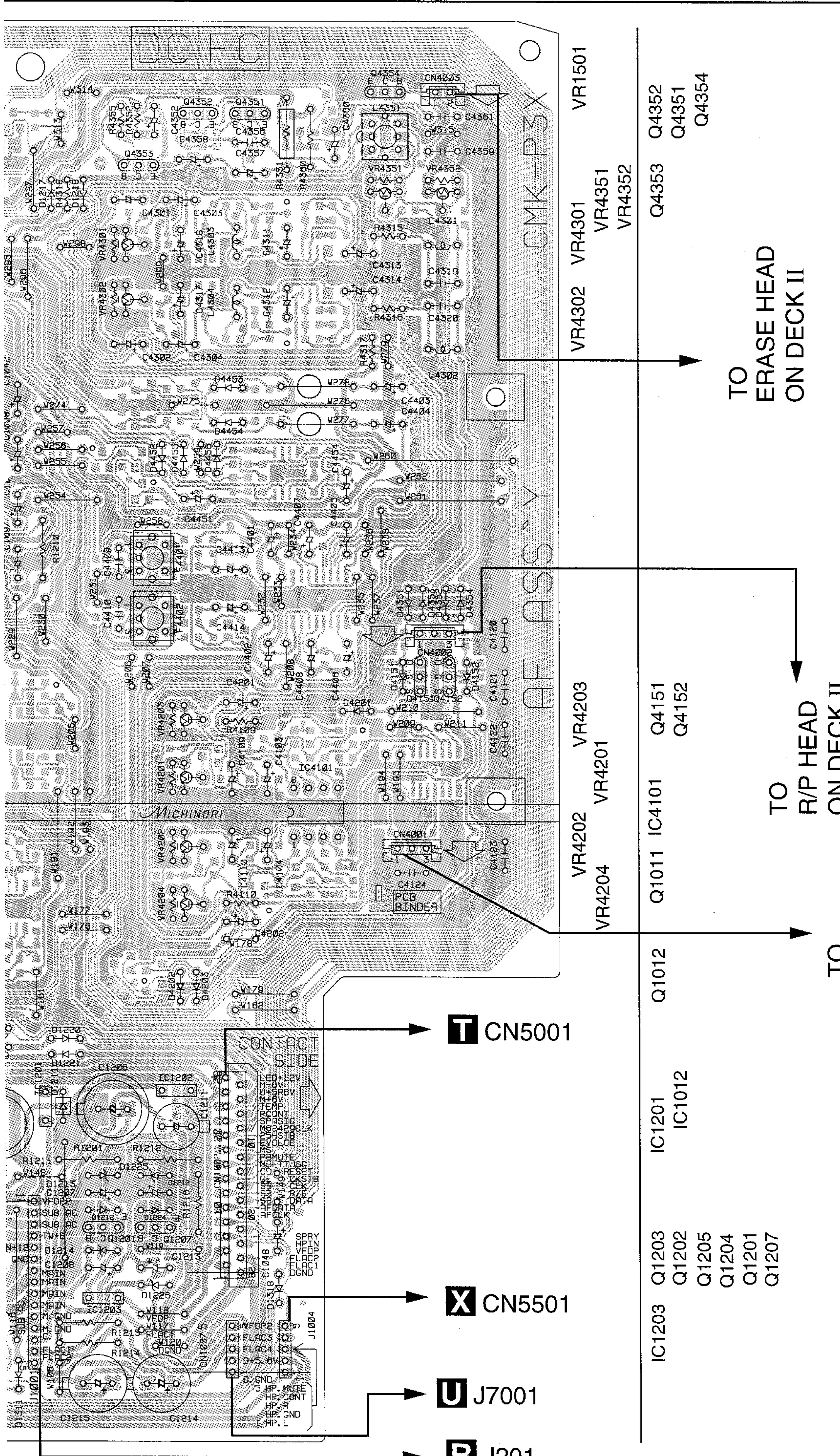

SIDE A

TX CONNECT ASSY

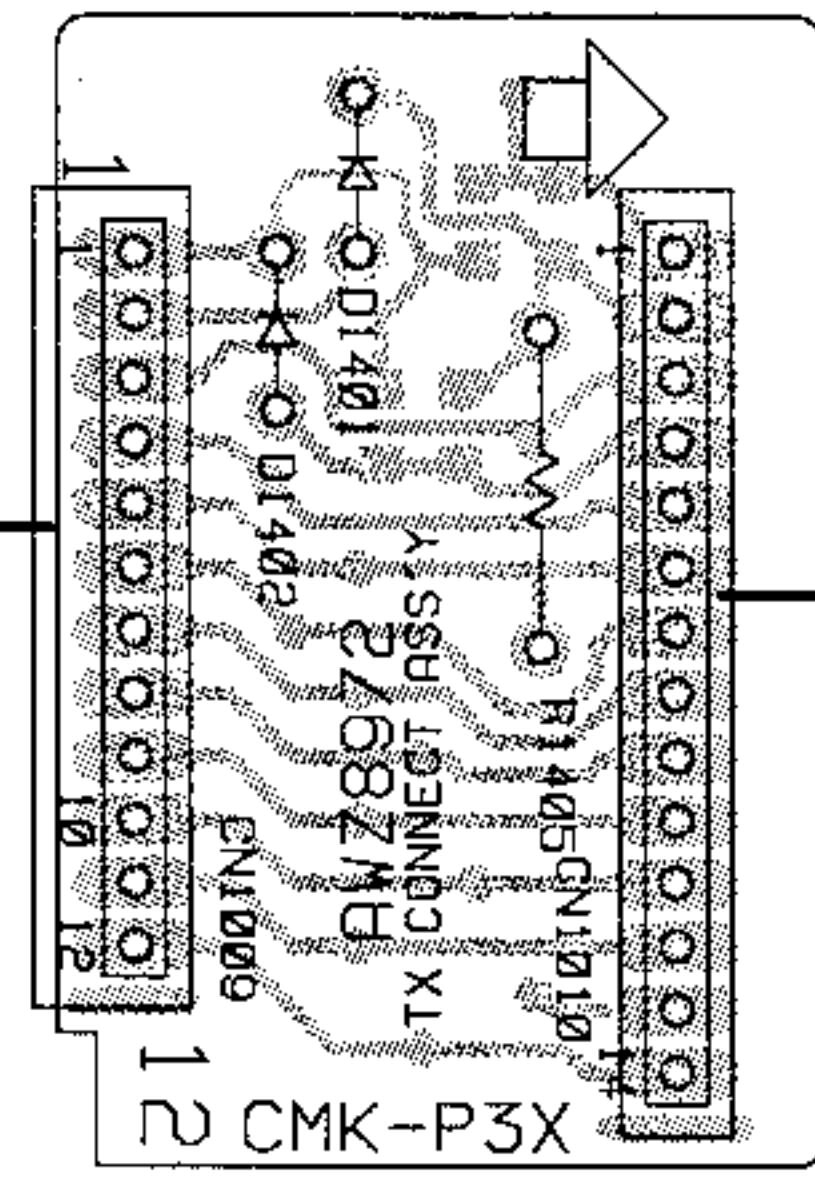

ANP7223-C

A CN6201

TO ERASE HEAD ON DECK II

TO R/P HEAD ON DECK II

TO PB HEAD ON DECK I

T CN5001

X CN5501

U J7001

R J201

NO

AF ASSY

SIDE B

TX CONNECT ASSY

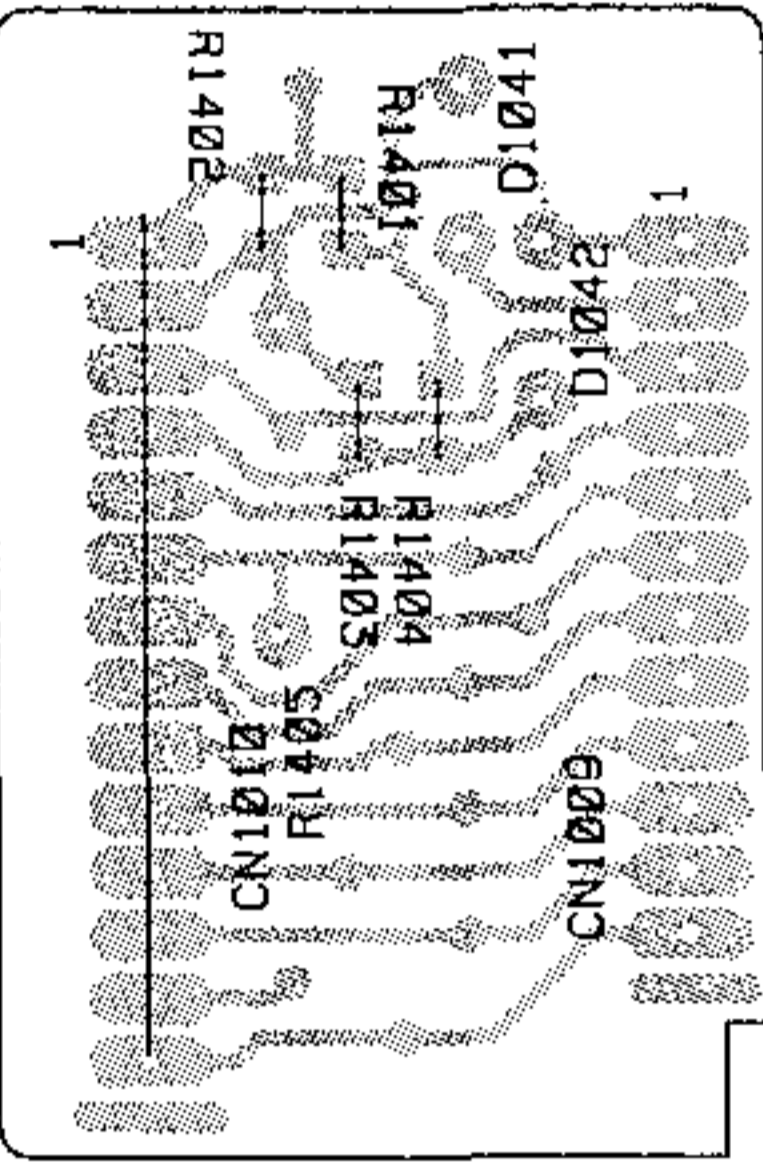

ANP7223-C

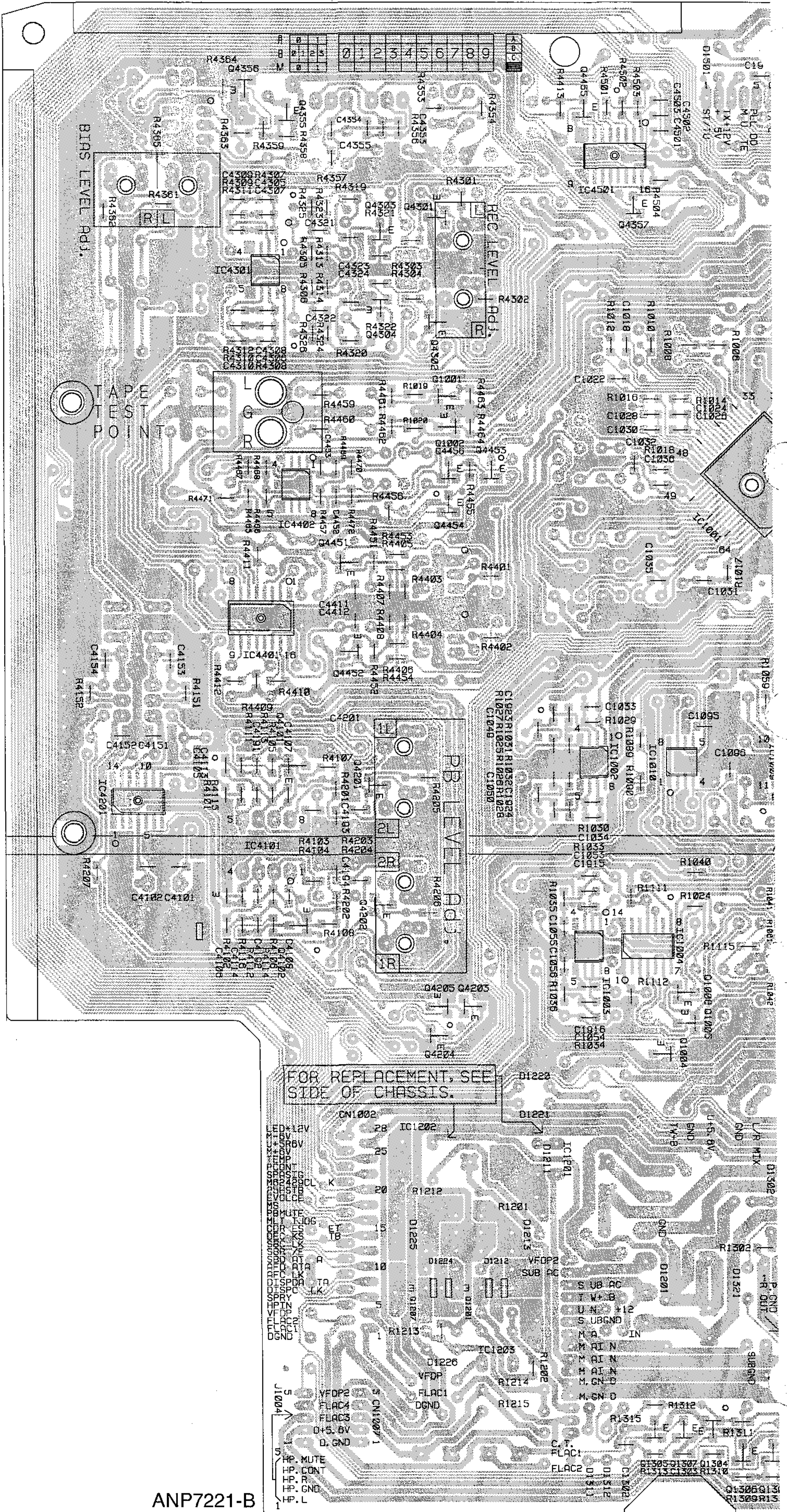

FOR REPLACEMENT, SEE SIDE OF CHASSIS.

ANP7221-B

4.7 POWER SUPPLY ASSY

XR-A800, XR-A700

Q POWER SUPPLY ASSY SIDE A

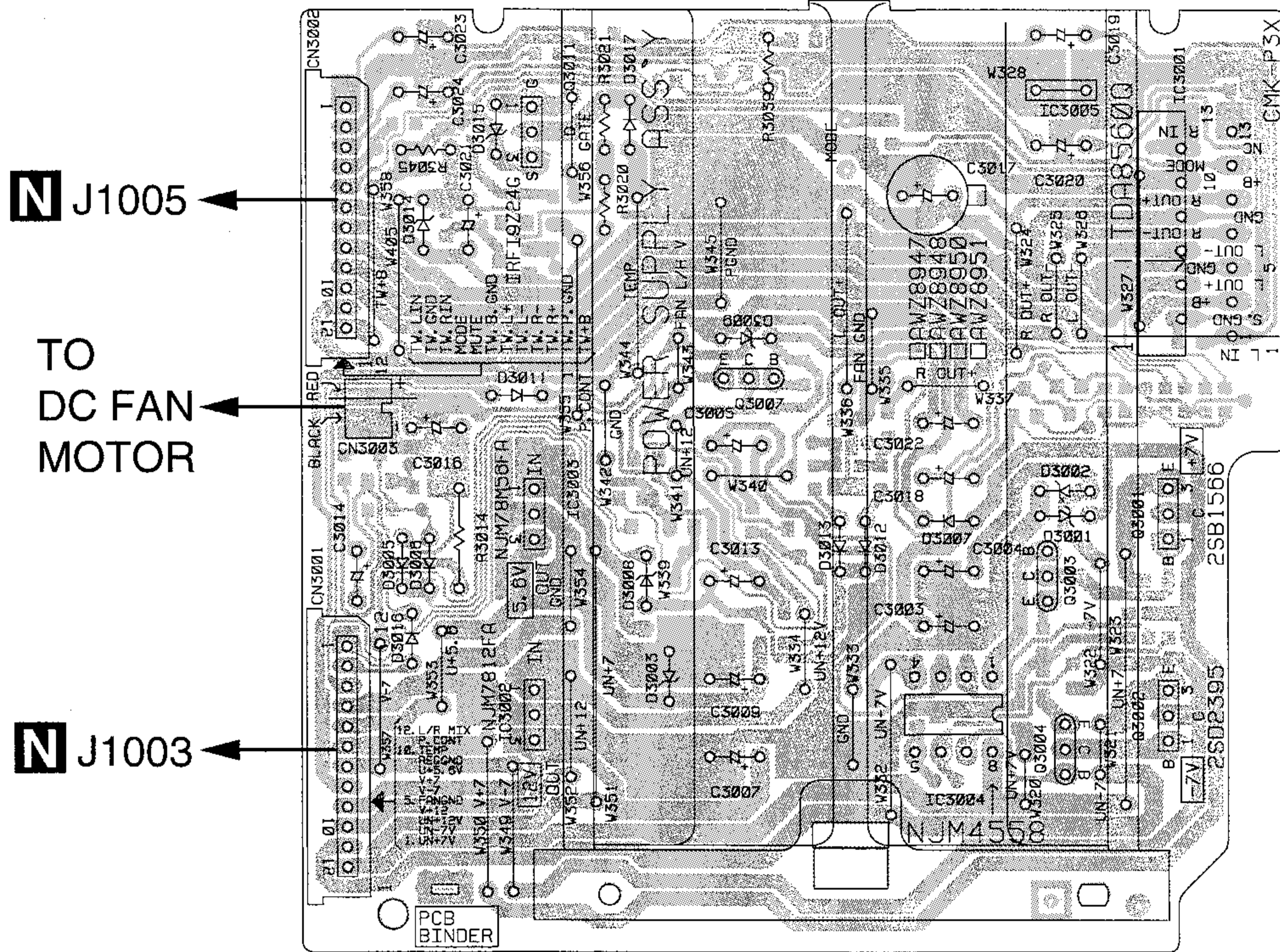

N J1005

TO
DC FAN
MOTOR

N J1003

ANP7221-B

- Q3011 Q3007 IC3005
- IC3003 Q3001
- IC3002 Q3003
- IC3004 Q3002
- Q3004

Q POWER SUPPLY ASSY SIDE B

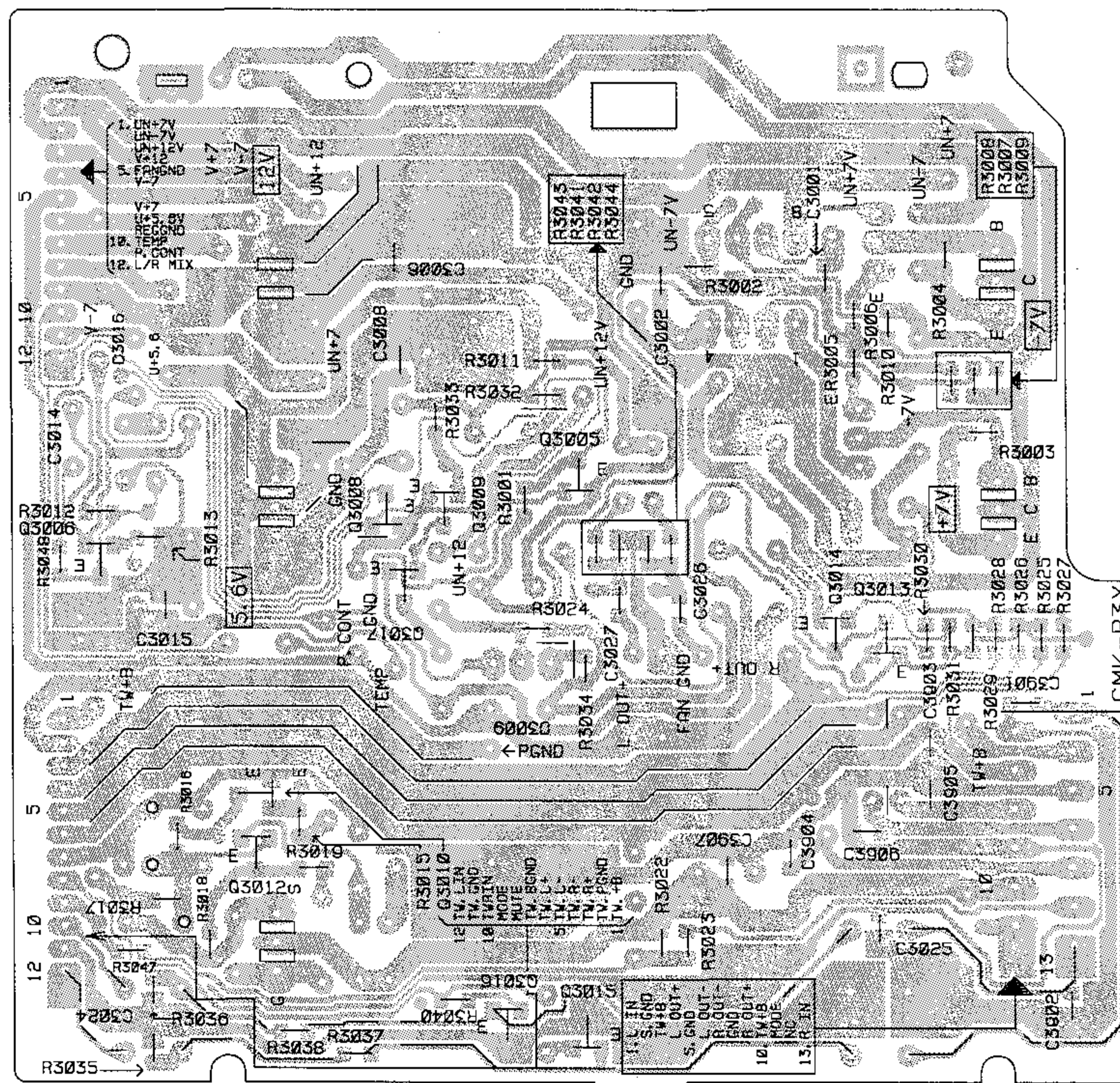

- Q3006 Q3010 Q3008 Q3005 Q3014
- Q3012 Q3009 Q3015 Q3013
- Q3017 Q3016



4.9 DISPLAY ASSY

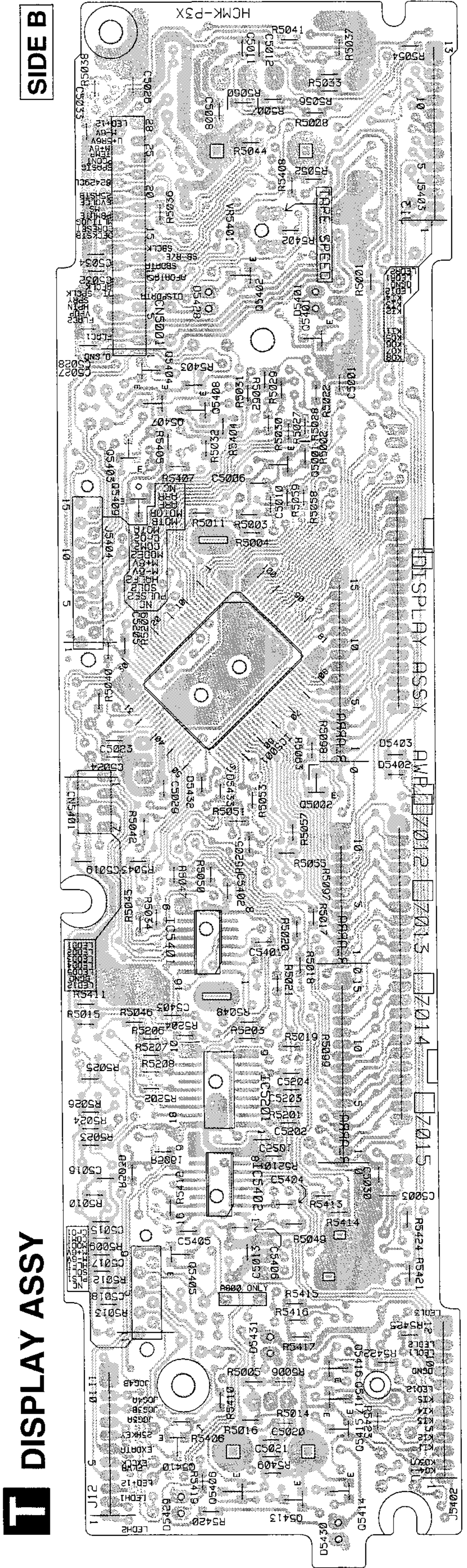
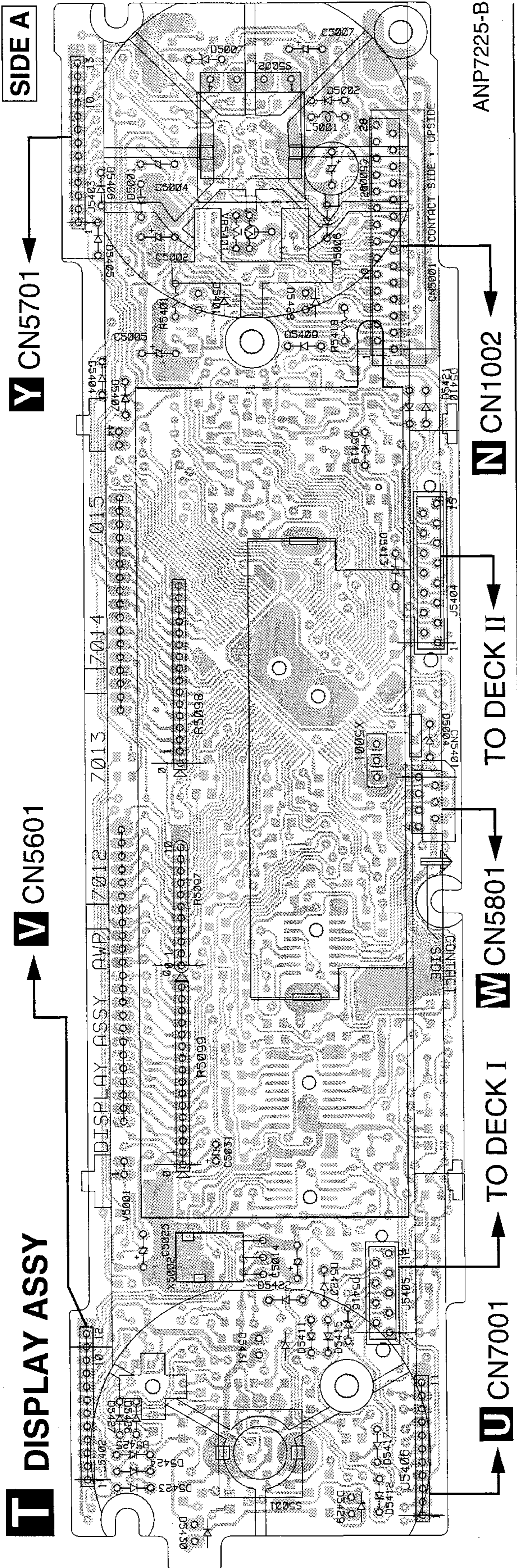

- Q5410 Q5416
- Q5406 Q5417
- Q5413 Q5415
- Q5414
- Q5409 Q5407 Q5401
- Q5403 Q5404 Q5402
- Q5408
- Q5001
- IC5001
- Q5002
- IC5401
- IC5201
- Q5405
- IC5402
- IC5202
- Q5411
- Q5412
- Q5413
- Q5414
- Q5415
- Q5416
- Q5417
- Q5418
- Q5419
- Q5420
- Q5421
- Q5422
- Q5423
- Q5424
- Q5425
- Q5426
- Q5427
- Q5428
- Q5429
- Q5430
- Q5431
- Q5432
- Q5433
- Q5434
- Q5435
- Q5436
- Q5437
- Q5438
- Q5439
- Q5440
- Q5441
- Q5442
- Q5443
- Q5444
- Q5445
- Q5446
- Q5447
- Q5448
- Q5449
- Q5450
- Q5451
- Q5452
- Q5453
- Q5454
- Q5455
- Q5456
- Q5457
- Q5458
- Q5459
- Q5460
- Q5461
- Q5462
- Q5463
- Q5464
- Q5465
- Q5466
- Q5467
- Q5468
- Q5469
- Q5470
- Q5471
- Q5472
- Q5473
- Q5474
- Q5475
- Q5476
- Q5477
- Q5478
- Q5479
- Q5480
- Q5481
- Q5482
- Q5483
- Q5484
- Q5485
- Q5486
- Q5487
- Q5488
- Q5489
- Q5490
- Q5491
- Q5492
- Q5493
- Q5494
- Q5495
- Q5496
- Q5497
- Q5498
- Q5499
- Q5500



4.10 SUB DISPLAY ASSY

U SUB DISPLAY ASSY (XR-A800 ONLY)

SIDE A

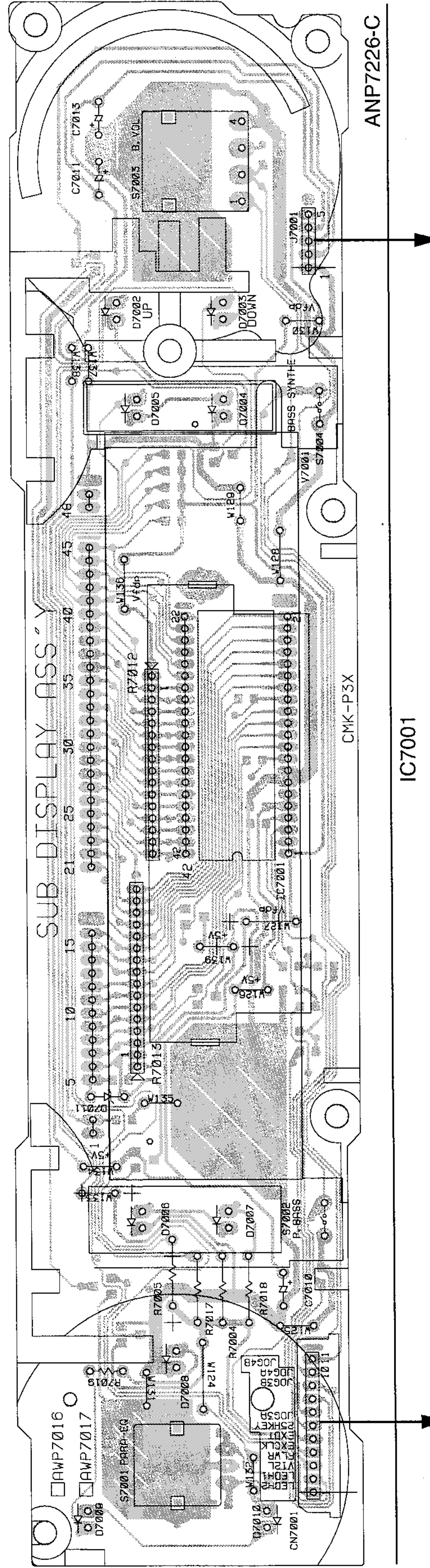

T J5406

N CN1007

U SUB DISPLAY ASSY (XR-A800 ONLY)

SIDE B

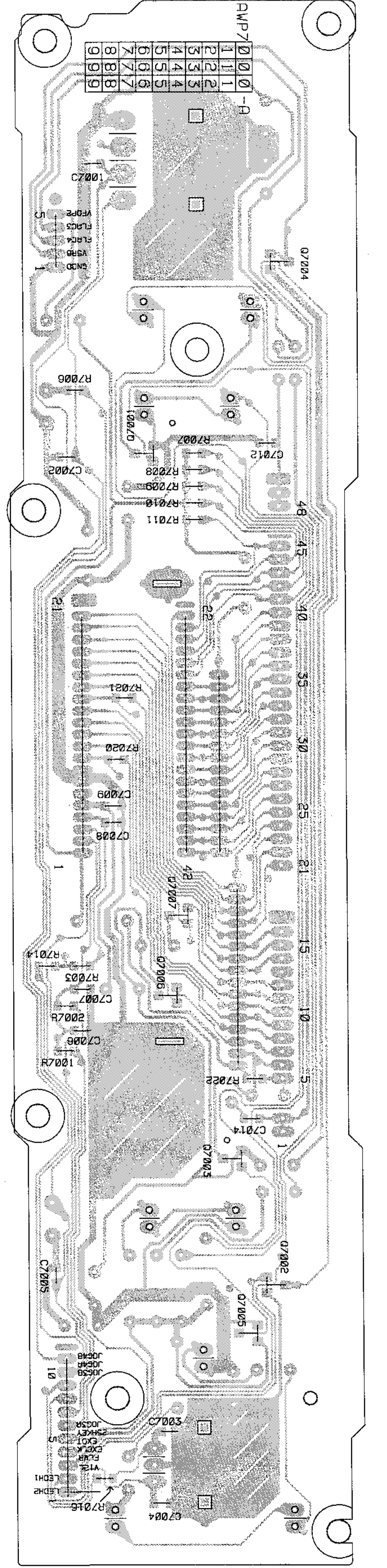

Q7005
Q7002

Q7003

Q7006

Q7007

Q7001

Q7004

5. PCB PARTS LIST

NOTES:

- Parts marked by "NSP" are generally unavailable because they are not in our Master Spare Parts List.
- The Δ mark found on some component parts indicates the importance of the safety factor of the part. Therefore, when replacing, be sure to use parts of identical designation.
- When ordering resistors, first convert resistance values into code form as shown in the following examples.
 - Ex.1 When there are 2 effective digits (any digit apart from 0), such as 560 ohm and 47k ohm (tolerance is shown by J=5%, and K=10%).

560	→	56×10^1	→	561	RD1/4PU	561J
47k	→	47×10^3	→	473	RD1/4PU	473J
0.5	→	R50			RN2H	R50K
1	→	1R0			RSIP	1R0K
 - Ex.2 When there are 3 effective digits (such as in high precision metal film resistors).

5.62k	→	562×10^1	→	5621	RN1/4PC	5621F
-------	---	-------------------	---	------	-------	---------	-------

Mark	No.	Description	Part No.
------	-----	-------------	----------

LIST OF ASSEMBLIES

NSP		MAIN ASSY (for XR-A800)	AWK7417
NSP		MAIN ASSY (for XR-A700)	AWK7414
		├ AF ASSY (for XR-A800)	AWZ8939
		├ AF ASSY (for XR-A700)	AWZ8937
		├ AMP ASSY (for XR-A800)	AWZ8944
		├ AMP ASSY (for XR-A700)	AWZ8941
		├ POWER SUPPLY ASSY (for XR-A800)	AWZ8950
		├ POWER SUPPLY ASSY (for XR-A700)	AWZ8947
NSP		├ SECONDARY ASSY (for XR-A800)	AWZ8956
NSP		├ SECONDARY ASSY (for XR-A700)	AWZ8953
NSP		COMPLEX ASSY (for XR-A800)	AWM7320
NSP		COMPLEX ASSY (for XR-A700)	AWM7316
		├ GM-CD ASSY (for XR-A800)]*1	AWZ8962
		├ GM-CD ASSY (for XR-A700)]*1	AWZ8959
NSP		├ HP ASSY (for XR-A800)]*2	AWZ8967
NSP		├ HP ASSY (for XR-A700)]*2	AWZ8965
NSP		├ RIGHT SW ASSY	AWZ8968
NSP		├ LEFT SW ASSY	AWZ8969
NSP		├ DOOR SW ASSY	AWZ8970
NSP		├ DOOR LED ASSY	AWZ8971
NSP		├ TX CONNECT ASSY	AWZ8972
NSP		├ DOOR MOTOR ASSY	AWZ8973
NSP		├ HOME SW ASSY	AWZ8975
NSP		├ PRIMARY ASSY (for XR-A800)]*3	AWZ8981
NSP		├ PRIMARY ASSY (for XR-A700)]*3	AWZ8977
		DISPLAY ASSY (for XR-A800)	AWP7015
		DISPLAY ASSY (for XR-A700)	AWP7013
		SUB DISPLAY ASSY (XR-A800 only)	AWP7017
		FM/AM TUNER MODULE	AXQ7061
NSP		GS SLOT-IN MECHANISM ASSY	AXA7044
NSP		├ SL MECHANISM ASSY	AWX7031
NSP		├ SENSOR BOARD ASSY	AWZ8560
NSP		├ LED BOARD ASSY	AWZ8561
NSP		├ MOTOR BOARD ASSY	AWZ8744
NSP		GS MECHANISM ASSY	AXA7047
NSP		├ LO MECHANISM BOARD ASSY	AWX7035
NSP		├ SENSOR PCB ASSY	AWZ7836
NSP		├ MOTOR PCB ASSY	AWZ7837
NSP		├ SW PCB ASSY	AWZ7838
NSP		├ MECHA PCB ASSY	AWZ8802
NSP		├ SERVO MECHANISM ASSY GM	AXA7028
NSP		├ MECHANISM BOARD ASSY	PWX1192

Mark	No.	Description	Part No.
------	-----	-------------	----------

NAF ASSY (for XR-A800)

SEMICONDUCTORS

Δ	IC1203	PROTECTOR (250mA)	AEK7002
Δ	IC1202	PROTECTOR (500mA)	AEK7005
Δ	IC1201	PROTECTOR (1A)	AEK7009
	IC1006		BU4052BCF
	IC1004, IC4201		BU4066BCF
	IC1101, IC4501		BU4094BCF
	IC4401		CXA1101M
	IC1001		LC75394NED
	IC1009		M51134FP
	IC1010		M62429FP
	IC4101		NJM4558DXP
	IC1002, IC1003, IC1005, IC1007, IC1008		NJM4558MD
	IC4301, IC4402		NJM4558MD
	Q1302, Q1303		2SA1037K
	Q1201, Q1207		2SA965
	Q1204, Q1205		2SB1237X
	Q4351-Q4353		2SC1815
	Q4354		2SC2240
	Q1001, Q1002, Q1206, Q1301, Q1307		2SC2412K
	Q4201, Q4202, Q4301, Q4302, Q4453		2SC2412K
	Q1202, Q1203		2SD1858X
	Q1009, Q1010, Q4451, Q4452		2SD2114K
	Q1011, Q1012, Q4151, Q4152		2SK373
	Q4357, Q4455, Q4456		DTA124EK
	Q1004, Q1005, Q1007, Q1306, Q4204		DTA143EK
	Q1305, Q4454		DTC124EK
	Q1006, Q1304, Q4203		DTC143EK
	D1001-D1003, D1101, D1103, D1104		1SS254
	D1212, D1224, D1301-D1312, D1314		1SS254
	D1316-D1321, D4151, D4152		1SS254
	D4201, D4202, D4351-D4354		1SS254
	D4452-D4456		1SS254
Δ	D1201		D2SBA20(B)
	D1222		MTZJ10B
	D1315		MTZJ12B

NOTE *1: Although AWZ8959 and AWZ8962 are different in part number, they have the same service parts.
 *2: Although AWZ8965 and AWZ8967 are different in part number, they have the same service parts.
 *3: Although AWZ8977 and AWZ8981 are different in part number, they have the same service parts.

XR-A800, XR-A700

Mark	No.	Description	Part No.
	CN4002	3P TOP POST (EH)	B3B-EH
	CN4001	3P TOP POST (RED)	B3B-EH-R
	CN1008	12P PLUG	KM200TA12
	JA1001	2P JACK	VKB1046
	JA1002	2P JACK	VKB1050

N AF ASSY (for XR-A700)

SEMICONDUCTORS

△	IC1203	PROTECTOR (250mA)	AEK7002
△	IC1201	PROTECTOR (750mA)	AEK7007
	IC4201		BU4066BCF
	IC4501		BU4094BCF
	IC4401		CXA1101M
	IC1001		LC75394NED
	IC4101		NJM4558DXP
	IC1007, IC1008, IC4301, IC4402		NJM4558MD
	Q1302, Q1303		2SA1037K
	Q1201		2SA965
	Q1204, Q1205		2SB1237X
	Q4351-Q4353		2SC1815
	Q4354		2SC2240
	Q1001, Q1002, Q1206, Q1301, Q1307		2SC2412K
	Q4201, Q4202, Q4301, Q4302, Q4453		2SC2412K
	Q1202, Q1203		2SD1858X
	Q4451, Q4452		2SD2114K
	Q4151, Q4152		2SK373
	Q4357, Q4455, Q4456		DTA124EK
	Q1007, Q1306, Q4204		DTA143EK
	Q1305, Q4454		DTC124EK
	Q1304, Q4203		DTC143EK
	D1001-D1003, D1101, D1212		1SS254
	D1301-D1312, D1316-D1321		1SS254
	D4151, D4152, D4201, D4202		1SS254
△	D4351-D4354, D4452-D4456		1SS254
△	D1201		D2SBA20(B)
	D1222		MTZJ10B
	D1213		MTZJ33A
	D1215, D1216		MTZJ5.6B
△	D1214		MTZJ6.2B
△	D1211		S5688G
	D1217-D1221		S5688G

COILS AND FILTERS

L1001, L1002 (1μH)	ATH-133
L4351	ATX7002
L4303, L4304	LTA332J
L4301, L4302	LTA822J
F4401, F4402	RTF1217

SWITCHES AND RELAYS

RY1001	ASR7008
--------	---------

CAPACITORS

△	C1203 (0.01μF/AC150V)	ACG1005
	C4319, C4320	CCCSL271K2H
	C4153, C4154	CCSQCH100D50

Mark	No.	Description	Part No.
	C1035, C1036, C4501-C4503		CCSQCH101J50
	C1001-C1004, C1045-C1047		CCSQCH221J50
	C4453		CCSQCH271J50
	C4151, C4152		CCSQCH681J50
	C4101, C4102		CCSQCH821J50
	C1013, C1014, C4405, C4406		CEASR68M50
	C1207, C1208, C4360, C4403, C4404		CEAT100M50
	C4407, C4408		CEAT100M50
	C1041-C1044, C1087, C1088		CEAT101M16
	C4401, C4402		CEAT101M16
△	C1206		CEAT101M2A
△	C1205		CEAT102M35
	C1048		CEAT1R0M50
	C4451		CEAT220M50
△	C1201, C1202		CEAT222M16
	C1204, C4103, C4104, C4311, C4312		CEAT330M16
	C4317, C4318, C4352, C4357, C4358		CEAT330M16
	C1209, C1210, C4109, C4110		CEAT470M25
	C1039, C1040, C4201, C4202		CEAT4R7M50
	C4301, C4302, C4313, C4314		CEAT4R7M50
	C1005-C1012, C1037, C1038		CEATR33M50
	C1093, C1094, C1097, C1098		CEJA2R2M50
	C1301, C1302, C4303, C4304		CEJA2R2M50
	C4413, C4414, C4454		CEJA2R2M50
	C1015, C1016		CEJAR47M50
	C1019, C1020		CFTYA394J50
	C1112, C4120		CGCYX104M25
	C4361		CKCYB681K2H
	C1029, C1030		CKSQYB122K50
	C4411, C4412		CKSQYB152K50
	C1079, C1080		CKSQYB184K16
	C4307, C4308		CKSQYB272K50
	C1023, C1024		CKSQYB273K50
	C4353, C4354		CKSQYB332K50
	C4323, C4324		CKSQYB333K50
	C1021, C1022		CKSQYB393K50
	C1025, C1026, C4355		CKSQYB472K50
	C4305, C4306		CKSQYB563K25
	C1027, C1028, C1031, C1032		CKSQYB682K50
	C4105, C4106		CKSQYB682K50
	C1017, C1018		CKSQYB683K25
	C1083-C1086, C1111, C1303, C1922		CKSQYF104Z50
	C1304, C4452		CKSQYF105Z16
	C1081, C1082		CKSQYF334Z16
	C4359		CQHA822J2A
	C4409, C4410		CQMA103J50
	C4356		CQMA223J50
	R1087, R1088, R1091, R1092		RD1/2PM100J
	R1201		RD1/2PM682J
△	R1210		RD1/2PMF470J
	R1209		RD1/4PU102J
	R4315, R4316		RD1/4PU103J
	R1316		RD1/4PU104J

RESISTORS

Mark	No.	Description	Part No.
	R4352		RD1/4PU222J
	R4355		RD1/4PU4R7J
	R4109, R4110, R4317, R4318		RD1/4PU820J
	R4351		RS1LMF151J
	R1211		RS3LMF271J
	R1307, R1308		RS3LMFR22J
	VR4301, VR4302 (4.7kΩ)		RCP1020
	VR4201-VR4204 (22kΩ)		RCP1046
	VR4351, VR4352 (220kΩ)		RCP1049
	Other Resistors		RS1/10S□□□J

OTHERS

CN1002	CONNECTOR 28P	9604S-28C
CN1001	CONNECTOR 35P	9604S-35C
CN1003	SPEAKER TERMINAL 4P	AKE7030
CN4003	2P TOP POST (EH)	B2B-EH
CN4002	3P TOP POST (EH)	B3B-EH
CN4001	3P TOP POST (RED)	B3B-EH-R
CN1008	12P PLUG	KM200TA12
JA1001	2P JACK	VKB1046
JA1002	2P JACK	VKB1050

P AMP ASSY

SEMICONDUCTORS

△	IC2003	PROTECTOR (1A)	AEK7009
△	IC2004	PROTECTOR (2.5A)	AEK7014
△	IC2002	IC PROTECTOR	ICP-N25
△	IC2001		STK4192-2GP
	Q2009		2SA1037K
	Q2004, Q2006		2SA992
	Q2003, Q2005		2SC1845
	Q2007, Q2008, Q2010		2SC2412K
	Q2011, Q2012		2SD2114K
△	Q2002		IRF540A
△	Q2001		IRF9540A
	D2009-D2013		1SS254
△	D2001		D3SBA20(B)
△	D2005, D2006		MTZJ18C
	D2007, D2008 (for XR-A800)		MTZJ27C
	D2007, D2008 (for XR-A700)		MTZJ24B
	D2003, D2004		MTZJ4.7B
	D2002		MTZJ5.6B
	TH2001		AEX7002

CAPACITORS

△	C2001, C2002 (3300μF/71V)	ACH7076
	C2015	CEANP470M50
	C2013, C2014, C2016	CEAT100M50
	C2003-C2006, C2018	CEAT101M16
	C2011, C2012, C2017	CEAT101M35
	C2009, C2010	CEAT220M50
	C2007, C2008, C2019, C2020	CEJA2R2M50
	C2021, C2022	CKCYB102K2H
	C2901, C2902	CKSQYB272K50

Mark	No.	Description	Part No.
RESISTORS			
	R2031-R2034		RD1/2PM332J
	R2029, R2030		RD1/2PM563J
△	R2043, R2044		RD1/2PMF222J
△	R2039, R2042		RD1/4LMF101J
△	R2038		RD1/4LMF102J
△	R2005, R2006		RFA1/4PS101J
	R2009, R2010		RN1/4PC1001F
	R2011, R2012 (for XR-A800)		RN1/4PC2701F
	R2011, R2012 (for XR-A700)		RN1/4PC2401F
	R2007, R2008 (for XR-A800)		RN1/4PC8201F
	R2007, R2008 (for XR-A700)		RN1/4PC7501F
	R2023, R2024		RS1/10S0R0J
	R2041, R2045, R2049, R2050		RS1/10S102J
	R2051, R2052		RS1/10S103J
	R2047, R2048		RS1/10S104J
	R2037		RS1/10S183J
	R2027, R2028		RS1/10S561J
	R2025, R2026		RS1/10S563J
	Other Resistors		RD1/4PU□□□J

Q POWER SUPPLY ASSY (for XR-A800)

SEMICONDUCTORS

△	IC3005	IC PROTECTOR	ICP-N25
	IC3004		NJM4558DXP
△	IC3002		NJM7812FA
△	IC3003		NJM78M56FA
△	IC3001		TDA8560Q
	Q3013, Q3014		2SA1037K
	Q3004		2SA1267
△	Q3001		2SB1566
	Q3006, Q3009, Q3010, Q3012		2SC2412K
	Q3003		2SC3199
	Q3007		2SD1858X
	Q3015, Q3016		2SD2114K
△	Q3002		2SD2395
	Q3017		DTA143EK
	Q3008		DTC114EK
	Q3005		DTC124EK
△	Q3011		IRFI9Z24G
	D3005-D3007, D3011-D3013		1SS254
	D3016, D3017		1SS254
	D3009, D3015		MTZJ18C
	D3014		MTZJ6.8B
	D3001		MTZJ8.2C
△	D3002, D3003		MTZJ8.2C

CAPACITORS

	C3022	CEAT100M50
	C3018	CEAT101M16
	C3017	CEAT101M35
	C3005, C3013	CEAT1R0M50
	C3003, C3004	CEAT470M25
	C3016	CEJA220M35
	C3007, C3009, C3014	CEJA2R2M50
	C3021	CEJA470M16

XR-A800, XR-A700

Mark	No.	Description	Part No.
	C3019, C3020 C3025		CEJAR47M50 CKSQYB102K50

C3006, C3008, C3015 C3026, C3027 C3001, C3002 C3023, C3024	CKSQYF104Z50 CKSQYF105Z16 CKSQYF473Z50 CQMA103J50
---	--

RESISTORS

R3014	RD1/2PM330J
R3039	RD1/4PU103J
R3045	RD1/4PU472J
R3020	RN1/4PC1001F
R3021	RN1/4PC1601F
Other Resistors	RS1/10S□□□J

OTHERS

PCB BINDER	DEF1012
------------	---------

Q POWER SUPPLY ASSY (for XR-A700)

SEMICONDUCTORS

IC3004	NJM4558DXP
△ IC3002	NJM7812FA
△ IC3003	NJM78M56FA
Q3004	2SA1267
△ Q3001	2SB1566
Q3006, Q3009	2SC2412K
Q3003	2SC3199
Q3007	2SD1858X
△ Q3002	2SD2395
Q3017	DTA143EK
Q3008	DTC114EK
Q3005	DTC124EK
D3005-D3007, D3016	1SS254
D3009	MTZJ18C
D3001	MTZJ8.2C
△ D3002, D3003	MTZJ8.2C

CAPACITORS

C3022	CEAT100M50
C3005, C3013	CEAT1R0M50
C3003, C3004	CEAT470M25
C3016	CEJA220M35
C3007, C3009, C3014	CEJA2R2M50
C3006, C3008, C3015 C3001, C3002	CKSQYF104Z50 CKSQYF473Z50

RESISTORS

R3014	RD1/2PM330J
Other Resistors	RS1/10S□□□J

OTHERS

PCB BINDER	DEF1012
------------	---------

Mark	No.	Description	Part No.
R	SECONDARY ASSY		

SEMICONDUCTORS

△ IC204 PROTECTOR (3.15A)	AEK7016
△ IC202 PROTECTOR (5A) (for XR-A800)	AEK7019
△ IC202 PROTECTOR (2.5A) (for XR-A700)	AEK7014
△ IC201 PROTECTOR (5A) (for XR-A800)	AEK7046
△ IC201 PROTECTOR (2.5A) (for XR-A700)	AEK7049

△ IC203 PROTECTOR (3.15A)	AEK7051
△ D201 (XR-A800 only)	D2SBA20(B)
△ D202, D203	S5688G

CAPACITORS

△ C202 (XR-A800 only)	CEAT332M35
-----------------------	------------

J GM-CD ASSY

SEMICONDUCTORS

IC8151	CXA1372BQ
IC8301	CXD2519Q
IC8203	LA6517
IC8201, IC8202	LA6520
IC8001	PD4859A
Q8002	2SC2712
Q8401, Q8402	2SD2114K
Q8301	2SK373
Q8302	DTA124EK
Q8403, Q8404	DTA143EK
Q8001, Q8303	DTC143EK
D8001, D8003, D8004, D8301-D8303	1SS254
D8401, D8402	DAN202K
D8219	MTZJ6.2B/C

COILS AND FILTERS

L8301	LAU1R2J
L8001	LAU220J

CAPACITORS

C8003 (0.047F/5.5V)	ACH1246
C8313	CCSQCH100D50
C8009, C8014-C8016, C8319, C8321	CCSQCH101J50
C8401, C8402	CCSQCH151J50
C8314	CCSQCH220J50
C8167	CCSQCH561J50
C8002	CEAT100M50
C8007	CEAT221M6R3
C8403, C8404	CEAT2R2M50
C8017	CEAT330M16
C8201, C8202	CEAT331M16
C8001	CEAT470M16
C8301	CEAT471M6R3
C8155, C8156	CEAT4R7M50
C8008, C8309	CEATR47M50
C8317	CGCYF104Z25
C8010, C8012, C8164, C8312, C8320	CKSQYB102K50
C8151, C8158, C8162, C8316, C8602	CKSQYB103K50
C8306	CKSQYB152K50
C8160, C8163, C8166	CKSQYB333K50

Mark	No.	Description	Part No.
	C8165		CKSQYB472K50
	C8004-C8006, C8307		CKSQYB473K50
	C8405, C8406		CKSQYB681K50
	C8159, C8205, C8210, C8215		CKSQYF103Z50
	C8219, C8220, C8225, C8230, C8235		CKSQYF103Z50
	C8245		CKSQYF103Z50
	C8019, C8152-C8154, C8157, C8161		CKSQYF104Z50
	C8303, C8318		CKSQYF104Z50

RESISTORS

R8248	RD1/4PU100J
R8001-R8003, R8011-R8013	RD1/4PU102J
R8035, R8036	RD1/4PU102J
R8015	RD1/4PU203J
R8409, R8410	RD1/4PU221J
R8023, R8024, R8221, R8222	RD1/4PU473J
R8226, R8227	RD1/4PU473J
VR8151, VR8152	RCP1103
Other Resistors	RS1/10S□□□J

OTHERS

CN8005 5P JUMPER CONNECTOR	52147-0510
CN8002 CONNECTOR 22P	HLEM22S-1
CN8001 CONNECTOR 35P	HLEM35S-1
CN8201 6P JACK	VKN-004
KN8001 EARTH METAL FITTING	VNF1084
X8301 CRYSTAL RESONATOR (33.8688MHz)	ASS7000
X8001 CERAMIC RESONATOR (4.19MHz)	VSS1014

X HP ASSY

SEMICONDUCTORS

Q5501-Q5504	2SD2114K
-------------	----------

CAPACITORS

C5504, C5505	CEANP4R7M50
C5503	CKSQYF104Z50

RESISTORS

R5505, R5506	RS3LMF331J
Other Resistors	RS1/10S□□□J

OTHERS

JACK	AKN7003
------	---------

Y RIGHT SW ASSY

SEMICONDUCTORS

Q5701, Q5702	DTC143EK
D5701-D5704 LED (PURE GREEN)	SLP7118C51H

SWITCHES AND RELAYS

S5701-S5718	ASG1034
-------------	---------

RESISTORS

All Resistors	RD1/4PM□□□J
---------------	-------------

Mark	No.	Description	Part No.
------	-----	-------------	----------

OTHERS

CN5701 13P JUMPER CONNECTOR	52151-1310
-----------------------------	------------

V LEFT SW ASSY

SEMICONDUCTORS

Q5601, Q5602	DTA143EK
Q5604-Q5606	DTC143EK
D5601-D5603 LED (PURE GREEN)	SLP7118C51H
D5604 LED (RED/GREEN)	VRBG3312X

SWITCHES AND RELAYS

S5601-S5610	ASG1034
-------------	---------

RESISTORS

R5603, R5606	RS1/10S473J
Other Resistors	RD1/4PM□□□J

L DOOR SW ASSY

SWITCHES AND RELAYS

S8002	DSG1016
S8003	PSG1008

W DOOR LED ASSY

SEMICONDUCTORS

Q5801-Q5805	DTC143EK
D5809, D5814 LED (GREEN)	SLP3118C51H
D5808, D5813 LED (YELLOW)	SLP4118C51H
D5807, D5812 LED (ORANGE)	SLP6118C51H
D5810, D5815 LED (PURE GREEN)	SLP7118C51H
D5806, D5811 LED (RED)	SLP9118C51H

RESISTORS

All Resistors	RD1/4PM□□□J
---------------	-------------

OTHERS

CN5801 CONNECTOR 7P	52045-0745
---------------------	------------

O TX CONNECT ASSY

SEMICONDUCTORS

D1401, D1402	1SS254
--------------	--------

RESISTORS

R1405	RD1/4PM473J
Other Resistors	RS1/10S□□□J

OTHERS

CN1010 14P PLUG	KM200IB14
CN1009 12P SOCKET	KP200TA12L

M DOOR MOTOR ASSY

OTHERS

J8009 3P JUMPER WIRE	D20PWW0310E
----------------------	-------------

XR-A800, XR-A700

Mark	No.	Description	Part No.
K		HOME SW ASSY	
		SWITCHES AND RELAYS	
	S8001		DSG1048
S		PRIMARY ASSY	
		COILS AND FILTERS	
△	L101		ATF1136
		SWITCHES AND RELAYS	
△	S101		AKX7006
		CAPACITORS	
△	C102 (0.01μF/AC250V)		ACG7020
		OTHERS	
	H101-H106 FUSE CLIP		AKR1004
T		DISPLAY ASSY	
		SEMICONDUCTORS	
	IC5201 (for XR-A800)		BA3834F
	IC5201 (for XR-A700)		BA3835F
	IC5401, IC5402		BU4094BCF
	IC5001		PDG205A
	Q5407		2SB1197K
	Q5001, Q5002		2SC2412K
	Q5409, Q5410		2SD1781K
	Q5403-Q5406		DTA124EK
	Q5408		DTC124EK
	Q5401, Q5402, Q5413-Q5417		DTC143EK
	D5001, D5404-D5407, D5409-D5413		1SS254
	D5422 (XR-A800 only)		1SS254
	D5415-D5417, D5419-D5421		1SS254
	D5423-D5427		1SS254
	D5402, D5403, D5432, D5433		1SS355
	D5006, D5007		MTZJ5.1B
	D5004		MTZJ6.2B
	D5002		S5688G
	D5401, D5428-D5431		SLP7118C51H
		COILS AND FILTERS	
	L5001		LAU220J
		SWITCHES AND RELAYS	
	S5002		ASX7012
	S5001		ASX7017
		CAPACITORS	
	C5029, C5030		CCSQCH101J50
	C5205		CCSQCH471J50
	C5031		CEAL220M35
	C5025		CEAT100M50
	C5002		CEJA100M50
	C5005		CEJA1R0M50
	C5009		CEJA221M10
	C5007, C5014		CEJA470M16

Mark	No.	Description	Part No.
	C5004		CEJAR47M50
	C5006, C5032-C5034		CKSQYB102K50
	C5015-C5018 (XR-A800 only)		CKSQYB103K50
	C5011-C5013		CKSQYB103K50
	C5020, C5021, C5023		CKSQYB103K50
	C5403, C5405		CKSQYB333K50
	C5019 (XR-A800 only)		CKSQYB473K50
	C5001, C5003, C5027, C5028		CKSQYB473K50
	C5008, C5010, C5026, C5201-C5204		CKSQYF104Z50
	C5024		CKSQYF105Z16
		RESISTORS	
	R5097		RA10T473J
	R5098, R5099		RA15T473J
	R5401, R5418		RD1/4PU681J
	VR5401 (2.2kΩ)		RCP1019
	Other Resistors		RS1/10S□□□J
		OTHERS	
	CABLE HOLDER 9P		51063-0905
	CABLE HOLDER 15P		51063-1505
	CN5401 CONNECTOR 7P		52045-0745
	CN5001 CONNECTOR 28P		9607S-28F
	V5001 FL TUBE		AAV7044
	X5001 CERAMIC RESONATOR (8MHz)		EFOEC8004A4
	REMOTE RECEIVER UNIT		GP1U28X
	FL HOLDER		VNF1087
U		SUB DISPLAY ASSY (XR-A800 only)	
		SEMICONDUCTORS	
	IC7001		LC7570
	Q7004, Q7006, Q7007		2SC2712
	Q7003		DTA143EK
	Q7005		DTC124EK
	Q7001, Q7002		DTC143EK
	D7004-D7007		MBG5074X
	D7002, D7003, D7008-D7010		SLP7118C51H
		SWITCHES AND RELAYS	
	S7002, S7004		ASG1034
	S7003		ASX7012
	S7001		ASX7017
		CAPACITORS	
	C7006-C7008		CCSQCH221J50
	C7010		CEAT100M50
	C7011, C7013		CEJA100M35
	C7001-C7005		CKSQYB102K50
	C7012, C7014		CKSQYB473K50
	C7009		CKSQYF104Z50
		RESISTORS	
	R7012, R7013		RA15T473J
	R7017, R7018		RD1/4PM561J
	R7004, R7005		RD1/4PM681J
	R7019		RD1/4PU391J
	Other Resistors		RS1/10S□□□J

Mark No.	Description	Part No.
OTHERS		
V7001	FL TUBE	AAV7043

A FM/AM TUNER MODULE

SEMICONDUCTORS

IC6201	LA1832ML
IC6202	LC72131MD
Q6402	2SC2223
Q6203	2SC2705
Q6201, Q6202	2SC2712
Q6214, Q6403	2SC2714
Q6404	2SK302
Q6401	3SK194
Q6204	DTA124ES
Q6205	DTC124EK
D6202	1SS254
D6401, D6402	1T363

COILS AND FILTERS

L6404	ATC1003
L6401	ATC1020
L6402	ATC1021
F6204	ATF-107
F6203	ATF-119
F6401	ATF-155
F6206	ATF7008
F6202	ATF7011
L6206, L6208, L6403	LAU2R2J

TRANSFORMERS

T6201	ATB7008
T6401	ATE7002

CAPACITORS

C6208	CCSQCH100D50
C6212, C6274, C6275, C6408	CCSQCH101J50
C6221, C6222, C6416	CCSQCH150J50
C6271	CCSQCH200J50
C6415	CCSQCH330J50
C6401, C6419	CCSQCH5R0C50
C6407	CCSQCK1R0C50
C6410	CCSQCK2R0C50
C6413	CCSQPH220J50
C6414	CCSQPH8R0D50
C6405	CCSQTH180J50
C6234, C6235	CEAL1R0M50
C6245	CEAL470M16
C6224	CEAS100M50
C6243	CEAS101M16
C6231	CEAS1R0M50
C6227	CEAS220M16
C6236	CEAS2R2M50
C6216	CEAS330M16
C6262	CEAS3R3M50
C6219	CEAS470M10
C6244	CEAS470M16

Mark No.	Description	Part No.
C6249, C6250, C6265, C6266		CEAS4R7M50
C6258		CEJA470M16
C6215		CFTLA103J50
C6214		CFTLA224J50
C6211, C6254, C6403, C6406, C6412		CKSQYB102K50
C6201, C6205, C6210, C6213, C6237		CKSQYB103K50
C6276, C6278, C6280, C6281, C6402		CKSQYB103K50
C6409, C6417, C6418		CKSQYB103K50
C6251, C6252		CKSQYB153K50
C6203, C6259		CKSQYB223K50
C6228		CKSQYB472K50
C6209		CKSQYB473K50
C6230		CKSQYB821K50
C6218, C6223, C6255		CKSQYF103Z50
C6220, C6226, C6242, C6256		CKSQYF223Z50
C6225		CKSQYF473Z50

RESISTORS

R6280	RD1/4PU101J
R6413, R6416, R6418, R6906, R6909	RS1/8S0R0J
R6401	RS1/8S470J
VR6201 (10kΩ)	RCP1045
Other Resistors	RS1/10S□□□J

OTHERS

BN6202	TERMINAL 4P	AKE7025
X6202	CERAMIC RESONATOR (456kHz)	ASS1066
X6201	CRYSTAL RESONATOR (7.2000MHz)	ASS1093
CN6201	14P SOCKET AM RF TUNING BLOCK	KP2001A14L AXX7041

G SENSOR BOARD ASSY

SEMICONDUCTORS

Q601-Q604	PS3322
-----------	--------

RESISTORS

All Resistors	RD1/4PU□□□J
---------------	-------------

OTHERS

CN601	7P JUMPER WIRE	52151-0710
-------	----------------	------------

H LED BOARD ASSY

SEMICONDUCTORS

D601-D604	AN329
-----------	-------

RESISTORS

All Resistors	RD1/4PU□□□J
---------------	-------------

OTHERS

J601	3P JUMPER WIRE	D20PWW0315E
------	----------------	-------------

I MOTOR BOARD ASSY

OTHERS

J602	3P JUMPER WIRE	D20PWW0305E
------	----------------	-------------

XR-A800, XR-A700

Mark No.	Description	Part No.
----------	-------------	----------

C SENSOR PCB ASSY

SEMICONDUCTORS

D652		GP1S24
------	--	--------

OTHERS

J652	3P JUMPER WIRE	D20PWW0315E
------	----------------	-------------

D MOTOR PCB ASSY

OTHERS

	LOADING MOTOR	VXM1034
--	---------------	---------

E SW PCB ASSY

SWITCHES AND RELAYS

S651, S652		VSG1006
------------	--	---------

OTHERS

J656	3P JUMPER WIRE	D20PWW0315E
------	----------------	-------------

F MECHA PCB ASSY

SEMICONDUCTORS

Q651		DTC124ES
------	--	----------

RESISTORS

R651, R652 (56k Ω)		ACN7012
R653 (220 Ω)		DCN1062
R654 (0 Ω)		DCN1065

OTHERS

CN652	12P CONNECTOR	12FMZ-AST
CN651	4P CONNECTOR	173979-4
CN653	22P CONNECTOR	SLEM22R-2

B MECHANISM BOARD ASSY

SWITCHES AND RELAYS

S610		DSG1016
------	--	---------

OTHERS

CN610	4P CONNECTOR	173979-4
-------	--------------	----------

Mark No.	Description	Part No.
----------	-------------	----------

6. ADJUSTMENT

6.1 TUNER SECTION

■ FM Tuner Section

- Set the mode selector to FM BAND.
- Connect the wiring as shown in Fig. 1-1.

Step No.	Adjustment Title	FM SG (1kHz, ± 75 kHz dev.)		Reception Frequency Display	Adjustment Location	Specifications
		Frequency (MHz)	Level (dB μ V)			
1	Front End Sensitivity	98	0-30	98MHz	L6402 T6401	Adjust so that the DC voltage between the IC6201-Pin 20 and GND becomes at maximum level.
2	TUNED IND. Lighting Level	98	18 \pm 2	98MHz	VR6201	Adjust so that the indicator of TUNED IND. starts to light up.

Notes:

- Before adjusting, make sure there is no gap between L6401 and L6402. If there is a gap between them, bring them into contact with each other first, and then make adjustments.

■ AM Tuner Section

- Set the mode selector to AM BAND.
- Connect the wiring as shown in Fig. 1-1.

Step No.	Adjustment Title	AM SG (400Hz, 30% Mod.)		Reception Frequency Display	Adjustment Location	Specifications
		Frequency (kHz)	Level (dB μ V/m)			
1	AM Front and Sensitivity Adjustment	999*1	35-45	999kHz*1	T6201	Adjust so that the DC voltage between the IC6201-Pin 20 and GND becomes at maximum level.

*1: For the area using 10kHz step, frequencies should be 1000 kHz

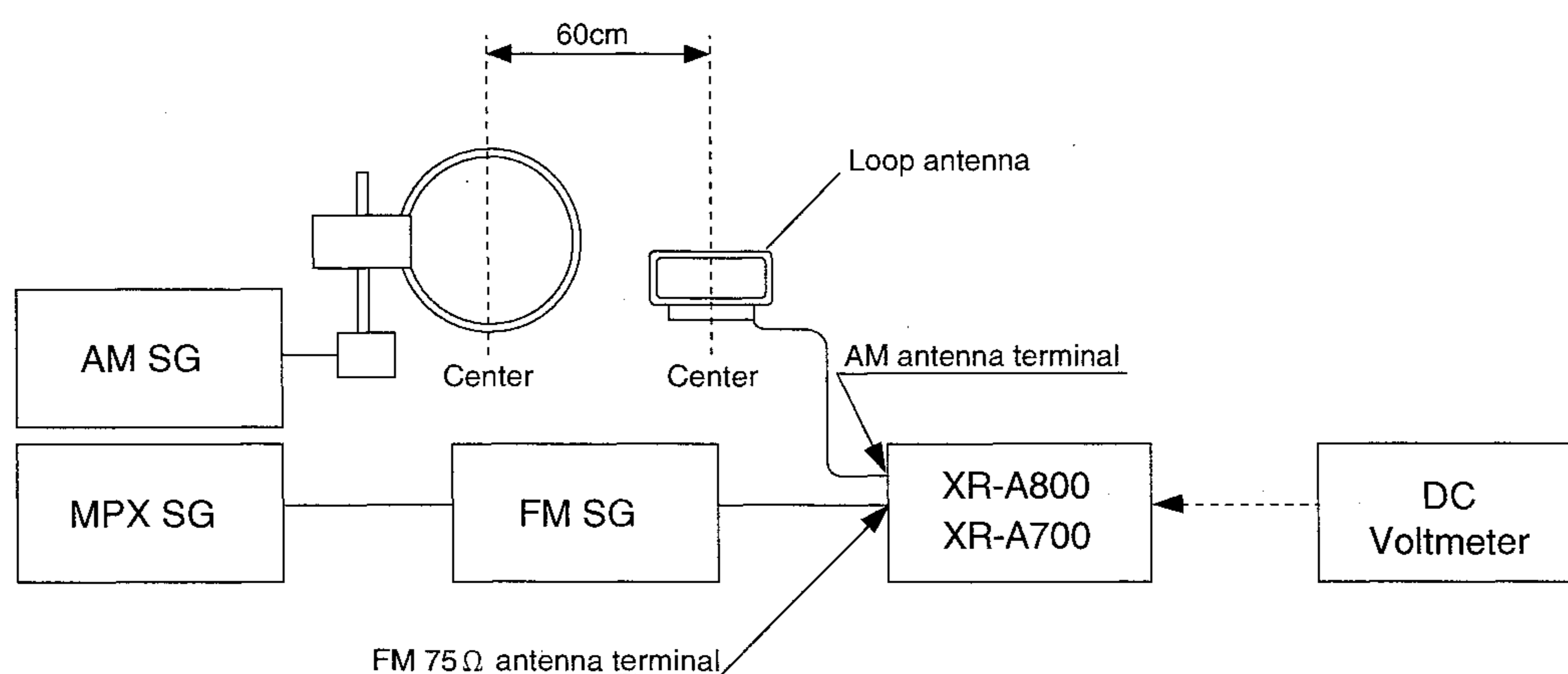

Fig. 1-1 AM and FM Adjustment Wiring Diagram

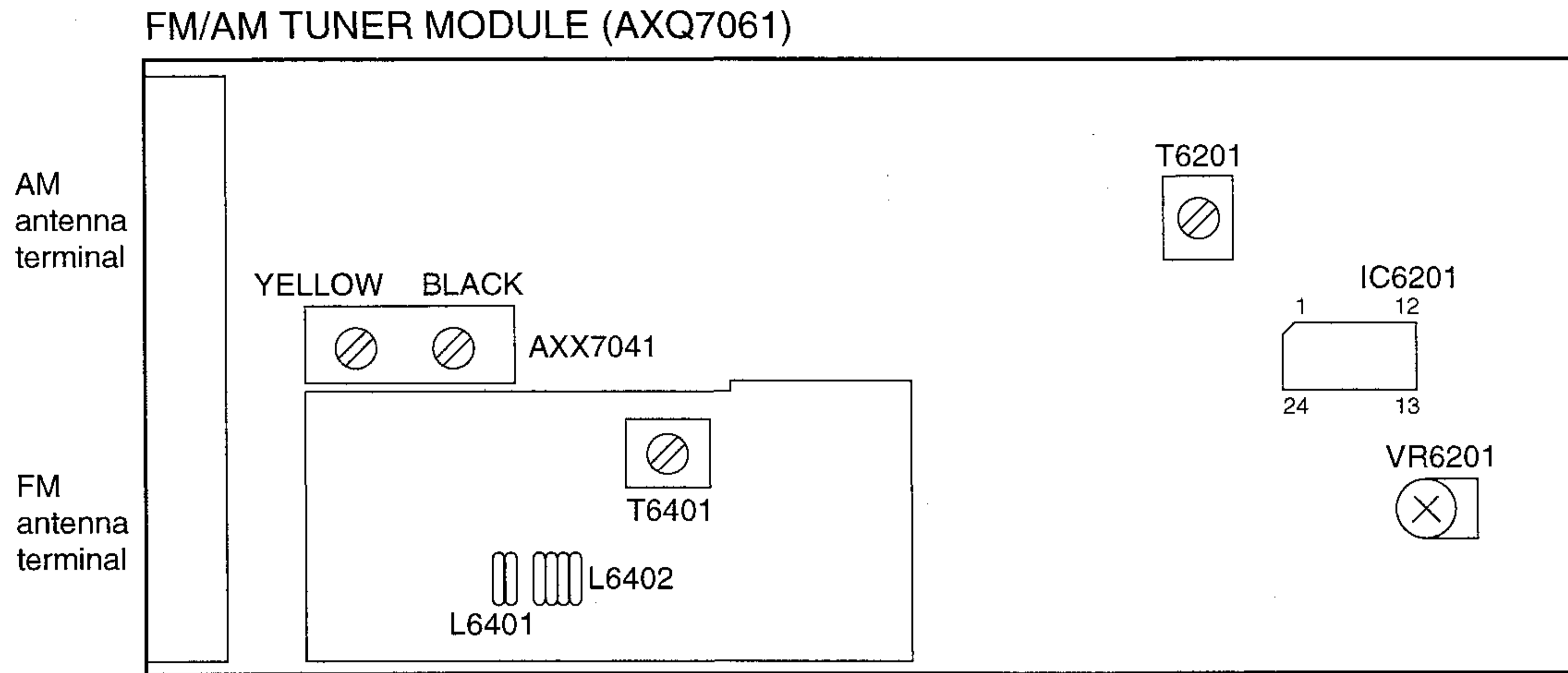

Fig. 1-2 Adjustment Points

6.2 CASSETTE DECK SECTION

● Adjustment points and test points are shown in Fig. 2-3 and Fig. 2-4.

■ Before Adjustment

1. For execution of head angle adjustment, first remove the Azimuth cover (L) and (R).
2. Open the cassette doors (L) and (R).
3. Insert your fingers into the cassette door, push down the two hooks at the upper side of the Azimuth cover, and push them slightly out to the front. Excessive pushing at this time may make it impossible to close the cassette door.
4. Confirm that the Azimuth cover (L) and (R) have been pushed out a little to the front, and then close the cassette doors (L) and (R) and remove the Azimuth cover.

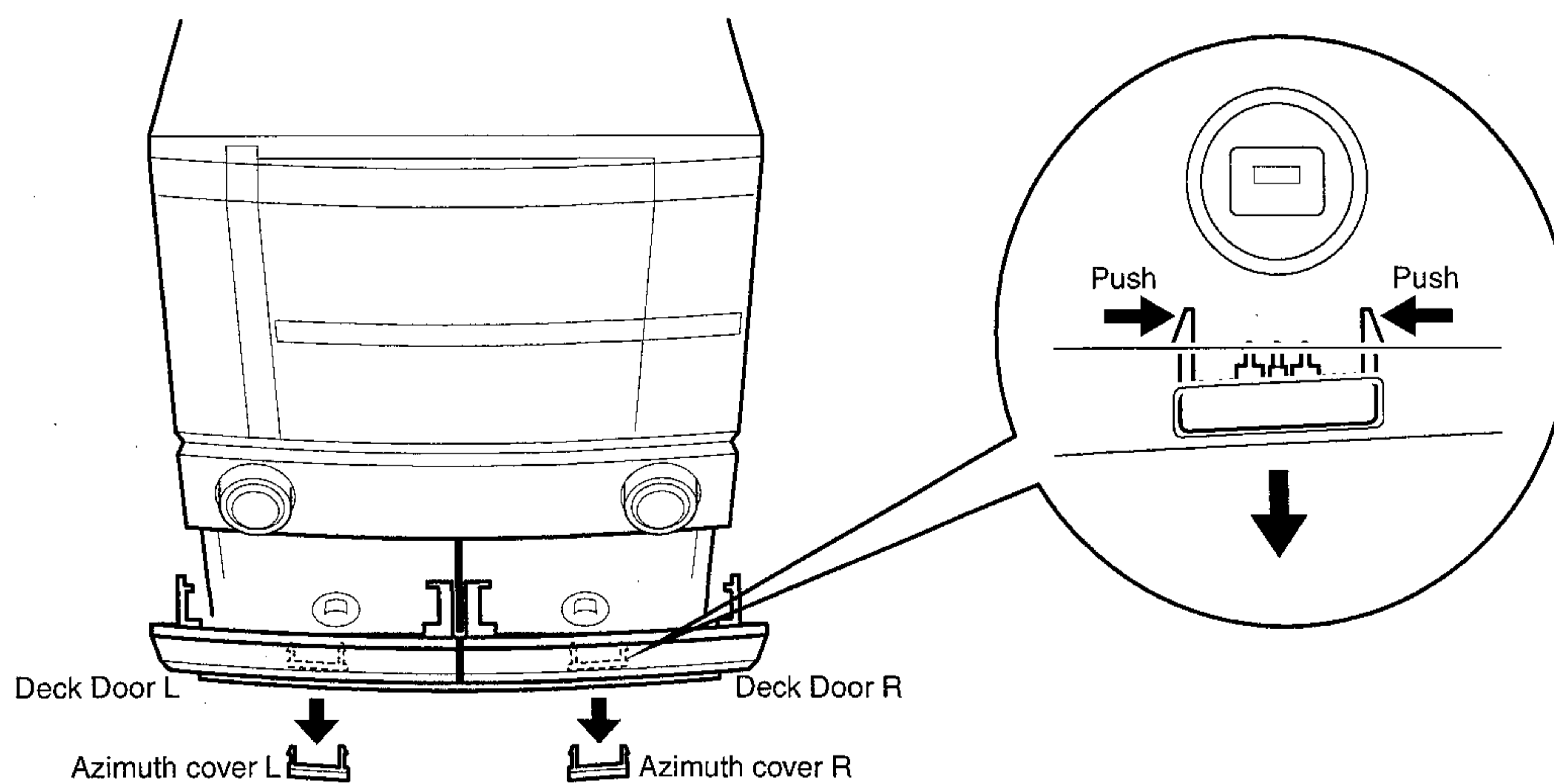

■ Mechanical Adjustment

● Test tape: NCT-111 (3kHz, 30min).

1. Tape Speed Adjustment

Remove the VOLUME KNOB to adjust tape speed.

No.	Mode	Test Tape	Adjusting Points	Measurement Points	Adjustment Procedure	Remarks
1	Deck I PLAY	NCT-111 (Playback: 3kHz)	DISPLAY Assy VR5401	TAPE TEST POINT (Rch) (AF Assy)	Press the PLAY SW and adjust so that the reading becomes 3000Hz \pm 20Hz. Confirm that wow & flutter level is below 0.2% (in the reverse direction, confirm that the reading is within 3000Hz \pm 60Hz).	

■ Electrical Adjustment

Check the following before starting.

1. Confirm that the tape speed adjustment has been completed.
2. Clean the heads and demagnetize them using a head eraser.
3. Set the measurement level to 0 dBV = 1 Vrms.
4. Use the specified tape for adjustment. Use the labeled (A) side of the test tape.

STD-331E: For playback adjustment

STD-632: Normal blank tape

5. Provide yourself with the following measuring devices:

- AC millivoltmeter
- Low-frequency oscillator
- Attenuator
- Oscilloscope

6. Adjust both right and left channels unless otherwise specified.
7. Turn the DOLBY NR switch off unless otherwise specified.
8. Warm up the unit for several minutes before adjustment. In particular, be sure to warm up the unit in the REC/PLAY mode for 3 to 5 minutes before starting recording/playback frequency characteristics adjustment.
9. Always follow the indicated adjustment order.
Otherwise, a complete adjustment may not be achieved.

Playback Adjustment (Decks I and II)

1. Head Azimuth Adjustment
2. Playback Level Adjustment

Recording Adjustment (Deck II)

1. Bias Oscillation Frequency Adjustment
2. Recording Bias Adjustment
3. Recording Level Adjustment.
4. ALC Operation Check

* As the reference recording level is 250nwb/m for STD-331E, the recording level will be higher by 4 dB for STD-331B (160nwb/m).
When adjusting, pay carefull attention to the type of tape used.

Dolby noise reduction manufactured under license from Dolby Laboratories Licensing Corporation.
"DOLBY" and the double-D symbol are trademarks of Dolby Laboratories Licensing Corporation.

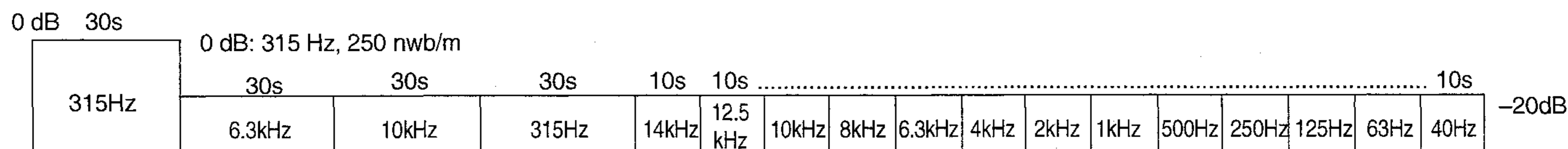

Fig. 2-1 STD-331E Test Tape

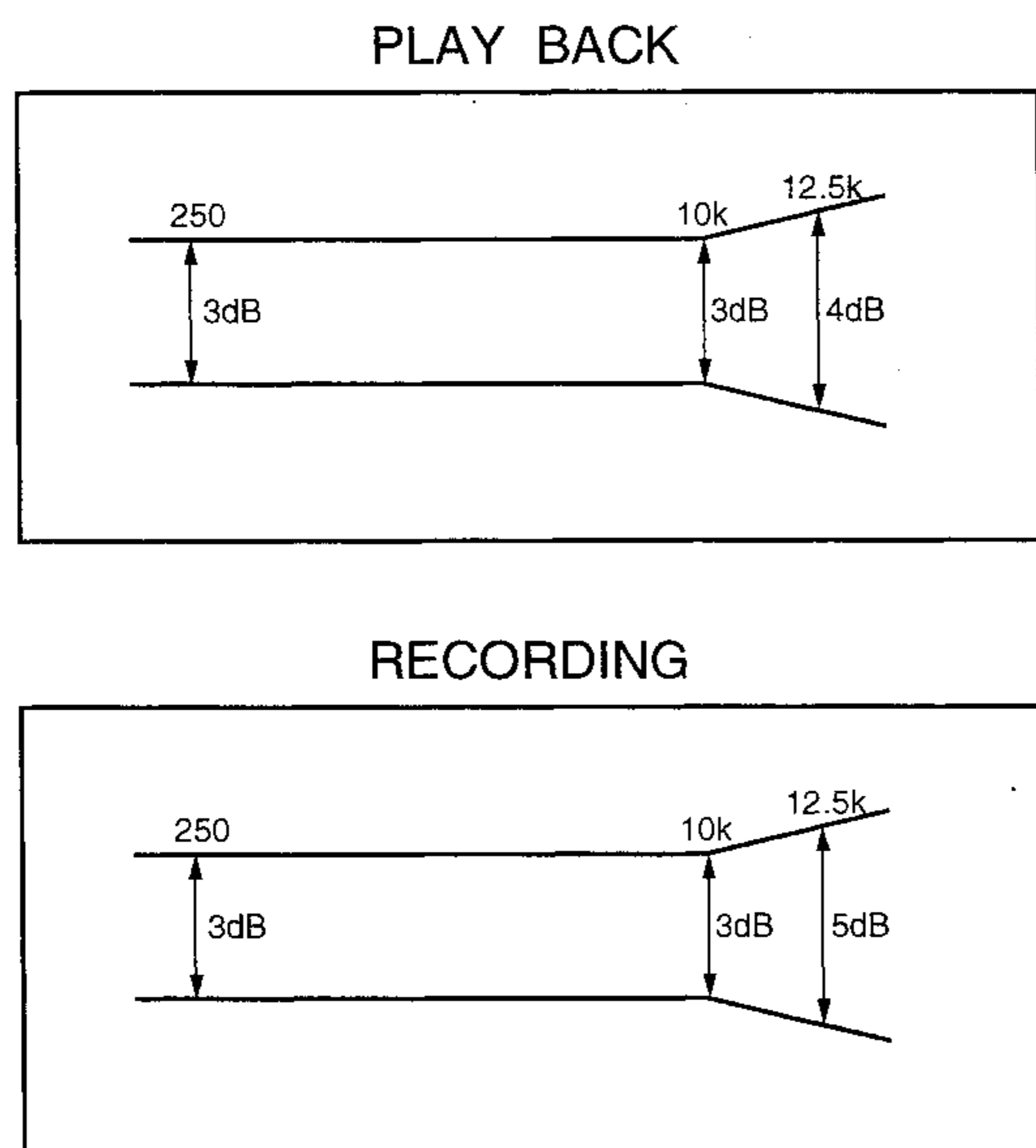
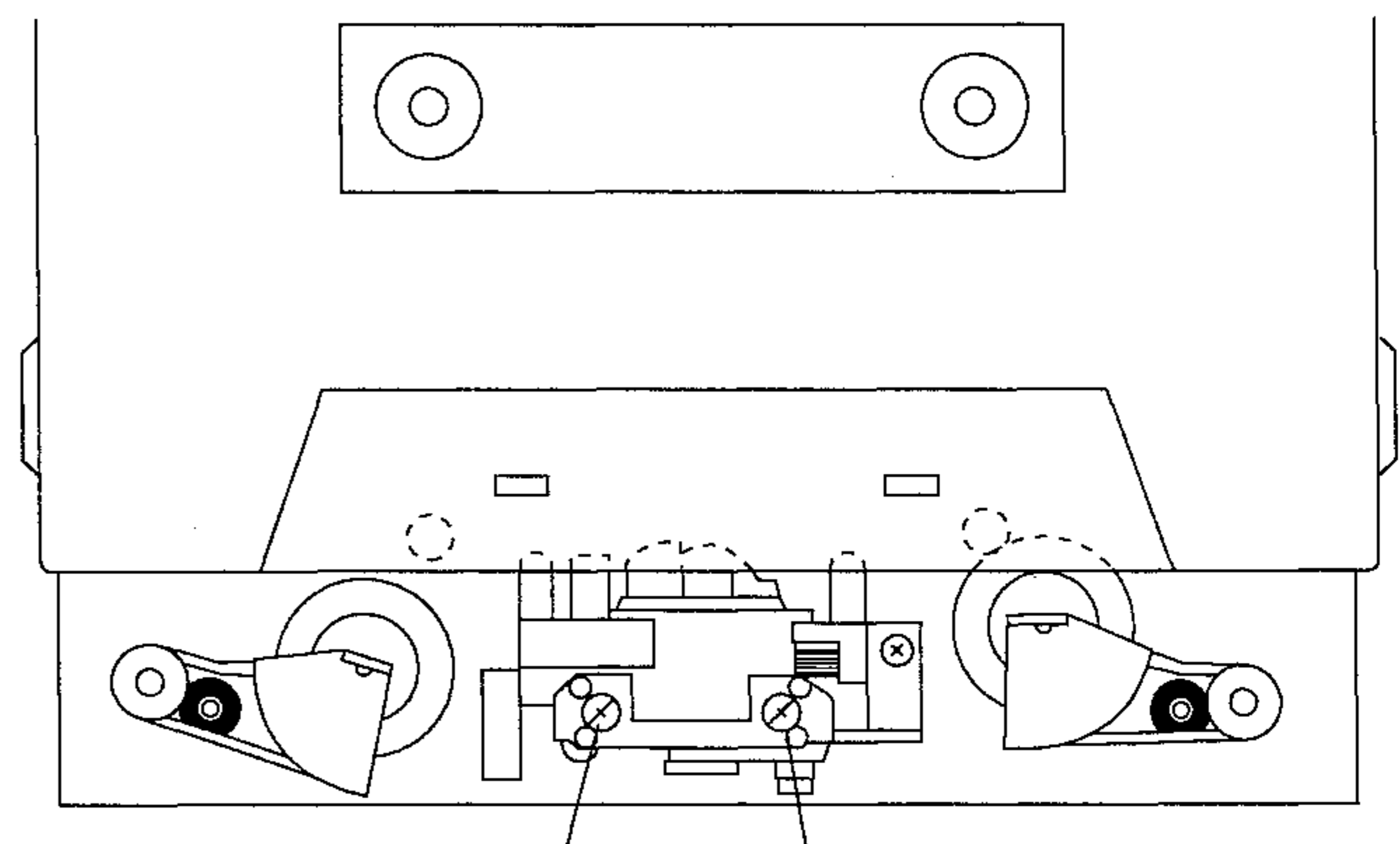

Fig. 2-2 Frequency Characteristics



FWD Azimuth Adjustment Screw REV Azimuth Adjustment Screw

Fig. 2-3 Head Azimuth Adjustment

XR-A800, XR-A700

■ Playback Adjustment

- This unit is equipped with auto tape selector.

1. Head Azimuth Adjustment

- Do not switch between forward and reverse operation with the screwdriver inserted.

Step	Tape Selector (AUTO)	Mode	Input Signal/ Test Tape	Adjusting Points		Measurement Points	Adjustment Value	Remarks
1	AUTO (NORMAL)	PLAY	STD-331E test tape (Playback: 10kHz, -20dB)	Deck I	Head azimuth adjustment screw (Fig. 2-3)	TAPE TEST POINT (L, Rch) (AF Assy)	Max. playback signal level	After adjustment, apply silicon bond to the head azimuth adjustment screw.
				Deck II				

2. Playback Level Adjustment

- Since this adjustment determines playback Dolby NR level, perform it carefully.

Step	Tape Selector (AUTO)	Mode	Input Signal/ Test Tape	Adjusting Points		Measurement Points	Adjustment Value	Remarks
1	AUTO (NORMAL)	PLAY	STD-331E test tape (Playback: 315Hz, 0dB)	Deck I	VR4203 (Lch) VR4204 (Rch)	TAPE TEST POINT (L, Rch) (AF Assy)	- 4.2 dBV	
				Deck II	VR4201 (Lch) VR4202 (Rch)			

Note: Please execute playback level adjustment always in the order of deck I → deck II

When deck I has been adjusted, always adjust deck II also.

■ Recording Adjustment

1. Bias Oscillation Frequency Adjustment

Step	Tape Selector (AUTO)	Mode	Input Signal/ Test Tape	Adjusting Points		Measurement Points	Adjustment Value	Remarks
1	AUTO (NORMAL)	REC	Load the STD-632 test tape and set the recording mode.	Deck I	—————	—————	Oscillation frequency to be 105.0kHz ±2kHz.	When the power is turned ON while the MEMORY button is depressed, the frequency will decrease 2 – 3 kHz.
				Deck II	L4351	Between (A) point in Fig. 2-4 and GND.		

2. Recording Bias Adjustment

Step	Tape Selector (AUTO)	Mode	Input Signal/Test Tape	Adjusting Points		Measurement Points	Adjustment Value	Remarks
1	AUTO (NORMAL)	REC	Input a 315Hz signal to the AUX terminal and set the input selector to AUX.	Deck I	—————	TAPE TEST POINT (L, Rch) (AF Assy)	- 24.2 dBV	
				Deck II	Input signal level			
2	AUTO (NORMAL)	REC → PLAY	Load the STD-632 test tape and record/playback the 315Hz and 10kHz signals. (see the Note below)	Deck I	—————	TAPE TEST POINT (L, Rch) (AF Assy)		Repeat adjustment until playback level of the 10kHz signal is within 0±0.5dB from that of the 315Hz signal.
				Deck II	VR4351 (Lch) VR4352 (Rch)			

Note: Set the 10kHz input signal level to the same value as the 315Hz input signal level of step 1.

3. Recording Level Adjustment

Step	Tape Selector (AUTO)	Mode	Input Signal/Test Tape	Adjusting Points	Measurement Points	Adjustment Value	Remarks
1	AUTO (NORMAL)	REC	Input a 315Hz signal to the AUX terminal and set the input selector to AUX.	Deck I Deck II	Input signal level	TAPE TEST POINT (L, Rch) (AF Assy)	- 8.2 dBV
2	AUTO (NORMAL)	REC → PLAY	STD-632 test tape and record/ playback the 315Hz signal.	Deck I Deck II	— VR4301 (Lch) VR4302 (Rch)	TAPE TEST POINT (L, Rch) (AF Assy)	Repeat recording, playback and adjustment until playback level of the 315Hz signal becomes -8.2dBV.

4. ALC Operation Check

Step	Tape Selector (AUTO)	Mode	Input Signal/Test Tape	Adjusting Points	Measurement Points	Adjustment Value	Remarks
1	AUTO (NORMAL)	REC	Input a 315Hz signal to the AUX terminal and set the input selector to AUX.	Input signal level	TAPE TEST POINT (L, Rch) (AF Assy)	- 8.2 dBV	
2				Set to a level +6 dB above the input level at step 1.		Confirm that the reading is -3.2 ± 2.5 dBV.	

AF ASSY

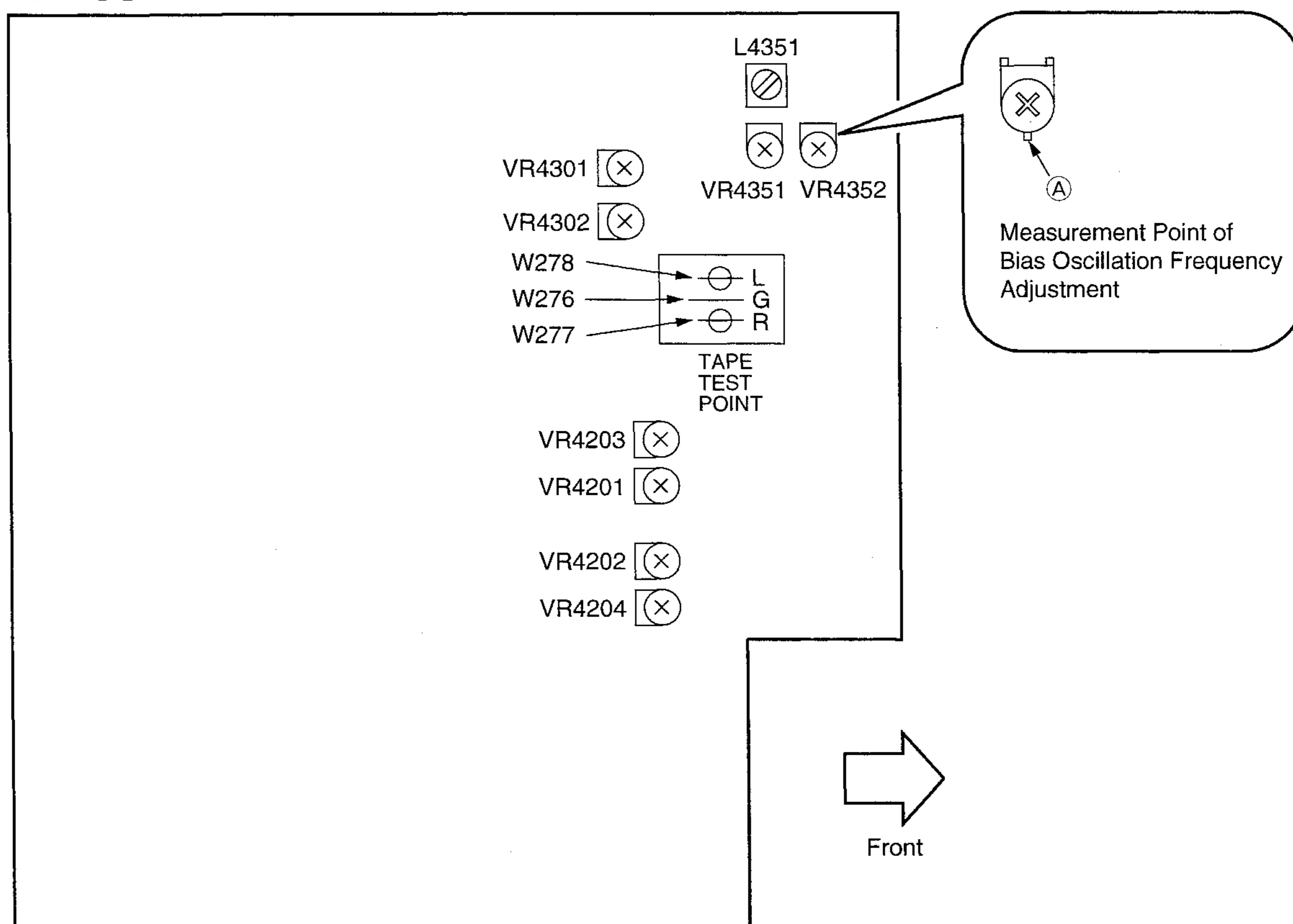

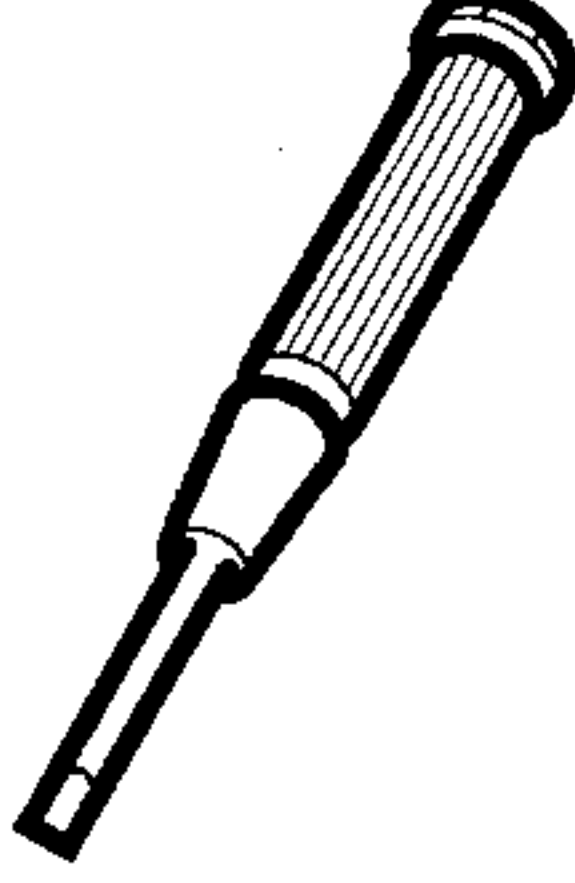
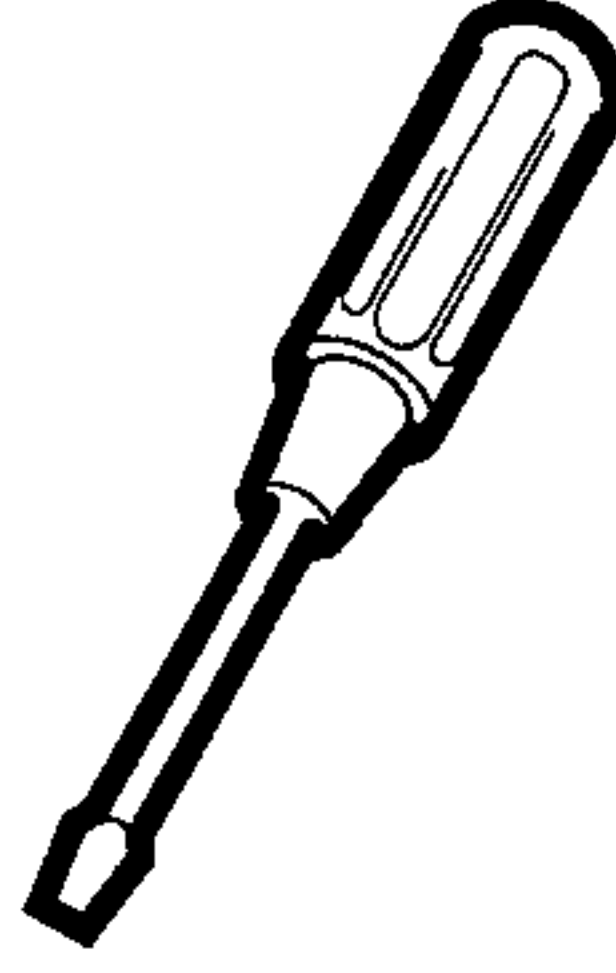
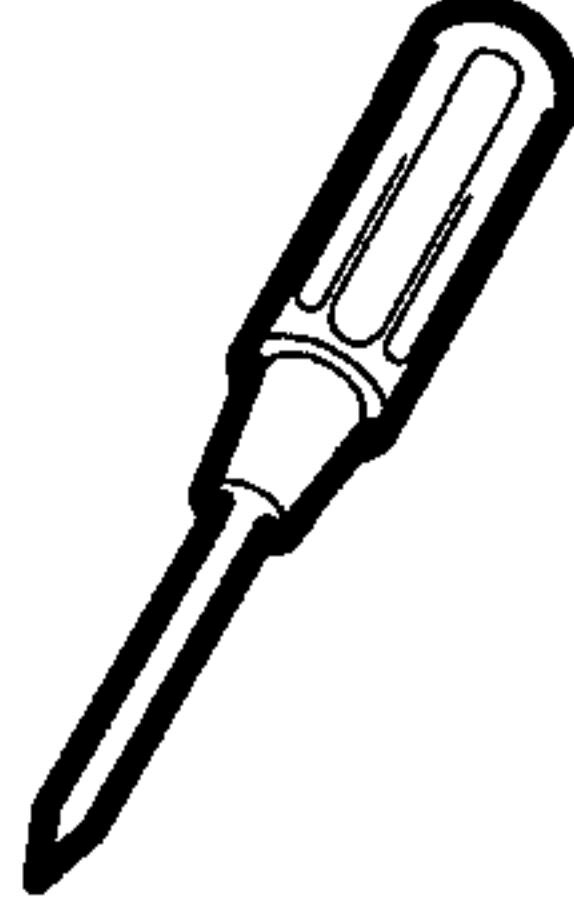
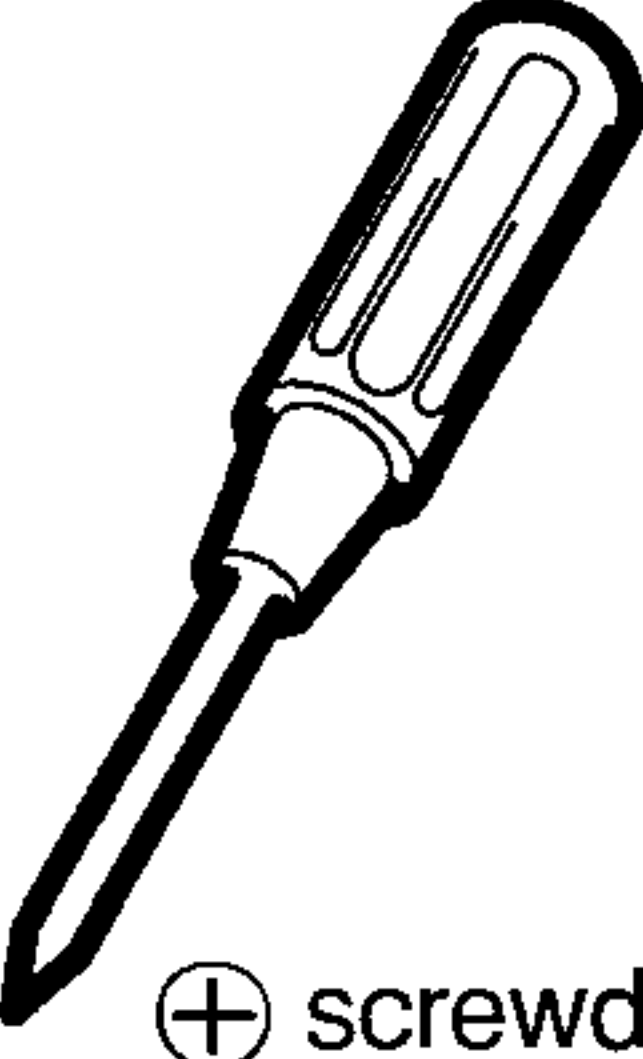
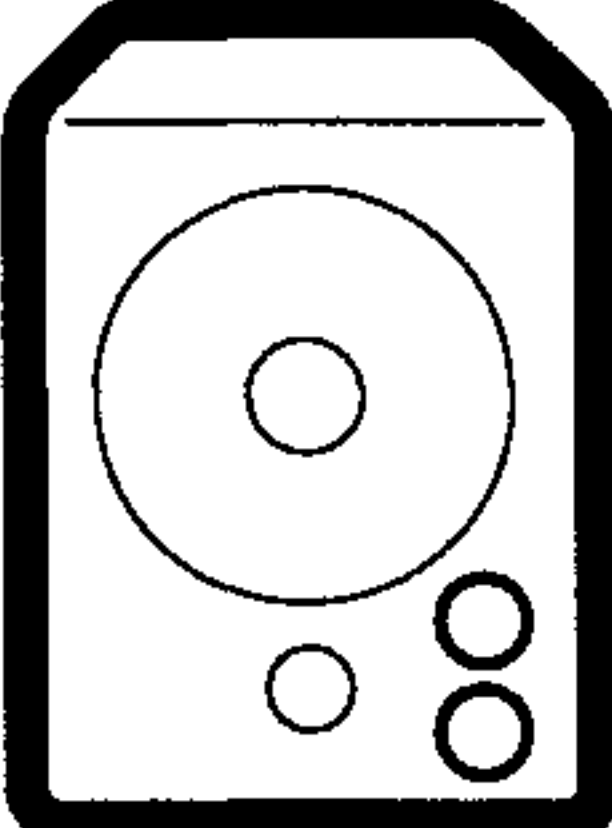
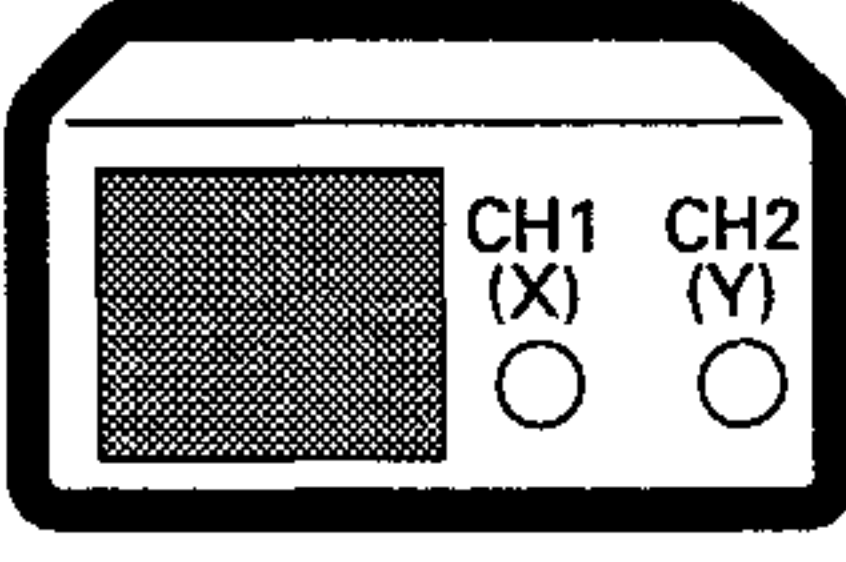
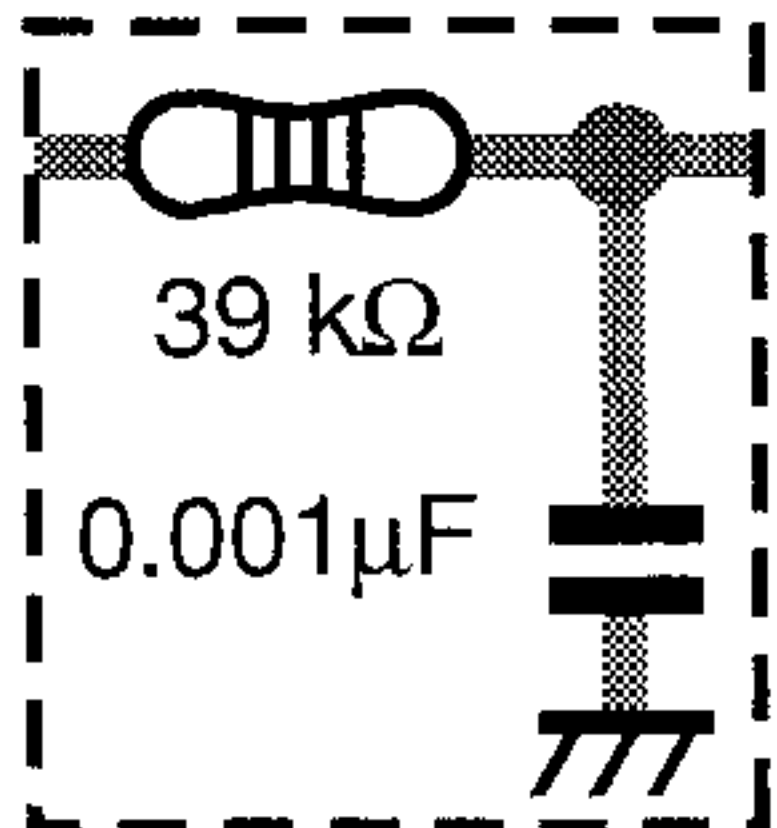

Fig. 2-4 Adjustment and Measurement points

6.3 CD SECTION (CD 部の調整)

1. PREPARATIONS (準備)

1.1 Jigs and Measuring Instruments (使用測定器 / 治工具類)

 <p>CD TEST DISC (YEDS-7)</p>	 <p>⊖ Precise screwdriver</p>	 <p>⊖ screwdriver (small)</p>	 <p>⊕ screwdriver (medium)</p>
 <p>⊕ screwdriver (large)</p>	 <p>Low-frequency oscillator</p>	 <p>Dual-trace oscilloscope (10 : 1 probe)</p>	 <p>Low pass filter (39 kΩ + 0.001μF)</p>

1.2 Necessary Adjustment Points (調整に必要な項目)

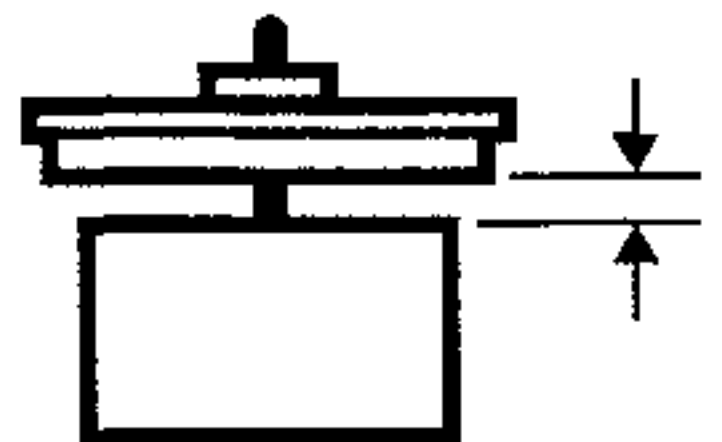
When (このような時)	Adjustment points
Exchange PICKUP (ピックアップを交換した時)	1.2.3.4.5.6. → Page 72—74
Exchange CD ASSY (CD ASSYを交換した時)	1.2.3.4.5.6. → Page 72—74
Exchange SERVO MECH ASSY (サーボメカ ASSYを交換した時)	1.2.3.4.5.6. → Page 72—74
Exchange SPINDLE MOTOR (スピンドルモーターを交換した時)	 ADJ → Page 13

2. ADJUSTMENT (調整)

2.1 How to Start/Cancel Test Mode (テストモードの設定/解除)

TEST MODE: ON

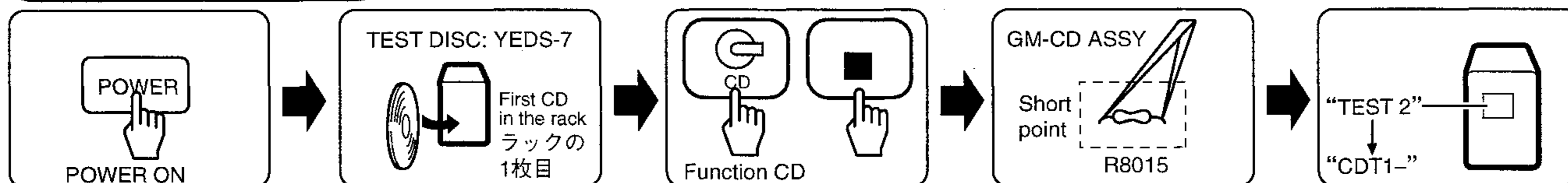

TEST MODE: PLAY

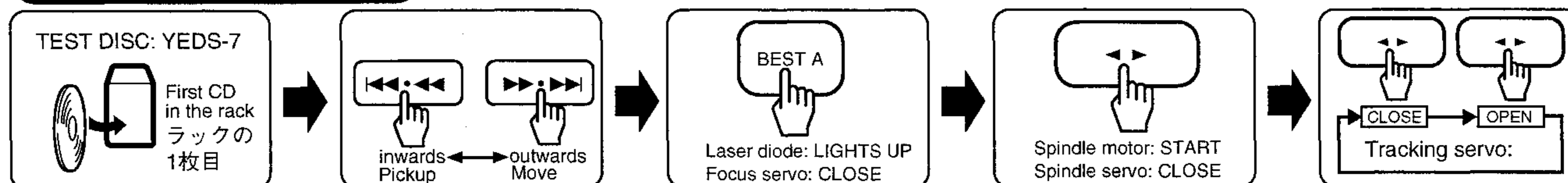

TEST MODE: STOP → CANCEL

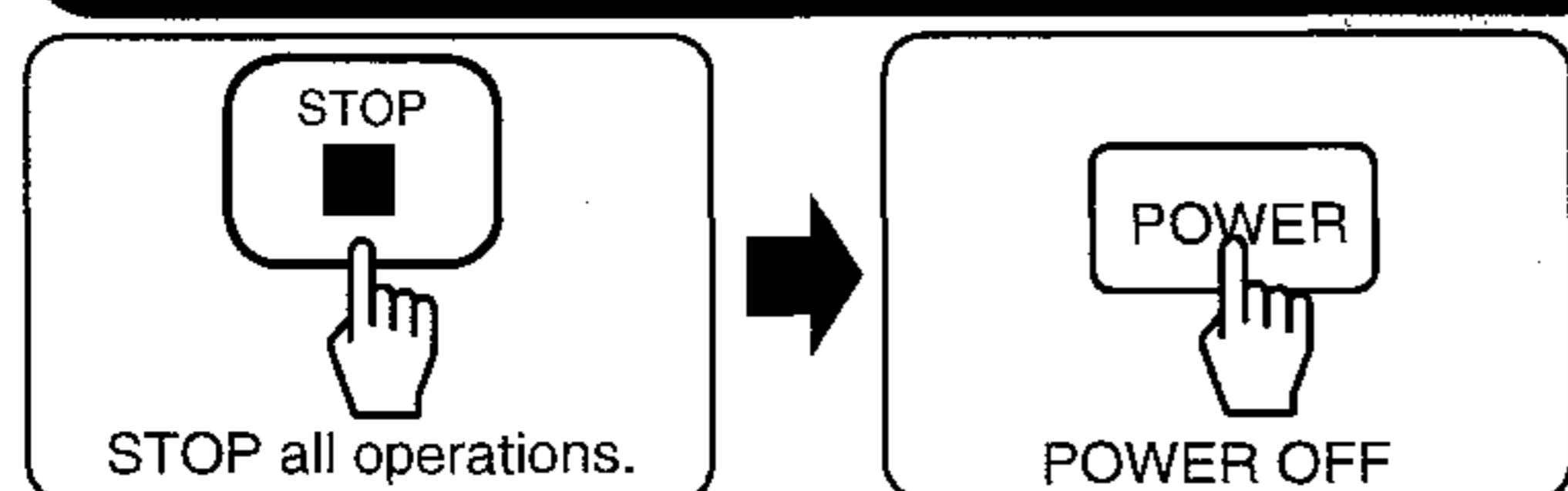

2.2 Adjustment Locations (テストポイントと調整用VRの位置)

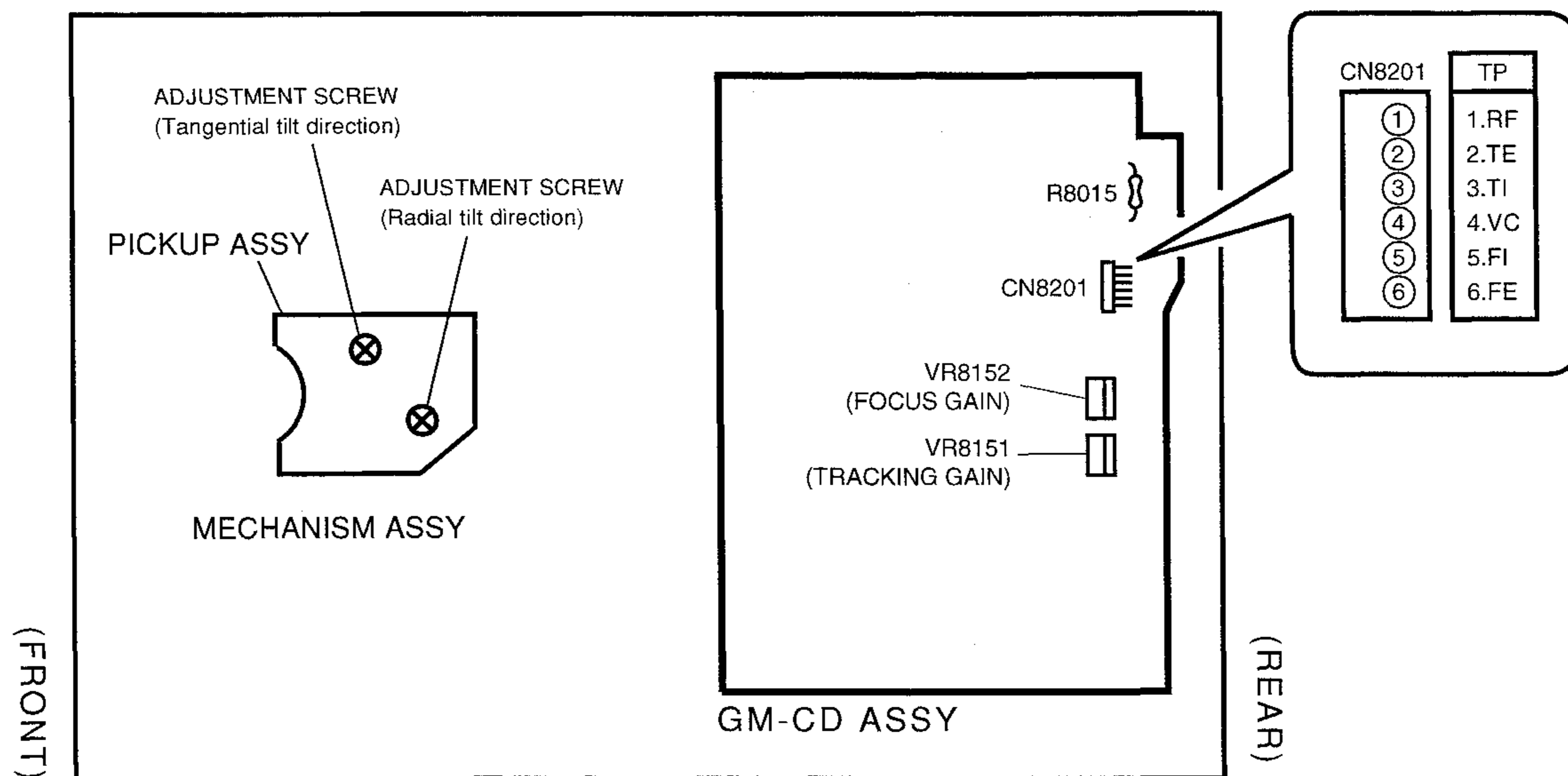

2.3 Check and Adjustment (確認、調整)

1. Focus Offset Check

(フォーカスオフセット確認)

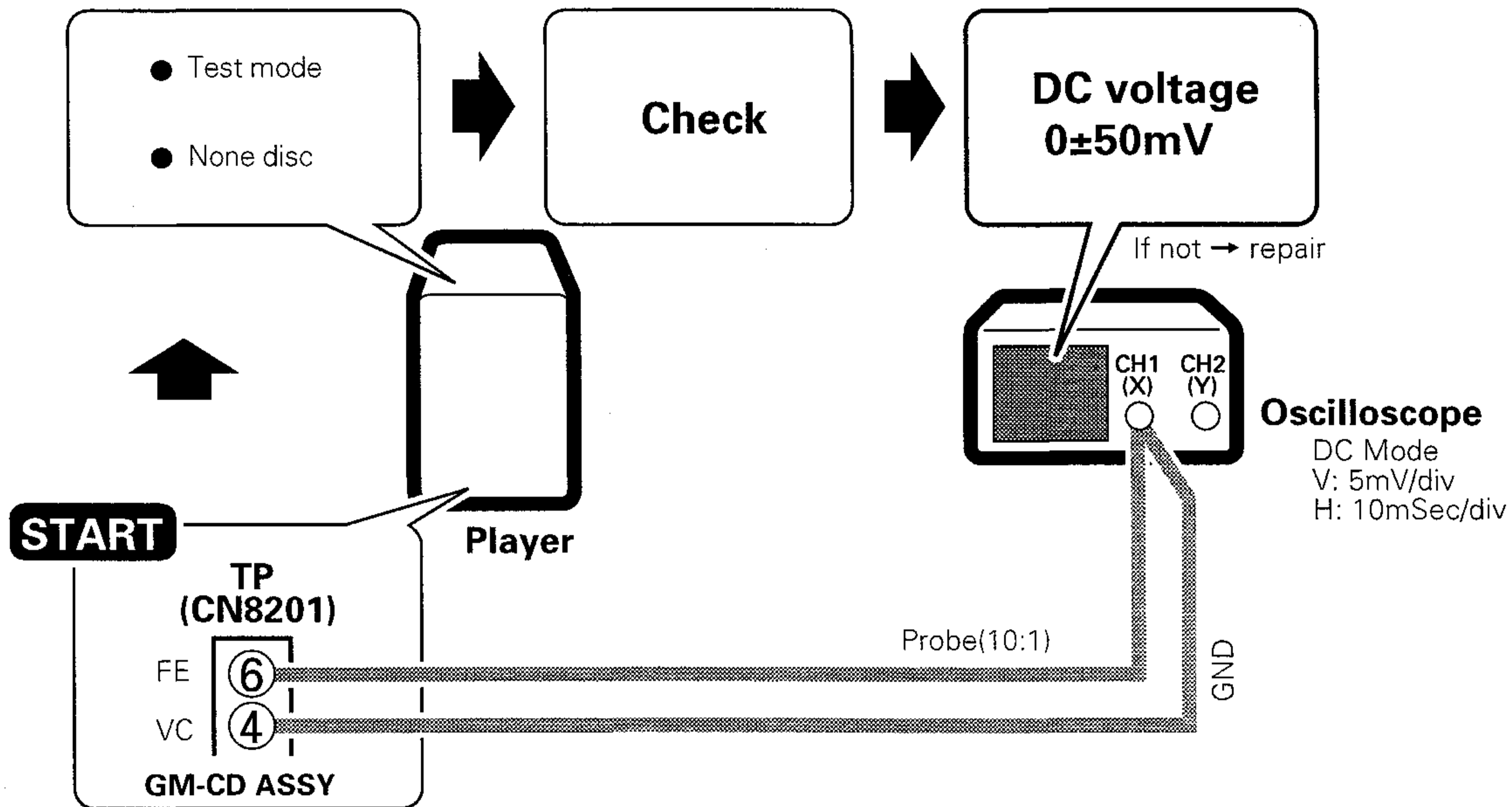

2. Tracking Error Balance Check

(トラッキングエラーバランス確認)

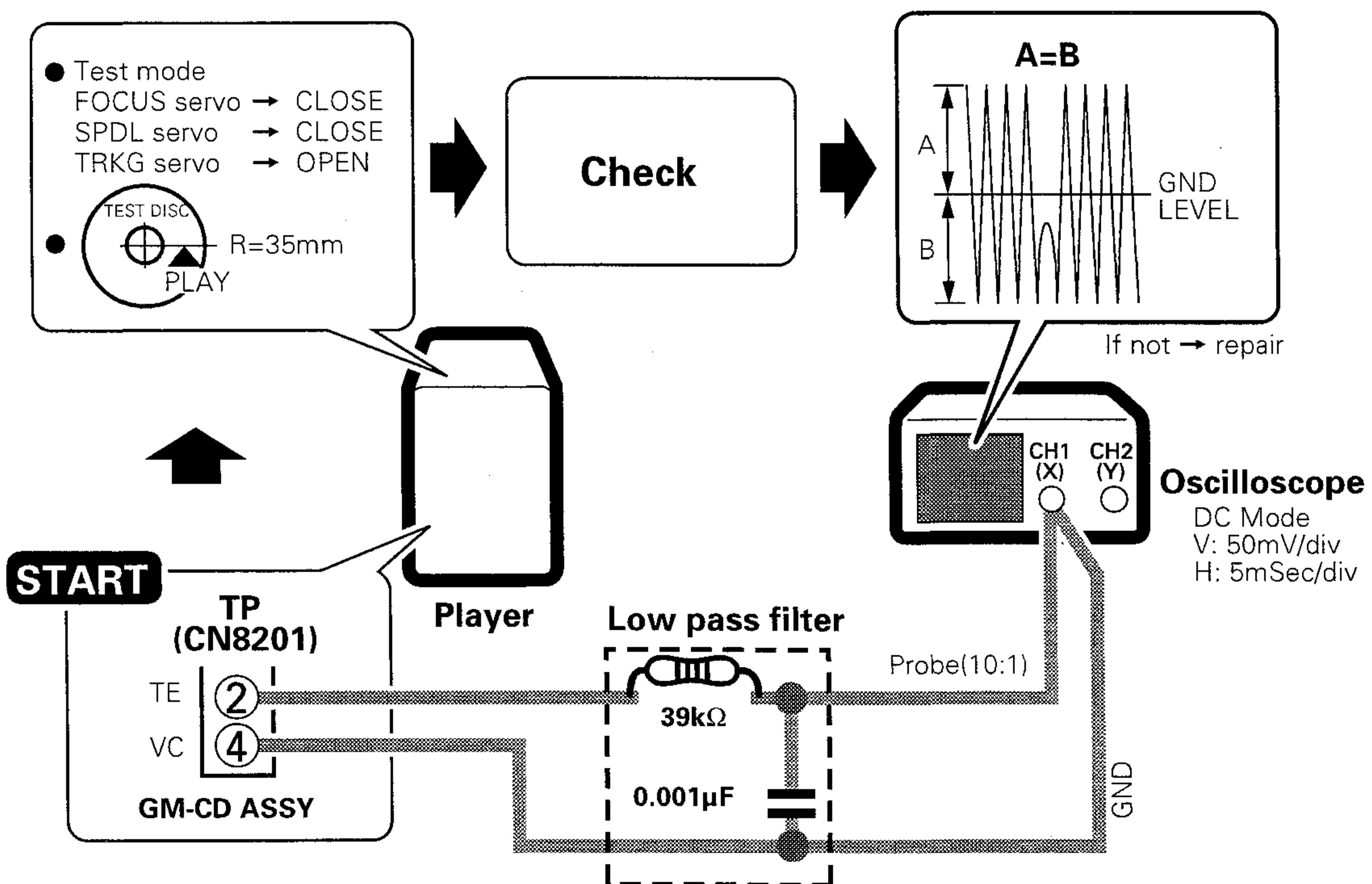

3. PICKUP ①RADIAL / ②TANGENTIAL DIRECTION TILT ADJUSTMENT

(ピックアップ①ラジアル方向②タンジェンシャル方向の傾き調整)

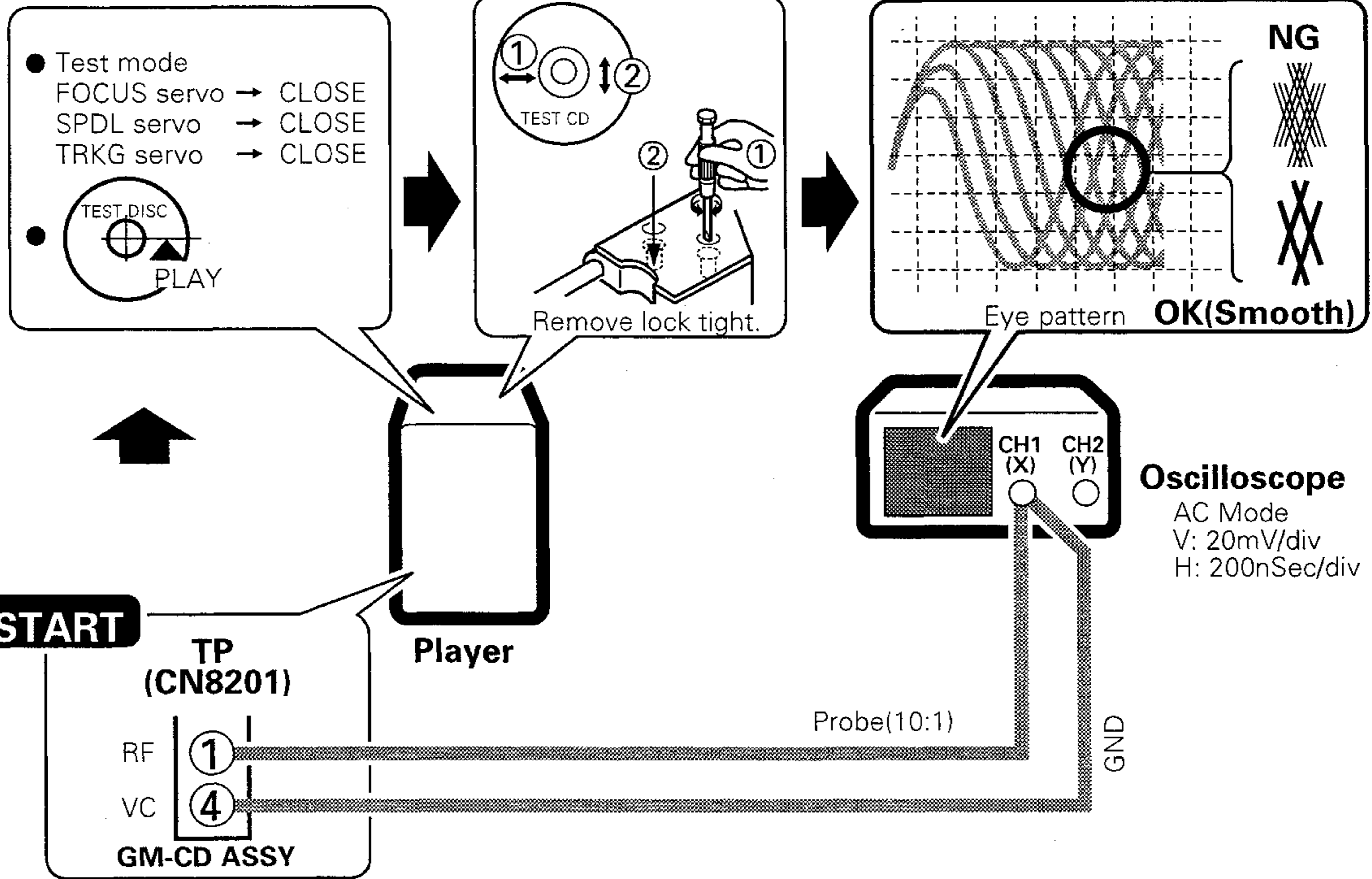

4. RF LEVEL CHECK

(RFレベル確認)

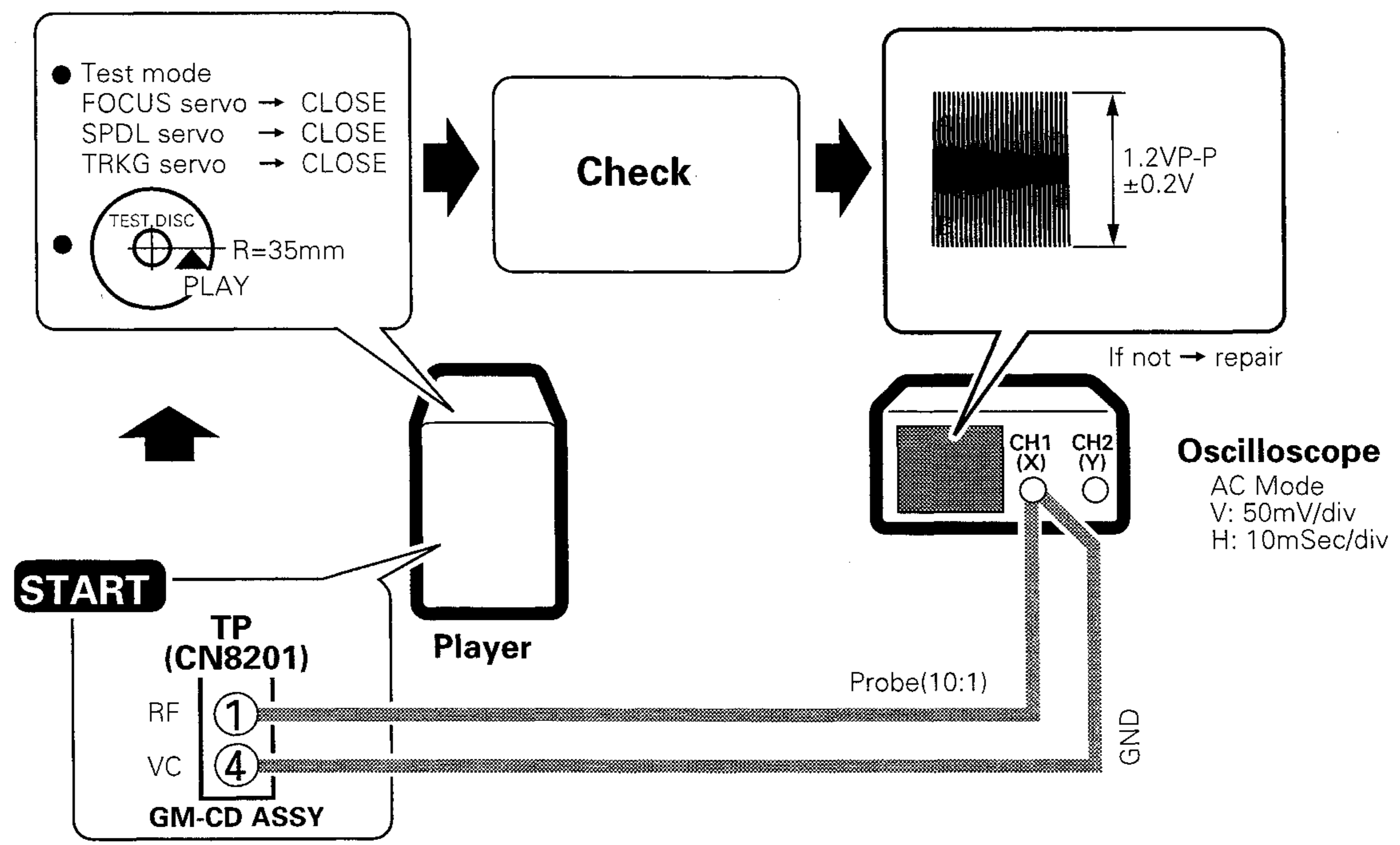

5. Focus Servo Loop Gain Adjustment

(フォーカスサーボループゲイン調整)

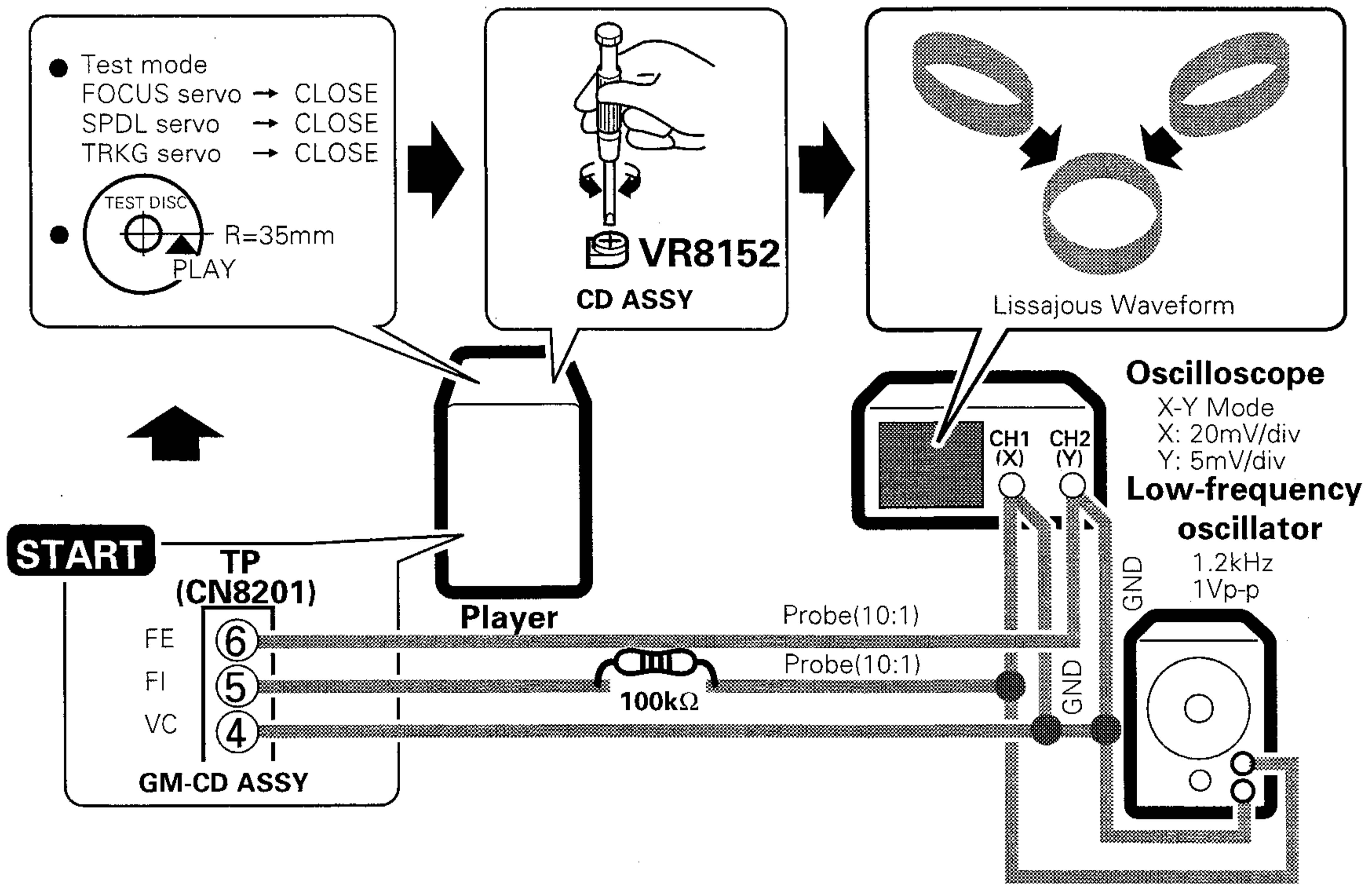

6. Tracking Servo Loop Gain Adjustment

(トラッキングサーボループゲイン調整)

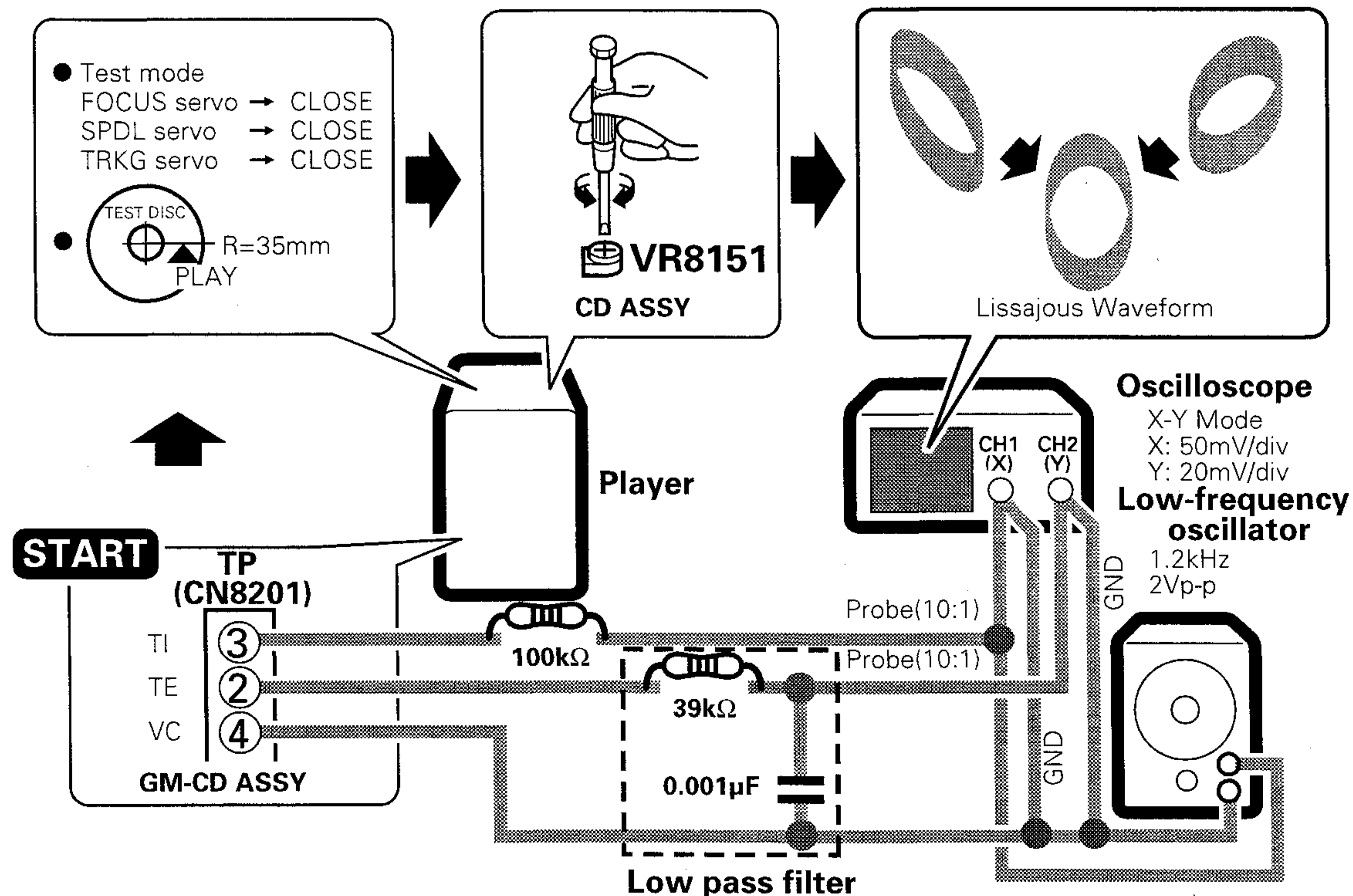

7. GENERAL INFORMATION

7.1 PARTS

7.1.1 IC

■ M51134FP (AF ASSY: IC1009) SUB HARMONIZER (BASS SYNTHESIZER)

● The information shown in the list is basic information and may not correspond exactly to that shown in the schematic diagrams.

● Pin Assignment

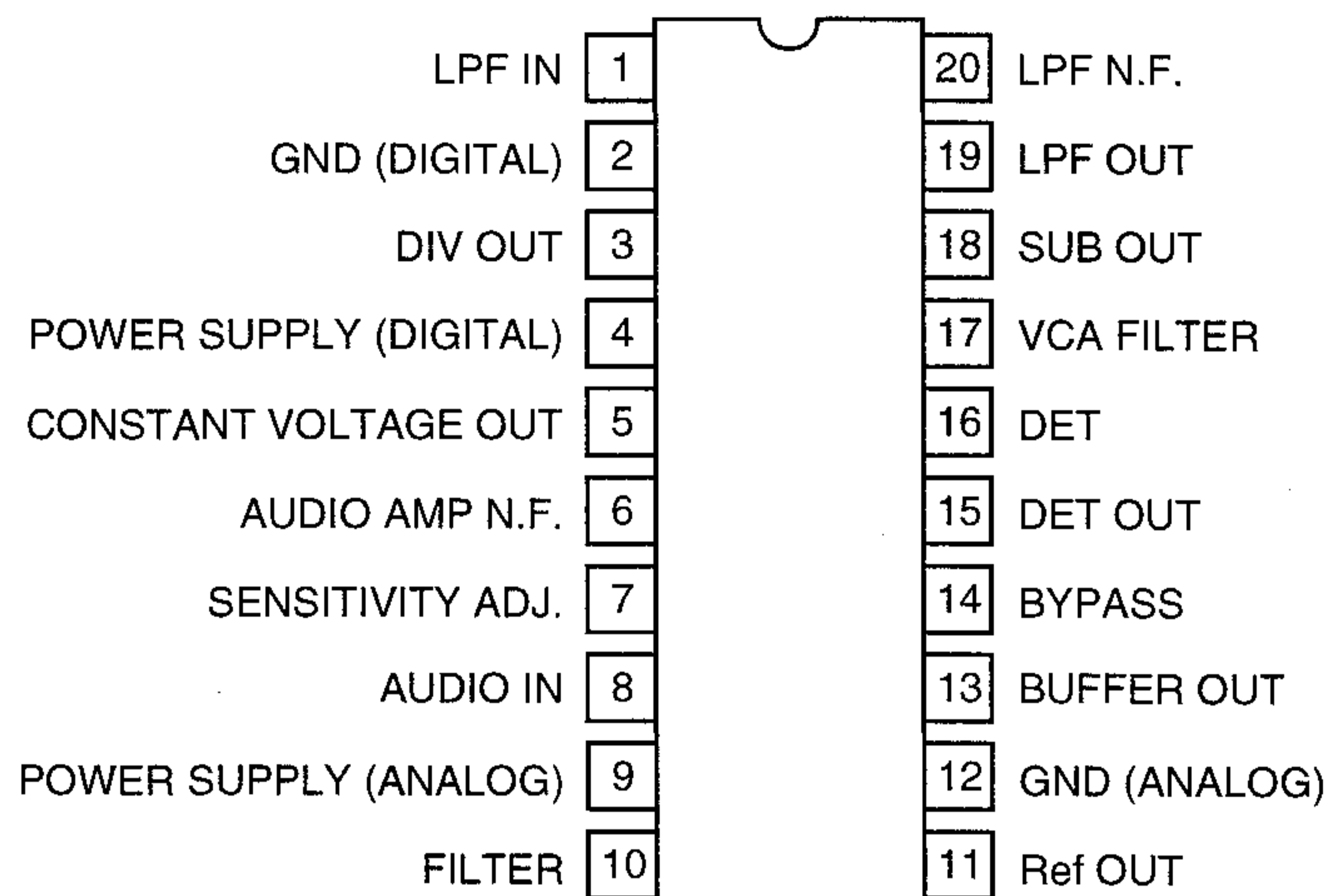

● Block Diagram

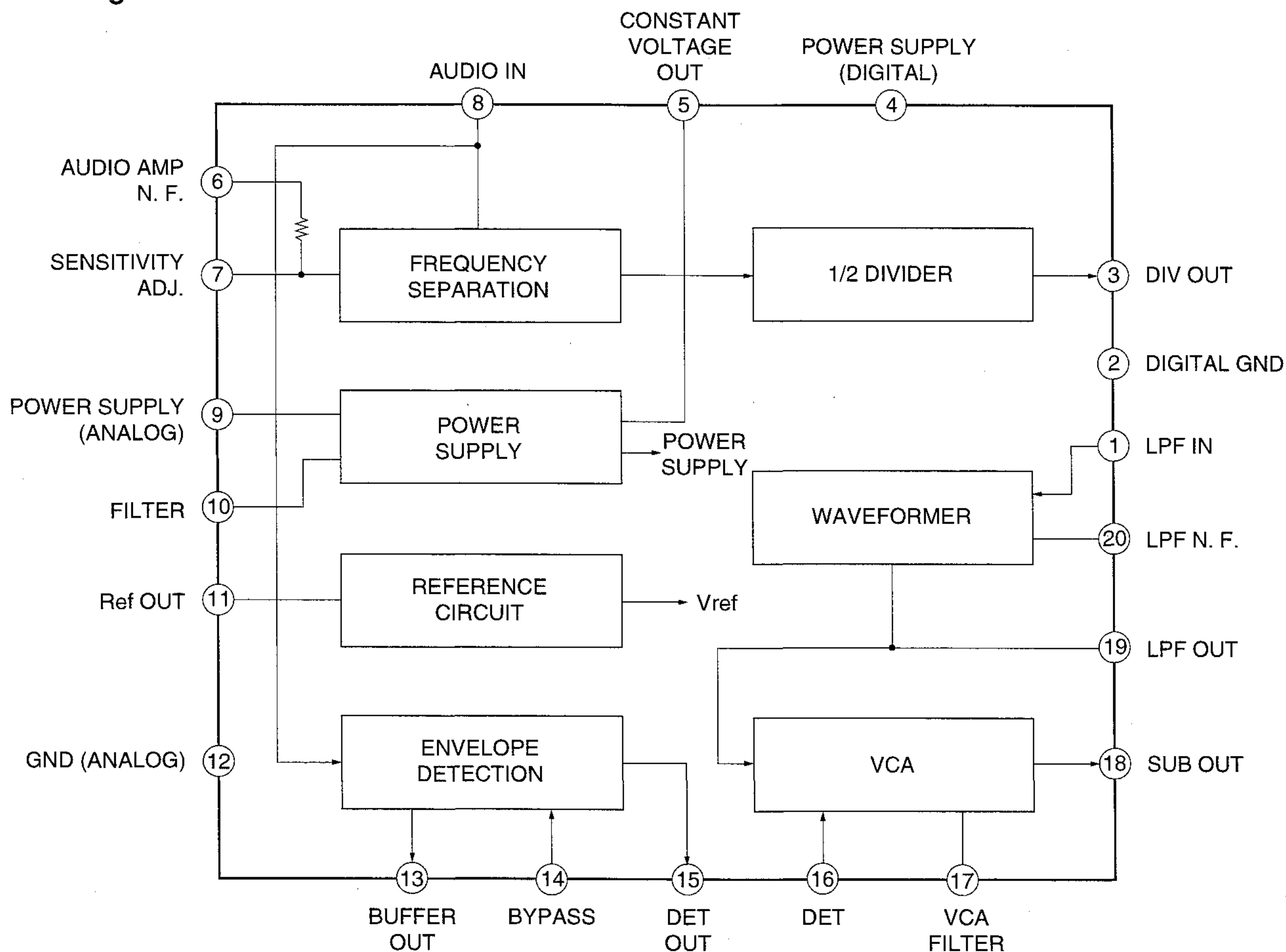

XR-A800, XR-A700

■ PDG205A (DISPLAY ASSY: IC5001) DISPLAY μ -COM

● Pin Function

No.	Function Name	Pin Name	I/O	Function	FL PIN NO.	
1	GA/A1	G2	O	FDP control grid	G16	
2	G0/A0	G1	O		G9	
3	NC	-	-	Not used.		
4	PE0/EC0/INT0	JOG2A	I	Pulse input for jog (for volume control)		
5	PE1/EC1/INT1	JOG2B	I			
6	PE2/INT2	PULSE1	I	Pulse input for deck 1 reel		
7	PE3/INT3/NMI	ACIN	I	AC pulse input (for clock, power supply monitor)		
8	PE4/RMC	RMC	I	Remote control signal input		
9	PE5	PULSE2	O	Pulse input for deck 2 reel		
10	PE6/PMW	M62429CLK	O	Clock output of the base synthesizer volume control IC M62429		
11	PE7/TO/ADJ	25HCLK	O	LC7570 clock output		
12	PC0/KR0	KI1	I	Key scan return input		
13	PC1/KR1	KI2	I			
14	PC2/KR2	KI3	I			
15	PC3/KR3	KI4	I			
16	PC4/KR4	KI5	I			
17	PC5/KR5	HPIN	I	Headphone detection H:IN		
18	PC6/KR6	JOG4A	I	Pulse input for jog (multi amplifier, woofer level)	XR-A700 I/O:Output "L" fixed.	
19	PC7/KR7	JOG4B	I			
20	PB0/CINT	JOG3A	I	Pulse input for jog (multi amplifier, P.BASS)		
21	PB1/CS0	JOG3B	I			
22	PB2/SCK0	DISPCLK	I	Serial clock input for CD tuner microprocessor display		
23	PB3/SI0	DISPDATA	I	Serial data input for CD tuner microprocessor display		
24	PB4/SO0	SBCLK	I/O	System bus serial clock input/output		
25	PB5/SCK1	SBDATA	O	System bus serial data output		
26	PB6/SI1	EXCLK	O	(LC75394NED, BU4094BCF) clock output		
27	PB7/SO1	EXDATA	O	(LC75394NED, BU4094BCF, M62429) data output		
28	AV _{REF}	AVREF	I	A/D converter reference voltage input		
29	PA0/AN0	SPAIN	I	Spectrum analyzer signal input		
30	PA1/AN1	KEYIN	I	Key scan input for multi amplifier (AD)	XR-A700 I/O:Output "L" fixed.	
31	PA2/AN2	MS	I	Deck MS signal input		
32	PA3/AN3	TEMP	I	Temperature detection		
33	PA4/AN4	25HDATA	O	LC7570 data output		
34	PA5/AN5	CDR/E	I/O	System bus CD communication request/enable. H:Request waiting L:Enable.		
35	PA6/AN6	JOG1A	I	Pulse input for jog (AD) (multi/MORPHING)		
36	PA7/AN7	NC	-	Not used.		
37	AV _{SS}	AVSS	-	A/D converter GND		
38	RST	RESET	I	CPU reset input. L: Reset H: -.		
39	EXTAL	XTAL	I	Connected to 8 MHz Ceramic resonator.		
40	XTAL	XTAL	O			
41	V _{SS}	D.GND	-	GND		
42	TX	NC	O	Not used.		
43	TEX	TEX	I	Not used.		
44	V _{DD}	Vdd	-	Positive power supply		
45	V _{FDP}	VFDP	-	Negative power supply for FL display		
46	PD0/A55	EVOL CE	O	Main volume control IC LC75394NED strobe output		
47	PD1/A54	PCONT	O	Power control		
48	PD2/A53	SOL2	O	Deck 2 solenoid control		
49	PD3/A52	SOL1	O	Deck 1 solenoid control		
50	PD4/A51	FLWR	O	LC7570 strobe output		

No.	Function Name	Pin Name	I/O	Function	
51	PD5/A50	LED2 STB	O	LED control IC BU4094BCF strobe output (2)	
52	PD6/A49	LED1 STB	O	LED control IC BU4094BCF strobe output (1)	
53	PD7/A48	DECKSTB2	O	Deck signal control IC BU4094BCF strobe output (2)	
54	PF0/A47	25HSTB	O	XR-A800: Control IC (BU4094BCF) strobe output/XR-A700:AF MUTE control L:ON	
55	PF1/A46	MOTOR	O	Deck motor control. H:ON.	
56	PF2/A45	SPAC	O	BA3835F output select control	
57	PF3/A44	SPAB	O		
58	PF4/A43	SPAA	O	XR-A800:BA3834F	
59	PF5/A42	PBMUTE	O	Deck playback mute control. H:Mute.	
60	PF6/A41	NC	O	Not used.	
61	PF7/A40	SPRY	O	Speaker relay control. H:Relay ON.	
62	PG0/A39	S24	O	FL display control anode	FL PIN NO. S17
63	PG1/A38	S23	O		S5
64	PG2/A37	S22	O		S6
65	PG3/A36	S21	O		S18
66	PG4/A35	S20	O		S19
67	PG5/A34	S19	O		S20
68	PG6/A33	S18	O		S21
69	PG7/A32	S17	O		S15
70	PH0/A31	S16	O		S4
71	PH1/A30	S15	O		S14
72	PH2/A29	S14	O		S16
73	PH3/A28	S13	O		S9
74	PH4/A27	S12/K04	O		FL display control anode/Key scan output
75	PH5/A26	S11/K03	O	S22	
76	PH6/A25	S10/K02	O	S23	
77	PH7/A24	S9/K01	O	S24	
78	A23	S8/K08	O	S2	
79	A22	S7/L07	O	S1	
80	A21	S6/K06	O	S12	
81	A20	S5/K05	O	S3	
82	A19	S4	O	FL display control anode	
83	A18	S3	O		S11
84	A17	S2	O		S8
85	A16	S1	O		S7
86	G15/A15	G16	O	FL display control grid	FL PIN NO. G8
87	G14/A14	G15	O		G7
88	G13/A13	G14	O		G6
89	V _{DD}	Vdd	-	Positive power voltage supply	
90	G12/A12	G13	O	FL display control grid	FL PIN NO. G5
91	G11/A11	G12	O		G4
92	G10/A10	G11	O		G3
93	G9/A9	G10	O		G2
94	G8/A8	G9	O		G1
95	G7/A7	G8	O		G10
96	G6/A6	G7	O		G11
97	G5/A5	G6	O		G12
98	G4/A4	G5	O		G13
99	G3/A3	G4	O		G14
100	G2/A2	G3	O		G15

XR-A800, XR-A700

7.1.2 DISPLAY

■ AAV7043 (SUB DISPLAY ASSY: V7001)

● External Dimensions

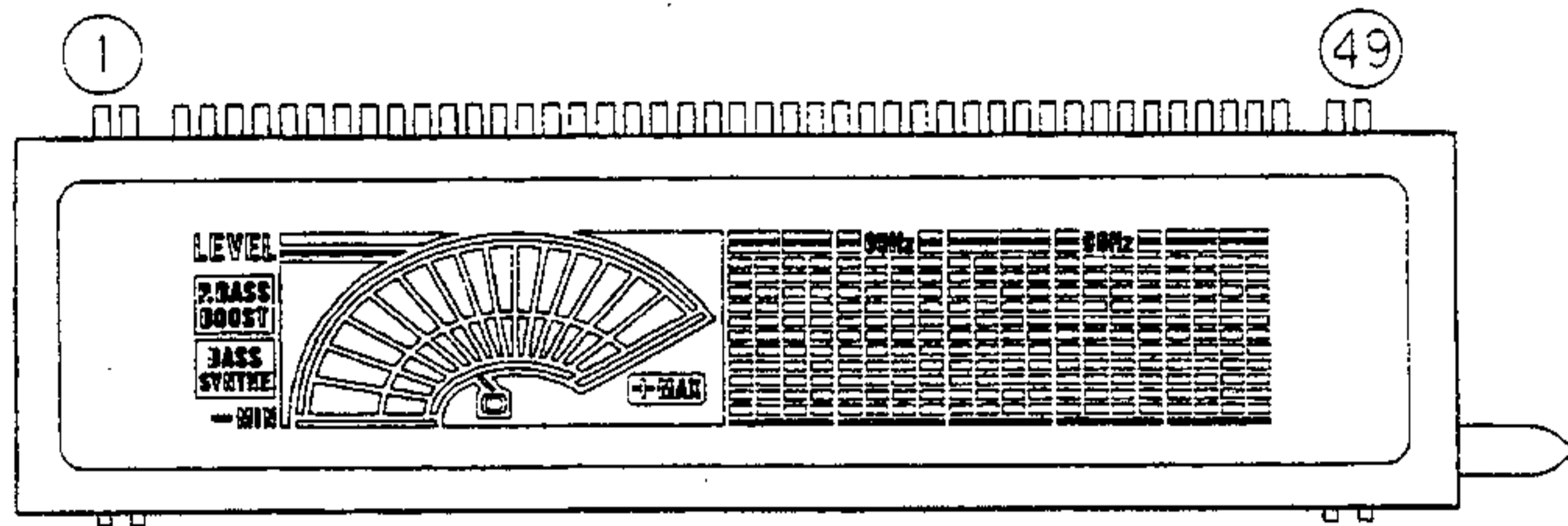

● Display Pattern

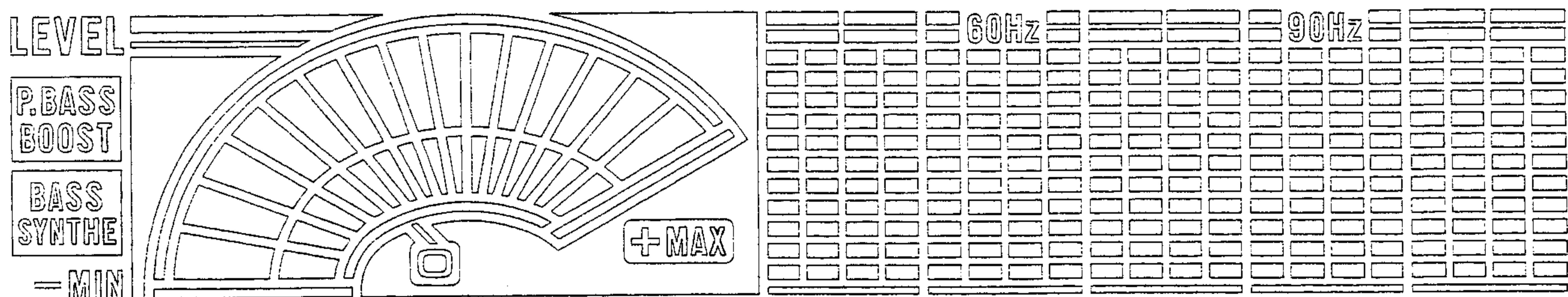

● Anode and Grid Assignment

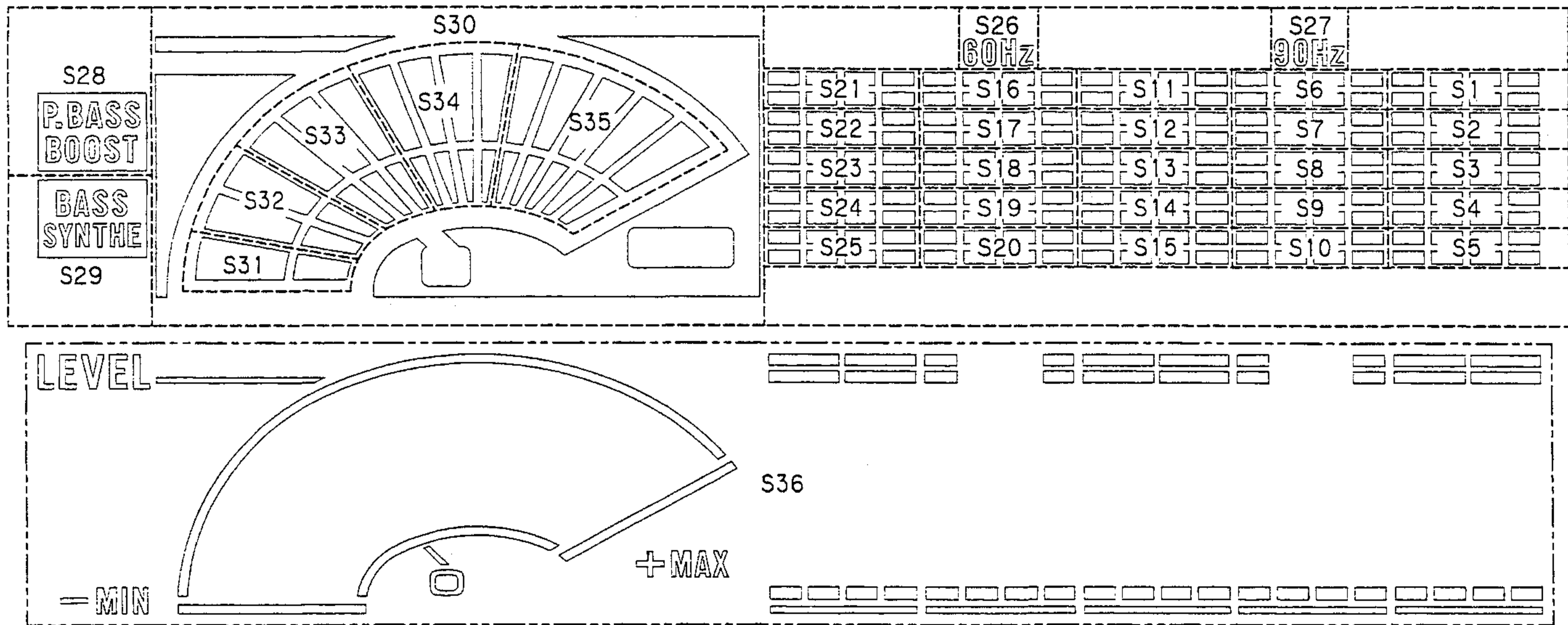

● Pin Assignment

Pin No.	1	2	3	4	5	6	7	8	9	10	11	12	13	14	15	16	17	18	19	20	21	22	23	24	25
Assignment	F1	F1	NP	NL	G	S36	S35	S34	S33	S32	S31	S30	S29	S28	S27	S26	NL	NL	NL	NL	S25	S24	S23	S22	S21

Pin No.	26	27	28	29	30	31	32	33	34	35	36	37	38	39	40	41	42	43	44	45	46	47	48	49
Assignment	S20	S19	S18	S17	S16	S15	S14	S13	S12	S11	S10	S9	S8	S7	S6	S5	S4	S3	S2	S1	NL	NP	F2	F2

F1, F2: Filament G: Grid S1-S36: Anode NP: No Pin NL: No Lead

7.2 DIAGNOSIS

7.2.1 DISASSEMBLY

- Cassette deck mechanism unit: Diagnosis and replacement → Remove the front panel. (Refer to "Removing the Front Panel".)
- Power amplifier: Diagnosis and replacement → Remove the rear panel. (Refer to "Removing the AMP ASSY".)
- CD (GS) mechanism ASSY: Diagnosis → Remove the rear panel.
Replacement → Remove the rear panel, and remove the whole sub chassis. (Refer to "Removing the CD Mechanism Block".)

■ Removing the Front Panel

1. Remove the bonnet case.

4. Remove link A.

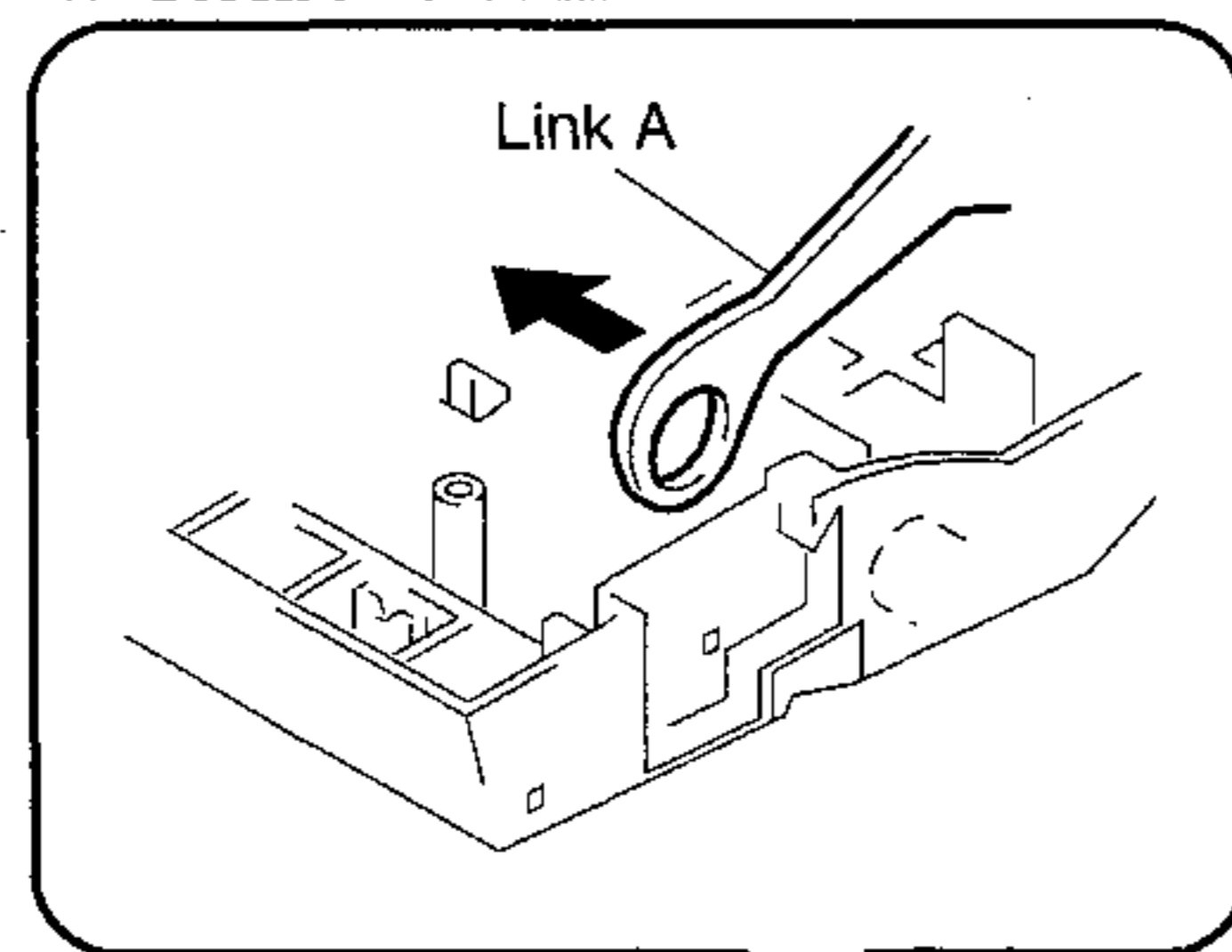

2. Open the CD door.

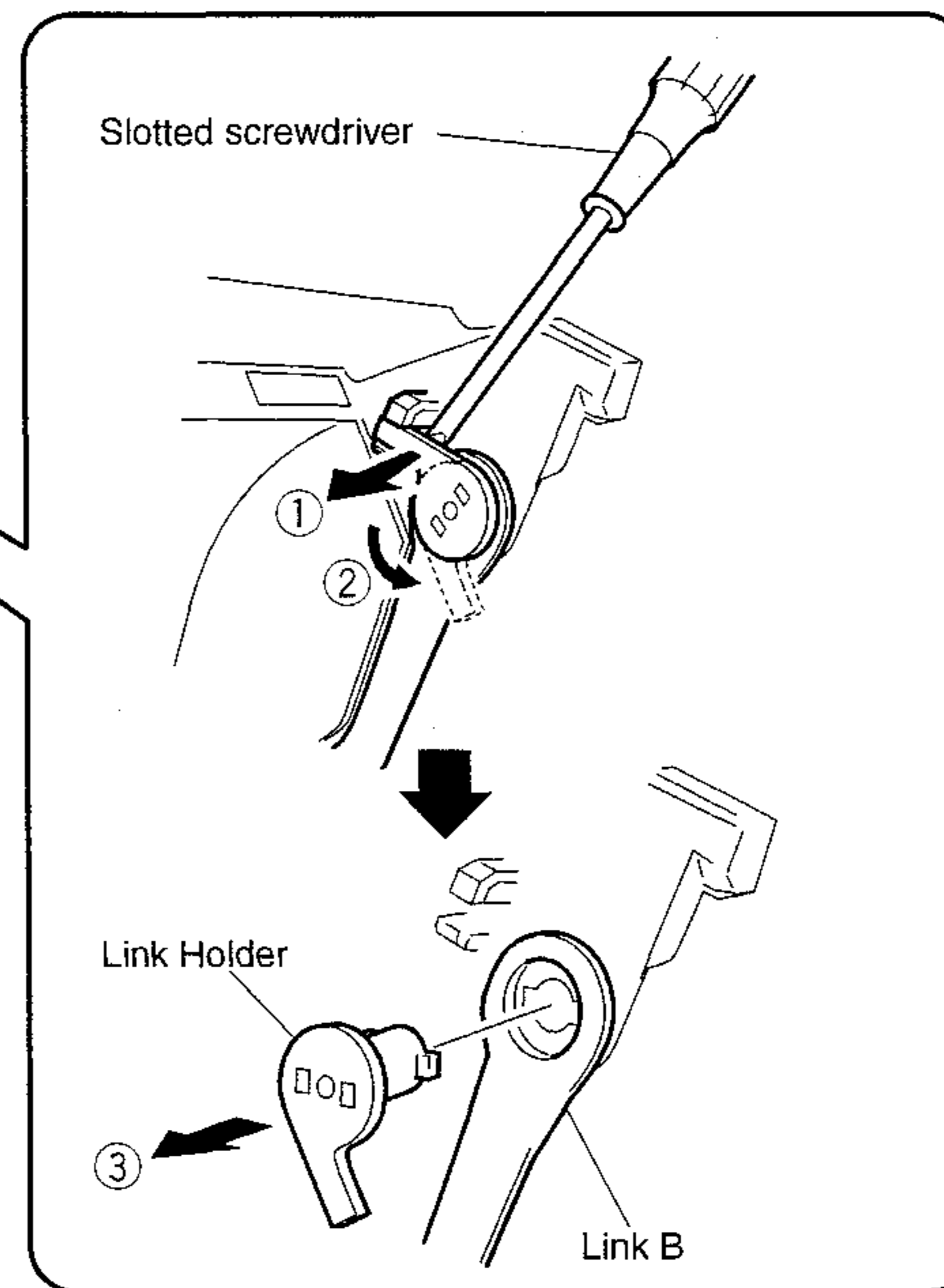
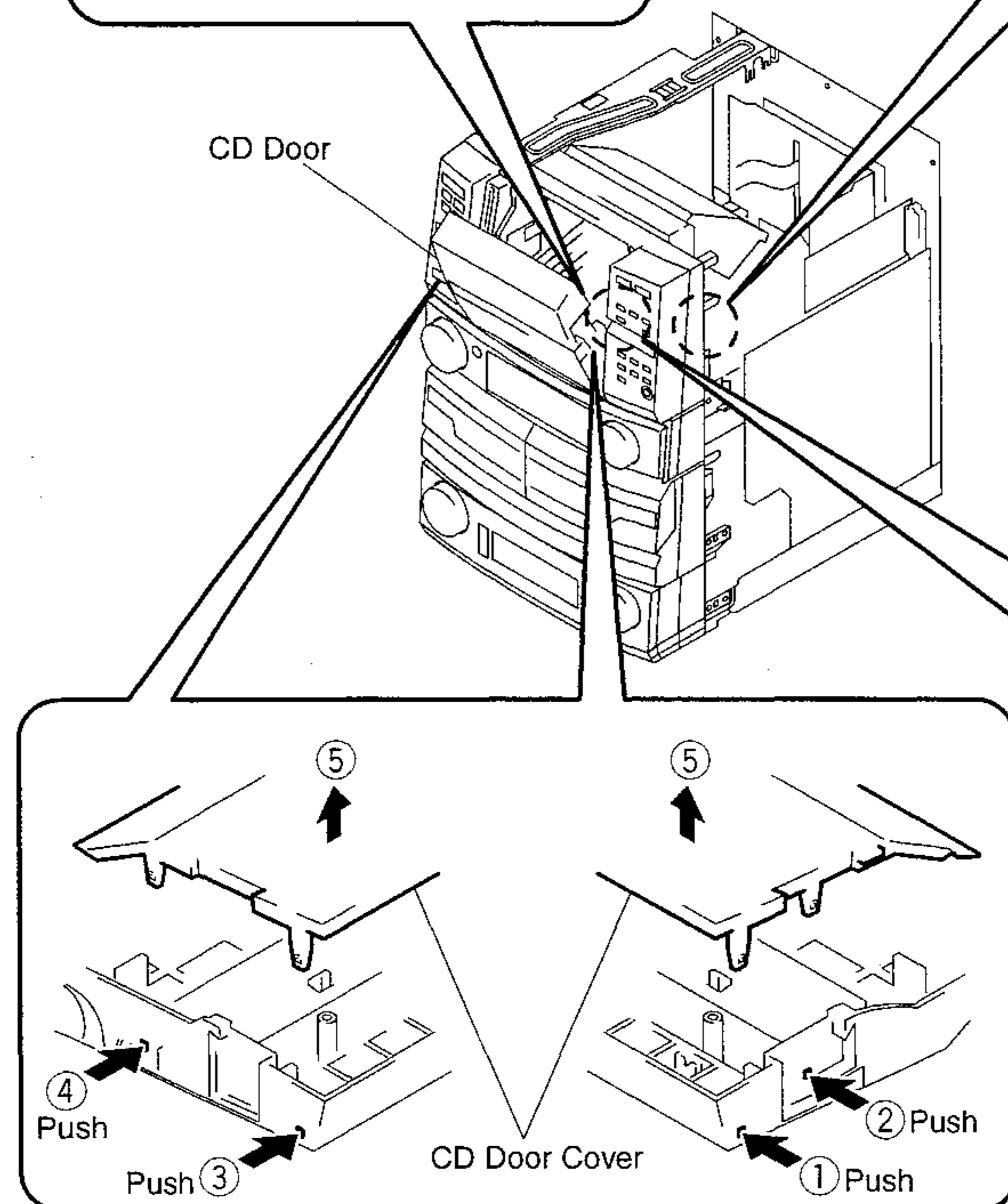
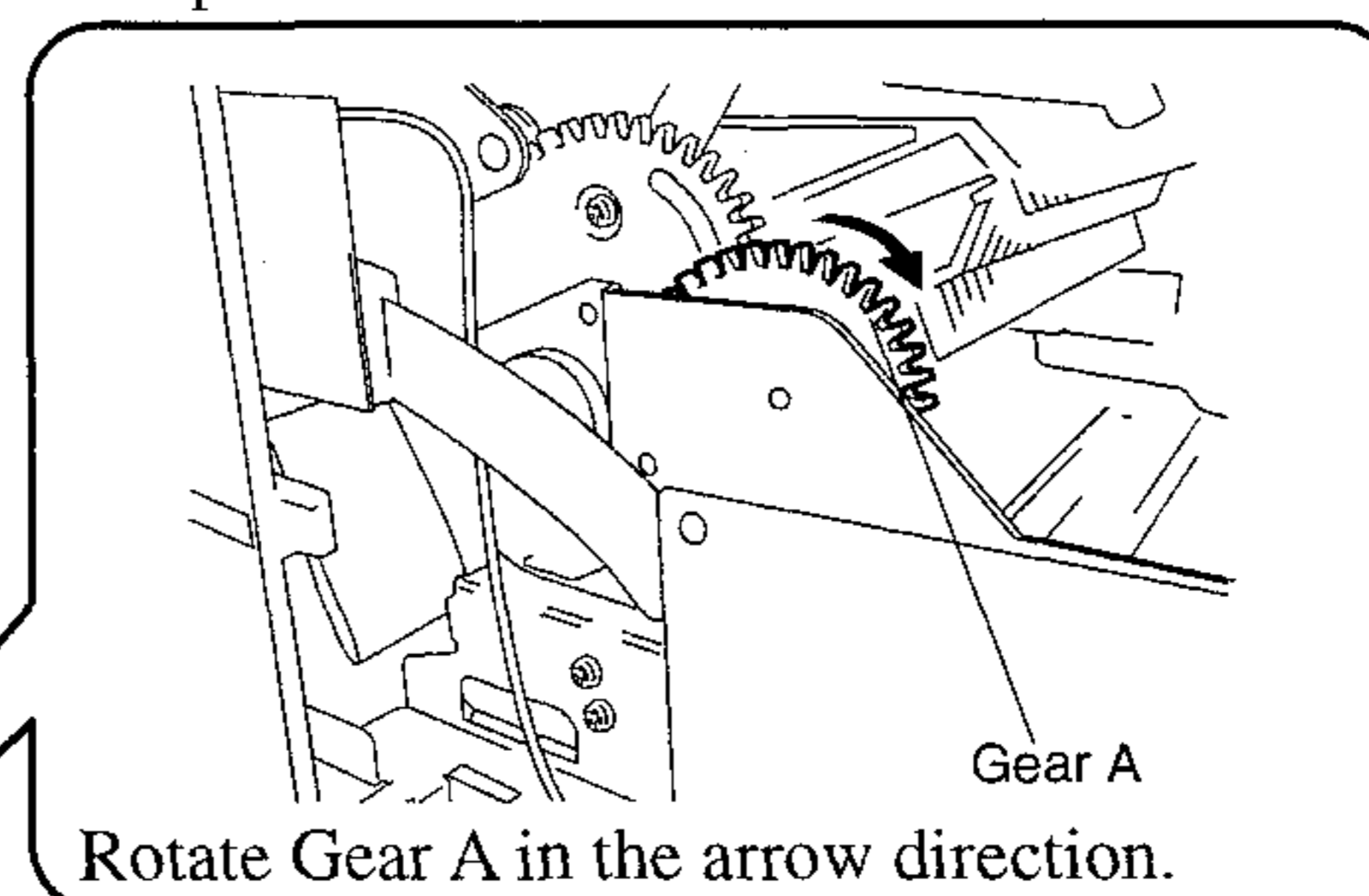

3. Remove the CD door cover.
6. Remove screws ① to ④, the rivet, and the parallel jumper wire.

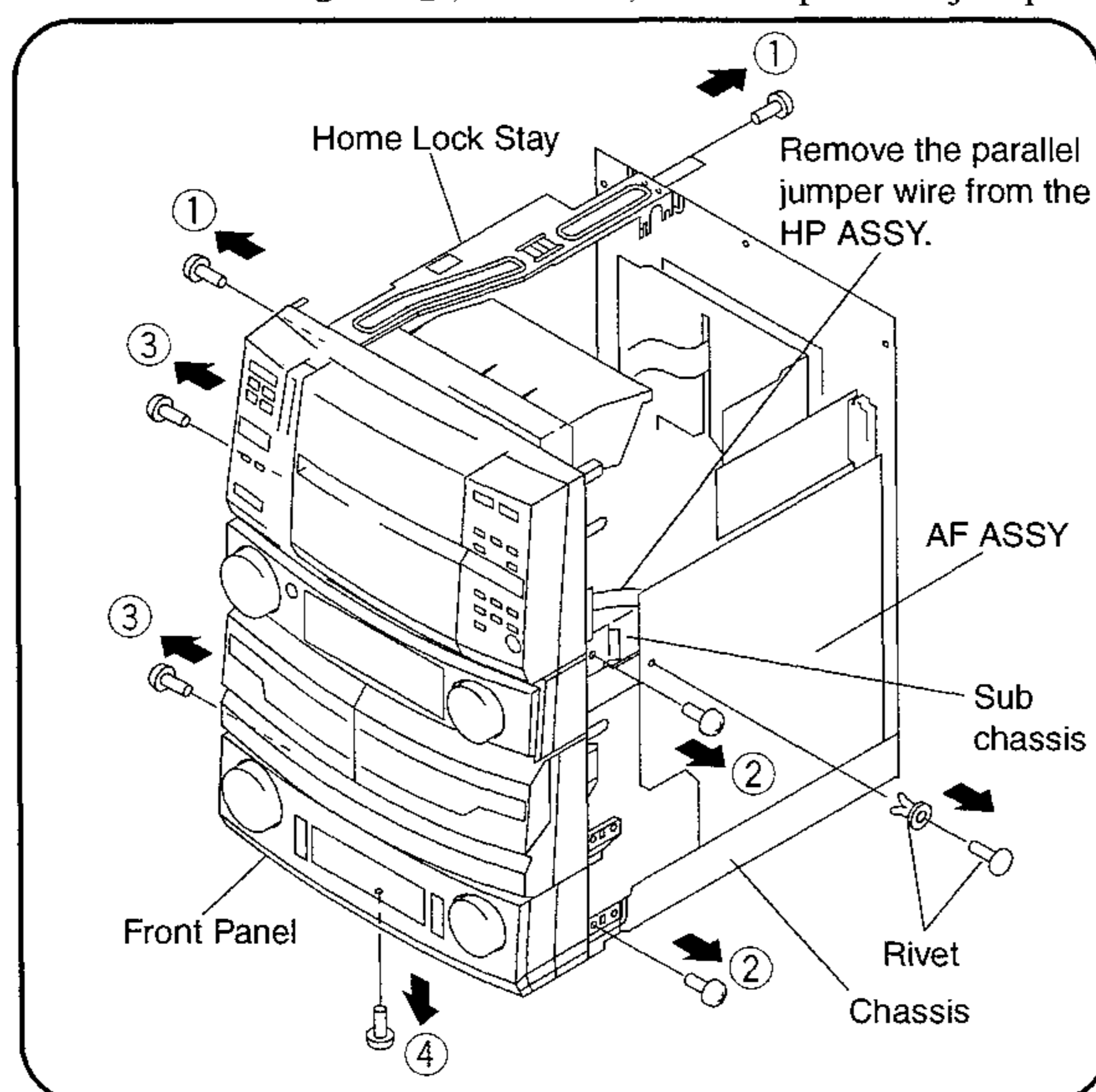

5. Remove the link folder and link B.

7. Pull out the front panel from the chassis and sub chassis.

NOTE: In this state, the operations of the cassette deck can be checked.

Perform the following to replace the cassette deck mechanism unit.

8. Remove the 3P connector of Deck I and 5P connector of Deck II.
9. Remove the flat cable (28P FFC) from the AF ASSY.
10. Remove the cassette deck mechanism unit from the front panel. (For XR-A800, remove the mechanism shield at the bottom of the cassette deck mechanism unit as well.)

■ Removing the AMP ASSY

1. Remove the bonnet.
2. Remove the home lock stay.
(Refer to "Removing the Front Panel".)
3. Remove the rear panel (remove the nine screws ③), and remove the rivet lock of the GM-CD ASSY.

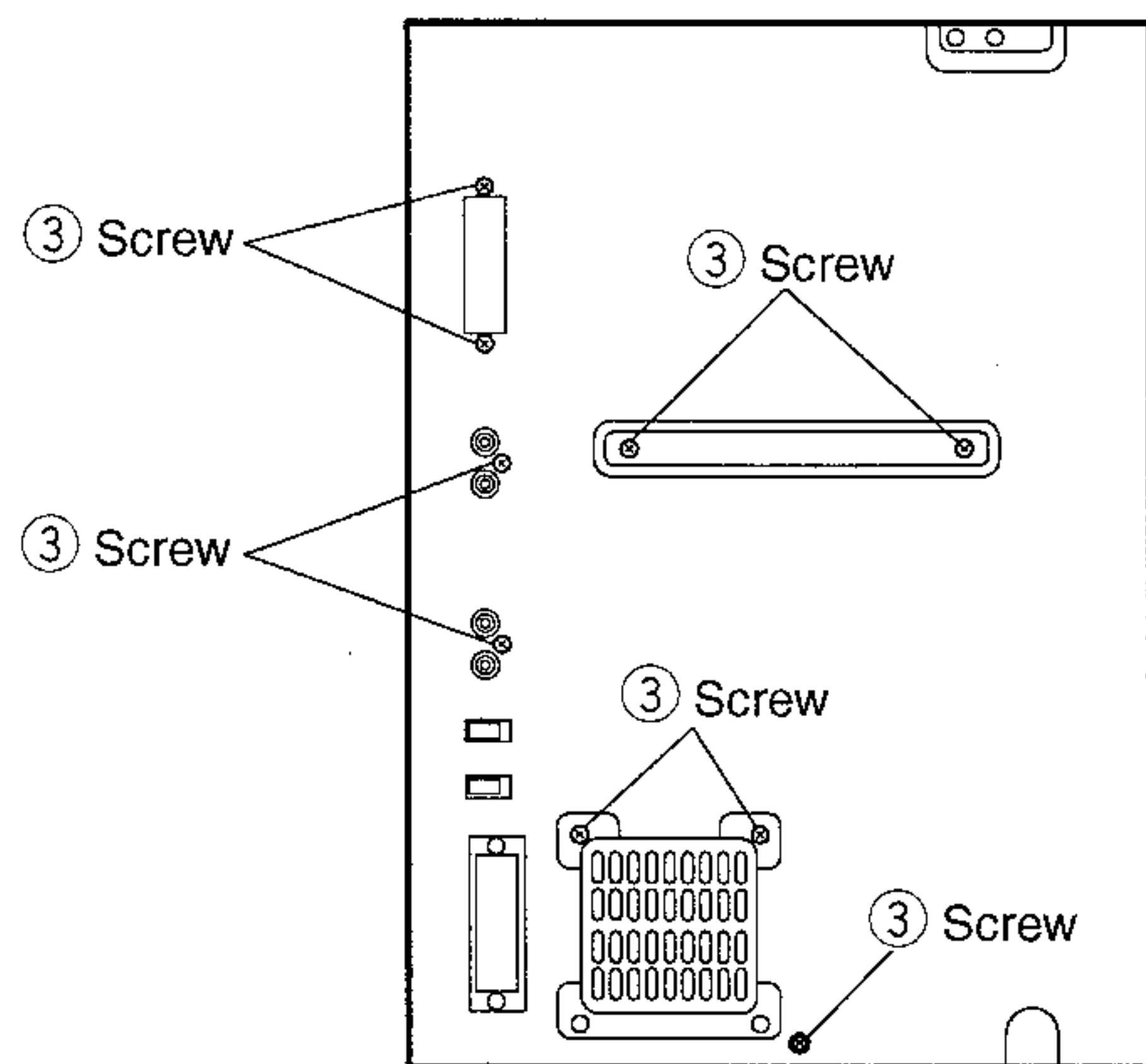

4. Remove the rivet ④ securing the AF ASSY.
5. Remove the AF hold plate (remove the four screws ⑤).

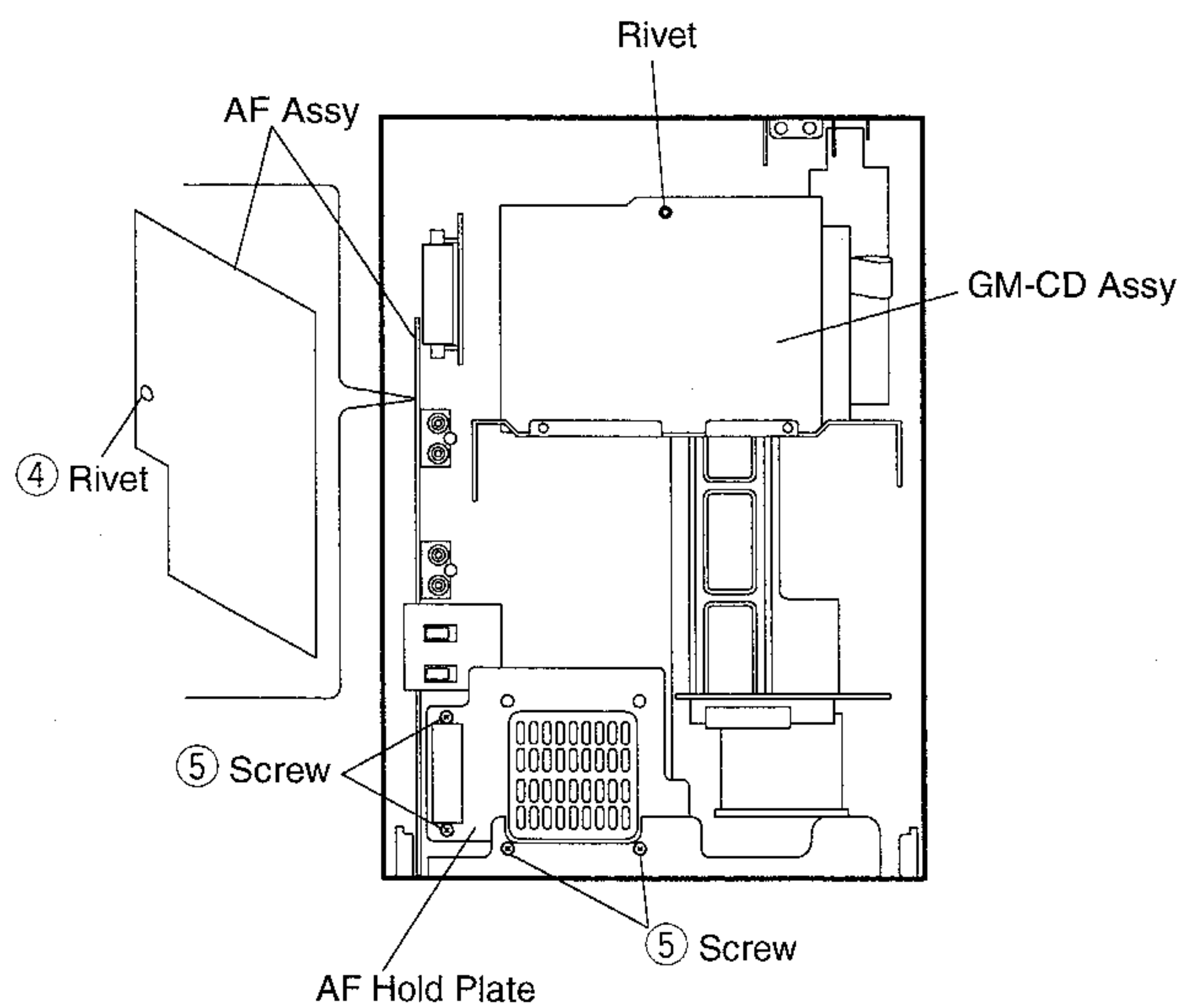

6. Pull out the AMP ASSY from the chassis.

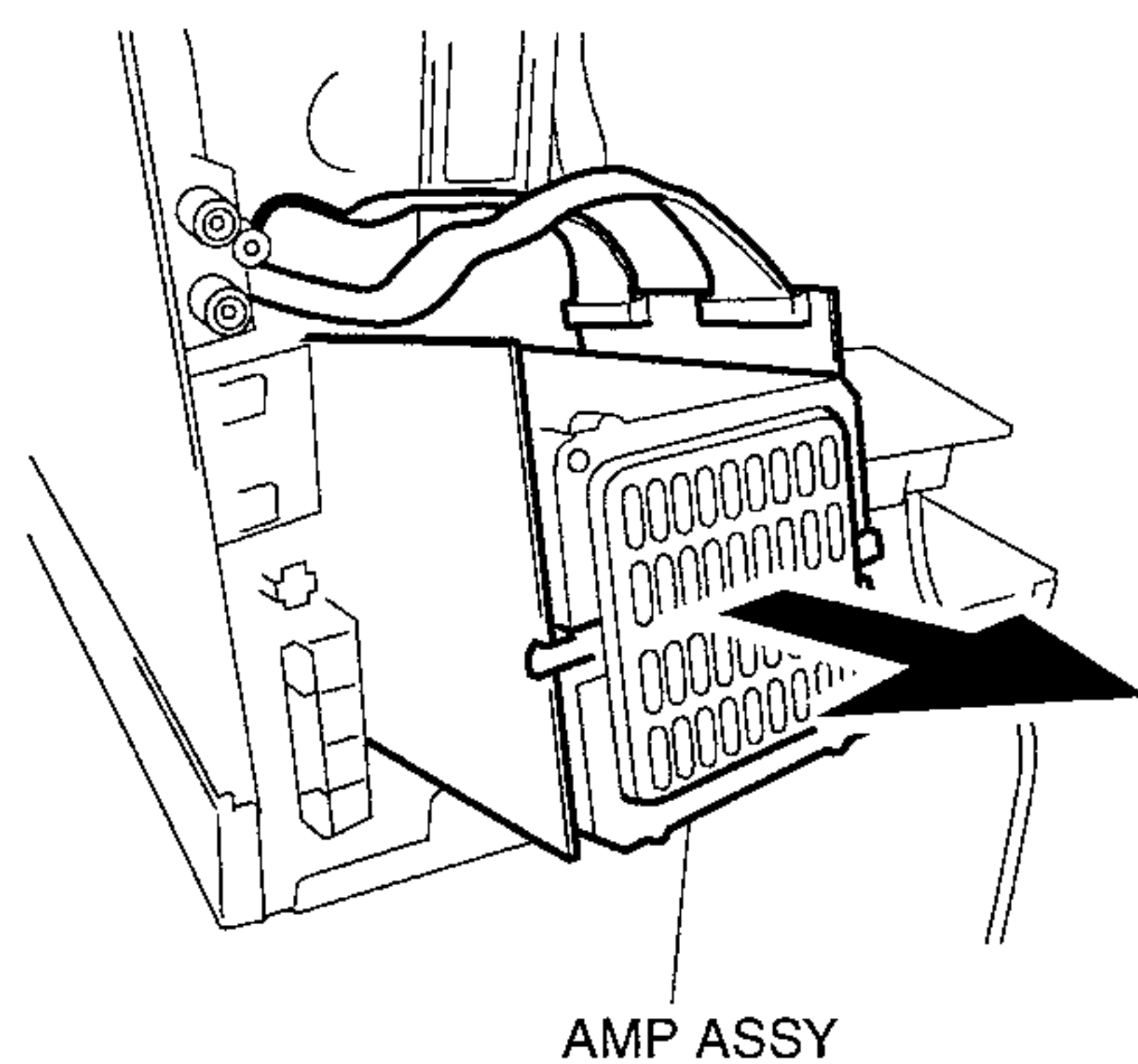

■ Removing the CD Mechanism Block (GS Mechanism Assy and GS Slot-In Mechanism Assy)

1. Remove the bonnet.
2. Remove the home lock stay. (Remove screw ①.)
3. Remove the rear panel.
(Refer to step 3 in "Removing the AMP ASSY".)
NOTE: The CD mechanism block can be diagnosed in this state.
4. Remove Link A and Link B.
(Refer to "Removing the Front Panel".)
(The front panel and CD mechanism block can be separated.)
5. Pull out the whole CD mechanism block with the sub chassis from the front panel. (Remove screw ②.)

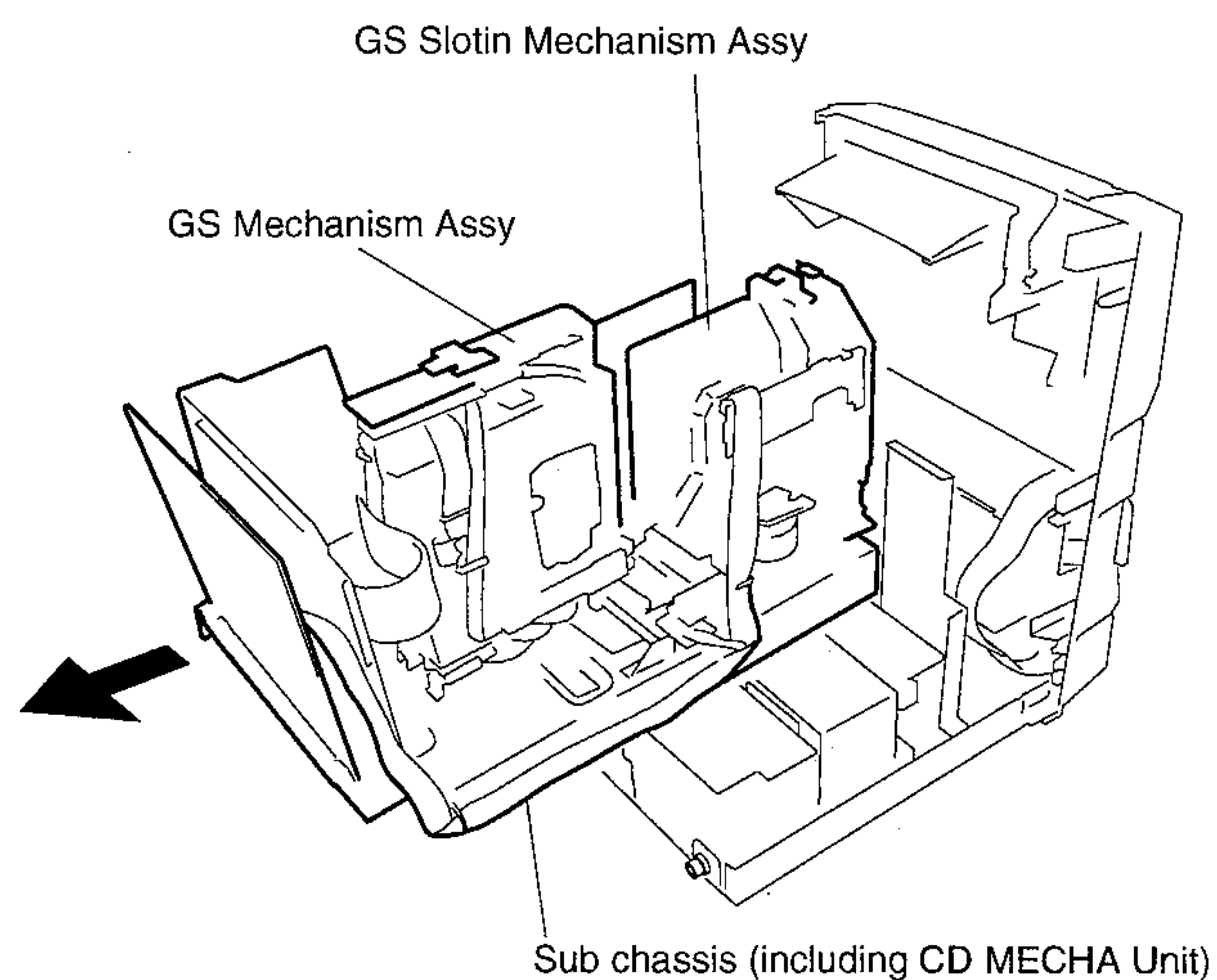
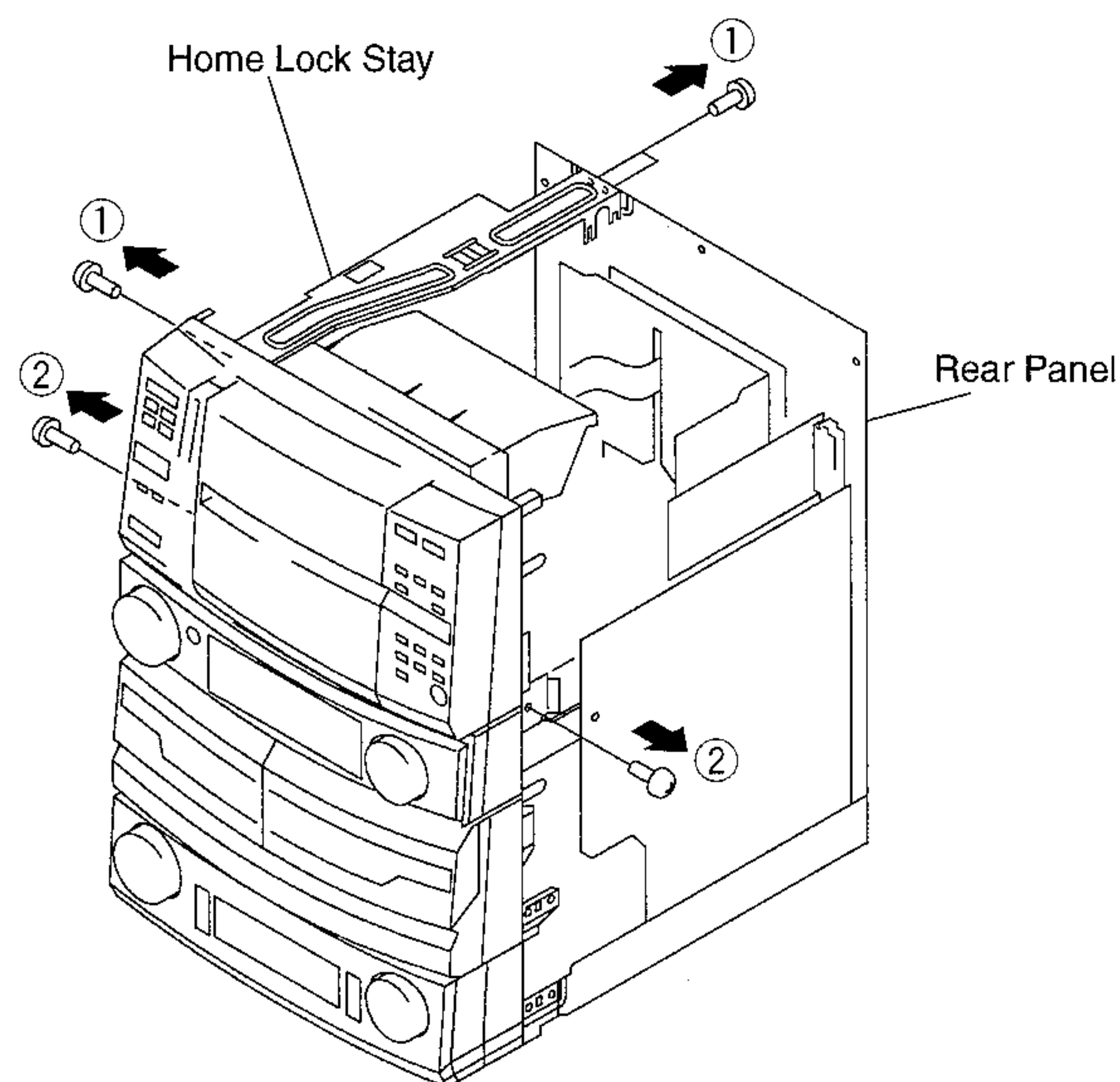

* In this state, the operations of the AMP ASSY can be diagnosed.
(However, be careful not to short-circuit the AF ASSY and chassis.)

7.2.2 PCB LOCATIONS

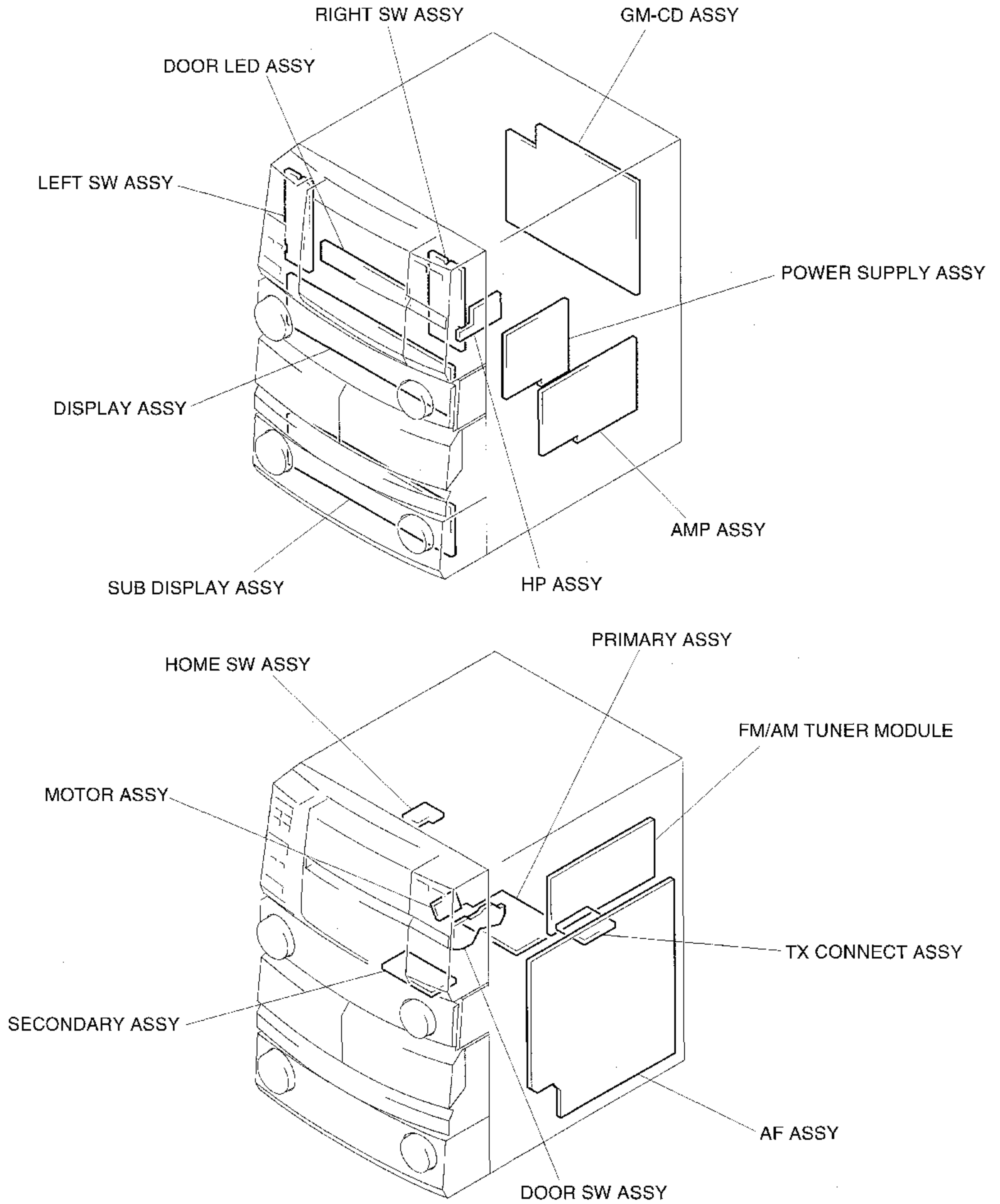

7.3 BLOCK DIAGRAM

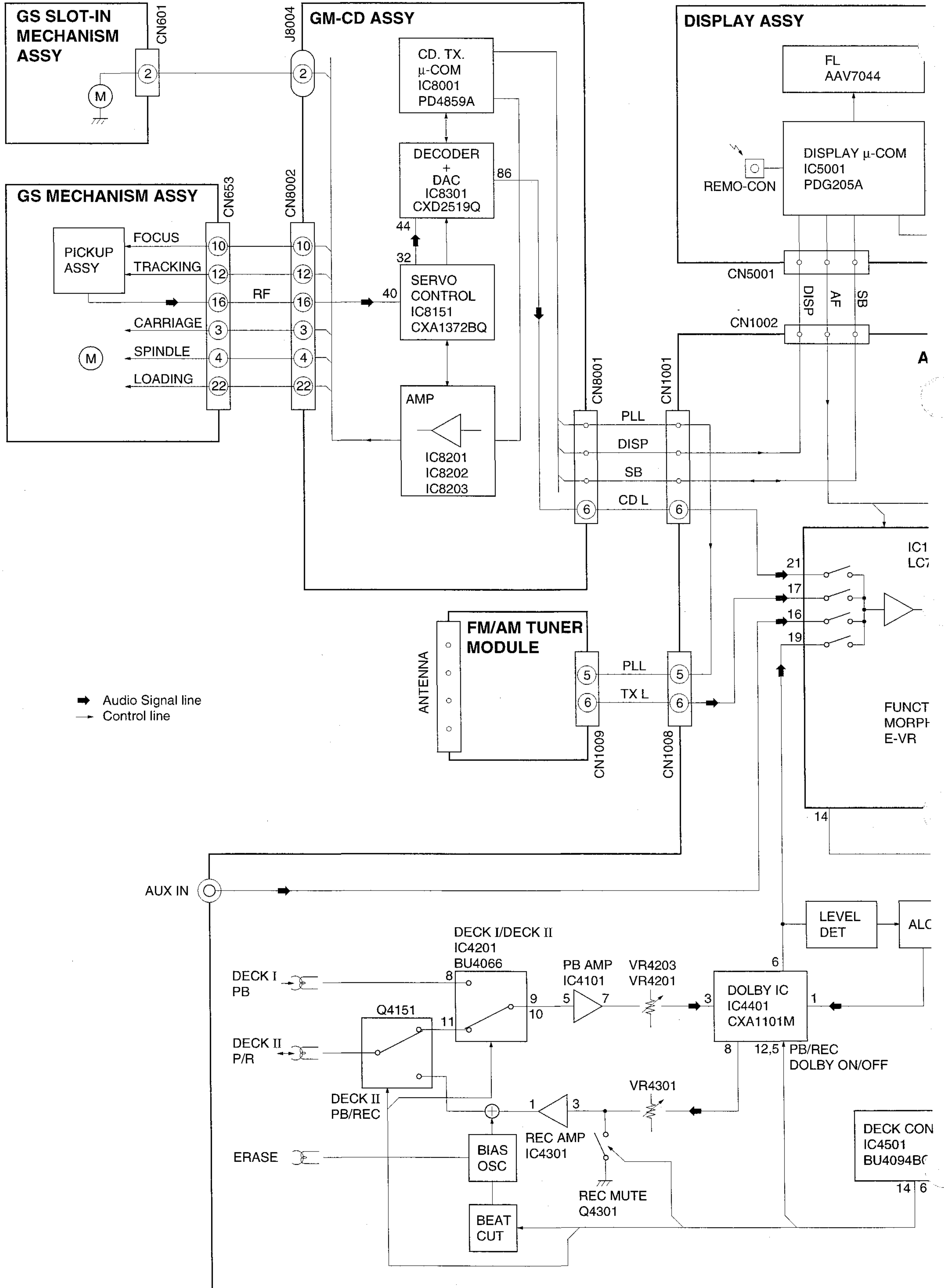

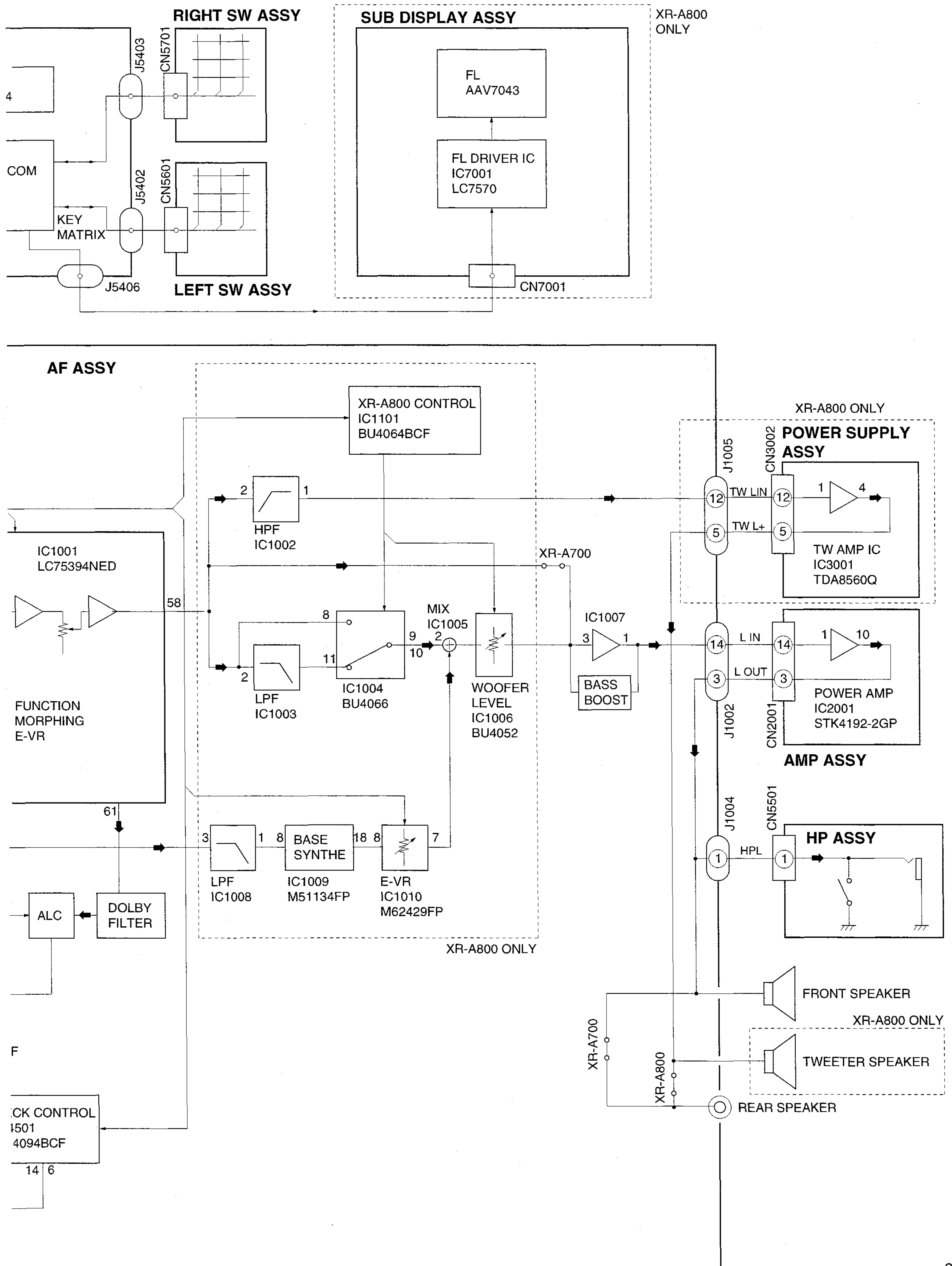

8. PANEL FACILITIES AND SPECIFICATIONS

8.1 PANEL FACILITIES

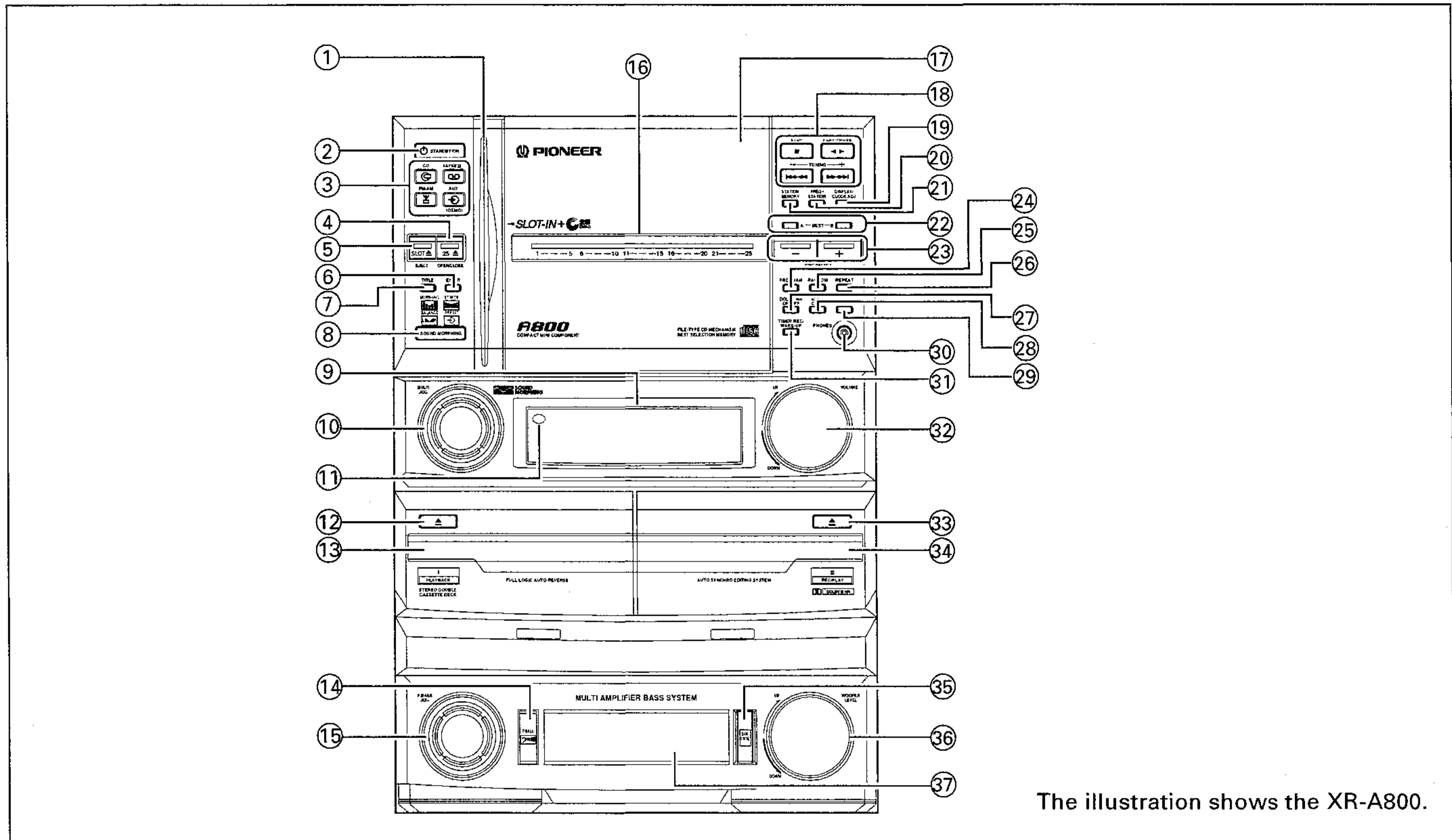

The illustration shows the XR-A800.

① Plus 1 disc slot

② STANDBY/ON switch

This is the switch for electric power.

ON : When set to the ON position, power is supplied and the unit becomes operational.

STANDBY : When set to the STANDBY position, the main power flow is cut and the unit is no longer fully operational. A minute flow of power feeds the unit to maintain operation readiness.

③ Function buttons

④ 25 OPEN/CLOSE button

⑤ SLOT EJECT button

⑥ ENTER button

⑦ TITLE button

⑧ SOUND MORPHING button
(MORPHING, ST.WIDE, BALANCE, PRESET: XR-A800)
(MORPHING, P.BASS, ST.WIDE, BALANCE, PRESET: XR-A700)

⑨ Display

⑩ SOUND MORPHING JOG/MULTI JOG* dial

⑪ Remote sensor

⑫ TAPE I Eject (▲)

⑬ TAPE I cassette door

⑭ P.BASS button (XR-A800 only)

⑮ P.BASS JOG dial (XR-A800 only)

⑯ 25 DISC indicator

⑰ CD Door panel

⑱ Common operation button section

⑲ DISPLAY/CLOCK ADJ button

⑳ FREQ/STATION button

㉑ STATION MEMORY button

㉒ BEST (A, B) buttons

㉓ DISC SELECT + (up)/- (down) buttons

㉔ PROGRAM button

㉕ RANDOM button

㉖ REPEAT button

㉗ Dolby** NR ON/OFF button

Each time this button is pressed, the Dolby NR system turns on and off.

㉘ ASES/COPY button

㉙ REC/STOP button (●/■)

㉚ Headphones jack (PHONES)

㉛ TIMER REC/WAKE-UP button

㉜ VOLUME control

㉝ TAPE II Eject (▲)

㉞ TAPE II cassette door

㉟ BASS SYNTH button (XR-A800 only)

㊱ WOOFER LEVEL control (XR-A800 only)

㊲ Display (XR-A800 only)

* SOUND MORPHING JOG/MULTI JOG dial is used for multi-functions.

**

● Dolby noise reduction manufactured under license from Dolby Laboratories Licensing Corporation.

● "DOLBY" and the double-D symbol are trademarks of Dolby Laboratories Licensing Corporation.

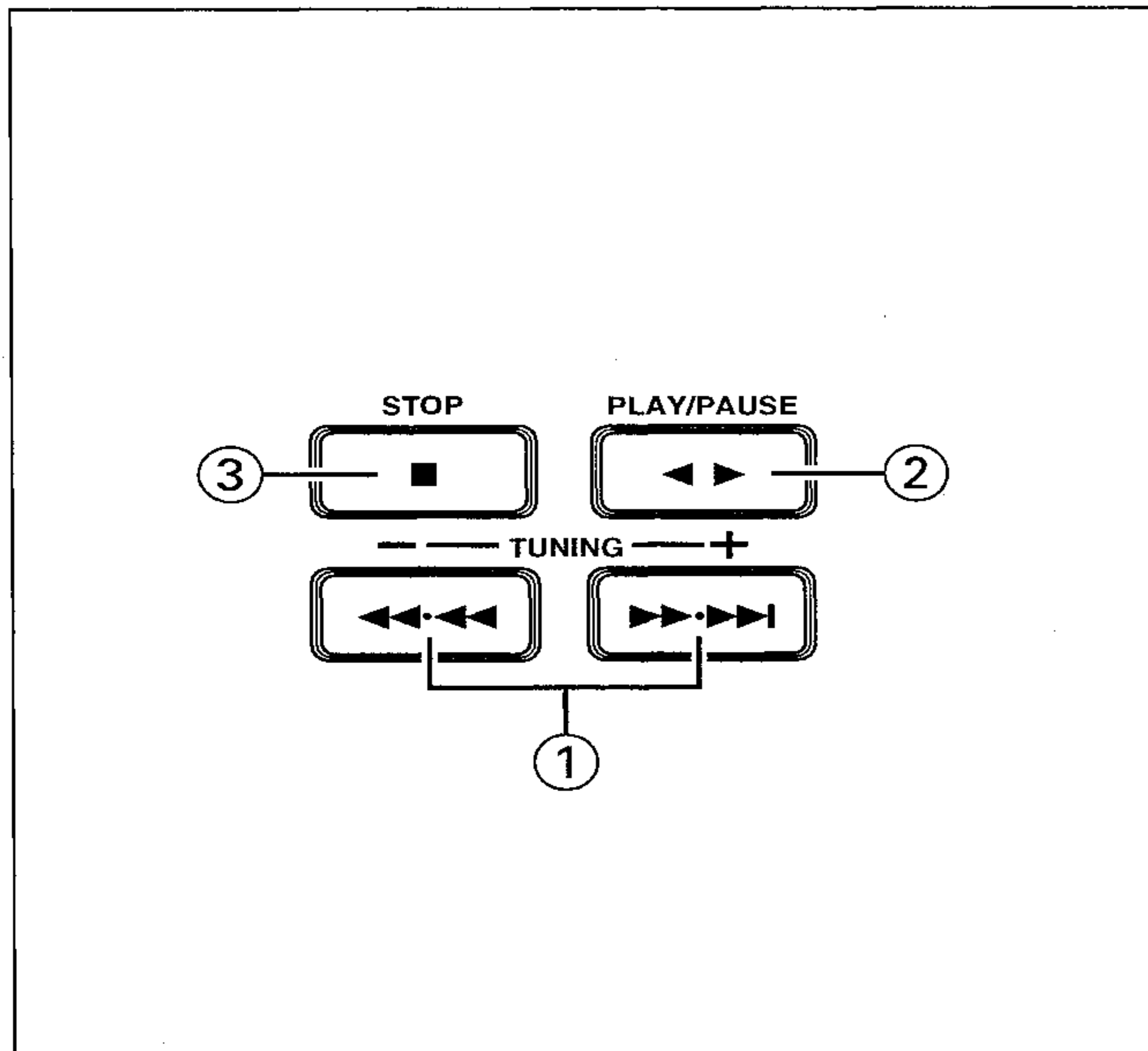

COMMON OPERATION BUTTON SECTION

- ① , buttons
- ② **PLAY/PAUSE** button (◀▶)
- ③ **STOP** button (■)

● Roles of the common operation buttons. (The roles of the buttons vary depending on the input functions as shown below.)

During CD input

- PLAY/PAUSE** : Play/Pause button
- STOP** : Stop button
- : Fast forward/track search button
- : Fast reverse/track search button

During cassette deck input

- ◀▶ : Play button/Tape transport direction
- STOP** : Stop button
- : Fast forward/Music search button
- : Rewind/Music search button

During tuner operation

- : Frequency and station + (up) button
- : Frequency and station - (down) button

DISPLAY

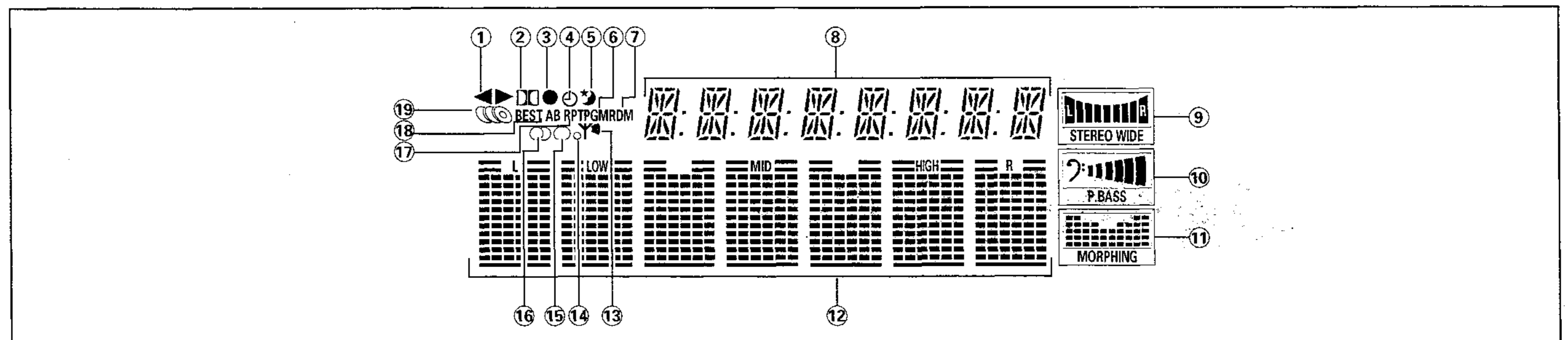

- ① Lights to show the tape II direction.
- ② Lights when Dolby NR is ON.
- ③ Lights during recording and timer recording operation.
- ④ Lights when setting the timer.
- ⑤ Lights during sleep timer operation.
- ⑥ Lights when you press the PGM button.
- ⑦ Lights when you press the RANDOM button.
- ⑧ Indicates the frequency and major operation status.
- ⑨ Displays the ST.WIDE mode.
- ⑩ Displays the P.BASS mode.
- ⑪ Displays the MORPHING mode.
- ⑫ Displays the spectrum analyzer patterns.
- ⑬ Lights during radio broadcast reception.
- ⑭ Lights when setting the Beat Cut function.
- ⑮ Lights when you press the MONO button.
- ⑯ Lights during FM stereo reception.
- ⑰ Lights during repeat play.
- ⑱ Flashes during Best Selection setting (A or B), and lights during play.
- ⑲ : Lights during ALL mode operation.
- ⑲ : Lights during SINGLE mode operation.

■ XR-A800 only ■

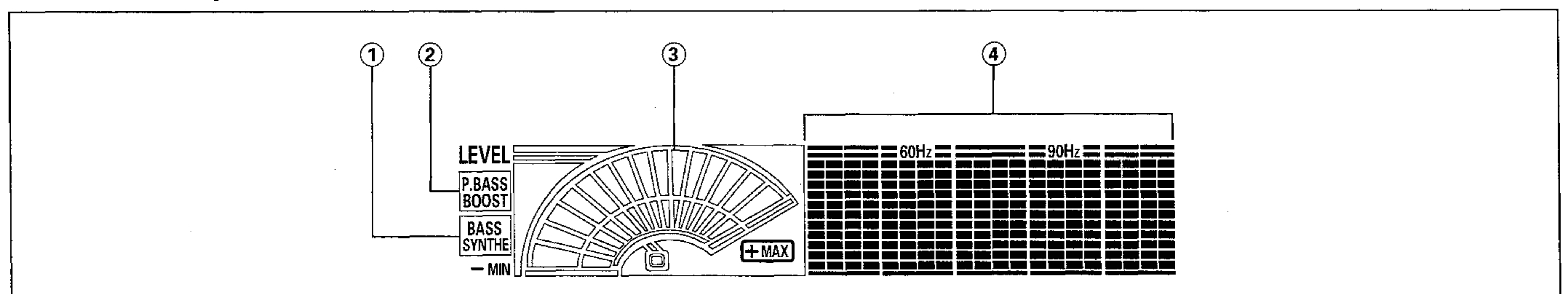

- ① Lights when BASS SYNTH button is ON.
- ② Lights when P.BASS button is ON.
- ③ Displays the woofer level.
- ④ Displays the spectrum analyzer patterns of the low frequencies.

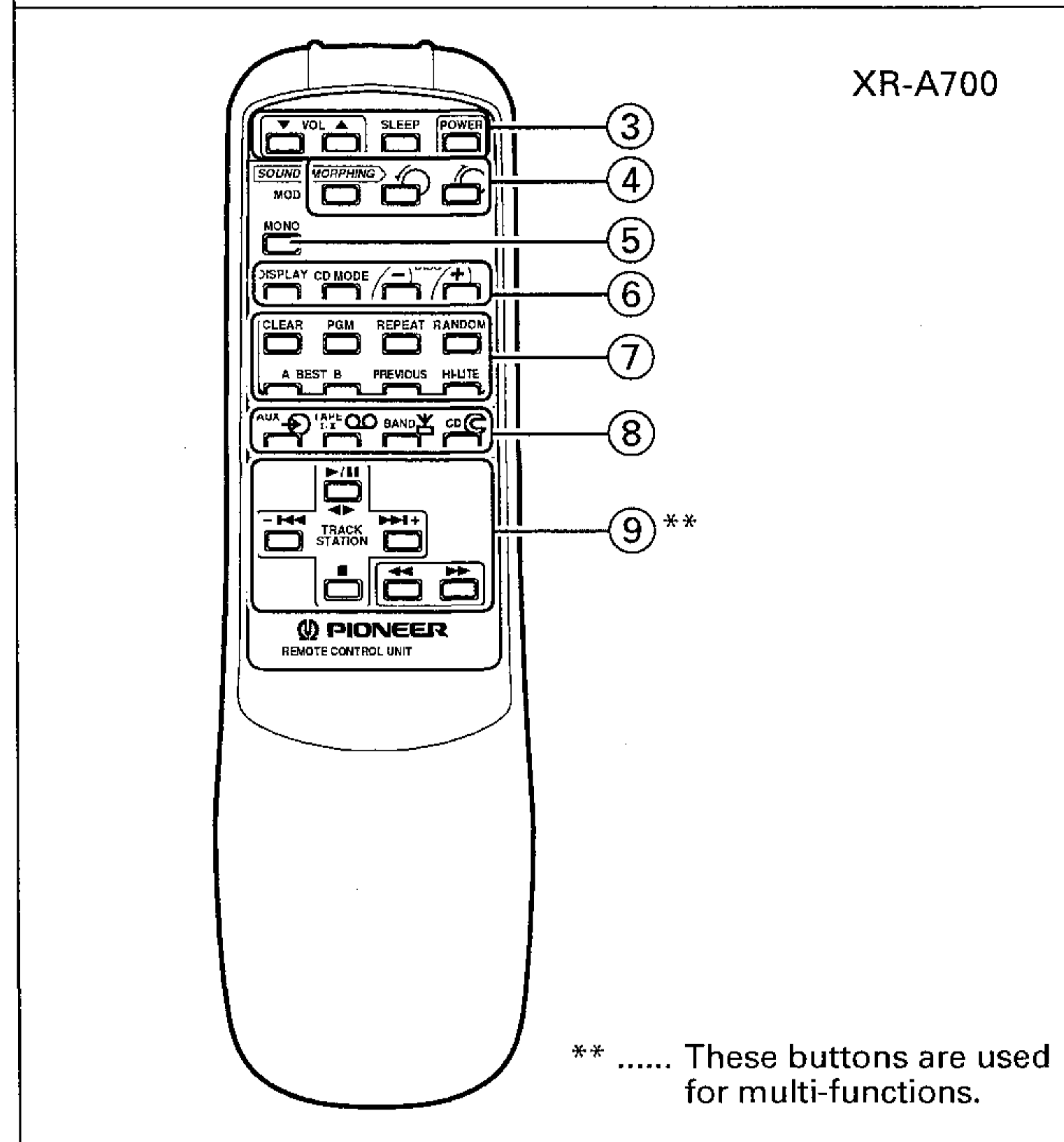
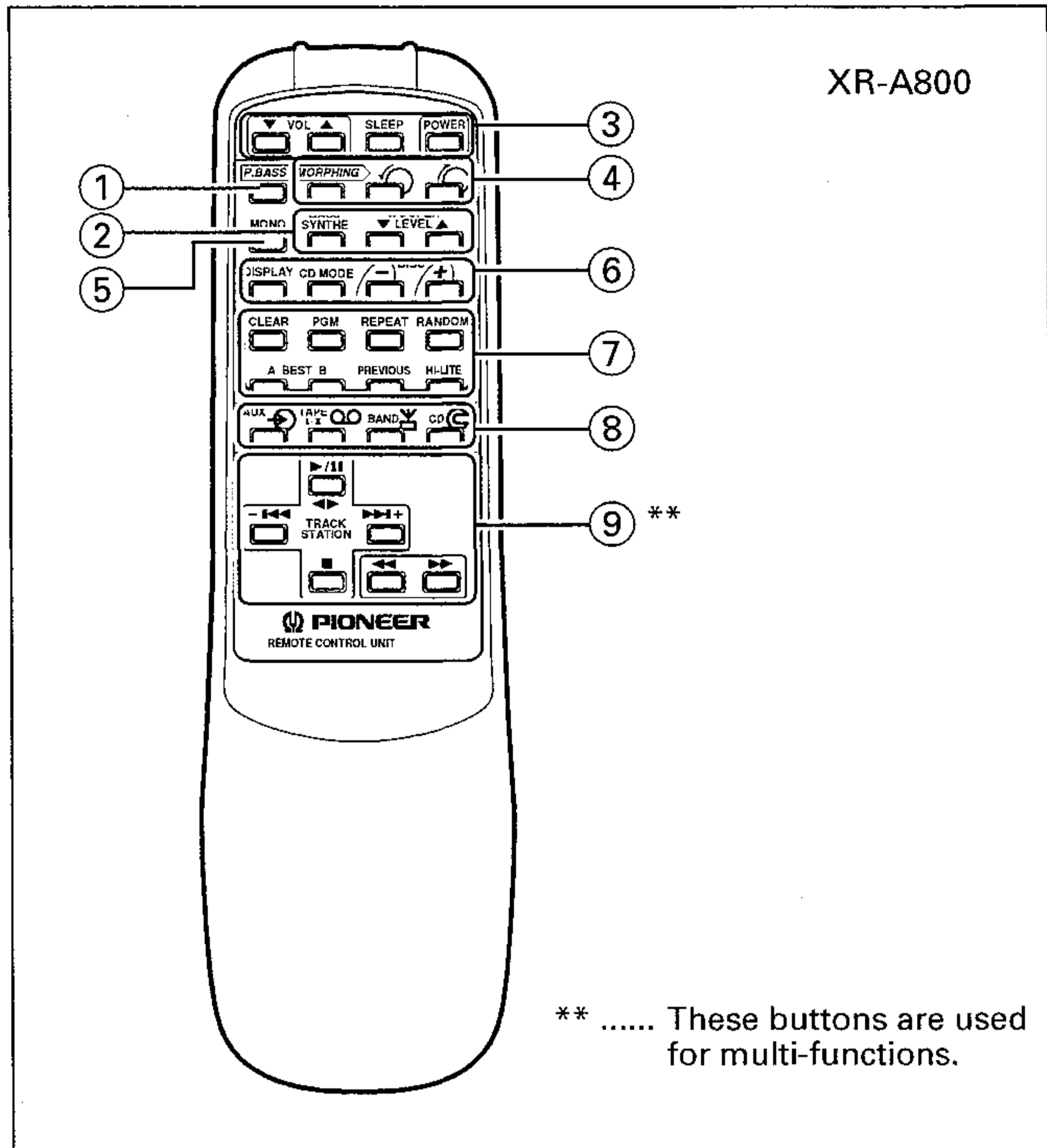











REMOTE CONTROL UNIT

The following instructions concern the XR-A800.

- ① **P.BASS** : P.BASS button
- ② **BASS SYNTHSE** : BASS SYNTHSE ON/OFF button
WOOFER ▼ LEVEL ▲ : WOOFER LEVEL ▼ (down) ▲ (up) buttons

The following instructions are for both the XR-A800 and the XR-A700.

- ③ **POWER** button
SLEEP : SLEEP button
VOLUME ▲ (up), ▼ (down) buttons
 Increases/decreases the sound volume of the unit.
- ④  : SOUND MORPHING JOG buttons
MORPHING : SOUND MORPHING button
- ⑤ **MONO** : MONO button
- ⑥ **- DISC +** : DISC (-, +) buttons
CD MODE : CD MODE button
DISPLAY : DISPLAY button
- ⑦ **RANDOM** : RANDOM button
REPEAT : REPEAT button
PGM : PROGRAM button
CLEAR : CLEAR button
HI-LITE : HI-LITE button
PREVIOUS : PREVIOUS button
A BEST B : BEST (A, B) buttons
- ⑧ **Input selector buttons**
 (CD, TUNER, TAPE, AUX)
- ⑨ **Common operation buttons**
During CD input
 : Play/Pause button
 : Track search button
 : Stop button
 : Fast reverse/Fast forward button
During cassette deck input
 : Play/Tape transport direction button
 : Music search button
 : Stop button
 : Rewind/Fast forward button
During tuner operation
 : Station - (down)/+ (up) button
 : Frequency down/up button

8.1 SPECIFICATIONS

■ STEREO FILE-TYPE CD CASSETTE DECK RECEIVER

Amplifier Section

Continuous Power Output (RMS)	
XR-A800	
Woofer	120 W + 120 W (100 Hz, T.H.D. 10 %, 8 Ω)
Tweeter	20 W + 20 W (1 kHz, T.H.D. 10 %, 4 Ω)
XR-A700	120 W + 120 W (1 kHz, T.H.D. 10 %, 6 Ω)

FM Tuner Section

Reception frequencies	87.5 MHz to 108 MHz
Antenna input	75 Ω unbalanced

AM Tuner Section

Reception frequencies	531 kHz to 1,602 kHz (9k)
	530 kHz to 1,700 kHz (10k)
Antenna	Loop antenna (included)

Double Cassette Deck Section

System type	4-track, 2-channel stereo
Heads	Recording/playback head x 1 Playback head x 1 Erasing head x 1
Motor	DC servo motor x 1
Frequency response	
Type I (Normal) tape	*35 Hz to 14,000 Hz ±6 dB (recorded at -20 dB)
SN ratio	*56 dB (peak recording level, audible compensation)
Dolby B type NR on	10 dB compensation at 5 kHz

* Values measured in accordance with EIAJ standards.

■ FILE TYPE CD PLAYER

Type	Compact disc audio system
Usable discs	Compact audio discs
Channels	2 channels (stereo)
Program steps	32 steps maximum

■ ELECTRICAL REQUIREMENTS, ETC.

Power Requirements	AC 110-127/220-230/240 V (switchable), 50/60 Hz
Power Consumption	
XR-A800	610 W
XR-A700	560 W
External dimensions	
XR-A800	270 (W) x 380 (H) x 369 (D) mm
XR-A700	270 (W) x 310 (H) x 369 (D) mm
Weight	
XR-A800	12.5 kg
XR-A700	11.5 kg

■ ACCESSORIES

Operating Instructions	1
FM antenna	1
AM loop antenna	1
Remote control unit	1
AA/R6P dry cell batteries	2

NOTE:

Specifications and design are subject to possible modifications without notice, due to improvements.

