

Service Manual

Pioneer

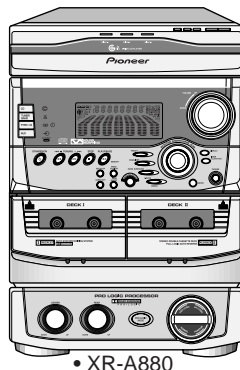

ORDER NO.
RRV2065

STEREO CD CASSETTE DECK RECEIVER

XR-A880 XR-A770

THIS MANUAL IS APPLICABLE TO THE FOLLOWING MODEL(S) AND TYPE(S).

Type	Model		Power Requirement	Remarks
	XR-A880	XR-A770		
KUCXJ	○	○	AC120V	
YPWXJ	○	○	AC240V	

CONTENTS

1. SAFETY INFORMATION	2	7. GENERAL INFORMATION	63
2. EXPLODED VIEWS AND PARTS LIST	4	7.1 PARTS	63
3. SCHEMATIC DIAGRAM	16	7.1.1 IC	63
4. PCB CONNECTION DIAGRAM	34	7.1.2 DISPLAY	69
5. PCB PARTS LIST	49	7.2 DISASSEMBLY	71
6. ADJUSTMENT	57	7.3 BLOCK DIAGRAM	74
		8. PANEL FACILITIES AND SPECIFICATIONS	76

PIONEER ELECTRONIC CORPORATION 4-1, Meguro 1-Chome, Meguro-ku, Tokyo 153-8654, Japan
PIONEER ELECTRONICS SERVICE, INC. P.O. Box 1760, Long Beach, CA 90801-1760, U.S.A.
PIONEER ELECTRONIC (EUROPE) N.V. Haven 1087, Keetberglaan 1, 9120 Melsele, Belgium
PIONEER ELECTRONICS ASIACENTRE PTE. LTD. 253 Alexandra Road, #04-01, Singapore 159936
 © PIONEER ELECTRONIC CORPORATION 1998

1. SAFETY INFORMATION

This service manual is intended for qualified service technicians; it is not meant for the casual do-it-yourselfer. Qualified technicians have the necessary test equipment and tools, and have been trained to properly and safely repair complex products such as those covered by this manual. Improperly performed repairs can adversely affect the safety and reliability of the product and may void the warranty. If you are not qualified to perform the repair of this product properly and safely, you should not risk trying to do so and refer the repair to a qualified service technician.

WARNING

This product contains lead in solder and certain electrical parts contain chemicals which are known to the state of California to cause cancer, birth defects or other reproductive harm.

Health & Safety Code Section 25249.6 – Proposition 65



NOTICE

(FOR CANADIAN MODEL ONLY)

Fuse symbols  (fast operating fuse) and/or  (slow operating fuse) on PCB indicate that replacement parts must be of identical designation.

REMARQUE

(POUR MODÈLE CANADIEN SEULEMENT)

Les symboles de fusible  (fusible de type rapide) et/ou  (fusible de type lent) sur CCI indiquent que les pièces de remplacement doivent avoir la même désignation.

(FOR USA MODEL ONLY)

1. SAFETY PRECAUTIONS

The following check should be performed for the continued protection of the customer and service technician.

LEAKAGE CURRENT CHECK

Measure leakage current to a known earth ground (water pipe, conduit, etc.) by connecting a leakage current tester such as Simpson Model 229-2 or equivalent between the earth ground and all exposed metal parts of the appliance (input/output terminals, screwheads, metal overlays, control shaft, etc.). Plug the AC line cord of the appliance directly into a 120V AC 60 Hz outlet and turn the AC power switch on. Any current measured must not exceed 0.5 mA.

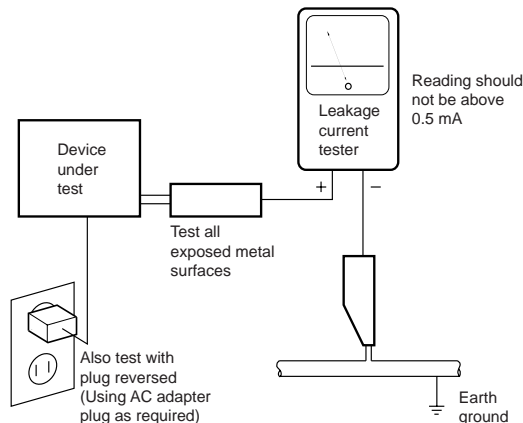

AC Leakage Test

ANY MEASUREMENTS NOT WITHIN THE LIMITS OUTLINED ABOVE ARE INDICATIVE OF A POTENTIAL SHOCK HAZARD AND MUST BE CORRECTED BEFORE RETURNING THE APPLIANCE TO THE CUSTOMER.

2. PRODUCT SAFETY NOTICE

Many electrical and mechanical parts in the appliance have special safety related characteristics. These are often not evident from visual inspection nor the protection afforded by them necessarily can be obtained by using replacement components rated for voltage, wattage, etc. Replacement parts which have these special safety characteristics are identified in this Service Manual.

Electrical components having such features are identified by marking with a Δ on the schematics and on the parts list in this Service Manual.

The use of a substitute replacement component which does not have the same safety characteristics as the PIONEER recommended replacement one, shown in the parts list in this Service Manual, may create shock, fire, or other hazards.

Product Safety is continuously under review and new instructions are issued from time to time. For the latest information, always consult the current PIONEER Service Manual. A subscription to, or additional copies of, PIONEER Service Manual may be obtained at a nominal charge from PIONEER.

LABEL CHECK (for YPWXJ type)

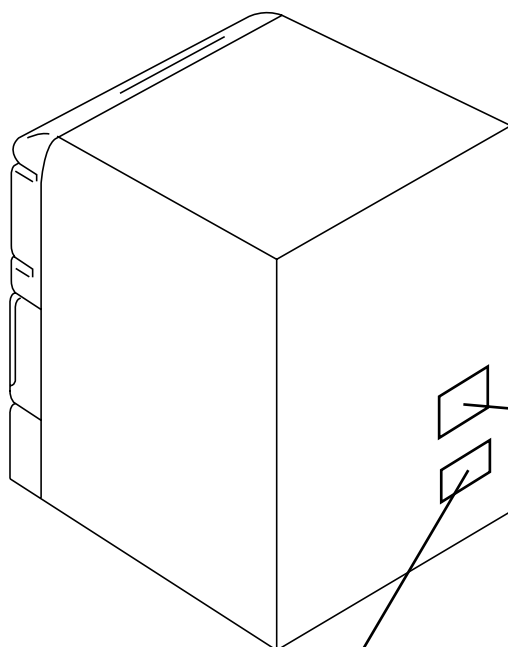

**CLASS 1
LASER PRODUCT**
Printed on the Rear Panel

CAUTION
INVISIBLE LASER
RADIATION WHEN OPEN,
AVOID EXPOSURE
TO BEAM PRW1018

— IMPORTANT —
THIS PIONEER APPARATUS CONTAINS
LASER OF CLASS 1.
SERVICING OPERATION OF THE APPARATUS
SHOULD BE DONE BY A SPECIALLY
INSTRUCTED PERSON.

— LASER DIODE CHARACTERISTICS —
MAXIMUM OUTPUT POWER: 1.3 mW
WAVELENGTH: 790 nm ± 25 nm

— Additional Laser Caution —

1. Laser Interlock Mechanism
The position of the switch (S8501) for detecting loading state is detected by the system microprocessor, and the design prevents laser diode oscillation when the switch (S8501) is pressed physically.
Thus, the interlock will no longer function if the switch (S8501) is released physically and deliberately.
The interlock also does not function in the test mode *.
Laser diode oscillation will continue, if pin 62 of LA9240ML (IC8101) on the CD ASSY mounted on the \$M Loading Mechanism assembly is connected to GND, or else the terminals of Q8101 are shorted to each other (fault condition).
2. When the cover is opened, close viewing of the objective lens with the naked eye will cause exposure to a Class 1 laser beam.

* : Refer to page 62.

(1) PACKING PARTS LIST

Mark	No.	Description	Part No.	Mark	No.	Description	Part No.
	1	FM Antenna	ADH7004		11	Packing Sheet	AHG7049
	2	Operating Instructions (English/French)	XRE3012	NSP	12	Warranty Card	See Contrast table (2)
	3	AM Loop Antenna	XTB3001	△	13	Power Cord	See Contrast table (2)
	4	Remote Control Unit	See Contrast table (2)	NSP	14	Polyethylene Bag	See Contrast table (2)
	5	Battery Cover	AZA7204		15	Operating Instructions	See Contrast table (2)
NSP	6	Dry Cell Battery (R6P, AA)	VEM-013				
	7	Polyethylene Bag (0.03 × 230 × 340)	Z21-038				
	8	Front Pad	See Contrast table (2)				
	9	Rear Pad	See Contrast table (2)				
	10	Packing Case	See Contrast table (2)				

(2) CONTRAST TABLE

XR-A880/KUCXJ, YPWXJ, XR-A770/KUCXJ and YPWXJ are constructed the same except for the following :

Mark	No.	Symbol and Description	Part No.				Remarks
			XR-A880 /KUCXJ	XR-A880 /YPWXJ	XR-A770 /KUCXJ	XR-A770 /YPWXJ	
	4	Remote Control Unit (CU-XR050)	XZN3008	XZN3008	Not used	Not used	
	4	Remote Control Unit (CU-XR049)	Not used	Not used	XZN3007	XZN3007	
	8	Front Pad	XHA3005	XHA3009	XHA3005	XHA3009	
	9	Rear Pad	XHA3006	XHA3010	XHA3006	XHA3010	
	10	Packing Case	XHD3072	XHD3052	XHD3049	XHD3048	
NSP	12	Warranty Card	ARY7023	ARY7027	ARY7023	ARY7027	
△	13	Power Cord	ADG7022	ADG1160	ADG7022	ADG1160	
NSP	14	Polyethylene Bag	AHG7033	Not used	AHG7033	Not used	
	15	Operating Instructions (English/French/German/ Italian/Dutch/Swedish/Spanish/Portuguese/Chinese)	Not used	Not used	XRE3016	XRE3016	
	15	Operating Instructions (English/French/Spanish/ Portuguese/Chinese)	XRE3018	XRE3018	Not used	Not used	

2.2 EXTERIOR (1/2)

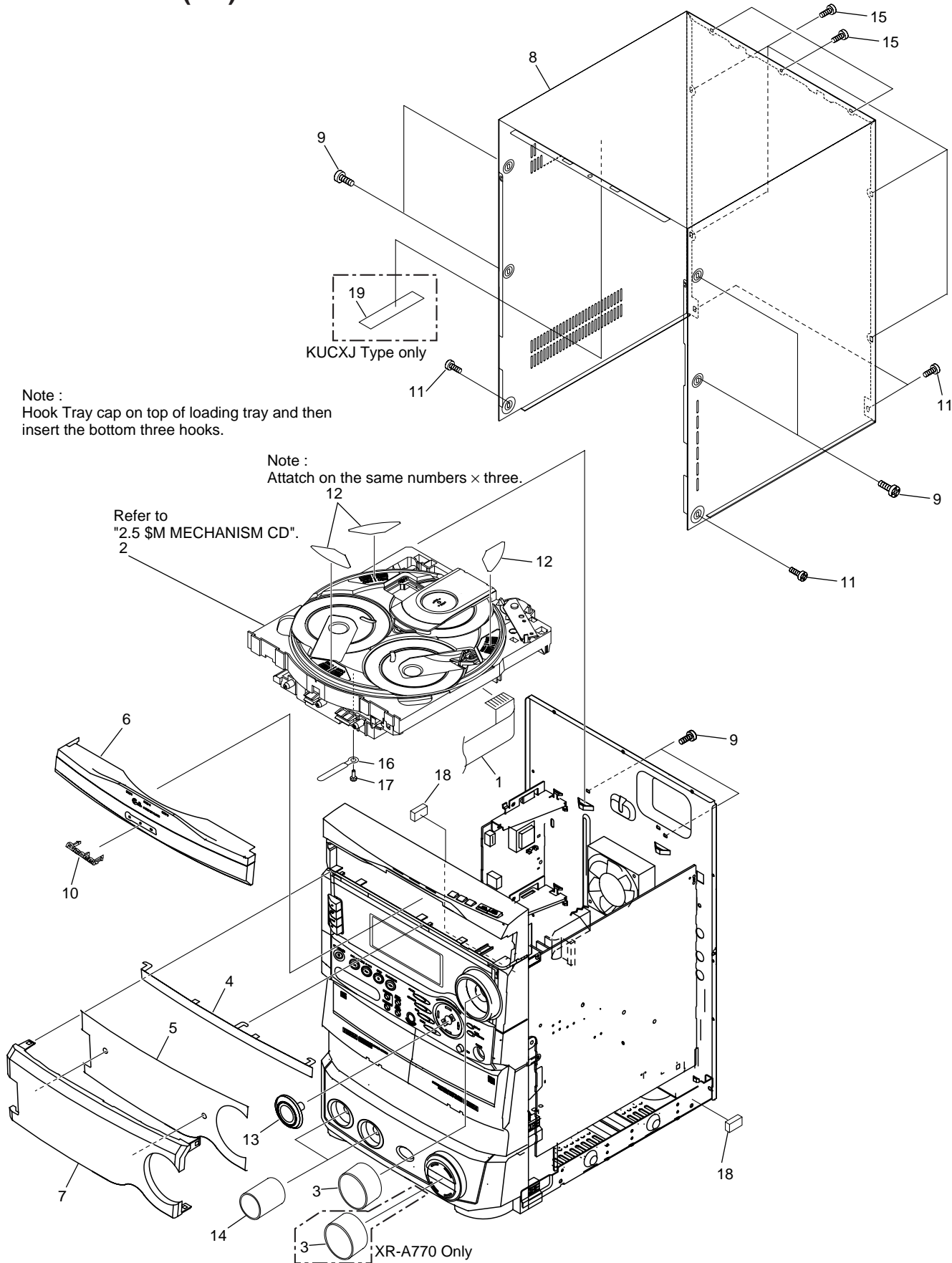

(1) EXTERIOR (1/2) PARTS LIST

Mark	No.	Description	Part No.
NSP	1	22P F.F.C/30V	XDD3018
	2	\$M Mechanism CD	XXA3006
	3	Volume Knob	XAA3005
	4	FL Cover A	XAK3026
	5	FL Cover B	XAK3036
	6	Tray Cap	XZN3047
	7	Display Panel	See Contrast table (2)
	8	Bonnet Case	XZN3040
	9	Screw	BPZ30P100FZK
	10	Pioneer Badge	XZN3049
	11	Screw	VBT30P080FZK
	12	Disc Label	XAX3127
	13	Jog Knob Assy	XXG3023
	14	Bass Knob	XAB3005
	15	Screw	BCZ30P080FZK
NSP	16	Cord Stopper	DNF1128
	17	Push Rivet	AEC7138
	18	Cushion Rubber	XEB3002
	19	65 Label	See Contrast table (2)

(2) CONTRAST TABLE

XR-A880/KUCXJ, YPWXJ, XR-A770/KUCXJ and YPWXJ are constructed the same except for the following :

Mark	No.	Symbol and Description	Part No.				Remarks
			XR-A880 /KUCXJ	XR-A880 /YPWXJ	XR-A770 /KUCXJ	XR-A770 /YPWXJ	
	7	Display Panel	XAK3065	XAK3029	XAK3060	XAK3028	
	19	65 Label	ORW1069	Not used	ORW1069	Not used	

2.3 EXTERIOR (2/2)

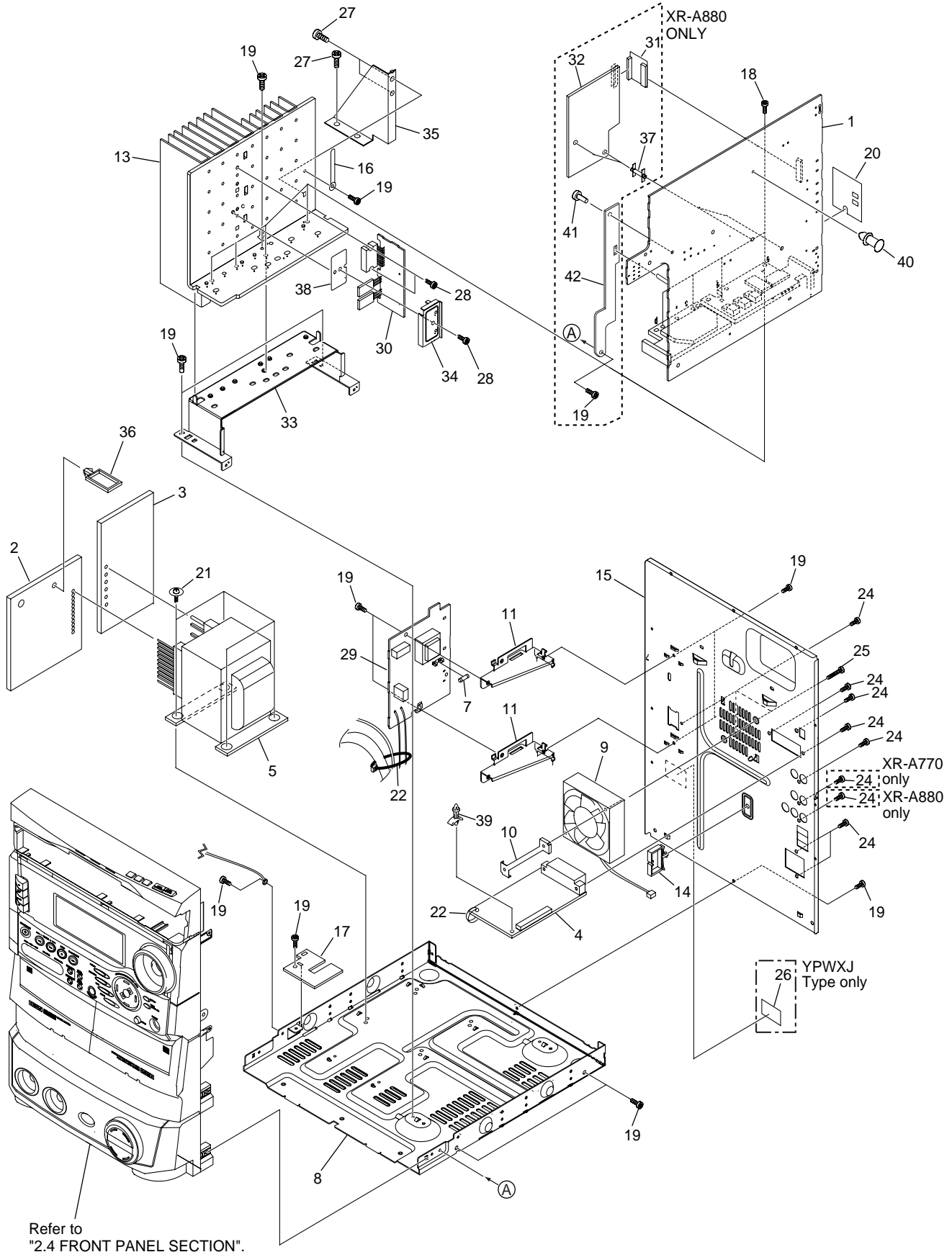

(1) EXTERIOR (2/2) PARTS LIST

Mark	No.	Description	Part No.	Mark	No.	Description	Part No.
⊗	1	AF Assy	See Contrast table (2)		21	Screw	ASZ40P060FMC
⊗	2	SECONDARY Assy	XWZ3137		22	Binder	ZCA-SKB90BK
⊗	3	PRIMARY Assy	See Contrast table (2)		23	•••••	
	4	FM/AM TUNER MODULE	AXQ7065		24	Screw	BPZ30P100FZK
△	5	Power Transformer (T1)	See Contrast table (2)		25	Screw	BBZ30P300FMC
	6	•••••			26	Caution Label	See Contrast table (2)
△	7	Fuse (FU1)	See Contrast table (2)		27	Screw	BBZ30P060FMC
NSP	8	Chassis	XNA3001		28	Screw	IBZ30P135FMC
	9	DC Fan Motor	AXM7003	⊗	29	SUB TRANS Assy	See Contrast table (2)
	10	Fan Plate	ANG7153	⊗	30	REAR AMP Assy	See Contrast table (2)
	11	PCB Bracket	XNG3006	⊗	31	TRADE Assy	See Contrast table (2)
	12	•••••		⊗	32	PRO LOGIC Assy	See Contrast table (2)
	13	Heat Sink	XNH3004		33	H.S.Bracket	XNG3007
	14	Wire Clip A	XEC3003		34	FET Bracket	XNG3009
	15	Rear Panel	See Contrast table (2)		35	H.S.Support	XNG3014
	16	Cord Stopper	DNF1128		36	Wire Clip B	XEC3004
NSP	17	SUPPORT Assy	XNP3009		37	PCB Spacer B	See Contrast table (2)
	18	Screw	BBZ30P140FMC		38	Mica Sheet	XEE3002
	19	Screw	VBZ30P080FZK		39	Locking Spacer	XEC3009
NSP	20	Tweeter Cover	See Contrast table (2)		40	Card Spacer	XEC3008
					41	Push Rivet	See Contrast table (2)
					42	Shield Plate	See Contrast table (2)

(2) CONTRAST TABLE

XR-A880/KUCXJ, YPWXJ, XR-A770/KUCXJ and YPWXJ are constructed the same except for the following :

Mark	No.	Symbol and Description	Part No.				Remarks
			XR-A880 /KUCXJ	XR-A880 /YPWXJ	XR-A770 /KUCXJ	XR-A770 /YPWXJ	
⊗	1	AF Assy	XWZ3134	XWZ3134	XWZ3114	XWZ3114	
⊗	3	PRIMARY Assy	XWZ3118	XWZ3115	XWZ3118	XWZ3115	
△	5	Power Transformer (T1 : AC120V)	XTS3029	Not used	XTS3029	Not used	
△	5	Power Transformer (T1 : AC240V)	Not used	XTS3018	Not used	XTS3018	
△	7	Fuse (FU1 : 6.3A)	REK1085	Not used	REK1085	Not used	
△	7	Fuse (FU1 : T4A)	Not used	AEK1060	Not used	AEK1060	
	15	Rear Panel	XNC3026	XNC3013	XNC3011	XNC3025	
NSP	20	Tweeter Cover	Not used	Not used	XAK3069	XAK3069	
	26	Caution Label	Not used	PRW1018	Not used	PRW1018	
⊗	29	SUB TRANS Assy	XWZ3119	XWZ3116	XWZ3119	XWZ3116	
⊗	30	REAR AMP Assy	XWZ3195	XWZ3195	XWZ3194	XWZ3194	
⊗	31	TRADE Assy	XWZ3140	XWZ3140	Not used	Not used	
⊗	32	PRO LOGIC Assy	XWZ3133	XWZ3133	Not used	Not used	
	37	PCB Spacer B	XEC3005	XEC3005	Not used	Not used	
	41	Push Rivet	AEC7069	AEC7069	Not used	Not used	
	42	Shield Plate	XNK3004	XNK3004	Not used	Not used	

2.4 FRONT PANEL SECTION

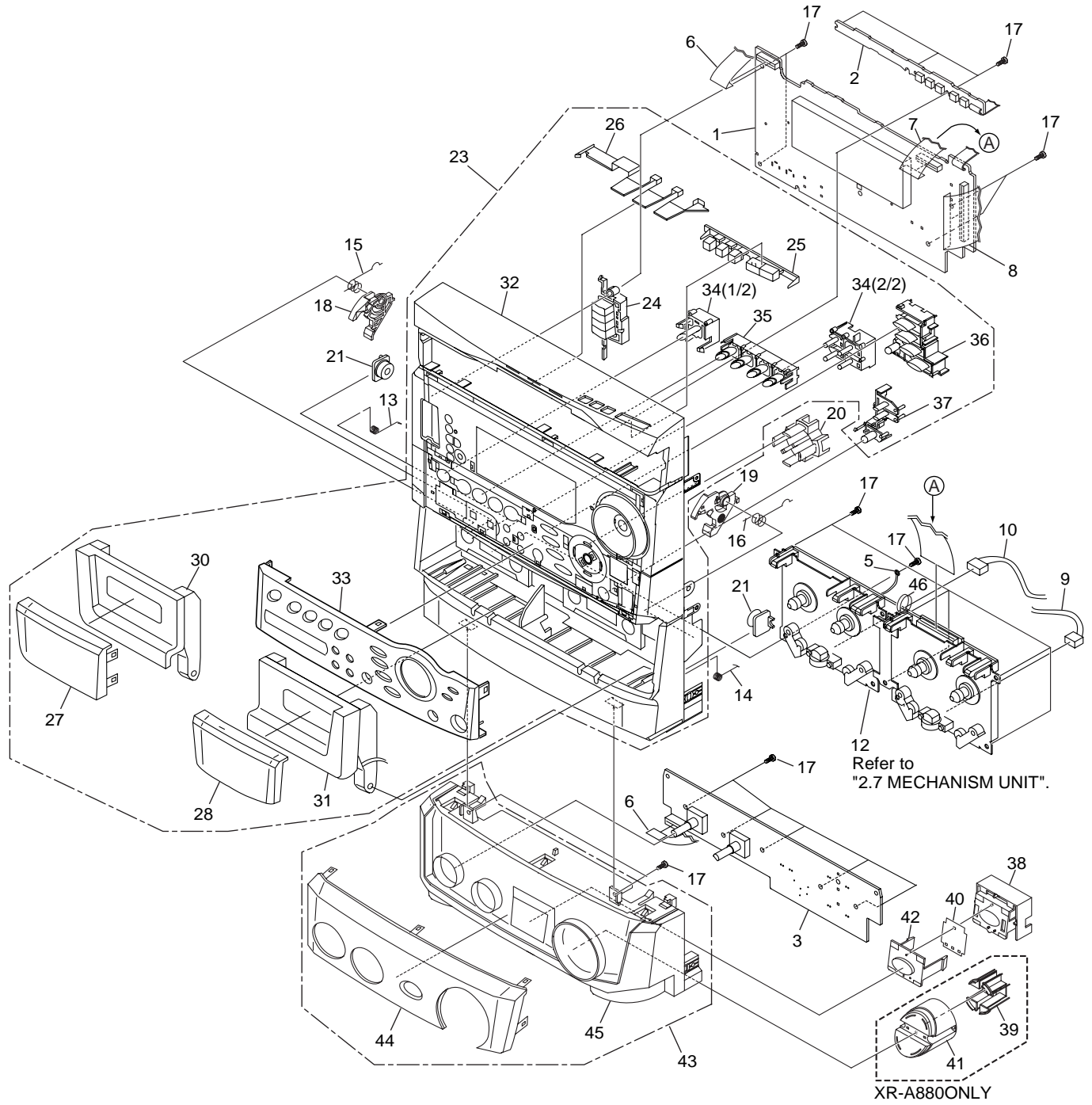

(1) FRONT PANEL SECTION PARTS LIST

Mark	No.	Description	Part No.	Mark	No.	Description	Part No.
⊗	1	DISPLAY Assy	See Contrast table (2)		26	CD Lens	XZN3037
⊗	2	CD SW LED Assy	XWZ3131		27	Deck Lens L	XZN3035
⊗	3	SUB DISPLAY Assy	See Contrast table (2)		28	Deck Lens R	XZN3036
	4	•••••			29	•••••	
NSP	5	Cord With Plug	DE007VE0		30	Door Pocket L	XZN3013
	6	Flexible Cable 14P	XDD3011		31	Door Pocket R	XZN3015
	7	Flexible Cable 19P	XDD3009		32	Front Panel A	XZN3011
	8	Flexible Cable 38P	XDD3004		33	Sub Panel A	See Contrast table (2)
	9	Connector Assy 3P	XDE3013		34	Power Button	XZN3022
	10	Connector Assy 5P	XDE3014		35	Play Button	XZN3024
	11	•••••			36	S.C. Button	XZN3025
	12	Mechanism Unit	XYM3003		37	TIMER Button	XZN3029
	13	Door Spring L	XBH3001		38	Sub Buttun	XAD3012
	14	Door Spring R	XBH3002		39	Dolby Lens	See Contrast table (2)
	15	Latch Spring L	ABH7130		40	Diffusion Sheet	XAK3035
	16	Latch Spring R	ABH7131		41	Dolby Panel	See Contrast table (2)
	17	Screw	BPZ30P100FZK		42	Button Lens	See Contrast table (2)
	18	Latch Mold L	XMR3001	NSP	43	Front Panel Assy B	See Contrast table (2)
	19	Latch Mold R	XMR3002		44	Sub Panel B	See Contrast table (2)
NSP	20	Jog Lens	XAK3025		45	Front Panel B	See Contrast table (2)
	21	Damper Assy	AXA7052		46	Binder	ZCA-SKB90BK
	22	•••••					
NSP	23	Front Panel Assy	See Contrast table (2)				
	24	Function Button	XZN3020				
	25	CD Button	XZN3018				

(2) CONTRAST TABLE

XR-A880/KUCXJ, YPWXJ, XR-A770/KUCXJ and YPWXJ are constructed the same except for the following :

Mark	No.	Symbol and Description	Part No.				Remarks
			XR-A880 /KUCXJ	XR-A880 /YPWXJ	XR-A770 /KUCXJ	XR-A770 /YPWXJ	
⊗	1	DISPLAY Assy	XWZ3135	XWZ3142	XWZ3117	XWZ3143	
⊗	3	SUB DISPLAY Assy	XWZ3132	XWZ3132	XWZ3112	XWZ3112	
NSP	23	Front Panel Assy	XXG3014	XXG3014	XXG3017	XXG3017	
	33	Sub Panel A	XZN3031	XZN3031	XZN3044	XZN3044	
	39	Dolby Lens	XAK3034	XAK3034	Not used	Not used	
	41	Dolby Panel	XAK3042	XAK3042	Not used	Not used	
	42	Button Lens	XAK3044	XAK3044	XAK3043	XAK3043	
NSP	43	Front Panel Assy B	XXG3027	XXG3027	XXG3026	XXG3026	
	44	Sub Panel B	XZN3053	XZN3053	XZN3052	XZN3052	
	45	Front Panel B	XZN3051	XZN3051	XZN3050	XZN3050	

2.5 \$M MECHANISM CD

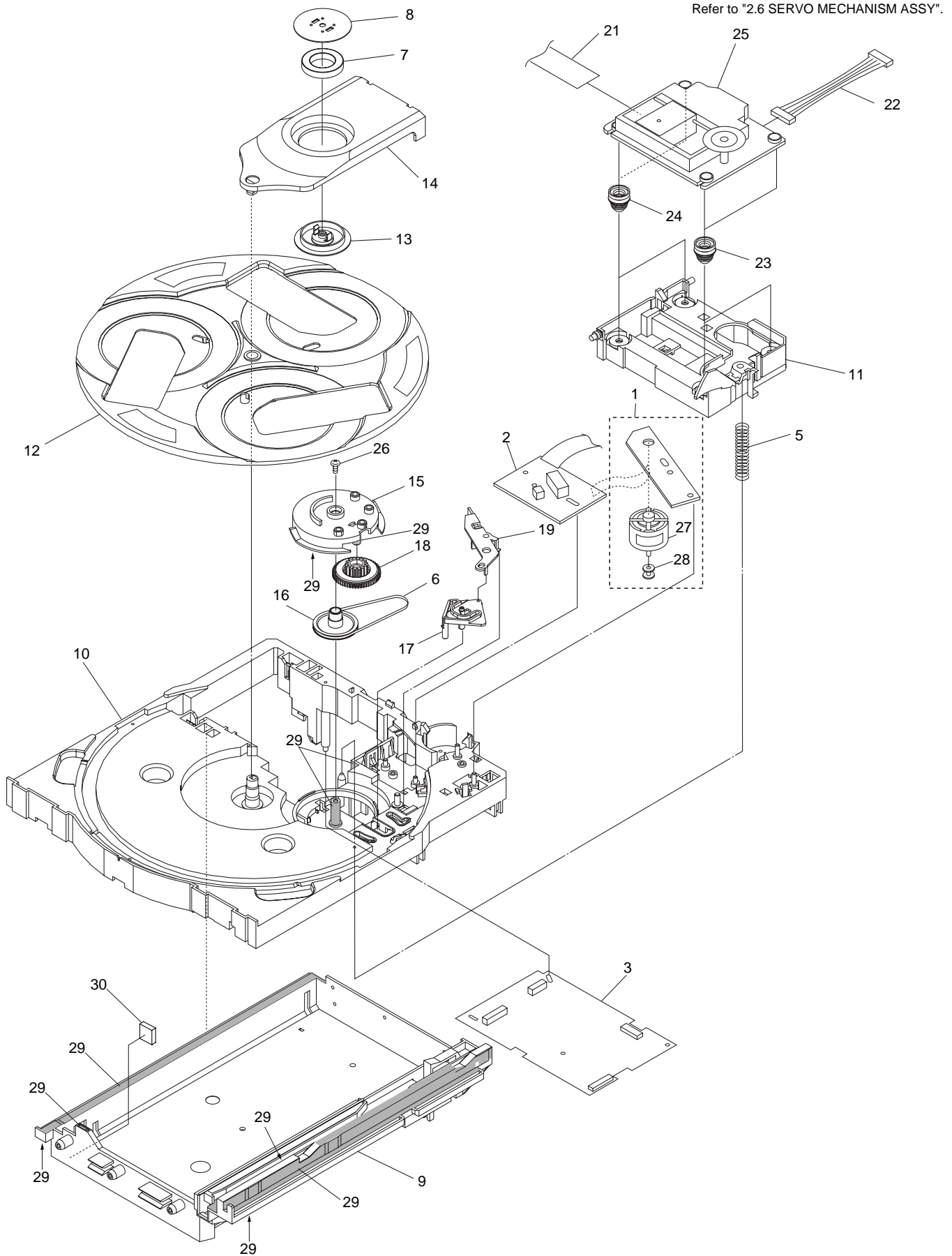

2.6 SERVO MECHANISM ASSY

● \$M MECHANISM CD PARTS LIST

Mark	No.	Description	Part No.
⊗	1	MOTOR Assy	AWZ8428
NSP	2	SW Assy	AWZ8429
⊗	3	CD Assy	AWZ3141
	4	•••••	
	5	Servo Spring	ABH7126
	6	Belt	AEB7072
	7	Clamp Magnet	AMF7001
	8	Yoke	ANB7067
	9	Mecha Base	ANW7125
	10	Loading Tray	ANW7088
	11	Servo Base	ANW7089
	12	Rotary Tray	ANW7113
	13	Clamper	ANW7091
	14	Clamper Holder	ANW7092
	15	Main Cam	ANW7093
	16	Gear Pulley	ANW7094
	17	Lock Lever	ANW7095
	18	Planet Gear	ANW7096
	19	Actuator	ANW7097
	20	•••••	
	21	15P F.F.C/30V	ADD7038
	22	Connector Assy (6P)	ADE7010
	23	Float Rubber A	AEB7063
	24	Float Rubber B	AEB7066
	25	Servo Mechanism Assy	AXA7039
	26	Screw	IPZ30P080FMC
	27	Carriage Motor	VXM1033
	28	Motor Pulley	PNW1634
	29	Ha Nari	GEM1016
	30	Cushion Rubber	XEB3003

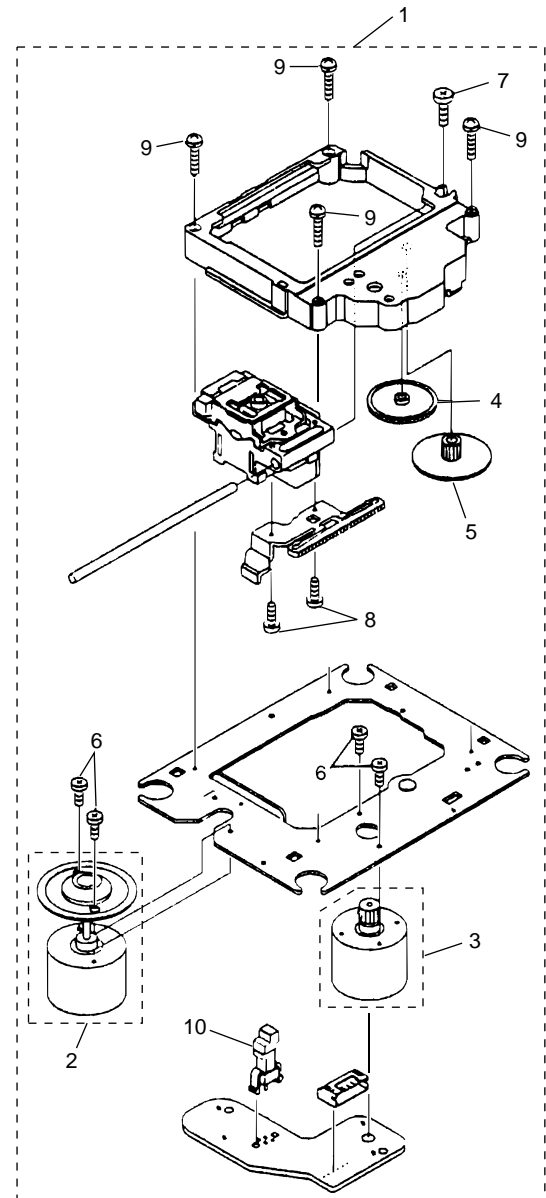

● SERVO MECHANISM ASSY PARTS LIST

Mark	No.	Description	Part No.
	1	Servo Mechanism	AXA7039
	2	SPINDLE MOTOR Assy	AEA7009
	3	SLEAD MOTOR Assy	AEA7010
	4	Gear A	AEA7013
	5	Gear B	AEA7014
	6	Screw	AEA7015
	7	Screw	AEA7016
	8	Screw	AEA7017
	9	Screw	AEA7018
	10	Leaf Switch	AEA7011

2.7 MECHANISM UNIT

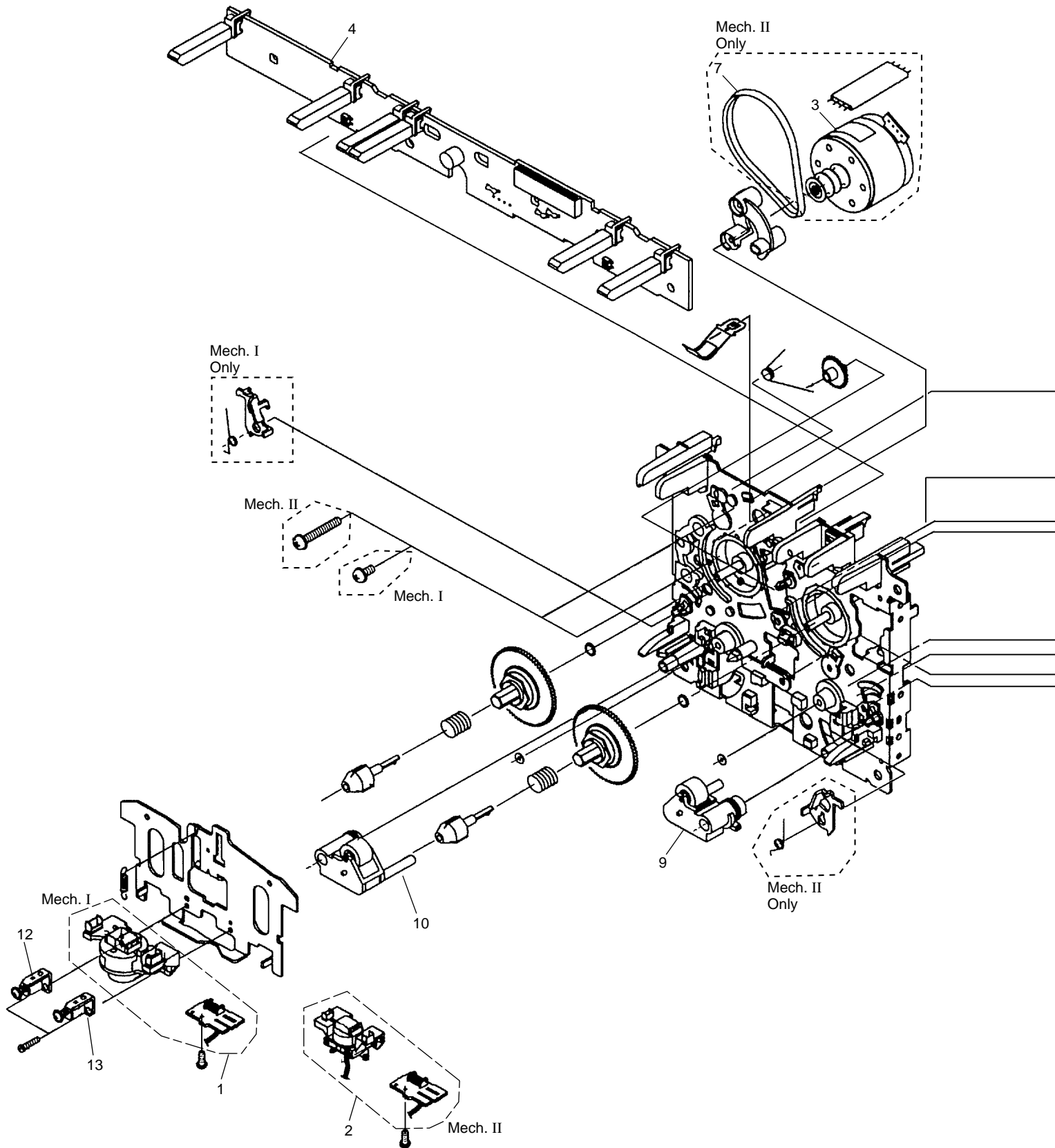

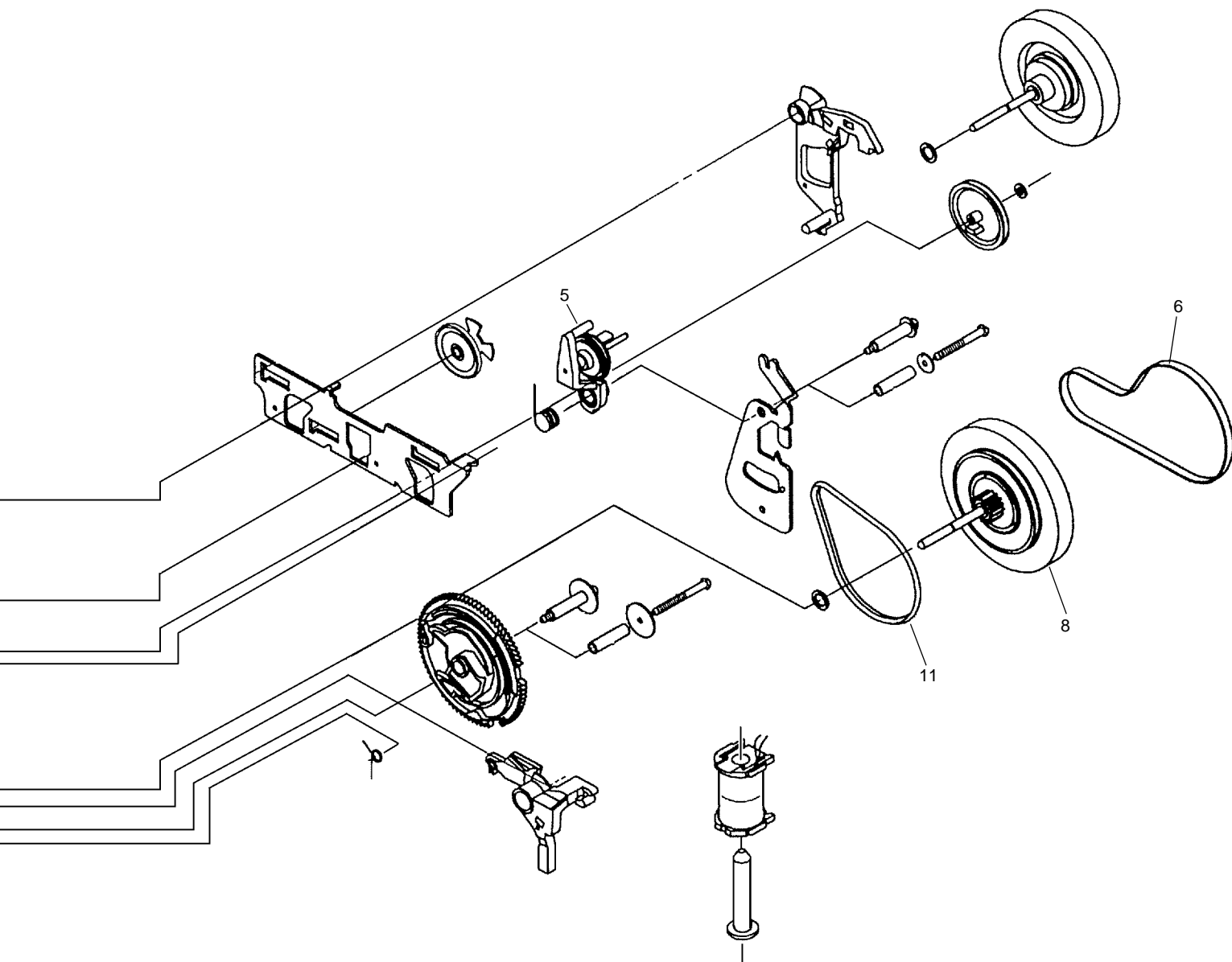

● MECHANISM UNIT PARTS LIST

Mark	No.	Description	Part No.
	1	Plate HD BLK (Mech. I)	F513-819
	2	Plate HD BLK (Mech. II)	F513-811
	3	Motor Main BLK (Mech. II only)	F525-324
	4	PCB Control BLK	F567-621
	5	Clutch Assy BLK	F522-037
	6	Main Belt	FF17G-31
	7	Joint Belt 113 (Mech. II only)	FF19D-21
	8	Clutch Assy BLK	F522-045
	9	Roller Pinch BLK R	F514-129
	10	Roller Pinch BLK L	F514-130
	11	F/R Belt	FF18W-12
	12	Plate Base BLK	F512-127
	13	Plate Base BLK	F512-128

3. SCHEMATIC DIAGRAM

3.1 OVERALL WIRING DIAGRAM

A

B

C

D

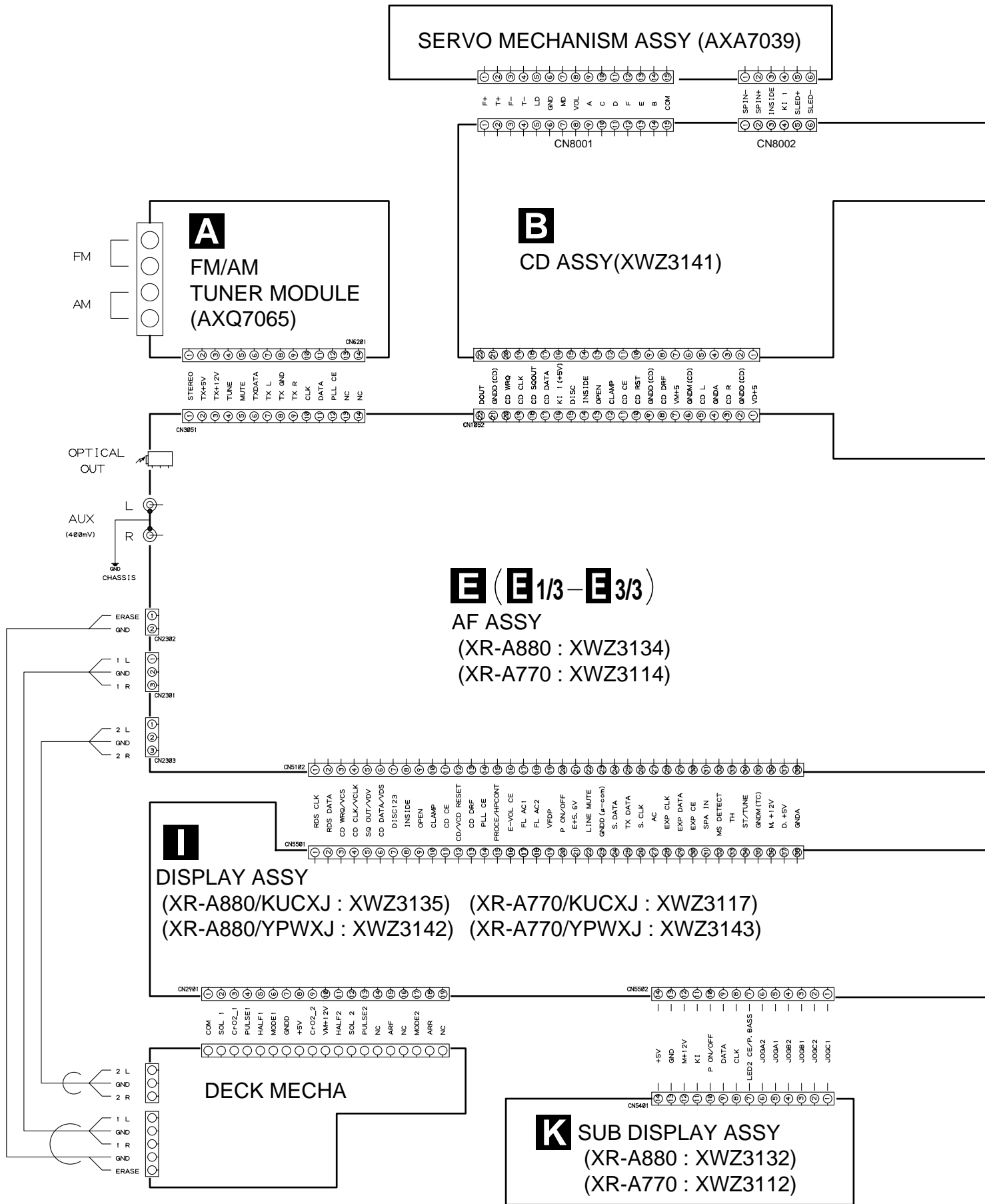

Note : When ordering service parts, be sure to refer to "EXPLODED VIEWS and PARTS LIST" or "PCB PARTS LIST".

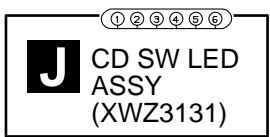
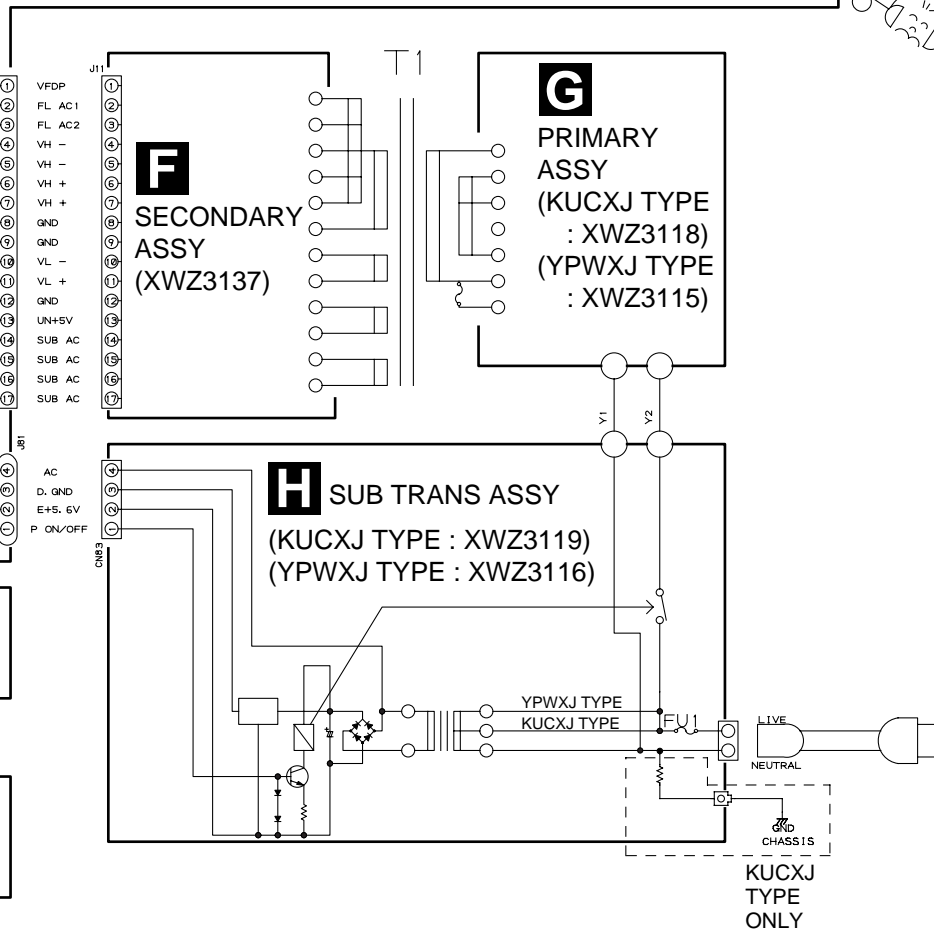
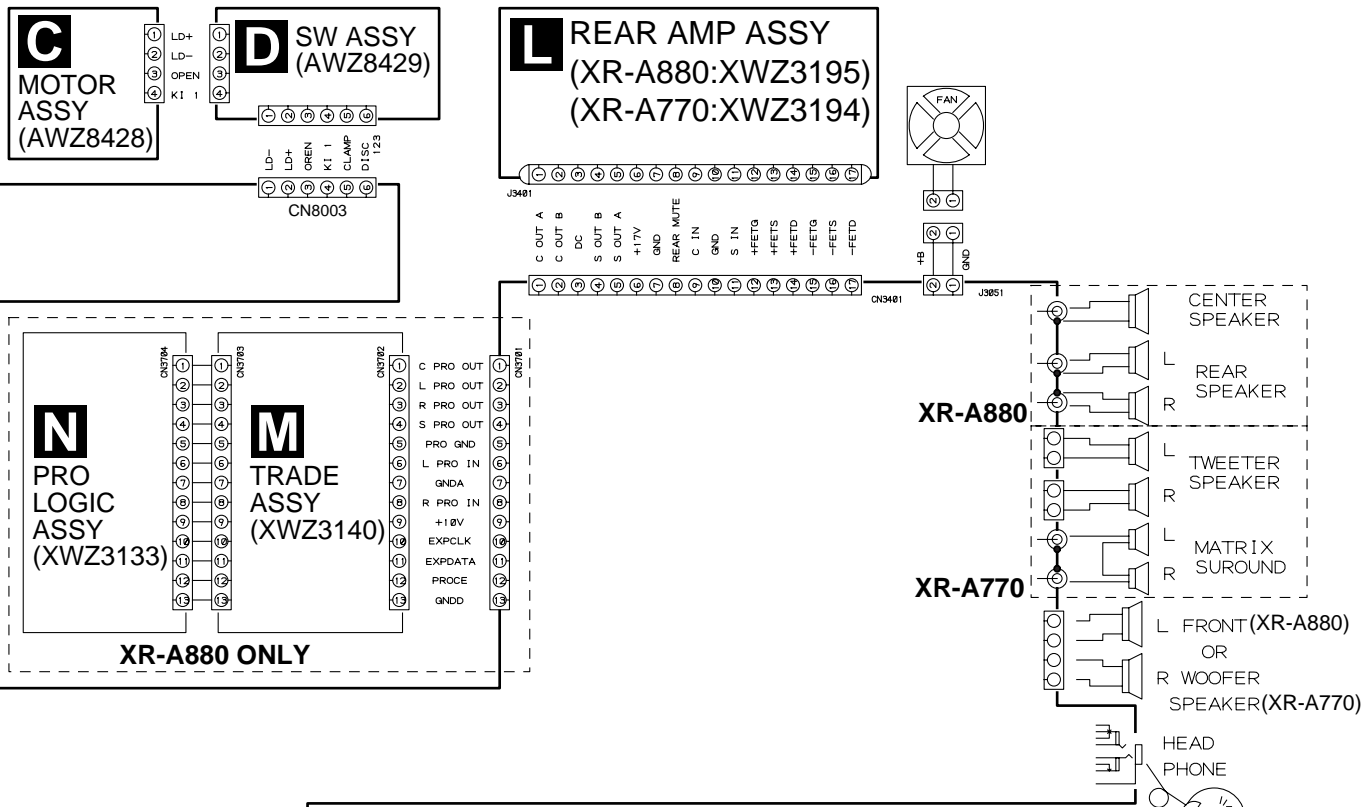

3.2 FM/AM TUNER MODULE

A

B

C

D

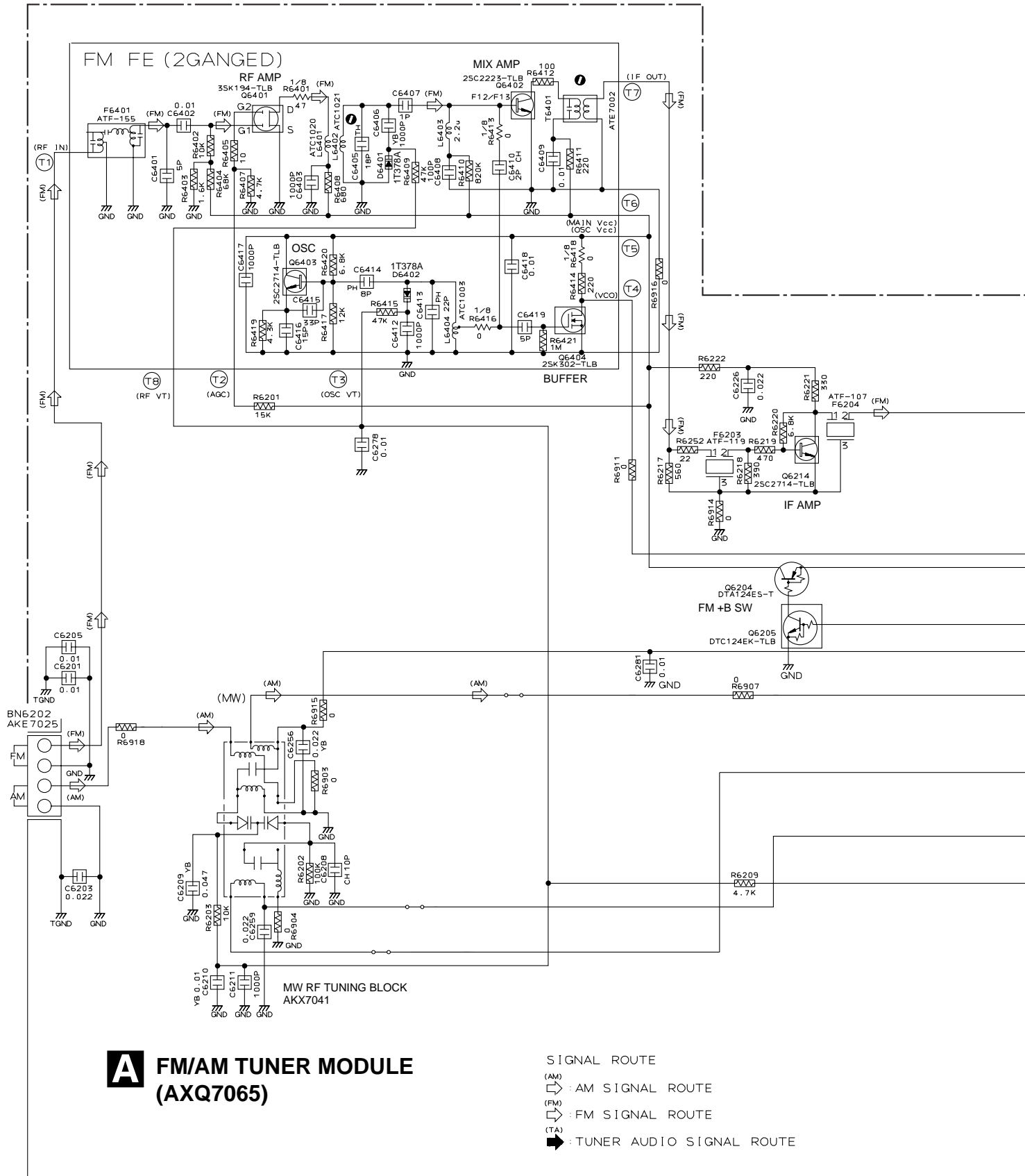

A **FM/AM TUNER MODULE (AXQ7065)**

- SIGNAL ROUTE
 (AM) AM SIGNAL ROUTE
 (FM) FM SIGNAL ROUTE
 (TA) TUNER AUDIO SIGNAL ROUTE

Notes

1. RESISTORS

Indicated in Ω , $1/10W \pm 5\%$ Tolerance unless otherwise noted K:K Ω , M:M Ω .

2. CAPACITORS

Indicated in Capacity (μF)/VOLTAGE (V) unless otherwise noted P:PF.

3. DIODES

No mark diode is 1SS254.

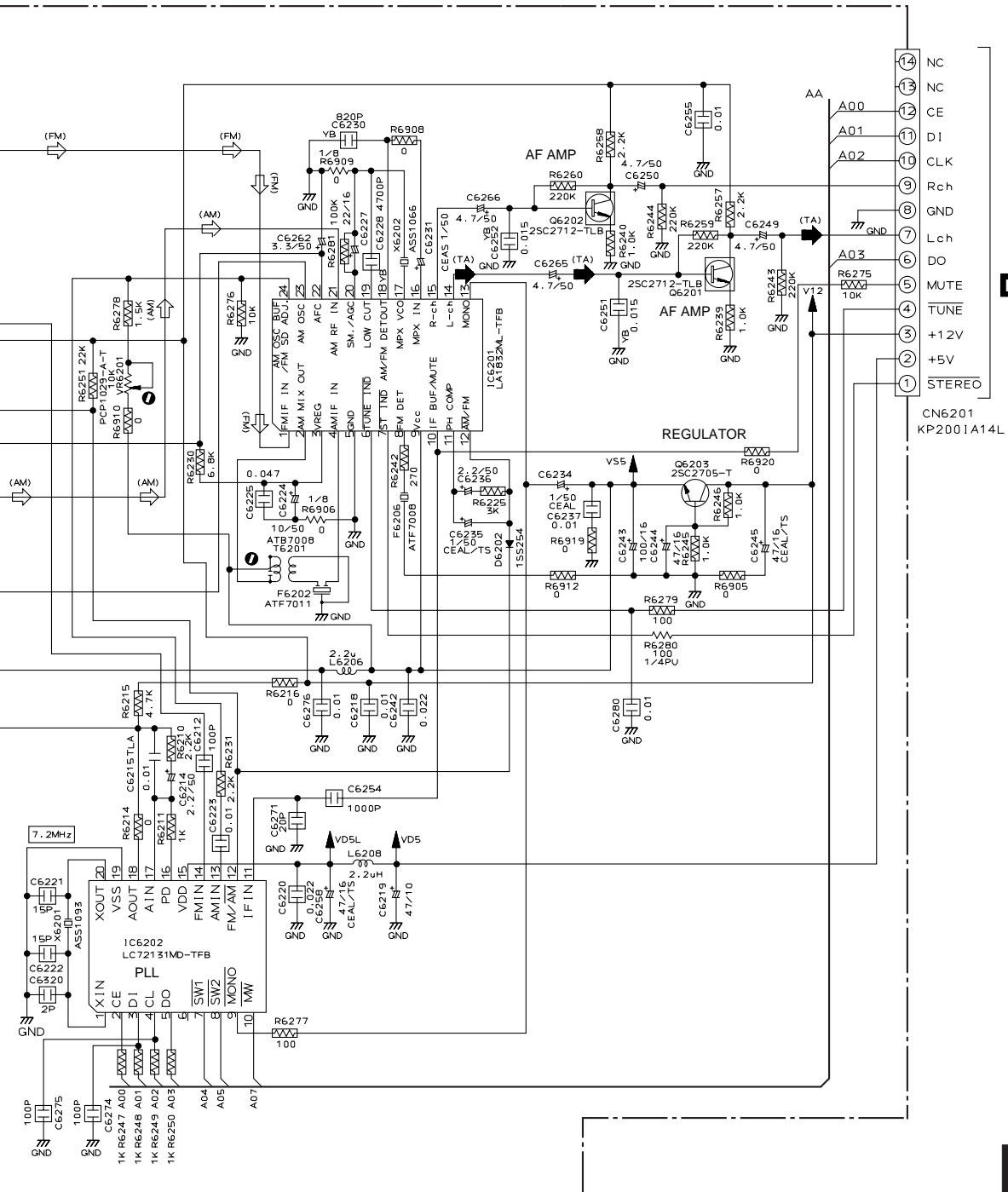

E2/3 CN3051

CN6201
KP2001A14L



3.3 CD, MOTOR and SW ASSEMBLIES

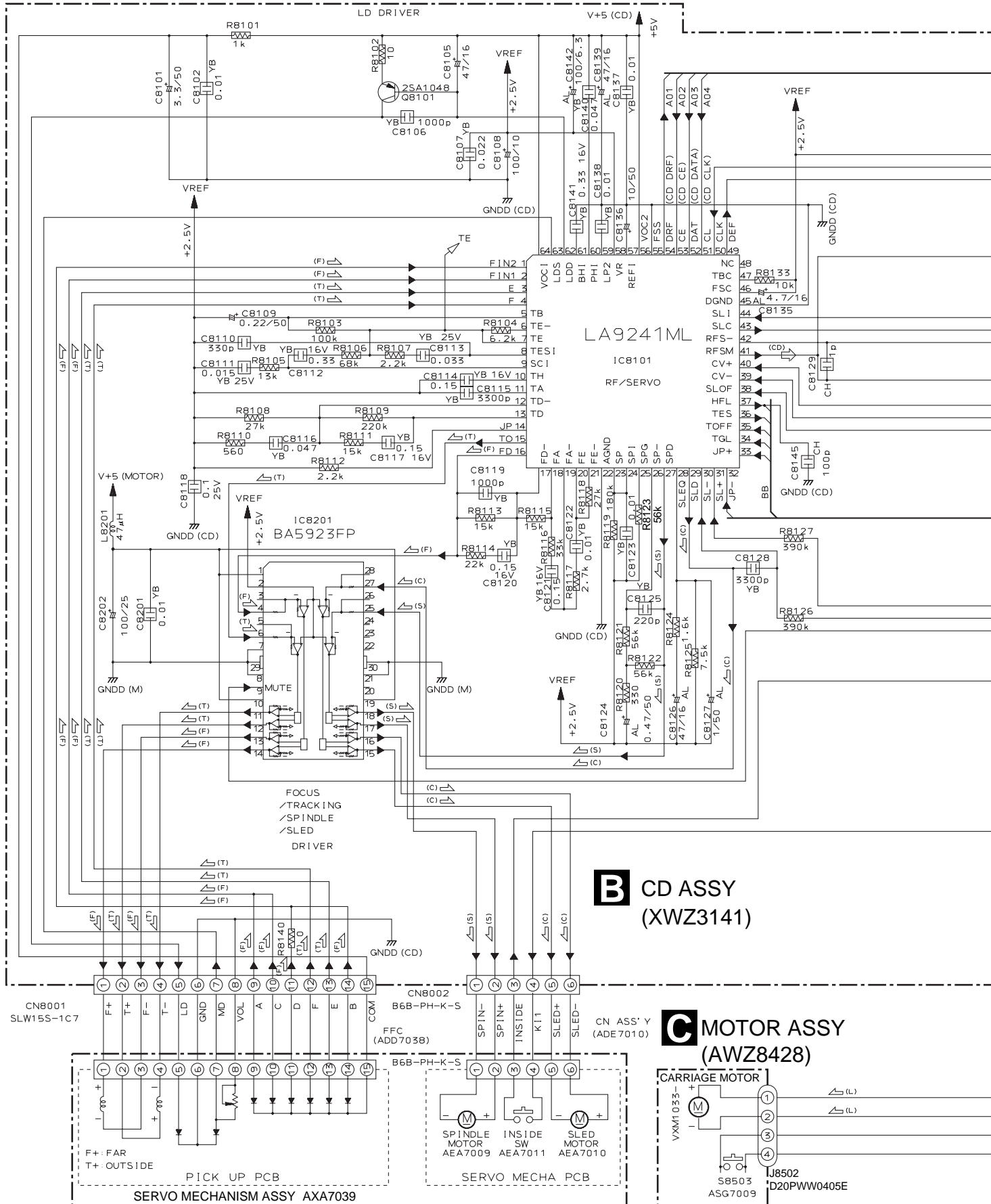

B CD ASSY (XWZ3141)

C MOTOR ASSY (AWZ8428)

SERVO MECHANISM ASSY AXA7039

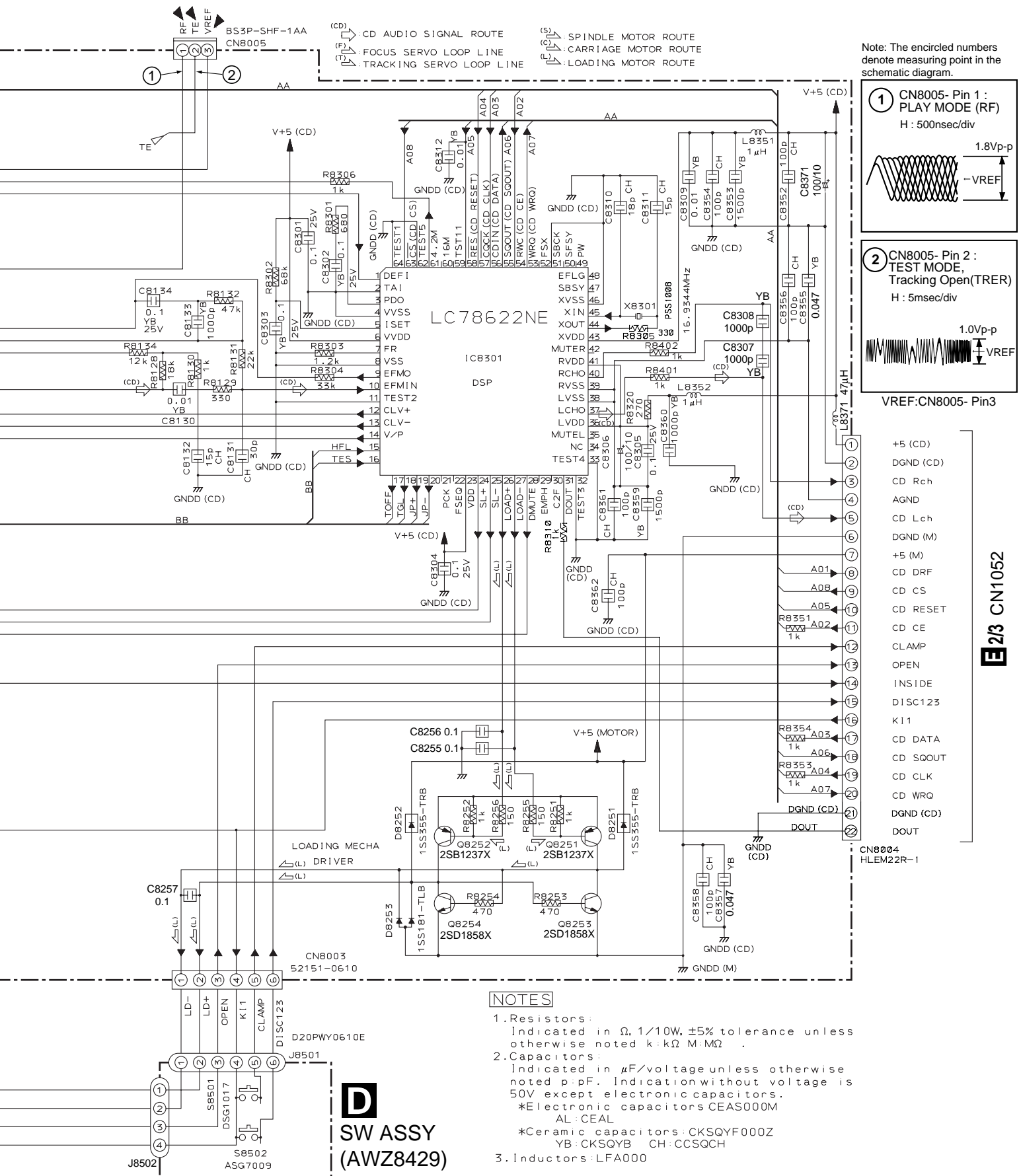

A

B

C

D



3.4 AF ASSY (1/3)

E 1/3

AF ASSY
 (XR-A880 : XWZ3134)
 (XR-A770 : XWZ3114)

→ : ISS133
 ⇨ : ISS355

(PB) ⇨ : DECK PB SIGNAL ROUTE
 (REC) ⇨ : DECK REC SIGNAL ROUTE

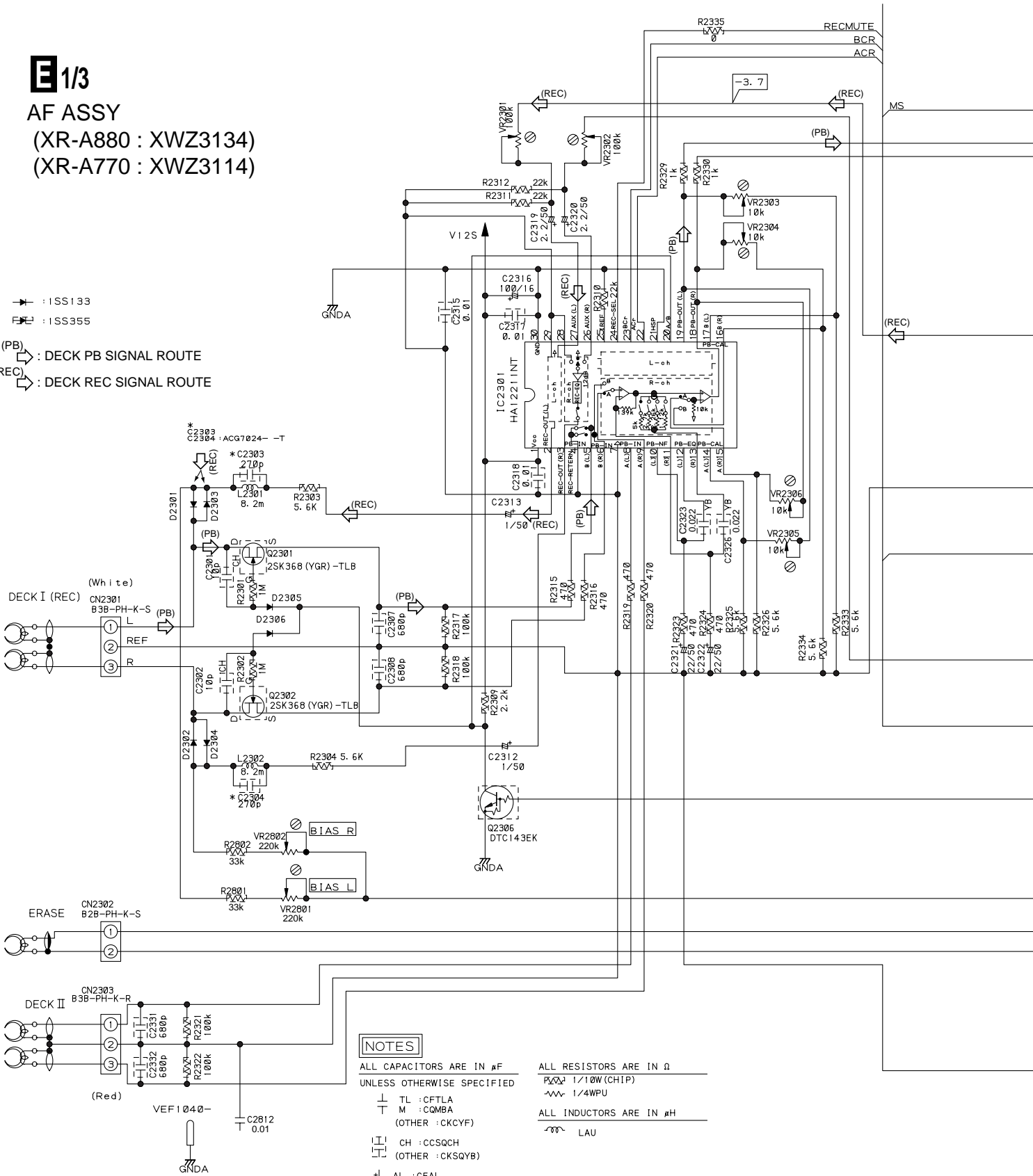

NOTES

- ALL CAPACITORS ARE IN μ F
- ALL RESISTORS ARE IN Ω
- UNLESS OTHERWISE SPECIFIED
- ⇨ 1/10W (CHIP)
- ⇨ 1/4WPU
- ALL INDUCTORS ARE IN μ H
- ⇨ LAU
- TL : CFTLA
- M : COMBA
- (OTHER : CKCYF)
- CH : CCSQCH
- (OTHER : CKSQYB)
- AL : CEAL
- HAQ : CEHAQ
- (OTHER : CEAS**M## or CEAT**M##M##)

E 1/3

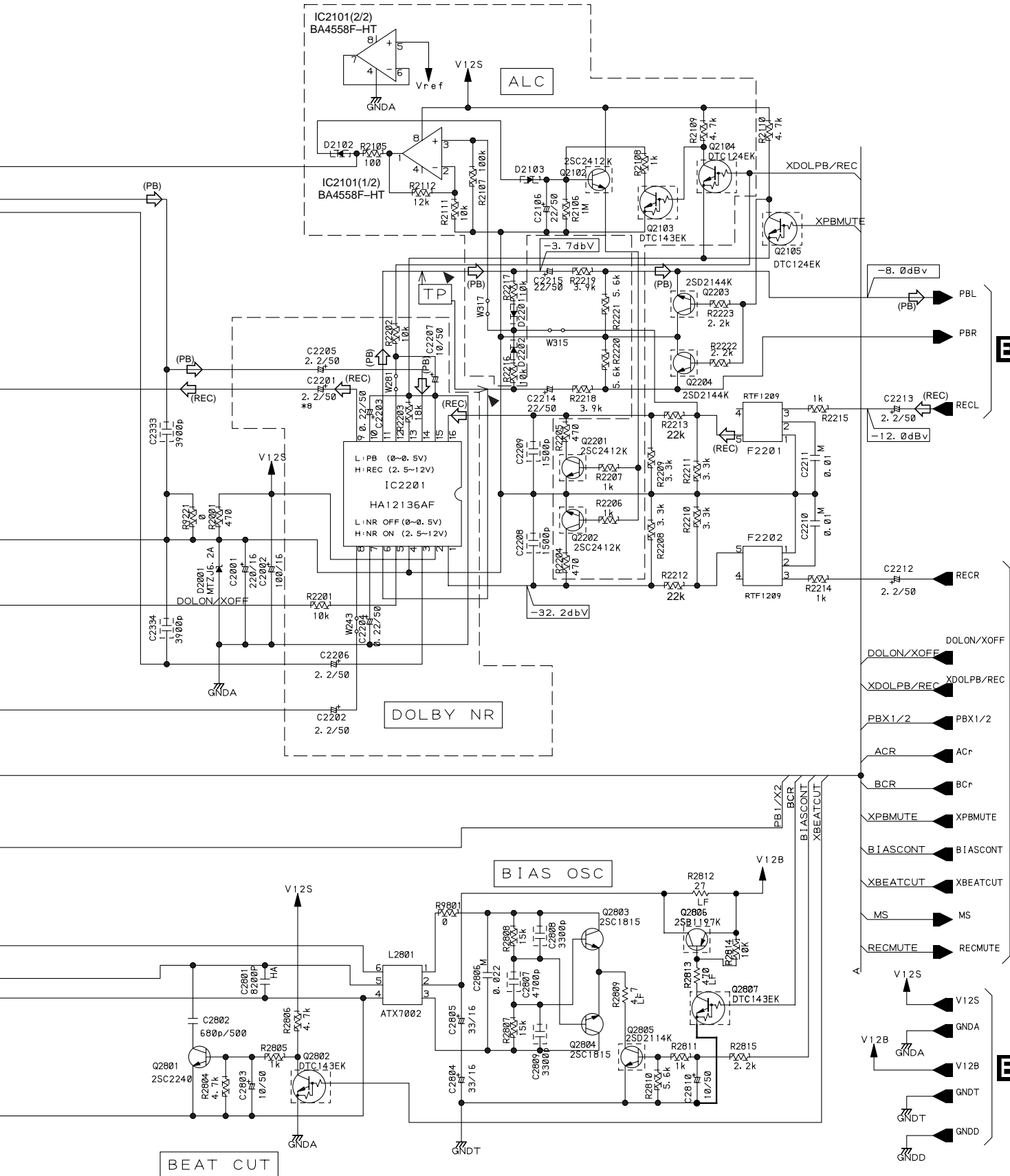

- A
 - B
 - C
 - D
- E/3
 - E/3
 - E/3
 - E/3
- PBL
 - PBR
 - RECL
 - RECR
 - DOLON/XOFF
 - XDOLPB/REC
 - PBX1/2
 - ACR
 - BCR
 - XPBMUTE
 - BIASCONT
 - XBEATCUT
 - MS
 - RECMUTE
 - V12S
 - GND A
 - V12B
 - GND T
 - GND D

1 2 3 4
XR-A880, XR-A770

3.5 AF ASSY (2/3)

B CN8004

E 3/3

A

B

C

D

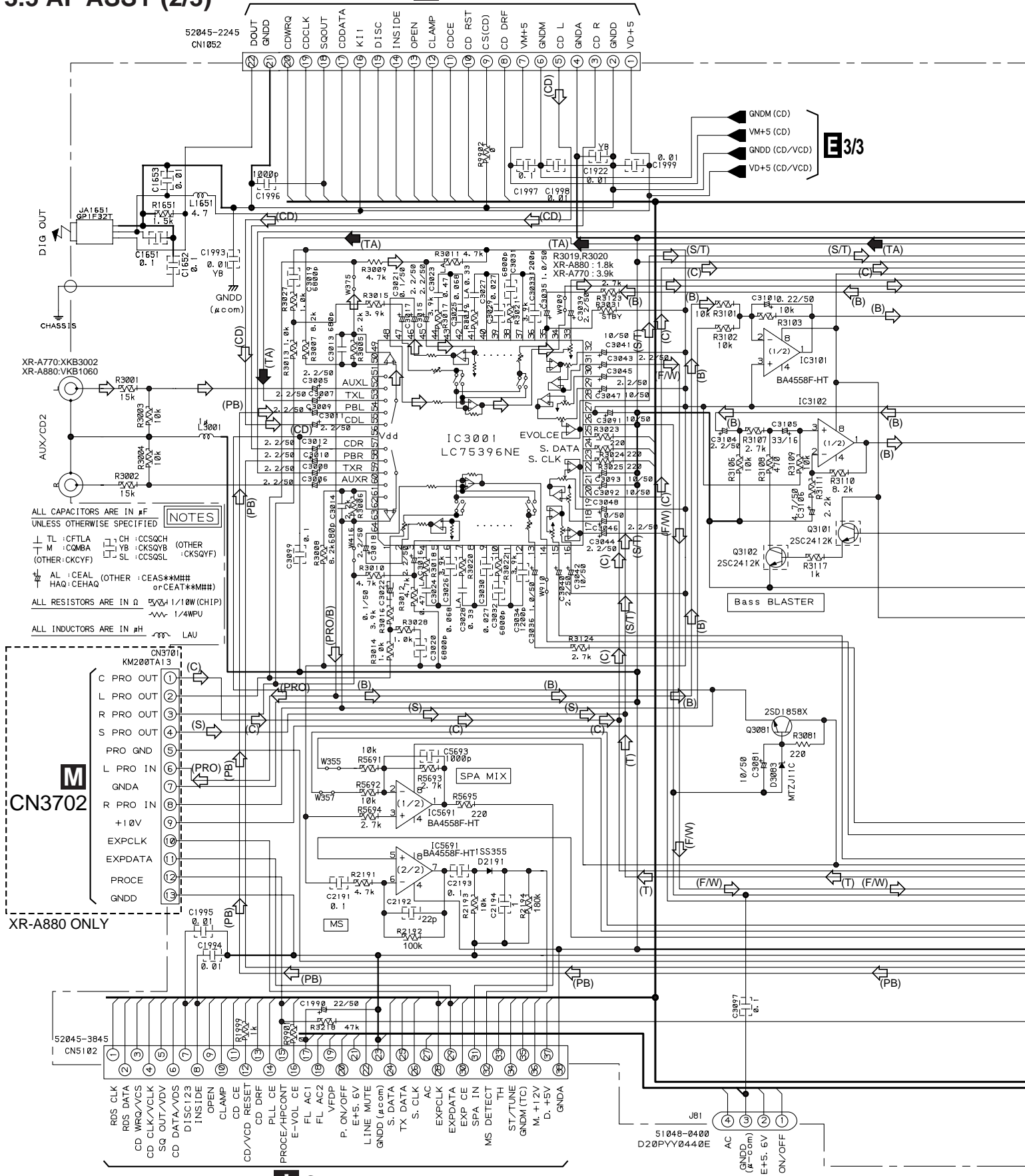

NOTES
ALL CAPACITORS ARE IN #F UNLESS OTHERWISE SPECIFIED
TL - CFTLA CH - CCSQCH
M - COMBA YB - CKSQYB (OTHER
(OTHER: CKCYF) SL - CCSQSL - CKSQYF
AL - CEAL (OTHER: CEAS*MM##
HAQ: CEHAQ or CEAT*MM##)
ALL RESISTORS ARE IN Ω $\frac{1}{5}$ W $\frac{1}{10}$ W (CHIP)
 \sim 1/4WPU
ALL INDUCTORS ARE IN #H
LAU

M CN3702

I CN5501

H CN83

A CN6201

E 2/3 AF ASSY
(XR-A880 : XWZ3134)
(XR-A770 : XWZ3114)

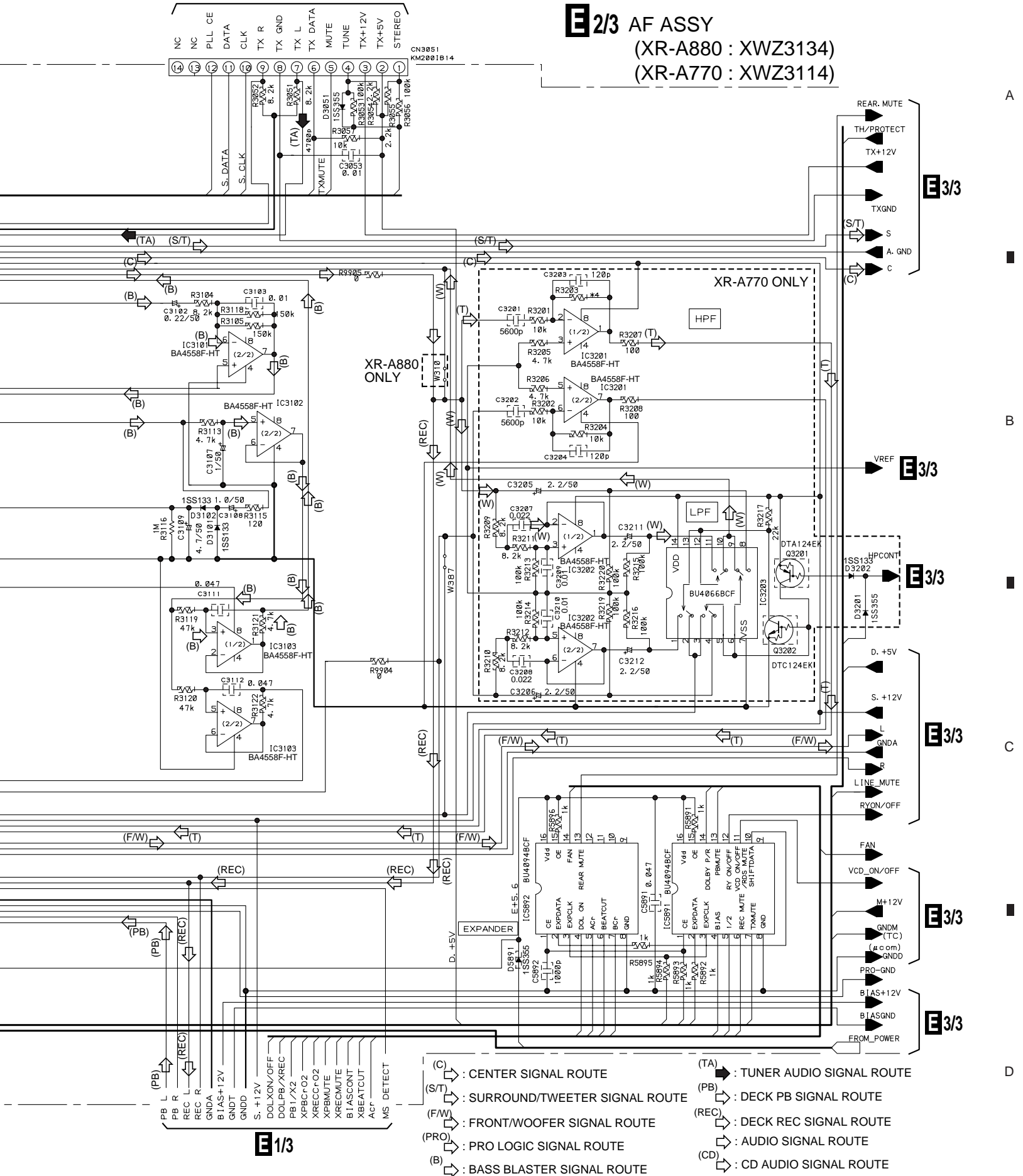

E 1/3

E 2/3 25

3.6 AF (3/3) and SECONDARY ASSEMBLIES

J3401

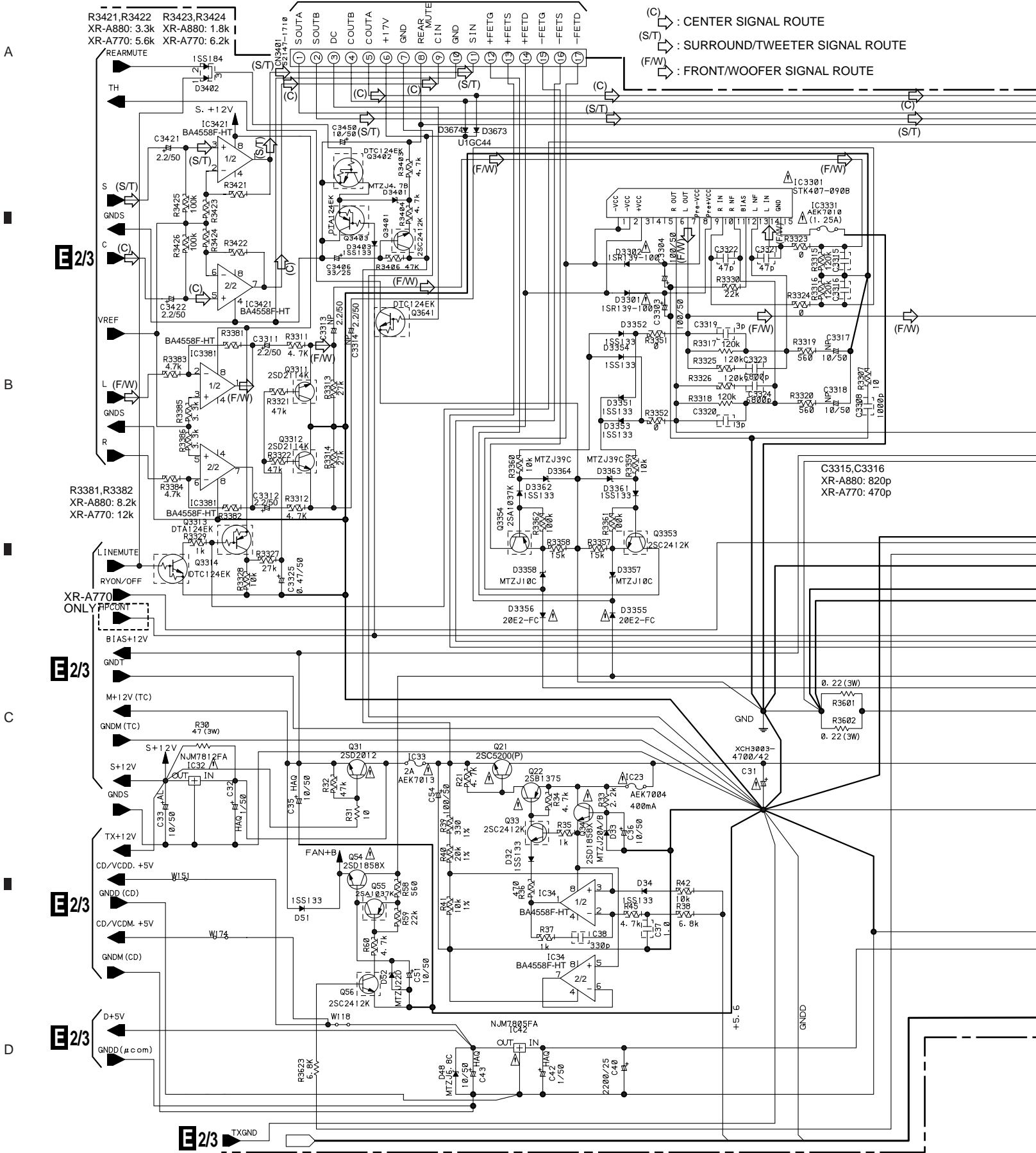

CAUTION : FOR CONTINUED PROTECTION AGAINST RISK OF FIRE. REPLACE ONLY WITH SAME TYPE NO. 491.400 MFD, BY LITTELFUSE INK. FOR IC23 (AEK7004).

CAUTION : FOR CONTINUED PROTECTION AGAINST RISK OF FIRE. REPLACE ONLY WITH SAME TYPE NO. 491002 MFD, BY LITTELFUSE INK. FOR IC33 (AEK7013).

CAUTION : FOR CONTINUED PROTECTION AGAINST RISK OF FIRE. REPLACE ONLY WITH SAME TYPE NO. 4911.25 MFD, BY LITTELFUSE INK. FOR IC3331 (AEK7010).

E 3/3 AF ASSY (XR-A880 : XWZ3134)(XR-A770 : XWZ3114)

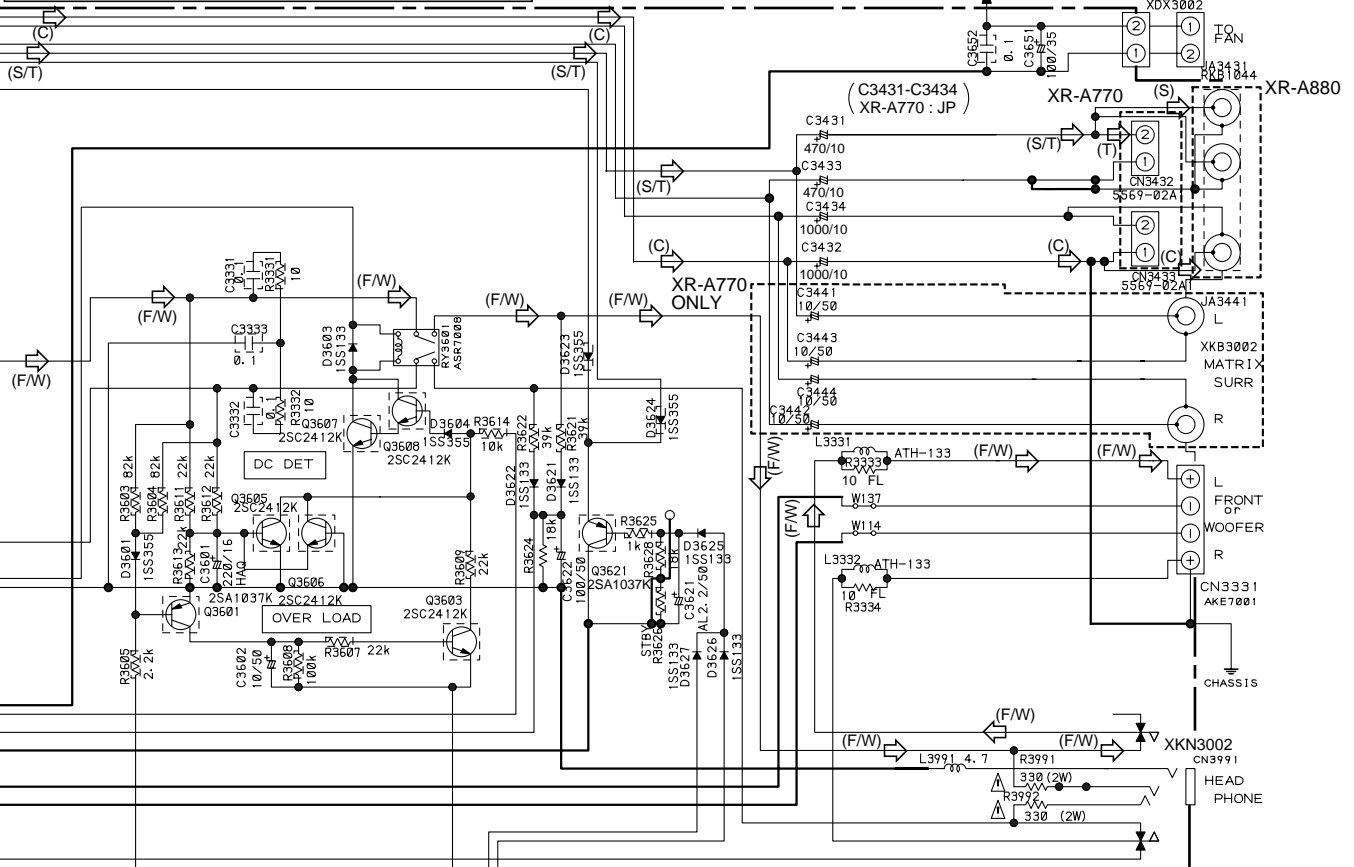

F SECONDARY ASSY(XWZ3137)

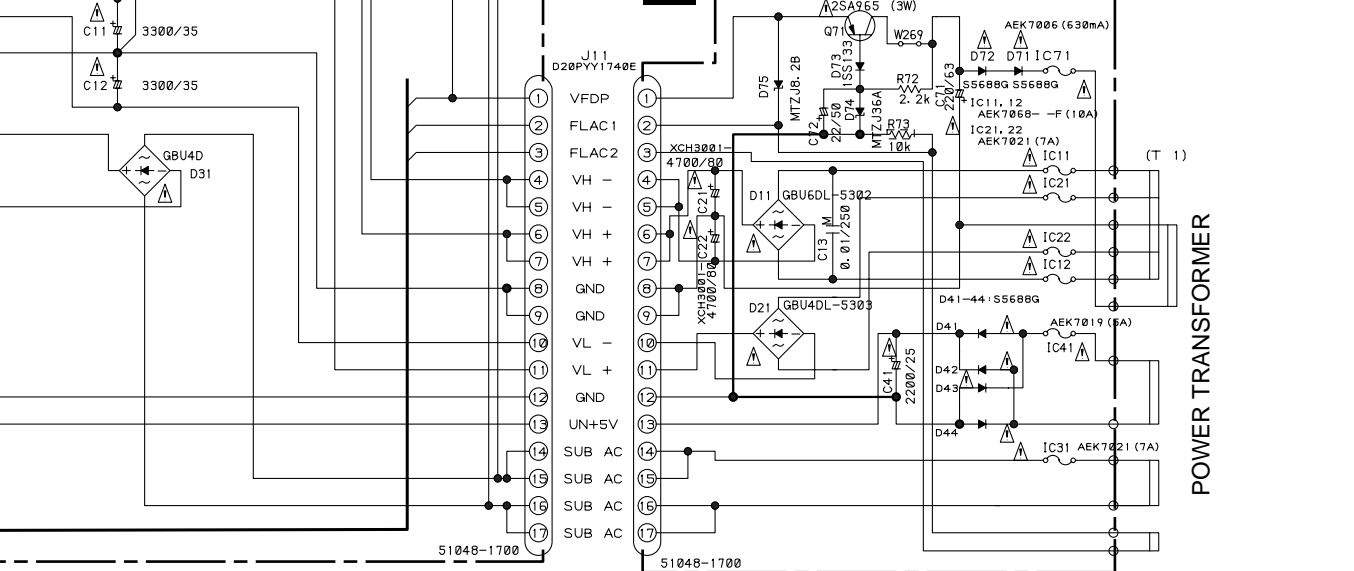

CAUTION : FOR CONTINUED PROTECTION AGAINST RISK OF FIRE. REPLACE ONLY WITH SAME TYPE NO. 491.630 MFD, BY LITTELFUSE INK. FOR IC71 (AEK7006).

CAUTION : FOR CONTINUED PROTECTION AGAINST RISK OF FIRE. REPLACE ONLY WITH SAME TYPE NO. 491007 MFD, BY LITTELFUSE INK. FOR IC21, 22, 31 (AEK7021).

CAUTION : FOR CONTINUED PROTECTION AGAINST RISK OF FIRE. REPLACE ONLY WITH SAME TYPE NO. 491010F MFD, BY LITTELFUSE INK. FOR IC11, 12 (AEK7068).

CAUTION : FOR CONTINUED PROTECTION AGAINST RISK OF FIRE. REPLACE ONLY WITH SAME TYPE NO. 491005 MFD, BY LITTELFUSE INK. FOR IC41 (AEK7019).

3.7 PRIMARY and SUB TRANS ASSEMBLIES

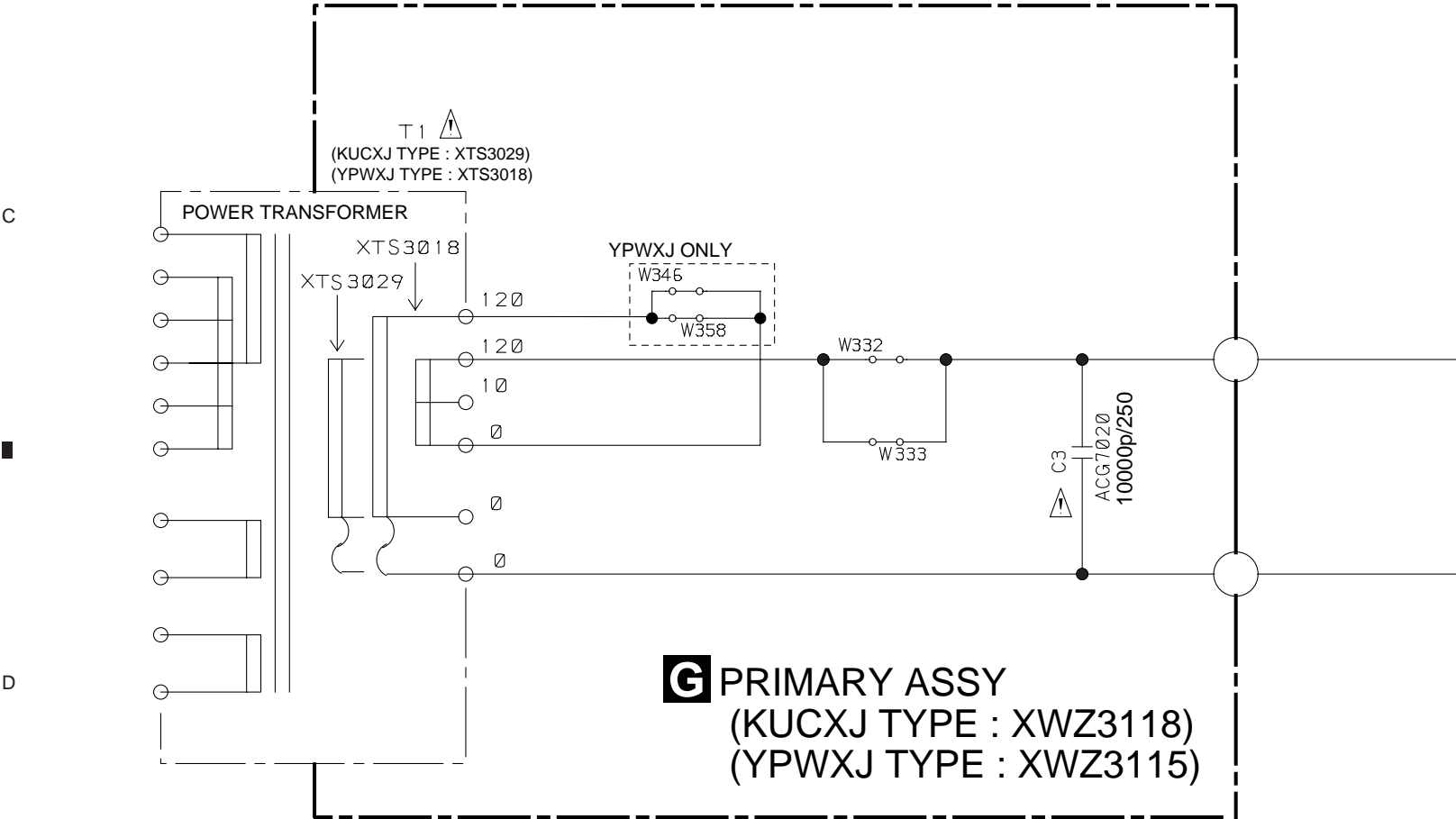
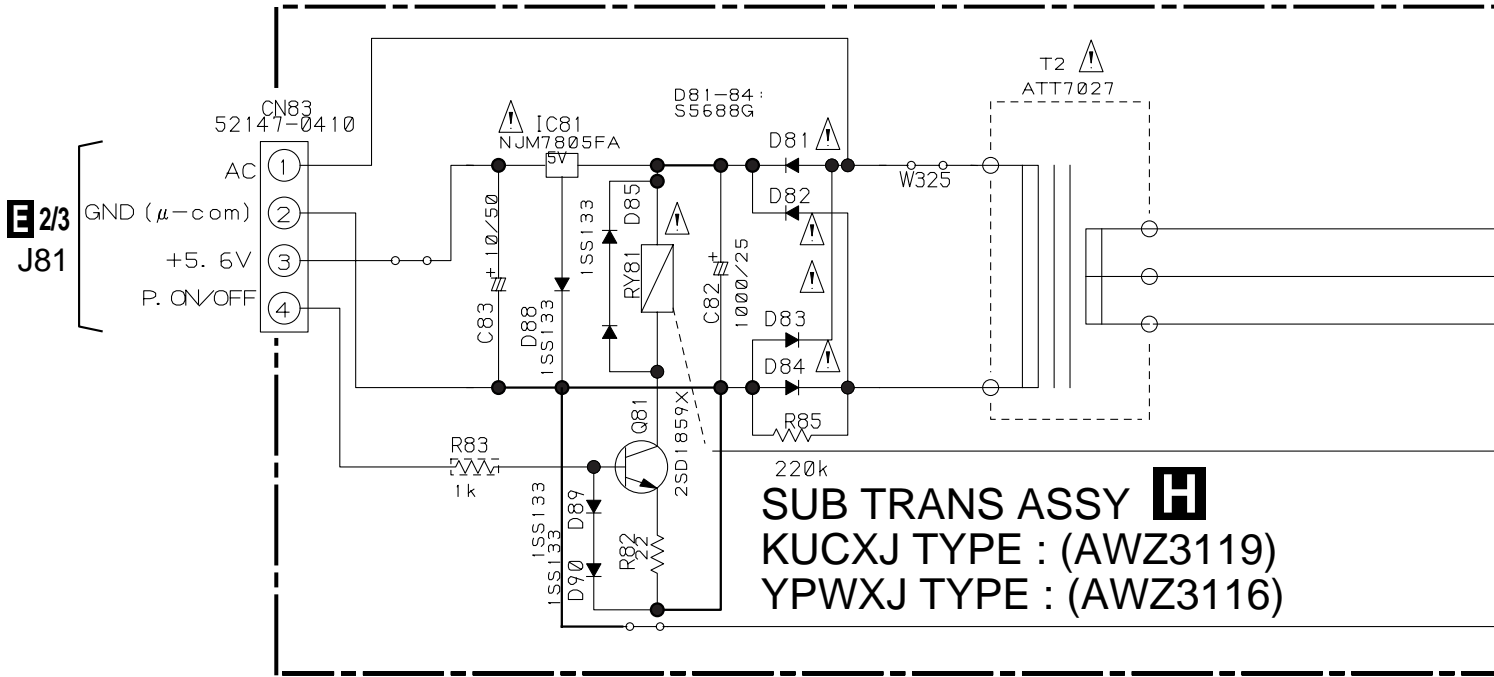

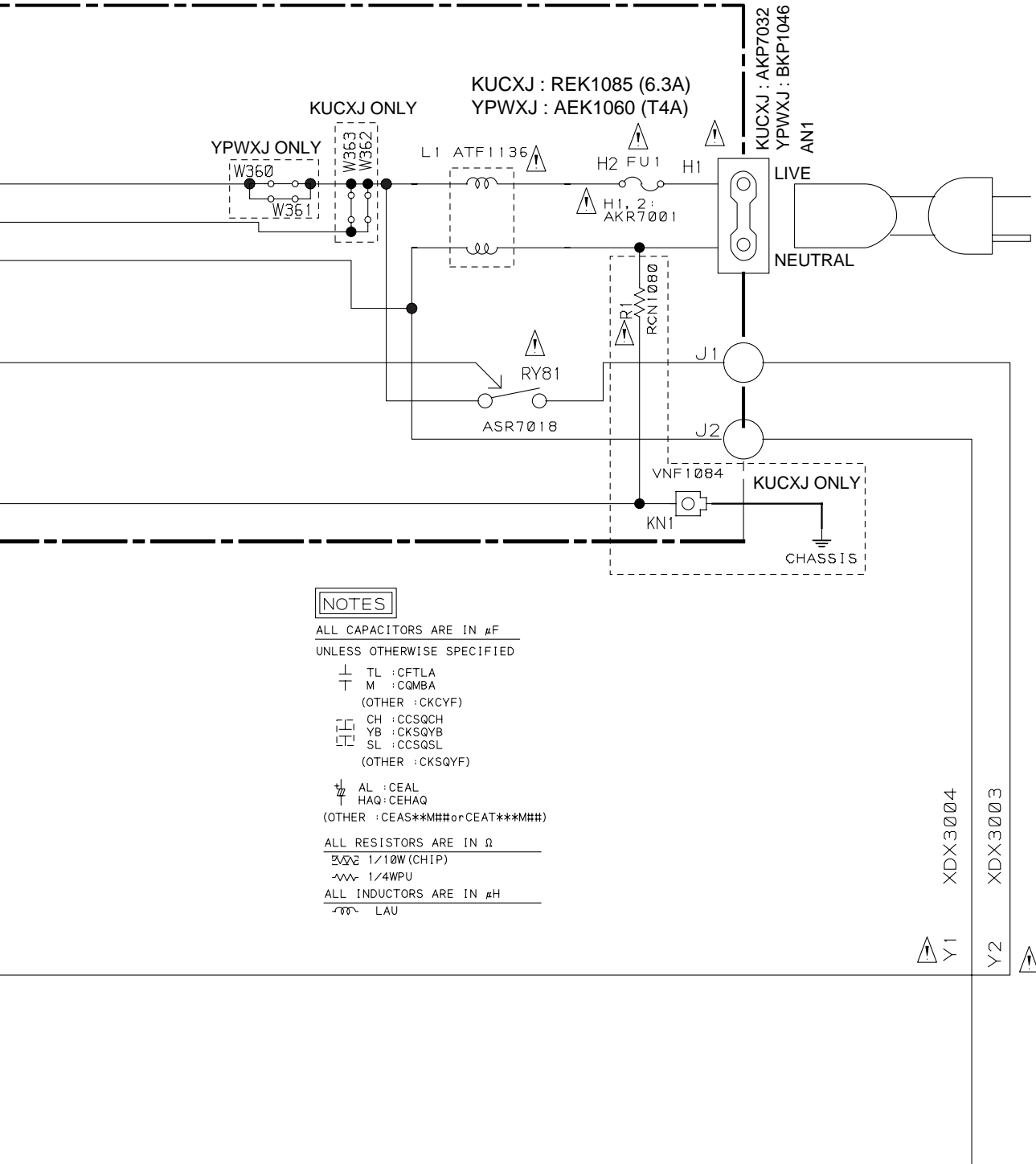

NOTES

ALL CAPACITORS ARE IN μ F
UNLESS OTHERWISE SPECIFIED

\perp TL :CFTLA
 T M :CQ MBA
 (OTHER :CKCYF)

CH :CCSQCH
 YB :CKSQYB
 SL :CCSQSL
 (OTHER :CKSQYF)

AL :CEAL
 HAQ :CEHAQ
 (OTHER :CEAS**M##orCEAT***M##)

ALL RESISTORS ARE IN Ω

1/10W (CHIP)
 1/4WPU

ALL INDUCTORS ARE IN μ H

LAU

XDX3004

XDX3003

Y1

Y2

• NOTE FOR FUSE REPLACEMENT
CAUTION -FOR CONTINUED PROTECTION AGAINST RISK OF FIRE.
 REPLACE WITH SAME TYPE AND RATINGS ONLY.



3.8 DISPLAY and CD SW LED ASSEMBLIES

DISPLAY ASSY

- S5911 : DISPLAY
- S5912 : TIMER/CLOCK ADJ
- S5913 : ENTER
- S5914 : P.BASS (XR-A880)
BALANCE (XR-A770)
- S5915 : ZOOM SURROUND
- S5916 : BASS BLASTER
- S5917 : EQUALIZER
- S5918 : PRESET
- S5919 : STANDBY/ON
- S5920 : TUNING ◀▶▶▶
- S5921 : TUNING + ▶▶▶▶
- S5922 : STOP (■)
- S5923 : PLAY/PAUSE
- S5924 : REC/STOP
- S5925 : FREQ/STATION
- S5926 : Dolby NR ON/OFF
- S5927 : ASES/COPY
- S5928 : AUX
- S5929 : TAPE I / II
- S5930 : TUNER/BAND
- S5931 : CD
- S5951 : VOLUME
- S5952 : SOUND MORPHING JOG



DISPLAY ASSY

- (XR-A880/KUCXJ : XWZ3135) (XR-A770/KUCXJ : XWZ3117)
- (XR-A880/YPWXJ : XWZ3142) (XR-A770/YPWXJ : XWZ3143)

NOTES

- ALL CAPACITORS ARE IN μ F UNLESS OTHERWISE SPECIFIED
- ALL RESISTORS ARE IN Ω
- ALL INDUCTORS ARE IN μ H
- AL : CEAL JA : CEJA HAQ : CEHAQ
- TL : CFTLA
- (OTHER : CEAS**M###orCEAT**M###)
- CH : CCSOCH YB : CKSQYB SL : CCSQSL (OTHER : CKSQYF)
- 1/10W (CHIP)
- 1/4WPU
- LAU

A

B

C

D

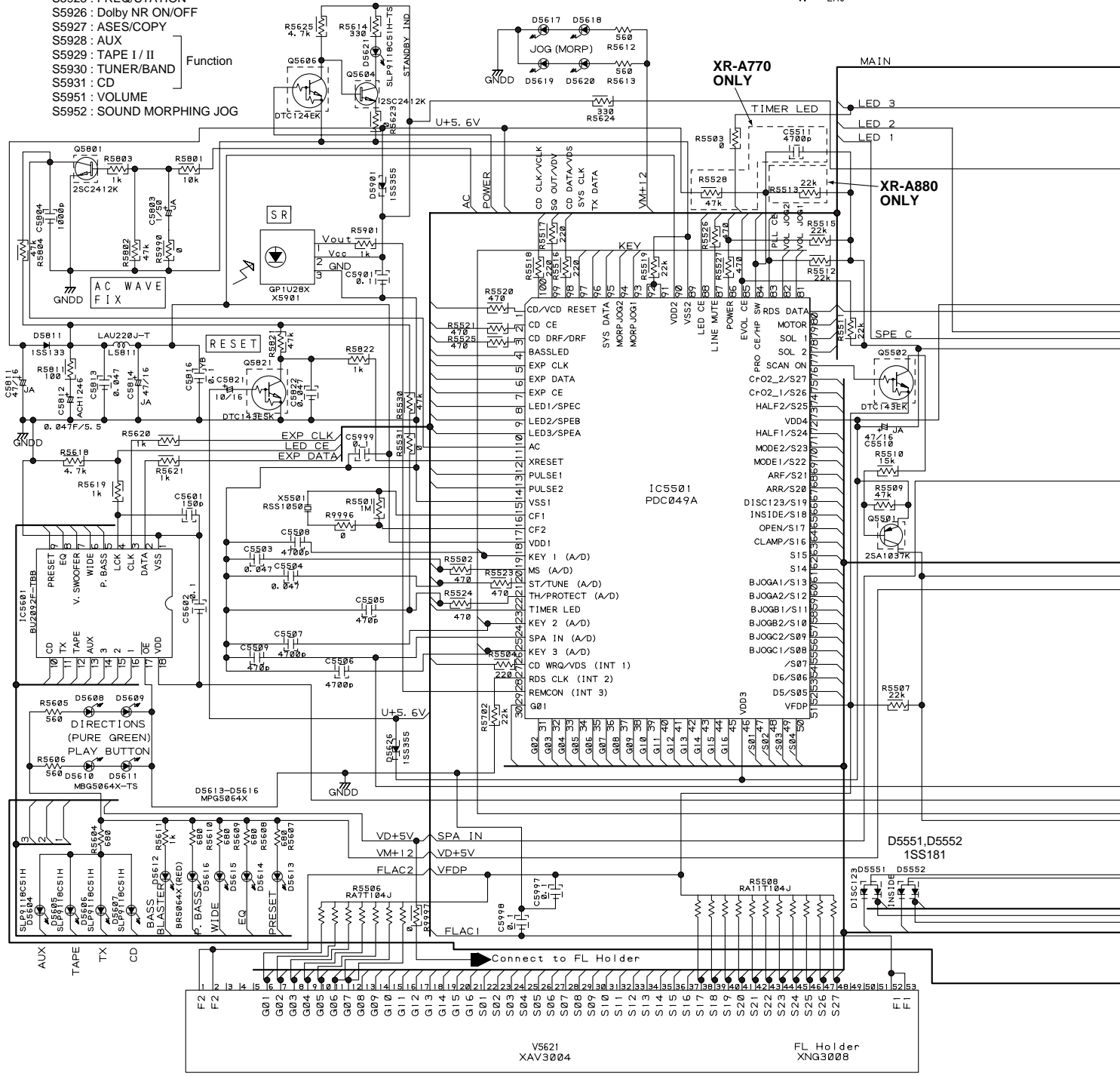

K CN5401

E 2/3 CN5102

CN5502
52045-1445

CN5501
52045-3845

CN2901
52045-1945

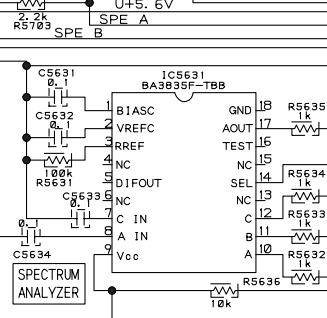
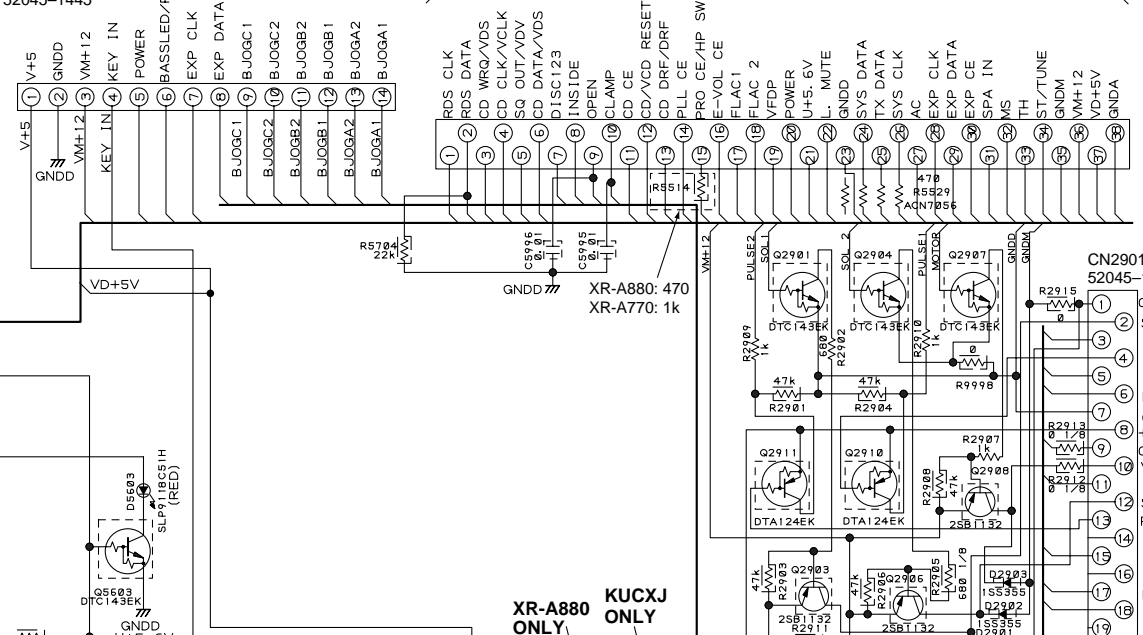

XR-A880 ONLY
KUCXJ ONLY

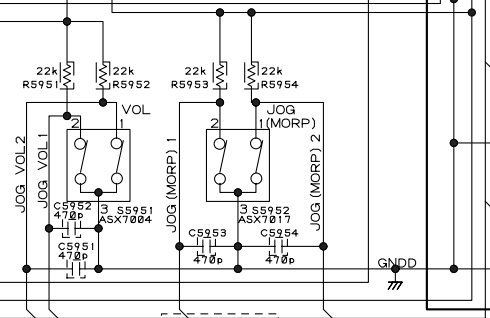
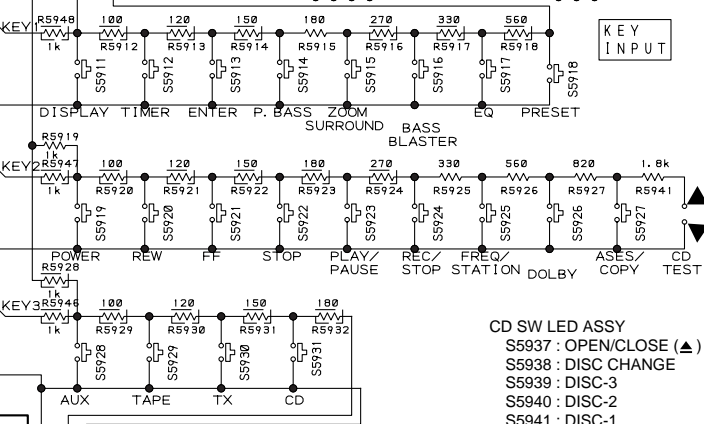
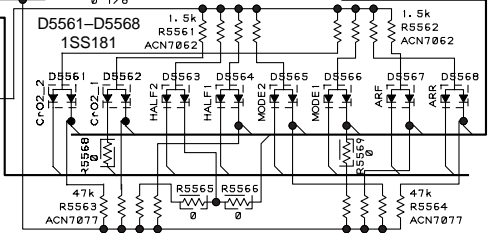

- CD SW LED ASSY
 S5937 : OPEN/CLOSE (▲)
 S5938 : DISC CHANGE
 S5939 : DISC-3
 S5940 : DISC-2
 S5941 : DISC-1

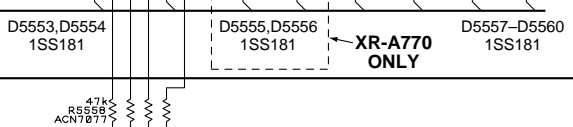

D5555, D5556 1SS181
XR-A770 ONLY

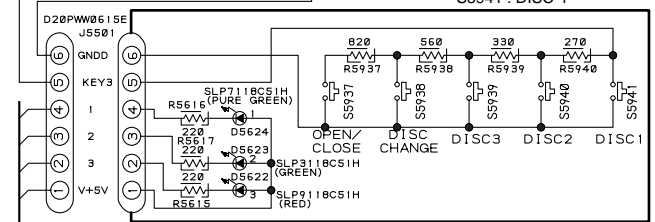

J CD SW LED ASSY (XWZ3131)



3.9 SUB DISPLAY and REAR AMP ASSEMBLIES

A

B

C

D

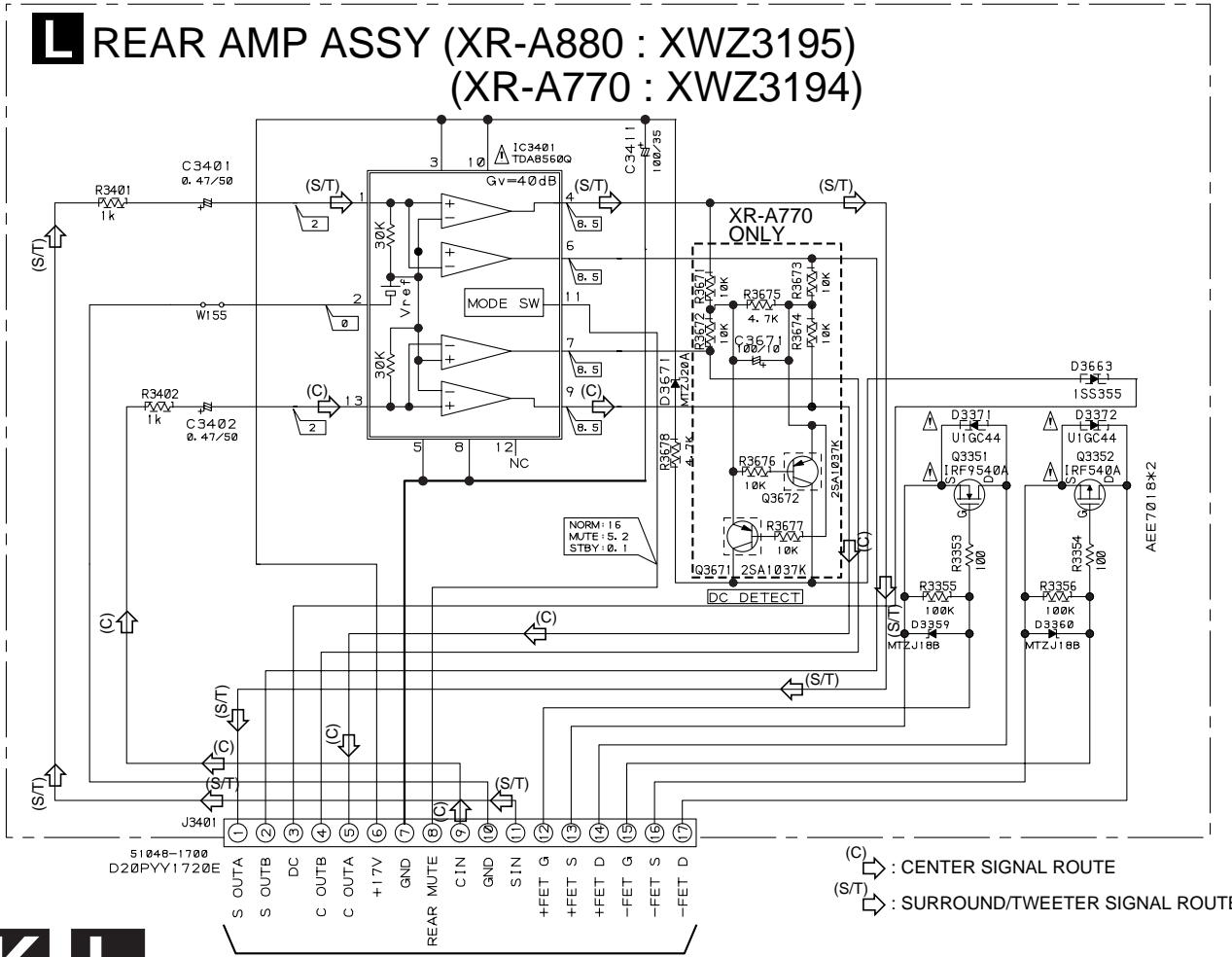
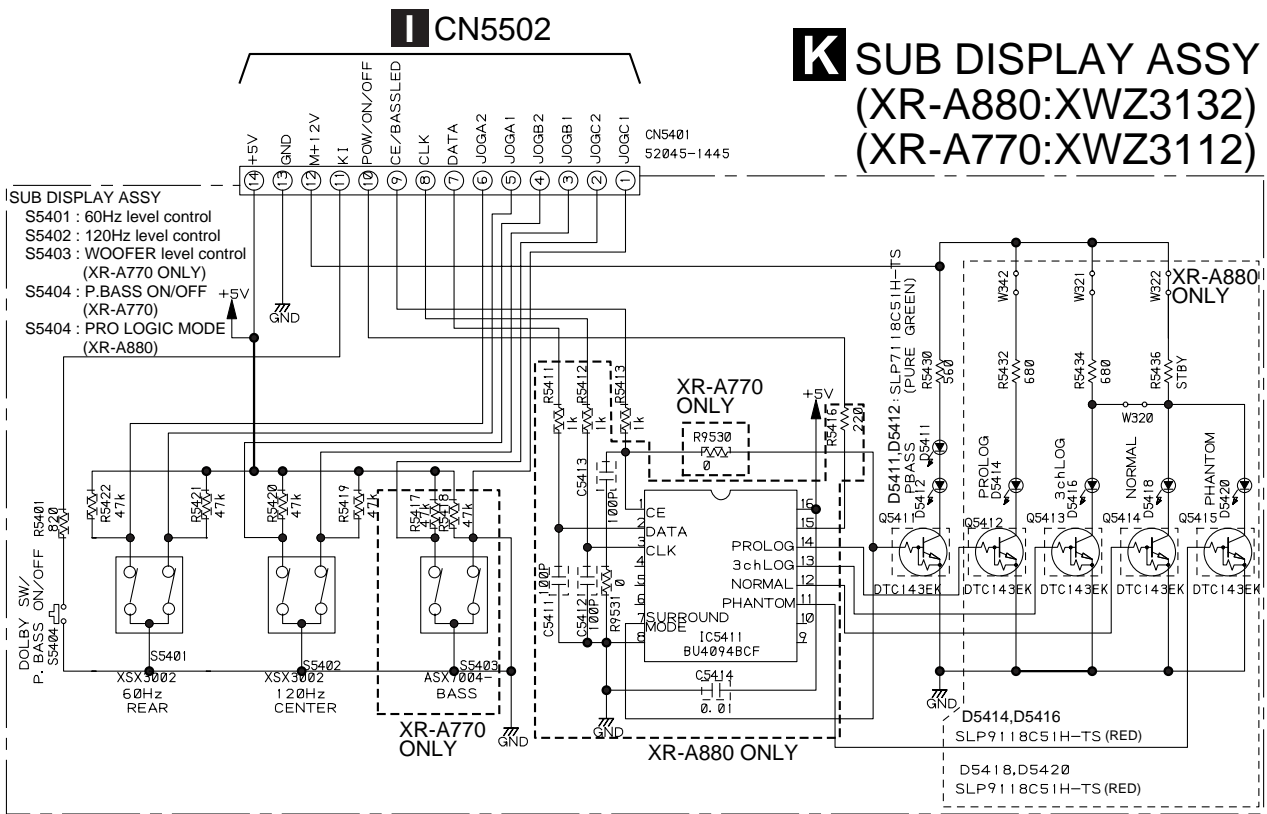



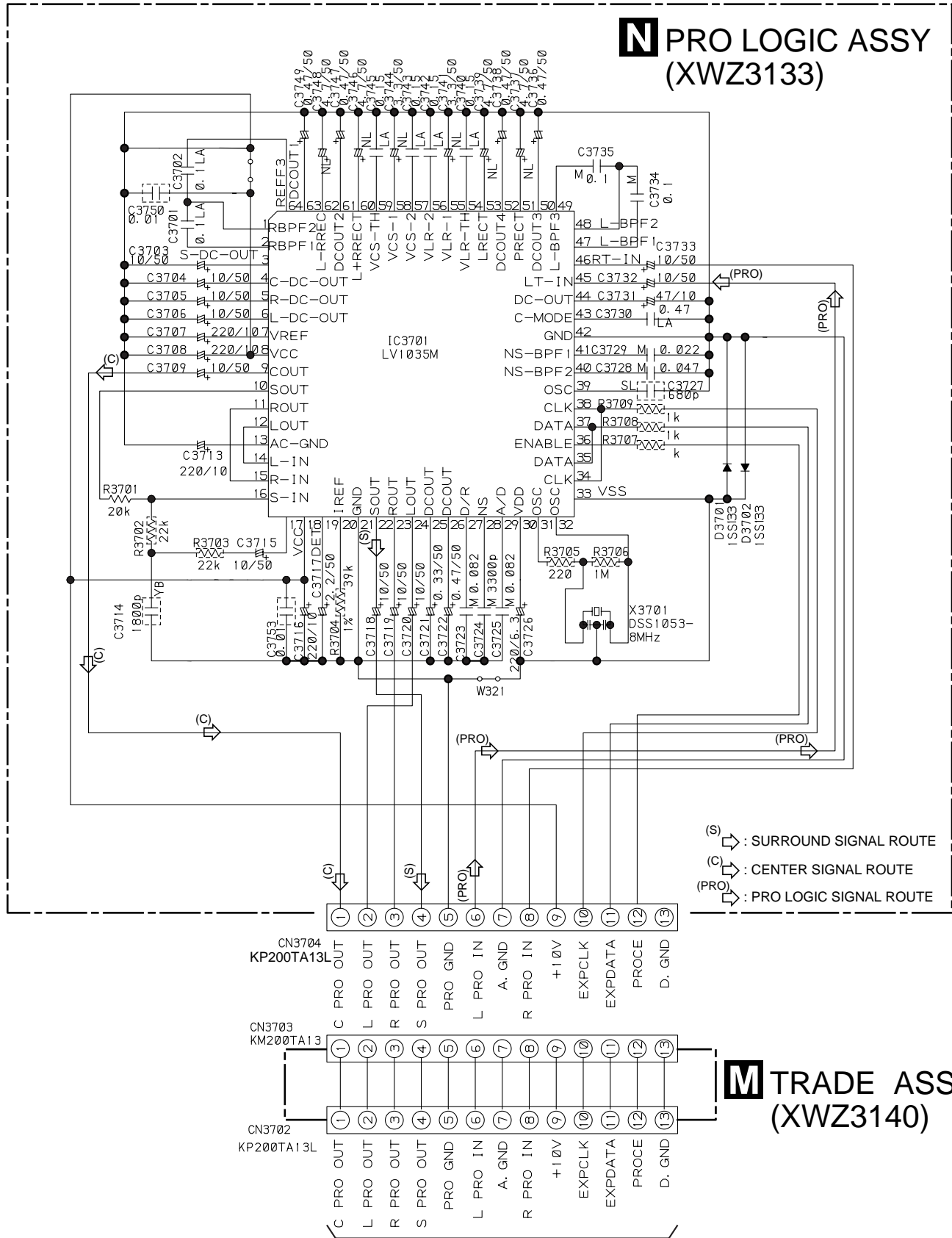





3.10 TRADE and PRO LOGIC ASSEMBLIES (XR-A880 ONLY)

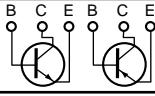

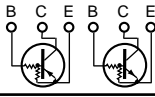
4. PCB CONNECTION DIAGRAM

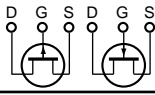
NOTE FOR PCB DIAGRAMS :

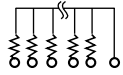
1. Part numbers in PCB diagrams match those in the schematic diagrams.
2. A comparison between the main parts of PCB and schematic diagrams is shown below.

Symbol In PCB Diagrams	Symbol In Schematic Diagrams	Part Name
		Transistor
		Transistor with resistor
		Field effect transistor
		Resistor array
		3-terminal regulator

3. The parts mounted on this PCB include all necessary parts for several destinations.
For further information for respective destinations, be sure to check with the schematic diagram.
4. View point of PCB diagrams.

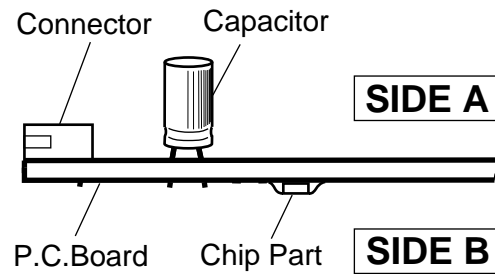

4.1 FM/AM TUNER MODULE

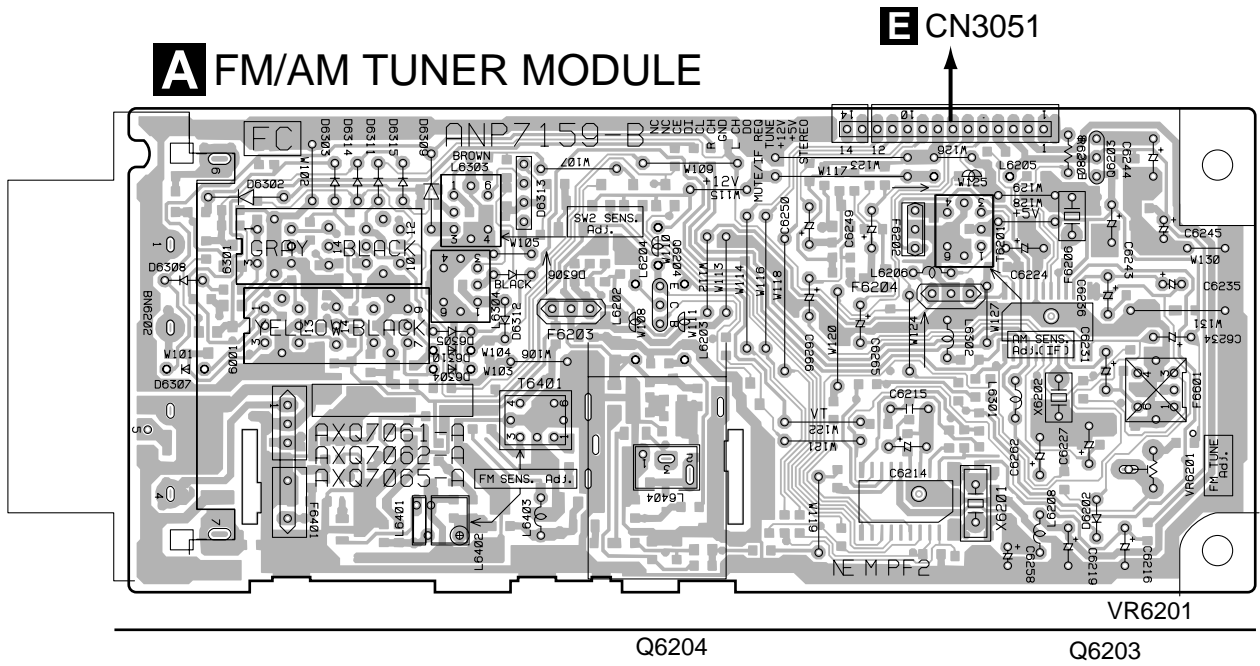

SIDE A

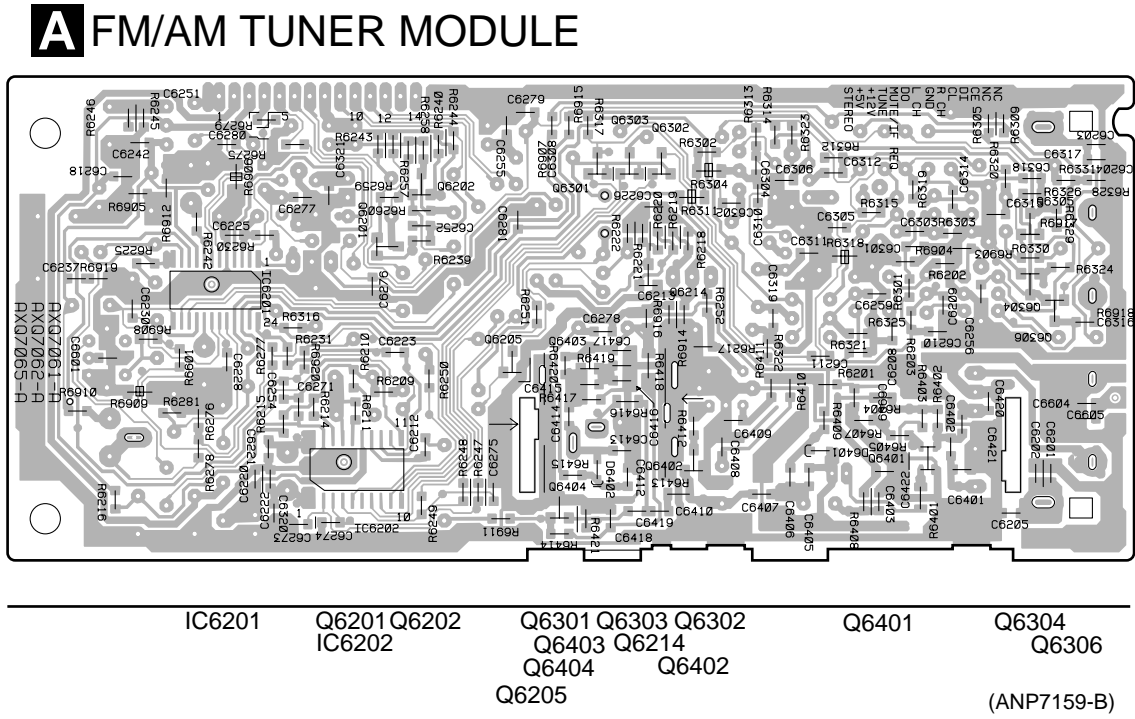

SIDE B



D SW ASSY

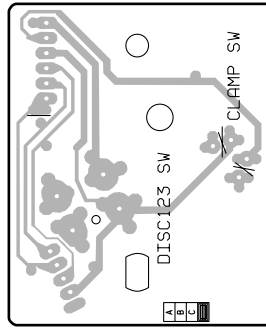

C MOTOR ASSY

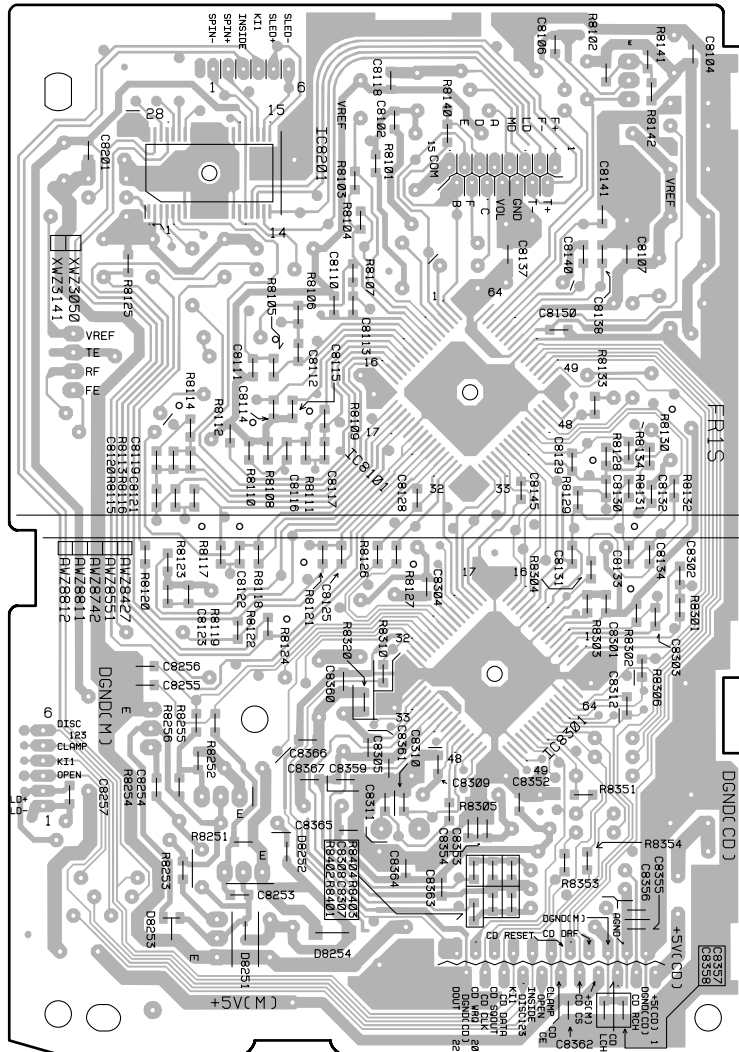
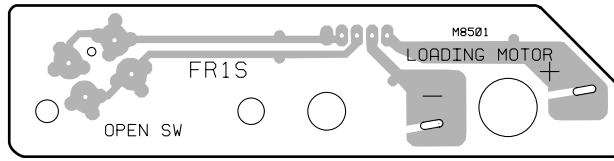

IC8201

IC8101

IC8301

B CD ASSY

(ANP7144-E)

SIDE B



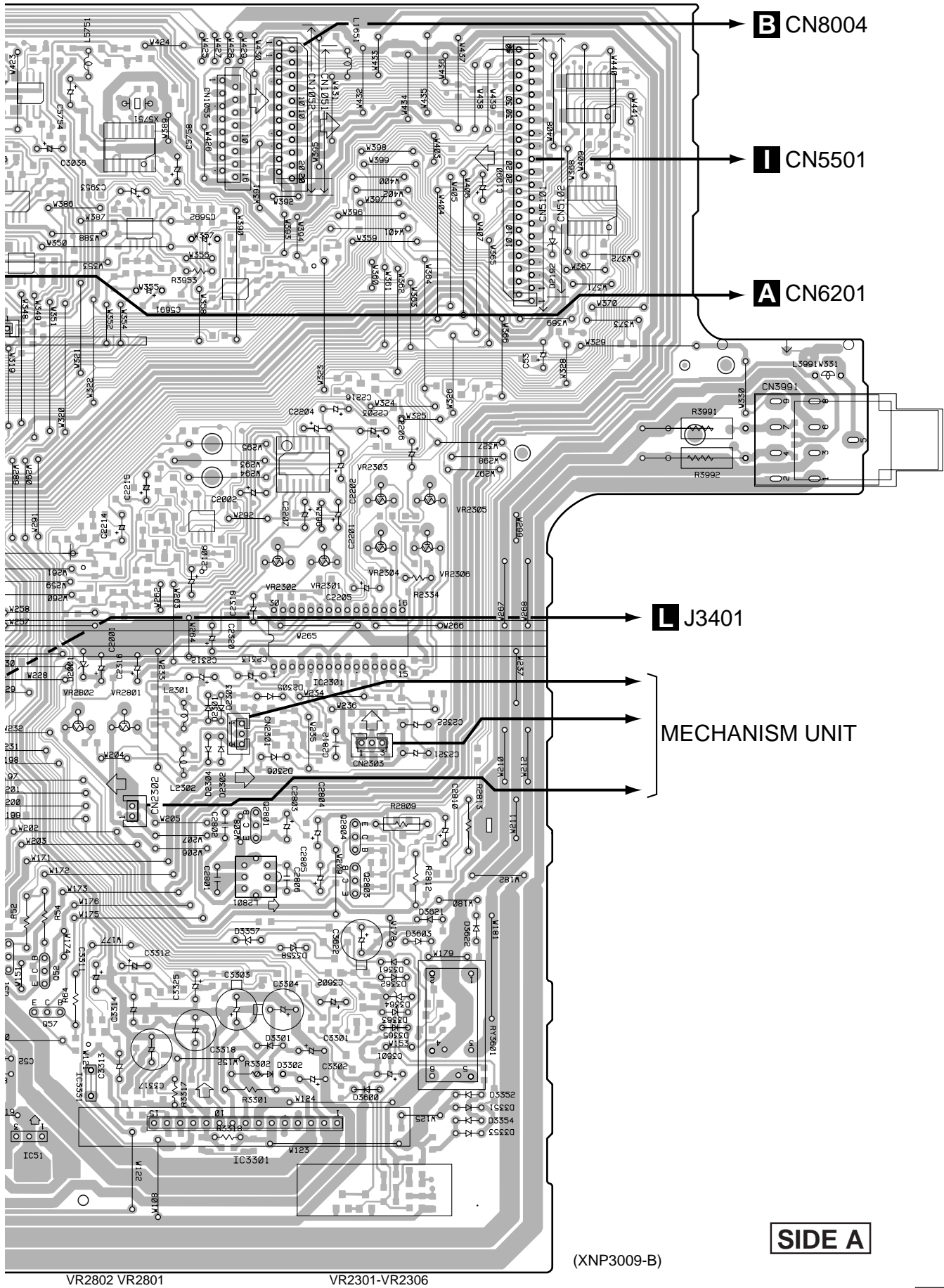

B CN8004

I CN5501

A CN6201

L J3401

MECHANISM UNIT

SIDE A

(XNP3009-B)

Q51 Q52 Q57
IC51 IC3331

IC2301
Q2801 Q2804
IC3301 Q2802

E AF ASSY

A

B

C

D

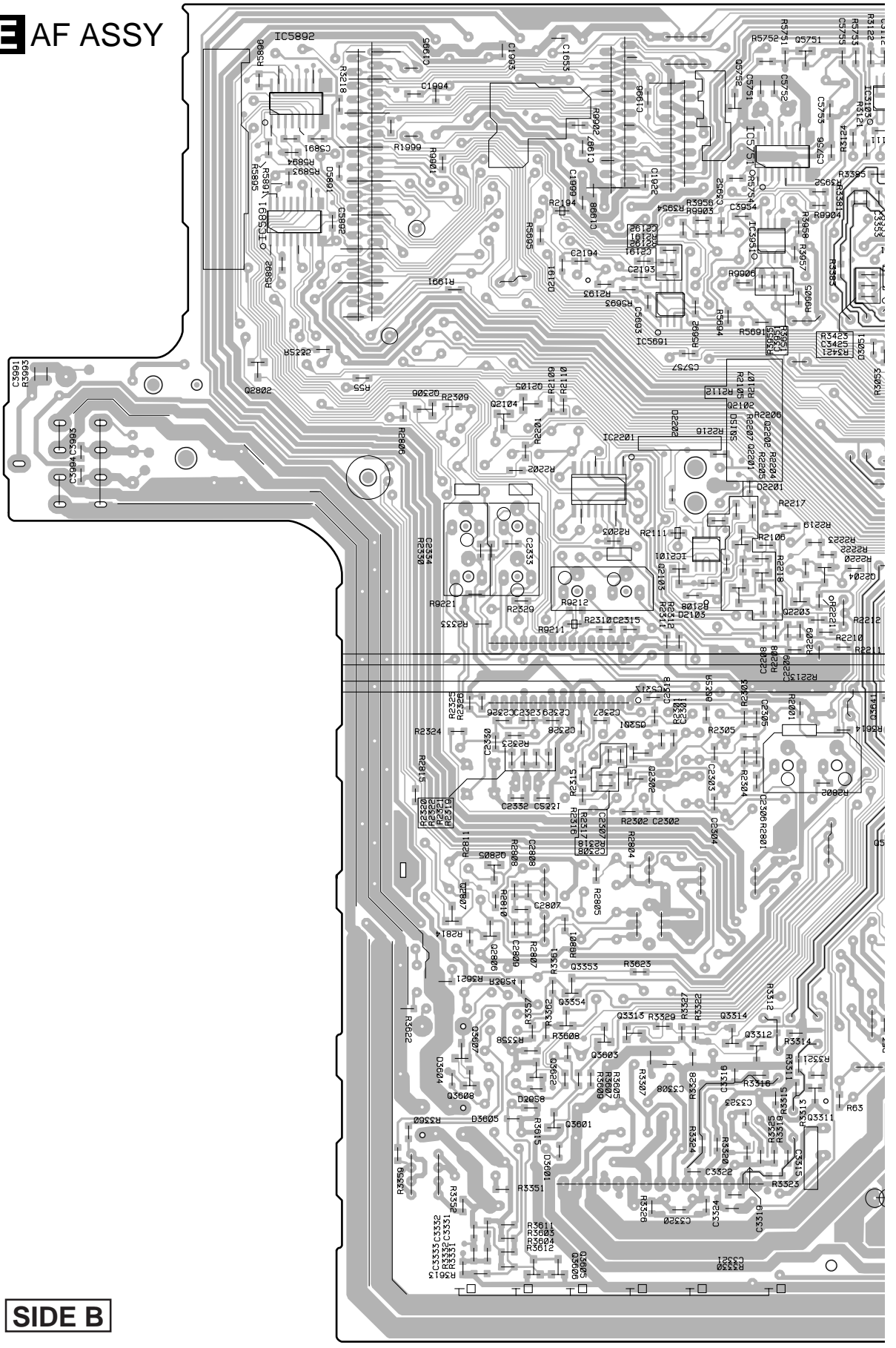

SIDE B



IC5892	IC5891	Q2306	Q2105	Q2104	IC2201	Q5751	Q5752	IC:
Q2802		Q2805-Q2807			IC2101	IC5751	IC5751	IC:
		Q3607			Q2301	Q3353	Q3354	Q2203
					Q3622	Q3611	Q3606	Q3605
						Q3611	Q3606	Q3605
						Q3311	Q3314	Q3311-Q3314

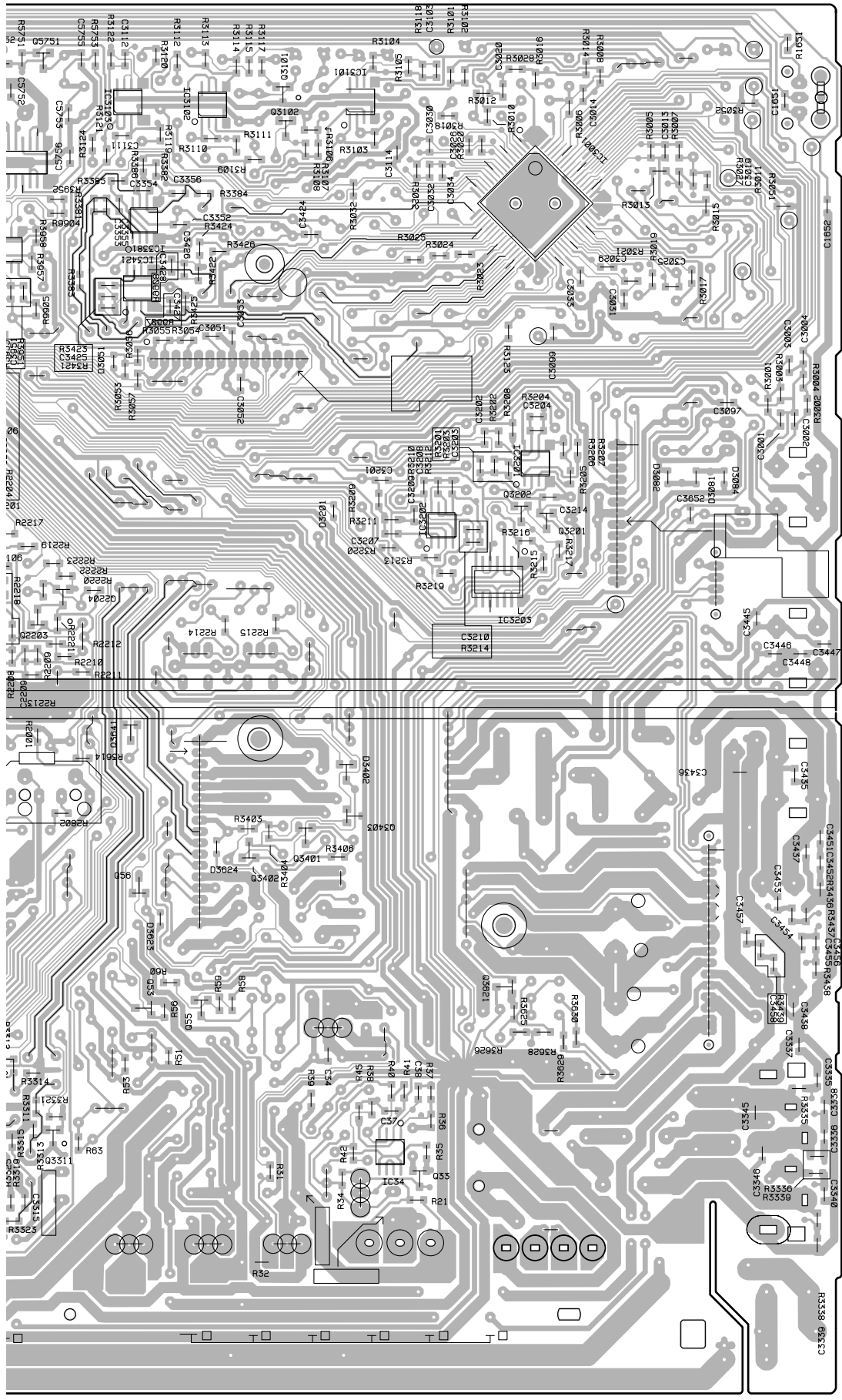

(XNP3009-B)

- 5751 Q5752 IC3101-IC3103 Q3101 Q3102 IC3001
- 5751 IC5751 IC3381 Q3401-Q3403 IC3201-IC3203 Q3202 Q3201
- Q2203 Q2204 Q56 Q53 Q55 IC34 Q33
- 3311-Q3314



4.4 SECONDARY ASSY

F SECONDARY ASSY

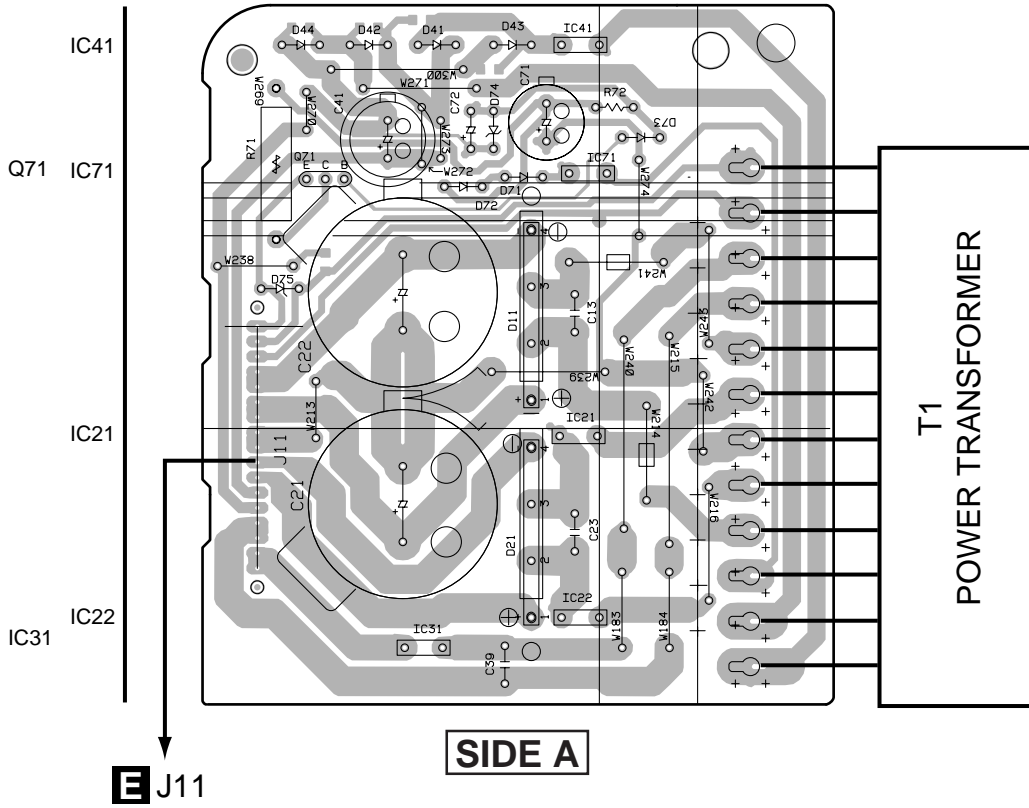

F SECONDARY ASSY

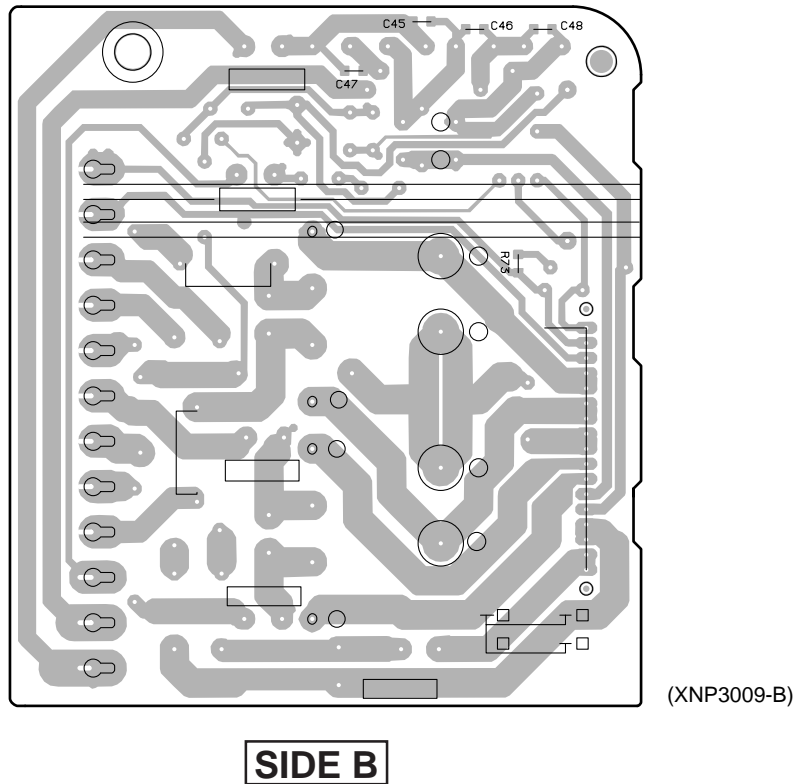

4.5 PRIMARY and SUB TRANS ASSEMBLIES

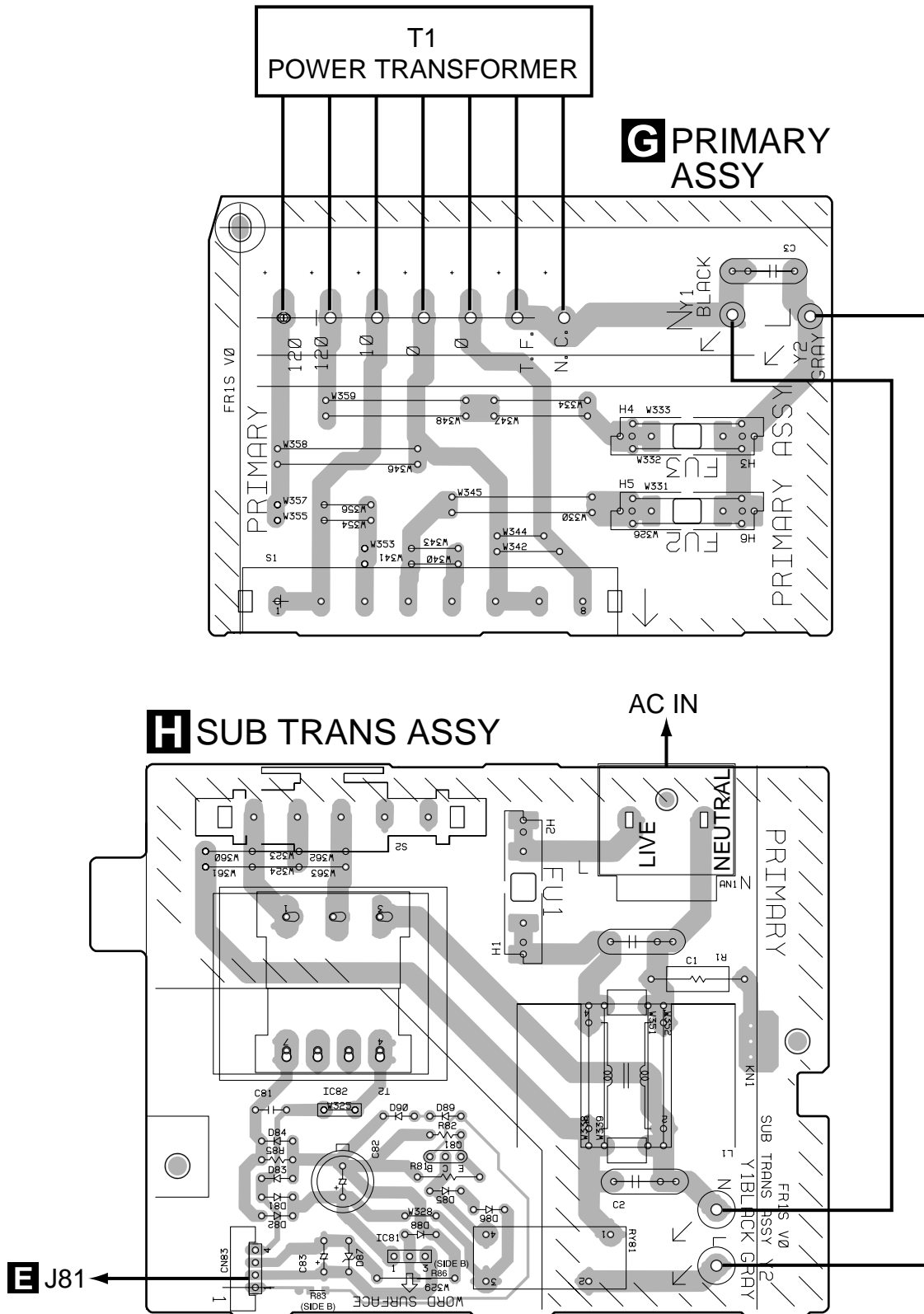

(XNP3013-B)

SIDE A



4.6 DISPLAY and CD SW LED ASSEMBLIES

A

B

C

D

SIDE A

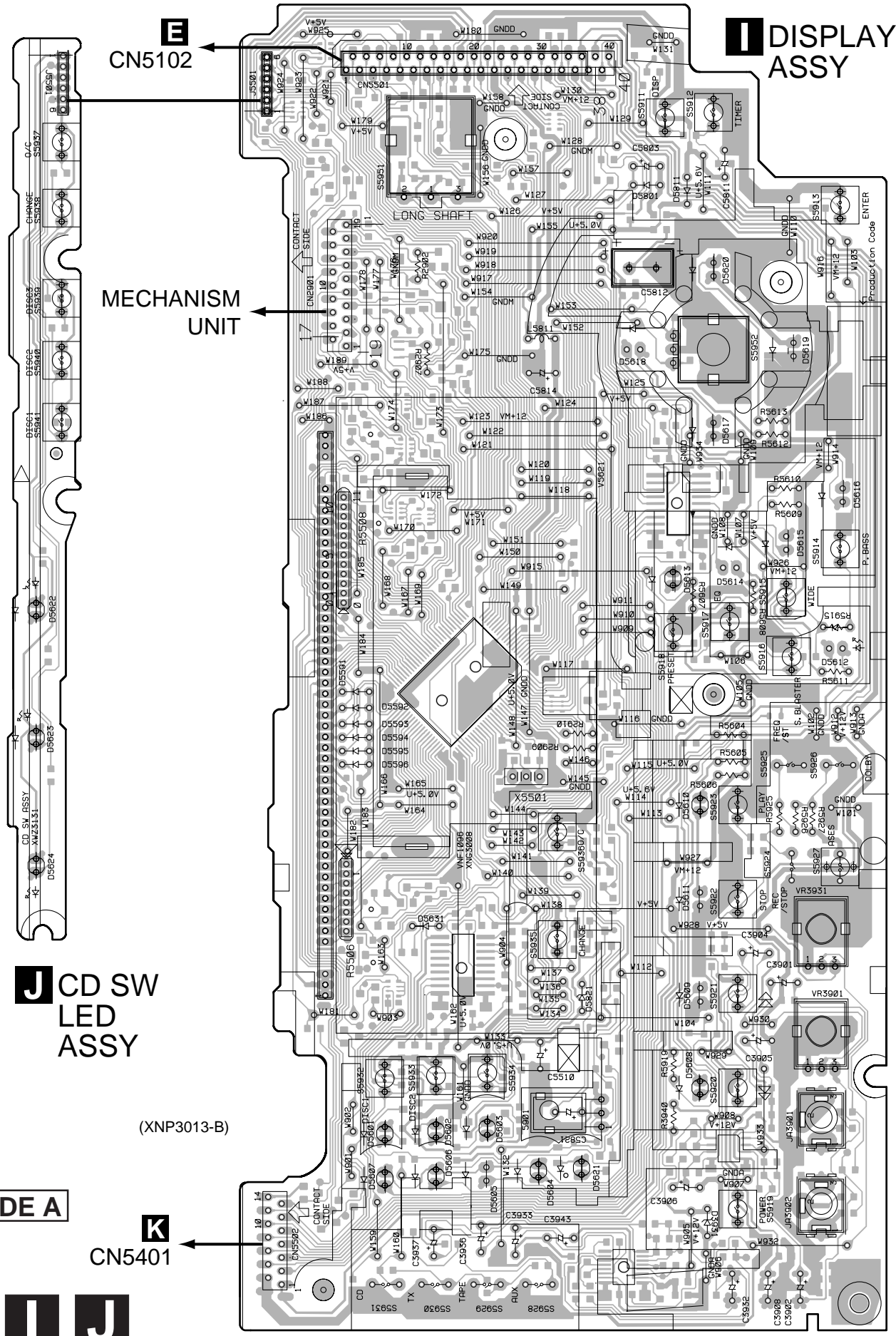

J CD SW LED ASSY

K CN5401

I DISPLAY ASSY

E CN5102

MECHANISM UNIT

(XNP3013-B)

I **J**

4.7 REAR AMP, TRADE and PRO LOGIC ASSEMBLIES

A

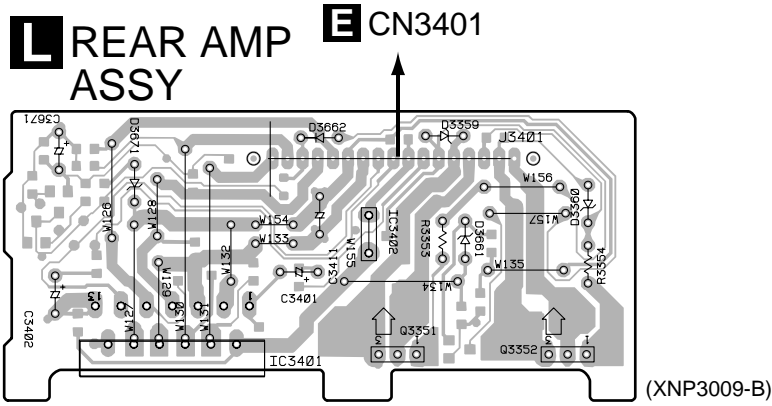

B

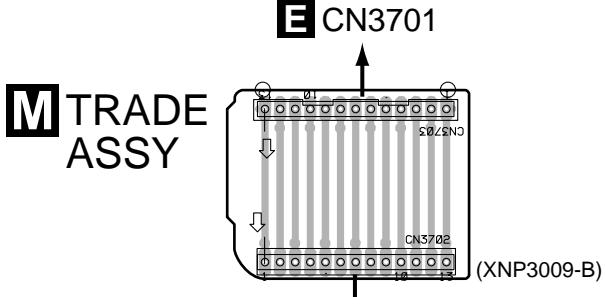

C

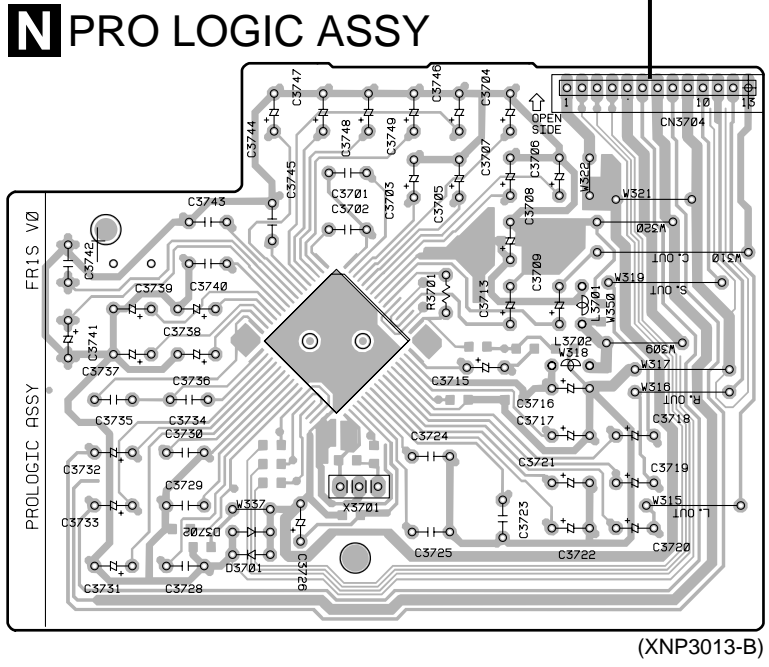

D

SIDE A

L REAR AMP ASSY

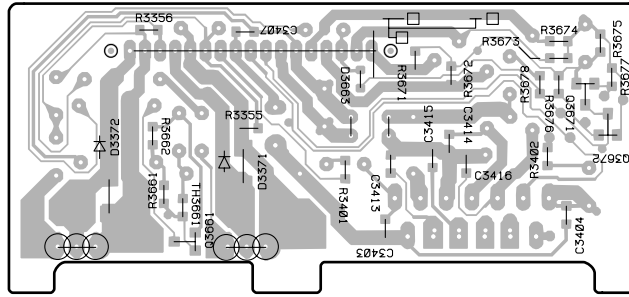

(XNP3009-B)

N PRO LOGIC ASSY

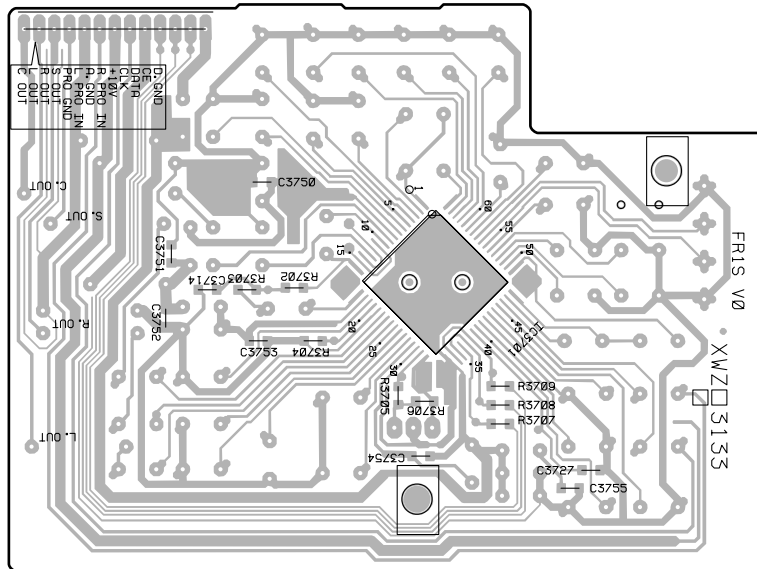

(XNP3013-B)

SIDE B

5. PCB PARTS LIST

NOTES: ●Parts marked by "NSP" and ⊗ can not be supplied.

●The Δ mark found on some component parts indicates the importance of the safety factor of the part. Therefore, when replacing, be sure to use parts of identical designation.

●When ordering resistors, first convert resistance values into code form as shown in the following examples.

Ex.1 When there are 2 effective digits (any digit apart from 0), such as 560 ohm and 47k ohm (tolerance is shown by J=5%, and K=10%).

560 Ω → 56 × 10¹ → 561 RD1/4PU 5 6 1 J
 47k Ω → 47 × 10³ → 473 RD1/4PU 4 7 3 J
 0.5 Ω → R50 RN2H R 5 0 K
 1 Ω → 1R0 RSIP 1 R 0 K

Ex.2 When there are 3 effective digits (such as in high precision metal film resistors).

5.62k Ω → 562 × 10¹ → 5621 RN1/4PC 5 6 2 1 F

LIST OF HOLE PCB ASSEMBLIES

Mark	Symbol and Description	Part No.				Remarks
		XR-A880	XR-A880	XR-A770	XR-A770	
		KUCXJ	YPWXJ	KUCXJ	YPWXJ	
	FM/AM TUNER MODULE	AXQ7065	AXQ7065	AXQ7065	AXQ7065	
NSP	SM SERVO BOARD ASSY	XWX3005	XWX3005	XWX3005	XWX3005	
⊗	└ CD ASSY	XWZ3141	XWZ3141	XWZ3141	XWZ3141	
⊗	└ MOTOR ASSY	AWZ8428	AWZ8428	AWZ8428	AWZ8428	
NSP	└ SW ASSY	AWZ8429	AWZ8429	AWZ8429	AWZ8429	
NSP	MAIN ASSY	XWM3068	XWM3068	XWM3061	XWM3061	
⊗	└ REAR AMP ASSY	XWZ3195	XWZ3195	XWZ3194	XWZ3194	
⊗	└ AF ASSY	XWZ3134	XWZ3134	XWZ3114	XWZ3114	
⊗	└ SECONDARY ASSY	XWZ3137	XWZ3137	XWZ3137	XWZ3137	
⊗	└ TRADE ASSY	XWZ3140	XWZ3140	Not used	Not used	
NSP	COMPLEX ASSY	XWM3070	XWM3069	XWM3063	XWM3062	
⊗	└ PRIMARY ASSY	XWZ3118	XWZ3115	XWZ3118	XWZ3115	
⊗	└ SUB TRANS ASSY	XWZ3119	XWZ3116	XWZ3119	XWZ3116	
⊗	└ DISPLAY ASSY	XWZ3135	XWZ3142	XWZ3117	XWZ3143	
⊗	└ CD SW LED ASSY	XWZ3131	XWZ3131	XWZ3131	XWZ3131	
⊗	└ SUB DISPLAY ASSY	XWZ3132	XWZ3132	XWZ3112	XWZ3112	
⊗	└ PRO LOGIC ASSY	XWZ3133	XWZ3133	Not used	Not used	

Mark	No.	Description	Part No.	Mark	No.	Description	Part No.
A		FM/AM TUNER MODULE			F6401		ATF-155
		SEMICONDUCTORS			F6206		ATF7008
	IC6201		LA1832ML		F6202		ATF7011
	IC6202		LC72131MD		L6206, L6208, L6403		LAU2R2J
	Q6402		2SC2223	TRANSFORMERS			
	Q6203		2SC2705		T6201		ATB7008
	Q6201, Q6202		2SC2712		T6401		ATE7002
	Q6214, Q6403		2SC2714	CAPACITORS			
	Q6404		2SK302		C6208		CCSQCH100D50
	Q6401		3SK194		C6212, C6274, C6275, C6408		CCSQCH101J50
	Q6204		DTA124ES		C6412		CCSQCH102J50
	Q6205		DTC124EK		C6221, C6222, C6416		CCSQCH150J50
	D6202		1SS254		C6271		CCSQCH200J50
	D6401, D6402		1T378A		C6415		CCSQCH330J50
					C6406		CCSQCH331J50
					C6401, C6419		CCSQCH5R0C50
COILS AND FILTERS					C6407		CCSQCK1R0C50
	L6404		ATC1003		C6410		CCSQCK2R0C50
	L6401		ATC1020				
	L6402		ATC1021		C6413		CCSQRH180J50
	F6204		ATF-107		C6414		CCSQRH8R0D50
	F6203		ATF-119		C6405		CCSQTH150J50
					C6234, C6235		CEAL1R0M50
					C6245		CEAL470M16

XR-A880, XR-A770

Mark	No.	Description	Part No.
	C6224		CEAT100M50
	C6243		CEAT101M16
	C6231		CEAT1R0M50
	C6227		CEAT220M25
	C6214, C6236		CEAT2R2M50
	C6262		CEAT3R3M50
	C6219		CEAT470M10
	C6244		CEAT470M16
	C6249, C6250, C6265, C6266		CEAT4R7M50
	C6258		CEJA470M16
	C6215		CFTLA103J50
	C6211, C6254, C6403, C6417		CKSQYB102K50
	C6201, C6205, C6210, C6237, C6276		CKSQYB103K50
	C6278, C6280, C6281, C6402, C6409		CKSQYB103K50
	C6418		CKSQYB103K50
	C6251, C6252		CKSQYB153K50
	C6203, C6259		CKSQYB223K50
	C6228		CKSQYB472K50
	C6209		CKSQYB473K50
	C6230		CKSQYB821K50
	C6218, C6223, C6255		CKSQYF103Z50
	C6220, C6226, C6242, C6256		CKSQYF223Z50
	C6225		CKSQYF473Z50

RESISTORS

R6280	RD1/4PU101J
R6413, R6416, R6418, R6906, R6909	RS1/8S0R0J
R6401	RS1/8S470J
VR6201 (10kΩ)	PCP1029
Other Resistors	RS1/10S□□□J

OTHERS

BN6202	4P ANTENNA TERMINAL	AKE7025
X6202	CERAMIC RESONATOR (456kHz)	ASS1066
X6201	CRYSTAL RESONATOR (7.2000MHz)	ASS1093
CN6201	14P SOCKET MW RF TUNING BLOCK	KP200IA14L AXX7041

B CD ASSY

SEMICONDUCTORS

IC8201	BA5923FP
IC8101	LA9241ML
IC8301	LC78622NE
Q8101	2SA1048
Q8251, Q8252	2SB1237X
Q8253, Q8254	2SD1858X
D8253	1SS181
D8251, D8252	1SS355

COILS AND FILTERS

L8351, L8352	LFA1R0K
L8201, L8371	LFA470J

CAPACITORS

C8145, C8352, C8354, C8356, C8358	CCSQCH101J50
C8361, C8362	CCSQCH101J50
C8132, C8311	CCSQCH150J50
C8310	CCSQCH180J50
C8131	CCSQCH300J50

Mark	No.	Description	Part No.
	C8129		CCSQCK1R0C50
	C8142		CEAL101M6R3
	C8127		CEAL1R0M50
	C8126, C8139		CEAL470M16
	C8135		CEAL4R7M16
	C8124		CEALR47M50
	C8136		CEAT100M50
	C8108, C8306, C8371		CEAT101M10
	C8202		CEAT101M25
	C8101		CEAT3R3M50
	C8105		CEAT470M16
	C8109		CEATR22M50
	C8106, C8119, C8133, C8307, C8308		CKSQYB102K50
	C8360		CKSQYB102K50
	C8102, C8122, C8123, C8130		CKSQYB103K50
	C8137, C8138, C8201, C8309, C8312		CKSQYB103K50
	C8134, C8302, C8303		CKSQYB104K25
	C8353, C8359		CKSQYB152K50
	C8111		CKSQYB153K25
	C8114, C8117, C8120, C8121		CKSQYB154K16
	C8125		CKSQYB221K50
	C8107		CKSQYB223K50
	C8110		CKSQYB331K50
	C8115, C8128		CKSQYB332K50
	C8113		CKSQYB333K25
	C8112, C8141		CKSQYB334K16
	C8116, C8140, C8355, C8357		CKSQYB473K50
	C8118, C8255-C8257, C8301		CKSQYF104Z25
	C8304, C8305		CKSQYF104Z25

RESISTORS

All Resistors	RS1/10S□□□J
---------------	-------------

OTHERS

CN8003	6P JUMPER CONNECTOR	52151-0610
CN8002	KR CONNECTOR	B6B-PH-K-S
CN8005	3P SIDE POST	BS3P-SHF-1AA
CN8004	FFC CONNECTOR 20P	HLEM22R-1
CN8001	FFC CONNECTOR	SLW15S-1C7
X8301	CERAMIC RESONATOR (16.9344MHz)	PSS1008

C MOTOR ASSY

SWITCHES AND RELAYS

S8503	ASG7009
-------	---------

OTHERS

J8502	JUMPER WIRE 4P	D20PWW0405E
	MOTOR PULLEY	PNW1634
	CARRIAGE MOTOR	VXM1033

D SW ASSY

SWITCHES AND RELAYS

S8502	ASG7009
S8501	DSG1017

OTHERS

J8501	JUMPER WIRE 6P	D20PWY0610E
-------	----------------	-------------

Mark	No.	Description	Part No.
E AF ASSY (XWZ3134)			
SEMICONDUCTORS			
△		IC23 (400mA)	AEK7004
△		IC3331 (1.25A)	AEK7010
△		IC33 (2A)	AEK7013
		IC2101, IC3101-IC3103, IC3381, IC34 IC3421, IC5691	BA4558F-HT BA4558F-HT
		IC5891, IC5892	BU4094BCF
		IC2201	HA12136AF
		IC2301	HA12211NT
		IC3001	LC75396NE
△		IC42	NJM7805FA
△		IC32	NJM7812FA
△		IC3301	STK407-090B
		Q3354, Q3601, Q3621, Q55	2SA1037K
		Q2806	2SB1197K
△		Q22	2SB1375
		Q2803, Q2804	2SC1815
		Q2801	2SC2240
		Q2102, Q2201, Q2202, Q3101, Q3102	2SC2412K
		Q33, Q3353, Q3401, Q3603	2SC2412K
		Q3605-Q3608, Q56	2SC2412K
△		Q21	2SC5200(P)
		Q3081	2SD1858X
△		Q34, Q54	2SD1858X
△		Q31	2SD2012
		Q2203, Q2204, Q2805, Q3311, Q3312	2SD2114K
		Q2301, Q2302	2SK368
		Q3313, Q3403	DTA124EK
		Q2104, Q2105, Q3314, Q3402, Q3641	DTC124EK
		Q2103, Q2306, Q2802, Q2807	DTC143EK
△		D3301, D3302	1SR139-100
		D2301-D2306, D3101, D3102, D32	1SS133
		D3351-D3354, D3361, D3362, D34	1SS133
		D3403, D3603, D3621, D3622	1SS133
		D3625-D3627, D51	1SS133
		D3402	1SS184
		D2102, D2103, D2191, D2201, D2202	1SS355
		D3051, D3601, D3604, D3623, D3624	1SS355
		D5891	1SS355
△		D3355, D3356	20E2-FC
△		D31	GBU4D
		D3357, D3358	MTZJ10C
		D3083	MTZJ11C
		D33	MTZJ20A
		D52	MTZJ22D
		D3363, D3364	MTZJ39C
		D3401	MTZJ4.7B
		D2001	MTZJ6.2A
		D48	MTZJ6.8C
		D3673, D3674	U1GC44
COILS AND FILTERS			
		L3331, L3332	ATH-133
		L2801	ATX7002
		L3001	LAU1R0J
		L1651, L3991	LAU4R7J
		L2301, L2302	LTA822J
		F2201, F2202	RTF1209

SWITCHES AND RELAYS

RY3601	ASR7008
--------	---------

Mark	No.	Description	Part No.
CAPACITORS			
		C2303, C2304 (270pF)	ACG7024
		C2301, C2302	CCSQCH100D50
		C2192	CCSQCH220J50
		C38	CCSQCH331J50
		C3319, C3320	CCSQCH3R0C50
		C3321, C3322	CCSQCH470J50
		C33	CEAL100M50
		C3621	CEAL2R2M50
		C3311, C3312	CEANL2R2M50
		C3317, C3318	CEANP100M35
		C3313, C3314	CEANP2R2M50
		C2207, C2803, C2810, C3041, C3042	CEAT100M50
		C3047, C3048, C3081, C3091-C3093	CEAT100M50
		C3450, C36, C3602, C51	CEAT100M50
		C2002, C2316	CEAT101M16
		C3651	CEAT101M35
		C3303, C3304, C3622, C54	CEAT101M50
		C3432, C3434	CEAT102M10
		C2312, C2313, C3035, C3036	CEAT1R0M50
		C3107, C3108	CEAT1R0M50
		C1990, C2106, C2214, C2215	CEAT220M50
		C2321, C2322	CEAT220M50
		C2001	CEAT221M16
		C40	CEAT222M25
		C2201, C2202, C2205, C2206	CEAT2R2M50
		C2212, C2213, C2319, C2320	CEAT2R2M50
		C3005-C3012, C3015-C3018	CEAT2R2M50
		C3039, C3040, C3043-C3046, C3104	CEAT2R2M50
		C3421, C3422	CEAT2R2M50
		C2804, C2805, C3105	CEAT330M16
△		C3406	CEAT330M25
		C11, C12	CEAT332M35
		C3431, C3433	CEAT471M10
		C3106, C3109	CEAT4R7M50
		C3021, C3022	CEATR10M50
		C2203, C2204, C3101, C3102	CEATR22M50
		C3325	CEATR47M50
		C35, C43	CEHAQ100M50
		C32, C42	CEHAQ1R0M50
		C3601	CEHAQ221M16
		C3027, C3028	CFTLA334J50
		C3023, C3024	CFTLA474J50
		C2812	CKCYB103K50
		C2802	CKCYB681K2H
		C1996, C3308, C5693, C5892	CKSQYB102K50
		C1653, C1922, C1993-C1995	CKSQYB103K50
		C1998, C1999, C2315, C2317, C2318	CKSQYB103K50
		C3053, C3103	CKSQYB103K50
		C1651, C1652, C1997, C2191, C2193	CKSQYB104K25
		C3097, C3099, C3652	CKSQYB104K25
		C3033, C3034	CKSQYB122K50
		C2208, C2209	CKSQYB152K50
		C2323, C2326	CKSQYB223K25
		C3029, C3030	CKSQYB273K25
		C2808, C2809	CKSQYB332K50
		C2333, C2334	CKSQYB392K50
		C2807	CKSQYB472K50
		C3111, C3112, C5891	CKSQYB473K25
		C2307, C2308, C2331, C2332	CKSQYB681K50
		C3013, C3014	CKSQYB681K50

XR-A880, XR-A770

Mark	No.	Description	Part No.
	C3019, C3020, C3031, C3032		CKSQYB682K50
	C3323, C3324		CKSQYB682K50
	C3025, C3026		CKSQYB683K25
	C3315, C3316		CKSQYB821K50
	C3331-C3333		CKSQYF104Z50
	C2194, C37		CKSQYF105Z16
	C2801		CQHA822J2A
	C2210, C2211		CQMBA103J50
	C2806		CQMBA223J50
△	C31 (4700μF/42V)		XCH3003

RESISTORS

R2809	RD1/2LMF4R7J
R2812	RD1/2PM270J
R2813	RD1/2PM471J
R3333, R3334	RD1/4LMF100J
R3116	RD1/4PU105J
R3317, R3318	RD1/4PU124J
R3081	RD1/4PU221J
R33	RD1/4PU222J
R3009	RD1/4PU472J
R2334	RD1/4PU562J
R41	RN1/10SE1002D
R40	RN1/10SE2002D
R39	RS1/10S3300F
R3991, R3992	RS2LMF331J
R30	RS3LMF470J
R3601, R3602	RS3LMFR22J
VR2303-VR2306 (10kΩ)	VCP1156
VR2301, VR2302 (100kΩ)	VCP1162
VR2801, VR2802 (220kΩ)	VCP1164
Other Resistors	RS1/10S□□□□

OTHERS

	4P CABLE HOLDER	51048-0400
CN1052	22P FFC CONNECTOR	52045-2245
CN5102	38P FFC CONNECTOR	52045-3845
CN3401	17P JUMPER CONNECTOR	52147-1710
CN3331	4P SPEAKER TERMINAL	AKE7001
CN2302	KR CONNECTOR	B2B-PH-K-S
CN2303	KR CONNECTOR	B3B-PH-K-R
CN2301	KR CONNECTOR 3P	B3B-PH-K-S
J81	JUMPER WIRE 4P	D20PYY0440E
JA1651	OPTICAL LINK OUT	GP1F32T
CN3051	14P PLUG	KM200IB14
CN3701	13P PLUG	KM200TA13
JA3431	3P PIN JACK	RKB1044
	PCB BINDER	VEF1040
JA3001	2P PIN JACK	VKB1060
J3051	CONNECTOR ASSY 2P	XDX3002
CN3991	HEADPHONE JACK	XKN3002

E AF ASSY (XWZ3114)

SEMICONDUCTORS

△	IC23 (400mA)	AEK7004
△	IC3331 (1.25A)	AEK7010
△	IC33 (2A)	AEK7013
	IC2101, IC3101-IC3103, IC3201	BA4558F-HT
	IC3202, IC3381, IC34, IC3421, IC5691	BA4558F-HT

Mark	No.	Description	Part No.
	IC3203		BU4066BCF
	IC5891, IC5892		BU4094BCF
	IC2201		HA12136AF
	IC2301		HA12211NT
	IC3001		LC75396NE
△	IC42		NJM7805FA
△	IC32		NJM7812FA
△	IC3301		STK407-090B
	Q3354, Q3601, Q3621, Q55		2SA1037K
	Q2806		2SB1197K

△	Q22	2SB1375
	Q2803, Q2804	2SC1815
	Q2801	2SC2240
	Q2102, Q2201, Q2202, Q3101, Q3102	2SC2412K
	Q33, Q3353, Q3401, Q3603	2SC2412K
	Q3605-Q3608, Q56	2SC2412K
△	Q21	2SC5200(P)
	Q3081	2SD1858X
△	Q34, Q54	2SD1858X
△	Q31	2SD2012
	Q2203, Q2204, Q2805, Q3311, Q3312	2SD2114K
	Q2301, Q2302	2SK368
	Q3201, Q3313, Q3403	DTA124EK
	Q2104, Q2105, Q3202, Q3314, Q3402	DTC124EK
	Q3641	DTC124EK

△	Q2103, Q2306, Q2802, Q2807	DTC143EK
	D3301, D3302	1SR139-100
	D2301-D2306, D3101, D3102, D32	1SS133
	D3202, D3351-D3354, D3361, D3362	1SS133
	D34, D3403, D3603, D3621, D3622	1SS133
	D3625-D3627, D51	1SS133
	D3402	1SS184
	D2102, D2103, D2191, D2201, D2202	1SS355
	D3051, D3201, D3601, D3604	1SS355
	D3623, D3624, D5891	1SS355

△	D3355, D3356	20E2-FC
△	D31	GBU4D
	D3357, D3358	MTZJ10C
	D3083	MTZJ11C
	D33	MTZJ20A
	D52	MTZJ22D
	D3363, D3364	MTZJ39C
	D3401	MTZJ4.7B
	D2001	MTZJ6.2A
	D48	MTZJ6.8C

COILS AND FILTERS

	L3331, L3332	ATH-133
	L2801	ATX7002
	L3001	LAU1R0J
	L1651, L3991	LAU4R7J
	L2301, L2302	LTA822J
	F2201, F2202	RTF1209

SWITCHES AND RELAYS

	RY3601	ASR7008
--	--------	---------

CAPACITORS

	C2303, C2304 (270pF)	ACG7024
	C2301, C2302	CCSQCH100D50
	C3203, C3204	CCSQCH121J50
	C2192	CCSQCH220J50
	C38	CCSQCH331J50

Mark	No.	Description	Part No.
	C3319, C3320		CCSQCH3R0C50
	C3321, C3322		CCSQCH470J50
	C33		CEAL100M50
	C3621		CEAL2R2M50
	C3311, C3312		CEANL2R2M50
	C3317, C3318		CEANP100M35
	C3313, C3314		CEANP2R2M50
	C2207, C2803, C2810, C3041, C3042		CEAT100M50
	C3047, C3048, C3081, C3091-C3093		CEAT100M50
	C3441-C3444, C3450, C36, C3602		CEAT100M50
	C51		CEAT100M50
	C2002, C2316		CEAT101M16
	C3651		CEAT101M35
	C3303, C3304, C3622, C54		CEAT101M50
	C2312, C2313, C3035, C3036		CEAT1R0M50
	C3107, C3108		CEAT1R0M50
	C1990, C2106, C2214, C2215		CEAT220M50
	C2321, C2322		CEAT220M50
	C2001		CEAT221M16
	C40		CEAT222M25
	C2201, C2202, C2205, C2206		CEAT2R2M50
	C2212, C2213, C2319, C2320		CEAT2R2M50
	C3005-C3012, C3015-C3018		CEAT2R2M50
	C3039, C3040, C3043-C3046, C3104		CEAT2R2M50
	C3205, C3206, C3211, C3212		CEAT2R2M50
	C3421, C3422		CEAT2R2M50
	C2804, C2805, C3105		CEAT330M16
	C3406		CEAT330M25
△	C11, C12		CEAT332M35
	C3106, C3109		CEAT4R7M50
	C3021, C3022		CEATR10M50
	C2203, C2204, C3101, C3102		CEATR22M50
	C3325		CEATR47M50
	C35, C43		CEHAQ100M50
	C32, C42		CEHAQ1R0M50
	C3601		CEHAQ221M16
	C3027, C3028		CFTLA334J50
	C3023, C3024		CFTLA474J50
	C2812		CKCYB103K50
	C2802		CKCYB681K2H
	C1996, C3308, C5693, C5892		CKSQYB102K50
	C1653, C1922, C1993-C1995		CKSQYB103K50
	C1998, C1999, C2315, C2317, C2318		CKSQYB103K50
	C3053, C3103, C3209, C3210		CKSQYB103K50
	C1651, C1652, C1997, C2191, C2193		CKSQYB104K25
	C3097, C3099, C3652		CKSQYB104K25
	C3033, C3034		CKSQYB122K50
	C2208, C2209		CKSQYB152K50
	C2323, C2326		CKSQYB223K25
	C3207, C3208		CKSQYB223K50
	C3029, C3030		CKSQYB273K25
	C2808, C2809		CKSQYB332K50
	C2333, C2334		CKSQYB392K50
	C3315, C3316		CKSQYB471K50
	C2807		CKSQYB472K50
	C3111, C3112, C5891		CKSQYB473K25
	C3201, C3202		CKSQYB562K50
	C2307, C2308, C2331, C2332		CKSQYB681K50
	C3013, C3014		CKSQYB681K50
	C3019, C3020, C3031, C3032		CKSQYB682K50

Mark	No.	Description	Part No.
	C3323, C3324		CKSQYB682K50
	C3025, C3026		CKSQYB683K25
	C3331-C3333		CKSQYF104Z50
	C2194, C37		CKSQYF105Z16
	C2801		CQHA822J2A
	C2210, C2211		CQMBA103J50
	C2806		CQMBA223J50
△	C31 (4700μF/42V)		XCH3003

RESISTORS

R2809	RD1/2LMF4R7J
R2812	RD1/2PM270J
R2813	RD1/2PM471J
R3333, R3334	RD1/4LMF100J
R3116	RD1/4PU105J
R3317, R3318	RD1/4PU124J
R3081	RD1/4PU221J
R33	RD1/4PU222J
R3009	RD1/4PU472J
R2334	RD1/4PU562J
R41	RN1/10SE1002D
R40	RN1/10SE2002D
R39	RS1/10S3300F
R3991, R3992	RS2LMF331J
R30	RS3LMF470J
R3601, R3602	RS3LMFR22J
VR2303-VR2306 (10kΩ)	VCP1156
VR2301, VR2302 (100kΩ)	VCP1162
VR2801, VR2802 (220kΩ)	VCP1164
Other Resistors	RS1/10S□□□□

OTHERS

4P CABLE HOLDER	51048-0400
CN1052 22P FFC CONNECTOR	52045-2245
CN5102 38P FFC CONNECTOR	52045-3845
CN3401 17P JUMPER CONNECTOR	52147-1710
CN3432, CN3433	5569-02A1
CN3331 4P SPEAKER TERMINAL	AKE7001
CN2302 KR CONNECTOR	B2B-PH-K-S
CN2303 KR CONNECTOR	B3B-PH-K-R
CN2301 KR CONNECTOR 3P	B3B-PH-K-S
J81 JUMPER WIRE 4P	D20PYY0440E
JA1651 OPTICAL LINK OUT	GP1F32T
CN3051 14P PLUG	KM200IB14
PCB BINDER	VEF1040
J3051 CONNECTOR ASSY 2P	XDX3002
JA3001, JA3441 2P PIN JACK	XKB3002
CN3991 HEADPHONE JACK	XKN3002

F SECONDARY ASSY

SEMICONDUCTORS

△ IC71 (630mA)	AEK7006
△ IC41 (5A)	AEK7019
△ IC21, IC22, IC31 (7A)	AEK7021
△ IC11, IC12 (10A)	AEK7068
△ Q71	2SA965
D73	1SS133
△ D21	GBU4DL-5303
△ D11	GBU6DL-5302
D74	MTZJ36A
D75	MTZJ8.2B
△ D41-D44, D71, D72	S5688G

XR-A880, XR-A770

Mark	No.	Description	Part No.
CAPACITORS			
	C72		CEAT220M50
△	C71		CEAT221M63
△	C41		CEAT222M25
	C13		CQMA103K2E
△	C21, C22 (4700μF/80V)		XCH3001

RESISTORS			
	R72		RD1/4PU222J
	Other Resistors		RS1/10S□□□□

OTHERS			
	J11	JUMPER WIRE 17P	D20PYY1740E

G PRIMARY ASSY

Although XWZ3118 and XWZ3115 are different in part number, they consist of the same components.

PARTS LIST FOR XWZ3118

CAPACITORS			
△	C3 (10000pF/AC250V)		ACG7020

H SUB TRANS ASSY

(1) CONTRAST TABLE

XWZ3119 and XWZ3116 are constructed the same except for the following :

Mark	Symbol and Description	Part No.		Remarks
		XWZ3119	XWZ3116	
△	R1 (2.2MΩ/ 1/2W)	RCN1080	Not used	
△	AN1 1P AC INLET	AKP7032	BKP1046	
	KN1 EARTH METAL FITTING	VNF1084	Not used	

(2) PARTS LIST FOR XWZ3119

SEMICONDUCTORS			
△	IC81		NJM7805FA
	Q81		2SD1859X
	D85, D88-D90		1SS133
△	D81-D84		S5688G

COILS AND FILTERS

△	L1	LINE FILTER	ATF1136
---	----	-------------	---------

TRANSFORMERS

△	T2		ATT7027
---	----	--	---------

SWITCHES AND RELAYS

△	RY81		ASR7018
---	------	--	---------

CAPACITORS

	C83		CEAT100M50
△	C82		CEAT102M25

RESISTORS

△	R1 (2.2MΩ/ 1/2W)		RCN1080
	R83		RS1/10S102J
	Other Resistors		RD1/4PU□□□□

Mark	No.	Description	Part No.
OTHERS			
	CN83	4P JUMPER CONNECTOR	52147-0410
△	AN1	1P AC INLET	AKP7032
	H1, H2	FUSE CLIP	AKR7001
	KN1	EARTH METAL FITTING	VNF1084

I DISPLAY ASSY (XWZ3135 and XWZ3142)

(1) CONTRAST TABLE

XWZ3135 and XWZ3142 are constructed the same except for the following :

Mark	Symbol and Description	Part No.		Remarks
		XWZ3135	XWZ3142	
	D5597	1SS355	Not used	

(2) PARTS LIST FOR XWZ3135

SEMICONDUCTORS			
	IC5631		BA3835F
	IC5601		BU2092F
	IC5501		PDC049A
	Q5501		2SA1037K
	Q2903, Q2906, Q2908		2SB1132
	Q5604, Q5801		2SC2412K
	Q2910, Q2911		DTA124EK
	Q5606		DTC124EK
	Q2901, Q2904, Q2907, Q5502, Q5603		DTC143EK
	Q5821		DTC143EK
	D5592, D5593, D5811		1SS133
	D5551-D5554, D5557-D5568		1SS181
	D2901-D2903, D5569, D5570, D5597		1SS355
	D5626, D5901		1SS355
	D5612		BR5064X
	D5608-D5611		MBG5064X
	D5613-D5616		MPG5064X
	D5617-D5620		SLP3118C51H
	D5603-D5607, D5621		SLP9118C51H

COILS AND FILTERS

L5811	LAU220J
-------	---------

SWITCHES AND RELAYS

S5951	ASX7004
S5952	ASX7017
S5911-S5931	XSG3001

CAPACITORS

C5812 (0.047F/5.5V)	ACH1246
C5601	CCSSQL151J50
C5821	CEJA100M16
C5803	CEJA1ROM50
C5510, C5811, C5814	CEJA470M16

C5804	CKSQYB102K50
C5995, C5996	CKSQYB103K50
C5816, C5997-C5999	CKSQYB104K25
C5505, C5509, C5951-C5954	CKSQYB471K50
C5506-C5508	CKSQYB472K50

C5602, C5631-C5634, C5901	CKSQYF104Z50
C5503, C5504, C5813, C5822	CKSQYF473Z50

Mark	No.	Description	Part No.
RESISTORS			
	R5529 (470Ω)		ACN7056
	R5554, R5556, R5561, R5562 (1.5kΩ)		ACN7062
	R5558, R5563, R5564 (47kΩ)		ACN7077
	R5508		RA11T104J
	R5506		RA7T104J
	R2907, R2909, R2910, R5611, R5919		RD1/4PU102J
	R5915		RD1/4PU181J
	R5925		RD1/4PU331J
	R5605, R5606, R5612, R5613, R5926		RD1/4PU561J
	R2902, R5604, R5607-R5610		RD1/4PU681J
	R5927		RD1/4PU821J
	R2911-R2913		RS1/8S0R0J
	R5702		RS1/8S223J
	R5614		RS1/8S331J
	R2905		RS1/8S681J
	Other Resistors		RS1/10S□□□□

OTHERS

CN5502	14P FFC CONNECTOR	52045-1445
CN2901	19P FFC CONNECTOR	52045-1945
CN5501	38P FFC CONNECTOR	52045-3845
X5901	REMOTE RECEIVER UNIT	GP1U28X
V5621	FL TUBE	XAV3004
2902	FL HOLDER	XNG3008
X5501	CERAMIC RESONATOR (6MHz)	RSS1050

I DISPLAY ASSY (XWZ3117 and XWZ3143)

(1) CONTRAST TABLE

XWZ3117 and XWZ3143 are constructed the same except for the following :

Mark	Symbol and Description	Part No.		Remarks
		XWZ3117	XWZ3143	
	D5597	1SS355	Not used	

(2) PARTS LIST FOR XWZ3117

SEMICONDUCTORS

IC5631		BA3835F
IC5601		BU2092F
IC5501		PDC049A
Q5501		2SA1037K
Q2903, Q2906, Q2908		2SB1132
Q5604, Q5801		2SC2412K
Q2910, Q2911		DTA124EK
Q5606		DTC124EK
Q2901, Q2904, Q2907, Q5502, Q5603		DTC143EK
Q5821		DTC143EK
D5592, D5811		1SS133
D5551-D5568		1SS181
D2901-D2903, D5569, D5570, D5597		1SS355
D5626, D5901		1SS355
D5612		BR5064X
D5608-D5611		MBG5064X
D5613-D5616		MPG5064X
D5617-D5620		SLP3118C51H
D5603-D5607, D5621		SLP9118C51H

COILS AND FILTERS

L5811	LAU220J
-------	---------

Mark	No.	Description	Part No.
SWITCHES AND RELAYS			
	S5951		ASX7004
	S5952		ASX7017
	S5911-S5931		XSG3001
CAPACITORS			
	C5812 (0.047F/5.5V)		ACH1246
	C5601		CCSQSL151J50
	C5821		CEJA100M16
	C5803		CEJA1R0M50
	C5510, C5811, C5814		CEJA470M16
	C5804		CKSQYB102K50
	C5995, C5996		CKSQYB103K50
	C5816, C5997-C5999		CKSQYB104K25
	C5505, C5509, C5951-C5954		CKSQYB471K50
	C5506-C5508, C5511		CKSQYB472K50
	C5602, C5631-C5634, C5901		CKSQYF104Z50
	C5503, C5504, C5813, C5822		CKSQYF473Z50

RESISTORS

R5529 (470Ω)		ACN7056
R5554, R5556, R5561, R5562 (1.5kΩ)		ACN7062
R5558, R5563, R5564 (47kΩ)		ACN7077
R5508		RA11T104J
R5506		RA7T104J
R2907, R2909, R2910, R5611, R5919		RD1/4PU102J
R5915		RD1/4PU181J
R5925		RD1/4PU331J
R5605, R5606, R5612, R5613, R5926		RD1/4PU561J
R2902, R5604, R5607-R5610		RD1/4PU681J
R5927		RD1/4PU821J
R2911-R2913		RS1/8S0R0J
R5702		RS1/8S223J
R5614		RS1/8S331J
R2905		RS1/8S681J
Other Resistors		RS1/10S□□□□

OTHERS

CN5502	14P FFC CONNECTOR	52045-1445
CN2901	19P FFC CONNECTOR	52045-1945
CN5501	38P FFC CONNECTOR	52045-3845
X5901	REMOTE RECEIVER UNIT	GP1U28X
V5621	FL TUBE	XAV3004
2902	FL HOLDER	XNG3008
X5501	CERAMIC RESONATOR (6MHz)	RSS1050

J CD SW LED ASSY

SEMICONDUCTORS

D5623	SLP3118C51H
D5624	SLP7118C51H
D5622	SLP9118C51H

SWITCHES AND RELAYS

S5937-S5941	XSG3001
-------------	---------

RESISTORS

All Resistors	RS1/10S□□□□
---------------	-------------

OTHERS

J5501	JUMPER WIRE	D20PWW0615E
-------	-------------	-------------

XR-A880, XR-A770

Mark No. Description Part No.

K SUB DISPLAY ASSY

(1) CONTRAST TABLE

XWZ3132 and XWZ3112 are constructed the same except for the following :

Mark	Symbol and Description	Part No.		Remarks
		XWZ3132	XWZ3112	
	IC5411	BU4094BCF	Not used	
	Q5412-Q5415	DTC143EK	Not used	
	D5414,D5416,D5418, D5420	SLP9118C51H	Not used	
	S5403	Not used	ASX7004	
	C5411-C5413	CCSQCH101J50	Not used	
	C5414	CKSQYB103K50	Not used	
	R5411,R5412	RD1/10S102J	Not used	
	R5416	RD1/4PU221J	Not used	
	R5417,R5418	Not used	RS1/10S473J	
	R5432,R5434	RD1/4PU681J	Not used	
	R9530	Not used	RS1/10S0R0J	

(2) PARTS LIST FOR XWZ3132

SEMICONDUCTORS

IC5411 BU4094BCF
 Q5411-Q5415 DTC143EK
 D5411, D5412 SLP7118C51H
 D5414, D5416, D5418, D5420 SLP9118C51H

SWITCHES AND RELAYS

S5404 XSG3001
 S5401, S5402 XSX3002

CAPACITORS

C5411-C5413 CCSQCH101J50
 C5414 CKSQYB103K50

RESISTORS

R5416 RD1/4PU221J
 R5430 RD1/4PU561J
 R5432, R5434 RD1/4PU681J
 Other Resistors RS1/10S□□□□J

OTHERS

CN5401 14P FFC CONNECTOR 52045-1445

L REAR AMP ASSY

(1) CONTRAST TABLE

XWZ3195 and XWZ3194 are constructed the same except for the following :

Mark	Symbol and Description	Part No.		Remarks
		XWZ3195	XWZ3194	
	Q3671,Q3672	Not used	2SA1037K	
	C3671	Not used	CEAT101M10	
	R3671-R3674,R3676	Not used	RS1/10S103J	
	R3677	Not used	RS1/10S103J	
	R3675	Not used	RS1/10S472J	

(2) PARTS LIST FOR XWZ3195

SEMICONDUCTORS

△ IC3401 TDA8560Q
 △ Q3352 IRF540A
 △ Q3351 IRF9540A
 D3663 1SS355
 D3359, D3360 MTZJ18B

Mark No. Description Part No.

D3671 MTZJ20A
 D3371, D3372 U1GC44

CAPACITORS

C3411 CEAT101M35
 C3401, C3402 CEATR47M50

RESISTORS

R3353, R3354 RD1/4PU101J
 Other Resistors RS1/10S□□□□J

OTHERS

J3401 JUMPER WIRE 17P D20PYY1720E

M TRADE ASSY

OTHERS

CN3703 13P PLUG KM200TA13
 CN3702 13P SOCKET KP200TA13L

N PRO LOGIC ASSY

SEMICONDUCTORS

IC3701 LV1035M
 D3701, D3702 1SS133

CAPACITORS

C3727 CCSQCH681J50
 C3741, C3744 CEANL3R3M50
 C3737, C3739, C3746, C3748 CEANL4R7M50
 C3703-C3706, C3709, C3715 CEAT100M50
 C3718-C3720, C3732, C3733 CEAT100M50

C3707, C3708, C3713, C3716 CEAT221M10
 C3726 CEAT221M6R3
 C3717 CEAT2R2M50
 C3731 CEAT470M10
 C3721 CEATR33M50

C3722, C3736, C3738, C3747, C3749 CEATR47M50
 C3701, C3702 CFTLA104J50
 C3740, C3742, C3743, C3745 CFTLA154J50
 C3730 CFTLA474J50
 C3750, C3753 CKSQYB103K50

C3714 CKSQYB182K50
 C3734, C3735 CQMBA104J50
 C3729 CQMBA223J50
 C3724 CQMBA332J50
 C3728 CQMBA473J50

C3723, C3725 CQMBA823J50

RESISTORS

R3701 RD1/4PU183J
 R3704 RS1/10S3902F
 Other Resistors RS1/10S□□□□J

OTHERS

CN3704 13P SOCKET KP200TA13L
 X3701 CERAMIC RESONATOR DSS1053
 (8MHz)

6. ADJUSTMENT

6.1 TUNER SECTION

■ FM Tuner Section

- Set the mode selector to FM BAND.
- Connect the wiring as shown in Fig. 1.

Step No.	Adjustment Title	FM SG (1kHz, ± 75kHz dev.)		Reception Frequency Display	Adjustment Location	Specifications
		Frequency (MHz)	Level (dBμV)			
1	Front End Sensitivity	98	0-30	98MHz	L6402 T6401	Adjust so that the DC voltage between the IC6201-pin 20 and GND becomes at maximum level.
2	TUNED IND. Lighting Level	98	18 ± 2	98MHz	VR6201	Adjust so that the indicator of TUNED IND. starts to light up.

Note:

Before adjusting, make sure there is no gap between L6401 and L6402. If there is a gap between them, bring them into contact with each other first, and then make adjustments.

■ AM Tuner Section

- Set the mode selector to AM BAND.
- Connect the wiring as shown in Fig. 1.

Step No.	Adjustment Title	AM SG (400Hz, 30% Mod.)		Reception Frequency Display	Adjustment Location	Specifications
		Frequency (kHz)	Level (dBμV/m)			
1	Front End Sensitivity	999 (*1)	35-45	999kHz (*1)	T6201	Adjust so that the DC voltage between the IC6201-pin 20 and GND becomes at maximum level.

Note (*1): For the area using 10kHz step, frequencies should be 1000kHz.

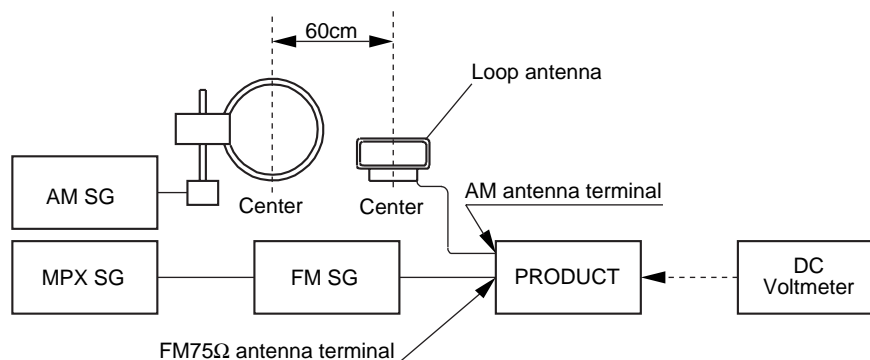

Fig. 1 AM and FM Adjustment Wiring Diagram

FM/AM TUNER MODULE

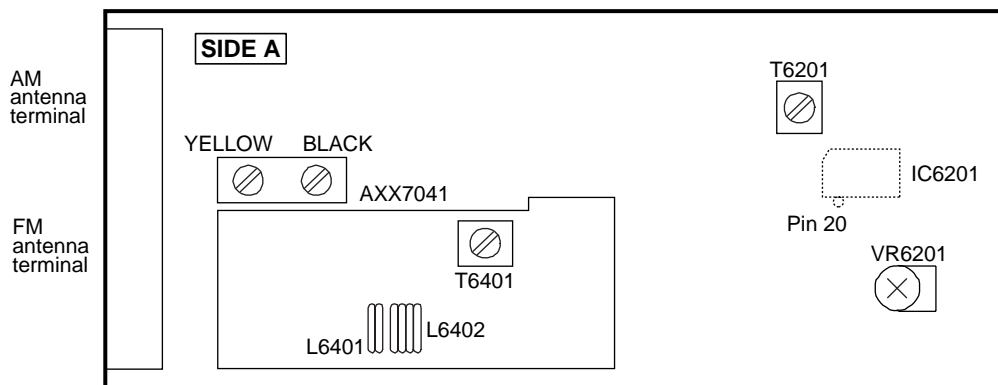

Fig. 2 Adjustment Point

6.2 CASSETTE DECK SECTION

- Adjustment points and test points are shown in Fig.3, Fig.5 and Fig.7.

■ Mechanical Adjustment

- Test tape: NCT-111 (3kHz, 30min).

1. Tape Speed Adjustment

No.	Mode	Test Tape	Adjusting Points	Measurement Points	Adjustment Procedure	Remarks
1	Deck I PLAY	NCT-111 (Playback : 3kHz)	ADJ. VR on CASSETTE MECHA(Fig. 3)	TAPE TEST POINT (Rch) (AF Assy)	Press the PLAY SW and adjust so that the reading becomes $3000\text{Hz} \pm 20\text{Hz}$. Confirm that wow & flutter level is below 0.3% (in the reverse direction, confirm that the reading is within $3000\text{Hz} \pm 60\text{Hz}$).	

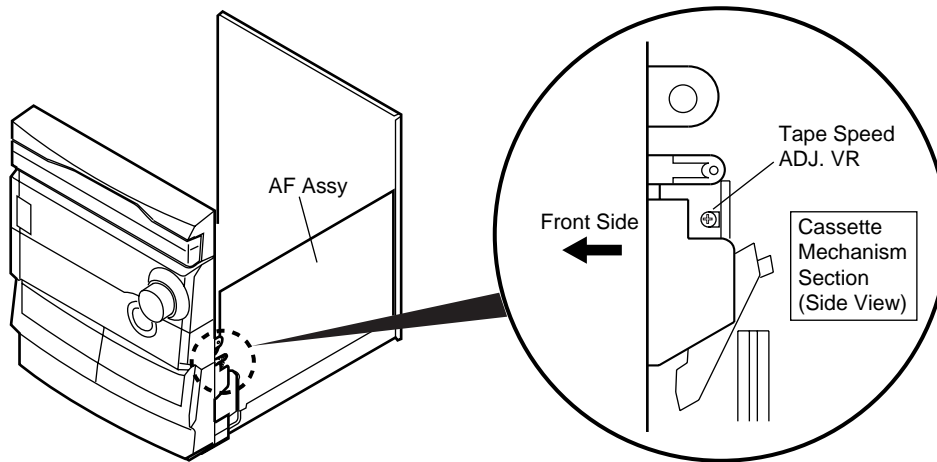

Fig.3 Tape Speed ADJ. Point

■ Electrical Adjustment

Check the following before starting.

- (1) Confirm that the tape speed adjustment has been completed.
- (2) Clean the heads and demagnetize them using a head eraser.
- (3) Set the measurement level to $0\text{ dBV} = 1\text{ Vrms}$.
- (4) Use the specified tape for adjustment. Use the labeled (A) side of the test tape.
STD-331E : For playback check
STD-632 : Normal blank tape
- (5) Provide yourself with the following measuring devices:
 - AC millivoltmeter
 - Low-frequency oscillator
 - Attenuator
 - Oscilloscope
- (6) Adjust both right and left channels unless otherwise specified.
- (7) Turn the DOLBY NR switch off unless otherwise specified.
- (8) Warm up the unit for several minutes before adjustment.
In particular, be sure to warm up the unit in the REC/PLAY mode for 3 to 5 minutes before starting recording/playback frequency characteristics adjustment.
- (9) Always follow the indicated adjustment order.
Otherwise, a complete adjustment may not be achieved.

Playback Adjustment (Decks I and II)

- (1) Head Azimuth Adjustment
- (2) Playback Level Adjustment

Recording Adjustment (Deck I)

- (1) Bias Oscillation Frequency Adjustment
- (2) Recording Bias Adjustment
- (3) Recording Level Adjustment.
- (4) ALC Operation Check

* As the reference recording level is 250nwb/m for STD-331E, the recording level will be higher by 4 dB for STD-331B (160nwb/m). When adjusting, pay careful attention to the type of tape used.

*Dolby noise reduction manufactured under license from Dolby Laboratories Licensing Corporation.
"DOLBY" and the double-D symbol are trademarks of Dolby Laboratories Licensing Corporation.*

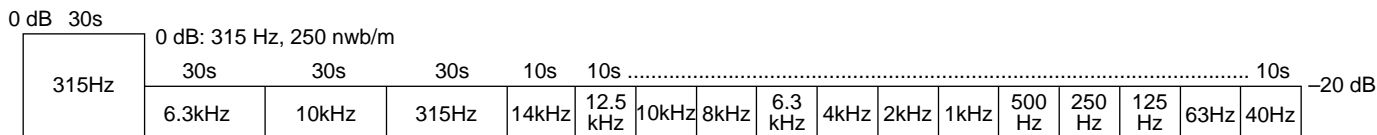

Fig. 4 STD-331E Test Tape

■ Playback Adjustment

(1) Head Azimuth Adjustment

- Do not switch between forward and reverse operation with the screwdriver inserted.

Step	Mode	Input Signal/ Test Tape	Adjusting Points		Measurement Points	Adjustment Value	Remarks
1	PLAY	STD-331E test tape (Playback: 10kHz, -20dB)	Deck I	Head azimuth adjustment screw (Fig. 5)	TAPE TEST POINT (L, Rch) (AF Assy)	Max. playback signal level	After adjustment, apply silicon bond to the head azimuth adjustment screw.
			Deck II				

(2) Playback Level Adjustment

- Since this adjustment determines playback Dolby NR level, perform it carefully.

Step	Mode	Input Signal/ Test Tape	Adjusting Points		Measurement Points	Adjustment Value	Remarks
1	PLAY	STD-331E test tape (Playback: 315Hz,0dB)	Deck I	VR2303(Lch) VR2304(Rch)	TAPE TEST POINT (L, Rch) (AF Assy)	- 3.7dBV	
			Deck II	VR2305(Lch) VR2306(Rch)			

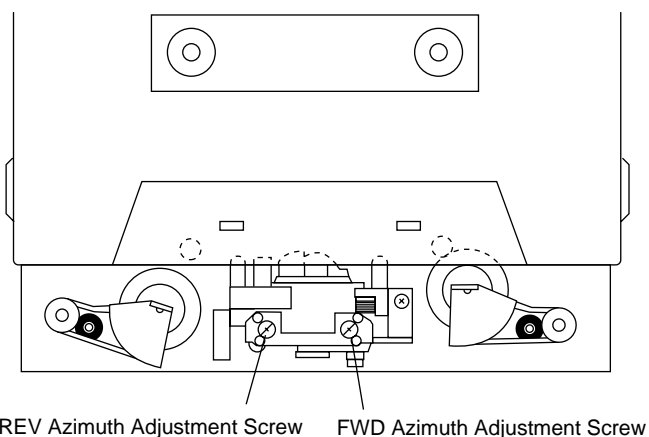

Fig. 5 Head Azimuth Adjustment Screw

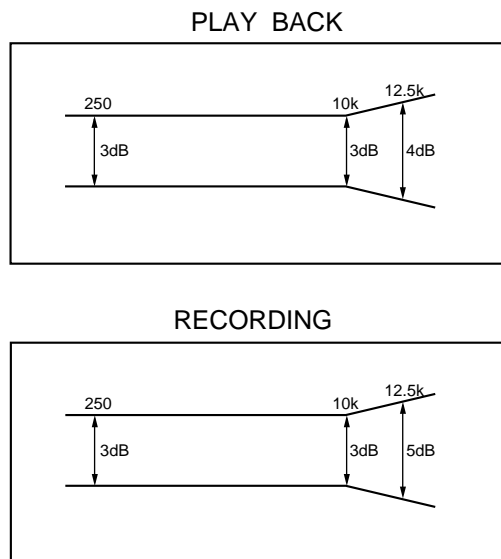

Fig. 6 Frequency Characteristics

■ Recording Adjustment

(1) Bias Oscillation Frequency Adjustment

Step	Mode	Input Signal/ Test Tape	Adjusting Points		Measurement Points	Adjustment Value	Remarks
1	REC	Load the STD-632 test tape and set the recording mode.	Deck II	_____	Between ① point in Fig.7 and GND.	Oscillation frequency to be 105.0kHz ± 2kHz.	If the REC/STOP button for four seconds while the power is in STAND BY mode, the frequency will decrease 2 to 3 kHz.
			DECK I	L2801 (AF Assy)			

(2) Recording Bias Adjustment

● Since this adjustment affects recording bias, prevent distortion from increasing due to underbias.

Step	Mode	Input Signal/Test Tape	Adjusting Points		Measurement Points	Adjustment Value	Remarks
1	REC	Input a 315Hz signal to the AUX terminal and set the input selector to AUX.	Deck II	_____	TAPE TEST POINT (L, Rch) (AF Assy)	- 23.7dBV	
			DECK I	Input signal level			
2	REC → PLAY	Load the STD-632 test tape and record/playback the 315Hz and 10kHz signals. (see the Note below)	Deck II	_____	TAPE TEST POINT (L, Rch) (AF Assy)	Repeat adjustment until playback level of the 10kHz signal is within 0 ± 0.5dB from that of the 315Hz signal.	
			DECK I	VR2801(Lch) VR2802(Rch)			

Note : Set the 10kHz input signal level to the same value as the 315Hz input signal level of step 1.

(3) Recording Level Adjustment

Step	Mode	Input Signal/Test Tape	Adjusting Points		Measurement Points	Adjustment Value	Remarks
1	REC	Input a 315Hz signal to the AUX terminal and set the input selector to AUX.	Deck II	Input signal level	TAPE TEST POINT (L, Rch) (AF Assy)	- 7.7dBV	
			DECK I				
2	REC → PLAY	Load the STD-632 test tape and record/playback the 315Hz signal.	Deck II	_____	TAPE TEST POINT (L, Rch) (AF Assy)	Repeat recording, playback and adjustment until playback level of the 315Hz signal becomes - 7.7dBV.	
			DECK I	VR2301(Lch) VR2302(Rch)			

(4) ALC Operation Check

Step	Mode	Input Signal/Test Tape	Adjusting Points		Measurement Points	Adjustment Value	Remarks
1	REC/ PAUSE	Input a 315Hz signal to the AUX terminal and set the input selector to AUX.	Input signal level		TAPE TEST POINT (L, Rch) (AF Assy)	- 8.2dBV	
2			Set to a level +10dB above the input level at step1.			- 2.2 ± 2.5dBV.	

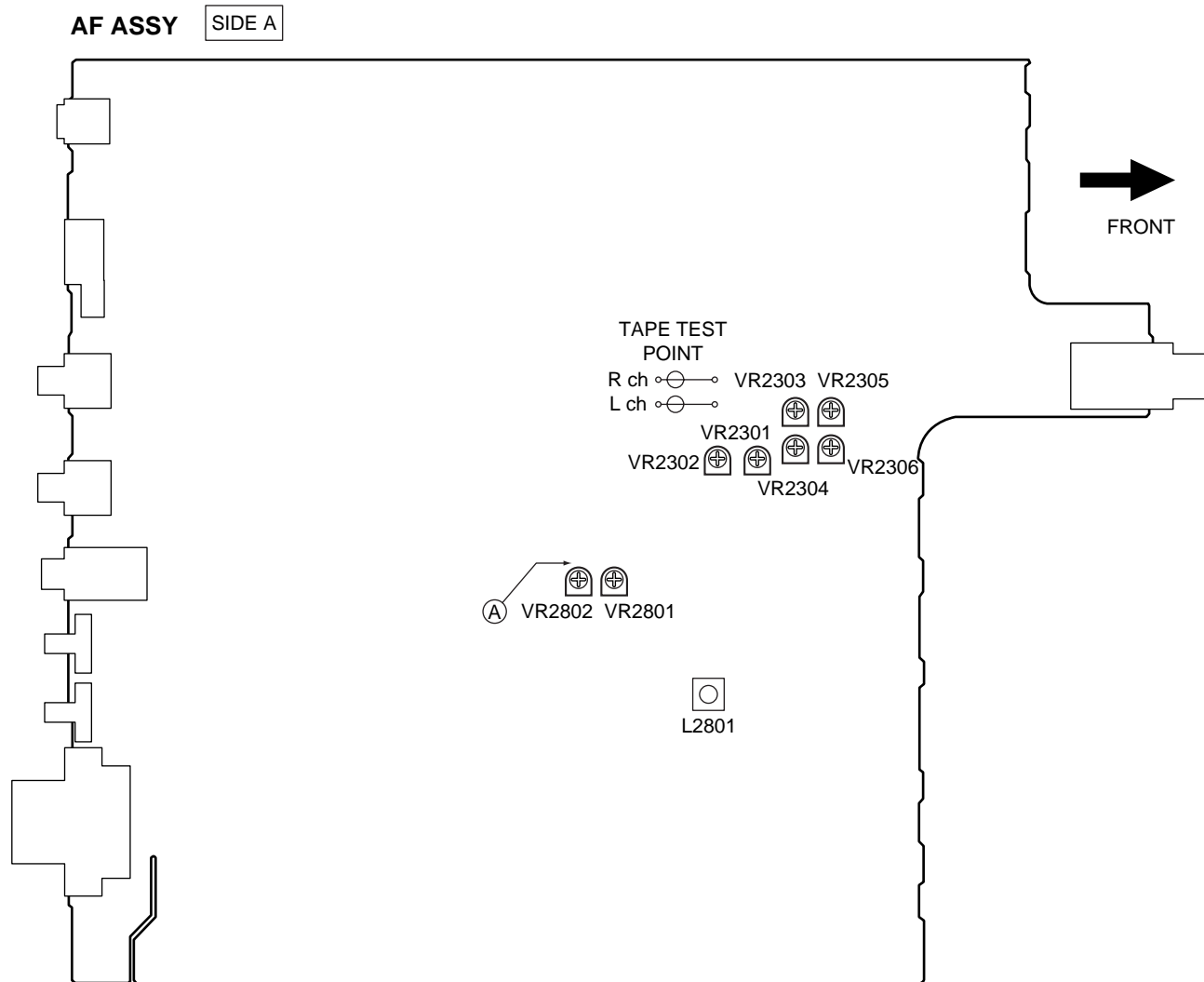

Fig.7 Adjustment and Measurement Points

6.3 TEST MODE

NOTE: There is no information to be shown in this CD adjustment.

■ How to Start/Cancel Test Mode

TEST MODE : ON

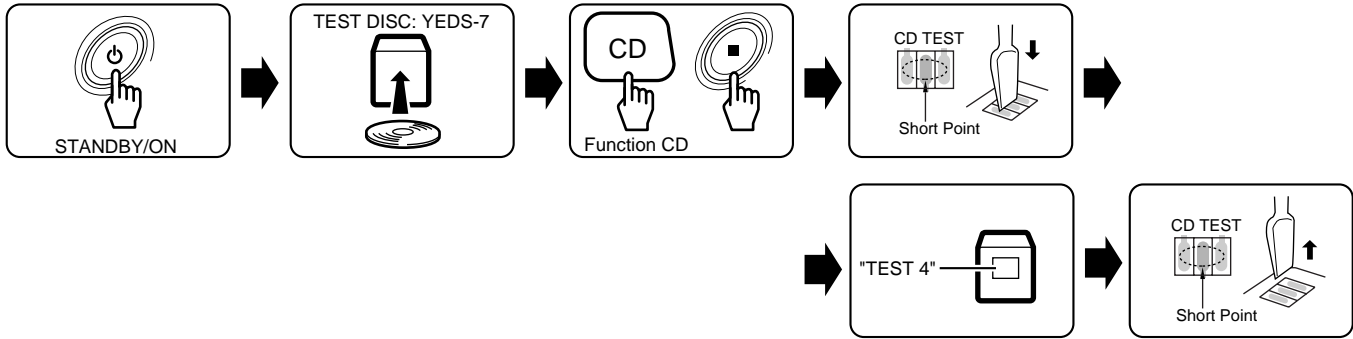

TEST MODE : PLAY

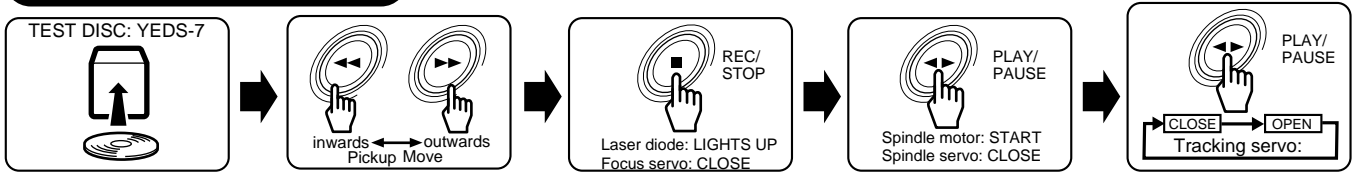

TEST MODE : STOP CANCEL

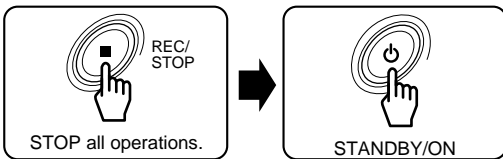

■ Test Point

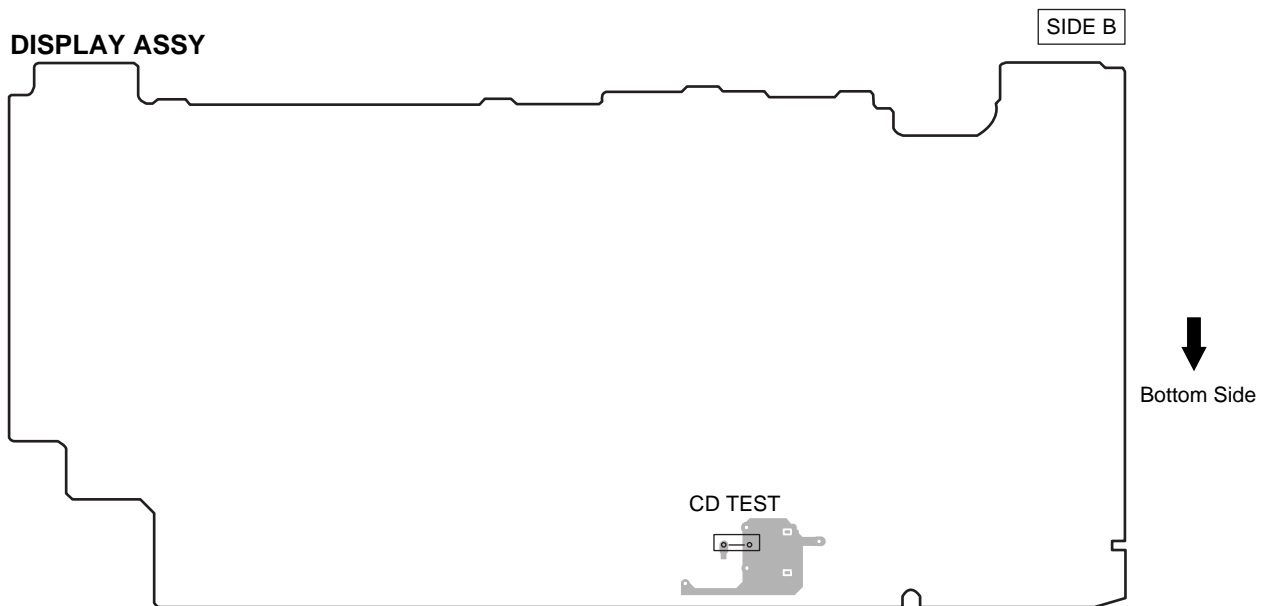

7. GENERAL INFORMATION

7.1 PARTS

7.1.1 IC

• The information shown in the list is basic information and may not correspond exactly to that shown in the schematic diagrams.

■ HA12136AF (AF ASSY : IC2201)

• Dolby B Type NR System IC

●Pin Function

No.	Pin Name	Function	No.	Pin Name	Function
1	REC IN	Recording (Encode) input	9	REC OUT	Recording (Encode) output
2	Vcc	Power supply	10	DET	Time constant pin for the level detector
3	PB IN	Playback (Decode) input	11	PB OUT	Playback (Decode) output
4	Vref	Reference voltage	12	REC/PB	Mode control pin for REC/PB (Encode/Decode) "H" : REC (Encode), "L" : PB (Decode)
5	NR ON/OFF	Mode control pin for NR ON/OFF "H" : NR ON, "L" : NR OFF	13	BIAS	Reference current input pin for the active filters
6	PB OUT	Playback (Decode) output	14	PB IN	Playback (Decode) input
7	DET	Time constant pin for the level detector	15	GND	Ground
8	REC OUT	Recording (Encode) output	16	REC IN	Recording (Encode) input

■ HA12211NT (AF ASSY : IC2301)

• REC Equalizer and PB Equalizer System IC

●Block Diagram

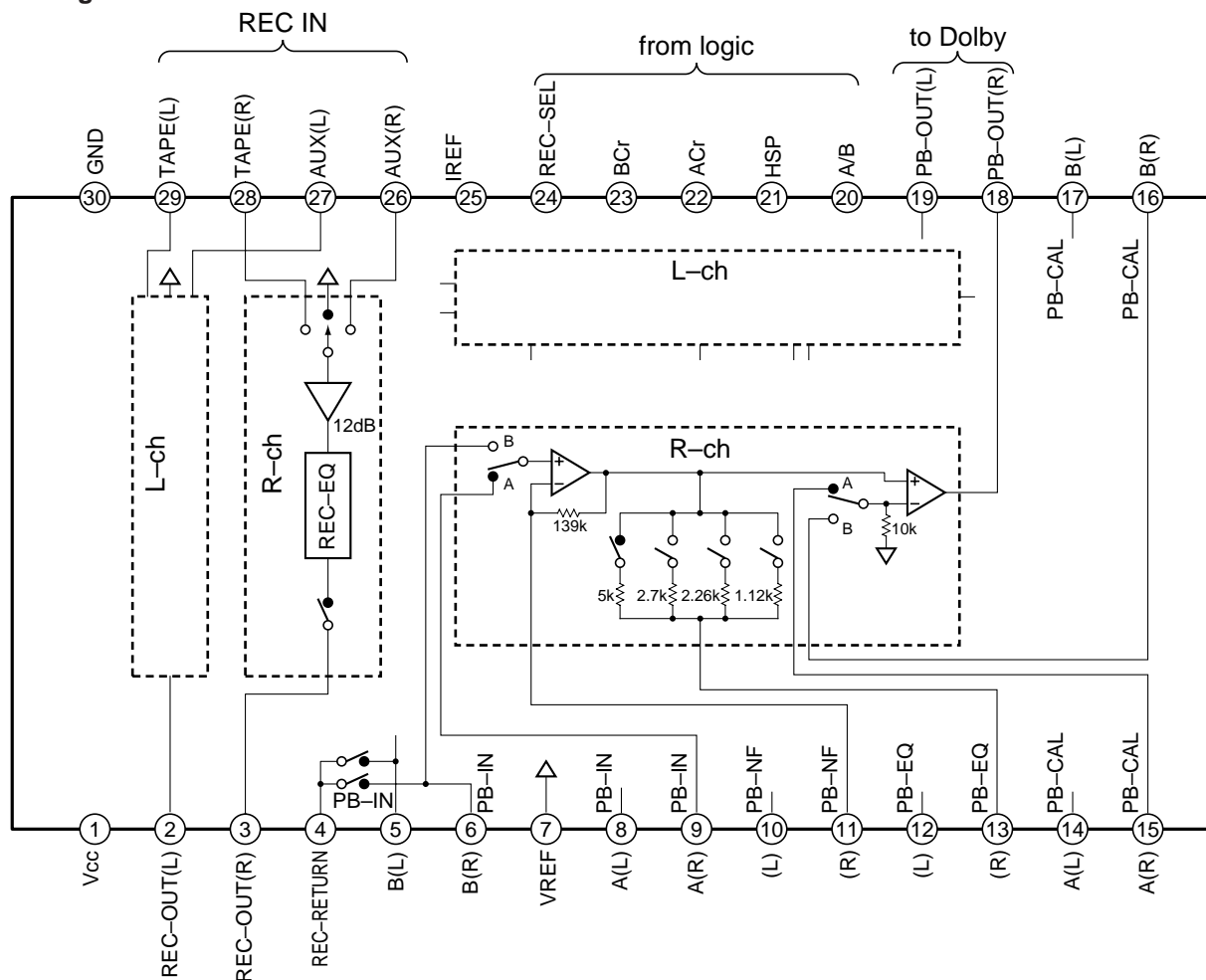

●Pin Function

No.	Pin Name	Function	No.	Pin Name	Function
1	Vcc	Vcc pin	16	PB-Cal B (R)	Feed back input for gain adjustment
2	RECOUT (L)	REC-EQ output	17	PB-Cal B (L)	
3	RECOUT (R)		18	PB OUT (R)	PB output
4	REC-RETURN	REC return	19	PB OUT (L)	
5	PB-IN B (L)	PB B deck input	20	A/B	Mode control input
6	PB-IN B (R)				
7	VREF	Reference voltage	21	HSP	
8	PB-IN A (L)	PB A deck input	22	Acr	
9	PB-IN A (R)				
10	PB-NF (L)	PB EQ feed back	23	Bcr	Mode control input
11	PB-NF (R)				
12	PB-EQ (L)	NAB output	24	REC-SEL	Equalizer reference current input
13	PB-EQ (R)				
14	PB-Cal A (L)		25	IREF	
15	PB-Cal A (R)	Feed back input for gain adjustment	26	AUX (R)	REC-EQ input
			27	AUX (L)	
			28	TAPE (R)	
			29	TAPE (L)	GND pin
			30	GND	

■ LC75396NE (AF ASSY : IC3001)

• Electrical Volume IC

●Block Diagram

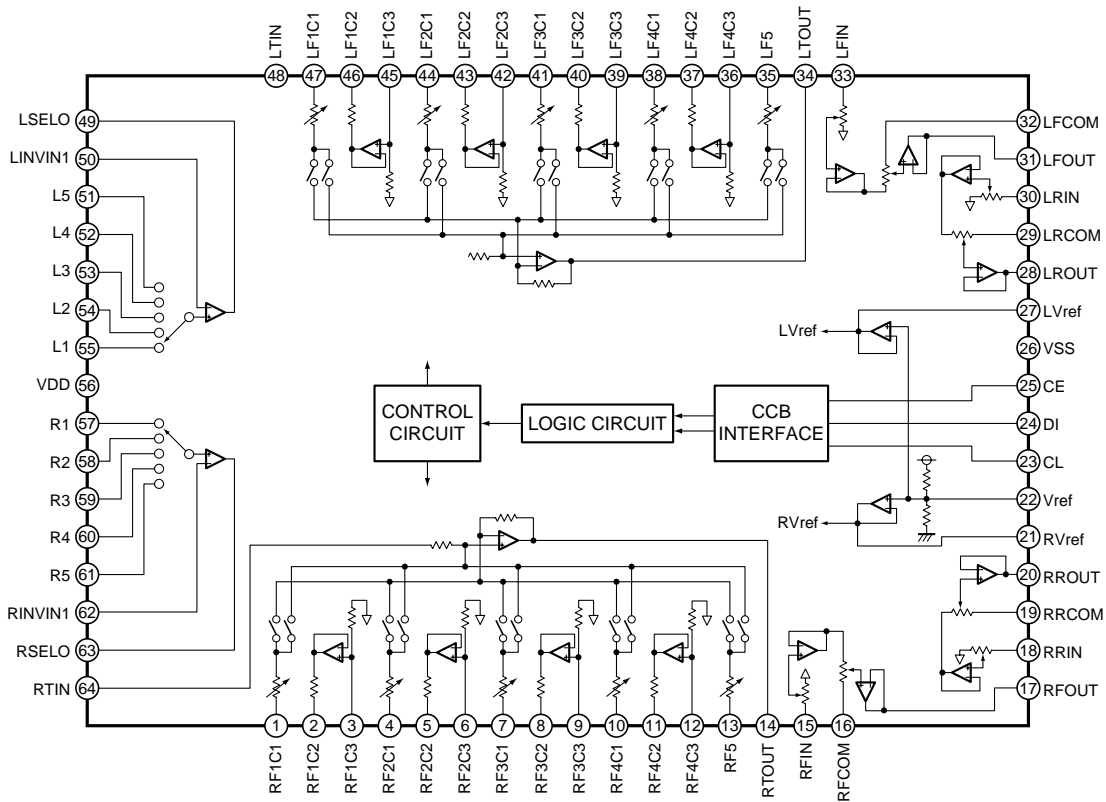

■ PDC049A (DISPLAY ASSY : IC5501)

• System Control Microcomputer

● Pin Function

No.	Pin Name	I/O	Function	No.	Pin Name	I/O	Function	
1	CD RESET	O	Reset output for CD LSI	51	VFDP	–		
2	CD CE	O	CD LSI strobe output	52	S*/D5593	*	FL display control anode	
3	CD DRF	I	RF level detection input	53	S*/D5592	*		
4	BASSLED/LED CE2	O	LED control for P.BASS indicator (LED BASS)	54	S*/D5591	*		
5	EXP CLK	O	Clock output for EXP IC (BU4094), LED IC (BU2092) and Prologic IC (LV1035)	55	S*/BJOGC2	I/O		
6	EXP DATA	O	Data output for EXP IC (BU4094), LED IC (BU2092) and Prologic IC (LV1035)	56	S*/BJOGC1	I/O		
7	EXP CE	O	EXP IC (BU4094), LED IC (BU2092) strobe output	57	S*/BJOGB2	I/O		
8	LED1/SPE A	O	LED control / Spectrum analyzer IC (BU1923) output control	58	S*/BJOGB1	I/O		
9	LED2/SPE B	O		59	S*/BJOGA2	I/O		
10	LED3/SPE C	O		60	S*/BJOGA1	I/O		
11	AC	I	AC pulse input (for clock , power supply monitor)	61	S*	I/O		
12	XRESET	I	CPU reset input	62	S*	I/O		
13	REEL1	I	Pulse input for deck 2 reel	63	S*/CLAMP	I/O		
14	REEL2	I	Pulse input for deck 1 reel	64	S*/OPEN	I/O		
15	VSS	–	Ground	65	S*/INSIDE	I/O		
16	CF1	I		66	S*/CDISC123	I/O		
17	CF2	O		67	S*/ARR	I/O		
18	VDD	–	Power supply	68	S*/ARF	I/O		
19	KEY1	I	Front key input	69	S*/MODE1	I/O		
20	MS	I	Deck MS signal input	70	S*/MODE2	I/O		
21	ST/TUNE	I	Tuner tuned (STEREO) detection	71	S*/HALF1	I/O		
22	TH	I	Temperature and protection circuit detection	72	VDD	–		
23	TIMER LED	O	LED control (for timer)	73	S*/HALF2	I/O		
24	KEY2	I	Front key input	74	S*/CrO2_1	I/O	FL display control anode	
25	SPE-IN	I	Spectrum analyzer signal input	75	S*/CrO2_2	I/O		
26	KEY3	I	Front key input	76	SCAN ON	O	Key scan input control	
27	CD WRQ	I	CD subcode Q data OK signal input	77	SOL2	O	Deck 1 solenoid control	
28	RDS CLK	I	Clock input for RDS IC (BU1923)	78	SOL1	O	Deck 2 solenoid control	
29	REMOCON	I	Remote control signal input	79	MOTOR	O	Deck motor control	
30	G*	O	FL display control anode	80	RDSDATA	I	Data input for RDS	
31	G*			81	VOLJOG1	I	Pulse input for volume jog	
32	G*			82	VOLJOG2			
33	G*			83	PLL CE	O	Tuner PLL IC strobe output	
34	G*			84	HPSW/PRO CE	I/O	Headphone SW detect input / Prologic IC (LV1035) strobe output	
35	G*			85	EVOL CE	O	Main volume control IC (LC75394) strobe output	
36	G*			86	POWER	O	Main power control	
37	G*			87	LINE MUTE	O	Line mute control	
38	G*			88	LED CE	O	LED control IC (BU2092) strobe output	
39	G*			89	VSS	–	Ground	
40	G*			90	VDD	–	Power supply	
41	G*			91	NC	I	No connection	
42	G*			92	NC			
43	G*			93	MORP JOG1	I	Pulse input for sound morphing jog	
44	G*			94	MORP JOG2			
45	G*			95	SYSDATA	O	Serial data output	
46	VDD	–	Power supply	96	TXDATA	I	Serial data input	
47	S*/D5597	O	FL display control anode	97	SCLK	O	Serial clock output	
48	S*/D5596	O		98	CD DATA	O	Serial data output for CD LSI	
49	S*/D5595	*		99	SQ OUT	I	Serial data (Q DATA) input for CD LSI	
50	S*/D5594	*		100	CD CLK	O	Serial clock output for LSI	

■ LC78622NE (CD ASSY : IC8301)

• CD DSP IC

● Block Diagram

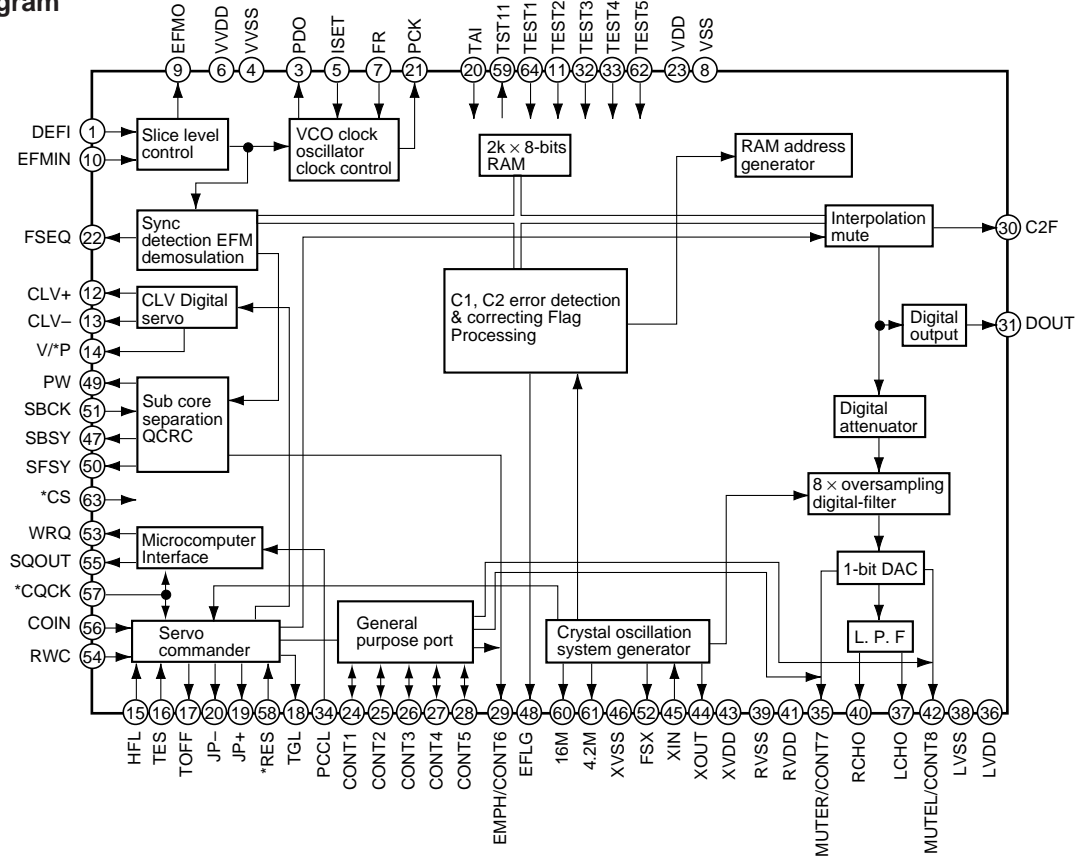

● Pin Function

No.	Pin Name	I/O	Function	
1	DEFI	I	Defect detection signal (DEF) input pin (Must be connected to 0V when unused).	
2	TAI	I	PLL pins	
3	PDO	O		External VCO control phase comparator output pin
4	VVSS	-		Internal VCO ground pin Must be connected to 0V.
5	ISET	AI		PDO output current adjustment resistor connection pin
6	VVDD	-		Internal VCO power supply pin
7	FR	AI		VCO frequency range adjustment
8	VSS	-		Digital system ground pin Must be connected to 0V.
9	EFMO	O	Slice level control	
10	EFMIN	I		EFM signal input pin
11	TEST2	I	Test input pin A pull-down resistor is built-in. Must be connected to 0V.	
12	CLV+	O	Disc motor control output	
13	CLV-	O	Can be set to three-value output by microprocessor command.	
14	V/*P	O	Rough servo/phase control automatic switching monitor output pin Outputs a high level during rough servo a low level.	
15	HFL	I	Track detection signal input pin This is a Schmitt input.	
16	TES	I	Tracking error signal input pin This is a Schmitt input.	
17	TOFF	O	Tracking off output pin	
18	TGL	O	Tracking gain switching output pin Increase the gain when low.	
19	JP+	O	Track jump output Three-value output is also possible when specified by microprocessor command.	
20	JP-	O		

No.	Pin Name	I/O	Function	
21	PCK	O	EFM data playback clock monitor pin Output pin 4.3218MHz when the phase is locked.	
22	FSEQ	O	Synchronization signal detection output pin Output a high level when the synchronization signal detected from the EFM signal and the internally generated synchronization signal range.	
23	VDD	–	Digital system power supply pin	
24	CONT1	I/O	General-purpose 1 General-purpose 2 General-purpose 3 General-purpose 4 General-purpose 5 Controlled by serial data commands from the microprocessor. Any of these that are unused must be either set up as input pin ports and connected to 0V, or set up as output pin ports and left open.	
25	CONT2			
26	CONT3			
27	CONT4			
28	CONT5			
29	EMPH/CONT6	O	De-emphasis monitor pin A high level indicates playback of a de-emphasis disk. / General-purpose 6	
30	C2F	O	C2 flag output pin	
31	DOUT	O	Digital output pin (EIJ format)	
32	TEST3	I	Test input pin A pull-down resistor is built-in. Must be connected to 0V.	
33	TEST4	I		
34	PCCL	I	General-purpose input / output command identifying pin Must be connected to 0V when used with functions similar to those of LC78622E. H: Control possible only for the general-purpose input / output port command L: Control possible for all commands	
35	MUTEL/CONT7	O	Left channel mute output pin	
36	LVDD	–	Left channel one-bit D/A converter Left channel power supply pin	
37	LCHO	O		Left channel output pin
38	LVSS	–		Left channel ground pin Must be connected to 0V.
39	RVSS	–		Right channel one-bit D/A converter Right channel ground pin Must be connected to 0V.
40	RCHO	O	Right channel output pin	
41	RVDD	–	Right channel power supply pin	
42	MUTER/CONT8	O	Right channel mute output pin	
43	XVDD	–	Crystal oscillator power supply pin	
44	XOUT	O	Connections for a 16.9344MHz crystal oscillator element pin	
45	XIN	I		
46	XVSS	–	Crystal oscillator ground pin Must be connected to 0V.	
47	SBSY	O	Subcode clock synchronization signal output pin	
48	EFLG	O	C1, C2 single and double error correction monitor pin	
49	PW	O	Subcode P, Q, R, S, T, U and W output pin	
50	SFSY	O	Subcode frame synchronization signal output pin This signal falls when the subcode are in standby state.	
51	SBCK	I	Subcode readout clock input pin This is a Schmitt input. (Must be connected to 0V when unused.)	
52	FSX	O	Output pin for the 7.35kHz synchronization signal divided from the crystal oscillator	
53	WRQ	O	Subcode Q output standby output pin	
54	RWC	I	Read/write control input pin This is a Schmitt input.	
55	SQOUT	O	Subcode Q output pin	
56	COIN	I	Command input pin from control microprocessor	
57	*CQCK	I	Input for both the command input acquisition clock and the SQOUT pin subcode readout clock input pin. This is a Schmitt input.	
58	*RES	I	Reset input pin This pin must be set low briefly after power is first applied.	
59	TST11	O	Test output pin Leave open. (Normally output a low level.)	
60	16M	O	16.9344MHz output pin	
61	4.2M	O	4.2336MHz output pin	
62	TEST5	I	Test input pin A pull-down resistor is built-in. Must be connected to 0V.	
63	*CS	I	Chip select input pin A pull-down resistor is built-in. Must be connected to 0V if not controlled.	
64	TEST1	I	Test input pin No pull-down resistor. Must be connected to 0V.	

Note: The same potential must be supplied to all power supply pins, i.e., VDD, VVDD, LVDD, RVDD and XVDD.

■ LV1035M (PRO LOGIC ASSY : IC3701)

• Dolby Pro Logic Decoder IC

● Block Diagram

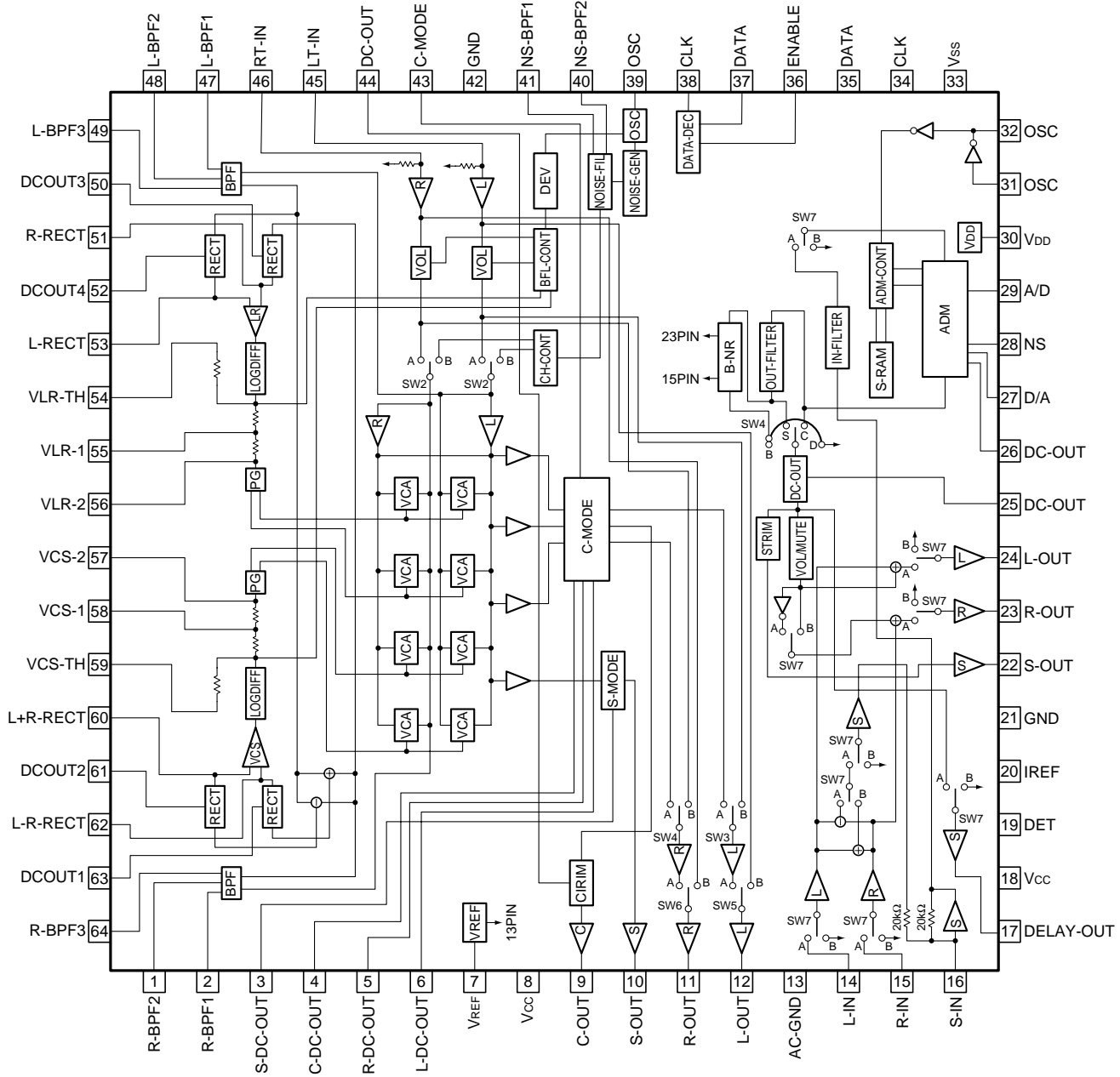

7.1.2 DISPLAY

■ XAV3004 (DISPLAY ASSY : V5621)

- FL Display

• Pin Assignment

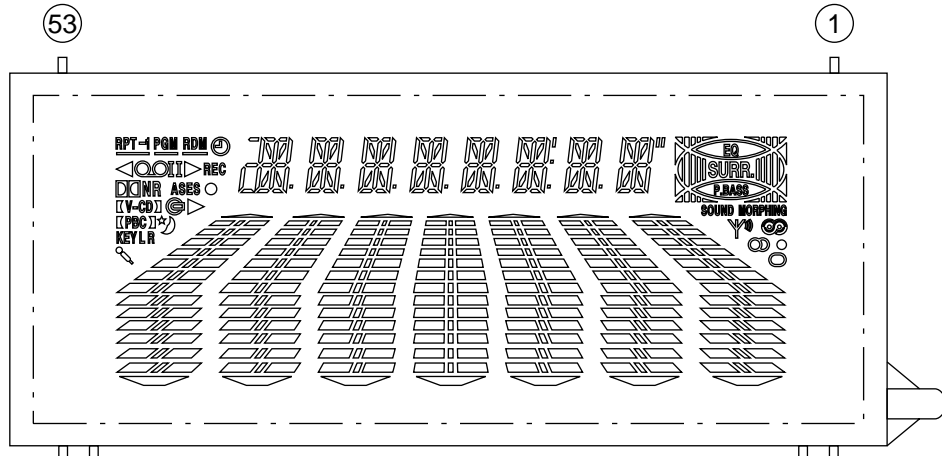

• Grid Assignment

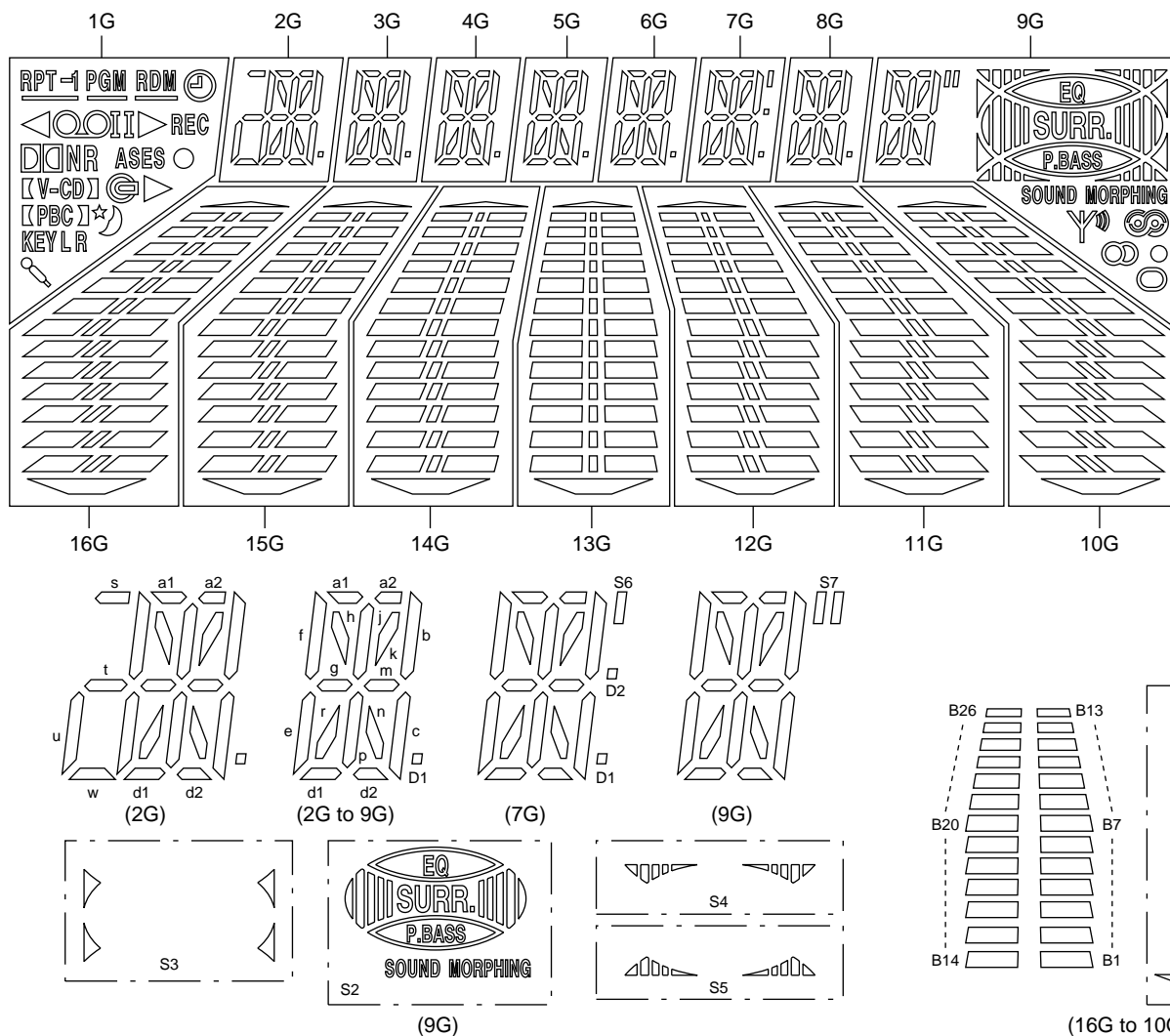

XR-A880, XR-A770

• Pin Connection

Pin No.	53	52	51	50	49	48	47	46	45	44	43	42	41	40	39	38	37	36	35	34	33	32	31	30	29	28	27
Connection	F2	F2	F2	NP	NP	1G	2G	3G	4G	5G	6G	7G	8G	9G	10G	11G	12G	13G	14G	15G	16G	P1	P2	P3	P4	P5	P6

Pin No.	26	25	24	23	22	21	20	19	18	17	16	15	14	13	12	11	10	9	8	7	6	5	4	3	2	1
Connection	P7	P8	P9	P10	P11	P12	P13	P14	P15	P16	P17	P18	P19	P20	P21	P22	P23	P24	P25	P26	P27	NP	NP	F1	F1	F1

NOTE 1) F1, F2..... Filament
 2) NP..... No pin
 3) DL..... Datum Line
 4) 1G to 16G..... Grid

• Anode Connection

	1G	2G	3G to 6G	7G	8G	9G	10G to 16G
P1	—	a1	a1	a1	a1	a1	B14
P2	⊖	a2	a2	a2	a2	a2	B15
P3	<u>RPT</u>	h	h	h	h	h	B16
P4	<u>PGM</u>	j	j	j	j	j	B17
P5	<u>RDM</u>	k	k	k	k	k	B18
P6	⊕	b	b	b	b	b	B19
P7	◁ (Left)	f	f	f	f	f	B20
P8	⊖⊖⊖	g	g	g	g	g	B21
P9	I (Right)	m	m	m	m	m	B1
P10	▷ (Upper right)	c	c	c	c	c	B2
P11	REC	e	e	e	e	e	B3
P12	<u>DN</u> R	r	r	r	r	r	B4
P13	ASES	p	p	p	p	p	B5
P14	○	n	n	n	n	n	B6
P15	[(V-CD)]	d1	d1	d1	d1	d1	B7
P16	V-CD	d2	d2	d2	d2	d2	B8
P17	⊕	s	—	—	—	S7	B22
P18	▷ (Under)	t	—	—	—	S2	B23
P19	[(PBC)]	u	—	—	—	S3	B24
P20	PBC	w	—	—	—	S4	B25
P21	☆)	—	—	—	—	S5	B9
P22	KEY	—	—	—	—	Y	B10
P23	L	—	—	—	—	⊕⊕	B11
P24	R	—	—	—	—	⊕⊕	B12
P25	⊖	D1	D1	D1	D1	○	B26
P26	—	—	—	D2	—	⊕	B13
P27	—	—	—	S6	—	—	S1

7.2 DISASSEMBLY

■ \$M MECHANISM CD

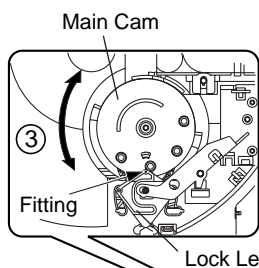
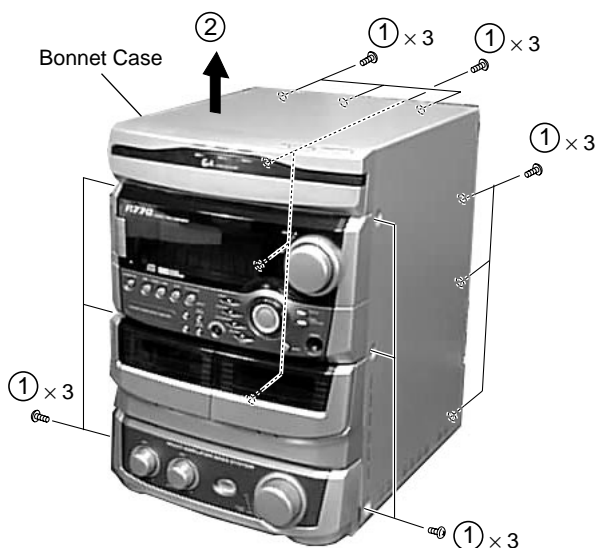

Note: The loading tray can be pulled out when the main cam is in this position. (The Lock Lever should be in the notch of the Main Cam.)

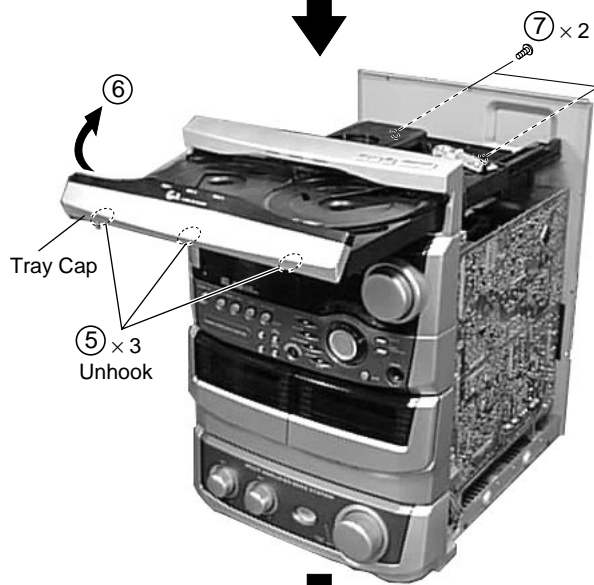

■ FRONT PANEL

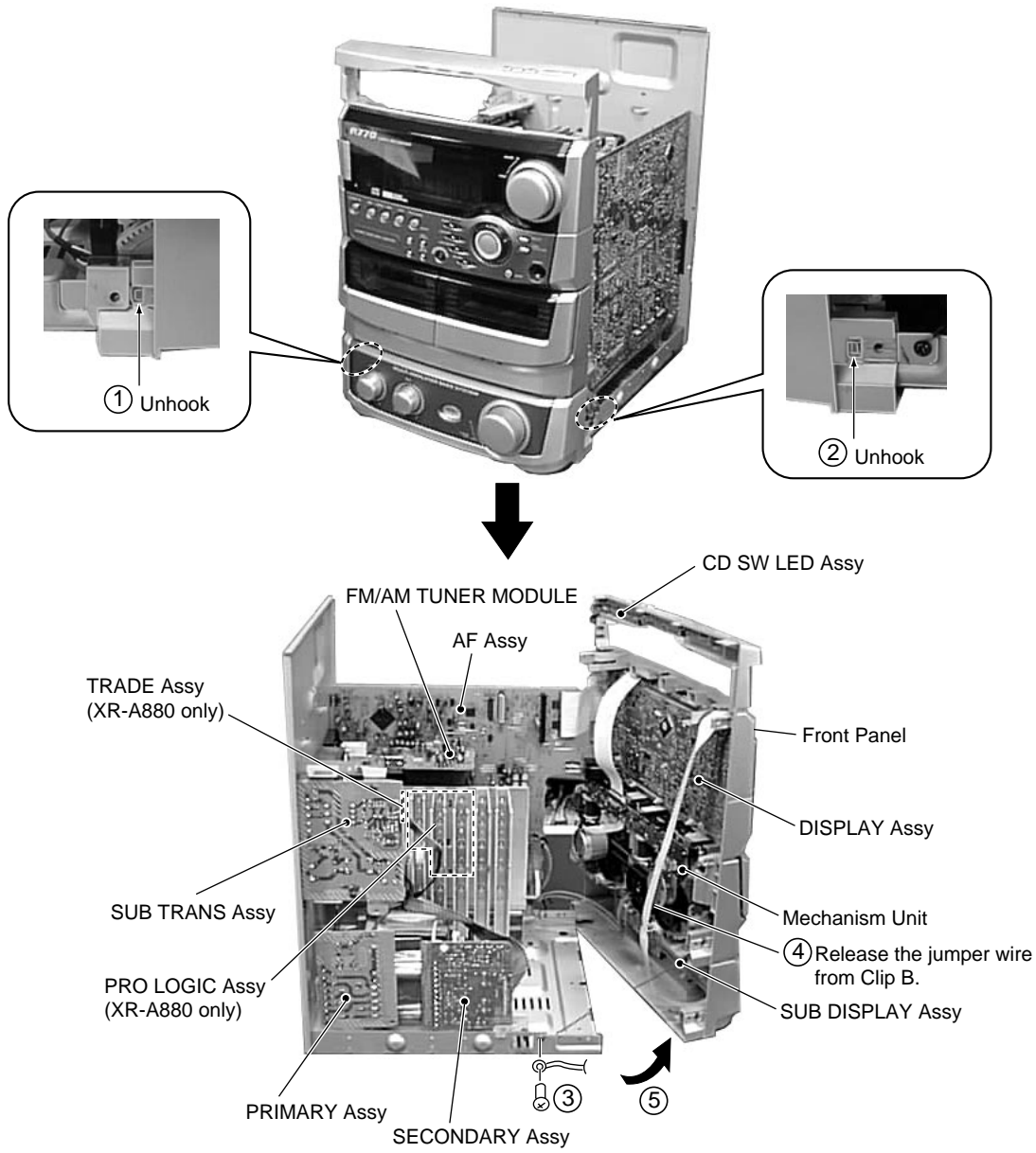

■ \$M MECHANISM CD ADDITIONAL TO JOB

● Mechanism Base (Bottom View)

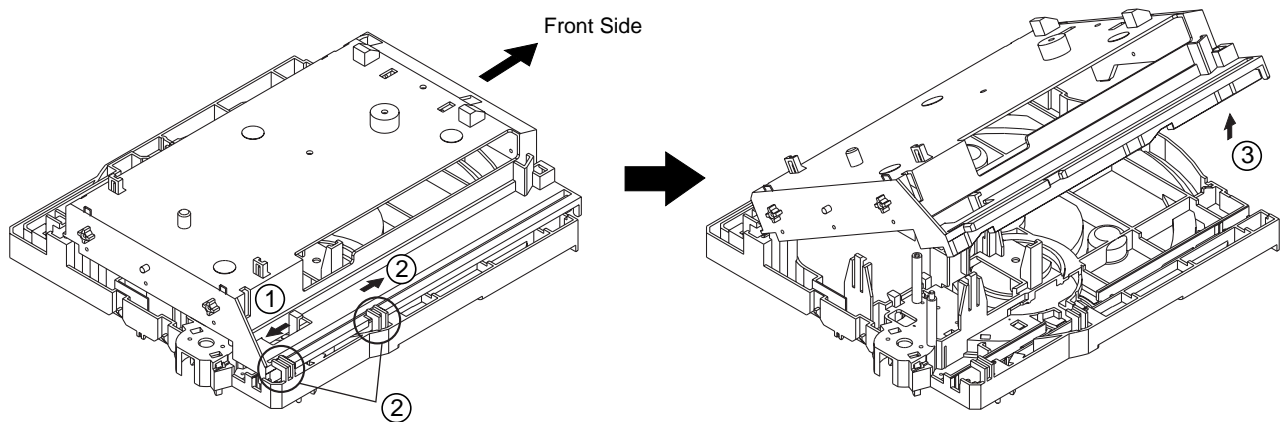

● Clamper Holder

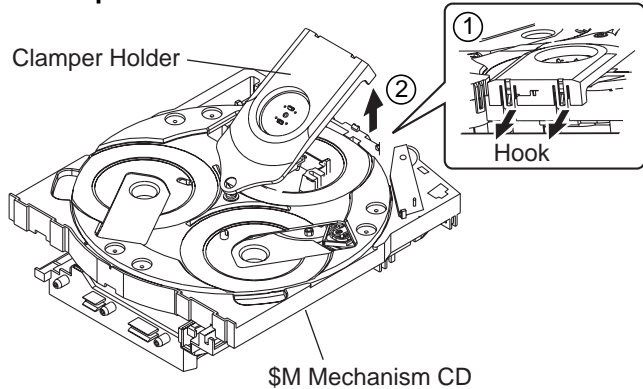

● Servo Base

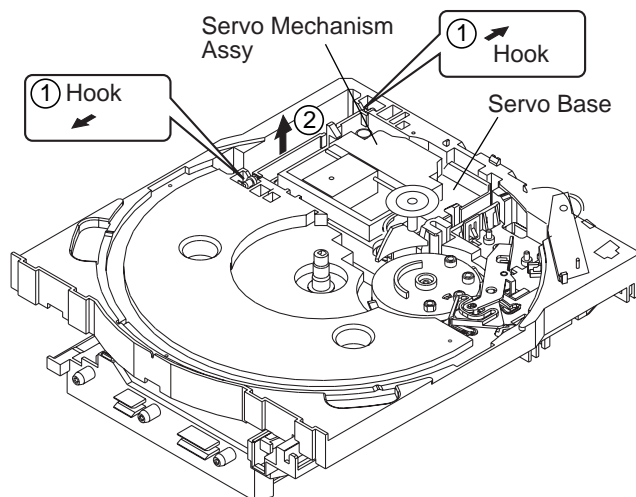

● Actuator

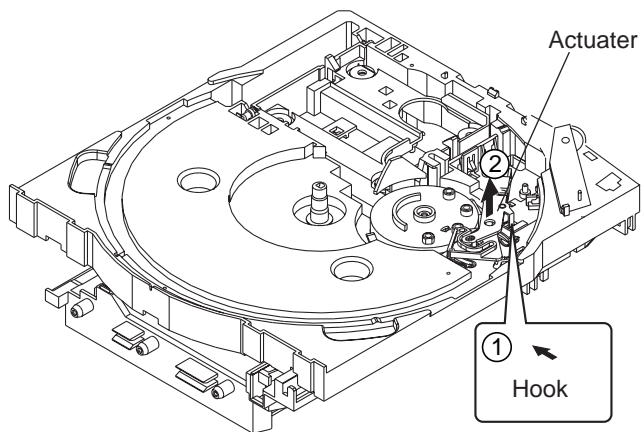

■ FITTING THE PULLEY INTO THE CARRIAGE MOTOR

For replacement of the carriage motor, fit the motor pulley by using the servicing pulley press-in station located on the loading tray, as shown in the figure on the right.

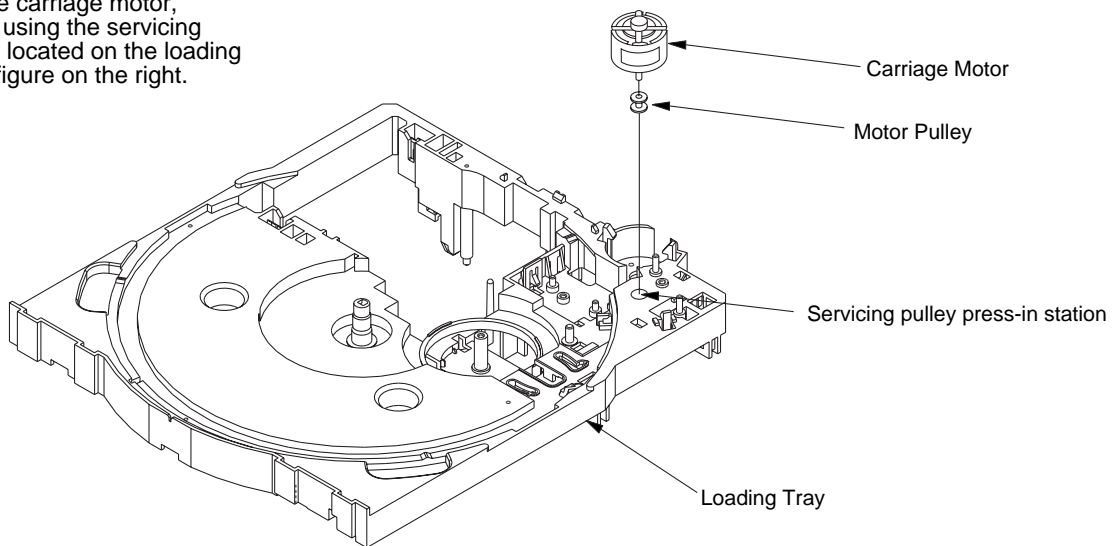

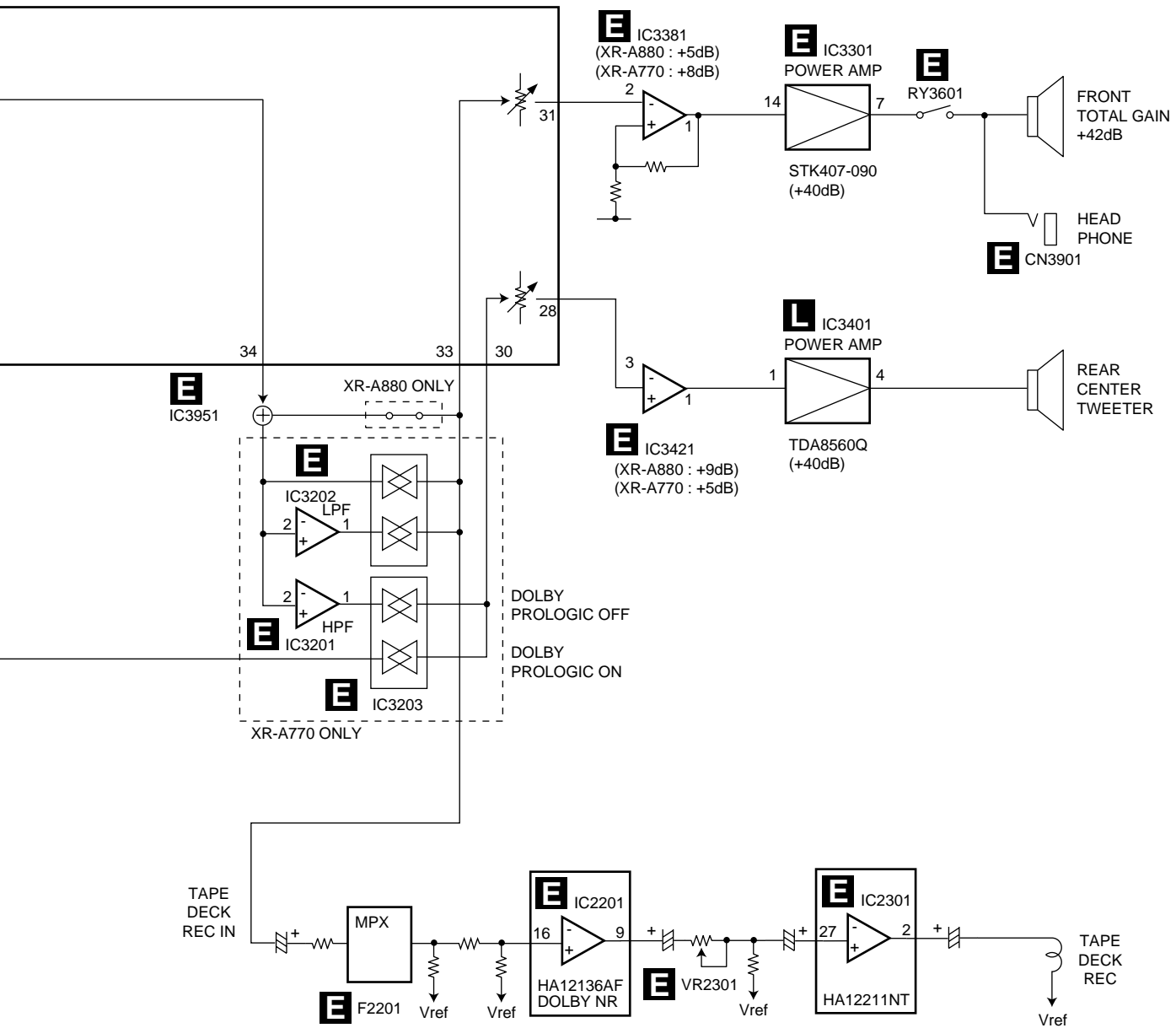

8. PANEL FACILITIES AND SPECIFICATIONS

• PANEL FACILITIES

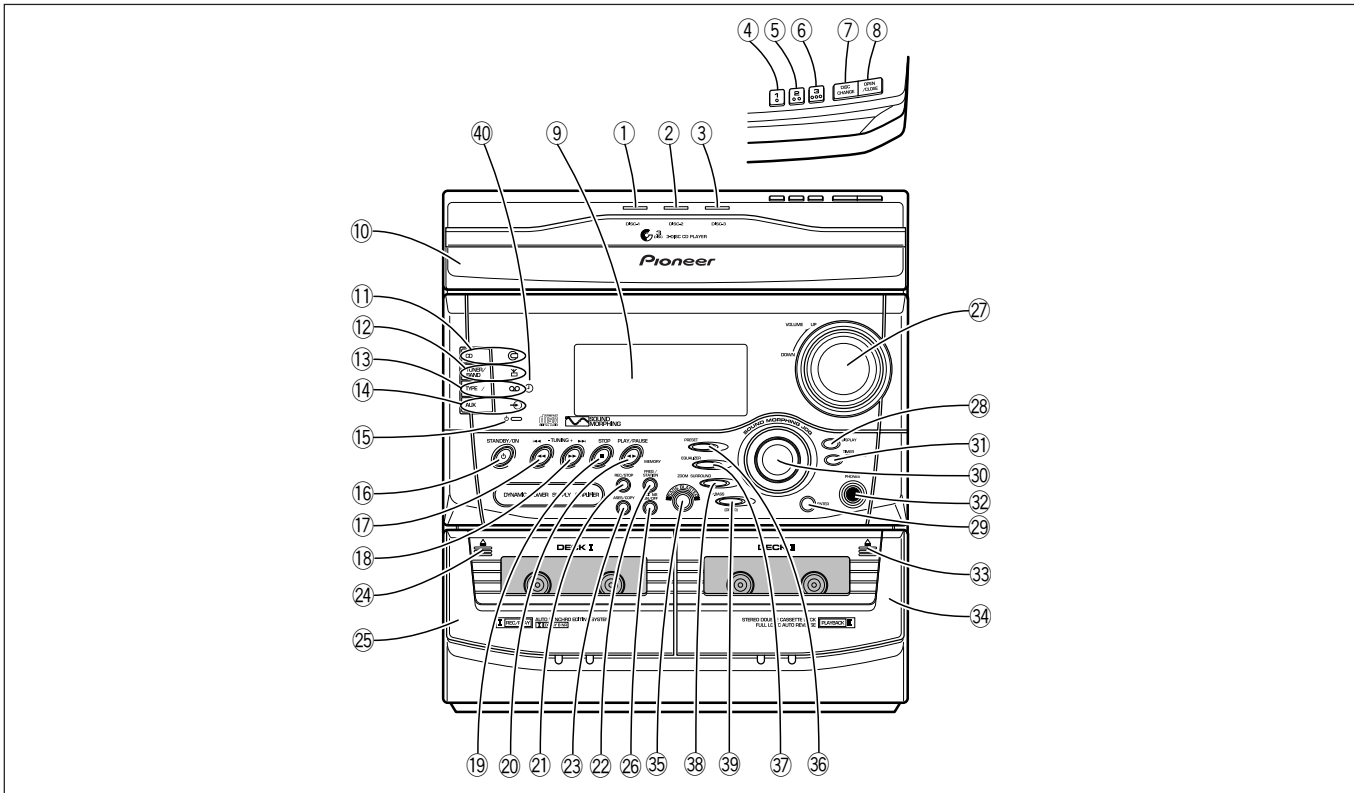

- | | |
|--|--|
| ① DISC-1 indicator | ②4 TAPE I Eject button (▲) |
| ② DISC-2 indicator | ②5 TAPE I cassette door |
| ③ DISC-3 indicator | ②6 Dolby** □ □ NR ON/OFF button |
| ④ DISC-1 select button | ②7 Volume control (VOLUME) |
| ⑤ DISC-2 select button | ②8 DISPLAY button |
| ⑥ DISC-3 select button | ②9 ENTER button |
| ⑦ DISC CHANGE button | ③0 S.M. JOG (Sound Morphing JOG) |
| ⑧ OPEN / CLOSE button | ③1 TIMER / CLOCK ADJ button |
| ⑨ Display | ③2 PHONES jack (Headphones) |
| ⑩ CD disc tray | ③3 TAPE II Eject button (▲) |
| ⑪ CD Function button & indicator | ③4 TAPE II cassette door |
| ⑫ TUNER / BAND Function button & indicator | ③5 BASS BLASTER button & indicator |
| ⑬ TAPE I / II Function button & indicator | ③6 PRESET button & indicator |
| ⑭ AUX Function button & indicator | ③7 EQUALIZER button & indicator |
| ⑮ STANDBY indicator | ③8 ZOOM SURROUND button & indicator |
| ⑯ STANDBY / ON switch | ③9 P.BASS (DEMO) button |
| ⑰ TUNNING ◀◀ ◀◀ - button * | (XR-A770 : BLANCE (DEMO) button) |
| ⑱ TUNNING + ▶▶ ▶▶ button * | ④0 TIMER indicator |
| ⑲ STOP (■) button * | Lights in Standby mode when the system has been set for timer operation. |
| ⑳ PLAY / PAUSE , MEMORY button * | |
| ㉑ REC / STOP button | * This button functions differently with CD, TUNER/BAND or TAPE I/II function. |
| ㉒ FREQ / STATION button | ** Dolby noise reduction manufactured under license from Dolby Laboratories Licensing Corporation. |
| ㉓ ASES / COPY button | • "DOLBY" and the double-D symbol are trademarks of Dolby Laboratories Licensing Corporation. |

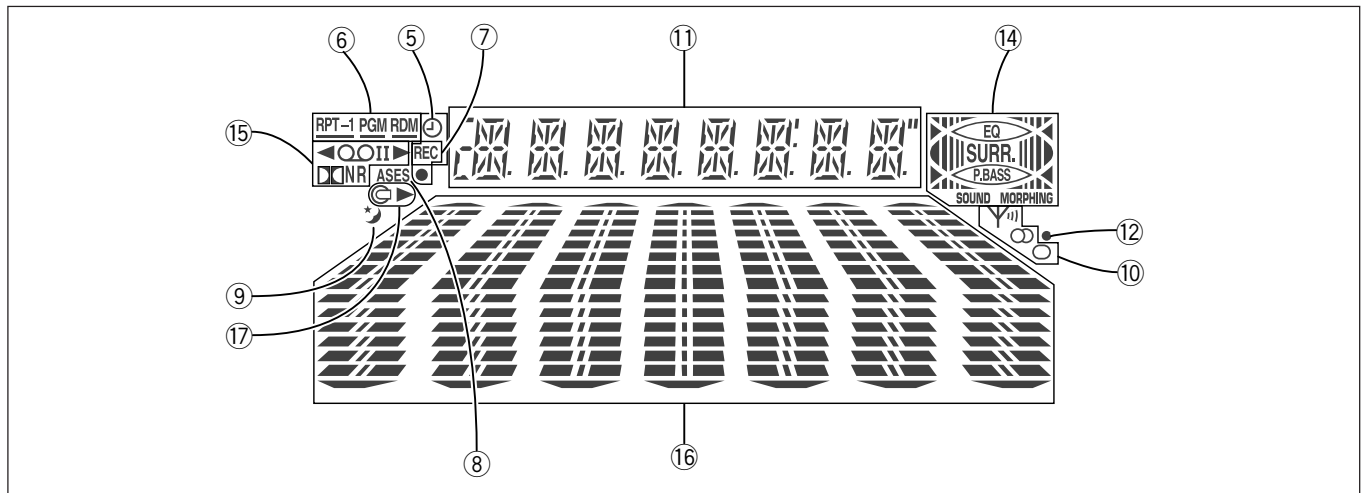

Display section

- ⑤ Displays timer function indications.
- ⑥ Indicates CD function status.
- ⑦ Lights during recording.
- ⑧ Lights during ASES operation.
- ⑨ Lights during Sleep Timer operation.
- ⑩ Indicates tuner operation status.
- ⑪ Displays a wide range of operation status indications.
- ⑫ Lights when BEAT CUT 2 is selected.
- ⑬ Indicates tuner reception status.
- ⑭ Indicates SOUND MORPHING status.
- ⑮ Indicates TAPE status.
- ⑯ Displays Audio level, spectrum analyzer and other indications.
- ⑰ Indicates CD player operation status.

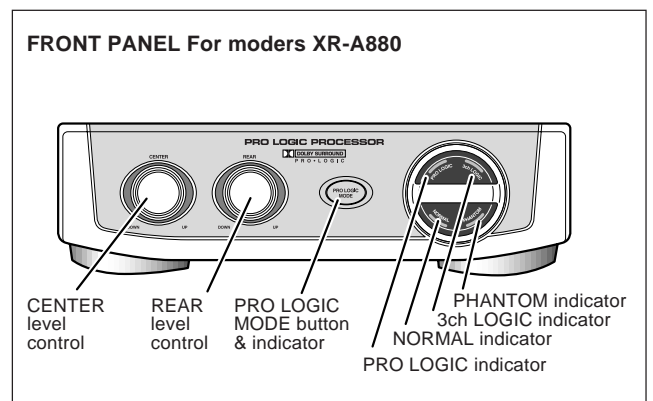
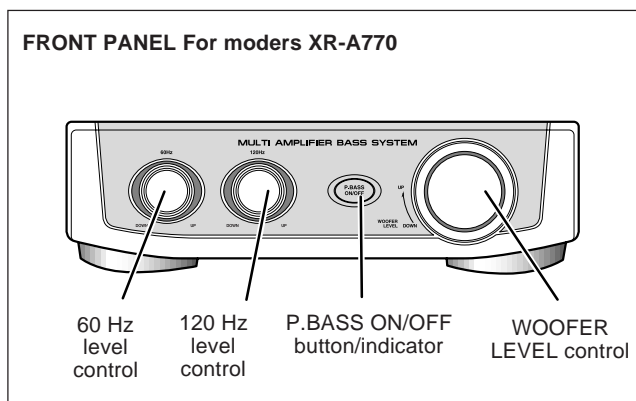

Function button section

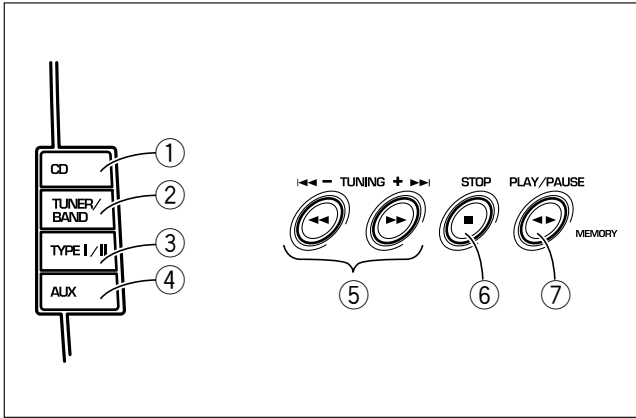

- ① CD function button
- ② TUNER/BAND function button
- ③ TAPE I/II function button
- ④ AUX function button
- ⑤ TUNING [◀◀,▶▶ (-), (+) ▶▶,▶▶] buttons
- ⑥ STOP button (■)
- ⑦ PLAY/PAUSE button (▶▶)

- Roles of the common operation buttons (The rules of the buttons vary depending on the input functions as shown below.)

During CD input

- PLAY/PAUSE: Play/pause button
- STOP: Stop button
- (+) ▶▶,▶▶: Fast forward/track search button
- ◀◀,◀◀ (-): Fast reverse/track search button

During cassette deck input

- PLAY/PAUSE: Play button/Tape transport direction
- STOP: Stop button
- (+) ▶▶,▶▶: Fast forward button/Music search button
- ◀◀,◀◀ (-): Rewind button/Music search button

During tuner operation

- PLAY/PAUSE MEMORY: STATION MEMORY button
- (+) ▶▶,▶▶: Frequency & Station + (up) button
- ◀◀,◀◀ (-): Frequency & Station - (down) button

■ Auto Play Function

If you press the CD function button when a CD is loaded, the CD automatically starts playing. If you press the TAPE I/II function button when a tape is loaded in the cassette deck, the tape automatically starts playing.

NOTE:

The function cannot be switched during recording and tape copying.

REMOTE CONTROL UNIT For moders XR-A770

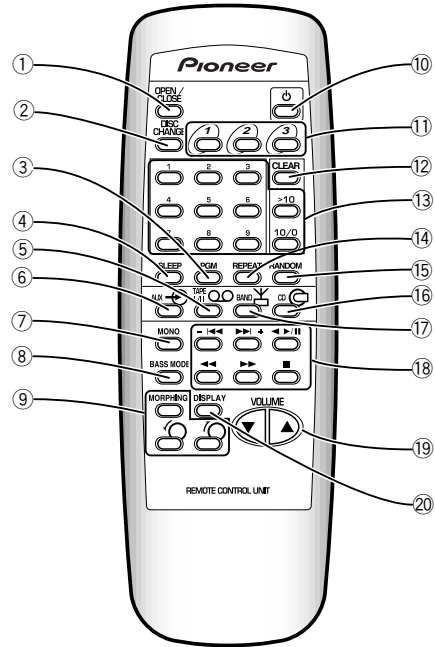

REMOTE CONTROL UNIT For moders XR-A880

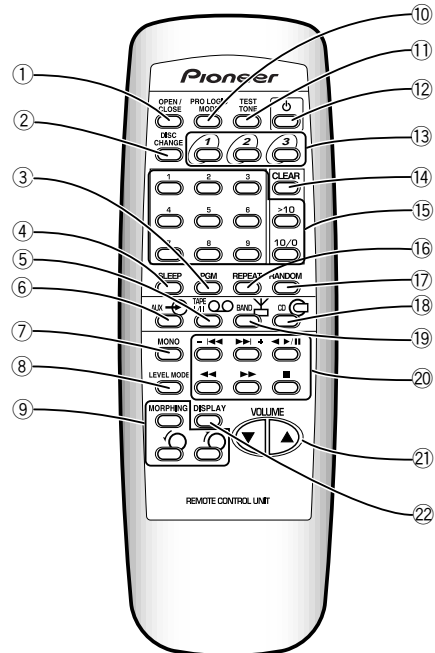

REMOTE CONTROL UNIT For moders XR-A770

- ① OPEN/CLOSE button
- ② DISC CHANGE button
- ③ PGM button
- ④ SLEEP timer button
- ⑤ TAPE I/II function button
- ⑥ AUX function button
- ⑦ MONO button
- ⑧ BASS MODE button
- ⑨ MORPHING MODE button & MORPHING jog control buttons
- ⑩ STANDBY/ON button
- ⑪ DISC select buttons (1–3)
- ⑫ CLEAR button
- ⑬ Numerical buttons

When using for radio station tuning:

Pressing these buttons tunes the unit to the frequencies stored in memory.

Examples:

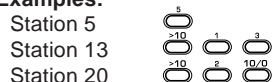

When using for the CD player:

Pressing these buttons lets you directly select the tracks you want from the program you entered.

Examples:



- ⑭ REPEAT button
 - ⑮ RANDOM button
 - ⑯ CD function button
 - ⑰ BAND button
- Use to switch between FM and AM bands.
- ⑱ CD/TAPE/STATION (up/down) operation buttons
- CD operation buttons
(Play/Pause ►/II, Track search I◀◀▶▶I, Stop ■, Fast ◀◀▶▶)
 - TAPE operation buttons
(Play ◀▶, Music search I◀◀▶▶I, Stop ■, Fast ◀◀▶▶)
 - TUNER buttons
 - + Stations change in order in the upward direction.
 - Stations change in order in the downward direction.
 - ◀◀ Frequency down.
 - ▶▶ Frequency up.
- ⑲ VOLUME ▲ (up), ▼ (down) buttons
 - ⑳ DISPLAY button

REMOTE CONTROL UNIT For moders XR-A880

- ① OPEN/CLOSE button
- ② DISC CHANGE button
- ③ PGM button
- ④ SLEEP timer button
- ⑤ TAPE I/II function button
- ⑥ AUX function button
- ⑦ MONO button
- ⑧ LEVEL MODE button
- ⑨ MORPHING MODE button & MORPHING jog control buttons
- ⑩ PRO LOGIC MODE button
- ⑪ TEST TONE button
- ⑫ STANDBY/ON button
- ⑬ DISC select buttons (1–3)
- ⑭ CLEAR button
- ⑮ Numerical buttons

When using for radio station tuning:

Pressing these buttons tunes the unit to the frequencies stored in memory.

Examples:

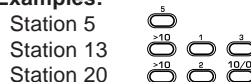

When using for the CD player:

Pressing these buttons lets you directly select the tracks you want from the program you entered.

Examples:



- ⑯ REPEAT button
 - ⑰ RANDOM button
 - ⑱ CD function button
 - ⑲ BAND button
- Use to switch between FM and AM bands.
- ⑳ CD/TAPE/STATION (up/down) operation buttons
- CD operation buttons
(Play/Pause ►/II, Track search I◀◀▶▶I, Stop ■, Fast ◀◀▶▶)
 - TAPE operation buttons
(Play ◀▶, Music search I◀◀▶▶I, Stop ■, Fast ◀◀▶▶)
 - TUNER buttons
 - + Stations change in order in the upward direction.
 - Stations change in order in the downward direction.
 - ◀◀ Frequency down.
 - ▶▶ Frequency up.
- ㉑ VOLUME ▲ (up), ▼ (down) buttons
 - ㉒ DISPLAY button

XR-A880, XR-A770

• SPECIFICATIONS

■ STEREO FILE-TYPE CD CASSETTE DECK RECEIVER

Amplifier Section

XR-A880 (U.S. and Canadian model)

[Front]

Continuous Average Power Output is 80 Watts* per channel, min., at 6 ohms from 60 Hertz to 15.000 Hertz, with no more than 5.0 %** total harmonic distortion.

[CENTER]

Continuous Average Power Output is 20 Watts* per channel, min., at 4 ohms from 60 Hertz to 15.000 Hertz, with no more than 5.0 %** total harmonic distortion.

[REAR]

Continuous Average Power Output is 20 Watts* per channel, min., at 4 ohms from 60 Hertz to 10.000 Hertz, with no more than 5.0 %** total harmonic distortion.

XR-A770 (U.S. and Canadian model)

[Woofer]

Continuous Average Power Output is 80 Watts* per channel, min., at 6 ohms from 60 Hertz to 1.000 Hertz, with no more than 5.0 %** total harmonic distortion.

[Tweeter]

Continuous Average Power Output is 20 Watts* per channel, min., at 4 ohms from 1.000 Hertz to 15.000 Hertz, with no more than 5.0 %** total harmonic distortion.

* Measured pursuant to the Federal Trade Commission's Trade Regulation rules on Power Output Claims for Amplifiers.

** Measured by Audio Spectrum Analyzer.

Continuous Power Output (RMS)

XR-A880

FRONT 120 W + 120 W(1 kHz, T.H.D. 10 %, 6 Ω)

REAR CENTER 30 W + 30 W(1 kHz, T.H.D. 10 %, 4 Ω)

XR-A770

Woofer 120 W + 120 W(100Hz, T.H.D. 10 %, 6 Ω)

Tweeter 30 W + 30 W(3 kHz, T.H.D. 10 %, 4 Ω)

FM/AM Tuner section

FM tuner section

Frequency Range 87.5 MHz to 108 MHz

Antenna input 75 Ω unbalanced

AM tuner section

Frequency Range 531 kHz to 1,602kHz

Antenna input Loop antenna

CD section

Type Compact disc digital audio system

Wow and Flutter Limit of measurement (±0.001 % W.PEAK) or less (EIAJ)

Cassette deck section

Systems 4 track, 2-channel stereo

Heads Recording/playback head x 1

..... Playback head x 1

..... Erasing head x 1

Motor DC servo motor x 1

Tape type

XR-A880 , XR-A770

..... TYPE I (Normal) tape / TYPE II (HIGH/CrO₂) tape

Miscellaneous

Power Requirements

U.S. and Canadian models AC120V, 60 Hz

Australian model AC240V, 50/60 Hz

Power Consumption

XR-A880

U.S. and Canadian models 230 W

Australian model 720 W

XR-A770

U.S. and Canadian models 230 W

Australian model 720 W

Power Consumption in standby mode 1 W

Dimensions

XR-A770, XR-A880 270 (W) x 300 (H) x 343 (D) mm

10-5/8 (W) x 11-13/16 (H) x 13-1/2 (D) in.

Weight (without package)

XR-A770, XR-A880 10 kg (22 lb 1 oz)

Accessories

Operating instructions 1

Remote control unit 1

Size AA/R6P dry cell batteries 2

FM antenna 1

AM loop antenna 1

Power Cord 1

NOTE:

Specifications and design subject to possible modification without notice due to improvement

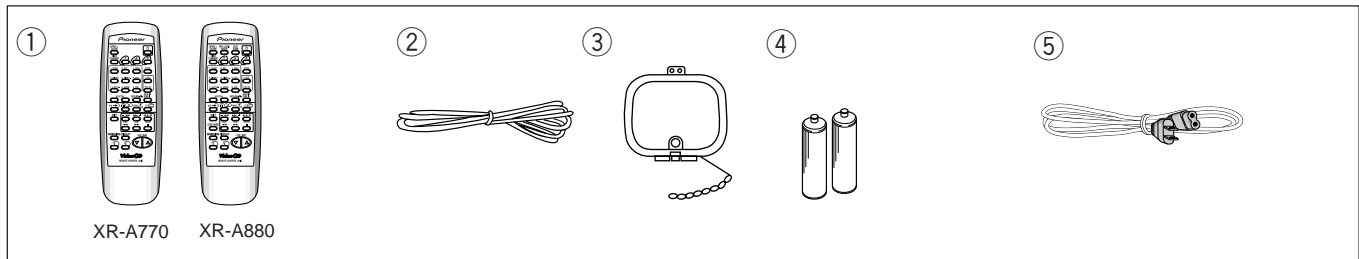

① Remote control unit x 1 : XZN3008 (CU-XR050/XR-A880)

XZN3007 (CU-XR049/XR-A770)

② FM antenna x 1 : ADH7004

③ AM loop antenna x 1 : XTB3001

④ AA/R6P dry cell batteries x 2

⑤ Power Cord x 1 : ADG7022 (KUCXJ type)

ADG1160 (YPWXJ type)