

Service Manual

ORDER NO.
RRV1063

STEREO MULTI-PLAY CD CASSETTE DECK RECEIVER

XR-P740M

XR-P640M

XR-P440M

XR-P340M

STEREO CD CASSETTE DECK RECEIVER

XR-P740

XR-P640

XR-P440

XR-P340

- Refer to the service manual RRV1023 for XR-P740M and XR-P340M.

SK49006
S.E. A49046A-G
S.E. A49060
S.E. A50009-G

THIS MANUAL IS APPLICABLE TO THE FOLLOWING MODEL(S) AND TYPE(S).

Type	Model								Power Requirement	The voltage can be converted by the following method.
	XR-P740M	XR-P740	XR-P640M	XR-P640	XR-P440M	XR-P440	XR-P340M	XR-P340		
HL	○	○	○	○	—	—	○	○	AC220-230V/240V	With the voltage selector
HEWZIXK	—	—	○	○	○	○	—	○	AC220-230V	AC240V, *

*: Alter the wiring of the Power-supply block at the primary winding of Power transformer referring to the "Line Voltage Selection" described in Service Manual.

XR-P740M, XR-P740, XR-P640M, XR-P640 XR-P440M, XR-P440, XR-P340M, XR-P340

1. SAFETY INFORMATION

(FOR EUROPEAN MODEL ONLY)

VARO!

AVATTAESSA JA SUOJALUKITUS
OHITETTAESSA OLET ALTTIINA
NÄKYMÄTTÖMÄLLE LASERSÄTEILYLLE.
ÄLÄ KATSO SÄTEESEEN.



LASER
Kuva 1
Lasersäteilyn
varoituserkki

WARNING!

DEVICE INCLUDES LASER DIODE WHICH
EMITS INVISIBLE INFRARED RADIATION
WHICH IS DANGEROUS TO EYES. THERE IS
A WARNING SIGN ACCORDING TO PICTURE
1 INSIDE THE DEVICE CLOSE TO THE LASER
DIODE.



LASER
Picture 1
Warning sign for
laser radiation

ADVERSEL:

USYNLIG LASERSTRÅLING VED ÅBNING
NÅR SIKKERHEDSAFBRYDERE ER UDE AF
FUNKTION UNDGÅ UDSÆTTELSE FOR
STRÅLING.

VARNING!

OSYNLIG LASERSTRÅLING NÅR DENNA
DEL ÄR ÖPPNAD OCH SPÄRREN
ÄR URKOPPLAD. BETRAKTA EJ STRÅLEN.

IMPORTANT

THIS PIONEER APPARATUS CONTAINS
LASER OF CLASS 1.
SERVICING OPERATION OF THE APPARATUS
SHOULD BE DONE BY A SPECIALLY
INSTRUCTED PERSON.

LASER DIODE CHARACTERISTICS

MAXIMUM OUTPUT POWER: 5 mw
WAVELENGTH: 780-785 nm

LABEL CHECK

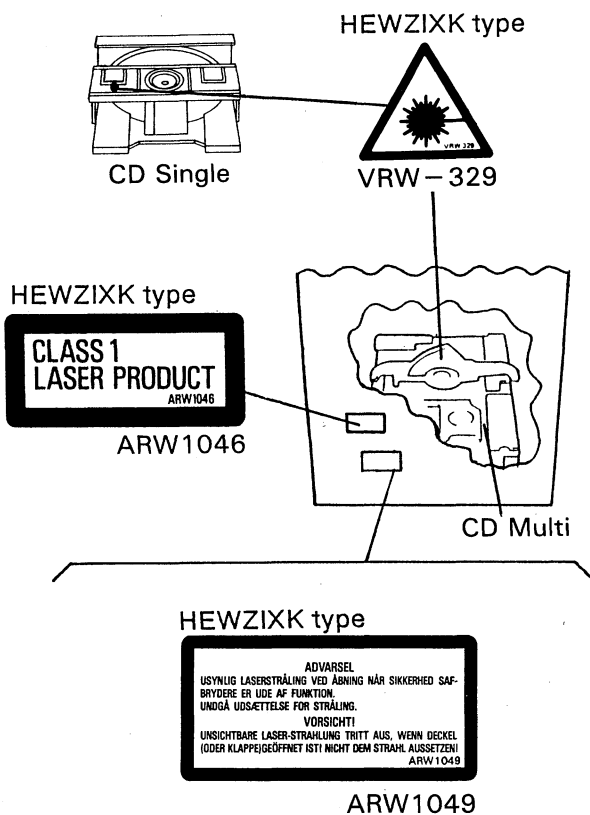

FOR CD MULTI

Additional Laser Caution

1. Laser Interlock Mechanism

The ON/OFF (ON : low level, OFF : high level) status of S601 (LPS1) and S602 (LPS2) switches for detecting the loading state is detected by the system microprocessor, and the design prevents laser diode oscillation except when both switches (LPS1 and LPS2) are ON (low level or clamped state).

Thus, interlock will no longer function if switches S601 (LPS1) and S602 (LPS2) are deliberately shorted.

The interlock also does not operate in the test mode*.

Laser diode oscillation will continue, if pin 1 of M51593FP (IC101) on the PRE-AMP BOARD assembly loaded on pickup assembly are connected to GND, or pin 19 is connected to low level (ON), or else the terminals of Q101 are shorted to each other (fault condition).

2. When the cover is opened with the servo mechanism block removed and turned over, close viewing of the objective lens with the naked eye will cause exposure to a Class 1 laser beam.

'92M1A

FOR CD SINGLE

Additional Laser Caution

1. Laser Interlock Mechanism

The position of the switch (S601) for detecting loading state is detected by the system microprocessor, and the design prevents laser diode oscillation when the switch (S601) is not on CLMP terminal side (CLMP signal is OFF or high level.).

Thus, the interlock will no longer function if the switch (S601) is deliberately set to CLMP terminal side. (low level).

The interlock also does not function in the test mode*.

Laser diode oscillation will continue, if pin 1 of M51593FP (IC101) on the PRE-AMP BOARD ASSY mounted on the pickup assembly is connected to GND, or pin 19 is connected to low level (ON), or else the terminals of Q101 are shorted to each other (fault condition).

2. When the cover is opened, close viewing of the objective lens with the naked eye will cause exposure to a Class 1 laser beam.

2. PART NUMBER DIFFERENCES BETWEEN XR – P740M/SD, XR – P740M/HL, XR – P740/HL, XR – P640M/HEWZIXK, HL, XR – P640/HEWZIXK AND HL

NOTES :

- Parts marked by “NSP” are generally unavailable because they are not in our Master Spare Parts List.
- The \triangle mark found on some component parts indicates the importance of the safety factor of the part. Therefore, when replacing, be sure to use parts of identical designation.
- Parts marked by “ \odot ” are not always kept in stock. Their delivery time may be longer than usual or they may be unavailable.
- The number in “No.” column correspond to the number on the packing and exploded views. Refer to “PACKING AND EXPLODED VIEWS” in the RRV1023 service manual.
- When ordering resistors, first convert resistance values into code form as shown in the following examples.

Ex. 1 When there are 2 effective digits (any digit apart from 0), such as 560 ohm and 47k ohm (tolerance is shown by J = 5%, and K = 10%).

560 Ω \rightarrow 56 \times 10¹ \rightarrow 561 RD1/8PM $\begin{matrix} 5 & 6 & 1 \\ \hline & & J \end{matrix}$

47k Ω \rightarrow 47 \times 10³ \rightarrow 473 RD1/4PS $\begin{matrix} 4 & 7 & 3 \\ \hline & & J \end{matrix}$

0.5 Ω \rightarrow 0R5 RN2H $\begin{matrix} 0 & R & 5 \\ \hline & & K \end{matrix}$

1 Ω \rightarrow 010 RS1P $\begin{matrix} 0 & 1 & 0 \\ \hline & & K \end{matrix}$

Ex. 2 When there are 3 effective digits (such as in high precision metal film resistors).

5.62k Ω \rightarrow 562 \times 10¹ \rightarrow 5621 RM1/4PC $\begin{matrix} 5 & 6 & 2 & 1 \\ \hline & & & F \end{matrix}$

- Part number differs between XR – P740M/SD, XR – P740M/HL, XR – P740/HL, XR – P640M/HEWZIXK, HL, XR – P640/HEWZIXK and HL.

(1) PACKING

Mark	No.	Description	Part No.							Remarks
			XR – P740M		XR – P740	XR – P640M		XR – P640		
			SD	HL	HL	HEWZIXK	HL	HEWZIXK	HL	
	1	Magazine assy	PXA1549	PXA1549	Not used	PXA1549	PXA1549	Not used	Not used	
	2	Operating instructions (English/Spanish/Chinese)	ARC7006	ARC7006	ARC7006	Not used	ARC7006	Not used	ARC7006	
	2	Operating instructions (German/Italian)	Not used	Not used	Not used	ARE7009	Not used	ARE7009	Not used	(See. A.48 (p.7))
	3	Remote control unit (CU – XR012)	AXD7007	AXD7007	AXD7007	Not used	Not used	Not used	Not used	
	3	Remote control unit (CU – XR010)	Not used	Not used	Not used	AXD7002	AXD7002	AXD7002	AXD7002	
	5	FM antenna	ADH1016	ADH1016	ADH1016	ADH1019	ADH1016	ADH1019	ADH1016	
	8	Front pad LR	AHA7004	AHA7004	AHA7004	AHA7008	AHA7004	AHA7008	AHA7004	
	9	Rear pad LR	AHA7005	AHA7005	AHA7005	AHA7009	AHA7005	AHA7009	AHA7005	
	10	Packing case	AHD7039	AHD7039	AHD7038	AHD7044	AHD7037	AHD7043	AHD7036	
	11	Sheet	AHG7004	AHG7004	AHG7004	AHG7005	AHG7004	AHG7005	AHG7004	

XR-P740M, XR-P740, XR-P640M, XR-P640 XR-P440M, XR-P440, XR-P340M, XR-P340

(2) EXPLODED VIEWS

■ Exterior

Note : For details regarding PCB assemblies, refer to “ (3) PCB ASSEMBLIES ”.

Mark	No.	Description	Part No.							Remarks
			XR-P740M		XR-P740	XR-P640M		XR-P640		
			SD	HL	HL	HEWZIXK	HL	HEWZIXK	HL	
△	1	T8005 Power transformer	ATS7015	ATS7015	ATS7015	ATS7014	ATS7013	ATS7014	ATS7013	
△	2	FU1 Fuse (T2.5A/250V)	AEK-512	AEK-512	AEK-512	Not used	AEK-512	Not used	AEK-512	
△	2	FU1 Fuse (T2A/250V)	Not used	Not used	Not used	AEK-511	Not used	AEK-511	Not used	
△	3	AC power cord	ADG1051	ADG1149	ADG1149	ADG1138	ADG1149	ADG1138	ADG1149	
△	69	S8001 Voltage selector (AC110V/120-127V/220V/240V)	AKX-507	Not used	Not used	Not used	Not used	Not used	Not used	
△	69	S8001 Voltage selector (AC220-230V/240V)	Not used	AKX1004	AKX1004	Not used	AKX1004	Not used	AKX1004	
△	70	FU2 Fuse (T2.5A/250V)	AEK-512	Not used	Not used	Not used	Not used	Not used	Not used	
NSP	7	MULTI MECHA assy	AXA7006	AXA7006	Not used	Not used	AXA7006	Not used	Not used	
	7	MULTI MECHA assy	Not used	Not used	Not used	PXA1469	Not used	Not used	Not used	*1
	7	SINGLE MECHA assy	Not used	Not used	AXA7004	Not used	Not used	Not used	AXA7004	
NSP	7	SINGLE MECHA assy	Not used	Not used	Not used	Not used	Not used	PXA1487	Not used	*2
NSP	9	Chassis	ANA7001	ANA7001	ANA7001	ANA7003	ANA7001	ANA7003	ANA7001	
	10	Rear panel	ANC7036	ANC7038	ANC7037	ANC7055	ANC7031	ANC7054	ANC7030	
	12	Trans frame	ANA7002	ANA7002	ANA7002	ANA7004	ANA7002	ANA7004	ANA7002	
	17	Front panel assy	AMB7084	AMB7084	AMB7083	AMB7026	AMB7082	AMB7025	AMB7081	*3
	19	Dolby plate	AAK7013	AAK7013	AAK7013	AAK7014	AAK7014	AAK7014	AAK7014	
	21	Tray cap	Not used	Not used	AAK7020	Not used	Not used	AAK7020	AAK7020	
	27	Bonnet	ANE7005	ANE7005	ANE7005	ANE7009	ANE7005	ANE7009	ANE7005	
	42	Screw (for CD MECHA assy)	BBZ30P080FZK	BBZ30P080FZK	BBZ30P160FMC	BBZ30P080FZK	BBZ30P080FZK	BBZ30P160FMC	BBZ30P160FMC	
	65	Multi button	AAD7009	AAD7009	Not used	AAD7009	AAD7009	Not used	Not used	
67	Lock lever spring	ABH7004	ABH7004	Not used	ABH7004	ABH7004	Not used	Not used		
NSP	71	Ground lead	ADB1005	ADB1005	Not used	ADB1005	ADB1005	Not used	Not used	
	72	Parallel wire (J2)	D20PYY0615E	D20PYY0615E	Not used	D20PYY0615E	D20PYY0615E	Not used	Not used	
	73	Caution label (G)	Not used	Not used	Not used	VRW-329	Not used	VRW-329	Not used	*4

*1 : Refer to “ ■ CD Multi Mecha Assy Section ”.

*2 : Refer to “ ■ CD Single Mecha Assy Section ”.

*3 : Refer to “ ■ Front Panel Assy Section ”.

*4 : Refer to page 2.

■ CD Multi Mecha Assy

Part number differs between AXA7006 and PXA1469.

Mark	No.	Description	Part No.		Remarks
			AXA7006	PXA1469	
NSP	104	Servo mechanism assy M	PXA1537	PXA1417	
NSP	105	LOADING BOARD assy	AWZ7207	PWZ2038	
NSP	109	SELECT BOARD assy	AWZ7209	PWZ2533	
NSP	110	MOTOR BOARD assy	AWZ7208	PWZ2040	
NSP	112	Earth lead unit	PDF1074	PDF1118	

**XR-P740M, XR-P740, XR-P640M, XR-P640
XR-P440M, XR-P440, XR-P340M, XR-P340**

CD Single Mecha Assy

Part number differs between AXA7004 and PXA1487.

Mark	No.	Description	Part No.		Remarks
			AXA7004	PXA1487	
NSP	5	Tray	PNW2265	PNW2455	
	7	Drive gear 2	PNW2369	PNW2266	
	9	Clamper base	PNW2375	PNW2035	
	20	Carriage base	PNW2058	PNW2445	
	41	Loading base	PNW2376	PNW2030	
NSP	43	Servo mechanism assy	PXA1536	PXA1478	
NSP	45	Connector assy (4P)	PDE1238	PDE1145	
NSP	46	Connector assy (5P)	PDE1239	PDE1201	

Front Panel Assy Section

Front panel assy AMB7084, AMB7083, AMB7026, AMB7082, AMB7025 and AMB7081 are composed of the following parts.

Mark	No.	Description	Part No.						Remarks
			AMB7084	AMB7083	AMB7026	AMB7082	AMB7025	AMB7081	
	47	Front panel A	-AMB7059	-AMB7058	-AMB7064	-AMB7056	-AMB7063	-AMB7055	
	50	Door-L	-AAN7016	-AAN7016	-AAN7018	-AAN7016	-AAN7018	-AAN7016	
	51	Door-R	-AAN7020	-AAN7020	-AAN7022	-AAN7020	-AAN7022	-AAN7020	
	52	Catcher	-AEC7001	-AEC7001	-AEC7001	-AEC7001	-AEC7001	-AEC7001	
	53	Door spring (L)	-ABH7001	-ABH7001	-ABH7001	-ABH7001	-ABH7001	-ABH7001	
	54	Door spring (R)	-ABH7002	-ABH7002	-ABH7002	-ABH7002	-ABH7002	-ABH7002	
	57	Damper assy	-AXA7001	-AXA7001	-AXA7001	-AXA7001	-AXA7001	-AXA7001	
	58	Keep plate (SR. 419025.6)	-ABK1017	-ABK1017	-ABK1017	-ABK1017	-ABK1017	-ABK1017	AMB7004
	59	Front panel B	-AMB7067	-AMB7067	-AMB7068	-AMB7065	-AMB7068	-AMB7065	
	44	Screw	-BPZ26P080FMC	-BPZ26P080FMC	-BPZ26P080FMC	-BPZ26P080FMC	-BPZ26P080FMC	-BPZ26P080FMC	
	56	S-CD panel	Not used	-AAK7053	Not used	Not used	-AAK7054	-AAK7053	
	56	M-CD panel	-AAK7016	Not used	AAK7016*	-AAK7016	Not used	Not used	
	48	LENS CAPACITOR (SR. 419025.6)	-AAK7021	-AAK7021	AAK7021*	-AAK7021	AAK7021*	-AAK7021	
	49	AMP. TUNER button	-AAD7048	-AAD7048	AAD7048*	-AAD7048	AAD7048*	-AAD7048	
	55	DECK. CD button	-AAD7049	-AAD7049	AAD7049*	-AAD7049	AAD7049*	-AAD7049	
	60	DOLBY button	-AAD7007	-AAD7007	AAD7007*	-AAD7007	AAD7007*	-AAD7007	
	61	Level button	-AAD7012	-AAD7012	AAD7012*	-AAD7012	AAD7012*	-AAD7012	
	62	DOOR SHAFT INSULATION TUBE (SR. 419025.6)	-AXA7003	Not used	AXA7003*	-AXA7003	Not used	Not used	
	63	Damper	-PXA1484	Not used	PXA1484*	-PXA1484	Not used	Not used	
	64	Door spring	-ABH7003	Not used	ABH7003*	-ABH7003	Not used	Not used	
	66	Multi door	-AAK7017	Not used	AAK7063*	-AAK7017	Not used	Not used	
	68	Screw	-BPZ20P080FMC	Not used	BPZ20P080FMC*	-BPZ20P080FMC	Not used	Not used	

Note : Parts marked with * are not included in the Front panel assy. * M.P. AAK7063 (SR. 419025.6) XR-P640M/HE 421XK
XR-P640 H/HE 71XK

**XR-P740M, XR-P740, XR-P640M, XR-P640
XR-P440M, XR-P440, XR-P340M, XR-P340**

(3) PCB ASSEMBLIES

List of Whole PCB Assemblies

Mark	Description	Part No.							Remarks
		XR-P740M		XR-P740	XR-P640M		XR-P640		
		SD	HL	HL	HEWZIXK	HL	HEWZIXK	HL	
MAIN assy	AWK7041	AWK7041	AWK7080	AWK7038	AWK7037	AWK7036	AWK7035	*2	
	—AF CD assy	AWZ7095	AWZ7095	AWZ7281	AWZ7092	AWZ7091	AWZ7090		AWZ7089
	—H. P assy	AWZ7105	AWZ7105	AWZ7105	AWZ7106	AWZ7105	AWZ7106		AWZ7105
	—SECONDRY TRANS assy	AWZ7288*1	AWZ7288	AWZ7288	AWZ7258	AWZ7288	AWZ7258		AWZ7288
—VR assy	AWZ7282	AWZ7282	AWZ7282	AWZ7100	AWZ7099	AWZ7100	AWZ7099		
COMPLEX assy (See. ANS101)	AWM7050	AWM7051	AWM7082	AWM7039	AWM7034	AWM7033	AWM7035	*3	
	—CD DECK SW assy	AWZ7125	AWZ7125	AWZ7124	AWZ7134	AWZ7125	AWZ7133		AWZ7124
	—TRANS PRIMARY assy	AWZ7130	AWZ7127	AWZ7127	AWZ7129	AWZ7127	AWZ7129		AWZ7127
	—DISPLAY assy	AWZ7215	AWZ7215	AWZ7214	AWZ7117	AWZ7118	AWZ7115		AWZ7116
PRO LOGIC assy	AWM7054	AWM7054	AWM7054	*4	
	—PROLOGIC assy	AWZ7138	AWZ7138	AWZ7138		
	—ADDON DISPLAY assy	AWZ7141	AWZ7141	AWZ7141		
DOLBY SURROUND assy	AWM7091	AWM7053	AWM7091	AWM7053	*5	
	—DOL SURR assy	AWZ7251	AWZ7137	AWZ7251	AWZ7137		
	—ADDON DISPLAY assy	AWZ7252	AWZ7139	AWZ7252	AWZ7139		
FM/AM TUNER MODULE	AXQ1012	AXQ1012	AXQ1012	AXQ3214	AXQ1012	AXQ3214	AXQ1012		
POWER MOD. F100+R20	AXQ1019	AXQ1019	AXQ1019	AXQ3219	AXQ1019	AXQ3219	AXQ1019	*6	
	—FRONT ASSY FOR 100W	AWZ5389	AWZ5389	AWZ5389	AWZ5444	AWZ5389	AWZ5444		AWZ5389
	—REAR, PWR, PRTEC ASSY	AWZ5391	AWZ5391	AWZ5391	AWZ5446	AWZ5391	AWZ5446		AWZ5391
CASSETTE MECHA MOD. BC	EXK2420	EXK2420	EXK2420	EXK2420	EXK2420	EXK2420	EXK2420	*7	
	—DECK unit	EWM1002	EWM1002	EWM1002	EWM1002	EWM1002	EWM1002		

*1 : In the service manual RRV1023 the part number of SECONDARY TRANS assy is AWZ7211. The part number has been changed from AWZ7211 to AWZ7288.

*2 : Although AWZ7258 and AWZ7288 are different in part number, they consist of the same components.

*3 : Although AWZ7134 and AWZ7125 are different in part number, they consist of the same components.

*4 : Although AWZ7129 and AWZ7130 are different in part number, they consist of the same components.

*5 : Although AWZ7118 and AWZ7215 are different in part number, they consist of the same components.

Although AWZ7116 and AWZ7214 are different in part number, they consist of the same components.

*6 : Although AWZ5444 and AWZ5389 are different in part number, they consist of the same components.

*7 : Although AWZ5446 and AWZ5391 are different in part number, they consist of the same components.

DISPLAY ASSY

Part number differs between AWZ7215, AWZ7214, AWZ7117 and AWZ7115.

Mark	Symbol & Description	Part No.				Remarks
		AWZ7215	AWZ7214	AWZ7117	AWZ7115	
IC1901	PD4493A	PD4492A	PD4493A	PD4492A		
D1819	HSS104-02	HSS104-02	Not used	Not used		
D1904	HZS7AL	HZS7AL	MTZJ6.8	MTZJ6.8		
D1951, D1953	HZS6CL	HZS6CL	MTZJ6.2	MTZJ6.2		
R1723-R1728	RS1/10S562J	Not used	RS1/10S562J	Not used		

**XR-P740M, XR-P740, XR-P640M, XR-P640
XR-P440M, XR-P440, XR-P340M, XR-P340**

VR ASSY

Part number differs between AWZ7282, AWZ7100 and AWZ7099.

Mark	Symbol & Description	Part No.			Remarks
		AWZ7282	AWZ7100	AWZ7099	
	C1507, C1508, C1515, C1516 VR301	Not used ACX1088	CCSQCH470J50 ACX1092	Not used ACX1092	*8

*8 : Refer to page 18.

H. P ASSY

Part number differs between AWZ7105 and AWZ7106.

Mark	Symbol & Description	Part No.		Remarks
		AWZ7105	AWZ7106	
	C1251, C1252	Not used	CCSQCH101J50	*9

*9 : Refer to page 18.

AF CD ASSY (See A50002)

Part number differs between AWZ7095, AWZ7281, AWZ7092, AWZ7091, AWZ7090 and AWZ7089.

Mark	Symbol & Description	Part No.						Remarks
		AWZ7095	AWZ7281	AWZ7092	AWZ7091	AWZ7090	AWZ7089	
	IC2203	NJM4558M-D	NJM4558M-D	Not used	Not used	Not used	Not used	
	D1010	HZS7BL	RD7.5ESB	MTZJ7.5	HZS7BL	MTZJ7.5	HZS7BL	
	D1011, D1012	RD5.6ESB2	RD5.6ESB2	MTZJ5.6B	RD5.6ESB2	MTZJ5.6B	RD5.6ESB2	
	D1023	RD30ESB4	RD30ESB4	MTZJ30D	RD30ESB4	MTZJ30D	RD30ESB4	
	D1151, D1152	RD5.1ESB	RD5.1ESB	MTZJ5.1	RD5.1ESB	MTZJ5.1	RD5.1ESB	
	D2201, D8211	HZS6CL	HZS6CL	MTZJ6.2	HZS6CL	MTZJ6.2	HZS6CL	
	L1301-L1304	Not used	Not used	ATH-059	Not used	ATH-059	Not used	
	C1311	Not used	Not used	CKCYF473Z50	Not used	CKCYF473Z50	Not used	
	C1312	Not used	Not used	CKSQYF473Z50	Not used	CKSQYF473Z50	Not used	
	C1313, C1315, C1332, C1334	Not used	Not used	CKSQYF104Z50	Not used	CKSQYF104Z50	Not used	
	C2503, C2504	CEASR15M50	CEYAR22M50	CEASR15M50	CEASR15M50	CEASR15M50	CEASR15M50	
	C2702, C2703	Not used	Not used	CKSQYB471K50	Not used	CKSQYB471K50	Not used	
	C8429, C8430	CCSQCH560J50	CCSQCH560J50	CCSQCH121J50	CCSQCH560J50	CCSQCH121J50	CCSQCH560J50	
	R1019	RD1/4PM511J	RD1/4PM511J	RD1/4PM102J	RD1/4PM511J	RD1/4PM102J	RD1/4PM102J	
	R1303, R1304	Not used	Not used	RD1/4PMFL101J	Not used	RD1/4PMFL101J	Not used	
	R1311, R1332	Not used	Not used	RS1/10S100J	Not used	RS1/10S100J	Not used	
	R2101, R2102	RD1/8PM102J	RD1/8PM102J	RD1/8PM222J	RD1/8PM102J	RD1/8PM222J	RD1/8PM102J	
	R2217, R2218	RS1/10S472J	RS1/10S472J	Not used	Not used	Not used	Not used	
	R2219, R2220	RS1/10S104J	RS1/10S104J	Not used	Not used	Not used	Not used	
	R5003, R5009	Not used	Not used	RS1/10S223J	RS1/10S223J	RS1/10S223J	RS1/10S223J	
	R5011, R5012	RS1/10S000J	RS1/10S000J	Not used	Not used	Not used	Not used	
	CN8203 (Connector 4P)	4-173981-4	Not used	4-173981-4	4-173981-4	Not used	Not used	
	CN8203 (Connector 5P)	Not used	VKN1052	Not used	Not used	VKN1052	VKN1052	
	CN8204 (Jumper connector 6P)	52147-0610	Not used	52147-0610	52147-0610	Not used	Not used	
	PCB binder	VEF1008	Not used	VEF1008	VEF1008	Not used	Not used	
	Speaker terminal 4-P	AKE1026	AKE1026	AKE7001	AKE1026	AKE7001	AKE1026	

Note : Refer to pages 16-18.

**XR-P740M, XR-P740, XR-P640M, XR-P640
XR-P440M, XR-P440, XR-P340M, XR-P340**

CD DECK SW ASSY

Part number differs between AWZ7125, AWZ7124 and AWZ7133.

Mark	Symbol & Description	Part No.			Remarks
		AWZ7125	AWZ7124	AWZ7133	
	Q1701-Q1706 D1709-D1714 S1828, S1830-S1835 S1836	2SA1048 AEL1132 ASG1034 Not used	Not used Not used Not used ASG1034	Not used Not used Not used ASG1034	*10
	R1705-R1710, R1729-R1734 R1711-R1716 R1717-R1722	RS1/10S301J RS1/10S273J RS1/10S272J	Not used Not used Not used	Not used Not used Not used	

*10 : Refer to AWZ7124 of XR-P740/SD in the RRV1023 service manual.

TRANS PRIMARY ASSY

Part number differs between AWZ7130 and AWZ7127.

Mark	Symbol & Description	Part No.		Remarks
		AWZ7130	AWZ7127	
	L1101 C1102 (0.01/400V)	ATF-151 ACG1003	JUMPER Not used	

DOL SURR ASSY

Part number differs between AWZ7137 and AWZ7251.

Mark	Symbol & Description	Part No.		Remarks
		AWZ7137	AWZ7251	
	D3409 L3402, L3403 C3438 C3443, C3444 R3455	RD5.1ESB Not used Not used Not used Not used	MTZJ5.1 ATH-059 CKCYF473Z50 CKSQYF104Z50 RD1/4PMFL100J	
	R3462 CN8206 Pin jack (2P)	Not used AKB1164	RS1/10S100J AKB1171	

Notes : Regard to AWZ7137, refer to AWZ7137 of XR-P640M/SD in the RRV1023 service manual.
Regard to AWZ7251, refer to "4.4 DOL SURR ASSY".

ADDON DISPLAY ASSY

Part number differs between AWZ7141, AWZ7252 and AWZ7139.

Mark	Symbol & Description	Part No.			Remarks
		AWZ7141	AWZ7252	AWZ7139	
	D3955	HZS6C1L	MTZJ6.2	HZS6C1L	
	R3968 R3969 R4030-R4032, R4034 R4033	Not used RS1/10S473J RD1/8PM102J RS1/10S102J	RS1/10S473J Not used Not used Not used	RS1/10S473J Not used Not used Not used	*11

*11 : Refer to AWZ7139 of XR-P640M/SD in the RRV1023 service manual.

XR-P740M, XR-P740, XR-P640M, XR-P640 XR-P440M, XR-P440, XR-P340M, XR-P340

FM/AM TUNER MODULE (AXQ3214)

Mark	No.	Description	Parts No.	Mark	No.	Description	Parts No.
SEMICONDUCTORS				RESISTORS			
	IC6201		LA1836M		VR6201 (4.7k) (Si-A49028)		ACP1055-2 ACP1056
	IC6202		LM7001J		VR6202		VRTB6VS223
	Q6102		2SC2223		R6299, R6300		RD1/8PM102J
	Q6203		2SC2235		R6115, R6119, R6123, R6127, R6129		RS1/8S000J
	Q6202, Q6218		2SC2712		R6268-R6271, R6275, R6276, R6278		RS1/8S000J
	Q6103, Q6214		2SC2714		R6283, R6284, R6293, R6294, R6297		RS1/8S000J
	Q6201		2SK208		R6302, R6303		RS1/8S000J
	Q6104, Q6105		2SK302		R6243, R6244		RS1/8S101J
	Q6101		3SK194		R6211, R6239		RS1/8S103J
	Q6204		XDA124EK		R6237		RS1/8S122J
	Q6217		XDC124EK		R6209		RS1/8S221J
	D6101-D6104		1SV228		R6112		RS1/8S473J
COILS AND FILTERS				OTHERS			
	L6106		ATC1003		BN6201 2P TERMINAL WITH PAL		AKA1017
	L6105		ATC1015		X6203 CRYSTAL RESONATOR		ASS1042
	L6101		ATC1016		(7.200MHz)		
	L6102		ATC1017		X6201 CRYSTAL RESONATOR		ASS1066
	L6103		ATC1018		(456kHz)		
	L6104		ATC1019		X6202 CERAMIC RESONATOR		ATF1027
	T6101		ATE-063		(450kHz)		
	L6207 (10.7MHZ)		ATE1013		AM RF TUNING BLOCK		AXX1025
	F6204		ATF-107				
	F6203		ATF-119				
	F6202 (450KHZ)		ATF1145				
	F6205		ATF1152				
	L6107		ATH1043				
	L6202, L6203, L6208		LCTA2R2J3225				
	L6205		LCTA680J3225				
CAPACITORS							
	C6204, C6234, C6236, C6269 (1.0µ/16V)		ACG1051				
	C6235 (0.47µ/25V)		ACG1052				
	C6120		CCSCH060D50				
	C6229		CCSCH821J50				
	C6111, C6122		CCSQCH010C50				
	C6112		CCSQCH020C50				
	C6118		CCSQCH080D50				
	C6113		CCSQCH101J50				
	C6116, C6208, C6221, C6222		CCSQCH150J50				
	C6117		CCSQCH330J50				
	C6272		CCSQSL470J50				
	C6105		CCSQSL471J50				
	C6101		CCSQTH110J50				
	C6119		CCSQTH150J50				
	C6109		CCSQTH270J50				
	C6107, C6110		CCSQTH300J50				
	C6106		CCSQTH330J50				
	C6261		CEAS010M50				
	C6224, C6231, C6233, C6246, C6262		CEAS100M50				
	C6216, C6217		CEAS330M16				
	C6219		CEAS470M10				
	C6243-C6245		CEAS470M16				
	C6227		CEAS470M25				
	C6238, C6248		CEJA100M16				
	C6249, C6250		CEJA4R7M35				
	C6215		CFTXA103J50				
	C6214		CFTXA224J50				
	C6115, C6125, C6126, C6207		CKSQYB102K50				
	C6102, C6114, C6121, C6124, C6210		CKSQYB103K50				
	C6264		CKSQYB103K50				

**XR-P740M, XR-P740, XR-P640M, XR-P640
XR-P440M, XR-P440, XR-P340M, XR-P340**

3. PART NUMBER DIFFERENCES BETWEEN XR-P340M/KU, XR-P440M/HEWZIXK, XR-P440/HEWZIXK, XR-P340M/HL, XR-P340/HEWZIXK AND HL

- Part number differs between XR-P340M/KU, XR-P440M/HEWZIXK, XR-P440/HEWZIXK, XR-P340M/HL, XR-P340/HEWZIXK and HL.

(1) PACKING

Mark	No.	Description	Part No.						Remarks
			XR-P340M	XR-P440M	XR-P440	XR-P340M	XR-P340		
			KU	HEWZIXK	HEWZIXK	HL	HEWZIXK	HL	
	1	Magazine assy	PXA1549	PXA1549	Not used	PXA1549	Not used	Not used	
	2	Operating instructions (English)	ARB7006	Not used	Not used	Not used	Not used	Not used	
	2	Operating instructions (English/Spanish/Chinese)	Not used	Not used	Not used	ARC7006	Not used	ARC7006	
	2	Operating instructions (German/Italian)	Not used	ARC7009	ARC7009	Not used	ARC7009	Not used	
	5	FM antenna (SE. A49038)	AHD 1016	ADH 1019	ADH 1019	ADH 1016	ADH 1019	ADH 1016	
	8	Front pad LR	AHA7002	AHA7006	AHA7006	AHA7002	AHA7006	AHA7002	
	9	Rear pad LR	AHA7003	AHA7007	AHA7007	AHA7003	AHA7007	AHA7003	
	10	Packing case	AHD7035	AHD7042	AHD7041	AHD7034	AHD7040	AHD7033	
	11	Sheet	AHG7003	AHG1090	AHG1090	AHG7003	AHG1090	AHG7003	

(2) EXPLODED VIEWS

■ Exterior (SE. A0010/PEE/95)

Note : For details regarding PCB assemblies, refer to " (3) PCB ASSEMBLIES ".

Mark	No.	Description	Part No.						Remarks
			XR-P340M	XR-P440M	XR-P440	XR-P340M	XR-P340		
			KU	HEWZIXK	HEWZIXK	HL	HEWZIXK	HL	
△	1	T8005 Power transformer	ATS7009	ATS7012	ATS7012	ATS7010	ATS7011	ATS7010	
△	2	FU1 Fuse (4A/125V)	AEK-125	Not used	Not used	Not used	Not used	Not used	
△	2	FU1 Fuse (T1.6A/250V)	Not used	AEK-510	AEK-510	Not used	Not used	Not used	
△	2	FU1 Fuse (T1A/250V)	Not used	Not used	Not used	AEK-508	Not used	AEK-508	
△	2	FU1 Fuse (T800mA/250V)	Not used	Not used	Not used	Not used	AEK-507	Not used	
△	3	AC power cord	ADG1146	ADG1138	ADG1138	ADG1049	ADG1138	ADG1049	
△	69	S8001 Voltage selector (AC220-230V/240V)	Not used	Not used	Not used	AKX1004	Not used	AKX1004	
	4	Cord stopper	AEP-113	AEC-882	AEC-882	AEC-882	AEC-882	AEC-882	
	7	MULTI MECHA assy	AXA7006	Not used	Not used	AXA7006	Not used	Not used	
NSP	7	MULTI MECHA assy	Not used	PXA1469	Not used	Not used	Not used	Not used	*1
	7	SINGLE MECHA assy	Not used	Not used	Not used	Not used	Not used	AXA7004	
NSP	7	SINGLE MECHA assy	Not used	Not used	PXA1487	Not used	PXA1487	Not used	*2
	8	CASSETTE MOD. B	EXK2430	Not used	Not used	EXK2410	EXK2410	EXK2410	
	8	CASSETTE MOD. BC	Not used	EXK2420	EXK2420	Not used	Not used	Not used	
NSP	9	Chassis	ANA7001	ANA7003	ANA7003	ANA7001	ANA7003	ANA7001	
	10	Rear panel	ANC7026	ANC7049	ANC7048	ANC7023	ANC7043	ANC7022	
	16	Front panel assy	AMB7075	AMB7024	AMB7023	AMB7075	AMB7022	AMB7074	*3
	18	Deck plate LR	AAK7018	AAK7018	AAK7018	AAK7018	Not used	AAK7018	
	18	Deck plate L	Not used	Not used	Not used	Not used	AAK7051	Not used	
	18	Deck plate R	Not used	Not used	Not used	Not used	AAK7052	Not used	

**XR-P740M, XR-P740, XR-P640M, XR-P640
XR-P440M, XR-P440, XR-P340M, XR-P340**

Mark	No.	Description	Part No.						Remarks
			XR-P340M	XR-P440M	XR-P440	XR-P340M	XR-P340		
			KU	HEWZIXK	HEWZIXK	HL	HEWZIXK	HL	
NSP	20	Tray cap	Not used	Not used	AAK7020	Not used	AAK7020	AAK7020	*4
	24	Bonnet	ANE7003	ANE7007	ANE7007	ANE7003	ANE7007	ANE7003	
	35	Screw	ASZ40P060FMC	ASZ40P060FMC	ASZ40P060FMC	ASZ30P060FZK	ASZ30P060FZK	ASZ30P060FZK	
	37	Screw (for CD MECHA assy)	BBZ30P080FZK	BBZ30P080FZK	BBZ30P160FMC	BBZ30P080FZK	BBZ30P160FMC	BBZ30P160FMC	
	54	Trans frame	ANA7002	ANA7004	ANA7004	Not used	Not used	Not used	
	55	65 label	ORW1069	Not used	Not used	Not used	Not used	Not used	
	58	Multi button	AAD7009	AAD7009	Not used	AAD7009	Not used	Not used	
	60	Lock lever spring	ABH7004	ABH7004	Not used	ABH7004	Not used	Not used	
	63	Ground lead	ADB1005	ADB1005	Not used	ADB1005	Not used	Not used	
	64	Parallel wire (J2)	D20PYY0615E	D20PYY0615E	Not used	D20PYY0615E	Not used	Not used	
	67	Caution label (G)	Not used	VRW-329	VRW-329	Not used	VRW-329	Not used	

*1 : Refer to page 4.

*2 : Refer to page 5.

*3 : Refer to "■ Front Panel Assy Section".

*4 : Refer to page 2.

■ Front Panel Assy Section

Front panel assy AMB7075, AMB7024, AMB7023, AMB7022 and AMB7074 are composed of the following parts.

Mark	No.	Symbol & Description	Part No.					Remarks
			AMB7075	AMB7024	AMB7023	AMB7022	AMB7074	
	42	Front panel A	-AMB7054	-AMB7062	-AMB7061	-AMB7060	-AMB7053	
	45	Door-L	-AAN7016	-AAN7018	-AAN7018	-AAN7017	-AAN7016	
	46	Door-R	-AAN7019	-AAN7022	-AAN7022	-AAN7021	-AAN7019	
	47	Catcher	-AEC7001	-AEC7001	-AEC7001	-AEC7001	-AEC7001	
	48	Door spring (L)	-ABH7001	-ABH7001	-ABH7001	-ABH7001	-ABH7001	
	49	Door spring (R)	-ABH7002	-ABH7002	-ABH7002	-ABH7002	-ABH7002	
	52	Damper assy	-AXA7001	-AXA7001	-AXA7001	-AXA7001	-AXA7001	
	53	Keep plate	-ABK1017	-ABK1017	-ABK1017	-ABK1017	-ABK1017	
	39	Screw	-BPZ26P080FMC	-BPZ26P080FMC	-BPZ26P080FMC	-BPZ26P080FMC	-BPZ26P080FMC	
	51	S-CD panel	Not used	Not used	-AAK7054	-AAK7054	-AAK7053	
	51	M-CD panel	-AAK7016	AAK7016*	Not used	Not used	Not used	
	43	Lens	-AAK7021	AAK7021*	AAK7021*	AAK7021*	-AAK7021	
	44	AMP. TUNER button	-AAD7048	AAD7048*	AAD7048*	AAD7048*	-AAD7048	
	50	DECK. CD button	-AAD7049	AAD7049*	AAD7049*	AAD7049*	-AAD7049	
	56	Door shaft	-AXA7003	AXA7003*	Not used	Not used	Not used	
	57	Door spring	-ABH7003	ABH7003*	Not used	Not used	Not used	
	59	Multi door	-AAK7017	AAK7063*	Not used	Not used	Not used	
	61	Damper	-PXA1484	PXA1484*	Not used	Not used	Not used	
	62	Screw	-BPZ20P080FMC	BPZ20P080FMC*	Not used	Not used	Not used	

Note : Parts marked with * are not included in the Front panel assy.

*AAK7063 = NSP (S-AM9092)

**XR-P740M, XR-P740, XR-P640M, XR-P640
XR-P440M, XR-P440, XR-P340M, XR-P340**

(3) PCB ASSEMBLIES

List of Whole PCB Assemblies

Mark	Symbol & Description	Part No.						Remarks
		XR-P340M	XR-P440M	XR-P440	XR-P340M	XR-P340		
		KU	HEWZIXK	HEWZIXK	HL	HEWZIXK	HL	
	MAIN assy	AWK7034	AWK7069	AWK7068	AWK7082	AWK7031-	AWK7081	
	└ AF CD assy	AWZ7088	AWZ7174	AWZ7173	AWZ7287	AWZ7085-	AWZ7286	
	└ H. P assy	AWZ7103	AWZ7104	AWZ7104	AWZ7103	AWZ7104-	AWZ7103	
	└ SECONDRY TRANS assy	AWZ7107	AWZ7253	AWZ7253	AWZ7289	AWZ7253	AWZ7289	
	└ VR assy	AWZ7270	AWZ7283	AWZ7283	AWZ7280	AWZ7098-	AWZ7280	
	COMPLEX assy	AWM7027	AWM7070	AWM7067	AWM7029	AWM7019	AWM7021	
	└ CD DECK SW assy	AWZ7125	AWZ7134	AWZ7133	AWZ7125	AWZ7133	AWZ7124	*1
	└ TRANS PRIMARY assy	AWZ7131	AWZ7129	AWZ7129	AWZ7127	AWZ7129	AWZ7127	
	└ DISPLAY assy	AWZ7113	AWZ7176	AWZ7175	AWZ7114	AWZ7109	AWZ7110	
	FM/AM TUNER MODULE	AXQ1012	AXQ3214	AXQ3214	AXQ1012	AXQ3214	AXQ1012	*2
	POWER MOD. F50	AXQ1018	AXQ3218	AXQ3218	AXQ1018	AXQ3218	AXQ1018	
	└ FRONT ASSY FOR 50W	AWZ5390	AWZ5445	AWZ5445	AWZ5390	AWZ5445	AWZ5390	*3
	└ REAR, PRTEC ASSY	AWZ5392	AWZ5447	AWZ5447	AWZ5392	AWZ5447	AWZ5392	*4
	CASSETTE MECHA MOD. B	EXK2430	EXK2410	EXK2410	EXK2410	
	└ DECK unit	EWM1001	EWM1001	EWM1001	EWM1001	
	CASSETTE MECHA MOD. BC	EXK2420	EXK2420	
	└ DECK unit	EWM1002	EWM1002	*5

*1 : Refer to page 8.

*2 : Refer to page 9.

*3 : Although AWZ5445 and AWZ5390 are different in part number, they consist of the same components.

*4 : Although AWZ5447 and AWZ5392 are different in part number, they consist of the same components.

*5 : Refer to CASSETTE MECHA SECTION in the RRV1023 service manual.

H. P ASSY

Part number differs between AWZ7103 and AWZ7104.

Mark	Symbol & Description	Part No.		Remarks
		AWZ7103	AWZ7104	
	C1251, C1252	Not used	CCSQCH101J50	*6

*6 : Refer to page 18.

SECONDRY TRANS ASSY

Part number differs between AWZ7107, AWZ7253, AWZ7289.

Mark	Symbol & Description	Part No.			Remarks
		AWZ7107	AWZ7253	AWZ7289	
	IC1006-IC1009	ICP-N70	Not used	Not used	

VR ASSY

Part number differs between AWZ7270, AWZ7283, AWZ7280 and AWZ7098.

Mark	Symbol & Description	Part No.				Remarks
		AWZ7270	AWZ7283	AWZ7280	AWZ7098	
	C1507, C1508 C1509 C1555, C1556 C1555, C1556 (0.082/50V) C1557, C1558	Not used CKSQYB473K50 CKSQYB473K50 Not used CKSQYB273K50	CCSQCH470J50 CKSQYB473K50 CKSQYB473K50 Not used CKSQYB273K50	Not used CKSQYB473K50 CKSQYB473K50 Not used CKSQYB393K50	CCSQCH470J50 Not used Not used ACG1050 CKSQYB273K50	*7
	R1505, R1506 R1555 - R1558	RS1/10S473J RS1/10S823J	RS1/10S473J RS1/10S823J	RS1/10S473J RS1/10S104J	RS1/10S223J RS1/10S563J	

*7 : Refer to page 18.

AF CD ASSY (SC-A1906A-G) (SC-A1906B-G)

Part number differs between AWZ7088, AWZ7174, AWZ7173, AWZ7287, AWZ7085 and AWZ7286.

Mark	Symbol & Description	Part No.						Remarks
		AWZ7088	AWZ7174	AWZ7173	AWZ7287	AWZ7085	AWZ7286	
	D1010 D1011, D1012 D1032, D1033 D1151, D1152 D1996, D1997	HZS7BL RD5.6ESB2 Not used RD5.1ESB Not used	MTZJ7.5 MTZJ5.6B 1SS252 MTZJ5.1 S5688G	MTZJ7.5 MTZJ5.6B 1SS252 MTZJ5.1 S5688G	RD7.5ESB RD5.6ESB2 HSS104-02 RD5.1ESB S5688G	MTZJ7.5 MTZJ5.6B 1SS252 MTZJ5.1 S5688G	RD7.5ESB RD5.6ESB2 HSS104-02 RD5.1ESB S5688G	
	D1998, D1999 D2201, D8211 L1301-L1304	JUMPER HZS6CL Not used	S5688G MTZJ6.2 ATH-059	S5688G MTZJ6.2 ATH-059	JUMPER RD5.6ESB Not used	S5688G MTZJ6.2 ATH-059	JUMPER RD5.6ESB Not used	
	C1001, C1002 (5600/56V) C1001, C1002 (3300/50V) C1311 C1312 C1313, C1315, C1332, C1334	ACH1211 Not used Not used Not used Not used	ACH7001 Not used CKCYF473Z50 CKSQYF473Z50 CKSQYF104Z50	ACH7001 Not used CKCYF473Z50 CKSQYF473Z50 CKSQYF104Z50	Not used ACH1066 Not used Not used Not used	Not used ACH1066 CKCYF473Z50 CKSQYF473Z50 CKSQYF104Z50	Not used ACH1066 Not used Not used Not used	
	C1351-C1353 C2503, C2504 C2702, C2703 C8429, C8430	Not used CEASR15M50 Not used CCSQCH560J50	CKSQYF102Z50 CEYAR22M50 CKSQYB471K50 CCSQCH121J50	CKSQYF102Z50 CEYAR22M50 CKSQYB471K50 CCSQCH121J50	Not used CEYAR22M50 Not used CCSQCH560J50	CKSQYF102Z50 CEASR15M50 CKSQYB471K50 CCSQCH121J50	Not used CEYAR22M50 Not used CCSQCH560J50	
	R1019 R1223 R1303, R1304 R1997 R1998 (SC-A5004) (392)	RD1/4PM511J RS1/10S303J Not used Not used Not used	RD1/4PM122J RS1/10S393J RD1/4PMFL101J Not used RS2LMF220J	RD1/4PM122J RS1/10S393J RD1/4PMFL101J Not used RS2LMF220J	RD1/4PM511J RS1/10S333J Not used RD1/8PM100J RS1LMF220J	RD1/4PM102J RS1/10S333J RD1/4PMFL101J Not used RS1LMF220J	RD1/4PM511J RS1/10S333J Not used RD1/8PM100J RS1LMF220J	
	R1999 R2101, R2102	Not used RD1/8PM102J	RS3LMF3R9J RD1/8PM222J	RS3LMF3R9J RD1/8PM222J	RS3LMF6R8J RD1/8PM102J	RS3LMF3R9J RD1/8PM222J	RS3LMF6R8J RD1/8PM102J	
	CN2101 (Pin jack 2P) CN8203 (Connector 4P) CN8203 (Connector 5P) CN8204 (Jumper connector 6P) Speaker terminal 4-P	AKB1146 4-173981-4 Not used 52147-0610 AKE1026	AKB1100 4-173981-4 Not used 52147-0610 AKE7001	AKB1100 Not used VKN1052 Not used AKE7001	AKB1146 4-173981-4 Not used 52147-0610 AKE1026	AKB1100 Not used VKN1052 Not used AKE7001	AKB1146 Not used VKN1052 Not used AKE1026	

Note : Refer to pages 16-18.

XR-P740M, XR-P740, XR-P640M, XR-P640 XR-P440M, XR-P440, XR-P340M, XR-P340

4.1 ADJACENCIES TO THE POWER TRANSFORMER

FOR XR-P740M, XR-P740,
XR-P640M, XR-P640/HL

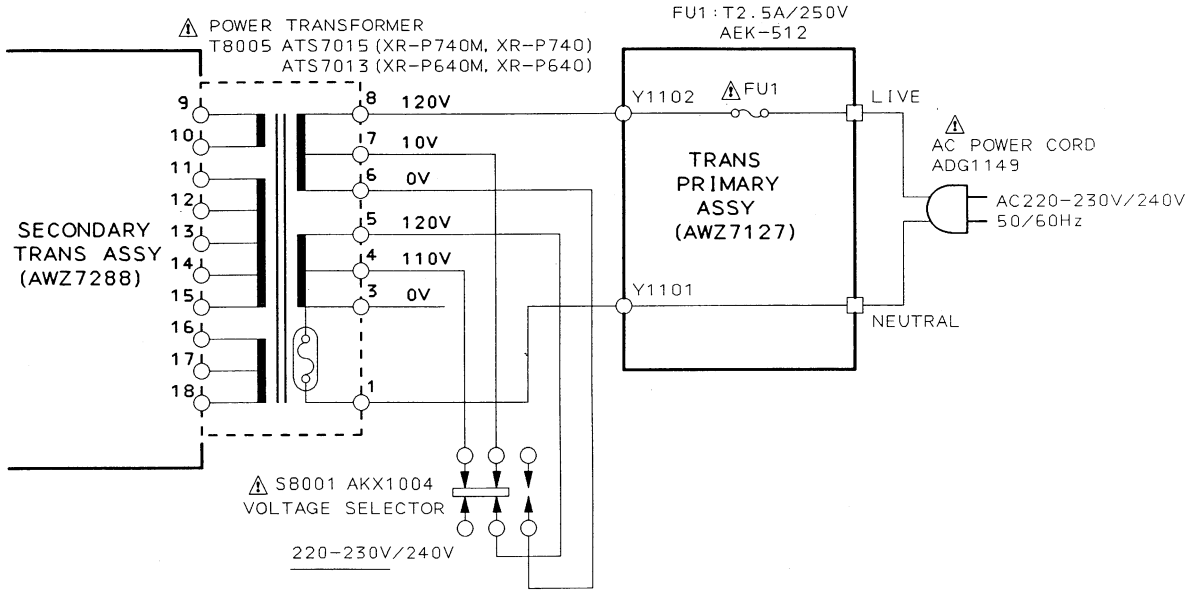

FOR XR-P340M, XR-P340/HL

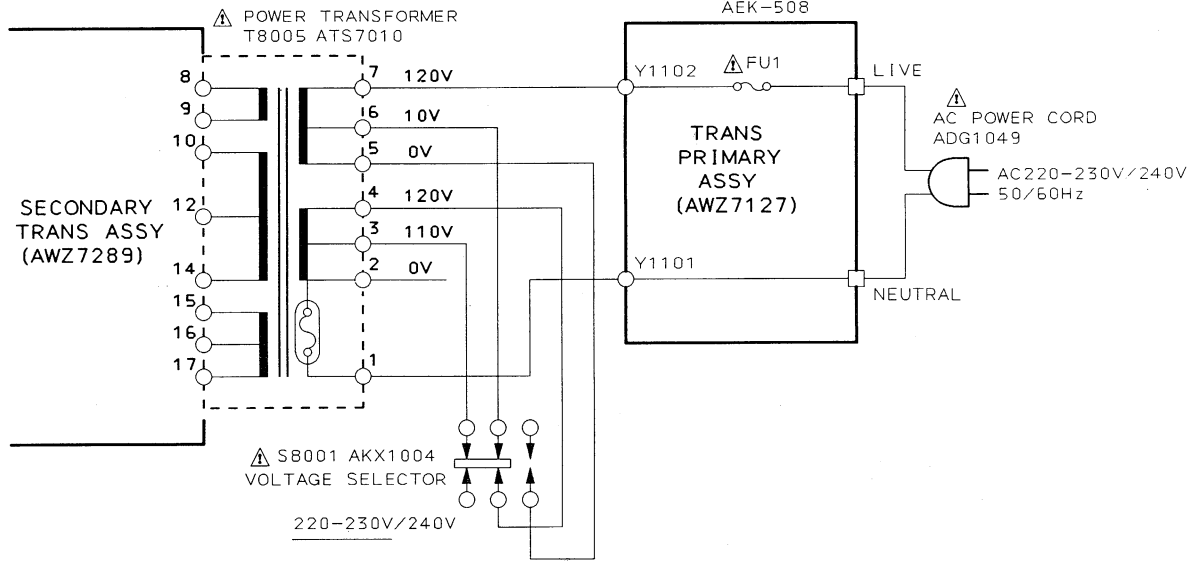

FOR XR-P640M, XR-P640, XR-P440M, XR-P440
XR-P340/HEWZIXK

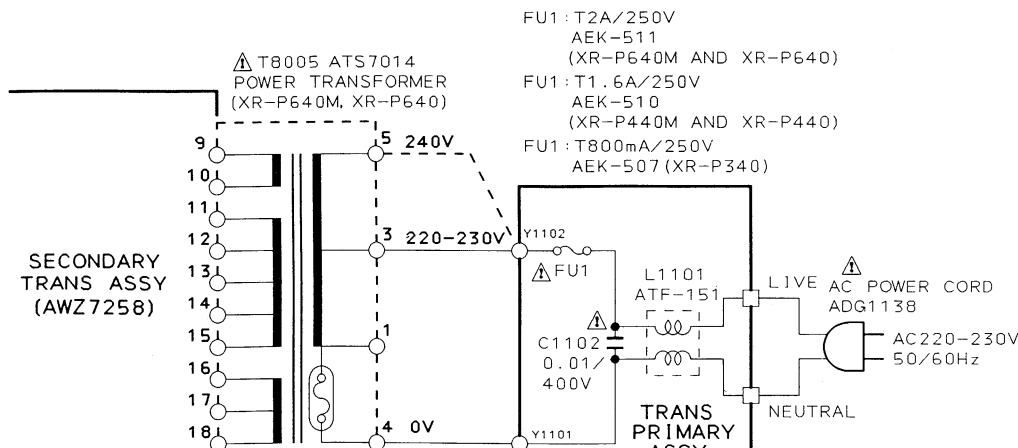

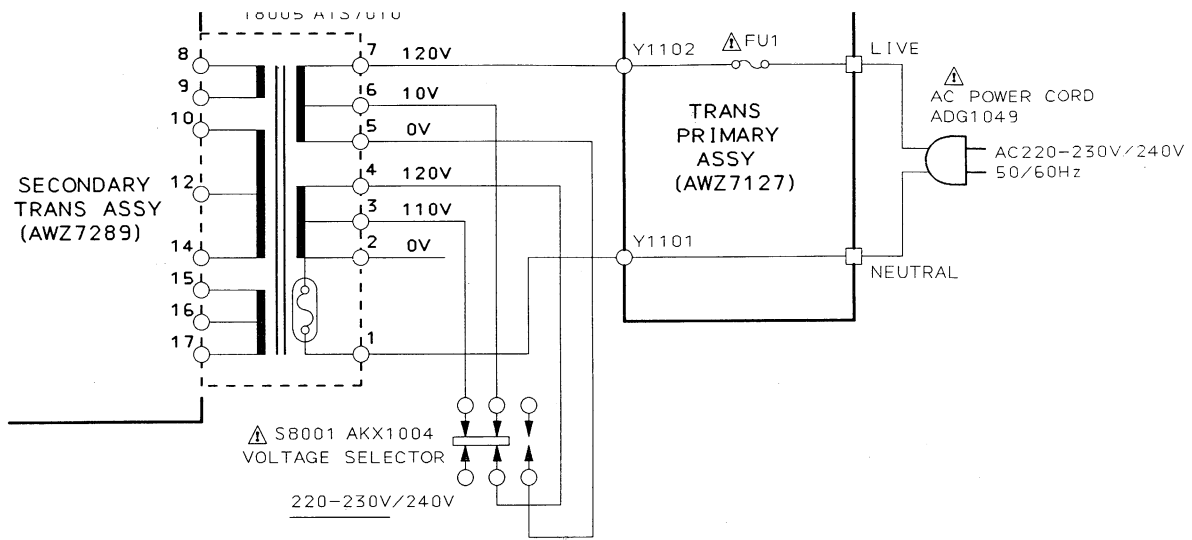

FOR XR-P640M, XR-P640, XR-P440M, XR-P440
XR-P340/HEWZIXK

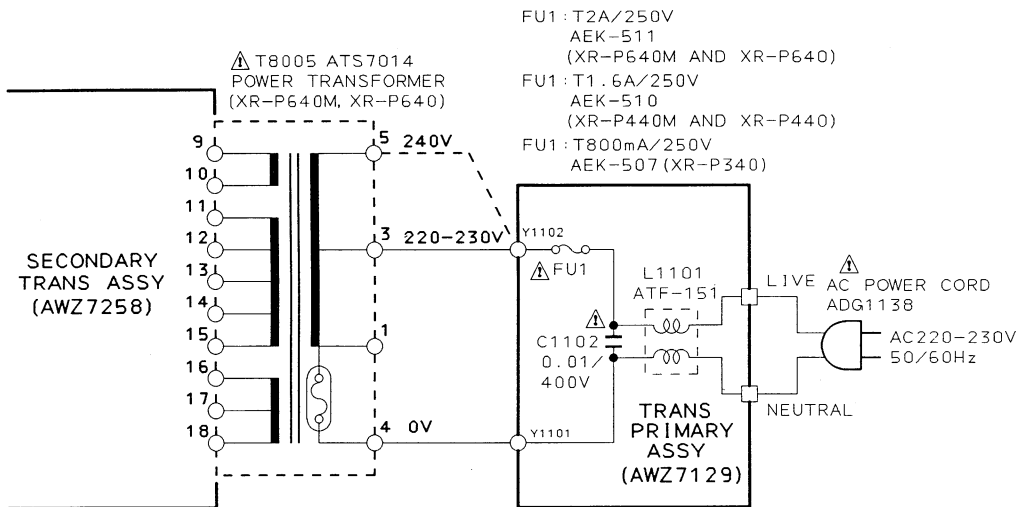

- FU1: T2A/250V
AEK-511
(XR-P640M AND XR-P640)
- FU1: T1.6A/250V
AEK-510
(XR-P440M AND XR-P440)
- FU1: T800mA/250V
AEK-507 (XR-P340)

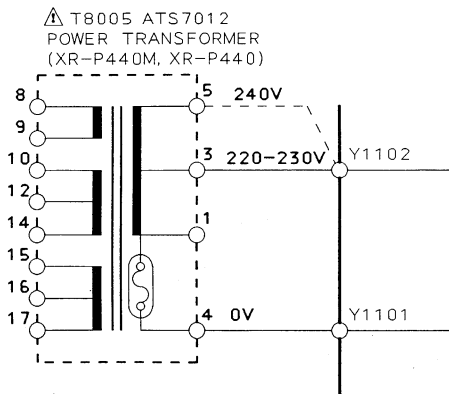

T8005 ATS7011
POWER TRANSFORMER
(XR-P340)

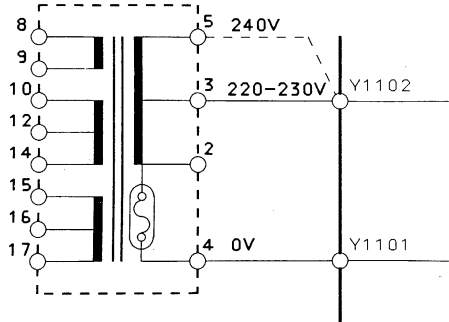

Line Voltage Selection

Line Voltage can be changed by the following modification:

1. Disconnect the AC power cord.
2. Remove the cover.
3. Change the connection of the power transformer primary taps.

Part No.	Description
AAX-193	220V label
AAX-192	240V label

ADJACENCIES TO THE
POWER TRANSFORMER

SCH-1F

XR-P740M, XR-P740, XR-P640M, XR-P640 XR-P440M, XR-P440, XR-P340M, XR-P340

4.2 AF CD ASSY (2/2), VR ASSY AND H. P ASSY

To PROLOGIC assy CN1002
(XR-P740M, XR-P740)
To DOL SURR assy CN1002 (→SCH-4F)
(XR-P640M, XR-P640)

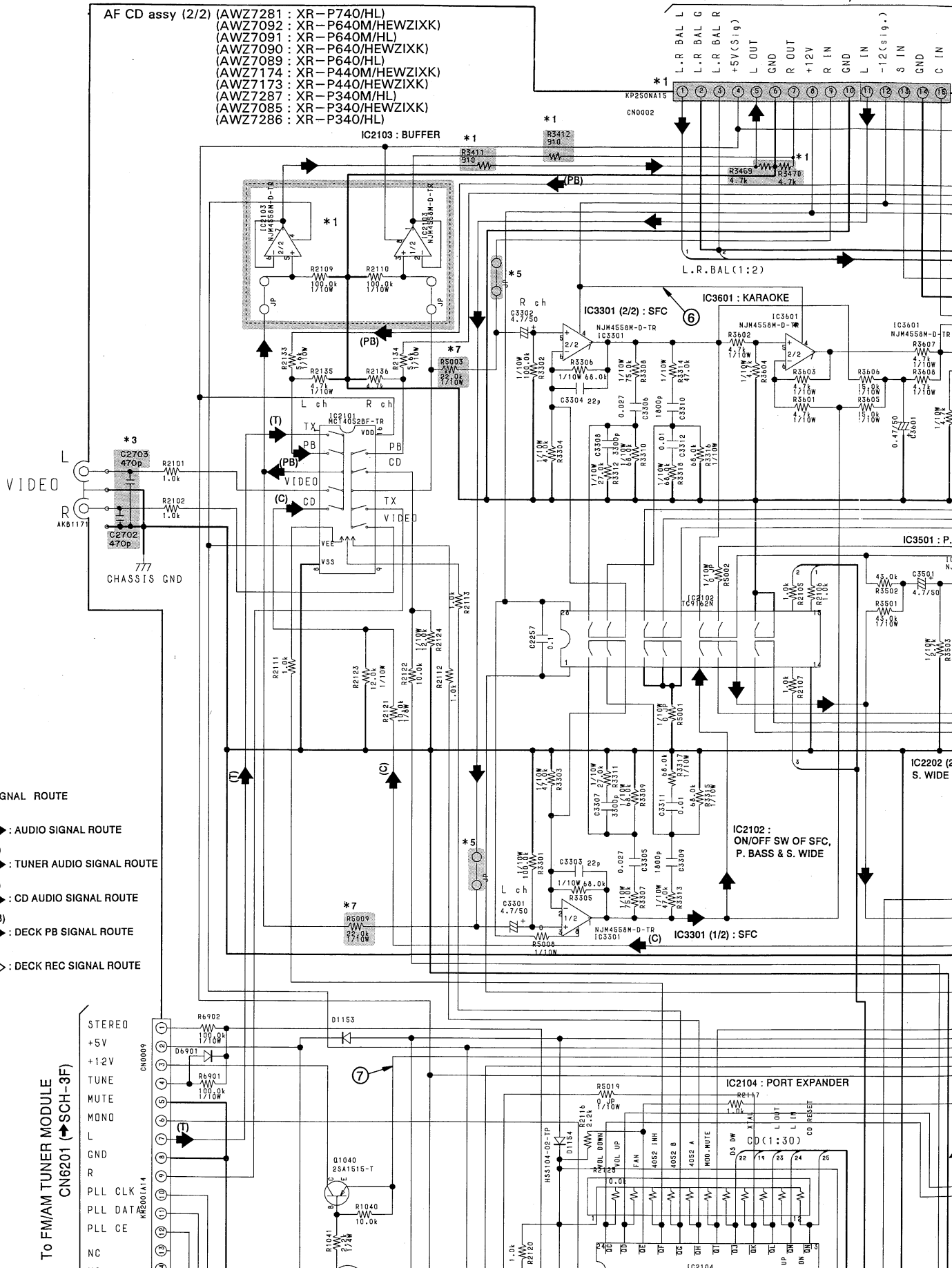

of HL and HEWZIXK types are the
 P740M/SD. Refer to the service
 manual for P740M/SD.

SCH-2F

VR Assy
 (AWZ7100 : XR-P640M, XR-P640/HEWZIXK)
 (AWZ7283 : XR-P440M, XR-P440/HEWZIXK)
 (AWZ7098 : XR-P340/HEWZIXK)

PARTS	XR-P640M/ XR-P640/ HEWZIXK	XR-P440M/ XR-P440/ HEWZIXK	XR-P340/ HEWZIXK
R1505 R1506	47k	47k	22k
R1555 R1556 R1557 R1558	82k	82k	56k
VR301	ACX1092	ACX1089	ACX1089
C1555 C1555	0.047	0.047	ACG1050 (0.082/50)
CN1004	KP2001A18L	KP2001A12L	KP2001A12L

	XR-P740M SERIES VOLTAGE (V)		XR-P340M SERIES VOLTAGE (V)	
	NO LOAD	DURING RATED OUTPUT	NO LOAD	DURING RATED OUTPUT
①	53.6	38.2	39.4	28.2
②	-53.6	-38.7	-39.4	-28.2
③	22.5	19.4	24.3	21.2
④	-23.7	-20.9	-26.0	-22.8
⑤	11.9	11.9	11.9	11.9
⑥	-11.9	-11.9	-11.9	-11.9
⑦	11.9	11.9	11.9	11.9
⑧	4.9	4.9	4.9	4.9
⑨	-30.7	-30.7	-30.7	-30.7
⑩	12.0	12.0	12.0	12.0

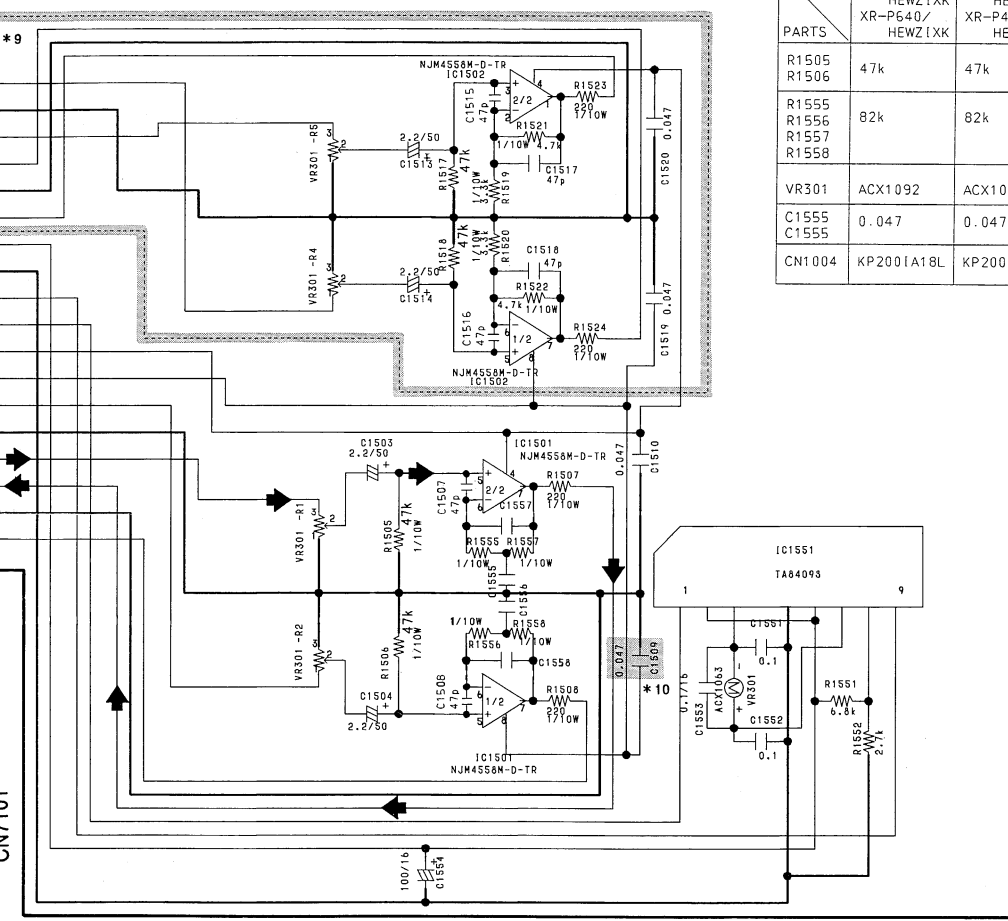

To FRONT assy FOR 100W
 (XR-P740M SERIES)
 To FRONT assy FOR 50W
 (XR-P340M SERIES)
 CN7502

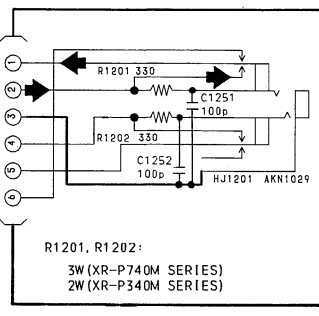
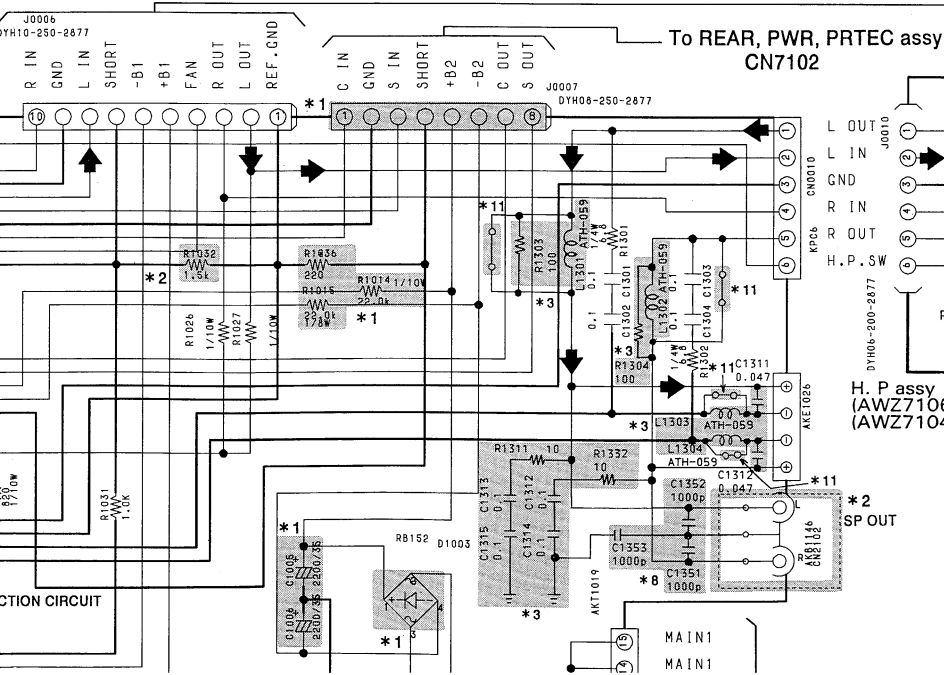

H. P. assy
 (AWZ7106 : XR-P640M, XR-P640/HEWZIXK)
 (AWZ7104 : XR-P440M, XR-P440, XR-P340/HEWZIXK)

PARTS	XR-P740 XR-P640M XR-P640	XR-P440M XR-P440 XR-P340M XR-P340
D1001	D5SB20F	D3SBA20 (A)
R1026	110k	82k (1/10W)
R1027	110k (1/10W)	1.5k
C1009	0.033/250	ACG1005

A

B

C

D

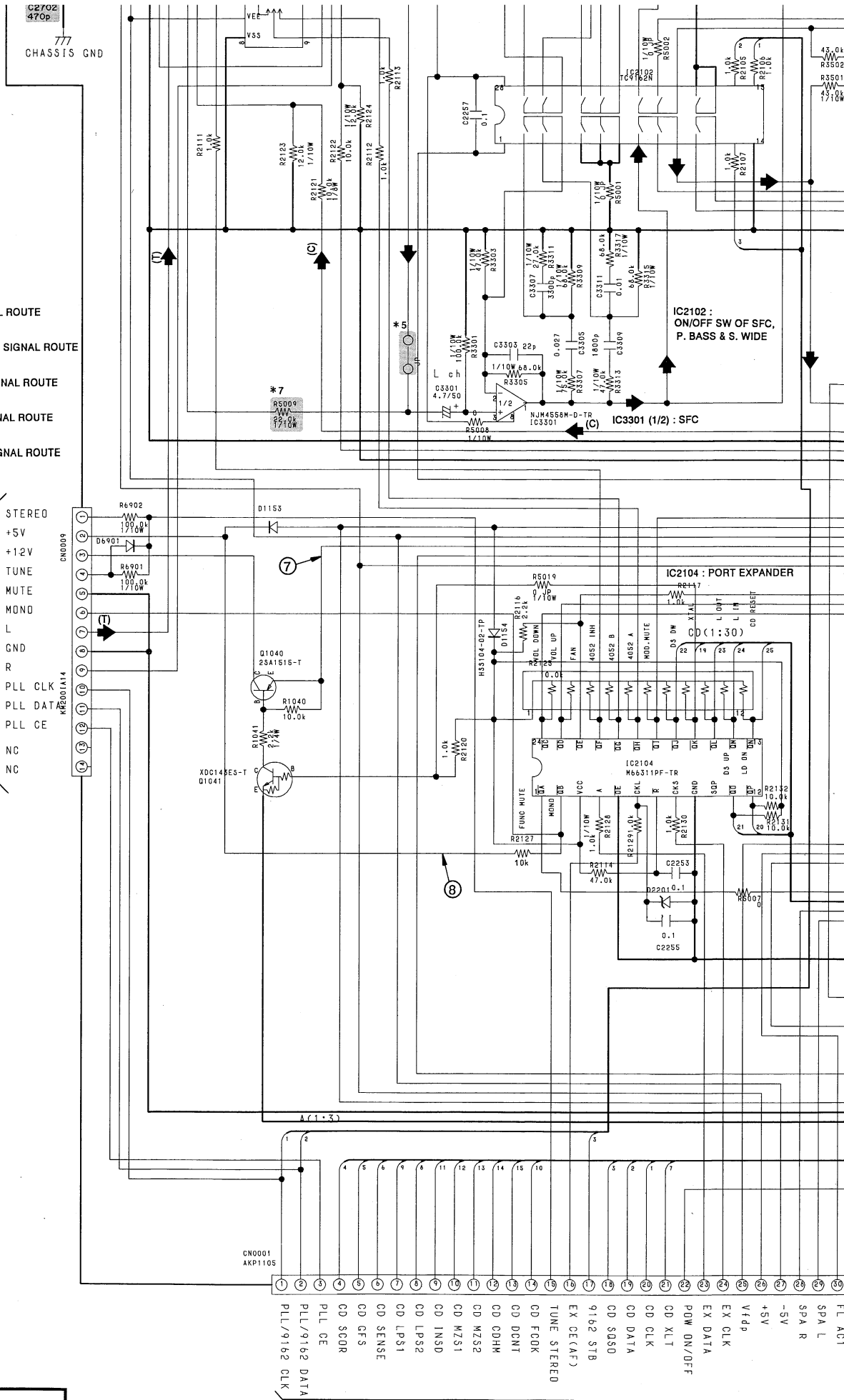

- SIGNAL ROUTE
- ▶ : AUDIO SIGNAL ROUTE
 - (T) : TUNER AUDIO SIGNAL ROUTE
 - (C) : CD AUDIO SIGNAL ROUTE
 - (PB) : DECK PB SIGNAL ROUTE
 - ◁ : DECK REC SIGNAL ROUTE

To FM/AM TUNER MODULE
CN6201 (SCH-3F)

- STEREO
- +5V
- +12V
- TUNE
- MUTE
- MONO
- L
- GND
- R
- PLL CLK
- PLL DAT
- PLL CE
- NC
- NC

- CN0001 AKP1105
- 1 PLL/9162 DATA
 - 2 PLL/9162 CLK
 - 3
 - 4
 - 5
 - 6
 - 7
 - 8
 - 9
 - 10
 - 11
 - 12
 - 13
 - 14
 - 15
 - 16
 - 17
 - 18
 - 19
 - 20
 - 21
 - 22
 - 23
 - 24
 - 25
 - 26
 - 27
 - 28
 - 29
 - 30
 - 31
 - 32
 - 33
 - 34
 - 35
 - 36
 - 37
 - 38
 - 39
 - 40
 - 41
 - 42
 - 43
 - 44
 - 45
 - 46
 - 47
 - 48
 - 49
 - 50
 - 51
 - 52
 - 53
 - 54
 - 55
 - 56
 - 57
 - 58
 - 59
 - 60
 - 61
 - 62
 - 63
 - 64
 - 65
 - 66
 - 67
 - 68
 - 69
 - 70
 - 71
 - 72
 - 73
 - 74
 - 75
 - 76
 - 77
 - 78
 - 79
 - 80
 - 81
 - 82
 - 83
 - 84
 - 85
 - 86
 - 87
 - 88
 - 89
 - 90
 - 91
 - 92
 - 93
 - 94
 - 95
 - 96
 - 97
 - 98
 - 99
 - 100

SCH-2F

AF CD ASSY (2/2), VR ASSY,
H. P ASSY

To DISPLAY assy CN1001

C

D

E

F

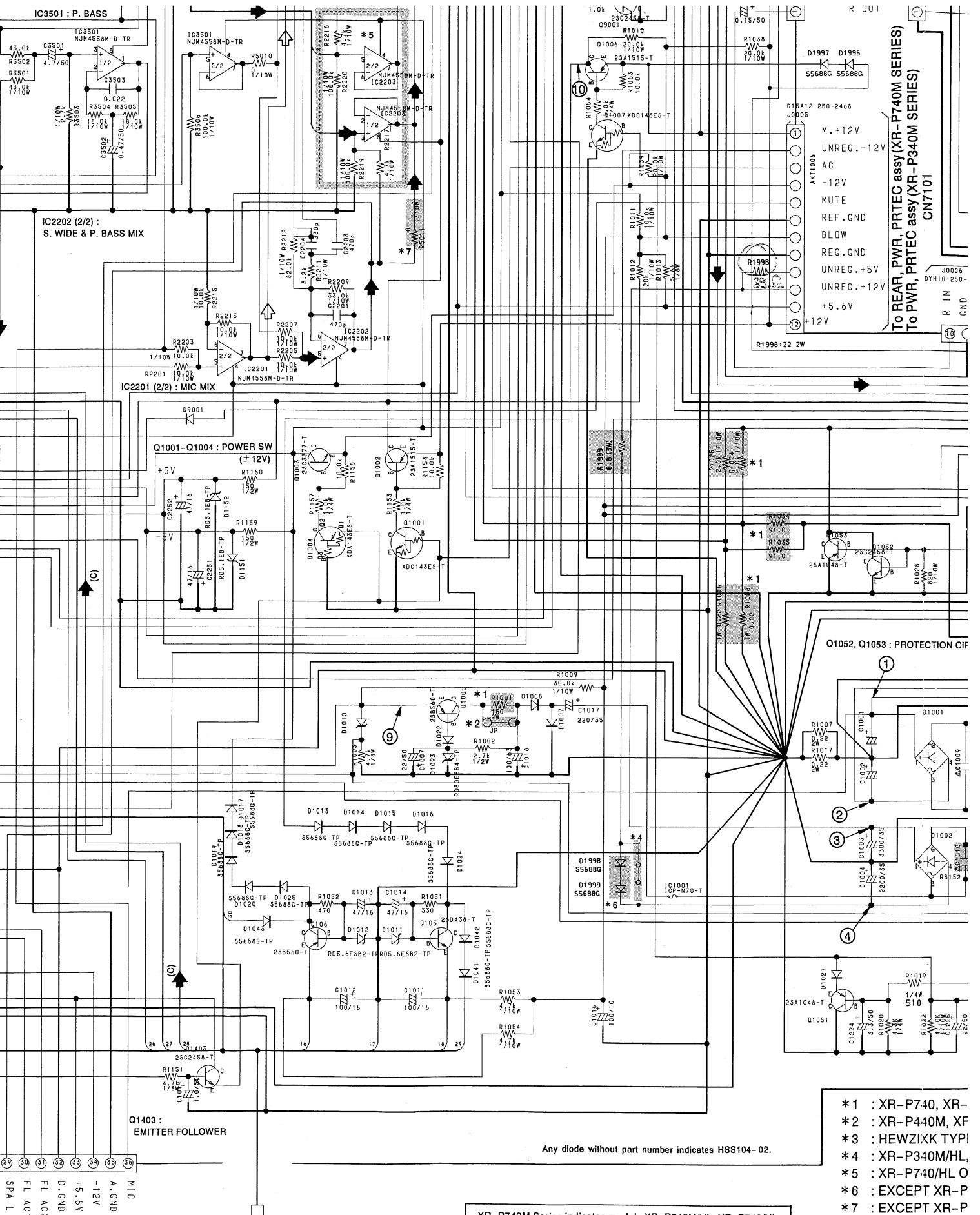

To REAR, PWR, PRTEC assy (XR-P740M SERIES)
 To PWR, PRTEC assy (XR-P340M SERIES)
 CN7101

Q1052, Q1053 : PROTECTION CIR

Q1403 :
EMITTER FOLLOWER

To AF CD assy (1/2)

Any diode without part number indicates HSS104-02.

XR-P740M Series indicates models XR-P740M/HL, XR-P740/HL,
 XR-P640M/HL, HEWZIXK, XR-P640/HL and HEWZIXK.
 XR-P340M Series indicates models XR-P440M/HEWZIXK,
 XR-P440/HEWZIXK, XR-P340M/HL, XR-P340/HL and HEWZIXK.

- * 1 : XR-P740, XR-
- * 2 : XR-P440M, XF
- * 3 : HEWZIXK TYP1
- * 4 : XR-P340M/HL,
- * 5 : XR-P740/HL O
- * 6 : EXCEPT XR-P
- * 7 : EXCEPT XR-P
- * 8 : XR-P440M/HE'
- * 9 : XR-P640M/HE'
- * 10 : XR-P640M, XR
- * 11 : HL TYPE ONLY

Handwritten notes:
 SA. A. 8000
 SA. A. 9000
 SA. A. 9000
 SA. A. 9000

CMK-P3X

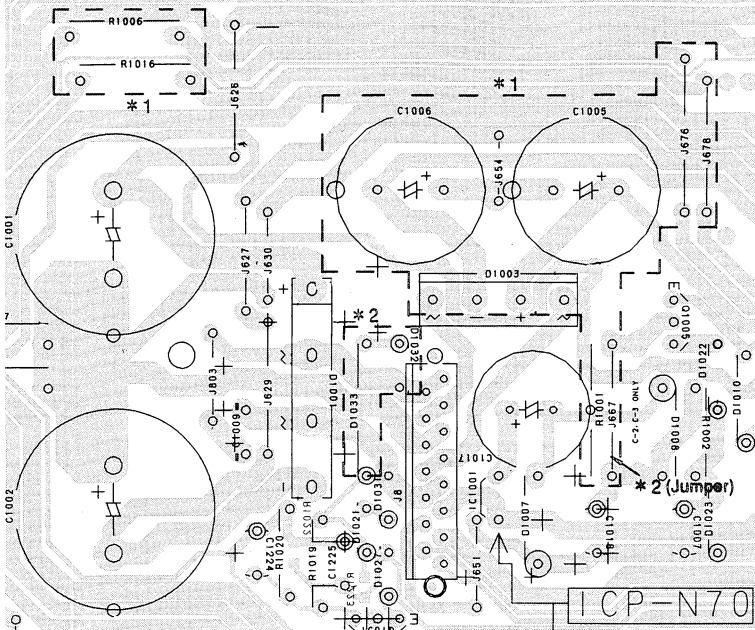

ATTENTION :REPLACER AVEC CAT. NO. CP-N70 POUR IC1001 (MFD. BY ROAM CO. LTD.)

CAUTION :REPLACE WITH CAT. NO. CP-N70 FOR IC1001 (MFD. BY ROAM CO. LTD.)

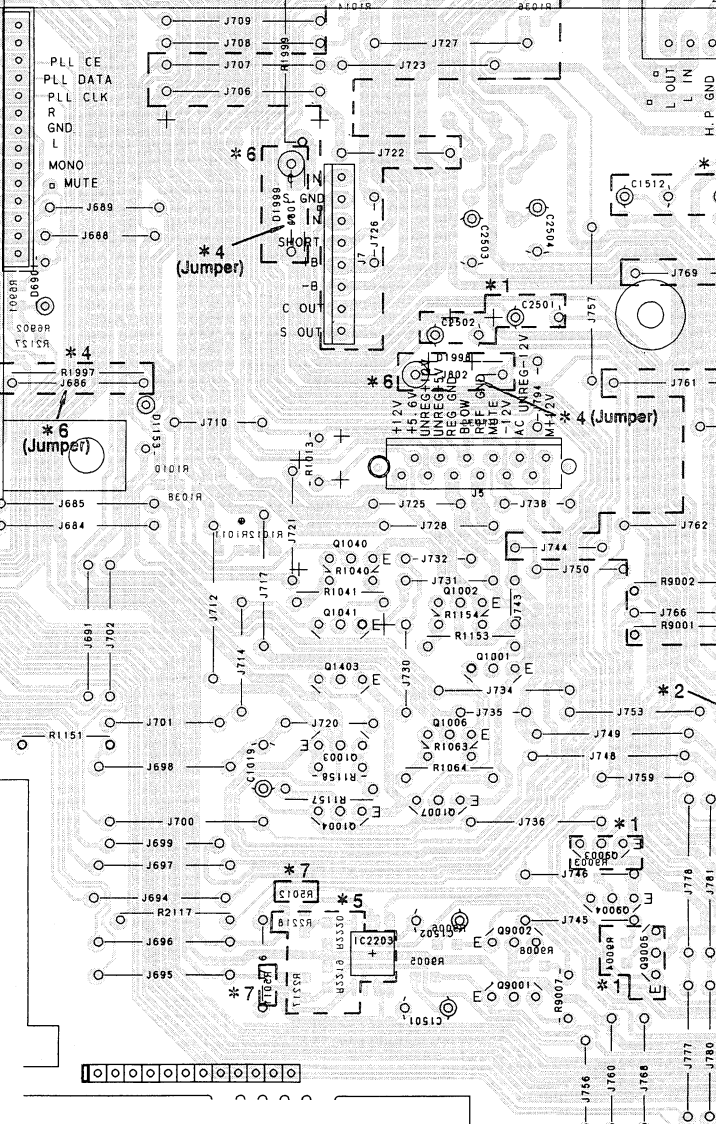
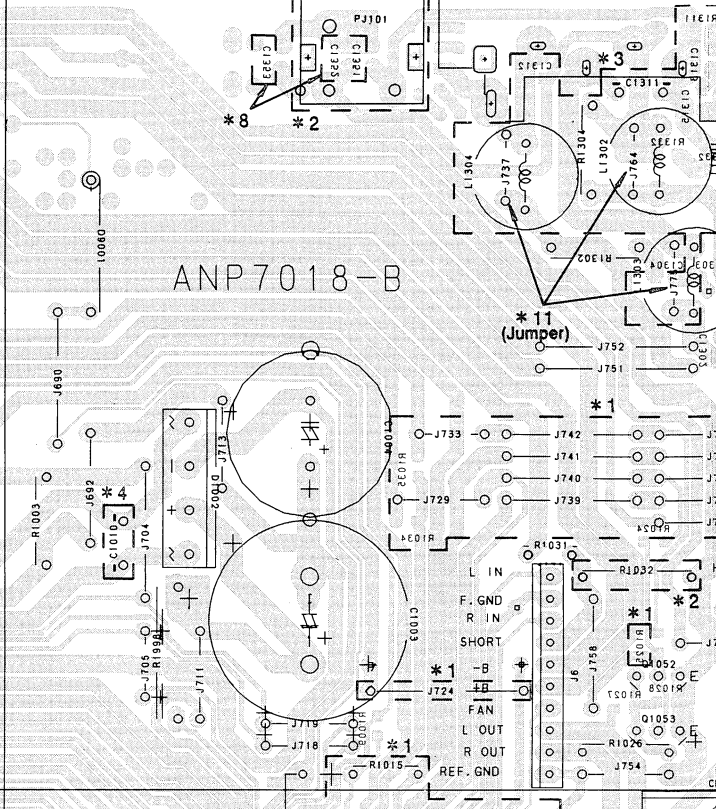
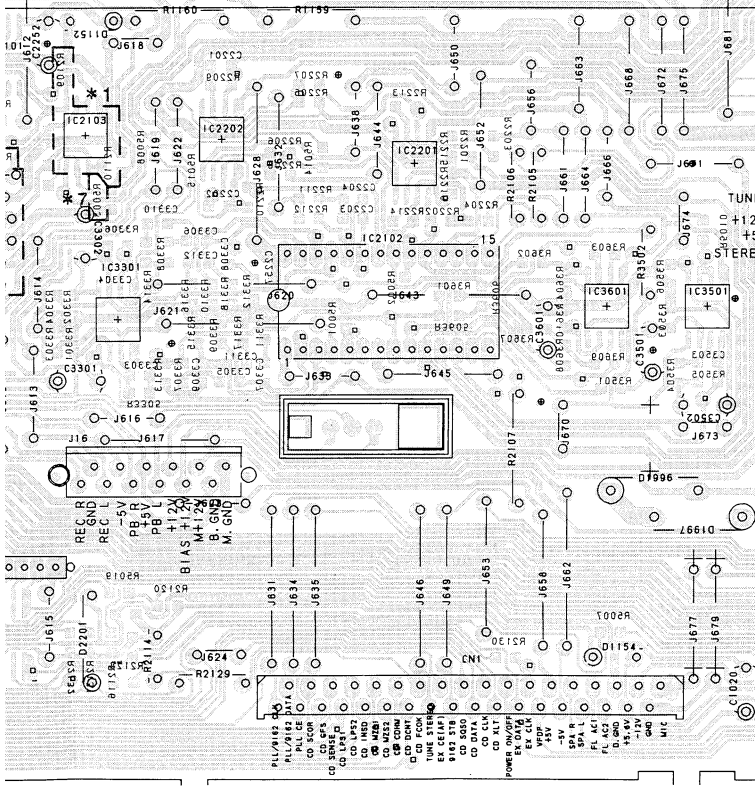

XR-P440M, XR-P440, XR-P40M, XR-P40
 XR-P740M, XR-P740, XR-P640M, XR-P640

A

B

C

D

• This diagram is viewed from the foil side.

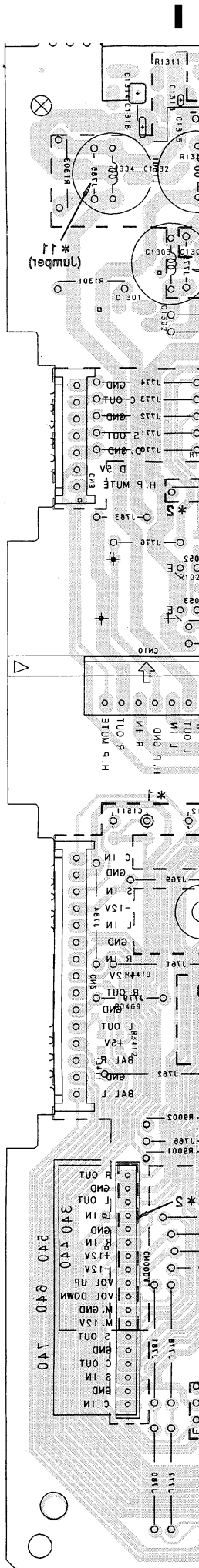
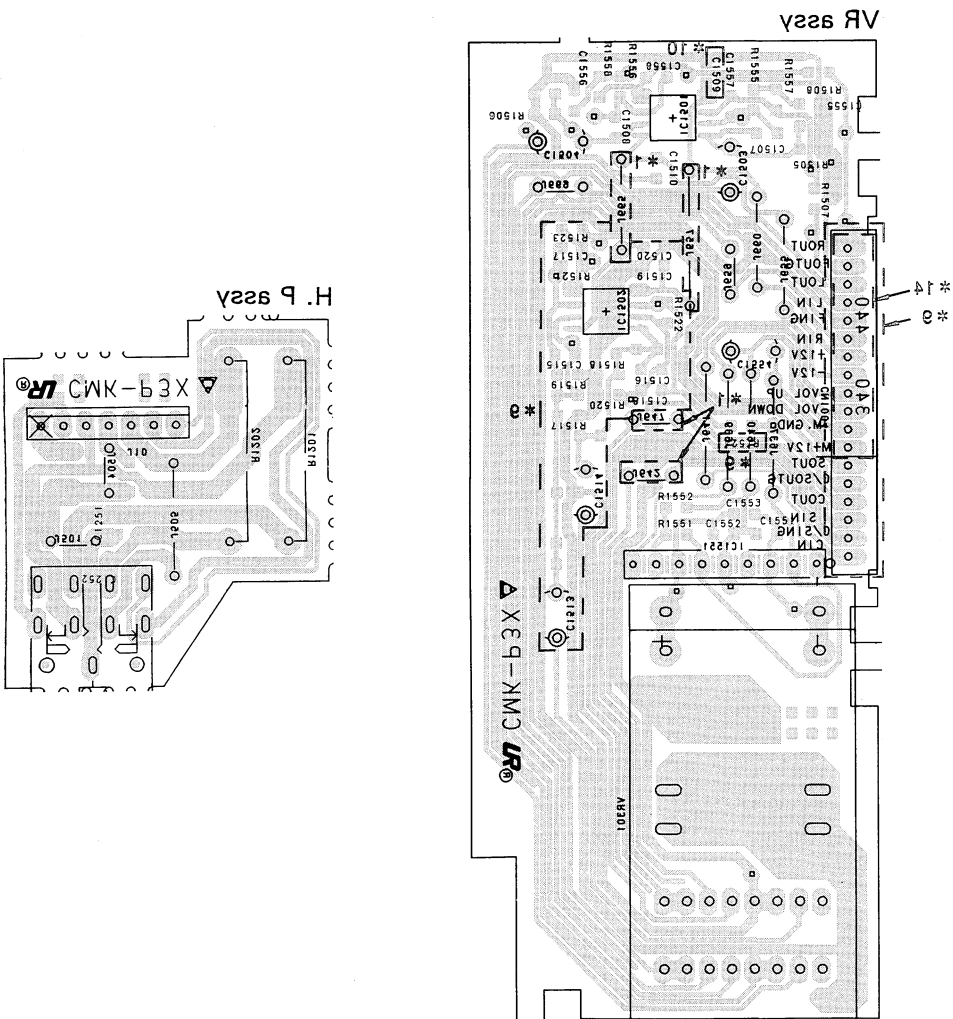

4.3 FM/AM TUNER MODULE

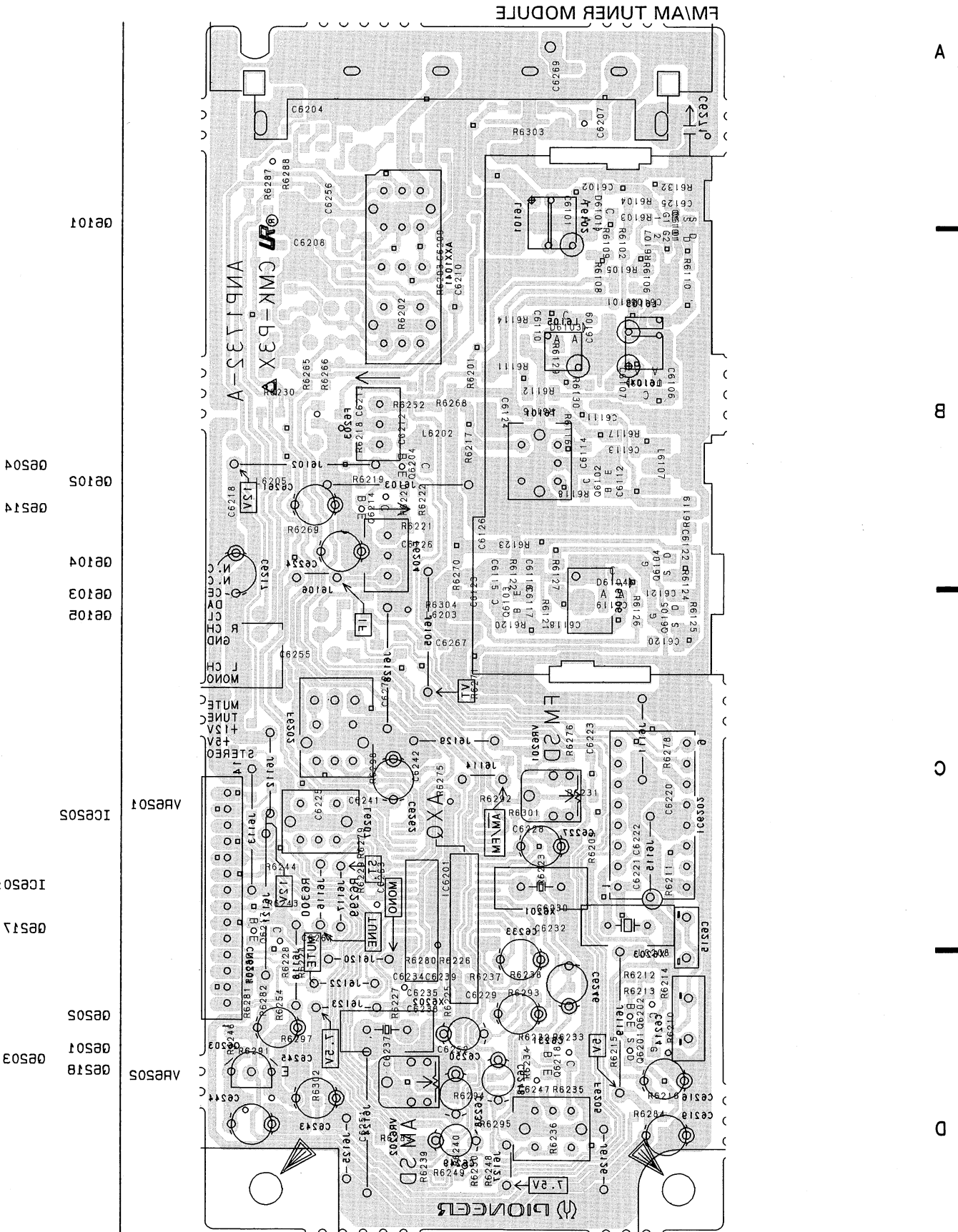

• This diagram is viewed from the foil side.

4.3 FM/AM TUNER MODULE

FM/AM TUNER MODULE

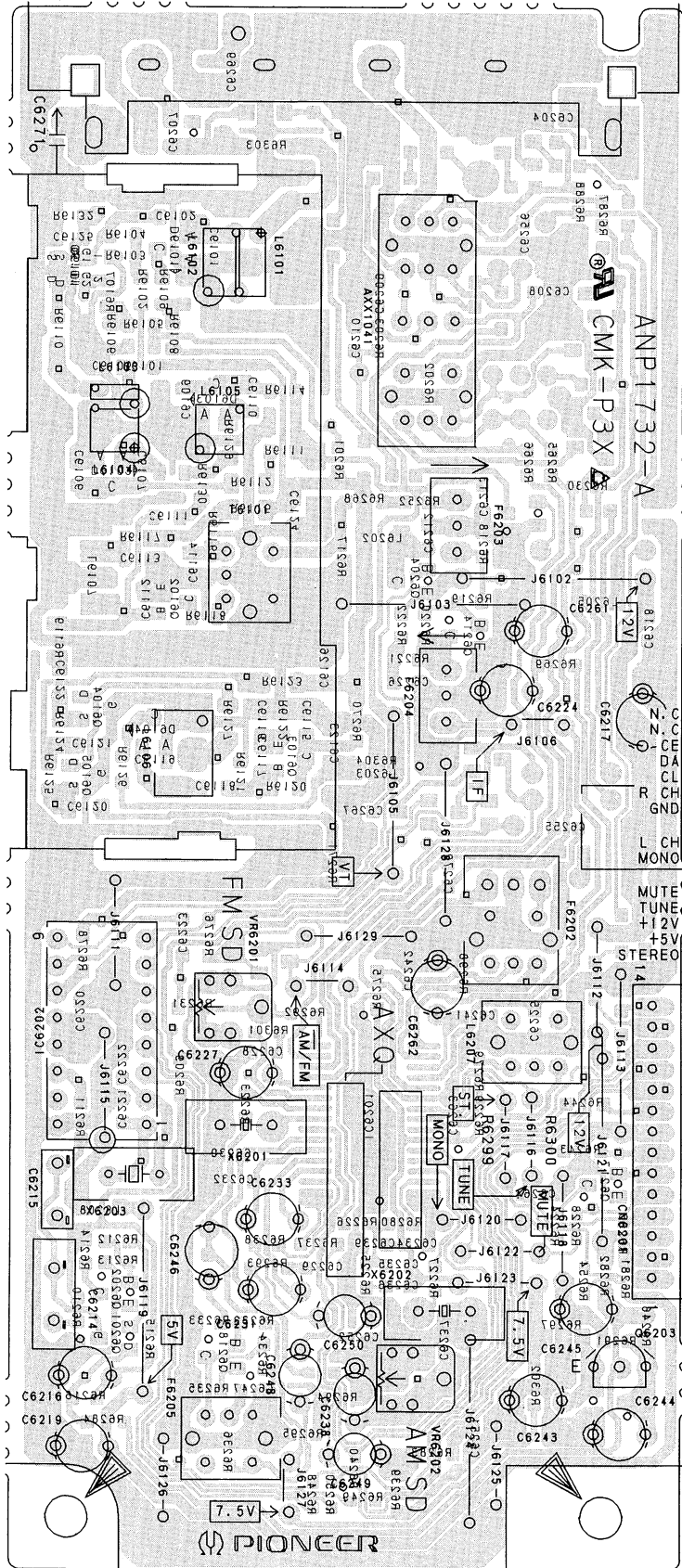

G6101

G6102

G6204

G6214

G6104

G6103

G6105

VR6201

IC6202

IC6201

G6217

G6202

G6201

G6203

VR6202

• This diagram is viewed from the mounted parts side.

A

B

C

D

FM/AM TUNER MODULE (AXQ3214)

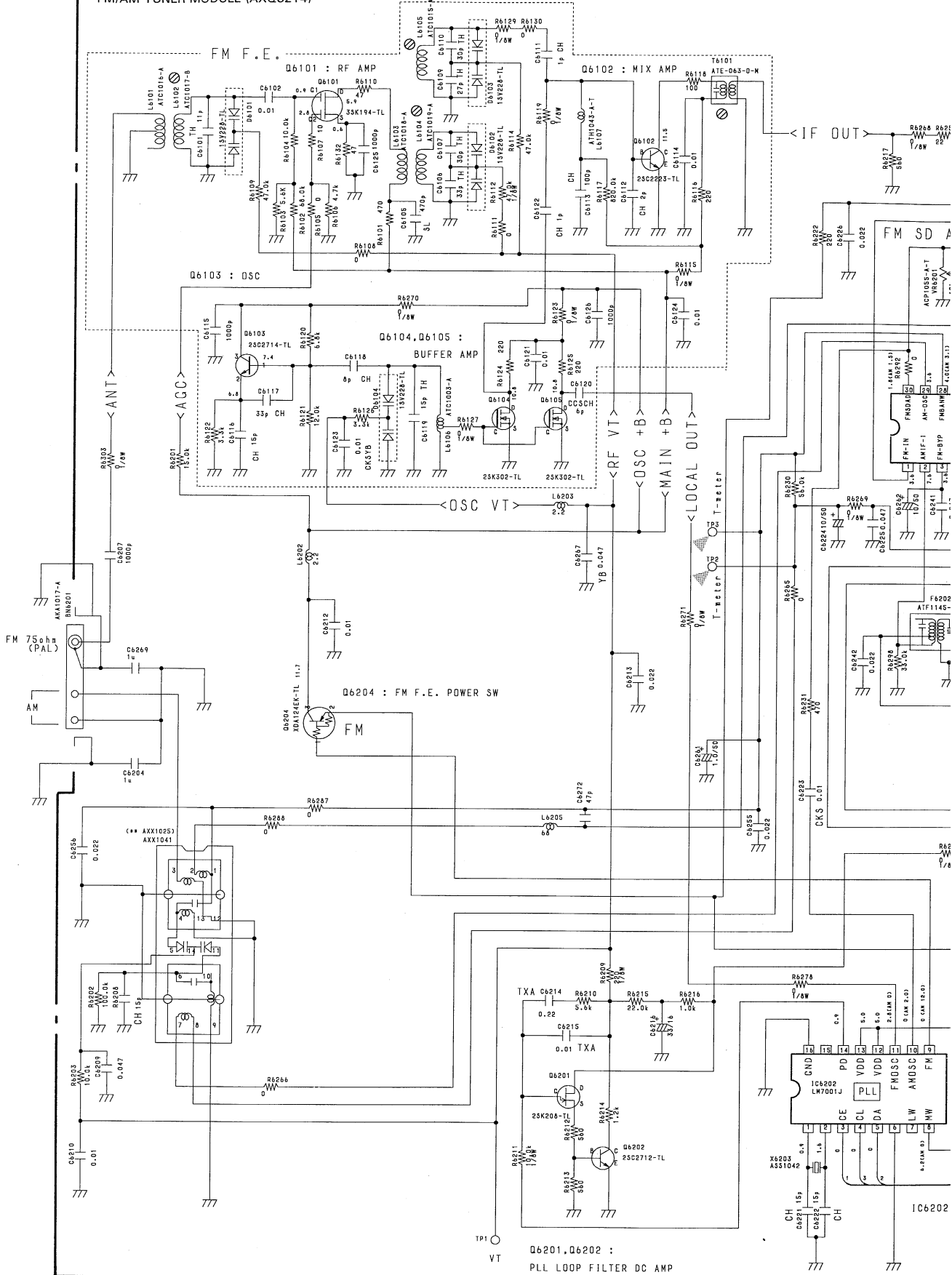

SCH-3F

FM/AM TUNER MODULE

XR-P740M, XR-P740, XR-P640M, XR-P640 XR-P440M, XR-P440, XR-P340M, XR-P340

NOTE: VOLTAGE AND CURRENT

mV : Signal voltage at FM 1kHz, 100% MOD.
or - V :

DC voltage (V) at no input signal unless otherwise noted.
Value in () is DC voltage at rated power.

mA or - mA :
DC current at no input signal unless otherwise noted.

SCH-3F

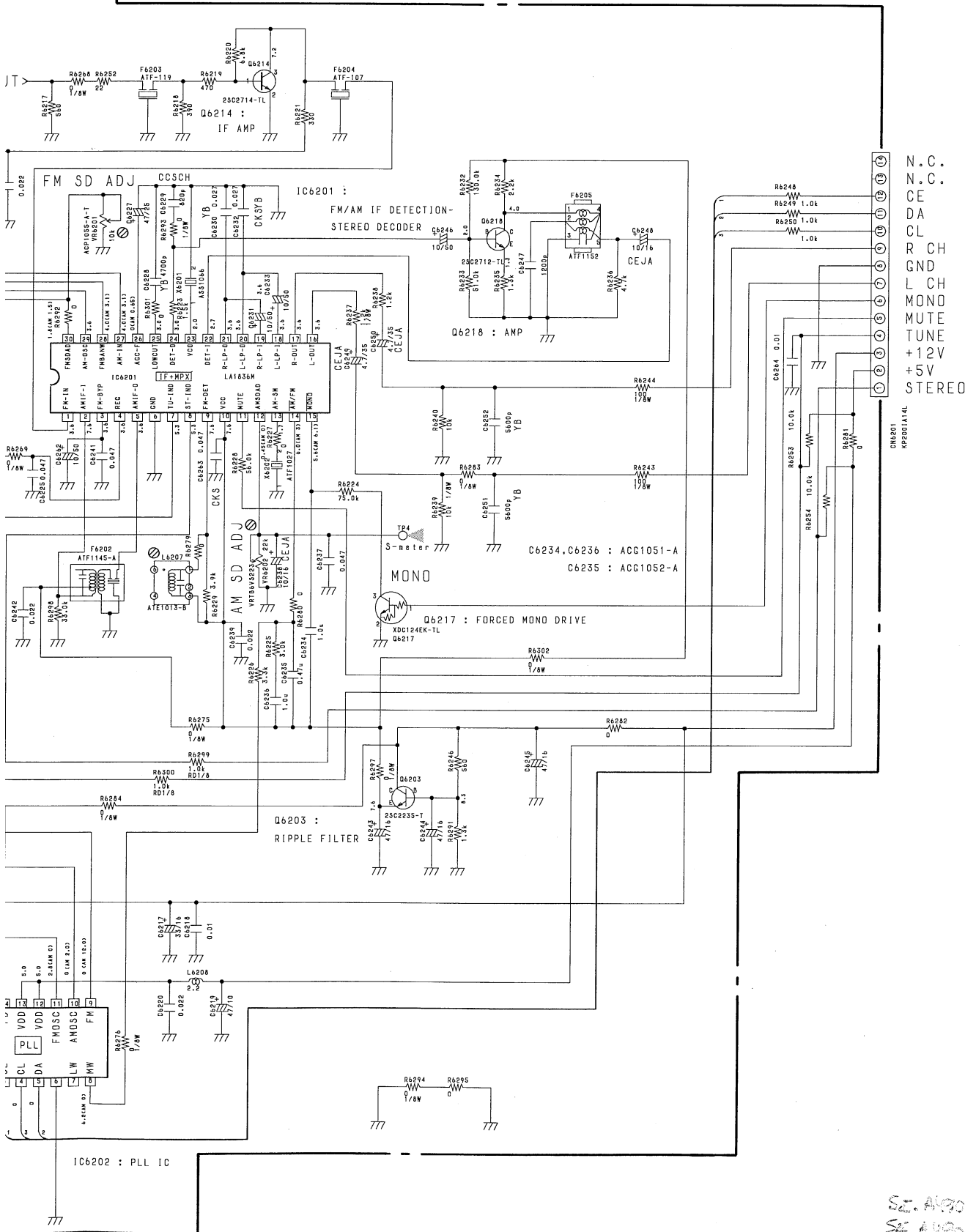

To AF CD assy (2/2) CND009 (SCH-2F)

- N.C.
- N.C.
- CE
- DA
- CL
- R CH
- GND
- L CH
- MONO
- MUTE
- TUNE
- +12V
- +5V
- STEREO

S. A. 1900
S. A. 1900

SCH-3F

FM/AM TUNER MODULE

4.4 DOL SURR ASSY

For XR-P640M, XR-P640

DOL SURR assy (AWZ7251)

A

B

C

D

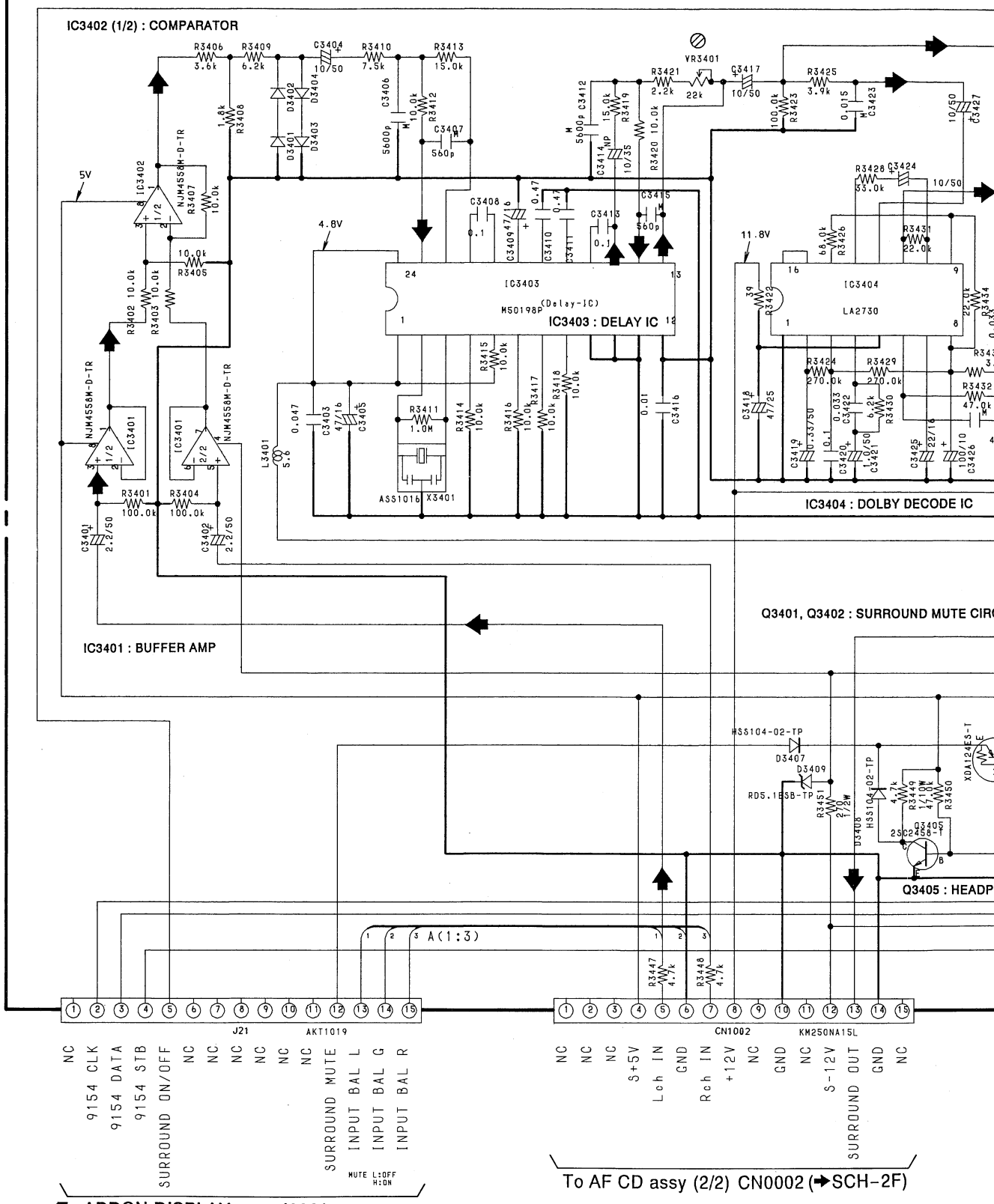

To ADDON DISPLAY assy J0021

To AF CD assy (2/2) CN0002 (SCH-2F)

SCH-4F

DOL SURR ASSY

SCH-4F

A

B

C

D

Q3403, Q3404 : SELECT SWITCH

Dolby Test Point
71mV (Video 260mV input)

IC3406 : ELECTRONIC VOLUME

IC3402 (2/2) : AMP

IC3405 : SWITCHING IC

IC3407 (2/2) : AMP

IC3407 (1/2) : BUFFER AMP

BY DECODE IC

ROUND MUTE CIRCUIT

Q3405 : HEADPHONE MUTE

1	2	3	4	5	6	7
H.P. MUTE	D+5.6V	D-CND	S-OUT	N	N	N

To AF CD assy (2/2) CN0003 (→SCH-2F)

SIGNAL ROUTE

➔ : AUDIO SIGNAL ROUTE

SCH-4F

DOL SURR ASSY

2F)

XR-P740M, XR-P740, XR-P640M, XR-P640 XR-P440M, XR-P440, XR-P340M, XR-P340

PCB-3F

- This diagram is viewed from the mounted parts side.

DOL SURR assy (For XR-P640M, XR-P640)

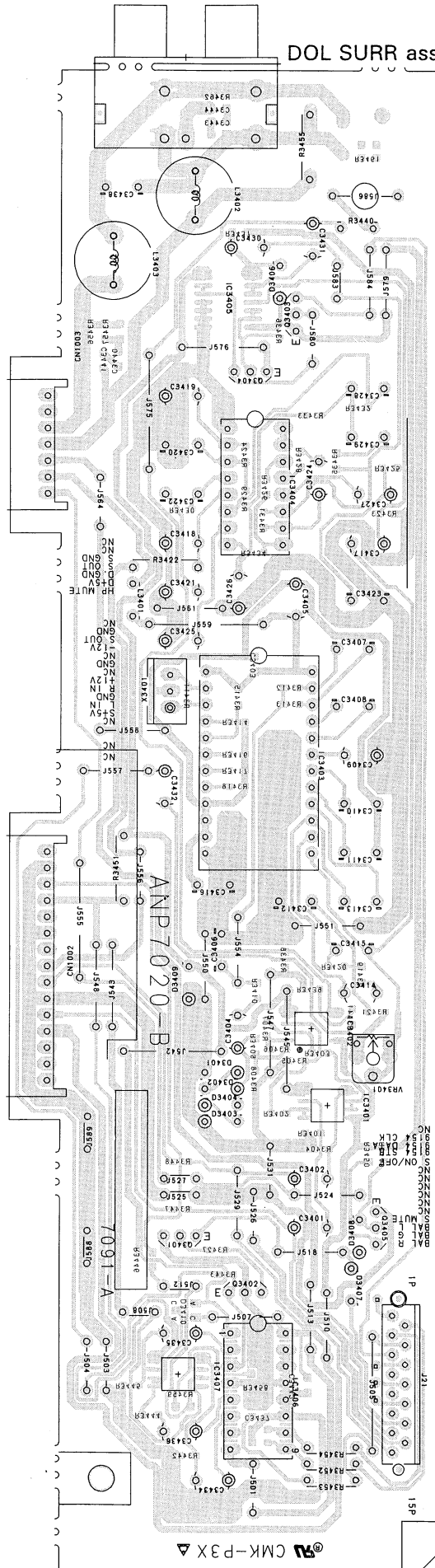

IC3405
Q3403

Q3404

IC3404

IC3403

IC3402

VR3401

IC3401

Q3405

Q3401

Q3402

IC3407

IC3406

XR-P440M, XR-P440, XR-P340M, XR-P340
 XR-P740M, XR-P740, XR-P640M, XR-P640

● This diagram is viewed from the foil side.

DOL SURR Assy (For XR-P640M, XR-P640)

A

B

C

D

32

IC3402

Q3404

IC3401

IC3403

IC3405

IC3401

Q3401

Q3405

IC3407

VR3401

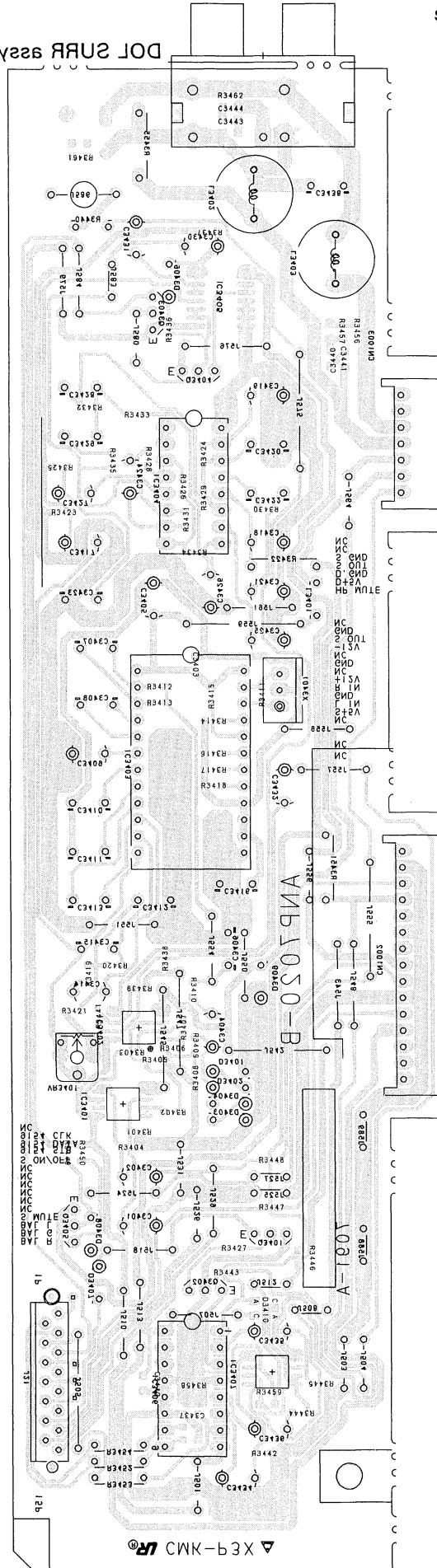

A

B

C

D

3

5. ADJUSTMENTS

Note : Adjustments for HEWZIXK type are the same as those of XR-P740M/SD except for the following:

■ FM Tuner Section (AXQ3214)

- Set the mode selector to FM BAND.
- Connect the wiring as shown in Fig. 1.

Step No.	Adjustment Title	FM SG (1kHz, ± 75 kHz dev.)		Reception Frequency Display	Adjustment Location	Specifications
		Frequency (MHz)	Level (dB μ V)			
1	Center Adjustment	98 Non modulation	80 or more	98MHz	L6207	Adjust so that the DC voltage between Pin 4 and Pin 28 of IC6201 becomes $0V \pm 50mV$.
2	Front End Sencitivity	106	0-30	106MHz	L6104 L6105 L6102 T6101	After adjusting L6104 and L6105 so that the DC voltage of the Pin 12 of IC6201 (S-meter) becomes at maximum level, adjust T6101 and L6102.
3	TUNED IND. Lighting Level	106	15 ± 2	106MHz	VR6201	Adjust so that the indicators of TUNED IND. start to light up.

Notes:

- Before adjusting, make sure there is no gap between L6101 and L6102 and between L6103 and L6104. If there is a gap between them, bring them into contact with each other first, and then make adjustments.
- Make indicator adjustments in order of AM \rightarrow FM.
- Adjustment sequence : L6104 \rightarrow L6105 \rightarrow L6102 \rightarrow T6101



Fig. 1 FM Adjustment Connection Diagram

FM/AM TUNER MODULE

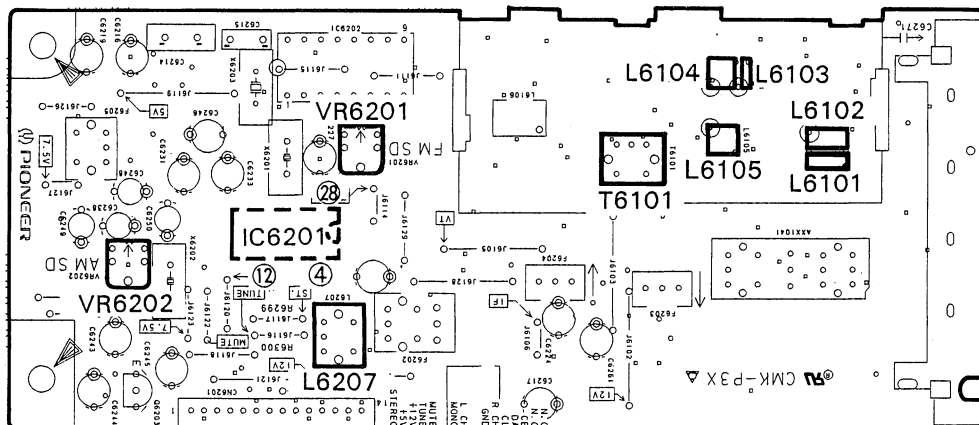

Fig. 2 Adjustment Points