

Service Manual

ORDER NO.
RRV1218

STEREO MULTI CD CASSETTE DECK RECEIVER

XR-P3500M

● Refer to the service manual RRV1207 for XR-P5500M/KU.

THIS MANUAL IS APPLICABLE TO THE FOLLOWING MODEL(S) AND TYPE(S).

Type	Model	Power Requirement	The voltage can be converted by the following method.
	XR-P3500M		
NB	○	AC230V	—
SD	○	AC110-115V/120-127V/220-230V/240V	With the voltage selector
YPW	○	AC240V	—
ME/EA	○	AC220-230V	—
ME/EB	○	AC220-230V	—

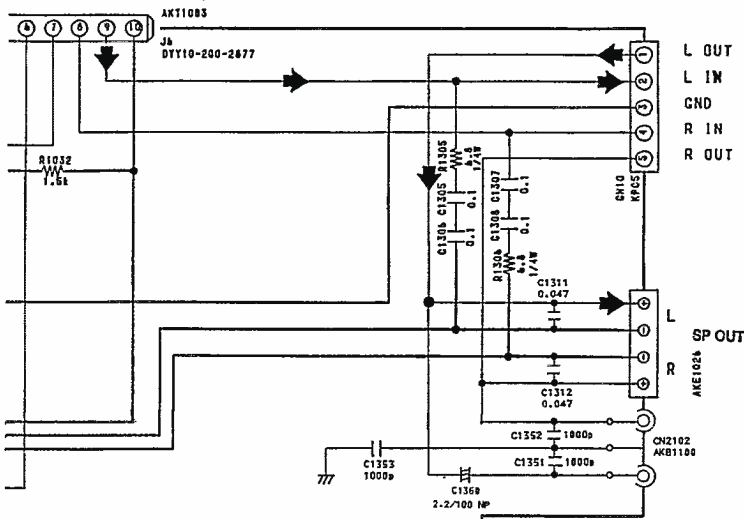

	XR-P5500M VOLTAGE (V)	XR-P3500M VOLTAGE (V)
①	60.3	44.0
②	-60.3	-44.5
③	24.8	28.0
④	-25.5	-31.0

AF CD ASSY (AWZ7540)

• NB series indicates models XR-P3500M/NB, ME/EA and ME/EB.

Note: For AF CD assy, only the differences between AWZ7540 and AWZ7544 are shown.

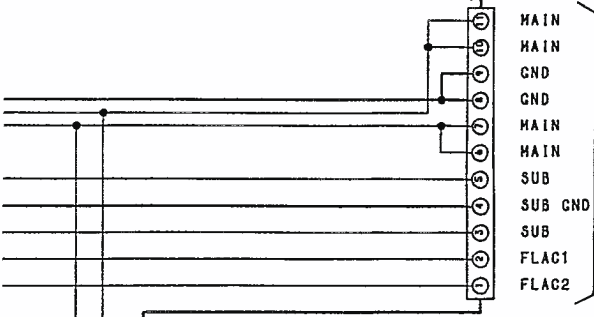

NB series, YPW TYPES

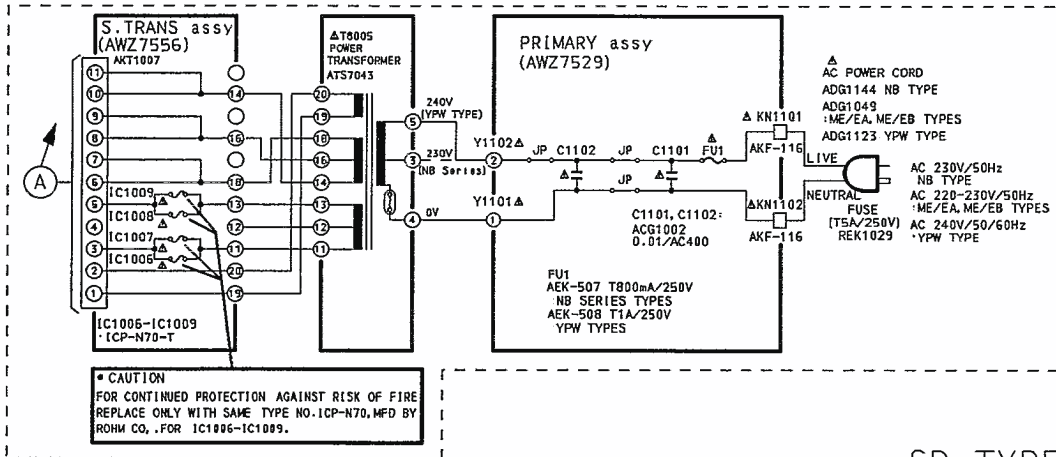

SD TYPE

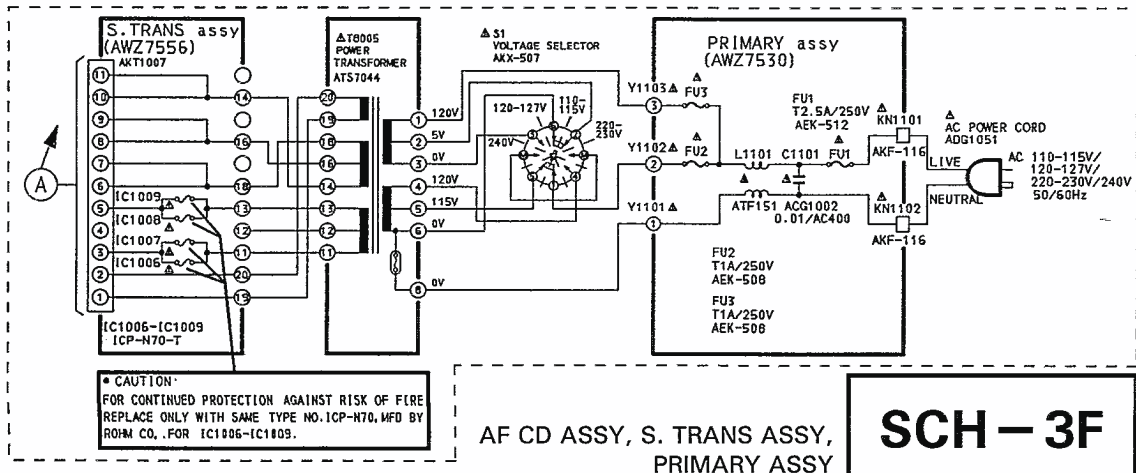

AF CD ASSY, S. TRANS ASSY,
PRIMARY ASSY

1. SAFETY INFORMATION

(FOR EUROPEAN MODEL ONLY)

VARO!

AVATTAESSA JA SUOJALUKITUS OHITETTAESSA OLET ALTTIINA NÄKYMÄTTÖMÄLLE LASERSÄTEILYLLE. ÄLÄ KATSO SÄTEESEEN.



LASER
Kuva 1
Lasersäteilyn varoitusmerkki

WARNING!

DEVICE INCLUDES LASER DIODE WHICH EMITS INVISIBLE INFRARED RADIATION WHICH IS DANGEROUS TO EYES. THERE IS A WARNING SIGN ACCORDING TO PICTURE 1 INSIDE THE DEVICE CLOSE TO THE LASER DIODE.



LASER
Picture 1
Warning sign for laser radiation

ADVERSEL:

USYNLIG LASERSTRÅLING VED ÅBNING NÅR SIKKERHEDSAFBYDRE ER UDE AF FUNKTION UNGDÅ UDSÆTTELSE FOR STRÅLING.

VARNING!

OSYNLIG LASERSTRÅLING NÅR DENNA DEL ÄR ÖPPNAD OCH SPÄRREN ÄR URKOPPLAD. BETRÄKTA EJ STRÅLEN.

IMPORTANT

THIS PIONEER APPARATUS CONTAINS LASER OF CLASS 1. SERVICING OPERATION OF THE APPARATUS SHOULD BE DONE BY A SPECIALLY INSTRUMENTED PERSON.

LASER DIODE CHARACTERISTICS

MAXIMUM OUTPUT POWER: 5 mw
WAVELENGTH: 780 - 785 nm

LABEL CHECK

NB, YPW, ME/EA and ME/EB types



NB, YPW, ME/EA and ME/EB types

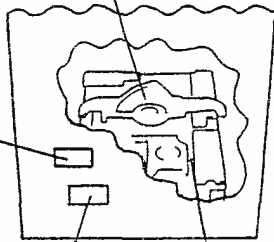

CD Multi

Additional Laser Caution

1. Laser Interlock Mechanism

The ON/OFF (ON : low level, OFF : high level) status of S601 (LPS1) and S602 (LPS2) switches for detecting the loading state is detected by the system microprocessor, and the design prevents laser diode oscillation except when both switches S601 and S602 are ON (low level or clamped state).

Thus, interlock will no longer function if switches S601 (LPS1) and S602 (LPS2) are deliberately shorted (low level).

The interlock also does not function in the test mode*. Laser diode oscillation will continue, if pin 1 of M51593FP (IC101) on the PRE-AMP BOARD ASSY mounted on the pickup assembly is connected to GND, or pin 19 is connected to low level (ON), or else the terminals of Q101 are shorted to each other (fault condition).

2. When the cover is opened with the servo mechanism block removed and turned over, close viewing of the objective lens with the naked eye will cause exposure to a Class 1 laser beam.

92M1B

* Refer to page 74 in the service manual RRV1207.

NB and YPW types



ME/EA and ME/EB types

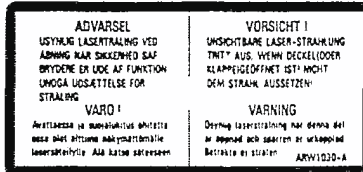

2. CONTRAST OF MISCELLANEOUS PARTS

NOTES :

- Parts marked by "NSP" are generally unavailable because they are not in our Master Spare Parts List.
- The Δ mark found on some component parts indicates the importance of the safety factor of the part. Therefore, when replacing, be sure to use parts of identical designation.
- Parts marked by "☉" are not always kept in stock. Their delivery time may be longer than usual or they may be unavailable.
- When ordering resistors, first convert resistance values into code form as shown in the following examples.

Ex. 1 When there are 2 effective digits (any digit apart from 0), such as 560 ohm and 47k ohm (tolerance is shown by J = 5%, and K = 10%).

560 Ω \rightarrow 56 \times 10¹ \rightarrow 561 RD1/8PM $\boxed{5}$ $\boxed{6}$ $\boxed{1}$ J

47k Ω \rightarrow 47 \times 10³ \rightarrow 473 RD1/4PS $\boxed{4}$ $\boxed{7}$ $\boxed{3}$ J

0.5 Ω \rightarrow 0R5 RN2H $\boxed{0}$ \boxed{R} $\boxed{5}$ K

1 Ω \rightarrow 010 RS1P $\boxed{0}$ $\boxed{1}$ $\boxed{0}$ K

Ex. 2 When there are 3 effective digits (such as in high precision metal film resistors).

5.62k Ω \rightarrow 562 \times 10¹ \rightarrow 5621 RM1/4PC $\boxed{5}$ $\boxed{6}$ $\boxed{2}$ $\boxed{1}$ F

XR-P3500M/NB, ME/EA, ME/EB, SD, YPW and XR-P5500M/KU have the same construction except for the following:

Mark	Symbol & Description	Part No.						Remarks
		XR-P5500M/ KU	XR-P3500M/ NB	XR-P3500M/ ME/EA	XR-P3500M/ ME/EB	XR-P3500M/ SD	XR-P3500M/ YPW	
	FM/AM TUNER MODULE	AXQ1012	AXQ1013	AXQ1013	AXQ1013	AXQ1012	AXQ1012	
	AF ass'y	AWK7108	AWK7103	AWK7103	AWK7103	AWK7104	AWK7104	
	AF CD assy	AWZ7544	AWZ7540	AWZ7540	AWZ7540	AWZ7540	AWZ7540	
	VR assy	AWZ7551	AWZ7546	AWZ7546	AWZ7546	AWZ7547	AWZ7547	
NSP	HEADPHONE assy	AWZ7555	AWZ7552	AWZ7552	AWZ7552	AWZ7552	AWZ7552	
NSP	S. TRANS assy	AWZ7557	AWZ7556	AWZ7556	AWZ7556	AWZ7556	AWZ7556	
NSP	COMPLEX ass'y	AWM7147	AWM7134	AWM7134	AWM7134	AWM7135	AWM7148	
	DISPLAY assy	AWZ7525	AWZ7522	AWZ7522	AWZ7522	AWZ7523	AWZ7523	
	PRIMARY assy	AWZ7535	AWZ7529	AWZ7529	AWZ7529	AWZ7530	AWZ7529	
	POWER MOD. F100	AXQ7017	Not used	Not used	Not used	Not used	Not used	
	POWER MOD. F50	Not used	AXQ7018	AXQ7018	AXQ7018	AXQ7018	AXQ7018	
	CASSETTE MOD. B	EXK2435	EXK2415	EXK2415	EXK2415	EXK2415	EXK2415	*1
Δ	S1 Voltage selector	Not used	Not used	Not used	Not used	AKX-507	Not used	*3
Δ	T8005 Power transformer (AC120V)	ATS7039	Not used	Not used	Not used	Not used	Not used	
Δ	T8005 Power transformer (AC230V/240V)	Not used	ATS7043	ATS7043	ATS7043	Not used	ATS7043	*3
Δ	T8005 Power transformer (AC110-115/120-127/220-230/240V)	Not used	Not used	Not used	Not used	ATS7044	Not used	*3
Δ	FU1 Fuse (6.3A/125V)	AEK-309	Not used	Not used	Not used	Not used	Not used	
Δ	FU1 Fuse (T800mA/250V)	Not used	AEK-507	AEK-507	AEK-507	Not used	Not used	
Δ	FU1 Fuse (T1A/250V)	Not used	Not used	Not used	Not used	Not used	AEK-508	
Δ	FU1 Fuse (T2.5A/250V)	Not used	Not used	Not used	Not used	AEK-512	Not used	
Δ	FU2 Fuse (T1A/250V)	Not used	Not used	Not used	Not used	AEK-508	Not used	
Δ	FU3 Fuse (T1A/250V)	Not used	Not used	Not used	Not used	AEK-508	Not used	
Δ	AC power cord	ADG1146	ADG1144*2	ADG1049	ADG1049	ADG1051	ADG1123	
Δ	Fuse (T5A/250V)	Not used	REK1029	Not used	Not used	Not used	Not used	*2
	Cord stopper	AEP-113	AEC-882	AEC-882	AEC-882	AEC-882	AEC-882	

Notes *1: For EXK2415, refer to page 88 in the service manual RRV1207.

*2, *3: Refer to "● Exploded Views".

Mark	Symbol & Description	Part No.						Remarks	
		XR-P5500M/ KU	XR-P3500M/ NB	XR-P3500M/ ME/EA	XR-P3500M/ ME/EB	XR-P3500M/ SD	XR-P3500M/ YPW		
NSP	Front panel assy	AMB7217	AMB7235	AMB7235	AMB7235	AMB7235	AMB7235		
	Front panel	AMB7213	AMB7153	AMB7153	AMB7153	AMB7153	AMB7153		
	Trans frame	ANA7002	Not used	Not used	Not used	Not used	Not used		
	Rear panel	ANC7143	ANC7175	ANC7148	ANC7148	ANC7145	ANC7146		
	Bonnet	ANE7045	ANE7044	ANE7044	ANE7044	ANE7044	ANE7044		
	Screw (for power transformer)	ASZ40P060FMC	ASZ30P060FZK	ASZ30P060FZK	ASZ30P060FZK	ASZ30P060FZK	ASZ30P060FZK		*3
	Packing case	AHD7081	AHD7083	AHD7083	AHD7083	AHD7082	AHD7147		
	FM antenna	ADH1016	Not used	Not used	Not used	ADH1016	ADH1016		
	FM antenna assy	Not used	ADH1019	ADH1019	ADH1019	Not used	Not used		
	65 label	ORW1069	Not used	Not used	Not used	Not used	Not used		
NSP	Caution label (G)	Not used	VRW-329	VRW-329	VRW-329	Not used	VRW-329	} Refer to page 2.	
NSP	Caution label (F)	Not used	ARW1021	ARW1021	ARW1021	Not used	ARW1021		
NSP	Caution label	Not used	ARW1023	ARW1030	ARW1030	Not used	ARW1023		
	Operating instructions (English)	ARB7021	ARB7021	Not used	ARB7021	ARB7021	ARB7021		
	Operating instructions (Spanish, Chinese)	Not used	Not used	Not used	Not used	ARC7030	Not used		
	Operating instructions (German, Italian)	Not used	Not used	ARC7031	Not used	Not used	Not used		
	Operating instructions (French, Dutch)	Not used	Not used	ARC7055	Not used	Not used	Not used		
	Operating instructions (French, Spanish, Swedish, Portuguese)	Not used	Not used	Not used	ARC7056	Not used	Not used		

Note *3: Refer to "● Exploded Views".

● Exploded Views

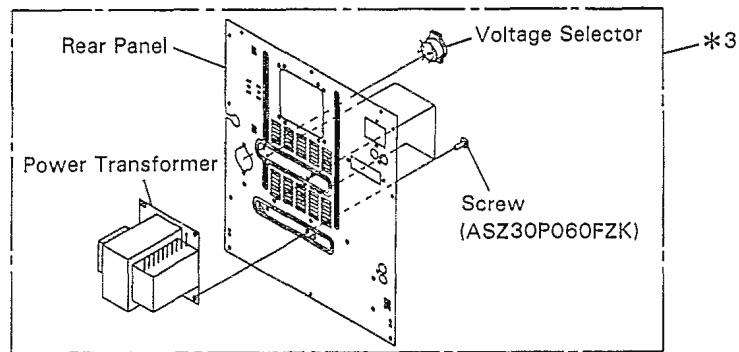
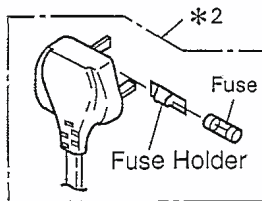

POWER MOD. F50

POWER MOD. F50 (AXQ7018) and POWER MOD. F100 (AXQ7017) have the same construction except for the following:

Mark	Symbol & Description	Part No.		Remarks
		AXQ7017	AXQ7018	
	FRONT 100W assy	AWZ7518	Not used	*
	FRONT 50W assy	Not used	AWZ7517	*
	REGULATOR assy	AWZ7520	AWZ7560	*
	Fan motor	AXM7003	AXM1019	
△	Q7511, Q7512	2SA1264N	2SA1263N	
△	Q7513, Q7514	2SC3181N	2SC3180N	
	Q7503, Q7504	2SC4793	Not used	
	Q7509, Q7510	2SA1837	Not used	

Note *: Refer to page 6.

XR-P3500M

FM/AM TUNER MODULE

AXQ1013 and AXQ1012 have the same construction except for the following :

Mark	Symbol & Description	Part No.		Remarks
		AXQ1012	AXQ1013	
	C6202 (1 μ F/16V) C6230 C6232 C6251 C6252	ACG1051 CKSQYB333K50 CKSYB333K50 CKSYB472K50 CKSQYB472K50	Not used CKSQYB273K50 CKSYB273K50 CKSYB822K50 CKSQYB822K50	
	C6268 C6269 C6270 (1 μ F/16V) R6288 BN6201 Terminal 4P BN6201 Terminal 2P with PAL	CCSQCH101J50 Not used Not used RS1/10S471J AKA1016 Not used	Not used CCSQCH101J50 ACG1051 RS1/10S000J Not used AKA1017	

AF CD Assy

AWZ7540 and AWZ7544 have the same construction except for the following :

Mark	Symbol & Description	Part No.		Remarks
		AWZ7544	AWZ7540	
	D1001 C1001, C1002 (4700/63V) C1001, C1002 (3300/50V) C1311 C1312	D5SB20F ACH1249 Not used Not used Not used	D3SBA20 (B) Not used ACH1066 CKCYF473Z50 CKSQYF473Z50	
	C1351-C1353 C1360 C8301, C8477 C1501, C1502 R1224	Not used Not used CKSQYF104Z50 CEAS2R2M50 RS1LMF472J	CKSQYF102Z50 CEANP2R2M100 Not used CEASR15M50 RS1LMF122J	
	CN2102 Pin jack 2P	Not used	AKB1100	

VR Assy

AWZ7546, AWZ7547 and AWZ7551 have the same construction except for the following :

Mark	Symbol & Description	Part No.			Remarks
		AWZ7551	AWZ7546	AWZ7547	
	C1511 C1555, C1556 C1557, C1558 R1505, R1506 R1555-R1558	CKPUYX182M16 CKSQYF104Z50 CKSQYB333K50 RS1/10S104J RS1/10S563J	CKPUYF104Z50 CKSQYB473K50 CKSQYB393K50 RS1/10S473J RS1/10S104J	CKPUYF104Z50 CKSQYB473K50 CKSQYB393K50 RS1/10S473J RS1/10S104J	

HEADPHONE Assy

AWZ7552 and AWZ7555 have the same construction except for the following :

Mark	Symbol & Description	Part No.		Remarks
		AWZ7555	AWZ7552	
	R1201, R1202	RS3LMF331J	RS2LMF331J	

S. TRANS Assy

AWZ7556 and AWZ7557 have the same construction except for the following :

Mark	Symbol & Description	Part No.		Remarks
		AWZ7557	AWZ7556	
△ △	IC1002-IC1005 IC1006-IC1009	ICP-N70 Not used	Not used ICP-N70	

DISPLAY Assy

AWZ7522, AWZ7523 and AWZ7525 have the same construction except for the following :

Mark	Symbol & Description	Part No.			Remarks
		AWZ7525	AWZ7522	AWZ7523	
	D1819 D1820	Not used Not used	Not used HSS104-02	HSS104-02 Not used	

PRIMARY Assy

AWZ7529, AWZ7530 and AWZ7535 have the same construction except for the following :

Mark	Symbol & Description	Part No.			Remarks
		AWZ7535	AWZ7529	AWZ7530	
△NSP	L1101 R1101 (2.2M, 1/2W) C1102 (0.01/400V) H1103-H1106 Y1103	ATF1136 ACN-208 Not used Not used Not used	Not used Not used ACG1002 Not used Not used	ATF-151 Not used Not used AKR1003 ADX1980	

FRONT 50W Assy

FRONT 50W assy (AWZ7517) and FRONT 100W assy (AWZ7518) have the same construction except for the following :

Mark	Symbol & Description	Part No.		Remarks
		AWZ7518	AWZ7517	
	IC7501 Q7515, Q7516 Q7517, Q7518	UPC4570G2 (5) Not used Not used	UPC4570G2 2SD1615 2SB1115	

REGULATOR Assy

AWZ7560 and AWZ7520 have the same construction except for the following :

Mark	Symbol & Description	Part No.		Remarks
		AWZ7520	AWZ7560	
	IC7201 R7206, R7207	PAC006C RS1/10S273J	PAC006B RS1/10S203J	

3. SCHEMATIC AND PCB DIAGRAMS

XR-P3500M

PCB-1F

3.1 FM/AM TUNER MODULE

Note: For FM/AM TUNER MODULE, only the differences between AXQ1013 and AXQ1012 are shown.

FM/AM TUNER MODULE

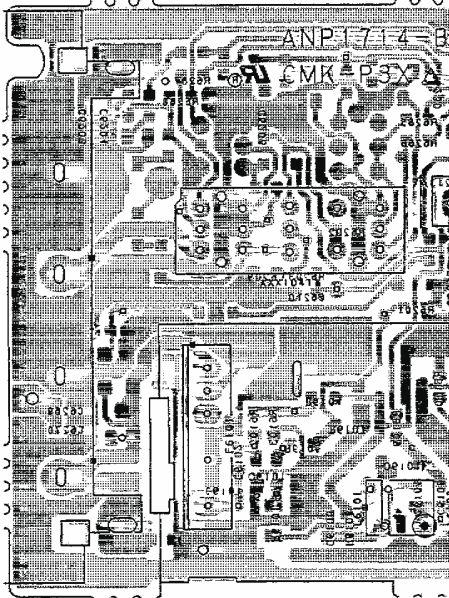

• This diagram is viewed from the mounted parts side.

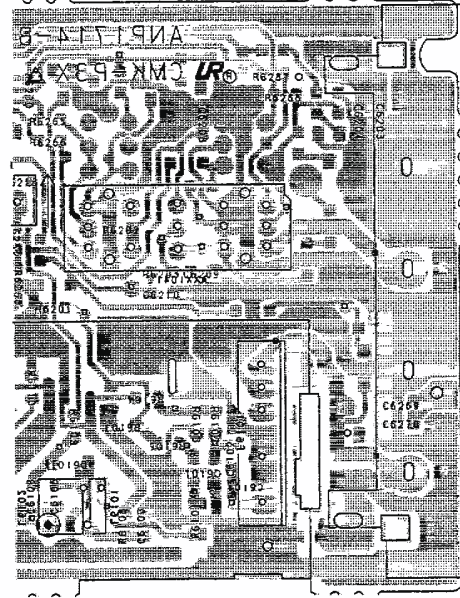

• This diagram is viewed from the foil side.

NOTE FOR PCB DIAGRAMS:

1. Part numbers in PCB diagrams match those in the schematic diagrams.
2. A comparison between the main parts of PCB and schematic diagrams is shown below.

Symbol in PCB Diagrams	Symbol in Schematic Diagrams	Part Name
		Transistor
		Diode
		Capacitor (Polarized)

3. The transistor terminal marked with E or shows the emitter.
4. The diode terminal marked with or shows cathode side.
5. The capacitor terminal marked with or shows negative terminal.

FM/AM TUNER MODULE (AXQ1013)

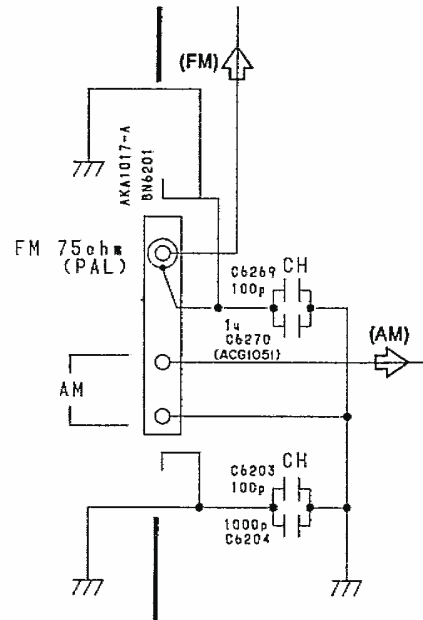

SCH-1F

FM/AM TUNER MODULE

- NB series indicates models XR-P3500M/NB, ME/EA and ME/EB.

- This diagram is viewed from the mounted parts side.

PCB-2F

FRONT 50W ASSY

A

07508
07507
07517
07518
IC7501
07501
07502
07513
07514
07505
07515
07603
07516
07506

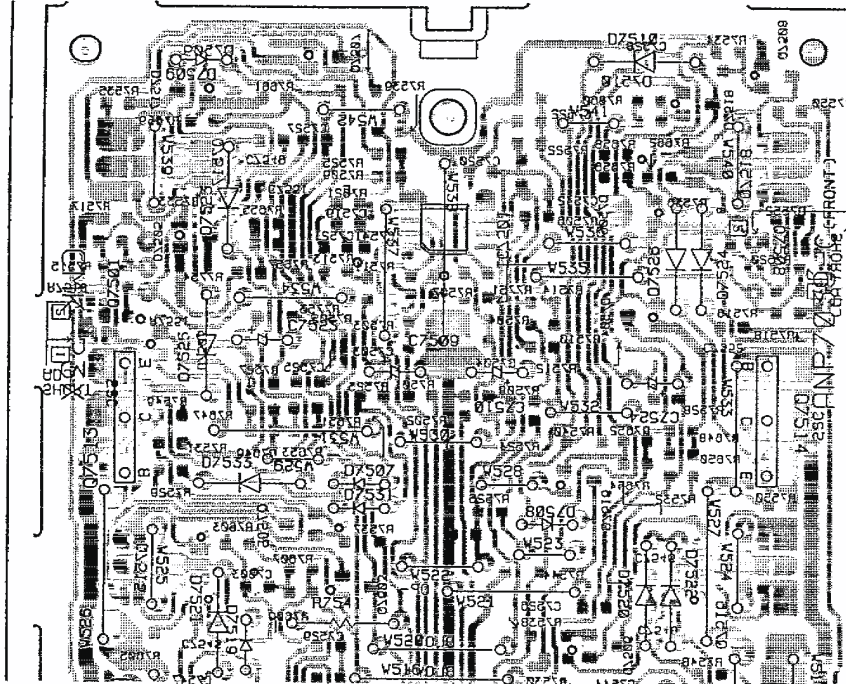

A

B

B

DISPLAY ASSY

C

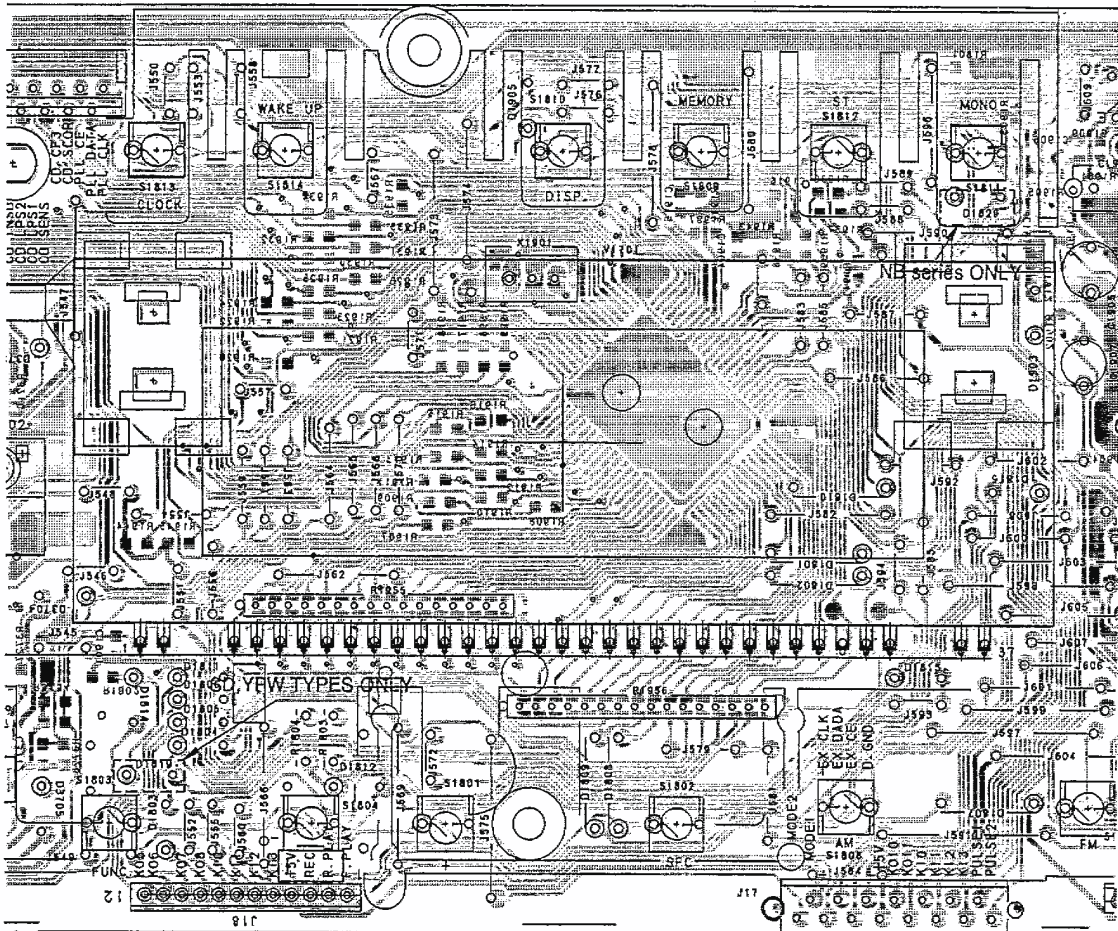

C

D

D

• This diagram is viewed from the foil side.

FRONT 50W ASSY

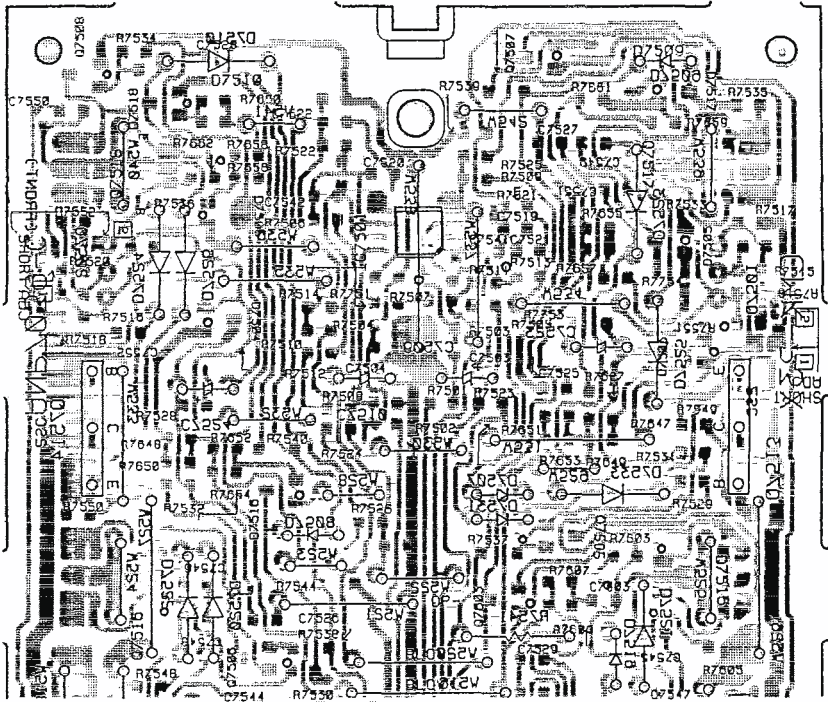

02808
02807
02817
02818
IC2501
02805
02801
02813
02814
02802
02812
02803
02819
02806

DISPLAY ASSY

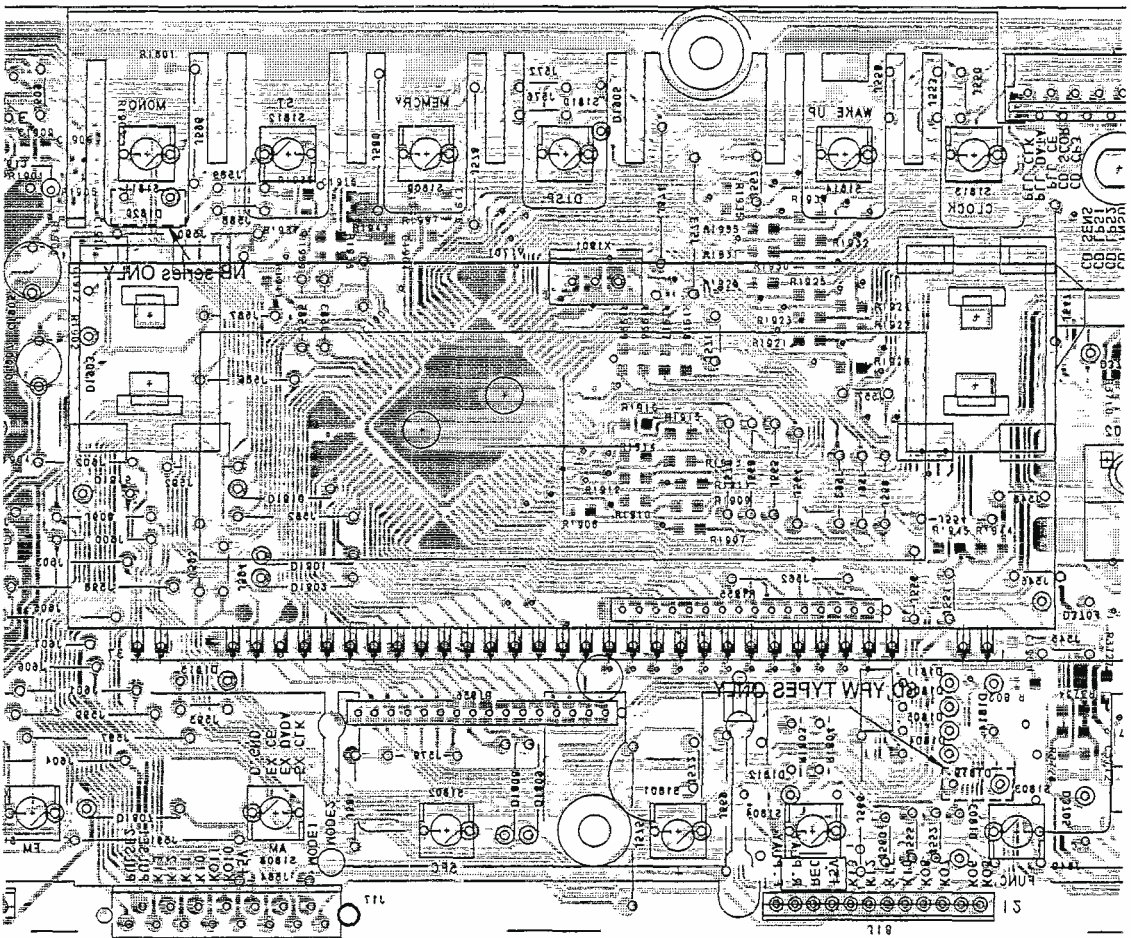

A

B

C

D

A

B

C

D

3.3 AF CD ASSY, S. TRANS ASSY, PRIMARY ASSY AND ADJACENCIES TO THE POWER TRANSFORMER

Note: For AF CD assy, only the differences between AWZ7540 and AWZ7544 are shown.

AF CD ASSY

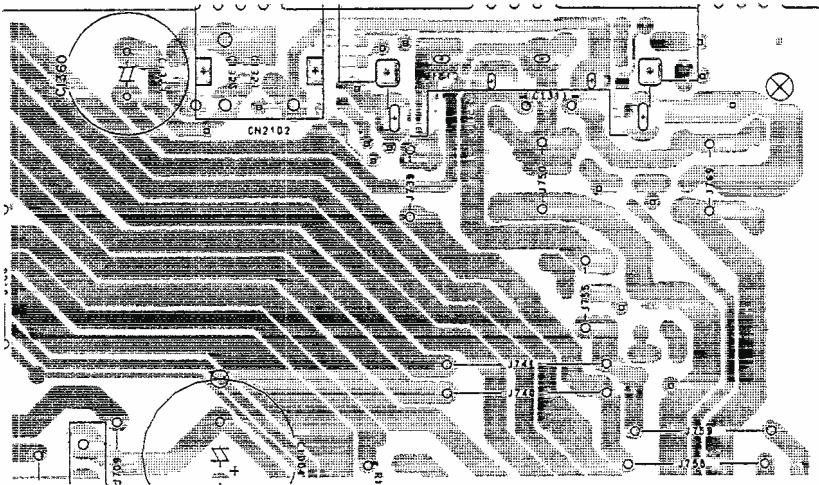

PCB-3F

A

A

B

B

• This diagram is viewed from the mounted parts side.

To POWER TRANSFORMER

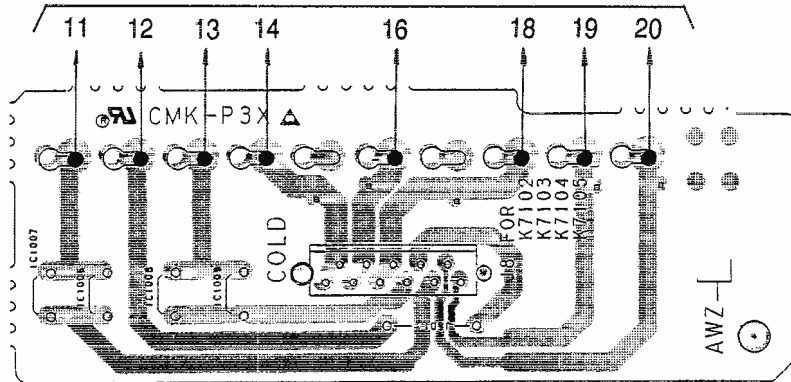

S. TRANS ASSY

To POWER TRANSFORMER 1

To VOLTAGE SELECTOR 1(SD TYPE)

- To POWER TRANSFORMER — 5, 3(NB series, YPW TYPE)
- 4(NB series, YPW TYPE)
- 8(SD TYPE)

PRIMARY ASSY

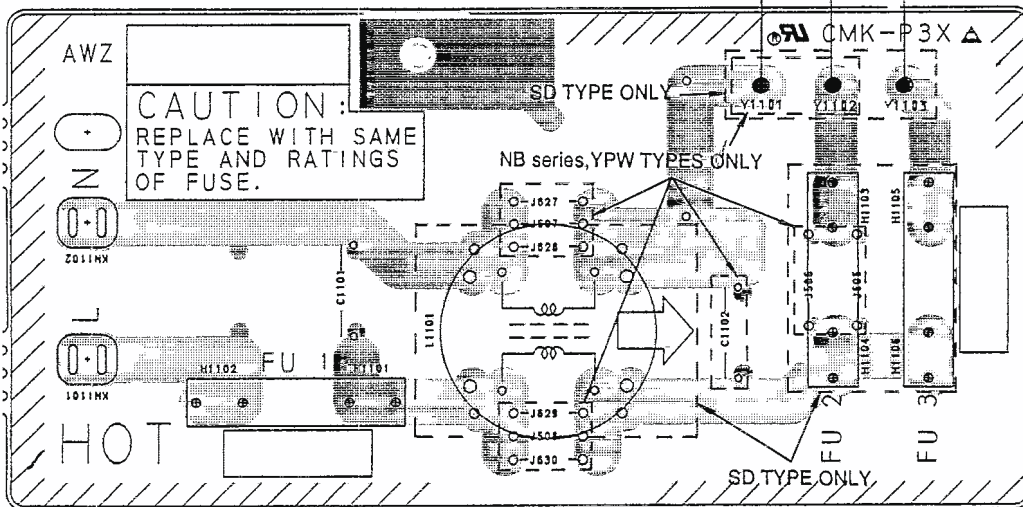

• NB series indicates models XR-P3500M/NB, ME/EA and ME/EB.

Service Manual

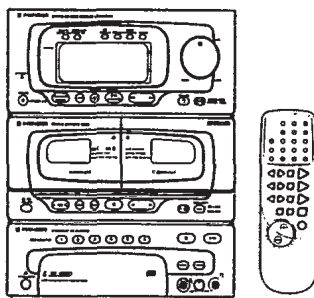

ORDER NO.
RRV1207

STEREO MULTI-PLAY CD CASSETTE DECK RECEIVER

XR-P5500M

XR-P4500M

THIS MANUAL IS APPLICABLE TO THE FOLLOWING MODEL(S) AND TYPE(S).

Type	Model		Power Requirement	Remarks
	XR-P5500M	XR-P4500M		
KU	○	○	AC120V	
KC	○	○	AC120V	

● For the following: XR-P5500M/KC; XR-P4500M/KU and KC, refer to page 87.

CONTENTS

1. SAFETY INFORMATION	2	6. ADJUSTMENTS	66
2. EXPLODED VIEWS, PACKING AND PARTS LIST	3	7. IC INFORMATION	82
3. BLOCK DIAGRAM	15	8. DISASSEMBLY	86
4. SCHEMATIC AND PCB CONNECTION DIAGRAMS	16	9. FOR XR-P5500M/KC, XR-P4500M/KU AND KC TYPES	87
5. PCB PARTS LIST	61	10. PANEL FACILITIES	89
		11. SPECIFICATIONS	91

1. SAFETY INFORMATION

This service manual is intended for qualified service technicians; it is not meant for the casual do-it-yourselfer. Qualified technicians have the necessary test equipment and tools, and have been trained to properly and safely repair complex products such as those covered by this manual.

Improperly performed repairs can adversely affect the safety and reliability of the product and may void the warranty. If you are not qualified to perform the repair of this product properly and safely, you should not risk trying to do so and refer the repair to a qualified service technician.



WARNING

Lead in solder used in this product is listed by the California Health and Welfare agency as a known reproductive toxicant which may cause birth defects or other reproductive harm (California Health & Safety Code, Section 25249.5).

When servicing or handling circuit boards and other components which contain lead in solder, avoid unprotected skin contact with the solder. Also, when soldering do not inhale any smoke or fumes produced.

NOTICE

(FOR CANADIAN MODEL ONLY)

Fuse symbols  (fast operating fuse) and/or  (slow operating fuse) on PCB indicate that replacement parts must be of identical designation.

REMARQUE

(POUR MODÈLE CANADIEN SEULEMENT)

Les symboles de fusible  (fusible de type rapide) et/ou  (fusible de type lent) sur CCI indiquent que les pièces de remplacement doivent avoir la même désignation.

(FOR USA MODEL ONLY)

1. SAFETY PRECAUTIONS

The following check should be performed for the continued protection of the customer and service technician.

LEAKAGE CURRENT CHECK

Measure leakage current to a known earth ground (water pipe, conduit, etc.) by connecting a leakage current tester such as Simpson Model 229-2 or equivalent between the earth ground and all exposed metal parts of the appliance (input/output terminals, screwheads, metal overlays, control shaft, etc.). Plug the AC line cord of the appliance directly into a 120V AC 60Hz outlet and turn the AC power switch on. Any current measured must not exceed 0.5mA.

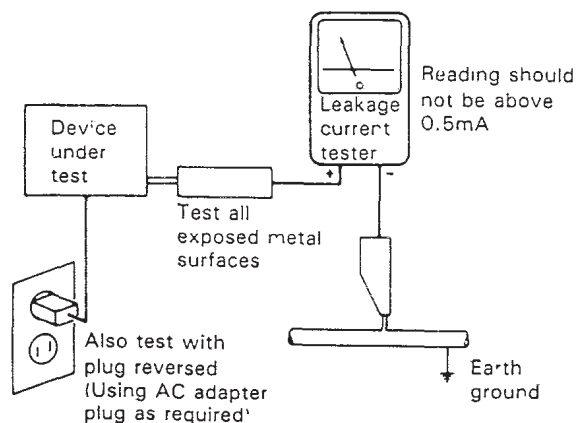

AC Leakage Test

ANY MEASUREMENTS NOT WITHIN THE LIMITS OUTLINED ABOVE ARE INDICATIVE OF A POTENTIAL SHOCK HAZARD AND MUST BE CORRECTED BEFORE RETURNING THE APPLIANCE TO THE CUSTOMER.

2. PRODUCT SAFETY NOTICE

Many electrical and mechanical parts in the appliance have special safety related characteristics. These are often not evident from visual inspection nor the protection afforded by them necessarily can be obtained by using replacement components rated for voltage, wattage, etc. Replacement parts which have these special safety characteristics are identified in this Service Manual.

Electrical components having such features are identified by marking with a Δ on the schematics and on the parts list in this Service Manual.

The use of a substitute replacement component which does not have the same safety characteristics as the PIONEER recommended replacement one, shown in the parts list in this Service Manual, may create shock, fire, or other hazards.

Product Safety is continuously under review and new instructions are issued from time to time. For the latest information, always consult the current PIONEER Service Manual. A subscription to, or additional copies of, PIONEER Service Manual may be obtained at a nominal charge from PIONEER.

2. EXPLODED VIEWS, PACKING AND PARTS LIST

NOTES :

- Parts marked by "NSP" are generally unavailable because they are not in our Master Spare Parts List.
- The \triangle mark found on some component parts indicates the importance of the safety factor of the part. Therefore, when replacing, be sure to use parts of identical designation.
- Parts marked by "☉" are not always kept in stock. Their delivery time may be longer than usual or they may be unavailable.

2.1 PACKING

Parts List of Packing

Mark	No.	Description	Parts No.
	1	MAGAZINE ASSY	PXA1549
	2	OPERATING INSTRUCTIONS (English)	ARB7021
	3	REMOTE CONTROL UNIT (CU-XR016)	AXD7037
	4	BATTERY COVER	AZA7050
	5	FM ANTENNA	ADH1016
NSP	6	BATTERY (R03, AAA)	AEX-021
	7	LOOP ANTENNA (L8043)	ATB1012
	8	FRONT PAD LR	AHA7038
	9	REAR PAD LR	AHA7043
	10	PACKING CASE	AHD7081
	11	SHEET	AHG7003

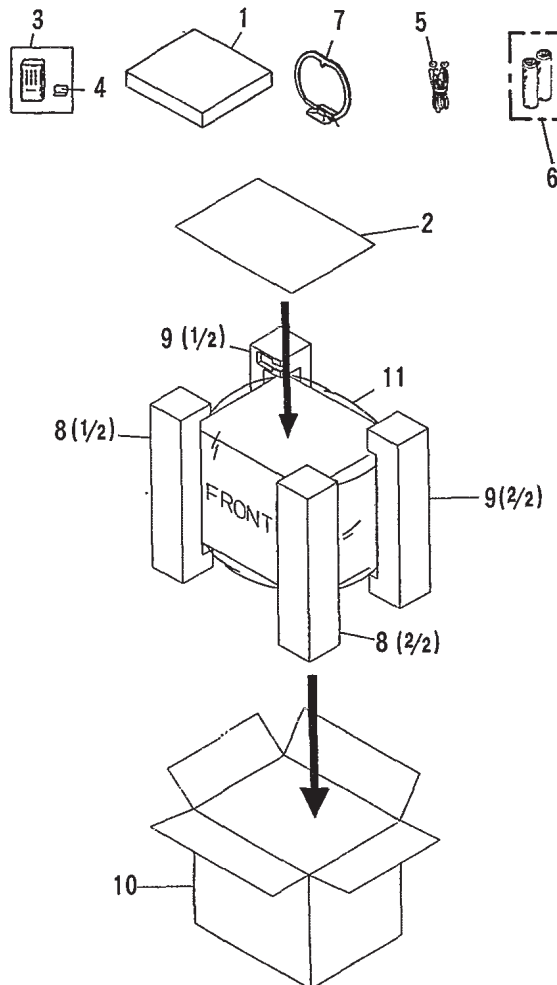

2.2 EXTEIOR

Parts List of Exterior

Mark	No.	Description	Parts No.	Mark	No.	Description	Parts No.
△	1	POWER TRANSFORMER	ATS7039	46	DOOR-R	AAN7066	
△	2	FUSE (6.3A/125V, FU1)	AEK-309	47	LATCH MOLD	AEC7016	
△	3	AC POWER CORD	ADG1146	48	DOOR SPRING (L)	ABH7046	
	4	CORD STOPPER	AEP-113	49	DOOR SPRING (R)	ABH7047	
NSP	5	GROUND LEAD	ADB1001	50	CD BUTTON	AAD7153	
△	6	FLEXIBLE CABLE (J1)	ADD1127	51	DECK BUTTON	AAD7154	
	7	MULTI MECHA ASSY	AXA7006	52	DAMPER ASSY	AXA7021	
	8	CASSETTE MOD. B	EXK2435	53	KEEP PLATE	ABK7001	
NSP	9	CHASSIS	ANA7001	54	TRANS FRAME	ANA7002	
	10	REAR PANEL	ANC7143	55	65 LABEL	ORW1069	
	11	RUBBER SHEET	AEB1111	56	LATCH SPRING	ABH7039	
	12	BRACKET	ANG7002	57	DOOR SPRING	ABH7038	
	13	NYLON BINDER	AEC-093	58	TIMER BUTTON	AAD7152	
	14	PCB SPACER (3×12)	AEC1372	59	MULTI DOOR	AAN7048	
	15	PCB CONNECTOR (PVC)	AEC1500	60	LOCK LEVER SPRING	ABH7004	
NSP	16	FRONT PANEL ASSY	AMB7217	61	DAMPER ASSY	AXA7021	
	17	AMPLIFIER PLATE	AAK7111	62		
	18	DECK PLATE L	AAK7112	63	GROUND LEAD	ADB1005	
	19	DECK PLATE R	AAK7113	NSP 64	PARALLEL WIRE (J2)	D20PYY0615E	
	20	SUPPORT ROD	AMR7034	65	LOCK LEVER	AEC7015	
	21	MIC ASSY	AWZ7539	66	SUPPORT PLATE	AMR7033	
	22	VOL KNOB	AAB7039	NSP 67	WIRE	YJ6HW0-30-35/35	
	23	MIC VOL KNOB	AAB7040	NSP 68	WIRE	YJ6HW8-30-35/35	
	24	BONNET	ANE7045	69	NYLON RIVET	AEC-525	
	25	AF CD ASSY	AWZ7544				
	26	VR ASSY	AWZ7551				
	27	HEADPHONE ASSY	AWZ7555				
	28	S. TRANS ASSY	AWZ7557				
	29	DISPLAY ASSY	AWZ7525				
	30	SW ASSY	AWZ7537				
	31	PRIMARY ASSY	AWZ7535				
	32	FM/AM TUNER MODULE	AXQ1012				
	33	POWER AMP MODULE	AXQ7017				
	34	SCREW (P2.6×8)	ABA1005				
	35	SCREW	ASZ40P060FMC				
	36	SCREW	BBZ30P060FMC				
	37	SCREW	BBZ30P080FZK				
	38					
	39	SCREW	VPZ30P080FMC				
	40	SCREW	CBZ30P080FMC				
	41	SCREW	VPZ30P080FZK				
	42	FRONT PANEL	AMB7213				
	43	STA. LENS	AAK7099				
	44	FUNCTION BUTTON	AAD7151				
	45	DOOR-L	AAN7065				

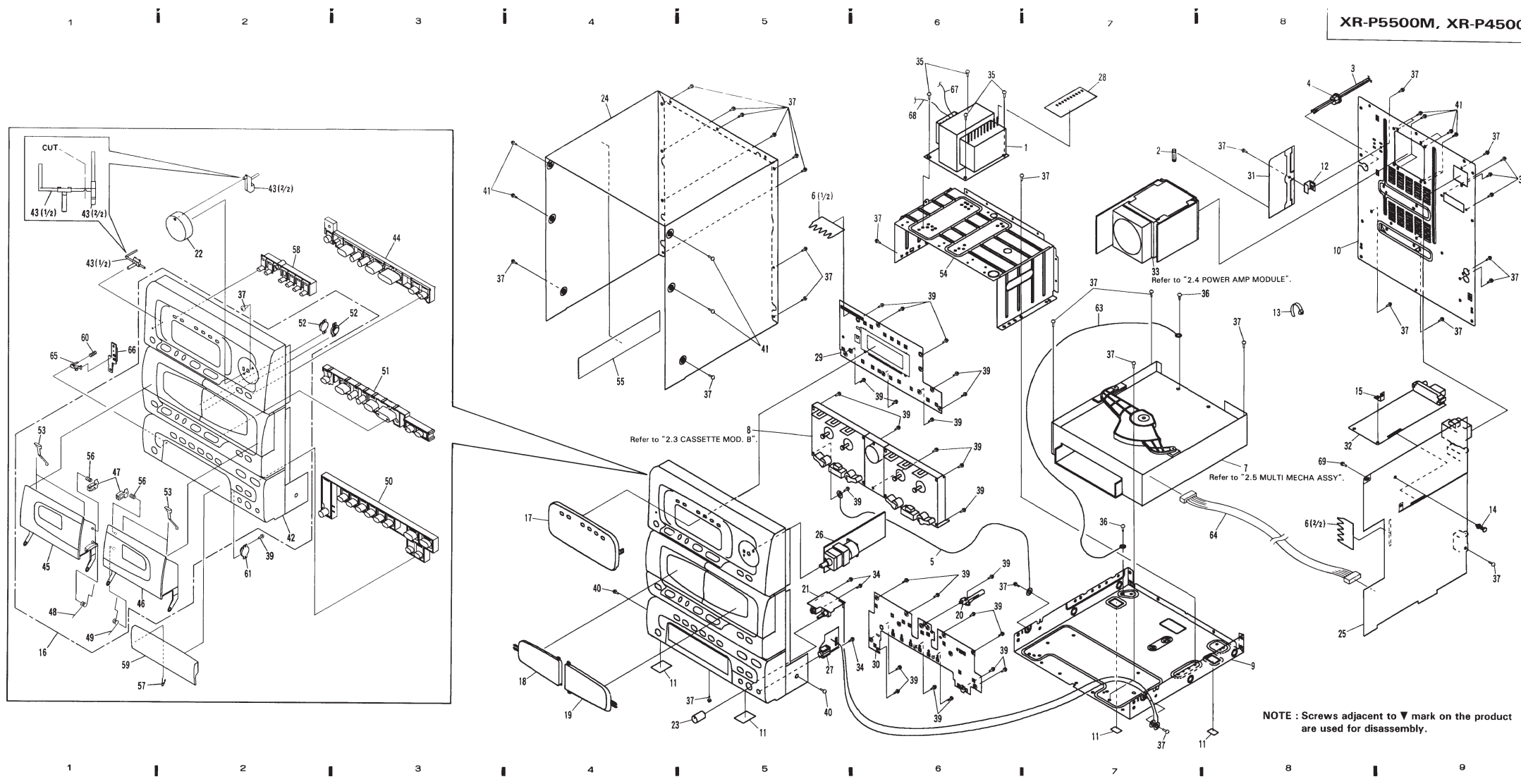

NOTE : Screws adjacent to ▼ mark on the product are used for disassembly.

XR-P5500M, XR-P4500M

2.3 CASSETTE MOD. B

Parts List of Cassette Mod. B

Mark	No.	Description	Parts No.	Mark	No.	Description	Parts No.
	1	SPRING	EBH1467		46	SCREW	ATZ26P060FMC
	2	SPRING	EBH1475		47	WASHER	EBF1028
	3	SPRING	EBL1023		48	WASHER	EBF1027
	4	SPRING	EBH1478		49	SWITCH (AR-R)	ESN1009
	5	SPRING	EBH1483		50	SWITCH (C-O2)	ESN1009
	6	SPRING	EBH1472		51	SWITCH (AR-F)	ESN1009
	7	SPRING	EBH1496		52	SWITCH (C-O2)	ESN1009
	8	SPRING	EBH1495		53	SWITCH (HALF)	ESG1003
	9	ARM	ENV1431		54	CONNECTOR (L5P)	EKS1012
	10	BRAKE	ENV1395		55	CONNECTOR (6P)	EKS1020
	11	ARM	ENV1394		56	PHOTO INTERRUPTER	ON1004
	12	GEAR	ENV1393		57	LEAD WIRE	EDD1012
	13	PULLEY	ENV1291		58	RESISTOR	ERR25T361S
	14	REEL	ENV1385		59	SCREW (For AZIMUTH)	EBA1034
	15	GEAR	ENV1383		60	CASSETTE MECHA UNIT	EXA1408
	16	REEL	ENV1384		61	SPRING	EBL1019
	17	ARM	ENV1400		62	HEAD UNIT	EKA1316
	18	REEL COLLAR UNIT	EXA1400		63	HEAD UNIT	EKA1317
	19	ARM	ENV1403		64	SPRING	EBH1473
	20	LIMITER UNIT	EXA1349		65	SPRING	EBH1474
	21	FLYWHEEL UNIT	EXA1330		66	SPRING	EBH1476
	22	FLYWHEEL UNIT	EXA1329		67	SPRING	EBH1479
	23	ROLLER UNIT	EXA1352		68	LEVER	ENC1349
	24	ROLLER UNIT	EXA1353		69	SCREW	EBA1035
	25	FLYWHEEL UNIT	EXA1322		70	SCREW	BBZ20P060FMC
	26	FLYWHEEL UNIT	EXA1321		71	ARM	ENC1402
	27	SHAFT	ELA1332		72	ARM	ENC1403
	28	SPRING	EBH1468		73	SPRING	EBH1525
	29	SOLENOID	EXP1011		74	SPRING	EBH1526
	30	ARM UNIT	EXA1372				
	31	ARM UNIT	EXA1371				
	32	BRACKET	ENC1357				
	33	BRACKET	AZN7094				
	34	BELT	ENT1033				
	35	BELT	ENT1032				
	36	CHASSIS UNIT	EXA1348				
	37	HEAD BASE ASSY	EXX1036				
	38	MOTOR ASSY	EXX1030				
	39	HEAD BASE ASSEMBLY	EXX1035				
	40	SUB COMPLEX PCB	ENX1032				
	41	SUB COMPLEX PCB	ENX1031				
	42	DECK UNIT	EWM1005				
	43	SCREW	BSL20P040FMC				
	44	SCREW	FMS26P025FUC				
	45	SCREW	BSL20P030FMC				

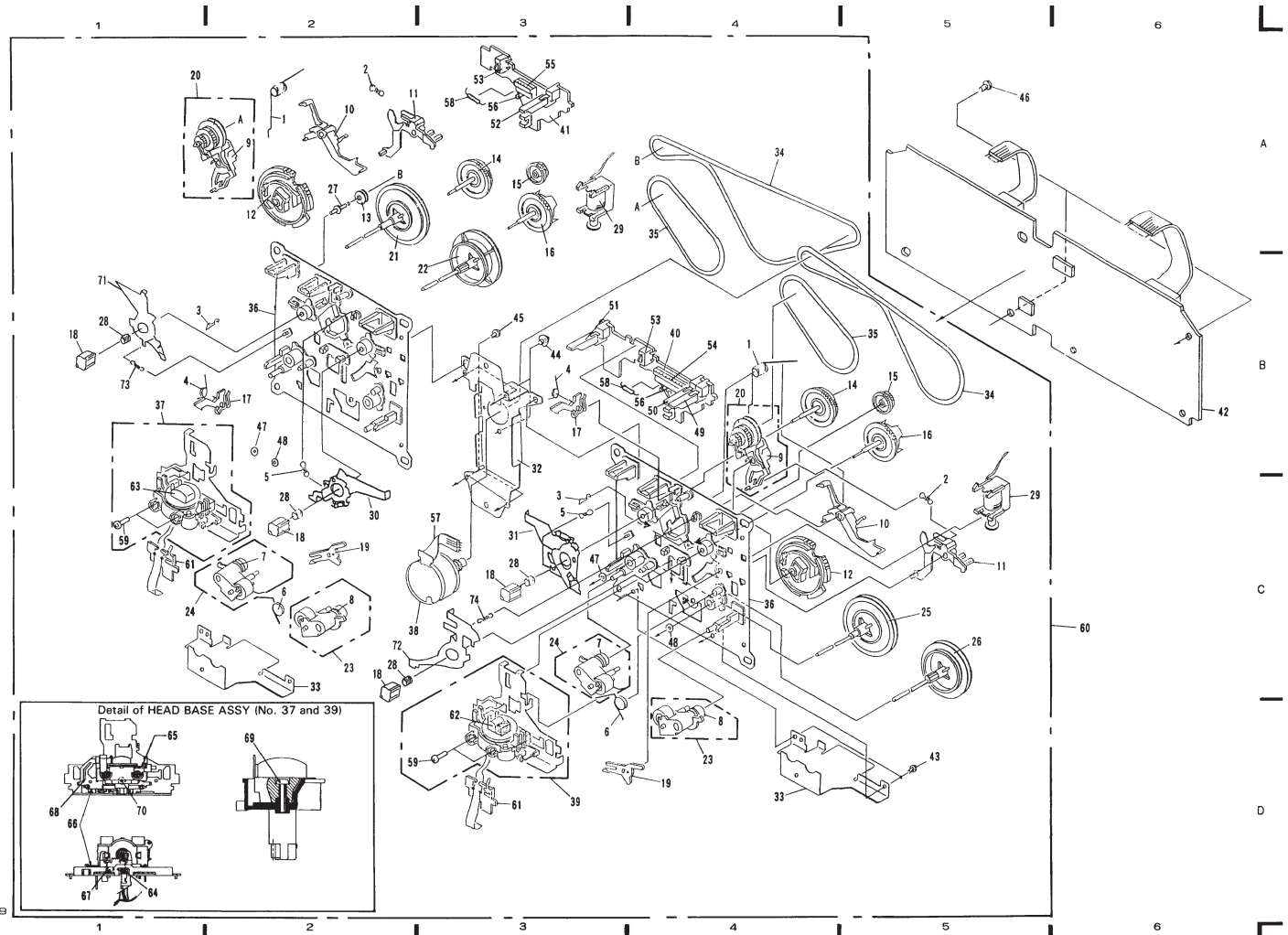

2.4 POWER AMP MODULE

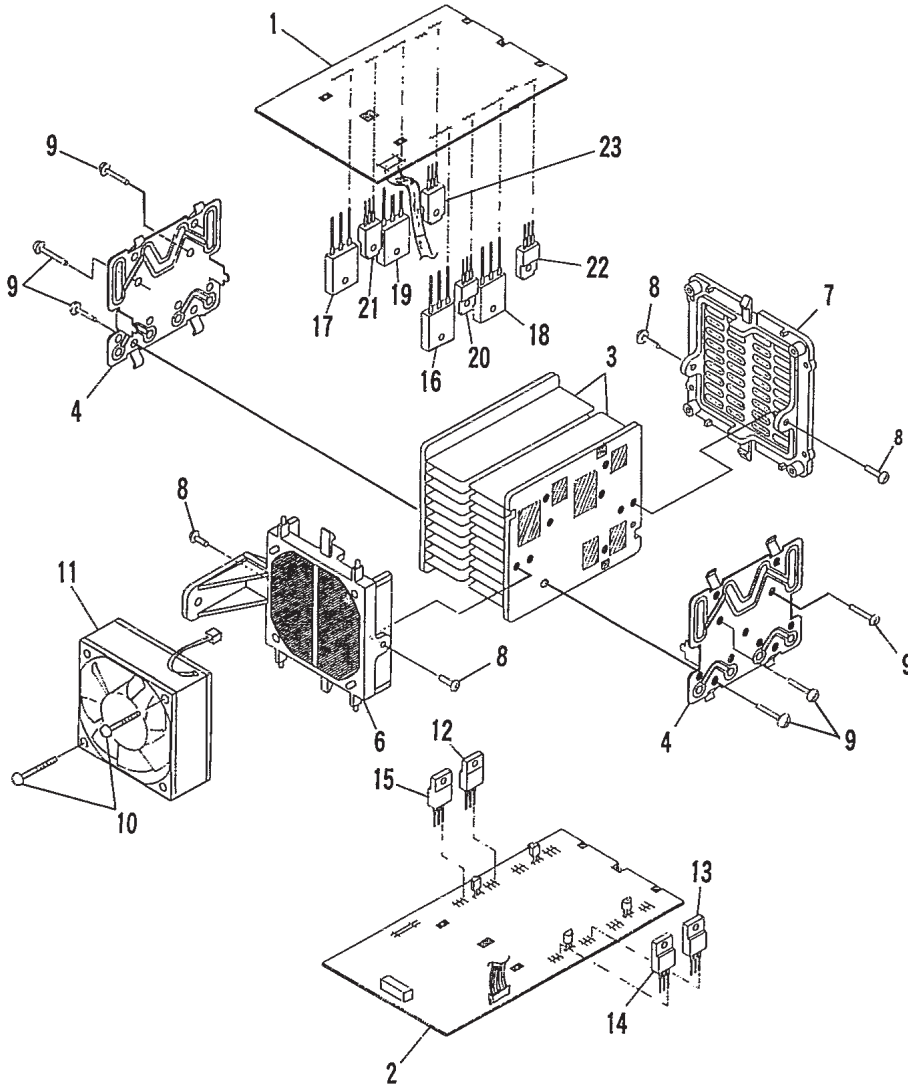

Note: Ensure that silicon grease does not adhere to the MOLD A (No. 6) and MOLD B (No. 7).

Parts List of Power Amp Module

Mark	No.	Description	Parts No.	Mark	No.	Description	Parts No.
	1	FRONT 100W ASSY	AWZ7518		13	REGULATOR IC (IC7402)	NJM7912FA
	2	REGULATOR ASSY	AWZ7520		14	REGULATOR IC (IC7403)	NJM7812FAS
	3	HEAT SINK (AL)	ANH7007		15	REGULATOR IC (IC7404)	NJM7805FAS
	4	BRACKET	ANG1868		16	TRANSISTOR (Q7511)	2SA1264N
	5		△	17	TRANSISTOR (Q7512)	2SA1264N
	6	MOLD A	AMR2594	△	18	TRANSISTOR (Q7513)	2SC3181N
	7	MOLD B	AMR2595	△	19	TRANSISTOR (Q7514)	2SC3181N
	8	SCREW (3×10)	ABA1021	△	20	TRANSISTOR (Q7503)	2SC4793
	9	SCREW	BBZ30P140FZK		21	TRANSISTOR (Q7504)	2SC4793
	10	SCREW	BPZ30P350FZK		22	TRANSISTOR (Q7509)	2SA1837
	11	FAN MOTOR	AXM7003		23	TRANSISTOR (Q7510)	2SA1837
	12	REGULATOR IC (IC7401)	NJM7812FAS				

2.5 MULTI MECHA ASSY

Parts List of Multi Mecha Assy

Mark	No.	Description	Parts No.	Mark	No.	Description	Parts No.
	1	MOTOR PULLEY	PNW1634		46	SILENT RING	PBK1093
	2	GEAR HOLDER	PNW1929		47	WASHER	WA62D130D025
	3	PU FREXIBLE CABLE	PNP1343		48	EARTH SPRING	PBH1132
	4	CAM GEAR	PNW1923		49	GUIDE BAR	PLA1094
	5	BELT	PEB1138		50	DISC TABLE	PNW1067
	6	TOP GUIDE N	PNW2441		51	GEAR 1	PNW2052
	7	GEAR PULLEY	PNW1918		52	GEAR 2	PNW2053
	8	GEAR S	PNW1919		53	GEAR 3	PNW2054
	9	GEAR L	PNW1920		54	PINION GEAR	PNW2055
	10	EJECT SPRING	PBH1107		55	PWB HOLDER	PNW2057
	11	SWITCH LEVER	PNW1927	NSP	56	CARRIAGE DC MOTOR/0.3W	PXM1027
	12	SEVEN BAR	PNW1931		57	D.C. MOTOR ASSY	PEA1235
	13	SUB ROTARY LEVER	PNW1933			(SPINDLE, with OIL)	
	14	SUB ROTARY LEVER SPRING	PBH1111		58	PICKUP ASSY	PEA1179
	15	ROTARY LEVER	PNW1932		59	DISC TABLE ASSY	PEA1035
					60	SCREW	BBZ26P060FMC
	16	DRIVE PLATE	PNW1930		61	SCREW	BPZ20P060FMC
	17	MOTOR SCREW	PBA-112		62	SCREW	BPZ26P100FMC
	18	HOLDER LEVER SPRING	PBH1110		63	SCREW	JFZ17P025FZK
	19	DISC HOLDER	PNW1924		64	SCREW	JFZ20P040FMC
	20	CUSHION A	PED1001		65	WASHER	WT12D032D025
	21	HOLDER LEVER	PNW1925				
	22	FLOAT RUBBER	PEB1014		66	
	23	FLOAT RUBBER	PEB1132		67	STOP SPRING	PBH1131
	24	FLOAT SCREW	PBA1073		68	STOPPER	PNW2069
	25	RELEASE LEVER	PNW1934		69	CARRIAGE DC MOTOR ASSY	PEA1246
	26	RELEASE SPRING	PBH1106				
	27	CLAMPER CAM	PNW1922				
	28	CLAMPER HOLDER	PNW1921	NSP	101	MOTOR	VXM1033
	29	CLAMPER SPRING	PBH1109		102	EJECT LEVER	PNB1306
	30	CLAMPER	PNW1857		103	UPPER CHASSIS N	PNB1267
				NSP	104	SERVO MECHANISM ASSY M	PXA1537
	31	LOCK LEVER	PNW1917	NSP	105	LOADING BOARD ASSY	AWZ7207
	32	LOCK SPRING	PBH1108				
	33	STAIR NL	PNW2443		106	SUB CHASSIS N	PNW2440
	34	STAIR NR	PNW2444		107	
	35	SYNCHRONIZE LEVER	PNW1926		108	MAIN CHASSIS	PNW2074
				NSP	109	SELECT BOARD ASSY	AWZ7209
	36	MOTOR ASSY (LOADING, DISC SELECT)	PEA1130	NSP	110	MOTOR BOARD ASSY	AWZ7208
	37	SCREW	PMZ26P040FMC	NSP	111	MECHANISM BOARD ASSY	PWX1192
	38	SCREW	PPZ30P080FMC	NSP	112	EARTH LEAD UNIT	PDF1074
	39	SCREW	BBZ30P060FMC		113	CLAMP MAGNET	PMF1014
	40	WASHER	WT26D047D025	NSP	114	GEAR STOPPER	PNB1303
				NSP	115	YOKE M	PNB1312
	41	WASHER	WA31D054D025				
	42	E RING	Z39-010	NSP	116	AV ANGLE	PNB1405
	43	SCREW	IPZ30P080FMC		117	CARRIAGE BASE	PNW2445
	44	RUBBER SPACER	PEB1238				
	45	RUBBER SPACER	PEB1179				

*1: Fix the motor (No. 101) on the LOADING BOARD ASSY (No. 105) so that the label attached on the motor faces the direction illustrated.

*1 Label

*2: Fix the motor (No. 101) on the MOTOR BOARD ASSY (No. 110) so that the label attached on the motor faces the direction illustrated.

*2 Label

• How to install the disc table

- ① Use nippers or other tool to cut the three sections marked ① and the three sections marked ② in figure. Then remove the spacer.
- ② While supporting the spindle motor shaft with the stopper, put spacer on top of yoke M, and stick the disc table on top (takes about 9kg pressure). Detach the spacer.

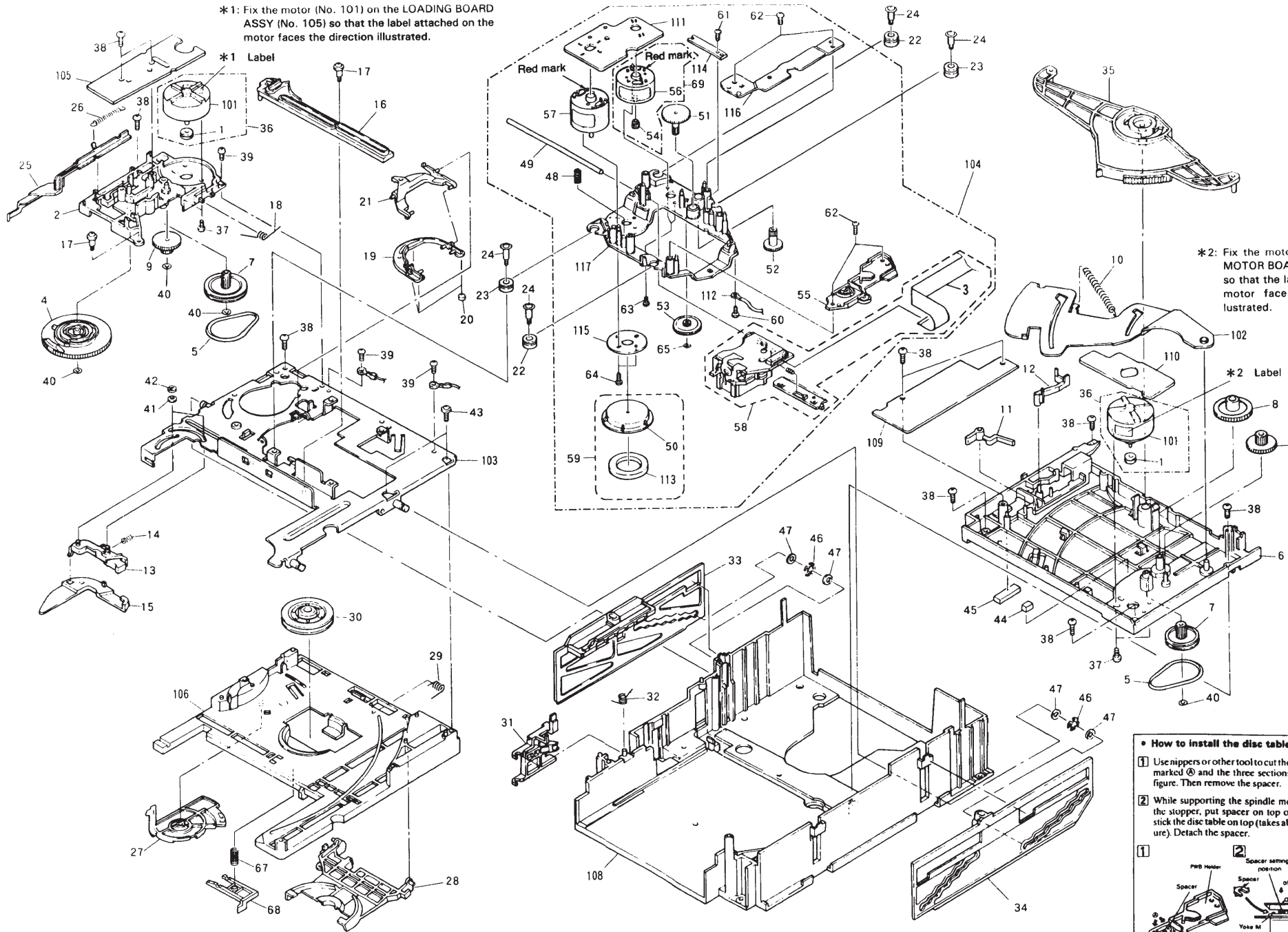
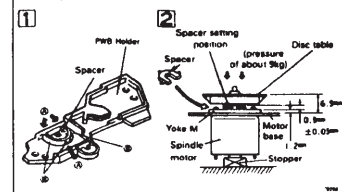

3. BLOCK DIAGRAM

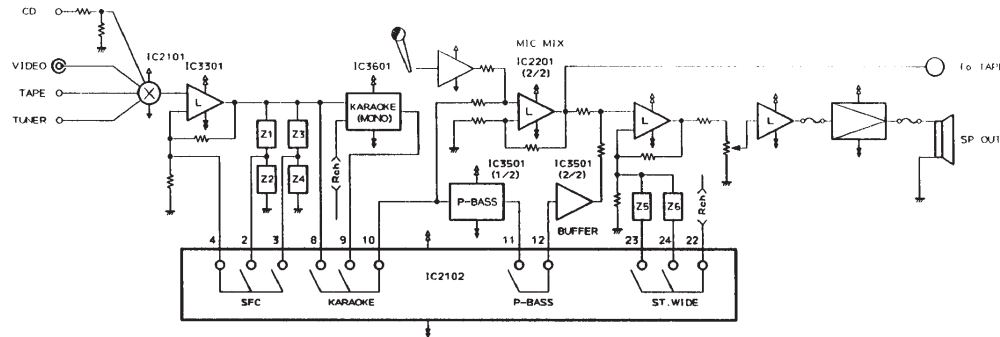

POWER AMP MODULE SECTION

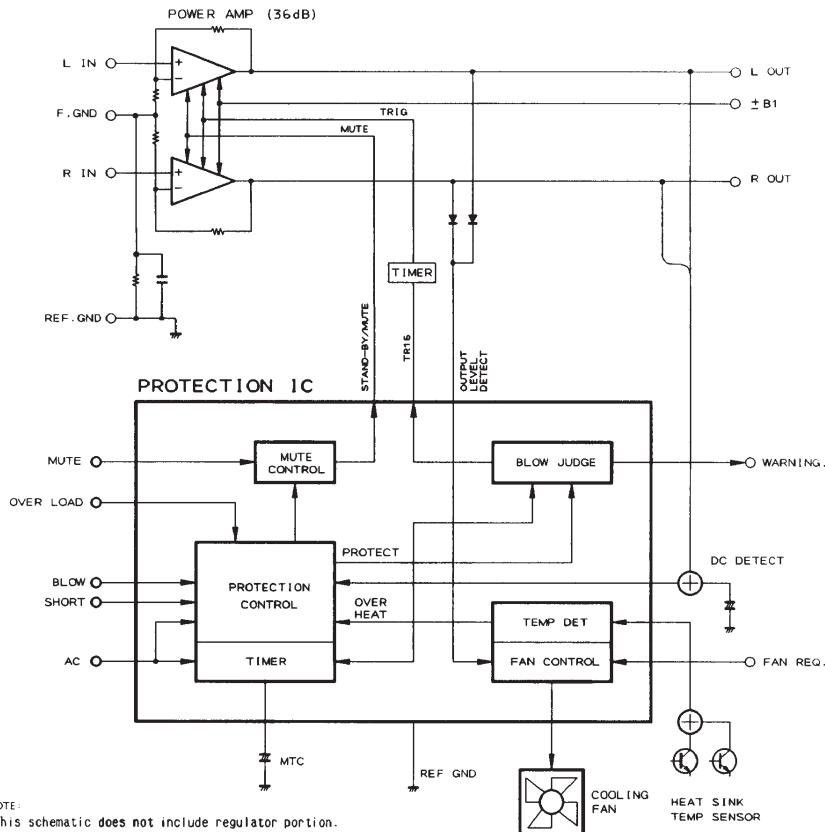

NOTE:
This schematic does not include regulator portion.

4. SCHEMATIC AND PCB CONNECTION DIAGRAMS

NOTE FOR SCHEMATIC DIAGRAMS (Type 1A)

1. When ordering service parts, be sure to refer to "PARTS LIST of EXPLODED VIEWS" or "PCB PARTS LIST".

2. Since these are basic circuits, some parts of them or the values of some components may be changed for improvement.

3. RESISTORS:

Unit: k:kΩ, M:MΩ, or Ω unless otherwise noted.

Rated power: 1/4W, 1/6W, 1/8W, 1/10W unless otherwise noted.

Tolerance: (F): ±1%, (G): ±2%, (K): ±10%, (M): ±20% or ±5% unless otherwise noted.

4. CAPACITORS:

Unit: p:pF or μF unless otherwise noted.

Ratings: capacitor (μF)/ voltage (V) unless otherwise noted.

Rated voltage: 50V except for electrolytic capacitors.

5. COILS:

Unit: m:mH or μH unless otherwise noted.

6. VOLTAGE AND CURRENT:

\square V : Signal voltage at rated output.

\square or - V :

DC voltage (V) at no input signal unless otherwise noted.

Value in () is DC voltage at rated power.

\square mA or - mA :

DC current at no input signal unless otherwise noted.

7. OTHERS:

• \odot or \emptyset : Adjusting point.

• --- : Measurement point.

• The Δ mark found on some component parts indicates the importance of the safety factor of the parts. Therefore, when replacing, be sure to use parts of identical designation.

8. SCH-□ ON THE SCHEMATIC DIAGRAM:

• SCH-□ indicates the drawing number of the schematic diagram. (SCH stands for schematic diagram.)

9. SWITCHES (Underline indicates switch position):

DISPLAY assy

- S1801 TUNING +
- S1802 SFC/KARAOKE
- S1803 FUNCTION (DEMO)
- S1804 TUNING -
- S1805 FM
- S1806 P. BASS
- S1807 SURROUND & STEREO WIDE
- S1808 AM
- S1809 MEMORY
- S1810 CD DISPLAY
- S1811 MONO
- S1812 FREQ/STATION
- S1813 CLOCK/CLOCK ADJ
- S1814 TIMER REC/WAKE-UP
- S1815 POWER STANDBY/ON

SW assy

- S1816 ◀ REV PLAY
- S1817 ▶ FWD PLAY
- S1818 ■ STOP (TAPE)
- S1819 TAPE I / II
- S1820 ■ STOP (CD)
- S1821 ▶|| PLAY/PAUSE
- S1822 ▶▶ FF
- S1823 DOLBY NR
- S1824 ●|| REC PAUSE
- S1825 ASES/COPY
- S1826 ◀◀ REW
- S1827 ▲ OPEN/EJECT
- S1828 ▶▶▶ TRACK/MANUAL FWD SERCH
- S1829 ◀◀◀ TRACK/MANUAL REV SERCH
- S1830 DISC SELECTOR 2
- S1831 DISC SELECTOR 1
- S1832 DISC SELECTOR 6
- S1833 DISC SELECTOR 5
- S1834 DISC SELECTOR 4
- S1835 DISC SELECTOR 3

4.1 OVERALL SCHEMATIC DIAGRAM

A
B
C
D
E
F

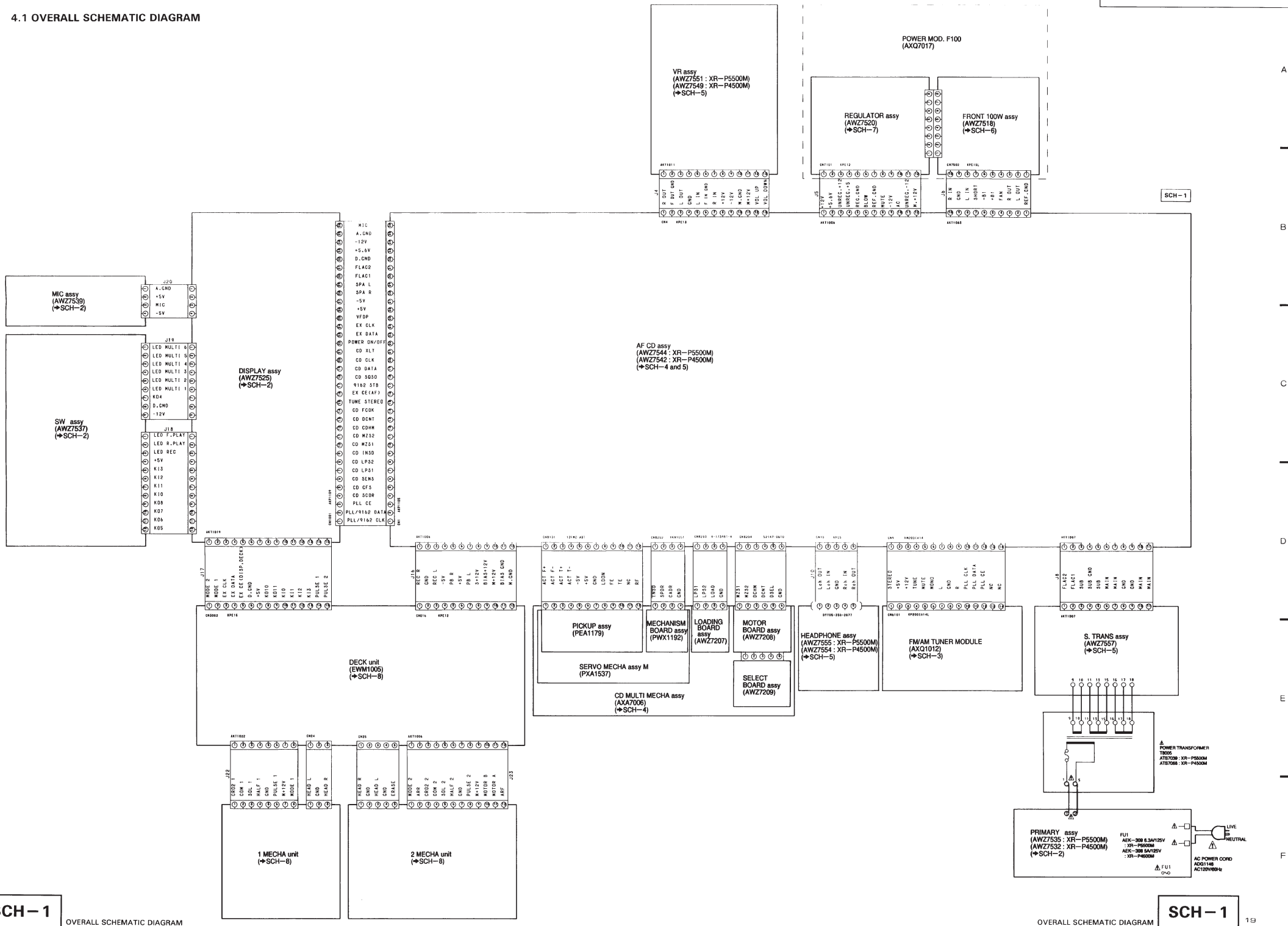

SCH-1

SCH-1

4.2 DISPLAY ASSY, SW ASSY, MIC ASSY AND PRIMARY ASSY

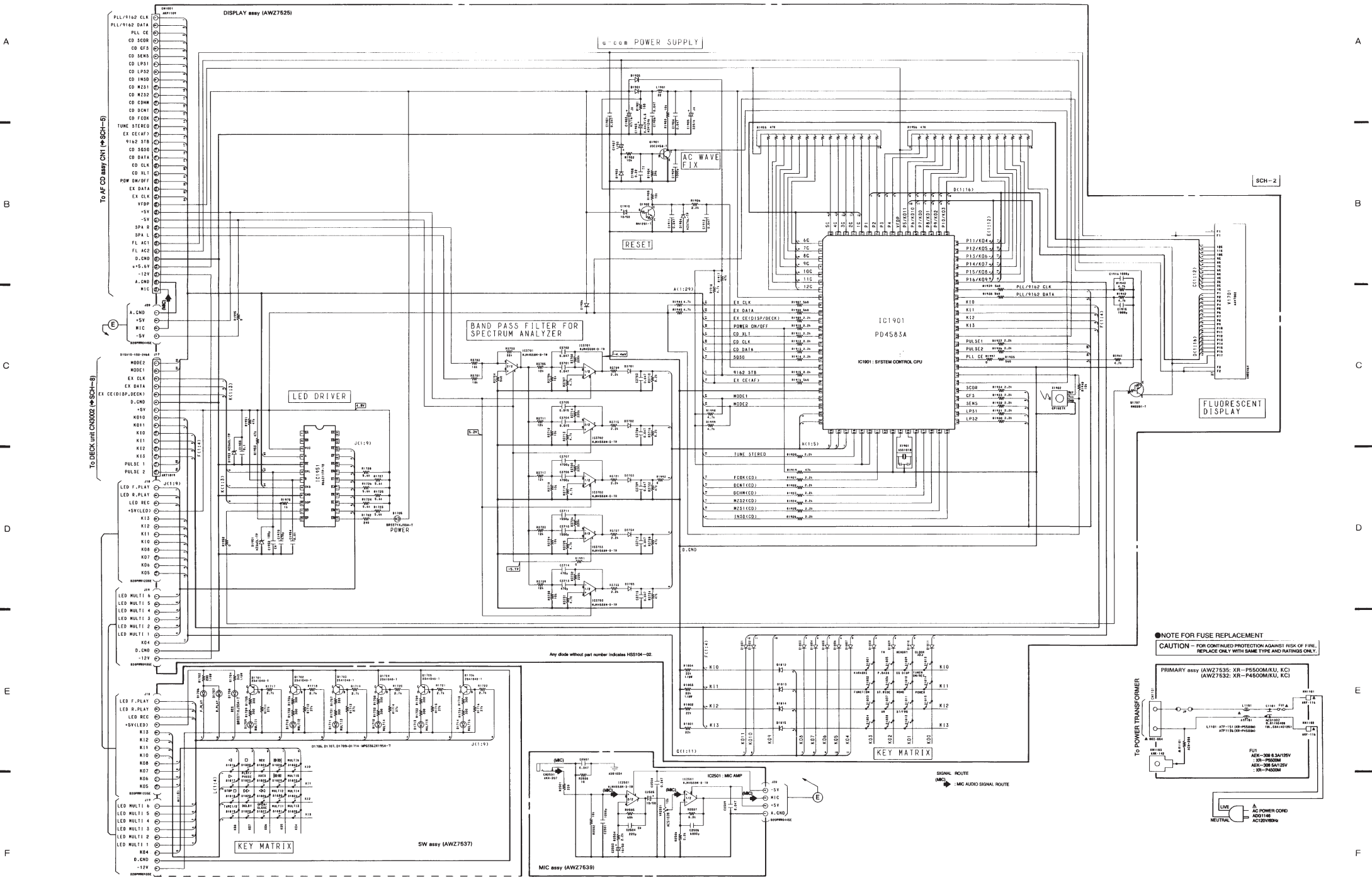

NOTE FOR FUSE REPLACEMENT
CAUTION - FOR CONTINUED PROTECTION AGAINST RISK OF FIRE, REPLACE ONLY WITH SAME TYPE AND RATINGS ONLY.

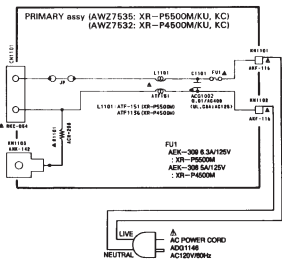

A

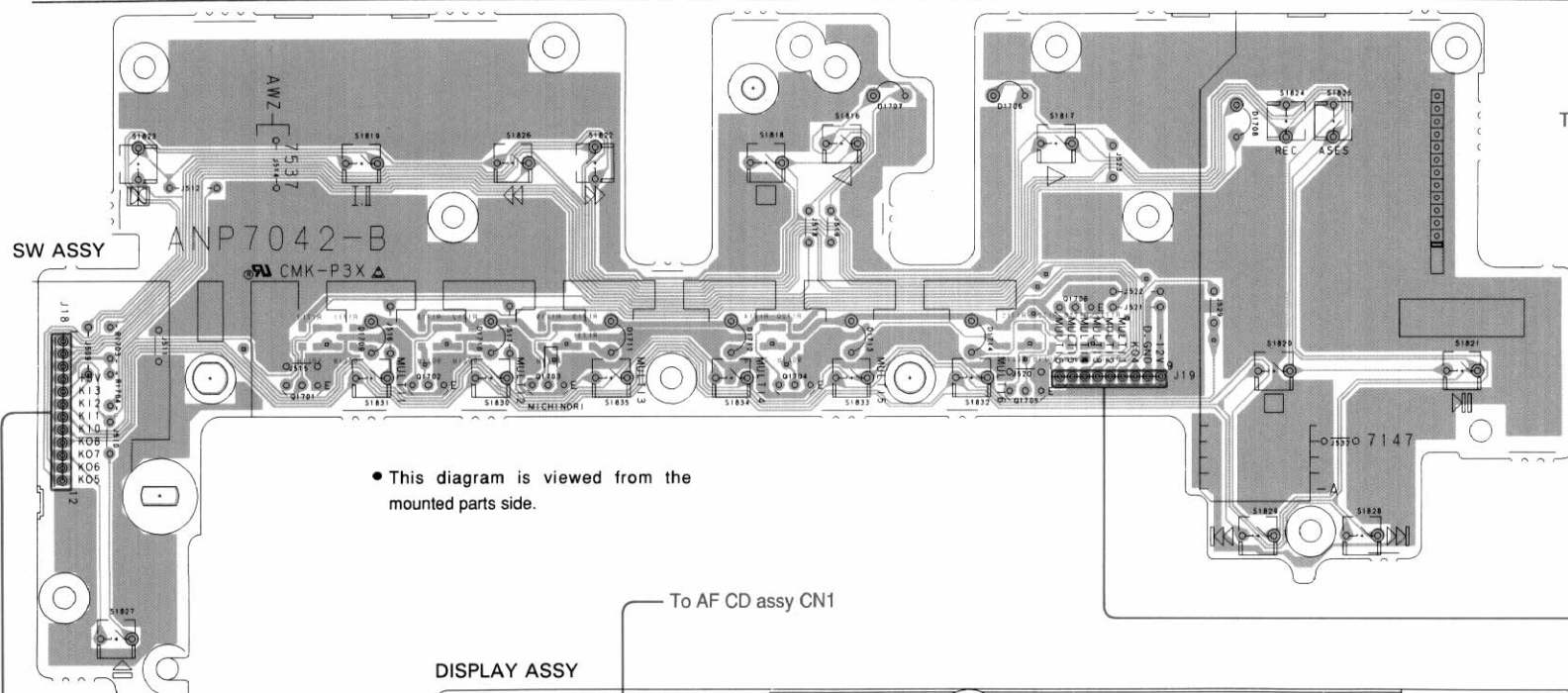

B

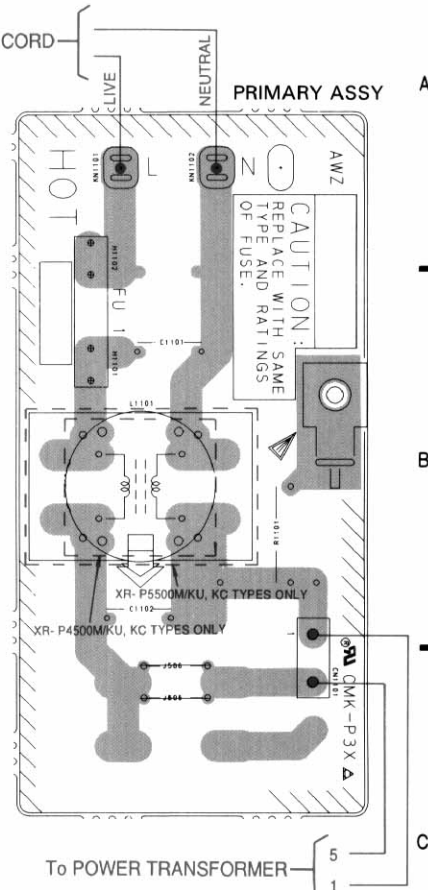

C

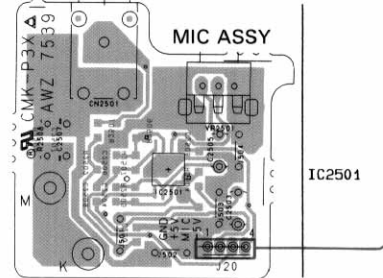

D

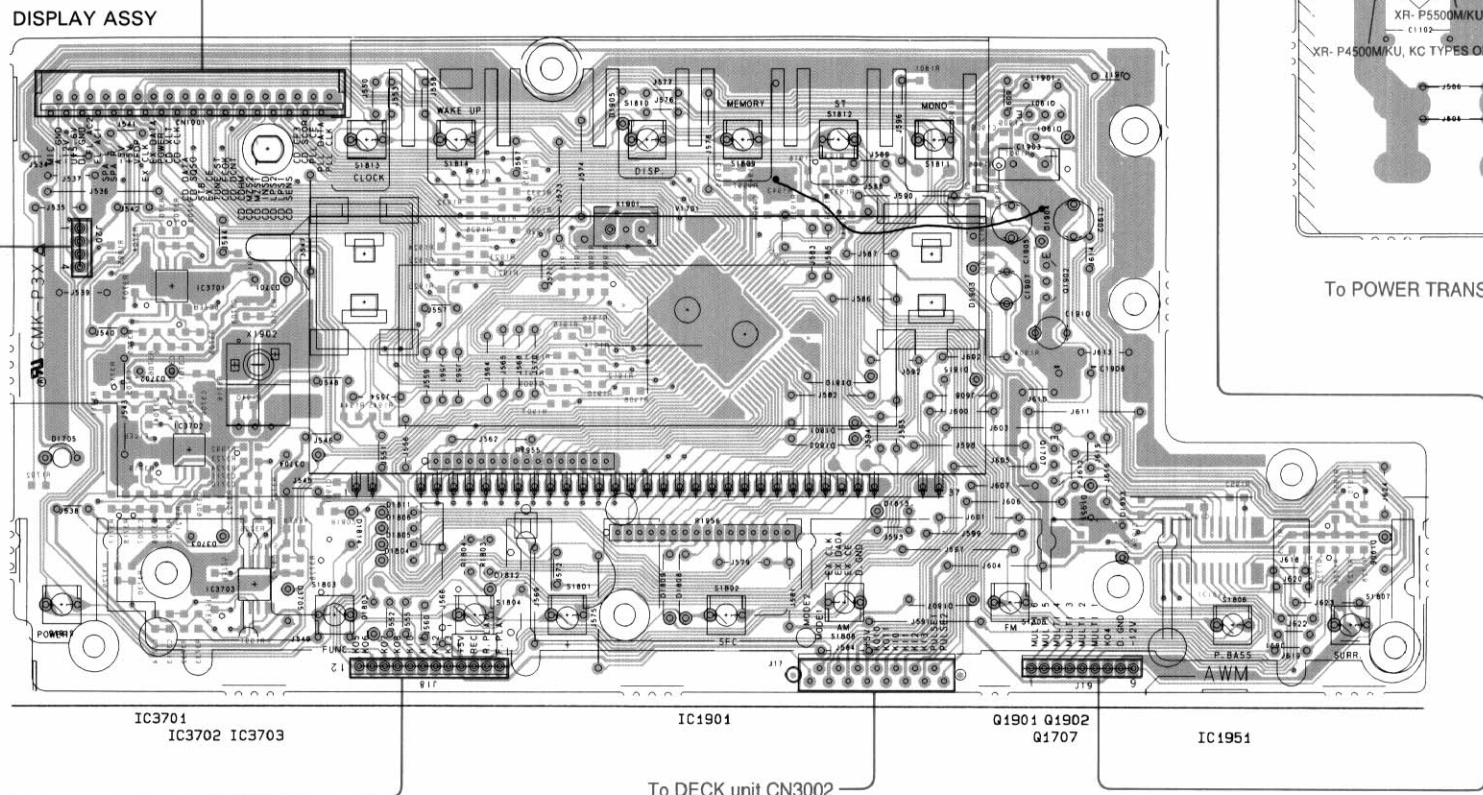

NOTE FOR PCB DIAGRAMS:
 1. Part numbers in PCB diagrams match those in the schematic diagrams.
 2. A comparison between the main parts of PCB and schematic diagrams is shown below.

Symbol in PCB Diagrams	Symbol in Schematic Diagrams	Part Name
<p>Q504</p>	<p>Q504</p>	Transistor
<p>D203</p>	<p>D203</p>	Diode
<p>C513</p>	<p>C513</p>	Capacitor (Polarized)

3. The transistor terminal marked with E or C shows the emitter.
 4. The diode terminal marked with @ or C shows cathode side.
 5. The capacitor terminal marked with @ or C shows negative terminal.

4.3 FM\AM TUNER MODULE

FM\AM TUNER MODULE

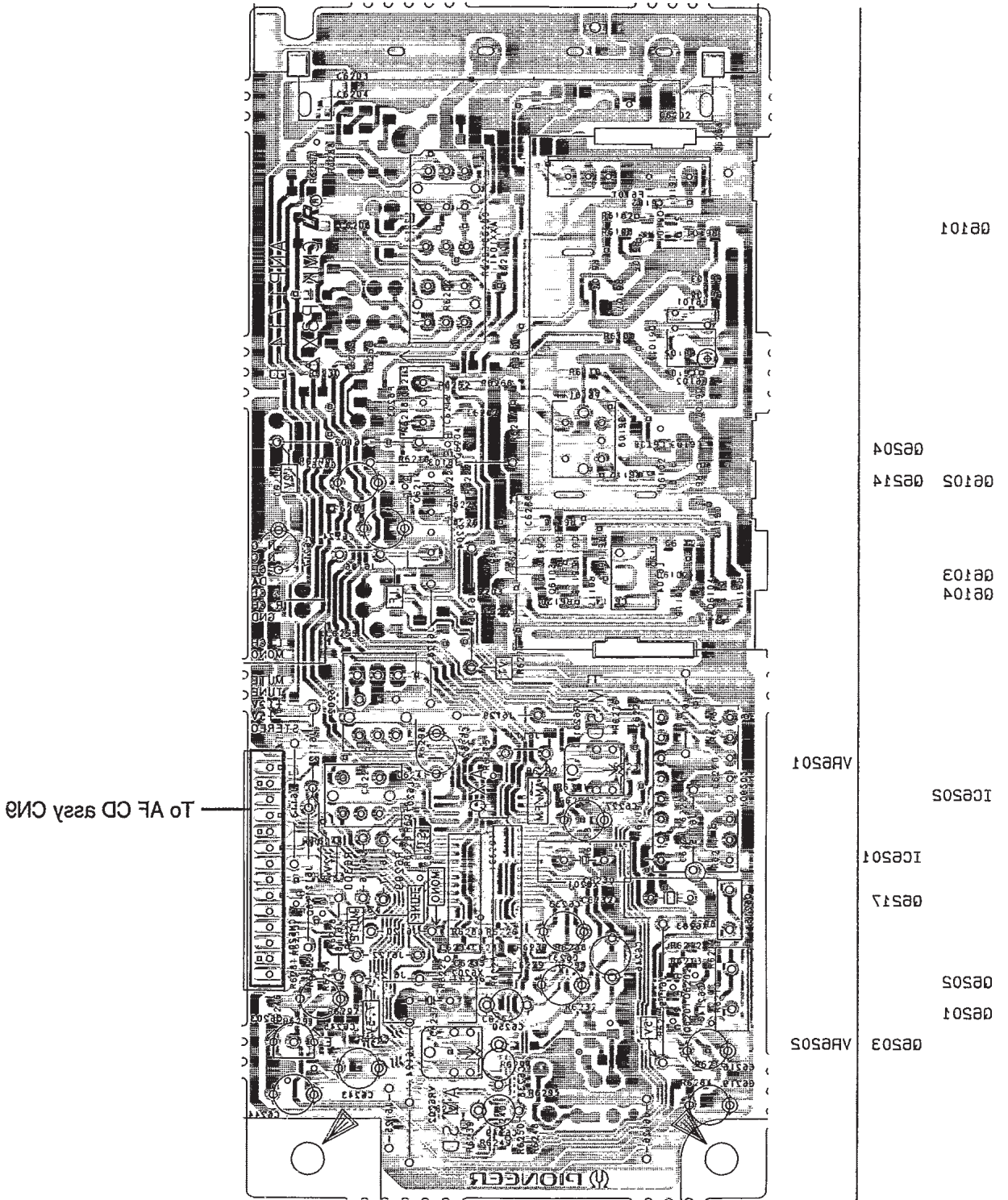

● This diagram is viewed from the foil side.

4.3 FM/AM TUNER MODULE

FM/AM TUNER MODULE

A

A

G6101

B

B

G6204
G6102 G6214

G6103
G6104

C

C

IC6202 VR6201
IC6201
G6217

G6202
G6201

G6203 VR6202

To AF CD assy CN9

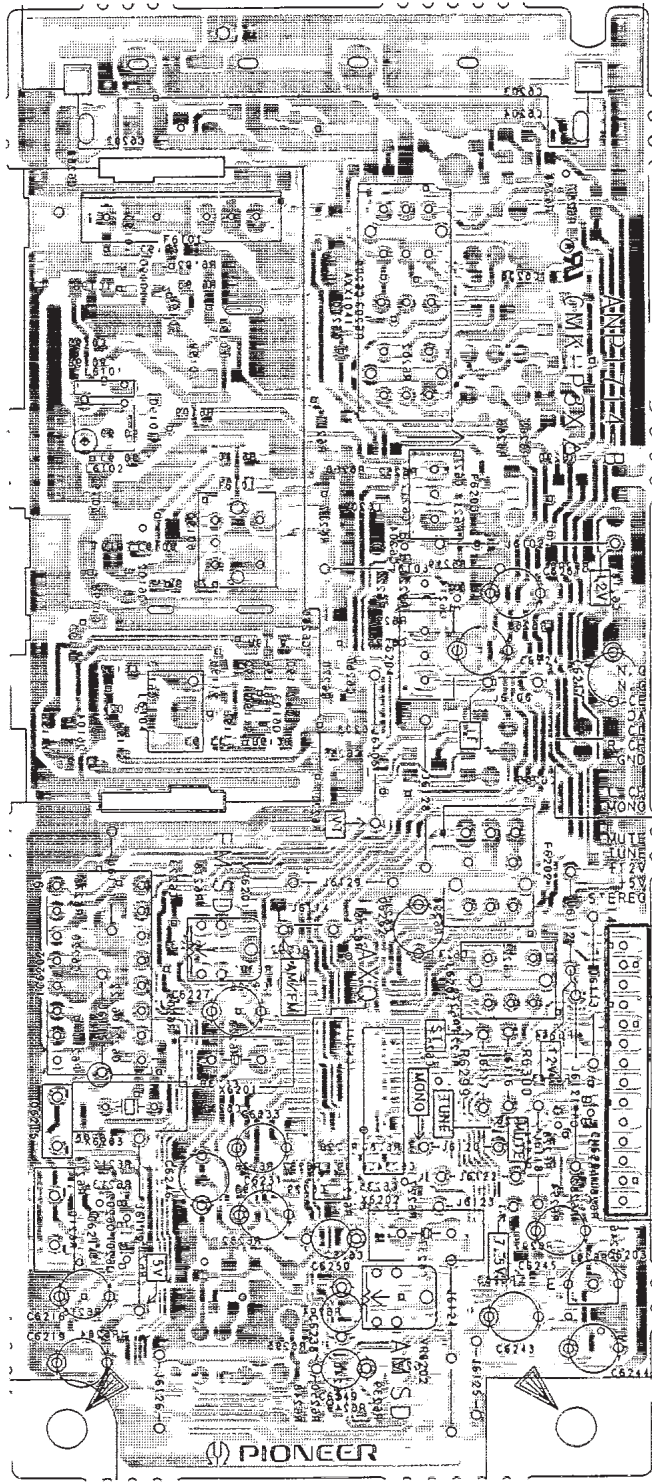

D

D

• This diagram is viewed from the mounted parts side.

4.4 AF CD ASSY, VR ASSY, HEADPHONE ASSY, S. TRANS ASSY AND MULTI MECHA ASSY

A
B
C
D
E
F

A
B
C
D
E
F

SCH-4

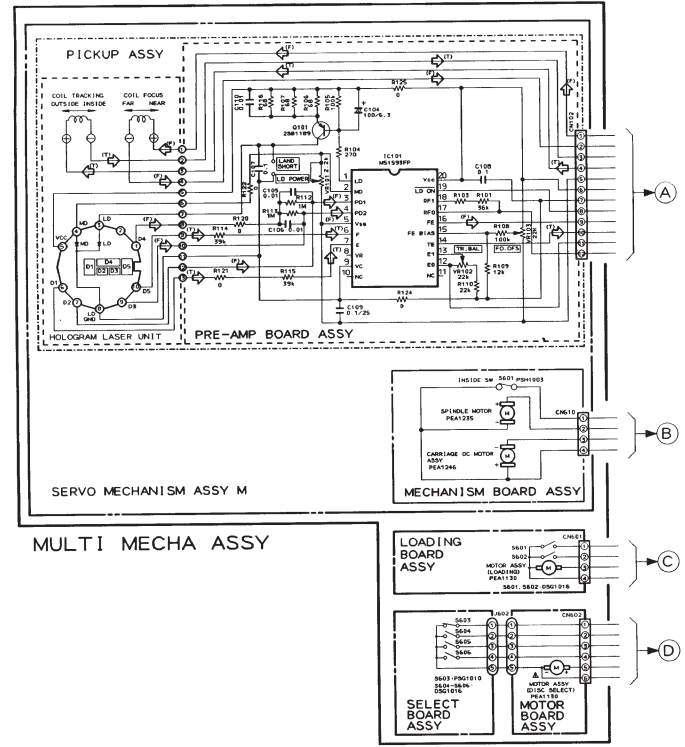

NOTE: VOLTAGE AND CURRENT
 □ or - V : DC voltage (V) in PLAY mode unless otherwise noted.
 □ mA : DC current in PLAY mode unless otherwise noted.
 □ : DC current in STOP mode.

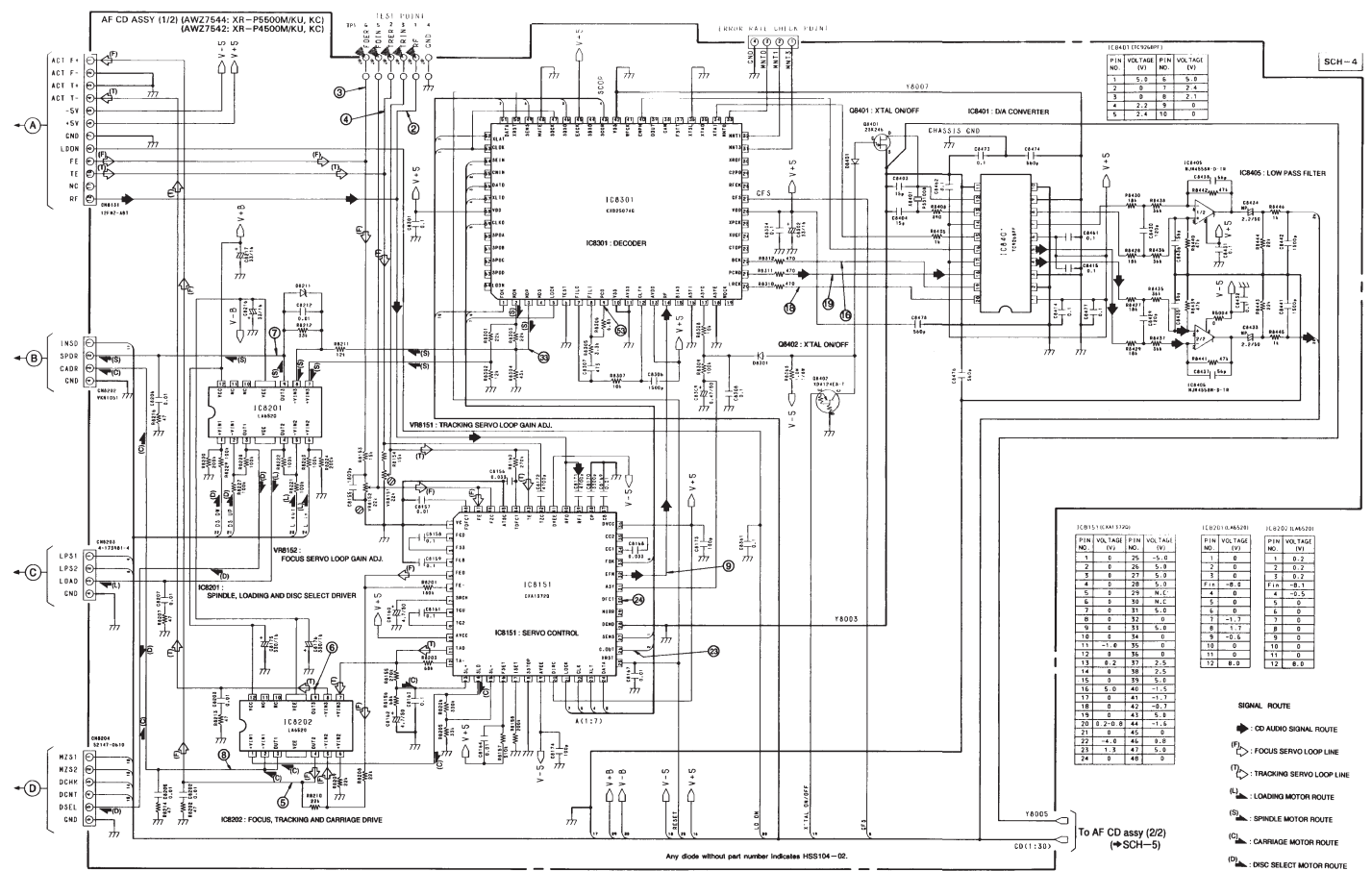

IC8301 (CXD2507AQ)

Pin No.	Voltage (V)	Pin No.	Voltage (V)	Pin No.	Voltage (V)	Pin No.	Voltage (V)
1	4.8	17	2.5	33	0	49	0
2	4.9	18	0	34	2.3	50	4.9
3	2.6	19	N.C.	35	N.C.	51	0
4	N.C.	20	2.5	36	0	52	4.8
5	4.9	21	2.5	37	N.C.	53	4.8
6	0	22	2.1	38	N.C.	54	4.9
7	2.6	23	0	39	N.C.	55	0
8	2.5	24	N.C.	40	0	56	0
9	2.5	25	N.C.	41	N.C.	57	5.0
10	0	26	5.0	42	0	58	5.0
11	0	27	5.0	43	0	59	5.0
12	2.7	28	N.C.	44	N.C.	60	N.C.
13	5.0	29	N.C.	45	5.0	61	N.C.
14	2.6	30	N.C.	46	0	62	N.C.
15	N.C.	31	4.5	47	4.8	63	N.C.
16	0	32	0	48	0	64	N.C.

SCH-4

IC8101 (CXD1320)				IC8201 (M4823)				IC8202 (M4823)			
Pin No.	Voltage (V)	Pin No.	Voltage (V)	Pin No.	Voltage (V)	Pin No.	Voltage (V)	Pin No.	Voltage (V)	Pin No.	Voltage (V)
1	0	25	5.0	1	0	25	5.0	1	0	25	5.0
2	0	26	5.0	2	0	26	5.0	2	0	26	5.0
3	0	27	5.0	3	0	27	5.0	3	0	27	5.0
4	0	28	5.0	4	0	28	5.0	4	0	28	5.0
5	0	29	N.C.	5	0	29	N.C.	5	0	29	N.C.
6	0	30	N.C.	6	0	30	N.C.	6	0	30	N.C.
7	0	31	5.0	7	0	31	5.0	7	0	31	5.0
8	0	32	0	8	0	32	0	8	0	32	0
9	0	33	5.0	9	0	33	5.0	9	0	33	5.0
10	0	34	0	10	0	34	0	10	0	34	0
11	-1.6	35	0	11	0	35	0	11	0	35	0
12	0	36	0	12	0	36	0	12	0	36	0
13	0	37	2.5	13	0	37	2.5	13	0	37	2.5
14	0	38	2.5	14	0	38	2.5	14	0	38	2.5
15	0	39	0	15	0	39	0	15	0	39	0
16	5.0	40	-1.5	16	5.0	40	-1.5	16	5.0	40	-1.5
17	0	41	-1.1	17	0	41	-1.1	17	0	41	-1.1
18	0	42	-2.1	18	0	42	-2.1	18	0	42	-2.1
19	0	43	5.5	19	0	43	5.5	19	0	43	5.5
20	0	44	-1.6	20	0	44	-1.6	20	0	44	-1.6
21	0	45	0	21	0	45	0	21	0	45	0
22	-4.0	46	0	22	-4.0	46	0	22	-4.0	46	0
23	1.8	47	5.0	23	1.8	47	5.0	23	1.8	47	5.0
24	0	48	0	24	0	48	0	24	0	48	0

- SIGNAL ROUTE
- : CD AUDIO SIGNAL ROUTE
 - : FOCUS SERVO LOOP LINE
 - : TRACKING SERVO LOOP LINE
 - : LOADING MOTOR ROUTE
 - : SPINDLE MOTOR ROUTE
 - : CARRIAGE MOTOR ROUTE
 - : DISC SELECT MOTOR ROUTE

Any diode without part number indicates HSB104-02.

SCH-4

AF CD ASSY (1/2), MULTI MECHA ASSY

SCH-4

AF CD ASSY (1/2), MULTI MECHA ASSY

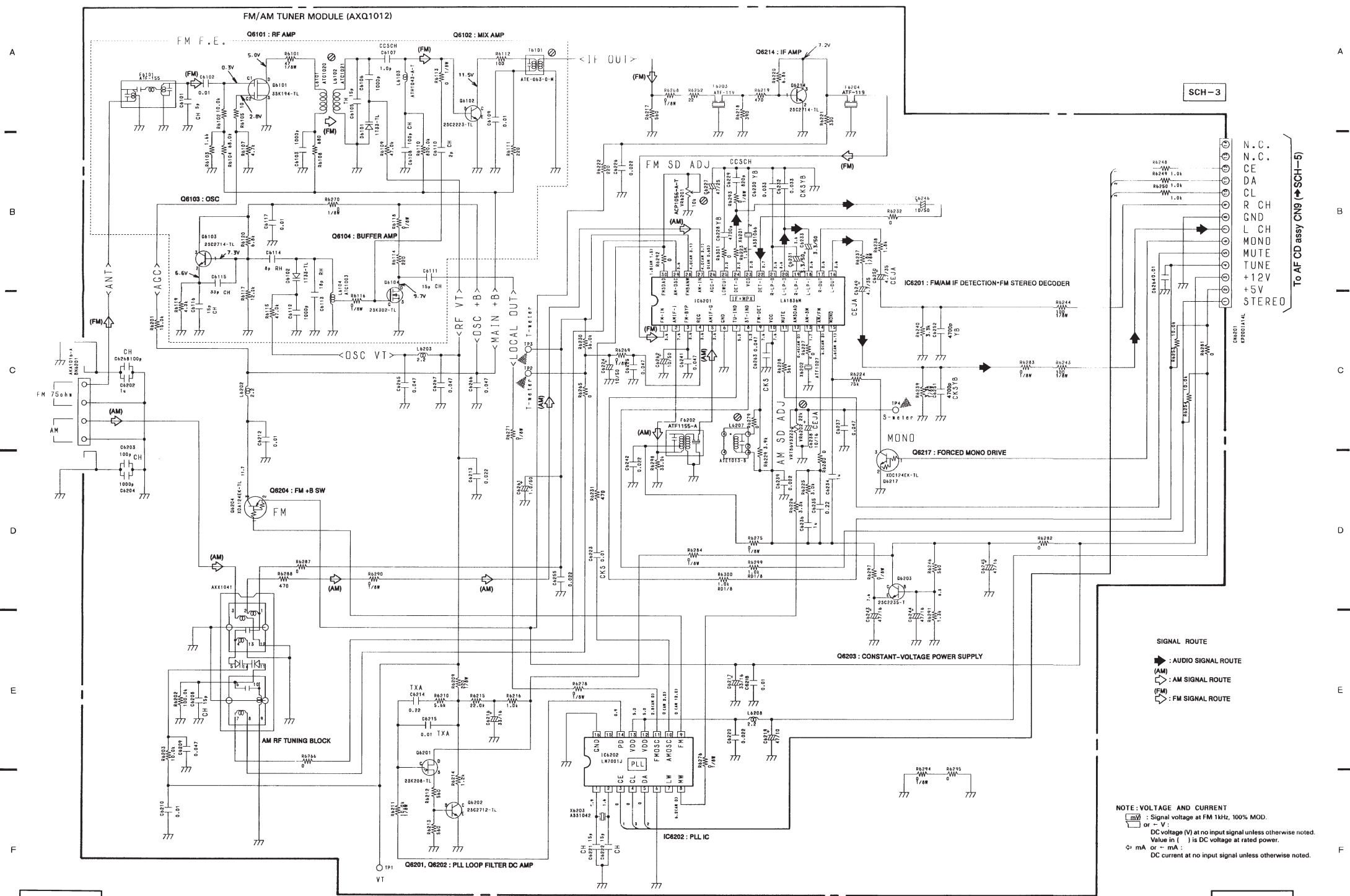

SIGNAL ROUTE
 ➔ : AUDIO SIGNAL ROUTE
 (AM) : AM SIGNAL ROUTE
 (FM) : FM SIGNAL ROUTE

NOTE: VOLTAGE AND CURRENT
 [Symbol] : Signal voltage at FM 1kHz, 100% MOD.
 or - V : DC voltage (V) at no input signal unless otherwise noted.
 Value in () is DC voltage at rated power.
 ⦿ mA or - mA : DC current at no input signal unless otherwise noted.

Waveforms

Note: The encircled numbers denote measuring point in the schematic diagram.

*1 50T-JUMP: After switching to the pause mode, press the manual search key.

*2 FOCUS-IN: Press the key without loading a disc.

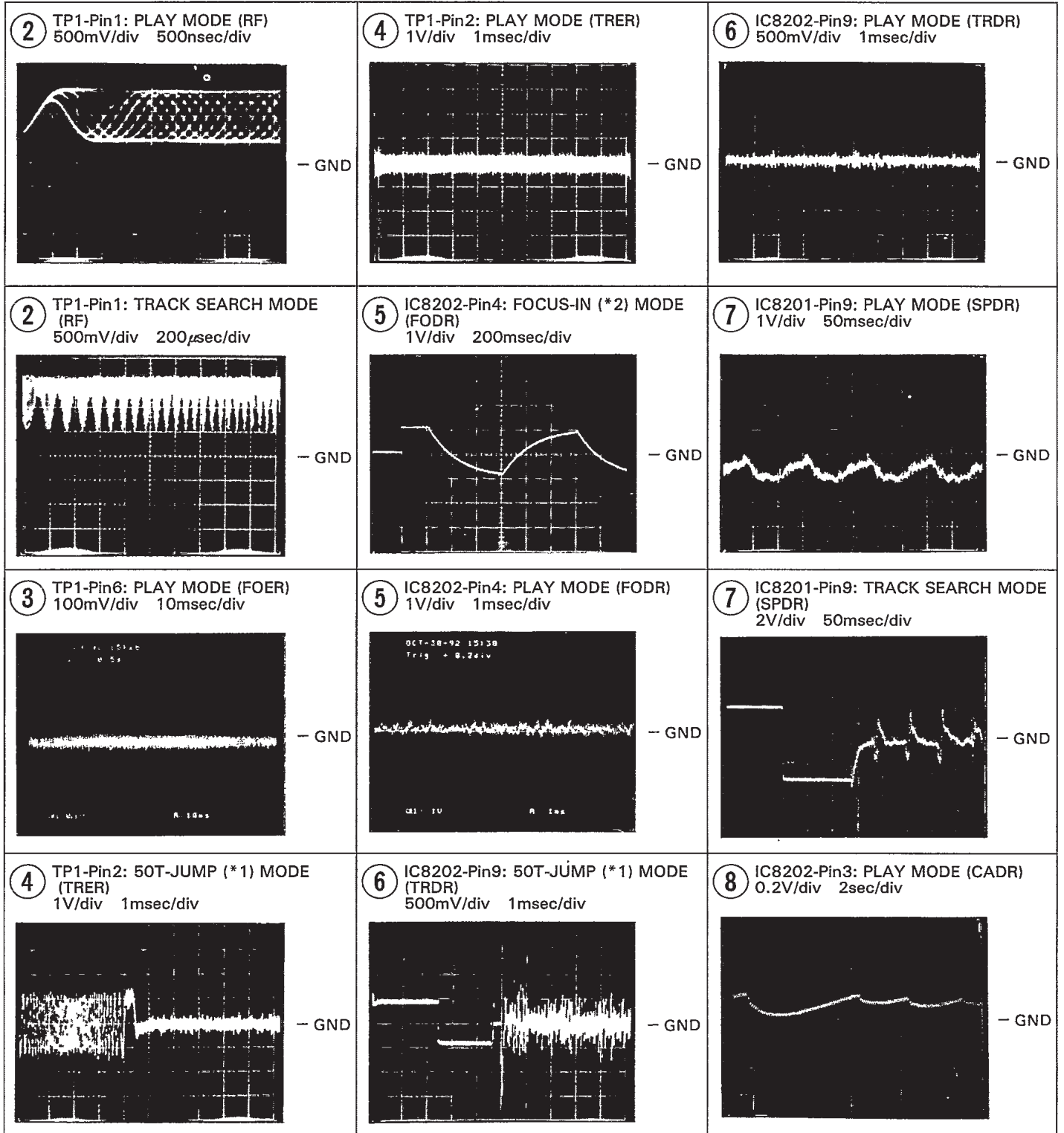

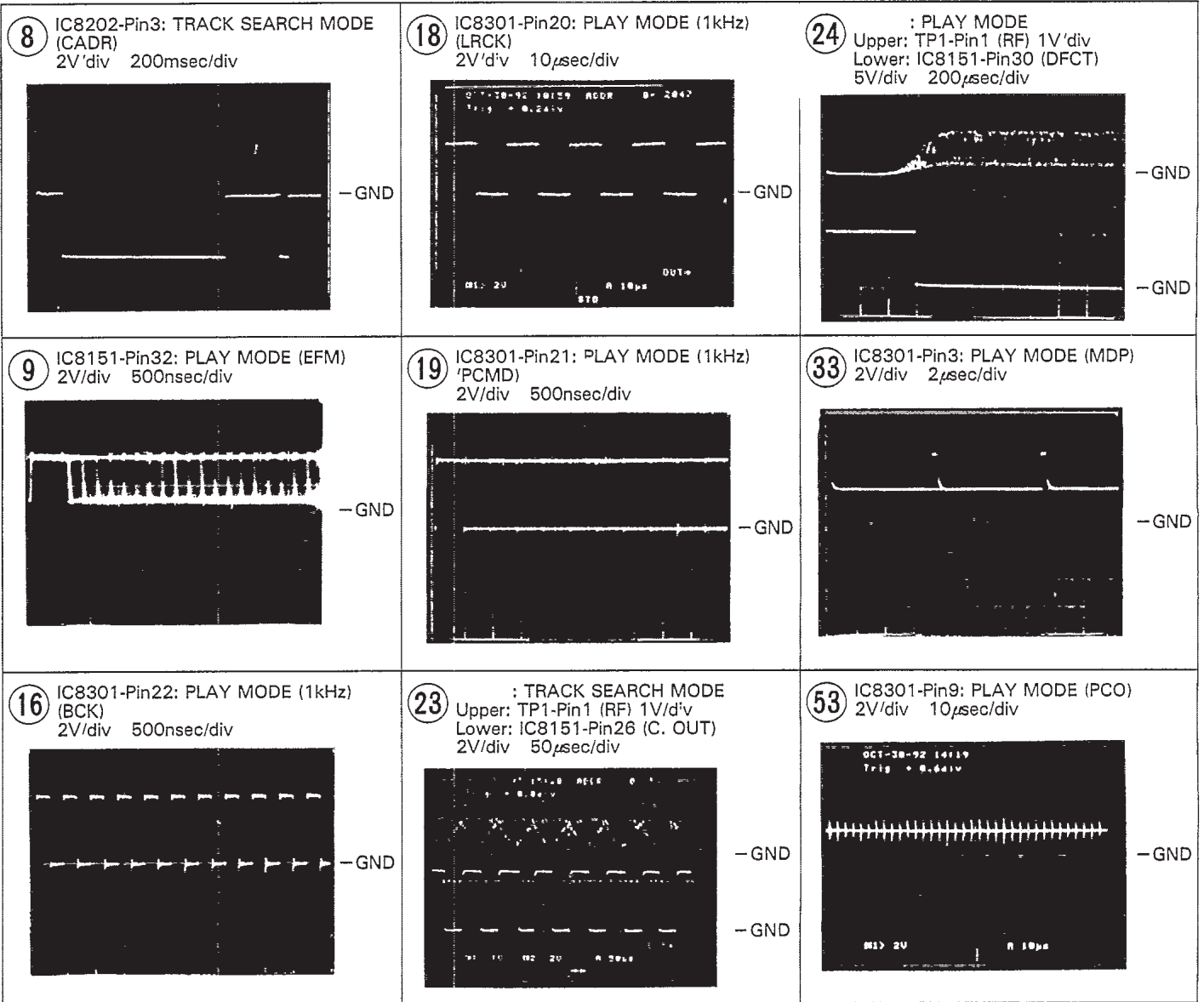

A

B

C

D

E

F

A

B

C

D

E

F

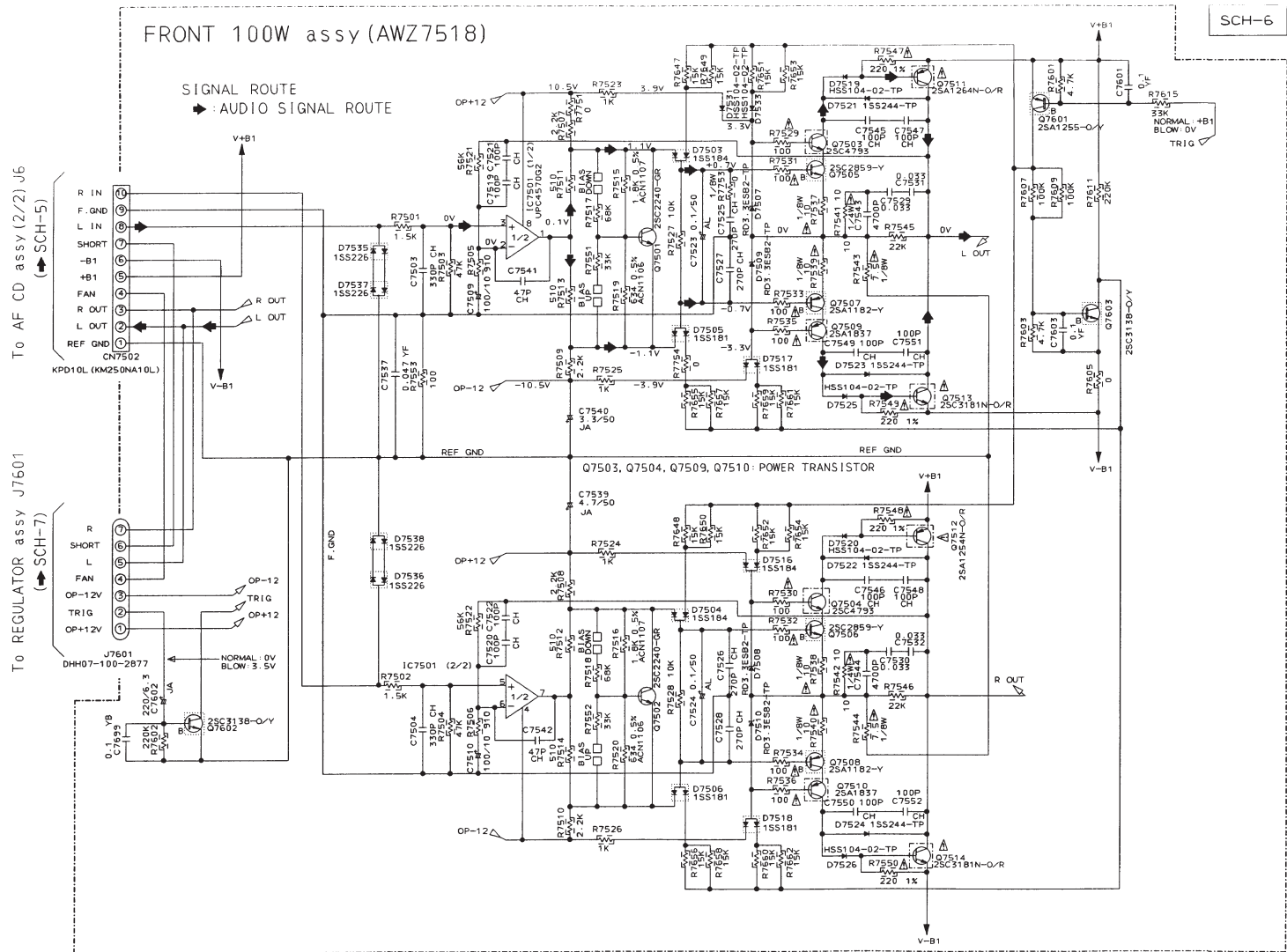

FRONT 100W assy (AWZ7518)

SIGNAL ROUTE
AUDIO SIGNAL ROUTE

SCH-6

SCH-6

SCH-6

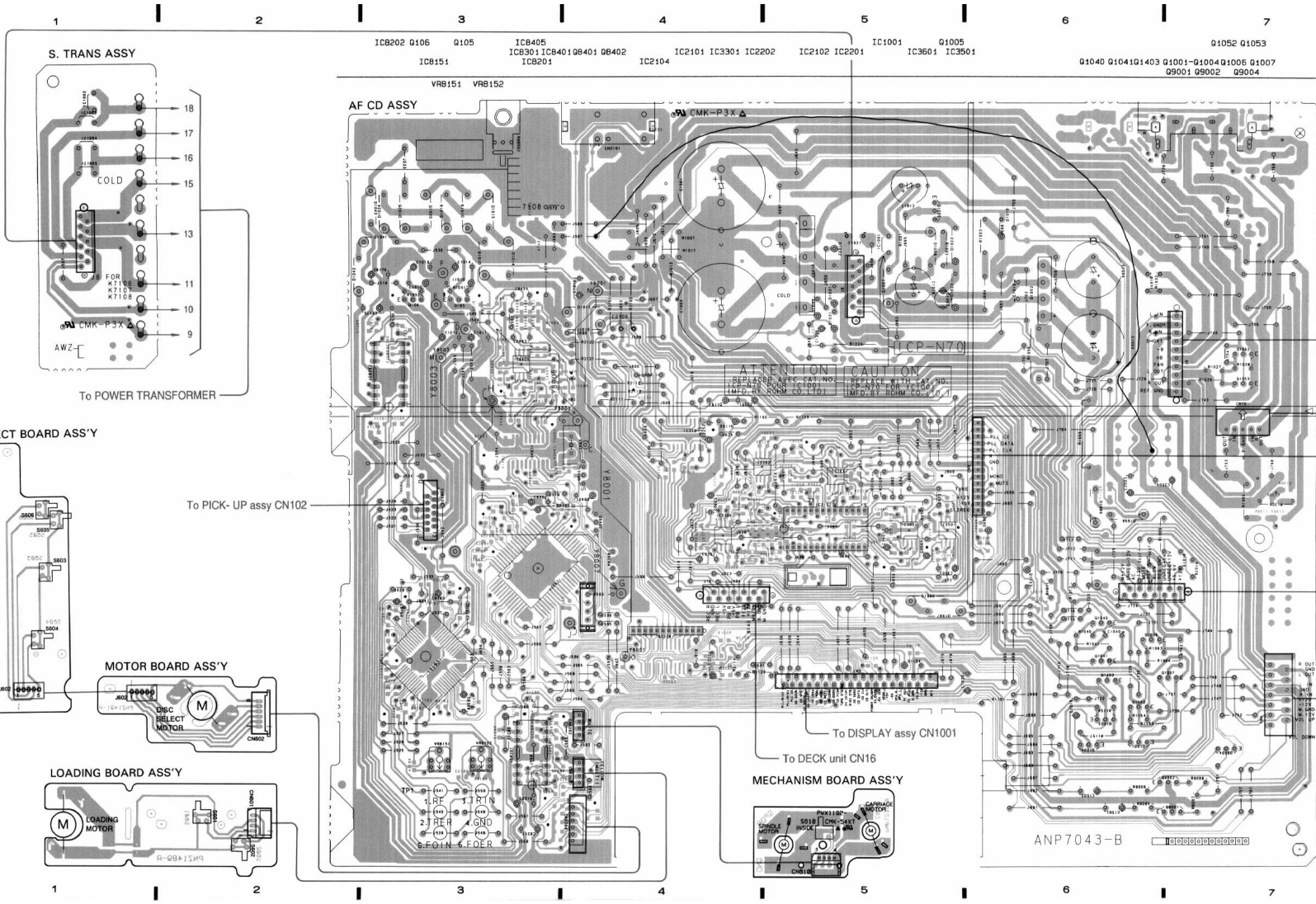

• This diagram is viewed from the mounted parts side.

S. TRANS ASSY

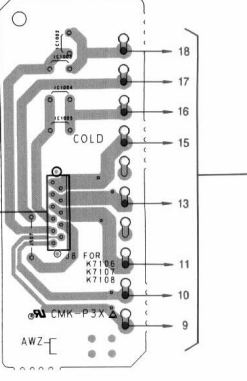

SELECT BOARD ASS'Y

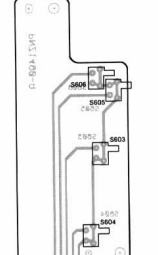

MOTOR BOARD ASS'Y

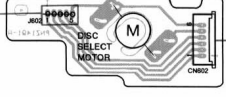

LOADING BOARD ASS'Y

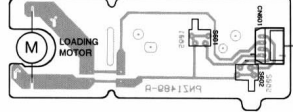

MECHANISM BOARD ASS'Y

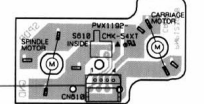

HEADPHONE ASSY

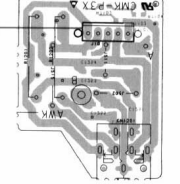

VR ASSY

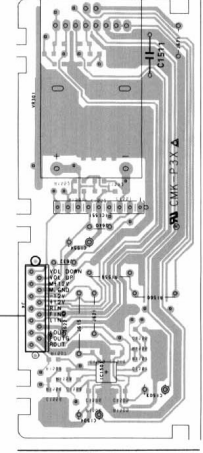

To FRONT 100W assy CN7502

To FM/AM TUNER MODULE CN6201

To REGULATOR assy CN7101

To DISPLAY assy CN101

To DECK unit CN16

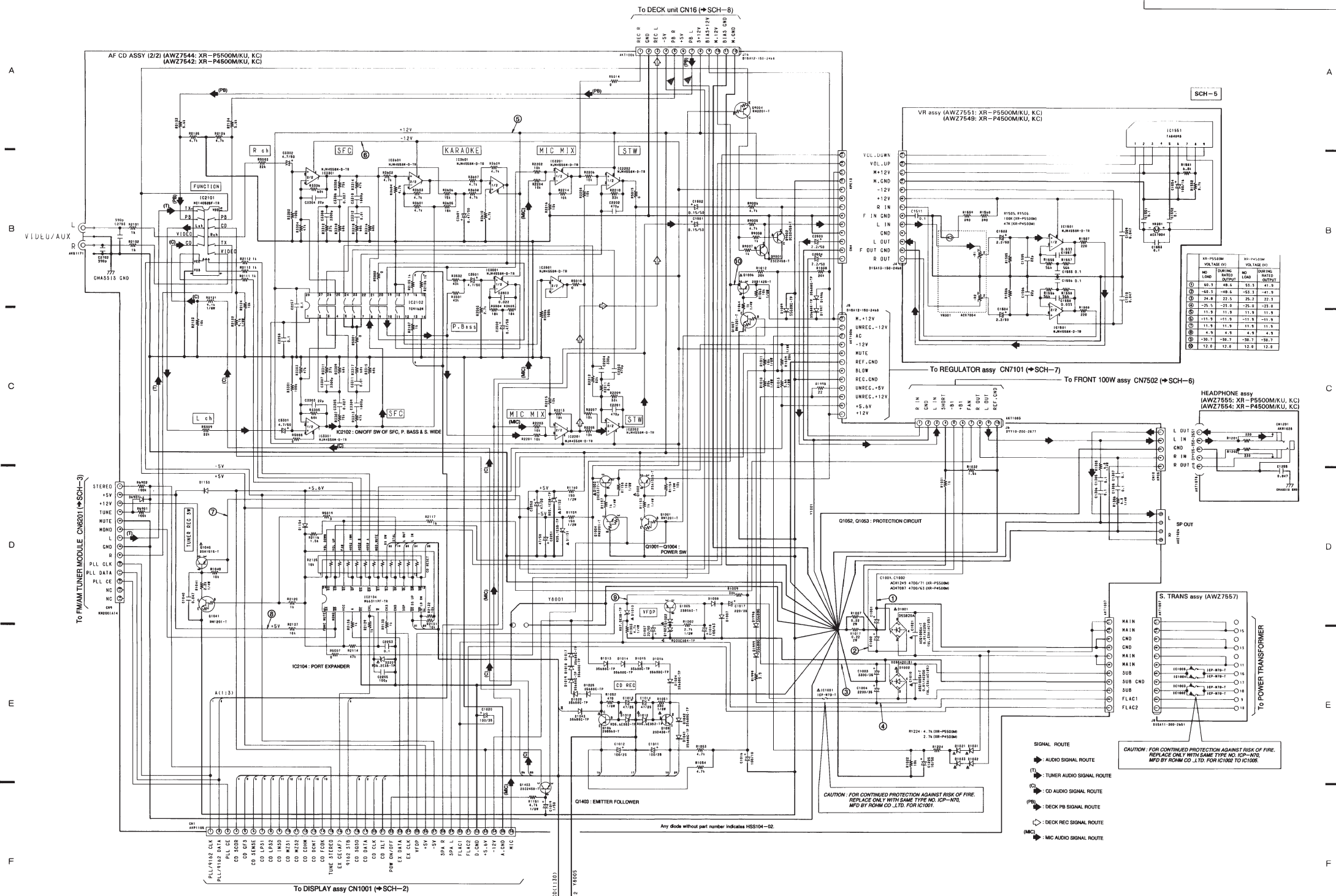

SCH-5

XR-P5500M		XR-P4500M	
NO.	LOAD	NO.	LOAD
①	40.3	①	40.3
②	48.5	②	48.5
③	48.6	③	48.6
④	24.8	④	25.2
⑤	25.5	⑤	25.0
⑥	11.9	⑥	11.9
⑦	11.9	⑦	11.9
⑧	11.9	⑧	11.9
⑨	4.9	⑨	4.9
⑩	19.7	⑩	19.7
⑪	12.8	⑪	12.8

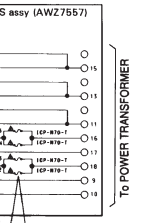
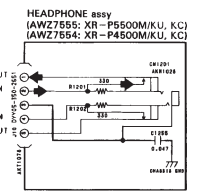

CAUTION: FOR CONTINUED PROTECTION AGAINST RISK OF FIRE, REPLACE ONLY WITH SAME TYPE NO. ICP-N70, MFD BY ROHM CO., LTD. FOR IC1002 TO IC1006.

CAUTION: FOR CONTINUED PROTECTION AGAINST RISK OF FIRE, REPLACE ONLY WITH SAME TYPE NO. ICP-N70, MFD BY ROHM CO., LTD. FOR IC1001.

- SIGNAL ROUTE
- ①: AUDIO SIGNAL ROUTE
- ②: TUNER AUDIO SIGNAL ROUTE
- ③: CD AUDIO SIGNAL ROUTE
- (PB): DECK PB SIGNAL ROUTE
- (R): DECK REC SIGNAL ROUTE
- (MC): MIC AUDIO SIGNAL ROUTE

SCH-5

SCH-5

FRONT 100W ASSY

A

A

Q7508
Q7507
Q7509
IC7501
Q7501
Q7513
Q7514
Q7505
Q7503
Q7603
Q7504
Q7506
Q7601
Q7511
Q7512

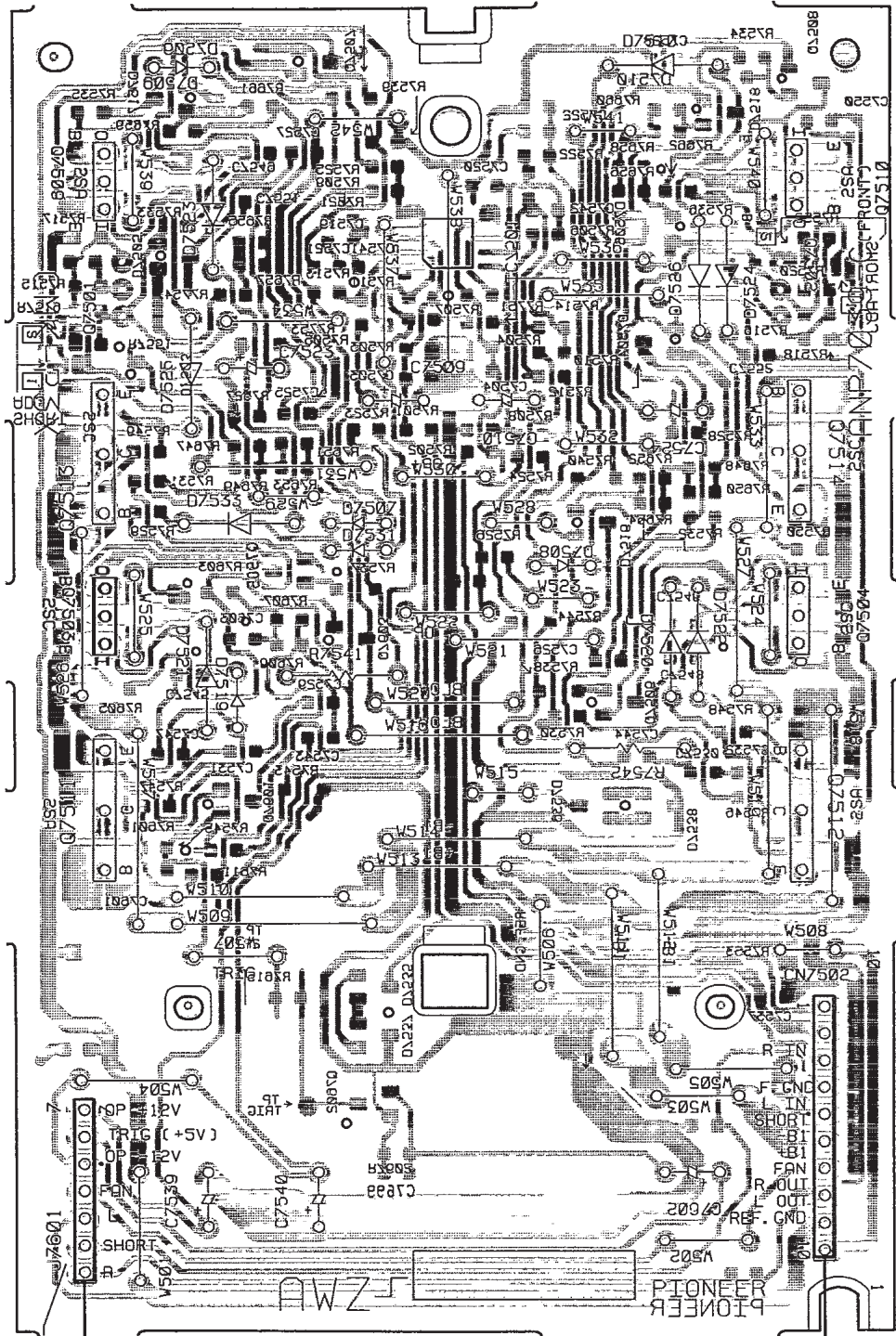

B

B

C

C

D

D

To REGULATOR assy J7601

To AF CD assy J6

- This diagram is viewed from the mounted parts side.

FRONT 100W ASSY

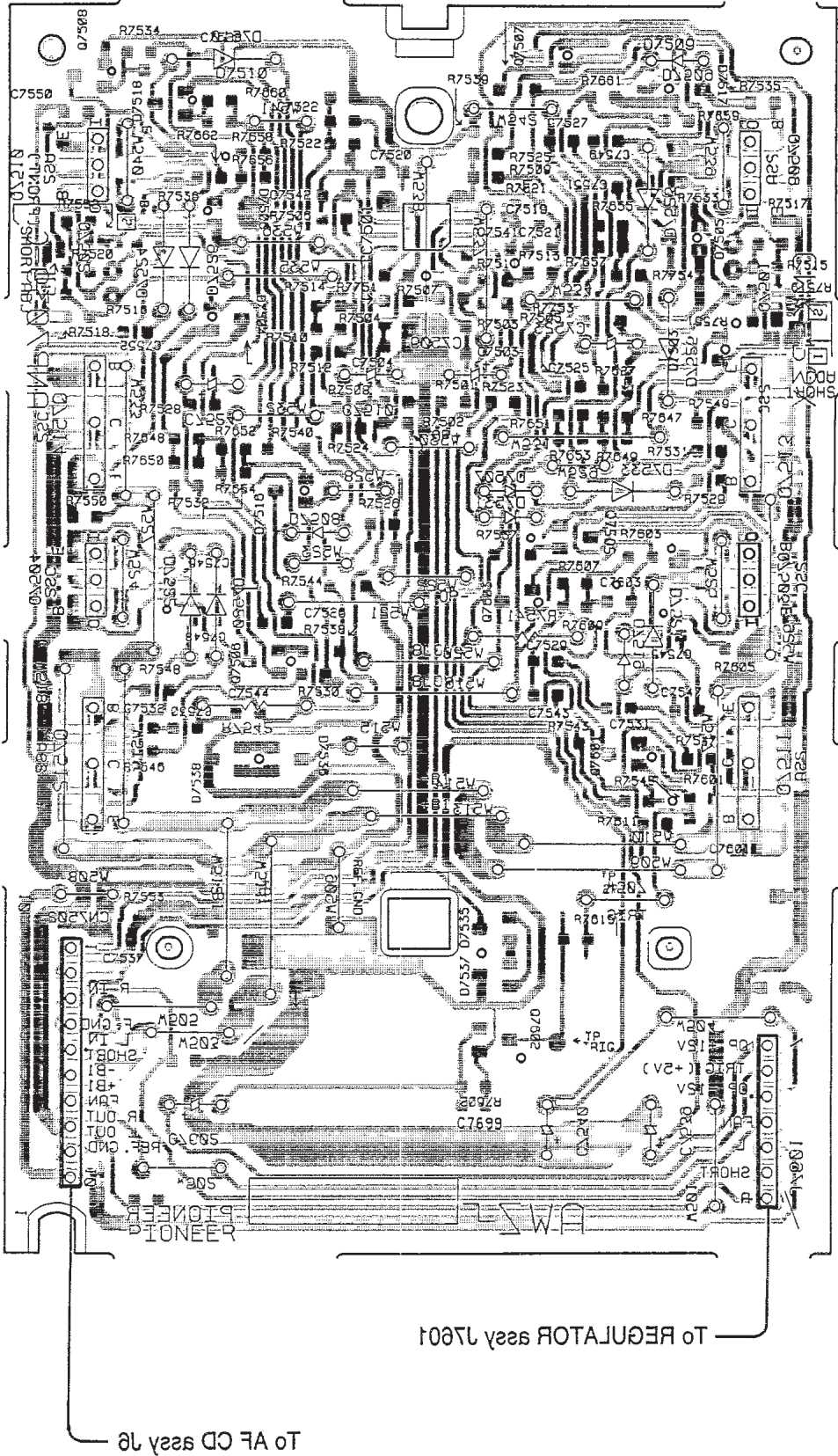

02508	02507
02508	02510
02501	IC7501
02505	02501
02514	02513
02502	02502
02503	02503
02504	02503
02508	02508
02501	02501
02515	02511
02505	

A
B
C
D

TO REGULATOR assy 17601

To AF CD assy 16

● This diagram is viewed from the foil side.

4.6 REGULATOR ASSY

REGULATOR ASSY

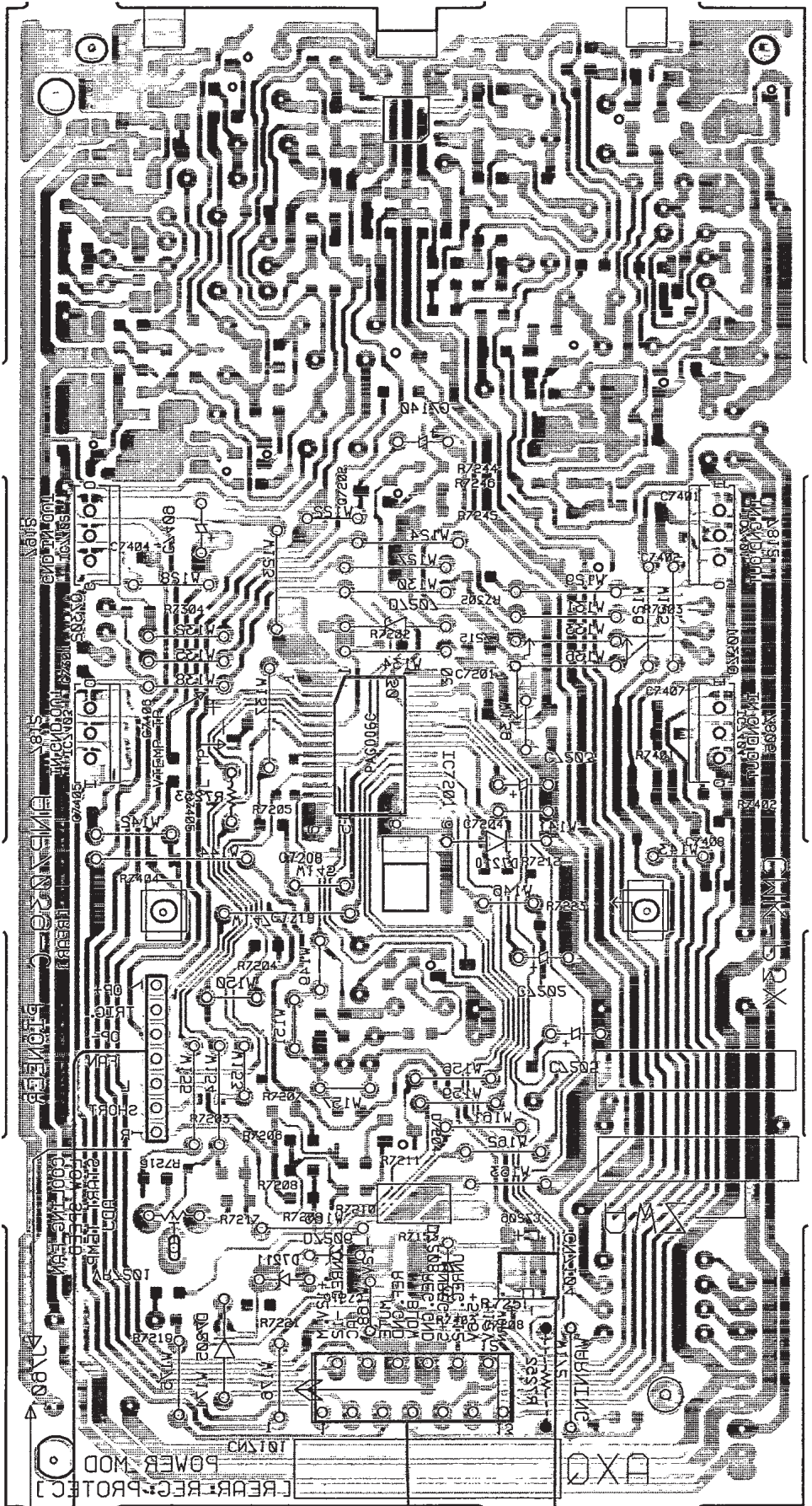

IC2501 IC2503
 02305
 02301
 IC2504 IC2505
 02306

VR3501

TO FAN MOTOR
 TO FRONT 100W assy 17601
 TO AF CD assy 12

REAR REG. PROTECT
 POWER MOD

• This diagram is viewed from the foil side.

4.6 REGULATOR ASSY

REGULATOR ASSY

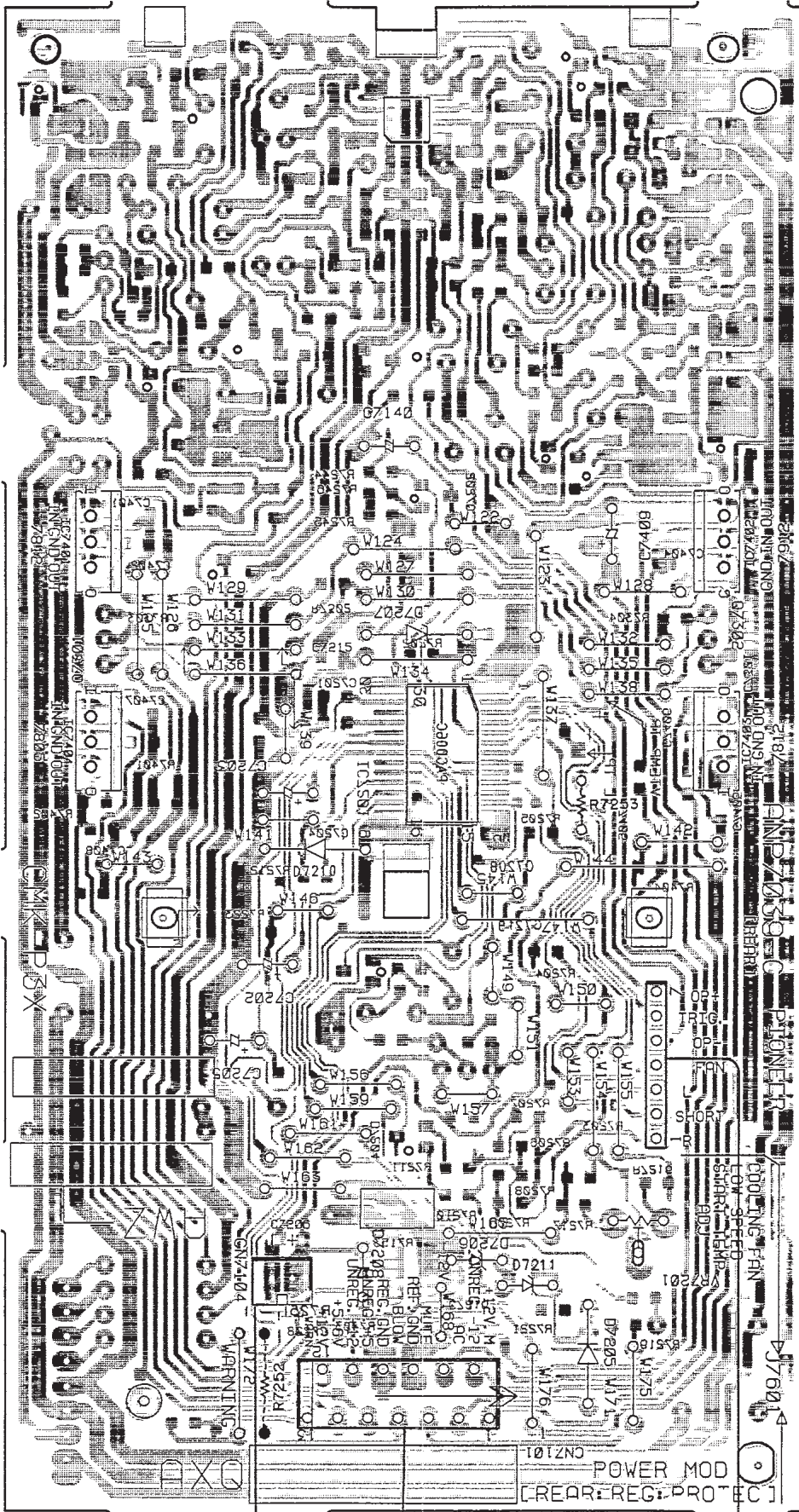

- G7202
- IC7401 IC7402
- G7301 G7302
- IC7404 IC7403
- IC7201

VR7201

To AF CD assy J5
 To FRONT 100W assy J7601
 To FAN MOTOR

• This diagram is viewed from the mounted parts side.

5. PCB PARTS LIST

NOTES :

- Parts marked by "NSP" are generally unavailable because they are not in our Master Spare Parts List.
- The Δ mark found on some component parts indicates the importance of the safety factor of the part. Therefore, when replacing, be sure to use parts of identical designation.
- Parts marked by "☉" are not always kept in stock. Their delivery time may be longer than usual or they may be unavailable.
- When ordering resistors, first convert resistance values into code form as shown in the following examples.

Ex. 1 When there are 2 effective digits (any digit apart from 0), such as 560 ohm and 47k ohm (tolerance is shown by J = 5%, and K = 10%).

560 Ω \rightarrow 56 \times 10¹ \rightarrow 561 RD1/8PM $\begin{matrix} 5 & 6 & 1 & J \end{matrix}$
 47k Ω \rightarrow 47 \times 10³ \rightarrow 473 RD1/4PS $\begin{matrix} 4 & 7 & 3 & J \end{matrix}$
 0.5 Ω \rightarrow 0R5 RN2H $\begin{matrix} 0 & R & 5 & K \end{matrix}$
 1 Ω \rightarrow 010 RS1P $\begin{matrix} 0 & 1 & 0 & K \end{matrix}$

Ex. 2 When there are 3 effective digits (such as in high precision metal film resistors).

5.62k Ω \rightarrow 562 \times 10¹ \rightarrow 5621 RM1/4PC $\begin{matrix} 5 & 6 & 2 & 1 & F \end{matrix}$

Mark	No.	Description	Parts No.	Mark	No.	Description	Parts No.
------	-----	-------------	-----------	------	-----	-------------	-----------

LIST OF ASSEMBLIES

		FM/AM TUNER MODULE	AXQ1012
		AF ASS'Y	AWK7018
		— AF CD ASSY	AWZ7544
		— VR ASSY	AWZ7551
NSP		— HEADPHONE ASSY	AWZ7555
NSP		— S. TRANS ASSY	AWZ7557
NSP		COMPLEX ASS'Y	AWM7147
		— DISPLAY ASSY	AWZ7525
		— PRIMARY ASSY	AWZ7535
		— SW ASSY	AWZ7537
		— MIC ASSY	AWZ7539
		POWER AMP MODULE	AXQ7017
		— FRONT 100W ASSY	AWZ7518
		— REGULATOR ASSY	AWZ7520
		CASSETTE MOD. B	EXK2435
		— DECK UNIT	EWM1005
		MULTI MECHA ASSY	AXA7006
NSP		— LOADING BOARD ASS'Y	AWZ7207
NSP		— MOTOR BOARD ASS'Y	AWZ7208
NSP		— SELECT BOARD ASS'Y	AWZ7209
NSP		— MECHANISM BOARD ASS'Y	PWX1192

FM/AM TUNER MODULE

SEMICONDUCTORS

IC6201	LA1836M
IC6202	LM7001J
Q6102	2SC2223
Q6203	2SC2235
Q6202	2SC2712
Q6103, Q6214	2SC2714
Q6201	2SK208
Q6104	2SK302
Q6101	3SK194
Q6204	XDA124EK
Q6217	XDC124EK
D6101, D6102	1T33

COILS AND FILTERS

L6104	ATC1003
L6101	ATC1020
L6102	ATC1021

T6101	ATE-063
L6207	ATE1013
F6203, F6204	ATF-119
F6101	ATF-155
F6202 (450KHZ)	ATF1155
L6103 (2.2 μ H)	ATH1043
L6202, L6203, L6208	LCTA2R2J3225

CAPACITORS

C6202, C6234, C6236 (1 μ F/16V)	ACG1051
C6107	CCSCH010C50
C6229	CCSCH821J50
C6110	CCSQCH020C50
C6101	CCSQCH050C50
C6108, C6203, C6268	CCSQCH101J50
C6111, C6116, C6208, C6221, C6222	CCSQCH150J50
C6115	CCSQCH330J50
C6114	CCSQRH080D50
C6113	CCSQRH180J50
C6105	CCSQTH150J50
C6261	CEAS010M50
C6224, C6246, C6262	CEAS100M50
C6216, C6217	CEAS330M16
C6231, C6233	CEAS3R3M50
C6219	CEAS470M10
C6243-C6245	CEAS470M16
C6227	CEAS470M25
C6238	CEJA100M16
C6249, C6250	CEJA4R7M35
C6215	CFTXA103J50
C6214	CFTXA224J50
C6103, C6106, C6112, C6204	CKSQYB102K50
C6102, C6109, C6117, C6210, C6264	CKSQYB103K50
C6213	CKSQYB223K50
C6230	CKSQYB333K50
C6228, C6252	CKSQYB472K50
C6209, C6237, C6265, C6267	CKSQYB473K50
C6212, C6218	CKSQYF103Z50
C6220, C6226, C6239, C6242, C6255	CKSQYF223Z50
C6235	CKSQYF224Z25
C6225, C6241, C6266	CKSQYF473Z50
C6232	CKSYB333K50
C6251	CKSYB472K50
C6223	CKSYF103Z50
C6263	CKSYF473Z50

XR-P5500M, XR-P4500M

Mark	No.	Description	Parts No.	Mark	No.	Description	Parts No.
RESISTORS				C3303, C3304		CCSQCH220J50	
	VR6201 (10k)		ACP1056	C2204		CCSQCH331J50	
	VR6202		VRTB6VS223	C8435--C8438		CCSQCH560J50	
	R6299, R6300		RD1/8PM102J	C2702, C2703		CCSQSL391J50	
	R6113, R6116, R6118, R6268-R6271		RS1/8S000J	C8433, C8434		CEANP2R2M50	
	R6275, R6276, R6278, R6283, R6284		RS1/8S000J				
	R6290, R6293, R6294, R6297		RS1/8S000J	C1019		CEAS010M50	
	R6243, R6244		RS1/8S101J	C1225		CEAS100M50	
	R6211		RS1/8S103J	C1016		CEAS101M10	
	R6237		RS1/8S182J	C1011, C1012		CEAS101M25	
	R6209		RS1/8S221J	C1020		CEAS101M35	
	R6239		RS1/8S332J	C1018		CEAS101M63	
	R6101		RS1/8S470J	C1007		CEAS220M50	
	Other Resistors		RS1/10S□□□□	C1017		CEAS221M35	
				C1004		CEAS222M35	
				C8216, C8217, C8302		CEAS330M35	
OTHERS				C8175, C8176		CEAS331M16	
	BN6201 TERMINAL 4-P		AKA1016	C1003		CEAS332M35	
	X6203 CRYSTAL RESONATOR (7.2MHz)		ASS1042	C1013, C1014		CEAS470M25	
	X6201 CRYSTAL RESONATOR (456kHz)		ASS1066	C2251, C2252		CEAS470M50	
	X6202 CERAMIC RESONATOR (450kHz)		ATF1027	C3301, C3302, C3501, C8160, C8162		CEAS470M50	
	AM RF TUNING BLOCK		AXX1041			CEAS470M50	
AF CD ASSY				C1501, C1502		CEASR15M50	
SEMICONDUCTORS				C3502, C3601, C8309		CEASR47M50	
	IC8151		CXA1372Q	C2503, C2504		CEYA2R2M50	
	IC8301		CXD2507AQ	C1040		CKCYF473Z50	
	IC1001		ICP-N70	C8164, C8167, C8169, C8212		CKSQYB103K50	
	IC8201, IC8202		LA6520				
	IC2104		M66311FP	C8306, C8441, C8442		CKSQYB152K50	
	IC2101		MC14052BF	C3309, C3310, C8155		CKSQYB182K50	
	IC2201, IC2202, IC3301, IC3501, IC3601		NJM4558M-D	C3503		CKSQYB223K50	
	IC8405		NJM4558M-D	C3305, C3306		CKSQYB273K50	
	IC2102		TC9162N	C3307, C3308, C8170		CKSQYB332K50	
	IC8401		TC9268F				
	Q1002, Q1040		2SA1515	C8156, C8168		CKSQYB333K50	
	Q1006		2SB1425	C2201-C2203		CKSQYB471K50	
	Q1005, Q106		2SB560	C8171, C8172		CKSQYB472K50	
	Q1403, Q9001, Q9002		2SC2458	C8307		CKSQYB473K50	
	Q1003		2SC3377	C8474, C8476, C8478		CKSQYB561K50	
	Q105		2SD438				
	Q8401		2SK246	C3311, C3312, C8157, C8202, C8203		CKSQYF103Z50	
	Q1001, Q1007, Q1041		RN1201	C8205-C8207		CKSQYF103Z50	
	Q1004, Q9004		RN2201	C1305-C1308, C2253, C2257, C2258		CKSQYF104Z50	
	Q8402		RN2203	C8158, C8159, C8161, C8163, C8301		CKSQYF104Z50	
	D1002		D2SBA20 (B)	C8304, C8308, C8361, C8414, C8415		CKSQYF104Z50	
	D1001		D5SB20F				
	D1021, D1022, D1031-D1033		HSS104-02	C8431, C8432, C8461, C8462, C8473		CKSQYF104Z50	
	D1153, D1154, D6901, D8301, D8401		HSS104-02	C8477		CKSQYF104Z50	
	D1023		RD30ESB4	RESISTORS			
	D1151, D1152		RD5.1ESB	VR8151, VR8152 (22k)		ACP1057	
	D1011, D1012		RD5.6ESB2	R2125		RA11T103J	
	D2201, D8211		RD6.2ESB	R1159, R1160		RD1/2PM151J	
	D1010		RD7.5ESB	R1064, R1153, R1157		RD1/4PM102J	
	D1007-D1009, D1013-D1020		S5688G	R1041		RD1/4PM222J	
	D1024, D1025, D1041-D1043		S5688G				
	D1996-D1999		S5688G	R1002		RD1/4PM272J	
CAPACITORS				R1003		RD1/4PM472J	
	C1010, C1021 (0.01/150V)		ACG1005	R1305, R1306		RD1/4PMF6R8J	
	C1001, C1002 (4700/63V)		ACH1249	R1031, R2101, R2102, R2105-R2107		RD1/8PM102J	
	C2255, C8173, C8174		CCSQCH101J50	R2111-R2113, R2129, R9007, R9008		RD1/8PM102J	
	C8429, C8430		CCSQCH121J50				
	C8403, C8404		CCSQCH150J50	R1011, R1040, R1063, R1154, R1158		RD1/8PM103J	
				R8368		RD1/8PM105J	
				R1032		RD1/8PM152J	
				R1012, R1039		RD1/8PM203J	
				R1009		RD1/8PM303J	
				R1051		RD1/8PM331J	
				R3502		RD1/8PM433J	
				R1052		RD1/8PM471J	
				R1151, R2136, R9005, R9006		RD1 8PM472J	

Mark	No.	Description	Parts No.
	R2114		RD1/8PM473J
	R1013		RD1/8PM562J
	R2121, R2122		RD1/8PM912J
	R1998		RS1LMF220J
	R1224		RS1LMF472J
	R1007, R1017		RS2LMFR22J
	R1999		RS3LMF3R9J
	Other Resistors		RS1/10S□□□□

OTHERS

CN8131	CONNECTOR	12FMZ-ABT
CN8203	CONNECTOR 4P	4-173981-4
CN8204	6P JUMPER CONNECTOR	52147-0610
CN2101	PIN JACK (2P)	AKB1171
	SPEAKER TERMINAL 4-P	AKE1026
CN1	36P SOCKET	AKP1105
CN10	CONNECTOR (5P)	KPC5
CN4	CONNECTOR (13P)	KPE13
X8401	XTAL RES (OSC) (16.9344MHz)	PSS1008
	PCB BINDER	VEF1008
CN8202	CONNECTER	VKN1051
KN8001	EARTH METAL FITTING	VNF1084

VR ASSY

SEMICONDUCTORS

IC1501		NJM4558M-D
IC1551		TA8409S

CAPACITORS

C1505, C1506		CCSQSL220J50
C1554		CEAS101M25
C1503, C1504		CEYA2R2M50
C1557, C1558		CKSQYB333K50
C1509, C1510		CKSQYB473K50
C1551-C1553, C1555, C1556		CKSQYF104Z50
C1511		CKPUYF104Z50

RESISTORS

VR301 (100K-B3×2)		ACX7004
R1559, R1560		RD1/8PM391J
Other Resistors		RS1/10S□□□□

HEADPHONE ASSY

CAPACITORS

C1255		CKSQYF473Z50
-------	--	--------------

RESISTORS

R1201, R1202		RS3LMF331J
--------------	--	------------

OTHERS

CN1201 JACK		AKN1028
-------------	--	---------

S.TRANS ASSY

SEMICONDUCTORS

IC1002-IC1005		ICP-N70
---------------	--	---------

DISPLAY ASSY

SEMICONDUCTORS

IC1951		M66311FP
IC3701-IC3703		NJM4558M-D
IC1901		PD4583A
Q1901		2SC2458
Q1902		RN1201

Mark	No.	Description	Parts No.
	Q1707		RN2201
	D1801-D1815, D1901, D1903		HSS104-02
	D1905, D1906, D3701-D3705		HSS104-02
	D1951, D1953		HZS6CL
	D1904		HZS7AL
	D1705		BR3371XJ30A

COILS AND FILTERS

L1901		LAU220J
-------	--	---------

SWITCHES AND RELAYS

S1801-S1815		ASG1051
-------------	--	---------

CAPACITORS

C1903 (0.047/5.6V)		ACH1246
C1952		CCSQCH101J50
C1907		CEAS010M50
C1910		CEAS100M50
C1905		CEJA221M6
C1902		CEJA470M16
C1908		CFTYA224J50
C1915, C1916		CKSQYB102K50
C1954		CKSQYB103K50
C3710, C3711		CKSQYB152K50

C3704, C3705		CKSQYB153K50
C1970, C3713, C3714		CKSQYB471K50
C3707, C3708		CKSQYB472K50
C3701, C3702		CKSQYB473K50
C1909		CKSQYF102Z50

C1955		CKSQYF103Z50
C1901, C1904, C1906, C1911, C1912		CKSQYF473Z50
C3703, C3706, C3709, C3712, C3715		CKSQYF473Z50

RESISTORS

R1955, R1956		RA15T473J
R1803, R1804		RD1/8PM223J
Other Resistors		RS1/10S□□□□

OTHERS

V1701 FL TUBE		AAV7002
CN1001 36P SOCKET		AKP1109
X1901 CERAMIC RESONATOR (4.19MHz)		ASS1018
X1902 REMOTE RECEIVER UNIT		GP1U27X

PRIMARY ASSY

COILS AND FILTERS

L1101		ATF1136
-------	--	---------

CAPACITORS

C1101 (0.01/400V)		ACG1002
-------------------	--	---------

RESISTORS

R1101 (2.2M, 1/2W)		ACN-208
--------------------	--	---------

SW ASSY

SEMICONDUCTORS

Q1701-Q1706		2SA1048
D1708		BR3371XJ30A
D1706, D1707, D1709-D1714		MPG3362X195A

SWITCHES AND RELAYS

S1816-S1835		ASG1051
-------------	--	---------

XR-P5500M, XR-P4500M

Mark	No.	Description	Parts No.
RESISTORS			
	R1703		RD1/8PM201J
	R1704		RD1/8PM241J
	Other Resistors		RS1/10S□□□□
MIC ASSY			
SEMICONDUCTORS			
	IC2501		NJM4558M-D
CAPACITORS			
	C2504		CCSLSL221J50
	C2503, C2505		CEAS100M50
	C2501		CKSQYB122K50
	C2507		CKSQYB473K50
	C2506		CKSQYB682K50
	C2508, C2509		CKSQYF473Z50
RESISTORS			
	VR2501 (10K-B)		ACS1028
	Other Resistors		RS1/10S□□□□
OTHERS			
	CN2501	JACK	AKN-207
FRONT 100W ASSY			
SEMICONDUCTORS			
	IC7501		UPC4570G2 (5)
	Q7507, Q7508		2SA1182
	Q7601		2SA1255
	Q7501, Q7502		2SC2240
	Q7505, Q7506		2SC2859
	Q7602, Q7603		2SC3138
	D7505, D7506, D7517, D7518		1SS181
	D7503, D7504, D7516		1SS184
	D7535-D7538		1SS226
	D7521-D7524		1SS244
	D7519, D7520, D7525, D7526, D7531		HSS104-02
	D7533		HSS104-02
	D7507-D7510		RD3.3ESB2
CAPACITORS			
	C7523, C7524		CEALR10M50
	C7519-C7522, C7545-C7552		CCSQCH101J50
	C7525-C7528		CCSQCH271J50
	C7503, C7504		CCSQCH331J50
	C7541, C7542		CCSQCH470J50
	C7509, C7510		CEAS101M10
	C7602		CEJA221M6R3
	C7540		CEJA3R3M50
	C7539		CEJA4R7M50
	C7529-C7532		CKSQYB333K50
	C7699		CKSQYB104K25
	C7543, C7544		CKSQYB472K50
	C7601, C7603		CKSQYF104Z50
	C7537		CKSQYF473Z50
RESISTORS			
	R7519, R7520 (634)		ACN1106
	R7515, R7516 (1.8k)		ACN1107
△	R7541, R7542		RD1/4PMF100J
△	R7547-R7550		RS1/10S2200F
	R7753		RS1/8S000J
△	R7537-R7540		RS1/8S100J
	R7553		RS1/8S101J
△	R7543, R7544		RS1/8S7R5J
	Other Resistors		RS1/10S□□□□

Mark	No.	Description	Parts No.
REGULATOR ASSY			
SEMICONDUCTORS			
	IC7201		PAC006C
	Q7301, Q7302		2SC1815
	Q7202		2SC2712
	D7204		1SS184
	D7205, D7208		HSS104-02
	D7210		RB441Q-40
	D7207		RD5.6ESB2
	D7206, D7211		RD4.7ESB
CAPACITORS			
	C7402, C7406, C7408 (0.082μF/25V)		ACG1050
	C7204 (1μF/16V)		ACG1051
	C7401, C7405, C7407 (0.33μF/50V)		ACG1053
	C7409 (10μF/35V)		ACH1150
	C7140		CEAS010M50
	C7205		CEJA101M10
	C7202		CEANL4R7M50
	C7203		CEJAR33M50
	C7201, C7208, C7219		CKSQYB103K50
	C7301		CKSQYB332K50
	C7206, C7215, C7216, C7404		CKSQYF104Z50
RESISTORS			
	VR7201 (22K)		RCP1103
△	R7403-R7405 (1Ω)		ACN1104
	R7252		RD1/6PM102J
	R7253		RD1/6PM103J
	R7303		RS1/10S1002F
	R7304		RS1/10S8200F
	Other Resistors		RS1/10S□□□□
OTHERS			
	CN7101	12P JUMPER CONNECTOR	KPE12
DECK UNIT			
SEMICONDUCTORS			
	IC4421		CXA1100P
	IC4901		M66320FP
	IC4202		MC14066BF
	IC4101, IC4151, IC4301		NJM4558M-D
	Q4111, Q4113, Q4161, Q4352		2SA1515
	Q4356		2SC2240
	Q4101, Q4102, Q4151, Q4152, Q4203-Q4206, Q4301, Q4302, Q4305, Q4306, Q4451-Q4454		2SC2458
	Q4355		2SC2712
	Q4353, Q4354		2SC3377
	Q4307, Q4308		2SK373
	Q4303, Q4901		XDA124ES
	Q4208		XDA143ES
	Q4112, Q4114, Q4155, Q4162, Q4357		XDC124ES
	Q4207, Q4351		XDC143ES
	D4111, D4161, D4201, D4202, D4301-D4306, D4451-D4453, D4901-D4906		HSS104-02
COILS AND FILTERS			
	F4401, F4402		ATF1064
	T4351		ATX-043
	L4301, L4302		LTA392J
	L4303, L4304		LTA822J

Mark	No.	Description	Parts No.
CAPACITORS			
	C4361 (2000P/630V)		ACE1020
	C4319, C4320		CCDSL271K500
	C4323, C4324		CCSQCH100D50
	C4902		CCSQCH101J50
	C4353		CCSQCH221J50
	C4109, C4110, C4159, C4160		CCSQCH471J50
	C4151, C4152		CCSQCH561J50
	C4101, C4102, C4321, C4322, C4355		CCSQCH681J50
	C4303, C4304, C4451, C4452		CEAS010M50
	C4359, C4360, C4364, C4403-C4405, C4407, C4454		CEAS100M50
	C4401, C4408		CEAS101M25
	C4365, C4366, C4453		CEAS220M50
	C4301, C4302, C4315, C4316		CEAS2R2M50
	C4103, C4104, C4153, C4154, C4309, C4310,		CEAS330M25
	C4317, C4318		
	C4357		CEAS3R3M50
	C4107, C4108, C4157, C4158		CEAS470M25
	C4351		CEAS470M25
	C4207, C4208		CEAS4R7M50
	C4402, C4406		CEASR22M50
	C4363		CKCYB222K500
	C4352, C4354, C4903, C4904		CKSQYB103K50
	C4313, C4314		CKSQYB152K50
	C4307, C4308		CKSQYB273K50
	C4305, C4306		CKSQYB333K50
	C4901		CKSQYF473Z50
	C4358		CQMA123K250
	C4356		CQMA153J50
	C4362		CQMA562K400
	C4105, C4106		CQMA682J50
	C4155, C4156		CQMA682J50
	C4311, C4312		CQMA823J50

Mark	No.	Description	Parts No.
RESISTORS			
	VR4111		VRTP6HS682
	VR4201-VR4204		VRTP6HS203
	VR4351, VR4352		VRTP6HS204
	VR4301, VR4302		VRTP6HS502
	R4353		RD1/2PM680J
	R4121		RD1/8PM163J
	R4401, R4402		RD1/8PM242J
	R4361, R4362		RD1/8PM333J
	R4357		RD1/8PM6R8J
	R4113, R4114, R4163, R4164, R4323, R4324		RD1/8PM820J
	R4452		RD1/8PM103J
	Other Resistors		RS1/10S□□□□

Mark	No.	Description	Parts No.
OTHERS			
	CN24	3P SOCKET	EKS1018
	CN25	5P SOCKET	EKS1019
	CN16	12P JUMPER CONNECTOR	KPE12
	CN3002	15P JUMPER CONNECTOR	KPE15

Mark	No.	Description	Parts No.
LOADING BOARD ASSY			
SWITCHES AND RELAYS			
	S601, S602		DSG1016

Mark	No.	Description	Parts No.
OTHERS			
	CN601	CONNECTOR 4P	4-173979-4

Mark	No.	Description	Parts No.
MOTOR BOARD ASSY			
OTHERS			
	CN602	6PJUMPER CONNECTOR	52151-0610
SELECT BOARD ASSY			
SWITCHES AND RELAYS			
	S604-S606		DSG1016
	S603		PSG1010
MECHANISM BOARD ASSY			
SWITCHES			
	S610		DSG1016
OTHERS			
	CN610	MT CONNECTOR 4P	173979-4

6. ADJUSTMENTS

6.1 TUNER SECTION

■ FM Tuner Section

- Set the mode selector to FM BAND.
- Connect the wiring as shown in Fig. 1-1.

Step No.	Adjustment Title	FM SG (1kHz, ± 75 kHz dev.)		Reception Frequency Display	Adjustment Location	Specifications
		Frequency (MHz)	Level (dB μ V)			
1	Center Adjustment	98 Non modulation	80 or more	—	L6207	Adjust so that the DC voltage between Pin 4 and Pin 28 of IC6201 becomes $0V \pm 50mV$.
2	Front End Sensitivity	98	10-30	98MHz	L6102 T6101	Adjust so that the DC voltage of the Pin12 of IC6201 (S-meter) becomes at maximum level.
3	TUNED IND. Lighting Level	98	15 ± 2	98MHz	VR6201	Adjust so that the indicators of TUNED IND. start to light up.

Notes:

- Before adjusting, make sure there is no gap between L6101 and L6102. If there is a gap between them, bring them into contact with each other first, and then make adjustments.
- Make indicator adjustments in order of AM \rightarrow FM.

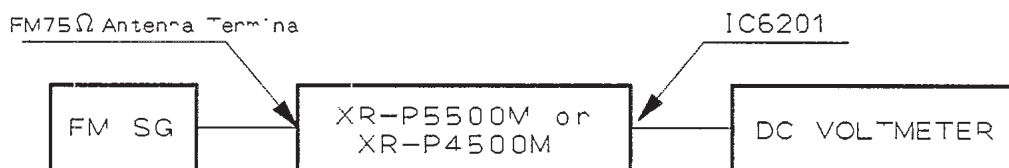

Fig. 1-1 FM Adjustment Connection Diagram

■ AM Tuner Section

- Set the mode selector to AM BAND.
- Connect the wiring as shown in Fig. 1-2.

Step No.	Adjustment Title	AM SG (400Hz, 30% Mod.)		Reception Frequency Display	Adjustment Location	Specifications
		Frequency (kHz)	Level (dB μ V/m)			
1	TUNED IND. Lighting Level	999	47 ± 2	999kHz	VR6202	Adjust so that the indicators of TUNED IND. start to light up.

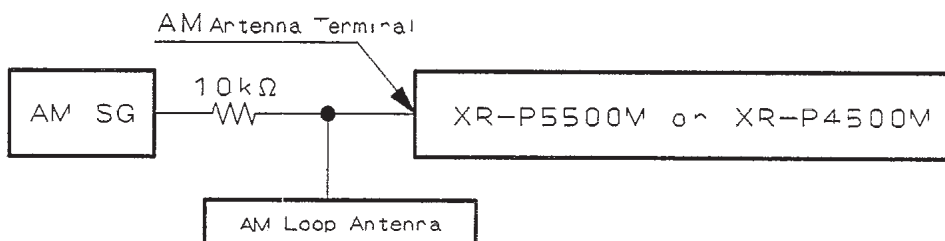

Fig. 1-2 AM Adjustment Connection Diagram

FM/AM TUNER MODULE

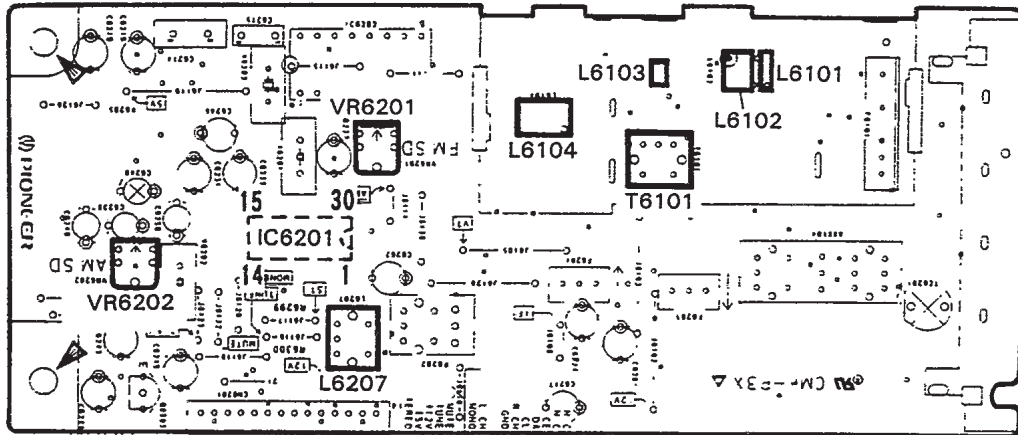

Fig. 1-3 Adjustment Points

6.2 POWER AMP MODULE SECTION (Refer to Fig. 2-1.)

1. Handling Precautions

- Since the heat sink and transistor metallic parts are connected to the Front Amp output, make sure they do not contact the GND (chassis) or other circuits.
- Since there is residual high voltage in the Power Amp Module $\pm B1$ (FRONT 100W ASSY) and $\pm B2$ (REGULATOR ASSY) even when the power is OFF, caution should be exercised. (If necessary, the voltage should be discharged).
- When handling the Power Amp Module, make sure you do not touch the fan motor blade.

2. Adjustment and Confirmation of Idle Current

- Basically, the idle current needs to be confirmed when replacing a power transistor, driver transistor, or bias transistor, or when the entire split board Assy of the Power Amp Module has been replaced.
- Make sure the heat sink has cooled sufficiently before measuring the idle current. (Temperature should be the same as room temperature; 25°C is ideal, if possible.)
- Idle current stipulated value: 3-50mA.

■ Front Amp Side (FRONT 100W ASSY)

Step	Measurement	Item	Remarks
1	Lch side	Insert a resistor (0.22Ω, 3W or more) in series in the connector CN7502 +B1 (or -B1) line (terminal No. 5 or 6). (Refer to Fig. 2-2.)	For measuring voltage at both sides of resistor
2		Short both sides of C7524.	Do not operate Rch side.
3		Turn the power ON, wait 6 seconds, and then measure the resistance voltage in Step 1.	Lch Idle current $I = V / 0.22 (\Omega)$
4	Rch side	<ul style="list-style-type: none"> ● Same as Step 1 above. ● Short both sides of C7523. 	Do not operate Lch side.
5		Turn the power ON under the above conditions, and after 6 seconds measure the resistance voltage in Step 1.	
6	—	If the measured idle current is greater than 50mA, perform the following procedure.	
7	Lch side	Short between the Point A pattern in Fig. 2-3 using solder.	Connect R7517 to R7515 in a parallel circuit.
8	Rch side	Short between the Point B pattern in Fig. 2-3 using solder.	Connect R7518 to R7516 in a parallel circuit.
9	—	After performing Steps 7 and 8, remeasure the idle current and confirm that it is below 50mA.	

Step	Measurement	Item	Remarks
10	—	If the measured idle current is below 3mA, perform the following procedure.	
11	Lch side	Short between the Point C pattern in Fig. 2-3 using solder.	Connect R7551 to R7519 in a parallel circuit.
12	Rch side	Short between the Point D pattern in Fig. 2-3 using solder.	Connect R7552 to R7520 in a parallel circuit.
13	—	After performing Steps 11 and 12, remeasure the idle current and confirm that it is greater than 3mA. (Within 3-50mA)	

FRONT 100W ASSY
(Front Amp Side)

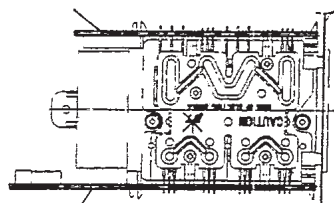

REGULATOR ASSY
(Rear Amp Side)

Fig. 2-1 Power Amp Module
(POWER MOD. F100)

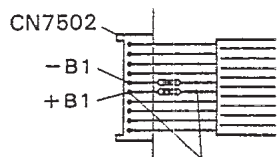

Resistor (0.22Ω, 3W or more)

Fig. 2-2 FRONT 100W ASSY

3. Adjusting the Operating Temperature Setting of the Fan Motor (VR7201)

This adjustment is necessary when IC7401 (+12V regulator), Q7301 and Q7302 (temperature sensors), IC7201 (protection IC), or VR7201 has been replaced, or when the entire split board Assy of the Power Amp Module has been replaced.

■ Adjustment-Related Cautions

- Make sure the heat sink has sufficiently cooled (is the same as room temperature Ta.)
- Once the power has been turned ON, make measurements and adjustments as quickly as possible. (If too much time is taken, the heat sink temperature will rise, and the measurements will deviate from the Ta measurement point.)

■ Adjustment

1. Connect a voltmeter between TEMP and VL (or between IC7201 terminals No.9 and 7). (Refer to Fig. 2-4.)
2. Determine the fan motor operating temperature setting by means of the following formula. (Tolerance is within ±30mV.)
Formula: $(75^{\circ}\text{C} - T_a) \times 19 \text{ (mV)}$
Ta: ambient temperature ($^{\circ}\text{C}$)
3. Adjust VR7201 so that the voltage between TEMP and VL is the value obtained from the above formula.

For example:
when the room temperature is 25 $^{\circ}\text{C}$,
set value = $(75 - 25) \times 19 \text{ (mV)}$
= 950mV (tolerance within ±30mV).

REGULATOR ASSY

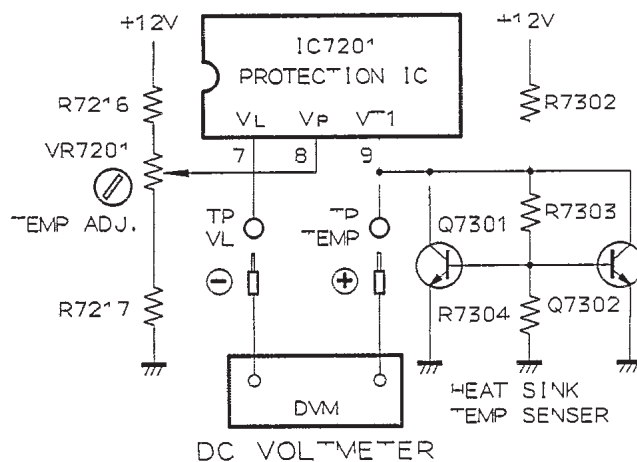

Fig. 2-4 Adjustment of Operating Temperature Setting of Fan Motor

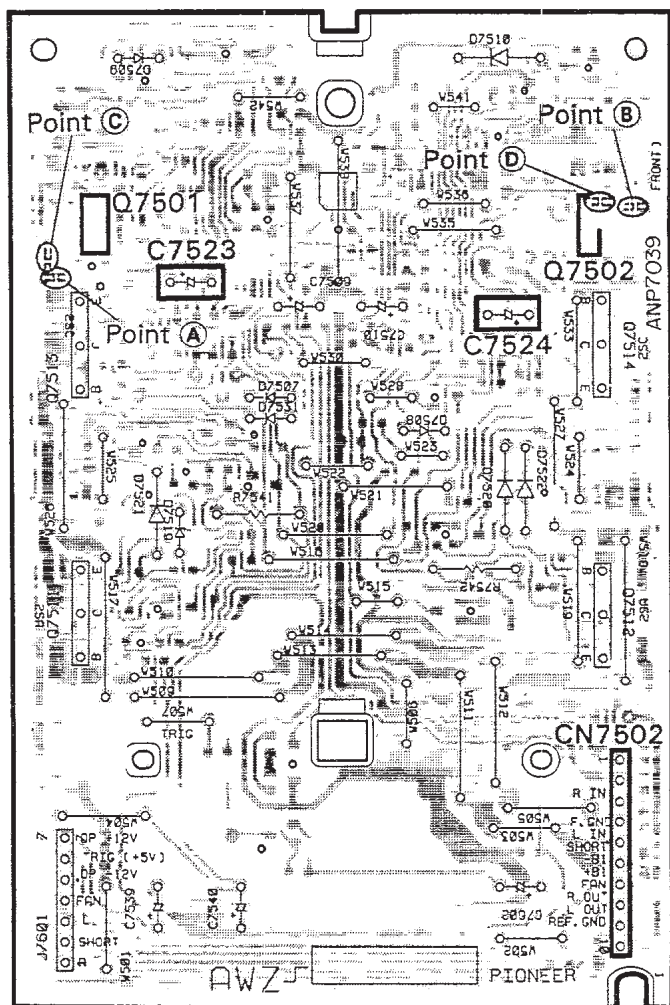

Fig. 2-3 FRONT 100W ASSY

6.3 CASSETTE DECK SECTION

- Adjustment points and test points are shown in Fig. 3-2 and Fig. 3-4.

■ Mechanical Adjustment

- Set the TAPE function.
- Test tape: STD-301 (3kHz, 30min).

1. Tape Speed Adjustment

No.	Mode	Test Tape	Adjusting Points	Measurement Points	Adjustment Procedure	Remarks
1	PLAY	STD-301 (Playback: 3kHz)	DECK Unit VR4111	TAPE TEST POINT (Rch) (AF CD Assy)	Press the PLAY SW and adjust so that the reading becomes 3010Hz ± 10Hz. Confirm that wow & flutter level is below 0.2% (in the reverse direction, confirm that the reading is within 3010Hz ± 60Hz).	

■ Electrical Adjustment

Check the following before starting.

1. Confirm that the tape speed adjustment has been completed.
2. Clean the heads and demagnetize them using a head eraser.
3. Set the measurement level to 0 dBV = 1 Vrms.
4. Use the specified tape for adjustment. Use the labeled (A) side of the test tape.
STD-331E: For playback adjustment
STD-631: Normal blank tape
5. Provide yourself with the following measuring devices:
 - AC millivoltmeter
 - Low-frequency oscillator
 - Attenuator
 - Oscilloscope
6. Adjust both right and left channels unless otherwise specified.
7. Turn the DOLBY NR switch off unless otherwise specified.
8. Warm up the unit for several minutes before adjustment. In particular, be sure to warm up the unit in the REC/PLAY mode for 3 to 5 minutes before starting recording/playback frequency characteristics adjustment.
9. Always follow the indicated adjustment order. Otherwise, a complete adjustment may not be achieved.

Playback Adjustment (Decks I and II)

1. Head Azimuth Adjustment
2. Playback Level Adjustment

Recording Adjustment (Deck II)

1. Bias Oscillation Frequency Adjustment
2. Recording Bias Adjustment
3. Recording Level Adjustment.
4. ALC Operation Check

**As the reference recording level is 250nwb/m for STD-331E, the recording level will be higher by 4 dB for STD-331B (160nwb/m). When adjusting, pay carefull attention to the type of tape used.*

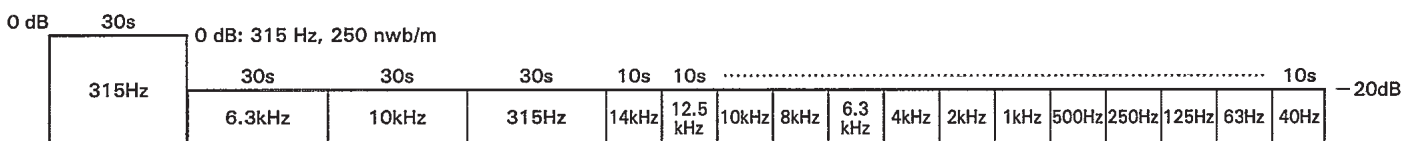

Fig. 3-1 STD-331E Test Tape

Dolby noise reduction manufactured under license from Dolby Laboratories Licensing Corporation.
 "DOLBY" and the double-D symbol \square are trademarks of Dolby Laboratories Licensing Corporation.

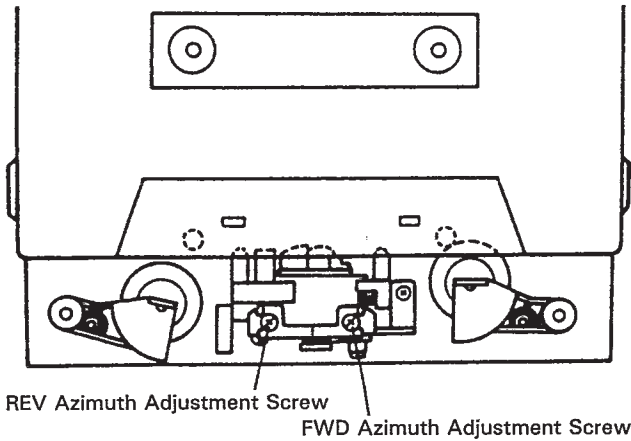
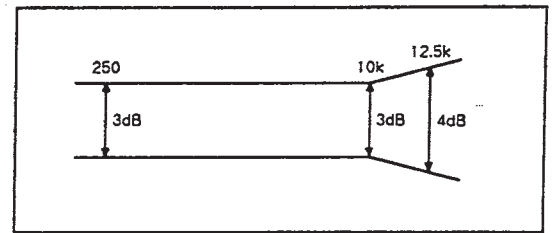

Fig. 3-2 Head Azimuth Adjustment

PLAY BACK



RECORDING

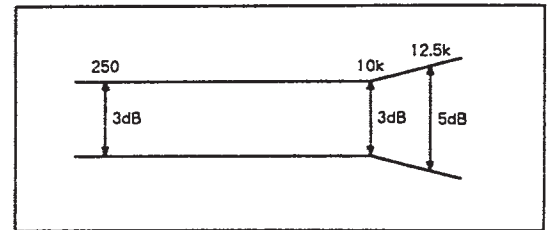

Fig. 3-3 Frequency Characteristics

● Playback Adjustment

1. Head Azimuth Adjustment

- This unit is equipped with auto tape selector.
- Do not switch between forward and reverse operation with the screwdriver inserted.

Step	Tape Selector (AUTO)	Mode	Input Signal/ Test Tape	Adjusting Points		Measurement Points	Adjustment Value	Remarks
1	NORMAL	PLAY	STD-331E test tape (Playback: 10kHz, -20dB)	Deck I	Head azimuth adjustment screw (Fig. 3-2)	TAPE TEST POINT (L, Rch) (AF CD Assy)	Max. playback signal level	After adjustment, apply silicon bond to the head azimuth adjustment screw.
				Deck II				

2. Playback Level Adjustment

- Since this adjustment determines playback Dolby NR level, perform it carefully.

Step	Tape Selector (AUTO)	Mode	Input Signal/ Test Tape	Adjusting Points		Measurement Points	Adjustment Value	Remarks
1	NORMAL	PLAY	STD-331E test tape (Playback: 315Hz, 0dB)	Deck I	VR4201 (Lch) VR4202 (Rch)	TAPE TEST POINT (L, Rch) (AF CD Assy)	-1.2 dBV	
				Deck II	VR4203 (Lch) VR4204 (Rch)			

● Recording Adjustment

1. Bias Oscillation Frequency Adjustment

Step	Tape Selector (AUTO)	Mode	Input Signal/Test Tape	Adjusting Points	Measurement Points	Adjustment Value	Remarks
1	NORMAL	REC	Load the STD-631 test tape and set the recording mode.	Deck I	—	Oscillation frequency to be 105.0kHz ± 2kHz.	When the power is turned ON while the BAND button is depressed, the frequency will decrease 2-3 kHz.
				Deck II	T4351		

2. Recording Bias Adjustment

● Since this adjustment affects recording bias, prevent distortion from increasing due to underbias.

Step	Tape Selector (AUTO)	Mode	Input Signal/Test Tape	Adjusting Points	Measurement Points	Adjustment Value	Remarks
1	NORMAL	REC	Input a 315Hz signal to the VIDEO/AUX IN terminal and set the input selector to VIDEO.	Deck I	—	TAPE TEST POINT (L, Rch) (AF CD Assy)	-25.2 dBV
				Deck II	Input signal level		
2	NORMAL	REC/PLAY	Load the STD-631 test tape and record/playback the 315Hz and 10kHz signals. (see the Note below)	Deck I	—	TAPE TEST POINT (L, Rch) (AF CD Assy)	Repeat adjustment until playback level of the 10kHz signal is within 0±0.5dB from that of the 315Hz signal.
				Deck II	VR4351 (Lch) VR4352 (Rch)		

Note: Set to the same level used for the 315Hz input signal at step 1.

3. Recording Level Adjustment

Step	Tape Selector (AUTO)	Mode	Input Signal/Test Tape	Adjusting Points	Measurement Points	Adjustment Value	Remarks
1	NORMAL	REC	Input a 315Hz signal to the VIDEO/AUX IN terminal and set the input selector to VIDEO.	Deck I	Input signal level	TAPE TEST POINT (L, Rch) (AF CD Assy)	-5.2 dBV
				Deck II			
2	NORMAL	REC/PLAY	STD-631 test tape and record/playback the 315Hz signal.	Deck I	—	TAPE TEST POINT (L, Rch) (AF CD Assy)	Repeat recording, playback and adjustment until playback level of the 315Hz signal becomes -5.2dBV.
				Deck II	VR4301 (Lch) VR4302 (Rch)		

4. ALC Operation Check

Step	Tape Selector (AUTO)	Mode	Input Signal/Test Tape	Adjusting Points	Measurement Points	Adjustment Value	Remarks
1	NORMAL	REC • PAUSE	Input a 315Hz signal to the VIDEO/AUX IN terminal and set the input selector to VIDEO.	Input signal level	TAPE TEST POINT (L, Rch) (AF CD Assy)	-5.2 dBV	
2				Set to a level +10dB above the input level at step 1.		-2.2 ± 2.5dBV	

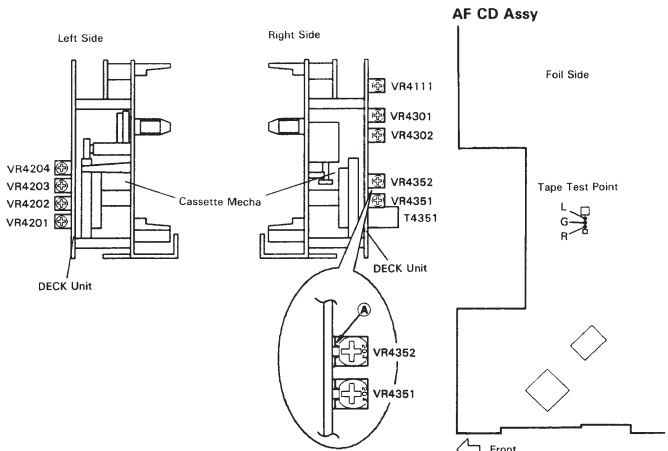

Fig. 3-4 Adjusting Points and Measurement Points

6.4 CD SECTION

■ Adjustment Methods

If a disc player is adjusted incorrectly or inadequately, it may malfunction or not work at all even though there is nothing at all wrong with the pickup or the circuitry. Adjust correctly following the adjustment procedure.

● Adjustment Items/Verification Items and Order

If the specified values cannot be obtained or no adjustment is possible by performing the verifications or adjustments described in steps 1-4, the pickup block may be defective.

Step	Item	Test Point	Adjustment Location
1	Focus offset verification	TP1, Pin6 (FOER)	None
2	Tracking error balance verification	TP1, Pin2 (TRER)	None
3	Pickup radial/tangential direction tilt adjustment	TP1, Pin1 (RF)	Radial tilt adjustment screw, Tangential tilt adjustment screw
4	RF level verification	TP1, Pin1 (RF)	None
5	Focus servo loop gain adjustment	TP1, Pin5 (FOIN) TP1, Pin6 (FOER)	VR8152 (FCS GAN)
6	Tracking servo loop gain adjustment	TP1, Pin3 (TRIN) TP1, Pin2 (TRER)	VR8151 (TRK GAN)

● Abbreviation Table

- FOER : Focus Error
- TRER : Tracking Error
- FCS GAN : Focus Gain
- TRK GAN : Tracking Gain
- FOIN : Focus In
- TRIN : Tracking In

● Measuring Instruments and Tools

1. Dual trace oscilloscope (10 : 1 probe)
2. Low-frequency oscillator
3. Test disc (VEDS-7)
4. Low pass filter (39kΩ + 0.001μF)
5. Resistor (100kΩ)
6. Standard tools

● Test Point and Adjustment Variable Resistor Positions

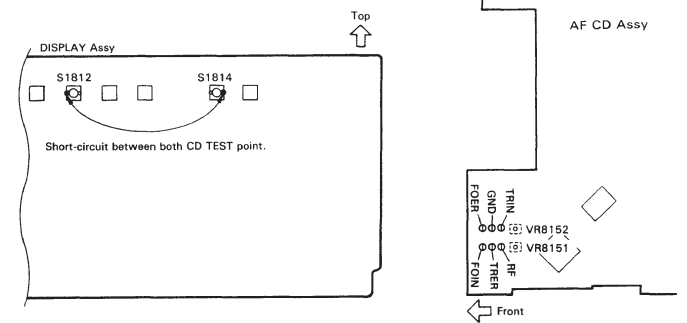

Fig. 1 Adjustment Location

● Notes

1. Use a 10 : 1 probe for the oscilloscope.
2. All the knob positions (settings) for the oscilloscope in the adjustment procedures are for when a 10 : 1 probe is used.

● Test Mode

These models have a test mode so that the adjustment and checks required for service can be carried out easily. When these models are in test mode, the keys on the front panel work differently from normal. Adjustments and checks can be carried out by operating these keys with the correct procedure. For these models, all adjustments are carried out in test mode.

[Setting these models to test mode]

How to set this model into test mode.

1. When the Power switch is activated, set the FUNCTION button to CD.
2. Short-circuit between both CD TEST points. (See Fig. 1)

When the test mode is set correctly, the display is different from what it usually is when the power is turned on. If the display is still the same as usual, test mode has not been set correctly, so repeat Steps 1 - 2.



[Release from test mode]

Here is the procedure for releasing the test mode:

1. Press the STOP key and stop all operations.
2. Turn off the power switch on the front panel.

[Operations of the keys in test mode]

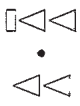
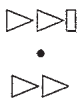
Code	Key Name	Function in Test Mode	Explanation
	DOLBY NR	Focus servo close	<p>The laser diode is lit up and the focus actuator is lifted up, then lowered slowly and the focus servo is closed at the point where the objective lens is focused on the disc.</p> <p>With the player in this state, if you lightly rotate the stopped disc by hand, you can hear the sound the focus servo.</p> <p>If you can hear this sound, the focus servo is operating correctly. If you press this key with no disc mounted, the laser diode lights up, the focus actuator is pulled up, then the actuator is lowered and raised three times and returned to its original position.</p>
▷/□□	PLAY/PAUSE	Spindle servo ON	<p>Starts the spindle motor in the clockwise direction and when the disc rotation reaches the prescribed speed (about 500rpm at the inner periphery), sets the spindle servo in a closed loop.</p> <p>Be careful. Pressing this key when there is no disc mounted makes the spindle motor run at the maximum speed.</p> <p>If the focus servo does not go correctly into a closed loop or the laser light shines on the mirror section at the outermost periphery of the disc, the same symptom is occurred.</p>
		Tracking servo close/open	<p>Pressing this key when the focus servo and spindle servo are operating correctly in closed loops puts the tracking servo into a closed loop, displays the track number being played back and the elapsed time on the front panel, and outputs the playback signal.</p> <p>If the elapsed time is not displayed or not counted correctly or the audio is not played back correctly, it may be that the laser is shining on the section with no sound recorded at the outer edge of the disc, that something is out of adjustment, or that there is some other problem.</p> <p>This key is a toggle key and open/close the tracking servo alternately. This key has no effect if no disc is mounted.</p>

Code	Key Name	Function in Test Mode	Explanation
	MANUAL/ TRACK SEARCH REV	Carriage reverse (inwards)	Moves the pickup position toward the inner diameter of the disc. When this key is pressed with the tracking servo in a closed loop, the tracking servo automatically goes into an open loop. Since the motor does not automatically stop at the mechanical end point in test mode, be careful with this operation.
	MANUAL/ TRACK SEARCH FWD	Carriage forward (outwards)	Moves the pickup position toward the outer diameter of the disc. When this key is pressed with the tracking servo in a closed loop, the tracking servo automatically goes into an open loop. Since the motor does not automatically stop at the mechanical end point in test mode, be careful with this operation.
	STOP	Stop	Initializes and the disc rotation stops. The pickup and disc remain where they are when this key is pressed.
	EJECT	CD magazine eject	Stores Disc 1 in the CD magazine, then ejects the CD magazine. However, even though the CD magazine is ejected, the pickup does not return to the park position. Even if the CD magazine is mounted again, the pickup remains where it is.

Note: When inserting the magazine, disc 1 of the magazine is loaded automatically.

[How to playback a disc in test mode]

In test mode, since the servos operate independently, playing back a disc requires that you operate the keys in the correct order to close the servos.

Here is the key operation sequence for playing back a disc in test mode.

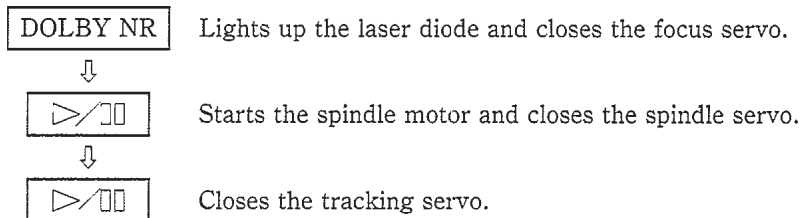

Wait at least 2–3 seconds between each of these operations.

1. Focus Offset Verification

● Objective	Verify the DC offset for the focus error amp.		
● Symptom when out of adjustment	The model does not focus in and the RF signal is dirty.		
● Measurement Instrument Connections	Connect the oscilloscope to TP1, Pin6 (FOER) [Settings] 5mV/division 10ms/division DC mode	● Player State ● Adjustment Location ● Disc	Test mode, stopped (just the Power switch on) None None needed
[Procedure] Verify the DC voltage at TP1, Pin6 (FOER) is $0 \pm 50\text{mV}$.			

Note: If the specified values cannot be obtained or no adjustment is possible by performing the verifications or adjustments described in adjustment items 1 – 4, the pickup block may be defective.

2. Tracking Error Balance Verification

● Objective	To verify that there is no variation in the sensitivity of the tracking photo diode.		
● Symptom when out of adjustment	Play does not start or track search is impossible.		
● Measurement Instrument Connections	Connect the oscilloscope to TP1, Pin2 (TRER). This connection may be via a low pass filter. [Settings] 50mV/division 5ms/division DC mode	● Player State ● Adjustment Location ● Disc	Test mode, focus and spindle servos closed and tracking servo open. None YEDS-7

[Procedure]

1. Move the pickup to midway across the disc (R=35mm) with the MANUAL/TRACK SEARCH FWD $\triangleright \triangleright \bullet \triangleleft \triangleleft$ key or REV $\triangleleft \triangleleft \bullet \triangleright \triangleright$ key.
2. Press the DOLBY NR key, then the PLAY/PAUSE \triangleright / \square key in that order to close the focus servo then the spindle servo.
3. Line up the bright line (ground) at the center of the oscilloscope screen and put the oscilloscope into DC mode.
4. Supposing that the positive amplitude of the tracking error signal at TP1, pin2 (TRER) is (A) and the negative amplitude is (B), the following expression is satisfied.

When $A \geq B$, $\frac{A-B}{C} \times \frac{1}{2} \leq 0.1$

When $A < B$, $\frac{B-A}{C} \times \frac{1}{2} \leq 0.1$

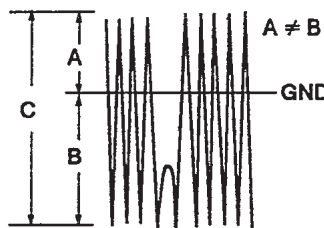

When there is a DC component

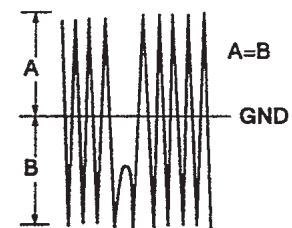

When there is no DC component

3. Pickup Radial/Tangential Tilt Adjustment

<ul style="list-style-type: none"> ● Objective 	To adjust the angle of the pickup relative to the disc so that the laser beams are shone straight down into the disc for the best read out of the RF signals.		
<ul style="list-style-type: none"> ● Symptom when out of adjustment 	Sound broken; some discs can be played but not others.		
<ul style="list-style-type: none"> ● Measurement Instrument Connections 	Connect the oscilloscope to TP1, Pin1 (RF). [Settings] 20mV/division 200ns/division AC mode	<ul style="list-style-type: none"> ● Player State ● Adjustment Location ● Disc 	Test mode, play Pickup radial tilt adjustment screw and tangential tilt adjustment screw YEDS-7

[Procedure]

1. Press the MANUAL/TRACK SEARCH FWD $\triangleright\triangleright \cdot \triangleright\triangleright$ key or REV $\triangleleft\triangleleft \cdot \triangleleft\triangleleft$ key to move the pickup to halfway across the disc (R=35mm). Press the DOLBY NR key, the PLAY/PAUSE \triangleright/\square key twice in that order to close the respective servos and put the player into play mode.
2. First, adjust the radial tilt adjustment screw with a Phillips screwdriver so that the eye pattern (the diamond shape at the center of the RF signal) can be seen the most clearly.
3. Next, adjust the tangential tilt adjustment screw with a Phillips screwdriver so that the eye pattern (the diamond shape at the center of the RF signal) can be seen the most clearly (Fig. 3).
4. Adjust the radial tilt adjustment screw and the tangential tilt adjustment screw again so that the eye pattern can be seen the most clearly. As necessary, adjust the two screws alternately so that the eye pattern can be seen the most clearly.
5. When the adjustment is completed, lock the radial and tangential adjustment screw.

Note: Radial and tangential mean the directions relative to the disc shown in Fig. 2.

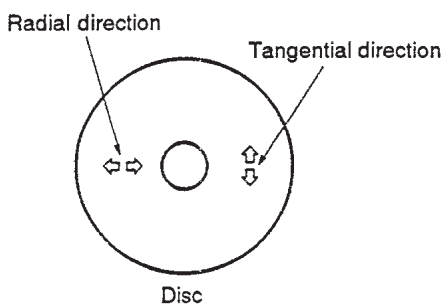
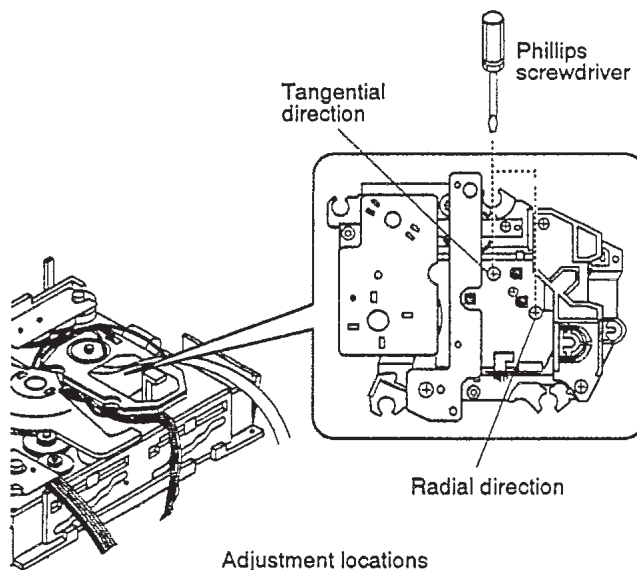

Fig. 2



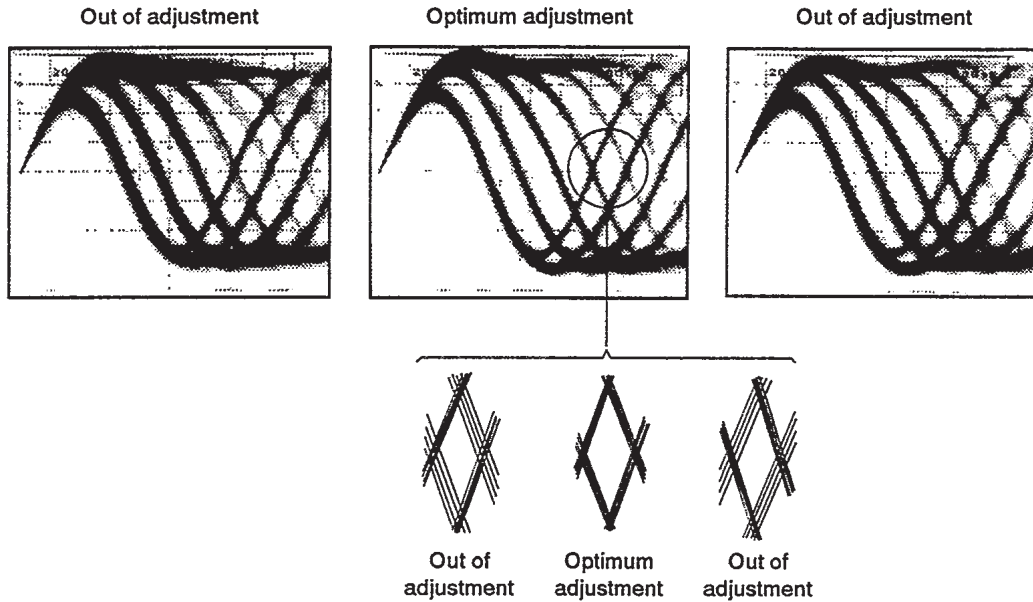

Fig. 3 Eye Pattern

4. RF Level Verification

● Objective	To verify the playback RF signal amplitude.		
● Symptom when out of adjustment	No play or no search		
● Measurement Instrument Connections	Connect the oscilloscope to TP1, Pin1 (RF). [Settings] 50mV/division 10ms/division AC mode	● Player State ● Adjustment Location ● Disc	Test mode, play None YEDS-7
[Procedure]			
1. Move the pickup to midway across the disc (R=35mm) with the MANUAL/TRACK SEARCH FWD $\triangleright\triangleright \bullet \triangleright\triangleright$ key or REV $\triangleleft\triangleleft \bullet \triangleleft\triangleleft$ key, then press the DOLBY NR key, the PLAY/PAUSE \triangleright/\square key twice in that order to close the respective servos and put the player into play mode.			
2. Verify the RF signal amplitude is $1.2V_{p-p} \pm 0.2V$.			

5. Focus Servo Loop Gain Adjustment

● Objective	To optimize the focus servo loop gain.		
● Symptom when out of adjustment	Playback does not start or focus actuator noisy.		
● Measurement Instrument Connections	See Fig. 4. [Settings] CH1 20mV/division X-Y mode CH2 5mV/division	● Player State ● Adjustment Location ● Disc	Test mode, play VR8152 (FCS GAN) YEDS-7

[Procedure]

1. Set the AF generator output to 1.2kHz and 1Vp-p.
2. Press the MANUAL TRACK SEARCH FWD $\triangleright \triangleright \bullet \triangleright \triangleright \square$ key or REV $\square \triangleleft \triangleleft \bullet \triangleleft \triangleleft$ key to move the pickup to halfway across the disc (R=35mm), then press the DOLBY NR key, the PLAY/PAUSE \triangleright / \square key twice in that order to close the corresponding servos and put the player into play mode.
3. Adjust VR8152 (FCS GAN) so that the Lissajous waveform is symmetrical about the X axis and the Y axis.

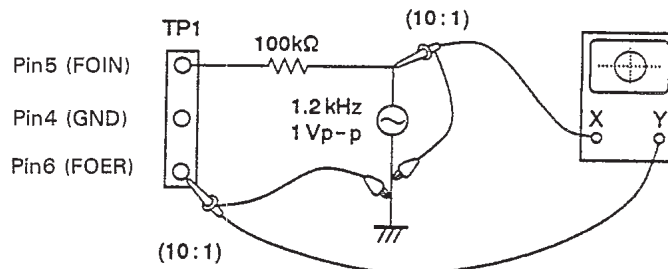
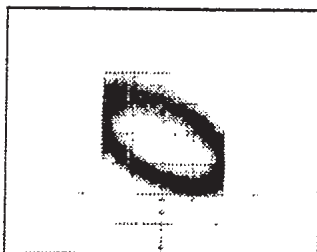
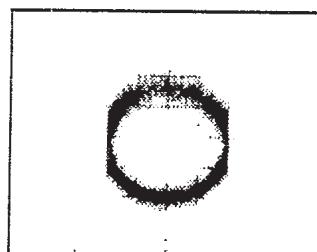

Fig. 4

Focus Gain Adjustment



Higher gain



Optimum gain

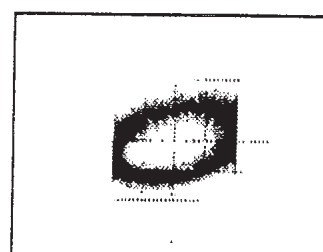

Lower gain

6. Tracking Servo Loop Gain Adjustment

● Objective	To optimize the tracking servo loop gain.		
● Symptom when out of adjustment	Playback does not start, during searches the actuator is noisy, or tracks are skipped.		
● Measurement Instrument Connections	See Fig. 5. [Settings] CH1 50mV/division X-Y mode CH2 20mV/division	● Player State ● Adjustment Location ● Disc	Test mode, play VR8151 (TRK GAN) YEDS-7

[Procedure]

1. Set the AF generator output to 1.2kHz and 2Vp-p.
2. Press the MANUAL/TRACK SEARCH FWD $\triangleright\triangleright \cdot \triangleright\triangleright$ key or REV $\triangleleft\triangleleft \cdot \triangleleft\triangleleft$ key to move the pickup to halfway across the disc (R=35mm), then press the DOLBY NR key, the PLAY/PAUSE \triangleright/\square key twice in that order to close the corresponding servos and put the player into play mode.
3. Adjust VR8151 (TRK GAN) so that the Lissajous waveform is symmetrical about the X axis and the Y axis.

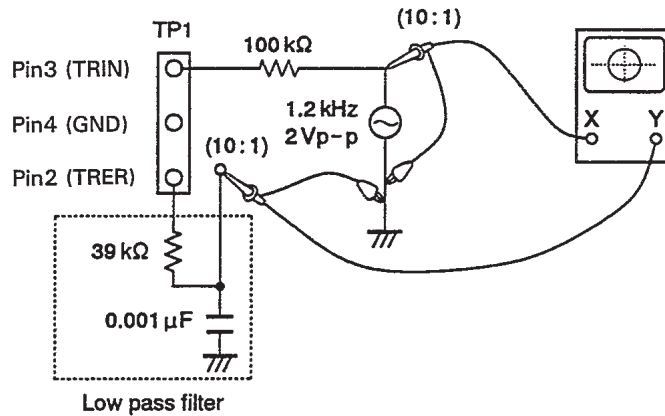
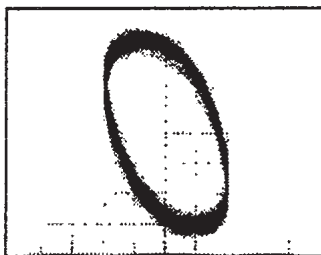
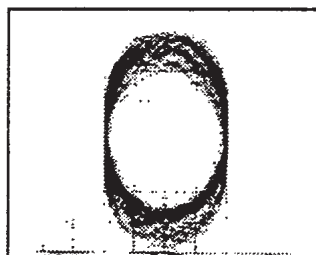

Fig. 5

Tracking Gain Adjustment



Higher gain



Optimum gain

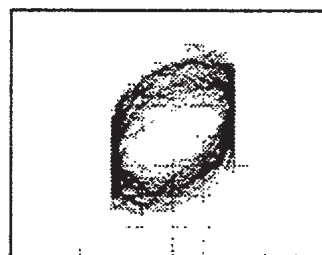

Lower gain

7. IC INFORMATION

- The information shown in the list is basic information and may not correspond exactly to that shown in the schematic diagrams.

PD4583A (IC1901 : DISPLAY ASSY)

- System Control Micro-computer
- Pin Assignment (Top View)

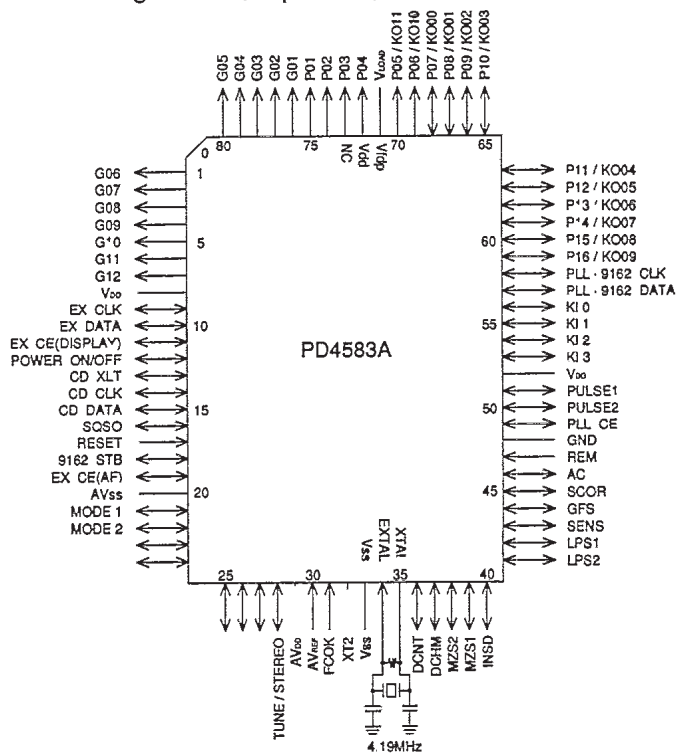

Pin Function

No.	Name	Function	I/O	Description
1	FIP6	6G	P	FL grid
2	FIP5	7G		
3	FIP4	8G		
4	FIP3	9G		
5	FIP2	10G		
6	FIP1	11G		
7	FIP0	12G		
8	VDD	VDD	-	Connected to +5V.
9	SCK0	EX CLK	N	Extension port serial clock output
10	SO0	EX DATA	N	Extension port serial data output
11	P25	EX CE (DISPLAY)	C	Extension port (display system) latch pulse
12	P24	POWER ON/OFF	C	POWER ON/OFF

No.	Name	Function	I/O	Description
13	P23	CD XLT	C	LSI control data latch pulse
14	SCK1	CD CLK	C	LSI control data serial clock
15	SO1	CD DATA	C	LSI control data serial output
16	SI1	SQSO	I	Subcode Q data serial input
17	RESET	-	-	Reset input
18	P74	9162 STB	N	9162 strobe output
19	P73	EX CE (AF)	N	Extension port (AF system) latch pulse
20	AVSS	AVSS	-	Connected to GND.
21	ANI7	MODE1	I	Tape1 mode SW input
22	ANI6	MODE2	I	Tape2 mode SW input
23	ANI5	-	A/D	Spectrum analyzer input
24	ANI4	-		
25	ANI3	-		
26	ANI2	-		
27	P11	-		
28	P10	TUNE/STEREO	A/D	TUNE/STEREO status discrimination input
29	AVDD	AVDD	-	Connected to +5V.
30	AVREF	AVREF	-	
31	P04	FCOK	I	Focus OK input
32	XT2	-	O	Open
33	VSS	-	-	Connected to GND.
34	X1	-	I	Connected to Oscillator (4.19MHz).
35	X2	-	O	
36	P37	DCNT	I	Disc count pulse input
37	P36	DCHM	I	Disc selector home SW input
38	P35	MZS2	I	Magazine discrimination SW input
39	P34	MZS1		
40	P33	INSD	I	Slider inside SW input

No.	Name	Function	I/O	Description
41	P32	LPS2	I	Load position discrimination input
42	P31	LPS1		
43	P30	SENS	I	LSI operating status multi-mode input
44	P03	GFS	I	Frame/synch/lock input
45	INTP2	SCOR	I	Subcode synch SO + SI input
46	INTP1	AC	I	AC pulse input
47	INTP0	REM	I	Remote control signal input
48	IC	—	—	Connected to GND.
49	P72	PLL CE	N	PLL latch pulse
50	P71	PULSE2	I	Tape 2 reel pulse input
51	P70	PULSE1	I	Tape 1 reel pulse input
52	V _{DD}	—	—	Connected to +5V.
53	P127	—	I	Key scan input
54	P126	—		
55	P125	—		
56	P124	—		
57	P123	PLL 9162 DATA	P	PLL and 9162 serial data
58	P122	PLL 9162 CLK	P	PLL and 9162 clock
59	FIP27	P16/KO9	P	FL segment and key scan output
60	FIP26	P15/KO8	P	
61	FIP25	P14/KO7	P	
62	FIP24	P13/KO6	P	
63	FIP23	P12/KO5	P	
64	FIP22	P11/KO4	P	
65	FIP21	P10/KO3	P	
66	FIP20	P9/KO2	P	

No.	Name	Function	I/O	Description
67	FIP19	P8/KO1	P	FL segment and key scan output
68	FIP18	P7/KO0	P	
69	FIP17	P6/KO10	P	
70	FIP16	P5/KO11	P	
71	V _{LOAD}	—	—	Connected to -30V.
72	FIP15	P4	P	FL segment
73	FIP14	P3	P	
74	FIP13	P2	P	
75	FIP12	P1	P	FL grid
76	FIP11	1G	P	
77	FIP10	2G	P	
78	FIP9	3G	P	
79	FIP8	4G	P	
80	FIP7	5G	P	

Note)

- I : Input
- A/D : Analog Input
- O : Cmos Output
- N : Nch Open Drain Output
- P : Pch Open Drain Output

■ CXD2507AQ (IC8301: AF CD ASSY)

- EFM Demodulator IC
- Pin Assignment (Top View)

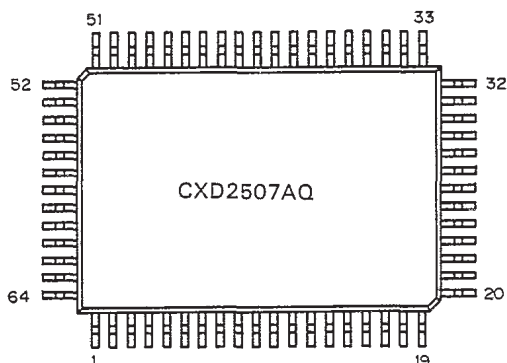

● Block Diagram

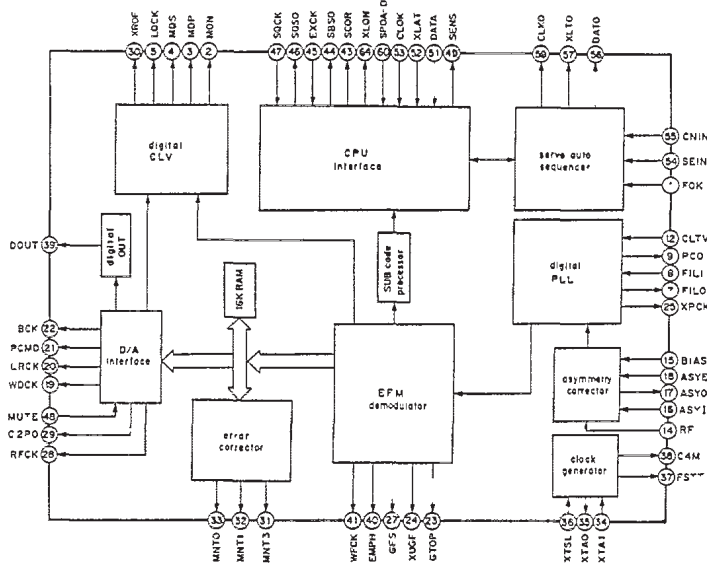

● Pin Function

Pin No.	Symbol	I/O	Function
1	FOK	I	Focus OK input pin. Used for SENS output and servo auto sequence.
2	MON	O	ON/OFF control output for spindle motor.
3	MDP	O	Spindle motor servo control.
4	MDS	O	Spindle motor servo control.
5	LOCK	O	High output GFS is sampled at 460 Hz and that is High; Low output when GFS is sampled 8 times and that is Low.
6	TEST	I	Test pin, normally GND.
7	FILO	O	Filter output for master PLL .(slave=digital PLL)
8	FILI	I	Master PLL filter input.
9	PCO	O	Master PLL charge pump output.
10	Vss	-	GND
11	AVss	-	Analog GND
12	CLTV	I	Master VCO control voltage input.
13	AVDD	-	Analog power supply. (+5V)
14	RF	I	EFM signal input.
15	BIAS	I	Asymmetry circuit constant current input.
16	ASYI	I	Asymmetry comparator voltage input.
17	ASYO	O	EFM full-swing output. (Low=Vss, High=Vdd)
18	ASYE	I	"L": Asymmetry circuit OFF, "H": Asymmetry circuit ON.
19	WDCK	O	D/A interface. Word clock f=2 Fs.
20	LRCK	O	D/A interface. LR clock f=Fs.
21	PCMD	O	D/A interface. Serial data . (2's COMP, MSB fast)
22	BCK	O	D/A interface. Bit clock.
23	GTOP	O	GTOP output.
24	XUGF	O	XUGF output.
25	XPCK	O	XPLCK output.

Pin No.	Symbol	I/O		Function
26	V _{DD}	–	–	Power supply . (+5V)
27	GFS	O	1, 0	GFS output.
28	RFCK	O	1, 0	RFCK output.
29	C2PO	O	1, 0	C2PO output.
30	XROF	O	1, 0	XRAOF output.
31	MNT3	O	1, 0	MNT3 output.
32	MNT1	O	1, 0	MNT1 output.
33	MNT0	O	1, 0	MNT0 output.
34	XTAI	I	–	Crystal oscillator circuit input. 16.9344 MHz or 33.8688 MHz input.
35	XTAO	O	1, 0	16.9344 MHz crystal oscillation circuit output.
36	XTSL	I	–	Crystal selection input. Low for 16.9344 MHz crystal; High for 33.8688 MHz crystal.
37	FSTT	O	1, 0	2/3 frequency divider input of Pins 34 and 35.
38	C4M	O	1, 0	4.2336 MHz output.
39	DOUT	O	1, 0	Digital Out output.
40	EMPH	O	1, 0	Playback disc emphasis mode output. (Low for no emphasis applied; High for emphasis applied)
41	WFCK	O	1, 0	WFCK output.
42	V _{SS}	–	–	GND
43	SCOR	O	1, 0	Subcode sync output. (High for subcode sync S0 or S1 detected)
44	SBSO	O	1, 0	Sub P to W serial output.
45	EXCK	I	–	SBSO readout clock input.
46	SQSO	O	1, 0	Sub Q 80-bit serial output.
47	SQCK	I	–	SQSO readout clock input.
48	MUTE	I	–	"H": Mute, "L": Release.
49	SENS	O	1, 0	SENS output .(Output to CPU)
50	XRST	I	–	System reset .(Low for reset)
51	DATA	I	–	Serial data input from CPU.
52	XLAT	I	–	Latch input from CPU. Latches serial data at falling edge.
53	CLOK	I	–	Serial data transfer clock input from CPU.
54	SEIN	I	–	Sense input from SSP.
55	CNIN	I	–	Track jump number count signal input.
56	DATO	O	1, 0	Serial data output to SSP.
57	XLTO	O	1, 0	Serial data latch output to SSP. Latches at falling edge.
58	V _{DD}	–	–	Power supply . (+5V)
59	CLKO	O	1, 0	Serial data transfer clock output to SSP.
60	SPOA	I	–	Microprocessor extension interface. (input A)
61	SPOB	I	–	Microprocessor extension interface. (input B)
62	SPOC	I	–	Microprocessor extension interface. (input C)
63	SPOD	I	–	Microprocessor extension interface. (input D)
64	XLON	O	1, 0	Microprocessor extension interface. (output)

8. DISASSEMBLY

■ CD MECHA ASSY DIAGNOSIS AND REPLACEMENT

1. Remove the cover.
2. Remove the nylon rivet (E) between the front panel and AF CD Assy.
3. Remove the 3 screws between the front panel and the chassis.
 - L/R sides: (A) × 2
 - Bottom side: (B) × 1
4. Remove the lead wire from the cassette mecha Assy from the chassis.
 - Screw: (C) × 1
5. Remove the front panel from the chassis (watching out for the claw on the left and right), and open the side of the AF CD Assy. (Refer to Fig. 1)

NOTE:

Do not remove the rear panel and AF CD Assy at this time.

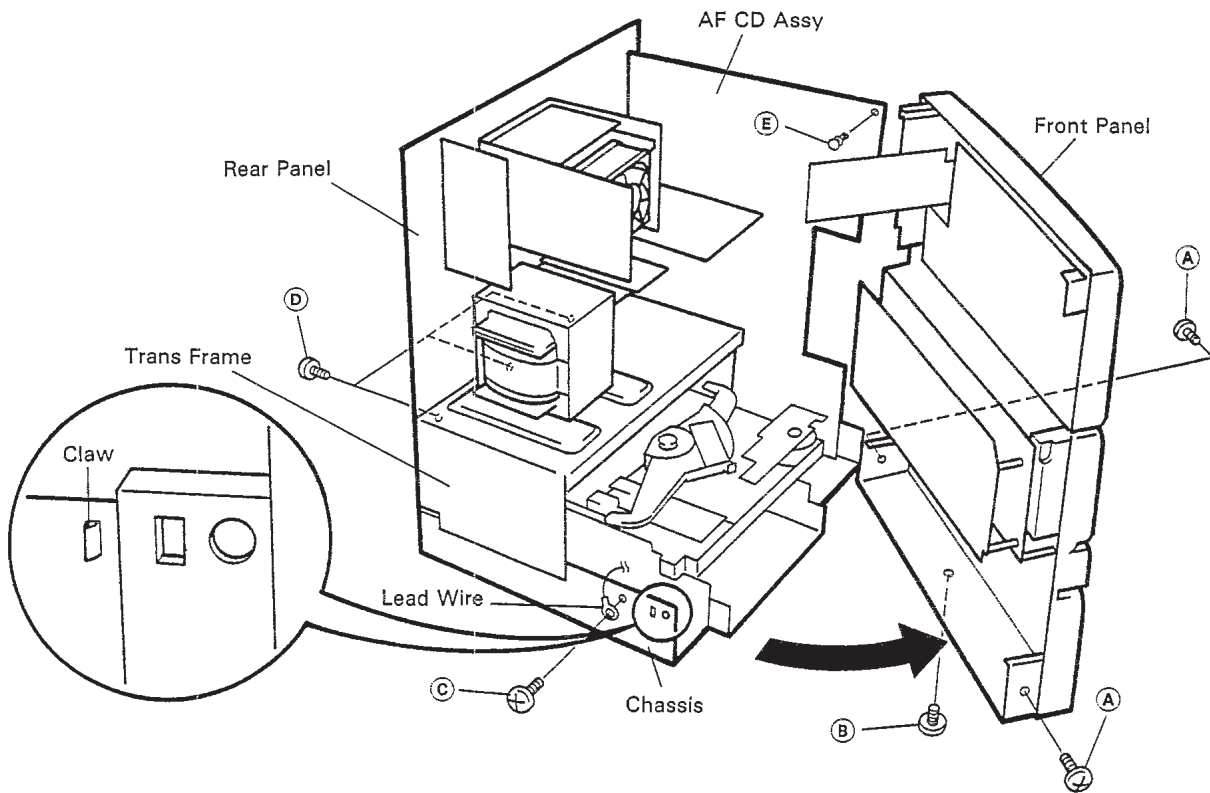

Fig. 1

Under these conditions, most of the PCB diagnosis and parts replacement can be performed.

■ REMOVAL OF AF CD ASSY

1. Under the conditions of the previous paragraph, remove the rear panel and AF CD Assy. (Do not separate the rear panel and AF CD Assy.)
 - Between rear panel and trans frame.
 - Screw: (D) × 3

**9. FOR XR – P5500M/KC, XR – P4500M/KU AND KC TYPES
CONTRAST OF MISCELLANEOUS PARTS**

- NOTES :**
- Parts marked by "NSP" are generally unavailable because they are not in our Master Spare Parts List.
 - The Δ mark found on some component parts indicates the importance of the safety factor of the part. Therefore, when replacing, be sure to use parts of identical designation.
 - Parts marked by "⊙" are not always kept in stock. Their delivery time may be longer than usual or they may be unavailable.
 - When ordering resistors, first convert resistance values into code form as shown in the following examples.
- Ex. 1** When there are 2 effective digits (any digit apart from 0), such as 560 ohm and 47k ohm (tolerance is shown by J = 5%, and K = 10%).
- 560 Ω \rightarrow $56 \times 10^1 \rightarrow 561$ RDI/SPM $\begin{bmatrix} \text{5} \\ \text{6} \end{bmatrix} \begin{bmatrix} \text{1} \\ \text{J} \end{bmatrix}$
- 47k Ω \rightarrow $47 \times 10^3 \rightarrow 473$ RD1/APS $\begin{bmatrix} \text{4} \\ \text{7} \end{bmatrix} \begin{bmatrix} \text{3} \\ \text{J} \end{bmatrix}$
- 0.5 Ω \rightarrow 0R5 RN2H $\begin{bmatrix} \text{0} \\ \text{5} \end{bmatrix} \begin{bmatrix} \text{K} \end{bmatrix}$
- 1 Ω \rightarrow 010 RS1P $\begin{bmatrix} \text{0} \\ \text{1} \end{bmatrix} \begin{bmatrix} \text{0} \\ \text{K} \end{bmatrix}$
- Ex. 2** When there are 3 effective digits (such as in high precision metal film resistors).
- 5.62k Ω \rightarrow $562 \times 10^1 \rightarrow 5621$ RM1/4PC $\begin{bmatrix} \text{5} \\ \text{6} \\ \text{2} \end{bmatrix} \begin{bmatrix} \text{1} \\ \text{F} \end{bmatrix}$

XR – P5500M/KC, XR – P4500M/KU, KC and XR – P5500M/KU have the same construction except for the following :

Mark	Symbol & Description	Part No.				Remarks
		XR – P5500M/KU	XR – P5500M/KC	XR – P4500M/KU	XR – P4500M/KC	
	AF assy	AWK7108	AWK7108	AWK7106	AWK7106	
	AF CD assy	AWZ7544	AWZ7544	AWZ7542	AWZ7542	
	VR assy	AWZ7551	AWZ7551	AWZ7549	AWZ7549	
NSP	HEADPHONE assy	AWZ7555	AWZ7555	AWZ7554	AWZ7554	*1
NSP	COMPLEX assy	AWM7147	AWM7147	AWM7137	AWM7137	
	PRIMARY assy	AWZ7535	AWZ7535	AWZ7532	AWZ7532	
	CASSETTE MOD. B	EXK2435	EXK2415	EXK2435	EXK2415	
Δ	T8005 Power transformer	ATS7039	ATS7039	ATS7068	ATS7068	
Δ	FU1 Fuse (6.3A/125V)	AEK – 309	AEK – 309	Not used	Not used	
Δ	FU1 Fuse (5A/125V)	Not used	Not used	AEK – 308	AEK – 308	
	Front panel	AMB7213	AMB7213	AMB7155	AMB7155	
	Rear panel	ANC7143	ANC7144	ANC7138	ANC7139	
	Bonnet case	ANE7045	ANE7045	ANE7044	ANE7044	
	Packing case	AHD7081	AHD7081	AHD7079	AHD7079	
	Operating instructions (English)	ARB7021	Not used	ARB7021	Not used	
	Operating instructions (English, French)	Not used	ARE7020	Not used	ARE7020	
	65 label	ORW1069	Not used	ORW1069	Not used	

Note:
*1 : Although AWZ7554 and AWZ7555 are different in part number, they have the same service parts.

AF CD ASSY

AWZ7542 and AWZ7544 have the same construction except for the following :

Mark	Symbol & Description	Part No.		Remarks
		AWZ7544	AWZ7542	
Δ	C1001, C1002 (4700/71)	ACH1249	Not used	
Δ	C1001, C1002 (4700/63)	Not used	ACH7007	
	R1224	RS1LMF472J	RS1LMF272J	
	R2116	RS1/10S152J	RS1/10S473J	

VR ASSY

AWZ7549 and AWZ7551 have the same construction except for the following :

Mark	Symbol & Description	Part No.		Remarks
		AWZ7551	AWZ7549	
	R1505, R1506	RS1/10S104J	RS1/10S473J	

PRIMARY ASSY

AWZ7532 and AWZ7535 have the same construction except for the following :

Mark	Symbol & Description	Part No.		Remarks
		AWZ7535	AWZ7532	
	L1101	ATF1136	ATF – 151	

CASSETTE MOD. B

EXK2415 and EXK2435 have the same construction except for the following :

Mark	Symbol & Description	Part No.		Remarks
		EXK2435	EXK2415	
	Cassette mecha unit	EXA1408	EXA1407	*2

Note:
*2 : Although EXA1407 and EXA1408 are different in part number, they consist of the same components.

10. PANEL FACILITIES

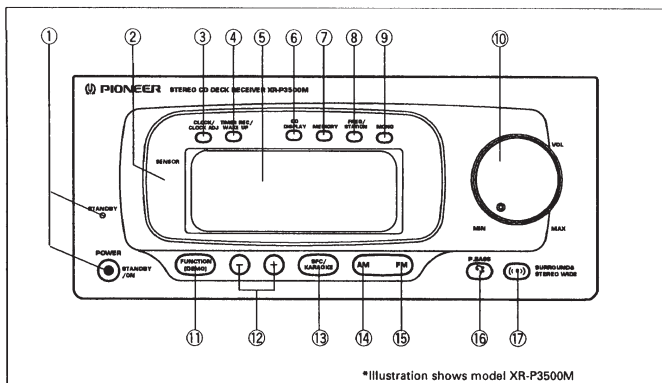

*Illustration shows model XR-P3500M

RECEIVER

① POWER STANDBY/ON switch and STANDBY indicator

This is the switch for electric power.
 ON: When set to the ON position, power is supplied and the unit becomes operational.
 STANDBY: When set to the STANDBY position, the main power flow is cut and the unit is no longer fully operational. A minute flow of power feeds the unit to maintain operation readiness. (The STANDBY indicator lights.)

- ② Remote sensor
- ③ CLOCK/CLOCK ADJ button
- ④ TIMER REC/WAKE-UP button
- ⑤ Display
- ⑥ CD DISPLAY button

⑦ MEMORY button

⑧ FREQ/STATION button

⑨ MONO button

⑩ VOLUME control

⑪ FUNCTION (*DEMO) button and indicators

Each time this button is pressed, the function changes in the following sequence (The selected function is displayed in the display window.):

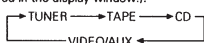

- ⑫ ⊖, ⊕ buttons
- ⑬ SFC (Sound Field Control)/KARAOKE button

⑭ AM button

⑮ FM button

⑯ P. BASS button

⑰ U.S. model : STEREO WIDE button
 U.K., Australian and Multivoltage models : SURROUND & STEREO WIDE button

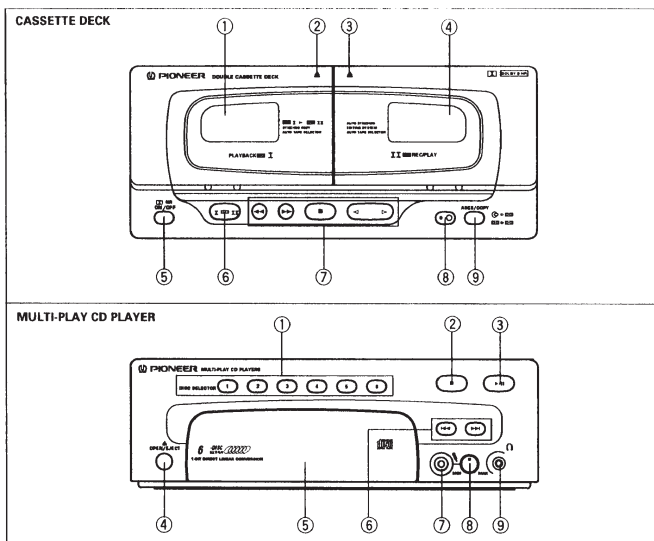

CASSETTE DECK

- ① TAPE I cassette door
- ② TAPE I EJECT section (▲)
- ③ TAPE II EJECT section (▲)
- ④ TAPE II cassette door
- ⑤ DOLBY* NR ON/OFF button
Each time this button is pressed, DOLBY NR system turns ON and OFF.
- ⑥ TAPE I/II selector button
- ⑦ TAPE operation buttons (Play ◀▶, Stop ■, Fast ◀◀▶▶)
- ⑧ Rec pause button (●)
- ⑨ ASES (Auto Synchro Editing System)/COPY button

■ Auto Function

This model is equipped with an "Auto Function" operation, so when the switch for PLAY/PAUSE, DISC SELECTOR 1-6, RND, TAPE VIII, PLAY (tape), or Band (FM, AM) is pressed, the function switches automatically. Use the FUNCTION button to select the component connected to the VIDEO/AUX IN jacks, since Auto Function is not effective for this.
NOTE:
 The function cannot be switched during recording and tape copying.

MULTI-PLAY CD PLAYERS

- ① DISC SELECTOR buttons (1-6)
- ② Stop button (■)
- ③ Play/Pause button (▶/||)
- ④ OPEN/EJECT button
- ⑤ Magazine slot door
- ⑥ Manual/Track search buttons (|◀◀, ▶▶|)
- ⑦ Microphone jack
- ⑧ Mic level control
- ⑨ Headphones jack

* Dolby noise reduction manufactured under license from Dolby Laboratories Licensing Corporation.
 • "DOLBY" and the double-D symbol are trademarks of Dolby Laboratories Licensing Corporation.

