

Service Manual

ORDER NO.
RRV 1724

STEREO CD CASSETTE DECK RECEIVER

XR-P470C

XR-P370CR

XR-P370C

● Refer to the service manual RRV1690 for XR-P470C/DD.

THIS MANUAL IS APPLICABLE TO THE FOLLOWING MODEL(S) AND TYPE(S).

Type	Model			Power Requirement	Remarks
	XR-P470C	XR-P370CR	XR-P370C		
MYXK	○	○	○	AC220 - 230V	
NVXK	○	-	○	AC230V	

CONTENTS

1. SAFETY INFORMATION	2
2. CONTRAST OF MISCELLANEOUS PARTS	3
3. PCB PARTS LIST	5
4. SCHEMATIC DIAGRAM	12
5. PCB CONNECTION DIAGRAM	20
6. ADJUSTMENT	22
7. GENERAL INFORMATION	24
7.1 DISPLAY	24

PIONEER ELECTRONIC CORPORATION



4-1, Meguro 1-Chome, Meguro-ku, Tokyo 153, Japan

PIONEER ELECTRONICS SERVICE, INC. P.O.Box 1760, Long Beach, CA 90801-1760, U.S.A.

PIONEER ELECTRONIC (EUROPE) N.V. Haven 1087, Keetberglaan 1, 9120 Melsele, Belgium

PIONEER ELECTRONICS ASIACENTRE PTE. LTD. 501 Orchard Road, #10-00 Lane Crawford Place, Singapore 0923

1. SAFETY INFORMATION

<p>VARO! AVATTAESSA JA SUOJALUKITUS OHITETTAESSA OLET ALTTIINA NÄKYMÄTTÖMÄLLE LASERSÄTEILYLLE. ÄLÄ KATSO SÄTEESEEN.</p>	 LASER Kuva 1 Lasersäteilyn varoitusmerkki	<p>WARNING! DEVICE INCLUDES LASER DIODE WHICH EMITS INVISIBLE INFRARED RADIATION WHICH IS DANGEROUS TO EYES. THERE IS A WARNING SIGN ACCORDING TO PICTURE 1 INSIDE THE DEVICE CLOSE TO THE LASER DIODE.</p>	 LASER Picture 1 Warning sign for laser radiation
<p>ADVARSEL: OSYNLIG LASERSTRÅLING VED ÅBNING NÅR SIKKERHED SAFBRYDERE ER UDE AF FUNKTION. UNDGÅ UDSÆTTELSE FOR STRÅLING.</p>		<p>IMPORTANT THIS PIONEER APPARATUS CONTAINS LASER OF CLASS 1. SERVICING OPERATION OF THE APPARATUS SHOULD BE DONE BY A SPECIALLY INSTRUCTED PERSON.</p>	
<p>VARNING! OSYNLIG LASERSTRÅLNING NÅR DENNA DEL ÄR ÖPPNAD OCH SPÄRREN ÄR URKOPPLAD. BETRakta EJ STRÅLEN.</p>		<p>LASER DIODE CHARACTERISTICS MAXIMUM OUTPUT POWER: 5 mw WAVELENGTH: 780-785 nm</p>	

LABEL CHECK

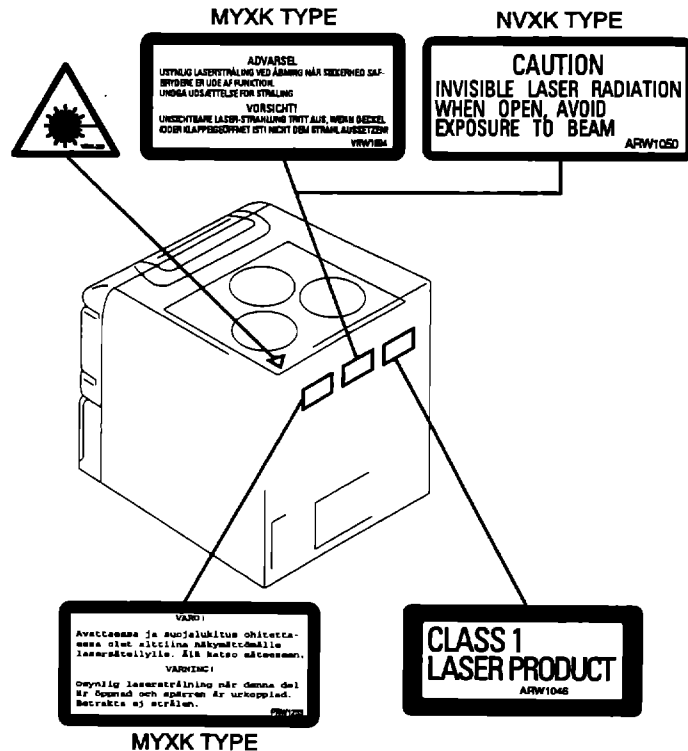

Additional Laser Caution

- Laser Interlock Mechanism**
The position of the switch (S8501) for detecting loading state is detected by the system microprocessor, and the design prevents laser diode oscillation when the switch (S8501) is pressed physically. Thus, the interlock will no longer function if the switch (S8501) is released physically and deliberately. The interlock also does not function in the test mode*. Laser diode oscillation will continue, if pin 62 of LA9240ML (IC8101) on the CD ASSY mounted on the \$M Loading Mechanism assembly is connected to GND, or else the terminals of Q8101 are shorted to each other (fault condition).
- When the cover is opened, close viewing of the objective lens with the naked eye will cause exposure to a Class 1 laser beam.

* : Refer to page 54 on the service manual RRV1690.

2. CONTRAST OF MISCELLANEOUS PARTS

NOTES: • Parts marked by "NSP" are generally unavailable because they are not in our Master Spare Parts List.

• The Δ mark found on some component parts indicates the importance of the safety factor of the part. Therefore, when replacing, be sure to use parts of identical designation.

■ CONTRAST TABLE

XR-P470C/MYXK, XR-P470C/NVXK, XR-P370CR/MYXK, XR-P370C/MYXK, XR-P370C/NVXK and XR-P470C/DD have the same construction except for the following:

Mark	Symbol & Description	Part No.						Remarks
		XR-P470C /DD	XR-P470C /MYXK	XR-P470C /NVXK	XR-P370CR /MYXK	XR-P370C /MYXK	XR-P370C /NVXK	
NSP	COMP. ASSY	AWM7276	AWM7279	AWM7279	AWM7281	AWM7280	AWM7280	
	└ AF ASSY	AWZ8470	AWZ8471	AWZ8471	AWZ8476	AWZ8472	AWZ8472	*1
	└ DISPLAY ASSY	AWZ8480	AWZ8482	AWZ8482	AWZ8479	AWZ8483	AWZ8483	*1
	└ SECONDARY ASSY	AWZ8489	AWZ8486	AWZ8486	AWZ8487	AWZ8487	AWZ8487	*1
	└ PRIMARY ASSY	AWZ8491	AWZ8493	AWZ8493	AWZ8493	AWZ8493	AWZ8493	*1
	└ POWER PACK ASSY	AWZ8492	AWZ8474	AWZ8474	AWZ8475	AWZ8475	AWZ8475	*1
	FM/AM TUNER MODULE	AXQ7051	AXQ7078	AXQ7078	AXQ7078	AXQ7078	AXQ7078	*2
	Mic Level Volume	AAB7113	Not used	Not used	Not used	Not used	Not used	
	FL Filter	Not used	Not used	Not used	AAK7320	AAK7320	AAK7320	*3
	Tray Cap	AAK7327	AAK7327	AAK7327	AAK7399	AAK7399	AAK7399	
	FL Lens	AAK7284	AAK7361	AAK7361	AAK7359	AAK7360	AAK7360	
	Spring (L)	RBH1411	ABH7028	ABH7028	ABH7028	ABH7028	ABH7028	
	Spring (R)	RBH1412	ABH7029	ABH7029	ABH7029	ABH7029	ABH7029	
Δ	AC Power Cord	ADG1157	ADG7008	ADG7007	ADG7008	ADG7008	ADG7007	
Δ	Fuse (T5A) (With in AC Plug)	Not used	Not used	AEK7001	Not used	Not used	AEK7001	
	Voltage Label	AAX7391	Not used	Not used	Not used	Not used	Not used	
	Heat Sink	ANH7059	ANH7047	ANH7047	ANH7047	ANH7047	ANH7047	
	FM T-type Antenna	ADH7007	ADH7005	ADH7005	ADH7005	ADH7005	ADH7005	
	Connector Assy 5P	RKP1582	ADX7045	ADX7045	ADX7045	ADX7045	ADX7045	
	Connector Assy 3P	RKP1583	ADX7046	ADX7046	ADX7046	ADX7046	ADX7046	
	Fuse Card	Not used	Not used	Not used	AAX7032	AAX7032	AAX7032	
Δ	FU1 Fuse (T1.25A)	AEK1055	AEK1055	AEK1055	Not used	Not used	Not used	
Δ	FU1 Fuse (800mA)	Not used	Not used	Not used	REK - 099	REK - 099	REK - 099	
Δ	FU2 Fuse (T1.25A)	AEK1055	Not used	Not used	Not used	Not used	Not used	
NSP	Battery (R6P, AA)	VEM - 013	AEX7001	AEX7001	AEX7001	AEX7001	AEX7001	
	Front Pad	AHA7144	AHA7154	AHA7154	AHA7154	AHA7154	AHA7154	
	Rear Pad	AHA7145	AHA7155	AHA7155	AHA7155	AHA7155	AHA7155	
	Sub Pad	AHA7162	Not used	Not used	Not used	Not used	Not used	
	Packing Case	AHD7411	AHD7416	AHD7416	AHD7417	AHD7418	AHD7418	
NSP	Catalog Bag	Not used	AHG1091	AHG1091	AHG1091	AHG1091	AHG1091	
	Polyethylene Bag (0.03X230X340)	Z21 - 038	Not used	Not used	Not used	Not used	Not used	
	Packing Sheet	AHG7003	AHG7001	AHG7001	AHG7001	AHG7001	AHG7001	
	Rear Cover	AMC7008	AMC7010	AMC7010	AMC7009	AMC7009	AMC7009	
	Eject Arm (L)	AMR7020	AMR7024	AMR7024	AMR7024	AMR7024	AMR7024	
	Eject Arm (R)	AMR7021	AMR7025	AMR7025	AMR7025	AMR7025	AMR7025	
	Transistor Holder	ANG7102	ANG7102	ANG7102	Not used	Not used	Not used	
	GND Plate	ANG7106	ANG7131	ANG7131	ANG7131	ANG7131	ANG7131	
	Operating Instructions (Portuguese)	ARC7137	Not used	Not used	Not used	Not used	Not used	
	Operating Instructions (English/Spanish/Chinese)	ARE7089	Not used	Not used	Not used	Not used	Not used	
	Operating Instructions (English/French/German/Italian)	Not used	ARE7090	Not used	ARE7090	ARE7090	Not used	
	Operating Instructions (English/French/German/Italian/Dutch/Swedish/Spanish/Portuguese) (RDS)	Not used	ARE7091	Not used	ARE7091	Not used	Not used	

XR-P470C, XR-P370CR, XR-P370C

Mark	Symbol & Description	Part No.						Remarks
		XR-P470C /DD	XR-P470C /MYXK	XR-P470C /NVXK	XR-P370CR /MYXK	XR-P370C /MYXK	XR-P370C /NVXK	
	Operating Instructions (Dutch/Swedish/Spanish/Portuguese)	Not used	ARE7092	Not used	ARE7092	ARE7092	Not used	
	Operating Instructions (English)	Not used	Not used	ARB7093	Not used	Not used	ARB7093	
	Operating Instructions (English)(RDS)	Not used	Not used	ARB7094	Not used	Not used	Not used	
NSP	Caution Label (F)	Not used	ARW1046	ARW1046	ARW1046	ARW1046	ARW1046	*4
	AM Loop Antenna	ATB7004	ATB7006	ATB7006	ATB7006	ATB7006	ATB7006	
△	T1 Power Transformer (AC110-127V/220-230V/240V)	ATS7157	Not used	Not used	Not used	Not used	Not used	
△	T1 Power Transformer (AC220-230V)	Not used	ATS7158	ATS7158	ATS7159	ATS7159	ATS7159	
	Remote Control Unit (CU - XR032)	AZN7656	Not used	Not used	Not used	Not used	Not used	
	Remote Control Unit (CU - XR031)	Not used	AZN7659	AZN7659	AZN7659	AZN7659	AZN7659	
	Front Panel	AZN7658	AZN7662	AZN7662	AZN7662	AZN7663	AZN7663	
	Ceramic Capacitor	Not used	CKDYB102K50	CKDYB102K50	CKDYB102K50	CKDYB102K50	CKDYB102K50	*5
	Caution Label HE	Not used	PRW1233	Not used	PRW1233	PRW1233	Not used	*4
	Caution Label (G)	Not used	VRW - 329	VRW - 329	VRW - 329	VRW - 329	VRW - 329	*4
	Caution Label	Not used	VRW1094	Not used	VRW1094	VRW1094	Not used	*4
NSP	Caution Label	Not used	Not used	ARW1050	Not used	Not used	ARW1050	*4

- Note
- *1 : Refer to "3. PCB PARTS LIST" and "4. SCHEMATIC DIAGRAM".
 - *2 : Refer to "3. PCB PARTS LIST", "4. SCHEMATIC DIAGRAM" and "5. PCB CONNECTION DIAGRAM".
 - *3 : Install between the FL TUBE of the DISPLAY ASSY and the Front Panel.
 - *4 : Refer to page 2.
 - *5 : Solder to the FM/AM TUNER MODULE and the GND Plate (ANG7106).

3. PCB PARTS LIST

- NOTES:
- Parts marked by "NSP" are generally unavailable because they are not in our Master Spare Parts List.
 - The Δ mark found on some component parts indicates the importance of the safety factor of the part. Therefore, when replacing, be sure to use parts of identical designation.
 - When ordering resistors, first convert resistance values into code form as shown in the following examples.

Ex.1 When there are 2 effective digits (any digit apart from 0), such as 560 ohm and 47k ohm (tolerance is shown by J = 5%, and K = 10%).

560 Ω	\rightarrow	56 \times 10 ¹	\rightarrow	561	RD1/4PU	$\overline{561}$ J
47k Ω	\rightarrow	47 \times 10 ³	\rightarrow	473	RD1/4PU	$\overline{473}$ J
0.5 Ω	\rightarrow	R50			RN2H	$\overline{R50}$ K
1 Ω	\rightarrow	1R0			RS1P	$\overline{1R0}$ K

Ex.2 When there are 3 effective digits (such as in high precision metal film resistors).

5.62k Ω	\rightarrow	562 \times 10 ¹	\rightarrow	5621	RN1/4PC	$\overline{5621}$ F
----------------	---------------	------------------------------	---------------	------------	---------	---------------------

■ LIST OF WHOLE PCB ASSEMBLIES

Mark	Symbol & Description	Part No.					Remarks
		XR-P470C /MYXK	XR-P470C /NVXK	XR-P370CR /MYXK	XR-P370C /MYXK	XR-P370C /NVXK	
NSP	COMP. ASSY	AWM7279	AWM7279	AWM7281	AWM7280	AWM7280	*
	— AF ASSY	AWZ8471	AWZ8471	AWZ8476	AWZ8472	AWZ8472	
	— POWER PACK ASSY	AWZ8474	AWZ8474	AWZ8475	AWZ8475	AWZ8475	
	— REGULATOR ASSY	AWZ8477	AWZ8477	AWZ8477	AWZ8477	AWZ8477	
	— DISPLAY ASSY	AWZ8482	AWZ8482	AWZ8479	AWZ8483	AWZ8483	
	— CD SWITCH ASSY	AWZ8484	AWZ8484	AWZ8484	AWZ8484	AWZ8484	
	— SECONDARY ASSY	AWZ8486	AWZ8486	AWZ8487	AWZ8487	AWZ8487	
	— PRIMARY ASSY	AWZ8493	AWZ8493	AWZ8493	AWZ8493	AWZ8493	
	FM/AM TUNER MODULE	AXQ7078	AXQ7078	AXQ7078	AXQ7078	AXQ7078	

Note *: Although AWZ8486 and AWZ8487 are different in part number, they consist of the same components.

■ CONTRAST OF PCB ASSEMBLIES

AF ASSY

AWZ8471, AWZ8476 and AWZ8472 have the same construction except for the following:

Mark	Symbol & Description	Part No.			Remarks
		AWZ8471	AWZ8476	AWZ8472	
IC3501		LA2232M	LA2232M	Not used	
Q3501		2SA1037K	2SA1037K	Not used	
Q3502		DTC143EK	DTC143EK	Not used	
Q3503		2SC2412K	2SC2412K	Not used	
D1071		Not used	S5688G	S5688G	
D1076		S5688G	Not used	Not used	
C1071		Not used	CEAS220M2A	CEAS220M2A	
C1072		CEAS101M63	CEAS220M2A	CEAS220M2A	
C1301		CEANP2R2M50	Not used	Not used	
C3501, C3507		CKSQYB103K50	CKSQYB103K50	Not used	
C3503, C3510, C3512		CEAS4R7M50	CEAS4R7M50	Not used	
C3504		CEAS220M50	CEAS220M50	Not used	
C3505, C3506		CKSQYB332K50	CKSQYB332K50	Not used	
C3508		CCSQCH271J50	CCSQCH271J50	Not used	
C1507, C1508		CKSQYB223K50	CKSQYB473K50	CKSQYB473K50	
C1509, C1510		CKSQYB104K25	CKSQYB563K50	CKSQYB563K50	
C3509, C3511		CEAS100M50	CEAS100M50	Not used	
C3513		CKSQYF223Z50	CKSQYF223Z50	Not used	
C3514, C3515		CKSQYB333K50	CKSQYB333K50	Not used	
C3516		CKSQYB682K50	CKSQYB682K50	Not used	

XR-P470C, XR-P370CR, XR-P370C

Mark	Symbol & Description	Part No.			Remarks
		AWZ8471	AWZ8476	AWZ8472	
	R3501, R3514 R3502, R3507, R3509, R3551 R3504 R3505 R3506	RS1/10S473J RS1/10S102J RS1/10S101J RD1/4PU221J RS1/10S472J	RS1/10S473J RS1/10S102J RS1/10S101J RD1/4PU221J RS1/10S472J	Not used Not used Not used Not used Not used	
	R3508 R3510 R3511 R3512 R3513	RS1/10S564J RS1/10S562J RS1/10S332J RS1/10S103J RS1/10S223J	RS1/10S564J RS1/10S562J RS1/10S332J RS1/10S103J RS1/10S223J	Not used Not used Not used Not used Not used	
	R3515, R3516 R1071 R3517 VR3501 (4.7kΩ/0.1W) X3501 (456kHz) JA1301	RD1/4PU102J RD1/2PMF272J RS1/10S104J PCP1028 ASS7001 VKB1050	RD1/4PU102J RD1/2PM472J RS1/10S104J RCP1028 ASS7001 Not used	Not used RD1/2PM472J Not used Not used Not used Not used	

POWER PACK ASSY

AWZ8474 and AWZ8475 have the same construction except for the following:

Mark	Symbol & Description	Part No.		Remarks
		AWZ8474	AWZ8475	
	Q1271 Q1272 Q1273, Q1275 Q1274, Q1276 D1271, D1272	IRFI9Z34G IRFI224G 2SC2458 2SA1048 MTZJ5.6C	Not used Not used Not used Not used Not used	
	D1273, D1274 D1275, D1276 D1277 - D1280 C1201, C1202 C1271, C1272	MTZJ18B MTZJ16B 1SS254 ACH7056 (3300μF/50V) CEAS100M50	Not used Not used Not used ACH1109 (2200μF/42V) Not used	
	C1273, C1274 R1242 R1243 R1271, R1272 R1273, R1274, R1283, R1284, R1287, R1288	CEAS470M16 RD1/4PU102J RD1/4PM392J RD1/4PM103J RD1/4PU102J	Not used RD1/4PU222J RD1/4PU682J Not used Not used	
△	R1229 R1275, R1276 R1277, R1278 R1279, R1280 R1281, R1282	RS1/10S1R2J RD1/4PU563J RFA1/4PS101J RD1/4PM392J RD1/4PM182J	RS1/10S000J Not used Not used Not used Not used	
	R1285, R1286, R1289, R1290	RD1/4PU103J	Not used	

DISPLAY ASSY

AWZ8482, AWZ8479 and AWZ8483 have the same construction except for the following:

Mark	Symbol & Description	Part No.			Remarks
		AWZ8482	AWZ8479	AWZ8483	
	D1851 D1852 R3709 R9035, R9037, R9038 R9036	1SS254 1SS254 RD1/4PU102J Not used RS1/10S0R0J	Not used Not used Not used RS1/10S0R0J Not used	Not used 1SS254 Not used RS1/10S0R0J Not used	
	V1901	AAV7032	AAV7036	AAV7036	

XR-P470C, XR-P370CR, XR-P370C

Mark No. Description Parts No.

■ PARTS LIST FOR XR-P470C/MYXK

BF AF ASSY

SEMICONDUCTORS

IC2202, IC4101	BU4066BCF
IC1991, IC1992	BU4094BCF
IC4401	CXA1101P
IC3501	LA2232M
IC2101	LC75394NHE
IC1501, IC3702, IC4102, IC4301	XLA4558F - P
Q3501	2SA1037K
Q1242, Q1254	2SA1048
Q4351	2SB1197K
Q1071	2SB1238X
Q4361	2SC2240
Q1252, Q3503, Q4101, Q4102	2SC2412K
Q4203 - Q4206, Q4451 - Q4454	2SC2412K
Q1243, Q1253, Q1255, Q1256	2SC2458
Q4353, Q4354	2SD1781K
Q4355	2SD2144S
Q4307, Q4308	2SK373
Q4301, Q4302	DTA114EK
Q4208	DTA143EK
Q4305, Q4306	DTC124EK
Q1241, Q2201, Q2202, Q3502, Q4207	DTC143EK
Q4209, Q4309, Q4352, Q4356, Q4362	DTC143EK
Q4455, Q4458	DTC143EK
D1054, D1074, D1241 - D1243, D1251	1SS254
D1253, D4201 - D4203, D4301 - D4306	1SS254
D4451, D4452, D4601	1SS254
D1981	1SS355
D1073	MTZJ36A
D1075	MTZJ7.5C
D1051, D1052, D1072, D1076	S5688G

COILS AND FILTERS

L1201, L1202 (5.3μH)	ATH - 133
L4351 (4.05mH, 105kHz)	ATX7002
L2181	LAU100J
L1981	LAU220J
L4301, L4302	LTA472J
L4303, L4304	LTA822J
F4401, F4402	RTF1209

SWITCHES AND RELAYS

RY1251 (12V)	ASR7007
--------------	---------

CAPACITORS

C4362	CCCSL151K2H
C4319, C4320	CCCSL271K2H
C4191, C4192, C4323, C4324	CCSQCH100D50
C4113, C4114	CCSQCH101J50
C4601	CCSQCH220J50
C3508	CCSQCH271J50
C4109, C4110	CCSQCH391J50
C1511, C1512	CCSQCH470J50
C4101, C4102	CCSQCH471J50
C4151, C4152	CCSQCH681J50

Mark No. Description Parts No.

C2121, C2122	CCSLSL151J50
C1301	CEANP2R2M50
C1252, C3509, C3511, C4364, C4405	CEAS100M50
C4407, C4454	CEAS100M50
C1513, C2133, C2134, C4401	CEAS101M16
C1072	CEAS101M63
C1073, C4453	CEAS220M35
C3504	CEAS220M50
C1253, C4408	CEAS221M10
C2132, C4103, C4104, C4309, C4310	CEAS330M16
C4357	CEAS3R3M50
C4107, C4351	CEAS470M16
C3503, C3510, C3512	CEAS4R7M50
C4402, C4406	CEASR68M50
C1241, C1501, C1502, C1515, C1516	CEJA2R2M50
C4207, C4208, C4301 - C4304	CEJA2R2M50
C4315, C4316, C4451, C4452	CEJA470M16
C4359, C4360	CEJAR10M50
C2115, C2116	CEJAR33M50
C2101 - C2110	
C1992, C2113, C2114, C4515, C4516	CKSQYB102K50
C3501, C3507	CKSQYB103K50
C1509, C1510, C4602, C4603	CKSQYB104K25
C2117, C2118	CKSQYB154K16
C4313, C4314	CKSQYB182K50
C2123, C2124, C3705	CKSQYB221K50
C1981, C1982	CKSQYB222K50
C1507, C1508	CKSQYB223K50
C4307, C4308	CKSQYB273K50
C2119, C3505, C3506, C4352, C4354	CKSQYB332K50
C1991, C3514, C3515, C4305, C4306	CKSQYB333K50
C2120, C2135, C2136, C4356	CKSQYB472K50
C2111, C2112, C3516, C4105, C4106	CKSQYB682K50
C4311, C4312, C4604	CKSQYB823K25
C3513	CKSQYF223Z50
C4409, C4410	CQMA103J50
C4358	CQMA223J50
C1227, C1228	CQMXA103J2A
C4361	CQPA822J2A
RESISTORS	
R4352	RD1/2PM471J
R1071	RD1/2PMF272J
R1223, R1224	RD1/4LMF101J
R4360	RD1/4LMF470J
R4357	RD1/4LMF4R7J
R4458	RD1/4PM102J
R1241, R1987, R1993, R3515, R3516	RD1/4PU102J
R4401, R4402, R4416	RD1/4PU102J
R1072, R1996	RD1/4PU103J
R1253	RD1/4PU152J
R3505	RD1/4PU221J
R2181, R2182	RD1/4PU271J
R1244	RD1/4PU392J
R1245	RD1/4PU562J
R1231, R1232	RS2LMF331J

XR-P470C, XR-P370CR, XR-P370C

Mark	No.	Description	Parts No.
	R1251, R1252		RS2LMFR22J
	VR3501, VR4301, VR4302 (4.7KΩ/0.1W)		PCP1028
	VR4201 – VR4204 (22KΩ/0.1W)		PCP1030
	VR4351, VR4352 (220KΩ/0.1W)		PCP1033
	Other Resistors		RS1/10S□□□J

OTHERS

J1001	CABLE HOLDER(12P)	51063 – 1205
CN1203	SPEAKER TERMINAL 4 – P	AKE7035
X3501	CERAMIC RESONATOR(456kHz)	ASS7001
CN4003	2P TOP POST	B2B – EH
CN4002	3P TOP POST(RED)	B3B – EH
CN4001	3P TOP POST(RED)	B3B – EH – R
CN1904	CONNECTOR 20P	HLEM20S – 1
CN1901	CONNECTOR	HLEM29S – 1
CN2102	14P PLUG	KM200IB14
CN1201	13P SOCKET	KP250NA13
CN1051	CONNECTOR(9P)	KPE9
JA9001	JACK	RKN1004
	PCB BINDER	VEF1008
JA1301, JA2101	JACK	VKB1050

DF POWER PACK ASSY

SEMICONDUCTORS

	IC1202 (1.25A/60V)	AEK7010
	IC1201	STK4152 – 2GP
	Q1274, Q1276	2SA1048
	Q1273, Q1275	2SC2458
	Q1271	IRFI9Z34G
	Q1272	IRFI224G
	D1277 – D1280	1SS254
	D1275, D1276	MTZJ16B
	D1273, D1274	MTZJ18B
	D1271, D1272	MTZJ5.6C

CAPACITORS

C1201, C1202 (3300μF/50V)	ACH7056
C1207, C1208	CEANP470M25
C1213	CEANP470M50
C1212, C1271, C1272	CEAS100M50
C1205, C1206	CEAS220M35
C1273, C1274	CEAS470M16
C1224	CGCYF104Z50
C1203, C1204	CKSQYB222K50
C1223, C1225, C1226	CKSQYF104Z50

RESISTORS

R1213, R1214	RD1/4LMF101J	
R1271, R1272	RD1/4PM103J	
R1281, R1282	RD1/4PM182J	
R1209 – R1212, R1216, R1217	RD1/4PM222J	
R1243, R1279, R1280	RD1/4PM392J	
R1207, R1208	RD1/4PM563J	
	R1277, R1278	RFA1/4PS101J
	R1221, R1222	RS1/10S100J
	R1225, R1226	RS1/10S102J
	R1229	RS1/10S1R2J

Mark	No.	Description	Parts No.
	R1203, R1204		RS1/10S563J
	R1215		RS1/2LMF102J
	Other Resistors		RD1/4PU□□□J

OTHERS

CN1202	13P PLUG	KM250NA13L
--------	----------	------------

EF REGULATOR ASSY

SEMICONDUCTORS

IC1051	NJM7805FA
IC1052	NJM7812FA
Q1052	2SA1182
Q1051	2SD2012
D1059, D1060	MTZJ15C
D1058	MTZJ6.8C

CAPACITORS

C1054 – C1056	CEJA100M16
C1051 – C1053	CQMA473J50

RESISTORS

R1055	RD1/4PU102J
-------	-------------

Other Resistors

RS1/10S□□□J

OTHERS

J1051	CABLE HOLDER(9P)	51063 – 0905
-------	------------------	--------------

GF DISPLAY ASSY

SEMICONDUCTORS

IC3701	BA3835F
IC1901	PDC036C
Q4501	2SB1197K
Q1901	2SC2412K
Q4512, Q4522	2SD1781K
Q1903, Q4513, Q4523	DTA124EK
Q1904	DTC124EK
Q1701 – Q1704, Q1791, Q1792, Q1902	DTC143EK
Q4502	DTC143EK
D1851, D1852, D1901 – D1903	1SS254
D1905, D1906, D1908, D4501, D4511	1SS254
D4513, D4514, D4517, D4518, D4521	1SS254
D4523 – D4528	1SS254
D1701 – D1704, D1791, D1792	MPG5064X
D1904, D1907	MTZJ6.8C

COILS AND FILTERS

L1901	LAU220J
L1231	LAU100J

SWITCHES AND RELAYS

S1811 – S1818, S1821 – S1829	ASG1034
S1836 – S1839	ASG1034
S1801	ASX7007

CAPACITORS

C1901 (0.047F/5.5V)	ACH1246
C1908	CEJA100M16
C1701, C1910	CEJA220M35
C1903, C1917	CEJA470M16
C1907	CEJAR47M50

XR-P470C, XR-P370CR, XR-P370C

Mark No.	Description	Parts No.
C1233, C1234, C1905		CKSQYB102K50
C3701 - C3704		CKSQYB104K25
C1801, C1802, C1912, C1915		CKSQYB222K50
C1811, C1821, C1831, C1902, C1904		CKSQYF473Z50
C1906, C1909, C1916		CKSQYF473Z50

RESISTORS

R1997, R1998	RA13T473J
R1999	RA7T473J
R4501	RD1/4PM102J
R4503	RD1/4PM222J
R1701, R1791, R1792	RD1/4PM561J

R1901	RD1/4PU101J
R1820, R1830, R1932, R1933, R3706	RD1/4PU102J
R3708 - R3710, R4512, R4522	RD1/4PU102J
R1954, R3707	RD1/4PU103J
R1950, R1951, R4531	RD1/4PU223J

R1816, R1826	RD1/4PU271J
R1817, R1827, R1837	RD1/4PU331J
R1942	RD1/4PU471J
R1905, R1935, R1946, R1956, R4523	RD1/4PU473J
R1818, R1828	RD1/4PU561J

VR4501 (4.7kΩ/0.1W)	PCP1028
Other Resistors	RS1/10S□□□J

OTHERS

J4511	CABLE HOLDER(9P)	51063 - 0905
J4521	CABLE HOLDER(15P)	51063 - 1505
CN9101	CONNECTOR	9607S - 29F
V1901	FL TUBE	AAV7032
JA1231	MINITURE JACK	AKN7005
X1902	REMOTE RECEIVER UNIT CERAMIC RESONATOR(6.00MHz) HOLDER	GP1U28X RSS1050 VNF1096

HF CD SWITCH ASSY

SWITCHES AND RELAYS

S1831 - S1835	ASG1034
---------------	---------

RESISTORS

R1832	RD1/4PU101J
Other Resistors	RS1/10S□□□J

FF SECONDARY ASSY

SEMICONDUCTORS

△ IC1006 (1.25A/60V)	AEK7010
△ IC1001, IC1002 (3A/60V)	AEK7015
D1201	D3SBA20(B)
D1001 - D1008	S5688G

CAPACITORS

C1002	CEAS222M25
C1001	CEAS222M35
C1009	CQMA333K2E

OTHERS

J1001	CABLE HOLDER(12P)	51063 - 1205
-------	-------------------	--------------

Mark No. Description Parts No.

CF PRIMARY ASSY

COILS AND FILTERS

△ L1101 (0.8mH/250V)	ATF - 151
----------------------	-----------

CAPACITORS

△ C1101 (10000pF/250V)	ACG7020
------------------------	---------

OTHERS

H1101, H1102 FUSE HOLDER	VKR1001
--------------------------	---------

AF FM/AM TUNER MODULE

SEMICONDUCTORS

IC6201	LA1832ML
IC6202	LC72131MD
Q6102	2SC2223
Q6203	2SC2705
Q6201, Q6202	2SC2712
Q6103, Q6214, Q6601	2SC2714
Q6104, Q6105	2SK302
Q6101	3SK194
Q6204	DTA124ES
Q6205	DTC124EK
D6202	1SS254
D6101 - D6104	1SV228

COILS AND FILTERS

L6106	ATC1003
L6105	ATC1015
L6101	ATC1016
L6102	ATC1017
L6103	ATC1018
L6104	ATC1019
F6203	ATF - 119
F6206	ATF7008
F6601	ATF7009
F6204	ATF7010
F6202	ATF7011
L6107 (455kHz)	ATH1043
L6602, L6603	LAU220J
L6206, L6208, L6605	LAU2R2J

TRANSFORMERS

T6201	ATB7008
T6101	ATE7002

CAPACITORS

C6113, C6212, C6274, C6275, C6611	CCSQCH101J50
C6116, C6208, C6221	CCSQCH150J50
C6222	CCSQCH180J50
C6271	CCSQCH200J50
C6117	CCSQCH330J50
C6608	CCSQCH680J50
C6118	CCSQCH8R0D50
C6111, C6122	CCSQCK1R0C50
C6112, C6127	CCSQCK2R0C50
C6105	CCSQSL471J50

XR-P470C, XR-P370CR, XR-P370C

Mark	No.	Description	Parts No.
	C6101		CCSQTH110J50
	C6119		CCSQTH150J50
	C6109		CCSQTH270J50
	C6107, C6110		CCSQTH300J50
	C6106		CCSQTH330J50
	C6234, C6235		CEAL1R0M50
	C6245		CEAL470M16
	C6224		CEAS100M50
	C6243		CEAS101M16
	C6231		CEAS1R0M50
	C6227		CEAS220M16
	C6236		CEAS2R2M50
	C6216		CEAS330M16
	C6262		CEAS3R3M50
	C6219		CEAS470M10
	C6244		CEAS470M16
	C6249, C6250, C6265, C6266		CEAS4R7M50
	C6258		CEJA470M16
	C6215		CFTXA103J50
	C6214		CFTXA224J50
	C6115, C6125, C6126, C6211, C6254		CKSQYB102K50
	C6601		CKSQYB102K50
	C6102, C6114, C6121, C6123, C6124		CKSQYB103K50
	C6210, C6213, C6237, C6267, C6276		CKSQYB103K50
	C6279, C6281, C6604		CKSQYB103K50
	C6251, C6252		CKSQYB123K50
	C6606, C6607		CKSQYB182K50
	C6203, C6259		CKSQYB223K50
	C6228		CKSQYB472K50
	C6209		CKSQYB473K50
	C6230		CKSQYB821K50
	C6218, C6223, C6255		CKSQYF103Z50
	C6220, C6226, C6242, C6256		CKSQYF223Z50
	C6225		CKSQYF473Z50
	C6610		CKSYB103K50

RESISTORS

R6602		RD1/4PU221J
R6115, R6119, R6123, R6127, R6129		RS1/8S0R0J
R6906, R6909, R6911		RS1/8S0R0J
R6112		RS1/8S473J
VR6201	(10k Ω /0.1W)	RCP1045
	Other Resistors	RS1/10S□□□J

OTHERS

BN6202	TERMINAL 4-P(10k Ω /0.1W) AKA7001
X6202	CRYSTAL RESONATOR(456kHz) ASS1066
X6201	CRYSTAL RESONATOR(7.2000MHz) ASS1093
CN6201	14P SOCKET KP2001A14L
	AM RF TUNING BLOCK AXX7043

4. SCHEMATIC DIAGRAM

Note: When ordering service parts, be sure to refer to "EXPLODED VIEWS AND PARTS LIST" or "PCB PARTS LIST".

4.1 FM/AM TUNER MODULE

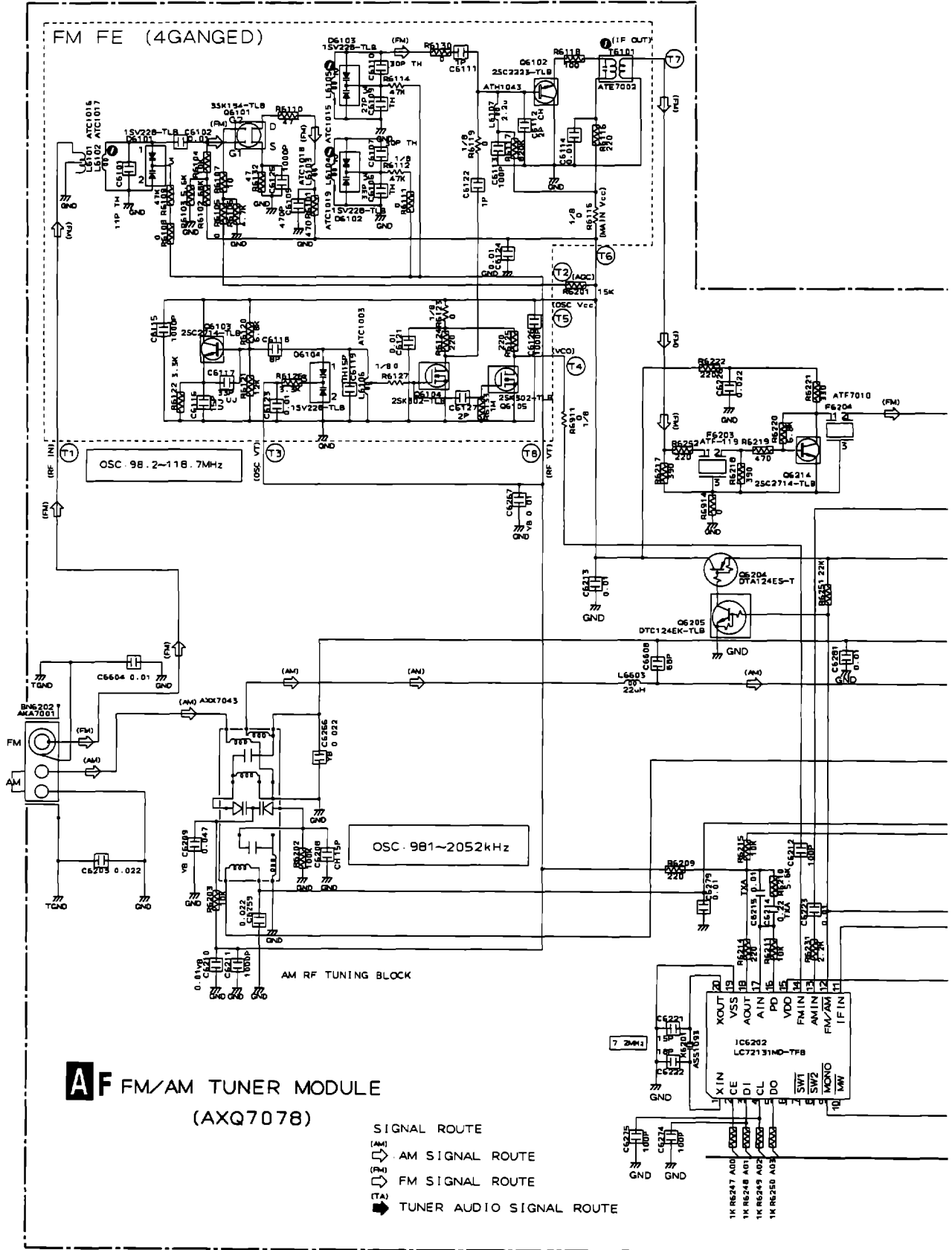

Notes

1. RESISTORS
Indicated in Ω , $1/10W \pm 5\%$ Tolerance unless otherwise noted K:K Ω , M:M Ω .
2. CAPACITORS
Indicated in Capacity (μ F)/VOLTAGE (V) unless otherwise noted P:PF.
3. DIODES
No mark diode is 1SS254.

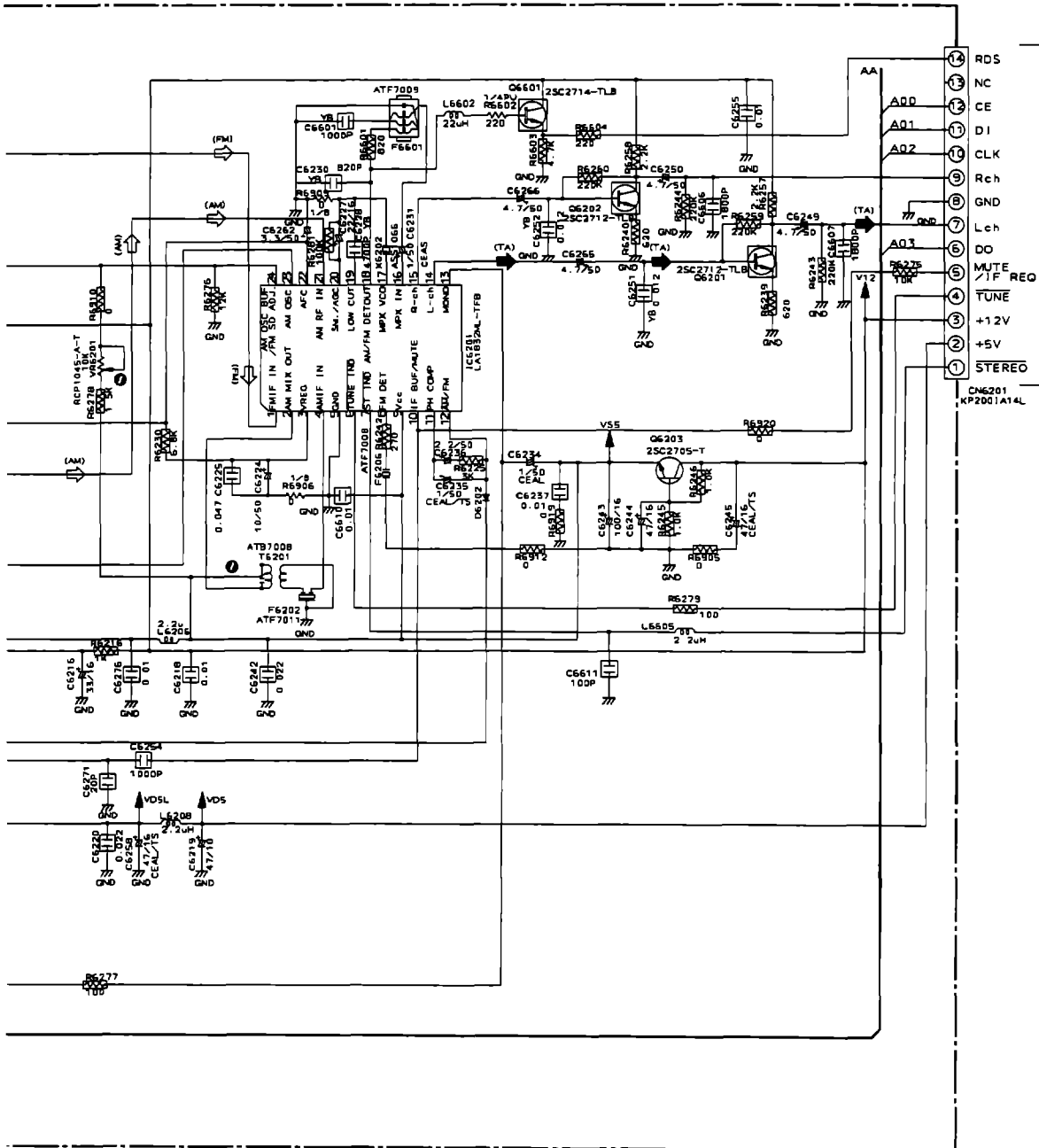

XR-P470C, XR-P370CR, XR-P370C

4.2 AF ASSY(1/2) AND PRIMARY ASSY

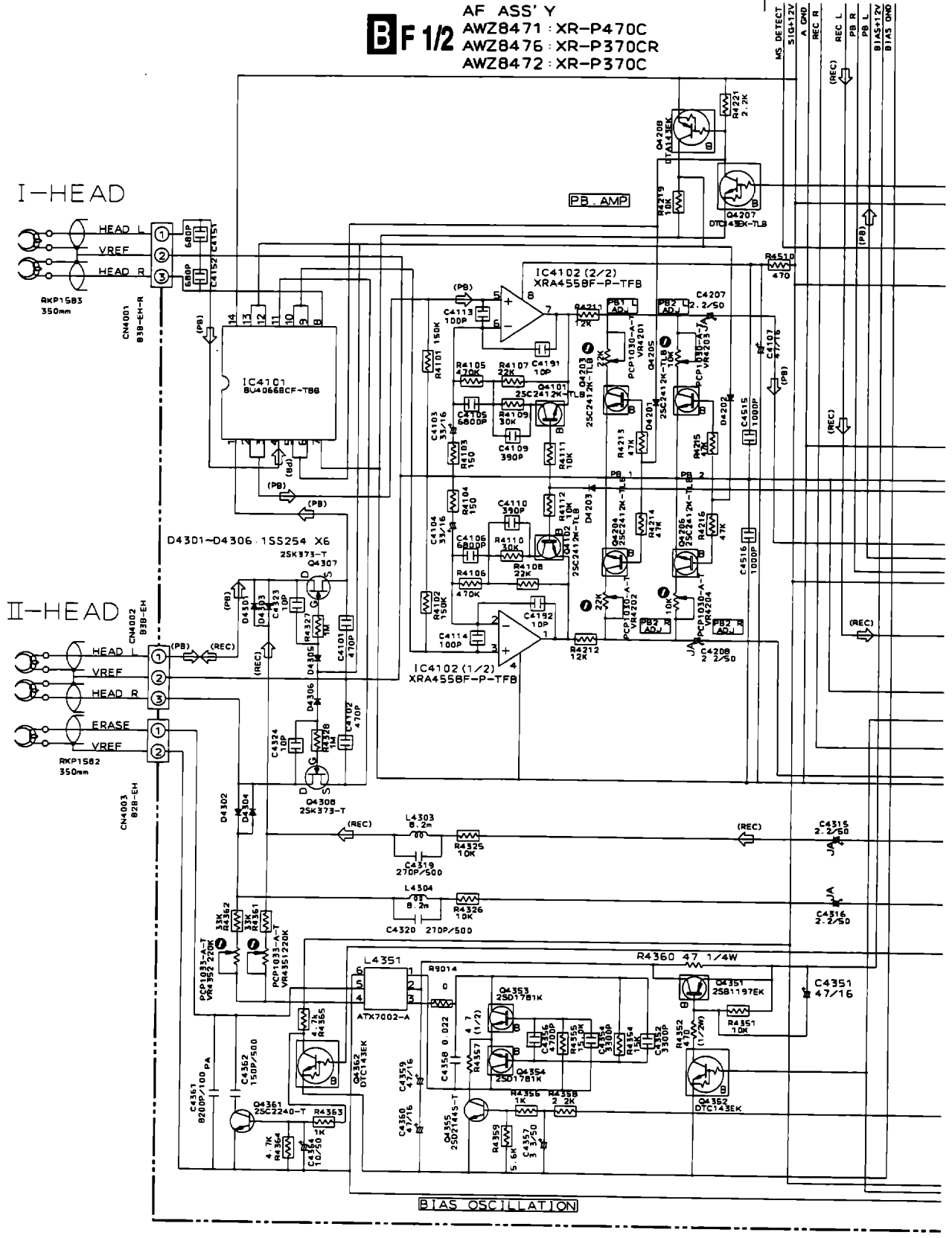

XR-P470C, XR-P370CR, XR-P370C

B F 2/2

E F

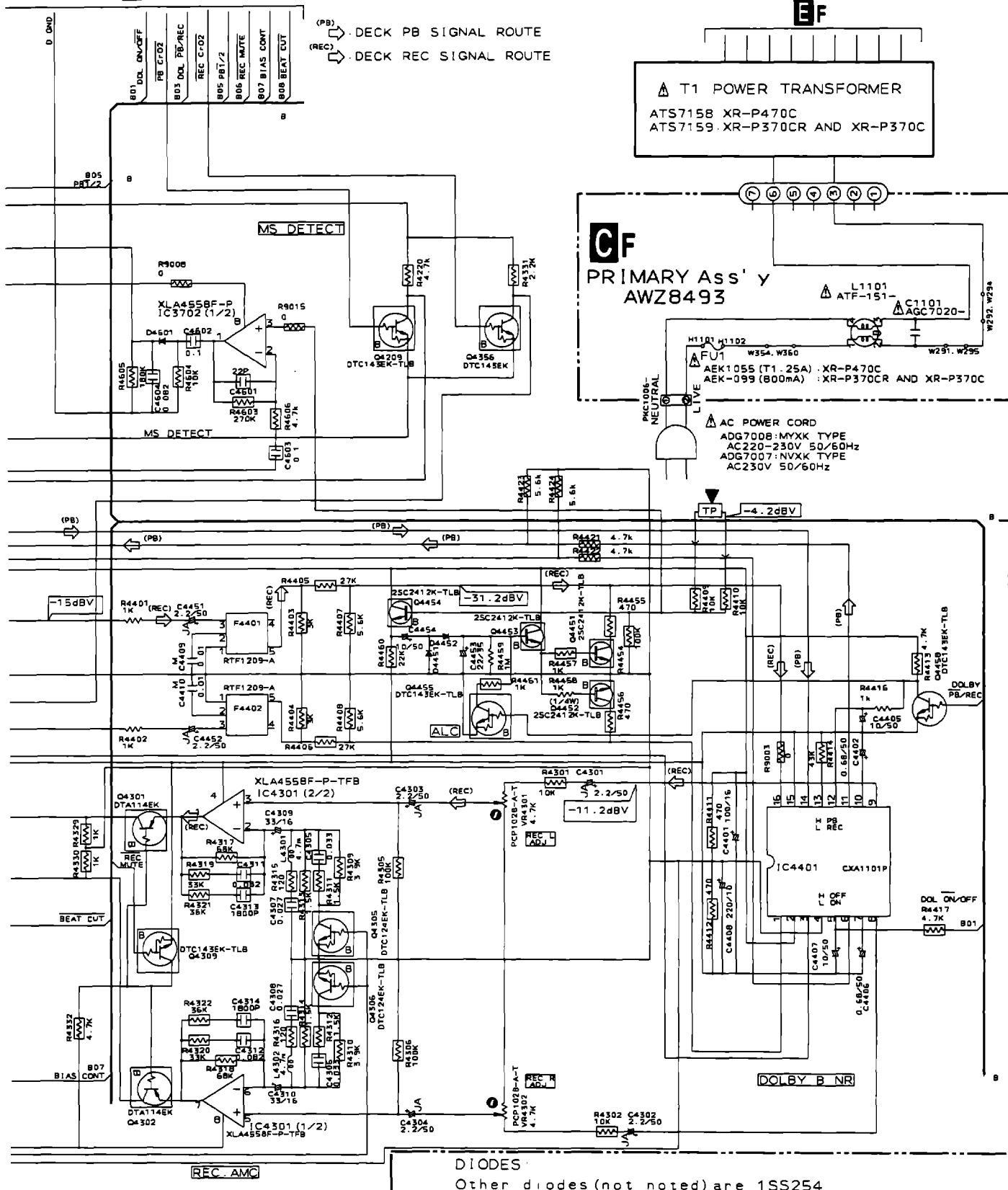

B F 1/2 **C** F 15

XR-P470C, XR-P370CR, XR-P370C

4.3 AF ASSY(2/2), POWER PACK ASSY, REGULATOR ASSY AND SECONDARY ASSY

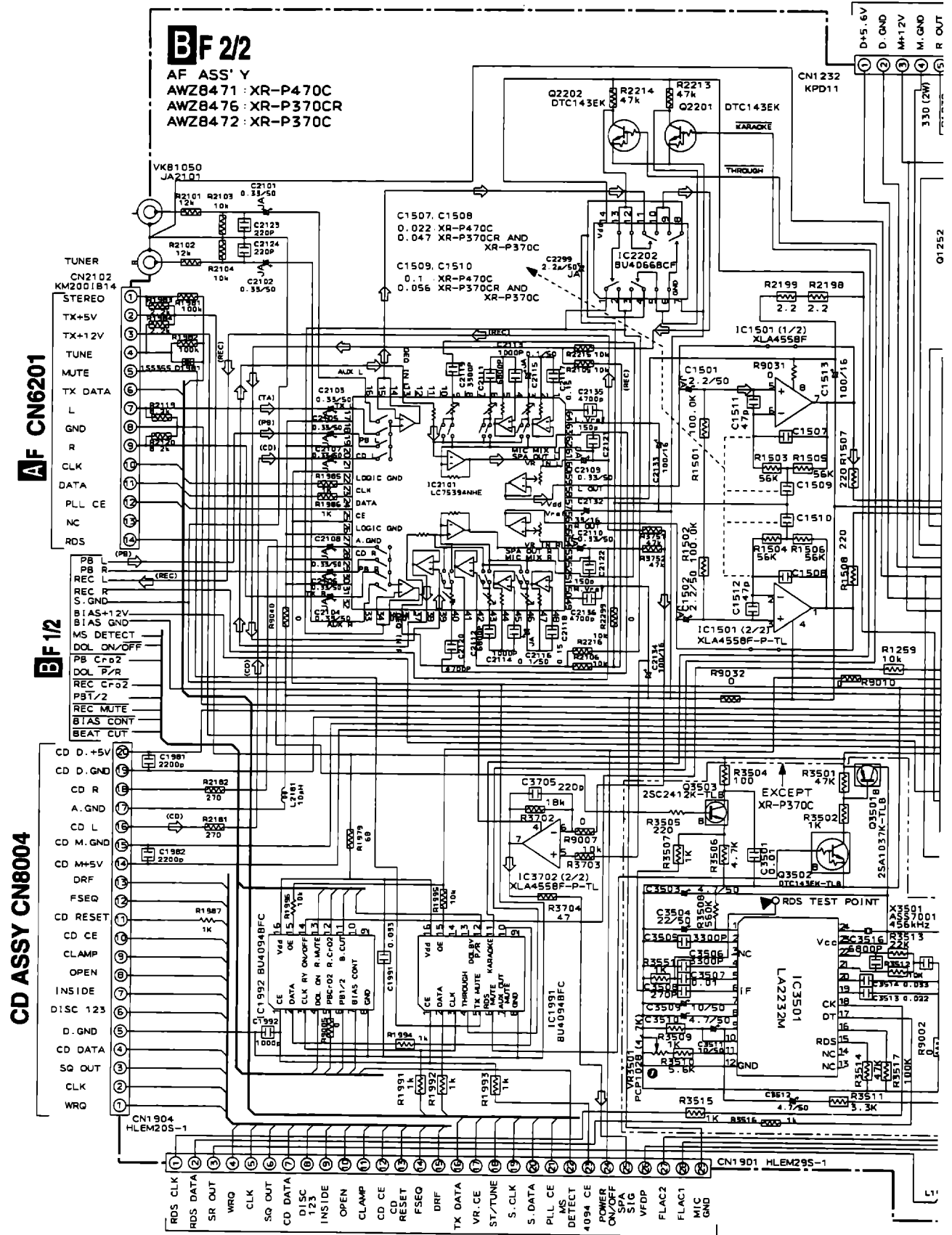

XR-P470C, XR-P370CR, XR-P370C

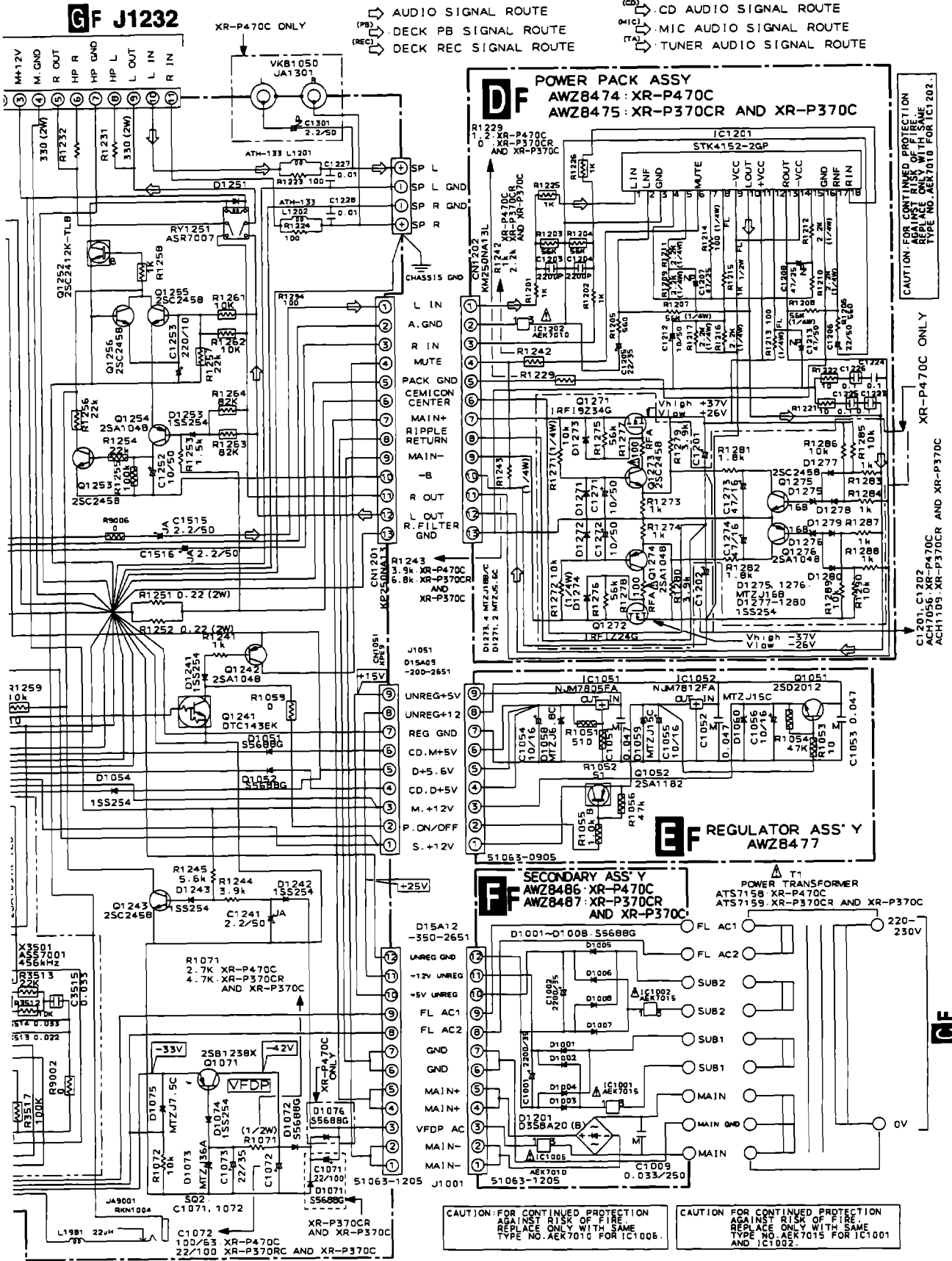

XR-P470C, XR-P370CR, XR-P370C

4.4 DISPLAY ASSY AND CD SWITCH ASSY

DISPLAY ASSY



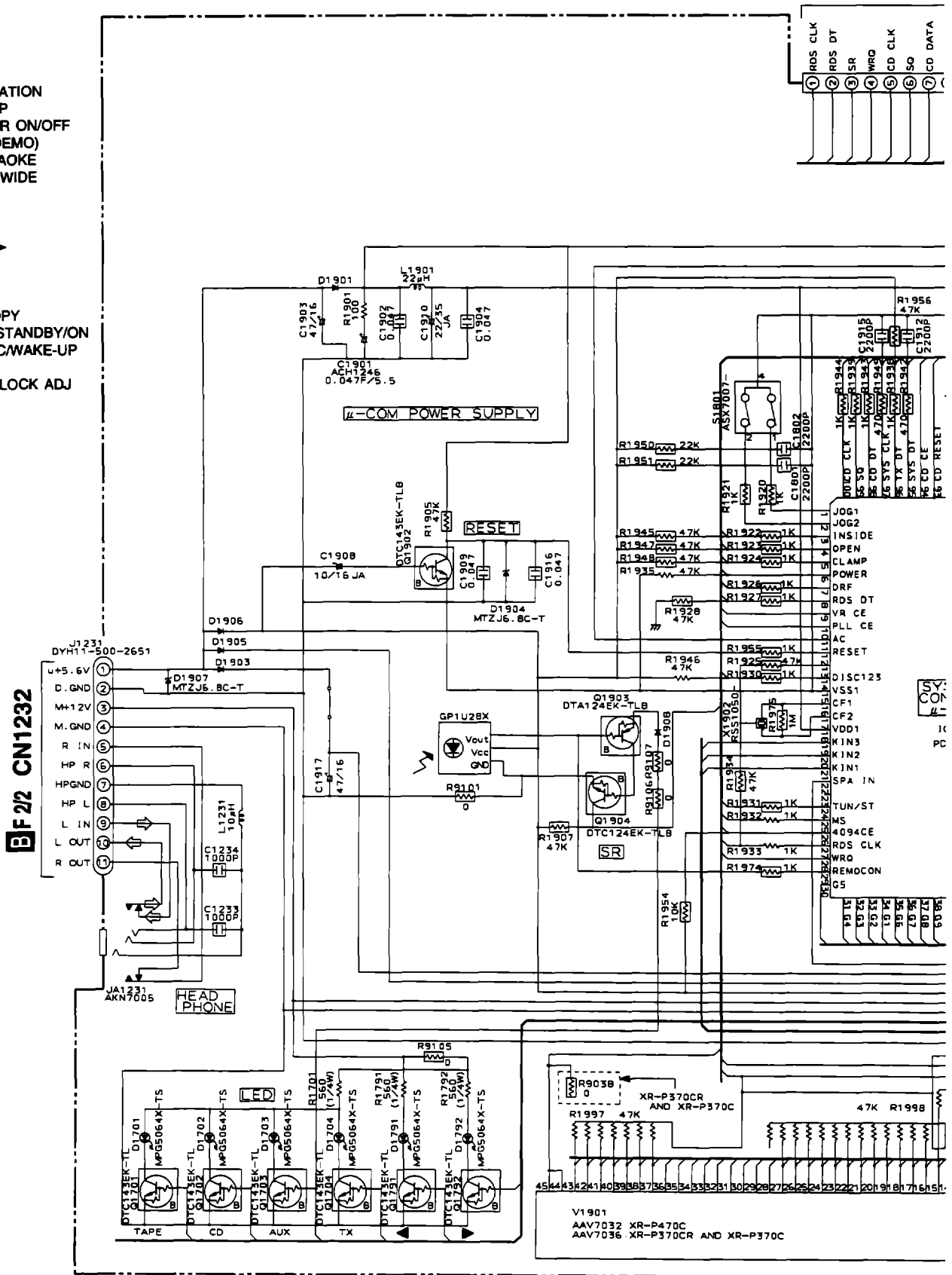



- S1801 : VOLUME
- S1811 : CD
- S1812 : TAPE I/II
- S1813 : FREQ STATION
- S1814 : REC/STOP
- S1815 : DOLBY NR ON/OFF
- S1816 : P.BASS(DEMO)
- S1817 : SFC/KARAOKE
- S1818 : STEREO WIDE
- S1821 : TUNER
- S1822 : MD/AUX
- S1823 : ■
- S1824 : ◀START▶
- S1825 : ▶▶▶
- S1826 : ◀◀◀
- S1827 : MEMORY
- S1828 : ASES COPY
- S1829 : POWER STANDBY/ON
- S1836 : TIME REC/WAKE-UP
- S1837 : MONO
- S1838 : CLOCK/CLOCK ADJ
- S1839 : DISPLAY

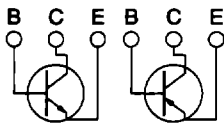

5. PCB CONNECTION DIAGRAM

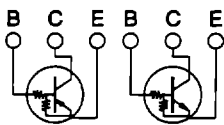
NOTE FOR PCB DIAGRAMS

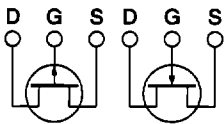
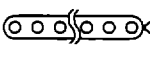
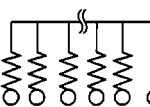
1. Part numbers in PCB diagrams match those in the schematic diagrams.
2. A comparison between the main parts of PCB and schematic diagrams is shown below.

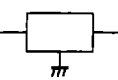
Symbol in PCB Diagrams	Symbol in Schematic Diagrams	Part Name
		Transistor
		Transistor with resistor
		Field effect transistor
		Resistor array
		3-terminal regulator

3. The parts mounted on this PCB include all necessary parts for several destinations.
For further information for respective destinations, be sure to check with the schematic diagram.

4. Viewpoint of PCB diagrams

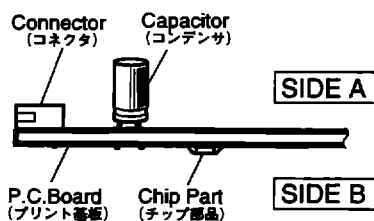

5.1 FM/AM TUNER MODULE

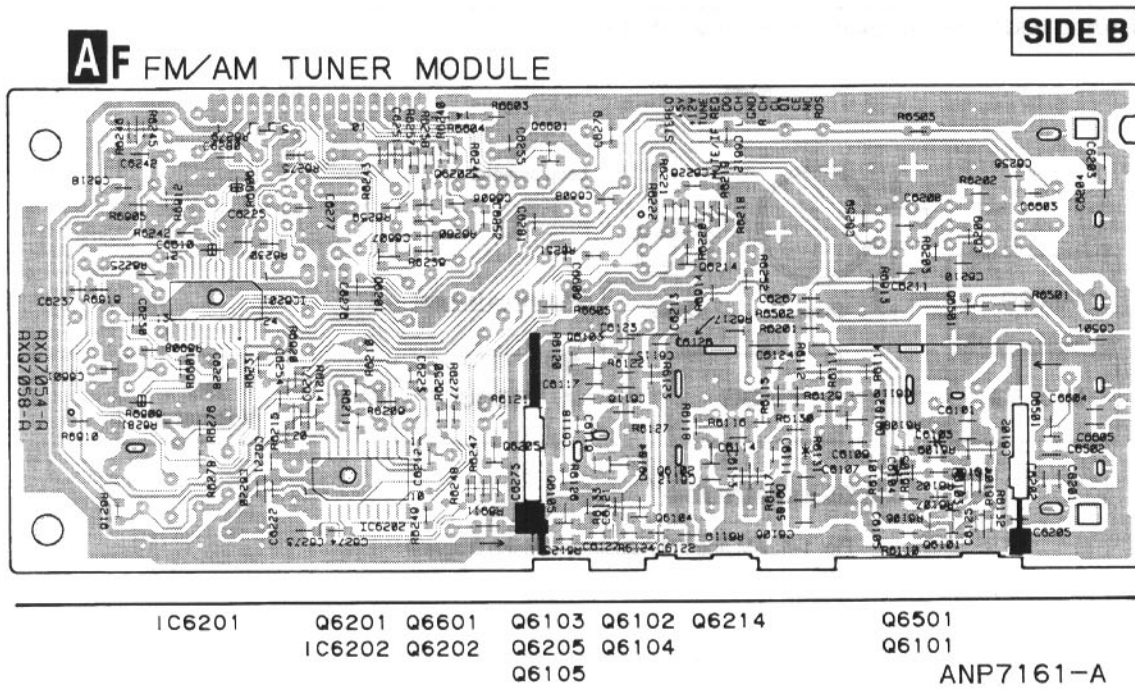
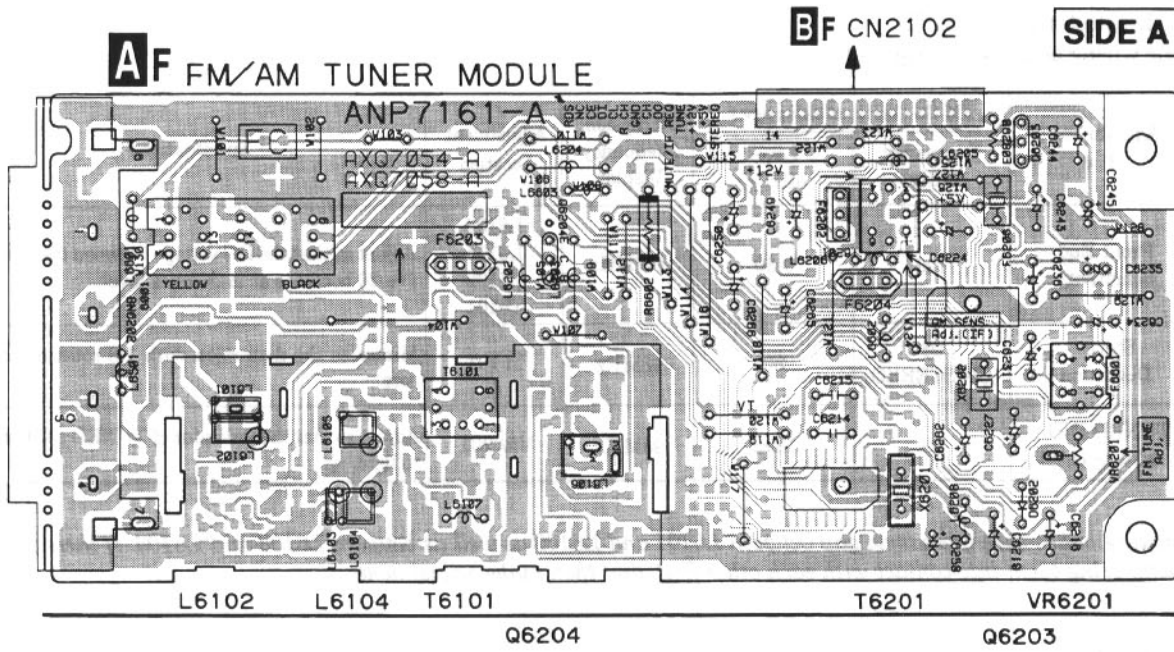

6. ADJUSTMENT

6.1 TUNER SECTION

■ FM Tuner Section

- Set the mode selector to FM BAND.
- Connect the wiring as shown in Fig. 1-1.

Step No.	Adjustment Title	FM SG (1kHz, ±75kHz dev.)		Reception Frequency Display	Adjustment Location	Specifications
		Frequency (MHz)	Level (dBμV)			
1	Front End Sensitivity	106	0-30	106MHz	L6104 L6105 L6102 T6101	Adjust so that the DC voltage between the IC6201-Pin 20 becomes at maximum level.
2	Stereo Distortion	98 (ON STEREO)	80	98MHz	T6101	Minimize the distortion with 1/8 rotation of the core.
3	TUNED IND. Lighting Level	98	18±2	98MHz	VR6201	Adjust so that the indicator of TUNED IND. starts to light up.

Notes:

- Before adjusting, make sure there is no gap between L6101 and L6102 as well as between L6103 and L6104. If there is a gap between them, bring them into contact with each other first, and then make adjustments.

■ AM Tuner Section

- Set the mode selector to AM BAND.
- Connect the wiring as shown in Fig. 1-1.

Step No.	Adjustment Title	AM SG (400Hz, 30% Mod.)		Reception Frequency Display	Adjustment Location	Specifications
		Frequency (kHz)	Level (dBμV/m)			
1	Front End Sensitivity	999*1	35-45	999kHz*1	T6201	Adjust so that the DC voltage between the IC6201-Pin 20 becomes at maximum level.

*1: For the area using 10kHz step, frequencies should be 1000kHz

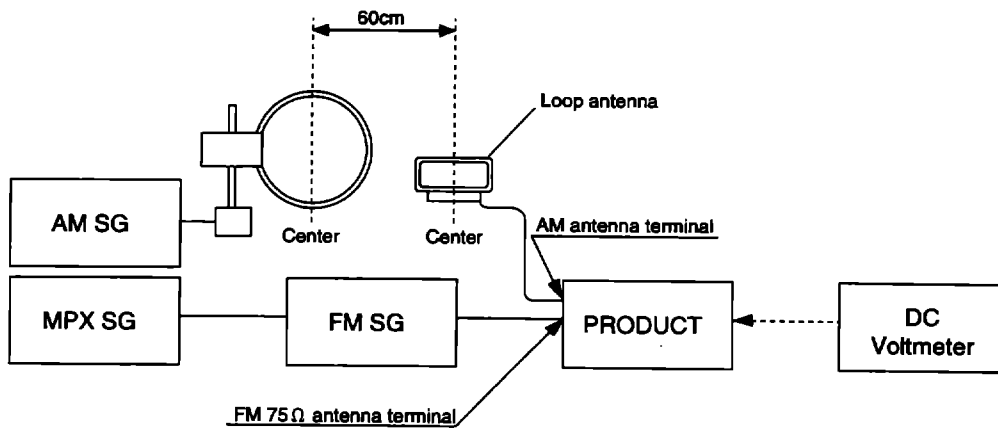

Fig. 1-1 AM and FM Adjustment Wiring Diagram

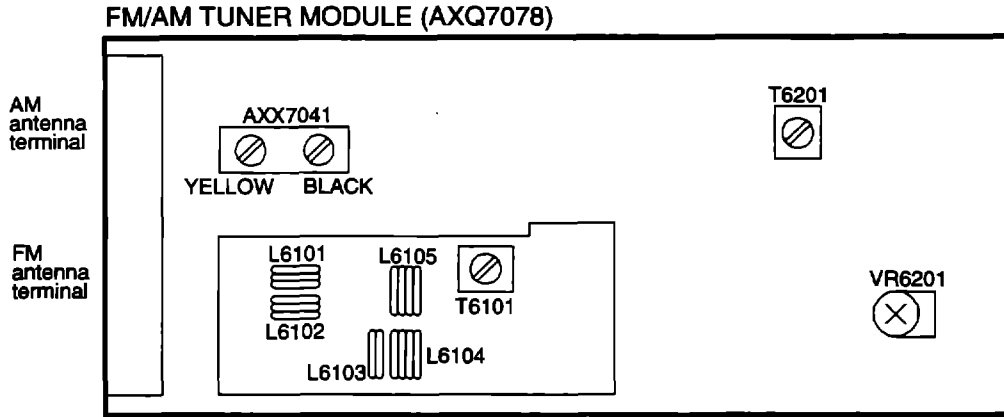

Fig. 1-2 Adjustment Points

6.2 RDS ADJUSTMENT (Except XR-P370C)

- Setting the RDS-Signal generator (*1).
- Set the mode selector to FM BAND.
- Connect the wiring as shown in Fig. 1-3.

*Note *1: Audio Main 1 kHz, 85%
Pilot 10% RDS 1.6%
SK 4.7%*

Step No.	Adjustment Title	FM SG (1kHz, ±75kHz dev.)		Reception Frequency Display	Adjustment Location	Specifications
		Frequency (MHz)	Level (dB μ V)			
1	RDS (BPF) Level	88	60	88 MHz	VR3501	Adjust so that the Waveform of TP3201 (RDS test point) becomes at maximum. (Photo 1)

Note: Entry into RDS mode is done by switching to the FM band and entering an RDS signal from FM (RDS) SG to the FM 75 Ω antenna terminal.

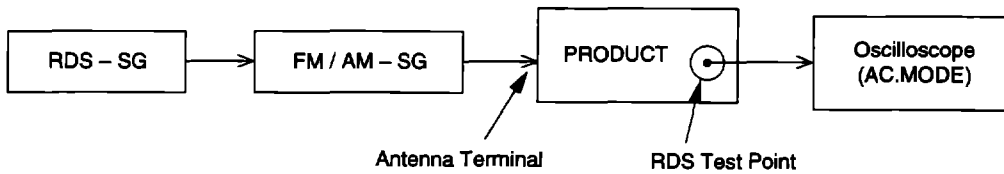

Fig. 1-3 RDS Adjustment Wiring Diagram

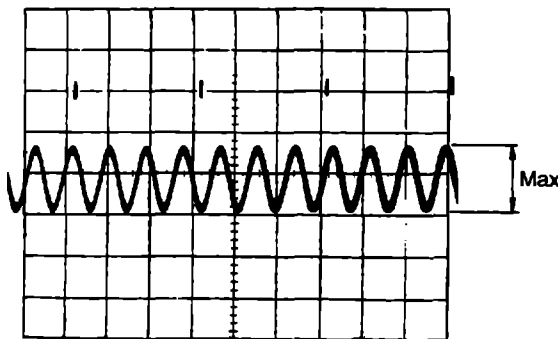

Photo 1

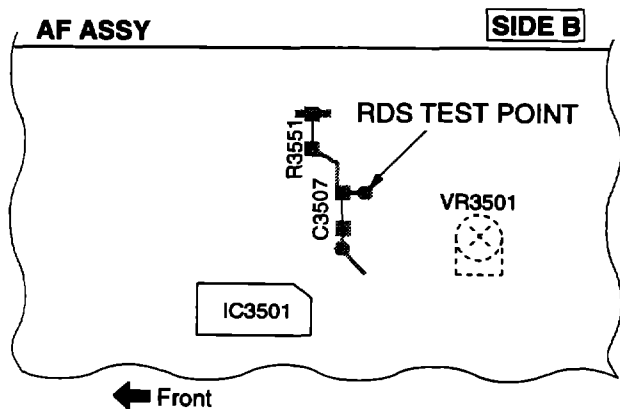

Fig. 1-4 Adjustment Points

