

Service Manual

PIONEER
The Art of Entertainment



ORDER NO.
RRV1464

STEREO CD CASSETTE DECK RECEIVER

X-P60C

XR-P60C

<http://schema99.d2.cz>

- X-P60C is composed of STEREO CD CASSETTE DECK RECEIVER XR-P60C and SPEAKER SYSTEM S-P60.
- Refer to the service manual RRV1480 for SPEAKER SYSTEM S-P60.

THIS MANUAL IS APPLICABLE TO THE FOLLOWING MODEL(S) AND TYPE(S).

Type	Model		Power Requirement	The voltage can be converted by the following method.
	X-P60C	XR-P60C		
KUXJ	○	○	AC120V	_____
KCXJ	○	○	AC120V	_____
SDXJ	○	○	AC110/120-127V/220-230V/240V	With the voltage selector
SDXJ/SA	○	○	AC110/120-127V/220-230V/240V	With the voltage selector
SXJ/NC	○	○	AC110/120-127V/220-230V/240V	With the voltage selector
YPWXJ	○	○	AC240V	_____

CONTENTS

1. SAFETY INFORMATION	2	6. FL INFORMATION	44
2. PACKING, EXPLODED VIEWS AND PARTS LIST	4	7. IC INFORMATION	45
3. SCHEMATIC AND PCB CONNECTION DIAGRAMS	13	8. DISASSEMBLY	54
4. PCB PARTS LIST	37	9. BLOCK DIAGRAM	55
5. ADJUSTMENTS	42	10. PANEL FACILITIES	57
		11. SPECIFICATIONS	61

PIONEER ELECTRONIC CORPORATION 4-1, Meguro 1-Chome, Meguro-ku, Tokyo 153, Japan
PIONEER ELECTRONICS SERVICE, INC. P.O. Box 1760, Long Beach, CA 90801-1760, U.S.A.
PIONEER ELECTRONICS (EUROPE) N.V. Haven 1097, Keetberglaan 1, 8120 Melsele, Belgium
PIONEER ELECTRONICS ASIACENTRE PTE. LTD. 501 Orchard Road, #10-00 Lane Crawford Place, Singapore 0923
 © PIONEER ELECTRONIC CORPORATION 1996

T-IFB MAR, 1998 Printed in Japan

1. SAFETY INFORMATION

This service manual is intended for qualified service technicians; it is not meant for the casual do-it-yourselfer. Qualified technicians have the necessary test equipment and tools, and have been trained to properly and safely repair complex products such as those covered by this manual. Improperly performed repairs can adversely affect the safety and reliability of the product and may void the warranty. If you are not qualified to perform the repair of this product properly and safely, you should not risk trying to do so and refer the repair to a qualified service technician.



WARNING

Lead in solder used in this product is listed by the California Health and Welfare agency as a known reproductive toxicant which may cause birth defects or other reproductive harm (California Health & Safety Code, Section 25249.5).

When servicing or handling circuit boards and other components which contain lead in solder, avoid unprotected skin contact with the solder. Also, when soldering do not inhale any smoke or fumes produced.



NOTICE

(FOR CANADIAN MODEL ONLY)

Fuse symbols  (fast operating fuse) and/or  (slow operating fuse) on PCB indicate that replacement parts must be of identical designation.

REMARQUE

(POUR MODÈLE CANADIEN SEULEMENT)

Les symboles de fusible  (fusible de type rapide) et/ou  (fusible de type lent) sur CCI indiquent que les pièces de remplacement doivent avoir la même désignation.

(FOR USA MODEL ONLY)

1. SAFETY PRECAUTIONS

The following check should be performed for the continued protection of the customer and service technician.

LEAKAGE CURRENT CHECK

Measure leakage current to a known earth ground (water pipe, conduit, etc.) by connecting a leakage current tester such as Simpson Model 229-2 or equivalent between the earth ground and all exposed metal parts of the appliance (input/output terminals, screwheads, metal overlays, control shaft, etc.). Plug the AC line cord of the appliance directly into a 120V AC 60Hz outlet and turn the AC power switch on. Any current measured must not exceed 0.5mA.

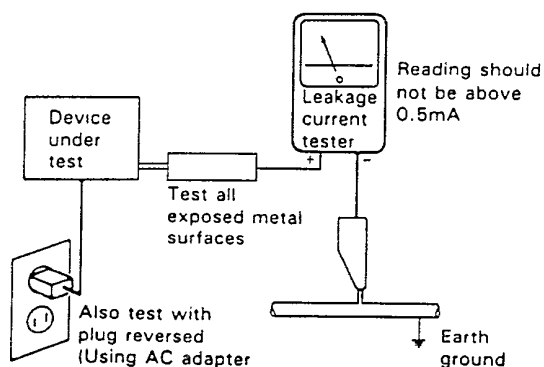

AC Leakage Test

ANY MEASUREMENTS NOT WITHIN THE LIMITS OUTLINED ABOVE ARE INDICATIVE OF A POTENTIAL SHOCK HAZARD AND MUST BE CORRECTED BEFORE RETURNING THE APPLIANCE TO THE CUSTOMER.

2. PRODUCT SAFETY NOTICE

Many electrical and mechanical parts in the appliance have special safety related characteristics. These are often not evident from visual inspection nor the protection afforded by them necessarily can be obtained by using replacement components rated for voltage, wattage, etc. Replacement parts which have these special safety characteristics are identified in this Service Manual.

Electrical components having such features are identified by marking with a Δ on the schematics and on the parts list in this Service Manual.

The use of a substitute replacement component which does not have the same safety characteristics as the PIONEER recommended replacement one, shown in the parts list in this Service Manual, may create shock, fire, or other hazards.

Product Safety is continuously under review and new instructions are issued from time to time. For the latest information, always consult the current PIONEER Service Manual. A subscription to, or additional copies of, PIONEER Service Manual may be obtained at a nominal charge from PIONEER.

X - P60C, XR - P60C

2.2 EXTERIOR (1/2) SECTION

NOTE: Screws adjacent to ▼ mark on the product are used for disassembly.

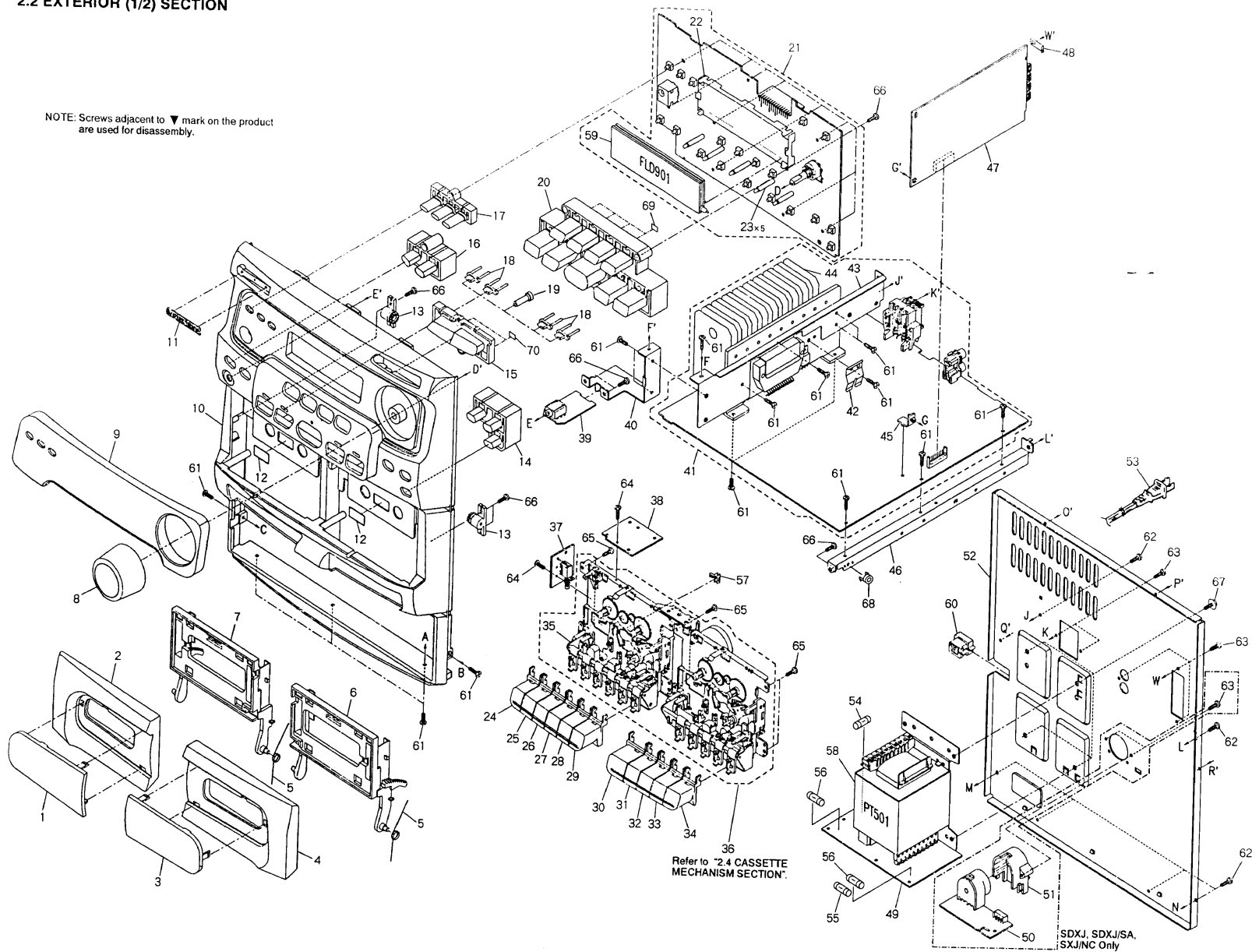

(1) CONTRAST OF XR- P60C/KUXJ, KCXJ, SDXJ, SDXJ/SA, SXJ/NC AND YPWXJ

XR- P60C/KUXJ, KCXJ, SDXJ, SDXJ/SA, SXJ/NC and YPWXJ have the same construction except for the following:

Mark	No.	Symbol & Description	Part No.						Remarks
			XR- P60C						
			KUXJ	KCXJ	SDXJ	SDXJ/SA	SXJ/NC	YPWXJ	
NSP NSP	21	FRONT PCB Assy	AZW7219	AZW7219	AZW7202	AZW7202	AZW7202	AZW7221	
	41	MAIN PCB Assy	AZW7207	AZW7207	AZW7235	AZW7235	AZW7235	AZW7207	
	49	AC SUPPLY PCB Assy	AZW7223	AZW7223	AZW7204	AZW7204	AZW7204	AZW7224	
	50	VOL. SEL. PCB Assy	Not used	Not used	AZW7209	AZW7209	AZW7209	Not used	
	51	Voltage Cover	Not used	Not used	AZN7093	AZN7093	AZN7093	Not used	
	52	Rear Panel	AZN7540	AZN7540	AZN7511	AZN7511	AZN7541	AZN7544	
△	53	AC Cord	AZD7079	AZD7079	AZD7075	AZD7075	AZD7075	AZD7083	
△	54	Fuse (F501, 3A/125V)	AZE7110	AZE7110	Not used	Not used	Not used	Not used	
△	54	Fuse (F501, T2AL/250V)	Not used	Not used	AZE7107	AZE7107	AZE7107	Not used	
△	54	Fuse (F501, T1.6AL/250V)	Not used	Not used	Not used	Not used	Not used	AZE7106	
△	55	Fuse (F502, 1.6A/125V)	AZE7109	AZE7109	Not used	Not used	Not used	Not used	
△	55	Fuse (F502, T1.6AL/250V)	Not used	Not used	AZE7106	AZE7106	AZE7106	AZE7106	
△	56	Fuse (F503, F504, 4A/125V)	AZE7108	AZE7108	Not used	Not used	Not used	Not used	
△	56	Fuse (F503, F504, T4AL/250V)	Not used	Not used	AZE7105	AZE7105	AZE7105	AZE7105	
△	58	Power Transformer (PT501, AC120V)	AZT7081	AZT7081	Not used	Not used	Not used	Not used	
△	58	Power Transformer (PT501, AC110V/120-127V/220-230V/240V)	Not used	Not used	AZT7075	AZT7075	AZT7075	Not used	
△	58	Power Transformer (PT501, AC240V)	Not used	Not used	Not used	Not used	Not used	AZT7084	

(2) PARTS LIST FOR XR- P60C/KUXJ

Mark	No.	Description	Part No.	Mark	No.	Description	Part No.
	1	Cassette Window (L)	AZA7167		30	Cassette Button Play (R)	AZA7174
	2	Cassette Door (L)	AZN7504		31	Cassette Button REW. (R)	AZA7178
	3	Cassette Window (R)	AZA7166		32	Cassette Button F.F. (R)	AZA7176
	4	Cassette Door (R)	AZN7503		33	Cassette Button Eject (R)	AZA7180
	5	Eject Spring	AZN7513		34	Cassette Button Pause (R)	AZA7182
	6	Door Holder (R)	AZN7508		35	Cassette Deck	AZX7035
	7	Door Holder (L)	AZN7509		36	Cassette Deck Assy	AZW7206
	8	Volume Knob	AZA7183	NSP	37	R/P SW PCB Assy	AZW7211
	9	Display Window	AZA7165	NSP	38	CONNECTOR PCB Assy	AZW7210
	10	Front Escutcheon	AZN7506	NSP	39	HEADPHONE PCB Assy	AZW7208
	11	Pioneer Badge	PAM1608	NSP	40	Heat Sink Bracket (B)	•••••
	12	Mirror	AZN7170		41	MAIN PCB Assy	AZW7207
	13	Gear Damper	AZN7179		42	Spring Transistor (B)	AZB7019
	14	Preset Knob	AZA7168		43	Heat Sink Bracket	AZN7142
	15	CD Open /Close Knob	AZA7186		44	Heat Sink Assy (7FIN)	AZN7641
	16	Bass Knob	AZA7169		45	PCB Hinge	AZN7517
	17	Timer Knob	AZA7170	NSP	46	Main PCB Bracket	•••••
	18	LED Lens	AZA7188		47	TUNER PCB Assy	AZW7205
	19	Indicator	AZA7190		48	Earth Terminal	AZN7536
	20	Function Knob	AZA7171	NSP	49	AC SUPPLY PCB Assy	AZW7223
	21	FRONT PCB Assy	AZW7219		50	•••••	
	22	Display Holder	AZN7538		51	•••••	
	23	LED Holder	AZN7539		52	Rear Panel	AZN7540
	24	Cassette Button Record	AZA7172	△	53	AC Cord	AZD7079
	25	Cassette Button Play (L)	AZA7173	△	54	Fuse (F501, 3A/125V)	AZE7110
	26	Cassette Button REW. (L)	AZA7177	△	55	Fuse (F502, 1.6A/125V)	AZE7109
	27	Cassette Button F.F. (L)	AZA7175	△	56	Fuse (F503, F504, 4A/125V)	AZE7108
	28	Cassette Button Eject (L)	AZA7179		57	Leaf Switch (ZEXSA)	AZS7033
	29	Cassette Button Pause (L)	AZA7181				

X - P60C, XR - P60C

Mark	No.	Description	Part No.
△	58	Power Transformer (PT501, AC120V)	AZT7081
	59	FLD BJ453GK	AZA7191
△	60	Cord Bushing	AZE7104
	61	Screw	BBZ30P060FMC
	62	Screw	BBZ30P060FZK
	63	Screw	BBZ30P100FZK
	64	Screw	IBZ20P050FMC
	65	Screw	IBZ30P080FMC
	66	Screw	IBZ30P100FMC
	67	Screw	IBZ40P080FCC
	68	Spacer Support	AZN7642
NSP	69	Spacer (T:0.2)	•••••
NSP	70	Spacer (T:0.4)	•••••

2.3 EXTERIOR (2/2) SECTION

Parts List

Mark	No.	Description	Part No.	Mark	No.	Description	Part No.
	1	2P CON. Assy	AZD7076		38	Chassis Assy	AZW7058
	2	Side Rail (L)	AZN7521		39	Motor Assy (SLED)	AZX7015
	3	Pulley (Side)	AZN7030		40	CD Mechanism CD94V5	AZN7281
NSP	4	Bottom Chassis	•••••		41	Changer Base	AZN7523
	5	Foot	AZN7512		42	Spring Holder	AZN7282
	6	Side Rail (R)	AZN7520		43	Main Base Cover	AZN7009
	7	Guide Pin Plate	AZN7522		44	E Ring 8Q	AZB7011
	8	Top Cover	AZN7505		45	Washer	AZB7010
	9	CD Window	AZA7184		46	Clutch Spring	AZB7016
	10	CD Front Panel	AZN7514		47	Poly Washer	AZB7047
	11	CD Display Lens	AZA7187		48	Cam Gear	AZN7510
NSP	12	CD LED PCB Assy	AZW7213		49	Tumtable	AZN7519
	13	CD Lens Holder	AZN7515		50	Transit Lock	AZN7103
	14	Switch Box	AZN7121		51	Poly Washer	AZB7012
	15	Switch Pin	AZN7276		52	Magnetic Holder	AZN7273
	16	Mounting Plate Assy	AZW7132		53	Magnet	AZN7114
	17	Fiber Washer	AZB7124		54	Arm Assy	AZW7131
	18	Wheel	AZN7057		55	Magnetic Cover	AZN7063
	19	Belt (60 × 1.6)	AZN7059		56	Leaf Switch MLS-1	AZS7003
	20	E Ring 2.5Q	AZB7007		57	Leaf Switch LSC-1223-31	AZS7001
	21	Motor Pulley	AZN7053		58	Tumtable Motor	AZX7003
	22	Motor Bracket	AZN7124			MMN-6E9D1	
	23	Spacer (4 × 13 × 2)	AZN7277		59	Drawer Motor	AZX7002
	24	Guide Plate	AZN7041			MEN-7E9T2	
NSP	25	CD SENSOR PCB Assy	AZW7214	NSP	60	Fix PCB 24.5 × 16 × 1.6mm	AZN7548
	26	Lever Plate	AZN7117		61	Screw	BBZ26P030FMC
	27	Sponge (5.5 × 7)	AZN7279		62	Screw	BBZ26P040FMC
	28	Shaft (Lever Switch)	AZN7116		63	Screw	BBZ26P080FZK
	29	Himelon Sheet	AZN7518		64	Screw	BBZ30P060FMC
	30	CD PCB Cover	AZN7644		65	Screw	BBZ30P080FMC
	31	Fiber Washer	AZB7125		66	Screw	BBZ30P100FZK
	32	CD DECODER PCB Assy	AZW7212		67	Screw	BBZ30P120FMC
	33	Gear Wheel	AZN7123		68	Screw	CBZ30P080FZK
	34	Wire Holder	AZN7122		69	Screw	IBZ20P050FMC
	35	Cushion Holder	AZN7125		70	Screw	IBZ26P060FMC
	36	PICKUP Assy	AZN7295		71	Screw	IBZ30P080FMC
	37	Leaf Switch (S17:LIMIT)	AZS7016		72	Screw	IBZ30P080FZK
					73	Screw	IBZ30P100FMC

X - P60C, XR - P60C

2.4 CASSETTE MECHANISM SECTION

Parts List

Mark	No.	Description	Part No.	Mark	No.	Description	Part No.
NSP	1	Sub Chassis	•••••	56	Rec Button Lever Spring	AZN7589	
NSP	2	Rec Button Lever (F)	•••••	57	Switch Lock Plate Spring	AZN7590	
NSP	3	Play Button Lever (F)	•••••	58	Play Button Lever Spring	AZN7591	
NSP	4	REW. Button Lever (F)	•••••	59	Eject Slide Lever Spring	AZN7592	
NSP	5	F.F. Button Lever (F)	•••••	60	R.F Clutch Spring	AZN7593	
NSP	6	Stop Button Lever (F)	•••••	61	Takeup Idler Gear Shaft	AZN7594	
NSP	7	Pause Button Lever (F)	•••••	62	Pinch Roller Shaft	AZN7595	
NSP	8	Push Button Actuator Plate	•••••	63	Capstan Metal	AZN7596	
NSP	9	Switch Actuator Plate	•••••	64	Takeup Reel Shaft	AZN7597	
NSP	10	Eject Lever	•••••	65	F.F. Gear Shaft	AZN7598	
NSP	11	REW. Fixed Plate	•••••	66	R.F. Shaft	AZN7599	
NSP	12	Head Panel R/P	•••••	67	Flywheel Shaft	AZN7600	
NSP	13	Head Panel P/B	•••••	68	Lug Plate	AZN7601	
NSP	14	Takeup Reel Plate	•••••	69	Head Screw ISO	AZB7126	
NSP	15	Flywheel Plate	AZN7551	70	Azimuth Screw	AZB7127	
NSP	16	Deck Angle Connector	•••••	71	E Head Screw	AZB7128	
NSP	17	P. Cancel Plate	AZN7552	72	Pack Spring Screw	AZB7129	
NSP	18	Main Base	AZN7553	73	C Tapping Screw	AZB7130	
NSP	19	E. Slide Lever (F)	AZN7554	74	TP Screw	AZB7131	
NSP	20	Auto Stop Lever	AZN7555	75	Special Screw	AZB7132	
NSP	21	Pause Lever	AZN7556	76	C Tapping Screw	AZB7133	
NSP	22	Pause Stopper	AZN7557	77	Special Screw	AZB7134	
NSP	23	Pinch Roller Arm	AZN7558	78	Motor Collar Screw	AZB7135	
NSP	24	Pinch Roller	AZN7559	79	Head (MS18R - AKONI)	AZP7019	
NSP	25	Head Base R/P	AZN7560	80	E Head (LE15B - CI)	AZP7020	
NSP	26	Head Base P/B	AZN7561	81	P Washer Cut	AZN7602	
NSP	27	Takeup Reel Cap	AZN7562	82	Leaf Switch	AZS7034	
NSP	28	Sensing Ring	•••••	83	Takeup Reel Felt	AZN7603	
NSP	29	Takeup Reel Disk	AZN7563	84	P Washer	AZN7604	
NSP	30	•••••	•••••	85	R.F Felt	AZN7605	
NSP	31	Takeup Reel Gear	AZN7564	86	Takeup Idler P Washer Cut	AZN7606	
NSP	32	F.F. Gear	AZN7565	87	Takeup Idler Gear Washer	AZN7607	
NSP	33	Reco. Safety Lever	AZN7566	88	Motor Felt	AZN7608	
NSP	34	R.F Gear	AZN7567	89	Motor Rubber	AZN7609	
NSP	35	R.F Arm	AZN7568	90	Motor (SHU2L - 70)	AZX7037	
NSP	36	R.F Spring Stopper	AZN7569	91	R.F Belt	AZN7610	
NSP	37	R.F Pulley	AZN7570	92	Main Belt (6KEY)	AZN7611	
NSP	38	R.F Disk	AZN7571	93	Main Belt (SKEY)	AZN7612	
NSP	39	Flywheel Gear	AZN7572	94	Rec Spring Plate	AZN7613	
NSP	40	Flywheel Pulley	AZN7573	95	Rec Spring Plate Screw	AZB7137	
NSP	41	T. Up Idler Gear	AZN7574	96	Button Frame	AZN7614	
NSP	42	Pause Cancel Arm	AZN7575	97	FH Screw for Camera	AZB7138	
NSP	43	Motor Pulley	AZN7576	98	Button Shaft	AZN7615	
NSP	44	E Head Spring	AZN7577	99	Button	AZN7616	
NSP	45	Head Spring	AZN7578	100	R.F Washer	AZN7617	
NSP	46	T. Up Idler PL. Spring	AZN7579	101	Leaf Switch	AZS7035	
NSP	47	Pinch Roller Spring	AZN7580	102	Washer Cut	AZN7618	
NSP	48	Auto Lever Spring	AZN7581	103	Rec Safety Lever Lock	AZN7619	
NSP	49	F/R Button Lever Spring	AZN7582	104	Takeup Reel Washer Cup	AZN7620	
NSP	50	S/P Button Lever Spring	AZN7583	105	5P Connector Assy	AZD7002	
NSP	51	Pause Spring	AZN7584	106	3P Connector Assy	AZD7003	
NSP	52	Pause Lever Spring	AZN7585	107	2P Connector Assy	AZD7004	
NSP	53	T. Up Reel Clutch Spring	AZN7586	108	Earth Terminal Assy	AZK7046	
NSP	54	Back Tension Spring	AZN7587	109	Screw	AZB7136	
NSP	55	Pack Spring (F)	AZN7588	110	P Kick Lever Spring	AZN7650	

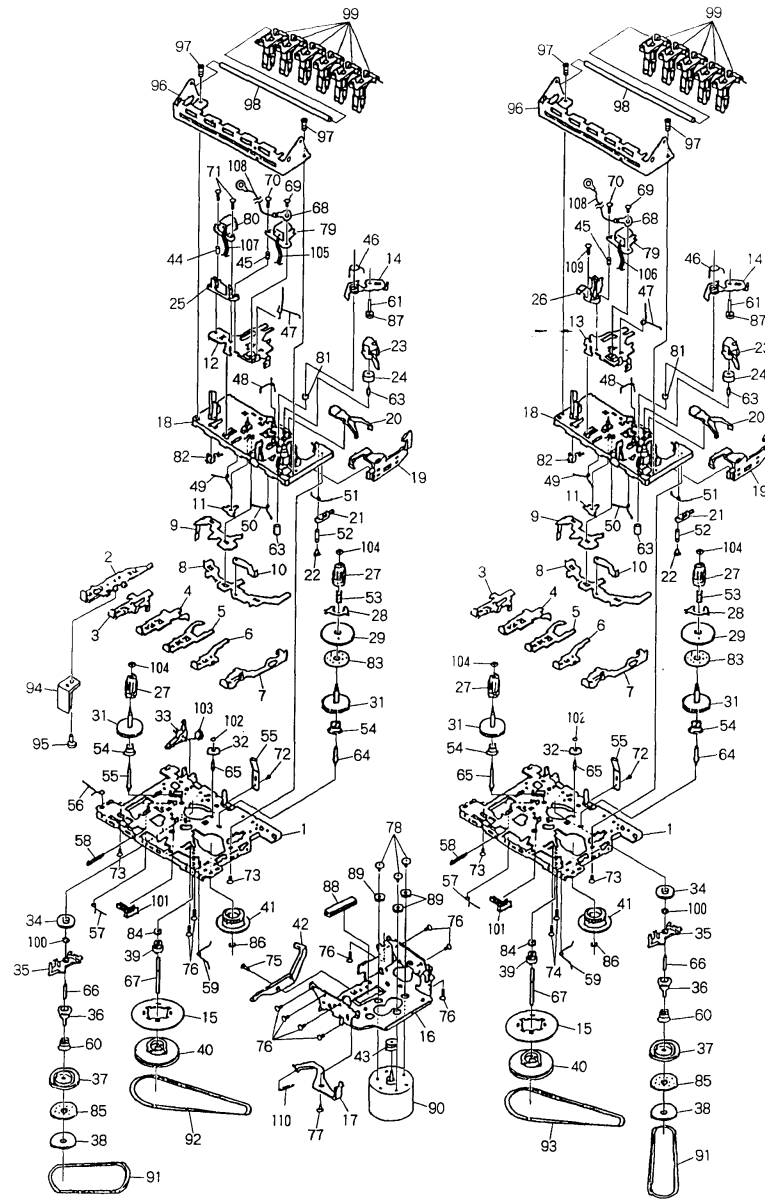

3. SCHEMATIC AND PCB CONNECTION DIAGRAMS

NOTE FOR SCHEMATIC DIAGRAMS

1. When ordering service parts, be sure to refer to "PARTS LIST of EXPLODED VIEWS" or "PCB PARTS LIST". (Type 1A)

2. Since these are basic circuits, some parts of them or the values of some components may be changed for improvement.

3. RESISTORS:

Unit: k:Ω, M:MΩ, or Ω unless otherwise noted.
 Rated power: 1/4W, 1/6W, 1/8W, 1/10W unless otherwise noted.
 Tolerance:(F): ± 1%, (G): ± 2%, (K): ± 10%, (M): ± 20% or ± 5% unless otherwise noted.

4. CAPACITORS:

Unit: p:pF or μF unless otherwise noted.
 Ratings: capacitor (μF) / voltage (V) unless otherwise noted.
 Rated voltage: 50V except for electrolytic capacitors.

5. COILS:

Unit: m:mH or μH unless otherwise noted.

6. VOLTAGE AND CURRENT:

: Signal voltage at rated output.
 or $\leftarrow V$:

DC voltage (V) at no input signal unless otherwise noted.
 Value in () is DC voltage at rated power.

\leftarrow mA or \leftarrow mA :

DC current at no input signal unless otherwise noted.

7. OTHERS:

- or : Adjusting point.
- : Measurement point.
- The Δ mark found on some component parts indicates the importance of the safety factor of the parts. Therefore, when replacing, be sure to use parts of identical designation.

8. SCH - □ ON THE SCHEMATIC DIAGRAM:

- SCH-□ indicates the drawing number of the schematic diagram. (SCH stands for schematic diagram.)

9. SWITCHES (Underline indicates switch position):

R/P SW PCB ASSY
 S604: R/P SW

FRONT PCB ASSY

- S901: POWER STANDBY/ON
- S902: TUNER/BAND
- S903: TAPE
- S904: AUX
- S905: SFC
- S906: P. BASS
- S907: TUNING + ()
- S908: TUNING - ()
- S909: PRESET UP
- S910: PRESET DOWN
- S911: MEMORY
- S912: (CD STOP)
- S913: CD /
- S914: PROGRAM
- S915: CLOCK
- S916: TIMER SET } TIMER
- S917: MODE
- S918: CD OPEN/CLOSE()
- S919: DISC SKIP

VOL. SEL. PCB ASSY(SDXJ, SDXJ/SA and SXJ/NC only)

S501: AM CHANNEL STEP 9kHz — 10kHz

S502: VOLTAGE SELECTOR

AC110V—AC120—127V—AC220—230V—AC240V

NOTE FOR PCB DIAGRAMS:

1. Part numbers in PCB diagrams match those in the schematic diagrams.
2. A comparison between the main parts of PCB and schematic diagrams is shown below.

Symbol in PCB Diagrams	Symbol in Schematic Diagrams	Part Name
		Transistor
		Diode
		Capacitor (Polarized)

3. The transistor terminal marked with E or shows the emitter.
4. The diode terminal marked with or shows cathode side.
5. The capacitor terminal marked with or shows negative terminal.

X- P60C, XR- P60C

• AC SUPPLY PCB AND VOL. SEL. PCB ASSEMBLIES

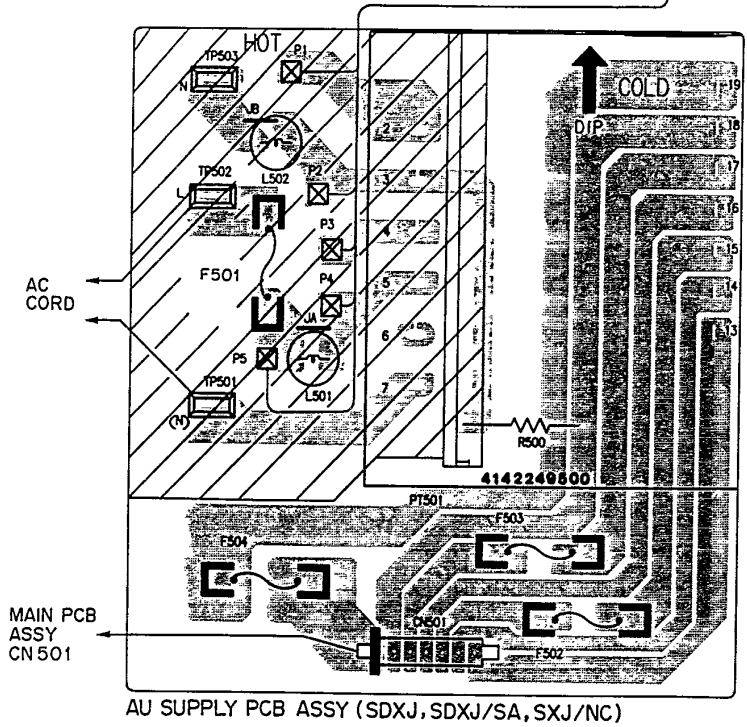
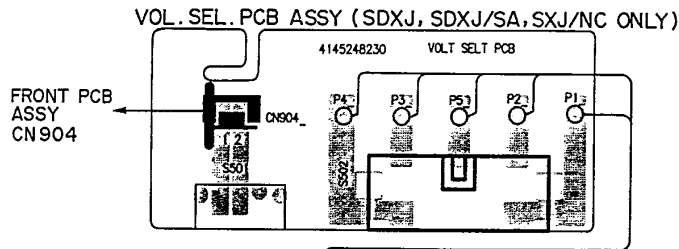
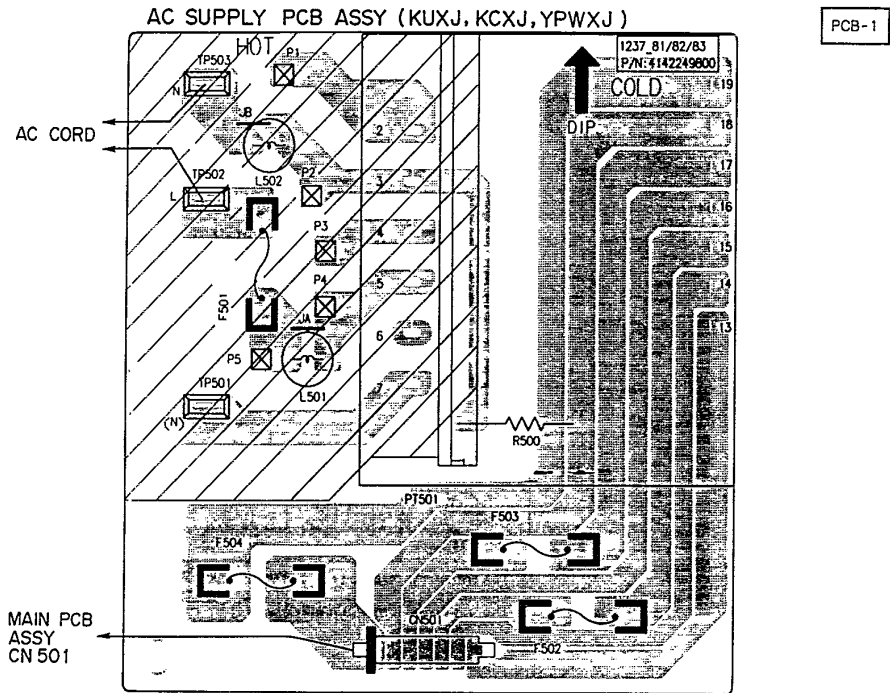

• This diagram is viewed from the mounted parts side.

• The parts mounted on this PCB include all necessary parts for several destinations. For further information for respective destinations, be sure to check with the schematic diagram.

3.1 OVERALL CONNECTIONS, AC SUPPLY PCB AND VOL. SEL. PCB ASSEMBLIES

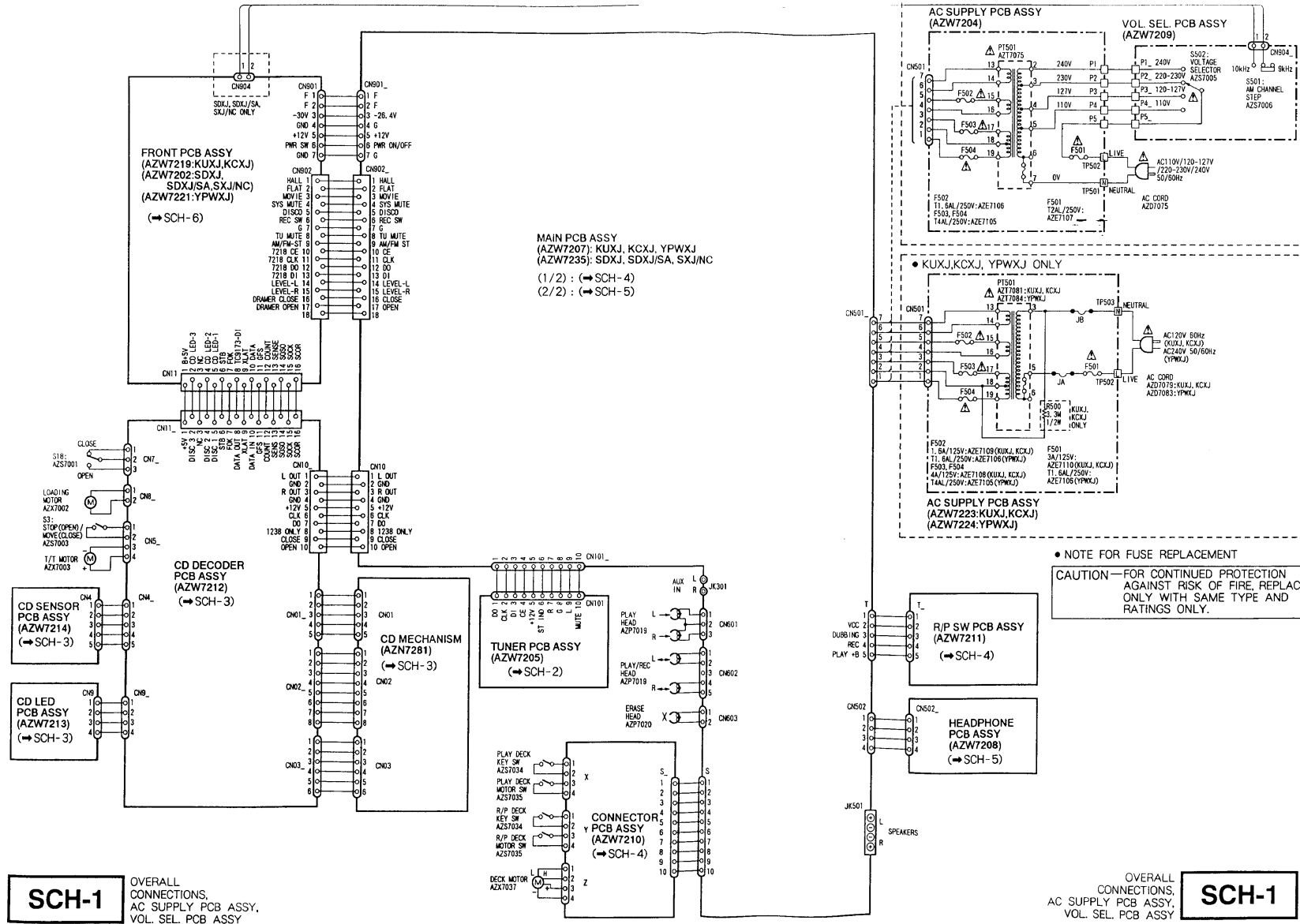

SCH-1 OVERALL CONNECTIONS, AC SUPPLY PCB ASSY, VOL. SEL. PCB ASSY

SCH-1 OVERALL CONNECTIONS, AC SUPPLY PCB ASSY, VOL. SEL. PCB ASSY

SCH-1

3.2 TUNER PCB ASSY

SCH-2

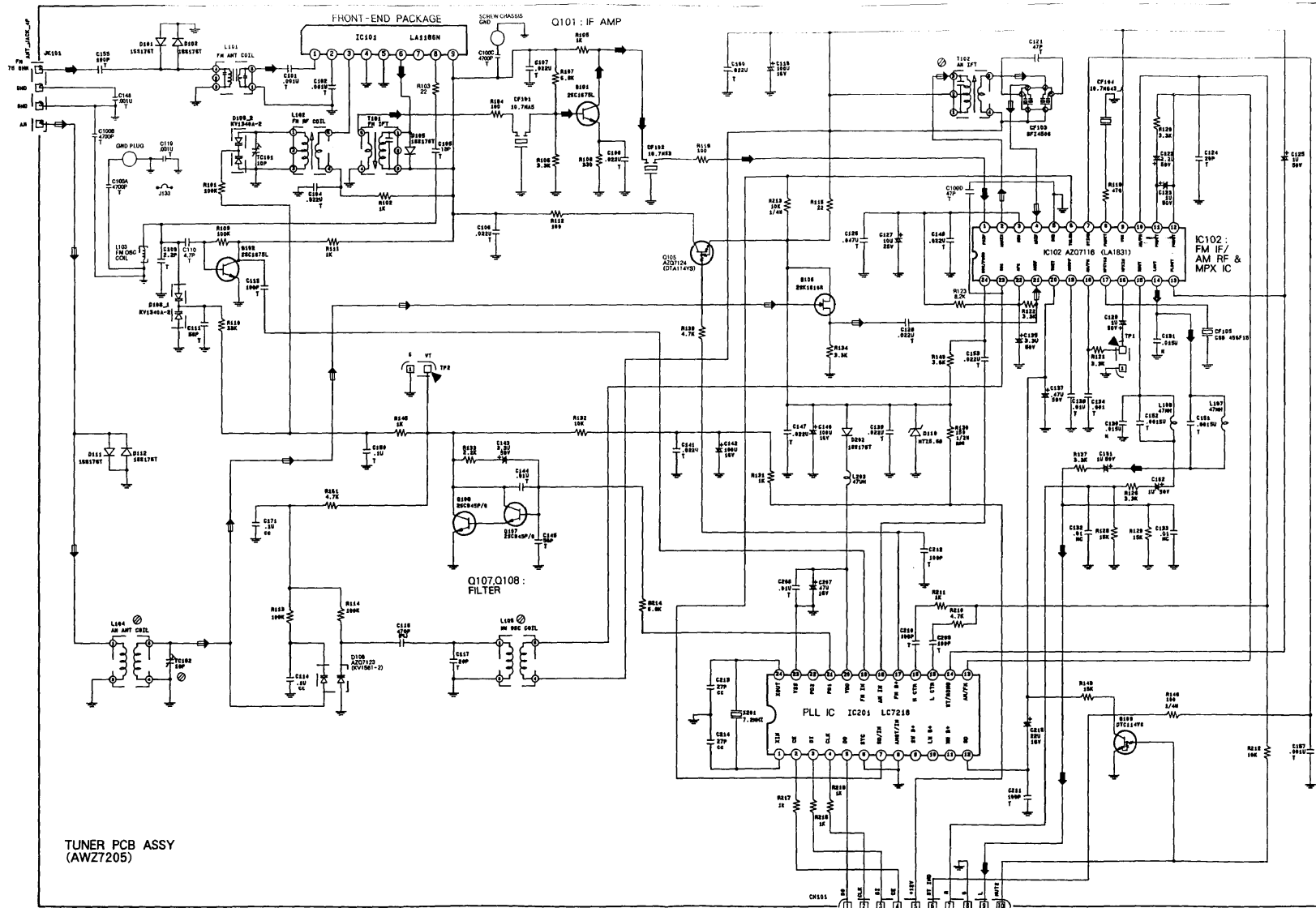

TUNER PCB ASSY (AWZ7205)

→ : TUNER FM SIGNAL ROUTE
- - - : TUNER AM SIGNAL ROUTE

MAIN PCB ASSY (2/2)
CN101 (→SCH-5)

TUNER PCB ASSY

SCH-2

SCH-2

X - P60C, XR - P60C

3.3 CD DECODER PCB, CD SENSOR PCB AND CD LED PCB ASSEMBLIES,
AND CD MECHANISM

SCH-3

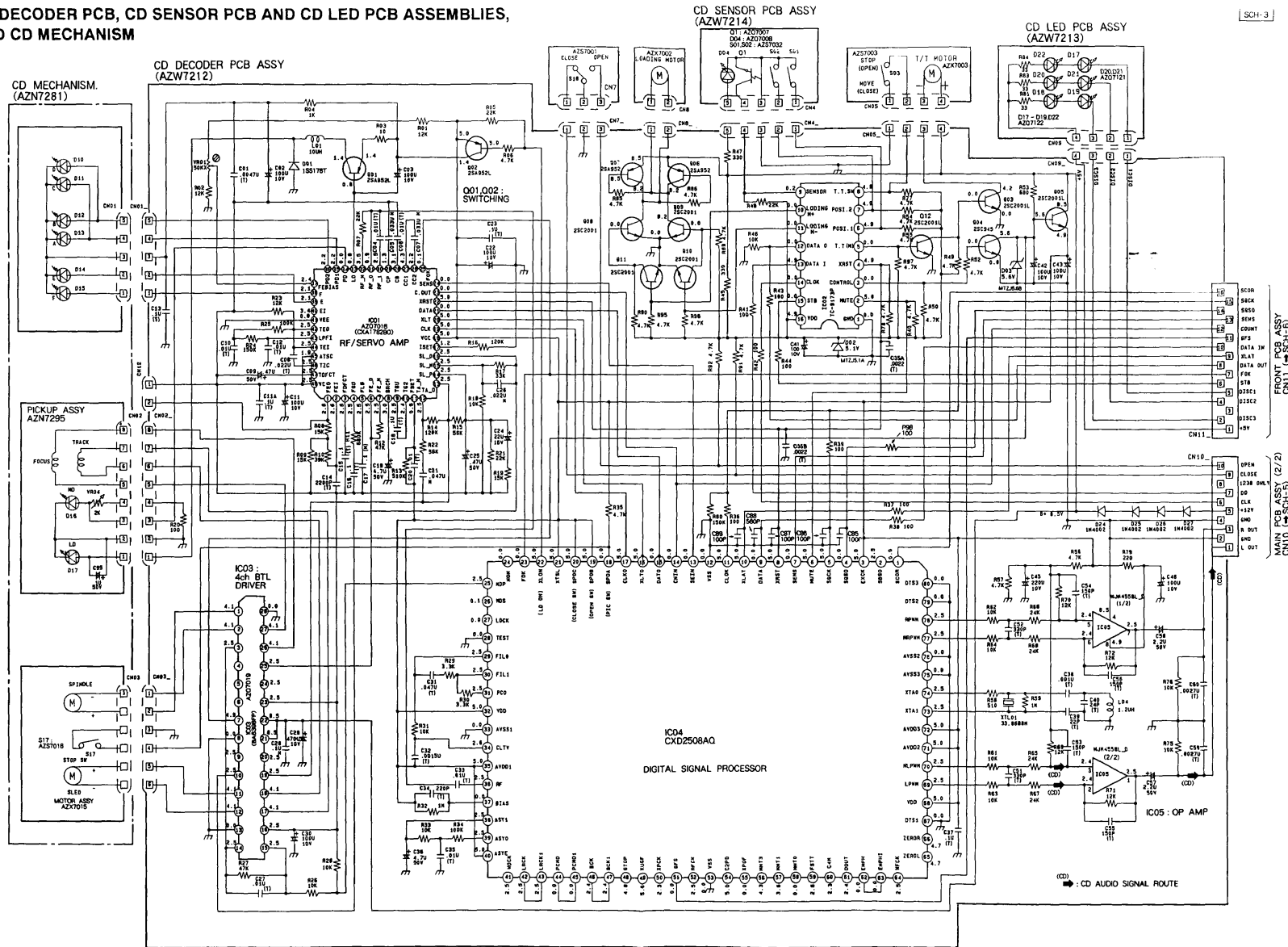

SCH-3

CD DECODER PCB ASSY,
CD SENSOR PCB ASSY,
CD LED PCB ASSY,
CD MECHANISM

SCH-3

CD DECODER PCB ASSY,
CD SENSOR PCB ASSY,
CD LED PCB ASSY,
CD MECHANISM

X - P60C, XR - P60C

3.4 MAIN PCB (1/2), CONNECTOR PCB AND R/P SW PCB ASSEMBLIES

MAIN PCB ASSY (1/2)
(AZW7207 : KUXJ.KCXJ.YPWXJ) (AZW7235 : SDXJ.SDXJ/SA,SXJ/NC)

SCH-4

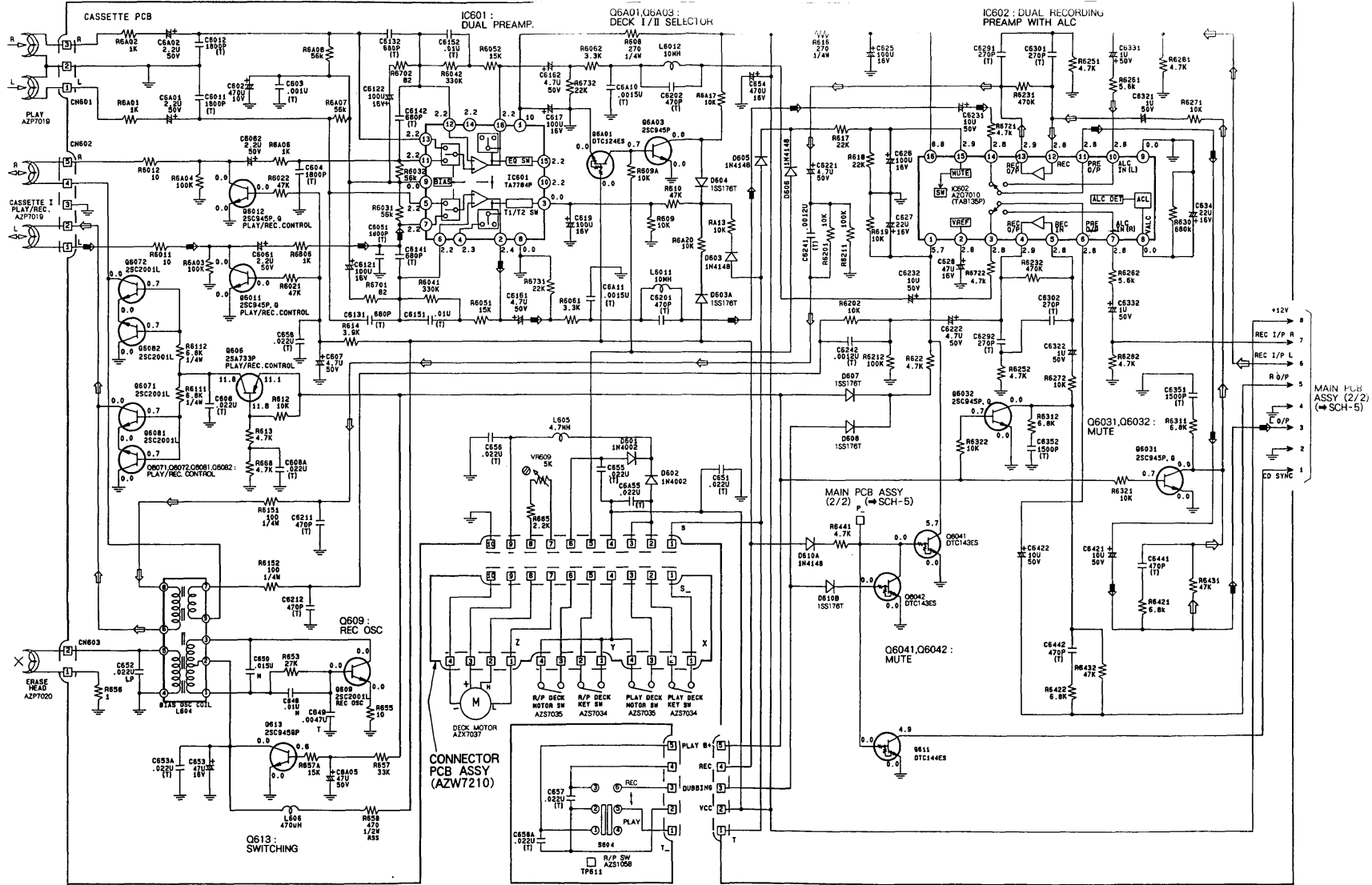

SCH-4

MAIN PCB ASSY (1/2),
CONNECTOR PCB ASSY,
R/P SW PCB ASSY

R/P SW PCB ASSY
(AZW7211)

➡ : DECK PB SIGNAL ROUTE
↻ : DECK REC SIGNAL ROUTE

MAIN PCB ASSY (1/2),
CONNECTOR PCB ASSY,
R/P SW PCB ASSY

SCH-4

VOLTAGES OF THE MAIN PCB ASSY (1/2)

(CASSETTE)-RECORD

1. IC

IC NO.	PIN NO.															
	1	2	3	4	5	6	7	8	9	10	11	12	13	14	15	16
IC601	10.25	2.27	1.83	2.2	2.14	2.16	2.15	0	2.18	0	2.15	2.16	2.15	2.19	2.2	2.26
IC602	0	2.82	2.81	2.88	2.82	2.82	2.81	0	0	2.81	2.82	2.82	2.88	2.81	2.98	8.99

2. TRANSISTORS

TR NO.	Q606	Q609	Q611	Q613	Q6011	Q6012	Q6031	Q6032	Q6041	Q6042	Q6071	Q6072	Q6081	Q6082	Q6A01	Q6A03
E	0	0.14	0	0	0	0	0	0	0	0	0	0	0	0	0	0
C	0	5.13	0	5.14	0	0	0	0	0	5.55	0	0	0	0	0	0.94
B	0	0.47	5.55	0	0.63	0.63	0	0	5.55	0	0	0	0	0	11.87	0

(CASSETTE)-PLAY

1. IC

IC NO.	PIN NO.															
	1	2	3	4	5	6	7	8	9	10	11	12	13	14	15	16
IC601	10.26	2.26	0	2.19	2.14	2.16	2.15	0	2.17	0	2.15	2.16	2.14	2.19	2.2	2.26
IC602	5.72	0	2.81	2.88	2.82	2.82	2.81	0	0	2.81	2.82	2.82	2.88	2.81	2.98	8.82

2. TRANSISTORS

TR NO.	Q606	Q609	Q611	Q613	Q6011	Q6012	Q6031	Q6032	Q6041	Q6042	Q6071	Q6072	Q6081	Q6082	Q6A01	Q6A03
E	11.88	0	0	0	0	0	0	0	0	0	0	0	0	0	0	0
C	11.85	0	4.98	0	0	0	0	0	5.73	0	0	0	0	0	0.7	0
B	11.16	0	0	0.65	0	0	0.7	0.7	0	0	0.67	0.67	0.67	0.67	0	0.7

VOLTAGES OF THE MAIN PCB ASSY (2/2)

1. IC

IC NO.	PIN NO.																			
	1	2	3	4	5	6	7	8	9	10	11	12	13	14	15	16	17	18	19	20
IC302	0	0	0	-10	0	0	0	10												
IC401	0	0	0	0	0	0	0	0	0	0	0	-12.7	0	0	0	0	0	12.6	12.5	-12.7
IC402	0	0	0	12.7	0	0	0	0	0	0	0	-12.8	0	0	0					
IC403	0	0	0	-10	0	0	0	10												
IC404	0	0	0	0	0	4.9	-6.7	0	0	0	0	0	0	6.7						
IC405	0	0	0	0	0	4.9	-6.7	0	0	0	0	0	0	6.7						
IC406	0	0	0	0	0	0	0	-12	11	0	0	0	0	0	5.4	0	0	0	0	0
IC407	0	0	0	-10	0	0	0	10												
IC409	0	18.1	0	0.4	0	11.8	0	4.2												
IC502	12	0	18																	
IC701	0	0	-30.7	30.7	30.7	-30.7	29.1	-29	0	0	0	0	0	0						

IC NO.	PIN NO.										TR NO.									
	21	22	23	24	25	26	27	28	29	30		Q301	Q302	Q401	Q402	Q403	Q404	Q501	Q502	Q503
IC401	0	0	0	0	0	0	0	0	0	0	E	0	0	-2	-2	0	0	13.9	-14	12
IC406	0	0									C	0	0	11	11	0	0	30	-30	11.8
											B	0	0	-1.4	-1.4	-3	-3	14.5	-14.5	11.1

2. TRANSISTORS

TR NO.	Q504	Q505	Q701	Q702	Q703	Q704	Q705	Q706	Q707	Q708	Q709	Q710
E	0	-28.3	-29.1	0.7	0.7	0	11.8	0	0	0	0	0
C	0	-38	-29	0.75	0.72	10.5	-3.2	0	10.5	-8.2	0	0
B	0.7	-29	-28.3	1.4	0	0	10.5	4.7	0	0	-8.2	-8.2

X - P60C, XR - P60C

3.5 MAIN PCB (2/2) AND HEADPHONE PCB ASSEMBLIES

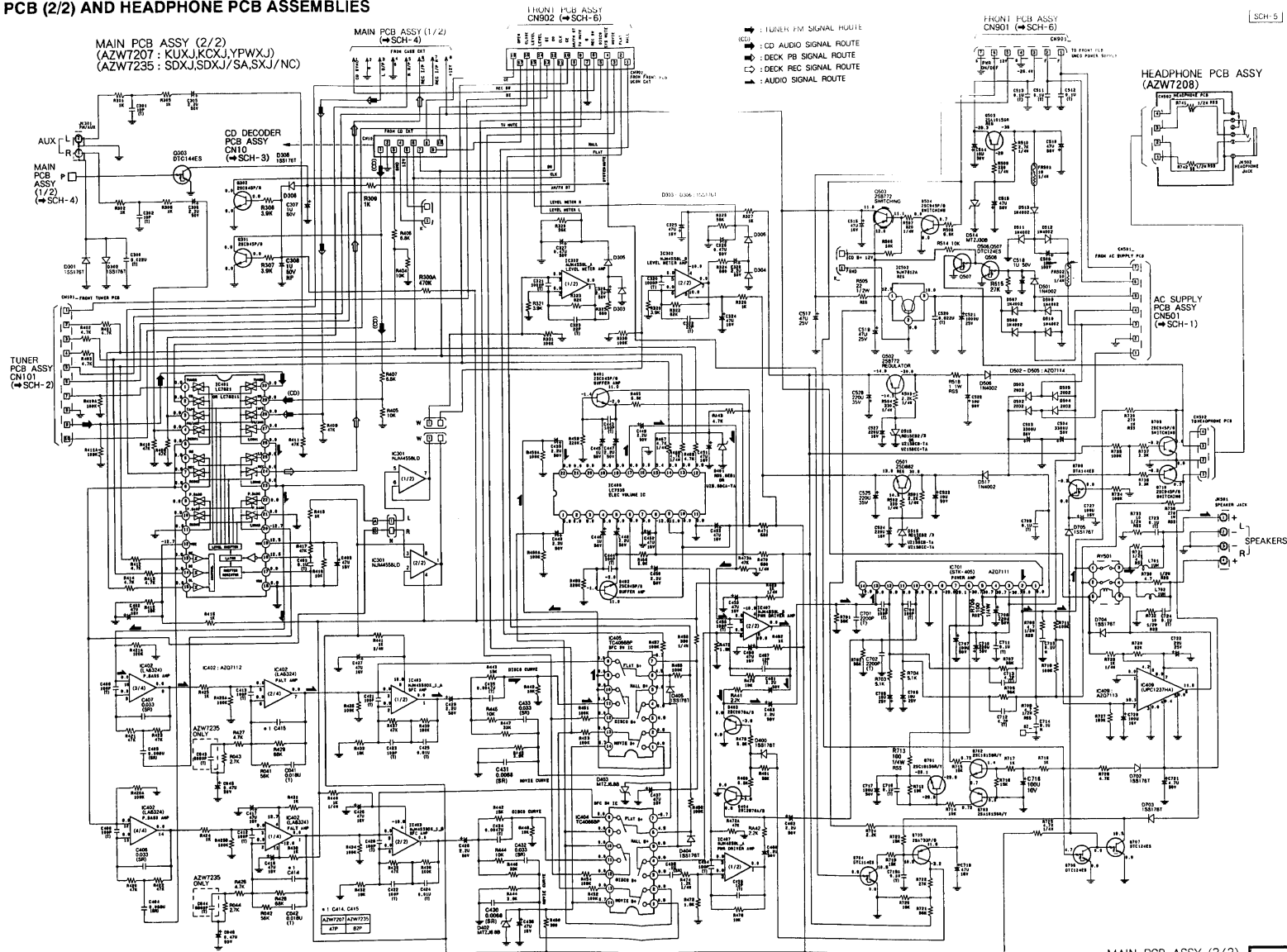

SCH-5

MAIN PCB ASSY (2/2),
HEADPHONE PCB ASSY

MAIN PCB ASSY (2/2),
HEADPHONE PCB ASSY
SCH-5

3.6 FRONT PCB ASSY

SCH-6

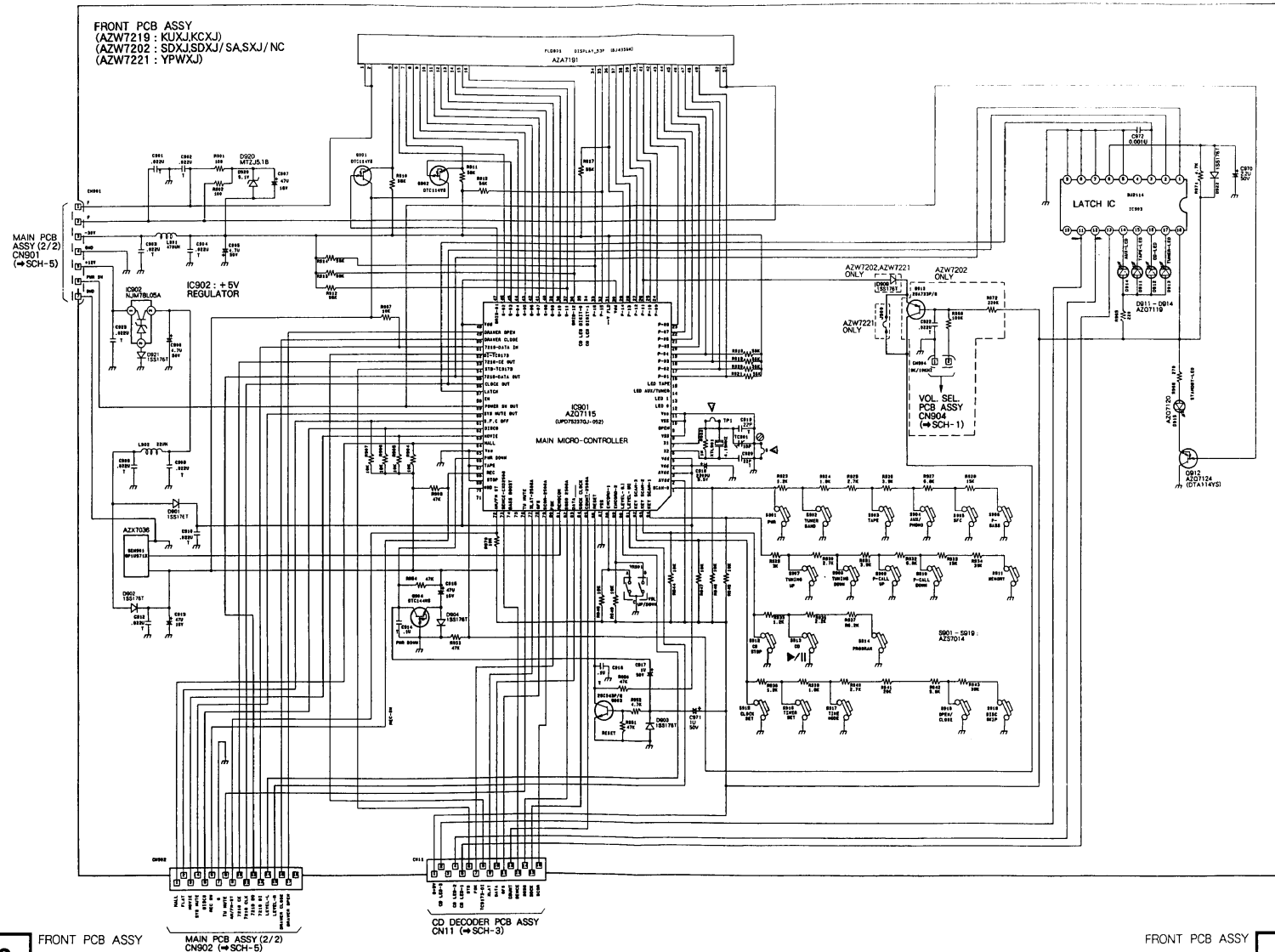

SCH-6

SCH-6

X - P60C, XR - P60C

4. PCB PARTS LIST

NOTES:

- Parts marked by "NSP" are generally unavailable because they are not in our Master Spare Parts List.
- The Δ mark found on some component parts indicates the importance of the safety factor of the part. Therefore, when replacing, be sure to use parts of identical designation.
- Parts marked by "⊙" are not always kept in stock. Their delivery time may be longer than usual or they may be unavailable.
- When ordering resistors, first convert resistance values into code form as shown in the following examples.
 - Ex.1 When there are 2 effective digits (any digit apart from 0), such as 560 ohm and 47k ohm (tolerance is shown by J=5%, and K=10%).
 - 560 Ω \rightarrow 56 \times 10¹ \rightarrow 561 RD114PU $\begin{matrix} \text{5} & \text{6} & \text{1} & \text{J} \\ \text{5} & \text{6} & \text{1} & \text{J} \end{matrix}$
 - 47k Ω \rightarrow 47 \times 10³ \rightarrow 473 RD114PU $\begin{matrix} \text{4} & \text{7} & \text{3} & \text{J} \\ \text{4} & \text{7} & \text{3} & \text{J} \end{matrix}$
 - 0.5 Ω \rightarrow 0R5 RN2H $\begin{matrix} \text{0} & \text{5} & \text{K} \\ \text{0} & \text{5} & \text{K} \end{matrix}$
 - 1 Ω \rightarrow 1R0 RS1P $\begin{matrix} \text{1} & \text{R} & \text{0} & \text{K} \\ \text{1} & \text{R} & \text{0} & \text{K} \end{matrix}$
 - Ex.2 When there are 3 effective digits (such as in high precision metal film resistors).
 - 5.62k Ω \rightarrow 562 \times 10¹ \rightarrow 5621 RN14PC $\begin{matrix} \text{5} & \text{6} & \text{2} & \text{1} & \text{F} \\ \text{5} & \text{6} & \text{2} & \text{1} & \text{F} \end{matrix}$

LIST OF WHOLE PCB ASSEMBLIES

Mark	Symbol & Description	Part No. of XR-P60C						Remarks
		KUXJ	KCXJ	SDXJ	SDXJ/SA	SXJ/NC	YPWXJ	
NSP	MAIN PCB ASSY KITS	AZW7216	AZW7216	AZW7201	AZW7201	AZW7201	AZW7216	
	MAIN PCB ASSY	AZW7207	AZW7207	AZW7235	AZW7235	AZW7207	AZW7207	
NSP	HEADPHONE PCB ASSY	AZW7208	AZW7208	AZW7208	AZW7208	AZW7208	AZW7208	
	VOL. SEL. PCB ASSY	Not used	Not used	AZW7209	AZW7209	AZW7209	Not used	
NSP	CONNECTOR PCB ASSY	AZW7210	AZW7210	AZW7210	AZW7210	AZW7210	AZW7210	
	R/P SW PCB ASSY	AZW7211	AZW7211	AZW7211	AZW7211	AZW7211	AZW7211	
NSP	FRONT PCB ASSY	AZW7219	AZW7219	AZW7202	AZW7202	AZW7202	AZW7221	
	CD DECODER ASSY KITS	AZW7203	AZW7203	AZW7203	AZW7203	AZW7203	AZW7203	
NSP	CD DECODER PCB ASSY	AZW7212	AZW7212	AZW7212	AZW7212	AZW7212	AZW7212	
	CD LED PCB ASSY	AZW7213	AZW7213	AZW7213	AZW7213	AZW7213	AZW7213	
NSP	CD SENSOR PCB ASSY	AZW7214	AZW7214	AZW7214	AZW7214	AZW7214	AZW7214	
	AC SUPPLY PCB ASSY	AZW7223	AZW7223	AZW7204	AZW7204	AZW7204	AZW7224	
NSP	TUNER PCB ASSY	AZW7205	AZW7205	AZW7205	AZW7205	AZW7205	AZW7205	

MAIN PCB ASSY

● CONTRAST OF AZW7207 AND AZW7235

AZW7207 and AZW7235 have the same construction except for the following :

Symbol & Description	Part No.	
	AZW7207	AZW7235
C414, C415	CCPUSL470J50	CKPUYB820K50
C43, C44	Not used	CKPUYX62M16

● PARTS LIST FOR AZW7207

Mark	No.	Description	Part No.
SEMICONDUCTORS			
	IC602		AZQ7010
	IC701		AZQ7111
	IC402		AZQ7112
	IC409		AZQ7113
	IC406		LC7535
	IC401		LC7821
	IC403		NJM4558DX
	IC301, IC302, IC407		NJM4558LD
	IC502		NJM7812AS
	IC601		TA7784P

Mark	No.	Description	Part No.
	IC404, IC405		TC4066BP
	Q505, Q703		2SA1015
	Q606, Q705		2SA733
	Q701, Q702		2SC1815
	Q6071, Q6072, Q6081, Q6082, Q609		2SC2001
	Q501		2SD882
	Q403, Q404		2SC2878A
	Q301, Q302, Q401, Q402, Q504, Q6A03		2SC945
	Q6011, Q6012, Q6031, Q6032, Q613		2SC945
	Q709, Q710		2SC945
	Q502, Q503		2SB772
	Q708		DTA144ES
	Q704		DTC114ES
	Q506, Q507, Q706, Q707, Q6A01		DTC124ES
	Q6041, Q6042		DTC143ES
	Q611, Q703		DTC144ES
	D501, D506-D513, D517, D601, D602		1N4002L
	D603, D605, D606, D610A		1N4148
	D301-D306, D308, D400, D404, D405, D603A		1SS176T
	D604, D607, D608, D610B, D702-D705		1SS176T
	D502-D505		AZQ7114
	D514		MTZ130B

Mark	No.	Description	Part No.
	D402, D403		MTZJ6.8B
	D515, D516		RD15EB2
	D401		R05.6EB1
RELAY			
	RY501		AZS7031
COILS			
	L6011, L6012	(10mH)	AZT7020
	L606	(470 μ H)	AZT7021
	L605	(4.7mH)	AZT7047
	L604	BIAS OSC COIL	AZT7048
	L701, L702	(1 μ H)	AZT7076
CAPACITORS			
	C503, C504 (3300/50V)		AZC7015
	C301, C302		CCPUSL100J50
	C456, C457		CCPUSL120J50
	C322, C323		CCPUSL220J50
	C414, C415		CCPUSL470J50
	C712, C713		CCPUSL4R7K50
	C308, C6321, C6322		CEANP010M50
	C460, C461		CEANP2R2M50
	C307, C445, C446, C518, C6331, C6332		CEAS010M50
	C508		CEAS100M100
	C705, C706		CEAS100M25
	C514, C522, C523, C6231, C6232, C6421		CEAS100M50
	C6422		CEAS100M50
	C718		CEAS101M10
	C617, C619, C625, C626, C720, C727		CEAS101M16
	C6121, C6122		CEAS101M16
	C707, C717		CEAS101M50
	C521		CEAS102M25
	C627, C634		CEAS220M16
	C722		CEAS220M25
	C524, C527		CEAS221M16
	C525, C528		CEAS221M35
	C708, C710		CEAS221M50
	C305, C306, C328, C329, C428, C429		CEAS2R2M50
	C439, C440, C447-C450, C462, C463		CEAS2R2M50
	C6A01, C6A02, C6061, C6062		CEAS2R2M50
	C324, C325, C402, C403, C416, C417		CEAS470M16
	C426, C427, C436, C437, C451-C453		CEAS470M16
	C458, C459, C516, C535, C628		CEAS470M16
	C517		CEAS470M25
	C653, C719		CEAS470M16
	C510, C515, C6A05		CEAS470M50
	C602		CEAS471M10
	C654		CEAS471M16
	C519		CEAS471M25
	C607, C6161, C6162, C6221, C6222		CEAS4R7M50
	C721		CEAS4R7M50
	C326, C327, C45, C46		CEAS4R7M50
	C41, C42		CGCYX183K25
	C406, C407, C432, C433		CGCYX333K25
	C430, C431		CGCYX682K25
	C404, C405		CGCYX883K25
	C408, C409, C412, C413		CKPUB101K50
	C420-C423, C443, C444, C454, C455		CKPUB101K50
	C703, C704		CKPUB101K50
	C320, C321, C603		CKPUYB102K50

Mark	No.	Description	Part No.
	C6291, C6292, C6301, C6302		CKPUYB271K50
	C6201, C6202, C6211, C6212, C6441		CKPUB471K50
	C6442		CKPUB471K50
	C6131, C6132, C6141, C6142		CKPUB681K50
	C401, C438, C511-C513, C709, C711		CKPUY104250
	C716, C719A, C723, C724		CKPUYF104250
	C300, C41, C42, C52K, C608, C608A		CKPUYF223225
	C651, C6A55, C653A, C655, C656, C658		CKPUYF223225
	C6241, C6242		CKPUYX122M16
	C6351, C6352, C6A10, C6A11		CKPUYX152M16
	C6011, C6012, C604, C6051		CKPUYX182M16
	C701, C702		CKPUYX222M16
	C434, C435, C649		CKPUYX472M16
	C424, C425, C6151, C6152		CKPUYX103M16
	C648		CQMKA103J100
	C714, C715		CQMKA104J100
	C650		CQMKA153J100
	C652		CQPA223J100
RESISTORS			
	FR501, FR502		RFAL1/4PS100J
	RS18		RF1/2LMF010J
	R705, R713		RFAL1/4PS101J
	RS05		RS1/2LMF220J
	R732, R733		RS1/2LMF100J
	R708, R709, R730, R731		RS1/2LMF4R7J
	R738, R739		RS1LMF271J
	VR609 (5k Ω)		VRTP6VS502
	Other Resistors		RD1/4PU□□□□
OTHERS			
	SPRING TR. (B)		AZB7019
	CN603 2P TOP BASE		AZK1073
	CN601 3P TOP BASE		AZK1074
	CN602 5P TOP BASE		AZK1076
	CN 5P FTW TOP BASE (2.0 (TO R/P SW PCB ASSY))		AZK7010
	10P FTW TOP BASE (TO CONNECTOR PCB ASSY)		AZK7067
	CN502 4P FTW TOP BASE (2.0)		AZK7096
	CN901 7P FTW TOP BASE		AZK7230
	CN902 18P FFC TOP BASE (1.25mm)		AZK7231
	CN10 10P FFC TOP BASE (1.25mm)		AZK7232
	JK501 4P SP. TERMINAL		AZK7233
	JK301 2P RCA JACK		AZK7234
	CN501 7P FTW BASE (2.5mm)		AZK7239
	CN101 10P HEADER 1MSA-9115		AZK7240
	HEAT SINK BRACKET		AZN7142
	HEAT SINK ASSY (7FIN)		AZN7525
	SCREW		BB230P060FMC
HEADPHONE PCB ASSY			
RESISTORS			
	R741, R742		RS1/2LMF680J
OTHERS			
	CN502 WIRE HOLDER 4P20		AZK7098
	JK502 HEADPHONE JACK		AZK7235
	H/P PCB 48 \times 28 \times 1.6MM		AZN7527

Mark No. Description Part No.

**VOL. SEL. PCB ASSY
(SDXJ, SDXJ/SA AND SXJ/NC ONLY)**

SWITCHES

△ S502 AZS7005
S501 AZS7006

OTHERS

CN904 2P FTW TOP BASE(2.0) AZK7011
VOL. SEL. PCB AZN7528

CONNECTOR PCB ASSY

OTHERS

4P CON. ASSY 140M/M AZD7021
WIRE HOLDER 4P25 AZK7054
WIRE HOLDER 10P20 AZK7055
CN 4P CON. ASSY 240M/M AZK7241
(TO DECK SW)
CONNECTOR PCB 44×41×1.6MM AZN7529

R/P SW PCB ASSY

SWITCH

S604 AZS1058

CAPACITORS

C657, C658A CKPUYF223Z25

OTHERS

WIRE HOLDER 5P20 AZK7051
TP611 TERMINAL PIN "K" AZK7052
R/P SW PCB 33×30×1.6MM AZN7530

FRONT PCB ASSY

• CONTRAST OF AZW7219, AZW7202 AND AZW7221

AZW7219, AZW7202 and AZW7221 have the same construction except for the following :

Mark	Symbol & Description	Part No.		
		AZW7219	AZW7202	AZW7221
	Q913	Not used	2SA733	Not used
	D909	Not used	1SS176T	1SS176T
	C922	Not used	CKPUYF223Z25	Not used
	R988	Not used	RD1/6W104J	Not used
	R972	Not used	RD1/6W224J	Not used
	CN904 WIRE HOLDER 2P20	Not used	AZK7081	Not used

• PART LIST FOR AZW7219

SEMICONDUCTORS

IC901 AZQ7115
IC902 NJM78L05A
IC903 BU2114
Q903 2SC945
Q912 (DTA114YS) AZQ7124

Mark No. Description Part No.

Q901, Q902 DTC114YS
Q904 DTC144WS
D901-D904, D921, D922 1SS176T
D911-D914 AZQ7119
D915 AZQ7120
D920 MTZJ5. 1B

SWITCHES

S901-S919 AZS7014

COILS

L901 (470 μH) AZT7077
L902 (22 μH) AZT7078

CAPACITORS

TC901 TRIMMER(10P) AZC7265
C919, C920 CCPUSL220J50
C918 (2200 μ, 5.5V) AZC7272
C917, C971 CEJA010M50
C970 CEJA2R2M50

C907, C913, C915 CEJA470M16
C905, C906 CEJA4R7M50
C972 CKPUYF103Z25
C914, C916 CKPUYF104Z50
C901-C904, C912, C908-C910, C923 CKPUYF223Z25

RESISTORS

VR901 ASX1021
Other Resistors RD1/4PU□□□□

OTHERS

FLD901 FLD BJ435GK AZA7191
XTL901 X'TAL(4.194304MHz) AZC7264
CN902 18P FFC TOP BASE AZK7231
CN11 16P FFC SIDE BASE AZK7236
CN901 WIRE HOLDER 7P20 AZN7537

DISPLAY HOLDER AZN7538
LED HOLDER AZN7539
SEN901 REMOTE SENSOR(GP1U571X) AZX7036

CD DECODER PCB ASSY

SEMICONDUCTORS

IC1 AZQ7016
IC3 AZQ7019
IC4 CXD2508AQ
IC5 NJM4558LD
IC2 TC9173P

Q1, Q2, Q6, Q7 2SA952
Q3, Q5, Q8-Q12 2SC2001
Q4 2SC945A
D24-D27 1N4002L
D1 1SS176T

D2 MTZJ5. 1A
D3 MTZJ5. 6B

COILS

L1 (10 μH) AZT7016
L4 (1.2 μH) AZT7017

X - P60C, XR - P60C

Mark No.	Description	Part No.
CAPACITORS		
C39		CCPUSL220J50
C40		CCPUSL240J50
C2, C3, C11, C22, C30, C41-C43, C46		CEAS101M10
C24		CEAS220M16
C45		CEAS221M10
C57, C58		CEAS2R2M50
C29		CEAS471M10
C19, C36		CEAS4R7M50
C9, C25		CEASR47M50
C85-C87, C89		CKPUYB101K50
C38		CKPUYB102K50
C53-C56		CKPUYB151K50
C34		CKPUYB221K50
C51, C52		CKPUYB331K50
C88		CKPUYB561K50
C11A, C13, C15, C16, C18, C23, C37		CKPUYF104Z50
C8		CKPUYF223Z25
C31		CKPUYF473Z50
C32		CKPUYX152M16
C14, C35A, C35B		CKPUYX222M16
C59, C60		CKPUYX272M16
C1		CKPUYX472M16
C4, C6, C10, C12, C20, C27, C33, C35		CKPUYY103M16
C17, C28		CQMXA104J100
C26		CQMXA223J100
C5, C7		CQMXA333J100
C21		CQMXA473J100

RESISTORS

VR1	SFR(50k Ω)	AZC7105
Other Resistors		RD1/4PU□□□J

OTHERS

XTL1	X'TAL(33.8688MHz)	AZC7058
	3P CON. ASSY 200M/M	AZD7017
	8P CON. ASSY 400M/M	AZD7034
	5P CON. ASSY (PH) 350M	AZD7077
CN3	6P CON. ASSY 400M/M	AZD7078
CN1	PH 5P TOP BASE	AZK7012
CN2	PH 8P TOP BASE	AZK7022
CN4	WIRE HOLDER 5P20	AZK7051
CN12	EH 2P TOP BASE	AZK7068
CN8	EH 2P SIDE BASE	AZK7085
CN7	EH 3P SIDE BASE	AZK7086
CN5	EH 4P SIDE BASE	AZK7087
CN9	WIRE HOLDER 4P20	AZK7098
P1	EARTH TER ASSY	AZK7105
CN11	16P FFC SIDE BASE	AZK7236
CN10	10P FFC SIDE BASE	AZK7237

Mark No.	Description	Part No.
CD LED PCB ASSY		
SEMICONDUCTORS		
	D20, D21	AZQ7121
	D17-D19, D22	AZQ7122
RESISTORS		
	All Resistors	RD1/4PU□□□J
OTHERS		
CN9	WIRE HOLDER 4P20	AZK7098
	CD LED PCB 140 \times 10 \times 1.6MM	AZN7533

CD-SENSOR PCB ASSY

Mark No.	Description	Part No.
SEMICONDUCTORS		
	Q1	AZQ7007
	D4	AZQ7008
SWITCHES		
	S1, S2	AZS7032
OTHERS		
CN4	WIRE HOLDER 5P20	AZK7051
	2 LED HOLDER	AZK7059
	CD SEN. PCB 39.9 \times 20 \times 1.6MM	AZN7534

AC SUPPLY PCB ASSY

• CONTRAST OF AZW7223, AZW7204 AND AZW7224

AZW7223, AZW7204 and AZW7224 have the same construction except for the following :

Mark	Symbol & Description	Part No.		
		AZW7223	AZW7204	AZW7224
	R500 (3.3M, 1/2W) AC SUP. PCB 60.5 \times 70 \times 1.6 MM	AZC7023	Not used	Not used
		AZN7550	AZN7535	AZN7550

• PARTS LIST FOR AZW7223

Mark No.	Description	Part No.
RESISTOR		
	R500(3.3M Ω , 1/2W)	AZC7023
OTHERS		
TP502, TP503	TERMINAL PIN "L"	AZK7079
	FUSE HOLDER	AZK7158
CN501	WIRE HOLDER 7P25	AZK7242
	AC SUP. PCB 60.5 \times 70 \times 1.6MM	AZN7550

Mark No.	Description	Part No.
TUNER PCB ASSY		
SEMICONDUCTORS		
IC102		AZQ7116
IC101		LA1186N
IC201		LC7218
Q101, Q102		2SC1675
Q107, Q108		2SC945
Q106		2SK161
Q105		AZQ7124
Q109		DTC114YS
D101, D102, D105, D111, D112, D202		1SS176T
D108		AZQ7123
D106-1, D106-2		AZQ7127
D110		MT25. 6B
COILS AND FILTERS		
L103	FM OSC. COIL	AZT1072
L102	FM RF COIL	AZT1074
L107, L108		AZT1078
L105	MW OSC. COIL	AZT7003
L104	AM ANT. COIL	AZT7029
L101	FM ANT. COIL	AZT7079
L203	P. COIL	AZT7080
CF103	CERAMIC F.	AZT7004
CF101	CERAMIC F.	AZT7015
CF102	CERAMIC F.	AZT7027
TRANSFORMERS		
T101	FM IF TRANS.	AZT1080
T102	AM IF TRANS.	AZT1082
CAPACITORS		
TC101, TC102	TRIMER (10P)	AZC7268
C213, C214		CCCCH270J50
C105		CCPUCH180J50
C109		CCPUCH2R2K50
C110		CCPUCH4R7K50
C117, C124		CCPUSL200J50
C121		CCPUSL470J50
C111, C145		CCPUSL560J50
C123, C125, C129, C161, C162		CEAS010M50
C127		CEAS100M25
C118, C140, C142		CEAS101M16
C215		CEAS220M16
C122		CEAS2R2M50
C135, C143		CEAS3R3M50
C207		CEAS470M16
C137		CEASR47M50
C114, C171		CGCYF104Z25
C112, C155, C209, C210-C212		CKPUYB101K50
C101, C102, C119, C134, C148, C157		CKPUYB102K50
C100D		CKPUYB470K50
C100A-C100C		CKPUYB472K50
C150		CKPUYF104Z50
C104, C106-C108, C128, C139, C141		CKPUYF223Z25
C147, C149, C153, C160		CKPUYF223Z25
C126		CKPUYF473Z16

Mark No.	Description	Part No.
C151, C152		CKPUYX152M16
C138, C144, C208		CKPUYY103M16
C132, C133		CQMXA103J100
C130, C131		CQMXA153J100
C116		CQPA471J100
RESISTORS		
R130		RS1/2LMF151J
Other Resistors		RD1/4PU□□□J
OTHERS		
X201	X'TAL (7.2MHz)	AZC1243
CF105	RESONATOR CSB456F15	AZC7266
CF104	RESONATOR CDA10.7MG43-A	AZC7267
JK101	4P ANT TER.	AZK7063
TP1, TP2	2P PIN HEADER (2.5mm)	AZK7157
CN101	10P SOCKET IMEA9115S	AZK7243
	EARTH TERMINAL	AZN7536

5. ADJUSTMENTS

5.1 TUNER SECTION

5.1.1 CLOCK FREQUENCY ADJUSTMENT

- (1) Connect a Frequency Counter to TP1 and G on the FRONT PCB ASSY via the BUFFER AMP PCB as shown in Fig. 1.
- (2) Adjust TC901 so that the frequency becomes $4.194304\text{MHz} \pm 40\text{Hz}$ (4.194264MHz to 4.194344MHz).

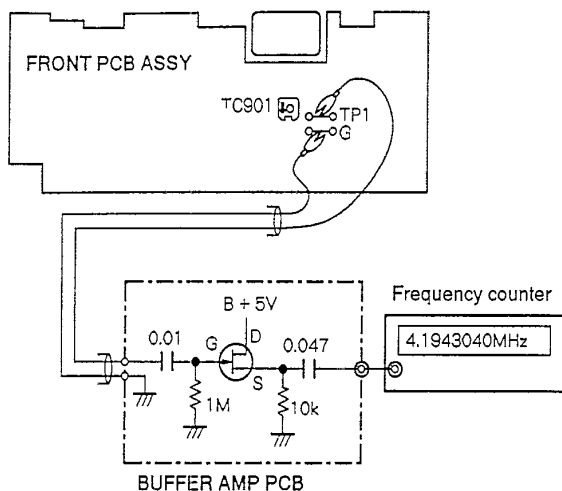

Fig. 1 Clock Frequency Adjustment

5.1.2 FM TUNER SECTION

■ FM Range Adjustment

- (1) FM RF signal generator input through Antenna output from JK501 Speaker terminal on the MAIN PCB ASSY.
- (2) Digital DC voltmeter connected to TP2 on the TUNER PCB ASSY.
- (3) Tuning to 87.5MHz, check counter reading as $1.6\text{V} \pm 0.05\text{V}$.
- (4) Tuning to 108MHz, check the reading as over 7.6V.
- (5) Repeat adjustments as necessary to minimize tracking error.

■ FM Sensitivity Adjustment

- (1) Tuning to 90MHz, turn VOLUME control (VR901) clockwise to 2/3 position and check 26dB quieting sensitivity under 20dB.
- (2) Tuning to 106MHz, turn VOLUME control (VR901) clockwise to 2/3 position and check 26dB quieting sensitivity under 20dB.

5.1.3 AM TUNER SECTION

■ AM Range Adjustment

- (1) AM RF signal generator output from loop antenna, and received by AM loop antenna.
- (2) Digital DC voltmeter connected to TP2 on the TUNER PCB ASSY.
- (3) Tuning to 530kHz, adjust L105 and let counter reading as $1.2\text{V} \pm 0.05\text{V}$.
- (4) Tuning to 1710kHz, check counter reading as 7.2V to 9.5V.
- (5) Repeat adjustments as necessary to minimize tracking error.
AM Frequency : 530kHz to 1710kHz (10kHz STEP)
522kHz to 1629kHz (9kHz STEP)

■ AM IF Adjustment

- (1) Connect AM SG (999kHz mod. 30%; 400Hz; 63dB) input from JK101 AM antenna terminal IN.
- (2) Connect the oscilloscope to TP1 on the TUNER PCB ASSY.
- (3) Adjust T102 on the TUNER PCB ASSY for maximum output. (Fig. 2)

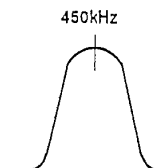

Fig. 2

■ AM Sensitivity Adjustment

- (1) Tuning to 600kHz, turn VOLUME control (VR901) clockwise to 2/3 position and adjust L104 on the TUNER PCB ASSY for maximum output. (Fig. 3)
- (2) Tuning to 1400kHz, turn VOLUME control (VR901) clockwise to 2/3 position and adjust TC102 for maximum output. (Fig. 3)
- (3) Repeat adjustments as necessary to minimize tracking error.

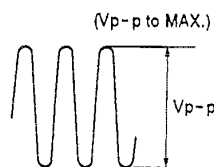

Fig. 3

5.2 CASSETTE DECK SECTION

■ Tape Speed Adjustment

- (1) Insert Test tape STD - 301E into Deck I , in play mode. (normal speed)
- (2) Digital counter connect to JK501 speaker terminal on the MAIN PCB ASSY.
- (3) Adjust VR609 on the MAIN PCB ASSY, let counter reading as 2940Hz to 3090Hz.

■ Head Azimuth Adjustment

- (1) Insert Test tape STD - 331E into Deck I , in play mode.
- (2) AC milli-voltmeter connect to JK501 Speaker terminal on the MAIN PCB ASSY.
- (3) Adjust the left side screw (A) for the maximum output. (Fig. 4)
- (4) Insert Test tape STD - 331E into deck II .
- (5) In play mode.
- (6) Adjust the left side screw (A) for the maximum output. (Fig. 4)

CASSETTE HEAD

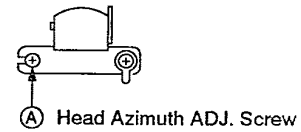

Fig. 4

5.3 CD SECTION

- (1) Stop the test disc after the play.
- (2) Connect the Voltmeter to CN12 on the CD DECODER PCB ASSY as shown in Fig. 5.
- (3) Adjust VR01 so that the voltage becomes $0mV \pm 20mV$.

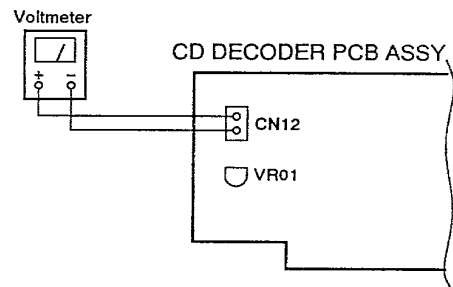

Fig. 5

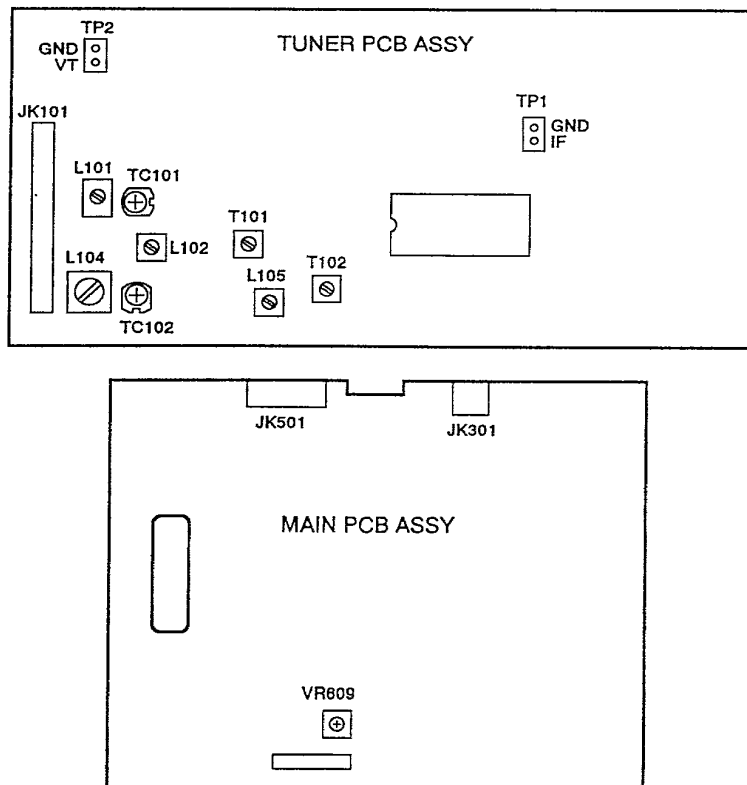

Fig.6 Adjustment points

X - P60C, XR - P60C

No.	Pin Name	I/O	Description
9	TGU	I	Time constant external connection terminal for tracking high-range gain switching.
10	TG2	I	
11	FSET	I	Terminal for peak setting for focus tracking phase compensation.
12	TAM	I	Tracking amplifier reversion input terminal
13	TAO	O	Tracking drive output
14	SLP	I	Sled amplifier non reversion input terminal
15	SLM	I	Sled amplifier reversion input terminal
16	SLO	O	Sled drive output
17	ISET	I	Current for decision of focus search, track jump, and sled kick height flows.
18	Vcc	-	
19	CLK	I	Serial data transmission clock input from the CPU (no pull-up resistor)
20	XLT	I	Latch input from the CPU (no pull-up resistor)
21	DATA	I	Serial data input from the CPU (no pull-up resistor)
22	XRST	I	Reset input terminal "L" = Reset (no pull-up resistor)
23	C.OUT	O	Signal output for track number count
24	SENS	O	Output of FZC, DFCT, TZC, Gain, BAL, etc. by command from the CPU.
25	FOK	O	Output terminal of the focus OK comparator
26	CC2	O	Input terminal for capacitive-coupled DEFECT bottom hold output
27	CC1	I	DEFECT bottom hold output terminal
28	CB	I	DEFECT bottom hold capacitor connection terminal
29	CP	I	MIRR hold capacitor connection terminal MIRR comparator non reversion input terminal
30	RFI	I	Input terminal for capacitive-coupled RF summing amplifier output
31	RFO	O	RF summing amplifier output terminal Eye pattern checkpoint

No.	Pin Name	I/O	Description
32	RFM	I	RF summing amplifier reversion input terminal The RF amplifier gain is decided by the resistor connected between this terminal and the RFO terminal.
33	LD	O	APC amplifier output terminal
34	PHD	I	APC amplifier input terminal
35	PHD1	I	RFI-V amplifier reversion input terminals Connected to the A+C, B+D terminals of the photodiode and receiving current input.
36	PHD2	I	
37	FEBIAS	I	Bias adjustment terminal of the focus error amplifier.
38	F	I	F, E I-V amplifier reversion input terminals Connected to F and E of the photodiode and receiving current input.
39	E	I	
40	EI	-	Gain adjustment terminal of the I-V amplifier. (when automatic BAL adjustment is not used)
41	VEE	-	
42	TEO	O	Output terminal of the tracking error amplifier. E-F signal output
43	LPFI	I	Comparator input terminal for BAL adjustment. (input from TEO via LPF)
44	TEI	I	Tracking error input terminal
45	ATSC	I	ATSC detection window comparator input terminal
46	TZC	I	Tracking zero cross comparator input terminal.
47	TDFCT	I	Time constant capacitor connection terminal at the time of a defect.
48	VC	O	$(VCC + VEE)/2$ DC voltage output terminal

■ CXD2508AQ (IC04 : CD DECODER PCB ASSY)
 • Digital Signal Processor

● Block Diagram

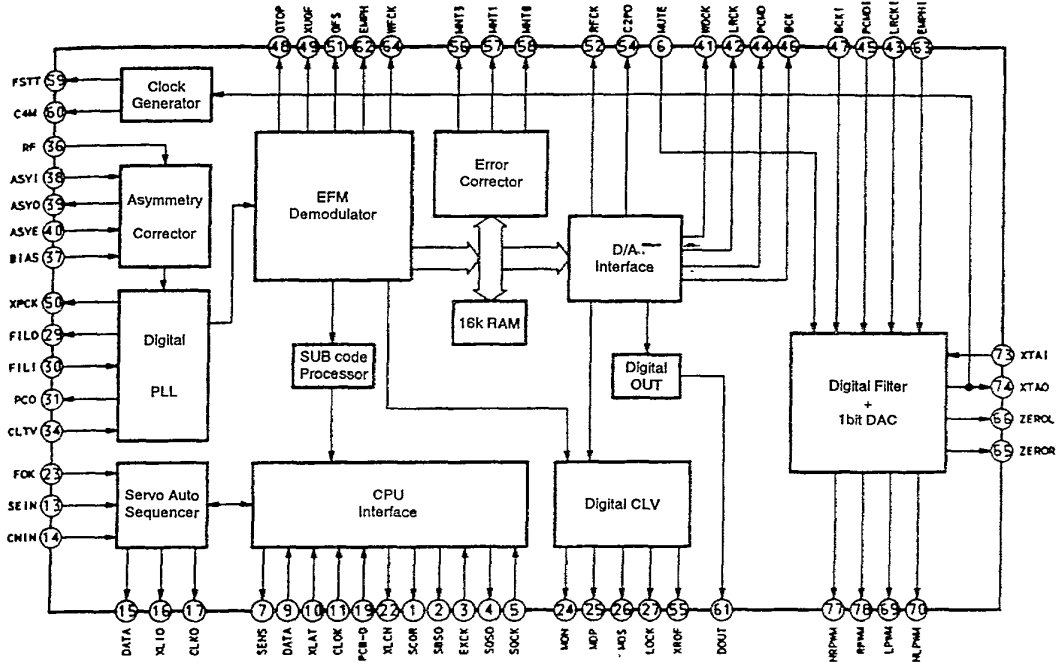

● Pin Function

No.	Pin Name	I/O	Description
1	SCOR	O	"H" when subcode sync S0 or S1 has been detected
2	SBSO	O	Serial output of SUBP to W
3	EXCK	I	Clock input for SBSO readout
4	SQSO	O	Serial output of SUBQ 80 BIT.
5	SQCK	I	Clock input for SQSO readout
6	MUTE	I	Mute with "H", cancellation with "L"
7	SENS	O	SENS output, output to the CPU
8	XRST	I	System reset, reset with "L"
9	DATA	I	Serial data input from the CPU
10	XLAT	I	Latch input from the CPU, serial data latching with drop
11	CLOK	I	Serial data transmission clock input from the CPU
12	Vss	-	GND

No.	Pin Name	I/O	Description
13	SEIN	I	Sensing input from SSP
14	CNIN	I	Track jump number count signal input
15	DATO	O	Serial data output to SSP
16	XLTO	O	Serial data latching output to SSP, latching with drop
17	CLKO	O	Serial data transmission clock output to SSP
18	SPOA	I	Microcomputer expansion interface (Input A)
19	SPOB	I	Microcomputer expansion interface (input B)
20	SPOC	I	Microcomputer expansion interface (input C)
21	XTSL	I	X'tal select input terminal L : 16.9344MHz , H : 33.8688MHz
22	XLON	O	Microcomputer expansion interface (output)
23	FOK	I	Focus OK input pin, used for SENS output and servo autosequencer

X - P60C, XR - P60C

No.	Pin Name	I/O	Description
24	MON	O	Spindle motor ON/OFF control output
25	MDP	O	Spindle motor servo control
26	MDS	O	
27	LOCK	O	GFS sampling at 460 Hz, "H" output when GFS is "H", "L" output with 8 consecutive times "L"
28	TEST	I	TEST pin, GND at the time of normal use
29	FILO	O	Filter output for master PLL (slave = digital PLL)
30	FILI	I	Filter input for master PLL
31	PCO	O	Charge pump output for master PLL
32	V _{DD}	-	Digital power supply for DSP
33	AV _{SS1}	-	Analog GND for DSP
34	CLTV	I	VCO control voltage input for master PLL
35	AV _{DD1}	-	Analog power supply for DSP
36	RF	I	EFM signal input
37	BIAS	I	Asymmetry compensation circuit constant current input
38	ASYI	I	Asymmetry compensation circuit comparison voltage input
39	ASYO	O	EFM full swing output ("L" = V _{SS} , "H" = V _{DD})
40	ASYE	I	"L": Asymmetry compensation OFF, "H": Asymmetry compensation ON
41	WDCK	O	48 bit slot D/A interface, read clock (2FS)
42	LRCK	O	48 bit slot D/A interface, LR clock (FS)
43	LRCKI	I	LR clock input to DAC (48 bit slot)
44	PCMD	O	D/A interface, serial data (2'SCOMP, MSB first)
45	PCMDI	I	Audio data input to DAC (48 bit slot)
46	BCK	O	D/A interface, bit clock
47	BCKI	I	Bit clock input to DAC (48 bit slot)
48	GTOP	O	GTOP output
49	XUGF	O	XUGF output
50	XPCK	O	XPLCK output
51	GFS	O	GFS output
52	RFCK	O	RFCK output

No.	Pin Name	I/O	Description
53	V _{SS}	-	GND
54	C2PO	O	C2PO output
55	XROF	O	XRAOF output
56	MNT3	O	MNT3 output
57	MNT1	O	MNT1 output
58	MNT0	O	MNT0 output
59	FSTT	O	2/3 frequency division output of the pins 73 and 74
60	C4M	O	4.2336 MHz output
61	DOUT	O	Digital Out output terminal
62	EMPH	O	"H" with emphasis for the playback disc, "L" with no emphasis
63	EMPHI	I	DAC deemphasis ON/OFF, ON with "H", OFF with "L"
64	WFCK	O	WFCK (WRITE FRAME CLOCK) output
65	ZEROL	O	No sound data detection output, "H" with no sound data detection (Lch)
66	ZEROR	O	No sound data detection output, "H" with no sound data detection (Rch)
67	DTSI	I	DAC test terminal 1, normally "L"
68	V _{DD}	-	DAC digital power supply
69	LPWM	O	Lch PWM output (reverse phase)
70	NLPWM	O	Lch PWM output (normal phase)
71	AV _{DD2}	-	Power supply for Lch PWM driver
72	AV _{DD3}	-	Power supply for Xtal
73	XTAI	I	Xtal oscillation circuit input for 33.8688 MHz
74	XTAO	O	Xtal oscillation circuit output for 33.8688 MHz
75	AV _{SS3}	-	GND for Xtal
76	AV _{SS2}	-	GND for PWM driver
77	NRPWM	O	Rch PWM output (reverse phase)
78	RPWM	O	Rch PWM output (normal phase)
79	DTS2	I	Test terminal 2 for DAC, normally "L"
80	DTS3	I	Test terminal 3 for DAC, normally "L"

■ AZQ7115 (IC901 : FRONT PCB ASSY)

• Microcomputer

• Block Diagram

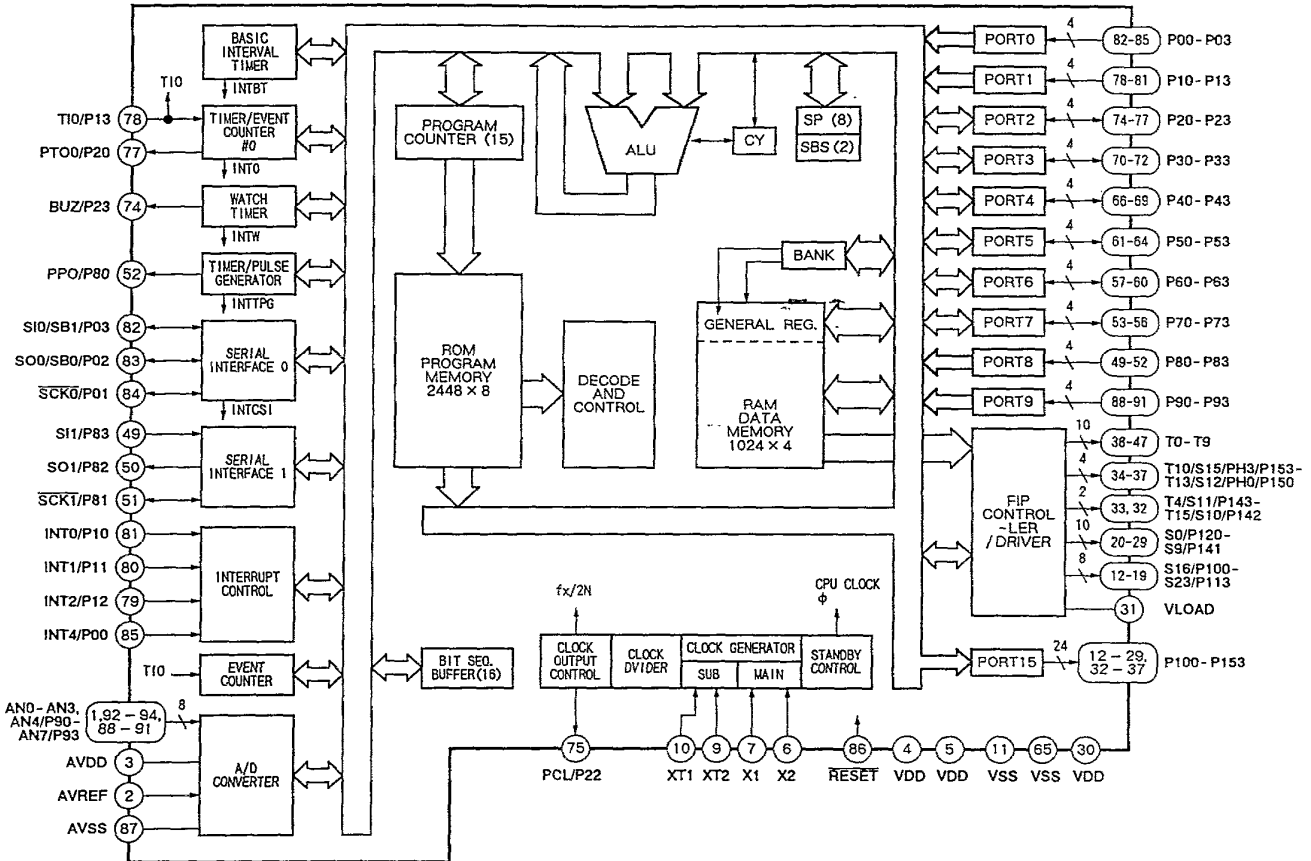

• Pin Function

No.	Pin Name	I/O	Function	No.	Pin Name	I/O	Function	
1	AN0	I	Analog input to A/D converter	16	S20/P110	O	Segment output / P-ch open drain 4 bit output port	
2	AVREF	I	Reference voltage input for A/D converter	17	S21/P111	O		
3	AVDD	—	Power supply for A/D converter	18	S22/P112	O		
4	VDD	—	Power supply voltage	19	S23/P113	O		
5	VDD	—	Power supply voltage	20	S0/P120	O	Segment output / P-ch open drain 4 bit output port	
6	X2	I	Connect the crystal or ceramic resonator for the main system clock oscillation	21	S1/P121	O		
7	X1	I						
8	IC	—	Connect the crystal resonator for the sub system clock oscillation Input to XT1 and XT2 is open	22	S2/P122	O		
9	XT2	—						
10	XT1	I	GND	23	S3/P123	O		
11	VSS	—		24	S4/P130	O		
12	S16/P100	O		Segment output / P-ch open drain 4 bit output port	25	S5/P131	O	
13	S17/P101	O			Segment output / P-ch open drain 4 bit output port	26	S6/P132	O
14	S18/P102	O	Power supply voltage			27	S7/P133	O
15	S19/P103	O				28	S8/P140	O
				29		S9/P141	O	
				30	VDD	—		

X - P60C, XR - P60C

No.	Pin Name	I/O	Function	No.	Pin Name	I/O	Function
31	VLOAD	—	FIP controller/connect a pull-down resistor of driver / Apply a power	63	P51	I/O	N-ch open drain 4 bit input/output port (PORT5)
32	T15/S10/P142	O	Digit/segment current output / P-ch open drain 4 bit output port	64	P50	—	
33	T14/S11/P143			65	VSS		GND
34	PH0/T13/S12/P150	O	Digit/segment current output / P-ch open drain 4 bit output port	66	P43	I/O	N-ch open drain 4 bit input/output port (PORT4)
35	PH1/T12/S13/P151			67	P42		
36	PH2/T11/S14/P152			68	P41		
37	PH3/T10/S15/P153			69	P40		
38	T9			70	P33		
39	T8	I/O	Current output for digit output	71	P32	I/O	Programmable 4 bit input/output port (PORT3)
40	T7			72	P31		
41	T6			73	P30		
42	T5			74	P23/BUZ		
43	T4	O	Current output for digit output	75	P22/PCL	I/O	4 bit input/output port (PORT2)/ Clock output
44	T3			76	P21	I/O	4 bit input/output port (PORT2)
45	T2			77	P20/PTO0	I/O	4 bit input/output port (PORT2)/ Timer / event counter output
46	T1			78	P13/TI0	I	4 bit input port (PORT1)/ External event pulse output to the timer/event counter #0 and #1
47	T0	I	Current output for digit output	79	P12/INT2	I	4 bit input port (PORT1)/ Edge detection testable input (non-synchronous)
48	VDD			—	Power supply voltage	80	P11/INT1
49	P83/SI1	I	4 bit input port (PORT8) / Serial data input	81	P10/INT0	I	4 bit input port (PORT1)/ Edge detection vector interrupt input (clock synchronous)
50	P82/SO1	I/O	4 bit input port (PORT8) / Serial data output	82	P03/SIO/SB1	I/O	4 bit input port (PORT0)/ Serial data input / Serial bus input/output
51	P81/SCKI	I/O	4 bit input port (PORT8) / Serial clock input/output	83	P02/SO0/SB0	I/O	4 bit input port (PORT0)/ Serial data output / Serial bus input/output
52	P80/PPO	I/O	4 bit input port (PORT8) / Pulse output of the timer/pulse generator	84	P01/SCK0	I/O	4 bit input port (PORT0)/ Serial clock input/output
53	P73	I/O	4 bit input/output port (PORT7)	85	P00/INT4	I	4 bit input port (PORT0)/ Edge detection vector interrupt input
54	P72			86	RESET	I	System reset input
55	P71			87	AVSS	—	Reference GND of A/D converter
56	P70			88	AN7/P93	I	Analog input to A/D converter / 4 bit input port (PORT9)
57	P63	89	AN6/P92				
58	P62	90	AN5/P91				
59	P61	I/O	Programmable 4 bit input/output port (PORT6)	91	AN4/P90	I	Analog input to A/D converter
60	P60			92	AN3		
61	P53			93	AN2		
62	P52	I/O	N-ch open drain 4 bit input/output port (PORT5)	94	AN1	I	

■ AZQ7019 (IC03 : CD DECODER PCB ASSY)
 • 4ch BTL Driver

• Block Diagram

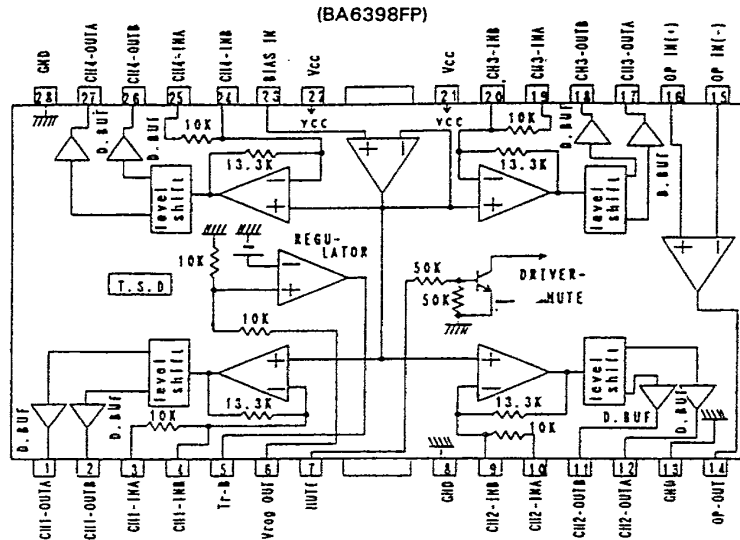

• Pin Function

No.	Pin Name	Description
1	CH1-OUT A	Inverted output of CH1
2	CH1-OUT B	Non inverted output of CH1
3	CH1-IN A	Input for CH1
4	CH1-IN B	Gain adjustment of CH1
5	Tr-B	Connection with BASE of PNP Tr
6	Vreg OUT	Output for regulator (5V) (*1)
7	MUTE	Mute Control
8	GND	Ground
9	CH2-IN B	Gain adjustment of CH2
10	CH2-IN A	Input for CH2
11	CH2-OUT B	Non inverted output of CH2
12	CH2-OUT A	Inverted output of CH2
13	GND	Substrate Ground
14	OP OUT	Output for OP-amp

No.	Pin Name	Description
15	OP IN (-)	Inverting input for OP-amp
16	OP IN (+)	Non inverting input for OP-amp
17	CH3-OUT A	Non inverted output of CH3
18	CH3-OUT B	Inverted output of CH3
19	CH3-IN A	Input for CH3
20	CH3-IN B	Gain adjustment of CH3
21	Vcc	Vcc
22		
23	BIAS IN	Input for reference voltage
24	CH4-IN B	Gain adjustment of CH4
25	CH4-IN A	Input for CH4
26	CH4-OUT B	Non inverted output of CH4
27	CH4-OUT A	Inverted output of CH4
28	GND	Substrate Ground

*1. Connect collector of external PNP Tr.

X - P60C, XR - P60C

■ AZQ7010 (IC602 : MAIN PCB ASSY)

• Dual Recording Pre-amp. with ALC

• Block Diagram

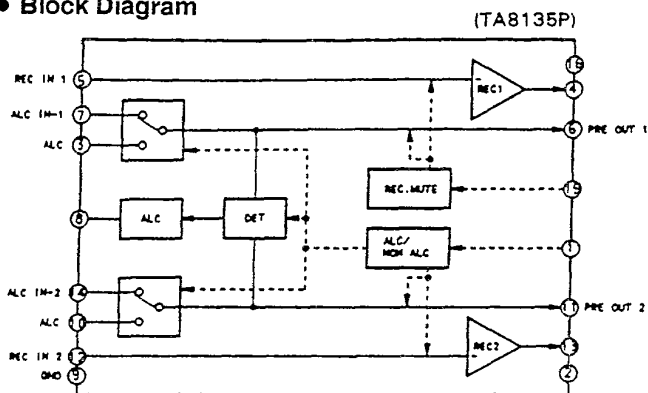

■ AZQ7111 (IC701 : MAIN PCB ASSY)

• AF Power Amplifier

• Block Diagram

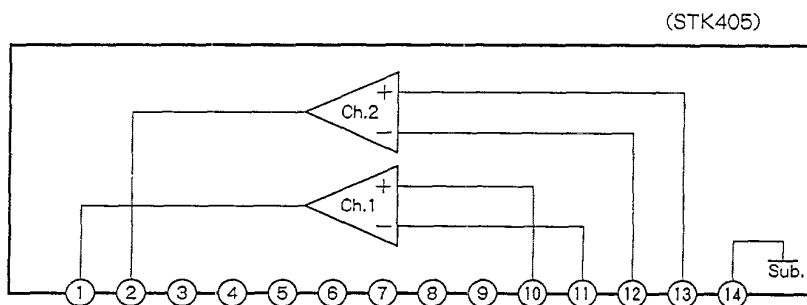

■ AZQ7113 (IC409 : MAIN PCB ASSY)

• Protection Circuit IC for Power Amplifier

• Block Diagram

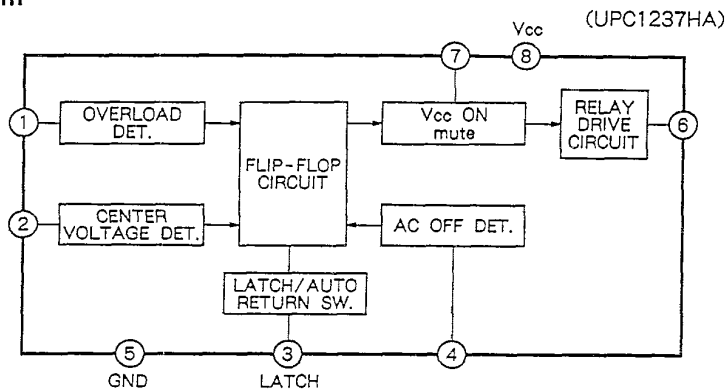

■ AZQ7112 (IC402 : MAIN PCB ASSY)

• Quad OP Amplifier

• Block Diagram

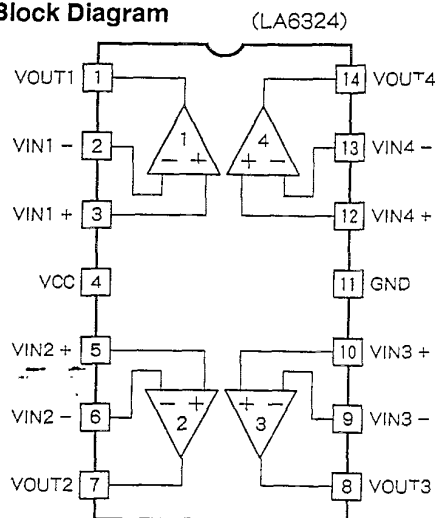

8. DISASSEMBLY

8.1 HOW TO REMOVE CHANGER BASE

Remove the Changer Base by removing the two screws (A) and pull out Changer Base from the Chassis.

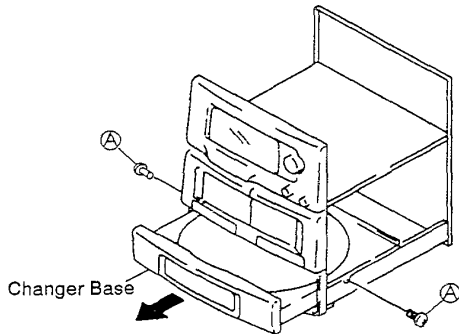

Fig. 1

8.2 HOW TO REMOVE TURNTABLE

1. Remove the Turntable by sliding the Guide Plate outward.
2. Disassemble the Base Cover by removing the 2 screws (B).

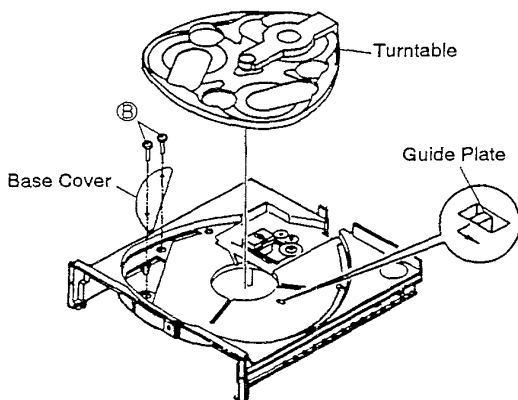

Fig. 2

After removing the Turntable, remove Magnetic Holder from the Arm Assy, and use it to clamp a CD.

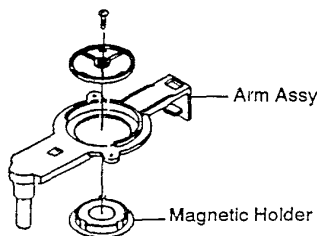

Fig. 3

8.3 LASER DIODE PROTECTION OF THE PICKUP

During transit, Laser diode of the Pickup is protected from an electrostatic damage, by shorting Vcc and GND of the Pickup Assy with solder. Remove the solder after you have mounted the Pickup Assy to the unit.

Laser diode will not light unless this protection solder is removed.

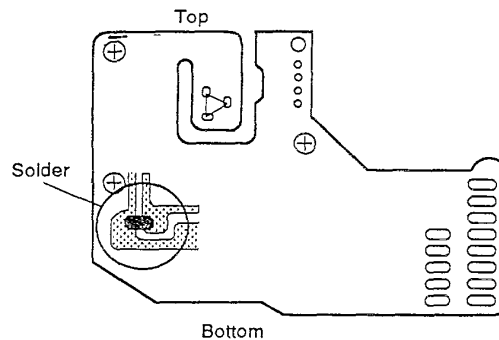

Fig. 4 Pickup Side View

8.4 HEIGHT OF SPINDLE MOTOR TURNTABLE

Spindle motor is available as CD mechanism Assy, and so the height adjustment of Spindle Motor Turntable is unnecessary. But in case of confirming the height level, refer to the following figure.

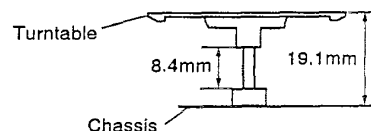
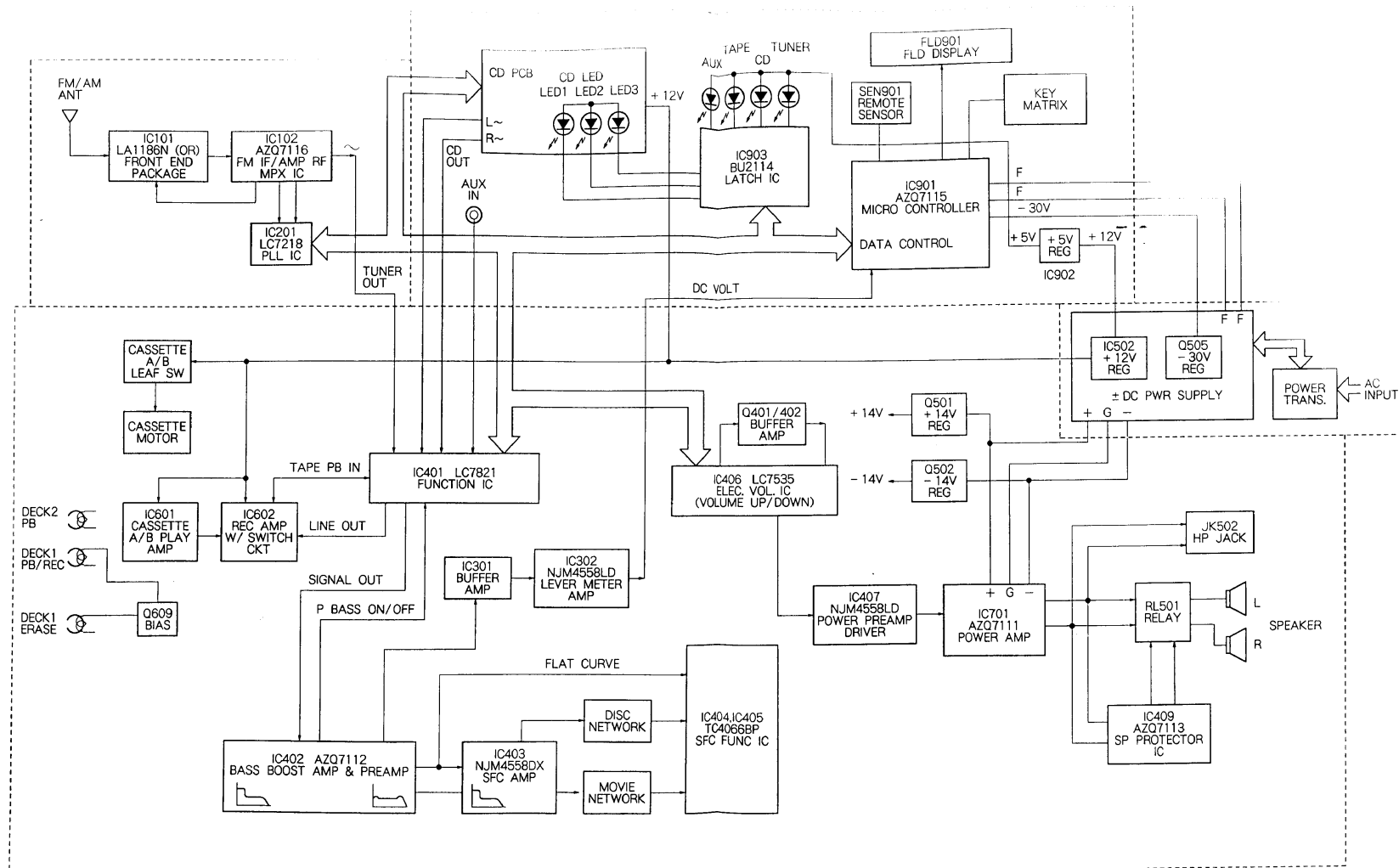
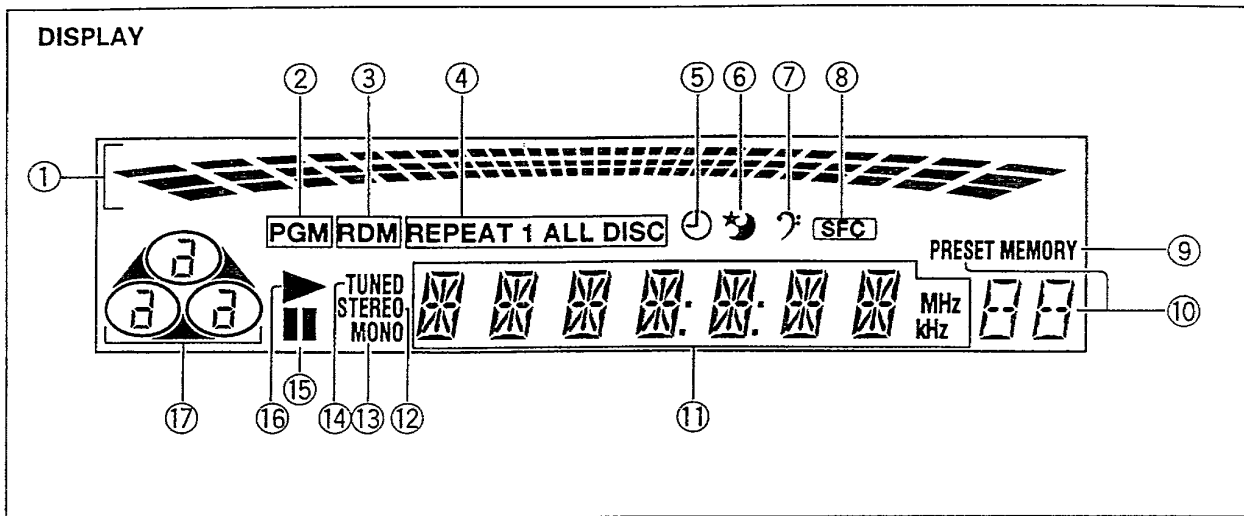

Fig. 5

9. BLOCK DIAGRAM





DISPLAY

- ① **Multi meter**
Provides a visual display of signal level, volume level or other operation conditions.
- ② **PGM (PROGRAM) indicator**
Lights during the program mode.
- ③ **RDM (RANDOM) indicator**
Lights during random playback mode.
- ④ **REPEAT indicators**
 - REPEAT 1: Lights during "repeat-1" playback mode.
 - REPEAT DISC: Lights when using repeat playback for a single disc.
 - REPEAT ALL DISC: Lights during "repeat all discs" playback mode.
- ⑤ **TIMER indicator**
Lights when the timer is set.
- ⑥ **SLEEP TIMER indicator**
Lights when the sleep timer is set.
- ⑦ **P. BASS indicator**
Lights when the P. BASS function is ON.
- ⑧ **SFC (Sound Field Control) indicator**
Lights when the SFC function is ON.
- ⑨ **MEMORY indicator**
Lights when the memory button is pressed during the manual preset operation.
- ⑩ **Preset number display**
When manual preset operation is used, the preset station number is displayed here.
- ⑪ **Displays broadcast reception frequencies and other main operating conditions.**
- ⑫ **STEREO indicator**
Lights during reception of a stereo broadcast.
- ⑬ **MONO indicator**
Lights when receiving a broadcast program in monaural.
- ⑭ **TUNED indicator**
Lights to indicate reception of a broadcast frequency.
- ⑮ **Pause indicator (||)**
Lights during pause mode.
- ⑯ **Play indicator (▶)**
Lights when playing a CD.
- ⑰ **Disc tray number indicator**
Lights when the function is set to CD. The currently playing disc number flashes.

X - P60C, XR - P60C

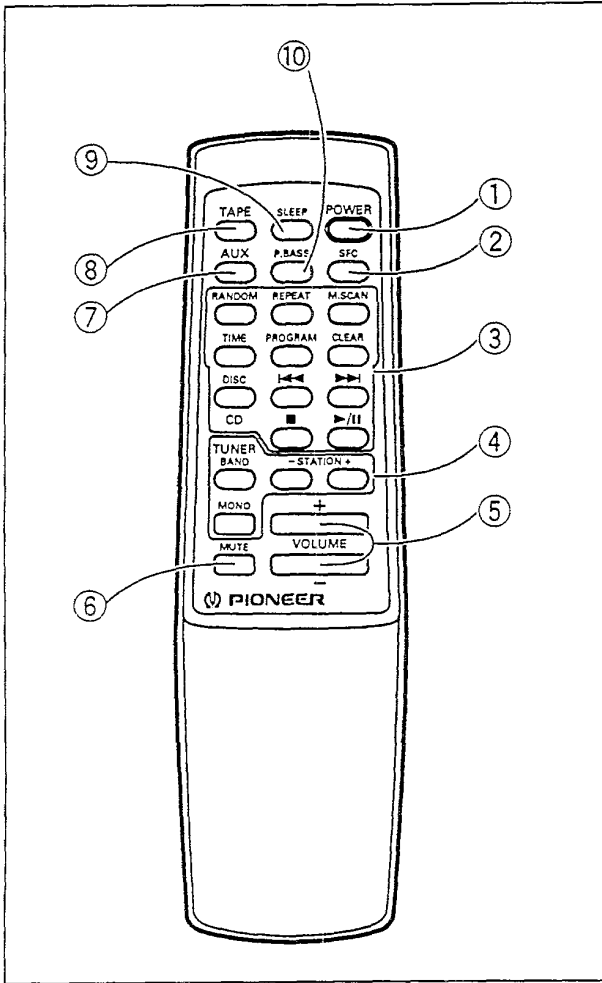

REMOTE CONTROL UNIT

① POWER button

② SFC (Sound Field Control) button

Each time this button is pressed, the mode changes in the following sequence:

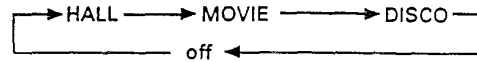

③ CD operation buttons

RANDOM: Random playback

REPEAT: Repeat playback

M.SCAN: Music (Intro) Scan

TIME: Select time display mode.

PROGRAM: Set to track programming mode.

CLEAR: Use to erase the track program.

DISC: Disc No. selection

◀◀: Manual/Track search (reverse)

▶▶: Manual/Track search (forward)

■: Stop

▶/||: Play/Pause

Each time this button is pressed, the mode changes between playback and pause.

④ TUNER operation buttons

STATION -/+ (down/up) button

Before operation, memorize broadcast stations with the STATION CALL buttons.

+ Stations change in order in the upward direction.

- Stations change in order in the downward direction.

MONO button

During reception of FM stereo broadcasts, use to switch between stereo and monaural reception.

BAND button

Use to switch between FM and AM bands.

⑤ VOLUME +/- button

Increases/decreases the sound volume of the unit.

⑥ MUTE button

Press to temporarily minimize sound volume. Press again (or use the VOLUME button) to restore sound to its original volume.

⑦ AUX function button

⑧ TAPE function button

⑨ SLEEP button

Each time this button is pressed, the setting changes in the following sequence:

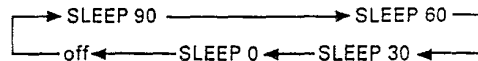

⑩ P. BASS button

11. SPECIFICATIONS

Amplifier section

<U.S. and Canadian models>

Continuous Average Power Output is 33 Watts* per channel, min., at 6 ohms from 80 Hertz to 15,000 Hertz with no more than 1 % total harmonic distortion.**

<U.K. model>

Continuous Power output (DIN)
..... 25 W+ 25 W (1 kHz, T.H.D. 1%, 6 Ω)
Continuous Power output (RMS)
..... 30 W+ 30 W (1 kHz, T.H.D. 10%, 6 Ω)

• Above specifications are for when power supply is 230V.

<Australian model>

Continuous Power output (DIN)
..... 25 W+ 25 W (1 kHz, T.H.D. 1%, 6 Ω)
Continuous Power output (RMS)
..... 30 W+ 30 W (1 kHz, T.H.D. 10%, 6 Ω)

FM/AM tuner section

FM Tuner Section

Frequency Range 87.5 MHz to 108.0 MHz
Antenna input 75 Ω unbalanced

AM (MW) Tuner Section

Frequency Range
With 9 kHz step 522 kHz to 1,611 kHz
(U.K. and Australian models)
With 10 kHz step 530 kHz to 1,720 kHz
(U.S. and Canadian models)
Antenna Loop antenna

CD Section

Type Compact disc digital audio system
Wow and Flutter Limit of measurement
(±0.001% W.PEAK) or less (EIAJ)

Cassette deck section

Systems 4 track, 2-channel stereo
Heads Recording/playback head x 1
Playback head x 1
Erasing head x 1
Motor DC servo motor x 1
Tape type TYPE I (Normal) tape

Miscellaneous

Power Requirements

Australian model AC 240 V, 50/60 Hz
U.S. and Canadian models AC 120 V, 60 Hz
U.K. model AC 230 V, 50/60 Hz

Power Consumption

Australian model 180 W
U.S. and Canadian models 130 W
U.K. model 180 W

Dimensions 280 (W) x 335 (H) x 345 (D) mm
11 (W) x 13-3/16 (H) x 13-9/16 (D) in

Weight (without package)

U.K. model 8.4 kg
Australian model 8.4 kg
U.S. and Canadian models 8.4 kg (18 lb 8oz)

Accessories

Operating Instructions 1
Remote Control Unit 1
Dry Cell Batteries (AAA/R03) 2
FM Antenna 1
AM Loop Antenna 1

NOTE:

Specifications and design subject to possible modifications without notice, due to improvements.