

# Service Manual

**PIONEER®**  
The Art of Entertainment

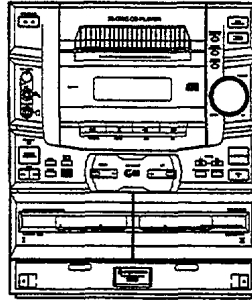

ORDER NO.  
RRV1712

STEREO FILE-TYPE CD CASSETTE DECK RECEIVER

# XR-P670F

THIS MANUAL IS APPLICABLE TO THE FOLLOWING MODEL(S) AND TYPE(S).

Type	Model	Power Requirement	Remarks
	XR-P670F		
KUXJ	○	AC120V	_____
KCXJ	○	AC120V	_____
DD	○	AC110-127V/220-230V/240V	With the voltage selector
DDXJ	○	AC110-127V/220-230V/240V	With the voltage selector
DDXJ/NC	○	AC110-127V/220-230V/240V	With the voltage selector
DLXJ/NC	○	AC110-120V/220-230V/240V	With the voltage selector
YPWXJ	○	AC240V	_____

• For the circuit and mechanism descriptions, refer to the service manual RRV1430 for XR-P760F.

## CONTENTS

1. SAFETY INFORMATION .....	2	7. GENERAL INFORMATION .....	74
2. EXPLODED VIEWS AND PARTS LIST .....	4	7.1 PARTS .....	74
3. SCHEMATIC DIAGRAM .....	18	7.1.1 IC .....	74
4. PCB CONNECTION DIAGRAM .....	40	7.1.2 DISPLAY .....	78
5. PCB PARTS LIST .....	56	7.2 DISASSEMBLY .....	80
6. ADJUSTMENT .....	64	7.3 BLOCK DIAGRAM .....	84
		8. PANEL FACILITIES AND SPECIFICATIONS .	86

**PIONEER ELECTRONIC CORPORATION** 4-1, Meguro 1-Chome, Meguro-ku, Tokyo 153, Japan

**PIONEER ELECTRONICS SERVICE, INC.** P.O. Box 1760, Long Beach, CA 90801-1760, U. S. A.

**PIONEER ELECTRONIC (EUROPE) N.V.** Haven 1087 Keetberglaan 1, 9120 Melsele, Belgium

**PIONEER ELECTRONICS ASIACENTRE PTE. LTD.** 501 Orchard Road, #10-00 Lane Crawford Place, Singapore 0923

© PIONEER ELECTRONIC CORPORATION 1996

T-SZE DEC. 1996 Printed in Japan

## 1. SAFETY INFORMATION

This service manual is intended for qualified service technicians; it is not meant for the casual do-it-yourselfer. Qualified technicians have the necessary test equipment and tools, and have been trained to properly and safely repair complex products such as those covered by this manual. Improperly performed repairs can adversely affect the safety and reliability of the product and may void the warranty. If you are not qualified to perform the repair of this product properly and safely, you should not risk trying to do so and refer the repair to a qualified service technician.



### WARNING

Lead in solder used in this product is listed by the California Health and Welfare agency as a known reproductive toxicant which may cause birth defects or other reproductive harm (California Health & Safety Code, Section 25249.5).

When servicing or handling circuit boards and other components which contain lead in solder, avoid unprotected skin contact with the solder. Also, when soldering do not inhale any smoke or fumes produced.



### NOTICE

(FOR CANADIAN MODEL ONLY)

Fuse symbols  (fast operating fuse) and/or  (slow operating fuse) on PCB indicate that replacement parts must be of identical designation.

### REMARQUE

(POUR MODÈLE CANADIEN SEULEMENT)

Les symboles de fusible  (fusible de type rapide) et/ou  (fusible de type lent) sur CCI indiquent que les pièces de remplacement doivent avoir la même désignation.

### (FOR USA MODEL ONLY)

#### 1. SAFETY PRECAUTIONS

The following check should be performed for the continued protection of the customer and service technician.

#### LEAKAGE CURRENT CHECK

Measure leakage current to a known earth ground (water pipe, conduit, etc.) by connecting a leakage current tester such as Simpson Model 229-2 or equivalent between the earth ground and all exposed metal parts of the appliance (input/output terminals, screwheads, metal overlays, control shaft, etc.). Plug the AC line cord of the appliance directly into a 120V AC 60 Hz outlet and turn the AC power switch on. Any current measured must not exceed 0.5 mA.

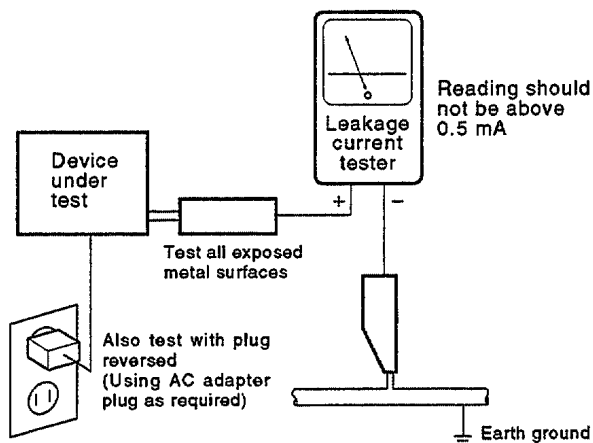

AC Leakage Test

**ANY MEASUREMENTS NOT WITHIN THE LIMITS OUTLINED ABOVE ARE INDICATIVE OF A POTENTIAL SHOCK HAZARD AND MUST BE CORRECTED BEFORE RETURNING THE APPLIANCE TO THE CUSTOMER.**



#### 2. PRODUCT SAFETY NOTICE

Many electrical and mechanical parts in the appliance have special safety related characteristics. These are often not evident from visual inspection nor the protection afforded by them necessarily can be obtained by using replacement components rated for voltage, wattage, etc. Replacement parts which have these special safety characteristics are identified in this Service Manual.

Electrical components having such features are identified by marking with a  on the schematics and on the parts list in this Service Manual.

The use of a substitute replacement component which does not have the same safety characteristics as the PIONEER recommended replacement one, shown in the parts list in this Service Manual, may create shock, fire, or other hazards.

Product Safety is continuously under review and new instructions are issued from time to time. For the latest information, always consult the current PIONEER Service Manual. A subscription to, or additional copies of, PIONEER Service Manual may be obtained at a nominal charge from PIONEER.

<p><b>VARO!</b> AVATTAESSA JA SUOJALUKITUS OHITETTAESSA OLET ALTTIINA NÄKYMÄTTÖMÄLLE LASERSÄTEILYLLE. ÄLÄ KATSO SÄTEESEEN.</p>		<p><b>WARNING!</b> DEVICE INCLUDES LASER DIODE WHICH EMITS INVISIBLE INFRARED RADIATION WHICH IS DANGEROUS TO EYES. THERE IS A WARNING SIGN ACCORDING TO PICTURE 1 INSIDE THE DEVICE CLOSE TO THE LASER DIODE.</p>	
<p><b>ADVARSEL:</b> USYNLIG LASERSTRÅLING VED ÅBNING NÅR SIKKERHED SAFBRYDERE ER UDE AF FUNKTION. UNDGÅ UDSÆTTELSE FOR STRÅLING.</p>	<p>LASER Kuva 1 Lasersäteilyn varoitusmerkki</p>	<p><b>IMPORTANT</b> THIS PIONEER APPARATUS CONTAINS LASER OF CLASS 1. SERVICING OPERATION OF THE APPARATUS SHOULD BE DONE BY A SPECIALLY INSTRUCTED PERSON.</p>	<p>LASER Picture 1 Warning sign for laser radiation</p>
<p><b>VARNING!</b> OSYNLIG LASERSTRÅLNING NÅR DENNA DEL ÄR ÖPPNAD OCH SPÄRREN ÄR URKOPPLAD. BETRAKTA EJ STRÅLEN.</p>		<p><b>LASER DIODE CHARACTERISTICS</b> MAXIMUM OUTPUT POWER: 5 mw WAVELENGTH: 780 – 785 nm</p>	

**LABEL CHECK (For DLXJ/NC and YPWXJ types)**

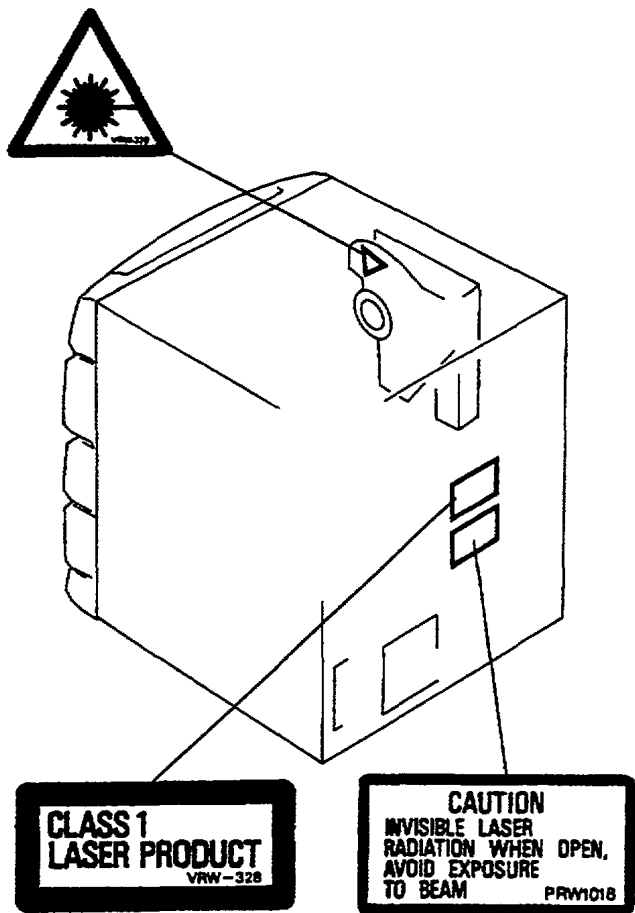

**Additional Laser Caution**

- 1. Laser Interlock Mechanism**  
The position of the switch (S651) for detecting loading state is detected by the system microprocessor, and the design prevents laser diode oscillation when the switch (S651) is not on CLMP terminal side (CLMP signal is OFF or high level.) Thus, the interlock will no longer function if the switch (S651) is deliberately set to CLMP terminal side. (low level)  
The interlock also does not function in the test mode\*. Laser diode oscillation will continue, if pin 1 of M51593FP (IC101) on the PRE-AMP BOARD ASSY mounted on the pickup assembly is connected to GND, or pin 19 is connected to low level (ON), or else the terminals of Q101 are shorted to each other (fault condition).
- 2. When the cover is opened, close viewing of the objective lens with the naked eye will cause exposure to a Class 1 laser beam.**

\* Refer to page 70.

## 2. EXPLODED VIEWS AND PARTS LIST

- NOTES:**
- Parts marked by "NSP" are generally unavailable because they are not in our Master Spare Parts List.
  - The  $\Delta$  mark found on some component parts indicates the importance of the safety factor of the parts. Therefore, when replacing, be sure to use parts of identical designation.
  - Screws adjacent to  $\nabla$  mark on the product are used for disassembly.

### 2.1 PACKING



#### (1) PARTS LIST

Mark	No.	Description	Parts No.
	1	FM Antenna	ADH7004
	2	CD Case Stand	See Contrast table (2)
	3	Operating Instructions (English)	See Contrast table (2)
	4	AM Loop Antenna	ATB7009
	5	Remote Control Unit (CU-XR036)	AXD7113
NSP	6	Battery (R6P, AA)	VEM-013
NSP	7	Polyethylene Bag	See Contrast table (2)
	8	Front Pad LR	AHA7142
	9	Rear Pad LR	AHA7143
	10	Packing Case	See Contrast table (2)
	11	Packing Sheet	AHG7003
	12	Battery Cover	AZA7123
	13	Operating Instructions (French)	See Contrast table (2)

#### (2) CONTRAST TABLE

Mark	No.	Symbol & Description	Part No.							Remarks
			XR-P670F							
			KUXJ	KCXJ	DD	DDXJ	DDXJ/NC	DLXJ/NC	YPWXJ	
NSP	2	CD Case Stand	AMR7072	AMR7072	AMR7066	AMR7072	AMR7072	AMR7072	AMR7072	
	3	Operating Instructions (English)	ARB7095	ARB7095	Not used	Not used	Not used	Not used	ARB7114	
	3	Operating Instructions (English/Spanish/Chinese)	Not used	Not used	ARE7096	ARE7096	Not used	Not used	Not used	
	3	Operating Instructions (English/Spanish/Portuguese)	Not used	Not used	Not used	Not used	ARE7102	Not used	Not used	
	3	Operating Instructions (English/Chinese)	Not used	Not used	Not used	Not used	Not used	ARE7103	Not used	
	7	Polyethylene Bag	AHG7030	AHG7032	Z21-040	AHG7032	AHG7032	AHG7032	AHG7032	
	10	Packing Case	AHD7381	AHD7381	AHD7386	AHD7382	AHD7383	AHD7383	AHD7384	
	13	Operating Instructions (French)	Not used	ARC 7139	Not used	Not used	Not used	Not used	Not used	

2.2 EXTERIOR

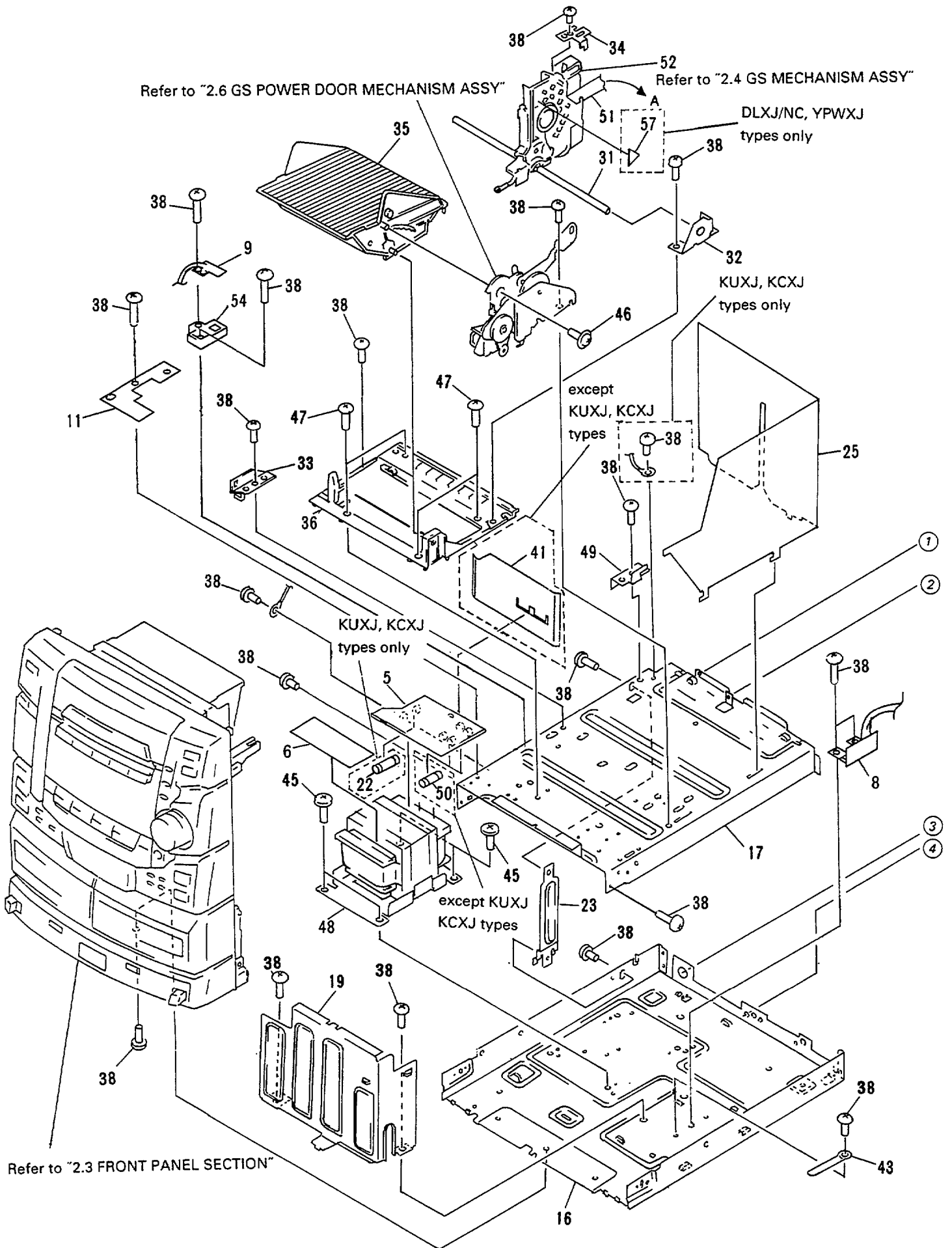

# XR-P670F

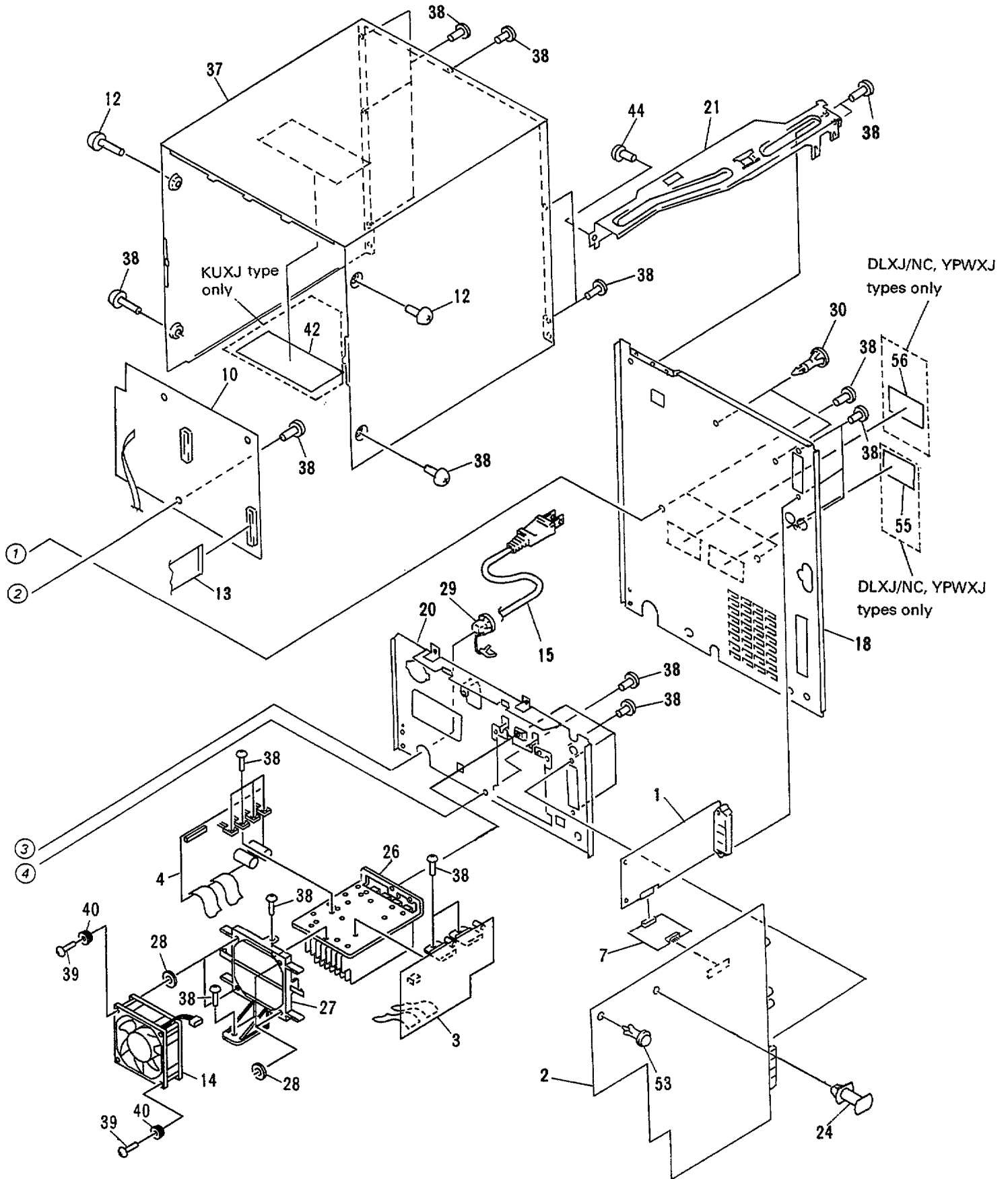

(1) PARTS LIST

Mark	No.	Description	Parts No.	Mark	No.	Description	Parts No.
	1	FM/AM TUNER MODULE	See Contrast table (2)	NSP	30	Locking Cade Spacer	VEC1596
	2	AF ASSY	See Contrast table (2)		31	Guide Shaft S	ALA7008
	3	AMP ASSY	AWZ8647		32	Shaft Holder	ANB7021
	4	POWER SUPPLY ASSY	AWZ8649		33	Shaft Holder GS	ANB7094
	5	PRIMARY ASSY	See Contrast table (2)		34	Assist Angle 2	ANB7065
NSP	6	SECONDARY ASSY	See Contrast table (2)		35	Disk Rack	ANW7069
	7	TX CONNECT ASSY	AWZ8660		36	Rackbase SP	ANW7109
	8	REGULATOR ASSY	AWZ8683		37	Bonnet Case	ANE7142
NSP	9	HOME SW ASSY	AWZ8685		38	Screw	BBZ30P080FZK
	10	GM-CD ASSY	See Contrast table (2)		39	Screw	ABA7026
NSP	11	PROTECTOR ASSY	AWZ8803		40	Floating Rubber	AEB7060
	12	Screw	VPZ30P080FZK		41	Voltage Cover	See Contrast table (2)
	13	35P F•F•C/30V	AAD7050		42	65 Label	See Contrast table (2)
	14	DC Fan Motor	AXM7003	NSP	43	Binder	RNE1277
△	15	AC Power Cord	See Contrast table (2)		44	Screw	BPZ30P120FZK
NSP	16	Chassis	See Contrast table (2)		45	Screw	BBZ40P080FZK
	17	Sub Chassis	See Contrast table (2)		46	Screw	IPZ30P080FMC
	18	Rear Panel	See Contrast table (2)		47	Screw C	PBA1106
	19	Front Stay	AND7009	△	48	Power Transformer	See Contrast table (2)
	20	Rear Stay	See Contrast table (2)		49	Lock Angle 2	ANG7117
△	21	Home Lock Stay	AND7022	△	50	Fuse (FU2, FU3 : T1.6A)	See Contrast table (2)
	22	Fuse (4A)	See Contrast table (2)		51	22P F•F•C/30V	ADD7016
	23	Side Angle	ANG7091	NSP	52	GS Mechanism Assy	AXA7047
NSP	24	PCB Spacer	See Contrast table (2)		53	Push Rivet	AEC7069
	25	CD Cover	AAK7333		54	Home Switch Mold	AMR7168
	26	Heat Sink	ANH7052		55	Caution Label	See Contrast table (2)
	27	Mold A	See Contrast table (2)	NSP	56	Label (F)	See Contrast table (2)
	28	Rubber Washer	AEB7080		57	Caution Label (G)	See Contrast table (2)
	29	Cord Stopper	See Contrast table (2)				

(2) CONTRAST TABLE

Mark	No.	Srmbol & Description	Part No.							Remarks
			XR-P670F							
			KUXJ	KCXJ	DD	DDXJ	DDXJ/NC	DLXJ/NC	YPWXJ	
	1	FM/AM TUNER MODULE	AXQ7061	AXQ7061	AXQ7051	AXQ7061	AXQ7061	AXQ7061	AXQ7061	
	2	AF ASSY	AWZ8643	AWZ8643	AWZ8644	AWZ8644	AWZ8644	AWZ8644	AWZ8644	
	5	PRIMARY ASSY	AWZ8651	AWZ8651	AWZ8652	AWZ8652	AWZ8652	AWZ8652	AWZ8652	
	6	SECONDARY ASSY	AWZ8656	AWZ8656	AWZ8657	AWZ8657	AWZ8657	AWZ8657	AWZ8657	
	10	GM-CD ASSY	AWZ8662	AWZ8662	AWZ8663	AWZ8663	AWZ8663	AWZ8663	AWZ8663	
△	15	AC Power Cord	PDG1057	PDG1057	PDG1056	ADG1157	ADG1157	PDG1058	ADG1159	
NSP	16	Chassis	ANA7034	ANA7034	ANA7053	ANA7034	ANA7034	ANA7034	ANA7034	
	17	Sub Chassis	ANA7057	ANA7057	Not used	ANA7057	ANA7057	ANA7057	ANA7057	
NSP	17	Sub Chassis	Not used	Not used	ANA7054	Not used	Not used	Not used	Not used	
	18	Rear Panel	ANC7514	ANC7544	ANC7521	ANC7515	ANC7516	ANC7517	ANC7518	
△	20	Rear Stay	AND7010	AND7010	AND7007	AND7010	AND7010	AND7010	AND7010	
NSP	22	Fuse (FU1 : 4A)	REK1082	REK1082	Not used	Not used	Not used	Not used	Not used	
	24	PCB Spacer	AEC7080	AEC7080	AEC1372	AEC7080	AEC7080	AEC7080	AEC7080	
	27	Mold A	AMR7005	AMR7005	AMR2594	AMR7005	AMR7005	AMR7005	AMR7005	
	29	Cord Stopper	CM-22C	CM-22C	CM-22B	CM-22B	CM-22B	CM-22B	CM-22B	
	41	Voltage Cover	Not used	Not used	AAK7387	AAK7387	AAK7387	AAK7387	Not used	
	42	65 Label	ORW1069	Not used	Not used	Not used	Not used	Not used	Not used	
△	48	Power Transformer (T1 : AC120V)	ATS7151	ATS7152	Not used	Not used	Not used	Not used	Not used	
△	48	Power Transformer (T1 : AC110-127V/220-240V)	Not used	Not used	ATS7153	ATS7153	ATS7153	ATS7153	Not used	
△	48	Power Transformer (T1 : AC240V)	Not used	Not used	Not used	Not used	Not used	Not used	ATS7154	
△	50	Fuse (FU2, FU3 : T1.6A/250V)	Not used	Not used	AEK1056	AEK1056	AEK1056	AEK1056	AEK1056	
NSP	55	Caution Label	Not used	Not used	Not used	Not used	Not used	PRW1018	PRW1018	
	56	Caution Label (F)	Not used	Not used	Not used	Not used	Not used	VRW-328	VRW-328	
	57	Caution Label (G)	Not used	Not used	Not used	Not used	Not used	VRW-329	VRW-329	

## 2.3 FRONT PANEL SECTION

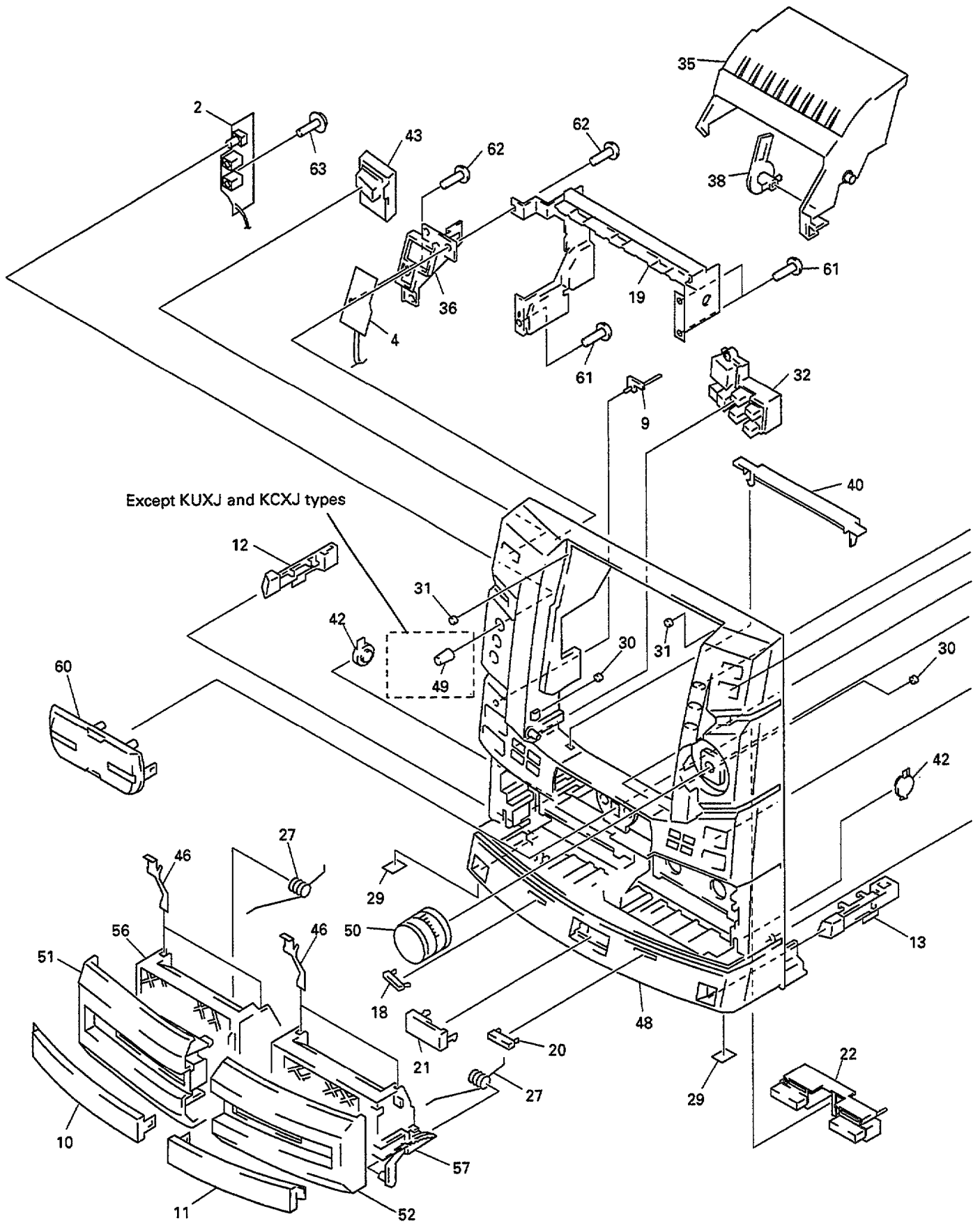



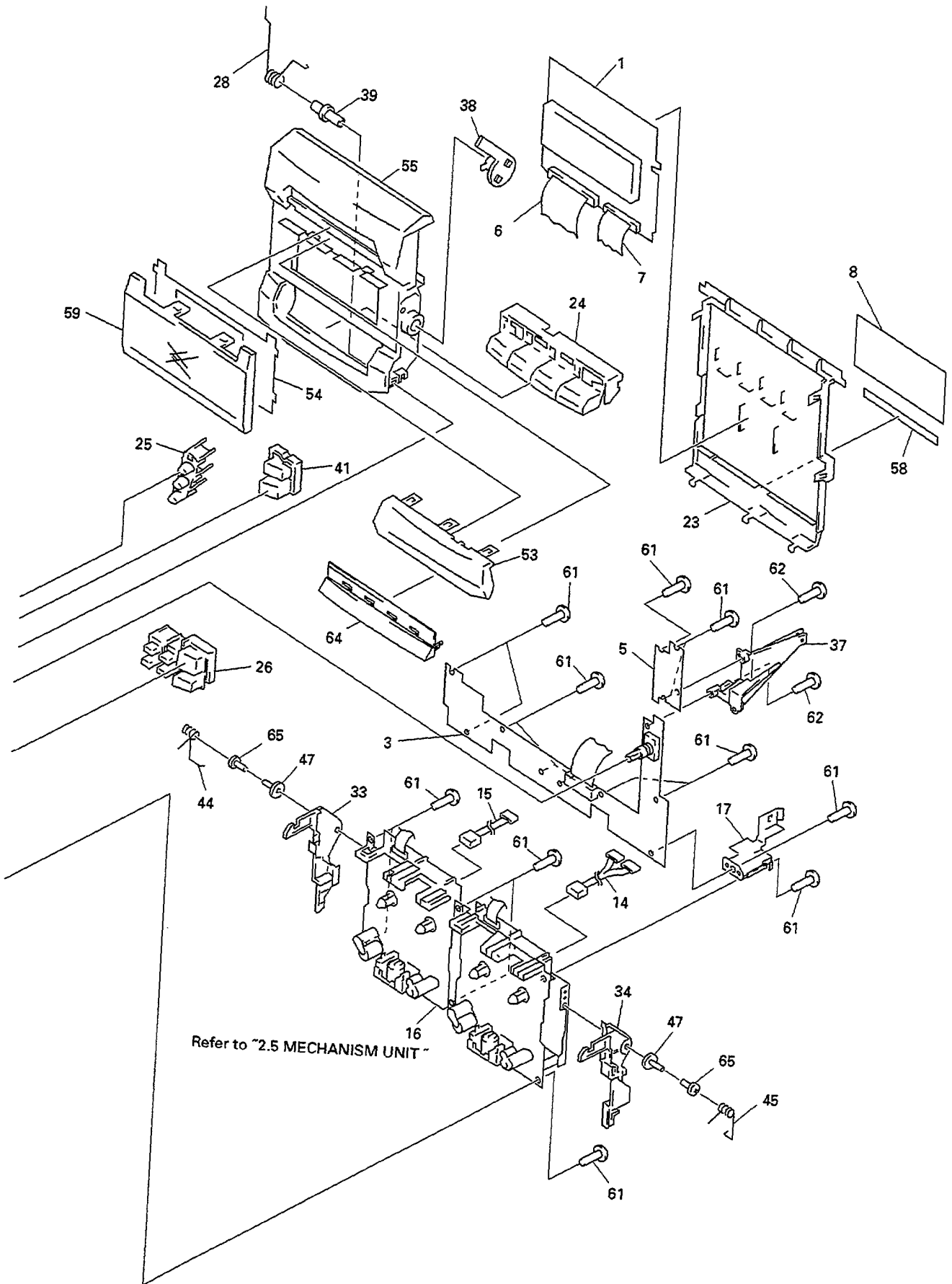

# XR-P670F

## (1) PARTS LIST

Mark	No.	Description	Parts No.	Mark	No.	Description	Parts No.
	1	DISPLAY ASSY	See Contrast table (2)	36	PCB Holder	AMR7140	
	2	MIC & HP ASSY	See Contrast table (2)	37	AF PCB Holder	AMR7141	
	3	CENTER SW ASSY	AWZ8677	38	Link Holder	AMR7142	
NSP	4	LEFT SW ASSY	AWZ8679	39	Shaft Mold	AMR7143	
NSP	5	RIGHT SW ASSY	AWZ8681	40	FFC Holder	AMR7159	
	6	35P FFC 30V	ADD7049	41	SFC Button	AAD7359	
	7	26P FFC 30V	ADD7048	42	Damper Assy	See Contrast table (2)	
	8	Caution Label	ARW7024	43	Slot Eject Button	AAD7358	
	9	Standby Lenz	AAK7310	44	Spring L	See Contrast table (2)	
	10	Door Window L	AAK7307	45	Spring R	See Contrast table (2)	
	11	Door Window R	AAK7308	46	Spring	RBK1004	
	12	Eject Button L	AAD7367	47	Corrar	RNK2135	
	13	Eject Button R	AAD7368	48	Front Panel	See Contrast table (2)	
	14	Connector Assy 5P	RKP1682	49	Mic Volume Knob	See Contrast table (2)	
	15	Connector Assy 3P	RKP1683	50	Vol Knob	AAB7117	
	16	Meshanism Unit	RYM1248	51	Cassette door Panel L	AZA7226	
	17	Earth Plate	ANG7110	52	Cassette door Panel R	AZA7227	
	18	Azimuth Cover L	AZA7223	53	Edge Light Cover	AMR7166	
	19	Sub panel	ANG7113	54	Amp Window Sheet	AAK7362	
	20	Azimuth Cover R	AZA7224	55	CD Door	AAN7152	
	21	Name Plate	AAK7351	56	Door Pocket L	AZA7253	
	22	Disc Select Button	AAD7364	57	Door Pocket R	AZA7254	
	23	CD Door Cover	See Contrast table (2)	58	Disc Rack Panel	AAK7251	
	24	Function Button	AAD7363	59	Amp Window	AAK7306	
	25	Timer Button	AAD7362	60	Disc Select Panel	AZA7225	
	26	Play Button	AAD7361	61	Screw	BPZ30P080FMC	
	27	Deck Door Spring	See Contrast table (2)	62	Screw	BPZ30P120FZK	
	28	CD Door Sping	ABH7143	63	Screw	ABA1005	
	29	Rubber Sheet	AEB1111	64	CD Door Plate	AAK7346	
	30	Rubber Sheet	AEB7054	65	Screw	BSZ20P120FMC	
	31	Cussion Rubber	AEB7068				
	32	Power Button	AAD7360				
	33	Eject Arm L	See Contrast table (2)				
	34	Eject Arm R	See Contrast table (2)				
	35	Barrier	AMR7135				

## (2) CONTRAST TABLE

Mark	No.	Srmbol & Description	Part No.							Remarks
			XR-P670F							
			KUXJ	KCXJ	DD	DDXJ	DDXJ/NC	DLXJ/NC	YPWXJ	
	1	DISPLAY ASSY	AWZ8667	AWZ8667	AWZ8668	AWZ8668	AWZ8668	AWZ8669	AWZ8668	
	2	MIC & HP ASSY	AWZ8672	AWZ8672	AWZ8673	AWZ8673	AWZ8673	AWZ8674	AWZ8673	
	23	CD Door Cover	AAK7424	AAK7424	AAK7318	AAK7424	AAK7424	AAK7424	AAK7424	
	27	Deck Door Spring	ABH7149	ABH7149	ABH7134	ABH7149	ABH7149	ABH7149	ABH7149	
	33	Eject Arm L	AMR7074	AMR7074	AMR7020	AMR7074	AMR7074	AMR7074	AMR7074	
	34	Eject Arm R	AMR7075	AMR7075	AMR7021	AMR7075	AMR7075	AMR7075	AMR7075	
	42	Damper Assy	AXA7051	AXA7051	AXA7021	AXA7051	AXA7051	AXA7051	AXA7051	
	44	Spring L	ABH7102	ABH7102	RBH1411	ABH7102	ABH7102	ABH7102	ABH7102	
	45	Spring R	ABH7103	ABH7103	RBH1412	ABH7103	ABH7103	ABH7103	ABH7103	
	48	Front Panel	AZA7216	AZA7216	AZA7217	AZA7217	AZA7217	AZA7217	AZA7217	
	49	Mic Volume Krnob	Not used	Not used	AAB7119	AAB7119	AAB7119	AAB7119	AAB7119	



## Servo Mechanism Assy GM

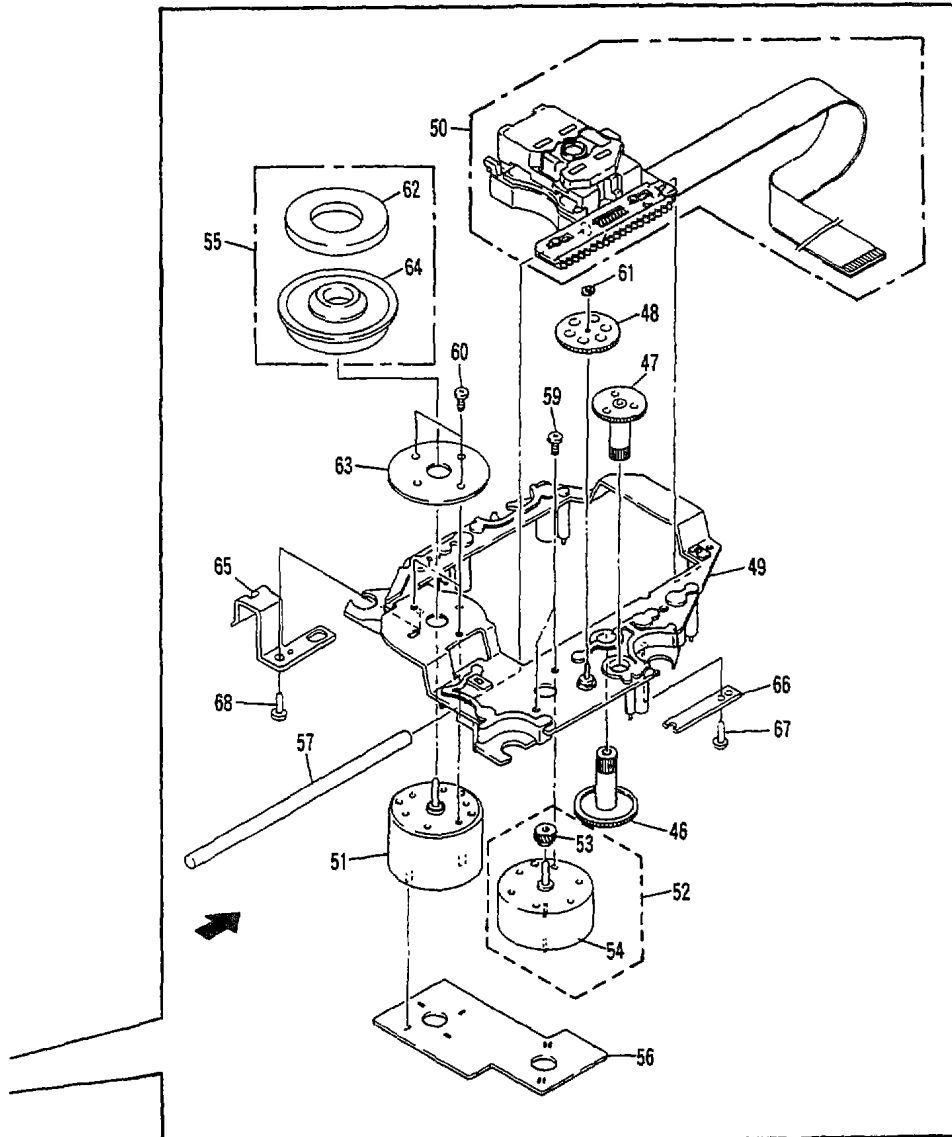

### ● How to install the disc table

- 1 Use nipper or other tool to cut the two sections marked (A) figure 1. Then remove the spacer.
- 2 While supporting the spindle motor shaft with the stopper, put spacer on top of the yoke M, and stick the disc table on top (takes about 9kg pressure). Take off the spacer.

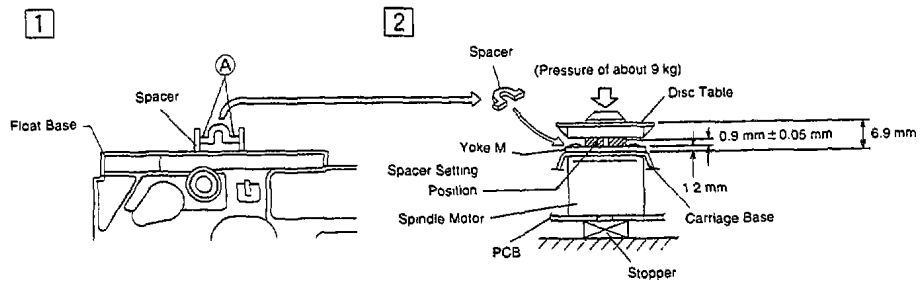

## PARTS LIST

Mark	No.	Description	Parts No.	Mark	No.	Description	Parts No.
NSP	1	MECHA PCB ASSY	AWZ8802		51	D.C. MOTOR ASSY (SPDL)	PEA1235
NSP	2	SENSOR PCB ASSY	AWZ7836		52	CARRIAGE DC MOTOR ASSY	
NSP	3	MOTOR PCB ASSY	AWZ7837				PEA1246
NSP	4	SW PCB ASSY	AWZ7838		53	PINION GEAR	PNW2055
	5	ARM A SPRING 2	ABH7124	NSP	54	CARRIAGE DC MOTOR/0.3W	PXM1027
	6	GEAR PLATE SPRING	ABH7051		55	DISC TABLE ASSY	PEA1314
	7	CLAMP SPRING	ABH7107		56	MECHANISM BOARD ASSY	
	8	LOCK LEVER SPRING B	ABH7142				PWX1192
	9	LOCK ANGLE SPRING 2	ABH7123				PLA1094
	10	LOADING BELT	AEB7029		57	GUIDE BAR	
					58	.....	
	11	BELT	AEB7030		59	SCREW	JFZ17P025FZK
NSP	12	LOCK ANGLE	ANB7027		60	SCREW	JFZ20P040FMC
NSP	13	LOCK LEVER	ANB7038				
NSP	14	SERVO STOPPER S	ANB7047		61	WASHER	WT12D032D025
	15	LOADING BASE	ANW7086		62	CLAMP MAGNET	PMF1014
					63	YOKE M	PNB1312
	16	CAM COVER	ANW7052	NSP	64	DISC TABLE	PNW2410
	17	MOTOR HOLDER	ANW7053	NSP	65	FLOAT ANGLE	ANB7020
	18	SENSOR HOLDER	ANW7054				
	19	FLOAT BASE	ANW7080		66	GEAR STOPPER	PNB1303
	20	CLAMPER HOLDER	ANW7084		67	SCREW	BPZ20P060FMC
					68	SCREW	BPZ26P100FMC
	21	ARM (A)	ANW7057				
	22	ARM (B)	ANW7058				
	23	DRIVE PLATE	ANW7059			FROIL (for service)	GYA1001
	24	ARM PLATE	ANW7060			HA NARL (for service)	GEM1016
	25	GEAR PLATE	ANW7111				
	26	GEAR PULLEY (B)	ANW7062				
	27	GEAR A	ANW7063				
	28	DRIVE GEAR	ANW7064				
	29	BEARING	ANW7065				
	30	GEAR PULLEY A	ANW7066				
	31	SELECT GEAR	ANW7067				
	32	ROLLER	ANW7068				
	33	.....					
	34	ROLLER B	ANW7075				
	35	MOTOR PULLEY	PNW1634				
	36	CLAMPER	PNW2692				
	37	FLOAT SPRING	ABH7049				
	38	CONNECTOR ASSY (4P)	ADE7006				
	39	FLOAT RUBBER	AEB7028				
NSP	40	SERVO MECHANISM ASSY GM	AXA7028				
	41	SCREW	IPZ20P080FMC				
	42	MOTOR ASSY (SELECT)	AEA7005				
NSP	43	MOTOR	PXM1002				
	44	MOTOR ASSY	AEA7006				
	45	LOADING MOTOR	VXM1034				
	46	GEAR 1	PNW2052				
	47	GEAR 2	PNW2053				
	48	GEAR 3	PNW2054				
	49	CARRIAGE BASE	PNW2699				
	50	PICKUP ASSY	AEA7004				



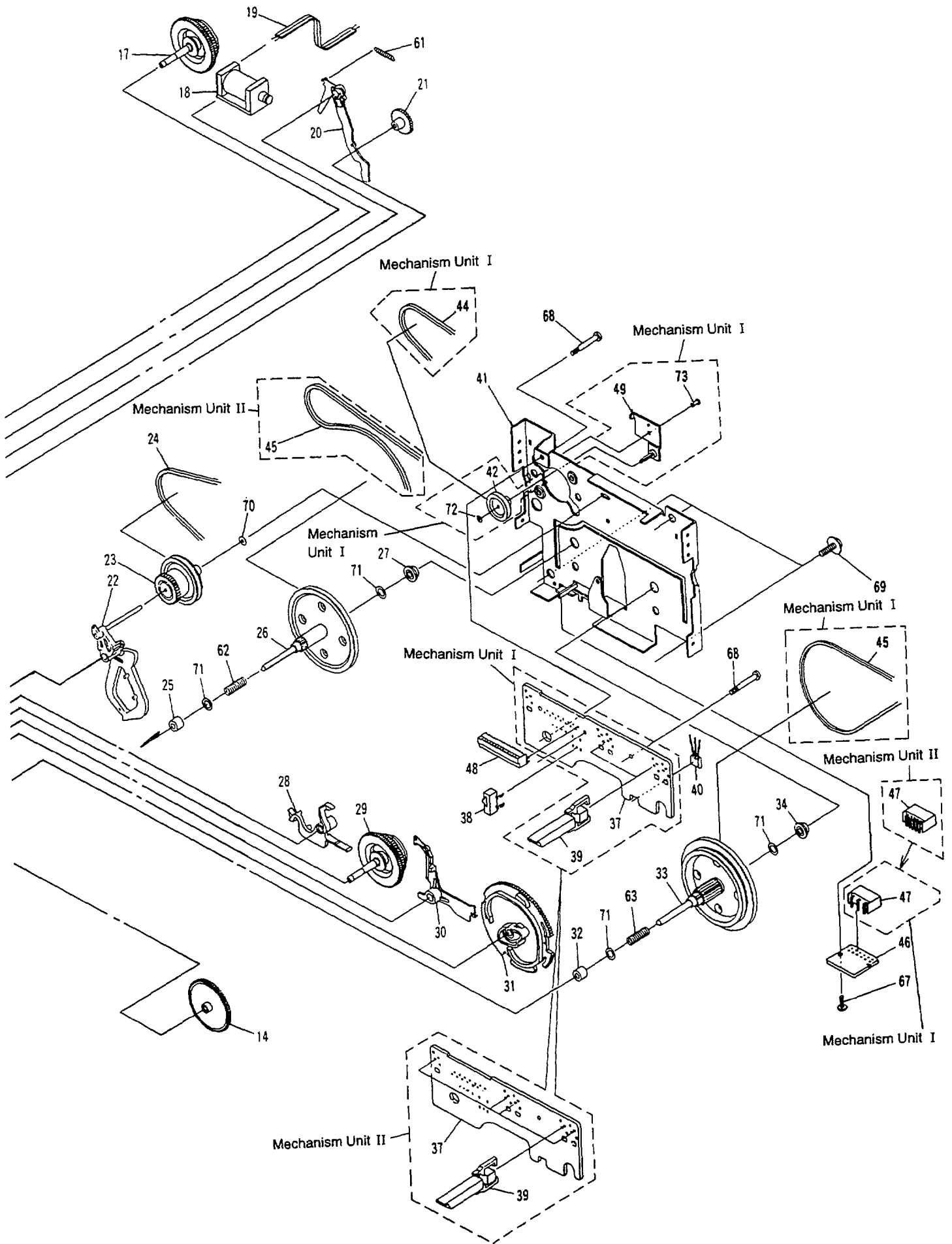

## PARTS LIST

### ■ Mechanism unit I and II (1/2)

Mark	No.	Description	Parts No.
	1	ASSY MOTOR	RXM1080
NSP	2	JUMPER WIRE	RDD1012
	3	BRACKET MOTOR	RNE1830
	4	SPACER	RNK1822
	5	SCREW	RBA1100
	6	SCREW	PCZ20P040FMC

### ■ Mechanism unit I and II (2/2)

Mark	No.	Description	Parts No.
	1	ASSY HOLDER HEAD (*1)	RXA1400
	1	ASSY HOLDER HEAD (*2)	RXA1664
	2	FRAME HEAD	RNK1715
	3	LEVER HEAD	RNK1716
	4	SPRING AZIMUTH	RBK1006
	5	ASSY ARM ASSIST	RXA1401
	6	GEAR ARM HEAD	RNK1717
	7	SPRING CASSETTE	RBK1039
	8	EJECT LOCK	RNK1718
	9	CAP REEL	RNK1719
	10	ASSY PINCH ARM L	RXA1403
	11	CHASSIS HEAD	RNE1437
	12	ASSY PINCH ARM R	RXA1404
	13	ARM PLAY L	RNK1866
	14	GEAR PLAY	RNK1867
	15	ARM PLAY R	RNK1868
	16	CHASSIS OS	RXA1411
	17	ASSY SUB REEL L	RXA1407
	18	SOLENOID	RXP1020
	19	WIRE	RDC1006
	20	ARM RVS	RNK1721
	21	GEAR FF	RNK1723
	22	ASSY ARM FR	RXA1412
	23	ASSY PULLEY FR	RXA1413
	24	BELT FR	REB1292
	25	METAL	RNG1048
	26	ASSY FLYWHEEL L	RXA1690
	27	METAL	RNG1005
	28	ARM BRAKE	RNK1724
	29	ASSY SUB REEL R	RXA1408
	30	ARM TRIGER	RNK1722
	31	GEAR CAM	RNK1725
	32	METAL	RNG1049
	33	ASSY FLYWHEEL R	RXA1691
	34	METAL	RNG1004
	35	.....	

Mark	No.	Description	Parts No.
	36	.....	
	37	P. C. BOARD	RNP1610
	38	SWITCH MODE	RSN1020
	39	SWITCH (LEAF)	RSN1019
	40	HALL IC	DN6851A
	41	BRACKET FW (*1)	RNE1854
	41	BRACKET FW (*2)	RNE1438
	42	PULLEY (*1 only)	RNK2132
	43	.....	
	44	BELT FW (*1 only)	REB1291
	45	BELT MAIN (* 1)	REB1290
	45	BELT MAIN (* 2)	REB1289
	46	P. C. BOARD	RNP1348
	47	HOUSING (*1)	RKP1396
	47	HOUSING (*2)	RKP1397
	48	CONNECTOR (*1)	RKP1713
	48	CONNECTOR (*2)	RKP1714
	49	ASSY HOLDER (*1 only)	RXA1689
	50	.....	
	51	SPRING	RBH1282
	52	SPRING	RBH1283
	53	SPRING	RBH1284
	54	SPRING	RBH1286
	55	SPRING	RBH1288
	56	SPRING	RBH1291
	57	SPRING	RBH1285
	58	SPRING	RBH1287
	59	SPRING	RBH1289
	60	SPRING	RBH1290
	61	SPRING	RBH1292
	62	FWP SP (SPRING)	RBH1061
	63	SPRING	RBH1325
	64	SCREW (For AZIMUTH)	RBA1023
	65	SCREW	RBA1027
	66	SCREW	RBA1030
	67	SCREW	PCZ20P040FMC
	68	SCREW	RBA1093
	69	SCREW	RBA1094
	70	WASHER	RBF1046
	71	WASHER	WA26D047D013
	72	WASHER (*1 only)	WT13D030D025
	73	SCREW (*1 only)	RBA1118

Note) \*1: Mechanism Unit I  
\*2: Mechanism Unit II



2.6 GS POWER DOOR MECHANISM ASSY

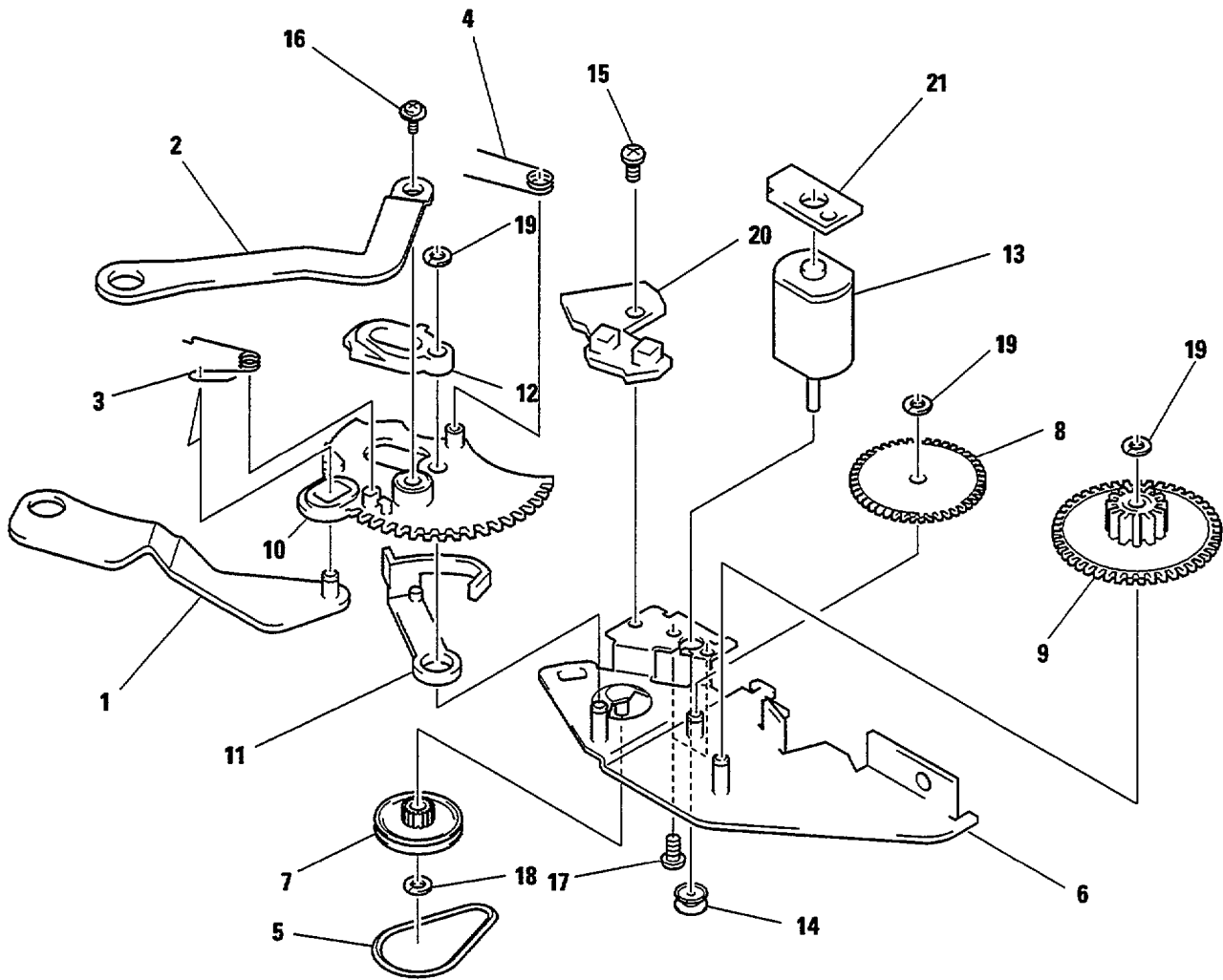

PARTS LIST

Mark No.	Description	Parts No.	Mark No.	Description	Parts No.
1	Link A	ANG7111			
2	Link B	ANG7115			
3	Door Spring	ABH7144			
4	Rack Spring	ABH7145			
5	Door Belt	AEB7067			
6	Base Plate	ANB7081			
7	Gear Pulley	ANW7103			
8	Gear B	ANW7104			
9	Gear A	ANW7105			
10	Drive Gear	ANW7115			
11	SW Lever	ANW7107			
12	Push Plate	ANW7108			
13	Motor	AXM7010	NSP		
14	Motor Pulley	PNW1634			
15	Screw	BBZ20P060FMC			
16	Screw	IPZ20P080FMC			
17	Screw	PMA20P030FMC			
18	Washer	WT26D060D025			
19	Washer	WT36D072D025			
20	Door SW Assy	AWZ8689	NSP		
21	Motor Assy	AWZ8687	NSP		



**NOTE: When ordering service parts, be sure to refer to "PARTS LIST of EXPLODED VIEWS" or "PCB PARTS LIST".**

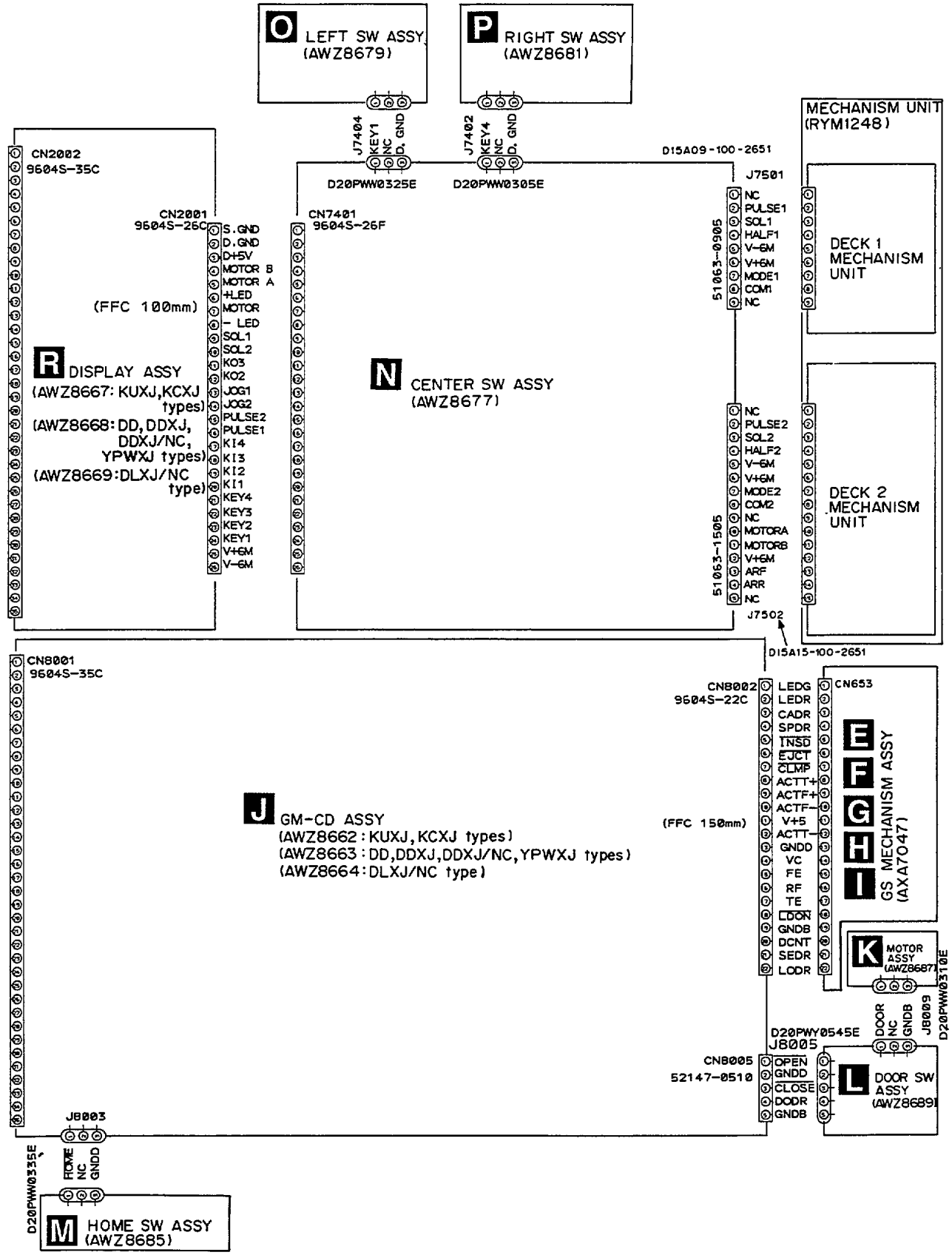









# XR-P670F

## 3.4 AF ASSY (2/2)

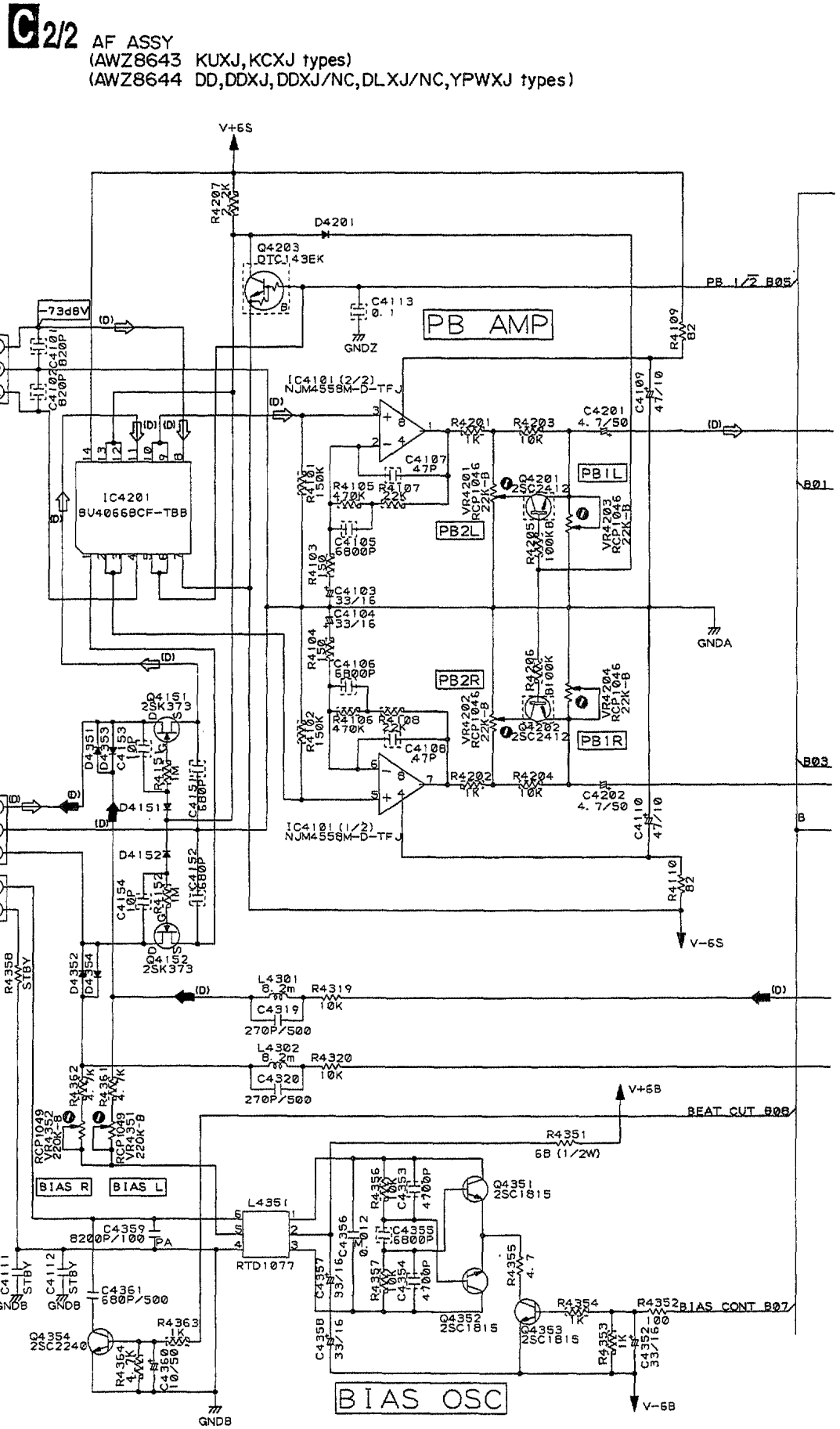

If the parts are not identified, the followings are used.

★ 155254-T



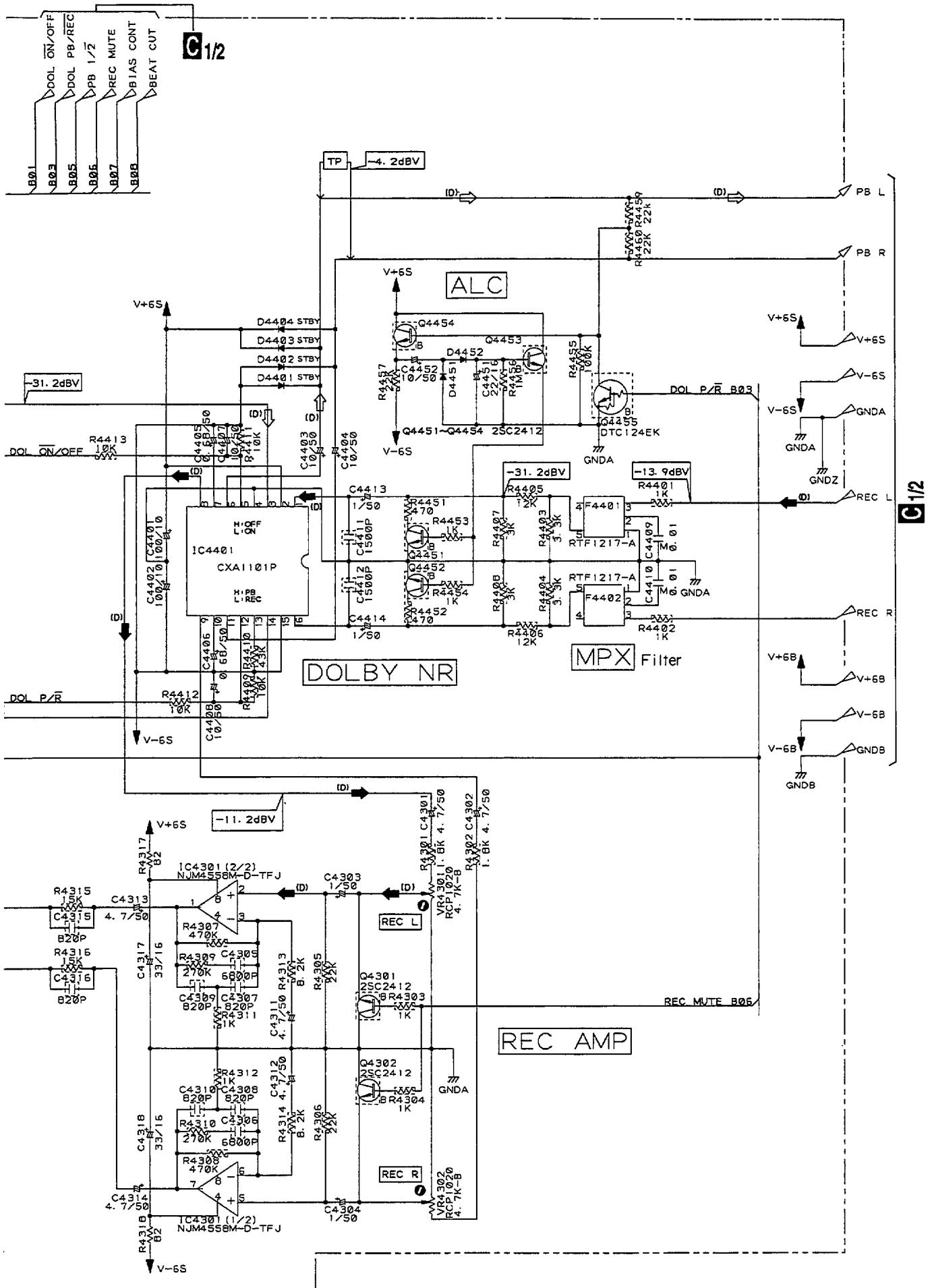

## 3.5 GS MECHANISM ASSY

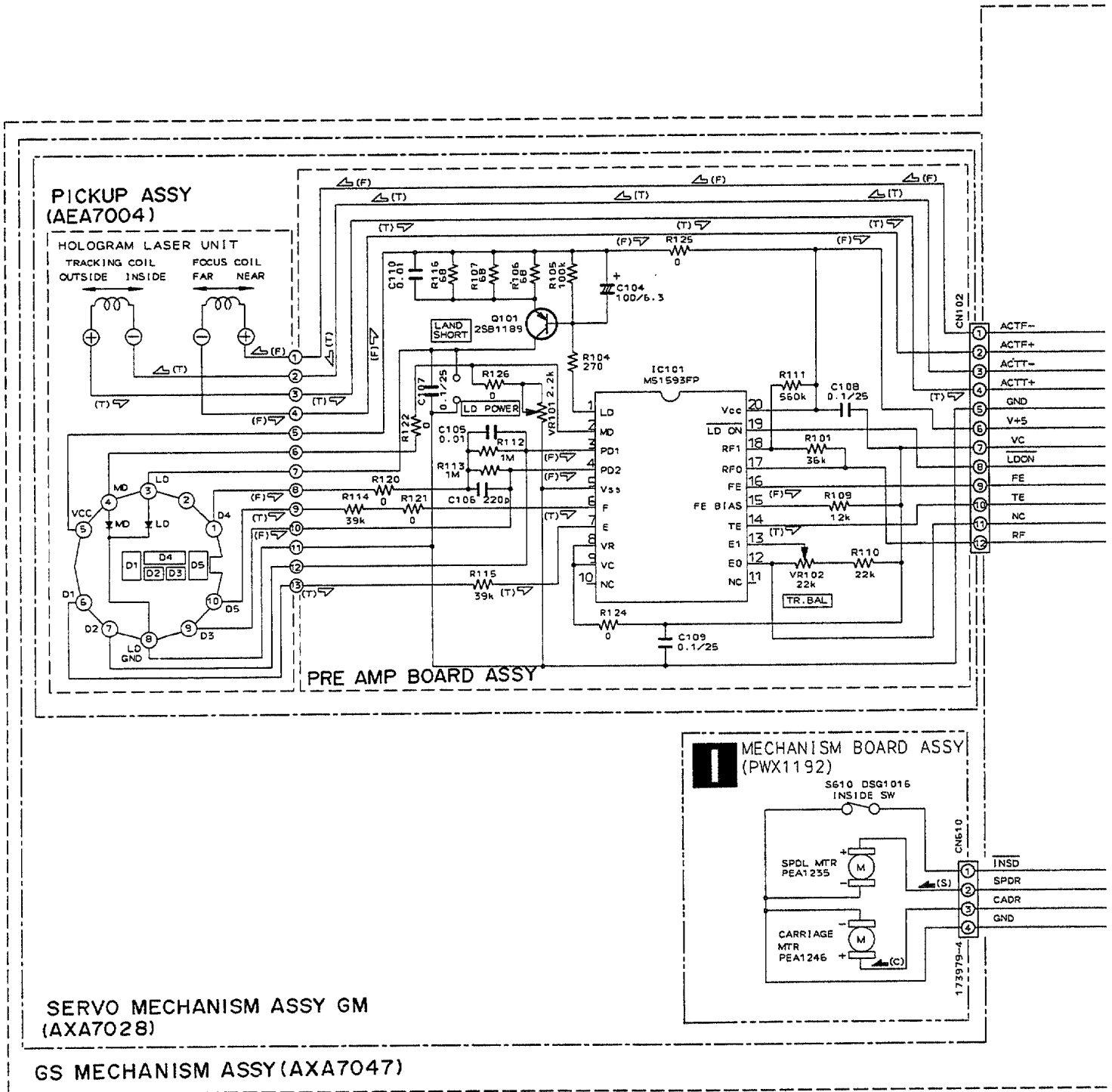

### SIGNAL ROUTE

- (F) . FOCUS SERVO LOOP LINE
- (T) . TRACKING SERVO LOOP LINE
- (L) . LOADING MOTOR ROUTE
- (S) . SPINDLE MOTOR ROUTE
- (C) . CARRIAGE MOTOR ROUTE



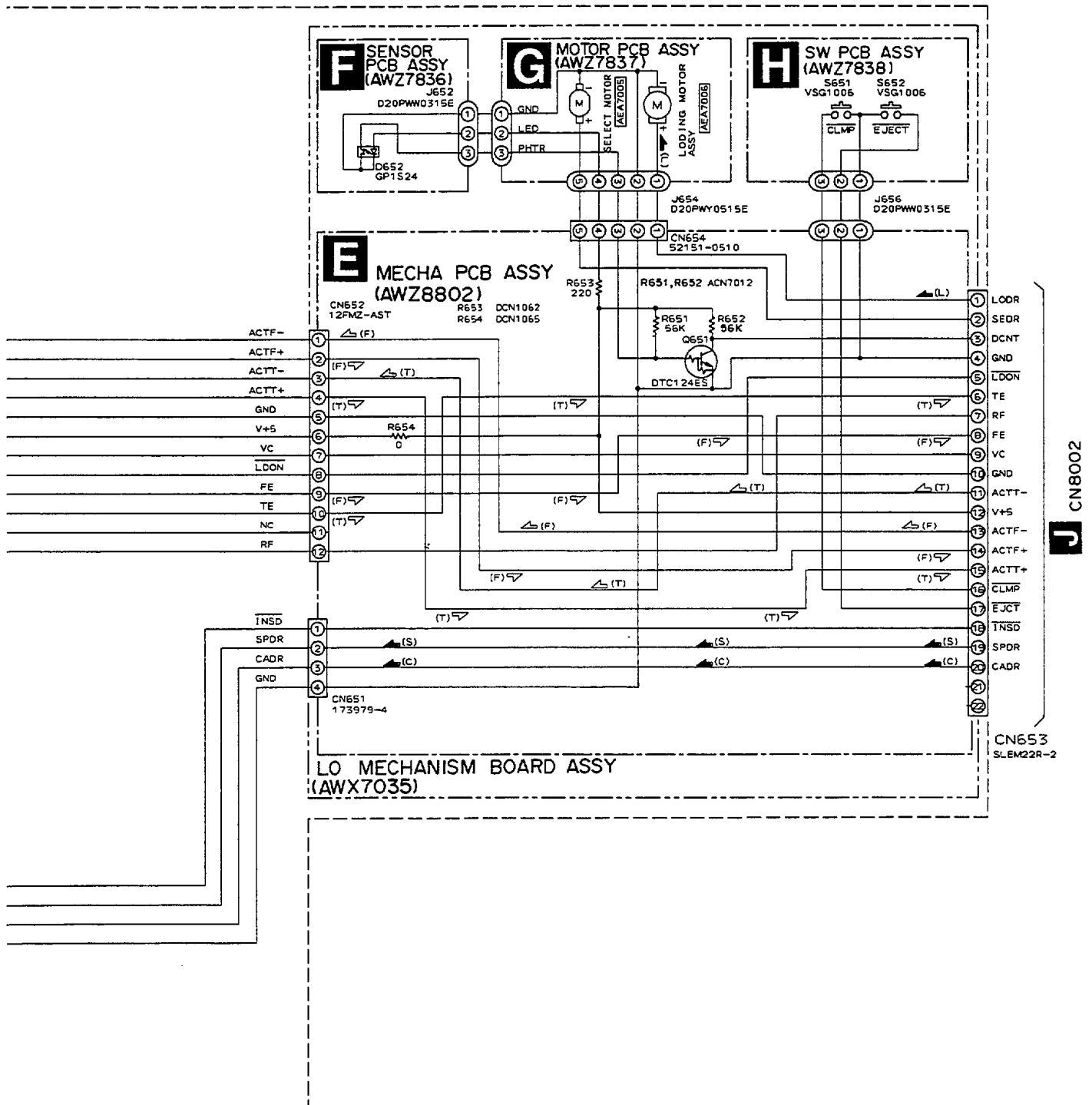

# XR-P670F

## 3.6 GM-CD ASSY, MOTOR ASSY, DOOR SW ASSY AND HOME SW ASSY

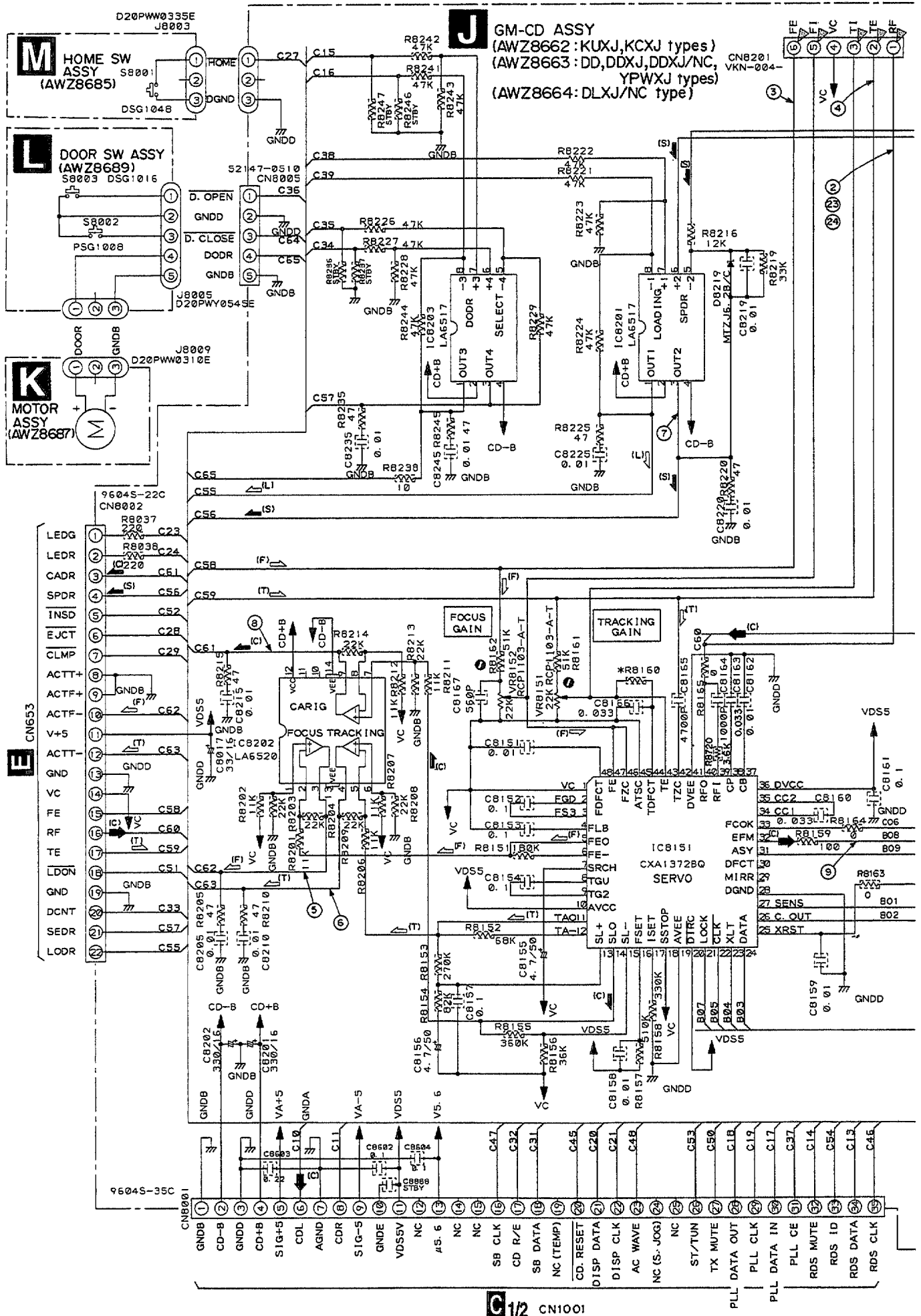

G1/2 CN1001



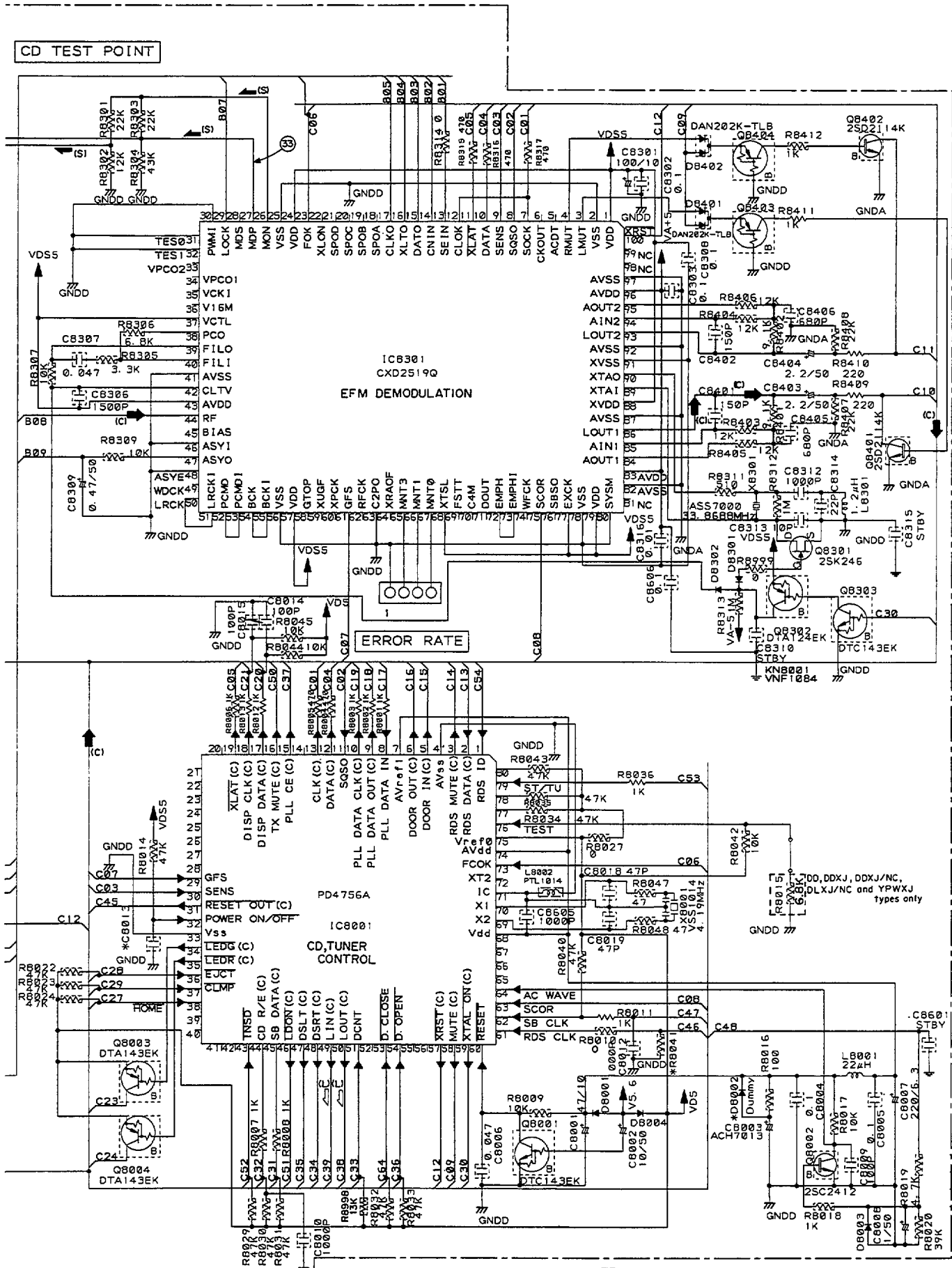

- SIGNAL ROUTE**
- (C) : CD AUDIO SIGNAL
  - (F) : FOCUS SERVO LOOP LINE
  - (T) : TRACKING SERVO LOOP LINE
  - (L) : LOADING MOTOR ROUTE
  - (S) : SPINDLE MOTOR ROUTE
  - (G) : CARRIAGE MOTOR ROUTE

If the parts are not identified, the following are used.  
 \* ISS254-T

# XR-P670F

## WAVEFORMS

Note : The encircled numbers denote measuring points in the schematic diagram.

\*1 FOCUS-IN : Press the key without loading a disc.

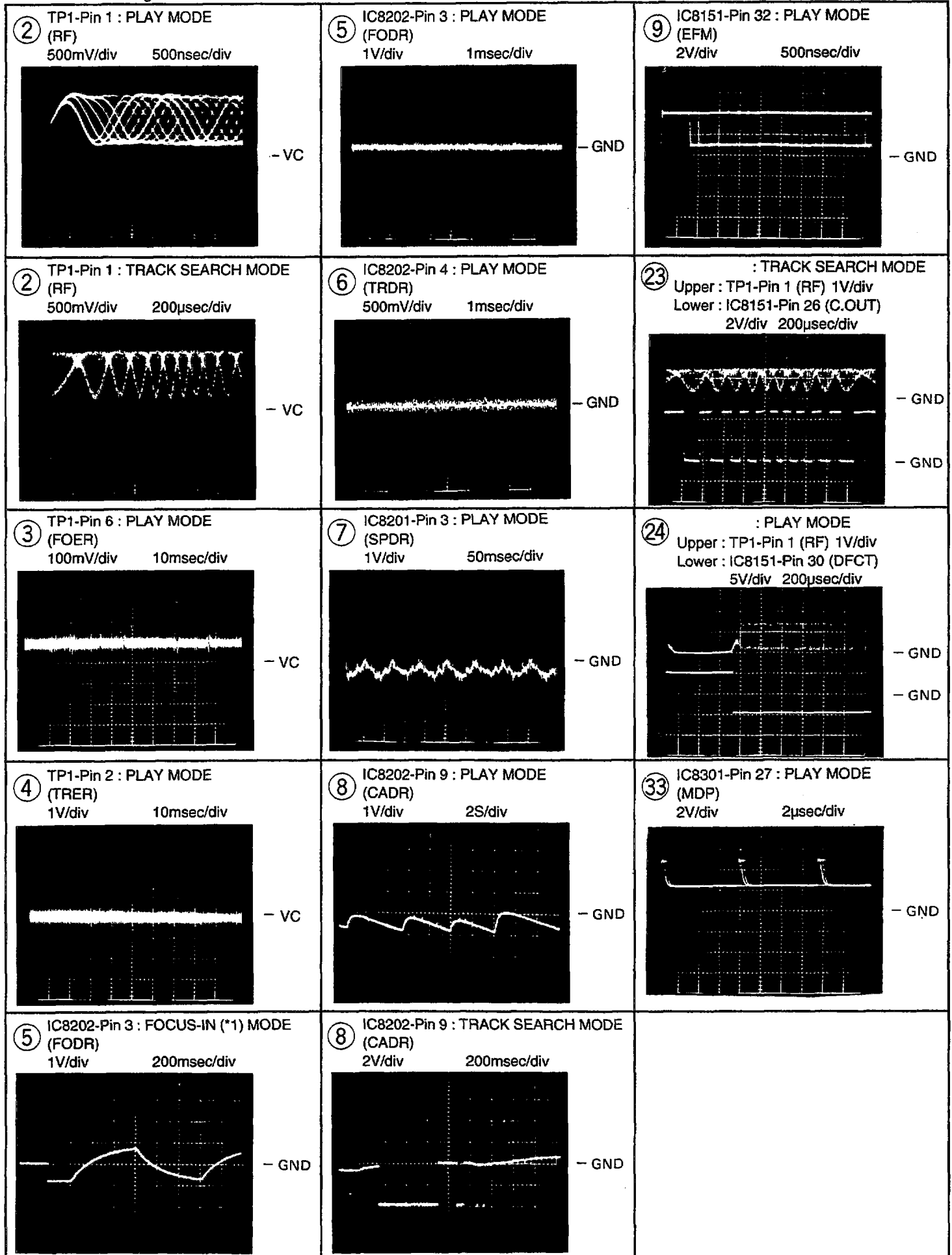



# XR-P670F

## 3.7 CENTER SW ASSY, LEFT SW ASSY, RIGHT SW ASSY AND MIC & HP ASSY

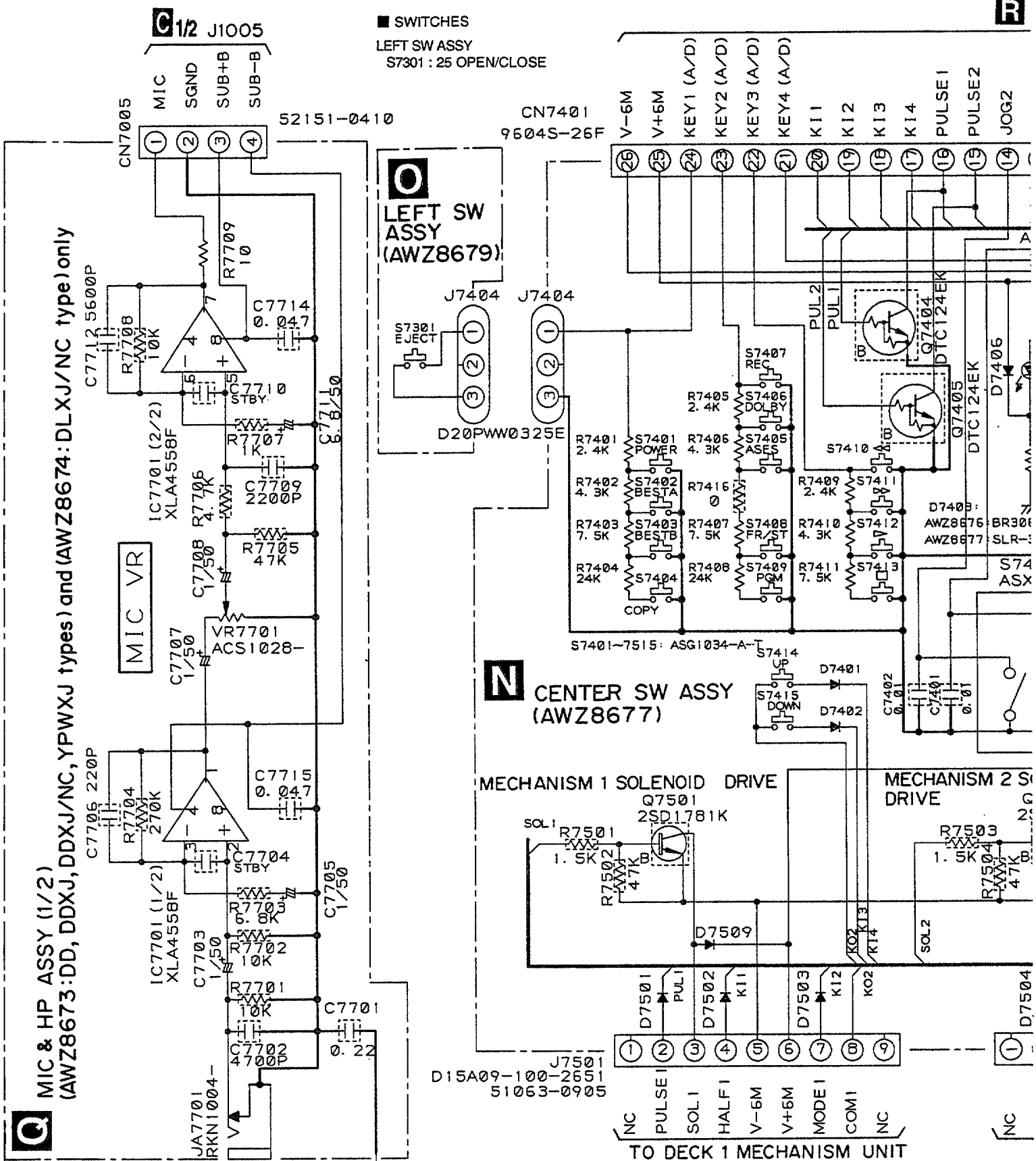



**R** CN2001

If the parts are not identified, the followings are used.

↑ 155254-T

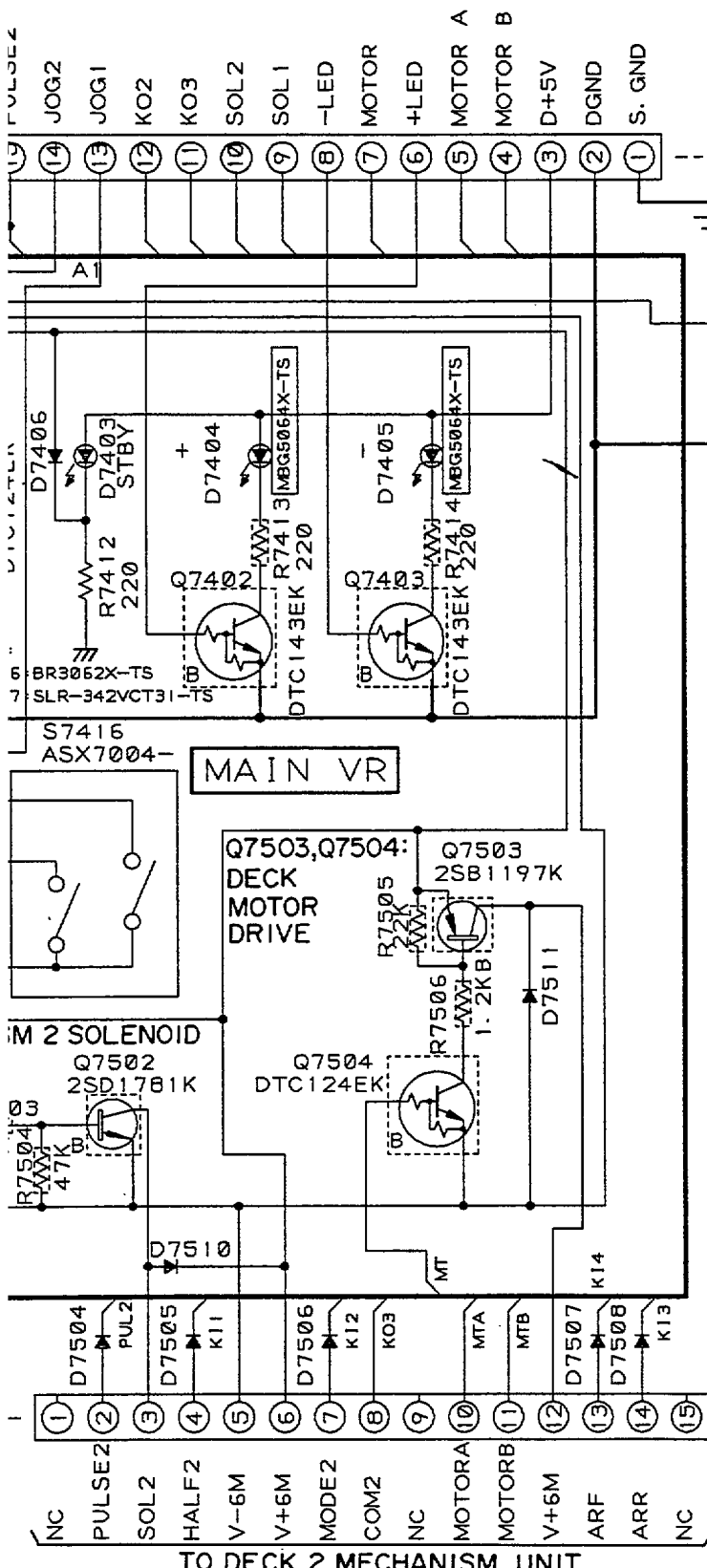

D15A15-100-2651

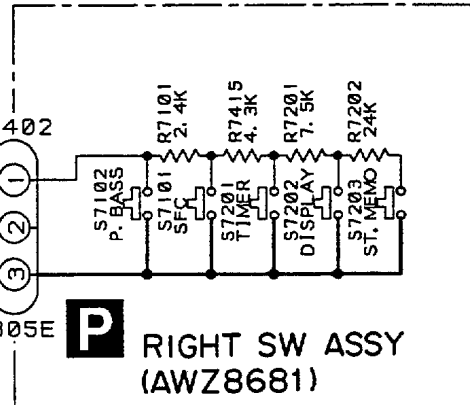

- SWITCHES**
- RIGHT SW ASSY
- S7101: SFC/KARAOKE
  - S7102: P.BASS(DEMO)
  - S7201: TIMER REC/WAKE-UP
  - S7202: DISPLAY CLOCK ADJ
  - S7203: STATION MEMORY

**HEADPHONE**

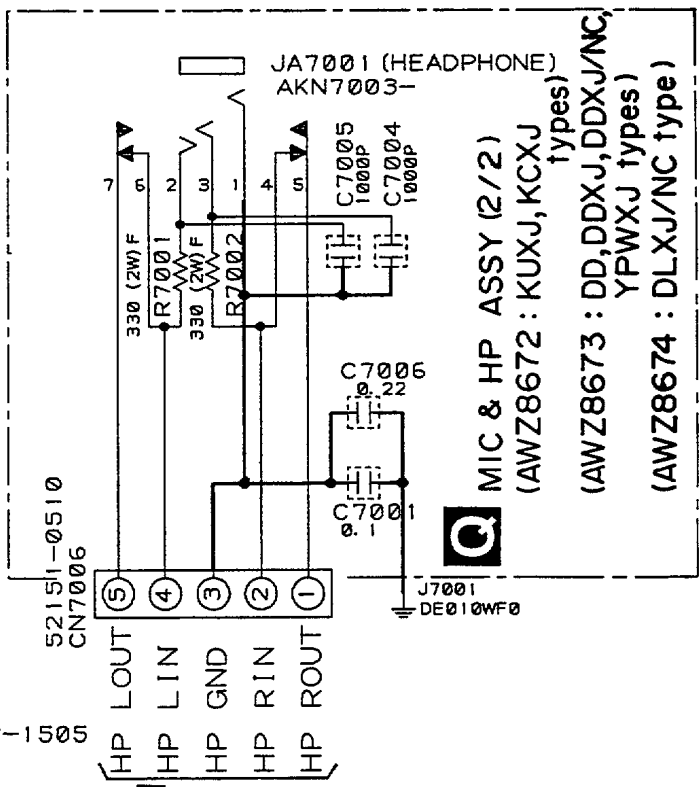

- MIC & HP ASSY (2/2)**
- (AWZ8672: KUXJ, KCXJ types)
  - (AWZ8673: DD, DDXJ, DDXJ/NC, YPWXJ types)
  - (AWZ8674: DLXJ/NC type)

**G12** J1006

3.8 DISPLAY ASSY

**R** DISPLAY ASSY  
 (AWZ8667 : KUXJ, KCXJ types)  
 (AWZ8668 : DD, DDXJ, DDXJ/NC, YPWXJ types)  
 (AWZ8669 : DLXJ/NC type)

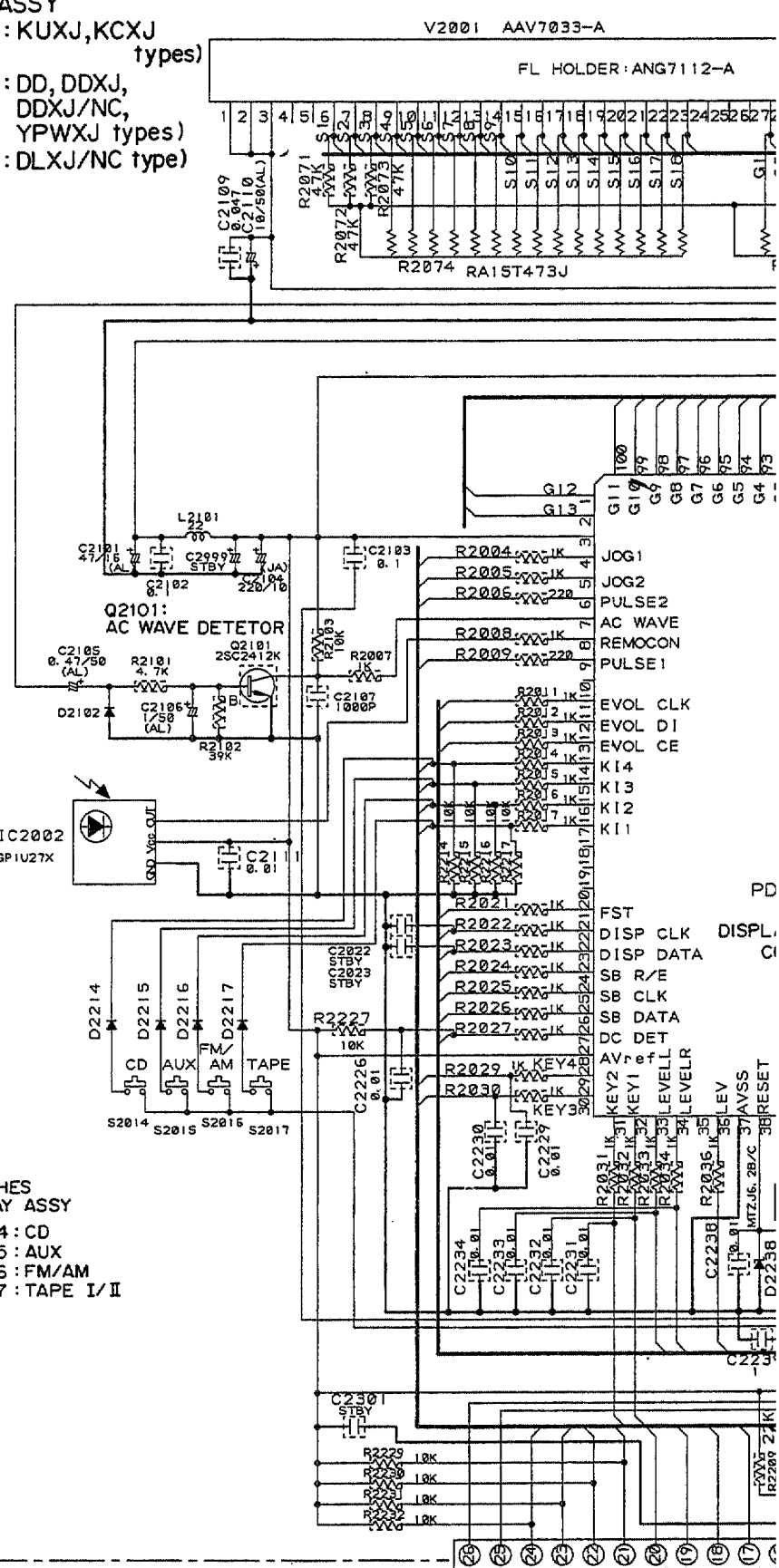

- SWITCHES  
 DISPLAY ASSY
- S2014 : CD
- S2015 : AUX
- S2016 : FM/AM
- S2017 : TAPE I/II

If the parts are not identified, the followings are used.

1S254-T



# XR-P670F

## 3.9 POWER SUPPLY ASSY, SECONDARY ASSY AND PRIMARY ASSY

If the parts are not identified, the followings are used.

★ ISS254-T

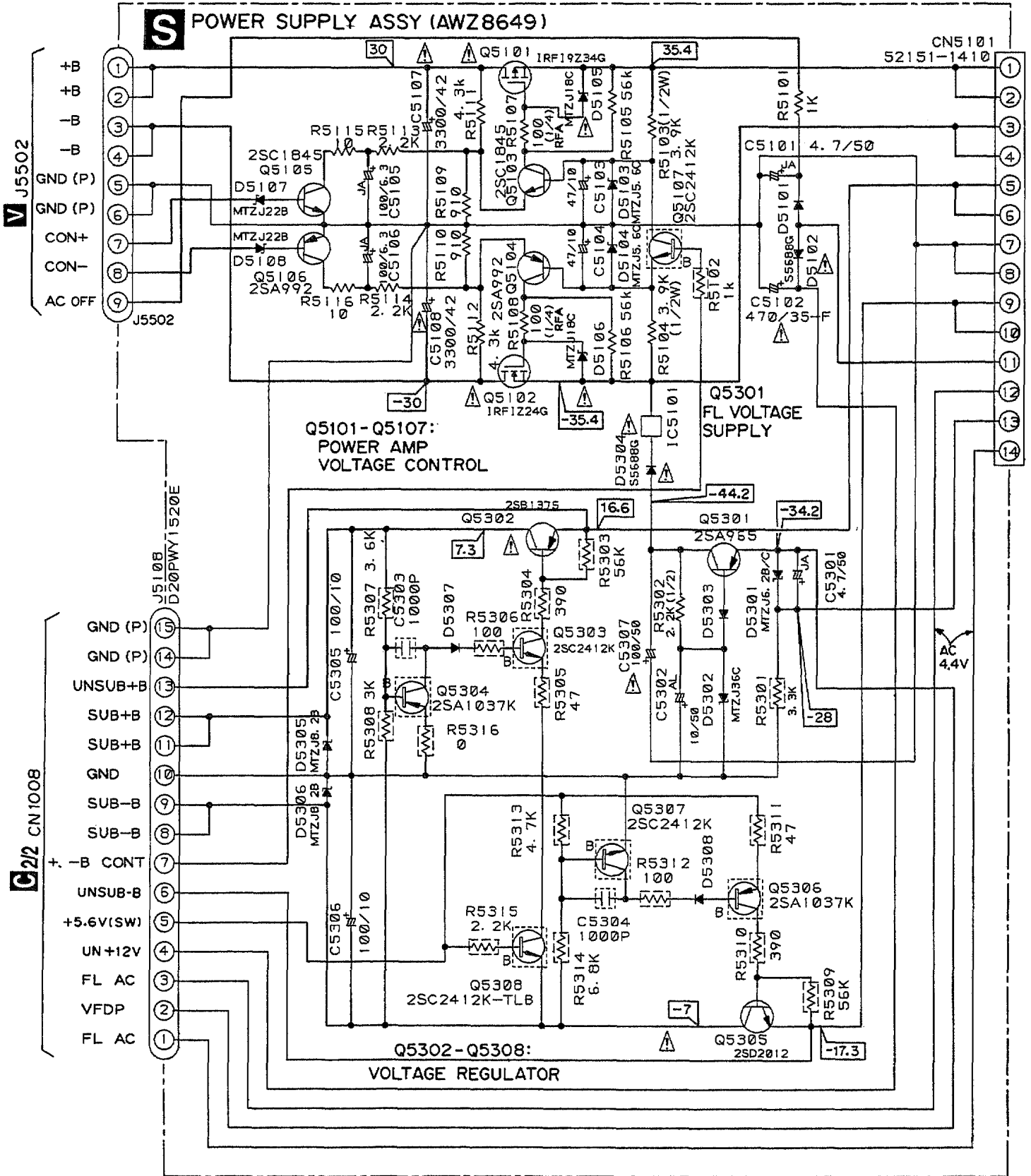

CAUTION : FOR CONTINUED PROTECTION AGAINST RISK OF FIRE, REPLACE WITH SAME TYPE No. 49103.5, 49102.5 MFD. BY LITTELFUSE INK FOR IC5001 - IC5003, IC5006 AND IC5007

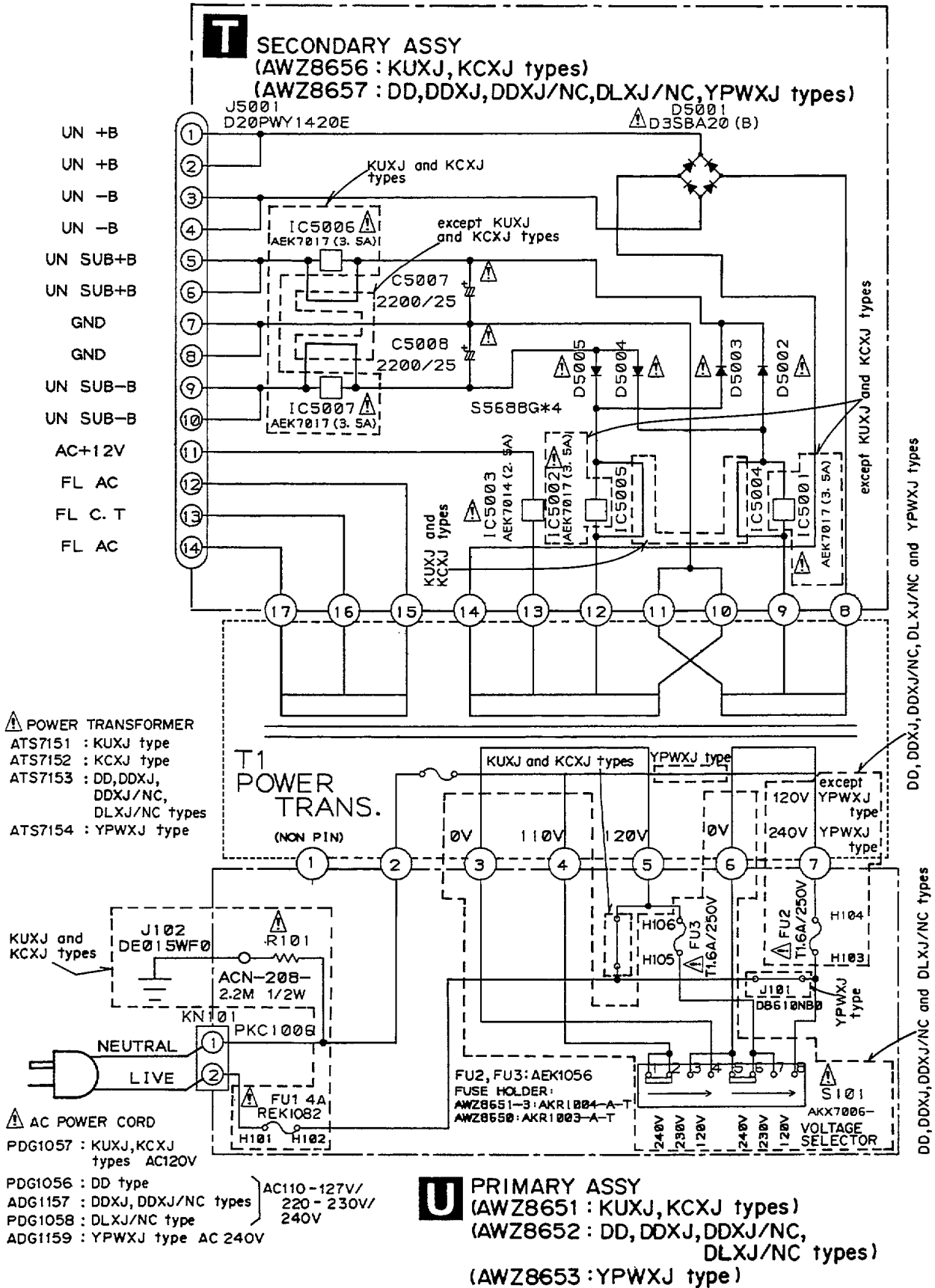

3.10 AMP ASSY

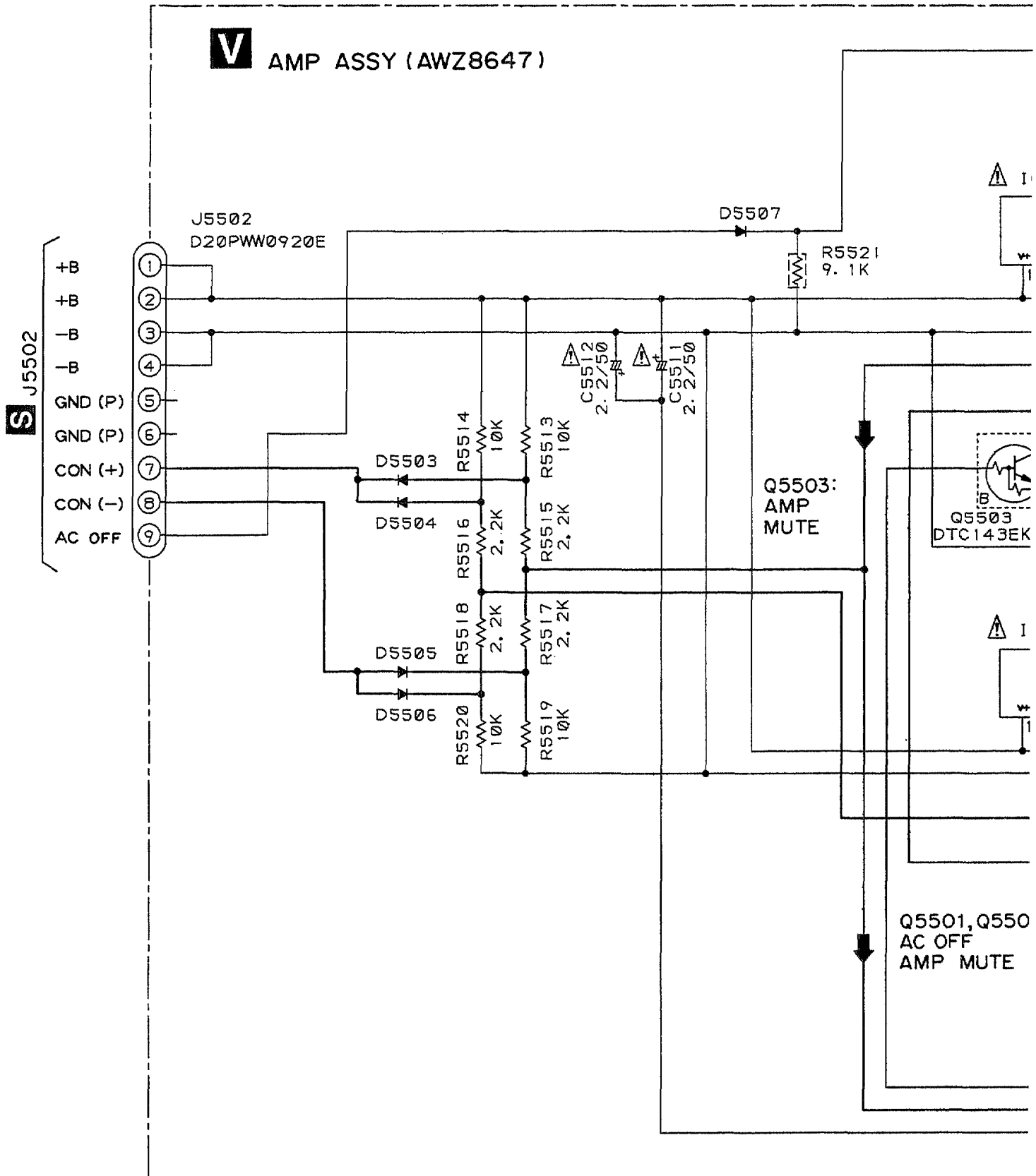

SIGNAL ROUTE  
 ➡ : AUDIO SIGNAL

If the parts are not identified the followings are used.

✦ 1SS254-T



CAUTION : FOR CONTINUED PROTECTION AGAINST RISK OF FIRE, REPLACE WITH SAME TYPE No. 491.400, 493.15 MFD. BY LITTELFUSE INK FOR IC5503 AND IC5504

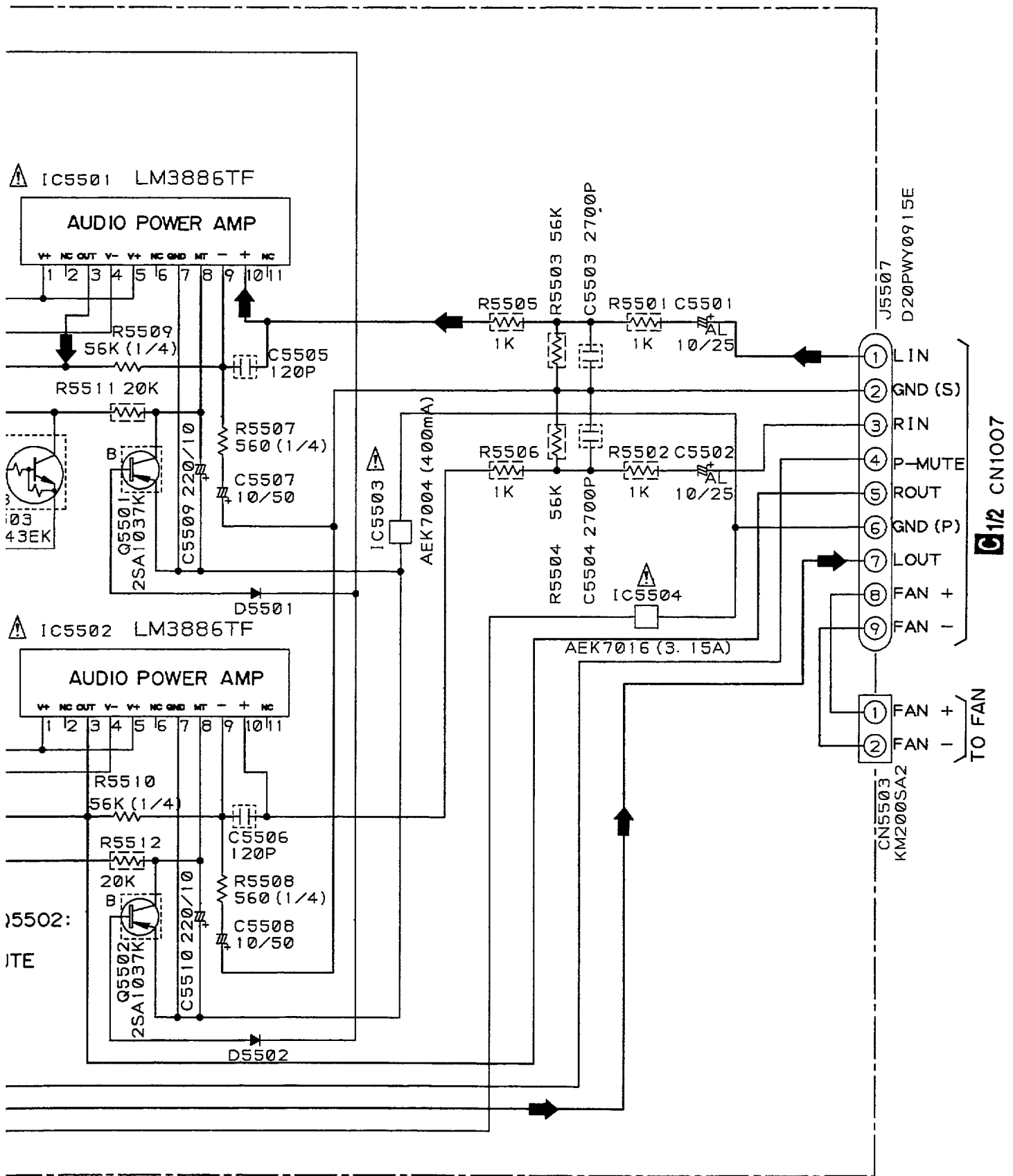

ntified.



# 4. PCB CONNECTION DIAGRAM

## 4.1 FM/AM TUNER MODULE

• AXQ7061 (except DD type)

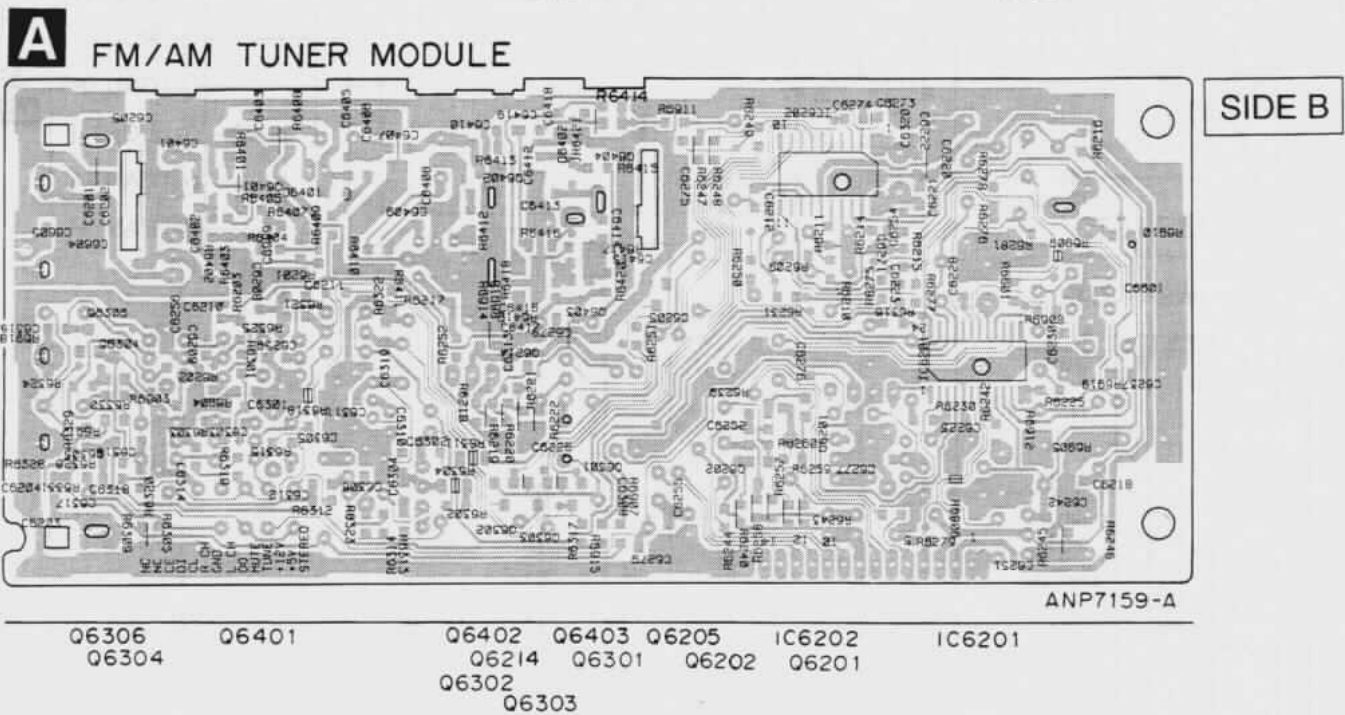
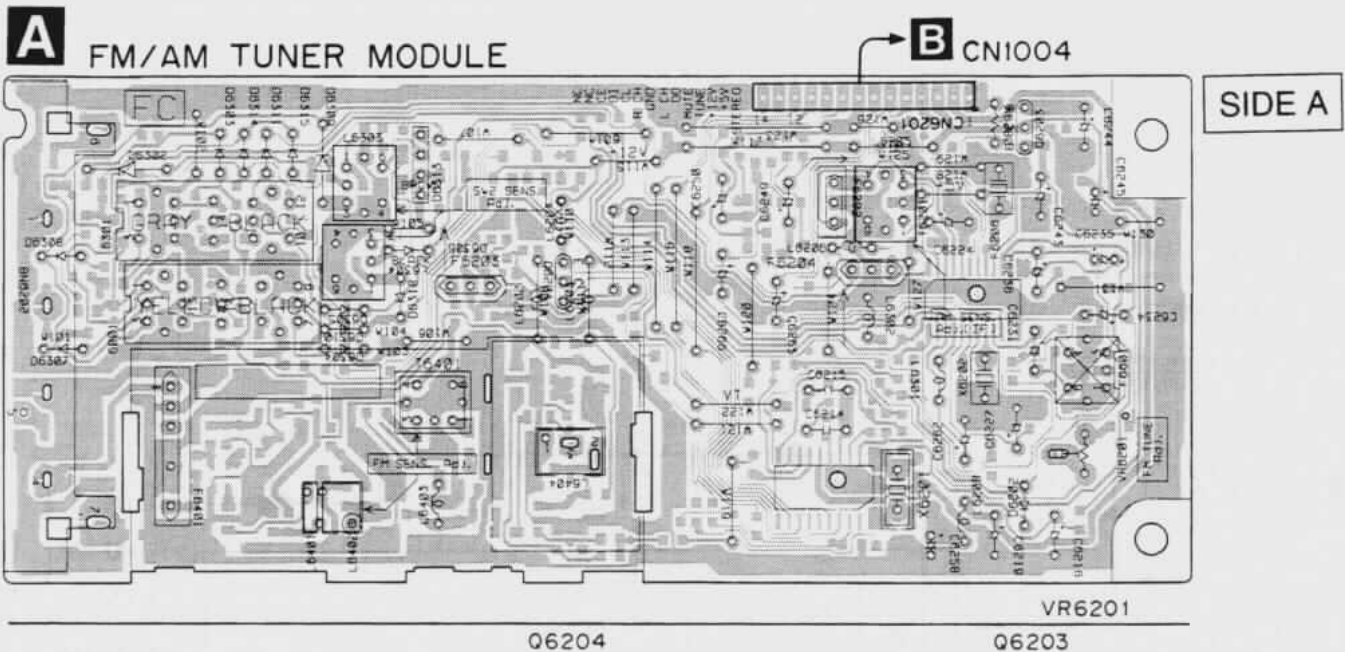

**NOTE FOR PCB DIAGRAMS:**

1. Part numbers in PCB diagrams match those in the schematic diagrams.
2. A comparison between the main parts of PCB and schematic diagrams is shown below.

Symbol in PCB Diagrams	Symbol in Schematic Diagrams	Part Name
		Transistor
		Transistor with resistor
		Field effect transistor

		Resistor array
		3-terminal regulator

3. The parts mounted on this PCB include all necessary parts for several destinations. For further information for respective destinations, be sure to check with the schematic diagram.



• AXQ7051 (for DD type)

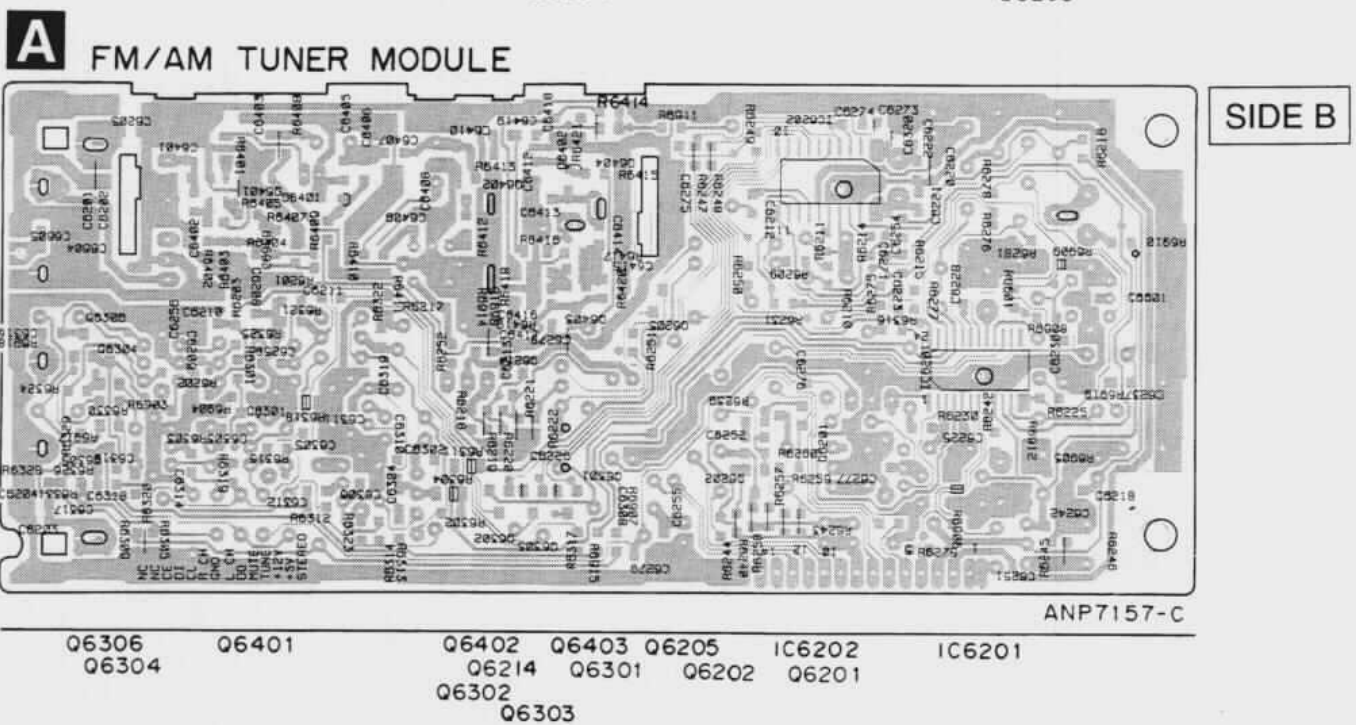
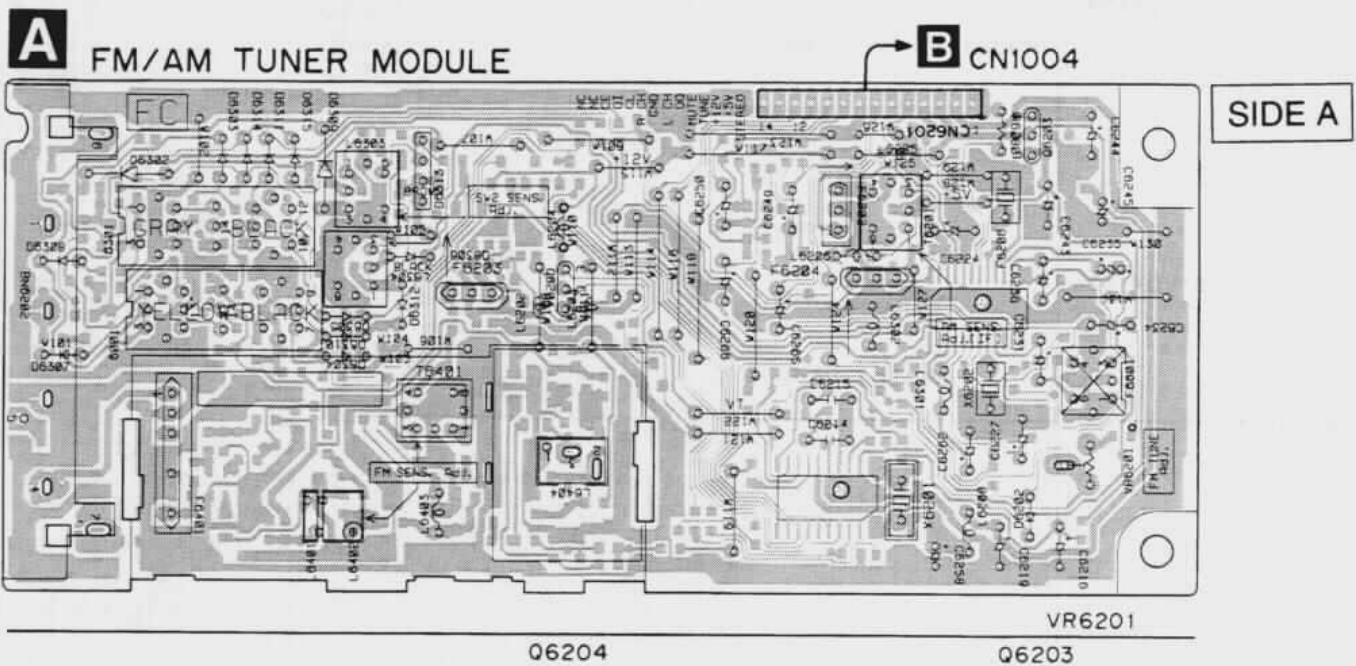

4. Viewpoint of PCB diagrams

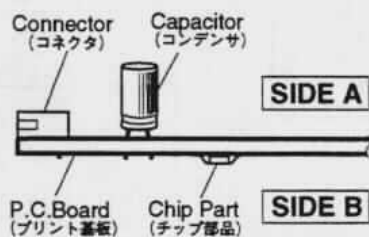

# XR-P670F

## 4.2 AF ASSY

## C AF ASSY

Q4351 Q4352

Q4353

Q4354

VR4301 VR4351 VR4352

VR4302

VR3501

Q4151 Q4152

IC4401

VR4203 VR4201

VR4204 VR4202

**J** CN8001 ←

Q1004

Q1003

Q1012

Q1013

Q1011

IC1008

**V** J5507 ←

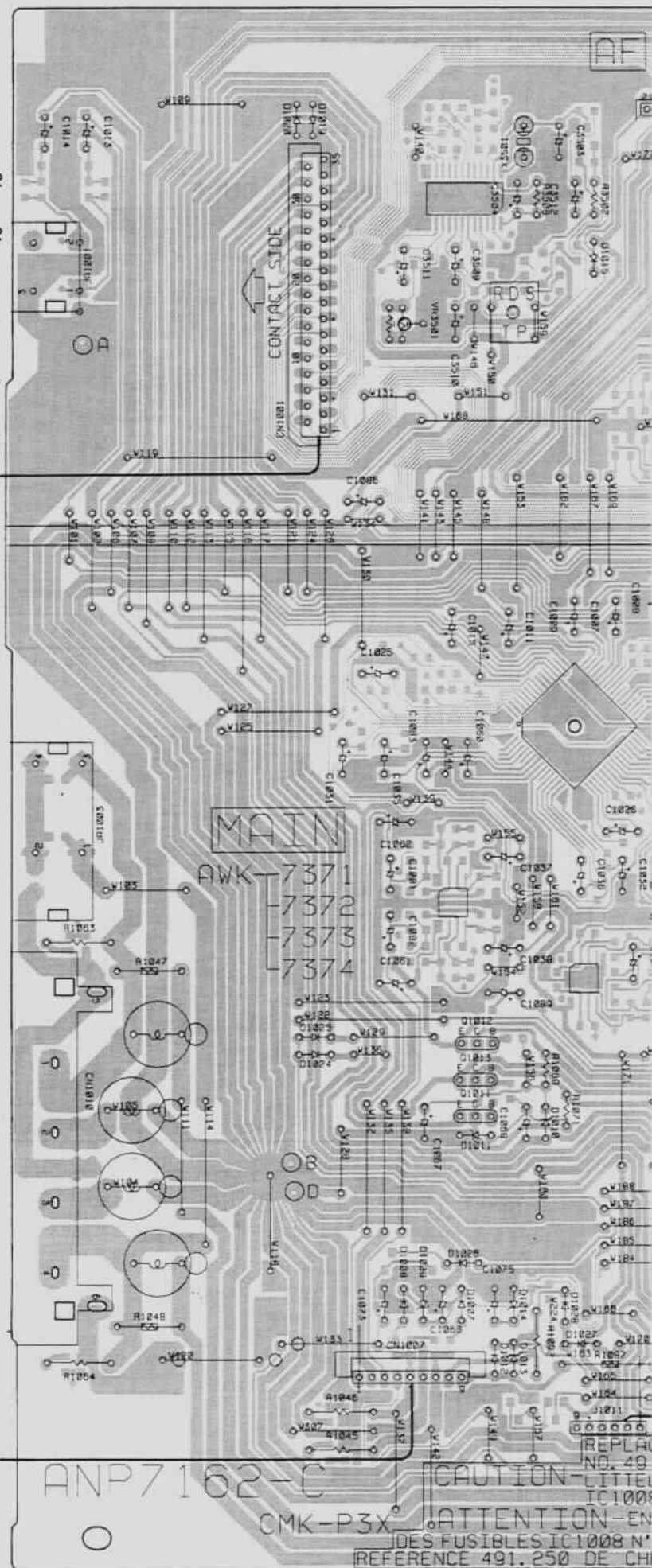



**C** AF ASSY

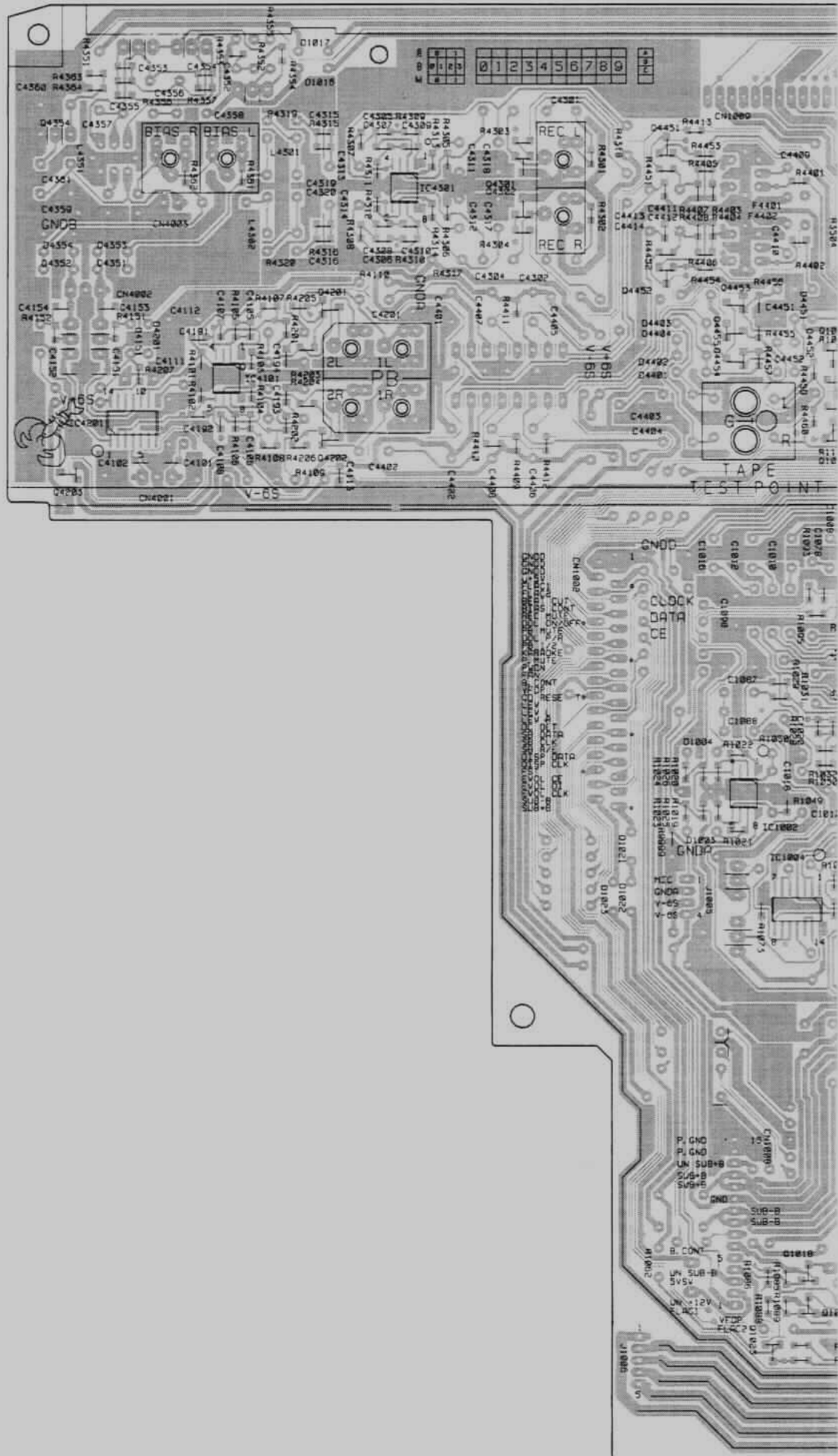

SIDE B

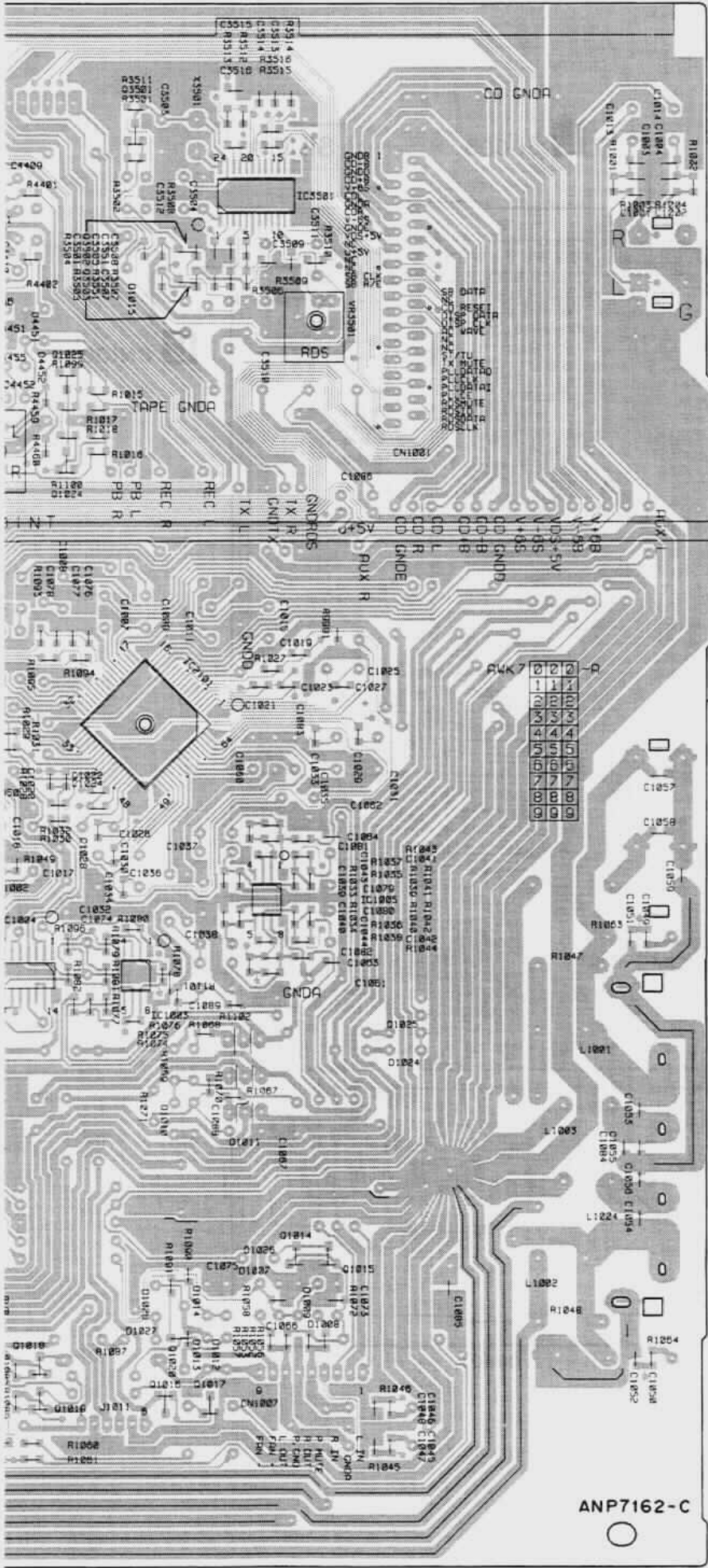

- Q3501
- Q4451
- Q4301 IC3501
- Q4302 IC4301
- Q3502
- Q4452 Q3503
- Q4453
- Q4455 Q1025
- Q4454
- IC4101
- IC4201
- Q1024
  
- IC2101
  
- IC1002
- IC1005
- IC1004
- IC1003
  
- Q1014 Q1015
  
- Q1020
- Q1018
- Q1019 Q1016 Q1017
  
- Q1023

ANP7162-C

4.3 GM-CD ASSY

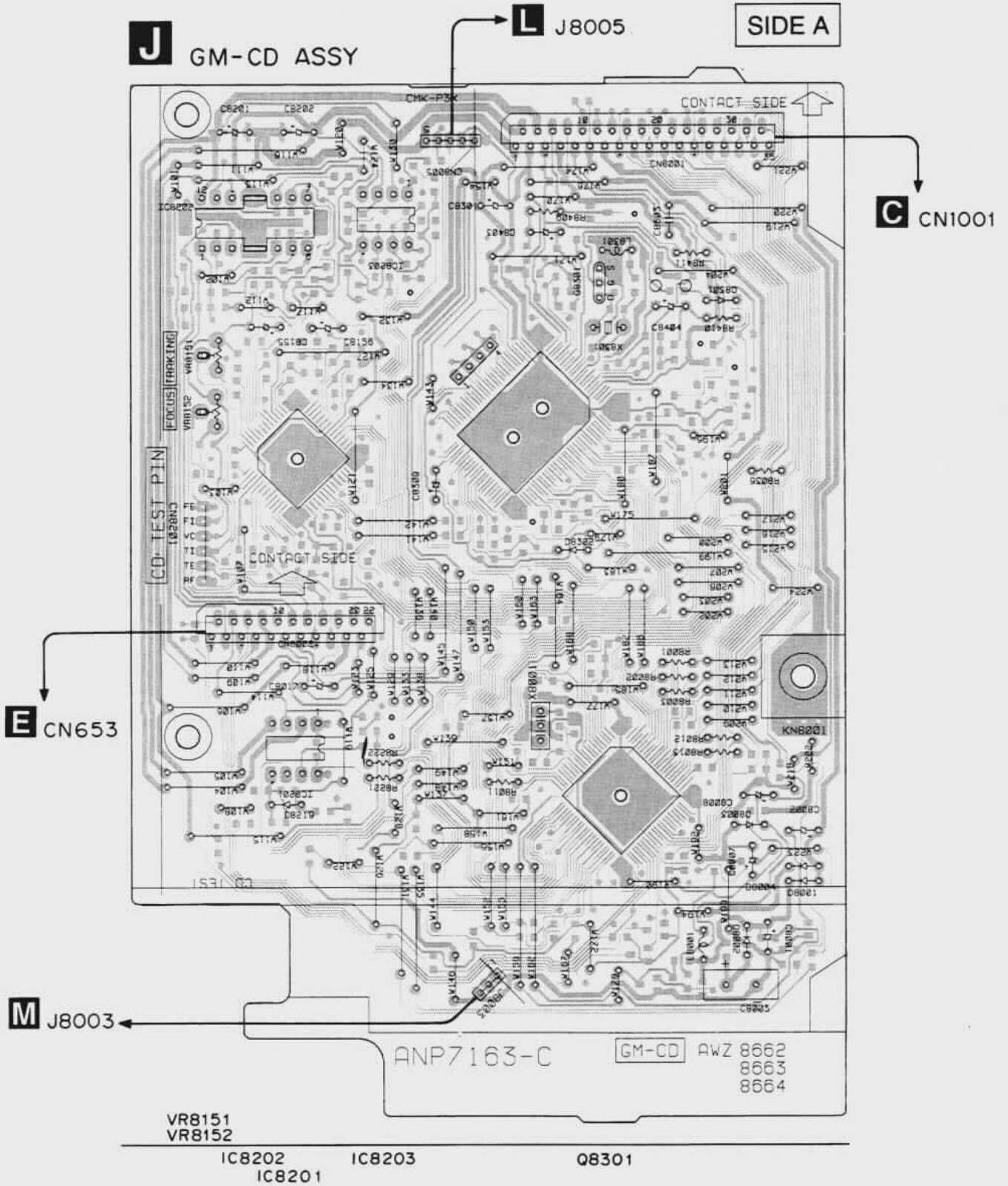

**J** GM-CD ASSY

**SIDE B**

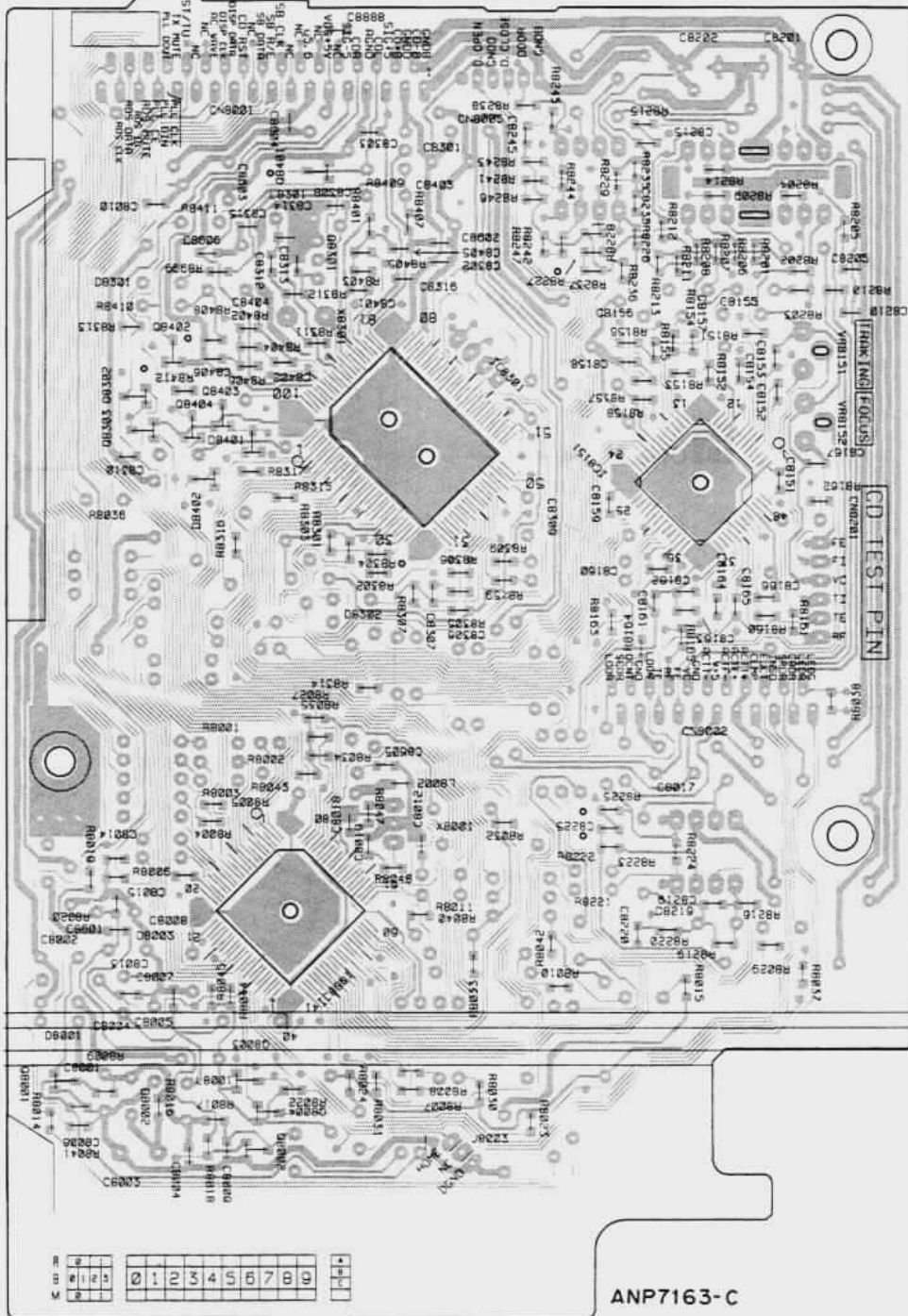

- Q8001 Q8402 Q8401 IC8301 IC8151
- Q8302 Q8403 IC8001
- Q8303 Q8404
- Q8003
- Q8004
- Q8002





**N** CENTER SW ASSY

SIDE B

- Q7402
- Q7504
- Q7503
- Q7502
- Q7405
- Q7403
- Q7501
- Q7404

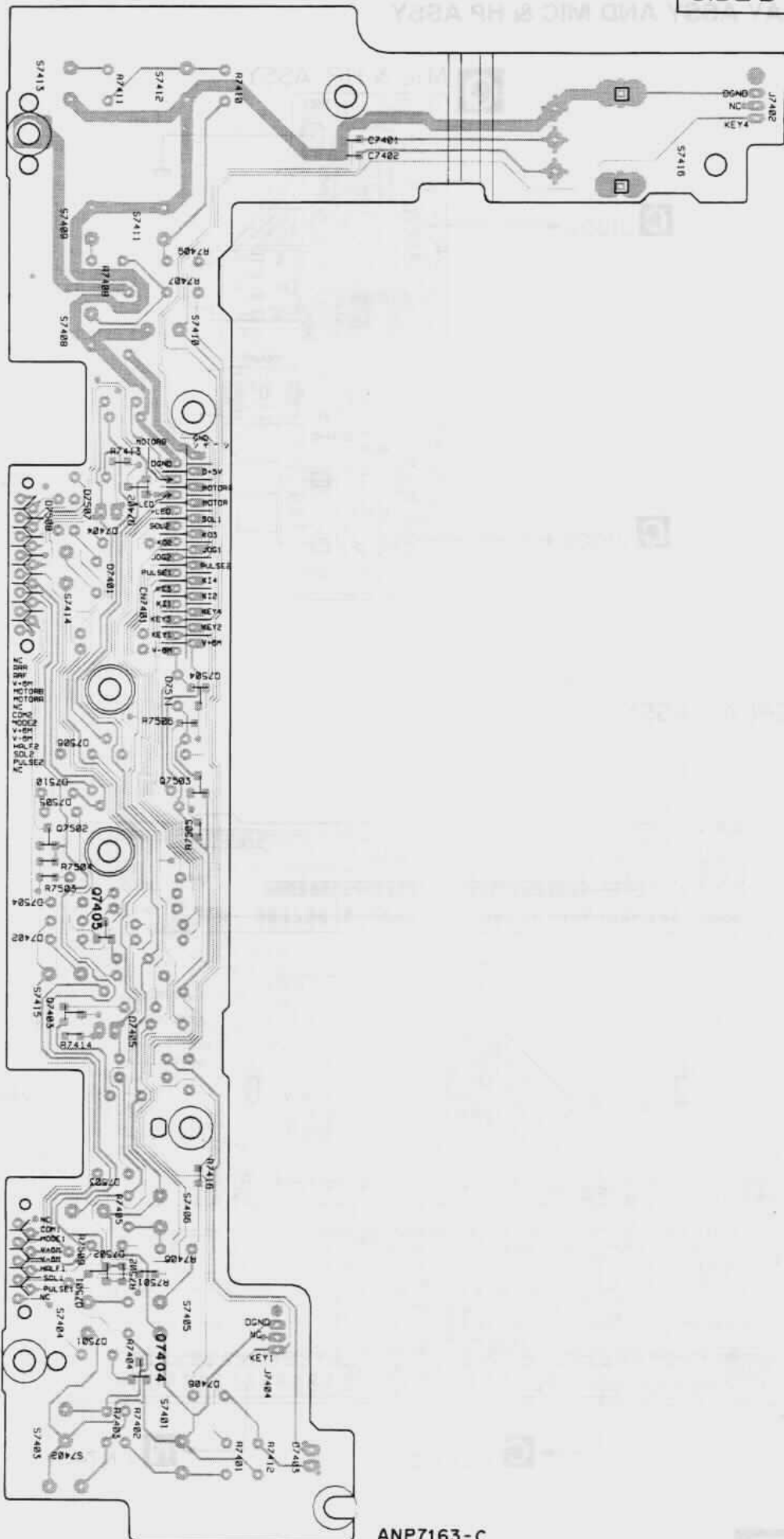

ANP7163-C







# XR-P670F

## 4.6 TX CONNECT ASSY, POWER SUPPLY AND AMP ASSY

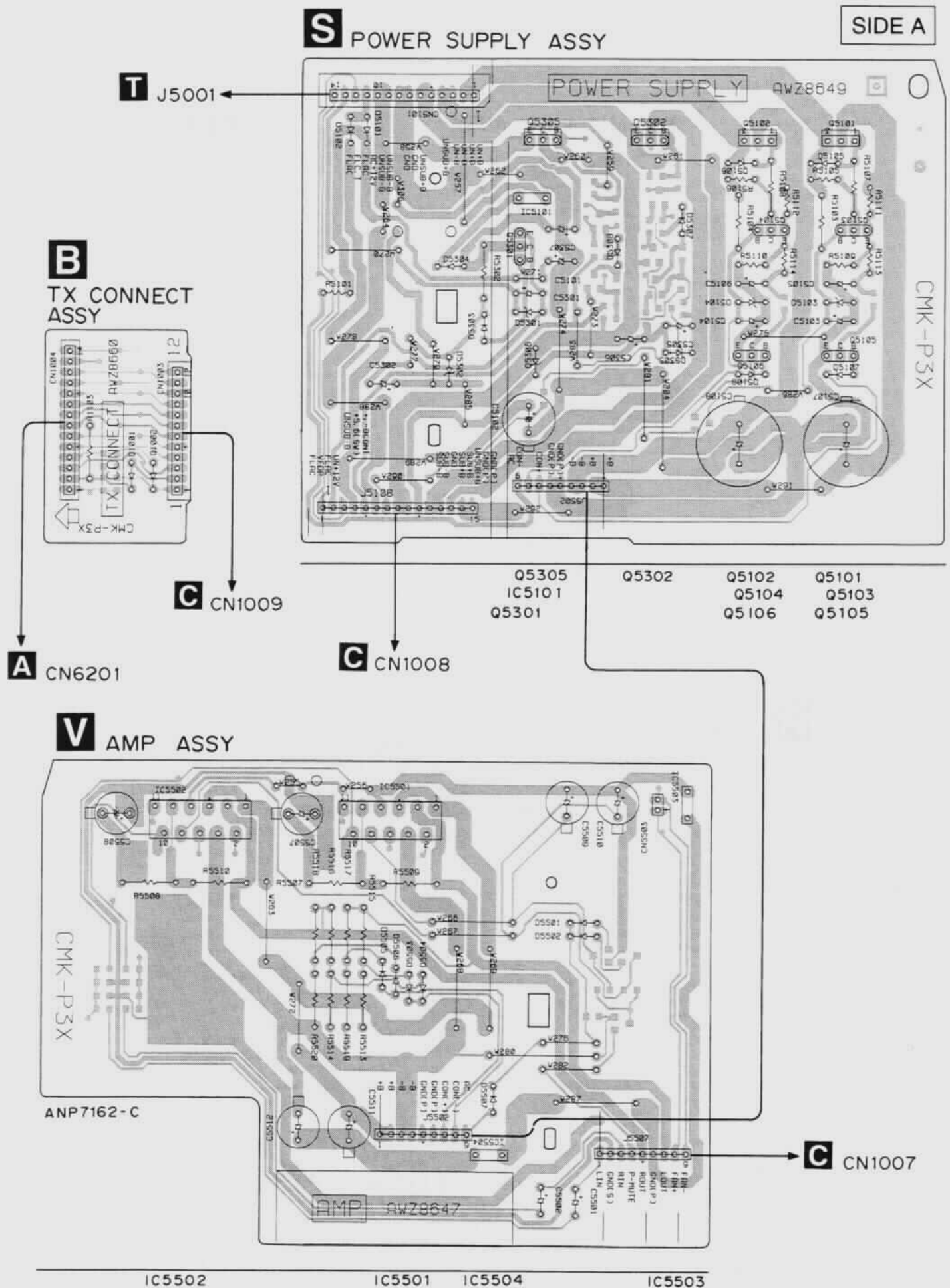



# XR-P670F

## 4.7 GS MECHANISM ASSY, MOTOR ASSY, DOOR SW ASSY AND HOME SW ASSY

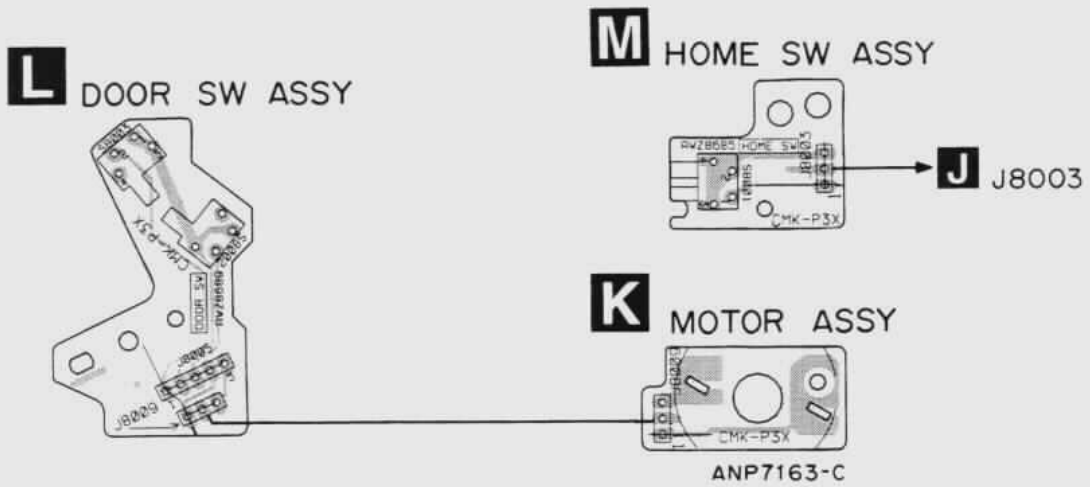
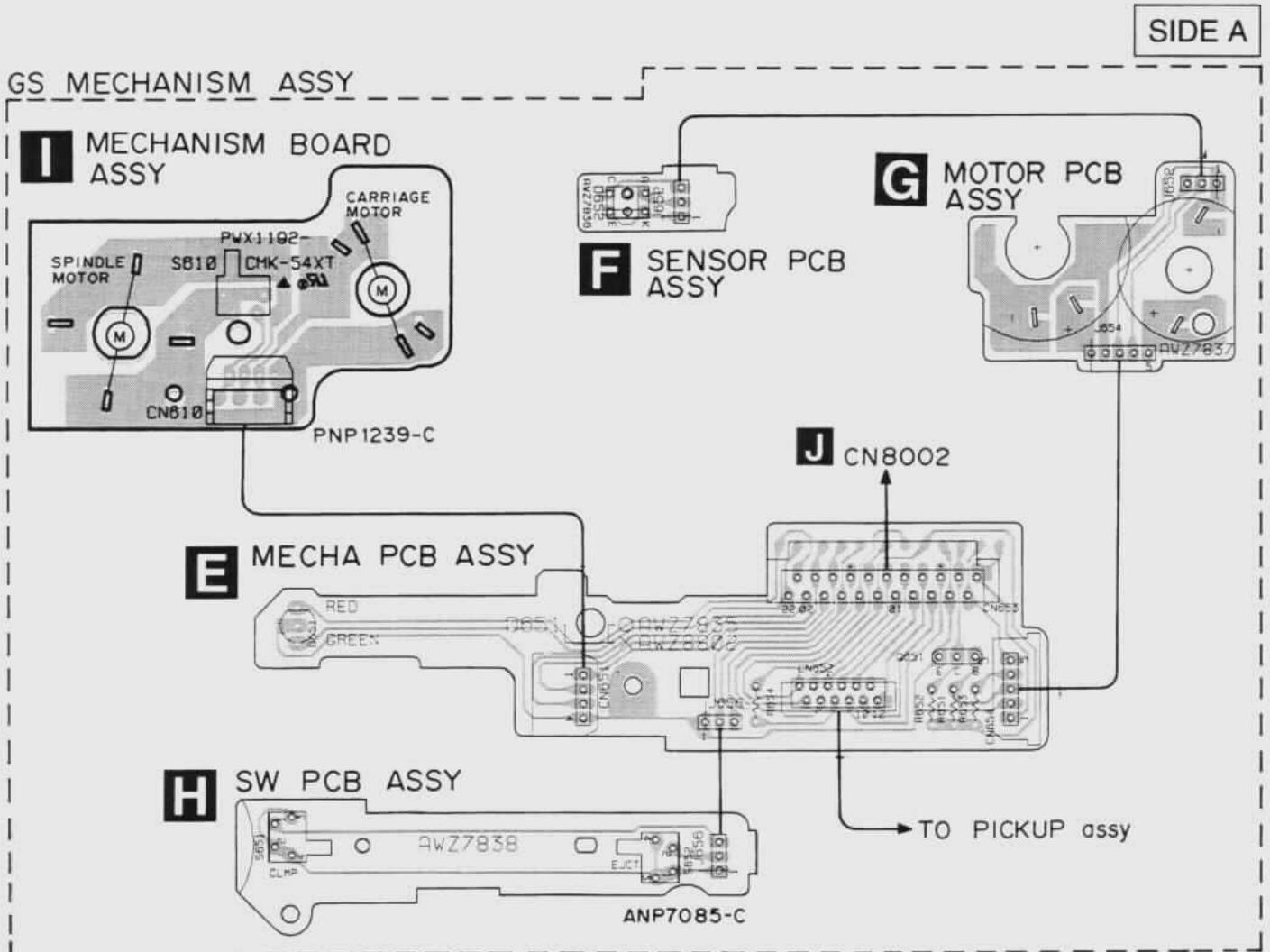

4.8 REGULATOR ASSY, SECONDARY ASSY, PRIMARY ASSY, LEFT SW ASSY AND RIGHT SW ASSY

**O** LEFT SW ASSY

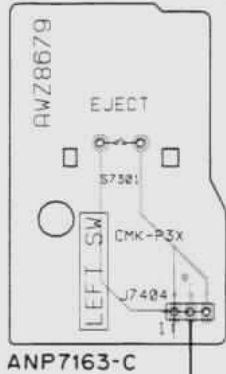

**N** J7404

**D** REGULATOR ASSY

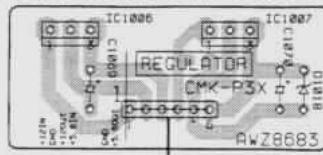

**C** J1011

**P** RIGHT SW ASSY

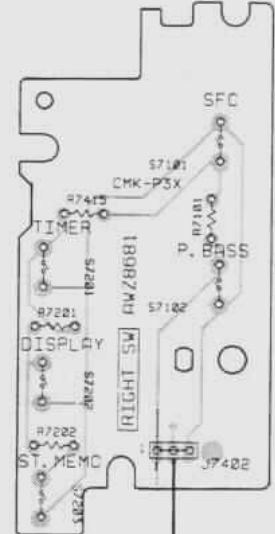

**N** J7402

SIDE A

**T** SECONDARY ASSY

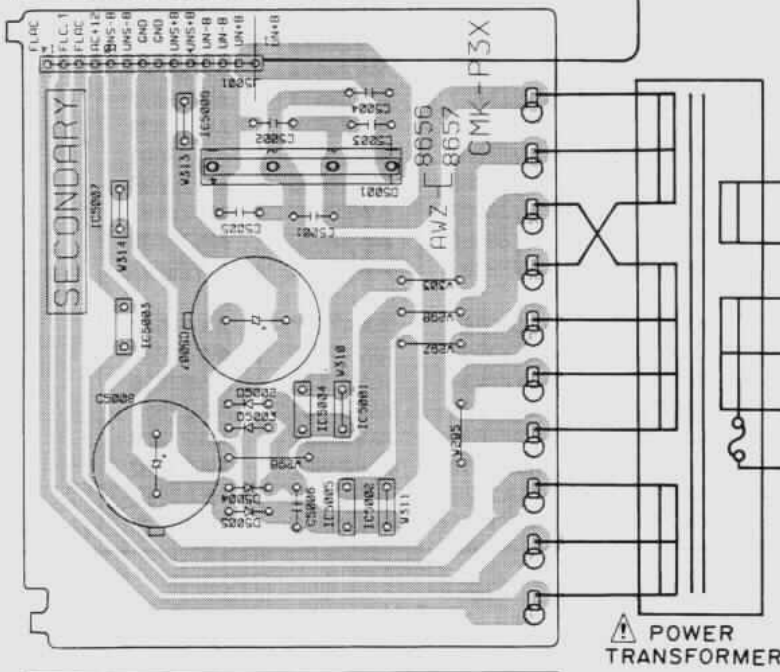

**S** CN5101

**U** PRIMARY ASSY

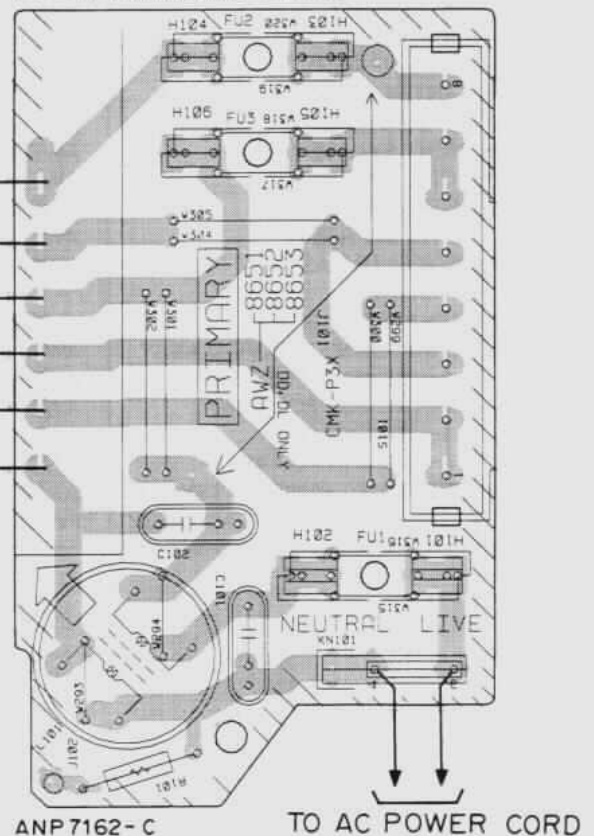

- IC5006
- IC5007    IC5004    IC5001
- IC5003    IC5005    IC5002

## 5. PCB PARTS LIST

- NOTES:**
- Parts marked by "NSP" are generally unavailable because they are not in our Master Spare Parts List.
  - The  $\Delta$  mark found on some component parts indicates the importance of the safety factor of the part. Therefore, when replacing, be sure to use parts of identical designation.
  - When ordering resistors, first convert resistance values into code form as shown in the following examples.  
*Ex.1* When there are 2 effective digits (any digit apart from 0), such as 560 ohm and 47K ohm (tolerance is shown by J=5%, and K=10%).

560  $\Omega$   $\rightarrow 56 \times 10^1 \rightarrow 561$  ..... RD1/4PU  $\overline{561} J$   
 47 k $\Omega$   $\rightarrow 47 \times 10^3 \rightarrow 473$  ..... RD1/4PU  $\overline{473} J$   
 0.5  $\Omega$   $\rightarrow R50$  ..... RN2H  $\overline{R50} K$   
 1  $\Omega$   $\rightarrow 1R0$  ..... RS1P  $\overline{1R0} K$

*Ex.2* When there are 3 effective digits (such as in high precision metal film resistors).  
 5.62 k $\Omega$   $\rightarrow 562 \times 10^1 \rightarrow 5621$  ..... RN1/4PC  $\overline{5621} F$

### ■ LIST OF WHOLE PCB ASSEMBLIES

Mark	PCB Assemblies	Part No.					Remarks
		KUXJ KCXJ	DD	DDXJ DDXJ/NC	DLXJ/NC	YPWXJ	
	FM/AM TUNER MODULE	AXQ7061	AXQ7051	AXQ7061	AXQ7061	AXQ7061	
NSP	MAIN ASSY	AWK7371	AWK7372	AWK7372	AWK7374	AWK7373	
	├ AF ASSY	AWZ8643	AWZ8644	AWZ8644	AWZ8644	AWZ8644	
	├ AMP ASSY	AWZ8647	AWZ8647	AWZ8647	AWZ8647	AWZ8647	
	├ POWER SUPPLY ASSY	AWZ8649	AWZ8649	AWZ8649	AWZ8649	AWZ8649	
	├ PRIMARY ASSY	AWZ8651	AWZ8652	AWZ8652	AWZ8652	AWZ8653	
	├ SECONDARY ASSY	AWZ8656	AWZ8657	AWZ8657	AWZ8657	AWZ8657	
NSP	├ TX CONNECT ASSY	AWZ8660	AWZ8660	AWZ8660	AWZ8660	AWZ8660	
	└ REGULATOR ASSY	AWZ8683	AWZ8683	AWZ8683	AWZ8683	AWZ8683	
NSP	COMPLEX ASSY	AWM7287	AWM7288	AWM7288	AWM7290	AWM7289	
	├ GM-CD ASSY	AWZ8662	AWZ8663	AWZ8663	AWZ8664	AWZ8663	
	├ DISPLAY ASSY	AWZ8667	AWZ8668	AWZ8668	AWZ8669	AWZ8668	
	├ MIC & HP ASSY	AWZ8672	AWZ8673	AWZ8673	AWZ8674	AWZ8673	
	├ CENTER SW ASSY	AWZ8677	AWZ8677	AWZ8677	AWZ8677	AWZ8677	
NSP	├ LEFT SW ASSY	AWZ8679	AWZ8679	AWZ8679	AWZ8679	AWZ8679	
NSP	├ RIGHT SW ASSY	AWZ8681	AWZ8681	AWZ8681	AWZ8681	AWZ8681	
NSP	├ HOME SW ASSY	AWZ8685	AWZ8685	AWZ8685	AWZ8685	AWZ8685	
NSP	├ MOTOR ASSY	AWZ8687	AWZ8687	AWZ8687	AWZ8687	AWZ8687	
NSP	├ DOOR SW ASSY	AWZ8689	AWZ8689	AWZ8689	AWZ8689	AWZ8689	
NSP	└ PROTECTOR ASSY	AWZ8803	AWZ8803	AWZ8803	AWZ8803	AWZ8803	
NSP	GS MECHANISM ASSY	AXA7047	AXA7047	AXA7047	AXA7047	AXA7047	
NSP	├ LO MECHANISM BOARD ASSY	AWX7035	AWX7035	AWX7035	AWX7035	AWX7035	
NSP	├ ─ SENSOR PCB ASSY	AWZ7836	AWZ7836	AWZ7836	AWZ7836	AWZ7836	
NSP	├ ─ MOTOR PCB ASSY	AWZ7837	AWZ7837	AWZ7837	AWZ7837	AWZ7837	
NSP	├ ─ SW PCB ASSY	AWZ7838	AWZ7838	AWZ7838	AWZ7838	AWZ7838	
NSP	├ ─ MECHA PCB ASSY	AWZ8802	AWZ8802	AWZ8802	AWZ8802	AWZ8802	
NSP	└ SERVO MECHANISM ASSY GM	AXA7028	AXA7028	AXA7028	AXA7028	AXA7028	
NSP	└ ─ MECHANISM BOARD ASSY	PWX1192	PWX1192	PWX1192	PWX1192	PWX1192	



**■ CONTRAST OF PCB ASSEMBLIES**

**A FM/AM TUNER MODULE**

AXQ7051 and AXQ7061 have the same construction except for the following.

Mark	Symbol & Description	Part No.		Remarks
		AXQ7061	AXQ7051	
	BN6202 TERMINAL 4-P	AKE7025	AKE7028	

**C AF ASSY**

AWZ8644 and AWZ8643 have the same construction except for the following.

Mark	Symbol & Description	Part No.		Remarks
		AWZ8643	AWZ8644	
	R9999	RS1/10S0R0J	Not used	

**U PRIMARY ASSY**

AWZ8652, AWZ8653 and AWZ8651 have the same construction except for the following.

Mark	Symbol & Description	Part No.			Remarks
		AWZ8651	AWZ8652	AWZ8653	
△	S101	Not used	AKX7006	Not used	
△	R101 (2.2M, 1/2W)	ACN-208	Not used	Not used	
	H101, H102 FUSE CLIP	AKR1004	Not used	Not used	
	H103, H104 FUSE CLIP	Not used	AKR1004	AKR1004	
	H105, H106 FUSE CLIP	Not used	AKR1004	Not used	

**T SECONDARY ASSY**

AWZ8657 and AWZ8656 have the same construction except for the following.

Mark	Symbol & Description	Part No.		Remarks
		AWZ8656	AWZ8657	
△	IC5001, IC5002	Not used	AEK7017	
△	IC5006, IC5007	AEK7017	Not used	

**J GM-CD ASSY**

AWZ8663, AWZ8664 and AWZ8662 have the same construction except for the following.

Mark	Symbol & Description	Part No.			Remarks
		AWZ8662	AWZ8663	AWZ8664	
	R8015	Not used	RS1/10S682J	RS1/10S682J	

**R DISPLAY ASSY**

Although AWZ8667, AWZ8668 and AWZ8669 are different in part number, they consist of the same components.

## **Q** MIC & HP ASSY

AWZ8673, AWZ8674 and AWZ8672 have the same construction except for the following.

Mark	Smbol & Description	Part No.			Remarks
		AWZ8672	AWZ8673	AWZ8674	
	IC7701	Not used	NJM4558M-D	NJM4558M-D	
	C7701	Not used	CKSQYF224Z25	CKSQYF224Z25	
	C7702	Not used	CKSQYB472K50	CKSQYB472K50	
	C7703, C7705, C7707, C7708	Not used	CEAS1ROM50	CEAS1ROM50	
	C7706	Not used	CCSQCH221J50	CCSQCH221J50	
	C7709	Not used	CKSQYB222K50	CKSQYB222K50	
	C7711	Not used	CEAS6R8M50	CEAS6R8M50	
	C7712	Not used	CKSQYB562K50	CKSQYB562K50	
	C7714, C7715	Not used	CKSQYF473Z50	CKSQYF473Z50	
	R7701, R7702, R7708	Not used	RS1/10S103J	RS1/10S103J	
	R7703	Not used	RS1/10S682J	RS1/10S682J	
	R7704	Not used	RS1/10S274J	RS1/10S274J	
	R7705	Not used	RS/110S473J	RS/110S473J	
	R7706	Not used	RS1/10S472J	RS1/10S472J	
	R7707	Not used	RS1/10S102J	RS1/10S102J	
	R7709	Not used	RD1/4PU100J	RD1/4PU100J	
	VR7701 (10K )	Not used	ACS1028	ACS1028	
	CN7005 3P JUMPER CONNECTOR	Not used	52151-0410	52151-0410	
	JA7701 JACK	Not used	RKN1004	RKN1004	

## ■ PARTS LIST FOR KUXJ

Mark	No.	Description	Parts No.	Mark	No.	Description	Parts No.
------	-----	-------------	-----------	------	-----	-------------	-----------

## **A** FM/AM TUNER MODULE

### SEMICONDUCTORS

IC6201	LA1832ML
IC6202	LC72131MD
Q6402	2SC2223
Q6203	2SC2705
Q6201, Q6202	2SC2712
Q6214, Q6403	2SC2714
Q6404	2SK302
Q6401	3SK194
Q6204	DTA124ES
Q6205	DTC124EK
D6202	1SS254
D6401, D6402	1T363

### COILS AND FILTERS

L6404	ATC1003
L6401	ATC1020
L6402	ATC1021
F6204	ATF-107
F6203	ATF-119
F6401	ATF-155
F6206	ATF7008
F6202	ATF7011
L6206, L6208, L6403	LAU2R2J

### TRANSFORMERS

T6201	ATB7008
T6401	ATE7002

### CAPACITORS

C6208	CCSQCH100D50
C6212, C6274, C6275, C6408	CCSQCH101J50
C6221, C6222, C6416	CCSQCH150J50
C6271	CCSQCH200J50
C6415	CCSQCH330J50
C6401, C6419	CCSQCH5R0C50
C6407	CCSQCK1R0C50
C6410	CCSQCK2R0C50
C6413	CCSQPH220J50
C6414	CCSQPH8R0D50
C6405	CCSQTH180J50
C6234, C6235	CEAL1R0M50
C6245	CEAL470M16
C6224	CEAS100M50
C6243	CEAS101M16
C6231	CEAS1R0M50
C6227	CEAS220M16
C6236	CEAS2R2M50
C6216	CEAS330M16
C6262	CEAS3R3M50
C6219	CEAS470M10
C6244	CEAS470M16

Mark	No.	Description	Parts No.
	C6249, C6250, C6265, C6266		CEAS4R7M50
	C6258		CEJA470M16
	C6215		CFTXA103J50
	C6214		CFTXA224J50
	C6211, C6254, C6403, C6406, C6412		CKSQYB102K50
	C6201, C6205, C6210, C6213, C6237		CKSQYB103K50
	C6276, C6278, C6280, C6281, C6402		CKSQYB103K50
	C6409, C6417, C6418		CKSQYB103K50
	C6251, C6252		CKSQYB153K50
	C6203, C6259		CKSQYB223K50
	C6228		CKSQYB472K50
	C6209		CKSQYB473K50
	C6230		CKSQYB821K50
	C6218, C6223, C6255		CKSQYF103Z50
	C6220, C6226, C6242, C6256		CKSQYF223Z50
	C6225		CKSQYF473Z50

## RESISTORS

R6280	RD1/4PU101J
R6413, R6416, R6418, R6906, R6909	RS1/8S0R0J
R6401	RS1/8S470J
VR6201 (10 kΩ)	RCP1045
Other Resistors	RS1/10S□□□J

## OTHERS

BN6202	TERMINAL 4P	AKE7025
X6202	CERAMIC RESONATOR (456 KHz)	ASS1066
X6201	CRYSTAL RESONATOR (7.2000 MHz)	ASS1093
CN6201	14P SOCKET AM RF TUNING BLOCK	KP200IA14L AXX7041

## AF ASSY

## SEMICONDUCTORS

△ IC1008	AEK7002
IC1004, IC4201	BU4066BCF
IC4401	CXA1101P
IC2101	LC75394NHE
IC1002, IC1003, IC1005, IC4101, IC4301	NJM4558M-D
Q1020, Q1023	2SA1037K
Q1013	2SB1237X
Q4351-Q4353	2SC1815
Q4354	2SC2240
Q1014, Q1015, Q1017-Q1019	2SC2412K
Q1024, Q1025, Q4201, Q4202	2SC2412K
Q4301, Q4302, Q4451-Q4454	2SC2412K
Q1011, Q1012	2SD1858X
Q4151, Q4152	2SK373
Q1016	DTA124EK
Q1003	DTA143ES
Q4455	DTC124EK
Q4203	DTC143EK
Q1004	DTC143ES
D1003, D1004, D1007, D1008, D1012	1SS254

Mark	No.	Description	Parts No.
	D1019, D1020, D1024-D1026		1SS254
	D4151, D4152, D4201, D4351-D4354		1SS254
	D4451, D4452		1SS254
	D1013		MTZJ27B
	D1009, D1014		MTZJ43C
	D1010, D1011		MTZJ5.6B
	D1016, D1017, D1021-D1023		S5688G
	D1027, D1028		S5688G

## COILS AND FILTERS

L1001, L1002	ATH-133
L4301, L4302	LTA822J
L4351	RTD1077
F4401, F4402	RTF1217

## CAPACITORS

C4319, C4320	CCCSL271K2H
C4153, C4154	CCSQCH100D50
C1001-C1004, C1076-C1078	CCSQCH221J50
C1039, C1040, C4107, C4108	CCSQCH470J50
C4151, C4152	CCSQCH681J50
C4101, C4102, C4307-C4310	CCSQCH821J50
C4315, C4316	CCSQCH821J50
C1061, C1062, C4360, C4403, C4404	CEAS100M50
C4407, C4408, C4452	CEAS100M50
C1031, C1032, C1060, C4401, C4402	CEAS101M10
C1083	CEAS101M16
C1066, C1075, C1086, C4303, C4304	CEAS1R0M50
C4413, C4414	CEAS1R0M50
C4451	CEAS220M16
C1073	CEAS221M10
C1087, C1088	CEAS2R2M50
C4103, C4104, C4317, C4318, C4352	CEAS330M16
C4357, C4358	CEAS330M16
C1067, C1068, C1089, C4109, C4110	CEAS470M10
C1015-C1018, C1037, C1038	CEAS4R7M50

C4201, C4202, C4301, C4302	CEAS4R7M50
C4311-C4314	CEAS4R7M50
C1025, C1026	CEASR10M50
C1007-C1014, C1035, C1036	CEASR33M50
C1074, C1081, C1082	CEASR47M50
C4405, C4406	CEASR68M50
C1090	CGCYF104Z50
C4361	CKCYB681K2H
C1023, C1024, C1033, C1034	CKSQYB102K50
C1085	CKSQYB103K50
C4411, C4412	CKSQYB152K50
C1027, C1028	CKSQYB154K16
C1019, C1020	CKSQYB222K50
C1029, C1030, C4353, C4354	CKSQYB472K50
C1021, C1022, C4105, C4106	CKSQYB682K50
C4305, C4306, C4355	CKSQYB682K50
C1043-C1048, C1055, C1084, C4113	CKSQYF104Z50
C1063, C1064	CKSQYF473Z50
C4409, C4410	CQMA103J50
C4356	CQMA123J50

# XR-P670F

Mark	No.	Description	Parts No.	Mark	No.	Description	Parts No.
	C4359		CQPA822J2A		R5513, R5514, R5519, R5520		RD1/4PU103J
					R5515-R5518		RD1/4PU222J
					Other Resistors		RS1/10S□□□
<b>RESISTORS</b>				<b>OTHERS</b>			
	R1047, R1048		RD1/2LMF101J		J5507	JUMPER WIRE 9P	D20PWY0915E
	R1092		RD1/2PM330J	<b>S POWER SUPPLY ASSY</b>			
	R4351		RD1/2PM680J	<b>SEMICONDUCTORS</b>			
	R1045, R1046		RD1/4PM4R7J	△	IC5101		AEK7009
	R4352		RD1/4PU101J		Q5304, Q5306		2SA1037K
					Q5301		2SA965
	R4319, R4320		RD1/4PU103J		Q5104, Q5106		2SA992
	R1062		RD1/4PU472J	△	Q5302		2SB1375
	R1050		RD1/4PU473J				
	R4355		RD1/4PU4R7J		Q5103, Q5105		2SC1845
	R1069, R1071		RD1/4PU560J		Q5107, Q5303, Q5307, Q5308		2SC2412K
				△	Q5305		2SD2012
	R4109, R4110, R4317, R4318		RD1/4PU820J	△	Q5101		IRFI9Z34G
	R1087		RS2LMF121J	△	Q5102		IRFIZ24G
	VR4301, VR4302 (4.7 kΩ)		RCP1020				
	VR4201-VR4204 (22 kΩ)		RCP1046		D5101, D5303, D5307, D5308		1SS254
	VR4351, VR4352 (47 kΩ)		RCP1049	△	D5105, D5106		MTZJ18C
	Other Resistors		RS1/10S□□□		D5107, D5108		MTZJ22B
<b>OTHERS</b>					D5302		MTZJ36C
	CN1007	9P JUMPER CONNECTOR	52147-0910		D5103, D5104		MTZJ5.6C
	CN1008	15P JUMPER CONNECTOR	52147-1510				
	CN1001, CN1002	35P FFC CONNECTOR	9604S-35C		D5301		MTZJ6.2B
	JA1001	2P PIN JACK (AUDIO)	AKB7043				
	CN1010	SPEAKER TERMINAL 4P	AKE7024		D5305, D5306		MTZJ8.2B
				△	D5102, D5304		S5688G
	CN4003	2P TOP POST	B2B-EH	<b>CAPACITORS</b>			
	CN4002	3P TOP POST	B3B-EH	△	C5107, C5108 (3300, μF/42V)		ACH1255
	CN4001	3P TOP POST	B3B-EH-R		C5302		CEAL100M50
	CN1009	CONNECTOR 12P	TUC-P12P-B1		C5305, C5306		CEAS101M10
		PCB BINDER	VEF1008	△	C5307		CEAS101M50
	JA1003	2P PIN JACK	VKB1050		C5103, C5104		CEAS470M10
<b>V AMP ASSY</b>							
<b>SEMICONDUCTORS</b>							
△	IC5503		AEK7004	△	C5102		CEAS471M35
△	IC5504		AEK7016		C5105, C5106		CEJA101M6R3
					C5101, C5301		CEJA4R7M50
△	IC5501, IC5502		LM3886TF		C5303, C5304		CKSQYB102K50
	Q5501, Q5502		2SA1037K	<b>RESISTORS</b>			
	Q5503		DTC143EK		R5302		RD1/2PM222J
	D5501-D5507		1SS254		R5103, R5104		RD1/2PM392J
<b>CAPACITORS</b>					R5101		RD1/4PU102J
	C5505, C5506		CCSQCH121J50		R5113, R5114		RD1/4PU222J
	C5501, C5502		CEAL100M25		R5111, R5112		RD1/4PU432J
	C5507, C5508		CEAS100M50				
	C5509, C5510		CEAS221M10		R5105, R5106		RD1/4PU563J
	C5511, C5512		CEAS2R2M50		R5109, R5110		RD1/4PU911J
				△	R5107, R5108		RFA1/4PS101J
	C5503, C5504		CKSQYB272K50		Other Resistors		RS1/10S□□□
<b>RESISTORS</b>				<b>U PRIMARY ASSY</b>			
	R5507, R5508		RD1/4PM561J	<b>RESISTORS</b>			
	R5509, R5510		RD1/4PM563J	△	R101 (2.2 MΩ, 1/2)		ACN-208

Mark	No.	Description	Parts No.
------	-----	-------------	-----------

### OTHERS

	H101, H102	FUSE CLIP	AKR1004
--	------------	-----------	---------

## T

### SECONDARY ASSY

### SEMICONDUCTORS

△	IC5003	AEK7014	
△	IC5006, IC5007	AEK7017	
△	D5001	D3SBA20(B)	
△	D5002-D5005	S5688G	

### CAPACITORS

△	C5007, C5008	CEAS222M25	
---	--------------	------------	--

## B

### TX CONNECT ASSY

### SEMICONDUCTORS

	D1001, D1002	1SS254	
--	--------------	--------	--

### RESISTORS

	R1103	RD1/4PU473J	
	Other Resistors	RS1/10S□□□	

### OTHERS

	CN1004	14P PLUG	KM200EB14
	CN1003	CONNECTOR 12P	TUC-P12X-B1

## D

### REGULATOR ASSY

### SEMICONDUCTORS

△	IC1006	NJM7812FA	
△	IC1007	NJM78M56FA	
	D1018	MTZJ8.2B	

### CAPACITORS

	C1069, C1070	CEAS100M50	
	C1071, C1072	CKSQYF104Z50	

## J

### GM-CD ASSY

### SEMICONDUCTORS

	IC8151	CXA1372BQ	
	IC8301	CXD2519Q	
	IC8201, IC8203	LA6517	
	IC8202	LA6520	
	IC8001	PD4756B	

	Q8002	2SC2412K	
	Q8401, Q8402	2SD2114K	
	Q8301	2SK246	
	Q8302	DTA124EK	
	Q8003, Q8004, Q8403, Q8404	DTA143EK	

	Q8001, Q8303	DTC143EK	
	D8001, D8003, D8004, D8301, D8302	1SS254	
	D8401, D8402	DAN202K	
	D8219	MTZJ6.2B	

Mark	No.	Description	Parts No.
------	-----	-------------	-----------

### COILS AND FILTERS

	L8301	LAU1R2J	
	L8001	LAU220J	
	L8002	PTL1014	

### CAPACITORS

	C8003	ACH7013	
	C8313	CCSQCH100D50	
	C8009, C8014, C8015	CCSQCH101J50	
	C8401, C8402	CCSQCH151J50	
	C8314	CCSQCH220J50	

	C8018, C8019	CCSQCH470J50	
	C8167	CCSQCH561J50	
	C8405, C8406	CCSQCH681J50	
	C8002	CEAS100M50	
	C8301	CEAS101M10	

	C8008	CEAS1R0M50	
	C8007	CEAS221M6R3	
	C8403, C8404	CEAS2R2M50	
	C8017	CEAS330M16	
	C8201, C8202	CEAS331M16	

	C8001	CEAS470M10	
	C8155, C8156	CEAS4R7M50	
	C8309	CEASR47M50	
	C8603	CGCYX224M12	
	C8010, C8012, C8164, C8312, C8605	CKSQYB102K50	

	C8151, C8158, C8159, C8162, C8205	CKSQYB103K50	
	C8210, C8215, C8219, C8220, C8225	CKSQYB103K50	
	C8235, C8245, C8316	CKSQYB103K50	
	C8306	CKSQYB152K50	
	C8160, C8163, C8166	CKSQYB333K50	

	C8165	CKSQYB472K50	
	C8004, C8005, C8152-C8154, C8157	CKSQYF104Z50	
	C8161, C8302, C8303, C8308, C8602	CKSQYF104Z50	
	C8604, C8606	CKSQYF104Z50	
	C8006, C8307	CKSQYF473Z50	

### RESISTORS

	R8001-R8003, R8011-R8013, R8036	RD1/4PU102J	
	R8411	RD1/4PU102J	
	R8409, R8410	RD1/4PU221J	
	R8221, R8222	RD1/4PU473J	
	VR8151, VR8152 (22 kΩ)	RCP1103	

	Other Resistors	RS1/10S□□□	
--	-----------------	------------	--

### OTHERS

	X8001	CERAMIC RESONATOR (4.19MHz)	VSS1014
	X8301	CRYSTAL RESONATOR (33.8688MHz)	ASS7000
	CN8005	5P JUMPER CONNECTOR	52147-0510
	CN8002	22P FFC CONNECTOR	9604S-22C
	CN8001	35P FFC CONNECTOR	9604S-35C
	CN8201	JACK	VKN-004
	KN8001	EARTH METAL FITTING	VNF1084

# XR-P670F

Mark	No.	Description	Parts No.
------	-----	-------------	-----------

## **R** DISPLAY ASSY

### SEMICONDUCTORS

IC2001	PDG190A
Q2101	2SC2412K
D2101-D2103, D2214-D2217	1SS254
D2238	MTZJ6.2B

### COILS AND FILTERS

L2101	LAU220J
L2001	PTL1014

### SWITCHES AND RELAYS

S2014-S2017	ASG1034
-------------	---------

### CAPACITORS

C2110, C2112	CEAL100M50
C2106	CEAL1R0M50
C2101	CEAL470M16
C2105	CEALR47M50
C2104	CEJA221M10
C2107	CKSQYB102K50
C2111, C2224-C2226, C2229-C2234	CKSQYB103K50
C2238	CKSQYB103K50
C2102, C2103	CKSQYF104Z50
C2239	CKSQYF105Z16
C2108, C2109	CKSQYF473Z50

### RESISTORS

R2090	RA13T473J
R2074	RA15T473J
VR2301 (2.2 kΩ)	RCP1019
Other Resistors	RS1/10S□□□

### OTHERS

X2001 CERAMIC RESONATOR	EFOEC8004A4
CN2001 26P FFC CONNECTOR	9604S-26C
CN2002 35P FFC CONNECTOR	9604S-35C
V2001 FL INDICATOR TUBE	AAV7033
IC2002 REMOTE RECEIVER UNIT	GPIU27X

## **Q** MIC & HP ASSY

### CAPACITORS

C7004, C7005	CKSQYB102K50
C7001	CKSQYF104Z50
C7006	CKSQYF224Z25

### RESISTORS

R7001, R7002	RS2LMF331J
--------------	------------

### OTHERS

JA7001 MINI JACK	AKN7003
------------------	---------

Mark	No.	Description	Parts No.
------	-----	-------------	-----------

## **N** CENTER SW ASSY

### SEMICONDUCTORS

Q7503	2SB1197K
Q7501, Q7502	2SD1781K
Q7404, Q7405, Q7504	DTC124EK
Q7402, Q7403	DTC143EK
D7401, D7402, D7406, D7501-D7511	1SS254
D7404, D7405	MBG5064X
D7403	SLR-342VCT31

### SWITCHES AND RELAYS

S7401-S7415	ASG1034
S7416	ASX7004

### CAPACITORS

C7401, C7402	CKSQYB103K50
--------------	--------------

### RESISTORS

R7416	RS1/10S0R0J
R7506	RS1/10S122J
R7501, R7503	RS1/10S152J
R7413, R7414	RS1/10S221J
R7505	RS1/10S223J
R7502, R7504	RS1/10S473J
Other Resistors	RD1/4PU□□□

### OTHERS

J7501 9P CABLE HOLDER	51063-0905
J7502 15P CABLE HOLDER	51063-1505
CN7401 26P FFC CONNECTOR	9604S-26F

## **O** LEFT SW ASSY

### SWITCHES AND RELAYS

S7301	ASG1034
-------	---------

## **P** RIGHT SW ASSY

### SWITCHES AND RELAYS

S7101, S7102, S7201-S7203	ASG1034
---------------------------	---------

### RESISTORS

All Resistors	RD1/4PU□□□
---------------	------------

### OTHERS

J7402 3P JUMPER WIRE	D20PWW0305E
----------------------	-------------

## **M** HOME SW ASSY

### SWITCHES AND RELAYS

S8001	DSG1048
-------	---------

Mark	No.	Description	Parts No.
------	-----	-------------	-----------

## **K** MOTOR ASSY

### OTHERS

J8009	3P JUMPER WIRE	D20PWW0310E
-------	----------------	-------------

## **L** DOOR SW ASSY

### SWITCHES AND RELAYS

S8002		DSG1016
S8003		PSG1008

## PROTECTOR ASSY

PROTECTOR ASSY has no service part.

## **F** SENSOR PCB ASSY

### SEMICONDUCTORS

D652		GP1S24
------	--	--------

### OTHERS

J652	3P JUMPER WIRE	D20PWW0315E
------	----------------	-------------

## **G** MOTOR PCB ASSY

### OTHERS

	LOADING MOTOR	VXM1034
--	---------------	---------

## **H** SW PCB ASSY

### SWITCHES AND RELAYS

S651, S652		VSG1006
------------	--	---------

### OTHERS

J656	3P JUMPER WIRE	D20PWW0315E
------	----------------	-------------

## **E** MECHA PCB ASSY

### SEMICONDUCTORS

Q651		DTC124ES
------	--	----------

### RESISTORS

R651, R652 (56 kΩ)		ACN7012
R653 (220 Ω)		DCN1062
R654		DCN1065

### OTHERS

CN652	CONNECTOR	I2FMZ-AST
CN651	CONNECTOR 4P	173979-4
CN653	22P FFC CONNECTOR	SLEM22R-2

Mark	No.	Description	Parts No.
------	-----	-------------	-----------

## **I** MECHANISM BOARD ASSY

### SWITCHES AND RELAYS

S610		DSG1016
------	--	---------

### OTHERS

CN610	CONNECTOR	173979-4
-------	-----------	----------

## 6. ADJUSTMENT

### 6.1 TUNER SECTION

#### ■ FM Tuner Section

- Set the mode selector to FM BAND.
- Connect the wiring as shown in Fig. 1-1.

Step No.	Adjustment Title	FM SG (1kHz, $\pm 75$ kHz dev.)		Reception Frequency Display	Adjustment Location	Specifications
		Frequency (MHz)	Level (dB $\mu$ V)			
1	Front End Sensitivity	98	0-30	98MHz	L6402 T6401	Adjust so that the DC voltage between the IC6201-Pin 20 becomes at maximum level.
2	TUNED IND. Lighting Level	98	18 $\pm$ 2	98MHz	VR6201	Adjust so that the indicator of TUNED IND. starts to light up.

#### Notes:

- Before adjusting, make sure there is no gap between L6401 and L6402. If there is a gap between them, bring them into contact with each other first, and then make adjustments.

#### ■ AM Tuner Section

- Set the mode selector to AM BAND.
- Connect the wiring as shown in Fig. 1-1.

Step No.	Adjustment Title	AM SG (400Hz, 30% Mod.)		Reception Frequency Display	Adjustment Location	Specifications
		Frequency (kHz)	Level (dB $\mu$ V/m)			
1	AM Front End Sensitivity Adjustment	999*1	35-45	999kHz*1	T6201	Adjust so that the DC voltage between the IC6201-Pin 20 becomes at maximum level.

\*1: For the area using 10kHz step, frequencies should be 1000 kHz

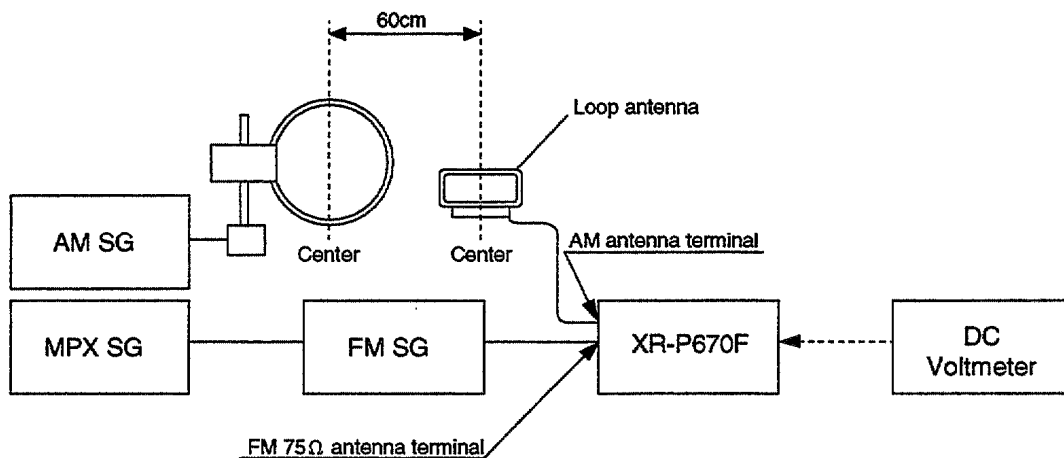

Fig. 1-1 AM and FM Adjustment Wiring Diagram



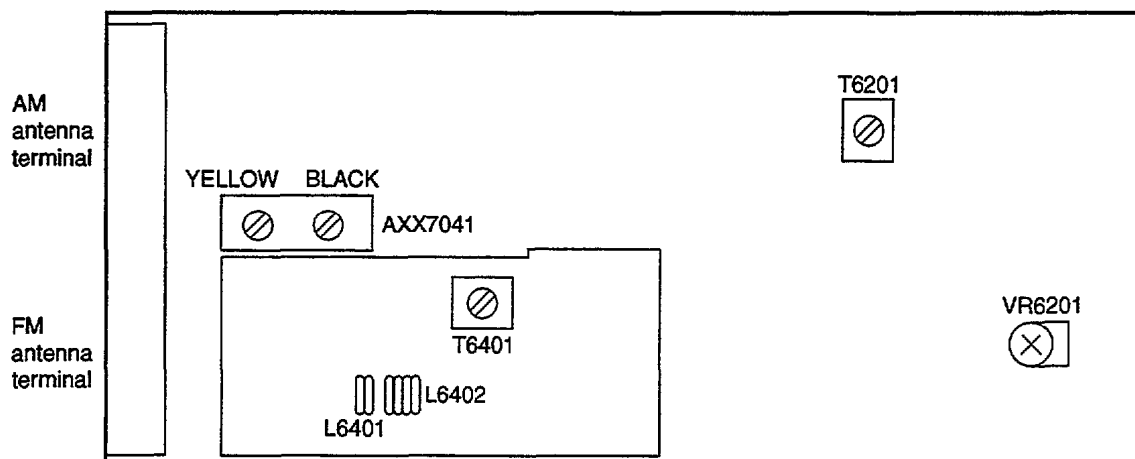

Fig. 1-2 Adjustment Points

## 6.2 CASSETTE DECK SECTION

● Adjustment points and test points are shown in Fig. 2-3 and Fig. 2-4.

### ■ Before Adjustment

1. For execution of head angle adjustment, first remove the Azimuth cover (L) and (R).
2. Open the cassette doors (L) and (R).
3. Insert your fingers into the cassette door, push down the two hooks at the upper side of the Azimuth cover, and push them slightly out to the front. Excessive pushing at this time may make it impossible to close the cassette door.
4. Confirm that the Azimuth cover (L) and (R) have been pushed out a little to the front, and then close the cassette doors (L) and (R) and remove the Azimuth cover.

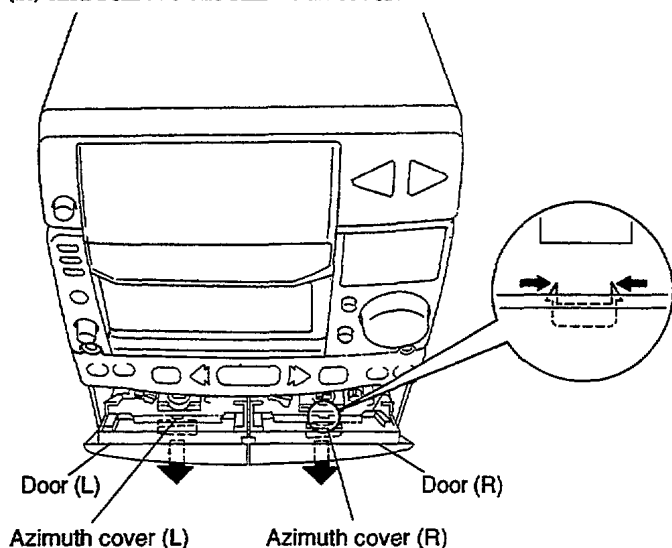

### ■ Mechanical Adjustment

● Test tape: STD-301 (3kHz, 30min).

#### (1) Tape Speed Adjustment

● Open the CD DOOR and remove the CD DOOR COVER to adjust tape speed.

No.	Mode	Test Tape	Adjusting Points	Measurement Points	Adjustment Procedure	Remarks
1	Deck PLAY	STD-301 (Playback: 3kHz)	DISPLAY ASSY VR2301	TAPE TEST POINT (Rch) (AF Assy)	Press the PLAY SW and adjust so that the reading becomes 3000Hz $\pm$ 20Hz. Confirm that wow & flutter level is below 0.2% (in the reverse direction, confirm that the reading is within 3000Hz $\pm$ 60Hz).	

## ■ Electrical Adjustment

Check the following before starting.

- (1) Confirm that the tape speed adjustment has been completed.
- (2) Clean the heads and demagnetize them using a head eraser.
- (3) Set the measurement level to 0 dBV = 1 Vrms.
- (4) Use the specified tape for adjustment. Use the labeled (A) side of the test tape.  
 STD-331E: For playback adjustment  
 STD-631 or STD-632: Normal blank tape
- (5) Provide yourself with the following measuring devices:
  - AC millivoltmeter
  - Low-frequency oscillator
  - Attenuator
  - Oscilloscope
- (6) Adjust both right and left channels unless otherwise specified.
- (7) Turn the DOLBY NR switch off unless otherwise specified.
- (8) Warm up the unit for several minutes before adjustment.  
 In particular, be sure to warm up the unit in the REC/PLAY mode for 3 to 5 minutes before starting recording/playback frequency characteristics adjustment.
- (9) Always follow the indicated adjustment order.  
 Otherwise, a complete adjustment may not be achieved.

## Playback Adjustment (Decks I and II)

- (1) Head Azimuth Adjustment
- (2) Playback Level Adjustment

## Recording Adjustment (Deck II)

- (1) Bias Oscillation Frequency Adjustment
- (2) Recording Bias Adjustment
- (3) Recording Level Adjustment.
- (4) ALC Operation Check

*\* As the reference recording level is 250nwb/m for STD-331E, the recording level will be higher by 4 dB for STD-331B (160nwb/m). When adjusting, pay carefull attention to the type of tape used.*

*Dolby noise reduction manufactured under license from Dolby Laboratories Licensing Corporation.  
 "DOLBY" and the double-D symbol are trademarks of Dolby Laboratories Licensing Corporation.*

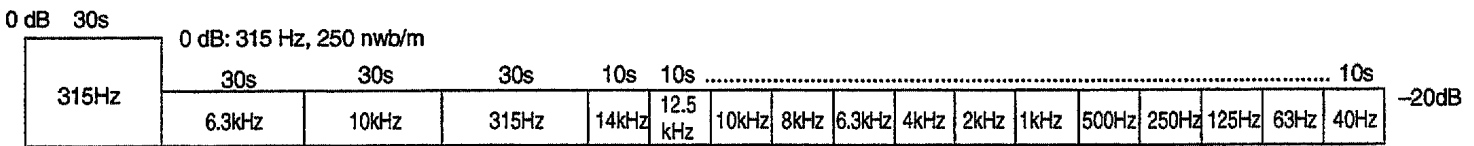

Fig. 2-1 STD-331E Test Tape

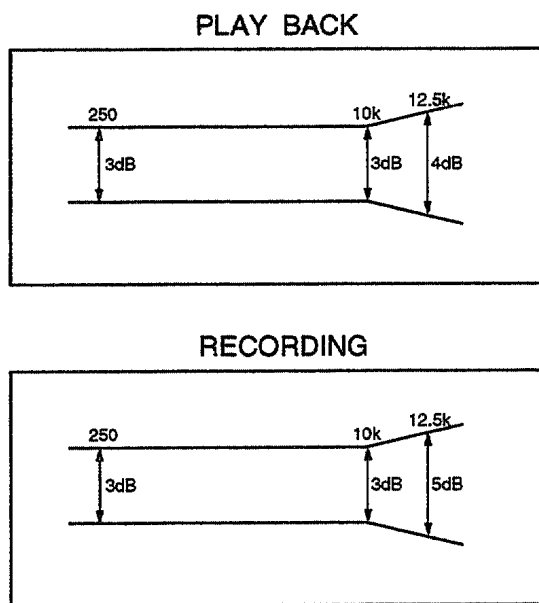

Fig. 2-2 Frequency Characteristics

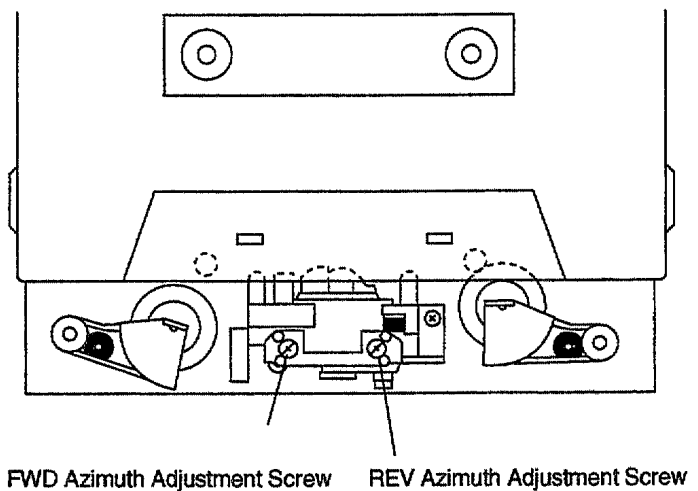

Fig. 2-3 Head Azimuth Adjustment

## ■ Playback Adjustment

### (1) Head Azimuth Adjustment

- This unit is equipped with auto tape selector.
- Do not switch between forward and reverse operation with the screwdriver inserted.

Step	Tape Selector (AUTO)	Mode	Input Signal/ Test Tape	Adjusting Points		Measurement Points	Adjustment Value	Remarks
1	AUTO (NORMAL)	PLAY	STD-331E test tape (Playback: 10kHz, -20dB)	Deck I	Head azimuth adjustment screw (Fig. 2-3)	TAPE TEST POINT (L, Rch)	Max. playback signal level	After adjustment, apply silicon bond to the head azimuth adjustment screw.
				Deck II				

### (2) Playback Level Adjustment

- Since this adjustment determines playback Dolby NR level, perform it carefully.

Step	Tape Selector (AUTO)	Mode	Input Signal/ Test Tape	Adjusting Points		Measurement Points	Adjustment Value	Remarks
1	AUTO (NORMAL)	PLAY	STD-331E test tape (Playback: 315Hz, 0dB)	Deck I	VR4203 (Lch) VR4204 (Rch)	TAPE TEST POINT (L, Rch)	- 4.2 dBV	
				Deck II	VR4201 (Lch) VR4202 (Rch)			

Note: Please execute playback level adjustment always in the order of deck I → deck II  
When deck I has been adjusted, always adjust deck II also.

## ■ Recording Adjustment

### (1) Bias Oscillation Frequency Adjustment

Step	Tape Selector (AUTO)	Mode	Input Signal/ Test Tape	Adjusting Points		Measurement Points	Adjustment Value	Remarks
1	AUTO (NORMAL)	REC	Load the STD-631 or STD-632 test tape and set the recording mode.	Deck I	—	Between ④ point in Fig. 2-4 and GND.	Oscillation frequency to be 105.0kHz ±2kHz.	When the power is turned ON while the MEMORY button is depressed, the frequency will decrease 2 - 3 kHz.
				Deck II	L4351			

### (2) Recording Bias Adjustment

Step	Tape Selector (AUTO)	Mode	Input Signal/Test Tape	Adjusting Points		Measurement Points	Adjustment Value	Remarks
1	AUTO (NORMAL)	REC	Input a 315Hz signal to the AUX terminal and set the input selector to AUX.	Deck I	—	TAPE TEST POINT (L, Rch)	- 24.2 dBV	
				Deck II	Input signal level			
2	AUTO (NORMAL)	REC→PLAY	Load the STD-631 or STD-632 test tape and record/playback the 315Hz and 10kHz signals. (see the Note below)	Deck I	—	TAPE TEST POINT (L, Rch)		Repeat adjustment until playback level of the 10kHz signal is within -1±0.5dB from that of the 315Hz signal.
				Deck II	VR4351 (Lch) VR4352 (Rch)			

Note: Set the 10kHz input signal level to the same value as the 315Hz input signal level of step 1.

## (3) Recording Level Adjustment

Step	Tape Selector (AUTO)	Mode	Input Signal/Test Tape	Adjusting Points	Measurement Points	Adjustment Value	Remarks
1	AUTO (NORMAL)	REC	Input a 315Hz signal to the AUX terminal and set the input selector to AUX.	Deck I	Input signal level	TAPE TEST POINT (L, Rch)	-8.2 dBV
				Deck II			
2	AUTO (NORMAL)	REC → PLAY	STD-631 or STD-632 test tape and record/playback the 315Hz signal.	Deck I	—	TAPE TEST POINT (L, Rch)	Repeat recording, playback and adjustment until playback level of the 315Hz signal becomes -8.2dBV.
				Deck II	VR4301 (Lch) VR4302 (Rch)		

## (4) ALC Operation Check

Step	Tape Selector (AUTO)	Mode	Input Signal/Test Tape	Adjusting Points	Measurement Points	Adjustment Value	Remarks
1	AUTO (NORMAL)	REC	Input a 315Hz signal to the AUX terminal and set the input selector to AUX.	Input signal level	TAPE TEST POINT (L, Rch)	-8.2 dBV	Confirm that the reading is $-3.2 \pm 2.5$ dBV.
2				Set to a level +10 dB above the input level at step 1.			

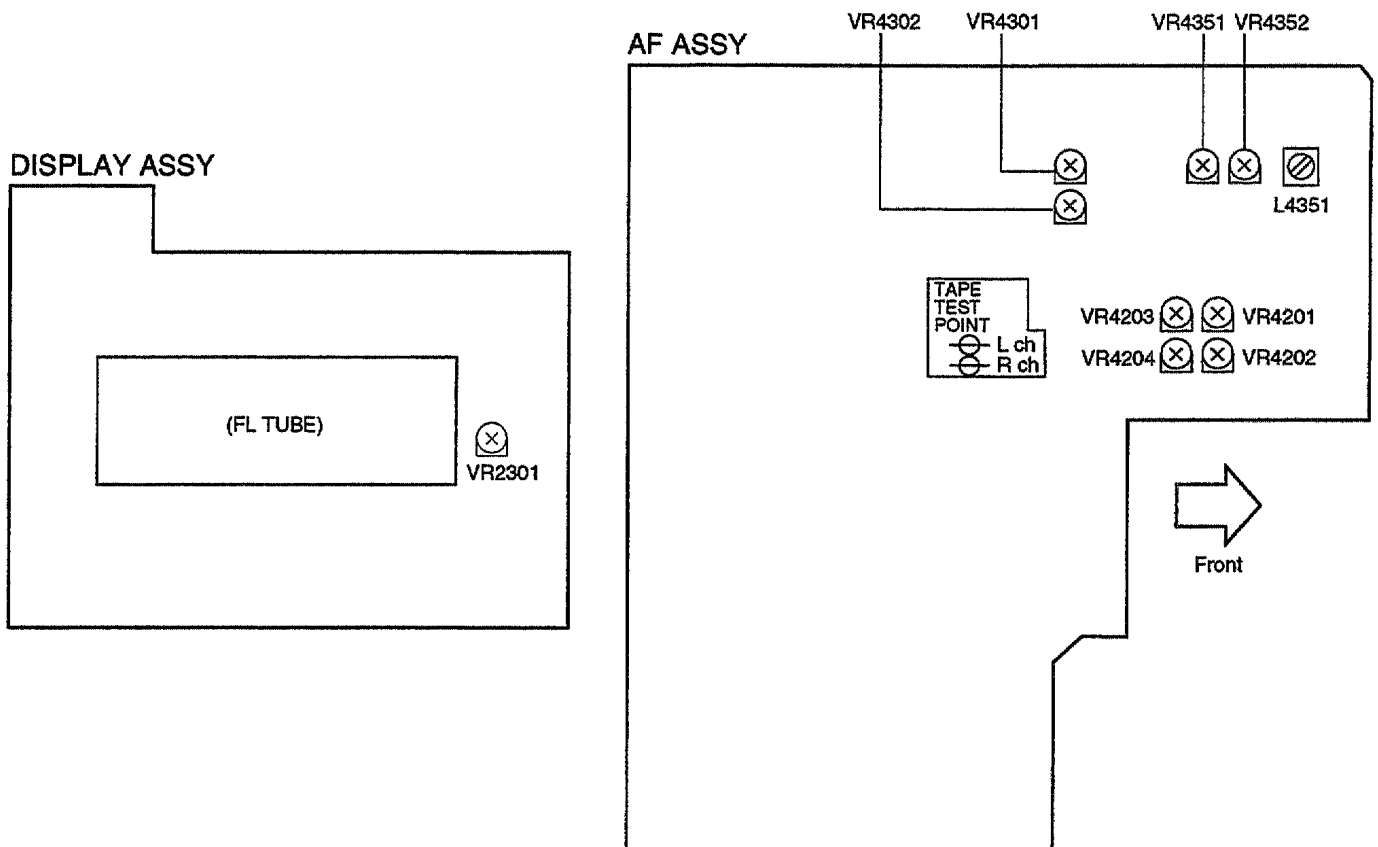



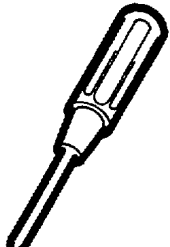
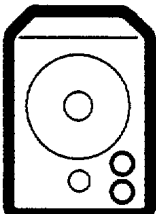
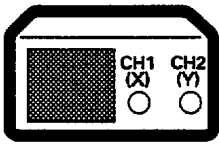
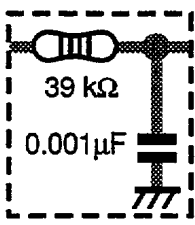

Fig. 2-4 Adjustment and Measurement points

6.3 CD SECTION (CD部の調整)

6.3.1 PREPARATIONS (準備)

(1) Jigs and Measuring Instruments (使用測定器/治工具類)

 <p>CD TEST DISC (YEDS-7)</p>	 <p>⊖ Precise screwdriver</p>	 <p>⊖ screwdriver (small)</p>	 <p>⊕ screwdriver (medium)</p>
 <p>⊕ screwdriver (large)</p>	 <p>Low-frequency oscillator</p>	 <p>Dual-trace oscilloscope (10 : 1 probe)</p>	 <p>Low pass filter (39 kΩ + 0.001μF)</p>

(2) Necessary Adjustment Points (調整に必要な項目)

When (このような時)	Adjustment points
Exchange PICKUP (ピックアップを交換した時)	1.2.3.4.5.6. → Page 71—73
Exchange CD ASSY (CD ASSYを交換した時)	1.2.3.4.5.6. → Page 71—73
Exchange SERVO MECH ASSY (サーボメカ ASSYを交換した時)	1.2.3.4.5.6. → Page 71—73
Exchange SPINDLE MOTOR (スピンドルモーターを交換した時)	 ADJ → Page 12

6.3.2 ADJUSTMENT (調整)

(1) How to Start/Cancel Test Mode (テストモードの設定/解除)

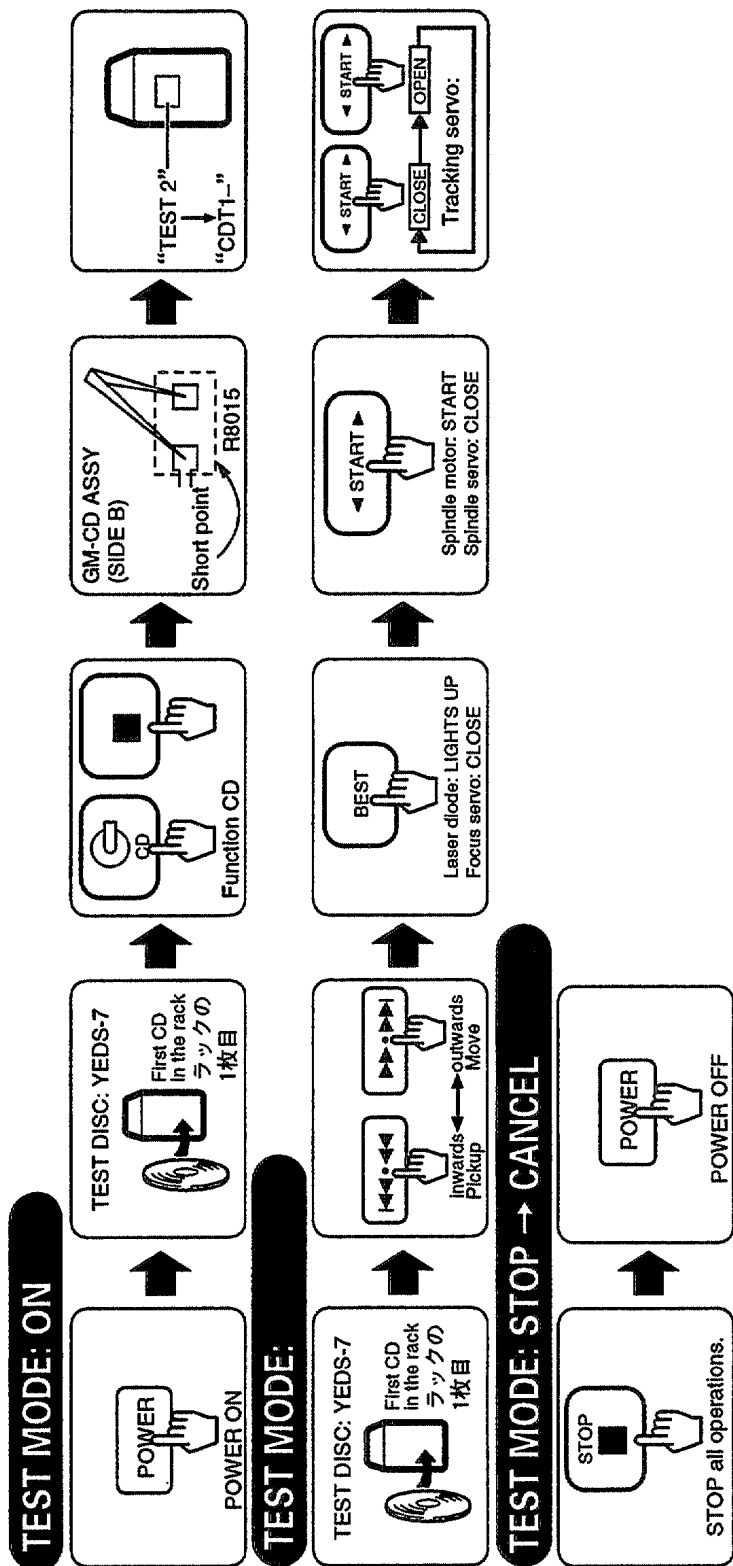

(2) Adjustment Locations (テストポイントと調整用VRの位置)

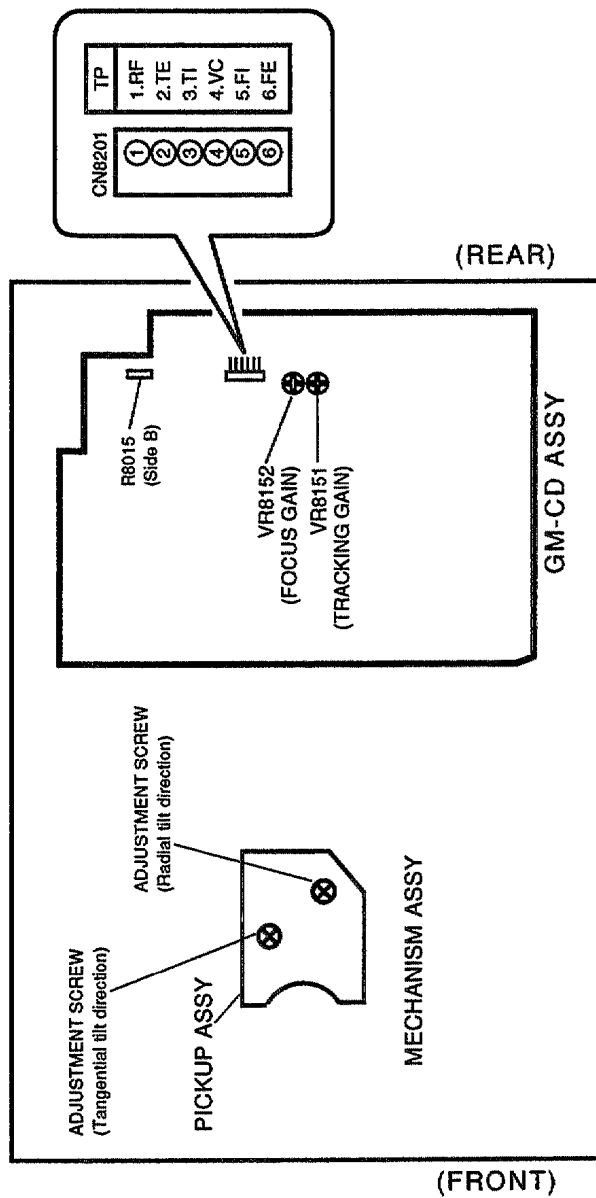

(3) Check and Adjustment (確認、調整)

1. Focus Offset Check

(フォーカスオフセット確認)

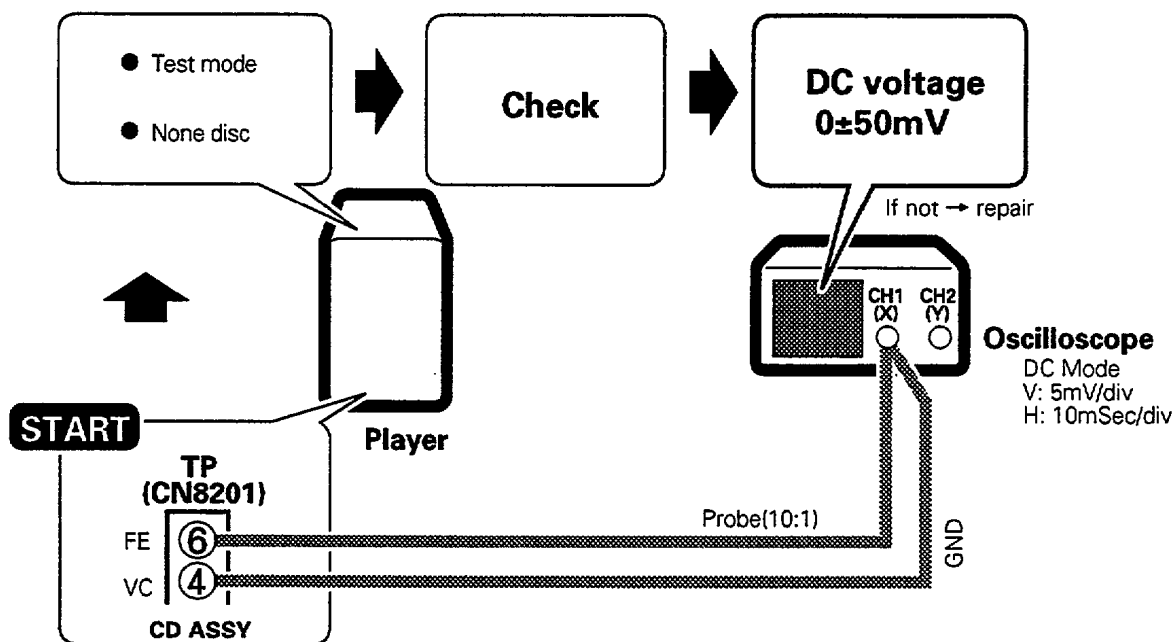

2. Tracking Error Balance Check

(トラッキングエラーバランス確認)

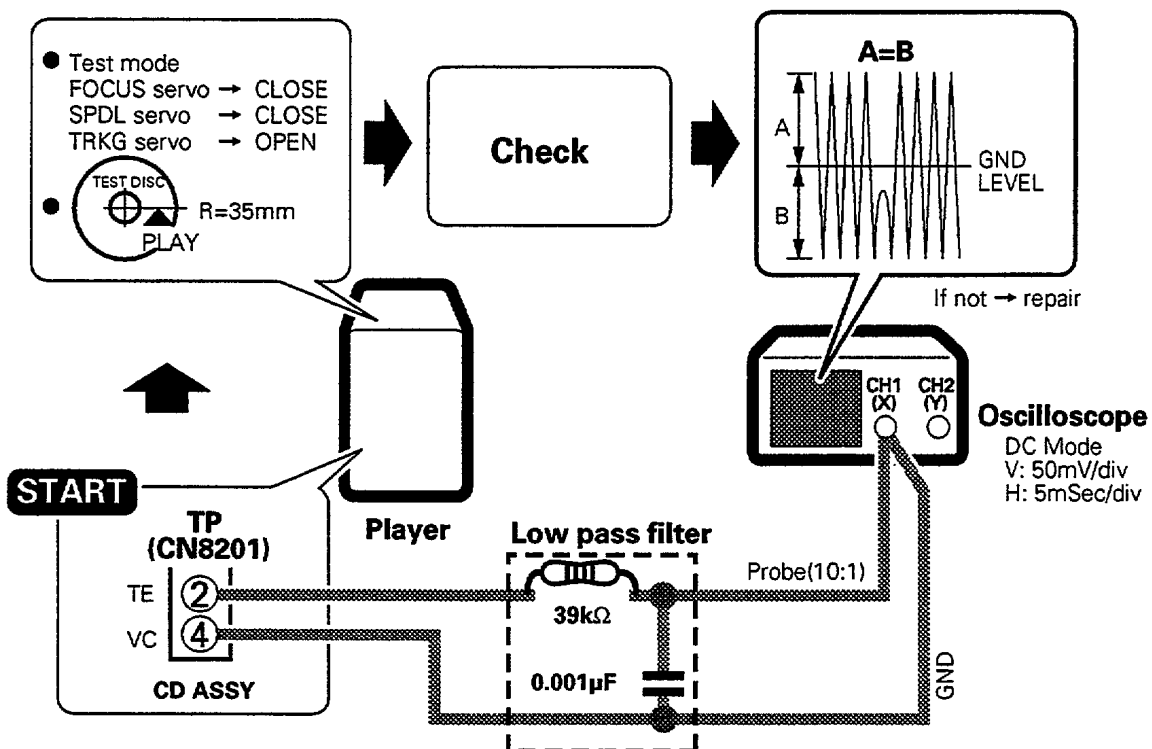

### 3. PICKUP ①RADIAL / ②TANGENTIAL DIRECTION TILT ADJUSTMENT

(ピックアップ①ラジアル方向②タンジェンシャル方向の傾き調整)

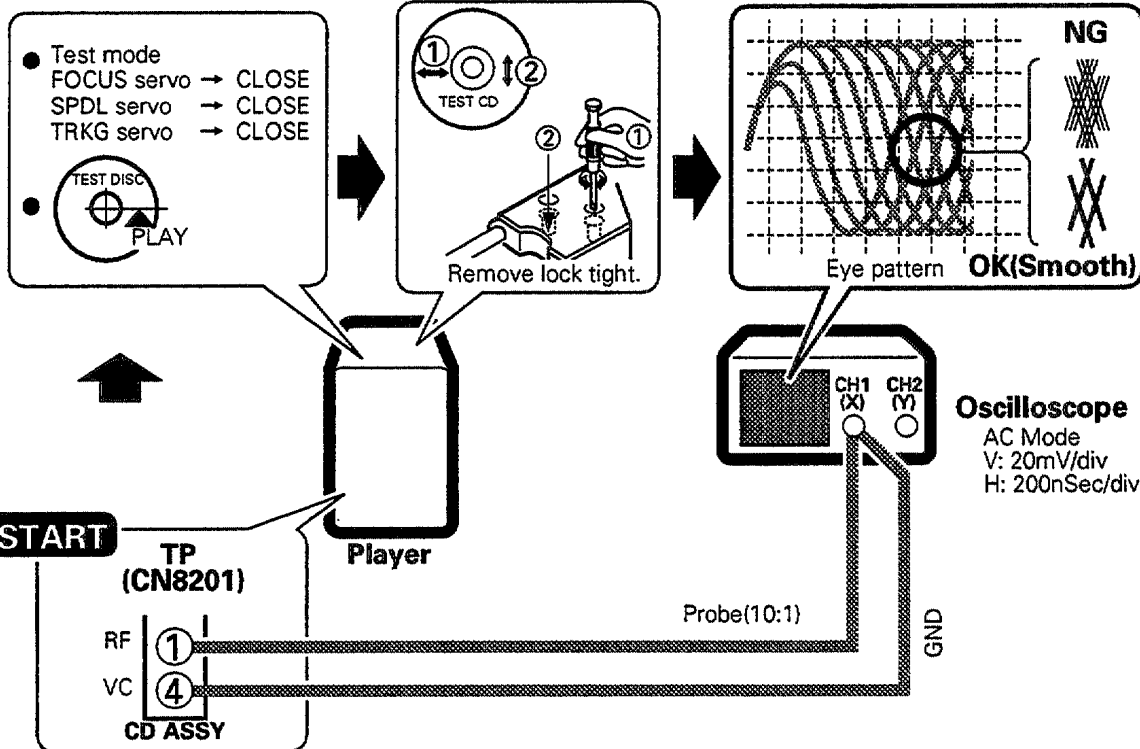

### 4. RF LEVEL CHECK

(RFレベル確認)

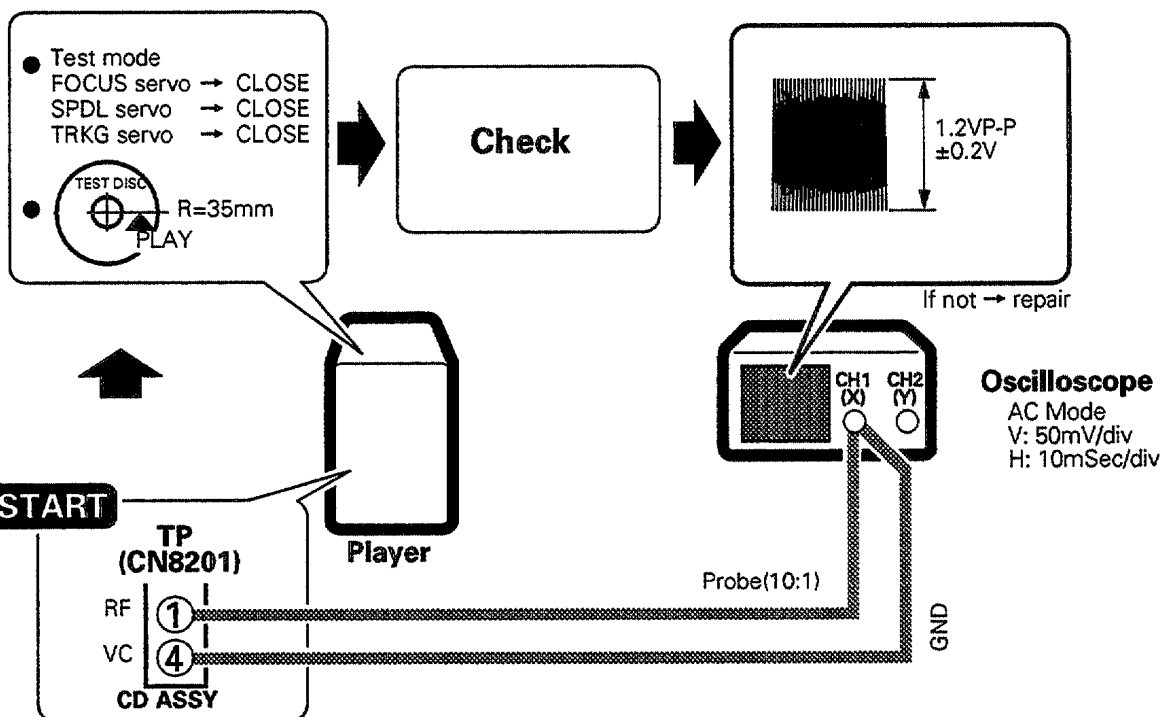



### 5. Focus Servo Loop Gain Adjustment

(フォーカスサーボループゲイン調整)

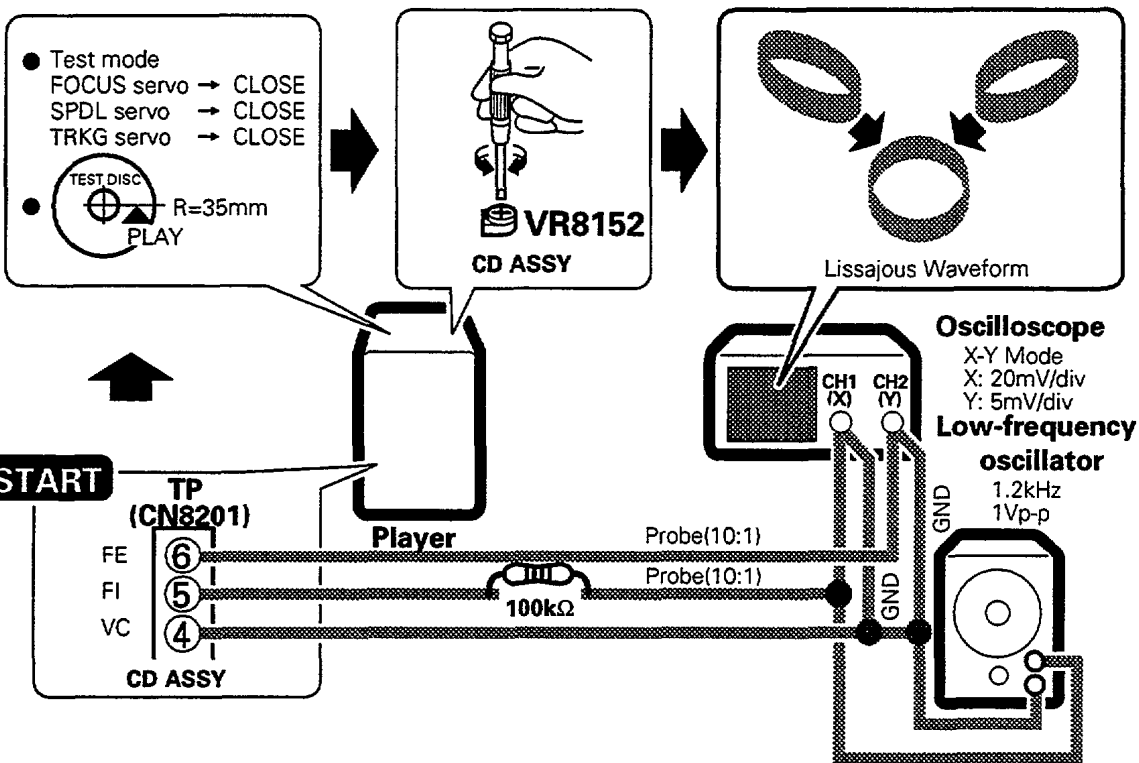

### 6. Tracking Servo Loop Gain Adjustment

(トラッキングサーボループゲイン調整)

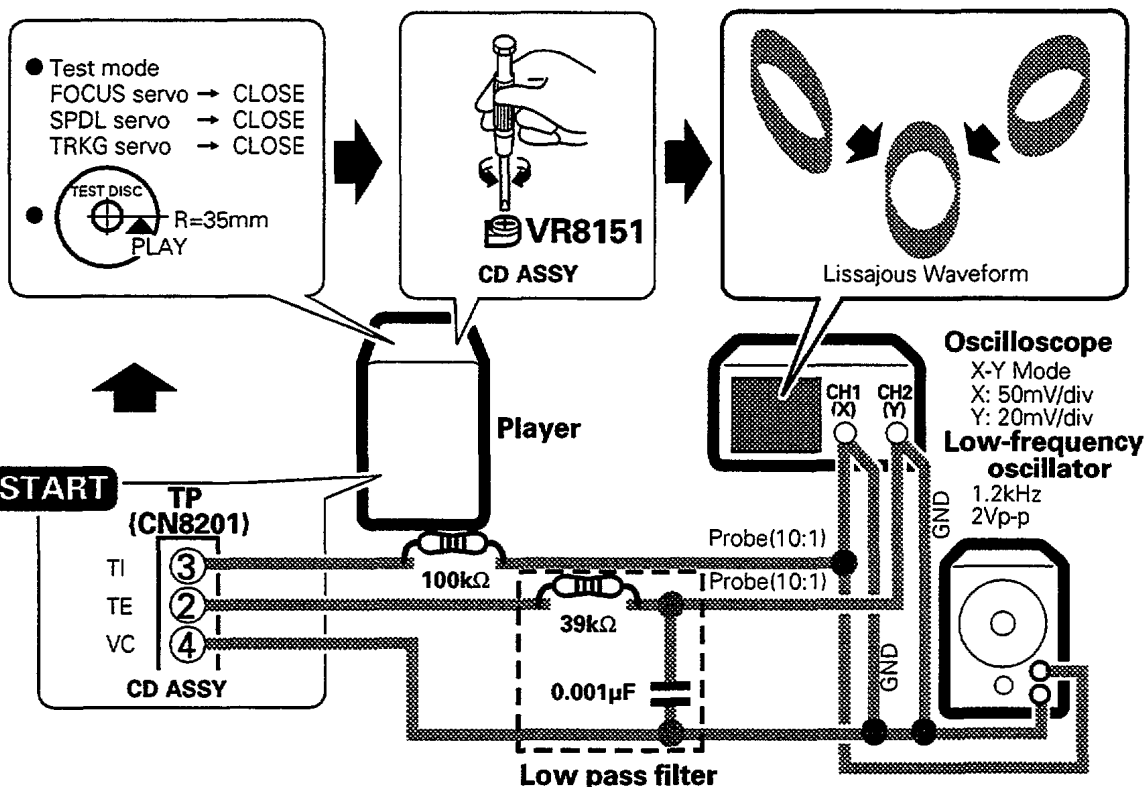

## 7. GENERAL INFORMATION

### 7.1 PARTS

#### 7.1.1 IC

• The information shown in the list is basic information and may not correspond exactly to that shown in the schematic diagrams.

#### ■ PD4756B (GM-CD ASSY : IC8001)

#### ● CD, Tuner Control Microcomputer

#### ● Pin Function

No.	Pin Name	I/O	Function CD/TUNER	Description	No.	Pin Name	I/O	Function CD/TUNER	Description
1	P15	I	TUNER	RDS ID	35	P57	O	CD	LEDR * LED Red L: lights (LED レッド L:点灯)
2	P16	I	TUNER	RDS DATA	36	P60	I	CD	EJECT * L: Complete return (L:リターン完)
3	P17	O	TUNER	RDS MUTE	37	P61	I	CD	CLMP * L: Complete clamp (L:クランプ完)
4	AVss	-	—	GND	38	P62	I	CD	HOME * L: Home position (L:ホーム位置)
5	P130	O	CD	DOOR IN *1	39	P63	I	—	NC
6	P131	O	CD	DOOR OUT *1	40	P64	I	—	NC
7	AVref1	-	—	+5V	41	P65	I	—	NC
8	P70	I	TUNER	PLL DATA IN	42	P66	I	—	NC
9	P71	O	TUNER	PLL DATA OUT	43	P67	I	CD	INSD *L: Carridge inside
10	P72	O	TUNER	PLL DATA CLK	44	P30	I/O	—	SB R/E
11	S11	I	CD	SQSO	45	P31	I/O	—	SB DATA
12	S01	O	CD	CD LSI DATA	46	P32	O	CD	LDON *L: LD ON
13	SCK 1	O	CD	CD LSI CLK	47	P33	O	CD	DSL T *2
14	P23/STB	O	—	NC	48	P34	O	CD	DSRT *2
15	P24	O	TUNER	PLL CE	49	P35	O	CD	L IN *3
16	P25	O	TUNER	TX MUTE	50	P36	O	CD	L OUT *3
17	S00	O	—	DISP DATA	51	P37	I	CD	D CNT
18	SCK0	O	—	DISP CLK	52	P120/RTP0	O	—	NC
19	P40	O	CD	XLAT	53	P121	I	CD	DOOR CLOSE *L: Complete close (L:クローズ完)
20	P41/AD1	O	—	NC	54	P122	I	CD	DOOR OPEN *L: Complete open (L:オープン完)
21	P42/AD2	O	—	NC	55	P123	O	—	NC
22	P43/AD3	O	—	NC	56	P124	O	—	NC
23	P44/AD4	O	—	NC	57	P125	O	CD	XRST
24	P45/AD5	O	—	NC	58	P126	O	CD	MUTE
25	P46/AD6	O	—	NC	59	P127	O	CD	XTAL ON/OFF
26	P47/AD7	O	—	NC	60	RESET	-	—	RESET
27	P50/A8	O	—	NC	61	INTP0	I	TUNER	RDS CLK
28	P51/A9	O	—	NC	62	INTP1	I	—	SB CLK
29	P52	I	CD	GFS	63	INTP2	I	CD	SCOR
30	P53	I	CD	SENS	64	INTP3	I	—	AC WAVE
31	P54	O	—	RESET OUT * System microprocessor hard reset output. (システムマイコンリセット出力)	65	P04/INTP4	-	—	NC
32	P55	I	—	POWER ON/OFF	66	P05/INTP5	-	—	NC
33	Vss	-	—	GND	67	P06/INTP6	-	—	NC
34	P56	O	CD	LEDG * LED Green L: lights (LED グリーン L:点灯)	68	Vdd	-	—	+5V
					69	X2	-	—	*Main system clock (4.19MHz)

No.	Pin Name	I/O	Function CD/TUNER	Description	No.	Pin Name	I/O	Function CD/TUNER	Description
70	X1	-	---	*Main system clock (4.19MHz)	76	ANI0	I	---	TEST * Type check when initialising (イニシャライズ時仕向チェック)
71	IC	-	---	GND	77	ANI1	I	---	PULL UP
72	XT2	-	---	NC	78	ANI2	I	---	PULL UP
73	P07	I	CD	FCOK	79	ANI3	I	TUNER	ST/TUNED
74	AVdd	-	---	+5V	80	P14	I	---	MODEL CHECK * L: GS2 system H: GS1 system
75	AVref0	-	---	+5V					

\*1 Electric door operation (電動ドア動作)

Operation	Door IN	Door OUT
STOP	L	L
OPEN	L	H
CLOSE	H	L
Setting prohibition	H	H

\*2 Select operation (セレクト動作)

Operation	DSL T	DSRT
STOP	L	L
Right direction (1 → 25)	L	H
Left direction (25 → 1)	H	L
Setting prohibition	H	H

\*3 Clamp/return operation (クランプ/リターン動作)

Operation	L IN	L OUT
STOP	L	L
RETURN	L	H
CLAMP	H	L
Setting prohibition	H	H

■ PDG190A (DISPLAY ASSY : IC2001)

● Display, Deck, Amp Control Microcomputer

● Block Diagram

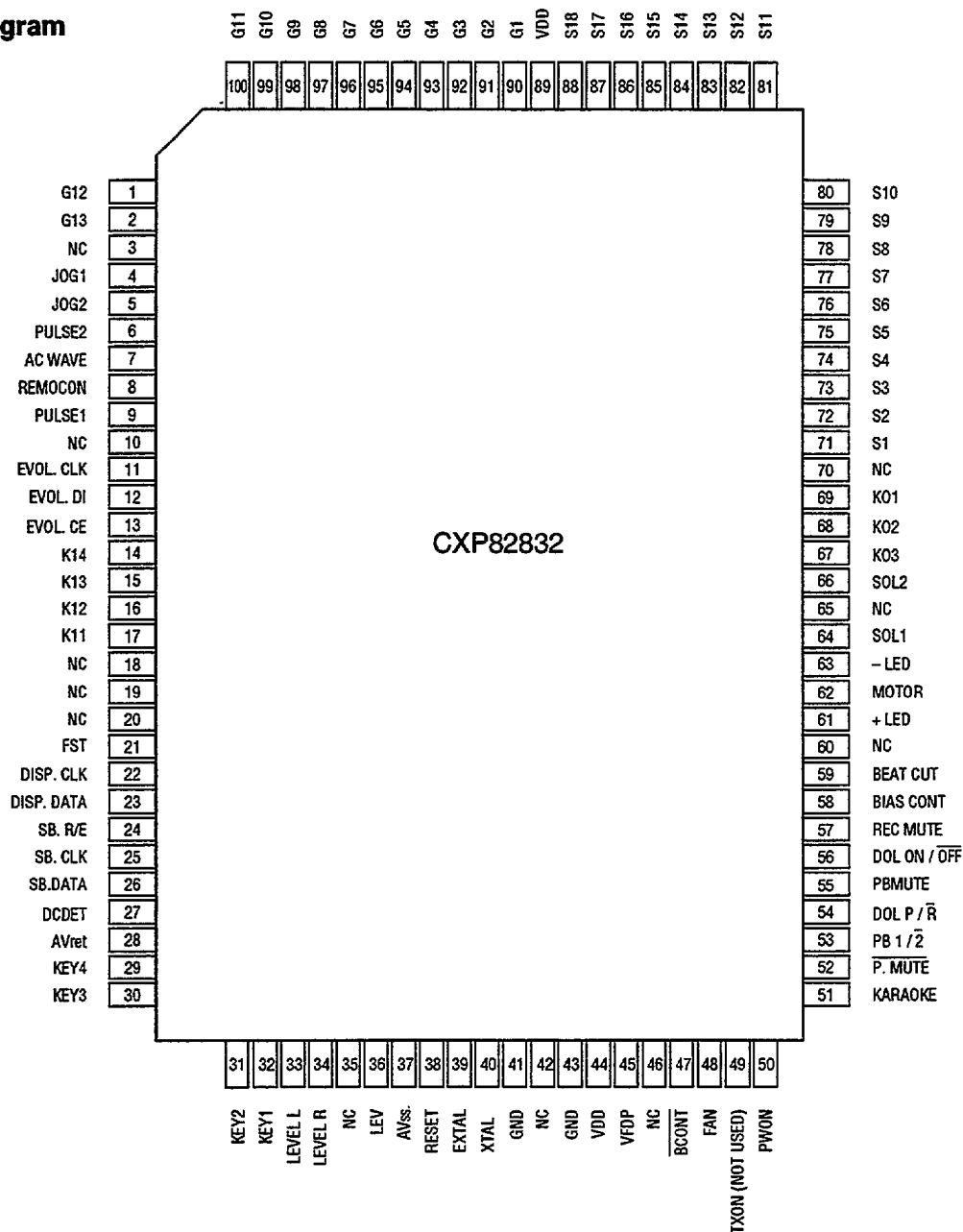

## ● Pin Function

Pin No.	Pin Name	I/O	Description	Pin No.	Pin Name	I/O	Description
1	G1/A1	O	G12	41	Vss	-	GND
2	G0/A0	O	G13	42	TX	-	NC
3	NC	-	VDD	43	TEX	-	GND
4	PE0	I	JOG1	44	VDD	-	VDD
5	PE1	I	JOG2	45	VFDP	-	VFDP
6	PE2	I	PULSE2	46	PD0	-	NC
7	PE3	I	AC WAVE	47	PD1	O	$\overline{\text{BCONT}}$
8	PE4	I	REMOCON	48	PD2	O	FAN
9	PE5	I	PULSE1	49	PD3	-	NC
10	PE6	-	NC	50	PD4	O	PWON
11	PE7	O	EVOL. CLK	51	PD5	O	KARAOKE
12	PC0	O	EVOL. DATA	52	PD6	O	$\overline{\text{PMUTE}}$
13	PC1	O	EVOL. CE	53	PD7	O	PB 1/2
14	PC2	I	K14	54	PF0	O	DOL P/R
15	PC3	I	K13	55	PF1	O	PBMUTE
16	PC4	I	K12	56	PF2	O	DOL ON/OFF
17	PC5	I	K11	57	PF3	O	REC MUTE
18	PC6	-	NC	58	PF4	O	BIAS CONT
19	PC7	-	NC	59	PF5	O	BEAT CUT
20	PB0	-	NC	60	PF6	-	NC
21	PB1	I	FST	61	PF7	O	+LED
22	PB2	I	DISP. CLK	62	PG0	O	MOTOR
23	PB3	I	DISP. DATA	63	PG1	O	-LED
24	PB4	I/O	SB. R/E	64	PG2	O	SOL1
25	PB5	O	SB. CLK	65	PG3	-	NC
26	PB6	I/O	SB. DATA	66	PG4	O	SOL2
27	PB7	I	DCDET	67	PG5	O	KO3
28	AVref	-	AVref	68	PG6	O	KO2
29	PA0	A/D	KEY4	69	PG7	O	KO1
30	PA1	A/D	KEY3	70	PH0	-	NC
31	PA2	A/D	KEY2	71	A30	O	S1
32	PA3	A/D	KEY1	72	A29	O	S2
33	PA4	A/D	LEVEL L	73	A28	O	S3
34	PA5	A/D	LEVEL R	74	A27	O	S4
35	PA6	-	NC	75	A26	O	S5
36	PA7	A/D	LEV	76	A25	O	S6
37	AVss	-	AVss	77	A24	O	S7
38	RESET	I	RESET	78	A23	O	S8
39	EXTAL	-	EXTAL	79	A22	O	S9
40	XTAL	-	XTAL	80	A21	O	S10

Pin No.	Pin Name	I/O	Description	Pin No.	Pin Name	I/O	Description
81	A20	O	S11	91	G11/A11	O	G2
82	A19	O	S12	92	G10/A10	O	G3
83	A18	O	S14	93	G9/A9	O	G4
84	A17	O	S15	94	G8/A8	O	G5
85	A16	O	S16	95	G7/A7	O	G6
86	A15	O	S17	96	G6/A6	O	G7
87	A14	O	S17	97	G5/A5	O	G8
88	A13	O	S18	98	G4/A4	O	G9
89	VDD	-	VDD	99	G3/A3	O	G10
90	G12/A12	O	G1	100	G2/A2	O	G11

I/O : INPUT/OUTPUT  
 I : INPUT  
 O : OUTPUT

## ■ LM3886TF (AMP ASSY : IC5501, IC5502)

### ● Audio Power Amplifier

### ● Block Diagram

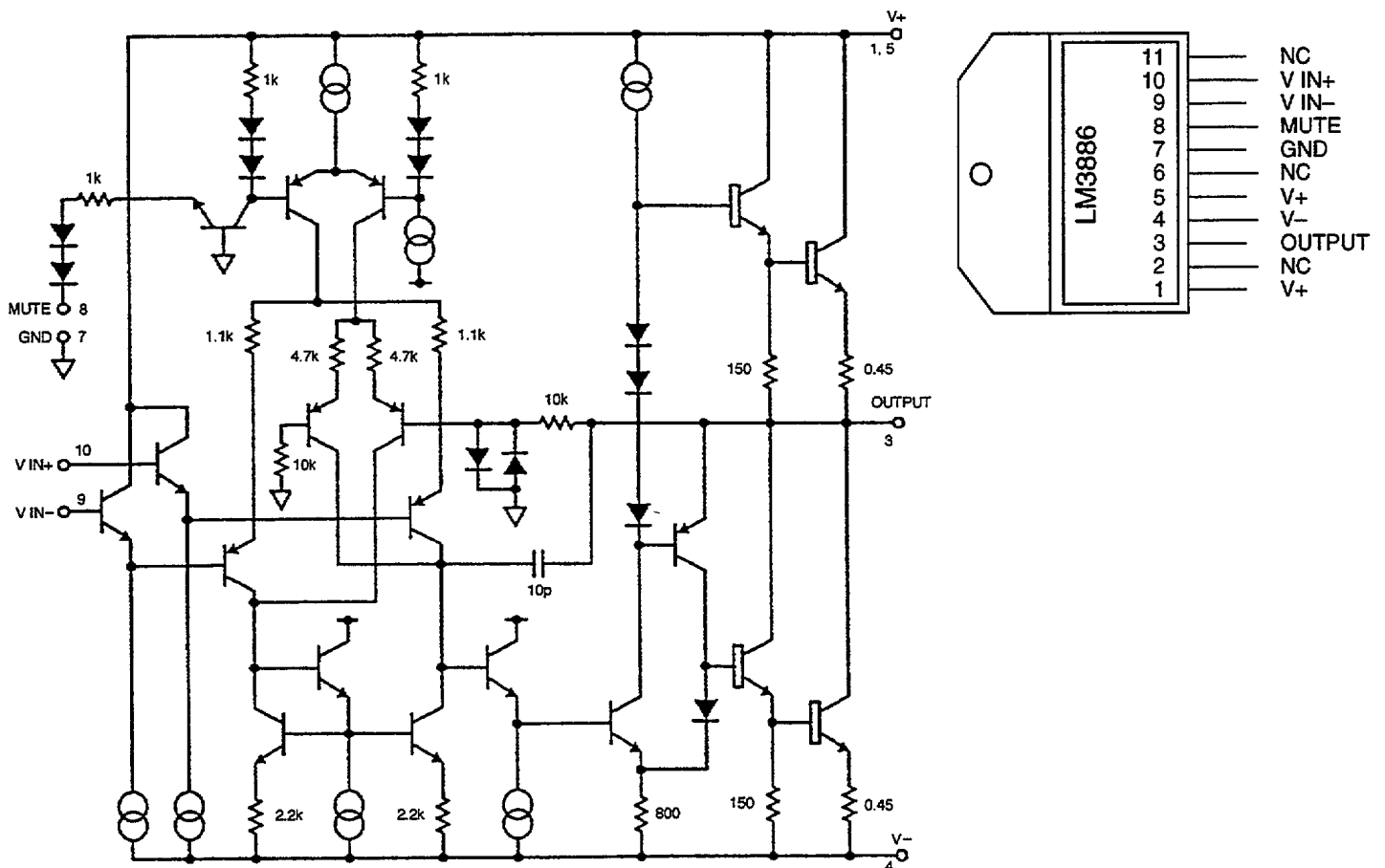

# XR-P670F

## 7.1.2 DISPLAY

### ■ AAV7033 (DISPLAY ASSY : V2001)

#### ● FL Tube

#### ● Pin Assignment

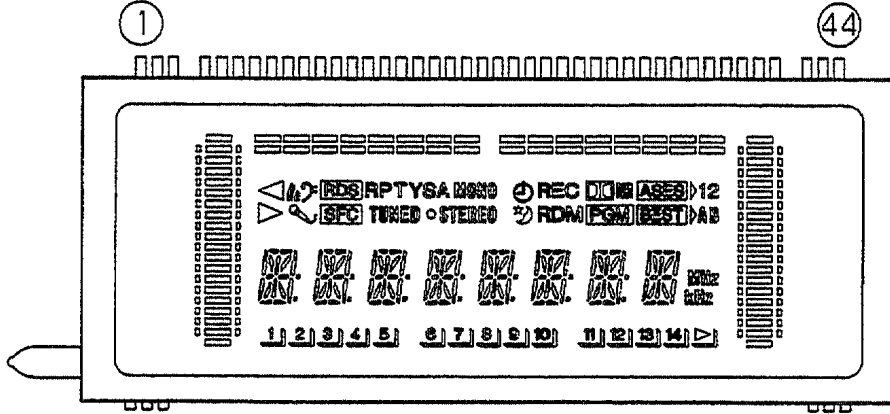

#### ● Anode and Grid Connection

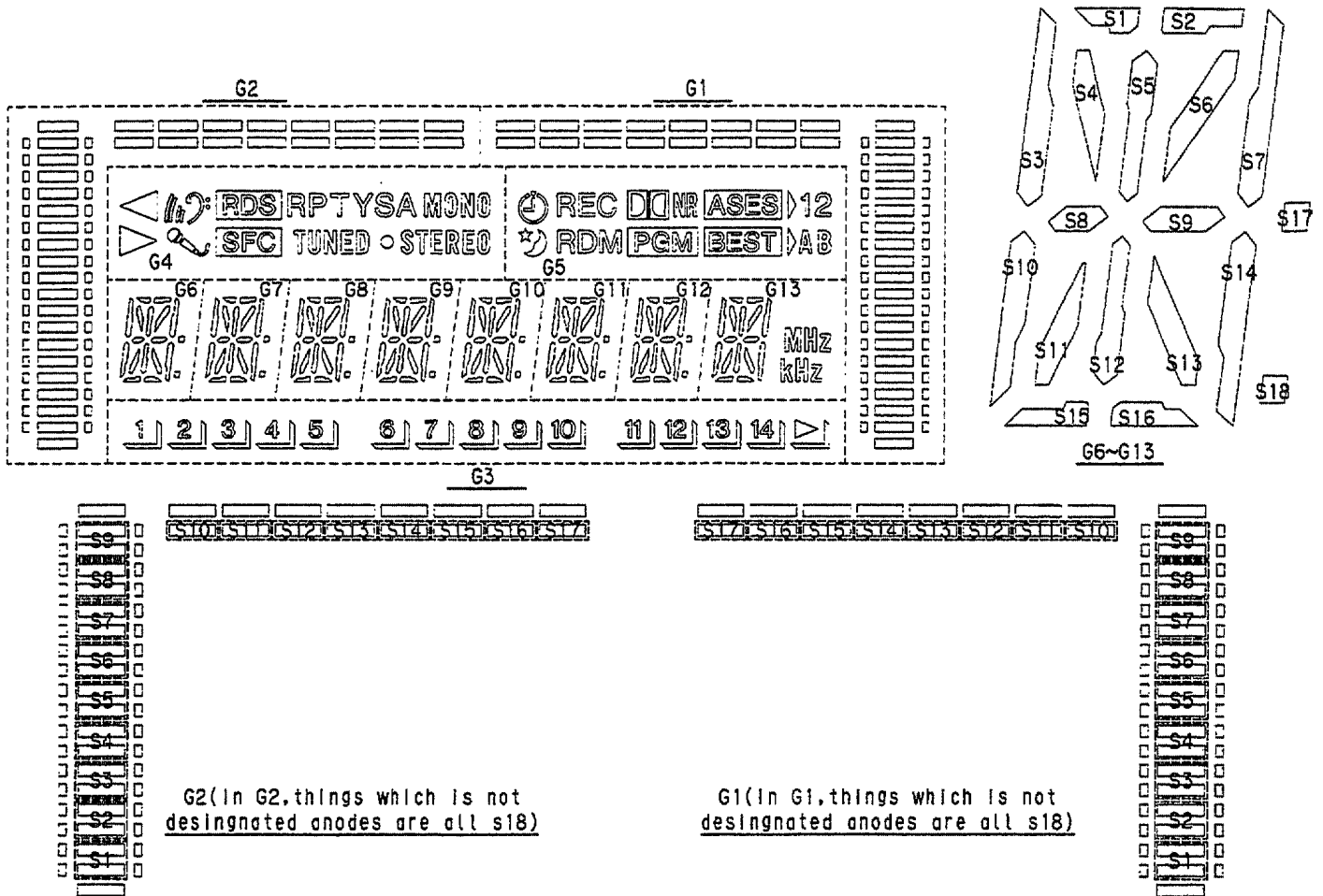

● Pin Connection

Pin No.	1	2	3	4	5	6	7	8	9	10	11	12	13	14	15	16	17	18	19	20	21	22
Assignment	F1	F1	F1	NP	NL	S1	S2	S3	S4	S5	S6	S7	S8	S9	S10	S11	S12	S13	S14	S15	S16	S17

Pin No.	23	24	25	26	27	28	29	30	31	32	33	34	35	36	37	38	39	40	41	42	43	44
Assignment	S18	NL	NL	NL	G1	G2	G3	G4	G5	G6	G7	G8	G9	G10	G11	G12	G13	NL	NP	F2	F2	F2

F1,F2:Filament G1-G13:Grid S1-S18:Anode NP:No Pin NL:No Lead

● Anode and Grid Assignment

	G1	G2	G3	G4	G5	G6~G12	G13
S1	S1	S1	1		PGM	S1	S1
S2	S2	S2	2		BEST	S2	S2
S3	S3	S3	3			S3	S3
S4	S4	S4	4	STEREO		S4	S4
S5	S5	S5	5	TUNED	(AB)	S5	S5
S6	S6	S6	6		A	S6	S6
S7	S7	S7	7	SFC	RDM	S7	S7
S8	S8	S8	8		(12)	S8	S8
S9	S9	S9	9		1	S9	S9
S10	S10	S10	10	RDS	2	S10	S10
S11	S11	S11	11	T	NR	S11	S11
S12	S12	S12	12	Y	REC	S12	S12
S13	S13	S13	13	P	ASES	S13	S13
S14	S14	S14	14	R	B	S14	S14
S15	S15	S15		S		S15	S15
S16	S16	S16	(15箇所)	A		S16	S16
S17	S17	S17				S17	MHz
S18	S18	S18		MONO		S18	KHz

## 7.2 DISASSEMBLY (各部のはずしかた)

### ■ REMOVING THE GS MECHANISM ASSY (GSメカASSYのはずしかた)

**NOTE:** Before removing the GS Mecha Assy, make sure you turn the power OFF and disconnect the AC power cord.

(注意: はずす前に必ず電源を切ってから電源コードを抜いてください。)

- 1 Remove the bonnet. (Since the front of the home lock stay makes contact, hold the bonnet in that place and pull and lift at the same time.)  
(ボンネットをはずす。ホームロックステイのフロント側があたるので、その箇所のボンネットを持ち上げながら引く。)

- 2 Move the GS Mechanism ASSY to the right (viewed from the rear), watching out for the 2 Lock locations (part A).  
(GSメカASSYをロック2ヶ所(A部)を解除して、リア側から見て右端に移動する。)

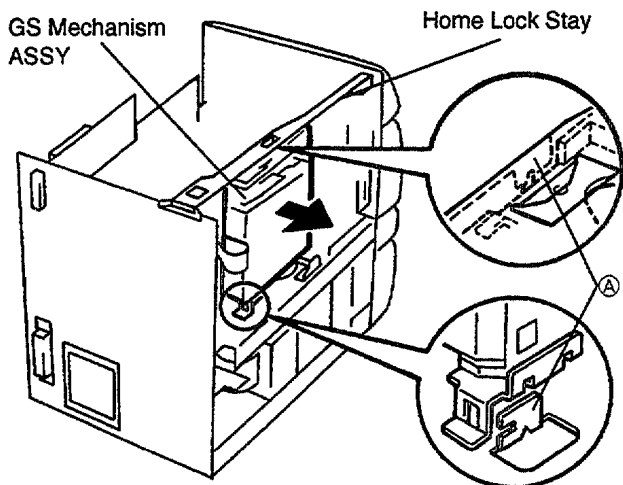

3

Release the shaft holder that fixes guide shaft-25 in place (screw ③), and remove the GS Mechanism ASSY together with the guide shaft.

(ガイドシャフトSを固定しているシャフトホルダーをはずし(ネジ③)、GSメカAssyのロック(A部)を解除して、ガイドシャフトSごとGSメカASSYをはずす。)

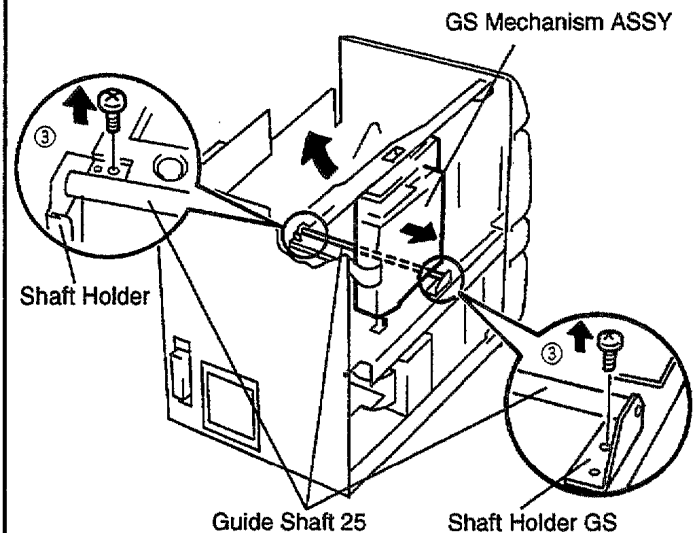

### ■ REMOVING THE FRONT PANEL (フロントパネルのはずしかた)

- 1 Remove the bonnet.  
(ボンネットをはずす。)

2 - 3

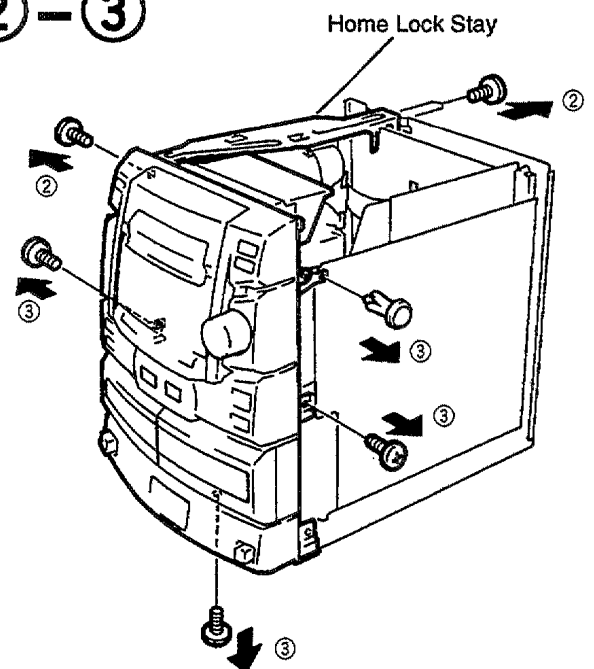



④ - ⑥

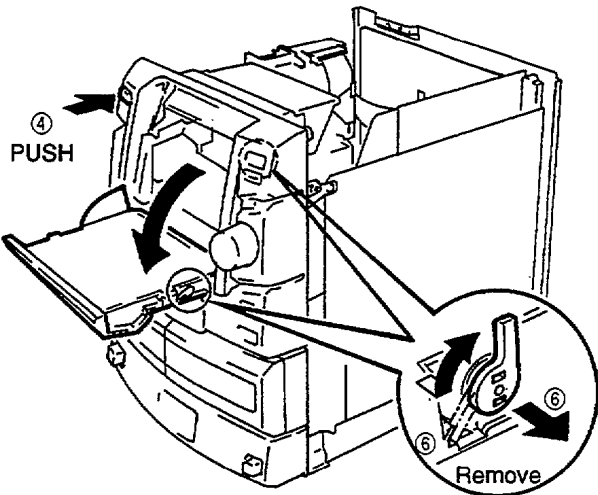

■ HOW TO REMOVE THE DOOR PANEL

(カセットドアパネルのはずしかた)

- ① Open the Cassette Door Panel.  
(カセットドアパネルをOPENする。)
- ② Slide the Cassette Door Panel, then remove it.  
(カセットドアパネルをスライドさせはずす。)

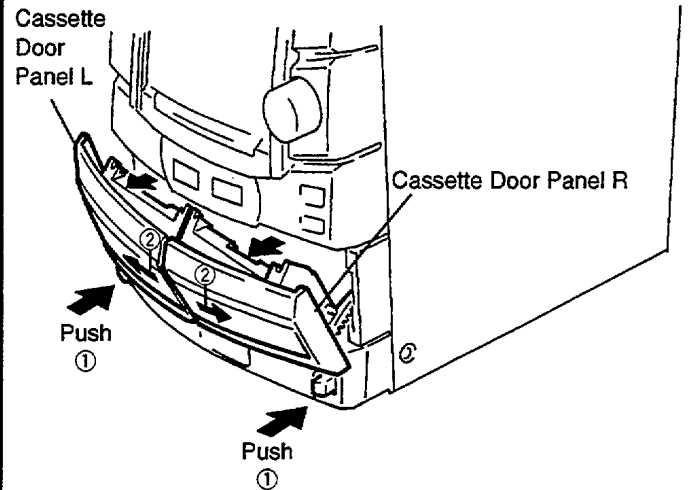

- ⑦ Shift the front panel slightly toward you, being cautious of the left and right catches on the chassis and sub chassis.

(フロントパネルをシャーシとサブシャーシの左右のツメに注意しながら手前に少しずらす。)

- ⑧ Pull the front panel further toward you, and remove it from the chassis.

(フロントパネルをさらに手前に引き、シャーシから抜く。)

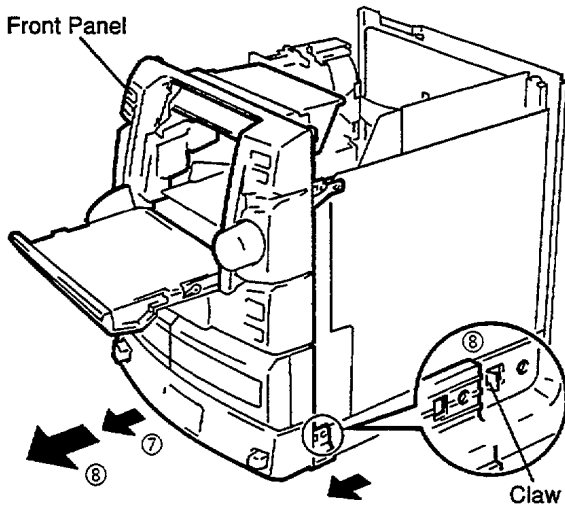

■ MICRO COMPUTER IC REPLACEMENT METHOD

(マイコンICの交換方法)

①, ②, ③

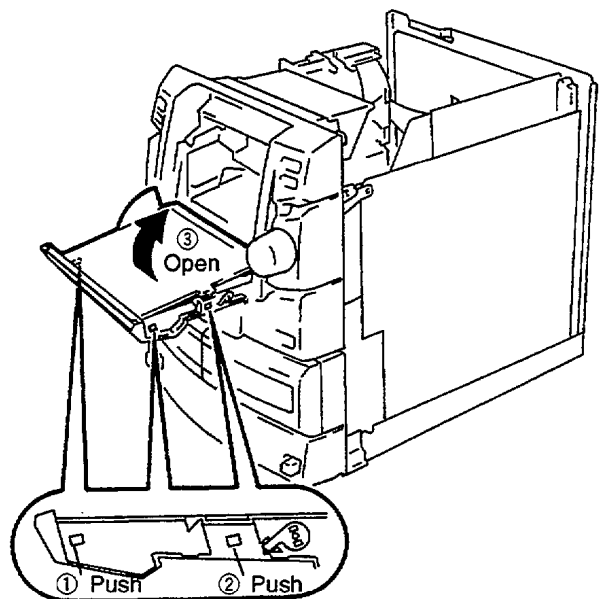

**REMOVING THE DISC RACK**  
(ディスクラックのはずしかた)

**1** Remove the front panel.  
(フロントパネルをはずす。)

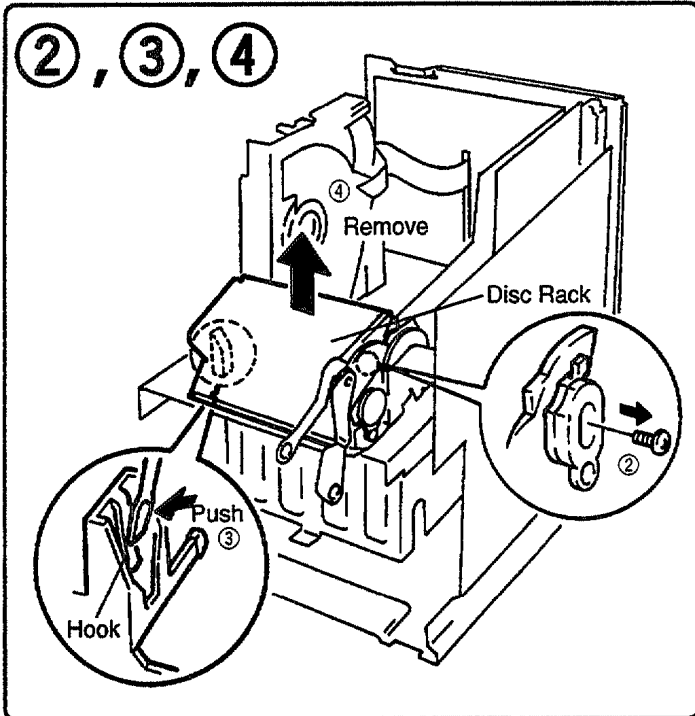

**REMOVING THE POWER AMP MODULE**  
(パワーアンプモジュールのはずしかた)

**1** Remove the bonnet and home lock stay.  
(Refer to "Removing the Front Panel")  
(ボンネットとホームロックステイをはずす。)  
(“フロントパネルのはずし方” 参照)

**2, 3**  
Remove the spacer from the GM-CD ASSY.  
(GM-CDASSYからロッキングカードスペーサをはずす。)

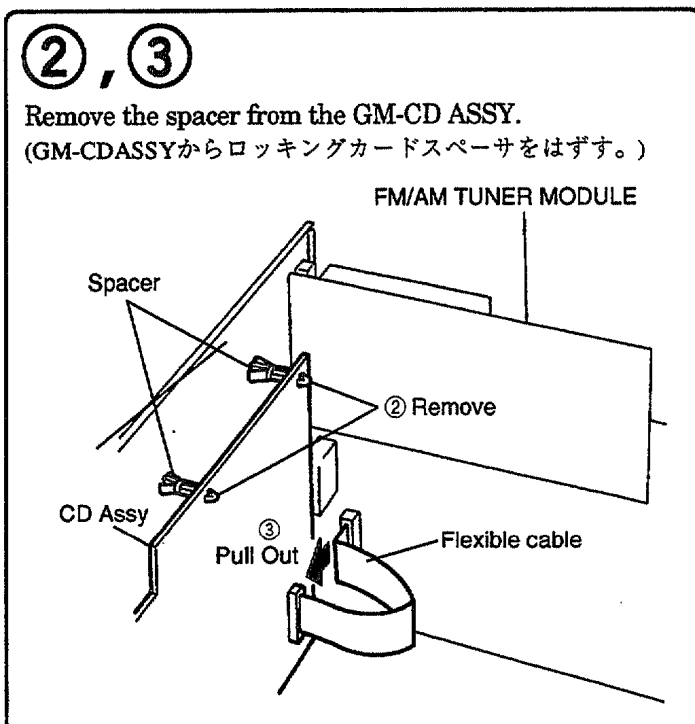

**4** Remove the rear panel (screw ④ x 5).  
(リアパネルをはずす。(ネジ④5本))

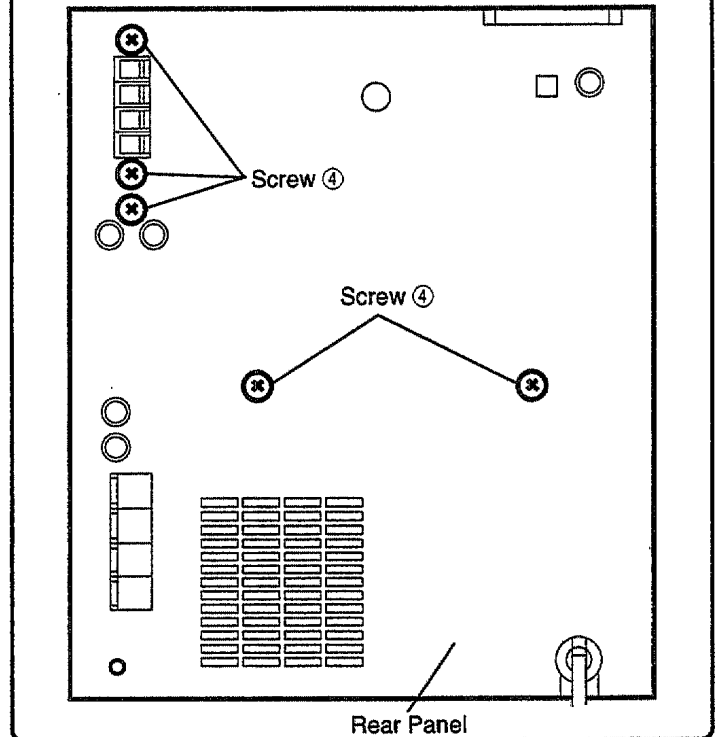

**5-7**

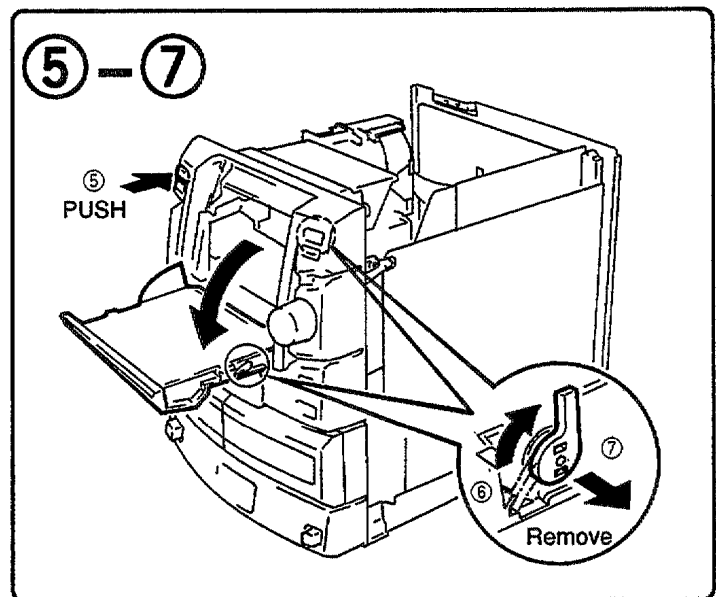

**⑧, ⑨, ⑩**

Remove screw ⑧, ⑨ and remove the sub chassis together with the GS Mechanism ASSY.

(ネジ⑧, ⑨をはずしてGSメカごとサブシャーシをはずす。)

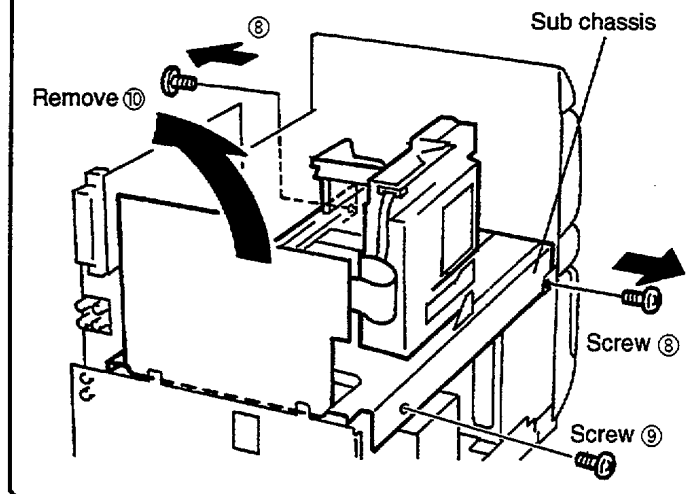

**⑪, ⑫**

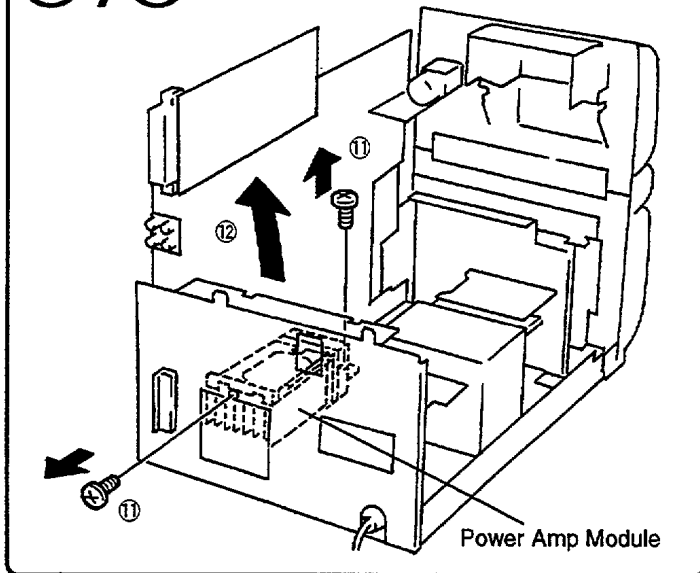

# XR-P670F

## 7.3 BLOCK DIAGRAM

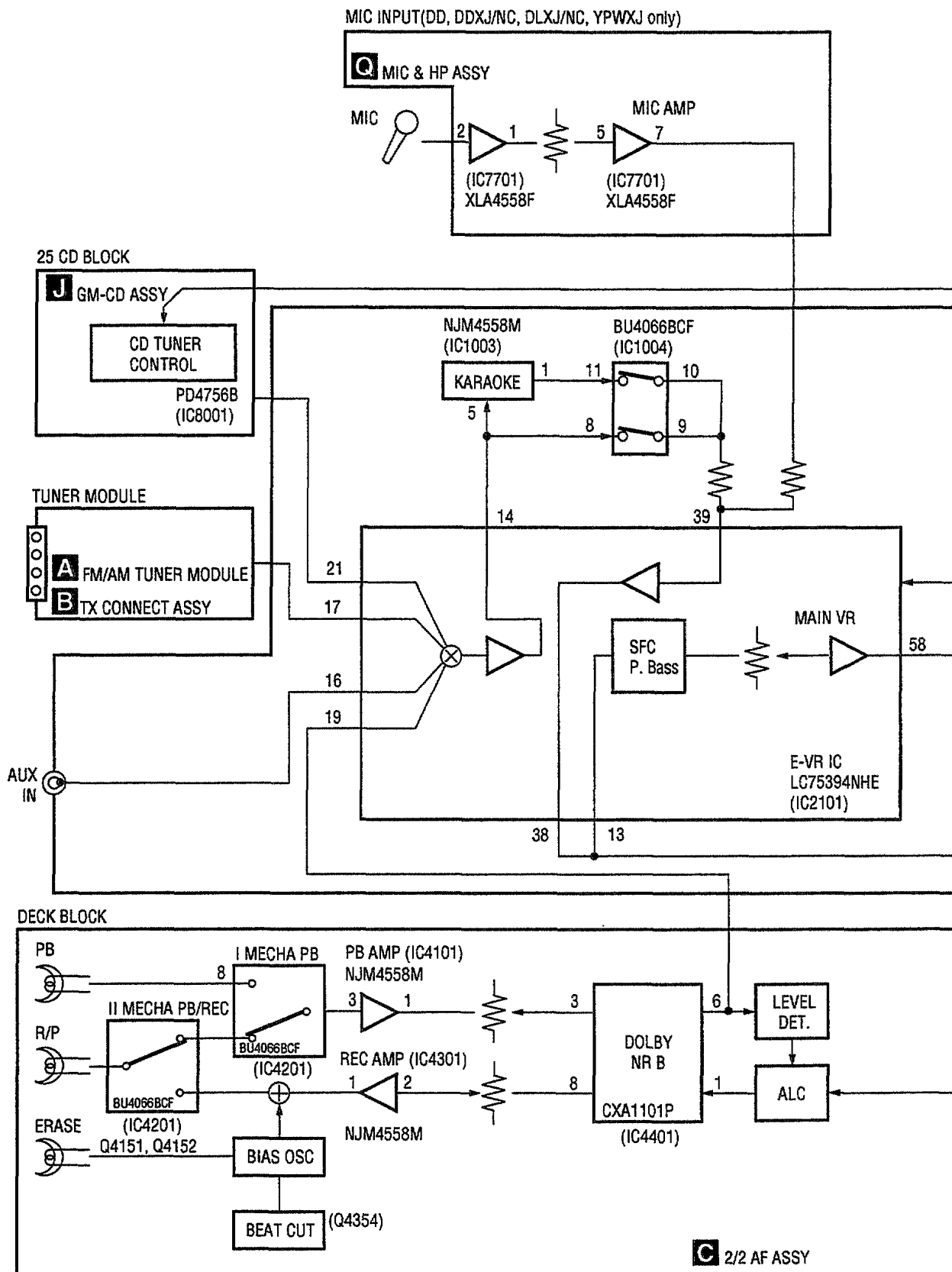

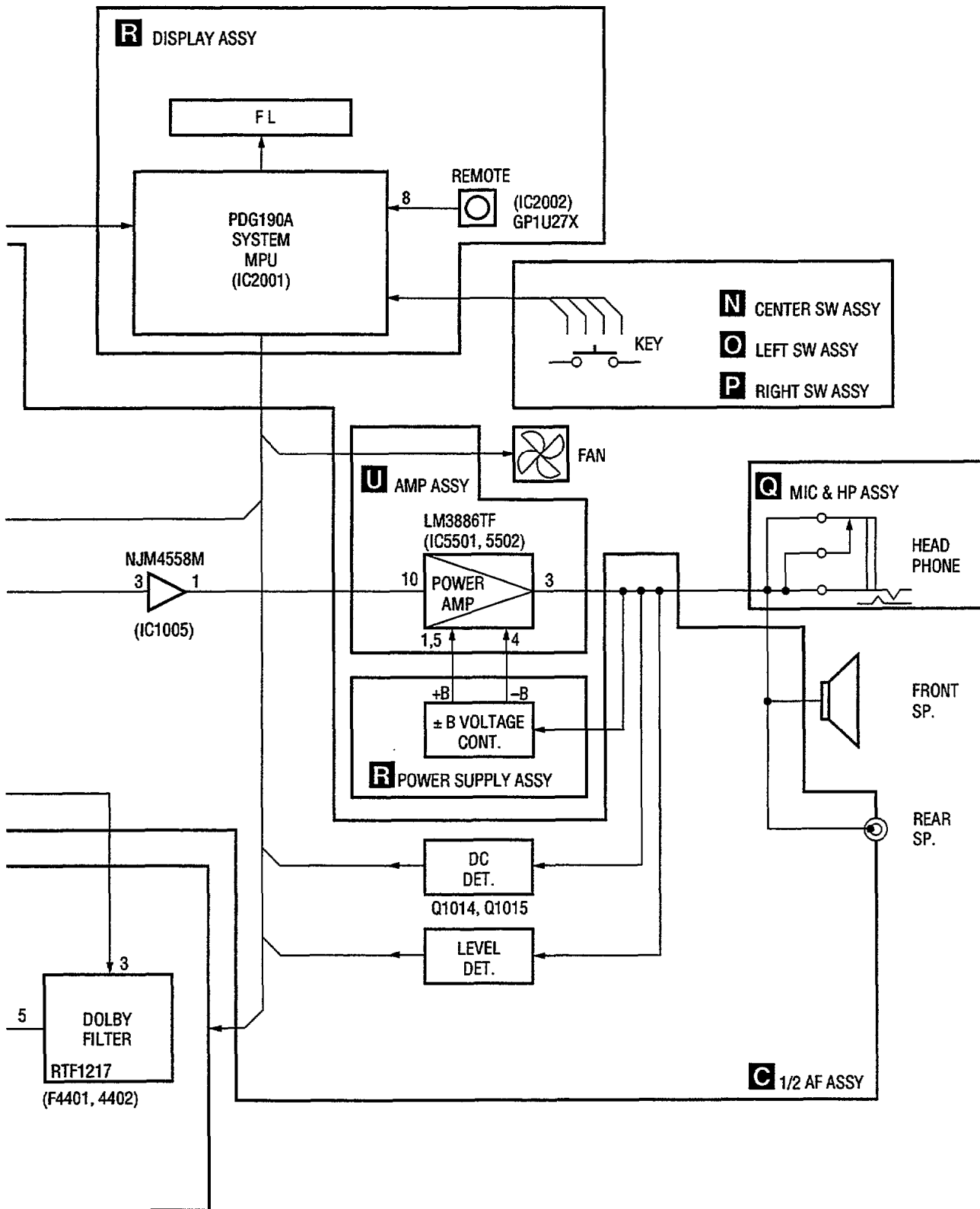

## 8. PANEL FACILITIES AND SPECIFICATIONS

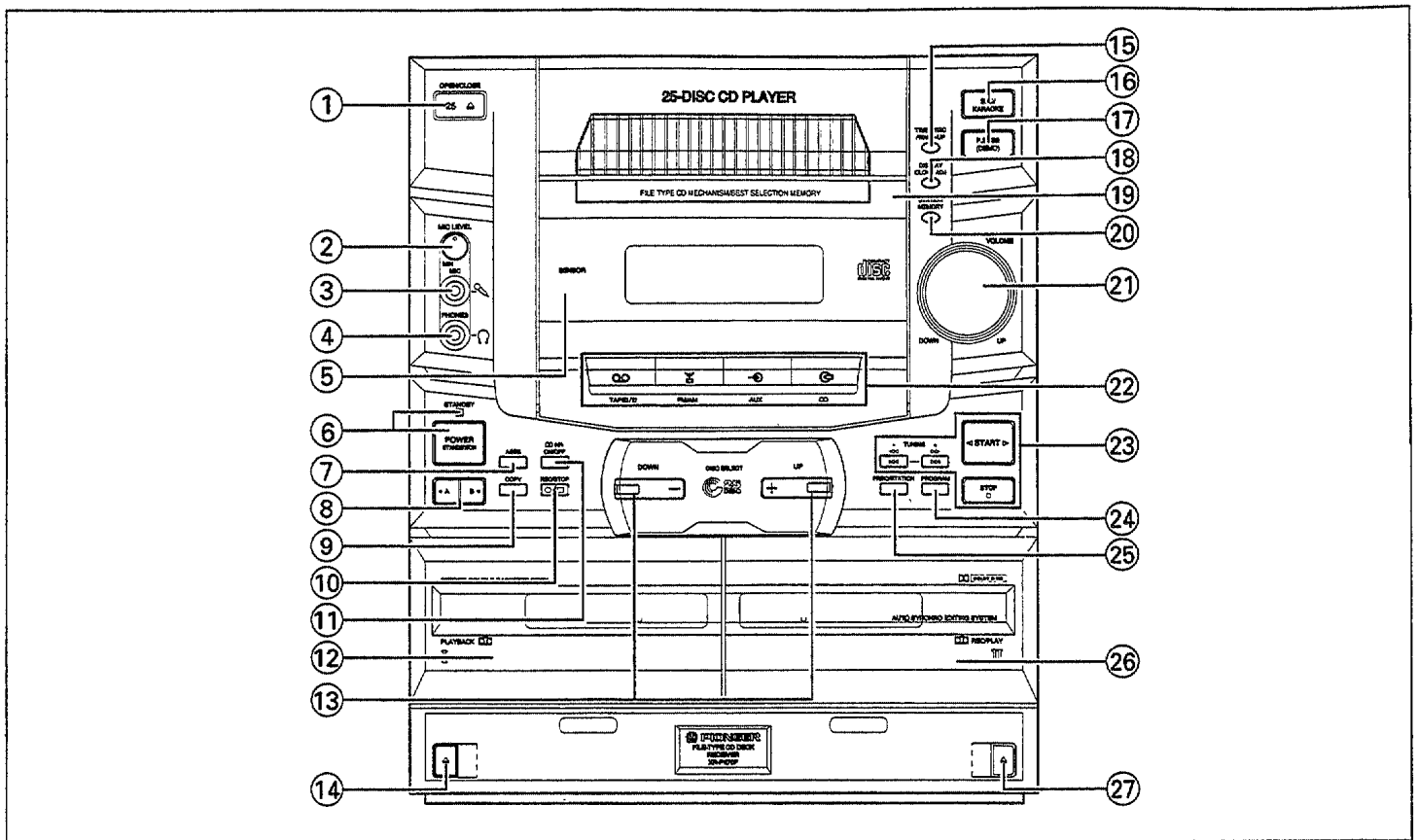

- ① 25 OPEN/CLOSE button
- ② Microphone level (MIC LEVEL)
- ③ Microphone jack (MIC)
- ④ Headphones jack (PHONES)
- ⑤ Remote sensor
- ⑥ POWER STANDBY/ON switch and STANDBY indicator  
This is the switch for electric power.  
**ON** : When set to the ON position, power is supplied and the unit becomes operational.  
**STANDBY** : When set to the STANDBY position, the main power flow is cut and the unit is no longer fully operational. A minute flow of power feeds the unit to maintain operation readiness. (The STANDBY indicator lights.)
- ⑦ ASSES button
- ⑧ BEST (A, B) button
- ⑨ COPY button
- ⑩ REC/STOP button (●/■)
- ⑪ Dolby\* NR ON/OFF button  
Each time this button is pressed, the Dolby NR system turns on and off.
- ⑫ TAPE I cassette door
- ⑬ DISC SELECT UP/DOWN (+, -) buttons
- ⑭ TAPE I Eject button (▲)
- ⑮ TIMER REC/WAKE-UP button

- ⑯ SFC/KARAOKE button  
Each time this button is pressed, the mode changes in the following sequence:

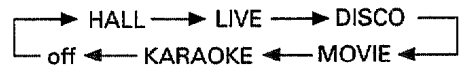

**NOTE:**  
If KARAOKE is selected, the vocal part in songs is muted and only the instrumental accompaniment (backup) is played.

- ⑰ P.BASS (DEMO) button
- ⑱ DISPLAY CLOCK ADJ button
- ⑲ Door panel
- ⑳ STATION MEMORY button
- ㉑ VOLUME control
- ㉒ Function buttons
- ㉓ Common operation button section
- ㉔ PROGRAM button
- ㉕ FREQ/STATION button
- ㉖ TAPE II cassette door
- ㉗ TAPE II Eject button (▲)

\*  
● Dolby noise reduction manufactured under license from Dolby Laboratories Licensing Corporation.  
● "DOLBY" and the double-D symbol are trademarks of Dolby Laboratories Licensing Corporation.

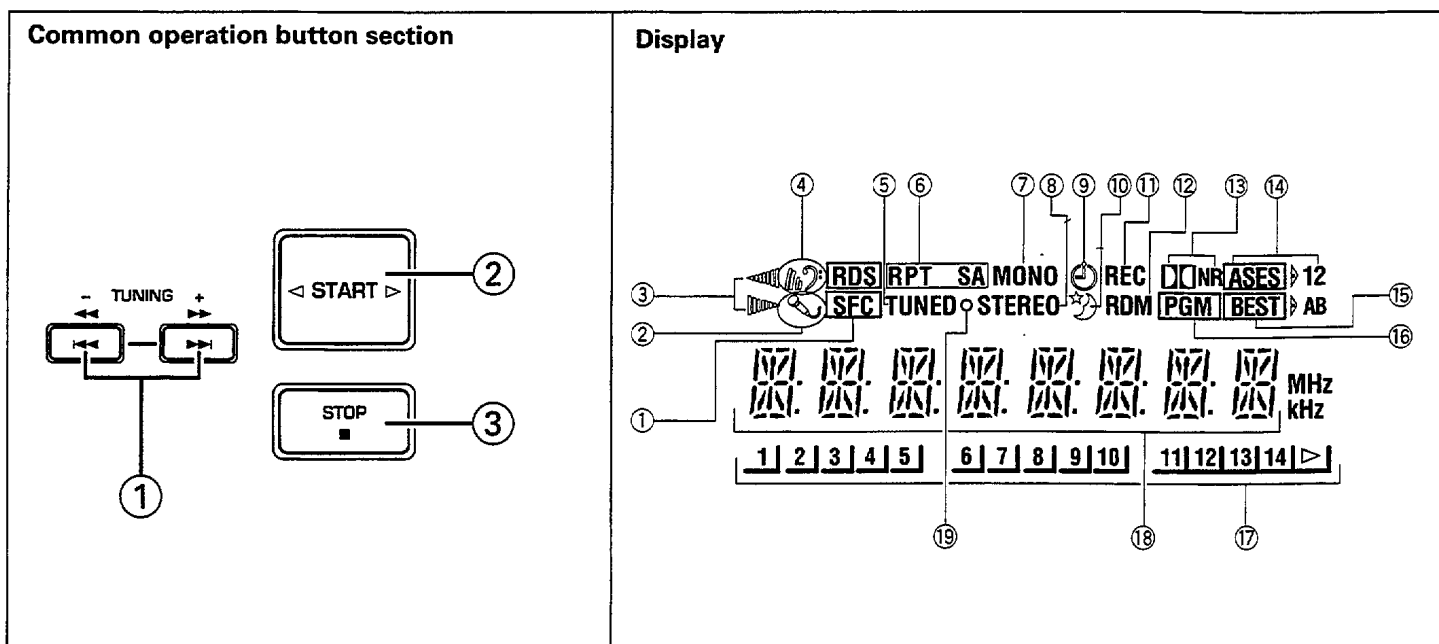

- ① , buttons
- ② **START** button (◀▶)
- ③ **STOP** button (■)

● Roles of the common operation buttons. (The roles of the buttons vary depending on the input functions as shown below.)

**During CD input**

- START** : Play/pause button
- STOP** : Stop button
- : Fast forward/track search button
- : Fast reverse/track search button

**During cassette deck input**

- START** : Play button/Tape transport direction
- STOP** : Stop button
- : Fast forward button
- : Rewind button

**During tuner operation**

- : Frequency Up button
- : Frequency Down button

**During timer setting**

- : Increasing timer button
- : Decreasing timer button

- ① Lights during SFC mode operation.
- ② Lights during KARAOKE mode operation.
- ③ Lights to show tape direction.  
Indicates direction of TAPE II except TAPE functions.
- ④ Lights when you press the P.BASS button.
- ⑤ Lights during radio broadcast reception.
- ⑥ RPT : Lights during repeat play.  
S : Lights during SINGLE mode operation.  
A : Lights during ALL mode operation.
- ⑦ Lights when you press the MONO button.
- ⑧ Lights during FM stereo reception.
- ⑨ Lights when setting the timer.
- ⑩ Lights during sleep timer operation.
- ⑪ Lights during recording and timer recording operation.
- ⑫ Lights when you press the RANDOM button.
- ⑬ Lights when Dolby NR is ON.
- ⑭ Lights when setting up A.S.E.S.
- ⑮ Flashes during Best Selection setting (A or B), and lights during play.
- ⑯ Lights when you press the PGM button.
- ⑰ Displays a CD track number. Playing track number and waiting track numbers are displayed. In program play, lights the programmed tracks. ▶ lights when programmed tracks are more than 15.
- ⑱ Indicates frequency and major operation status.
- ⑲ Lights when setting the Beat Cut function.

# XR-P670F

## ■ STEREO FILE-TYPE CD CASSETTE DECK RECEIVER:

### Amplifier Section

Continuous Power Output (RMS) ..... 70 W + 70 W  
 (1 kHz, T.H.D. 10 %, 8 Ω)  
 Peak Music Power Output ..... 1100 W

### FM Tuner Section

Reception frequencies ..... 87.5 MHz to 108 MHz  
 Antenna input ..... 75 Ω unbalanced

### AM Tuner Section

Reception frequencies ..... 531 kHz to 1,602 kHz (9k)  
 530 kHz to 1,700 kHz (10k)  
 Antenna ..... Loop antenna (included)

### Double Cassette Deck Section

System type ..... 4-track, 2-channel stereo  
 Heads ..... Recording/playback head x 1  
 Playback head x 1  
 Erasing head x 1  
 Motor ..... DC servo motor x 1  
 Frequency response  
 Type I (Normal) tape ..... \*35 Hz to 14,000 Hz ±6 dB  
 (recorded at -20 dB)  
 SN ratio ..... \*56 dB  
 (peak recording level, audible compensation)  
 Dolby B type NR on ..... 10 dB compensation at 5 kHz

\* Values measured in accordance with EIAJ standards.

## ■ FILE TYPE CD PLAYER

Type ..... Compact disc audio system  
 Usable discs ..... Compact audio discs  
 Channels ..... 2 channels (stereo)  
 Program steps ..... 32 steps maximum

## ■ ELECTRICAL REQUIREMENTS, ETC.

Power Requirements ..... AC 110-127/220-230/240 V  
 (switchable), 50/60 Hz  
 Power Consumption ..... 350 W  
 External dimensions ..... 260 (W) x 310 (H) x 371.5 (D) mm  
 Weight ..... 9.8 kg

## ■ ACCESSORIES

Operating Instructions .....	1
FM antenna .....	1
AM loop antenna .....	1
Remote control unit .....	1
AA/R6P dry cell batteries .....	2
CD case stand .....	1

### NOTE:

Specifications and design are subject to possible modifications without notice, due to improvements.

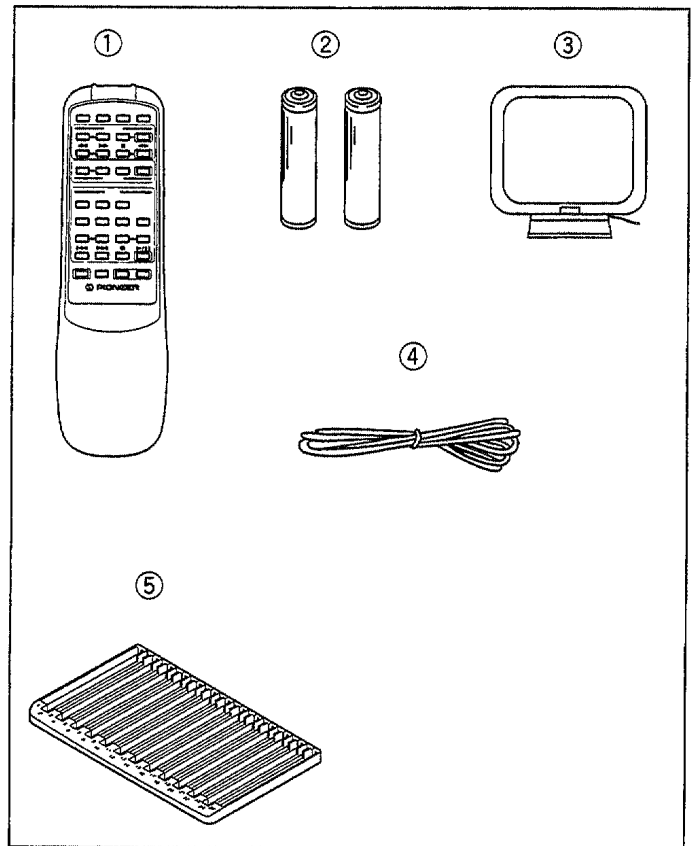

- ① Remote control unit x 1
- ② AA/R6P dry cell batteries x 2
- ③ AM loop antenna x 1 (shown assembled)
- ④ FM antenna x 1
- ⑤ CD case stand x 1