

Service Manual

ORDER NO.
RRV2390

STEREO DVD CASSETTE DECK RECEIVER

XR-VS500D XR-VS300D

THIS MANUAL IS APPLICABLE TO THE FOLLOWING MODEL(S) AND TYPE(S).

Type	Model		Power Requirement	Region No.	The voltage can be converted by the following method.
	XR-VS500D	XR-VS300D			
DBXJN	○	○	AC110-127V/220-230V/240V	3	With the voltage selector
DDXJN/RA	○	○	AC110-127V/220-230V/240V	1	With the voltage selector
DDXJN/RB	○	○	AC110-127V/220-230V/240V	2	With the voltage selector
DDXJN/RD	○	—	AC110-127V/220-230V/240V	4	With the voltage selector
DLXJN/NC	○	○	AC110-127V/220-230V/240V	3	With the voltage selector

● This service manual should be used together with the following manual(s):

Model No.	Order No.	Remarks
XR-A9800D/KUCXJ	RRV2329	

CONTENTS

1. SAFETY INFORMATION	2
2. CONTRAST OF MISCELLANEOUS PARTS	3
3. SCHEMATIC DIAGRAM	10
4. PCB CONNECTION DIAGRAM	20
5. GENERAL INFORMATION	22

1. SAFETY INFORMATION

This service manual is intended for qualified service technicians ; it is not meant for the casual do-it-yourselfer. Qualified technicians have the necessary test equipment and tools, and have been trained to properly and safely repair complex products such as those covered by this manual.

Improperly performed repairs can adversely affect the safety and reliability of the product and may void the warranty. If you are not qualified to perform the repair of this product properly and safely, you should not risk trying to do so and refer the repair to a qualified service technician.

LABEL CHECK (For DLXJN/NC Type)

WARNING !

THE AEL (ACCESSIBLE EMISSION LEVEL) OF THE LASER POWER OUTPUT IS LESS THAN CLASS 1 BUT THE LASER COMPONENT IS CAPABLE OF EMITTING RADIATION EXCEEDING THE LIMIT FOR CLASS 1.
A SPECIALLY INSTRUCTED PERSON SHOULD DO SERVICING OPERATION OF THE APPARATUS.

LASER DIODE CHARACTERISTICS

FOR DVD : MAXIMUM OUTPUT POWER : 5 mW
WAVELENGTH : 655 nm
FOR CD : MAXIMUM OUTPUT POWER : 5mW
WAVELENGTH : 785 nm

Printed on the Rear Panel

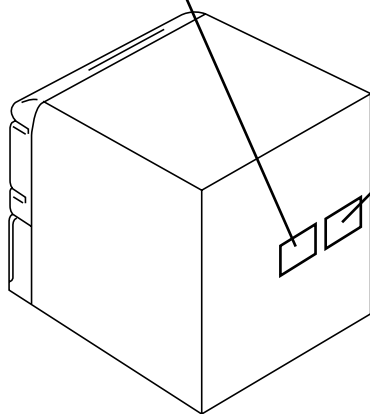

Additional Laser Caution

1. Inside detection switch (S201 on the SMEB assy) and loading-status detection switch (S9503 on the MOTOR assy) are detected by the microprocessor (IC11 in the DVDM assy).
 - To permit the laser diode to oscillate, it is required to set the inside detection switch for the inside position (S201 : ON) and to set the loading-status detection switch for the clamp position (the center terminal of S9503 is shorted to +5V). The 655 nm laser diode for DVD oscillation will continue if pin 19 of IC1 is shorted to +5V (fault condition) in the DVDM assy. The 785 nm laser diode for CD oscillates if pin 20 of IC1 is shorted to +5V in the DVDM assy. In the test mode * , the laser diode oscillates when microprocessor detects a PLAY signal, or when the PLAY key is pressed (S5931 ON in the DISPLAY assy), with the above requirements satisfied.
2. When the cover is open, close viewing through the objective lens with the naked eye will cause exposure to the laser beam.

* : Refer to page 82 on the service manual RRV2329.

2. CONTRAST OF MISCELLANEOUS PARTS

NOTES: ● Parts marked by "NSP" are generally unavailable because they are not in our Master Spare Parts List.

● The Δ mark found on some component parts indicates the importance of the safety factor of the part. Therefore, when replacing, be sure to use parts of identical designation.

● Screws adjacent to ∇ mark on product are used for disassembly.

● Reference Nos. indicate the pages and Nos. in the service manual for the base model.

● When ordering resistors, first convert resistance values into code form as shown in the following examples.

Ex.1 When there are 2 effective digits (any digit apart from 0), such as 560 ohm and 47k ohm (tolerance is shown by J=5%, and K=10%).

560 → 56 x 10¹ → 561 RD1/APU 561J
 47k → 47 x 10³ → 473 RD1/APU 473J
 0.5 → R50 RN2H/R 50K
 1 → 1R0 RSIP/R 10K

Ex.2 When there are 3 effective digits (such as in high precision metal film resistors).

5.62k → 562 x 10¹ → 5621 RN1/APC 5621F

■ CONTRAST TABLE for XR-VS500D

XR-VS500D/DBXJN, DDXJN/RA, DDXJN/RB, DDXJN/RD, DLXJN/NC and XR-A9800D/KUCXJ are constructed the same except for the following :

Ref. No.	Mark	Symbol and Description	Part No.						Remarks
			XR-A9800D /KUCXJ	XR-VS500D /DBXJN	XR-VS500D /DDXJN/RA	XR-VS500D /DDXJN/RB	XR-VS500D /DDXJN/RD	XR-VS500D /DLXJN/NC	
PCB ASSEMBLIES									
P5-1		MAIN ASSY	XWM3174	XWM3172	XWM3172	XWM3172	XWM3172	XWM3172	
		└ AF ASSY	XWZ3330	XWZ3322	XWZ3322	XWZ3322	XWZ3322	XWZ3322	
P5-4		COMPLEX ASSY	XWM3178	XWM3176	XWM3176	XWM3176	XWM3176	XWM3176	
		└ PRIMARY ASSY	XWZ3332	XWZ3326	XWZ3326	XWZ3326	XWZ3326	XWZ3326	
P7-1		└ DISPLAY ASSY	XWZ3331	XWZ3324	XWZ3324	XWZ3324	XWZ3324	XWZ3324	
PACKING SECTION									
P3-1	Δ	Power Cord	ADG7022	ADG1158	ADG1158	ADG1158	ADG1158	ADG1158	
P3-5		Remote Control Unit	XZN3109	XZN3110	XZN3110	XZN3110	XZN3110	XZN3110	
P3-11		Packing Case	XHD3144	XHD3166	XHD3166	XHD3166	XHD3166	XHD3166	
P3-12	NSP	Warranty Card	ARY7045	Not used	Not used	Not used	Not used	Not used	
P3-14		Operating Instructions (English/French)	XRE3036	Not used	Not used	Not used	Not used	Not used	
		Operating Instructions (English/Chinese)	Not used	XRE3035	XRE3035	XRE3035	XRE3035	XRE3035	
		Operating Instructions (Spanish/Arabian)	Not used	Not used	XRC3022	XRC3022	XRC3022	Not used	
		Region Label	Not used	Not used	VRW1708	VRW1701	VRW1705	Not used	For Packing Case Accessories
		Caution Sheet	Not used	Not used	XRH3001	Not used	XRH3001	Not used	
EXTERIOR SECTION									
P5-12	Δ	Power Transformer (T1) (AC120V)	XTS3042	Not used	Not used	Not used	Not used	Not used	
P5-12	Δ	Power Transformer (T1) (AC110-127V/220-230V/240V)	Not used	XTS3038	XTS3038	XTS3038	XTS3038	XTS3038	
P5-13	Δ	Fuse (FU1 : 6.3A)	REK1085	Not used	Not used	Not used	Not used	Not used	
P5-13	Δ	Fuse (FU1 : T5A)	Not used	AEK1061	AEK1061	AEK1061	AEK1061	AEK1061	
P5-25		Rear Panel	XNC3065	XNC3066	XNC3066	XNC3066	XNC3066	XNC3066	
P5-26		SEC Holder	XMR3032	XMR3035	XMR3035	XMR3035	XMR3035	XMR3035	
P5-38		Tray Cap	XAK3157	XAK3210	XAK3210	XAK3210	XAK3210	XAK3210	
P5-41	NSP	Fuse Card	AAX2374	Not used	Not used	Not used	Not used	Not used	
P5-42	NSP	Getter	XAX3175	XAX3176	XAX3176	XAX3176	XAX3176	XAX3176	
P5-43	Δ	65 Label	ARW7050	Not used	Not used	Not used	Not used	Not used	
		Fuse (FU2, FU3 : T3.15A)	Not used	AEK1059	AEK1059	AEK1059	AEK1059	AEK1059	*1
		Name Label	Not used	XAL3067	XAL3068	XAL3068	XAL3068	Not used	*2
		Region Label	Not used	Not used	XAX3183	XAX3184	XAX3185	Not used	For Rear Panel
		Caution Label	Not used	Not used	Not used	Not used	Not used	PRW1018	*3
	NSP	SISIR Label	Not used	Not used	Not used	Not used	Not used	XAX3181	For Rear Panel
FRONT PANEL SECTION									
P7-19		JOG Knob	XAA3015	XAA3019	XAA3019	XAA3019	XAA3019	XAA3019	
P7-21		FUNC Button L	XAD3061	XAD3089	XAD3089	XAD3089	XAD3089	XAD3089	
P7-22		FUNC Button R	XAD3051	XAD3090	XAD3090	XAD3090	XAD3090	XAD3090	
P7-23		FUNC Frame L	XAD3052	XAD3091	XAD3091	XAD3091	XAD3091	XAD3091	
P7-24		FUNC Frame R	XAD3053	XAD3092	XAD3092	XAD3092	XAD3092	XAD3092	

XR-VS500D, XR-VS300D

Ref. No.	Mark	Symbol and Description	Part No.						Remarks
			XR-A9800D	XR-VS500D	XR-VS500D	XR-VS500D	XR-VS500D	XR-VS500D	
			/KUCXJ	/DBXJN	/DDXJN/RA	/DDXJN/RB	/DDXJN/RD	/DLXJN/NC	
P7-25		DV ENT Button	XAD3056	XAD3085	XAD3085	XAD3085	XAD3085	XAD3085	
P7-26		Display Panel	XAK3135	XAK3207	XAK3207	XAK3207	XAK3207	XAK3207	
P7-33		FL Cover	XAK3164	XAK3163	XAK3163	XAK3163	XAK3163	XAK3163	
P7-42		Sub Panel	XAK3203	XAK3208	XAK3208	XAK3208	XAK3208	XAK3208	
P7-50		DV Button L	XAD3057	XAD3086	XAD3086	XAD3086	XAD3086	XAD3086	
P7-51		DV Button R	XAD3059	XAD3088	XAD3088	XAD3088	XAD3088	XAD3088	
		Mic Knob	Not used	XAB3007	XAB3007	XAB3007	XAB3007	XAB3007	No. 1

Notes : For PCB ASSEMBLIES, Refer to “CONTRAST OF PCB ASSEMBLIES” and “3. SCHEMATIC DIAGRAM”.

The numbers in the remarks column correspond to the numbers on the “EXPLODED VIEWS”.

*1 Refer to “3. SCHEMATIC DIAGRAM”. *2 Stick Name Label on the Rear Panel. *3 Refer to “LABEL CHECK”.

■ CONTRAST TABLE for XR-VS300D

XR-VS300D/DBXJN, DDXJN/RA, DDXJN/RB, DLXJN/NC and XR-A9800D/KUCXJ are constructed the same except for the following :

Ref. No.	Mark	Symbol and Description	Part No.					Remarks
			XR-A9800D	XR-VS300D	XR-VS300D	XR-VS300D	XR-VS300D	
			/KUCXJ	/DBXJN	/DDXJN/RA	/DDXJN/RB	/DLXJN/NC	
		PCB ASSEMBLIES						
P5- 1		MAIN ASSY	XWM3174	XWM3171	XWM3171	XWM3171	XWM3171	
P5- 2		└ AF ASSY	XWZ3330	XWZ3316	XWZ3316	XWZ3316	XWZ3316	
		└ SECONDARY ASSY	XWZ3323	XWZ3317	XWZ3317	XWZ3317	XWZ3317	
		COMPLEX ASSY						
P5- 3		└ REAR AMP ASSY	XWM3178	XWM3175	XWM3175	XWM3175	XWM3175	
P5- 4		└ PRIMARY ASSY	XWZ3325	XWZ3319	XWZ3319	XWZ3319	XWZ3319	
P7- 1		└ DISPLAY ASSY	XWZ3332	XWZ3320	XWZ3320	XWZ3320	XWZ3320	
		PACKING SECTION						
P3- 1	△	Power Cord	ADG7022	ADG1158	ADG1158	ADG1158	ADG1158	
P3- 5		Remote Control Unit	XZN3109	XZN3108	XZN3108	XZN3108	XZN3108	
P3-11		Packing Case	XHD3144	XHD3163	XHD3163	XHD3163	XHD3164	
P3-12	NSP	Warranty Card	ARY7045	Not used	Not used	Not used	Not used	
P3-14		Operating Instructions (English/French)	XRE3036	Not used	Not used	Not used	Not used	
		Operating Instructions (English/Chinese)	Not used	XRE3035	XRE3035	XRE3035	XRE3035	
		Operating Instructions (Spanish/Arabian)	Not used	Not used	XRC3022	XRC3022	Not used	
		Region Label	Not used	Not used	VRW1708	VRW1701	Not used	For Packing Case
		Caution Sheet	Not used	Not used	XRH3001	Not used	Not used	Accessories
		EXTERIOR SECTION						
P5-12	△	Power Transformer (T1) (AC120V)	XTS3042	Not used	Not used	Not used	Not used	
P5-12	△	Power Transformer (T1) (AC110-127V/220-230V/240V)	Not used	XTS3039	XTS3039	XTS3039	XTS3039	
P5-13	△	Fuse (FU1 : 6.3A)	REK1085	Not used	Not used	Not used	Not used	
P5-13	△	Fuse (FU1 : T5A)	Not used	AEK1061	AEK1061	AEK1061	AEK1061	
P5-15		Power Bracket	XNG3033	Not used	Not used	Not used	Not used	
P5-25		Rear Panel	XNC3065	XNC3063	XNC3063	XNC3063	XNC3064	
P5-26		SEC Holder	XMR3032	XMR3036	XMR3036	XMR3036	XMR3036	
P5-38		Tray Cap	XAK3157	XAK3210	XAK3210	XAK3210	XAK3210	
P5-41	NSP	Fuse Card	AAX2374	Not used	Not used	Not used	Not used	
P5-42	NSP	Getter	XAX3175	XAX3174	XAX3174	XAX3174	XAX3174	
P5-43		65 Label	ARW7050	Not used	Not used	Not used	Not used	
P5-44	NSP	\$M Mecha. DVD (5p)	XXA3019	Not used	Not used	Not used	Not used	
P5-44	NSP	\$M Mecha. DVD (2p)	Not used	XXA3018	XXA3018	XXA3018	XXA3018	
	△	Fuse (FU2, FU3 : T3.15A)	Not used	AEK1059	AEK1059	AEK1059	AEK1059	*1
	NSP	Name Label	Not used	XAL3064	XAL3065	XAL3065	Not used	*2
	NSP	Region Label	Not used	Not used	XAX3183	XAX3184	Not used	For Rear Panel
		Caution Label	Not used	Not used	Not used	Not used	PRW1018	*3
	NSP	SISIR Label	Not used	Not used	Not used	Not used	XAX3181	For Rear Panel

Ref. No.	Mark	Symbol and Description	Part No.					Remarks
			XR-A9800D	XR-VS300D	XR-VS300D	XR-VS300D	XR-VS300D	
			/KUCXJ	/DBXJN	/DDXJN/RA	/DDXJN/RB	/DLXJN/NC	
FRONT PANEL SECTION								
P7-19		JOG Knob	XAA3015	XAA3019	XAA3019	XAA3019	XAA3019	
P7-21		FUNC Button L	XAD3061	XAD3089	XAD3089	XAD3089	XAD3089	
P7-22		FUNC Button R	XAD3051	XAD3090	XAD3090	XAD3090	XAD3090	
P7-23		FUNC Frame L	XAD3052	XAD3091	XAD3091	XAD3091	XAD3091	
P7-24		FUNC Frame R	XAD3053	XAD3092	XAD3092	XAD3092	XAD3092	
P7-25		DV ENT Button	XAD3056	XAD3085	XAD3085	XAD3085	XAD3085	
P7-26		Display Panel	XAK3135	XAK3205	XAK3205	XAK3205	XAK3205	
P7-33		FL Cover	XAK3164	XAK3163	XAK3163	XAK3163	XAK3163	
P7-42		Sub Panel	XAK3203	XAK3208	XAK3208	XAK3208	XAK3208	
P7-50		DV Button L	XAD3057	XAD3087	XAD3087	XAD3087	XAD3087	
P7-51		DV Button R	XAD3059	XAD3088	XAD3088	XAD3088	XAD3088	
		Mic Knob	Not used	XAB3007	XAB3007	XAB3007	XAB3007	No. 1

Notes : For PCB ASSEMBLIES, Refer to “CONTRAST OF PCB ASSEMBLIES” and “3. SCHEMATIC DIAGRAM”.

The numbers in the remarks column correspond to the numbers on the “ EXPLODED VIEWS ”.

*1 Refer to “3. SCHEMATIC DIAGRAM”. *2 Stick Name Label on the Rear Panel. *3 Refer to “LABEL CHECK”.

■ EXPLODED VIEWS

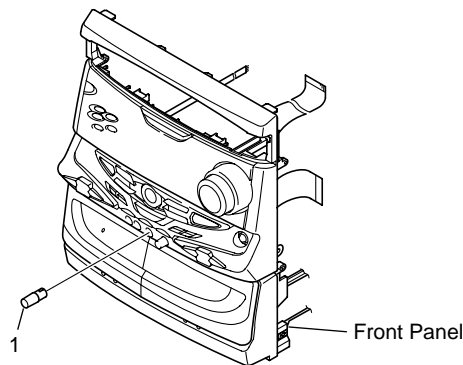

■ CONTRAST OF \$M MECHA. DVD

XXA3018 and XXA3019 are constructed the same except for the following :

Ref. No.	Mark	Symbol and Description	Part No.		Remarks
			XXA3019 (XR-A9800D)	XXA3018 (XR-VS300D)	
P5-10		CONNECT ASSY (6CH)	XWX3023	Not used	
P5-10		CONNECT ASSY (2CH)	Not used	XWX3019	
P5-14		25P Flexible Cable	XDD3046	Not used	
P5-14		15P Flexible Cable	Not used	XDD3049	
P5-18		30P Flexible Cable	XDD3044	Not used	
P5-18		16P Flexible Cable	Not used	XDD3043	
P5-21		7P Flexible Cable/30V	XDD3053	ADD7197	
P5-23		DVD Base	XNG3034	ANG7262	
P5-24		DVD Shield	XNK3006	ANK7066	
P5-55		21P Flexible Cable	XDD3052	Not used	
P5-55		7P Flexible Cable	Not used	XDD3045	

Notes : For PCB ASSEMBLIES, Refer to “PCB PARTS LIST”, “3. SCHEMATIC DIAGRAM” and “4. PCB CONNECTION DIAGRAM”.

■ CONTRAST OF PCB ASSEMBLIES

J F SECONDARY ASSY

XWZ3317 and XWZ3323 are constructed the same except for the following :

Mark	Symbol and Description	Part No.		Remarks
		XWZ3323	XWZ3317	
△	C33, C34 (4700µF/80V)	ACH7071	Not used	
△	C33, C34 (4700µF/71V)	Not used	XCH3001	

I F AF ASSY

XWZ3322, XWZ3316 and XWZ3330 are constructed the same except for the following :

Mark	Symbol and Description	Part No.			Remarks
		XWZ3330	XWZ3322	XWZ3316	
△	IC3301	STK407-070B	STK407-070B	STK407-090B	
△	IC3305, IC3306 (5A)	AEK7019	AEK7019	Not used	
△	IC3305, IC3306 (7A)	Not used	Not used	AEK7021	
	IC3835	Not used	M65847AFP	M65847AFP	
△	Q3351	IRFI9Z34G	IRFI9Z34G	IRF9540A	
	Q3352	IRFIZ34G	IRFIZ34G	IRF540A	
△	Q3803	Not used	2SD1858X	2SD1858X	
	D3002	1SS133	1SS133	Not used	
	D3803	Not used	MTZJ5.6B	MTZJ5.6B	
	F2201, F2202	RTF1209	XTF3002	XTF3002	
	L3065 CHIP BEAD	VTL1081	VTL1081	Not used	
	L3065	Not used	Not used	LCTB4R7K1608	
	C3011, C3012	Not used	Not used	CEAT100M50	
	C3042, C3991	CKSRYB103K50	CKSRYB103K50	Not used	
	C3623, C3624	CKSRYB471K50	CKSRYB471K50	Not used	
	C3625	CEAT330M16	CEAT330M16	Not used	
	C3815	Not used	CEAT100M50	CEAT100M50	
	C3816, C3819	Not used	CEAT470M16	CEAT470M16	
	C3817	Not used	CCSRYB473K16	CCSRYB473K16	
	C3818	Not used	CCSRCH101J50	CCSRCH101J50	
	C3828-C3830	Not used	CKSRYB683K16	CKSRYB683K16	
	C3831	Not used	CKSRYB102K50	CKSRYB102K50	
	C3832	Not used	CKSRYB122K50	CKSRYB122K50	
	C3833-C3836	Not used	CKSRYB103K50	CKSRYB103K50	
	C3837	Not used	CCSRCH471J50	CCSRCH471J50	
	C3838	Not used	CKSRYB472K50	CKSRYB472K50	
	C3839, C3840	Not used	CKSRYB224K10	CKSRYB224K10	
	C3842, C3843	Not used	CEAT2R2M50	CEAT2R2M50	
	C3858	CEAT100M50	Not used	Not used	
	C3890	Not used	CKSRYB822K50	CKSRYB822K50	
	R3010	RS1/16S822J	RS1/16S822J	RS1/16S472J	
	R3026	RD1/4PU822J	RS1/4PU822J	RD1/4PU472J	
	R3627	RS1/16S471J	RS1/16S471J	Not used	
	R3831	Not used	RS1/4PU102J	RD1/4PU102J	
	R3832-R3834	Not used	RS1/16S102J	RS1/16S102J	
	R3835, R3839	Not used	RS1/16S682J	RS1/16S682J	
	R3836, R3837	Not used	RS1/16S472J	RS1/16S472J	
	R3838, R3846	Not used	RS1/16S153J	RS1/16S153J	
	R3840-R3842, R3844, R3845	Not used	RS1/16S103J	RS1/16S103J	
	R3843	Not used	RS1/16S562J	RS1/16S562J	
	R3855	Not used	RS1/16S680J	RS1/16S680J	
	CN3601 4P SPEAKER TERMINAL	AKE7018	XKE3004	XKE3004	
	CN3603 9P JUMPER CONNECTOR	KPE9	KPE9	Not used	
	CN5104 30P FFC CONNECTOR	HLEM30R-1	HLEM30R-1	Not used	
	CN5104 16P FFC CONNECTOR	Not used	Not used	HLEM16R-1	
	JA3441 2P PIN JACK	Not used	Not used	VKB1060	
	JA3991 HEADPHONE JACK	XKN3007	XKN3007	XKN3004	
	SCREW	Not used	Not used	BBZ30P140FMC	
	MICA SHEET	Not used	Not used	XEE3003	
	FET BRACKET	Not used	Not used	XNG3016	



XWZ3319 and XWZ3325 are constructed the same except for the following :

Mark	Symbol and Description	Part No.		Remarks
		XWZ3325	XWZ3319	
△	IC3401 Q3401-Q3404 Q3405, Q3410 Q3406-Q3409, Q3411-Q3413, Q3415 Q3414, Q3471, Q3472	STK402-230 2SD2114K DTA124EK 2SC2412K 2SA1037K	Not used Not used Not used Not used Not used	
	D50, D3425, D3426, D3471, D3472 D61, D62, D3403-D3408, D3427, D3428 D3409 D3429 L3401-L3403 AF CHOKE COIL	1SS355 1SS133 MTZJ12C MTZJ4.7B ATH-133	Not used Not used Not used Not used Not used	
	L3404 CHIP BEAD RY3401, RY3402 C3401-C3403 C3404-C3406 C3407-C3409	VTL1081 ASR7017 CEANP2R2M50 CKSRYB222K50 CCSRCH221J50	Not used Not used Not used Not used Not used	
	C3410-C3412 C3413-C3415 C3416, C3417, C3431 C3419 C3420	CEANP100M35 CCSRCJ3R0C50 CEAT101M50 CEATR47M50 CEAT101M10	Not used Not used Not used Not used Not used	
	C3421 C3422, C3471, C3472 C3423, C3424, C3429 C3425-C3428 C3432	CEAT100M50 CCSRCH100D50 CKSRYB103K50 CKSRYF104Z25 CEAT221M16	Not used Not used Not used Not used Not used	
	R3401-R3404 R3405-R3408 R3409-R3411 R3412 R3413-R3415	RS1/16S332J RS1/16S102J RS1/10S273J RS1/10S104J RS1/16S563J	Not used Not used Not used Not used Not used	
	R3416-R3418 R3419-R3421 R3422 R3424 R3425-R3428	RS1/10S561J RD1/4PU563J RS1/10S223J RS1/16S102J RS1/10S823J	Not used Not used Not used Not used Not used	
	R3429, R3430, R3432 R3433 R3434, R3475, R3476 R3435 R3436-R3437, R3439, R3440	RS1/10S153J RS1/16S273J RS1/10S392J RS1/16S104J RS1/16S223J	Not used Not used Not used Not used Not used	
	R3438 R3441 R3442-R3444 R3445-R3447 R3448	RS1/16S103J RS1/16S224J RD1/4LMF100J RS1/16S100J RS3LMF102J	Not used Not used Not used Not used Not used	
	R3449 R3471-R3473 R3477-R3478 CN3401 1P PIN JACK CN3404 FFC CONNECTOR 25P	RD1/4PU681J RS1LMFR22J RD1/4MUF101J AKB7042 HLEM25R-1	Not used Not used Not used Not used Not used	
	CN3404 FFC CONNECTOR 15P J3401 JUMPER WIRE JA3403 AUDIO 3P PIN JACK 9P CABLE HOLDER	Not used D15A09-100-2651 XKB3007 51063-0905	HLEM15R-1 Not used Not used Not used	

LF PRIMARY ASSY

XWZ3326, XWZ3320 and XWZ3332 are constructed the same except for the following :

Mark	Symbol and Description	Part No.			Remarks
		XWZ3332	XWZ3326	XWZ3320	
△	S1 VOLTAGE SELECTOR	Not used	XKX3001	XKX3001	
△	R1 (2.2MΩ/ 1/2W)	RCN1080	Not used	Not used	
△	AN1 1P AC INLET	XKP3042	XKP3041	XKP3041	
△	CN2 4P VH CONNECTOR	Not used	B4P7-VH	B4P7-VH	
	H3-H6 FUSE CLIP	Not used	AKR7001	AKR7001	

MF DISPLAY ASSY

XWZ3324, XWZ3318 and XWZ3331 are constructed the same except for the following :

Mark	Symbol and Description	Part No.			Remarks
		XWZ3331	XWZ3324	XWZ3318	
	IC3931	Not used	M65855FP	M65855FP	
	IC5601	HEF4794BT	HEF4794BT	Not used	
	Q5822-Q5824, Q5827	Not used	Not used	DTC143EK	
	D3931	Not used	MTZJ5.1B	MTZJ5.1B	
	D5592	1SS133	Not used	Not used	
	D5593	1SS133	1SS133	Not used	
	D5595	1SS181	1SS181	Not used	
	L3921, L3922 CHIP BEAD	VTL1081	VTL1081	Not used	
	L3931	Not used	LCTB100K2125	LCTB100K2125	
	C3931, C3934, C3940	Not used	CKSRYB103K50	CKSRYB103K50	
	C3932	Not used	CEJAR47M50	CEJAR47M50	
	C3933	Not used	CEJQ220M10	CEJQ220M10	
	C3935	Not used	CKSRYB473K16	CKSRYB473K16	
	C3937	Not used	CEJA4R7M50	CEJA4R7M50	
	C3938	Not used	CKSRYB472K50	CKSRYB472K50	
	C3939	Not used	CKSRYB123K50	CKSRYB123K50	
	C3942	Not used	CKSRYF104Z25	CKSRYF104Z25	
	C3943	Not used	CEJQ101M10	CEJQ101M10	
	C5601	CCSRCH101J50	CCSRCH101J50	Not used	
	C5603, C5604	CCSRCH100D50	CCSRCH100D50	Not used	
	R3931	Not used	RS1/16S472J	RS1/16S472J	
	R3932, R3937, R3938	Not used	RS1/16S123J	RS1/16S123J	
	R3933	Not used	RS1/16S153J	RS1/16S153J	
	R3934	Not used	RS1/16S124J	RS1/16S124J	
	R3935	Not used	RS1/16S822J	RS1/16S822J	
	R3936	Not used	RS1/16S103J	RS1/16S103J	
	R3939	RS1/16S0R0J	Not used	Not used	
	R3940	Not used	RD1/4PU121J	RD1/4PU121J	
	R5590, R5984, R5985, R5987, R5990	RS1/16S473J	RS1/16S473J	Not used	
	R5591	RS1/16S152J	RS1/16S152J	Not used	
	R5610	Not used	Not used	RS1/16S0R0J	
	R5619	RS1/16S221J	RS1/16S221J	Not used	
	R5620, R5621, R5626	RS1/16S102J	RS1/16S102J	Not used	
	R5986, R5988, R5989	RS1/16S103J	RS1/16S103J	Not used	
	VR3931 (10kΩ-B)	Not used	XCS3002	XCS3002	
	CN5502 FFC CONNECTOR 21P	52492-2120	52492-2120	Not used	
	CN5502 FFC CONNECTOR 7P	Not used	Not used	52492-0720	

Mark	No.	Description	Part No.	Mark	No.	Description	Part No.
------	-----	-------------	----------	------	-----	-------------	----------

● PCB PARTS LIST for XR-VS300D

GF CONNECT ASSY (2CH)

SEMICONDUCTORS

IC8202		LA7137M
IC8203		NJM78L08A
IC8301		PCM1716E
IC8201		TA7302P
Q8203, Q8204		2PB709A
Q8205, Q8206		2SD2114K
Q8302		DTA124EK
Q8201		DTC114YK
Q8301		DTC124EK
Q8202		PDTA124EK
D8304, D8305		1SS355

COILS AND FILTERS

L8201		LCTA470J2520
L8241-L8245	CHIP BEADS	VTL1081
L8103	CHIP BEADS	VTL1095
L8205	CHIP SOLID INDUCTOR	VTL1145

CAPACITORS

C8104		CCSRCH101J50
C8105, C8106, C8109, C8110, C8316		CCSRCH221J50
C8201		CCSRCH390J50
C8111		CEAT102M10
C8311, C8312		CEJA100M16
C8209, C8210, C8217, C8226, C8227		CEJA101M10
C8235		CEJA101M10
C8212, C8223		CEJA331M6R3
C8301, C8302, C8305, C8306, C8309		CEJA470M10
C8315, C8317		CGCYX104K25
C8101, C8232, C8233, C8304		CKSRYB103K50
C8202-C8206, C8208, C8211		CKSRYB104K16
C8213, C8214, C8216, C8221, C8222		CKSRYB104K16
C8228, C8236, C8237, C8308		CKSRYB104K16
C8313, C8314		CKSRYB681K50

RESISTORS

All Resistors		RS1/16S□□□J
---------------	--	-------------

OTHERS

CN8202	4P MINI DIN SOCKET	AKP7008
JA8203	OPTICAL LINK OUT	GP1F32T
CN8105	FFC CONNECTOR 15P	HLEM15S-1
CN8103	FFC CONNECTOR 16P	HLEM16S-1
CN8104	FFC CONNECTOR 7P	HLEM7S-1
JA8201	1P PIN JACK	VKB1063
CN8106	7P FFC CONNECTOR	VKN1183
CN8102	27P FFC CONNECTOR	VKN1203
CN8107	7P FFC CONNECTOR	VKN1211
CN8101	32P FFC CONNECTOR	VKN1263
KN8301	EARTH METAL FITTING	VNF1084
S8201	SLIDE SWITCH	VSH1020

3. SCHEMATIC DIAGRAM

3.1 CONNECT ASSY (2CH) for XR-VS300D

A

B

C

D

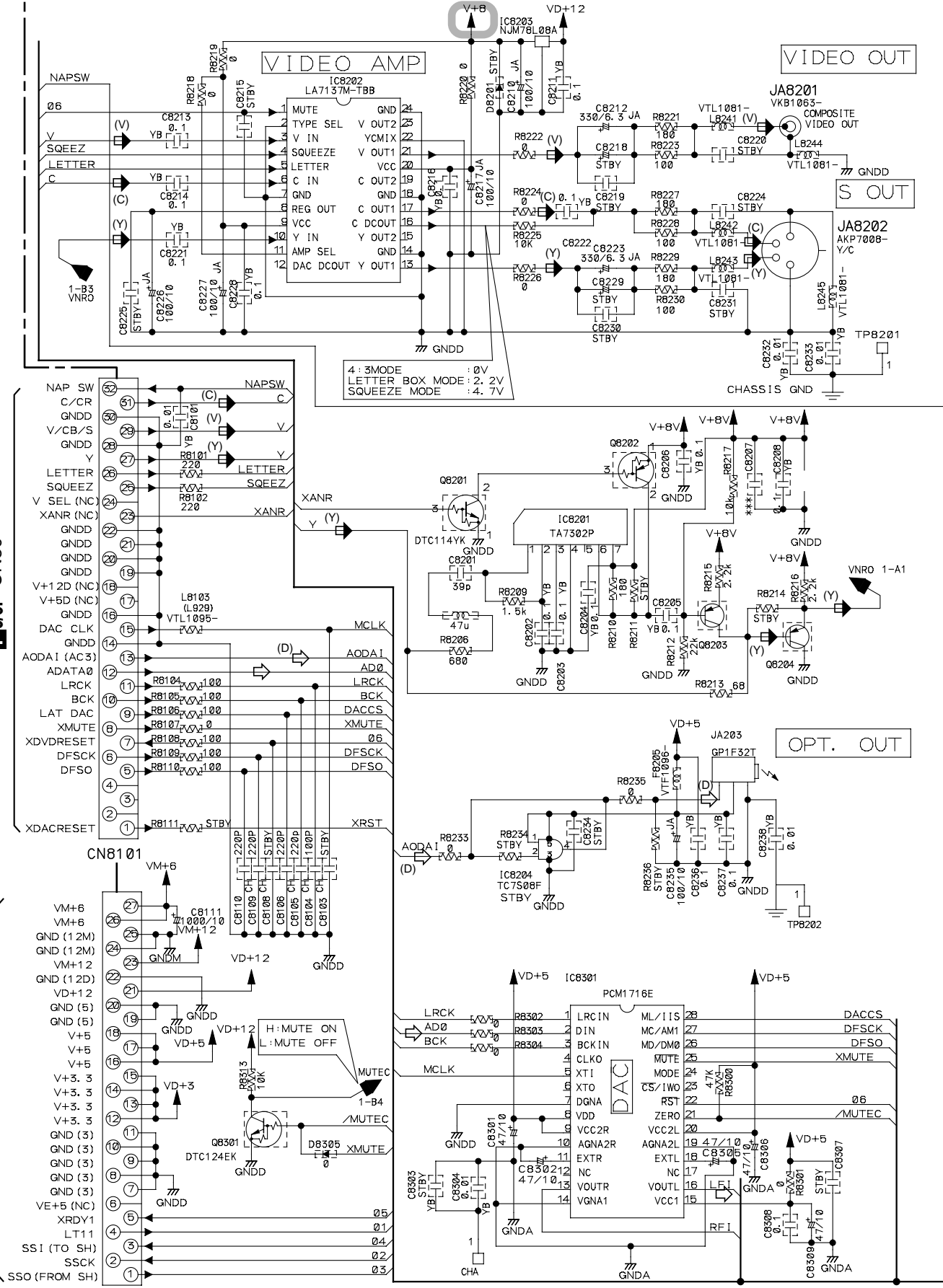

Note : When ordering service parts, be sure to refer to "EXPLODED VIEWS and PARTS LIST" or "PCB PARTS LIST"

GF CONNECT ASSY (2 CH) (XWX3019)

O : The power supply is shown with the marked box.

- ◇ : AUDIO SIGNAL ROUTE
- (D) ◇ : DVD AUDIO SIGNAL ROUTE
- (V) ◇ : V SIGNAL ROUTE
- (Y) ◇ : Y SIGNAL ROUTE
- (C) ◇ : C SIGNAL ROUTE

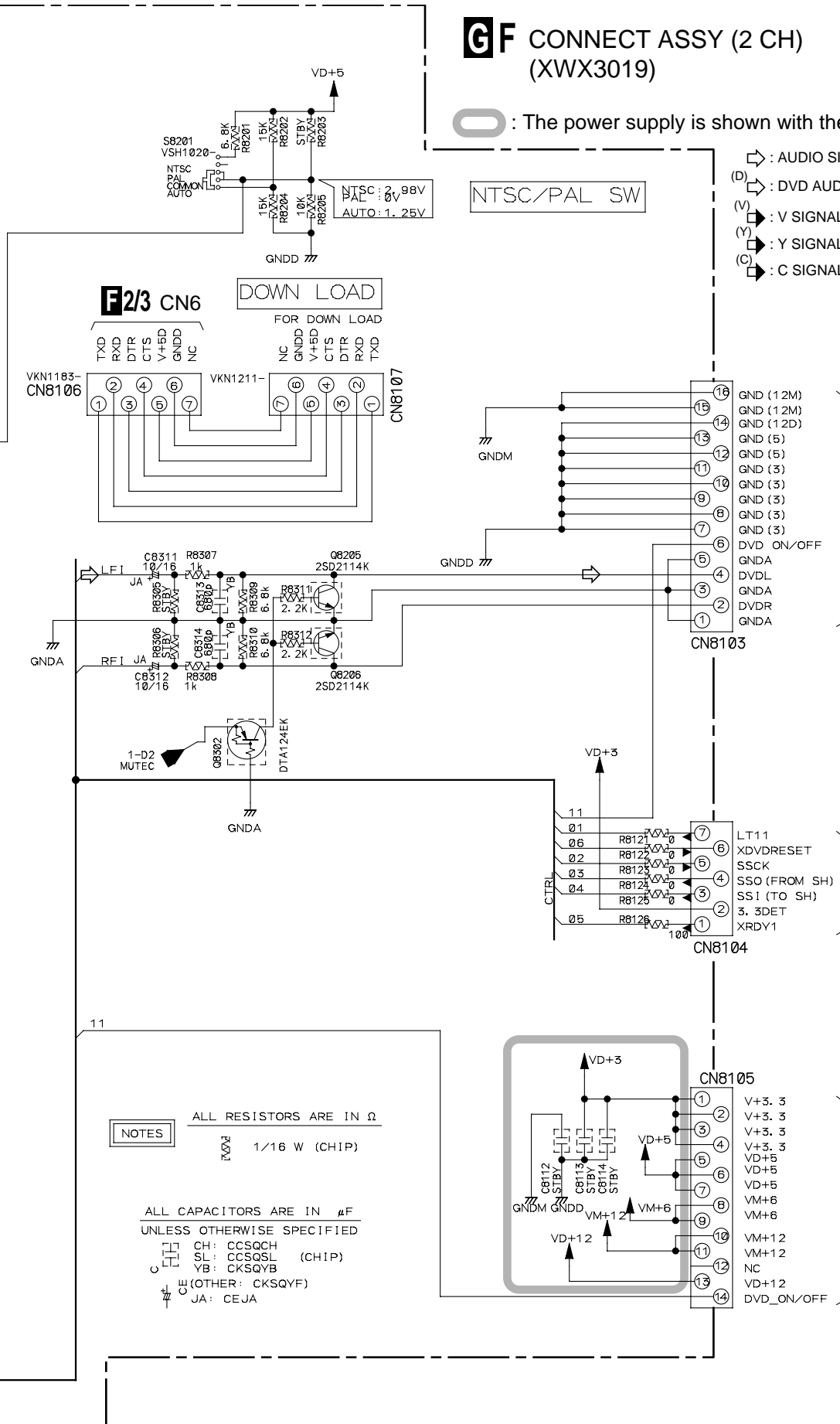

F 2/3 CN6

DOWN LOAD
FOR DOWN LOAD

NTSC/PAL SW

I 2/3F CN5104

M F CN5502

K CN3404

NOTES

ALL RESISTORS ARE IN Ω
 1/16 W (CHIP)

ALL CAPACITORS ARE IN μF
 UNLESS OTHERWISE SPECIFIED

CH: CCSQCH
 SL: CCSQSL (CHIP)
 YB: CKSQYB
 CE (OTHER: CKSQYF)
 JA: CEJA

3.2 AF (2/3) ASSY

A

B

C

D

- (TA) : TUNER AUDIO SIGNAL ROUTE
- (OUT) : REC OUT SIGNAL ROUTE
- ↔ : AUDIO SIGNAL ROUTE
- (F) : AUDIO (FRONT) SIGNAL ROUTE
- (PB) : DECK PB SIGNAL ROUTE
- (REC) : DECK REC SIGNAL ROUTE
- (K) : KARAOKE SIGNAL ROUTE
- (MIC) : MIC SIGNAL ROUTE

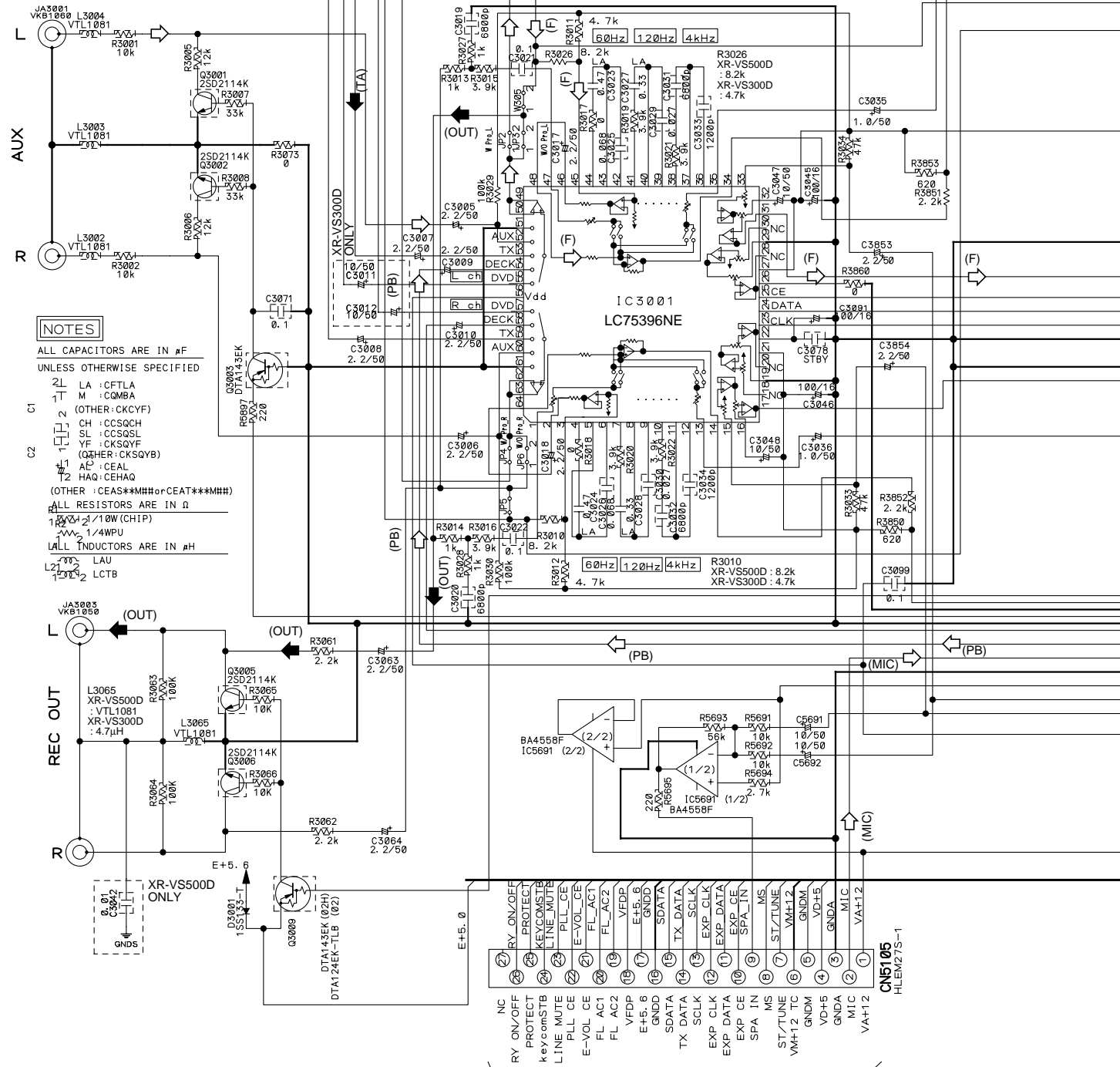

NOTES

- ALL CAPACITORS ARE IN μ F UNLESS OTHERWISE SPECIFIED
- LA : CFTLA
- M : CMBA (OTHER:CKCYF)
- CH : CCSQCH
- SL : CCSQSL
- YF : CKSQYF
- (OTHER:CKSQYB)
- AF : CEAL
- HAO:CEHAO
- (OTHER:CEAS**MH#orCEAT***M#H#)
- ALL RESISTORS ARE IN Ω UNLESS OTHERWISE SPECIFIED
- 1/10W (CHIP)
- 1/4WPU
- LAU
- LCTB

FOR XR-VS300D **GF CN8103** FOR XR-VS500D **G4/4 CN8103**

MF CN5501

3.3 AF (3/3) and SECONDARY ASSYS

3/3F AF ASSY (XR-VS500D : XWZ3322) (XR-VS300D : XWZ3316)

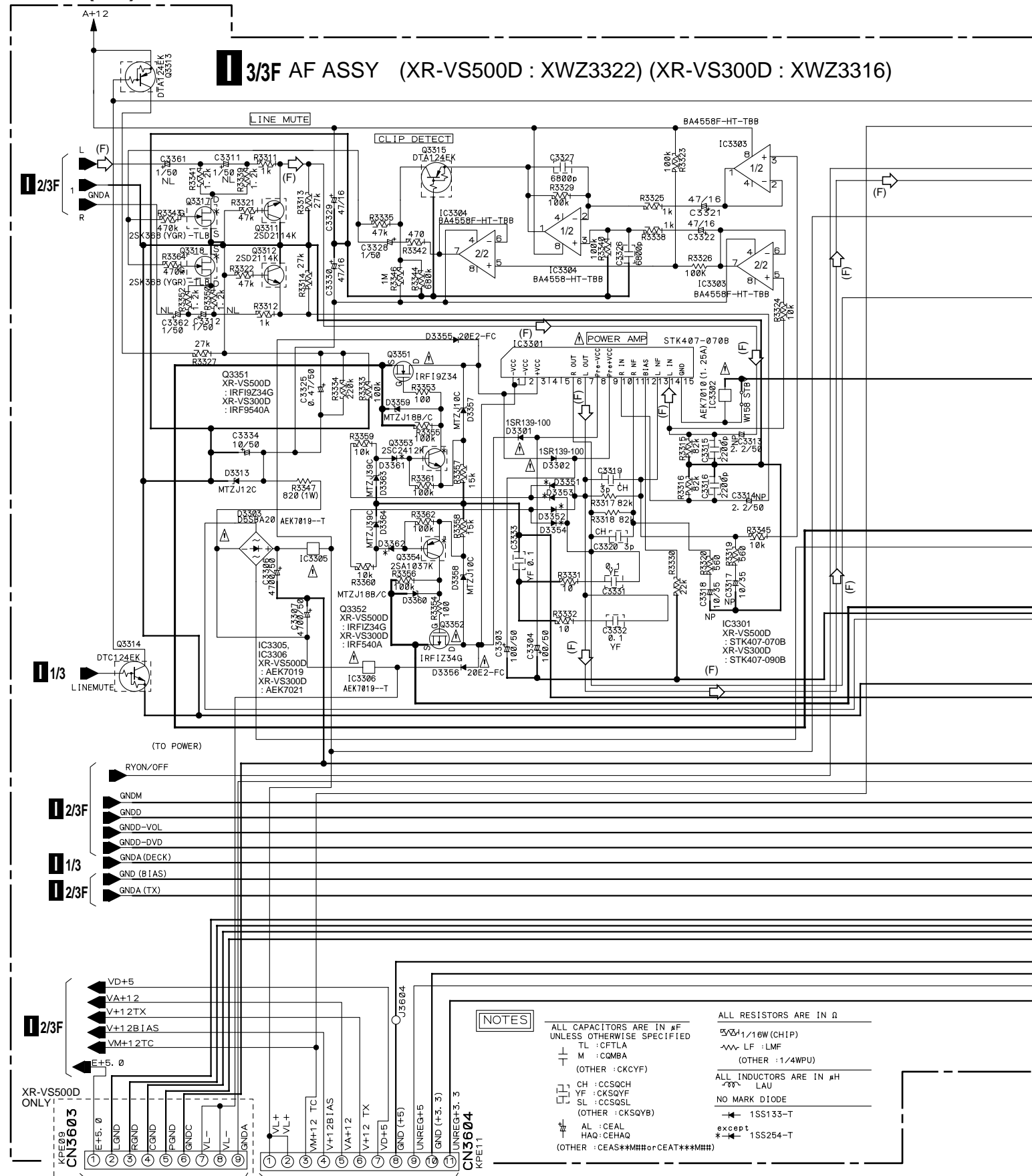

NOTES

- ALL CAPACITORS ARE IN #F UNLESS OTHERWISE SPECIFIED
 - TL : CFTLA
 - M : CMBA
 - (OTHER : CKCYF)
 - CH : CCSQCH
 - YF : CKSQYF
 - SL : CCSQSL
 - (OTHER : CKSQYB)
 - AL : CEAL
 - HAQ : CEHAQ
 - (OTHER : CEAS**M## or CEAT***M##)
- ALL RESISTORS ARE IN Ω
 - 1/16W (CHIP)
 - LF : LMF
 - (OTHER : 1/4WPU)
 - ALL INDUCTORS ARE IN #H
 - LAU
 - NO MARK DIODE
 - 1SS133-T
 - except
 - 1SS254-T

K J3401

K J3402

3/3F

3.4 PRIMARY ASSY

NOTES

ALL CAPACITORS ARE IN μF

UNLESS OTHERWISE SPECIFIED

TL : CFTLA
 M : CQ MBA
 (OTHER : CKCYF)

CH : CCSRCH
 YF : CKSRYF
 SL : CCSRSL
 (OTHER : CKSRYB)

AL : CEAL
 HAQ : CEHAQ

(OTHER : CEAS**M## or CEAT**M##)

ALL RESISTORS ARE IN Ω

1/16W (CHIP)

1/4WPU

ALL INDUCTORS ARE IN μH

LAU

NO MARK DIODE

1SS133

POWER TRANSFORMER
 XR-VS500D : XTS3038
 XR-VS300D : XTS3039

JF SECONDARY ASSY

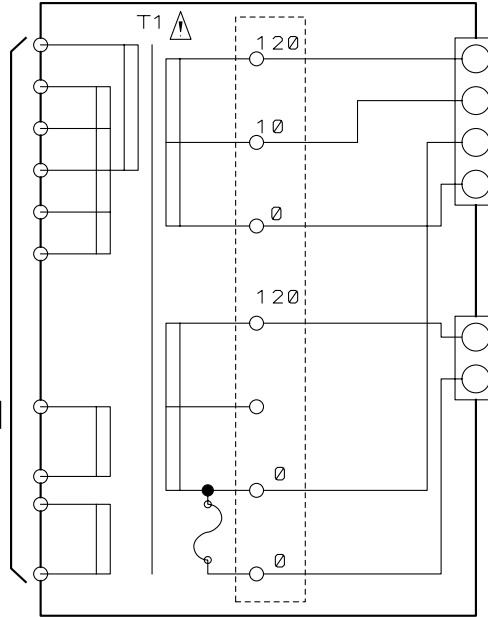

CN2
 B4P7-VH

CN1
 B2P3-VH

MF J81

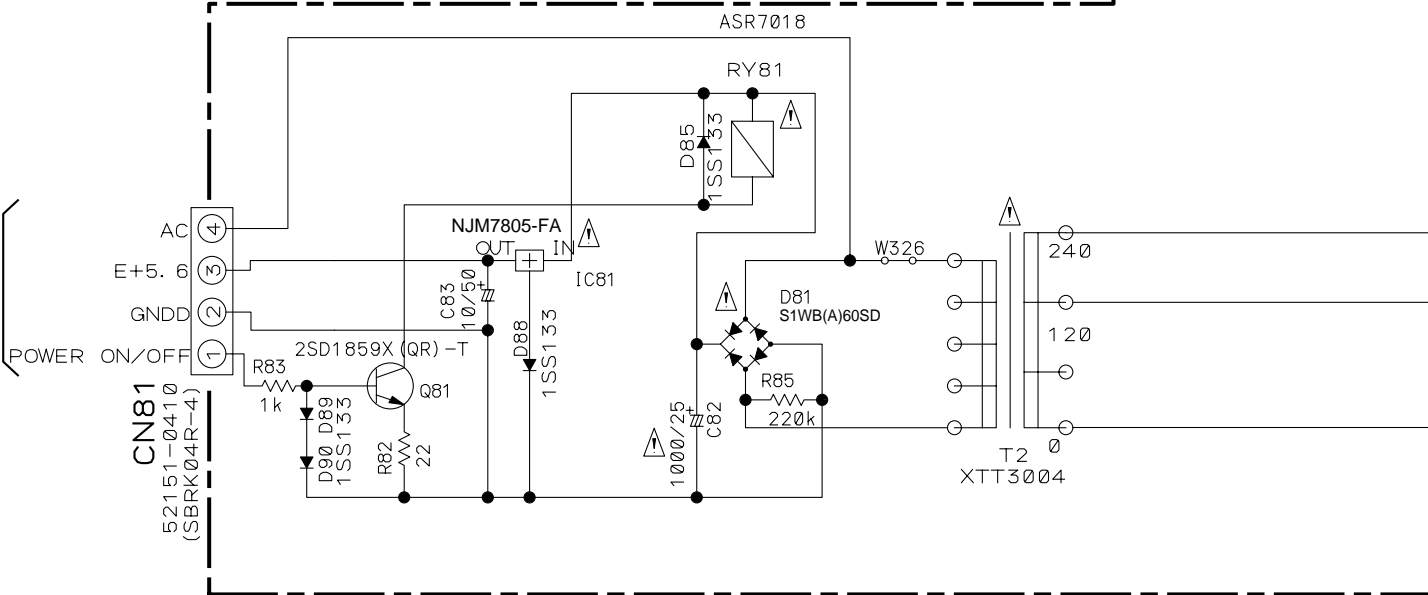

ASR7018

RY81

NJM7805-FA

IC81

C83

100/50

D88

1SS133

Q81

2SD1859X (QR) -T

R82

22

R83

1k

D90

D89

1SS133

D85

1SS133

W326

T2

XTT3004

C82

1000/25

D81

S1WB(A)60SD

R85

220k

240

120

0

AC

E+5.6

GNDD

POWER ON/OFF

CN81

52151-0410

(SBRK04R-4)

LF PRIMARY ASSY
 (XR-VS500D : XWZ3326)
 (XR-VS300D : XWZ3320)

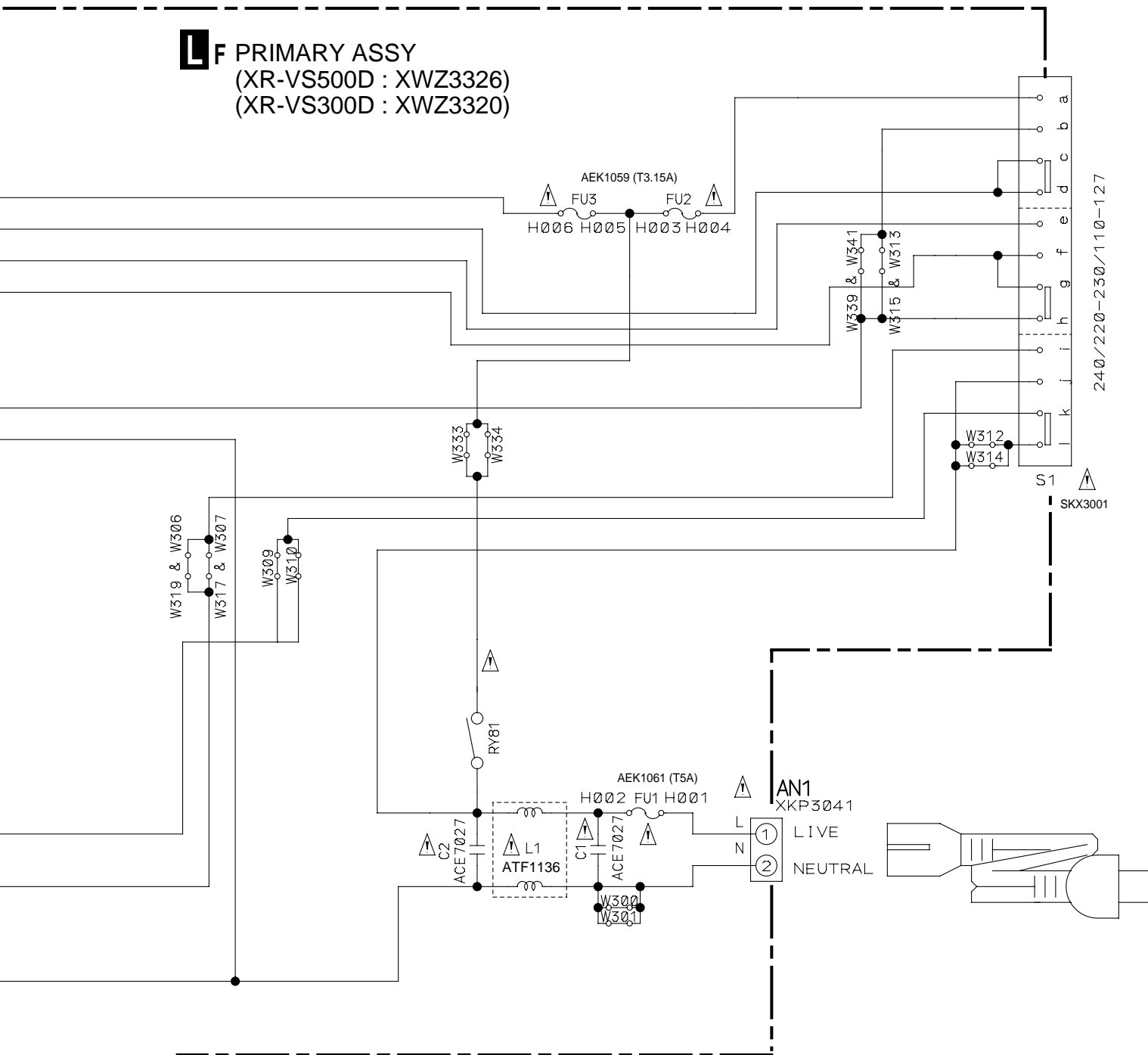

• NOTE FOR FUSE REPLACEMENT
CAUTION -FOR CONTINUED PROTECTION AGAINST RISK OF FIRE.
 REPLACE WITH SAME TYPE AND RATINGS ONLY.

3.5 DISPLAY and BLUE LED ASSYS

A

B

C

D

NOTES

ALL CAPACITORS ARE IN #F
UNLESS OTHERWISE SPECIFIED
TL : CFTLA
M : COMA
CH : CCSRCH
YF : CKSRYF
SL : CCSRSL
(OTHER : CKSRYB)

AL : CEAL JA : CEJA
HAQ : CEHAQ TS : CEJA**M-TS
(OTHER : CEAS**M#H#orCEAT**M#H#-T)

ALL RESISTORS ARE IN Ω
1/16W (CHIP)
1/4WPU

ALL INDUCTORS ARE IN #H

LCTB***K1608
DTC143EK-TLB
1S5133-T
1S5355-TRB

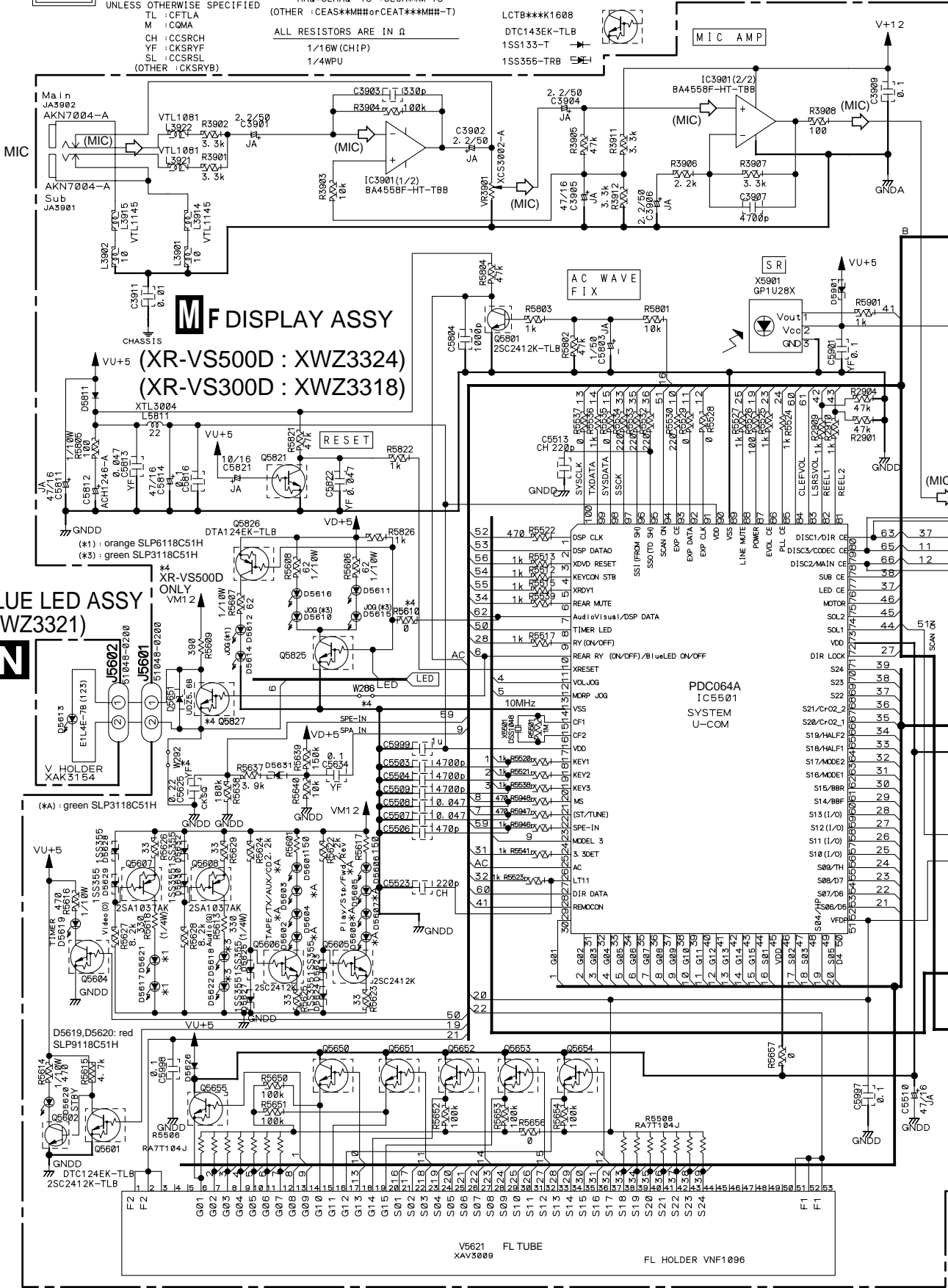

FOR XR-VS500D **G4/4 CN8104** FOR XR-VS300D **GFC CN8104**

 : The power supply is shown with the marked box.

LFCN81

FOR XR-VS500D
(pin 1 to 21)
52492-2120

FOR XR-VS300D
(pin 1 to 7)
52492-0720

1/2/3F CN5105

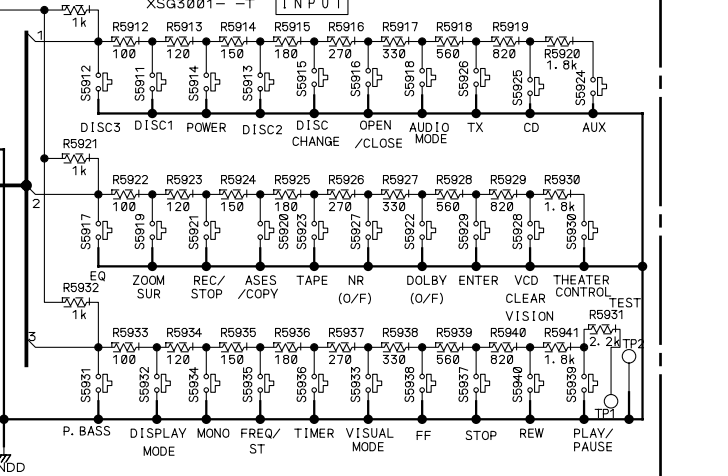
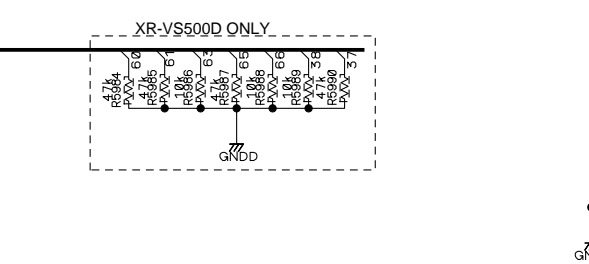
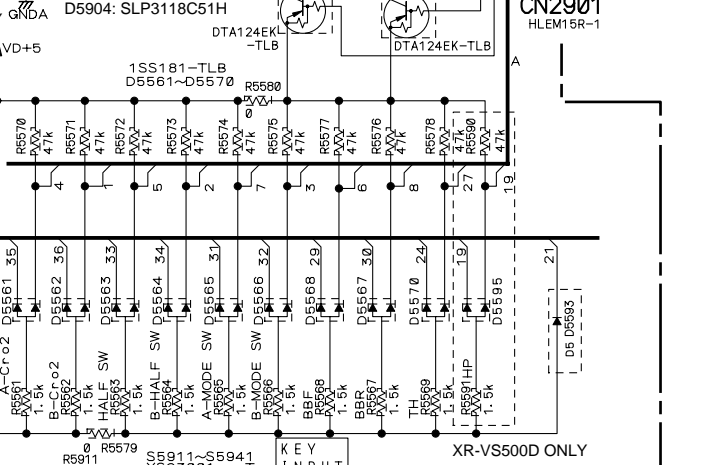
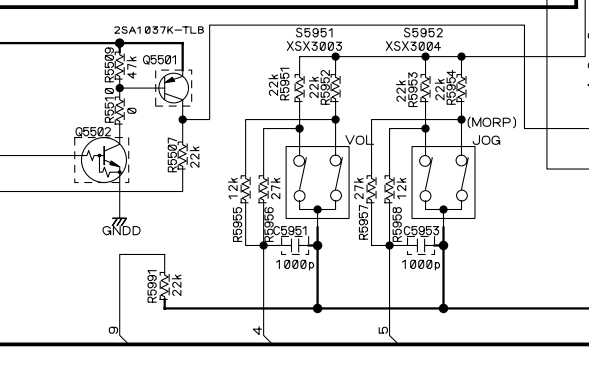
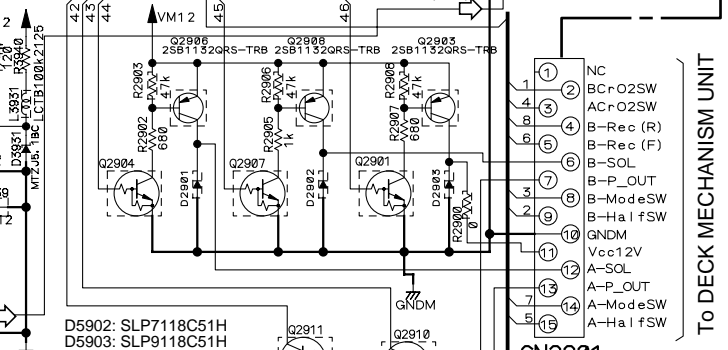
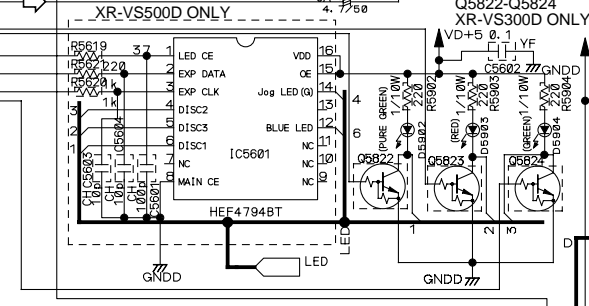
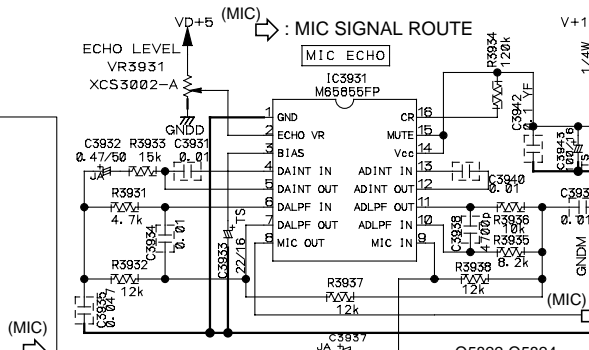
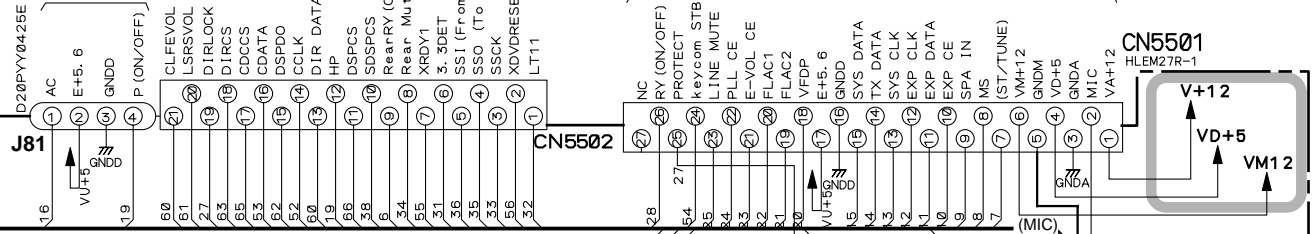

- S5911 : DISC 1
- S5912 : DISC 3
- S5913 : DISC 2
- S5914 : STANDBY/ON
- S5915 : DISC CHANGE
- S5916 : OPEN/CLOSE
- S5917 : EQUALIZER
- S5918 : AUDIO MODE
- S5919 : ZOOM SURROUND
- S5920 : ASES/COPY
- S5921 : REC/STOP
- S5922 : DOLBY/DTS
- S5923 : TAPE I/II
- S5924 : AUX
- S5925 : DVD/CD
- S5926 : TUNER BAND
- S5927 : ON/OFF
- S5928 : VIDEO NR
- S5929 : SET
- S5930 : THEATER CONTROL
- S5931 : P.BASS(DEMO)
- S5932 : DISPLAY MODE
- S5933 : VISUAL MODE
- S5934 : MONO
- S5935 : FREQ/STATION
- S5936 : TIMER/CLOCK ADJ
- S5937 : (STOP/ST.MEMORY)
- S5938 : (TUNING+)
- S5939 : (PLAY/PAUSE)
- S5940 : (TUNING-)
- S5951 : VOLUME UP/DPWN
- S5952 : JOG dial



4. PCB CONNECTION DIAGRAM

4.1 CONNECT ASSY (2CH) for XR-VS300D

GF CONNECT ASSY (2CH)

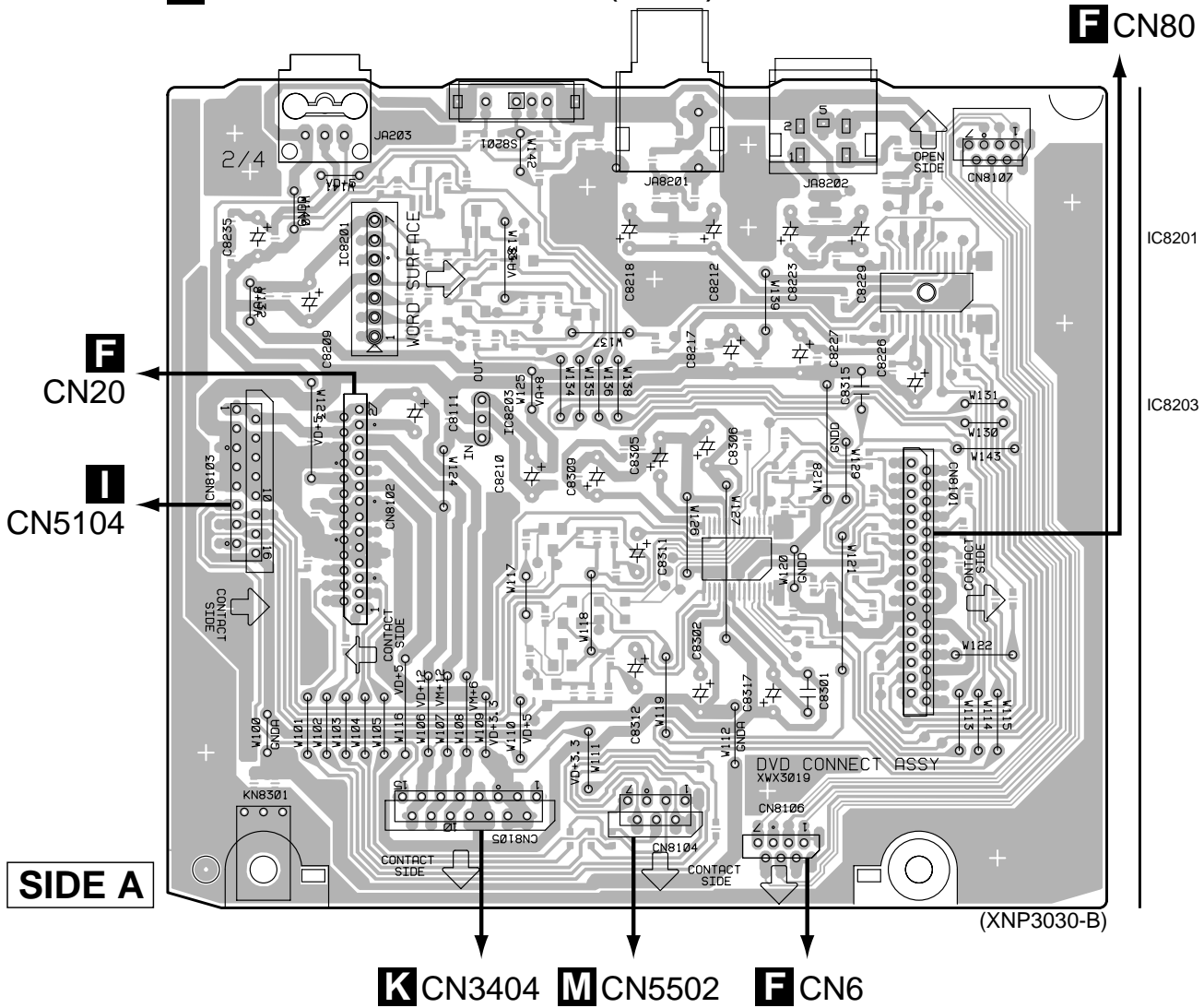

GF CONNECT ASSY (2CH)

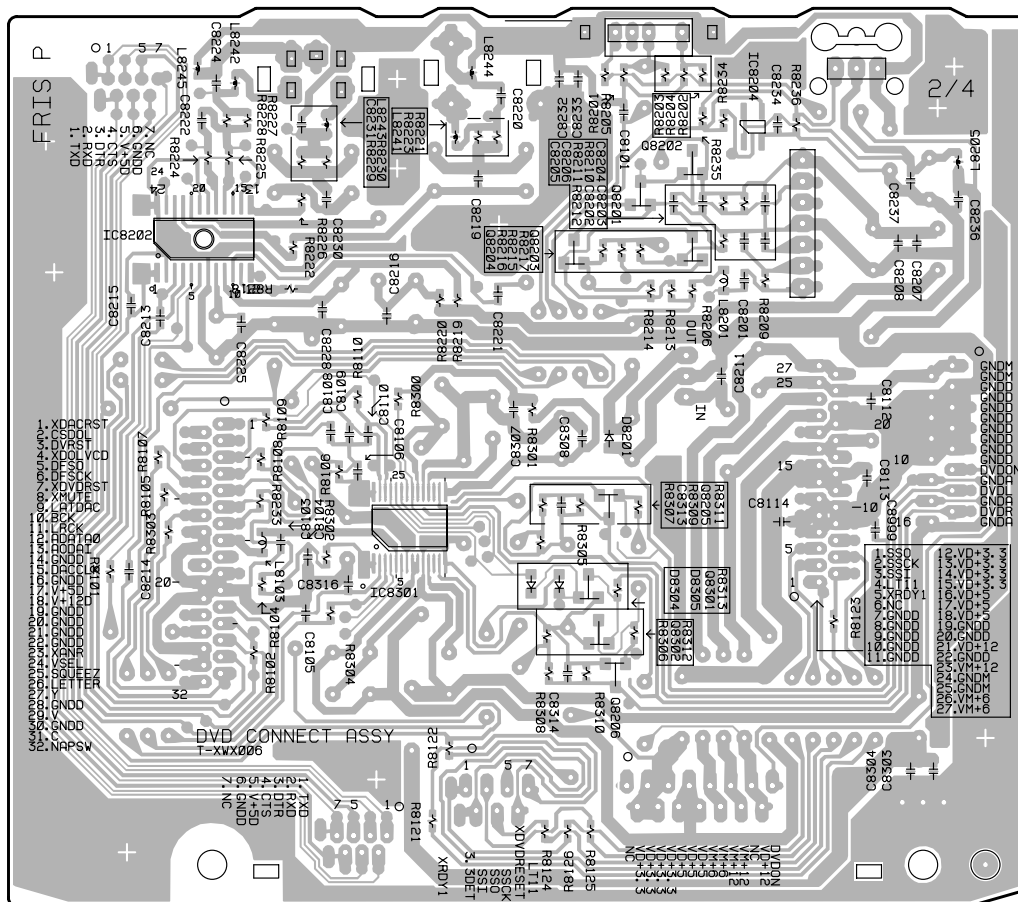

SIDE B

(XNP3030-B)

- IC8204
- Q8202
- Q8201
- IC8202
- Q8204
- Q8203
- Q8205
- IC8301
- Q8301
- Q8302
- Q8206

5. GENERAL INFORMATION

5.1 IC

• The information shown in the list is basic information and may not correspond exactly to that shown in the schematic diagrams.

■ PDC064A (DISPLAY ASSY : IC5501) for XR-VS300D

• System Control Microcomputer

● Pin Function

No.	Pin Name	I/O	Function
1	--	O	
2	--	O	
3	XDVDRESET	O	Reset output of DVD microcomputer
4	KYC STB	O	Strobe output of Keycom IC (M65847AFP)
5	XRDY1	O	Communication ready output of DVD microcomputer
6	--	O	
7	A/V MODE LED	O	AUDIO/VISUAL mode LED output
8	TIMER LED	O	Timer LED output
9	RY ON/OFF	O	Relay ON/OFF
10	BLUE LED	O	BLUE LED output
11	XRESET	--	
12	VOL JOG	I	Volume JOG input
13	MORP JOG	I	Sound Morphing JOG input
14	VSS	--	Ground
15	CF1	--	
16	CF2	--	
17	VDD	--	Power supply
18	KEY1	I	Key input 1 (A/D)
19	KEY2	I	Key input 2 (A/D)
20	KEY3	I	Key input 3 (A/D)
21	MS	I	Deck MS input
22	ST/TUNE	I	Tuner STEREO/TUNE input
23	SPE-IN	I	Spectrum analyzer signal input
24	3.3DETECT	I	DVD 3.3V detection input
25	MODEL3	I	Model distinguish input 3
26	AC	I	AC pulse interrupt input
27	LT11	I	Communication latch input of DVD microcomputer
28	--	O	
29	REMOCON	I	Remote control interrupt input
30	G01	O	Grid 1 output
31	G02		Grid 2 output
32	G03		Grid 3 output
33	G04		Grid 4 output
34	G05		Grid 5 output
35	G06		Grid 6 output
36	G07		Grid 7 output
37	G08		Grid 8 output
38	G09		Grid 9 output
39	G10		Grid 10 output
40	G11		Grid 11 output
41	G12		Grid 12 output
42	G13		Grid 13 output
43	G14		Grid 14 output
44	G15		Grid 15 output
45	S01	O	Segment 1 output
46	VDD	--	Power supply
47	S02/D5597	I/O	Segment 2 output
48	S03/D5596		Segment 3 output
49	S04/D5595		Segment 4 output
50	S05/D5594		Segment 5 output/Destination SW4 input

No.	Pin Name	I/O	Function
51	VFDP	–	
52	S06/D5593	I/O	Segment 6 output/Destination SW3 input
53	S07/D5592		Segment 7 output/Destination SW2 input
54	S08/D5591		Segment 8 output/Destination SW1 input
55	S09/TH		Segment 9 output/Protection input
56	S10		Segment 10 output
57	S11		Segment 11 output
58	S12		Segment 12 output
59	S13		Segment 13 output
60	S14/ARF		Segment 14 output/DECK ARF SW input
61	S15/ARR		Segment 15 output/DECK ARR SW input
62	S16/MODE1		Segment 16 output/DECK MODE SW1 input
63	S17/MODE2		Segment 17 output/DECK MODE SW2 input
64	S18/HALF1		Segment 18 output/DECK HALF SW1 input
65	S19/HALF2		Segment 19 output/DECK HALF SW2 input
66	S20/CrO2_1		Segment 20 output/DECK CrO2 SW1 input
67	S21/CrO2_2	Segment 21 output/DECK CrO2 SW2 input	
68	S22	O	Segment 22 output
69	S23		Segment 23 output
70	S24		Segment 24 output
71	--	I	Pull-up/Down
72	VDD	–	Power supply
73	SOL2	O	DECK solenoid output 2
74	SOL1		DECK solenoid output 1
75	MOTOR	O	DECK motor output
76	--	O	
77	--	O	
78	LED DISC3	O	DISC3 LED output
79	LED DISC2	O	DISC2 LED output
80	LED DISC1	O	DISC1 LED output
81	REEL1	I	DECK reel pulse input 1
82	REEL2		DECK reel pulse input 2
83	--	O	
84	--	O	
85	PLL CE	O	Chip enable output of Tuner PLL
86	EVOL CE	O	Chip enable output of electronic volume IC
87	POWER	O	Power output
88	LINE MUTE	O	Line mute output
89	VSS	–	Ground
90	VDD	–	Power supply
91	EXP CLK	O	Clock output for EXP IC
92	EXP DATA	O	Data output for EXP IC
93	EXP CE	O	Chip enable output of EXP IC (BU4094BCF)
94	SCAN ON	O	Outputs for SW reading
95	SSI(SSO)	O	Communication data output of DVD microcomputer (outputs at AMP side)
96	SSO(SSI)	I	Communication data input of DVD microcomputer (inputs at AMP side)
97	SSCK	O	Communication clock output of DVD microcomputer
98	SYSDATA	O	Data output of the Tuner PLL data/electronic volume IC
99	TXDATA	I	Tuner data input
100	SYSCCLK	O	Clock output of the Tuner PLL data/electronic volume IC