

Pioneer

Service Manual



XV-BD422B

ORDER NO.
RRV4334

Blu-ray Disc receiver

XV-BD422B

XV-BD122B

XV-BD122FSB

THIS MANUAL IS APPLICABLE TO THE FOLLOWING MODEL(S) AND TYPE(S).

Model	Type	Power Requirement	DVD Region No.	BD Region No.	Serial No.	Remarks
XV-BD422B	YXE8	AC 110 V to 240 V	2	B	&&&&#####YY	YY: Europe
XV-BD422B	VXE8	AC 110 V to 240 V	2	B	&&&&#####GB	GB: U.K
XV-BD122B	YXE8	AC 110 V to 240 V	2	B	&&&&#####YY	YY: Europe
XV-BD122B	VXE8	AC 110 V to 240 V	2	B	&&&&#####GB	GB: U.K
XV-BD122FSB	YXE8	AC 110 V to 240 V	2	B	&&&&#####YY	YY: Europe



PIONEER CORPORATION 1-1, Shin-ogura, Saiwai-ku, Kawasaki-shi, Kanagawa 212-0031, Japan

PIONEER ELECTRONICS (USA) INC. P.O. Box 1760, Long Beach, CA 90801-1760, U.S.A.

PIONEER EUROPE NV Haven 1087, Keetberglaan 1, 9120 Melsele, Belgium

PIONEER ELECTRONICS ASIACENTRE PTE. LTD. 253 Alexandra Road, #04-01, Singapore 159936

©PIONEER CORPORATION 2012

K-MZV JULY 2012 Printed in Japan

1

2

3

4

SAFETY INFORMATION

A

LASER DIODE CHARACTERISTICS

For BD Wave length : 398 - 412 nm
Output Power : Less than Class 1

For DVD Wave length : 650 - 664 nm
Output Power : Less than Class 1

For CD Wave length : 784 - 796 nm
Output Power : Less than Class 1

B

C

LABEL CHECK

D

The following caution appears on your unit.
Location: inside of the unit

CAUTION: INVISIBLE LASER RADIATION WHEN OPEN
DO NOT STARE INTO BEAM

DANGER: INVISIBLE LASER RADIATION WHEN OPEN
AVOID DIRECT EXPOSURE TO THE BEAM

(Printed on the rear panel)

CLASS 1 LASER PRODUCT
APPAREIL À LASER DE CLASSE 1

E

F

2

1

2

XV-BD422B

3

4

CONTENTS

SAFETY INFORMATION	2	
1. SERVICE PRECAUTIONS.....	4	
1.1 NOTES ON SOLDERING	4	A
2. SPECIFICATIONS.....	5	
3. BASIC ITEMS FOR SERVICE	6	
3.1 CHECK POINTS AFTER SERVICING	6	
3.2 JIGS LIST	6	
3.3 PCB LOCATIONS	7	
4. BLOCK DIAGRAM	8	
4.1 OVERALL WIRING DIAGRAM	8	
4.2 OVERALL BLOCK DIAGRAM	10	
5. DIAGNOSIS	12	
5.1 TROUBLESHOOTING.....	12	
6. SERVICE MODE.....	15	
6.1 SERVICE MODE	15	B
7. DISASSEMBLY	21	
8. EACH SETTING AND ADJUSTMENT	28	
8.1 ADJUSTMENT REQUIRED WHEN THE UNIT IS REPAIRED OR REPLACED.....	28	
8.2 UPDATING OF THE FIRMWARE	30	
9. EXPLODED VIEWS AND PARTS LIST	32	
9.1 PACKING SECTION.....	32	
9.2 EXTERIOR SECTION	34	
10. SCHEMATIC DIAGRAM.....	38	
10.1 MAIN BOARD ASSY (1/13)	38	
10.2 MAIN BOARD ASSY (2/13)	40	
10.3 MAIN BOARD ASSY (3/13)	42	
10.4 MAIN BOARD ASSY (4/13)	44	C
10.5 MAIN BOARD ASSY (5/13)	46	
10.6 MAIN BOARD ASSY (6/13)	48	
10.7 MAIN BOARD ASSY (7/13)	50	
10.8 MAIN BOARD ASSY (8/13)	52	
10.9 MAIN BOARD ASSY (9/13)	54	
10.10 MAIN BOARD ASSY (10/13)	56	
10.11 MAIN BOARD ASSY (11/13).....	58	
10.12 MAIN BOARD ASSY (12/13)	60	
10.13 MAIN BOARD ASSY (13/13)	62	
10.14 FRONT BOARD ASSY	64	
10.15 AMP BOARD ASSY (1/3)	66	
10.16 AMP BOARD ASSY (2/3)	68	D
10.17 AMP BOARD ASSY (3/3)	70	
10.18 AV BOARD ASSY	72	
10.19 SYSTEM POWER SUPPLY ASSY	74	
11. PCB CONNECTION DIAGRAM	76	
11.1 MAIN BOARD ASSY.....	76	
11.2 FRONT BOARD ASSY	80	
11.3 AMP and AV BOARD ASSYS.....	82	
11.4 SYSTEM POWER SUPPLY ASSY	84	

1. SERVICE PRECAUTIONS

1.1 NOTES ON SOLDERING

- A
 - For environmental protection, lead-free solder is used on the printed circuit boards mounted in this unit. Be sure to use lead-free solder and a soldering iron that can meet specifications for use with lead-free solders for repairs accompanied by reworking of soldering.
 - Compared with conventional eutectic solders, lead-free solders have higher melting points, by approximately 40 °C. Therefore, for lead-free soldering, the tip temperature of a soldering iron must be set to around 373 °C in general, although the temperature depends on the heat capacity of the PC board on which reworking is required and the weight of the tip of the soldering iron.

Do NOT use a soldering iron whose tip temperature cannot be controlled.

- B
 - Compared with eutectic solders, lead-free solders have higher bond strengths but slower wetting times and higher melting temperatures (hard to melt/easy to harden).

The following lead-free solders are available as service parts:

- Parts numbers of lead-free solder:
 - GYP1006 1.0 in dia.
 - GYP1007 0.6 in dia.
 - GYP1008 0.3 in dia.

C

D

E

F

2. SPECIFICATIONS

General (XV-BD422B/XV-BD122B)	
Power requirements	AC 110 V to 240 V, 50 Hz/60 Hz
Power consumption	190 W (In Standby mode: Less than 0.5 W)
Dimensions (W x H x D)	Approx. 430 mm x 345 mm x 62 mm
Net Weight (Approx.)	3.4 kg
Operating temperature	5 °C to 35 °C
Operating humidity	5 % to 85 %

General (XV-BD122FSB)	
Power requirements	AC 110 V to 240 V, 50 Hz/60 Hz
Power consumption	105 W (In Standby mode: Less than 0.5 W)
Dimensions (W x H x D)	Approx. 430 mm x 345 mm x 62 mm
Net Weight (Approx.)	3.3 kg
Operating temperature	5 °C to 35 °C
Operating humidity	5 % to 85 %

Inputs/Outputs	
VIDEO OUT	1.0 V (p-p), 75 Ω, sync negative, RCA jack x 1
HDMI IN/OUT (video/audio)	19 pin (HDMI®/™ Connector)
ANALOG AUDIO IN	2.0 Vrms (1 kHz, 0 dB), 600 Ω, RCA jack (L, R) x 1
DIGITAL IN (OPTICAL)	3 V (p-p), Optical jack x 2 (48 kHz, 96 kHz sampling)
PORTABLE IN	0.5 Vrms (3.5 mm stereo jack)
ADAPTER PORT	5 V, 100 mA
MIC	Mic jack x 1
USB	4 pin A Type x 2

Tuner	
FM Tuning Range	87.5 MHz to 108.0 MHz
Antenna input	75 Ω unbalanced

Amplifier (XV-BD422B/XV-BD122B)	
Power output (RMS) THD 30 %	
Total	1100 W
Front	170 W × 2 (4 Ω)
Center	250 W (3 Ω)
Rear	170 W × 2 (4 Ω)
Sub-Woofer	250 W (3 Ω)

Amplifier (XV-BD122FSB)	
Power output (RMS) THD 30 %	
Total	550 W
Front	170 W × 2 (4 Ω)
Sub-Woofer	250 W (3 Ω)

System	
Laser	Semiconductor laser
Signal system	Standard PAL/NTSC colour TV system
LAN port	Ethernet jack x 1, 10BASE-T / 100BASE-TX
Bus Power Supply (USB)	DC 5 V  500 mA

Accessories

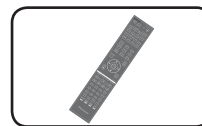

Remote control (AXD7655)
(06-BCS727-A000)

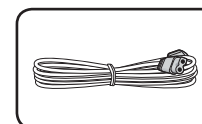

Power cord
(XV-BD422B/YXE8, XV-BD122B/YXE8,
XV-BD122FSB/YXE8: 51-DC0120-0CRA3)
(XV-BD422B/VXE8, XV-BD122B/VXE8
: 51-DC0120-0CRD4)

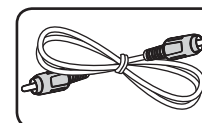

Video cable
(41-UH1200-0KK1E)

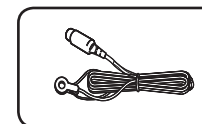

FM antenna
(47-ANT022-XX0)

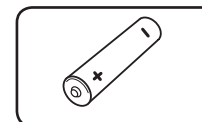

Battery (x2)

- Warranty card
- Operating instructions
(XV-BD422B/YXE8, XV-BD122B/YXE8,
XV-BD122FSB/YXE8: 72-BD122B-EU0B1)
(XV-BD422B/VXE8, XV-BD122B/VXE8:
72-BD122B-GBR1)

3. BASIC ITEMS FOR SERVICE

3.1 CHECK POINTS AFTER SERVICING

A Items to be checked after servicing

To keep the product quality after servicing, confirm recommended check points shown below.

No.	Procedure	Check points
1	Confirm the firmware version on Service mode.	The version of the firmware must be latest. Update firmware to the latest one, if it is not the latest.
2	Confirm whether the customer complain has been solved. If the customer complain occurs with the specific disc, use it for the operation check.	The customer complain must not be reappeared. Video, audio and operations must be normal.
3	Check the CD playback. (Track search)	Audio and operations (search etc.) must be normal.
4	Check the DVD playback. (Operation, Title/Chapter search)	Video, audio and operations (search etc.) must be normal.
5	Check the BD playback. (Operation, Title/Chapter search)	Video, audio and operations (search etc.) must be normal.
6	Check the tuner (FM) operations.	Video, audio and operations (search etc.) must be normal.
7	Check supported file playback by USB memory.	Video, audio and operations must be normal.
8	Check supported file playback from same network device by LAN connection at Home MEDIA GALLERY .	Video, audio and operations must be normal.
9	Select [Scan] on [Wireless Setting] and then check access points are displayed on screen. (*)	Correct access point name (SSID) must be displayed. (*)
10	Check the appearance of the product.	No scratches or dirt on its appearance after receiving it for service.

(*) Wireless model only (XV-BD121W/122W/222W/421W/422W/921FSW/922FSW/821FSW/ 822FSW/621FSW/521FSW)

See the table below for the items to be checked regarding video and audio.

Item to be checked regarding video	Item to be checked regarding audio
Block noise	Distortion
Horizontal noise	Noise
Dot noise	Volume too low
Disturbed image (video jumpiness)	Volume too high
Too dark	Volume fluctuating
Too bright	Sound interrupted
Mottled color	

3.2 JIGS LIST

Jigs List

Jig Name	Part No.	Remarks
BD Test disc	GGV1368	Use with "6. SERVICE MODE".
Emergency disc ejection rod	GGF1529	Refer to "7. DISASSEMBLY".

Cleaning



Before shipping out the product, be sure to clean the following positions by using the prescribed cleaning tools.

Position to be cleaned	Name	Part No.	Remarks
Pickup lenses	Cleaning liquid	GEM1004	Refer to "7. DISASSEMBLY".
	Cleaning paper	GED-008	
Fan	Cleaning paper	GED-008	Refer to "9.2 EXTERIOR SECTION".

3.3 PCB LOCATIONS

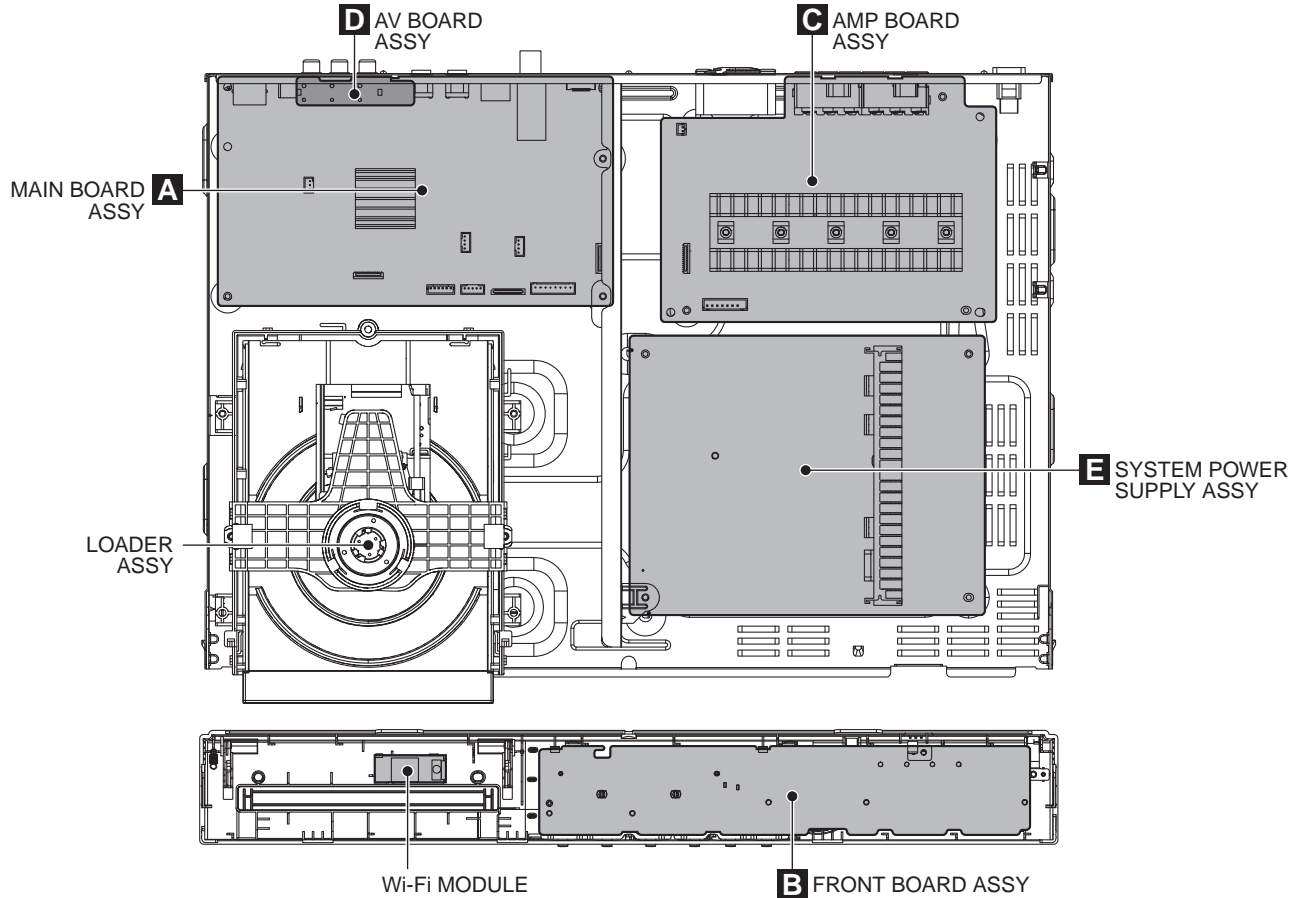

NOTES: ● Parts marked by “NSP” are generally unavailable because they are not in our Master Spare Parts List.
 ● The \triangle mark found on some component parts indicates the importance of the safety factor of the part.
 Therefore, when replacing, be sure to use parts of identical designation.

Mark No.	Description	Part No.	Mark No.	Description	Part No.
LIST OF ASSEMBLIES					
1..	MAIN BOARD ASSY	08-H555DU-MA1R/YXV	1..	AV BOARD ASSY	AZW7613
1..	FRONT BOARD ASSY	08-BCS727-FVY	1..	SYSTEM POWER SUPPLY ASSY	08-K250HE-PW1
1..	AMP BOARD ASSY	AZW7611		LOADER ASSY	08-LTCA19-222026
	(XV-BD422B, XV-BD122B)				
1..	AMP BOARD ASSY	AZW7612			
	(XV-BD122FSB)				

4. BLOCK DIAGRAM

4.1 OVERALL WIRING DIAGRAM

A
B
C
D
E
F

D

AV BOARD ASSY (AZW7613)

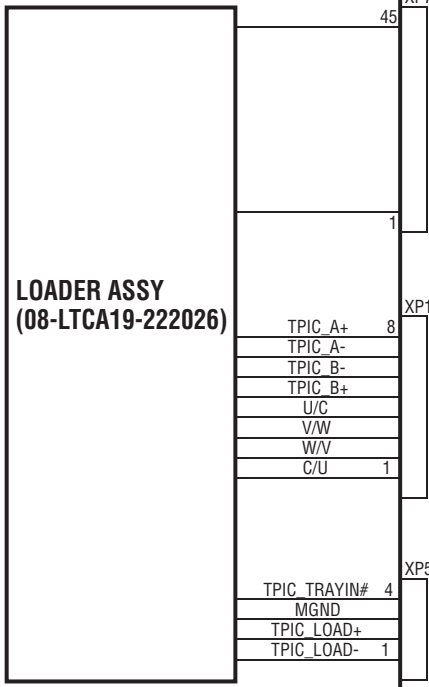
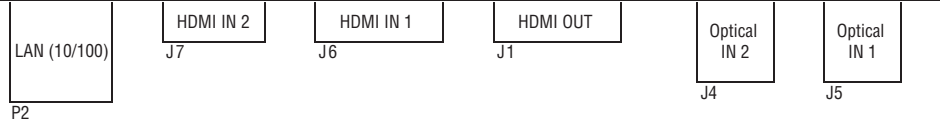
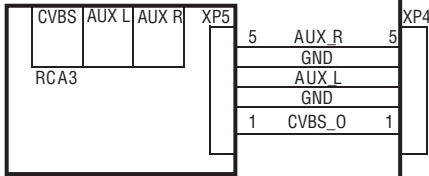

A (A1/13- A13/13)
MAIN BOARD ASSY (08-H555DU-MA1R/YXV)

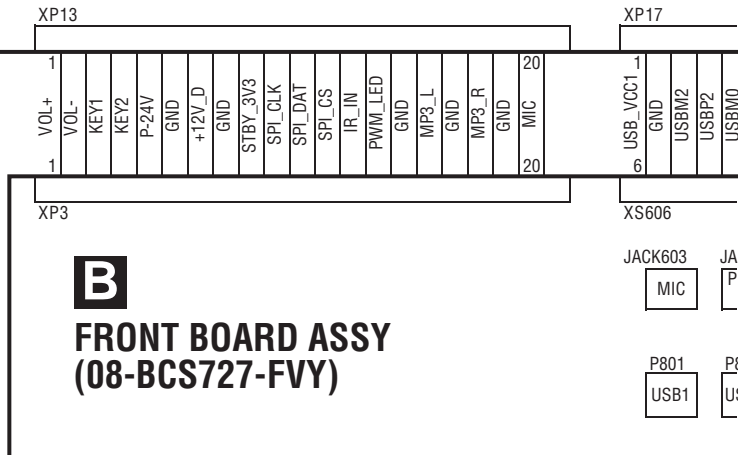
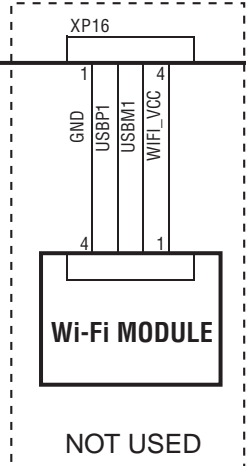

NOT USED

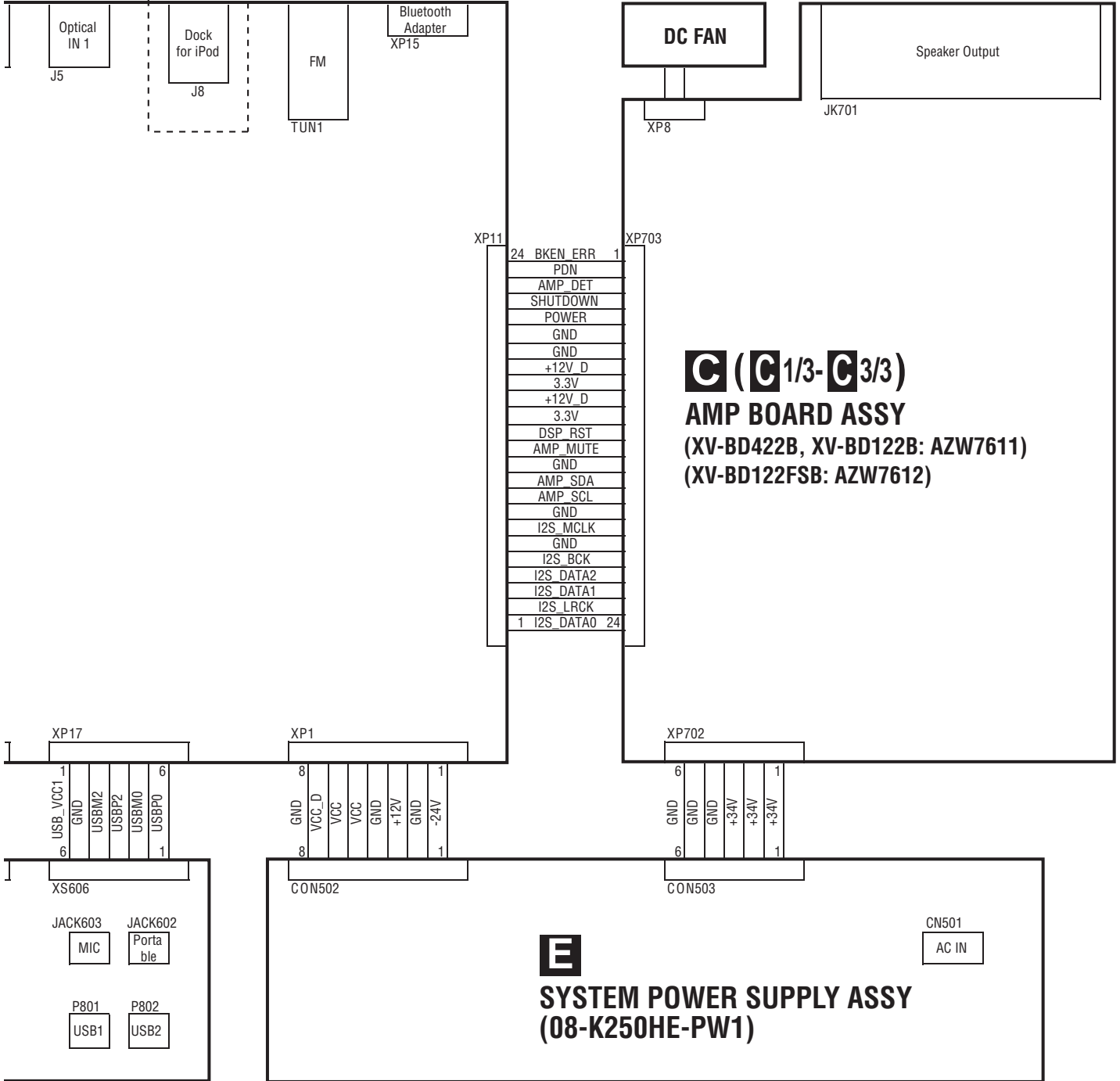

- When ordering service parts, be sure to refer to "EXPLODED VIEWS and PARTS LIST" or "PCB PARTS LIST".
- The Δ mark found on some component parts indicates the importance of the safety factor of the part. Therefore, when replacing, be sure to use parts of identical designation.

4.2 OVERALL BLOCK DIAGRAM

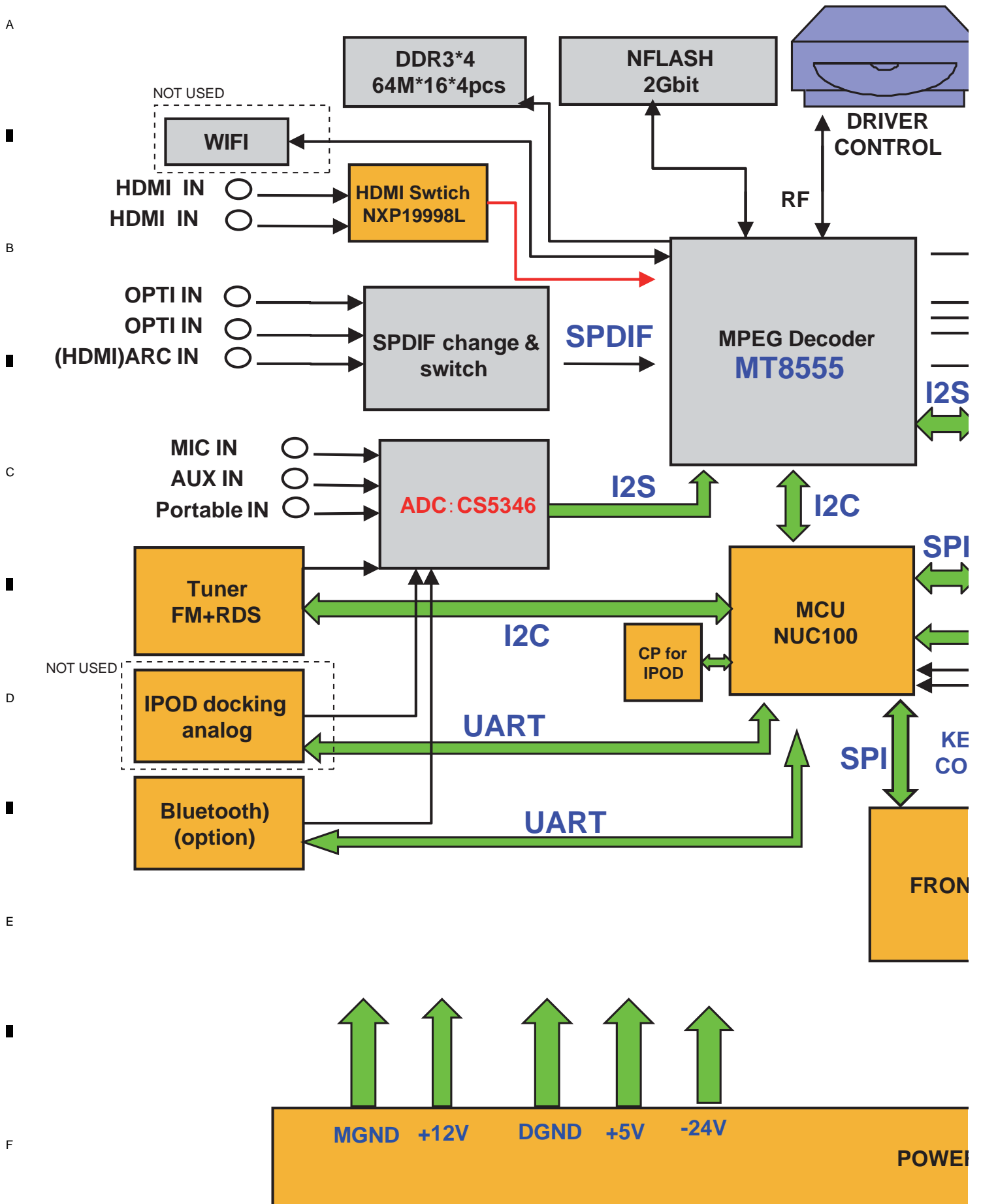

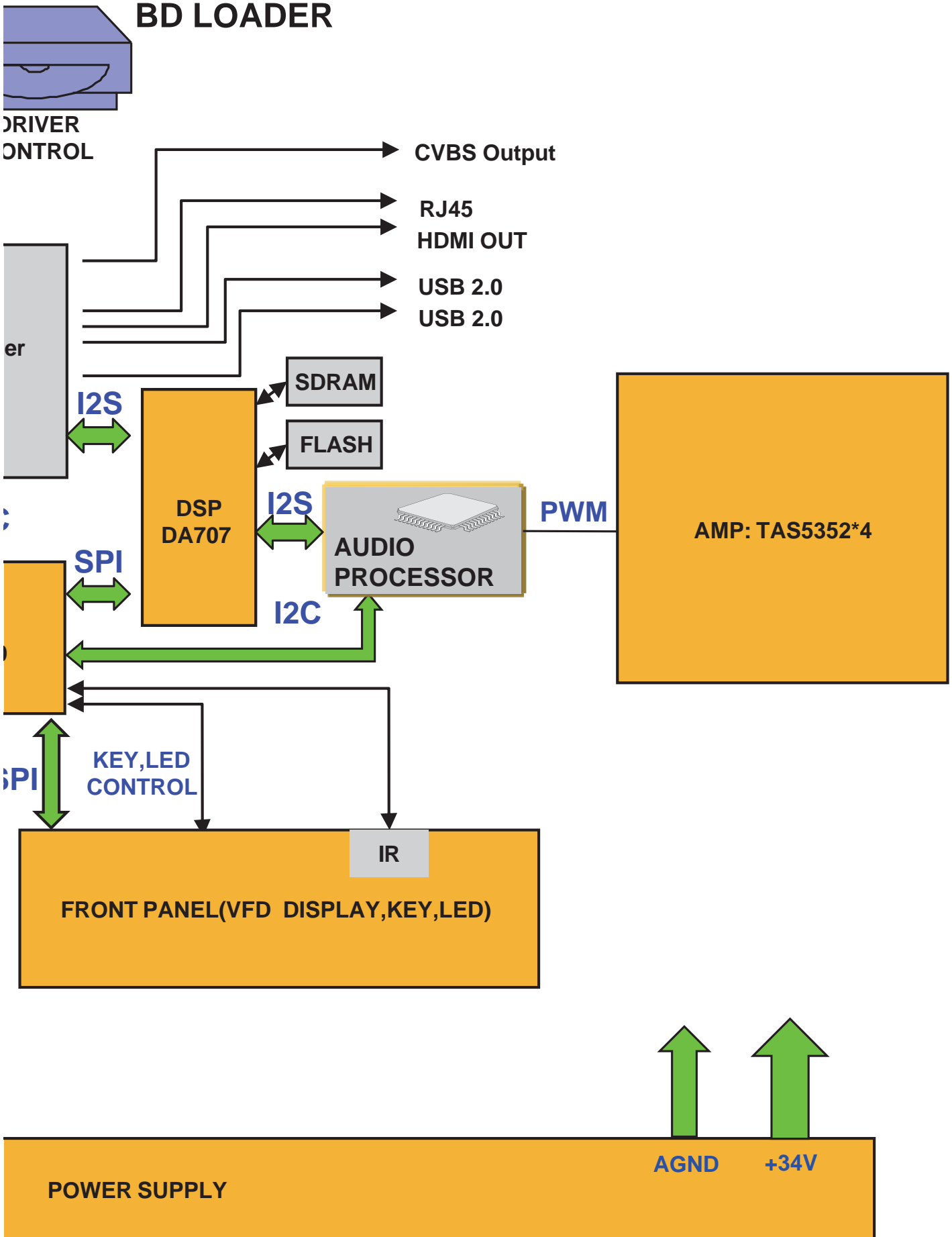

5. DIAGNOSIS

5.1 TROUBLESHOOTING

A No power

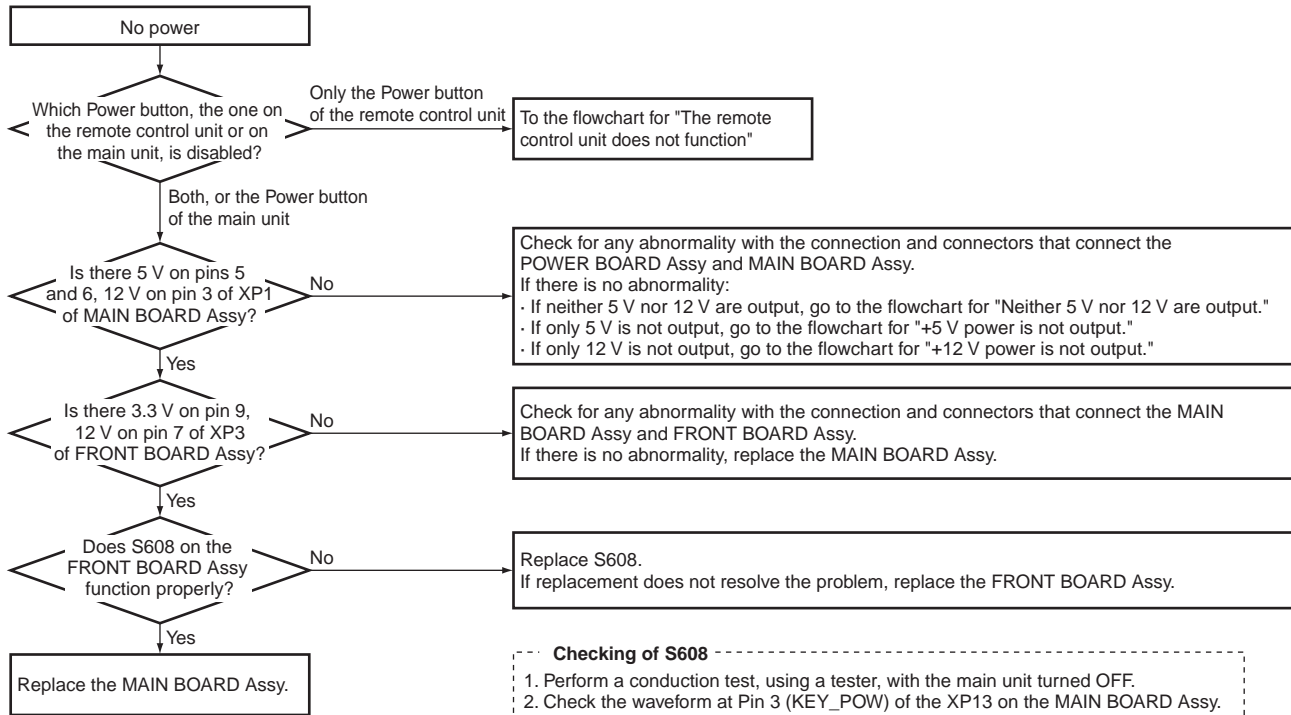

Waveform of KEY_POW

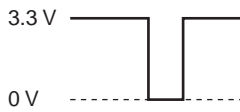

D

Neither 5 V nor 12 V are output

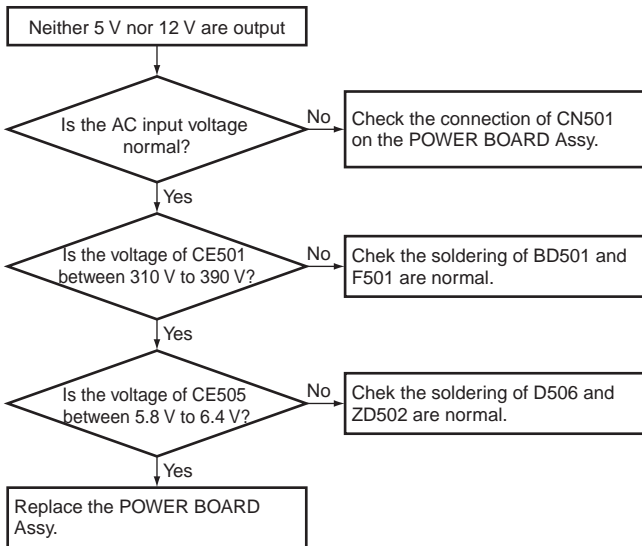

+5 V power is not output

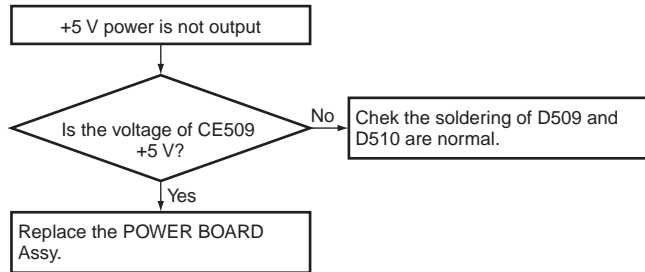

+12 V power is not output

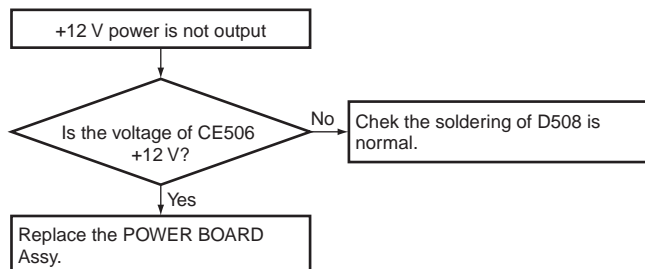

F

No display on VFD, and buttons do not work

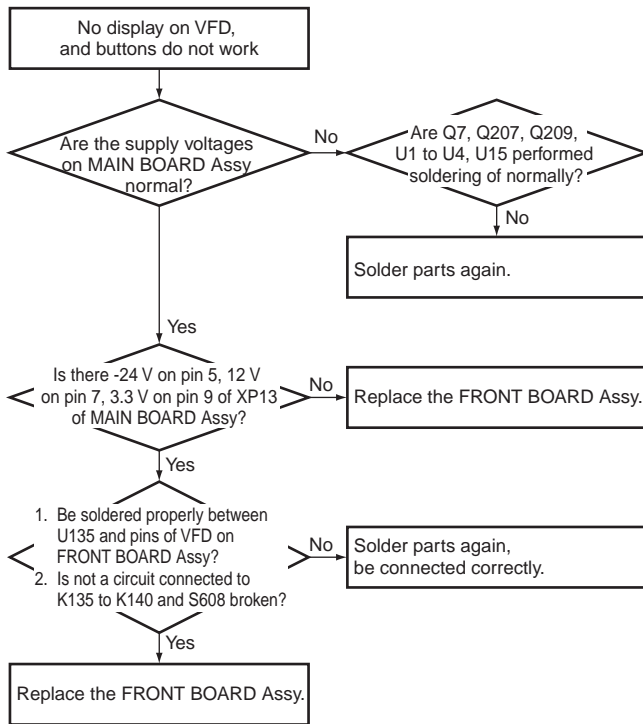

Remote control unit does not function

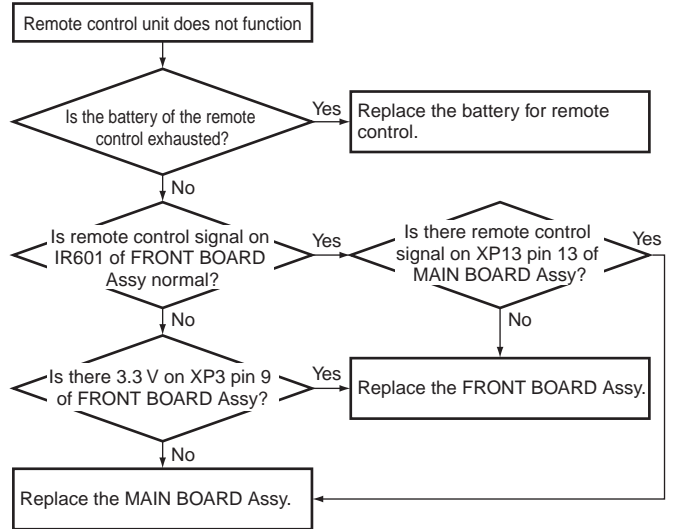

No audio output

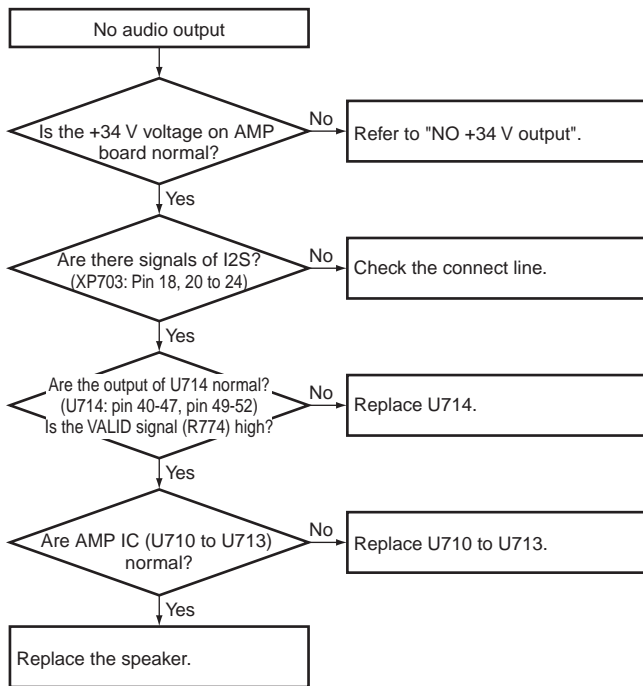

Can't read disc or can't open the tray

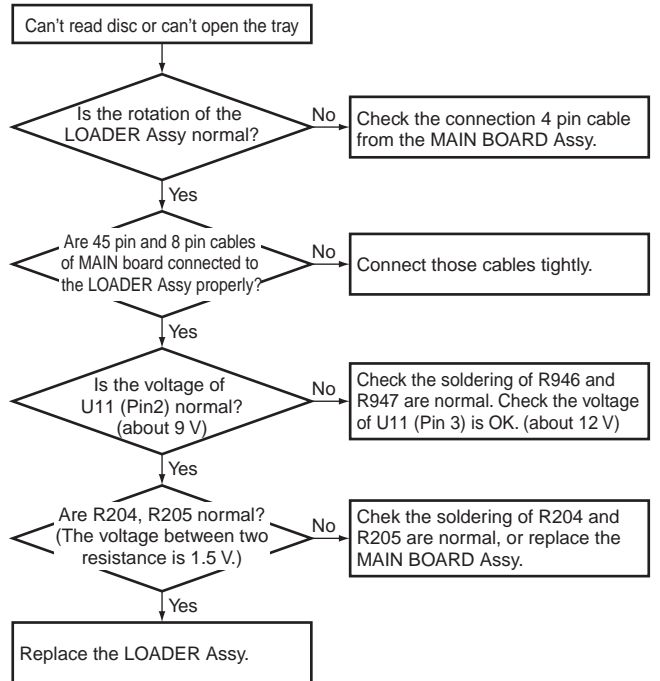

A No analog video display

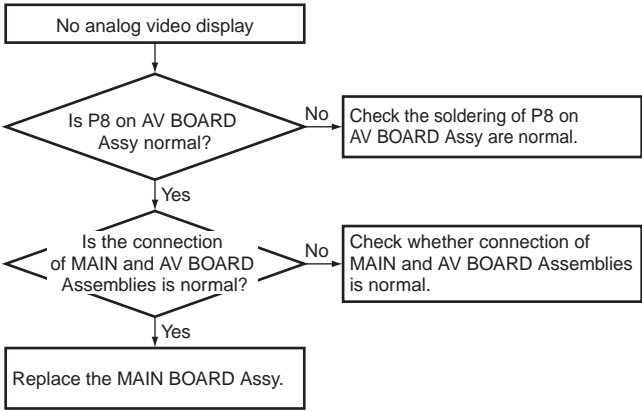

No output by "OPTICAL IN 1 or 2"

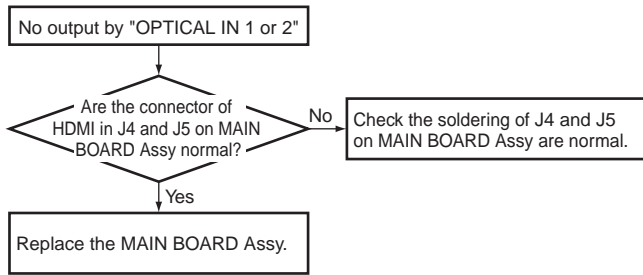

B

Can not connect to network by LAN

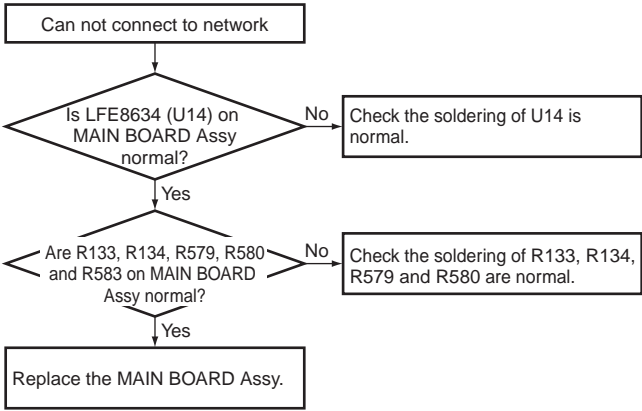

C

No output by "HDMI IN 1 or 2"

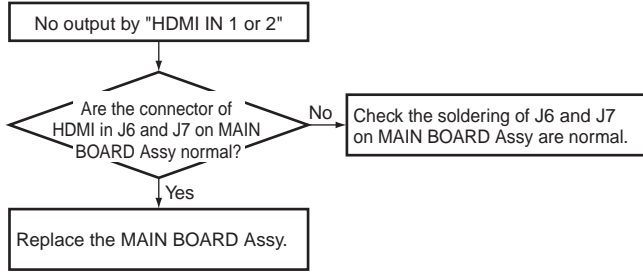

D

E

F

6. SERVICE MODE

6.1 SERVICE MODE

In Service Mode, there is a mixture of Design and Development, Production Line Menu and Service Menu. Here, menu items that are usable in Service and instructions are listed. Only use the menu explained in this document. Others are for Design and Product lines.

1. HOW TO ENTER TO SERVICE MODE

1. Press [Home Menu] on the remote controller and select "Initial Setup" from the home menu.



2. Pressing the number keys on the remote control in the following order [5] ⇒ [1] ⇒ [7] ⇒ [7] will display the Menu screen. (If it does not appear, slowly press the number keys with a 1 second interval.)

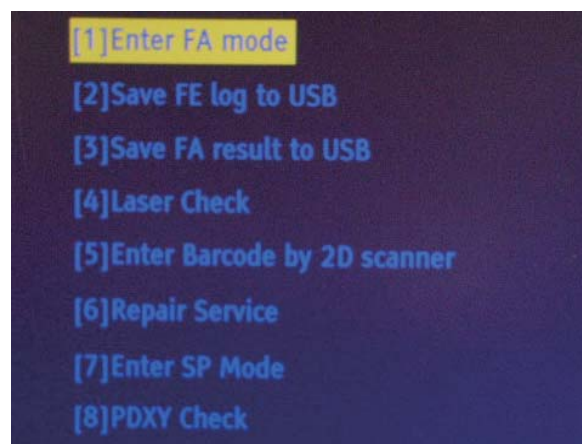

2. DESCRIPTION OF EACH ITEM

- [1] Enter FA mode
Implemented when exchanging the LOADER Assy and MAIN BOARD Assy. Refer to "FA Mode" for details.
- [2] Save FE log to USB
For Design and Development purposes and cannot be used for Service.
- [3] Save FA result to USB
For Design and Development purposes and cannot be used for Service.
- [4] Laser Check
Verifies laser diode. Refer to "Laser Check" for details.
- [5] Enter Barcode by 2D scanner
For Production line purposes and cannot be used for Service.
- [6] Repair Service
For the former model and will not be used to exchange this Loader.
- [7] Enter SP Mode
Mainly for Production Line, but some items can be used in Service. Please see "SP Mode" for details.
- [8] PDXY Check
Verifies misalignment of optical axis. Refer to "PDXY Check" for details.

A 3. DETAILED DESCRIPTION OF ITEMS USED IN SERVICE

1. [1] Enter FA mode

In "FA mode," playback of the pick-up area is adjusted first, and then playback verification process is done on all playable discs. Adjustments on initial playback need to be made when exchanging the Loader and MAIN BOARD Assy in Service, so implement "FA mode" as in the following instructions.

- ① Select "[1] Enter FA mode" with the up-and-down key on the remote control on the Service Mode screen and press the [ENTER] key. (Window below will appear)

B

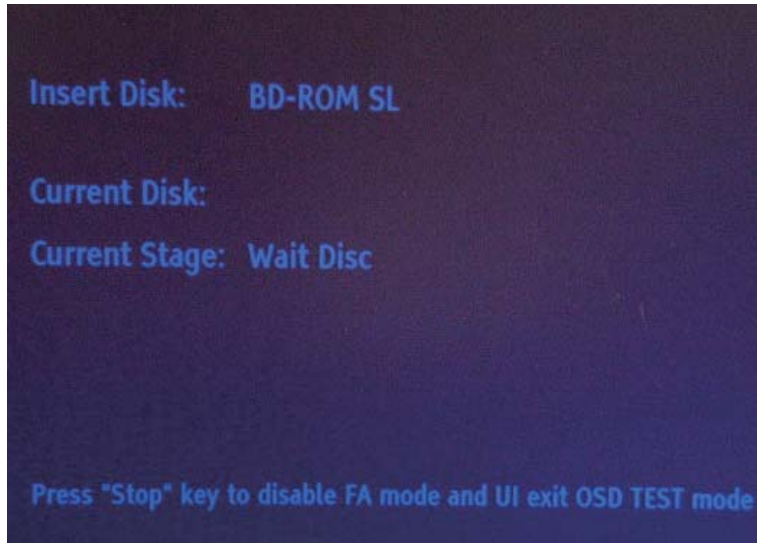

- ② The tray will open automatically, so insert GGV1368 and close the tray manually. (push the tray in)

- ③ Adjustments will initiate, and when they are properly completed, the tray will re-open and [Insert Disc: BD-R DL] will appear.

D

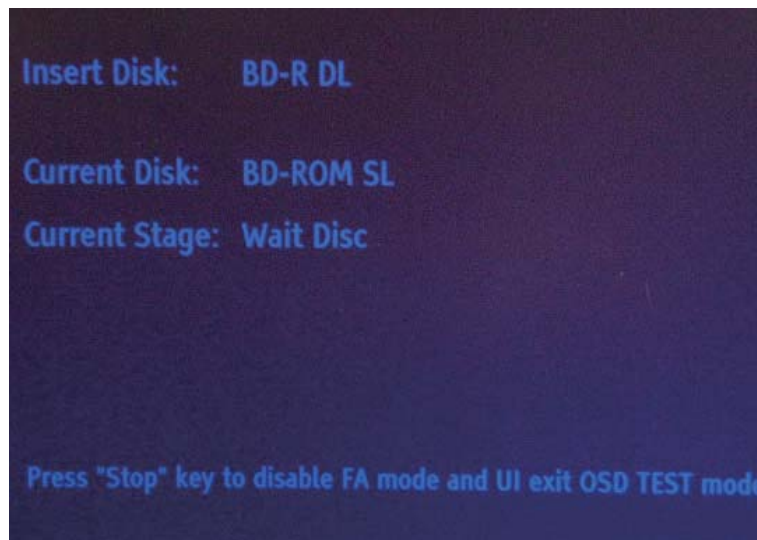

- ④ Remove the disc from the tray and press the [Stop] key. You will exit Service Mode and return to the Home Menu screen and finish.

F

2. [4] Laser Check

Verifies the output value of each laser diode inside the pick-up area. Implement according to the following procedures.

- ① Select "[4] Laser Check" with the ▼ key from the Service Mode screen and press the "ENTER" key. (perform without disc in tray)
- ② After a few seconds, measurement and judgment results will be displayed as follows, and the tray will open automatically. If all Measurement values (Meas) are less than the total numeric value of the Target value (hex) and 80 (hex) combined, [PASS] will appear, and if any of them goes over, [NG] will appear.

Example BD

Target: 0x41d Meas: 0x43 OK because
 ↓
 → 0x41d+0x80=0x49d Meas is 0x49d or less

[BD Measurement values: The hexadecimal single-digit will not be displayed in Meas. Therefore in the above example, Measurement values of up to 0x49 are considered OK, and 0x50 are considered NG.]

DVD
 Target: 0x53c Meas: 0x5a7 | OK
 ↓
 → 0x53c+0x80=0x5bc

CD
 Target: 0x560 Meas: 0x5d7 | OK
 ↓
 → 0x560+0x80=0x5e0

("0x" is simply to express the hex, so it is not necessary in the calculation)

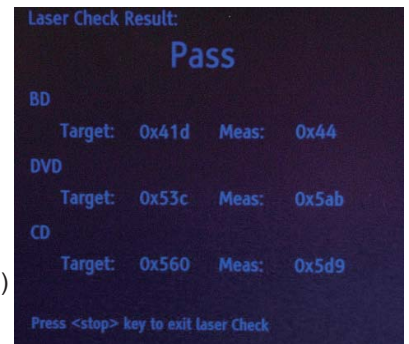

3. [7] Enter SP Mode

There are 15 items in the SP Mode, the main items being for Production line and Design/Development. The following is to explain items usable in Service. Other items require time for completion, or are not suited for Service purposes. If you select them by mistake, press the [Stop] key to end that item you accidentally selected. (none of the items will affect the main unit)

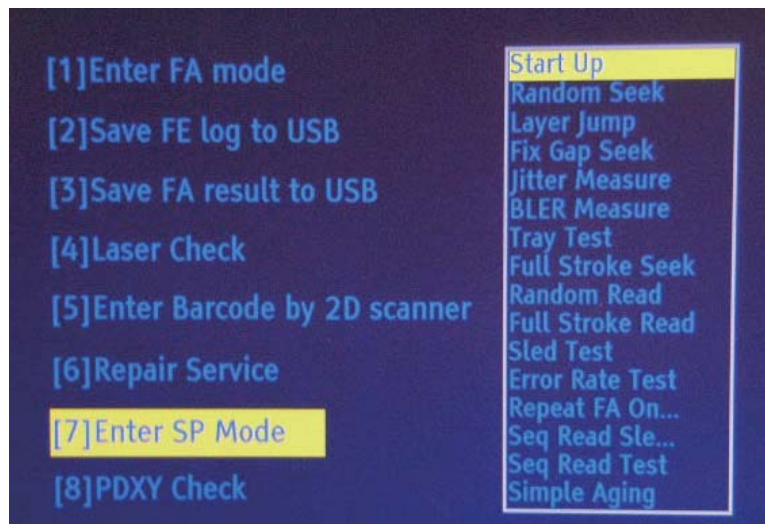

A 3-1. Start Up

[Content of test]

Implements initial movement of the disc servo continuously. Implement the following process 20,000 cycles.

· Tray Close → · Focus ON → · TOC Read → · Tray Open



(1 cycle 15 seconds x 20000=completed in approx. 83 hours 20 minutes)

Can be implemented on all of CD, DVD, and BD. Cannot change disc during process.

B [Instructions]

- ① Select "[7] Enter SP Mode" with the ▼ key from the Service Mode screen, and press the [ENTER] key.
- ② The SP Mode window menu will be displayed, so select "Start Up" and press the [ENTER] key.
- ③ The tray will automatically open and the dedicated screen will appear. Place the disc you wish to use on the tray, and push it in manually. ([Close] key will not function)
- ④ Start Up mode will be initiated, and count will start. Implement 20,000 times (4E20 in hex), and if no errors occur, "Pass" will appear. If errors do occur, they will be counted. Therefore, errors can be identified without finishing the process.

C [Effective indications]

- Tray sometimes does not open, discs sometimes are not recognized, discs sometime do not playback. (When indications are related to discs, implement on the type of disc which has been pointed out. If it is the disc on which the indications occurred, possibility of reoccurrence is higher.)

3-2. Jitter Measure / BLER Measure

[Content of test]

Measures the Jitter or the Block Error Rate (BLER) of the disc inserted.

Only Pass or NG will be displayed, not Measurement values.

All of CD, DVD, and BD can be judged.

[Instructions]

- ① Select "[7] Enter SP Mode" with the ▼ key from the Service Mode screen, and press the [ENTER] key.
- ② The SP Mode window menu will be displayed, so select either "Jitter Measure" or "BLER Measure," and press the [ENTER] key.
- ③ The tray will automatically open and the dedicated screen will appear. Place the disc you wish to use on the tray, and push it in manually. ([Close] key will not function)
- ④ The tray will reopen automatically. Measurement will start when you push the tray in manually.
- ⑤ When test is completed, "Pass" or "NG" is displayed.

[Effective indications]

Defect related to playback. (blocked noise, sound jumping, image jumping, disc is paused, freeze of screen etc.) However, even if Pass is displayed after this test, it is difficult to determine that the Drive is normal with these Pass judgments only.

If an NG is generated in a specific disc only, the defect is likely to be caused by the disc. If an NG is generated in other discs too, the defect is likely to be caused by the drive part.

3-3. Simple Aging

[Content of Test]

Performs random playback of disc randomly. Implement the following process 800 cycles.

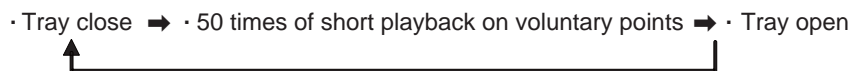

1cycle BD : 75 seconds x 800 times = Completed in a total of approx. 16 hours 40 minutes

DVD: Approx. 100 seconds x800 times = Completed in a total of approx. 22 hours 12 minutes

CD : Approx. 105 seconds x800 times = Completed in a total of approx. 23 hours 20 minutes

[Instructions]

- ① Select "[7] Enter SP Mode" with the ▼ key from the Service Mode screen, and press the [ENTER] key.
- ② The SP Mode window menu will be displayed, so select "Simple Aging" and press the [ENTER] key.
- ③ The tray will automatically open and the dedicated screen will appear. Place the disc you wish to use on the tray, and push it in manually. ([Close] key will not function)
- ④ The tray will reopen automatically. Aging will start when you push the tray in manually.

Note 1: [Total test count] display should always be 1 (essentially, 9C40, which is the hex of the 40000, the total of Random 50-time playback x 800 times should be displayed.

Note 2: Accumulated sum for [Current test count] is counted up until "9C3D" (39997 in decimal), however later it is expressed as "32" and is finished.

Note 3: DVD and BD disc can be checked with Single Layer (SL) disc only.
If they are checked with Dual Layer (DL) disc, an Error is generated.

Note 4: Set [Auto Power OFF] function in the setting of main unit to [OFF].
If the function is executed in any setting status, the power supply is turned OFF at the time.

· Error List

The following serves as the Error List generated in SP Mode.

Error code	Error name	Discription
12	PWR_CURVE_ERROR	Power curve chk-sum error
22	STARTUP_TIMEOUT_ERROR	Over time-out criteria
23	MEDIA_MISMATCH	Wrong disc
25	DISCID_ERROR 0x25	Disc ID error
26	MEDIUM_SUPPORT_ERROR	Unsupported disc
31	TRAYOUT_ERROR	Over tray-out time-out criteria
32	TRAYIN_ERROR	Over tray-in time-out criteria
33	FLASH_UPDATE_ERROR	Updating FA result failed
36	OPU_TEMP_ERROR	Abnormal OPU temperature
41	SEEK_TIMEOUT_ERROR	Over seek time-out criteria
42	SEEK_CMD_FAIL_ERROR	Seek cmd failed
51	READ_TOC_ERROR	Read TOC cmd failed
52	TOC_TIMEOUT_ERROR	Over read TOC time-out criteria
61	PIPO_TIMEOUT_ERROR	Over time-out criteria
62	PIPO_C1C2_ERROR	Read PIPO cmd failed
63	PIPO_C1C2_OVER	Over PIPO criteria
71	RD_CMD_FAIL_ERROR	Read cmd failed
72	RD_CMD_ERROR	Cmd error or illegal mode
73	RD_TIME_OUT_ERROR	Over read cmd time-out criteria
81	CHECK_FA_TABLE_ERROR	FA table chk-sum error

A 4. [8] PDXY Check

For PDXY Check, the misalignment of pick-up optical axis can be checked.

The optical axis misalignments of X-axis and Y-axis are displayed [PDX] and [PDY] with %, respectively. All of CD, DVD, and BD can be measured. The method for calculating PDX and PDY is shown below.

$$PDX = ((A+B)-(C+D)) / (A+B+C+D)$$

$$PDY = ((A+D)-(B+C)) / (A+B+C+D)$$

B [Instructions]

- ① Insert a disc (BD, DVD, CD) in a normal mode. If the playback starts, pause it.
Display the home menu and enter into the Service Mode.
In this mode, the measurement can be carried out at an arbitrary place. After a disc is inserted, play and stop the point you want to measure, and then enter into the Service Mode.
(The pick-up position does not return even in this status. The measurement at the place is available.)
- ② Select "[8] PDXY Check" with the ▼ key from the Service Mode screen, and press the [ENTER] key.
- ③ After the measurement is started and completed, the measurement value is displayed.
If the value is within the reference value, "Pass" is displayed.

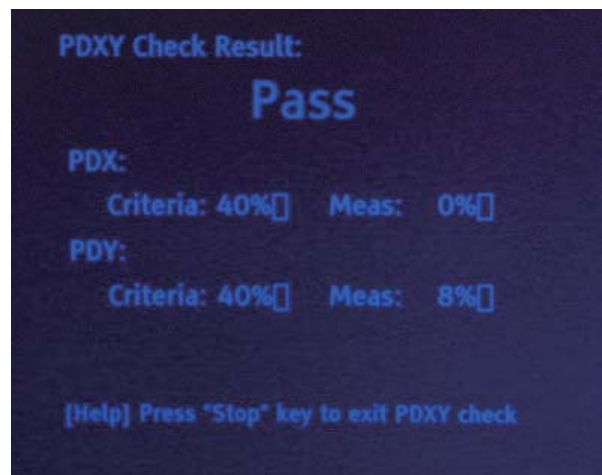

C [Effective indications]

Defect related to playback. (block noise, sound jumping, image jumping, disc is paused, freeze of screen etc.)

If an NG is generated in a specific disc only, the defect is likely to be caused by the disc. If an NG is generated in other discs too, the defect is likely to be caused by the pick-up part. If the measurement value is very close to 40% even if an NG is not generated, the NG is likely to be caused by the disc.

5

6

7

8

7. DISASSEMBLY

Note:

(1) Do NOT look directly into the pickup lens. The laser beam may cause eye injury.
 (2) Even if the unit shown in the photos and illustrations in this manual may differ from your product, the procedures described here are common.

[1] LOADER Assy

Remove the top cover by removing the six screws.

(1) Disconnect the two flexible cables and one connector.
 (XP5, 7, 10)
 (2) Remove the two screws.
 (63-B30070-3H4)
 (3) Unhook the one hooks.

• Top view

XP7
 ①
 XP10 XP5
 ① ①
 ② ②
 ③
 LOADER Assy

(4) Remove the LOADER Assy.

LOADER Assy
 ④

XV-BD422B

5

6

7

8

21

A Case of replacing to a New LOADER Assy

After connecting LOADER Assy and MAIN BOARD Assy with FFC, please remove solder at protection point to the arrow-mark direction by using soldering iron with your right-hand while holding the pick-up portion with your left-hand. (Photo shows the situation after the removal of solder.)

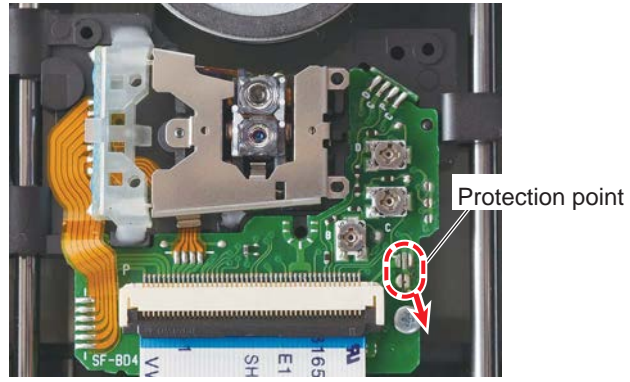

B

C

How to open the tray when the power cannot be on

When the tray cannot be opened because the power cannot be turned on, it can be opened using the emergency disc ejection rod (GGF1529). (A long, thin rod about 1 mm in diameter can be used in place of the rod.)

D Insert emergency disc ejection rod (GGF1529) into the side located at the chassis, and slide the loading rack in the LOADER Assy in the direction of the arrow, as indicated in the photo. If the tray pops out a little, fully pull it out by hand.

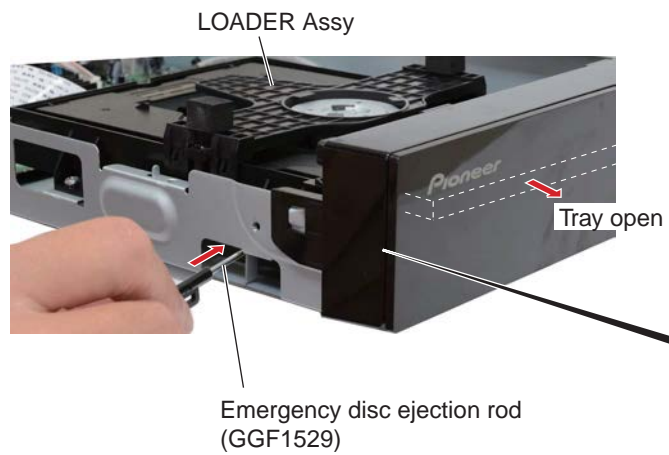

Note: The Emergency disc ejection rod will not reach the Loading rack unless it is inserted in slant upward direction.

 A close-up photograph of the emergency disc ejection rod being inserted into the loading rack mechanism of the loader assembly. Labels include 'LOADER Assy', 'Emergency disc ejection rod (GGF1529)', and 'Loading rack'.

E

F

Cleaning

(1) Unhook the four hooks.

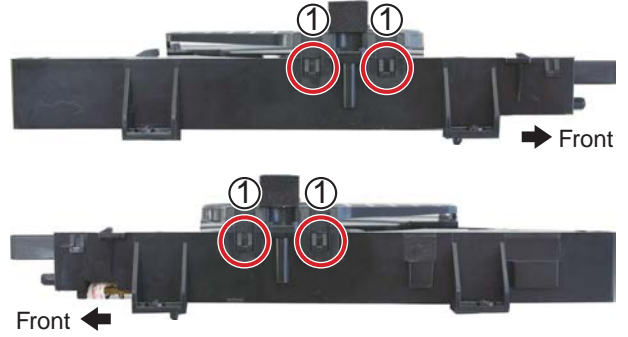

(2) Remove the top cover.



Clean the pickup lenses when it is stained, using the following cleaning materials:

Cleaning liquid : GEM1004
Cleaning paper: GED-008

Caution:

The pickup for Blu-ray is a high-precision component; therefore, clean the lens with enough care so as not to cause a misalignment in the optical axis.

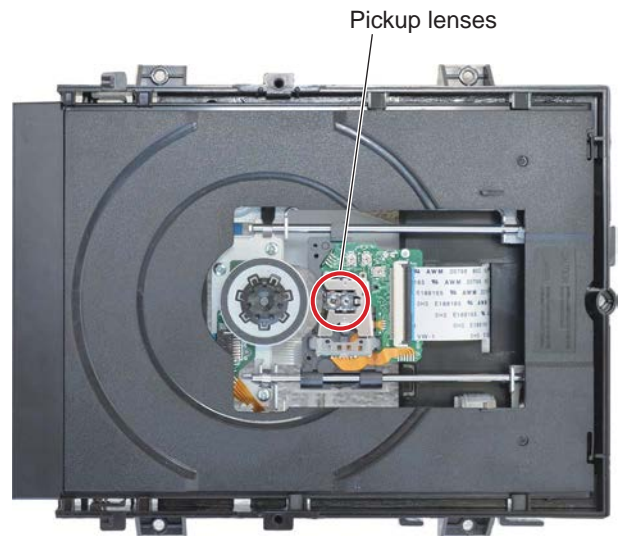

A [2] Front Panel Section

- (1) Disconnect the one flexible cable and one connector.
(XP13, 17)

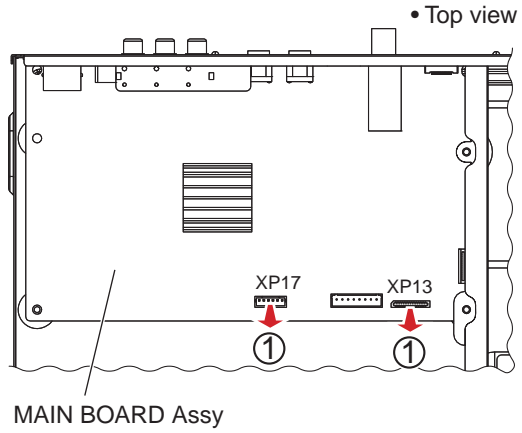

- (2) Unhook the four hooks.

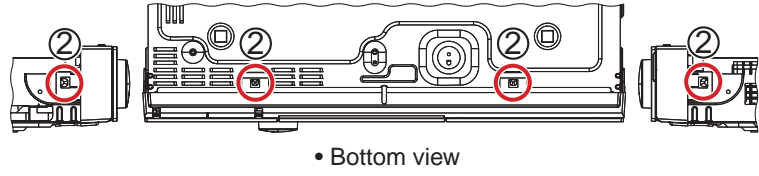

- (3) Remove the front panel section.

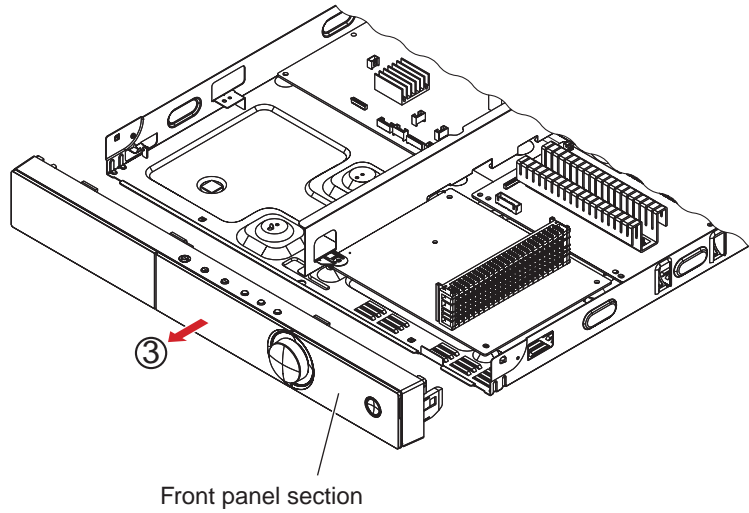

(4) Remove the VOL knob Assy.

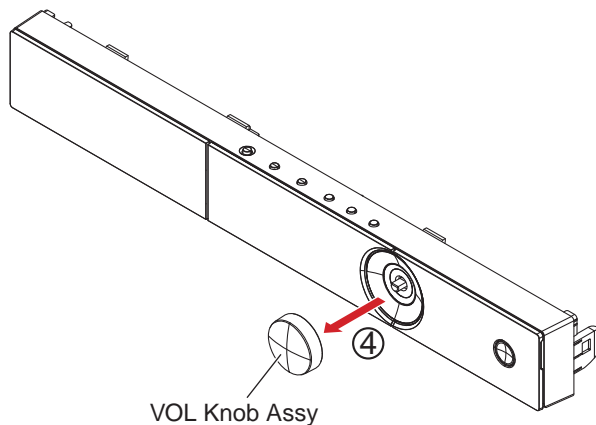

- (5) Remove the five screws.
(63-B26080-BF4)
- (6) Unhook the two hooks.
- (7) Remove the FRONT BOARD Assy.

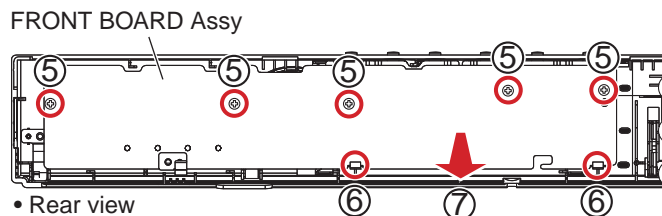

A [3] MAIN BOARD Assy

- (1) Remove the four screws.
(63-B30070-3H4)
- (2) Remove the stay.

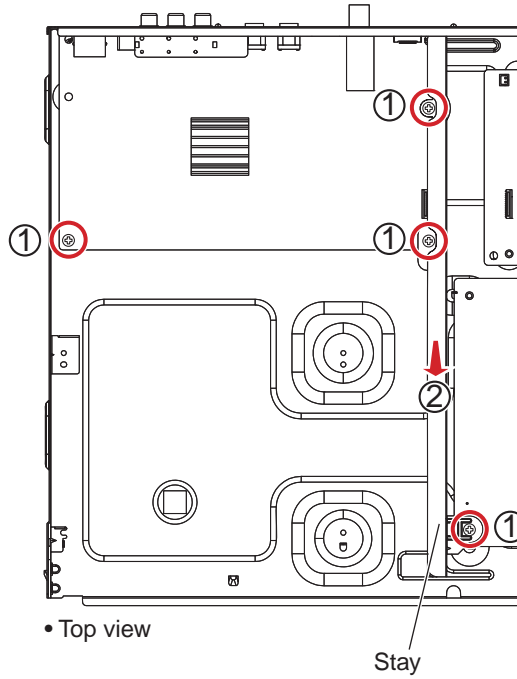

- (3) Remove the three screws.
(63-B30070-3H4)
- (4) Remove the three screws.
(64-B30040-304)

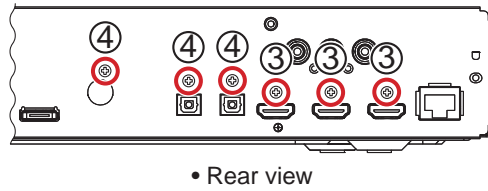

- (5) Disconnect the one flexible cable and two connectors.
(XP1, 4, 11)
- (6) Remove the MAIN BOARD Assy.

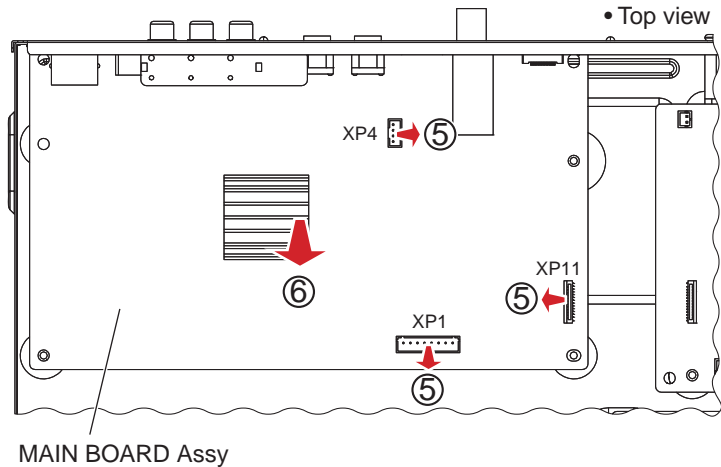

[4] AMP BOARD and SYSTEM POWER SUPPLY Assy

- (1) Remove the two screws. (64-B30040-304)
(XV-BD422B, XV-BD122B)
- (1) Remove the one screw. (64-B30040-304)
(XV-BD122FSB)

XV-BD422B, XV-BD122B
only

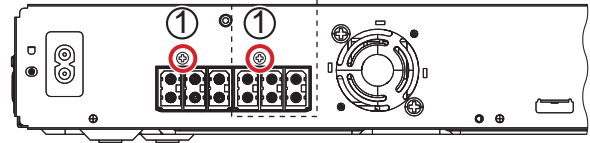

• Rear view



- (2) Remove the five screws.
(63-B30070-3H4)
- (3) Disconnect the two connectors.
(XP702, CN501)
- (4) Remove the AMP BOARD and SYSTEM
POWER SUPPLY Assy.

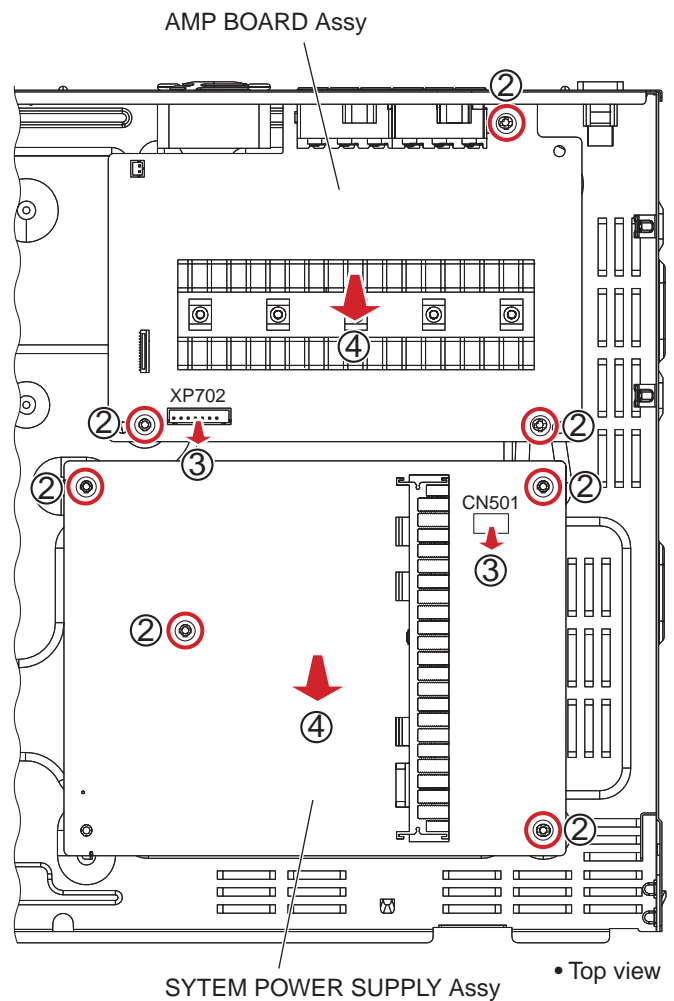

8. EACH SETTING AND ADJUSTMENT

8.1 ADJUSTMENT REQUIRED WHEN THE UNIT IS REPAIRED OR REPLACED

Note:
Be sure to update the firmware before starting adjustments or settings.

When any of the following assemblies is replaced

LOADER Assy

FA TEST

MAIN BOARD Assy

FA TEST

See "[1] Enter FA mode" in "6.1 SERVICE MODE".

Note:

- Change the Destination setting after MAIN BOARD Assy is replaced. After that, update the latest firmware.
- Please confirm that the USB memory is recognized after inserting the USB memory to the USB port.
(Due to protect wrong connection)

Procedures for Changing the Destination setting after the MAIN BOARD Assy is replaced

1. Updating MPEG firmware for Service

- Update MPEG Firmware for service of the product.

BSC727 series

BCS727_SP.bin

- ① Rename "BCS727_V00.99.bin" and put it in the root path of USB memory.
- ② Please insert the USB memory into machine and turn Power ON.
Please press HomeMenu button to enter the menu, after that, please find "Home Menu" → "Initial Setup" → "Options" → "Update" → "USB Storage".
- ③ After press the enter button, the system will search the upgrade file itself to upgrade.
- ④ After reset, unplug the USB memory.

2. Changing the Destination Setting

- ① Display the HOME MENU screen, move the cursor to Initial Setup, then press the ENTER button.
- ② With the Initial Setup screen displayed, press the numeric buttons 5, 1, 7, then 7, in that order, on the supplied remote control unit. Then Menu screen will be displayed.
- ③ Select [9] Change Area at the bottom then press the ENTER button.
(If MPEG Firmware for service isn't updated, [9] Change Area isn't displayed.)
- ④ Select the destination by moving the cursor then press the ENTER button.



Tip: Though Model name is XV-BD***, XV_BD*** is displayed on screen.
Even if the destination is changed, key data (CPRM key, NETFLIX ESN, etc) isn't written or removed.

- ⑤ Turn the unit OFF then back ON again.
(Be sure to do this after changing the destination setting.)

3. Confirming the Destination Change

Check if the destination setting has been properly changed.

- ① Press the HOME MENU button to display the HOME MENU screen, move the cursor to Initial Setup, then press the ENTER button.
- ② With the Initial Setup screen displayed, press the numeric buttons 8, 5, 2, then 0, in that order, on the supplied remote control unit.
- ③ On the BUDA Information screen, if the destination that was selected on step 4 in "2. Changing the Destination Setting" is displayed for the "Model" item, the destination change has been successfully finished.

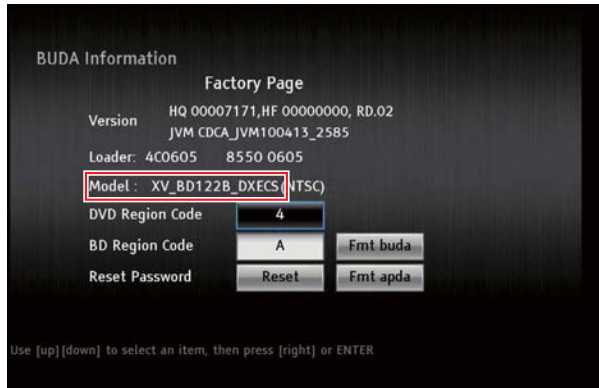

Tip: It is recommended to confirm the region code at the same time.

- ④ Press the HOME MENU button to return to the HOME MENU screen.

4. Updating the Latest Firmware to the Product

Please refer to "Firmware Update" in details.

Caution:

Be sure to write the latest Firmware that suits the destination of the product, because the product will not operate properly with the firmware for service, which is used for changing the destination setting.

8.2 UPDATING OF THE FIRMWARE

A ■ Firmware Update

This unit has four firmwares. (MPEG, SERVO, DSP and MCU)

You can update all firmwares at the same time by copying them into one USB memory.

- **MPEG firmware**
BCS727_V00.**.bin
(* is Version Number of MPEG Firmware)
DLdiscidentifier.txt
- **SERVO firmware**
DVD.bin
- **DSP firmware**
BCS727_DSP.bin
- **MCU firmware**
BCS727_MCU.bin
DLdiscidentifier_MCU.txt

- B (*) The required time for Firmware Update
MPEG firmware (SERVO firmware): About 30 seconds to 1 minutes
DSP firmware: About 10 to 12 minutes
MCU firmware: About 3 to 5 minutes

[1] Before Firmware Update, please check the current firmware version installed in this unit.
Please refer to "How to confirm the versions".

[2] Please copy the updating file into the USB memory route path.

(*) New SERVO firmware and DSP firmware may not be released in the future. Then, please copy MPEG firmware and MCU firmware (BCS727_V00.**.bin, DLdiscidentifier.txt, BCS727_MCU.bin, DLdiscidentifier_MCU.txt) into the USB memory.

[3] After step 2, please insert the USB memory into unit and turn Power ON. Please press "HOME MENU" button to enter the menu, after that, please select "Home Menu" ⇒ "Initial Setup" ⇒ "Options" ⇒ "Update" ⇒ "USB Storage".

[4] Fig. 2 is displayed after displaying Fig.1. Then, firmware update starts by pressing ENTER button.

(*) Never press any buttons on Remote Control or Front Panel until finishing the update.

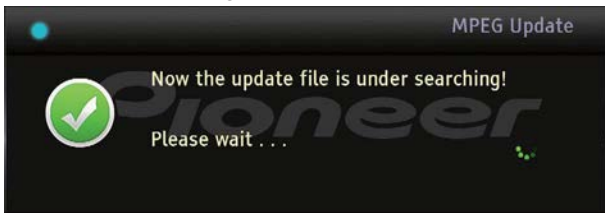

Fig. 1

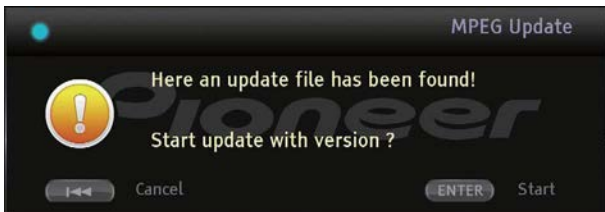

Fig. 2

[5] Firmware update is executed by the following sequence.
MPEG firmware + SERVO firmware ⇒
DSP firmware ⇒ MCU firmware

[6] When the update for MPEG firmware starts, the following GUI is displayed. Then "MPEG UPG" is displayed on FL tube. If there is SERVO firmware in USB memory, SERVO firmware is updated at same time.

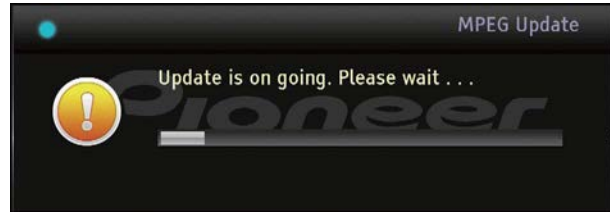

Fig. 3

[7] After finishing the update for MPEG firmware, the update for DSP firmware starts automatically. Then, the following GUI is displayed and "DSP UPG" is displayed on FL tube. If there isn't DSP firmware in USB memory, the update for DSP firmware will be skipped.

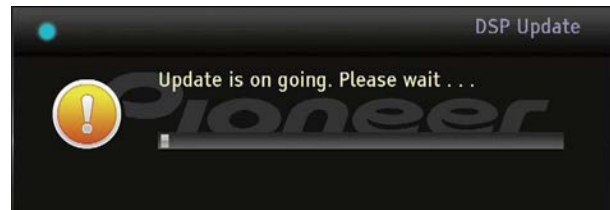

Fig. 4

[8] After finishing the update for DSP firmware, the update for MCU firmware starts automatically. Then, the following screen is displayed and "MCU UPG" is displayed on FL tube.

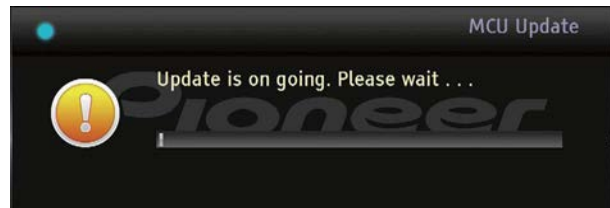

Fig. 5

Attention

The update for MCU Firmware doesn't finish fairly infrequently. If it doesn't finish after 10 minutes, please execute firmware update again by the following procedure.

- ① Unplug Power cord.
- ② Plug Power cord again and press "STANDBY/ON" button.
- ③ When this unit turns power on, the following message is displayed on screen. Please execute firmware update again.



Fig. 6

- [9] After finishing the update for MCU firmware, the following message is displayed. This unit reboots automatically after 5 seconds. After reboot, firmware update finishes. Please confirm the firmware version in this unit.



Fig. 7

How to confirm the versions

You can press "HOME MENU" button to enter the menu, after that, press "↑/↓/←/→" buttons to display "Home Menu" ⇒ "Initial Setup" ⇒ "Options" ⇒ "System Information", then you can see the information of current firmware version by pressing the "ENTER" button.

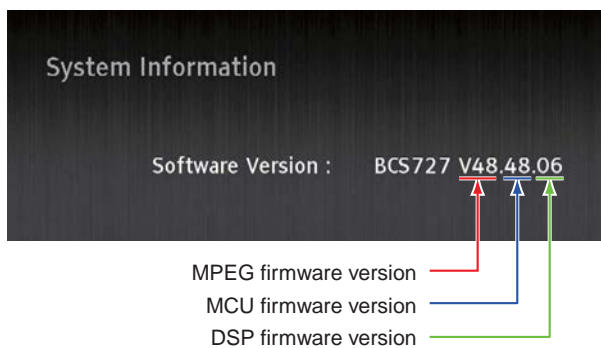

(*) How to confirm SERVO firmware

Only as for SERVO firmware, a version confirmation method differs. With the Initial Setup screen displayed, press the numeric buttons "8" ⇒ "5" ⇒ "2" ⇒ "0". Then BUDA Information is displayed on screen.

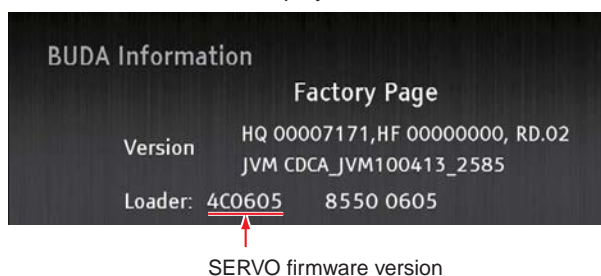

9. EXPLODED VIEWS AND PARTS LIST

- NOTES:
- Parts marked by "NSP" are generally unavailable because they are not in our Master Spare Parts List.
 - The \triangle mark found on some component parts indicates the importance of the safety factor of the part. Therefore, when replacing, be sure to use parts of identical designation.
 - Screws adjacent to ∇ mark on product are used for disassembly.
 - For the applying amount of lubricants or glue, follow the instructions in this manual. (In the case of no amount instructions, apply as you think it appropriate.)

9.1 PACKING SECTION

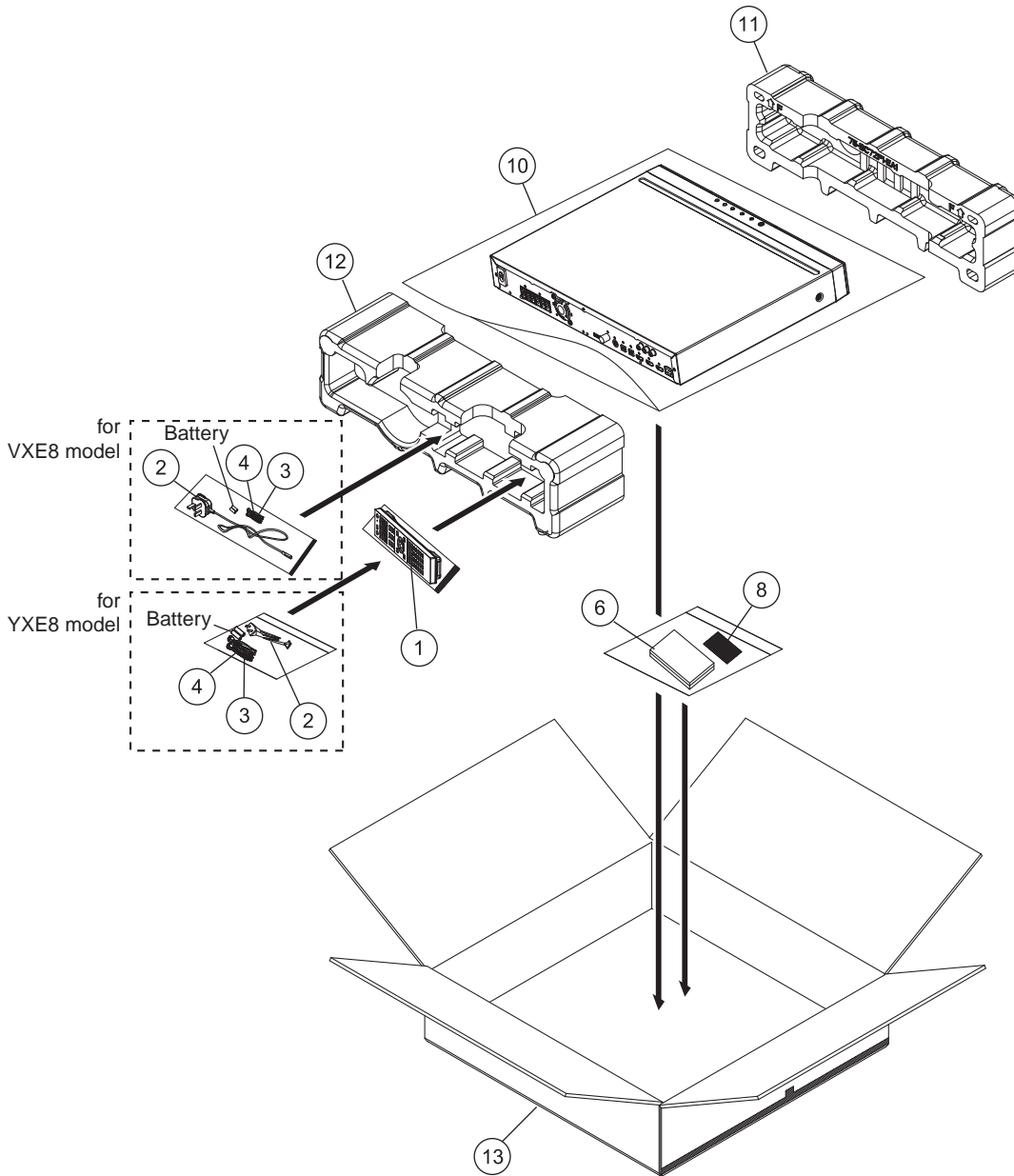

(1) PACKING SECTION PARTS LIST

<u>Mark No.</u>	<u>Description</u>	<u>Part No.</u>
	1 Remote Control	06-BCS727-A000
⚠	2 Power Cord	See Contrast table (2)
	3 Video Cable	41-UH1200-0KK1E
	4 FM Antenna	47-ANT022-XX0
	5 •••••	
	6 Operating Instructions	See Contrast table (2)
	7 •••••	
NSP	8 Warranty Card	70-PIONBD-WARB1
	9 •••••	
	10 Poly Bag	74-550520-50GB1
	11 Back Foam	75-BC72B1-EA1
	12 Front Foam	75-BC72F1-EA1
	13 Carton Box	See Contrast table (2)

(2) CONTRAST TABLE

XV-BD422B/YXE8, VXE8, XV-BD122B/YXE8, VXE8 and XV-BD122FSB/YXE8 are constructed the same except for the following:

Mark	No.	Symbol and Description	XV-BD422B /YXE8	XV-BD422B /VXE8	XV-BD122B /YXE8	XV-BD122B /VXE8	XV-BD122FSB /YXE8
⚠	2	Power Cord	51-DC0120-0CRA3	51-DC0120-0CRD4	51-DC0120-0CRA3	51-DC0120-0CRD4	51-DC0120-0CRA3
	6	Operating Instructions (En, Fr, De, It, Ni, Es)	72-BD122B-EU0B1	Not used	72-BD122B-EU0B1	Not used	72-BD122B-EU0B1
	6	Operating Instructions (En)	Not used	72-BD122B-GBRB1	Not used	72-BD122B-GBRB1	Not used
	13	Carton Box	76-119750-0ATB3	76-119750-0ATB9	76-119750-0ATC1	76-119750-0ATC2	76-119750-0ATB4

1 2 3 4

9.2 EXTERIOR SECTION

A

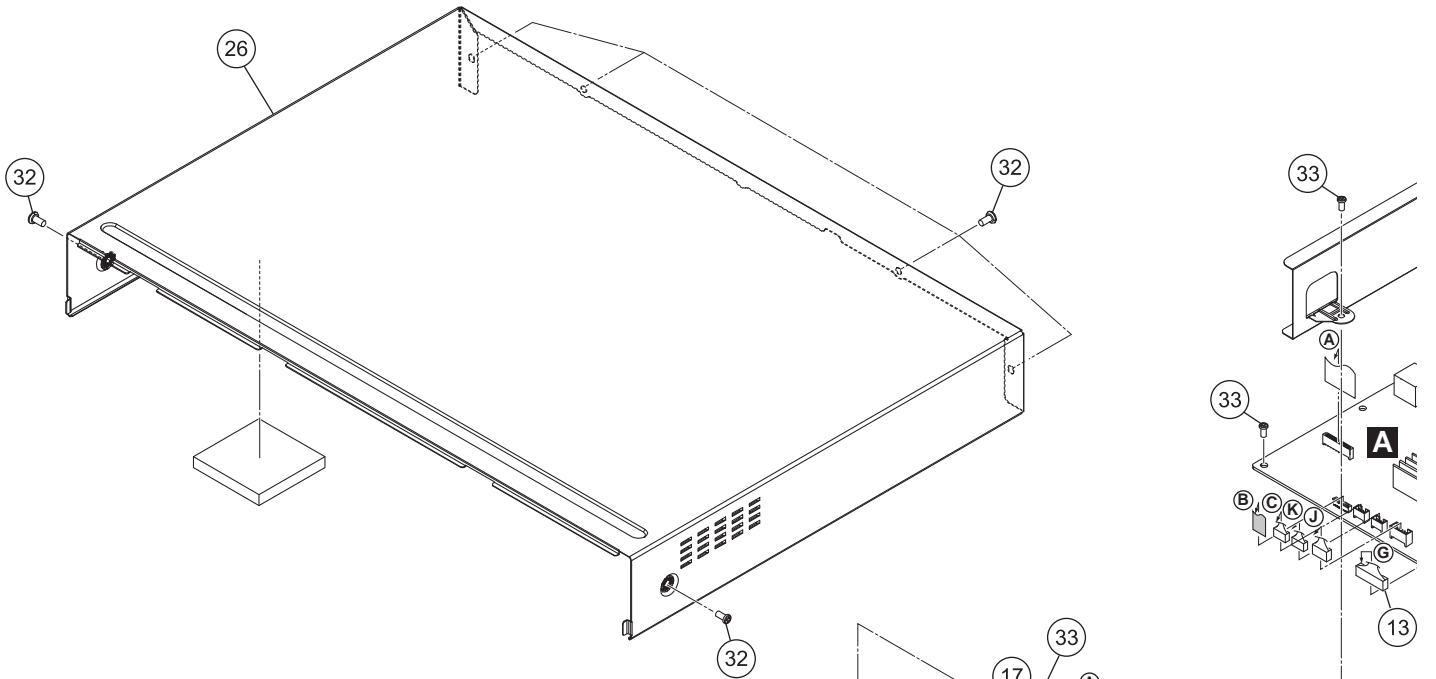

B

C

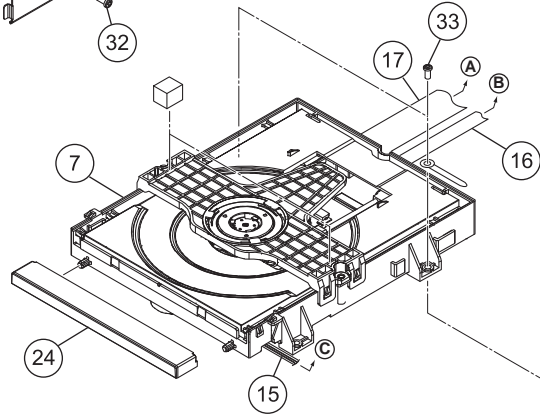

D

E

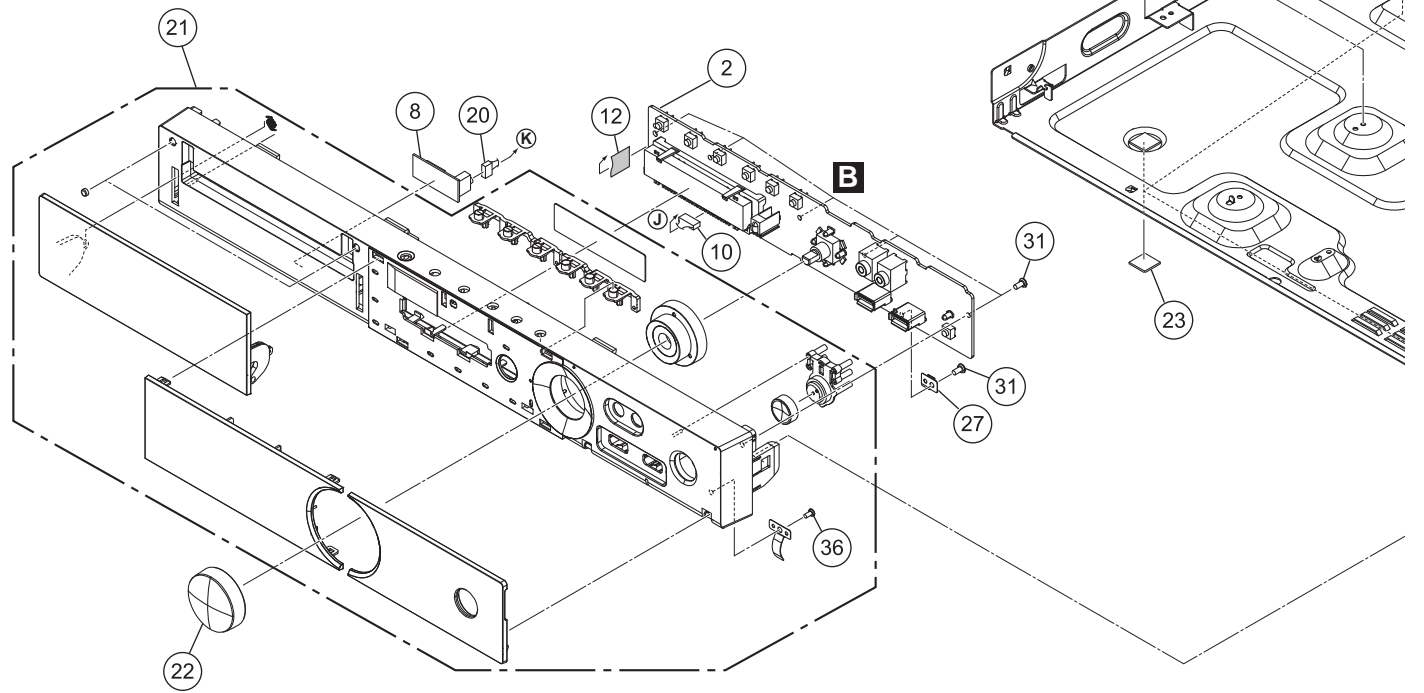

F

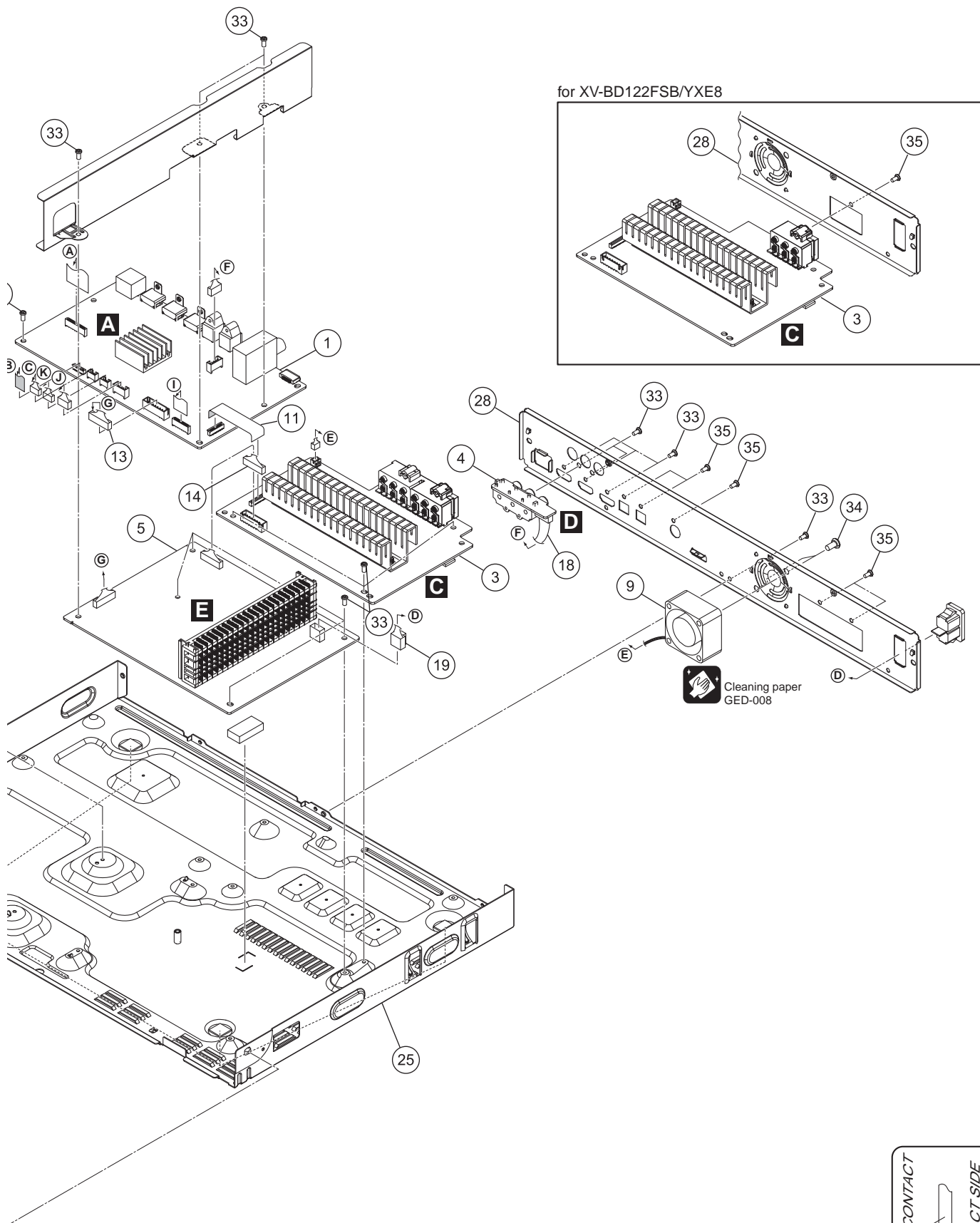

for XV-BD122FSB/YXE8

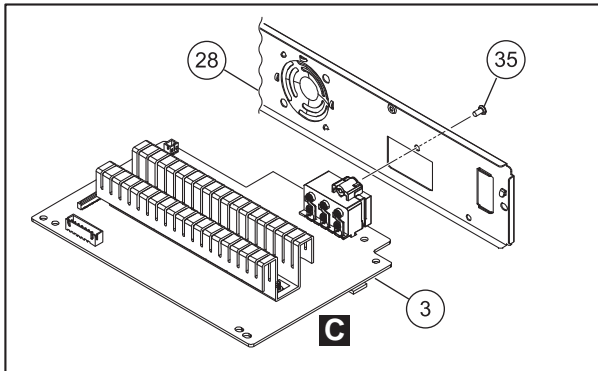

 Cleaning paper
GED-008

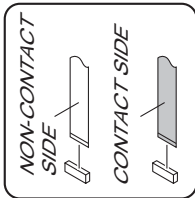

(1) EXTERIOR SECTION PARTS LIST

<u>Mark No.</u>	<u>Description</u>	<u>Part No.</u>	<u>Mark No.</u>	<u>Description</u>	<u>Part No.</u>
A	1 MAIN BOARD Assy	08-H555DU-MA1R/YXV	21	Front Panel Assy	See Contrast table (2)
	2 FRONT BOARD Assy	08-BCS727-FVY	22	VOL Knob Assy	02-DC22N1-XX0B2
	3 AMP BOARD Assy	See Contrast table (2)	23	Cushion	54-103870-000
	4 AV BOARD Assy	AZW7613	24	CD Door	55-BC72D3-0HA
	5 SYSTEM POWER SUPPLY Assy	08-K250HE-PW1	25	Bottom Plate	67-BC72R1-0E0
	6		26	Top Cover	67-BC72T1-0E0B1
	7 LOADER Assy	08-LTCA19-222026	27	Ground Plate	67-BD14Q1-0B0
	8		28	Back Panel	See Contrast table (2)
	9 DC Fan	43-FM412S-211	29	
	10 6 Pin 2.0mm L=300mmM USB Line	46-FH030F-06NA	30	
B	11 0.5x24Px80mm Type A FFC	46-KK008C-24AU	31	S/T Screw B 2.6x8 BF	63-B26080-BF4
	12 20 Pin 1.0mm L=240mm FFC Line	46-KK024C-20BV	32	Screw	63-B30060-3H3
	13 8 Pin Cable 2.5mm 180mm TJC3-SCN	46-CD018T-08K	33	Screw	63-B30070-3H4
	14 TJC3/SCN 40mm 6 Pin 1007#26 Line	46-CD004T-06X	34	S/T Screw B 4x8 BF	63-B40080-BF4
	15 Cable PH-4Y,JC20-4P	46-FH026T-04I	35	Triangle M/C Screw B 3x4	64-B30040-304
	16 1.0mm pitch B Type Flat Flexible	46-FF020C-8BV	36	Screw 2.6*6	63-P26060-BF4
	17 45 Pin FFC Cable	46-KF022C-45BU			
	18 Cable 5 Pin 80mm FH-SAN	46-FG008T-05P			
	19 2 Pin Cable	See Contrast table (2)			
C	20				

(2) CONTRAST TABLE

XV-BD422B/YXE8, VXE8, XV-BD122B/YXE8, VXE8 and XV-BD122FSB/YXE8 are constructed the same except for the following:

Mark	No.	Symbol and Description	XV-BD422B /YXE8	XV-BD422B /VXE8	XV-BD122B /YXE8	XV-BD122B /VXE8	XV-BD122FSB /YXE8
D	3	AMP BOARD Assy	AZW7611	AZW7611	AZW7611	AZW7611	AZW7612
	19	2 Pin Cable	Not used	46-KL020T-03XC	46-KL020T-03XC	46-KL020T-03XC	Not used
	19	3 Pin Cable	46-KL018T-03XC	Not used	Not used	Not used	46-KL018T-03XC
	21	Front Panel Assy	08-BD422B-001	08-BD422B-002	08-BD122B-002	08-BD122B-003	08-BD122B-001
	28	Back Panel	67-BC72B3-0E0B1	67-BC72B3-0E0B1	67-BC72B3-0E0B2	67-BC72B3-0E0B2	67-BC72B4-0E0B1

■

5

■

6

■

7

■

8

■

A

■

B

■

C

■

D

■

E

■

F

■

5

■

6

XV-BD422B

■

7

■

8

■

10. SCHEMATIC DIAGRAM

10.1 MAIN BOARD ASSY (1/13)

A

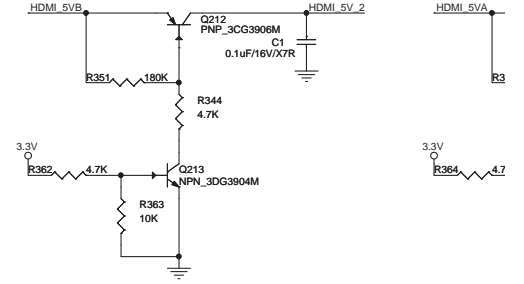
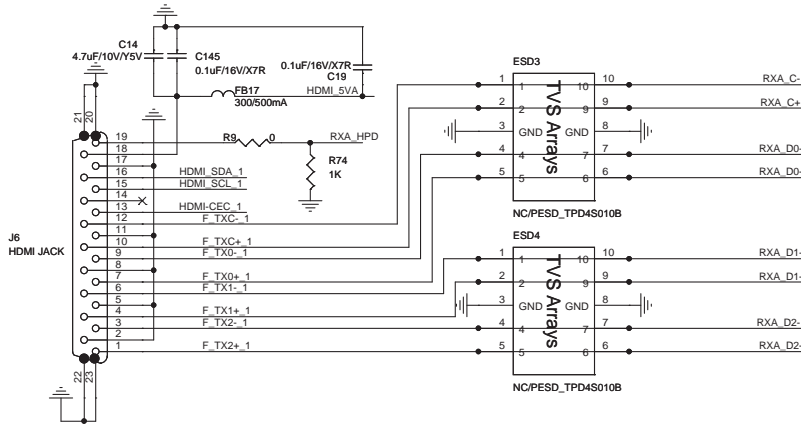

B

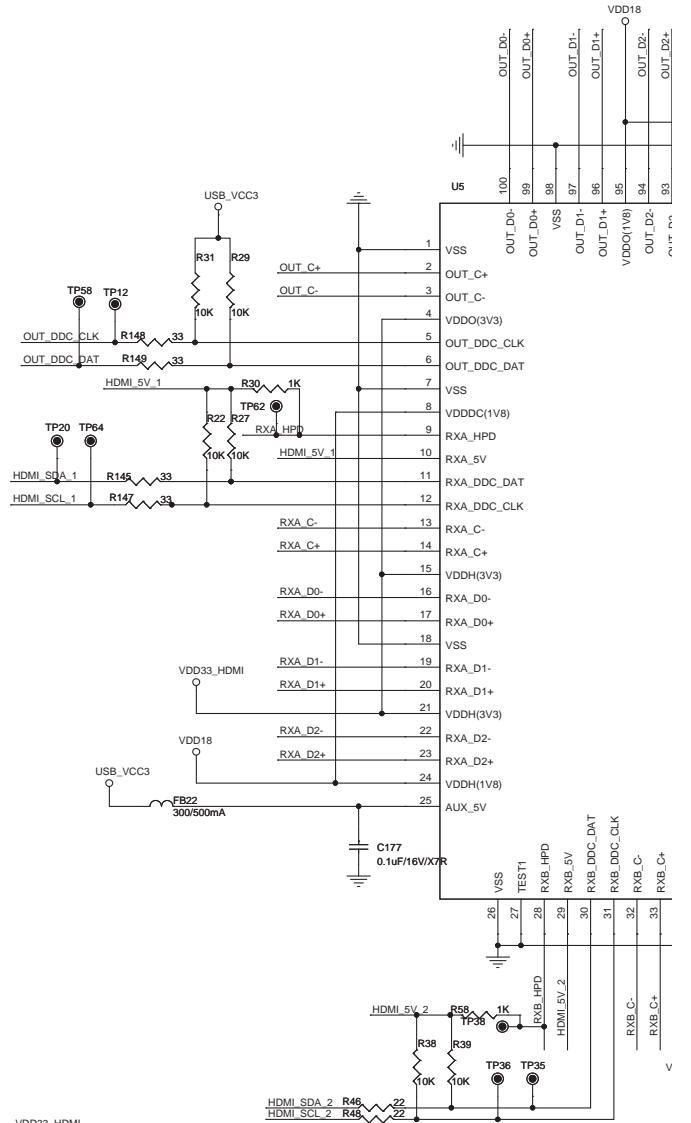
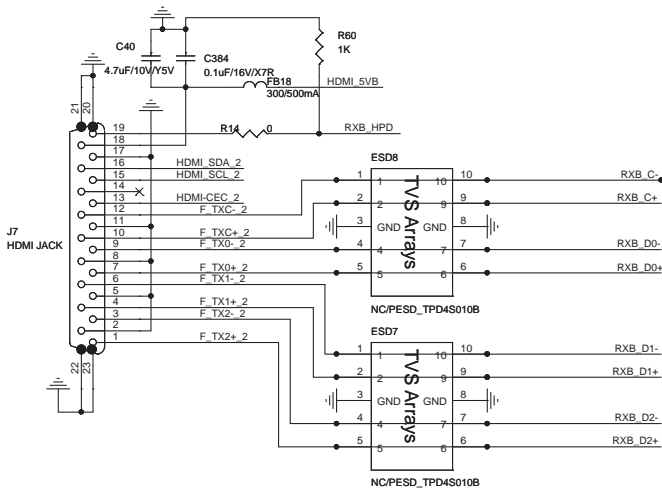

D

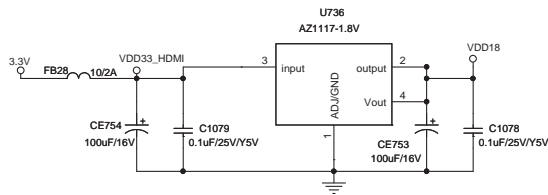

F

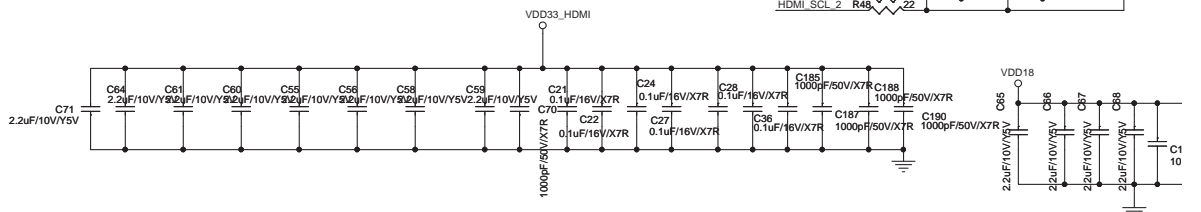

A/1/13 MAIN BOARD ASSY (08-H555DU-MA1R/YXV)

• HDMI IN NXP BLOCK

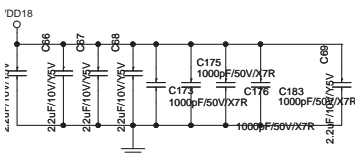
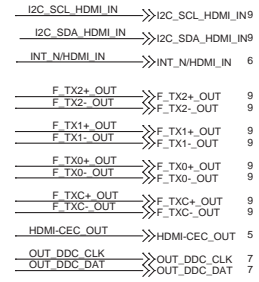
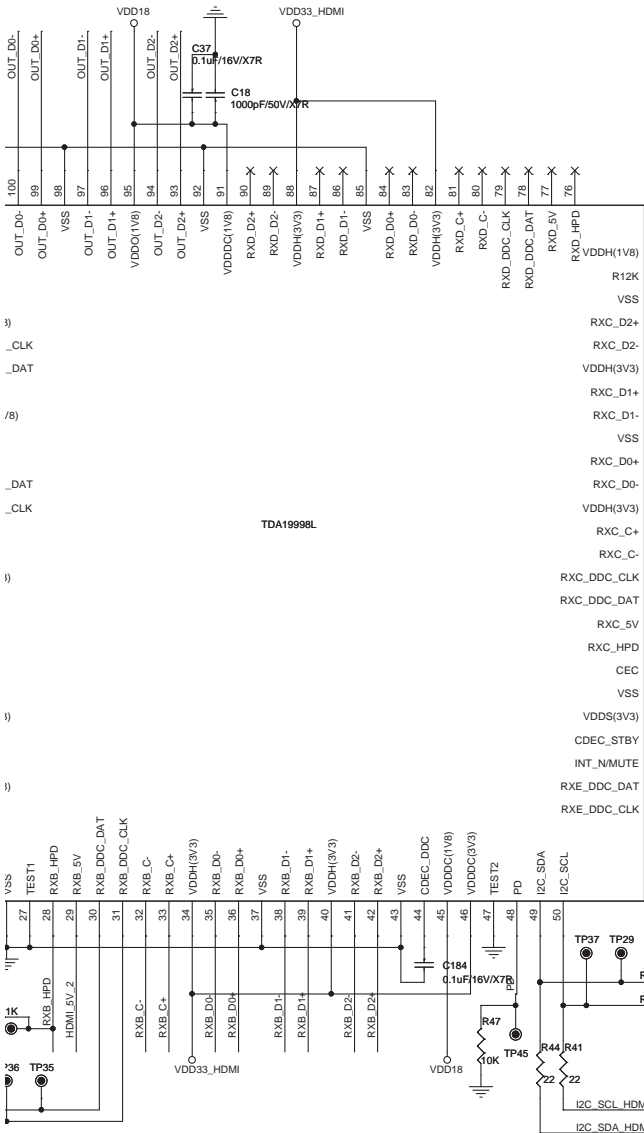
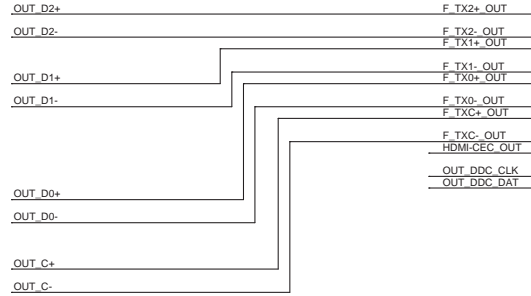
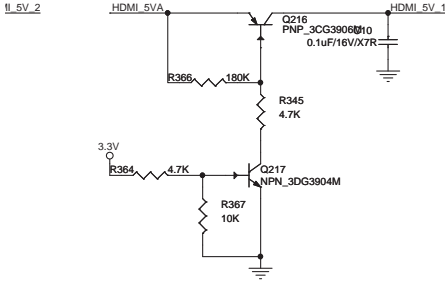

A 2/13 MAIN BOARD ASSY (08-H555DU-MA1R/YXV) • DSP BLOCK

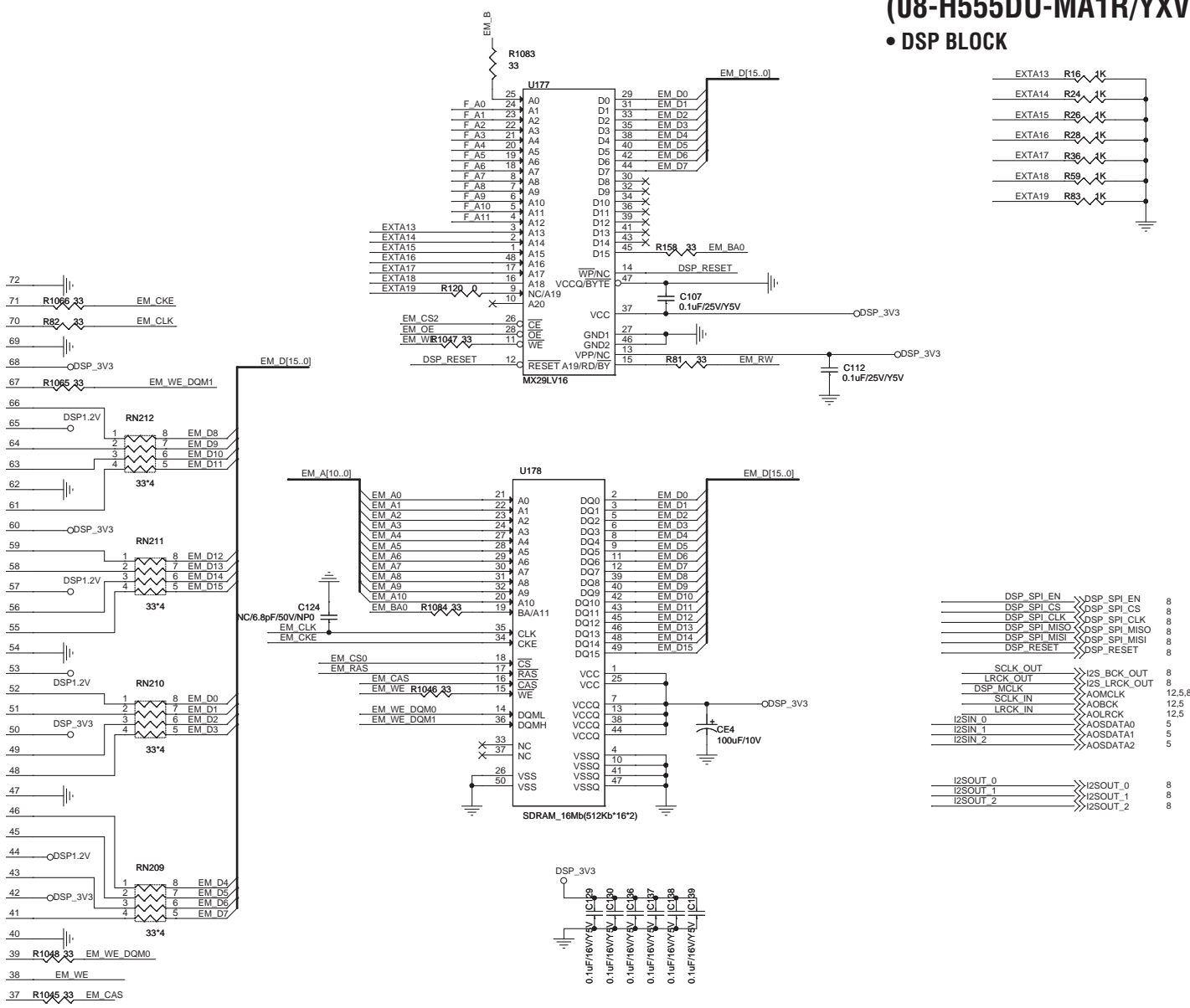

DSP SPI EN	DSP_SPI_EN	8
DSP SPI CS	DSP_SPI_CS	8
DSP SPI CLK	DSP_SPI_CLK	8
DSP SPI MISO	DSP_SPI_MISO	8
DSP SPI MISI	DSP_SPI_MISI	8
DSP RESET	DSP_RESET	8
SCLK_OUT	I2S_BCK_OUT	8
LRCK_OUT	I2S_LRCK_OUT	8
DSP_MCLK	AOMCLK	12,5,8
LRCK_IN	AQBCK	12,5
I2SIN_0	AQSRCK	12,5
I2SIN_1	AOSDATA0	5
I2SIN_2	AOSDATA1	5
I2SOUT_0	AOSDATA2	5
I2SOUT_1	I2SOUT_0	8
I2SOUT_2	I2SOUT_1	8
	I2SOUT_2	8

TDI_DSP	
PD_DSP	
TDO_DSP	
EMU1	
TCK_DSP	
EMU0	

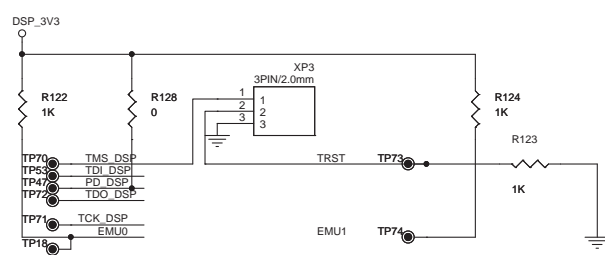

10.3 MAIN BOARD ASSY (3/13)

A

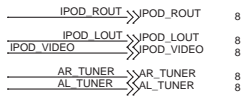

B

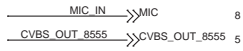

C

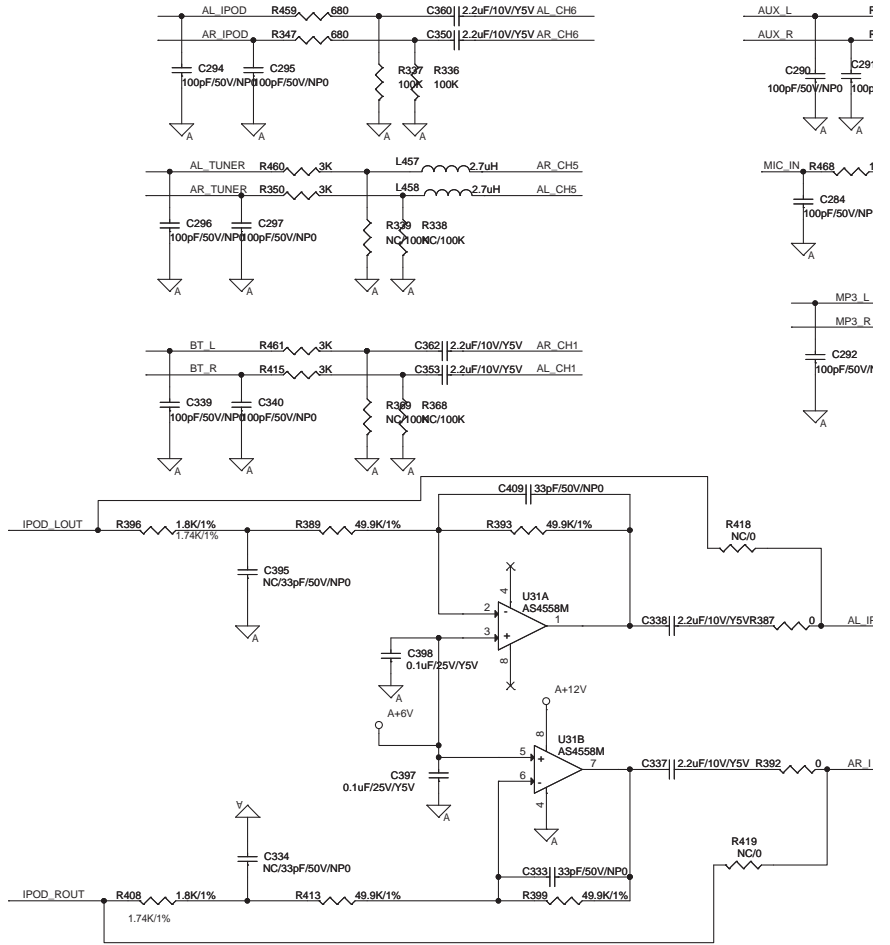

D

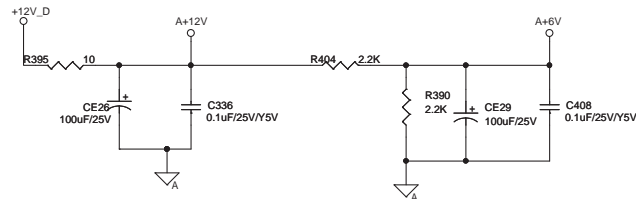
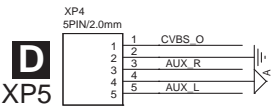

E

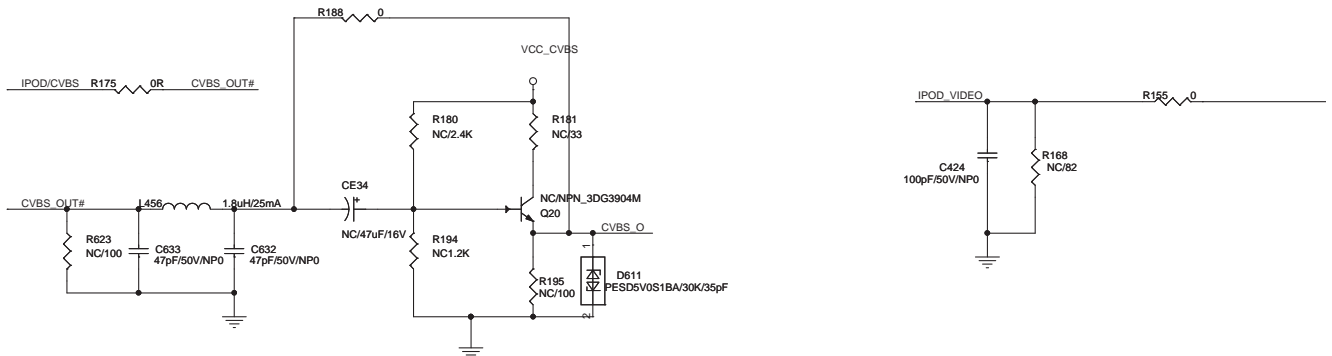

F

A3/13 MAIN BOARD ASSY (08-H555DU-MA1R/YXV)

• Audio IN & CVBS OUT BLOCK

A
B
C
D
E
F

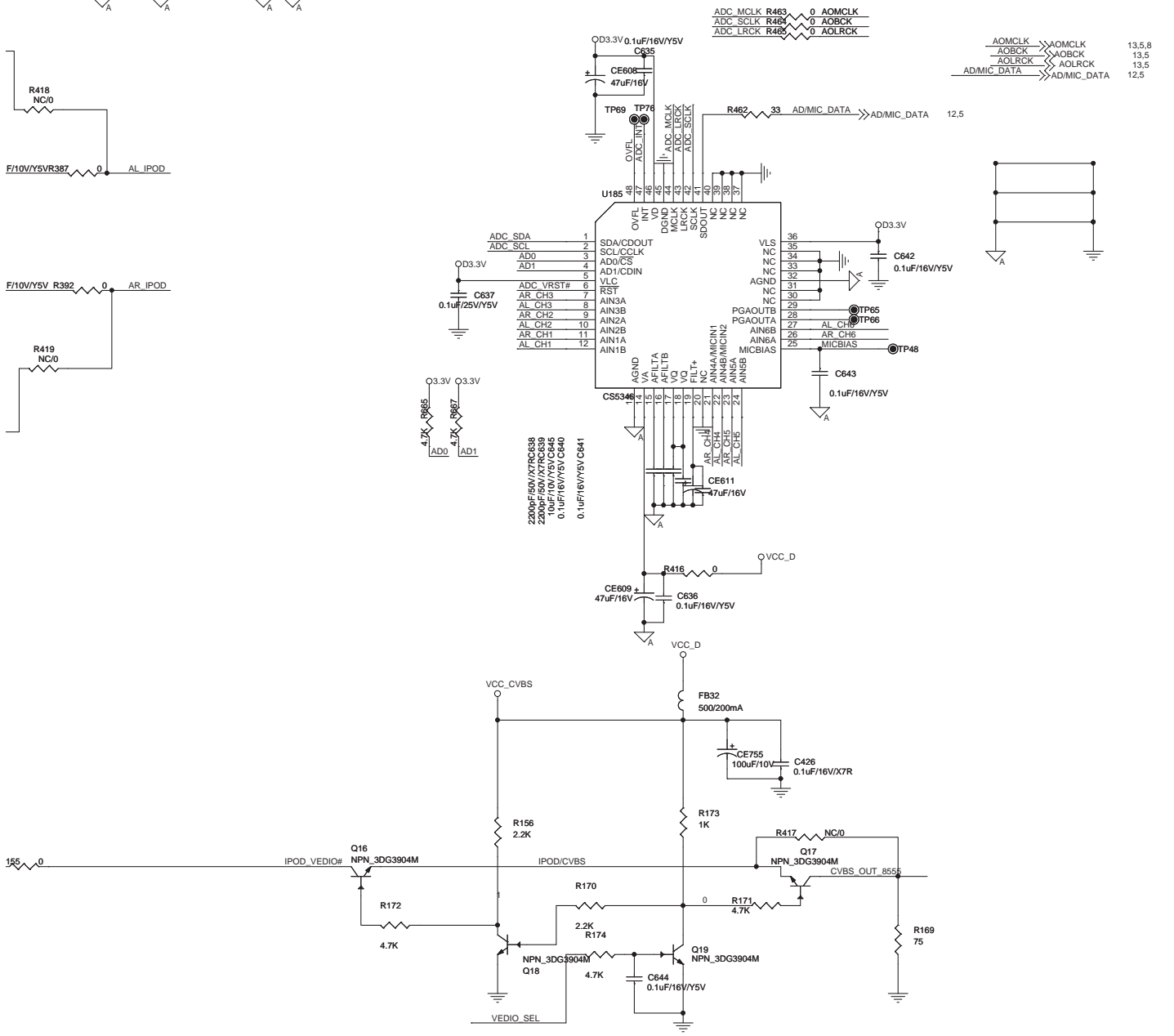
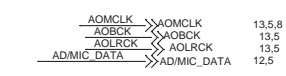
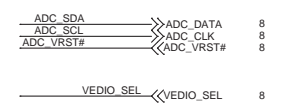
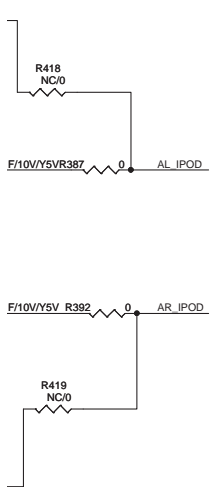
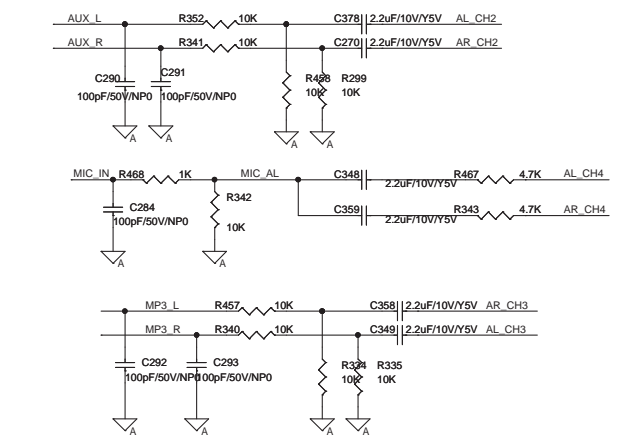

10.4 MAIN BOARD ASSY (4/13)

A

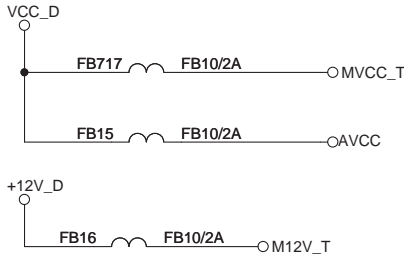

B

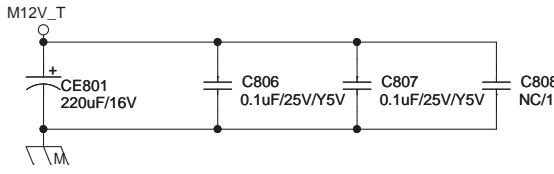

C

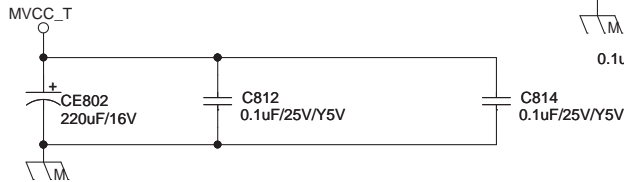

D

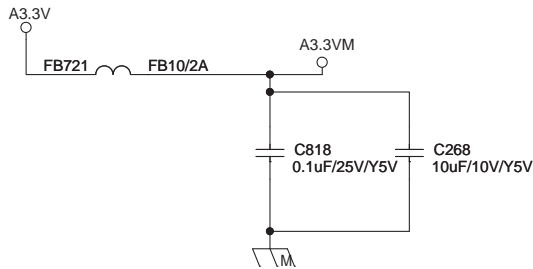

E

F

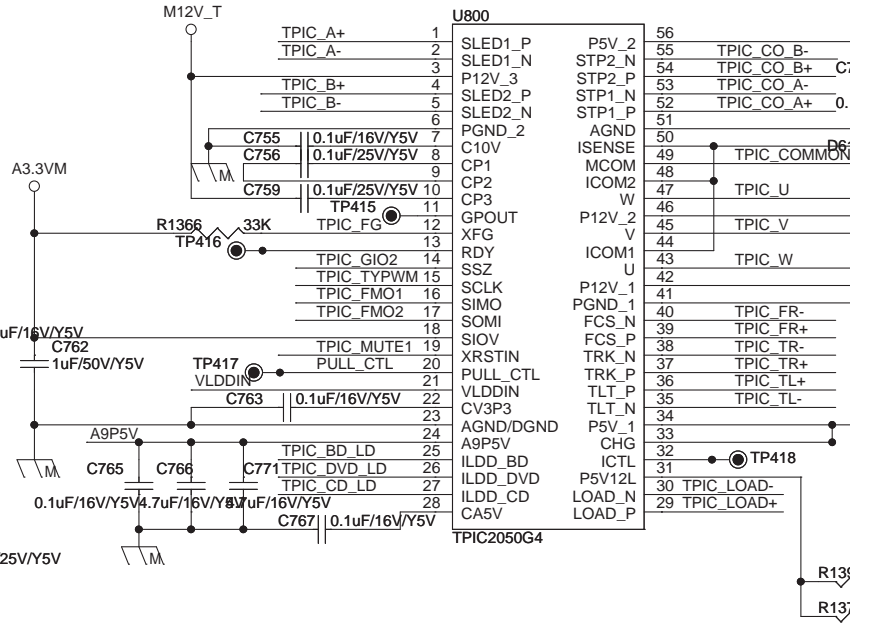

10 TPIC_TR+	TPIC_TR+
10 TPIC_TR-	TPIC_TR-
10 TPIC_TL-	TPIC_TL-
10 TPIC_TL+	TPIC_TL+
10 TPIC_FR-	TPIC_FR-
10 TPIC_FR+	TPIC_FR+
10 TPIC_CO_B-	TPIC_CO_B-
10 TPIC_CO_B+	TPIC_CO_B+
10 TPIC_CO_A+	TPIC_CO_A+
10 TPIC_CO_A-	TPIC_CO_A-
10 TPIC_FMO2	TPIC_FMO2
10 TPIC_FMO1	TPIC_FMO1
10 TPIC_TYPWM	TPIC_TYPWM
10 TPIC_MUTE1	TPIC_MUTE1
10 TPIC_TRAYIN#	TPIC_TRAYIN#
10 TPIC_FG	TPIC_FG
10 TPIC_GIO2	TPIC_GIO2
10 TPIC_VWDC2O	TPIC_VWDC2O
10 TPIC_BD_LD	TPIC_BD_LD
10 TPIC_DVD_LD	TPIC_DVD_LD
10 TPIC_CD_LD	TPIC_CD_LD

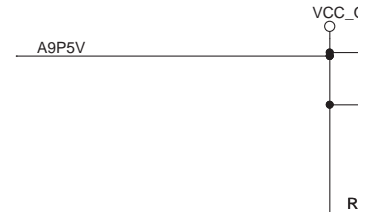

10.5 MAIN BOARD ASSY (5/13)

1

2

3

4

A

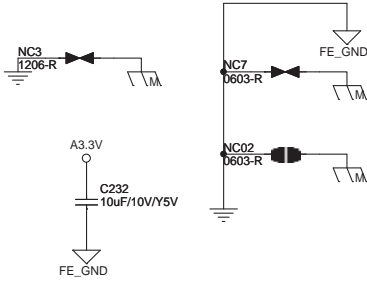

B

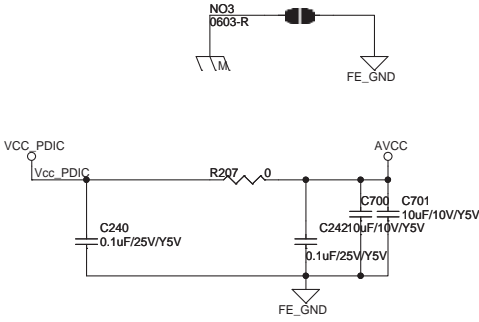

C

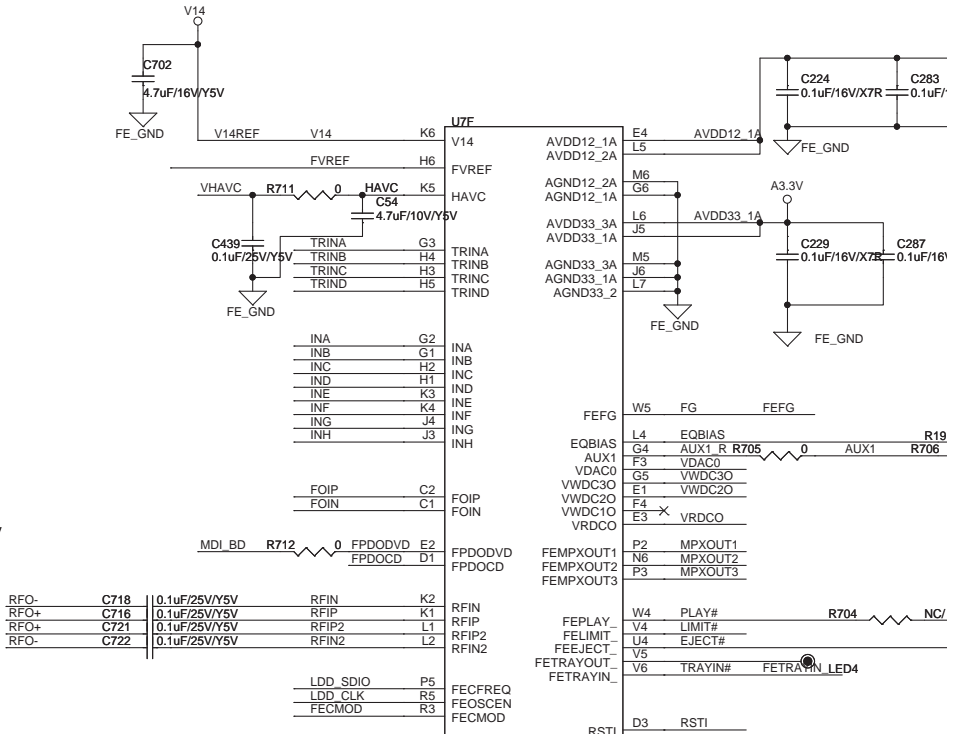

D

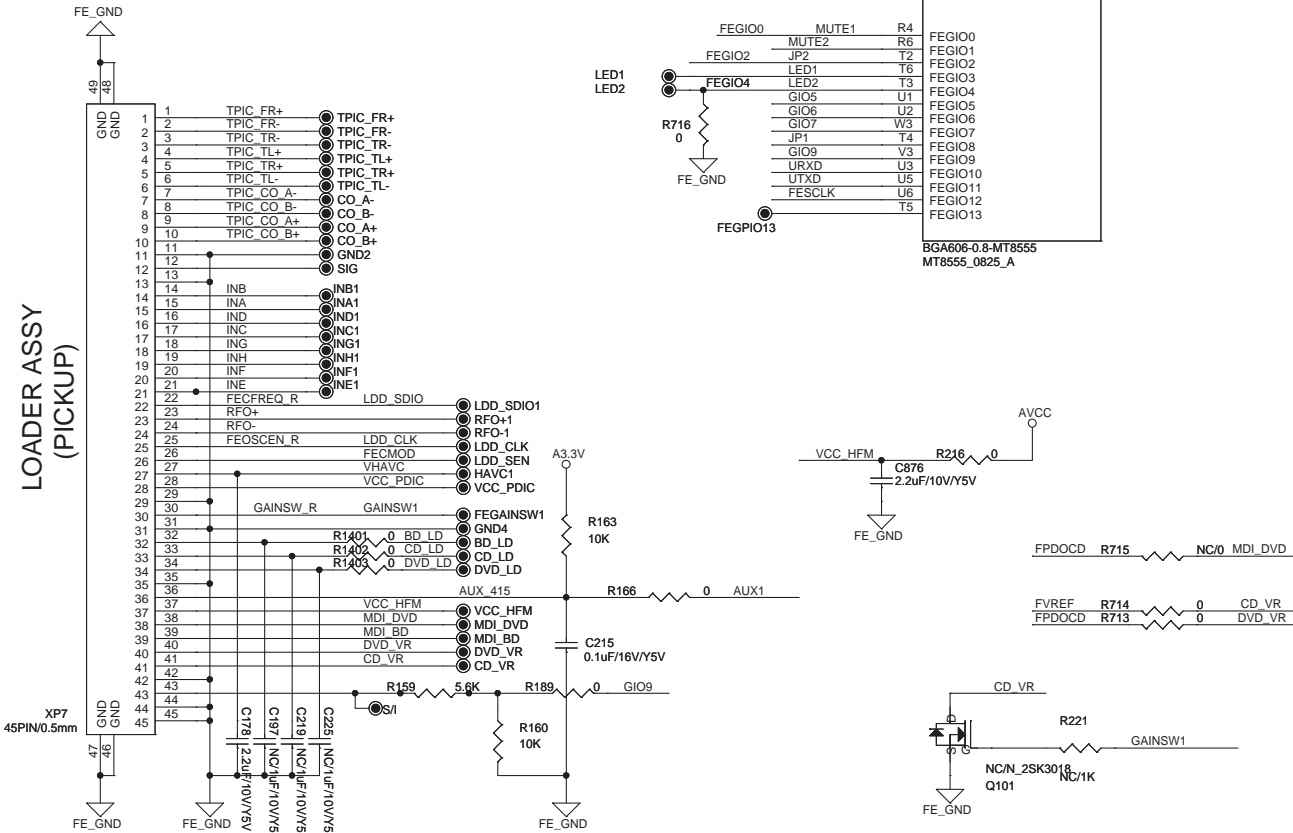

F

1

2

3

4

A5/13 MAIN BOARD ASSY (08-H555DU-MA1R/YXV) • MT8555 FE BLOCK

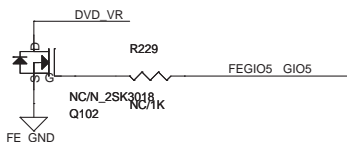
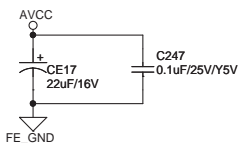
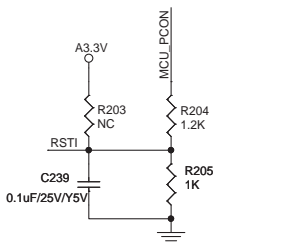
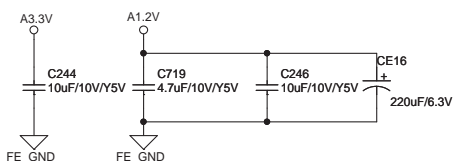
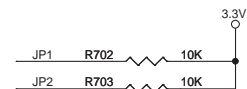
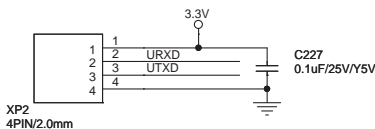
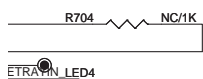
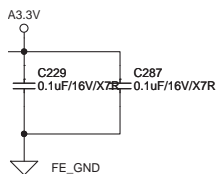
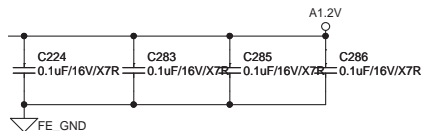

RST1	RST1
RFO-	RFO-
RFO+	RFO+
VDAC0	VDAC0
TM88	AUX_415
VRDC0	VRDC0
VWDC20	VWDC20
VWDC30	VWDC30
TP86	GAINSW1
GAINSW2	GAINSW2
FESCLK	FESCLK
UTXD	UTXD
URXD	URXD
EJECT#	EJECT#
PLAY#	PLAY#
LIMIT#	LIMIT#
MUTE2	TRAYIN#
MUTE1	MUTE1
FG	FG
TLO	TLO
FOO	FOO
TRO	TRO
FMO1	FMO1
FMO2	FMO2
FMO3	FMO3
FMO4	FMO4
DMO	DMO

TRINA	TRINA
TRINB	TRINB
TRINC	TRINC
TRIND	TRIND
INA	INA
INB	INB
INC	INC
IND	IND
INE	INE
INF	INF
ING	ING
INH	INH
FOIP	FOIP
FOIN	FOIN
FPDOCD	FPDOCD
V14	V14
HAVC	HAVC
JP2	JP2
GIO5	GIO5
GIO6	GIO6
GIO7	GIO7
JP1	JP1
GIO9	GIO9
MPXOUT1	MPXOUT1
MPXOUT2	MPXOUT2
MPXOUT3	MPXOUT3
LDD_SDIO	LDD_SDIO
LDD_CLK	LDD_CLK
TM10026	TM10026
FVREF	FVREF

MCU_PCON	MCU_PCON	8
TPIC FR+	TPIC FR+	11
TPIC FR-	TPIC FR-	11
TPIC TL+	TPIC TL+	11
TPIC TL-	TPIC TL-	11
TPIC TR+	TPIC TR+	11
TPIC TR-	TPIC TR-	11
TPIC CO B-	TPIC CO B-	11
TPIC CO B+	TPIC CO B+	11
TPIC CO A+	TPIC CO A+	11
TPIC CO A-	TPIC CO A-	11

FETRYPWM	R228	TPIC TYPWM	TPIC_TYPWM	11
FEFMO2	R227	TPIC FMO2	TPIC_FMO2	11
FEFMO	R219	TPIC FMO1	TPIC_FMO1	11
FETRAYIN	R167	TPIC TRAYIN#	TPIC_TRAYIN#	11
FEFG		TPIC FG	TPIC_FG	11
FEGIO0		TPIC MUTE1	TPIC_MUTE1	11
FEGIO2	R232	TPIC GIO2	TPIC_GIO2	11
VWDC20		TPIC VWDC20	TPIC_VWDC20	11
DVD_LD		TPIC DVD_LD	TPIC_DVD_LD	11
CD_LD		TPIC CD_LD	TPIC_CD_LD	11
BD_LD		TPIC BD_LD	TPIC_BD_LD	11

10.6 MAIN BOARD ASSY (6/13)

A

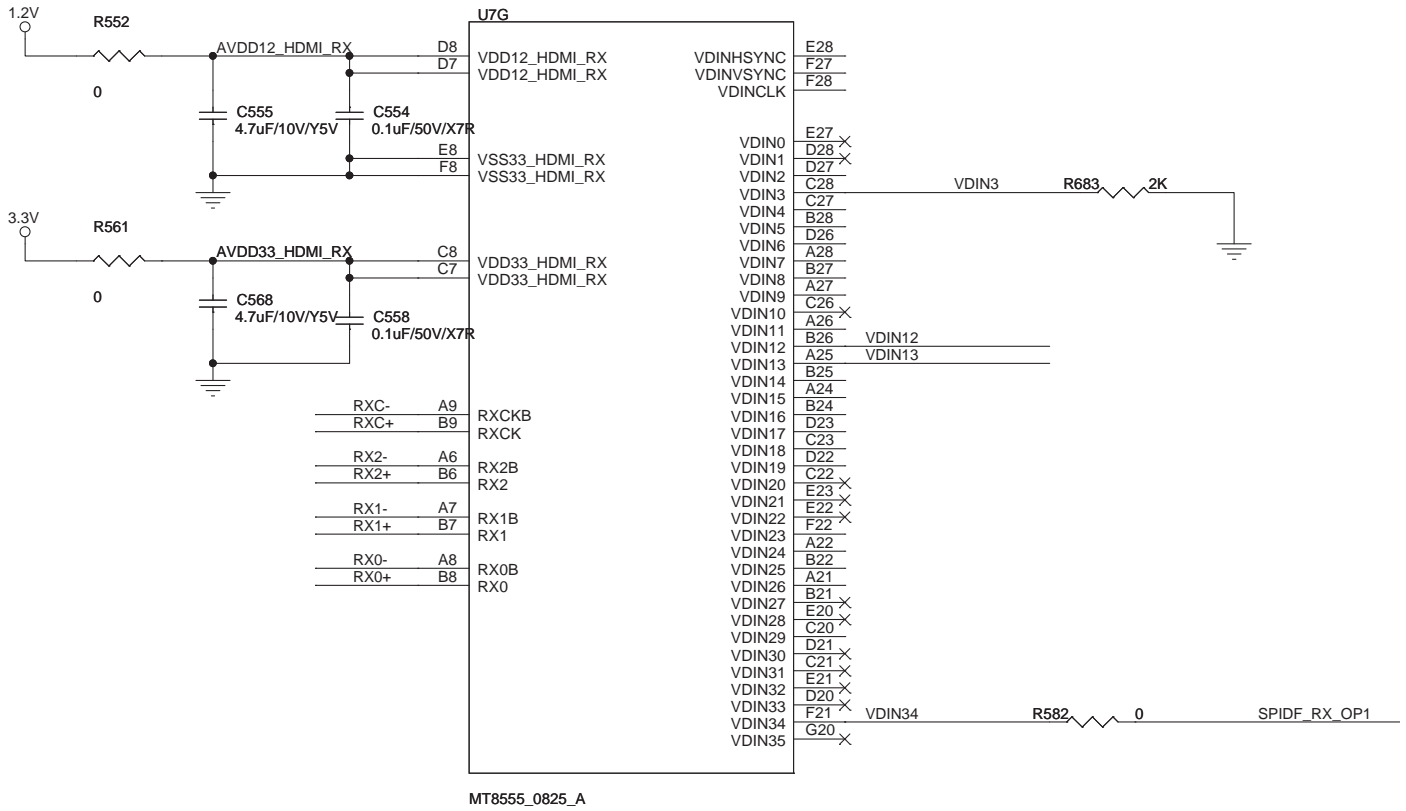

B

C

MT8555_0825_A

SPDIF_IN SPDIF_RX_OP1

D

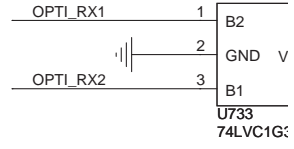
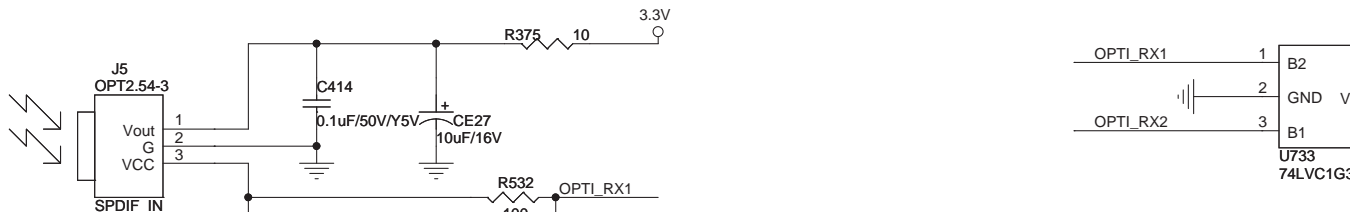

E

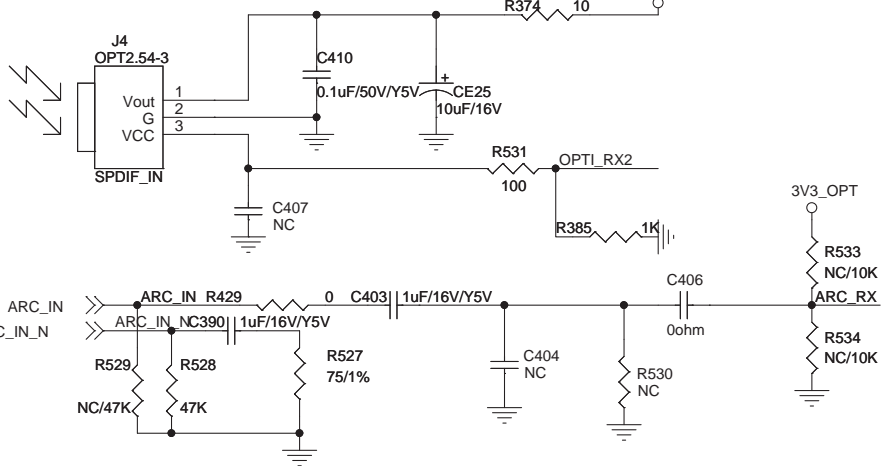

F

A/6/13 MAIN BOARD ASSY (08-H555DU-MA1R/YXV) • MT8555 HDMI IN & SPDIF BLOCK

A
B
C
D
E
F

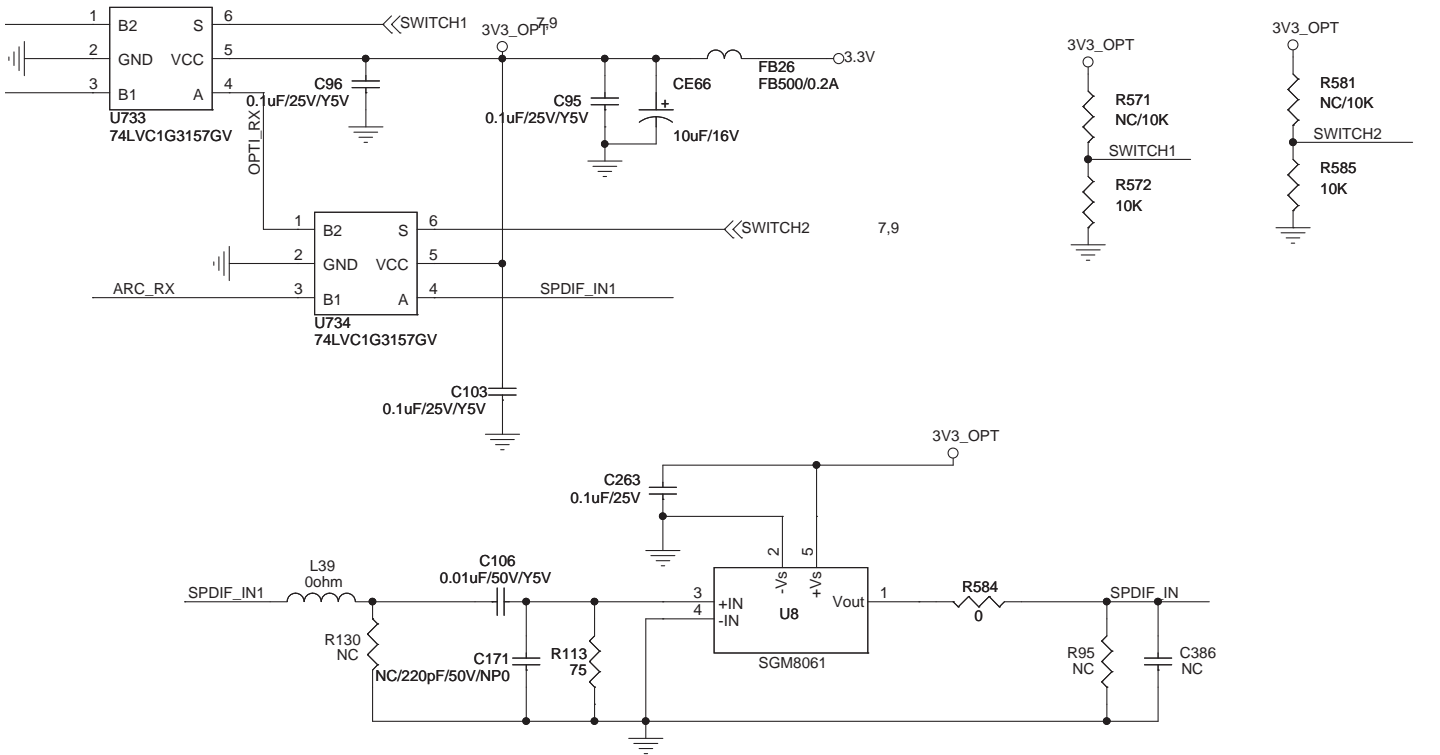
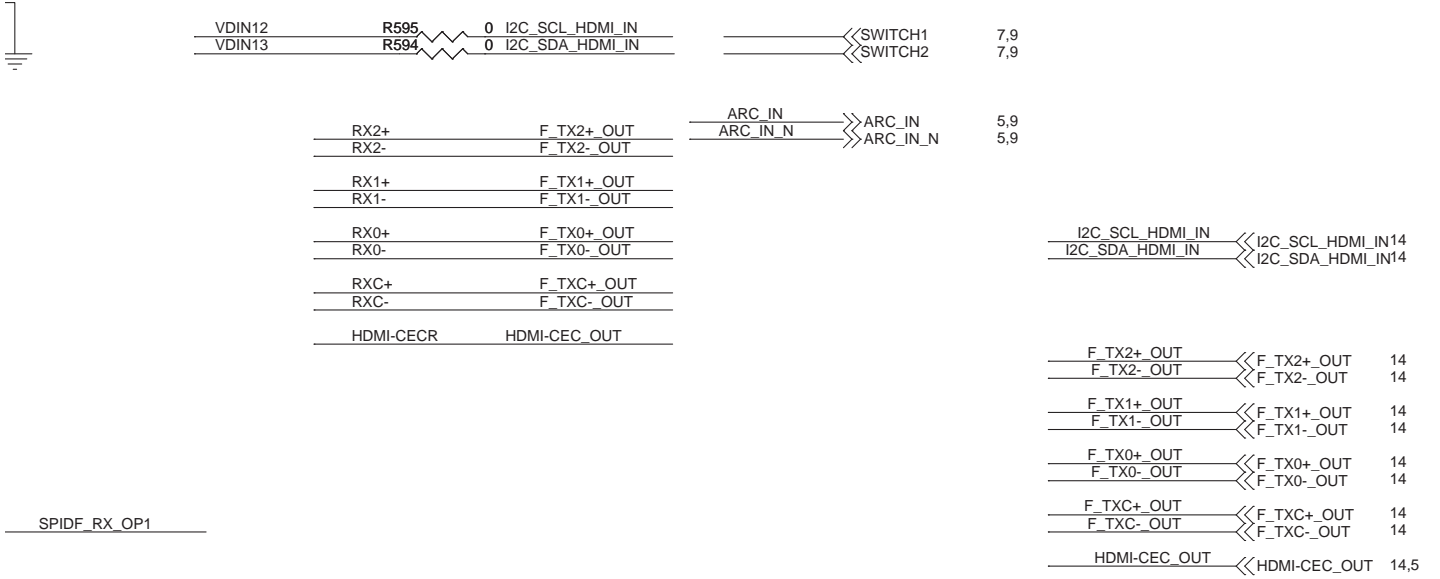

A 7/13 MAIN BOARD ASSY

(08-H555DU-MA1R/YXV)

• MCU NUC100 BLOCK

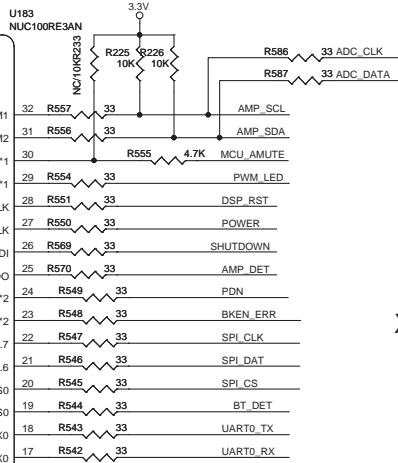
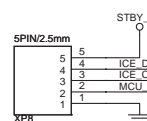
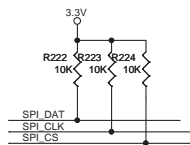
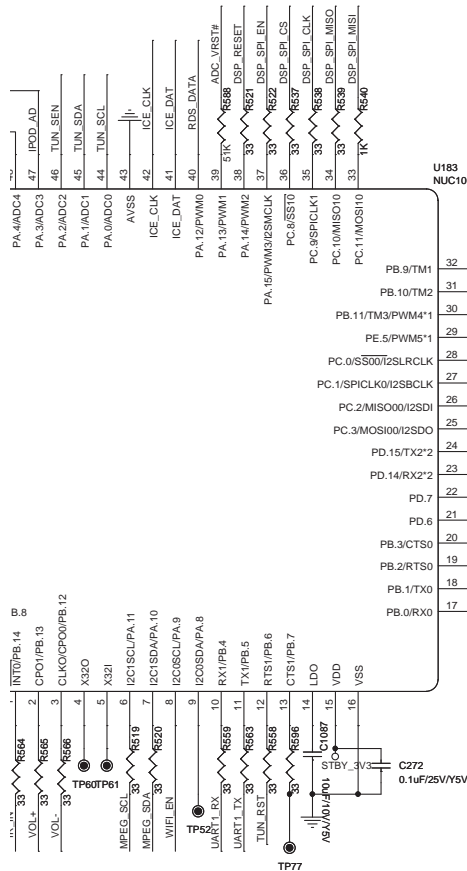

C2/3
XP703

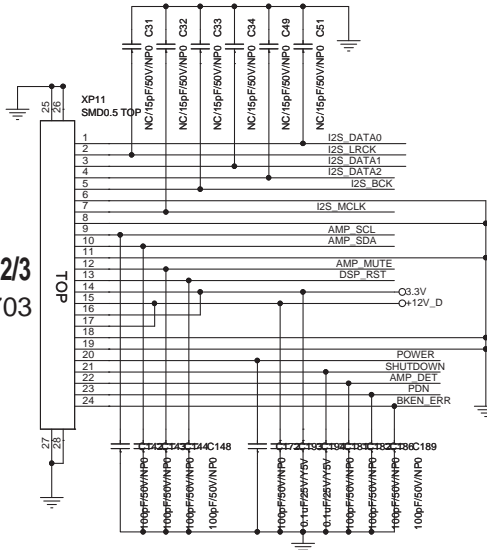

WIFI_EN	WIFI_EN	6	
MCU_PCON	MCU_PCON	6	
FE_RES	FE_RES	2	
MCU_INT	MCU_INT	7	
MPEG_SCL	MCU_SCL	6	
MPEG_SDA	MCU_SDA	6	
IR_OUT	IR_OUT	7	
DSP_SPL_EN	DSP_SPL_EN	13	
DSP_SPL_CS	DSP_SPL_CS	13	
DSP_SPL_CLK	DSP_SPL_CLK	13	
DSP_SPL_MISO	DSP_SPL_MISO	13	
DSP_SPL_MISI	DSP_SPL_MISI	13	
DSP_RESET	DSP_RESET	13	
VEDIO_SEL	VEDIO_SEL	12	
I2S_BCK	SCLK_OUT	I2S_BCK_OUT	13
I2S_LRCK	LRCK_OUT	I2S_LRCK_OUT	13
I2S_MCLK	DSP_MCLK	I2S_LRCK_OUT	12,13,5
I2SOUT_0	I2S_DATA0	I2SOUT_0	13
I2SOUT_1	I2S_DATA1	I2SOUT_1	13
I2SOUT_2	I2S_DATA2	I2SOUT_2	13
BD_MUTE	BD_MUTE	5	
IPOD_ROUT	IPOD_ROUT	12	
IPOD_LOUT	IPOD_LOUT	12	
AR_TUNER	AR_TUNER	12	
AL_TUNER	AL_TUNER	12	
BT_R	BT_R	12	
BT_L	BT_L	12	
MP3_R	MP3_R	12	
MIC	MIC	12	
IPOD_VIDEO	IPOD_VIDEO	12	
ADC_DATA	ADC_DATA	12	
ADC_CLK	ADC_CLK	12	
ADC_VRST#	ADC_VRST#	12	

B
XP3

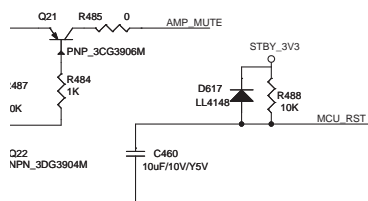
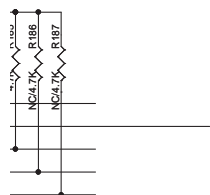
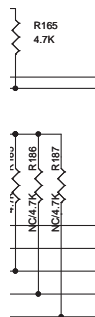
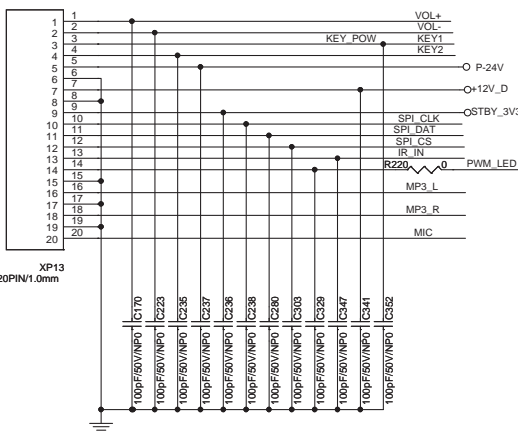

10.8 MAIN BOARD ASSY (8/13)

A

B

C

D

E

F

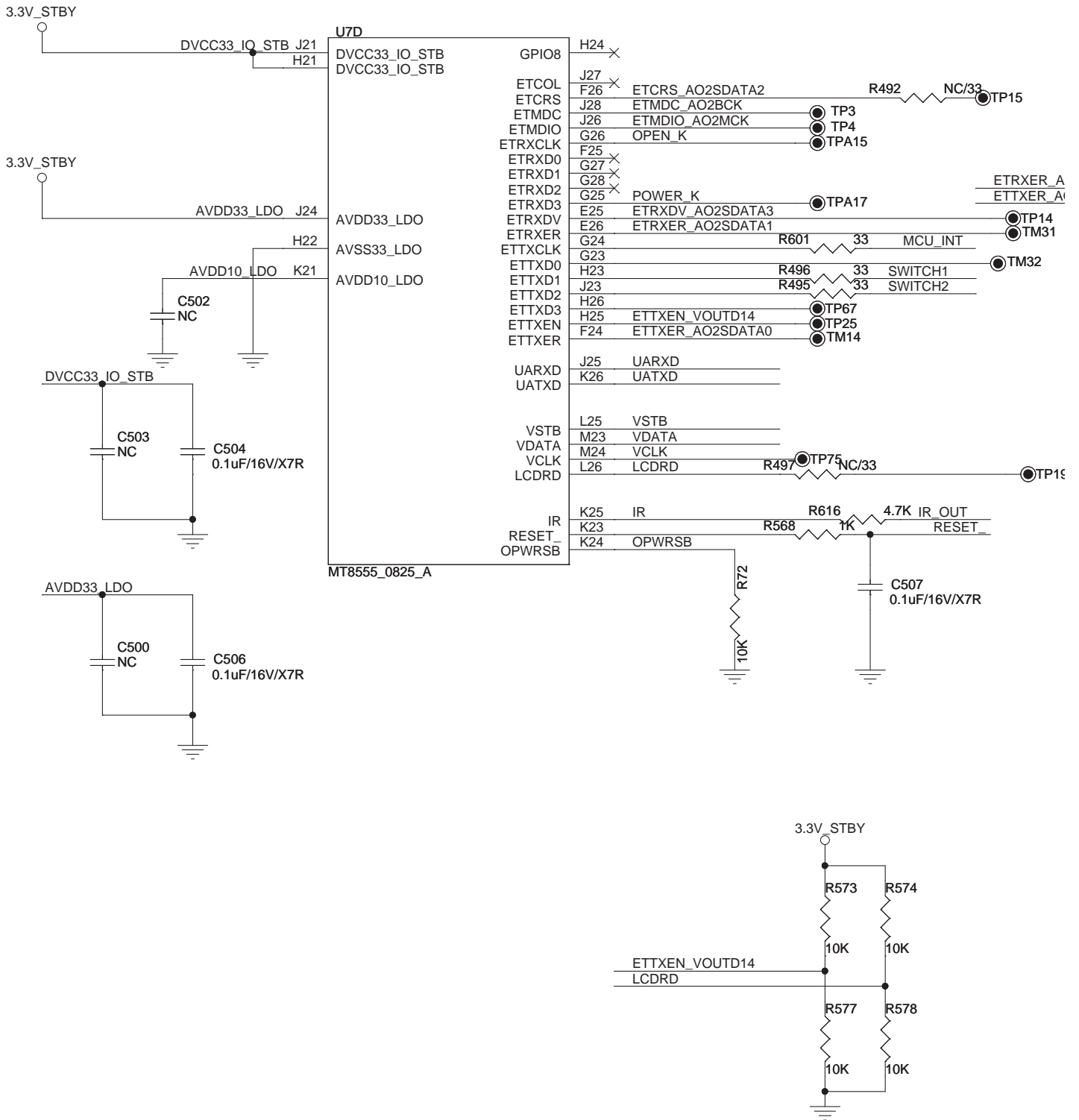

A 8/13 MAIN BOARD ASSY (08-H555DU-MA1R/YXV) • MT8555 VFD & IR BLOCK

NC/33 TP15

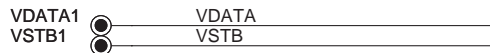
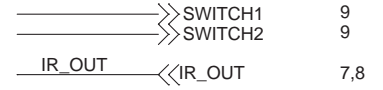
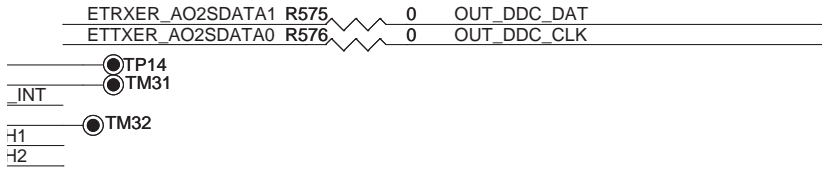

TP19

OUT
 RESET

6V/X7R

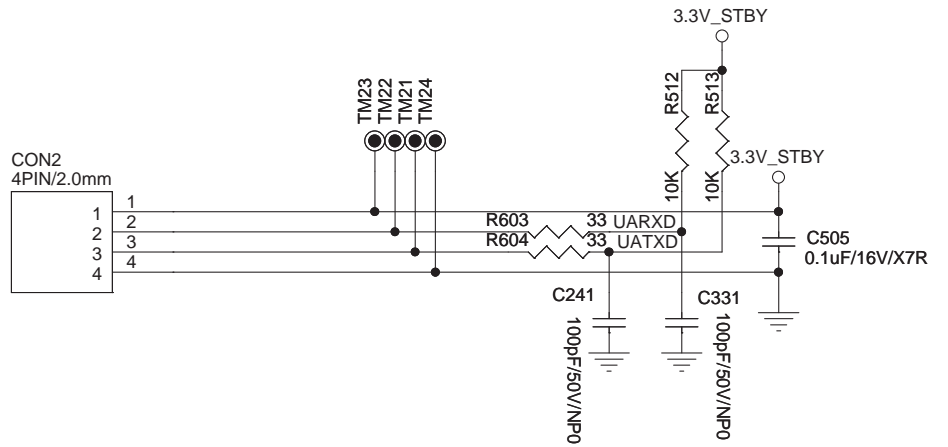

10.9 MAIN BOARD ASSY (9/13)

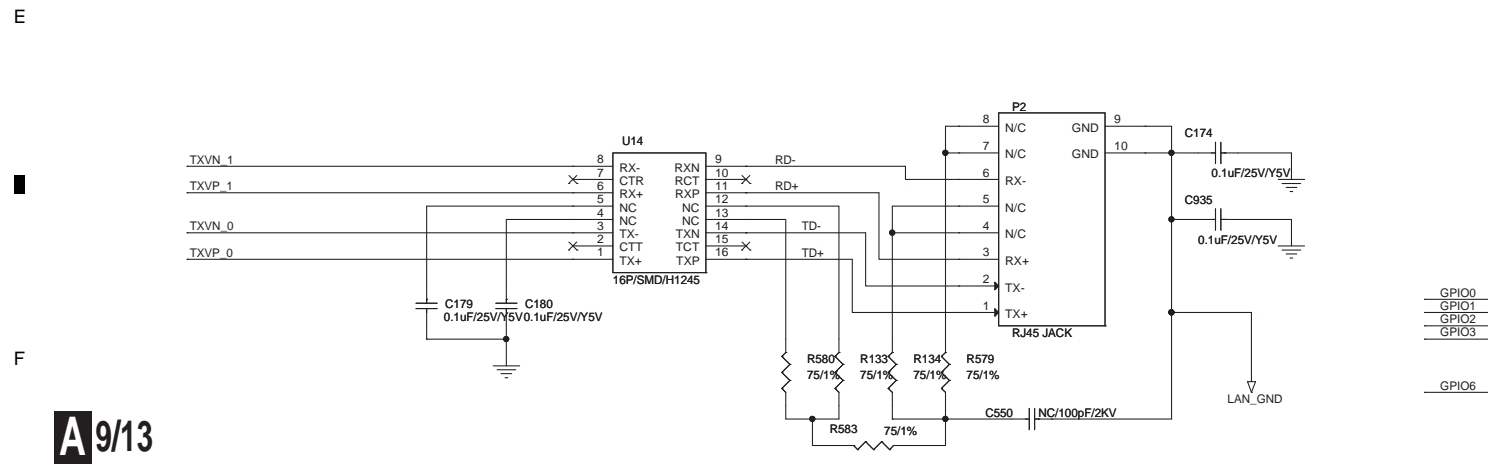
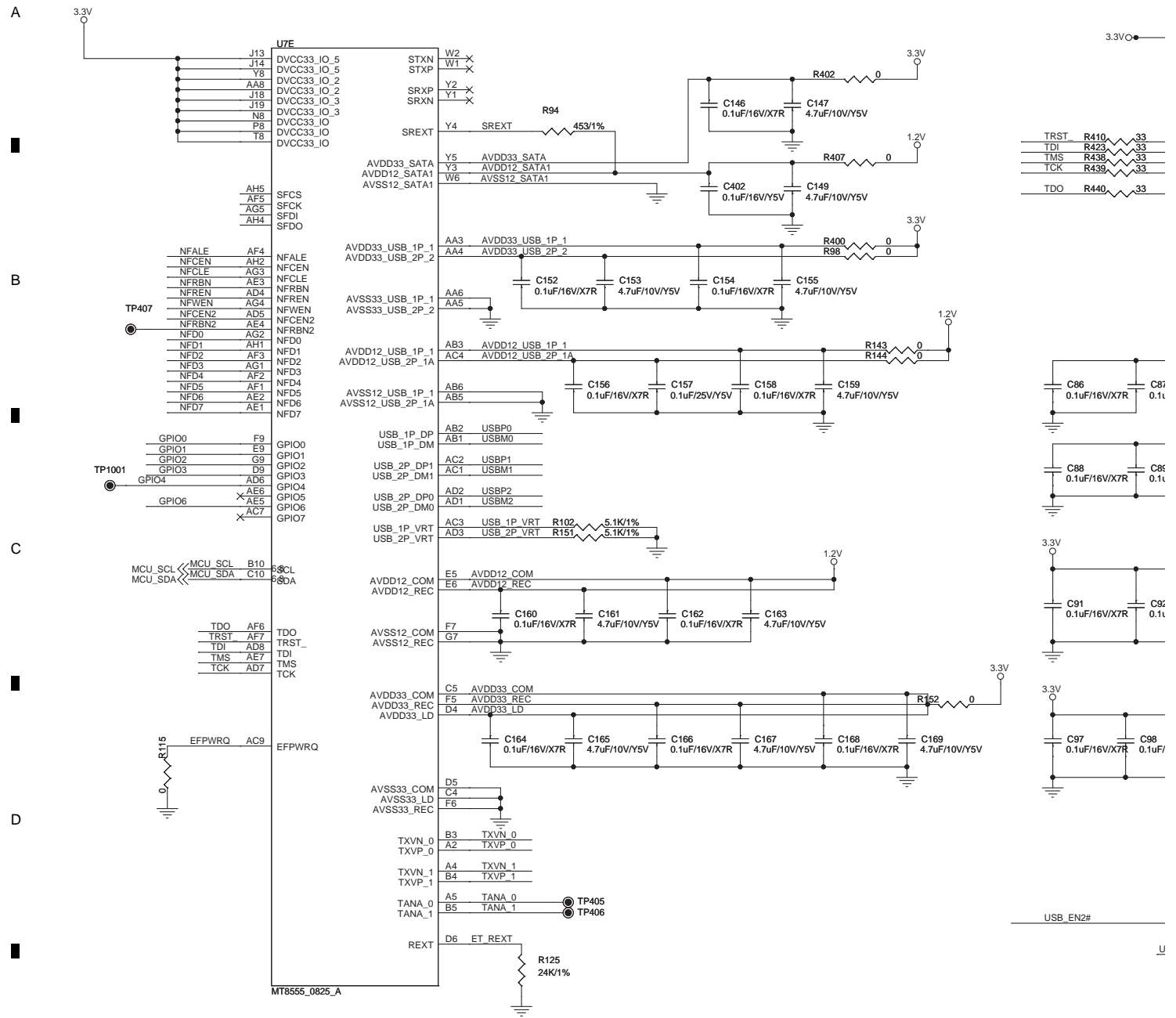

A9/13 MAIN BOARD ASSY (08-H555DU-MA1R/YXV) • MT8555 FLASH BLOCK

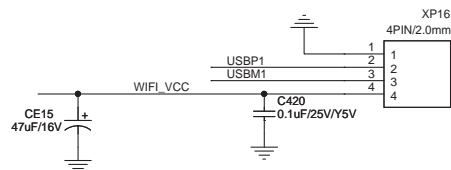
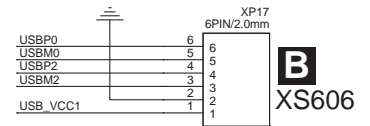
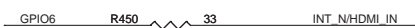
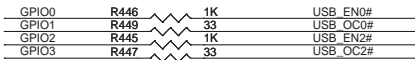
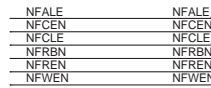
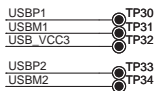
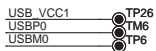
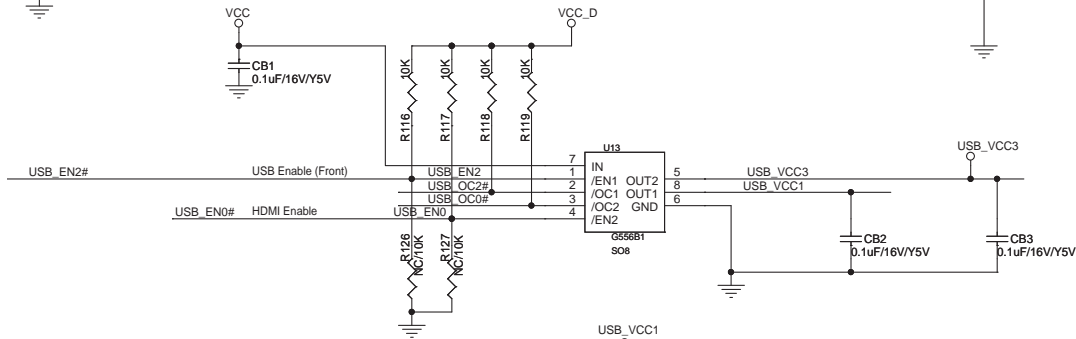
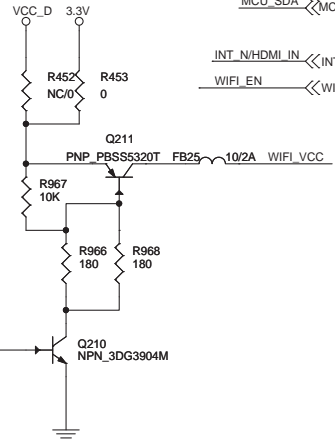
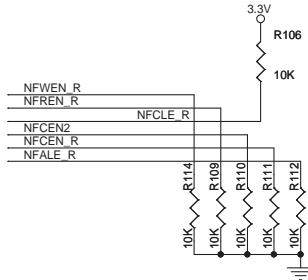
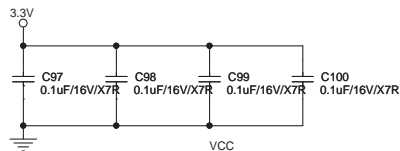
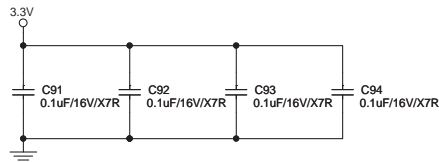
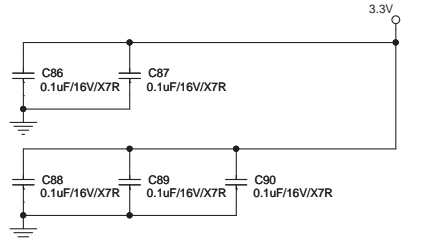
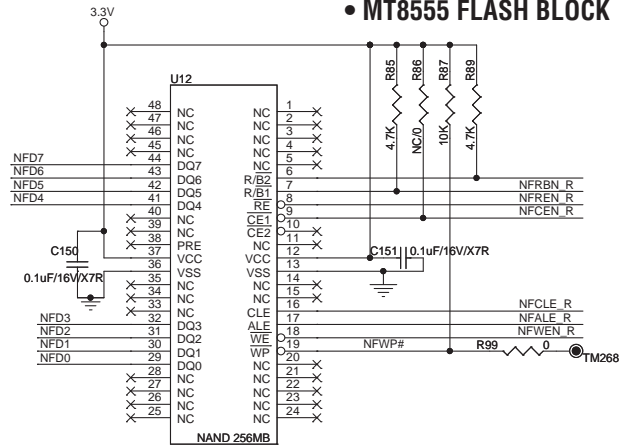
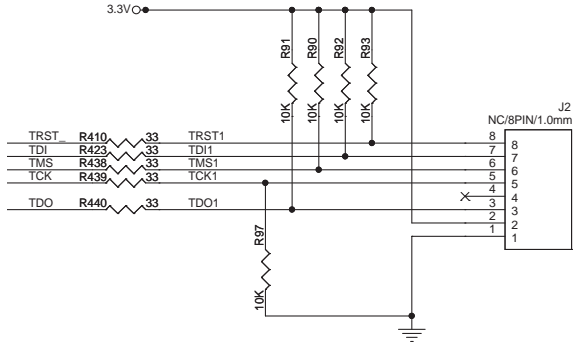

10.10 MAIN BOARD ASSY (10/13)

1 2 3 4

A

B

C

D

E

F

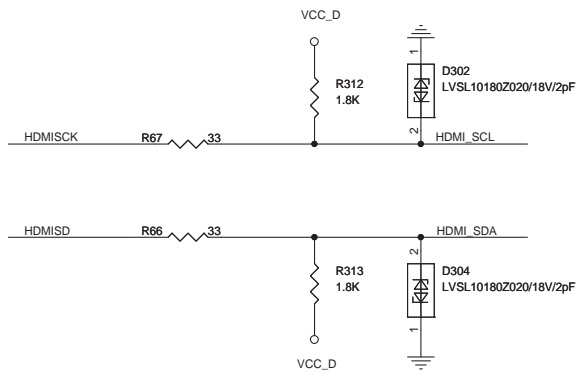
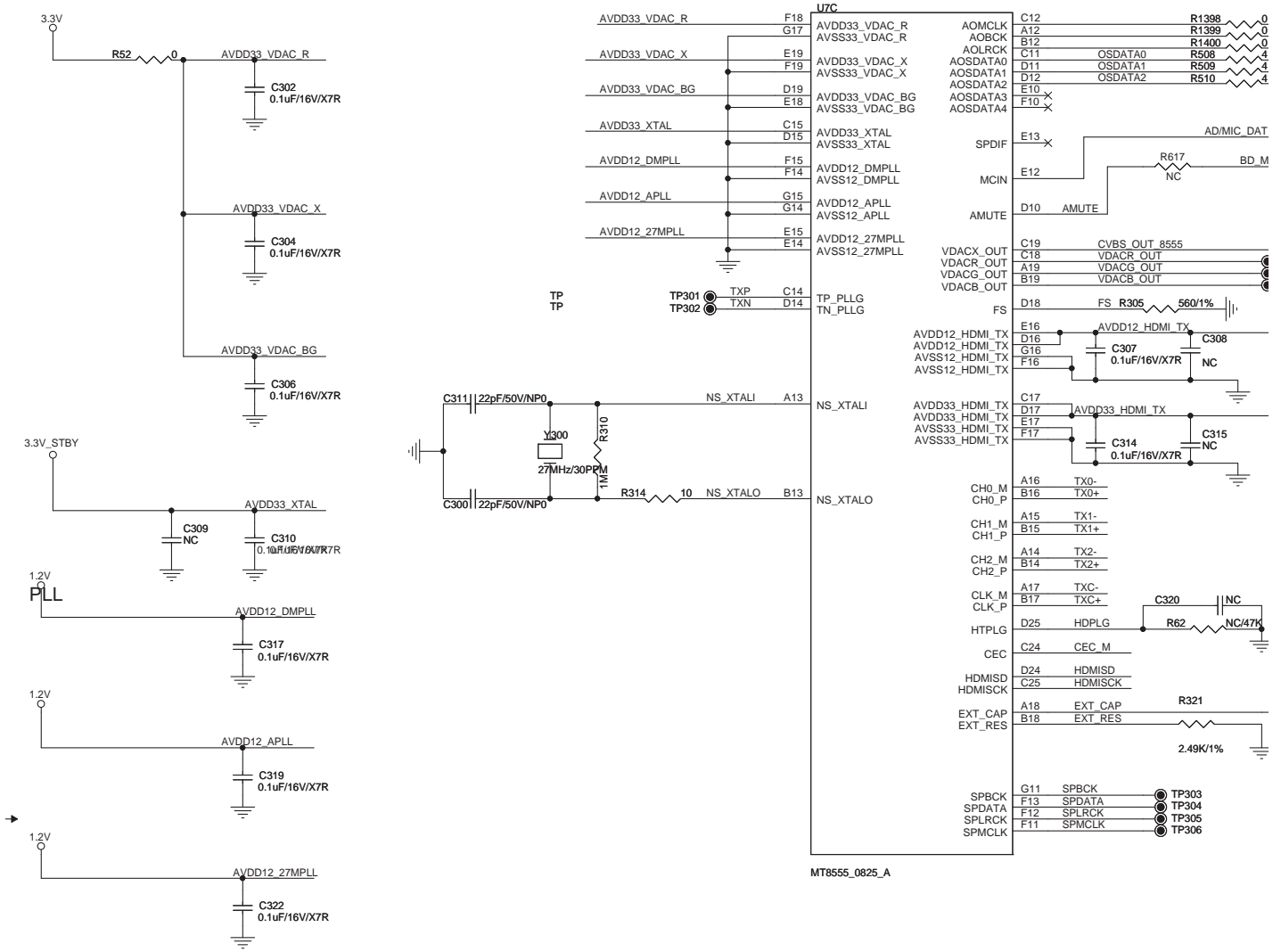

1 2 3 4

A 10/13 MAIN BOARD ASSY (08-H555DU-MA1R/YXV) • MT8555 HDMI OUT BLOCK

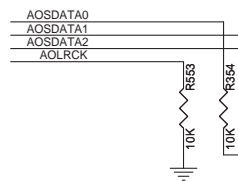
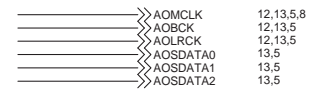
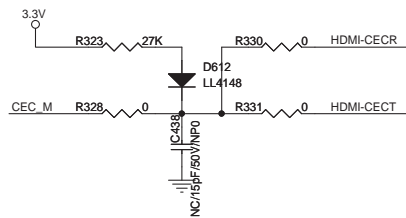
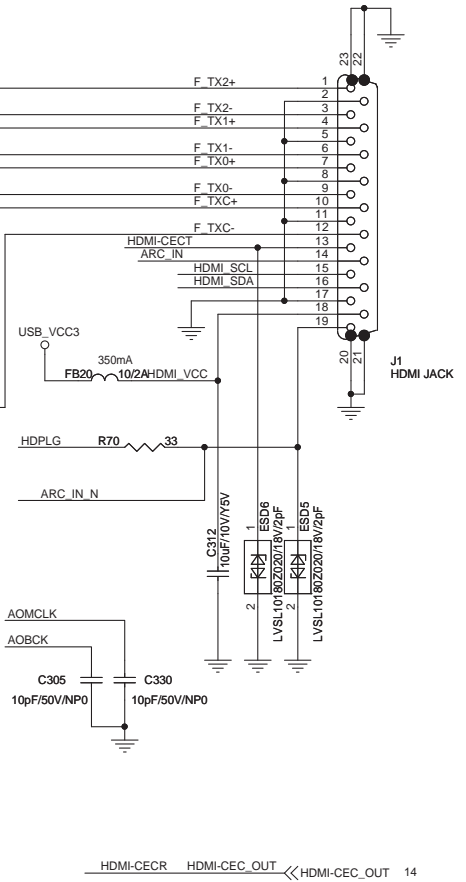
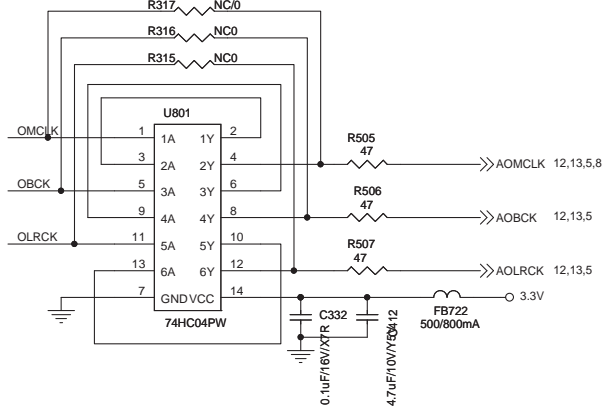
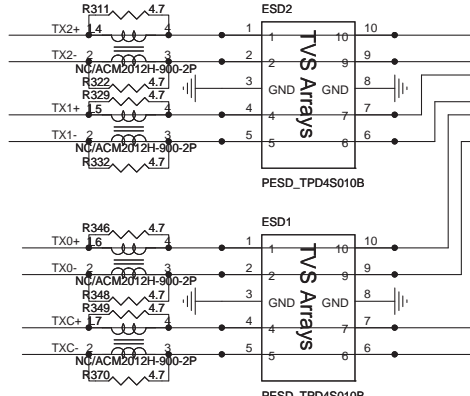
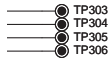
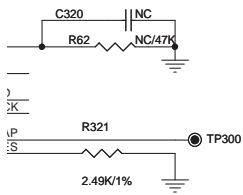
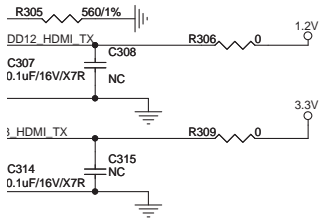
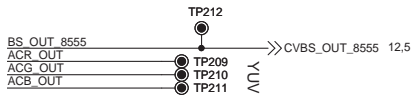
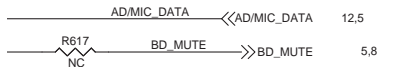
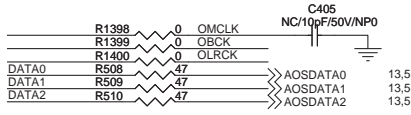

10.11 MAIN BOARD ASSY (11/13)

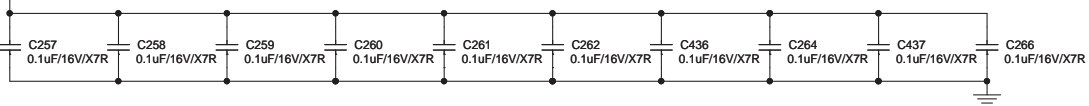
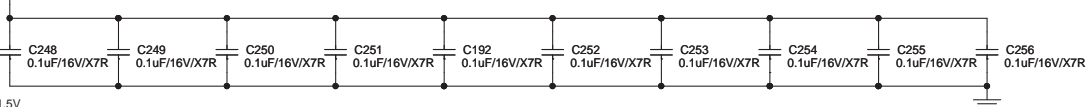
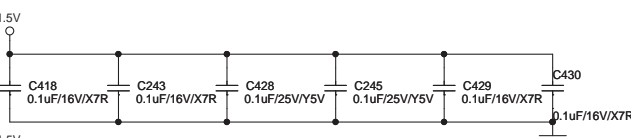
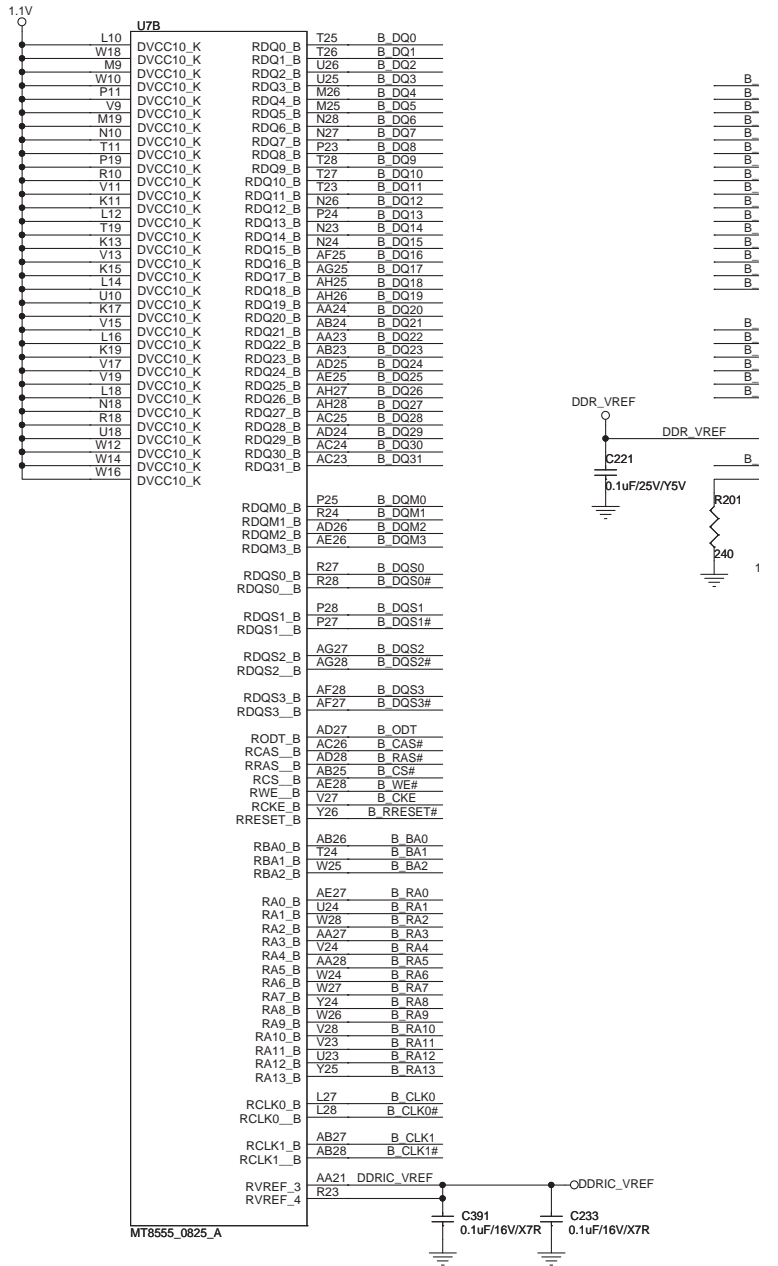
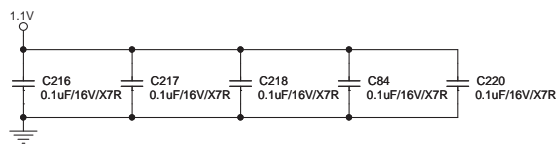
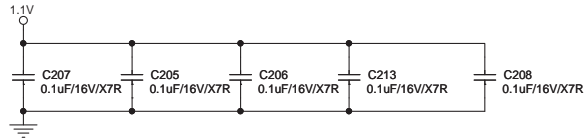
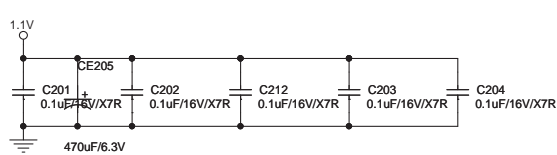

A 11/13 MAIN BOARD ASSY (08-H555DU-MA1R/YXV)

• MT8555 DDR PART II BLOCK

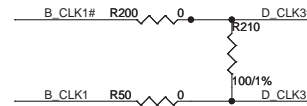
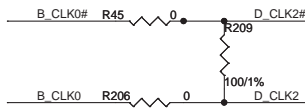
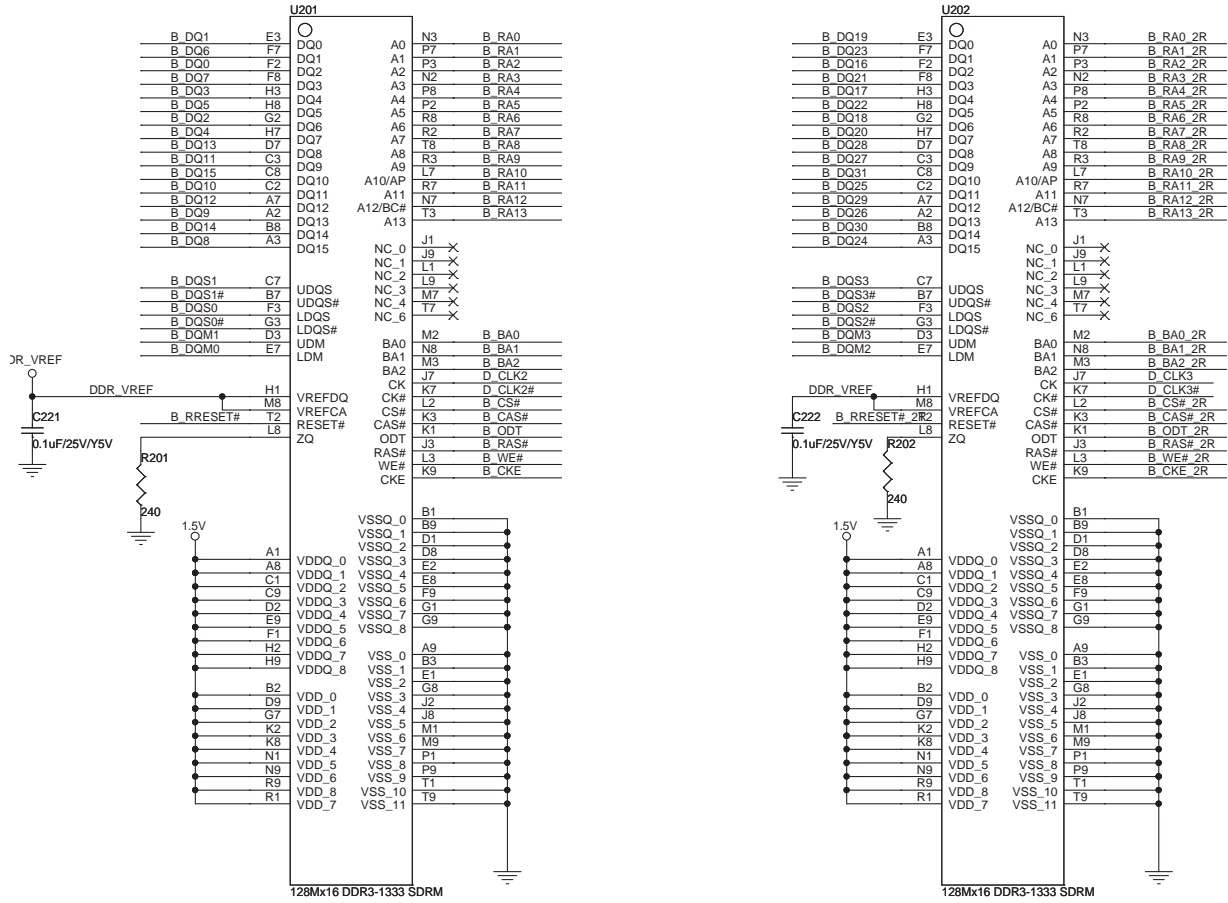

JDRIC_VREF
133
uF/16V/X7R

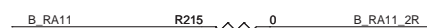
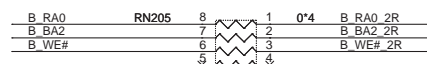
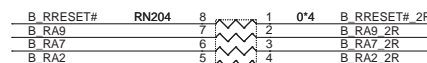
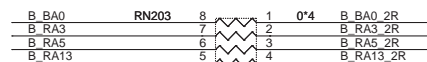
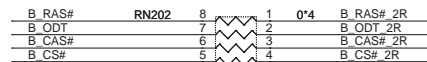
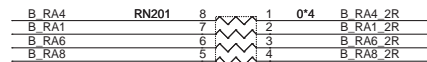
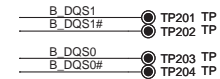
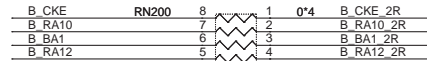

10.12 MAIN BOARD ASSY (12/13)

1

2

3

4

A

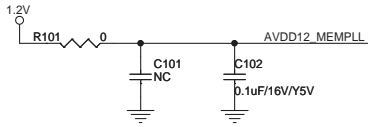

B

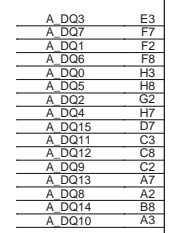
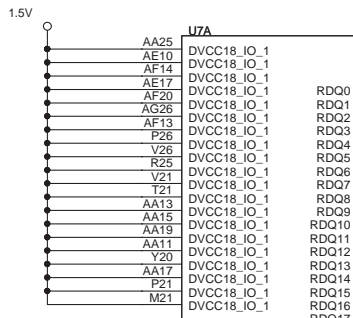

C

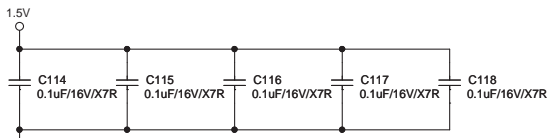
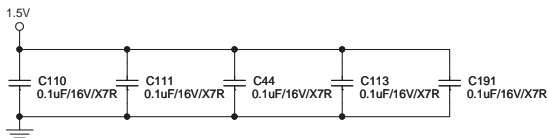
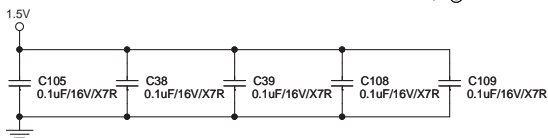

D

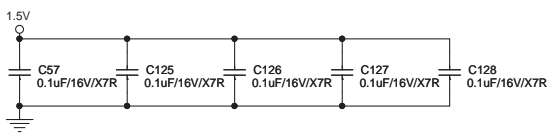
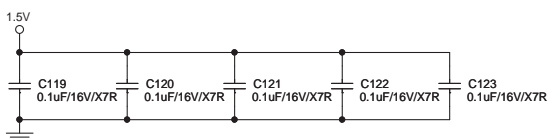

E

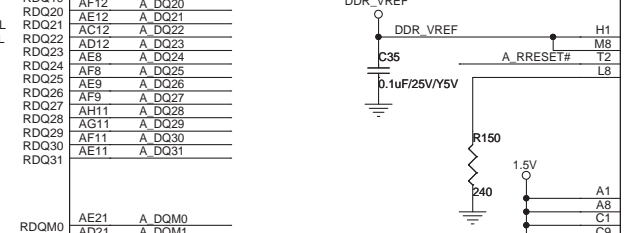

F

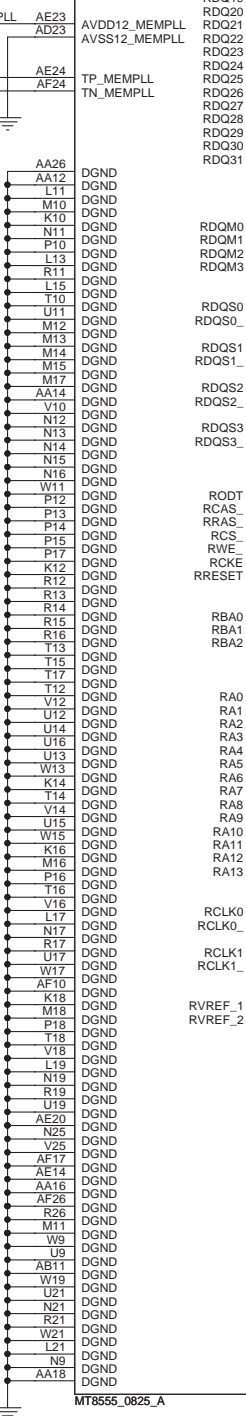
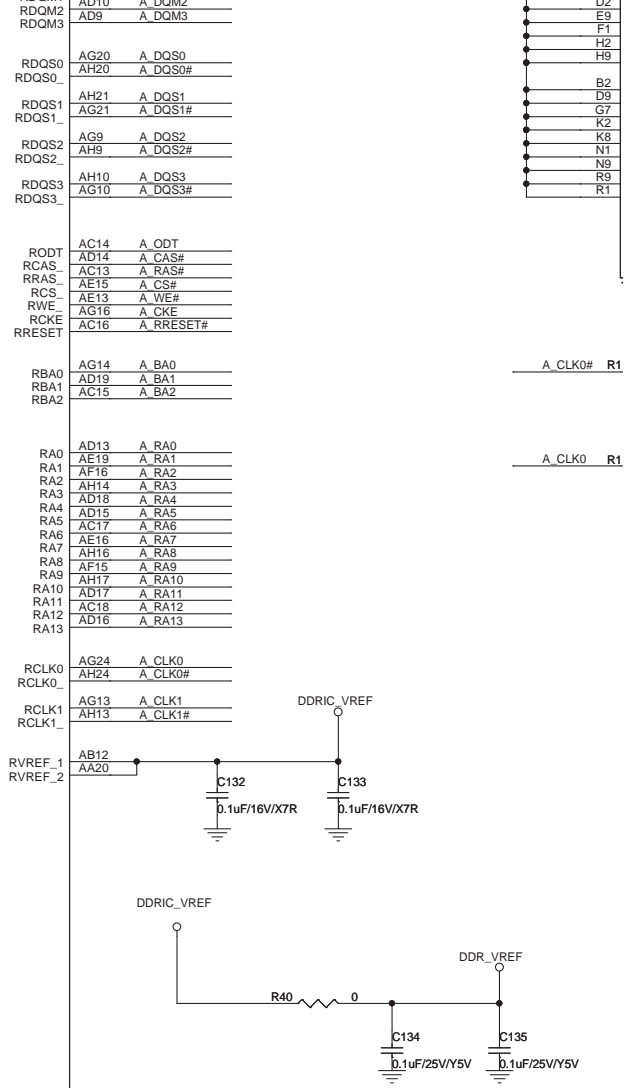

1

2

3

4

A 12/13 MAIN BOARD ASSY (08-H555DU-MA1R/YXV)

• MT8555 DDR PART I BLOCK

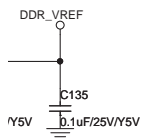
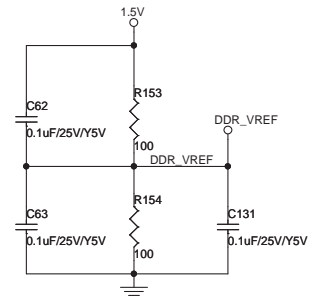
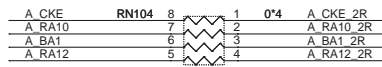
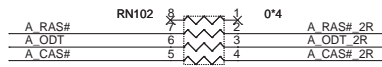
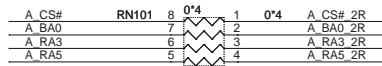
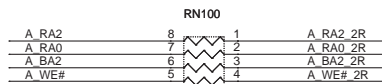
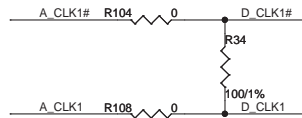
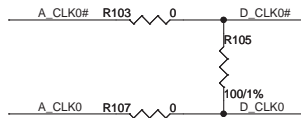
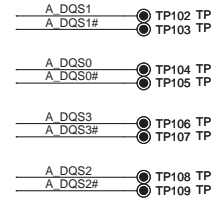
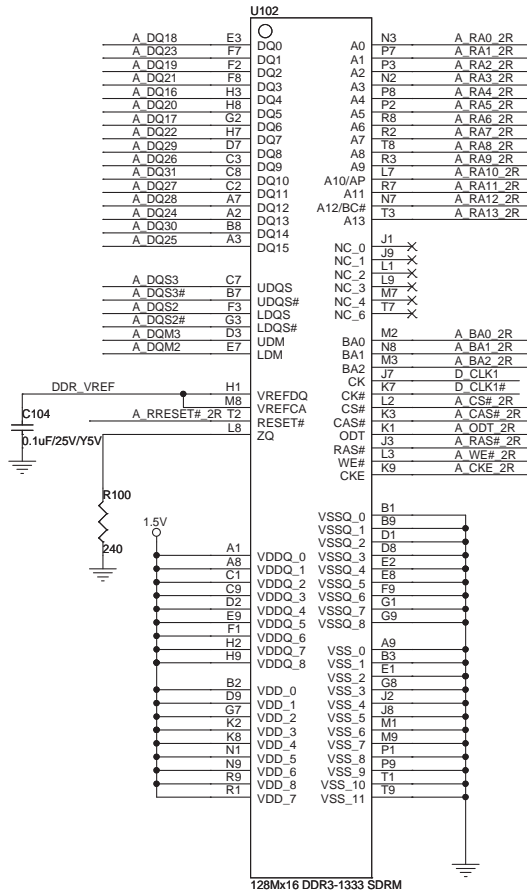
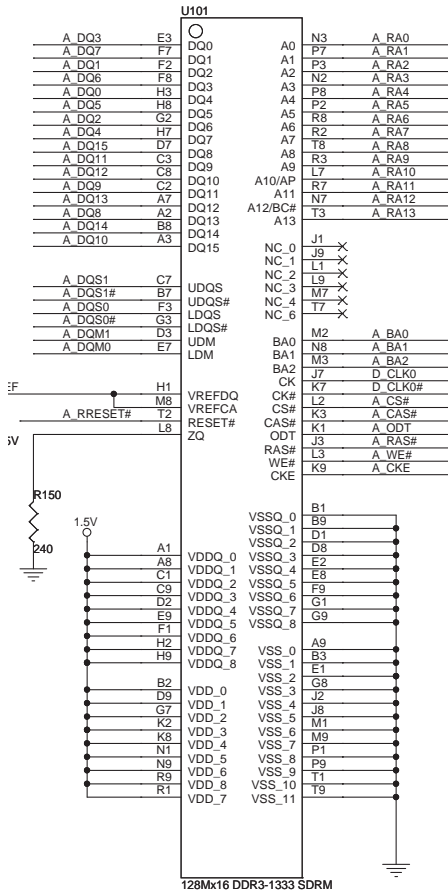

XV-BD422B

10.13 MAIN BOARD ASSY (13/13)

1 2 3 4

A

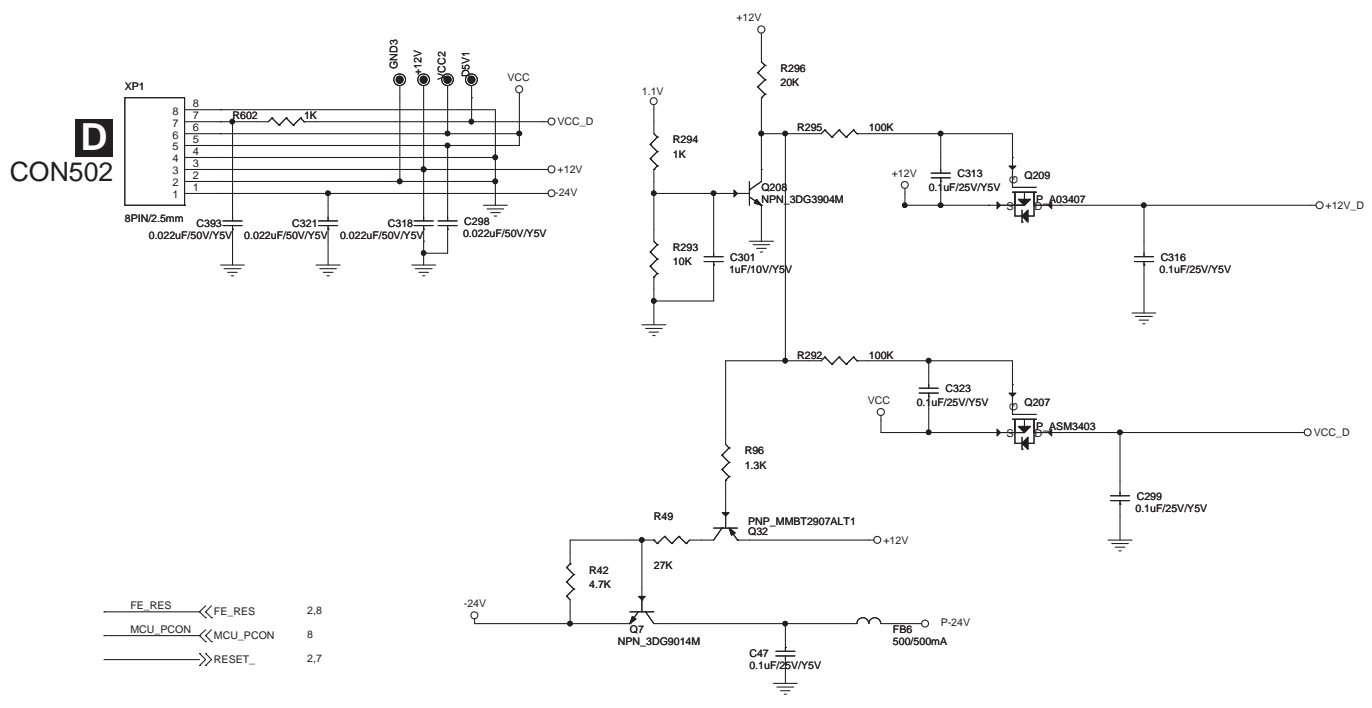

FE_RES	<<FE_RES	2.8
MCU_PCON	<<MCU_PCON	8
	>>RESET_	2.7

B

C

D

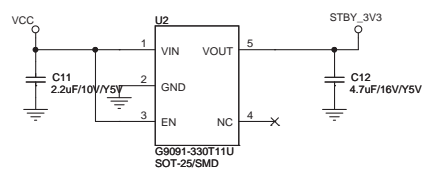

E

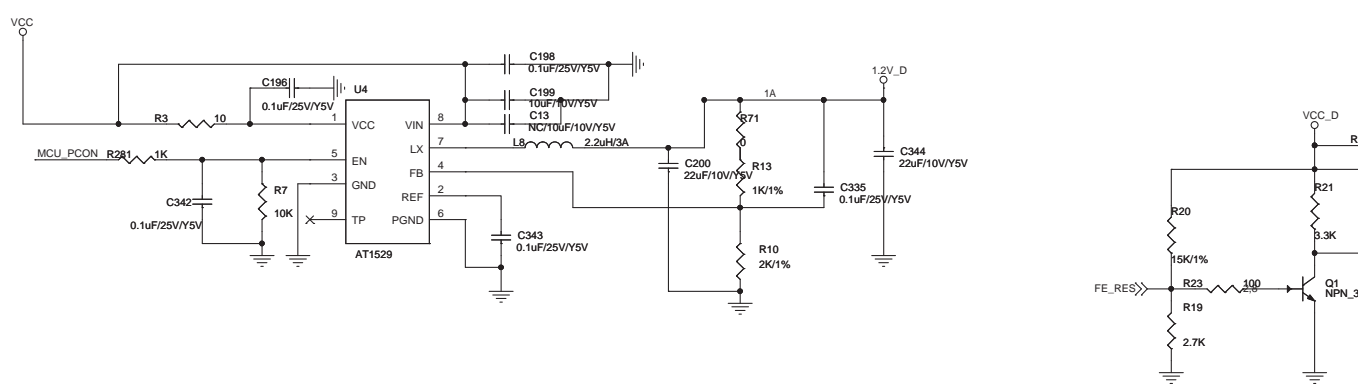

F

1 2 3 4

A 13/13 MAIN BOARD ASSY (08-H555DU-MA1R/YXV) • Power Source BLOCK

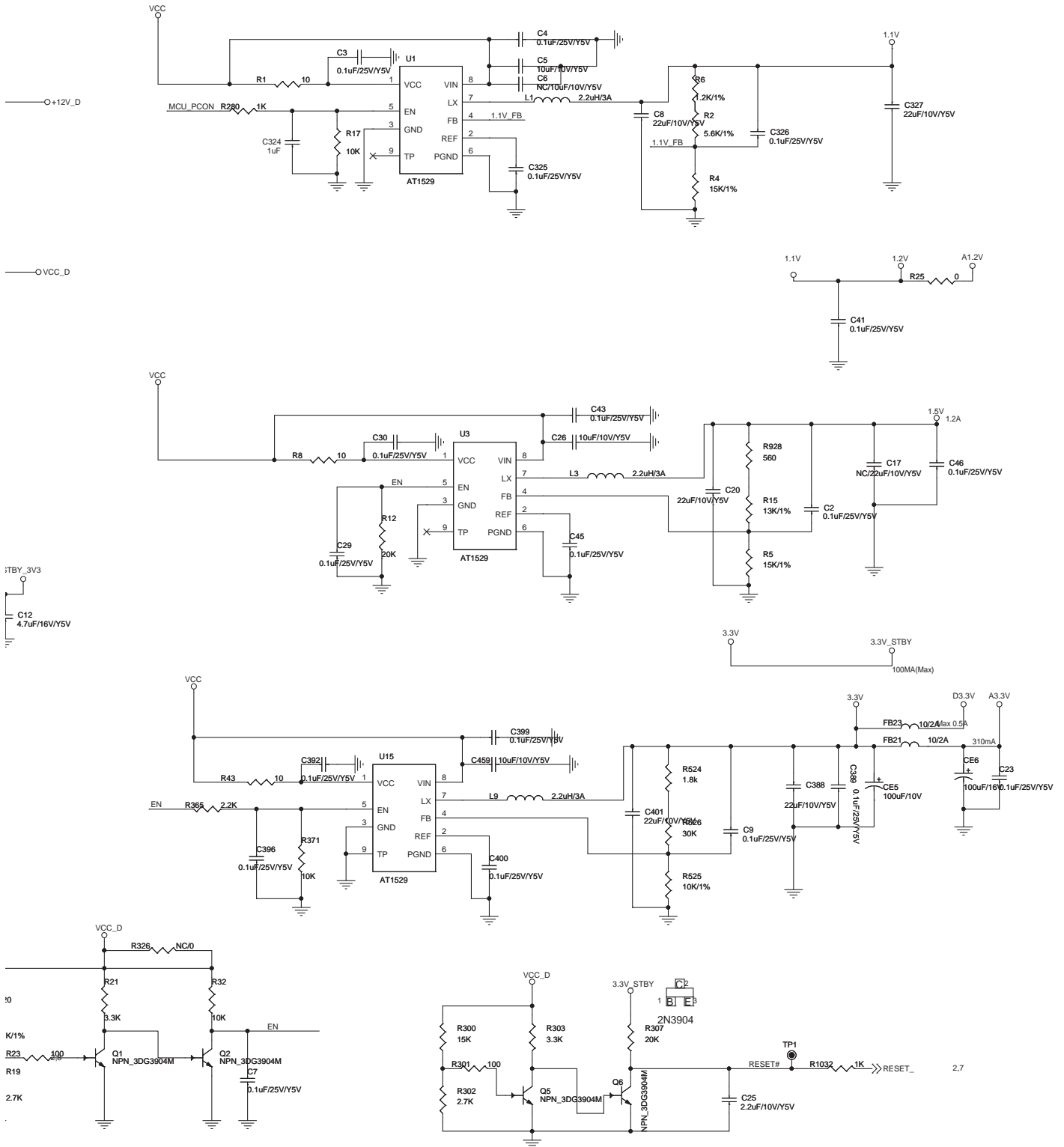

10.14 FRONT BOARD ASSY

1 2 3 4

A

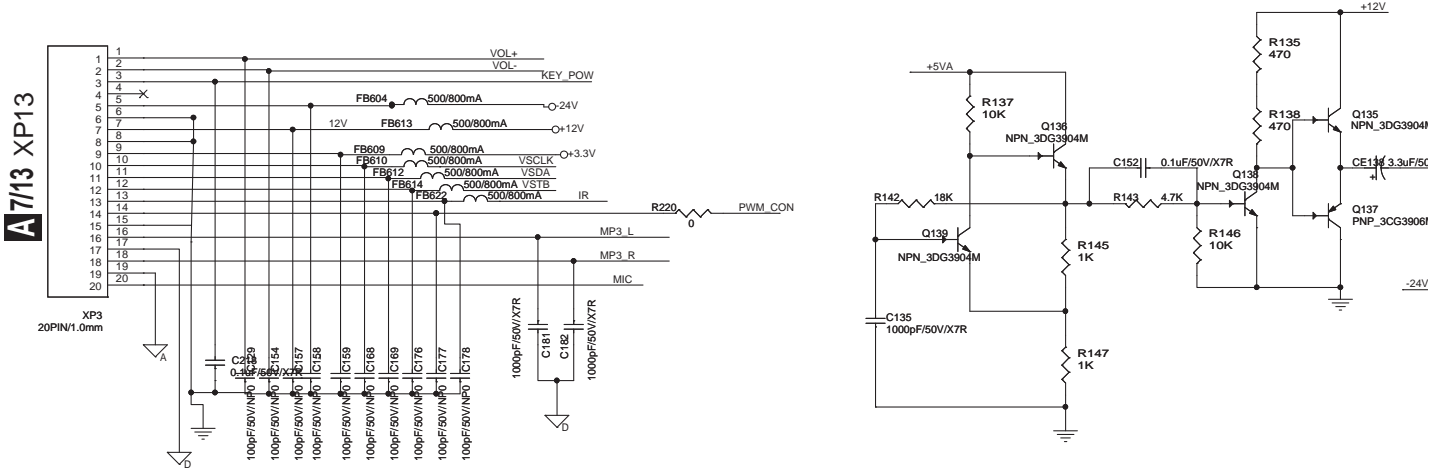

B

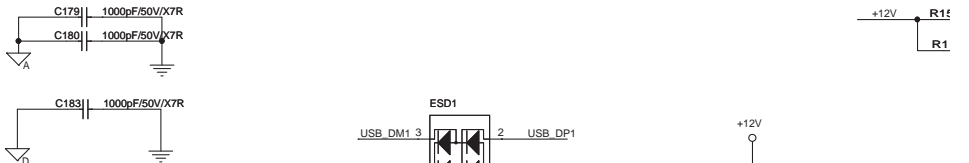

C

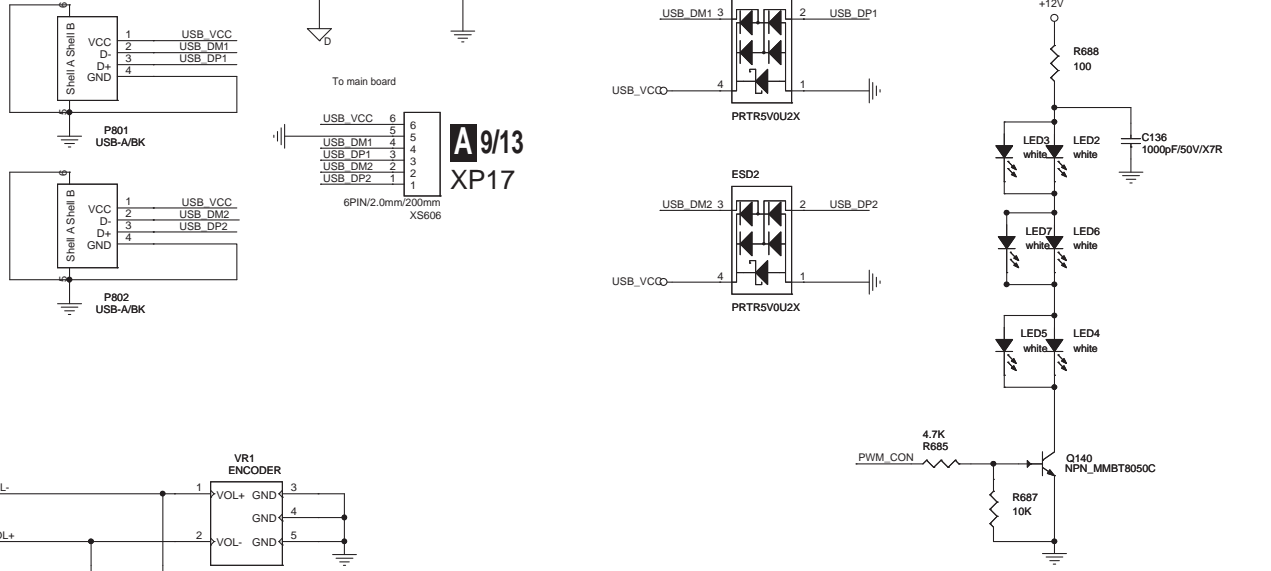

D

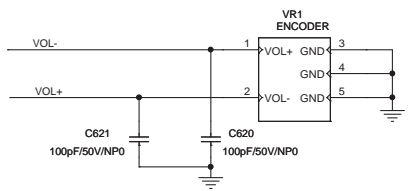

E

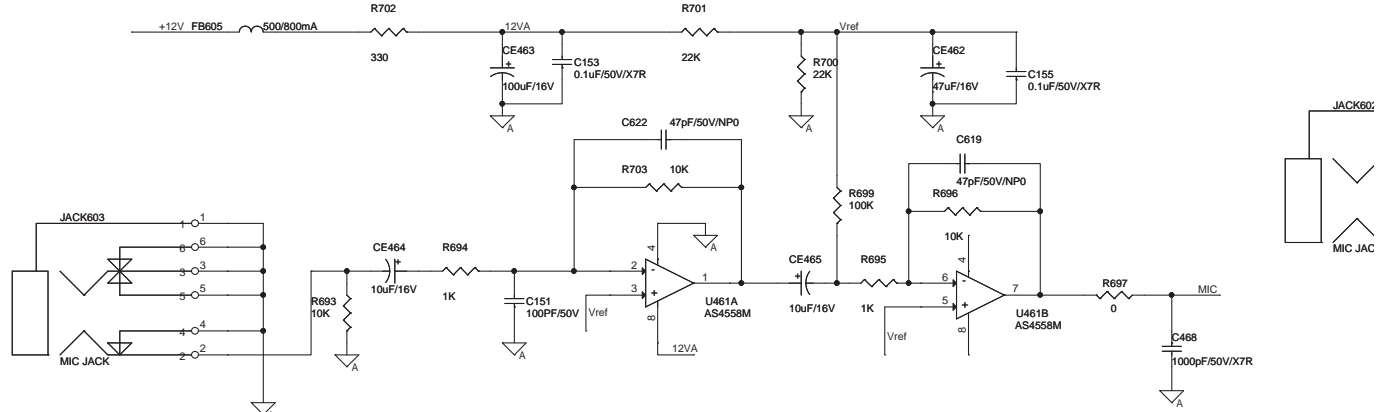

F

B

1 2 3 4

B FRONT BOARD ASSY (08-BCS727-FVY)

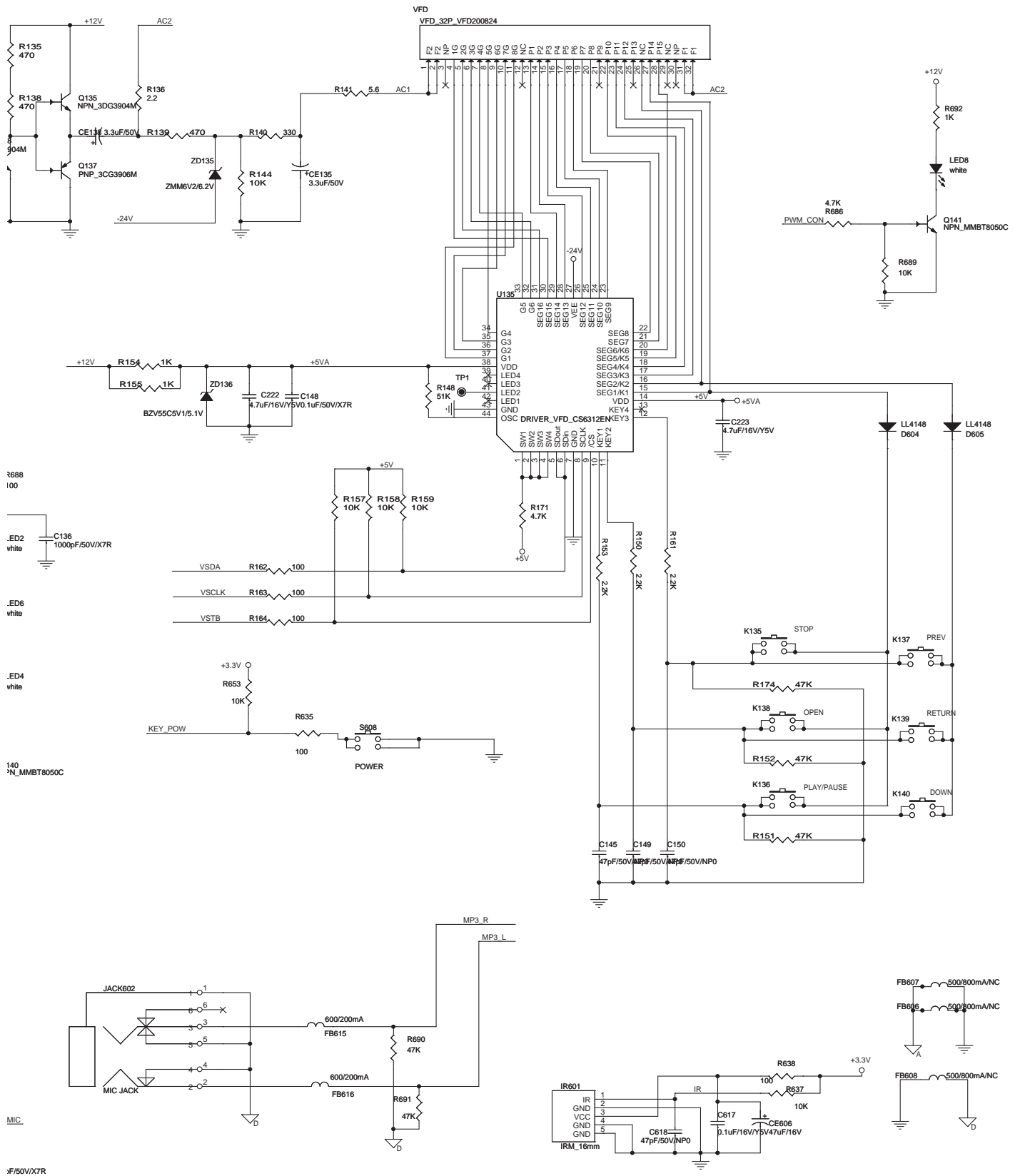

10.15 AMP BOARD ASSY (1/3)

1

2

3

4

A

B

C

D

E

F

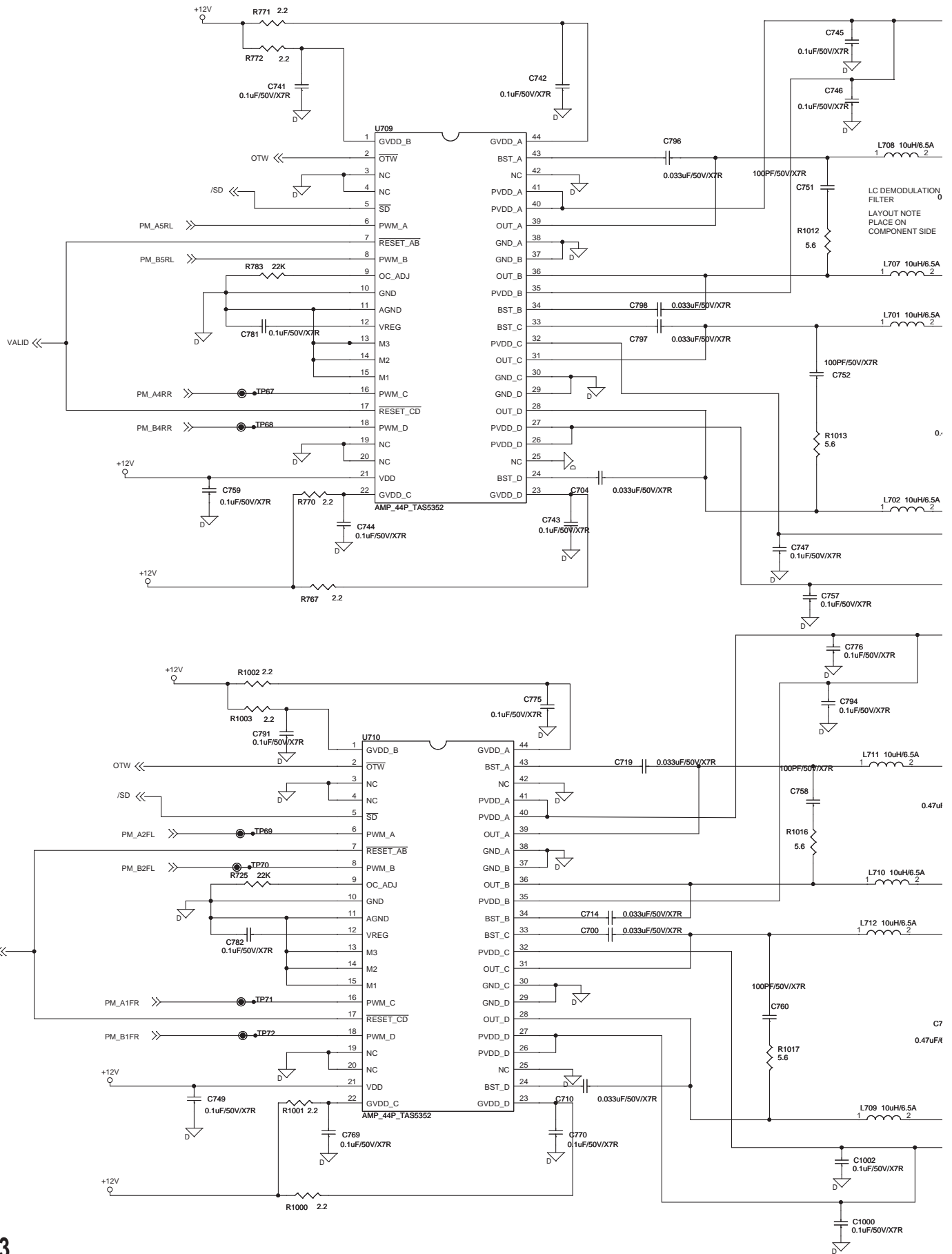

1

2

3

4

C1/3 AMP BOARD ASSY (XV-BD422B, XV-BD122B: AZW7611) (XV-BD122FSB: AZW7612)

• L+SLR+SR OUT BLOCK

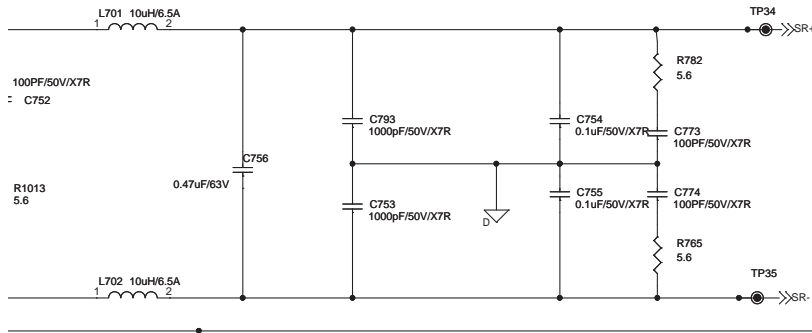
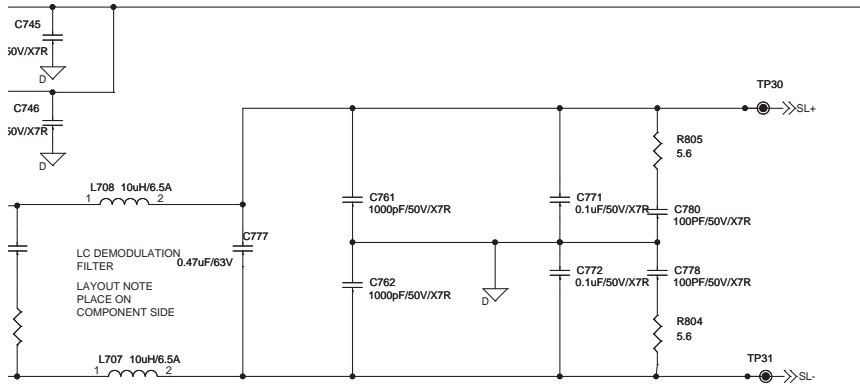

V/X7R
C757
0.1uF/50V/X7R

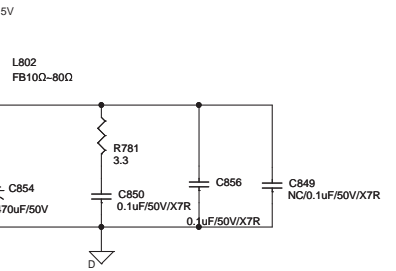
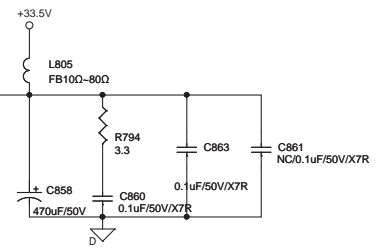
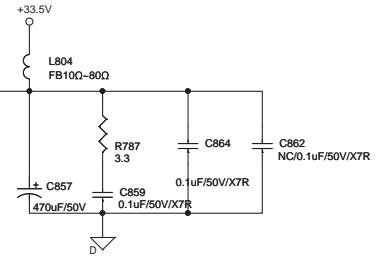
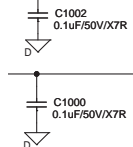
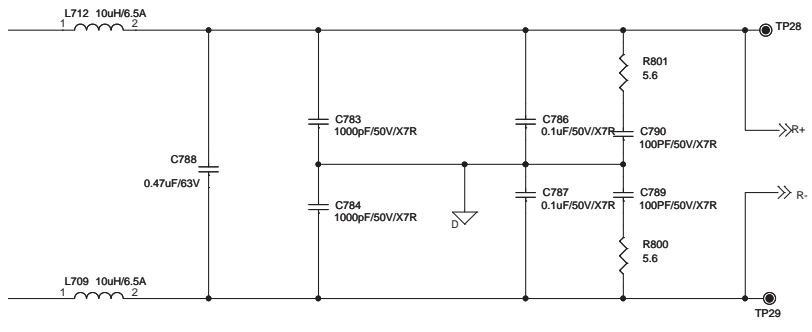
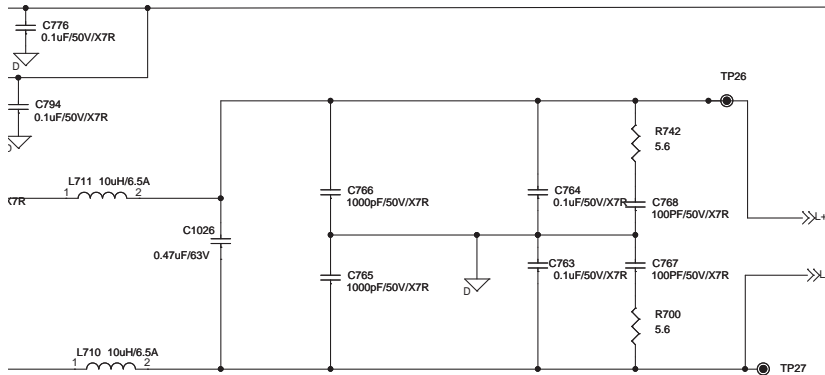

LAYOUT NOTE:
PLACE ON C845
COMPONENT SIDE

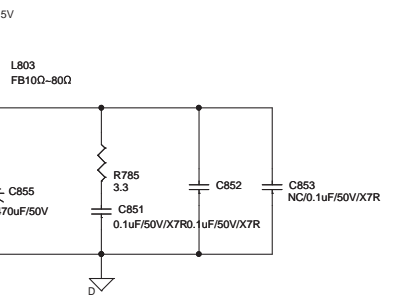

10.16 AMP BOARD ASSY (2/3)

1 2 3 4

A

B

C

D

E

F

A7/13
XP11

C2/3

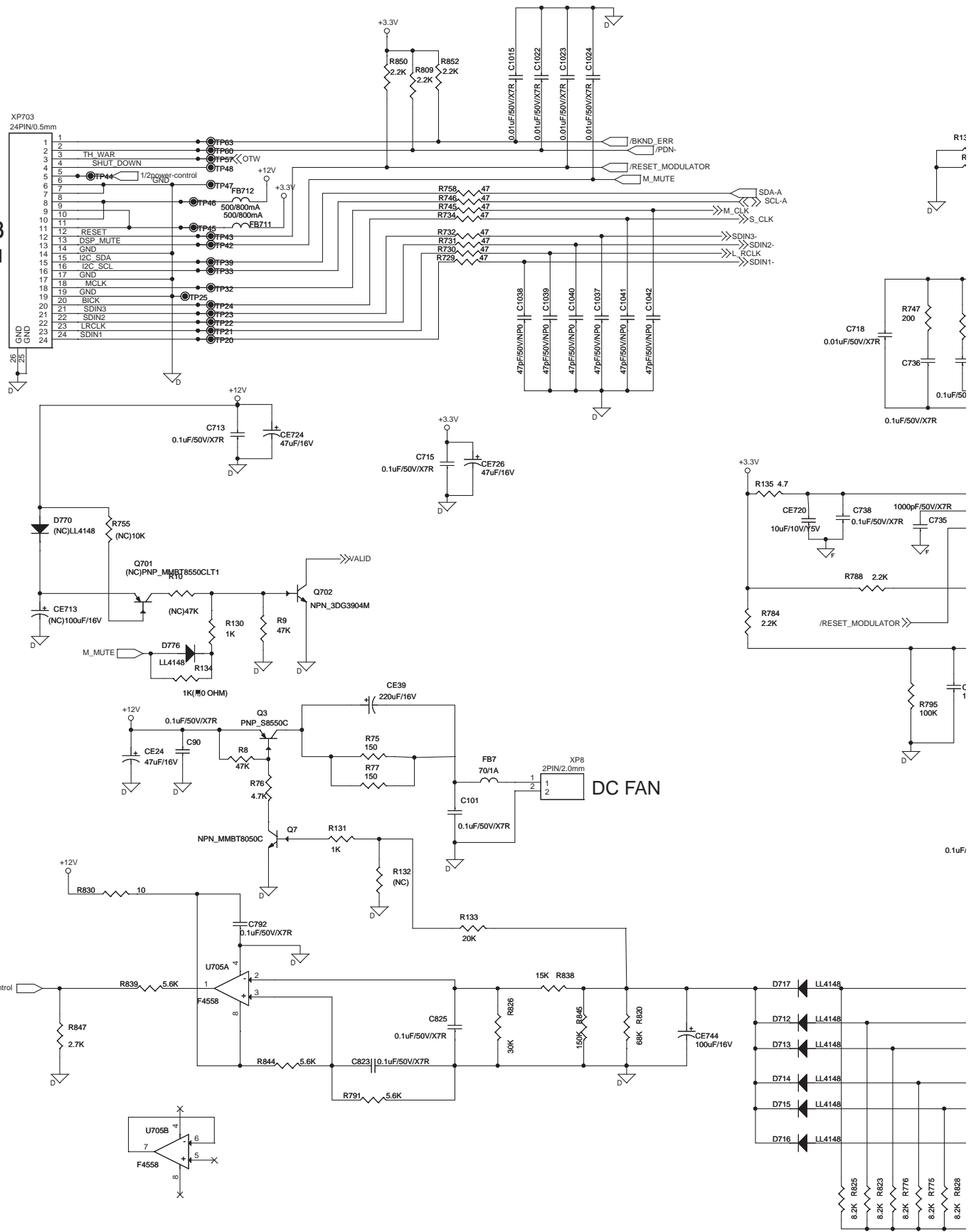

1 2 3 4

C2/3 AMP BOARD ASSY

(XV-BD422B, XV-BD122B: AZW7611)
 (XV-BD122FSB: AZW7612)

• DSP BLOCK

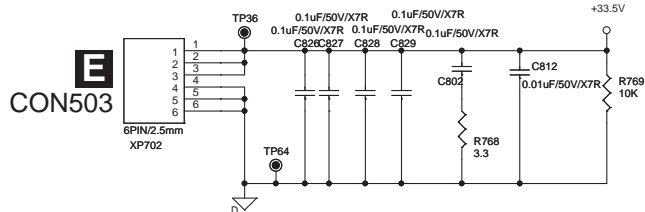
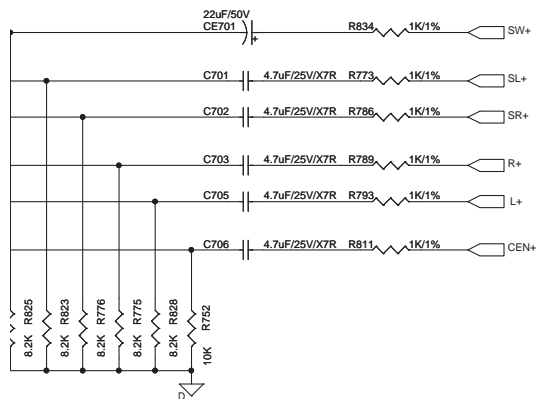
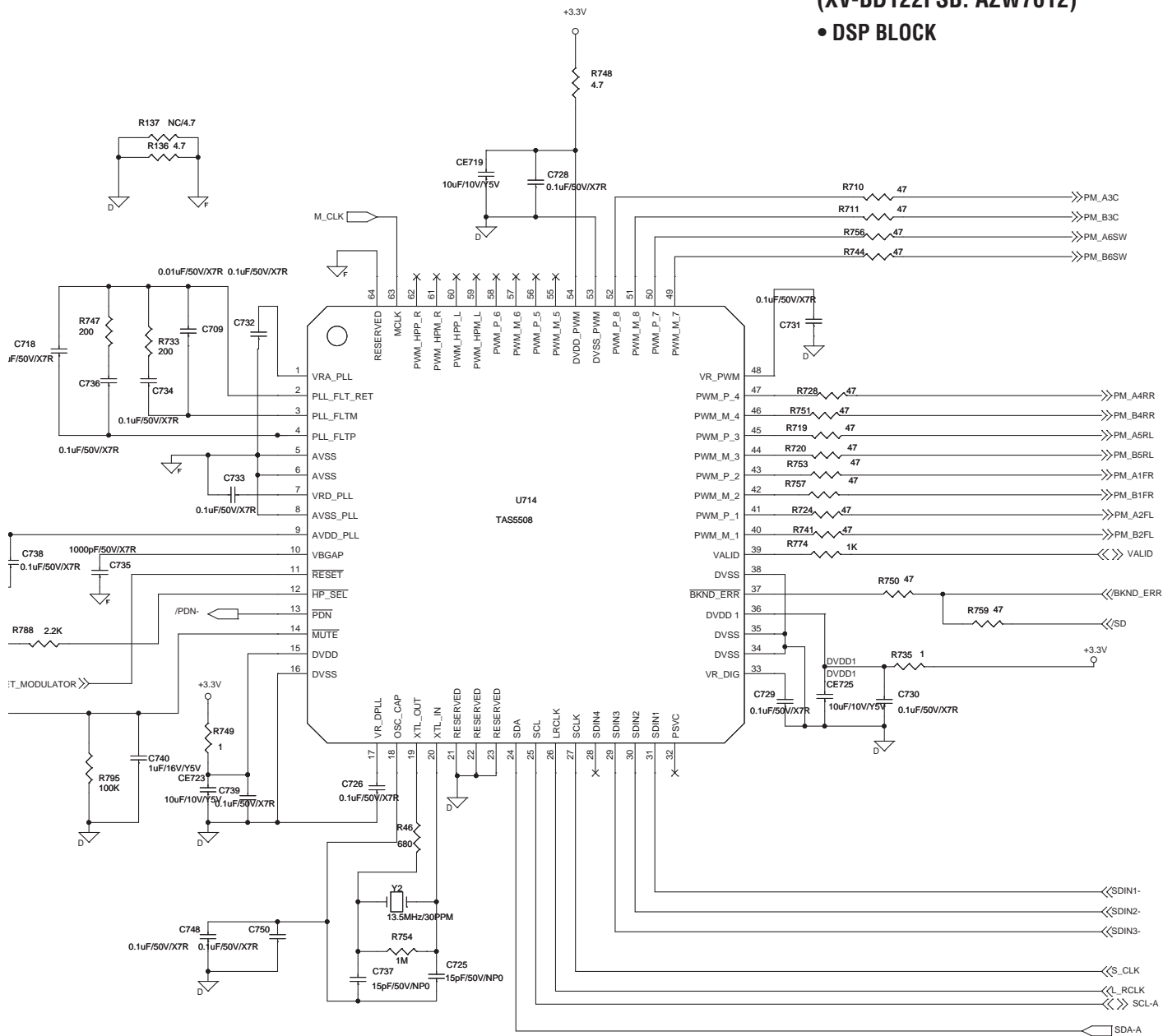

10.17 AMP BOARD ASSY (3/3)

1 2 3 4

A

B

C

D

E

F

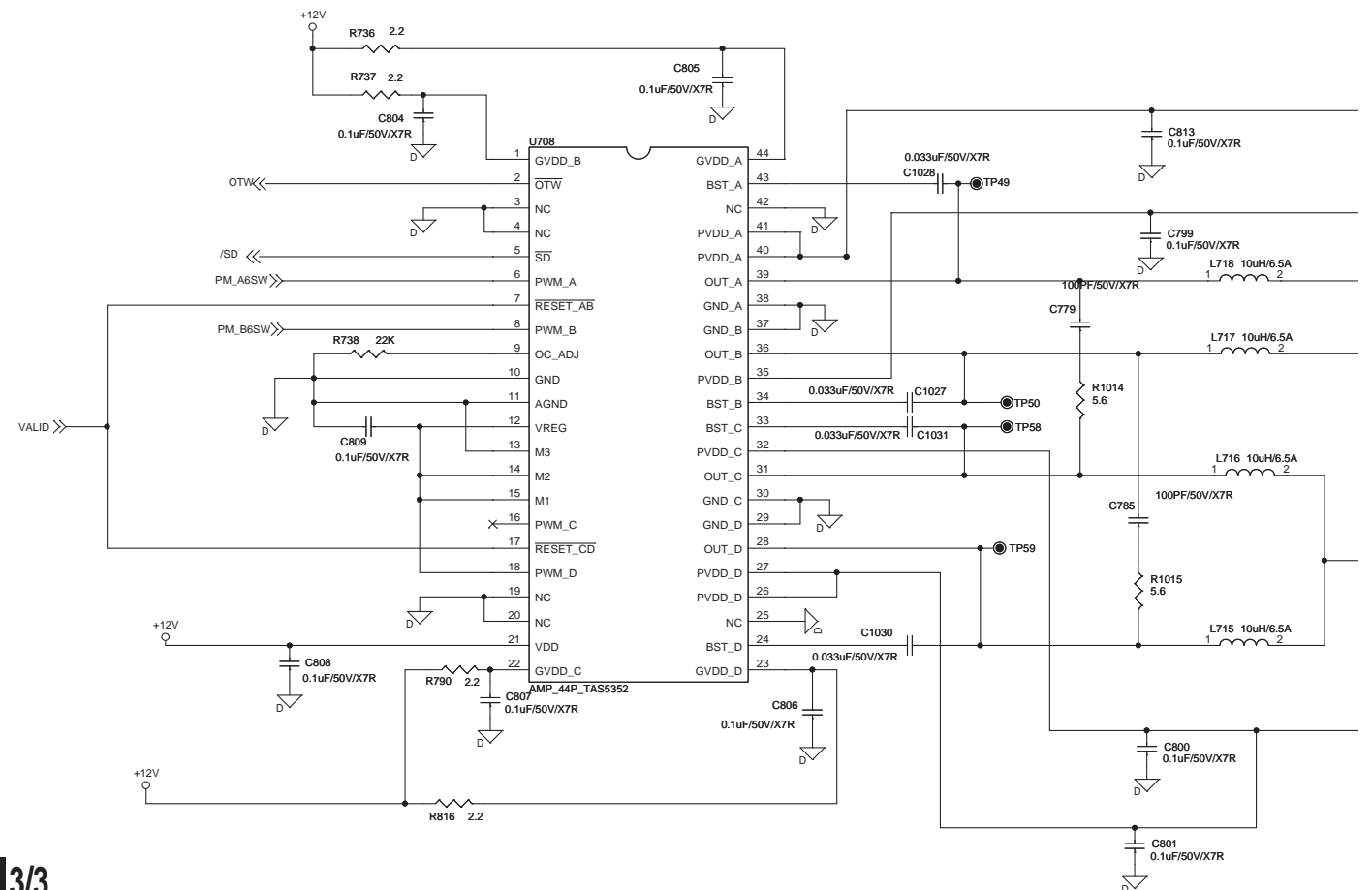
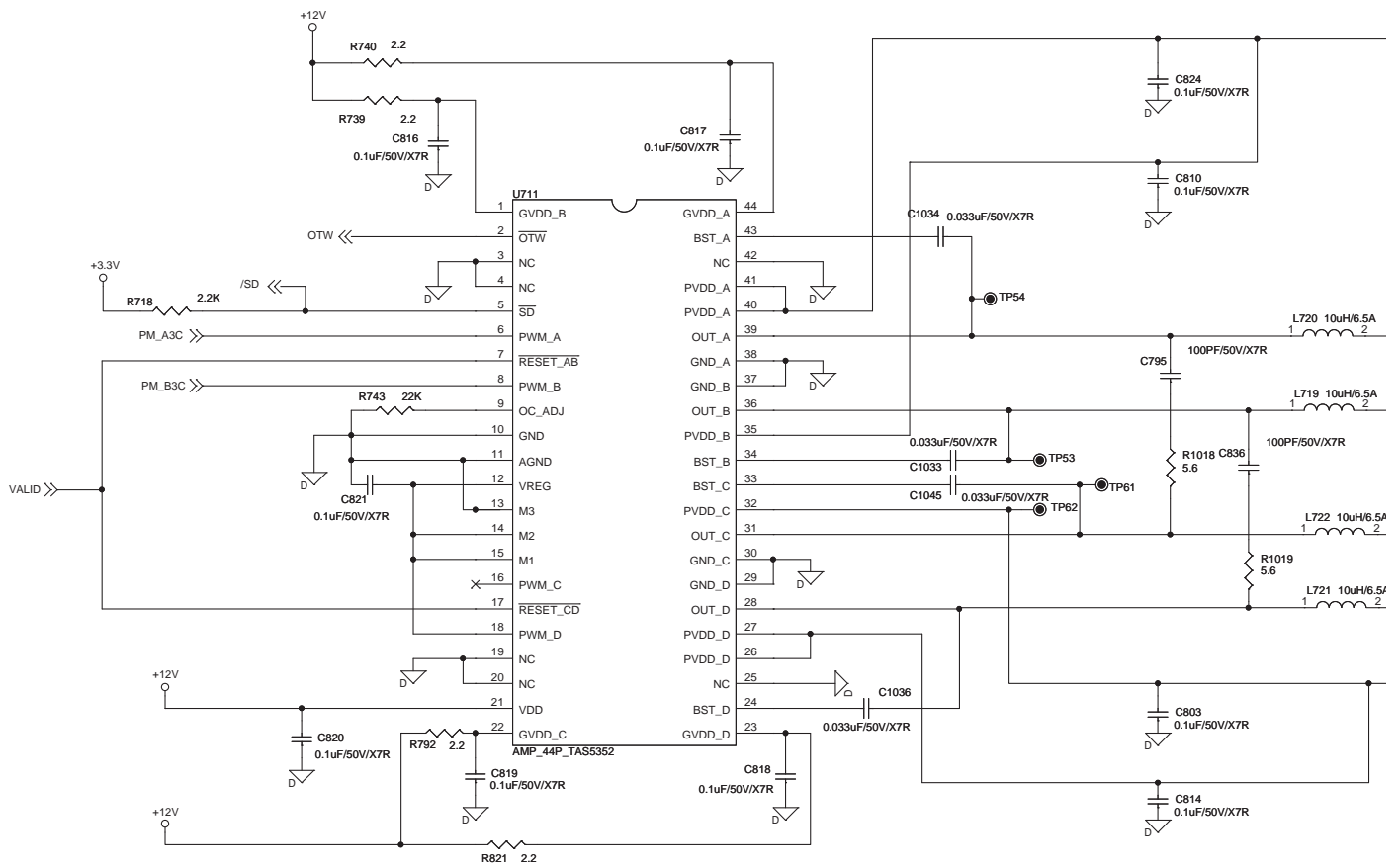

1 2 3 4

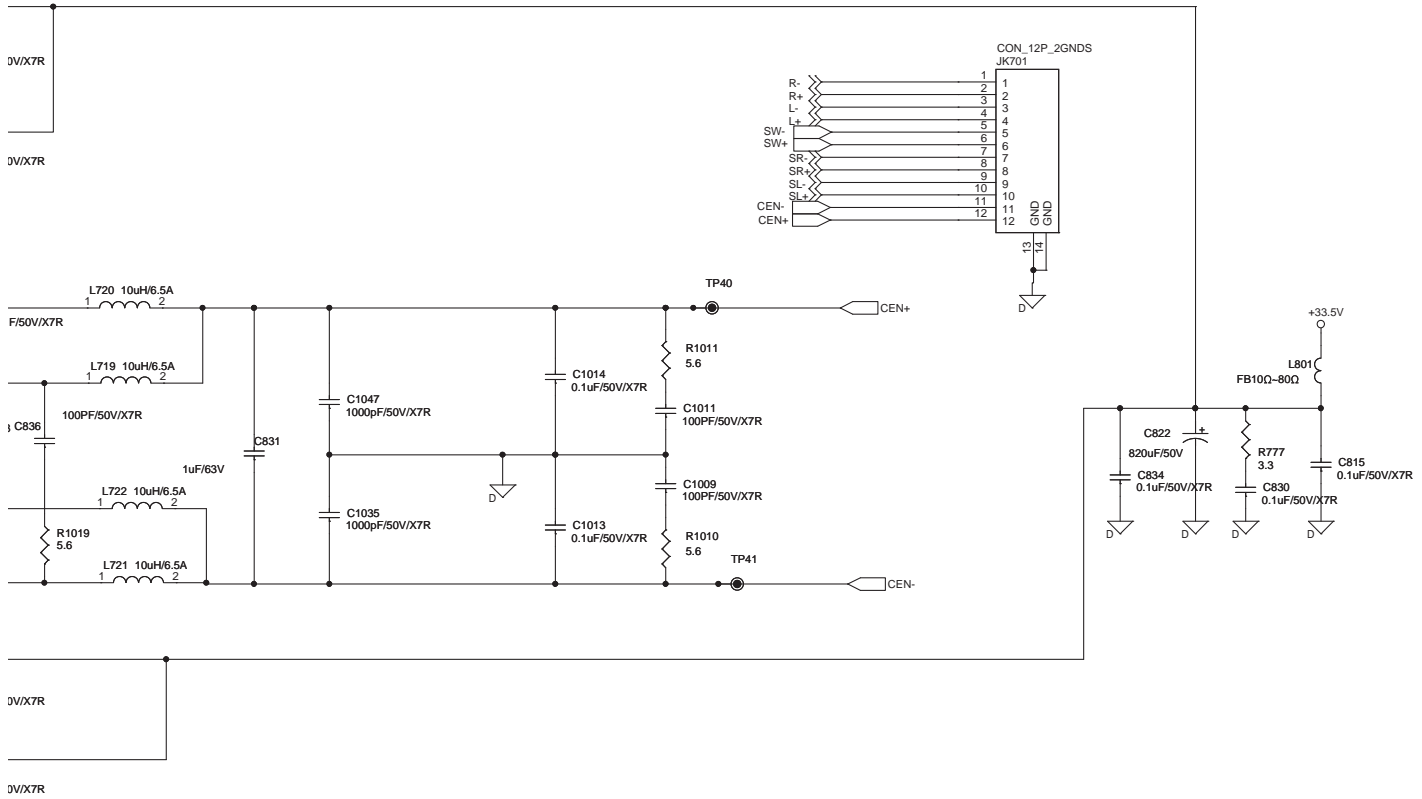

C3/3 AMP BOARD ASSY
 (XV-BD422B, XV-BD122B: AZW7611)
 (XV-BD122FSB: AZW7612)
 • CEN+SW OUT BLOCK

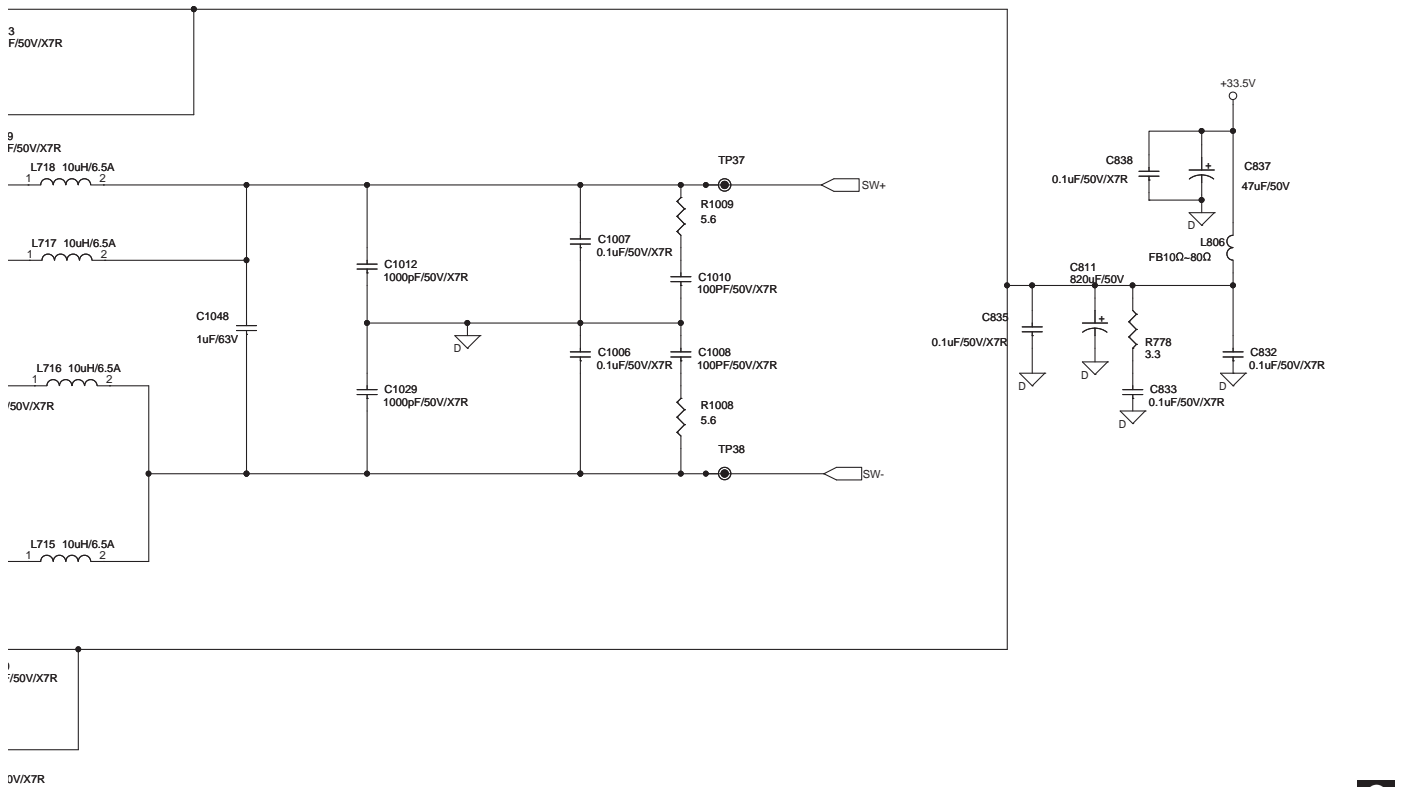

10.18 AV BOARD ASSY

D AV BOARD ASSY (AZW7613)

• Audio & Video BLOCK

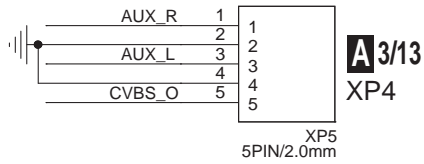
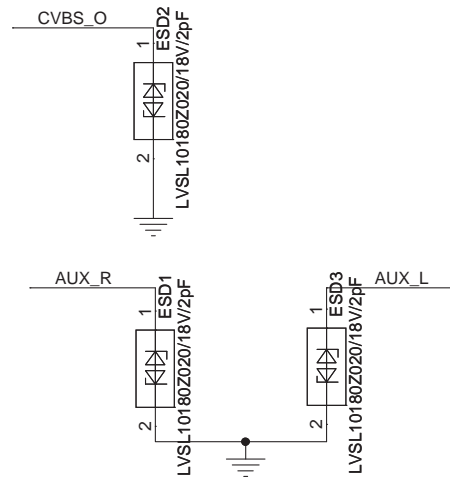
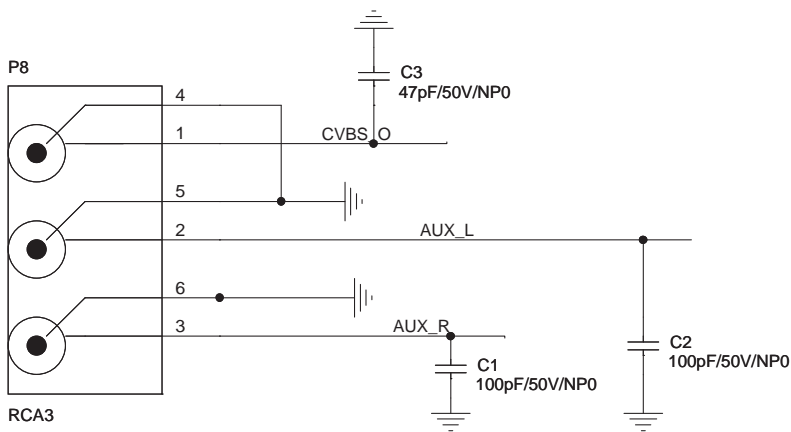

■

5

■

6

■

7

■

8

■

A

■

B

■

C

■

D

■

E

■

F

■

5

■

6

XV-BD422B

■

7

■

8

■

10.19 SYSTEM POWER SUPPLY ASSY

• NOTE FOR FUSE REPLACEMENT

CAUTION - FOR CONTINUED PROTECTION AGAINST RISK OF FIRE, REPLACE WITH SAME TYPE AND RATINGS OF FUSE.

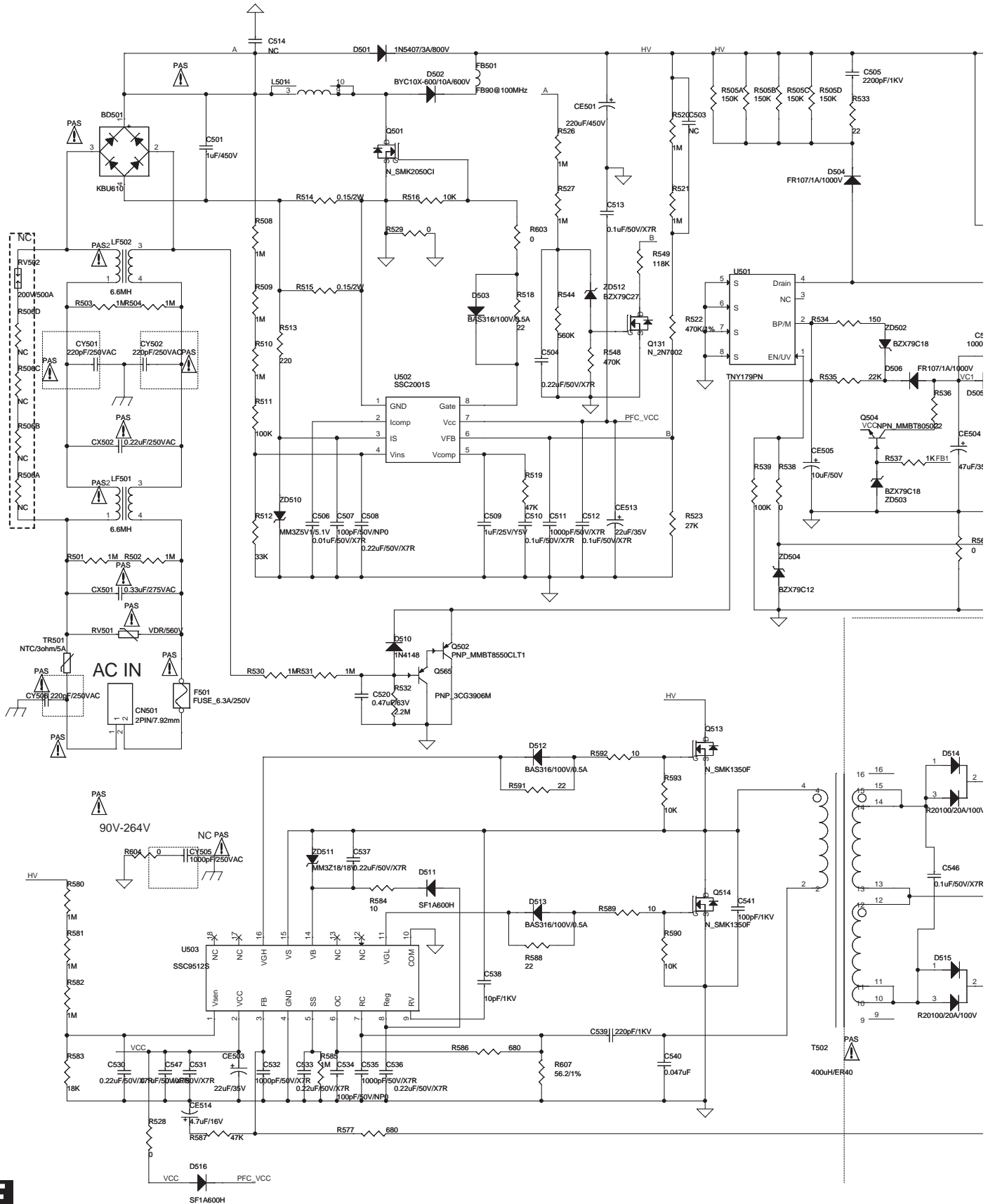

SYSTEM POWER SUPPLY ASSY (08-K250HE-PW1)

A
B
C
D
E
F

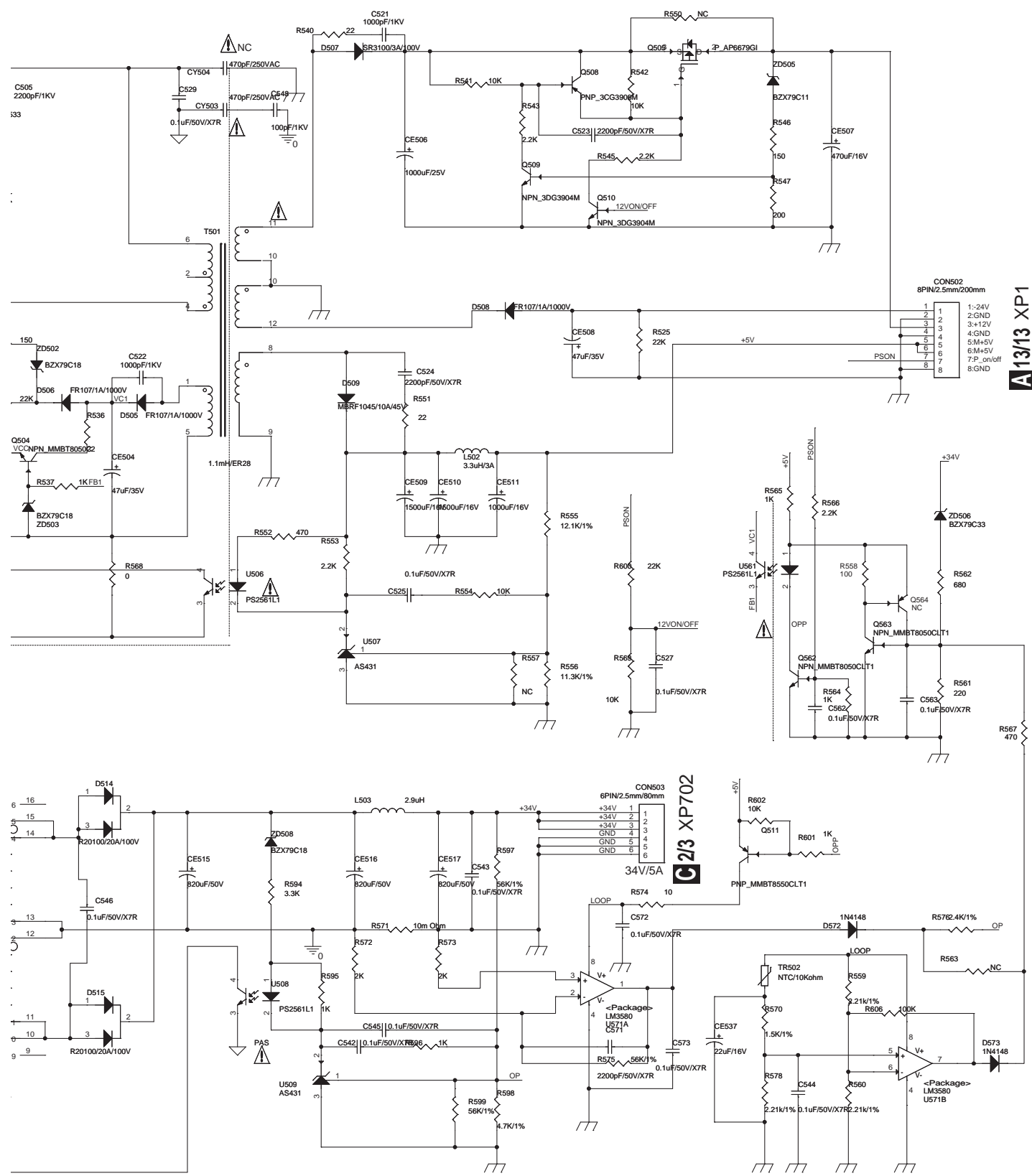

A13/13 XP1

C2/3 XP702



11. PCB CONNECTION DIAGRAM

11.1 MAIN BOARD ASSY

SIDE A

A MAIN BOARD ASSY

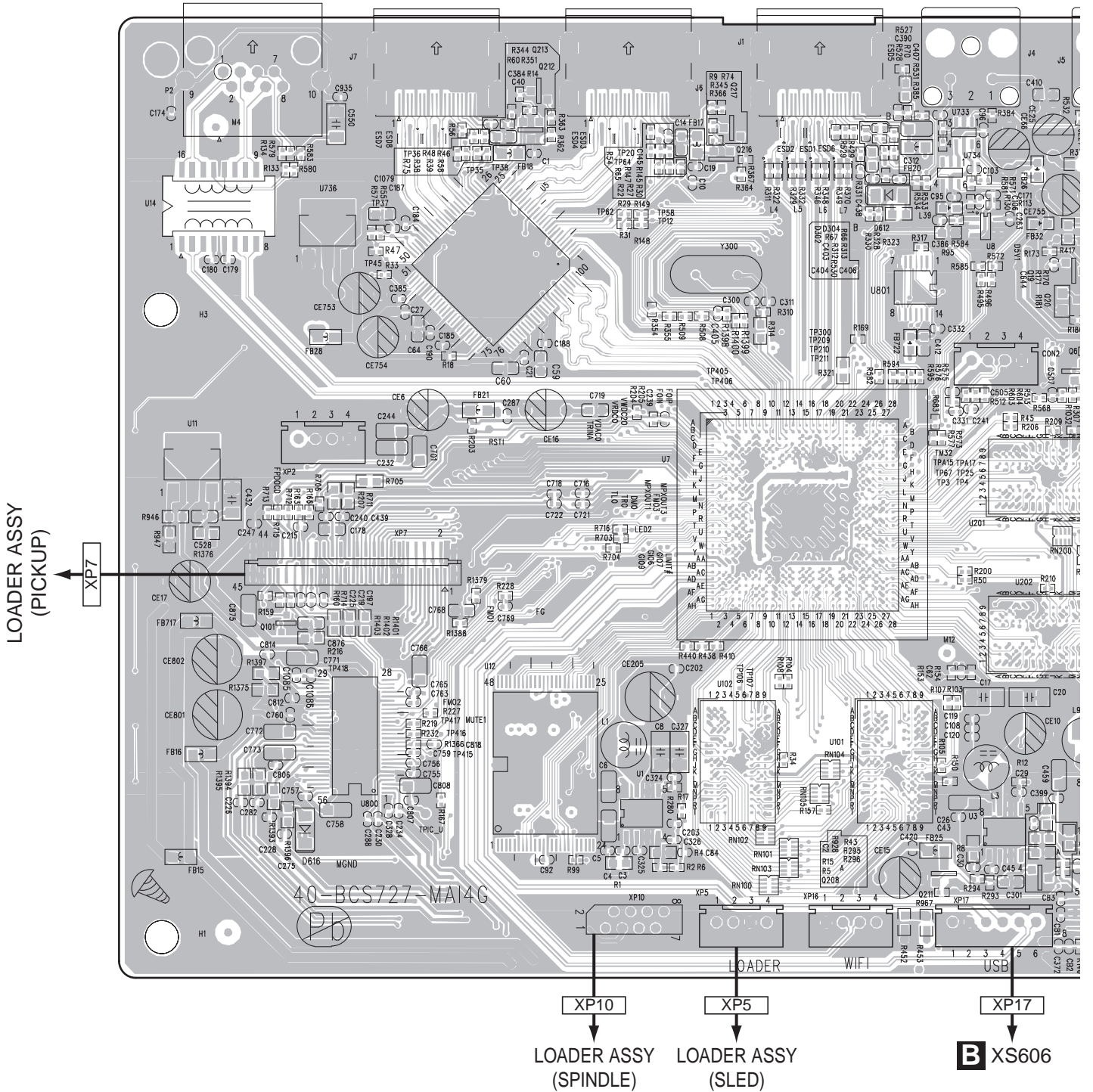

U14	Q213	Q217	U733
U11	Q212	U102	U8
Q101	U12	U7	U801
U800			U8
			U101
			Q211
			U3
			U201
			U202

A

SIDE A

A

D XP5

XP4

NOTE FOR PCB DIAGRAMS :

1. The parts mounted on this PCB include all necessary parts for several destinations. For further information for respective destinations, be sure to check with the schematic diagram.

2. View point of PCB diagrams.

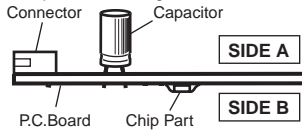

B

C

D

E

F

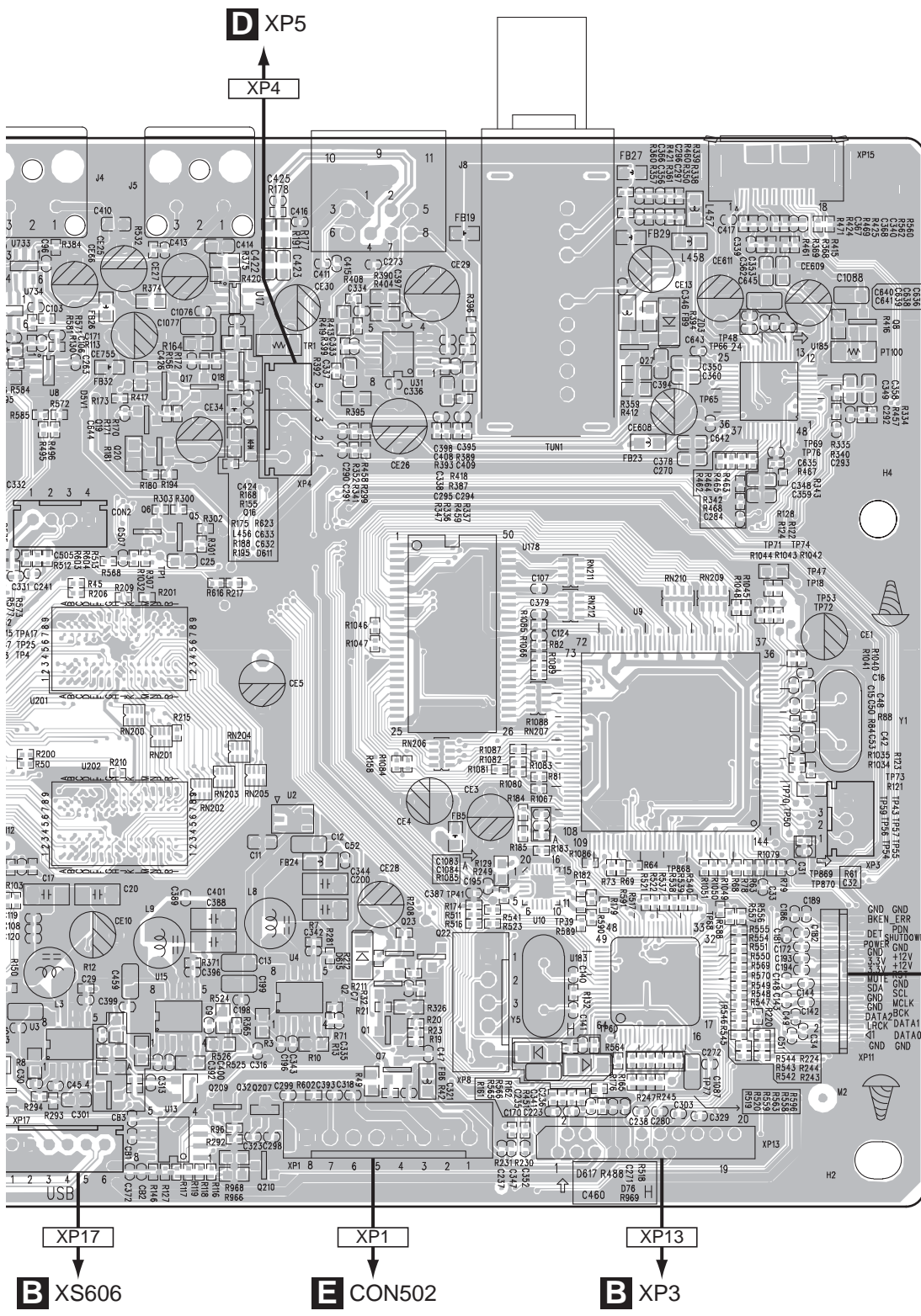

A

SIDE B

A

A MAIN BOARD ASSY

J8

XP4

B

C

D

E

F

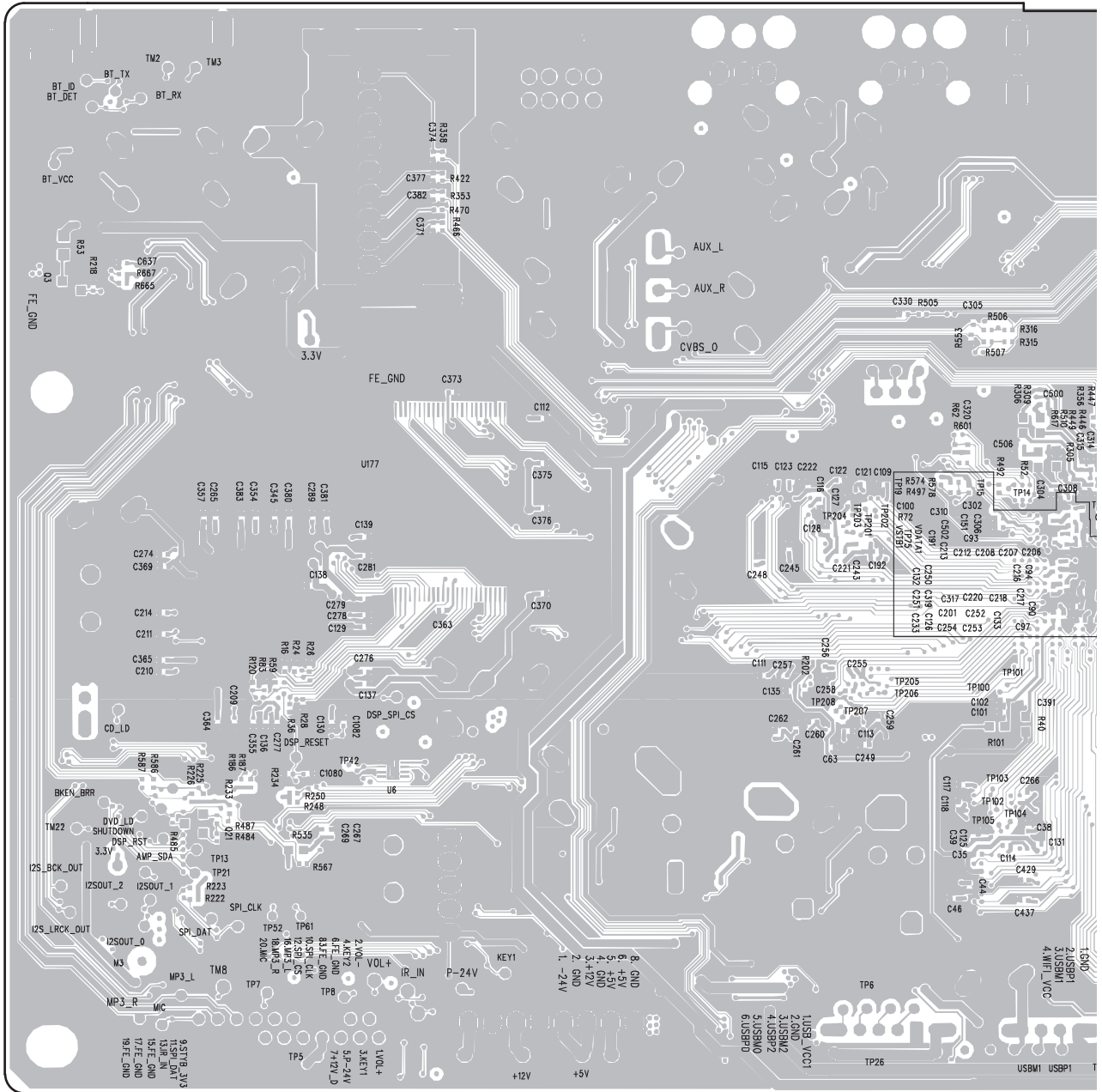

XP11

XP13

XP1

XP17

XP16

Q3

Q21

U177 U6

A

SIDE B

A

B

C

D

E

F

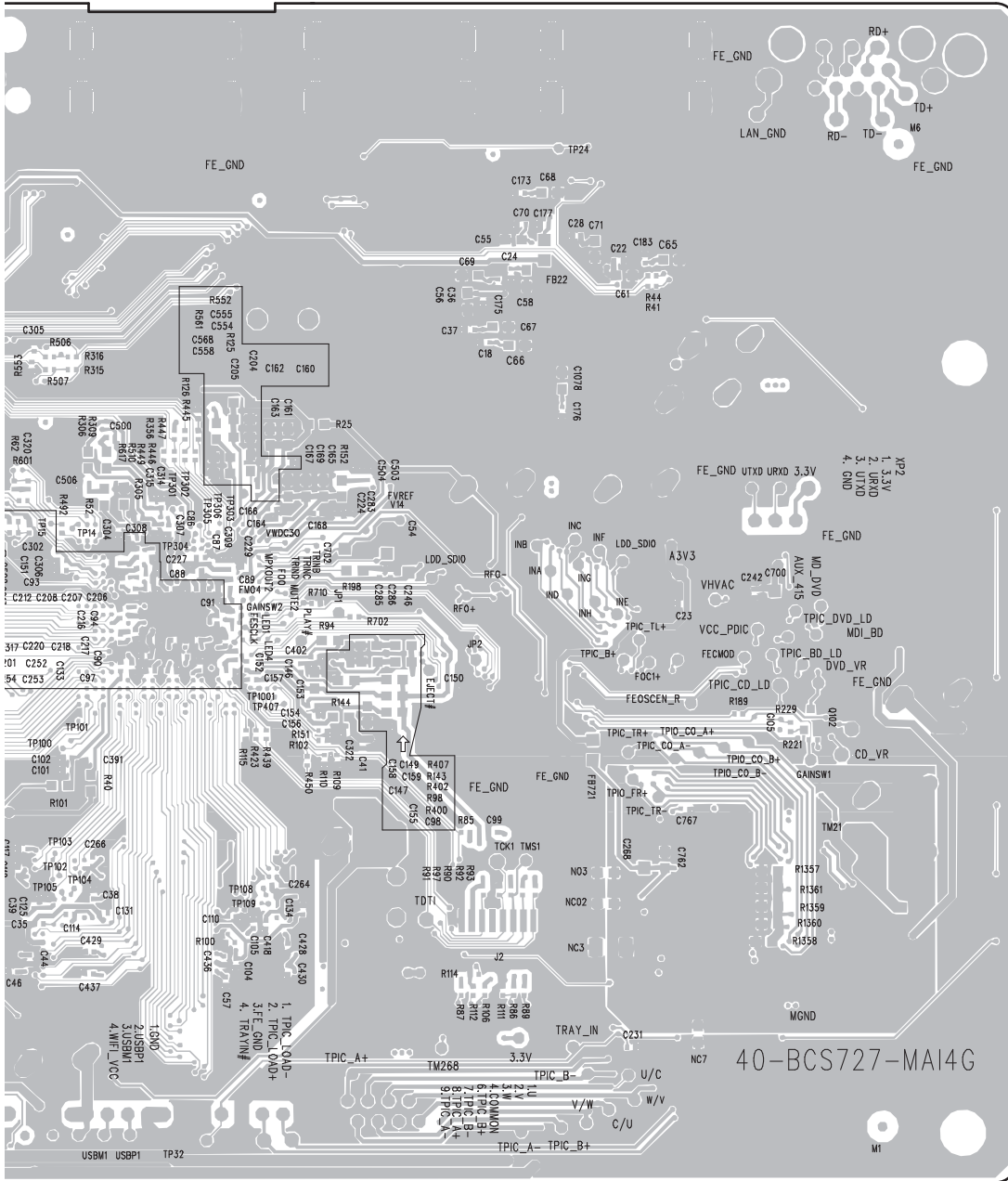

XP16

XP5

XP10

XP7

40-BCS727-MAI4G

Q102

XV-BD422B

A

11.2 FRONT BOARD ASSY

SIDE A

B FRONT BOARD ASSY

A XP13

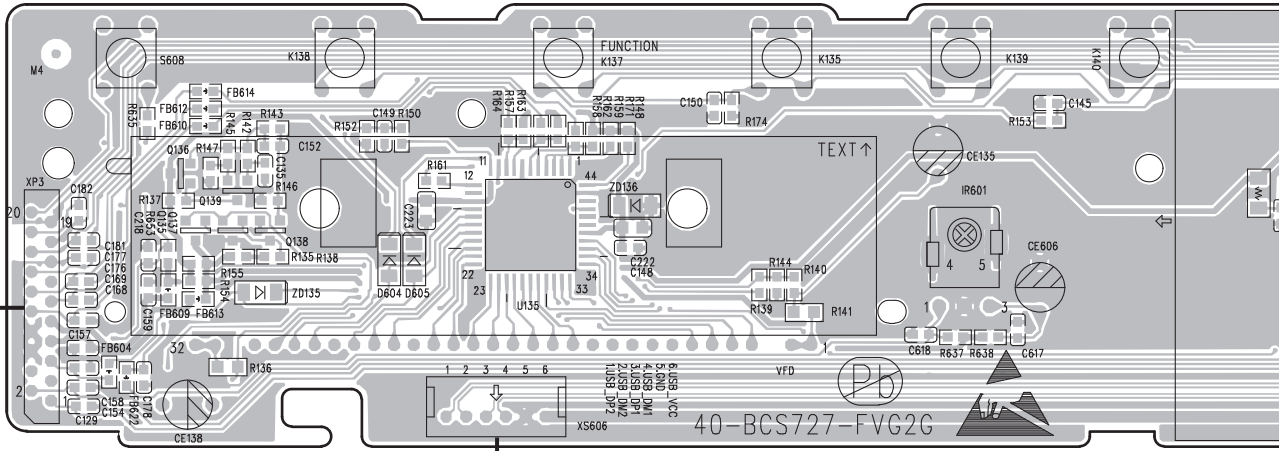

A XP17

Q136 Q139
Q135 Q137 Q138 U135

SIDE B

B FRONT BOARD ASSY

A XP3

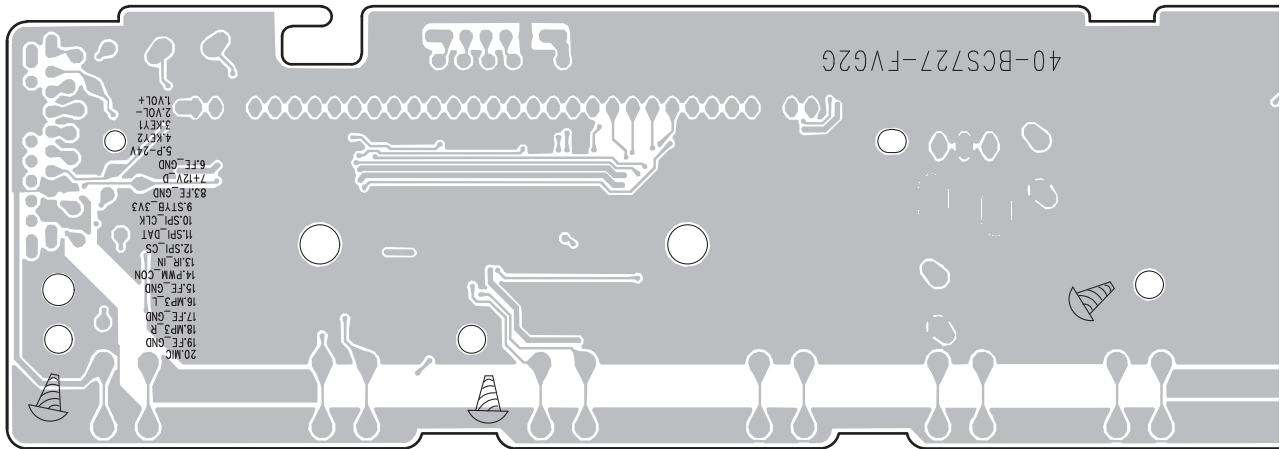

A XS606

B

SIDE A

A

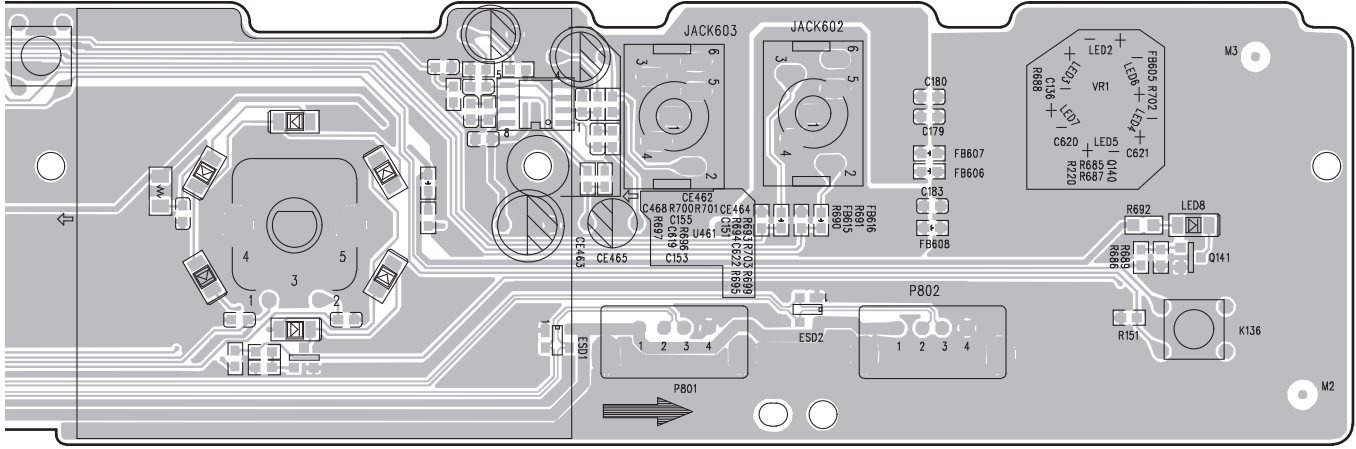

B

C

Q141

SIDE B

D

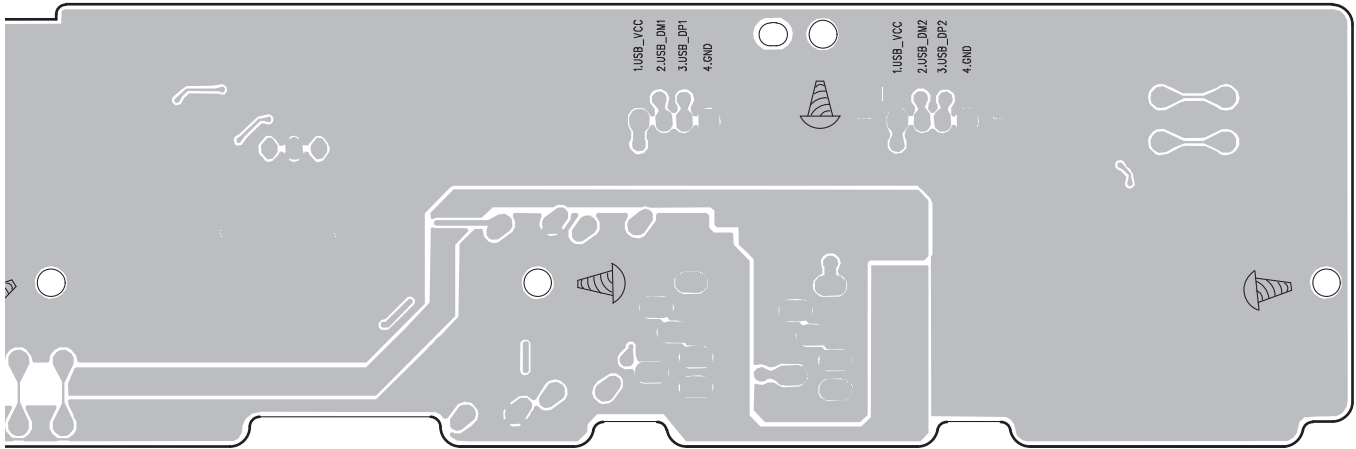

E

F

B

11.3 AMP and AV BOARD ASSYS

SIDE A

SIDE A

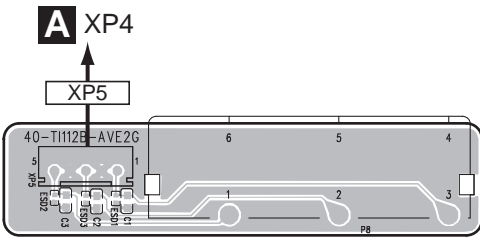

D AV BOARD ASSY

C AMP BOARD ASSY

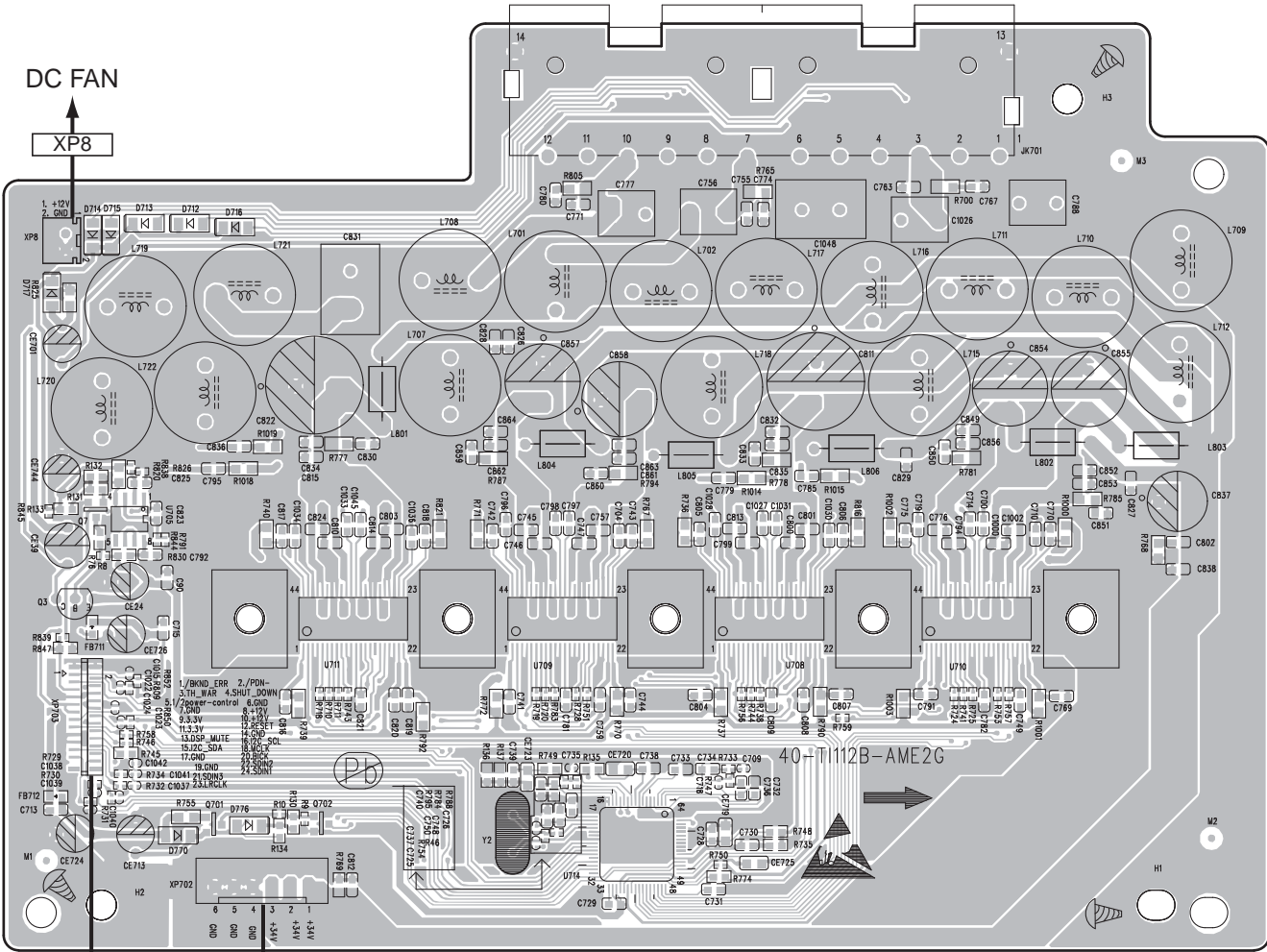

A XP11

E CON503

C D

SIDE B

SIDE B

A

XP5



D AV BOARD ASSY

C AMP BOARD ASSY

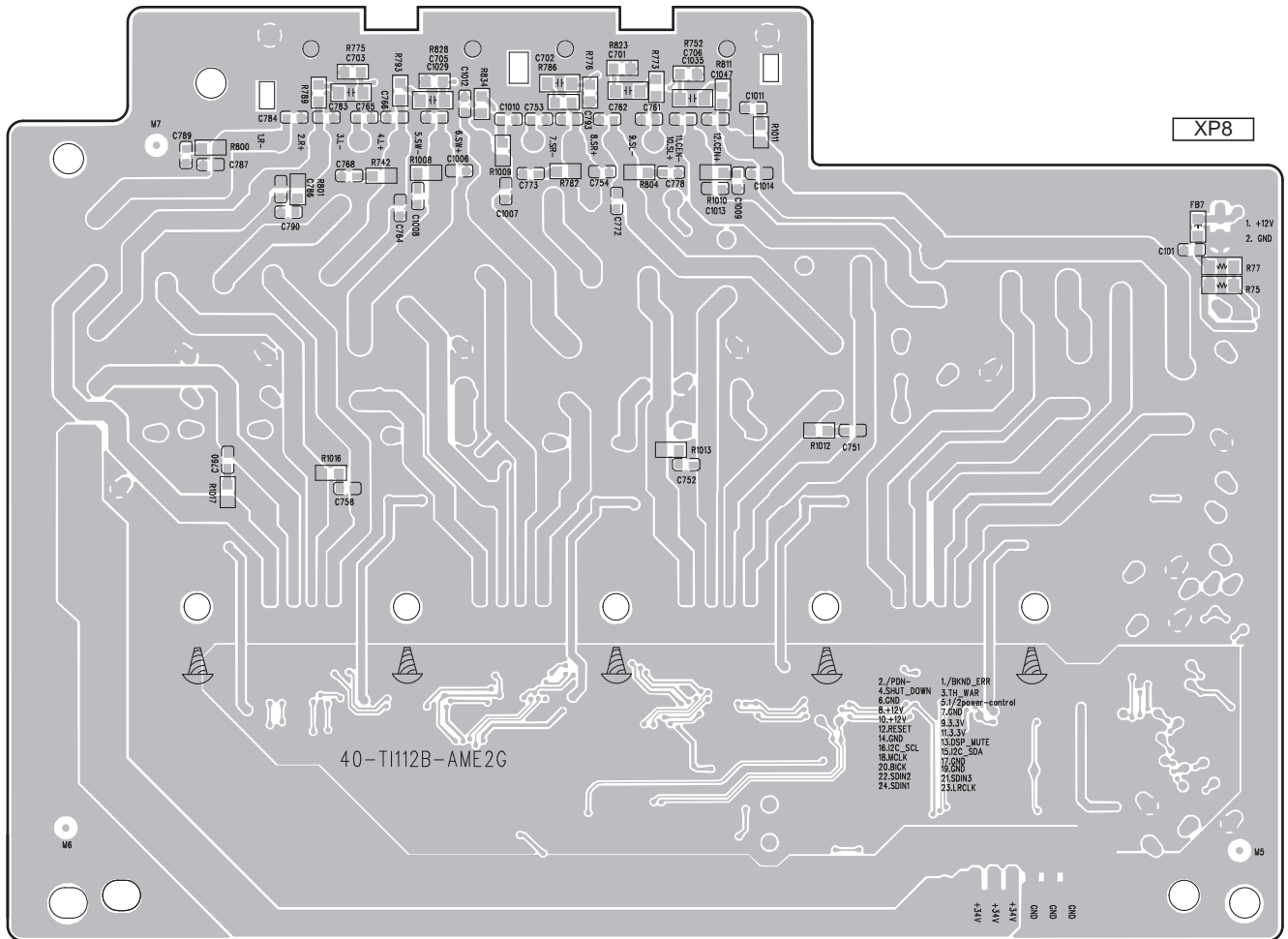

XP8

B

C

D

XP702

XP703

E

F

C D

11.4 SYSTEM POWER SUPPLY ASSY

SIDE A

SIDE A

E SYSTEM POWER SUPPLY ASSY

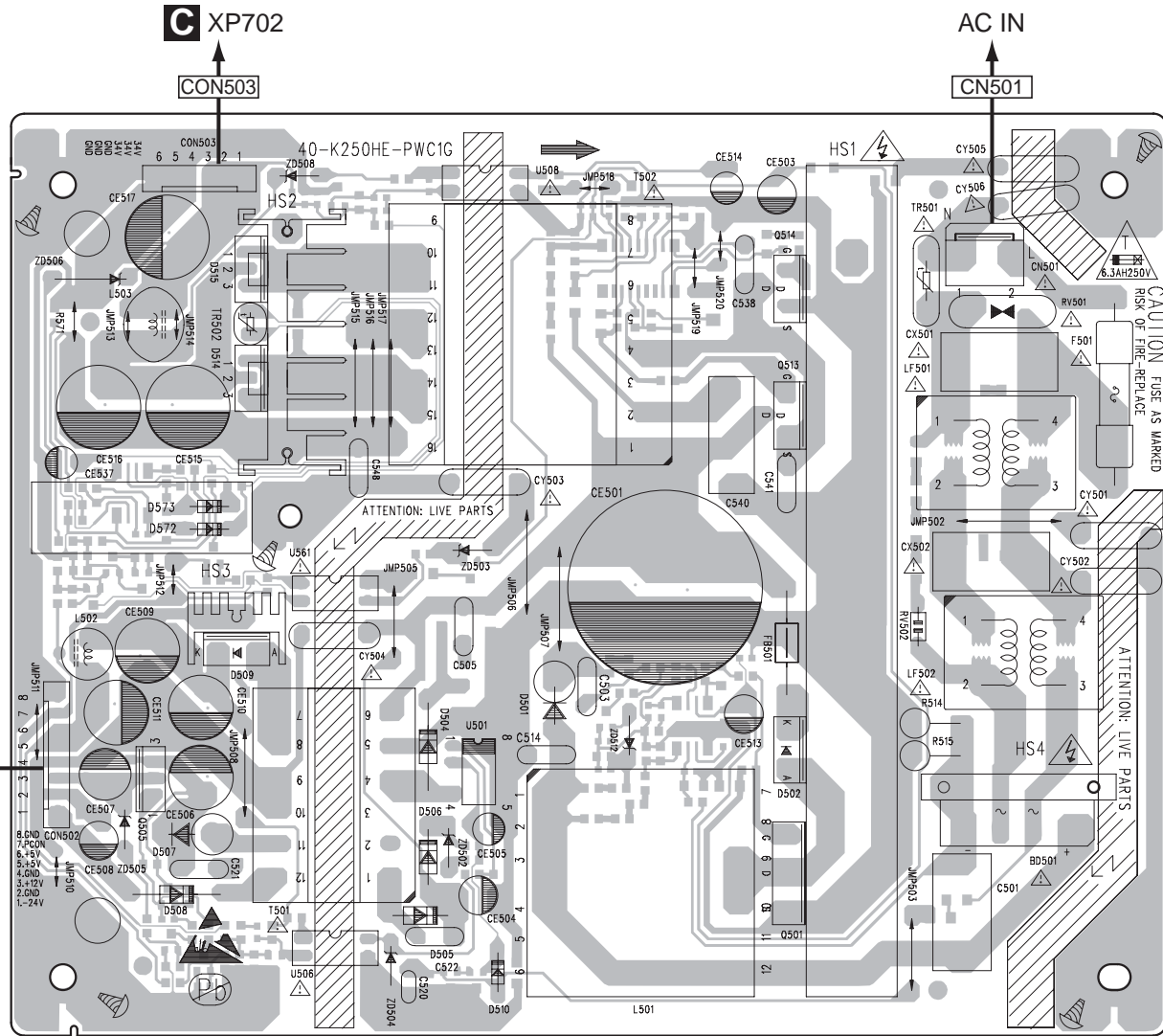

		U508	Q514
Q505		U501	Q513
	U506		Q501



SIDE B

SIDE B

SYSTEM POWER SUPPLY ASSY

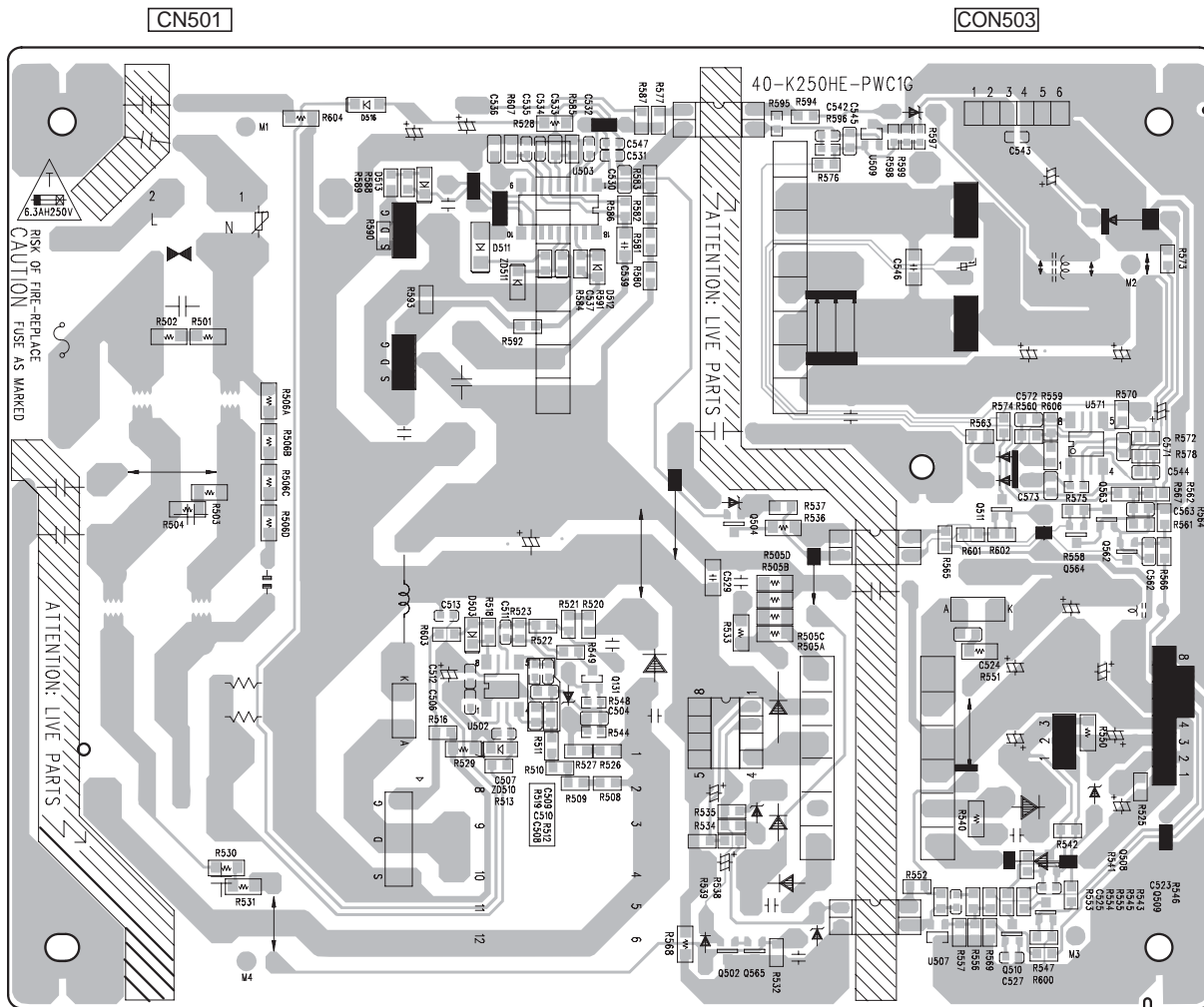

- U503
- Q504
- U509
- U571
- Q563
- Q564
- Q562
- U502
- Q131
- Q502
- Q565
- U507
- Q510
- Q508
- Q509

