

# Service Manual

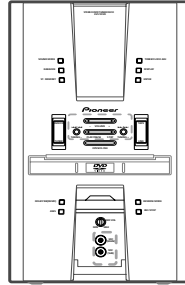

XV-EV51

ORDER NO.  
**RRV2636**

STEREO DVD TUNER DECK

# XV-EV51

## XV-EV21

**THIS MANUAL IS APPLICABLE TO THE FOLLOWING MODEL(S) AND TYPE(S).**

Model	Type	Power Requirement	Regional restriction codes (Region No.)	Remarks
XV-EV51	ZLXJ/NC	DC Power supplied from other system component	4	
XV-EV21	ZLXJ/NC	DC Power supplied from other system component	4	

**This product does not function properly independently; to avoid malfunctions, be sure to connect it to the prescribed system component(s), otherwise damage may result.**

Component	System	System	Service manual
MINI SYSTEM	EVA-5CH	EVA-2CH	
Stereo DVD Tuner Deck	XV-EV51	XV-EV21	RRV2636(This manual)
Stereo Power Amplifier	M-EV51	M-EV21	RRV2663(EV51), RRV2664(EV21)
Speaker System	S-EV51V	S-EV21V	RRV2640(EV51), RRV2641(EV21)



# SAFETY INFORMATION



This service manual is intended for qualified service technicians ; it is not meant for the casual do-it-yourselfer. Qualified technicians have the necessary test equipment and tools, and have been trained to properly and safely repair complex products such as those covered by this manual. Improperly performed repairs can adversely affect the safety and reliability of the product and may void the warranty. If you are not qualified to perform the repair of this product properly and safely, you should not risk trying to do so and refer the repair to a qualified service technician.

## WARNING !

THE AEL (ACCESSIBLE EMISSION LEVEL) OF THE LASER POWER OUTPUT IS LESS THAN CLASS 1 BUT THE LASER COMPONENT IS CAPABLE OF EMITTING RADIATION EXCEEDING THE LIMIT FOR CLASS 1.  
A SPECIALLY INSTRUCTED PERSON SHOULD DO SERVICING OPERATION OF THE APPARATUS.

## LASER DIODE CHARACTERISTICS

FOR DVD : MAXIMUM OUTPUT POWER : 5 mW  
WAVELENGTH : 650 nm  
FOR CD : MAXIMUM OUTPUT POWER : 5 mW  
WAVELENGTH : 780 nm

## LABEL CHECK

**CAUTION** : VISIBLE AND INVISIBLE LASER RADIATION WHEN OPEN. AVOID EXPOSURE TO BEAM.  
**VORSICHT** : SICHTBARE UND UNSICHTBARE LASERSTRAHLUNG, WENN ABDECKUNG GEÖFFNET  
NICHT DEM STRAHL AUSSETZEN!  
**ADVARSEL** : SYNLIG OG USYNLIG LASERSTRÅLING VED ÅBNING UND GÅ UDSÆTTELSE FOR STRÅLING.  
**VARNING** : SYNLIG OCH OSYNLIG LASERSTRÅLNING NÄR DENNA DEL ÄR ÖPPNAD. BETRÄKTA EJ STRÅLEN.  
**VARO!** : AVATTAESSA ALTIKUT NÄKYVÄ JA NÄKYMÄTTÖMÄLLE LASERSATEIL YLLE. ÄLÄ KATSO SÄTEESÄ.  
VWV1699

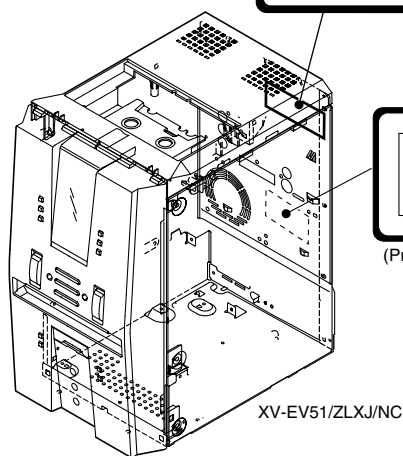

**CLASS 1  
LASER PRODUCT**

(Printed on the Rear Panel A)

## Additional Laser Caution

- Laser Interlock Mechanism**
  - Loading switch (S101 on the LOAB Assy) is used for interlock mechanism of the laser.  
When this switch turned ON in SW2 (XCLOSE) side (OPEN signal is 0V and XCLOSE signal is 3.5V), a laser becomes the status which can completely oscillation.  
Furthermore, the laser completely oscillates in the disc judgment and disc playback.  
When player is power ON state and laser diode is not completely oscillating, 780nm laser diode is always oscillating by half power.
  - Laser diode is driving with Q101 (650nm LD) and Q102 (780nm LD) on the DVDM Assy.  
Therefore, when short-circuit between the emitter and collector of these transistors or the base voltage is supplied for transistors turn on, the laser oscillates. (failure mode)
  - In the test mode \*, there is the mode that the laser oscillates except for the disc judgment and playback. LD ON mode in the test mode oscillates with the laser forcibly.  
The interlock mechanism mentioned above becomes invalid in this mode.
- When the cover is open, close viewing through the objective lens with the naked eye will cause exposure to the laser beam.

\* : See page 80.

### [ Important symbols for good services ]

In this manual, the symbols shown-below indicate that adjustments, settings or cleaning should be made securely. When you find the procedures bearing any of the symbols, be sure to fulfill them:

#### 1. Product safety



You should conform to the regulations governing the product (safety, radio and noise, and other regulations), and should keep the safety during servicing by following the safety instructions described in this manual.

#### 2. Adjustments



To keep the original performances of the product, optimum adjustments or specification confirmation is indispensable. In accordance with the procedures or instructions described in this manual, adjustments should be performed.

#### 3. Cleaning



For optical pickups, tape-deck heads, lenses and mirrors used in projection monitors, and other parts requiring cleaning, proper cleaning should be performed to restore their performances.

#### 4. Shipping mode and shipping screws



To protect the product from damages or failures that may be caused during transit, the shipping mode should be set or the shipping screws should be installed before shipping out in accordance with this manual, if necessary.

#### 5. Lubricants, glues, and replacement parts



Appropriately applying grease or glue can maintain the product performances. But improper lubrication or applying glue may lead to failures or troubles in the product. By following the instructions in this manual, be sure to apply the prescribed grease or glue to proper portions by the appropriate amount. For replacement parts or tools, the prescribed ones should be used.

## Discs compatible with this player

Any disc that displays one of the following logos should play in this player. Other formats, including DVD-Audio, DVD-RAM, DVD-ROM, CD-ROM (except those that contain MP3 files), SACD and Photo CD will not play.



DVD-Video



Audio-CD



Video-CD



CD-R \*



CD-RW \*

\* : Video Mode Only

# CONTENTS

	SAFETY INFORMATION .....	2
	1. SPECIFICATIONS .....	5
A	2. EXPLODED VIEWS AND PARTS LIST .....	6
	2.1 PACKING .....	6
	2.2 EXTERIOR SECTION.....	8
	2.3 FRONT PANEL SECTION .....	10
	2.4 LOADING MECHANISM ASSY .....	12
	2.5 TRAVERSE MECHANISM ASSY.....	14
	3. BLOCK DIAGRAM AND SCHEMATIC DIAGRAM .....	16
	3.1 BLOCK DIAGRAM .....	16
	3.2 OVERALL WIRING DIAGAM .....	20
	3.3 FM/AM TUNER MODULE .....	24
	3.4 IF ASSY .....	26
	3.5 AF ASSY(1/2) .....	28
B	3.6 AF ASSY(2/2) .....	30
	3.7 DECK ASSY .....	32
	3.8 DVDM ASSY(1/2).....	34
	3.9 DVDM ASSY(2/2).....	36
	3.10 DVD IF ASSY .....	38
	3.11 DISP1, DISP2, DISP3 and LED ASSYS .....	40
	3.12 DSP ASSY .....	42
	3.13 MIC ASSY .....	44
	4. PCB CONNECTION DIAGRAM .....	46
	4.1 LOAB ASSY .....	46
	4.2 FM/AM TUNER MODULE .....	47
	4.3 DVDM ASSY .....	48
C	4.4 DVD IF ASSY .....	52
	4.5 IF ASSY .....	54
	4.6 AF ASSY .....	56
	4.7 DECK ASSY .....	58
	4.8 DISP1, DISP2, DISP3 and LED ASSYS .....	60
	4.9 MIC ASSY .....	62
	4.10 DSP ASSY(XV-EV51 Only).....	63
	5. PCB PARTS LIST .....	64
	6. ADJUSTMENT .....	72
	6.1 DECK SECTION .....	72
	6.1.1 Adjustment condition .....	72
	6.1.2 Playback and Recording section .....	73
D	6.2 TUNER SECTION .....	75
	6.3 DVD SECTION ADJUSTMENT ITEMS ana LOCATION.....	76
	6.4 JIGS and MEASURING INSTRUMENTS .....	76
	6.5 NECESSARY ADJUSTMENT POINTS .....	77
	6.6 TEST MODE .....	78
	6.7 MECHANISM ADJUSTMENT .....	79
	7. GENERAL INFORMATION .....	82
	7.1 DIAGNOSIS .....	82
	7.2 PARTS.....	101
	7.3 CLEANING.....	120
	8. PANEL FACILITIES .....	121

# 1. SPECIFICATIONS

## Specifications

### Amplifier Section

X-EV51DVD model

Continuous Power Output:

Front ..... 80 W per channel  
(1kHz, 10 %, 8 Ω)  
Center ..... 33 W (1kHz, 10 %, 8 Ω)  
Surround ..... 33 W per channel  
(1kHz, 10 %, 8 Ω)

X-EV21DVD model

Continuous Power (RMS) ..... 80 W + 80 W  
(1 kHz, THD 10%, 8Ω)

### Disc section

Digital audio characteristics ..... DVD fs: 96 kHz, 24-bit  
Type ..... DVD system, Video CD system and  
Compact Disc digital audio system  
Frequency response ..... 4 Hz to 44 kHz  
S/N ratio ..... 95 dB  
Dynamic range ..... 95 dB  
Total harmonic distortion ..... 0.005 %  
Wow and Flutter ..... Limit of measurement  
(±0.001 % W.PEAK) or less (EIAJ)

### Cassette deck section

Systems ..... 4 track, 2-channel stereo  
Heads ..... Recording/playback head x 1  
Erasing head x 1  
Motor ..... DC servo motor x 1  
Tape types ..... TYPE I (Normal)

### FM tuner section

Frequency Range ..... 87.5 - 108MHz  
Antenna ..... 75Ω, unbalanced

### AM tuner section

Frequency Range  
With 9 kHz step ..... 531 kHz to 1,602 kHz  
With 10 kHz step ..... 530 kHz to 1,700 kHz  
Antenna ..... Loop antenna

*Manufactured under license from Dolby Laboratories. "Dolby", "Pro Logic", and the double-D symbol are trademarks of Dolby Laboratories.*

*"DTS" and "DTS Digital Surround" are registered trademarks of Digital Theater Systems, Inc. Manufactured under license from Digital Theater Systems, Inc.*

### Miscellaneous

Power Requirements

Multi voltage model ..... AC 110-127/ 220-230/  
240V(switchable), 50/60 Hz

Power Consumption

X-EV51DVD model

Singapore, Malaysia, Hong Kong models ..... 175 W  
All other model ..... 465 W

X-EV21DVD model

Singapore, Malaysia models ..... 150 W  
All other model ..... 540 W

Power Consumption in standby mode ..... 1 W

Dimensions:

DVD Tuner Deck ..... 170 (W) x 292.5(H)  
x 260 (D) mm  
Power Amplifier ..... 170 (W) x 190 (H)  
x 254 (D) mm

Weight:

DVD Tuner Deck  
XV-EV51 ..... 3.6 kg  
XV-EV21 ..... 3.5 kg  
Power Amplifier  
M-EV51 ..... 5.3 kg  
M-EV21 ..... 4.8 kg

### Accessories (Stereo DVD Tuner Deck)

Operating instructions ..... 2

### Accessories (Stereo Power Amplifier)

Remote control ..... 1  
Power cord  
Australian, New Zealand, Central  
and South American models ..... 2  
All other models ..... 1  
Power plug adapter (excluding Singapore,  
Hong Kong and Malaysian models) ..... 1  
Video cord ..... 1  
System cable (EV51DVD) ..... 2  
System cable (EV21DVD) ..... 1  
FM antenna ..... 1  
AM loop antenna ..... 1  
Dry cell batteries (AA/R6) ..... 2

### Note

- Specifications and design subject to possible modification without notice, due to improvements.

## Accessories

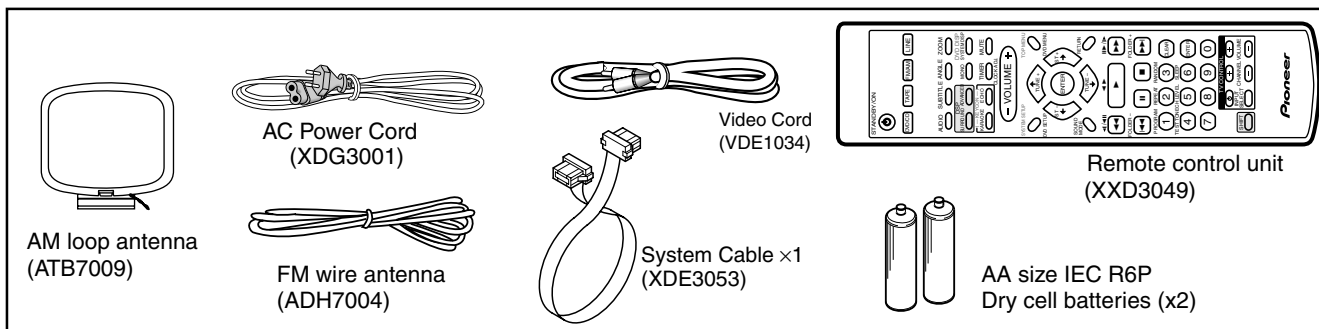

# 2. EXPLODED VIEWS AND PARTS LIST

- NOTES:
- Parts marked by "NSP" are generally unavailable because they are not in our Master Spare Parts List.
  - The  $\triangle$  mark found on some component parts indicates the importance of the safety factor of the part. Therefore, when replacing, be sure to use parts of identical designation.
  - Screws adjacent to  $\blacktriangledown$  mark on product are used for disassembly.
  - For the applying amount of lubricants or glue, follow the instructions in this manual.  
(In the case of no amount instructions, apply as you think it appropriate.)

## 2.1 PACKING

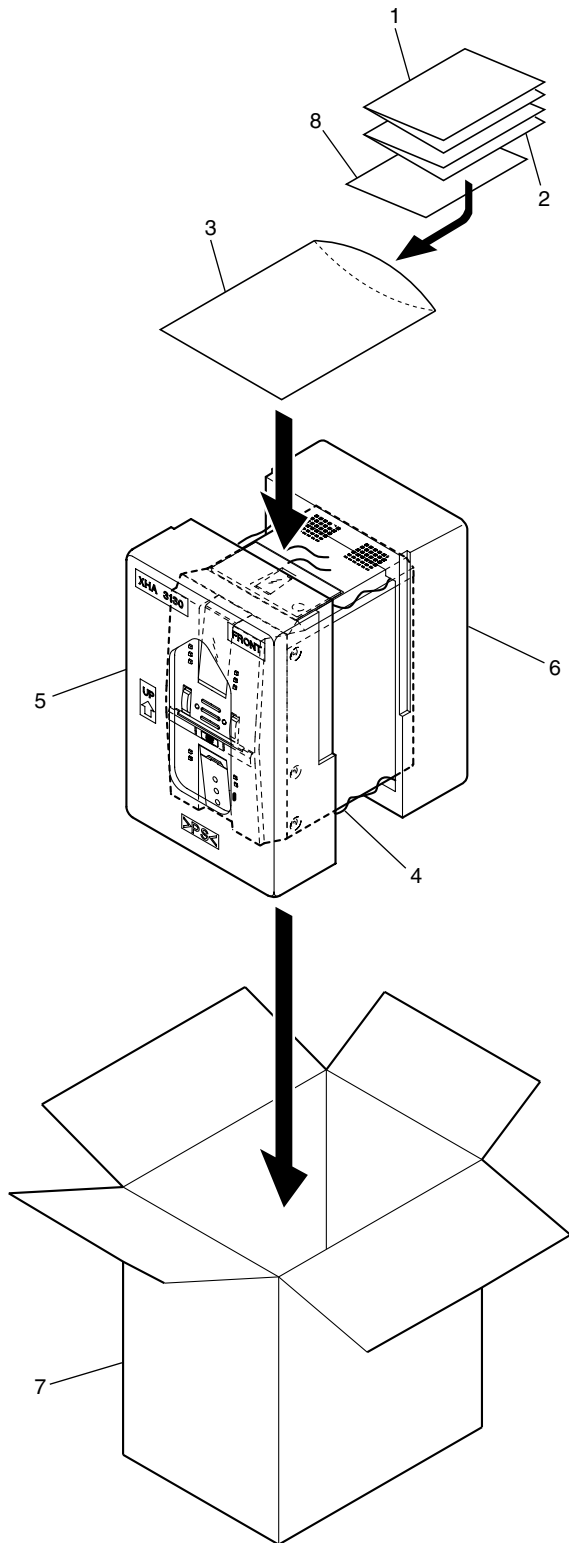

**PACKING parts List**

<u>Mark No.</u>	<u>Description</u>	<u>Part No.</u>	<u>Mark No.</u>	<u>Description</u>	<u>Part No.</u>
1	Operating Instructions (English)	XRB3017	5	Front Pad M	XHA3130
2	Operating Instructions (Chinese)	XRC3073	6	Rear Pad M	XHA3131
NSP 3	Polyethylene Bag (0.03 x 230 x 340)	Z21-038	7	Packing Case	See Contrast table (2)
4	Packing Sheet	AHG7053	8	Correct Sheet	XRH3007

**(2) CONTRAST TABLE**

XV-EV51/ZLXJ/NC and XV-EV21/ZLXJ/NC are constructed the same except for the following :

Mark	No.	Symbol and Description	XV-EV51/ZLXJ/NC	XV-EV21/ZLXJ/NC
	7	Packing Case	XHD3305	XHD3308





## EXTERIOR SECTION parts List

Mark No.	Description	Part No.	Mark No.	Description	Part No.
1	FM/AM TUNER Module	AXQ7228	27	Deck Lens	XAK3327
2	IF Assy	See Contrast table (2)	28	Deck Door	XAN3047
3	AF Assy	See Contrast table (2)	29	Ratch Mold	XMR3001
4	DECK Assy	See Contrast table (2)	30	Side Bonnet L	XNE3026
5	DVDM Assy	AWM7684	31	Side Bonnet R	XNE3027
6	DVD IF Assy	AWM7677	32	Binder	ZCA-SKB90BK
7	DSP Assy	See Contrast table (2)	33	Tray Cap	XAK3325
8	DECK Mechanism Unit	XYM3015	34	DVD Badge	XAK3331
NSP 9	LOADING MECHA Assy	VWT1203	35	Top Panel	XAK3326
10	DC Fan Motor	AXM7025	NSP 36	Front Panel Assy	See Contrast table (2)
NSP 11	Earth Lead Wire	DE012VF0	NSP 37	Top Panel Assy	XXG3131
12	11P Flat Flexible Cable	XDD3114	38	Screw	VPZ30P080FZK
13	13P Flat Flexible Cable	XDD3115	39	Screw	BBZ30P080FZK
14	30P Flat Flexible Cable	XDD3116	40	Screw	BBZ30P080FMC
15	16P Flat Flexible Cable	XDD3117	41	Screw	BPZ30P350FZK
16	Connector Assy 5P	XDE3055	42	Screw	VPZ30P080FNI
NSP 17	Chassis	XNA3011	43	Screw	BBZ30P080FNI
18	Rear Panel A	See Contrast table (2)	44	Adapter 02 L	ANW7247
19	Rear Panel B	See Contrast table (2)	45	Adapter 02 R	ANW7248
20	Mecha Frame	XNG3082	46	Shield Case	ANK7108
21	DVD Shield	XNG3083	47	Heat plate	ANG7426
22	GND Plate	XNG3084	48	Radiation Sheet	AEB7255
23	Ratch Spring	ABH7130	49	Cushion	AEB7267
24	Damper Assy	AXA7052	50	FFC Barrier	AEC7443
25	Door Spring L	XBH3010	51	FFC Spacer	AEC7442
26	Leg Cushion	XEB3028	52	Caution Label	VRW1699

### (2) CONTRAST TABLE

XV-EV51/ZLXJ/NC and XV-EV21/ZLXJ/NC are constructed the same except for the following :

Mark	NO	Symbol and Description	XV-EV51/ZLXJ/ NC	XV-EV21/ZLXJ/NC
	2	IF Assy	XWZ3617	XWZ3627
	3	AF Assy	XWZ3618	XWZ3628
	4	DECK Assy	XWX3067	XWX3066
	7	DSP Assy	AWX8059	Not used
	18	Rear Panel A	XNC3160	XNC3180
	19	Rear Panel B	XNC3161	XNC3176
NSP	37	Front Panel Assy	XXG3129	XXG3130



## FRONT PANEL SECTION parts List

<u>Mark No.</u>	<u>Description</u>	<u>Part No.</u>	<u>Mark No.</u>	<u>Description</u>	<u>Part No.</u>
1	DISP 1 Assy	XWZ3619	21	Display Button L	XAD3149
2	DISP 2 Assy	XWZ3620	22	Display Button R	XAD3150
3	DISP 3 Assy	XWZ3621	23	Play Button	XAD3151
4	LED Assy	XWZ3622	24	Dolby Button L	XAD3154
5	MIC Assy	See Contrast table (2)	25	Dolby Button R	XAD3155
6	LED (D5107, D5108)	NSPWF50BS-9706	26	FUNC. Button L	XAD3152
7	LCD	XAV3016	27	FUNC. Cover L	XAK3328
8	11P Flat Flexible Cable	XDD3113	28	FUNC. Button R	XAD3153
9	LCD Holder	XMR3052	29	FUNC. Cover R	XAK3329
10	MIC Knob	XAA3024	30	Front Panel M	See Contrast table (2)
11	Diffusion Sheet	XAK3321	31	Damper Assy	XXA3029
12	Display Window	See Contrast table (2)	32	Leg Cushion	XEB3028
13	LCD LT Cond	XAK3323	33	Screw	VPZ30P080FZK
14	LCD Cover	XAK3324	34	FUNC. Assy R	XAD3158
15	Sensor Cover	XAK3330	35	FUNC. Assy L	XAD3157
16	Tray Lens	XAK3332	36	Cushion	XEB3004
17	FUNC. LT Cond	XAK3333	37	Gap Cover	XMR3055
18	LT Cond	XAK3334	38	Magnet	XMF3003
19	LT Cover	XAK3335	39	Screw 2x4 B	XBA3011
20	Jack Door	XAN3048			

## (2) CONTRAST TABLE

XV-EV51/ZLXJ/NC and XV-EV21/ZLXJ/NC are constructed the same except for the following :

Mark	No.	Symbol and Description	XV-EV51/ZLXJ/NC	XV-EV21/ZLXJ/NC
	5	MIC Assy	XWZ3626	XWZ3623
	12	Display Window	XAK3322	XAK3343
	30	Front Panel M	XMB3084	XMB3089

## 2.4 LOADING MECHANISM ASSY

### Note :



Refer to  
"Application of Lubricant".

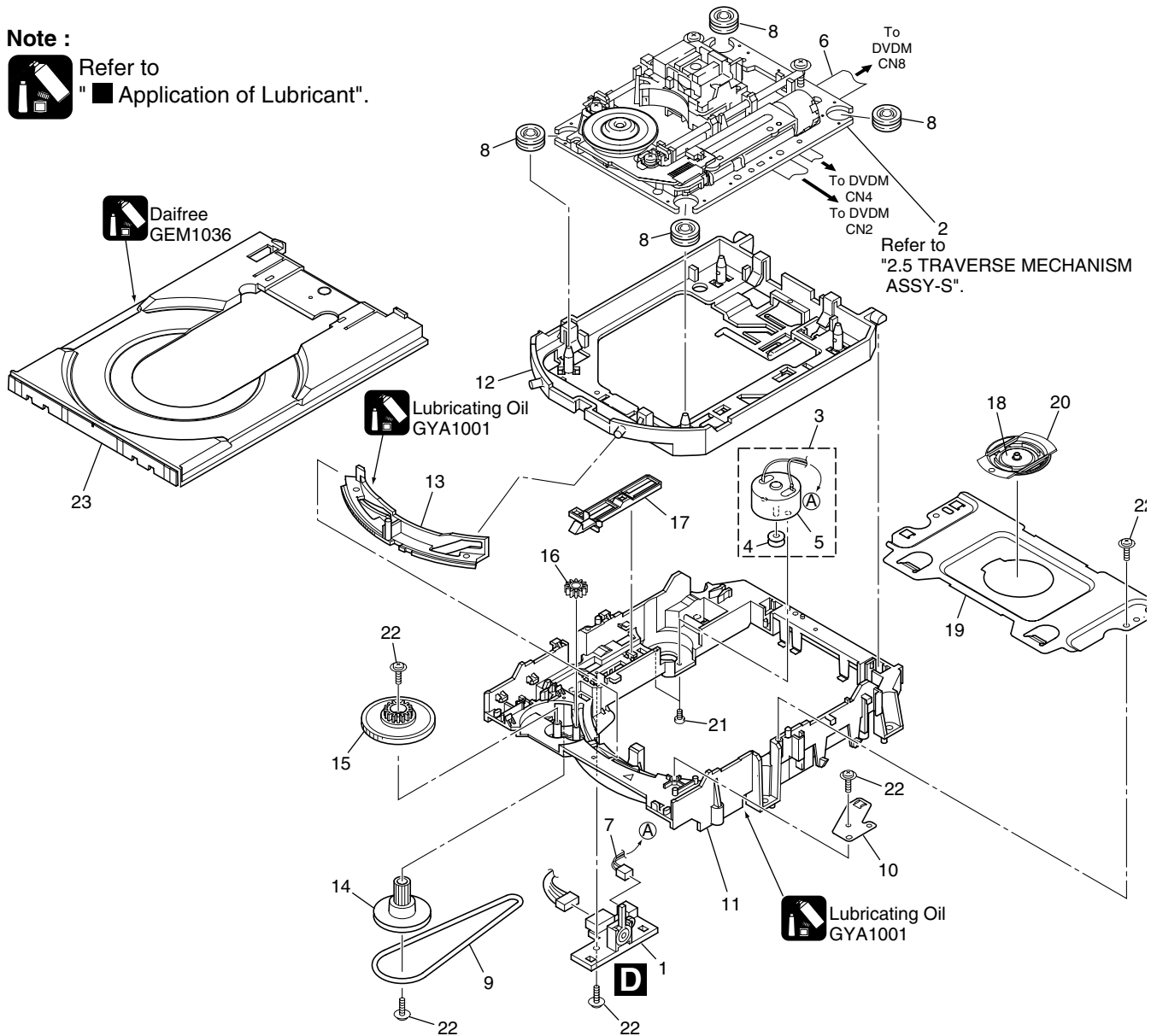

### LOADING MECHANISM ASSY parts List

Mark No.	Description	Part No.	Mark No.	Description	Part No.
NSP 1	LOAB Assy	VWG2346	16	Drive Gear	VNL1923
2	Traverse Mechanism Assy-S	VXX2858	17	SW Lever	VNL1925
3	Loading Motor Assy	VXX2505	18	Clamper Plate	VNE2251
4	Motor Pulley	PNW1634	19	Bridge	VNE2252
5	Carriage DC Motor / 0.3W	PXM1027	20	Clamper	VNL1924
6	Flexible Cable (26P)	VDA1864	21	Screw	JGZ17P028FMC
7	Connector Assy 2P	VKP2253	22	Screw	Z39-019
8	Float Rubber	VEB1327	23	Tray	VNL1920
9	Belt	VEB1330			
10	Stabilizer	VNE2253			
11	Loading Base	VNL1917			
12	Float Base DVD	VNL1918			
13	Drive Cam	VNL1919			
14	Gear Pulley	VNL1921			
15	Loading Gear	VNL1922			

# Application of Lubricant

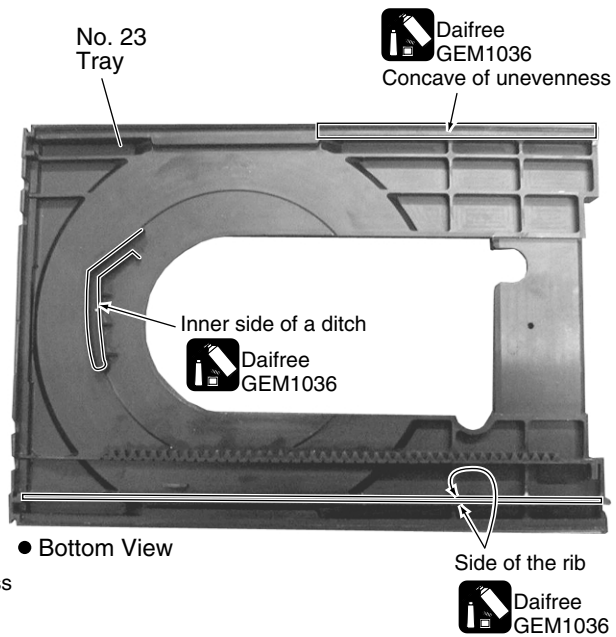
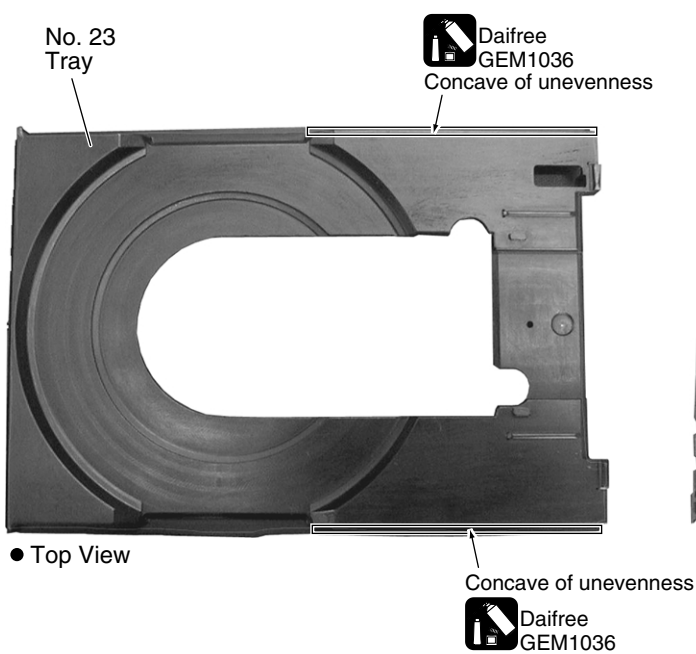
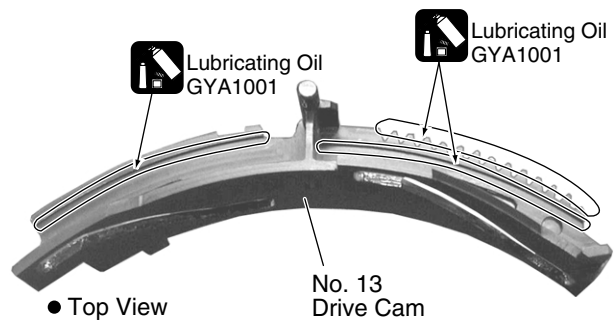
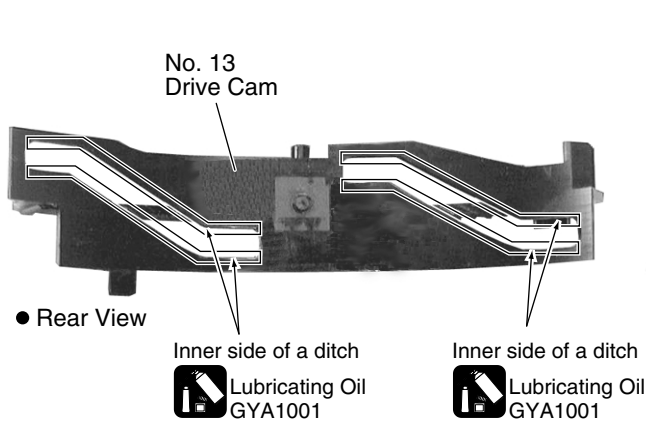
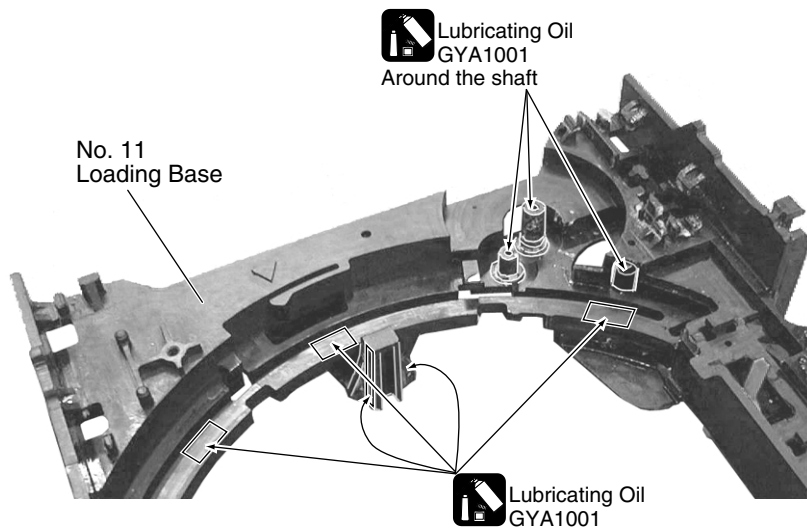

# 2.5 TRAVERSE MECHANISM ASSY

A

B

C

D

E

F

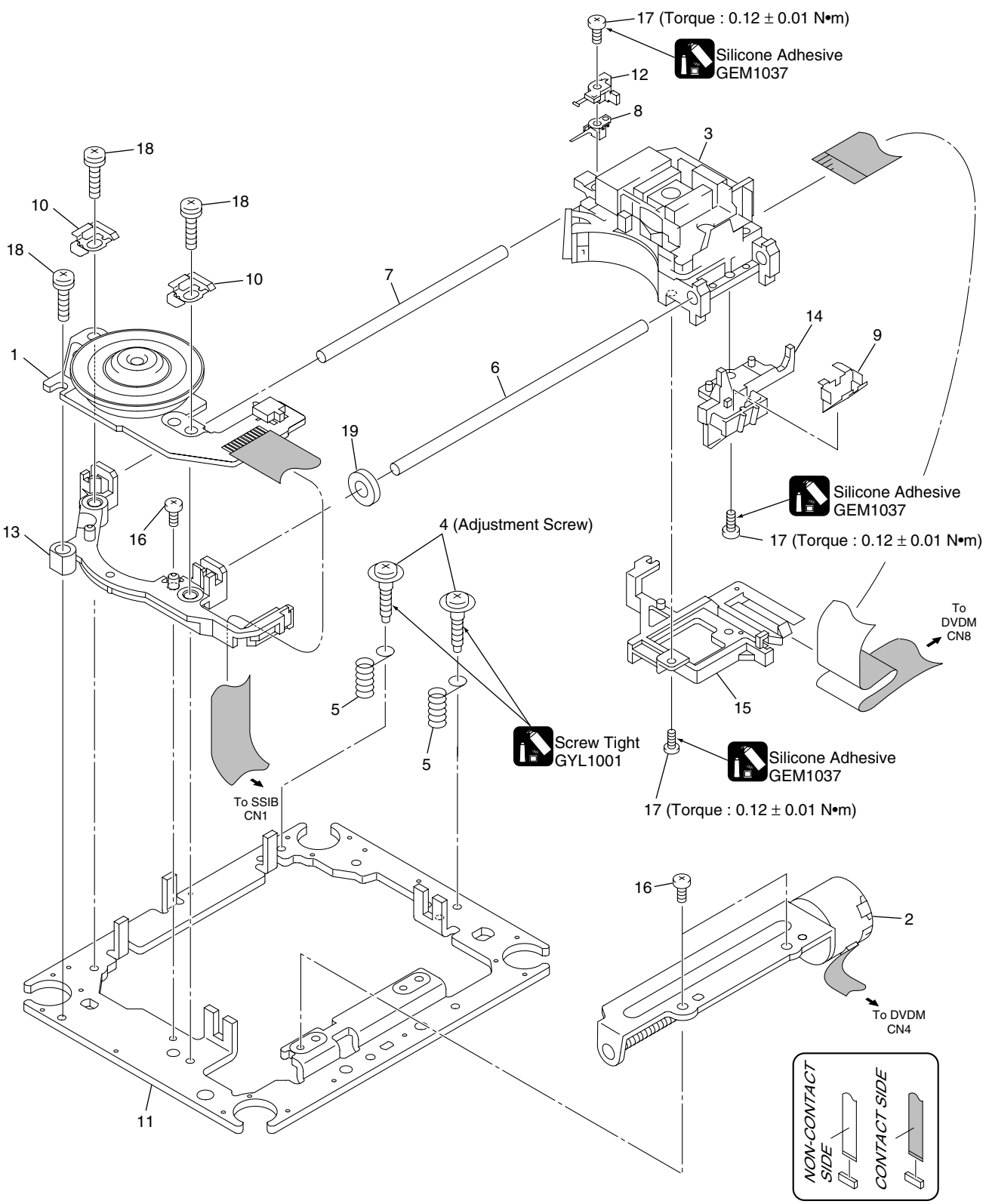

## TRAVERSE MECHANISM ASSY parts List

<u>Mark No.</u>	<u>Description</u>	<u>Part No.</u>
1	Spindle Motor	VXM1088
2	Stepping Motor	VXM1090
 3	Pickup Assy-S	OXX8004
4	Skew Screw	VBA1080
5	Skew Spring	VBH1335
6	Guide Bar	VLL1514
7	Sub Guide Bar	VLL1515
8	Hold Spring	VNC1017
9	Joint Spring	VNC1019
10	Support Spring	VNC1020
NSP 11	Mechanism Chassis	VNE2248
12	Slider	VNL1811
13	Spacer	VNL1913
14	Joint	VNL1914
15	FFC Holder	VNL1915
16	Screw	BBZ20P050FZK
17	Tapping Screw	OBA8009
18	Screw	PMA26P100FMC
19	Damper Sheet	VEB1335

A

B

C

D

E

F

# 3. BLOCK DIAGRAM AND SCHEMATIC DIAGRAM

## 3.1 BLOCK DIAGRAM

### 3.1.1 SIGNAL ROUTE(1/2)

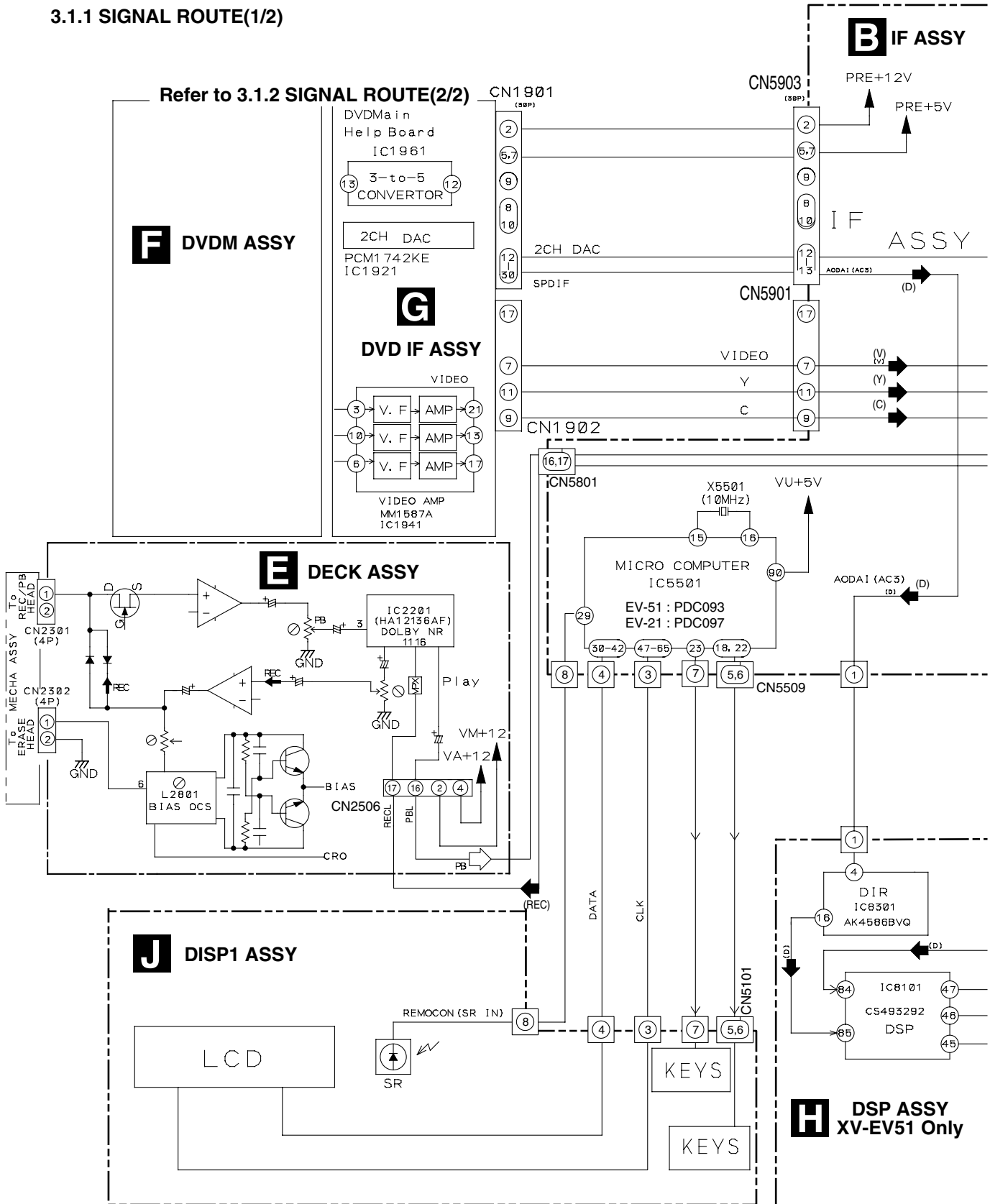



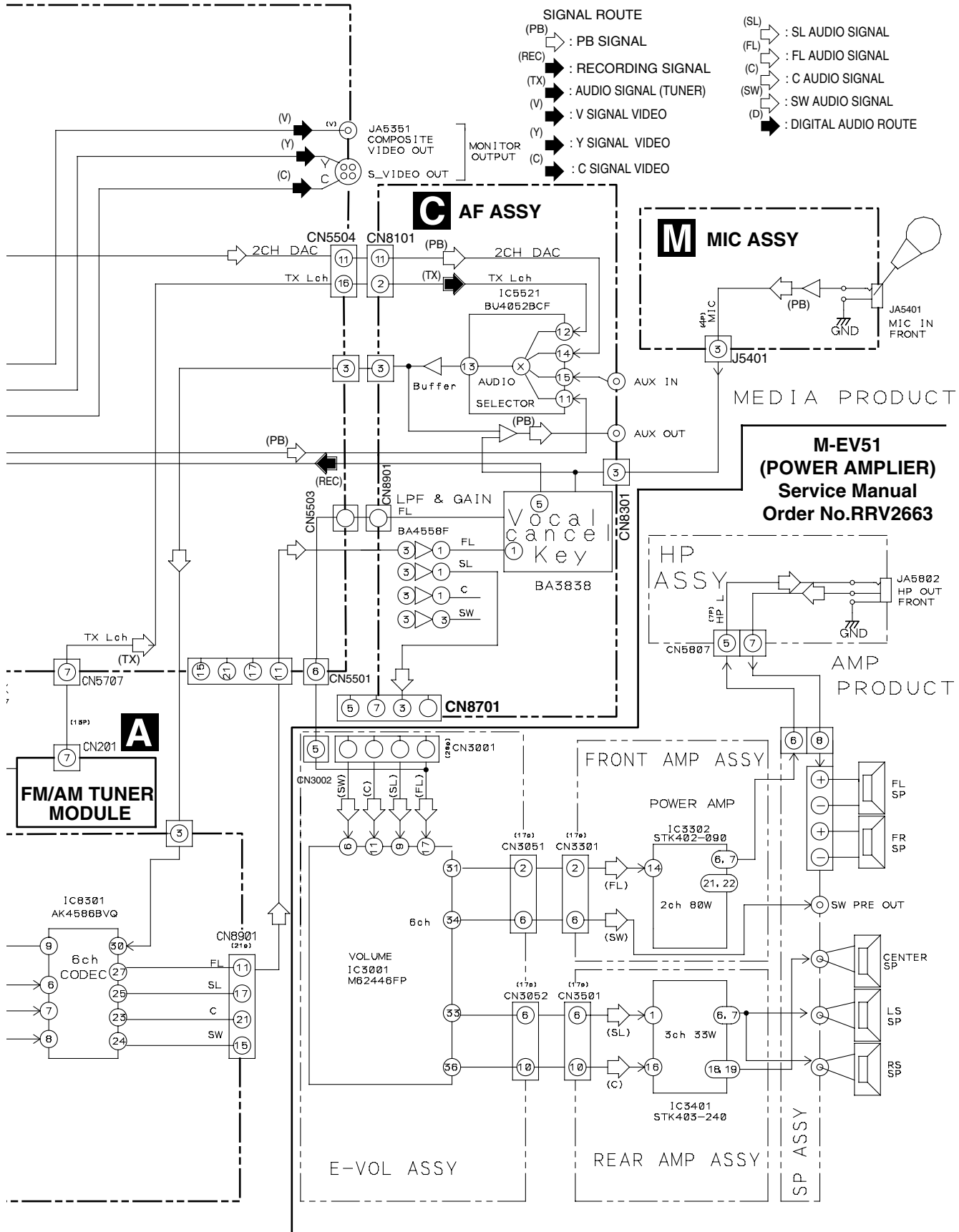

### 3.1.2 SIGNAL ROUT(2/2)

A

B

C

D

E

F

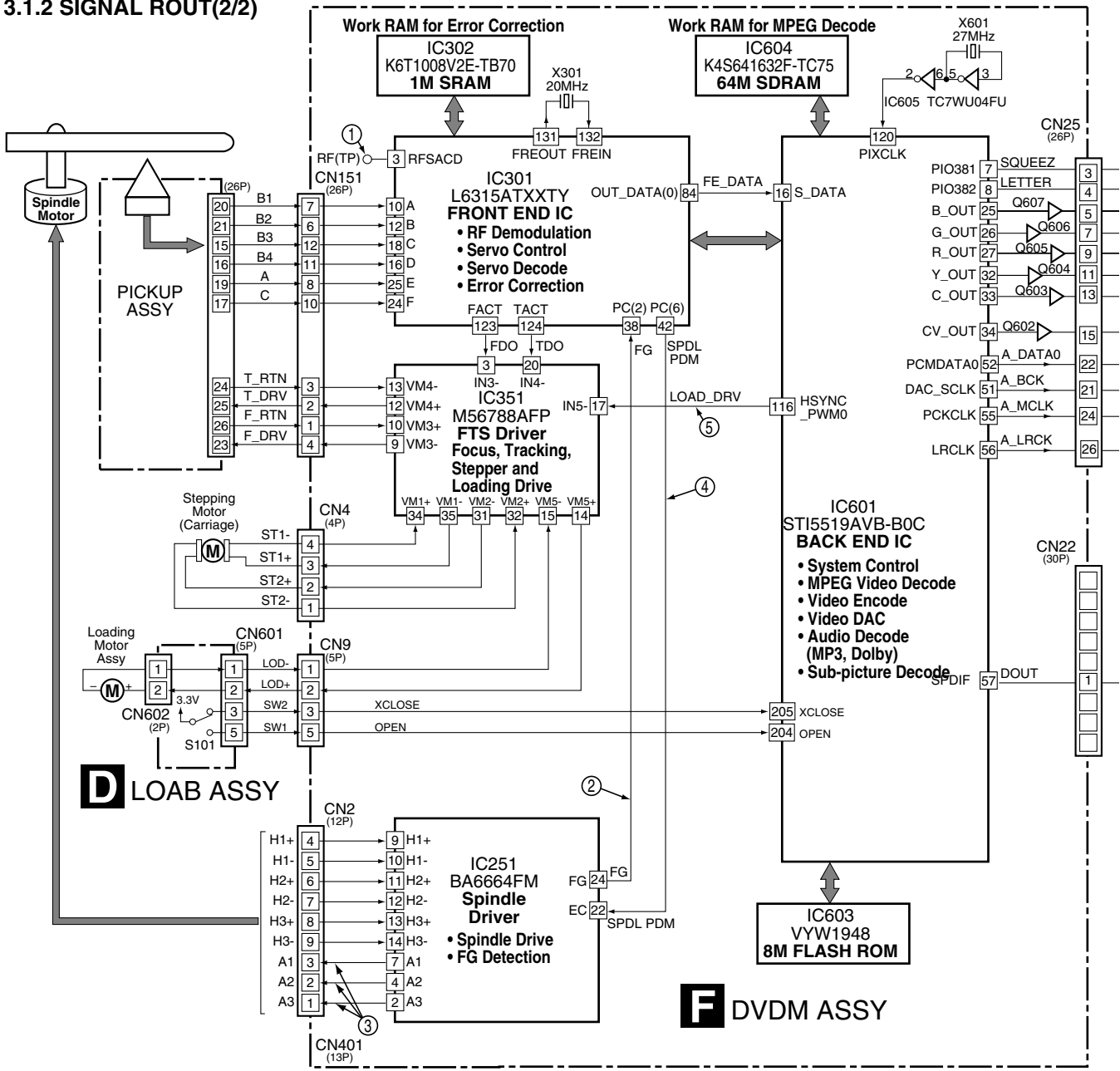

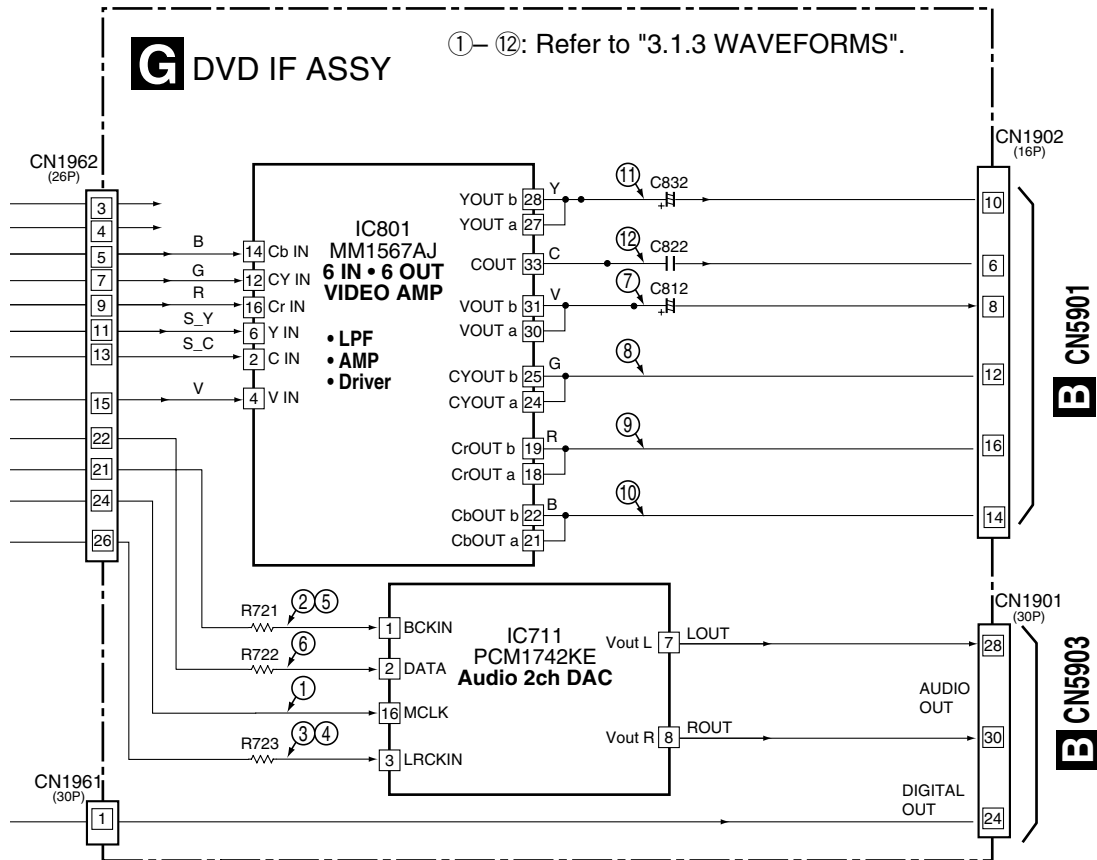

### 3.1.3 WAVEFORMS

Note : The encircled numbers denote measuring point in the schematic diagram.

### F DVDM ASSY

Measurement condition : No. 1 and 2 : reference A1 (DVD), T2-chp 19, Color-bar

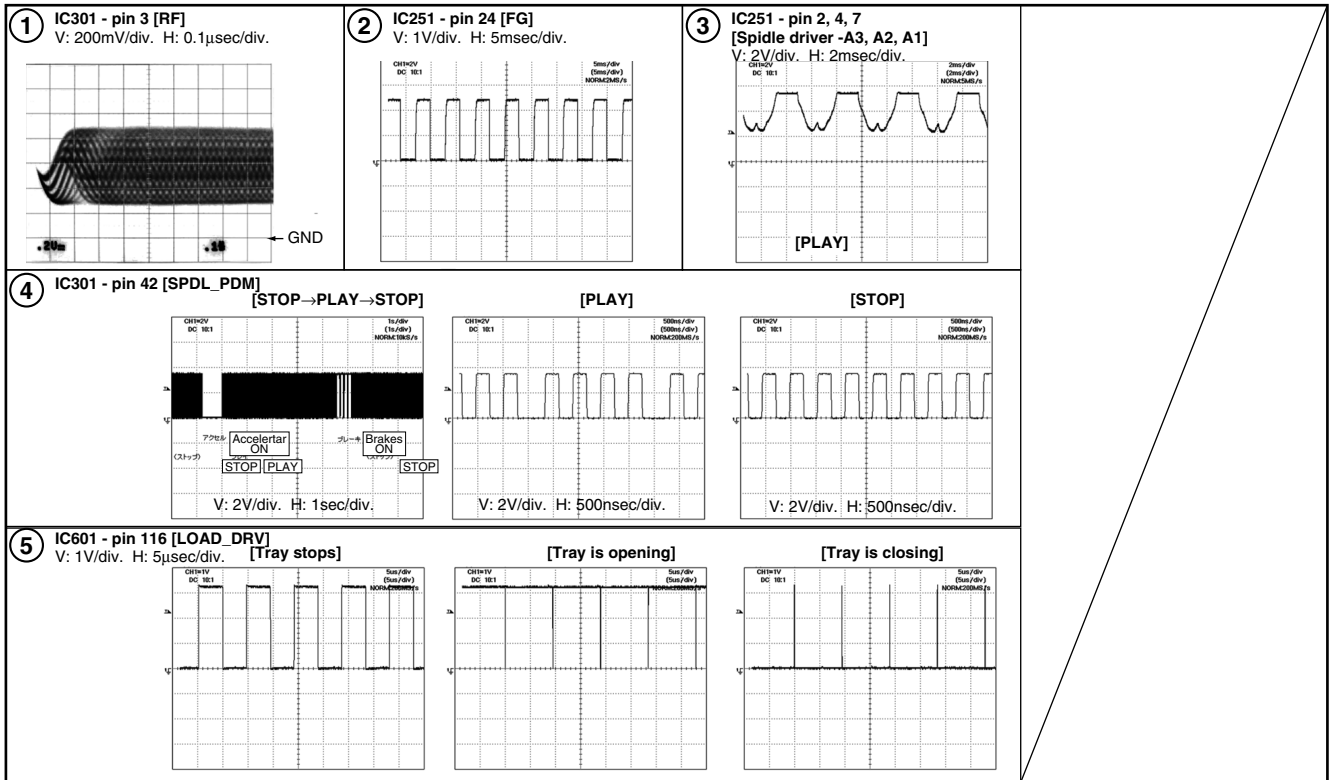

# 3.2 OVERALL WIRING DIAGRAM

## 3.2.1 OVERALL WIRING DIAGRAM(MEDIA PART 1/2)

Note : When ordering service parts, be sure to refer to "EXPLODED VIEWS and PARTS LIST" or "PCB PARTS LIST"

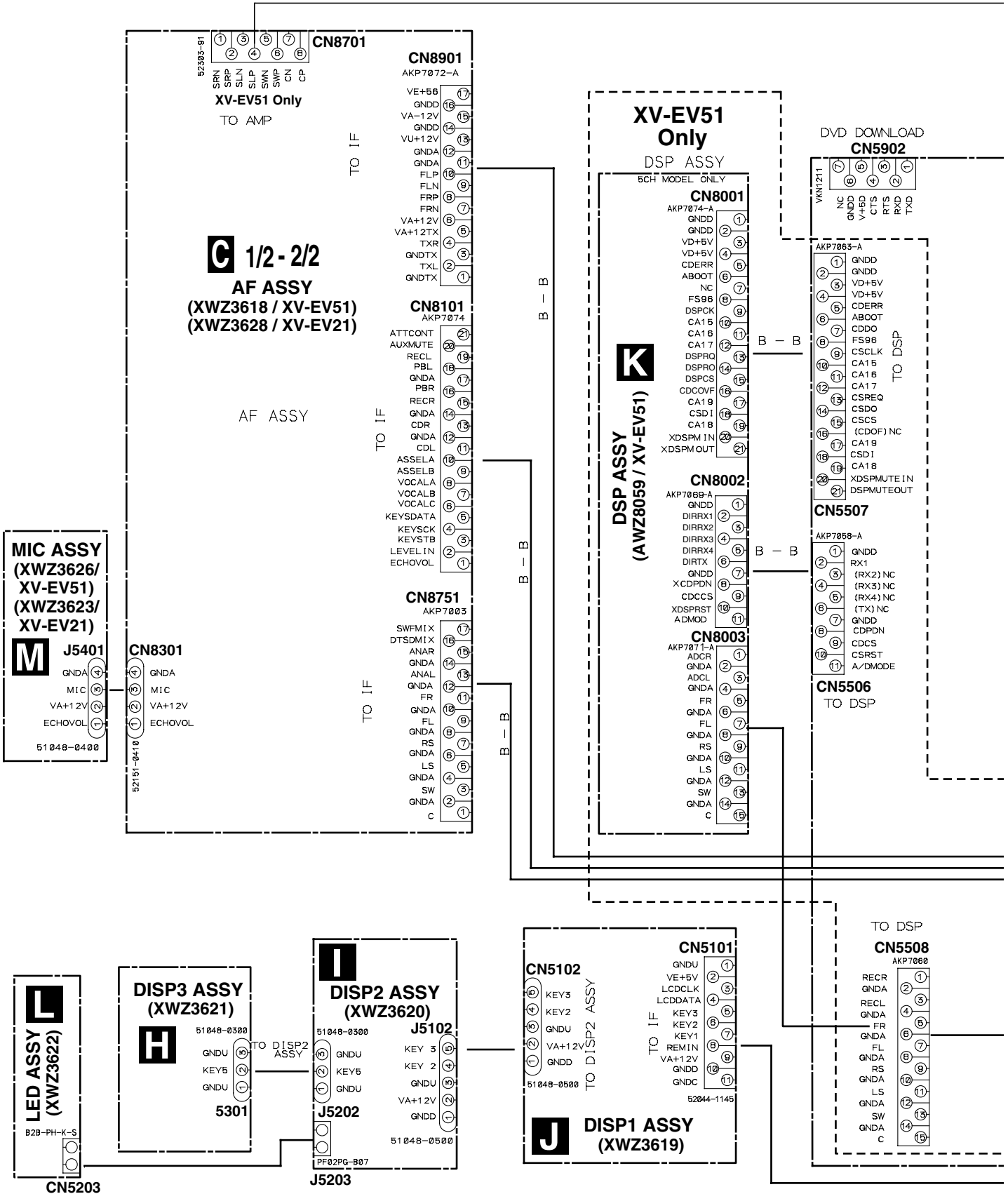



### 3.2.2 OVERALL WIRING DIAGRAM (MEDIA PART 2/2)

A  
B  
C  
D  
E  
F

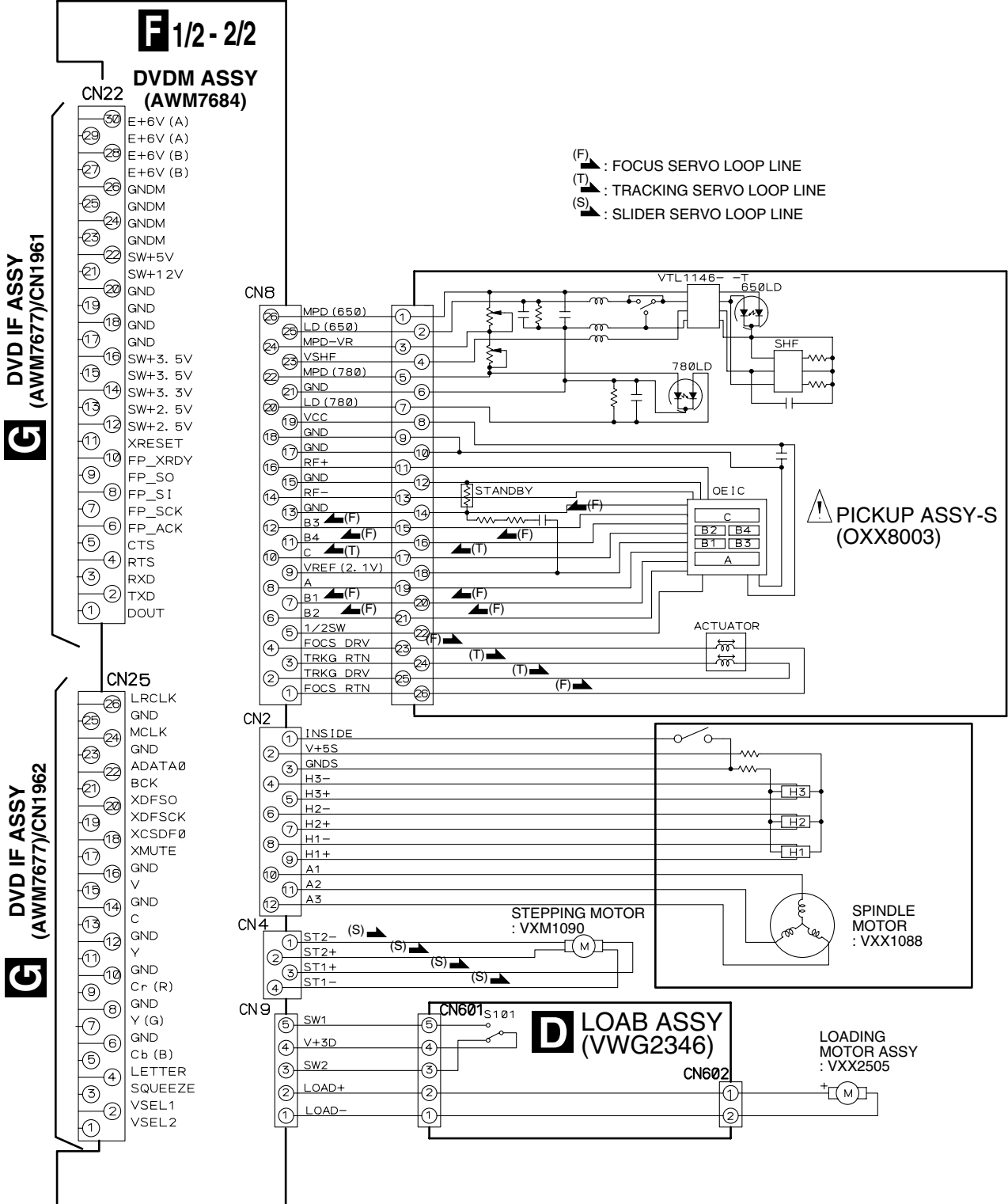

### 3.1.3 WAVEFORMS

Note : The encircled numbers denote measuring point in the schematic diagram.

## F DVDM ASSY

Measurement condition : No. 1 and 2 : reference A1 (DVD), T2-chp 19, Color-bar

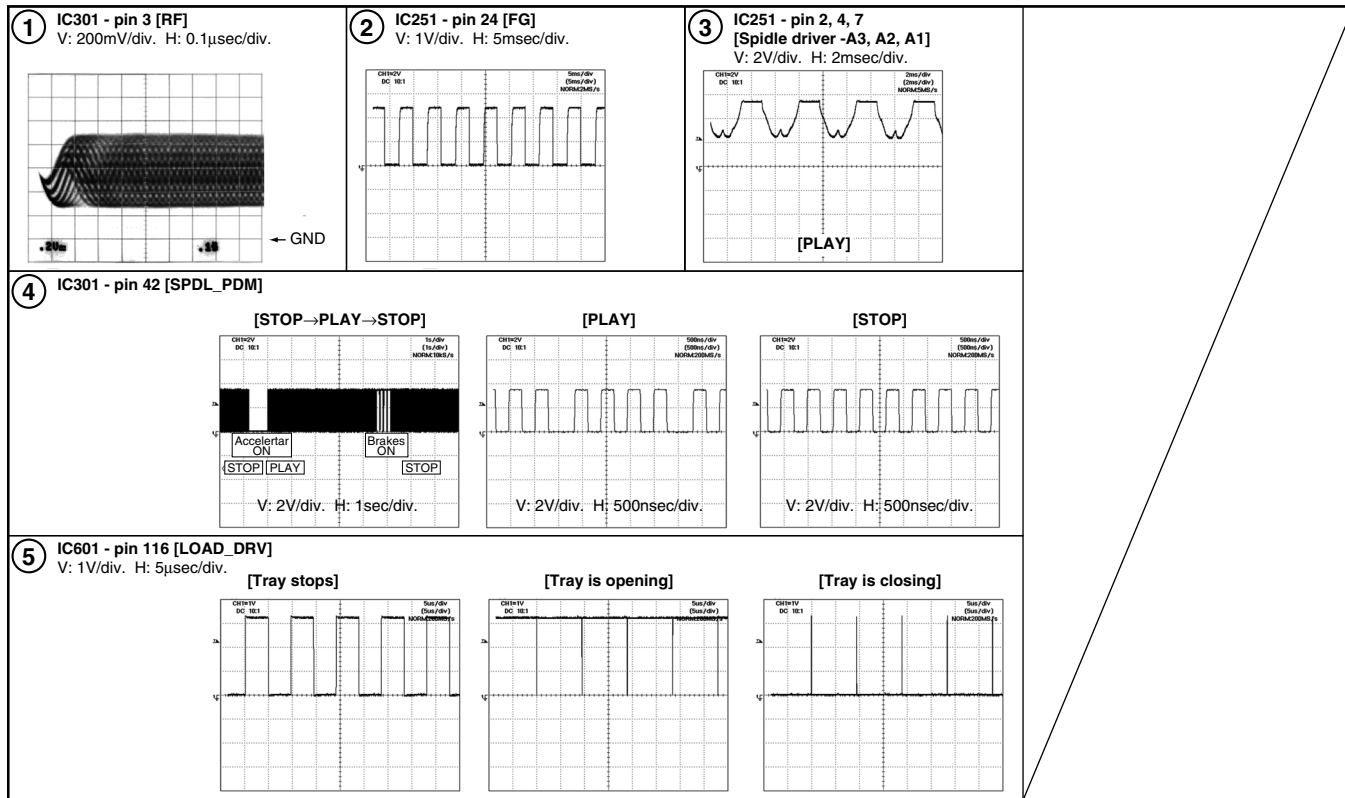

## G DVD IF ASSY

Measurement condition : No. 1 to 6 : reference A1 (DVD), T2-chp 1  
No. 7 to 12 : reference A1 (DVD), T2-chp 19, Color-bar

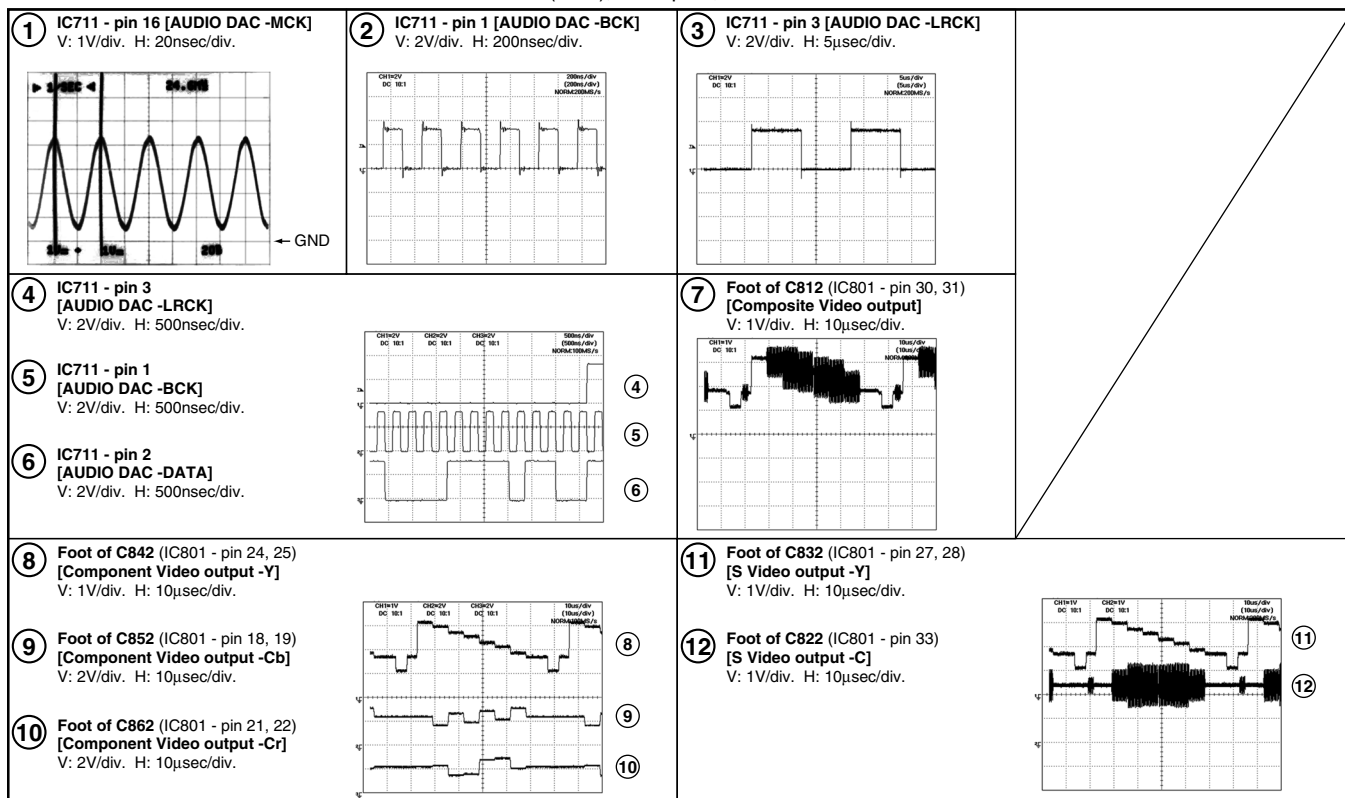

# 3.3 FM/AM TUNER MODULE

## A FM/AM TUNER MODULE (AXQ7228)

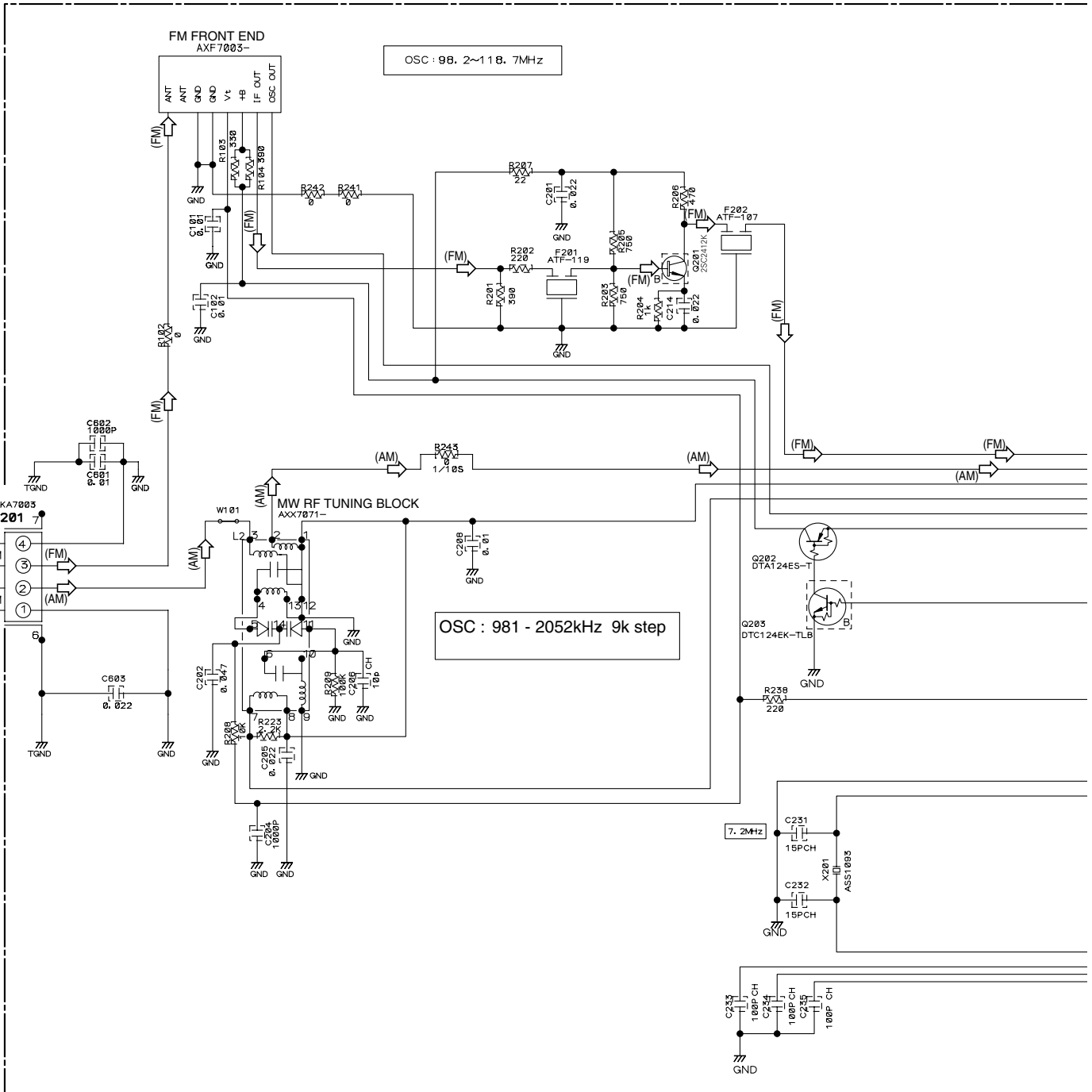



Notes

1. RESISTORS

Indicated in Ω, 1/16W±5% Tolerance unless otherwise noted K:KΩ, M:MΩ.

2. CAPACITORS

Indicated in Capacity (μF)/VOLTAGE (V) unless otherwise noted P:PF.

3. DIODES

No mark diode is 1SS133.

 : The power supply is shown with the marked box.

(TX)  : AUDIO SIGNAL ROUTE (TUNER)

(AM)  : AM SIGNAL ROUTE

(FM)  : FM SIGNAL ROUTE

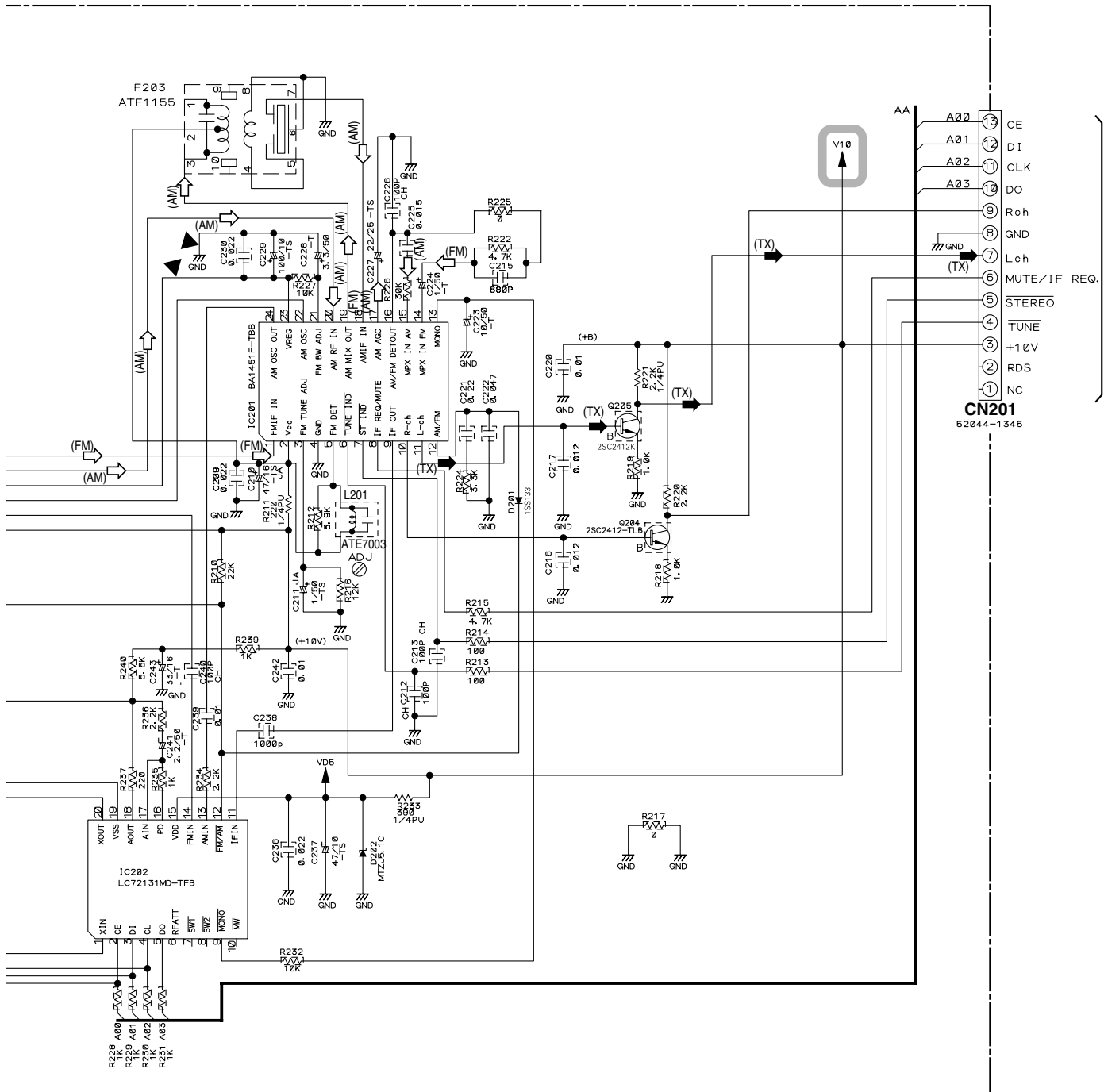

**B** CN5701

**A**

# 3.4 IF ASSY

## NOTES

ALL CAPACITORS ARE IN  $\mu$ F UNLESS OTHERWISE SPECIFIED

CH: CCSRCH\*\*\*  
OTHER: CKSRVB\*\*\*

TS: CE\*\*\*\*\*#-TS  
AL: CEAL\*\*\*\*\*#-\*  
(OTHER: CEAT\*\*\*\*\*#)

ALL INDUCTORS ARE IN  $\mu$ H UNLESS OTHERWISE SPECIFIED

LAU\*\*\*J

ALL RESISTORS ARE IN  $\Omega$  UNLESS OTHERWISE SPECIFIED

1/16W 1/4WPU  
(1/2W): RD1/2PM\*\*\*J

ALL DIODE ARE 1SS133

UNLESS OTHERWISE SPECIFIED

UDZS\*\*\*  
MTZJ\*\*\* 1SS355

**B** IF ASSY  
(XWZ3617 / XV-EV51)  
(XWZ3627 / XV-EV21)

**G** CN1902 TO DVD IF

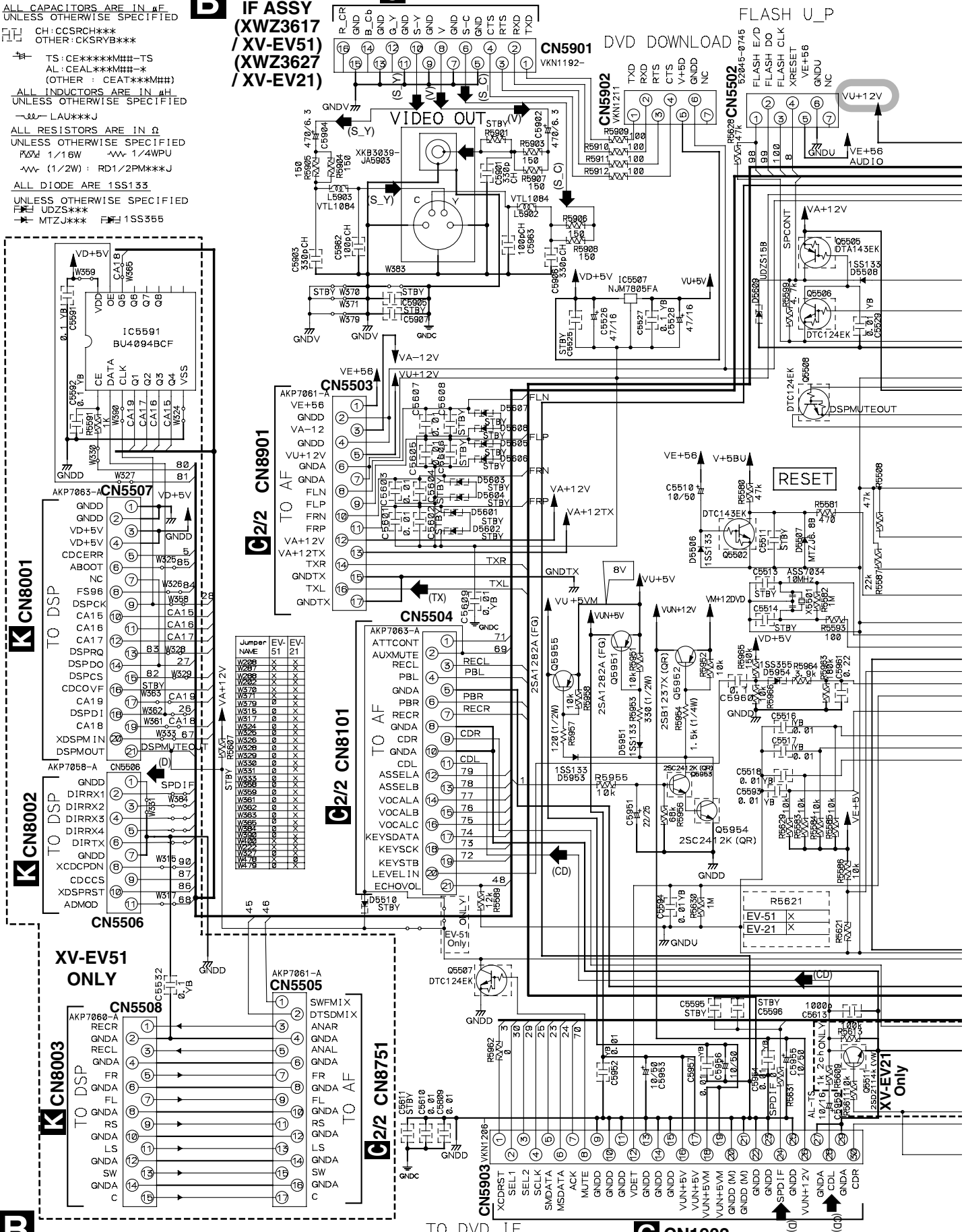

Jumper	NAME	EV-51	EV-21
W328	W328	XXXX	XXXX
W329	W329	XXXX	XXXX
W330	W330	XXXX	XXXX
W331	W331	XXXX	XXXX
W332	W332	XXXX	XXXX
W333	W333	XXXX	XXXX
W334	W334	XXXX	XXXX
W335	W335	XXXX	XXXX
W336	W336	XXXX	XXXX
W337	W337	XXXX	XXXX
W338	W338	XXXX	XXXX
W339	W339	XXXX	XXXX
W340	W340	XXXX	XXXX
W341	W341	XXXX	XXXX
W342	W342	XXXX	XXXX
W343	W343	XXXX	XXXX
W344	W344	XXXX	XXXX
W345	W345	XXXX	XXXX
W346	W346	XXXX	XXXX
W347	W347	XXXX	XXXX
W348	W348	XXXX	XXXX
W349	W349	XXXX	XXXX
W350	W350	XXXX	XXXX
W351	W351	XXXX	XXXX
W352	W352	XXXX	XXXX
W353	W353	XXXX	XXXX
W354	W354	XXXX	XXXX
W355	W355	XXXX	XXXX
W356	W356	XXXX	XXXX
W357	W357	XXXX	XXXX
W358	W358	XXXX	XXXX
W359	W359	XXXX	XXXX
W360	W360	XXXX	XXXX
W361	W361	XXXX	XXXX
W362	W362	XXXX	XXXX
W363	W363	XXXX	XXXX
W364	W364	XXXX	XXXX
W365	W365	XXXX	XXXX
W366	W366	XXXX	XXXX
W367	W367	XXXX	XXXX
W368	W368	XXXX	XXXX
W369	W369	XXXX	XXXX
W370	W370	XXXX	XXXX
W371	W371	XXXX	XXXX
W372	W372	XXXX	XXXX
W373	W373	XXXX	XXXX
W374	W374	XXXX	XXXX
W375	W375	XXXX	XXXX
W376	W376	XXXX	XXXX
W377	W377	XXXX	XXXX
W378	W378	XXXX	XXXX
W379	W379	XXXX	XXXX
W380	W380	XXXX	XXXX
W381	W381	XXXX	XXXX
W382	W382	XXXX	XXXX
W383	W383	XXXX	XXXX
W384	W384	XXXX	XXXX
W385	W385	XXXX	XXXX
W386	W386	XXXX	XXXX
W387	W387	XXXX	XXXX
W388	W388	XXXX	XXXX
W389	W389	XXXX	XXXX
W390	W390	XXXX	XXXX
W391	W391	XXXX	XXXX
W392	W392	XXXX	XXXX
W393	W393	XXXX	XXXX
W394	W394	XXXX	XXXX
W395	W395	XXXX	XXXX
W396	W396	XXXX	XXXX
W397	W397	XXXX	XXXX
W398	W398	XXXX	XXXX
W399	W399	XXXX	XXXX
W400	W400	XXXX	XXXX



# 3.5 AF ASSY(1/2)

A

B

C

D

E

F

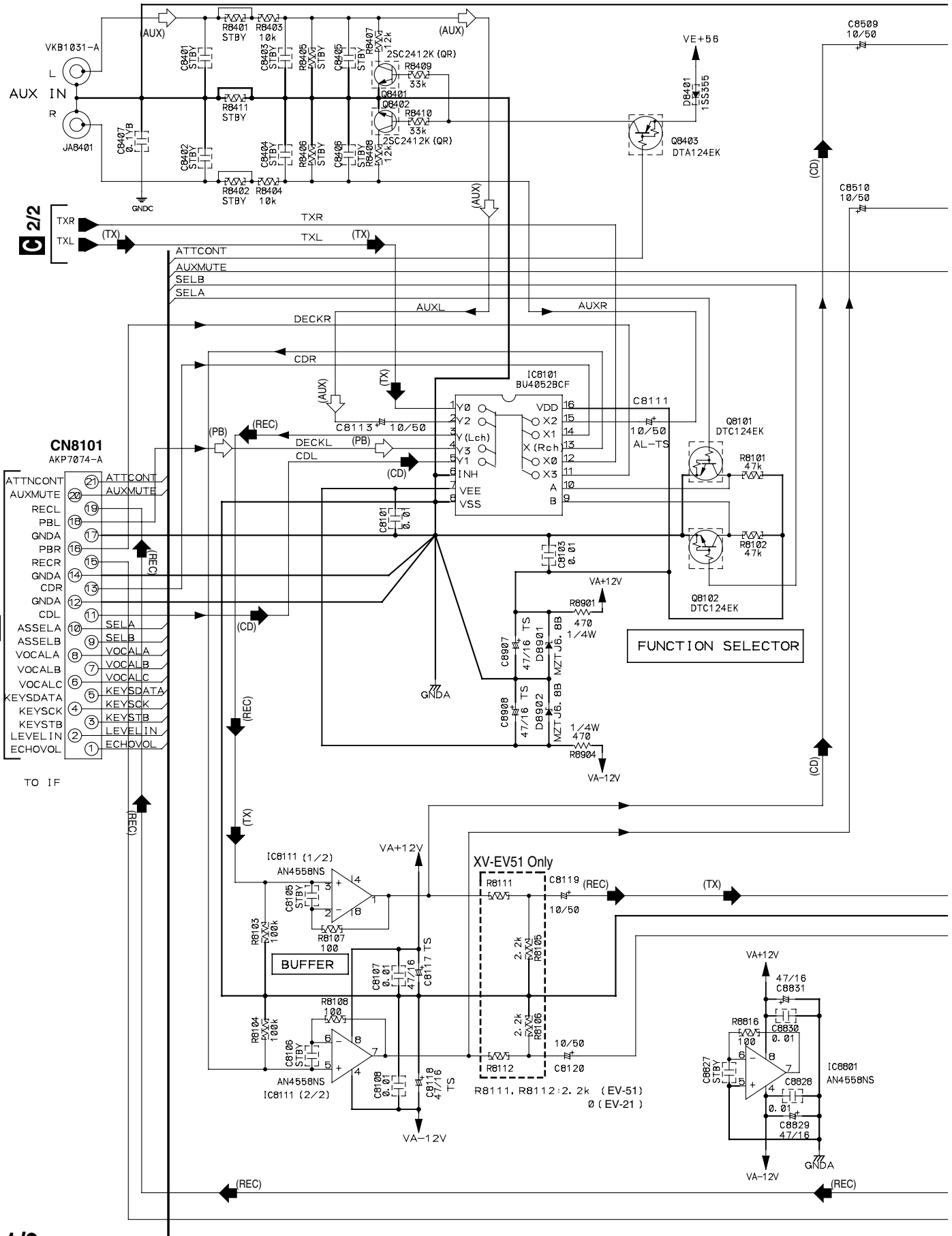

**C** 1/2

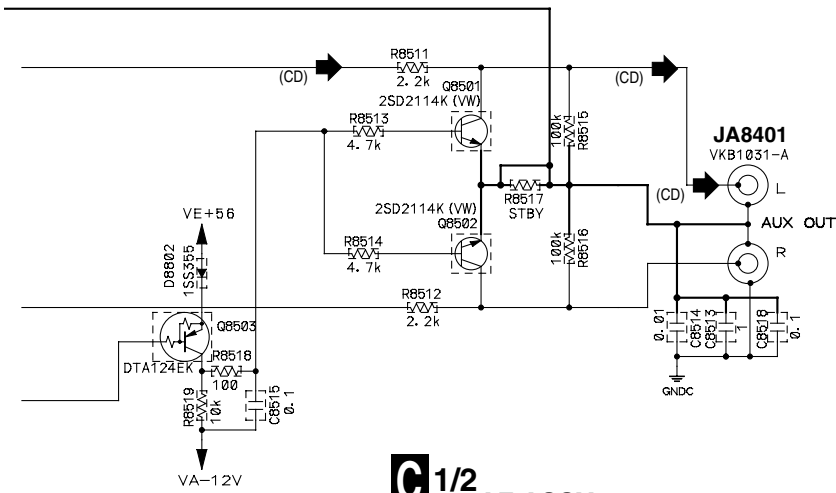

**SIGNAL ROUTE**

(PB) : PB SIGNAL  
 (REC) : RECORDING SIGNAL  
 (TX) : AUDIO SIGNAL (TUNER)  
 (CD) : CD SIGNAL

(AUX) : AUX SIGNAL  
 (MIC) : MIC OUT SIGNAL

**NOTES**

ALL CAPACITORS ARE IN  $\mu$ F UNLESS OTHERWISE SPECIFIED

CH : CCSRCH\*\*\*  
 YF : CKSRYP\*\*\*  
 OTHER : CKSRYP\*\*\*

ALL DIODES ARE 1SS133 UNLESS OTHERWISE SPECIFIED

1SS355  
 MTZJ\*\*\*

ALL RESISTORS ARE IN  $\Omega$  UNLESS OTHERWISE SPECIFIED

1/16W  
 1/4WPU

**C 1/2 AF ASSY**  
 (XWZ3618 / XV-EV51)  
 (XWZ3628 / XV-EV21)

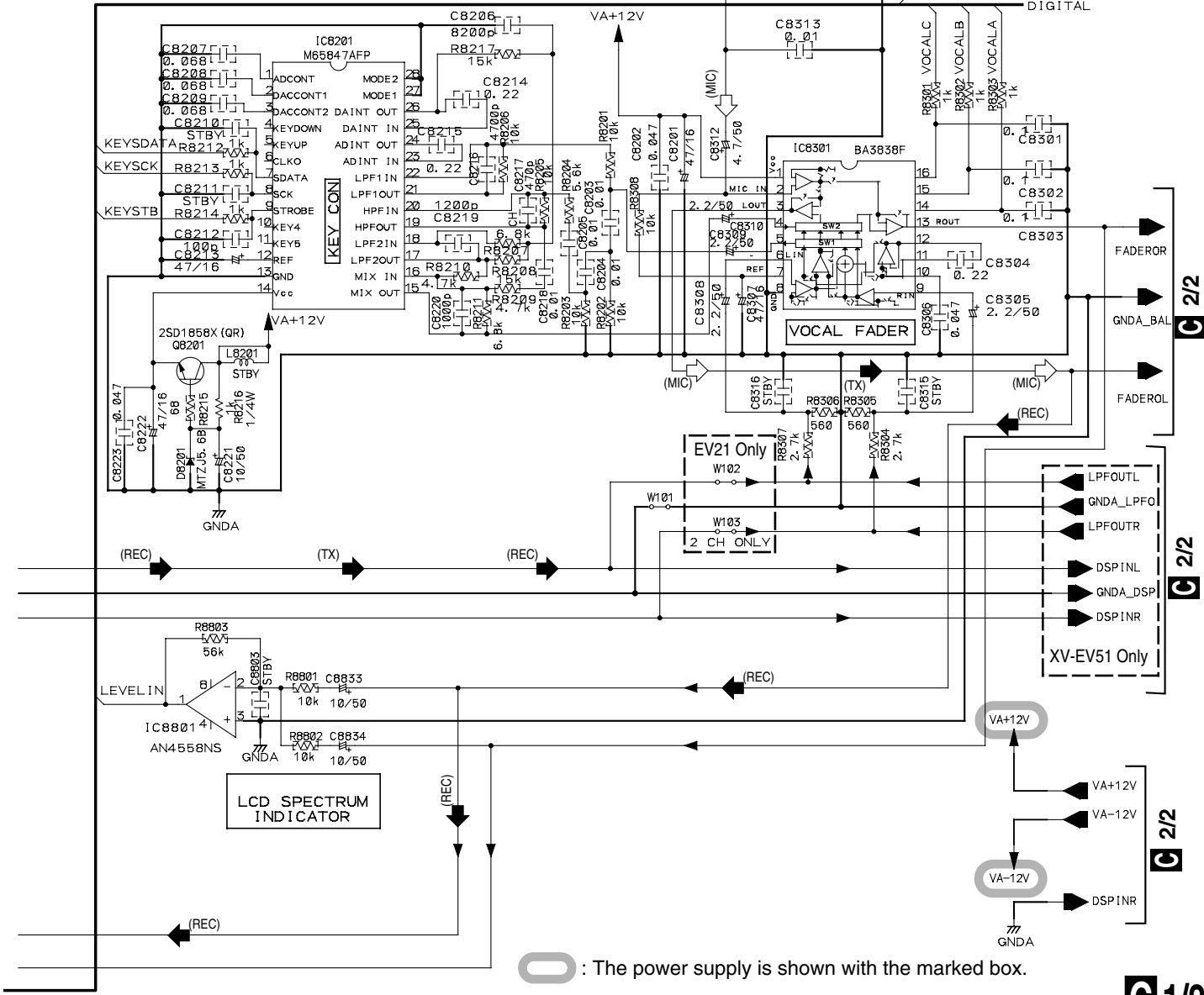

: The power supply is shown with the marked box.

**C 1/2**

# 3.6 AF ASSY(2/2)

A

B

C

D

E

F

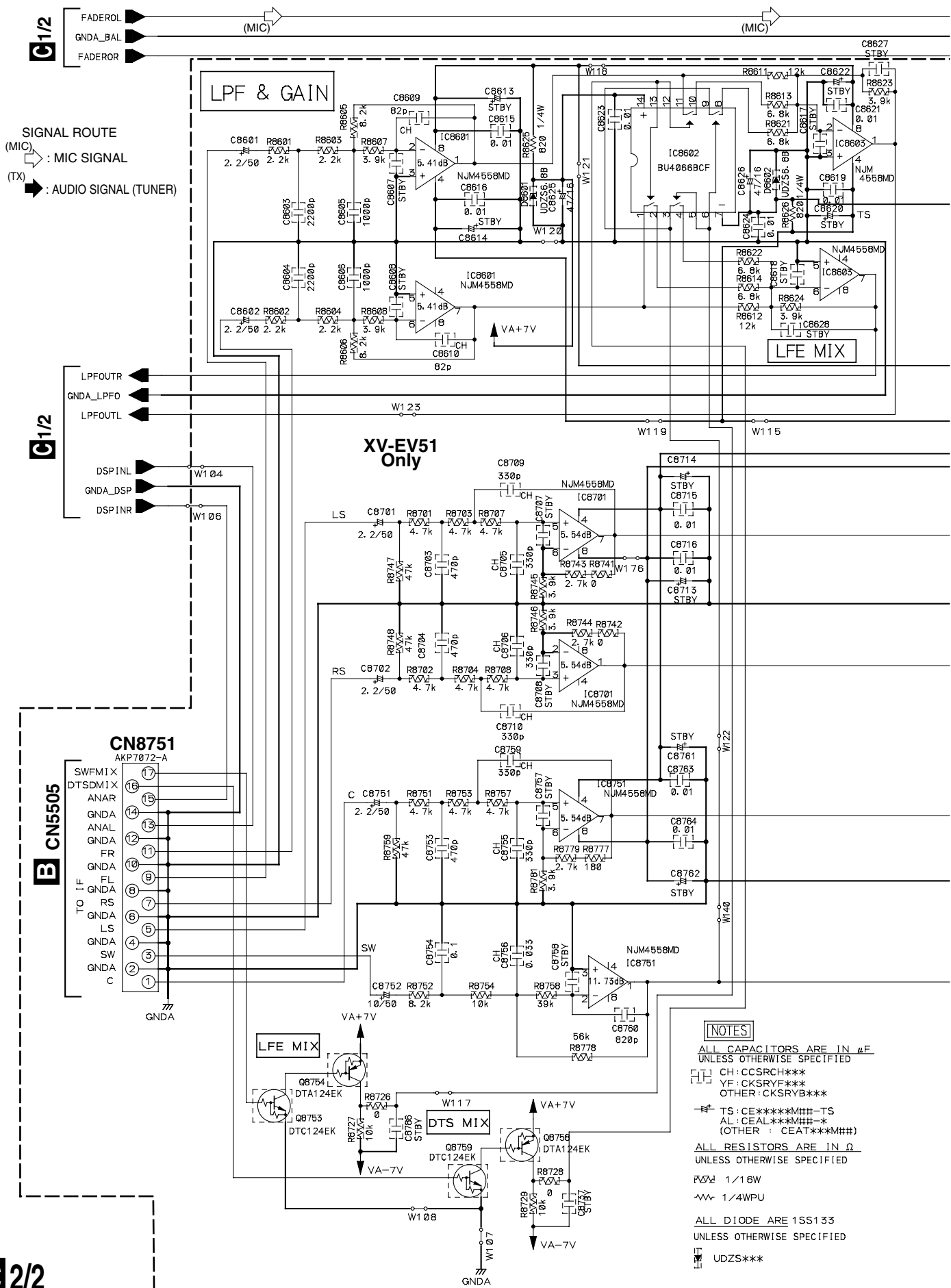

- [NOTES]**
- ALL CAPACITORS ARE IN  $\mu$ F UNLESS OTHERWISE SPECIFIED
  - CH: CCSRCH\*\*\*
  - YF: CKSRFY\*\*\*
  - OTHER: CKSRYB\*\*\*
  - TS: CE\*\*\*\*MH##-TS
  - AL: CEAL\*\*\*\*MH##-\*
  - (OTHER : CEAT\*\*\*\*MH##)
  - ALL RESISTORS ARE IN  $\Omega$  UNLESS OTHERWISE SPECIFIED
  - $\text{P}\text{W}\text{V}$ : 1/16W
  - $\text{W}$ : 1/4WPU
  - ALL DIODE ARE 1SS133 UNLESS OTHERWISE SPECIFIED
  - UDZS\*\*\*

C2/2

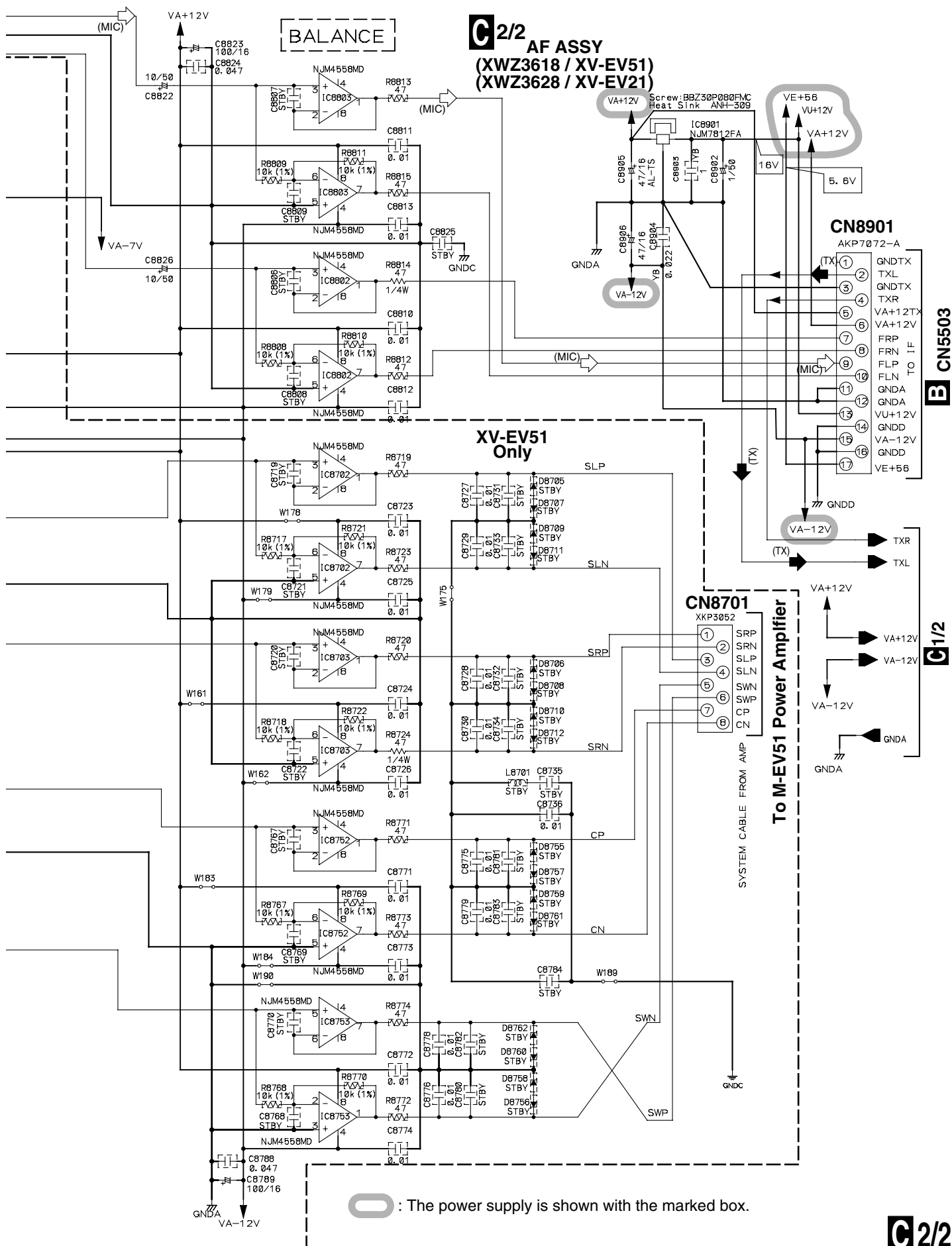

**G2/2 AF ASSY**  
**(XWZ3618 / XV-EV51)**  
**(XWZ3628 / XV-EV21)**

**BALANCE**

**XV-EV51 Only**

**To M-EV51 Power Amplifier**

: The power supply is shown with the marked box.





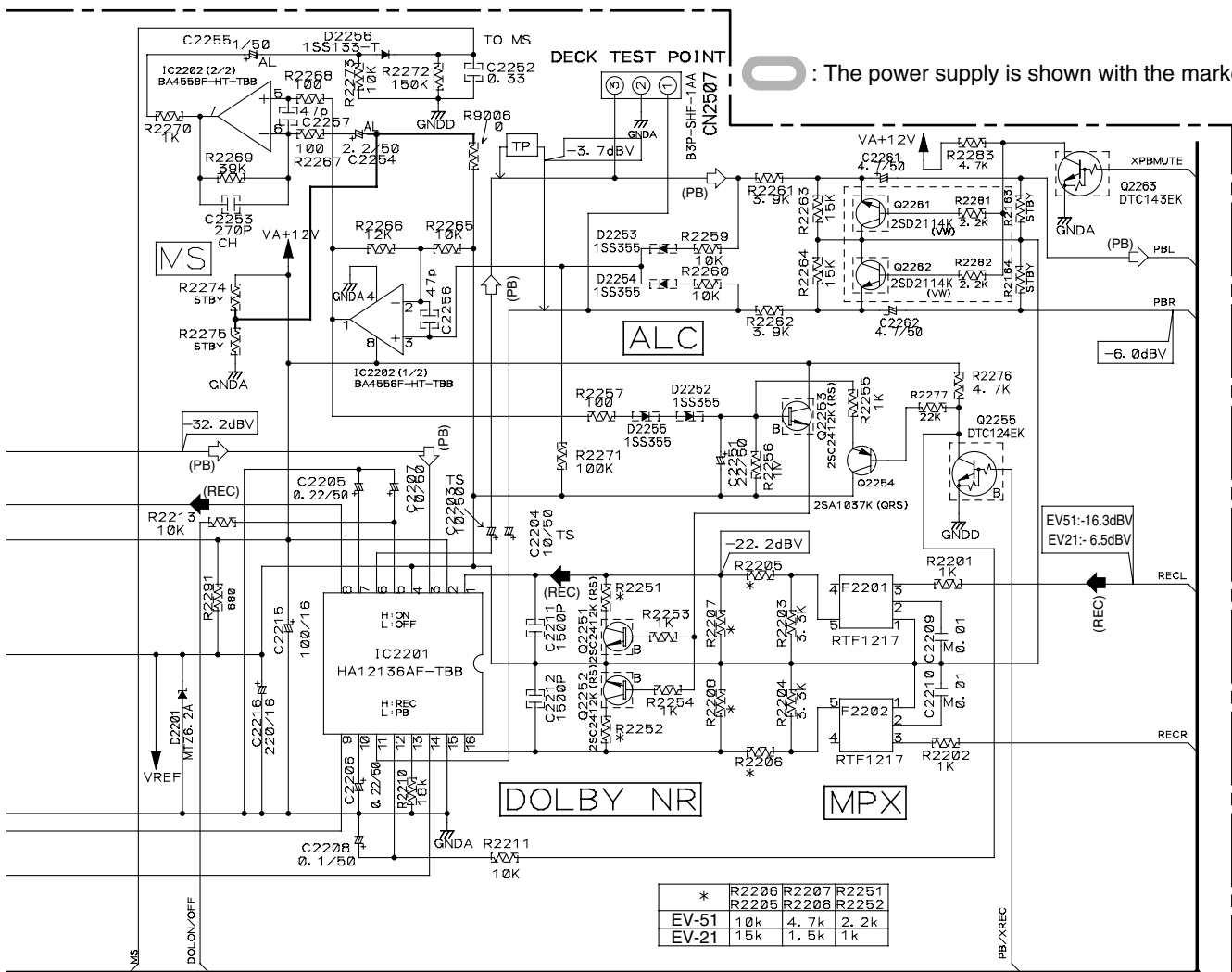

SIGNAL ROUTE

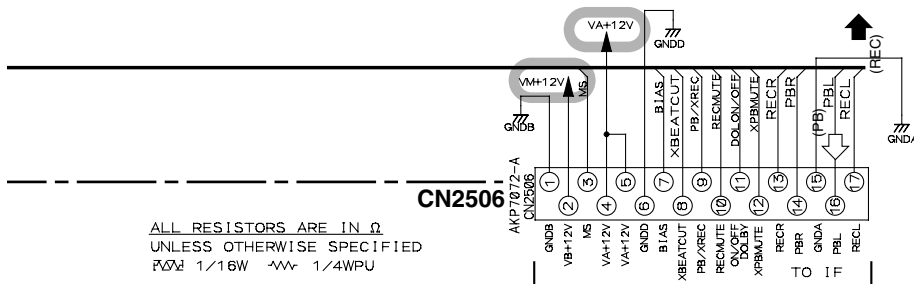
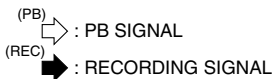

ALL RESISTORS ARE IN Ω  
 UNLESS OTHERWISE SPECIFIED  
 1/16W 1/4WPU  
 ALL COILS ARE IN μH  
 UNLESS OTHERWISE SPECIFIED  
 LAU\*\*\*J

ALL DIODES ARE 1SS133  
 UNLESS OTHERWISE SPECIFIED  
 1SS133 1SS355  
 MTZJ\*\*\*

**B** CN5801



# 3.8 DVDM ASSY(1/2)

A

B

C

D

E

F

## F 1/2 DVDM ASSY (AWM7684)

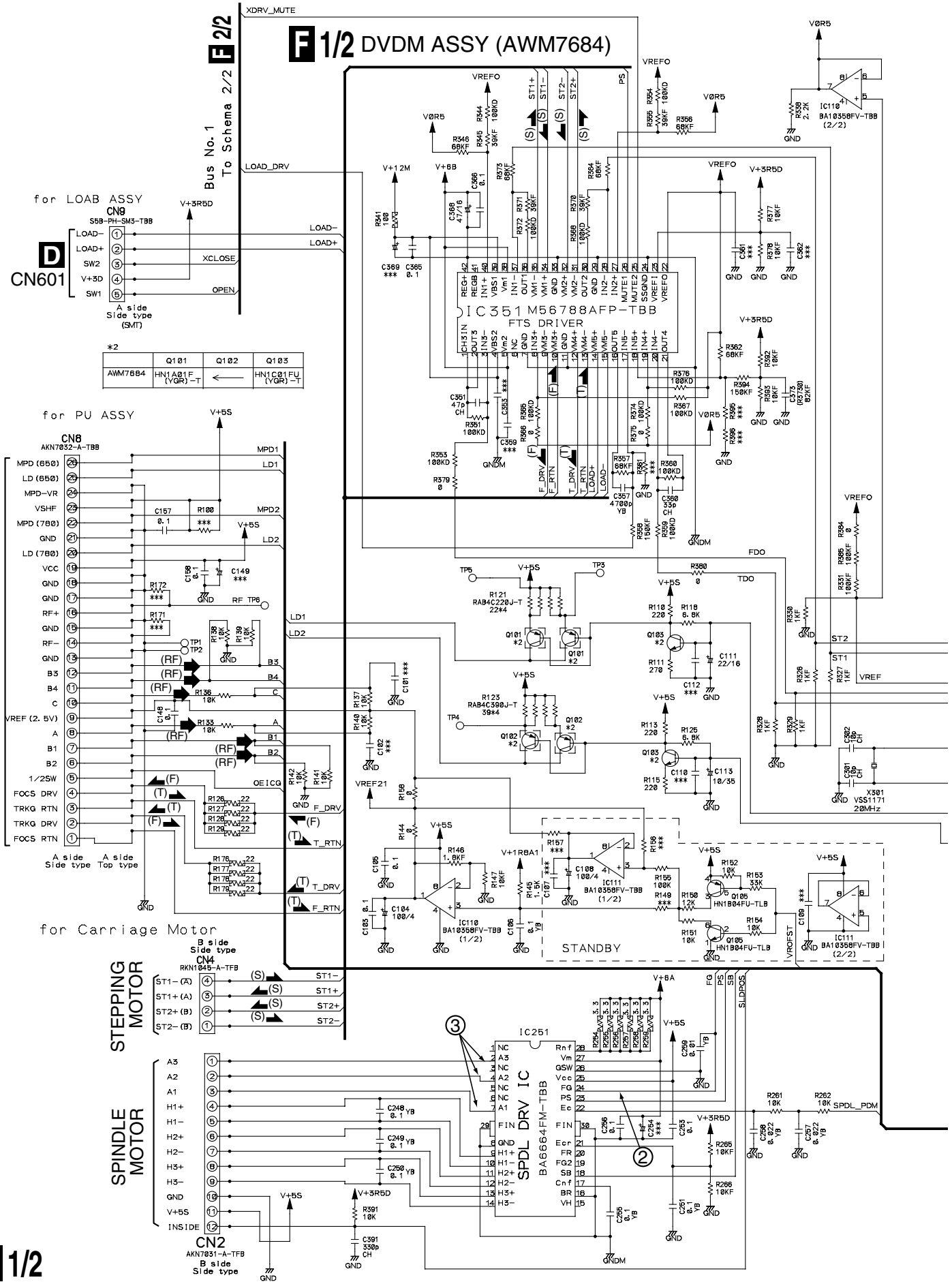

## F 1/2



# 3.9 DVDM ASSY(2/2)

## F 2/2 DVDM ASSY (AWM7684)

A

B

C

D

E

F

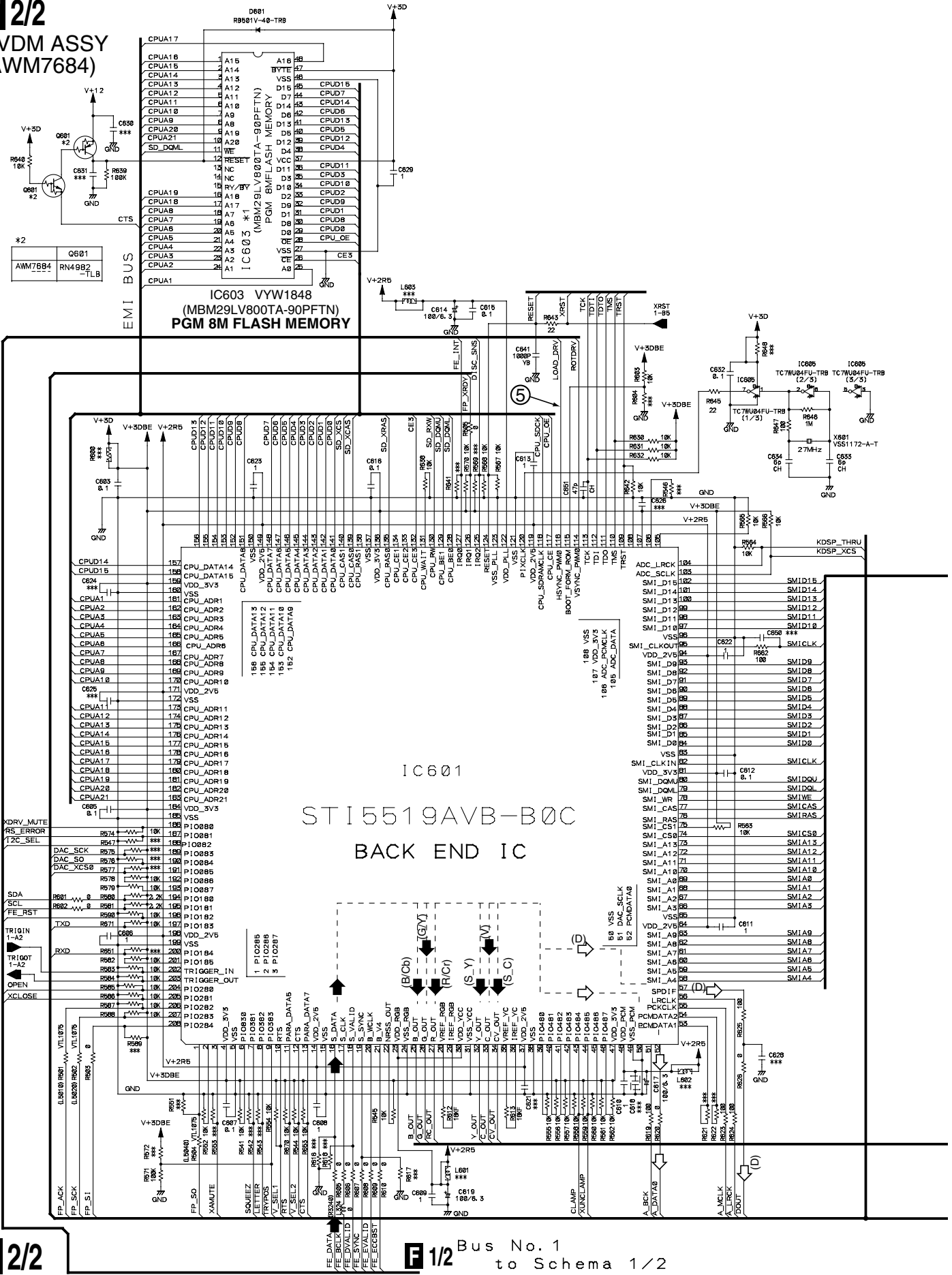



# 3.10 DVD IF ASSY

## DVD IF ASSY (AWM7677)

	Q1921	Q1922	Q1932	Q1941	Q1942	Q1961
AWM7677	UN5212	←	←	RN1903	RN2903	RN1903

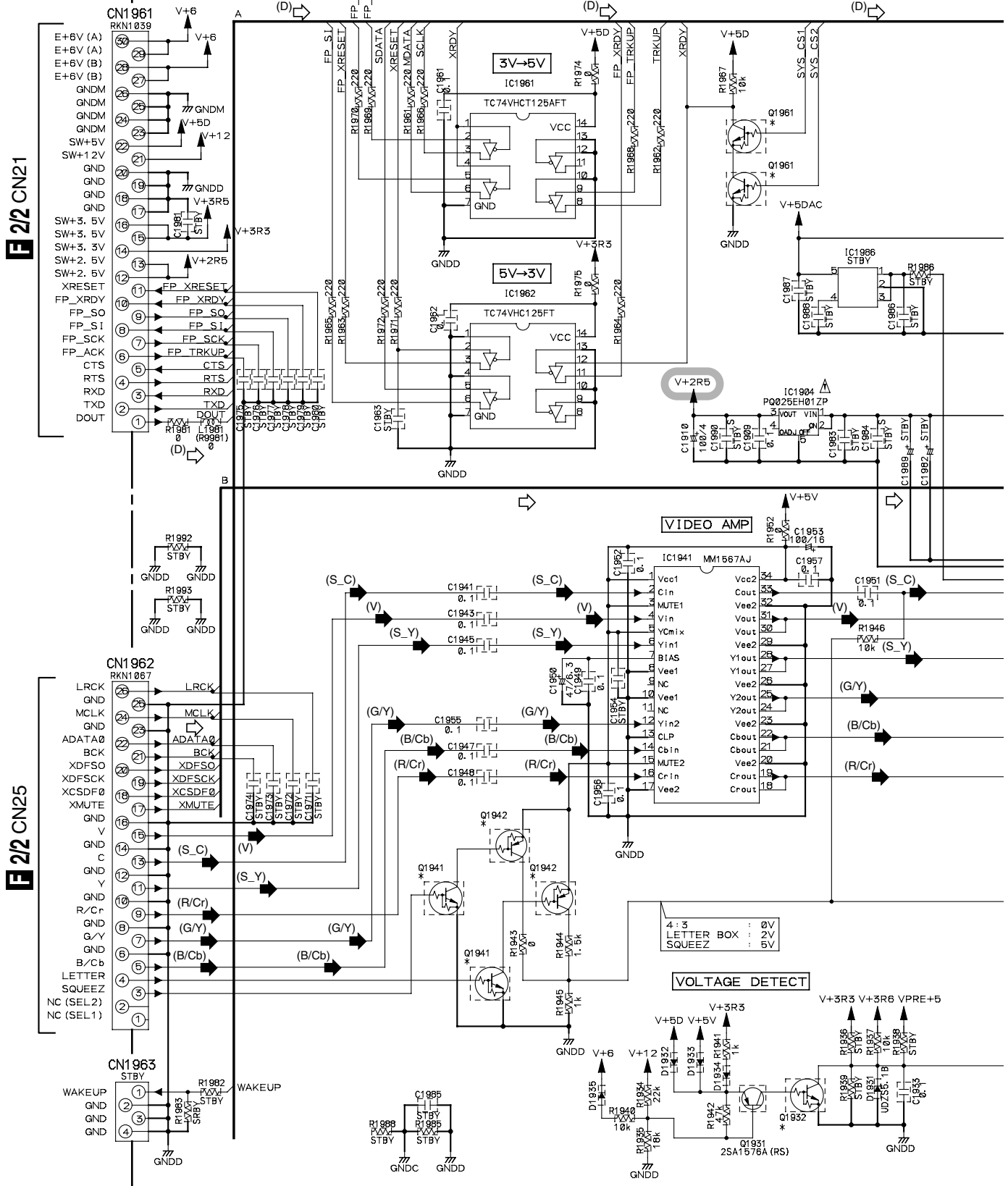



### 3.11 DISP1, DISP2, DISP3 and LED ASSYS

A  
B  
C  
D  
E  
F

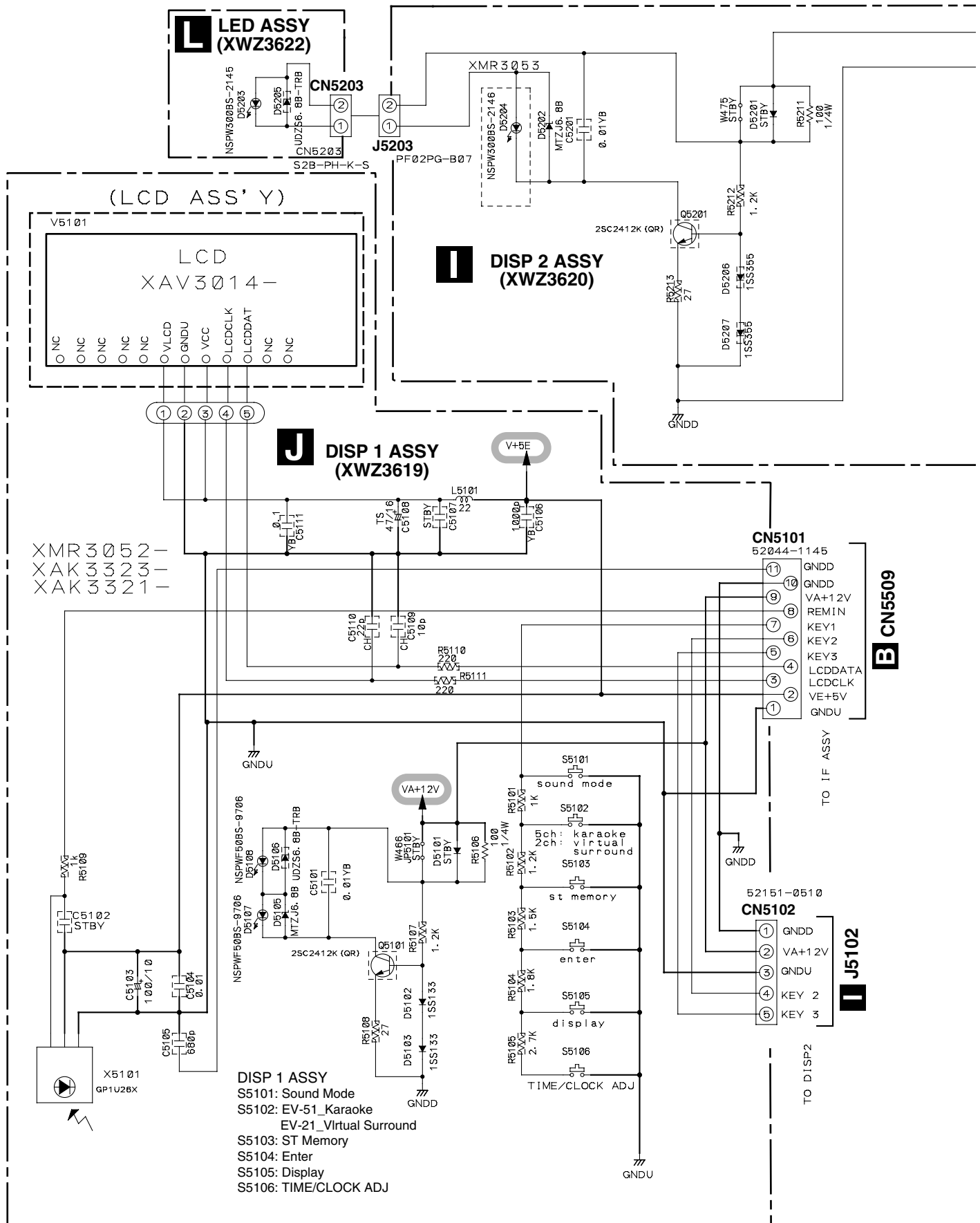



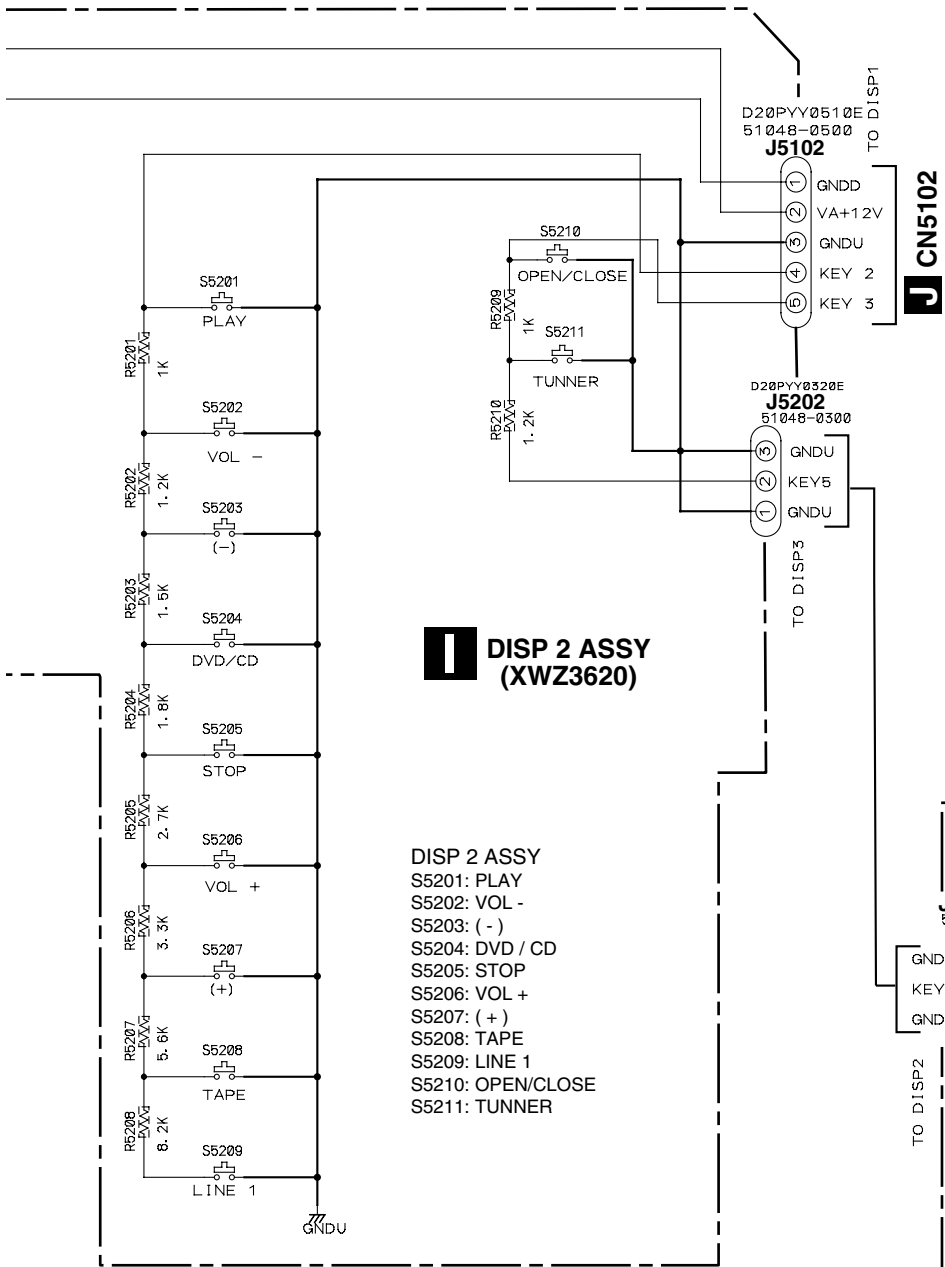

**NOTES**

ALL CAPACITORS ARE IN  $\mu$ F  
UNLESS OTHERWISE SPECIFIED

CH:CCSRCH\*\*\*  
YF:CKSRV\*\*\*  
OTHER:CKSRVB\*\*\*

TS:CE\*\*\*\*\*M##-TS  
(OTHER : CEAT\*\*\*M##)

ALL INDUCTORS ARE IN  $\mu$ H  
UNLESS OTHERWISE SPECIFIED.

ALL DIODES ARE 1SS133  
UNLESS OTHERWISE SPECIFIED.

1SS133

1SS355

MTZJ\*\*\*

UDZS\*\*\*

ALL RESISTORS ARE IN  $\Omega$   
UNLESS OTHERWISE SPECIFIED.

1/16W

1/4WPU

ALL SWITCHES ARE IN ASG7013,  
UNLESS OTHERWISE SPECIFIED.

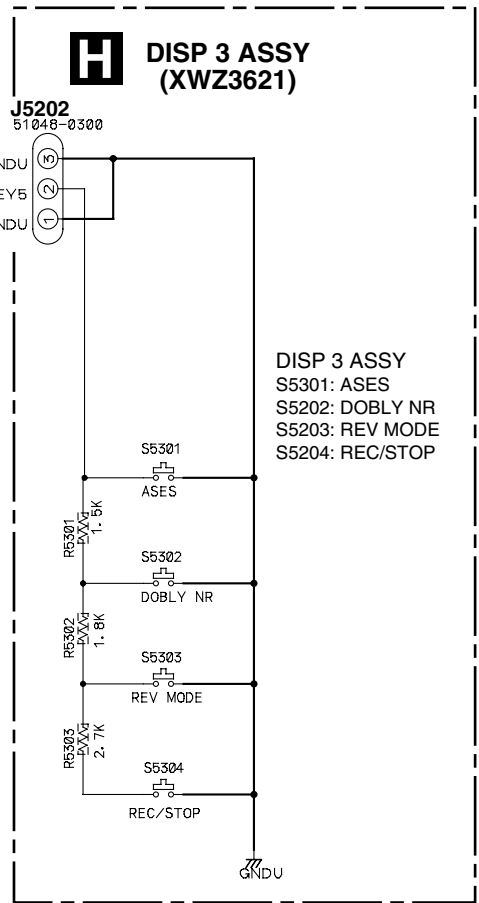

 : The power supply is shown with the marked box.





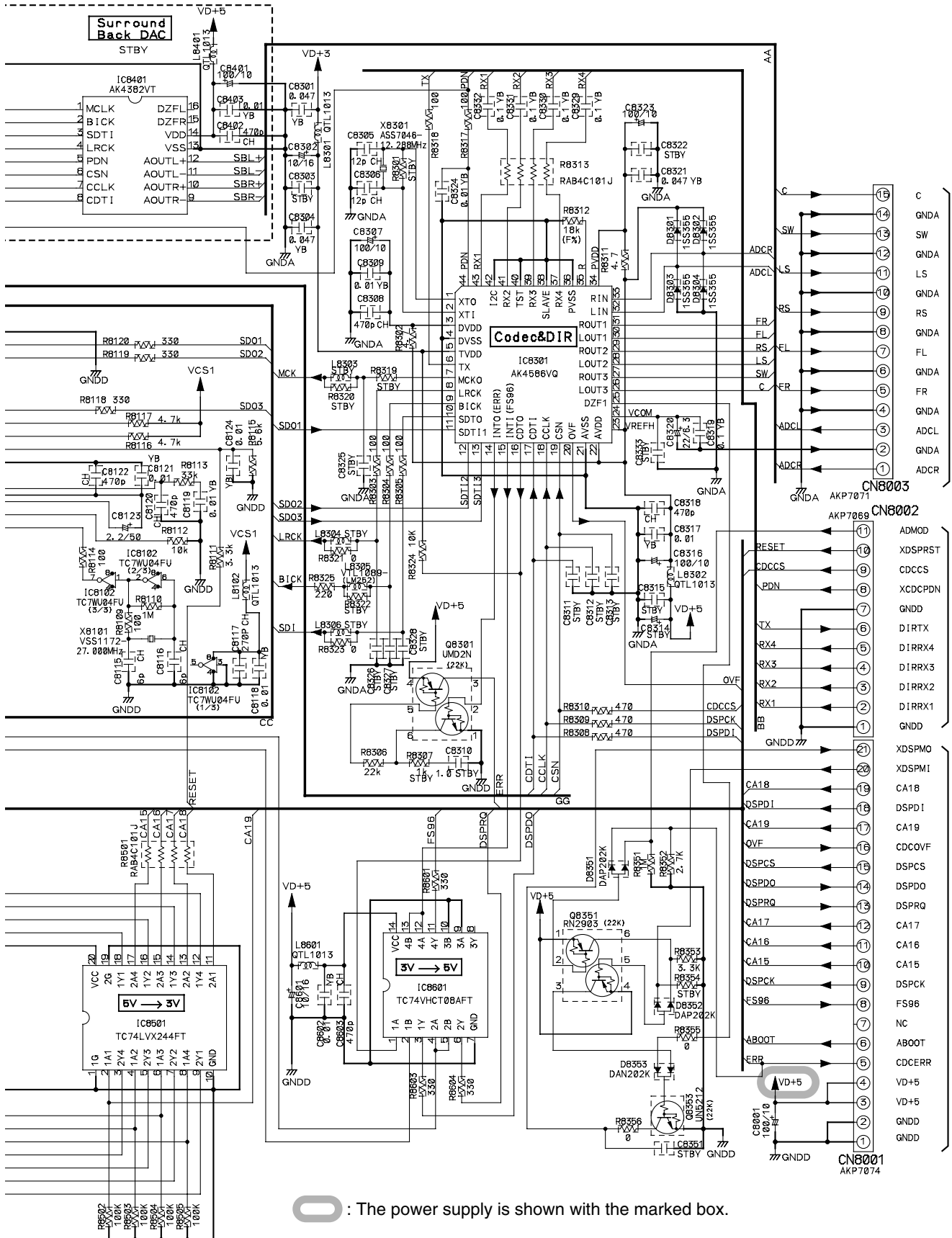

O : The power supply is shown with the marked box.

**B** CN5503

**B** CN5506

**B** CN5504

- C
- GNDA
- SW
- GNDA
- LS
- GNDA
- RS
- GNDA
- FL
- GNDA
- FR
- GNDA
- ADCL
- GNDA
- ADCR
- AKP7071
- CN8003
- CN8002
- ADMOD
- XDSPRST
- CDCCS
- XCDCPDN
- GNDD
- DIRTX
- DIRRX4
- DIRRX3
- DIRRX2
- DIRRX1
- GNDD
- XDSPMO
- XDSPMI
- CA18
- DSPDI
- CA19
- QVF
- CDCOVF
- DSPCS
- DSPDO
- DSPRQ
- CA17
- CA16
- CA15
- DSPCK
- FS96
- NC
- ABOOT
- CDCERR
- VD+5
- VD+5
- GNDD
- GNDD
- AKP7074
- CN8001

# 3.13 MIC ASSY

## M MIC ASSY (XWZ3626 / XV-EV51) (XWZ3623 / XV-EV21)

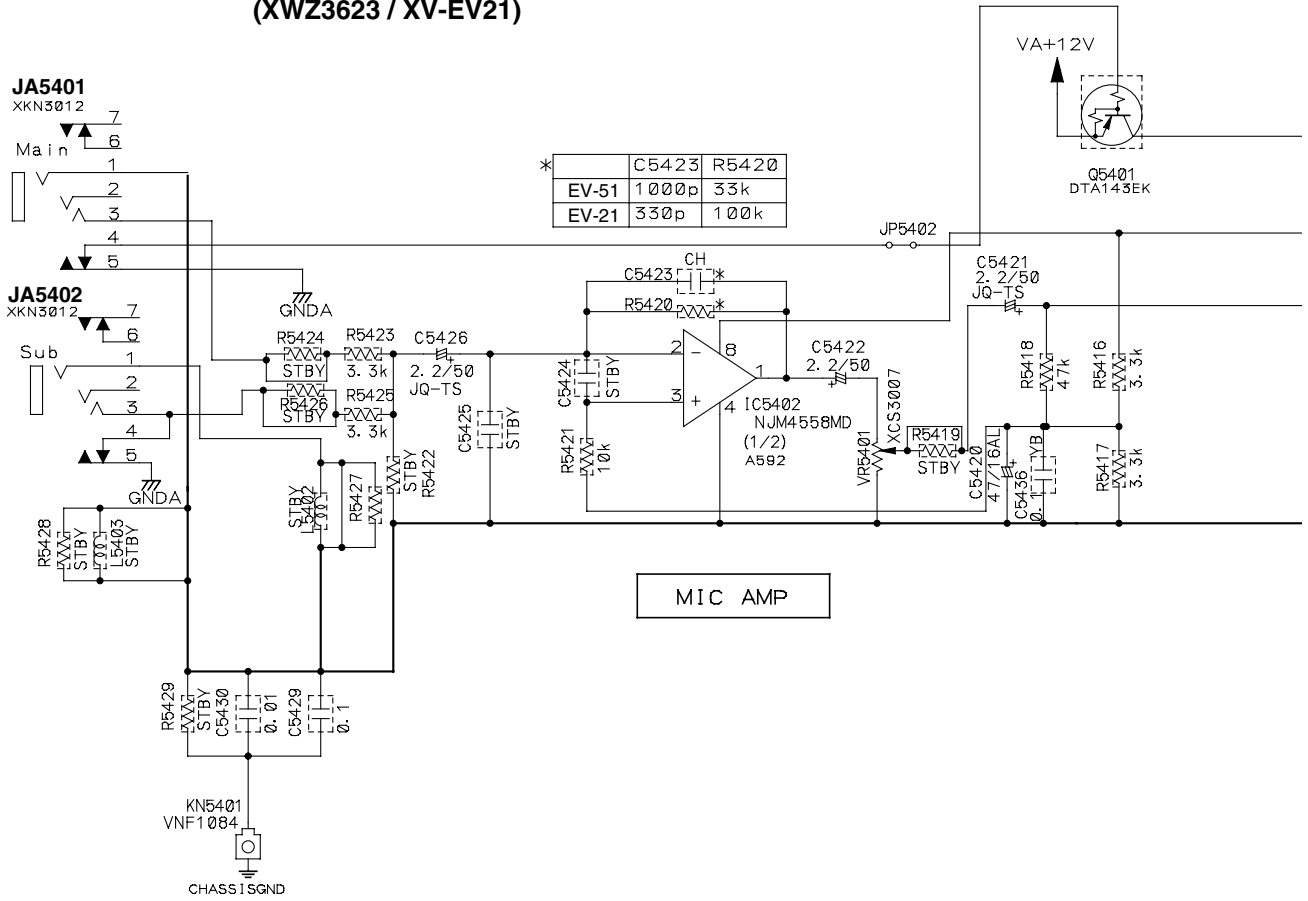

### NOTES

ALL CAPACITORS ARE IN  $\mu$ F  
UNLESS OTHERWISE SPECIFIED

CH : CCSRCH\*\*\*  
OTHER : CKSRYB\*\*\*

TS : CE\*\*\*\*M##-TS  
JQ : CEJQ\*\*\*\*M##-\*  
AL : CEAL\*\*\*\*M##-\*  
OTHER : CEAT\*\*\*\*M##

ALL INDUCTORS ARE IN  $\mu$ H  
UNLESS OTHERWISE SPECIFIED.

LAU\*\*\*J

ALL RESISTORS ARE IN  $\Omega$ .  
UNLESS OTHERWISE SPECIFIED.

1/16W

1/4WPU

ALL DIODES ARE 1SS133  
UNLESS OTHERWISE SPECIFIED.

MTZJ\*\*\*

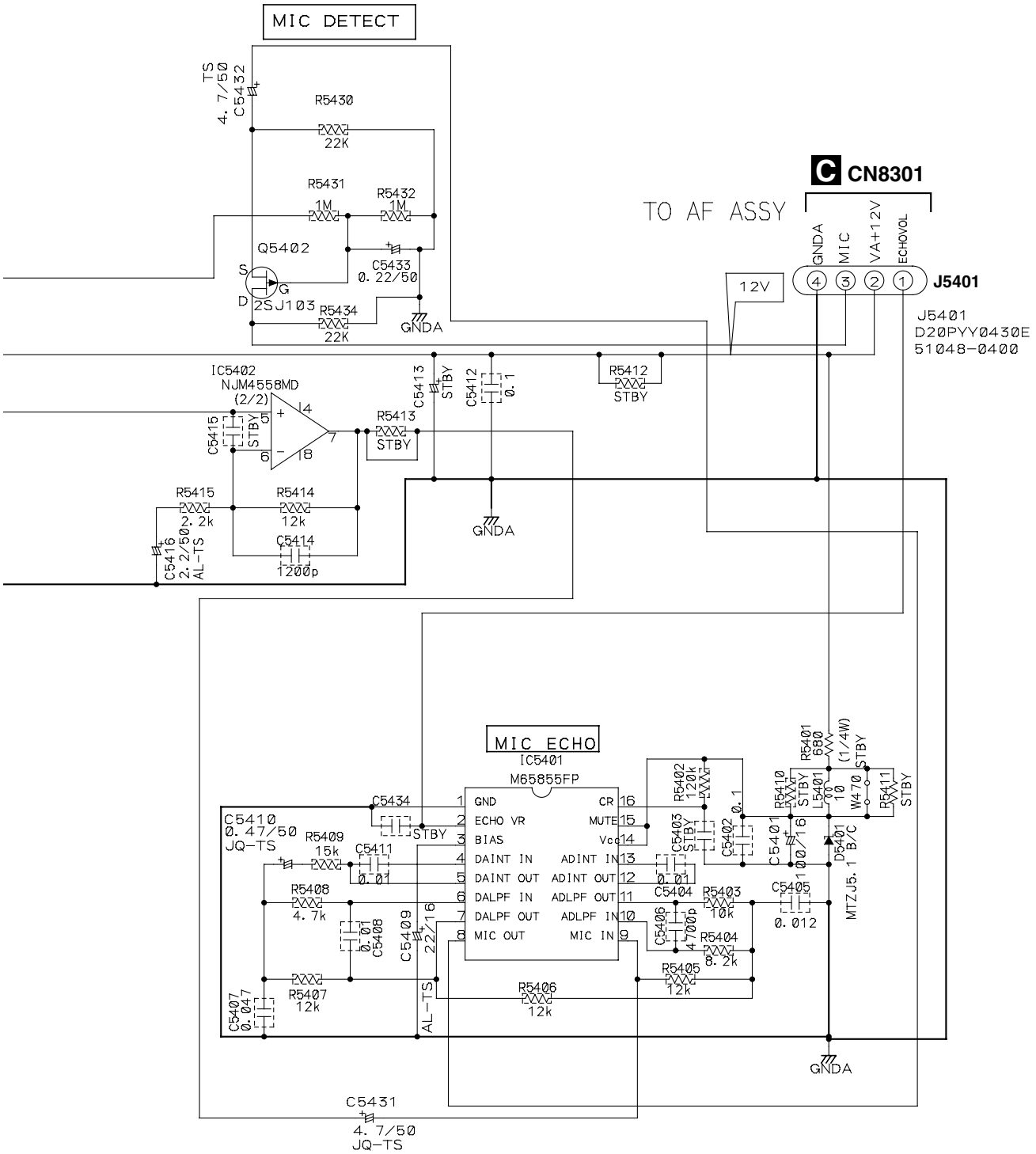

# 4. PCB CONNECTION DIAGRAM

## 4.1 LOAB ASSY

### NOTE FOR PCB DIAGRAMS :

1. Part numbers in PCB diagrams match those in the schematic diagrams.
2. A comparison between the main parts of PCB and schematic diagrams is shown below.

Symbol In PCB Diagrams	Symbol In Schematic Diagrams	Part Name
		Transistor
		Transistor with resistor
		Field effect transistor
		Resistor array
		3-terminal regulator

3. The parts mounted on this PCB include all necessary parts for several destinations.
- For further information for respective destinations, be sure to check with the schematic diagram.
4. View point of PCB diagrams.

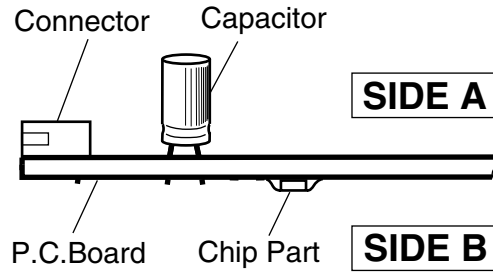

**SIDE A**

**SIDE B**

### **D** LOAB ASSY

### **D** LOAB ASSY

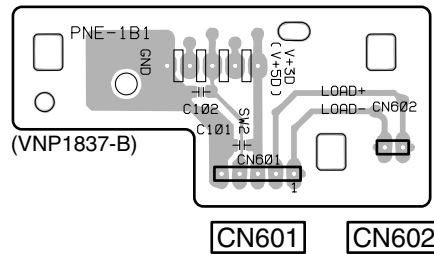
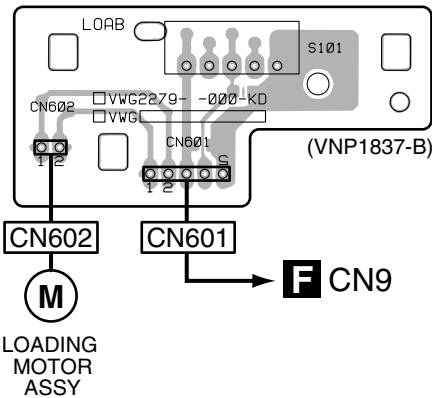

**D**

# 4.2 FM/AM TUNER MODULE

**SIDE A**

**SIDE B**

## A FM/AM TUNER MODULE

**SIDE A**

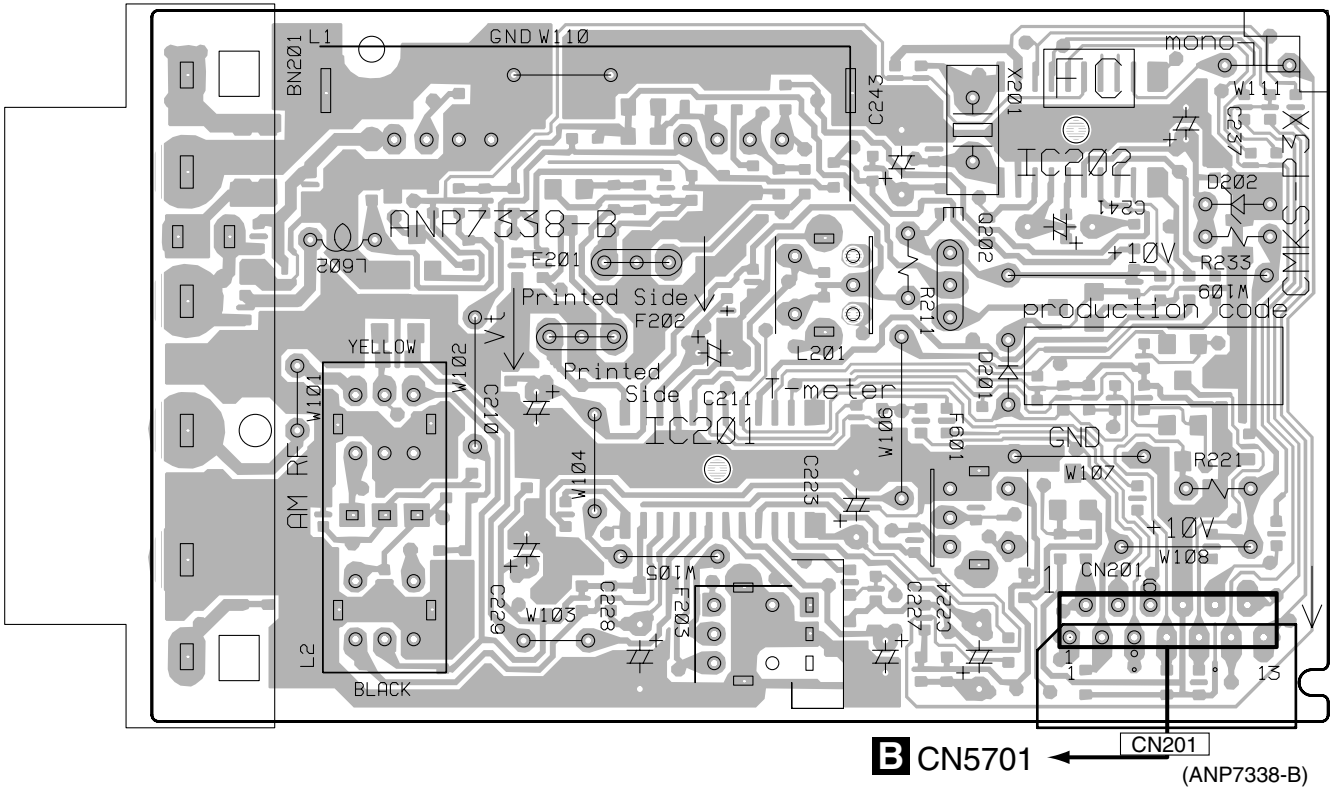

**B** CN5701 ← CN201  
 (ANP7338-B)

Q202

## A FM/AM TUNER MODULE

**SIDE B**

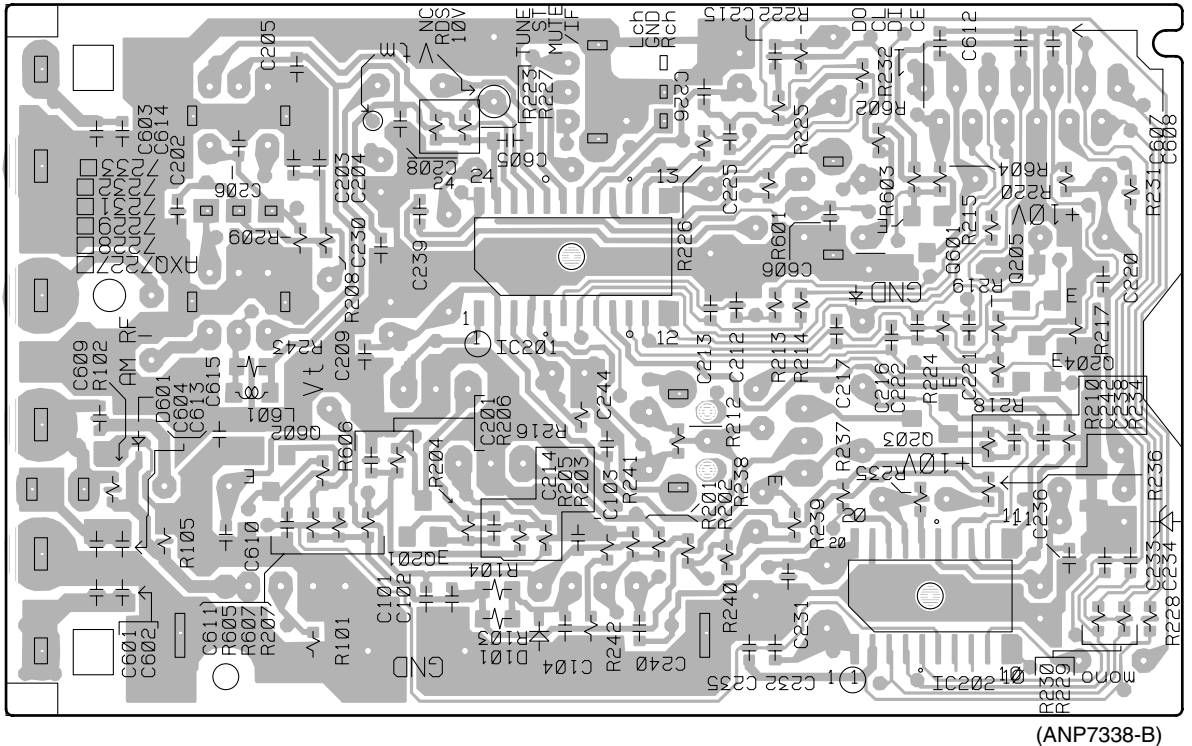

(ANP7338-B)

Q201

IC201

Q203

IC202

Q205

Q204

**A**

**A**

# 4.3 DVDM ASSY

**SIDE A**

## F DVDM ASSY

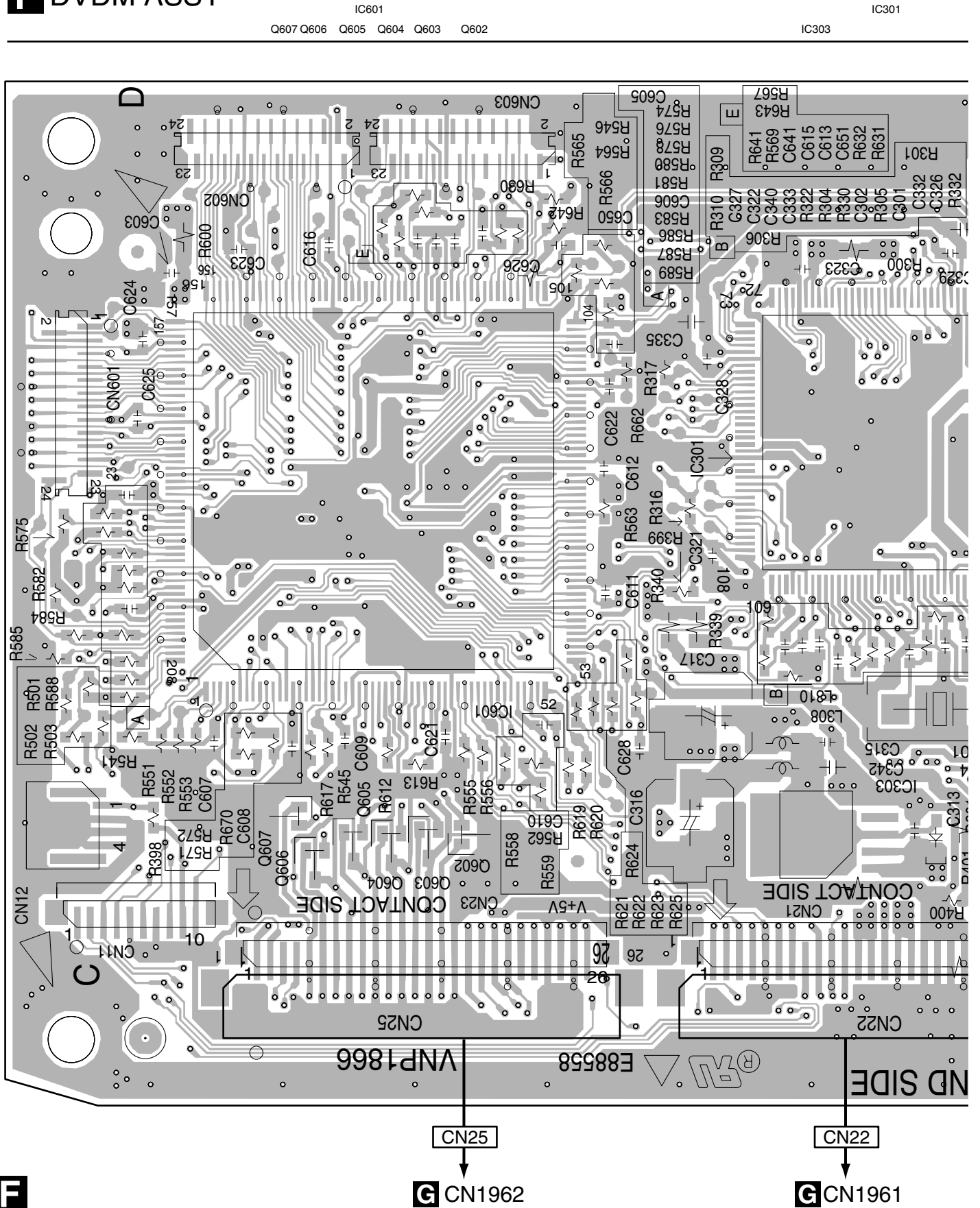



IC301

IC251 IC351 Q101

IC110 IC111

Q102

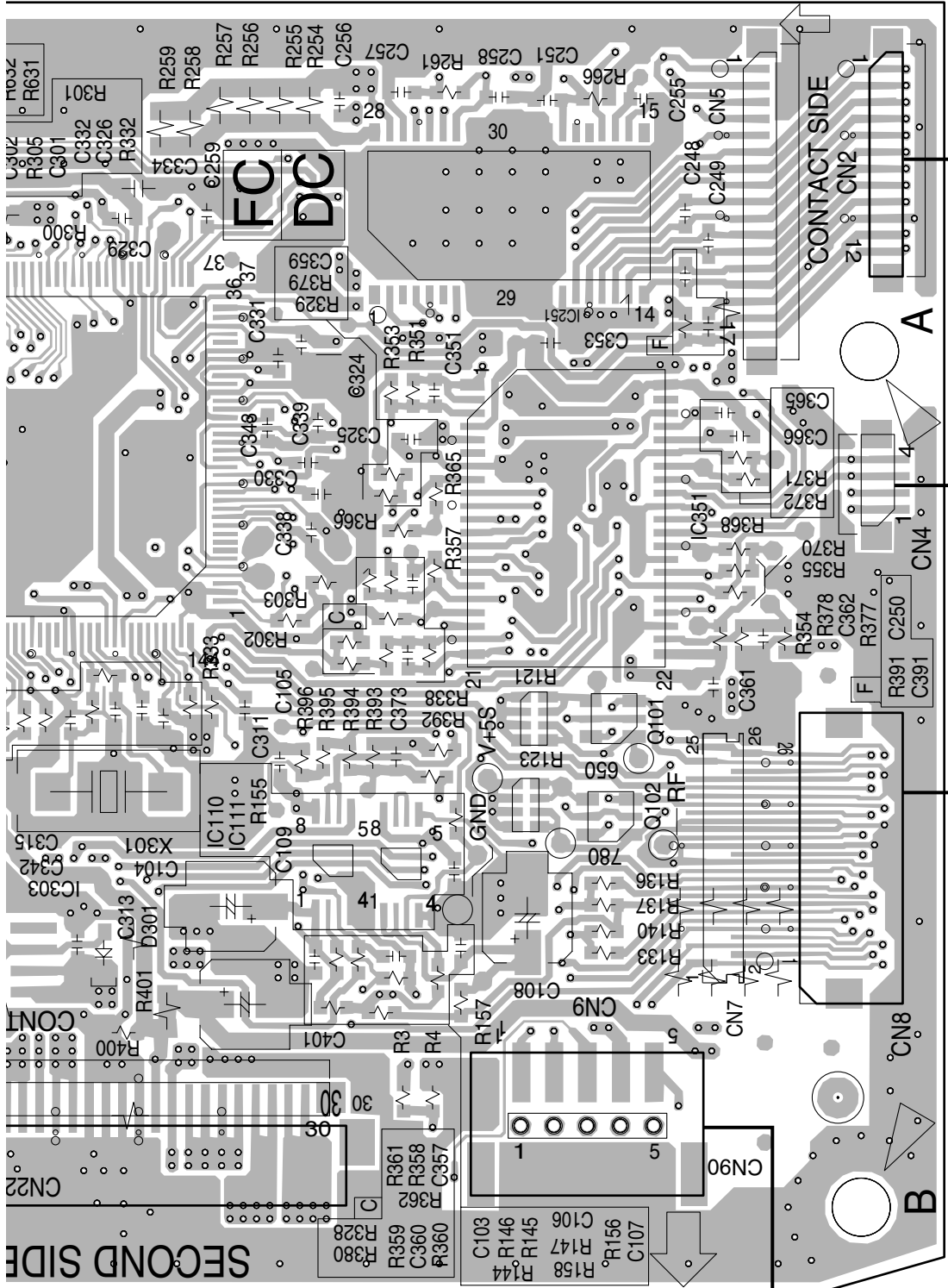

CN2  
 ↓  
 SPINDLE MOTOR

CN4  
 ↓  
 STEPPING MOTOR

CN8  
 ↓  
 PICKUP ASSY

CN9

D CN601

F

(VNP1866-D)

2

1961

SIDE B

# DVDM ASSY

IC302  
Q300

Q103

Q105

IC

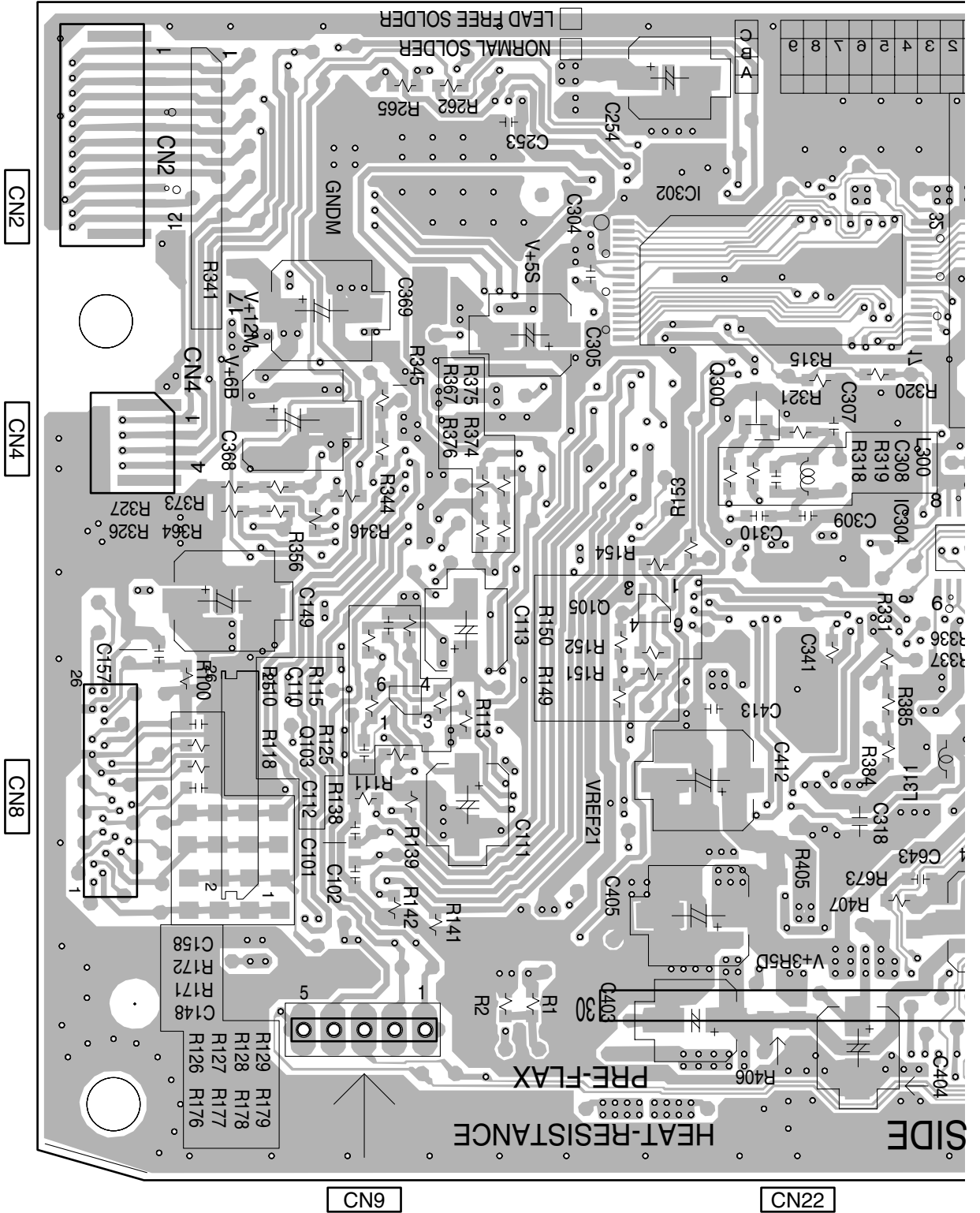

F

IC304

IC604

Q601

IC605

IC603

Q651

Q652

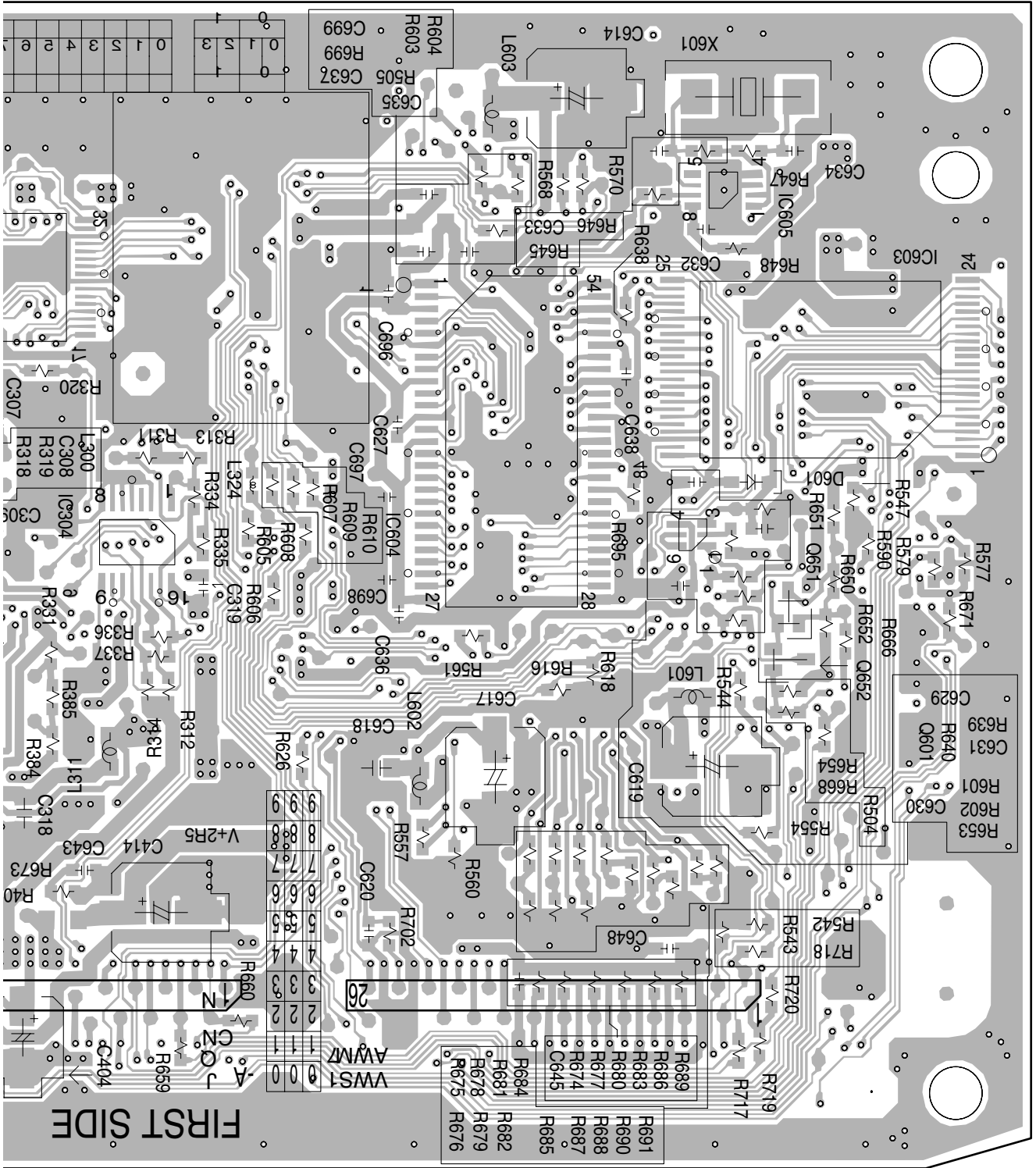

FIRST SIDE

CN25

(VNP1866-D)

# 4.4 DVD IF ASSY

**SIDE A**

**SIDE A**

## G DVDIF ASSY

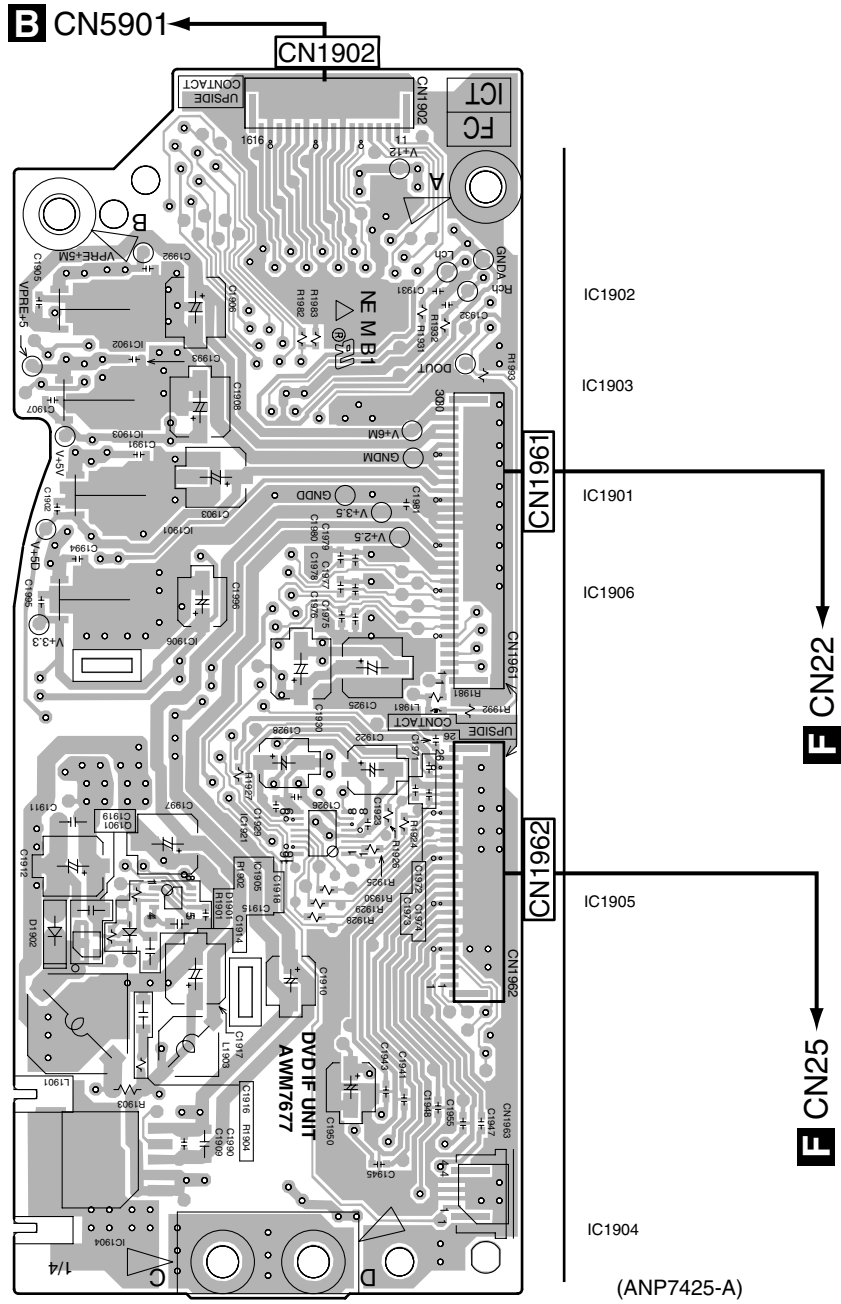





**SIDE B**

**B** IF ASSY

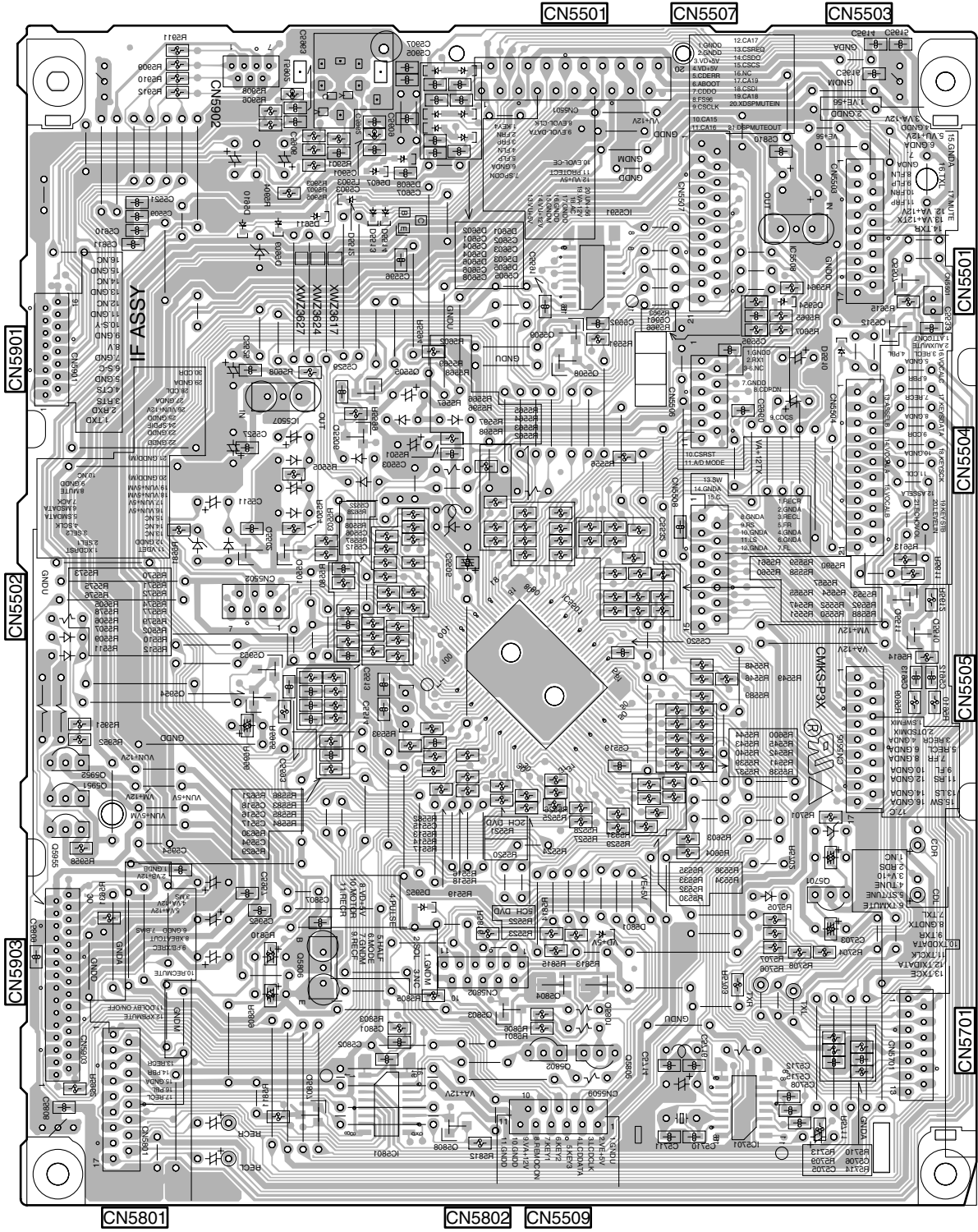

- IC5591
- IC5508
- Q5507
- Q5512
- Q5509
- Q5529
- Q5508
- Q5505
- IC5507
- Q5506
- Q5502
- Q5501
- IC5501
- Q5511
- Q5510
- Q5593
- Q5954
- Q5952
- Q5951
- Q5955
- Q5701
- Q5806
- Q5804
- Q5803
- Q5801
- Q5802
- Q5805
- Q5807
- IC5701
- Q5808
- Q5801

(XNP3060-D)

**B**

# 4.6 AF ASSY

**SIDE A**

**C** AF ASSY

TO. STEREO POWER AMPLIFIER  
(M-EV51 CN-3002)

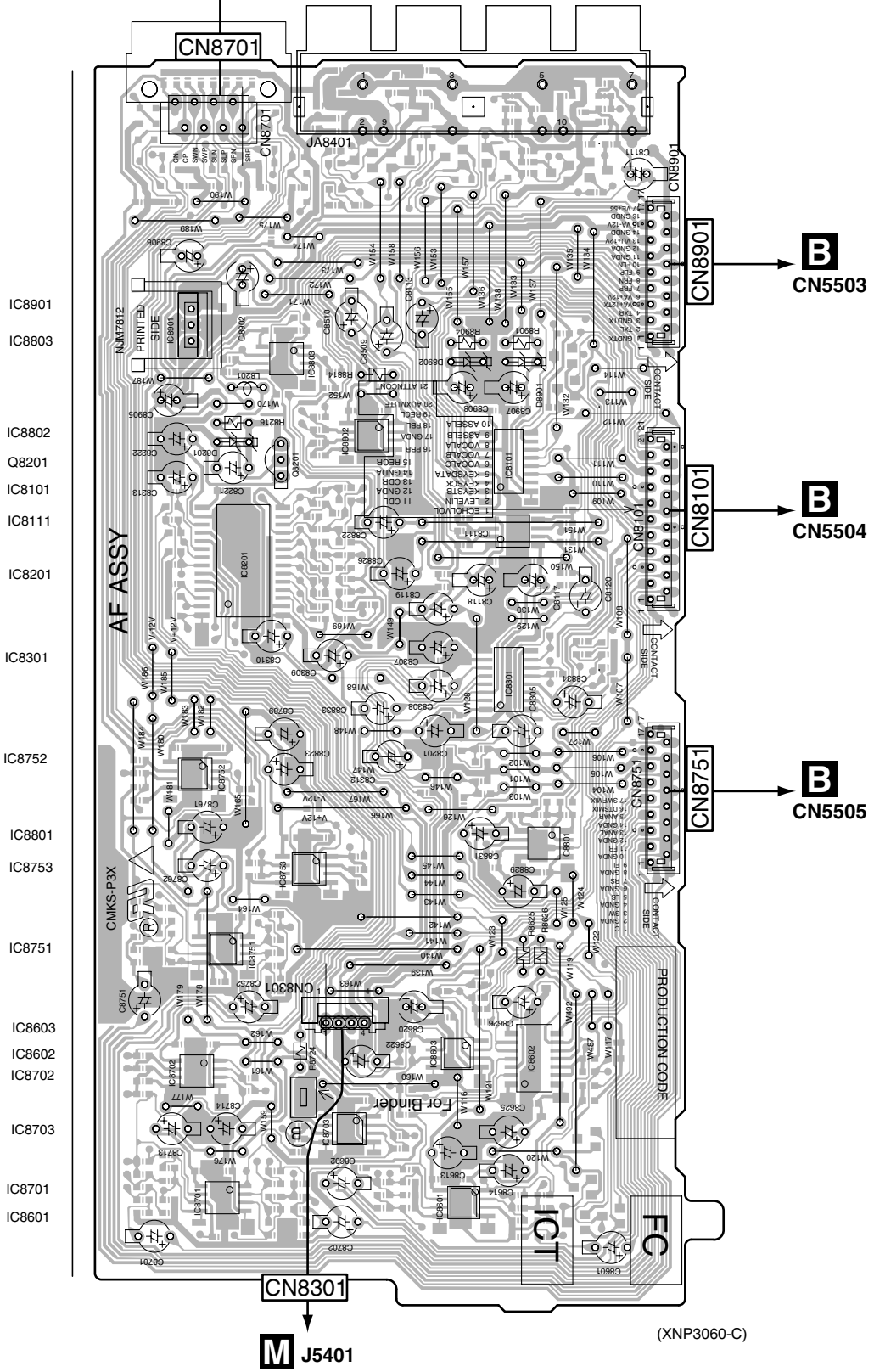

**B** CN5503

**B** CN5504

**B** CN5505

**M** J5401

(XNP3060-C)

XV-EV51

**C**



**SIDE B**

**C AF ASSY**

**CN8701**

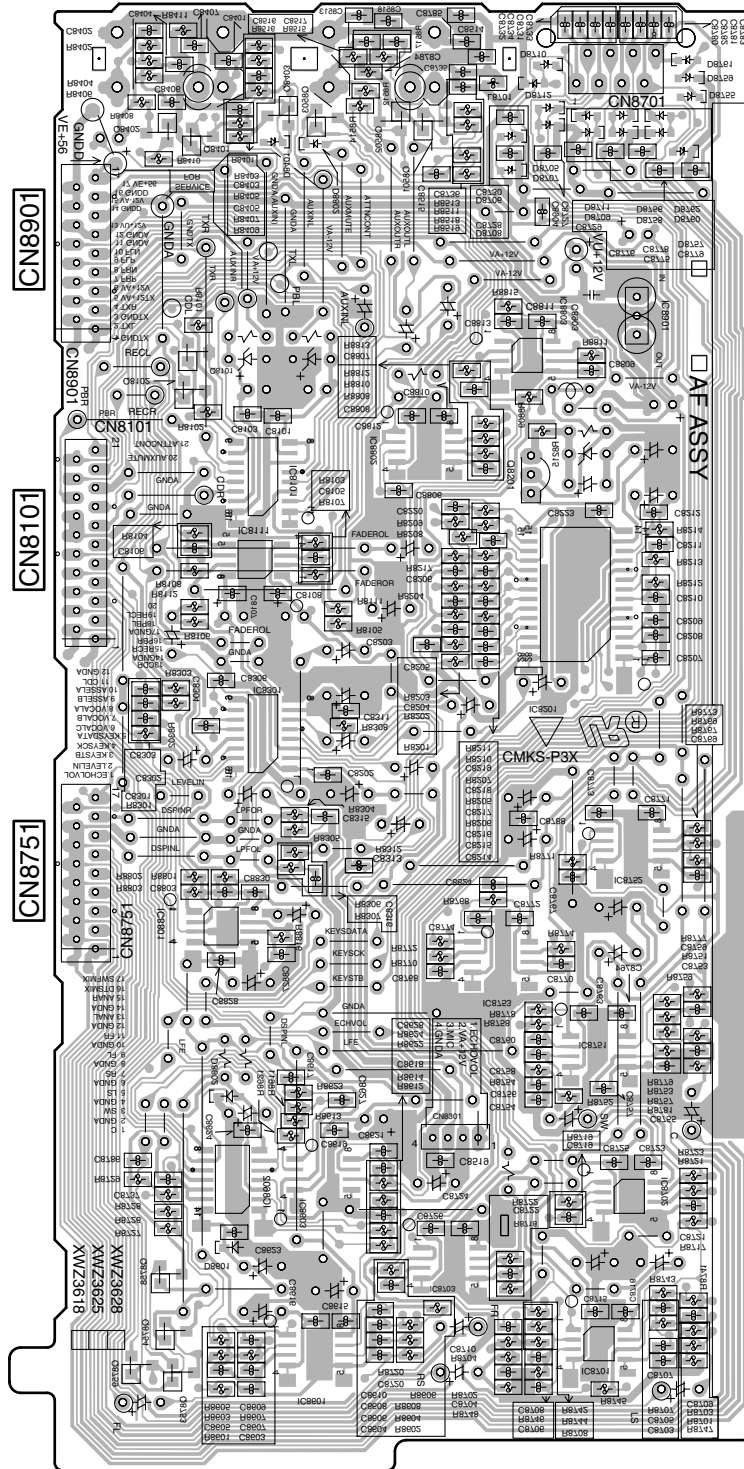

- Q8403
- Q8503
- Q8502
- Q8402
- Q8501
- Q8401
- IC8901
- IC8803
- Q8101
- Q8102
- IC8802
- IC8101
- Q8201
- IC8111
- IC8201
- IC8301
- Q3010
- Q3009
- Q4002
- Q301
- IC8801
- IC8753
- IC8751
- IC8602
- IC8702
- IC8603
- IC8703
- Q8758
- Q8754
- Q8759
- IC8701
- Q8753
- IC8601

(XNP3060-C)

**C**

# 4.7 DECK ASSY

**SIDE A**

**E** DECK ASSY

DECK MECHA

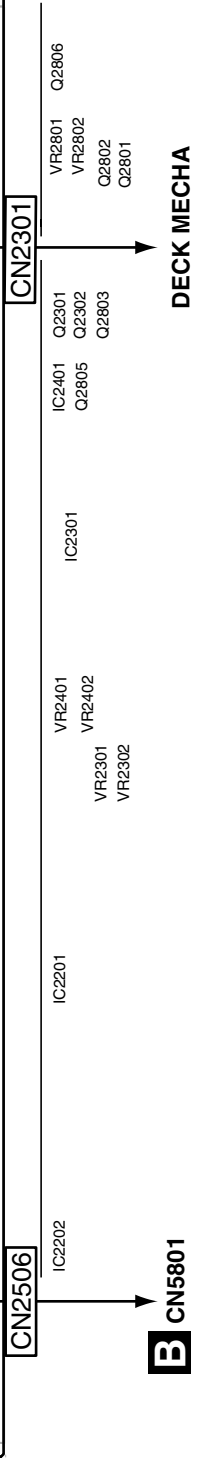
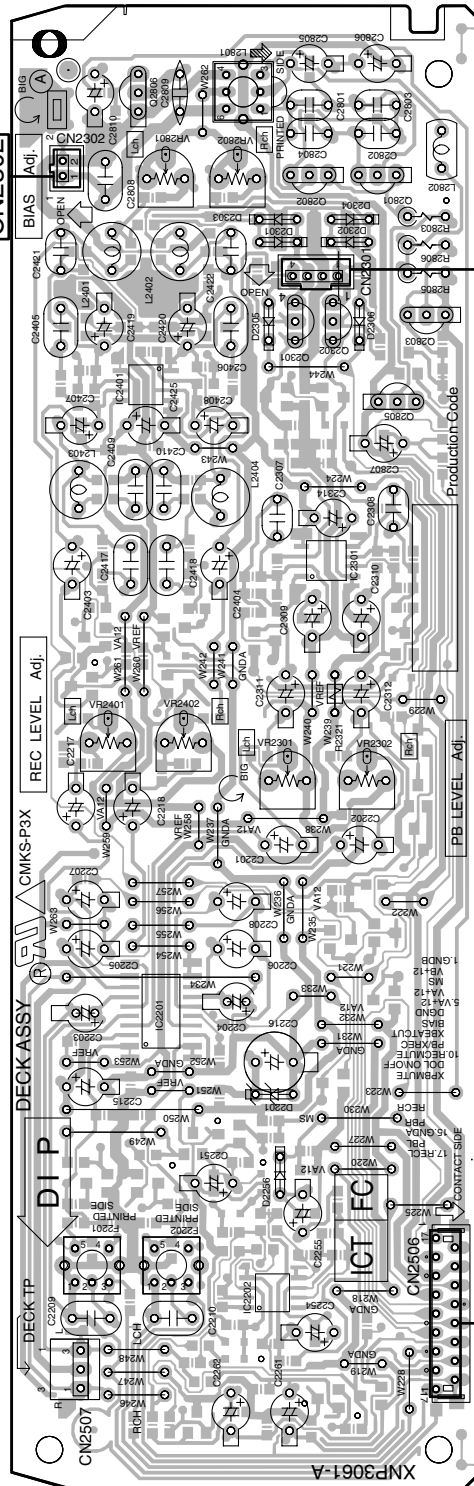

(XNP3061-A)

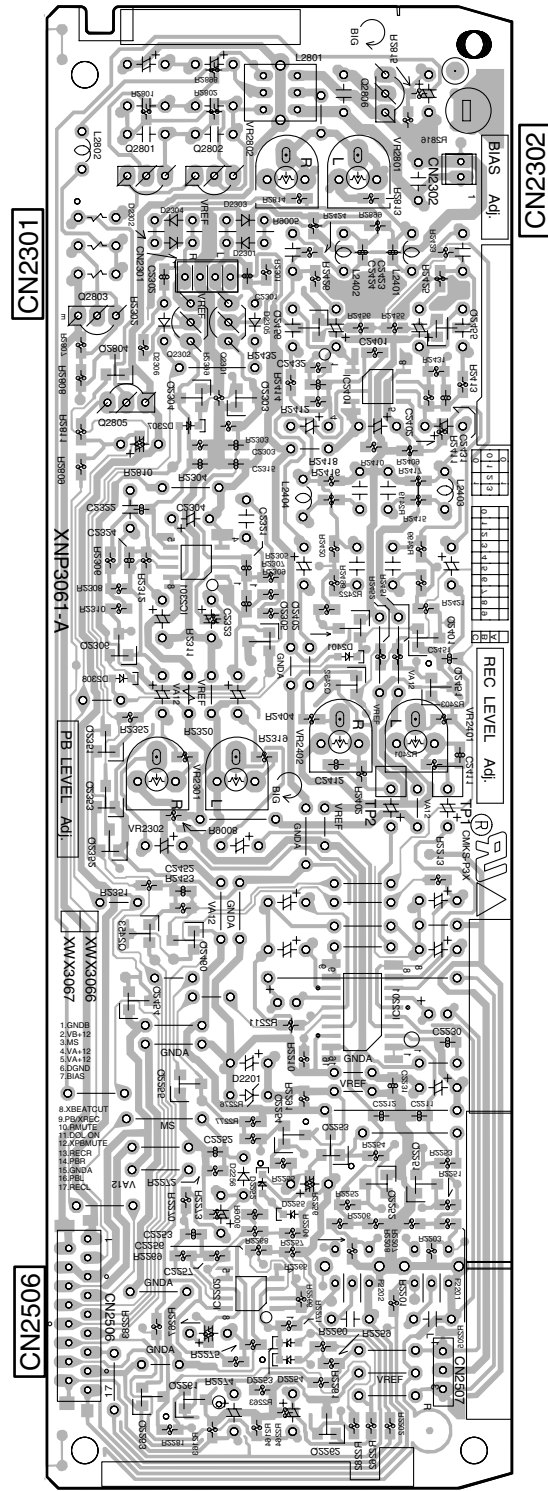

(XNP3061-A)

Q2806	VR2801	Q2803	Q2804	Q2805	IC2201	Q2306	Q2452	Q2351	Q2353	Q2352	Q2453	Q2454	Q2252	Q2263
VR2801	VR2801	Q2302	Q2304	Q2802	Q2301	Q2303	Q2451	VR2402	VR2401	Q2254	IC2202	Q2253	IC2202	Q2263
Q2801	Q2801	Q2456	IC2401	Q2801	Q2401	Q2401	VR2301	VR2301	VR2302	Q2252	Q2251	Q2252	Q2251	Q2262
		Q2455												





# 4.9 MIC ASSY

**SIDE A**

**SIDE A**

## M MIC ASSY

**C** CN8301

J5401

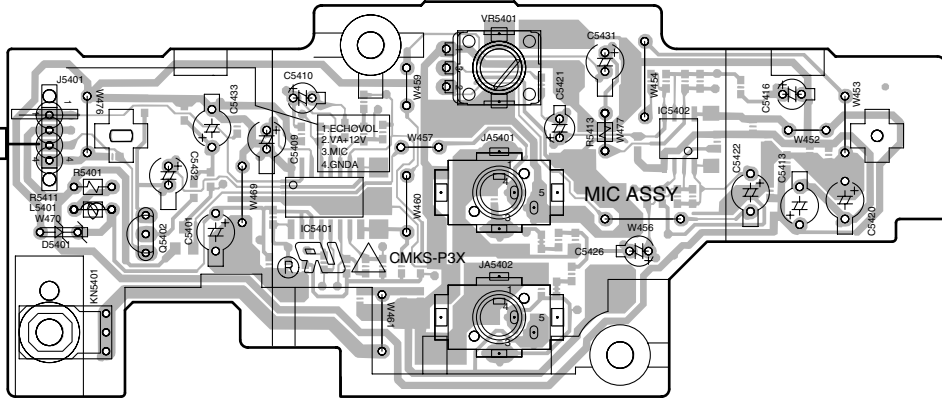

(XNP3060-C)

Q5402

IC5401

IC5402

**SIDE B**

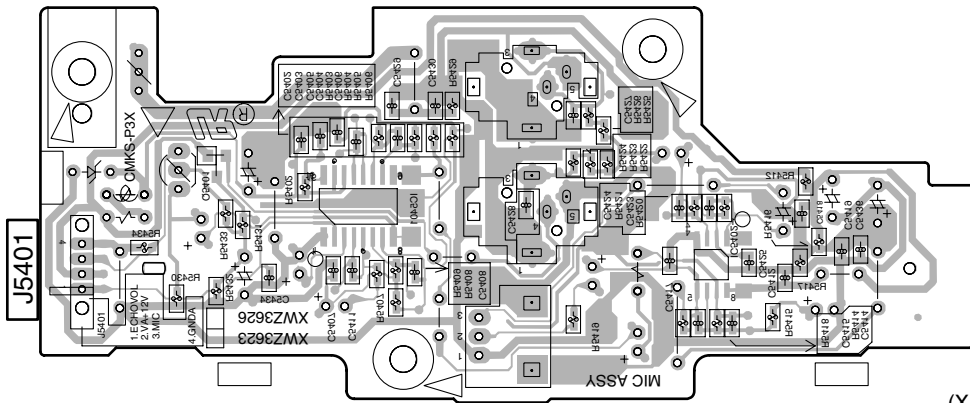

(XNP3060-C)

Q5401

IC5401

IC5402

# 4.10 DSP ASSY(XV-EV51 Only)

**SIDE A**

**SIDE A**

## **K** DSP ASSY(XV-EV51\_Only)

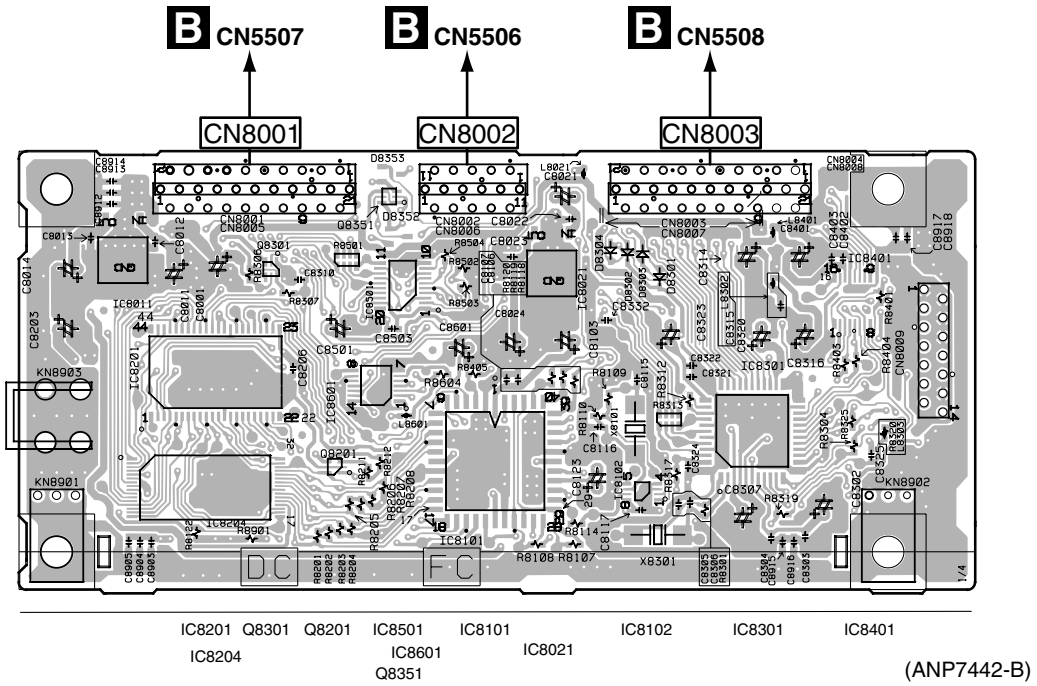

**SIDE B**

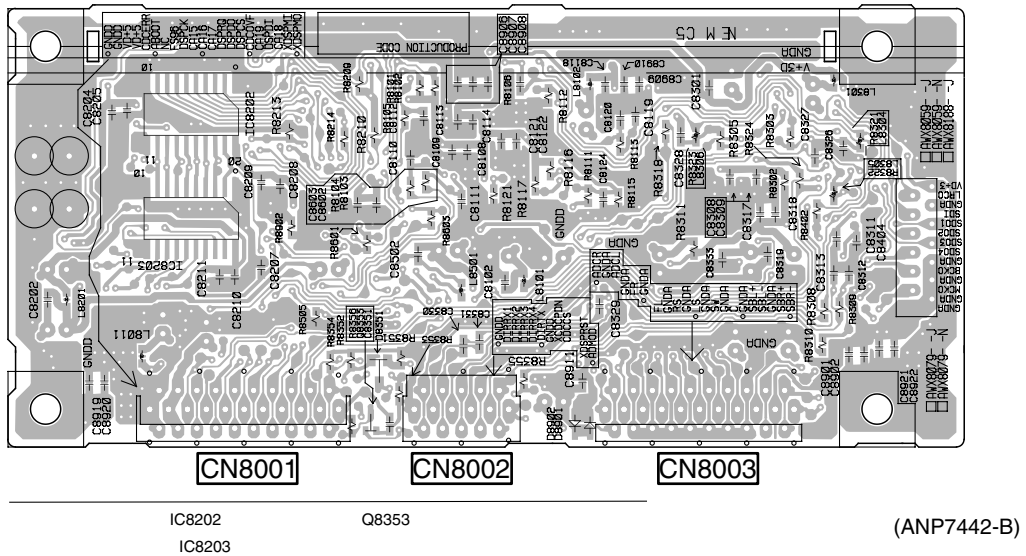

**K**

**K**

# 5. PCB PARTS LIST

NOTES: ● Parts marked by "NSP" are generally unavailable because they are not in our Master Spare Parts List.

● The  $\Delta$  mark found on some component parts indicates the importance of the safety factor of the part. Therefore, when replacing, be sure to use parts of identical designation.

● When ordering resistors, first convert resistance values into code form as shown in the following examples.

Ex.1 When there are 2 effective digits (any digit apart from 0), such as 560 ohm and 47k ohm (tolerance is shown by J=5%, and K=10%).

560  $\Omega$   $\rightarrow$  56 x 10<sup>1</sup>  $\rightarrow$  561 ..... RD1/4PU  $\overline{561}J$

47k  $\Omega$   $\rightarrow$  47 x 10<sup>3</sup>  $\rightarrow$  473 ..... RD1/4PU  $\overline{473}J$

0.5  $\Omega$   $\rightarrow$  R50 ..... RN2H  $\overline{R50}K$

1  $\Omega$   $\rightarrow$  1R0 ..... RS1P  $\overline{1R0}K$

Ex.2 When there are 3 effective digits (such as in high precision metal film resistors).

5.62k  $\Omega$   $\rightarrow$  562 x 10<sup>1</sup>  $\rightarrow$  5621 ..... RN1/4PC  $\overline{5621}F$

## Mark No. Description Part No.

### LIST OF ASSEMBLIES

XV-EV51/ZLXJ/NC  
1..DSP ASSY AWX8059

NSP 1..MEDIA ASSY XWM3206  
2..IF ASSY XWZ3617  
2..AF ASSY XWZ3618  
2..DISP 1 ASSY XWZ3619  
2..DISP 2 ASSY XWZ3620  
2..DISP 3 ASSY XWZ3621  
2..LED ASSY XWZ3622  
2..MIC ASSY XWZ3626

1..DECK ASSY XWZ3067

NSP 1..DVD ASSY AXA7110  
2..DVD IF ASSY AWM7677  
2..DVDM ASSY AWM7684

NSP 1..LOADING MECHANISM ASSY VWT1203  
NSP 2..LOAB ASSY VWG2346

1..FM/AM TUNER MODULE AXQ7228

XV-EV21/ZLXJ/NC

NSP 1..MEDIA ASSY XWM3208  
2..IF ASSY XWZ3627  
2..AF ASSY XWZ3628  
2..DISP 1 ASSY XWZ3619  
2..DISP 2 ASSY XWZ3620  
2..DISP 3 ASSY XWZ3621  
2..LED ASSY XWZ3622  
2..MIC ASSY XWZ3623

1..DECK ASSY XWZ3066

NSP 1..DVD ASSY AXA7110  
2..DVD IF ASSY AWM7677  
2..DVDM ASSY AWM7684

NSP 1..LOADING MECHANISM ASSY VWT1203  
NSP 2..LOAB ASSY VWG2346

1..FM/AM TUNER MODULE AXQ7228

## Mark No. Description Part No.

### **K** DSP Assy (EV51 Only)

#### SEMICONDUCTORS

IC8301 AK4586VQ

## Mark No. Description Part No.

IC8101 CS493292  
 $\Delta$  IC8021 NJM2391DL1-25  
 $\Delta$  IC8011 NJM2391DL1-33  
IC8201 PD8104A

IC8501 TC74LVX244FT  
IC8202, IC8203 TC74VHC574F  
IC8601 TC74VHCT08AFT  
IC8102 TC7WU04FU  
Q8351 RN2903

Q8301 UMD2N  
Q8353 UN5212  
D8301-D8304 1SS355  
D8353 DAN202K  
D8351, D8352 DAP202K

#### COILS AND FILTERS

L8011, L8102, L8201 Chip Inductor QTL1013  
L8301, L8302, L8501, L8601 QTL1013  
L8305 Chip Beads VTL1089

#### CAPACITORS

C8305, C8306 CCSRCH120J50  
C8117 CCSRCH271J50  
C8107, C8109, C8113, C8120, C8122 CCSRCH471J50  
C8205, C8206, C8209, C8210, C8308 CCSRCH471J50  
C8318, C8503, C8603 CCSRCH471J50

C8115, C8116 CCSRCH6R0D50  
C8302, C8501, C8601 CEAL100M16  
C8001, C8014, C8024, C8103, C8307 CEAL101M10  
C8316, C8323 CEAL101M10  
C8320 CEAL220M6R3

C8123 CEAL2R2M50  
C8011, C8021 CEAL4R7M16  
C8906 CKSRYB102K50  
C8102, C8106, C8108, C8114 CKSRYB103K50  
C8118, C8119, C8121, C8124, C8202 CKSRYB103K50

C8204, C8207, C8208, C8211, C8309 CKSRYB103K50  
C8317, C8324, C8502, C8602, C8920 CKSRYB103K50  
C8319, C8329-C8332, C8903, C8907 CKSRYB104K25  
C8911 CKSRYB104K25  
C8301, C8304, C8321 CKSRYB473K25

#### RESISTORS

R8313, R8501 RAB4C101J  
R8312 RS1/16S1802F  
Other Resistors RS1/16S###J

#### OTHERS

CN8002 11P SOCKET AKP7069  
CN8003 15P SOCKET AKP7071



Mark No.	Description	Part No.
CN8001	21P SOCKET	AKP7074
X8301	CRYSTAL RES.(12.28MHz)	ASS7046
8903	SCREW PLATE	VNE1948
KN8901, KN8902	EARTH METAL FIT.	VNF1084
X8101	CRYSTAL RES.(27MHz)	VSS1172

## **A** FM/AM TUNER MODULE

### **SEMICONDUCTORS**

IC201	BA1451F
IC202	LC72131MD
Q201, Q204, Q205	2SC2412K
Q202	DTA124ES
Q203	DTC124EK
D201	1SS133
D202	MTZJ5.1C

### **COILS AND FILTERS**

L201 (FM Detector coil)	ATE7003
F202 (Ceramic filter)	ATF-107
F201 (Ceramic filter)	ATF-119
F203 (AM Ceramic filter)	ATF1155

### **CAPACITORS**

C206	CCSRCH100D50
C212, C213, C226, C233-C235	CCSRCH101J50
C240	CCSRCH101J50
C231, C232	CCSRCH150J50
C223	CEAT100M50
C229	CEAT101M10
C224	CEAT1R0M50
C227	CEAT220M25
C241	CEAT2R2M50
C243	CEAT330M16
C228	CEAT3R3M50
C237	CEAT470M10
C211	CEJA1R0M50
C210	CEJA470M16
C204, C238, C602	CKSRYB102K50
C101, C102, C208, C220, C239	CKSRYB103K50
C242, C601	CKSRYB103K50
C216, C217	CKSRYB123K50
C225	CKSRYB153K50
C201, C205, C209, C214, C230	CKSRYB223K50

C236, C603	CKSRYB223K50
C221	CKSRYB224K10
C202, C222	CKSRYB473K16
C215	CKSRYB681K50

### **RESISTORS**

R211	RD1/4PU221J
R221	RD1/4PU222J
R233	RD1/4PU391J
R243	RS1/10S0R0J
R103	RS1/10S331J

R104	RS1/10S391J
Other Resistors	RS1/16S###J

### **OTHERS**

CN201	13P Connector	52044-1345
BN201	4P Terminal	AKA7003
	Shield Case T	ANK7072
	Shield Case B	ANK7073

Mark No.	Description	Part No.
X201	Crystal RES.(7.2MHz)	ASS1093

## **B** IF ASSY (XWZ3617)

### **SEMICONDUCTORS**

IC5591, IC5801	BU4094BCF
△ IC5507	NJM7805FA
△ IC5508	NJM78M56FA
IC5501	PDC093A
Q5951, Q5801, Q5952	2SB1237X
Q5501, Q5953, Q5954	2SC2412K
Q5701	2SD1858X
Q5806	2SD2012
Q5803	DTA124EK
Q5505, Q5509	DTA143EK
Q5506, Q5507, Q5508	DTC124EK
Q5502, Q5807, Q5808, Q5802, Q5805	DTC143EK
D5501, D5502, D5506, D5508, D5509	1SS133
D5703, D5951, D5953, D5801, D5952	1SS133
D5954	1SS355
D5511	MTZJ11B
D5701	MTZJ11C
D5507	MTZJ6.8B
D5609, D5512, D5513, D5514	UDZS6.8B

### **COILS AND FILTERS**

L5501	LAU220J
-------	---------

### **CAPACITORS**

C5502 (0.047F)	ACH1246
C5962, C5963,	CCSRCH101J50
C5901, C5903, C5906	CCSRCH331J50
C5958, C5959	CEAL100M16
C5531	CEAL100M50
C5530	CEAL1R0M50
C5510, C5702, C5717, C5718, C5803	CEAT100M50
C5804, C5953, C5955, C5956	CEAT100M50
C5526	CEAT101M16
C5507, C5805	CEAT1R0M50
C5951	CEAT220M50
C5501, C5504, C5806	CEAT470M16
C5528	CEAT470M50
C5902, C5904	CEAT471M6R3
C5506, C5612,	C5613CKSRYB102K50
C5516, C5517, C5518, C5521, C5529	CKSRYB103K50
C5593, C5594, C5601, C5603, C5605	CKSRYB103K50
C5607, C5609, C5610, C5703, C5808	CKSRYB103K50
C5809, C5810, C5952, C5954, C5957	CKSRYB103K50
C5503, C5505, C5509, C5512, C5515	CKSRYB104K16
C5527, C5532, C5591, C5616, C5802	CKSRYB104K16
C5960	CKSRYB104K16
C5592, C5801	CKSRYB221K50
C5961	CKSRYB224K10
C5807	CKSRYB473K25
C5614	CKSRYF105Z10

### **RESISTORS**

R5957	RD1/2PM121J
R5953	RD1/2PM331J
R5802, R5804, R5807	RD1/4PU102J
R5954	RD1/4PU152J
R5601, R5606	RD1/4PU473J

Mark No.	Description	Part No.
	Other Resistors	RS1/16S###J

### OTHERS

CN5502 7P Connector	52045-0745
CN5509, CN5802 11P Connector	52045-1145
CN5701 13P Connector	52045-1345
CN5506 11P Plug	AKP7058
CN5508 15P Plug	AKP7060

CN5503, CN5505, CN5801 17P Plug	AKP7061
CN5504, CN5507 21P Plug	AKP7063
X5501 Ceramic RES. (10MHz)	ASS7034
CN5510 2P Plug	KM200SA2
CN5901 16P Connector	VKN1192

CN5903 30P Connector	VKN1206
CN5902 7P Connector	VKN1211
KN5501, KN5502 Earth metal FIT.	VNF1084
KN5503 Earth metal FIT.	VNF1084
JA5903 2P Pinjack	XKB3039

CN5501 20P Socket	XKP3051
-------------------	---------

## B IF ASSY(XWZ3627)

### SEMICONDUCTORS

IC5801	BU4094BCF
⚠ IC5507	NJM7805FA
⚠ IC5508	NJM78M56FA
IC5501	PDC097A
Q5951, Q5955	2SA1282

Q5801, Q5804	2SB1132
Q59522	SB1237X
Q5501, Q5701	2SD1858X
Q5806	2SD2012
Q5510, Q5511	2SD2114K

Q5512, Q5803	DTA124EK
Q5505, Q5509	DTA143EK
Q5506-Q5508	DTC124EK
Q5502, Q5805	DTC143ES
D5501, D5502, D5504, D5506	1SS133

D5508, D5509, D5703, D5951, D5953	1SS133
D5510, D5801, D5952, D5954	1SS355
D5511	MTZJ11B
D5701	MTZJ11C
D5507	MTZJ6.8B

D5609, D5610	UDZS15B
D5512-D5514	UDZS6.8B

### COILSANDFILTERS

L5501	LAU220J
-------	---------

### CAPACITORS

C5502 (0.047F)	ACH1246
C5962, C5963	CCSRCH101J50
C5901, C5903, C5906	CCSRCH331J50
C5958, C5959	CEAL100M16
C5531	CEAL100M50

C5530	CEAL1R0M50
C5510, C5702, C5717, C5718	CEAT100M50
C5803, C5804, C5953, C5955, C5956	CEAT100M50
C5507, C5805	CEAT1R0M50
C5951	CEAT220M50

Mark No.	Description	Part No.
C5501, C5504, C5526, C5806		CEAT470M16
C5528		CEAT470M50
C5902, C5904		CEAT471M6R3
C5506, C5612, C5613		CKSRYP102K50
C5516-C5518, C5521, C5529		CKSRYP103K50

C5593, C5594, C5601, C5603, C5605	CKSRYP103K50
C5607, C5609, C5610, C5703	CKSRYP103K50
C5808-C5810, C5952, C5954, C5957	CKSRYP103K50
C5503, C5505, C5509, C5512, C5515	CKSRYP104K16
C5527, C5532, C5616, C5802, C5960	CKSRYP104K16

C5801	CKSRYP221K50
C5961	CKSRYP224K10
C5807	CKSRYP473K25

### RESISTORS

R5957	RD1/2PM121J
R5953	RD1/2PM331J
R5802, R5804, R5807	RD1/4PU102J
R5954	RD1/4PU152J
R5601, R5606	RD1/4PU473J

### OTHERS

CN5502 7P Connector	52045-0745
CN5509, CN5802 11P Connector	52045-1145
CN5701 13P Connector	52045-1345
CN5503, CN5801 17P Plug	AKP7061
CN5504 21P Plug	AKP7063

X5501 Ceramic RES. (10MHz)	ASS7034
CN5510 2P Plug	KM200SA2
CN5901 16P Connector	VKN1192
CN5903 30P Connector	VKN1206
CN5902 7P Connector	VKN1211

KN5501, KN5502 Earth metal FIT.	VNF1084
L5902, L5903	VTL1084
JA5903 2P Pinjack	XKB3039
CN5501 20P Socket	XKP3051

## C AF ASSY(XWZ3618)

### SEMICONDUCTORS

IC8111, IC8801	AN4558NS
IC8301	BA3838F
IC8101	BU4052BCF
IC8602	BU4066BCF
IC8201	M65847AFP

IC8601, IC8603, IC8701, IC8702,	IC8703NJM4558MD
IC8751, IC8752, IC8753, IC8802,	IC8803NJM4558MD
IC8901	NJM7812FA
Q8401, Q8402	2SC2412K
Q8201	2SD1858X

Q8501, Q8502	2SD2114K
Q8403, Q8503, Q8754, Q8758	DTA124EK
Q8101, Q8102, Q8753, Q8759	DTC124EK
D8401, D8802	1SS355
D8201	MTZJ5.6B

D8901, D8902	MTZJ6.8B
D8601, D8602	UDZS6.8B

### CAPACITORS

C8212	CCSRCH101J50
C8705, C8706, C8709, C8710, C8755	CCSRCH331J50
C8759	CCSRCH331J50
C8217	CCSRCH471J50

Mark No.	Description	Part No.
C8609, C8610		CCSRCH820J50
C8111		CEAL100M50
C8113, C8119, C8120, C8221, C8509		CEAT100M50
C8510, C8752, C8752, C8822, C8826		CEAT100M50
C8833, C8834		CEAT100M50
C8789, C8823		CEAT101M16
C8902		CEAT1R0M50
C8305, C8308, C8309, C8310, C8601		CEAT2R2M50
C8602, C8701, C8702, C8751		CEAT2R2M50
C8117, C8118, C8201, C8213, C8222		CEAT470M16
C8307, C8625, C8626, C8829, C8831		CEAT470M16
C8905, C8906, C8907, C8908		CEAT470M16
C8312		CEAT4R7M50
C8903		CKSQYF105Z25
C8220, C8605, C8606		CKSRYB102K50
C8101, C8103, C8107, C8108, C8203		CKSRYB103K50
C8204, C8205, C8218, C8313, C8514		CKSRYB103K50
C8519, C8615, C8616, C8619, C8621		CKSRYB103K50
C8623, C8624, C8715, C8716, C8723		CKSRYB103K50
C8724, C8725, C8726, C8727, C8728		CKSRYB103K50
C8729, C8730, C8736, C8763, C8764		CKSRYB103K50
C8771, C8772, C8773, C8774, C8775		CKSRYB103K50
C8776, C8778, C8779, C8810, C8811		CKSRYB103K50
C8812, C8813, C8828, C8830		CKSRYB103K50
C8301, C8302, C8303, C8407, C8515		CKSRYB104K16
C8518, C8754		CKSRYB104K16
C8219		CKSRYB122K50
C8603, C8604		CKSRYB222K50
C8904		CKSRYB223K50
C8304		CKSRYB224K10
C8756		CKSRYB333K25
C8703, C8704, C8753		CKSRYB471K50
C8216		CKSRYB472K50
C8202, C8223, C8306, C8788, C8824		CKSRYB473K25
C8207, C8208, C8209		CKSRYB683K16
C8760		CKSRYB821K50
C8206		CKSRYB822K50
C8513		CKSRYF105Z10
C8214, C8215		CKSRYF224Z16
<b>RESISTORS</b>		
R8216		RD1/4PU102J
R8724, R8814		RD1/4PU470J
R8901, R8904		RD1/4PU471J
R8625,		R8626RD1/4PU821J
R8717, R8718,		R8721RS1/16S1002F
R8722, R8767, R8768, R8769		RS1/16S1002F
R8770, R8808, R8809, R8810, R8811		RS1/16S1002F
Other Resistors		RS1/16S###J
<b>OTHERS</b>		
CN8301 4P Jumper connector		52147-0410
CN8751, CN8901 17P Socket		AKP7072
CN8101 21P Socket		AKP7074
Heat sink		ANH-309
Screw		BBZ30P080FMC
JA8401 4P Pinjack		XKB3040
CN8701 8P Socket		XKP3052

**C** AF ASSY(XWZ3628)

Mark No.	Description	Part No.
<b>SEMICONDUCTORS</b>		
IC8111, IC8801		AN4558NS
IC8301		BA3838F
IC8101		BU4052BCF
IC8201		M65847AFP
IC8802, IC8803		NJM4558MD
IC8901		NJM7812FA
Q8401, Q8402		2SC2412K
Q8201		2SD1858X
Q8501, Q8502		2SD2114K
Q8403, Q8503		DTA124EK
Q8101, Q8102		DTC124EK
D8401, D8802		1SS355
D8201		MTZJ5.6B
D8901, D8902		MTZJ6.8B
<b>CAPACITORS</b>		
C8212		CCSRCH101J50
C8217		CCSRCH471J50
C8111		CEAL100M50
C8113, C8119, C8120, C8221		CEAT100M50
C8509, C8510, C8822, C8826		CEAT100M50
C8833, C8834		CEAT100M50
C8789, C8823		CEAT101M16
C8902		CEAT1R0M50
C8305, C8308-C8310		CEAT2R2M50
C8117, C8118, C8201, C8213, C8222		CEAT470M16
C8307, C8829, C8831, C8905-C8908		CEAT470M16
C8312		CEAT4R7M50
C8903		CKSQYF105Z25
C8220		CKSRYB102K50
C8101, C8103, C8107, C8108		CKSRYB103K50
C8203-C8205, C8218, C8313, C8514		CKSRYB103K50
C8519, C8810-C8813, C8828, C8830		CKSRYB103K50
C8301-C8303, C8407, C8515, C8518		CKSRYB104K16
C8219		CKSRYB122K50
C8904		CKSRYB223K50
C8304		CKSRYB224K10
C8216		CKSRYB472K50
C8202, C8223, C8306, C8788, C8824		CKSRYB473K25
C8207-C8209		CKSRYB683K16
C8206		CKSRYB822K50
C8513		CKSRYF105Z10
C8214, C8215		CKSRYF224Z16
<b>RESISTORS</b>		
R8216		RD1/4PU102J
R8814		RD1/4PU470J
R8901, R8904		RD1/4PU471J
R8808-R8811		RS1/16S1002F
<b>OTHERS</b>		
CN8301 4P Jumper connector		52147-0410
CN8901 17P Socket		AKP7072
CN8101 21P Socket		AKP7074
Heat sink		ANH-309
Screw		BBZ30P080FMC
JA8401 4P Pinjack		XKB3040

**J** DISP 1 ASSY

**Mark No. Description Part No.**

**SEMICONDUCTORS**

Q5101 2SC2412K  
D5102, D5103 1SS133  
D5105, D5106 MTZJ6.8B

**COILS AND FILTERS**

L5101 LAU220J

**SWITCHES AND RELAYS**

S5101, S5102, S5103, S5104, S5105 ASG7013

**CAPACITORS**

C5109 CCSRCH100D50  
C5110 CCSRCH220J50  
C5103 CEAT101M10  
C5108 CEAT470M16  
C5106 CKSRYB102K50  
  
C5101, C5104 CKSRYB103K50  
C5111 CKSRYB104K16  
C5105 CKSRYB681K50

**RESISTORS**

R5106 RD1/4PU101J  
Other Resistors RS1/16S###J

**OTHERS**

CN5101 11P Connector 52044-1145  
5101 Remote receiver unit GP1U26X

**I DISP 2 ASSY**

**SEMICONDUCTORS**

Q5201 2SC2412K  
D5206, D5207 1SS355  
D5202, D5204 MTZJ6.8B

**SWITCHES AND RELAYS**

S5201, S5202, S5203, S5204, S5205 ASG7013  
S5206, S5207, S5208, S5209, S5210 ASG7013  
S5211 ASG7013

**CAPACITORS**

C5201 CKSRYB103K50

**RESISTORS**

R5211 RD1/4PU101J  
Other Resistors RS1/16S###J

**OTHERS**

5202 3P Cable holder 51048-0300  
5201 5P Cable holder 51048-0500  
J5202 3P Jumper wire D20PYY0320E  
J5102 Jumper wire D20PYY0510E  
J5203 Connector Assy PF02PG-B07  
  
LED Holder XMR3053

**H DISP 3 ASSY**

**SWITCHES AND RELAYS**

S5301, S5302, S5303 ASG7013

**RESISTORS**

Other Resistors RS1/16S###J

**OTHERS**

**Mark No. Description Part No.**

5301 3P Cable holder 51048-0300

**L LED ASSY**

**SEMICONDUCTORS**

D5203, D5205 UDZS6.8B

**OTHERS**

CN5203 KR Connector S2B-PH-K

**M MIC ASSY**

**SEMICONDUCTORS**

IC5401 M65855FP  
IC5402 NJM4558MD  
Q5402 2SJ103  
Q5401 DTA143EK  
D5401 MTZJ5.1B

**COILS AND FILTERS**

L5401 LAU100J

**CAPACITORS**

C5418, C5419, C5427, C5428 CCSRCH101J50  
C5409 CEAL220M16  
C5416 CEAL2R2M50  
C5401 CEAT101M16  
C5422 CEAT2R2M50

C5420 CEAT470M16  
C5432 CEAT4R7M50  
C5433 CEATR22M50  
C5421, C5426 CEJQ2R2M50  
C5431 CEJQ4R7M50

C5410 CEJQR47M50  
C5423 (XWZ3626) CKSRYB102K50  
C5423 (XWZ3623) CKSRYB331K50  
C5404, C5408, C5411, C5430 CKSRYB103K50  
C5402, C5412, C5429, C5436 CKSRYB104K16

C5414 CKSRYB122K50  
C5405 CKSRYB123K50  
C5406 CKSRYB472K50  
C5407 CKSRYB473K25

**RESISTORS**

R5401 RD1/4PU561J  
VR5401 10k-B XCS3007  
Other Resistors RS1/16S###J

**OTHERS**

5401 4P Cable holder 51048-0400  
J5401 Jumper wire D20PYY0430E  
KN5401 Earth metal FIT. VNF1084  
JA5401, JA5402 MIC Jack XKN3012

**G DVD IF ASSY**

**SEMICONDUCTORS**

⚠ IC1902 BA06FP  
IC1941 MM1567AJ  
⚠ IC1906 NJM2391DL1-33  
⚠ IC1901, IC1903 NJM78M05DL1A  
IC1921 PCM1742KE

⚠ IC1904 PQ025EH01ZP

Mark No.	Description	Part No.
⚠ IC1905S-8540		B00FN-IMA
IC1962		TC74VHC125FT
IC1961		TC74VHCT125AFT
Q1931		2SA1576A
⚠ Q1901C		PH6312
Q1941, Q1961		RN1903
Q1942		RN2903
Q1921, Q1922, Q1932		UN5212
D1901, D1932-D1935		1SS355
D1902		RB051L-40
D1931		UDZS5.1B

### COILSANDFILTERS

L1901 (SMP Power Inductor)	ATL7003
L1902 (SMP Power Inductor)	ATL7004
L1903 (SMP Power Inductor)	ATL7005

### CAPACITORS

C1931, C1932	CCSRCH102J50
C1920	CCSRCH121J50
C1901, C1904, C1906, C1912, C1925	CEV101M16
C1930, C1953	CEV101M16
C1910, C1917	CEV221M4
C1903, C1908, C1928, C1950, C1996	CEV470M6R3
C1915	CKSQYB105K16
C1902, C1905, C1907, C1909, C1918	CKSRYB104K16
C1923, C1924, C1926, C1929, C1933	CKSRYB104K16
C1941, C1943, C1945, C1947-C1949	CKSRYB104K16
C1951, C1952, C1955-C1957	CKSRYB104K16
C1961, C1962, C1991-C1995	CKSRYB104K16
C1914, C1999	CKSYB475K16
C1916, C1919, C1998 (Ceramic C)	DCH1148

### RESISTORS

R1903 (0.068 1/4w)	ACN7113
R1904 (0.1 1/10w)	ACN7114
R1994, R1995	RS1/10S0R0J
R1907	RS1/16S1502F
R1906	RS1/16S3902F
R1908	RS1/16S4700F

### OTHERS

CN1901, CN1961 30P Connector	RKN1039
CN1902 16P Connector	RKN1057
CN1962 26P Connector	RKN1067

## **F** DVDM ASSY

### SEMICONDUCTORS

IC110	BA10358FV
IC251	BA6664FM
IC604	K4S641632F-TC75
IC302	K6T1008V2E-TB70
IC301	L6315ATXXTY
IC351	M56788AFP
⚠ IC303 (1.8V)	PQ018EZ01ZP
IC601	STI5519AVB-B0C
IC605	TC7WU04FU
IC603	VYW1948
Q300, Q602-Q607	2SA1576A
Q652	DTC114TUA
Q101, Q102	HN1A01F
Q103	HN1C01FU
Q601	RN4982

Mark No.	Description	Part No.
D601		RB501V-40

### COILSANDFILTERS

L6990 (330mH)	ATL7007
L300	LCYA2R7J2520
L5010, L5020, L5040 ( Chip 60mH)	VTL1075

### CAPACITORS

C301, C302	CCSRCH100D50
C310	CCSRCH151J50
C307	CCSRCH180J50
C360	CCSRCH330J50
C391	CCSRCH331J50
C351, C651	CCSRCH470J50
C627, C638, C696	CCSRCH471J50
C309	CCSRCH560J50
C633, C634	CCSRCH6R0D50
C308	CCSRCH7R0D50

C113	CEV100M35
C104	CEV101M4
C316, C317, C405, C617, C619	CEV101M6R3
C111, C404	CEV220M16
C368	CEV470M16

C334	CKSQYB225K10
C340, C641	CKSRYB102K50
C259, C311	CKSRYB103K50
C106, C248-C251, C255, C313	CKSRYB104K16
C315, C636, C637, C697	CKSRYB104K16

C257, C258	CKSRYB223K50
C357	CKSRYB472K50
C103, C105, C148, C157, C158	CKSRYF104Z25
C253, C256, C304, C321-C333	CKSRYF104Z25
C365, C366, C603, C605, C607	CKSRYF104Z25

C612, C615, C616, C632	CKSRYF104Z25
C606, C608-C611, C613	CKSRYF105Z10
C622, C623, C629, C635, C699	CKSRYF105Z10

### RESISTORS

R121	RAB4C220J
R123	RAB4C390J
R340, R407	RS1/10S0R0J
R341	RS1/10S101J
R126-R129, R176-R179	RS1/10S220J

R254-R259	RS1/10S3R3J
R326-R330	RS1/16S1001F
R147, R265, R266, R304, R322	RS1/16S1002F
R377, R378, R392, R393	RS1/16S1002F
R344, R351, R353, R354	RS1/16S1003D

R359, R360, R365, R367, R368	RS1/16S1003D
R372, R374, R376	RS1/16S1003D
R331, R385	RS1/16S1003F
R302	RS1/16S1202F
R358, R394	RS1/16S1503F

R146	RS1/16S1801F
R612, R613	RS1/16S1802F
R675, R678, R681, R684, R687	RS1/16S2700F
R690	RS1/16S2700F
R345, R355, R370, R371	RS1/16S3902F

R346, R356, R357, R362, R364	RS1/16S6802F
R373	RS1/16S6802F
R3730	RS1/16S8202F

**Mark No. Description Part No.**

**OTHERS**

A	CN2 12P Connector	AKN7031
	CN8 26P Connector	AKN7032
	CN4 4P Connector	RKN1045
	CN9 PH Connector	S5B-PH-SM3
	7P Flexible Cable	VDA1681
	CN25 26P Connector	VKN1318
	CN22 30P Connector	VKN1322
	X301 Crystal RES.(20MHz)	VSS1171
	X601 Crystal RES.(27MHz)	VSS1172

**D LOAB ASSY**

**OTHERS**

B	CN602 KR Connector	S2B-PH-K
	CN601 KR Connector	S5B-PH-K
	PCB BORD	VNP1836
	101 Reaf SWITCH	VSK1011

**E DECK ASSY(XWX3067)**

**SEMICONDUCTORS**

C	IC2202, IC2301, IC2401	BA4558F-HT
	IC2201	HA12136AF
	Q2254	2SA1037K
	Q2801, Q2802, Q2805	2SC1815
	Q2806	2SC2240
	Q2251-Q2253	2SC2412K
	Q2261, Q2262, Q2301, Q2302	2SK373
	Q2351, Q2460	DTA124EK
	Q2303, Q2304	DTC114TK
	Q2255, Q2352, Q2263	DTC143EK
	D2256, D2301-D2306	1SS133
	D2252-D2255, D2307	1SS355
	D2201	MTZJ6.2A

**COILSANDFILTERS**

	L2802	LFA121J
	L2801 (OSC 105kHz)	RTD1082
	L2401, L2402 (10mH)	RTF1004
	L2403, L2404 (4.7mH)	RTF1021
	F2201, F2202 (MPX. Filter)	RTF1217

**CAPACITORS**

E	C2809	CCCSL151K2H
	C2301, C2302	CCSRCH100D50
	C2423, C2424	CCSRCH221J50
	C2253	CCSRCH271J50
	C2256, C2257, C2321-C2324	CCSRCH470J50
	C2401, C2402	CCSRCH470J50
	C2303, C2304	CCSRCH681J50
	C2807	CEAL470M6R3
	C2203, C2204, C2207, C2311, C2312	CEAT100M50
	C2215	CEAT101M16
	C2201, C2202, C2217, C2218, C2255	CEAT1R0M50
	C2404, C2419, C2420	CEAT1R0M50
	C2251	CEAT220M50
	C2216	CEAT221M16
F	C2254	CEAT2R2M50
	C2309, C2310, C2407, C2408	CEAT330M50
	C2425	CEAT470M16
	C2261, C2262	CEAT4R7M50

**Mark No. Description Part No.**

	C2208	CEATR10M50
	C2205, C2206	CEATR22M50
	C2403	CEJQ1R0M50
	C2805, C2806, C2810	CEJQ330M10
	C2314	CEJQ470M16
	C2315	CKSRYB102K50
	C2231	CKSRYB103K50

	C2431, C2432	CKSRYB122K50
	C2211, C2212	CKSRYB152K50
	C2252	CKSRYB334K10
	C2808	CQHA822J2A
	C2801	CQMA123J50

	C2421, C2422	CQMA152J50
	C2409, C2410	CQMA223J50
	C2803, C2804	CQMA472J50
	C2802	CQMA682J50
	C2209, C2210	CQMBA103J50

	C2307, C2308	CQMBA682J50
	C2405, C2406	CQMBA683J50

**RESISTORS**

	R2805	RD1/2VM161J
	R2803	RD1/2VM4R7J
	VR2301, VR2302, VR2401, VR2402(4.7k)	PCP1028
	VR2801, VR2802(100k-B)	PCP1032

**OTHERS**

	CN2506	AKP7072
	CN2302	B2B-PH-K
	CN2507	B3P-SHF-1AA
	CN2301	B4B-PH-K
	PCB	VEF1040

**E DECK ASSY(XWX3066)**

**SEMICONDUCTORS**

	IC2202, IC2301, IC2401	BA4558F-HT
	IC2201	HA12136AF
	Q2254	2SA1037K
	Q2801, Q2802, Q2805	2SC1815
	Q2806	2SC2240
	Q2251-Q2253	2SC2412K
	Q2261, Q2262, Q2301, Q2302	2SK373
	Q2351, Q2460	DTA124EK
	Q2303, Q2304	DTC114TK
	Q2255, Q2352, Q2263	DTC143EK
	D2256, D2301-D2306	1SS133
	D2252-D2255, D2307	1SS355
	D2201	MTZJ6.2A

**COILSANDFILTERS**

	L2802	LFA121J
	L2801 (OSC Coil 105k)	RTD1082
	L2401, L2402 (10mH)	RTF1004
	L2403, L2404 (4.7mH)	RTF1021
	F2201, F2202 (MPX FIL.)	RTF1217

**CAPACITORS**

	C2809	CCCSL151K2H
	C2301, C2302	CCSRCH100D50
	C2423, C2424	CCSRCH221J50
	C2253	CCSRCH271J50
	C2303, C2304	CCSRCH681J50

<u>Mark No.</u>	<u>Description</u>	<u>Part No.</u>
C2807		CEAL470M6R3
C2203, C2204, C2207, C2311, C2312		CEAT100M50
C2215		CEAT101M16
C2201, C2202, C2217, C2218, C2255		CEAT1R0M50
C2404, C2419, C2420		CEAT1R0M50
C2251		CEAT220M50
C2216		CEAT221M16
C2254		CEAT2R2M50
C2309, C2310, C2407, C2408		CEAT330M50
C2425		CEAT470M16
C2261, C2262		CEAT4R7M50
C2208		CEATR10M50
C2205, C2206		CEATR22M50
C2403		CEJQ1R0M50
C2805, C2806, C2810		CEJQ330M10
C2314		CEJQ470M16
C2315		CKSRYB102K50
C2231		CKSRYB103K50
C2431, C2432		CKSRYB122K50
C2211, C2212		CKSRYB152K50
C2252		CKSRYB334K10
C2808		CQHA822J2A
C2801		CQMA123J50
C2421, C2422		CQMA152J50
C2409, C2410		CQMA223J50
C2803, C2804		CQMA472J50
C2802		CQMA682J50
C2209, C2210		CQMBA103J50
C2307, C2308		CQMBA682J50
C2405, C2406		CQMBA683J50
<b><u>RESISTORS</u></b>		
R2805		RD1/2VM161J
R2803		RD1/2VM4R7J
VR2301, VR2302, VR2401, VR2402(4.7k)		PCP1028
VR2801, VR2802 (100k-B)		PCP1032
<b><u>OTHERS</u></b>		
CN2506 17P SOCKET		AKP7072
CN2302 CONNECTOR POST		B2B-PH-K
CN2507 3P CONNECTOR		B3P-SHF-1AA
CN2301 KR CONNECTOR		B4B-PH-K
PCB BINDER		VEF1040

# 6. ADJUSTMENT

## 6.1 DECK SECTION

### 6.1.1 Adjustment condition

For adjustment, use the stereo power amplifier (M-EV51 or M-EV21).

#### Adjustment Condition

- (1) The ground at the time of adjustment shall be W166.  
(Refer to Fig. 6-3).
- (2) Clean the heads and demagnetize them using a head eraser.
- (3) Set the measurement level to 0 dBV = 1 Vrms.
- (4) Use the specified tape for adjustment. Use the labeled (A) side of the test tape.

- NCT-111 : For Tape Speed adjustment
- NCT-112 : For Playback adjustment
- STD-633 : Normal blank tape

\* As the reference recording level is 250 nwb/m for NCT-112, the recording level will be higher than 4 dB for NCT-112 (160nwb/m). When adjusting, pay carefully attention to the type of tape used.

- (5) Provide yourself with the following measuring devices:

- AC millivoltmeter
- Low-frequency oscillator
- Attenuator
- Oscilloscope

- (6) Adjust both right and left channels unless other wise specified.
- (7) Turn the DOLBY NR switch off unless otherwise specified.
- (8) Warm up the unit for several minutes before adjustment. In particular, be sure to warm up the unit in the REC/PLAY mode for 3 to 5 minutes before starting recording/playback frequency characteristics adjustment.
- (9) Always follow the indicated adjustment order.  
Otherwise, a complete adjustment may not be achieved.

#### List of Adjustments

##### ● Playback Section

- (1) Tape Speed Confirmation
- (2) Head Azimuth Adjustment
- (3) Playback Level Adjustment

##### ● Recording Section

- (1) Recording Bias Adjustment
- (2) Recording Level Adjustment

#### PLAY BACK

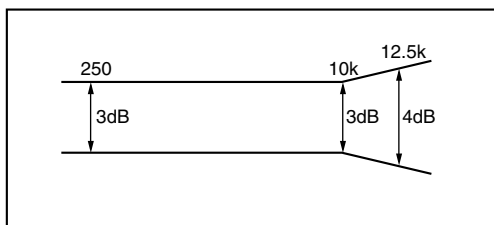

#### RECORDING

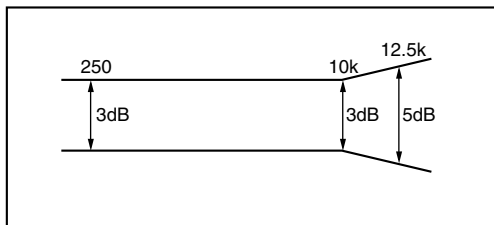

Fig. 6-1 Frequency Characteristics

Dolby noise reduction manufactured under license from Dolby Laboratories Licensing Corporation.  
"DOLBY" and the double-D symbol are trademarks of Dolby Laboratories Licensing Corporation.

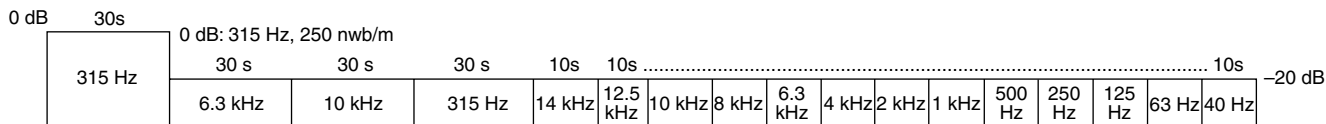

Fig. 6-2 Test Tape NCT-112



## 6.1.2 Playback and Recording section

### ■ Playback Section

#### (1) Tape Speed Confirmation

No.	Mode	Input Signal/Test Tape	Adjustment Points	Measurement Points	Adjustment Value	Remarks
1	PLAY	NCT-111 (3 kHz)	VR2701 (DECK ASSY) (Refer to Fig. 6-3)	P1 R (CN2507) (DECK ASSY)	3000 Hz $\begin{smallmatrix} +10 \\ -10 \end{smallmatrix}$ Hz	FWD adjustment REV Confirmation ( 3000 Hz $\begin{smallmatrix} +40 \\ -40 \end{smallmatrix}$ Hz )

#### (2) Head Azimuth Adjustment

- This unit is equipped with auto tape selector.
- Do not switch between forward and reverse operation with the screwdriver inserted.

No.	Mode	Input Signal/Test Tape	Adjustment Points	Measurement Points	Adjustment Value	Remarks
1	PLAY	NCT-110 test tape (Playback: 10 kHz, -20 dB)	Head azimuth adjustment Screw (Refer to Fig. 6-3)	P3 L (CN2507) P1 R (CN2507) (DECK ASSY)	Max. Playback signal level	After adjustment, apply silicon bond to the head azimuth adjustment screw.

#### (3) Playback Level Adjustment

- Since this adjustment determines playback DolbyNR level, Perform it carefully.

No.	Mode	Input Signal/Test Tape	Adjustment Points	Measurement Points	Adjustment Value	Remarks	
1	PLAY	NCT-112 test tape (Playback: 315 Hz, 4 dB)	L ch	VR2301	P3 L (CN2507) P1 R (CN2507) (DECK ASSY)	-3.7 dBV	
			R ch	VR2302			

### ■ Recording Section

#### (1) Recording Bias Adjustment

- After the adjustment, caution should be exercised so as not to become under bias by checking the distortion rate.

No.	Mode	Input Signal/Test Tape	Adjustment Points	Measurement Points	Adjustment Value	Remarks
1	REC/ PAUSE	Input a 315Hz signal to the LINE - IN terminal. *	Input signal level		P3 L (CN2507) P1 R (CN2507) (DECK ASSY)	-23.7 dBV
2	REC → PLAY	Load the STD-633 test tape and record/playback the 315Hz and 10kHz signals. (see the Note below)	L ch	VR2801		Repeat adjustment until playback level of the 10kHz signal is within 0dBV $\pm$ 0.5dB from that of the 315Hz signal.
			R ch	VR2802		

Note: Set the 10kHz input signal level to the same value as the 315Hz input signal level of step 1.

#### (2) Recording Level Adjustment

No.	Mode	Input Signal/Test Tape	Adjustment Points	Measurement Points	Adjustment Value	Remarks
1	REC/ PAUSE	Input a 315Hz signal to the LINE- IN terminal.*	Input signal level		P3 L (CN2507) P1 R (CN2507) (DECK ASSY)	-7.7 dBV
2	REC → PLAY	STD-633 test tape and record/ playback the 315Hz signal.	L ch	VR2401		Repeat recording, playback and adjustment until playback level of the 315Hz signal becomes -7.7dBV $\pm$ 0.5dB.
			R ch	VR2402		

● DECK ASSY **E**

A

B

C

D

E

F

● MECHANISM UNIT

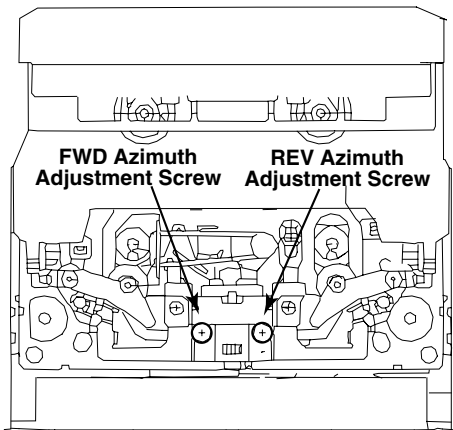

● CN2507 (DECK TP)

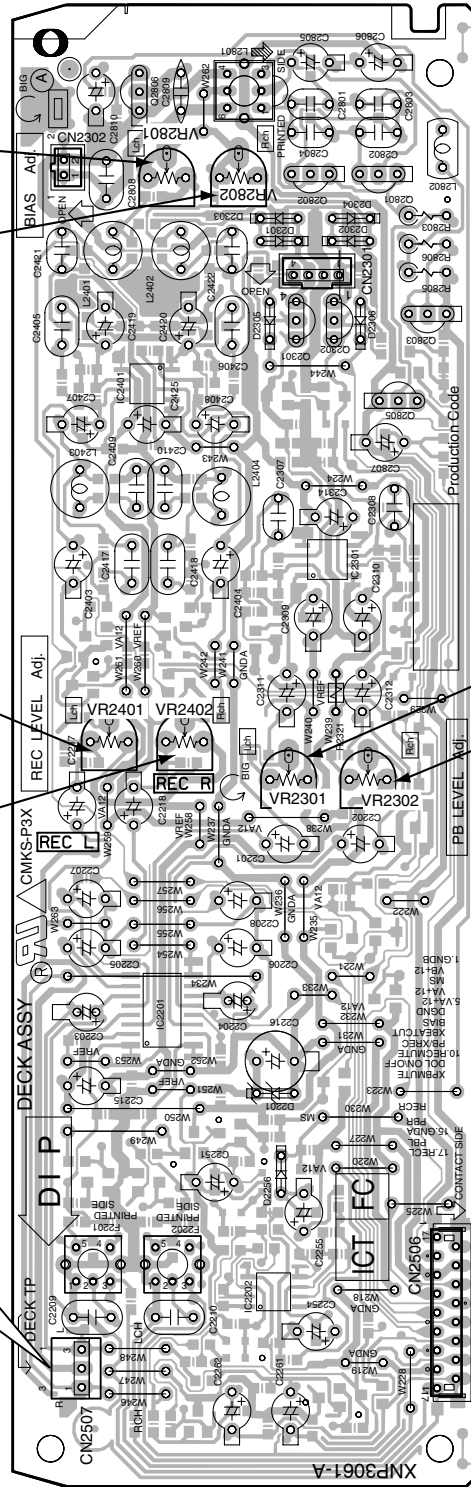

**SIDE A**

VR2801 (Lch)  
VR2802 (Rch)

**BIAS**

VR2401 (Lch)  
VR2402 (Rch)

**REC LEVEL**

VR2301 (Lch)  
VR2302 (Rch)

**PB LEVEL**

Fig. 6-3 Adjustment and Measurement Points

## 6.2 TUNER SECTION

### 6.2.1 AM TUNER SECTION

There is no adjustment in the AM tuner.

### 6.2.2 FM TUNER SECTION

Set the mode selector to FM BAND.

Connect the wiring as shown in Fig. 6-5.

Step No.	Adjustment Title	ANT. Input level and signal condition			Adjustment	
		Frequency (MHz)	Modulation	Input Level (dB $\mu$ V)	Adjust point	Contents
1	T-METER Adjustment	98	OFF	80	L201	Adjust L201 so that the DC voltage between Pin 21 and Pin 23 of IC201 (Test point V <sub>tm</sub> ) gets within $0 \pm 50$ mV.

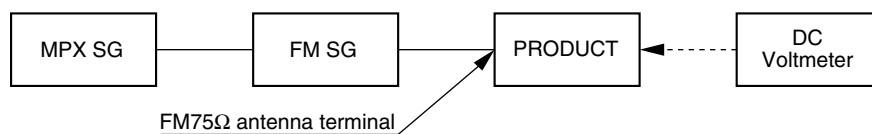

Fig.6.5 Adjustment Wiring Diagram

### A FM/AM TUNER UNIT

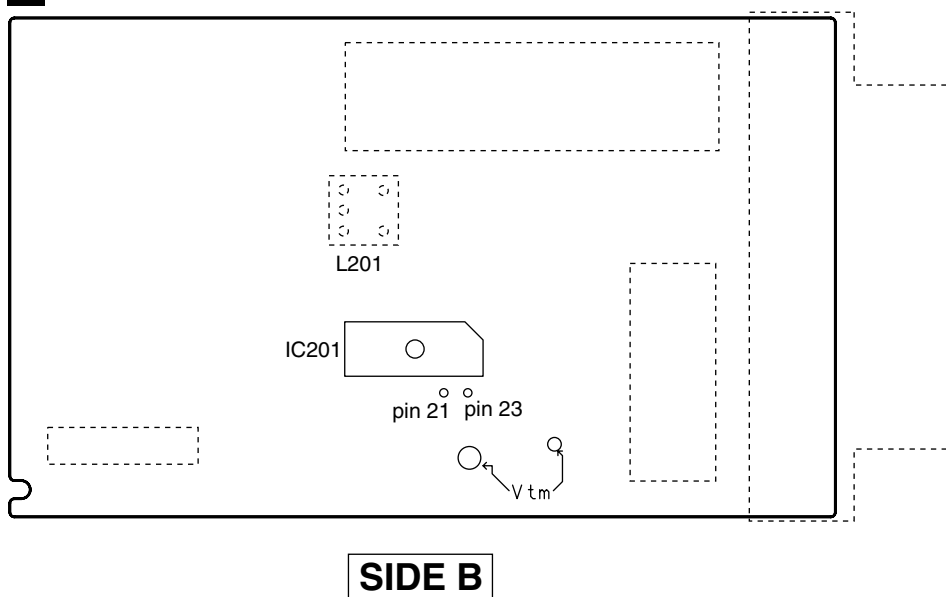

Fig.6.6 Adjustment Point

### 6.3 DVD SECTION ADJUSTMENT ITEMS ana LOCATION

#### ■ Adjustment Items

#### ■ Adjustment Points (Mechanism Part)

[Mechanism Part]

- ① Tangential and Radial Height Coarse Adjustment
- ② DVD Jitter Adjustment
- ③ Initialize the Focus Sweep Setting



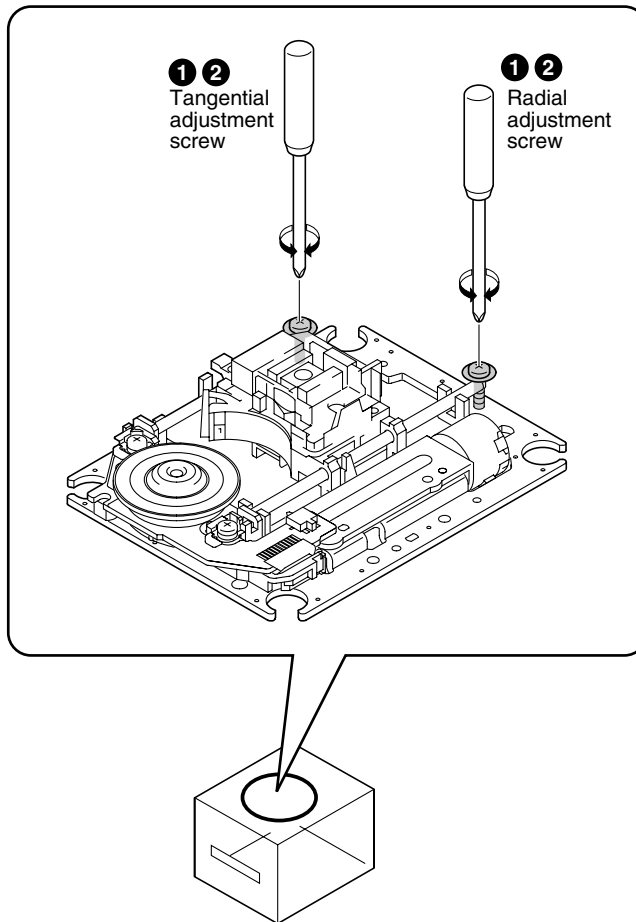

**Cautions:** After adjustment, adjustment screw locks with the Screw tight.

[Electrical Part]

Electrical adjustments are not required.

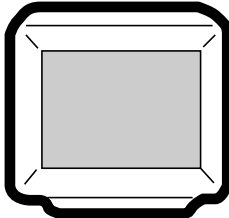
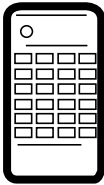

### 6.4 JIGS and MEASURING INSTRUMENTS

 <p>⊕ Screwdriver (large)</p>	 <p>⊕ Screwdriver (medium)</p>	 <p>TV monitor</p>	 <p>Test mode remote control unit (GGF1067)</p>
 <p>⊕ Precise screwdriver</p>	 <p>DVD test disc (GGV1025)</p>	<p>Screw tight (GYL1001)</p>	

5

6

7

8

## 6.5 NECESSARY ADJUSTMENT POINTS

When

Adjustment Points

### ■ Exchange Parts of Mechanism Assy

Exchange the Pickup

Mechanical point

①, ②, ③

\* After adjustment, screw locks with the Screw tight.

Electric point

\_\_\_\_\_

Exchange the Traverse Mechanism

Mechanical point

③

Electric point

\_\_\_\_\_

Exchange the Spindle Motor

Mechanical point

②, ③

\* After adjustment, screw locks with the Screw tight.

Electric point

\_\_\_\_\_

### ■ Exchange PCB Assy

Exchange PC Board

LOAB, DVDIF and DVDM ASSY

Mechanical point

\_\_\_\_\_

Electric point

\_\_\_\_\_

\*

**Purpose:** To set the sweep which was correct with the individual Traverse mechanism.

Be sure to perform the following step finally when replaced Pickup, Traverse Mechanism and Spindle Motor.

GGF1067  
Test mode  
remote control  
unit

ESC → CLEAR

(It is necessary when performed adjustment procedure ②.)

XV-EV51

5

6

7

8

77

# 6.6 TEST MODE

A

## TEST MODE: ON

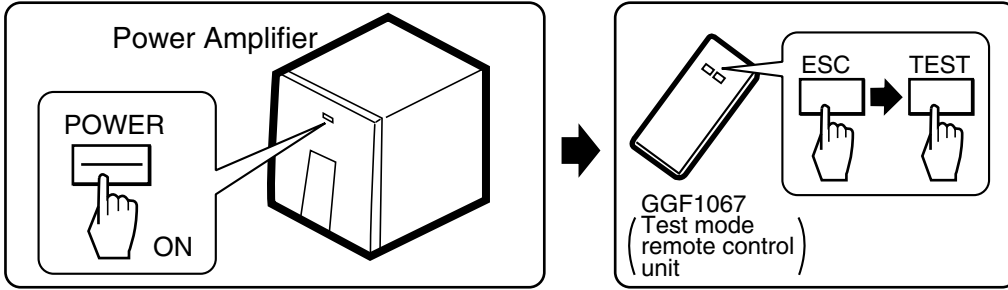

B

## TEST MODE: DISC SET

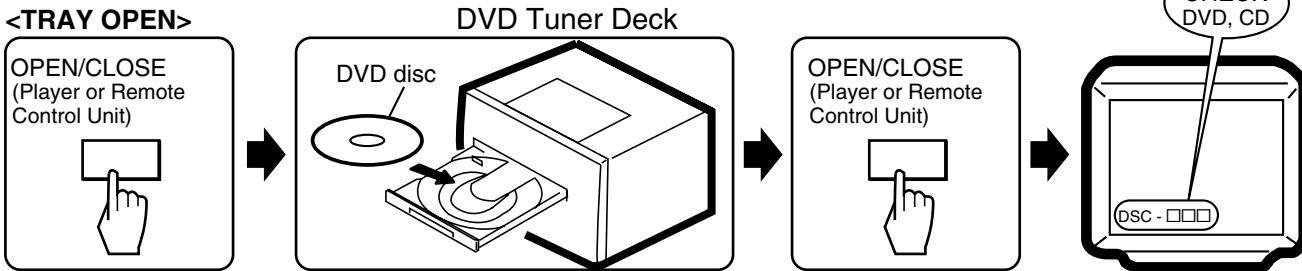

C

## TEST MODE: PLAY

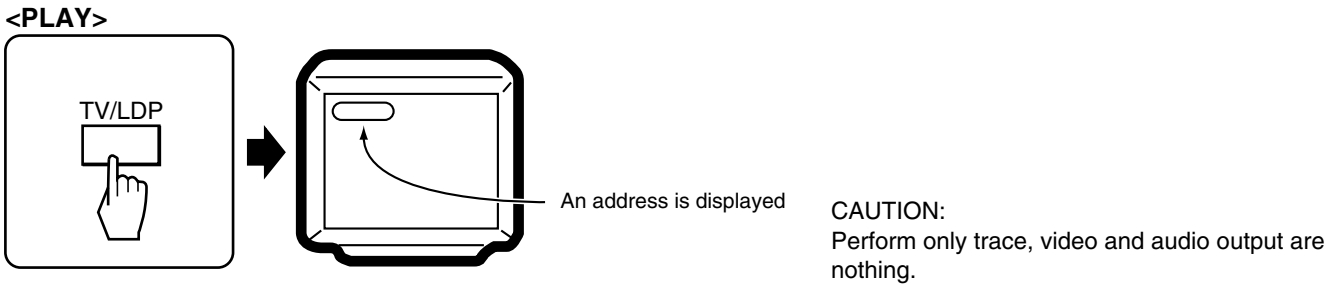

D

### < When playback with the target address of disc (DVD)>

For example, when playback with # 30000

During PLAY [+10] → [3] → [0] → [0] → [0] → [0] → [CHP/TIM] Press keys in order

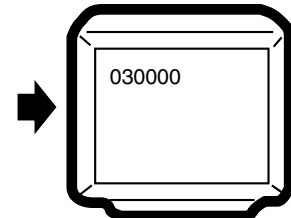

E

## TEST MODE: OFF

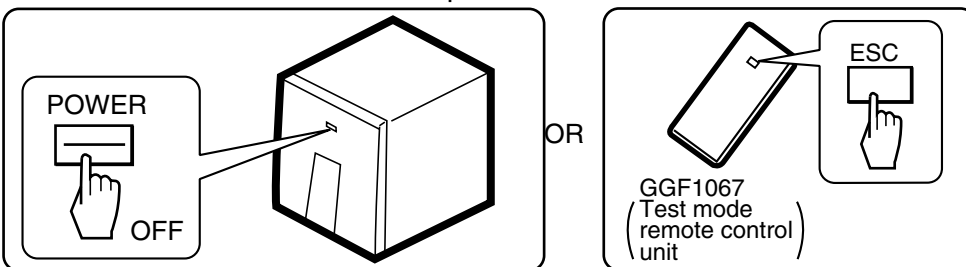

F

# 6.7 MECHANISM ADJUSTMENT



## 1 Tangential and Radial Height Coarse Adjustment

### START

- Remove the servo mechanism.
- Remove a Spacer for height adjustment attached to the back side (shaded area) of the Servo Mechanism (Float Base) with nippers.

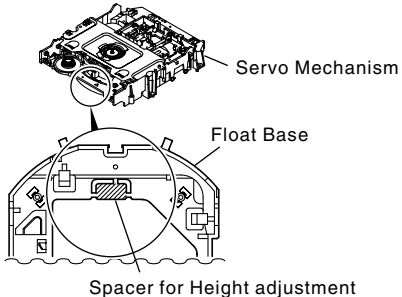

**Note:**  
Turn the Short switch to Short side when removing the Pickup Flexible Cable. (Refer to "7.1.6 DISASSEMBLY".)



### Cautions:

Because there is not a Spacer for height adjustment in adjustment after the second time, will keep it at need. (This parts is Traverse mechanism exclusive use of a model for 2001 years)



Put a spacer between a Tangential (or Radial) adjustment screw and Mechanism Base and turn each screw to adjust the height. (Refer to "6.3 ADJUSTMENT ITEMS AND LOCATION".)

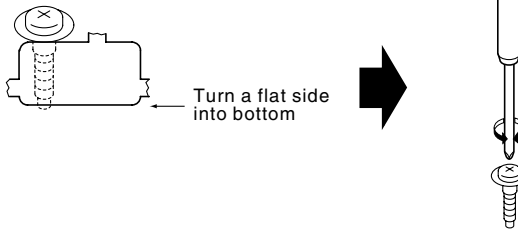

## 2 DVD Jitter Adjustment

- Playback method of inner and outer address for the purpose is referred to "6.6 TEST MODE".
- Jitter indication of the monitor is referred to "7.1.1 TEST MODE (Display Specification of the Test Mode)".

Use disc: GGV1025

### START

- Test mode
- Play the DVD test disc at outer track (around #200000)

Mechanism Assy

Adjust the Tangential Adjustment Screw so that jitter becomes minimum.

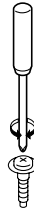

J : Min

- Play the DVD test disc at inner track (around #30000)

Mechanism Assy

Adjust the Radial Adjustment Screw so that jitter becomes minimum.



J : Min

- Play the DVD test disc at outer track (around #200000)

Mechanism Assy

Readjust the Tangential Adjustment Screw so that jitter becomes minimum.

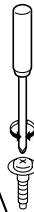

J : Min

Test mode end

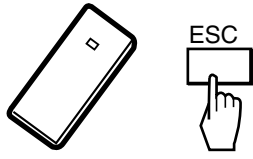

### CHECK

Turn the POWER OFF in case of NG once, and perform the adjustment once again.

NG

Confirm the error rate that is displayed "OK"  
(Example ERROR RATE: 6.60e - 6 OK)

OK

If error rate is OK, locks a root of tangential and radial adjustment screws with the Screw tight, and go to step 3.



Screw tight: GYL1001

Disc playback normally.

- The measurement of block error rate

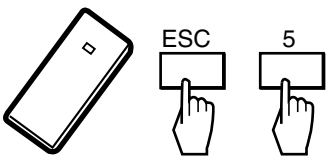
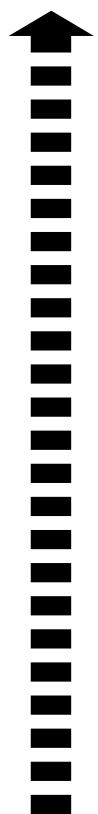

### 3 Initialize the Focus Sweep Setting

**Purpose:** To set the sweep which was correct with the individual Traverse mechanism.

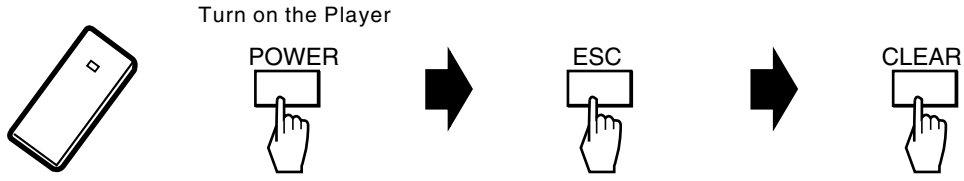

**Note:** Be sure to perform this step when replaced the Pickup or Traverse mechanism.

A  
B  
C  
D  
E  
F

# 7. GENERAL INFORMATION

## 7.1 DIAGNOSIS

### 7.1.1 TEST MODE

#### ■ Test Mode Functional Specification

##### ① How to Enter Test mode

Turn the power on while short-circuiting with TEST jumper (W284) and VE+5 jumper (W282) on the IF Assy. Indicate with "U-TEST" in this time.

##### ② Release the test mode

- Turn off the power.
- Press the [ESC] (A8-5F) key of the remote control unit and reset it.

##### ③ Tray open / close

- Press the [REPEAT A-B] (A8 - 48) key of the remote control unit.
- Press the [OPEN / CLOSE] key of the main unit from the stop state.

##### ④ Playback stop

- Press the [REPEAT] (A8 - 44) key of the remote control unit from the playback state.

##### ⑤ LD ON

DVD : Press the [TEST] (A8-5E) and [1] (A8-01) keys in order, and turn on the laser diode (650n).  
 CD : Press the [TEST] (A8-5E) and [4] (A8-04) keys in order, and turn on the laser diode (780n).

##### ⑥ Focus on / sweep

1. Lock the focus by pressing the [TEST] (A8-5E) and [2] (A8-02) keys in order.
2. Repeat focus sweep by pressing the [TEST] (A8-5E) and [3] (A8-03) keys in order.

##### ⑦ Spindle FG servo

CAV : Press the [TEST] (A8-5E) and [5] (A8-05) keys in order, then rise up the spindle and it becomes FG servo on.  
 CLV : Press the [TEST] (A8-5E) and [9] (A8-09) keys in order, then rise up the spindle and it becomes FG servo on.

##### ⑧ Tracking open / close

1. Open tracking by pressing the [STEP FWD] (A8-54) key of the remote control unit in the play state.
2. Close tracking by pressing the [STEP REV] (A8-50) key of the remote control unit in the play state.

##### ⑨ Slider servo on/off

1. Turn on the slider servo by pressing the [TEST] (A8-5E) and [CX] (A8-0E) keys in order.
2. Turn off the slider servo by pressing the [TEST] (A8-5E) and [TV/LDP] (A8-0F) keys in order.

##### ⑩ Slider in / out

Slider in : In the tracking off state, press the [SCAN REV] (A8-11) key of the remote control unit.  
 Slider out : In the tracking off state, press the [SCAN FWD] (A8-10) key of the remote control unit.

##### ⑪ Play (perform only the ID search and trace to the specified location)

Press the [TV/LDP] (A8-0F) key of the remote control unit from the stop state.  
 Perform only trace, video and audio output are nothing.

##### ⑫ Screen display ON/OFF

1. Turn off the display by pressing the [AUDIO] (A8-1E) key of the remote control unit.
2. Turn on the display by pressing the [DISPLAY] (A8-43) key of the remote control unit.

### ⑬ Search

#### 1. Search address input entry

- It becomes the address input mode when pressing the [+10] (A8-1F) key. (Most significant digit of an address displays ">".)
- In this time, display the last address as the initial state.

#### 2. Search address input

- Press the [0] to [9] (A8-00 to 09) keys of the remote control unit. In the DVD, set an address with hexadecimal.
- In the address input mode, turn to the hexadecimal input by pressing the [PROGRAM] (A8-4C) key (display a "\*" mark) and [1] to [6] keys are each input as A to F.
- In this time, do not accept the [7],[8],[9] and [0] keys. Hexadecimal input and decimal input can switch with toggle.
- In case of CD, perform only the absolute time search.

#### 3. Search execution

- Press the [CHP/TM] (A8-13) key of the remote control unit.
- After the search, perform only trace and video and audio outputs are nothing.

#### 4. Release the Search address input

- Clear the address by pressing the [CLEAR] (A8-45) key. Release the address input mode when pressing the [CLEAR] key once again.

## Display Specification of the Test Mode

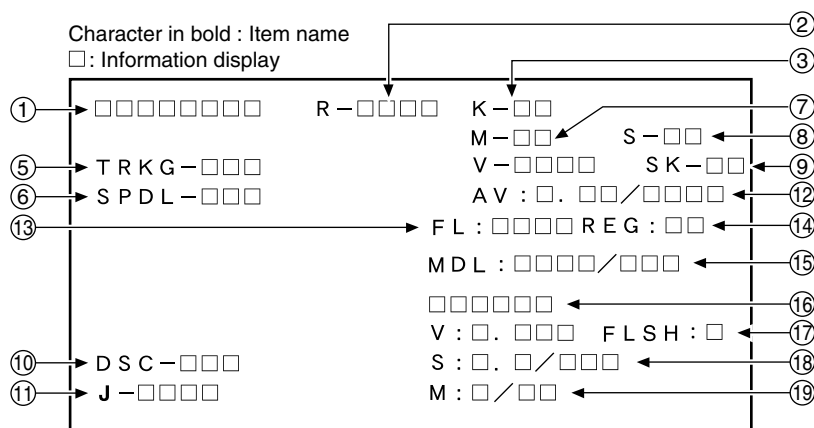

### ① Address indication

The address being traced is displayed in number.  
(as for the DVD, indication of decimal number is possible.)  
DVD : ID indication (hexadecimal number, 8 digits)

[\*\*\*\*\*]  
CD : A-TIME (min. sec.) [0 0 0 0 \*\*\*\*\*]

### ② Code indication of remote control unit [R - \* \* \* \*]

In case of double code, display a 2nd code.

### ③ Main unit keycode indication [K - \* \* \*]

### ⑤ Tracking status [TRKG - \* \* \*]

Tracking on : [ON]  
Tracking off : [OFF]

### ⑥ Spindle status [SPDL - \* \* \*]

[OFF], [A/B] (ACC/BRK), [CAV], [CLV]

### ⑦ Mechanism (loading) position value [M - \* \* \*]

Unknown : [01] or [41]  
Open state : [04]  
Close state : [08]  
During opening : [12]  
During closing : [22]

### ⑧ Slider position [S - \* \* \* \*]

CD TOC area : [IN ]  
CD active area : [CD]

### ⑨ Output video system [V - \* \* \* \*]

NTSC system : [NTSC]  
PAL system : [PAL]  
Automatic setting : [AUTO]

### Scart terminal output [SK - \* \*]

(Display only the WY model which can do the output setting of scart terminal.)

VIDEO : [00]  
S-VIDEO : [01]  
RGB : [02]

### ⑩ Disc sensing [DSC - \* \* \*]

The type of discs loaded is displayed.  
[DVD], [CD ], [VCD], [ ]

### ⑪ Jitter value [J - \* \* \* \*]

### ⑫ Version of the AV-1 chip / version of firmware

[AV: \*\* / \*\*\*\*\*]

### ⑬ Version of the FL controller [FL: \* \* \* \*]

### ⑭ Region setting of the player [REG: \*]

Setting value : [1] to [6]

### ⑮ Destination setting of the FL controller

[MDL: \*\*\*\* / \*\*\*\*]

Four characters in the front represent the type of model.  
Three characters in the back represent the destination code.  
J: /J, K: /KU, /KC, /KU/KC, R: /RAM/RL/RD, LB: /LB,  
WY: /WY

### ⑯ Part number of the flash ROM

[\*\*\*\*\*]

### ⑰ Version of the flash ROM [V: \* . \* \* \*]

Flash ROM size [FLSH = \*]

### ⑱ Revision of the system controller [S: \* . \* / \* \* \* \*]

### ⑲ Revision of the DVD mechanism controller

[M: \* / \* \*]

## Shortcut key Functional Specification

Only in the normal playback, the following setting can be made by pressing the required key after having pressed the "TEST" key of the remote control unit. How to release: Press the "ESC" key. (function with indication)

Command Contents	Conditions	Remote Control Key Name	Remote Control Code
Memory clear & region / revision indication		CLEAR (LD remote control unit)	A8-45
Average value measurement of DVD error rate		5 (LD remote control unit)	A8-05
CD error rate measurement		5 (LD remote control unit)	A8-05
Aspect: Pan scan		2	A6-01
Aspect: Letter box		3	A6-02
Aspect: Wide		4	A6-03
Digital: PCM		5	A6-04
Digital: AC-3/PCM		6	A6-05
Virtual Dolby: VDD=OFF	Only correspondence model	7	A6-06
Virtual Dolby: VDD=ON	Only correspondence model	8	A6-07
Digital output ON		REPEAT A	A6-A1, AF-E8
Digital output OFF		REPEAT B	A6-95
DTS Digital Out ON		STEP FWD	A6-A1, AF-B7
DTS Digital Out OFF		STEP REV	A6-A1, AF-B8
Scart terminal output: VIDEO	WY, Model to include scart	AUDIO	A6-A1, AF-BE
Scart terminal output: S-VIDEO	WY, Model to include scart	SUBTITLE	A6-A1, AF-36
Scart terminal output: RGB	WY, Model to include scart	ANGLE	A6-A1, AF-B5
Audio 5.1CH ON	Only correspondence model	KD_ENTER	A6-74
FL indication of EDC / ID error		CX (LD remote control unit)	A8-0E
ZOOM ON	Only correspondence model	ZOOM	A6-A1, AF-37
ZOOM OFF	Only correspondence model	< X3 (LD remote control unit)	A8-59
Service mode indication (error rate indication, etc.)		CHP/TIM (LD remote control unit)	A8-13
Model information indication		CHAP (LD remote control unit)	A8-40
Background color change		+10 (LD remote control unit)	A8-1F
Audio last stage mute ON		9	A6-08
Audio last stage mute OFF		0	A6-09
Title search Input mode IN Title No. input Search execution		SIDE A (LD remote control unit) Numbers (LD remote control unit) PLAY (LD remote control unit)	A8-4D A8-00 to A8-09 A8-17
Region confirmation mode		AUDIO (LD remote control unit) Numbers (LD remote control unit)	A8-1E A8-01 to A8-08

### • Service mode indication

ID Address

Always display error rate. Exponential indication  $***e*$  (with both DVD and CD)

EDC/ID/AV1 error history (ID Address, EDC/ID/AV1 Error, errors of past eight times)

Self-diagnostic function (when mechanism error occurred, display the mechanism error history)

### • Error rate average value total (ESC +5)

Calculation number of times displays exponent from average value of eight times.

After the calculation result, display OK/NG. Tray is open in case of NG (with both DVD and CD)

DVD: OK with less than  $8.0e-4$  CD: OK with less than  $7.6e-4$

Note: Because an OK/NG judgment cannot be DVD with a static image mode as menu screen, confirm it by an animation.

### • Model information indication contents (ESC+CHAP)

Display ⑫ to ⑰ in the test mode indication. However, Change the indication of S as B.E VERSION and it of M as F.E VERSION.

Refer to the "Specification of Model Information Display".

### • Background color change (ESC+ +10)

Change black and green with toggle whenever pressing the key (the background color that green is using with SETUP NAVIGATOR).

### • Region confirmation mode (ESC+ A.MON + 1to 8)

Input region No. after pressing the ESC+A.MON keys. When it is different from the setting, display and open the tray.

# Specification of Model Information Display

## • Display contents

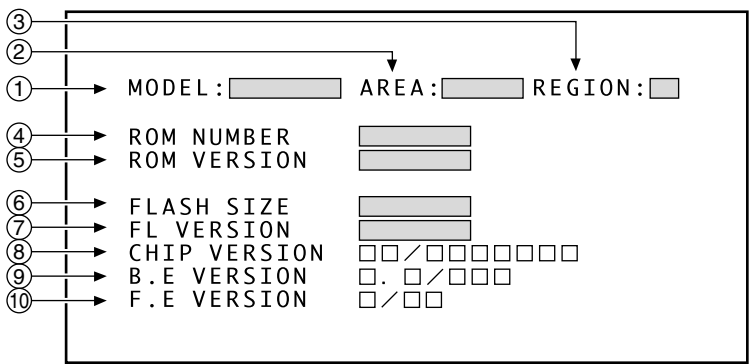

Character in bold : Item name  
 □ : Information display

- ① **Model name**  
Display it according to model information set from the FL controller.
- ② **Destination indication**  
Display it according to model information set from the FL controller.
- ③ **Region No.**
- ④ **Part number**
- ⑤ **ROM version**
- ⑥ **Flash size**
- ⑦ **FL controller version**

⑧ **CHIP VERSION**  
 Version of ST CHIP  
 CUT ID / JTAG ID  
 ↑                    ↑  
 (two columns) (eight columns)

⑨ **B.E VERSION**  
 Version of BACK END (version of ST core software)  
 □.□                    / □□□  
 softwareVersion . softwareRevision / buildNumber

⑩ **F.E VERSION**  
 Version of FRONT END (version of mechanism controller CHIP software)  
 □ / □□  
 MainVersion / SubVersion

# Functional Specification of the Service Mode

## • FL indication of EDC / ID error (short cut function)

Display it in FL with ESC+CX keys (LD remote control unit).  
Indication is released with ESC key during indication.

FL indication contents

0 0 / 0 0 / 0 1 \*

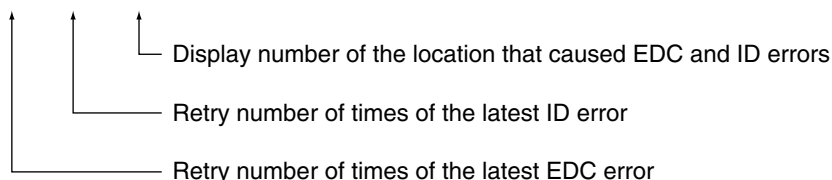

\* mark: When even once causes AV1 error, lights.

## • Service mode screen display

Display to the screen with ESC+CHP/TIM keys.  
Release the indication with ESC key.

Indication contents

ID Address ①

Always indicate error rate ② and exponent indication

EDC/ID/AV1 error history (ID Address, EDC/ID/AV1 Error, past eight times) ③

Contents of AV1 error

BIT 0: EDC error, FEC I/F buffer overflow and not valid occur in the BE code (B.E error).

BIT 1: ID is different from the target in the BE code (B.E error).

BIT 2: There is error in the EDC data of 2 bytes which added to the FE (F.E error).

## • Self-diagnostic function ④

Check that the F.E is normal or not.

FE OK : Abnormality is not found in the F.E.

FE Error : Abnormality is found in the F.E.

Indicate the mechanism error history by pressing the CHP/TIM key once again.

Change indication by pressing the CHP/TIM key with toggle afterwards.

Refer to the "Display of the Mechanism Error History".

Indication plan contents

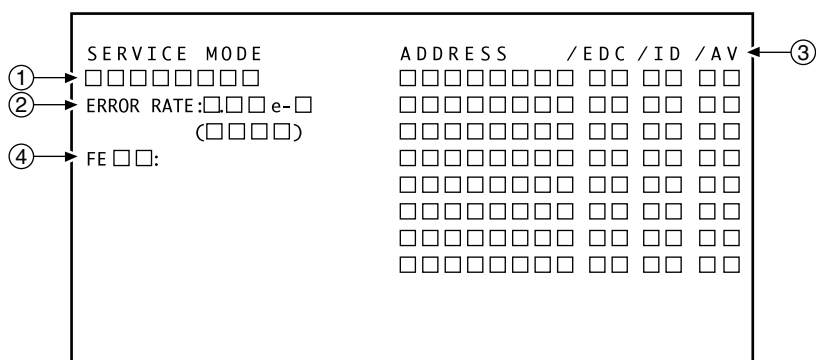

Character in bold : Item name  
□ : Information display

## 7.1.2 DISPLAY OF THE MECHANISM ERROR HISTORY

When mechanism error (FE error) occurred, the mechanism error history of maximum past eight times is displayed by pressing the CHP/TIM key during service mode screen display.

Indication displayed in the screen upper part is new error.

### • Indication contents

#### ① Error code

Two characters in the front represent the Error Code and two characters in the back represent the Servo State. The detail is as follows.

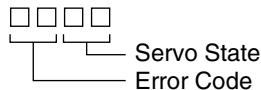

#### ② Error occurrence time

Error indicates the time which occurred after system turned on the power supply.

\* When time of new error is short, it becomes assumed power off once.

#### ③ Error contents indication

Indicate the error contents which occurred with character.

Examples: When Error code is 0x13 (Focus lost timeout) and Servo state is 0x05 (Disc judge), "Focus lost timeout in Disc judge"

\* Movement in the error occurrence: open the tray when SERVO STATE is Disc Judgs, and others stop. However, error code is exception in the device error of 0xd\*.

Indication contents

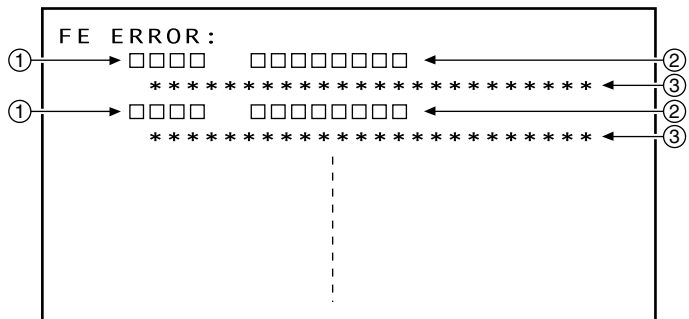

### • Table of Error Code

<b>FOCUS ERROR</b>	0x0*	<b>FOCUS TIMEOUT</b>	0x1*
Focus on error	0x01	Focus on timeout	0x11
Focus off error	0x02	Focus off timeout	0x12
Focus lost error	0x03	Focus lost timeout	0x13
Focus balance adjust error	0x04	Focus balance adjust timeout	0x14
Focus gain adjust error	0x05	Focus gain adjust timeout	0x15
Focus sweep error	0x06	Focus sweep timeout	0x16
Focus reflection error	0x07	Focus reflection timeout	0x17
<b>TRACKING ERROR</b>	0x2*	<b>TRACKING TIMEOUT</b>	0x3*
Tracking on error	0x21	Tracking on timeout	0x31
Tracking off error	0x22	Tracking off timeout	0x32
Tracking lost error	0x23	Tracking lost timeout	0x33
Tracking balance adjust error	0x24	Tracking balance adjust timeout	0x34
Tracking gain adjust error	0x25	Tracking gain adjust timeout	0x35
Tracking jump error	0x26	Tracking jump timeout	0x36
<b>STEPPING ERROR</b>	0x4*	<b>STEPPING TIMEOUT</b>	0x5*
Stepping on error	0x41	Stepping on timeout	0x51
Stepping off error	0x42	Stepping off timeout	0x52
Stepping lost error	0x43	Stepping lost timeout	0x53
Stepping move error	0x44	Stepping move timeout	0x54
<b>SPINDLE ERROR</b>	0x6*	<b>SPINDLE TIMEOUT</b>	0x7*
Spindle on error	0x61	Spindle on timeout	0x71
Spindle off error	0x62	Spindle off timeout	0x72
Spindle lost error	0x63	Spindle lost timeout	0x73
Spindle CAV error	0x64	Spindle CAV timeout	0x74
Spindle CLV error	0x65	Spindle CLV timeout	0x75
<b>ACQUISITION ERROR</b>	0x8*	<b>ACQUISITION TIMEOUT</b>	0x9*
PLL lost error	0x83	PLL lost timeout	0x93
<b>DECODER ERROR</b>	0xa*	<b>DECODER TIMEOUT</b>	0xb*
ID lost error	0xa3	ID lost timeout	0xb3
<b>DEVICE ERROR</b>	0xd*	<b>FAIL SAFE</b>	0xe*
SRAM error	0xd1	unexpected error	0xe1

### • Table of Servo State

0x00	Reset
0x01	Stop (inside position)
0x02	Stop (any position)
0x03	Braking for stop
0x04	New disc
0x05	Disc judge
0x06	Reserved 1
0x07	Playing
0x08	Start up
0x09	Seeking
0x0A	Pausing
0x0B	Reading BCA
0x0C	Reserved 2
0x0D	
0x0E	
0x0F	



## ERROR CODE TABLE

Error Name	No.	Causes	Check Item	Possibility of Trouble	Remarks
<b>FOCUS ERROR (0 x 0*)</b>					
Focus on error	0 x 01	Focus on could not be completed	Are not there a dirt or a scratch in the Disc? Does LD become weak? Does the lens move up and down?	1. Pickup 2. Driver 3. L6315 (Front End IC)	
Focus off error	0 x 02	Focus off could not be completed	Unknown		
Focus lost error	0 x 03	Focus servo is lost	Are not there a dirt or a scratch in the Disc? Does LD become weak?	1. Pickup	
Focus balance adjust error	0 x 04	AFB on could not be completed			
Focus gain adjust error	0 x 05	Focus AGC could not be completed			
Focus sweep error	0 x 06				
Focus reflection error	0 x 07	Dimensions of S curve did not reach to the aim value	Does LD become weak?	1. Pickup	
<b>FOCUS TIMEOUT (0 x 1*)</b>					
Focus on timeout	0 x 11	Did timeout at focus on	Are not there a dirt or a scratch in the Disc? Does LD become weak? Does the lens move up and down?	1. Pickup 2. Driver 3. L6315 (Front End IC)	
Focus off timeout	0 x 12	Did timeout at focus off			
Focus lost timeout	0 x 13	Did timeout at focus backup			
Focus balance adjust timeout	0 x 14	Did timeout at AFB			
Focus gain adjust timeout	0 x 15	Did timeout at AGC			
Focus sweep timeout	0 x 16				
<b>TRACKING ERROR (0 x 2*)</b>					
Tracking on error	0 x 21	Tracking on could not be completed		1. Pickup 2. Driver 3. L6315 (Front End IC)	
Tracking off error	0 x 22	Tracking off could not be completed			
Tracking lost error	0 x 23	Tracking servo is lost		1. Pickup	
Tracking balance adjust error	0 x 24	ATB could not be completed		1. Pickup	
Tracking gain adjust error	0 x 25	AGC could not be completed		1. Pickup	
Tracking jump error	0 x 26	Tracking jump could not be completed			
<b>TRACKING TIMEOUT (0 x 3*)</b>					
Tracking on timeout	0 x 31	Did timeout at tracking on	Are not there a dirt or a scratch in the Disc?	1. Pickup 2. Driver 3. L6315 (Front End IC)	
Tracking off timeout	0 x 32	Did timeout at tracking off			
Tracking lost timeout	0 x 33	Did timeout at tracking backup	Are not there a dirt or a scratch in the Disc?	1. Pickup	
Tracking balance adjust timeout	0 x 34	Did timeout at ATB		1. Pickup	
Tracking gain adjust timeout	0 x 35	Did timeout at AGC		1. Pickup	
Tracking jump timeout	0 x 36	Did timeout at tracking jump			
<b>STEPPING ERROR (0 x 4*)</b>					
Stepping on error	0 x 41	Stepping on could not be completed		1. Pickup 2. Driver 3. L6315 (Front End IC)	
Stepping off error	0 x 42	Stepping off could not be completed			
Stepping lost error	0 x 43	Stepping servo is lost			
Stepping move error	0 x 44	Stepping could not move	Do move to inner and outer periphery of the stepping in the test mode? Do indicate "S-04" at the most inner periphery of the stepping?	1. Stepping motor 2. Inside switch 3. Driver	
<b>STEPPING TIMEOUT (0 x 5*)</b>					
Stepping on timeout	0 x 51	Did timeout at stepping on		1. Pickup 2. Driver 3. L6315 (Front End IC)	
Stepping off timeout	0 x 52	Did timeout at stepping off			
Stepping lost timeout	0 x 53	Did timeout at stepping backup			
Stepping move timeout	0 x 54	Did timeout at stepping movement	Do move to inner and outer periphery of the stepping in the test mode? Do indicate "S-04" at the most inner periphery of the stepping?	1. Stepping motor 2. Inside switch 3. Driver	

Error Name	No.	Causes	Check Item	Possibility of Trouble	Remarks
<b>SPINDLE ERROR (0 x 6*)</b>					
Spindle on error	0 x 61	Spindle on could not be completed			
Spindle off error	0 x 62	Spindle off could not be completed			
Spindle lost error	0 x 63	Spindle lost control			
Spindle CAV error	0 x 64	CAV on could not be completed			
Spindle CLV error	0 x 65	CLV on could not be completed			
<b>SPINDLE TIMEOUT (0 x 7*)</b>					
Spindle on timeout	0 x 71	Did timeout at spindle on			
Spindle off timeout	0 x 72	Did timeout at spindle stop			
Spindle lost timeout	0 x 73	Did timeout at spindle backup	Are not there a dirt or a scratch in the Disc? Is FG output from the driver?	1. Spindle motor 2. Spindle driver	
Spindle CAV timeout	0 x 74	Did timeout at CAV on	Is spindle rotating? Is FG output from the driver? Is the PDM output from L6315?	1. Spindle motor 2. Spindle driver 3. L6315 (Front End IC)	
Spindle CLV timeout	0 x 75	Did timeout at CLV on			
<b>ACQUISITION ERROR (0 x 8*)</b>					
PLL lost error	0 x 83	PLL is lost	Are not there a dirt or a scratch in the Disc?	1. Pickup 2. L6315 (Front End IC)	
<b>ACQUISITION TIMEOUT (0 x 9*)</b>					
PLL lost timeout	0 x 93	Did timeout at PLL backup	Are not there a dirt or a scratch in the Disc?	1. Pickup 2. L6315 (Front End IC)	
<b>DECODER ERROR (0 x a*)</b>					
ID lost error	0 x a3	ID is not readable	Are not there a dirt or a scratch in the Disc?	1. Pickup 2. L6315 (Front End IC)	
<b>DECODER TIMEOUT (0 x b*)</b>					
ID lost timeout	0xb3	Did timeout at ID backup	Are not there a dirt or a scratch in the Disc?	1. Pickup 2. L6315 (Front End IC)	
<b>DEVICE ERROR (0 x d*)</b>					
SRAM error	0 x d1	Cannot access SRAM	Power supply of SRAM Is not bus line short-circuiting?	1. SRAM 2. L6315 (Front End IC) 3. L6315-SRAM bus line	
<b>FAILSAFE (0 x e*)</b>					
Unexpected error	0 x e1	Unexpected error		1. software runaway 3. Software bug	

### 7.1.3 TRUBLE SHOOTNG

Confirm the error history at first.

When a history was not displayed, refer to the following table.

No.	Symptoms	Diagnosis Contents	Defectiveness Assumption Points
1	Cannot power on	Check Voltage of CN8901-17pin(VE+56) on the AF assy.	M-EV51(21) , system cable connection
		Check the stand by indicator. If the indicator brinking , the protect circuit working. (Stand by indicator brinking)	AMP PROTECT , DVD POWER SUPPLY
		Check IC5501-4pin(AC PULSE).	M-EV51(21) , system cable connection
		Check IC5501-12pin,13pin (CF1,CF2)	U-COM
2	Standby indicator brinking (DVD ERR)	Check IC5501-17pin(VDET) is 3.5V	1.Connection of DVDIF assy & IF assy. 2.DVD power supply, 3.M-EV51(21) POWER SUPPLY
	Standby indicator brinking (AMP ERR)	Check FAN connect in M-EV51(21).	M-EV51(21) , system cable connection
		Check IC3301,IC3401 in AMP module.	M-EV51(21) , system cable connection
3	Audio is not out put	Check connection AF assy & IF assy.	AF ASSY & IF ASSY
		Check signal waveform of CN8751 1,3,5,7,9,11pin (C,SW,LS,RS,FL,FR) at DOLBY PROLOGIC mode.	DSP ASSY
		Check signal waveform at CN8701-all pin., CN8751-13,15pin(ANAL,ANAR)	AF ASSY
4	VIDEO no out put	Are the signals output from IC11-pin 9, 8 and 7 on the FLKB Assy ? (around 0-3V)	IF assy & DVD IF assy connection. DVD IF ASSY

No.	Symptoms	Diagnosis Contents	Defectiveness Assumption Points
A 4	Cannot open a tray (An opening screen is displayed on the monitor)	Does voltage of CN9-pin 3 and 5 on the DVDM Assy change normally ? pin 3 (XCLOSE) : It is "H" level by the state that has finished doing CLOSE. pin 5 (OPEN) : It is "H" level by the state that has finished doing OPEN.	Tray switch
		Does LOAD_DRV signal come ?	BACK END IC (DVDM IC601)
		Is a signal output from IC351-pin 14 and 15 (CN9-pin 1 and 2) on the DVDM Assy ? (pin 15 : It is about 6V during tray opening, It is about 0V during tray closing) (pin 14 : It is about 0V during tray opening, It is about 6V during tray closing)	FTS Driver IC (DVDM IC351)
		Are not there wire rod coming out, damage the connectors of CN9 and CN5 on the DVDM Assy ?	Connector / wire rod
		Does voltage of CN5-pin 1 on the DVDM Assy change when pressed the inside switch ?	Inside switch
B 5	Cannot playback (Focus does not inn)	Are the signals output from IC351-pin 9 and 10 on the DVDM Assy ?	FTS Driver IC (DVDM IC351)
		Does 650 LD emit light ? Does a pickup lens do up / down ? Does not an actuator spring bend ?	Pickup
		Are not resin part damage, a shaft missing ? Are not there falling off of turn table, lean abnormality ?	Mechanism Assy
		Is not flexible cable of CN7 on the DVDM Assy coming off and damaged ?	Flexible cable / connector
		Is signal output from IC301-pin 123 (FACT) on the DVDM Assy ? (Device control of around 500 mV is output usually. It is $\pm$ around 100 mV swing by focus up / down.)	FRONT END IC (DVDM IC301)
C 6	Cannot playback (Spindle does not turn)	Are the signals output from IC251-pin 2 (A3), pin 4 (A2) and pin 7 (A1) on the DVDM Assy ? It is fixed, and is not there pin 18 HIGH whether it is fixed, and there is not pin 23 LOW ?	Spindle Driver IC (DVDM IC251)
		Are not there part falling off, alien substance adhesion in spindle motor part ?	Mechanism Assy (Spindle motor)
		Is not flexible cable of CN7 on the DVDM Assy coming off and damaged ?	Flexible cable / connector
		Is signal output from IC301-pin 123 (SPDL_PDM) on the DVDM Assy ?	FRONT END IC (DVDM IC301)
D 7	Cannot playback (Playback stops)	Does not 650nm LD deteriorate ? If there is the both ends voltage of R121 on the DVDM Assy more than 0.7V, 650nm LD deteriorates surely.	650nm LD deteriorates. (Cannot playback DVD)
		Does not 780nm LD deteriorate ? If there is the both ends voltage of R123 on the DVDM Assy more than 1.2V, 780nm LD deteriorates surely.	780nm LD deteriorates. (Cannot playback CD)
		Is not there abnormality in FG waveform ?	FG output : Spindle Driver IC (DVDM IC251)
		Are not there scratch and a dirt on the disc ?	Disc
8	Picture disturbance during playback (block noise, freeze, other)	Are not there scratch and a dirt on the disc ? Do not you set a disc of standard outside ?	Disc
9	Audio is not output (Picture is normal)	Check the waveform (BCK, LRCK, MCLK, DATA).	BACK END IC (DVDM IC601)
		Is signal output from IC711-pin 7 and 8 on the JCKB Assy ?	AUDIO DAC IC (JCKB IC711)

## EVA emergency processing specification

### 1. About Emergency process

When abnormality of hardware of power supply short circuits and so on occurred, turn the power OFF without an usual step in a moment. And perform process to limit the later power ON operation.

### 2. Category of error to perform the Emergency process

As for the error to perform the Emergency process, there are two kinds of the following.

- PROTECT error: Error by power supply of the amplifier section and abnormality of the fan  
Overcurrent detection of amplifier  
DC voltage detection of amplifier  
Fan open and lock detection  
Abnormal detection of 8V and 15V

- DVD error: Error by power-failure in the DVD module

### 3. Condition to enter Emergency process

- PROTECT error: When PROTECT port (pin 92) of the microcomputer was L more than 90 mS (less than 0.15VDD +0.4V).
- DVD error: When 3.3DET port (pin 17) of the microcomputer was more than 90mS, and were less than 2.5V or more than 4.25V.
- \* Do not perform the error detection during 1.5 seconds after the power ON operation start at both ports.

### 4. State after the power OFF

STANDBY LED flashes in case of both of PROTECT and DVD errors

### 5. Possibility or no of re-power ON

- PROTECT error: Power ON is once again possible after the power OFF 60 seconds later.  
Indicates "POW ERR" instead of "WELCOME" in this time.  
\* When pulled the AC power cord out after the power OFF within 60 seconds, cannot turn the power ON for 60 seconds after inserting the AC power cord once again.  
\* Flash of STANBY LED is continued even if it passes after the power OFF for 60 seconds.
- DVD error: Power ON is once again possible after the power OFF 60 seconds later.  
Indicates "DVD ERR" instead of "WELCOME" in this time.  
\* When pulled the AC power cord out after the power OFF within 60 seconds, cannot turn the power ON for 60 seconds after inserting the AC power cord once again.  
\* Flash of STANBY LED is continued even if it passes after the power OFF for 60 seconds.

### 6. Recovery method of within 60 seconds after PROTECT error, and after DVD error

When turn the power ON once again after turning the power OFF within 60 seconds in the PROTECT error, and after turned the power OFF in the DVD error, it is necessary to start with the test mode.

To enter the Test mode, turn the power on while short-circuiting with TEST jumper (W284) and VE+5 jumper (W282) on the IF Assy.

Indicate with "U-TEST" in this time.

In addition, RAM of the microcomputer is reset to the factory shipping state when releasing the service test mode with the power OFF. Then power ON can normally from the next time.

(When error is left, enter the Emergency process once again.)

## Protection circuit

### 1 Diagnosis method when the protection circuit turned to OFF at normal connection (MEDIA-AMP)



When enter the individual operation mode, a protection circuit does not work.

### 2 The release method that "power cannot turn on for 60 seconds"



Enter the test mode by supplying AC power (or DC power in the individual operation) while short-circuiting the jumpers with "TEST" indication on the IF ASSY, waiting for 60 seconds is released. Be because the microcomputer was reset then.

## ■ SINGLE OPERATION METHOD

Individual operation method of XV-EV51, EV21 (MEDIA)

### ■ Jigs and Measuring instruments

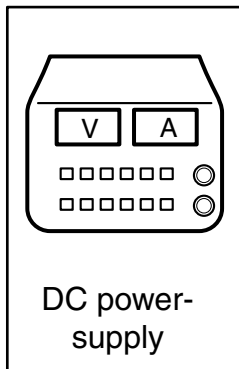

### ■ Single purpose operation method.

- ① Supply DC power to each point, and all the divided GND short-circuits.

#### DC apply point

	Voltage	Locations	Apply Point Name	Assy Name
1	8V	W497	IC5508 IN	IF Assy
2	8V	W264	V+8V	IF Assy
3	16V	C8902 + side	VU+12V	AF Assy

#### IGND short circuit point

	Locations	GND Name	Assy Name
1	CN8901 16PIN	GNDD	AF ASSY
2	W132	GNDA	AF ASSY
3	W395	GNDM	IF ASSY

- ② Supply a DC power while short-circuiting the jumpers (W282 and W285) with "SERVICE" indication on the IF Assy.

### TEST MODE : STOP → CANCEL

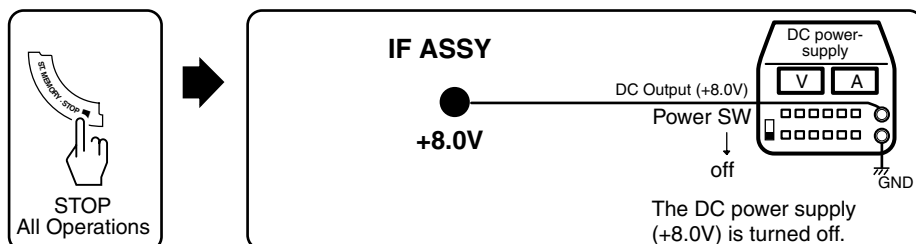

### 7.1.4 SEQUENCE AFTER POWER ON

Flow chart from power on to the picture output

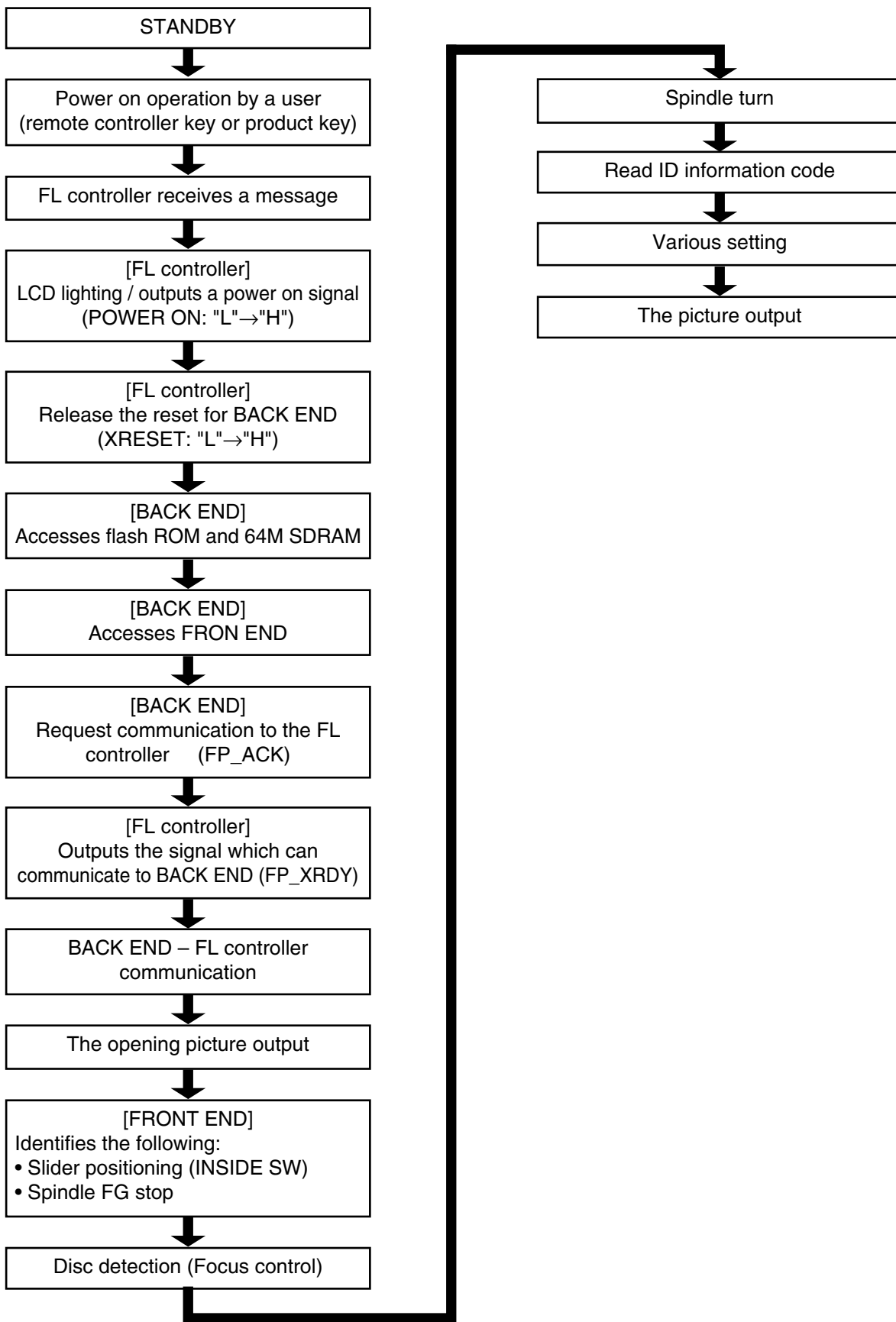

### 7.1.5 DISASSEMBLY

#### 1 Deck Mechanism Section

- ① Remove the Side Bonnet L and R (screws × 14)
- ② Remove two screws

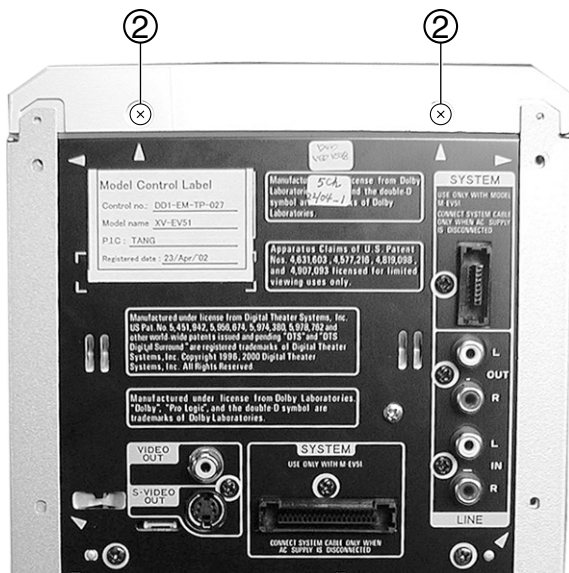

● Rear View

- ③ Release two binders
- ④ Remove the earth lead wire (screw × 1)
- ⑤ Remove the Deck Mechanism Section (FFC × 1, connectors × 2)

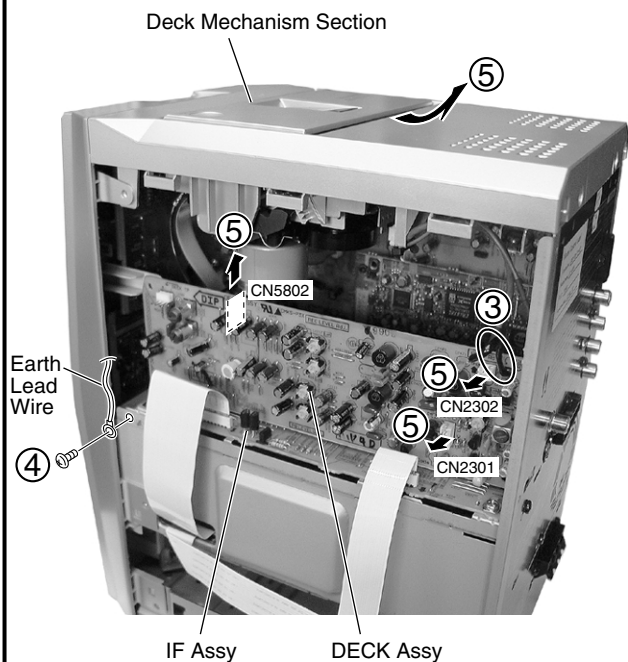

**Note :** Operation check of the main unit is possible even if removes the Deck Mechanism Section.

#### 2 Front Panel Section

- ① Remove two screws
- ② Remove a FFC and connector
- ③ Unhook × 4
- ④ Remove the Front Panel Section

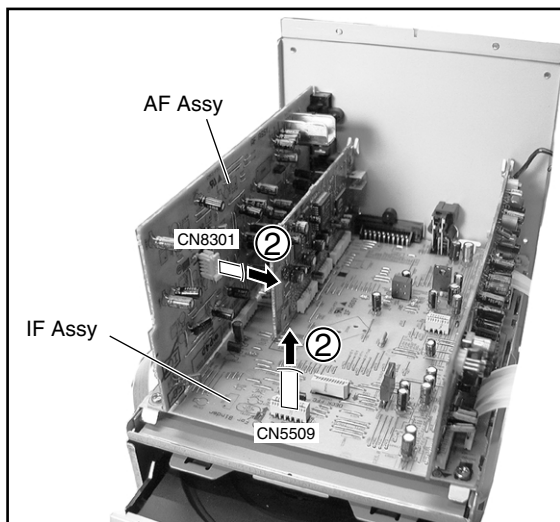

**Note :** Front Panel can removes with the state which Tray Panel was attached to it. In this time, remove bottom part of the Front Panel first so that the Tray Panel is not caught.



### 3 DVD Mechanism Section

① Remove three screws

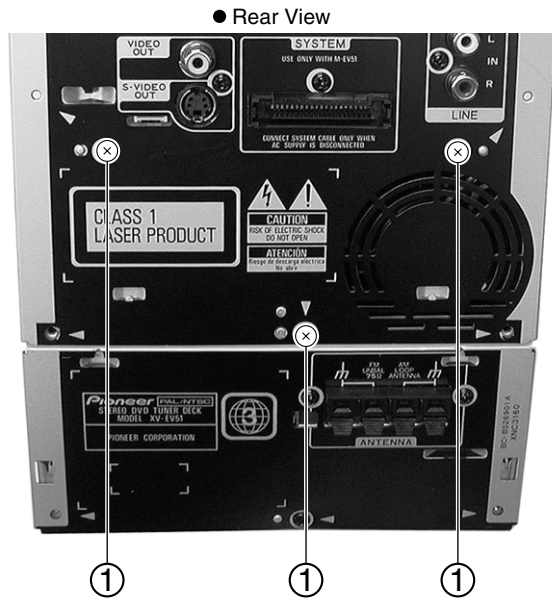

② Remove a screw

③ Remove a Fan connector

④ Remove the DVD Shield Section

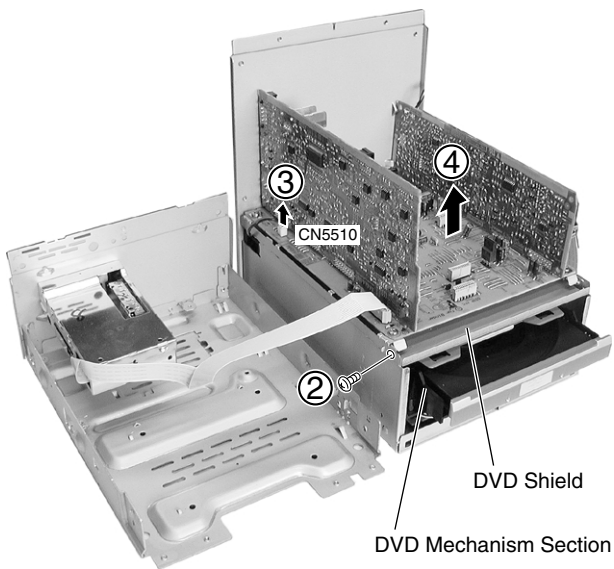

⑤ Remove four screws

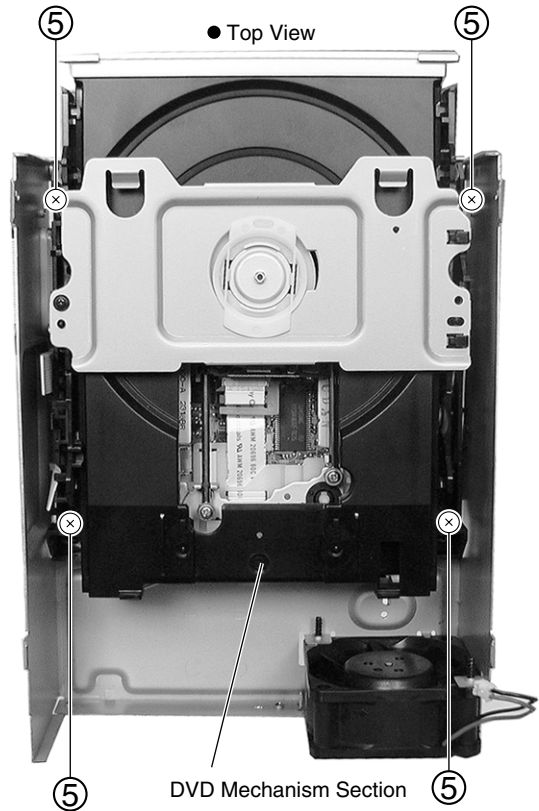

⑥ Remove the DVDM and DVD IF Assys (screws × 6) (with Shield Plate and Plastic Plate)

**Caution :** Be careful to installation order of the Shield Plate and Plastic Plate.

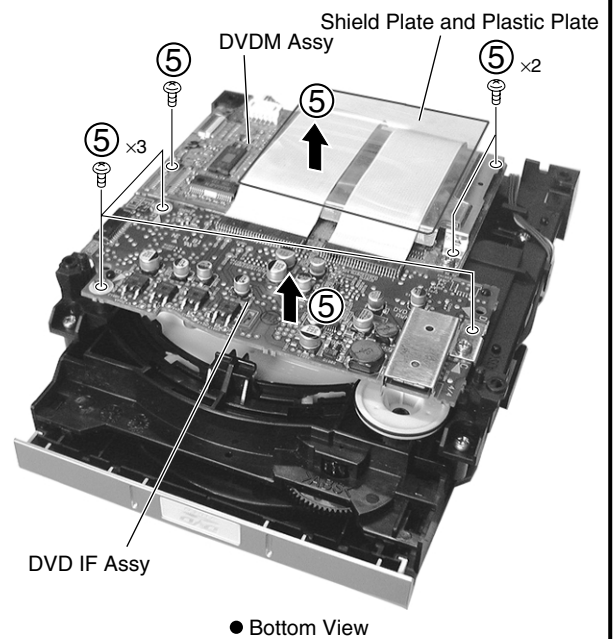

⑦ Styling like figure below.

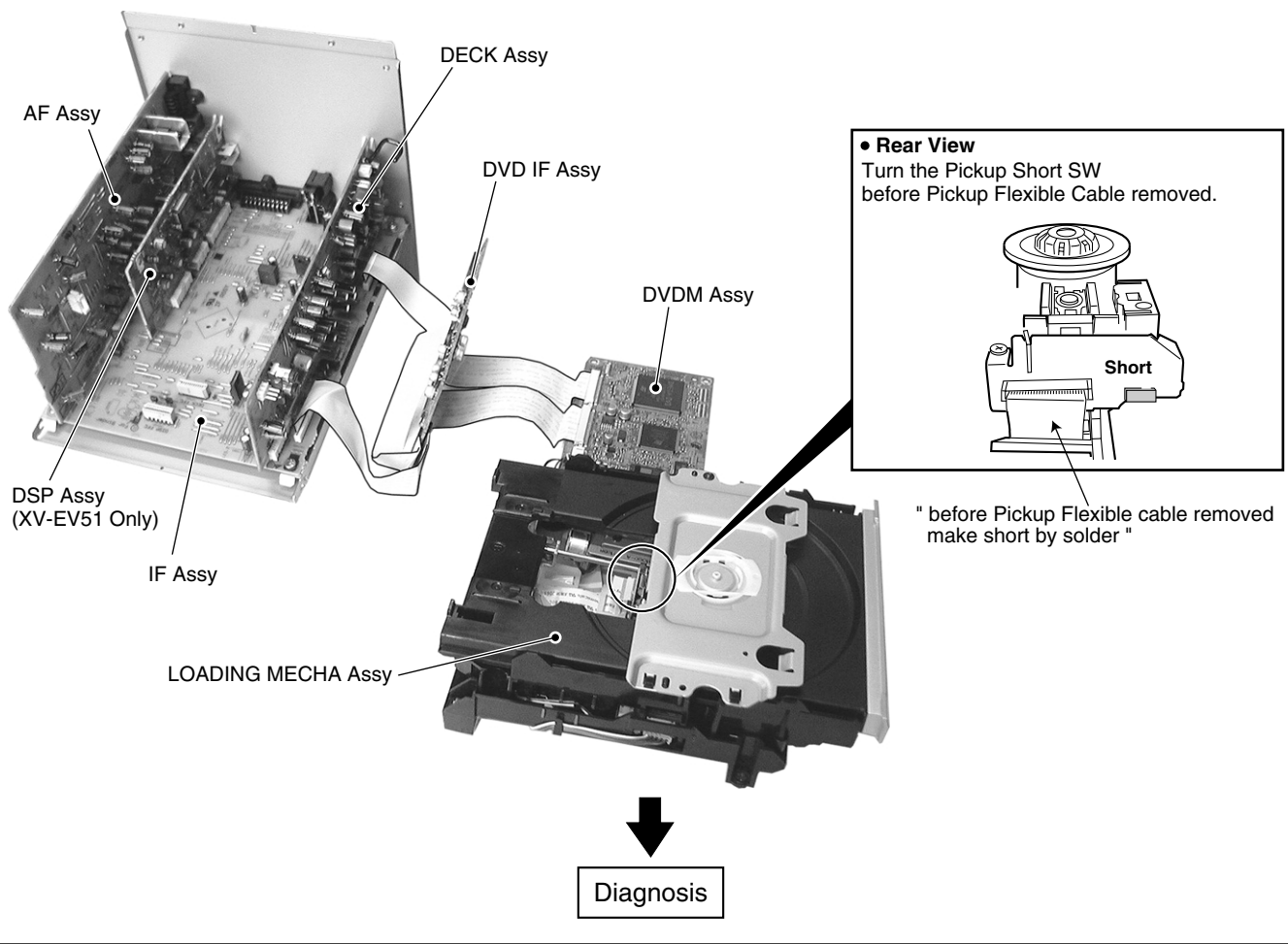

### 4 Tray

- ① Remove the Bridge (screw ×1).
- ② Pull out the Tray and remove it while unhooking a hook.

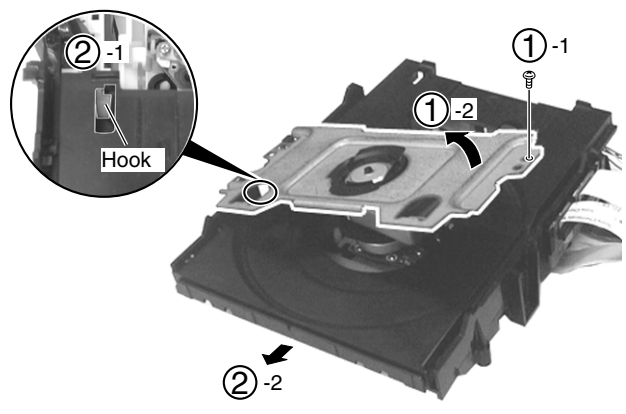

**Caution in the Tray Insertion**

In the Tray insertion, insert it after matching a triangle mark of the Loading Base and a position of pin of the Drive Cam.



### 5 Traverse Mechanism Assy-S

- ① Remove the FFC Holder with the state which Flexible Cable was attached. (Screw × 1)

**Cautions :**  
Screw is locked with Silicone Adhesive.  
Please lock it with Silicone Adhesive when installs it.

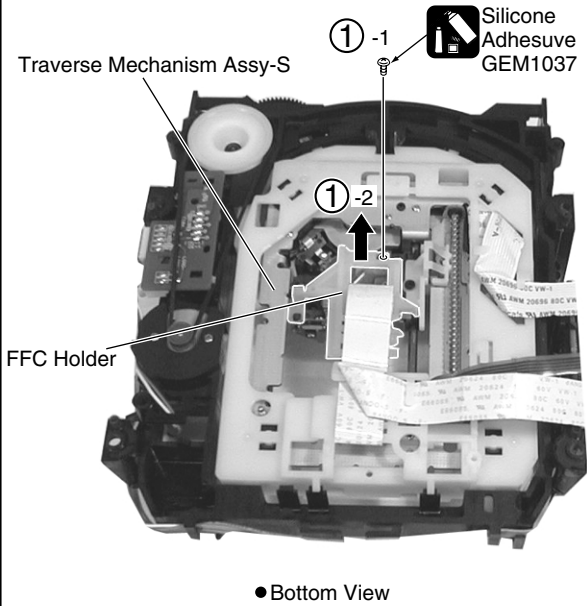

- ② Remove the Pickup Flexible Cable



- ③ Unhook ( × 4)

- ④ Remove the Traverse Mechanism Assy-S

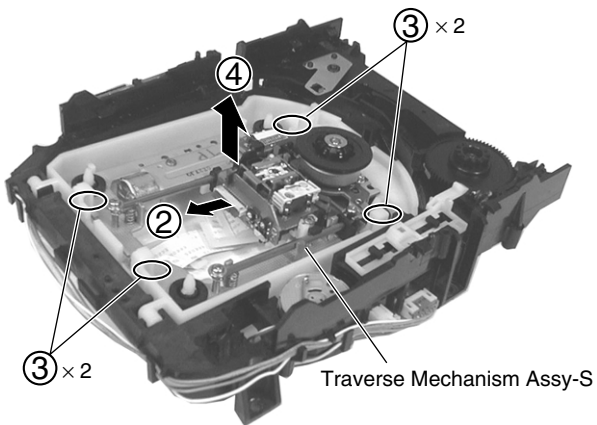

### ● When Removing The Pickup Assy-S

- ③ Remove two Skew Screws and two Skew Springs

- ④ Remove the Pickup Assy-s

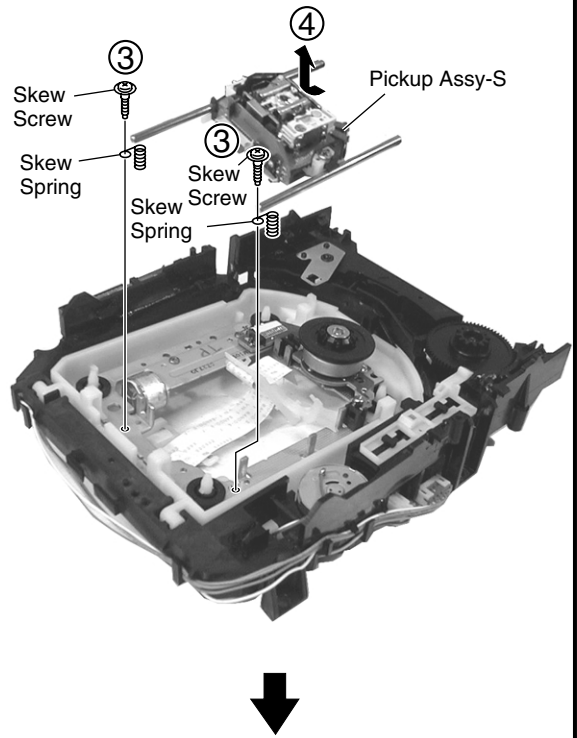

- ⑤ Remove two Screws

**Cautions :**  
Screw is locked with Silicone Adhesive.  
Please lock it with Silicone Adhesive when installs it.

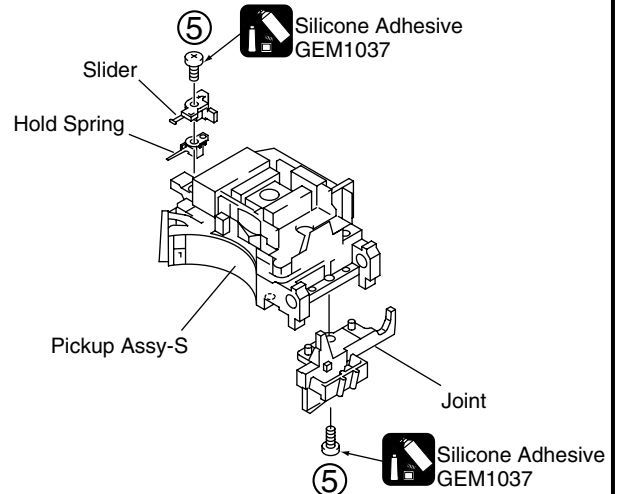

### STYLING THE PICKUP FLEXIBLE CABLE

- ① FOLD a edge of lining part of the Pickup Flexible Cable.
- ② Insert the Pickup Flexible Cable in connector, and lock it surely.

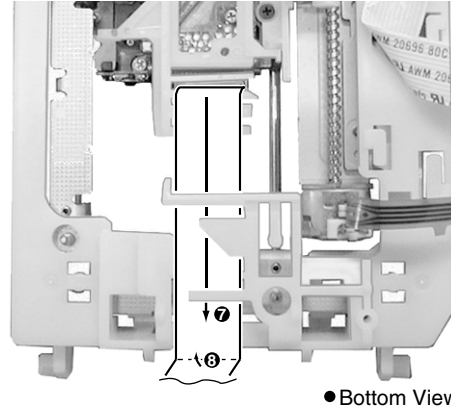
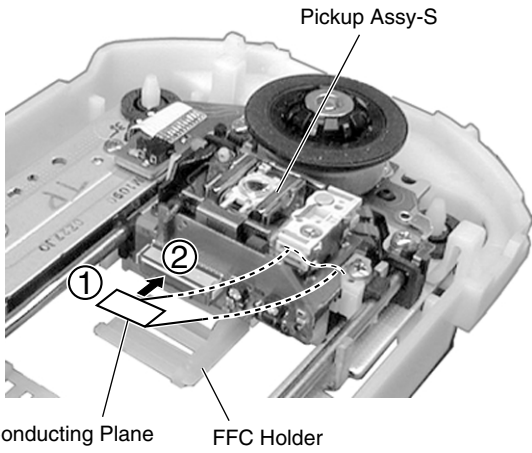

● Bottom View

**Caution :**  
Move the Pickup to the innermost of the disc

- ③ Perform the styling as shown in figure below.

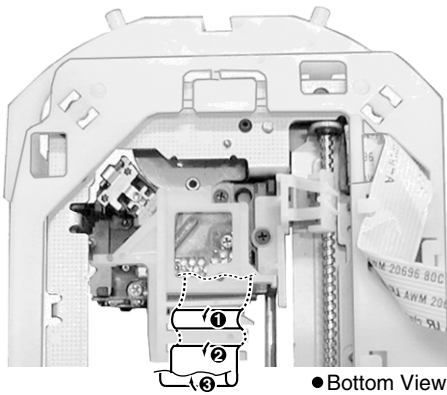

● Bottom View

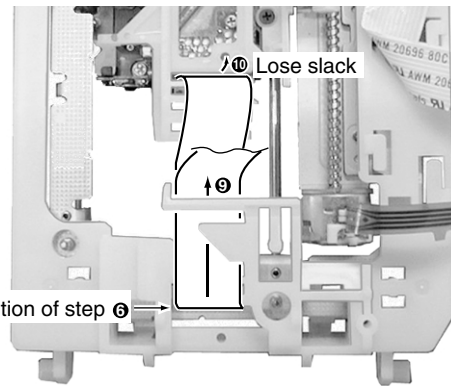

Fold position of step ③

● Bottom View

Fold at the position of reference line. ⑥

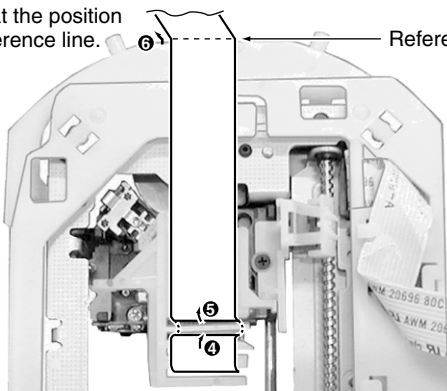

● Bottom View

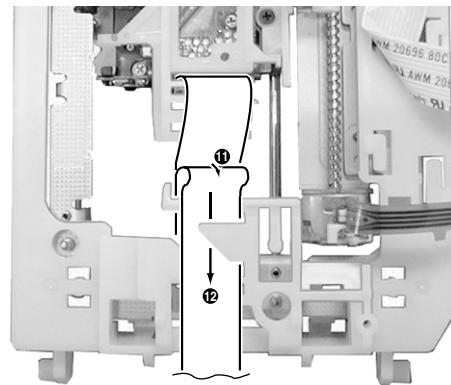

● Bottom View

## 7.2 PARTS

• The information shown in the list is basic information and may not correspond exactly to that shown in the schematic diagrams.

### • List of IC

BA6664FM, L6315ATXXY, M5678AFP, STI5519AVB-B0C, PCM1742KE, MM1567AJ, PDC093

### ■ BA6664FM (DVDM ASSY : IC251)

• Spindle Driver

### • Block Diagram

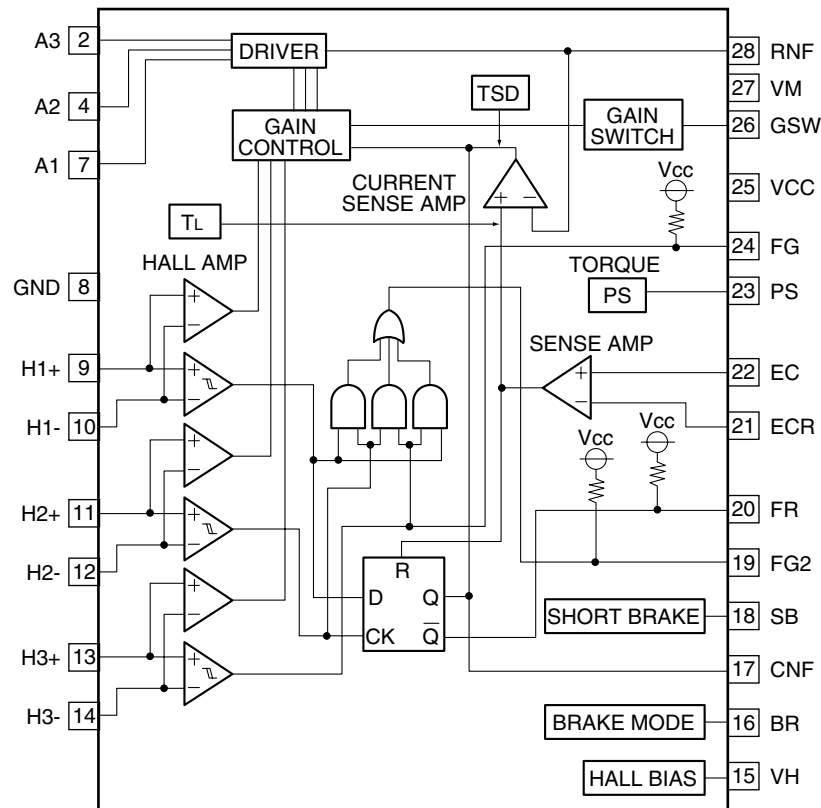

### • Pin Function

No.	Pin Name	Pin Function	No.	Pin Name	Pin Function
1	N.C.	N.C.	16	BR	Brake mode switching pin
2	A3	Output pin	17	CNF	Capacitor connection pin for phase compensation
3	N.C.	N.C.	18	SB	Short brake pin
4	A2	Output pin	19	FG2	FG 3-phase mix signal output pin
5	N.C.	N.C.	20	FR	Rotation detecting pin
6	N.C.	N.C.	21	ECR	Control reference pin of output voltage
7	A1	Output pin	22	EC	Output voltage control pin
8	GND	GND pin	23	PS	Power save pin
9	H1+	Hall signal input pins	24	FG	FG signal output pin
10	H1-		25	VCC	Power supply pin
11	H2+		26	GSW	Gain switching pin
12	H2-		27	VM	Motor power pin
13	H3+		28	RNF	Resistor connection pin for output current detection
14	H3-		FIN	FIN	GND
15	VH	Hall bias pin			

# L6315ATXXY (DVDM ASSY : IC301)

• Front End IC

## ● Block Diagram

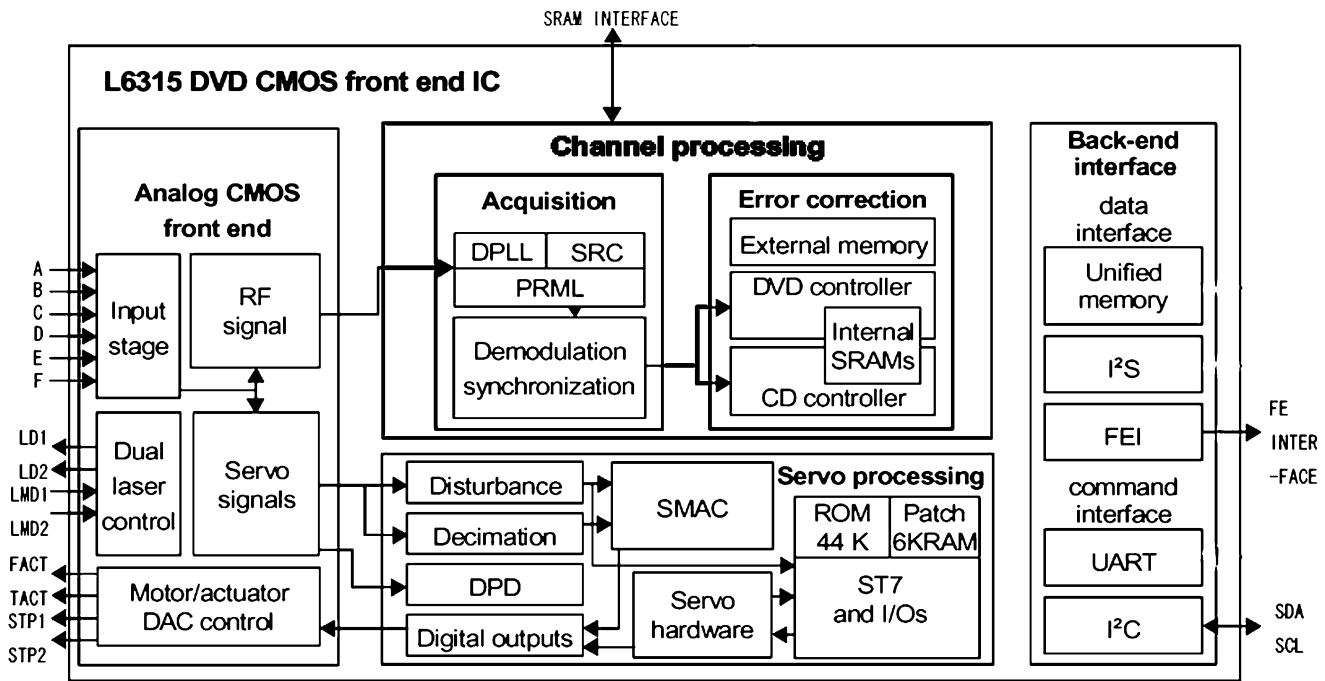

## ● Pin Function

No.	Pin Name	I/O	Pin Function
1	IREF	Analog input	Bandgap filtering input
2	GNDAI	Analog ground	Analog power supply ground
3	RFSACD	Analog output	RF output for SA-CD support
4	RFIN	Analog input	RF path data input (after AC coupling)
5	RFOUT	Analog output	RF path data output (before AC coupling)
6	VCCA18	Analog supply	Input stage power supply
7	TST_ADC	Analog output	RF path analog test pin
8	TST_SLICE	Analog output	PM analog test pin
9	TST_PM	Analog output	PM analog test pin
10	A	Analog input	Input stages laser diode A
11	GNDMN	Analog ground	Input stages ground main
12	B	Analog input	Input stages laser diode B
13	VCC33MN	Analog supply	Input stages 3.3 V misc.
14	REFD	Analog output	Reference voltage for pickup
15	VCC18IS	Analog supply	Input stages 1.8 V main
16	D	Analog input	Input stages laser diode D
17	VCCA18IS	Analog supply	Input stages 1.8 V misc.
18	C	Analog input	Input stages laser diode C
19	VCC33IS	Analog supply	Input stages 3.3 V misc.
20	GNDAIS	Analog ground	Input stages ground misc.
21	VCC33SD	Analog supply	Input stages 3.3 V side
22	VCC18SD	Analog supply	Input stages 1.8 V side
23	GNDSD	Analog ground	Input stages ground side
24	F	Analog input	Input stages laser diode F
25	E	Analog input	Input stages laser diode E
26	VSHIELIS	Analog ground	IS shield
27	VDDADC	Analog supply	ADC digital power supply
28	VSSADC	Analog ground	ADC digital ground supply
29	VCCADC	Analog supply	ADC analog power supply
30	GNDADC	Analog ground	ADC analog ground supply
31	VSHIELDADC	Analog ground	ADC shield
32	NC	–	–
33	BOOT_MODE	Digital input	Boot mode
34	VSS	Digital ground	VSS I/O
35	VDD3	Digital supply	VDD I/O (3.3 V)
36	PC[0] (NC)	Digital I/O	–
37	PC[1] (PS)	Digital I/O	Driver IC power save
38	PC[2] (FG)	Digital I/O	FG pulse input
39	PC[3] (SB)	Digital I/O	Spindle short brake
40	PC[4] (SLDPOS)	Digital I/O	Slider position input

No.	Pin Name	I/O	Pin Function
41	PC[5] (VROFST)	Digital I/O	VREF offset adjustment (stand-by)
42	PC[6] (SPDL_PDM)	Digital I/O	Spindle drive output
43	PC[7] (OEICG)	Digital I/O	OEIC gain sw
44	VSS	Digital ground	VSS core
45	VDD3S	Digital supply	VDD core
46	VSS_SPL	Digital ground	VSS I/O
47	RAM_DQM	Digital output	SDRAM DQM
48	RAM_WEN	Digital output	RAM write enable
49	RAM_CASN / Sradr14	Digital output	SRAM address
50	RAM_RASN / Sradr15		
51	RAM_A[13]		
52	RAM_A[12]		
53	RAM_A[11]		
54	RAM_A[10]		
55	RAM_A[0]		
56	RAM_A[1]		
57	RAM_A[2]		
58	RAM_A[3]		
59	RAM_A[4]		
60	RAM_A[5]		
61	RAM_A[6]		
62	RAM_A[7]		
63	RAM_A[8]		
64	RAM_A[9]		
65	RAM_CLK / Sradr16		
66	VDD_SPL	Digital supply	VDD I/O
67	VDD3	Digital supply	VDD I/O
68	VSS	Digital ground	VSS I/O
69	RAM_DQ[0]	Digital I/O	SRAM data
70	RAM_DQ[1]		
71	RAM_DQ[2]		
72	RAM_DQ[3]		
73	RAM_DQ[4]		
74	RAM_DQ[5]		
75	RAM_DQ[6]		
76	RAM_DQ[7]		
77	VDD3S	Digital supply	VDD core
78	VSS	Digital ground	VSS core
79	OUT_REQ	Reserved	Must be set to ground
80	OUT_ERR	Digital output	Output interface



No.	Pin Name	I/O	Pin Function
81	OUT_SYNC	Digital output	Output interface
82	OUT_DVALID	Digital output	Output interface
83	OUT_CLK	Digital output	Output interface
84	OUT_DATA[0] (FE_DATA)	Digital output	Output interface
85	OUT_DATA[1] (FE_EVALID)	Digital output	Output interface: BW com
86	OUT_DATA[2] (FE_ECCBST)	Digital output	Output interface: BW com
87	OUT_DATA[3]	Digital output	Reserved
88	OUT_DATA[4]		
89	OUT_DATA[5]		
90	OUT_DATA[6]		
91	OUT_DATA[7]		
92	VDD3	Digital supply	VDD I/O
93	VSS	Digital ground	VSS I/O
94	PE[0] (FE_INIT)	Digital I/O	FE initialize input
95	PE[1] (NC)	Digital I/O	–
96	PE[2] (DMA)	Digital I/O	DMA input
97	PE[3] (SCL)	Digital I/O	I2C clock input
98	PE[4] (SDA)	Digital I/O	I2C data input
99	PD[0] (NC)	Digital I/O	–
100	PD[1] (NC)	Digital I/O	–
101	PD[2] (NC)	Digital I/O	–
102	PD[3] (NC)	Digital I/O	–
103	PD[4] (NC)	Digital I/O	–
104	PD[5] (NC)	Digital I/O	–
105	PD[6] (NC)	Digital I/O	–
106	PD[7] (NC)	Digital I/O	–
107	VDD3	Digital supply	VDD I/O
108	VSS	Digital ground	VSS I/O
109	VPP_TEST	Digital input	Test input
110	VCCD_BYP	Digital supply	VDD core
111	VCCD_OUT	–	No voltage to be applied
112	VSS	Digital ground	VSS core
113	VDD3S	Digital supply	VDD core
114	VSS	Digital ground	VSS I/O
115	VDD3	Digital supply	VDD I/O
116	RESET_IN	Digital input	Global reset signal
117	VCC18DAC	Analog supply	DAC analog power supply
118	STEPPER1	Analog output	DAC spindle motor
119	STEPPER2	Analog output	DAC sled motor
120	REFEXT	Analog input	DAC external reference

No.	Pin Name	I/O	Pin Function
121	REFGND	Analog ground	DAC analog ground supply
122	REFDAC	Analog output	DAC reference voltage
123	FACT	Analog output	DAC focus actuator
124	TACT	Digital output	DAC tracking actuator
125	GNDDAC	Analog ground	DAC analog ground
126	NC	–	–
127	VCCA33	Analog supply	DAC analog power supply
128	NC	–	–
129	GNDPLL	Analog ground	PM analog ground
130	PLLOFF	Analog input	PM reference disable PLL
131	FREOUT	Analog output	PM reference frequency output
132	FREIN	Analog input	PM reference frequency input
133	VCCPLL	Analog supply	PM analog power supply
134	SREG1	Analog output	External bipolar base
135	VCCR33	Analog supply	Analog power supply for regulator
136	SREG2	Analog output	External bipolar base
137	LD1	Analog output	Laser control laser diode 1
138	LD2	Analog output	Laser control laser diode 2
139	VCCA33	Analog supply	Analog power supply for input stages +
140	LCREF	Analog output	Laser control DAC reference
141	LMD1	Analog input	Laser control monitor diode 1
142	LMD2	Analog input	Laser control monitor diode 2
143	GNDL	Analog ground	Ground for laser control detection
144	VBGFILT	Analog input	Bandgap filtering input

# M56788AFP (DVDM ASSY : IC351)

• FTS Driver IC

## ● Block Diagram

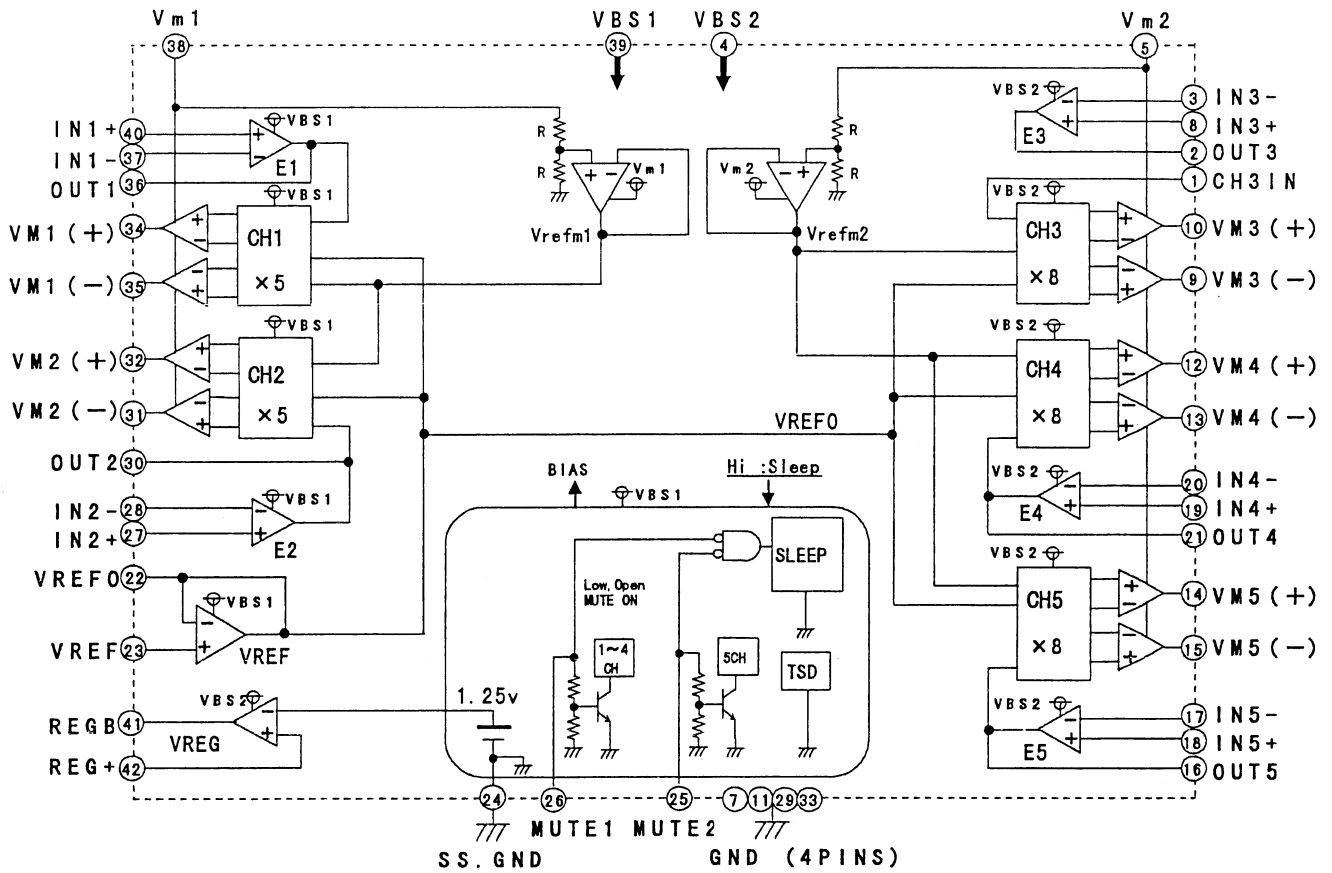

A  
B  
C  
D  
E  
F

# STI5519AVB-B0C (DVDM ASSY : IC601)

• Back End IC

## • Block Diagram

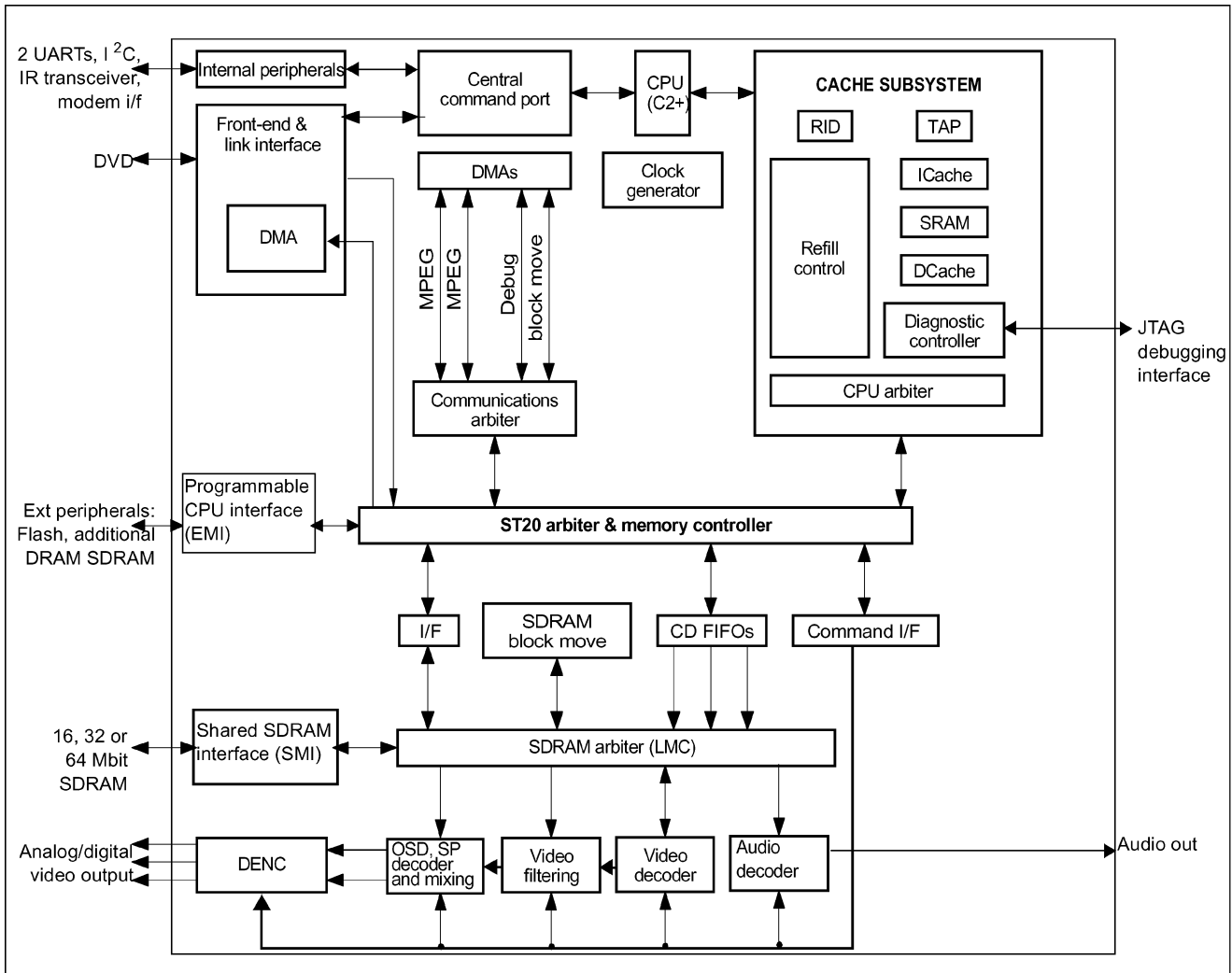

### ● Pin Function

No.	Pin Name	I/O	Pin Function
1	FP_SO	OUT	Front Panel interface. (Soft) Serial transfer data output.
2	A_DATA3	OUT	Reserved
3	XAMUTE	OUT	Analog audio output line muteing output 'L'.
4	VDD_3V3	–	3.3 V Power supply
5	VSS	–	Ground
6	AQE_XCS	OUT	Reserved Audio Quality Enhancer IC's chip-select output.
7	SQUEEZ	OUT	S-Video output S1/S2 control signal at squeeze output mode 'H'.
8	LETTER	OUT	S-Video output S1/S2 control signal & EURO(SCART) connector (FUNCTION SWITCHING) signal at letter-box output mode 'H'.
9	TRYPOS	OUT	In case of NOT carousel 5 disc changer, this port is N.C.(output)
	TRYPOS	IN	Carousel 5 Disc Changer only Tray rotete puls input. Capture function can be used.
10	V_SEL1	OUT	For EURO(SCART) connector (BLINKING) signal 'L' : RGB output disable 'H' : RGB output enable
11	RTS	OUT	UART(RS-232C) Request To Send signal output.
12	V_SEL2	OUT	For EURO(SCART) connector V/Y, R/C signal select 'L' : VRGB output = VRGB 'H' : VRGB output = YCGB
13	CTS	IN	UART(RS-232C) Clear To Send signal input.
14	VDD_2V5	–	2.5 V Power supply
15	VSS	–	Ground
16	FE_DATA	IN	Front-End L6315 stream interface. Serial data input.
17	FE_BCLK	IN	Front-End L6315 stream interface. Serial clock input.
18	FE_DVALID	IN	Front-End L6315 stream interface. Data valid flag input.
19	FE_SYNC	IN	Front-End L6315 stream interface. Serial synchronize flag input.
20	FE_EVALID	IN	Front-End L6315 stream interface. If STI5588 then RS-SPLIT error valid flag.
21	FE_ECCBST	IN	Front-End L6315 stream interface. If STI5588 then RS-SPLIT ECC Block Start flag.
22	TP- ( VQE_XCS )	OUT	Reserved
23	VDD_RGB	–	RGB circuit 2.5 V Power supply
24	VSS_RGB	–	RGB circuit Ground
25	B_OUT	OUT	B / Cb
26	G_OUT	OUT	G / Y
27	RC_OUT	OUT	R / Cr
28	VREF_RGB	IN	RGB DAC reference
29	IREF_RGB	IN	RGB DAC electric current reference
30	VDD/YCC	–	YC circuit 2.5 V Power supply
31	VSS_YCC	–	YC circuit Ground
32	Y_OUT	OUT	Y
33	C_OUT	OUT	C
34	CV_OUT	OUT	CV
35	VREF_YC	IN	YCC DAC reference

No.	Pin Name	I/O	Pin Function
36	IREF_YC	IN	YCC DAC electric current reference
37	VDD_2V5	–	2.5 V Power supply
38	VSS	–	Ground
39	XAMUTE2	OUT	In case of NOT Karaoke model, this port is N.C.(output). Karaoke model Before MIC mixing stage audio muteing output 'L'.
40	MIC_XON1	OUT	In case of NOT Karaoke model, this port is N.C.(output). Karaoke model MIC mixing chanel control output.
41	MIC_XON2	OUT	In case of NOT Karaoke model, this port is N.C.(output).
		OUT	MIC_ON2 : MIC_ON1 : mode 0 0 : Don't use. 0 1 : Mix to Center Speaker 1 0 : Mix to main L/R channel 1 1 : OFF
42	TP-x	OUT	Reserved
43	CLAMP	OUT	In case of NOT carusel 5 disc changer, this port is N.C.(output)
		IN	Carousel 5 Disc Chenger only. 'H' show disc clampe complete postion.
44	XUNCLAMP	OUT	In case of NOT carusel 5 disc changer, this port is N.C.(output)
		IN	Carousel 5 Disc Chenger only. 'H' show disc un-clampe complete postion.
45	KDSP_RST	OUT	Reserved
46	44X48	OUT	In case of NOT Karaoke model, this port is N.C.(output) Karaoke model KARAOKE-DSP master clock 1/2 mode 'L'.
47	VDD3V3	–	3.3 V Power supply
48	VDD_PCM	–	2.5 V Power supply
49	VSS_PCM	–	Ground
50	VSS	–	Ground
51	A_BCK	OUT	Audio DAC clock
52	A_DATA0	OUT	Audio DAC Front L,R data
53	A_DATA1	OUT	Audio DAC Center, LFE data
54	A_DATA2	OUT	Audio DAC Surround L,R data
55	A_MCLK	OUT	Audio DAC Master clock
56	A_LRCK	OUT	Audio DAC L/R clock
57	DOUT	OUT	S/PDIF(IEC60958) digital audio output.
58	SMI_A4	OUT	SMI SDRAM addresss
59	SMI_A5		
60	SMI_A6		
61	SMI_A7		
62	SMI_A8		
63	SMI_A9		
64	VDD_2V4	–	2.5 V Power supply

No.	Pin Name	I/O	Pin Function
65	VSS	–	Ground
66	SMI_A3	OUT	SMI SDRAM address
67	SMI_A2		
68	SMI_A1		
69	SMI_A0		
70	SMI_A10		
71	SMI_A11		
72	SMI_A12		
73	SMI_A13		
74	SMI_CS0	OUT	SMI SDRAM chip select
75	SMI_CS1	OUT	2nd SMI SDRAM chip select
76	SMI_RAS	OUT	SMI SDRAM RAS
77	SMI_CAS	OUT	SMI SDRAM CAS
78	SMI_WE	OUT	SMI SDRAM Write Enable
79	SMI_DQML	OUT	SMI SDRAM Lower DQM
80	SMI_DQMU	OUT	SMI SDRAM Upper DQM
81	VDD_3V3	–	3.3 V Power supply
82	SMI_CLK	IN	SDRAM clock input.
83	VSS	–	Ground
84	SMI_D0	I/O	SMI SDRAM data
85	SMI_D1		
86	SMI_D2		
87	SMI_D3		
88	SMI_D4		
89	SMI_D5		
90	SMI_D6		
91	SMI_D7		
92	SMI_D8		
93	SMI_D9		
94	VDD_2V5	–	2.5 V Power supply
95	SMI_CLK	OUT	SDRAM clock output.
96	VSS	–	Ground
97	SMI_D10	I/O	SMI SDRAM data
98	SMI_D11		
99	SMI_D12		
100	SMI_D13		
101	SMI_D14		
102	SMI_D15		
103	KDSP_XCS	OUT	In case of NOT Karaoke model, this port is N.C.(output). Karaoke model Exteranal DSP chip select 'L'.
104	KDSP_THRU	OUT	In case of NOT Karaoke model, this port is N.C.(output). Karaoke model Exteranal DSP through pass mode 'L'.

No.	Pin Name	I/O	Pin Function
105	LFEON	OUT	Reserved for high-quality audio model's LFE control.
106	TP-	OUT	Not use.
107	VDD_3V3	-	3.3 V Power supply
108	VSS	-	Ground
109	TRST		Diagnostic Controle Unit interface
110	TMS		Diagnostic Controle Unit interface
111	TDTO		Diagnostic Controle Unit interface
112	TDTI		Diagnostic Controle Unit interface
113	TCK		Diagnostic Controle Unit interface
114	ROTDREV	OUT	Carousel 5 disc changer model Tray rotation drive PWM output.
115	B_F_ROM	IN	Boot select 'L' : Boot from DCU. 'H' : Boot form ROM.
116	LOAD_DRV	OUT	Tray Open/Close drive PWM output (SINGL & CAROUSEL)
117	CPU_OE	OUT	8M / 16M bits FLASH memory for firmware.
118	CPU_SDCK	OUT	64M bits SDRAM for debugging firmware .
119	VDD_2V5	-	2.5 V Power supply
120	CLK27M	IN	Master 27MHz system clock input.
121	VSS	-	Ground
122	VDD_PLL	-	Clock PLL circuit 2.5 V Power supply
123	VSS_PLL	-	Clock PLL circuit Ground
124	RESET	IN	Power ON system RESET signal 'L' input.
125	DISC_SNS	IN	In case of NOT carusel 5 disc changer, this port is N.C.(input). Carousel 5 disc changer model Disc sense input. Pull up resistor is in another changer board.
126	FP_XRDY	IN	Front Panel interface. Hand-shake(request) input.
127	FE_INT	IN	Front-End L6315 Interrupt request input.
128	SD_DQML	OUT	Flash memory write enable 'L'. Debug SDRAM Lower DQM.
129	SD_DQMU	OUT	Debug SDRAM Upper DQM
130	SD_RXW		Debug SDRAM Read/~Write
131	CPU_WAIT	OUT	CPU wait 'H' input
132	CE3	OUT	Flash memory Chip Eenable 'L'
133	-	OUT	TP-x
134	-	OUT	TP-x
135	SD_XRAS	OUT	Debug SDRAM RAS 'L'
136	VDD_3V3	-	3.3V Vdd
137	VSS	-	GND
138	-	OUT	TP-x
139	SD_XCAS	OUT	Debug SDRAM CAS 'L'
140	SD_XCS	OUT	Debug SDRAM Chip Select 'L'



No.	Pin Name	I/O	Pin Function
141	CPU_D0	I/O	FLASH, Debug SDRAM DATA
142	CPU_D1		
143	CPU_D2		
144	CPU_D3		
145	CPU_D4		
146	CPU_D5		
147	CPU_D6		
148	CPU_D7		
149	VDD_2V5	–	2.5 V Power supply
150	VSS	–	Ground
151	CPU_D8	I/O	FLASH, Debug SDRAM DATA
152	CPU_D9		
153	CPU_D10		
154	CPU_D11		
155	CPU_D12		
156	CPU_D13		
157	CPU_D14		
158	CPU_D15		
159	VDD_3V3	–	3.3 V Power supply
160	VSS	–	Ground
161	CPU_A1	OUT	FLASH, Debug SDRAM address
162	CPU_A2		
163	CPU_A3		
164	CPU_A4		
165	CPU_A5		
166	CPU_A6		
167	CPU_A7		
168	CPU_A8		
169	CPU_A9		
170	CPU_A10		
171	VDD_2V5	–	2.5 V Power supply
172	VSS	–	Ground
173	CPU_A11	OUT	FLASH, Debug SDRAM address
174	CPU_A12		
175	CPU_A13		
176	CPU_A14		
177	CPU_A15		
178	CPU_A16		
179	CPU_A17		
180	CPU_A18		
181	CPU_A19		
182	CPU_A20		
183	CPU_A21		
184	VDD_3V3	–	3.3 V Power supply

No.	Pin Name	I/O	Pin Function
185	VSS	–	Ground
186	XDRVMUTE	OUT	Motor driver muting signal 'L'.
187	RS_ERROR	IN	Front-End L6315 stream interface. If STi5588 then ECC Error flag.
188	I2C_SEL	OUT	Reserved (Front-End L6315 command interface.) (‘L’ : I2C bus connect to I2C_DMA) (‘H’ : I2C bus connect to I2C_COMAND)
189	DAC_SCK	OUT	Audio DAC serial control clock output.
190	DAC_SO	OUT	Audio DAC serial control data output.
191	DAC_XCS0	OUT	Audio DAC serial control chip select output.
192	DAC_XCS1	OUT	Reserved (Audio DAC serial control chip select output. For addition DAC)
193	6CH_MODE	OUT	In case of NOT 6ch audio output model, this port is N.C.(output). 6ch audio output model Audio quality up control signal output.
194	SDA	SDA	Front-End L6315 command interface I2C bus serial data line.
195	SCL	SCL	Front-End L6315 command interface I2C bus serial clock line.
196	FE_RST	OUT	Front-End L6315 Hard reset output.
197	TXD	TXD	UART(RS-232C) data output
198	VDD_2V5		2.5 V Power supply
199	VSS	IN	Ground
200	RXD	RXD	UART(RS-232C) data input
201	TP-x	OUT	Reserved
202	TRIGIN	–	Diagnostic Controle Unit interface
203	TRIGOUT	–	Diagnostic Controle Unit interface
204	OPEN	IN	'H' show tray loading "OPEN" complete position.
205	XCLOSE	IN	'H' show tray loading "CLOSE" complete position.
206	FP_ACK	OUT	Front Panel interface. Hand-shake (acknowledge) output.
207	FP_SCK	OUT	Front Panel interface. (Soft) Serial transfer clock output.
208	FP_SI	IN	Front Panel interface. (Soft) Serial transfer data input.

# PCM1742KE (DVD IF ASSY : IC1921)

• D/A Converter

## • Pin Arrangement



## • Pin Function

No.	Pin Name	I/O	Pin Function
1	BCK	I	Audio data bit clock input
2	DATA	I	Audio data digital input
3	LRCK	I	L-channel and R-channel Audio data latch enable input
4	DGND	-	Digital ground
5	VDD	-	Digital power supply +3.3V
6	VCC	-	Analog power supply +5V
7	VoutL	O	Analog output for L-channel
8	VoutR	O	Analog output for R-channel
9	AGND	-	Analog ground
10	VCOM	-	Common voltage decoupling
11	ZEROR/ZEROA	O	Zero flag output for R-channel / Zero flag output for L/R-channel
12	ZEROL/NA	O	Zero flag output for L-channel / No assign
13	MD	I	Mode control data input
14	MC	I	Mode control clock input
15	ML	I	Mode control latch input
16	SCK	I	System clock input

## • Block Diagram

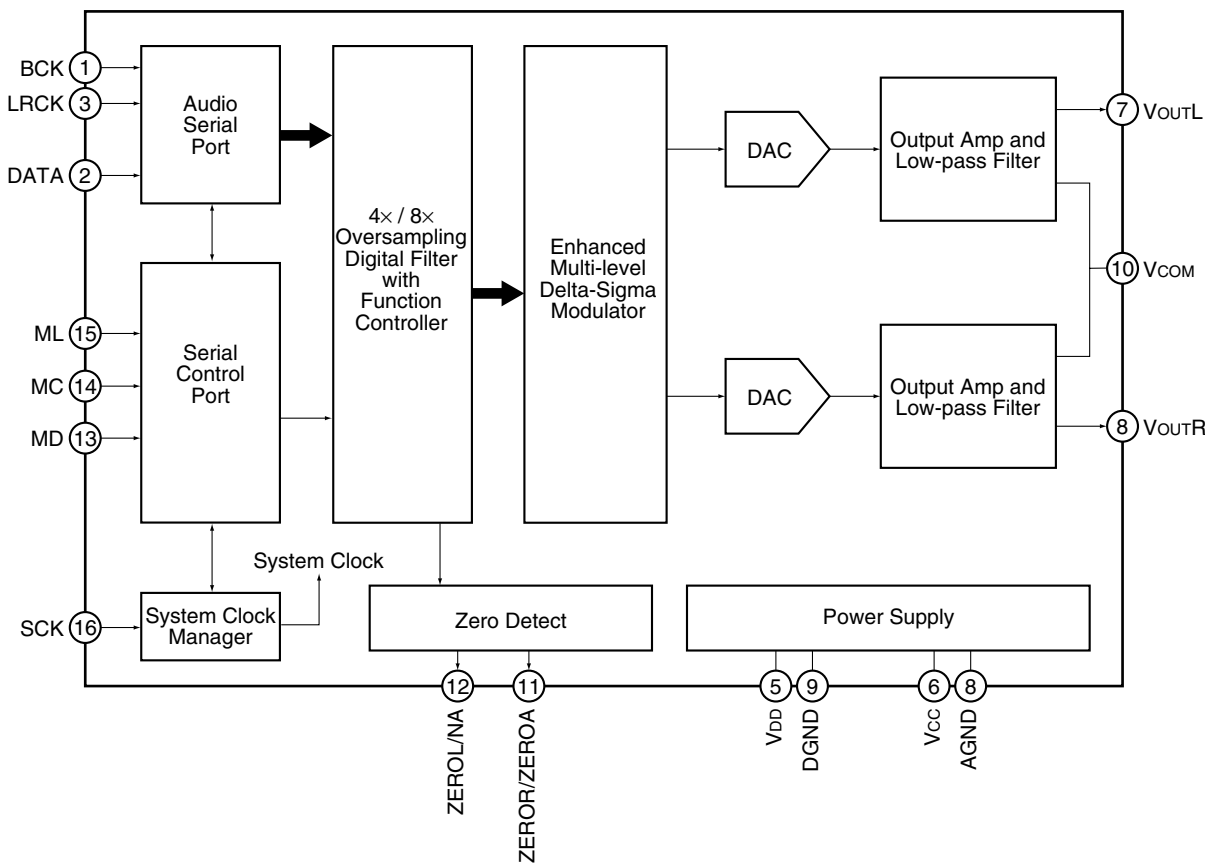

# MM1567AJ (DVD IF ASSY : IC1941)

• DVD Video Amp. IC

## Block Diagram

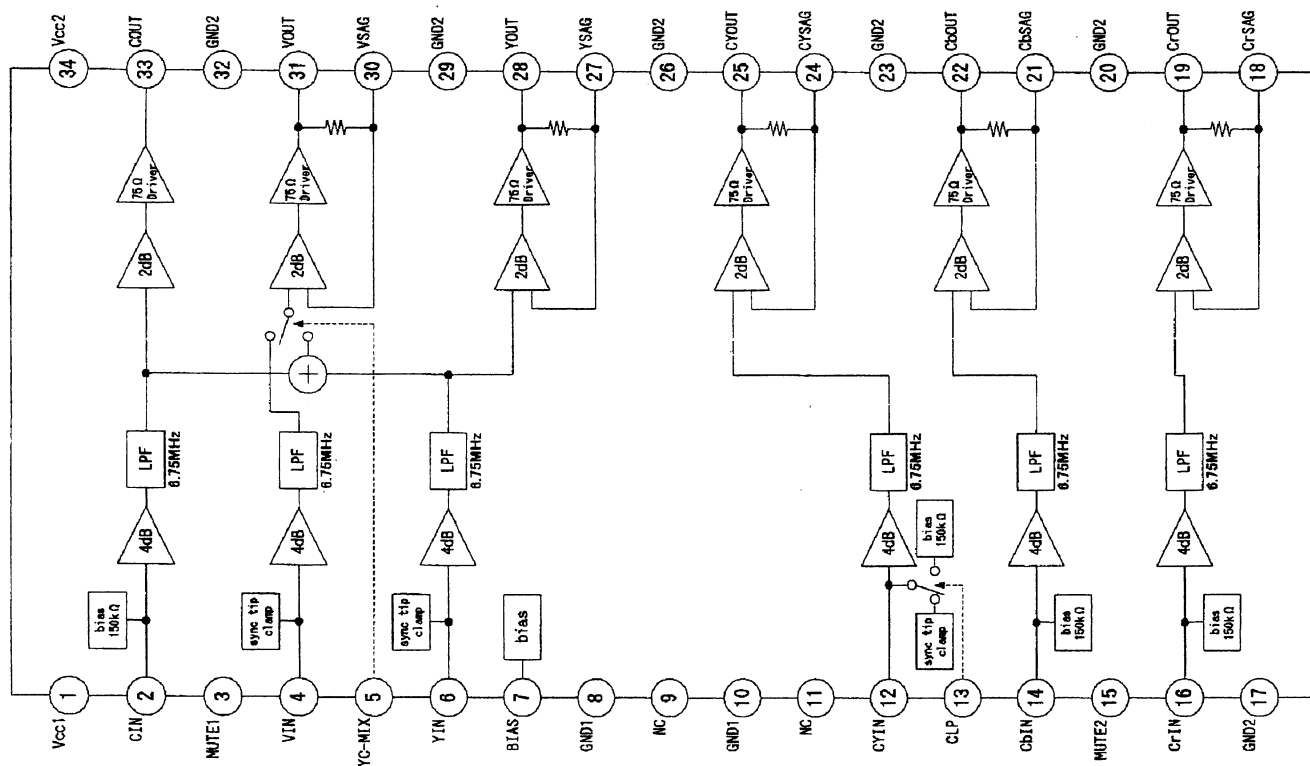

## Pin Function

No.	Pin Name	Pin Function	No.	Pin Name	Pin Function
1	VCC1	VCC	18	CrOUT	Signal output (Cr)
2	CIN	Crroma input	19	CrSAG	SAG correction (Cr)
3	MUTE1	Mute select	20	GND2	GND
4	VIN	Video input	21	CbOUT	Signal output (Cb)
5	YC MIX	YC MIX select	22	CbSAG	SAG correction (Cb)
6	YIN	Video input (Y)	23	GND2	GND
7	BIAS	Bias	24	CYOUT	Signal output (CY)
8	GND1	GND	25	CYSAG	SAG correction (CY)
9	NC	NC	26	GND2	GND
10	GND1	GND	27	YOUT	Signal output (Y)
11	NC	NC	28	YSAG	SAG correction (Y)
12	CYIN	Luminance input	29	GND2	GND
13	CLP	Input clamp select	30	VOUT	Signal output (V)
14	CbIN	Component input (Cb)	31	VSAG	SAG correction (V)
15	MUTE2	Mute select	32	GND2	GND
16	CrIN	Component input (Cr)	33	COOUT	Chromatic output
17	GND2	GND	34	VCC2	VCC

## ■ PDC093 (IF ASSY : IC5501)

- System Control Microcomputer

### ● Pin Function

No.	Port Name	Pin Name	I/O	Function
1	PA3/WR#	DVD ON/OFF	O	Control power supply for DVD
2	PA4/RD#	(HPDET)	O	Detect to insert headphone (reserve) → If don't use, set I/O to output
3	PA5/RS	XCDRST	O	Reset for CD / VCD / DVD microcomputer
4	P70 / INT0 / T0LCP / AN8	ACPULSE	I	AC PULSE input
5	P71 / INT1 / T0HCP / AN9	CDERR	I	ERR and OVER input from CODEC
6	P72 / INT2 / T0IN	RDSCLK	I	Clock input from RDS decoder (without RDS : Low output)
7	P73 / INT3 / T0IN	REMOCON	I	REMOCON signal input
8	RES#	XRESET	I	Reset input
9	XT1 / AN10	–	–	
10	XT2 / AN11	–	–	
11	VSS1	–	–	
12	CF1	–	–	
13	CF2	–	–	
14	VDD1	–	–	Power supply
15	P80 / AN0	SIMUKE	I	Destination setting input
16	P81 / AN1	LEVELIN	I	Level meter signal input
17	P82 / AN2	3.3DETECT	I	DVD 3.3V detection input
18	P83 / AN3	KEY4	I	Key input (for AMP)
19	P84 / AN4	ST/TUNE	I	STEREO tuned detection input
20	P85 / AN5	KEY1	I	Key input
21	P86 / AN6	KEY2	I	Key input
22	P87 / AN7	KEY3	I	Key input
23	P10/SO0	SYS_DOUT	O	System bus data output (AMP side output)
24	P11 / SI0 / SB0	SYS_DIN	I	System bus data input (AMP side input)
25	P12 / SCK0	SYS_CLK	I	System bus clock input
26	P13 / SO1	DSPDIN	O	Data output for CODEC + DIR IC, TC9164, EXPAND IC (only for DSP), CRISTAL's DSP (AMP side output) [DSP core CDDI + CSDI]
27	P14 / SI1 / SB1	DSPDOUT	I	Data input for CODEC + DIR IC, TC9164, EXPAND IC (only for DSP), CRISTAL's DSP (AMP side input) [DSP core CDDO + CSDO]
28	P15 / SCK1	DSPCLK	O	Clock for CODEC + DIR IC, TC9164, EXPAND IC (only for DSP), CRISTAL's DSP [DSP core CDCK + CSCK]
29	P16/T1PWML	SYS_CS2	O	Chip select 2 for system bus
30	P17/T1PWH/BUZ	SYS_CS1	O	Chip select 1 for system bus
31	PE0	TCEXPOE	O	Output enable to EXPAND IC for deck
32	PE1	TCEXPCLK	O	Clock to EXPAND IC for deck
33	PE2	TCEXPCE	O	Chip enable to EXPAND IC for deck
34	PE3	TCEXPDAT	O	Data to EXPAND IC for deck
35	PE4	TCHALF	I	Input switch of mecha half
36	PE5	TCMODE	I	Input switch of mecha mode
37	PE6	TCRECF	I	Input switch of mecha during recording forward
38	PE7	TCRECR	I	Input switch of mecha during recording reverse
39	VSS4	–	–	Ground
40	VDD4	–	–	Power supply

No.	Port Name	Pin Name	I/O	Function
41	PF0	TCMSIN	I	Input MS signal
42	PF1	TCPULSE	I	Input pulse of TC reel
43	PF2	XTESTMODE	I	Set TEST MODE for product line (service) and unit checker
44	PF3	SERVICE	I	Set SELF CHECK for service
45	PF4	DTSDMIX	O	Control of gain-up for dts down-mix
46	PF5	SWFMIX	O	Control for subwoofer mix
47	PF6	EHCNT1	O	Control of echo level 1
48	PF7	EHCNT2	O	Control of echo level 2
49	SI2P0/SO2	LCDDAT	O	Data for FL (LCD) driver
50	SI2P1/SI2/SB2	LCDCE	O	Chip enable for FL (LCD) driver
51	SI2P2/SCK2	LCDCLK	O	Clock for FL (LCD) driver
52	SI2P3/SCK20	LCDRST	O	Reset for FL (LCD) driver
53	PWM1	-	-	
54	PWM0	-	-	
55	VDD2	-	-	Power supply
56	VSS2	-	-	Ground
57	P00	TXCE	O	Chip enable for tuner LSI
58	P01	NC	O	No connection
59	P02	XTMRLED	O	Control timer standby LED
60	P03	XSTBYLED	O	Control standby LED
61	P04	TXCLK	O	Clock for tuner LSI
62	P05	TXIDAT	O	Data for tuner LSI
63	P06	TXMUTE	O	Control mute of tuner
64	P07	RDSP0W	O	Control power supply of RDS
65	P20/INT4/T1IN	RDSDATA	I	Input RDS data
66	P21/INT4/T1IN	TXODAT	I	Input data from tuner LSI
67	P22/INT4/T1IN	XDSPMUTE	O	Control mute of DSP (board)
68	P23/INT4/T1IN	A/D MODE	O	DSP mute when ANALOG
69	P24/INT5/T1IN	AUXMUTE	O	Control mute of AUX output
70	P25/INT5/T1IN	DVDLAT	I	Input latch signal from DVD connection
71	P26/INT5/T1IN	ATTCONT	O	Control ATT of AUX
72	P27/INT5/T1IN	KCONSTB	O	Strobe for Key Control IC
73	P30	KCONCLK	O	Clock for Key Control IC
74	P31	KCONDATA	O	Data for Key Control IC
75	P32	VOCALC	O	
76	P33	VOCALB	O	
77	P34	VOCALA	O	
78	P35	ASSELB	O	Audio source select B
79	P36	ASSELA	O	Audio source select A (CD, TUNER, TAPE, AUX) BU4052
80	PB7/D7	DSP EXP CS	O	Chip select for EXPAND

No.	Port Name	Pin Name	I/O	Function
81	PB6/D6	DSP EXP OE	O	Output enable for EXPAND (no use)
82	PB5/D5	CSCS	O	Chip select for CRISTAL's DSP
83	PB4/D4	CSREQ	I	Request for CRISTAL's DSP
84	PB3/D3	FS96	I	96k input from CODEC
85	PB2/D2	ABOOT	O	Chip select for SRAM / P2ROM
86	PB1/D1	CSRST	O	RESET for CRISTAL's DSP
87	PB0/D0	CDCS	O	Chip select for CODEC
88	VSS3	–	–	Ground
89	VDD3	–	–	Power supply
90	PC7/A7	CDPDN	O	Power down (RESET) for CODEC
91	PC6/A6	SYSPOW	O	Control power supply of system
92	PC5/A5	PROTECT	I	Protection and Fan Error detection input
93	PC4/A4	SPCONT	O	Control relay of speaker output
94	PC3/A3	SYSTEMUTE	O	Control mute of system
95	PC2/A2	VOLCE	O	Chip enable for E-vol IC
96	PC1/A1	VOLCLK	O	Clock for E-vol IC
97	PC0/A0	VOLDATA	O	Data for E-vol IC
98	PA0/CS2#	FLASH E/D	–	for FLASH writing
99	PA1/CS1#	FLASH DO	–	for FLASH writing
100	PA2/CS0#	FLASH CLK	–	for FLASH writing

- Port 0 (P00-P07) can be selected for input or output by each 4 bits (P00-P03, P04-P07). Set for input when reset. And it can be set C-MOS or Nch-OD by each 1 bit in option.
- Port 1 (P10-P17) can be selected for input or output by each 1 bit. Set for input when reset. And it can be set C-MOS or Nch-OD by each 1 bit in option.
- Port 2 (P20-P27) can be selected for input or output by each 1 bit. Set for input when reset. And it can be set C-MOS or Nch-OD by each 1 bit in option.
- Port 3 (P30-P36) can be selected for input or output by each 1 bit. Set for input when reset. And it can be set C-MOS or Nch-OD by each 1 bit in option.
- Port 7 (P70-P73) can be selected for input or output by each 1 bit. Set for input when reset.
- Port 8 (P80-P87) can be selected for input or output by each 1 bit. Set for input when reset.
- Port A (PA0-PA5) can be selected for input or output by each 1 bit. Set for input when reset. And it can be set C-MOS or Nch-OD by each 1 bit in option.
- Port B (PB0-PB7) can be selected for input or output by each 1 bit. Set for input when reset. And it can be set C-MOS or Nch-OD by each 1 bit in option.
- Port C (PC0-PC7) can be selected for input or output by each 1 bit. Set for input when reset. And it can be set C-MOS or Nch-OD by each 1 bit in option.
- Port E and PortF can be selected for input or output by each 2 bits.
- In case of without RDS, it is best that RDSDATA and RDSCLK are assigned as I/O port which can be set output and output low level.
- Port 0 cannot output High level during HALT mode.

# 7.3 CLEANING

A



Before shipping out the product, be sure to clean the following positions by using the prescribed cleaning tools:

Position to be cleaned	Cleaning tools
Pickup lenses	Cleaning liquid : GEM1004 Cleaning paper : GED-008

B

C

D

E

F



# 8. PANEL FACILITIES

## Front panel



### Note

The front panel controls for the EV51DVD model are shown in the illustrations below.

- 1 SURROUND** (EV51DVD mode)  
Selects a surround listening mode
- SFC** (EV21DVD mode)  
Selects sound modes or custom settings from the Sound Field Control
- 2 STANDBY/ON**  
Switches the player on or into standby
- 3 ADVANCED SURROUND** (EV51DVD model)  
Selects an advanced listening mode
- CENTER SP (ON/OFF)** (EV21DVD model)  
Switches the center speaker on or off

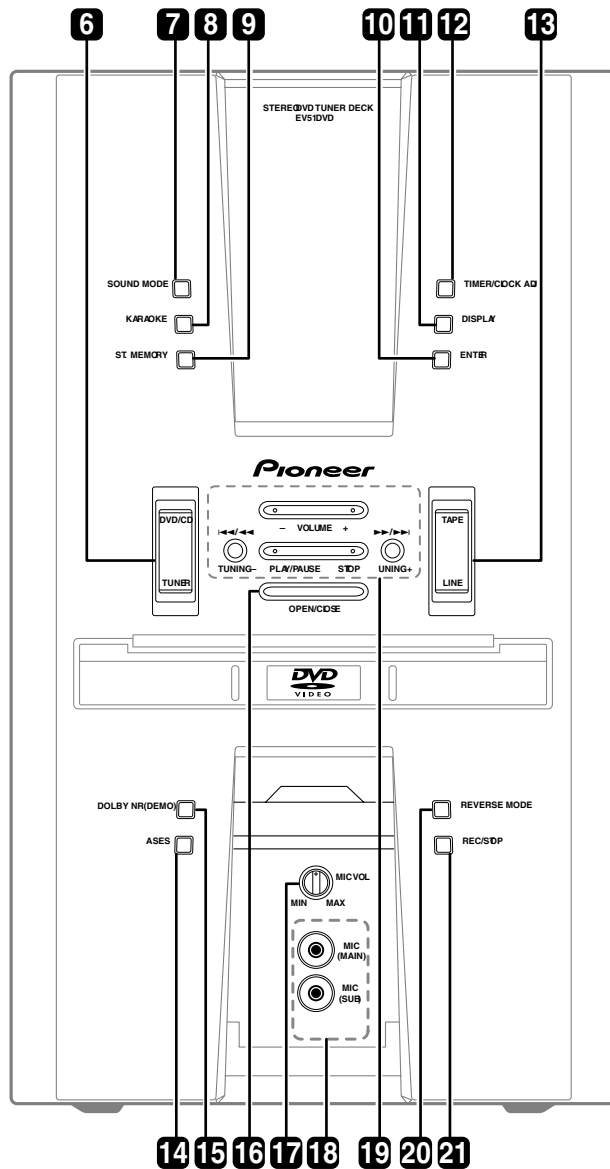
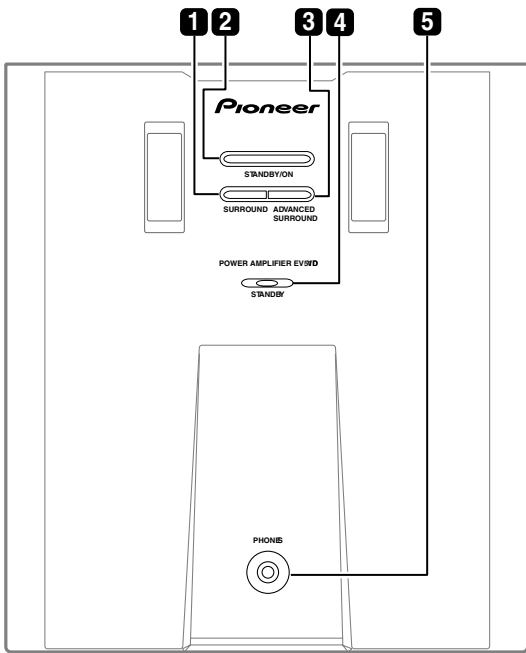

A

**4 STANDBY indicator**

Lights when the system is in standby

**5 PHONES jack**

Headphone jack

**6 DVD/CD and TUNER select button**

Press to select the source you want to listen to

**7 SOUND MODE**

Adjusts the tone, balance and (EV51DVD model only ) DSP controls

**8 KARAOKE (EV51DVD model)**

Selects audio channels for karaoke

**VIRTUAL SURROUND (EV21DVD model)**

Switches the Virtual Surround effect on or off

**9 ST. MEMORY**

Use for saving and listening to station presets

**10 ENTER**

Select an option or execute a command

**11 DISPLAY**

Changes the information shown in the display

**12 TIMER/CLOCK ADJ**

Use for setting the clock, as well as for setting and checking the timers

**13 TAPE and LINE select button**

Press to select the source you want to listen to

**14 ASES**

Press for CD-to-tape synchro recording

**15 DOLBY NR (DEMO)**

Switches Dolby Noise Reduction on or off

**16 OPEN/CLOSE**

Opens the disc tray

**17 MIC VOL**

Controls the volume of the karaoke mics

**18 MIC input jacks****19 VOLUME, TUNING and playback control buttons**

The **TUNING** /scan/skip buttons are used for tuning into stations, skipping or scanning tracks on discs or tapes. The playback control button is used for playing, pausing and stopping playback.

**20 REVERSE MODE**

Selects the playback mode for tapes

**21 REC/STOP**

Starts/stops recording on the tape deck

B

C

D

E

F

## Controls and displays

### Remote control



#### Note

The remote control for the EV51DVD model is shown in the illustration below

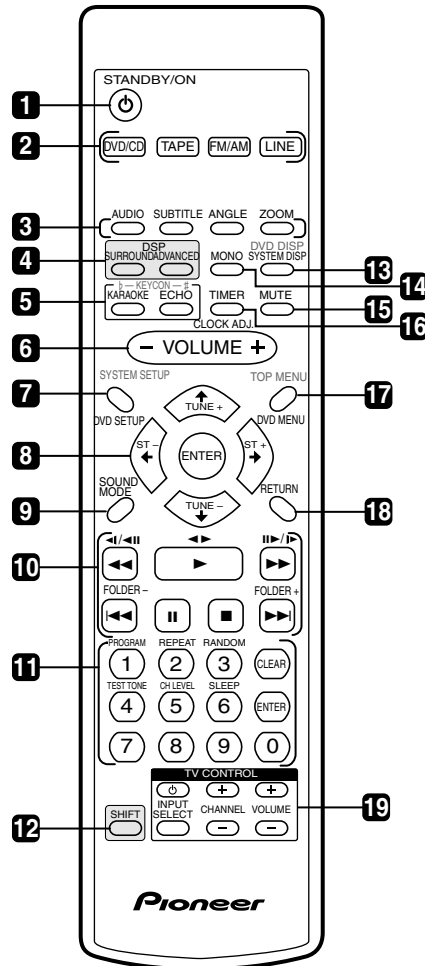

#### 1 **STANDBY/ON**

Switches the player on or into standby

#### 2 **Function select buttons**

Selects the source you want to listen to

#### 3 **DVD control buttons**

##### AUDIO

Selects the audio channel or language

##### SUBTITLE

Selects a subtitle display

##### ANGLE

Changes the camera angle during DVD multi-angle scene playback

##### ZOOM

Changes the zoom level

#### 4 **DSP buttons** (EV51DVD model)

##### SURROUND

Selects a surround mode for multi-channel sound

##### ADV. SURROUND

Selects a DSP mode for multi-channel sound

##### Sound Field buttons (EV21DVD model)

##### SFC

Selects sound modes or custom settings from the Sound Field Control

##### VIRT. SURR.

Switches the Virtual Surround effect on or off

#### 5 **KARAOKE buttons**

##### KARAOKE

Selects audio channels for karaoke

##### ECHO

Changes the echo level on the karaoke mics

##### KEYCON (SHIFT+KARAOKE/ECHO)

Lowers/raises the pitch of the backing track

## Controls and displays

### 6 VOLUME

Adjusts the volume level

### 7 DVD SETUP

Press to make DVD settings

**SYSTEM SETUP (SHIFT+DVD SETUP)**  
(EV51DVD model)

Press to make DSP settings

### 8 ENTER, TUNE & cursor control buttons

Navigates on-screen displays and menus. **ENTER** selects an option or executes a command.

### 9 SOUND MODE

Adjusts the tone, balance and (EV51DVD model only ) DSP controls

### 10 Playback controls

▶  
Starts/resumes playback

◀◀ and ◀|/◀||

Use for reverse slow motion playback, frame reverse and reverse scanning

▶▶ and ||▶/▶|

Use for forward slow motion playback, frame advance and forward scanning

◀◀

Jumps to the beginning of the current chapter or track, then to previous chapters/tracks

▶▶| Jumps to the next chapter or track

|| Pauses playback; press again to restart

■ Stops playback

### 11 Number buttons and SHIFT functions

The number buttons can be used for selecting tracks directly, the functions above the buttons are accessed by pressing **SHIFT** at the same time as the button.

**PROGRAM (SHIFT+1)**

Use to program/play a program list

**REPEAT (SHIFT+2)**

Selects a repeat play mode

**RANDOM (SHIFT+3)**

Selects a random play mode

**TEST TONE (SHIFT+4)**

(EV51DVD model only)

Outputs the test tone for speaker setup (EV51DVD model only)

**CH LEVEL (SHIFT+5)**

Press to adjust the speaker level

**SLEEP (SHIFT+6)**

Switches the sleep timer on or off

**CLEAR**

Clears an entry

**ENTER**

Selects menu options, etc. (works exactly the same as the **ENTER** button in 8 above)

### 12 SHIFT

Press to access the functions/commands written in green on the remote

### 13 SYSTEM DISP

Switches between information and clock displays

**DVD DISP (SHIFT+SYSTEM DISP)**

Changes the information shown in the display

### 14 MONO

Press to listen to a stereo FM broadcast in mono (sound quality is usually improved)

**CENTER SP (SHIFT+MONO)**

(EV21DVD model only)

Switches the center speaker on or off

### 15 MUTE

Mutes the volume

### 16 TIMER/CLOCK ADJ.

Use for setting the clock, as well as for setting and checking the timers

### 17 DVD MENU

Displays the DVD menu (for CDs, Video CDs, and MP3 discs, the Disc Navigator screen appears)

**TOP MENU (SHIFT+DVD MENU)**

Displays the top menu of a DVD disc

### 18 RETURN

Press to return to a previous menu screen

### 19 TV CONTROL



**Note**

Refer to Setting the remote to control your TV on page 27 to use these controls with your TV.

⏻ Switches the TV on or into standby

**INPUT SELECT**

**Switches the TV input**

**CHANNEL +/-**

Selects channels

**VOLUME +/-**

Adjusts the volume on the TV

## Controls and displays

### Display



#### Note

The front panel display for the EV51DVD model is shown in the illustration below

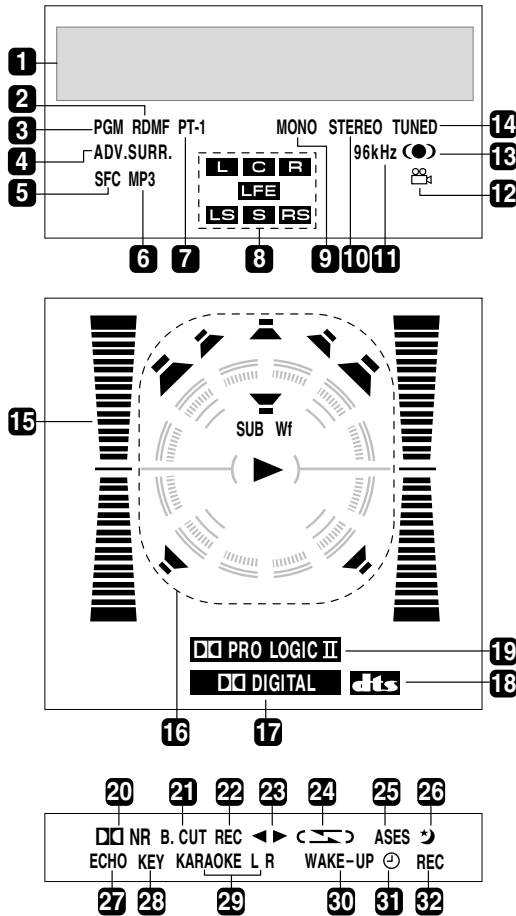

#### 1 Character display

#### 2 RDM

Lights during random playback

#### 3 PGM

Lights during program play

#### 4 ADV. SURR. (EV51DVD model only)

Lights when one of the Advanced Surround listening modes is selected

#### 5 SFC (EV21DVD model only)

Lights when one of the Sound Field Control listening modes is selected

#### 6 MP3

Lights during playback of an MP3 disc

#### 7 RPT-1

RPTlights during repeat play ( RPT-1 lights during repeat one-track play)

#### 8 Format indicator (EV51DVD model only)

These indicators will light according to which channels are encoded on the Dolby Digital or DTS multi-channel disc currently in the player. LFE lights when the disc has an LFE channel.

#### 9 MONO

Lights when FM mono reception is selected

#### 10 STEREO

Lights when a stereo FM broadcast is being received in auto stereo mode

#### 11 96 kHz

Lights when a 96kHz source is detected (won't light if the source is copy-protected)

#### 12

Lights during multi-angle scenes on a DVD disc

#### 13

Lights when Virtual Surround is switched on

#### 14 TUNED

Lights when a broadcast is being received

#### 15 Level meter

Shows the level of the source selected

#### 16 Speaker and playback indicators

The speaker indicators () show the speakers currently active. The playback indicator () lights during playback.

#### 17

This lights to indicate decoding of a Dolby Digital signal

#### 18 DTS

This lights to indicate decoding of a DTS signal

#### 19 PRO LOGIC II (EV51DVD model only)

This lights to indicate Prologic II decoding

#### 20 NR

Lights when Dolby Noise Reduction is on

## Controls and displays

### 19 PRO LOGIC II (EV51DVD model only)

This lights to indicate Prologic II decoding

### 20 NR

Lights when Dolby Noise Reduction is on

### 21 **B.CUT**

Lights when the beat cut mode has been switched to **B.CUT2**

### 22 **REC**



Lights when recording to the tape deck

### 23

Indicates the direction of tape playback

### 24

Indicates the reverse mode:

-  - Single side playback
-  - Auto-reverse playback: stops after finishing playback in the reverse (◀) direction
-  - Continuous playback (up to 16 complete plays)

### 25 **ASES**

Lights during ASES recording

### 26

Lights when the sleep timer is active

### 27 **ECHO**

Lights when the Karaoke **ECHO** effect is selected

### 28 **KEY**

Lights when the Karaoke pitch control is selected

### 29 **KARAOKE LR**

Lights when one of the Karaoke modes is selected:

- **KARAOKE** (Vocal cancel) - Vocals in the backing track are partially eliminated using EQ.
- **L** - Left channel only. Use for tracks that have a vocal recorded in the right channel.
- **R** - Right channel only. Use for tracks that have a vocal recorded in the left channel.
- **L R** - Use to put a a single-channel vocal track into the center of the mix.

### 30 **WAKE-UP**

Lights in standby when the wake-up timer is set and flashes when the wake-up timer activates

### 31

Lights in standby when either timer is set and flashes when they activate

### 32 **REC**

Lights in standby when the record timer is set and flashes when the timer starts recording