



PRIMARE



**CD 21 CD-Player
Service Manual**

1. Circuit Diagrams

2. Technical Specifications

Confidential !

This document is not allowed to show for third part without written permission from Primare Systems AB.

This document is subject to change without notice.

Author:

Bjorn Holmqvist
Primare Systems AB
bjorn@primare.net

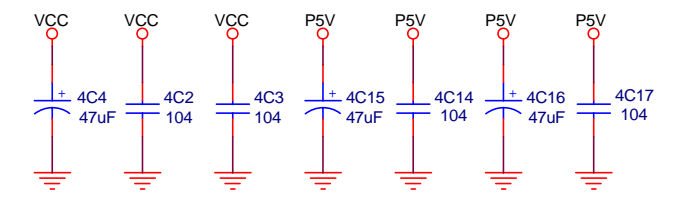
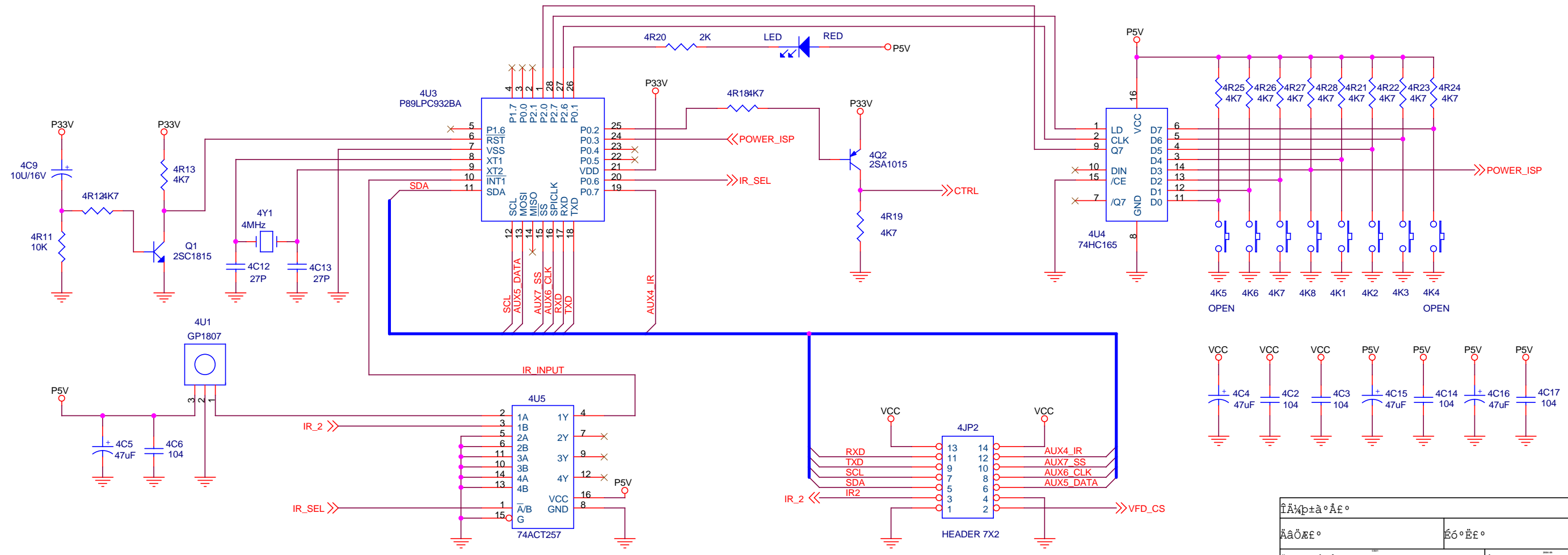
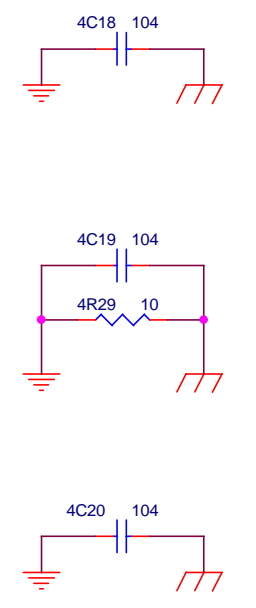
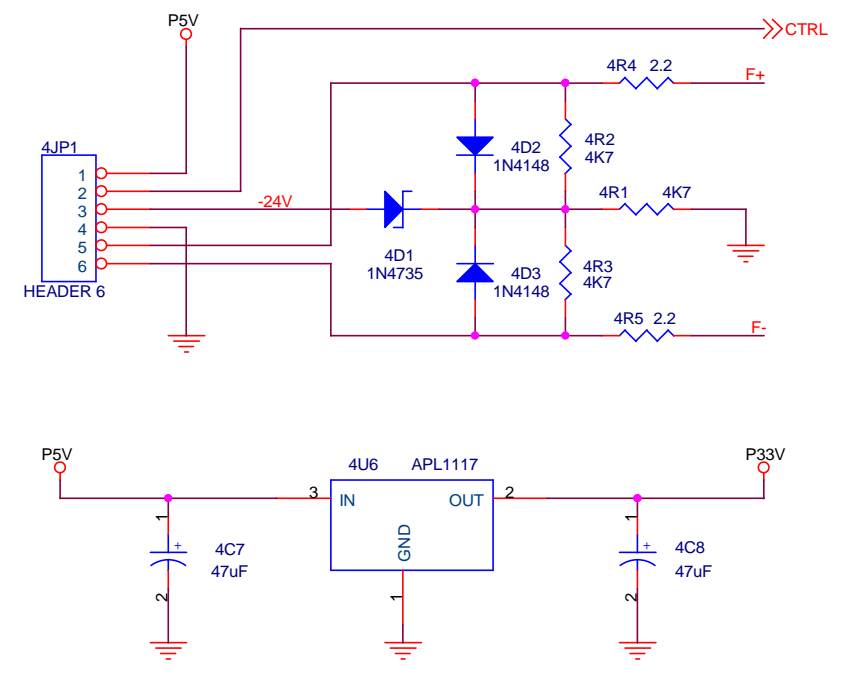
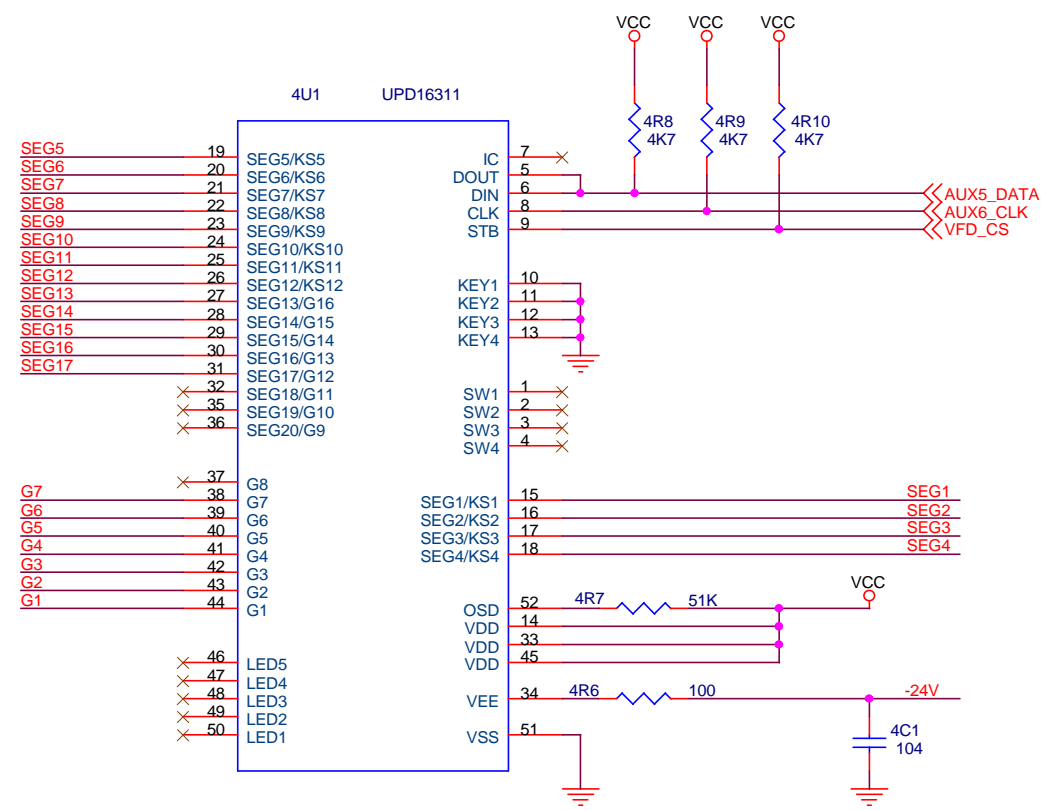
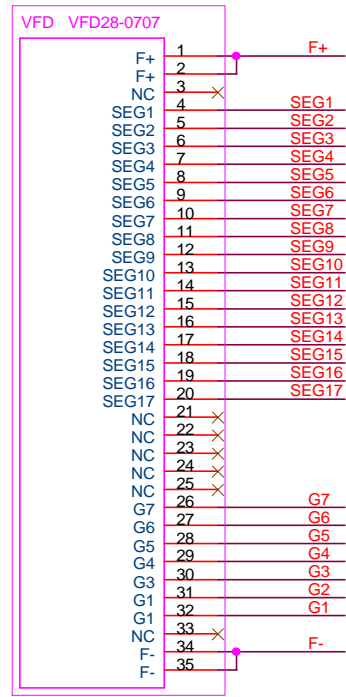

Имя файла	№ документа
Авторы	Область применения
Исполнитель	Содержит
Проверенный	Дата

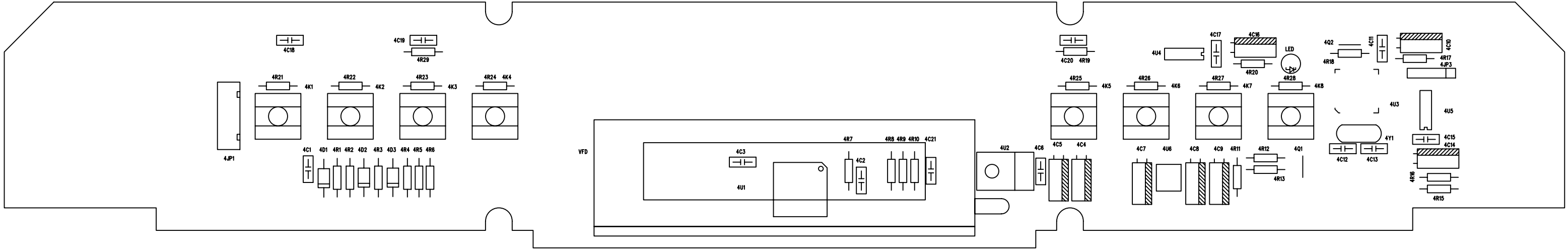

ES60x8

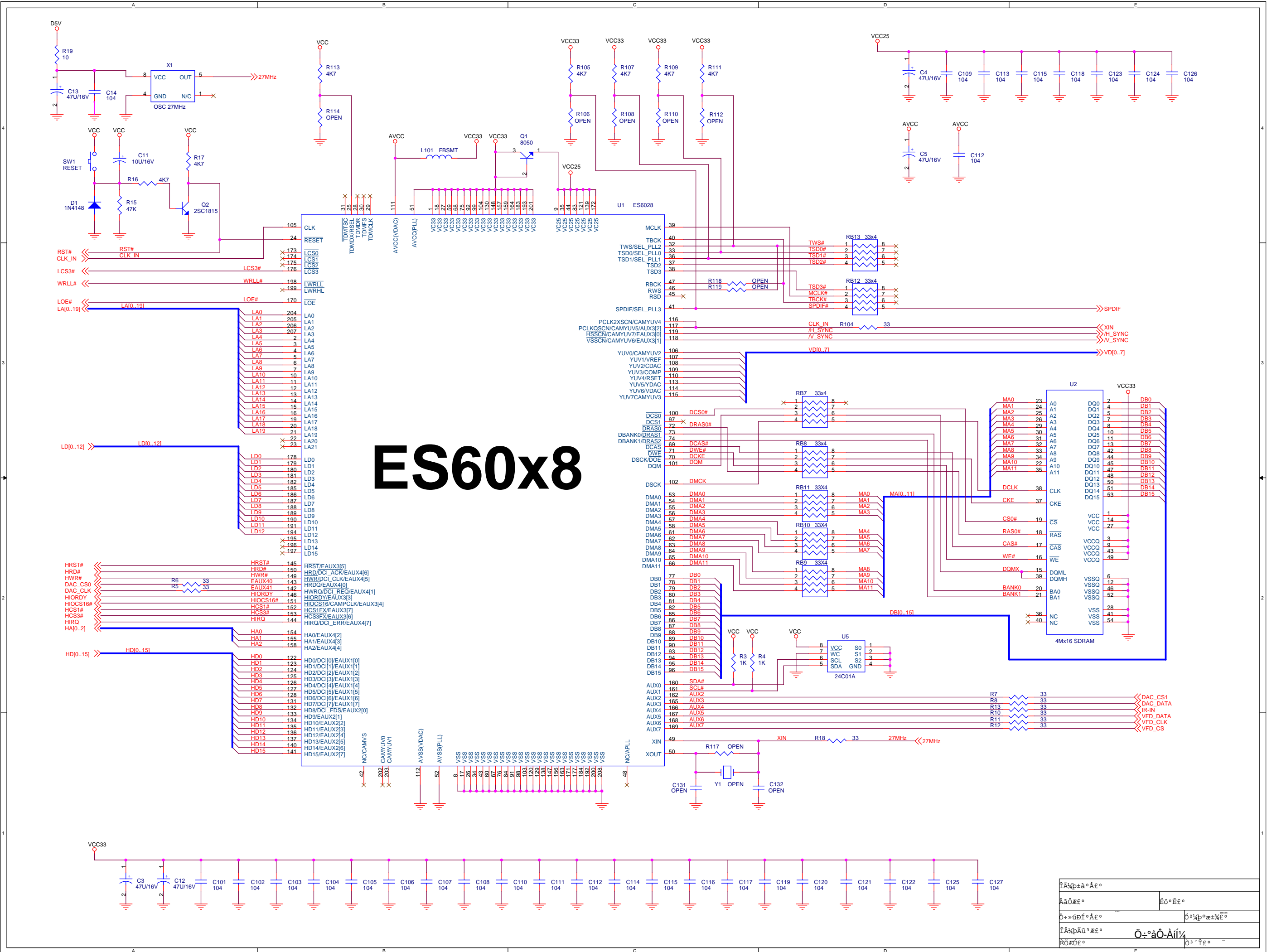

IA4p±à°Æ°	Σó°Æ°
ÅäÖÆ°	ó²¼p°æ±¼Æ°
Ö→→úDí°Æ°	Ö→→úDí°Æ°
IA4pÄÜ³Æ°	Ö→→úDí°Æ°
ËÖÆÜ°	Ö→→úDí°Æ°

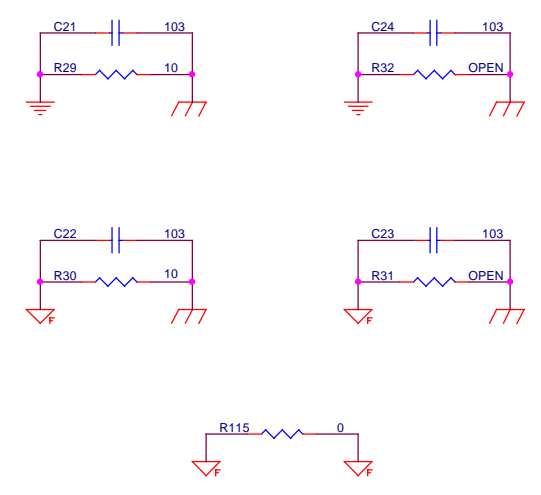
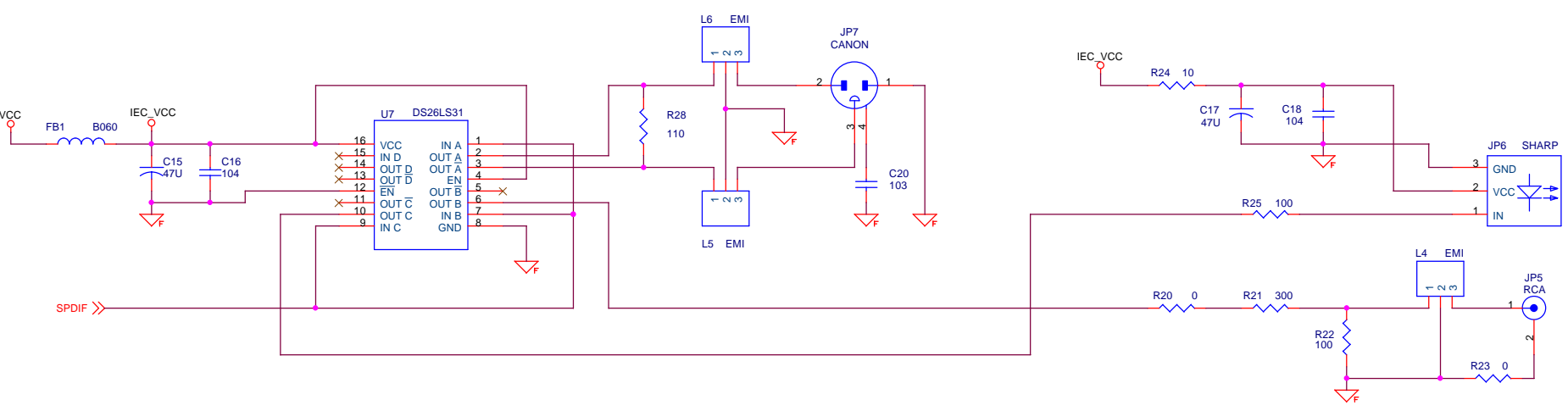
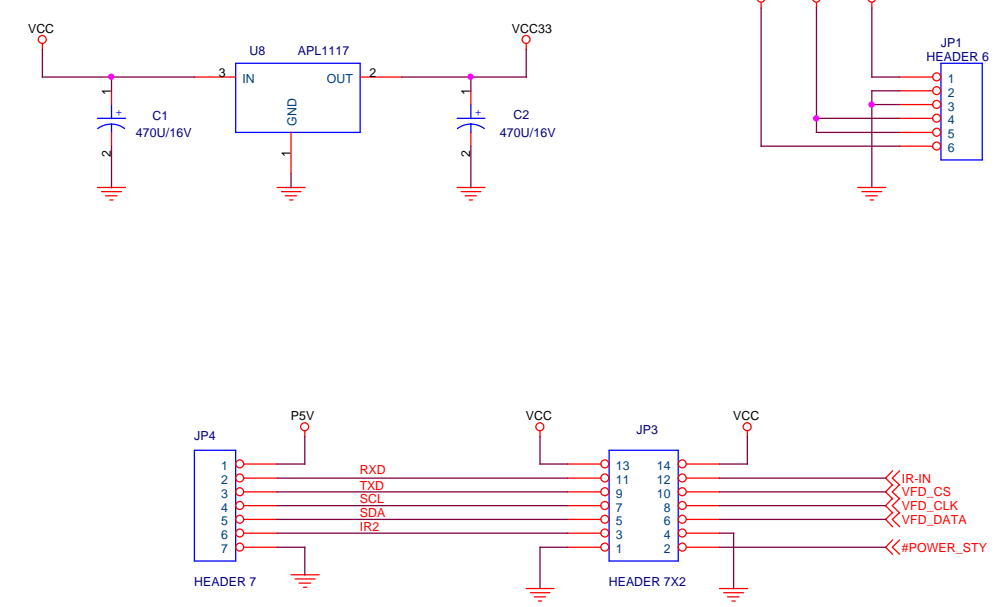
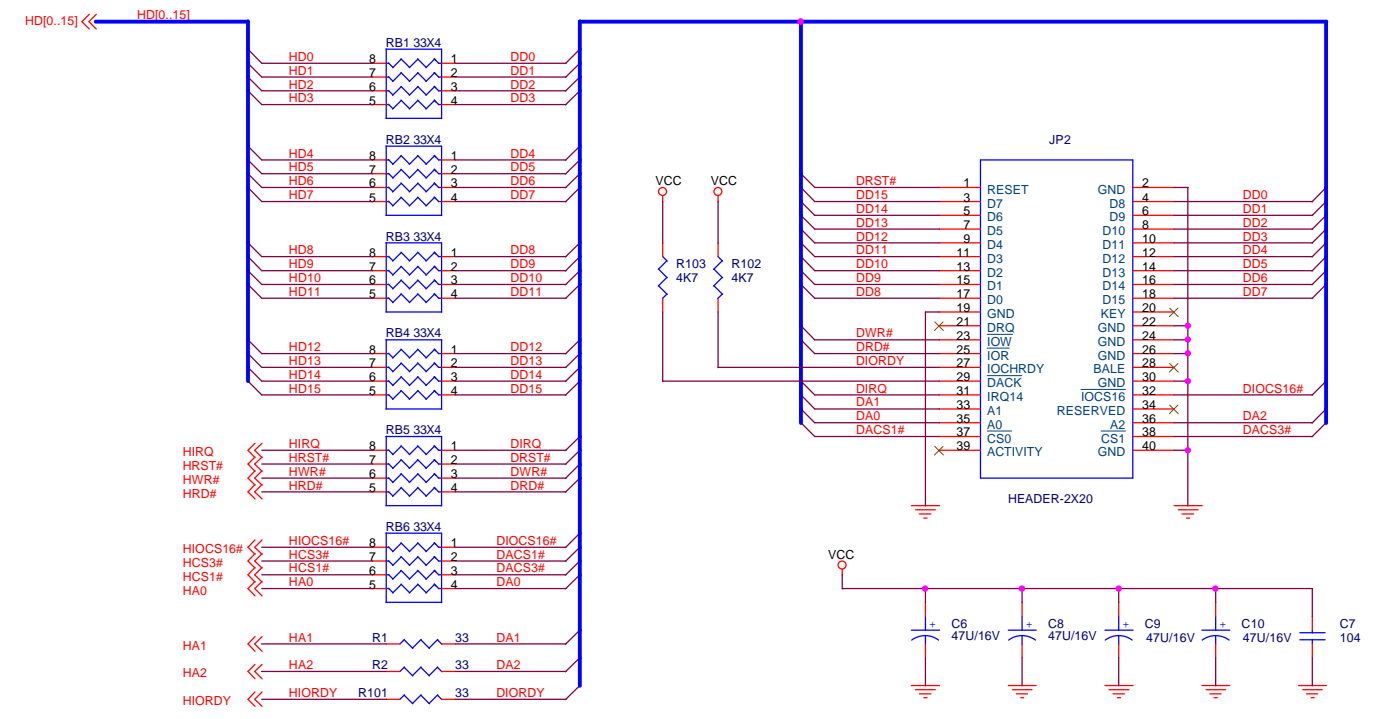
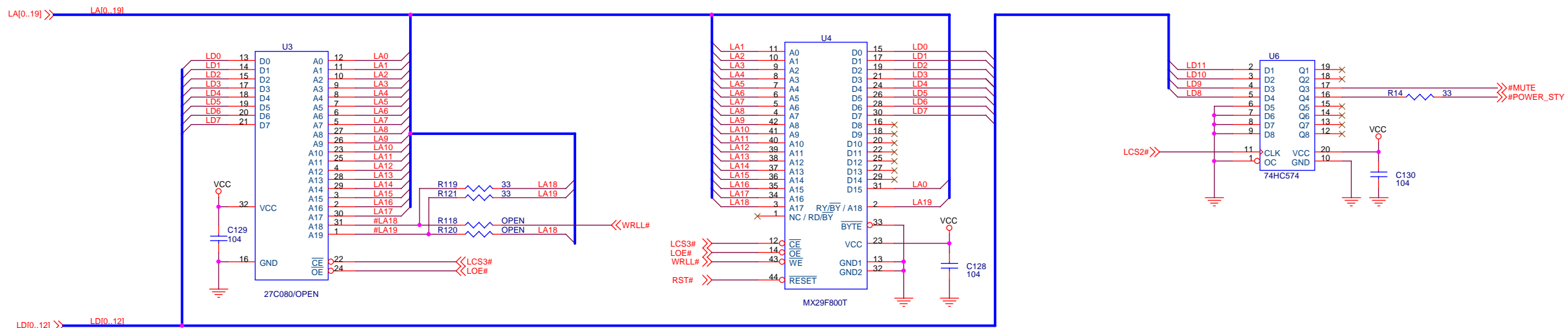

IA4p±à°ÀÉ°	
ÀàÖÆÉ°	Èó°ÈÉ°
Ö±±úDÍ°ÀÉ°	ò²¼p°æ±¼É°
IA4pÄÜ³ÆÉ°	Ö±±à°Äü¼
BÖÆÜÉ°	ò²¼É°

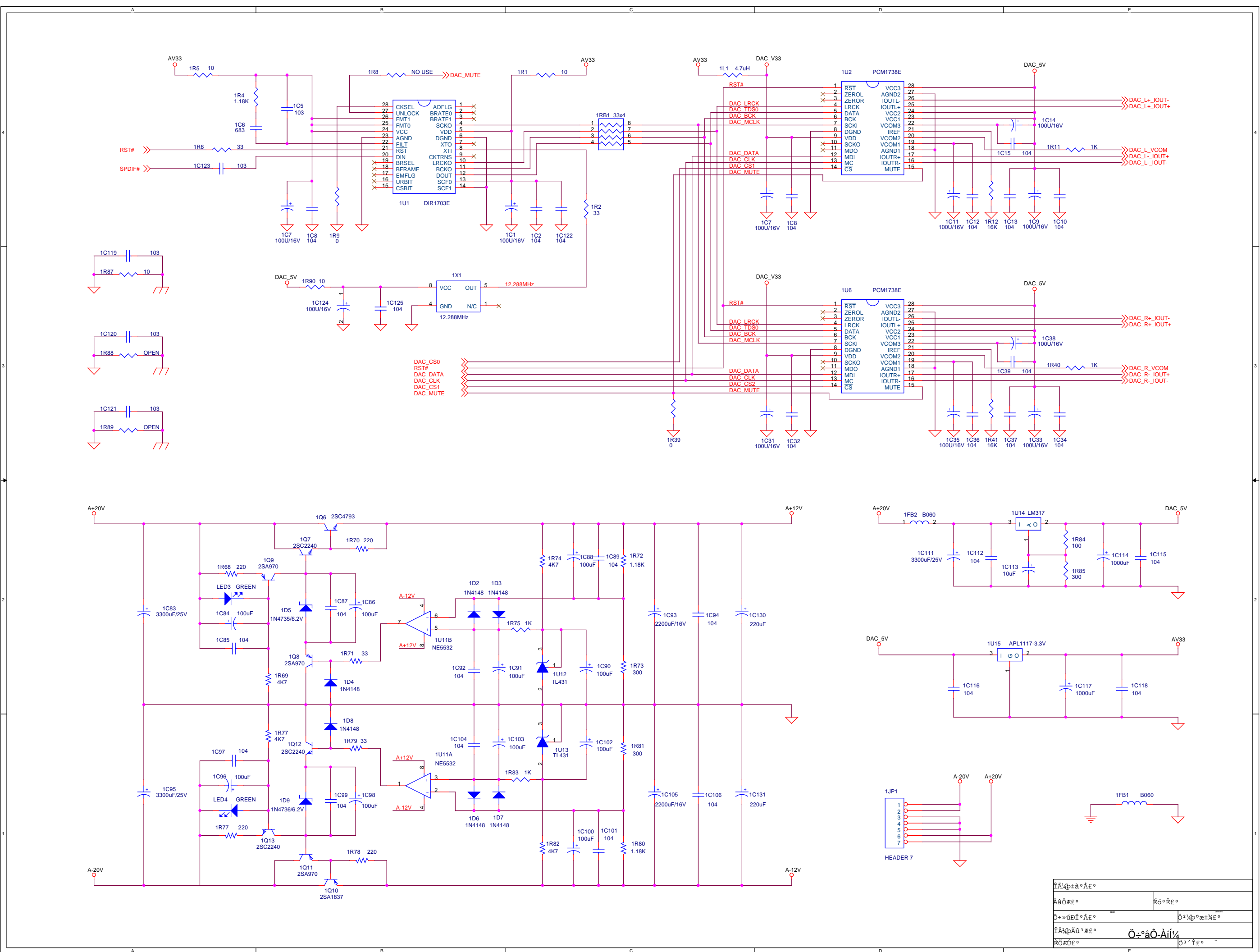

1	2	3	4	5	6	7
1	2	3	4	5	6	7
1	2	3	4	5	6	7
1	2	3	4	5	6	7

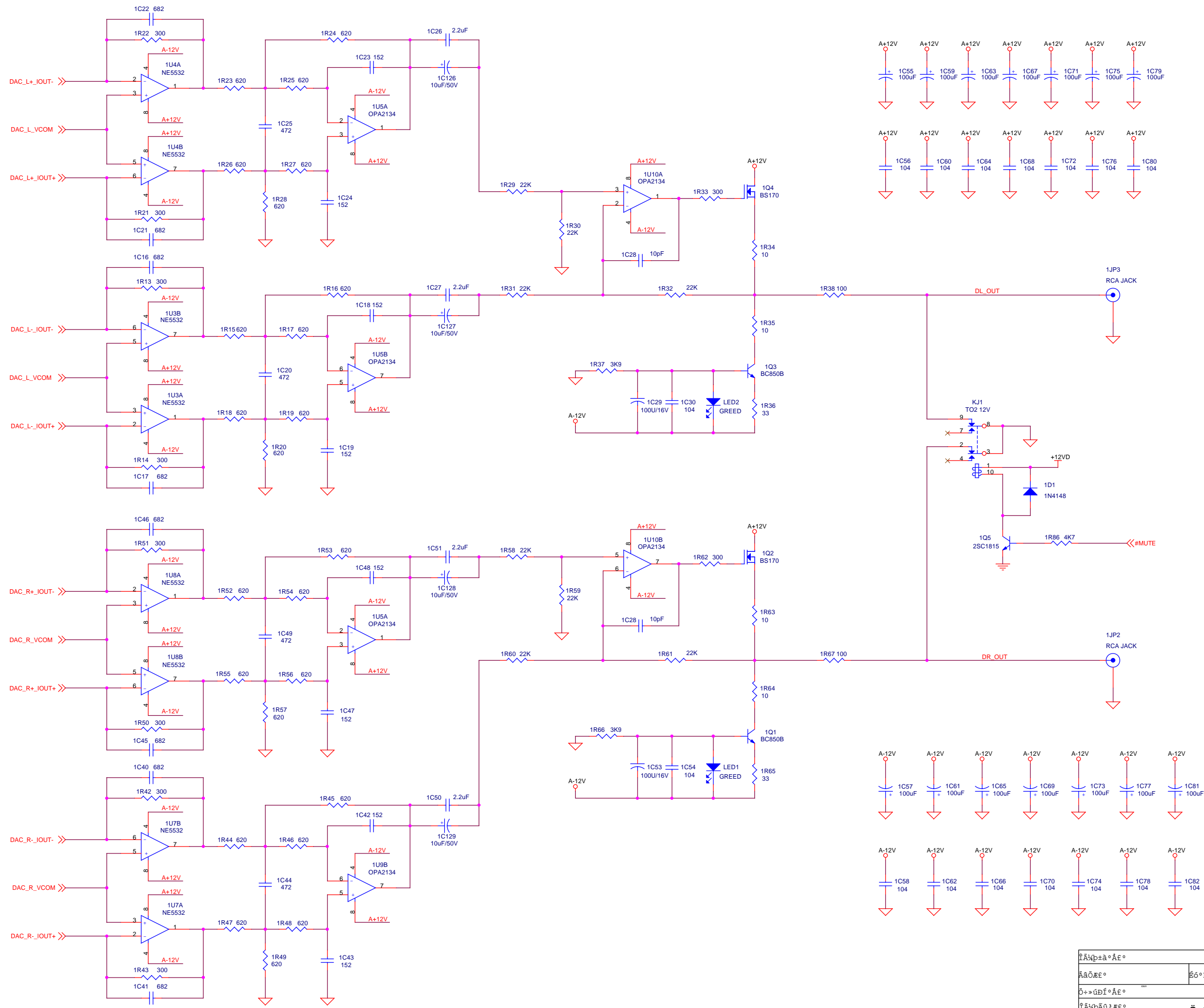

Исполнитель	№ документа
Адрес	Область
Сведения об исполнителе	Сведения о документе
Исполнитель	Исполнитель
Область	Исполнитель

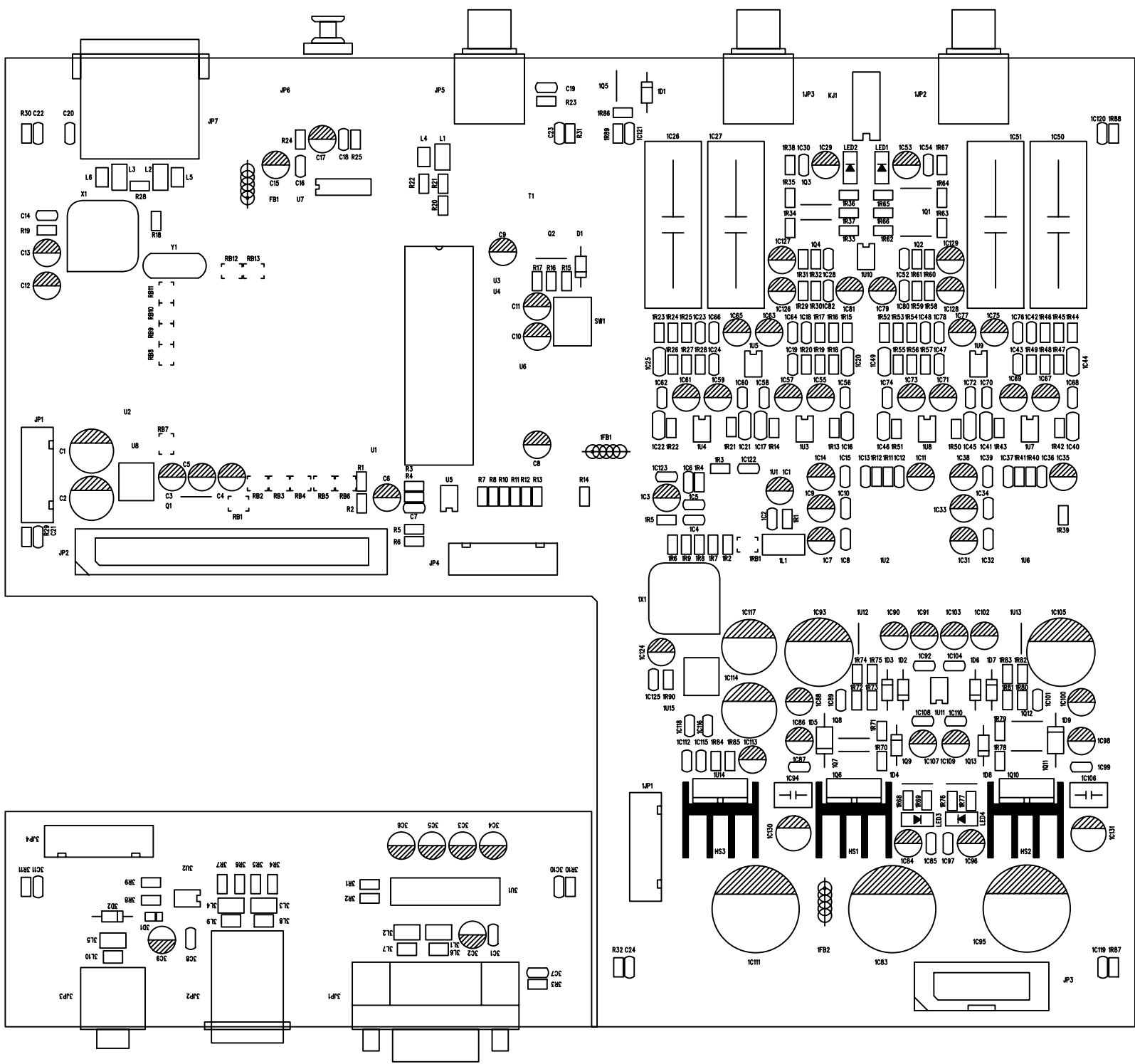

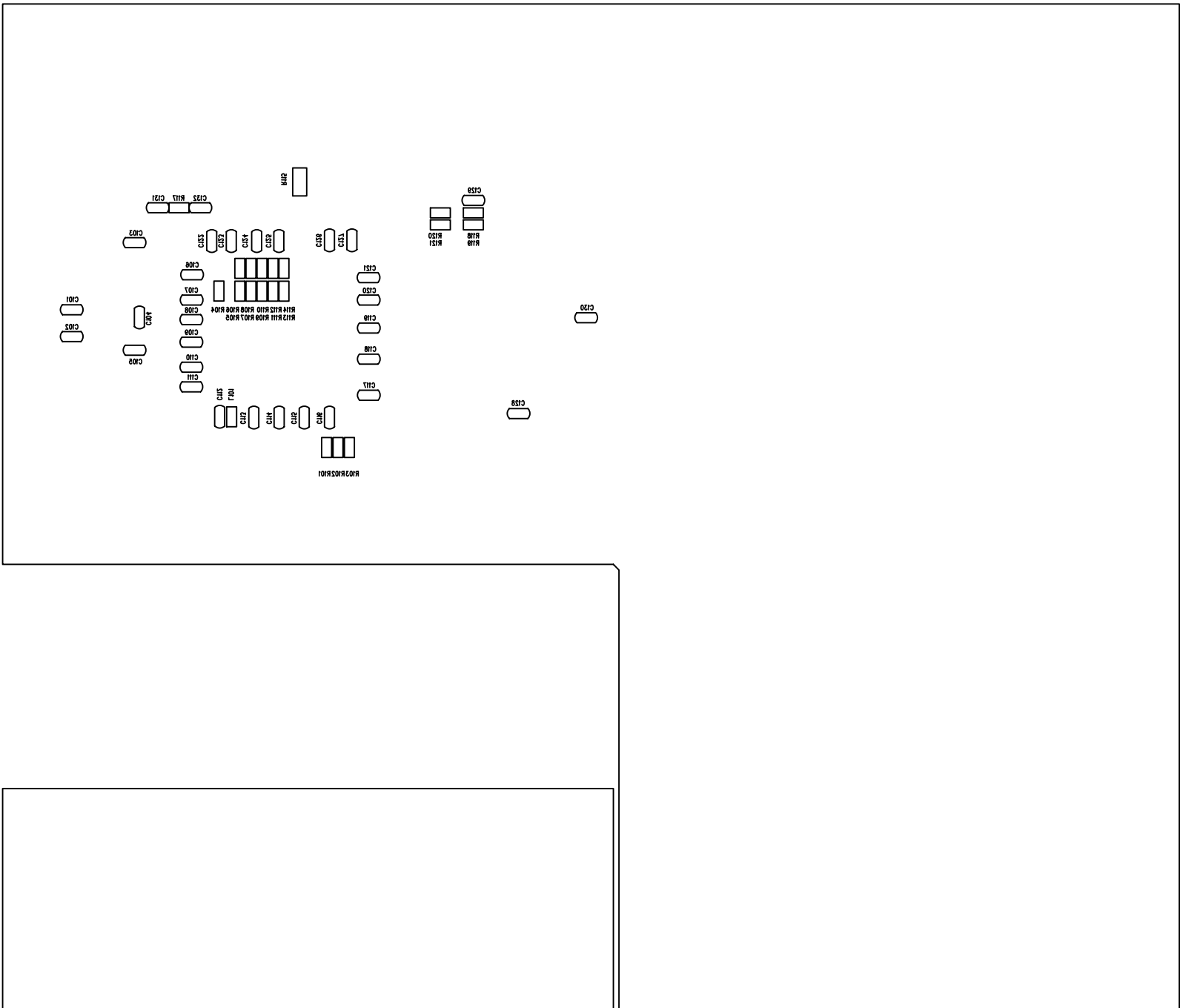

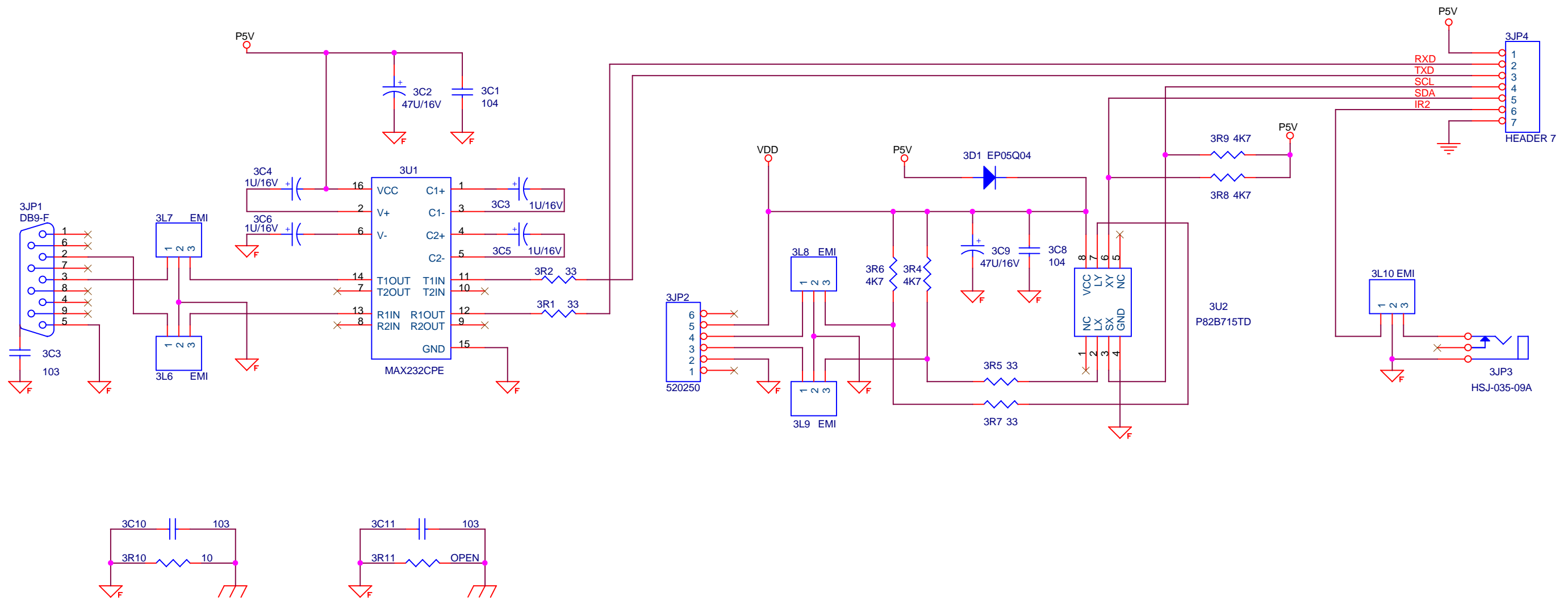

RS232-Á-Áí¼	
Á-Áí¼	Á-Áí¼
Á-Áí¼	Á-Áí¼
Á-Áí¼	Á-Áí¼

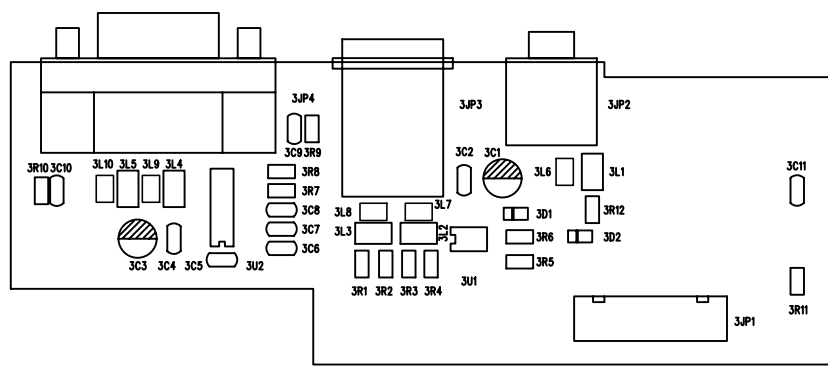

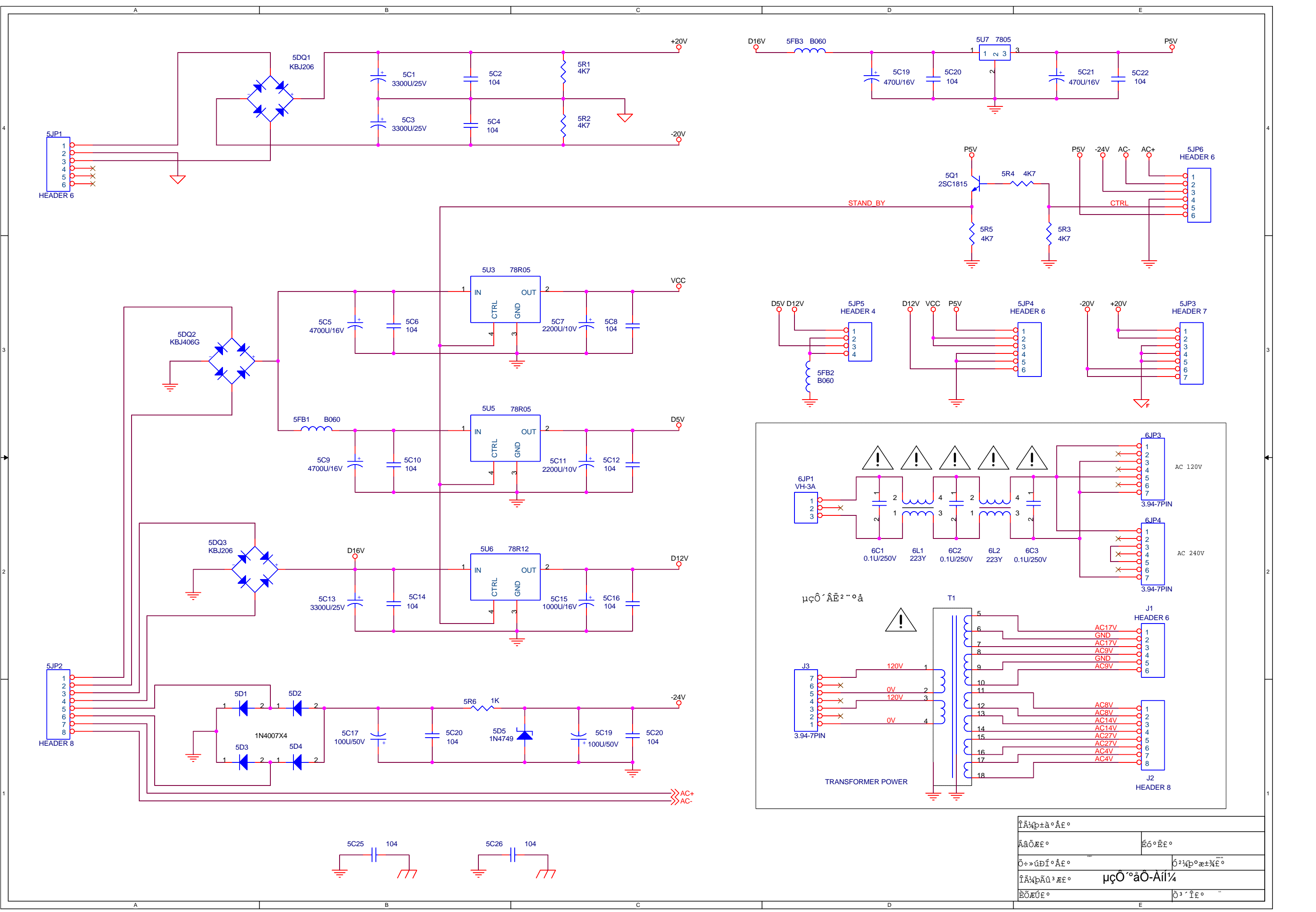

ΑΑΟΕΕ°	ΕΟ°ΕΕ°
Ο+»ΑΔΙ°ΑΕ°	Ο²¼Ρ°±¼Ε°
ÎÄ¼PÄÙ³ ΕΕ°	μçÔ°äÖ-Aί¼
ÈÖÈÚΕ°	Ï³·îΕ°

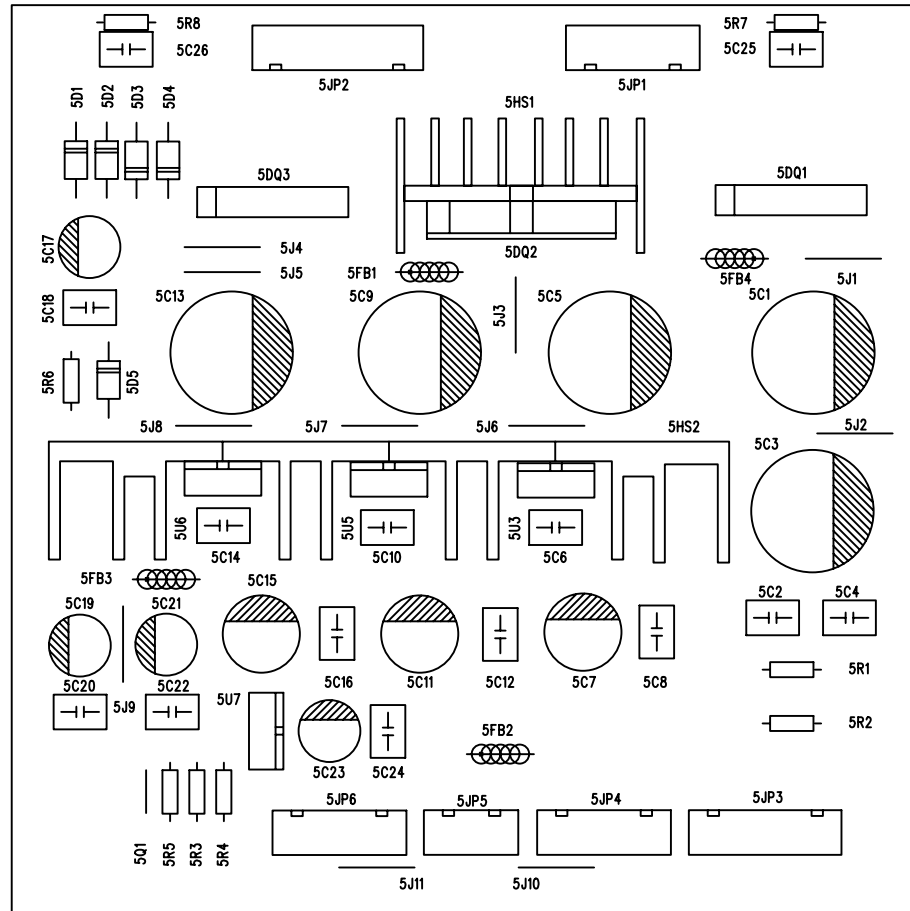

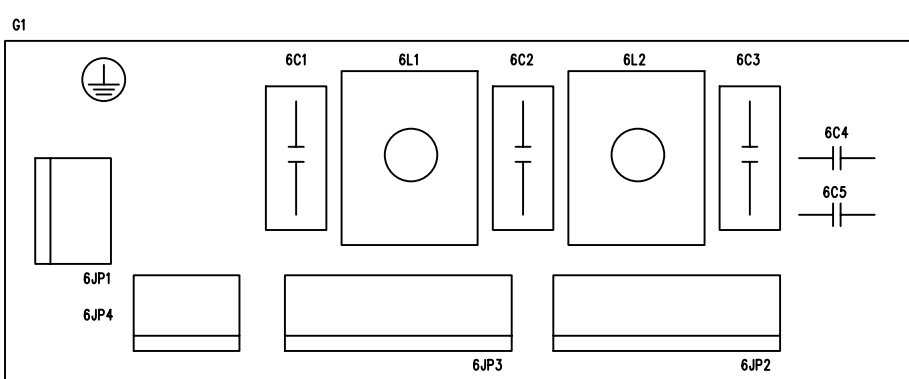

Technical specification

Mechanism DVS "Ultra Silent"

D/A Converter 2 x Burr-Brown PCM 1738

Output Analogue 2.0 VRMS

Output Impedance 100Ω

Frequency Response 20Hz – 20kHz (+0/0.2dB)

Signal to Noise Ratio 105dBA

Harmonic Distortion <0.01% (20Hz – 20kHz)

Digital Output 75Ω coaxial (SPDIF)

110Ω AES/EBU

TOSlink

Power Consumption Standby <16W

Dimensions 430 x 385 x 100mm

Weight 10kg