

ORIGINAL IN REV

Part # 900071

OR 940755

Print #

Release date:

Type of release: Prototype Pilot
 1st production Revision

Comments:

Drafting approval: _____ Engineering approval: _____

Issued by: Duff Bradley Date: 8-5-91

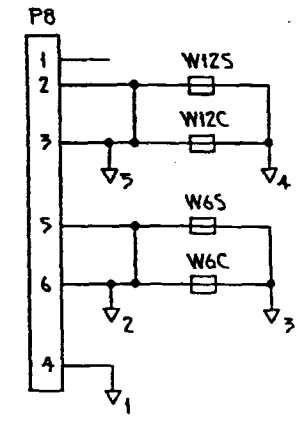
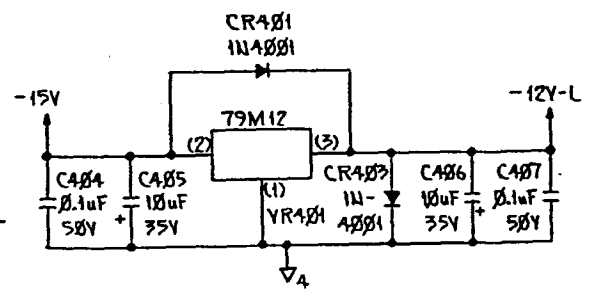
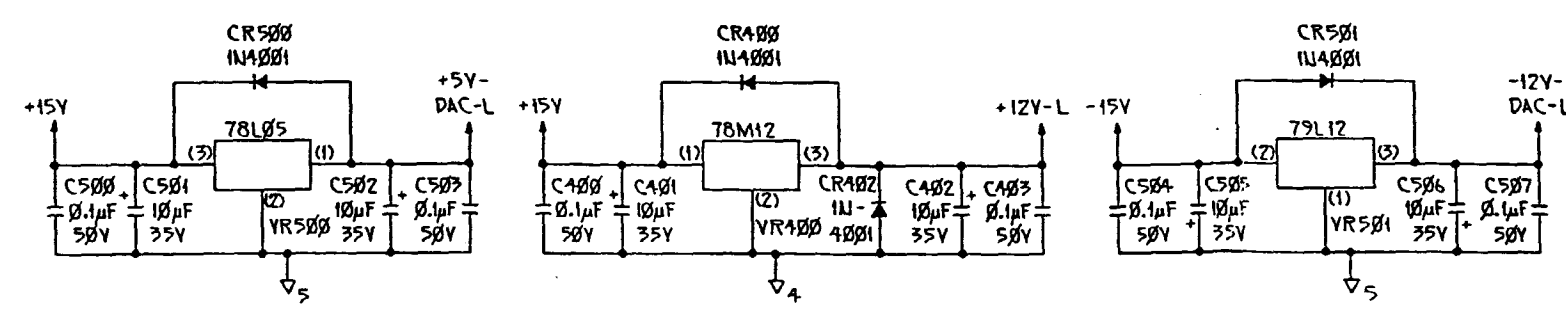

REV	DATE	DRAWN	CHECKED
3	2/5/91	ARTER	BB

TITLE

SCHMATIC

AUDIO BOARD SERIES 2

DRAWING NO. 1DSCH PAGE 1 OF 2

CONNECTORS	
P1	CONNECTOR FOR RIGHT CHANNEL XLR
P2	CONNECTOR FOR RIGHT CHANNEL NGNINV
P3	CONNECTOR FOR LEFT CHANNEL XLR
P4	CONNECTOR FOR LEFT CHANNEL NGNINV
P5	CONNECTOR FOR DAS-OUTPUT
P6	CONNECTOR TO DECCDR 30AHD
P7	CONNECTOR TO MAINS SCARD

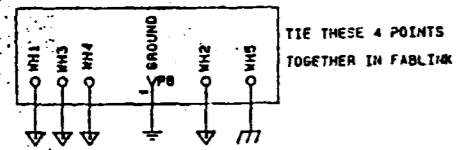
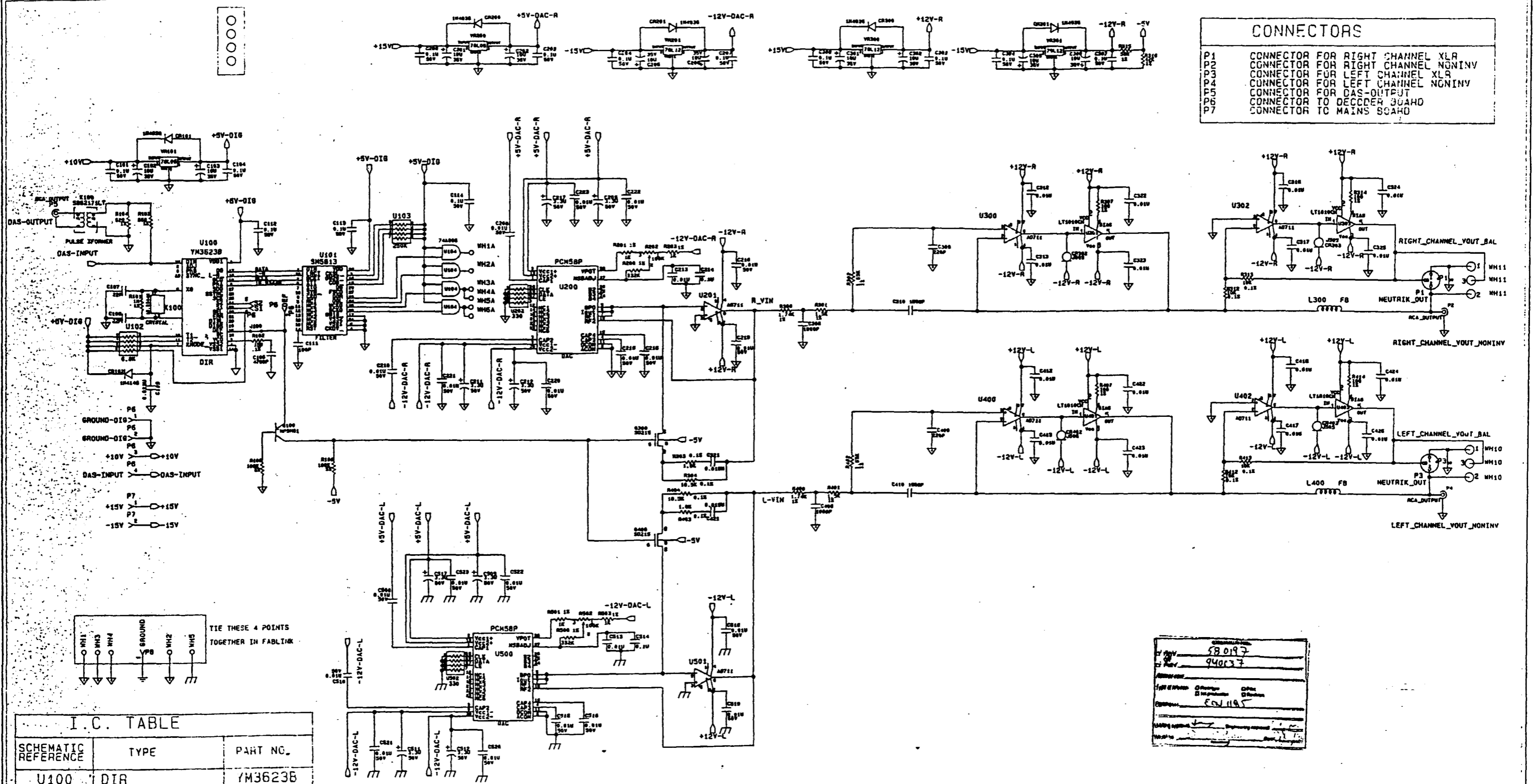

580197
 940137
 ECW 1185

I.C. TABLE		
SCHEMATIC REFERENCE	TYPE	PART NO.
U100	DIR	YM3623B
U101	FILTER	SM5813
U200	DAC	PCM1700P
U300	OPAMPDIR	NE5534
U301	POWER BUFFER	LT1010CH
U302	OPAMP	NE5534
U303	PCR BUFFER	LT1010CH
U400	OPAMPDIR	NE5534
U401	POWER BUFFER	LT1010CH
U402	OPAMP	NE5534
U403	PCR BUFFER	LT1010CH
X1	CRYSTAL 16MHZ	XXXXXX
Q1	DUAL CASCODED N-JFET AMP	IT503
Q2	DUAL CASCODED N-JFET AMP	IT503

CAD ID "MS/SA_CD/SCHEM/AUDIO_BO"

ISSUE		REVISION	DATE	SCALE	MATERIAL		SHEET OF		SIZE
					AUDIO BOARD		940137		D

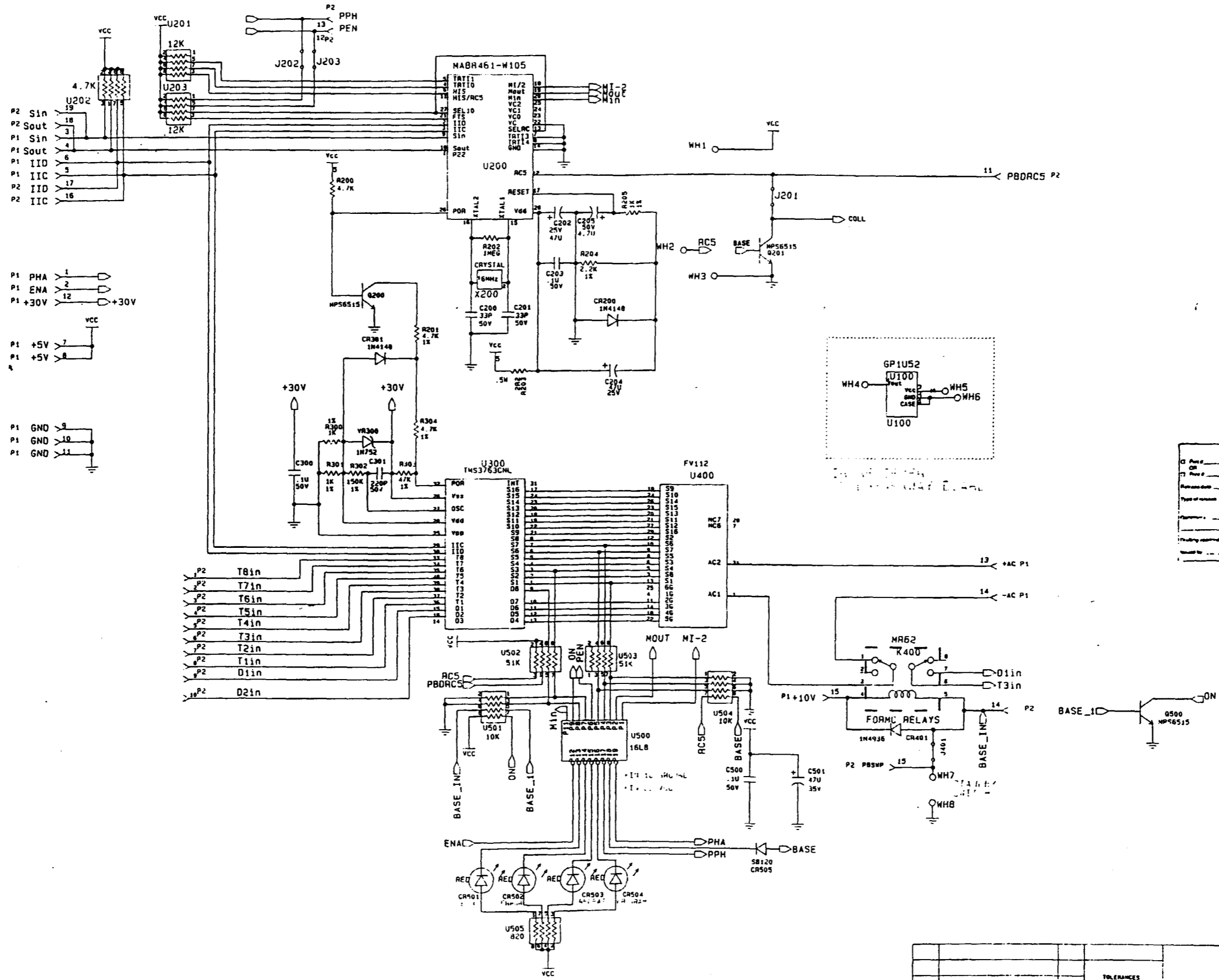

ORIGINAL IN RED

Part of 580196

Rev 1

Rev 2

Rev 3

Rev 4

Rev 5

Rev 6

Rev 7

Rev 8

Rev 9

Rev 10

Rev 11

Rev 12

Rev 13

Rev 14

Rev 15

Rev 16

Rev 17

Rev 18

Rev 19

Rev 20

Rev 21

Rev 22

Rev 23

Rev 24

Rev 25

Rev 26

Rev 27

Rev 28

Rev 29

Rev 30

Rev 31

Rev 32

Rev 33

Rev 34

Rev 35

Rev 36

Rev 37

Rev 38

Rev 39

Rev 40

Rev 41

Rev 42

Rev 43

Rev 44

Rev 45

Rev 46

Rev 47

Rev 48

Rev 49

Rev 50

Rev 51

Rev 52

Rev 53

Rev 54

Rev 55

Rev 56

Rev 57

Rev 58

Rev 59

Rev 60

Rev 61

Rev 62

Rev 63

Rev 64

Rev 65

Rev 66

Rev 67

Rev 68

Rev 69

Rev 70

Rev 71

Rev 72

Rev 73

Rev 74

Rev 75

Rev 76

Rev 77

Rev 78

Rev 79

Rev 80

Rev 81

Rev 82

Rev 83

Rev 84

Rev 85

Rev 86

Rev 87

Rev 88

Rev 89

Rev 90

Rev 91

Rev 92

Rev 93

Rev 94

Rev 95

Rev 96

Rev 97

Rev 98

Rev 99

Rev 100

TOLERANCES UNLESS SPECIFIED		FRACTION ±.010		DECIMAL ±.005		ANGLE ±1°	
DR. A. N. 3-19-90		DATE 3-19-90		USED IN SA CD		SHEET OF SIZE C	
CH. XXX 0-00-00		DATE 0-00-00		NAME		NO. 940139	
ISSUE		REVISION		DATE		SCALE:	
						DISPLAY BOARD	

MAINSTREET

2001 south main street sturbridge connecticut 06457 u.s.a.

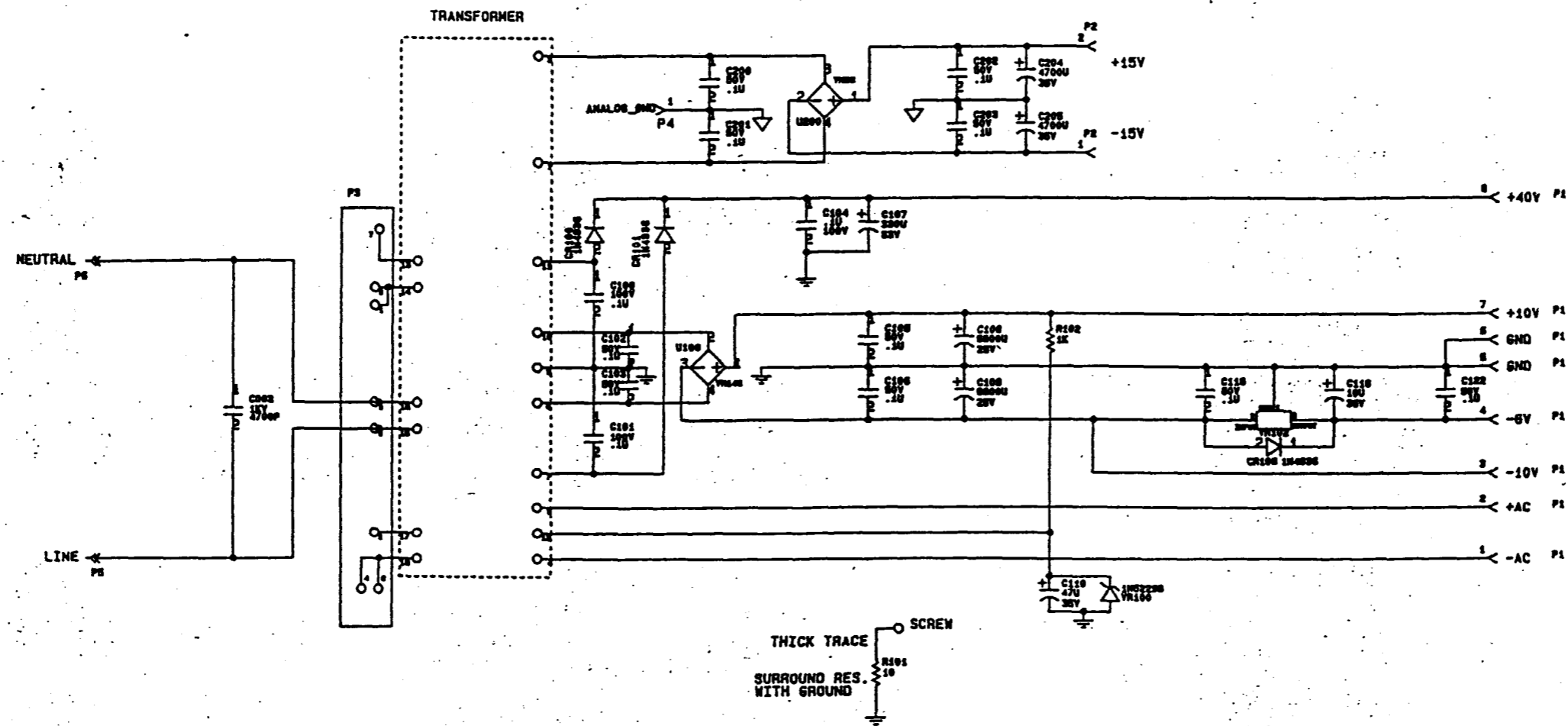

ORIGINAL FILED

Part # 58002

OR

Part #

Release to

Type of release Inventory Disposition Other

Comments

Drawing approval D. J. B. 12/1/89

THICK TRACE
SURROUND RES.
WITH GROUND

NOTES

AC MAINS	JUMP PINS ON TERMINAL BLOCK	
100V	5-6	2-3
120V	6-7	3-4
200V	1-2	
220V	4-5	
240V	7-8	

TELEPHONE		MAINSTREET	
RELEASE SPECIFICATION		2001 main street additonal connections 0007 U.S.A.	
FRONTIER 4-100		MATERIAL	
ORIGINAL 4-100		SHEET OF SIZE	
SCALE 4-1/2"		C	
OR	DATE	USED IN	No.
A.L.N.	2-21-88	SA/CD	
OR	DATE	NAME	00-0000-00-00-00
REV	8-26-88	MAINS BOARD	
ISSUE	REVISION	DATE	SCALE

CONNECTORS

- P1 CONNECTOR TO AUDIO CARD OR PERS BOARD
- P2 CONNECTOR TO MAINS BOARD
- P3 CONNECTOR TO DISPLAY BOARD
- P4 CONNECTOR TO SERVO BOARD
- P5 CONNECTOR TO TRANSPORT LIMIT SWITCHES
- P6 CONNECTOR TO TRANSPORT DRAWER MOTOR

I.C. TABLE

SCHEMATIC REFERENCE	TYPE	PART NO.
U100	MICROPROCESSOR	MAB 8441-T082
U200	DECODER	SAA7210
U300	DRAM	MN4264
U400	FILTER	SAA7220
U600	MOTOR DRIVER	UDN2993B
VR001	+15 VOLT REG.	78L15
VR002	+5 VOLT REG.	7805

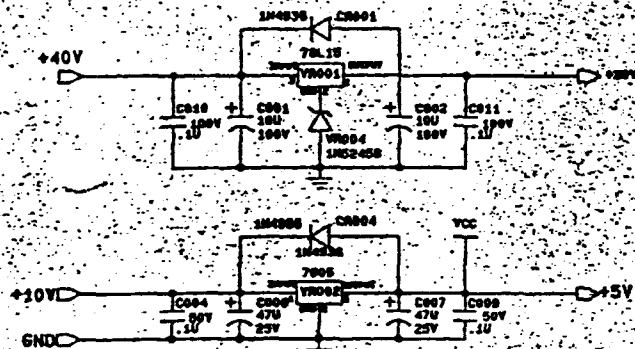

CONNECTOR TO PERS BOARD
CONNECTOR TO AUDIO CARD

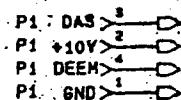

CONNECTOR TO DISPLAY BOARD

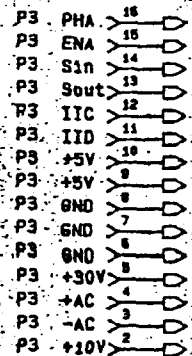

CONNECTOR TO MAINS BOARD

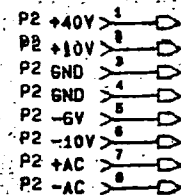

CONNECTORS TO TRANSPORT AND SERVO BOARD

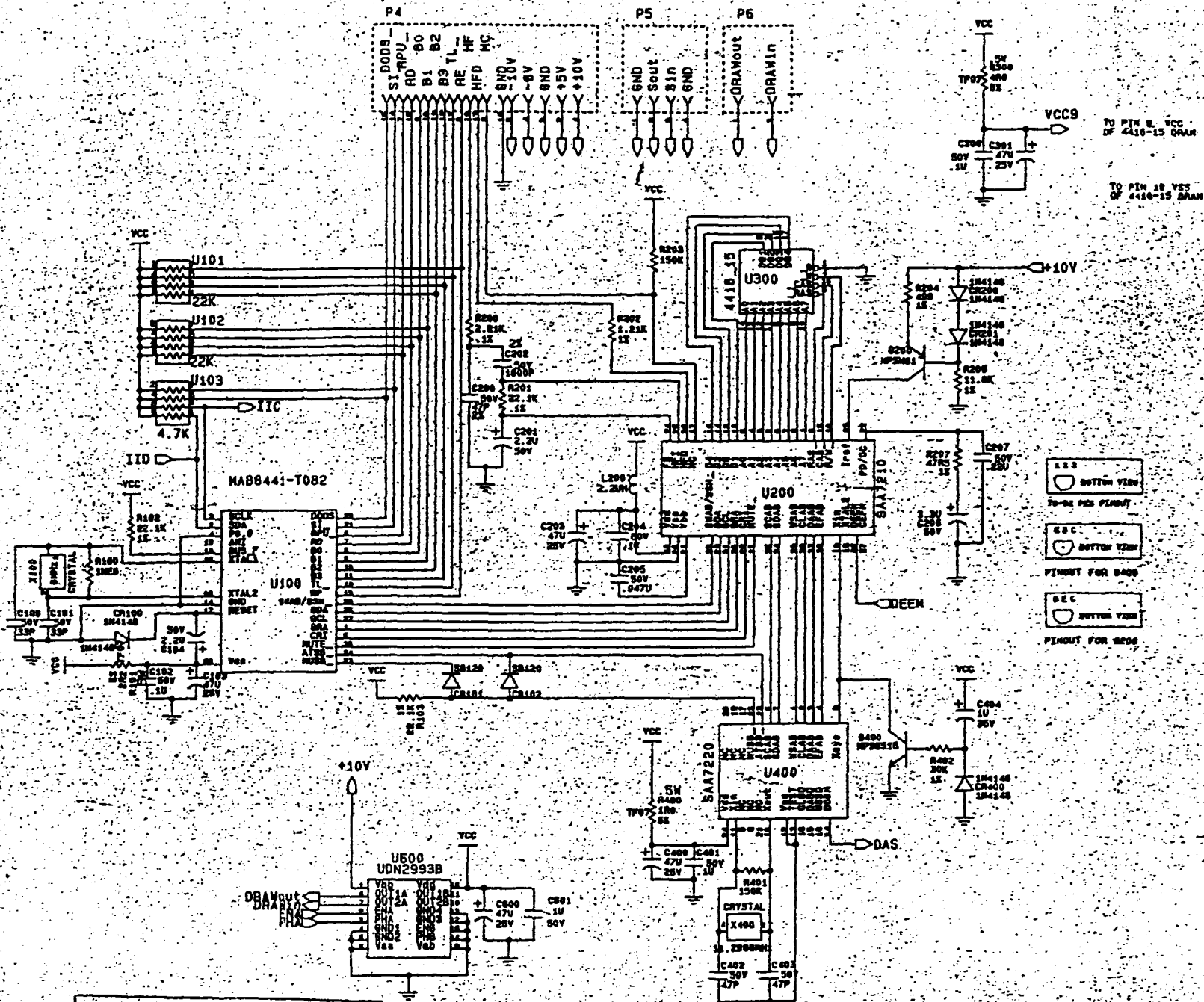
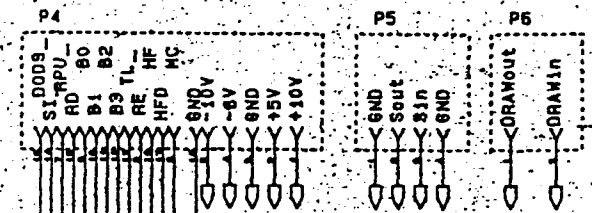

ORIGINAL BY RED
 Part # 580204
 CR 940138
 Release date: 4/4/90
 Type of release: Production For production
 Comments: Rev 4.5 with 4 new pins + VCC
 217 580204 REV 1187
 Drawing approved: [Signature] Engineering approved: [Signature]
 Drawn by: [Signature] Date: 4/4/90

CAD ID : MS/SA_CD/SCHEM/DECODER_BD
 COPIED FROM : MS/SA_CD/PCB/DECODER_BD/DESIGN 3-20-90

3-20-90		MAINSTREET	
TOLERANCES UNLESS SPECIFIED	SHEET 3 OF 3		
FRONTION ±.010	MATERIAL		
DRILLING ±.005	USED IN SACD		
ANGLE ±1/2°	NAME DECODER_BD		
DATE 11-14-88	No. 940138		
DATE 8-8-88			
ISSUE	REVISION	DATE	SCALE

DISPLAY CABLE

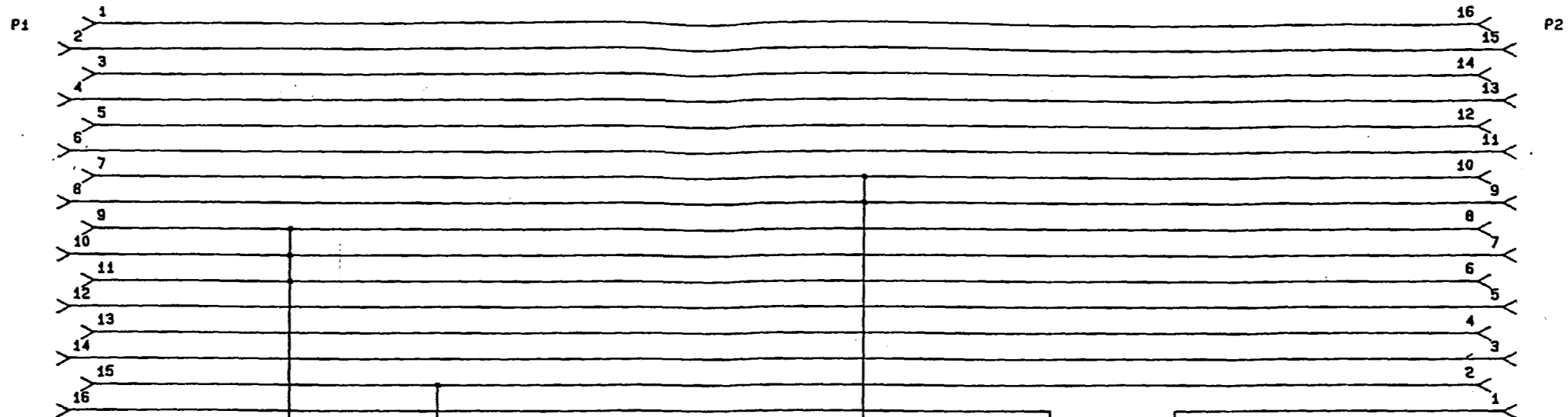

DECODER SOCKET

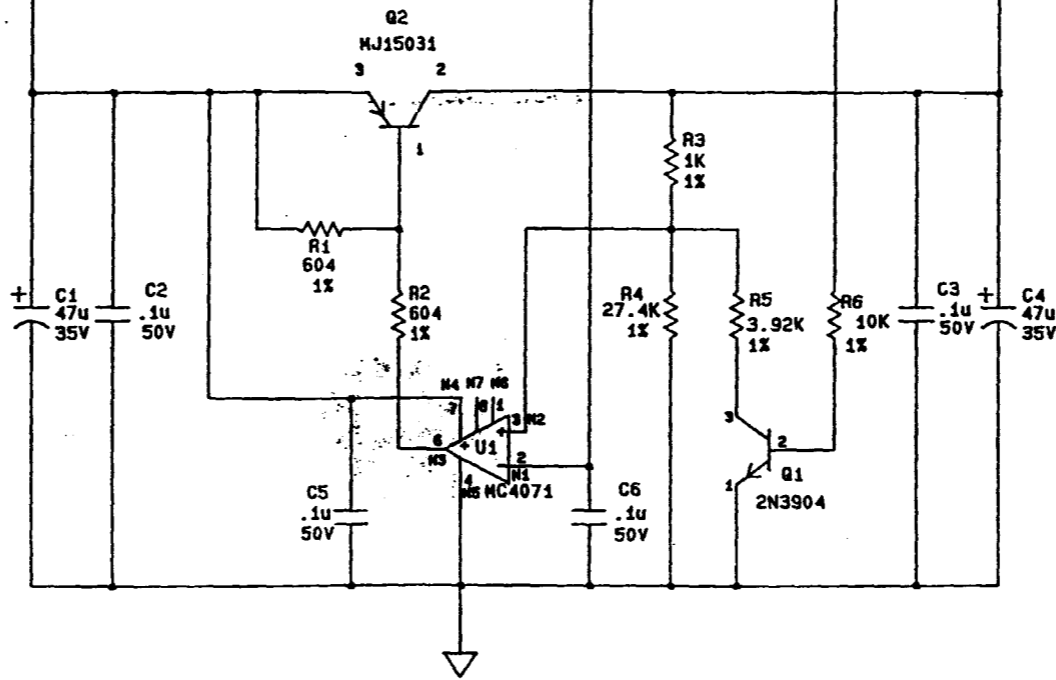

940512A
 12T13-70
 X
[Signature]

				TOLERANCES UNLESS SPECIFIED FRACTION $\pm .010$ DECIMAL $\pm .005$ ANGLE $\pm 1/2^\circ$		MAINSTREET 2081 south main street middletown connecticut 06457 u.s.a.				
				DR. D.S. DATE 10-30-90		MATERIAL SA_CD		SHEET OF A 90 B C D E		SIZE B
A ARTWORK REVISED 12/12				CH. XXX DATE 0-00-00		USED IN NAME DRAWER_TACKON		NO.		940512A
ISSUE	REVISION		DATE	SCALE:						

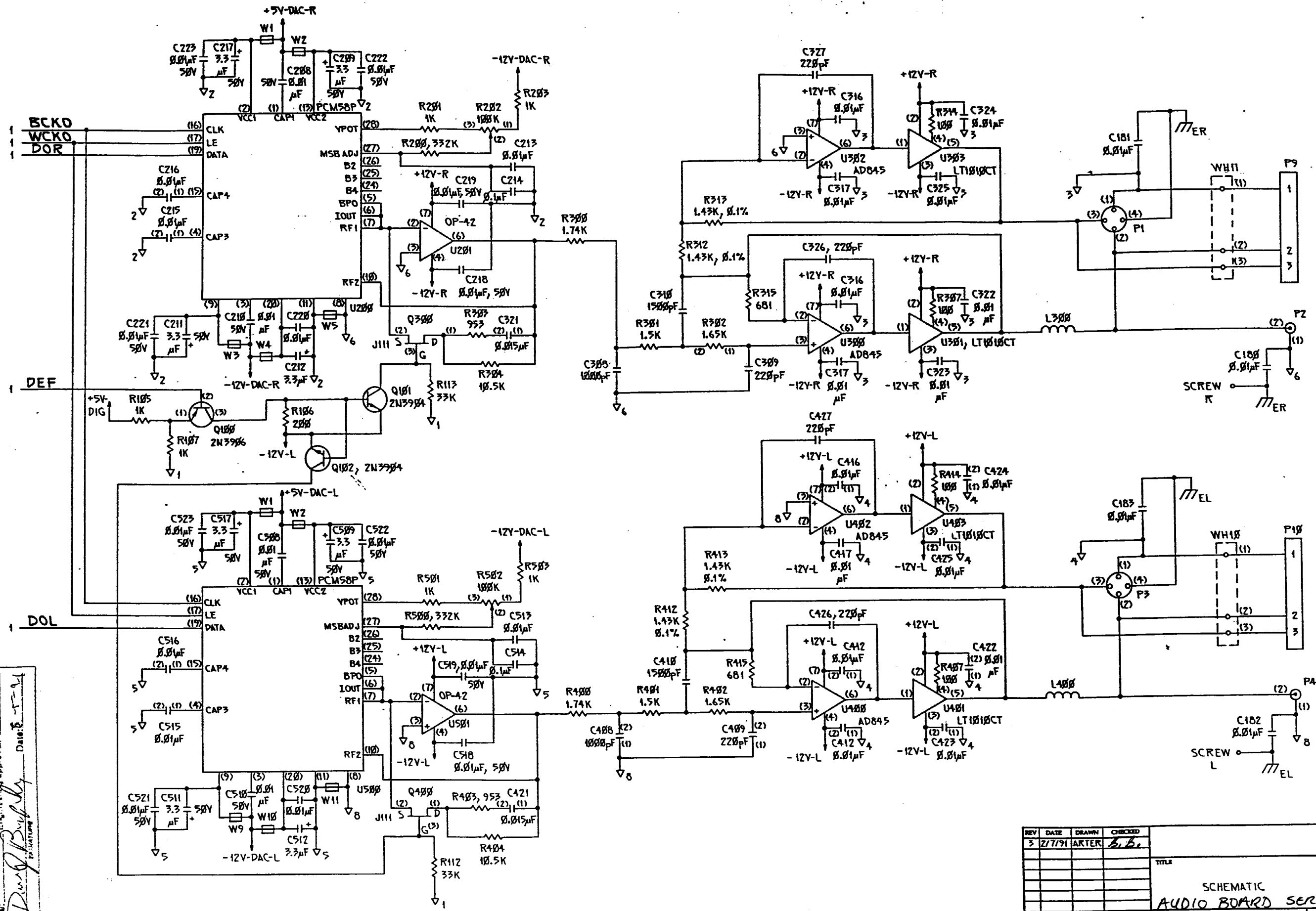

900071
 940755

Parts
 OR
 Print
 Release date:

Prototype
 Int. Prod.

Final
 Revision

Comments:

Drawing approval: *Daryl Buckley* Date: 8-1-94
 Issued by:

REV	DATE	DRAWN	CHECKED
3	2/7/91	ARTER	S.B.

TITLE: SCHEMATIC
 AUDIO BOARD SERIES 2
 DRAWING NO.: DSCH
 PAGE 2 OF 2

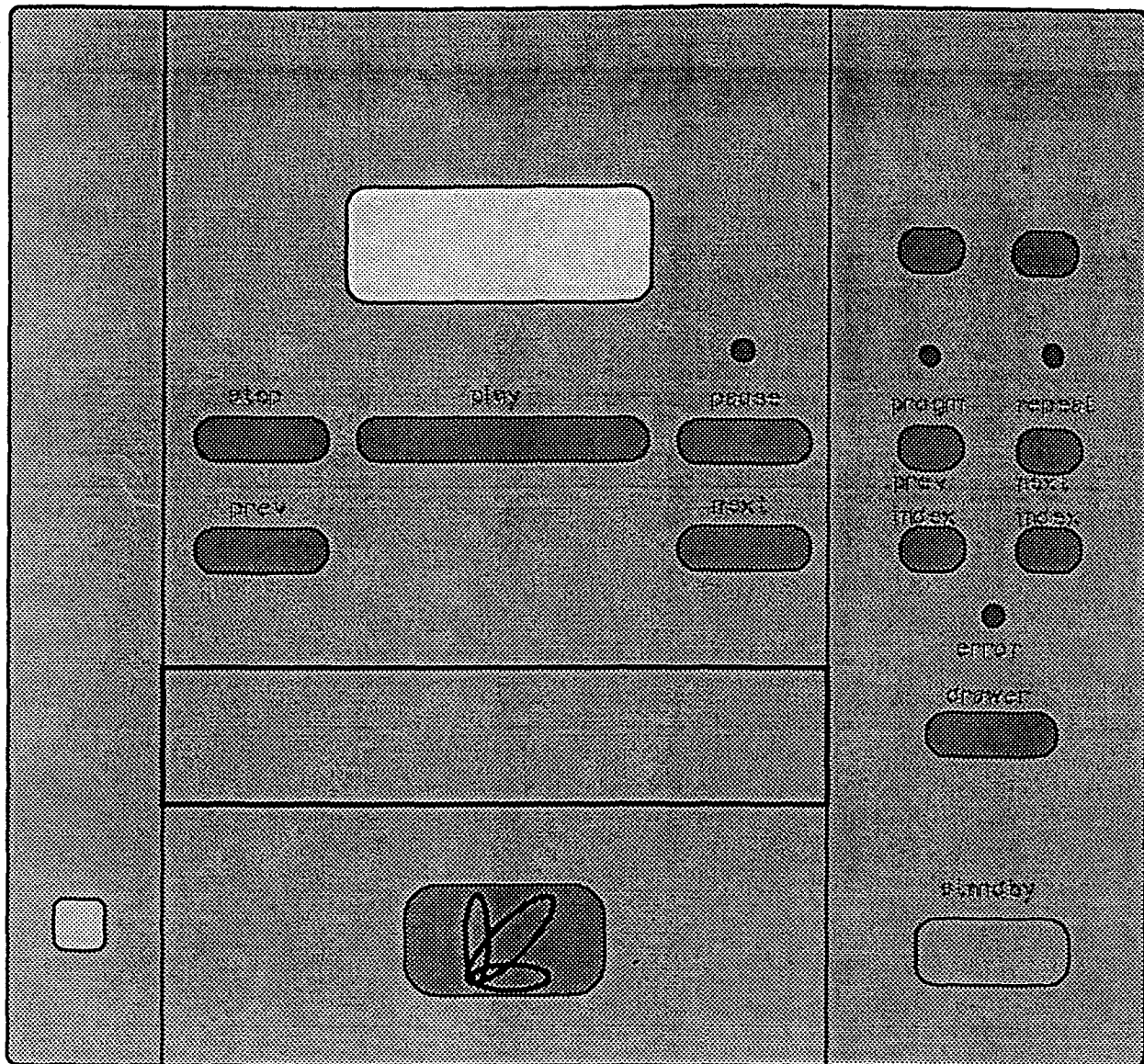

PROCEED™ COMPACT DISK/
DIGITAL TRANSPORT (1 AND 2)
SERVICE MANUAL

MADRIGAL AUDIO LABORATORIES, INC.

TABLE OF CONTENTS

Theory of Operation.....	1
Block Diagrams.....	6
Troubleshooting Charts.....	8
Disassembly Procedure.....	11
Assembly Views.....	15
Miscellaneous parts.....	28
Adjustment Procedure.....	29
Specifications.....	30
Schematics.....	31

THEORY OF OPERATION

1.0 THE AUDIO PCB

The audio board performs the digital oversampling, filtering, digital to analog conversion and analog lowpass filtering functions to create the audio output of the CD player. It has been optimized to be a low noise conversion system.

The audio card is composed of five distinct circuit areas. They are the digital section, the left DAC, the right DAC, the left audio section and the right audio section.

1.1 The Audio Card Power and Grounding System

Research has shown that the optimal noise performance in a conversion system occurs when the system ground connection between the digital and analog subsystems occurs directly under the converter.

Additionally, it has been shown that the best noise performance in a stereo audio system will occur when a dual monoraul design is adopted for power and ground. The reference ground for the system is placed such that noise in one channel does not affect the other.

Since the audio card contains a digital conversion subsystem, a stereo analog conversion subsystem and a stereo audio system, the best performance will be found by developing five separate ground areas that are connected directly between the converters. This system ground, or ground zero, is made to be the lowest potential point in the system. Thus noise in one subsystem will not affect any other.

The audio PCB itself is a two sided board that utilizes extensive ground plane areas in a unique arrangement that facilitate a low noise conversion system and are carefully separated at adjoining edges to prevent crosstalk. They are all brought together at P8, which is surrounded by its common ground plane area.

The card uses a separate IC regulator section for each of the five areas as well. Each positive regulator is of the 78LXX type. Each negative regulator is of the 79LXX type. Each is filtered on the input and output sides by a 10 mF electrolytic capacitor, bypassed by .1 mF metalized mylar film capacitors. The film capacitors are used throughout the audio card instead of the ceramic bypasses used elsewhere because of the film capacitors superior high frequency characteristics.

The digital section requires a single +5 V supply. The input to the 78L05 regulator VR100 is the same +10 V preregulated DC supply that feed the regulator on the decoder board.

The DACs each require a +5V and a -12 V supply. Each channel has a 78L05 (VR200 and VR500), and a 79L12 (VR201 and VR501). The input to the regulators is the ± 15 V analog preregulated DC brought to the audio card by P7.

Also supplied by the ± 15 V analog preregulated DC are the ± 12 V regulators required by the audio channels. Each channel has a 78L12 (VR300 and VR400) and a 79L12 (VR301 and VR401)

1.2 The Digital Section

The audio card has three main functional blocks. First is the digital section, comprised of the YM3623B Digital Interface Receiver, SM5813 Digital Filter, and 74ALS04 Quad Two-input AND Gate, with associated passive circuitry. Second is the DAC section, comprised of a pair of PCM58P DACs, and OP-42 op amps. And third, the analog filter section, comprised of a pair of active lowpass filters using AD711 op-amps.

Audio information is input to the audio card in the form of DAS, which is output from the SAA7220 on the decoder board. The DAS is fed to the Yamaha YM3623 digital interface receiver, which derives the left and right channel data, bit clock and word clock from it.

The data and clocks are passed to the SM5813 digital filter, which performs 8-times oversampling and increases the resolution of the data to 18 bits per sample. These oversampled signals are buffered by the 74ALS04 before the DACs.

The DAS signal which is fed to the DIR is also available as a direct digital output at P5.

1.3 The DAC Section

Digital to analog conversion is performed for both channels by a Burr Brown PCM 58P DAC, U200 for the right channel, and U500 for the left. The PCM 58 is a monolithic 18 bit serial input DAC which provides a current output.

1.3 The Filter Section

Once D/A conversion has taken place, the remaining high frequency images must be removed by an analog filter. The audio card uses a third order active Bessel filter. This filter is 0.2 dB down at 20 KHz, and exhibits a constant group delay, or linear frequency response, to 40 KHz. The active device in the filter is a composite op amp created from an AD845 operational amplifier (U300 and U500), and an LT1010 current driver (U301 and U401).

The LT1010 of the filters feed the single ended outputs (P2 and P4) directly. The system develops a balanced capability by inverting the filter output with a composite inverting buffer (U302 and U303 for the right channel, U402 and U403 for the left channel). The inverted and noninverted outputs are fed to XLR type connectors, P1 and P3, along with the channel ground.

2.0 MAINS PCB

The Proceed CD player is expected to function at any standard AC wall voltage and a line frequency of 50 or 60 Hz. The digital mains board therefore contains the input protection circuitry, transformers, rectifiers and filters needed to convert 100 V, 120 V, 200 V, 220 V, or 240 V AC mains power to preregulated DC power to supply the motors and regulator sections in the CD player. It also contains the -6 V DC regulator section that supplies the transport and servo board.

2.1 The Transformer

The transformer is a PC mount E-core(or toroidal) with a universal primary. This means that there are actually two multi-tapped 120 V rms primaries, that can be jumpered to allow the transformer to be used with AC mains voltages of 100 V, 120 V, 200 V, 220 V, or 240 V. This allows one transformer to be installed, then changed for a product destined for use in any country. The jumper pattern to set the transformer for any given input voltage is shown on the mains board schematic.

The first secondary has five taps, including a center tap (pin 9) that is the digital ground reference. Pins 8 and 10 are rated at 17.6 V @ 3600 mA. This voltage, when rectified by U100 provides the ± 10 V nominal for the motors, the +5 V digital circuitry regulators, and the -6 V digital circuitry regulator. Pins 11 and 7 develop 53.6 V @ 120 mA between them. This voltage, when rectified by CR100 and CR101, provides the preregulated +37 volts for VR001 on the decoder board.

The second secondary, (pins 4, 5 and 12) is also center tapped. It provides ± 1.7 V at 100 mA to power the filament of the Vacuum Florescent Display.

2.2 Voltage Rectification and Filtering

The first rectifier is U100, a dual complementary 10 V supply. A dual complementary supply is a full wave bridge rectifier with the addition of a center tap ground reference half way between the two AC taps. The rectified DC is then filtered by a pair of 6800 mF electrolytic capacitors C108 and C109. These large energy storage capacitors are for the removal of ripple from the preregulated voltages. They are each bypassed to ground by .1 mF ceramic capacitors.

The second rectifier is a full wave center tapped rectifier formed by CR100 and CR101. The resulting DC level is 35.6 V. Ripple filtering is provided by C107, a 330 mf electrolytic capacitor, which is bypassed to ground by C104, a .1 mF ceramic.

The third rectifier is U200, a ± 15 V dual complementary supply similar to U100. It has a lower current demand, so it uses smaller ripple rejection capacitors, 4700 mF electrolytics, C204 and C205.

2.3 The Transport Regulator

Voltage regulation from -10 V down to -6 V is provided on the mains board for use on the transport.

The -6V regulation is provided by 7906 IC regulator VR102. The 7906 can supply 1 A maximum current. The 7906 maintains less than 100 mV ripple due to line and load changes with any supply voltage $-8 \text{ V} > V_{in} > -25 \text{ V}$ and load current $5 \text{ mA} < I_o < 100 \text{ mA}$. The draw on this regulator is 25mA maximum.

3.0 TRANSPORT

The transport is the subassembly that performs the electrical and mechanical functions related to the loading of the disc, spinning the disc, and reading the audio and subcode data that is on the disc. This subassembly includes the CDM 1 Mk II, the servo board, and the loader. The transport requires DC power, digital ground, and an array of signals from the decoder board to perform its functions.

The CDM 1 Mk II contains the CD turntable that supports and spins the compact disc during play, the laser diode that illuminates the data tracks on the disc, and the array of four photo diodes that reads the varying intensity of reflected light and converts it to an electrical signal. The laser and photodiode array together are called the pickup.

The output signal, (the current induced in the photo diodes as a result of the amount of laser light reflected) is a type of sinusoidal signal called the High Frequency signal, which is also known as the eye pattern. It is monitored by the photodiode signal processor on the servo board.

The turntable uses a brushless DC Hall effect motor that spins at 200 - 600 RPM. The laser operates at 780 nm, and has an output of 3 mW. The pickup is mounted in a motor driven radial swing arm assembly that moves the pickup to the correct area, and tracks the disc as it spins during playback. A motor driven focus actuator moves the laser vertically to allow tracking of warped discs, or tracking during vibrations.

3.1 Servo Board

The servo board powers the CDM 1 Mk II, controls the pick-up arm of the CDM 1 Mk II during playback, track jumping and searching, corrects radial and focus errors, allows adjustment of the laser output and focus offset, and amplifies and equalizes the eye pattern from the photo diode array for the decoder board.

3.2 The Loader

The loader is comprised of the disc drawer, drawer motor, limit switches, and frame. The frame has mounting points for the drawer, the motor, the switches, the CDM 1 Mk II and the servo board. The transport subassembly is then secured to the CD player chassis by the frame.

3.2.1 The Drawer Motor

The drawer motor is a bipolar brushless DC type. It draws a maximum of 250 mA, which is supplied by the UDN2993 motor drive IC on the decoder board. The function of the UDN2993 will be described in the decoder board section. The drawer motor is mounted to the frame. It is connected to the decoder board by a preassembled three conductor cable. The cable is supplied with soldered connections at the motor, and a three pin socket for the decoder board.

3.2.2 The Limit Switches

Two switches, Sin and Sout, limit the disc drawer travel in both directions. The limit switches are mounted on the frame. Each consists of a normally open single pole snap-switch which has one side at digital ground, and one side wired to input ports pin 9 (Sin) or pin 10 (Sout) of the display microprocessor, which is the user interface microprocessor, located on the display board. The display processor is described in detail in the display board section.

4.0 DISPLAY PCB

The display board performs the human interface functions which allow the user to enter commands to the CD player, via a keypad or remote control, and have the current function of the player reported back, via a vacuum fluorescent display.

The display board has three functional blocks. They are the MAB8461-W105 display microprocessor, the TMS3763CNL display driver with keypad and display and the PAL16L8 programmable logic device.

The display processor receives user commands either as remote commands from the RC-5, or keyboard commands from the TMS3763. It delivers these commands to the servo processor which controls the system. It receives subcode data from the servo processor, and uses it to send track, time and function display information to the display controller. The display processor communicates with the servo processor and the TMS3763 display controller on the IIC bus.

The display processor also controls the action of the loader drawer motor, through the PAL. The position of the drawer is reported to the display processor by the two limit switches Sin and Sout. Sin grounds pin 9 to indicate the drawer is in the full closed position. Sout grounds pin 10 to indicate the drawer is in the full open position. Operation of the drawer motor drive circuit is controlled by pins 18 (MI/2), 19 (Min) and 20 (Mout).

4.1 Standby

The standby circuit includes K400, Q500, and the standby switch. The switch is a pushbutton alternate action type. When the switch is open, the relay K400 is in its normally open (NO) position, and the user control system functions.

When the switch closes it energizes the relay. This causes the connection to AC1, the filament supply for the VFD to be broken, darkening the display. It shorts D1 to T3

on the TMS3763, causing the STOP function to be continually read by the display processor. This overrides all other commands that may be entered by the user. It also causes the signal ON to the PAL (pin 9) to disable the front panel IR and the disc drawer.

5.0 DECODER PCB

The decoder board performs the essential signal processing and error correction functions to transform the eye-pattern received from the servo board into DAS data, which is used on the audio board. DAS is the digital audio standard data format. The decoder board has four major functional blocks. They are the MAB8441-T082 servo microprocessor, SAA7210 decoder IC with associated DRAM, SAA7220 digital filter IC, and the UDN2993 DC motor driver IC. Also included, is DC power regulation for the decoder board and the display board.

The servo processor is the control system master. It asks for and responds to commands from the display microprocessor. It formats its current state and subcode data as information for the display microprocessor. It insures that the turntable rotates counterclockwise at startup and controls the pick-up during run-up, fast search, keyboard controlled pauses and track search operations. It communicates with the SAA7210 and SAA7220 ICs to mute the audio during search or track loss.

5.1 Interface to the SAA7210 decoder IC

The SAA7210 receives subcode data from the disc, demodulates it, and stores it to be read by the servo processor. When the servo processor wants data, a request is sent via the QRA (pin 1) line to the SAA7210. The SAA7210 acknowledges the request and enables the serial data output QDA (pin 26) to shift out Q-channel data using the clock QCL (pin 27), which is generated by the servo pr3.3.

5.2 The SAA7220 Digital Filter IC

The SAA7220 is a four times oversampling DIR interpolating filter. It is primarily designed for use with digital audio data at 44.1 KHz sampling rates, but can be used in systems with data sampling rates of 32 KHz and 48 KHz. For the Proceed CD player, the four times oversampling filter onboard the SAA7220 will not be used. Therefore a description of the filter is not included in this theory of operation.

5.3 Drawer Motor Drive

The drawer motor on the transport is driven by a Sprague UDN2993B dual half-bridge motor driver. It can provide up to 500 mA continuous current at 10 V to DC stepper or brushless motors. Since the motor draws a maximum of 250 mA, it has ample capacity. It was necessary to provide some logic to convert the three bit drive logic of the processor to the correct enable (EN pin 2) and direction (f pin 3) signals for the Sprague part.

The expected audio output from this digital control and signal processing section is to be DAS that is then fed to the audio card for oversampling, digital to analog conversion and analog filtering. The SAA7220 digital filter has the hardware that formats the digital audio standard (DAS) output for the audio card. No separate digital interface transmitter (DIT) is required to feed the audio card.

BLOCK DIAGRAM (PCD/PCD2)

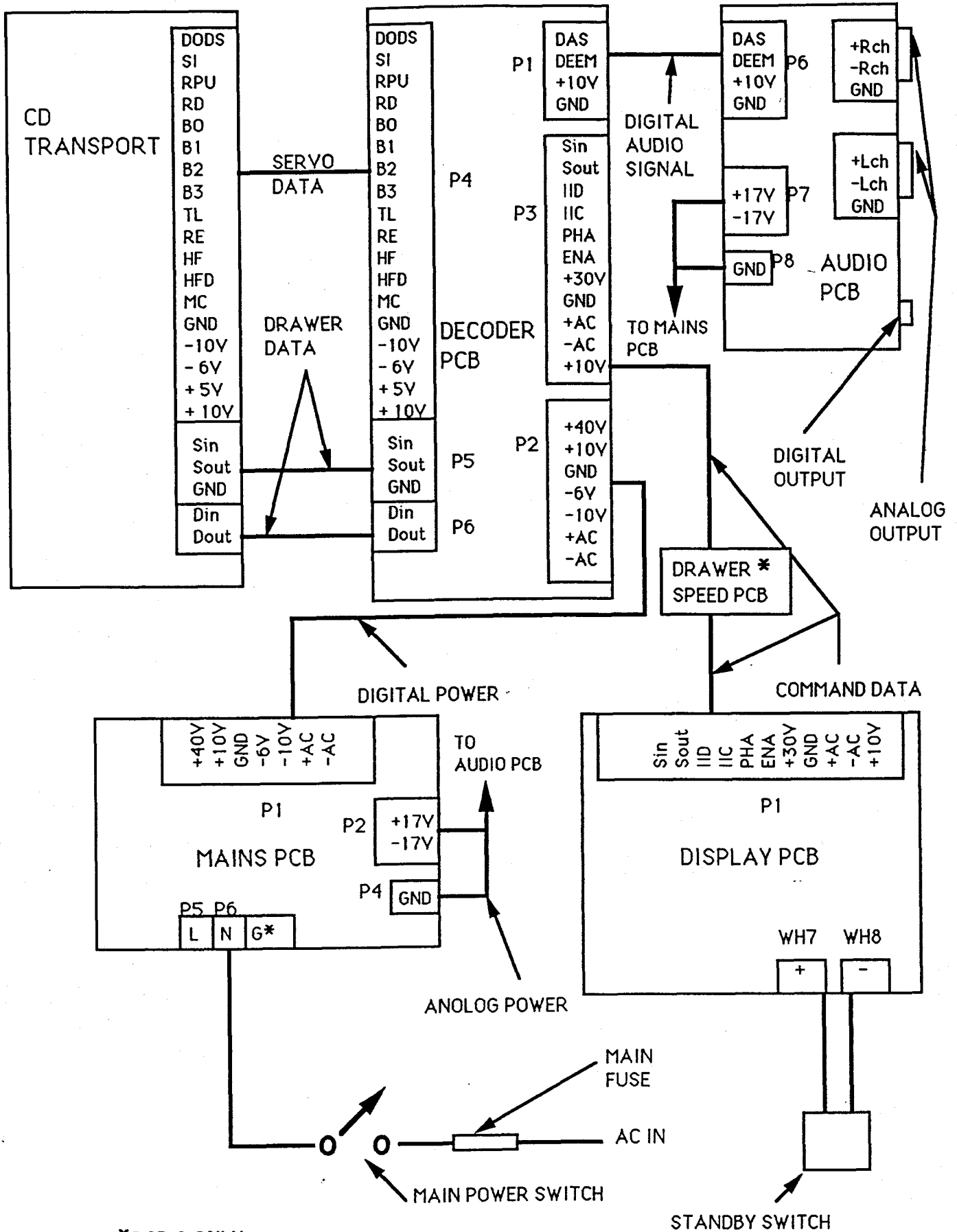

*PCD 2 ONLY

BLOCK DIAGRAM (PDT/PDT2)

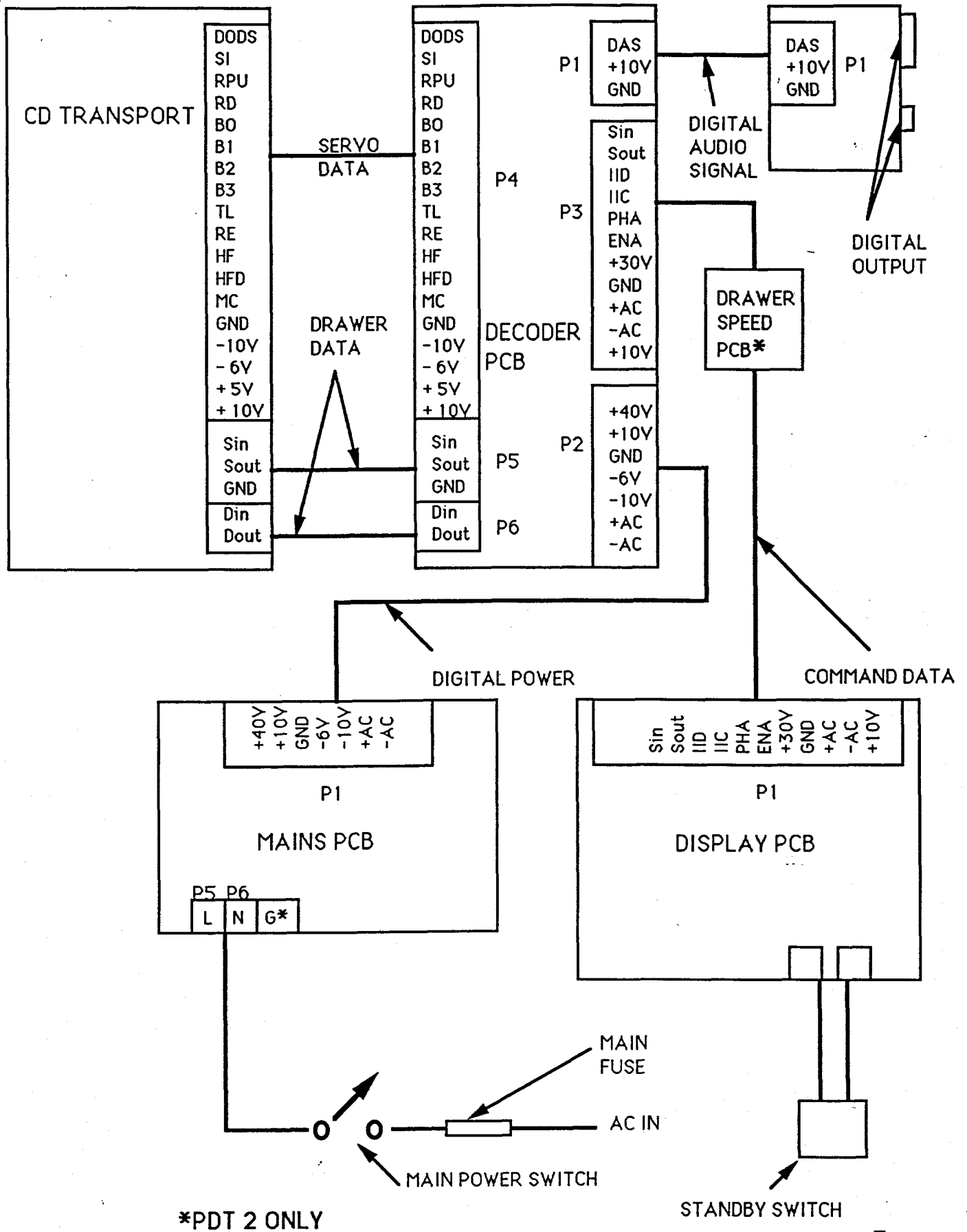

*PDT 2 ONLY

TROUBLESHOOTING CHART (ALL)

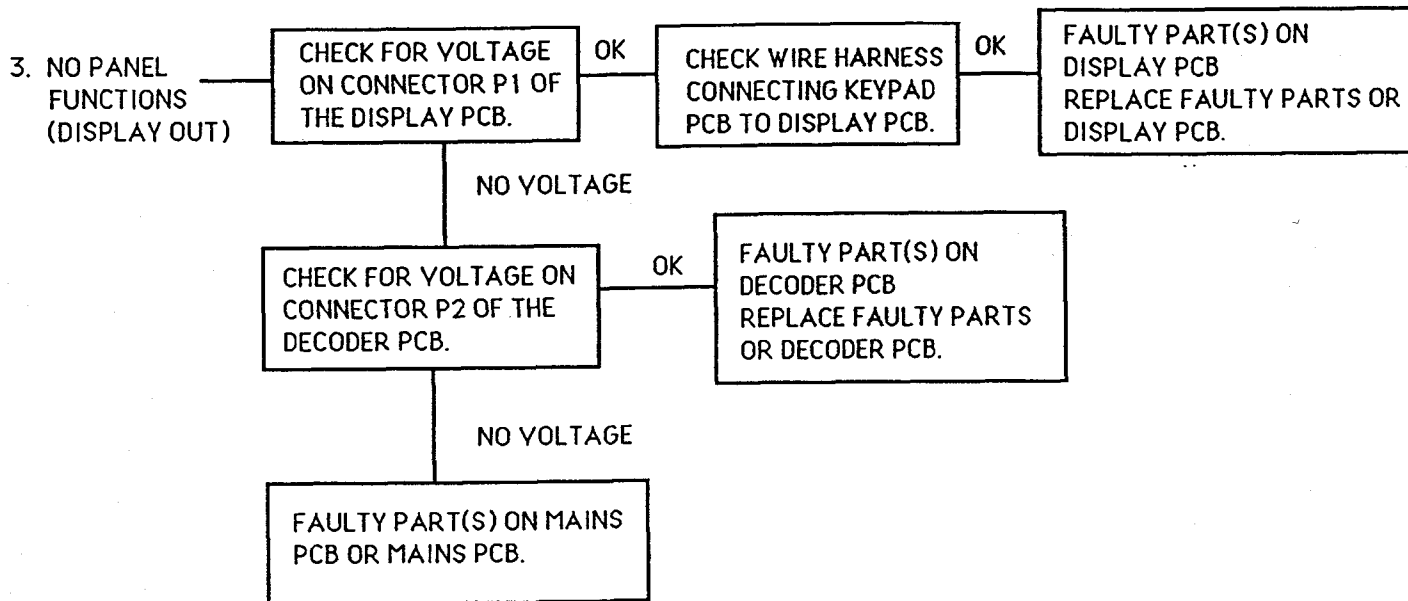
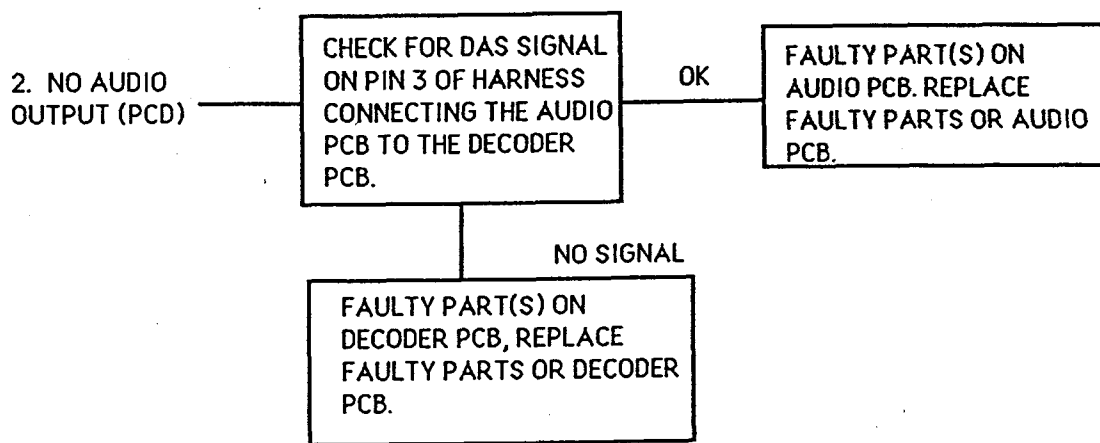
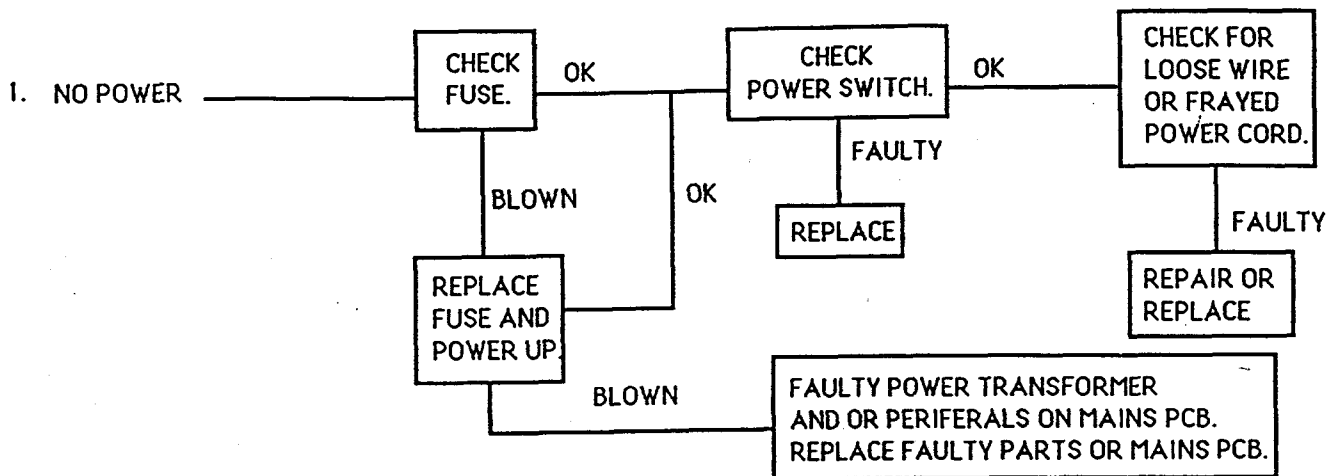

TROUBLESHOOTING (CONT.)

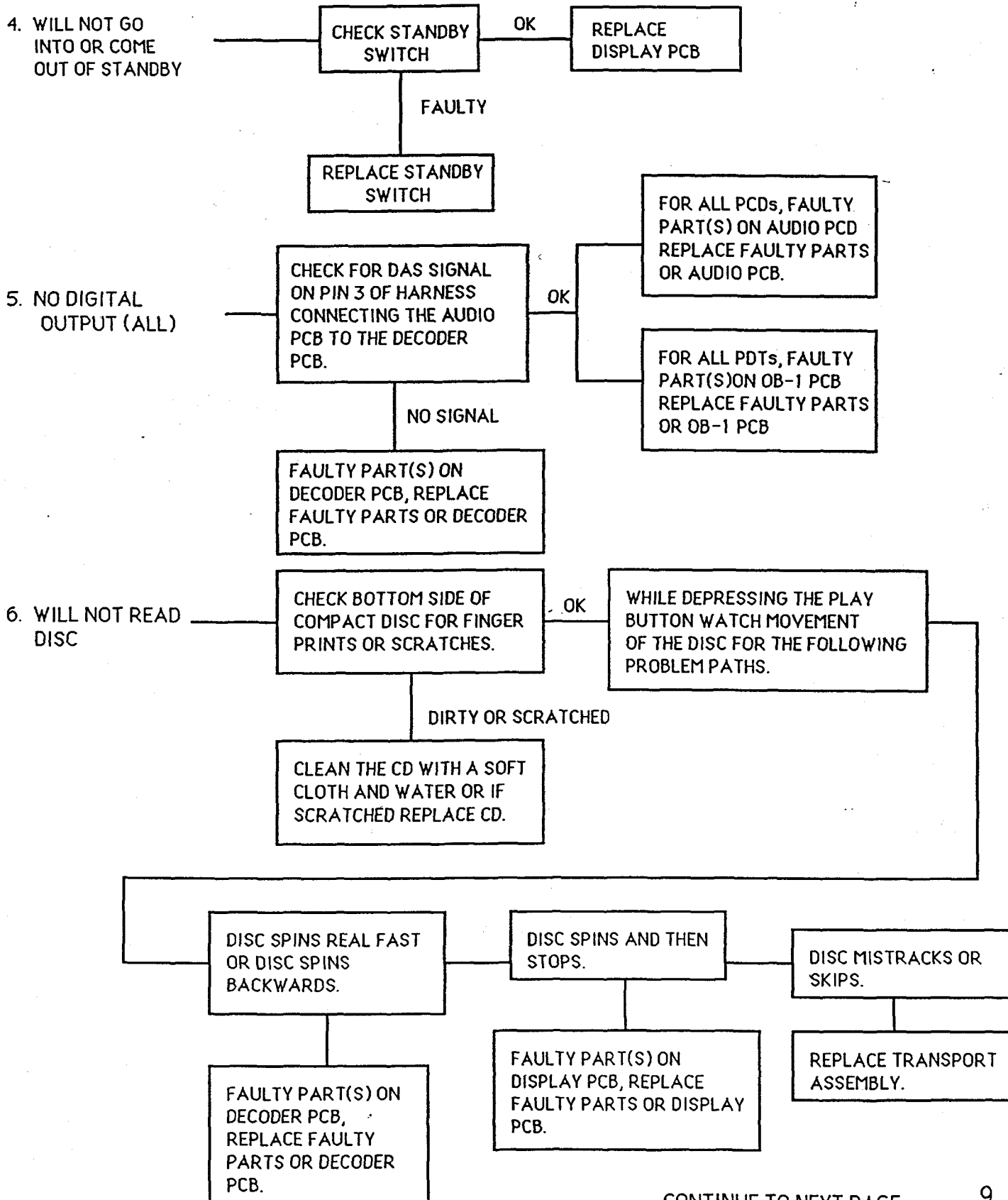

TROUBLESHOOTING (CONT.)

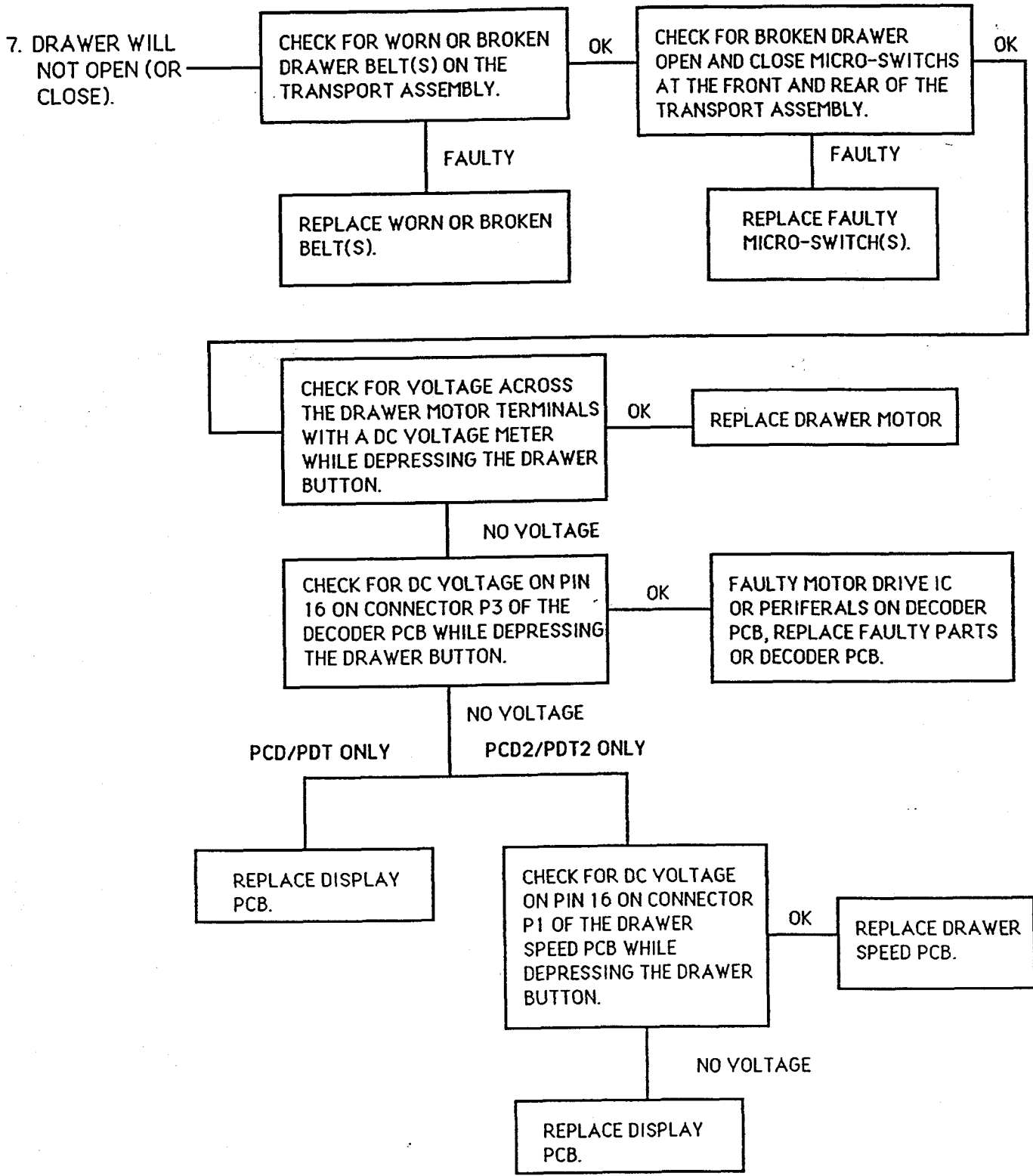

DISASSEMBLY PROCEDURE

CAUTION! Hazardous voltages available inside unit. Before removing the top cover be sure to disconnect AC power from outlet.

CAUTION! Static sensitive parts and assemblies inside unit. Observe proper grounding procedures before removing top cover.

WARNING! Although the PCD/PCD2 and PDT/PDT2 appear to be assembled with the same subassembly PCBs, they can not be interchanged between version 1 players and version 2 players or severe component damage may occur. Consult with the MADRIGAL AUDIO LABS TECHNICAL SERVICE DEPARTMENT.

REPLACING THE FRONT PANEL (ALL)

1. Remove 6 screws securing the top plate, and remove the top plate.
2. Carefully pull the disk drawer out half way so the drawer plate can be removed. Remove the drawer plate by sliding it to the left and tilt it downward. Push the disk drawer back into the unit.
3. Remove 4 screws (2 on the top, 2 on the bottom) securing the front panel to the chassis.
4. Carefully pull the front panel straight out approximately 2 inches. Remove the gray ribbon cable from connector P1 on the Display PCB and then unsolder the standby switch wires from the Display PCB (note the location of each wire when removing).
5. Remove 4 screws securing the Display PCB to the front panel. Remove 1 screw securing the IR PCB to the front panel. Remove the white wire harness from connector P2 on the Display PCB. Remove 2 screws securing the top portion of the display securing plate to the front plate. Carefully remove the Display PCB by guiding the display out from under the securing plate.
6. Install the new front plate by reversing steps 1 to 5. Be sure display is down all the way in the pocket and straight before installing display securing plate screws.

REPLACING THE DISPLAY PCB (ALL)

1. Follow the steps in REPLACING THE FRONT PANEL and install the new Display PCB at step 5.

REPLACING THE DECODER PCB (ALL)

1. Remove 6 screws securing the top plate, and remove the top plate.
2. Remove 5 ribbon cables from connectors P1,P3,P4,P5,and P6 on the Decoder PCB. Remove 3 screws securing the Decoder PCB to the chassis. Carefully pull up on the Decoder PCB to disconnect it from the mains PCB.
3. To install new Decoder PCB reversing steps 1 and 2.

REPLACING THE MAINS PCB (ALL)

1. Remove 6 screws securing the top plate, and remove the top plate.
2. Remove 5 ribbon cables from connectors P1,P3,P4,P5,and P6 on the Decoder PCB. Remove 3 screws securing the Decoder PCB to the chassis. Carefully pull up on the Decoder PCB to disconnect it from the mains PCB and set it aside.
3. Remove 7 screws securing the rear panel to the chassis, then separate the rear panel from the chassis taking care not to lose 4 blue rectangular insulators located between them. Disconnect the following connections from the Mains PCB,P2,P4,P5, and P6. Set rear panel assembly aside.
4. Remove 4 screws from the bottom of the unit that secure the Mains PCB to the bottom panel.
5. Remove 2 screws securing the Mains PCB to the chassis and remove Mains PCB.
6. To install new Mains PCB reverse steps 1 to 5. Be sure to reinstall the 4 blue rectangular insulators in between the rear panel and chassis.

REPLACING THE TRANSPORT (ALL)

1. Remove 6 screws securing the top plate, and remove the top plate.
2. Carefully pull the disk drawer out half way so the drawer plate can be removed. Remove the drawer plate by sliding it to the left and tilting it downward. Push the disk drawer back into the unit.
3. Remove 4 screws (2 on the top, 2 on the bottom) securing the front panel to the chassis.

4. Carefully pull the front panel straight out approximately 2 inches. Remove the gray ribbon cable from connector P1 on the Display PCB and then unsolder the standby switch wires from the Display PCB (note the location of each wire when removing). Set front panel assembly aside.
5. Disconnect the following connections from the Decoder PCB, P4,P5, and P6. Remove 3 screws securing the transport to the chassis. Maneuver the transport out the front of the unit. Remove the 19 pin wire harness from the faulty transport and install it on the new transport.
6. To install the new transport reverse steps 1 to 5. Be sure that the transport harnesses do not interfere with the movement of the disk drawer.

REPLACING THE STANDBY SWITCH (ALL)

1. Remove 6 screws securing the top plate, and remove the top plate.
2. Disconnect red and black wire from standby switch and remove bad switch.
3. Install new standby switch making sure that the locking nut is tight against the body of the switch. Check the operation of the standby switch and adjust locking nut as required. Solder black wire to the center pin of the standby switch and the red wire to either one of the other pins.

REPLACING THE AUDIO PCB (PCD/PCD2)

1. Remove 6 screws securing the top plate, and remove the top plate.
2. Remove 4 screws securing the transformer shield to the Audio PCB and put the screws and the shield aside.
3. Disconnect P6, and P7 from the Audio PCB.
4. Remove 7 screws securing the rear panel to the chassis, then separate the rear panel from the chassis taking care not to lose 4 blue rectangular insulators located between them.
5. Allow the rear panel to tilt down and remove ground wire P8 from the Audio PCB.
6. Carefully unsolder 2 XLR type connectors and 3 RCA type connectors from the Audio PCB.
7. Remove 7 screws (4 on the rear panel, 3 on the Audio PCB) that secure the Audio PCB to the rear panel and remove the Audio PCB.
8. Install new Audio PCB by reversing steps 1 to 7.

9. For MSB adjustment, see ADJUSTMENTS section of this manual.

REPLACING THE OB-1 PCB (PDT/PDT2)

1. Remove 6 screws securing the top plate, and remove the top plate.
2. Remove connector P1 from OB-1 PCB.
3. Remove 7 screws securing the rear panel to the chassis, then separate rear panel from taking care not to lose 4 blue rectangular insulators located between them.
4. Allow rear panel to tilt down, and carefully unsolder 1 XLR type connector 1 RCA type connector from the OB-1 PCB.
5. Remove 2 screws securing the OB-1 PCB to the rear panel and remove the OB-1 PCB.
6. Install the new OB-1 PCB by reversing steps 1 to 5.

FRONT PANEL VIEW (ALL)

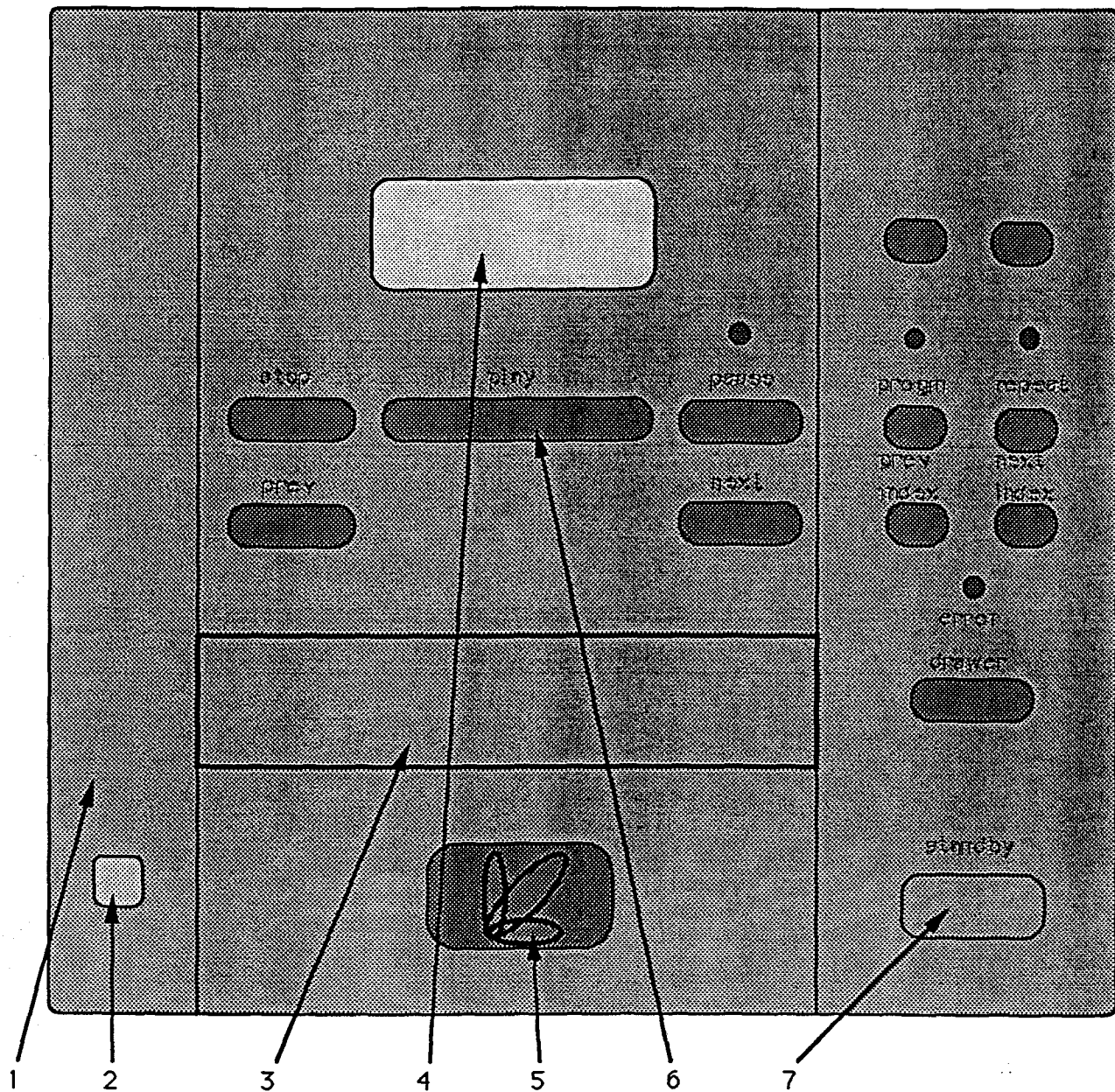

PART DESCRIPTIONS AND PARTS

1. Front panel	P/N 500012J
2. IR lense	P/N 540001
3. Drawer panel	P/N 500015J
4. Display lense	P/N 540000J
5. PROCEED logo	P/N 480000
6. Keypad	P/N 910000
7. Standby button	P/N 500001J
Spring	P/N 430000
Clip	P/N 430007
MISC.	
Display securing plate	P/N 500018J
Securing plate screws	P/N 420077

REAR PANEL VIEW (PCD/PCD2)

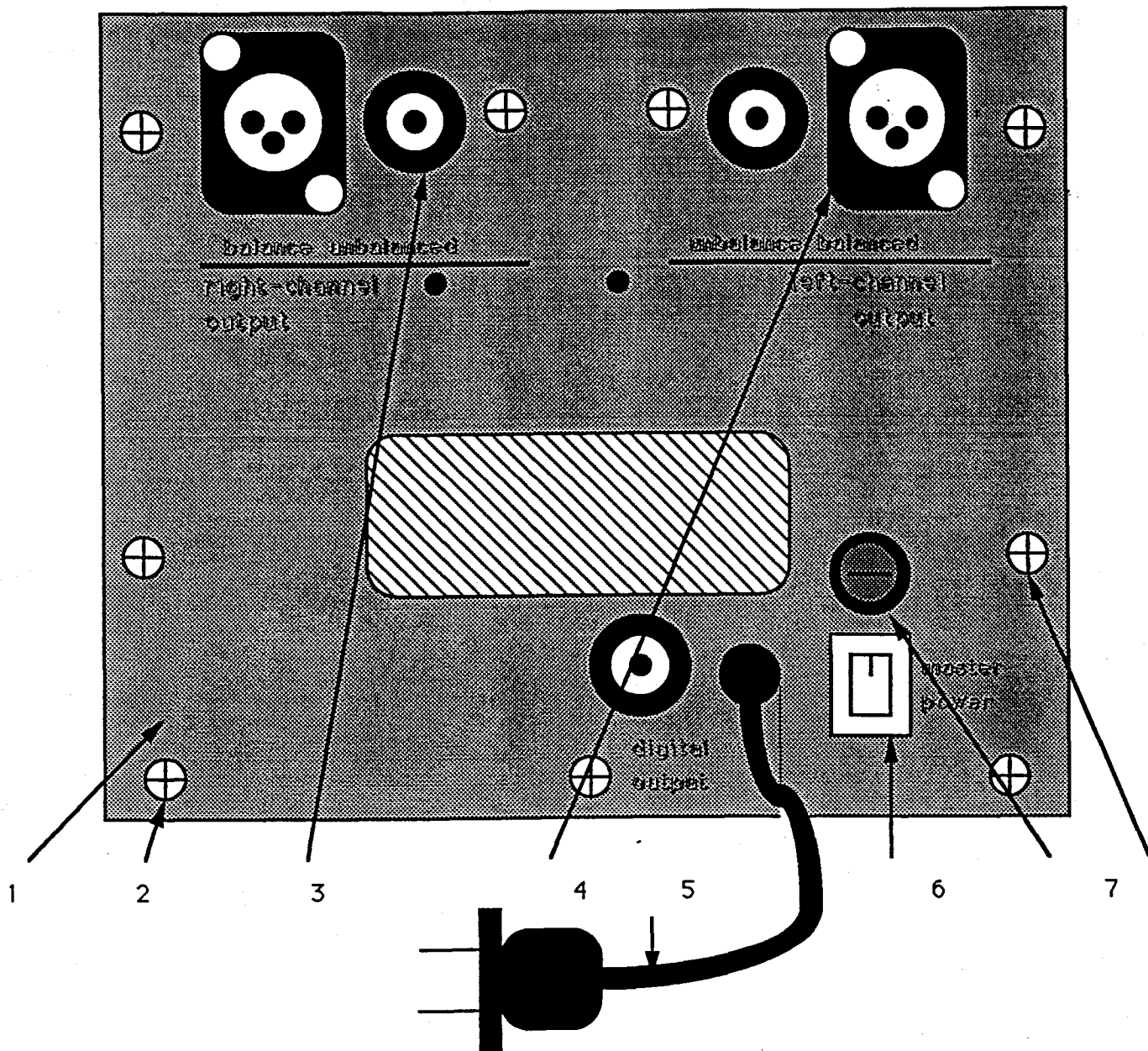

PART DESCRIPTIONS AND NUMBERS

1. Rear panel	P/N 500016J
2. Panel screw (short)	P/N 420010
3. RCA jack chassis mount	P/N 330144
4. Female XLR chassis mount	P/N 330184
5. Power cord (2 conductor)	P/N 310010
(3 conductor)	P/N 310400
6. Power switch	P/N 350099
7. Fuse holder	P/N 350097
8. Panel screw (long)	P/N 420003
MISC	
1A fuse (100V, 120V)	P/N 350073
0.5A fuse (220V, 240V)	P/N 350072
XLR mounting screws	P/N 420011

REAR PANEL VIEW (PDT/PDT2)

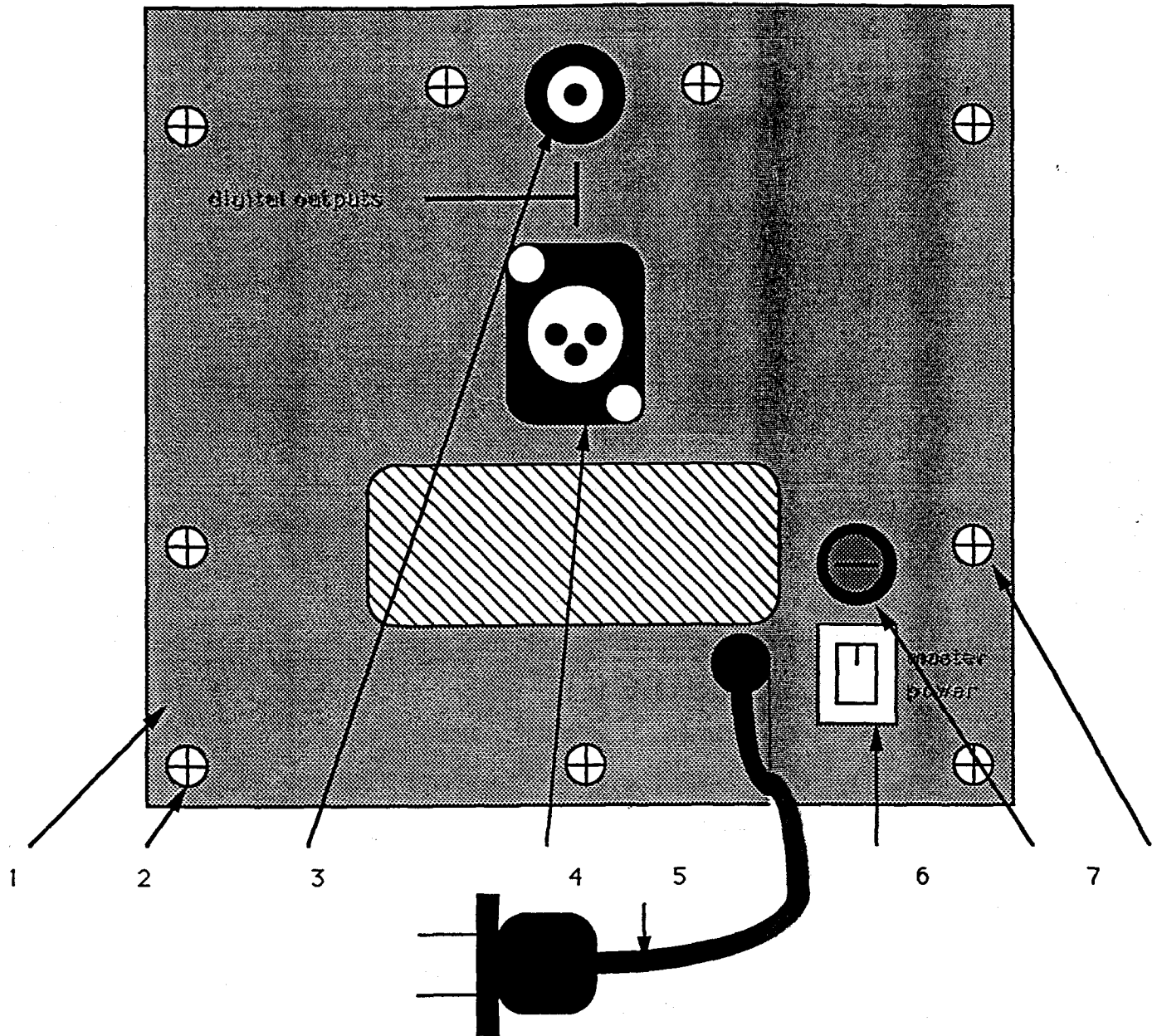

PART DESCRIPTIONS AND NUMBERS

1. Rear panel	P/N 500488J
2. Panel screw (short)	P/N 420010
3. RCA jack chassis mount	P/N 330144
4. Female XLR chassis mount	P/N 330184
5. Power cord (2 conductor)	P/N 310010
(3 conductor)	P/N 310400
6. Power switch	P/N 350099
7. Fuse holder	P/N 350097
8. Panel screw (long)	P/N 420003
MISC	
1A fuse (100V, 120V)	P/N 350073
0.5A fuse (220V, 240V)	P/N 350072
XLR mounting screws	P/N 420011

TOP VIEW (PCD/PCD2)

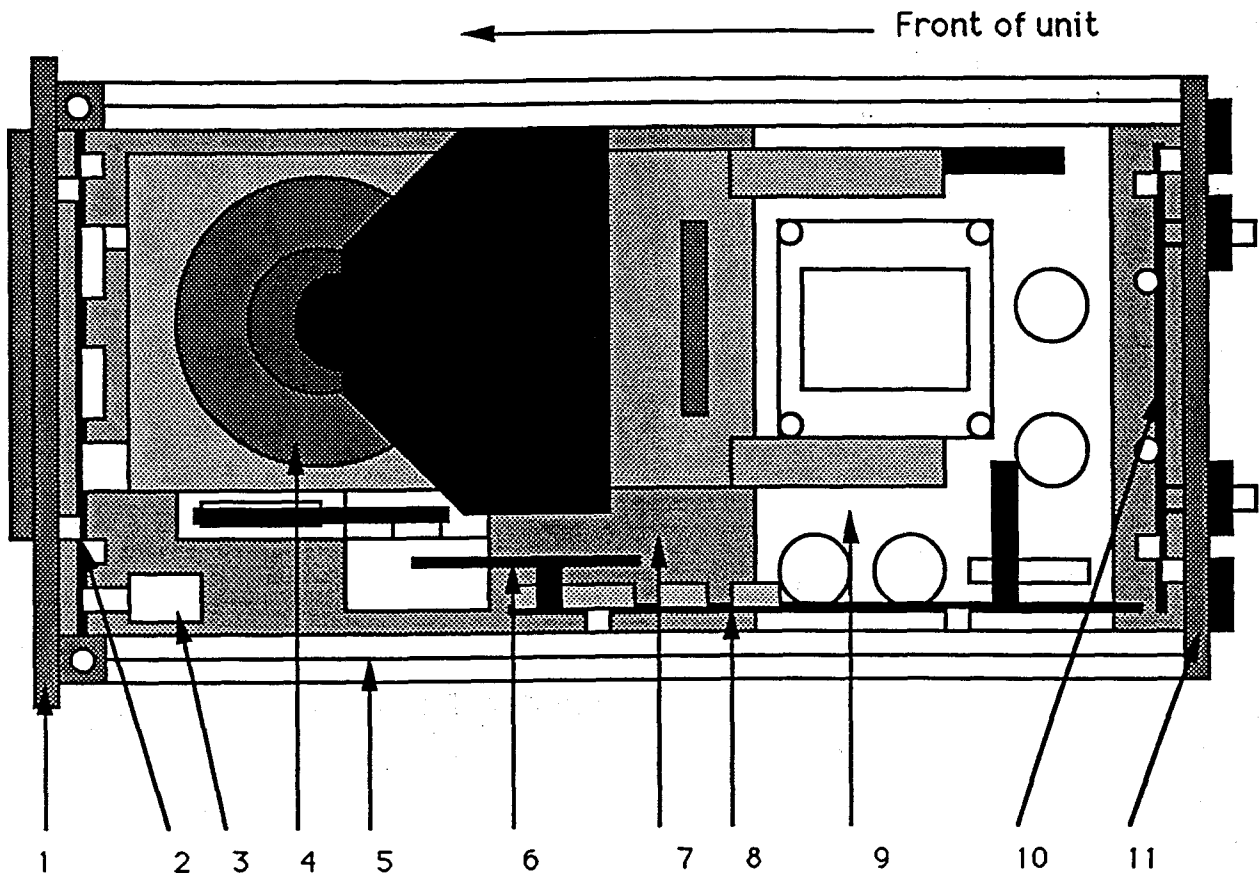

PART DESCRIPTIONS AND NUMBERS

1. Front panel assembly	P/N M10024	6. Drawer Speed PCB	P/N M10151
Screws	P/N 420030	(PCD 2 only)	
Flat washers	P/N 420107	7. Bottom plate	P/N 500013J
2. Display PCB assembly	P/N M10004	Feet	P/N 430002
Screws	P/N 420077	Screws	P/N 420029
3. Standby switch	P/N 350144	8. Decoder PCB assembly	P/N M10000
4. CD Transport assembly	P/N 900001	Screws	P/N 420002
Screws	P/N 420030	9. Mains PCB (E-core)	P/N M10007
5. Chassis bars		PCD 2(Toroidal)	P/N MA1020
X1	P/N 500006J	Screws	P/N 420030
X2	P/N 500007J	Black screws	P/N 420029
ZRT	P/N 500005J	10. Audio PCB assembly	P/N M10013
ZLT	P/N 500004J	(PCD 2)	P/N MA1020
YR2	P/N 500011J	Screws	P/N 420010
YL2	P/N 500009J	11. Rear panel assembly	P/N MB1001
YL1	P/N 500008J		
YR1	P/N 500010J		
Screws	P/N 420002		

TOP VIEW (PDT/PDT2)

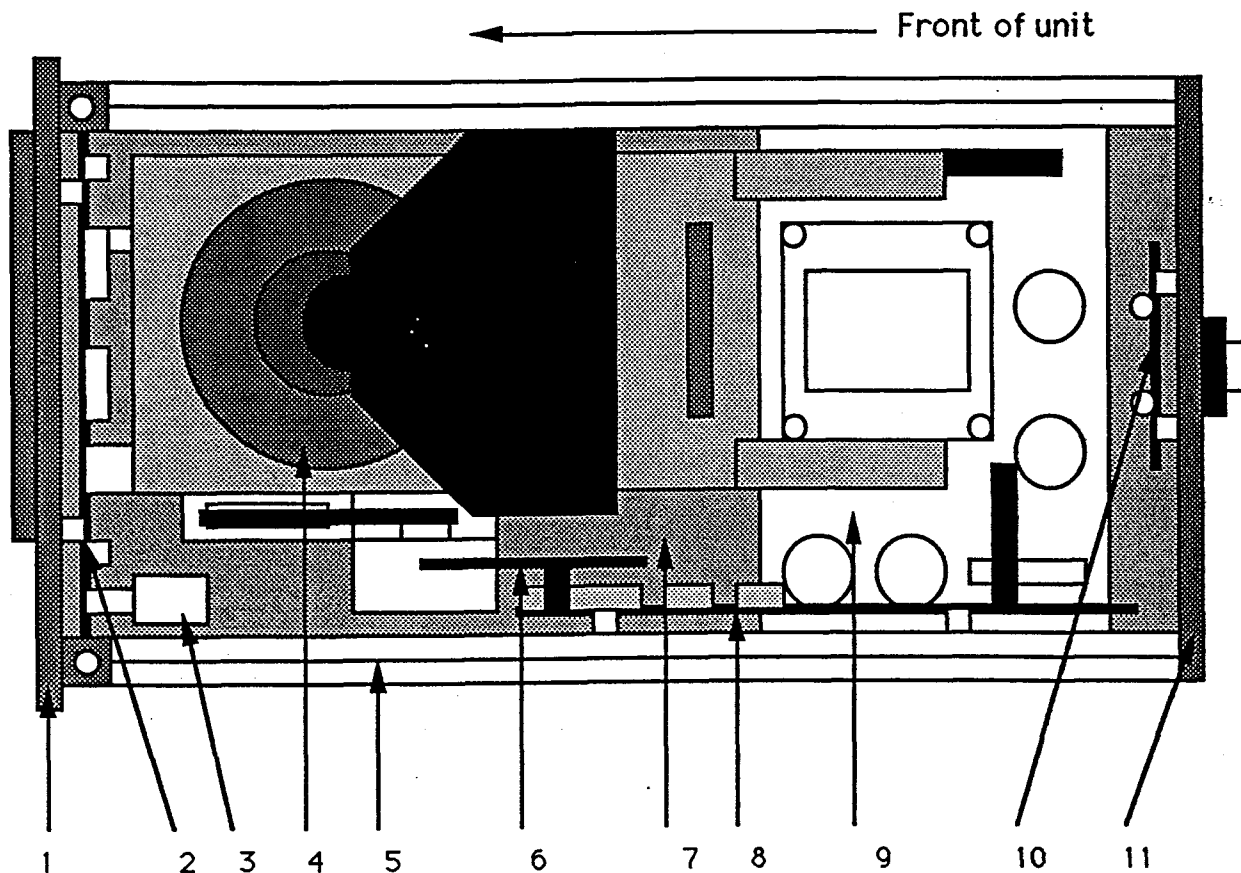

PART DESCRIPTIONS AND NUMBERS

1. Front panel assembly	P/N M10024	6. Drawer Speed PCB	P/N M10151
Screws	P/N 420030	(PDT2 only)	
Flat washers	P/N 420107	7. Bottom plate	P/N 500013J
2. Display PCB assembly	P/N M10004	Feet	P/N 430002
Screws	P/N 420077	Screws	P/N 420029
3. Standby switch	P/N 350144	8. Decoder PCB assembly	P/N M10000
4. CD Transport assembly	P/N 900001	Screws	P/N 420002
Screws	P/N 420030	9. Mains PCB (E-core)	P/N M10007
5. Chassis bars		PDT2(Toroidal)	P/N MA1020
X1	P/N 500006J	Screws	P/N 420030
X2	P/N 500007J	Black screws	P/N 420029
ZRT	P/N 500005J	10. OB-1 PCB assembly	P/N M10073
ZLT	P/N 500004J	Screws	P/N 420010
YR2	P/N 500011J	11. Rear panel assembly	P/N M10074
YL2	P/N 500009J		
YL1	P/N 500008J		
YR1	P/N 500010J		
Screws	P/N 420002		

AUDIO PCB P/N M10071 (MA1021 PCD 2)

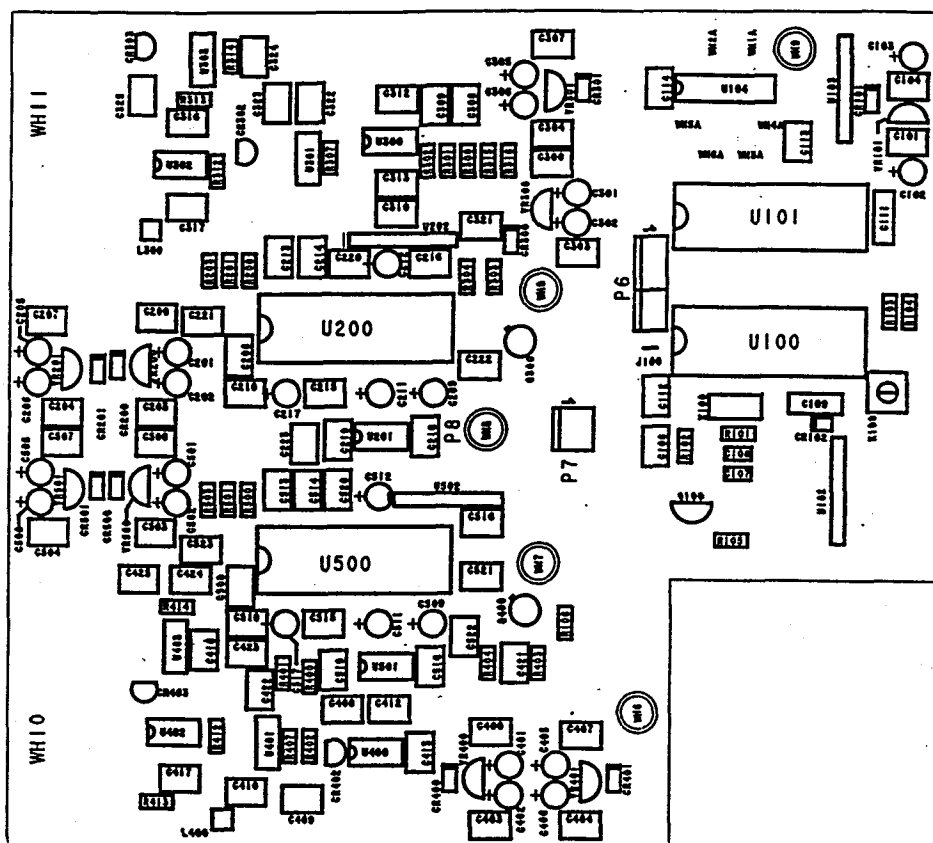

PART DESCRIPTION AND NUMBERS

R101	1Mohm res	P/N 100023
R102	150ohm res	P/N 100345
R103	562ohm res	P/N 100346
R104	619ohm res	P/N 100347
R105,106	100Kohm res	P/N 100348
R201, 203, 303, 403, 501, 503	1000ohm res	P/N 100350
R200, 500	332Kohm res	P/N 100349
R300, 400	1730ohm res	P/N 100351
R301, 401	1500ohm res	P/N 100352
R302, 402	1660ohm res	P/N 100353
R304, 404	10.5Kohm res	P/N 100027
R307, 314, 407, 414	100ohm res	P/N 100354
R312, 313, 412, 413	10Kohm res	P/N 100355
R315	59Kohm	P/N 100356
R316	42.2Kohm	P/N 100357
VR1,2	100Kohm	P/N 150000

PART DESCRIPTION AND NUMBERS (CONT)

C101, 104, 112, 113, 114, 200, 203, 204, 207, 214, 300, 303, 304, 307, 400, 403, 404, 407, 500, 503, 504, 507, 514	0.1uF 63V capacitor	P/N 220001
C102, 103, 201, 202, 205, 206, 301, 302, 305, 306, 401, 402, 405, 406, 501, 502, 505, 506	10uF 50V capacitor	P/N 200002
C209, 211, 212, 217, 509, 511, 512, 517	3.3uF 50V capacitor	P/N 200006
C106	4700uF 63V capacitor	P/N 220006
C107, 108	22pF 200V capacitor	P/N 230008
C109	100pF 50V capacitor	P/N 230002
C210, 213, 215, 216, 219, 220, 222, 223, 312, 313, 316, 317, 321, 322, 323, 523, 324, 325, 412, 413, 416, 417, 422, 423, 424, 425, 506, 510, 513, 516, 520, 521, 522	0.01uF 63V capacitor	P/N 220018
C111	22nF 50V capacitor	P/N 230000
C306, 409	220uF 100V capacitor	P/N 220009
C308, 406	1000pF 100V capacitor	P/N 220014
C321, 421	15nF 63V capacitor	P/N 220002
C410	1500uF 100V capacitor	P/N 220021
CR101, 200, 201, 300, 301, 400, 401, 500, 501	1N4936 diode	P/N 700006
CR102	1N4148 diode	P/N 700039
U100	YM 3623 DIR IC	P/N 760003
U101	SM 5813AP DF IC	P/N 760004
U102	6800ohm SIP ARRAY	P/N 100368
U103	390Kohm SIP ARRAY	P/N 100371
U104	DM74S08N 4X AND GATE IC	P/N 760008
U200, 500	PCM58P MONO DAC IC	P/N 780007
U201, 300, 302, 400, 402, 501	AD711 OP-AMP IC	P/N 780009
U202, 502	10Kohm SIP ARRAY	P/N 100391
U301, 303, 401, 403	LT1010CT OP-AMP IC	P/N 780008
Q100	MPS81 transistor	P/N 720000
Q300, 400	SD215 FET	P/N 720002
YR101	MC78L05 voltage regulator	P/N 780004
YR200, 300, 400, 500	MC78L12 voltage regulator	P/N 780005
YR201, 301, 401, 501	MC79L12 voltage regulator	P/N 780006
K100	58521 pulse transformer	P/N 290001
X100	16.9344 X-tal	P/N 810002
P6	7 pin header	P/N 330181
P7	2 pin header	P/N 330141

OB-1 PCB P/N M10073 (PDT/PDT2)

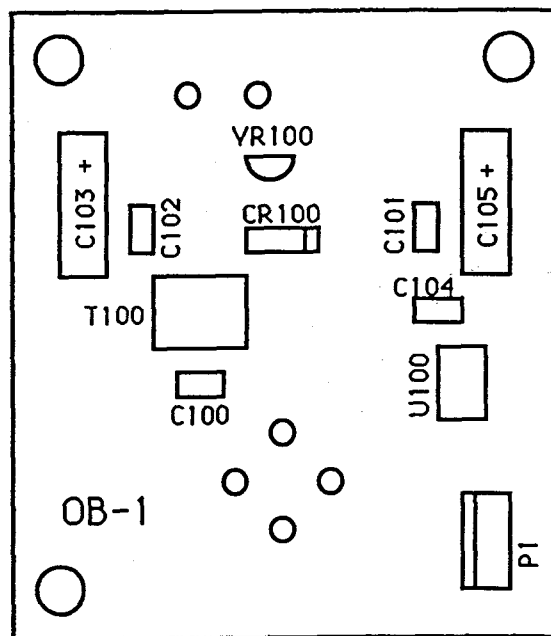

PART DESCRIPTIONS AND NUMBERS

C100,101,102,103	0.1uF 50V capacitor	P/N 230005
C104,105	47uF 25V capacitor	P/N 200010
VR100	78L5 5V regulator	P/N 780004
CR100	1N4936n diode	P/N 700006
U100	SN75179BP IC	P/N 780020
T100	Pulse transformer	P/N 290002
P1	4 pin header	P/N 330137

MAINS PCB P/N M10007(E-CORE),MA1020(TORIODAL)

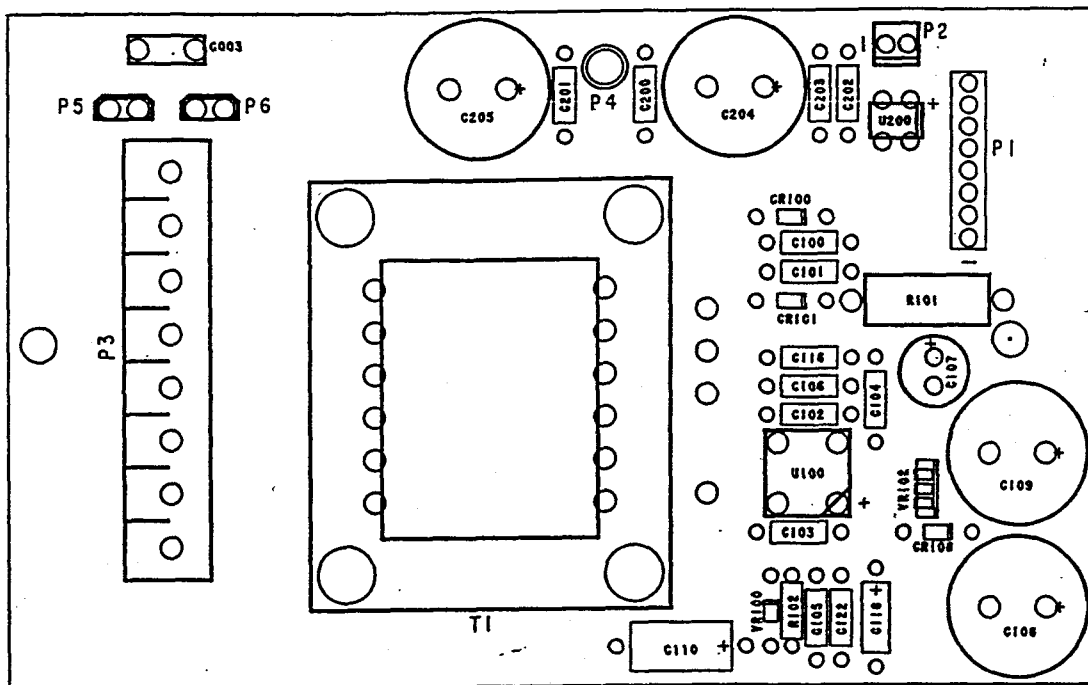

PART DESCRIPTION AND NUMBERS

R101	10ohm 5w res	P/N 110019
R102	1kohm res	P/N 100013
D100,101,108	1N4936 diode	P/N 700006
VR100	1N5229 zener	P/N 700001
C100,101,104	0.1uF 100V capacitor	P/N 230004
C102,103,105, 106,116,122,200, 201,202,203	0.1uF 50V capacitor	P/N 230005
C107	330uF 63V capacitor	P/N 200007
C108,109,204,205	6800uF 25V capacitor	P/N 200011
C110	47uF 25V capacitor	P/N 200010
C118	10uF 35V capacitor	P/N 200001
C003	4700pF capacitor	P/N 220045
	4700uF Y capacitor	P/N 220110
T1	Transformer(E-core)	P/N 290000
	Transformer(Toriodal)	P/N 290090
U100	KBPC602 rectifier	P/N 700098
U200	DFO2815M rectifier	P/N 700004
VR102	L79S06 IC	P/N 780003
P1	8pin header	P/N 330140
P3	Terminal block	P/N 330142
P5,6	P.C tabs	P/N 400114

DECODER PCB P/N(M10000 AND M10072)

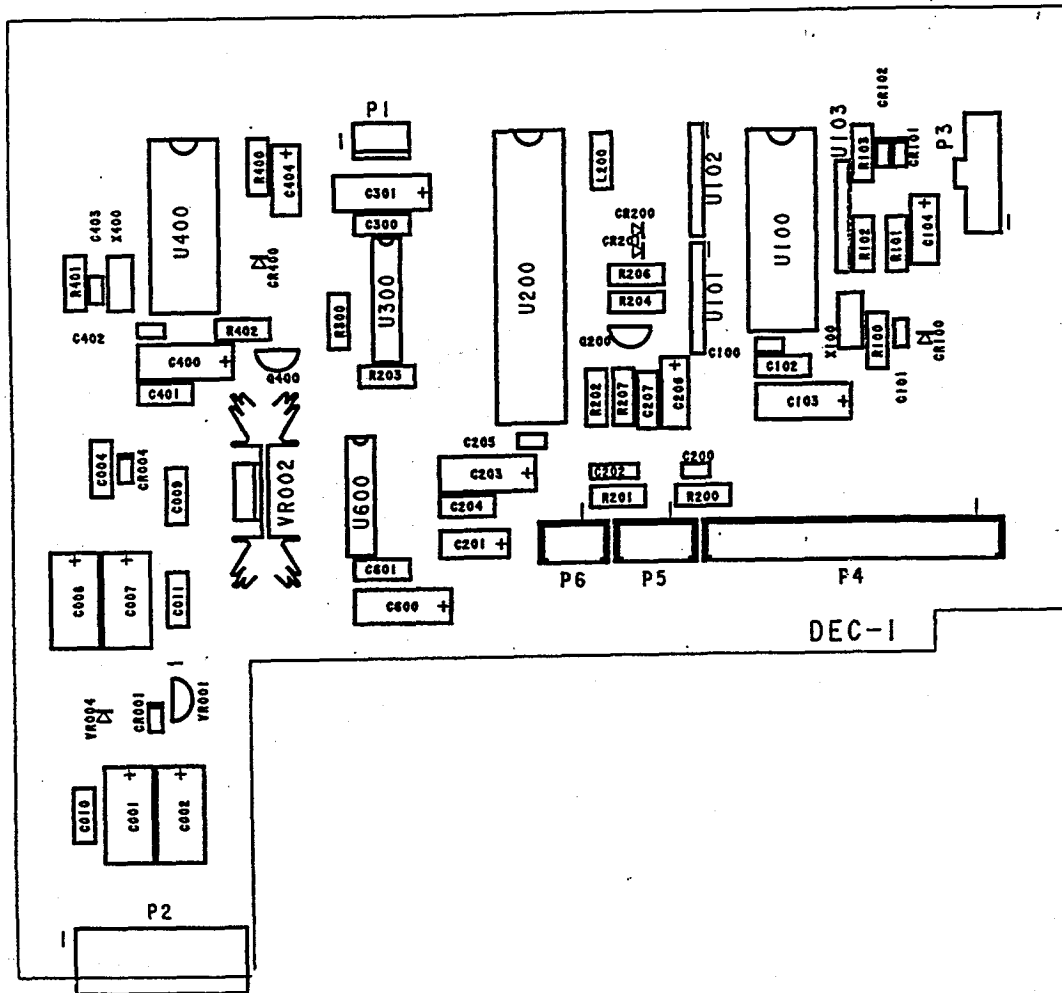

PART DESCRIPTIONS AND NUMBERS

R100	100kohm resistor	P/N100360
R101	2ohm resistor	P/N100161
R102,103	22.1kohm resistor	P/N100358
R200,201	2.21kohm resistor	P/N100359
R202	1.21kohm resistor	P/N100044
R203,401	15Mohm resistor	P/N100342
R204	499ohm resistor	P/N100243
R206	11kohm resistor	P/N100033
R207	47.5ohm resistor	P/N100340
R300	30.1kohm resistor	P/N100166
R400	1ohm resistor	P/N100108

DECODER PCB P/N(M10000 AND M10072) CONT.

PART DESCRIPTIONS AND NUMBERS

C100,101	33pF 50V capacitor	P/N230009
C102,201,204,300, 401,004,009	0.1uF 50V capacitor	P/N230005
C103,203,301,400, 600,006,007	47uF 25V capacitor	P/N200010
C104	2.2uF 63V capacitor	P/N200004
C205	47nF 50V capacitor	P/N230001
C206	3.3uF 63V capacitor	P/N200005
C207	22uF 50V capacitor	P/N230007
C402,403	47pF 50V capacitor	P/N230011
C404	1uF 50V capacitor	P/N200003
C001,002	10uF 100V capacitor	P/N200000
C010,011	0.1uF 100V capacitor	P/N230004
L200	2.2uH inductor	P/N280000
CR100,200,201,400	1N4148 diode	P/N700039
CR101,102	SB120 diode	P/N700002
CR001,004	1N4936 diode	P/N700006
VR001	78L15 15V regulator	P/N780001
VR002	78L05 5V regulator	P/N780000
VR004	1N5245 zener	P/N700000
Q200	MPSH81 transistor	P/N720000
Q400	MPS6515 transistor	P/N720001
U100	MAB8441 IC	P/N770000
U101,102	22kohm sip array	P/N100663
U103	4.7kohm sip array	P/N100364
U200	SAA7210 IC	P/N760000
U300	MN4264P DRAM IC	P/N790000
U400	SAA7220 IC	P/N760001
U600	UDN2993 H-bridge IC	P/N780002
X100	6.000MHz X-tal	P/N810000
X400	11.289MHz X-tal	P/N810001
INSULATOR	INSULATOR	P/N430001
P1	4 pin header	P/N330137
P2	8 pin socket	P/N330139
P3	16 pin header	P/N330132
P4	20 pin header	P/N330128
P5	4 pin header	P/N330127
P6	3 pin header	P/N330126

DISPLAY PCB P/N MA1001 (ALL)

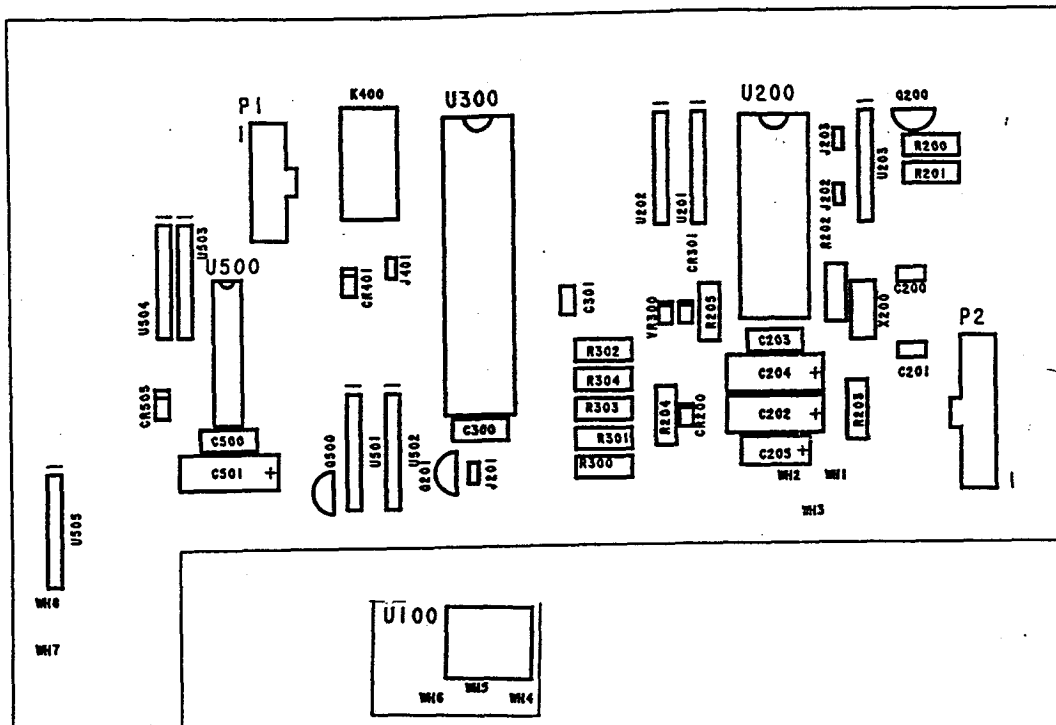

PART DESCRIPTIONS AND NUMBERS

R200,201, 304	4.75kohm res	P/N 100343	YR300	1N5245 zener	P/N700000
R202	1Mohm res	P/N100360	Q200,201, 500	MPS6515 trans	P/N720001
R203	2ohm res	P/N100161	U100	IR receiver	P/N760099
R204	2.21kohm res	P/N100129	U200	MAB8461 processor IC	P/N770001
R205,300, 301	1kohm res	P/N100013	U201,203	12kohm sip array	P/N100365
R302	15Mohm res	P/N100342	U202	4.7kohm sip array	P/N100364
R303	47.5kohm res	P/N100342	U300	U3090 display process IC	P/N760002
C200,201	33pF 50V cap	P/N230009	U400	Vacuum tube display	P/N770008
C202,204, 501	47uF 25V cap	P/N200010	U500	PAL IC	P/N770002
C203,300, 500	0.1uF 50V cap	P/N230005	U501,504	10kohm sip array	P/N100369
C205	4.7uF 6.3V cap	P/N200008	U502,503	51kohm sip array	P/N100366
C301	220pF 50V cap	P/N230006	U505	82ohm sip array	P/N100367
CR200,301	1N4148 diode	P/N700039	K400	Audio relay	P/N350096
CR401	1N4936 diode	P/N700006	X200	6.000MHz X-tal	P/N810000
CR505	SB120 diode	P/N700002	P1	16 pin header	P/N330132
CR501,502, 503,504	LED	P/N710000	P2	20 pin header	P/N330134

DRAWER SPEED PCB P/N M10151 (PDT/PDT2 ONLY)

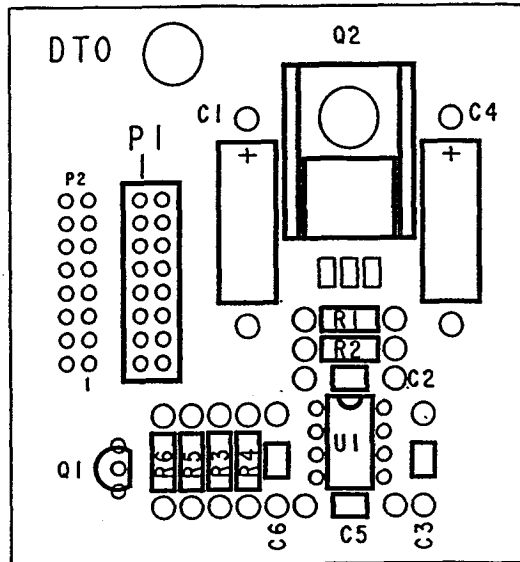

PART DESCRIPTIONS AND NUMBERS

R1,2	604 ohm resistor	P/N 100271
R3	1kohm resistor	P/N 100012
R4	2.43kohm resistor	P/N 100638
R5	3.92kohm resistor	P/N 100204
R6	10kohm resistor	P/N 100014
C1,4	47uF 25V capacitor	P/N 200010
C2,3,5,6	0.1uF 50V capacitor	P/N 230005
Q1	2N3904 Transistor	P/N 720118
Q2	MJE15031 Transistor	P/N 720070
P1	16 pin header	P/N 330132
P2	16 pin socket	P/N 330731

MISCELLANEOUS

PART DESCRIPTIONS AND NUMBERS

Top cover	P/N500014J
Top cover screws(short)	P/N420010
Top cover screws(long)	P/N420003
Transformer shield	P/N500020J
Keypad PCB	P/N900008
Keypad PCB screws	P/N900009
Remote control	P/N900000
PACKING	
Outer wrap	P/N600112
Outer box white	P/N600111
Foam end cap	P/N600110
Transport screws	P/N460070
Bag	P/N600009
Owners manual	P/N630000
Remote control	P/N900000

ADJUSTMENT PROCEDURE

MSB ADJUSTMENT(PCD/PCD2 ONLY)

EQUIPMENT REQUIRED

1. Distortion Analyzer (Ex. Sound Technology 1700B or Tektronics AA501A.... etc.)
2. Test CD (CBS CD-1, Phillips Audio Signals Disc 1, or other CD conforming to EIAJ CP-308 "Test CD for Compact Disc Players").

PROCEDURE

1. Turn on the PCD and allow it to reach operating temperature which is a minimum of one hour.
2. Connect the single-ended output of the PCD to the distortion analyzer.
3. Play track 29 on the PASD 1 or track 18 index 10 on the CBS CD-1 which are 1kHz -60dB signals.
4. Starting with the right channel, measure the noise, and adjust the trimpot for minimum noise.(right ch. trimpot accessible from the bottom of the processor closer to the front of the unit).
5. Same procedure for the left channel.
6. Play track 1 on either the PASD 1 or the CBS CD-1, which is a 1kHz 0dB signal, and check THD+Noise to specifications.

SPECIFICATIONS (EIAJ)

SPECS(PCD/PCD2)

Frequency response:	10Hz- 20kHz +0 dB, -0.2dB
Total harmonic distortion(THD):	0.004% @ 1 kHz, 0 dB
Dynamic range:	98dB (or better)
Signal-to-noise ratio:	105dB
Channel separation:	120dB
Intermodulation distortion (SMPTE IMD):	0.009%
Digital to analog conversion:	Two precision 18-bit DACs
Filtering:	8x oversampling digital filter Analog filter, linear phase to 40kHz
Low-level linearity:	Deviation unmeasurable to below -70dB approximately + 1.7dB below -90dB (undithered, ref 0 dB @ 1kHz)
Output impedance:	1 ohm
Mains voltage: (ALL)	120VAC U.S. service
Mains frequency: (ALL)	50/60 Hz
Power consumption: (ALL)	25W @ 120V ,60Hz
Shipping weight: (ALL)	27 lbs/12.24 kg
Overall dimensions(ALL)	
Width:	8.4 in/214 mm
Height:	8.9 in/227mm
Depth:	13.25 in/337 mm

CONNECTOR P1 4 PIN .100 PIN 4 NO CONNECTION

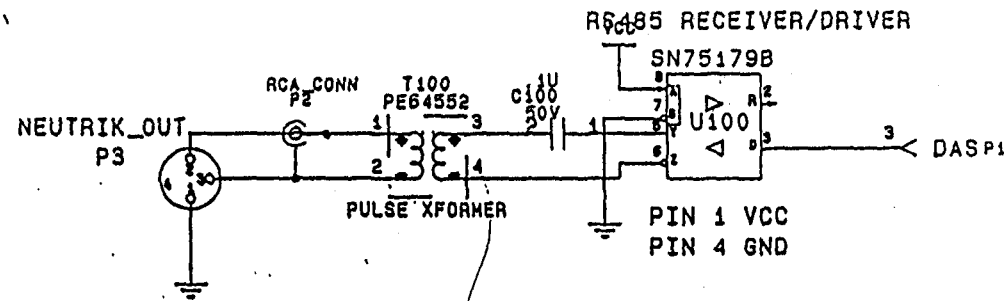
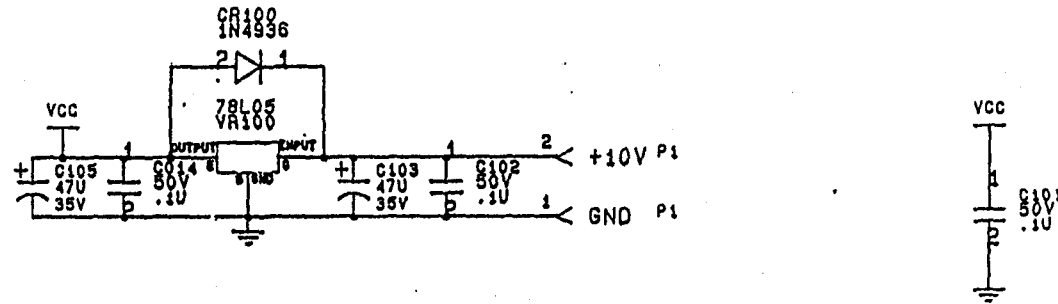

MS/SA_CD/PCB/OUT_BD/DESIGN

				<p>TOLERANCES UNLESS SPECIFIED</p> <p>FRACTION $\pm .010$ DECIMAL $\pm .005$ ANGLE $\pm 1/2^\circ$</p>		<p>MAINSTREET Audio Laboratories, Inc. 2081 South Main Street Middletown Connecticut 06457 U.S.A.</p>	
				MATERIAL		SHEET OF 1000	
				USED IN		A B C D E	
				STAND ALONE CD TRANSPORT		NO.	
				NAME		00-0000-00-00-00	
ISSUE	REVISION	DATE	SCALE:	OUTPUT BOARD			

MADRIGAL

Madrigal Audio Laboratories, Inc.

2081 South Main Street, P.O. Box 781
Middletown, Connecticut 06457 USA

Telephone (203) 346-0896 or 344-9300
ITT Telex: 4942158
Fax: (203) 346-0896

BRS

CONNECTORS

- P1 CONNECTOR FOR RIGHT CHANNEL XLR
- P2 CONNECTOR FOR RIGHT CHANNEL NGN1V
- P3 CONNECTOR FOR LEFT CHANNEL XLR
- P4 CONNECTOR FOR LEFT CHANNEL NGN1V
- P5 CONNECTOR FOR DAS-OUTPUT
- P6 CONNECTOR TO DECEDEC 3U4HD
- P7 CONNECTOR TO MAINS BOARD

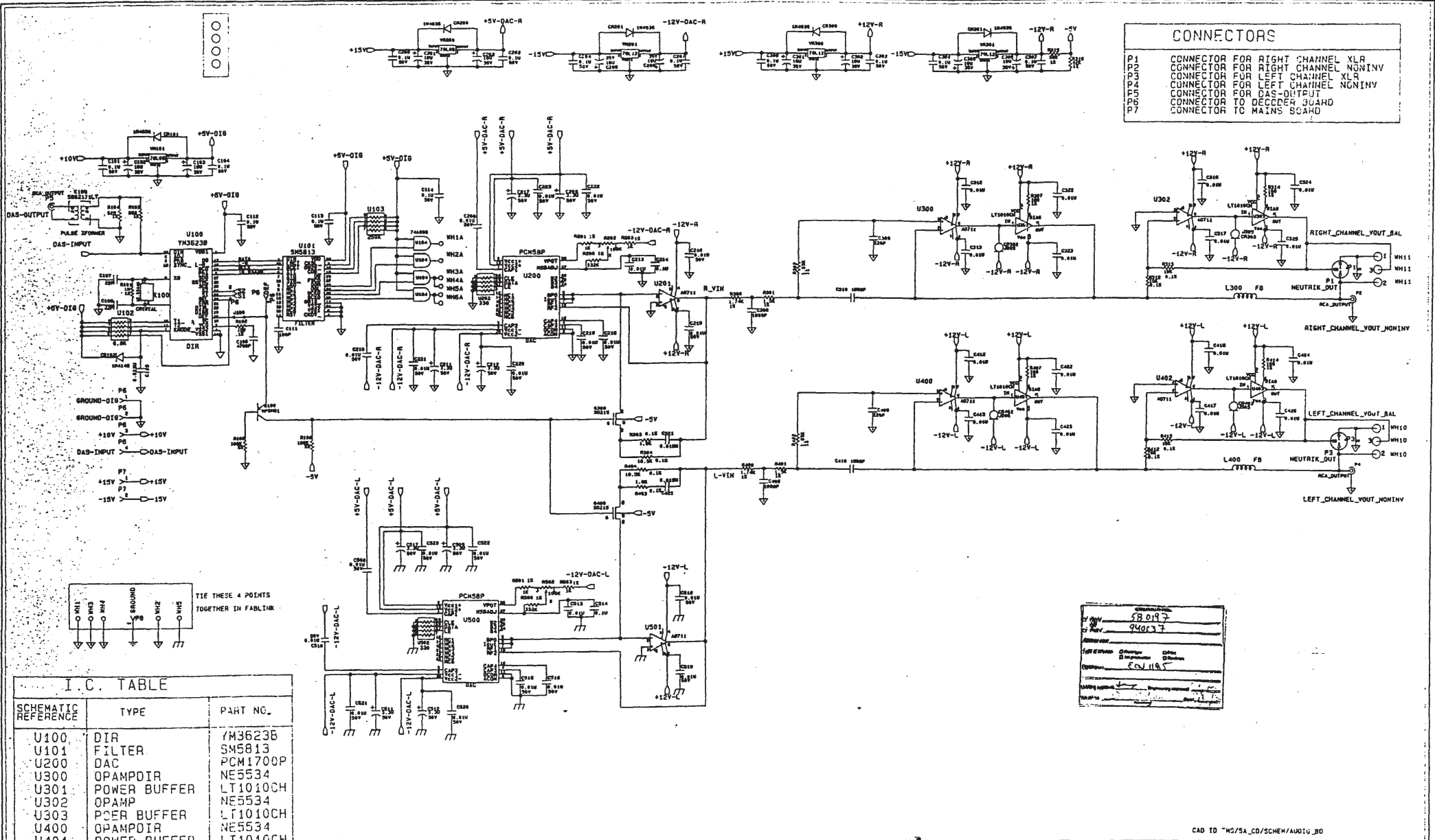

TIE THESE 4 POINTS TOGETHER IN FAB/PCB

58017
94017
EJW/HS

I.C. TABLE		
SCHEMATIC REFERENCE	TYPE	PART NO.
U100	DIR	YM3623B
U101	FILTER	SM5813
U200	DAC	PCM1700P
U300	OPAMPDIR	NE5534
U301	POWER BUFFER	LT1010CH
U302	OPAMP	NE5534
U303	POWER BUFFER	LT1010CH
U400	OPAMPDIR	NE5534
U401	POWER BUFFER	LT1010CH
U402	OPAMP	NE5534
U403	POWER BUFFER	LT1010CH
X1	CRYSTAL 16MHZ	XXXXXX
Q1	DUAL CASCODED N-JFET AMP	IT503
Q2	DUAL CASCODED N-JFET AMP	IT503

REVISION		DATE	SCALE	SHEET				SIZE
				A	B	C	D	
				940137				

CAD ID "HS/SA_CD/SCHEM/AUDIO_BD"

MAINSTREET

DATE: 11/15/85
 DRAWN BY: [blank]
 CHECKED BY: [blank]
 MATERIAL: [blank]
 USED IN: [blank]
 SA CD: [blank]
 NAME: AUDIO BOARD

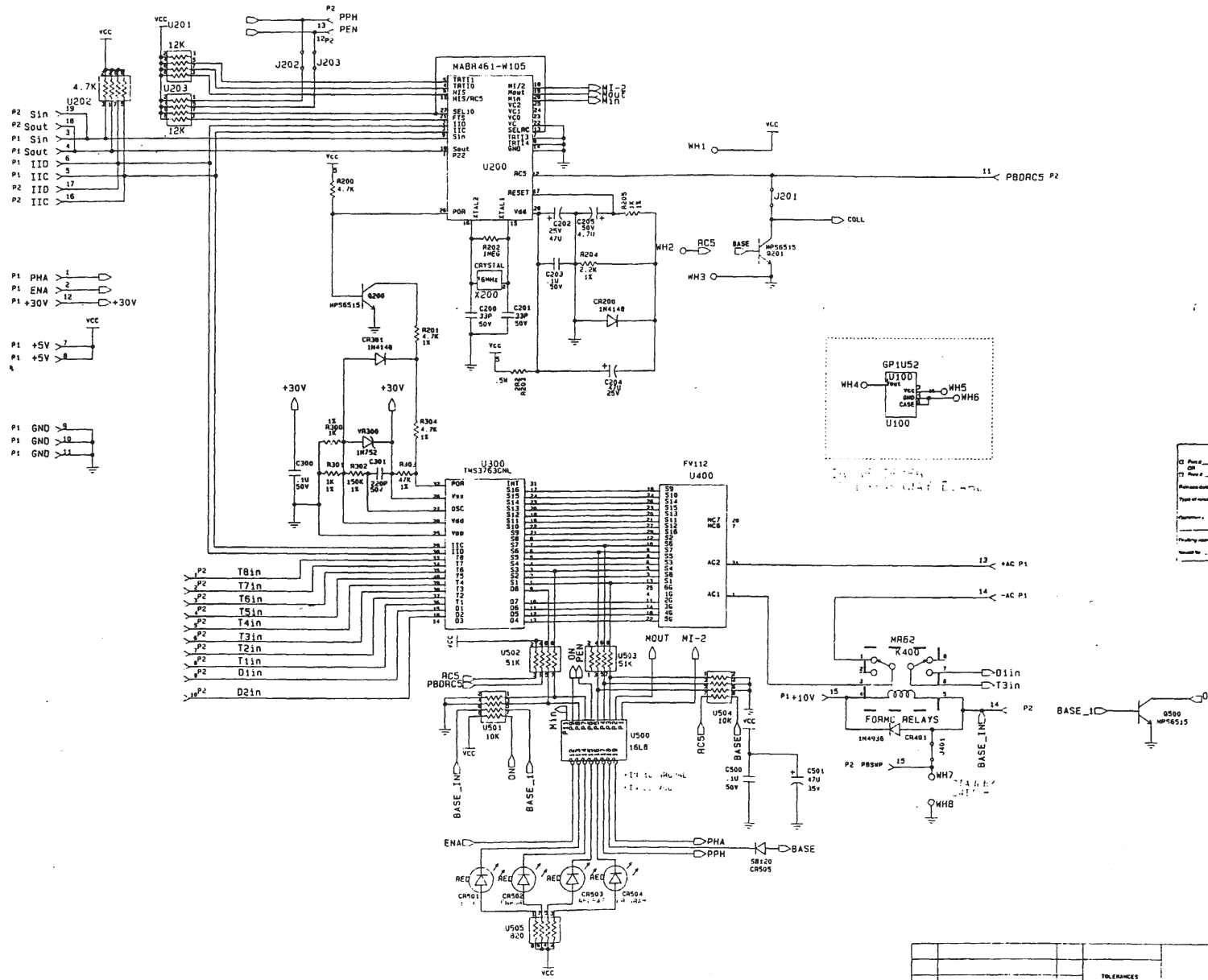

ORIGINAL IN HAND

5/8/90

5/8/90

ESN 1186

TOLERANCES UNLESS SPECIFIED		MAINSTREET	
FRACTION - .010		2001 south main street waterbury connecticut 06907 u.s.a.	
DECIMAL - .005		MATERIAL	
ANGLE - 1/2"		SA CD	
DR. N. N.	DATE 3-19-90	USED IN	SHEET OF SIZE
CH. XXX	DATE 0-00-00	NAME	A B C D E
ISSUE	REVISION	DATE	NO.
		SCALE:	940139
		DISPLAY BOARD	

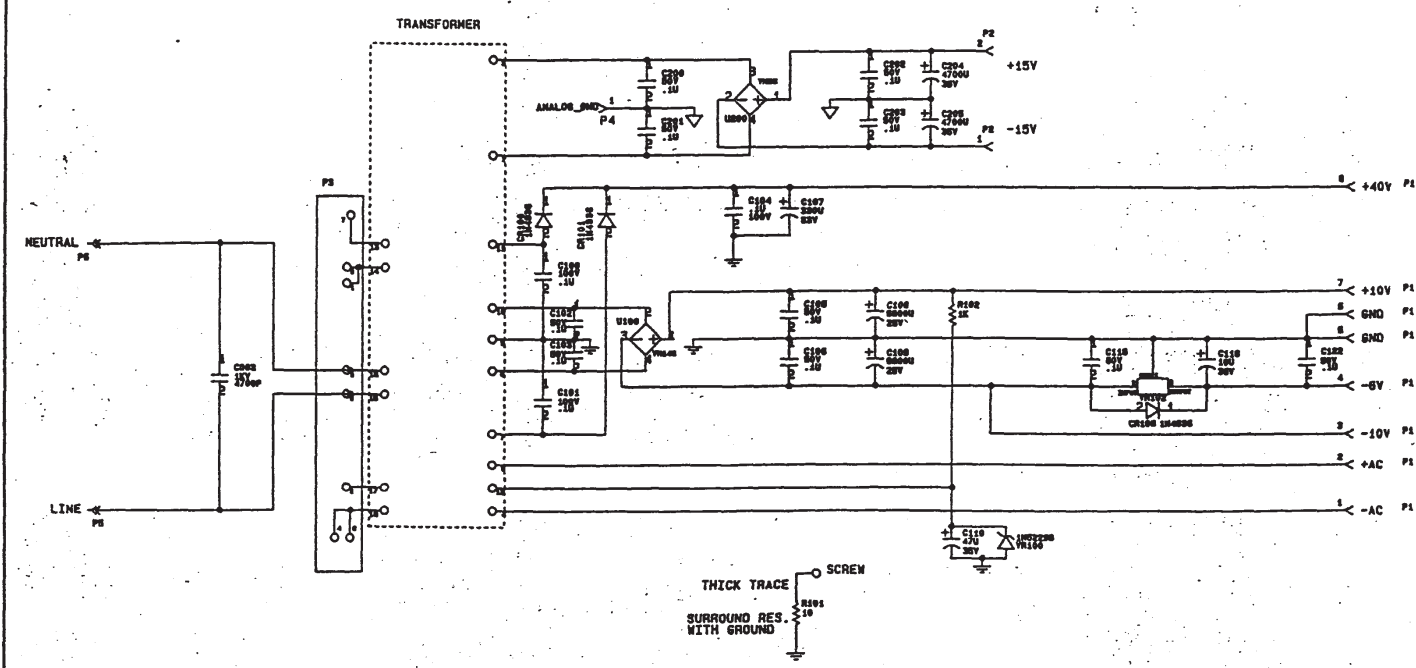

ORIGINAL PART NO

Part # 58002

DR

Part #

Release date

Type of release Prototype Final Production Other

Comments

Drawing approval Dingle 11/1/89

THICK TRACE
SURROUND RES
WITH GROUND

NOTES

AC MAINS	JUMP PINS ON TERMINAL BLOCK	
100V	5-6	2-3
120V	6-7	3-4
200V	1-2	
220V	4-5	
240V	7-8	

TELEPHONE				MAINSTREET			
UNLESS SPECIFIED				SEE MAIN STREET ADDITIONAL CONNECTIONS 6027 2-4-89			
FRONTIER 0-.005				MATERIAL			
MATERIAL 0-.005				SHEET OF SIZE			
MATERIAL 0-.005				A B C D E C			
DATE 0-11-89				USED IN			
BY SA/CO				NAME			
DATE 0-11-89				MATERIAL			
NAME				00-0000-00-00-00			
ISSUE	REVISION	DATE	SCALE:	MATERIAL			

CONNECTORS

P1 CONNECTOR TO AUDIO CARD OR PERS BOARD
 P2 CONNECTOR TO MAINS BOARD
 P3 CONNECTOR TO DISPLAY BOARD
 P4 CONNECTOR TO SERVO BOARD
 P5 CONNECTOR TO TRANSPORT LIMIT SWITCHES
 P6 CONNECTOR TO TRANSPORT DRAWER MOTOR

I.C. TABLE

SCHEMATIC REFERENCE	TYPE	PART NO.
U100	MICROPROCESSOR	MAB 8441-T082
U200	DECODER	SA47210
U300	DRAM	MN4264
U400	FILTER	SA47220
U600	MOTOR DRIVER	UDN2993B
VR001	+15 VOLT REG.	78L15
VR002	+5 VOLT REG.	7805

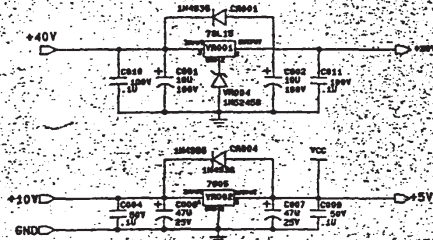

CONNECTOR TO PERS BOARD
 CONNECTOR TO AUDIO CARD

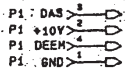

CONNECTOR TO DISPLAY BOARD

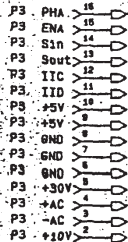

CONNECTOR TO MAINS BOARD

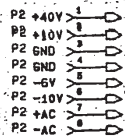

CONNECTORS TO TRANSPORT AND SERVO BOARD

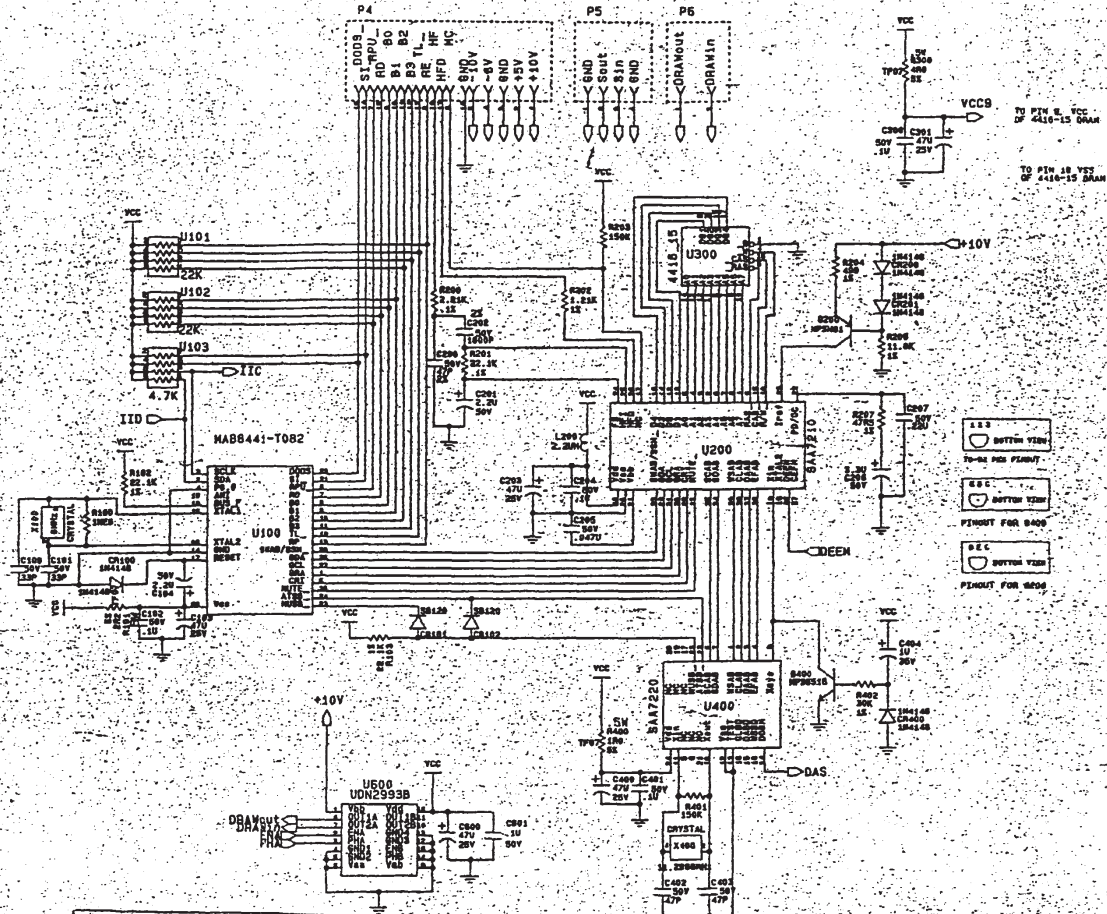

ORIGINAL OF RED
 Part No. 580204
 OR
 Part No. 940138
 Revision: 4/4/90
 Type of release: Prototype Final
 Comments: REV 4.2 WITH NEW CODES
580204 REV 11.87
 Drawing prepared by: [Signature] Engineering Supervisor
 Checked by: [Signature] Designer

CAD ID: MS/SA_CD/SCHEM/DECODER_BD
 COPIED FROM: MS/SA_CD/PCB/DECODER_BD/DESIGN 3-20-90

ISSUE	REVISION	DATE	SCALE	NAME	DECODER_BD	SHEET	OF	SIZE	
						MAINSTREET 3841 SOUTH MAIN STREET BOSTON CONNECTION 02107 U.S.A.			
						MATERIAL			
						USED IN	SACD		
						NO.	940138		

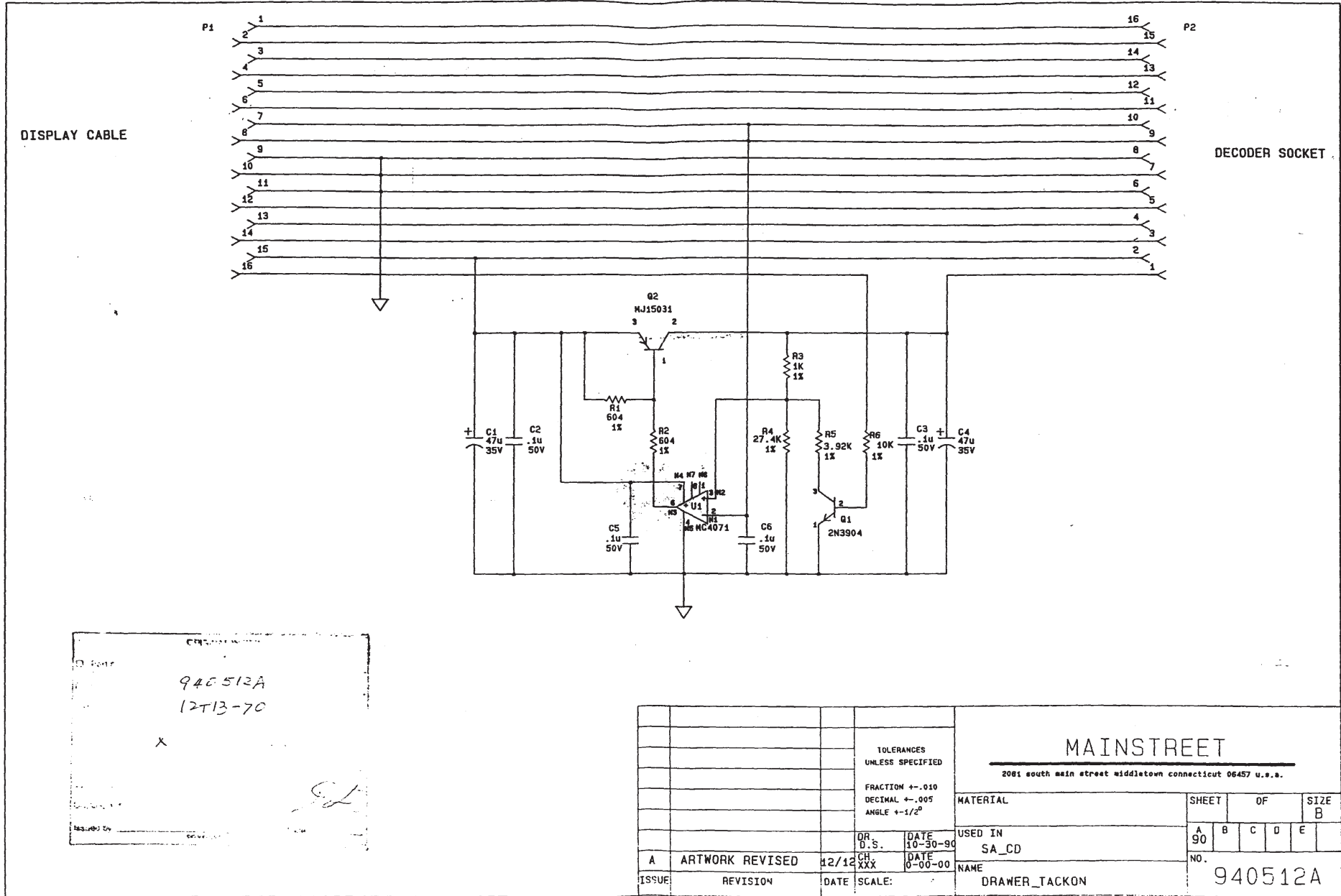

940512A
12/13-70

X

[Signature]

			TOLERANCES UNLESS SPECIFIED		MAINSTREET							
			FRACTION $\pm .010$		2081 south main street middletown connecticut 06457 u.s.a.							
			DECIMAL $\pm .005$		MATERIAL			SHEET	OF	SIZE		
			ANGLE $\pm 1/2^\circ$		USED IN			A	B	C	D	E
			OR D.S.		SA_CD			NO.				
			DATE 10-30-90		DRAWER_TACKON			940512A				
A			ARTWORK REVISED		DATE 12/12/70							
ISSUE			REVISION		DATE			SCALE:				

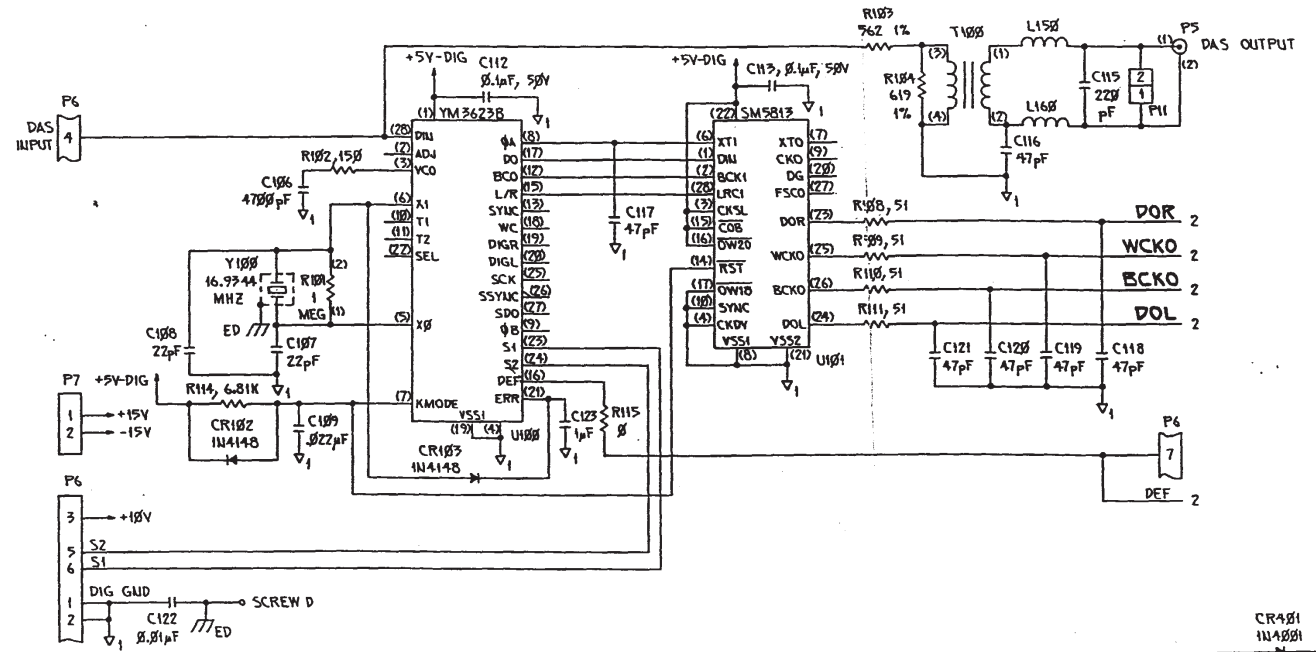
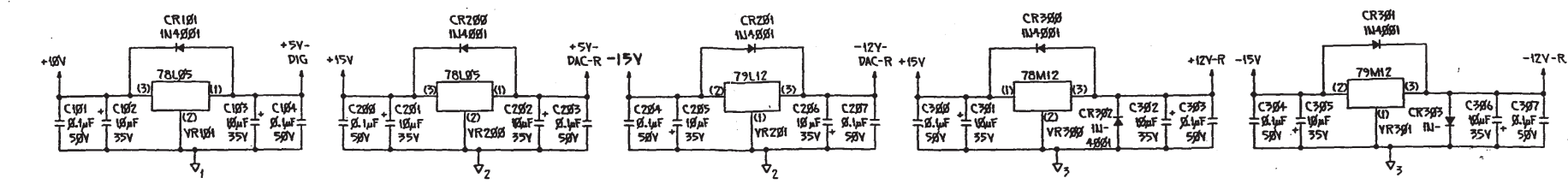

ORIGINAL IN REV

Part # 900071

OR

Print # 940755

Release date:

Type of release: Prototype Pilot
 1st production Revision

Comments:

Drafting approval: _____ Engineering approval: _____

Issued by: Daryl Bradley Date: 8-5-91

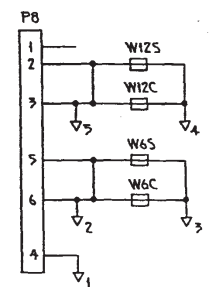
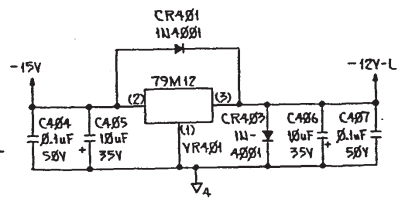
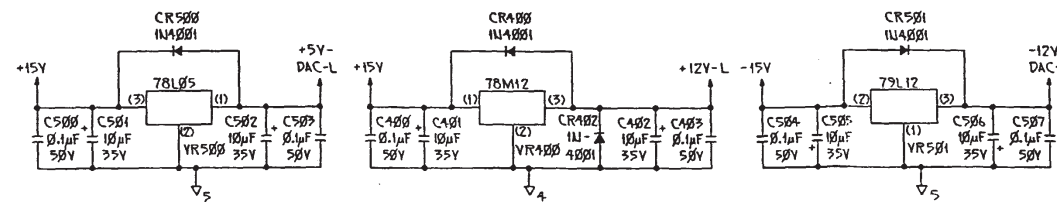

REV	DATE	DRAWN	CHECKED
3	2/5/91	ARTER	BB

TITLE

SCHEMATIC
AUDIO BOARD SERIES 2

DRAWING NO. 1DSCH PAGE 1 OF 2

Part # 900071
OR Print # 940755

PC board date: _____
Type of release: Pick up Revision
 Production

Comment: _____
Drawing approval: *Daryl B. Kelly* Date: 1-1-79
Issued by: *Daryl B. Kelly*

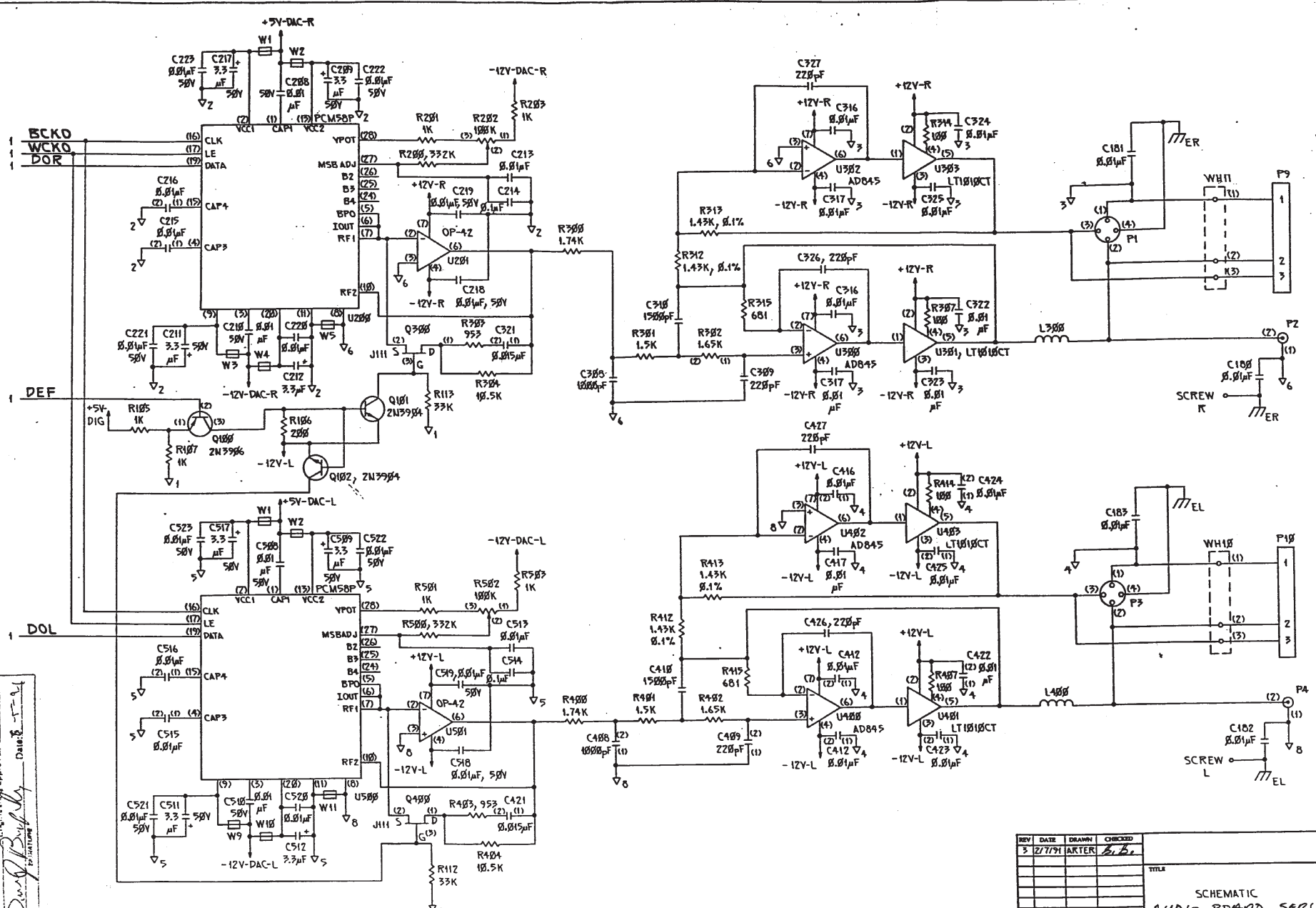

REV	DATE	DRAWN	CHECKED
3	2/7/91	ARTER	<i>h.b.</i>

TITLE: SCHEMATIC AUDIO BOARD SERIES 2
DRAWING NO.: D5CH PAGE 2 OF 2